



VICTORIA GOVERNMENT GAZETTE.

Published by Authority.

[Registered at the General Post Office, Melbourne, for transmission by post as a newspaper.]

No. 750]

WEDNESDAY, AUGUST 27.

[1952

ACTS OF PARLIAMENT.

PROCLAMATION

By the Lieutenant-Governor, as Deputy for His Excellency the Governor of the State of Victoria and its Dependencies in the Commonwealth of Australia, &c., &c., &c.

I, THE Lieutenant-Governor, as Deputy for the Governor of the State of Victoria, in the Commonwealth of Australia, do hereby declare that I have this day assented, in Her Majesty's name, to the Bills passed by the Parliament of the said State, the titles whereof are hereunder set forth, that is to say:—

No. 5624. "An Act to amend the Forests (Exchange of Lands) Act 1943."

No. 5625. "An Act with respect to the Funds of and the Raising of Loans and the Issue of Debentures and Inscribed Stock by the Geelong Harbor Trust Commissioners, and for other purposes."

Given under my Hand and the Seal of the State of Victoria aforesaid, at Melbourne, this twenty-sixth day of August, in the year of our Lord One thousand nine hundred and fifty-two, and in the first year of the reign of Her Majesty Queen Elizabeth II.

(L.S.) E. F. HERRING.

By His Excellency's Command,
JOHN G. B. McDONALD,
Premier.

GOD SAVE THE QUEEN!

The Fisheries Acts.

CLOSE SEASON FOR MACQUARIE PERCH, CALLOP AND SILVER PERCH OR GRUNTER.

PROCLAMATION

By the Lieutenant-Governor, as Deputy for His Excellency the Governor of the State of Victoria and its Dependencies in the Commonwealth of Australia, &c., &c., &c.

I, THE Lieutenant-Governor, as Deputy for the Governor of the State of Victoria, in the Commonwealth of Australia, by and with the advice of the Executive Council of the said State, and in pursuance of the provisions of the Fisheries Acts and all other powers me enabling in that behalf, do by this my Proclamation revoke the Proclamation made the first day of September, 1937, and published in the *Government Gazette* of the eighth day of September, 1937, respecting the close season for Macquarie

Perch, &c., and prescribe as a close season for Macquarie Perch, Callop (Golden Perch or Yellow Belly), and Silver Perch or Grunter, the period in each year from the first day of September to the thirtieth day of November next following (both days inclusive).

Given under my Hand and the Seal of the State of Victoria aforesaid, at Melbourne, this nineteenth day of August, in the year of our Lord One thousand nine hundred and fifty-two, and in the first year of the reign of Her Majesty Queen Elizabeth II.

(L.S.) E. F. HERRING.

By His Excellency's Command,
K. DODGSHUN,
Chief Secretary.

GOD SAVE THE QUEEN!

(Published in lieu of Proclamation appearing on page 4604 of *Government Gazette* dated the 20th August, 1952.)

MARKETING OF PRIMARY PRODUCTS ACT 1935
(No. 4337).

PROCLAMATION

By the Lieutenant-Governor, as Deputy for His Excellency the Governor of the State of Victoria and its Dependencies in the Commonwealth of Australia, &c., &c., &c.

IN pursuance of the provisions in that behalf contained in sub-section 2 of section 4 of the *Marketing of Primary Products Act 1935* (No. 4337), I, the Lieutenant-Governor, as Deputy for the Governor of the State of Victoria, in the Commonwealth of Australia, by and with the advice of the Executive Council of the said State, do by this my Proclamation declare the following to be a product for the purposes of the said Act (that is to say):—

SEED BEANS.

Given under my Hand and the Seal of the State of Victoria aforesaid, at Melbourne, this nineteenth day of August, in the year of our Lord One thousand nine hundred and fifty-two, and in the first year of the reign of Her Majesty Queen Elizabeth II.

(L.S.) E. F. HERRING.

By His Excellency Command,
GEORGE C. MOSS,
Minister of Agriculture.

GOD SAVE THE QUEEN!

Soldier Settlement Act 1946 (No. 5179).
ROADS CLOSED.

PROCLAMATION

By the Lieutenant-Governor, as Deputy for His Excellency the Governor of the State of Victoria and its Dependencies in the Commonwealth of Australia, &c., &c., &c.

WHEREAS section 6 (1) of the *Soldier Settlement Act 1946 (No. 5179)* prescribes that where any road (whether used or unused and whether formed or unformed) forms part of or intersects any estate and the Soldier Settlement Commission, after consultation with the council or councils of the municipality or municipalities concerned, certifies that the said road is unsuited to the proper subdivision of the estate:

And whereas the Soldier Settlement Commission, after consultation with the councils of the municipalities concerned, has so certified:

Now therefore, I, the Lieutenant-Governor, as Deputy for the Governor of the State of Victoria, in the Commonwealth of Australia, by and with the advice of the Executive Council of the said State, and in pursuance of section 6 of the *Soldier Settlement Act 1946 (No. 5179)*, do by this my Proclamation direct that the roads, as described hereunder, be closed, that is to say:—

Parish of Boikerbert, County of Lowan, being the road indicated by hachure on plan hereunder.—(B.643⁽²⁾) (D.4581).

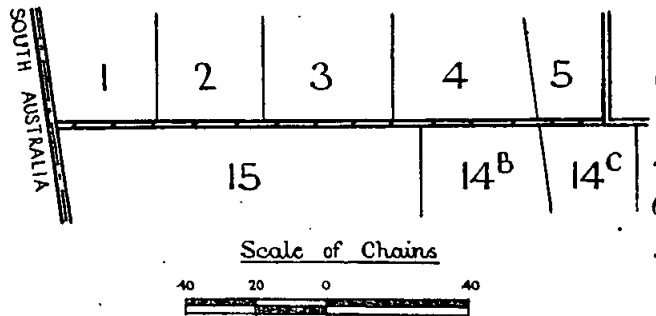

Parish of Boikerbert, County of Lowan, being the road between allotments 17, 18, 19E, 19D, 19B, Parish of Boikerbert, and allotments 39, 38, 38A, 37B, 37A, Parish of Wytwarrone.—(B.643⁽²⁾) (W.294⁽²⁾) (D.4581).

Parish of Wytwarrone, County of Lowan, being the road between allotments 37A, 37c, 37E, 37F, 37D and allotments 36A, 36B.—(W.294⁽²⁾) (D.4581).

Parish of Wytwarrone, County of Lowan, being the road between allotment 30A and allotment 31B.—(W.294⁽²⁾) (D.4581).

Parish of Darlington West, County of Hampden, being the road between allotments 43B, 44A, 44B, 45A, 45B and allotments 61A, 60A, 59A, 58A.—(D.5⁽²⁾) (D.909).

Parish of Mardan, County of Buln Buln, being the road indicated by hachure on plan hereunder.—(M.524⁽⁴⁾) (D.13525).

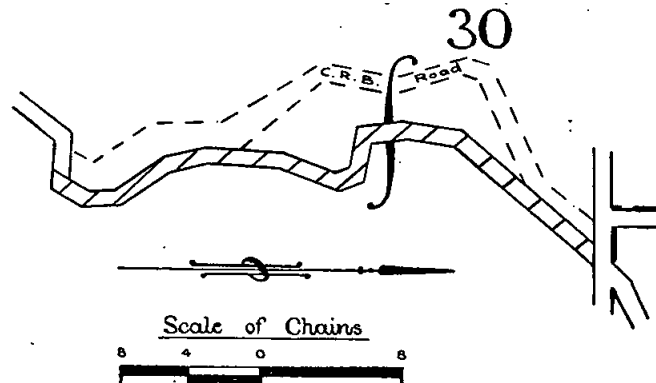

Parishes of Dunkeld and Moutajup, Counties of Villiers and Dundas, being the roads indicated by hachure on plan hereunder.—(D.142⁽¹⁾) (M.421⁽²⁾) (D.3144).

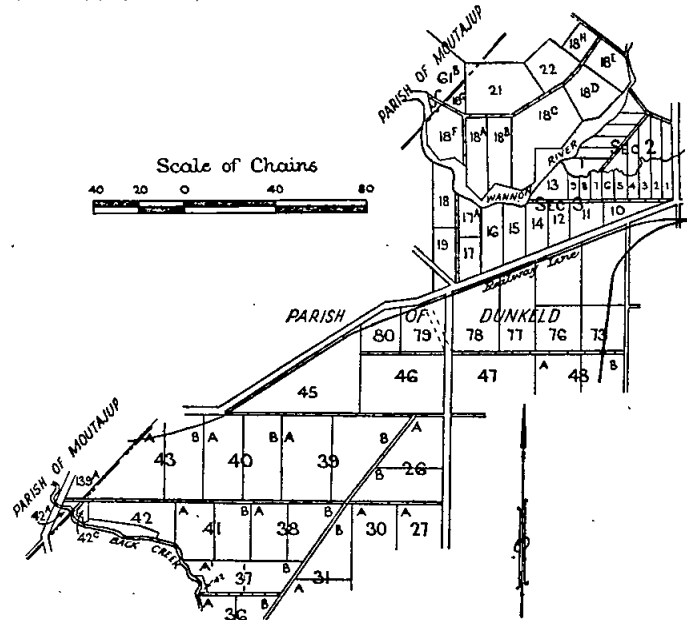

Parish of Moutajup, County of Dundas, being the roads indicated by hachure on plan hereunder.—(M.421⁽²⁾) (D.3144).

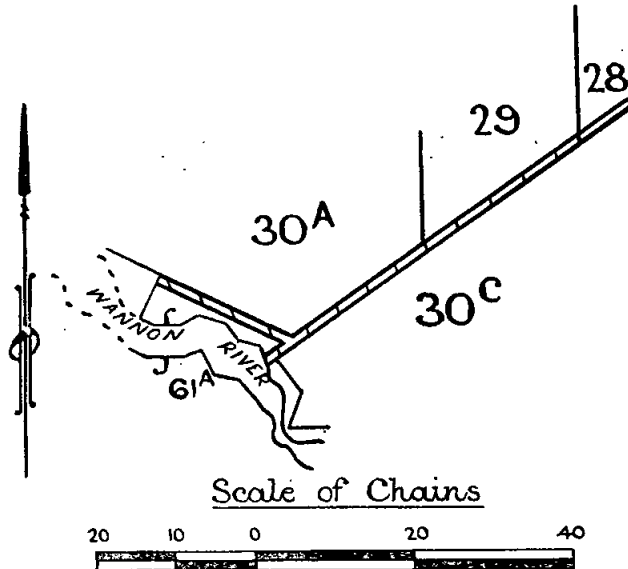

Parish of Moutajup, County of Dundas, being the road indicated by hachure on plan hereunder.—(M.421⁽²⁾) (D.3144).

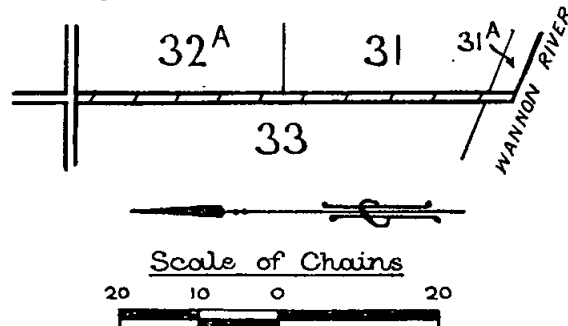

Parish of Dunkeld, County of Villiers, being the roads indicated by hachure on plan hereunder.—(D.142⁽¹⁾) (D.3144).

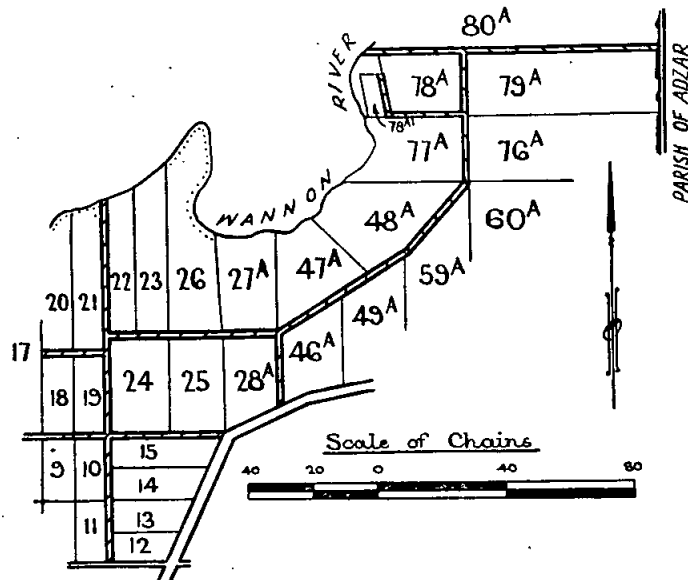

Parish of Moutajup, County of Dundas, being the road indicated by hachure on plan hereunder.—(M.421⁽²⁾) (D.3144).

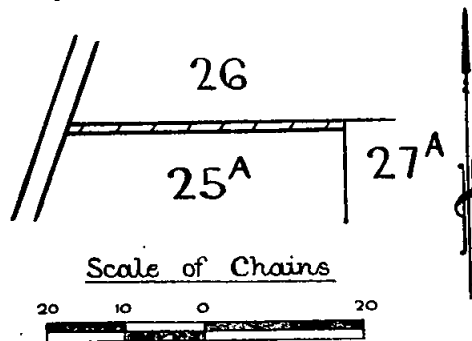

Parish of Merrymbuela, County of Ripon, being the roads indicated by hachure on plan hereunder.—(M.404⁽²⁾) (D.1325).

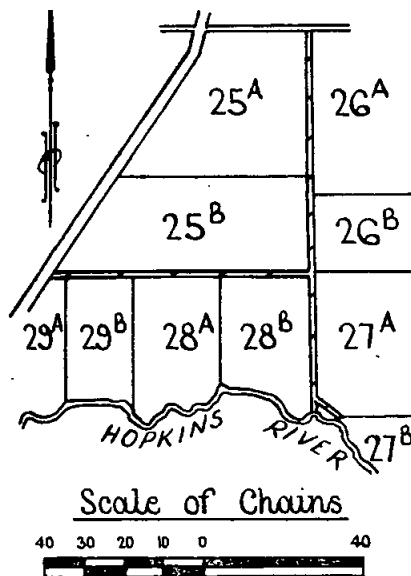

Parish of Eurambeen, County of Ripon, being the road between allotments 51A, 51B, Parish of Eurambeen, and allotments 88, 89A, 89B, Parish of Shirley.—(E.94⁽²⁾) (S.265⁽²⁾) (D.17299).

Parish of Shirley, County of Ripon, being the road between allotments 84, 93 and allotments 85, 92.—(S.265⁽²⁾) (D.17299).

Parish of Woodnaggerak, County of Ripon, being the road between allotments 83A, 83B, 84A, 84B, Parish of Woodnaggerak, and allotments 77, 100, Parish of Shirley.—(W.251⁽³⁾) (S.265⁽²⁾) (D.17299).

Parish of Woodnaggerak, County of Ripon, being the road between allotment 90 and allotment 91.—(W.251⁽³⁾) (D.17299).

Parish of Harrow, County of Lowan, being the road between allotment 9 and allotment 16.—(H.49⁽²⁾) (D.17507).

Parish of Merrymbuela, County of Ripon, being the road between allotments 16A, 15A, 14B, 13B² and allotments 17A, 18A, 19A, 20A.—(M.404⁽²⁾) (D.1325).

Parish of Merrymbuela, County of Ripon, being the road between allotments 22B, 23A, 23B and allotments 30A, 30B.—(M.404⁽²⁾) (D.1325).

Parish of Merrymbuela, County of Ripon, being the road between allotments 35B, 34B, 33B, 32B and allotments 36A, 37C, 37A², 38A, 39A, 39A¹.—(M.404⁽²⁾) (D.1325).

Parish of Mageppa, County of Follett, being the road between allotments 10, 13 and allotments 25, 24.—(M.460(A⁴)) (D.13410).

Parish of Numbie-Munjie, County of Tambo, being the road between allotment 3, the western portion of allotment 4, section 3, and the eastern portion of allotment 4, section 3.—(N.92⁽²⁾) (D.16405).

Parish of Numbie-Munjie, County of Tambo, being the road between allotment 10, section 3, and allotment 10A, section 3.—(N.92⁽²⁾) (D.16405).

Parish of Samaria, County of Delatite, being the road between allotment 4, the western portion of allotment 61, and allotments 5, 36.—(S.236⁽⁴⁾) (D.5483).

Parish of Samaria, County of Delatite, being the road between allotments 5, 6, 7, 8 and allotments 36, 35, 34, 33.—(S.236⁽⁴⁾) (D.5483).

Parish of Samaria, County of Delatite, being the road between allotments 8, 33 and allotments 9, 32.—(S.236⁽⁴⁾) (D.5483).

Parish of Kalyrna, County of Ripon, being the roads indicated by hachure on plan hereunder.—(K.99⁽²⁾) (M.404⁽²⁾) (D.1325).

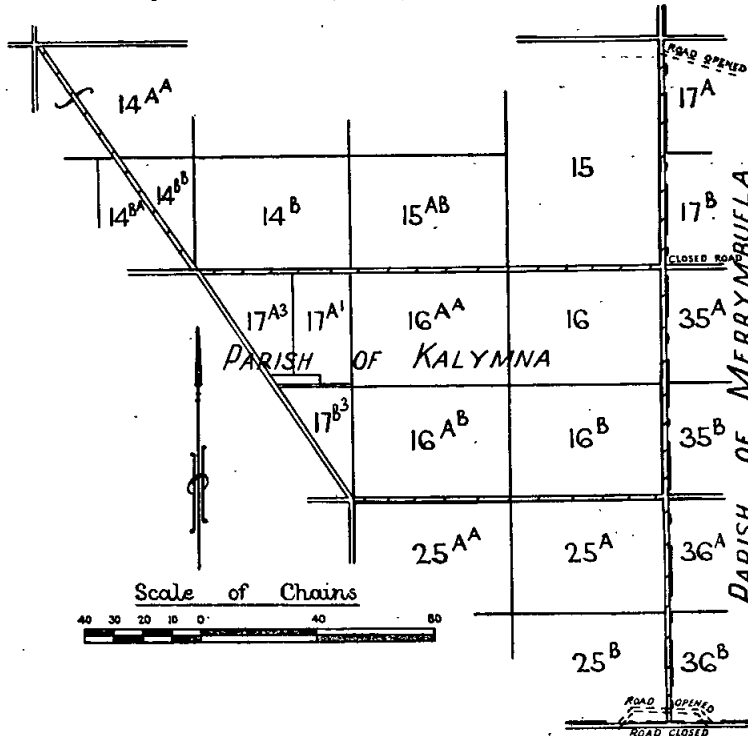

Parish of Samaria, County of Delatite, being the roads indicated by hachure on plan hereunder.—(S.236⁽⁴⁾) (D.5483).

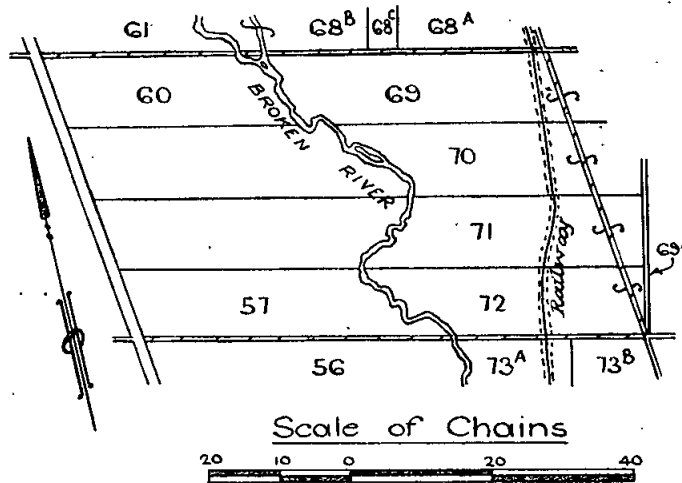

Given under my Hand and the Seal of the State of Victoria aforesaid, at Melbourne, the twenty-sixth day of August, in the year of our Lord One thousand nine hundred and fifty-two, and in the first year of the reign of Her Majesty Queen Elizabeth II.

(L.S.)

E. F. HERRING.

By His Excellency's Command,

A. E. LIND,

Commissioner of Crown Lands and Survey.

GOD SAVE THE QUEEN!

Health Acts.

AMENDMENT OF PROCLAMATION CONSTITUTING A MEAT AREA.

PROCLAMATION

By the Lieutenant-Governor, as Deputy for His Excellency the Governor of the State of Victoria and its Dependencies in the Commonwealth of Australia, &c., &c.

BY virtue of the powers conferred by the Health Acts, I, the Lieutenant-Governor, as Deputy for the Governor of the State of Victoria, in the Commonwealth of Australia, on the recommendation of the Commission of Public Health, and by and with the advice of the Executive Council of the said State, do by this my Proclamation amend the Proclamation dated the seventh day of September, 1948, constituting the Kyneton Meat Area by deleting therefrom the expression:—

"This Proclamation shall take effect on the first day of September, 1952,"

and substituting therefor the expression:—

"This Proclamation shall take effect on the first day of January, 1953."

Given under my Hand and the Seal of the State of Victoria aforesaid, at Melbourne, this twenty-sixth day of August, in the year of our Lord One thousand nine hundred and fifty-two, and in the first year of the reign of Her Majesty Queen Elizabeth II.

(L.S.)

E. F. HERRING.

By His Excellency's Command,

W. O. FULTON,

Minister of Health.

GOD SAVE THE QUEEN!

Health Acts.

AMENDMENT OF PROCLAMATION CONSTITUTING A MEAT AREA.

PROCLAMATION

By the Lieutenant-Governor, as Deputy for His Excellency the Governor of the State of Victoria and its Dependencies in the Commonwealth of Australia, &c., &c.

BY virtue of the powers conferred by the Health Acts, I, the Lieutenant-Governor, as Deputy for the Governor of the State of Victoria, in the Commonwealth of Australia, on the recommendation of the Commission of Public Health, and by and with the advice of the Executive Council of the said State, do by this my Proclamation amend the Proclamation dated the eighteenth day of March, 1947, constituting the Corangamite Meat Area, by deleting therefrom the expression:—

"This Proclamation shall take effect on the first day of September, 1952."

and substituting therefor the expression:—

"This Proclamation shall take effect on the first day of January, 1953."

Given under my Hand and the Seal of the State of Victoria aforesaid, at Melbourne, this twenty-sixth day of August, in the year of our Lord One thousand nine hundred and fifty-two, and in the first year of the reign of Her Majesty Queen Elizabeth II.

(L.S.)

E. F. HERRING.

By His Excellency's Command,

W. O. FULTON,

Minister of Health.

GOD SAVE THE QUEEN!

LOCAL GOVERNMENT ACT.

PROCLAMATION EXTENDING THE OPERATION OF THE UNIFORM BUILDING REGULATIONS.

By the Lieutenant-Governor, as Deputy for His Excellency the Governor of the State of Victoria and its Dependencies in the Commonwealth of Australia, &c., &c., &c.

WHEREAS section 900 (2) of the *Local Government Act 1946* provides—*inter alia*—that the Governor in Council may, by Proclamation published in the *Government Gazette*, at the request of the council of any municipality (not being a city or town), extend the operation of the Regulations made under Part XLIX. of the Act to the municipal district of such municipality or any part thereof:

And whereas the operation of the said Regulations was extended to part of the municipal district of the Shire of Morwell by an Order in Council published in the *Government Gazette* of the 16th January, 1946:

And whereas the operation of the said Regulations was extended to part of the municipal district of the Shire of Tambo by an Order in Council published in the *Government Gazette* of the 29th September, 1948:

And whereas the Councils of the Shires of Morwell and Tambo have requested that the operation of the said Regulations be extended to further parts of the municipal districts of such municipalities:

Now, therefore, I, the Lieutenant-Governor, as Deputy for the Governor of the State of Victoria, by and with the advice of the Executive Council thereof, by this, my Proclamation, do hereby extend the operation of the Regulations made under Part XLIX. of the *Local Government Act 1946* to those parts of the municipal district of the Shire of Morwell to which the operation of the Regulations has not previously been extended, and to those parts of the municipal district of the Shire of Tambo described hereunder:—

- (1) All that piece of land commencing at Maringa Creek on the eastern boundary of Crown allotment 5A, Parish of Colquhoun; thence northerly along said boundary to the angle in the road in Crown allotment 103; thence easterly along the southern boundaries of Crown allotments 103, 102A, and 102B; thence northerly to the southern corner of Crown allotment 101H; thence north-easterly along the boundary of Crown allotment 101H to a point on the eastern side of the Princes Highway; thence north-westerly along the boundary of Crown allotment 90 to the western corner of said Crown allotment; thence north-easterly and easterly along the northern boundaries of Crown allotments 90, 85A, and 85 to a point on the western coast of the north arm opposite said northern boundary of Crown allotment 85; thence southerly, south-westerly, and westerly along the coast lines of the north arm and Maringa Creek to the commencing point, but excluding the Township of Kalimna; and
- (2) all that piece of land commencing at a point on the eastern coast of the north arm opposite the north-west corner of Crown allotment 5, section A, Parish of Colquhoun; thence north-easterly along the northern boundaries of Crown allotments 5, 4, 3, and 1, section A, to the north-east corner of Crown allotment 1, section A; thence in a straight line across Crown allotment 124 to the north-west corner of Crown allotment 126; thence generally easterly along the northern boundaries of Crown allotments 126 and 30A in the Parish of Colquhoun, and the northern boundaries of Crown allotments 31, 37, and 38 in the Township of Cunninghame, to a point on the western boundary of Crown allotment 17 opposite said northern boundaries; thence in a clockwise direction around the boundaries of the Township of Cunninghame to the coastline of Cunninghame Arm; thence south-westerly along the coastline of Cunninghame Arm to the North Arm; thence generally north-easterly and northerly along the coastline of the North Arm to the commencing point, but excluding the Township of Lakes Entrance;
- (3) all that land in the Township of Bruthen, commencing on the bank of the Tambo River at the south-east corner of Crown allotment J; thence north-westerly along the western boundaries of Crown allotments 1 and 24; thence north-easterly along the northern boundary of Crown allotment 24 to the south-west corner of Crown allotment 25A; thence north-westerly along the western

boundary of Crown allotment 25A; thence north-easterly along the northern boundary of Crown allotment 25A produced to the western boundary of Crown allotment 27; thence northerly along the western boundary of Crown allotment 27 to the north-west corner of Crown allotment 27; thence north-easterly along the northern boundary of Crown allotment 27; thence north-westerly along the western boundary of Crown allotment 27A to the north-west corner of said allotment; thence north-easterly along the northern boundary of Crown allotment 27A to the south-west corner of Crown allotment 27B; thence northerly along the western boundary of Crown allotment 27B; thence easterly along the northern boundary of Crown allotment 27B; thence southerly along the eastern boundary of Crown allotment 27B to a point opposite the northern boundary of section A; thence easterly along the northern boundary of section A to the north-east corner of Crown allotment 15, section A; thence southerly and south-westerly along the eastern boundaries of Crown allotments 15, 16, 17, 18, 19, 20, 34, 35, 36, 37, and 38, section A, and Crown allotments 24A¹ and 24A to the south-east corner of Crown allotment 24A; thence in a straight line to the Tambo River at the most southern point of Crown allotment 30; thence generally westerly along the bank of the Tambo River to the commencing point, but excluding the Township of Bruthen.

And do further provide that the said Regulations (other than those contained in Parts I. and II. of Chapter 8 thereof) shall come into operation in the above-mentioned parts of the municipal districts of the Shires of Morwell and Tambo on publication of this Proclamation in the *Government Gazette*, and that the Regulations contained in the said Parts I. and II. of Chapter 8 shall come into operation therein on the 13th day of November, 1952.

Given under my Hand and the Seal of the State of Victoria aforesaid, at Melbourne, this nineteenth day of August, in the year of our Lord One thousand nine hundred and fifty-two, and in the first year of the reign of Her Majesty Queen Elizabeth II.

(L.S.)

E. F. HERRING.

By His Excellency's Command,

P. T. BYRNES,
Commissioner of Public Works.

GOD SAVE THE QUEEN!

PUBLIC HIGHWAY—SHIRE OF CRANBOURNE.

AMENDMENT OF PROCLAMATION

By the Lieutenant-Governor, as Deputy for His Excellency the Governor of the State of Victoria and its Dependencies in the Commonwealth of Australia, &c., &c., &c.

WHEREAS it is provided under section 518 of the *Local Government Act 1946* that, when in regard to any Proclamations made by the Governor in Council pursuant to this section or any corresponding previous enactment, the Minister is satisfied that an error or misdescription has been made, the Governor in Council may rescind, revoke, amend, or vary such Proclamation in whole or in part, as the case requires:

And whereas in a Proclamation dated the 8th day of April, 1952, and published in the *Government Gazette* of the 18th April, 1952, at page 1847, an error or misdescription was made:

Now, therefore, I, the Lieutenant-Governor, as Deputy for the Governor of the State of Victoria, by and with the advice of the Executive Council thereof, do hereby vary such Proclamation by substituting, in the description of East-road, for the words and figures "Crown Allotment 56," the words and figures "Crown Allotment 58."

Given under my Hand and the Seal of the State of Victoria, at Melbourne, this nineteenth day of August, in the year of our Lord One thousand nine hundred and fifty-two, and in the first year of the reign of Her Majesty Queen Elizabeth II.

(L.S.)

E. F. HERRING.

By His Excellency's Command,

P. T. BYRNES,
Commissioner of Public Works.

GOD SAVE THE QUEEN!

PUBLIC HIGHWAY—BOROUGH OF RINGWOOD.

PROCLAMATION

By the Lieutenant-Governor, as Deputy for His Excellency the Governor of the State of Victoria and its Dependencies in the Commonwealth of Australia, &c., &c., &c.

WHEREAS by the *Local Government Act 1946* (No. 5203), section 518, it is amongst other things enacted that it shall be lawful for the Governor in Council at any time, and from time to time, upon the request of the council of any municipality, by notice in the *Government Gazette*, to declare any land reserved, used, or by purchase or exchange acquired for a street, road, highway, thoroughfare, bridge, square, court, alley or right-of-way, to be a public highway, and that such land shall thereupon and thenceforth from the date of such Proclamation become and be absolutely dedicated to the public as a public highway within the meaning of any law then or thereafter in force: And whereas the Council of the Borough of Ringwood has requested that the land hereinafter mentioned, which has been used for a street within the Borough, be so declared to be a public highway: Now, therefore, I, the Lieutenant-Governor, as Deputy for the Governor of the State of Victoria, in the Commonwealth of Australia, by and with the advice of the Executive Council of the said State, do, by this Proclamation declare that all that piece of land described hereunder, being part of Crown allotment 20A, Parish of Ringwood, County of Mornington, shown as Leonard-street on plan of subdivision No. 11019, lodged at the Office of Titles, shall be a public highway within the meaning of the said Act, viz.:—

LEONARD-STREET.

Commencing at a point on the north side of Maroondah Highway, 740 ft. 3 in. north-easterly from the eastern intersection of the Government road shown as Rupert-street on lodged plan No. 11019; thence bounded by a line bearing 314 deg. 14 min. for a distance of 142 ft. 4½ in.; thence bearing 332 deg. 58 min. for a distance of 74 ft. 1 in.; thence bearing 314 deg. 14 min. for a distance of 849 ft. 10 in.; thence bearing 84 deg. 16 min. for a distance of 65 ft. 4 in.; thence bearing 134 deg. 14 min. for a distance of 811 ft. 0 in.; thence bearing 152 deg. 58 min. for a distance of 74 feet; thence bearing 134 deg. 14 min. for a distance of 134 feet back to the northerly building line of Maroondah Highway; thence south-westerly along the northern building line of Maroondah Highway for a distance of 50 feet to the commencing point.

Given under my Hand and the Seal of the State of Victoria aforesaid, at Melbourne, this nineteenth day of August, in the year of our Lord One thousand nine hundred and fifty-two, and in the first year of the reign of Her Majesty Queen Elizabeth II.

(L.S.) E. F. HERRING.

By His Excellency's Command,
P. T. BYRNES,
Commissioner of Public Works.
GOD SAVE THE QUEEN!

PUBLIC HOLIDAYS.

PROCLAMATION

By the Lieutenant-Governor, as Deputy for His Excellency the Governor of the State of Victoria and its Dependencies in the Commonwealth of Australia, &c., &c., &c.

IN pursuance of the provisions contained in Part III. of the *Public Service Act 1946*, I, the Lieutenant-Governor of the State of Victoria, in the Commonwealth of Australia, by and with the advice of the Executive Council of the said State, do by this my Proclamation appoint the days and dates hereunder mentioned to be observed as Public Holidays or Public Half-Holidays (as the case may be) at the places respectively specified, viz.:—

Public Holidays:—

WEDNESDAY, THE 24TH DAY OF SEPTEMBER, 1952, throughout the Shire of Kilmore.
WEDNESDAY, THE 8TH DAY OF OCTOBER, 1952, throughout the Central Riding of the Shire of Rochester, and throughout the Shire of Rutherglen.
THURSDAY, THE 9TH DAY OF OCTOBER, 1952, throughout the Shire of Warracknabeal.

FRIDAY, THE 31ST DAY OF OCTOBER, 1952, throughout the South and West Ridings of the Shire of Huntly, and throughout the Shire of Marong.

SATURDAY, THE 27TH DAY OF DECEMBER, 1952, throughout the State of Victoria.

FRIDAY, THE 2ND DAY OF JANUARY, 1953, throughout the State of Victoria.

Public Half-Holidays from the Hour of Twelve o'clock noon:—

THURSDAY, THE 9TH DAY OF OCTOBER, 1952, throughout the Shire of Seymour.

WEDNESDAY, THE 15TH DAY OF OCTOBER, 1952, throughout the Shire of Cohuna.

FRIDAY, THE 31ST DAY OF OCTOBER, 1952, throughout the Borough of Eaglehawk.

Given under my Hand and the Seal of the State of Victoria aforesaid, at Melbourne, this twenty-sixth day of August, in the year of our Lord One thousand nine hundred and fifty-two, and in the first year of the reign of Her Majesty Queen Elizabeth II.

(L.S.) E. F. HERRING.

By His Excellency's Command,
K. DODGSHUN,
Chief Secretary.

GOD SAVE THE QUEEN!

BANK HOLIDAYS.

PROCLAMATION

By the Lieutenant-Governor, as Deputy for His Excellency the Governor of the State of Victoria and its Dependencies in the Commonwealth of Australia, &c., &c., &c.

IN pursuance of the provisions of the Banks and Currency Acts, I, the Lieutenant-Governor of the State of Victoria, in the Commonwealth of Australia, do by this my Proclamation appoint the days and dates named hereunder special days to be observed as Bank Holidays or Bank Half-Holidays (as the case may be) at the places respectively mentioned, that is to say:—

Bank Holiday:—

SATURDAY, THE 13TH DAY OF SEPTEMBER, 1952, at Wodonga.
Bank Half-Holiday from the Hour of Twelve o'clock noon:—

THURSDAY, THE 9TH DAY OF OCTOBER, 1952, at Warracknabeal.

Given under my Hand and the Seal of the State of Victoria aforesaid, at Melbourne, this twenty-sixth day of August, in the year of our Lord One thousand nine hundred and fifty-two, and in the first year of the reign of Her Majesty Queen Elizabeth II.

(L.S.) E. F. HERRING.

By His Excellency's Command,
K. DODGSHUN,
Chief Secretary.

GOD SAVE THE QUEEN!

Weights and Measures Act 1928, section 35.

FIRST MEETING OF MANAGERS FOR EAST LODDON WEIGHTS AND MEASURES UNION.

PURSUANT to the provisions of section 35 of the *Weights and Measures Act 1928*, I hereby fix the time of the first meeting of the managers for the East Loddon Weights and Measures Union, comprising the Borough of Inglewood and the Shires of Bet Bet, East Loddon, Gordon, Korong, and Wycheproof as Friday, the nineteenth day of September, 1952, and do fix the Council Chambers, Shire Hall, Wycheproof, as the place of such meeting.

K. DODGSHUN,
Chief Secretary.

Chief Secretary's Office,
Melbourne, 12th August, 1952.

APPOINTMENTS.

THE Lieutenant-Governor, as Deputy for His Excellency the Governor of the State of Victoria, by and with the advice of the Executive Council thereof, has, by Orders made on the 19th day of August, 1952, been pleased to make the under-mentioned appointments, viz.:

DEPARTMENT OF CROWN LANDS AND SURVEY.

Bailiff of Crown Lands.

NEIL COX, 17 Cobden-street, South Melbourne, to be a Bailiff of Crown Lands, without salary.

LAW DEPARTMENT.

Magistrates.

GEORGE MAHONEY, Junior, Fernhurst, via Mysia, and NORMAN JOSEPH OLIVER, 498 Hargreaves-street, Bendigo,

to Keep the Peace in the Midland Bailiwick of the State of Victoria;

GERALD ALBERT BARRY, 108 Warrigal-road, Mentone, and

HECTOR FRASER ALCOCK, 19 Pollina-street, East Bentleigh,

to Keep the Peace in the Central Bailiwick of the State of Victoria;

SAMUEL HUGH SLATER, Corack East, via Donald, and THOMAS MONTGOMERY BRADSHAW, Terang,

to Keep the Peace in the Western Bailiwick of the State of Victoria; and

JAMES FRANCIS WHELAHAN, Duncan-street, Ballan, to Keep the Peace in the Central and Southern Bailiwicks of the State of Victoria.

Commissioners for Taking Declarations, &c.

ERIC WILLIAM POPPLE, Goulburn-street, Seymour, EDWARD JAMES WILLEY, 18 Hutchinson-street, Sunshine, EWART MCKILLOP CAPPUR WEBB, Seymour, GEORGE MORISON, Mangalore Park, Mangalore, EILEEN EDWARDS, Seymour,

PERCY WILLIAM FLINTON, 4 Spring-street, Box Hill, ROBERT GEORGE BENNETT, Jenner-street, Birregurra, HERMINE LOTTIE PAULINE GILBERT, 41 Kensington-street, South Yarra,

DAVID JOSEPH TIMOTHY ANGLIM, 641 Punt-road, South Yarra,

DAVID HENDERSON, Unit 13 E Area, Fawkner Park, South Yarra, and

FRANCIS JAMES REEVES, c/o George Pizzev and Son Ltd., Johnston-street, Fitzroy,

to be Commissioners for taking Declarations and Affidavits, pursuant to the provisions of Division 8 of Part IV. of the *Evidence Act 1928*, to resign upon removing from the neighbourhood of the addresses stated; and

EUSTACE LEONARD WHEARE, c/o Australian Mutual Provident Society, 425 Collins-street, Melbourne,

to be a Commissioner for taking Declarations and Affidavits, pursuant to the provisions of Division 8 of Part IV. of the *Evidence Act 1928*, to resign upon ceasing to be an officer of the Australian Mutual Provident Society; and

ALBERT LESLIE AKERS, RAEMOND HAROLD HOOPER, RONALD WILLIAM HOWLETT, ROBERT WILLIAM MUNSON, CHARLES MAURICE O'CONNELL, HENRY JOHN POCKNEE, and JOHN ALFRED SPARKES,

Inspectors of Land Settlement, Department of Lands and Survey, Melbourne,

to be Commissioners for taking Declarations and Affidavits, pursuant to the provisions of Division 8 of Part IV. of the *Evidence Act 1928*, to resign upon ceasing to occupy their present positions.

Probation Officers for Children's Courts.

GEOFFREY CLEUGH DERMER, Prisoners' Aid Society, Russell-street, Melbourne,

to be a Probation Officer for the Children's Court at Melbourne, pursuant to the provisions of section 8 of the *Children's Court Act 1928*.

SYDNEY ALFRED GODDARD, 4 Lyons-street south, Ballarat, to be a Probation Officer for the Children's Court at Ballarat, pursuant to the provisions of section 8 of the *Children's Court Act 1928*.

ANDREW BOAG, Tatura,

to be a Probation Officer for the Children's Court at Tatura, pursuant to the provisions of section 8 of the *Children's Court Act 1928*.

JOHN WILLIAM ROBERT WESTERMAN, Korumburra, to be a Probation Officer for the Children's Court at Korumburra, pursuant to the provisions of section 8 of the *Children's Court Act 1928*.

JAMES CAHILL, 5 Banks-street, East Brunswick, to be a Probation Officer for the Children's Court at Brunswick, pursuant to the provisions of section 8 of the *Children's Court Act 1928*.

WILLIAM GEORGE O'CONNOR, 423 Dorcas-street, South Melbourne,

to be a Probation Officer for the Children's Court at South Melbourne, pursuant to the provisions of section 8 of the *Children's Court Act 1928*.

Clerk of Children's Courts.

EWEN LESLIE ROSS,

to be Clerk of the Children's Courts at Wodonga, Chiltern, and Rutherglen, during the absence on annual leave of H. V. Boarder, to take effect from the date of commencement of duty.

DEPARTMENT OF WATER SUPPLY.

Waterworks Trust Commissioners.

GORDON WILLIAM COSSENS

to be a Commissioner of the Murrayville Waterworks Trust, *vice* James Vincent Murphy, resigned, and to hold office as such from the date hereof until the 16th day of April, 1955, subject to the provisions of the Water Acts; and

ERNEST ALEXANDER RIED

to be a Commissioner of the Tallangatta Waterworks Trust for a period of four years from the date hereof, subject to the provisions of the Water Acts.

A. MAHLSTEDT,

Clerk of the Executive Council.

At the Executive Council Chamber, Melbourne, 19th August, 1952.

RESIGNATION.

THE Lieutenant-Governor, as Deputy for His Excellency the Governor of the State of Victoria, by and with the advice of the Executive Council thereof, has, by Order made on the 19th day of August, 1952, accepted the resignation of the person named hereunder of the office mentioned, viz.:

LAW DEPARTMENT.

JOHN MERTON HEAD, as a Commissioner for taking Declarations and Affidavits, pursuant to the provisions of the *Evidence Act 1928*.

A. MAHLSTEDT,

Clerk of the Executive Council.

At the Executive Council Chamber, Melbourne, 19th August, 1952.

Dairy Products Acts.

QUOTAS FOR BUTTER AND CHEESE.

BUTTER QUOTA.

I GEORGE COLIN MOSS, Minister of Agriculture in the State of Victoria, after consultation with the Victorian Dairy Products Board, and after ascertaining that the supply and distribution of butter at reasonable prices to consumers thereof in Victoria will be ensured, hereby determine a quota for butter as follows:—

The proportion shall be sixty-three point one six per cent.

The period for which this quota is to operate shall be the month of September, 1952.

CHEESE QUOTA.

I GEORGE COLIN MOSS, Minister of Agriculture in the State of Victoria, after consultation with the Victorian Dairy Products Board, and after ascertaining that the supply and distribution of cheese at reasonable prices to consumers thereof in Victoria will be ensured, hereby determine a quote for cheese as follows:—

The proportion shall be fifty-two point three eight per cent.

The period for which this quota is to operate shall be the month of September, 1952.

GEORGE C. MOSS,

Minister of Agriculture.

19th August, 1952.

CONTRACTS ACCEPTED.—(Series 1952-53.)

Contract No.	Particulars.	Amount.	Name of Contractor.	Charge Against Vote or Fund.
	GOVERNMENT PRINTER— Supply and delivery of Printing Paper, Writing Paper, &c., required by the Government Printer for the year 1952-53—			
914	Schedule No. 1.—Printing Paper, Writing Paper, &c.	Rates as per annex	B. J. Ball Ltd.	Contingencies, 1952-53
915	" " " "	"	Bowater Paper Co. Ltd.	
916	" " " "	"	Alex. Cowan (Australia) Pty. Ltd.	
917	" " " "	"	J. C. Day and Co. Pty. Ltd.	
918	" " " "	"	Edwards Dunlop and Co. Ltd.	
919	" " " "	"	Gordon and Gotch (Australasia) Ltd.	
920	" " " "	"	P. Rowe (Vic.) Pty. Ltd.	
921	" " " "	"	Sands and McDougall Pty. Ltd.	
922	" " " "	"	Spicers (Australia) Ltd.	
923	" " " "	"	Tomasetti and Son Pty. Ltd.	
924	" " " "	"	L. A. Wade Pty. Ltd.	
925	" " " "	"	Wiggins, Teape and Alex. Pirie (Export) Ltd.	
926	" " " "	"	Max Wurcker (1930) Pty. Ltd.	

Approved—J. G. B. McDONALD, Treasurer. 22.8.52.

ANNEX TO CONTRACTS NOS. 1952/914 TO 1952/926.
Schedule No. 1.

PRINTING PAPER, WRITING PAPER, ETC.

- 1952/914.—*B. J. Ball Ltd.* Security, £600.
- 1952/915.—*Bowater Paper Co. Ltd.* Security, £670.
- 1952/916.—*Alex. Cowan (Australia) Pty. Ltd.* Security, £700.
- 1952/917.—*J. C. Day and Co. Pty. Ltd.* Security, £52.
- 1952/918.—*Edwards Dunlop and Co. Ltd.* Security, £630.
- 1952/919.—*Gordon and Gotch (Australasia) Ltd.* Security, £560.
- 1952/920.—*P. Rowe (Vic.) Pty. Ltd.* Security, £250.
- 1952/921.—*Sands and McDougall Pty. Ltd.* Security, £110.
- 1952/922.—*Spicers (Australia) Ltd.* Security, £600.
- 1952/923.—*Tomasetti and Son Pty. Ltd.* Security, £700.
- 1952/924.—*L. A. Wade Pty. Ltd.* Security, £600.
- 1952/925.—*Wiggins, Teape and Alex. Pirie (Export) Ltd.* Security, £1,300.
- 1952/926.—*Max Wurcker (1930) Pty. Ltd.* Security, £78.

ADJUSTMENT OF CONTRACT RATES.

All rates are subject to adjustment in accordance with the special conditions of the respective contracts. Notification of such adjustments will be published in the *Government Gazette* as required. Contracts for a number of items are subject to special conditions regarding availability of supplies, delivery dates, and import licences, &c.

AGREEMENTS.

Where the name of the supplier opposite any item is shown in italics, with the sign (A), no contract has been executed nor security lodged; requirements of such items are to be purchased from the supplier named, under Tender Board Agreement.

B. British. C. Commonwealth. F. Foreign.

Item No.	Description.	Quantity.	Rate.	Country of Origin.	Name of Contractor.
WHITE PRINTING PAPER.			£ s. d.		
	<i>Sample No. 1—</i>		per lb.		
1	Quadruple Foolscap, 35 lb., 27 in. x 34 in.	4,500 reams	0 1 4½†	C.	<i>B. J. Ball Ltd.</i>
3	Double Demy, 30 lb., 22½ in. x 35 in.	1,500 "	0 1 4½†	C.	<i>Edwards Dunlop and Co. Ltd.</i>
4	Double Royal, 38 lb., 25 in. x 40 in.	1,750 "	0 1 4½†	C.	<i>Gordon and Gotch (Australasia) Ltd.</i>
WHITE OFFSET PRINTING PAPER.					
	<i>Sample No. 2—</i>				
8	Quadruple Crown, 90 lb., 30 in. x 40 in.	50 reams	0 1 4½†	C.	<i>Gordon and Gotch (Australasia) Ltd.</i>
COLORED PRINTING PAPER.					
	<i>Sample No. 3—</i>		per ream.		
12	Pink Quadruple Foolscap, 45 lb., 27 in. x 34 in.	50 reams	3 11 6	F.	} <i>B. J. Ball Ltd.</i>
13	Yellow Quadruple Foolscap, 45 lb., 27 in. x 34 in.	150 "	3 11 6	F.	
13A	Green Quadruple Foolscap, 45 lb., 27 in. x 34 in.	100 "	3 11 6	F.	
16	Pink Double Royal, 48 lb., 25 in. x 40 in.	75 "	3 16 3	F.	

† Rate plus 1½ per cent.

CONTRACTS ACCEPTED—continued.

Item No.	Description.	Quantity.	Rate.	Country of Origin.	Name of Contractor.
SUPER-CALENDERED PAPER.					
<i>Sample No. 6—</i>					
33	Quadruple Foolscap, 55 lb., 27 in. x 34 in.	200 reams	per lb. 0 1 3½†	C.	Edwards Dunlop and Co. Ltd.
34	Double Demy, 48 lb., 22½ in. x 35 in.	750 ..	0 1 3½†	C.	Wiggins, Teape and Alex. Pirie (Export) Ltd.
35	Double Royal, 60 lb., 25 in. x 40 in.	1,000 ..	0 1 3½†	C.	Spicers (Australia) Ltd.
36	Quadruple Crown, 72 lb., 30 in. x 40 in.	1,750 ..	0 1 3½†	C.	Edwards Dunlop and Co. Ltd.
38	Reels, 39 in.	160,000 lb.	0 1 3½†	C.	Bowater Paper Co. Ltd.
38A	Super-calendered Double Imperial, 79½ lb., 30 in. x 44 in. . .	3,500 reams	0 1 3½†	C.	{ Tomasetti and Son Pty. Ltd. L. A. Wade, Pty. Ltd.
M.G. (LITHO.) PAPER.					
<i>Sample No. 7—</i>					
39	Quadruple Crown, 48 lb., 30 in. x 40 in.	500 reams	per ton 228 0 0*	C.	Australian Paper Manufacturers Ltd. (A)
BLUE WOVE WRITING PAPER (STATIONERY).					
<i>Sample No. 9—</i>					
45	Quadruple Foolscap, 58 lb., 27 in. x 34 in.	400 reams	per lb. †0 1 4½†	C.	Bowater Paper Co. Ltd
46	Quadruple Foolscap, 44 lb., 27 in. x 34 in.	1,750 ..	†0 1 4½†	C.	Spicers (Australia) Ltd.
CREAM WOVE WRITING PAPER (STATIONERY).					
<i>Sample No. 10—</i>					
51	Quadruple Foolscap, 48 lb., 27 in. x 34 in.	3,000 reams	0 1 3½†	C.	Wiggins, Teape and Alex. Pirie (Export) Ltd.
53	Double Large Post, 36 lb., 21 in. x 33 in.	250 ..	0 1 3½†	C.	Bowater Paper Co. Ltd.
TINTED BOND WRITING PAPER (STATIONERY).					
<i>Sample No. 12A—</i>					
55A	Old Gold Quadruple Foolscap, 40 lb., 27 in. x 34 in.	400 reams	0 1 6½	F.	} Tomasetti and Son Pty. Ltd.
55B	Green Quadruple Foolscap, 40 lb., 27 in. x 34 in.	175 ..	0 1 6½	F.	
55C	Russett Quadruple Foolscap, 40 lb., 27 in. x 34 in.	150 ..	0 1 6½	F.	
55D	Canary Quadruple Foolscap, 40 lb., 27 in. x 34 in.	100 ..	0 1 6½	F.	
55E	Blue Quadruple Foolscap, 40 lb., 27 in. x 34 in.	50 ..	0 1 6½	F.	
55F	Buff Quadruple Foolscap, 40 lb., 27 in. x 34 in.	50 ..	0 1 6½	F.	
HAND-MADE PAPER (STATIONERY).					
<i>Sample No. 13—</i>					
56	Blue Laid Imperial, 74 lb., 22½ in. x 30½ in.	10 reams	per ream 23 18 7	B.	} Wiggins, Teape and Alex. Pirie (Export) Ltd.
60	Blue Laid Double Demy, 48 lb., 20½ in. x 31½ in.	20 ..	15 10 6	B.	
LEDGER PAPER.					
<i>Sample No. 14—</i>					
66	Double Demy, 48 lb., 20 in. x 31 in.	250 reams	per lb. †0 1 7½†	C.	Gordon and Gotch (Australasia) Ltd.
67	Quadruple Foolscap, 60 lb., 27 in. x 34 in.	600 ..	†0 1 7½†	C.	L. A. Wade Pty. Ltd.
67A	Buff Machine Posting, 82 lb., 25½ in. x 30½ in.	25 ..	per ream 12 13 6	B.	} Wiggins, Teape and Alex. Pirie (Export) Ltd.
67B	White Machine Posting, 82 lb., 25½ in. x 30½ in.	20 ..	12 13 6	B.	
67C	Buff Machine Posting, 90 lb., 23 in. x 36 in.	25 ..	13 18 3	B.	
CREAM LAID WRITING PAPER (STATIONERY).					
<i>Sample Nos. 15 and 16—</i>					
69B	Quadruple Foolscap, 55½ lb., 27 in. x 34 in.	200 reams	per lb. †0 1 3½†	C.	Tomasetti and Son Pty. Ltd.
72	Double Foolscap, 24 lb., 17 in. x 27 in., ruled faint lines . .	1,500 ..	per ream †2 3 11	C.	Spicers (Australia) Ltd.
CREAM WOVE BOND WRITING PAPER (STATIONERY).					
<i>Sample No. 18—</i>					
83	Quadruple Foolscap, 72 lb., 27 in. x 34 in.	150 reams	per ream 9 12 10½	B.	Edwards Dunlop and Co. Ltd.
84A	Double Large Post, 36 lb., 21 in. x 33 in., surface sized . .	1,000 ..	per lb. †0 1 4½†	C.	Tomasetti and Son Pty. Ltd.
84B	Quadruple Foolscap, 48 lb., 27 in. x 34 in.	4,000 ..	†0 1 4½†	C.	Alex. Cowan (Australia) Pty. Ltd.

‡ Rate subject to surcharge of 28s. per ream. † Rate subject to surcharge of £8 per ton for packing in cases.
 † Rate plus 1½ per cent. * Rate less maximum discount of £5 per ton.

CONTRACTS ACCEPTED—continued.

Item No.	Description.	Quantity.	Rate.	Country of Origin.	Name of Contractor.
LOAN PAPER (STATIONERY).					
<i>Sample No. 19—</i>					
86	Double Foolscap, 50 lb., 17 in. x 27 in.	200 reams	per ream 15 10 0	B.	Wiggins, Teape and Alex. Pirio (Export) Ltd.
87	Double Foolscap, 20 lb., 17 in. x 27 in.	50 "	10 6 4	B.	
INVICTA PARCHMENT PAPER (STATIONERY).					
<i>Sample No. 20—</i>					
91	Reinforced paper, 70 lb., 17 in. x 27 in.	100 reams	28 6 5	B.	Wiggins, Teape and Alex. Pirio (Export) Ltd.
CREAM WOVE BANK PAPER (STATIONERY).					
<i>Sample No. 22—</i>					
93	Double Large Post, 22 lb., 21 in. x 33 in.	500 reams	Purchase (Clause 67)
95	Double Medium, 26 lb., 23 in. x 36 in.	750 "	
96	Quadruple Foolscap, 28 lb., 27 in. x 34 in.	2,500 "	
COLORED BANK PAPER (STATIONERY).					
<i>Sample No. 23—</i>					
97	Pink Quadruple Foolscap, 28 lb., 27 in. x 34 in.	500 reams	2 5 4	F.	Wiggins, Teape and Alex. Pirio (Export) Ltd.
98	Blue Quadruple Foolscap, 28 lb., 27 in. x 34 in.	200 "	2 5 4	F.	
100C	Pink Double Post, 22 lb., 21 in. x 33 in.	200 "	1 15 8	F.	
100D	Buff Double Post, 22 lb., 21 in. x 33 in.	200 "	1 15 8	F.	
100E	Green Double Post, 22 lb., 21 in. x 33 in.	100 "	1 15 8	F.	
100F	Old Gold Double Post, 22 lb., 21 in. x 33 in.	100 "	1 15 8	F.	
100G	Blue Double Post, 22 lb., 21 in. x 33 in.	100 "	1 15 8	F.	
MANIFOLDING PAPER (STATIONERY).					
<i>Sample No. 24—</i>					
101	Quadruple Foolscap, 20 lb., 27 in. x 34 in.	500 reams	1 19 6	F.	L. A. Wade Pty. Ltd.
CARTRIDGE PAPER (STATIONERY).					
<i>Sample No. 26—</i>					
108	Imperial, 60 lb., smooth, 22 in. x 30 in.	600 reams	per lb. 0 1 5 $\frac{1}{2}$ †	C.	Spicers (Australia) Ltd.
109	Royal, 45 $\frac{1}{2}$ lb., smooth, 20 in. x 25 in.	50 "	0 1 5 $\frac{1}{2}$ †	C.	
BLOTTING PAPER (STATIONERY).					
<i>Sample No. 30—</i>					
115	White Demy, 38 lb., 17 $\frac{1}{2}$ in. x 22 $\frac{1}{2}$ in., flat	400 reams	0 1 5 $\frac{1}{2}$	C.	B. J. Ball Ltd.
BROWN PAPER (STATIONERY).					
<i>Sample No. 31—</i>					
123	Kraft, 45 lb., 30 in. x 45 in., folded M.F., No. 15501	800 reams	Purchase (Clause 67)
124	Kraft, 63 lb., 30 in. x 45 in., flat M.G., No. 15617	750 "	
124A	Kraft, 63 lb., 30 in. x 45 in., folded M.F., No. 15501	750 "	
124A	Kraft, 83 lb., 30 in. x 45 in., folded M.F., No. 15501	500 "	
COVER PAPER (STATIONERY).					
<i>Sample No. 32—</i>					
126	Dove Grey, 60 lb., 20 $\frac{1}{2}$ in. x 30 $\frac{1}{2}$ in.	50 reams	per ton 192 0 0	C.	Australian Paper Manufacturers Ltd. (A)
129	Wedgwood Blue, 60 lb. S.G., 20 $\frac{1}{2}$ in. x 30 $\frac{1}{2}$ in.	150 "	192 0 0	C.	
129A	Wedgwood Blue, 60 lb. L.G., 20 $\frac{1}{2}$ in. x 30 $\frac{1}{2}$ in.	75 "	192 0 0	C.	
131	Cream, 60 lb., 20 $\frac{1}{2}$ in. x 30 $\frac{1}{2}$ in.	50 "	192 0 0	C.	
136	Hazel Brown, 80 lb., 23 in. x 36 in.	50 "	192 0 0	C.	
138	Wedgwood Blue, 80 lb., 23 in. x 36 in.	50 "	192 0 0	C.	
140	Cream, 80 lb., 23 in. x 36 in.	50 "	192 0 0	C.	
DUPLICATING PAPER (STATIONERY).					
<i>Sample No. 35—</i>					
146	White Wove S.S. Quadruple Foolscap, 44 lb., 27 in. x 34 in.	1,000 reams	per lb. 0 1 4 $\frac{1}{2}$ †	C.	Gordon and Gotch (Australasia) Ltd.
146A	White Wove H.S. Quadruple Foolscap, 44 lb., 27 in. x 34 in.	1,000 "	0 1 4 $\frac{1}{2}$ †	C.	
TRACING CLOTH (STATIONERY).					
<i>Sample No. 37—</i>					
152	Dull Back, 42 in. (20 yards)	200 rolls	per yard 0 6 2 $\frac{1}{2}$	B.	P. Rowe (Vic.) Pty. Ltd.

† Rate plus 1 $\frac{1}{2}$ per cent.

CONTRACTS ACCEPTED—continued.

Item No.	Description.	Quantity.	Rate.	Country of Origin.	Name of Contractor.
PASTEBOARDS (STATIONERY).					
<i>Sample No. 38—</i>					
155	Double Royal, 4-sheet, 25 in. x 40 in., 42 lb. per 100 boards	20,000 boards	£ s. d. per lb. 0 1 8½	C.	Bowater Paper Co. Ltd.
156	Mottled, 4-sheet, 25½ in. x 30½ in.	4,000 gross	per ton 178 0 0*†	C.	Australian Paper Manufacturers Ltd. (A)
SYSTEM BOARDS (STATIONERY).					
<i>Sample No. 42—</i>					
171	Fawn, 25½ in. x 30½ in., 6-sheet, 44 lb. per 100 boards	5,000 boards	per 100 4 12 5	B.	} Wiggins, Teape and Alex. Pirie (Export) Ltd.
172	Primrose, 25½ in. x 30½ in., 6-sheet, 44 lb. per 100 boards	5,000 "	4 12 5	B.	
173	Salmon, 25½ in. x 30½ in., 4-sheet, 28 lb. per 100 boards	15,000 "	2 18 10	B.	
174	Buff, 25½ in. x 30½ in., 4-sheet, 28 lb. per 100 boards	50,000 "	2 18 10	B.	
176	Green, 25½ in. x 30½ in., 4-sheet, 28 lb. per 100 boards	10,000 "	2 18 10	B.	
177	Pink, 25½ in. x 30½ in., 4-sheet, 28 lb. per 100 boards	6,000 "	2 18 10	B.	
180	White, 25½ in. x 30½ in., 4-sheet, 32½ lb. per 100 boards	100,000 "	per lb. 0 1 8½	C.	Bowater Paper Co. Ltd.
183B	White, 25½ in. x 30½ in., 4-sheet, 28 lb. per 100 boards	50,000 "	per 100 2 18 10	B.	} Wiggins, Teape and Alex. Pirie (Export) Ltd.
	Pink, 25½ in. x 30½ in., 3-sheet, 22 lb. per 100 boards	2,500 "	2 5 6	B.	
STRAWBOARDS.					
<i>Sample No. 43—</i>					
186	Imperial, 16-oz., 22½ in. x 32 in., 56 lb. per 56 boards	500 bundles	per ton 87 0 0*	C.	} Australian Paper Manufacturers Ltd. (A)
188	Imperial, 24-oz., 22½ in. x 32 in., 56 lb. per 38 boards	80 "	99 0 0*	C.	
189	Imperial, 32-oz., 22½ in. x 32 in.	60 "	114 0 0*	C.	
189A	Imperial, 64-oz., 22½ in. x 32 in.	40 "	99 0 0*	C.	
199	Royal, 20-oz., 20½ in. x 27 in., 56 lb. per 57 boards	40 "	114 0 0*	C.	
201A	Royal, 64-oz., 20½ in. x 27 in.	60 "	92 0 0*†	C.	
204	Large Middle, 16-oz., 18½ in. x 23½ in., 56 lb. per 92 boards	40 "	99 0 0*	C.	
212	Double Crown, 24-oz., 20 in. x 30 in., 56 lb. per 44 boards	40 "	92 0 0*†	C.	
215	Double Foolscap, 12-oz., 18 in. x 27 in., 56 lb. per 111 boards	40 "	99 0 0*†	C.	
217	Double Foolscap, 20-oz., 18 in. x 27 in., 56 lb. per 68 boards	40 "	99 0 0*†	C.	
STATIONERY.					
248A	Tracing Paper, 30 in. x 50 yards	300 rolls	per roll 2 12 6½	B.	Max Wurcker (1930) Pty. Ltd.
ENVELOPES.					
249	Demy, 10½ in. x 4½ in., Kraft Brown, Banker's, gummed	400,000	per 1,000 2 0 0	C.	Alex. Cowan (Australia) Pty. Ltd.
257	10½ in. x 7½ in., Kraft Brown, Pocket, gummed	150,000	4 10 0	C.	Spicers (Australia) Ltd.
259	15 in. x 11 in., pocket, gummed, Kraft Brown	5,000	9 10 0	C.	T. T. Eadie Pty. Ltd. (A)
260	12 in. x 6 in., Kraft Brown, Pocket, gummed	25,000	4 10 0	C.	Alex. Cowan (Australia) Pty. Ltd.
262	7 in. x 5 in., Manila, Pocket, gummed	300,000	1 17 9	C.	Pty. Ltd.
265	5½ in. x 3½ in., Window Face, secretive, Bankers, gummed	500,000	1 13 0	C.	Sands and McDougall Pty. Ltd.
266	9 in. x 4 in., Window Face, secretive, Bankers, gummed	750,000	Purchase (Clause 67)
267	6½ in. x 3½ in., Window Face, secretive, Bankers, gummed	750,000	1 18 9	C.	Sands and McDougall Pty. Ltd.
268	9 in. x 4 in., Blue Wove, Pocket, gummed	400,000	0 14 0§	C.	Spicers (Australia) Ltd.
BOOKBINDERS' LEATHER.					
271	Calf, Law, smooth, 29 in. x 19½ in.	36 skins	per foot 0 2 2	C.	Purchase (Clause 67)
274	Basil, Green, 30 in. x 27 in.	48 "	0 2 2	C.	} J. C. Day and Co. Pty. Ltd.
275	Basil, Black, 30 in. x 27 in.	48 "	0 2 2	C.	
277	Sheep, rough, 30 in. x 27 in.	244 "	per doz. 7 4 0	C.	
278	Sheep, smooth, 29 in. x 19½ in.	36 "	..	C.	Purchase (Clause 67)
279	Roan, Red, Straight-grained, 30 in. x 27 in.	112 "	per foot 0 2 0	C.	} J. C. Day and Co. Pty. Ltd.
282	Roan, Blue, Straight-grained, 30 in. x 27 in.	112 "	0 2 0	C.	
283	Roan, Purple, Straight-grained, 30 in. x 27 in.	112 "	0 2 0	C.	
284	Roan, Maroon, Straight-grained, 30 in. x 27 in.	112 "	0 2 0	C.	
290	Skiver, Purple, Straight-grained, 30 in. x 27 in.	12 "	..	C.	
292	Skiver, Mauve, smooth, 30 in. x 27 in.	72 "	..	C.	Purchase (Clause 67)
293	Skiver, Orange, smooth, 30 in. x 27 in.	24 "	..	C.	
BOOKBINDERS' CANVAS.					
317	Brown, sheets, 38 in. x 33½ in.	5,000 sheets	per sheet 0 2 9	B.	} P. Rowe (Vic.) Pty Ltd.
318	Red, sheets, 38 in. x 33½ in.	5,000 "	0 2 9	B.	
310	Blue, sheets, 38 in. x 33½ in.	5,000 "	0 2 9	B.	
321	Grey, sheets, 38 in. x 33½ in.	5,000 "	0 2 9	B.	
322	Drab, sheets, 38 in. x 33½ in.	5,000 "	0 2 9	B.	

* Rate less maximum rebate of £2 per ton. † Rate plus cutting charge of £3 per ton. § Making only from paper supplied.
 ‡ Rate plus £3 per ton for counting and wrapping in one-gross lots. ¶ Rate less 2½% discount, 30 days. || Rate plus 1¼ per cent.

CONTRACTS ACCEPTED.—(Series 1952-53.)**VICTORIAN RAILWAYS.**

18. Wheel centres, at rates (Contract 59433).—Thompsons (Castlemaine) Ltd. 19. Distillate, at 2s. 1d. per gallon (Contract 59457).—Vacuum Oil Co. Pty. Ltd. 20. Distillate, at 2s. 1d. per gallon (Contract 59661).—The Shell Co. of Aust. Ltd. 21. Distillate, at 2s. 1d. per gallon (Contract 59662).—Atlantic Union Oil Co. Ltd.

By order of the Victorian Railways Commissioners,
N. QUAIL, Secretary. 22.8.52.

SUPPLY OF PRISONERS' MEALS IN LOCK-UPS.**CONTRACTS CANCELLED.**

Gazette No. 553, 16th July, 1952, Prisoners' Meals, Collingwood.—Contract No. 236 is hereby cancelled.

Gazette No. 553, 16th July, 1952, Prisoners' Meals, Beechworth.—Contract No. 278 is hereby cancelled.

CONTRACTS ACCEPTED.

912. For the supply of Prisoners' Meals at Collingwood, from 1st July, 1952, to 30th June, 1953, at 2s. for breakfast and tea, and 2s. for hot dinner.—M. M. Orchard.

913. For the supply of Prisoners' Meals at Beechworth, from 1st July, 1952, to 30th June, 1953, at rates approved for Contract No. 278.—R. K. Irvine.

CEREALS.

Requirements under Sub-Schedule No. 5 of Schedule No. 1 for the month of September, 1952, are to be purchased, under agreement, from the under-mentioned firms, at the rates per cwt. respectively indicated, viz., Robert Harper and Co. Ltd., Barley—pearl, 41s. 6d., less 2½ per cent. 28 days, or 3 per cent. 7 days; H. S. K. Ward Pty. Ltd., Oatmeal—plain, 61s.; Peas—split, yellow, 94s.: less 3 per cent., 14 days, or 2½ per cent., 30 days. Rates are subject to variations in accordance with determinations of the Prices Decontrol Commissioner.

W. H. RUTHERFORD, Secretary to the Tender Board.
26.8.52.

PUBLIC WORKS.

746. South Melbourne, Public Works Department Storeyard, (1) supply of oregon, £227 11s. 6d.—W. S. Neelands Pty. Ltd.

747. South Melbourne, Public Works Department Storeyard, (1) supply of bath screens, £116 16s.—Southern Plating and Manufacturing Co. Pty. Ltd.

748. Melbourne, Various Public Offices, (1) daily cleaning 1/2/52 to 31/1/53, £16,984 2s. 7d.—Utility Cleaning Company.

749. South Melbourne, Public Works Department Storeyard, (1) supply of wheelbarrows, £156 0s. 11d.—Kelso Trading Supply Pty. Ltd.

750. Balnarring, Tourist Resort, (1) supply of building slabs and posts, £157 17s. 2d.—Monier Pipe Co. Pty. Ltd.

751. Port Melbourne, Public Works Department Depot, (1) plant building removals; supply of redgum, £501 3s. 4d.—Caldon Timbers Pty. Ltd.

752. Various, Queenscliff and Altona, (1) supply of timber, foreshore, £149 19s. 6d.—N. F. Gordon.

753. South Melbourne, Public Works Department Storeyard, (1) purchase of timber from Tasmania, £366 15s. 9d.—William Cook Pty. Ltd.

754. Kew, Mental Hospital, (1) supply of hardwood, £151 2s. 5d.—Broons Timbers Pty. Ltd.

755. Melbourne, Shrine of Remembrance, (1) renovations to stonework, £114 6s. 6d.—A. Crewther and Son.

756. Cobram, Consolidated School, (1) temporary lavatory accommodation, &c., Junior Wing, £679 15s. 9d.—Keith G. Hooker Pty. Ltd.

757. Warrnambool, High School, (1) electrical installations (3) prefabricated teachers' residences, £100 15s. 10d.—Leahy's Electrical Industries Ltd.

758. Melbourne, Education Various, (1) sorting and stacking charges "Hawksley" prefabricated class-rooms, £108 3s. 6d.—The United Stevedoring Pty. Ltd.

759. Upper Ferntree Gully, State School No. 3926, (1) supply of toppings, screenings, and sand, £102 10s.—Arthur F. Pickett.

760. Port Melbourne, Public Works Department Depot, (1) supply of screenings, £158 8s. 8d.—Willis Quarries.

761. Frankston, High School, (1) supply of screenings, £108 19s. 2d.—Albion Quarrying Co. Pty. Ltd.

762. Geelong, Foreshore, (1) protective works, Toorak to Bell-parade, £103 15s. 2d.—City of Geelong West.

763. Mildura, State School No. 4664, (1) installation of power points for fans, &c., Migrant Centre, £143.—R. J. Wilson.

764. Dookie, Agricultural College, (1) supply of joinery, Science Master's residence, £294 1s. 6d.—Smith Bros. Pty. Ltd.

765. Flemington, Travancore Developmental Centre, (1) supply of bedsteads, wire mattresses, fireside chairs, &c., £441 1s. 6d.—Johnston's Pty. Ltd.

766. Ararat, Mental Hospital, (2) supply and laying rubber flooring, £106 6s. 6d.—Clark Matting and Rubber Ltd.

767. Royal Park, Mental Hospital, (1) supply of curtains, £117 5s.—A. E. Hoad and Company.

768. French Island, McLeod Settlement Penal Establishment, (3) supply of doors and frames, £231 16s. 9d.—W. S. Neelands Pty. Ltd.

769. Beechworth, Mental Hospital, P.A.X. Telephones, (1) supply and installation of auto telephones in Wards M.1, M.10, and in hut at main gate, £117 10s.—British Automatic Telephone and Electrical Pty. Ltd.

770. Melbourne, Motor Registration Branch, (5) supply of pigeonholes, £130 17s. 6d.—Kennett Bros. and Rayner Pty. Ltd.

771. Melbourne, Motor Registration Branch, (1) supply and installation of four air inlet fans for mezzanine floor, £122.—S. N. Lythgo.

772. Mont Park, Larundel Mental Hospital, (1) overhaul of hot-water and central-heating system, £146 15s. 6d.—G. C. Kippe.

773. Ararat, Mental Hospital, (1) supply of floor polisher, £288 1s. 6d.—Australian General Electric Pty. Ltd.

774. Melbourne, Motor Registration Branch, (1) supply of 85 card cabinets for power punch card system, £4,037 10s.—E. T. Brown Ltd.

775. Ballarat, Mental Hospital, (2) supply and laying of 120 yards of rubber flooring, £402 10s.—Clark Matting and Rubber Ltd.

776. Merri, State School No. 3110, (1) repairs to non-party fencing, £208.—F. T. Pulling.

777. Melbourne, Parliament House, (1) supply and delivery of two evaporators with condensing units, complete with motor and controls for refrigerator cabinet, £320 16s.—A.X. Refrigeration Installation and Maintenance Pty. Ltd.

778. Port Melbourne, Public Works Department Depot, (1) supply and delivery of an additional 200 wire guards for kerosene heaters for use in various schools, £410.—A. Jones and Company.

779. Robinvale, Consolidated School, (1) erection of fencing and gates (labour only) for two residences, £208.—W. V. Clarke.

780. Fitzroy, Girls' Secondary School, (1) supply and installation of two exhaust fans and louvre shutters, £107 10s.—S. N. Lythgo.

781. Port Melbourne, Public Works Department Depot, (1) supply of 200 garbage bins, £212 10s.—A. G. Way and Co. Pty. Ltd.

782. Mont Park, Larundel Mental Hospital, Nurses' Quarters, (2) curtains, £384.—A. E. Hoad and Company; mirrors, £150 16s.—F. Cotterell and Company.

783. Mitre, State School No. 2498, (2) supply and fixing fibro-plaster sheeting, £303 15s.—Carine Bros.

784. Werribee, State School No. 649, (1) construction of concrete drain and provision of 4-in. pipe drains, £238.—J. Stangherlin.

785. Gresswell, Sanatorium, (3) supply of settees, Therapy Block, £149 19s. 6d.—A. Hunt, Son, and Oliver Pty. Ltd.

786. Fairfield, Infectious Diseases Hospital, (1) installation of gas service to laboratories in Tuberculosis Section, £194 2s. 3d.—Gas and Fuel Corporation of Victoria.

787. Pyramid Hill, Police Station and Residence, (2) supply and fixing of fibrous-plaster sheeting, £311.—Pearse Bros.

788. Janefield, Mental Hospital, (1) supply and installation of new coil in steam generator, £250.—Presha Engineering Co. (Vic.) Pty. Ltd.

789. Port Melbourne, Public Works Department Depot, (3) general, supply of 200 Aladdin heaters, £1,532 10s.—Aladdin Industries Pty. Ltd.

790. Port Melbourne, Public Works Department Depot, (1) supply of Bedford model truck, equipped with front and rear and spare tires, £1,247 3s.—S. A. Cheney Pty. Ltd.

791. Beechworth, Mental Hospital, (1) supply of 80 cubic yards metal, £208.—Glenrowan Quarrying Company.

792. Port Melbourne, Public Works Department Depot, (1) supply of 98 cubic yards screenings, £153 8s. 8d.—Willis Quarries.

793. Barwon Heads, Flood Protection, (1) supply of salt bags, £220.—Walter Cant.

794. Altona, Truganina Explosives Reserve, (1) supply of redgum sleepers, £170 12s. 7d.—Caldon Timber Pty. Ltd.

795. Various, Mornington, Cowes, and Sorrento Jetties, (1) supply of timber, £137 7s. 11d.—Albert R. Weisselberg Timber Trading Company.

796. Port Melbourne, Public Works Department Depot, (1) fit one only P.C.U. to Crawler tractor, £887.—Victorian and Industrial Sales Pty. Ltd.

797. Werribee, Research Farm, (1) supply of "Qualtex" electric oven, £116 10s.—Watson Victor Ltd.

798. Ararat, Mental Hospital, (1) supply of gravel, £280.—P. W. Woods, Ararat.

799. South Melbourne, Public Works Department Store-yard, (1) supply of flywire, £179 5s.—Cyclone Co. of Aust. Ltd.

800. Coburg, Pentridge, (1) supply of timber, £127 8s.—Coldon Timbers Pty. Ltd.

801. Swan Hill, High School, (1) supply and installation of air gas plant in Science Room, £109 10s.—Geo. Turner.

802. Red Hill, Consolidated School, (1) supply and fixing of malthoid roofing to classrooms and covered way, £241 10s.—Flat Top Roofing (Don Campbell) Pty. Ltd.

803. Tatura, Research Station, (3) supply of pipes and fittings, £1,193 7s. 4d.—Humes Ltd.

804. Pakenham, Consolidated School, (6) supply of furniture, £295 10s.—Hunt and Keeley.

805. Elingamite, State School No. 1424, (1) supply and fixing fibro-plaster walls and ceilings, £302 8s.—R. W. Eagles Camperdown Plaster Works.

806. Melbourne, Health Department, "Milton House," Flinders-lane, (1) electrical installation, X-ray Division, £2,020 10s. 2d.—Colmax Electric Pty. Ltd.

807. Evelyn, State School No. 3642, (3) supply and delivery of 300 cubic yards gravel, at rates.—F. O'Brien.

808. Melbourne, State Immigration Office, 56 William-street, (5) pigeonhole wall fittings, £172.—Hunt and Keeley.

809. Melbourne, Parliament House, (3) two exhibit cases, £177 10s.—Johnston's Furniture Productions Pty. Ltd.

810. Benalla, State School No. 36, (1) concrete paving and drains, £110.—A. Barrass.

811. Wangaratta South, State School No. 1580, (1) concrete paths and assembly area, £192 10s.—A. Barrass.

812. Port Melbourne, Public Works Department Depot, (3) 30 C.I. portable copper frames, £210.—Cox and Rizzette; twenty Sandilux sanitary containers, £250.—Sandilux Pty. Ltd.

813. Melbourne, State Public Offices, Treasury Buildings, (1) cleaning windows and partitions, &c., £545.—Utility Cleaning Company.

814. Port Melbourne, Public Works Department Depot, (1) supply of 99 cubic yards metal, £144 15s. 9d.—Albion Quarrying Co. Pty. Ltd.

815. Melbourne, Public Works Department Garage, (1) supply of lubricating oil, £142 9s. 8d.—Caltex Oil (Australia) Pty. Ltd.

816. Altona, Explosives Reserve, Truganina, (1) supply of timber, £186 12s. 9d.—Frederick Ladner.

817. Port Melbourne, Public Works Department Depot, (1) supply of 60 cubic yards grit, £103.—Associated Quarries Pty. Ltd.

818. Williamstown, Dredging Depot, (1) supply of 140 yards proofed flax canvas, £124 5s.—F. Radin and Son Pty. Ltd.

819. East Loddon, Consolidated School, (1) supply of screenings, £148 10s.—H. W. Snell.

820. Geelong, Matthew Flinders Girls' School, (1) excavations, carting, &c., £250.—S. J. Hopkins and Company.

821. Melbourne, Geological Museum, (1) supply of mild steel plate, £159 4s. 2d.—State Electricity Commission.

822. South Melbourne, Public Works Department Store-yard, (1) supply of cement sheets, cover mould, &c., £135 16s. 2d.—James Hardie and Co. Pty. Ltd.

823. Janefield, Mental Hospital, (1) supply of cement sheets, cover mould, &c., £203 18s. 3d.—James Hardie and Co. Pty. Ltd.

824. Various, Jetties, Mornington, Cowes, and Sorrento, (1) supply of timber, £128 13s. 10d.—Albert R. Weisselberg Timber Trading Co.

825. Various, Foreshore, Queenscliff and Altona, (1) supply of timber, £126 10s. 5d.—N. F. Gordon.

826. South Melbourne, Public Works Department Store-yard, (1) supply of redgum, £333 17s. 11d.—Coldon Timbers Pty. Ltd.

827. Gresswell, Sanatorium, (3) supply of bookshelves and cupboards, Therapy Block, £297 10s.—Campbell and Ibbotson.

P. T. BYRNES, Commissioner of Public Works. 19.8.52.

828. Ascot Vale, Royal Agricultural Showgrounds, (10) painting of Government Pavilion, £1,135.—Anglo-Dutch Painting Company.

829. Ardmuna, State School No. 1563, (7) internal and external painting and renovations, &c., £461 12s.—White and Anselmi.

830. Ararat, Soil Conservation Authority, (1) provision of gas hot-water service, residence, Hewitt-street, £149 10s.—The Gas Supply Co. Ltd.

831. Alvie, Consolidated School, (3) provision of combined out-offices and store, &c., £826.—W. Uebergang.

832. Alvie, State School No. 3038, (1) provision of new fencing, &c., £478.—W. Uebergang.

833. Armadale, "Larnook" Domestic Arts Teachers' College, (3) provision of new jarrah stairs, £365.—G. Taylor.

834. Armadale, Frank Tate House, Dandenong-road, (3) supply and installation of sump pump, £101 16s.—T. J. Tait.

835. Ballarat, Public Works Department, Inspector of Works Residence, 1018 Ligar-street, (6) erection of new sleepout, £230.—G. S. Rose.

836. Ballarat, Mental Hospital, (1) supply and installation of hot cathode fluorescent units, &c., £175 9s. 6d.—Sunray Fluorescent (Vic.) Pty. Ltd.

837. Ballarat North, State School No. 4690, (5) electrical installation, £765 10s. 6d.—A. Johns.

838. Brighton, Technical School, (1) installation of new boiler and re-organizing pipe work, £250 16s.—Kirkpatrick and Nielson.

839. Boronia, State School No. 4081, (1) additional boys' and girls' out-offices, drinking facilities, &c., £850.—H. L. Wood.

840. Bendigo, State School No. 877, (1) provision of new spouting and roof repairs, &c. (Violet-street), £296 15s.—J. G. Hibberd.

841. Bendigo, School of Mines, (3) electrical installation in two classrooms, £184 10s.—Bendigo Radio Service.

842. Burwood, State School No. 461, (1) erection of "Bristol" four-classroom prefabricated building, £4,309.—Overseas Corporation (Aust.) Ltd.

843. Currajung, State School No. 3545, (1) provision of new bath, &c., residence, £102 12s.—R. T. Coulthard.

844. Colac, High School, (3) provision of party and non-party fencing, £308 16s.—W. Uebergang.

845. Devenish, State School No. 1764, (1) construction of new school, £3,280 9s. 6d.—K. H. Johnston.

846. Eltham, State School No. 209, (1) remodelling of fireplaces, new doorway, &c., £238.—R. W. Sherwin.

847. Glenburn, State School No. 3169, (1) supply and installation of hot-water service, residence, £148 10s.—L. J. Bishop and Son.

848. Janefield, Mental Colony, (3) repairs and painting and concreting, cow shed and dairy, £1,179 16s.—W. F. Jones.

849. Janefield, Mental Colony, (4) supply and installation of warm-air ventilation system, Recreation Hall, £1,370.—T. J. Tait.

850. Kaniva, Consolidated School, (2) provision of new fencing, &c., £1,657 10s.—George Lange and Sons.

851. Kangaroo Flat, State School No. 981, (1) provision of heating system, £1,741 10s.—Ian Hendy Heating Industries Pty. Ltd.

852. Kew, Mental Hospital, (1) enclosing verandah at laundry, £146.—F. H. Jarman.

853. Long Gully, Bendigo, State School No. 2120, (1) repairs, &c., £110.—Rigby and Pearce.

854. Marungi, State School No. 2236, (1) repairs and renewals, &c., £215.—C. C. Brereton.

P. T. BYRNES, Commissioner of Public Works. 20.8.52.

855. Stawell, Pleasant Creek Special School, (1) supply and fixing of fibro-plaster to sewing room, office, and storeroom, £123 9s. 6d.—A. R. Rashgeber and Sons.

856. South Yarra, Psychiatric Clinic, (1) supply of 60 stackable chairs and four stackable tables, £328 12s.—D. F. Cowan.

857. Port Melbourne, Public Works Department Depot, (1) supply of 89 cubic yards toppings, £163 6s. 8d.—Willis Quarries.

858. Various, Mont Park, (1) Larundel and Bundoora sewerage, supply of non-reinforced concrete pipes, £216 11s. 7d.—Concrete Constructions Pty. Ltd.

859. Red Hill, Consolidated School, (1) supply of flywire screen, £319 16s.—The Bronze Window Frame Co. Pty. Ltd.

860. South Melbourne, Public Works Department Store-yard, (1) supply of 5,000 sand bags, £572 18s. 4d.—A. Abrahams and Sons Pty. Ltd.

861. South Melbourne, Public Works Department Store-yard, (1) supply of screen wire cloth, £113 2s.—Cyclone Company of Australia Ltd.

862. Williamstown, Dredge *Matthew Flinders*, (1) take out galley stove and supply and install 4-ft. galley stove, £172 10s.—F. Pullinger.

863. Melbourne, Hospitals and Charities Commission, (1) supply and laying of linoleum, rooms 20, 21, 23, and 25, £103 16s. 8d.—Flor-lyfe.

864. Bundoora, Repatriation Mental Hospital, (1) supply of 50 iron bedsteads, combination asylum pattern, £328 2s. 6d.—C. Mott.

865. Ballarat, Mental Hospital, (1) supply of 24 sheets of laminex, 8 ft. x 4 ft., green cambric, £192.—John Sharp and Sons Pty. Ltd.

866. Coburg, Pentridge Gaol, (1) supply of replacement parts for sprinkler system at prison farm, £144 4s. 6d.—Webb Industries Ltd.

867. Royal Park, Mental Hospital, (1) installation of hot-water service in new residence for Medical Officer, £186 5s. 6d.—Gas and Fuel Corporation of Victoria.

868. Sandringham, Technical School, (2) chalk board and cupboards, £458 15s.—Johnston's Furniture Products Pty. Ltd.

869. Melbourne, Public Works Department, (1) supply of one only Mercedes accounting machine, £1,792 13s. 9d.—Business Equipment Pty. Ltd.

870. Kew, Mental Hospital, Water Supply, (1) supply of faucet valves, £154.—West Footscray Engineering Works Pty. Ltd.

871. Donald, State School No. 1465, (1) supply of toppings and sand, £110.—H. A. Hooppell.

872. Williamstown, *Matthew Flinders*, (1) supply of bunker coal, £640 1s. 3d.—Melbourne Steamship Co. Ltd.

873. South Melbourne, Storeyard, (1) supply of 1,000 louvre blades, £170 16s. 8d.—Oliver Davey Glass Co. Pty. Ltd.

874. Broadmeadows, Police Stud Farm, (1) supply of stoves and cooker, £118 1s. 6d.—Metters K.F.B. Pty. Ltd.

875. Sea Lake, State School No. 3273, (1) repairs, ant damage, residence, £158.—W. V. Clarke.

876. Donald, District Hospital, (1) supply of seven exhaust fans for sterilizing rooms, utility rooms, &c., £214.—Amalgamated Wireless (Australasia) Ltd.

877. Flemington, Travancore Development Centre, (2) provision of 80 single bedspreads and 24 single bedspread coverlets, £592.—A. E. Hoad and Co.

878. Melbourne, Crown Law Department, (4) provision of shelving in Parliamentary Draughtsman's Office, £106 10s.—Hunt and Keeley.

879. Mont Park, Mental Hospital, (1) provision of lathe, electric welding set, and other tools, £575 8s. 9d.—McPherson's Ltd.

880. Coburg, Gaol (Pentridge), (1) supply of portable pilot arc welder, £139 19s. 6d.—E.M.F. Electric Co. Pty. Ltd.

881. Mont Park, Mental Hospital, (1) provision of double-ended pedestal grinder complete, £103.—Herbert Osborne Pty. Ltd.

882. Myrtleford, Tobacco Research Station, (1) extension of electricity supply, £510.—State Electricity Commission of Victoria.

883. Flemington, Travancore Developmental Centre, (1) supply of kindergarten furniture, £210 10s. 6d.—G. E. Wright.

884. Mentone, Police Station, (1) supply and installation of two gas fires, sink heater, and grill, £128 13s. 2d.—Gas and Fuel Corporation of Victoria.

885. Tottenham, State School No. 3890, (1) making good fire damage to converted Army hut, £125.—F. T. Pulling.

886. Port Melbourne, Public Works Department Depot, (1) supply of 98 cubic yards of toppings, £157 16s. 5d.—Willis Quarries.

887. Coburg, Pentridge Gaol, (1) overhaul A.G.A. cooker, £113 10s. 6d.—Levin and Co. Ltd.

888. Larundel, Mental Hospital, (1) supply of two (2) toaster grillers, £150.—State Electricity Commission of Victoria.

889. Merbein, Higher Elementary School No. 3687, (1) white ant repairs, £208 5s.—R. H. Hutchinson.

890. Molesworth, State School No. 2232, (7) minor repairs and internal painting, residence, £257.—W. L. Gair.

891. Moorabbin West, State School No. 4643, (1) erection and completion of three-classroom "Bristol" prefabricated building, £3,849 10s.—Overseas Corporation (Aust.) Ltd.

892. Mildura, Law Courts, (1) supply and installation of evaporative cooling plenum system, £5,427.—Ian Hendy Heating Industries Pty. Ltd.

893. Melbourne, Emily McPherson College of Domestic Economy, Russell-street, (1) electrical additions, &c., £267 12s.—J. P. Wallish.

894. Melbourne, Boys' High School, (1) installation of new laboratory sinks, &c., £458 10s.—A. F. McDermott.

895. Narrawong, State School No. 2918, (1) painting of classroom, new tanks and stand, &c., £180 12s. 6d.—J. J. McLaren.

896. Orbost, Police Station, (1) repairs to quarters, £180.—A. Cadman.

897. Penders Grove, State School No. 3806, (2) blackboards, display boards, &c., £261.—T. Kenny.

898. Prahran, Technical School, (5) repairs to roof, £1,030 10s.—A. F. McDermott.

899. Preston West, State School No. 3885, (1) provision of party and non-party fencing, &c., £290.—H. Rogers.

900. Richmond, State School No. 2084, (4) new external staircase, £656 17s. 6d.—H. R. Thompson.

901. Red Hill, Consolidated School, (1) replacement of hot-water service cylinder, £424 16s. 6d.—Kirkpatrick and Nielsen.

902. Sunbury, Mental Hospital, (2) extension to hot-water service, Ward F.4, £227 10s.—J. Wilson.

903. Sunbury, Mental Hospital, (2) installation of kerosene hot-water service at Engineer's residence, £168 10s.—J. Wilson.

904. Shepparton North, State School No. 4657, (6) electrical installation, £1,063 6s.—W. G. Sanderson.

905. Stawell, Pleasant Creek Special School, (1) provision of gas hot-water service, Engineer's residence, £149 10s.—The Gas Supply Co. Ltd.

906. Sale, Tuberculosis Chalet, (1) alterations, &c., hot water and steam supply, £990 10s.—H. J. Templeton and Sons.

907. Sale, State School No. 545, (1) internal painting to residence, 3 McMillan-street, £144.—A. Cadman.

908. Tatong, State School No. 3006, (2) demolishing existing front fence, &c., £107 13s. 6d.—K. H. Johnston.

909. Tallangatta, State School No. 1365, (1) erection of shelter pavilion, £569 19s.—J. Davis.

910. Warrnambool, Technical School, (1) provision of stainless steel sink, &c., £167 8s. 6d.—R. Turland.

911. Sunshine East, State School No. 4645, (3) provision of three shelter sheds, £4,890.—W. Sinclair.

P. T. BYRNES, Commissioner of Public Works. 21.8.52.

ORDER IN COUNCIL.—(Series 1950-51.)

FORESTS COMMISSION.

Loan Fund Act No. 5588, Item 8—

5291. To the purchase of portion of Crown allotment 5A, section 1, Parish of Whitfield, County of Delatite, for forest purposes, £68 1s. 2d.—Mr. Sydney Ernest Torr Thomas, of Whitfield.

Approved by the Governor in Council, 14th November, 1950.—A. MAHLSTEDT, Clerk of the Executive Council.

DEPARTMENT OF MINES.

SUBJECT to any necessary excisions, &c., it is proposed to grant the following mining leases:—

8274, Beechworth; Matthew Bernard Haylock and Bernard Ratcliffe; 31a. 3r. 32p., Parish of Goulburn.

7083, Maryborough; Eric Llewellyn Robertson; 9a. 3r., Parish of Warrenmang.

11286, Bendigo; Frank Abbott and John Ford Paterson; 48a. 3r. 29p., Parish of Moora.

7255, Mineral; Harcourt Granite Pty. Ltd.; 4a. 1r. 16p., Parish of Harcourt.

APPLICATION FOR MINING LEASE REFUSED.

7340, Mineral; Andrew Rodoni; 15 acres, Parish of Wombat.

EXTENSION OF TERM OF PETROLEUM PROSPECTING LICENCE.

The term of the under-mentioned licence has been extended for a period of one year from 1st August, 1952:—

151, Petroleum Prospecting Licence; Gippsland Oil Company Ltd.; approximately 16 square miles, in the Parishes of Colquhoun and Bumberrah.

TAILINGS LICENCES GRANTED.

2341, Tailings Licence; E. J. Antonio; Parish of Smythesdale.

2342, Tailings Licence; John Alan Svanosio and Neil Leslie Svanosio; Parish of Huntly.

2347, Tailings Licence; John F. McKay; 7a. 3r., Parish of Smythesdale (in lieu of Tailings Licence No. 2252, expired).

TAILINGS LICENCES EXPIRED.

2131, Tailings Licence; The Ballarat Water Commissioners; Ballarat East.

2275, Tailings Licence; Country Roads Board; Parish of Lynchfield.

2277, Tailings Licence; A. Sist; Parish of Raglan.

G. C. MOSS,
Minister of Mines.

Transport Regulation Acts.
 TRANSPORT REGULATION BOARD.
 NOTICES OF PUBLIC HEARINGS.

NOTICE is hereby given that the applications made by the persons named below for licences to operate the commercial goods vehicles on the route or routes, or in the manner set out opposite their names, will be heard at a time and place to be communicated to the parties concerned:—

Name and Address; Nature of Application.

- CAIRNS, P., Coster-street, Alexandra; application to vary the terms of existing licence No. T.T.D.1094 by deleting present conditions and adding, in lieu:—Logs from Snobs Creek and Dry Creek areas to Cook's mill at Thornton, Ruokak Timbers at Alexandra, State Rivers and Water Supply Commission's mill at Eildon Weir, and Victoria Oak's mill at Marysville.
- CONN, L. C., Castlemaine; 1 commercial goods vehicle (100 cwt.) for the carriage of pine logs from forest landings within a radius of 50 miles of Harcourt to the Harcourt Co-operative Sawmills at Harcourt.
- CURRIE, V., 266 Auburn-road, Hawthorn; 1 commercial goods vehicle (70 cwt.) to operate throughout the State of Victoria in the course of business as "marine dealer."
- DALZIEL, J. C., 421 Lyons-street, Ballarat; application to vary the terms of existing licence No. D.7139 by deleting paragraph (b) and including in lieu:—Throughout the State of Victoria in the course of business as earth-moving contractor—earth-moving plant and equipment, and maintenance supplies incidental thereto.
- FALKENBERG, L., Woori Yallock; 1 commercial goods vehicle (200 cwt.) to operate from E. Fall's property at Hoddles Creek to Burrow's timber yards at Box Hill—case logs.
- GORDON, I., 237th Glen Eira-road, Caulfield; 1 commercial goods vehicle (6 cwt.) to operate within a radius of 50 miles of Melbourne, and to and from Warragul for the carriage of own goods—drapery.
- HARCOURT CO-OPERATIVE FRUIT GROWERS LTD., Harcourt; 1 commercial goods vehicle (83 cwt.) for the carriage of—(a) general goods within a radius of 20 miles of Harcourt, (b) bran, pollard, and wheat between Maryborough and Harcourt, (c) within a radius of 30 miles of Harcourt—pine logs, (d) throughout the State of Victoria—fresh fruit.
- HARCOURT CO-OPERATIVE FRUIT GROWERS LTD., Harcourt; 1 commercial goods vehicle (100 cwt.) to operate—(a) within a radius of 20 miles of Harcourt—general goods, (b) throughout the State of Victoria in the course of business as "fruit growers"—fresh fruit.
- HERMON, R. J., Yarra-street, Yarra Junction; 1 commercial goods vehicle (171 cwt.) for the carriage of—(a) logs from any forest landing in the Niagaroon and Upper Yarra forestry districts, and the North Big River area to Warburton and Yarra Junction Railway Stations and 20 miles of such stations, (b) sawn timber from Yarra Junction to the Warburton and Yarra Junction Railway Stations and places within 20 miles of such stations, and to places within a radius of 25 miles of Melbourne but not within 8 miles of Melbourne.
- HIRSCH, A., corner Argyle and Chapel streets, St. Kilda; 1 commercial goods vehicle (5 cwt.) to operate throughout the State of Victoria as "hawker"—drapery.
- POWER, F. J. & H. KIRCHHUBEL, Fraser-avenue, Edithvale; application to vary the terms of existing licence No. T.T.D.1192 by the deletion of logs, and the inclusion in lieu thereof of sawn timber from Tanjil Bren to the Noojee Railway Station, or if delivered *en route* to such station or to a timber yard or building site within a radius of 20 miles of such station.
- QUICK, J. W. W., Lorne; 3 commercial goods vehicles (80, 100, and 100 cwt.) to operate—(a) between Melbourne and Lorne and places *en route* beyond Geelong—general goods, (b) between Geelong and Lorne and places *en route*—general goods, (c) between Lorne and Colac—general goods.
- QUICK, J. W. W., Lorne; 1 commercial goods vehicle (100 cwt.) to operate—(a) between Geelong and Lorne and places *en route*—general goods, (b) between Lorne and Colac—general goods.
- These are applications for a part of "D" licences now held by Trans-Otway Ltd., Geelong.
- ROCHE BROS. PTY. LTD., 22 Dynon-road, South Kensington; 1 commercial goods vehicle (91 cwt.) to operate—(a) throughout the State of Victoria in the course of business as "earth-moving contractors"—tools of trade, plant, and equipment incidental to business, (b) earth and other excavated material from the site of excavation to the place of disposal.

No. 750.—8253/52.—2

ROWE, L. & M., 65 King-street, Hamilton; application to vary the terms of existing licence No. T.T.D.1286 by deleting present conditions and including in lieu—(a) logs from any forest landings within a radius of 50 miles of Hamilton to applicant's own mill at Hamilton, (b) sawn timber from applicant's own mill at Hamilton to consignees at Horsham, Warrnambool, Port Fairy, Portland, Mortlake, and within a radius of 50 miles of applicant's mill at Hamilton.

SHEEHY, Mrs. V., 510 Waverley-road, East Malvern; 1 commercial goods vehicle (12 cwt.) to operate throughout the State of Victoria in the course of business as "hawker"—drapery.

NOTICE is hereby given that the application made by the person named below for renewal of licence to operate the commercial goods vehicle on the route or routes, or in the manner set out opposite his name, will be heard at a time and place to be communicated to the parties concerned:—

Name and Address; Present Franchise; Licence No.; Date of Expiry.

MARTUCCI, J., P.O. Box 118, Horsham; road contracting plant and materials throughout the State of Victoria; D.3770; 16th September, 1952.

NOTICE is hereby given that the applications made by the persons named below for renewal of temporary licences to operate the commercial goods vehicles on the route or routes, or in the manner set out opposite their names, will be heard at a time and place to be communicated to the parties concerned:—

Name and Address; Present Franchise; Licence No.; Date of Expiry.

WILKINSON, R. H., 386 Spencer-street, Melbourne; (1) logs from any forest landing in the Upper Yarra forestry district, (a) to the railway station at Noojee and to any mill or dump which is located within a radius of 20 miles of such landing or of the railway station at Noojee, (b) to any mill situated (i) on or within 5 miles of Princes Highway East between Warragul and Berwick, (ii) south of the River Yarra within a radius of 25 miles but not within 8 miles of the G.P.O., Melbourne, (2) logs from such other areas or to such other destinations as may be authorized in writing by the Board from time to time; T.T.D.1250; 14th November, 1952.

HUME & ISER PTY. LTD., 35-47 Charleston-street, Bendigo; sawn timber from Kyneton and within a radius of 60 miles from Bendigo, including Herrod and Maher's mill at Korweinguboora, Frith's mill at Bullarto, O'Hehir's mill at Trentham, Dwyer's mill at Spargo Creek, Dwyer's mill at Sailors Falls, and Evans Bros.' mill at Echuca, to holder's own timber yards at Bendigo; T.T.D.1252; 14th November, 1952.

WILLIAMS, K. F., 125 Tucker-road, Bentleigh; (1) mill and case logs from any forest landing in the Bullengarook area to Spence and Co's sawmills at Hampton, (2) firewood from Bullengarook area to yards in the metropolitan area; T.T.D.1439; 19th November, 1952.

TERRETT, F. H., 225 Bridge-street, Benalla; (1) logs from any forest landing in the Bulla and Toombullup areas to Terrett's sawmills at Benalla, (2) sawn timber from Terrett's sawmills at Benalla to consignees at Shepparton and Numurkah and Echuca; T.T.D.1440; 19th November, 1952.

BLENNERHASSETT, J., A. R. HASSETT, & VIDA V. BLENNERHASSETT (trading as J. and A. R. Hassett), Young-street, Drouin; (1) logs from any forest landing in the Jeeralang area to the Drouin Sawmills at Drouin, (2) sawn timber from the Drouin Sawmills at Drouin to building sites in the metropolitan area; T.T.D.1443; 19th November, 1952.

BRITTON, HAROLD, LAURA, HENRY, P., & N. R. (trading as H. and L. Britton and Sons), Russells Creek, Warrnambool; logs from Boyd's private landing in the Heytesbury area to Le Couteur's sawmill at Warrnambool and to Alstergren's sawmill at Caramut; T.T.D.1444; 19th November, 1952.

BOUCHER, W. N., 2 Orford-street, Ashburton; case logs from the Forest Commission's forest landing in the Matlock area to L. J. Smith's case manufacturing yards at Gold-street, Collingwood; T.T.D.1445; 19th November, 1952.

BOUCHER, J. K., 2 Orford-street, Ashburton; case logs from the Forest Commission's forest landing in the Matlock area to L. J. Smith's case manufacturing yards at Gold-street, Collingwood; T.T.D.1446; 19th November, 1952.

- HASSETT, J. & A. R., Young-street, Drouin; (1) logs from any forest landing in the Jeeralang area to the Drouin Sawmills at Drouin, (2) sawn timber from the Drouin Sawmills at Drouin to building sites in the metropolitan area; T.T.D.1447; 19th November, 1952.
- DUNSTAN, A., & SONS, 1-7 Tallangatta-road, Wodonga; (1) logs from the Forest Commission's lease at Mount Wills to holder's sawmill at Eskdale, (2) sawn timber from holder's own sawmills at Eskdale to holder's own timber yard at Wodonga, also to railway yards at Wodonga and Albury; T.T.D.1339; 20th November, 1952.
- WALKER, J. W., Chum Creek-road, Healesville; (1) logs from any forest landing in the Niagaroon and Upper Yarra forestry districts and the North Big River area (a) to the railway station at Healesville and to any mill or dump which is located within a radius of 20 miles of such landing or of the railway station at Healesville, (b) to any mill situated south of the River Yarra within a radius of 25 miles but not within 8 miles of the G.P.O., Melbourne, (2) logs from such other areas or to such other destinations as may be authorized in writing by the Board from time to time; T.T.D.1340; 20th November, 1952.
- HOLLINGSWORTH, J. W., 31 Macarthur-street, Bairnsdale; 1 commercial goods vehicle for the carriage of hewn timber under contract to the State Electricity Commission from Bairnsdale to Yallourn and Morwell areas; T.T.D.1341; 20th November, 1952.
- WALKER, W. C., Buxton-road, Marysville; (1) logs from any forest landing in the Niagaroon and Upper Yarra forestry districts and the North Big River area (a) to the railway station at Warburton and/or Yarra Junction, and to any mill or dump which is located within a radius of 20 miles of such landing or of the railway stations at Warburton and/or Yarra Junction, (b) to any mill or yard within a radius of 25 miles of the G.P.O., Melbourne, (2) logs from such other areas or to such other destinations as may be authorized in writing by the Board from time to time; T.T.D.1448; 26th November, 1952.
- SMITH, V. K., 54 Skene-street, Colac; (1) logs from any forest landing within a radius of 50 miles from Colac to Gellibrand sawmills and H.P. sawmills at Colac, (2) sawn timber from Gellibrand sawmills, H.P. sawmills at Colac, and Kincaid's timber mills at Colac to building sites within a radius of 50 miles from Colac (in house lots only); T.T.D.1449; 26th November, 1952.
- GORDON, F. O. & M. (trading as Beech Timber and Trading Co.), Nepean Highway, Mentone; (1) logs from any forest landing in the Ryton and Buln Buln areas to holder's sawmills at Gembrook and Pakenham, (2) sawn timber from holder's sawmills at Gembrook and Pakenham to holder's timber yards at Mentone, (3) sawn timber to any merchant or builder if delivered to timber yard or direct on to building site which is situated within a radius of 25 miles of the G.P.O., Melbourne; T.T.D.1451, T.T.D.1452; 26th November, 1952.
- ALLAN, T. W., Lamplough, via Avoca; (1) redgum logs from Avoca to the Terang sawmills at Terang, (2) sawn timber and fencing posts from holder's own sawmills at Lamplough to Macarthur's timber yards at Ararat, P Stone's mill at Mortlake and Terang, also to Camperdown timber yards; T.T.D.1453; 26th November, 1952.
- HALL, S. G., Narbethong; palings and short rails from holder's own sawmills at Narbethong to J. Davies fencing contractor's yards at East Malvern; T.T.D.1455; 26th November, 1952.
- JOHNSON, T. I., & A. H. RIELLY, Keilor-road, Keilor; (1) logs from any forest landing in the Lancefield and Woodend areas to holder's own mill at Keilor, (2) sawn timber from holder's mill at Lancefield to holder's own timber yards at Keilor, (3) sawn timber from holder's own mill at Keilor to consignees within a radius of 25 miles of the G.P.O., Melbourne; T.T.D.1457; 26th November, 1952.
- BROWN, D. McM., 321 Canterbury-road, Canterbury; application for variation of regulated private hire licence Nos. M.H.849 and M.H.751 to vary depot from 321 Canterbury-road, Canterbury, and instead to include the ability to operate under radio control from Canterbury area directions by Embassy Private Hire Service.
- BELL, K. C., 9 Sutton-parade, Mont Albert North; application for variation of licence Nos. M.H.730 and M.H.917 to delete the restriction authorizing operations from Sutton-parade, Mont Albert, only, and instead to operate from Melbourne Taxi Service Pty. Ltd., Bridge-road, Richmond.
- DAVIES, E., Bus Service, Valley-street, East Oakleigh; application for variation of Route 39A to extend from present terminal at the corner of Springvale and Waverley roads, along Springvale-road to High Street-road to Norton's-lane, returning via same route, for the carriage of school children.
- FRASER, D. W., 12 Wallace-avenue, Glen Iris; application for variation of regulated private hire licence No. M.H.820 to vary depot from 234 Glenferrie-road, Malvern, to operate from 494 Bridge-road, Richmond, Melbourne Taxi Service.
- INNES, J. D., 16 Browning-street, South Yarra; 1 commercial passenger vehicle, with seating capacity for five persons, to operate as a metropolitan taxi cab for the carriage of passengers otherwise than at separate and distinct fares for each passenger on journeys commencing within the metropolitan area to places situate within a radius of 50 miles of the General Post Office, Melbourne (subject to the cancellation of metropolitan taxi cab licence No. M.T.1026, at present held by R. F. Beddison).
- JOHNSTON, A. H., 16 Boorool-road, East Kew; application for variation of regulated private hire licence No. M.H.799 to vary depot from 16 Boorool-road, East Kew, to operate from Melbourne Taxi Service Pty. Ltd., Bridge-road, Richmond.
- MANN, G. F., 20 Yarra-street, Williamstown; application for variation of regulated private hire licence Nos. M.H.895 and M.H.778 to vary depot from 20 Yarra-street, Williamstown, to include the ability to operate from depots at 164 Barkly-street, Footscray, in addition to existing depot at 20 Yarra-street, Williamstown.
- MCQUIRE, N. J., 10 Woolcock-avenue, East Kew; application for variation of regulated private hire licence No. M.H.924 to vary depot from 31 Cotham-road, Kew, and instead to operate from Melbourne Taxi Service, Bridge-road, Richmond.
- PATRIKIOS, A. P., 31 Toorak-road, Hawthorn East; 1 commercial passenger vehicle, with seating capacity for five persons, to operate as a metropolitan private hire car for the carriage of passengers otherwise than at separate and distinct fares for each passenger throughout Victoria, with the proviso that the vehicle shall be ordered or be bespoken from place of business at Melbourne Taxi Co., 494 Bridge-road, Richmond (subject to the cancellation of metropolitan private hire car licence No. 454, at present in the name of K. A. Spear).
- ROGERS, V. A., 16 Reaburn-crescent, West Brunswick; application for variation of regulated private hire licence No. M.H.842 to vary depot from 16 Reaburn-crescent, West Brunswick, to operate from Melbourne Taxis Service, Bridge-road, Richmond.
- ROSENFELD, R. J., 52 Kooyong-road, Caulfield; application for variation of regulated private hire licence No. M.H.797 to include the ability to operate from Embassy Taxis, Exhibition-street, Melbourne, in addition to 52 Kooyong-road, Caulfield.
- STAPLETON, S. G. (estate of the late, per S. J. Stapleton, executrix), 1120 Sturt-street, Ballarat; 1 commercial passenger vehicle, with seating capacity for five persons, for the carriage of passengers otherwise than at separate and distinct fares for each passenger to places situate in the State of Victoria beyond the urban district of Ballarat, with the proviso that the vehicle shall be ordered or be bespoken from place of business or approved stands in the Ballarat urban district (subject to the cancellation of urban taxi licence No. 1, at present in the name of the late S. G. Stapleton).
- SUTHERLAND, K. L., 420 Doveton-street north, Ballarat; 1 commercial passenger vehicle, with seating capacity for five persons, to operate for the carriage of passengers at otherwise than at separate and distinct fares for each passenger from places situate in the State of Victoria beyond the urban district of Ballarat, with the proviso that the vehicle shall be ordered or be bespoken from place of business or approved stands in the Ballarat urban district. (NOTE.—Vehicle holds urban taxi cab licence No. 43.)

NOTICE is hereby given that the applications made by the persons named below for licences to operate commercial passenger vehicles on the route or routes, or in the manner set out opposite their names, will be heard at a time and place to be communicated to the parties:—

Name of Applicant; Nature of Application.

- BRAUMAN, HERBERT (estate of the late), 74 Lincoln-road, Essendon; application for variation of regulated private hire licence No. M.H.829 to vary depot from Eglington-street, Kew, to operate above car from Melbourne Taxi Service, Bridge-road, Richmond.

WARD, M. J., 218 Berkeley-street, Carlton; 1 commercial passenger vehicle, with seating capacity for five persons, to operate as a metropolitan private hire car for the carriage of passengers otherwise than at separate and distinct fares for each passenger to places throughout Victoria, with the proviso that the vehicle be ordered or be bespoken from place of business at Embassy Taxis, Eastern Market, Melbourne (subject to the cancellation of licence No. M.H.193, at present held by E. J. Ward, 18 Strode-street, Richmond).

LANE, A. L., Warrnambool; application for variation of licence No. A.216 to include the ability to extend the Warrnambool-Allansford service to Panmure, on the following time-table:—

Monday to Friday inclusive.

Depart Panmure 8.00 a.m.
Depart Warrnambool 5.40 p.m.

Saturday.

Depart Warrnambool 12.15 p.m.

MOE COACH LINES PTY. LTD., Moore-street, Moe; application for variation of all "A" licences to include the ability to operate at separate and distinct fares on Sundays and public holidays only to the following places (one place only to be operated to on any one day):—

Moe-Frankston.
Moe-Carrum.
Moe-Mordialloc.

Return fare only—
Adults—25s.
Children, 4-14 years—15s.

THOMPSON, B. W., Coffee Palace, Main-street, Koondrook; application for renewal of licence No. C.271 (expiring 22nd November, 1952) to operate under charter conditions within a radius of 20 miles of the Post Office at Koondrook.

NOTICE is hereby given that the applications made by the persons named below for licences to operate commercial passenger vehicles on the route or routes, or in the manner set out opposite their names, will be heard at a time and place to be communicated to the parties:—

Name of Applicant; Nature of Application.

BENNETT, J. V., 15 Menzie-street, Charlton; 1 commercial passenger vehicle, with seating capacity for 27 persons, to operate as follows:—(a) For the carriage of school children only between Wooroonook and the Charlton Higher Elementary School, under contract to the Education Department, (b) as a special service omnibus (charter conditions) within a radius of 50 miles of Charlton Post Office.

CLARKE, W., Back Beach-road, Sorrento; 1 commercial passenger vehicle, with seating capacity for five persons, to operate as follows:—(a) At separate and distinct fares within a radius of 5 miles of Sorrento Post Office, (b) under private hire conditions within a radius of 50 miles of Sorrento Post Office. (NOTE.—Restoration of licence No. A.495, which was held by the applicant up to the 1st April, 1952.)

FLETCHER, M. C. (trading as "Wheal's Taxi Service"), Marine-parade, Lorne; 1 commercial passenger vehicle, with seating capacity for five persons, to operate as follows:—(a) At separate and distinct fares within a radius of 5 miles of Lorne Post Office, (b) under private hire conditions within a radius of 50 miles of Lorne Post Office (subject to the cancellation of licence No. A.690, at present in the name of G. W. Wheal, Lorne).

HARVEY, V., The Parade, Ocean Grove; 1 commercial passenger vehicle, with seating capacity for five persons, to be purchased, to operate as follows:—(a) At separate and distinct fares within a radius of 5 miles of Ocean Grove, (b) under private hire conditions within a radius of 50 miles of Ocean Grove.

KINGSTON, F. C., 19 Wimmera-street, Stawell; application for variation of licence Nos. A.364, A.365, A.467, and A.2900 to delete the present private hire operations within a radius of 50 miles of Stawell, and instead to operate under private hire conditions throughout Victoria from Stawell.

KLIPPEL, O. M., Albury; application for variation of licence No. A.11 to delete the present time-table on Tuesdays, Thursdays, and Saturdays on the route between Corryong and Albury, and instead on these days to operate as follows:—

Albury	Arrive	7.30 a.m.
Talgarno	Depart	6.45 a.m.
Granya	Depart	6.25 a.m.
Bungil	Depart	
Thologolong	Depart	5.50 a.m.
Burrawye	Depart	5.35 a.m.
Mt. Alfred	Depart	5.25 a.m.
Jingellic	Depart	5.05 a.m.
Walwa	Depart	5.00 a.m.
Tintaldra	Depart	4.30 a.m.
Towong	Depart	4.05 a.m.
Corryong	Depart	3.55 a.m.

(b) To provide special day return fares as follows:—

	s.	d.
Corryong	40	0
Towong	38	0
Tintaldra	36	0
Walwa	30	0
Jingellic	29	0
Mt. Alfred	27	0
Burrawye	25	0
Thologolong	21	0
Bungil	18	6
Granya	16	0
Talgarno	11	0

APPLICATIONS for licences to operate commercial passenger vehicles, with seating capacity for five persons, for the carriage of passengers throughout Victoria otherwise than at separate and distinct fares for each passenger:—

BUTTERWORTH, R. A., 31 White-street, Beaumaris (subject to the cancellation of licence Nos. P.H.207 and P.H.217, at present in the name of L. R. Blackam, Beaumaris).

FLETCHER, M. C. (trading as Wheal's Taxi Service), Marine-parade, Lorne (subject to the cancellation of licence No. P.H.2027, at present in the name of G. W. Wheal, Lorne).

PILKINGTON, L. C., High-street, Wodonga.

APPLICATION for renewal of private hire licence expiring in October, 1952:—

FYFE, O., Launching Place-road, Gembrook; P.H.782.

NOTICE is hereby given that the applications made by the persons named below for renewal of licences to operate commercial passenger vehicles in the manner set out in each case will be heard at a time and place to be communicated to the parties:—

Name and Address; Present Franchise; Licence No.; Date of Expiry.

POPE, T., & SON (trading as Consolidated Bus Lines), Timboon; (a) the vehicle so licensed may be operated as a stage omnibus on a round route commencing from Timboon, thence via Digney's Bridge, Main-road, and Scott's Creek back to Timboon—school service, under contract to the Education Department, (b) under charter conditions within a radius of 20 miles of the Post Office at Timboon; A.2519; 22nd November, 1952.

DUNN, R., Fraser-street, Clunes; as a stage omnibus on the following routes:—(a) Between Clunes and Ballarat, via Tourello, Ascot, Blowhard, and Miners Rest, (b) between Creswick and the factory of Clunes Interknit Hosiery Company at Clunes—only employees of the Clunes Interknit Hosiery Company shall be carried on the said route, (c) between Ascot and the Ballarat High, Technical, and Girls' Schools, under contract to the Education Department—on the route defined in part (a) of "routes" above goods may be carried, subject to the following conditions:—(1) Goods to a total weight of 30 cwt. may be carried, subject to the condition that on any journey to or from Ballarat such goods shall not be picked up or set down at any point within a radius of 2 miles from the railway station at Clunes, (2) fruit and vegetables may be carried without restriction, subject to the condition that the total weight of such fruit and vegetables carried at any one time shall not exceed 2 cwt., (d) no goods whatsoever shall be carried on the vehicles along the route defined in part (b) of "routes" above, (e) the terminal point of the service in the City of Ballarat on the route defined in part (a) of "routes" above shall be the premises of 12 Lydlard-street, Ballarat, occupied by William Edward Rafferty, there carrying on business under the name or style of Central Booking Office and Exchange Service Station, and on any and

every journey into or out of the City of Ballarat the vehicle or vehicles shall arrive at and depart from the said premises, (f) under charter conditions within a radius of 20 miles of the Clunes Post Office and from Clunes to Amphitheatre, Avoca, Blackwood, Dunolly, Elmhurst, Gisborne, Kyneton, Lismore, Maldon, Mt. Macedon, Macedon, Streatham, Skipton, and Woodend; A.1743; 18th November, 1952.

EASTERN ROADLINES PTY. LTD., Tallangatta-road, Wodonga; (1) each one of the vehicles so licensed may be operated as stage omnibuses on any one of the routes referred to in Schedule "C" to "R" inclusive attached hereto for the carriage of passengers and also mails and parcels where specially authorized, and when so operated on any of such routes the vehicle or vehicles shall adhere and be subject to all of the terms and conditions set out in the respective Schedule relating to the particular stage omnibus route upon which the vehicle or vehicles is or are being operated, (2) each one of the vehicles hereby licensed, where the seating capacity of such vehicle is not less than twenty persons, may also be operated as a special service omnibus within the following radii, subject to the conditions set out in Schedule "A" attached hereto, entitled Conditions Relating to Operations as a Special Service Omnibus, subject also to any special condition set out hereunder:—In respect to operations from the particular radius point referred to—(a) within a radius of 20 miles from the Post Office at Corryong, and from Corryong to Tallangatta, Eskdale, Mitta Mitta, Omeo, Glen Wills, Bright, Mt. Buffalo, Wodonga, and Albury, New South Wales, subject to the special conditions that not more than one vehicle may be so operated at any one time, (b) within a radius of 20 miles from the Post Office at Tallangatta, and from Tallangatta to Mitta Mitta, Yackandandah, Corryong, Glen Wills, Omeo, Eskdale, Bogong, Bright, Mt. Buffalo, Wodonga, and Albury, New South Wales, subject to the special condition that not more than three vehicles may be so operated at any one time, (c) within a radius of 20 miles from the Post Office at Omeo, and from Omeo to Mitta Mitta, Bright, Mt. Hotham, Wodonga, Albury, New South Wales, Ensay, Bruthen, Bairnsdale, and Lakes Entrance, subject to the special conditions that not more than four vehicles may be so operated at any one time, (d) within a radius of 20 miles from the Post Office at Mitta Mitta, and from Mitta Mitta to Tallangatta, Glen Wills, Omeo, Bogong, Wodonga, and Albury, New South Wales, subject to the special condition that not more than two vehicles may be so operated at any one time, (e) within a radius of 20 miles from the Post Office at Bairnsdale to Orbost, Buchan, Nowa Nowa, Lakes Entrance, Tambo Crossing, Ensay, Swifts Creek, Omeo, Dargo, Maffra, Stratford, Sale, Rosedale, and Seaspray, subject to the special condition that not more than ten vehicles may be so operated at any one time, (f) within a radius of 20 miles from the Post Office at Tawonga, and from Tawonga to Tallangatta, Albury, New South Wales, Wodonga, Omeo, Glen Wills, Bright, Mt. Buffalo, Myrtleford, Beechworth, Yackandandah, Wangaratta, Chiltern, subject to the special condition that not more than two vehicles may be so operated at any one time, (g) within a radius of 20 miles from the Post Office at Bright, and from Bright to Wangaratta, Myrtleford, Beechworth, Yackandandah, Tallangatta, Mitta Mitta, Dederang, Wodonga, and Albury, New South Wales, subject to the special condition that not more than one vehicle may be so operated at any one time, (h) within a radius of 20 miles from the Post Office at Wodonga and within a radius of 20 miles from a point on the Victorian-New South Wales border nearest to Albury, New South Wales, and from Wodonga and the said point to Cudgewa, Tallangatta, Jingellic, Eskdale, Mitta Mitta, Beechworth, Bright, Bogong, Mt. Buffalo, Tawonga, Mudgegonga, Chiltern, Rutherglen, Wangaratta, Wahgunyah, Corowa, New South Wales, Myrtleford, Dederang, and Yarrowonga, subject to the special condition that not more than seventeen vehicles may be so operated at any one time, (i) within a radius of 20 miles from the Post Office at Lakes Entrance, and from Lakes Entrance to Buchan, Orbost, Marlo, Lindenow, Ensay, Swifts Creek, Stratford, and Sale, subject to the special condition that not more than five vehicles may be so operated at any one time, (j) specified day tours from Wodonga and the border of New South Wales, *en route* from Albury, New South Wales—Route: (1) From Wodonga via Staghorn Flat, Yackandandah, returning via Dederang, Kiewa Valley-road, and the Hume Weir, (2) from Wodonga via the Omeo Highway to Tallangatta, returning via Bulloh, Granya, Talgarno, Bethanga Bridge, and the Hume Weir, (3) from Wodonga via Yackandandah to Beechworth, returning

via Chiltern and the Hume Highway, (4) from Wodonga to Bogong, via Yackandandah and Tawonga, returning via the Kiewa Valley-road and the Hume Weir, (5) from Wodonga to Bright, via Yackandandah and Myrtleford, returning via Kancoona-road or alternately the Bright Gap, and thence via the Kiewa Valley-road, (6) From Wodonga to Mt. Buffalo and/or Mt. Hotham, via Yackandandah or Beechworth, Myrtleford, and Bright, subject to the condition that this tour shall not be operated on any Saturday, (7) from Wodonga to the Hume Weir, via the Omeo Highway, returning via Huon-road, Bluff, Kiewa, and the Kiewa-road, (8) from Wodonga to Yackandandah, returning via Indigo Falls and Leneva-road, (9) from Wodonga to Tallangatta, via the Hume Weir and Bethanga Bridge, returning via Kiewa, (10) from Wodonga via the Hume Weir, Ebdon to Tallangatta, Granya, Tintaladra, Corryong, Cudgewa, Keetong, Tallangatta, Mt. Buffalo Plateau, The Alpine Highway, Mitta Mitta, Glen Wills, Omeo, Mt. Hotham, Harrietville, Bright, Mt. Buffalo Plateau, Bright, Tawonga, Yackandandah, and return to Wodonga via the Hume Weir, (11) from Lakes Entrance via the Prince's Highway East and the Buchan-road to Buchan Caves, returning via Red Knobb, the State Forest, and the Prince's Highway East, (12) from Lakes Entrance via the Prince's Highway East to Marlo, returning via Newmeralla Look-out and the Prince's Highway East, (13) from Lakes Entrance via the State Forest to Metung, and return via Mangurner, Wyemolong, and Kalinna, (14) from Lakes Entrance to Lake Tyers and Aborigine Reserve, and return via the same route, (15) from Bright to the Tawonga Gap, via Wandiligong, and return, (16) from Bright to Porepunkah and the Buckland Valley, and return, (17) from Bright to Mt. Buffalo, via Porepunkah, and return, (18) from Bright to Bogong, via Tawonga Gap, Tawonga, and Mt. Beauty, and return, (k) in addition to the round tours set out above, each vehicle may also be operated on the following day tours, subject to compliance with all of the conditions set out in the aforesaid Schedule "B," entitled Conditions Relating to Operations as a Touring Omnibus—Route: (1) From Bairnsdale to Lakes Entrance, and return, (2) from Bairnsdale to Paynesville, (3) from Bairnsdale to Eagle Point, (l) in addition to the round tours set out above, such vehicle may also be operated on the following conducted tour of the State Electricity Commission area at Bogong, subject to compliance with all of the terms and conditions set out in the aforesaid Schedule "B"—From Mt. Beauty to the State Electricity Commission area at Pretty Valley, via Bogong, and return via Mt. Beauty, (m) in addition to the round tours and day tours set out above, the vehicles may also be operated on round tours on any route or routes within a radius of 20 miles from the Post Office at Lakes Entrance, but only under an arrangement with the Victorian Railway Commissioners whereby passengers are to be carried by road on the vehicles hereby licensed as part of a round tour commenced and completed by rail at Melbourne or at some other railway station within Victoria, subject to the conditions that not more than six vehicles may be so operated at any one time, and when so operated the vehicles shall adhere and be subject to all of the terms and conditions set out in the aforesaid Schedule, each one of the vehicles so licensed where the seating capacity of the vehicle does not exceed seven persons may also be operated for the carriage of passengers otherwise than at separate and distinct fares for each passenger within the following radii, subject to any special conditions as set out in respect to operations from the particular town referred to:—(i) Within a radius of 50 miles from the Post Office at Mitta Mitta, subject to the condition that not more than one vehicle may be operated at any one time, (ii) within a radius of 20 miles from the Post Office at Omeo, subject to the condition that not more than one vehicle may be so operated at any one time, (iii) within a radius of 50 miles from the Post Office at Lakes Entrance, subject to the condition that not more than one vehicle may be so operated at any one time; A.2527, A.2522, A.2523, A.2524, A.2525; 22nd November, 1952.

GRENDIA, G. F., 3B Warrigal-road, Oakleigh; as a stage omnibus on the following routes:—(a) Between the Dandenong Railway Station and Beaconsfield, via Foster-street, Lonsdale-street, and Prince's Highway East, passing through Hallam, Narre Warren, and Berwick *en route*, and returning via the same route, (b) on a round route leaving Dandenong Railway Station, thence to Berwick and Beaconsfield via the same route as per (a) above, thence via Clyde-road and Hallam Valley to Cranbourne-road, thence via Prince's Highway to Dandenong, (c) on a round route

leaving Dandenong Railway Station; thence to Berwick and Beaconsfield as per route (a) above, thence via Harkaway, Narre Warren North, and the Prince's Highway to Dandenong, (d) between the Dandenong Railway Station and Nar-Nar-Goon, via Berwick, Pakenham, and the Prince's Highway East, (e) between the Dandenong Railway Station and Bunyip, via the Prince's Highway East, and returning via Garfield, Tynong, Nar-Nar-Goon, and Pakenham, thence to Dandenong via the Prince's Highway, alternately the vehicles may proceed via the Prince's Highway East to Pakenham, thence via Nar-Nar-Goon, Tynong, and Garfield, and returning via the Prince's Highway direct, (f) between the Dandenong Railway Station and Pakenham Railway Station, via the Prince's Highway East, (g) between the Dandenong Railway Station and Hampton Park, via the South Gippsland Highway, (h) between the Dandenong Railway Station and the Oakleigh Railway Station, via Foster-street, Lonsdale-street, Atherton-road, and Station-street, passing through Noble Park, Harrisfield, Springvale, Clayton, and East Oakleigh *en route*, (i) between Oakleigh Railway Station and the Royal Hotel, Upper Ferntree Gully, Houghton-road, North-road, Wellington-road, and Lysterfield-road, Recreation-road, and Ferntree Gully-road, (j) between the Oakleigh Railway Station and Heeney Park, via the same route as defined in part (l) above as far as Wellington-road, thence deviating to the said park at the corner of Stud-road and Wellington-road, (k) between the Dandenong Market and the Cheltenham Railway Station, via Lonsdale-street, Centre Dandenong-road, Nepean Highway, Station-road, Charman-road, and Park-road, and passing through Keysborough and Dingley *en route*, and return via Cheltenham-road, Centre Dandenong-road, and Lonsdale-street, (l) between the Dandenong Market and the Chelsea Railway Station, via Hammond-road, Worsley-road, Thompson-road, Wells-road, and Thames-promenade, (m) between Lysterfield and the Dandenong High School, via Scoresby and Rowville, no vehicle other than the vehicle licensed by licence No. A.1447 shall be operated on this route, under contract to the Education Department, (n) between Upper Pakenham and the Pakenham Consolidated School, no vehicle other than vehicle licensed No. A.584 shall be operated on this route, under contract to the Education Department, (o) between Blacks Corner and the Pakenham Consolidated School, no vehicle other than licensed vehicle No. A.2813 shall be operated on this route, under contract to the Education Department, (p) between Tynong North and the Pakenham Consolidated School, no vehicle other than the vehicle licensed by licence No. A.757 shall be operated along this route, under contract to the Education Department, (q) not more than four vehicles may be operated on the routes defined in parts (a) to (f) inclusive of "routes" above at any one and the same time, (r) not more than three vehicles may be operated on the route defined in part (h) of "routes" above at any one and the same time, (s) not more than two vehicles may be operated on each of the routes defined in parts (l) to (i) inclusive of "routes" above at any one and the same time, (t) on all services operating through, into, or out of the Town of Dandenong passengers shall not be taken up or set down at any point within the main shopping area of the Town of Dandenong other than at the following stands appointed by the Dandenong Shire Council, (u) specified day tours from Dandenong—Routes: (1) Dandenong to the Dandenong Ranges, via Stud-road and Ferntree Gully-road, Upper Ferntree Gully, Tremont, Sassafras, Olinda, Mt. Dandenong, Montrose, Croydon, Lilydale, Mt. Evelyn, Silvan, Monbulk, Kallista, Belgrave, Menzies Creek, Emerald, Cockatoo, Gembrook, and Pakenham, and return via the Prince's Highway, (2) from Dandenong to Marysville and Acheron Way, via Stud-road to Ringwood, thence to Lilydale, Healesville, Narbethong, Buxton, and Marysville, and return via Acheron Way, Warburton, Lilydale, Croydon, and Scoresby, (3) from Dandenong to Healesville, via Prince's Highway to Caulfield, thence via Burke-road to Heidelberg, thence via Bell-street to Preston, Whittlesea, Kinglake, Mount Slide, and Toolangi, and return via Lilydale and Ringwood, (4) from Dandenong to Strezlecki Ranges, via Warragul, Grand Ridge-road, Ranceby, and Poowong, and return via South Gippsland Highway, (5) from Dandenong to Cowes, via Coast-road and San Remo, thence a tour of Phillip Island, and return via San Remo and the same route, (6) from Dandenong to Portsea and Sorrento, via Nepean Highway to Frankston and Mornington, thence via Marine-drive to Dromana, Rosebud, Rye, Sorrento, and Portsea, and return via Nepean Highway and Arthur's Seat, (7) from Dandenong to Flinders and Dromana, via

Frankston-road to Frankston, thence via Nepean Highway to Mornington, thence via Marine-drive to Dromana, Arthur's Seat, and Flinders, and return via Balnarring, Hastings, Somerville, Pearceedale, and Cranbourne, (8) from Dandenong to Rosebud, via Frankston-road and Nepean Highway to Mornington, thence via Marine-drive to Dromana and Rosebud, and return via Nepean Highway and Frankston-road, (9) from Dandenong to Hastings, via Frankston-road and Nepean Highway to Mornington, thence via Marine-drive to Dromana and Bittern, and return via Hastings, Somerville, Pearceedale, and Cranbourne, (10) from Dandenong to the Dandenong Ranges, via Stud-road and Ferntree Gully-road to Upper Ferntree Gully, Tremont, Sassafras, Olinda, Mt. Dandenong, Montrose, Mt. Evelyn, Silvan, Monbulk, Kallista, Belgrave, and Belgrave Heights, and return via Narre Warren North and Narre Warren and Prince's Highway, (11) from Dandenong to the Dandenong Ranges and City of Melbourne, via Ferntree Gully, Tremont, Sassafras, Olinda, Mt. Dandenong, Montrose, Croydon, and Ringwood to Melbourne, thence via St. Kilda-road, Fitzroy-street, and St. Kilda-esplanade to North-road, thence via the Prince's Highway, (12) from Dandenong to Emerald, via Beaconsfield and Upper Beaconsfield, and return via Monbulk, Belgrave, and Ferntree Gully, (v) each of the vehicles hereby licensed having a seating capacity greater than twenty passengers may also be operated as a special service omnibus within the following radii, subject to the proviso that no journey shall be made to or through the metropolitan area as defined in the *Transport Regulation Act 1933*, amended by the *Transport Regulation Act 1951*, and subject to all of the conditions set out in the Schedule attached hereto, entitled Schedule of Conditions Relating to Operations as a Special Service Omnibus:—
(i) Within a radius of 50 miles from the Post Office at Dandenong, (ii) within a radius of 50 miles from the Post Office at Beaconsfield, (iii) within a radius of 50 miles from the Post Office at Pakenham, (iv) within a radius of 50 miles from the Post Office at Tynong North; A.383; 22nd November, 1952.

FONTANA, M., Barnawartha; (a) school service between Chiltern and Wangaratta High and Technical Schools, under contract to the Education Department, (b) the vehicle may also be operated for the carriage of pupils of the Wangaratta High and Technical Schools from Wangaratta to school sports meetings and on educational and similar excursions within a radius of 20 miles from Wangaratta, but only as and when required by the headmaster of either of the said schools, (c) under charter conditions within a radius of 20 miles of the Post Office at Chiltern; A.2502; 22nd November, 1952.

FLOOD, T. R., 157 Arnold-street, Bendigo; as a stage omnibus between Rochester and Shepparton, via Kyabram, Lancaster, Merrigum, Byrneside, Tatura, and Mooroopna; A.2536; 22nd November, 1952.

GREGORY, C., 2 Westbrook-road, Yallourn; (a) at separate and distinct fares within a radius of 5 miles of the Post Office at Yallourn, (b) under private hire conditions within a radius of 50 miles of the Post Office at Yallourn; A.2824; 22nd November, 1952.

JARVIS, F., Ford-street, Beechworth; (a) at separate and distinct fares within a radius of 5 miles of the Post Office at Beechworth, (b) under private hire conditions within a radius of 50 miles of the Post Office at Beechworth; A.22; 30th November, 1952.

LATROBE VALLEY BUS LINES, 66-68 Princes-street, Traralgon; to operate as a stage omnibus under the same terms and conditions as contained in additional conditions document No. A.130; A.2560; 15th November, 1952.

MARTIN, R. C., Post Office, Bairnsdale West; (a) the vehicle may be operated between Bairnsdale and Ellaswood, via Wy-yung, (b) mails may be carried and parcels also may be carried to or from any place along the route defined above, but so that the weight of any one parcel shall not exceed 14 lb. and so also that the total weight of parcels carried at any one time shall not exceed 56 lb., (c) the vehicle may also be operated on the route between Bairnsdale and Lakes Entrance for the carriage of mails and parcels only, subject to the following conditions:—(1) No passengers shall be carried on the said route, (2) the following time-table only will be adhered to:—Depart Bairnsdale 10 a.m., arrive Lakes Entrance 11 a.m., (3) the vehicle shall return empty upon the return journey between Lakes Entrance and Bairnsdale, (d) the only rates to be charged for the carriage of parcels pursuant to the conditions of this licence shall be as set out in the Schedule attached hereto, entitled "Parcels Schedule"; A.2497; 22nd November, 1952.

MAYZE, A., 36 Narracan-avenue, Yallourn; (a) at separate and distinct fares within a radius of 5 miles of the Post Office at Yallourn, (b) under private hire conditions within a radius of 50 miles of the Post Office at Yallourn; A.2731; 23rd November, 1952.

MCCOOMS, A. J., Armstrong-street, Yarra Glen; as a stage omnibus on the following routes:—(a) Between Yarra Glen Railway Station and Dixons Creek, (b) between Yarra Glen Railway Station and Steel's Creek, (c) mails and parcels may be carried to or from any place along the routes, but so that the weight of any one parcel shall not exceed 14 lb. and so also that the total weight of parcels carried at any one time shall not exceed 56 lb., (d) the vehicle may also be operated for the carriage of passengers otherwise than at separate and distinct fares for each passenger within a radius of 50 miles from the railway station at Yarra Glen; A.1669; 3rd November, 1952.

MCCAFFIN, W. J., Morkalla; (a) school service between Morkalla and Meringur Consolidated School, under contract to the Education Department, (b) under private hire conditions within a radius of 20 miles of the Post Office at Morkalla; A.2905; 22nd November, 1952.

MCINTOSH, H. C. (Ailema), Sydney-road, Beechworth; (a) at separate and distinct fares within a radius of 5 miles of the Beechworth Post Office, (b) under private hire conditions within a radius of 50 miles of the Beechworth Post Office; A.2507; 15th November, 1952.

MCMILLAN, H. F., 26 Benbow-street, Ararat; as a stage omnibus on the following routes:—(a) Between Lake Goldsmith and the Beaufort Higher Elementary School, under contract to the Education Department, (b) between Beaufort and the Ballarat Picture Theatre (on Saturday nights only), depart Beaufort 6 p.m., depart Ballarat at conclusion of picture show, (c) under charter conditions within a radius of 50 miles from the Post Office at Beaufort, (d) the vehicle may be operated after the hour of Six o'clock post-meridian (6 p.m.) on any day as a special service omnibus, under modified charter conditions, within a radius of 30 miles from the Post Office at Beaufort, (e) specified day tours from Beaufort, (f) route—(1) Beaufort to The Grampians, via Ararat and Stawell, and return, (2) Beaufort to Daylesford, and return, (3) Beaufort to Geelong, and return; A.2897; 23rd November, 1952.

ROBINSON, J., Post Office, Brown Coal Mine; (a) at separate and distinct fares within a radius of 5 miles of the Post Office at Brown Coal Mine, (b) under private hire conditions within a radius of 50 miles of the Post Office at Brown Coal Mine; A.2718; 22nd November, 1952.

ROGERS, H. (trading as Roger Brothers), 75 Broome-crescent, Wonthaggi; the holder of this licence is also the holder of certain "A" licence Nos. A.157, A.212, and A.2266, which authorize the vehicles thereby licensed to be operated *inter alia* as stage omnibuses on the following routes:—(a) Between Wonthaggi and Inverloch, (b) between Wonthaggi and Cape Patterson, (c) between Wonthaggi and San Remo, via Dalyston and Anderson, (d) between Wonthaggi and Cowes, via Dalyston, Anderson, and San Remo, (e) the holder of this licence is also the holder of licence No. A.2266, which authorized the vehicle thereby licensed to be operated *inter alia* as a stage omnibus between Wonthaggi and Melbourne, via Kilcunda, San Remo, Grantville, the South Gippsland Highway, and the Prince's Highway East, the vehicle hereby licensed may also be operated on the said route only and not otherwise in substitution for but not in addition to the vehicle licensed by the said licence No. A.2266, and when so operated shall adhere and be subject to all of the terms and conditions to which the said licence is subject, (f) under charter conditions within a radius of 20 miles of the Post Office at Wonthaggi; A.2513; 22nd November, 1952.

THOMSON, I. J., Nicholson-street, Orbost; (a) at separate and distinct fares within a radius of 5 miles of the Post Office at Orbost, and from Orbost to Marlo, (b) the vehicle may also be operated for the carriage of passengers otherwise than at separate and distinct fares for each passenger from the licensee's place of business at Orbost to places within the State of Victoria; A.2506; 15th November, 1952.

TROTTER, H. B., 38 Atkinson-parade, Oakleigh; as a stage omnibus on the following routes:—(a) Between the Oakleigh Railway Station and Syndal, via Station-street, Atherton-road, Dandenong-road, Ferntree Gully-road, Box Hill-road, Waverley-road, and May-road, (b) between the Oakleigh Railway Station to corner of High-street and Nortons-lane, via Station-street, Atherton-road, Drummond-street, Ferntree Gully-road, Box Hill-road, Waverley-road, Springvale-road, and High-street, (c) between the Oakleigh Rail-

way Station and the Mount Waverley Reserve, High-street, via Station-street, Atherton-road, Drummond-street, Dandenong-road, Ferntree Gully-road, Box Hill-road, Waverley-road, Stevensons-road, and High-street; A.1651; 3rd November, 1952.

TURNBALL, A. A., Commercial-road, Yarram; school service —(a) between Little River and the Geelong High, Technical, and Girls' Schools, under contract to the Education Department, (b) as a stage omnibus on the following route:—Between Little River and Geelong, via Avalon and Lara, (c) the terminal point of the route defined in part (b) of "Routes" above in the City of Geelong shall be the premises at "The Block" in the City of Geelong occupied by the Geelong Publicity Council, and on any and every journey into or out of the City of Geelong the vehicle shall arrive at and depart from the said premises, (d) under charter conditions within a radius of 20 miles of the Post Office at Little River; A.2505; 15th November, 1952.

VENTURA MOTORS PTY. LTD., 885 Canterbury-road, Box Hill; as a stage omnibus on the following route:—Between the Box Hill Railway Station and the Mordialloc Railway Station, via Carrington and Elgar roads, Box Hill, Mont Albert-road and Leopold-crescent, Mont Albert, Windsor-crescent and Union-road, Surrey Hills, Through-road and Toorak-road to the Burwood tram terminus, thence via Warrigal-road past the Holmesglen and Oakleigh Railway Stations to the corner of Point Nepean-road and Balcombe-road and Mentone-parade to the Mentone Railway Station, thence via Mentone-parade, Beach-road, and Main-street, Mordialloc; A.2496; 22nd November, 1952.

VENTURA MOTORS PTY. LTD., 885 Canterbury-road, Box Hill; (a) the holder of this licence is also the holder of licence Nos. A.217, A.218, A.219, A.220, A.221, A.222, A.2050, A.223, A.224, A.595, A.712, A.1450, A.2043, A.2044, A.2045, A.2046, A.2047, A.2048, A.2049, A.2496, A.2544, and A.2552, which authorize the vehicles thereby licensed to be operated in the manner and subject to the conditions set out in a document entitled additional conditions of licence No. A.217, (b) the vehicle hereby licensed may be operated in substitution for but not in addition to any one of the vehicles licensed by the other said licences numbered as aforesaid, and when so operated shall adhere and be subject to all of the terms and conditions to which the said licences are subject; A.2517; 17th November, 1952.

WEDGE, D. E., Curdie-street, Cobden; (a) school service between Glenfyne and Timboon, via Curdie's River, under contract to the Education Department, (b) under charter conditions within a radius of 20 miles of the post office at Cobden and from Cobden to Mailor's Flat, Lake Bolac, Skipton, Cressy, Colac, Lorne, Apollo Bay, Port Campbell, Princetown, Peterborough, Narin-gal, Darlington, Derrinallum, Lismore, Nalingal, and Warrnambool via Glenfyne; A.2518; 23rd November, 1952.

WEDGE, D. E., Curdie-street, Cobden; school service between Eastern Creek and Timboon, under contract to the Education Department; A.2509; 22nd November, 1952.

WISE, G. M., 45 Albert-street, Kerang; as a stage omnibus on the following routes:—(a) Between Murrabit West and Kerang High School, via Murrabit and Westby, under contract to the Education Department, (b) urgent parcels may be carried on the vehicle but so that the total weight of parcels carried at any one time shall not exceed 14 lb., (c) under charter conditions within a radius of 20 miles of the post office at Kerang and from Kerang to Boort, Swan Hill, Pyramid Hill, Gunbower, Quambatook, Wycheproof, Serpentine, Wedderburn, and Mitiamo; A.2495; 22nd November, 1952.

LYON, J., Main-street, Eltham; as an additional vehicle on all licensed routes; A.968; 22nd November, 1952.

APPLICATIONS for renewal of private hire licences expiring in November, 1952:—

BURNS, L. S., Post Office, Erica; P.H.1323, P.H.1322.

COLVIN, A. S., Station-street, Koo-Wee-Rup; P.H.1049.

CROOK, J., Kallista; P.H.1307.

PETTIGREW, W. J. (trading as Garden Motors), Post Office, Box 37, Yallourn; P.H.1615.

GILBERT, J. B., & SON, 67 Lydiard-street, Ballarat; P.H.1510.

GREGORY, C., 2 Westbrook-road, Yallourn; P.H.1051.

HICKS, A. A. (Mrs.), 10 Campbell-crescent, Ballarat; P.H.1091.

ROBINSON, J., care of Post Office, Yallourn North; P.H.619.

SPEHER, E. A., 10 Garden-street, Geelong; P.H.480.

STOLL, G. M., Drouin; P.H.1056.

APPPLICATIONS for renewal of metropolitan private hire cars expiring in September, to operate for the carriage of passengers otherwise than at separate and distinct fares for each passenger throughout Victoria, with the proviso that the vehicle shall be ordered or be bespoken from place of business as indicated hereunder:—

Name and Address; Licence Number; To Operate from.
 COOPER, W., 12 McRae-street, Elwood; M.H.389; Abbey Taxis, 78 Acland-street, St. Kilda.
 DALTON, G. B., 126 Mitchell-street, Northcote; M.H.457; Ambassadors private hire depots.
 GANGE, A., 214 Brunswick-street, Fitzroy; M.H.119, M.H.68, M.H.67; Astoria private hire depots.
 FAIRHALL, R. W., 4 Clasham-street, Balwyn; M.H.393; Ambassador Taxis.
 SAW, A. A. J., 17 Jenkin-street, Northcote; M.H.380; Embassy Taxis, Eastern Market, Melbourne.
 ROWE, J., 72 Wellington-street, St. Kilda; M.H.527; Embassy Taxis, Eastern Market.
 HOWSON, R. S., 309 High-street, Preston; M.H.392; Ambassador Private Hire Service, 27 Little Bourke-street, Melbourne.

Notice of any objection should be forwarded to reach the Secretary to the Board not later than Wednesday, 10th September, 1952.

E. V. FIELD,
 Secretary.

Exhibition Buildings, Rathdown-street, Carlton, N.3,
 27th August, 1952.

COUNTRY ROADS BOARD.

NOTICE OF FIXING A NEW ALIGNMENT OF SPRINGVALE-ROAD IN THE SHIRE OF MULGRAVE.

NOTICE is hereby given that the Country Roads Board, under the powers conferred upon it by the *Country Roads Act 1948* (No. 5290), has fixed a new alignment for the east side of Springvale-road, in the Shire of Mulgrave, as described hereunder, that is to say:—

Commencing at a point on the northern boundary of lot 11 on plan of subdivision numbered 13304, lodged in the Office of Titles, and being part of Crown portion 99 of the Parish of Mulgrave, the said point being distant 270 deg. 19 min. 92 feet from the north-eastern angle of the said lot; thence by lines bearing respectively 225 deg. 9 min. 21 ft. 2 in., 180 deg. 0 min. 250 feet, and 135 deg. 9 min. 21 ft. 31 in. to a point on the southern boundary of lot 15 on the said plan of subdivision distant 270 deg. 19 min. 92 feet from the south-eastern angle of the lot last named—which said new alignment is shown on survey plan numbered 5496, lodged in the Office of the Country Roads Board.

Copies of the said survey plan are lodged in the offices of the Country Roads Board, the municipality of the Shire of Mulgrave, the Registrar of Titles, and the Registrar-General respectively, and may be inspected by any person without a fee at any time at which such offices are open for business.

Dated this 21st day of August, 1952.

W. H. NEVILLE,
 Secretary, Country Roads Board.
 Exhibition Building, Rathdown-street, Carlton, N.3.

VICTORIAN RAILWAYS.

VICTORIAN RAILWAYS COMMISSIONERS.

Amendment of By-law No. 370.

THE Victorian Railways Commissioners, in the exercise of the powers conferred upon them by the Railways Act, do hereby amend clause 1, paragraph (a), of By-law 370, as follows:—

For the words "Class 'A'" there shall be substituted the words "Classes 'A' and 'AA,'" and for the words "Class 'B'" there shall be substituted the words "Classes 'B' and 'BB.'"

In witness whereof the common seal of the Victorian Railways Commissioners was affixed hereto, this twelfth day of August, 1952, in the presence of—

(SEAL) A. G. FLETCHER,
 O. G. MEYER,
 Victorian Railways Commissioners.

Confirmed by the Governor in Council.
 19th August, 1952.

A. MAHLSTEDT,
 Clerk of the Executive Council.

NOTICE TO MARINERS.

[No. 21 of 1952.]

AUSTRALIA.—VICTORIA.

CORNER INLET APPROACH AND BASIN.—INFORMATION ABOUT BUOYAGE.

(1) Buoy Permanently Withdrawn.

Former Notice.—(3) of No. 4 of 1947, hereby cancelled.
Position.—1.81 miles 112 deg., from the Cairn (W), Mt. Singapore summit, lat. 38 deg. 47 min. 03 sec. S., long 146 deg. 26 min. 33 sec. E.

Remarks.—The buoy formerly moored on this station has been permanently withdrawn.

(2) Alterations in Buoy-stations.

Former Notice.—4 (c) of No. 5 of 1943, hereby cancelled.
Position.—Welshpool pier-head light, lat. 38 deg. 42 min. 28 sec. S., long. 146 deg. 26 min. 47 sec. E.

Alterations—

(a) The black barrel buoy formerly moored at 1.45 cables 122 deg. from the above light is now moored at 1.1 cables 140 deg. therefrom, and 0.5 cables 269 deg. from its former station, coloured red, and numbered 7, in a depth of 8 feet, sand.

(b) The black can buoy formerly moored at 4.2 cables 102½ deg. from New pier-head, is now moored at 3.7 cables 107½ deg. from the above light and 0.45 cables 237½ deg. from its former station, coloured red, and numbered 9, in a depth of 10 feet, sand.

(c) No. 2 Buoy—Corner Inlet Approach.

Former Notice.—No. 7 of 1944 (1) (a).

Position.—Front light, 272 deg. 20 min. leading line, Wilson's Promontory, lat. 38 deg. 50 min. 40 sec. S., long. 146 deg. 28 min. 19 sec. E.

Position of Buoy.—5.83 miles 091 deg. 16 min. from the above light, and 8 cables 086 deg. from its former station.

Depth at Buoy.—27 feet, sand.

Description.—First class steel nun buoy, coloured black, and numbered 2.

Remarks.—The buoy station is on the boundary line of the port of Corner Inlet and Port Albert, which bears 044 deg. from the south-eastern extreme of Rabbit Island through Fairway buoy on the leading line of Port Albert entrance.

(3) Port of Corner Inlet and Port Albert—Synopsis of Buoyage as at 24th July, 1952:—

No. 2—Corner Inlet.—As defined in (2) (c) above.

No. 4—Corner Inlet.—First class steel nun buoy, numbered, coloured black.

No. 6—Corner Inlet.—First class steel nun buoy, numbered, coloured black.

No. 1—Corner Inlet.—First class wooden can buoy, numbered, coloured red.

No. 3—Corner Inlet.—Second class wooden can buoy, numbered, coloured red.

No. 5.—Corner Inlet.—Second class wooden can buoy, numbered, coloured red.

Corner Basin—Benison Spit (Southern Buoy).—200-gallon steel cask buoy, red and white horizontal stripes, not numbered.

Corner Basin—Franklin Spit (Northern Buoy).—200-gallon steel cask buoy, red and white horizontal stripes, not numbered.

Corner Basin—Welshpool (No. 7).—200-gallon wooden cask buoy, coloured red, and numbered.

Corner Basin—Welshpool (No. 9).—Second class wooden can buoy, coloured red, and numbered.

Port Albert—Fairway buoy.—First class steel can buoy, coloured red, not numbered, as per N.M. 17/1952.

Remarks.—Nos. 4, 6, 1, 3, 5, of Corner Inlet, the two cask buoys of Corner Basin, and the Port Albert Fairway buoy practically are all moored on their original and charted stations with new moorings.

Charts Affected.—B.A. Nos. 1703-1695A. Departmental plans, Corner Inlet, No. 1—Corner Basin No. 2.

Publications.—*General Notice to Mariners, Victoria*, 1942, pages 226, 230, 233, 242, and 247. *Australia Pilot*, Vol. II., 1944, pages 184 and 185.

D. S. STEVENSON,
 Port Officer.

Ports and Harbors Branch,
 Department of Public Works,
 Melbourne, C.2, 20th August, 1952.

4 GEORGE VI. No. 4755, SECTION 6.

I HEREBY give notice that, on the 1st August, 1952, I filed an election to administer the following deceased person's estate, in accordance with section 6 of the *Public Trustee Act 1940*:—

O'CALLAGHAN, ARTHUR HENRY, late of 154 Buckley-street, Footscray, pensioner, died 7th August, 1951, intestate.

I HEREBY give notice that, on the 13th August, 1952, I filed elections to administer the following deceased persons' estates, in accordance with section 6 of the *Public Trustee Act 1940*:—

*DYER, HARRIETT, late of 46 Clyde-street, St. Kilda, married woman, died 12th May, 1952.

HULL, WILLIAM HENRY, late of Alexandra, chief electrician, died 9th July, 1951, intestate.

LEESON, NINA MARY EILEEN REBECCA LEESON, late of 2 Glen Iris-road, Camberwell, nursing sister, died 30th June, 1952, intestate.

*TROTMAN, HENRY, also known as Harry, late of 107 Moroney-street, Bairnsdale, retired, died 31st May, 1952.

* According to the provisions of the will.

I HEREBY give notice that, on the 14th August, 1952, I filed elections to administer the following deceased persons' estates, in accordance with section 6 of the *Public Trustee Act 1940*:—

GRUER, ELIZABETH, formerly of 462A Williamstown-road, Port Melbourne, but late of Sunbury, pensioner, died 12th September, 1951, intestate.

MARSDEN, LEONARD GEORGE, late of William Booth Memorial Hostel, Lonsdale-street, Melbourne, labourer, died 14th May, 1952, intestate.

MINOGUE, NORA MATILDA, late of Little Sisters of the Poor, Northcote, home duties, died 12th June, 1952, intestate.

SMITH, JOHN ABERDEEN, late of Bendigo Benevolent Home, Bendigo, labourer, died 13th October, 1950, intestate.

*SOMERVILLE, GEORGE, late of 7 Elm-place, Windsor, house decorator, died 13th May, 1952.

Soo CHEONG, also known as Sue Cheong, late of 247 Franklin-street, Melbourne, watchman, died 17th May, 1952, intestate.

* According to the provisions of the will.

I HEREBY give notice that, on the 15th August, 1952, I filed elections to administer the following deceased persons' estates, in accordance with section 6 of the *Public Trustee Act 1940*:—

EASTWELL, WILLIAM THOMAS, late of 139 Richardson-street, Middle Park, plumber, died 7th May, 1952, intestate.

*FANKHAUSER, ISABELLA ALICE, formerly of 86 Grant-street, Bairnsdale, but late of 46 Day-street, Bairnsdale, home duties, died 21st May, 1952.

NATCOTT, LILY, late of Cheltenham, spinster, died 13th September, 1946, intestate.

NATCOTT, ROSETTA ELIZABETH, late of "Betheny," Camberwell-road, Camberwell, spinster, died 27th January, 1948, intestate.

SABASTINI, PHILLIP, late of Mont Park, hospital attendant, died 17th June, 1952, intestate.

STOREY, WILLIAM JOHN, late of Antonios Hotel, Flinders-street, Melbourne, wharf labourer, died between 24th and 27th May, 1952, intestate.

* According to the provisions of the will.

I HEREBY give notice that, on the 18th August, 1952, I filed elections to administer the following deceased persons' estates, in accordance with section 6 of the *Public Trustee Act 1940*:—

ELLIS, ANNIE, late of Bendigo Benevolent Home, Bendigo, pensioner, died 29th March, 1952, intestate.

GIBSON, RICHARD NEVILLE, late of 41 Grosvenor-street, St. Kilda, retired wool classer, died 29th May, 1952, intestate.

GLEESON, WILLIAM FRANCIS, late of 29 Lithgow-street, Abbotsford, cleaner, died 25th June, 1952, intestate.

GREEN, JOHN WILLIAM, late of Little River, labourer, died 18th or 19th May, 1952, intestate.

GRIME, JEFFREY JAMES, late of 42 Dudley-street, West Melbourne, gardener, died 25th May, 1952, intestate.

*HAND, ADA ANN, formerly of 62 Mitchell-street, Bentleigh, but late of Sunbury, widow, died 11th May, 1952.

* According to the provisions of the will.

I HEREBY give notice that, on the 19th August, 1952, I filed elections to administer the following deceased persons' estates, in accordance with section 6 of the *Public Trustee Act 1940*:—

BODA, LAJOS, late of No. 2 Hostel, Williamstown, labourer, died 21st October, 1950, intestate.

DOUGLAS, GEORGE, late of 70 Coronation-street, West Footscray, watchman, died 9th May, 1952, intestate.

SHERLOCK, ADA ELIZABETH, formerly of 87 Leonards-road, Ascot Vale, and of 156 Arden-street, North Melbourne, but late of Royal Park, spinster, died 30th May, 1952, intestate.

TABB, MARY ELLEN, late of Bendigo Benevolent Home, Bendigo, widow, died 20th October, 1951, intestate.

TEMPLEMAN, JAMES ROBERT, late of 2 Raphael-street, Abbotsford, steward, died 28th June, 1952, intestate.

TURNER, BERTHA ALISON, late of 5 Broadway, Elwood, widow, died 2nd October, 1948, intestate.

C. J. GARDNER,
Public Trustee.

412 Collins-street, Melbourne, C.1, 20th August, 1952.

NOTICE.

ADMINISTRATION of the estate of each of the under-mentioned deceased persons has been granted to me, and creditors, next of kin, and all others having claims against the estate of any of the persons so mentioned are required to send particulars of their claims to the Public Trustee, No. 412 Collins-street, Melbourne, on or before the 29th October, 1952, or they will be excluded from the distribution of the estate when the assets are being distributed:—

BODA, LAJOS, late of No. 2 Hostel, Williamstown, labourer, died 21st October, 1950, intestate.

DOUGLAS, GEORGE, late of 70 Coronation-street, West Footscray, watchman, died 9th May, 1952, intestate.

*DYER, HARRIETT, late of 46 Clyde-street, St. Kilda, married woman, died 12th May, 1952.

EASTWELL, WILLIAM THOMAS, late of 139 Richardson-street, Middle Park, plumber, died 7th May, 1952, intestate.

ELLIS, ANNIE, late of Bendigo Benevolent Home, Bendigo, pensioner, died 29th March, 1952, intestate.

*FANKHAUSER, ISABELLA ALICE, formerly of 86 Grant-street, Bairnsdale, but late of 46 Day-street, Bairnsdale, home duties, died 21st May, 1952.

GIBSON, RICHARD NEVILLE, late of 41 Grosvenor-street, St. Kilda, retired wool classer, died 29th May, 1952, intestate.

GLEESON, WILLIAM FRANCIS, late of 29 Lithgow-street, Abbotsford, cleaner, died 25th June, 1952, intestate.

GREEN, JOHN WILLIAM, late of Little River, labourer, died 18th or 19th May, 1952, intestate.

GRIME, JEFFREY JAMES, late of 42 Dudley-street, West Melbourne, gardener, died 25th May, 1952, intestate.

GRUER, ELIZABETH, formerly of 462A Williamstown-road, Port Melbourne, but late of Sunbury, pensioner, died 12th September, 1951, intestate.

*HAND, ADA ANN, formerly of 62 Mitchell-street, Bentleigh, but late of Sunbury, widow, died 11th May, 1952.

†HAWTHORN, MABEL LILLA RABONE, late of Wellington, New Zealand, spinster, died 31st January, 1952.

†HODGSON, GEORGE WRAY, late of 38 Arundel-crescent, Surrey Hills, manager, died 23rd March, 1952.

†HORNE, WILLIAM JOHN, late of 25 Grantham-street, West Brunswick, pensioner, died 27th May, 1952.

HULL, WILLIAM HENRY, late of Alexandra, chief electrician, died 9th July, 1951, intestate.

LEESON, NINA MARY EILEEN REBECCA LEESON, late of 2 Glen Iris-road, Camberwell, nursing sister, died 30th June, 1952, intestate.

MARSDEN, LEONARD GEORGE, late of William Booth Memorial Hostel, Lonsdale-street, Melbourne, labourer, died 14th May, 1952, intestate.

MINOGUE, NORA MATILDA, late of Little Sisters of the Poor, Northcote, home duties, died 12th June, 1952, intestate.

†MCBEAN, CHARLES HOPE, late of 102 Argyle-road, Kew, sales manager, died 16th May, 1952.

†MCFARLANE, JOHN, formerly of Manly, but late of Buderim, both in Queensland, share farmer, in the will called fruit preserver, died 24th April, 1935.

NATCOTT, LILY, late of Cheltenham, spinster, died 13th September, 1946, intestate.

NATCOTT, ROSETTA ELIZABETH, late of "Betheny," Camberwell-road, Camberwell, spinster, died 27th January, 1948, intestate.

O'CALLAGHAN, ARTHUR HENRY, late of 154 Buckley-street, Footscray, pensioner, died 7th August, 1951, intestate.

SABASTINI, PHILLIP, late of Mont Park, hospital attendant, died 17th June, 1952, intestate.

SHERLOCK, ADA ELIZABETH, formerly of 87 Leonards-road, Ascot Vale, and of 156 Arden-street, North Melbourne, but late of Royal Park, spinster, died 30th May, 1952, intestate.

SINTON, WILLIAM, late of 101 Ballarat-road, Footscray, builder, died 20th December, 1951, intestate.

SMITH, JOHN ABERDEEN, late of Bendigo Benevolent Home, Bendigo, labourer, died 13th October, 1950, intestate.
*SOMERVILLE, GEORGE, late of 7 Elm-place, Windsor, house decorator, died 13th May, 1952.

SOO CHEONG, also known as Sue Cheong, late of 247 Franklin-street, Melbourne, watchman, died 17th May, 1952, intestate.

STOREY, WILLIAM JOHN, late of Antonios Hotel, Flinders-street, Melbourne, wharf labourer, died between 24th and 27th May, 1952, intestate.

TABB, MARY ELLEN, late of Bendigo Benevolent Home, Bendigo, widow, died 20th October, 1951, intestate.

TEMPLEMAN, JAMES ROBERT, late of 2 Raphael-street, Abbotsford, steward, died 28th June, 1952, intestate.

*TROTMAN, HENRY, also known as Harry, late of 107 Moroney-street, Bairnsdale, retired, died 31st May, 1952.

TURNER, BERTHA ALISON, late of 5 Broadway, Elwood, widow, died 2nd October, 1948, intestate.

* According to the provisions of the will.

† With the will annexed.

C. J. GARDNER,
Public Trustee.

Melbourne, 20th August, 1952.

NAGAMBIE WATERWORKS TRUST.

RATING BY-LAW FOR 1952.

THE Nagambie Waterworks Trust, in pursuance and exercise of the powers conferred by the Water Acts, doth hereby make a rate for the supply of water for domestic purposes of One shilling and nine pence (1s. 9d.) in the pound (£1) of the annual municipal valuation of lands and tenements liable to be rated within the Nagambie Urban District.

Provided that in no case shall the amount of rate payable per annum in respect of any tenement (other than on land on which there is no building) be less than Thirty shillings (30s.), and in respect of any land on which there is no building be less than Fifteen shillings (15s.).

Such rates are made and shall be levied upon the occupiers or owners of the said lands and tenements for the year commencing on the 1st day of January, 1952, and shall be payable on the 2nd day of September, 1952, at the Trust Office.

The maximum quantity of water to be supplied in any one year without further charge to any property rated by the Trust is hereby fixed at the quantity which, at a charge of Two shillings (2s.) per 1,000 gallons, would produce an amount equal to the amount of the rate levied on such property for the said year.

The charge for water supplied by measure to any property rated by the Trust in excess of such maximum quantity, computed as in the last preceding clause, is hereby fixed at Two shillings per thousand gallons.

The charge for water supplied by measure to any property not rated by the Trust is hereby fixed at Two shillings (2s.) per thousand gallons, and the minimum quantity of water to be charged for in cases where water is so supplied is fixed at (10,000) ten thousand gallons.

The charge for water supplied by measure shall be payable, on demand, at the office of the Trust.

Dated the 11th day of August, 1952.

(SEAL) D. H. COULTER, Chairman.
F. M. CHAPMAN, Secretary.

Approved, 20th August, 1952.—R. K. BROSS, Minister of Water Supply.

Approved by the Governor in Council, 26th August, 1952.—A. MAHLSTEDT, Clerk of the Executive Council.

SUMMONING OFFICER.

I HEREBY appoint the under-mentioned person, under section 31 of the *Education Act 1928*, to summon parents within the State of Victoria:—

Senior Constable GUSTAV HENRY HAAG, No. 8925.

P. P. INCHBOLD,
Minister of Education.

Education Department,
Melbourne, 15th August, 1952.

Country Fire Authority Acts.

PERMISSION TO HOLD FIRE BRIGADE DEMONSTRATION.

IN pursuance with the provisions of section 79 (1) and (2) of the *Country Fire Authority Act 1944*, the Country Fire Authority has granted permission for the holding of a fire brigade demonstration as under:—

Urban Fire Brigades.

At Leongatha, on Saturday, 13th December, 1952.

G. G. SINCLAIR,
Secretary.

20th August, 1952.

Town and Country Planning Acts.

SHIRE OF MANSFIELD.

INTERIM DEVELOPMENT ORDER.

WHEREAS by virtue of the powers conferred by the Town and Country Planning Acts and every other power enabling them in that behalf, the preparation of a planning scheme in accordance with the said Acts has been commenced by the Council of the Shire of Mansfield (hereinafter referred to as the "Responsible Authority"), which hereby makes the following Interim Development Order:—

1. The development of all lands referred to in the Schedule, and the erection, construction, and carrying out of any buildings, roads, or other works on any of the said lands, is hereby prohibited.

2. Any person may apply to the Responsible Authority for permission to develop, subdivide, or otherwise use any land, or erect or construct any buildings, roads, or other works, during the operation of this Order.

3. Any application for permission to develop, subdivide, or otherwise use any land, or erect or construct any building, roads, or other works, may be granted by the Responsible Authority, subject to such conditions as are specified in the permit, or may be refused.

4. Any owner of any land who, after the publication of this Order in the *Government Gazette*, contravenes any of the provisions contained herein shall, when directed by notice in writing, remove, pull down, take up, or alter any building, road, or other works, and, if any owner fails to do so within the time specified by the notice, the Responsible Authority may carry out all or any of such works, and recover all expenses incurred, after due notice has been given to the owner, lessee, and/or occupier in accordance with the provisions of section 12, sub-section 3, of the Act.

5. None of the provisions of this Order shall prohibit the continuance of the use of any land or buildings for the purpose for which it was used immediately before the coming into operation of this Order.

6. This Order shall remain in operation until the approval of the planning scheme in accordance with the Town and Country Planning Acts, or until this Interim Development Order is revoked by the Governor in Council.

7. Schedule of land affected:—All that piece of land within the Township of Jamieson and Parish of Jamieson commencing at a point on the Goulburn River where the south-east boundary of allotment 3 of section A abuts thereon; bounded thence north-easterly by the said allotment and a line to the south-west angle of allotment 1 of section C; thence south-easterly and northerly by allotment 10A of section C to a point in line with the north side of the road forming the south boundaries of sections 17 and 16; thence south-easterly by a line and the north side of the said road, southerly by the east side of the road forming the western boundaries of sections 14 and 13, and westerly by the south side of the road forming the north boundaries of allotments 10c and 10b of section H, and south-westerly and southerly by the west boundary of the last-mentioned allotment and a line to the north boundary of allotment 2 of section 5; thence westerly by that allotment, allotment 1, and a line bearing N. 77 deg. 5 min. W. to the Goulburn River aforesaid; and thence northerly by that river to the point of commencement.

Dated the 6th day of August, 1952.

(SEAL) GEORGE CUMMINS, President.
D. A. BLAIR, Councillor.
R. WOMERSLEY, Secretary.

Approved by the Governor in Council,
26th August, 1952.

A. MAHLSTEDT,
Clerk of the Executive Council.

VICTORIAN RAILWAYS.

At the Executive Council Chamber, Melbourne, the
fifth day of August, 1952.

PRESENT:

The Lieutenant-Governor, as Deputy for His Excellency
the Governor of Victoria.

Mr. Byrnes | Mr. Brose.

REGULATIONS.—BOARD OF DISCIPLINE.

THE Lieutenant-Governor, as Deputy for His Excellency the Governor of the State of Victoria, by and with the advice of the Executive Council thereof, doth hereby, in the exercise of the powers conferred in that behalf by section 166 of the *Railways Act 1928*, make the Regulation following, that is to say:—

“On and from the first day of August, 1952, the provisions of Parts I., II., III., and IV. of Schedule F to the Board of Discipline Regulations made on the 9th day of May, 1923, in the exercise of the powers conferred in that behalf by the *Railways (Board of Discipline) Act 1922* are hereby repealed and the following provisions shall apply:—

SCHEDULE F.

Railways Act 1928.

VICTORIAN RAILWAYS.

Scales of fees and expenses payable to witnesses being persons who are not employed in the railway service.

Part I.—Fees payable in respect of attendance before the Board.

(1) Professional men, including—	<i>Allowance Per Day.</i>
Medical practitioners	} £2 2s.
Legal practitioners	
Architects	
Engineers	
Surveyors	
Dentists	
Veterinary surgeons	
University professors	
Accountants (practising as principals)	
Patent attorneys	
Merchants, auctioneers	
Estate agents, sharebrokers	
Bank managers	
Company managers	
(2) Farmers or graziers	} £1 5s.
Master tradesmen	
Persons in business such as hotel-keepers, shop-keepers, commission agents, and so on	} 10s. or the amount of salary or wages actually lost but not in any event exceeding £1 10s.
Gentlemen	
(3) Adult male persons in receipt of salary or wages	} Same amount as male witness of similar class.
(5) Female witness not engaged in profession or business and not in receipt of salary or wages	
(5) Female witness not engaged in profession or business or in receipt of salary or wages	8s.
(6) Persons under 21 years of age in receipt of salary or wages	} 5s. or amount of salary or wages actually lost, whichever is the greater, but not in any event exceeding £1 10s.
(7) Interpreter	Not exceeding £2 2s.

Part II.—Fees payable in respect of time occupied in qualifying to give evidence.

- (8) Professional, scientific, or expert witnesses may be allowed in respect of each day which, in the opinion of the Board, was necessarily occupied in qualifying to give evidence, such fee, not exceeding £2 2s., as the Board considers reasonable.

Part III.—Travelling expenses.

- (9) If the witness is resident, or his place of business is situate more than 4 miles from the place of hearing, the sum reasonably and actually paid by the witness and certified by the Board.

Part IV.—Sustenance expenses.

- (10) In cases where a witness is compelled to be absent from home overnight, a reasonable sum, which must not in any event exceed £1, may be allowed by the Board in respect of each night of such absence."

And the Honorable Russell Thomas White, for and on behalf of Her Majesty's Minister of Transport for the State of Victoria, shall give the necessary directions herein accordingly.

A. MAHLSTEDT,
Clerk of the Executive Council.

MILK AND DAIRY SUPERVISION ACT 1943 (No. 4997).

*At the Executive Council Chamber, Melbourne, the
nineteenth day of August, 1952.*

PRESENT:

The Lieutenant-Governor, as Deputy for His Excellency the
Governor of Victoria.

Mr. Brose | Mr. Harvey.

REGULATION PRESCRIBING A MILK DEPOT.

IN pursuance of the powers conferred by Part I. of the *Milk and Dairy Supervision Act 1943* (No. 4997), the Lieutenant-Governor, as Deputy for His Excellency the Governor of the State of Victoria, by and with the advice of the Executive Council thereof, doth hereby prescribe as a Milk Depot the premises occupied by the company named hereunder at the location stated:—

Name; Location.

South-Eastern Milk Products Limited; Traralgon.

And the Honorable George Colin Moss, Her Majesty's Minister of Agriculture for the State of Victoria, shall give the necessary directions herein accordingly.

A. MAHLSTEDT,
Clerk of the Executive Council.

MARKETING OF PRIMARY PRODUCTS ACT 1935 (No. 4337).

*At the Executive Council Chamber, Melbourne, the
nineteenth day of August, 1952.*

PRESENT:

The Lieutenant-Governor, as Deputy for His Excellency the
Governor of Victoria.

Mr. Brose | Mr. Harvey.

REGULATIONS.

IN pursuance of the powers conferred by the *Marketing of Primary Products Act 1935* (No. 4337), the Lieutenant-Governor, as Deputy for His Excellency the Governor of the State of Victoria, by and with the advice of the Executive Council thereof, doth hereby make the following Regulation (that is to say):—

For the purposes of any petition, poll or election under the above-mentioned Act, a "producer of seed beans" shall be deemed to be a producer who, during the year ended 30th June, 1952, planted with bean seed at least 2 acres solely for seed purposes.

And the Honorable George Colin Moss, Her Majesty's Minister of Agriculture for the State of Victoria, shall give the necessary directions herein accordingly.

A. MAHLSTEDT,
Clerk of the Executive Council.

MARKETING OF PRIMARY PRODUCTS ACTS.

*At the Executive Council Chamber, Melbourne, the
nineteenth day of August, 1952.*

PRESENT:

The Lieutenant-Governor, as Deputy for His Excellency the
Governor of Victoria.

Mr. Brose

Mr. Harvey.

EGG AND EGG PULP MARKETING BOARD REGULATIONS
AMENDED.

IN pursuance of the powers conferred by the Marketing of Primary Products Acts, the Lieutenant-Governor, as Deputy for His Excellency the Governor of the State of Victoria, by and with the advice of the Executive Council thereof and on the recommendation of the Egg and Egg Pulp Marketing Board, doth hereby amend the Egg and Egg Pulp Marketing Board Regulations 1941 made on the 13th May, 1941, as amended on the 16th July, 1946, the 5th September, 1950, the 13th September, 1950, and the 9th October, 1951, as follows (that is to say):—

In Regulation 2 there shall be added the following definition:—

“ ‘ Preserved eggs ’ mean eggs which have been subjected to any preservative treatment other than artificial cooling.”

In Regulation 19, paragraph (iii) shall be deleted and the following paragraph substituted in lieu thereof:—

“ (iii) Payments to producers in respect of eggs delivered to the Board shall be made by cheque, or in such cases as the Board directs, by cash. If made by cheque, the cheque shall be signed by the Secretary or other officer authorized by the Board.”

Regulation 43 and Form 6 of the Schedule shall be deleted and the following Regulation substituted in lieu thereof:—

“ 43. Every producer owning or controlling or having upon his premises more than 40 adult female domesticated fowls shall register such flock with the Board, and every producer who, by reason of the purchase or other acquisition by him, becomes the owner or controller of, or permits to be held upon his premises more than 40 adult female domesticated fowls shall, by notice in writing, inform the Board of such purchase or other acquisition within fourteen days thereof; and every producer who, by reason of the sale or other disposition by him, ceases to be the owner or controller of, or to have upon his premises more than 40 adult female domesticated fowls shall, by notice in writing, inform the Board of such sale or other disposition within fourteen days thereof.”

Regulation 45 shall be deleted and the following Regulation substituted in lieu thereof:—

“ 45. No person shall without the consent of the Board place or cause to be placed any eggs in any cold storage premises nor subject any eggs to any preservative treatment.

Provided that nothing in these Regulations shall prevent a person or owner of any eggs preserving a quantity of eggs not exceeding 30 dozen for his own domestic requirements.”

In Regulation 47, after paragraph (d) there shall be added the following additional paragraph:—

“ (e) No person shall without the consent of the Board by any process of manufacture or otherwise convert eggs into whole egg pulp or separate whites from the yolks thereof.”

Regulation 48 shall be deleted and the following sub-heading and Regulations substituted in lieu thereof:—

“ RETAILERS’ RETURNS.

48. The records required to be kept, in accordance with section 8 of the *Marketing of Primary Products (Egg and Egg Pulp) Act 1951*, by any person who sells or who offers to sell eggs by retail, shall be in or to the effect of Form 6 of the Schedule.

49. Every person who contravenes or fails to comply with these Regulations shall be guilty of an offence and liable to a penalty of not more than Fifty pounds (£50).”

In the Schedule to these Regulations, after Form 5 there shall be inserted the following Form 6:—

THE EGG AND EGG PULP MARKETING BOARD.

FORM 6 (REGULATION 48).

Section 8, Sub-section (1), *Marketing of Primary Products (Egg and Egg Pulp) Act 1951.*

RETAILER'S RECORD OF EGGS PURCHASED.

Date.	Name and Address of Person or Persons from Whom Eggs Purchased.	Quantity Purchased.	Price Paid per Dozen.

And the Honorable George Colin Moss, Her Majesty's Minister of Agriculture for the State of Victoria, shall give the necessary directions herein accordingly.

A. MAHLSTEDT,
Clerk of the Executive Council.

MARKETING OF PRIMARY PRODUCTS ACTS.

At the Executive Council Chamber, Melbourne, the nineteenth day of August, 1952.

PRESENT:

The Lieutenant-Governor, as Deputy for His Excellency the Governor of Victoria.

Mr. Brose | Mr. Harvey.

APPOINTMENT OF SECRETARY OF EGG AND EGG PULP MARKETING BOARD.

IN pursuance of the powers in that behalf conferred by section 5 of the *Marketing of Primary Products (Egg and Egg Pulp) Act 1951* (No. 5612) and all other powers enabling him in that behalf, the Lieutenant-Governor, as Deputy for His Excellency the Governor of the State of Victoria, by and with the advice of the Executive Council thereof, doth by this Order hereby appoint—

KENNETH GRAHAM LEE

as Secretary of the Egg and Egg Pulp Marketing Board at a salary at the rate of One thousand three hundred and five pounds (£1,305) per annum, plus a cost of living allowance as determined from time to time, pursuant to the provisions of section 39 of the *Public Service Act 1946* (No. 5124) and Regulation 78 of the Public Service (Public Service Board) Regulations, to hold office for a period up to and including the 30th June, 1957, and doth hereby fix the travelling expenses which the Secretary of the said Board shall be entitled to receive at the rates and in accordance with the conditions prescribed in the Regulations under the *Public Service Act 1946* for personal expenses for officers, other than permanent heads, whose salaries are more than £900 a year.

And the Honorable George Colin Moss, Her Majesty's Minister of Agriculture for the State of Victoria, shall give the necessary directions herein accordingly.

A. MAHLSTEDT,
Clerk of the Executive Council.

SOIL CONSERVATION AND LAND UTILIZATION ACTS.

At the Executive Council Chamber, Melbourne, the nineteenth day of August, 1952.

PRESENT:

The Lieutenant-Governor, as Deputy for His Excellency the Governor of Victoria.

Mr. Brose | Mr. Harvey.

APPOINTMENT OF MEMBERS, DISTRICT ADVISORY COMMITTEE.

IN pursuance of the powers conferred by the Soil Conservation and Land Utilization Acts, the Lieutenant-Governor, as Deputy for His Excellency the Governor of the State of Victoria, by and with the advice of the Executive Council thereof, doth hereby appoint the follow-

ing persons to be members of the District Advisory Committee of the Northern Mallee Soil Conservation District, in accordance with the provisions of section 15 of the *Soil Conservation and Land Utilization Act, 1947*, for a term of three years:—

WILLIAM LOUIS PICKERING, being a person elected to represent grazing, agricultural, and other relevant interests in the district.

FRANCIS OSCAR BEER, being a person elected to represent grazing, agricultural, and other relevant interests in the district.

ERNEST PAUL JOHANN RUCHELL, being a person elected to represent grazing, agricultural, and other relevant interests in the district.

ALBERT JAMES BROWN, being a person elected to represent grazing, agricultural, and other relevant interests in the district.

WILLIAM LAURENCE TURNER, being a person elected to represent grazing, agricultural, and other relevant interests in the district.

ANTHONY GORDON RAE, being the person representing the Soil Conservation Authority.

And the Honorable Richard Keats Brose, Her Majesty's Minister for Conservation in the State of Victoria, shall give the necessary directions herein accordingly.

A. MAHLSTEDT,
Clerk of the Executive Council.

DEPARTMENT OF CROWN LANDS AND SURVEY.

At the Executive Council Chamber, Melbourne, the nineteenth day of August, 1952.

PRESENT:

The Lieutenant-Governor, as Deputy for His Excellency the Governor of Victoria.

Mr. Brose | Mr. Harvey.

REVOCATION OF ORDER IN COUNCIL WITHHOLDING FROM SALE, LEASING, OR LICENSING CERTAIN LAND.

THE Lieutenant-Governor, as Deputy for His Excellency the Governor of the State of Victoria, by and with the advice of the Executive Council thereof, doth hereby, in pursuance of the provisions of the *Land Act 1928*, revoke the withholding from sale, leasing, and licensing of the land mentioned hereunder:—

EILDON.—The withholding from sale, leasing, and licensing, by Order in Council of the 10th July, 1876 (see *Government Gazette* of the 14th July, 1876, page 1299) of 10 acres of land in the Parish of Eildon, is hereby revoked.—(E.100b(4) (H.022405).)

And the Honorable Sir Albert Eli Lind, Her Majesty's Commissioner of Crown Lands and Survey for the State of Victoria, shall give the necessary directions herein accordingly.

A. MAHLSTEDT,
Clerk of the Executive Council.

DEPARTMENT OF CROWN LANDS AND SURVEY.

At the Executive Council Chamber, Melbourne, the nineteenth day of August, 1952.

PRESENT:

The Lieutenant-Governor, as Deputy for His Excellency the Governor of Victoria.

Mr. Brose | Mr. Harvey.

REVOCATIONS OF TEMPORARY RESERVATIONS OF LANDS (AS TO PORTIONS).

THE Lieutenant-Governor, as Deputy for His Excellency the Governor of the State of Victoria, by and with the advice of the Executive Council thereof, doth hereby, in pursuance of the provisions of the *Land Act 1928*, revoke portions of the temporary reservations of lands by Orders in Council hereinafter referred to, viz.:—

ORBOST.—Order in Council of the 14th December, 1891, of 1 acre 0 roods 18 perches of land in the Township of Orbost, as a site for Public Buildings, so far as regards the portion thereof comprised within the boundaries published in the *Government Gazette* of the 30th July, 1952, and containing 30 perches.

PRAHRAN.—Order in Council of the 24th January, 1938, of 13 acres 2 roods 6 1/10 perches of land in the Parish of Prahran as a site for Public Recreation, so far as regards the portion thereof comprised within the boundaries published in the *Government Gazette* of the 23rd July, 1952, and containing 2/10 perches.

And the Honorable Sir Albert Eli Lind, Her Majesty's Commissioner of Crown Lands and Survey for the State of Victoria, shall give the necessary directions herein accordingly.

A. MAHLSTEDT,
Clerk of the Executive Council.

DEPARTMENT OF CROWN LANDS AND SURVEY.

At the Executive Council Chamber, Melbourne, the nineteenth day of August, 1952.

PRESENT:

The Lieutenant-Governor, as Deputy for His Excellency the Governor of Victoria.

Mr. Brose | Mr. Harvey.

LANDS TEMPORARILY RESERVED AS SITES.

THE Lieutenant-Governor, as Deputy for His Excellency the Governor of the State of Victoria, by and with the advice of the Executive Council thereof, doth hereby, in pursuance of the provisions of the *Land Act 1928*, reserve, temporarily, and also except from occupation for mining purposes under any miner's right, the lands hereinafter described:—

KILNOORAT.—Site for Supply of Gravel, 2 acres 3 roods 10 perches, more or less, Parish of Kilnoorat, County of Hampden, as indicated by hachure on plan hereunder.—(K.53⁽²⁾) (Rs.6998).

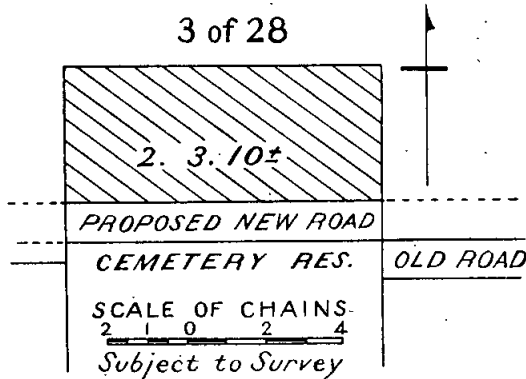

CARAMUT.—Site for Public Recreation, 5 acres, more or less, Town of Caramut, Parish of Caramut, County of Villiers, as indicated by hachure on plan hereunder.—(C.190⁽¹⁾) (Rs.7005).

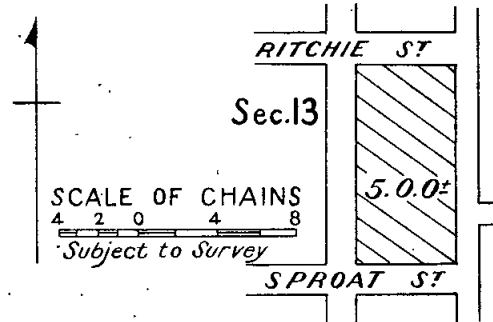

CASTLEMAINE.—Site for a Municipal Depot, 2 acres 30 perches, more or less, Township of Castlemaine, Parish of Castlemaine, County of Talbot, as indicated by hachure on plan hereunder.—(C.99⁽⁴⁾) (Rs.3317).

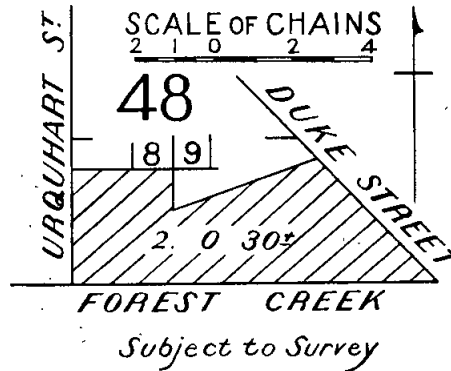

DARGO.—Site for Camping purposes, 40 acres, more or less, Parish of Dargo, County of Dargo, as indicated by hachure on plan hereunder.—(D.163⁽³⁾) (Rs.7007).

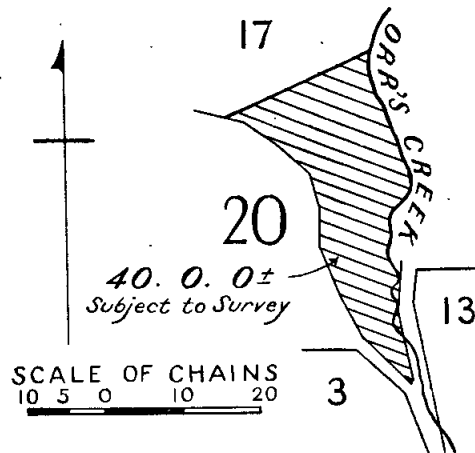

And the Honorable Sir Albert Eli Lind, Her Majesty's Commissioner of Crown Lands and Survey for the State of Victoria, shall give the necessary directions herein accordingly.

A. MAHLSTEDT,
Clerk of the Executive Council.

DEPARTMENT OF CROWN LANDS AND SURVEY.

At the Executive Council Chamber, Melbourne, the nineteenth day of August, 1952.

PRESENT:

The Lieutenant-Governor, as Deputy for His Excellency the Governor of Victoria.

Mr. Brose | Mr. Harvey

UNUSED AND UNMADE ROAD CLOSED.

THE Lieutenant-Governor, as Deputy for His Excellency the Governor of the State of Victoria, by and with the advice of the Executive Council thereof, doth hereby direct that, in pursuance of the provisions of section 304 of the *Land Act 1928*, the unused and unmade road referred to hereunder be closed, viz.:

Town of Queenscliff, Parish of Paywit, County of Grant, being the portion of Queen-street between allotments 1, 2, and 4, section 23, and allotments 28 and 27, section 22.—(Q.34^(a)) (C.89776).

And the Honorable Sir Albert Eli Lind, Her Majesty's Commissioner of Crown Lands and Survey for the State of Victoria, shall give the necessary directions herein accordingly.

A. MAHLSTEDT,
Clerk of the Executive Council.

KIEWA RIVER IMPROVEMENT TRUST.

At the Executive Council Chamber, Melbourne, the nineteenth day of August, 1952.

PRESENT:

The Lieutenant-Governor, as Deputy for His Excellency the Governor of Victoria.

Mr. Brose | Mr. Harvey.

LOAN OF £1,000.

IN pursuance of the powers conferred by section 43 of the *River Improvement Act 1948*, and all other powers him thereunto enabling, the Lieutenant-Governor, as Deputy for His Excellency the Governor of the State of Victoria, by and with the advice of the Executive Council of the said State, doth by this Order—

- (1) Make advance by way of loan to the Kiewa River Improvement Trust of a sum of One thousand pounds (£1,000); and
- (2) Apply the following terms and conditions:—
 - (a) That the said sum shall be used for the purposes of payment of preliminary expenses in connexion with the constitution of the Trust, the preparation of plans, specifications, and estimates of river improvement works in the district, and carrying out such urgent works as are approved by the State Rivers and Water Supply Commission.
 - (b) That the Kiewa River Improvement Trust shall in respect of such advance by way of loan be subject to the powers, rights, duties, and obligations conferred and imposed by—
 - (i) the provisions of sections 269, 270, 272 to 277, 279 and 280 of Part VII. of the *Water Act 1928*, so adapted that the word "Authority" therein shall mean the "Kiewa River Improvement Trust"; and
 - (ii) the provisions of section 281 of the said Part VII. of the *Water Act 1928* so adapted as if for the expressions "Any waterworks trust or local governing body" and "such waterworks trust or local governing body" there were substituted the expression the "Kiewa River Improvement Trust."

And the Honorable Richard Keats Brose, Her Majesty's Minister of Water Supply for the State of Victoria, shall give the necessary directions herein accordingly.

A. MAHLSTEDT,
Clerk of the Executive Council.

WATER ACTS.

At the Executive Council Chamber, Melbourne, the nineteenth day of August, 1952.

PRESENT:

The Lieutenant-Governor, as Deputy for His Excellency the Governor of Victoria.

Mr. Brose | Mr. Harvey.

KIEWA RIVER IMPROVEMENT TRUST.

WHEREAS by Order dated the nineteenth day of August, 1952, His Excellency the Governor in Council made advance by way of loan to the Kiewa River Improvement Trust: And whereas it was a condition of such advance that the said Trust should be subject to the provisions of section 273 of the *Water Act 1928* as adapted by that Order: Now therefore, in pursuance of the powers conferred upon him by the said section as so adapted, the Lieutenant-Governor, as Deputy for His Excellency the Governor of the State of Victoria, by and with the advice of the Executive Council of the said State, doth by this Order direct that the total amount of the sums owing at any one time by the said Trust in respect of moneys borrowed pursuant to the said section as so adapted shall not exceed the sum of Six hundred pounds (£600), and that moneys shall be borrowed pursuant to the said section as so adapted only from the Australia and New Zealand Bank Limited at Yackandandah.

And the Honorable Richard Keats Brose, Her Majesty's Minister of Water Supply for the State of Victoria, shall give the necessary directions herein accordingly.

A. MAHLSTEDT,
Clerk of the Executive Council.

COUNTRY ROADS BOARD.

At the Executive Council Chamber, Melbourne, the nineteenth day of August, 1952.

PRESENT:

The Lieutenant-Governor, as Deputy for His Excellency the Governor of Victoria.

Mr. Brose | Mr. Harvey.

ORDER APPROVING OF A NEW MAIN ROAD IN THE SHIRE OF DUNDAS.

WHEREAS the Country Roads Board constituted under the *Country Roads Act 1928* (No. 3662) has represented to His Excellency the Governor in Council that it appears to it desirable that the new Hamilton-Port Fairy road in the Shire of Dundas should be made by the said Board: And whereas the said Board in accordance with the requirements of section 19 of the said cited Act has caused to be prepared a map plan and estimate showing the points between which and on and through what land the said new road is proposed to be made and the cost of acquiring the land and constructing the said new road: And whereas on an inspection of the said map and plan and a consideration of the said estimate His Excellency the Governor in Council is satisfied that there are funds legally available for acquiring the land and constructing the said new road: Now therefore be it known by this present Order that the Lieutenant-Governor, as Deputy for His Excellency the Governor of the State of Victoria, with the advice of the Executive Council thereof doth hereby approve of the said road being made, that is to say:—

All that piece of land in the Parish of Byaduk, the boundaries of which are as follow:—Commencing at the south-western angle of subdivision B, of allotment 5, section 2, of the said parish; thence by lines bearing respectively 36 deg. 51 min. 22.7 links, 157 deg. 14 min. 23 links, and 277 deg. 35 min. 22.7 links to the point of commencement—which said piece of land is particularly delineated and shown coloured red on survey plan No. 5535, lodged in the office of the Country Roads Board.

And the Honorable Percy Thomas Byrnes, Her Majesty's Commissioner of Public Works for the State of Victoria, shall give the necessary directions herein accordingly.

A. MAHLSTEDT,
Clerk of the Executive Council.

COUNTRY ROADS BOARD.

At the Executive Council Chamber, Melbourne, the nineteenth day of August, 1952.

PRESENT:

The Lieutenant-Governor, as Deputy for His Excellency the Governor of Victoria.

Mr. Brose | Mr. Harvey.

ORDER APPROVING OF A NEW MAIN ROAD IN THE SHIRE OF MORNINGTON.

WHEREAS the Country Roads Board constituted under the *Country Roads Act 1928* (No. 3662) has represented to His Excellency the Governor in Council that it appears to it desirable that the new Mornington-Dromana road in the Shire of Mornington should be made by the said Board: And whereas the said Board in accordance with the requirements of section 19 of the said cited Act has caused to be prepared a map plan and estimate showing the points between which and on and through what land the said new road is proposed to be made and the cost of acquiring the land and constructing the said new road: And whereas on an inspection of the said map and plan and a consideration of the said estimate His Excellency the Governor in Council is satisfied that there are funds legally available for acquiring the land and constructing the said new road: Now therefore be it known by this present Order that the Lieutenant-Governor, as Deputy for His Excellency the Governor of the State of Victoria, with the advice of the Executive Council thereof doth hereby approve of the said road being made, that is to say:—

All those pieces of land in the Parish of Moorooduc, the boundaries of which are as follow:—

- (a) Commencing at the northern angle of allotment 37, section 22 of the said parish; thence by a line bearing 146 deg. 37 min. 56 ft. 9½ in.; thence westerly by the arc of a circle of radius of 50 feet a distance of 84 ft. 10½ in., the chord of which arc bears 277 deg. 58½ min. to the north-western boundary of the said allotment; thence by a line bearing 49 deg. 20 min. 56 ft. 9½ in. to the point of commencement.
- (b) Commencing at the northern angle of lot 5 on plan of subdivision No. 5867, lodged in the Office of Titles, and being part of allotment 42, section 22 of the said parish; thence by lines bearing respectively 238 deg. 19 min. 64 ft. 8 in., 230 deg. 18 min. 49 ft. 0½ in., 185 deg. 18 min. 21 ft. 2½ in., 320 deg. 18 min. 38 feet, and 64 deg. 21 min. 132 feet to the point of commencement.
- (c) Commencing at the northern angle of lot 7 on plan of subdivision No. 5867, lodged in the Office of Titles and being part of allotment 43, section 22 of the said parish; thence by lines bearing respectively 140 deg. 18 min. 39 feet, 267 deg. 58 min. 18 ft. 4 in., 215 deg. 39 min. 48 ft. 11 in., 208 deg. 14 min. 58 ft. 2½ in., 204 deg. 18 min. 229 ft. 4 in., 172 deg. 19 min. 16 ft. 11½ in., 320 deg. 20 min. 15 ft. 7 in., and 24 deg. 18 min. 368 ft. 2 in. to the point of commencement.
- (d) Commencing at the northern angle of lot 1 on plan of subdivision No. 12087, lodged in the Office of Titles, and being part of allotment 44, section 22 of the said parish; thence by lines bearing respectively 140 deg. 17½ min. 20 ft. 7 in., 262 deg. 9 min. 15 ft. 10 in., 204 deg. 0½ min., 210 ft. 7 in., 202 deg. 33 min. 56 ft. 7 in., 196 deg. 56 min. 45 ft. 9½ in., 166 deg. 21 min. 25 ft. 10 in., 315 deg. 46½ min. 30 feet, and 24 deg. 0½ min. 339 ft. 6 in. to the point of commencement.
- (e) Commencing at the northern angle of allotment 34, section 25 of the said parish; thence by a line bearing 135 deg. 22½ min. 168 ft. 11 in.; thence south-westerly by the arc of a circle of radius of 44 feet a distance of 115 ft. 10 in. to the western boundary of the said allotment, the chord of which arc bears 239 deg. 58½ min; thence by a line bearing 344 deg. 34½ min. 168 ft. 11 in. to the point of commencement—

which said pieces of land are particularly delineated and shown coloured red on survey plans numbered 5530 and 5541, lodged in the office of the Country Roads Board.

And the Honorable Percy Thomas Byrnes, Her Majesty's Commissioner of Public Works for the State of Victoria, shall give the necessary directions herein accordingly.

A. MAHLSTEDT,
Clerk of the Executive Council.

COUNTRY ROADS BOARD.

At the Executive Council Chamber, Melbourne, the nineteenth day of August, 1952.

PRESENT:

The Lieutenant-Governor, as Deputy for His Excellency the Governor of Victoria.

Mr. Brose | Mr. Harvey.

ORDER APPROVING OF A DEVIATION FROM A TOURISTS' ROAD IN THE SHIRE OF BASS.

WHEREAS the Country Roads Board constituted under the *Country Roads Act 1928* (No. 3662) has represented to His Excellency the Governor in Council that it appears to it desirable that the deviation hereinafter referred to from the existing Phillip Island-road in the Shire of Bass (declared to be a tourists' road under the *Country Roads (Tourists' Roads) Act 1936* (No. 4405) which declaration was confirmed by the Order in Council published in the *Government Gazette* of the 22nd January, 1941, on page 203) should be made by the said Board: And whereas the said Board in accordance with the requirements of section 19 of the said cited Act and section 6 of the *Country Roads (Tourists' Roads) Act 1936* has caused to be prepared a map plan and estimate showing the points between which and on and through what land the said deviation is proposed to be made and the cost of acquiring the land and constructing the said deviation: And whereas on an inspection of the said map and plan and a consideration of the said estimate His Excellency the Governor in Council is satisfied that there are funds legally available for acquiring the land and constructing the said deviation: Now therefore be it known by this present Order that the Lieutenant-Governor, as Deputy for His Excellency the Governor of the State of Victoria, with the advice of the Executive Council thereof doth hereby approve of the said road being made, that is to say:—

All those pieces of land in the Parish of Woolamai, the boundaries of which are as follow:—

- (a) Commencing at a point on the eastern boundary of Crown portion 6 of the said parish, distant 360 deg. 0 min. 372.2 links from the south-eastern angle of the said Crown portion; thence by lines bearing respectively 317 deg. 23½ min. 239.8 links, 273 deg. 25½ min. 372.9 links, 74 deg. 28 min. 554.8 links, and 180 deg. 0 min. 347.3 links to the point of commencement.
- (b) Commencing at a point on the eastern boundary of Crown portion 6 of the said parish, distant 360 deg. 0 min. 822.5 links from the south-eastern angle of the said Crown portion; thence by lines bearing respectively 254 deg. 26 min. 1,360.8 links, 239 deg. 15 min. 888 links, 270 deg. 6 min. 381.4 links, 73 deg. 4½ min. 507.6 links, 59 deg. 37½ min. 727.8 links, 73 deg. 58½ min. 1,127.1 links, 50 deg. 4 min. 216 links, 9 deg. 10½ min. 283.5 links, 84 deg. 50½ min. 49.2 links, and 180 deg. 10 min. 431.3 links to the point of commencement.
- (c) Commencing at a point on the southern boundary of Crown portion 5 of the said parish, distant 270 deg. 5 min. 2,049.9 links, and 270 deg. 6 min. 2,661.7 links from the south-eastern angle of Crown portion 6 of the said parish; thence by lines bearing respectively 270 deg. 6 min. 597.3 links, 316 deg. 28 min. 1,062 links, 122 deg. 0½ min. 931.8 links, 121 deg. 26 min. 297.1 links, and 113 deg. 11 min. 310.2 links to the point of commencement—

which said pieces of land are particularly delineated and shown coloured red on survey plan numbered 5539, lodged in the office of the Country Roads Board.

And the Honorable Percy Thomas Byrnes, Her Majesty's Commissioner of Public Works for the State of Victoria, shall give the necessary directions herein accordingly.

A. MAHLSTEDT,
Clerk of the Executive Council.

COUNTRY ROADS BOARD.

At the Executive Council Chamber, Melbourne, the nineteenth day of August, 1952.

PRESENT:

The Lieutenant-Governor, as Deputy for His Excellency the Governor of Victoria.

Mr. Brose | Mr. Harvey.

DECLARATION OF A DEVIATION FROM THE WILD DOG VALLEY ROAD IN THE SHIRE OF KORUMBURRA.

WHEREAS by sections 78 and 58 of the *Country Roads Act 1928* (No. 3662) it is amongst other things enacted that when the Country Roads Board under the provisions of the Country Roads Act has by Resolution declared a deviation to be a developmental road the said Board may also declare that such deviation shall be in lieu of any existing road or part thereof named in such Resolution and that on publication in the *Government Gazette* of the Order confirming such Resolution the existing road or part thereof shall cease to be a developmental road or be discontinued as provided in the Resolution: And whereas the said Board has by Resolution declared the deviation on the land described in the First Schedule to such Resolution to be a developmental road and has also declared that such deviation shall be in lieu of the part of the existing road being the land described in the Second Schedule to the said Resolution and that such part of the said existing road shall be discontinued: Now therefore the Lieutenant-Governor, as Deputy for His Excellency the Governor of the State of Victoria, by and with the advice of the Executive Council thereof doth hereby confirm the said Resolution.

Resolution for Declaration of a Deviation under the Country Roads Act.

Whereas the land the site of the road the course of which is below set out was taken by the Board under the provisions of the *Country Roads Act 1928* for the purpose of constructing such road deviation which road deviation has now been laid out and formed on the same: And whereas the said Board (being the Country Roads Board incorporated under the said Act) thinks that the road aforesaid is fit to be used as a public highway such Board at a meeting now holden acting under the authority conferred upon it by sections 78 and 58 of the said Act doth by this present Resolution hereby declare the said road deviation the course of which is described in the First Schedule hereto with the commencing and terminating points thereof respectively specified to be part of a developmental road within the meaning and for the purposes of the *Country Roads Act 1928*: And the said Board doth also declare that such deviation shall be in lieu of the existing road or part thereof described in the Second Schedule hereto and that such part of the said existing road shall be discontinued.

FIRST SCHEDULE.

Shire of Korumburra.

15. *Wild Dog Valley road* (9015).—All that piece of land in the Parish of Allambee, being part of allotment 83c of the said parish and commencing at a point on the southern boundary of that allotment, distant 278 deg. 42 min. 128.6 links from the south-eastern angle thereof; thence by lines bearing respectively 278 deg. 42 min. 159.2 links, 317 deg. 36 min. 495.6 links, 331 deg. 52 min. 290.7 links, 3 deg. 21 min. 524.7 links, 26 deg. 44 min. 492.6 links, 193 deg. 22 min. 457.6 links, 213 deg. 0 min. 32.4 links, 183 deg. 21 min. 470 links, 151 deg. 52 min. 250 links and 137 deg. 36 min. 607 links to the point of commencement—which said piece of land is particularly delineated and shown coloured red and yellow on survey plan No. 2680, lodged in the office of the Country Roads Board.

SECOND SCHEDULE.

Shire of Korumburra.

15. *Wild Dog Valley road*.—All that piece of land in the Parish of Allambee, being part of allotment 83c of the said Parish, and commencing at a point on the southern boundary of that allotment distant 278 deg. 42 min. 136.0 links from the south-eastern angle thereof; thence by lines bearing respectively 278 deg. 42 min. 151.8 links, 319

deg. 55 min. 550.4 links, 338 deg. 49 min. 191.7 links, 3 deg. 47 min. 173.5 links, 13 deg. 22 min. 377.9 links, 33 deg. 0 min. 297.6 links, 193 deg. 22 min. 650 links, 183 deg. 47 min. 143 links, 158 deg. 49 min. 153 links, and 139 deg. 55 min. 648 links to the point of commencement—which said piece of land is particularly delineated and shown coloured blue and yellow on survey plan No. 2680, lodged in the office of the Country Roads Board.

Save and except such part of the said land as is included within the boundaries of the land described in the First Schedule hereof.

The common seal of the Country Roads Board was hereto affixed, at Melbourne, this eleventh day of August, One thousand nine hundred and fifty-two, in the presence of—

(SEAL) D. V. DARWIN, Chairman.
F. N. CORRIGAN, Member.
W. H. NEVILLE, Secretary.

And the Honorable Percy Thomas Byrnes, Her Majesty's Commissioner of Public Works for the State of Victoria, shall give the necessary directions herein accordingly.

A. MAHLSTEDT,
Clerk of the Executive Council.

COUNTRY ROADS BOARD.

At the Executive Council Chamber, Melbourne, the nineteenth day of August, 1952.

PRESENT:

The Lieutenant-Governor, as Deputy for His Excellency the Governor of Victoria.

Mr. Brose | Mr. Harvey.

ORDER APPROVING OF A DEVIATION FROM A MAIN ROAD IN THE SHIRE OF HEYTESBURY.

WHEREAS the Country Roads Board constituted under the *Country Roads Act 1928* (No. 3662) has represented to His Excellency the Governor in Council that it appears to it desirable that the deviation hereinafter referred to from the existing Timboon-Scotts Creek road in the Shire of Heytesbury (declared to be a main road under the said Act which declaration was confirmed by the Order in Council published in the *Government Gazette* of the 19th February, 1941, on page 911) should be made by the said Board: And whereas the said Board in accordance with the requirements of section 19 of the said cited Act has caused to be prepared a map plan and estimate showing the points between which and on and through what land the said deviation is proposed to be made and the cost of acquiring the land and constructing the said deviation: And whereas on an inspection of the said map and plan and a consideration of the said estimate His Excellency the Governor in Council is satisfied that there are funds legally available for acquiring the land and constructing the said deviation: Now therefore be it known by this present Order that the Lieutenant-Governor, as Deputy for His Excellency the Governor of the State of Victoria, with the advice of the Executive Council thereof doth hereby approve of the said road being made, that is to say:—

All that piece of land in the Parish of Timboon, the boundaries of which are as follow:—Commencing at a point on the western boundary of allotment 63c of the said parish, distant 45 deg. 38 min. 1,129 links from the south-western angle of the said allotment; thence by lines bearing respectively 12 deg. 56 min. 186 links, 44 deg. 13 min. 1,108.6 links, 32 deg. 45 min. 150.8 links, 23 deg. 39 min. 315 links, 180 deg. 13 min. 251.5 links, 203 deg. 39 min. 257 links, and 225 deg. 27 min. 1,289 links to the point of commencement—which said piece of land is particularly delineated and shown coloured red on survey plan numbered 5523, lodged in the office of the Country Roads Board.

And the Honorable Percy Thomas Byrnes, Her Majesty's Commissioner of Public Works for the State of Victoria, shall give the necessary directions herein accordingly.

A. MAHLSTEDT,
Clerk of the Executive Council.

COUNTRY ROADS BOARD.

At the Executive Council Chamber, Melbourne, the
nineteenth day of August, 1952.

PRESENT:

The Lieutenant-Governor, as Deputy for His Excellency the
Governor of Victoria.

Mr. Brose | Mr. Harvey.

DECLARATION OF THE HEATHCOTE-BENDIGO
ROAD IN THE SHIRE OF MCIVOR.

WHEREAS by the Resolution set out below and dated the eleventh day of August, One thousand nine hundred and fifty-two the Country Roads Board incorporated under the *Country Roads Act 1928* (No. 3662) being of opinion that the highway in the State of Victoria set out or described in the Schedule to the same is of sufficient importance to be a main road and acting under the powers in that behalf conferred upon it by the said Act declared such highway to be a main road within the meaning and for the purposes of the Act aforesaid: And whereas the said Act amongst other things provides that the Governor in Council may by Order published in the *Government Gazette* confirm such Resolution whereupon any road mentioned in such Resolution shall be a main road: And whereas it is deemed desirable to confirm the Resolution so made and passed by the said Country Roads Board: Now therefore the Lieutenant-Governor, as Deputy for His Excellency the Governor of the State of Victoria, by and with the advice of the Executive Council thereof doth hereby confirm such Resolution and declare upon the publication of this Order in the *Government Gazette* the road mentioned in the Schedule to such Resolution of the Country Roads Board a main road within the meaning and for the purposes of the *Country Roads Act 1928*.

Resolution for Declaration of a Main Road under the
Country Roads Act.

The Country Roads Board incorporated under the *Country Roads Act 1928* (No. 3662) at a meeting now holden being of opinion that the highway within the State of Victoria set out or described in the Schedule hereunder written is of sufficient importance to be a main road acting under the powers conferred upon it by the said Act doth by this Resolution hereby declare such highway to be a main road within the meaning and for the purposes of the said *Country Roads Act 1928*.

SCHEDULE.

Shire of McIvor.

1. *Heathcote-Bendigo road* (11601).—Commencing at its junction with the Northern Highway near the north-western angle of allotment 9, section 29, Town of Heathcote, Parish of Heathcote; thence north-westerly through the said town to the eastern angle of allotment 48, Parish of Heathcote and further north-westerly to and across the bridge over Mount Ida Creek near the south-eastern angle of allotment 16, Parish of Knowsley; thence generally northerly to and crossing the railway and again northerly to the most eastern angle of allotment 18c of the parish last named; thence generally north-westerly to a point on the eastern boundary of allotment 54, Parish of Knowsley, distant 18 deg. 20 min. 360.2 links from the southern angle of that allotment; thence north-westerly through that allotment and allotment 50 to the southern boundary of the said allotment 50 (S.P. 5061); thence north-westerly to and along the boundary between the Parishes of Knowsley and Weston to the north-western angle of allotment 59, Parish of Knowsley; thence north-westerly and westerly to and through allotment 20 and portion B, Parish of Axedale, to a point on the north-western boundary of the said portion B, distant 244 deg. 50 min. 204.5 links from the north-western angle of the said allotment 20 (S.P. 3779); thence south-westerly and north-westerly to the north-western angle of allotment 19b, Parish of Axedale; thence generally southerly and westerly to and across the bridge over Campaspe River, near the north-eastern angle of allotment 11, section 12, Town of Axedale, Parish of Axedale, on the western boundary of the Shire.

NOTE.—The above description is in lieu of the description of Kilmore-Heathcote-Bendigo road, published in the *Government Gazette* of 9th June, 1915, on page 2029.

The common seal of the Country Roads Board was hereto affixed, at Melbourne, this eleventh day of August, One thousand nine hundred and fifty-two, in the presence of—

(SEAL) D. V. DARWIN, Chairman.
F. N. CORRIGAN, Member.
W. H. NEVILLE, Secretary.

And the Honorable Percy Thomas Byrnes, Her Majesty's Commissioner of Public Works for the State of Victoria, shall give the necessary directions herein accordingly.

A. MAHLSTEDT,
Clerk of the Executive Council.

COUNTRY ROADS BOARD.

At the Executive Council Chamber, Melbourne, the
nineteenth day of August, 1952.

PRESENT:

The Lieutenant-Governor, as Deputy for His Excellency the Governor of Victoria.

Mr. Brose | Mr. Harvey.

ORDER APPROVING OF A DEVIATION FROM A STATE
HIGHWAY IN THE BOROUGH OF QUEENSCLIFFE
AND SHIRE OF BELLARINE.

WHEREAS the Country Roads Board constituted under the *Country Roads Act 1928* (No. 3662) has represented to His Excellency the Governor in Council that it appears to it desirable that the deviation hereinafter referred to from the existing Bellarine Highway in the Borough of Queenscliffe and Shire of Bellarine (declared to be a State Highway under the said Act which declaration was confirmed by the Order in Council published in the *Government Gazette* of the 3rd December, 1947, on pages 5946-7) should be made by the said Board: And whereas the said Board in accordance with the requirements of section 19 of the said cited Act has caused to be prepared a map plan and estimate showing the points between which and on and through what land the said deviation is proposed to be made and the cost of acquiring the land and constructing the said deviation: And whereas on an inspection of the said map and plan and a consideration of the said estimate His Excellency the Governor in Council is satisfied that there are funds legally available for acquiring the land and constructing the said deviation: Now therefore be it known by this present Order that the Lieutenant-Governor, as Deputy for His Excellency the Governor of the State of Victoria, with the advice of the Executive Council thereof doth hereby approve of the said road being made, that is to say:—

All those pieces of land in the Parish of Paywit, the boundaries of which are as follow:—

- (a) Commencing at a point in allotment 1 of the said parish, distant 25 deg. 4 min. 2,532 links, 24 deg. 56 min. 1,199.5 links; and 340 deg. 7 min. 192.5 links from the south-eastern angle of the said allotment; thence by lines bearing respectively 312 deg. 41 min. 295.6 links, 305 deg. 5 min. 282.5 links, 298 deg. 2 min. 452.8 links, 295 deg. 18½ min. 1,908.5 links, 25 deg. 24 min. 17.4 links, 115 deg. 24 min. 845 links, 115 deg. 17 min. 1,900.5 links, and 160 deg. 7 min. 247.2 links to the point of commencement.
- (b) Commencing at a point in allotment 1 of the said parish, the said point being at the south-western angle of the land comprised in Certificate of Title entered in the Register Book, volume 7009, folio 1401655; thence by lines bearing respectively 38 deg. 30 min. 35.2 links, 115 deg. 18½ min. 2,185 links, 76 deg. 9 min. 197 links, 16 deg. 13 min. 226 links, 343 deg. 40 min. 257.4 links, 145 deg. 13 min. 348 links, 196 deg. 29 min. 406 links, 295 deg. 17 min. 1,665 links, and 295 deg. 24 min. 838 links to the point of commencement.
- (c) Commencing at the north-western angle of allotment 12 of the said parish; thence by lines bearing respectively 115 deg. 0 min. 936 ft. 1½ in., 183 deg. 0 min. 10 ft. 2½ in., 294 deg. 50 min. 939 ft. 11½ in., and 25 deg. 0 min. 12 ft. 2 in. to the point of commencement.

- (d) Commencing at the north-eastern angle of allotment 13 of the said parish; thence by lines bearing respectively 205 deg. 10 min. 5 ft. 7 in., 300 deg. 25 min. 59 ft. 1 in., and 115 deg. 0 min. 58 ft. 10 in. to the point of commencement.
- (e) Commencing at the south-western angle of allotment 21 of the said parish; thence by lines bearing respectively 25 deg. 23 min. 24 ft. 8 in., 116 deg. 37 min. 194 ft. 3 in., 115 deg. 16 min. 419 feet, 112 deg. 50 min. 291 ft. 5 in., 104 deg. 32 min. 240 feet, 95 deg. 46 min. 209 ft. 6 in., 205 deg. 0 min. 132 ft. 0½ in., 252 deg. 30 min. 23 ft. 1 in., 295 deg. 18½ min. 487 ft. 8 in., 295 deg. 0 min. 165 feet, and 295 deg. 17½ min. 668 ft. 4 in. to the point of commencement—

which said pieces of land are particularly delineated and shown coloured red and yellow on survey plans numbered 5554, 5555, 5556, and 5557, lodged in the office of the Country Roads Board.

And the Honorable Percy Thomas Byrnes, Her Majesty's Commissioner of Public Works for the State of Victoria, shall give the necessary directions herein accordingly.

A. MAHLSTEDT,
Clerk of the Executive Council.

COUNTRY ROADS BOARD.

At the Executive Council Chamber, Melbourne, the nineteenth day of August, 1952.

PRESENT:

The Lieutenant-Governor, as Deputy for His Excellency the Governor of Victoria.

Mr. Brose | Mr. Harvey.

ORDER APPROVING OF A NEW STATE HIGHWAY IN THE SHIRE OF FLINDERS.

WHEREAS the Country Roads Board constituted under the *Country Roads Act 1928* (No. 3662) has represented to His Excellency the Governor in Council that it appears to it desirable that the new Nepean Highway in the Shire of Flinders should be made by the said Board: And whereas the said Board in accordance with the requirements of section 19 of the said cited Act has caused to be prepared a map plan and estimate showing the points between which and on and through what land the said new highway is proposed to be made and the cost of acquiring the land and constructing the said new highway: And whereas on an inspection of the said map and plan and a consideration of the said estimate His Excellency the Governor in Council is satisfied that there are funds legally available for acquiring the land and constructing the said new highway: Now therefore be it known by this present Order that the Lieutenant-Governor, as Deputy for His Excellency the Governor of the State of Victoria, with the advice of the Executive Council thereof doth hereby approve of the said highway being made, that is to say:—

All that piece of land in the Parish of Kangerong, the boundaries of which are as follow:—Commencing at the northern angle of lot 2, on plan of subdivision, numbered 22806, lodged in the Office of Titles, and being part of Jamieson's Crown special survey in the said parish; thence south-westerly and south-easterly by the arc of a circle of radius of 94 ft. 7½ in. a distance of 215 ft. 9 in. to a point on the southern boundary of lot 4 on the said subdivision, distant 270 deg. 0 min. 4 ft. 11½ in. from the south-eastern angle of the lot last-named; thence by lines bearing 270 deg. 0 min. 205 ft. 9½ in., and 40 deg. 36 min. 205 ft. 9½ in. to the point of commencement—which said piece of land is particularly delineated and shown coloured red on survey plan numbered 5552, lodged in the office of the Country Roads Board.

And the Honorable Percy Thomas Byrnes, Her Majesty's Commissioner of Public Works for the State of Victoria, shall give the necessary directions herein accordingly.

A. MAHLSTEDT,
Clerk of the Executive Council.

COUNTRY ROADS BOARD.

At the Executive Council Chamber, Melbourne, the nineteenth day of August, 1952.

PRESENT:

The Lieutenant-Governor, as Deputy for His Excellency the Governor of Victoria.

Mr. Brose | Mr. Harvey.

ORDER APPROVING OF A NEW MAIN ROAD IN THE SHIRE OF ARAPILES.

WHEREAS the Country Roads Board constituted under the *Country Roads Act 1928* (No. 3662) has represented to His Excellency the Governor in Council that it appears to it desirable that the new Apsley-Natimuk road in the Shire of Arapiles should be made by the said Board: And whereas the said Board in accordance with the requirements of section 19 of the said cited Act has caused to be prepared a map plan and estimate showing the points between which and on and through what land the said new road is proposed to be made and the cost of acquiring the land and constructing the said new road: And whereas on an inspection of the said map and plan and a consideration of the said estimate His Excellency the Governor in Council is satisfied that there are funds legally available for acquiring the land and constructing the said new road: Now therefore be it known by this present Order that the Lieutenant-Governor, as Deputy for His Excellency the Governor of the State of Victoria, with the advice of the Executive Council thereof doth hereby approve of the said road being made, that is to say:—

All that piece of land in the Parish of Natimuk, the boundaries of which are as follow:—Commencing at the south-eastern angle of allotment 31A of the said parish; thence by lines bearing respectively 261 deg. 57 min. 618 links, 71 deg. 21 min. 660.4 links, 58 deg. 15 min. 640.8 links, 227 deg. 19 min. 66.7 links, and 261 deg. 57 min. 69 links to the point of commencement—which said piece of land is particularly delineated and shown coloured red on survey plan No. 5549, lodged in the office of the Country Roads Board.

And the Honorable Percy Thomas Byrnes, Her Majesty's Commissioner of Public Works for the State of Victoria, shall give the necessary directions herein accordingly.

A. MAHLSTEDT,
Clerk of the Executive Council.

COUNTRY ROADS BOARD.

At the Executive Council Chamber, Melbourne, the nineteenth day of August, 1952.

PRESENT:

The Lieutenant-Governor, as Deputy for His Excellency the Governor of Victoria.

Mr. Brose | Mr. Harvey.

ORDER APPROVING OF A NEW STATE HIGHWAY IN THE SHIRE OF ARAPILES.

WHEREAS the Country Roads Board constituted under the *Country Roads Act 1928* (No. 3662) has represented to His Excellency the Governor in Council that it appears to it desirable that the new Henty Highway in the Shire of Arapiles should be made by the said Board: And whereas the said Board in accordance with the requirements of section 19 of the said cited Act has caused to be prepared a map plan and estimate showing the points between which and on and through what land the said highway is proposed to be made and the cost of acquiring the land and constructing the said highway: And whereas on an inspection of the said map and plan and a consideration of the said estimate His Excellency the Governor in Council is satisfied that there are funds legally available for acquiring the land and constructing the said highway: Now therefore be it known by this present Order that the Lieutenant-Governor, as Deputy for His Excellency the

Governor of the State of Victoria, with the advice of the Executive Council thereof doth hereby approve of the said highway being made, that is to say:—

All that piece of land in the Parish of Dollin, the boundaries of which are as follow:—Commencing at a point on the western boundary of allotment 62 of the said parish, distant 157 deg. 55 min. 3,735.9 links from the north-western angle of the said allotment; thence by lines bearing respectively 152 deg. 30 min. 711.5 links, 144 deg. 12 min. 740.3 links, 319 deg. 54 min. 784.9 links, and 337 deg. 55 min. 681.1 links to the point of commencement—which said piece of land is particularly delineated and shown coloured red on survey plan numbered 5553, lodged in the office of the Country Roads Board.

And the Honorable Percy Thomas Byrnes, Her Majesty's Commissioner of Public Works for the State of Victoria, shall give the necessary directions herein accordingly.

A. MAHLSTEDT,
Clerk of the Executive Council.

THE NORTH-WEST MALLEE SETTLEMENT AREAS ACT 1948.

At the Executive Council Chamber, Melbourne, the nineteenth day of August, 1952.

PRESENT:

The Lieutenant-Governor, as Deputy for His Excellency the Governor of Victoria.

Mr. Brose | Mr. Harvey.

FEEs AND EXPENSES PAYABLE TO MEMBERS.

THE Lieutenant-Governor, as Deputy for His Excellency the Governor of the State of Victoria, by and with the advice of the Executive Council thereof, and in pursuance of the provisions of the North-West Mallee Settlement Areas Act and all other powers him thereunto enabling, doth hereby amend the Order of the twelfth day of October, 1948, as follows:—

Paragraphs (2) and (3) are deleted, and the following substituted in lieu thereof:—

(2) Prescribe that the fees which the member of the Committee appointed pursuant to section 3, sub-section (1), paragraph (d), shall be entitled to receive shall be in accordance with the following scale, that is to say:—

(a) For each day or part of a day on which he attends a meeting of the Committee or on which he is engaged on an inspection authorized by the Committee, a fee of £3 3s.; and

(b) for each day or part of a day necessarily spent by him on travelling from or to his place of residence—

(i) to or from any meeting of the Board, or

(ii) to or from any place for the purpose of making any such inspection, a fee of £1 15s.;

provided that such member shall not receive by way of fees more than £3 3s. in respect of any one day.

(3) Prescribe that the travelling expenses which the Chairman and each member of the Committee shall be entitled to receive shall be in accordance with the following, that is to say:—

Each member being an officer or employee of the Public Service of Victoria, during his absence from his place of residence in the performance of duties connected with the Committee, exclusive of any conveyance paid by him when so travelling, the rate payable in accordance with the Public Service Regulations.

And the Honorable Sir Albert Eli Lind, Her Majesty's Commissioner of Crown Lands and Survey for the State of Victoria, shall give the necessary directions herein accordingly.

A. MAHLSTEDT,
Clerk of the Executive Council.

LANDLORD AND TENANT ACTS.

At the Executive Council Chamber, Melbourne, the twenty-sixth day of August, 1952.

PRESENT:

The Lieutenant-Governor, as Deputy for His Excellency the Governor of Victoria.

Mr. Brose | Mr. Harvey.

ORDER EXCLUDING CERTAIN PREMISES FROM THE OPERATION OF THE PROVISIONS CONTAINED IN PARTS III. AND V. OF THE LANDLORD AND TENANT ACT 1948.

IN pursuance of the powers conferred upon him by the *Landlord and Tenant Act 1948*, the Lieutenant-Governor, as Deputy for His Excellency the Governor of Victoria, by and with the advice of the Executive Council thereof, doth hereby declare that the premises known as No. 107 Gheringhap-street, Geelong, shall be excluded from the operation of the whole of the provisions contained in Parts III. and V. of the *Landlord and Tenant Act 1948*.

And the Honorable Thomas Walter Mitchell, Her Majesty's Attorney-General in and for the State of Victoria, shall give the necessary directions herein accordingly.

A. MAHLSTEDT,
Clerk of the Executive Council.

TARWIN RIVER IMPROVEMENT TRUST.

At the Executive Council Chamber, Melbourne, the twenty-sixth day of August, 1952.

PRESENT:

The Lieutenant-Governor, as Deputy for His Excellency the Governor of Victoria.

Mr. Brose | Mr. Harvey.

LOAN OF £2,000.

IN pursuance of the powers conferred by section 43 of the *River Improvement Act 1948* and all other powers him thereunto enabling, the Lieutenant-Governor, as Deputy for His Excellency the Governor of the State of Victoria, by and with the advice of the Executive Council of the said State, doth by this Order—

(1) Make advance by way of loan to the Tarwin River Improvement Trust of a sum of Two thousand pounds (£2,000), and

(2) Apply the following terms and conditions:—

(a) That the said sum shall be used for the carrying out of works of river improvement within the boundaries of the Tarwin River Improvement District, as set forth in the detailed statement bearing date the 21st day of August, 1952, and verified under the seal of the State Rivers and Water Supply Commission.

(b) That the Tarwin River Improvement Trust shall in respect of such advance by way of loan be subject to the powers, rights, duties, and obligations conferred and imposed by—

(i) the provisions of sections 269, 270, 273 to 277, and 279 and 280, of Part VII. of the *Water Act 1928*, as amended by any other Act, so adapted that the word "Authority" shall mean the "Tarwin River Improvement Trust," and

(ii) the provisions of section 281 of the said Part VII. of the *Water Act 1928*, so adapted as if for the expressions "any waterworks trust or local governing body," and "such waterworks trust or local governing body," there were substituted the expression "the Tarwin River Improvement Trust."

And the Honorable Richard Keats Brose, Her Majesty's Minister of Water Supply for the State of Victoria, shall give the necessary directions herein accordingly.

A. MAHLSTEDT,
Clerk of the Executive Council.

KING RIVER IMPROVEMENT TRUST.

At the Executive Council Chamber, Melbourne, the
twenty-sixth day of August, 1952.

PRESENT:

The Lieutenant-Governor, as Deputy for His Excellency
the Governor of Victoria.

Mr. Brose | Mr. Harvey.

LOAN OF £1,500.

IN pursuance of the powers conferred by section 43 of
the *River Improvement Act 1948* and all other powers
him thereunto enabling, the Lieutenant-Governor, as
Deputy for His Excellency the Governor of the State of
Victoria, by and with the advice of the Executive Council
of the said State, doth by this Order—

(1) Make advance by way of loan to the King River
Improvement Trust of a sum of One thousand five
hundred pounds (£1,500), and

(2) Apply the following terms and conditions:—

(a) That the said sum shall be used for the
carrying out of works of river improvement
within the boundaries of the King River
Improvement District, as set forth in the
detailed statement bearing date the 21st day
of August, 1952, and verified under the seal
of the State Rivers and Water Supply Com-
mission.

(b) That the King River Improvement Trust
shall in respect of such advance by way of
loan be subject to the powers, rights,
duties, and obligations conferred and
imposed by—

(i) the provisions of sections 269, 270, 273
to 277, and 279 and 280, of Part VII.
of the *Water Act 1928*, as amended
by any other Act, so adapted that
the word "Authority" shall mean
the "King River Improvement
Trust," and

(ii) the provisions of section 281 of the
said Part VII. of the *Water Act*
1928, so adapted as if for the
expressions "any waterworks trust
or local governing body," and
"such waterworks trust or local
governing body," there were sub-
stituted the expression "the King
River Improvement Trust."

And the Honorable Richard Keats Brose, Her Majesty's
Minister of Water Supply for the State of Victoria, shall
give the necessary directions herein accordingly.

A. MAHLSTEDT,
Clerk of the Executive Council.

BENEFIT ASSOCIATIONS ACT 1951.

At the Executive Council Chamber, Melbourne, the
twenty-sixth day of August, 1952.

PRESENT:

The Lieutenant-Governor, as Deputy for His Excellency
the Governor of Victoria.

Mr. Brose | Mr. Harvey.

ASSOCIATIONS DECLARED TO BE EXEMPT FROM
THE ACT.

THE Lieutenant-Governor, as Deputy for His Excellency
the Governor of the State of Victoria, in the Com-
monwealth of Australia, by and with the advice of the
Executive Council of the said State, and in pursuance of
the provisions of the *Benefit Associations Act 1951*, doth
by this Order declare every Bush Nursing Hospital
affiliated with the Victorian Bush Nursing Association to
be exempt from the provisions of the said Act.

And the Honorable Keith Dodgshun, Her Majesty's Chief
Secretary for the State of Victoria, shall give the
necessary directions herein accordingly.

A. MAHLSTEDT,
Clerk of the Executive Council,

BENEFIT ASSOCIATIONS ACT 1951.

At the Executive Council Chamber, Melbourne, the
twenty-sixth day of August, 1952.

PRESENT:

The Lieutenant-Governor, as Deputy for His Excellency
the Governor of Victoria.

Mr. Brose | Mr. Harvey.

ASSOCIATION DECLARED TO BE EXEMPT FROM
THE ACT.

THE Lieutenant-Governor, as Deputy for His Excellency
the Governor of the State of Victoria, in the Com-
monwealth of Australia, by and with the advice of the
Executive Council of the said State, and in pursuance of
the provisions of the *Benefit Associations Act 1951*, doth
by this Order declare the association known as the
Colonial Sugar Refining Company Limited Employees'
Benefit Society to be exempt from the provisions of the
said Act.

And the Honorable Keith Dodgshun, Her Majesty's Chief
Secretary for the State of Victoria, shall give the
necessary directions herein accordingly.

A. MAHLSTEDT,
Clerk of the Executive Council.

APPROACHING LAND SALES.

SALES of Crown lands, in fee-simple, will be held at the
under-mentioned places and dates, viz.:—

	No. of Gazette.
Bendigo.—Thursday, 11th September, 1952 ..	580
Castlemaine.—Wednesday, 10th September, 1952	580
Dartmoor.—Thursday, 4th September, 1952 ..	575
Daylesford.—Wednesday, 10th September, 1952	580
Heywood.—Thursday, 4th September, 1952 ..	575
Rutherglen.—Tuesday, 30th September, 1952 ..	750
Shepparton.—Monday, 29th September, 1952 ..	750
Wodonga.—Tuesday, 30th September, 1952 ..	750
Yarrawonga.—Monday, 29th September, 1952	750

SALES OF CROWN LANDS BY AUCTION.

The lands will be sold in fee-simple, and subject to the
covenants, conditions, exceptions, and reservations directed
by the Governor in Council by an Order in Council dated
the 5th August, 1930, and published in the *Government
Gazette* of the 8th August, 1930, varied as herein.

A deposit of at least twelve and a half per centum of
the price at which each lot is sold must be paid by the
purchaser at the time of sale, and such payments shall be
made in coin, bank notes or cheques approved by the officer
conducting the sale, and the residue of such price will be
payable in equal instalments, in accordance with the
scale hereunder, on the last day of each successive period
of six months from the time of sale, or, if the purchaser
chooses, at any earlier time or times; and such residue of
the purchase money shall bear interest at the rate of Five
pounds per centum per annum, to be computed with
respect to each instalment for the period which has elapsed
between the time of sale and the time of the payment
of such instalment. If the residue of the price be paid
within thirty days after the time of the sale no interest
will be payable thereon.

The Governor in Council may allow a transfer of the
purchaser's interest to an approved person at any time
before the final payment of the purchase money is made.
The fee for transfer shall be One pound and such
transfer will be subject to payment of stamp duty.

SCALE OF PAYMENTS OF RESIDUE.

£20 and under, 6 instalments.
Over £20, and not exceeding £50, 8 instalments.
Over £50, and not exceeding £100, 10 instalments.
Over £100, and not exceeding £200, 12 instalments.
Over £200, and not exceeding £300, 14 instalments.
Over £300, and not exceeding £400, 16 instalments.
Over £400, and not exceeding £500, 18 instalments.
Over £500, 20 instalments.

FEES, ETC.

The amount payable for Assurance Fund (One halfpenny for each £1 of purchase price) and Crown grant fee must be paid with the balance of purchase money. The following is the scale of fees for Crown grants:—

- 50 acres and under, £1 10s.
Over 50 acres, £2.

Where the purchase money does not exceed £5, the grant fee is £1.

Valuations of improvements (if not purchased by the owner thereof), and charges for survey, must also be paid at the time of sale.

A. E. LIND,

Commissioner of Crown Lands and Survey.

Office of Crown Lands and Survey,
Melbourne, 25th August, 1952.

SHEPPARTON.—Sale (No. 10962) of Crown lands in fee-simple by auction, will be held at the LAND INSPECTOR'S OFFICE, SHEPPARTON, on MONDAY, the 29th SEPTEMBER, 1952, at half-past Ten o'clock a.m. To be conducted by J. A. TIPPING, Land Officer, Beechworth.

PARISH OF SHEPPARTON, COUNTY OF MOIRA.

One and a half mile North-west of Township.

Upset price £20 the lot. Charge for survey £5 7s. 6d.

Lot 1. Area 1a. 0r. 24p. (subject to survey), allotment 81c. One month allowed for removal of fencing.

Upset price £20 the lot. Charge for survey £5 5s.

Lot 2. Area 3r. 7p. (subject to survey), allotment 81h. One month allowed for removal of fencing.

Upset price £20 the lot. Charge for survey £5.

Lot 3. Area 1r. 38p. (subject to survey), allotment 81j. One month allowed for removal of fencing.

YARRAWONGA.—Sale (No. 10963), of Crown lands in fee-simple by auction, will be held at the LAND INSPECTOR'S OFFICE, YARRAWONGA, on MONDAY, the 29th SEPTEMBER, 1952, at Three o'clock p.m. To be conducted by J. A. TIPPING, Land Officer, Beechworth.

KATAMATITE, PARISH OF KATAMATITE, COUNTY OF MOIRA.

Fronting Main-road; near Boosey Creek.

Upset price £5 the lot. Charge for survey £5 10s.

Lot 1. Area 2 roods, allotment 1 of section 35.

ALSO

Freehold land under the Transfer of Land Act offered for and on behalf of the Minister of Education.

PARISH OF YOUARANG, COUNTY OF MOIRA.

Burramine West School Site.

Upset price £30 the lot.

Lot 2. Area 2 acres, allotment 27A of section C, being the whole of the land more particularly described in Crown grant, volume 1787, folio 357389.

Sale of lot 2 is subject to the following conditions:—

- (a) The purchaser shall pay the purchase money in full at the sale;
(b) the preparation and registration of the transfer under the Transfer of Land Act shall be attended to by the purchaser or his solicitor, and all costs relating thereto shall be borne by the purchaser.

RUTHERGLEN.—Sale (No. 10964) of Crown lands in fee-simple by auction, will be held at the COURT HOUSE, RUTHERGLEN, on TUESDAY, the 30th SEPTEMBER, 1952, at Ten o'clock a.m. To be conducted by J. A. TIPPING, Land Officer, Beechworth.

PARISH OF CARLYLE, COUNTY OF BOGONG.

North of Rutherglen Township.

Upset price £45 the lot. Charge for survey £5 15s.

Lot 1. Area 3a. 1r. 11p., allotment 8 of section 45. One month allowed for removal of fencing.

ALSO

Freehold land under the Transfer of Land Act offered for and on behalf of the Minister of Education.

PARISH OF NORONG, COUNTY OF BOGONG.

Norong School Site.

Upset price £164 the lot, including improvements.

Lot 2. Area 3a. 0r. 27 7/10p., being part of allotment 3 of section 0 and 4A of section 0, and being the whole of the land more particularly described in Certificate of Title volume 3593, folio 718448, and Crown grant volume 2230, folio 445891.

Sale of lot 2 is subject to the following conditions:—

- (a) The purchaser shall pay the purchase money in full at the sale;
(b) the preparation and registration of the transfer under the Transfer of Land Act shall be attended to by the purchaser or his solicitor, and all costs relating thereto shall be borne by the purchaser.

WODONGA.—Sale (No. 10965) of Crown lands in fee-simple by auction, will be held at the LAND INSPECTOR'S OFFICE, WODONGA, on TUESDAY, the 30th SEPTEMBER, 1952, at Two o'clock p.m. To be conducted by J. A. TIPPING, Land Officer, Beechworth.

BETHANGA, PARISH OF BERRINGA, COUNTY OF BENAMBRA.

Fronting Lobban-street.

Upset price £10 the lot. Charge for survey £5 10s.

Lot 1. Area 1r. 20p. (subject to survey), allotment 20A of section M.

BOORGUNYAH, PARISH OF BARNAWARTHIA NORTH, COUNTY OF BOGONG.

Upset price £5 the lot. Charge for survey £5 15s.

Fronting Gregory-street.

Lot 2. Area 2r. 20p., allotment 1 of section 4. One month allowed for removal of fencing.

PROPOSED REVOCATIONS OF ORDERS IN COUNCIL WITHHOLDING CERTAIN LANDS FROM SALE, LEASING, AND LICENSING.

IN pursuance of the provisions of the Land Act 1928, notice is hereby given that it is the intention of the Governor in Council to revoke the temporary reservations and the withholding from sale, leasing, and licensing of the lands by Orders in Council, hereinafter referred to:—

The following Notices were published 1° on the 20th August, 1952, pursuant to Orders of the 12th August, 1952.

RUTHERGLEN.—The temporary reservation as a site for Public Buildings and the withholding from sale, leasing, and licensing, by Order in Council of the 27th January, 1881, of 2 roods 29 perches of land in the municipal district of Rutherglen, is about to be revoked.—(R.50(2) (Rs.5444).

DIMBOOLA.—The temporary reservation as a site for a Court House and the withholding from sale, leasing, and licensing, by Order in Council of the 3rd April, 1876, of 2 roods of land in the Parish of Dimboola, at Dimboola, is about to be revoked so far only as the portion containing 24 perches, more or less, indicated by hachure on plan hereunder, is concerned.—(D.150(7) (Rs.5984).

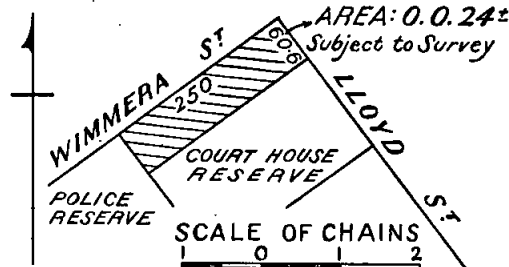

A. E. LIND,

Commissioner of Crown Lands and Survey.

PROPOSED REVOCATION OF TEMPORARY RESERVATION OF LAND BY ORDER IN COUNCIL.

IN pursuance of the provisions of the Land Act 1928, notice is hereby given that it is the intention of the Governor in Council to revoke the temporary reservation of land by the Order in Council hereunder referred to, viz:—

The following Notice was published 1° on the 27th August, 1952, pursuant to Order of the 19th August, 1952.

BAIRNSDALE.—The temporary reservation, by Order in Council of the 1st August, 1870, of 3 acres 1 rood 26 perches of land at Bairnsdale as a site for Market purposes, is about to be revoked.—(B.67(5) (C.52358).

A. E. LIND,

Commissioner of Crown Lands and Survey.

PROPOSED REVOCATIONS OF TEMPORARY RESERVATIONS OF LANDS BY ORDERS IN COUNCIL.

IN pursuance of the provisions of the *Land Act 1928*, notice is hereby given that it is the intention of the Governor in Council to revoke the temporary reservations of lands by the Orders in Council hereunder referred to, viz.:—

The following Notice was published 1° on the 20th August, 1952, pursuant to Orders of the 12th August, 1952.

BOORONGIE.—The temporary reservation, by Order in Council of the 16th December, 1913, of 3 roods 38 perches of land in the Parish of Boorongie, as a site for a Public Hall, is about to be revoked.—(B.772^(*)) (Rs.1953).

ENFIELD.—The temporary reservation, by Order in Council of the 11th May, 1874, of 1 acre 3 roods 11 perches of land in the Parish of Enfield, as a site for State School purposes, is about to be revoked.—(E.52^(*)) (Rs.6976).

GLENMONA.—The temporary reservation, by Order in Council of the 18th June, 1907, of 12 acres of land in the Parish of Glenmona, as a site for Supply of Gravel, is about to be revoked.—(G.155^(*)) (Rs.3720).

RUTHERGLEN.—The temporary reservation, by Order in Council of the 30th December, 1867, of 1 acre 0 roods 35 perches of land in the Township of Rutherglen, as a site for Police purposes, is about to be revoked.—(R.50^(*)) (Rs.5443).

A. E. LIND,
Commissioner of Crown Lands and Survey.

PROPOSED REVOCATION OF ORDER IN COUNCIL WITHHOLDING CERTAIN LAND FROM SALE, LEASING, AND LICENSING.

IN pursuance of the provisions of the *Land Act 1928*, notice is hereby given that it is the intention of the Governor in Council to revoke the temporary reservation and the withholding from sale, leasing, and licensing of certain land by Order in Council hereinafter referred to, viz.:—

The following Notice was published 1° on the 13th August, 1952, pursuant to Order of the 5th August, 1952.

TALLYGAROPNA.—The temporary reservation as a site for Conservation of Water, and the withholding from sale, leasing, and licensing, by Order in Council of the 9th August, 1881, of 2 roods of land in the Parish of Tallygaropna, being part of allotment 17, section B.—(T.234^(*)) (C.93605).

A. E. LIND,
Commissioner of Crown Lands and Survey.

PROPOSED REVOCATION OF TEMPORARY RESERVATION AND THE WITHHOLDING OF CERTAIN LAND FROM SALE, LEASING, AND LICENSING.

IN pursuance of the provisions of the *Land Act 1928*, notice is hereby given that it is the intention of the Governor in Council to revoke the temporary reservation and the withholding from sale, leasing, and licensing of land by Order in Council hereunder referred to, viz.:—

The following Notice was published 1° on the 27th August, 1952, pursuant to Order of the 19th August, 1952.

POWLETT.—The temporary reservation as a site for Public purposes (State School) and the withholding from sale, leasing, and licensing, by Order in Council of the 25th October, 1880, of 2 acres of land in the Parish of Powlett, is about to be revoked.—(P.36^(*)) (C.93802).

A. E. LIND,
Commissioner of Crown Lands and Survey.

Soldier Settlement Acts.

REVOCATION OF NOTICE DECLARING FARMING LAND SUITABLE FOR SOLDIER SETTLEMENT.

I, ALBERT ELI LIND, Her Majesty's Commissioner of Crown Lands and Survey, do hereby declare that the Notice made under the provisions of section 88 (1) of the *Soldier Settlement Act 1946* (No. 5179), and published in the *Government Gazette* of the 28th September, 1949, whereby the land described in the Schedule hereto was declared to be land suitable for soldier settlement, shall no longer remain in force in respect to that land.

SCHEDULE.

All those pieces of land comprising—firstly, 12,524 acres 2 roods 8 perches, being Crown allotments 1 to 11, section 4, Crown allotments 1 to 9, 12, 13, 14, 17 to 21, 24 to 27, 30 to 33, and parts of Crown allotments 10, 11, 15, 16, 22, 23, 28, 29, and 34, section 23, Parish of Brewster; Crown portions 30, 31, and 32, and Crown allotment 33, Parish of

Carngham; Crown allotments 1, 1A, 2, 2A, 3, 3A, and 4 to 11, section 1, Crown allotments 1 to 9, section 2, Crown allotments 5 to 9, and part of Crown allotments 1 to 4, section 3, Crown allotments 1 to 12, section 4, Crown allotments 1 to 11, section 5, Crown allotment 5, section 6, part of Crown allotments 8, 9, 10, and 11, section 7, Crown allotments 1 and 2, and part of Crown allotments 3 and 4, section 8, Parish of Chepstowe (title reference F.C.T., volume 6417, folio 1283208); secondly, 35 acres and 17 perches, being allotments 1 and 2, Parish of Carngham (F.C.T., volume 6417, folio 1283207); thirdly, 2 acres 3 roods 33 perches, being allotment 11A, Parish of Chepstowe (C.G. volume 5462, folio 1092241); fourthly, 2 acres 2 roods 20 perches, being allotment 14A, Parish of Chepstowe (C.G. volume 5462, folio 1092242); fifthly, 8 acres 1 rood 3 perches, being allotment 8A, Parish of Chepstowe (C.G. volume 5462, folio 1092240); sixthly, 3997 acres and 37 perches, being Crown allotments 1, 1A, and 2 to 17, section 1, Crown allotments 1 to 5, and part of Crown allotment 6, section 2, Crown allotments 1 to 12 and 14 to 19, and part of Crown allotment 13, section 3, Crown allotments 23, 24, 25, 30, and 31, section C, Parish of Haddon (F.C.T., volume 6417, folio 1283209); seventhly, 635 acres 2 roods 20 perches, being Crown section A (being known as Carngham Pre-emptive Right), Parish of Chepstowe (F.C.T., volume 2802, folio 560333); the whole being in the Counties of Grenville and Ripon.

Signed at Melbourne this 25th day of August, 1952.

A. E. LIND,
Commissioner of Crown Lands and Survey.

Soldier Settlement Acts.

REVOCATION OF NOTICE DECLARING FARMING LAND SUITABLE FOR SOLDIER SETTLEMENT.

I, ALBERT ELI LIND, Her Majesty's Commissioner of Crown Lands and Survey, do hereby declare that the Notice made under the provisions of section 88 (1) of the *Soldier Settlement Act 1946* (No. 5179), and published in the *Government Gazette* of the 5th March, 1952, whereby the land described in the Schedule hereto was declared to be land suitable for soldier settlement, shall no longer remain in force in respect to that land.

SCHEDULE.

All those pieces of land, comprising 23,876 acres 2 roods 15 perches, more or less, being allotments 1A, 1B, 109B1, 109B2, 110B, 111A, 111B, 112A, 112B, 126A, 126B, 133A, 133B, AA, Y, Z1, and Z2, Parish of Woorndoo; allotments 1, 2, and 3, section 1, and allotment 10, section 12, Parish of Chatsworth West; lots 2 to 15 (both inclusive) on P/S No. 10339, and being allotments 1A, 1B, 2A, and 2B, parts of allotments 3A, 3B, 4A, and 4B, section 5, allotments 2A1, 2A2, and 2B, section 6, Parish of Ecklin, allotments 1A, 1B, 2A, 3A, and 4A, section 8, and part of allotments 1A, 2A, 2B, 6A, and 6B, section 13, Parish of Elingamite; allotments B1, B2, C, D, E, F1, F2, G, K2, N1, N2, 55A, 56A, 56B, 57A, 57B1, 57B2, 66A, 66B, 67A, 67B, 68A, 68B, 72, 74A, 74B, 75A, 75B, 78A, 78B1, 79A, 79B, 82, 87A, 87B, 88A, 88B, 89A, 89B, Crown portion 70, and parts of Crown portions 69 and 71, lots 3 and 4, on P/S No. 9105, and being allotments 53A, 53B, 54A, and parts of allotments 54B, and 55B, and part of Crown portion 69, Parish of Pircarra; subdivisions A and B of allotments 5 to 9 (both inclusive), 15 to 22 (both inclusive), 24, 25, 26, 27, 29 to 41 (both inclusive), 41C, 42, 42C, 43, 43C, 55 to 64 (both inclusive), 68 to 86 (both inclusive), subdivision A of allotments 23 and 28 of allotments 23B and 28B, Parish of Cobra Killuc.

Signed at Melbourne this 25th day of August, 1952.

A. E. LIND,
Commissioner of Crown Lands and Survey.

Soldier Settlement Acts.

REVOCATION OF NOTICE DECLARING FARMING LAND SUITABLE FOR SOLDIER SETTLEMENT.

I, ALBERT ELI LIND, Her Majesty's Commissioner of Crown Lands and Survey, do hereby declare that the Notice made under the provisions of section 88 (1) of the *Soldier Settlement Act 1946* (No. 5179), and published in the *Government Gazette* of the 29th November, 1950, whereby the land described in the Schedule hereto was declared to be land suitable for soldier settlement, shall no longer remain in force in respect to that land.

SCHEDULE.

All those pieces of land, comprising 11,344 acres 2 roods 13 perches, more or less, and being Crown portion 1 and parts of Crown portion 2, section A, Crown allotments 1, 2, and 3, section 29B, Crown allotments R4, R5, 11A1, 11A2, 11B, 12B, 28A, 28B, 29A, 29B, 36A, 36B, 37A1, 70B, 73B, 73C,

74, 74A, 62A, 63A2, 63B2, A1, C, D, R1, R2, R3, R6, 30A, 31A, 31B, 32A, 51A, 51B, 52A, 52B, 57A, 57B, 57C, 58C, 61A, 61B, 63B1, 65A, 65B, 68A, 68B, parts of Crown allotments 30B, 32B, 33, 34, 35, 62, 63A1, and A2, Parish of Eurambeen, Crown allotments O, 81A, 81B, 82A, 82B, 83A, 83B, 84A, 84B, 86A, 86B, 87A, 87B, 88A, 88B, 91A, 91B, 10A, 10B, 11A, 11B, and part of Crown allotments 92A, 93B, Parish of Woodnaggerak; Crown allotments 1, 2, 3, and 4, section 3, 1A, 2A, 3A, 65, 65A, 66, 67A, 67B, 68, 69A, 69B, 70A, 70B, 70C, 70D, 71A, 71B, 71C, 71D, 72A, 72B, 72C, 72D, Town and Parish of Shirley; Crown allotments 1, 2A, 2B, 3, 4, 4A, 5, 5A, 6, 7, 8, 9, 10, 11, and part 14, section 1, allotments 1 and 2, section 2, allotments 1, 2, 3, 4, 5, 6, 7, 8, 9, and 10, section 3, allotments 62, 63, 73, 74, 77, 78, 79, 80, 81, 82, 83, 84, 85, 86, 87, 88, 89A, 89B, 90, 91, 92, 93, 94, 95, 96, 97, 98, 99, and 100, Parish of Shirley—the whole being in the County of Ripon.

Signed at Melbourne this 25th day of August, 1952.

A. E. LIND,
Commissioner of Crown Lands and Survey.

Soldier Settlement Acts.

NOTICE OF DISCONTINUANCE OF COMPULSORY ACQUISITION.

WHEREAS His Excellency the Governor of the State of Victoria, by and with the advice of the Executive Council of the said State, by an Order made on the 5th day of December, 1950, a copy of which Order was published in the *Government Gazette* dated 6th December, 1950, directed that all those pieces of land described in the Schedule hereto be acquired compulsorily for the purposes of the Soldier Settlement Acts: And whereas it is provided by section 38 of the *Soldier Settlement Act 1945* (No. 5107), as amended by section 2 (1) (d) of the *Soldier Settlement (Amendment) Act 1949* (No. 5438), that the Soldier Settlement Commission may publish a notice of discontinuance of compulsory acquisition in respect of such land: Take notice that the said Commission, pursuant to the power conferred upon it by the said section 38, hereby gives notice of discontinuance of compulsory acquisition of the said land.

SCHEDULE.

All those pieces of land comprising 11,344 acres 2 roods 13 perches, more or less, and being Crown portion 1 and parts of Crown portion 2, section A, Crown allotments 1, 2, and 3, section 29D, Crown allotments R4, R5, 11A1, 11A2, 11D, 12B, 28A, 28B, 29A, 29B, 36A, 36B, 37A1, 70B, 73B, 73C, 74, 74A, 62A, 63A2, 63B2, A1, C, D, R1, R2, R3, R6, 30A, 31A, 31B, 32A, 51A, 51B, 52A, 52B, 57A, 57B, 57C, 58C, 61A, 61B, 63B1, 65A, 65B, 68A, 68B, parts of Crown allotments 30B, 32B, 33, 34, 35, 62, 63A1, and A2, Parish of Eurambeen, Crown allotments O, 81A, 81B, 82A, 82B, 83A, 83B, 84A, 84B, 86A, 86B, 87A, 87B, 88A, 88B, 91A, 91B, 10A, 10B, 11A, 11B, and part of Crown allotments 92A, 93B, Parish of Woodnaggerak; Crown allotments 1, 2, 3, and 4, sections 3, 1A, 2A, 3A, 65, 65A, 66, 67A, 67B, 68, 69A, 69B, 70A, 70B, 70C, 70D, 71A, 71B, 71C, 71D, 72A, 72B, 72C, 72D, Town and Parish of Shirley; Crown allotments 1, 2A, 2B, 3, 4, 4A, 5, 5A, 6, 7, 8, 9, 10, 11, and part 14, section 1, allotments 1 and 2, section 2, allotments 1, 2, 3, 4, 5, 6, 7, 8, 9, and 10, section 3, allotments 62, 63, 73, 74, 77, 78, 79, 80, 81, 82, 83, 84, 85, 86, 87, 88, 89A, 89B, 90, 91, 92, 93, 94, 95, 96, 97, 98, 99, and 100, Parish of Shirley—the whole being in the County of Ripon.

Dated at Melbourne this 25th day of August, 1952.

S. P. BROMFIELD,
Deputy Secretary Soldier Settlement Commission.

HEARING OF REASONS AGAINST THE FORFEITURE OF CERTAIN LICENCES AND LEASES BY PERSONS APPOINTED UNDER 34TH SECTION OF THE LAND ACT 1928.

NOTICE is hereby given that reasons against the forfeiture of the licences and leases in the Schedule hereto, which are deemed liable to forfeiture under the provisions of the Land Acts, will be publicly heard by the persons appointed by me, the responsible Minister of the Crown administering the said Acts, to hear the same and report thereon in writing to me, when the persons in the said Schedule mentioned as holders of such licences and leases will be allowed to show cause against the same at the places and on the dates mentioned in the Schedule hereto.

A. E. LIND,
Commissioner of Crown Lands and Survey.

Department of Crown Lands and Survey,
Melbourne, 27th August, 1952.

SCHEDULE.

OFFICE OF INSPECTOR OF LAND SETTLEMENT, PORTLAND, Thursday, 11th September, 1952, at 10 a.m., H. E. Michell, Land Officer—

432/44, M. L. Hollis, 62a. 1r. 2p., Gorea; 455/44, A. J. Clapson, 192a. 2r. 19p., Mouzie.

LAND OFFICE, BENDIGO, Tuesday, 16th September, 1952, at 10 a.m., H. J. Henkel, Land Officer—

0803/129, R. J. O'Connor, 1 rood, Kangaroo Flat; 0806/129, R. Whittle, 1 rood, Kangaroo Flat; 0854/129, E. B. Perkin, 1 rood, Kangaroo Flat; 0857/129, R. J. Connolly, 1 rood, Kangaroo Flat; 0860/129, A. J. Tamblyn, 1 rood, Kangaroo Flat; 0882/129, E. L. Turner, 1 rood, Kangaroo Flat; 0920/129, S. J. Sutherland, 1 rood, Kangaroo Flat; 0901/129, D. A. Goodman, 1 rood, Kangaroo Flat; 0769/129, W. R. Stone, 1 rood, Bendigo; 0975/129, J. W. Smee, 1 rood, Bendigo; 0778/129, A. L. Brown, 1 rood, Bendigo; 0982/129, I. V. Clayton, 1 rood, Sandhurst.

PUBLIC HEARING BY A PERSON APPOINTED UNDER THE 34TH SECTION OF THE LAND ACT 1928.

NOTICE is hereby given that at the time and place mentioned in the Schedule hereunder, applications for leases and licences under the Land Acts, objections to such applications, objections to proposed proclamations, alterations, additions, diminutions, revocations, or unions of commons, and reasons against forfeiture of any leases or licences under the Land Acts deemed liable to forfeiture, will be publicly heard by the person whose name is set opposite such place in such Schedule, being a person appointed by me, the responsible Minister of the Crown administering the Land Acts, to hear the same and report thereon in writing to me.

A. E. LIND,
Commissioner of Crown Lands and Survey, and
President of the Board of Land and Works.

Department of Crown Lands and Survey,
Melbourne, 27th August, 1952.

SCHEDULE.

LAND INSPECTOR'S OFFICE, PORTLAND, Thursday, 11th September, 1952, at 10 a.m., H. E. Michell, Land Officer.

Land Act 1928.

PERMIT CANCELLED.

NOTICE is hereby given that the Permit mentioned in the Schedule hereunder has been cancelled.

District.	Corr. No.	Name of Permit Holder.	Parish.	Allotment.	Section.	Area.
Melbourne ..	1889/44	Carl Augustus Noske ..	Corinolla ..	213r	..	A. R. P. 254 0 0

Office of Crown Lands and Survey,
Melbourne, 27th August, 1952.

A. E. LIND,
Commissioner of Crown Lands and Survey.

LIST OF CROWN LANDS AVAILABLE.

THE under-mentioned areas are available for application as provided by various sections of the *Land Act 1928*, and all applications received on or before Wednesday, 24th September, 1952, will be deemed to have been simultaneously made, but any application lodged after such date may be considered if received in time for inclusion in the advertisement of the cases to be heard at the Local Land Board. Applications on proper form, accompanied by 5s. duty stamp uncancelled (registration fee), may be delivered or forwarded by post to the Local Land Officer or to any Crown Lands Office in Victoria. Applicants may obtain from Local Land Officers, or the Crown Lands Department, Melbourne, a certificate authorizing the issue by the Railway Department of a return ticket at concession fares to enable them to inspect available areas or to attend Local Land Boards.

Subject to the approval of the Secretary for Lands, when the survey fee exceeds £25 but does not exceed £50, a deposit of £25 may be paid, and when the fee exceeds £50 a deposit of 50 per cent. of the fee, the balance in either case being payable over six years in half-yearly instalments.

Marked plans of any particular area, application forms, and any further information may be obtained from the Crown Lands Department, Melbourne, and Land Officers, Bendigo and Red Cliffs.

Department of Crown Lands and Survey, Melbourne, 27th August, 1952. A. E. LIND, Commissioner of Crown Lands and Survey.

* Improvements may be subject to re-valuation after land has been granted to an applicant.

Local Land Office.	County.	Parish.	Allotment.	Section.	Area.	How Available.		Survey Fee.	Valuation of improvements (if any).	Location of Land, &c.	Nearest Railway Station or Township and Distance in miles therefrom.	How Accessible.	Water Supply.	General Description of Land—Soil, Timber, Suitability (Grazing, &c.).
						Classification.	Value per Acre.							
						A.	B.	C.	D.	E.	F.	G.	H.	I.
						£.	s.	d.	£.	s.	d.	£.	s.	d.
AGRICULTURAL AND GRAZING LANDS—SELECTION PURCHASE ALLOTMENTS.														
DIVISION 4, PART I., LAND ACT 1928.														
Bendigo	Karkaroc	Larundel	15b		32 2 29	2nd	1 10 0	8 10 0	Nil	In west of parish	Leippar R.S., 3 miles	By road	To be con-served	Suitable for grazing or cultivation. (M.38447)
Bendigo (b, c)	Tatchera	Meering	9b	2	317 1 32	2nd	4 0 0	18 12 6	£80	In the south-east corner of the parish	Appin township 4 miles, Macorna R.S., 15 miles	"	To be con-served. Area also carries a water right of 58 acre-feet	Poor grazing land. (0734/121)
AVAILABLE UNDER SECTION 129, LAND ACT 1928.														
Red Cliffs (a)	Karkaroc	Colignan	3a	B	3 0 0	Dwelling and Garden	Annual rental to be fixed	5 12 6	Nil	At Grace's Bend	Boonoonar R.S., 8 miles	By road	To be con-served and Murray River	Suitable for a dwelling site and garden. (M.32909)
"	"	Mildura	16c	C	1 0 0	"	"	5 5 0	"	In north-west of parish	Merbein R.S., 5 miles	"	To be con-served	" (M.38444)

(a) Subject to survey.—(b) Subject to re-survey.—(c) Subject to any necessary easements.

Land Act 1928.

LICENCES UNDER THE LAND ACTS 1915 AND 1928 DECLARED VOID.

NOTICE is hereby given that the Licences in the Schedule hereunder have been declared void for the reason specified in each case.

District.	Corr. No.	Name of Licensee.	Section of Land Act under which Licensed.	Parish.	Allotment.	Section.	Area.	Annual Rental.	Reasons for Voiding.
							A. R. P.	£ s. d.	
St. Arnaud	0204/129	Kenneth Robert Baker	129	Wedderburne	10H	5	3 0 0	1 0 0	Non-compliance with conditions
Ararat ..	98/129	James Francis Ryan	129	Town and Parish of Ararat	11	75	0 0 3 ¹ / ₁₀	1 0 0	Licensee's request
Bendigo ..	0986/129	A. Comte	129	Sandhurst ..	Former Water Reserve	..	1 2 8	4 0 0	Licensee's request

Department of Crown Lands and Survey,
Melbourne, 27th August, 1952.

A. E. LIND,
Commissioner of Crown Lands and Survey.

TENDERS.

TENDERS will be received at this office until **TEN A.M.** on the days and for the purposes under mentioned.

Particulars may be learnt at this Office and also at places shown in parenthesis.

W.O. means Inspector of Works Office; P.S.—Police Station; T.S.—Technical School; H.E.S.—Higher Elementary School; S.S.—State School; H.S.—High School.

The Board of Land and Works will not necessarily accept the lowest or any tender.

NOTE.—No preliminary deposits are to be lodged with tenders, but a deposit, in accordance with the following Schedule, will be required from the successful tenderer:—

For contract amounts not exceeding £200	2
For contract amounts exceeding £200 and not exceeding £500	5
For contract amounts exceeding £500 and not exceeding £1,000	10
For contract amounts exceeding £1,000—1 per cent. of tender	500
	(maximum deposit)

2nd September, 1952.

Buffalo.—External painting and minor repairs to residence, S.S. No. 3240. (W.O., Korumburra; S.S., Buffalo.)

Flinders.—Supply and delivery of piles, Jetty, Department of Public Works.

Janefield.—Installation of electric light and power in Wards "B" and "C," Mental Colony.

Kew.—Renewal of electric lighting under covered ways, Children's Cottages, Mental Hospital.

Lake Boga.—Repairs and painting, P.S. (W.O., Swan Hill; P.S., Lake Boga.)

Mont Park.—Brick garage maintenance Engineers' workshop and Plumbers shop, Mental Hospital.

Point Nepean.—Supply and delivery of stone spalls at Point Nepean (300 tons), Harbor Works, Public Works Department.

Prahran.—Supply, delivery, and installation of new gas hot-water service, new gas sink heater, and complete removal of existing electrical hot-water service, P.S.

Toorak.—Repairs and painting, P.S.

Various.—Manufacture and delivery of Composite Iron Pile Shoes (2000 No.), Harbour Works, Department of Public Works.

9th September, 1952.

Ararat.—Fireproofing "J" Ward, Mental Hospital. (W.O., Ararat; Mental Hospital, Ararat.)

Armadale.—Supply and installation of Gas hot-water service, Teacher's Hostel, 3 Karbarook-avenue.

Ballarat.—Supply and installation of extensions to hot-water service in Female Ward F.10, Mental Hospital. (W.O., Ballarat.)

Gresswell.—Supply and installation of oil storage tank, &c., and one automatic steam generator, Sanatorium.

Kaniva.—Supply and installation of sump pump in septic tank, Consolidated School. (P.S., Kaniva.)

Kerang.—Electrical installation in a two (2) class-room "Bristol" Prefabricated Unit, H.S. (W.O., Swan Hill; H.S., Kerang.)

Longerenong.—Supply and installation of a hard fuel hot-water service, Farm Workers' Quarters, Agricultural College. (W.O., Horsham; Agricultural College, Longerenong.)

Port Welshpool.—Supply and delivery of Piles, Harbour Works, Department of Public Works.

Prahran.—Additions to Boys' Dormitory, Blind Institute, Roslyn.—Sale and removal of residence adjoining school, S.S. No. 4663. (W.O., Geelong; S.S., Roslyn.)

Royal Park.—New toilets in Hospital Ward, Receiving Depot, Children's Welfare Department.

Stawell.—Supply and delivery of dishwashers and benches for Sculleries, Pleasant Creek Special School.

Sunbury.—Conversion of single room to lavatory, Ward M.3, Mental Hospital.

Tynong and Tynong North.—Purchase and removal of two out-offices from each school, S.S. Nos. 2854 and 4464 (W.O., Korumburra; P.S., Pakenham.)

Violet Town.—Re-blocking of residence, repairs, and painting to residence, P.S. (W.O., Benalla; P.S., Violet Town.)

16th September, 1952.

Ballarat.—The supply and installation of a central heating system and hot-water service, "Beaufort House," Teachers' Hostel. (W.O., Ballarat, Bendigo.)

Coburg.—Supply and installation of Winding Machine, Pentridge.

Deer Park.—Purchase and removal of residence, S.S. No. 1434.

Fairfield.—Repairs &c., and painting, new water service, "Fairlea House," Infectious Diseases Hospital.

Geelong.—Repairs and renovations to Junior School, Gordon Institute of Technology. (W.O., Geelong; Gordon Institute of Technology, Geelong.) (Amended specification.)

Heidelberg.—Sewerage, plumbing, and drainage water service extension &c., S.S. No. 4656, Bellfield Estate.

Kyneton.—Repairs and renovations, P.S. (W.O., Bendigo, Kyneton; P.S., Kyneton.)

Melbourne.—Installation of wiring to Combination Fire Alarm and Watchman's Check Points, Government Printing Office.

Melbourne.—Installation of wiring to Watchman's Check Points, 61 Spring-street, Public Offices.

Melbourne.—Installation of wiring to Combination Fire Alarm and Watchman's Check Points, New Treasury Buildings, Department of Public Works.

Melbourne.—Installation of wiring to Combination Fire Alarm and Watchman's Check System, Department of Agriculture, Treasury Place.

Rutherglen.—Repairs and painting to Bottling Wing, Viticultural Station, Department of Agriculture. (W.O., Wangaratta; Viticultural Station, Rutherglen.)

Tarnagulla.—Purchase and removal of old Powder Magazine, Department of Public Works. (W.O., Maryborough.)

Timberoo East.—Purchase and removal of school and all out-buildings but excluding fencing, S.S. No. 4011. (W.O., Mildura.)

Various.—Provision of two hundred and thirty (230) "Commode Chairs," Mental Hospitals.

Tenders to be addressed to the Honorable the Commissioner of Public Works, and envelope containing tender marked "Tender for"

P. T. BYRNES,
Commissioner of Public Works.

Public Works Department,
Melbourne, 26th August, 1952.

PUBLIC SERVICE NOTICES.

PUBLIC SERVICE OF VICTORIA—VACANCIES.

APPLICATIONS will be received by the Public Service Board up to Wednesday, the 10th September, 1952, from persons employed in the Public Service of Victoria, who are eligible and qualified, for appointment to the under-mentioned positions:—

ADMINISTRATIVE DIVISION.

Clerk, Class "C1," Department of Crown Lands and Survey.

Yearly Salary.—£605, minimum; £657, maximum.

Duties.—To keep the general ledgers of the Soldier Settlement Commission and subsidiary records; to assist in the preparation of stock trading accounts, revenue accounts, balance sheets and statements of receipts and disbursements; to prepare financial statements and to supervise the preparation of loan repayment tables.

Qualifications.—To be a qualified Accountant with a thorough knowledge of mechanized accounting; to have had experience of cost accounts and to have a knowledge of stock and station accounts; to have a good knowledge of the Soldier Settlements Acts and the Agreement relating to War Service Land Settlement.

Clerk, Class "C," Department of Crown Lands and Survey.

Yearly Salary.—£475, minimum; £579, maximum.

Duties.—To assist the Trust Officer; to supervise and control the collections accounts of officers in country centres; to conduct the internal audit of the departmental rent rolls.

Qualifications.—To have a knowledge of the Land Acts and the Closer Settlement Act and the departmental procedure whereby revenue is collected and brought to account in the Treasury.

Clerk, Class "C," Department of Water Supply.

Yearly Salary.—£475, minimum; £579, maximum.

Duties.—To assist in the examination of wages sheets and accounts, the charging of expenditure to appropriate Treasury funds, and the preparation of reimbursements for the Treasury; to record advances and recoups.

Qualifications.—To possess a thorough knowledge of the Treasury Regulations respecting Public Accounts, and the Commission's system of expenditure control accounting.

PROFESSIONAL DIVISION.

Assistant Works Manager, Cool Stores, Class "B," Department of Agriculture.

Yearly Salary.—£761, minimum; £839, maximum.

Duties.—Subject to the direction of the Manager to supervise the operation and maintenance of the machinery and plant. To keep an accurate check on the correct temperature control of produce in store and at time of delivery; to direct the placing of produce into storage chambers and to assist the Manager generally.

Qualifications.—To possess a sound knowledge and practical experience of the maintenance of machinery and plant of a large cool store and a knowledge of modern technique of refrigeration practice. Experience in cool storage management and the possession of a first class Board of Trade Certificate or other recognized qualification in Mechanical Engineering is desirable. Ability to control a large staff is essential.

Manager, Mallee Research Station, Class "C2," Department of Agriculture.

Yearly Salary.—£683, minimum; £735, maximum.

Duties.—Under the Agricultural Superintendent, to manage the Mallee Research Station including the supervision of staff, employees, catering, and accommodation. To supervise research, demonstrational and advisory work associated with the Station and to initiate proposals for the investigation of district agricultural problems.

Qualifications.—To possess a Degree in Agricultural Science of the Melbourne University, or its equivalent. Experience in farm management operations and in the conduct of agricultural research and extension work.

Senior Draughtsman, Class "C2," Department of Water Supply.

Yearly Salary.—£683, minimum; £735, maximum.

Duties.—To supervise and plan the work of draughtsmen and tracers engaged on the preparation of engineering drawings, graphs, sketches, and maps in connexion with investigation and design of irrigation and water supply works.

Qualifications.—To have had experience in irrigation and water supply draughting work and in the supervision of a draughting office.

Field Officer (Male), Class "C1," Free Library Service Board, Public Library Branch, Department of Chief Secretary.

Yearly Salary.—£605, minimum; £657, maximum.

Duties.—To assist in all technical aspects of the initiation and re-organization of Municipal Library Services; to inspect libraries as directed and to assist generally in the technical advisory services offered by the Board.

Qualifications.—To hold a University Degree in an appropriate Course; to have completed a course of training at an approved Library Training School, or to have passed the Preliminary Examination of the Library Association of Australia and to have had some experience in a library of a recognized standard. To have a sound knowledge of an ability to advise on recognized practice in cataloguing classification, book selection, and other library routines.

Draughtsman, Class "C," Office of the Housing Commission, Department of Treasurer.

Yearly Salary.—£475, minimum; £579, maximum.

Duties.—Under the direction of the Officer in Charge of the Draughting Section to organize and direct all phases of draughting operations undertaken within the Estates Branch; to issue instructions to private surveyors regarding surveys carried out on behalf of the Commission and to apply thereto the provisions of the Survey Co-ordination Act.

Qualifications.—To be a competent survey draughtsman with a knowledge of survey computations and some knowledge of survey practice and procedure in the field. Ability to collect and collate information from Titles Office records is desirable.

Draughtsman, Class "C," Department of Public Works.

Yearly Salary.—£475, minimum; £579, maximum.

Duties.—To prepare preliminary sketches, contract plans, details and specifications for modern buildings.

Qualifications.—To be qualified in building construction and capable of preparing contract plans and specifications for modern buildings for departmental purposes.

NOTE.—This advertisement is in lieu of the advertisement for a reclassified office of Draughtsman, Class "C," naming P. G. Martin as the officer recommended for appointment which appeared under Regulation 39—Reclassification in *Government Gazette* No. 709 of the 20th August, 1952.

Draughtsman, Class "C," Department of Water Supply.

Yearly Salary.—£475, minimum; £579, maximum.

Duties.—Under direction, to carry out details of designs and drawings and to prepare details and draft copies of specifications.

Qualifications.—The possession of a Technical School Diploma in Mechanical or Electrical Engineering or equivalent; to have had approved experience and suitable training in the design of mechanical plant and installations.

Cadet Valuer, Class "D," Office of the Housing Commission, Department of Treasurer.

Yearly Salary.—£338, minimum; £436, maximum.

Duties.—To assist Valuers in the collection of statistical information and the preparation of costs, graphs, &c., to relate cost data to the various types of construction and to assist at inspections as required.

Qualifications.—To possess Leaving Certificate and to have a sound knowledge of building construction and a general knowledge of the principles of valuation and real estate usages and to be prepared to undertake a course of study with the Commonwealth Institute of Valuers.

TECHNICAL AND GENERAL DIVISION.

Dairy and Piggery Instructor, Longerenong Agricultural College, Department of Agriculture.

Yearly Salary.—£475, minimum; £579, maximum; less deduction of £120 a year for board and lodging.

Duties.—Under the direction of the Principal, to take charge of and to be responsible for the management of the Dairy and Piggery Branch of the College; to deliver lectures and give demonstrations in accordance with the syllabus of the College in dairying and, if required, in pig husbandry; to perform such other staff duties as the Principal may require.

Qualifications.—To possess sound training and experience in dairying, together with a knowledge of the manufacture of butter and cheese, and in pig husbandry; ability to lecture and demonstrate to students.

NOTE.—Accommodation available only for single man.

Pre-School Adviser (Female), Maternal and Child Hygiene Branch, Department of Health.

Yearly Salary.—£453, minimum; £479, maximum.

Duties.—To assist in the inspection and supervision of Pre-school Centres, and general duties associated with pre-school activities.

Qualifications.—To be a graduate of an approved Training College specializing in pre-school education.

Farm Manager, Grade I., Kew Mental Hospital, Department of Health.

Yearly Salary.—£458, minimum; £471, maximum.

Duties.—To take charge of the farm and staff thereof and to be responsible for the care of the hospital grounds, live stock, and vehicles.

Qualifications.—A thorough knowledge of general farm work, including agriculture and care of live stock, and ability to handle with tact and judgment a staff of farm hands and patients. Possession of a Diploma or Certificate of an Agricultural College is desirable.

Assistant (Male), Senior, Grade II., Office of the Housing Commission, Department of Treasurer.

Yearly Salary.—£442, minimum; £468, maximum.

Duties.—To act as the Commission's Inquiry Officer, to tender advice in regard to applications for tenancy of homes and upon other matters relating to the Commission's activities.

Qualifications.—To have had experience in dealing with the public and be capable of answering inquiries regarding the various phases of the Commission's activities; to have a sound knowledge of the Commission's policy regarding tenancy applications and the allocation of homes and the operations of the State Accommodation Officer.

Inspector, Grade II., Millewa Centre, Department of Water Supply.

Yearly Salary.—£396, minimum; £435, maximum.

Duties.—Under the District Inspector to supervise and control the maintenance of existing channels, structures, and works appertaining to the Millewa system, and construction of new works; to direct the work of gangs of workmen and to assist in the supervision of water distribution.

Qualifications.—To be capable of generally supervising work of repair gangs and mechanical plant engaged on maintenance of channels and structures. Ability to carry out survey work will be an advantage.

Head Water Bailiff, Shepparton Centre, Department of Water Supply.

Yearly Salary.—£409, minimum; £422, maximum.

Duties.—To control a complete zone of district channels; to regulate supplies between Water Bailiffs; to supervise water distribution, repairs, and maintenance of channels within the zone; to advise District Engineer of daily water requirements of each Bailiff, and to check Bailiffs' returns.

Qualifications.—Ability to take charge of a number of Water Bailiffs; experience in the regulation and distribution of water; a knowledge of water requirements for crops and grasses grown under irrigation, and of the methods of preparation of land for same, and experience in channel and drain maintenance.

Plumber, Ballarat Mental Hospital, Department of Health.

Yearly Salary.—£377, minimum; £403, maximum.

Duties.—Under the direction of the Engineer, to do general plumbing work, mainly maintenance.

Qualifications.—To be a qualified plumber.

Assistant Officer in Charge, Truganina Explosives Reserve, Explosives Branch, Department of Chief Secretary.

Yearly Salary.—£356, minimum; £382, maximum.

Duties.—To be Assistant Officer in Charge of the Truganina Explosives Reserve; to carry out duties as directed by the Chief Inspector of Explosives.

Qualifications.—An intimate knowledge of the Explosives Act and Regulations; experience in the handling, storing, and transport of explosives; ability to control staff.

Water Bailiff, Department of Water Supply.

(Tatura Centre—one vacancy.)

(Cobram Centre—one vacancy.)

Yearly Salary.—£331, minimum; £370, maximum.

Qualifications.—Ability to control and regulate the supply of water to irrigators and to keep the necessary records and make arithmetical computations in connexion therewith; a knowledge of water requirements for crop and grasses grown under irrigation, the methods of preparation of land for same and methods of channel and drain construction and maintenance.

Farm Assistant, Mont Park Mental Hospital, Department of Health.

Yearly Salary.—£312, minimum; £351, maximum.

Duties.—To assist in all farm work.

Qualifications.—Ability to carry out all ordinary farm work.

Female, Believer, Travancore Developmental Centre, Mental Hygiene Branch, Department of Health.

Yearly Salary.—£270, minimum; £283, maximum.

Duties.—To relieve and assist in kitchen and laundry or domestic services.

Qualifications.—Ability to prepare and cook meals, and experience in laundry work.

NOTE.—In addition to the salary rates quoted, a cost of living adjustment (£360 a year for adult males and £270 a year for adult females), which varies in accordance with the rise or fall in the index number of the cost of living, is payable.

By order,

E. F. FITZGIBBON,

Secretary.

Office of the Public Service Board,
Melbourne, 26th August, 1952.

PUBLIC SERVICE OF VICTORIA—VACANCY.

TEMPORARY APPOINTMENT.

APPLICATIONS will be received by the Public Service Board up to Wednesday, the 10th September, 1952, from persons who are qualified, for appointment to the under-mentioned position:—

DRAUGHTSMAN, GRADE I., DEPARTMENT OF PUBLIC WORKS.

Yearly Salary.—£553, minimum; £579, maximum.

Duties.—To prepare, under direction, plans, specifications and estimates of electrical installations and services in all types of public buildings; to generally assist engineers where directed in investigation work and testing, &c.

Qualifications.—To have had sound training in electrical engineering, together with several years drawing office experience in electric light and power; to possess a good knowledge of the design and layout of electric light and power installations including illumination design of all types.

NOTE.—In addition to the salary rate quoted, a cost of living adjustment (£360 a year for adult males), which varies in accordance with the rise or fall in the index number of the cost of living, is payable.

By order,

E. F. FITZGIBBON,

Secretary.

Office of the Public Service Board,
Melbourne, 26th August, 1952.

No. 382.

Public Service Act 1946, Section 50.

REGULATIONS.—PART III.—SALARIES, INCREMENTS, AND ALLOWANCES.

THE Public Service Board, in pursuance of the powers conferred by the Public Service Act 1946, hereby amends the Public Service (Public Service Board) Regulations as shown below:—

The Fifth Schedule to these Regulations is revoked, and the following Schedule inserted in lieu thereof:—

FIFTH SCHEDULE.

TEMPORARY EMPLOYEES.

DEPARTMENT OF HEALTH.

MENTAL HYGIENE.

Designations of Positions and Rates of Salaries.

Designation of Position.	Yearly Rate of Salary.		Increments (Annual).
	Minimum.	Maximum.	
Assistant (Female)—	£	£	
Junior—			
Under 16 years of age	91	..
At 16 years of age	117	..
At 17 years of age	130	..
At 18 years of age	156	..
At 19 years of age	182	..
At 20 years of age	221	..
Adult	260	273*	..
Assistant (Male), Senior	442	455	..
Assistant (Male), Grade I	403	429	1 of £26
Assistant (Male), Grade II.—			
Junior—			
Under 16 years of age	130	..
At 16 years of age	156	..
At 17 years of age	169	..
At 18 years of age	195	..
At 19 years of age	247	..
At 20 years of age	273	..
Adult	325	377	2 of £13 and 1 of £26
Carpenter	364	..
Cleaner and Labourer	292	305	..
Cook (Male)	367	..
Cook (Female)	296	..
Electrical Mechanic	377	..
Farm Assistant	312	338	..
Female Reliever	270	..
Fireman	341	..
Gardener	364	..
General Assistant	312	..
Guidance Kindergartner, Travancore Developmental Centre	302	315	..
Hairdresser (Female)	304	..
Kitchenman	312	..
Kitchen Maid—			
Junior—			
At 16 years of age	98	..
At 17 years of age	120	..
At 18 years of age	142	..
At 19 years of age	164	..
At 20 years of age	186	..
Adult	201	..
Kitchen and Wardsmaid—			
Junior—			
At 16 years of age	98	..
At 17 years of age	120	..
At 18 years of age	142	..
At 19 years of age	164	..
At 20 years of age	186	..
Adult	201	..
Labourer	286	..
Laboratory Attendant	373	386	..
Laundress—			
Junior—			
At 18 years of age	171	..
At 19 years of age	197	..
At 20 years of age	236	..
Adult	275	..
Laundryman	325	338	..
Messenger—			
Junior—			
Under 16 years of age	91	..
At 16 years of age	104	..
At 17 years of age	117	..
At 18 years of age	143	..
At 19 years of age	169	..
At 20 years of age	208	..
Adult	325	..
Messroom Attendant	257	..
Nurse, Child Psychiatric Clinic	350	363	..
Nurse, Clinic	380	..

FIFTH SCHEDULE—continued.

Designation of Position.	Yearly Rate of Salary.		Increments (Annual).
	Minimum.	Maximum.	
Nurse, Hospital (Bundoor)	£	£	
Nurse, Psychiatric Clinic, Travancore Developmental Centre	380	406	1 of £26
Painter	364	..
Plumber	377	..
Seamstress	275	..
Shoemaker	364	..
Shorthand Writer and Typist (Female)—			
Junior—			
Under 16 years of age	130	..
At 16 years of age	156	..
At 17 years of age	169	..
At 18 years of age	182	..
At 19 years of age	221	..
At 20 years of age	247	..
Adult	273	299	..
Storeman—			
Junior—			
At 19 years of age	182	..
At 20 years of age	221	..
Supervisor, Moorakynne Hostel	358	..
Supervisor, Assistant, Moorakynne Hostel	319	..
Tailor	364	..
Tailoress—			
Junior—			
At 20 years of age	262	..
Adult	301	..
Telephonist (Female)—			
Junior—			
At 16 years of age	143	..
At 17 years of age	156	..
At 18 years of age	169	..
At 19 years of age	208	..
At 20 years of age	234	..
Adult	260	286	..
Therapist (Female)	311	..
Therapist, Assistant (Female)	261	..
Typist (Female)—			
Junior—			
Under 16 years of age	117	..
At 16 years of age	143	..
At 17 years of age	156	..
At 18 years of age	169	..
At 19 years of age	208	..
At 20 years of age	234	..
Adult	260	286	..
Upholsterer	364	..
Ward Assistant (Female)	254	..
Ward Assistant (Male)	290	..

* Employees appointed prior to the 1st October, 1944, shall receive a further increment of £13 after twelve months' satisfactory service on the maximum rate of salary.

The relevant provisions contained in the footnote to the Seventh Schedule to these Regulations shall be deemed to be included in this Schedule.

This Regulation shall have effect as on and from the 31st August, 1952.

D. D. PAINE, Chairman.

E. F. FITZGIBBON, Secretary.

Office of the Public Service Board,
Melbourne, 12th August, 1952.

No. 379.

PUBLIC SERVICE ACT 1946.

THE Public Service Board, in pursuance of the powers conferred by the Public Service Act 1946, hereby amends the Public Service (Public Service Board) Regulations as follows:—

PART III.—SALARIES, INCREMENTS, AND ALLOWANCES.

Overtime Allowances.

In sub-regulations (1) and (2) of Regulation 75 the words "Five shillings", where appearing, are deleted and the words "Six shillings" inserted in lieu thereof.

PART VI.—TRAVELLING EXPENSES.

In sub-regulation (1) of Regulation 96 the amount "5s." appearing in clause (b) is deleted and the amount "6s." inserted in lieu thereof.

This Regulation shall have effect as on and from the 17th August, 1952.

D. D. PAINE, Chairman.

E. F. FITZGIBBON, Secretary.

Office of the Public Service Board,
Melbourne, 18th August, 1952.

No. 381.

Public Service Act 1946, Section 50.

REGULATIONS—PART III.—SALARIES, INCREMENTS,
AND ALLOWANCES.

THE Public Service Board, in pursuance of the powers conferred by the Public Service Act 1946, hereby amends the Public Service (Public Service Board) Regulations as shown below:—

The Seventh Schedule to these Regulations is revoked, and the following Schedule inserted in lieu thereof:—

SEVENTH SCHEDULE.
TECHNICAL AND GENERAL DIVISION.
DEPARTMENT OF HEALTH.
MENTAL HYGIENE.
Offices and Rates of Salaries.

Office.	Yearly Rate of Salary.		Increments (Annual).
	Minimum.	Maximum.	
GENERAL STAFF—MALES.			
Assistant (Male), Senior, Grade I.	404	520	1 of £26
Assistant (Male), Senior, Grade II.	442	468	1 of £26
Assistant (Male), Grade I.	416	429	..
Assistant (Male), Grade II.	325	390	2 of £13, 1 of £26, and 1 of £13
Chauffeur, Senior Departmental	360	399	1 of £26 and 1 of £13
Chauffeur, Departmental	334	347	..
Chiropodist	455	494	1 of £26 and 1 of £13
Curator of Gardens	396	448*	2 of £26
Dental Mechanic	378	404	1 of £26
Engineer	540	592*	2 of £26
Engineer Mechanic, Grade I.	..	458*	..
Engineer Mechanic, Grade II.	..	429*	..
Engineer Mechanic, Grade III.	377	403	1 of £26
Engineer Mechanic, Senior	484	510*	1 of £26
Farm Manager (Mont Park)	484	510*	1 of £26
Farm Manager, Grade I.	458	471*	..
Farm Manager, Grade II.	410	445*	1 of £26
Farm Manager, Assistant	..	350	..
Hall Porter	334	386	2 of £13 and 1 of £26
Laboratory Attendant	373	412	1 of £26 and 1 of £13
Nurse, Male, Head, Assistant	494	520	1 of £26
Nurse, Male, Head	546	572*	1 of £26
Nurse, Male, Principal	611	637*	1 of £26
Shorthand Writer and Typist (Male), Grade II.	332	410	2 of £13 and 2 of £26
Supervisor of Catering, Grade I. (Kew, Mont Park, Sunbury)	452	478	1 of £26
Supervisor of Catering, Grade II. (Ararat, Ballarat, Beechworth)	426	462	1 of £26
Therapist	395	408	..
GENERAL STAFF—FEMALES.			
Guidance Kindergartner, Travancore Developmental Centre	302	341	..
Hostel Supervisor	..	410†	..
Housekeeper	436	462†	1 of £26
Nurse, Principal	553	579†	1 of £26
Nurse, Head	488	514†	1 of £26
Nurse, Head, Assistant	436	462	1 of £26
Nurse, Children's Court Clinic	380	419	1 of £26 and 1 of £13
Nurse, Child Psychiatric Clinic	350	389	1 of £13 and 1 of £26
Nurse, Psychiatric Clinic, Travancore Developmental Centre	380	419	1 of £26 and 1 of £13
Shorthand Writer and Typist (Female), Grade I.	273	299†	..
Shorthand Writer and Typist (Female), Grade II.	209	312†	..
Shorthand Writer and Typist (Female), Grade III.	325	338†	..
Shorthand Writer and Typist (Female), Senior	338	351	..

SEVENTH SCHEDULE—continued.

Office.	Yearly Rate of Salary.		Increments (Annual).
	Minimum.	Maximum.	
GENERAL STAFF—FEMALES—continued.			
Telephonist (Female), Grade I.—Junior—	..	143	..
At 16 years of age	..	156	..
At 17 years of age	..	169	..
At 18 years of age	..	208	..
At 19 years of age	..	234	..
At 20 years of age	..	286	..
Adult	260	396	..
Therapist, Organizing	..	353	..
Therapist, Senior	..	337	..
Therapist	311	337	..
Typist (Female), Grade I.—Junior—	..	143	..
At 16 years of age	..	156	..
At 17 years of age	..	169	..
At 18 years of age	..	208	..
At 19 years of age	..	234	..
At 20 years of age	..	286	..
Adult	260	337	..
ARTISANS AND SERVANTS—MALES.			
Blacksmith	377	403	1 of £26
Bricklayer	377	403	1 of £26
Butcher, Senior	377	403	1 of £26
Butcher	..	364	..
Carpenter, Foreman	421	434	..
Carpenter, Senior	377	403	1 of £26
Carpenter	..	364	..
Cleaner and Labourer	292	305	..
Cook, Senior	380	406	1 of £26
Cook	..	367	..
Electrical Mechanic, Senior	..	429	..
Electrical Mechanic	377	403	1 of £26
Farm Assistant	312	351	..
Fireman	341	367	..
Gardener, Senior	377	403*	1 of £26
Gardener	..	364	..
General Assistant	312	338	..
Kitchenman	..	312	..
Laundry Foreman	393	406	..
Laundryman	325	364	..
Motor Mechanic	377	403	1 of £26
Motor Truck Driver	343	356	..
Painter, Senior	377	403	1 of £26
Painter	..	364	..
Plumber	377	403	1 of £26
Shoemaker, Senior	377	403	1 of £26
Shoemaker	..	364	..
Soapmaker	377	403	1 of £26
Storekeeper (Mont Park)	462	488	1 of £26
Storeman, Grade I.	416	436	1 of £20
Storeman, Grade II.	390	416	1 of £26
Storeman, Grade III.	338	364	..
Tailor, Senior	377	403	1 of £26
Tailor	..	364	..
Tinsmith	367	393	1 of £26
Upholsterer, Senior	377	403	1 of £26
Upholsterer	..	364	..
Watchman	299	351	..
ARTISANS AND SERVANTS—FEMALES.			
Cook, Head	..	322	..
Cook	296	309	..
Female Reliever	270	283	..
Hairdresser—Junior	..	257	..
Adult	304	317	..
Laundress, Senior	301	314	..
Laundress—Junior—	..	171	..
At 18 years of age	..	197	..
At 19 years of age	..	236	..
At 20 years of age	..	288	..
Adult	275	288	..
Mess Room Attendant	..	257	..
Seamstress, Senior	301	314	..
Seamstress	275	288	..
Tailoress	301	314	..

SEVENTH SCHEDULE—continued.

Office.	Yearly Rate of Salary.		Increments (Annual).
	Minimum.	Maximum.	
	£	£	
NURSES—MALES.			
Nurse, Charge	442	468	1 of £26
Nurse, Charge, Deputy .. .	390	416	1 of £26
Nurse, Staff .. .	351	364	..
Nurse, Student .. .	299	325	..
Ward Assistant .. .	299	338§	..
NURSES—FEMALES.			
Nurse, Charge .. .	384	410	1 of £26
Nurse, Charge, Deputy .. .	345	358	..
Nurse, Staff .. .	306	319	..
Nurse, Student .. .	254	280	..
Ward Assistant .. .	254	293§	..

* Less deductions for quarters and allowances.
 † Less deductions for quarters, allowances and rations.
 ‡ See Regulation 55 of the Public Service (Public Service Board) Regulations.
 § An allowance of £13 a year may be paid to Ward Assistants who have completed six years' service.

NOTE.—When an officer is required to reside at the institution a charge of £120 a year will be made (except where otherwise specified in these Regulations) for quarters and rations.

All Nurses designated as such, Ward Assistants (Female), Housekeepers, Cooks, and Laundresses will be provided with uniforms.

Male Nurses and Ward Assistants (Male) will be provided with one tunic and two pairs of trousers annually.

Deductions from Salaries of Officers Residing in Separate Quarters in the Reserves of the Various Mental Institutions.

Deductions will be made from the salaries of these officers in accordance with the schedule hereunder:—

Rent	As fixed
Fuel	£27 a year
Light	£11 a year
Water	£2 a year
Vegetables	£33 a year
Milk	£19 a year
Laundry	£19 a year

Principal and Head Nurses and Housekeepers will be charged £120 a year for rations and allowances other than quarters.

Rent for quarters will be charged as under—

For quarters occupied by—

Principal Male Nurses .. .	£20 a year
Head Male Nurses .. .	£20 a year
Farm Managers .. .	£20 a year
Mechanics .. .	£20 a year
Engineers .. .	£20 a year
Curator of Gardens .. .	£20 a year
Gardeners .. .	£20 a year
Head Nurses .. .	£16 a year
Housekeepers .. .	£16 a year
Principal Nurses .. .	£16 a year

Officers who are allowed Quarters for themselves only and Rations—

Deductions will be made from the salaries of these officers as under—

Rent and allowances .. .	£25 a year
Rations .. .	£95 a year

Officers who are not supplied with quarters will be charged £54 a year for meals provided in an Institution.

This Regulation shall have effect as on and from the 31st August, 1952.

D. D. PAINE, Chairman.
 E. F. FITZGIBBON, Secretary.

Office of the Public Service Board,
 Melbourne, 12th August, 1952.

No. 380.

Public Service Act 1946, Section 50.

REGULATIONS.—PART III.—SALARIES, INCREMENTS, AND ALLOWANCES.

THE Public Service Board, in pursuance of the powers conferred by the Public Service Act 1946, hereby amends its Regulations as shown below:—

SIXTH SCHEDULE.

TEMPORARY EMPLOYEES.

Designations of Positions and Rates of Salaries.

Department and Designation of Position.	Yearly Rate of Salary.		Increments (Annual).
	Minimum.	Maximum.	
	£	£	
DEPARTMENT OF PUBLIC WORKS.			
<i>Delete—</i> Draughtswoman, Grade II. . .	299	351	2 of £13 and 1 of £26
<i>Add—</i> Draughtswoman, Grade II. . .	338	364	..

D. D. PAINE, Chairman.
 E. F. FITZGIBBON, Secretary.

Office of the Public Service Board,
 Melbourne, 11th August, 1952.

No. 383.

Public Service Act 1946, Section 50.

REGULATIONS.—PART III.—SALARIES, INCREMENTS, AND ALLOWANCES.

THE Public Service Board, in pursuance of the powers conferred by the Public Service Act 1946, hereby amends its Regulations as shown below:—

SIXTH SCHEDULE.

TEMPORARY EMPLOYEES.

Designations of Positions and Rates of Salaries.

Department and Designation of Position.	Yearly Rate of Salary.		Increments (Annual).
	Minimum.	Maximum.	
	£	£	
DEPARTMENT OF LAW.			
CROWN SOLICITOR'S OFFICE.			
<i>Delete—</i> Professional Assistant (Male)	436	..
<i>Add—</i> Professional Assistant (Male), Grade I.	475	553	3 of £26
Professional Assistant (Male), Grade II.	436	..

This Regulation shall have effect as on and from the 17th August, 1952.

D. D. PAINE, Chairman.
 E. F. FITZGIBBON, Secretary.

Office of the Public Service Board,
 Melbourne, 15th August, 1952.

No. 378.

Public Service Act 1946, Section 50.

REGULATIONS.—PART III.—SALARIES, INCREMENTS, AND ALLOWANCES.

THE Public Service Board, in pursuance of the powers conferred by the *Public Service Act 1946*, hereby amends its Regulations as shown below:—

SECOND SCHEDULE.
TECHNICAL AND GENERAL DIVISION.
Offices and Rates of Salaries.

Department and Office.	Yearly Rate of Salary.		Increments (Annual).
	Minimum.	Maximum.	
	£	£	
DEPARTMENT OF TREASURER.			
HOUSING COMMISSION.			
<i>Add—</i>			
Building Inspector	436	488	2 of £26
Housing Inspector	475	527	2 of £26

This Regulation shall have effect as on and from the 6th July, 1952.

D. D. PAINE, Chairman.
E. F. FITZGIBBON, Secretary.

Office of the Public Service Board,
Melbourne, 14th August, 1952.

No. 377.

Public Service Act 1946, Section 50.

REGULATIONS.—PART III.—SALARIES, INCREMENTS, AND ALLOWANCES.

THE Public Service Board, in pursuance of the powers conferred by the *Public Service Act 1946*, hereby amends its Regulations as shown below:—

SIXTH SCHEDULE.
TEMPORARY EMPLOYEES.
Designations of Positions and Rates of Salaries.

Department and Designation of Position.	Yearly Rate of Salary.		Increments (Annual).
	Minimum.	Maximum.	
	£	£	
DEPARTMENT OF STATE FORESTS.			
<i>Add—</i>			
Plantation Research Officer ..	475	527	2 of £26

D. D. PAINE, Chairman.
E. F. FITZGIBBON, Secretary.

Office of the Public Service Board,
Melbourne, 11th August, 1952.

PUBLIC SERVICE (PUBLIC SERVICE BOARD) REGULATION 39.—RECLASSIFICATION.

THE Public Service Board has raised the classification of the under-mentioned office as shown, and the Permanent Head of the Department has recommended the officer named for appointment.

Office and Present Classification.	Revised Classification.	Duties.	Qualifications.	Officer Recommended for Appointment.		
				Name.	Classification.	Date of Classification.

PROFESSIONAL DIVISION.

DEPARTMENT OF HEALTH.

General Health Branch.

Senior Building Inspector (Electrical), Class "C"	Class "C1"	To examine plans and specifications of electric lighting and power installations in public buildings, including hospitals, schools, theatres, and cinemas; to inspect such installations on completion, to prepare and submit reports and to conduct legal proceedings when so authorized by the Commission of Public Health	To have had a sound electrical training and practical experience in carrying out electrical installations, and to hold both the "A" grade Wireman's and the Cinematograph Operator's Licences; to have a thorough knowledge of electrical apparatus, cinematograph projectors and associated equipment and experience in the inspection of electrical installations	Curzon-Siggers, F. W. H.	Senior Building Inspector (Electrical), Class "C"	1.5.50
---	------------	--	---	--------------------------	---	--------

Appeals against such recommendations should be lodged with the Secretary to the Public Service Board not later than Saturday, the 6th September, 1952.

By order,

E. F. FITZGIBBON,
Secretary.

Office of the Public Service Board,
Melbourne, 28th August, 1952.

PUBLIC SERVICE (PUBLIC SERVICE BOARD) REGULATION 39.—VACANCIES.

THE Permanent Heads of the Departments shown have recommended the officers named hereunder for appointment to the under-mentioned vacancies.

Office and Classification.	Duties.	Qualifications.	Officer Recommended for Appointment.		
			Name.	Classification.	Date of Classification.
ADMINISTRATIVE DIVISION.					
DEPARTMENT OF TREASURER.					
<i>Office of the Housing Commission.</i>					
Clerk, "B1"	To control all activities in connexion with the selection of tenants and the allocation of houses throughout the State, and to undertake the management of all housing estates in every particular except maintenance and rent collection and advise the Commission on policy matters relative thereto	A thorough knowledge of the Housing Acts and Regulations, and the policy of the Commission in connexion with selections of tenants and the management of housing estates, ability to control a large staff and conduct interviews, and a wide experience in dealing with the public	Parker, E. A. . .	Clerk, Class "B"	28.8.50
PROFESSIONAL DIVISION.					
DEPARTMENT OF LAW.					
<i>Office of Titles.</i>					
Surveyor and Chief Draughtsman and Titles Office Survey Officer, Class "A1" (£1,250-£1,350)	To direct the work of the Survey Branch and advise the Commissioner of Titles and Registrar of Titles on all Survey matters relating to the rectification and preparation of Certificates of Title.	To be a Licensed Surveyor and possess a sound knowledge of the Transfer of Land Act and all other Acts pertaining to land tenure; to be experienced in the principles and application of the Survey Co-ordination Act; to have had extensive experience in the direction of staff and administration of all phases of work carried out in the Survey Branch	Shea, H. N. . .	Assistant Chief Draughtsman, Titles Office, Classes "A" and "A1"	1.1.50
DEPARTMENT OF MINES.					
Senior Draughtsman, Class "B"	To compile geological and topographical maps for reproduction from aerial photographs and surveyor's field notes; to do the work necessary in the preparation of geological plans by lithography, and to take charge of the branch in the absence of the Superintending Draughtsman	To be a competent Survey Draughtsman; to have a thorough knowledge of the preparation of plans, &c., from aerial photographs, and sufficient experience of lithography for the reproduction of such plans	McInnes, D. W. . .	Draughtsman, Class "C2"	5.12.49
TECHNICAL AND GENERAL DIVISION.					
DEPARTMENT OF MINES.					
Drill Sub-foreman, Failing Drill	Under the direction of the Foreman to be responsible for the operation of the drill during a shift	To have a sound knowledge of drilling practice and of the operation of a rotary-type drilling plant; to be capable of controlling the work of a shift	Thompson, K. O. J.	Drill Sub-foreman	28.5.52

Appeals against such recommendations should be lodged with the Secretary to the Public Service Board not later than Saturday, the 6th September, 1952.

Office of the Public Service Board,
Melbourne, 26th August, 1952.

By order,
E. F. FITZGIBBON,
Secretary.

PRIVATE ADVERTISEMENTS.

I, CYRIL BARRY-MURPHY, of 58 Thomas-street, Hampton, investor, hereby give notice that by deed poll dated the 18th day of August, 1952, and filed in the office of the Registrar-General on the 21st day of August, 1952, I formally renounced and abandoned the name of Cyril Barry Murphy, and I intend henceforth to use and be called, known, and described by the name of Cyril Barry-Murphy.

Dated the 21st day of August, 1952.

CYRIL BARRY-MURPHY.

Witness—R. G. PELLE, solicitor, 99 Queen-street, Melbourne.

No. 750.—8253/52.—4

NOTICE OF INTENTION TO APPLY FOR A LICENCE TO DIVERT WATER AND CUT RACES FROM THE DEEP CREEK AT CARISBROOK.

I HEREBY give notice that I intend to apply for a licence empowering me to divert water for a term of fifteen years to the extent of 20 acre-feet per annum at a maximum rate of 2 acre-feet per day of 24 hours for irrigation of 10 acres, being part of allotments 3 and 4, Parish of Carisbrook, and to occupy certain Crown lands for works of storage and diversion, and to cut a race thereon.

Any objection to such application must be forwarded, in writing, to the State Rivers and Water Supply Commission, Melbourne, within 30 days of the date hereof.

THOMAS HENRY DOOLY.

Carisbrook, 15th July, 1952. 2220

NOTICE OF INTENTION TO APPLY FOR A LICENCE TO DIVERT WATER AND CUT RACES FROM THE DEEP CREEK AT EDDINGTON.

I HEREBY give notice that I intend to apply for a licence empowering me to divert water for a term of fifteen years to the extent of 8 acre-feet per annum at a maximum rate of 2 acre-feet per day of 24 hours for irrigation of 4 acres, being part of allotment 2D, section 14, and Parish of Eddington, and to occupy certain Crown lands for works of storage and diversion, and to cut a race thereon.

Any objection to such application must be forwarded, in writing, to the State Rivers and Water Supply Commission, Melbourne, within 30 days of the date hereof.

MILDRED J. TUCKETT,

Betley P.O., 15th July, 1952. 2221

NOTICE OF INTENTION TO APPLY FOR A LICENCE TO DIVERT WATER AND CUT RACES FROM THE HEPBURN (LAGOON) DEEP CREEK, AT CARISBROOK NORTH.

I HEREBY give notice that I intend to apply for a licence empowering me to divert water for a term of fifteen years to the extent of 40 acre-feet per annum at a maximum rate of 1½ acre-foot per day of 24 hours for irrigation of 20 acres, being part of allotments 11B, 13B, and 13C, section 7, and Parish of Eddington, and to occupy certain Crown lands for works of storage and diversion, and to cut a race thereon.

Any objection to such application must be forwarded, in writing, to the State Rivers and Water Supply Commission, Melbourne, within 30 days of the date hereof.

SAMUEL H. DORAN.

Carisbrook, 1st August, 1952. 2222

NOTICE OF INTENTION TO APPLY FOR A LICENCE TO DIVERT WATER AND CUT RACES FROM THE HEPBURN (LAGOON) DEEP CREEK, AT CARISBROOK.

I HEREBY give notice that I intend to apply for a licence empowering me to divert water for a term of fifteen years to the extent of 30 acre-feet per annum at a maximum rate of 1 acre-foot per day of 24 hours for irrigation of 15 acres, being part of allotment 30, section 2, and Parish of Carisbrook.

Any objection to such application must be forwarded, in writing, to the State Rivers and Water Supply Commission, Melbourne, within 30 days of the date hereof.

SAMUEL H. DORAN.

Carisbrook, 5th August, 1952. 2223

CITY OF CAULFIELD.

BY-LAW No. 86.

A By-law of the City of Caulfield, No. 86, made under the Local Government Acts, and particularly under Part VII. of the *Local Government Act 1946*, for prescribing residential areas and for repealing portion of By-law No. 66 and the whole of By-law No. 79, and for substituting for area 21, described in the Schedule to the said By-law No. 66, as amended the area described in the Schedule to this By-law No. 86.

A COPY of the above By-law is open for inspection free of charge during office hours at the office of the Council, Town Hall, Caulfield.

Resolution for passing this By-law was agreed to by the Council on the 19th day of December, 1951, and confirmed on the 29th day of January, 1952.

The corporate seal of the Mayor, Councillors, and Citizens of the City of Caulfield was hereunto affixed in the presence of—

(L.S.) W. R. THOMSON, Councillor.
2265 JAMES R. BRIGGS, Town Clerk.

CITY OF COLLINGWOOD.

BY-LAW No. 83.

A By-law of the City of Collingwood, made under sections 197 and 769 of the *Local Government Act 1946*, and numbered 83, for the care, protection, and management of public reserves, of which the management is vested in the council, and also lands, grounds, tree reserves, ornamental plantations, and other places within the

municipal district purchased or provided by the council and used as pleasure grounds, gardens, or places of public resort or recreation.

IN pursuance of the powers conferred by the *Local Government Act 1946*, the Mayor, Councillors, and Citizens of the City of Collingwood, with the approval of the Governor in Council, order as follows:—

That By-law of the City of Collingwood, No. 54, shall be and is hereby repealed.

No persons shall interfere with the trees, shrubs, grass, flowers, statuary, fountains, fish, or any property in any of the said public reserves, lands, grounds, tree reserves, ornamental plantations, and other places, or throw stones or any missile, or commit any nuisance or light fires therein, or leave therein any bottles, paper, or any litter.

No person shall climb or jump over the seats or fences in or around any of the said public reserves, lands, grounds, tree reserves, ornamental plantations, or other places or lie on the seats, or stick bills on the fences, gates, or trees, or cut letters or marks on the trees, seats, gates, posts, or fences, or otherwise deface the same or write thereon.

No person except those in the employ of or authorized by the council shall bring into any of the said public reserves, lands, grounds, tree reserves, ornamental plantations, or other places, any horse, cattle or other animal or vehicle, or enter plots of ground therein enclosed for plantations or other purposes.

No person shall bring into or have in the public reserves, lands, grounds, tree reserves, ornamental plantations or other places, any dog; all dogs found wandering in the reserves shall be liable to be destroyed.

Preaching in any of the said public reserves, lands, grounds, tree reserves, ornamental plantations or other places, or public harangues whereby a crowd is collected, shall not be permitted without the authority, in writing, of the council.

Any person found in a state of intoxication or behaving in a disorderly or objectionable manner, or creating or taking part in any disturbance or committing in any of the said public reserves, lands, grounds, tree reserves, or ornamental plantations or other places any act of indecency shall be liable to be forthwith removed by the curator or other authorized officer or servant of the council or by a constable, and shall be guilty of an offence against this By-law.

No person shall play cricket or football or engage in any athletic sports in the public reserve, lands, grounds, tree reserves, ornamental plantations or other places without the permission, in writing, of the council first being obtained.

No person shall camp in the public reserves, lands, grounds, tree reserves, ornamental plantations and other places, nor erect therein any building or any booth or other structure for the purpose of offering for sale any articles without the permission, in writing, of the council first being obtained.

No person except those in the employ of or authorized by the council shall ride or drive any bicycle, motor car, or other vehicle in any of the said public reserves, lands, grounds, tree reserves, ornamental plantations, or other places.

Any person who is guilty of any wilful act or default contrary hereto, shall on conviction forfeit and pay a penalty not exceeding £10.

This By-law shall apply to and have operation throughout the following public reserves, lands, grounds, tree reserves, ornamental plantations or other places, viz.:—

Gahan Reserve, Park-street;
Victoria-parade Reserves;
Alexandra-parade Reserves;
Brown's Reserve, Nicholson-street;
Evans Reserve, Dight-street;
Cambridge-street Reserve;
McNamara Reserve, corner of Gold and Keele streets;
Ramsden-street Reserve;
Rain Reserve, Queen's-parade;
Heidelberg-road Reserves; and
Hodde-street Reserves.

The Resolution for passing this By-law was agreed to by the council on the 10th day of June, 1952, and confirmed on the 7th day of July, 1952.

The common seal of the Mayor, Councillors, and Citizens of the City of Collingwood was hereto affixed by order of the council on the 14th day of July, 1952, in the presence of—

(SEAL) G. I. MAXWELL, Mayor.
W. H. REID, Councillor.
G. J. BROWN, Town Clerk.

Approved by the Governor in Council on the 12th day of August, 1952.—A. MAHLSTEDT, Clerk of the Executive Council. 2263

CITY OF MOORABBIN.

BY-LAW No. 160.

A By-law of the City of Moorabbin, made under the *Local Government Act 1946* and the Uniform Building Regulations (Victoria), and numbered 160, for the purpose of amending By-law No. 101 of the said city.

IN pursuance of the powers conferred by the *Local Government Act 1946* and the Uniform Building Regulations (Victoria), the Mayor, Councillors, and Citizens of the City of Moorabbin order as follows:—

1. By-law No. 101 of the City of Moorabbin is hereby amended by the deletion of Area 19 from the First Schedule thereto, and the substitution of the following areas therefor:—

- (a) All the land fronting to or abutting on the north side of Centre-road between the east side of Tucker-road and the west side of East Boundary-road to a depth of 140 feet; and
- (b) All the land fronting to or abutting on the south side of Centre-road between the east side of Browns-road and the west side of East Boundary-road to a depth of 140 feet.

2. This By-law shall have operation throughout those parts of the municipal district of Moorabbin set out in clause 1 hereof.

The Resolution for making and passing this By-law was agreed to by the Council at a meeting on the 3rd day of December, 1951, and confirmed on the 18th day of February, 1952.

The common seal of the Mayor, Councillors, and Citizens of the City of Moorabbin was hereunto affixed this 18th day of February, 1952, in pursuance of a Resolution of the Council, and in the presence of—

(SEAL) E. I. HALLEY, Mayor.
L. R. COATES, Councillor.
W. B. THOMAS, Town Clerk.

Approved by the Governor in Council, the 12th day of August, 1952.—A. MAHLSTEDT, Clerk of the Executive Council. 2266

CITY OF MOORABBIN.

BY-LAW No. 156.

A By-law of the City of Moorabbin made under the *Local Government Act 1946* and the Uniform Building Regulations (Victoria) and numbered 156, for the purpose of amending By-law No. 101 of the said City.

IN pursuance of the powers conferred by the *Local Government Act 1946* and the Uniform Building Regulations (Victoria) the Mayor, Councillors, and Citizens of the City of Moorabbin order as follows:—

1. By-law No. 101 of the City of Moorabbin is hereby amended by—

- (a) Repealing area 44 described in the First Schedule thereto and substituting therefor the following area:—

“Commencing at the intersection of the west street alignment of Charman-road and the north street alignment of Balcombe-road; thence westerly along the north alignment of Balcombe-road for a distance of 145 ft. 11 in.; thence northerly on a bearing of 0 deg. 38 min., for a distance of 163 ft. 2 in.; thence easterly on a bearing of 90 deg. 38 min., for a distance of 144 ft. 1 in., to the west street alignment of Charman-road, and southerly along the west street alignment of Charman-road to the commencing point.”

- (b) By adding the following additional areas to the said First Schedule—

“(i) Commencing at a point on the east street alignment of Parkside-street, 25 feet south of the southern street alignment of Weatherall-road; thence easterly and parallel to Weatherall-road for a distance of 273 ft. 6 in.; thence southerly and parallel to Parkside-street for a distance of 114 feet; thence westerly and parallel to Weatherall-road for a distance of 273 ft. 6 in.; thence northerly along the east street alignment of Parkside-street to the commencing point.

- (ii) Commencing at a point on the west alignment of Church-street, 10 feet north of the intersection of the north alignment

of Balcombe-road; thence westerly and parallel to Balcombe-road for a distance of 260 feet; thence northerly along the east alignment of Michael-street for a distance of 110 feet; thence easterly and parallel to Balcombe-road for a distance of 260 feet; thence southerly along the west alignment of Church-street to the commencing point.”

2. This By-law shall have operation throughout the whole of the municipal district of the City of Moorabbin.

The resolution for making and passing this By-law was agreed to by the Council at a meeting held on the 1st day of October, 1951, and confirmed on the 5th day of November, 1951.

The common seal of the Mayor, Councillors, and Citizens of the City of Moorabbin was hereto affixed in pursuance of a resolution of the Council and in the presence of—

(SEAL) E. I. F. HALLEY, Mayor.
L. R. COATES, Councillor.
W. B. THOMAS, Town Clerk.

Approved by the Governor in Council, 12th August, 1952.
—A. MAHLSTEDT, Clerk of the Executive Council. 2234

CITY OF MOORABBIN.

BY-LAW No. 162.

A By-law of the City of Moorabbin, made under the provisions of the *Local Government Act 1946* and the Uniform Building Regulations (Victoria), and numbered 162, for amending By-law No. 101 of the City of Moorabbin.

IN pursuance of the powers conferred by the *Local Government Act* and the Uniform Building Regulations, the Mayor, Councillors, and Citizens of the City of Moorabbin order as follows:—

1. By-law No. 101 of the City of Moorabbin is hereby amended by the addition of the following area to the Second Schedule thereto—

“Commencing at a point on the west street alignment of Warrigal-road 200 feet south of the south street alignment of Keys-road; thence southerly along the west street alignment of Warrigal-road for a distance of 968 ft. 2½ in. on a bearing of 180 deg. 32 min.; thence westerly for a distance of 864 ft. 3½ in. on a bearing of 270 deg. 22 min.; thence northerly for a distance of 904 ft. 1 in. on a bearing of 0 deg. 34 min.; thence north-westerly a distance of 64 ft. 10 in. on a bearing of 351 deg. 59 min.; thence easterly a distance of 873 ft. 5½ in. on a bearing of 90 deg. 22 min. back to the commencing point.”

2. This By-law shall come into operation and have effect immediately upon its publication in the *Victoria Government Gazette*.

Resolution for passing this By-law was agreed to by the Council on the 5th day of May, 1952, and confirmed on the 2nd day of June, 1952.

The common seal of the Mayor, Councillors, and Citizens of the City of Moorabbin was hereunto affixed this 2nd day of June, 1952, in pursuance of a Resolution of the Council, and in the presence of—

(SEAL) E. I. HALLEY, Mayor.
L. R. COATES, Councillor.
W. B. THOMAS, Town Clerk.

Approved by the Governor in Council, the 12th day of August, 1952.—A. MAHLSTEDT, Clerk of the Executive Council. 2267

CITY OF SHEPPARTON.

BY-LAW No. 36.

NOTICE is hereby given that the Council of the City of Shepparton has made a By-law, under the provisions of sections 197 and 228 of the *Local Government Act 1946* and section 6 of the *Police Offences Act 1928*, and any amendments thereof, and numbered 36, for the following purposes:—

- (a) Altering By-law No. 28, as altered by By-law No. 35.
- (b) Altering By-law No. 35.
- (c) For regulating traffic and processions, and for prescribing the routes to be observed by all carriages, carts, vehicles, and persons, and for

keeping good order in carriageways and footways and for preventing any obstruction thereof, whether by the assemblage of persons or otherwise.

A copy of this By-law is open for inspection, free of charge, during office hours at the office of the Council, Town Hall, Shepparton.

Resolution for the passing of this By-law was agreed to by the Council of the City of Shepparton on the 14th day of July, 1952, and confirmed on the 11th day of August, 1952.
2206 R. WEST, Town Clerk.

BOROUGH OF BENALLA.

LOAN No. 4.

Notice of Intention to Borrow the Sum of £6,000 for Permanent Works and Undertakings.

NOTICE is hereby given that the Council of the Borough of Benalla proposes to borrow the sum of Six thousand pounds (£6,000) on the credit of the municipal revenues of the Mayor, Councillors, and Burgesses of the said borough, such sum to be raised by the issue of debentures, in accordance with the provisions of the Local Government Acts.

1. The maximum rate of interest that may be paid is 4 2s. 6d. per centum per annum.

2. The purpose for which the loan is to be applied is road construction, concrete kerbs and channels, and purchase of land and construction of building for a Council depot to house plant, &c.

3. The period of the loan shall be ten years with repayments based on a twenty-year term.

4. The moneys borrowed shall be repayable by providing out of the Municipal Fund two half-yearly instalments of approximately £221 14s. 10d. each, including principal and interest, on the 1st day of October and the 1st day of April during the currency of the loan. The first instalment shall be paid on the 1st day of April, 1953.

5. Such money shall be repayable at the National Bank of Australasia Ltd., Melbourne, or at the Council's bankers for the time being in Melbourne.

6. The plans and specifications and the estimate of the cost of the proposed works, and a statement showing the proposed expenditure of the moneys to be borrowed, are open for inspection at the office of the Council, 86 Bridge-street, Benalla, during office hours.

2231 D. C. LATCH, Town Clerk.

BOROUGH OF MARYBOROUGH.

By-LAW No. 69.

A By-law of the Borough of Maryborough, made under section 197 of the *Local Government Act 1946*, and numbered 69, to amend By-law No. 60 for regulating traffic and controlling behaviour in streets.

IN pursuance of the powers conferred by the *Local Government Act 1946*, the Mayor, Councillors, and Burgesses of the Borough of Maryborough order as follows:—

1. That this By-law shall be read and construed as one with By-law No. 60.

2. (a) In clause 3 following sub-clause (f) shall be added the following sub-clause:—

"(g) Nolan-street, south side, from 30 feet to 70 feet from intersection east of Napier-street."

(b) Clause 2 (b) of By-law 63 amending clause 3 of By-law 60 shall be amended as follows:—

Following the words "sub-clause (a), (b)" delete the words "and (d)" and insert "(d) and (g)".

3. In clause 8 following the words "verandah posts" delete the words "nor more than 18 inches from the building line."

Resolution for passing this By-law No. 69 agreed to the 5th day of June, 1952, and confirmed the 3rd day of July, 1952.

In witness whereof the common seal of the Mayor, Councillors, and Burgesses of the Borough of Maryborough was hereunto affixed this 4th day of July, 1952, in the presence of—

(L.S.) S. A. DOUGLASS, Mayor.
A. HOWARTH, Councillor.
F. H. ROGAN, Town Clerk.

Approved by the Governor in Council, 5th August, 1952.
—A. MAHLSTEDT, Clerk of the Executive Council. 2264

SHIRE OF DANDENONG.

A By-law of the Shire of Dandenong, made under section 197 (1) (vi) and (xi), and numbered 107, for the purpose of preventing and extinguishing fires and suppressing nuisances within the municipality of the Shire of Dandenong.

IN pursuance of the powers conferred by the *Local Government Act 1946* and of every other power it thereunto enabling, the President, Councillors, and Ratepayers of the Shire of Dandenong order as follows:—

1. Every person carrying on sawmilling, joinery, or similar operations shall forthwith destroy all sawdust produced in the course of such operations.

2. Every person who destroys sawdust by burning shall—

(a) burn such sawdust in an incinerator so designed and constructed as to prevent the escape of fire sparks or burning material therefrom;

(b) place or construct such incinerator in a position where there will be no risk of fire spreading therefrom;

(c) keep a space 15 feet wide around such incinerator clear of all sawdust and other burnable material so as to minimize the risk of fire spreading from such incinerator;

(d) take such other precautions as may in the circumstances be necessary to minimize the risk of fire spreading from such incinerator; and

(e) provide and keep in a fit state for immediate use such fire buckets, chemical extinguishers, and other appliances for preventing and extinguishing fires as shall be required and in such a position as is determined by either the engineer to the Council of the Shire of Dandenong or the proper officer appointed under the *Country Fire Authority Act 1944*.

3. Every person guilty of a wilful breach of this By-law shall be liable to a penalty of not less than £1 or more than £20, and in case of a continuing breach to a further penalty of not more than £5 for each day on which the offence against this By-law is continued after a conviction or order by any court.

4. This By-law shall apply to and have operation throughout the whole of the municipal district of the Shire of Dandenong.

Resolution for passing this By-law agreed to by the Council on the 7th day of July, 1952, and confirmed on the 18th day of August, 1952.

The common seal of the President, Councillors, and Ratepayers of the Shire of Dandenong was hereunto affixed by order of the Council this 18th day of August, 1952, in the presence of—

(SEAL) R. A. JEFFERS, Shire President.
N. C. SULLIVAN, Councillor.
G. T. ANDREWS, Councillor.
R. BOOTH, Shire Secretary.

2212

SHIRE OF MILDURA.

I HEREBY give notice that Sergeant John Charles Henry Quill, No. 8752, has been appointed Prosecuting Officer for the Red Cliffs district, within the Shire of Mildura, as from Friday, 1st day of August, 1952, *vice* Sergeant Arthur Leslie Bell, resigned.

2255 A. D. HARVEY, Shire Secretary.

SHIRE OF WYCHEPROOF.

LOAN No. 14.

Notice of Intention to Borrow the Sum of £11,500 for Permanent Works and Undertakings.

NOTICE is hereby given that the Council of the Shire of Wycheproof proposes to borrow the sum of £11,500 on the credit of the municipal revenues of the President, Councillors, and Ratepayers of the said shire, such sum to be raised by the issue of debentures, in accordance with the provisions of the Local Government Acts.

1. The maximum rate of interest that may be paid is 4½ per cent. per annum.

2. The purpose for which the loan is to be applied is—

(a) Purchase and installation of 300-h.p.	£
A.C. generating set	10,800
(b) Extension of power house	700

3. The period of the loan shall be twenty years.

4. The moneys borrowed shall be repayable by providing out of the Municipal Fund 40 half-yearly instalments of approximately £439 1s. each, including principal and interest, on the 1st day of December and the 1st day of June during the currency of the loan. The first instalment shall be payable on the 1st day of June, 1953.

5. Such moneys shall be repayable at the Australia and New Zealand Bank Limited, Melbourne, or at the Council's bankers for the time being in Melbourne.

The plans and specifications and the estimate of cost of the proposed works, and a statement showing the proposed expenditure of the moneys to be borrowed, are open for inspection at the Shire Office, Wycheproof.

Dated 18th August, 1952.

2208

R. K. SOULSBY, Shire Secretary.

SHIRE OF WYCHEPROOF.

LOAN No. 15.

Notice of Intention to Borrow the Sum of £1,500 for Permanent Works and Undertakings.

NOTICE is hereby given that the Council of the Shire of Wycheproof proposes to borrow the sum of £1,500 on the credit of the municipal revenues of the President, Councillors, and Ratepayers of the said shire, such sum to be raised by the issue of debentures, in accordance with the provisions of the Local Government Acts.

1. The maximum rate of interest that may be paid is 4½ per cent. per annum.

2. The purpose for which the loan is to be applied is—
Purchase of new utility truck, £1,500.

3. The period of the loan shall be ten years.

4. The moneys borrowed shall be repayable by providing out of the Municipal Fund twenty half-yearly instalments of approximately £93 19s. 6d. each, including principal and interest, on the 1st day of December and the 1st day of June during the currency of the loan. The first instalment shall be payable on the 1st day of June, 1953.

5. Such moneys shall be repayable at the Australia and New Zealand Bank Limited, Melbourne, or at the Council's bankers for the time being in Melbourne.

The plans and specifications and the estimate of cost of the proposed works, and a statement showing the proposed expenditure of the moneys to be borrowed, are open for inspection at the Shire Office, Wycheproof.

2207

R. K. SOULSBY, Shire Secretary.

NOTICE OF DISSOLUTION.

NOTICE is hereby given that the partnership heretofore subsisting between the undersigned, William Lewington and Jack Green, carrying on business at Camp-street, Kangaroo Flat, under the name of "Lewington and Green," has been dissolved by mutual consent as from the 6th day of July, 1952. All debts due to and owing by the late firm will be received and paid by the said William Lewington, who will continue to carry on the business at the same place.

Dated at Melbourne the 22nd day of August, 1952.

W. LEWINGTON.
J. GREEN.

Witness—T. J. CROWE.

2224

NOTICE is hereby given that the partnership of Stanley Phillips Bishop (now deceased) and George Waterman Earl, trading as "Bishop and Earl," has been dissolved as from the 28th day of July, 1951 (the date of death of the said Stanley Phillips Bishop), and all debts payable to the firm are now receivable by and all debts owed by the firm at that date are payable by George Waterman Earl, of 253 Mitchell-street, Bendigo.

E. M. BISHOP, } Executors of S. P. Bishop,
L. BISHOP, } deceased.
GEO. W. EARL, }

H. E. Every, solicitor, 59 View-street, Bendigo. 2235

NOTICE is hereby given that the partnership heretofore subsisting between Sydney Samuel Shilkin and Asriel Baumann, carrying on business of manufacturers of rain-coats and ladies' mantles, at 223 Victoria-street, Melbourne, under the firm name of "Rainmaster Manufacturing Co.," has been dissolved by mutual consent as from the 20th day of August, 1952. All debts due to and owing by the said late firm will be received and paid by the said Sydney Samuel Shilkin, who will continue to trade under the said firm name as sole proprietor.

Dated this 20th day of August, 1952.

S. S. SHILKIN.
A. BAUMANN.

M. David Firstenberg, LL.B., solicitor, 473 Bourke-street, Melbourne. 2243

NOTICE is hereby given that the partnership heretofore subsisting between John Barnard Welch, of Roslyn-court, McKinnon, and Norman Lindsay Fritzlaff, of 2 Maple-grove, Toorak, carrying on business as advertisers at 64 Elizabeth-street, Melbourne, under the style or firm of "Welch-Fritzlaff Advertising," has been dissolved as from the 18th day of August, 1952. All debts due to and owing by the said late firm will be received and paid respectively by John Barnard Welch, who will continue to carry on business, under the trade name of "Welch-Fritzlaff Advertising," at 64 Elizabeth-street, Melbourne.

Dated this 18th day of August, 1952.

N. L. FRITZLAFF.
JOHN B. WELCH.

Witness—M. MEERKIN, clerk.

Maddock, Lonie, and Chisholm, solicitors for Norman Lindsay Fritzlaff, of 2 Maple-grove Toorak. 2242

NOTICE is hereby given that the partnership heretofore subsisting between McGregor Aulsebrook Kean, of 16 Dawson-avenue, Elwood, and Arthur Keith Veall, of 36 Brandon-street, Burwood, carrying on business at 26 McCann-street, Geelong, for the purpose of buying land, the erection of buildings, and the sale of same has been dissolved as from the 14th day of August, 1952.

Dated at Melbourne the 14th day of August, 1952.

McG. A. KEAN.

Witness—C. A. GUILD, solicitor, 431 Bourke-street, Melbourne. 2215

NOTICE is hereby given that the partnership between the undersigned Charles Geoffrey Hildebrandt and Douglas Selby Neeson, carrying on business as manufacturers of fibrous plaster products at Chandos-street, Cheltenham, under the firm name of Selby Plaster Products Co., has been dissolved by mutual consent, as from the 1st day of July, 1952. All debts due to and owing by the partnership will be received and paid by the said Douglas Selby Neeson, who will continue to carry on the said business at the same place.

Dated this 11th day of August, 1952.

C. G. HILDEBRANDT.
D. S. NEESON.

Witness to both signatures—J. MCKENNA.

McKenna and Taibot, solicitors, 423 Little Collins-street, Melbourne. 2299

NOTICE is hereby given that the partnership previously carried on under the firm name of Saunders and Ziebell, 32 Lonsdale-street, Melbourne, was dissolved on the 21st July, 1952. Henceforth the former partners, namely, H. M. Saunders and M. T. Ziebell, will continue to carry on business as customs and shipping agents under their own name. H. M. Saunders will carry on business at 48 William-street, and M. T. Ziebell will carry on business at 468 Little Collins-street, Melbourne.

M. T. ZIEBELL.
H. M. SAUNDERS.

2283

Companies Act 1938.

JUNIOR LEGACY OF MELBOURNE.

NOTICE OF INTENTION TO APPLY TO ATTORNEY-GENERAL FOR LICENCE, PURSUANT TO SECTION 18 (1).

I, GEORGE LEONARD EKINS, of 43 Rix-street, Glen Iris, for and on behalf of Junior Legacy of Melbourne, being an association about to be formed as a company limited by guarantee for the purpose of promoting the benefit, care, education, advancement in life, and general well-being of widows and children of deceased returned ex-servicemen, hereby give notice of intention to apply to the Attorney-General for a licence directing that the said association be registered as a company with limited liability without the addition of the word "Limited" to its name.

Dated the 22nd day of August, 1952.

G. L. EKINS, Honorary Secretary.

Rylah and Rylah, of 349 Collins-street, Melbourne, solicitors for the applicant. 2297

Companies Act 1938.

AARONS MILLER PROPRIETARY LIMITED

(IN VOLUNTARY LIQUIDATION).

PURSUANT TO SECTION 236.

IT is hereby notified that the Final General Meeting of the said company will be held at the office of the liquidator, 11-19 Bank-place, Melbourne, on the 30th day of September, 1952, at 9.30 o'clock a.m., for the purpose of receiving the liquidator's final account.

2301

MALCOLM G. ROBERTS, Liquidator.

The Companies Act 1938.

SELECTO TEXTILES PTY. LTD. (IN LIQUIDATION).

AT an Extraordinary General Meeting of the members of Selecto Textiles Pty. Ltd., duly convened and held at the Board Room of the Institute of Chartered Accountants in Australia, 18 Queen-street, Melbourne, on the 7th day of August, 1952, the following Extraordinary Resolution was duly passed:—

"That the company cannot by reason of its liabilities continue its business and that it be wound up voluntarily, and that the nominee of the company for the position of liquidator be J. K. Hall, chartered accountant (Aust.), 390 Little Collins-street, Melbourne."

Dated this 18th day of August, 1952.

H. SLONIM, Director.

Hall and Rose, chartered accountants (Aust.), 390 Little Collins-street, Melbourne, C.1. 2247

Companies Act 1938.

SELECTO TEXTILES PTY. LTD. (IN LIQUIDATION).

NOTICE is hereby given that I, John Kenneth Hall, chartered accountant (Aust.), of 390 Little Collins-street, Melbourne, have been duly appointed liquidator of the above-named company. All persons having in their possession any of the assets of the company must deliver them to me, and all debts due to the company must be paid to me as such liquidator. Creditors having claims against the company should lodge proofs of debt forthwith.

Dated this 18th day of August, 1952.

J. K. HALL, Liquidator.

Hall and Rose, chartered accountants (Aust.), 390 Little Collins-street, Melbourne, C.1. 2246

The Companies Act 1938.

CASTELL CONSTRUCTIONS PTY. LTD. (IN LIQUIDATION).

AT an Extraordinary General Meeting of the members of Castell Constructions Pty. Ltd., duly convened and held at the Board Room, Institute of Chartered Accountants in Australia, 18 Queen-street, Melbourne, on the 25th day of July, 1952, the following Extraordinary Resolution was duly passed:—

"That the company cannot by reason of its liabilities continue its business, it will be wound up voluntarily, and that the nominee of the company for the position of liquidator be J. K. Hall, chartered accountant (Aust.), of 390 Little Collins-street, Melbourne."

Dated this 18th day of August, 1952.

H. S. BAWDEN, Director.

Registered proprietors: Cooper and Castell. 2238

The Companies Act 1938.

CASTELL CONSTRUCTIONS PTY. LTD. (IN LIQUIDATION).

NOTICE is hereby given that I, John Kenneth Hall, chartered accountant (Aust.), of 390 Little Collins-street, Melbourne, have been duly appointed liquidator of the above-named company. All persons having in their possession any of the assets of the company must deliver them to me, and all debts due to the company must be paid to me as such liquidator. Creditors having claims against the company should lodge proofs of debt forthwith.

Dated this 18th day of August, 1952.

J. KENNETH HALL, Liquidator.

Registered proprietors: Cooper and Castell.

Hall and Rose, chartered accountants (Aust.), 390 Little Collins-street, Melbourne, C.1. 2237

PIVOT WOOL COMPANY PROPRIETARY LIMITED
(IN VOLUNTARY LIQUIDATION).

NOTICE is hereby given that at a General Meeting of the members of the above-named company held on the 31st day of July, 1952, the following Special Resolution was duly passed:—

"That the company be wound up voluntarily and that Alfred Blenkiron Elvish, chartered accountant (Aust.), of 20 Queen-street, Melbourne, be, and he is hereby appointed liquidator of the company for the purposes of such winding up."

Dated the 13th day of August, 1952.

2305

A. B. ELVISH, Liquidator.

CREDITORS, next of kin, and others having claims in respect of the estate of Margery Elizabeth Harper, late of Wanganui, New Zealand, married woman, deceased (who died on the 10th day of August, 1951), are to send the particulars of their claims to The Equity Trustees, Executors, and Agency Company Limited, of 472 Bourke-street, Melbourne, by the 30th day of October, 1952, after which date it will distribute the assets, having regard only to the claims of which it then has notice.

McNAB & McNAB, 422 Collins-street, Melbourne, 2241
proctors.

ALBERT GEORGE SWAN, DECEASED.

PURSUANT to the *Trustee Act 1928*, all persons having claims against the estate of Albert George Swan, late of Speewa Post Office, Victoria, share farmer, deceased, intestate (who died on the 2nd day of February, 1951), are required by the administrator of his estate, Eric Albert Swan, of Speewa aforesaid, farmer, to whom letters of administration of such estate have been granted by the Supreme Court of Victoria probate jurisdiction, to send particulars of such claims to him, in the care of the undersigned solicitors, on or before the 29th day of October, 1952, after which date the said administrator will proceed to distribute the assets of the said deceased amongst the persons entitled thereto, having regard only to the claims of which he then has had notice.

Dated the 20th day of August, 1952.

DAVIES & HAYES, of Campbell-street, Swan Hill, 2226
solicitors for the administrator.

NOTICE TO CREDITORS AND OTHERS.—RE SARAH
HANNAH ELLIS, DECEASED.

PURSUANT to the *Trustee Act 1928*, notice is hereby given that Rylands Ellis, of 10 Russell-street, East Prahran, tramway employee, administrator of the estate of Sarah Hannah Ellis, late of 10 Russell-street, East Prahran, married woman, deceased (who died on 27th February, 1952), intends to convey or distribute the estate of the said deceased to or among the persons entitled thereto, and requires all persons and creditors interested to send to the said administrator, care of Septimus A. Ralph and Son, solicitors, 430 Little Collins-street, C.1, on or before the 30th day of October, particulars, in writing, of their claims against the said estate, after which date the said administrator may convey or distribute the said estate to or among the persons entitled thereto, having regard only to the claims, whether formal or not, of which he shall have had notice.

Dated the 27th day of August, 1952.

SEPTIMUS A. RALPH & SON, 430 Little Collins-street, Melbourne, C.1, solicitors to the estate. 2252

PURSUANT to the *Trustee Act 1928*, notice is hereby given that all creditors, next of kin, and others having claims against the property or estate of Dorothy Alma Rogers, late of 235 Alma-road, East St. Kilda, spinster, deceased (who died on 24th May, 1952, and probate of whose will was granted by the Supreme Court of Victoria to one of the executors thereof, Clive Ernest Tayler, of 38 Fuchsia-street, Blackburn, manufacturer's agent), are hereby required to forward particulars, in writing, of their claims to the said executor, in care of the undersigned solicitors, on or before the 29th day of October, 1952, after which date the said executor will convey and distribute such property or estate to or amongst the persons entitled, having regard only to those claims of which he shall then have had notice.

W. H. FLOOD & PERMEZEL, solicitors, 379 Collins-street, Melbourne. 2250

PURSUANT to the *Trustee Act 1928*, notice is hereby given that all creditors, next of kin, and others having claims against the property or estate of Charles Taylor, late of 15 Suvla-grove, North Coburg, retired farmer, deceased (who died on the 12th day of March, 1952, and probate of whose will was granted by the Supreme Court of Victoria to the executor thereof, Cecil James Stewart, of 379 Collins-street, Melbourne, estate agent), are hereby required to forward particulars, in writing, of their claims to the said executor, in care of the undersigned solicitors, on or before the 29th day of October, 1952, after which date the said executor will convey or distribute such property or estate to or amongst the persons entitled, having regard only to those claims of which he shall then have had notice.

W. H. FLOOD & PERMEZEL, solicitors, 379 Collins-street, Melbourne. 2240

WILLIAM BROCKET, late of 36 Paisley-street, Footscray, solicitor, DECEASED.

CREDITORS, next of kin, and others having claims in respect of the estate of the above named (who died on the 16th day of May, 1952), are to send particulars of their claims to the executors, William Eckford Brocket and Clarence Nixon Cuttriss, care of the undersigned solicitors, by the 30th day of October, 1952, after which date they will proceed to distribute the assets, having regard only to the claims of which they then have notice.

BROCKET & WOODS, solicitors, 108 Queen-street, Melbourne. 2279

EDWARD REUBEN WILLIAMSON CROSSLEY, late of 7 Munro-street, Armadale, retired bank inspector, DECEASED.

CREDITORS, next of kin, and others having claims in respect of the estate of the above named (who died on the 10th day of May, 1952), are to send particulars of their claims to the executor, Kenric Grainger Glover Crossley, care of the undersigned solicitors, by the 30th day of October, 1952, after which date he will distribute the assets, having regard only to the claims of which he then has notice.

BROCKET & WOODS, solicitors, 108 Queen-street, Melbourne. 2278.

CREDITORS, next of kin, and others having claims against the estate of Minnie Polley, formerly of 232 Moreland-road, West Brunswick, and Blackburn-road, Blackburn North, but late of 54 Main-street, Box Hill, widow, deceased (who died on the 7th March, 1952), are to send particulars of such claims to Frederic Norman Howard Atkyns and Jean Butcher, care of the under-mentioned solicitors, by the 30th October, 1952, after which date the executors will distribute the assets, having regard only to claims of which they then have notice.

E. A. ATKYNS & SON, 422 Little Collins-street, Melbourne, solicitors. 2277

WILLIAM GORDON BINNEY (formerly of 26 Mackay-street, Yarraville, labourer), but late of Caldwell-street, Heathcote, in the State of Victoria, cartage contractor, DECEASED (who died on the 15th April, 1952).

CREDITORS, next of kin, and all other persons having claims against the estate of the above-named deceased are required by the executrix, Beryl Agnes Binney (formerly of Caldwell-street, Heathcote, married woman), but now of 49 Herbert-street, Dandenong, in the said State, widow, to send particulars of such claims to her, care of the undersigned, on or before the 30th day of October, 1952, after which date she will distribute the assets, having regard only to the claims of which she has then had notice as aforesaid.

JONES & KENNEDY, solicitors, 213 Nicholson-street, Footscray. 2292

JOHANN FREDERICK WILHELM SCHLUTER, DECEASED.

PERSONS having claims against the estate of the above-named, late of Ruby, in the State of Victoria, labourer, deceased (who died on the 21st day of December, 1951, probate of whose estate was granted to Donald McArthur, of Korumburra, in the said State, solicitor), are to send particulars of their claims to the said Donald McArthur, care of the under-mentioned solicitors, on or before the 31st day of October, 1952, after which date he will distribute the assets of the said estate among the persons entitled thereto, having regard only to the claims of which he then has notice.

Dated this 22nd day of August, 1952.

BOOTHBY & BOOTHBY, solicitors, Korumburra, and at 408 Collins-street, Melbourne. 2270

HENRY RIECKEN, DECEASED.

PERSONS having claims against the estate of the above-named, late of Korumburra, in the State of Victoria, labourer, deceased (who died on the 18th day of August, 1951, probate of whose estate was granted to Donald McArthur, of Korumburra, in the said State, solicitor), are to send particulars of their claims to the said Donald McArthur, care of the under-mentioned solicitors, on or before the 31st day of October, 1952, after which date he will distribute the assets of the said estate among the persons entitled thereto, having regard only to the claims of which he then has notice.

Dated this 22nd day of August, 1952.

BOOTHBY & BOOTHBY, solicitors, Korumburra, and at 408 Collins-street, Melbourne. 2269

TRUSTEE ACT 1928.

NOTICE is hereby given that creditors, next of kin, and others having claims against the estates specified below are required to send particulars, in writing, of such claims to the personal representatives, in care of Morrison and Teare, solicitors, Numurkah, on or before the 30th day of September, 1952, after which date the assets of the estates will be conveyed or distributed among the persons entitled thereto, having regard only to the claims of which representatives shall then have had notice:—

Allan Francis Hodge, late of Katamatite, farmer, deceased, intestate (died 9th February, 1951).

Caroline Louisa McKinnon, late of Yielima, widow, deceased (died 8th November, 1950).

Robert Blair Purdie, late of Wunghnu, farmer, deceased (died 22nd April, 1951).

James Levings, late of 26 Edgar-street, East Malvern, retired carpenter, deceased (died 8th August, 1951).

John Calder, late of 119 The Righi, Heidelberg, retired school teacher, deceased (died 5th October, 1951).

Charles Ralph Gray, late of Numurkah, farmer, deceased (died 21st December, 1951).

William Herbert Hodge, late of Numurkah, retired farmer, deceased (died 26th December, 1951).

Robert Hatty, late of Ulupna, farmer, deceased (died 4th December, 1951).

Charlotte Elizabeth Allen, late of Numurkah, spinster, deceased (died 9th May, 1952).

John Purdie, late of Wunghnu, farmer, deceased (died 5th June, 1952).

William Francis Wall, formerly No. 18754, Royal Australian Air Force, late of Numurkah, radio dealer, deceased (died 6th March, 1952).

Thomas Irvin, late of Cobram, retired farmer, deceased (died 7th May, 1952).

Dated the 16th day of July, 1952.

MORRISON & TEARE, solicitors, Numurkah. 2256

Alfred William Gheelan, late of Inglis-street, Long Gully, Bendigo, in the State of Victoria, labourer, who died on the 1st day of January, 1952.—Claims to the executor, Farmers and Citizens Trustees Company Bendigo Limited, of Charing Cross, Bendigo, in the said State, in care of the undersigned, not later than the 25th day of October, 1952. Tatchell, Dunlop, Smalley, and Balmer, solicitors, Bendigo. 2254

Michael Russell, late of Koroit, retired butcher, deceased, died 16th June, 1952.—Claims to the executor, Thomas Russell, of Koroit, farmer, care of Conlan and Leishman, solicitors, 36 Bank-street, Port Fairy, by 29th October, 1952. 2275

Eliza Gladys Barton, formerly of 28 Greeves-street, St. Kilda, late of 31 Glencairn-street, East Brighton, widow, deceased, died on the 22nd July, 1952.—Claims to the executor, National Trustees, Executors, and Agency Company of Australasia Limited, the registered office of which is at 95 Queen-street, Melbourne, in the said State, by the 30th day of October, 1952. T. A. Kennedy, LL.B., solicitor, 443 Bourke-street, Melbourne. 2271

Peter Anton Carlsen, deceased, late of 8 Newington-parade, Chelsea, and formerly of the Albion Hotel, North Melbourne, died on 27th May, 1952.—Claims to Walter Kemp, of 340 Collins-street, Melbourne, solicitor, by the 29th October, 1952. Walter Kemp and Townsend, solicitors, of 340 Collins-street, Melbourne. 2275

NOTICE TO CREDITORS.

HUMPHREY NASH, late of 8 Fitzroy-street, East Geelong, in the State of Victoria, retired farmer, DECEASED.

PURSUANT to the *Trustees Act 1928*, creditors, next of kin, and all other persons having claims against the estate of the above-named deceased (who died on the 5th day of June, 1952), are required by the executor, The Fidelity Trustee Company Limited, whose registered office is situate at 101 Lydiard-street north, Ballarat, in the said State, to whom probate of deceased's will has been granted, to send particulars of such claims to the executor, at its Melbourne office, 50 Market-street, Melbourne, on or before the 31st day of October, 1952, after which date the executor will distribute the assets of the said deceased, having regard only to the claims of which it then had notice.

W. L. ARCHER & NAUGHTIN, solicitors, Mortlake. 2268

ALL persons having claims against the estate of Percy Greville Willmott, late of Sundorne, 27 Upper Abbey-road, Brighton, England, gentleman, deceased (who died on the 9th September, 1951, and probate of whose will was on the 3rd April, 1952, granted by Her Majesty's High Court of Justice, England, to Gertrude Louisa Willmott, the widow of the deceased, and application to the Supreme Court of Victoria (probate jurisdiction) by the Perpetual Executors and Trustees Association of Australia Limited to seal such probate having been granted on the 21st August, 1952), are hereby required to send particulars of such claims to The Perpetual Executors and Trustees Association of Australia Limited, at its registered office at 100-104 Queen-street, Melbourne, on or before 28th October, 1952, after which date the said company will proceed to transfer, convey, or distribute the said estate to or among the persons entitled thereto, having regard only to the claims of which it shall then have had notice, and will not be liable for the assets so transferred, conveyed, or distributed to any persons of whose claim it shall not then have had notice.

RYLAH & RYLAH, solicitors, 349 Collins-street, Melbourne. 2300

CREDITORS, next of kin, and others having claims against the estate of Elizabeth Ann Luxton Helyer, formerly of Nhill, in the State of Victoria, married woman, but late of 9 Moss-street, Prahran, in the said State, widow, deceased (who died on the 12th day of May, 1952), are required to send particulars, in writing, of their claims to Reginald Blachley Turner, of Nhill aforesaid, solicitor (the executor to whom probate of the last will of the said deceased was granted), care of the undersigned, on or before the 31st day of October, 1952, after which date he will distribute the assets, having regard only to those claims of which he then has notice.

Dated the 20th day of August, 1952.

TURNER & HOBDAY, 10 Victoria-street, Nhill, solicitors for the said executor. 2304

CREDITORS, next of kin, and others having claims in respect of the estate of Gwendoline Joseph, late of 60 (in will wrongly called 16) Lewisham-road, Prahran, in the State of Victoria, widow, deceased (who died on the 25th day of June, 1952), are to send particulars of their claims to The Equity Trustees, Executors, and Agency Company Limited, of 472 Bourke-street, Melbourne, by the 31st day of October, 1952, after which date it will distribute the assets, having regard only to the claims of which it then has notice.

Dated this 27th day of August, 1952.

STRONGMAN & CROUCH, of 403 Bourke-street, Melbourne, solicitors for the above-named company. 2303

SARAH MCCREERY, DECEASED.

CREDITORS, next of kin, and others having claims in respect of the estate of Sarah McCreery, late of private bag, Kyneton, in the State of Victoria, widow, deceased (who died on the 29th day of September, 1951), are to send the particulars of their claims to The Union Trustee Company of Australia Limited, of 333 Collins-street, Melbourne, in the said State, by the 15th day of November, 1952, after which date it will distribute the assets, having regard only to the claims of which it then has notice.

H. HURRY & SON, solicitors, Kyneton, and at Woodend and Gisborne. 2280

CREDITORS, next of kin, and others having claims against the estate of Enid Beryl Brown, late of 54 Radnor-street, Camberwell, married woman, deceased, intestate (who died on the 9th of February, 1952), are to send particulars of their claims to James Isles Brown, the administrator, care of the under-mentioned solicitors, on or before the 30th of October, after which date he will distribute the assets, having regard only to the claims of which he then has notice.

E. A. ATKYNS & SON, 422 Little Collins-street, Melbourne, solicitors. 2276

CREDITORS, next of kin, and others having claims in respect of the estate of Thomas Sleep, formerly of 3 Orford-street, Moonee Ponds, but late of Mental Hospital, Ballarat, labourer, deceased (who died on the 26th June, 1952), are to send written particulars of such claims to Reginald Gordon Sleep, and Pearl Etta Myrtle Sleep, care of the undersigned solicitors, by the 28th day of October, 1952, after which date the executors will distribute the assets, having regard only to the claims of which they then have notice.

PROUDFOOT & HORTON, solicitors, 87 Queen-street, Melbourne. 2236

MADGE MASADIE KILLINGBECK, late of 211 Somerville-road, Kingsville, in the State of Victoria, spinster, DECEASED, intestate (who died on the 11th October, 1951).

CREDITORS, next of kin, and all other persons having claims against the estate of the above-named deceased are required by the administrator, Edward James Killingbeck, of 211 Somerville-road, Kingsville, in the said State, police constable, to send particulars of such claims to him, care of the undersigned, on or before the 30th day of October, 1952, after which date he will distribute the assets, having regard only to the claims of which he has then had notice as aforesaid.

JONES & KENNEDY, solicitors, 213 Nicholson-street, Footscray. 2291

EDMUND EDWARD O'GRADY, late of 21 Smith-street, Thornbury, in the State of Victoria, retired police magistrate, DECEASED (who died on the 19th February, 1952).

CREDITORS, next of kin, and all other persons having claims against the estate of the above-named deceased are required by the executor, The Equity Trustees, Executors, and Agency Company Limited, of 472 Bourke-street, Melbourne, in the said State, to send particulars of such claims to the said company, at its registered office aforesaid, on or before the 30th day of October, 1952, after which date the said company will distribute the assets of the said deceased, having regard only to the claims of which it then has had notice.

JONES & KENNEDY, solicitors, 213 Nicholson-street, Footscray. 2290

EDWIN ARTHUR HOY, late of 12 Stafford-street, Footscray, in the State of Victoria, retired contractor, DECEASED, intestate (who died on the 17th August, 1951).

CREDITORS, next of kin, and all other persons having claims against the estate of the above-named deceased are required by the administrator, Walter Edwin Arthur Hoy, of Dromana, in the said State, school teacher, to send particulars thereof to him, care of the undersigned, on or before the 30th day of October, 1952, after which date he will distribute the assets, having regard only to the claims of which he has then had notice as aforesaid.

JONES & KENNEDY, solicitors, 213 Nicholson-street, Footscray. 2289

RE ALICE MAUD BASFORD, DECEASED.

NOTICE is hereby given that all persons having claims against the property or estate of Alice Maud Basford, late of 78 Elizabeth-street, Geelong West, widow, deceased (who died on the 4th day of June, 1952, and probate of whose will was granted to Lorna Grace Merle Sadler, of 78 Elizabeth-street, Geelong West, married woman, and William George Leach, of 11 Charles-street, North Williamstown, railway employee), are hereby required to send, in writing, particulars of such claims to the said executors, in the care of the under-mentioned solicitors, on or before the 30th day of October, 1952, after which date they will convey or distribute such property or estate to or among the persons entitled thereto, having regard only to the claims of which they shall then have had notice.

HARWOOD & PINCOTT, 51 Yarra-street, Geelong, solicitors for the said executors. 2214

CREDITORS, next of kin, and others having claims in respect of the estate of Susan Golding Smart, late of 13 Tower Hill-road, Glen Iris, in the State of Victoria, widow, deceased (who died on the 28th day of July, 1951), are to send the particulars of their claims to the Equity Trustees, Executors, and Agency Company Limited, of 472 Bourke-street, Melbourne, in the said State, by the 29th day of October, 1952, after which date it will distribute the assets, having regard only to the claims of which it then has notice.

KEITH A. NESS, solicitor, 411 Collins-street, Melbourne. 2295

CREDITORS, next of kin, and others having claims in respect of the estate of Thomas Collis, late of 9 Normanby-road, Caulfield, in the State of Victoria, retired commercial traveller, deceased (who died on the 24th day of April, 1952), are to send the particulars of their claims to The Equity Trustees, Executors, and Agency Company Limited, of 472 Bourke-street, Melbourne, in the said State, by the 29th day of October, 1952, after which date it will distribute the assets, having regard only to the claims of which it then has notice.

KEITH A. NESS, solicitor, 411 Collins-street, Melbourne. 2296

RE PATRICK McMANAMNY, late of 354 Albert-road, South Melbourne, in the State of Victoria, ex-superintendent of police. DECEASED.

CREDITORS, next of kin, and others having claims in respect of the estate of the above-named deceased (who died on the 9th day of June, 1923), are required to send particulars of their claims to George Michael McManamny, the administrator (with the will annexed) of the unadministered estate of the said deceased, care of the under-mentioned solicitors, by the 28th day of October, 1952, after which date the administrator will distribute the assets of the deceased, having regard to only the claims of which he then has notice.

GILLOTT, MOIR, & AHERN, 95 Queen-street, Melbourne, solicitors for the administrator. 2286

PURSUANT to the *Trustee Act* 1928, all persons having claims against the estate of Joseph David Holmes, late of 2 Raymond-grove, Caulfield South, in the State of Victoria, relieving postmaster, deceased (who died on 12th April, 1952, and probate of whose will was granted by the Supreme Court of Victoria, on 25th August, 1952, to Howard Vernon Tinkler, of 24 Dover-street, Caulfield, clerk, Alfred John Judd, of 37 Filbert-street, Caulfield, automotive engineer, and Thomas Edward Pink, of Thomas-avenue, Moorabbin, Harbour Trust employee, the executors appointed by deceased's will, are hereby required to send particulars of such claims to the said executors, care of the under-mentioned solicitors, on or before the 28th October, 1952, after which date the said executors will distribute the assets, having regard only to the claims of which notice has then been received.

MARTIN & MARTIN, solicitors, 37 Queen-street, Melbourne. 2294

RE GEORGE THOMAS LEVERITT, late of Howe-crescent, South Melbourne, in the State of Victoria, engraver, DECEASED.

CREDITORS, next of kin, and others having claims in respect of the estate of the above-named deceased (who died on the 23rd day of March, 1899), are required to send particulars of their claims to George Michael McManamny and Joseph Stanislaus McManamny, the trustees of the will and estate of the deceased, care of the under-named solicitors, by the 28th day of October, 1952, after which date the trustees will distribute the assets of the deceased, having regard to only the claims of which they then have notice.

GILLOTT, MOIR, & AHERN, of 95 Queen-street, Melbourne, solicitors for the trustees. 2284

CREDITORS, next of kin, and others having claims in respect of the estate of Edith Annie Wentworth Cocks (also known as Annie E. Cocks), late of 383 Toorak-road, South Yarra, in Victoria, spinster, deceased (who died on the 17th day of May, 1952, and probate of whose will was granted by the Supreme Court of Victoria on the 20th day of August, 1952, to Sydney de Bohun Cocks, Hubert Silvers Black, and The Union Trustee Company of Australia Limited, the executors named in the said will), are to send particulars of their claims to the said executors, care of the said company, at its address 333 Collins-street, Melbourne, by the 29th day of October, 1952, after which date they will distribute the assets, having regard only to the claims of which they then have notice.

Dated this 22nd day of August, 1952.

BLAKE & RIGGALL, 120 William-street, Melbourne, solicitors for the said executors. 2282

CREDITORS, next of kin, and others having claims in respect of the estate of Stanley James Mundie, late of Selman-avenue, Lower Fern Tree Gully, in the State of Victoria, builder, deceased (who died on the 15th day of September, 1951), are required by The Union Trustee Company of Australia Limited, of 333 Collins-street, Melbourne, the administrator to whom letters of administration of the estate of the said deceased (with his will dated the 29th day of January, 1942, annexed) were granted, to send particulars, in writing, of their claims to the said The Union Trustee Company of Australia Limited, at its address aforesaid, by the 31st day of October, 1952, after which date it will distribute the assets of the said deceased among the parties entitled thereto, having regard only to the claims of which it then has notice.

Dated this 27th day of August, 1952.

AKEHURST, FRIEND, & HAACK, 405 Collins-street, Melbourne, solicitors for the administrator. 2281

No. 750.—8253/52.—5

RE JOHN ROBERTSON, DECEASED.

NOTICE is hereby given that all persons having claims against the property or estate of John Robertson, late of Koo-Wee-Rup, health inspector, deceased (who died on the 20th day of February, 1952, and probate of whose will was granted to Jane Gilfillan Duff, of 61 Mount Pleasant-road, Belmont, Geelong, spinster), are hereby required to send, in writing, particulars of such claims to the said executrix, in the care of the under-mentioned solicitors, on or before the 30th day of October, 1952, after which date she will convey or distribute such property or estate to or among the persons entitled thereto, having regard only to the claims of which she shall then have had notice.

HARWOOD & PINCOTT, 51 Yarra-street, Geelong, solicitors for the said executrix. 2213

RE WILLIAM CECIL PRIOR, formerly of 81 Ormond-road, Elwood, but late of 733 Hawthorn-road, East Brighton, in the State of Victoria, wire worker, DECEASED.

CREDITORS, next of kin, and others having claims in respect of the estate of the above-named deceased (who died on the 5th day of December, 1951), are required to send particulars of their claims to Annis Adelaide Gomm, of 733 Hawthorn-road, East Brighton aforesaid, spinster, the executrix appointed by the will of the deceased, care of the under-mentioned solicitors, by the 28th day of October, 1952, after which date the administrator will distribute the assets of the said deceased, having regard to only the claims of which she then has notice.

GILLOTT, MOIR, & AHERN, 95 Queen-street, Melbourne, solicitors for the executrix. 2288

ANGUS MACARTHUR, late of 484 Napier-street, North Fitzroy, in the State of Victoria, ex-sergeant of police, DECEASED.

CREDITORS, next of kin, and others having claims in respect of the estate of the above-named deceased (who died on the 30th day of April, 1951), are required to send particulars of their claims to William Edward Williams, of 5 Hortense-road, Burwood, in the said State, retired horticulturist, the administrator (with the will annexed) of the estate of the said deceased, care of the under-mentioned solicitors, by the 28th day of October, 1952, after which date the administrator will distribute the assets of the deceased, having regard to only the claims of which he now has notice.

GILLOTT, MOIR, & AHERN, of 95 Queen-street, Melbourne, solicitors for the administrator. 2287

PURSUANT to the provisions of the *Trustee Act* 1928, notice is hereby given that all persons claiming against the estate of William Thomas Chambers, late of 127 Williams-road, Prahran, in the State of Victoria, gentleman, deceased (who died on the 27th day of May, 1952, and probate of whose will was on the 26th day of June, 1952, granted by the Supreme Court of Victoria to Frank Jason Cave, of 27 The Ridge, Canterbury, in the said State, publicity manager, the proving executor appointed thereby), are hereby required to send particulars, in writing, of such claims to the said Frank Jason Cave, to care of Malleson, Stewart and Co., at the address below, on or before the 30th day of October, 1952, after which date the said executor will proceed to convey or distribute the said estate to or among the persons entitled thereto, having regard only to the claims, whether formal or not, of which he shall then have had notice, and will not be liable for the assets so distributed to any person of whose claim he shall not then have had notice.

MALLESON, STEWART & CO., solicitors, 46 Queen-street, Melbourne. 2293

PURSUANT to the *Trustee Act* 1928, notice is hereby given that Percy Charles Fallshaw, of 48 Stevenson-street, Kew, in the State of Victoria, manufacturer, the executor of the will of Alice Maud Fallshaw, late of 36 North-street, Ascot Vale, in the said State, widow, deceased (who died on the 31st day of March, 1952), intends to convey or distribute the estate of the said deceased to or among the persons entitled thereto, and requires all persons and creditors interested to send to him, care of his under-mentioned solicitors, on or before the 29th day of October, 1952, particulars, in writing, of their claims against the said estate, after which date the said executor may convey or distribute the said estate to or among the persons entitled thereto, having regard only to the claims, whether formal or not, of which he shall then have had notice.

RIGBY & FIELDING, 60 Market-street, Melbourne, solicitors for the executor. 2302

PURSUANT to the *Trustee Act 1928*, all persons having claims against the estate of Cecilia Britt, late of 13 Carmichael-street, Footscray, in the State of Victoria, spinster, deceased (who died on the 5th January, 1952, and probate of whose will was granted by the Supreme Court of Victoria, on 28th March, 1952, to Leslie Richard Chapple, of 13 Carmichael-street, Footscray, machinist, the executor appointed by deceased's will), are hereby required to send particulars of such claims to the said executor, care of the under-mentioned solicitors, on or before the 28th October, 1952, after which date the said executor will distribute the assets, having regard only to the claims of which notice has then been received.

MARTIN & MARTIN, solicitors, 37 Queen-street, Melbourne. 2298

CREDITORS, next of kin, and others having claims against the estate of William Gunn, late of Paisley-street, Footscray, gentleman, deceased (who died on the 20th day of August, 1951), are requested to send particulars of their claims to the executors, Ellen Gunn, James Aston Harris, and George William Waller, care of the under-signed solicitors, by the 30th day of October, 1952, after which date they will proceed to distribute the assets, having regard only to the claims of which they then have notice.

BROCKET & WOODS, solicitors, 108 Queen-street, Melbourne. 2249

NOTICE TO CREDITORS.—KATHLEEN MARY SIMPSON, DECEASED, intestate.

CREDITORS, next of kin, and others having claims in respect of the estate of Kathleen Mary Simpson, late of 92 Asling-street, Gardenvale, in the State of Victoria married woman (who died on the 27th day of July, 1951), are to send the particulars of their claims to National Trustees, Executors, and Agency Company of Australasia, Limited, whose registered office is at 95 Queen-street, Melbourne, in Victoria, by the 27th day of October, 1952, after which date the said company will distribute the assets, having regard only to the claims of which it then has notice.

F. J. CORDER, solicitor, 108 Queen-street, Melbourne. 2251

CREDITORS, next of kin, and others having claims in respect of the estate of Ann Alethea Reddan, late of 68 Toorak-road west, South Yarra, widow, deceased (who died on the 4th day of March, 1952), are required to send particulars of their claims to National Trustees, Executors, and Agency Company of Australasia, Limited, whose registered office is at 95 Queen-street, Melbourne, by the 15th day of November, 1952, after which date it will distribute the assets, having regard only to the claims of which it then has notice.

Dated the 21st day of August, 1952.

MADDEN & CANDY, solicitors, 443 Little Collins-street, Melbourne. 2245

RE ANNIE LOUISA McMANAMNY, late of 354 Albert-road, South Melbourne, widow, DECEASED.

CREDITORS, next of kin, and others having claims in respect of the estate of the above-named deceased (who died on the 20th day of November, 1951), are required to send particulars of their claims to George Michael McManamny and Joseph Stanislaus McManamny, the executors of the deceased, care of the under-named solicitors, by the 28th day of October, 1952, after which date the executors will distribute the assets of the deceased, having regard only to the claims of which they then have notice.

GILLOTT, MOIR, & AHERN, of 95 Queen-street, Melbourne, solicitors for the executors. 2285

DENNIS PATRICK O'BRIEN, late of Derby, in the State of Victoria, farmer, DECEASED.

CREDITORS, next of kin, and all other persons having claims against the estate of the said deceased are required by Michael O'Brien, of Derby aforesaid, farmer, and Martin O'Brien, of 226 McCrae-street, Bendigo, in the said State, labourer, the executors of the will of the above-named deceased, to send particulars thereof to them, care of the under-mentioned solicitors, on or before the 27th day of October, 1952, after which date the executors will proceed to distribute the assets of the said deceased among the persons entitled thereto, having regard only to the claims of which they shall then have notice.

Dated the 22nd day of August, 1952.

T. M. WILLIAMS, WATSON, & JAMES, of Bull-street, Bendigo, solicitors for the executors. 2233

CREDITORS, next of kin, or others having claims in respect of the estate of William Carter, late of Kaniva, in the State of Victoria, farmer, deceased (who died on the 11th day of January, 1952), are required by the executors of his will Gordon Alfred Carter, of Kaniva aforesaid, and Percy Arthur Allan Rideout, of Miram, in the said State, both farmers, to send particulars of their claims to the executors, care of John Charles Williams of Kaniva aforesaid, solicitor, by the 15th day of October, 1952, after which date the said executors will proceed to distribute the assets of the said deceased, having regard only to the claims of which they shall then have had notice.

J. C. WILLIAMS, Kaniva, solicitor for the executors. 2216

RUBY SIMMONS, late of 129 Forest-street, Bendigo, spinster, DECEASED, intestate (who died on the 18th day of June, 1952).

CREDITORS, next of kin, and all other persons having claims against the estate of the said deceased are required by the administrator, Farmers and Citizens Trustees Company, Bendigo, Limited, of Charing Cross, Bendigo, to send particulars thereof to it, on or before the 22nd day of October, 1952, after which date it will distribute the assets, having regard only to the claims of which it then has notice.

Dated the 19th day of August, 1952.

HYETT, WILLIS, & HYETT, 51 Bull-street, Bendigo, solicitors for the administrator. 2217

ELIZABETH HANNAH PORTER, formerly of 3 Junction-street, Eaglehawk, but late of 148 Rowan-street, Bendigo, widow, DECEASED (who died on the 8th day of July, 1952).

CREDITORS, next of kin, and all other persons having claims against the estate of the said deceased are required by the executrix, Gladys Doreen Cockerell, of 148 Rowan-street, Bendigo, married woman, to send particulars thereof to her, care of the under-mentioned solicitors, on or before the 22nd day of October, 1952, after which date she will distribute the assets, having regard only to the claims of which she then has notice.

Dated the 19th day of August, 1952.

HYETT, WILLIS, & HYETT, 51 Bull-street, Bendigo, solicitors for the executrix. 2218

CREDITORS, next of kin, and others having claims against the estate of Alice Ellen Jones, late of 247 Heidelberg-road, Ivanhoe, widow, deceased (who died on the 15th January, 1952), are requested to send particulars of their claims to the executor, Benjamin George Rennie McArthur, care of the under-signed solicitors, by the 30th day of October, 1952, after which date he will proceed to distribute the assets, having regard only to the claims of which he then has notice.

BROCKET & WOODS, solicitors, 108 Queen-street, Melbourne. 2248

CREDITORS, next of kin, and others having claims in respect of the estate of Anna Laffan, formerly of 5 Stoke-avenue, Kew, but late of 18 Lambeth-avenue, Malvern, widow, deceased (who died on the 10th day of July, 1952), are to send their claims to National Trustees, Executors, and Agency Company of Australasia, Limited, of 95 Queen-street, Melbourne, in the State of Victoria, by the 31st day of October, 1952, after which date it will distribute the assets, having regard only to the claims of which it then has notice.

HOLT, GRAHAM, & NEWMAN, 178 Collins-street, Melbourne, solicitors for the applicant. 2244

JOHN ANDREW KELLY, late of Burn-street, Golden Square, in the State of Victoria, farmer, DECEASED.

CREDITORS, next of kin, and all other persons having claims against the estate of the said deceased are required by Sandhurst and Northern District Trustees, Executors, and Agency Company Limited, of View-street, Bendigo, the executor of the will of the above-named deceased, to send particulars thereof, in writing, to the said company, on or before the 27th day of October, 1952, after which date the said company will proceed to distribute the assets of the said deceased among the persons entitled thereto, having regard only to the claims of which it shall then have notice.

Dated the 22nd day of August, 1952.

T. M. WILLIAMS, WATSON, & JAMES, of Bull-street, Bendigo, solicitors for the executor. 2232

In the Supreme Court of the State of Victoria.—*Fi. Fa.*

NOTICE is hereby given that, under and by virtue of certain process issued out of the Supreme Court of the State of Victoria, and directed to the Sheriff, requiring him to levy certain moneys of the real and personal estate of Beatrice Babington, of 4 Ida-street, Ballarat, spinster, the said Sheriff will on Friday, the 19th day of September, 1952, at the hour of Two o'clock in the afternoon, cause to be sold at the Police Station, Victoria-street, Ballarat (unless the said process shall have been previously satisfied or the said Sheriff be otherwise stayed):—

All the right, title, estate, and interest (if any) of the said Beatrice Babington, of 4 Ida-street, Ballarat, in and to all that piece of land being part of Crown allotment 1, section 1, Town of Ballarat East, Parish of Ballarat, County of Grant, and being land having a frontage of 18 ft. 1½ in. by a depth of 82 ft. 6 in. to Peel-street, and being land more particularly described in certificate of title, volume 5031, folio 1006092, and all that piece of land being part of Crown allotment 1, section 1, Town of Ballarat East, Parish of Ballarat, County of Grant, and having a frontage of 18 ft. 1½ in. by a depth of 82 ft. 6 in. to Government road, and being land more particularly described in certificate of title, volume 5381, folio 1076130, and all that piece of land being part of Crown allotment 1, section 17, City and Parish of Ballarat, County of Grenville, and being land having a frontage of 33½ links by a depth varying from 62 links to 81½ links to Drummond-street, and being land more particularly described in certificate of title, volume 4421, folio 884175.

N.B.—Terms: Cash. No cheques taken.

Dated at Ballarat this 18th day of August, 1952.

2219 JOHN ALBERT SLEETH, Sheriff's Officer.

In the High Court of Australia.—*Fi. Fa.*

NOTICE is hereby given that, under and by virtue of certain process issued out of the High Court of Australia and directed to the Deputy Marshal, requiring him to levy certain moneys of the real and personal estate of Goldsmith Collins, of 29 Andrew-street, Northcote, engineer, the said Deputy Marshal will, on Tuesday, the 7th day of October, 1952, at the hour of Eleven o'clock in the forenoon, cause to be sold at the Police Station, James-street, Northcote (unless the said process shall have been previously satisfied or the said Deputy Marshal be otherwise stayed):—

All the right, title, estate, and interest (if any) of the said Goldsmith Collins, in and to all that piece of land, being part of Crown portion 101, Parish of Jika Jika, County of Bourke, more particularly described in the certificate of title entered in the register book of the Office of Titles, at Melbourne, in volume 5100, folio 1019934.

N.B.—Terms: Cash. No cheques taken.

Dated at Melbourne this 25th day of August, 1952.

2273 FRANCIS H. TUCKER, Marshal's Officer.

In the Supreme Court of the State of Victoria.—*Fi. Fa.*

NOTICE is hereby given that, under and by virtue of certain process issued out of the Supreme Court of the State of Victoria and directed to the Sheriff, requiring him to levy certain moneys of the real and personal estate of O. A. Joyce, of lot 28, Electric-avenue, Glenroy, clerk, the said Sheriff will, on Monday, the 6th day of October, 1952, at the hour of Eleven o'clock in the forenoon, cause to be sold at the Police Station, Pascoe Vale-road, Glenroy (unless the said process shall have been previously satisfied or the said Sheriff be otherwise stayed):—

All the right, title, estate, and interest (if any) of the said O. A. Joyce, in and to all that piece of land, being lot 28 on plan of subdivision No. 8981, lodged in the Office of Titles, and being part of Crown portion 1, section 2, Parish of Will Will Rook, County of Bourke, and being the whole of the land comprised in certificate of title, volume 7490, folio 089.

N.B.—Terms: Cash. No cheques taken.

Dated at Melbourne this 21st day of August, 1952.

2272 FRANCIS H. TUCKER, Sheriff's Officer.

MINING NOTICE.

SOUTH CAULFIELD GOLD & MINERAL MINES
NO LIABILITY.

NOTICE is hereby given that a Call (No. 1) of Six pence per share (making shares paid to 3s. 2d. each) has been made on ordinary shares in the company, due and payable at the registered office, 15 Jupiter-street, South Caulfield, on Wednesday, 10th September, 1952.

By order of the Board,

2274 G. A. FAWCUS, Secretary-Manager.

IMPOUNDINGS.

ARARAT.—Impounded in Ararat Pound.

1 Jersey heifer calf, no visible brand

If not claimed and expenses paid, to be sold on 10th September, 1952.

D. J. BOWER,
Poundkeeper.

2315—6/6

BOX HILL.—Impounded in Box Hill Pound, by W. Spence.

1 grey pony mare, aged, poor condition, no visible brand

If not claimed and expenses paid, to be sold on 11th September, 1952.

H. J. BARRETT,
Poundkeeper.

2314—6/6

BROADMEADOWS.—Impounded in Campbellfield Pound.

1 bay draught mare, star, hind feet white, white collar mark, no visible brand

1 chestnut mare, star, S/E near shoulder

1 bay pony mare, white face, off hind foot white, JC near shoulder

1 cream-coloured filly, no visible brand

If not claimed and expenses paid, to be sold on 11th September, 1952.

E. F. SMILEY,
Shire Secretary.

2313—11/11

BUNINYONG.—Impounded in Buninyong Pound, from Warrenheip.

1 black pony gelding, no visible brand

1 bay draught gelding, blaze face, near hind leg three-quarters white, no visible brand

If not claimed and expenses paid, to be sold on 6th September, 1952.

C. W. EASON,
Poundkeeper.

2259—9/9

COBURG.—Impounded in Coburg Pound.

1 bay gelding, white blaze on face, hind socks white, indistinct brand

If not claimed and expenses paid, to be sold on 3rd September, 1952.

E. S. McNABB,
Poundkeeper.

2210—7/7

CRANBOURNE.—Impounded in Cranbourne Pound, by Ranger.

1 red and white pony gelding, five years, about 14.3 hands, shod, no visible brand

1 bay hack gelding, five years, off hind foot white, good condition, no visible brand

1 bay draught gelding, aged, star, hind feet white, good condition, no visible brand

If not claimed and expenses paid, to be sold on 11th September, 1952.

F. C. CLARK,
Poundkeeper.

2306—13/

DANDENONG.—Impounded in Dandenong Pound, by Shire Ranger E. Osborne, off Wells-road, Edithvale.

1 medium draught bay mare, off front sock white, white down face, lame, unshod, no visible brand

If not claimed and expenses paid, to be sold on 12th September, 1952.

A. WALKER,
Poundkeeper.

2260—8/8

DONALD.—Impounded in Donald Pound, on 25th August, 1952.

1 bay delivery horse, about six years, unbroken, no visible brand

If not claimed and expenses paid, to be sold on 19th September, 1952.

H. C. SMALE,
Acting Poundkeeper.

2307—8/8

DUNOLLY.—Impounded in Dunolly Pound.

1 bay mare, white blaze down face, front feet white, no visible brand

1 bay gelding, off hind foot white, no visible brand

If not claimed and expenses paid, to be sold on 12th September, 1952.

W. STRAHAN,
Acting Poundkeeper.

2261—8/8

KYABRAM.—Impounded in Kyabram Pound.

1 brown aged gelding, white star on forehead, shod, no visible brand
 If not claimed and expenses paid, to be sold on 4th September, 1952.
 S. ANDERSON,
 Poundkeeper.
 2209—7/7

LAKE BENETOOK.—Impounded in Lake Benetook (Mildura) Pound.

1 black draught gelding, blazed face, hind and off front feet white, like M in diamond near shoulder
 1 bay draught gelding, blazed face, white socks, white patch off side, no visible brand
 1 brown draught gelding, bar, hind and offside front feet white, no visible brand
 If not claimed and expenses paid, to be sold on 11th September, 1952.
 S. C. JESSOP,
 Poundkeeper.
 2309, 2310—13/

MAFFRA.—Impounded in Maffra Pound, by W. McMahon.

1 red nobbie heifer, V out back near ear, like CS off rump
 1 red brindle heifer, full ears, like 2 off rump
 1 Jersey heifer, V out back near ear, 2 off rump
 1 red Shorthorn heifer, V out back near ear, 2 off rump
 1 red Hereford steer, V out front near ear, V out back off ear, V near rump
 1 Jersey heifer, like W out back off ear, blotch brand off rump
 1 Hereford baldy heifer, V out top near ear, V out back off ear, no visible brand
 1 poley Jersey cow, slit out point square out bottom near ear, like WZ conjoined near rump
 If not claimed and expenses paid, to be sold on 19th September, 1952.
 J. H. GIESCHEN,
 Poundkeeper.
 2253—18/5

MIRBOO NORTH.—Impounded in Mirboo North Pound, from Mirboo.

1 black pony mare, blaze face, near hind foot white, no visible brand
 1 black pony gelding, no visible brand
 1 black pony, yearling, no visible brand
 1 light-bay mare, blaze face, white feet, no visible brand
 1 light-bay mare, blaze face, off hind foot white, no visible brand
 If not claimed and expenses paid, to be sold on 23rd September, 1952.
 J. G. BIRD,
 Poundkeeper.
 2258—14/1

NAGAMBIE.—Impounded in Nagambie Pound.

1 black horse, one eye, no visible brand, wearing head stall
 If not claimed and expenses paid, to be sold on 6th September, 1952.
 N. E. SULLIVAN,
 Poundkeeper.
 2257—6/6

NEWHAVEN.—Impounded in Newhaven Pound by the Ranger, on 16th August, 1952.

1 yearling heifer, no visible brand
 If not claimed and expenses paid to be sold on 25th August, 1952.
 A. MURDOCH,
 Poundkeeper.
 2211—7/7

NHILL.—Impounded in Nhill Pound.

1 Red Poll bull, under twelve months, no visible brand
 If not claimed and expenses paid, to be sold on 12th September, 1952.
 A. J. HANN,
 Poundkeeper.
 2262—6/6

STAWELL.—Impounded in Stawell Pound.

1 bay mare, white blaze, hind and off front feet white, no visible brand
 If not claimed and expenses paid, to be sold on 8th September, 1952.
 V. GRAHAM,
 Poundkeeper.
 2316—7/7

TRARALGON.—Impounded in Traralgon Pound, by Road Ranger, from Shire roads, on 17th August, 1952.

1 black gelding hack, hind feet white, no visible brand
 1 light-bay delivery mare, aged, star, no visible brand
 If not claimed and expenses paid, to be sold on 15th September, 1952.
 ADAM WILSON,
 Poundkeeper.
 2312—8/8

WODONGA.—Impounded in Wodonga Pound, by S. Samford, on 8th August, 1952.

1 red Shorthorn steer, club-shaped earmark, branded T inside a circle over a bar
 Impounded by C. Whitehead, on 17th August, 1952.
 1 brindle Jersey bull, no visible brand
 1 bald Hereford cow, half-moon shaped earmark on near side ear, club shaped brand on near side rump
 If not claimed and expenses paid, to be sold on 6th September, 1952.
 Impounded by McNamara's Wodonga Branch, on 18th August, 1952.
 5 baldy Hereford steers, half-moon shaped, slit ear, and half-diamond earmarks, no visible brand
 If not claimed and expenses paid, to be sold on 13th September, 1952.
 A. J. HUGGINS,
 Poundkeeper.
 2227, 2228, 2229, 2230—19/6

YARRA JUNCTION.—Impounded in Yarra Junction Pound.

1 red cow, no visible brand, headstall on
 1 yellow Jersey cow, short tail, no visible brand
 1 silver-coloured Jersey cow, no visible brand
 If not claimed and expenses paid, to be sold on 12th September, 1952.
 M. BERUDE,
 Poundkeeper.
 2308—9/9

CONTENTS.

	PAGE
Acts of Parliament	5015
Appointments	5023
Bank Holidays	5022
Contracts	5024
Country Roads Board	5037, 5045
Estates of Deceased Persons	5038
Government Notices	5022
Impoundings	5073
Lands	5051
Mining	5030, 5073
Notice to Mariners	5037
Orders in Council	5040
Private Advertisements	5063
Proclamations	5015
Public Holidays	5022
Public Service Notices	5057
Resignations	5023
Tenders	5056
Transport Regulation Board—Public Hearings	5031
Waterworks Trust	5039