



VICTORIA GOVERNMENT GAZETTE

Published by Authority

[Registered at the General Post Office, Melbourne, for transmission by post as a newspaper.]

No. 193]

WEDNESDAY, JUNE 26

[1957

ACTS OF PARLIAMENT.

PROCLAMATION

By His Excellency the Lieutenant-Governor of the State of Victoria and its Dependencies in the Commonwealth of Australia, &c., &c., &c.

I, THE Lieutenant-Governor of the State of Victoria, in the Commonwealth of Australia, do hereby declare that I have this day assented, in Her Majesty's name, to the Bills passed by the Parliament of the said State, the titles whereof are hereunder set forth, that is to say:—

No. 6090. "An Act to amend the Housing Acts, and for other purposes."

No. 6091. "An Act to amend Paragraph 5 of the Fourth Schedule to the *Police Regulation Act 1928* and Section Three of the *Police Regulation Act 1946* and for other purposes."

No. 6092. "An Act to re-constitute the Trotting Control Board and to make Provision relating to the Use of the Royal Agricultural Showgrounds for Trotting Races, and for other purposes."

No. 6093. "An Act to amend the Weights and Measures Acts."

No. 6094. "An Act to amend the Benefit Associations Acts."

No. 6095. "An Act to provide for the Licensing of certain Boats operating in or near Westernport Bay and for other purposes."

No. 6096. "An Act to amend the *Labour and Industry Act 1953* in relation to the Age of Chairmen of Wages Boards, the Hours for Closing Shops for the Sale of Motor Cars, and the Publication of Industrial Determinations."

No. 6097. "An Act to amend Section Thirty-five of the *Game Act 1928*."

Given under my Hand and the Seal of the State of Victoria aforesaid, at Melbourne, this nineteenth day of June, in the year of our Lord One thousand nine hundred and fifty-seven, and in the sixth year of the reign of Her Majesty Queen Elizabeth II.

(L.S.)

E. F. HERRING.

By His Excellency's Command,

HENRY E. BOLTE,
Premier.

GOD SAVE THE QUEEN!

Police Offences Acts.

APPLICATION OF PROVISIONS OF DIVISION 6 OF PART VII. OF THE POLICE OFFENCES ACT 1928 TO THE CITY OF BROADMEADOWS.

PROCLAMATION

By His Excellency the Lieutenant-Governor of the State of Victoria and its Dependencies in the Commonwealth of Australia, &c., &c., &c.

IN pursuance of the powers conferred by the *Police Offences Act 1928*, as amended by the *Police Offences (Trespass to Farms) Act 1956, I*, the Lieutenant-Governor of the State of Victoria, in the Commonwealth of Australia, by and with the advice of the Executive Council of the said State and on the application of the Council of the City of Broadmeadows, do by this my Proclamation declare the municipal district of the City of Broadmeadows to be a district to which Division 6 of Part VII. of the *Police Offences Act 1928* applies.

Given under my Hand and the Seal of the State of Victoria aforesaid, at Melbourne, this twenty-fifth day of June, in the year of our Lord One thousand nine hundred and fifty-seven, and in the sixth year of the reign of Her Majesty Queen Elizabeth II.

(L.S.)

E. F. HERRING.

By His Excellency's Command,

A. G. RYLAH,
Chief Secretary.

GOD SAVE THE QUEEN!

Police Offences Acts.

APPLICATION OF PROVISIONS OF DIVISION 6 OF PART VII. OF THE POLICE OFFENCES ACT 1928 TO THE SHIRE OF WANNON.

PROCLAMATION

By His Excellency the Lieutenant-Governor of the State of Victoria and its Dependencies in the Commonwealth of Australia, &c., &c., &c.

IN pursuance of the powers conferred by the *Police Offences Act 1928*, as amended by the *Police Offences (Trespass to Farms) Act 1956, I*, the Lieutenant-Governor

of the State of Victoria, in the Commonwealth of Australia, by and with the advice of the Executive Council of the said State and on the application of the Council of the Shire of Wannon, do by this my Proclamation declare the municipal district of the Shire of Wannon to be a district to which Division 6 of Part VII. of the *Police Offences Act 1928* applies.

Given under my Hand and the Seal of the State of Victoria aforesaid, at Melbourne, this twenty-fifth day of June, in the year of our Lord One thousand nine hundred and fifty-seven, and in the sixth year of the reign of Her Majesty Queen Elizabeth II.

(L.S.)

E. F. HERRING.

By His Excellency's Command,

A. G. RYLAH,
Chief Secretary.

GOD SAVE THE QUEEN!

Police Offences Acts.

APPLICATION OF PROVISIONS OF DIVISION 6 OF PART VII. OF THE POLICE OFFENCES ACT 1928 TO THE SHIRE OF WANGARATTA.

PROCLAMATION

By His Excellency the Lieutenant-Governor of the State of Victoria and its Dependencies in the Commonwealth of Australia, &c., &c., &c.

IN pursuance of the powers conferred by the *Police Offences Act 1928*, as amended by the *Police Offences (Trespass to Farms) Act 1956*, I, the Lieutenant-Governor of the State of Victoria, in the Commonwealth of Australia, by and with the advice of the Executive Council of the said State and on the application of the Council of the Shire of Wangaratta, do by this my Proclamation declare the municipal district of the Shire of Wangaratta to be a district to which Division 6 of Part VII. of the *Police Offences Act 1928* applies.

Given under my Hand and the Seal of the State of Victoria aforesaid, at Melbourne, this twenty-fifth day of June, in the year of our Lord One thousand nine hundred and fifty-seven, and in the sixth year of the reign of Her Majesty Queen Elizabeth II.

(L.S.)

E. F. HERRING.

By His Excellency's Command,

A. G. RYLAH,
Chief Secretary.

GOD SAVE THE QUEEN!

Police Offences Acts.

APPLICATION OF PROVISIONS OF DIVISION 6 OF PART VII. OF THE POLICE OFFENCES ACT 1928 TO THE CITY OF CHELSEA.

PROCLAMATION

By His Excellency the Lieutenant-Governor of the State of Victoria and its Dependencies in the Commonwealth of Australia, &c., &c., &c.

IN pursuance of the powers conferred by the *Police Offences Act 1928*, as amended by the *Police Offences (Trespass to Farms) Act 1956*, I, the Lieutenant-Governor of the State of Victoria, in the Commonwealth of Australia, by and with the advice of the Executive Council of the said State and on the application of the Council of the City of Chelsea, do by this my Proclamation declare the municipal district of the City of Chelsea to be a district to which Division 6 of Part VII. of the *Police Offences Act 1928* applies.

Given under my Hand and the Seal of the State of Victoria aforesaid, at Melbourne, this nineteenth day of June, in the year of our Lord One thousand nine hundred and fifty-seven, and in the sixth year of the reign of Her Majesty Queen Elizabeth II.

(L.S.)

E. F. HERRING.

By His Excellency's Command,

MURRAY PORTER,
for Chief Secretary.

GOD SAVE THE QUEEN!

POUNDS (FEES) ACT 1957, No. 6062.

DAY OF COMING INTO OPERATION.

PROCLAMATION

By His Excellency the Lieutenant-Governor of the State of Victoria and its Dependencies in the Commonwealth of Australia, &c., &c., &c.

WHEREAS by an Act of the Parliament of the State of Victoria passed in the sixth year of the reign of Her Majesty Queen Elizabeth II., intitled the *Pounds (Fees) Act 1957*, it is amongst other things enacted that the said Act shall come into operation on a day to be fixed by Proclamation of the Governor in Council published in the *Government Gazette*:

Now, therefore, I, the Lieutenant-Governor of the State of Victoria in the Commonwealth of Australia, by and with the advice of the Executive Council of the said State, do by this my Proclamation fix Monday, the 1st day of July, One thousand nine hundred and fifty-seven, as the day on which the said *Pounds (Fees) Act 1957*, No. 6062, shall come into operation.

Given under my Hand and the Seal of the State of Victoria aforesaid, at Melbourne, this nineteenth day of June, in the year of our Lord One thousand nine hundred and fifty-seven, and in the sixth year of the reign of Her Majesty Queen Elizabeth II.

(L.S.)

E. F. HERRING.

By His Excellency's Command,

T. K. MALTBY,
Commissioner of Public Works.

GOD SAVE THE QUEEN!

Local Government Acts.

PROCLAMATION EXTENDING THE OPERATION OF THE UNIFORM BUILDING REGULATIONS.

PROCLAMATION

By His Excellency the Lieutenant-Governor of the State of Victoria and its Dependencies in the Commonwealth of Australia, &c., &c., &c.

WHEREAS section 900 (2) of the *Local Government Act 1946* provides—*inter alia*—that the Governor in Council may, by Proclamation published in the *Government Gazette*, at the request of the council of any municipality, not being a city or town, extend the operation of the Regulations made under Part XLIX. of the Act to the municipal district of such municipality or any part thereof:

And whereas by Proclamation published in the *Government Gazette* of the 27th August, 1952, the operation of the Uniform Building Regulations was extended to part of the municipal district of the Shire of Tambo:

And whereas the Council of the Shire of Tambo has requested that the operation of the said Regulations be extended to a further part of the municipal district of such municipality:

Now, therefore, I, the Lieutenant-Governor of the State of Victoria, by and with the advice of the Executive Council thereof, by this, my Proclamation, do hereby extend the operation of the Regulations made under Part XLIX. of the *Local Government Act 1946* to the Township of East Cunninghame in the municipal district of the Shire of Tambo and order that the said Regulations shall come into operation in such part of the municipal district of the Shire of Tambo on publication of this Proclamation in the *Government Gazette*, provided that Parts I. and II. of Chapter 8 thereof shall not be deemed to come into operation till the 16th September, 1957, except in so far as may be necessary to enable the Council of the said municipality to make by-laws pursuant to the powers conferred by Part III. of the said Chapter, and provided, further, that no such by-law shall come into operation before the 16th September, 1957.

Given under my Hand and the Seal of the State of Victoria aforesaid, at Melbourne, this nineteenth day of June, in the year of our Lord One thousand nine hundred and fifty-seven, and in the sixth year of the reign of Her Majesty Queen Elizabeth II.

(L.S.)

E. F. HERRING.

By His Excellency's Command,

T. K. MALTBY,
Commissioner of Public Works.

GOD SAVE THE QUEEN!

PENAL REFORM ACT 1956.

DATE OF OPERATION.

PROCLAMATION

By His Excellency the Lieutenant-Governor of the State of Victoria and its Dependencies in the Commonwealth of Australia, &c., &c., &c.

WHEREAS by an Act of Parliament of the State of Victoria passed in the fifth year of the reign of Her Majesty Queen Elizabeth II. intitled the *Penal Reform Act 1956* (No. 5961) it is amongst other things enacted by sub-section (2) of section one thereof that save as otherwise provided, the said Act shall come into operation on a day to be fixed by Proclamation of the Governor in Council published in the *Government Gazette*:

Now, therefore I, the Lieutenant-Governor of the State of Victoria, in the Commonwealth of Australia, by and with the advice of the Executive Council of the said State, do by this my Proclamation fix the first day of July, One thousand nine hundred and fifty-seven, as the day upon which so much of the said *Penal Reform Act 1956* as is not already in operation shall come into operation.

Given under my Hand and the Seal of the State of Victoria aforesaid, at Melbourne, this twenty-fifth day of June, in the year of our Lord One thousand nine hundred and fifty-seven, and in the sixth year of the reign of Her Majesty Queen Elizabeth II.

(L.S.)

E. F. HERRING.

By His Excellency's Command,

A. G. RYLAH,
Chief Secretary.

GOD SAVE THE QUEEN!

PUBLIC HALF-HOLIDAY.

PROCLAMATION

By His Excellency the Lieutenant-Governor of the State of Victoria and its Dependencies in the Commonwealth of Australia, &c., &c., &c.

IN pursuance of the provisions contained in Part III. of the *Public Service Act 1946*, I, the Lieutenant-Governor of the State of Victoria, in the Commonwealth of Australia, by and with the advice of the Executive Council of the said State, do by this my Proclamation appoint the day and date hereunder mentioned to be observed as a Public Half-Holiday at the place specified, viz.:—

Public Half-Holiday from the Hour of Twelve o'clock noon:—

THURSDAY, THE 29TH DAY OF AUGUST, 1957, throughout the North Riding of the Shire of Arapiles.

Given under my Hand and the Seal of the State of Victoria aforesaid, at Melbourne, this twenty-fifth day of June, in the year of our Lord One thousand nine hundred and fifty-seven, and in the sixth year of the reign of Her Majesty Queen Elizabeth II.

(L.S.)

E. F. HERRING.

By His Excellency's Command,

A. G. RYLAH,
Chief Secretary.

GOD SAVE THE QUEEN!

BARLEY MARKETING ACTS.

I, GILBERT LAWRENCE CHANDLER, Minister of Agriculture, do hereby appoint Thursday, the 22nd day of August, 1957, as the day for the holding of an election of a Representative of Growers of Barley in Victoria on the Australian Barley Board, and do further appoint Thursday, the 18th day of July, 1957, as the day for nominations to be lodged with the Returning Officer, S. R. McColl, Department of Agriculture, Treasury Gardens, Melbourne, C.2.

Nominations will close at noon on nomination day.

G. L. CHANDLER,
Minister of Agriculture.

24th June, 1957.

DEPARTMENT OF MINES.

SUBJECT to any necessary excisions, &c., it is proposed to grant the following lease:—

9158, Castlemaine; Denzil Isidro Hartley; 211a. 2r. 14p., Parish of Wombat.

APPLICATIONS FOR LEASES DECLARED ABANDONED.

7571, Mineral; Mervyn John Morrison; 40 acres, Parish of Boola Boola.

7572, Mineral; Mervyn John Morrison; 40 acres, Parish of Numbruk.

APPLICATION FOR PETROLEUM EXPLORATION PERMIT DECLARED ABANDONED.

13, Petroleum Exploration Permit; Murray Basin Oil Syndicate Ltd.; 740 square miles, Counties of Follett and Dundas.

EXTENSION OF TERM OF PETROLEUM PROSPECTING LICENCE.

The term of the under-mentioned licence has been extended for a period of one year as from 1st June, 1957:—

157, Petroleum Prospecting Licence; Frome-Lakes Pty. Ltd.; 200 square miles, Parishes of Stradbroke, Mullungdung, Darriman, Woodside, Wonwron, Boodyarn, Yarram Yarram, Woranga, Albeton East, Bruthen, Balloong, and Tarra Tarra.

CONSENT GRANTED TO TRANSFER MINING LEASE.

6966, Mineral; From Norman Frederick McBride to Norman Frederick McBride and Norman George Howlett.

W. J. MIBUS,
Minister of Mines.

MINING LEASE AND LICENCE DECLARED VOID.

7549, Mineral; Ralph Recklaw and Harold Archer; 12a. 3r. 10p., Parish of Faraday.

2580, Tailings Licence; The President, Councillors, and Ratepayers of the Shire of Orbost, Parish of Bonang.

J. B. TILLEY,
Secretary for Mines.

THE COUNCIL OF PUBLIC EDUCATION.

MEMBERS OF REGISTRATION COMMITTEE.

IN pursuance of the provisions of section 90 of the *Education Act 1928*, the Council of Public Education hath, on this the 11th day of June, 1957, appointed the following Members of the said Council to be the Registration Committee, that is to say:—

PROFESSOR WILFRED HENRY FREDERICK, M.A., Dip.Ed.
THE REVEREND DANIEL JOHN CONQUEST, B.A., Dip.Ed.
THE REVEREND JOHN FRANCIS KELLY.
ALEXANDER McDONELL, B.A., B.Sc., B.Ed.
JOHN GEORGE CANNON, B.A., M.Ed.
MAJOR-GENERAL ALAN HOLICK RAMSAY, C.B., C.B.E., D.S.O., E.D., B.Sc., Dip.Ed.
Miss DOROTHY JEAN ROSS, M.A., B.S.C., Dip.Ed.
THE REVEREND ALFRED HAROLD WOOD, D.D., M.A., Dip.Ed.

The appointment of the above Registration Committee shall be for the period from the first day of July, 1957, to the thirtieth day of June, 1958.

A. H. RAMSAY, President.
W. R. STEVENSON, Registrar.

Education Office, Melbourne, C.2.

Stock Diseases Act 1928 (No. 3779).

QUARANTINE DISTRICTS UNDER REGULATION 37.

THE quarantine restrictions imposed on the following properties have been removed:—

Name; Address.

Cumming, D. C.; Numurkah.
Eddy, R. (Mrs.); Numurkah.
Heil, E. A.; Numurkah.
Wise, T. J.; Rochester.

A. R. GRAYSON,
Chief Inspector of Stock.

Transport Regulation Acts.
TRANSPORT REGULATION BOARD.
NOTICES OF PUBLIC HEARINGS.

NOTICE is hereby given that the applications made by the persons named below for licences to operate commercial passenger vehicles on the route or routes, or in the manner set out opposite their names, will be heard at a time and place to be communicated to the parties:—

Name and Address; Nature of Application.

- WALTERS, G. C., Nandaly; application for renewal of licence No. T.S.250, expiring 11th February, 1956, authorizing operations as a stage omnibus under the same terms and conditions.
- TROLLOP, L. T., Woods-street, Donald; application for renewal of licence No. T.C.T.733, expiring 11th September, 1957, authorizing operations as a country taxi from Donald.
- CASEY, L. G. & W. D., Toole-street, Hopetoun; 1 commercial passenger vehicle, with seating capacity for 31 persons, to operate for the carriage of school children only between Lascelles and Hopetoun, under contract to the Education Department.
- MILL, A. W., Ford-street, Hopetoun; 1 commercial passenger vehicle, with seating capacity for twenty persons, to operate for the carriage of school children only between Hopevale and Hopetoun, under contract to the Education Department.
- BINKS, W. H., Rutland-avenue, Mt. Eliza; application for variation of licence No. C.T.711, operating as a country taxi-cab at Frankston, to include the ability to be bespoken and engaged under hire from private home address at Rutland-avenue, Mt. Eliza.
- WILSON'S (BENALLA) TRANSPORT PTY. LTD., 202-208 East Bridge-street, Benalla; 1 commercial goods vehicle, to operate daily (Monday to Saturday inclusive) between Benalla and Alexandra, via Mansfield, and returning to Benalla, via Mansfield, for the carriage of newspapers, parcels, and two passengers.

Fares to be Charged—

- Benalla to Mansfield—10s. single.
Benalla to Alexandra—20s. 6d. single.
Mansfield to Alexandra—10s. 6d. single.

Sections.—Any first 10 miles, 3s. single. Each additional 10 miles or part thereof—an extra 2s. 6d. single. Minimum fare—3s.

Time-table to be Observed—

Monday to Saturday—

Depart Benalla	.. 5.30 a.m.
Depart Mansfield	.. 6.25 a.m.
Arrive Alexandra	.. 7.30 a.m.
Depart Alexandra	.. 8.30 a.m.
Depart Mansfield	.. 10.00 a.m.
Arrive Benalla	.. 11.00 a.m.

N.B.—Total weight of parcels carried on one trip not to exceed 10 cwt., individual parcels not to exceed 2 cwt.

Note.—This application replaces application gazetted 16th January, 1957.

- WISE, R. D., 328 Kooba-street, North Albury, N.S.W.; 1 commercial passenger vehicle, with seating capacity for eight persons, to operate for the carriage of mails, parcels, and passengers between Wodonga and Talgarno on Monday, Wednesday, Friday, Saturday, and between Wodonga and Bethunga on Tuesday and Thursday under contract to the Postmaster-General's Department.
- PANORAMA TAXI SERVICE, BELGRAVE TAXI SERVICE, & B. K. TAXIS, Belgrave; application for variation of all taxi-cab licences held by the applicants to include the ability to pick up passengers at the Ferntree Gully Railway Station when there are no local taxis available.
- CLARINDA TRANSPORT PTY. LTD., 3b Atkinson-parade, Oakleigh; application for variation of Route No. 39A (Oakleigh-Glen Waverley-Wheeler's Hill)—(a) to include an extension on the short trips now operated from Oakleigh to Macrina-street, to the corner of Macrina and Nonna streets, East Oakleigh. Frequency on short trips to be increased to approximately half-hour service, (b) to operate an extension of Route No. 39A from the corner of Burlington-street and Huntingdale-road, Ross-street to the corner of Ross-street and Fenton-street. (Sections, fares, and time-tables to be arranged.)
- PARLORCARS PTY. LTD., 244 Nicholson-street, Fitzroy; application for variation of licences Nos. M.C. 268, 262, 263, 32, 265, 304, 34, 267, 303 and 302, to include the ability to conduct a day tour to Apollo Bay as follows:—Depart Melbourne 8.45 a.m., via Princes

Highway to Winchelsea, Deann's Marsh, Otway Range, to Lorne, via Great Ocean-road, Apollo Bay, returning by the Great Ocean-road, via Lorne, Airey's Inlet, to Geelong, thence via Princes Highway to Melbourne. (Arriving in Melbourne, 9 p.m.)

- JOHNSON, T. C., 119 Clyde-street, Thornbury, L. S. BARBER, 78 Brewer-road, Bentleigh, and A. R. CADDY, 105 Victoria-road, Northcote; application for variation of Route No. 53A (Northcote-Fairfield) to delete all service on Sundays.
- JOINER, J. H., 31 Rose-street, Altona; application for variation of Route No. 100A (Altona-North Williamstown) to extend from the present prescribed terminus at the corner of Maidstone and Blyth streets, via Maidstone-street, Queen-avenue, Explosives Reserve-road, Merton-street, Princes Highway, to Laverton Air Station. *Fares:* 2s. single from North Williamstown.
- STANDARD VACUUM REFINING CO. AUST. PTY. LTD., Box 15, Williamstown; application for permit authority to operate Bedford Bus, registered No. GRT-805, for the carriage of employees of Standard Vacuum Refining Co. Aust. Pty. Ltd., free of charge, between the refinery, Millers-road, Altona, and Williamstown Dock, via the most direct route and other places as required.
- CURREN, R. W. & W. T., 31 Clarinda-road, Essendon; application for variation of Route No. 39 (Flemington Bridge-Essendon Railway Station)—(a) to delete that portion of Route No. 39 between Flemington Bridge and the corner of Mount Alexander-road and Puckle-street on all trips except one trip morning and one evening for the carriage of workers to the Commonwealth Serum Laboratories, (b) and instead to include turning procedure at Moonee Ponds as follows:—Turning left from Puckle-street, via Ascot Vale-road, Alexandra-avenue, McPherson-street, Dean-street, to Puckle-street, thence to normal route.

NOTICE is hereby given that the applications made by the persons named below for renewal of licences to operate the commercial goods vehicles on the route or routes or in the manner set out opposite their names, will be heard at a time and place to be communicated to the persons concerned:—

Name and Address; Present Franchise; Licence No.; Date of Expiry.

- CAMPBELL, P. W., 3 Wattle-grove, Hawthorn, E.2; 1 commercial goods vehicle (7 cwt.) to operate throughout the State of Victoria in the course of business as "maintenance engineer" for the purpose of installing and repairing new and second-hand scales, cash registers, and food processing machines—tools of trade and spare parts for use on own contracts; D.7988; 21st September, 1957.
- HOWIE, W. G., Old Fernshaw-road, Healesville; 1 commercial goods vehicle (96 cwt.) to operate—(a) within a radius of 20 miles from the post office at Healesville—general goods, (b) within a radius of 50 miles from the post office at Healesville—road-contracting plant and materials; D.7980; 21st September, 1957.
- PARRIS, F. W., & SONS PTY. LTD., High-street, Nagambie; 1 commercial goods vehicle (200 cwt.) to operate for the carriage of own goods in the course of business as "straw and lucerne pressing specialists"—(a) within a radius of 20 miles from the post office at Nagambie, (b) from and to the Township of Nagambie to and from the Township of Broadford; D.5561; 1st August, 1957.

NOTICE is hereby given that the applications made by the persons named below for licences to operate commercial goods vehicles on the route or routes, or in the manner set out opposite their names, will be heard at a time and place to be communicated to the persons concerned:—

Name and Address; Nature of Application.

- BENNETT, W. H., & SONS PTY. LTD., P.O. Box 100, Colac; 1 commercial goods vehicle (228 cwt.) to operate—(a) from forest landings at Deans Marsh to own mill at Deans Marsh—logs, (b) within a radius of 20 miles from own mill at Deans Marsh and to consignees at Geelong and Colac—own sawn timber.
- JAS. BROWN'S GENERAL CLEANING CO. PTY. LTD., 367 High-street, Kew, E.4; 1 commercial goods vehicle (10 cwt.) to operate within a radius of 50 miles from own premises at Kew in the course of business as "dry cleaners"—(a) goods to be dry cleaned or having been dry cleaned, (b) equipment and plant incidental to own business.

CRANES & SHOVELS PTY. LTD., Cochrane-road, Moorabbin; (1) 1 commercial goods vehicle (13 cwt.) to operate throughout the State of Victoria for the purpose of servicing and maintaining earth-moving and agricultural equipment—tools of trade, spare parts, and materials incidental to such servicing and maintenance. (2) 1 commercial goods vehicle (15 cwt.) to operate—(a) within a radius of 50 miles from own premises at Moorabbin in the course of business as "earth-moving and agricultural equipment manufacturers"—own goods, (b) throughout the State of Victoria for the display and demonstration of own machinery with the ability to make an urgent incidental delivery.

JACKSON, R., & SONS PTY. LTD., a'Beckett-street, Yea; 1 commercial goods vehicle (245 cwt.) to operate within a radius of 20 miles from own sawmill at Yea and to consignees at Rushworth, Nagambie, Murchison, Puckapunyal, and Seymour—own fencing timber (rails).

MCCLUSKEY, N. F., Bostock-street, Warrnambool; 2 commercial goods vehicle (86 cwt. and 105 cwt.) to operate within the Warrnambool Division of the Country Roads Board—road-contracting plant and materials.

MCINERNEY, T. J., 29 Milan-street, Bell Park; 1 commercial goods vehicle (60 cwt.) to operate throughout the State of Victoria in the course of business as "marine dealer"—marine stores and old metals.

O'BRIEN, W. E., 47 Wellington-street, Richmond; 1 commercial goods vehicle (76 cwt.) to operate throughout the State of Victoria in the course of business as "marine dealer"—marine stores and old metals.

NOTICE is hereby given that the application made by the person named below for renewal of the licence with variation to operate the commercial goods vehicle on the route or routes, or in the manner set out opposite his name, will be heard at a time and place to be communicated to the party concerned:—

Name and Address; Present Franchise; Amended Conditions; Licence No.; Expiry Date.

MCCLURE, M. J., Lawrence-street, Castlemaine; 1 commercial goods vehicle (105 cwt.) to operate throughout the State of Victoria—road-contracting plant and materials.

1 commercial goods vehicle (105 cwt.) to operate—(a) within the Bendigo Division of the Country Roads Board—road-contracting plant and materials; (b) within a radius of 50 miles from the chief post office at Castlemaine under contract to local shires—road-contracting plant and materials; D.7732; 23rd June, 1957.

Notice of any objection should be forwarded to reach the Secretary of the Board not later than Wednesday, 10th July, 1957.

E. V. FIELD,
Secretary.

Exhibition Buildings, Rathdown-street, Carlton, N.3,
24th June, 1957.

NOTICE.

ADMINISTRATION of the estate of each of the under-mentioned deceased persons has been granted to the Public Trustee, and creditors, next of kin, and all others having claims against the estate of any of the persons so mentioned are required to send particulars of their claims to the Public Trustee, No. 412 Collins-street, Melbourne, on or before the 29th August, 1957, or they will be excluded from the distribution of the estate when the assets are being distributed:—

*AITKEN, ADA FLORENCE, late of 9 Francis-street, Prahran, married woman, died 25th September, 1955.

BLAKE, JOHN, formerly of Hedge-road, Garristown, County of Meath, Eire, but late of Leaks Boarding-house, Shepparton, linesman, died 4th April, 1954, intestate.

†BRUCE, MARGARET MABEL, late of 5 Moule-avenue, Brighton, spinster, died 25th January, 1954.

†DAVIS, PATRICK, late of Macedon-avenue, Dromana, naval pensioner, died 22nd April, 1957.

†EARL, LILIAN EDNA, also known as Edna Lilian Earl, formerly of 9 Glass-street, East Kew, but late of 78 Melville-street, Hawthorn, spinster, died 10th April, 1957.

†EDWARDS, ERNEST ARTHUR, late of 448 Station-street, Carrum, pensioner, died 20th October, 1956.

†GLENN, ANNIE, late of 66 Albion-street, East Brunswick, widow, died 6th March, 1957.

HAWKINS, WILLIAM HENRY, late of 7 East-street, Glenroy, cemetery employee, died 14th February, 1957, intestate.

*HEALY, EUGENE FRANCIS, late of 11 The Grove, Moreland, and Selborne Chambers, Melbourne, gentleman, died 30th September, 1956.

HUNTER, HENRIETTA, late of 12 Walcott-street, Mt. Lawley, Western Australia, home duties, died 5th December, 1947, intestate.

HUNTER, WILLIAM JOHN, late of 535 King-street, West Melbourne, process worker, died 1st April, 1957, intestate.

†KELSEY, JANE WILGAR, late of Herbert-street, Bowen, Queensland, wife of George Herbert Kelsey, of the same place, retired grazier, died on or about 21st February, 1956.

MARKS, HARRY, formerly* of 117 King William-street, Fitzroy, but late of 195 Young-street, Fitzroy, labourer, died 15th March, 1957, intestate.

†MOLLOY, WILLIAM, late of 20 Gordon-street, Footscray, war pensioner, died 19th March, 1957.

†MULLEN, GEORGINA, late of 47 Grenville-street, Hampden, widow, died 31st March, 1957.

MCLEAN, EMILY, late of 34 The Avenue, Parkville, widow, died 9th August, 1956, intestate.

NOTT, EILEEN WINIFRED RUTH, late of Mont Park, widow, died 21st October, 1956, intestate.

REDMOND, FLORENCE MARGARET ELIZABETH, also known as Florence Margaret Redmond, late of 9 Elaroo-avenue, Camberwell, married woman, died 1st May, 1957, intestate.

*WRAITH, JAMES STANLEY, late of 28 Salisbury-avenue, Ivanhoe, retired accountant, died 24th April, 1957.

* According to the provisions of the will.
† With the will annexed.

H. C. CHIPMAN,
Public Trustee.

Melbourne, 19th June, 1957.

4 GEORGE VI. No. 4755, SECTION 6.

I HEREBY give notice that on the 11th June, 1957, the Public Trustee filed elections to administer the following deceased persons' estates, in accordance with section 6 of the Public Trustee Act 1940:—

HUNTER, WILLIAM JOHN, late of 535 King-street, West Melbourne, process worker, died 1st April, 1957, intestate.

MARKS, HARRY, formerly of 117 King William-street, Fitzroy, but late of 195 Young-street, Fitzroy, labourer, died 15th March, 1957, intestate.

MCLEAN, EMILY, late of 34 The Avenue, Parkville, widow, died 9th August, 1956, intestate.

REDMOND, FLORENCE MARGARET ELIZABETH, also known as Florence Margaret Redmond, late of 9 Elaroo-avenue, Camberwell, married woman, died 1st May, 1957, intestate.

*WRAITH, JAMES STANLEY, late of 28 Salisbury-avenue, Ivanhoe, retired accountant, died 24th April, 1957.

* According to the provisions of the will.

I HEREBY give notice that on the 13th June, 1957, the Public Trustee filed elections to administer the following deceased persons' estates, in accordance with section 6 of the Public Trustee Act 1940:—

*AITKEN, ADA FLORENCE, late of 9 Francis-street, Prahran, married woman, died 25th September, 1955.

*HEALY, EUGENE FRANCIS, late of 11 The Grove, Moreland, and Selborne Chambers, Melbourne, gentleman, died 30th September, 1956.

HUNTER, HENRIETTA, late of 12 Walcott-street, Mt. Lawley, Western Australia, home duties, died 5th December, 1947, intestate.

* According to the provisions of the will.

H. C. CHIPMAN,
Public Trustee.

412 Collins-street, Melbourne, 19th June, 1957.

LAW DEPARTMENT.

CHILDREN'S COURT AT MELBOURNE.—DAYS AND HOURS APPOINTED.

HIS Excellency the Lieutenant-Governor of the State of Victoria, by and with the advice of the Executive Council thereof, doth by Order made on the 25th day of June, 1957, pursuant to the provisions of the Children's Court Act 1956, appoint every Monday at 10 a.m. and every Thursday at 2 p.m. as the days and hours for the holding of the Children's Court at Melbourne, in lieu of the day and hour heretofore appointed—to take effect as from and including the 1st July, 1957.

A. MAHLSTEDT,
Clerk of the Executive Council.

At the Executive Council Chamber,
Melbourne, 25th June, 1957.

LAW DEPARTMENT.

COURTS OF PETTY SESSIONS, MURTOA.—DAYS AND HOURS APPOINTED.

HIS Excellency the Lieutenant-Governor of the State of Victoria, by and with the advice of the Executive Council thereof, doth by Order made on the 19th day of June, 1957, pursuant to the provisions of section 61 of the *Justices Act 1928*, appoint every alternate Tuesday, at 10 a.m., as from and inclusive of the 16th July, 1957, for the holding of Courts of Petty Sessions at Murtoa, in lieu of the days and hours heretofore appointed.

A. MAHLSTEDT,
Clerk of the Executive Council.

At the Executive Council Chamber,
Melbourne, 19th June, 1957.

LAW DEPARTMENT.

COURT OF PETTY SESSIONS, HAMILTON.—
ADDITIONAL DAY APPOINTED.

HIS Excellency the Lieutenant-Governor of the State of Victoria, by and with the advice of the Executive Council thereof, doth by Order made on the 25th day of June, 1957, pursuant to the provisions of section 61 of the *Justices Act 1928*, appoint Wednesday, the 26th June, 1957, at 10 a.m., a day for the holding of the Court of Petty Sessions at Hamilton, in addition to the days and hours heretofore appointed.

A. MAHLSTEDT,
Clerk of the Executive Council.

At the Executive Council Chamber,
Melbourne, 25th June, 1957.

RULES OF THE SUPREME COURT.

IN pursuance of the powers conferred by the Supreme Court Acts and all other powers hereunto enabling the following amendments to Chapter 1 of the Rules of the Supreme Court are made and shall take effect from the first day of August, 1957:—

1. For Rules 16 and 16A of Order XLII. there shall be substituted the following Rules:—

16. Every writ of execution for the recovery of money shall be endorsed with a direction to the Sheriff (or other officer or person to whom the writ is directed) to levy—

- (a) the amount really due and payable and sought to be recovered under the judgment or order stating, the total amount, the amount exclusive of taxed costs and the amount of any taxed costs; and
- (b) interest at the rate of £8 per cent. per annum (or such other rate as may have been agreed upon by the parties) calculated from the date of judgment or order on the amount thereof exclusive of taxed costs and from the date of the Taxing Master's certificate of costs or such other date as the Court or a Judge has ordered on the amount of any taxed costs.

16A. Every writ of *fi fa* shall be endorsed as follows:—

“Levy £ (being £ due and payable exclusive of taxed costs and £ for taxed costs) and £ for costs of execution and also interest at 8 per cent. per annum (or other agreed rate) on £ (amount of judgment or order exclusive of taxed costs) from the day of (date of judgment or order) and on £ (amount of taxed costs) from the day of (date of Taxing Master's certificate or other date ordered by the Court or a Judge) till payment, plus Sheriff's poundage, officer's fees, cost of levying, the fees, expenses and costs mentioned in Order XLII. Rule 15A if and when incurred, and all other legal incidental expenses.”

2. For the note to Form I. of Appendix H there shall be substituted the following note:—

“Date of judgment or order, date of Taxing Master's certificate of costs or other date ordered by the Court or a Judge, as the case may be.”

3. At the end of Rule 2 of Order LXVII. there shall be inserted the following expression “or if posted in a prepaid registered envelope addressed to the person to be served at such address for service as aforesaid: provided that where service under this Rule is made by registered post, the time at which the document so posted would be delivered in the ordinary course of post shall be considered as the time of service thereof.”

E. F. HERRING, C.J.
CHARLES J. LOWE, J.
C. GAVAN DUFFY, J.
NORMAN O'BRYAN, J.
JOHN V. BARRY, J.
ARTHUR DEAN, J.
E. H. HUDSON, J.
R. V. MONAHAN, J.
G. A. PAPE, J.

County Court Act 1928.

RULES OF COURT.

WE, the undersigned Judges of County Courts, in exercise of the powers conferred by section 87 of the County Court Act 1928 do hereby amend the County Court Rules 1930 as follows:—

1. In Order XII. the following Rule shall be added:—

“ 5. (1) Where, in any action in which damages are claimed against an alleged tortfeasor, a defendant takes proceedings (in this rule referred to as “contribution proceedings”) to recover contribution or indemnity pursuant to section 2 of the *Wrongs (Tortfeasors) Act 1949*, against any person, whether a defendant to the action or not, any party to the contribution proceedings may at any time serve upon the other party or all of the other parties (if more than one) to the contribution proceedings a notice in writing stating his willingness—

(a) that liability to the plaintiff shall be admitted by all parties to the contribution proceedings who are defendants in the action; and

(b) himself to pay a proportion, specified in the notice, of whatever damages and costs the plaintiff may recover in the action.

In such notice he may in addition, if he so desires, state his willingness to contribute in the said proportion towards a specified total sum to be paid into Court with an admission of liability by a defendant to be named in such notice.

(2) (a) Subject to paragraphs (b), (c) and (d) of this sub-rule, any such notice, whether or not it is expressed to be without prejudice, shall stand in the same position as regards admissibility in evidence in any proceedings as if it were an offer of settlement expressed to be without prejudice;

(b) No communication or disclosure of the contents of any such notice or of the fact that a notice has been served under this Rule shall be made either to the Judge or to the Jury at the trial of the action or the contribution proceedings until all issues in the action and in such proceedings have been determined;

(c) After all such issues have been determined any party may prove the service of any such notice and the Judge may thereupon, in exercising his discretion as to costs as between the party serving the notice and the party or parties served, take into account the service and contents of the notice provided that he is satisfied that the party serving it was in fact at all material times willing and able to carry out his part of what was proposed therein;

(d) The costs referred to in paragraph (c) shall include costs recoverable by the plaintiff against any party to the contribution proceedings, as well as costs incurred in defending the action and in the contribution proceedings but shall not include the costs incurred by any party in relation to the issue of damages in the action unless the party serving the notice shall have signified in the manner aforesaid his willingness to contribute towards the payment into Court of a total sum not less than the damages adjudged to be paid and the contribution by him as so proposed is not less than the amount which he is bound by order or agreement to contribute towards those damages.

(3) (a) Where any sum is paid into Court by one of two or more defendants either in conformity with, or under an agreement or arrangement arising out of, a notice given pursuant to this Rule the notice of payment given under Order XVII. shall state this fact and the name and address for service of each party to the contribution proceedings (not being a defendant to the action) who is a party to the agreement or arrangement under which such payment into Court is made and except by leave of the Court or a Judge the sum paid in shall not be paid out to the party claiming the damages in respect of which the payment in has been made until he files and serves upon all the defendants in the action notice that he accepts the sum paid in in satisfaction of his claim to such damages against every defendant in the action against whom such damages were claimed and executes in favour of each such party to the contribution proceedings a binding release from any claim to such damages which he may have against him.

(b) Any sum contributed by a party and paid into Court by any other party either in conformity with, or under an agreement or arrangement arising out of, a notice given pursuant to this Rule and which is not taken out of Court by, or ordered to be paid out of Court to, the party claiming the damages in respect of which such payment in was made, shall be dealt with as between the party who contributed such sum and the party who paid the same into Court as the Judge at the trial, if any, shall order or if no such order is made as may be ordered by a Judge in Chambers.”

2. (1) In sub-rule (3) of Rule 1 of Order XVII. before the word “Form” there shall be inserted the words “or to the effect of.”

(2) For sub-rule (1) of Rule 2 of Order XVII. there shall be substituted the following new sub-rule:—

“ (1) Where money is paid into Court under Rule 1 the plaintiff may within seven days of the receipt of the notice of payment into Court accept the whole sum or any one or more of the specified sums in satisfaction of the cause or causes of action to which the specified sum or sums relate by giving notice to the defendant in or to the effect of Form 51 and complying with sub-rule (3) (a) of Rule 5 of Order XII. in cases to which it applies; and thereupon he shall be entitled to receive payment of the accepted sum or sums in satisfaction as aforesaid.”

(3) For sub-rule (2) of Rule 4 of Order XVII. there shall be substituted the following new sub-rule:—

“ (2) If the Plaintiff elects within seven days after receipt of notice of payment into Court to accept the sum or sums paid into Court he shall give notice in or to the effect of Form 51 to each defendant and complying with sub-rule (3) (a) of Rule 5 of Order XII. in cases to which it applies.”

3. For Rule 1 of Order XXII. there shall be substituted the following new Rule:—

“ 1. Unless otherwise ordered a list of actions and all other business for hearing shall be made out by the Registrar as follows:—

(a) Jury Actions,

(b) Non Jury Actions and all other business to be dealt with by a Judge sitting alone.

In making out such list the Registrar shall set out the actions and other business in the order of the date upon which each such action or other business was commenced in or remitted to the Court."

4. For Rule 8 of Order XXII. there shall be substituted the following new Rule:—

" 8. (a) In addition to the powers conferred by these Rules of transferring an action or matter from one Court to another a Court or a Judge may in any action or matter in which it or he thinks fit and at any stage of such action or matter direct that the hearing or further hearing thereof or the taking of accounts or all or any further proceedings therein shall be heard and taken in any other Court and such hearing or further hearing or taking of accounts or further proceedings shall be heard and taken in such last-mentioned Court accordingly.

(b) Whenever the powers conferred by this Rule have been exercised the final judgment decree or order shall be entered and all proceedings for enforcing the same shall be taken in the Court in which such action or matter was commenced unless the Court or Judge by which such judgment decree or order was made shall otherwise order."

5. For paragraph (d) of Rule 2 of Order LI. there shall be substituted the following new paragraph:—

" (d) Subject to the provisions of these Rules, all costs taxed by the Registrar shall be taxed as follows:—

(i) As to all business done on or after the first day of July, 1957, according to the Schedule of Scale of Costs which came into force on the sixth day of May, 1953, with the addition thereto of fifty per centum on all allowances set forth in that Scale (other than for Counsel's fees and other disbursements and payments);

(ii) As to all business done on or after the Sixth day of May, 1953, but before the First day of July, 1957, according to the Schedule of Scale of Costs which came into force on the Sixth day of May, 1953;

(iii) As to all business done on or after the First day of November, 1949, but before the Sixth day of May, 1953, according to the Schedule of Scale of Costs which came into force on the Nineteenth day of December, 1930, with the addition thereto of fifty per centum on all allowances set forth in that Scale (other than for Counsel's fees and other disbursements and payments);

(iv) As to all business done on or after the First day of February, 1947, but before the First day of November, 1949, according to the Schedule of Scale of Costs which came into force on the Nineteenth day of December, 1930, with the addition thereto of twenty per centum on all allowances set forth in that Scale (other than for Counsel's fees and other disbursements and payments); and

(v) As to all business done prior to the First day of February, 1947, according to the Schedule of Scale of Costs which came into force on the Nineteenth day of December, 1930."

6. Items 76 to 89 in the Schedule of Scale of Costs are repealed and the following items are substituted therefor:—

No. of Item.	Subject Matter.	" A "	" B "	" C "	" D "	" E "	" F "
		Under £50.	£50 and under £100.	£100 and under £250.	£250 and under £500.	£500 and under £1,000.	£1,000 and Upwards.
		£ s. d.	£ s. d.	£ s. d.	£ s. d.	£ s. d.	£ s. d.
76	To settle notice before action, if allowed by Judge or Registrar, and actually paid, not exceeding	2 4 6	2 4 6	2 4 6	3 5 6	3 5 6	3 5 6
77	On application for final judgment, where certified for and actually paid, not exceeding	2 4 6	2 4 6	3 5 6	3 5 6	4 6 6	4 6 6
78	(a) On trial, or hearing before Arbitrator or Referee, amount actually paid, not exceeding	7 12 0	8 13 0	11 0 0	16 5 0	19 8 0	27 6 0
	(b) In circuit cases a further fee may be allowed and the amount thereof fixed by order of the Judge if, in his opinion (having regard to all the circumstances, including travelling expenses, living expenses and absence from Chambers) the scale fee is insufficient, but the total amount of the scale fee and the further fee shall not exceed the fee marked on the brief ..						
79	On conference, when allowed by Judge or Registrar, amount actually paid, not exceeding	2 7 0	2 7 0	2 7 0	2 7 0	2 7 0	3 8 0
	(Only one conference shall be allowed) ..						
80	Refresher fee	3 5 6	6 11 0	8 13 0	11 0 0	13 2 0	17 6 0
81	To hear deferred judgment, when certified for by Judge, or allowed by Registrar ..	2 4 6	2 4 6	2 4 6	2 4 6	3 5 6	3 5 6
82	To support or oppose any motion or application, amount actually paid, not exceeding	2 4 6	2 4 6	3 5 6	3 5 6	4 6 6	4 6 6
83	To settle interrogatories or answers thereto, when allowed on taxation amount actually paid, not exceeding	2 4 6	2 4 6	2 4 6	3 5 6	3 5 6	3 5 6
84	To settle Particulars of Claim, Counter Claim, Set Off, Special Defence, or further particulars of foregoing, or to settle special case, answer or award	2 4 6	2 4 6	2 4 6	3 5 6	4 6 6	4 6 6

No. of Item.	Subject Matter.	" A "	" B "	" C "	" D "	" E "	" F "
		Under £50.	£50 and under £100.	£100 and under £250.	£250 and under £500.	£500 and under £1,000.	£1,000 and Upwards.
		£ s. d.	£ s. d.	£ s. d.	£ s. d.	£ s. d.	£ s. d.
85	On Examination under Imprisonment of Fraudulent Debtors Act, not exceeding ..	2 4 6	2 4 6	2 4 6	3 5 6	4 6 6	4 6 6
86	To settle Notice of Appeal, when allowed on taxation	2 4 6	2 4 6	2 4 6	3 5 6	4 6 6	4 6 6
87	To settle draft Appeal Case, when allowed on taxation	2 4 6	2 4 6	2 4 6	3 5 6	3 5 6	4 6 6
88	Fee on settling Appeal Case before Judge, when allowed on taxation	2 4 6	2 4 6	2 4 6	3 5 6	3 5 6	3 5 6
89	To advise on evidence, when allowed on taxation	3 5 6	3 5 6	4 6 6	4 6 6

7. For paragraph (c) of Item 94 in the Schedule of Scale of Costs there shall be substituted the following new paragraph :—

	£ s. d.	£ s. d.	£ s. d.	£ s. d.	£ s. d.	£ s. d.
" (c) Counsel's fee ..	3 5 6	4 6 6	5 10 0	8 13 0	11 0 0	13 2 0."

8. The above amendments shall apply to all business done on or after the First day of July, 1957.

9. Rules 19 and 20 of Order IV. are hereby repealed.

10. For Order XXXIX. shall be inserted the following Order :—

" Order XXXIX.—Proceedings under the *Marriage (Property) Act 1956*.

1. (a) When application is made pursuant to sub-section (1) of Section 7 of the *Marriage (Property) Act 1956*, particulars of the question to be submitted to the Judge, and a short statement of the facts giving rise thereto shall be filed with the Registrar, together with an affidavit deposing to those facts. Thereupon a summons or notice in or to the effect of the form in the Schedule shall be issued with the particulars annexed thereto.

(b) The same fee shall be paid and taken on the summons or notice as upon the entry of a plaint.

(c) The summons or notice shall be made returnable before the Judge in Chambers, and shall be served on the opposite party.

(d) Upon the return of the summons or notice the Judge may hear and determine the question or may refer it into a list for hearing or otherwise dispose of the matter as he thinks fit.

11. For Form 156 in the Schedule shall be inserted the following new Form :—

" Summons (or Notice)

Under the *Marriage (Property) Act 1956* "

In the County Court
at

In the matter of an Application pursuant to
Section 7 (1) of the *Marriage (Property) Act*
1956, wherein

is Applicant

and

is Respondent.

To

Respondent.

You are hereby required at the instance of _____ of _____
to appear before the Judge in Chambers at _____ on _____ day the
day of _____ 19 _____ at the hour of _____ o'clock in the _____ noon, when
the Judge will proceed to consider the question hereunto annexed, and to make an order with
respect to the property in dispute or otherwise dispose of the matter as he thinks fit.

Dated the _____

day of _____

19 _____

Registrar."

And we do hereby certify the above under our hands this tenth day of June, 1957.

LEONARD E. B. STRETTON
J. H. MOORE
A. L. READ
NORMAN MITCHELL
F. B. GAMBLE
G. L. DETHRIDGE
J. F. MULVANY
C. McC. T. STAFFORD
A. M. FRASER
F. R. NELSON
J. G. NORRIS
BEN. J. DUNN
E. H. E. BARBER

} Judges of County Courts.

I direct the foregoing Rules of Court to be published in the *Government Gazette*.

Health Act 1956.

ADDITIONS TO THE REGISTER OF PROPRIETARY MEDICINES.

THE following additions to the Register of Proprietary Medicines are published in accordance with the provisions of the *Health Act 1956*, section 265 (4).

Department of Health,
Melbourne, 12th June, 1957.

K. BRENNAN,
Chief Health Officer.

Distinctive Name of Proprietary Medicine.	Serial Number.	Date of Registration.	Purposes for which the Medicine may be sold.
Achromycin Intravenous	6138	12.6.57	An antibiotic for the treatment of infections due to aureomycin-sensitive bacteria
Achromycin Ointment	6139	12.6.57	An antibiotic for the treatment of infections of the skin due to aureomycin-sensitive bacteria
Achromycin Ointment (Ophthalmic) with Hydrocortisone	6162	12.6.57	For the treatment of ocular infections due to achromycin-sensitive bacteria where the addition of an adrenocorticotrophic hormone is desired
Achromycin Ophthalmic Ointment 1%	6140	12.6.57	An antibiotic for use in infections of the eye due to achromycin-sensitive bacteria
Achromycin Oral Suspension	6141	12.6.57	An antibiotic for the treatment of infections due to aureomycin-sensitive bacteria
Achromycin Pediatric Drops	6142	12.6.57	An antibiotic for the treatment of infections due to aureomycin-sensitive bacteria
Achromycin Spersoids	6163	12.6.57	An antibiotic for the treatment of infections due to aureomycin-sensitive bacteria
Achromycin SV Capsules	6164	12.6.57	An antibiotic for the treatment of infections due to achromycin-sensitive bacteria
Achromycin Syrup	6165	12.6.57	An antibiotic for the treatment of infections due to aureomycin-sensitive bacteria
Achromycin Tablets	6143	12.6.57	An antibiotic for the treatment of infections due to aureomycin-sensitive bacteria
Adovit Oil	6173	12.6.57	For vitamin A and D deficiency
Adexolin Liquid	6204	12.6.57	To maintain resistance against respiratory and other infections and as a general tonic. (In lieu of Serial No. 3618 of 30.7.54)
Aminopterin	6144	12.6.57	For acute leukaemia in children
Anabalm	6170	12.6.57	For the relief of pain in rheumatic and allied conditions
Aniseen	6183	12.6.57	A soothing syrup for flatulence and hicough in infants
Anusol Haemorrhoidal Ointment	6130	12.6.57	For relief of the discomfort of haemorrhoids and resultant inflammatory conditions of the ano-rectal region
A.P.E. Laxative Pills	6184	12.6.57	A laxative pill for certain types of constipation
Aronson's Vitamin B Complex Plus Tablets	6205	12.6.57	For the treatment of vitamin deficiencies
Artane	6145	12.6.57	For use in the treatment of Parkinson's disease
Aureomycin Calcium Oral Drops	6166	12.6.57	An antibiotic for the treatment of infections due to aureomycin-sensitive bacteria
Aureomycin Capsules	6146	12.6.57	An antibiotic for the treatment of infections due to aureomycin-sensitive bacteria
Aureomycin Hydrochloride Crystalline Dental Cones	6147	12.6.57	For the treatment of dental conditions due to aureomycin-sensitive bacteria
Aureomycin Hydrochloride Crystalline Ointment	6148	12.6.57	An antibiotic for local treatment of conditions due to aureomycin-sensitive bacteria
Aureomycin Hydrochloride Crystalline Ophthalmic	6149	12.6.57	An antibiotic for the treatment of eye diseases due to aureomycin-sensitive bacteria
Aureomycin Hydrochloride Crystalline Ophthalmic Ointment	6150	12.6.57	An antibiotic for the treatment of eye infections due to aureomycin-sensitive bacteria
Aureomycin Hydrochloride Crystalline Otic	6151	12.6.57	An antibiotic for the treatment of infections of the ears caused by aureomycin-sensitive bacteria
Aureomycin Hydrochloride Crystalline Soluble Tablets	6152	12.6.57	For the preparation of solutions for testing antibiotic sensitivity
Aureomycin Hydrochloride Crystalline Spersoids	6153	12.6.57	An antibiotic for the treatment of infections due to aureomycin-sensitive bacteria
Aureomycin Hydrochloride Crystalline Surgical Powder	6154	12.6.57	An antibiotic for use in surgery
Aureomycin Hydrochloride Crystalline Troches	6155	12.6.57	An antibiotic for the treatment of infections of the mouth due to aureomycin-sensitive bacteria
Aureomycin Hydrochloride Crystalline Vaginal Powder	6156	12.6.57	An antibiotic for the treatment of infections due to aureomycin-sensitive bacteria
Aureomycin Hydrochloride Crystalline Vaginal Suppositories	6157	12.6.57	An antibiotic for the treatment of aureomycin-sensitive bacteria
Aureomycin Hydrochloride Intravenous	6158	12.6.57	An antibiotic for the treatment of infections due to aureomycin-sensitive bacteria
Barnes' Honey Balsam	6124	12.6.57	For relief of coughs of colds and bronchitis and the irritation of sore throat
Benactone B Tablets	6136	12.6.57	For use in the treatment of emotional disturbances of anxiety, tension, confusion, restlessness and agitation, and as an adjunct to the treatment of psychogenic asthma and eczema, and pre-operatively, to allay fears and apprehensions
Bepanthen Ampoules	6175	12.6.57	For the treatment of diseases associated with pantothenic acid deficiency
Bepanthen Lozenges	6176	12.6.57	For the treatment of diseases associated with pantothenic acid deficiency
Bepanthen Ointment	6225	12.6.57	For the treatment of diseases associated with pantothenic acid deficiency
Bepanthen Solution	6177	12.6.57	For the treatment of diseases associated with pantothenic acid deficiency
Biliodyl Tablets	6217	12.6.57	As a contrast medium in cholecystography and cholangiography
Bowden's Cold Sore Lotion	6159	12.6.57	For cold sores and cracked lips
Carboxymethylcellulose Jelly	6125A	12.6.57	For use with Varidase (Reg. Vic. 6125)
Cellumine Tablets	6137	12.6.57	For the control of overweight. Subject to Food and Drug Standards Regulation No. 76
Chilblain Cream	6197	12.6.57	For relief of the pain of chilblains
Children's Cough Linctus	6198	12.6.57	A mild sedative to suppress night coughs in children
Chilvit Tablets	6160	12.6.57	For the relief of irritation and swelling arising from chilblains
Colecemid Ampoules	6180	12.6.57	As a cytostatic agent

ADDITIONS TO REGISTER OF PROPRIETARY MEDICINES—*continued.*

Distinctive Name of Proprietary Medicine.	Serial Number.	Date of Registration.	Purposes for which the Medicine may be sold.
Colcemid Ointment	6181	12.6.57	As a cytostatic agent
Colcemid Tablets	6182	12.6.57	As a cytostatic agent
Cold Sore Lotion	6185	12.6.57	For cold sores or cracked lips
Cold Sore Lotion	6206	12.6.57	For the treatment of cold sores
Collotone	6223	12.6.57	A general tonic
Coloxyl with Danthron Tablets	6128	12.6.57	For constipation
Constipation Pills	6172	12.6.57	For the relief of constipation
Contraverm	6208	12.6.57	For use in the treatment of intestinal worms
Croft's Cough Balsam	6127	12.6.57	For the relief of coughs of colds, bronchitis and hoarseness, and to allay irritation of the throat and chest
Egocappol	6216	12.6.57	For use in the removal of cradle cap in infants
Federal Cough Balsam	6135	12.6.57	For the relief of coughs of colds, bronchitis, and hoarseness, and to allay irritation of the throat and chest
Fewtrell's Antiseptic Mouth Wash	6178	12.6.57	As an antiseptic mouth wash
Fewtrell's Cold Sore Lotion	6179	12.6.57	For the treatment of cold sores and cracked lips
Folvite Tablets	6167	12.6.57	For the treatment of megaloblastic anemias
Ford's Tablets (Corporeal)	6193	12.6.57	As an adjunct with restricted diets. (In lieu of Serial No. 2506 of 30.7.53)
Hostacortine H Tablets	6129	12.6.57	For the treatment of rheumatoid arthritis, rheumatic fever, rheumatic carditis, rheumatic spondylitis, thrombocytopaenic purpura, lymphatic leukaemia, gout, polyarteritis nodosa, nephrosis, bronchial asthma, sarcoidosis, dermatoses, lupus erythematosus, pemphigus, atopic dermatitis, exfoliative dermatitis, erythema multiforme, dermatitis herpetiformis, contact dermatitis, scleroderma and parapsoriasis. Subject to Food and Drug Standards Regulation No. 76
Infalax	6126	12.6.57	A cherry-flavoured laxative
Juni-Tabs	6132	12.6.57	For use during convalescence and as a general tonic. To supplement the daily vitamin intake and for mineral and vitamin deficiencies in growing children and children who are pale or run-down
Ledinac	6168	12.6.57	As a protein supplement
Magic Lotion	6186	12.6.57	An antiseptic lotion for cuts, wounds, and burns
"Maredox" brand Cyclizine Hydrochloride 50 mg. with Pyridoxine Hydrochloride 50 mg. Mentholine	6189	12.6.57	For relief of nausea and vomiting in pregnancy
Mestionon Tablets 60 mg.	6219	12.6.57	For relief of the discomfort of coughs of colds, influenza, and throat troubles. To alleviate headache, toothache, neuralgia, and sciatica. (In lieu of Serial No. 524 of 1.9.48)
Nailsol	6171	12.6.57	As an antimuscular, parasympathicomimetic and curare antidote
N.A.I. Vitamin Compound	6199	12.6.57	For poisoned nails
Nyal Esterin Tablets	6133	12.6.57	For use in the treatment of vitamin deficiencies
Onitzone Foot Cream	6161	12.6.57	For the relief of periodic pain, headache, neuralgia, nerve pains, muscular pain, and sleeplessness when due to pain, and to reduce temperature. (In lieu of Serial No. 2139 of 3.12.52)
Oxytip Elixir	6196	12.6.57	For the relief of tired feet
Pastavit Tablets	6209	12.6.57	For the elimination of threadworms
Pholcodine Cough Linctus	6200	12.6.57	For the treatment of vitamin deficiencies
Pholcolin	6224	12.6.57	For the relief of irritating night coughs
Plestran Tablets	6131	12.6.57	As a sedative cough linctus
Proladone Ampoules	6190	12.6.57	For use as a metabolism regulator
Pyridoxine	6174	12.6.57	A prolonged-action analgesic
Respenyl Tablets	6191	12.6.57	For nausea and vomiting of pregnancy, radiation sickness, post-anaesthetic vomiting and nausea, and vomiting of migraine
Robinson's Corn Cure	6187	12.6.57	An expectorant for the relief of cough
Ruby Linctus	6188	12.6.57	For removing corns and callouses
Salpix Contrast Medium	6214	12.6.57	A palatable sedative for relieving persistent and irritating coughs
Sodium Citrate 2 grains	6201	12.6.57	A contrast medium for use in hysterosalpingography
Effervescent Tablets	6202	12.6.57	As an adjunct in feeding
Sodium Citrate 2 grains	6211	12.6.57	As an adjunct in feeding
Sodium Salicylate gr. 10	6211	12.6.57	For the relief of the pain of rheumatism, gout, neuralgia, sciatica, migraine, tonsillitis, fibrositis, and feverish conditions
Sonergan Tablets	6218	12.6.57	As a sedative and hypnotic
Sore Throat Gargle	6207	12.6.57	For the relief of sore and inflamed throats
Sparine Injection	6212	12.6.57	For use in the management of acutely disturbed patients
Sparine Tablets	6213	12.6.57	For use in the management of acutely disturbed patients
Sparna Balm	6215	12.6.57	For the relief of muscular pain in rheumatism, fibrositis, lumbago, sciatica and cramp, stiffness and soreness after exertion, and sore and aching feet
Squill's Expectorant Mixture	6195	12.6.57	For the relief of coughs of colds
Stim Phosphated Tonic	6222	12.6.57	As a general tonic and to improve the appetite
Suntan Oil	6194	12.6.57	To protect the skin from harmful rays of the sun and to promote suntan
Suppositories of Aminophyllin gr. 2½	6220	12.6.57	For vasodilator effect
Suppositories of Aminophyllin gr. 5½	6221	12.6.57	For vasodilator effect
Trillekamin	6192	12.6.57	For the treatment of chronic leukaemias and Hodgkin's disease. Subject to Food and Drug Standards Regulation No. 76. (In lieu of Serial No. 3409 of 1.7.54)
Varidase	6125	12.6.57	For use in enzymatic debridement
Vi-Magna Capsules	6169	12.6.57	For the treatment of multi-vitamin deficiencies
Vita-Diet Tablets	6203	12.6.57	For temporary reduction of the sensations of hunger
Vitamed Tonic	6210	12.6.57	For vitamin B deficiencies and as a general tonic

Police Regulation Act 1946.

POLICE FORCE OF VICTORIA.

DETERMINATION NO. 63 OF THE POLICE CLASSIFICATION BOARD.

THE Police Classification Board, in pursuance of the powers in that behalf conferred by the *Police Regulation Act 1946*, hereby makes the following Determination, that is to say:—

1. The Determination No. 59 of the Police Classification Board of the 23rd July, 1956, and published in the *Government Gazette* of the 21st August, 1956, as amended, is hereby further amended as follows:—

(a) In paragraph 2 by deleting the definition "Officer" and substituting therefor the following:—

"Officer" means the Inspecting Superintendent and any Superintendent, Chief Inspector, Inspector, or (unless expressly stated otherwise) Station Officer."

(b) By deleting sub-paragraph (a) of paragraph 7 and substituting therefor the following:—

"(a)

Officers.

<i>Rank.</i>	<i>Salary Per Annum. £</i>
Inspecting Superintendent	2,500
Superintendent, Grade I.	2,072
Superintendent, Grade II.	1,872
Chief Inspector	1,662
Inspector	1,557
Station Officer	1,405."

(c) In paragraph 9 by inserting immediately before the expression and figures "Officer in Charge, Melbourne District 100 0 0", the expression and figures:—

"Assistant Law Instructor, being a member admitted to practise as a Barrister and Solicitor in the State of Victoria (inclusive of any other Special Duties allowance) 150 0 0."

(d) In paragraph 9 by inserting the expression:—

"Station Officer or" before the expression "Sub-Officer in Charge, Russell-street Station."

(e) In paragraph 18 by deleting the expression:—

"Supervising Sub-Officer,"

and substituting therefor the expression:—

"Supervising Station Officer or Sub-Officer";

and by deleting the expression:—

"Sub-Officer in Charge of Foot Section of Branch",

and substituting therefor the expression:—

"Station Officer or Sub-Officer in Charge of Foot Section of Branch".

(f) In paragraph 21 by adding after the word "Officers" the expression:—

"not including Station Officers)";

and by deleting the expression:—

"Sub-Officers, First Constables and Constables"

and substituting therefor the expression:—

"Station Officers, Sub-Officers, First Constables and Constables."

(g) In sub-paragraph (a) of paragraph 22 by inserting the words "Station Officers", after the word "all."

(h) In paragraph 24 by deleting the expression:—

"Chief Inspector and Inspectors" and substituting therefor the expression "Chief Inspectors and Inspectors"; and by inserting immediately below the expression "Chief Inspectors and Inspectors" the expression:—

"Station Officers 70."

(i) In paragraph 25 by adding the expression "(other than a Station Officer)" after the word "Officer".

- (j) In paragraph 26 by deleting the expression "(other than an officer)" and substituting therefor the expression "(including a Station Officer, but not including an Officer)".
- (k) In paragraph 28 by adding the expression:—
 "(other than a Station Officer)" after the word "Officer".
- (l) In paragraph 29 by deleting the expression:—
 "(other than an Officer)" and substituting therefor the expression:—
 "(including a Station Officer but not including an Officer)".
- (m) In paragraph 34 by substituting the words "Station Officer" for the word "Sergeant".
- (n) In paragraph 35 by adding the expression and figures:—
 "Station Officers 100"
 immediately above the expression and figures:—
 "Sergeants 100"
- (o) In paragraph 37 by substituting the words "Station Officer" for the word "Sergeant"; and adding the expression:—
 "(other than a Station Officer)" after the word "Officer".
- (p) In sub-paragraph (a) of paragraph 38 by substituting the words "Station Officer" for the word "Sergeant".
- (q) In paragraph 40 by substituting the words "Station Officer" for the words "Sergeant".
- (r) In sub-paragraph (a) of paragraph 41 by substituting the words "Station Officer" for the word "Sergeant".
- (s) In sub-paragraph (a) of paragraph 42 by adding the expression:—
 "(other than a Station Officer)" after the word "Officer";
 and in sub-paragraph (b) thereof by substituting the word "such" for the word "an" wherever occurring.
- (t) In paragraph 44 by substituting the words "Station Officer" for the word "Sergeant"; and by adding the expression:—
 "(other than a Station Officer)" after the word "Officer".
- (u) In paragraph 126 by:—
 (i) Adding the expression "(not including Station Officers)" after the heading "Officers".
 (ii) Adding the words "Station Officers", at the beginning of the heading "Sub-Officers and Constables (Foot Police)".
 (iii) Adding the words "Station Officers", before the word "Sub-Officers" where second occurring under the sub-heading "Caps".
 (iv) Adding the words "Station Officers," before the word "Sergeants" under the sub-heading "Summer Uniform".
 (v) Adding the expression "(not including Station Officers)" after the word "Officers"; and adding the words "Station Officers," before the words "Sub-Officers and Constables" under the sub-heading "Buttons".
- (v) In paragraph 134 by:—
 (i) Adding the expression "(other than Station Officers)" after the word "Officers" in sub-paragraph (1).
 (ii) Adding the words "(other than Station Officers)" after the word "Officers" in sub-paragraph (2).
 (iii) Adding the words "Station Officers," before the word "Sub-Officers" in sub-paragraph (3).

(iv) Adding the expression:—

"Station Officer. A silver and red Crown enclosed by a laurel wreath worn on each sleeve, midway between the elbow and the sleeve head." before the word "Sergeant" in clause (a) of sub-paragraph (3).

(v) Adding the expression:—

"Station Officer. A navy-blue and red embroidered Crown enclosed by a laurel wreath, worn as prescribed for the uniform tunic." before the word "Sergeant" in clause (b) of sub-paragraph (3).

(w) In paragraph 135 by:—

(i) Adding the expression:—

"(not including Station Officers)" after the heading "Officers".

(ii) Adding the words "Station Officers," in the heading before the words "Sub-Officers and Constables".

(iii) Adding the words "Station Officers," before the word "Sub-Officers" in the sub-heading "Buttons".

(x) By adding to the captions under photographs Nos. 1 and 2 in the First Schedule in each instance after the word "Officer" the words "(not including Station Officer)"; and to those under photographs Nos. 1, 2, 3, 4, and 5 of the Second Schedule in each instance the words "Station Officers," before the word "Sub-Officers".

2. This Determination shall come into operation on the 30th day of June, 1957.

Dated at Melbourne, this 18th day of June, 1957.

J. F. MULVANY,

A Judge of County Courts, Chairman and
Member of the Police Classification Board.

S. R. MUDIE,

Member of the Police Classification Board.

F. G. HOLLAND,

Member of the Police Classification Board.

ORDERS IN COUNCIL.—(Series 1956-57.)**EDUCATION DEPARTMENT.**

6629. One only Hilger TT 288 inspection enlarger, 15 in. x 12 in. screen, complete with lenses, micrometer, co-ordinator stage, centre holder for screws, and spare lamp, for Ballarat School of Mines, £658 9s.—William Adams and Co. Ltd., 521-523 Collins-street, Melbourne.

6630. One only Crosley kitchen freezer, for Gordon Institute of Technology, Geelong, £187 5s.—James N. Kirby Sales Pty. Ltd., Cato-street, Hawthorn East.

6631. One only shaping machine, for Gordon Institute of Technology, Geelong, £567 9s.—William Adams and Co., Collins-street, Melbourne.

6632. One only valve refacing machine, for Gordon Institute of Technology, Geelong, £116.—Replacement Parts Pty. Ltd., 263 Moorabool-street, Geelong.

6633. One only electronic adjustable speed drive control unit, for Gordon Institute of Technology, Geelong, £423.—Stewart J. Mathews, William-street, Melbourne.

6634. One only tape recorder, for Gordon Institute of Technology, Geelong, £110.—Velco Sound Systems Pty. Ltd., 520 Bridge-road, Richmond.

Approved by the Governor in Council, 19th June, 1957.
—A. MAHLSTEDT, Clerk of the Executive Council.

STATE ELECTRICITY COMMISSION.

6635. The supply of three-phase windings for 22 kV and 6.6 kV transformers, Newport Power Station, to Quotation No. 5276, £9,981.—Australian Electrical Industries Pty. Ltd.

6636. The construction of office and amenities block, Maintenance Workshops, Morwell Project, to Specification No. 56-57/136, £5,330.—J. J. Marr and Sons Pty. Ltd.

Approved by the Governor in Council, 11th June, 1957.
—A. MAHLSTEDT, Clerk of the Executive Council.

CONTRACTS ACCEPTED.—(Series 1956-57.)**VICTORIAN RAILWAYS.**

156. Equipment for automatic signalling on Glen Waverley line, at rates (Contract 60532).—McKenzie and Holland (Aust.) Pty. Ltd. 157. Roofing East End, No. 1 Platform, Flinders-street, for £1,625 17s. (Contract 61149).—Nuroof (Vic.) Pty. Ltd. 158. Bread and bread rolls, at rates (Contract 61154).—Universal Bakeries Pty. Ltd.

By order of the Victorian Railways Commissioners,

P. FARNAN, Secretary. 21.6.57.

PUBLIC WORKS.

6547. Toorak, Teachers' College, (1) supply and fix fibrous plaster sheeting, £226 13s.—Pascoe Plaster Products.

6548. Toorak, Teachers' College, (1) reconditioning of whole staircase and extending same, £1,787 15s.—H. S. Kent.

6549. Chadstone Park, State School No. 4669, (2) supply and installation of Goodrid incinerator, £123.—J. D. MacDonald Engineering Co. Pty. Ltd.

6550. Mont Park, Mental Hospital, (1) conversion of storeroom to bathroom and lavatory, £237 10s.—P. C. Brewer.

6551. Longford, State School No. 194, (2) removal of old fence, supply and erection of new post and wire fencing, £148.—R. Logan.

6552. Melbourne, Public Library, (3) structural alterations to penthouse over supervisor's quarters, £230.—C. E. Nicholls.

6553. Melbourne, "Milton House," Flinders-lane, (1) installation of fluorescent fittings, £220.—J. Newall.

6554. Melbourne, Public Library, (3) partitions and ventilation, &c., £245.—L. A. Stronach.

6555. Lallat Plains, State School No. 1686, (1) re-bracing of buildings, &c., £128 4s.—C. W. Taylor.
6556. Alphington, State School No. 3599, (1) supply and installation of gas thermolator heating, £392 13s.—Gas and Fuel Corporation of Victoria.
6557. Ararat, Mental Hospital, (1) electrical installation, £193 10s.—Pain and Gemmola.
6558. Cheitenham, Court House, (1) supply and installation of gas heaters and gas sink heaters, £386.—Gas and Fuel Corporation of Victoria.
6559. Carlton, Bouverie-street Clinic, (1) provision of hand basin, &c., £131 18s. 5d.—W. J. Bugg and Son.
6560. Sunbury, Mental Hospital, (1) repairs, &c., to verandah, ward M.6, £269 18s.—L. W. Friezer.
6561. Ballarat, State School No. 695, (1) supply and installation of thermolators and fires, &c., £1,091 6s. 3d.—Ballarat Gas Co.
6562. Stawell, High School, (2) internal and external painting, £225.—F. H. Wilson.
6563. Melbourne, Cancer Institute, (1) alterations to passenger lift, £953.—Johns and Waygood Ltd.
6564. Yarrunga, State School No. 4761, (1) supply and installation of gas thermolators, £257 8s. 3d.—Colonial Gas Association Ltd.
6565. Geelong, Police Station, (1) patching, grading, and resealing roadway, £466 8s.—J. H. Lewis and Son.
6566. Williamstown, Dredging Depot, Launch Bass, (1) supply and fitting type 616 M.G.R. Lister marine diesel engine, 62 b.h.p., &c., £2,143.—Mitchell and Co. Pty. Ltd.
6567. Ellinbank, Dairy Research Station, (1) supply and erection of hay shed, £647.—Welch, Perrin and Co. Pty. Ltd.
6568. Blackburn, High School, (1) sewer extension, £253 3s. 5d.—Melbourne and Metropolitan Board of Works.
6569. Highett, State School No. 4267, (1) repairs, &c., to storm damage, £325.—B. Motton.
6570. Myrtleford, Tobacco Research Station, (1) supply and installation of slow-combustion stove and hot-water service, £279 10s.—Ross's Pty. Ltd.
6571. North Fitzroy, State School No. 1490, (1) supply and installation of gas thermolators, £1,090.—Gas and Fuel Corporation of Victoria.
6572. Melbourne, Titles Offices, (2) renewal of spouting, down pipes, &c., £395.—A. Crewther and Son Pty. Ltd.
6573. South Melbourne, Public Works Department Storeyard, (1) supply of fencing wire, £189 13s. 3d.—Greer and Ashburner Pty. Ltd.
6574. Burwood, Teachers' Training College Hostel (1) supply of door jams, £221 5s.—W. S. Neelands Pty. Ltd.
6575. Werribee, State Research Farm, (1) supply of hardwood timber, flooring, beading, skirting, &c., £226 19s. 6d.—Brunswick Timber Co. Pty. Ltd.
6576. South Melbourne, Public Works Department Storeyard, (1) supply of 1 ton of deck spikes, £123 5s.—McPherson's Ltd.
6577. Geelong, Gordon Institute of Technology, (1) supply of suds, pump motor, and strainer, £122.—William Adams and Co. Ltd.
6578. Melbourne, Royal Melbourne Technical College, (1) supply of 280 feet of mild steel angles and 136 checker plates, £267 15s.—H. S. Kent.
6579. South Melbourne, Public Works Department Storeyard, (1) supply of 2,000 earthenware pipes, £356 5s.—Melbourne Pottery Co. Pty. Ltd.
6580. Werribee South, Foreshore, (1) supply and delivery of spalls, £224 5s.—H. L. B. Powell.
6581. Mt. Buller, Tourist Resort, (1) cartage of stone, sand, &c., £168 10s.—Max Otter.
6582. Beechworth, Reformatory Prison, (1) supply of hardwood, £219 18s. 8d.—Australian Furniture Timbers Pty. Ltd.
6583. McKinnon, High School, (1) supply of electric incinerators, £114 4s.—Noyes Bros. (Melbourne) Pty. Ltd.
6584. Beechworth, Mental Hospital, (1) supply of wire netting, £115 19s.—Briscoe and Co. Ltd.
6585. Preston, Girls' School, (1) supply of electric hot press, £212 10s.—K. G. Luke (A/sia) Ltd.
6586. Nhill, High School, (1) supply of concrete pipes, £517 11s.—Rocla Pipes Ltd.
6587. Burwood, Teachers' Training College, (1) supply of oregon and hardwood timber, £125 15s. 7d.—W. S. Neelands Pty. Ltd.
6588. Footscray, Technical School, (1) supply of industrial unit lamps complete, £132.—Australian Electrical Industries Pty. Ltd.
6589. Burwood, Technical School, (1) supply of saw bench complete with motor, £478.—Wolfenden Machinery Pty. Ltd.
6590. Ouyen, High School, (1) supply of ice cream cabinet and soup urn, £548.—M. F. Ahearn and Co. Pty. Ltd.
6591. Coburg, Penal and Gaols, (1) supply of plumbing materials, £466.—John McIlwraith Industries Ltd.
6592. Dookie, Agricultural College, (1) supply of hardwood timber, £114 9s.—Brunswick Timber Co. Pty. Ltd.
6593. Kyneton, High School, (1) supply of Leonard long-door refrigerator, £113 10s. 3d.—Warburton, Franki (Melbourne) Pty. Ltd.
6594. Oak Park, State School No. 4721, (1) supply of premix screenings and salamander, £283 16s.—Albion Quarrying Co. Pty. Ltd.
6595. Mt. Waverley, State School No. 3432, (1) supply of concrete pipes, £110 2s. 8d.—Rocla Pipes Ltd.
6596. Melbourne, Public Works Department, Treasury Buildings, (1) supply of six (6) typewriters, £437 3s. 6d.—Control Systems (A/sia) Pty. Ltd.
6597. Belmont, High School, (1) supply of bench grinder with accessories, £155 4s.—Frank Vial and Sons Pty. Ltd.
6598. Kew, Mental Hospital, (1) supply of washing machines, £126 7s. 4d.—Lightburn and Co. Ltd.
6599. Ferntree Gully, Tourist Resort, (1) supply of bricks, £280.—Glen Iris Brick, Tile and Terra Cotta Co. Pty. Ltd.
6600. Bellvue, State School No. 4733, (1) supply and delivery of crushed rock, £155.—D. Germano and Son.
6601. Elwood, High School, (1) supply of crushed rock, £330.—D. Germano and Son.
6602. Bennettswood, State School No. 4693, (1) supply and delivery of crushed rock, £150.—D. Germano and Son.
6603. Caulfield South, State School No. 4315, (1) supply and delivery of crushed rock, £434.—D. Germano and Son.
6604. Trafalgar, State School No. 2185, (1) supply of screenings, sand, &c., £235 10s.—Ern Cook.
6605. St. Albans, State School No. 4741, (1) supply of salamander and screenings, &c., £270.—Albion Quarrying Co. Pty. Ltd.
6606. Fawkner, High School, (1) supply of salamander, £228.—Albion Quarrying Co. Pty. Ltd.
6607. Pascoe Vale, Girls' School, (1) supply of salamander and screenings, £102 12s.—Reid Bros. and Reid Pty. Ltd.
6608. Fawkner, High School, (1) supply of salamander, £190.—Albion Quarrying Co. Pty. Ltd.
6609. Werribee South, Foreshore Works, (4) supply of spalls, £585.—H. L. B. Powell.
6610. Port Melbourne, Public Works Department Depot, (1) supply of metal, £103 2s. 6d.—Reid Bros. and Reid Pty. Ltd.
6611. Port Melbourne, Public Works Department Depot, (1) supply of screenings, £144 10s.—G. H. Reid and Sons.
6612. Port Melbourne, Public Works Department Depot, (1) supply of toppings, £370 0s. 3d.—Willis Quarries.
6613. Bacchus Marsh, High School, (1) supply of screenings, metal, &c., £115 8s.—J. T. Madden Pty. Ltd.
6614. Braybrook, State School No. 1102, (1) supply of screenings, £154 0s. 6d.—Albion Quarrying Co. Pty. Ltd.
6615. Melbourne, additional State Offices, (1) supply of oregon and hardwood, £304 3s. 9d.—H. Beecham and Co. Ltd.
6616. Mont Park, Gresswell Sanatorium, (1) supply of one set of developing tanks, £284 10s.—Medical Equipment Services Pty. Ltd.
6617. Ballarat, Mental Hospital, (1) supply of fencing material, including field gates, chain mesh, pipes, &c., £302.—A. Arnold's Fences Pty. Ltd.
6618. Springvale, "Quonset," (1) supply of air circulators and oscillating desk fans, £258 10s.—British General Electric Co. Pty. Ltd.
6619. Melbourne, Cancer Institute, (1) supply of electric peeler, stainless steel peel trap, and gravity food slicing machine, £284 15s.—Brice Scale and Slicer Co. Pty. Ltd.
6620. Various, South Pier, Queenscliff and Wedge Light, (1) supply of sawn hardwood, £173 2s. 3d.—S. A. Armistead Pty. Ltd.
6621. Port Melbourne, Public Works Department Depot, (3) supply of two (2) Imperial road and path rollers with worm and wheel enclosed steering, &c., and equipment, £2,568.—A. H. McDonald and Co. Pty. Ltd.
6622. Brunswick South-west, State School No. 4304, (1) supply of bituminous screenings and toppings, £224 5s. 6d.—Albion Quarrying Co. Pty. Ltd.
6623. St. Leonards, Pier reconstruction, (1) supply of spalls, £221 6s. 10d.—J. Starbuck and Sons.
6624. Kyneton, High School, (1) supply of workshop equipment, £700 18s. 6d.—McPherson's Ltd.
6625. Foster, High School, (1) supply of lathes, hack saw, machines, and tools, £711 17s. 6d.—McPherson's Ltd.
6626. South Yarra, Park Mansions, (1) supply of sawn oregon, £189 9s. 8d.—W. S. Neelands Pty. Ltd.
6627. Pascoe Vale, Melbourne Textile Trades School, (1) supply of screenings, £183 10s. 6d.—Willis Quarries.
6628. Kew, Glendonald School for Deaf, No. 4683, (1) supply of lathes, tools, &c., £230 8s.—McPherson's Ltd.

CONTRACTS ACCEPTED.—(Series 1957-58.)

Contract No.	Particulars.	Amount.	Name of Contractor.	Charge against Vote or Fund.
1	CARTAGE (METROPOLITAN)— Cartage and delivery of Goods and Parcels, as may be required to be forwarded to and from the various Government Offices, Railways, &c., by the Stores and Transport Office for and on behalf of the Government of Victoria, as per Schedule No. 1, from 1st July, 1957, to the 30th June, 1958	Rates as per annex	Mayne Nickless Limited	Contingencies, 1957-58.

Approved—H. E. BOLTE, Treasurer. 18.6.57.

ANNEX TO CONTRACT No. 1957/1.
Schedule No. 1.

CARTAGE AND DELIVERY OF GOODS AND PARCELS.
(METROPOLITAN.)
1957/1.—Mayne Nickless Limited, 94 York-street, South Melbourne.
Security, £40.

Item.	Service.	At.	Rate.
1	Cartage and Delivery of Goods and Parcels (with the exceptions set out in Clause 1 of the Conditions of Contract) within the City Boundaries and a radius of twelve (12) miles of the Melbourne (Elizabeth-street) Post Office— Two vehicles, 30-cwt. capacity, motor driven, with drivers (for full-time service)	per week ..	£ s. d. 90 0 0

CONTRACTS ACCEPTED.—(Series 1957-58.)

Contract No.	Particulars.	Amount.	Name of Contractor.	Charge against Vote or Fund.
2	CARTAGE (METROPOLITAN)— Cartage and delivery of Heavy Goods as per Schedule No. 2, from 1st July, 1957, to 30th June, 1958	Rates as per annexe	Thomas Warr and Co. Pty. Ltd.	} Contingencies, 1957-58
3	Cartage and delivery of Coal, as per Schedule No. 3, from 1st July, 1957, to 30th June, 1958	Ditto ..	N. F. Matthews	

Approved—H. E. BOLTE, Treasurer. 18.6.57.

ANNEX TO CONTRACT No. 1957/2.
Schedule No. 2.

1957/2.—Thomas Warr and Co. Pty. Ltd., 2 King-street, Melbourne, C.1. Security, £10.
CARTAGE AND DELIVERY OF HEAVY GOODS (METROPOLITAN).

The service tendered shall include the cartage and delivery of Machinery and other Heavy Goods and Materials, as required; the rates tendered to include the provision of all labour, gear, and appliances required for loading the goods from ground to vehicle, and vice versa, and from railway truck, wharf, &c., to vehicle, and vice versa. Distances to be calculated by the shortest reasonable route. Fractions of a mile to be calculated to the nearest quarter mile and fractions of a ton to the nearest quarter ton.

Service.	Rate per Ton.		Rate per Ton per Mile. (Calculated from Point of Pick-up to Point of Delivery.)						Rate per Mile per Vehicle (Empty Running—One Way).*
	To or from Public Works Department and S.E. and W.S. Commission Storeyards, South Melbourne, and—		Up to 2 Miles.	Over 2 Miles Up to 4 Miles.	Over 4 Miles Up to 6 Miles.	Over 6 Miles Up to 10 Miles.	Over 10 Miles Up to 20 Miles.	Over 20 Miles.	
	Spencer-street Railway Goods Yards.								
Cartage and Delivery— By vehicles other than Low-Loader	s. d.	s. d.	s. d.	s. d.	s. d.	s. d.	s. d.	s. d.	
By Low-Loader	11 0	6 9	3 6	2 8	2 3	1 4	1 3	1 6	
	15 0	8 6	7 3	5 6	5 0	2 9	1 6	2 11	
								Rate per Hour.	
								£ s. d.	
Additional labour†	Per man	Per man and Gear (including use of motor vehicle)	0 9 3	
								1 4 6	

* Rate for empty running will be allowed only where the points of pick-up and delivery are both situated outside a radius of six (6) miles of the Melbourne (Elizabeth-street) Post Office; distances to be calculated from the said Post Office to point of pick-up only.
† Additional labour required for sorting, stacking, signing out, or for other purposes, to be provided only when authorized by the Officer requiring the service. The contractor shall not be bound to provide such additional labour if same is not available when required.

Detention Rate per hour—Truck—5-6 ton, 18s. 11d. .. Semi-Trailer, 22s. 9d. .. Low-Loaders, 30s.
 Mobile Crane Rate per hour, 27s. 6d. .. Lifting capacity over two tons or jib longer than 15 feet, 47s. 6d.

SPECIAL CONDITIONS.

Rates for cartage of goods not provided for in Schedule—Apply Tender Board.
 Time Basis.—Where it is not practicable to carry out the work on a tonnage basis and for cartage of small lots of 1 ton or under, the following rates per hour will apply:—

Truck.—5-6 ton, £1 4s. 6d.; semi-trailer, £1 11s. 6d.

Heavy Lifts.—To and from wharf, rail, and storeyards: charges to be by arrangements governed by weights and ruling rates. Saturday and Sunday or Public Holiday work to be charged at rate and a quarter and rate and a half, respectively.

ANNEX TO CONTRACT NO. 1957/3.

Schedule No. 3.

1957/3.—N. F. Matthews, 22 Westgarth-street, Northcote. Security, £10.

CARTAGE OF COAL (METROPOLITAN).

From the under-mentioned Railway Stations to places indicated hereunder.

Bags to be provided by Contractor, and sewn up if required. Bags to be collected by the Contractor when empty.

Item.	Railway Station.	Place where Delivery is Required.	Rate per Ton.	Name of Contractor.
1	South Brunswick ..	To Mental Hospital, Receiving House, and Children's Welfare Department, Royal Park ..	£ s. d. 0 8 0	} N. F. Matthews
2	Coburg	To Penal Establishment, Pentridge	0 8 0	
3	Kew	To Mental Hospital, Kew	0 8 0	
4	Victoria Park ..	To Exhibition Buildings and Public Offices, Melbourne	0 8 0	
5	Spencer-street or other Stations within the Metropolitan Area	To Government offices and institutions (other than those specified under Items 1 to 4), within a radius of 10 miles from the Melbourne (Elizabeth-street) Post Office	To be arranged by State Coal Mine	

CONTRACTS ACCEPTED.—(Series 1957-58.)

Contract No.	Particulars.	Amount.	Name of Contractor.	Charged against Vote or Fund.
	CARTAGE (COUNTRY)— Cartage and delivery of goods and parcels and removals of Officers' furniture, &c., as may be required for State Departments, from 1st July, 1957, to 30th June, 1958—			
4	Ararat: Security, £10	Rates as per Annex	Schirmer and Powell ..	} Contingencies, 1957-58
5	Bairnsdale .. £10	Ditto	J. G. Ashby and Co. ..	
6	Ballarat .. £10	Ditto	Kennedy, Murray Pty. Ltd.	
7	Bendigo .. £10	Ditto	W. McCulloch and Co. Pty. Ltd.	
8	Castlemaine .. £10	Ditto	L. Chapman	
9	Hamilton .. £10	Ditto	E. B. Preston	
10	Nowa Nowa .. £10	Ditto	R. R. Hodder	
11	Stawell .. £10	Ditto	G. P. Frencham	
12	Warnambool .. £10	Ditto	A. Muffett	

Approved—H. E. Bolte, Treasurer. 18.6.57.

ANNEX TO CONTRACT NOS. 1957/4 TO 1957/12.

	No. 4, Ararat, Schirmer and Powell.		No. 5, Bairnsdale, J. G. Ashby and Co.		No. 6, Ballarat, Kennedy, Murray Pty. Ltd.		No. 7, Bendigo, W. McCulloch and Co. Pty. Ltd.		No. 8, Castlemaine, L. Chapman.	
	Goods Generally.	Furniture.	Goods Generally.	Furniture.	Goods Generally.	Furniture.	Goods Generally.	Furniture.	Goods Generally.	Furniture.
	<i>s. d.</i>	<i>s. d.</i>	<i>s. d.</i>	<i>s. d.</i>	<i>s. d.</i>	<i>s. d.</i>	<i>s. d.</i>	<i>s. d.</i>	<i>s. d.</i>	<i>s. d.</i>
Over 28 lb. ..	2 6	4 6	1 0	1 6	1 6	2 6	2 0	2 6	1 9	1 9
Up to 28 lb. for ..	3 6	6 6	1 6	2 0	2 3	3 6	2 3	3 0	2 0	2 0
56 ..	4 6	8 6	1 9	2 6	2 9	4 6	2 6	3 6	2 3	2 3
84 ..	6 0	10 6	2 0	3 0	3 6	5 6	3 0	5 0	2 6	2 6
1 cwt. ..	7 0	12 6	2 6	3 6	4 0	7 0	4 0	6 0	3 3	3 3
2 ..	8 0	15 6	3 0	4 0	5 0	8 9	4 6	6 6	4 0	4 0
3 ..	9 6	18 6	3 6	5 0	6 3	10 9	6 0	8 0	5 6	5 6
4 ..	12 6	22 0	4 0	6 0	7 3	14 0	7 0	10 0	5 6	5 6
5 ..	16 6	30 0	6 0	7 0	10 6	22 0	9 0	15 6	9 6	9 6
10 ..	20 0	35 0	7 6	8 0	13 6	30 0	13 6	27 6	11 0	11 0
15 ..	20 0	40 0	8 0	10 0	14 6	40 0	15 6	32 6	12 0	12 0
1 ton, at per ton ..	20 0	40 0	8 0	10 0	14 6	40 0	12 6	37 6	12 0	12 0
Removal by furniture van (or as stated) of Officers' furniture and effects, including loading and reloading, at per van per hour	<i>s. d.</i> 40 0	<i>s. d.</i> 20 0	<i>s. d.</i> 26 0	<i>s. d.</i> 38 0	<i>s. d.</i> 26 0	<i>s. d.</i> 40 0	<i>s. d.</i> 40 0	<i>s. d.</i> 35 0	<i>s. d.</i> 35 0	<i>s. d.</i> 35 0

CONTRACTS ACCEPTED.—(Series 1957-58.)

	No. 9. Hamilton. E. B. Preston.		No. 10. Nowa Nowa. R. R. Hodder.		No. 11. Stawell. G. P. Frencham.		No. 12. Warrnambool. A. Murfett.					
	Goods Generally.	Furniture.	Goods Generally.	Furniture.	Goods Generally.	Furniture.	Goods Generally.	Furniture.	Mental Hospital.			
									Goods Generally.	Furniture.		
	<i>s. d.</i>	<i>s. d.</i>	<i>s. d.</i>	<i>s. d.</i>	<i>s. d.</i>	<i>s. d.</i>	<i>s. d.</i>	<i>s. d.</i>	<i>s. d.</i>	<i>s. d.</i>		
Up to 28 lb. for	2 9	3 9	} 20s. per ton	} 20s. per ton	1 0	1 6	1 6	1 6	2 0	2 6		
Over 28 lb. .. 56 ..	3 9	4 6			1 6	2 0	2 0	2 6	3 0	3 0	3 6	
.. 56 84 ..	4 6	5 9			1 9	2 0	2 6	3 0	4 0	4 0	4 6	
.. 84 112 ..	5 9	6 6			2 0	2 6	3 0	3 6	5 0	5 0	5 6	
.. 1 cwt. .. 2 cwt. for	6 6	7 6			2 6	3 0	3 6	4 0	6 0	6 0	7 6	
.. 2 3 ..	7 6	10 0			2 9	3 9	4 6	5 0	6 6	6 6	8 6	
.. 3 4 ..	10 0	12 6			3 6	4 6	5 6	6 0	7 6	7 6	9 6	
.. 4 5 ..	12 6	15 0			4 6	5 0	6 6	7 6	8 6	8 6	10 0	
.. 5 10 ..	20 0	20 0			5 6	6 6	8 6	12 6	15 0	15 0	15 0	
.. 10 15 ..	30 0	30 0			7 6	9 0	10 6	15 0	17 6	17 6	22 6	
.. 15 1 ton for	40 0	40 0			9 0	12 0	15 0	30 0	25 0	25 0	30 0	
.. 1 ton, at per ton	45 0	45 0			12 0	15 0	12 6	25 0	20 0	20 0	20 0	
Removal by furniture van (or as stated) of Officers' furniture and effects, including loading and reloading, at per van per hour	<i>s. d.</i> 30 0 (by lorry) including extra man 42s. 6d.				..		<i>s. d.</i> 30 0		<i>s. d.</i> 25 0			

CONTRACTS ACCEPTED.—(Series 1957-58.)

Contract No.	Particulars.	Amount.	Name of Contractor.	Charge against Vote or Fund.
13	CARTAGE (METROPOLITAN)— Cartage, delivery, or storage of Migrants' Baggage as per Schedule No. 1A from 1st July, 1957, to 30th June, 1958	Rates as per annex	F. H. Stephens (Vic.) Pty. Ltd.	Contingencies, 1957-58

Approved—H. E. BOLTE, Treasurer. 18.6.57.

ANNEX TO CONTRACT NO. 1957/13.
Schedule No. 1A.

1957/13.—F. H. Stephens (Vic.) Pty. Ltd., off 554 Flinders-street, Melbourne. Security, £30.

CARTAGE OF MIGRANTS' BAGGAGE.

The service tendered shall include superintending discharge, customs clearance from Port Melbourne, River Yarra, or Victoria Dock berths, and delivery or storage within the Metropolitan Area, as required; the rates tendered to include the provision of all labour, gear, and appliances required for loading or storing the baggage. City delivery to include East Melbourne.

Description of Baggage.	Superintending Discharge, Portage, Customs Clearance, Sorting at Victoria Dock or River Yarra Berths and Port Melbourne, and Delivery to—		Re-delivery from Store to—		Storage (per Week).	Charges for Attendance at Customs House for Lodging Customs Entry and Preparing Necessary Statutory Declarations, &c.
	Store, Rail, or City.	Suburbs up to Ten Miles from Elizabeth-street Post Office.	Rail or City.	Suburbs up to Ten Miles from Elizabeth-street Post Office.		
Suit cases, hat boxes, &c. ..	<i>s. d.</i> 3 6	<i>s. d.</i> 4 6	<i>s. d.</i> 2 6	<i>s. d.</i> 3 0	<i>d.</i> 6	<i>s. d.</i> 17 6
Cabin trunks, packing cases—up to 6 cubic feet ..	5 0	6 6	4 0	4 0	6	17 6
Saratoga trunks, wardrobe trunks, packing cases—up to 10 cubic feet	5 0	6 6	4 0	4 0	6	17 6
Packages—over 10 cubic feet and up to 20 cubic feet ..	5 0	6 6	4 0	4 0	6	17 6
Packages—over 20 cubic feet ..	4d. per cub. ft.	6d. per cub. ft.	4d. per cub. ft.	4d. per cub. ft.	8d. per cub. ton	17 6

CONTRACTS ACCEPTED.—(Series 1957-58.)

Contract No.	Particulars.	Amount.	Name of Contractor.	Vote or Fund.
14	PURCHASE OF RAGS— Purchase and removal of Rags from the various Government institutions, in such quantities as the contractor may be required to remove, for the period 1st July, 1957, to 30th June, 1958, at	per cwt. £ <i>s. d.</i> 4 5 3	Riviera Trading Co. Pty. Ltd., 80 Baker's-road, North Coburg	No. 9 Miscellaneous. Sale of Government Property

Approved—H. E. BOLTE, Treasurer. 18.6.57.

CONTRACTS ACCEPTED.—(Series 1957-58.)
CEREALS.

Requirements under Sub-Schedule No. 7 of Schedule No. 1 for the month of July, 1957, are to be purchased under agreement from the under-mentioned firms at the rates per cwt. respectively indicated, viz., Robert Harper and Co. Ltd.—Oatmeal—plain, 39s. 9d.; Rice—unpolished, 90s., less 3 per cent. 14 days or 2½ per cent. 28 days. H. S. K. Ward Pty. Ltd.—Barley—pearl, 43s.; Oatmeal—flaked, 49s.; Peas—split—yellow, 76s. 6d.; Rice—dressed, 88s., less 3 per cent. 14 days or 2½ per cent. 30 days.

W. H. RUTHERFORD, Secretary to the Tender Board.
24.6.57.

APPOINTMENT.

CHAIRMAN OF THE COAL MINE WORKERS' PENSIONS TRIBUNAL.

HIS Excellency the Lieutenant-Governor of the State of Victoria, by and with the advice of the Executive Council thereof, and in pursuance of the provisions of section 18 of the *Coal Mine Workers' Pensions Act 1942*, doth by Order made on the 25th day of June, 1957, appoint

ERNEST WILLIAM LESLIE BUCK
to be Chairman of the Pensions Tribunal, in the place of Thomas Charles Worboys, resigned.

A. MAHLSTEDT,
Clerk of the Executive Council

At the Executive Council Chamber,
Melbourne, 25th June, 1957.

STATE RIVERS AND WATER SUPPLY COMMISSION.

BY-LAW No. 5141.—CHARGE FOR WATER DIVERTED FROM DRAINAGE CHANNELS.

THE State Rivers and Water Supply Commission, in pursuance and exercise of the powers conferred by the Water Acts, doth hereby make the By-law following:—

1. The following charge for water is hereby made under the provisions of the Water Acts and shall be levied

upon the occupiers or owners of all lands to which water is authorized by agreement to be diverted for irrigation from drainage channels in the Deakin, Dingle, Katandra, Shepparton, North Shepparton, Rochester, Tongala-Stanhope, Tragowel Plains, Murray Valley, Cohuna, Kerang, Swan Hill, Central Gippsland, Maffra-Sale, and Werribee Irrigation and Water Supply Districts:—

The charge for the diversion of water from drainage channels for the irrigation of lands in the aforesaid districts shall be—

(a) At the rate of 7s. 6d. for each acre-foot of water to be diverted where such diversion is by gravitation, and

(b) at the rate of 2s. 6d. for each acre-foot of water authorized to be diverted where such diversion is by pumping.

2. Such charge is made and shall be levied for the period beginning with the 1st day of July in each year and ending with the 30th day of June in the year next ensuing, and shall be payable on the 1st day of July in each year at the office of the State Rivers and Water Supply Commission, at 100 Exhibition-street, Melbourne.

3. Such person or persons as the State Rivers and Water Supply Commission may from time to time appoint for that purpose shall be and is or are hereby authorized to demand, receive, collect, and recover the said charge for water diverted for irrigation from drainage channels.

The foregoing By-law was made by the State Rivers and Water Supply Commission on the eighteenth day of June, 1957, and the common seal of the said Commission was hereunto affixed the 21st day of June, 1957, in the presence of—

(SEAL) L. R. EAST, Chairman.
H. W. McCAY, Commissioner.
J. A. AIRD, Commissioner.

Approved by the Governor in Council, 25th June, 1957.—
A. MAHLSTEDT, Clerk of the Executive Council.

STATE RIVERS AND WATER SUPPLY COMMISSION.

LICENCES TO DIVERT WATER AND CUT RACES, PURSUANT TO THE PROVISION OF THE WATER ACTS.

LICENCES as detailed hereunder for the term of years from the date specified in each case have been granted by the Governor in Council to the persons named in the following Schedule:—

SCHEDULE.

Licence No.	Term of Licence and Commencing Date.	Name and Address of Person to Whom Licence is to be Granted.	Source of Supply.	Area Authorized to be Irrigated per Annum.	Volume of Water Authorized to be Diverted per Annum.
				acres.	ac. ft.
1095	Fifteen years from 1.7.57 ..	Thomas Mossop (junior), Bear's Lagoon	Serpentine Creek ..	30	60
1096	Fifteen years from 1.7.57 ..	Keith Frederick Perry, Bear's Lagoon ..	Serpentine Creek ..	30	60
1097	Fifteen years from 1.7.57 ..	Cecil Claude Taylor, Serpentine ..	Serpentine Creek ..	50	100
1098	Fifteen years from 1.7.57 ..	The Executors of the Estate of Clare K. Long, Serpentine	Serpentine Creek ..	50	100
1099	Fifteen years from 1.7.57 ..	The Executors of the Estate of William T. H. Long, Serpentine	Serpentine Creek ..	50	100
1100	Fifteen years from 1.7.57 ..	Alan Gillespie Long, Serpentine ..	Serpentine Creek ..	50	100
1101	Fifteen years from 1.7.57 ..	Stephen McNamara, Serpentine ..	Serpentine Creek ..	20	40
1102	Fifteen years from 1.7.57 ..	Mary Dora Gray, Serpentine ..	Serpentine Creek ..	50	100
1103	Fifteen years from 1.7.57 ..	John Pitman Charles Tresise, Serpentine	Serpentine Creek ..	40	80
1104	Fifteen years from 1.7.57 ..	Gilbert George Gladman, Serpentine ..	Serpentine Creek ..	12	24
1105	Fifteen years from 1.7.57 ..	Wilton Cameron McKean and Jean Thelma McKean, Bendigo	Serpentine Creek ..	50	100
1106	Fifteen years from 1.7.57 ..	Mary Iris Tuohy, Serpentine ..	Serpentine Creek ..	30	60
1107	Fifteen years from 1.7.57 ..	Stephen Joseph Tuohy, Serpentine ..	Serpentine Creek ..	75	150
1108	Fifteen years from 1.7.57 ..	The Executors of the Estate of Thomas Mossop (senior), Bear's Lagoon	Serpentine Creek ..	20	40
1109	Fifteen years from 1.7.57 ..	Norman John Payne, Serpentine ..	Serpentine Creek ..	50	100
1110	Fifteen years from 1.7.57 ..	John Lionel Alexander Lea, Serpentine ..	Serpentine Creek ..	5	10
1111	Fifteen years from 1.7.57 ..	The Executors of the Estate of H. P. Adam (deceased), Bear's Lagoon	Serpentine Creek ..	50	100
1112	Fifteen years from 1.7.57 ..	John Thomas Berrigan, Red Cliffs ..	River Murray ..	1	3
1113	Fifteen years from 1.7.57 ..	The Executors of the Estate of G. R. Hope (deceased), Moorabool	Moorabool River ..	5	10
1114	Fifteen years from 1.7.57 ..	P. V. Feltham, Shepparton ..	Goulburn River ..	50	100
1115	Two years from 1.7.57 ..	The Executors of the Estate of J. H. Vains, Fish Point	Tatchewop Outfall	32	64
1116/369	Five years from 1.7.57 ..	Giuseppe D'Anna, Robinvale ..	River Murray ..	66	132
1117/746	Four years from 1.7.57 ..	Maxwell Joseph Judd, Gunbower	Gunbower Creek ..	25	50
143	Fifteen years from 1.7.57 ..	George Edward Heath, Piangil ..	River Murray ..	40	120

Office of the State Rivers and Water Supply Commission,
Melbourne, 19th June, 1957.

E. BROWN, Secretary.
State Rivers and Water Supply Commission.

LONGWOOD WATERWORKS TRUST.
RATING BY-LAW FOR THE YEAR 1957.

THE Longwood Waterworks Trust, in pursuance and exercise of the powers conferred by the Water Acts, doth hereby make the following rates for the supply of water for domestic purposes on lands and tenements liable to be rated within the district of the Trust.

On such lands and tenements a rate of Five shillings in the pound on the amount of the annual municipal valuation not exceeding Thirty-five pounds, and Four shillings in the pound on the amount of the annual municipal valuation exceeding Thirty-five pounds but not exceeding Fifty pounds, and Three shillings and six pence in the pound on the amount of the annual municipal valuation exceeding Fifty pounds but not exceeding Seventy-five pounds, and Three shillings in the pound on the amount of the annual municipal valuation exceeding Seventy-five pounds, provided that in no case shall the amount of rate payable per annum in respect of any tenement (other than land on which there is no building) be less than One hundred shillings, and in respect of any land on which there is no building less than Forty-five shillings.

Such rates are made and shall be levied upon the occupiers or owners of the said lands or tenements for the year commencing on the 1st day of January, 1957, and shall be payable on the 11th day of July, 1957, at the office of the said Trust.

Passed this 22nd day of May, 1957.

(SEAL.) R. J. HOUSTON, Chairman.
L. GRANT, Secretary.

Approved, 20th June, 1957.—G. O. REID, for Minister of Water Supply.

LANG LANG WATERWORKS TRUST.

FIXING THE LIMIT OF A BANK OVERDRAFT.

HIS Excellency the Lieutenant-Governor of the State of Victoria, by and with the advice of the Executive Council thereof, doth by Order made on the 19th day of June, 1957, in pursuance of the provisions of section 273 of the Water Act 1928, fix the limit of the overdraft to be obtained by the Lang Lang Waterworks Trust from the Bank of New South Wales, Warragul, at an amount not to exceed at any one time the sum of Eight thousand pounds (£8,000).

A. MAHLSTEDT,
Clerk of the Executive Council.

At the Executive Council Chamber,
Melbourne, 19th June, 1957.

NAGAMBIE WATERWORKS TRUST.

FIXING THE LIMIT OF A BANK OVERDRAFT.

HIS Excellency the Lieutenant-Governor of the State of Victoria, by and with the advice of the Executive Council thereof, doth by Order made on the 25th day of June, 1957, in pursuance of the provisions of section 273 of the Water Act 1928, fix the limit of the overdraft to be obtained by the Nagambie Waterworks Trust from the Commercial Bank of Australia Limited, Nagambie, at an amount not to exceed at any one time the sum of Five hundred pounds (£500).

A. MAHLSTEDT,
Clerk of the Executive Council.

At the Executive Council Chamber,
Melbourne, 25th June, 1957.

COMPANIES ACT 1938.

STATEMENT of the Registrar-General in pursuance of section 302 of the Companies Act 1938 showing amounts paid into the Supreme Court, Melbourne, and the particular Companies out of whose estates such amounts have been derived.

Date.	Name of Company.	Amount Paid into the Supreme Court.
		£ s. d.
5th June, 1957	P. Bird Pty. Ltd.	61 10 0
14th June, 1957	The Villa Building Co. Pty. Ltd.	4 10 0

T. S. WEJSH,
Deputy Registrar-General.

MELBOURNE AND METROPOLITAN BOARD OF WORKS.

NOTICE TO THE OWNERS OF TENEMENTS IN THE UNDER-MENTIONED STREETS, AND THE PRIVATE STREETS, LANES, COURTS, AND ALLEYS OPENING THERETO.

THE main pipe in the said streets being laid down, the owners of all tenements situated as under are hereby required, on or before 29th July, 1957, to cause a proper pipe and stop cocks to be laid, so as to supply water within such tenements from the main pipe.

C. F. TRATHAN,
Secretary.

18th June, 1957.

STREET AND POSITION.

Altona.

Maidstone-street, from 7½ chains north of Linnet-street to Morrow-street.

Morrow-street, from Maidstone-street to Galvin-street.

Galvin-street, from Morrow-street southwards 11½ chains.

Broadmeadows.

West-street, from 5½ chains north of South-street to Stella-street.

West-street, from Glenroy-road northwards 16½ chains.

Coburg.

The Boulevard, from Coonans-road westwards 5 chains.

Eltham.

Graeme-avenue, from Sherbourne-road to Baldwin-street.

Essendon.

Corio-street, from 3½ chains west of Aberfeldie-street westwards 3 chains.

Heidelberg.

Kanimbla-court, from Ramu-parade northwards 5 chains.

Crecy-court, from Waterdale-road westwards 3½ chains.

Right-of-way (2½ chains north of Norman-street), from Noel-street eastwards 2½ chains.

Mulgrave.

William-street, from Park-lane eastwards 11½ chains.

Madeline-street, from North-road southwards 15 chains.

Park-lane, from Princetown-road to William-street.

Sherwood-road, from Stevensons-road westwards 14½ chains.

Sherwood-road (south arm), from 3½ chains west of Stevensons-road southwards 2 chains.

Sherwood-road, from Park-lane to Cranleigh-grove.

Oakleigh.

Hargreaves-street, from Huntingdale-road to Shafton-street.

Hargreaves-street, from 1 chain west of Fenton-street westwards 7 chains.

Clifford-street, from Huntingdale-road eastwards 6½ chains.

Stafford-street, from Huntingdale-road eastwards 8½ chains.

Prahran.

Right-of-way (2 chains north of High-street), from Regent-street westwards 1 chain and thence northwards ½ chain.

Preston.

Summerhill-road, from Seston-street to Autumndale-avenue.

Autumndale-avenue, from Summerhill-road to Clingin-street.

Nisbett-street, from Seston-street to Autumndale-avenue.

Clingin-street, from Seston-street to Autumndale-avenue.

Wood-street, from Sheila-street eastwards 11 chains.

Ambon-street, from Wood-street to Tyler-street.

Laha-crescent, from Ambon-street westwards, northwards, and eastwards 23½ chains.

Whittlesea.

Norman-grove, from Caroline-street southwards 1½ chain.

ANNUAL LICENCE.

A LICENCE to carry on in Victoria, from 24th June, 1957, to 31st December, 1957, Fire, Marine, and Fidelity Guarantee Insurance business was issued to the under-mentioned company, on 24th June, 1957:—

THE AUSTRALIAN INDEMNITY INSURANCE CO. LTD.

D. G. RICHARDS,
Comptroller of Stamps.

State Electricity Commission Acts.
AGREEMENT RELATING TO THE ACQUISITION BY THE STATE ELECTRICITY COMMISSION OF VICTORIA OF AN ELECTRICITY SUPPLY UNDERTAKING AT APOLLO BAY OPERATED BY HUBERT ALEXANDER BLOCK.

HIS Excellency the Lieutenant-Governor of the State of Victoria, by and with the advice of the Executive Council thereof, doth by Order made on the 19th day of June, 1957, approve the terms of an agreement between the State Electricity Commission of Victoria and Hubert Alexander Block relating to the acquisition by the Commission of the electricity supply undertaking at Apollo Bay operated by the said Hubert Alexander Block, as authorized by the Apollo Bay Electric Lighting Order No. 294, 1956.

A. MAHLSTEDT,
 Clerk of the Executive Council.

At the Executive Council Chamber,
 Melbourne, 19th June, 1957.

Marine Act 1928.

APPOINTMENT.

HIS Excellency the Lieutenant-Governor of the State of Victoria, by and with the advice of the Executive Council thereof, and in pursuance of the provisions of section 95 of the *Marine Act 1928*, doth hereby approve the appointment by the Marine Board of—

JAMES DEMPSEY MACKAY,
 as Engineer-Surveyor for the period of six months commencing on the 1st July, 1957.

A. MAHLSTEDT,
 Clerk of the Executive Council.

At the Executive Council Chamber,
 Melbourne, 19th June, 1957.

Nurses Act 1956.

VICTORIAN NURSING COUNCIL.

ELECTION OF MEMBERS BY REGISTERED GENERAL NURSES.

PURSUANT to the Nurses Regulations, I hereby give notice that, for the forthcoming election of two registered general nurses for appointment to the Victorian Nursing Council, the following registered general nurses have been nominated:—

CUTHBERT, MARGARET BLYTH.
 DAVIES, SHIRLEY HELEN.
 DAWSON, EDITH MARY.
 HANNA, MARGARET JEAN.
 HEADBERRY, JEAN EVELYN.
 LONG, NANCY WINIFRED.
 MCMAHON, HELENA ELIZABETH.

E. F. FITZGIBBON,
 Returning Officer.

Department of Health, 295 Queen-street, Melbourne,
 20th June, 1957.

PUBLIC NOTICE.

AN auction of unclaimed and confiscated liquor in the possession of the Police will be held at the Police Licensing Branch, 43 Little Bourke-street, Melbourne, on Tuesday, the 23rd day of July, 1957, at 10 a.m.

S. H. PORTER,
 Chief Commissioner of Police.

STAMPS ACT 1946.

IN pursuance of the powers contained in the *Stamps Act 1946*, I hereby certify, until further notice, that New Dawn Consolidated No Liability is a company engaged solely or principally in the search or mining for gold.

Dated the 26th day of June, 1957.

D. G. RICHARDS,
 Comptroller of Stamps.

APPOINTMENTS.

HIS Excellency the Lieutenant-Governor of the State of Victoria, by and with the advice of the Executive Council thereof, has, by Orders made on the 19th day of June, 1957, been pleased to make the under-mentioned appointments, viz.:—

CHIEF SECRETARY'S DEPARTMENT.
Electoral Registrar (Acting).

GEORGE MORRIS BOURKE
 to be Electoral Registrar (Acting) for the Ascot Vale and Newmarket Subdivisions of the Electoral District of Flemington; and for the Carlton South, Melbourne, North

Melbourne, and Parkville Subdivisions of the Electoral District of Melbourne, to take effect on and from 11th June, 1957, during the absence on leave of Keith Reginald Jones.

DEPARTMENT OF CROWN LANDS AND SURVEY.

Bailiff of Crown Lands.

EDWIN TAME, Inspector of Land Settlement, Department of Crown Lands and Survey,
 to be a Bailiff of Crown Lands, without additional salary.

DEPARTMENT OF HEALTH.

Directors of Tuberculosis.

HOWARD MAXWELL JAMES, M.B., et Ch.B., J.P.,
 pursuant to the provisions of section 145 of the *Health Act 1956*, to be Director of Tuberculosis for the period 14th June, 1957, to the 10th August, 1957; and

DAVID BRAHAM ROSENTHAL, M.D., B.S., M.R.C.P.,
 pursuant to the provisions of section 145 of the *Health Act 1956*, to be Director of Tuberculosis for a period of five (5) years from the 11th day of August, 1957.

Government Representatives on Hospital Committees.

DAVID WILLIAM HAWTHORNE, A.I.C.A.,
 to be Government Representative on the Committee of Management of the Kerang and District Hospital, pursuant to the provisions of section 48 of the *Hospitals and Charities Act 1948*, for a term of three years, *vice* F. Quinn, resigned; and

WILLIAM ROBERT ARBLASTER
 to be Government Representative on the Committee of Management of the Castlemaine District Hospital, pursuant to the provisions of section 48 of the *Hospitals and Charities Act 1948*, for a further term of three years as from the 24th July, 1957.

LAW DEPARTMENT.

Chairman of General Sessions.

MAURICE LEO CUSSEN, a Barrister at Law of Victoria who has practised for a longer period than five years,
 to be a Chairman of General Sessions for the period from the 1st July, 1957, to the 30th June, 1958, both dates inclusive, to take effect from the date of commencement of duty.

Judge's Associate.

EWEN WANLISS, Associate,
 to be Associate (part-time) to His Honour Mr. Justice Reginald Richard Sholl, to take effect as on and from the 1st July, 1957, until the return of the Honorable Mr. Justice Sholl from extended approved leave and whilst Mr. Wanliss is engaged as assistant to the Librarian of the Supreme Court during that period.

Magistrates.

DUDLEY PEARCE SCHUBERT, 14 Kennealy-street, Surrey Hills,
 KENNETH JOHN CRAWFORD, Dandenong-road, Springvale North,
 WILLIAM STAFFORD, 24 Collins-street, Melbourne,
 ALFRED BRUCE ANDERSON, 67 Walsh-street, South Yarra,
 and
 ROBERT ANDREW FLETCHER, Athol-road, Noble Park,
 to Keep the Peace in the Central Bailiwick of the State of Victoria;
 JACK HILLARD STRAHAN, 9 Gordon-street, Boort,
 JOHN OWEN WOOD, Perrin-street, Robinvale, and
 RONALD JAMES GRAY, Warlen-avenue, Robinvale,
 to Keep the Peace in the Midland Bailiwick of the State of Victoria;
 ERNEST CHARLES MITCHELL, 3 Vale-street east, Moe;
 and
 ALBERT EDWARD HOLLONDS, "Mainlands," Benambra,
 to Keep the Peace in the Eastern Bailiwick of the State of Victoria; and
 JAMES RICHARDSON KEDDIE, 1 Vincent-avenue, Geelong West,
 to Keep the Peace in the Southern Bailiwick of the State of Victoria.

Commissioners for Taking Declarations, &c.

ROBERT EDWIN TANNER, Rosedale,
 EDWARD FRANCIS CAMPBELL, 589 Nepean Highway, Carrum, and
 MALCOLM JAMES WHIFFIN, 287 Camberwell-road, Camberwell,
 to be Commissioners for taking Declarations and Affidavits, pursuant to the provisions of the *Evidence Act 1928*, to resign upon removing from the neighbourhood of the addresses stated; and

EDWIN TAME, Inspector of Land Settlement, Department of Crown Lands and Survey, Melbourne, to be a Commissioner for taking Declarations and Affidavits, pursuant to the provisions of the *Evidence Act 1928*, to refrain from charging fees and to resign upon ceasing to occupy his present position.

Probation Officers for Children's Courts.

JOSEPH THOMAS JOHN GOFF, The Methodist Mission, 44 Errol-street, North Melbourne, to be a Probation Officer for the Children's Court at North Melbourne, pursuant to the provisions of the *Children's Court Act 1956*; and

THOMAS WILLIAM HEWLETT, Browning-street, Orbst, to be a Probation Officer for the Children's Court at Orbst, pursuant to the provisions of the *Children's Court Act 1956*.

Clerk of Children's Courts.

REGINALD JOHN MCALLISTER to be Clerk of the Children's Court at Yarram, Foster, and Toora, during the absence on annual leave of F. L. McConvill, to take effect from the date of commencement of duty.

Clerk of Petty Sessions.

PETER CHARLES CLOTHIER to be Clerk of Petty Sessions at Collingwood and Heidelberg, during the absence on sick leave of H. W. Pascoe, to take effect from the date of commencement of duty.

DEPARTMENT OF THE TREASURER.

Receivers of Revenue.

REGINALD JOHN MCALLISTER to act temporarily as Receiver of Revenue, Yarram, during the absence of E. L. McConvill on leave;

WILLIAM MICHAEL MURRAY to act temporarily as Receiver of Revenue, Ballarat, during the absence of N. J. Scannell on leave; and

RICHARD JOHN CANNING to act temporarily as Receiver of Revenue, Warrnambool, during the absence of J. F. O'Hara on leave.

Collectors of Imposts.

ROBERT LACEY to act temporarily as Collector of Imposts, Boiler Inspection Branch, Mines Department, during the absence of H. Cawley on leave;

WILLIAM PATRICK CUMMANS to act temporarily as Collector of Imposts, State Immigration Office, during the absence of B. N. Benedict on leave; and

JOHN PATRICK O'FARRELL to act temporarily as Collector of Imposts, Motor Registration Branch, during the absence of A. H. O'Dee on leave.

DEPARTMENT OF WATER SUPPLY.

Waterworks Trust Commissioner.

JAMES FREDERICK DARMODY to be a Commissioner of the Marysville Waterworks Trust for a period of four years from the date hereof, subject to the provisions of the Water Acts.

A. MAHLSTEDT,

Clerk of the Executive Council.

At the Executive Council Chamber,
Melbourne, 19th June, 1957.

RESIGNATIONS.

HIS Excellency the Lieutenant-Governor of the State of Victoria, by and with the advice of the Executive Council thereof, has, by Orders made on the 19th day of June, 1957, accepted the resignations of the persons named hereunder of the offices mentioned, viz.:—

CHIEF SECRETARY'S DEPARTMENT.

DAVID THOMAS JONES, as Chief Probation Officer for Victoria, to date from and inclusive of the 1st July, 1957.

LAW DEPARTMENT.

STAN THWAITES, as a Commissioner for taking Declarations and Affidavits, pursuant to the provisions of the *Evidence Act 1928*.

CHARLES JAMES DUNNE, as a Commissioner for taking Declarations and Affidavits, pursuant to the provisions of the *Evidence Act 1928*.

A. MAHLSTEDT,

Clerk of the Executive Council.

At the Executive Council Chamber,
Melbourne, 19th June, 1957.

TROTTLING RACES ACTS.

At the Executive Council Chamber, Melbourne, the nineteenth day of June, 1957.

PRESENT:

His Excellency the Lieutenant-Governor of Victoria.
Mr. Reid | Mr. McArthur.

APPOINTMENT OF MEMBERS OF THE TROTTLING CONTROL BOARD.

IN pursuance of the powers conferred by the Trotting Races Acts and all other powers him thereunto enabling, His Excellency the Lieutenant-Governor of the State of Victoria, in the Commonwealth of Australia, by and with the advice of the Executive Council of the said State, doth by this Order make the following appointments to the Trotting Control Board for a term of three years (that is to say):—

DUKE DOUGLAS PAINE, who shall be Chairman;

ARNALDO JOSEPH LEWIS JAMES,

LINDSAY GEORGE CURRELL NICHOLAS,

HERBERT FITZGERALD YUNCKEN

(appointed on the nomination of the executive committee of the Royal Agricultural Society of Victoria);

KEITH EDMUND BRAY,

ROBERT GRAHAM COCHRAN,

JOHN DANIEL MCPHAIL

(appointed from a panel of the names of five persons submitted by the executive committee of the Metropolitan and Country Trotting Association of Victoria).

And the Honorable Arthur Gordon Rylah, Her Majesty's Chief Secretary for the State of Victoria, shall give the necessary directions herein accordingly.

A. MAHLSTEDT,

Clerk of the Executive Council.

ELECTRIC LIGHT AND POWER ACT 1928 AND STATE ELECTRICITY COMMISSION ACTS.

At the Executive Council Chamber, Melbourne, the nineteenth day of June, 1957.

PRESENT:

His Excellency the Lieutenant-Governor of Victoria.
Mr. Reid | Mr. McArthur.

THE WALWA ELECTRIC LIGHTING ORDER
No. 260, 1948.—AMENDMENT TO TARIFF.

WHEREAS on the sixth day of April, 1948, Otto Adolf Hoffman was granted an Order in Council under the *Electric Light and Power Act 1928*, cited as the Walwa Electric Lighting Order No. 260, 1948 (hereinafter called "the said Order"), authorizing the said O. A. Hoffmann to supply electricity in and in respect of the whole of the area of supply under the said Order as specified in the First Schedule thereto, and being all that land contained within a circle having a radius of one-half of a mile with the centre at the intersection of the west side of Shelley-road with the south side of Church-street, being a point 472 ft. 10½ in. south-east 173 deg. 3 min. from the north-east corner of Crown allotment 6, section 3, Parish of Walwa, for a period of fifteen years commencing on the sixth day of April, 1948: And whereas, in pursuance of a deed of assignment dated the tenth day of December, 1949, between Otto Adolf Hoffmann and Mrs. Bessie Regina McCausland, the Governor in Council, on the seventeenth day of January, 1950, approved of the transfer of the powers, duties, and liabilities under the said Order to the aforesaid Mrs. Bessie Regina McCausland: And whereas, in pursuance of a deed of assignment dated the sixteenth day of May, 1951, between Mrs. Bessie Regina McCausland of the one part and John Henry Ferris and Alan Joseph Thomson of the other part, the Governor in Council, on the twelfth day of June, 1951, approved of the transfer of the powers, duties, and liabilities under the said Order to the aforesaid John Henry Ferris and Alan Joseph Thomson (hereinafter called "the undertakers"): And whereas by

Orders dated the 4th September, 1951, and the 25th October, 1955, the Governor in Council did approve of amendments varying the maximum charges which may be charged for electricity supplied: And whereas the undertakers have made application to have a further amendment made to the Fourth Schedule annexed to the said Order: Now therefore, His Excellency the Lieutenant-Governor of the State of Victoria, by and with the advice of the Executive Council thereof, acting pursuant to the provisions of section 13 of the *Electric Light and Power Act 1928*, doth hereby vary the maximum charges which may be charged for electricity supplied by substituting the following sections for those set forth in the Fourth Schedule annexed to the said Order, that is to say:—

SECTION 1.

Where the undertakers charge any consumer by the electrical quantity supplied to him, they shall be entitled to charge him at the following rates:—

For electricity supplied for lighting purposes—
Two shillings and six pence (2s. 6d.) per unit.

For electricity supplied for purposes other than lighting—
One shilling and six pence (1s. 6d.) per unit.

SECTION 3.

Notwithstanding anything contained in this Order, the undertakers may charge any consumer a minimum charge of 12s. 6d. per month irrespective of whether the supply is used for lighting or other purposes. Such minimum charge shall be exclusive of meter rent.

And the foregoing amendment shall be effective as from the date on which the Governor in Council approves of such amendment.

And the Honorable George Oswald Reid, Her Majesty's Minister of Electrical Undertakings for the State of Victoria, shall give the necessary directions herein accordingly.

A. MAHLSTEDT,
Clerk of the Executive Council.

WORKERS COMPENSATION ACTS.

At the Executive Council Chamber, Melbourne, the nineteenth day of June, 1957.

PRESENT:

His Excellency the Lieutenant-Governor of Victoria.

Mr. Reid | Mr. McArthur.

AMENDMENT OF REGULATIONS.

IN pursuance of the powers conferred by the Workers Compensation Acts and all other powers him thereunto enabling, His Excellency the Lieutenant-Governor of the State of Victoria, in the Commonwealth of Australia, by and with the advice of the Executive Council of the said State, doth hereby further amend the Workers Compensation Regulations 1954 as follows (that is to say):—

1. Condition No. 10 contained in Form 1 is hereby revoked and the following condition substituted therefor:—

“10. In the event of the Insured letting any Contract during the period of indemnity the Insured shall immediately notify the Insurer and give the Insurer all such particulars in regard thereto as may be required and shall pay to the Insurer forthwith on demand the premium required to cover the Insured's liability with respect thereto.”

2. Form 18 is hereby revoked, and the following form substituted therefor:—

FORM 18.

Prescribed by the Workers Compensation Regulations 1954.

Employers' Liability (including Workers Compensation) Insurance Business.

ANALYSIS OF COLUMN HEADED “CLAIMS FOR COMPENSATION OR DAMAGES” IN FORM 17.

Year Ended 30th June, 19

DISSECTION OF TOTAL PAID.

Type of Payment.	Amount Paid.	
	Details.	Total.
	£	£
A. Under Workers Compensation Act—		
(a) Compensation—		
(i) Weekly compensation (including lump sums paid in redemption thereof)		
(ii) Lump sum—Death (including burial and cremation claims)		
(iii) Lump sum—Maim		
(b) Medical, &c., Services—		
(i) Doctor		
(ii) Hospital		
(iii) Chemist or Registered Nurse		
(iv) Ambulance		
(v) Other Curative or Rehabilitation Services		
(c) Legal Costs and other Out-of-Pocket Expenses		
B. Under other Acts and at Common Law—		
Damages at Common Law and/or Acts other than Workers Compensation Acts (including costs)		
Total paid as per Form 17		

Name of Insurer

3. Form 19 is hereby revoked, and the following form substituted therefor:—

FORM 19.

G.S.O. Number of Report

Prescribed by the Workers Compensation Regulations 1954. Employers' Liability (including Workers Compensation) Insurance Business.

REPORT ON CLAIM CLOSED DURING THE YEAR ENDED 30TH JUNE, 19 , OR OF UNCLOSED CLAIM OF THREE YEARS' DURATION.

NOTE.—Closed claims to be reported as soon as practicable.

Name of Insurer or Self-insurer—		Code No.	
Insurer's or Self-insurer's Claim Number			
Nature of Report	1. First report	1. <input type="checkbox"/>	
	2. Previously reported, now re-opened	2. <input type="checkbox"/>	
	3. Not previously reported, now re-opened (Mark a tick (✓) in square applicable)	3. <input type="checkbox"/>	
Code number of Classification of Trade or Occupation		Code No.	
Age in years		years	
Worker	Sex (Mark a tick (✓) in square applicable)	1. <input type="checkbox"/> Male 2. <input type="checkbox"/> Female	
	Date of accident / /19 .		
Duration of Incapacity for work (if Fatal Claim, insert "Fatal")		weeks days	
If claim unclosed after three years mark a tick (✓) in square		<input type="checkbox"/>	
Injury or Disease	Occurred—		
	1. Arising out of employment (i.e., due to nature of employment)	1. <input type="checkbox"/>	
	2. In course of employment but not due to nature of employment	2. <input type="checkbox"/>	
	3. During a recess period	3. <input type="checkbox"/>	
	4. On journey to or from employment, &c. (Mark a tick (✓) in square applicable)	4. <input type="checkbox"/>	
	Cause (state what happened)—		(For office use only.)
	Nature (give medical diagnosis)—		
Location of Injury (in main claim give exact details)—			
Result—			
1. Death		1. <input type="checkbox"/>	
2. Disability (Mark a tick (✓) in square applicable)		2. <input type="checkbox"/>	
Weekly earnings (including overtime) of the worker at time of the injury		£	
Total amount paid including compensation, medical, &c.. services, costs, and damages		£	

Insurer. }
Self-insurer. } *Strike out term inapplicable.*

Signed—
Date—

And the Honorable Arthur Gordon Rylah, Her Majesty's Chief Secretary for the State of Victoria, shall give the necessary directions herein accordingly.

A. MAHLSTEDT,
Clerk of the Executive Council.

STAWELL BOROUGH COUNCIL.

At the Executive Council Chamber, Melbourne, the nineteenth day of June, 1957.

PRESENT:

His Excellency the Lieutenant-Governor of Victoria.
Mr. Reid | Mr. McArthur.

ADDITIONAL LOAN OF £21,979.

UNDER the powers conferred by the Water Acts and all other powers enabling him in that behalf, His Excellency the Lieutenant-Governor of the State of Victoria, by and with the advice of the Executive Council of

the said State, doth hereby grant an additional loan of Twenty-one thousand nine hundred and seventy-nine pounds (£21,979) to the Stawell Borough Council for the construction of pipe mains and the purchase and installation of meters, as set forth in the detailed statement bearing date the 13th June, 1957, and verified under the seal of the State Rivers and Water Supply Commission.

The loan hereby granted shall be subject to the provisions of the Water Acts.

And the Honorable Wilfred John Mibus, Her Majesty's Minister of Water Supply for the State of Victoria, shall give the necessary directions herein accordingly.

A. MAHLSTEDT,
Clerk of the Executive Council.

DEPARTMENT OF CROWN LANDS AND SURVEY.

At the Executive Council Chamber, Melbourne, the nineteenth day of June, 1957.

PRESENT:

His Excellency the Lieutenant-Governor of Victoria. Mr. Reid | Mr. McArthur.

REVOCATION OF PORTION OF TEMPORARY RESERVATIONS OF LANDS BY ORDERS IN COUNCIL.

HIS Excellency the Lieutenant-Governor of the State of Victoria, by and with the advice of the Executive Council thereof, doth hereby, in pursuance of the provisions of the Land Act 1928, revoke portions of the temporary reservations of the lands by Orders in Council hereinafter referred to, viz.:-

NELSON.—Order in Council of 12th October, 1937, of 3 acres 3 roods 12 perches of land in the Township of Nelson as a site for Public purposes, so far only as regards the portion thereof comprised within the boundaries published in the Government Gazette of 22nd May, 1957, and containing 20 perches, more or less.—(Rs.4731.)

WONGA WONGA SOUTH.—Order in Council of 20th February, 1902, of 9 acres 2 roods 20 perches of land in the Parish of Wonga Wonga South as a site for Supply of Gravel, so far only as regards the portion thereof comprised within the boundaries published in the Government Gazette of 22nd May, 1957, and containing 1 acre 2 roods, more or less.—(C.96938.)

And the Honorable Keith Hector Turnbull, Her Majesty's Commissioner of Crown Lands and Survey for the State of Victoria, shall give the necessary directions herein accordingly.

A. MAHLSTEDT, Clerk of the Executive Council.

DEPARTMENT OF CROWN LANDS AND SURVEY.

At the Executive Council Chamber, Melbourne, the nineteenth day of June, 1957.

PRESENT:

His Excellency the Lieutenant-Governor of Victoria. Mr. Reid | Mr. McArthur.

LANDS TEMPORARILY RESERVED AS SITES.

HIS Excellency the Lieutenant-Governor of the State of Victoria, by and with the advice of the Executive Council thereof, doth hereby, in pursuance of the provisions of the Land Act 1928, reserve, temporarily, and also except from occupation for mining purposes under any miner's right, the lands hereinafter described:-

GANNAWARRA.—Site for Public Hall and Public Recreation, 1 acre 3 roods 8 perches, Parish of Gannawarra, County of Gunbower, as indicated by hachure on plan hereunder.—(G.211(+)) (Rs.7580).

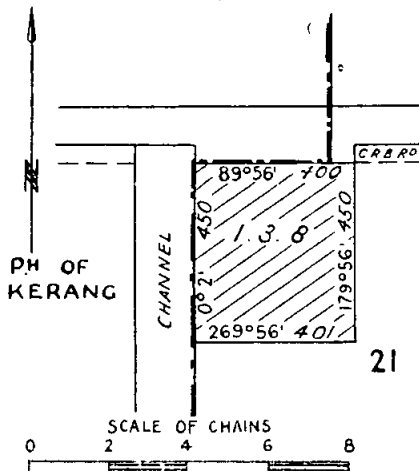

BOROONDARA.—Site for Government Buildings, 3 roods 34 perches, Parish of Boroondara, County of Bourke, as indicated by hachure on plan hereunder.—(B.415(3)) (Rs.7575).

COTHAM RD

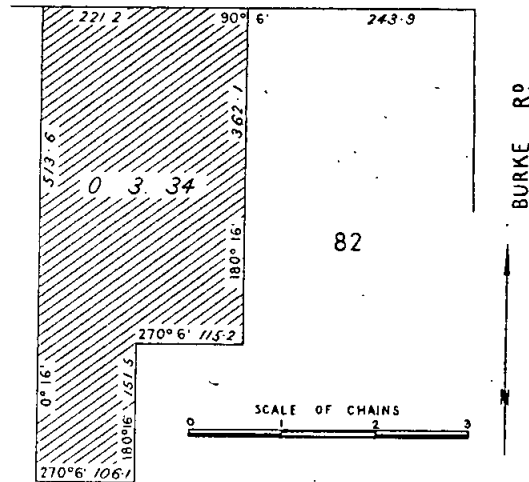

MANSFIELD.—Site for the purposes of the Forests Act, 1 rood, Township of Mansfield, Parish of Mansfield, County of Delatite, as indicated by hachure on plan hereunder.—(M.35(3)) (Rs.7590).

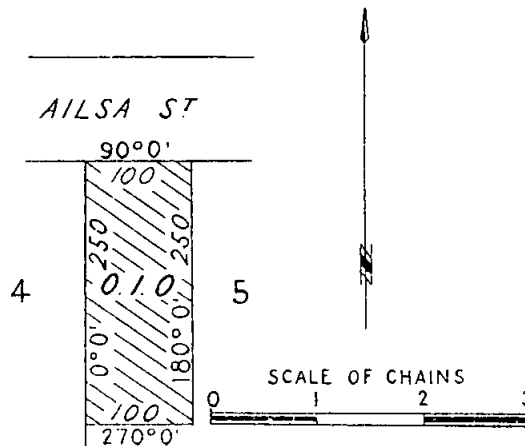

SEC 2

YIELIMA.—Site for the purposes of the Forests Act, 5 acres, more or less, Parish of Yielima, County of Moira, as indicated by hachure on plan hereunder.—(Y.103(3)) (Rs.7587).

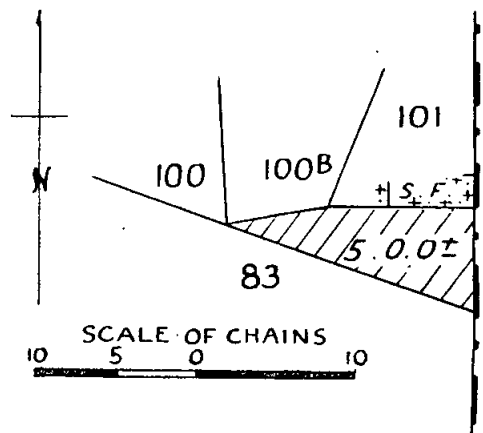

LEONGATHA.—Site for a Public Park and for Public Recreation, 2 acres 1 rood 27 perches, Township of Leongatha, Parish of Leongatha, County of Buln Buln, as indicated by hachure on plan hereunder.—(L.167^(e)) (Rs.7571).

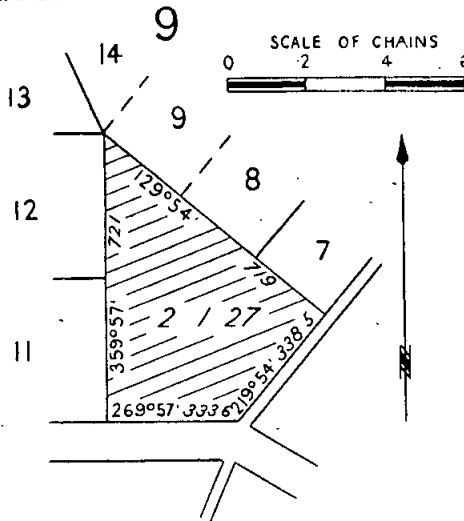

TAMBORITHA.—Site for the purposes of the Forests Act, 5 acres, more or less, Parish of Tamboritha, County of Wonnangatta, as indicated by hachure on plan hereunder.—(T.308) (Rs.7591).

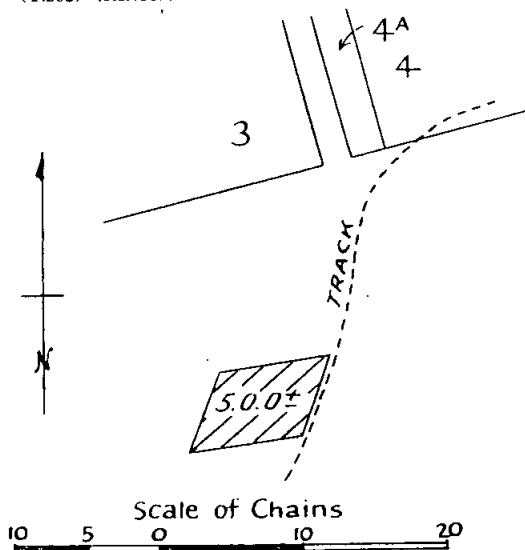

And the Honorable Keith Hector Turnbull, Her Majesty's Commissioner of Crown Lands and Survey for the State of Victoria, shall give the necessary directions herein accordingly.

A. MAHLSTEDT,
Clerk of the Executive Council.

DEPARTMENT OF CROWN LANDS AND SURVEY.

At the Executive Council Chamber, Melbourne, the nineteenth day of June, 1957.

PRESENT:

His Excellency the Lieutenant-Governor of Victoria.
Mr. Reid | Mr. McArthur.

UNUSED ROADS CLOSED.

HIS Excellency the Lieutenant-Governor of the State of Victoria, by and with the advice of the Executive Council thereof, doth hereby direct that, in pursuance of

the provisions of section 304 of the Land Act 1928, the unused roads referred to hereunder be closed, viz.:—

Parish of Wandin Yallock, County of Evelyn, being the road between allotment 125 and allotment 127.—(W.295⁽⁷⁾) Misc. 2885).

Parish of Monbulk, County of Evelyn, being the road between allotments 1, section O, Parish of Monbulk, 130, Parish of Wandin Yallock, and allotments 1, 2, 3, 4, 5, 11, Parish of Monbulk.—(M.555⁽⁸⁾) (Misc. 2885).

And the Honorable Keith Hector Turnbull, Her Majesty's Commissioner of Crown Lands and Survey for the State of Victoria, shall give the necessary directions herein accordingly.

A. MAHLSTEDT,
Clerk of the Executive Council.

DRAINAGE AREAS ACTS.

At the Executive Council Chamber, Melbourne, the nineteenth day of June, 1957.

PRESENT:

His Excellency the Lieutenant-Governor of Victoria.
Mr. Reid | Mr. McArthur.

CONSTITUTION OF THE PEJARK (SHIRE OF MORTLAKE) DRAINAGE AREA.

PURSUANT to the provisions of the Drainage Areas Acts, and in compliance with the prayer of a petition presented by a majority of the owners of certain land within a portion of the Mortlake Shire, notice of which petition was duly published in the *Government Gazette* on the 13th February, 1957, His Excellency the Lieutenant-Governor of the State of Victoria, by and with the advice of the Executive Council thereof, by this Order directs that the portion of the said shire described hereunder be constituted a drainage area within the meaning of the above-mentioned Acts, under the name of the Pejark (Shire of Mortlake) Drainage Area:—

Commencing at the north-western corner of Crown allotment 9A, section XIVA., Parish of Keilambete; thence easterly by the northern boundary of the said allotment to the north-eastern corner thereof; thence southerly by the eastern boundaries of Crown allotments 9A, 9B, section XIVA., and Crown allotment 1, section VA.; thence south-westerly by the south-eastern boundaries of Crown allotments 2, 3, 4, and 5, section VA., to the southern corner of allotment 5, section VA. aforesaid; thence southerly by the eastern boundary of Crown allotment 6, section VA., to the south-eastern corner thereof; thence westerly by the southern boundary of allotment 6 to the south-western corner thereof; thence southerly by the western boundaries of Crown allotments 2 and 3, section VIA., to the southern boundary of the road opened by the Shire Council through Crown allotment 3, section VIA.; thence easterly by the southern boundary of the said road to the road on the eastern boundary of allotment 3, section VIA., and by the southern side of the said road bearing south 39 deg. 37 min. east to the south-east corner of Crown allotment 3; thence north-easterly along the Government road for a distance of 1,298 links; thence by a line bearing south to the southern boundary of Crown allotment 2, section VIIA.; thence westerly by the southern boundaries of Crown allotments 2, section VIIA., and 34B, 34A, and 35A to the south-western corner of allotment 35A, northerly along the west boundary of Crown allotment 35A, and easterly along the northern boundaries of Crown allotments 35A and 34A to the point of intersection with the southern prolongation of the west boundary of Crown allotment 33B; thence along the western and northern boundaries of Crown allotments 33B, 32B, and 23; thence northerly by the western boundary of Crown allotments 22 and 21, section XIVA.; thence easterly by the northern boundary of Crown allotment 21; thence northerly by the western boundaries of Crown allotments 9B and 9A, section XIVA., to the point of commencement.

And the Honorable Sir Thomas Karran Maltby, Her Majesty's Commissioner of Public Works for the State of Victoria, shall give the necessary directions herein accordingly.

A. MAHLSTEDT,
Clerk of the Executive Council.

BENEFIT ASSOCIATIONS ACTS.

At the Executive Council Chamber, Melbourne, the nineteenth day of June, 1957.

PRESENT:

His Excellency the Lieutenant-Governor of Victoria.
Mr. Reid | Mr. McArthur.

DECLARATION OF CITY AND SUBURBAN FUNERALS PROPRIETARY LIMITED AS AN ASSOCIATION EXEMPT FROM THE PROVISIONS OF THE BENEFIT ASSOCIATIONS ACTS.

IN pursuance of the powers conferred by the Benefit Associations Acts and all other powers him thereunto enabling, His Excellency the Lieutenant-Governor of Victoria, in the Commonwealth of Australia, by and with the advice of the Executive Council of the said State, doth by this Order declare City and Suburban Funerals Proprietary Limited, an association carrying on funeral benefit business, shall be exempt from the provisions of the Benefit Associations Acts, subject to the terms and conditions following (that is to say):—

1. That Nelson Brothers transfer certain securities to Trustees as set out in an agreement dated 10th August, 1956, entered into with the Government of Victoria by Nelson Brothers and City and Suburban Funerals Proprietary Limited (hereinafter called "the company").

2. That the benefits under contracts which were in force as at the 8th May, 1952, be restored, subject to the following conditions:—

- (a) Where contributions are not fully paid at least four weeks' contributions are to be paid to the company before the 1st of October, 1957. After that date contributions are to be paid regularly as provided for in the contracts.
- (b) Where all payments had ceased under the contract as at the 8th of May, 1952, such contract will be restored and be operative.
- (c) All contributions which would have fallen due since the 8th of May, 1952, are to be paid to the company either in one lump sum or by instalments before 1st October, 1952.
- (d) Where the death of a contributor or his or her dependants occurs between 8th May, 1952, and 1st October, 1957, and but for the winding-up order such contributor would have been eligible for benefits and where funeral arrangements in respect of such death are or were carried out by undertakers other than Nelson Brothers, the company will refund to such contributor an amount which the Trustees may determine, such amount to be not less than the amount of the contributions paid.
- (e) If Nelson Brothers or the company is unable to or refuses to carry out the funeral of a contributor which inability or refusal shall be determined by the Trustees, the company will refund to the contributor an amount which the Trustees shall determine, such amount being not less than the amount of the contributions paid.
- (f) Where any payment or refund is made in respect of any contract or where a benefit is given under any contract or where in the opinion of the Registrar such payment, refund or benefit should have been made or given the amount of payment, refund or benefit, as the case may be, shall be reduced by the amount of arrears of contributions outstanding.
- (g) Arrears of contributions will be calculated from the date to which contributions were paid to the date of death, and in determining such period the full period of time which has elapsed since the last date to which contributions are paid and the date of death will be allowed without regard to the winding-up order.

3. That in the event of any dispute arising under a contract or as to whether any person is or has been a contributor or as to the amount of contributions paid or as to the date to which contributions have been paid or as to whether the conditions of this exemption have been observed, it shall be referred for decision to the Registrar, whose decision shall be final.

4. No contract shall operate to provide any funeral benefit to any person other than children who were not entitled to such benefit as at the 8th of May, 1952, nor shall any such benefit be increased beyond the benefit operating as at the 8th of May, 1952.

5. That the securities shall be held upon trust by the Trustees and if an order is made pursuant to the Act for the winding up of the company the Trustees shall apply them as directed by the Registrar for the purpose of winding up the company in accordance with the Benefit Associations Acts, but so that each of the contributors shall be entitled to payment of at least one-half of the amount remaining after deduction from the contributions paid by him to the company on or before the date of winding up of the amount of benefits received in respect of his contract with the company.

6. That so long as the securities are held by the Trustees and until an order is made pursuant to the Act for the winding up of the company, the company shall within 42 days after the end of each quarter ending 31st March, 30th June, 30th September, and 31st December—

- (i) pay to the Trustees an amount equal to one-half of the contributions due by the contributors surviving at the end of the quarter and one-half of any arrears of contributions paid by those contributors during the quarter;
- (ii) furnish the Trustees with a statement as to the contributors who have died during the quarter, together with such other information as the Trustees may require.

7. That until an order is made pursuant to the Act for winding up the company the Trustees shall hold the securities and any moneys paid to them pursuant to the last preceding paragraph upon trust—

- (i) within 90 days after the end of each quarter release to the company the securities and money so held to the extent of an amount equal to the interest on the securities received by the Trustees during the quarter and one-half of the amount remaining after deduction from the contributions paid by contributors dying during the quarter to the end of the last preceding quarter the amount of the benefits received in respect of the contracts of those contributors with the company.

Provided that if—

- (A) the Government Statist for the time being of the said State certifies that in his opinion, having regard to the interests of surviving contributors, the amount to be released should be reduced to an amount specified in the certificate then the Trustees shall be obliged only to release the amount so specified; and
- (B) at any time by reason of the securities not being divisible in amount the Trustees are unable to comply with the foregoing provisions of this subparagraph without releasing an amount greater than that to which the company is entitled then the Trustees may retain the securities until they have been varied in accordance with paragraph 8 hereof so as to enable the release of the amount to which the company is entitled;
- (ii) within 90 days after the end of the quarter in which the last surviving contributor dies to release to the company the residue (if any) of the securities and moneys so held.

8. That the Trustees from time to time may—

- (i) invest any moneys held by them on the trusts hereof in any investment or investments for the time being authorized by law for the investment of trust money; and
- (ii) vary and transpose all or any of the securities (other than money) and all or any of the other investments held by them hereunder for or into any investment or investments for the time being so authorized.

9. That the company will furnish the Registrar, within a time to be fixed by him, with such documents, returns or other information which he or the Government Statist may require in connexion with their duties under the conditions of this exemption.

10. The company will provide to the Registrar by the 30th June, 1957, a list setting out the names and addresses of each contributor in lexicographical order showing for each contributor the total amount of contribution paid to the 8th May, 1952, the amount of contribution payable each week, the amount of benefit paid as at the date of the winding-up order and the benefit payable in respect of each person covered.

11. The company will forward to the last-known address of each contributor, and where possible the addresses will be submitted by the Registrar, setting out the terms and conditions of the Exemption Order in précis form for the notice of each contributor.

12. The Trustees to have power by themselves or their agents to inspect books and documents as required.

13. Books of account will be kept by the company as required by the Trustees, and such books will be audited once every six months at the expense of the company.

14. Any questions arising as to repayments and entitlements generally as to the contract shall be determined by the Trustees, who shall act upon such evidence as they shall require or deem necessary, and the decision of the Trustees shall be final.

And the Honorable Arthur Gordon Rylah, Her Majesty's Chief Secretary for the State of Victoria, shall give the necessary directions herein accordingly.

A. MAHLSTEDT,
Clerk of the Executive Council.

COUNTRY ROADS BOARD.

At the Executive Council Chamber, Melbourne, the nineteenth day of June, 1957.

PRESENT:

His Excellency the Lieutenant-Governor of Victoria.
Mr. Reid | Mr. McArthur.

ORDER APPROVING OF A DEVIATION FROM A STATE HIGHWAY IN THE SHIRE OF CORIO.

WHEREAS the Country Roads Board constituted under the *Country Roads Act 1928* (No. 3662) has represented to His Excellency the Governor in Council that it appears to it desirable that the deviation herein-after referred to from the existing Midland Highway in the Shire of Corio (declared to be a State highway under the said Act which declaration was confirmed by the Order in Council published in the *Government Gazette* of the 8th November, 1933, on page 2830) should be made by the said Board: And whereas the said Board in accordance with the requirements of section 19 of the said cited Act has caused to be prepared a map plan and estimate showing the points between which and on and through what land the said deviation is proposed to be made and the cost of acquiring the land: And whereas on an inspection of the said map and plan and a consideration of the said estimate His Excellency the Governor in Council is satisfied that there are funds legally available for acquiring the land: Now therefore be it known by this present Order that His Excellency the Lieutenant-Governor of the State of Victoria with the advice of the Executive Council thereof doth hereby approve of the said highway being made, that is to say:—

All those pieces of land in the Parish of Moorpanyal, the boundaries of which are as follow:—

- (a) Commencing at an angle in the southern boundary of the existing Midland Highway through portion 10, section A, of the said parish, the said angle being formed by lines bearing respectively 89 deg. 6 min. and 132 deg. 56½ min.; thence by lines bearing respectively 132 deg. 56½ min. 945.5 links, 119 deg. 8 min. 154.5 links, 114 deg. 30½ min. 2,934.3 links, 98 deg. 43½ min. 1,599.5 links, 203 deg. 17 min. 97.6 links, 278 deg. 40 min. 1,649.4 links, 293 deg. 27½ min. 4,186 links, 284 deg. 37½ min. 363 links, 180 deg. 31 min. 2.5 links, 269 deg. 21 min. 100 links, 0 deg. 31 min. 252 links, 89 deg. 21 min. 100 links, and 89 deg. 6 min. 780 links to the point of commencement.
- (b) Commencing at an angle in the northern boundary of the existing Midland Highway through portion 10, section A, of the said parish, the said angle being formed by lines bearing 278 deg. 40 min. and 294 deg. 27 min.; thence by lines bearing respectively 294 deg. 27 min. 371.8 links, 109 deg. 51 min. 334.2 links, 102 deg. 7 min. 602.8 links, and 278 deg. 40 min. 571.7 links to the point of commencement.
- (c) Commencing at a point on the northern boundary of the existing Midland Highway through portion 10, section A, of the said parish, the said point being the south-western angle of land described in book 495, memorial 848, registered at the Office of Titles; thence by lines

bearing respectively 0 deg. 34 min. 21.5 links, 94 deg. 37 min. 220.8 links, and 269 deg. 2 min. 220.4 links to the point of commencement—

which said pieces of land are particularly delineated and shown coloured red on survey plan numbered 6591, lodged in the office of the Country Roads Board.

And the Honorable Sir Thomas Karran Maltby, Her Majesty's Commissioner of Public Works for the State of Victoria, shall give the necessary directions herein accordingly.

A. MAHLSTEDT,
Clerk of the Executive Council.

COUNTRY ROADS BOARD.

At the Executive Council Chamber, Melbourne, the nineteenth day of June, 1957.

PRESENT:

His Excellency the Lieutenant-Governor of Victoria.
Mr. Reid | Mr. McArthur.

ORDER APPROVING OF A DEVIATION FROM A STATE HIGHWAY IN THE SHIRE OF AVON.

WHEREAS the Country Roads Board constituted under the *Country Roads Act 1928* (No. 3662) has represented to His Excellency the Governor in Council that it appears to it desirable that the deviation herein-after referred to from the existing Princes Highway in the Shire of Avon (declared to be a State highway under the said Act which declaration was confirmed by the Order in Council published in the *Government Gazette* of the 8th July, 1925 on pages 2371-3 and 22nd May, 1935, on page 1405) should be made by the said Board: And whereas the said Board in accordance with the requirements of section 19 of the said cited Act has caused to be prepared a map plan and estimate showing the points between which and on and through what land the said deviation is proposed to be made and the cost of acquiring the land: And whereas on an inspection of the said map and plan and a consideration of the said estimate His Excellency the Governor in Council is satisfied that there are funds legally available for acquiring the land: Now therefore be it known by this present Order that His Excellency the Lieutenant-Governor of the State of Victoria with the advice of the Executive Council thereof doth hereby approve of the said highway being made, that is to say:—

All that piece of land in the Parishes of Nuntin and Stratford, the boundaries of which are as follow:—Commencing at a point on the western boundary of allotment 13, section 3, of the Parish of Nuntin distant 180 deg. 0 min. 459.8 links from the north-western angle of the said allotment; thence by lines bearing respectively 360 deg. 0 min. 970.2 links, 29 deg. 4½ min. 3,457.9 links, 22 deg. 22 min. 327.8 links, 120 deg. 6 min. 303.1 links, 202 deg. 22 min. 304.8 links, 209 deg. 4½ min. 3,367.2 links, and 198 deg. 54 min. 971.4 links to the point of commencement—which said piece of land is particularly delineated and shown coloured red on survey plans numbered 6579 and 6580, lodged in the office of the Country Roads Board.

And the Honorable Sir Thomas Karran Maltby, Her Majesty's Commissioner of Public Works for the State of Victoria, shall give the necessary directions herein accordingly.

A. MAHLSTEDT,
Clerk of the Executive Council.

COUNTRY ROADS BOARD.

At the Executive Council Chamber, Melbourne, the nineteenth day of June, 1957.

PRESENT:

His Excellency the Lieutenant-Governor of Victoria.
Mr. Reid | Mr. McArthur.

ORDER APPROVING OF WIDENING AN EXISTING STATE HIGHWAY IN THE SHIRE OF MILDURA.

WHEREAS the Country Roads Board constituted under the *Country Roads Act 1928* (No. 3662) has represented to His Excellency the Governor in Council

that it appears to it desirable that the existing Calder Highway in the Shire of Mildura (declared to be a State highway under the said Act which declaration was confirmed by the Order in Council published in the *Government Gazette* of the 6th December, 1944, on page 2948) should be widened by the said Board: And whereas the said Board in accordance with the requirements of section 19 of the said cited Act has caused to be prepared a map plan and estimate showing the points between which and on and through what land the said widening is proposed to be made: And whereas on an inspection of the said map and plan and a consideration of the said estimate His Excellency the Governor in Council is satisfied that there are funds legally available for acquiring the land: Now therefore be it known by this present Order that His Excellency the Lieutenant-Governor of the State of Victoria with the advice of the Executive Council thereof doth hereby approve of the said road being widened, that is to say:—

All that piece of land in the Parish of Mildura, the boundaries of which are as follow:—Commencing at the northern angle of section 49, block F, on plan of subdivision numbered 2380, lodged in the Office of Titles, and being part of Crown portion 2 of the said parish; thence by lines bearing respectively 135 deg. 16 min. 757.5 links, 225 deg. 16 min. 9.9 links, 315 deg. 16 min. 626.5 links, 279 deg. 55 min. 86.9 links, 260 deg. 37 min. 104 links, and 45 deg. 16 min. 145 links to the point of commencement—which said piece of land is particularly delineated and shown coloured red on survey plan numbered 6594, lodged in the office of the Country Roads Board.

And the Honorable Sir Thomas Karran Maltby, Her Majesty's Commissioner of Public Works for the State of Victoria, shall give the necessary directions herein accordingly.

A. MAHLSTEDT,
Clerk of the Executive Council.

APOLLO BAY WATERWORKS TRUST.

At the Executive Council Chamber, Melbourne, the nineteenth day of June, 1957.

PRESENT:

His Excellency the Lieutenant-Governor of Victoria.
Mr. Reid | Mr. McArthur.

ADDITIONAL LOAN OF £8,979.

UNDER the powers conferred by the Water Acts and all other powers enabling him in that behalf, His Excellency the Lieutenant-Governor of the State of Victoria, by and with the advice of the Executive Council of the said State, doth hereby grant an additional loan of Eight thousand nine hundred and seventy-nine pounds (£8,979) to the Apollo Bay Waterworks Trust for the construction of pipe mains and the purchase and installation of meters, as set forth in the detailed statement bearing date the 14th June, 1957, and verified under the seal of the State Rivers and Water Supply Commission.

The loan hereby granted shall be subject to the provisions of the Water Acts.

And the Honorable Wilfred John Mibus, Her Majesty's Minister of Water Supply for the State of Victoria, shall give the necessary directions herein accordingly.

A. MAHLSTEDT,
Clerk of the Executive Council.

BAIRNSDALE WATERWORKS TRUST.

At the Executive Council Chamber, Melbourne, the nineteenth day of June, 1957.

PRESENT:

His Excellency the Lieutenant-Governor of Victoria.
Mr. Reid | Mr. McArthur.

ADDITIONAL LOAN OF £32,575.

UNDER the powers conferred by the Water Acts and all other powers enabling him in that behalf, His Excellency the Lieutenant-Governor of the State of Victoria, by and with the advice of the Executive Council

of the said State, doth hereby grant an additional loan of Thirty-two thousand five hundred and seventy-five pounds (£32,575) to the Bairnsdale Waterworks Trust for the construction of pumping plant, pipe mains, and the purchase and installation of meters, as set forth in the detailed statement bearing date the 13th June, 1957, and verified under the seal of the State Rivers and Water Supply Commission.

The loan hereby granted shall be subject to the provisions of the Water Acts.

And the Honorable Wilfred John Mibus, Her Majesty's Minister of Water Supply for the State of Victoria, shall give the necessary directions herein accordingly.

A. MAHLSTEDT,
Clerk of the Executive Council.

LANG LANG WATERWORKS TRUST.

At the Executive Council Chamber, Melbourne, the nineteenth day of June, 1957.

PRESENT:

His Excellency the Lieutenant-Governor of Victoria.
Mr. Reid | Mr. McArthur.

CONSENT TO BORROWING £5,000.

UNDER the powers conferred by the Water Acts and all other powers enabling him in that behalf, His Excellency the Lieutenant-Governor of the State of Victoria, by and with the advice of the Executive Council of the said State, doth hereby consent to the Lang Lang Waterworks Trust borrowing by the issue of debentures the sum of Five thousand pounds (£5,000), bearing interest at the rate of £5 10s. per centum per annum, for the construction of a new town water supply scheme for the Township of Lang Lang, as set forth in the detailed statement bearing date the 13th June, 1957.

And the Honorable Wilfred John Mibus, Her Majesty's Minister of Water Supply for the State of Victoria, shall give the necessary directions herein accordingly.

A. MAHLSTEDT,
Clerk of the Executive Council.

LATROBE VALLEY WATER AND SEWERAGE BOARD.

At the Executive Council Chamber, Melbourne, the nineteenth day of June, 1957.

PRESENT:

His Excellency the Lieutenant-Governor of Victoria.
Mr. Reid | Mr. McArthur.

ADDITIONAL LOAN OF £220,000.

UNDER the powers conferred by the Latrobe Valley Water and Sewerage Acts and all other powers enabling him in that behalf, His Excellency the Lieutenant-Governor of the State of Victoria, by and with the advice of the Executive Council of the said State, doth hereby grant an additional loan of Two hundred and twenty thousand pounds (£220,000) to the Latrobe Valley Water and Sewerage Board for the purpose of constructing sewers, pipe lines, channels, storages, pumping stations and rising mains, and purchase of land and construction or purchase of works or buildings, as set forth in the detailed statement bearing date the 13th June, 1957, and verified under the seal of the State Rivers and Water Supply Commission.

The loan hereby granted shall be subject to the provisions of the Latrobe Valley Water and Sewerage Acts.

And the Honorable Wilfred John Mibus, Her Majesty's Minister of Water Supply for the State of Victoria, shall give the necessary directions herein accordingly.

A. MAHLSTEDT,
Clerk of the Executive Council.

TRAFALGAR WATERWORKS TRUST.

At the Executive Council Chamber, Melbourne, the nineteenth day of June, 1957.

PRESENT:

His Excellency the Lieutenant-Governor of Victoria.
Mr. Reid | Mr. McArthur.

CONSENT TO BORROWING £7,000.

UNDER the powers conferred by the Water Acts and all other powers enabling him in that behalf, His Excellency the Lieutenant-Governor of the State of Victoria, by and with the advice of the Executive Council of the said State, doth hereby consent to the Trafalgar Waterworks Trust borrowing, by the issue of debentures, the sum of Seven thousand pounds (£7,000), bearing interest at the rate of £5 10s. per centum per annum, for the construction of pipe mains, as set forth in the detailed statement bearing date the 13th June, 1957.

And the Honorable Wilfred John Mibus, Her Majesty's Minister of Water Supply for the State of Victoria, shall give the necessary directions herein accordingly.

A. MAHLSTEDT,
Clerk of the Executive Council.

SHIRE OF KOWREE WATERWORKS TRUST.

At the Executive Council Chamber, Melbourne, the nineteenth day of June, 1957.

PRESENT:

His Excellency the Lieutenant-Governor of Victoria.
Mr. Reid | Mr. McArthur.

ADDITIONAL LOAN OF £8,893.

UNDER the powers conferred by the Water Acts and all other powers enabling him in that behalf, His Excellency the Lieutenant-Governor of the State of Victoria, by and with the advice of the Executive Council of the said State, doth hereby grant an additional loan of Eight thousand eight hundred and ninety-three pounds (£8,893) to the Shire of Kowree Waterworks Trust for the completion of new town water supply schemes at Edenhope and Goroke, as set forth in the detailed statement bearing date the 13th June, 1957, and verified under the seal of the State Rivers and Water Supply Commission.

The loan hereby granted shall be subject to the provisions of the Water Acts.

And the Honorable Wilfred John Mibus, Her Majesty's Minister of Water Supply for the State of Victoria, shall give the necessary directions herein accordingly.

A. MAHLSTEDT,
Clerk of the Executive Council.

NAGAMBIE WATERWORKS TRUST.

At the Executive Council Chamber, Melbourne, the twenty-fifth day of June, 1957.

PRESENT:

His Excellency the Lieutenant-Governor of Victoria.
Mr. Turnbull | Mr. McArthur.

REPEAL OF ORDER.

UNDER the powers conferred by the Water Acts and all other powers enabling him in that behalf, His Excellency the Lieutenant-Governor of the State of Victoria, by and with the advice of the Executive Council of the said State, doth hereby repeal the Order made by the Governor in Council on the 24th May, 1949, as amended by Order made on the 19th June, 1950, and published in the *Victoria Government Gazette* dated 1st June, 1949, and 21st June, 1950, respectively, fixing the

limit of the overdraft to be obtained by the Nagambie Waterworks Trust from the Commercial Bank of Australia Limited, Nagambie, at One thousand pounds (£1,000).

And as on from the date hereof the said Order of the Governor in Council shall be deemed to be repealed accordingly.

And the Honorable Wilfred John Mibus, Her Majesty's Minister of Water Supply for the State of Victoria, shall give the necessary directions herein accordingly.

A. MAHLSTEDT,
Clerk of the Executive Council.

ROCHESTER WATERWORKS TRUST.

At the Executive Council Chamber, Melbourne, the twenty-fifth day of June, 1957.

PRESENT:

His Excellency the Lieutenant-Governor of Victoria.
Mr. Turnbull | Mr. McArthur.

ADDITIONAL LOAN OF £19,000.

UNDER the powers conferred by the Water Acts and all other powers enabling him in that behalf, His Excellency the Lieutenant-Governor of the State of Victoria, by and with the advice of the Executive Council of the said State, doth hereby grant an additional loan of Nineteen thousand pounds (£19,000) to the Rochester Waterworks Trust for the construction of pumping plant and pipe mains, as set forth in the detailed statement bearing date the 20th June, 1957, and verified under the seal of the State Rivers and Water Supply Commission.

The loan hereby granted shall be subject to the provisions of the Water Acts.

And the Honorable Wilfred John Mibus, Her Majesty's Minister of Water Supply for the State of Victoria, shall give the necessary directions herein accordingly.

A. MAHLSTEDT,
Clerk of the Executive Council.

LANDLORD AND TENANT ACT 1948.

At the Executive Council Chamber, Melbourne, the twenty-fifth day of June, 1957.

PRESENT:

His Excellency the Lieutenant-Governor of Victoria.
Mr. Turnbull | Mr. McArthur.

ORDER AMENDING ORDER CONSTITUTING CERTAIN FAIR RENTS BOARDS.

WHEREAS under the powers given by the *Landlord and Tenant Act 1948* the Governor in Council may by Order published in the *Government Gazette* constitute Fair Rents Boards at such places and in respect of premises in such areas as he thinks fit and may amend or vary any Order so made: And whereas by Order made on the 1st September, 1953, and published in the *Government Gazette* of the 2nd September, 1953, at page 4494, certain Boards were constituted: And whereas by subsequent Orders such first-mentioned Order was amended: And whereas it is expedient further to amend such Order: Now therefore His Excellency the Lieutenant-Governor of Victoria, by and with the advice of the Executive Council thereof and in pursuance of the powers aforesaid, doth hereby further amend the Order of the 1st September, 1953, by substituting for the words "Southern Riding and Northern Riding" appearing in the First Schedule thereto the words "Northern, Montmorency, and Eltham Ridings."

And the Honorable Arthur Gordon Rylah, Her Majesty's Attorney-General for the State of Victoria, shall give the necessary directions herein accordingly.

A. MAHLSTEDT,
Clerk of the Executive Council.

HOUSING ACTS.

At the Executive Council Chamber, Melbourne, the twenty-fifth day of June, 1957.

PRESENT:

His Excellency the Lieutenant-Governor of Victoria.
Mr. Turnbull | Mr. McArthur.

DECLARATION OF RECLAMATION AREA AT PORT MELBOURNE.

WHEREAS within an area in the City of Port Melbourne described in the Schedule hereto there are houses which—

- (a) are unfit for human habitation and
- (b) are in the opinion of the Housing Commission insanitary or unhealthy by reason of—
 - (i) the excessive number of buildings within the area;
 - (ii) the bad arrangement of buildings within the area; and
 - (iii) the bad arrangement or narrowness of streets within the area.

And whereas the Housing Commission considers that housing conditions within this area cannot satisfactorily be dealt with unless the said area is dealt with under Part III. of the *Slum Reclamation and Housing Act 1938* (No. 456S) as a Reclamation area and has recommended that the said area should be constituted a Reclamation Area:

And whereas the Housing Commission, having duly complied with the provisions of sub-section (3) of section 19 of the said Act, has submitted to the Governor in Council its recommendation that the said area should be constituted a Reclamation Area:

Now therefore I, the Lieutenant-Governor of the State of Victoria, in the Commonwealth of Australia, by and with the advice of the Executive Council of the said State, do hereby declare the said area to be a Reclamation Area.

SCHEDULE.

All that land situate within the municipality of the City of Port Melbourne being Crown allotments 2, 3, 4, 5 and part of Crown allotments 1 and 20, all of section 9, in the City of Port Melbourne, Parish of Melbourne South, and being the land bounded by a line commencing at a point on the south-eastern alignment of Stokes-street being the most western angle of Crown allotment 5 aforesaid; thence north-easterly by the said south-eastern alignment of Stokes-street to the intersection of same with the north-eastern alignment of Florence-place;

thence south-easterly by the said north-eastern alignment of Florence-place to the intersection of same with the south-eastern boundary of Crown allotment 20 aforesaid; thence south-westerly by the said south-eastern boundary of Crown allotment 20 and by the south-eastern boundaries of Crown allotments 2, 3, 4, and 5 aforesaid to the most southern angle of the said Crown allotment 5; thence north-westerly by the southern boundary of the said Crown allotment 5 to the point of commencement.

And the Honorable Horace Rostill Petty, Her Majesty's Minister of Housing for the State of Victoria, shall give the necessary directions herein accordingly.

A. MAHLSTEDT,
Clerk of the Executive Council.

HOUSING ACTS.

At the Executive Council Chamber, Melbourne, the twenty-fifth day of June, 1957.

PRESENT:

His Excellency the Lieutenant-Governor of Victoria.
Mr. Turnbull | Mr. McArthur.

CLOSING OF A ROAD—SHIRE OF DANDENONG.

WHEREAS by virtue and in exercise of the powers contained in the Housing Acts the Housing Commission has recommended to the Governor in Council that the road described in the Schedule hereto be closed:

Now therefore His Excellency the Lieutenant-Governor of the State of Victoria, in the Commonwealth of Australia, by and with the advice of the Executive Council thereof, doth, in pursuance of the powers conferred by the said Acts and upon such recommendation, consent and by this Order hereby close such road.

SCHEDULE.

So much of Campbell-street shown coloured brown on plan of subdivision No. 21161, lodged in the Office of Titles, as lies to the west of the southerly prolongation of the western alignment of Lexton-avenue shown coloured brown on the said plan of subdivision lodged as aforesaid.

And the Honorable Horace Rostill Petty, Her Majesty's Minister of Housing for the State of Victoria, shall give the necessary directions herein accordingly.

A. MAHLSTEDT,
Clerk of the Executive Council.

POLICE REGULATION ACTS.

At the Executive Council Chamber, Melbourne, the twenty-fifth day of June, 1957.

PRESENT:

His Excellency the Lieutenant-Governor of Victoria.
Mr. Turnbull | Mr. McArthur.

AMENDMENT OF REGULATIONS.

HIS Excellency the Lieutenant-Governor of the State of Victoria, in the Commonwealth of Australia, by and with the advice of the Executive Council of the said State, and in pursuance of the powers conferred by the Police Regulation Acts, doth further amend the Police Regulations 1951 as follows (that is to say):—

After clause 4 of Chapter 2 there shall be inserted the following clause—

“5. All members of the Force holding the rank of Superintendent on the 30th June, 1957, shall be deemed to hold the rank of Superintendent Grade II. as on and from that date.”

And the Honorable Arthur Gordon Rylah, Her Majesty's Chief Secretary for the State of Victoria, shall give the necessary directions herein accordingly.

A. MAHLSTEDT,
Clerk of the Executive Council.

Water Acts.

STATE RIVERS AND WATER SUPPLY COMMISSION.

*At the Executive Council Chamber, Melbourne, the
twenty-fifth day of June, 1957.*

PRESENT:

His Excellency the Lieutenant-Governor of Victoria.
Mr. Turnbull | Mr. McArthur.

RODNEY IRRIGATION AND WATER SUPPLY
DISTRICT.—PORTIONS EXCISED.

UNDER the powers conferred by the Water Acts and all other powers enabling him in that behalf, His Excellency the Lieutenant-Governor of the State of Victoria, with the advice of the Executive Council of the said State, on the recommendation of the State Rivers and Water Supply Commission, doth hereby declare, order, and direct as follows:—

That there shall be excised from the Rodney Irrigation and Water Supply District those portions of the same set out and described in the Schedule hereto, which portions as from the thirtieth day of June, 1957, shall be deemed to be excised accordingly.

SCHEDULE.

Portion 1.—Commencing at the north-western angle of lot 47 on lodged plan of subdivision No. 4466, being a point in the northern boundary of allotment 3, Parish of Kyabram East, County of Rodney; thence easterly by the northern boundary of said lot 47 a distance of approximately 850 links to the boundary of the Rodney Irrigation and Water Supply District prior to this Order; thence southerly and westerly by that District boundary to the western boundary of the southern portion of the lands described in certificate of title, volume 8087, folio 615; thence northerly and easterly by the western and northern boundaries of the last-mentioned portion to the point of commencement.

Portion 2.—Commencing at the north-eastern angle of lot 6 on lodged plan of subdivision No. 34060, being part of allotment 6, Parish of Kyabram East, County of Rodney; thence southerly by the eastern boundaries of lots 6 to 12 inclusive and by a line in continuation thereof to a point distant 3 chains northerly from the northern boundary of Allan-street; thence westerly by a line parallel to that street boundary to a point in line with the eastern boundary of lot 98 on lodged plan of subdivision No. 11064; thence by a line bearing north 0 deg. 6 min. west to a point in line with the northern boundary of lot 6 on lodged plan of subdivision No. 34060 aforesaid; thence easterly by a line and the last-mentioned boundary to the point of commencement.

Portion 3.—Commencing at a point in the eastern boundary of allotment 33c, Parish of Kyabram East, County of Rodney, distant 350 links southerly from the north-eastern angle of that allotment; thence by lines bearing south 89 deg. 49 min. west 200 links, north 0 deg. 6 min. west 100 links, and south 89 deg. 49 min. west to the eastern boundary of allotment 33A; thence northerly by the last-mentioned boundary to a point in line with the southern boundary of lot 3 on lodged plan of subdivision No. 27460; thence westerly by a line and the southern boundaries of lots 3, 2, and 1 to a point in the southern boundary of said lot 1 distant 33 1/10 links easterly from the south-western angle of that lot; thence northerly by a line parallel to the western boundary of said lot 1 to the southern boundary of Racecourse-road; thence westerly by that road boundary to the eastern boundary of allotment 32A; thence northerly by that allotment boundary to the southern boundary of allotment 32; thence easterly by the last-mentioned boundary to a point distant 1,000 links westerly from the south-eastern angle of the last-mentioned allotment; thence by lines bearing north 0 deg. 5 min. west 634 links and north 89 deg. 46 min. east to the eastern boundary of said allotment 32; thence southerly by that allotment boundary a distance of 45 links and by a line bearing north 89 deg. 51 min. east to the eastern boundary of Lake-road; thence southerly by that road boundary to a point due east of the aforesaid point of commencement; thence west by a line to the point of commencement.

Portion 4.—Commencing at a point in the southern boundary of allotment 5, Parish of Kyabram East, County of Rodney, distant 700 links easterly from the south-western angle of that allotment; thence by lines bearing south 0 deg. 16 min. east 550 links and south 89 deg. 54 min. east and distant approximately 500 links to a point in line with the eastern boundary of lot 5 on lodged

plan of subdivision No. 11064, being part of allotment 6; thence northerly by a line and the last-mentioned lot boundary to the southern boundary of allotment 5 aforesaid; thence westerly by that allotment boundary to the point of commencement.

The portions described in the foregoing Schedule are shown on a plan approved by the Governor in Council, and deposited in the office of the State Rivers and Water Supply Commission, Melbourne.—(Corres. Nos. 56/15743, 56/16525, 57/12682, 57/13238, 57/13239, 57/13721.)

And the Honorable Wilfred John Mibus, Her Majesty's Minister of Water Supply for the State of Victoria, shall give the necessary directions herein accordingly.

A. MAHLSTEDT,
Clerk of the Executive Council.

Water Acts.

STATE RIVERS AND WATER SUPPLY COMMISSION.

*At the Executive Council Chamber, Melbourne, the
twenty-fifth day of June, 1957.*

PRESENT:

His Excellency the Lieutenant-Governor of Victoria.
Mr. Turnbull | Mr. McArthur.

WEST LODDON WATERWORKS DISTRICT.—
DISTRICT EXTENDED.

UNDER the powers conferred by the Water Acts and all other powers enabling him in that behalf, His Excellency the Lieutenant-Governor of the State of Victoria, with the advice of the Executive Council of the said State, on the recommendation of the State Rivers and Water Supply Commission, doth hereby declare, order, and direct as follows:—

That the West Loddon Waterworks District be extended by adding to the same the lands set out and described in the Schedule hereto, and as on and from the date of this Order such district shall be deemed to be so extended.

SCHEDULE.

1. Commencing at the south-eastern angle of allotment 27, section D, Parish of Boort, County of Gladstone; thence generally southerly by the eastern boundaries of allotments 23, 22, and 21, a line connecting those boundaries and generally westerly by the northern boundaries of allotment 20 to the most western angle of that allotment; thence north-westerly by a line to the most southern angle of allotment 26A; thence generally north-easterly by the eastern boundaries of said allotment 26A and the southern boundaries of aforesaid allotment 27 to the point of commencement.

2. Commencing at the most western angle of allotment 19, section D, Parish of Boort, County of Gladstone; thence generally southerly by the western boundaries of allotments 19 and A (Boort P.R.) and a line connecting those boundaries to a point in line with the northern boundary of allotment 34A, section G; thence westerly by a line and the northern boundaries of allotments 34A and 34 to a point due south of the south-eastern angle of allotment 16A; thence north by a line to that angle; thence generally north-westerly by the eastern boundaries of allotments 16A and 17 and westerly by the northern boundary of said allotment 17 to a point due south of the eastern angle of allotment 19, all of said section G; thence north by a line to that angle; thence by a line bearing north 8 deg. 30 min. east and distant approximately 200 links to the shore of Lake Boort; thence generally north-easterly by that shore boundary to its intersection with a line bearing south 26 deg. 23 min. west from a point in the southern boundary of allotment 15B, section F, distant 2,123.6 links easterly from the south-western angle of that allotment; thence by a line bearing north 26 deg. 23 min. east to the southern boundary of said allotment 15B; thence easterly by the last-mentioned boundary to the south-eastern angle of the last-mentioned allotment; thence easterly by a line to the south-western angle of allotment 20A, section D; thence generally south-easterly by the southern boundary of said allotment 20A, and the south-western boundary of allotment 20 to the point of commencement.

3. Commencing at the north-eastern angle of allotment 24A, section D, Parish of Boort, County of Gladstone; thence easterly by a line in production of the northern boundary of said allotment 24A to the western boundary

of allotment 16; thence generally southerly by the eastern boundary of a Government road to the south-western angle of allotment 14; thence westerly by a line in production of the southern boundary of said allotment 14 to the western boundary of the aforesaid Government road; thence generally northerly by that road boundary to the point of commencement.

4. Commencing at the north-eastern angle of allotment 13, section D, Parish of Boort, County of Gladstone; thence easterly by a line in production of the northern boundary of said allotment 13 to the western boundary of allotment 12; thence southerly by the last-mentioned boundary and by a line in continuation thereof to the northern boundary of allotment 64, Parish of Mysia; thence westerly by that allotment boundary to a point in line with the eastern boundary of allotment 13, section D, Parish of Boort aforesaid; thence northerly by a line and the last-mentioned boundary to the point of commencement.

5. Commencing at the north-eastern angle of allotment 67, Parish of Mysia, County of Gladstone; thence easterly by a line to the most northern angle of allotment 183; thence generally southerly by the western boundaries of said allotment 183 to the south-western angle thereof; thence west by a line to the eastern boundary of allotment 68; thence northerly by the western boundary of a road to the point of commencement.

The lands set out and described in the foregoing Schedule are shown on a plan approved by the Governor in Council, and deposited in the office of the State Rivers and Water Supply Commission, Melbourne.—(Corres. No. 57/10815.)

And the Honorable Wilfred John Mibus, Her Majesty's Minister of Water Supply for the State of Victoria, shall give the necessary directions herein accordingly.

A. MAHLSTEDT,
Clerk of the Executive Council.

WATER ACTS.

*At the Executive Council Chamber, Melbourne, the
twenty-fifth day of June, 1957.*

PRESENT:

His Excellency the Lieutenant-Governor of Victoria.
Mr. Turnbull | Mr. McArthur.

KYABRAM WATERWORKS TRUST.—EXTENT OF DISTRICT INCREASED.

UNDER the powers conferred by the Water Acts and all other powers enabling him in that behalf, His Excellency the Lieutenant-Governor of the State of Victoria, with the advice of the Executive Council of the said State, doth hereby declare, order, and direct as follows:—

That the extent of the Waterworks District of the Kyabram Waterworks Trust be increased by adding to the same the lands set out and described in the Schedule hereto, and as on and from the 1st day of July, 1957, the extent of such district shall be deemed to be increased accordingly.

SCHEDULE.

1. Commencing at the north-western angle of lot 47 on lodged plan of subdivision No. 4466, being a point in the northern boundary of allotment 3, Parish of Kyabram East, County of Rodney; thence easterly by the northern boundary of said lot 47 a distance of approximately 850 links to the boundary of the Waterworks District of the Kyabram Waterworks Trust prior to this Order; thence southerly and westerly by that District boundary to the western boundary of the southern portion of the lands described in certificate of title, volume 8087, folio 615; thence northerly and easterly by the western and northern boundaries of the last-mentioned portion to the point of commencement.

2. Commencing at the north-eastern angle of lot 6 on lodged plan of subdivision No. 34060, being part of allotment 6, Parish of Kyabram East, County of Rodney; thence southerly by the eastern boundaries of lots 6 to 12 inclusive and by a line in continuation thereof to a point distant 3 chains northerly from the northern boundary of Allan-street; thence westerly by a line parallel to that street boundary to a point in line with the eastern boundary of lot 98 on lodged plan of subdivision No. 11064; thence by a line bearing north 0 deg.

6 min. west to a point in line with the northern boundary of lot 6 on lodged plan of subdivision No. 34060 aforesaid; thence easterly by a line and the last-mentioned boundary to the point of commencement.

3. Commencing at a point in the eastern boundary of allotment 33c, Parish of Kyabram East, County of Rodney, distant 350 links southerly from the north-eastern angle of that allotment; thence by lines bearing south 89 deg. 49 min. west 200 links, north 0 deg. 6 min. west 100 links, and south 89 deg. 49 min. west to the eastern boundary of allotment 33a; thence northerly by the last-mentioned boundary to a point in line with the southern boundary of lot 3 on lodged plan of subdivision No. 27460; thence westerly by a line and the southern boundaries of lots 3, 2 and 1 to a point in the southern boundary of said lot 1 distant 33 1/10 links easterly from the south-western angle of that lot; thence northerly by a line parallel to the western boundary of said lot 1 to the southern boundary of Racecourse-road; thence westerly by that road boundary to the eastern boundary of allotment 32a; thence northerly by that allotment boundary to the southern boundary of allotment 32; thence easterly by the last-mentioned boundary to a point distant 1,000 links westerly from the south-eastern angle of the last-mentioned allotment; thence by lines bearing north 0 deg. 5 min. west 634 links, and north 89 deg. 46 min. east to the eastern boundary of said allotment 32; thence southerly by that allotment boundary a distance of 45 links and by a line bearing north 89 deg. 51 min. east to the eastern boundary of Lake-road; thence southerly by that road boundary to a point due east of the aforesaid point of commencement; thence west by a line to the point of commencement.

4. Commencing at a point in the southern boundary of allotment 5, Parish of Kyabram East, County of Rodney, distant 700 links easterly from the south-western angle of that allotment; thence by lines bearing south 0 deg. 16 min. east 550 links and south 89 deg. 54 min. east, and distant approximately 500 links to a point in line with the eastern boundary of lot 5 on lodged plan of subdivision No. 11064, being part of allotment 6; thence northerly by a line and the last-mentioned lot boundary to the southern boundary of allotment 5 aforesaid; thence westerly by that allotment boundary to the point of commencement.

The lands described in the foregoing Schedule are shown on a plan approved by the Governor in Council and deposited in the office of the State Rivers and Water Supply Commission, Melbourne.—(Corres. Nos. 56/15743, 56/16525, 57/12682, 57/13238, 57/13239, 57/13721.)

And the Honorable Wilfred John Mibus, Her Majesty's Minister of Water Supply for the State of Victoria, shall give the necessary directions herein accordingly.

A. MAHLSTEDT,
Clerk of the Executive Council.

Water Acts.

STATE RIVERS AND WATER SUPPLY COMMISSION.

*At the Executive Council Chamber, Melbourne, the
twenty-fifth day of June, 1957.*

PRESENT:

His Excellency the Lieutenant-Governor of Victoria.
Mr. Turnbull | Mr. McArthur.

BOORT IRRIGATION AND WATER SUPPLY DISTRICT.—DISTRICT EXTENDED.—PORTION EXCISED.

UNDER the powers conferred by the Water Acts and all other powers enabling him in that behalf, His Excellency the Lieutenant-Governor of the State of Victoria, with the advice of the Executive Council of the said State, on the recommendation of the State Rivers and Water Supply Commission, doth hereby declare, order, and direct as follows:—

1. That the Boort Irrigation and Water Supply District be extended by adding to the same the lands set out and described in the First Schedule hereto, and as on and from the date of this Order such district shall be deemed to be so extended.

2. That there shall be excised from the Boort Irrigation and Water Supply District the portion of the same set out and described in the Second Schedule hereto, which portion as from the date of this Order shall be deemed to be excised accordingly.

FIRST SCHEDULE.

1. Commencing at the north-western angle of allotment 12, section D, Parish of Boort, County of Gladstone; thence southerly by the western boundary of said allotment 12 to a point in line with the southern boundary of allotment 14; thence westerly by a line to the south-eastern angle of the last-mentioned allotment; thence northerly by the eastern boundary of said allotment 14 to a point in line with the northern boundary of allotment 12 aforesaid; thence easterly by a line to the point of commencement.

2. That portion of a Government road forming the southern boundaries of allotments 8 and 12, section D, Parish of Boort, County of Gladstone.

SECOND SCHEDULE.

Commencing at the most western angle of allotment 19, section D, Parish of Boort, County of Gladstone; thence generally southerly by the western boundaries of allotments 19 and A (Boort P.R.), and a line connecting those boundaries to the south-western angle of the last-mentioned allotment; thence easterly by the southern boundary of said allotment A, Parish of Boort, to the north-eastern angle of a water reserve, Parish of Mysia; thence southerly and easterly by the eastern and northern boundaries of that reserve to the north-eastern angle thereof; thence south-easterly by a line to the most southern angle of allotment 68A; thence generally north-easterly by the south-eastern boundaries of said allotment 68A to the most eastern angle thereof; thence northerly by a line to the most southern angle of allotment 68; thence generally northerly and easterly by the eastern and southern boundaries of said allotment 68 to the western boundary of allotment 183A; thence generally southerly by the western boundaries of allotments 183A, 61A, and 61 and a line connecting those boundaries to the south-western angle of the last-mentioned allotment; thence south-westerly by a line to the most eastern angle of allotment 70; thence northerly by a line to the most southern angle of allotment 69; thence generally northerly, westerly, and southerly by the eastern, northern, and western boundaries of said allotment 69 to the north-eastern boundary of a 3-chain road; thence westerly by a line to the northern angle of allotment 70B; thence generally southerly by the western boundary of the last-mentioned allotment and the north-western boundaries of a 3-chain road to the eastern boundary of allotment 1; thence northerly by that boundary and generally westerly by the northern boundaries of the last-mentioned allotment to the south-eastern angle of a water reserve, Parish of Mysia; thence generally north-westerly by the southern and western boundaries of that water reserve and the south-western boundaries of the Boort Creek frontage reserve to the north-eastern angle of allotment 34A, section G, Parish of Boort; thence westerly by the northern boundaries of allotments 34A and 34 to a point due south of the south-eastern angle of allotment 16A; thence northerly by a line, the eastern boundary of said allotment 16A and a line in continuation of the last-mentioned boundary to the south-western boundary of the Lake Boort frontage reserve; thence generally north-westerly by that reserve boundary to its intersection with a line bearing north 8 deg. 30 min. east from the most eastern angle of allotment 19 of said section G; thence by a line bearing north 8 deg. 30 min. east to the southern shore of Lake Boort; thence generally northerly by that shore boundary to its intersection with a line bearing south 26 deg. 23 min. west from a point in the southern boundary of allotment 15B, section F, distant 2,123.6 links easterly from the south-western angle of that allotment; thence by a line bearing north 26 deg. 23 min. east to the southern boundary of said allotment 15B; thence easterly by the last-mentioned boundary to the south-eastern angle of the last-mentioned allotment; thence easterly by a line to the south-western angle of allotment 20A, section D; thence generally south-easterly by the southern boundary of said allotment 20A and the south-western boundary of allotment 20 to the point of commencement.

The lands set out and described in the First Schedule and the portion set out and described in the Second Schedule are shown on a plan approved by the Governor in Council, and deposited in the office of the State Rivers and Water Supply Commission, Melbourne.—(Corres. No. 57/10815.)

And the Honorable Wilfred John Mibus, Her Majesty's Minister of Water Supply for the State of Victoria, shall give the necessary directions herein accordingly.

A. MAHLSTEDT,
Clerk of the Executive Council.

Water Acts.

STATE RIVERS AND WATER SUPPLY COMMISSION.

At the Executive Council Chamber, Melbourne, the twenty-fifth day of June, 1957.

PRESENT:

His Excellency the Lieutenant-Governor of Victoria.
Mr. Turnbull | Mr. McArthur.

CAMPERDOWN URBAN DISTRICT—DISTRICT EXTENDED.

UNDER the powers conferred by the Water Acts and all other powers enabling him in that behalf, His Excellency the Lieutenant-Governor of the State of Victoria, with the advice of the Executive Council of the said State, on the recommendation of the State Rivers and Water Supply Commission, doth hereby declare, order, and direct as follows:—

That the Camperdown Urban District be extended by adding to the same the lands set out and described in the Schedule hereto, and as on and from the date of this Order such district shall be deemed to be so extended.

SCHEDULE.

All that piece of land comprising the whole of lots 1 to 11 inclusive on lodged plan of subdivision No. 34861, being parts of Crown portions G and F, section 13, Parish of Colongulac, County of Hampden.

The lands described in the foregoing Schedule are shown on a plan approved by the Governor in Council, and deposited in the office of the State Rivers and Water Supply Commission, Melbourne.—(Corres. 57/11394.)

And the Honorable Wilfred John Mibus, Her Majesty's Minister of Water Supply for the State of Victoria, shall give the necessary directions herein accordingly.

A. MAHLSTEDT,
Clerk of the Executive Council.

APPROACHING LAND SALES.

SALES of Crown lands, in fee-simple, will be held at the under-mentioned places and dates, viz.:—

	No. of Gazette.
Bendigo.—Thursday, 11th July, 1957	.. 184
Mallacoota.—Thursday, 4th July, 1957	.. 184
Shepparton.—Thursday, 4th July, 1957	.. 184

CLOSER SETTLEMENT ACT 1938.

Red Cliffs.—Thursday, 11th July, 1957	.. 184
Shepparton.—Thursday, 4th July, 1957	.. 184

Soldier Settlement Acts.

FINAL NOTICE OF COMPULSORY ACQUISITION.

WHEREAS His Excellency the Governor of the State of Victoria, by and with the advice of the Executive Council of the said State, by an Order made on the twenty-fifth day of September, 1956, a copy of which Order was published in the *Government Gazette* dated 26th September, 1956, directed that all that piece of land comprising 743 acres 2 roods 16 perches, being allotments 31A¹, 31A², 35A¹, 35B¹, part allotments A1 and A2, Parish of Cooramook, County of Villiers, be acquired compulsorily for the purposes of the Soldier Settlement Acts: And whereas it is provided by section 38 of the *Soldier Settlement Act 1945* (No. 5107), as amended by section 2 (i) (d) of the *Soldier Settlement (Amendment) Act 1949* (No. 5438), that the Soldier Settlement Commission may publish a final notice of compulsory acquisition in respect of such land: Take notice that the said Commission, pursuant to the power conferred upon it by the said section 38, hereby gives final notice of compulsory acquisition of the said land.

Signed at Melbourne this twenty-fourth day of June, 1957.

For and on behalf of the Soldier Settlement Commission,
I. K. MORTON,
Secretary.

LIST OF CROWN LANDS AVAILABLE.

THE under-mentioned areas are available for application as provided by various sections of the *Land Act 1928*, and all applications received on or before Wednesday, 24th July, 1957, will be deemed to have been made simultaneously, but any application lodged after such date may be considered if received in time for inclusion in the advertisement of the cases to be heard at the Local Land Board. Applications on proper form, accompanied by 5s. duty stamp uncancelled (registration fee), may be delivered or forwarded by post to the Local Land Officer or to any Crown Lands Office in Victoria. Subject to the approval of the Secretary for Lands, when the survey fee exceeds £25 but does not exceed £50, a deposit of £25 may be paid, and when the fee exceeds £50, a deposit of 50 per cent. of the fee, the balance in either case being payable over six years in half-yearly instalments.

Marked plans of any particular area, application forms, and any further information may be obtained from the Crown Lands Department, Melbourne, and Land Officers, Beechworth, Benalla, Hamilton, St. Arnaud, and Sale.
Department of Crown Lands and Survey,
Melbourne, 26th June, 1957.

KEITH TURNBULL,
Commissioner of Crown Lands and Survey.

* Improvements may be subject to re-valuation after land has been granted to an applicant.

Local Land Office.	County.	Parish.	Allotment.	Section.	Area.	How Available.		Valuation of Improvements (if any).	Location of Land, &c.	Nearest Railway Station or Town and Distance in miles therefrom.	How Accessible.	Water Supply.	General Description of Land—Soil, Timber, Suitability (Grazing, &c.).	
						Classification.	Value per Acre.							
AGRICULTURAL AND GRAZING LANDS—SELECTION PURCHASE ALLOTMENTS.														
Division 4, Part I, LAND Act 1928.														
		A.		B.		F.		£ s. d.		£ s. d.				
Beechworth (a, b, c)	Bogong	Yaakandandah	6B	01	475 0 0	3rd	1 10 0	52 10 0	Nil	North-west of parish	Yaakandandah, 2½ miles	By road	To be conserved	Steep to moderate slopes; light gravelly loam; stringybark, box, bluegum, &c.; grazing. (412/121)
Beechworth (a)	Delatite	Carboor	10	14	68 0 0	3rd	1 5 0	21 7 6	To be valued	In south-west of parish	Edi Township, 5 miles	By road	To be conserved	Moderate slopes; fair gravelly loam; box, stringybark, and wattles; grazing. (H.024892)
Beechworth (a)	Delatite	Edi	2A	15	44 0 0	3rd	1 0 0	16 2 6	To be valued	In east of parish	Edi Township, approx. 10 miles	By road	To be conserved	Pair gravelly soil; apple box and blue gum; suitable for grazing. (801/44)
Benalla (a)	Delatite	Whitfield South	6	1	180 0 0	3rd	1 0 0	33 7 6	To be valued	In north of parish	Whitfield, 16 miles	By road	To be conserved	Undulating; fair to good quality brown loam; bracken fern, peppermint, messmate, gum, and wattle; grazing. (127 44)
Hamilton (a)	Lowan	Harrow	16B	..	137 0 0	3rd	1 10 0	23 15 0	To be valued	North of Township of Harrow	Harrow, 3 miles	By road	To be conserved	Slightly undulating; light sandy soil; bracken, stringybark, messmate; suitable for grazing. (Z.27392)
St. Arnaud (a, b)	Gladstone	Wedderburne	19 and 20	12	36 1 24	3rd	1 10 0	13 2 6	Nil	In north-west of parish	Wedderburn, 2 miles	By road	To be conserved	Undulating country, timbered with box and gum (freewood); brown loam, mostly gravelly, with patches of fair to good quality soil; suitable for cultivation. (W.08914)
Sale (a, b, d)	Bulu Bulu	Gifford	13 and 13A	C	540 0 0 374 0 0	3rd 3rd	1 0 0 1 0 0	37 12 6 46 10 0	To be valued	In north-east of parish	Sale, 18 miles	Fronting South Gippsland Highway	To be conserved	Flat to gently undulating; poor sandy soil over sand, gravel, and clay; some reedy swamps; stringybark, honeysuckle, bracken, ti-tree, and scrub; grazing. (H.024490)
Hamilton (a)	Lowan	Harrow	43B	..	140 0 0	3rd	1 10 0	23 15 0	To be valued	North of Township of Harrow	Harrow, 3 miles	By road	To be conserved	Slightly undulating; light sandy soil; bracken, stringybark, messmate; suitable for grazing. (Z.27392)

(a) Subject to Survey.—(b) Subject to Mining Condition.—(c) Subject to Erosion Condition.—(d) Subject to Timber Condition.

Land Act 1928.

LEASES AND LICENCES UNDER THE LAND ACTS 1915 AND 1928 DECLARED VOID.

NOTICE is hereby given that the Leases and Licences mentioned in the Schedule hereunder have been Declared Void by the Governor in Council for the reason specified in each case.

District.	Corr. No.	Name of Lessee.	Section of Land Act under which Leased.	Parish.	Allotment.	Area.	Class.	Annual Rental.	Reasons for Voiding.
						A. R. F.		£ s. d.	
Bendigo ..	01273/129	J. Dempster ..	129	Sandhurst at Bendigo	100G, section K	0 0 38	..	2 10 0	Non-compliance with conditions
Mallee ..	2312K/218	Department of Education	..	Eureka ..	Pt. 27	3 0 0	Surrendered— Lessee's request
St. Arnaud ..	0187/141	H. W. Matthews	141	Woosang ..	Pt. 59	175 0 0	..	1 0 0	Surrendered— Licensee's request
St. Arnaud ..	0230/129	A. M. Whitmore	129	and Town of Carisbrook	1, section 33	0 2 36	..	3 15 0	Surrendered— Licensee's request
Melbourne ..	0626/125	Union Steamship Company of New Zealand Limited	125	Melbourne South City of South Melbourne	55B ²	0 1 2 ¹ / ₁₀	..	345 0 0	Expired—New lease to issue for period of one year
Sale ..	130/50	W. R. Whykes	Holey Plains	34D and 34E	255 0 0	3	9 11 4	Non-compliance with conditions
Bendigo ..	01817/129	N. H. Bice ..	129	Sandhurst at Bendigo	36, section P	0 0 23	..	2 15 0	Surrendered— Licensee's request

Department of Crown Lands and Survey,
Melbourne, 12th June, 1957.

KEITH TURNBULL,
Commissioner of Crown Lands and Survey.

PROPOSED REVOCATIONS OF PORTIONS OF TEMPORARY RESERVATIONS OF LANDS BY ORDERS IN COUNCIL.

IN pursuance of the provisions of the *Land Act 1928*, notice is hereby given that it is the intention of the Governor in Council to revoke portions of the temporary reservations of lands by the Orders in Council hereunder referred to, viz.:—

The following Notices were published 1° on the 19th June, 1957, pursuant to Orders of the 14th May, 1957.

NELSON.—The temporary reservation, by Order in Council of the 12th October, 1937, of 3 acres 3 roods 12 perches of land in the Township of Nelson, as a site for Public purposes, so far only as the portion containing 20 perches, more or less, indicated by hachure on plan hereunder, is concerned.—(N.51⁽²⁾) (Rs.4731).

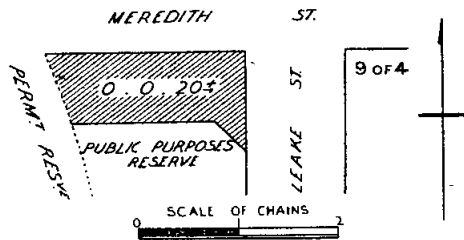

WONGA WONGA SOUTH.—The temporary reservation, by Order in Council of the 20th February, 1902 (see *Government Gazette* of the 26th February, 1902, page 930), of 9 acres 2 roods 20 perches of land in the Parish of Wonga Wonga South, as a site for Supply of Gravel, revoked as to part by Order of the 14th February, 1939, so far only as the portion containing 1 acre 2 roods, more or less, indicated by hachure on plan hereunder, is concerned.—(W.353⁽²⁾) (C.96938).

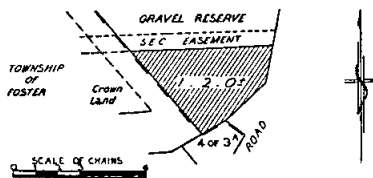

KEITH TURNBULL,
Commissioner of Crown Lands and Survey.

(Published in lieu of Notices which appear in *Government Gazettes* dated the 22nd and the 29th May, 1957, and the 5th June, 1957, respectively.)

PROPOSED REVOCATIONS OF TEMPORARY RESERVATIONS OF LANDS BY ORDERS IN COUNCIL.

IN pursuance of the provisions of the *Land Act 1928*, notice is hereby given that it is the intention of the Governor in Council to revoke the temporary reservations of lands by Orders in Council hereunder referred to, viz.:—

The following Notices were published 1° on the 19th June, 1957, pursuant to Orders of the 11th June, 1957.

OAKLEIGH.—The temporary reservation, by Order in Council of the 22nd November, 1921, of 1 rood 2 perches of land in the Township of Oakleigh as a site for a Public Hall, is about to be revoked.—(O.1⁽²⁾) (Rs.2382).

TELANGATUK.—The temporary reservation as a site for Public purposes (State School) and the withholding from sale, leasing and licensing, by Order in Council of the 20th September, 1881, of 5 acres 0 roods 3 perches of land in the Parish of Telangatuk, are about to be revoked.—(T.195⁽⁴⁾) (M.37685).

KEITH TURNBULL,
Commissioner of Crown Lands and Survey.

PROPOSED REVOCATIONS OF TEMPORARY RESERVATIONS OF LANDS BY ORDERS IN COUNCIL.

IN pursuance of the provisions of the *Land Act 1928*, notice is hereby given that it is the intention of the Governor in Council to revoke the temporary reservations of lands by the Orders in Council hereunder referred to, viz.:—

The following Notices were published 1° on the 12th June, 1957, pursuant to Orders of the 4th June, 1957.

BRUARONG.—The temporary reservation, by Orders in Council of the 6th July, 1885, and the 2nd September, 1913, of 2 acres 2 roods of land in the Parish of Bruarong as a site for a State School, is about to be revoked.—(B.639⁽²⁾) (H.023361).

LARA.—The temporary reservation, by Order in Council of the 19th August, 1872, of 36 acres, more or less, of land in the Township of Lara as a site for Watering purposes, is about to be revoked.—(M.205⁽²⁾) (W.203⁽²⁾) (Rs.2512).

ROWSLEY.—The temporary reservation, by Order in Council of the 14th November, 1892, of 1 rood of land in the Township of Rowsley as a site for a Mechanics' Institute, is about to be revoked.—(R.23⁽¹⁾) (Rs.1826).

UPOTIPOPON.—The temporary reservation as a site for Public purposes (State School) and the withholding from sale, leasing, and licensing, by Order in Council of the 16th June, 1884, of 5 acres of land in the Parish of Upotipotpon, are about to be revoked.—(U.53⁽³⁾) (C.96577).

RICHMOND.—The temporary reservation, by Order in Council of the 4th July, 1906, of 1 acre 1 rood 10 perches of land in the City of Richmond as a site for Public Park and Recreation, is about to be revoked so far only as the portion containing 1 rood 5 perches, more or less, indicated by hachure on plan hereunder, is concerned.—(R.19⁽²⁾) (Rs.152).

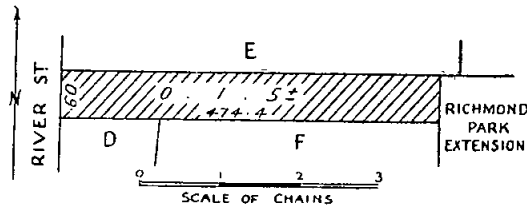

KEITH TURNBULL,
Commissioner of Crown Lands and Survey.

PROPOSED REVOCATIONS OF TEMPORARY
RESERVATIONS OF LANDS BY ORDERS IN
COUNCIL.

IN pursuance of the provisions of the *Land Act 1928*, notice is hereby given that it is the intention of the Governor in Council to revoke the temporary reservations of lands by Orders in Council hereunder referred to, viz.:

The following Notices were published 1° on the 26th June, 1957, pursuant to Orders of the 19th June, 1957.

BAULKAMAUGH.—The temporary reservation as a site for Public purposes (State School) and the withholding from sale, leasing, and licensing, by Order in Council of the 25th May, 1880, of 2 acres of land in the Parish of Baulkamaugh, situate in section C.—(B.718⁽²⁾) (C.97037).

COOLUNGOOLUN.—The temporary reservation as a site for Public purposes (State School) and the withholding from sale, leasing, and licensing, by Order in Council of the 11th November, 1879, of 5 acres of land in the Parish of Coolungoolun.—(C.422⁽⁶⁾) (H.021436).

COPE COPE.—The temporary reservation as a site for Weighbridge, and the withholding from sale, leasing, and licensing, by Order in Council of the 14th August, 1882, of 1 acre of land in the Township of Cope Cope.—(C.425⁽²⁾) (W.67961).

GRETA.—The temporary reservation, by Order in Council of the 31st January, 1951, of 2 roods 32 perches of land in the Township of Greta, as a site for Public Hall and Public Recreation.—(G.131⁽⁶⁾) (Rs.1299).

MANSFIELD.—The temporary reservation, by Order in Council of the 13th November, 1934, of 1 acre, more or less, of land in the Parish of Mansfield, as a site for Public purposes (Swimming Pool).—(M.35⁽³⁾) (Rs.4414).

MERINO.—The temporary reservation, by Order in Council of the 16th February, 1874, of 2 acres of land in the Township of Merino, as a site for State School purposes.—(M.248⁽⁴⁾) (Rs.6325).

MOOROOLBARK.—The temporary reservation, by Order in Council of the 27th October, 1910, of 1 acre 2 roods 25 perches of land in the Parish of Mooroolbark, as a site for a Mechanics' Institute.—(M.152 B⁽³⁾) (Rs.2190).

KEITH TURNBULL,
Commissioner of Crown Lands and Survey.

COMMITTEES OF MANAGEMENT OF RESERVES.

APPOINTMENTS.

WHEREAS by section 184 of the *Land Act 1928* it is provided that it shall be lawful for the Governor in Council or the Board of Land and Works to appoint and remove any number of persons, not less than three, or any municipal council, or the governing body of any corporation, to be a Committee of Management of any specified

Crown land reserved either temporarily or permanently for any of the purposes set out in section 14 of the *Land Act 1928*, and not conveyed to or vested in trustees: Now therefore the Board of Land and Works doth hereby appoint the under-mentioned persons to be members of the Committee of Management of the Reserves named:—

"PORT FAIRY SHOWGROUNDS RESERVE."

William Raymond Harris, Joseph Baden Powell, William Henry Sheehan, Stanley Michael Phylard, Keith William Lyfield, Arthur John Wright, Richard Andrew Gibson, William Stanislaus Hyland, and George Coffey as a Committee of Management for a period of three (3) years of the land temporarily reserved by Order in Council dated 30th April, 1912, as a site for Showgrounds in the Borough of Port Fairy, and known as the "Port Fairy Showgrounds Reserve."—(Corres. Rs.1794.)

"BOWENVALE PUBLIC HALL RESERVE."

Raymond Edward Wills, Donald Leslie Penrose, Elsby Clarence Rowe, Norman Christian Saul, Alexander Leo Cameron, Henry Ballantine, and William Alan Long as a Committee of Management for a period of three (3) years from 19th June, 1957, of the land temporarily reserved by Order in Council dated 20th April, 1885, as a site for a Free Library in the Parish of Maryborough, and known as the "Bowenvale Public Hall Reserve."—(Corres. Rs.4884.)

"BOWSER PUBLIC HALL RESERVE."

William Byrne, John Cain, John Patrick Bourke, Allan Card, Denis Larkin, Hugh Hector Bell, and B. Moore as a Committee of Management for a period of three (3) years of the land temporarily reserved by Order in Council dated the 30th September, 1912, as a site for a Public Hall in the Parish of Carraragarmungee, and known as the "Bowser Public Hall Reserve."—(Corres. Rs.5521.)

"WOOMELANG PUBLIC PARK."

Robert Henry Ernest Ackland, Gordon Daniel Barbary, George Carl Dettmann, Humphrey Johns Binder, and Walter A. Ussing as a Committee of Management for a period of three (3) years of the land temporarily reserved by Order in Council dated the 17th August, 1914, as a site for a Public Park and Garden in the Township of Woomelang, and known as the "Woomelang Public Park."—(Corres. Rs.616.)

"WOOMELANG SOLDIER'S MEMORIAL PARK AND CHILDREN'S
PLAYGROUND."

Harry William Ackland, George Carl Dettmann, Walter Algreen Ussing, Gordon Daniel Barbary, and Humphrey Johns Binder as a Committee of Management for a period of three (3) years of the land temporarily reserved by Order in Council dated the 20th November, 1906, as a site for Public Recreation in the Parish of Cronomby, and known as the "Woomelang Soldiers' Memorial Park and Children's Playground."—(Corres. Rs.471.)

"PINE GROVE RECREATION RESERVE."

Richard James Jasper, James Sinclair, John McBeath, Ernest Benjamin Snowdon Cant, Edwin Albert Chappel, and Raymond Carlyle James as the Committee of Management for a period of three (3) years from 4th June, 1957, of the land temporarily reserved by Order in Council dated 15th March, 1887, as a site for Public Recreation in the Parish of Wanurp, and known as the "Pine Grove Recreation Reserve."—(Corres. Rs.1753.)

"GORMANDALE RECREATION RESERVE."

Frank Easton Giblett, Lindsay Alfred Onley, William Alan Bissett, Hubert James Huffer, Maxwell John King, Colin Randle Missen, and James Charles Thexton as a Committee of Management for a period of three (3) years of the land in the Parish of Willung temporarily reserved as a site for Public Recreation by Orders in Council dated the 21st November, 1950, and 18th March, 1952, and known as the "Gormandale Recreation Reserve."—(Corres. Rs.6595.)

"MITCHELL PARK," PYRAMID HILL.

Ian Campbell MacRae, Kenneth Humphrey Harrison, John Ambrose Stone, Graham Clover Hose McDonald, Albert Lindsay Godward, Edward Joseph Wall, Robert Arnold Ritchie, Leslie Peter Hamill, and Alan Neil Brooks as a Committee of Management for a period of three (3) years of the land temporarily reserved by Order in Council dated the 8th October, 1940, as a site for Showgrounds and Public Recreation in the Parish of Mincha West at Pyramid Hill, and known as the "Mitchell Park."—(Corres. Rs.5076.)

"EMU PLAINS RACECOURSE AND RECREATION RESERVE."

William Charles Crow, Norman Richardson, Richard Joseph Audley, Charles Gilbert James Temby, and Horace Weir as a Committee of Management for a period of three (3) years of the land temporarily reserved by Order in Council dated the 5th November, 1924, as a site for a Racecourse and Public Recreation Reserve in the Parish of Bittern, and known as the "Emu Plains Racecourse and Recreation Reserve."—(Corres. Rs.3025.)

"MIDDLE CREEK PUBLIC HALL RESERVE."

Colin Bert Peters, Joseph Daniel Kneebone, Alfred James Hillman, John Maxwell Roberts, and Claude Edward Waldron as a Committee of Management for a period of three (3) years from 23rd June, 1957, of the land temporarily reserved by Order in Council dated 11th December, 1876, as a site for Public purposes in the Parish of Buangor, and known as the "Middle Creek Public Hall Reserve."—(Corres. Rs.4883.)

"CANNUM (AUBREY) RECREATION RESERVE."

David Aubrey Clyne, Ivor Merlin Clyne, Eric Croser, Frederic Wilhelm Graetz, James Kelly, and Allen Campbell McKenzie as a Committee of Management for a period of three (3) years of the land temporarily reserved by Order in Council dated the 16th September, 1929, as a site for Public Recreation in the Parish of Cannum, and known as the "Cannum (Aubrey) Recreation Reserve."—(Corres. Rs.3890.)

"SARSFIELD RECREATION RESERVE."

Cecil Thomas Filmer, Harold Ramsdell Haggard, and Joseph Thomas Coster as a Committee of Management for a period of three (3) years of the land temporarily reserved by Order in Council dated the 24th October, 1892, as a site for Public Recreation in the Township of Sarsfield, and known as the "Sarsfield Recreation Reserve."—(Corres. Rs.1457.)

"ANZAC MEMORIAL PARK," WARRACKNABEAL.

Robert Shannon King as a Member of the Committee of Management for a period ending 11th October, 1959, of the land temporarily reserved by Order in Council dated 7th September, 1903, as a site for Public Recreation in the Town of Warracknabeal, and known as "Anzac Memorial Park," Warracknabeal, in the place of Charles Berry Parsons, resigned.—(Corres. Rs.2154.)

"CHINKAPOOK RECREATION RESERVE."

Allan Frederick Fletcher, Ronald Gordon Horsburgh, John Peter McRae, Philip Kevin Templeton, David Patrick Barry, Cavell Charles Millstead, and Josiah James Hatt as a Committee of Management for a period of three (3) years of the land in the Township of Chinkapook temporarily reserved as a site for Public Recreation by Order in Council of the 22nd August, 1956, and known as the Chinkapook Recreation Reserve."—(Corres. Rs.7479.)

"SEA LAKE RACECOURSE RESERVE."

William John McInerney, John Stanley Bailey, Charles Joseph Bowd, John Stewart, Clive Malcolm McLennan, Kenneth Samuel Lockhart, and Richard George Jarry as a Committee of Management for a period of three (3) years of the land in the Parish of Burupga temporarily reserved by Order in Council dated the 21st August,

1916, as a site for Racecourse and Public Recreation, and known as the "Sea Lake Racecourse Reserve."—(Corres. Rs.1181.)

"WODONGA RECREATION RESERVE."

Jack Stanley Hore, Robert Richardson, Oscar Gordon Hartsman, Ernest Barrett Mann, Arthur Gordon Richardson, Dudley John Schuber, James Stewart Noel Harris, John Clarence McKenzie-McHarg, Arthur Bligh Smith Collins, Charles Felix Follard, Marcus Henry Buntz, Frank John Audas Grant, Percival John Newbound, and George Alfred William Boyes as a Committee of Management for a period of three (3) years of the land temporarily reserved for a Racecourse, Showground, and Public Recreation Ground in the Parish of Wodonga, and known as the "Wodonga Recreation Reserve."—(Corres. Rs.1734.)

In witness whereof the common seal of the Board of Land and Works was hereunto affixed this twelfth day of June, One thousand nine hundred and fifty-seven, in the presence of—

(SEAL) KEITH TURNBULL, President.
W. T. LONG, Member.

COMMITTEES OF MANAGEMENT OF RESERVES.

APPOINTMENTS.

WHEREAS by section 184 of the *Land Act* 1928 it is provided that it shall be lawful for the Governor in Council or the Board of Land and Works to appoint and remove any number of persons, not less than three, or any municipal council, or the governing body of any corporation, to be a Committee of Management of any specified Crown land reserved either temporarily or permanently for any of the purposes set out in section 14 of the *Land Act* 1928, and not conveyed to or vested in trustees: Now therefore the Board of Land and Works doth hereby appoint the under-mentioned persons to be members of the Committee of Management of the Reserves named:—

"POUND CREEK HALL RESERVE."

Harold Kinnish, Geoffrey Reid Beard, Clifford Mitchell, William McCaughan, Ronald Claude Wisdom, Ronald John Jones, George Frederick Furnston, Arthur Mervyn Drowley, Neil James Sommers, and Norman George Keith Ashley as a Committee of Management for a period of three (3) years of the land temporarily reserved by Order in Council dated 4th July, 1922, as a site for a Mechanics' Institute in the Parish of Drumdemara, and known as the "Pound Creek Hall Reserve."—(Corres. Rs.2522.)

"GARFIELD RECREATION RESERVE."

Albert John Payne, Leonard John Branchley, Frederick Charles Cox, Charles Macedon Styles, Thomas Keith Gladstone Sarah, Charles Henry Grey, Alfred Henry Bassed, Clifford George Pringle, and Leonard Claude Austin as a Committee of Management for a period of three (3) years of the land temporarily reserved by Order in Council dated the 4th July, 1899, as a site for Public Recreation in the Parish of Koo-Wee-Rup East, and known as the "Garfield Recreation Reserve."—(Corres. Rs.2187.)

"LAVERS HILL RECREATION RESERVE."

Michael Harrington, Stuart Webster, and Edwardian Anderson as a Committee of Management for a period of three (3) years of the land in the Parish of Barwongmoong temporarily reserved as a site for Public Recreation by Order in Council dated 3rd May, 1949, and known as the "Lavers Hill Recreation Reserve."—(Corres. Rs.6345.)

"MANSFIELD (LORD'S) CRICKET AND RECREATION RESERVE."

Cyril Gordon McMillan as a Member of the Committee of Management for the period ending 14th November, 1958, of the land temporarily reserved by Order in Council dated 28th November, 1887, as a site for Cricket and other purposes of Public Recreation in the Town of Mansfield, and known as the "Mansfield (Lord's) Cricket and Recreation Reserve," in the place of Leonard Adelberg, resigned.—(Corres. Rs.2021.)

"BALLAARAT CIVIC HALL."

The Council of the City of Ballaarat as a Committee of Management of the land in the Township of Ballaarat temporarily reserved as a site for a Public Hall by Order in Council of the 11th May, 1954, and known as the "Ballaarat Civic Hall."—(Corres. Rs.4443.)

In witness whereof the common seal of the Board of Land and Works was hereunto affixed this nineteenth day of June, One thousand nine hundred and fifty-seven, in the presence of—

(SEAL) KEITH TURNBULL, President.
W. T. LONG, Member.

REGULATIONS FOR THE CARE, PROTECTION AND MANAGEMENT OF THE "PICOLA RECREATION RESERVE."

WHEREAS by section 181 of the *Land Act* 1928, as re-enacted by section 9 of the *Land Act* 1941, power is given to the Board of Land and Works to make Regulations in respect of the care, protection, and management of any Crown land which has been reserved under the *Land Acts* for any public purpose whatsoever and which has not been conveyed to or vested in trustees, and for the further purposes as enacted: Now therefore the Board of Land and Works, in pursuance of the power conferred as aforesaid, doth hereby make the following Regulations in respect of the land in the Parish of Picola, temporarily reserved by Order in Council of the 3rd November, 1954, as a site for Public Recreation, known as the "Picola Recreation Reserve," hereinafter referred to as the "Reserve." The Reserve has been placed under the control of a Committee of Management, hereinafter referred to as the "Committee":—

REGULATIONS.

1. The Reserve shall be open to the public from sunrise to sunset, free of charge, except on such days, not exceeding 52 in any one year, as the Reserve may be set apart for cricket or football matches, fêtes, sports, or holiday amusements, on any of which occasions a sum not exceeding Five shillings may be charged and taken for admission of every adult to the Reserve.

2. No person shall—

- (a) Enter or remain in the Reserve who may offend against decency as regards dress, language, or conduct, or who may behave in a disorderly, unseemly, or offensive manner, or create or take part in any disturbance.
- (b) Enter or remain in the Reserve whilst in a state of intoxication.
- (c) Bring any intoxicating liquor on to the Reserve without the consent of the Committee first obtained.
- (d) Exercise or train any horse or pony on the Reserve, or any part thereof, without the consent of the Committee first obtained.

3. The Committee shall have the power to hold entertainments, shows, or performances on the Reserve, and to make a charge for admission thereto as hereinbefore provided.

4. The Committee shall have power to let any portion of the Reserve to any club, association, person, or society for the purpose of holding entertainments, performances, shows, or sports, subject to the payment of such fees and on such terms as it may deem reasonable and consistent with these Regulations, and to authorize any club, association, society, or person to make a charge for admission thereto as hereinbefore provided in these Regulations.

5. No person, except the Committee or its officers or employees on duty, shall enter any part of the Reserve on an occasion when a charge is made for admission thereto without first paying the fees chargeable for such admission.

6. The Committee may set apart the whole or any part of the Reserve as a place for the parking of vehicles.

7. No person shall park a vehicle within the Reserve, except in places set apart by the Committee for the parking of vehicles.

8. The Committee may fix such fee, not exceeding 2s. per day, as they think fit as the fee for the parking of vehicles in any place set apart within the Reserve for the parking of vehicles.

9. Every person who parks a vehicle in a place set apart for the parking of vehicles shall pay to the Committee or its authorized representatives, on demand, such fee as has been fixed by the Committee pursuant to these Regulations as the fee for parking in such place.

10. Every person bringing a vehicle into the Reserve shall obey the reasonable direction of the Committee or its authorized representatives in relation to the driving or parking of such vehicles within the Reserve.

11. No person shall, in the Reserve, interfere with or break or damage any of the trees, plants, or shrubs, or pluck any flowers, or climb, jump, or get over or under any of the fences, gates, seats, or any other structures therein, or roll or throw stones or other missiles, or leave any bottles, broken glass, paper, orange peel, banana skins, or any rubbish whatever therein, or post bills or advertisements on any of the fences, gates, seats, or other structures therein.

12. No person shall put in the Reserve any cattle, horses, sheep, goats, pigs, or other animals without the permission, in writing, of the Committee first obtained.

13. No person shall camp in the Reserve, nor erect therein any building or any booth for the purpose of offering for sale any article without permission, in writing, of the Committee first obtained.

14. No person shall bet publicly in any part of the Reserve without permission, in writing, of the Committee first obtained.

15. No person, club, or other body shall, without the consent of the Committee first obtained, grade or scrape the ground off or cut or burn any grass growing on any part of the Reserve.

16. No person shall remove any earth, sand, stone, marl, or gravel from the Reserve.

17. The Committee shall not be held responsible in any way for any accident or injury sustained by or to any person or persons whilst within the boundaries of the Reserve.

18. No person shall light a fire in the Reserve, except at such place or places as is or are set aside for that purpose by the Committee.—(Rs.7298.)

The common seal of the Board of Land and Works was hereunto affixed this twelfth day of June, 1957, in the presence of—

(SEAL) KEITH TURNBULL, President.
W. T. LONG, Member.

Every person who contravenes or fails to comply with these Regulations shall, in accordance with the provisions of section 181 of the *Land Act* 1928, as re-enacted by section 9 of the *Land Act* 1941, for each offence be liable to a penalty of not more than Five pounds, and every person who contravenes or fails to comply with any such Regulation, and who, after he has been warned by any bailiff or member of the Police Force, does not desist therefrom may be forthwith apprehended by such bailiff or member of the Police Force and taken before some justice to be dealt with according to law, and shall be liable to a penalty of not more than Ten pounds.

AMENDMENT OF REGULATIONS FOR THE CARE, PROTECTION, AND MANAGEMENT OF THE ORBOST RECREATION RESERVE.

THE Board of Land and Works, in pursuance of the powers conferred on it, doth hereby amend the Regulations made on 23rd November, 1928, and 17th March, 1956, for the care, protection, and management of the Reserve for Cricket and other purposes of Public Recreation in the Township of Orbost, by the substitution in Regulation 1 for the words "Two shillings" the words "Three shillings."

And by the deletion of the words "on Sunday or" from Regulation No. 11.—(Rs.2684.)

The common seal of the Board of Land and Works was hereunto affixed this nineteenth day of June, 1957, in the presence of—

(SEAL) KEITH TURNBULL, President.
W. T. LONG, Member.

PUBLIC SERVICE NOTICES

PUBLIC SERVICE (PUBLIC SERVICE BOARD) REGULATION 39.—RECLASSIFICATIONS.

THE Public Service Board has raised the classification of the under-mentioned offices as shown, and the Permanent Heads of the Departments have recommended the officers named for appointment.

Office and Present Classification.	Revised Classification.	Duties.	Qualifications.	Officer Recommended for Appointment.		
				Name.	Classification.	Date of Classification.
ADMINISTRATIVE DIVISION.						
DEPARTMENT OF CHIEF SECRETARY.						
<i>Fisheries and Game Branch.</i>						
Clerk, Class "B"	Class "B1"	Under the direction of the Director of Fisheries and Game to act as Secretary of the Branch; to draft regulations under the Fisheries and Game Acts; to act as Collector of Imposts; to conduct correspondence and interviews and to take charge of the Branch during the absence of the Director	To possess administrative ability and a thorough knowledge of the Fisheries and Game Acts and regulations thereunder; ability to draft regulations; to conduct correspondence and to deal with interviews respecting the activities of the Branch	Bell, H.	Clerk, Class "B"	2.9.55
<i>Chief Secretary's Office.</i>						
Clerk, Class "C2"	Class "B"	To be Gazette Officer; to edit the <i>Government Gazette</i> and to perform other special duties, including those requiring literary ability, as may be directed from time to time	Ability to draft Orders in Council, Proclamations, &c., and a thorough knowledge of the various Acts so far as relates to the publication of matter in the <i>Government Gazette</i> and of the procedure to be adopted in connection therewith; experience in editorial duties and printing procedure is essential	Wheelock, W. J. T.	Clerk, Class "C2"	10.4.52
<i>Office of the Government Statist.</i>						
Clerk, Class "C1"	Class "C2"	Under the direction of the Metropolitan Registrar of Births and Deaths to have charge of registration of deaths and to carry out the statutory duties of a Registrar in relation thereto; to prepare certificates of death for issue under the provisions of the Friendly Societies Act; to supervise notification of deaths to various statutory authorities; to assist and relieve the Metropolitan Registrar in his duties when required	Sound knowledge of registration of Births, Deaths, and Marriages Acts and of regulations thereunder; experience in dealing with public	Hornan, H. T.	Clerk, Class "C1"	10.8.50
DEPARTMENT OF TREASURER.						
<i>Registry of Co-operative Societies.</i>						
Clerk, Class "B1"	Chief Clerk, Class "A" (£1,550-£1,600)	To assist the Registrar in the administration of the Registry of Co-operative Housing Societies and Co-operative Societies and in the administration of the Home Finance Section of the Treasury; to undertake such functions of the Registrar as may be delegated under the Public Service Act	To have a thorough knowledge of the Co-operative Housing Societies Acts, Co-operation Act and Home Finance Acts; to be fully conversant with the operations of co-operative housing societies and co-operative societies; to have had experience in connection with housing loans; to possess ability to control and direct staff	Brodie, W. J.	Clerk, Class "B1"	23.12.53
<i>Office of the Housing Commission.</i>						
Clerk, Class "C2"	Class "B"	To be in charge of the Eastern District Office of the Housing Commission at Morwell; to be responsible for the collection of rentals of the Commission's estates in that district, for the banking of such moneys and accounting for same to Head Office; and to exercise general supervision over the estates in regard to tenancy and maintenance of houses	To have administrative ability; to be capable of controlling a staff; to be experienced in dealing with the public; to have a knowledge of Housing Commission policy and practice; to hold a car driver's licence	Drew, W. L.	Clerk, Class "C2"	7.1.54

PUBLIC SERVICE (PUBLIC SERVICE BOARD) REGULATION 39.—RECLASSIFICATIONS—*continued.*

Office and Present Classification.	Revised Classification.	Duties.	Qualifications.	Officer Recommended for Appointment.		
				Name.	Classification.	Date of Classification.
DEPARTMENT OF TREASURER—<i>continued.</i>						
<i>Taxation (Land Tax) Office.</i>						
Clerk, Class "C1"	Class "C2"	To have charge of General and Divisional Ledgers, and keep Land Tax and Probate Duty Accounts; to be responsible for the certification of all accounts affecting assessments and amendments, and for all demands issued in respect of overdue accounts; to refer cases of unpaid tax for legal action, and to deal with inquiries and correspondence in connection with accounts; to be responsible for the prosecution work of the Branch and to relieve the Accountant when required	To be competent to undertake the work of keeping ledgers in use in recording assessments and revenue under the Land Tax Act and Administration and Probate (Estates) Act; to have a knowledge of assessing and of the Land Tax Act and Regulations, and of Departmental procedure; ability to conduct correspondence and control staff	Wilson, R. J.	Clerk, Class "C1"	16.4.51
DEPARTMENT OF PUBLIC WORKS.						
Clerk, Class "C"	Class "C1"	To act as Staff Officer	To possess a thorough knowledge of the Public Service Acts and Regulations and of staff personnel and requirements; to have an intimate knowledge of departmental organization and procedure and to possess ability to conduct correspondence; to be capable of interviewing the public with respect to appointments and to be experienced in the direction and control of staff	Hanley, E. A.	Clerk, Class "C"	28.3.55
DEPARTMENT OF AGRICULTURE.						
Clerk, Class "C"	Class "C1"	To act as sub-editor of the <i>Journal of Agriculture</i> and to assist in the preparation and publication of Departmental bulletins and pamphlets and in publicity work generally; to carry out the clerical duties associated with this work	Experience in the sub-editing of technical writings on agricultural subjects and in the make-up of technical publications; experience in the handling and layout of advertisements is essential	Taylor, B. H. R.	Clerk, Class "C"	5.2.51
PROFESSIONAL DIVISION.						
DEPARTMENT OF PREMIER.						
<i>Office of the Public Service Board.</i>						
Public Service Inspector (Industrial), Class "A" (£1,550-£1,650)	Classes "A" and "A1" (£1,550-£1,800)	To advise on industrial questions; to deal with matters relating to industrial co-ordination between State departments and instrumentalities; and to appear before Commonwealth industrial tribunals	To be a graduate in Law or Commerce and to be an experienced industrial officer and advocate	McDermott, K. W.	Public Service Inspector (Industrial), Class "A" (£1,550-£1,650)	1.1.57
DEPARTMENT OF TREASURER.						
<i>Taxation (Land Tax) Office.</i>						
Cadet Valuer, Class "D"	Assistant Valuer, Class "C"	To assist valuers in field and office work in connection with the valuation of properties for State Land Tax, Probate Duty and Stamp Duty purposes	To possess a knowledge of the principles governing the valuation of land and improvements; ability to analyse data and field notes prepared by district valuers, and to make reports on various properties for use by district valuers; applicants must have passed at least the first year's course of the Commonwealth Institute of Valuers, and to have had two years' practical experience in valuation work	O'Bree, L. J.	Cadet Valuer, Class "D"	8.8.55

PUBLIC SERVICE (PUBLIC SERVICE BOARD) REGULATION 39.—RECLASSIFICATIONS—continued.

Office and Present Classification.	Revised Classification.	Duties.	Qualifications.	Officer Recommended for Appointment.		
				Name.	Classification.	Date of Classification.
DEPARTMENT OF PUBLIC WORKS.						
Engineer, Class "B"	Class "B1"	Under the direction of the Local Government Engineer to investigate, inspect, and report on engineering and allied matters submitted by Local Government Authorities; to prepare schedules of allocation of Government funds towards the cost of Municipal works; to investigate and report on drainage and flooding problems and on matters associated with the Drainage Areas and River Improvement Acts	To possess a Diploma of Civil Engineering or to be the holder of a certificate issued by the Municipal Engineers Board of Victoria; to be versed in the methods of modern engineering design and practice and to have had experience as a Local Government Engineer	McCabe, C. S.	Engineer, Class "B"	27.7.53
Engineering, Surveyor, Class "C2"	Class "B"	To carry out engineering and land surveys and to prepare relevant reports; to set out construction works and when required to supervise the execution of such works	To have had experience in the carrying out of land and civil engineering surveys and of setting out civil engineering construction works; to have had construction experience on civil engineering work in the field	Speed, F. A. . .	Engineering Surveyor, Class "C2"	13.2.50
Senior Draughtsman, Class "C1" (two offices)	Class "C2" (two offices)	To prepare under direction plans, specifications, and estimates of electrical installations and services in all types of public buildings; to assist in the checking of plans and specifications of work prepared by a section of the electrical draughting staff	To have approved technical school training and a good practical drawing office experience in electric light and power and to possess a good knowledge of the design and layout of electric light and power installations, including illumination design of all types, both office and industrial	Leversha, H. W.	Senior Draughtsman, Class "C1"	5.12.55
				Buckett, F. L.		26.4.56
DEPARTMENT OF MINES.						
Superintending Draughtsman, Class "B1"	Chief Draughtsman, Class "A" (£1,550)	To have charge of the computing, draughting, cartographic and lithographic work in connexion with the preparation of geological maps and plans	To have a thorough knowledge of all sections of the work prepared by the draughting staff, the administrative ability and personal qualities necessary for the control of varied technical staff	McInnes, D. W.	Superintending Draughtsman, Class "B1"	28.9.53
DEPARTMENT OF AGRICULTURE.						
Cereal Chemist, Class "C2"	Cereal Chemist, Class "B"	Under general direction, to control the work of the cereal chemistry section; to undertake investigations on the milling and baking quality of flour and on other cereals and cereal products, and to act as certifying officer in connexion with export flour shipments	To hold a University degree with chemistry as a major subject; to have had experience in cereal chemistry, in investigational work and in controlling a small chemical staff	Moss, H. J. . .	Chemist, Class "C2"	9.5.54
Seeds Analyst (Female), Class "C1"	Class "C2"	Under the Senior Agrostologist, to take charge of the Seed Testing Laboratory; to undertake the examination of seed samples and to report on their purity and germination; to act as Deputy Botanist in accordance with the provisions of the Seeds Acts and to undertake research in seed testing	To possess a Degree in Agricultural Science or Science, experience in seed testing and the identification of weed seeds, a knowledge of International Seed Testing Association rules and ability to control and direct staff	Easton, Gwen R.	Seeds Analyst (Female), Class "C1"	21.11.49
TECHNICAL AND GENERAL DIVISION.						
DEPARTMENT OF PREMIER.						
<i>Audit Office.</i>						
Assistant (Male), Grade II.	Grade I. (£481-£494)	To assist generally on the audit and examination of the accounts of the Forests Commission, and the Rural Finance Corporation	To have a knowledge of the Audit Act and the regulations thereunder and the accounting systems of the Forests Commission and the Rural Finance Corporation	Jurek, C. . .	Assistant (Male), Grade II.	8.10.54

PUBLIC SERVICE (PUBLIC SERVICE BOARD) REGULATION 39.—RECLASSIFICATIONS—*continued.*

Office and Present Classification.	Revised Classification.	Duties.	Qualifications.	Officer Recommended for Appointment.		
				Name.	Classification.	Date of Classification.
DEPARTMENT OF WATER SUPPLY.						
Inspector ..	Works Inspector (£565-£617)	To supervise the maintenance of the Bunyip Main Race comprising concrete-lined and earthen channels and pipe syphons; to attend to the reticulation, tapping, and scouring of mains; to affix and read water meters and to keep accurate records thereof and to supervise the work of licensed plumbers; to control the supply to storage basins connected with the Mornington Peninsula Scheme, and to repair and do necessary tappings to main pipe lines; to carry out the duties of Turncock when required	To be competent to do minor repairs to wood stave, steel, fibrolite, and concrete mains and to be able to tap same; to have had experience in plumbing work associated with water-supply installations, and to be capable of driving a truck. Possession of an Intermediate Technical School Certificate is desirable	Perkins, P. T.	Inspector ..	13.10.55

Appeals against such recommendations should be lodged with the Secretary to the Public Service Board not later than Saturday, the 6th July, 1957.

Office of the Public Service Board,
Melbourne, 25th June, 1957.

By order,
V. P. SCULLY,
Secretary.

PUBLIC SERVICE (PUBLIC SERVICE BOARD) REGULATION 39.—VACANCIES.

THE Permanent Head of the Department shown has recommended the officers named hereunder for appointment to the under-mentioned vacancies.

Office and Classification.	Duties.	Qualifications.	Officer Recommended for Appointment.		
			Name.	Classification.	Date of Classification.
ADMINISTRATIVE DIVISION. DEPARTMENT OF PREMIER. <i>Office of the Public Service Board.</i>					
Assistant Chief Public Service Inspector, Classes "A" and "A1" (£1,550-£2,000)	As prescribed by Section 44 (2) of the <i>Public Service Act</i> 1946, and to assist in co-ordinating the duties of other Public Service Inspectors	To possess a Diploma in Public Administration or other appropriate qualification; to have a sound knowledge of the Public Service Acts and the Regulations thereunder and of the general organization and working of departments; to have had experience in investigation work and in the compilation of reports; to be competent to carry out investigations into all phases of departmental organization and procedure including staffing, classification, and office efficiency	Veitch, R. W.	Public Service Inspector, Class "A" (£1,550-£1,650)	1.1.57
Clerk, "B1" Class	To act as Assistant Secretary	To possess an intimate knowledge of the Public Service Acts and Regulations, of the functions of the various Departments, and of the procedure and practice of the Board's Office	Hall, J. F. ..	Clerk, Class "B"	10.11.55
<i>Audit Office.</i>					
Clerk, "C2" Class	To examine the Treasurer's accounts, particularly those relating to the Departments of Premier, Chief Secretary, Treasurer, and Health	To be a certificated accountant; to have a thorough knowledge of the Audit Act and the Regulations thereunder and of the Treasury system of accounts	Tutty, K. J. ..	Clerk, Class "C1"	6.8.56

Appeals against such recommendations should be lodged with the Secretary to the Public Service Board not later than Saturday, the 6th July, 1957.

Office of the Public Service Board,
Melbourne, 25th June, 1957.

By order,
V. P. SCULLY,
Secretary.

PUBLIC SERVICE OF VICTORIA.—VACANCIES.

A PPLICATIONS will be received by the Public Service Board up to Wednesday, the 10th July, 1957, from persons employed in the Public Service of Victoria, who are eligible and qualified, for appointment to the under-mentioned positions:—

ADMINISTRATIVE DIVISION.

Secretary, Housing Commission, Classes "A" and "A1," Office of the Housing Commission, Department of Treasurer.

Yearly Salary.—£1,550, minimum; £1,800, maximum.

Qualifications.—To possess a thorough knowledge of the functions of the Commission and the Acts and regulations under which it operates; to be competent to advise the Commission on matters of policy and to undertake special duties; and to be capable of controlling a large staff.

Clerk, Class "C2," Department of Mines.

Yearly Salary.—£940, minimum; £1,030, maximum.

Duties.—To act as Registrar under the Coal Mine Workers Pensions Acts, and in that capacity to carry out the decisions of the Tribunal, and in all respects to attend to the detailed administration of such Acts.

Qualifications.—To possess administrative and executive ability, experience in secretarial duties, governmental accounting procedure and in dealing with the public, and to have the capacity to interpret Acts and Regulations. A knowledge of the Coal Mine Workers Pensions Acts and the Commonwealth Social Services Act is desirable.

Clerk, Class "C1," Department of Crown Lands and Survey.

Yearly Salary.—£785, minimum; £875, maximum.

Duties.—Under direction to take charge of the clerical staff of the Survey Co-ordination Branch; to supervise the purchase of and to arrange for the importation of survey and photographic equipment and materials; to check accounts for payment.

Qualifications.—Knowledge of the Survey Co-ordination Act and of the Regulations concerning Public Accounts; knowledge of the Central Plan Office and its functions; to be experienced in dealing with the public.

PROFESSIONAL DIVISION.

Senior Conservation Officer, Classes "B"—"B1," Soil Conservation Authority, Department of Premier.

Yearly Salary.—£1,100, minimum; £1,400, maximum.

Duties.—Under direction, to assist in the development of the Soil Conservation advisory service to landholders and public authorities and to direct the work of the District Conservation Officers.

Qualifications.—To be qualified in accordance with the provisions of Public Service (Public Service Board) Regulation 43 (1); to have extensive experience in soil conservation and to have proved administrative ability.

Architect, Class "B," Architectural Branch, Department of Public Works.

Yearly Salary.—£1,100, minimum; £1,200, maximum.

Duties.—To prepare, under the direction of the Chief Architect, preliminary and contract plans, details, specifications, reports and estimates, and to generally supervise and guide a section of the draughting staff as may be required.

Qualifications.—To be a qualified architect experienced in planning modern buildings for State purposes.

Conservation Officer, Classes "C"—"C2," Soil Conservation Authority, Department of Premier.

Yearly Salary.—£683, minimum; £1,030, maximum. (Commencing salary in accordance with experience.)

Duties.—To advise landholders on soil conservation measures on their property; to carry out surveys for contour layout; to assist in the carrying out of soil conservation works.

Qualifications.—To have a thorough knowledge of the characteristics and use of land; experience in the practice of agriculture and a knowledge of the principles and application of soil conservation methods; to hold the degree of Bachelor of Agricultural Science of the University of Melbourne or an equivalent degree of any University approved by the Public Service Board.

Assistant Horticultural Research Officer, Classes "C"—"C2," Department of Agriculture.

Yearly Salary.—£683, minimum; £1,030, maximum. (Commencing salary in accordance with experience.)

Duties.—To assist in investigations into horticultural problems and in the demonstrational and advisory work of the Horticultural Division.

Qualifications.—A degree in Agricultural Science of the Melbourne University or its equivalent.

Assistant Quantity Surveyor, Class "C1," Department of Public Works.

Yearly Salary.—£785, minimum; £875, maximum.

Duties.—To assist in the preparation of bills of quantities, variations, estimates, schedules, reports and site survey in connexion with tasks generally executed in the Quantity Survey Section.

Qualifications.—To have completed a substantial portion of a quantity surveying course at a recognized technical school and to have had three years' practical experience and training in an established office.

TECHNICAL AND GENERAL DIVISION.

Apprenticeship Supervisor, Apprenticeship Commission, Department of Labour and Industry.

Yearly Salary.—£638, minimum; £728, maximum.

Duties.—To visit places of employment and to assist in the supervision over the employment of apprentices in accordance with the requirements of the Apprenticeship Acts and Regulations; to report as required on the extent and nature of the practical experience obtained by apprentices and generally to encourage apprenticeship up to the limit prescribed by Regulations.

Qualifications.—To have had approved practical experience in the Electrical Trades, approved technical qualifications, and a knowledge of industrial conditions, labour laws, and Apprenticeship Acts; to be capable of conducting investigations efficiently and of compiling reports in connexion therewith. Approved experience in the technical training of apprentices is desirable.

Engineer Mechanic, Buchan Caves, Department of Crown Lands and Survey.

Yearly Salary.—£450, minimum; £489, maximum.

Duties.—To be responsible for the operation of a diesel generating plant (D.C.) and the maintenance of electrical reticulation and wiring in the Caves; to carry out other duties required by the Officer in Charge.

Qualifications.—To possess an "A" or "B" Grade Electrical Mechanic's Licence issued by the State Electricity Commission of Victoria; to have had good general experience in maintenance of electric light and power installation and the operation of diesel generating plant.

NOTE.—A residence is available in the Reserve for the successful applicant, if married, for which rental of 10 per cent. of standard salary, plus £16 per annum, will be charged.

Warden, Grade II., Fisheries and Game Branch, Department of Chief Secretary.

Yearly Salary.—£364, minimum; £455, maximum.

Duties.—Under the direction of the Director to enforce the provisions of the Fisheries and Game Acts and the Regulations thereunder and generally to assist in the outside work of the Branch.

Qualifications.—An applicant must be strong, healthy and active, able to drive a motor vehicle and to manage a motor boat. He should have a good

knowledge of and be able to effect running repairs to motor vehicles, and marine engines. A knowledge of all classes of fish and native game and the methods of fishermen and shooters would be an advantage. An education to Intermediate standard is desirable. Applicants should be under forty (40) years of age.

NOTE.—The salary rates quoted above do not include the additional amounts which are payable under Regulation 77A of the Board's Regulations.

By order,

V. P. SCULLY,
Secretary.

Office of the Public Service Board,
Melbourne, 25th June, 1957.

"Survey Draughting I," and the words "or Draughting Practice II," are inserted immediately after the words "Survey Draughting II."

The subject "Engineering Surveying B (Licensed Surveyors' Examination)" is inserted immediately following the words "together with one of the following subjects:—"

A. GARRAN, Chairman.
V. P. SCULLY, Secretary.

Office of the Public Service Board,
Melbourne, 6th June, 1957.

PUBLIC SERVICE OF VICTORIA.—VACANCIES.

(TEMPORARY APPOINTMENTS.)

APPLICATIONS will be received by the Public Service Board up to Wednesday, the 10th July, 1957, from persons, who are qualified, for appointment to the under-mentioned positions:—

Technical Works Officer, Grade I, Architectural Branch, Department of Public Works.

Yearly Salary.—£559, minimum; £663, maximum.

Duties.—To measure buildings and drawings and to assist generally in the preparation of Estimates of Cost for all types of building work and to maintain certain technical records in the Quantity Survey Office.

Qualifications.—To have had extensive training and practical experience in one or more branches of the building industry; possession of technical certificates in building construction desirable.

(This advertisement is in lieu of advertisement appearing on page 2012 of *Government Gazette* 189, dated the 19th June, 1957.)

Sister, "Winlton" Girls' Juvenile School, Nunawading, Children's Welfare Branch, Department of Chief Secretary.

Yearly Salary.—£438, minimum; £464, maximum.

Duties.—To have charge of the surgery at "Winlton"; to assist the visiting doctor during his attendances; to provide first aid treatment and attend to cases of minor illness.

Qualifications.—To possess a General Nursing Certificate.

NOTE.—Quarters and rations provided, if required, at a charge of £166 a year. Uniforms supplied free of charge.

The salary rates quoted above do not include the additional amounts which are payable under Regulation 77A of the Board's Regulations.

By order,

V. P. SCULLY,
Secretary.

Office of the Public Service Board,
Melbourne, 25th June, 1957.

No. 611.

PUBLIC SERVICE ACT 1946.

THE Public Service Board, in pursuance of the powers conferred by the *Public Service Act* 1946, hereby amends the Public Service (Public Service Board) Regulations as follows:—

PART II.—PROMOTIONS AND TRANSFERS.

REGULATION 38.

After sub-regulation (9) the following proviso is inserted:—

" : Provided that the Board may authorize similar reimbursement in cases where, in its opinion, the appeal of an unsuccessful appellant is based on substantial grounds."

A. GARRAN, Chairman.
V. P. SCULLY, Secretary.

Office of the Public Service Board,
Melbourne, 10th June, 1957.

No. 612.

Public Service Act 1946, Section 50.

REGULATIONS—PART III.—SALARIES, INCREMENTS, AND ALLOWANCES.

THE Public Service Board, in pursuance of the powers conferred by the *Public Service Act* 1946, hereby amends its Regulations as shown below:—

SECOND SCHEDULE.

TECHNICAL AND GENERAL DIVISION.

Offices and Rates of Salaries.

Department and Office.	Yearly Rate of Salary.		Increments (Annual).
	Minimum.	Maximum.	
DEPARTMENT OF TREASURER.	£	£	
HOUSING COMMISSION.			
<i>Delete</i> — District Maintenance Officer	754	806	2 of £26
<i>Add</i> — District Works Officer	806	871	1 of £39, and 1 of £26

A. GARRAN, Chairman.
V. P. SCULLY, Secretary.

Office of the Public Service Board,
Melbourne, 18th June, 1957.

No. 613.

PUBLIC SERVICE ACT 1946.

THE Public Service Board, in pursuance of the powers conferred by the *Public Service Act* 1946, hereby amends the Public Service (Public Service Board) Regulations as follows:—

PART III.—SALARIES, INCREMENTS, AND ALLOWANCES.

REGULATION 74.

SUB-REGULATION (1).

Survey Draughtsman.

Under the heading "Recognized Examination regarded as Optional Equivalent" the words "or Draughting Practice I." are inserted immediately after the words

Teaching Service Act 1946.

TEACHING SERVICE (TEACHERS TRIBUNAL) REGULATIONS.

AMENDMENT No. 201.

THE Teachers Tribunal, in pursuance of the powers conferred by the Teaching Service Act 1946, hereby amends Regulation 1 of the Teaching Service (Teachers Tribunal) Regulations in the manner following, that is to say:—

REGULATION 1.

In clause 8, delete the scale of rates and substitute the following scale in lieu thereof:—

	For the First 5,000 Miles in a Financial Year.	Mileage Over 5,000 Miles in a Financial Year.
	a mile d.	a mile d.
Motor Cars—		
Over 24 h.p.	13·9	9·5
Over 12 h.p. and up to 24 h.p.	11·5	8·3
12 h.p. and under	10·3	7·4
Motor cycles, with side cars	5·2	3·7
Motor cycles	4·4	3·2
Bicycles	1·6d. a mile irrespective of mileage.	

(To take effect from and inclusive of the 1st July, 1957.)

LOUIS F. C. GARLICK, Chairman.
G. FENNELL, Secretary.

Office of the Teachers Tribunal,
Melbourne, 24th June, 1957.

TENDERS—PUBLIC WORKS DEPARTMENT

TENDERS will be received at this office until **TEN a.m.** on the days and for the purposes under mentioned. Particulars may be learnt at this Office and also at places shown in parenthesis.

W.O. means Inspector of Works Office; P.S.—Police Station; T.S.—Technical School; H.E.S.—Higher Elementary School; S.S.—State School; H.S.—High School.

The Board of Land and Works will not necessarily accept the lowest or any tender.

NOTE.—No preliminary deposits are to be lodged with tenders, but a deposit, in accordance with the following Schedule, will be required from the successful tenderer:—

For contract amounts exceeding £200 and not exceeding £500	£
For contract amounts exceeding £500 and not exceeding £1,000	b
For contract amounts exceeding £1,000—1 per cent. of tender	10
	500
	(maximum deposit)

All tenders should be on a "firm tender" basis.

In preparing tenders, regard should be had to the decision of the Commonwealth Court of Conciliation and Arbitration and the resultant effects in respect of wages and materials.

2nd July, 1957.

Albert Park.—Rewiring of electrical installation in Main School Building, S.S. No. 1181. (S.S., Albert Park.)
Ballarat.—Repairs and painting, residence, 1128 Eyre-street, Mines Department. (W.O., Ballarat.)
Ballarat.—Lining of hut and painting of fence, School of Mines. (W.O., Ballarat.)

Ballarat.—Supply, delivery, installation, and testing of exhaust system in Blacksmith's Shop, School of Mines. (W.O., Ballarat.)
Ballendella.—Repairs, renovations, drainage, &c., at school and residence, S.S. No. 3732. (W.O., Bendigo; S.S., Ballendella.) (Amended specification.)
Beeac.—Repairs and painting, and rebuilding kitchen chimney, Police Station. (W.O., Camperdown; P.S., Beeac.)

Benalla East.—Repairs and painting of detached buildings, S.S. No. 2256. (W.O., Benalla; S.S., Benalla East.)

Box Hill.—Internal and external repairs and painting, Court House. (P.S., Box Hill.)

Box Hill.—Construction of grease trap, Girls' Technical School. (Girls' Technical School, Box Hill.)

Breadford.—Reblocking, internal and external painting, S.S. No. 1125. (W.O., Alexandra; P.S., Seymour, Euroa; S.S., Breadford.)

Carlton.—New non-party boundary fence, Education Department Bulk Store.

Chatsworth.—Erection of a new out-office and woodshed, S.S. No. 1382. (W.O., Hamilton, Warrnambool; S.S., Chatsworth.)

Clayton North.—Electrical installation in out-buildings and additions in main building, S.S. No. 734. (S.S., Clayton North.)

Cobram.—Repairs and painting to residence, Market-street, Consolidated School. (W.O., Benalla, Shepparton; Consolidated School, Cobram.)

Colac West.—Provision of external staircase, S.S. No. 4064. (W.O., Camperdown; S.S., Colac West.) (Amended specification.)

Dimboola.—Supply and installation of slow combustion stove and water softening plant, Police Station. (W.O., Horsham; P.S., Dimboola.)

Drik Drik.—Repairs and painting of school and out-buildings, S.S. No. 971. (W.O., Warrnambool, Hamilton; S.S., Drik Drik.)

Dunrobin.—Erection of 20 ft. by 10 ft. shelter pavilion, S.S. No. 3777. (W.O., Hamilton; S.S., Dunrobin.)

Echuca.—External repairs and painting, residence, Fisheries and Game Department. (W.O., Shepparton; P.S., Echuca.)

Echuca.—Construction of new out-offices and woodshed, laying of sewer drains, and water supply, Technical School. (W.O., Shepparton; T.S., Echuca.)

Ellinbank.—Electrical installation, Dairy No. 3, Dairy Research Farm. (W.O., Korumburra.)

Elwood.—Electrical installation unit Nos. 2, 3, and 4. High School.

Flemington.—Erection of additional toilet for staff, Girls' Secondary School. (Girls' Secondary School, Flemington.)

Geelong West.—Supply, delivery, and installation of sawdust extraction plant, Technical School. (W.O., Geelong.)

Gladysdale.—Internal and external repairs and painting, S.S. No. 3982. (S.S., Gladysdale.)

Hamilton.—Erection of first section in L.T.C., High School. (W.O., Hamilton.)

Hamilton.—Electrical installation in modified stage 1, High School. (W.O., Hamilton.)

Heidelberg.—Internal and external repairs and painting to cleaner's residence, S.S. No. 294. (P.S., Heidelberg; S.S., Heidelberg.)

Kaniva.—Renewal of party and non-party fencing, repairs to plaster, Police Station. (W.O., Horsham; P.S., Kaniva, Nhill.)

Longford.—Repairs, internal and external painting to school and residence, S.S. No. 1694. (W.O., Traralgon; S.S., Longford.)

Merlynston.—External and internal painting, new sink, renewals, &c., S.S. No. 4328. (S.S., Merlynston.)

Merrilands.—Erection of first and second sections, High School.

Merrilands.—Electrical installation in stages 1 and 2, High School.

Merrilands.—Supply, delivery, installation, and testing of the mechanical services for stages 1 and 2 of the building programme, High School.

Mildura.—Laying of sewer drains, erection of new out-office block, extension of water supply, High School. (W.O., Mildura.)

Moorabbin.—Non party fencing, Technical School. (T.S., Moorabbin.)

Mordialloc.—Renewal of roof sheeting in glazed manganese tiles, S.S. No. 846. (S.S., Mordialloc.)

Morwell.—Erection of new timber staff residence, garage, fencing, sewerage, &c., High School. (W.O., Traralgon; H.S., Morwell.)

Mount Taylor.—Repairs and painting to the school and out-buildings, S.S. No. 3467. (W.O., Bairnsdale; S.S., Mount Taylor.)

Newhaven.—Repairs and painting to school and residence, S.S. No. 3053. (W.O., Korumburra; S.S., Newhaven.)

North Carlton.—Repairs and painting to main and Infants' School Buildings, &c., S.S. No. 1252. (S.S., North Carlton.)

Nunawading.—Additional toilet accommodation, S.S. No. 4190. (S.S., Nunawading.)

Outtrim.—Reblocking, repairs, and painting, S.S. No. 3229. (W.O., Korumburra; S.S., Outtrim.)

Parklands.—Supply and erection of chain wire mesh and pipe rail fencing, including gates, S.S. No. 4738.

Pascoe Vale South.—New party and non-party boundary fences, S.S. No. 4704. (S.S., Pascoe Vale South.)

Portland.—Repairs, painting, and non-party fencing, Quarters No. 2, Police Station. (W.O., Warrnambool; P.S., Portland.)

Port Melbourne.—Renewal of roof, S.S. No. 2932.

Royal Park.—Supply, erection, and connexion of lighting columns and reinstatement of cables, Mental Hospital.

Rupanyup South.—Repairs, alteration, and construction of new porch, internal and external painting, S.S. No. 3872. (W.O., Warracknabeal, Horsham; S.S., Rupanyup South.)

South Melbourne.—Extension of partitions, Technical School. (T.S., South Melbourne.)

South Yarra.—Rewiring of and additions to electrical installation, Toorak Teachers' Training College, 19 Park-street.

Stanhope South.—Repairs and painting to school and residence, S.S. No. 4325. (W.O., Shepparton; S.S., Stanhope South.)

Toolleen.—Repairs and painting, &c., residence and S.S. No. 1336. (W.O., Shepparton; S.S., Toolleen.)

Tottenham.—Electrical installation in stage 1, Technical School.

Upper Sandy Creek.—Repairs and painting to school and out-buildings, S.S. No. 3145. (W.O., Wangaratta; S.S., Upper Sandy Creek.)

Warburton.—Non-party fencing, S.S. No. 1485. (S.S., Warburton.)

Werribee.—Extension of Cereal Laboratory, Research Farm. (Research Farm, Werribee.)

Werribee.—Electrical installation in the extension of Cereal Laboratory, Research Farm. (Research Farm, Werribee.)

Werribee.—Additions to electrical installation in main school and Bristol prefabs, S.S. No. 649. (S.S., Werribee.) (Amended specification.)

Whorouly South.—Repairs and painting, S.S. No. 4208. (W.O., Benalla, Wangaratta; S.S., Whorouly South.)

Winchelsea.—External and internal renovations, roof repairs, and renewal of out-office and residence, S.S. No. 2015. (W.O., Geelong; S.S., Winchelsea.)

Yallourn.—Repairs and painting, Technical School. (W.O., Traralgon; T.S., Yallourn.)

Yallourn.—Retiling and overhaul roof, High School. (W.O., Traralgon; H.S., Yallourn.)

Yallourn North.—Additional lavatory accommodation, sewerage, and water installation, S.S. No. 3967. (W.O., Traralgon; S.S., Yallourn North.)

Yarram.—Supply and erection of approximately 660 feet of pipe and chain mesh fence, High School. (W.O., Traralgon; H.S., Yarram.)

9th July, 1957.

Aberfeldie.—Relaying section of sewerage drain, S.S. No. 4220. (S.S., Aberfeldie.)

Benalla.—Erection of Public Offices. (W.O., Benalla; Wangaratta.)

Blackburn East.—Erection of six-classroom primary school building, S.S. No. 4800.

Blackburn East.—Electrical installation, new six (6) classrooms, &c., L.T.C., S.S. No. 4800.

Blackburn East.—Heating/ventilation system in new six-classroom primary school building, S.S. No. 4800.

Cheltenham.—Construction of new out-office block and connecting same to sewer, &c., S.S. No. 84. (S.S., Cheltenham.)

Dandenong.—Central heating to existing buildings, High School. (H.S., Dandenong.)

Dingley.—Septic tank installation and laying of sewer drains, &c., S.S. No. 4257. (S.S., Dingley.)

Ellinbank.—Supply and installation of milking machinery and mechanical services in the No. 3 Dairy, Dairy Research Station. (Dairy Research Station, Ellinbank.)

Erica.—Installation of hot-water service, Police Station. (P.S., Erica.)

Flemington.—Renewal of chalkboards with cupboards under, S.S. 250. (S.S., Flemington.)

Glengarry West.—Repairs and painting to the school and residence, S.S. No. 4426. (W.O., Traralgon; S.S., Glengarry West.)

Heatherton.—Removal of small building and extensions to same, Sanatorium.

Heatherton.—Supply and delivery of steam-heated bain marie and hot press, nurses' dining-room, Sanatorium.

Horsham.—Repairs and painting to residence, corner Alexandra-avenue and Wavell-street, Lands Department. (W.O., Horsham.)

Kew.—Supply and delivery and placing in position on site new hot press and bain marie for male staff mess, Mental Hospital.

Lakes Entrance.—Additional out-offices, drinking facilities, &c., S.S. No. 2672. (W.O., Bairnsdale; P.S., Lakes Entrance.)

Manangatang.—Erection of new shelter pavilion, conversion of existing to storeroom, Consolidated and Higher Elementary School. (W.O., Swan Hill; Consolidated School, and Higher Elementary School, Manangatang.)

Melbourne.—Repairs to steel window frames, Taxation Office.

Mitcham.—Additional out-offices, drinking and washing facilities, S.S. No. 2904. (S.S., Mitcham.)

Rushworth.—Rewiring of and additions to electrical installation, Higher Elementary and S.S. No. 1057. (W.O., Bendigo, Shepparton; H.E. and S.S., Rushworth.)

Seaford.—Erection of a shelter pavilion, 32 ft. x 16 ft., and additional lavatories, S.S. No. 3835. (S.S., Seaford.)

Shepparton.—Electrical installation, old primary school at Technical School. (W.O., Shepparton; T.S., Shepparton.)

South Melbourne.—Soundproofing between offices and classrooms, Technical School. (T.S., South Melbourne.)

Sunshine East.—Supply and erection of chain wire mesh and pipe-rail fencing, including gates (New Infants' School), S.S. No. 4645. (S.S., Sunshine East.)

Templestowe.—Additional out-office accommodation, drinking and washing facilities, S.S. No. 1395. (S.S., Templestowe.)

Warragul North.—Fencing of school site in pipe rail and chain mesh, and post and wire, S.S. No. 4695. (W.O., Traralgon; S.S., Warragul North.)

Watsonia.—Electrical installation in stage 1, Technical School.

Watsonia.—Mechanical services for stage 1, Technical School.

Watsonia.—Erection of first section in L.T.C., Technical School.

16th July, 1957.

Ballarat.—Conversion of the existing steam generators to heavy oil burning, and the supply and installation of new steam header and relevant pipework and fittings, &c., in the boiler house, Mental Hospital. (W.O., Ballarat.)

Carlton.—Various minor works, Teachers' College Hostel, Drummond-street.

Caulfield North.—Installation of two sinks and sewerage drains, S.S. No. 3820.

Drouin.—Erection of pipe and chain mesh fence on street frontage (943 feet non-party), High School. (W.O., Traralgon; H.S., Drouin.)

Drouin.—Internal renovations, S.S. No. 1924. (W.O., Traralgon; S.S., Drouin.)

Geelong North.—Repairs and renewal of fencing, party and non-party, S.S. No. 1889. (W.O., Geelong; S.S., Geelong North.)

Glenrowan.—Purchase and removal of residence, S.S. No. 1742. (W.O., Benalla.)

Grass Flat.—Repairs and renovations, S.S. No. 3192. (W.O., Horsham; S.S., Grass Flat.)

Hawthorn.—Erection of timber crossover, Swinburne Technical College. (Swinburne Technical College, Hawthorn.)

Heatherton.—Alterations and additions to medical superintendent's brick residence at Sanatorium.

Heatherton.—Repairs and painting, S.S. No. 938. (S.S., Heatherton.)

Hughesdale.—Renewal of chalkboards and two drinking troughs, S.S. No. 4176. (S.S., Hughesdale.)

Lavers Hill.—Erection of four-unit teachers' flats, Consolidated School. (W.O., Warrnambool, Camperdown.)

Malvern.—External painting and roof repairs, infant school building, S.S. No. 1604. (S.S., Malvern.)

Melbourne.—External painting and repairs, Government Statist's Office.

Melbourne.—Supply and installation of room air-conditioning unit and water cooling unit in Photographic Laboratory, Scientific Section, Police Headquarters, Russell-street.

Moe.—Erection of shelter pavilion, S.S. No. 2142. (W.O., Traralgon; S.S., Moe.)

Mordialloc-Chelsea.—Erection of No. 2 shelter pavilions, 32 ft. x 16 ft., High School. (H.S., Mordialloc-Chelsea.)

Myrtleford.—Installation of slow-combustion stoves and hot-water services in two residences, Tobacco Research Station. (W.O., Wangaratta; Tobacco Research Station, Myrtleford.)

Nambrook West.—Erection of timber residence, garage, fencing, &c., S.S. No. 3648. (W.O., Traralgon; S.S., Nambrook West.)

Newcomb.—Erection of six-classroom primary school in L.T.C., S.S. No. 4776. (W.O., Geelong.)

Prospect Estate.—Repairs and painting, S.S. No. 4324. (W.O., Bairnsdale; S.S., Prospect Estate.)

Shepparton.—Supply and installation of air-conditioning system, Supreme Court. (W.O., Shepparton.)

South Melbourne.—Additional toilets for policewomen, Police Depot, St. Kilda-road.

South Yarra.—Installation of sanitary fittings, alterations to sewer drains, water supply, &c., "Park Mansions," 19 Park-street, T.B. Convalescent Hospital.

Strathmore.—Supply, delivery, installation, and testing of the mechanical services for stages 1 and 2 of building programme, High School.

Warrnambool.—Internal and external repairs and painting to residence, 38 Princess-street, S.S. No. 1743. (W.O., Warrnambool; S.S., Warrnambool.)

Yinnar.—Renovations to school and residence, new out-offices, S.S. No. 2419. (W.O., Traralgon; S.S., Yinnar.) (Amended specification.)

23rd July, 1957.

Dandenong.—Erection of first and second sections of concrete veneer and timber-framed Girls' Secondary School.

Dandenong.—Electrical services in first and second sections, Girls' Secondary School.

Dandenong.—Mechanical services for stages 1 and 2, Girls' Secondary School. (P.S., Dandenong.)

All tenders should be on a "firm tender" basis.

In preparing tenders, regard should be had to the decision of the Commonwealth Court of Conciliation and Arbitration and the resultant effects in respect of wages and materials.

Tenders to be addressed to the Honorable the Commissioner of Public Works, and envelope containing tender marked "Tender for _____ due _____"

T. K. MALTBY,
Commissioner of Public Works.

Public Works Department,
Melbourne, 25th June, 1957.

PRIVATE ADVERTISEMENTS

AUSTRALIAN BARLEY BOARD.

FINAL DATE FOR DELIVERY OF BARLEY, No. 18 POOL,
SEASON 1956-57.

IN accordance with sub-clause (2) of clause 16 of the *Victorian Barley Marketing Act 1948*, the Australian Barley Board hereby notifies barley growers that the 30th June, 1957, is the final day on which barley of the No. 18 Pool, 1956-57 season's crop will be accepted, unless the grower makes and forwards a declaration in accordance with sub-clause (1) of clause 16 of the *Victorian Barley Marketing Act 1948*.

Dated 19th June, 1957.
1392 K. K. ANGEL, Secretary.

WE, Wasylus Morozovas and Elena Morozovas, both of 6 Moffat-street, South Yarra, in the State of Victoria, waiter, and married woman respectively, heretofore called and known by the names of Wasylus Morozovas and Elena Morozovas, hereby give public notice that by deed poll dated the 12th day of June, 1957, duly executed and attested and deposited with the Registrar-General of the said State on the 14th day of June, 1957, we formally and absolutely renounced and abandoned the use of our respective names of Wasylus Morozovas and Elena Morozovas, and declared that we had assumed and adopted and intended henceforth on all occasions whatsoever to use and sign the names of William Moore and Helen Moore respectively as our Christian and surnames, in lieu of the Christian and surnames of Wasylus Morozovas and Elena Morozovas.

Dated the 20th day of June, 1957.

WILLIAM MOORE.
HELEN MOORE.

R. E. Lewis, Orr and Gibson, solicitors, 379 Collins-street, Melbourne. 1437

NOTICE OF INTENTION TO APPLY FOR A LICENCE TO DIVERT WATER AND CUT RACE FROM THE LONG LAKE CHANNEL AT LONG LAKE.

I HEREBY give notice that I intend to apply for a licence empowering me to divert water for a term of fifteen years to the extent of 44 acre-feet per annum at a maximum rate of 1 acre-foot per day of 24 hours for the irrigation of 22 acres, being part of allotments 2b and 2c, section 2, Parish of Kunat Kunat, and to occupy certain Crown lands for works of diversion, and to cut a race thereon.

Any objection to such application must be forwarded, in writing, to the State Rivers and Water Supply Commission, Melbourne, within 30 days of the date hereof.

THOMAS EDWARD LIGHTFOOT.

Box 50, Lake Boga, Victoria, 23rd May, 1957. 1388

NOTICE OF INTENTION TO APPLY FOR A LICENCE TO DIVERT WATER AND CUT RACE FROM THE GUNBOWER CREEK AT COHUNA.

I HEREBY give notice that I intend to apply for a licence empowering me to divert water for a term of fifteen years to the extent of 20 acre-feet per annum at a maximum rate of 4 acre-feet per day of 24 hours for the irrigation of 10 acres, being part of allotment 52, section 8, Parish of Gunbower West, and to occupy certain Crown lands for works of diversion, and to cut a race thereon.

Any objection to such application must be forwarded, in writing, to the State Rivers and Water Supply Commission, Melbourne, within 30 days of the date hereof.

JOHN SAVILLE.

Dalton's Bridge, Cohuna, 26th June, 1957. 1387

NOTICE OF INTENTION TO APPLY FOR A LICENCE TO DIVERT WATER AND CUT RACE FROM THE GUNBOWER CREEK AT COHUNA.

I HEREBY give notice that I intend to apply for a licence empowering me to divert water for a term of fifteen years to the extent of 210 acre-feet per annum at a maximum rate of 6 acre-feet per day of 24 hours for the irrigation of 105 acres, being part of allotments 70A, 25, 26, 32, section 8, Parish of Gunbower West, and to occupy certain Crown lands for works of diversion, and to cut a race thereon.

Any objection to such application must be forwarded, in writing, to the State Rivers and Water Supply Commission, Melbourne, within 30 days of the date hereof.

FREDERICK ALLEN CRADDOCK.

Box 147, Cohuna, 26th June, 1957. 1382

NOTICE OF INTENTION TO APPLY FOR A LICENCE TO DIVERT WATER AND CUT RACE FROM THE GUNBOWER CREEK AT COHUNA.

I HEREBY give notice that I intend to apply for a licence empowering me to divert water for a term of fifteen years to the extent of 14 acre-feet per annum at a maximum rate of 3 acre-feet per day of 24 hours for the irrigation of 7 acres, being part of allotments 31 and 31A, section 8, Parish of Gunbower West, and to occupy certain Crown lands for works of diversion, and to cut a race thereon.

Any objection to such application must be forwarded, in writing, to the State Rivers and Water Supply Commission, Melbourne, within 30 days of the date hereof.

ALYSE MAUDE CRADDOCK.

Box 147, Cohuna, 26th June, 1957. 1383

NOTICE OF INTENTION TO APPLY FOR A LICENCE TO DIVERT WATER AND CUT RACE FROM THE GUNBOWER CREEK.

I HEREBY give notice that I intend to apply for a licence empowering me to divert water for a term of fifteen years to the extent of 80 acre-feet per annum at a maximum rate of 4 acre-feet per day of 24 hours for the irrigation of 40 acres, being part of allotments 22 and 22A, section 7, Parish of Gunbower, and to occupy certain Crown lands for works of diversion, and to cut a race thereon.

Any objection to such application must be forwarded, in writing, to the State Rivers and Water Supply Commission, Melbourne, within 30 days of the date hereof.

ALBERT EDWARD MUNZEL.

12 Carpenter-street south, Bendigo, 26th June, 1957.
1384

NOTICE OF INTENTION TO APPLY FOR A LICENCE TO DIVERT WATER AND CUT RACE FROM THE RIVER MURRAY AT BOUNDARY BEND.

I HEREBY give notice that I intend to apply for a licence empowering me to divert water for a term of fifteen years to the extent of 225 acre-feet per annum at a maximum rate of 4 acre-feet per day of 24 hours for irrigation of 75 acres, being part of allotment 2, Parish of Narrung, and to occupy certain Crown lands for works of storage and diversion, and to cut a race thereon.

Any objection to such application must be forwarded, in writing, to the State Rivers and Water Supply Commission, Melbourne, within 30 days of the date hereof.

BARRY HERBERT CLEARY.

Boundary Bend, 19th June, 1957. 1393

BENALLA SEWERAGE AUTHORITY.

SEWERAGE AREA No. 17.

THE Benalla Sewerage Authority, having made provision for carrying off sewage from each and every property which, or any part of which, is within the Sewerage Area hereinafter described doth hereby declare that, on and after the 22nd day of July, 1957, each and every property which, or any part of which, is within the said Sewerage Area shall be deemed to be a seweraged property within the meaning of the *Sewerage Districts Act 1928*.

The boundaries of the Sewerage Area hereinbefore mentioned are as follows:—Commencing at the intersection of Bridge and Clarke streets; thence westerly along Bridge-street for a distance of 4½ chains; thence by lines bearing south 242 links, west 200 links, south 400 links, east 250 links to the centre of Clarke-street; thence northerly by Clarke-street to the point of commencement.

For the purposes of this description the street names shall be taken as those similarly designated on the official plan of the Benalla Sewerage Authority.

1371 D. C. LATCH, Secretary.

DANDENONG SEWERAGE AUTHORITY.

GENERAL NOTICE.

THE Dandenong Sewerage Authority, having made provision for carrying off the sewage from each and every property which or any part of which is within the sewerage area hereinafter described, doth hereby declare that on and after the 1st day of July, 1957, each and every property which or any part of which is within the said sewerage area shall be deemed to be a seweraged property within the meaning of the *Sewerage Districts Act 1928*.

The boundaries of the sewerage area hereinbefore referred to are:—

Sewerage Area No. 23.

Commencing at a point being the intersection of the north side of Heatherton-road and the east side of Gladstone-road; thence northerly along the east side of Gladstone-road to its intersection with the south side of McFees-road; thence easterly along the south side of McFees-road to a point distant 2,653 feet east from the east side of Gladstone-road; thence southerly by a line bearing 180 deg. 23 min. a distance of 600 feet; thence westerly by a line bearing 270 deg. 18 min. a distance of 714 ft. 9½ in.; thence southerly by a line bearing 180 deg. 18½ min. a distance of 1,429 ft. 3½ in. to a point on the north side of Heatherton-road, such point being 1,924 ft. 7¼ in. east of the east side of Gladstone-road; thence westerly along the north side of Heatherton-road to the point of commencement.

By order of the Dandenong Sewerage Authority,

G. T. ANDREWS, Chairman.
R. A. JEFFERS, Member.
C. H. MASTERS, Secretary.

1381

No. 193.—6040/57.—4

CITY OF BOX HILL.

LOAN No. 91.

Notice of Intention to Borrow the Sum of £15,000 for Permanent Works and Undertakings.

NOTICE is hereby given that the Council of the City of Box Hill proposes to borrow the sum of Fifteen thousand pounds on the credit of the municipal revenues of the Mayor, Councillors and Citizens of the said City, such sum to be raised by the issue of debentures in accordance with the provisions of the Local Government Acts.

1. The maximum rate of interest that may be paid is 5½ per cent. per annum.

2. The purpose for which the loan is to be applied is—
Road construction and re-construction—

Eley-road from Station-street to Christina-street £10,000

Main drain construction—

Drewett-street from Shepherd-street to Erasmus-street to Newton-street 5,000

Total £15,000

3. The period of the loan shall be 25 years.

4. The moneys borrowed shall be repayable by providing out of the Municipal Fund 50 half-yearly instalments of approximately £555 12s. 3d. each, including principal and interest on the first day of April and the first day of October, during the currency of the loan. The first instalment shall be payable on the first day of April, 1958.

5. Such moneys shall be repayable at the English, Scottish and Australian Bank Limited, Melbourne, or at the Council's bankers for the time being in Melbourne.

The plan and specifications and the estimate of the cost of the proposed works, and a statement showing the proposed expenditure of the moneys to be borrowed, are open for inspection at the Town Hall.

1452 A. N. WALLS, Town Clerk.

CITY OF BOX HILL.

LOAN No. 93.

Notice of Intention to Borrow the Sum of £15,000 for Permanent Works and Undertakings.

NOTICE is hereby given that the Council of the City of Box Hill proposes to borrow the sum of Fifteen thousand pounds on the credit of the municipal revenues of the Mayor, Councillors, and Citizens of the said City, such sum to be raised by the issue of debentures in accordance with the provisions of the Local Government Acts.

1. The maximum rate of interest that may be paid is 5½ per cent. per annum.

2. The purpose for which the loan is to be applied is capital works in the Council's electric supply undertaking.

3. The period of the loan shall be ten years.

4. The moneys borrowed shall be repayable by providing out of the Municipal Fund twenty half-yearly instalments of approximately £985 1s. 6d. each, including principal and interest, on the 1st day of April and the 1st day of October during the currency of the loan. The first instalment shall be payable on the 1st day of April, 1958.

5. Such moneys shall be repayable at the English, Scottish and Australasian Bank Limited, Melbourne, or at the Council's bankers for the time being in Melbourne.

The plans and specifications and the estimate of the cost of the proposed works, and a statement showing the proposed expenditure of the moneys to be borrowed, are open for inspection at the Town Hall, Box Hill.

1444 A. N. WALLS, Town Clerk.

CITY OF FOOTSCRAY.

BY-LAW No. 215.

A By-law of the City of Footscray, made under the Local Government Acts, for regulating the sale of goods from stalls, receptacles, or vehicles.

THE Mayor, Councillors, and Citizens of the City of Footscray, in pursuance of the powers conferred by the Local Government Acts and every other Act or power enabling it in that behalf, order as follows:—

1. Subject only to the provisions of By-law No. 43 of the City of Footscray, no person shall, after the coming into operation of this By-law, sell goods from stalls, motor cars, carts, trucks, barrows, boxes, baskets, crates, bags,

or other vehicles or receptacles standing or placed on any street, road, or public place within the area of the municipal district of the City of Footscray.

Resolution for passing this By-law was agreed to by the Council of the City of Footscray on the 18th day of February, 1957, and confirmed on the 18th day of March, 1957.

The common seal of the Mayor, Councillors, and Citizens of the City of Footscray was hereto affixed, in the presence of—

(SEAL) A. N. BARLOW, Mayor.
R. BASSETT, Councillor.
E. J. SMITH, Town Clerk.

Approved by the Governor in Council, 4th June, 1957.
—A. MAHLSTEDT, Clerk of the Executive Council. 1402

Local Government Act 1946.

CITY OF HEIDELBERG.

NOTICE TO ALL WHOM IT MAY CONCERN.

WHEREAS the Council of the municipality of the City of Heidelberg in the State of Victoria deems it expedient to execute a certain work or undertaking for the purpose of implementing a scheme under section 594 of the *Local Government Act 1946*, for the widening of Lower Plenty-road, Rosanna, for the purposes whereof it is in the opinion of the said Council necessary and desirable that the said Council exercise its power of taking land compulsorily within the municipal district of the said Council, as provided by the *Local Government Act 1946*, and the said Council has caused its surveyor to prepare specifications, maps, plans, sections, and elevations of the said work or undertaking as are necessary and in which are expressed the nature and extent of such work or undertaking and the exact site and admeasurements thereof and on and through what land the said work or undertaking is proposed to be placed and the names of the owners or reputed owners, lessees or reputed lessees, and the occupiers of such land so proposed to be taken so far as known, and the said specifications, maps, plans, sections, and elevations so prepared have been approved by the said Council.

In pursuance of the provisions of the *Local Government Act 1946*, the said Council doth hereby publish and give notice that the description shortly of the purport of the said work or undertaking and of the said specifications, maps, plans, sections, and elevations is as follows:—

The implementation of a scheme under section 594 of the *Local Government Act 1946*, approved by the Governor in Council on the 26th May, 1953, for the widening of Lower Plenty-road, Rosanna, on the south-eastern side for a distance of approximately 438 feet in a south-westerly direction from Beetham-parade, and to open a new street off Lower Plenty-road through lot 4, and to increase the width of right-of-ways at the rear of Lower Plenty-road and Beetham-parade, and to close approximately 171 feet of right-of-way running in a south-westerly direction off Beetham-parade between lots 1 and 5, and to close portion of right-of-way at the rear of lots 6, 7, 8, and 9 Lower Plenty-road.

And the said Council doth hereby give further notice that the said specifications, maps, plans, sections, and elevations are deposited at the office of the said Council, Town Hall, Upper Heidelberg-road, Ivanhoe, and are there open for inspection and perusal on all the days and between the hours the municipal office is appointed to be open for the space of 40 clear days from the date of the publication of this notice in the *Government Gazette*.

And the said Council doth hereby call upon all persons interested in or affected by the said proposed work or undertaking to set forth, in writing, addressed to the said Council or the Town Clerk thereof, at the Town Hall, Upper Heidelberg-road, Ivanhoe, within 40 clear days from the date of the publication of this notice as aforesaid, all objections which they may have to the said work or undertaking.

Dated this 18th day of June, 1957.

The common seal of the Mayor, Councillors, and Citizens of the City of Heidelberg was hereto affixed by me—

F. PHILLIPS, Town Clerk.

in the presence of—

(SEAL) A. E. CARLYLE, Mayor.
W. BENNETT, Councillor.

1389

CITY OF OAKLEIGH.

BY-LAW No. 139.

A By-law of the City of Oakleigh made under the provisions of the Local Government Acts, and numbered 139 for the purpose of prohibiting the driving of cattle in or along any specified street in the municipal district.

IN pursuance of the powers conferred by the Local Government Acts and of any and every other power thereunto enabling the Mayor, Councillors, and Citizens of the City of Oakleigh order as follows:—

1. By-law No. 128 is hereby repealed.

2. No person shall drive any cattle in or along any specified street in the municipal district of the City of Oakleigh; provided that this shall not apply to—

- (a) cattle drawing vehicles;
- (b) cattle carried on a vehicle; or
- (c) cattle securely attached to a rope or chain held in the hand of a person.

3. All streets within the municipal district of the City of Oakleigh shall be "specified streets" for the purpose of this By-law.

4. "Cattle" includes any horse, mare, gelding, colt, filly, or foal, and any bull, cow, ox, steer, heifer, or calf, and any ram, ewe, sheep, or lamb, and any ass, mule, goat, or pig.

The Resolution for making and passing this By-law was agreed to by the Council at a meeting held on the 3rd day of December, 1956, and confirmed at a meeting held on the 4th day of February, 1957.

In witness whereof the common seal of the Mayor, Councillors, and Citizens of the City of Oakleigh was hereto affixed this 11th day of February, 1957.

(SEAL) A. P. DONNELLY, Mayor.
F. B. LINTON, Councillor.
J. A. PRICE, Town Clerk.

Approved by the Governor in Council, 11th June, 1957.—
A. MAHLSTEDT, Clerk of the Executive Council. 1445

TOWN OF CASTLEMAINE.

LOAN No. 22.

Notice of Intention to Borrow the Sum of £4,000 for Permanent Works and Undertakings.

NOTICE is hereby given that the Council of the Town of Castlemaine proposes to borrow the sum of £4,000 (Four thousand pounds), on the credit of the municipal revenues of the Mayor, Councillors, and Burgesses of the said Town, such sum to be raised by the issue of debentures, in accordance with the provisions of the Local Government Acts.

1. The maximum rate of interest that may be paid is 5½ per cent. per annum.

2. The purpose for which the loan is to be applied is:—
To finance the Council's proportion of contribution necessary for constructing and sealing of roads under Country Roads Board grants.

3. The period of the loan shall be ten years.

4. The moneys borrowed shall be repayable by providing out of the municipal fund twenty half-yearly instalments of approximately £262 13s. 6d. each, including principal and interest on the 1st days of September and March during the currency of the loan. The first instalment shall be payable on 1st March, 1958.

5. Such moneys shall be repayable at The National Bank of Australasia Limited, Melbourne, or at the Council's bankers for the time being in Melbourne.

The plans and specifications and the estimate of the cost of the proposed works and a statement showing the proposed expenditure of the moneys to be borrowed, are open for inspection at the Town Hall, Castlemaine.

Date: 21st June, 1957.

1446

G. R. GOUGH, Town Clerk.

SHIRE OF BIRCHIP.

APPOINTMENT OF POUNDKEEPER.

NOTICE is hereby given that Joseph B. Neal was appointed Poundkeeper by the Council of the Shire of Birchip, on the 10th day of June, 1957.

1391

JOSEPH B. NEAL, Shire Secretary.

Local Government Act 1946.

SHIRE OF BRIGHT.

ORDER DECLARING PUBLIC HIGHWAY.

IN pursuance of the powers conferred by section 521 of the *Local Government Act 1946*, the Council of the Shire of Bright hereby orders that the land hereinafter described which has been made available to the said Council shall be a public highway from and after the date of publication of this order in the *Government Gazette*:—

All that piece of land, being part of Crown allotment 26A, section 9A, Parish of Myrtleford, County of Bogong, commencing at a point 395 ft. 5½ in. from the intersection of Lawrence-street and Myrtleford-Yackandandah road, bearing north 29 deg. 47 min. east from such corner; thence by a line forming an arc of a circle of radius 100 feet and length 69 ft. 9½ in.; thence by a line bearing 350 deg. 56 min. 40 sec. in a north-westerly direction for a distance of 287 ft. 9 in.; thence by a line forming an arc of a circle of radius 40 feet and length 35 ft. 10 in.; thence westerly on a bearing of 299 deg. 36 min. a distance of 109 ft. 4 in.; thence by a line forming an arc of a circle of radius 40 feet and length 178 ft. 4½ in.; thence easterly on a bearing of 119 deg. 36 min. a distance of 70 ft. 7 in.; thence by a line forming an arc of a circle of radius 90 feet and length 80 ft. 8 in.; thence southerly on a bearing of 170 deg. 56 min. 40 sec. a distance of 189 ft. 11½ in.; thence by a line forming an arc of a circle of radius 25 feet and length 61 ft. 7 in. to the western boundary of Lawrence-street; thence southerly on a bearing of 209 deg. 47 min. a distance of 185 ft. 11 in. to the point of commencement, such street to be called Heather-grove.

In witness whereof the President, Councillors and Ratepayers of the Shire of Bright have caused their common seal to be hereunto affixed this 13th day of June, 1957.

The common seal of the Shire of Bright was hereunto affixed, in pursuance of an Order of the Council, made the 13th day of June, 1957, in the presence of—

1401 (SEAL) S. K. PEARCE, President.
A. C. McLAUGHLIN, Councillor.
H. G. HAYMES, Secretary.

SHIRE OF PHILLIP ISLAND.

LOAN No. 22.

Notice of Intention to Borrow the Sum of £8,000 for Permanent Works and Undertakings.

NOTICE is hereby given that the Council of the Shire of Phillip Island proposes to borrow the sum of £8,000 on the credit of the municipal revenues of the President, Councillors and Ratepayers of the said Shire, such sum to be raised by the issue of debentures, in accordance with the provisions of the *Local Government Acts*.

1. The maximum rate of interest that may be paid is 5½ per cent. per annum.

2. The purposes for which the loan is to be applied are—

- | | |
|---|--------|
| (a) Purchase of land at Newhaven for a recreation reserve | £1,000 |
| (b) Permanent road works, Township of Cowes | £7,000 |

3. The period of the loan shall be ten years.

4. The moneys borrowed shall be repayable by providing out of the municipal fund twenty half-yearly instalments of approximately £523 7s. 6d. each, including principal and interest on the first day of March and the first day of September during the currency of the loan. The first instalment shall be payable on the first day of March, 1958.

5. Such moneys shall be repayable at The National Bank of Australasia Limited, Melbourne, or at the Council's bankers for the time being in Melbourne.

The plans and specifications and the estimate of the cost of the proposed works, and a statement showing the proposed expenditure of the moneys to be borrowed, are open for inspection at the Shire Offices, Cowes.

1370 D. McADIE, Shire Secretary.

SHIRE OF RODNEY.

LOAN No. 34.

Notice of Intention to Borrow the Sum of £10,000 for Permanent Works and Undertakings.

NOTICE is hereby given that the Council of the Shire of Rodney proposes to borrow the sum of Ten thousand pounds on the credit of the municipal revenues of the President, Councillors and Ratepayers of the said

Shire, such sum to be raised by the issue of debentures in accordance with the provisions of the *Local Government Acts*.

1. The maximum rate of interest that may be paid is 5½ per cent. per annum.

2. The purpose for which the loan is to be applied is for drainage works at Tatura.

3. The period of the loan shall be ten years.

4. The moneys borrowed shall be repayable by providing out of the Municipal Fund twenty half-yearly instalments of approximately £656 14s. 4d. each, including principal and interest on the first day of March and the first day of September during the currency of the loan. The first instalment shall be payable on the first day of March, 1958.

5. Such moneys shall be repayable at the Commercial Banking Company of Sydney Limited, Melbourne, or at the Council's bankers for the time being in Melbourne.

The plans and specifications and the estimate of the cost of the proposed works, and a statement showing the proposed expenditure of the moneys to be borrowed, are open for inspection at the Shire Office, Tatura.

1396

W. T. A. MARTIN, Shire Secretary.

Local Government Act 1946.

SHIRE OF SPRINGVALE AND NOBLE PARK.

NOTICE OF INTENTION TO TAKE LAND COMPULSORILY.

NOTICE is given that it is the intention of the Council of the Shire of Springvale and Noble Park, in exercise of the powers conferred on it by the *Local Government Act 1946*, to take compulsorily a drainage easement over:—

All that piece of land being part of Crown allotment 2, section 6, Parish of Mordialloc, County of Bourke, and being part of the land described in conveyance registered No. 276, book 580, and delineated and coloured blue on the plan hereinafter referred to and deposited as stated.

The said easement is required for and being taken for the purpose of executing the following work or undertaking by the said Council:—The construction of drains for the drainage of lands within its municipal district.

The Council has caused to be prepared specifications, map, and plan showing the nature and extent of such work or undertaking and more particularly describing the said land and the exact site and measurements thereof, and stating that the name of the owner and occupier of the said land is David Samuel Whiteside, of Clayton-road, Clayton, wholesale butcher.

The said specifications, map, and plan have been approved by the Council and are now deposited for inspection by all persons interested at the offices of the Shire of Springvale and Noble Park, situate at 273 Springvale-road, Springvale, and may be inspected there during office hours.

All persons affected by the proposed work and undertaking are hereby required to set forth, in writing addressed to the said Council or to the Municipal Clerk within 40 clear days from the publication of this notice in the *Government Gazette*, all objections which they may have to such work or undertaking.

Dated the 21st day of June, 1957.

By order of the Council,

1373 H. L. WILLIAMS,
Shire Secretary and Municipal Clerk.

SHIRE OF STRATHFIELDSAYE.

LOAN No. 3—(PRIVATE STREET CONSTRUCTION).

NOTICE is hereby given that, at a meeting held at the Shire Hall, Strathfieldsaye, on the 16th May, the following Resolution was passed:—

"That the sum of £12,000 (Twelve thousand pounds) be borrowed by the issue of debentures in accordance with the provisions of the *Local Government Acts*. Rate of interest, £5 10s. per annum.

The sum shall be repaid at the Commercial Banking Company of Sydney Ltd., Melbourne, or at the Council's bankers for the time being in the City of Melbourne by twenty half-yearly instalments of approximately £788 1s. each, including principal and interest. The first instalment shall be payable on the 1st day of October, 1957.

The purpose for which the loan is to be applied is for construction of roads and private street (Mahon-avenue). £6,000 shall be repaid from General Revenue, £6,000 from receipts of money payable under Division 10 of Part XIX.—construction of private streets."

1385

M. BRENNAN, Shire Secretary.

Local Government Act 1946.

SHIRE OF WARRAGUL.

DECLARATION OF PRIVATE STREET AS PUBLIC HIGHWAY.

THE Council of the Shire of Warragul, having considered the application of the Victorian Railways Commissioners, owners of property in Coleman-street, being the owners of premises fronting on such street as in rateable value are a greater part of all the premises so fronting, which street is not less than 15 feet in width and is constructed to the satisfaction of the Council of the said Shire of Warragul, do hereby declare the said Coleman-street hereinafter described to be a public highway within the meaning of the *Local Government Act 1946*, viz.:—

All that piece of land being part of Crown allotment 93, Parish of Drouin East, County of Buln Buln, known as Coleman-street, Warragul.

Commencing on the south-western side of Skinners-road at a point 261 ft. 3 in. in a north-westerly direction from its intersection with the line of the western boundary with King-street measured on a bearing of 34 deg. 54 min.; thence 14 ft. 1½ in. westerly on a line bearing 89 deg. 54 min.; thence south-westerly on a line bearing 44 deg. 54 min.; thence 20 ft. 2 in. southerly on a line bearing 27 deg. 6 min.; thence 572 feet in a southerly direction on a line bearing 9 deg. 17 min.; thence for a distance of 229 ft. 8½ in. in a circular arc of radius 146 ft. 3 in., the chord of which arc bears 144 deg. 17 min.; thence 150 feet in an easterly direction on a line bearing 99 deg. 17 min.; thence 58 feet in a southerly direction on a line bearing 9 deg. 17 min.; thence 142 feet in a westerly direction on a line bearing 99 deg. 17 min.; thence for a distance of 320 ft. 9½ in. in a circular arc of radius 204 ft. 3 in., the chord of which arc bears 144 deg. 17 min.; thence in a northerly direction 565 ft. 8 in. on a line bearing 9 deg. 17 min.; thence for a distance of 64 ft. 0½ in. in a circular arc of radius 103 feet, the chord of which arc bears 27 deg. 6 min.; thence 103 ft. 0½ in. in a north-easterly direction on a line bearing 44 deg. 54 min.; thence 14 ft. 1½ in. in a northerly direction on a line bearing 179 deg. 54 min.; thence 70 feet in a south-easterly direction on a line bearing 134 deg. 54 min. to the point of commencement.

The common seal of the said Shire of Warragul was hereunto affixed, in pursuance of an order of the Council made on the 11th day of June, 1957, in the presence of—

(SEAL) MAC. STEWARD, President.
E. H. BAKER, Councillor.
1375 L. A. HEMLEY, Shire Secretary.

Local Government Act 1946.

SHIRE OF WARRAGUL.

DECLARATION OF PRIVATE STREET AS PUBLIC HIGHWAY.

THE Council of the Shire of Warragul, having considered the application of the Victorian Railways Commissioners, owners of property in Philip-street, being the owners of premises fronting on such street as in rateable value are a greater part of all the premises so fronting, which street is not less than 15 feet in width and is constructed to the satisfaction of the Council of the said Shire of Warragul, do hereby declare the said Philip-street hereinafter described to be a public highway within the meaning of the *Local Government Act 1946*, viz.:—

All that piece of land being part of Crown allotment 93, Parish of Drouin East, County of Buln Buln, known as Philip-street.

Commencing on the southern side of Skinners-road; thence for a distance of 31 ft. 6 in. in a circular arc of radius 20 feet, the chord of which arc bears 54 deg. 17 min.; thence 223 ft. 4 in. in a southerly direction on a line bearing 9 deg. 23 min.; thence southerly 177 feet on a line bearing 15 deg. 35 min.; thence southerly 123 ft. 8 in. on a line bearing 9 deg. 17 min.; thence 14 ft. 1½ in. in a south-easterly direction on a line bearing 144 deg. 17 min.; thence 60 feet in a westerly direction on line bearing 99 deg. 17 min.; thence 136 ft. 5 in. in a northerly direction on a line bearing 9 deg. 17 min.; thence 176 ft. 11½ in. on a line bearing 15 deg. 35 min.; thence 220 ft. 7½ in. on a line bearing 9 deg. 23 min.; thence for a distance of 31 ft. 6 in. in a circular arc of radius 20 feet, the chord of which arc bears 144 deg. 23 min.; thence 70 feet in an easterly direction on a line bearing 99 deg. 23 min. to the point of commencement.

The common seal of the said Shire of Warragul was hereunto affixed, in pursuance of an order of the Council made on the 11th day of June, 1957, in the presence of—

(SEAL) MAC. STEWARD, President.
E. H. BAKER, Councillor.
1377 L. A. HEMLEY, Shire Secretary.

Local Government Act 1946.

SHIRE OF WARRAGUL.

DECLARATION OF PRIVATE STREET AS PUBLIC HIGHWAY.

THE Council of the Shire of Warragul, having considered the application of the Victorian Railways Commissioners, owners of property in Fenton-street, being the owners of premises fronting on such street as in rateable value are a greater part of all the premises so fronting, which street is not less than 15 feet in width and is constructed to the satisfaction of the Council of the said Shire of Warragul, do hereby declare the said Fenton-street hereinafter described to be a public highway within the meaning of the *Local Government Act 1946*, viz.:—

All that piece of land being part of Crown allotment 93, Parish of Drouin East, County of Buln Buln, known as Fenton-street, Warragul.

Commencing on the east side of Lilleys-road at a point 230 feet in a southerly direction from its intersection with the line of the southern boundary with Skinners-road measured on a bearing of 9 deg. 17 min.; thence 14 ft. 2 in. south-easterly on a line bearing 144 deg. 20 min.; thence 668 ft. 7½ in. in an easterly direction on a line bearing 99 deg. 23 min.; thence 14 ft. 1½ in. north-easterly on a line bearing 54 deg. 23 min.; thence 10 ft. 7½ in. in a southerly direction on a line bearing 9 deg. 23 min.; thence 59 ft. 8 in. on a line bearing 15 deg. 35 min.; thence 13 ft. 4 in. north-westerly on a line bearing 147 deg. 29 min.; thence 663 ft. 1½ in. in a westerly direction on a line bearing 99 deg. 23 min.; thence 14 ft. 1½ in. in a south-westerly direction on a line bearing 54 deg. 20 min.; thence 70 feet in a northerly direction on a line bearing 9 deg. 17 min. to the point of commencement.

The common seal of the said Shire of Warragul was hereunto affixed, in pursuance of an order of the Council made on the 11th day of June, 1957, in the presence of—

(SEAL) MAC. STEWARD, President.
E. H. BAKER, Councillor.
1374 L. A. HEMLEY, Shire Secretary.

Local Government Act 1946.

SHIRE OF WARRAGUL.

DECLARATION OF PRIVATE STREET AS PUBLIC HIGHWAY.

THE Council of the Shire of Warragul, having considered the application of the Victorian Railways Commissioners, owners of property in McDonald-street, being the owners of premises fronting on such street as in rateable value are a greater part of all the premises so fronting, which street is not less than 15 feet in width and is constructed to the satisfaction of the Council of the said Shire of Warragul, do hereby declare the said McDonald-street hereinafter described to be a public highway within the meaning of the *Local Government Act 1946*, viz.:—

All that piece of land being part of Crown allotment 93, Parish of Drouin East, County of Buln Buln, known as McDonald-street, Warragul.

Commencing on the western side of Coleman-street at a point 486 ft. 4½ in. measured in a southerly direction from its intersection with the line of the south-western boundary with Skinners-road, such measurement being along the line of the said side; thence 14 ft. 1½ in. south-westerly on a line of bearing 54 deg. 17 min.; thence 345 feet in a westerly direction on a line bearing 99 deg. 17 min.; thence 50 feet in a southerly direction on a line bearing 9 deg. 17 min.; thence 345 feet in an easterly direction on a line bearing 99 deg. 17 min.; thence 14 ft. 1½ in. in a south-easterly direction on a line bearing 144 deg. 17 min.; thence 70 feet in a northerly direction on a line bearing 9 deg. 17 min. to the point of commencement.

The common seal of the said Shire of Warragul was hereunto affixed, in pursuance of an order of the Council made on the 11th day of June, 1957, in the presence of—

(SEAL) MAC. STEWARD, President.
E. H. BAKER, Councillor.
1376 L. A. HEMLEY, Shire Secretary.

SHIRE OF WYCHEPROOF.

NOTICE is hereby given that Senior Constable Joseph Disher Darley, No. 9876, has been appointed Prosecuting Officer of the Shire of Wycheproof.

1398 A. SAYERS, Shire Secretary.

SHIRE OF WYCHEPROOF.

NOTICE is hereby given that First Constable Frank Gilbert Baker, No. 8771, has been appointed Prosecuting Officer of the Shire of Wycheproof.

1399 A. SAYERS, Shire Secretary.

SHIRE OF WYCHEPROOF.

NOTICE is hereby given that First Constable Leslie Arthur Wallace, No. 9526, has been appointed Prosecuting Officer of the Shire of Wycheproof.

1400 A. SAYERS, Shire Secretary.

Partnership Act 1928.

NOTICE OF DISSOLUTION OF PARTNERSHIP OF GILLON AND SHARP.

NOTICE is hereby given that the partnership heretofore subsisting between Leslie Miles Gillon and James Cuming Sharp, carrying on business as sharebrokers, at 381-387 Little Collins-street, Melbourne, under the style or firm name of Gillon and Sharp, has been dissolved by mutual consent as from the 30th day of June, 1957.

Dated this 25th day of June, 1957.

L. M. GILLON.
J. C. SHARP.

Witness to both above signatures—S. DALRYMPLE. 1448

NOTICE is hereby given that the partnership heretofore subsisting between Leonard Edward Nicholls and Michael Gregory Weidemann, carrying on business as printers, at 2 Bleazby-street, Bentleigh, under the firm name of "Posiedon Press," has been dissolved by mutual consent as from the 24th day of June, 1957. All debts due to or owing by the said late firm will be received and paid by the said Leonard Edward Nicholls, who will continue to carry on the said business under the said firm name as sole proprietor.

Dated this 24th day of June, 1957.

L. E. NICHOLLS.

Witness—WILLIAM H. MILLER, solicitor, Melbourne.

M. G. WEIDEMANN

Witness—M. DAVID FIRSTENBERG, solicitor, Melbourne. 1416

NOTICE is hereby given that the partnership heretofore subsisting between the undersigned Robert Scott Kay and Jean Roxburgh, carrying on business as furniture dealers under the names of Robt. S. Kay and Treasure Cove, has been dissolved by mutual consent as from the 18th day of June, 1957. All debts due to and owing by the said firm will be received and paid by Robert Scott Kay, who will continue to carry on the business in the same premises.

Dated at Benalla this 18th day of June, 1957.

Signed by the said Robert Scott Kay.

R. S. KAY.

Signed by the said Jean Roxburgh.

J. ROXBURGH.

1397

NOTICE is hereby given that the partnership heretofore subsisting between Clarence Maldon Williams, Ralph Spencer, and Keith David Joseph Williams, all of Maldon, miners, has been dissolved with effect from the 19th day of June, 1957. The business of the partnership has been acquired by the said Clarence Maldon Williams and Keith David Joseph Williams, to whom all moneys owing to the partnership should be paid, and who will be responsible for all partnership liabilities.

Dated the 19th day of June, 1957.

H. S. W. LAWSON & CO., solicitors, Castlemaine. 1368

In the Supreme Court of Victoria.—In the matter of Part 1 of the *Companies Act 1938*, and in the matter of AUTOCRAFT PROPRIETARY LIMITED.

NOTICE is hereby given that the Order of the Supreme Court dated the 13th day of June, 1957, confirming the reduction of the capital of the above-named company from £500,000 divided into 495,000 ordinary shares of One pound each (372,200 of which are issued and fully

paid) and 5,000 preference shares of One pound each (all of which are issued and fully paid) to £172,800 divided into 167,800 ordinary shares of One pound each and 5,000 preference shares of One pound each and that such reduction be effected by returning to the holder of the ordinary shares the whole of the amount paid up in respect of 327,200 shares held by such shareholder (the capital represented thereby being in excess of the wants of the company) and that such last-mentioned shares and all liabilities thereon be wholly extinguished and the Minute approved by the Supreme Court showing with respect to the capital of the company as altered the several particulars required by the above Statute were registered by the Registrar-General on the 18th day of June, 1957, and further that the said Minute is in the words and figures following:—

"The capital of Autocraft Proprietary Limited henceforth is One hundred and seventy-two thousand eight hundred pounds divided into One hundred and sixty-seven thousand eight hundred ordinary shares of One pound each and Five thousand preference shares of One pound each instead of the original capital of Five hundred thousand pounds divided into Four hundred and ninety-five thousand ordinary shares of One pound each and Five thousand preference shares of One pound each. At the time of the registration of this Minute Forty-five thousand of the said ordinary shares numbered one to forty-five thousand are issued and have been and are deemed to be fully paid up and all of the said Five thousand preference shares numbered one to five thousand are issued and have been and are deemed to be fully paid up. The residue of the said ordinary shares, namely, One hundred and twenty-two thousand eight hundred, are unissued."

Dated this 21st day of June, 1957.

CORR & CORR, 104 Queen-street, Melbourne, solicitors for the above-named company. 1417

The *Companies Act 1938*.—In the matter of ALLEN & ZENT PROPRIETARY LIMITED (in Voluntary Liquidation).

NOTICE is hereby given that at an Extraordinary Meeting of the members of the above-named company held on Wednesday, 19th June, 1957, it was resolved that the company be wound up voluntarily, and at a meeting of creditors held on the same day, pursuant to section 238, it was resolved that for such purpose Edward Ronald Smail, of 31 Queen-street, Melbourne, chartered accountant (Aust.), be appointed liquidator.

Notice is also given that after 21 days from this date I shall proceed to distribute the assets. All creditors having any claims against the company should furnish particulars of same by that date, otherwise I shall proceed to distribute the assets without regard to their claim.

Dated this 26th day of June, 1957.

E. R. SMAIL, Liquidator.

Kennedy, Smail and Middlemiss, 31 Queen-street, Melbourne. 1424

Companies Act 1938.—In the matter of VICTOR LEGGO MINING COMPANY PROPRIETARY LIMITED (in Voluntary Liquidation).

NOTICE is hereby given that at an Extraordinary General Meeting of the company held at the registered office of the company, 212 a Beckett-street, Melbourne, on the 20th day of June, 1957, at Three o'clock in the afternoon, the following Special Resolution was passed:—

"That the company be wound up voluntarily."

Maurice Irving Tomlins, chartered accountant (Aust.), of 360 Collins-street, Melbourne, was duly appointed liquidator.

1423

A. H. LEGGO, Chairman.

HENDERSON'S COLORTEX PTY. LTD. (IN LIQUIDATION).
NOTICE CONVENING FINAL MEETING.

NOTICE is hereby given in pursuance of section 236 of the *Companies Act 1938*, that a General Meeting of the members of the above-named company will be held at the office of H. G. McCutcheon and Company, 34 Queen-street, Melbourne, on Thursday, 18th day of July, 1957, at Eleven o'clock in the morning, for the purpose of having an account laid before them showing the manner in which the winding up has been conducted and the property of the company disposed of and of hearing any explanation that may be given by the liquidator.

1422

H. W. MCCUTCHEON, Liquidator.

JUNCTION BUILDINGS PTY. LTD.

NOTICE is hereby given that in pursuance of section 245 (2) of the *Companies Act 1938*, a Final Meeting of the shareholders of Junction Buildings Proprietary Limited will be held at 16 Lyon-street, Essendon, on the 31st day of July, 1957, at Three o'clock p.m. for the purpose of laying before the shareholders a statement of account showing the manner in which the winding up of the company has been conducted and the property of the company disposed of.

Dated this 12th day of June, 1957.

1432 J. S. FINDLAY, Liquidator.

The *Companies Act 1938*.—In the matter of BAK RAINCOAT PROPRIETARY LIMITED (IN VOLUNTARY LIQUIDATION).

NOTICE is hereby given that, pursuant to section 245 of the *Companies Act* a Final Meeting of the creditors of the above company will be held at the offices of Kennedy, Smail and Middlemiss, 31 Queen-street, Melbourne, on Wednesday, the 17th July, 1957, at 2.30 p.m.

Business.—To receive the liquidator's accounts.

Dated this 26th day of June, 1957.

E. R. SMAIL & J. K. HALL, Co-liquidators.
Kennedy, Smail and Middlemiss, 31 Queen-street, Melbourne. 1425

The *Companies Act 1938*.—In the matter of STEWART-WARNER INDUSTRIES (AUSTRALIA) PROPRIETARY LIMITED.—Notice re Meeting of Creditors, Pursuant to Section 238.

NOTICE is hereby given that a Meeting of Creditors of the above-named company will be held in the Board Room of the Honorary Justices' Association, 34 Queen-street, Melbourne, on Wednesday, the 26th June, 1957, at Eleven o'clock a.m., the company having convened a meeting of its members for the same day for the purpose of considering a Resolution that the company be wound up voluntarily.

Dated this 20th day of June, 1957.

J. CAMPBELL, Director.
G. R. DUNKLEY, Director.
Kennedy, Smail and Middlemiss, 31 Queen-street, Melbourne. 1431

Form No. 54.

A. H. SCHULZ & SONS PROPRIETARY LIMITED.

NOTICE is hereby given that a meeting of the creditors of the above-named company will be held at 1 Lincoln-street, Richmond, on Friday, the 28th day of June, 1957, at Eleven o'clock in the forenoon for the purpose of considering the position of the company's affairs, the company having convened an Extraordinary General Meeting of its members to be held at the same address, on Friday, the 28th day of June, 1957, at 10.30 o'clock in the forenoon, for the purpose of considering, and if deemed expedient, passing, as an Extraordinary Resolution the Resolution following, that is to say:—

"That it has been proved to the satisfaction of this meeting that the company cannot by reason of its liabilities continue its business, and that it is advisable to wind up the same, and accordingly that the company be wound up voluntarily."

A Resolution will be submitted to the meeting for the nomination of a person acceptable to the creditors to be the liquidator of the company for the purposes of the winding up.

Dated the 20th day of June, 1957.

By order of the Board,

A. H. SCHULZ, Managing Director.
1 Lincoln-street, Richmond, Victoria. 1428

In the Supreme Court of Victoria and in the matter of the *Companies Act 1938*, and in the matter of GREER & ASHURNER PROPRIETARY LIMITED, and in the matter of a Petition for an Order confirming a Reduction of Share Capital.

NOTICE is hereby given that the Order of the Supreme Court of Victoria dated the 30th day of May, 1957, confirming the reduction of the capital of the above-named company from £96,800 to £70,000 and the minute approved by the court showing with respect to the capital of the company as altered the several particulars required by the above-named Act was registered by the Registrar-General on the 21st day of June, 1957.

Dated this 21st day of June, 1957.

HODGSON & FINLAYSON,
Solicitors to the company.
1427

The *Companies Act 1938*.—In the matter of BERYL SHOE COMPANY PROPRIETARY LIMITED.—Notice re Meeting of Creditors, Pursuant to Section 238.

NOTICE is hereby given that a Meeting of Creditors of the above-named company will be held at the offices of Kennedy, Smail and Middlemiss, 31 Queen-street, Melbourne, on Tuesday, the 2nd of July, 1957, at Two-thirty p.m., the company having convened a meeting of its members for the same day for the purpose of considering a Resolution that the company be wound up voluntarily.

Dated this 25th day of June, 1957.

G. BEST, Director.
Kennedy, Smail and Middlemiss, 31 Queen-street, Melbourne. 1453

Companies Act 1938.

THE KARAWINNA WEIGHBRIDGE COMPANY PROPRIETARY LIMITED.

SPECIAL RESOLUTION TO WIND UP, PURSUANT TO SECTION 226.

AT an Extraordinary General Meeting of the above-named company duly convened and held at 71 Deakin-avenue, Mildura, on Wednesday, the 19th day of June, 1957, the following Resolution was duly passed as a Special Resolution:—

"That the company be wound up voluntarily."

And, at such last-mentioned meeting, John McKendrick, of 71 Deakin-avenue, Mildura, was appointed liquidator for the purposes of the winding up.

Dated the 19th day of June, 1957.

1369 L. C. S. ROGERS, Chairman.

BETTA PACK FRUIT STORAGE PTY. LTD. (IN LIQUIDATION).

NOTICE CONVENING FINAL MEETING.

NOTICE is hereby given, in pursuance of section 236 of the *Companies Act 1938*, that a General Meeting of the members of the above-named company will be held at the office of H. G. McCutcheon and Company, 34 Queen-street, Melbourne, on Thursday, 18th day of July, 1957, at 10.30 o'clock in the morning, for the purpose of having an account laid before them showing the manner in which the winding up has been conducted and the property of the company disposed of, and of hearing any explanation that may be given by the liquidator.

1421 H. W. McCUTCHEON, Liquidator.

Companies Act 1938.

CYPRUS-TURKISH ASSOCIATION.

NOTICE OF INTENTION TO APPLY TO ATTORNEY-GENERAL FOR LICENCE, PURSUANT TO SECTION 18 (1).

CYPRUS-TURKISH ASSOCIATION, of 588 Rathdown-street, North Carlton, being an association formed for the purposes of amusement and recreation, hereby give notice of intention to apply to the Attorney-General for a licence directing that the said association be registered as a company with limited liability, without the addition of the word "Limited" to its name.

Dated the 27th day of May, 1957.

1420 T. ENVER, Secretary.

A. SHERLOCK & SONS PTY. LTD.

SPECIAL RESOLUTION TO WIND UP, PURSUANT TO SECTION 226.

AT an Extraordinary General Meeting of the members of the above-named company, duly convened and held at 9 Glen Eira-avenue, Ripponlea, on the 19th day of June, 1957, the following Special Resolution was duly passed:—

That the company be wound up voluntarily and that Arthur Sherlock, director, be appointed liquidator of the company.

Dated the 19th June, 1957.

1395 ARTHUR SHERLOCK, Liquidator.

WUNDERLICH LIMITED.

LOST STOCK CERTIFICATE.

APPLICATION has been made for the issue of a duplicate certificate for 115 stock units registered in the name of Alwyn Mark Reid, upon a statement that the original certificate No. C28 has been lost (or destroyed). Notice is hereby given that unless there is received some objection within 21 days from the date of this notice, the directors will proceed to deal with the application.

1378

E. G. SCOTT, Secretary.

Companies Act 1938.

REES CASH GROCERY PTY. LTD.

NOTICE OF SPECIAL RESOLUTION TO WIND UP, PURSUANT TO SECTION 226.

AT an Extraordinary General Meeting of the above-named company, duly convened and held at 40 Karma-avenue, East Malvern, on the 14th day of June, 1957, the following Resolution was duly passed as a Special Resolution:—

"That the company be wound up voluntarily."

And at such last-mentioned meeting, Wesley McMullen Henshaw, chartered accountant (Aust.), 98 Collins-street, Melbourne, was appointed liquidator for the purposes of the winding up.

Dated this 18th day of June, 1957.

1433 W. M. HENSHAW, Chairman.

*Companies Act 1938.*POWER EXCAVATORS PTY. LTD.
(IN VOLUNTARY LIQUIDATION).

NOTICE CONVENING FINAL MEETING, PURSUANT TO SECTION 236.

NOTICE is hereby given, in pursuance of section 236 of the *Companies Act 1938*, that a General Meeting of the members of the above-named company will be held at 37-45 Thistlethwaite-street, South Melbourne, on Tuesday, the 30th day of July, 1957, at Ten o'clock in the forenoon, for the purpose of having an account laid before them showing the manner in which the winding up of the company has been conducted and the property of the company disposed of, and of hearing any explanation that may be given by the liquidator.

K. A. RAWSON, Liquidator.

589 Riversdale-road, Surrey Hills. 1405

*The Companies Act 1938.*MONARCH SHOES PROPRIETARY LIMITED
(IN VOLUNTARY LIQUIDATION).

NOTICE CONVENING FINAL MEETING, PURSUANT TO SECTION 236 (2).

NOTICE is hereby given, in pursuance of section 236 (2) of the *Companies Act 1938*, that a General Meeting of the members of the above-named company will be held at the registered office of the company, 1-3 Palmerston-crescent, South Melbourne, S.C.5, on Monday, the 29th day of July, 1957, at Two o'clock in the afternoon, for the purpose of having an account laid before them showing the manner in which the winding up has been conducted and the property of the company disposed of, and of hearing any explanation that may be given by the liquidator.

Dated this 13th day of June, 1957.

1394 K. J. BROWNE, Liquidator.

*The Companies Act 1938.*CASTELL CONSTRUCTIONS PTY. LTD.
(IN LIQUIDATION).

NOTICE CONVENING FINAL MEETING OF MEMBERS, PURSUANT TO SECTION 245.

NOTICE is hereby given, in pursuance of section 245 of the *Companies Act 1938*, that a general meeting of the members of the above-named company will be held at 390 Little Collins-street, Melbourne, on Thursday, the 25th July, 1957, at Four o'clock in the afternoon, for the purpose of having an account laid before them, showing the manner in which the winding up has been conducted and the property of the company disposed of, and of hearing any explanation that may be given by the liquidator.

Dated the 20th June, 1957.

J. K. HALL, Liquidator.

Hall and Rose, chartered accountants (Aust.), 390 Little Collins-street, Melbourne. 1406

WILLIAM JAMES MELVILLE, late of Markwood, DECEASED, intestate.

CREDITORS, next of kin, and others having claims in respect of the deceased (who died on the 21st day of August, 1956), are required by the administratrix, Mary Melville, care of the undersigned solicitor, to send particulars to her, by the 26th day of August, 1957, after which date the administratrix may convey or distribute the assets, having regard only to the claims of which she shall then have notice.

JOSEPH E. DAILY, LL.B., solicitor, Clyde-street, Myrtleford. 1372

MARTIN JOSEPH MORAN, late of Clarke's Hill, farmer, DECEASED, intestate.

CREDITORS, next of kin, and others having claims in respect of the estate of the above-named deceased (who died on the 7th day of February, 1957), are required by The Fidelity Trustee Company Limited, whose registered office is at 101 Lydiard-street north, Ballarat, to send particulars, in writing, of such claims to the said company, on or before the 29th day of August, 1957, after which date the said company will distribute the assets of the said deceased amongst the persons entitled thereto, having regard only to the claims of which it shall then have had notice.

JOHN F. CARROLL, LL.B., solicitor, 4 Paisley-street, Footscray. 1441

ALICE BURTON, late of 16 Karrakatta-street, Black Rock, widow, DECEASED.

CREDITORS, next of kin, and others having claims in respect of the estate of the deceased (who died on the 28th day of November, 1956), are required by the personal representative, Herbert Partington, of 16 Karrakatta-street, Black Rock, to send particulars to him, by the 10th September, 1957, after which date the personal representative may convey or distribute the assets, having regard only to the claims of which he then has notice.

Dated the 21st day of June, 1957.

LEACH & THOMSON, solicitors, 472 Bourke-street, Melbourne. 1440

CREDITORS, next of kin, and others having claims in respect of the estate of Eliza Mary Sharp (also known as Elizabeth and Mary Sharp and Mary Sharp), formerly of "Aloha," St. Kilda-road, Melbourne, but late of "Illoura," 424 St. Kilda-road, Melbourne, in the State of Victoria (who died on the 5th day of March, 1957), are to send particulars of their claims to Edward Samuel Boulter, the executor named in the will of the deceased, care of John D. Muir, solicitor, 411 Collins-street, Melbourne aforesaid, by 6th September, 1957, after which date he will distribute the assets, having regard only to the claims of which he then had notice.

JOHN D. MUIR, solicitor, 411 Collins-street, Melbourne. 1439

HAROLD HARTLEY BROWNING, late of 96 Hawthorn-road, Caulfield, in the State of Victoria, retired architect, DECEASED.

CREDITORS, next of kin, and others having claims in respect of the estate of the said deceased (who died on the 18th day of March, 1957), are to send particulars of their claims to Margaret Anne Sloan, the executrix of the will of the said deceased, care of the under-mentioned solicitors, by the 1st day of September, 1957, after which date the said executrix will distribute the assets in the said estate, having regard only to claims of which she then has notice.

ELLISON, HEWISON & WHITEHEAD, solicitors, 352 Collins-street, Melbourne. 1435

MARGARET JANET ROBINSON, late of 11 Alexander-street, Box Hill, in the State of Victoria, widow, DECEASED.

CREDITORS, next of kin, and others having claims in respect of the estate of the said deceased (who died on the 24th day of January, 1957), are to send particulars of their claims to Angus Lochiel Parris and Fred Stirling Parris, the executors of the will of the said deceased, care of the under-mentioned solicitors, by the 1st day of September, 1957, after which date the said executors will distribute the assets in the said estate, having regard only to the claims of which they then have notice.

ELLISON, HEWISON & WHITEHEAD, solicitors, 352 Collins-street, Melbourne. 1434

PURSUANT to the Trustee Companies Acts, creditors, next of kin, and others having claims in respect of the estate of Robert Anderson Ryan, late of 9 Moama-road, East Malvern, in the State of Victoria, commission agent, deceased (who died on the 18th day of March, 1957), are to send the particulars of their claims to National Trustees, Executors and Agency Company of Australasia Limited, of 95 Queen-street, Melbourne, by the 2nd day of September, 1957, after which date it will distribute the assets, having regard only to the claims of which it then has notice.

Dated the 20th day of June, 1957.

BULLEN & WIMPOLE, 20 Queen-street, Melbourne, solicitors. 1429

Trustee Act 1953.

NOTICE TO CLAIMANTS.

PURSUANT to the *Trustee Act 1953*, creditors, next of kin, and all other persons having claims in respect of the estate of any deceased person named below are required to send particulars thereof to the legal personal representative or representatives at the addresses stated below, on or before the dates stated, after which dates the representatives will distribute the assets, having regard only to the claims of which notice has been received:—

Lillian May Quinlivan, late of 26 Mercil-road, Alphington, married woman, deceased, died 2nd January, 1957.—Claims to the executors, John Lawrence Quinlivan, of 26 Mercil-road, Alphington, traveller, and National Trustees, Executors, and Agency Company of Australasia Limited, whose registered office is at 95 Queen-street, Melbourne, to be sent to the said company, at its registered office, by 4th September, 1957. J. W. Glover, L.L.B., 422 Collins-street, Melbourne. 1438

CREDITORS, next of kin, and others having claims in respect of the estate of Dinah Dickinson Wilson, late of Longwood, in the State of Victoria, widow, deceased (who died on the 5th day of November, 1956, and probate of whose will was granted by the Supreme Court of Victoria on the 13th day of June, 1957, to National Trustees, Executors and Agency Company of Australasia Limited, whose registered office is at 95 Queen-street, Melbourne, in the said State), are required to send particulars of their claims to the said executor, at its address aforesaid, on or before the 31st day of August, 1957, after the expiration of which time the said executor will proceed to distribute the assets of the said deceased amongst the persons entitled thereto, having regard only to the claims of which it shall then have had notice.

Dated this 21st day of June, 1957.

J. J. TEHAN & CO., Binney-street, Euroa, solicitors for the said executor. 1436

CREDITORS, next of kin, and others having claims in respect of the estate of John Higgins, late of 321 Riversdale-road, Camberwell, retired district engineer, deceased (who died on the 6th day of January, 1957), are required by his executors, Ruth Sankey and Muriel Sankey, both of 321 Riversdale-road, Camberwell, spinsters, to send particulars of their claims, care of the under-mentioned solicitors, by the 27th day of August, 1957, after which date they will distribute the assets, having regard only to the claims of which they have then had notice.

Dated this 26th day of June, 1957.

MCCRACKEN & MCCRACKEN, solicitors, 317 Collins-street, Melbourne. 1418

CREDITORS, next of kin, and others having claims in respect of the estate of Williamina McNab Campbell Hendrie, late of "Catriona," Lake Tyers, in the State of Victoria, widow, deceased (who died on the 5th day of August, 1957), are required by her executors, John Taylor Hendrie and Hamilton Campbell Hendrie, farmers, of "Catriona," Lake Tyers, to send particulars of their claims, care of the under-mentioned solicitors, by the 27th day of August, 1957, after which date they will distribute the assets, having regard only to the claims of which they have then had notice.

Dated this 26th day of June, 1957.

MCCRACKEN & MCCRACKEN, solicitors, 317 Collins-street, Melbourne. 1419

PURSUANT to the *Trustee Act 1928*, notice is hereby given that all persons having claims against the estate of Frances Jane Ann Murray, late of St. Lorraine Private Hospital, 79 Finch-street, East Malvern, in the State of Victoria, widow, deceased (who died on the 9th day of May, 1955, and probate of whose will was granted on the 23rd day of September, 1955, by the Supreme Court of the said State in its probate jurisdiction, to Allan Graeme Murray, of Solway-street, East Malvern, aforesaid accountant), are hereby required to send particulars, in writing, of such claims to Allan Graeme Murray, care of Akehurst, Friend and Haack, of 405 Collins-street, Melbourne, in the said State, solicitors, on or before the 31st day of August, 1957, after which date the said Allan Graeme Murray will proceed to distribute the assets of the said Frances Jane Ann Murray, deceased, which shall have come to his hands, amongst the persons entitled thereto, having regard only to the claims of which he shall then have had notice.

AKEHURST, FRIEND & HAACK, of 405 Collins-street, Melbourne, solicitors for estate. 1430

CREDITORS, next of kin, and others having claims in respect of the estate of Thomas Hartley Bateson, late of 12 Myamyn-street, Malvern, mechanic, deceased, intestate (who died on the 26th February, 1956), are to send particulars of their claims to John Edward Bateson, the administrator, care of the under-mentioned solicitor, by the 28th August, 1957, after which date the said administrator will distribute the assets, having regard only to the claims of which he then has notice.

ROYSTON T. CAHIR, solicitor, 108 Queen-street, Melbourne. 1415

CREDITORS, next of kin, and others having claims in respect of the estate of John Cushen, late of 63 St. George's-road, Preston, motor driver, deceased (who died on the 15th January, 1957), are to send particulars of their claims to Thomas John Cushen and Joyce Barnes, executors of the will of the said deceased, care of the under-mentioned solicitor, by the 28th day of August, 1957, after which date the said executors will distribute the assets, having regard only to the claims of which they then have notice.

ROYSTON T. CAHIR, solicitor, 108 Queen-street, Melbourne. 1414

CREDITORS, next of kin, and others having claims in respect of the estate of Annie Firmin, late of Yinnar, spinster, deceased (who died on the 8th day of December, 1954), are to send particulars of their claims to Alice Smith, of Yinnar, by the 31st day of August, 1957, after which date she will distribute the assets, having regard only to claims of which she then has notice.

BRUCE, LITTLETON, & WATT, solicitors, Morwell. 1386

WILLIAM HENRY ALBERT CARTLIDGE, late of 25 Bath-road, Burwood, technician, DECEASED.

CREDITORS, next of kin, and all other persons having claims against the estate of the said deceased, are required by the administratrix, Rita Ellen Stuart, of 34 Ardour-street, North Balwyn, married woman, to send particulars to her, care of the undersigned, on or before the 29th day of August, 1957, after which date she will distribute the assets, having regard only to the claims of which she then has notice.

WISEWOULD, DUNCAN, & HANGER, solicitors, 26-32 King-street, Melbourne. 1407

JESSIE JOSEPHINE ROBINSON, late of 14 Lithgow-street, Burwood, spinster, DECEASED.

CREDITORS, next of kin, and all other persons having claims against the estate of the said deceased, are required by the executor, William Leslie Neville, of 30 Florizel-street, Burwood, retired, to send particulars to him, care of the undersigned, on or before the 29th day of August, 1957, after which date he will distribute the assets, having regard only to the claims of which he then has notice.

WISEWOULD, DUNCAN, & HANGER, solicitors, 26-32 King-street, Melbourne. 1408

MAUDE GLADYS LIVINGSTONE, late of 89 Hannan-street, Williamstown, widow, DECEASED.

CREDITORS, next of kin, and all other persons having claims against the estate of the said deceased, are required by the executors, Robert Keith Livingstone, of "Fairy Dell," Healesville, saw mill hand, and Kenneth James Livingstone, of 41 Newcastle-street, Newport, marine engineer, sons of the deceased, to send particulars to them, care of the undersigned, on or before the 29th day of August, 1957, after which date they will distribute the assets, having regard only to the claims of which they then have notice.

WISEWOULD, DUNCAN, & HANGER, solicitors, 26-32 King-street, Melbourne. 1409

IRENE ROBENA MYRTLE CARR, late of 6 Princess-street, Seddon, married woman, DECEASED.

CREDITORS, next of kin, and all other persons having claims against the estate of the said deceased, are required by the executrix, Brenda Madge Yvette Blythe, of 14 Fuller-street, Essendon, married woman, a niece of the deceased, to send particulars to her, care of the undersigned, on or before the 29th day of August, 1957, after which date she will distribute the assets, having regard only to the claims of which she then has notice.

WISEWOULD, DUNCAN, & HANGER, solicitors, 26-32 King-street, Melbourne. 1410

PETER RAYMOND BURNS, late of Derrinallum, in the State of Victoria, grazier and dairy farmer, DECEASED.

CREDITORS, next of kin, and others having claims in respect of the estate of the said deceased (who died on the 6th day of October, 1956), are required by the executors, Thomas Alexander John Brown and Jack Raymond Burns, to send particulars of their claims to the said executors at the office of C. D. Gavan Duffy, solicitor, 100 Manifold-street, Camperdown, by the 31st day of August, 1957, after which date the executors will distribute the assets, having regard only to the claims of which they then have notice.

Dated the 18th day of June, 1957.

C. D. GAVAN DUFFY, solicitor, Camperdown. 1403

CREDITORS, next of kin, and others having claims against the estate of William Henry Jones, late of 25 Oxford-street, Burwood, in the State of Victoria, builder, deceased (who died on the 6th day of May, 1956), are requested to send particulars of their claims to the executrix, Isabella Phoebe Jones, of 25 Oxford-street, Burwood aforesaid, care of Davis, Cooke, and Cussen, solicitors, of 422 Collins-street, Melbourne, in the said State, by the 31st day of August, 1957, after which date she will distribute the assets, having regard only for the claims of which she then has notice.

DAVIS, COOKE, & CUSSEN, solicitors, 422 Collins-street, Melbourne. 1379

MARY ANN TAIT, late of Collopy-street, Mansfield, married woman, DECEASED.

CREDITORS, next of kin, and others having claims in respect of the deceased (who died on the 31st day of December, 1956), are requested by her trustees, Lindsay Gordon Tait, of Bonnie Doon, grazier, and Jessie Margaret Clarke, of Whittlesea, married woman, to send particulars to them, care of the under-mentioned firm of solicitors, by the 30th day of August, 1957, after which date the trustees may convey and distribute the assets, having regard only to the claims of which they then have notice.

Dated the 19th day of June, 1957.

MAL. RYAN & GLEN, High-street, Mansfield, solicitors for the trustees. 1380

JOHN MOUG, formerly of 41 Regent-street, Prahran, late of Alexandra Hospital, Haythorn-road, Caulfield, retired, DECEASED.

CREDITORS, next of kin, and others having claims in respect of the estate of the deceased (who died 23rd day of May, 1957), are required by the trustee, David Hedley Thomas, of 140 Queen-street, Melbourne, solicitor, to send particulars to him by the 8th day of September, 1957, after which date the trustee may convey or distribute the assets, having regard only to the claims of which he then has notice.

DAVID THOMAS, solicitor, of 140 Queen-street, Melbourne. 1411

CREDITORS, next of kin, and others having claims in respect of the estate of Lydia Watson Fox, late of 3 Fulton-street, East St. Kilda, in the State of Victoria, widow, deceased (who died on the 11th day of March, 1957, and probate of her will, dated 26th March, 1953, was granted to The Union Trustee Company of Australia Limited, of 333 Collins-street, Melbourne, in the said State, on 13th June, 1957), are hereby requested to send particulars of such claims to the said company, at its address, on or before the 1st day of September, 1957, after which date the said company will proceed to distribute the assets of the said deceased amongst the persons entitled thereto, having regard only to the claims of which it shall then have had notice.

Dated this 26th day of June, 1957.

D. BRUCE TUNNOCK & CLARKE, 452 Lonsdale-street, Melbourne, solicitors for the executor. 1412

CREDITORS, next of kin, and others having claims in respect of the estate of Michael Colin Lalor, late of 84 Marshall-street, Ivanhoe, retired gardener, deceased (who died on the 21st February, 1957, are to send particulars of their claims to Thomas Carr Lalor, executor of the will of the said deceased, care of the under-mentioned solicitor, by the 26th August, 1957, after which date the said executor will distribute the assets, having regard only to the claims which he then has notice.

ROYSTON T. CAHIR, solicitor, 108 Queen-street, Melbourne. 1413

EMILY KATHERINE DAISH, formerly of 31 Faircroft-avenue, Glen Iris, but late of "Broughton Hall," Berwick-street, Camberwell, both in the State of Victoria, spinster, DECEASED.

CREDITORS, next of kin, and others having claims in respect of the estate of the above-named deceased (who died on the 25th day of February, 1957), are required by George Raymond Cummins, of Nyah, in the said State, horticulturist, and Tom Compson Trumble, of 105 King-street, Melbourne, in the said State, solicitor, the executors to whom probate of the deceased's will and four codicils thereto was granted by the Supreme Court of Victoria in its probate jurisdiction on the 19th day of June, 1957, to send to them, care of the under-mentioned solicitors, particulars of any such claims, by the 5th day of September, 1957, after which date the said executors may convey or distribute the assets of the estate of the said deceased, having regard only to the claims of which they then have notice.

Dated this 24th day of June, 1957.

MALLESON, STEWART, & CO., solicitors, 105 King-street, Melbourne. 1426

MINING NOTICE

WOODSIDE (LAKES ENTRANCE) OIL COMPANY N.L.

NOTICE is hereby given that a Call (the Third) of Six pence (6d.) per share on all the issued contributing shares in the capital of the company has been made due and payable at the registered office of the company, 178 Victoria-parade, East Melbourne, on Wednesday, 10th July, 1957.

19th June, 1957.

By order of the Board.

1404 REES B. WITHERS, Legal Manager.

IMPOUNDINGS

DROUIN.—Impounded in Drouin Pound, from Neerim Junction.

1 white heavy pony gelding, no visible brand

If not claimed and expenses paid, to be sold on 12th July, 1957.

1454—10/6 FRED. P. JONES, Poundkeeper.

HORSHAM.—Impounded in Horsham Pound.

1 red heifer, two notches out of left ear, one notch out of right ear, no visible brand

If not claimed and expenses paid, to be sold on 13th July, 1957.

1450—10/6 A. G. FRASER, Poundkeeper.

KEILOR.—Impounded in Keilor Pound.

1 brown, black, and white poley cow with red calf, no visible brand

If not claimed and expenses paid, to be sold on 11th July, 1957.

1442—10/6 D. PASCOE, Poundkeeper.

KYNETON.—Impounded in Kyneton Pound.

1 thoroughbred bay mare, no visible brand

If not claimed and expenses paid, to be sold on 5th July, 1957.

1443—9/ J. ROGERS, Poundkeeper.

LANCEFIELD.—Impounded in Lancefield Pound, by Ranger.

3 red Shorthorn steers, 2-year-olds, no visible brand
1 white Shorthorn steer, 2-year-old, no visible brand

If not claimed and expenses paid, to be sold on 12th July, 1957.

1390—12/ C. O. HORNER, Poundkeeper.

MILDURA.—Impounded in Lake Benetook Pound.

- 1 red bull vealer, no visible brand
- 1 red and white brindle heifer, no visible brand
- 1 yellow and white heifer, ear snipped near forehead, no visible brand

If not claimed and expenses paid, to be sold on 11th July, 1957.

S. C. JESSOP,
Poundkeeper.

1456—13/6

MULGRAVE.—Impounded in Mulgrave Pound.

- 1 brown Shetland pony gelding, white saddle mark, white noseband mark, no visible brand

If not claimed and expenses paid, to be sold on 11th July, 1957.

J. H. HOCKING,
Shire Secretary.

1455—10/6

ORBOST.—Impounded in Orbost Shire Pound, by Shire Herdsman.

- 1 draught mare, baldy face, no visible brand

If not claimed and expenses paid, to be sold after fourteen days.

H. DOMINEY,
Poundkeeper.

1449—10/6

TALLANGATTA.—Impounded in Tallangatta Pound.

- 1 brindle heifer, notch back and front of off ear, no visible brand
- 1 Black Poll steer, notch out of front of off ear, no visible brand

If not claimed and expenses paid, to be sold on 5th July, 1957.

THOS. J. KIRK,
Poundkeeper.

1451—16/6

STATE ACTS, 1955

COPIES of the following Acts of Parliament of Victoria may be obtained at the Government Printing Office, or from any bookseller, at the price set opposite to each:—

No.	Price.
	£. d.
5854. Consolidated Revenue	0 6
5855. Statute Law Revision Committee (Amendment)	0 6
5856. Consolidated Revenue	0 6
5857. Auditor-General's Salary	0 6
5858. Consolidated Revenue	0 6
5859. Hide and Leather Industries (Repeal)	0 6
5860. Teaching Service (Amendment)	0 6
5861. Maintenance (Enforcement of Orders)	0 6
5862. Companies (Names)	0 9
5863. Legal Profession Practice (Amendment)	0 6
5864. Newport "A" Power Station	0 6
5865. Adoption of Children	0 6
5866. Geelong Waterworks and Sewerage (Amendment)	0 6
5867. Parliamentary Elections (State Servants) Amendment	0 6
5868. Firearms (Olympic Games)	0 6
5869. Justices (Amendment)	0 9
5870. Country Fire Authority (Financial)	0 6
5871. Supreme Court and County Court (Judges)	0 6
5872. Railway Deviations	0 9
5873. State Savings Bank (Amendment)	0 6
5874. Crown Proceedings	0 6
5875. Gas and Fuel Corporation (Financial)	0 6
5876. Children's Welfare (Amendment)	0 6
5877. Evidence (Amendment)	0 9
5878. Land Tax (Exemptions and Rates)	0 6
5879. Health (Offensive Trades)	0 6
5880. Dietitians Registration (Amendment)	0 6
5881. Medical (Pharmacy Board Fees)	0 6
5882. Benefit Associations (Amendment)	0 6
5883. Surplus Revenue	0 6
5884. Landlord and Tenant (Amendment)	1 3
5885. Police Offences (Valueless Cheques)	0 6
5886. Dairy Produce (Cheese)	0 6
5887. Coal Mine Workers Pensions (Amendment)	0 6
5888. Parking of Vehicles (Amendment)	0 6
5889. Public Service (Amendment)	0 6
5890. Police Regulation (Junior Trainees)	0 6
5891. Wonthaggi Railway Land	0 9
5892. Licensing	0 6
5893. Stock Medicines (Amendment)	0 6
5894. Marine (Temporary Exemptions)	0 6
5895. Administration and Probate (Estates)	0 9

STATE ACTS, 1955.—continued.

No.	Price.
	£. d.
5896. Statute Law Revision	0 9
5897. Police Regulation (Pensions)	0 6
5898. Bailiffs	0 6
5899. Housing	1 0
5900. Soldier Settlement (Amendment)	0 9
5901. Old Colonists' Association	0 6
5902. Supreme Court (Officers)	0 6
5903. Co-operative Housing Societies (Amendment)	0 6
5904. Dog Races	0 6
5905. Olympic Games	0 6
5906. Water Supply Loan Application	1 0
5907. Friendly Societies (Amendment)	0 6
5908. Licensing (Amendment)	1 0
5909. Revocation and Excision of Crown Reservations	1 3
5910. Forests (Amendment)	0 6
5911. Superannuation	1 3
5912. Fisheries (Proclamation)	0 6
5913. Melbourne Market and Park Lands	0 6
5914. Limitation of Actions	1 9
5915. Motor Car (Amendment)	0 9
5916. Milk Board (Amendment)	0 6
5917. Crimes (Amendment)	0 9
5918. Railways (Amendment)	0 9
5919. Labour and Industry (Long Service Leave)	0 6
5920. Home Finance	0 6
5921. Public Works Loan Application	0 6
5922. State Forests Loan Application	0 6
5923. Mental Hygiene (Amendment)	0 9
5924. Local Government (Amendment)	0 9
5925. Mines (Petroleum)	1 0
5926. Geelong Market Site	0 6
5927. Railway Loan Application	1 3
5928. Lang Lang Land	0 6
5929. Geelong Harbor Trust (Amendment)	0 6
5930. Transport Regulation	1 9
5931. Commercial Goods Vehicles	1 6
5932. Motor Car (Road Safety)	0 6
5933. Public Officers Salaries	0 6
5934. Property Law and Transfer of Land	0 9
5935. Companies	1 6
5936. Crimes (Driving Offences)	0 9
5937. Labour and Industry (Shops)	0 9
5938. Mines (Uranium and Thorium)	0 9
5939. Railways Dismantling	0 9
5940. Appropriation of Revenue	4 3

W. M. HOUSTON,
Government Printer.

STATE ACTS, 1956

COPIES of the following Acts of Parliament of Victoria may be obtained at the Government Printing Office, or from any bookseller, at the price set opposite to each:—

No.	Price.
	£. d.
5941. Limitation of Actions (Extension)	0 6
5942. Serviceton Public Hall	0 6
5943. Keilor (Unimproved Rating Poll)	0 6
5944. Portland Harbor Trust (Land)	0 6
5945. Motor Car (Third-Party Insurance)	0 6
5946. Local Government (Broadmeadows)	0 6
5947. Melbourne Harbor Trust (Amendment)	0 6
5948. Returned Servicemen's Badges	0 6
5949. Grain Elevators (Financial)	0 6
5950. Workers' Compensation (Police)	0 6
5951. North Carlton Land	0 6
5952. Superannuation (Amendment)	0 6
5953. Country Fire Authority (Borrowing)	0 6
5954. Operation Gratitude Race Meeting	0 6
5955. Rural Finance Corporation (Amendment)	0 6
5956. Melbourne College of Divinity (Amendment)	0 6
5957. Supreme Court (Wards of Court)	0 6
5958. Stamps (Amendment)	0 6
5959. Cancer Institute (Loan Mo/ieys)	0 6
5960. The Victoria Racing Club	0 6
5961. Penal Reform	1 9
5962. Police Offences (Control of Raffles)	0 6
5963. Process Servers and Inquiry Agents	1 3
5964. Consolidated Revenue	0 6
5965. Medical (Registration)	0 6
5966. Gas and Fuel Corporation (Castlemaine Undertaking)	0 9
5967. Home Finance	0 9
5968. Police Offences (Amendment)	0 6
5969. Judges Salaries and Allowances	0 6
5970. Public Officers Salaries and Allowances	0 9
5971. Motor Car (Registration Fees)	0 6
5972. Melbourne Subways (Borrowing)	0 6
5973. Railways (Commissioners)	0 6

STATE ACTS, 1956.—*continued.*

No.	Price s. d.
5974. Game (Destruction)	0 6
5975. Boilers Inspection (Amendment)	0 6
5976. The Geelong Gas Company's	0 6
5977. St. Kilda and Brighton Electric Street Railway (Partial Dismantling)	0 9
5978. Country Roads	1 0
5979. Health (Narcotics)	0 6
5980. Water (Compensation)	0 9
5981. Land (Improvement Purchase Lease)	0 9
5982. Melbourne and Metropolitan Board of Works	1 3
5983. Road Traffic	1 0
5984. Housing (Slum Research Officer)	0 6
5985. Firearms (Industrial Tools)	0 6
5986. Hospitals and Charities (Liability of Patients)	0 6
5987. The Constitution Act Amendment (Committee of Public Accounts)	0 6
5988. Local Government (Building Regulations)	0 9
5989. Estate Agents	2 3
5990. Freedom of the City of Melbourne	0 6
5991. Subordinate Legislation Committee	0 6
5992. Local Authorities Superannuation	0 6
5993. West Melbourne Market Land	0 6
5994. Consolidated Revenue	0 6
5995. Juries	1 9
5996. Administration and Probate	0 6
5997. Consolidated Revenue	0 6
5998. Amendments Incorporation	0 6
5999. Labour and Industry (Long Service Leave)	0 6
6000. Melbourne Racing Club	1 3
6001. State Electricity Commission	0 6
6002. Gas and Fuel Corporation (Acquisition)	0 6
6003. Land (Unused Roads)	0 6
6004. Police Regulation (Retirement)	0 6
6005. Labour and Industry (Wages Boards)	0 6
6006. The Constitution Act Amendment	8 6
6007. Sheep (Foot Rot)	0 9
6008. The Ballarat Gas Company's	0 6
6009. Veterinary Surgeons (Amendment)	0 6
6010. Gas Regulation (Amendment)	0 9
6011. Land Tax (Rates)	0 6
6012. Registrar-General's Fees	1 0
6013. Instruments (Amendment)	0 9
6014. Entertainments Tax (Rates)	0 6
6015. Soldier Settlement (Amendment)	0 6
6016. Electoral	1 6
6017. Police Regulation (Reservists)	0 9
6018. Police Pensions Fund (Investment)	0 6
6019. Revenue Deficit Funding	0 6
6020. Portland Harbor Trust (Borrowing Powers)	0 6
6021. Stamps (Cheques and Receipts)	0 6
6022. Motor Car (Driving Licences)	0 6
6023. National Parks	1 0
6024. Health	7 9
6025. National Art Gallery and Cultural Centre	0 9
6026. Youth Organizations Assistance	0 6
6027. Appleton Dock Railway Construction	0 6
6028. Co-operative Housing Societies (Guarantees and Indemnities)	0 6
6029. Education (Kindergarten Teachers)	0 6
6030. Teaching Service (Married Women)	1 0
6031. Workers Compensation (Supplementary Board)	0 6
6032. Hospital Benefits (Amendment)	0 6
6033. Railways (Malvern Subways)	0 6
6034. Water Supply Loan Application	1 3
6035. Nurses	1 9
6036. Housing (Land)	1 0
6037. Police Offences (Trespass to Farms)	0 6
6038. Motor Car (Fees)	0 6
6039. Police Offences (Cruelty to Animals)	0 6
6040. State Forests Loan Application	0 6
6041. Melbourne and Metropolitan Board of Works (Borrowing Powers)	0 6
6042. Racing (Finance)	0 6
6043. Railway Loan Application	1 3
6044. Gas and Fuel Corporation (Frankston and Dandenong Undertakings)	1 0
6045. Stamps (Hire-Purchase Agreements)	0 6
6046. Forests (Masonite Agreement)	1 3
6047. Companies (Unit Trusts)	0 9
6048. Local Government (Amendment)	0 6
6049. Public Works Loan Application	0 9
6050. Marriage (Property)	0 9
6051. Parliamentary Contributory Retirement Fund (Amendment)	0 6
6052. Housing (Broadmeadows Land)	0 6
6053. Children's Court	2 0
6054. Housing (Staff)	0 6
6055. Appropriation of Revenue	4 3
6056. Governor's Salary	0 6

W. M. HOUSTON,
Government Printer.

STATE ACTS, 1957

COPIES of the following Acts of Parliament of Victoria may be obtained at the Government Printing Office, or from any bookseller, at the price set opposite to each:—

No.	Price s. d.
6057. Trinity College	0 6
6058. Vermin and Noxious Weeds (Financial)	0 6
6059. Victorian Inland Meat Authority (Financial)	0 6
6060. Melbourne and Metropolitan Board of Works (Contributions)	0 6
6061. Moorabbin Land	0 6
6062. Pounds (Fees)	0 6
6063. Dried Fruits (Amendment)	0 6
6064. Public Account (Amendment)	0 6
6065. Rabbit (Biological Destruction)	0 6
6066. Public Works Loan Application	0 6
6067. Game (Destruction)	0 6

W. M. HOUSTON,
Government Printer.

THE "VICTORIA GOVERNMENT GAZETTE."

ATTENTION is invited to the following procedure in relation to the publication of official matter in the *Government Gazette*:—

1. *Matter submitted to the Executive Council.*
Matter submitted to the Executive Council which requires gazettal will normally be published in the issue of the following week.
Where urgent gazettal is required, special arrangements should be made with the *Gazette* Officer.
Publication will be facilitated by the submission of carbon copies for the use of the *Gazette* Officer.
2. *Other matter.*
(a) All other matter duly certified by a responsible officer for publication should be lodged with the *Gazette* Officer not later than half-past Ten a.m. on Tuesday.
(b) Lengthy or involved notices should be forwarded several days before publication.
(c) Proofs, which will be supplied only when specifically requested, or at the direction of the *Gazette* Officer, should be returned promptly to avoid delay in publication.
(d) No additions or amendments to matter for publication will be accepted by telephone.

THE VICTORIA GOVERNMENT GAZETTE is published on WEDNESDAY EVENING in each week, and Notices for insertion will be received by the Government Printer at or before Two p.m. at ordinary rates, and late advertisements between Two p.m. and Five p.m. at double rates on the day preceding the day of publication.

Single copies of the VICTORIA GOVERNMENT GAZETTE are One shilling, posted One shilling and three pence.

No GAZETTES prior to January, 1950, in stock.

***ALL PAYMENTS ARE REQUIRED IN ADVANCE.—Remittances should be made by postal note, money order, or draft in favour of the Government Printer. Advertisements unaccompanied by a remittance sufficient to cover the cost of insertion will be returned unpublished.

SUBSCRIPTIONS.—The subscription, including postage, is £2 15s. per annum, £1 7s. 6d. half-yearly, or 13s. 9d. per quarter, payable in advance.

Subscriptions are required to commence and terminate with a month.

A lesser period than three months cannot be subscribed for.

Subscribers do not receive the Acts of Parliament with the GAZETTE.

ADVERTISEMENTS are charged at the rate of 1s. 6d. per line single column, and 3s. per line double column.

The title (£5 Reward, Dissolution of Partnerships, &c.) forms one or more lines as a heading.

On an average, ten words make a line.

Every signature must likewise be counted as a line.

The final words of a paragraph, though only portion of a line, must be counted as one line.

SIGNATURES (in particular) and proper names must be written very plainly in the text; ONE SIDE ONLY of each slip of paper should be WRITTEN UPON.

ALL COMMUNICATIONS should be addressed to "The Government Printer, Melbourne."

ALL DOCUMENTS illegibly written will be returned unpublished, and, where brands occur unprovided for by the ordinary letters of the alphabet, a worded explanatory description must be furnished.

AGENTS FOR THE "VICTORIA GOVERNMENT GAZETTE."

THE following have been appointed agents to receive Advertisements and Subscriptions for the *Victoria Government Gazette*:—

- ARMSTRONG'S AGENCY, 143 Queen-street, Melbourne.
- ARMSTRONG BROS., Kyneton.
- MESSRS. ARNALL & JACKSON, 115 Barkly-street, West Brunswick.
- BERRY, ANDERSON, & CO., 207 Sturt-street, Ballarat.
- MR. WM. DAVIS, Mildura.
- A. J. DIGBY (B. S. and N. W. Cash), Main-street, Bairnsdale.
- EDGAR'S NEWS AGENCY, Hargreaves-street, Bendigo.
- MESSRS. HENRY FRANKS & CO., Booksellers and Stationers, Market-square, Geelong.
- MESSRS. GORDON & GOTCH, News Agents, 511 Little Collins-street, Melbourne; and corner Barrack and Clarence streets, Sydney.
- A. C. HAMPTON, 243 Mitchell-street, Bendigo.
- MESSRS. HARSTON, PARTRIDGE, & CO., 455 Little Collins-street, Melbourne.
- MR. C. F. LATIMER, News Agent, Casterton.
- MCCARTHUR'S AUTHORIZED NEWSAGENCY, 345 Wyndham-street, Shepparton.
- MESSRS. R. H. & W. M. PETTY, News Agent, Wangaratta.
- MESSRS. POWELL & DIXON, 89 Firebrace-street, Horsham.
- J. PURDIE & CO., 138 Moorabool-street, Geelong.
- F. W. RASHLEIGH & SON, Nunn-street, Benalla.
- ROBERTSON & MULLENS LTD., Elizabeth-street, Melbourne.
- SALE AUTHORIZED NEWS AGENTS, Sale.
- SKINNER'S AUTHORIZED NEWSAGENCY, 49-51 Franklin-street, Traralgon.

- MESSRS. SMITH & DUNNON, Hamilton.
 - THE MERCANTILE EXCHANGE, 380 Collins-street, Melbourne.
 - F. D. & J. R. TRAINOR, 246 Wyndham-street, Shepparton.
 - C. F. & H. J. VERNON, 162 Bridge-road, Richmond.
 - VIEW POINT AUTHORIZED NEWSAGENCY, 4 View Point, Bendigo.
 - E. W. B. WELSH, Hogan-street, Tatura.
- A copy of the *Gazette* filed at each place for public reference.

CONTENTS.

	PAGE
Acts of Parliament	2047
Acts of Parliament on sale at the Government Printing Office	2104
Appointments	2067
Contracts	2060
Country Roads Board	2074
Courts	2051
Estates of Deceased Persons	2051
Government Notices	2049
Impoundings	2103
Lands	2080
Melbourne and Metropolitan Board of Works—Notice	2066
Mining	2049, 2103
Orders in Council	2068
Police Sale	2067
Private Advertisements	2094
Proclamations	2047
Public Half-Holiday	2049
Public Service Notices	2086
Resignations	2068
State Rivers and Water Supply Commission	2065
Tenders	2092
Transport Regulation Board—Public Hearings	2050
Waterworks Trusts	2066