



# VICTORIA GOVERNMENT GAZETTE

Published by Authority

[Registered at the General Post Office, Melbourne, for transmission by post as a newspaper.]

No. 3]

WEDNESDAY, JANUARY 15

[1958

Country Fire Authority Acts.

## CREATION OF A NEW URBAN FIRE DISTRICT IN THE NINTH FIRE CONTROL REGION.

### PROCLAMATION

By His Excellency the Governor of the State of Victoria and its Dependencies in the Commonwealth of Australia, &c., &c., &c.

WHEREAS by a Proclamation of the Governor in Council issued on the sixteenth day of November, 1954, and published in the *Government Gazette* of the seventeenth day of November, 1954, for the purposes of the *Country Fire Authority Act 1944*, certain parts of the country area of Victoria were proclaimed as fire control regions; and certain parts of such fire control regions were proclaimed to be urban fire districts; and the remainder (if any) of each such fire control region (being the area not included in any urban fire district) was proclaimed to be a rural district:

And whereas by section sixteen of the *Country Fire Authority Act 1944*, it is (amongst other things) enacted that the Governor in Council may from time to time, after consideration of a report submitted by the Country Fire Authority by Proclamation published in the *Government Gazette*, create any new urban fire district and amend or alter the boundaries of rural fire districts within any fire control region:

And whereas the Country Fire Authority has submitted a report that it is necessary and desirable that the part of the Ninth Fire Control Region which is described in the Schedule hereto should be created an urban fire district and that a corresponding alteration of the boundaries of the rural fire district within the Ninth Fire Control Region should be made:

Now therefore, I, the Governor of the State of Victoria, in the Commonwealth of Australia, by and with the advice of the Executive Council of the said State, after consideration of the said report of the Country Fire Authority, and in pursuance of the powers conferred by the *Country Fire Authority Acts*, do by this my Proclamation:—

- (a) Create as a new urban fire district that part of the Ninth Fire Control Region which is described in the Schedule hereto; and
- (b) alter the boundaries of the rural fire district within the Ninth Fire Control Region to the extent rendered necessary by the excision of the part of such region which is described as aforesaid:

### SCHEDULE.

Commencing at a point on the western boundary of allotment 104 Parish of Allambee East distant 150 feet northerly from the south-western angle of that allotment; thence easterly by a line to a point in the prolongation northerly of the eastern boundary of allotment 13 section A Township of Mirboo North and distant 1,200 feet from the north-eastern angle of that allotment; thence southerly by a line, the eastern boundary of the afore-mentioned allotment and a line the prolongation southerly of such boundary to the southern boundary of allotment 38 Parish of Mirboo; thence westerly by the southern boundary of allotment 38 and allotment 41 to the south-western angle of the last-mentioned allotment; thence by a line to the southernmost angle of the north-western part of allotment 8 Parish of Mardan; thence northerly by the western boundary of allotment 8 to the north-western angle of that allotment; thence by a line to the south-western angle of allotment 104 Parish of Allambee East; thence northerly by the western boundary of the last-mentioned allotment to the point of commencement.

Given under my Hand and the Seal of the State of Victoria aforesaid, at Melbourne, this fourteenth day of January, in the year of our Lord, One thousand nine hundred and fifty-eight, and in the sixth year of the reign of Her Majesty Queen Elizabeth II.

(L.S.)

DALLAS BROOKS.

By His Excellency's Command,

MURRAY PORTER,  
for Chief Secretary.

GOD SAVE THE QUEEN!

Country Fire Authority Acts.

## CREATION OF A NEW URBAN FIRE DISTRICT IN THE ELEVENTH FIRE CONTROL REGION.

### PROCLAMATION

By His Excellency the Governor of the State of Victoria and its Dependencies in the Commonwealth of Australia, &c., &c., &c.

WHEREAS by a Proclamation of the Governor in Council issued on the sixteenth day of November, 1954, and published in the *Government Gazette* of the seventeenth day of November, 1954, for the purposes of

the *Country Fire Authority Act 1944*, certain parts of the country area of Victoria were proclaimed as fire control regions; and certain parts of such fire control regions were proclaimed to be urban fire districts; and the remainder (if any) of each such fire control region (being the area not included in any urban fire district) was proclaimed to be a rural district:

And whereas by section sixteen of the *Country Fire Authority Act 1944*, it is (amongst other things) enacted that the Governor in Council may from time to time, after consideration of a report submitted by the Country Fire Authority by Proclamation published in the *Government Gazette*, create any new urban fire district and amend or alter the boundaries of rural fire districts within any fire control region:

And whereas the Country Fire Authority has submitted a report that it is necessary and desirable that the part of the Eleventh Fire Control Region which is described in the Schedule hereto should be created an urban fire district and that a corresponding alteration of the boundaries of the rural fire district within the Eleventh Fire Control Region should be made:

Now therefore, I, the Governor of the State of Victoria, in the Commonwealth of Australia, by and with the advice of the Executive Council of the said State, after consideration of the said report of the Country Fire Authority, and in pursuance of the powers conferred by the Country Fire Authority Acts, do by this my Proclamation:—

- (a) Create as a new urban fire district that part of the Eleventh Fire Control Region which is described in the Schedule hereto; and
- (b) alter the boundaries of the rural fire district within the Eleventh Fire Control Region to the extent rendered necessary by the excision of the part of such region which is described as aforesaid.

## SCHEDULE.

Commencing at the most northerly angle of allotment 11 section B Township of Bruthen; thence south-easterly; easterly and generally north-easterly by the boundary of the Permanent Forest to the northern boundary of allotment 28 section B; thence easterly by the northern boundaries of allotment 28 and 29 section B and a line to the north-western angle of allotment 28A no section; thence southerly by the western boundary of the last-mentioned allotment to the south-western angle of the allotment; thence easterly by the southern boundary of allotment 28A no section to a road; thence southerly by this road to the most easterly angle of allotment 24A no section; thence by a line to the north-western angle of allotment 29 no section; thence southerly by the western boundary of the last-mentioned allotment to the Tambo River; thence generally westerly by the Tambo River and Deep Creek to the south-western angle of allotment 25B no section; thence northerly by the western boundary of the last-mentioned allotment and a line to a point in the northerly prolongation of the western boundary of allotment 25B no section on the north-western boundary of allotment 9 section B; thence north-easterly by the north-western boundaries of allotments 9 and 11 section B to the point of commencement.

Given under my Hand and the Seal of the State of Victoria aforesaid, at Melbourne, this fourteenth day of January, in the year of our Lord, One thousand nine hundred and fifty-eight, and in the sixth year of the reign of Her Majesty Queen Elizabeth II.

(L.S.)

DALLAS BROOKS.

By His Excellency's Command,

MURRAY PORTER,  
for Chief Secretary.

GOD SAVE THE QUEEN!

## JUSTICES ACT 1957.

## PROCLAMATION

By His Excellency the Governor of the State of Victoria and its Dependencies in the Commonwealth of Australia, &c., &c., &c.

WHEREAS by an Act of Parliament of the State of Victoria intituled the *Justices Act 1957* it is provided in sub-section (2) of section 24 thereof that the Governor in Council may by Proclamation published in the *Government Gazette* specify municipal districts for the purpose of section 24 of the said Act: And whereas it is considered desirable that the municipal districts

named in the Schedule hereto be so specified: Now therefore I the Governor of the said State of Victoria, by and with the advice of the Executive Council thereof, do by this my Proclamation hereby specify for the purpose of the said section 24 of the said Act the several municipal districts whose names appear in the said Schedule—to take effect as on and from the 17th February 1958.

## SCHEDULE.

The Shire of Dandenong.  
The City of Bendigo.  
The Borough of Eaglehawk.  
The Township described as Kangaroo Flat located within the Shire of Marong.  
The Township described as Huntly located within the Shire of Huntly.

Given under my Hand and the Seal of the State of Victoria aforesaid at Melbourne this fourteenth day of January One thousand nine hundred and fifty-eight and in the sixth year of the reign of Her Majesty Queen Elizabeth II.

(L.S.)

DALLAS BROOKS.

By His Excellency's Command.

MURRAY PORTER,  
for Attorney-General.

GOD SAVE THE QUEEN!

## JUDICIAL PROCEEDINGS (REGULATION OF REPORTS) ACT 1957 (No. 6113).

DATE OF COMING INTO OPERATION.

## PROCLAMATION

By His Excellency the Governor of the State of Victoria and its Dependencies in the Commonwealth of Australia, &c., &c., &c.

WHEREAS by an Act of the Parliament of the State of Victoria passed in the sixth year of the reign of Her Majesty Queen Elizabeth II, intituled the *Judicial Proceedings (Regulation of Reports) Act 1957* (No. 6113), it is amongst other things enacted that the said Act shall come into operation on a day to be fixed by Proclamation of the Governor in Council published in the *Government Gazette*; Now therefore I, the Governor of the State of Victoria, acting by and with the advice of the Executive Council thereof, do by this my Proclamation fix Wednesday the fifteenth day of January One thousand nine hundred and fifty-eight as the day upon which the *Judicial Proceedings (Regulation of Reports) Act 1957* (No. 6113) shall come into operation.

Given under my Hand and the Seal of the State of Victoria aforesaid at Melbourne this fourteenth day of January in the year of our Lord One thousand nine hundred and fifty-eight and in the sixth year of the reign of Her Majesty Queen Elizabeth II.

(L.S.)

DALLAS BROOKS.

By His Excellency's Command.

MURRAY PORTER,  
for Attorney-General.

GOD SAVE THE QUEEN!

## PROPERTY LAW (AMENDMENT) ACT 1957 (No. 6123).

DATE OF COMING INTO OPERATION.

## PROCLAMATION

By His Excellency the Governor of the State of Victoria and its Dependencies in the Commonwealth of Australia, &c., &c., &c.

WHEREAS by an Act of the Parliament of the State of Victoria passed in the sixth year of the reign of Her Majesty Queen Elizabeth II, intituled the *Property Law (Amendment) Act 1957* (No. 6123) it is amongst other things enacted that the said Act shall come into operation on a day to be fixed by Proclamation of the Governor in Council published in the *Government Gazette*: Now therefore I, the Governor of the State of Victoria, acting by and with the advice of the Executive Council thereof, do by this my Proclamation

fix Wednesday the 15th day of January One thousand nine hundred and fifty-eight as the day upon which the *Property Law (Amendment) Act 1957* (No. 6123) shall come into operation.

Given under my Hand and the Seal of the State of Victoria aforesaid at Melbourne this fourteenth day of January in the year of our Lord One thousand nine hundred and fifty-eight and in the sixth year of the reign of Her Majesty Queen Elizabeth II.

(L.S.) DALLAS BROOKS.

By His Excellency's Command,

MURRAY PORTER,  
for Attorney-General.

GOD SAVE THE QUEEN!

FRIENDLY SOCIETIES (AMENDMENT) ACT 1957,  
No. 6145.

DATE OF COMING INTO OPERATION.

PROCLAMATION

By His Excellency the Governor of the State of Victoria and its Dependencies in the Commonwealth of Australia, &c., &c., &c.

WHEREAS by an Act of Parliament of the State of Victoria passed in the sixth year of the reign of Her Majesty Queen Elizabeth II., intituled the *Friendly Societies (Amendment) Act 1957*, No. 6145, it is amongst other things enacted that the said Act shall come into operation on a day to be fixed by Proclamation of the Governor in Council published in the *Government Gazette*:

Now therefore I, the Governor of the State of Victoria, in the Commonwealth of Australia, by and with the advice of the Executive Council of the said State, do by this my Proclamation fix Wednesday, the fifteenth day of January, One thousand nine hundred and fifty-eight, as the day on which the said *Friendly Societies (Amendment) Act 1957*, No. 6145, shall come into operation.

Given under my Hand and the Seal of the State of Victoria aforesaid, at Melbourne, this fourteenth day of January, in the year of our Lord, One thousand nine hundred and fifty-eight, and in the sixth year of the reign of Her Majesty Queen Elizabeth II.

(L.S.) DALLAS BROOKS.

By His Excellency's Command,

MURRAY PORTER,  
for Chief Secretary.

GOD SAVE THE QUEEN!

EDUCATION ACT 1957.

DATE OF COMING INTO OPERATION.

PROCLAMATION

By His Excellency the Governor of the State of Victoria and its Dependencies in the Commonwealth of Australia, &c., &c., &c.

WHEREAS by an Act of Parliament of the State of Victoria passed in the sixth year of the reign of Her present Majesty Queen Elizabeth II., intituled the *Education Act 1957*, it is amongst other things enacted that the said Act shall come into operation on a day to be fixed by Proclamation of the Governor in Council published in the *Government Gazette*: Now therefore I, the Governor of the State of Victoria, acting by and with the advice of the Executive Council thereof, do by this my Proclamation fix Monday, the twentieth day of January, One thousand nine hundred and fifty-eight, as the day upon which the said Act shall come into operation.

Given under my Hand and the Seal of the State of Victoria aforesaid, at Melbourne, this fourteenth day of January, in the year of our Lord One thousand nine hundred and fifty-eight, and in the sixth year of the reign of Her Majesty Queen Elizabeth II.

(L.S.) DALLAS BROOKS.

By His Excellency's Command,

J. S. BLOOMFIELD,  
Minister of Education.

GOD SAVE THE QUEEN!

BANK HOLIDAYS.

PROCLAMATION

By His Excellency the Governor of the State of Victoria and its Dependencies in the Commonwealth of Australia, &c., &c., &c.

IN pursuance of the provisions of the Banks and Currency Acts, I, the Governor of the State of Victoria, in the Commonwealth of Australia, do by this my Proclamation appoint the days and dates named hereunder special days to be observed as Bank Holidays or Bank Half-Holidays (as the case may be) at the places respectively mentioned, that is to say:—

*Bank Holiday:—*

SATURDAY, THE 1ST FEBRUARY, 1958, at Edenhope.

*Bank Half-Holiday from the Hour of Eleven a.m.:—*

WEDNESDAY, THE 5TH FEBRUARY, 1958, at Colac.

Given under my Hand and the Seal of the State of Victoria aforesaid, at Melbourne, this fourteenth day of January, in the year of our Lord One thousand nine hundred and fifty-eight, and in the sixth year of the reign of Her Majesty Queen Elizabeth II.

(L.S.) DALLAS BROOKS.

By His Excellency's Command,

A. G. RYLAH,  
Chief Secretary.

GOD SAVE THE QUEEN!

PUBLIC HOLIDAYS.

PROCLAMATION

By His Excellency the Governor of the State of Victoria and its Dependencies in the Commonwealth of Australia, &c., &c., &c.

IN pursuance of the provisions contained in Part III. of the *Public Service Act 1946*, I, the Governor of the State of Victoria, in the Commonwealth of Australia, by and with the advice of the Executive Council of the said State, do by this my Proclamation appoint the days and dates hereunder mentioned to be observed as Public Holidays or Public Half-Holidays (as the case may be) at the places respectively specified, viz.:—

*Public Holidays:—*

\*WEDNESDAY, THE 19TH DAY OF FEBRUARY, 1958, throughout the Shire of South Gippsland.

FRIDAY, THE 14TH FEBRUARY, 1958, throughout the Shire of Healesville.

SATURDAY, THE 15TH FEBRUARY, 1958, throughout the Shire of Whittlesea.

WEDNESDAY, THE 22ND JANUARY, 1958, throughout the Shire of Bairnsdale.

*Public Half-Holidays from the Hour of Twelve o'clock noon:—*

WEDNESDAY, THE 12TH FEBRUARY, 1958, throughout the Townships of Pakenham, Pakenham East, Pakenham Upper, Pakenham South, Nar-Nar-Goon and Officer.

THURSDAY, THE 16TH JANUARY, 1958, throughout the City of Warrnambool.

WEDNESDAY, THE 5TH FEBRUARY, 1958, throughout the Town of Colac.

THURSDAY, THE 6TH MARCH, 1958, throughout the City of Sale.

\*WEDNESDAY, THE 5TH MARCH, 1958, throughout the Borough of Wonthaggi.

\* Agricultural Show.

Given under my Hand and the Seal of the State of Victoria aforesaid, at Melbourne, this fourteenth day of January, in the year of our Lord One thousand nine hundred and fifty-eight, and in the sixth year of the reign of Her Majesty Queen Elizabeth II.

(L.S.) DALLAS BROOKS.

By His Excellency's Command,

MURRAY PORTER,  
for Chief Secretary.

GOD SAVE THE QUEEN!

**PUBLIC HOLIDAY—AUSTRALIA DAY.**

It is hereby notified that on—  
**MONDAY, THE 27TH JANUARY, 1958,**  
 the Public Offices will be closed, such day having been appointed by the *Public Service Act 1946*, to be observed as a holiday in the Public Offices throughout the State of Victoria.

This notice relates only to the closing of the State Public Offices. All inquiries regarding the holiday in other offices and in shops and industry should be directed to the Department of Labour and Industry, Old Treasury Building, Spring-street, Melbourne, C.1. (Telephone MF 0321, Extension 266 or 6382.)

A. G. RYLAH,  
 Chief Secretary.  
 Chief Secretary's Office,  
 Melbourne, C.1, 10th January, 1958.

**AUCTION SALES ACT 1928.**

LIST of persons to whom Auctioneers' Licences have been issued during the month of November, 1957.

Name.	Address.	Date of Issue.
McGauchie, A. A. J.	Cobram	1.11.57
Ridgway, C. V.	29 Welfare-parade, Burwood	21.11.57

A. T. SMITHERS,  
 Director of Finance.  
 The Treasury,  
 Melbourne, C.2, 3rd January, 1958.

**MONEY LENDERS ACT 1938.**

IN accordance with the provisions of the above-mentioned Act, the following is published for general information:—

*List of persons to whom Money Lenders' Licences have been issued for the year ending 30th June, 1958.*

Name.	Authorized Name.	Authorized Address.	Date of Issue.
Advance Supply Agency Pty. Ltd. (J. L. Harper, appointee)	Advance Supply Agency Pty. Ltd.	230 Collins-street, Melbourne ..	3.12.57
Federal Finance Proprietary Limited (C. R. Wilson, appointee)	Federal Finance Proprietary Limited	129 William-street, Melbourne ..	28.11.57
Holmes Agencies Pty. Limited (K. A. Lafferty, appointee)	Holmes Agencies Pty. Limited..	560 Lonsdale-street, Melbourne..	26.11.57
U.K. Finance Pty. Limited (S. Simons, appointee)	U.K. Finance Pty. Limited ..	3 Queens-road, Melbourne ..	26.11.57

State Treasury,  
 Melbourne, C.2, 3rd January, 1958.

M. A. R. SYNNOT,  
 Registrar.

**LAW DEPARTMENT.**

**ANNUAL SITTINGS OF LICENSING COURT.**

HIS Excellency the Governor of the State of Victoria by and with the advice of the Executive Council thereof, doth by Order made on the fourteenth day of January, 1958, pursuant to the provisions of Section 87 of the *Licensing Act 1928* as amended by Section 15 of the *Licensing (Amendment) Act 1953*, extend the times for holding the Annual Sittings for the Victorian Licensing Court for the Licensing Areas set out in the first column of the Schedule hereunder for a period not exceeding two months from the last day of the period appointed as indicated in the second column of such Schedule.

**SCHEDULE.**

Licensing Area.	Date of Sittings.
Eastern Metropolitan .. .. .	31st December, 1957
Bairnsdale .. .. .	31st December, 1957
Geelong .. .. .	31st December, 1957
Hamilton .. .. .	31st December, 1957
Mildura .. .. .	31st December, 1957
Shepparton.. .. .	31st December, 1957
Warrnambool .. .. .	31st December, 1957

A. MAHLSTEDT,  
 Clerk of the Executive Council.  
 At Government House  
 Melbourne, 14th January, 1958.

**MINING LEASES GRANTED.**

- 7483, Mineral; Lindsay Gordon McRae and Keith McRae; 18a. 3r. 22p., Parish of Buchan.
- 7484, Mineral; Lindsay Gordon McRae and Keith McRae; 18a. 2r., Parish of Colquhoun East.

**CONSENT GRANTED TO TRANSFER MINING LEASE.**

- 7516, Mineral; from John Boff to John Boff and Kenneth Bernard Hulse.

**TAILINGS LICENCES GRANTED.**

- 2809, Tailings Licence; J. F. Stewart; Parish of Yehrip. (In lieu of Tailings Licence No. 2722, expired.)
- 2812, Tailings Licence; The President, Councillors, and Ratepayers of the Shire of Marong; Parish of Nerring. (In lieu of Tailings Licence No. 2719, expired.)
- 2815, Tailings Licence; R. A. Watts; Parish of Yehrip. (In lieu of Tailings Licence No. 2718, expired.)
- 2817, Tailings Licence; Norris Bros.; at Bendigo.
- 2818, Tailings Licence; Norris Bros.; at Bendigo.
- 2819, Tailings Licence; The President, Councillors, and Ratepayers of the Shire of Yarrowonga; Parish of Chiltern West.
- 2821, Tailings Licence; Alfred George Leech; Parish of Bet Bet. (In lieu of Tailings Licence No. 2748, expired.)
- 2822, Tailings Licence; Guiseppe Mioni; Parish of Korumburra. (In lieu of Tailings Licence No. 2759, expired.)
- 2823, Tailings Licence; The President, Councillors, and Ratepayers of the Shire of Ballarat; Parish of Smythesdale. (In lieu of Tailings Licence No. 2554, expired.)
- 2824, Tailings Licence; Gisborne Slate Co.; Parish of Bullengarook. (In lieu of Tailings Licence No. 2724, expired.)
- 2825, Tailings Licence; The President, Councillors, and Ratepayers of the Shire of Rutherglen; Parish of Lilliput. (In lieu of Tailings Licence No. 2599, expired.)
- 2826, Tailings Licence; A. Sist; Parish of Raglan. (In lieu of Tailings Licence No. 2755, expired.)

W. J. MIBUS,  
 Minister of Mines.

**DEPARTMENT OF MINES.**

SUBJECT to any necessary excisions, &c., it is proposed to grant the following leases:—

- 3326, Beechworth; Norman Staff and Catherine Lily Irene Staff; 7a. 0r. 4p., Parish of Hotham.
- 3327, Beechworth; Norman Staff and Catherine Lily Irene Staff; 13a. 2r. 24p., Parish of Hotham.
- 7568, Mineral; Bolton Gypsum and Plaster Company Pty. Ltd.; 82a. 0r. 21p., Parishes of Koonda and Wootwoara.

**APPLICATION FOR LEASE DECLARED ABANDONED.**

- 7566, Mineral; Rupert-F. Vian; 39a. 3r. 38p., Parish of Wodonga.

## Transport Regulation Acts.

## TRANSPORT REGULATION BOARD.

## NOTICES OF PUBLIC HEARINGS.

NOTICE is hereby given that the applications made by the persons named below for renewal of licences to operate the commercial goods vehicles on the route or routes, or in the manner set out opposite their names, will be heard at a time and place to be communicated to the persons concerned:—

*Name and Address; Present Franchise; Licence Number; Date of Expiry.*

ASHBY, R. C., 1A Woolton-avenue, Thornbury; 1 commercial goods vehicle (15 cwt.) to operate throughout the State of Victoria in the course of business as "plumber"—tools of trade and materials for use in connexion with the execution of installation contracts by the licence holder; D.5970; 20th March, 1958.

B.H.B. TIMBER PTY. LTD., c/o V.I.A. Ltd., Matthews-avenue, Essendon; 1 commercial goods vehicle (11 cwt.) to operate—(a) within a radius of 50 miles from the post office at Heyfield in the course of business as "sawmillers"—own material, equipment, and gear, (b) from and to the Township of Heyfield to and from the City of Melbourne and within a distance of 8 miles of the limits thereof in the course of business as "sawmillers"—urgently required spare parts for mill and machinery; D.A.10812; 22nd March, 1958.

BUCHANAN, S. A., Wallace-street, Bairnsdale West; 1 commercial goods vehicle (108 cwt.) to operate—(a) within a radius of 20 miles from the post office at Bairnsdale—general goods, (b) within the Shires of Rosedale, Avon, Bairnsdale and Tambo, and the City of Sale, under contract to the Country Roads Board—road-contracting plant and materials; D.A.12693; 22nd March, 1958.

CARLTON & UNITED BREWERIES LTD., 16 Bouverie-street, Carlton; 2 commercial goods vehicles (15 and 7 cwt.) to operate—(a) within a radius of 50 miles from the G.P.O., Melbourne, in the course of business as "brewers"—own goods, (b) throughout the State of Victoria for the purpose of undertaking maintenance and servicing work at hotels and canteens—tools of trade, plumbers' equipment, and incidental materials to such servicing and maintenance; D.A.808/1, D.A.808/2; 22nd March, 1958.

CHISLETT, W. A. R., PTY. LTD., 154 Commercial-street, Merbein; 1 commercial goods vehicle (100 cwt.) to operate in the course of business as "manufacturers of aerated waters"—own manufactured aerated waters and empty returns only in the under-mentioned areas:—(a) Within a radius of 20 miles of the post office at Merbein, (b) from and to own premises at Merbein to and from the Township of Murrayville and townships *en route* via the Calder Highway to the Township of Ouyen, and thence via the Ouyen-Pinnaroo Highway *en route* to the Township of Murrayville; D.8189; 23rd February, 1958.

COMMONWEALTH AIRCRAFT CORPORATION PTY. LTD., Lorimer-street, Port Melbourne; 2 commercial goods vehicles (each 165 cwt.) to operate—(a) within a radius of 25 miles from the G.P.O., Melbourne, in the course of business as "aircraft manufacturers"—own goods, (b) from and to the radius described in paragraph (a) above to and from the Avalon Airfield situate at Lara—own aircraft spare parts and assemblies for use in the construction, assembly, and repair of aircraft on behalf of the Defence Department; D.A.2387/1, D.A.2387/2, 22nd March, 1958.

GIPPSLAND GATE GARAGE PTY. LTD., 85 Lonsdale-street, Dandenong; 1 commercial goods vehicle (70 cwt.) to operate throughout the State of Victoria for the purpose of repairing or towing disabled or wrecked vehicles to or from the licensee's premises at Dandenong—tools of trade, spare parts and materials incidental to trade; D.A.10335; 22nd March, 1958.

LOBB, B., 5 Burlington-street, Oakleigh; 1 commercial goods vehicle (99 cwt.) to operate—(a) within a radius of 25 miles from the G.P.O., Melbourne—general goods, (b) within a radius of 70 miles from the G.P.O., Melbourne—bricks; D.A.12543; 15th March, 1958.

MONTIMER, A. S., 360 Auburn-road, Hawthorn; 1 commercial goods vehicle (88 cwt.) to operate—(a) within a radius of 25 miles from the G.P.O., Melbourne—general goods, (b) within a radius of 70 miles from the premises of the Co-operative Brick Co. Pty. Ltd. at Auburn—bricks on behalf of the said company; D.A.1634; 15th March, 1958.

MCCABE, J., Belmore-street, Yarrowonga; 1 commercial goods vehicle (13 cwt.) to operate throughout the State of Victoria in the course of business as "construction engineer"—own prefabricated grain storage silos, agricultural tank stands for erection, tools of trade, equipment and materials incidental to and required for erection purposes; D.8155; 2nd March, 1958.

NIVEN, C. J. T., PTY. LTD., Somerville-road, Footscray; 1 commercial goods vehicle (10 cwt.) to operate throughout the State of Victoria in connexion with the servicing and maintenance of chain saws and kiln-drying units—tools of trade, spare parts and materials incidental to such servicing and maintenance work, also chain saws for demonstration purposes only; D.6043; 20th March, 1958.

PASSIONA BOTTLING CO. (MELB.) LTD., 314 Toorak-road, Burwood; 1 commercial goods vehicle (141 cwt.) to operate within a radius of 50 miles of the G.P.O., Melbourne, in the course of business as "aerated water manufacturers"—own goods; D.8180; 8th February, 1958.

ROCHE BROS. PTY. LTD., 22 Dynon-road, South Kensington; 2 commercial goods vehicles (111 and 92 cwt.) to operate—(a) throughout the State of Victoria in the course of business as "earth-moving contractors"—tools of trade, plant and equipment for use solely in connexion with own contracts, (b) earth and other excavated materials from the site of excavation to any place of disposal within a radius of 50 miles of such point of excavation; D.5991, 20th March, 1958, D.A.1941, 15th March, 1958.

SINGER SEWING MACHINE CO., 109A Ryrie-street, Geelong; 1 commercial goods vehicle (24 cwt.) to operate within a radius of 50 miles from the post office in the City of Geelong—new sewing machines, machines for repair or having been repaired, sewing machine accessories, tools of trade, spare parts and materials incidental to repair and servicing such sewing machines; D.A.9336/1; 15th March, 1958.

Notice of any objection should be forwarded to reach the Secretary of the Board not later than 22nd January, 1958.

E. V. FIELD,  
Secretary.

Exhibition Buildings, Rathdown-street, Carlton, N.3,  
6th January, 1958.

NOTICE is hereby given that the applications made by the persons named below for licences to operate the commercial goods vehicles on the route or routes, or in the manner set out opposite their names, will be heard at a time and place to be communicated to the persons concerned:—

*Name and Address; Nature of Application.*

BENTLEY, W. A., St. Aidan's-road, Bendigo; variation of the terms of existing licence No. D.A.31357 by adding the ability to operate from and to Bendigo to and from Swan Hill, Kerang, and Donald, and towns *en route* in the course of business as "washine machine specialist"—tools of trade, spare parts, and materials incidental to the repair and servicing of washing machines.

COCA-COLA BOTTLERS (MELBOURNE) PTY. LTD., 66 Dawson-street, Brunswick; 1 commercial goods vehicle, to be purchased (approximately 240 cwt.), to operate from own factory in Brunswick to own depots at Moe, Morwell, and Traralgon in the course of business as "aerated beverage manufacturers"—own aerated beverages and empty returns.

EVANS, D. & J., PTY. LTD., 171-193 Camberwell-road, Hawthorn East; 1 commercial goods vehicle (223 cwt.) to operate for the carriage of—(1) logs from forest landing in the Niagaroon and Upper Yarra forestry districts and the North Big River area to D. and J. Evans Pty. Ltd. sawmill at Toolangi, (2) sawn timber from D. and J. Evans Pty. Ltd. sawmill at Toolangi to—(a) the railway station at Healesville, (b) any customer if delivered within a radius of 20 miles of the Healesville Railway Station, (c) any merchant or builder, if delivered to a timber yard or direct on to a building site which is situated within a radius of 25 miles of the G.P.O., Melbourne, and to D. and J. Evans Pty. Ltd. yards at Hawthorn.

GARDNER, J. A., & L. D. FREGON, P.O. Box 9, Oakleigh; 1 commercial goods vehicle (101 cwt.) to operate within a radius of 70 miles of the premises of the New Gamble Brick Co. Pty. Ltd., at Oakleigh—bricks on behalf of the said company.

- GOVAN, G. R., Rosslyn-avenue, Seaford; 1 commercial goods vehicle (72 cwt.) to operate within the Bendigo division of the C.R.B.—road contracting plant and materials.
- GREEN, A. W., 170 Melville-street, Numurkah; 1 commercial goods vehicle (18 cwt.) to operate—(a) to soldier settlement sites throughout the State of Victoria from the nearest railway station or most convenient supplier within a radius of 50 miles of each respective site—building materials used in the construction of dairies on such sites on behalf of the Soldier Settlement Commission, (b) own plant, tools of trade, and camping gear from site to site.
- HARRIS, E. S. & Co. PTY. LTD., 43 Kepler-street, Warrnambool; variation of licence numbered D.A.21645/1 by the addition of the ability to operate within the Warrnambool division of the C.R.B.—road contracting plant and equipment.
- HAMILTON WRECKING Co. PTY. LTD., Coleraine-road, Hamilton; 1 commercial goods vehicle (30 cwt.) to operate within a radius of 100 miles of Hamilton in the course of business as "motor wreckers" for the purpose of towing disabled or wrecked vehicles.
- HALLAM, J. V., 123 Helen-street, Morwell; 1 commercial goods vehicle (87 cwt.) to operate from Tyers Extension open cut to Yarram, via Traralgon, Gormandale, and Carrajung, or alternatively via Sale—brown coal.
- JOHANSSON, V. J., Jetty-road, Rosebud; 1 commercial goods vehicle (89 cwt.) to operate within the Dandenong division of the C.R.B.—road contracting plant and materials.
- K.M. PLASTER PRODUCTS PTY. LTD., Bald Hill-road, Pakenham East; variation of licence No. D.A.31354 by the deletion of present conditions and adding in lieu the ability to operate in the course of business as "fibro-plaster manufacturers"—(a) within a radius of 20 miles of Pakenham East—own goods, (b) east of a north-south line drawn through Dandenong—fibro-plaster sheets, mouldings, hemp, sisal, and fixing materials.
- LEURY, T. & A. (trading as Leury Bros.), 12 Burnell-street, West Brunswick; variation of licences Nos. D.A.1491/1, D.A.1491/2, D.A.1491/3, and D.A.1491/4 by the addition of the ability to operate within a radius of 70 miles of the G.P.O., Melbourne—bricks, roofing tiles, and sewerage pipes.
- MILLER, W. F., Wills-street, Bright; 1 commercial goods vehicle (251 cwt.) to operate for the carriage of—(1) redgum logs and woollybut logs from the Forests Commission forest landing within a radius of 40 miles of the Glenberrie Timber Co. sawmill at Porepunkah, (2) sawn timber from Glenberrie Timber Co. at Porepunkah to consignees within a radius of 20 miles of Glenberrie Timber Mills at Porepunkah.
- MARSHALL, W. B., High-street, Wedderburn; variation of licence No. D.6001 by the addition of the ability to operate to and from trotting meetings throughout the State of Victoria—racehorses, sulkies, and sundry equipment.
- POCOCK, M. D., 107 Booth-street, Golden Square; 1 commercial goods vehicle (120 cwt.) to operate within the Bendigo division of the C.R.B.—road contracting plant and materials.
- RAMAGE BROS. PTY. LTD., 38 Reid-street, Wangaratta; 1 commercial goods vehicle (15 cwt.) to operate throughout the State of Victoria in the course of business as "earth moving contractors"—tools of trade, equipment, and materials incidental to own contracts.
- RIPPON, G., Lyon-street, Skipton; 1 commercial goods vehicle (91 cwt.) to operate within a radius of 50 miles of Skipton—road contracting plant and materials.
- SHERLOCK & HAY PTY. LTD., 81 Young-street, Frankston; 1 commercial goods vehicle (100 cwt.) to operate within a radius of 25 miles of Frankston in the course of business as "builders and sawmillers"—own goods.
- SLEEP, C., Galah; 1 commercial goods vehicle (110 cwt.) to operate within the Shires of Stawell and Ouyen—road contracting plant and materials.
- SHILTON, O. A., Aitken-street, Gisborne; 1 commercial goods vehicle (15 cwt.) to operate within a radius of 40 miles of Gisborne as a tow truck for the purpose of repairing or towing disabled or wrecked vehicles.
- THOMPSON, J., Nyah West; variation of licence No. D.A.30847 by the addition of the ability to operate within a radius of 50 miles of Nyah West—fencing posts and poles.
- VEAL, R. C., 36A Laurie-street, Ballarat; 1 commercial goods vehicle (72 cwt.) to operate within the Ballarat division of the C.R.B.—road contracting plant and materials.
- WILSON HOT WATER PTY. LTD., 233 Burwood-road, Hawthorn; 1 commercial goods vehicle (11 cwt.) to operate throughout the State of Victoria in the course of business as "Hot water engineers" for the purpose of sales promotion of own hot water systems with the ability to make an urgent incidental delivery.
- WOODTLI, J. A., 10 Stratford-road, Maffra; 1 commercial goods vehicle (100 cwt.) to operate—(a) within a radius of 20 miles of Maffra—general goods, (b) within a radius of 50 miles of Maffra—road contracting plant and materials.
- BOURDON, A. A. & G. C. (trading as Warrnambool Motor Wreckers), 2 Jamieson-street, Warrnambool; 1 commercial goods vehicle (97 cwt.) to operate throughout the State of Victoria in the course of business as "marine dealers"—marine stores and old metals.
- WILLIAMS, S. & E., 27 Golf-road, Oakleigh; 1 commercial goods vehicle (126 cwt.) to operate within a radius of 50 miles of the G.P.O., Melbourne—road contracting plant and materials.

NOTICE is hereby given that the applications made by the persons named below for licences to operate commercial passenger vehicles on the route or routes, or in the manner set out opposite their names, will be heard at a time and place to be communicated to the parties:—

*Name and Address; Nature of Application.*

- BENDER'S BUSWAYS PTY. LTD., Edol-street, North Geelong; application for permits on U.O. licences to include the ability to operate between Geelong and Melbourne to Christmas decorations in Spencer-street, Collins-street, Spring-street, Bourke-street, Elizabeth-street, Lonsdale-street, and Swanston-street. *Fare:* Adults £1, Children 10s. Orchid week—Melbourne Town Hall and Lane's Motors. *Fare:* 15s. plus admission charge. Motor Show—Exhibition Buildings, Carlton. *Fare:* 15s. plus admission charge. Garden Week—Melbourne Town Hall or site of display. *Fare:* 15s. plus admission charge.
- TALENT, R. A., 15 Orange-avenue, Mildura; 1 commercial passenger vehicle, with seating capacity for five persons, to operate for the carriage of passengers otherwise than at separate and distinct fares for each passenger throughout Victoria from 15 Orange-avenue, Mildura.
- MURTACH, R. J., Myrtleford; 1 commercial passenger vehicle, to be purchased, with seating capacity for five persons, to operate for the carriage of passengers otherwise than at separate and distinct fares for each passenger throughout Victoria from Myrtleford.
- WILKIE, D. G., 101 Anderson-street, Bendigo; application for variation of licence No. C.O.297 to increase the weight of general goods from 56 lb. to 1 cwt.
- WILKIE, D. G., 101 Anderson-street, Bendigo; 1 commercial passenger vehicle, to be purchased, with seating capacity for eight persons, to operate under the same terms and conditions as licence No. C.O.297, at present in the name of the applicant. *Note.*—This licence is to replace licence No. C.O.854.
- READ & BRACK PTY. LTD., 6 Nunn-street, Benalla; 1 commercial passenger vehicle, with seating capacity for five persons, to operate as follows:—(a) At separate and distinct fares within a radius of 5 miles of Benalla Post Office, (b) under private hire conditions throughout Victoria from 6 Nunn-street, Benalla.
- JAMIESON, P. F., 149 Blackburn-road, Blackburn; application for renewal of licence No. C.T.261, expiring 18th April, 1958, authorizing operations as a country taxi from Blackburn.
- MEADE, J. J., 41 Rennison-street, Parkdale; application for renewal of licence No. C.T.103, expiring 13th April, 1958, authorizing operations as a country taxi from Parkdale.
- GARDNER, K. M. (trading as Rosebud Taxi Service), Second-avenue, Rosebud; application for renewal of licence No. T.C.T.52, expiring 16th April, 1958, authorizing operations as a country taxi from Rosebud.
- VALENTINE, C. E., 2 Federation-street, Nathalia; application for renewal of licence No. C.T.752, expired 10th November, 1957, authorizing operations as a country taxi from Nathalia.
- LOCKWOOD, R. J., Box 123, Birchip; application for renewal of licence No. T.P.78, expiring 15th April, 1958, authorizing operations as a stage omnibus under the same terms and conditions.
- GREYHOUND LINES OF AUSTRALIA PTY. LTD., 138 Elizabeth-street, Melbourne; application for renewal of licences Nos. T.O.25, T.O.31, T.O.33, and T.O.52, expiring 25th April, 1958, authorizing operations as stage omnibuses under the same terms and conditions.
- GEELONG CHURCH OF ENGLAND GRAMMAR SCHOOL, Corio. Geelong; application for renewal of licence No. T.P.35, expiring 31st March, 1958, authorizing operations as a stage omnibus under the same terms and conditions.

DEAN, J. K. & E., 163 Hayes-street, Shepparton; application for renewal of licence No. T.S.169, expiring 23rd March, 1958, authorizing operations as a stage omnibus under the same terms and conditions.

PYLE, T. J., Tawonga South; application for renewal of licence No. T.P.46, expiring 9th March, 1958, authorizing operations as a stage omnibus under the same terms and conditions.

PINCINI, E. J. & L., Pty. Ltd., Station-street, Mirboo North; 1 commercial passenger vehicle, with seating capacity for five persons, to operate for the carriage of passengers otherwise than at separate and distinct fares for each passenger throughout Victoria from Station-street, Mirboo North (subject to the cancellation of licence No. C.T.566, at present in the name of the applicant company).

ELSTON, G. F., 22 Ludstone-street, Hampton; application for variation of Route No. 218A to delete 7.45 a.m. trip ex Old Dandenong-road, via Kingston-road, Warrigal-road, Bernard-street, Chesterville-road, Witham-road, and Nepean Highway to Moorabbin Railway Station, and instead to operate, via Kingston-road, Warrigal-road, Bernard-street, Turner-road, Nepean Highway to the Moorabbin Railway Station.

CURREN, R. W., 528 Barkers-road, Hawthorn East; application for variation of Route No. 78A (Camberwell-Canterbury-East Kew) to operate a deviation of service from the corner of Balwyn and Doncaster roads, via Doncaster-road and Tannock-street to the corner of Ordvel-street, Balwyn North. (Sections, fares, and time-tables to be arranged.)

SHAVE, O. C., 1964 Malvern-road, Malvern; application for one additional commercial passenger vehicle, with seating capacity for 28 passengers, registered No. GTX-492, to operate on Route No. 47A (Carnegie-Holmesglen-Syndal, via Oakleigh) under the same terms and conditions as vehicles already licensed in the name of the applicant.

HINTON, R. J., 27 Royal-parade, Pascoe Vale South; application for one commercial passenger vehicle, with seating capacity for 23 persons, to operate as a substitute vehicle on Route No. 9A (Brunswick-Essendon) under the same terms and conditions as licence No. M.O.216, held in the name of the applicant.

BLUE & SILVER BUS LINES, 250 Balcombe-road, Mentone; application for variation of conditions of licences Nos. C.O.33 and C.O.27, operating on Route No. 204A (Mordialloc-Mentone-Cheltenham) to delete that portion of the route from the corner of Nepean Highway and Devon-street, via Nepean Highway and Evesham-road, and Ward-street to the corner of Ward-street and Follet-road, and instead to operate from the corner of Nepean Highway and Devon-street, via Devon-street Mena-avenue, Follet-road, thence via route described.

HOLBOROW, W., & HAROLD S. COLLINS (trading as Heidelberg-Eltham Bus Service), 101 Bell-street, Heidelberg; application for renewal of licence No. M.O.510, expiring 16th February, 1958, authorizing operations on Route No. 87A (Heidelberg-Eltham: Heidelberg-Greensborough-Briar Hill) as prescribed.

HEYWOOD, R. N., 6 Skipton-road, Hughesdale; application for renewal of licences Nos. T.M.O.645 and T.M.O.647, expiring 1st March, 1958, authorizing operations on Route No. 88A (Bentleigh-Hughesdale-East Malvern) as prescribed.

EDWARDS, W. M., 28 Darlington-grove, East Coburg; 1 commercial passenger vehicle, with seating capacity for five persons, to operate as a metropolitan private hire car under composite conditions from an approved depot in Zone "J." (This replaces the application gazetted on 18th December, 1957.)

HOWLETT, E. N., 10 Moylan-street, East Bentleigh; 1 commercial passenger vehicle, with seating capacity for five persons, to operate as a metropolitan taxi-cab.

CORNWELL, J., 275 Pascoe Vale-road, Essendon; 1 commercial passenger vehicle, with seating capacity for five persons, to operate as a metropolitan taxi-cab.

ROSENFELD, R. J., 2A Garrell-street, Caulfield; 1 commercial passenger vehicle, with seating capacity for five persons, to operate as a metropolitan taxi-cab, subject to the cancellation of licence No. M.H.797, in the name of the applicant.

ROSENFELD, R. J., 2A Garrell-street, Caulfield; 1 commercial passenger vehicle, with seating capacity for five persons, to operate as a metropolitan taxi-cab, subject to the cancellation of licence No. M.H.583, in the name of the applicant.

MILLAR, R. H., 57 Hoffmans-road, West Essendon; 1 commercial passenger vehicle, with seating capacity for five persons, to operate as a metropolitan private hire car under composite conditions from an approved depot in Zone "H" and Zone "J" respectively.

NOTICE is hereby given that the application made by the person named below for renewal of the licence with variation to operate the commercial goods vehicle on the route or routes, or in the manner set out opposite his name, will be heard at a time and place to be communicated to the parties concerned:—

*Name and Address; Present Conditions; Amended Conditions; Licence Number; Date of Expiry.*

KIERCE, M. J., 19 Rice-street, Ballarat; 1 commercial goods vehicle (108 cwt.) to operate throughout the State of Victoria under contract to the Country Roads Board—road-contracting plant and materials; 1 commercial goods vehicle (108 cwt.) to operate within the Ballarat Division of the Country Roads Board—road-contracting plant and materials; D.8186; 22nd February, 1958.

Notice of any objection should be forwarded to reach the Secretary of the Board not later than Wednesday, 29th January, 1958.

E. V. FIELD,  
Secretary.

Exhibition Buildings, Rathdown-street, Carlton, N.3,  
13th January, 1958.

Transport Regulation Acts.  
TRANSPORT REGULATION BOARD.

NOTICE No. 43.

*Stands Approved by the Board for Use by Commercial Passenger Vehicles Within the Shire of Morwell.*

(1) Notification of Stands for the use of vehicles licensed under the classification of "Country Taxi-cab," and authorized to operate within a specified radius from the principal post office at Morwell—

*Type of Stand; Location; Number of Vehicles.*

Hire Stand; Commercial-road, Morwell, north side, extending 40 feet east from a point 40 feet east from the prolongation of the eastern alignment of Tarwin-street—vehicles to stand parallel to the kerb; two.

Hire Stand; Tarwin-street, Morwell, west side, extending 40 feet south from a point 30 feet south from the southern boundary of Commercial-road—vehicles to stand parallel to the kerb; two.

Hire Stand; Tarwin-street, Morwell, in the centre of the road at right angles to the kerb line, extending 60 feet south from a point 49 feet south of the southern alignment of Commercial-road; six.

(2) Notification of Stands for the use of vehicles licensed under the classification of "Country Stage Omnibuses" authorized to operate on routes into and out of Morwell—

*Location.*

A) that area bounded by—

Commencing at a point 173 feet east of the intersection of the eastern building alignment of Tarwin-street and the northern kerb of Commercial-road by a line north-east extending 103 feet; thence by a fence bounding the Railway Reserve extending east 153 feet; thence by a line extending south 80 feet; and thence by the aforesaid kerb extending west 236 feet to the point of commencement.

By order of the Transport Regulation Board.

E. V. FIELD,  
Secretary.

Transport Regulation Acts.  
TRANSPORT REGULATION BOARD

NOTICE No. 44.

*Appointment of Inspectors.*

TAKE notice that, pursuant to the powers conferred on the Board by the provisions of Regulation 4 of Part I. of the Transport Consolidated Regulations, the Board notifies the repeal of the appointment as Inspector of—

DAVID DON NAPIER,

formerly Traffic Officer of the Shire of Dandenong.

Appointment was notified in Notice No. 36, contained in *Victoria Government Gazette*, No. 893, dated 7th November, 1956.

By order of the Transport Regulation Board,

E. V. FIELD,  
Secretary.

Transport Regulation Acts.  
TRANSPORT REGULATION BOARD.

NOTICE No. 45.

Stand for Omnibuses Within the City of Bendigo.

NOTIFICATION of Stand approved by the Board for the use of commercial passenger vehicles licensed under any classification of "Omnibus," and authorized to operate to or through the City of Bendigo—

Type of Stand; Location of Stand; Number of Vehicles.  
Waiting Stand; Howard-lane, west side, from 30 feet north from Bridge-street to 30 feet south from Chapel-street; unlimited.

By order of the Transport Regulation Board,  
E. V. FIELD,  
Secretary.

CONTRACTS ACCEPTED.—(Series 1956-57.)  
GENERAL STORES.

Gazette No. 142, 27th March, 1957, Schedule No. 56.—Motor Spirit, &c. For Item No. 14 substitute £13 per ton. as from 23th December, 1957.

CONTRACTS ACCEPTED.—(Series 1957-58.)  
GENERAL STORES.

Gazette No. 206, 18th July, 1957, Schedule No. 13.—Acids, &c. For Item Nos. 6, 7 and 8 substitute £11 4s. per cwt., 2s. 5d. per lb. and 2s. 10d. per lb. respectively, as from 8th July, 1957.

FIREWOOD.—COUNTRY TOWNS, ETC.

CONTRACT CANCELLED.

Gazette No. 252, 30th October, 1957.—Firewood—Geelong. Contract No. 1487 is hereby cancelled, as from 1st October, 1957.

CONTRACT ACCEPTED.

Firewood—Geelong. For the supply of firewood in 2-ft. billets and 6-ft. lengths at £9 5s. and £5 15s. per cord respectively, as from 1st October, 1957.—E. J. Riches, 80 Ormond-road East Geelong.

W. H. RUTHERFORD, Secretary to the Tender Board.  
13.1.58.

ORDERS IN COUNCIL.—(Series 1957-58.)  
STATE ELECTRICITY COMMISSION.

1994. The construction of reinforced concrete foundations, floors, and beams for Transformer Repair Building and Tests Annex, Fisherman's Bend, to Specification No. 57-58/100, £14,800.—Boulder Pty. Ltd.

1995. The purchase of land at Dimboola having a frontage of 63 feet to the south-west side of Lloyd-street by a depth of 123 feet along the north-west side of Lochiel-street, and being part of Crown allotment 1, section 8, Town and Parish of Dimboola, and being the whole of the land comprised in certificate of title, volume 6128, folio 467, together with all improvements erected thereon, for use as district premises, £7,200.—Permewan Wright Ltd.

1996. The transportation of brown coal from Yallourn North Extension Open Cut to railway loading facilities at Yallourn North, for a period of six months, to Specification No. 57-58/89, at Schedule rates.—H. D. A. Vinall Pty. Ltd.

Approved by the Governor in Council, 10th December, 1957.—A. MAHLSTEDT, Clerk of the Executive Council.

Co-operation Act 1953.

ROBINVALE COMMUNITY CO-OPERATIVE SOCIETY LIMITED.

NOTICE OF DISSOLUTION OF SOCIETY.

NOTICE is hereby given that I have this day registered the dissolution of the above-named society and cancelled its registration under the above-named Act.

Dated at Melbourne this 6th day of January, 1958.

W. J. BRODIE,  
Acting Registrar of Co-operative Societies.

Country Roads Acts.  
COUNTRY ROADS BOARD.

NOTICE OF FIXING NEW ALIGNMENTS OF TYABB-ROAD IN THE SHIRE OF MORNINGTON.

NOTICE is hereby given that the Country Roads Board under the powers conferred upon it by the *Country Roads Act 1948* (No. 5290) has fixed new alignments for the east and west sides of Tyabb-road in the Shire of Mornington as described hereunder, that is to say:—

(a) Commencing at a point in allotment 8, section 22, Parish of Moorooduc, distant 157 deg. 53 min. 40 feet and 19 deg. 57 min. 17 ft. 10 in. from the western angle of the said allotment; thence by lines bearing respectively 157 deg. 58½ min. 758 ft. 2½ in., 109 deg. 23 min. 33 ft. 1 in., 240 deg. 47 min. 25 feet, 155 deg. 27 min. 65 ft. 8 in., 59 deg. 38 min. 25 feet, 196 deg. 46 min. 36 ft. 7½ in., 153 deg. 53 min. 907 ft. 11½ in., 107 deg. 27 min. 27 ft. 7 in., 241 deg. 1½ min. 20 feet, 153 deg. 36½ min. 66 ft. 9 in., 61 deg. 22 min. 20 feet, 197 deg. 29 min. 28 ft. 10 in., 153 deg. 36½ min. 515 ft. 7½ in., 107 deg. 25½ min. 20 ft. 9 in., 241 deg. 14½ min. 15 feet, 153 deg. 36½ min. 50 ft. 6 in., 63 deg. 37½ min. 15 feet, 198 deg. 37 min. 21 ft. 2½ in. and 153 deg. 36½ min. 682 ft. 8 in.; thence by the arc of a circle of radius 100 feet a distance of 80 ft. 1 in., the chord of which arc bears 130 deg. 40 min. to a point in lot 13 on plan of subdivision numbered 7872, lodged in the Office of Titles, and being part of allotment 6, section 22, of the said parish, the said point being distant 243 deg. 42½ min. 150 ft. 3½ in. and 121 deg. 22 min. 47 ft. 1½ in. from the northern angle of the said lot 13.

(b) Commencing at a point in allotment 30, section 22, Parish of Moorooduc, distant 157 deg. 55½ min. 40 feet and 289 deg. 59½ min. 16 ft. 2 in. from the north-eastern angle of the said allotment; thence by lines bearing respectively 157 deg. 55½ min. 816 ft. 6½ in., 154 deg. 3½ min. 204 ft. 8 in., 198 deg. 7 min. 23 ft. 9 in., 62 deg. 11½ min. 20 feet, 154 deg. 3½ min. 66 feet, 242 deg. 13 min. 20 feet, 108 deg. 9 min. 27 ft. 10 in., 154 deg. 3½ min. 431 ft. 3 in., 198 deg. 11 min. 28 ft. 8½ in., 62 deg. 18 min. 20 feet, 153 deg. 33 min. 66 ft. 4½ in., 241 deg. 5 min. 20 feet, 107 deg. 19 min. 27 ft. 8 in., 153 deg. 33 min. 191 ft. 2 in., 197 deg. 38 min. 21 ft. 6½ in., 61 deg. 43 min. 15 feet, 153 deg. 33 min. 50 feet, 241 deg. 44 min. 15 feet, 107 deg. 39 min. 20 ft. 10½ in., 153 deg. 33 min. 293 ft. 7½ in., 198 deg. 33 min. 21 ft. 2½ in., 63 deg. 33 min. 15 feet, 153 deg. 33 min. 49 ft. 9 in., 243 deg. 33 min. 15 feet, 108 deg. 33 min. 21 ft. 2½ in., 153 deg. 33 min. 282 feet, 198 deg. 33 min. 21 ft. 2½ in., 63 deg. 33 min. 15 feet, 153 deg. 33 min. 50 feet, 243 deg. 36 min. 15 feet, 108 deg. 36 min. 21 ft. 2½ in., 153 deg. 33 min. 516 ft. 6 in. and 156 deg. 20 min. 54 ft. 10½ in. to a point on the south-eastern boundary of lot 1 on plan of subdivision numbered 16143, lodged in the Office of Titles, and being part of allotment 32, section 22, of the said parish, the said point being distant 50 deg. 51 min. 130 feet from the southern angle of the said lot 1—

which said new alignments are shown on survey plans numbered 6649, 6650, 6651 and 6652, lodged in the office of the Country Roads Board.

Copies of the said survey plans are lodged in the offices of the Country Roads Board, the municipality of the Shire of Mornington, the Registrar of Titles, and the Registrar-General respectively, and may be inspected by any person without a fee at any time at which such offices are open for business.

Dated the thirteenth day of January, 1958.

R. E. V. DONALDSON,  
Secretary.

Country Roads Board, Exhibition Buildings, Rathdown-street, Carlton, N.3.

SALE OF MOTOR CYCLE.

AN owner is required for an A.J.S. motor cycle, engine No. 38/26 6930/A. The motor cycle came into the possession of the Police during January, 1957, and if not claimed will be sold by public auction at the Bendigo Police Station at 2 p.m. on Thursday, 27th February, 1958.

S. H. PORTER,  
Chief Commissioner of Police.



**BENALLA WATERWORKS TRUST.****RATING BY-LAW FOR THE YEAR 1958.**

**T**HE Benalla Waterworks Trust, in pursuance and exercise of the powers conferred by the Water Acts, doth hereby make a rate for the supply of water for domestic purposes of One shilling and three pence in the pound on the annual municipal valuations of lands and tenements liable to be rated within the Benalla Urban District.

Provided that in no case shall the amount of rate payable per annum in respect of any tenement (other than land on which there is no building) be less than Forty shillings, and in respect of land on which there is no building less than Thirty shillings.

Such rates are made and shall be levied upon the occupiers or owners of the said lands and tenements for the year commencing the 1st day of January, 1958, and shall be payable in one sum on the 22nd day of January, 1958, at the office of the said Trust.

The maximum quantity of water to be supplied in any one year without further charge to any property rated by the Trust is hereby fixed at the quantity which, at a charge of One shilling per 1,000 gallons, would produce an amount equal to the amount of the rate levied on such property for the said year.

The charge for water supplied by measure to any property rated by the Trust in excess of such maximum quantity, computed as in the last preceding clause, is hereby fixed at One shilling per 1,000 gallons.

The charge for water supplied by measure to any property shall be payable, on demand, at the office of the said Trust.

Signed and sealed this 16th day of December, 1957.

(SEAL) W. McCALL SAY, Chairman.  
E. STRAUGHAIR, Commissioner.  
D. C. LATCH, Secretary.

Approved, 13th January, 1958.—W. J. MIBUS, Minister of Water Supply.

**GISBORNE WATERWORKS TRUST.****RATING BY-LAW FOR THE YEAR 1958.**

**T**HE Gisborne Waterworks Trust, in pursuance and exercise of the powers conferred by the Water Acts, doth hereby make a rate for the supply of water for domestic purposes of Twenty-one pence in the pound of the annual municipal valuation of lands and tenements within the Gisborne Urban District.

Provided that in no case shall the amount of rate payable per annum in respect of any tenement (other than land on which there is no building) be less than Three pounds, and in respect of any land on which there is no building less than One pound ten shillings.

Such rate is made for the year commencing the 1st day of January, 1958, and shall be payable on the 23rd day of January, 1958, at the office of the said Trust.

The maximum quantity of water to be supplied in any one year without further charge to any property rated by the Trust is hereby fixed at the quantity which, at a charge of Twenty-four pence per 1,000 gallons, would produce an amount equal to the amount of rate levied on such property for the said year.

The charge for water supplied by measure to any property rated by the Trust in excess of such maximum quantity, computed as in the last preceding clause, is hereby fixed at Twenty-four pence per 1,000 gallons.

The charge for water supplied by measure shall be payable, on demand, at the office of the Trust.

Passed this 12th day of December, 1957.

(SEAL) A. MCKIM, Chairman.  
T. RYAN, Commissioner.  
K. V. ROBINSON, Secretary.

Approved, 13th January, 1958.—W. J. MIBUS, Minister of Water Supply.

**LANCEFIELD WATERWORKS TRUST.****RATING BY-LAW FOR THE YEAR 1958.**

**T**HE Lancefield Waterworks Trust, in pursuance and exercise of the powers conferred by the Water Acts, doth hereby make a rate for the supply of water for domestic purposes of Two shillings and nine pence (2s. 9d.) in the pound (£1) of the annual municipal valuation of lands and tenements liable to be rated within the Lancefield Urban District.

Provided that in no case shall the amount of rate payable per annum in respect of any tenement (other than land on which there is no building) be less than Seventy shillings (70s.), and in respect of any land on which there is no building less than Twelve shillings and six pence (12s. 6d.).

Such rates are made and shall be levied upon the occupiers or owners of the said lands and tenements for the year commencing the 1st day of January, 1958, and shall be payable on the 22nd day of January, 1958, at the office of the said Trust.

The maximum quantity of water to be supplied in any one year without further charge to any property rated by the Trust is hereby fixed at the quantity which, at the charge of One shilling per 1,000 gallons, would produce an amount equal to the amount of the rate levied on such property for the said year.

The charge for water supplied by measure to any property rated by the Trust in excess of such maximum quantity, computed as in the last preceding clause, is hereby fixed at One shilling and six pence per 1,000 gallons.

The charge for water supplied by measure shall be payable, on demand, at the office of the Trust.

Dated this 17th day of December, 1957.

(SEAL) WILLIAM J. CHISHOLM, Chairman.  
OWEN MALONE, Secretary.

Approved, 13th January, 1958.—W. J. MIBUS, Minister of Water Supply.

**MALMSBURY WATERWORKS TRUST.****RATING BY-LAW FOR 1958.**

**T**HE Malmsbury Waterworks Trust, in pursuance and exercise of the powers conferred by the Water Acts, doth hereby make and levy a rate for the supply of water for domestic purposes of Twenty-four pence in the pound on the annual municipal valuation of lands and tenements liable to be rated in the Malmsbury Urban District.

Provided that in no case shall the amount payable per annum in respect of any tenement (other than land on which there is no building) be less than Forty shillings.

Such rate is for the year commencing the 1st day of January, 1958, and shall be due and payable at the Town Hall, Malmsbury, on the 23rd day of January, 1958.

Passed this 25th day of November, 1957.

(SEAL) JOSEPH DONOVAN, Chairman.  
S. G. PORTER, Secretary.

Approved, 13th January, 1958.—W. J. MIBUS, Minister of Water Supply.

**PORTLAND WATERWORKS TRUST.****RATING BY-LAW FOR THE YEAR 1958.**

**T**HE Portland Waterworks Trust, in pursuance and exercise of the powers conferred by the Water Acts, doth hereby make a rate for the supply of water for domestic purposes of Ten pence (10d.) in the pound (£1) on the municipal valuation of all lands and tenements liable to be rated within the Portland Urban District.

Such rate is made for the year commencing on the 1st day of January, 1958, and shall be payable in one sum on the 20th day of January, 1958, at the office of the Trust.

The maximum quantity of water to be supplied in any one year without further charge to any property rated by the Trust is hereby fixed at the quantity which, at a charge of One shilling (1s.) per 1,000 gallons, would produce an amount equal to the amount of the rate levied on such property for the said year.

The charge for water supplied by measure to any property rated by the Trust in excess of such maximum quantity, computed as in the last preceding clause, is hereby fixed at One shilling (1s.) per 1,000 gallons, except in cases of special agreement with the Trust.

The charge for water supplied by measure shall be payable, on demand, at the office of the Trust.

Dated this 16th day of December, 1957.

(SEAL) L. MIBUS, Chairman.  
E. NOEL T. HENRY, Secretary.

Approved, 13th January, 1958.—W. J. MIBUS, Minister of Water Supply.

## MURTOA WATERWORKS TRUST.

## RATING BY-LAW FOR THE YEAR 1958.

**T**HE Murtoa Waterworks Trust, in pursuance and exercise of the powers conferred by the Water Acts, doth hereby make a rate for the supply of water for domestic purposes of Fifteen pence in the pound on the annual municipal valuation of lands and tenements liable to be rated within the Murtoa Urban District.

Provided that in no case shall the amount of rate payable per annum in respect of any tenement (other than land on which there is no building) be less than Thirty shillings, and in respect of any land on which there is no building less than Ten shillings.

Such rates are made and shall be levied upon the occupiers or owners of the said lands and tenements for the year commencing the 1st day of January, 1958, and shall be payable on the 15th day of January, 1958, at the office of the said Trust.

The maximum quantity of water to be supplied in any one year without further charge to any property rated by the Trust is hereby fixed at the quantity which, at a charge of Fifteen pence per 1,000 gallons, would produce an amount equal to the amount of the rate levied on such property for the said year.

The charge for water supplied by measure to any property rated by the Trust in excess of such maximum quantity, computed as in the last preceding clause, is hereby fixed at One shilling per 1,000 gallons.

The charge for water supplied by measure shall be payable, on demand, at the office of the Trust.

Dated this 16th day of December, 1957.

S. G. RAE, Chairman.

(SEAL) W. W. SCHODDE, Commissioner.

V. J. EDMONDS, Commissioner.

H. G. CRAM, Secretary.

Approved, 13th January, 1958.—W. J. MIBUS, Minister of Water Supply.

## WEDDERBURN AND KORONG VALE WATER SUPPLY DISTRICTS.

## RATING BY-LAW FOR THE YEAR COMMENCING 1ST OCTOBER, 1957.

**T**HE Council of the Shire of Korong, in pursuance and exercise of the powers conferred by the Water Acts, doth hereby make a rate for the supply of water for domestic purposes of Thirty-six pence in the pound on the annual municipal valuation of lands and tenements liable to be rated within the Wedderburn and Korong Vale Water Supply Districts.

Provided that in no case shall the amount of rate payable per annum in respect of any tenement (other than land on which there is no building) be less than Five pounds, and in respect of land on which there is no building less than Two pounds.

Such rates are made and shall be levied upon the occupiers or owners of the said lands and tenements for the year commencing the 1st day of October, 1957, and ending on the 30th day of September, 1958, and shall be payable on the 22nd day of January, 1958, at the office of the said Council, Wedderburn.

The maximum quantity of water to be supplied in any one year without further charge to any property rated by the Council is hereby fixed at the quantity which, at a charge of One shilling and six pence per 1,000 gallons, would produce an amount equal to the amount of the rate levied on such property for the said year.

The charge for water supplied by measure to any property rated by the Council in excess of maximum quantity, computed as in the last preceding clause, is hereby fixed at One shilling and six pence per 1,000 gallons.

The charge for water supplied by measure shall be payable, on demand, at the office of the Council.

Passed this 22nd day of October, 1957.

S. R. CATTO, President.

(SEAL) E. M. PERRYMAN, Councillor.

A. E. COOPER, Secretary.

Approved, 13th January, 1958.—W. J. MIBUS, Minister of Water Supply.

## BUNINYONG WATERWORKS TRUST.

## AUTHORITY TO OBTAIN A BANK OVERDRAFT.

**H**IS Excellency the Governor of the State of Victoria, by and with the advice of the Executive Council thereof, doth, by Order made on the 14th day of January, 1958, authorize the Buninyong Waterworks Trust to obtain, in pursuance of the provisions of section 271 of the Water Act 1928 (No. 3801) an advance or advances during the year 1958 from the National Bank of Australasia Limited, Ballarat, by overdraft of the Trust's current account thereat, such overdraft not to exceed at any one time the sum of Three hundred pounds (£300).

A. MAHLSTEDT,

Clerk of the Executive Council.

At the Executive Council Chamber,  
Melbourne, 14th January, 1958.

## BOROUGH OF INGLEWOOD.—WATER SUPPLY DISTRICT.

## AUTHORITY TO OBTAIN BANK OVERDRAFT.

**H**IS Excellency the Governor of the State of Victoria, by and with the advice of the Executive Council thereof, doth, by Order made on the 14th day of January, 1958, authorize the Council of the Borough of Inglewood to obtain, in pursuance of the provisions of section 271 of the Water Act 1928 (No. 3801) an advance or advances during the year ending 30th September, 1958, from the Bank of New South Wales, Inglewood, by overdraft of the Council's current account thereat, such overdraft not to exceed at any one time the sum of Five hundred pounds (£500).

A. MAHLSTEDT,

Clerk of the Executive Council.

At the Executive Council Chamber,  
Melbourne, 14th January, 1958.

## CORYYONG WATERWORKS TRUST.

## AUTHORITY TO OBTAIN BANK OVERDRAFT.

**H**IS Excellency the Governor of the State of Victoria, by and with the advice of the Executive Council thereof, doth, by Order made on the 14th day of January, 1958, authorize the Corryong Waterworks Trust to obtain, in pursuance of the provisions of section 271 of the Water Act 1928 (No. 3801), an advance or advances during the year 1958 from the Bank of New South Wales, Corryong, by overdraft of the Trust's current account thereat, such overdraft not to exceed at any one time the sum of One thousand five hundred pounds (£1,500).

A. MAHLSTEDT,

Clerk of the Executive Council.

At the Executive Council Chamber,  
Melbourne, 15th January, 1958.

## WODONGA WATERWORKS TRUST.

## AUTHORITY TO OBTAIN BANK OVERDRAFT.

**H**IS Excellency the Governor of the State of Victoria, by and with the advice of the Executive Council thereof, doth, by Order made on the 14th day of January, 1958, authorize the Wodonga Waterworks Trust to obtain, in pursuance of the provisions of section 271 of the Water Act 1928 (No. 3801), an advance or advances during the year 1958 from the Commercial Banking Company of Sydney Limited, Wodonga, by overdraft of the Trust's current account thereat, such overdraft not to exceed at any one time the sum of Two thousand pounds (£2,000).

A. MAHLSTEDT,

Clerk of the Executive Council.

At the Executive Council Chamber,  
Melbourne, 15th January, 1958.

## BOROUGH ECHUCA WATER TRUST.

## AUTHORITY TO OBTAIN BANK OVERDRAFT.

**H**IS Excellency the Governor of the State of Victoria, by and with the advice of the Executive Council thereof, doth, by Order made on the 14th day of January, 1958, authorize the Borough Echuca Water Trust to obtain, in pursuance of the provisions of section 271 of the Water Act 1928 (No. 3801), an advance or advances during the year 1958 from the Bank of New South Wales, Echuca, by overdraft of the Trust's current account thereat, such overdraft not to exceed at any one time the sum of Two thousand pounds (£2,000).

A. MAHLSTEDT,

Clerk of the Executive Council.

At the Executive Council Chamber,  
Melbourne, 14th January, 1958.

## INVERLOCH WATERWORKS TRUST.

## FIXING THE LIMIT OF A BANK OVERDRAFT.

HIS Excellency the Governor of the State of Victoria, by and with the advice of the Executive Council thereof, doth, by Order made on the 14th day of January, 1958, in pursuance of the provisions of section 273 of the *Water Act 1928* (No. 3801), fix the limit of the overdraft to be obtained by the Inverloch Waterworks Trust from the National Bank of Australasia Limited, Wonthaggi, at an amount not to exceed at any one time the sum of Ten thousand pounds (£10,000).

A. MAHLSTEDT,  
Clerk of the Executive Council.

At the Executive Council Chamber,  
Melbourne, 14th January, 1958.

## LORNE WATERWORKS TRUST.

## FIXING THE LIMIT OF A BANK OVERDRAFT.

HIS Excellency the Governor of the State of Victoria, by and with the advice of the Executive Council thereof, doth, by Order made on the 14th day of January, 1958, in pursuance of the provisions of section 273 of the *Water Act 1928* (No. 3801), fix the limit of the overdraft to be obtained by the Lorne Waterworks Trust from the National Bank of Australasia Limited, Winchelsea, at an amount not to exceed at any one time the sum of Six thousand pounds (£6,000).

A. MAHLSTEDT,  
Clerk of the Executive Council.

At the Executive Council Chamber,  
Melbourne, 14th January, 1958.

## VEGETATION AND VINE DISEASES ACT 1928.

I, THE undersigned, Gilbert Lawrence Chandler, being the responsible Minister of the Crown for the time being administering the *Vegetation and Vine Diseases Act 1928*, in accordance with the provisions of section 9 of the said Act, do hereby appoint the under-mentioned persons to exercise with respect to any land whatsoever in that part of Victoria which lies within the limits of the Central Balliwick of the Supreme Court of Victoria as defined in the Third Schedule to the *Supreme Court Act 1928*, the following powers, that is to say, to enter upon any such land whatsoever at any time with or without assistants to search for diseased trees, plants, or vegetables, and to remain thereon so long as may be reasonable for such purpose—

ALEXANDER, RALPH WILLIAM,  
HURNALL, BRIAN DEAN,  
JACKSON, ARTHUR FREDERICK,  
JEREMIAH, LESLIE ALBERT,  
LENON, JOHN,  
LUMB, JOHN ALBERT.

Given under my hand, at Melbourne, the 23rd day of  
December, 1957.

G. L. CHANDLER,  
Minister of Agriculture.

## VEGETATION AND VINE DISEASES ACT 1928.

I, THE undersigned, Gilbert Lawrence Chandler, being the responsible Minister of the Crown for the time being administering the *Vegetation and Vine Diseases Act 1928*, in accordance with the provisions of section 9 of the said Act, do hereby appoint the under-mentioned persons to exercise with respect to any land whatsoever in that part of Victoria which lies within the limits of the Eastern, Western, Midland, Northern and Southern Balliwicks of the Supreme Court of Victoria as defined in this Third Schedule to the *Supreme Court Act 1928*, the following powers, that is to say, to enter upon any such land whatsoever at any time with or without assistants to search for diseased trees, plants or vegetables, and to remain thereon so long as may be reasonable for such purpose—

ALEXANDER, RALPH WILLIAM,  
HURNALL, BRIAN DEAN,  
JACKSON, ARTHUR FREDERICK,  
JEREMIAH, LESLIE ALBERT,  
LENON, JOHN,  
LUMB, JOHN ALBERT.

Given under my hand, at Melbourne, the 23rd day of  
December, 1957.

G. L. CHANDLER,  
Minister of Agriculture.

*Land Surveyors' Act 1942.*

## SURVEYORS' BOARD OF VICTORIA.

THE Surveyors' Board of Victoria hereby gives notice that the following gentlemen have been granted licences to practise as Surveyors in Victoria, and have been duly registered:—

EDWIN CONRAD CRICHTON LUSK,  
WILLIAM TREVENA,  
RAYMOND GLEN MCCOMB,  
LAURENCE WILLIAM STOTT,  
JOHN ULRICK RANSOM,  
RICHARD FRANCIS COMBER,  
DONALD IAN KIRKPATRICK,  
JAMES ALEX. THOMPSON,  
BRIAN ANTHONY REBBECHI,  
RAYMOND JOSEPH THOMAS NESTOR,

JOHN MALCOLM HORNE,  
RONALD LLOYD STREATFIELD,  
JOHN CHRISTOPHER ARMSTRONG,  
DAVID WILLIAM DOUBLEDAY,  
on the qualifications of the Board's "Certificate of Competency", and  
RICHARD BRIGGS and  
ALFRED RODNEY ASHWORTH,  
on "Letters of Recommendation" from the Survey Board of New South Wales.

By order,

J. B. M. KENNEDY,

Secretary.

Office of the Surveyors' Board,  
Department of Crown Lands and Survey,  
Treasury Buildings, Melbourne, C.2.

*Electric Light and Power Act 1928.*

## ORDERS GRANTED BY THE GOVERNOR IN COUNCIL.

IT is hereby notified that Orders, pursuant to the provisions of the *Electric Light and Power Act 1928* (No. 3672), as hereunder mentioned, have been granted by His Excellency the Governor in Council, viz.:—

Order No. 303.—Order under section 6 of the above-mentioned Act granted to the City of Northcote in respect of land within the City of Brunswick.

Order No. 304.—Order under section 10 of the above-mentioned Act granted to Sidney Francis Block in respect of the Township of Jeparit and environs.

G. O. REID,

Minister of Electrical Undertakings.

State Electricity Commission of Victoria,  
14th January, 1958.

*State Savings Bank Act 1928, Section 31.*

## THE STATE SAVINGS BANK OF VICTORIA.

## ESTABLISHMENT OF BRANCH.

THE Commissioners of the State Savings Bank of Victoria, hereby give notice of their intention to establish a Branch of the Bank at Upper Ferntree Gully on 31st January, 1958.

O. R. CARLSON,  
General Manager.

## APPOINTMENTS.

HIS Excellency the Governor of the State of Victoria, by and with the advice of the Executive Council thereof, has, by Orders made on the 14th day of January, 1958, been pleased to make the under-mentioned appointments, viz.:—

## DEPARTMENT OF WATER SUPPLY.

*Waterworks Trusts Commissioners.*

LACHLAN CAMPBELL MYERS  
to be a Commissioner of the Ballan Waterworks Trust for a period of four years from the date hereof, subject to the provisions of the Water Acts;

COLIN WILLIAM MACGILL  
to be a Commissioner of the Bright Waterworks Trust, and to hold such position during the present term of office of Charles Henry Harrison as a Councillor for the North Riding of the Shire of Bright, subject to the provisions of the Water Acts;

ALBERT JOHN COCKERELL  
to be a Commissioner of the Apollo Bay Waterworks Trust for a period of four years from the date hereof, subject to the provisions of the Water Acts;

CHARLES STANLEY RAYMOND HAWTHORN JAMES to be a Commissioner of the Skipton Waterworks Trust, to hold office as such from the date hereof until the fourth Thursday in the month of October in the year 1960, subject to the provisions of the Water Acts;

LEONARD ABRAM ALLEN to be a Commissioner of the Lorne Waterworks Trust for a period of four years from the date hereof, subject to the provisions of the Water Acts;

JAMES CURTIS to be a Commissioner of the Tatura Waterworks Trust, and to hold such position during the present term of office of John Eamer Downer as a Councillor for the Tatura Riding of the Shire of Rodney, subject to the provisions of the Water Acts; and

ERNEST ALEXANDER RIED to be a Commissioner of the Tallangatta Waterworks Trust for a period of four years from the date hereof, subject to the provisions of the Water Acts.

A. MAHLSTEDT,  
Clerk of the Executive Council.

At Government House,  
Melbourne, 14th January, 1958.

STATE SAVINGS BANK ACT 1928 No. 3777.

At Government House, Melbourne, the  
fourteenth day of January, 1958.

PRESENT:

His Excellency the Governor of Victoria.  
Mr. McArthur | Mr. Porter.  
Mr. Fraser |

IN accordance with the provisions of the *State Savings Bank Act 1928, No. 3777*, His Excellency the Governor of the State of Victoria, by and with the advice of the Executive Council thereof, doth by this Order hereby appoint

WILLIAM LIONEL MOSS  
to be Chairman of the Commissioners of the State Savings Bank of Victoria for the year commencing on the 1st January, 1958.

And the Honorable Henry Edward Bolte, Her Majesty's Treasurer for the State of Victoria, shall give the necessary directions herein accordingly.

A. MAHLSTEDT,  
Clerk of the Executive Council.

FISH CREEK WATERWORKS TRUST.

At Government House, Melbourne, the  
fourteenth day of January, 1958.

PRESENT:

His Excellency the Governor of Victoria.  
Mr. McArthur | Mr. Porter.  
Mr. Fraser |

UNDER the powers conferred by the Water Acts and all other powers enabling him in that behalf, His Excellency the Governor of the State of Victoria, by and with the advice of the Executive Council of the said State, doth hereby approve of the application of the Councillors for the Shire of South Gippsland for the constitution of a Waterworks Trust and for a loan subject to the provisions of the said Acts to carry out works for the supply of water to the township of Fish Creek and doth order and appoint as follows:—

1. The construction of the said waterworks.
2. That the three Councillors for the time being of the West Riding of the Shire of South Gippsland and three other persons shall be Commissioners of the Waterworks Trust.
3. That the amount of loan to be granted to such Trust shall be Twenty-eight thousand pounds (£28,000).
4. That the amount of money which may be borrowed by the Trust pursuant to the *Water Act 1952, No. 5637*, shall not exceed in the whole the sum of Twenty thousand pounds (£20,000).
5. That the limits of the lands within which the said Waterworks Trust shall have authority shall be those within the boundaries in the Schedule hereto.

SCHEDULE.

Site of Reservoir.

The site of the reservoir shall comprise the land occupied by the said reservoir on Battery Creek and adjacent land within Crown Allotments 50 and 51A, Parish of Doomburrin, County of Buln Buln.

Portion II.—Site of Main Pipe Line.

Commencing at a point on the western boundary of Crown Allotment 51A, Parish of Doomburrin, County of Buln Buln, being a point on the site for the Reservoir; thence generally north-westerly by a strip of land 50 links in width being 25 links on either side of the centre-line of the pipeline, through Crown Allotments 51, 80A and 50, across a road, through Crown Allotment 79b, across a road, through Crown Allotment 25, across a road, through Crown Allotments 25 and 26 and across a road to a point on the eastern boundary of the Fish Creek Reticulation Area.

Portion III.—Fish Creek Reticulation Area.

Commencing at the intersection of the south-western boundary of Crown Allotment 24, Parish of Doomburrin, County of Buln Buln, and the southern boundary of a Permanent Reserve on the left bank of Fish Creek; thence south-easterly along the said south-western boundary of Crown Allotment 24 to a point on the northern boundary of the South Eastern Railway Reserve; thence by a line bearing S 60° W, a distance of approximately 530 links across the said South-Eastern Railway Reserve to a point on its southern boundary; thence southerly by a line a distance of approximately 100 links across a road to the intersection of the southern boundary of the said road and the eastern boundary of a C.R.B. main road known as Promontory Road; thence generally southerly along the said eastern boundary of Promontory Road to a point on the south-western boundary of Crown allotment 25 being in line with the north-eastern boundary of lot 32 on lodged plan of subdivision numbered 4473; thence north-westerly by a line across the said Promontory Road to the most north-easterly angle of the said lot 32; thence north-westerly along the said north-eastern boundary of lot 32 to its most northerly angle; thence southerly along the western boundary of the said lot 32 to a point in line with the north-western boundary of lot 23; thence south-westerly by a line across a road to the most northerly angle of the said lot 23; thence south-westerly along the north-western boundary of the said lot 23 to the most easterly angle of lot 22; thence generally north-westerly along the north-eastern boundaries of the said lot 22 and of lots 21 and 20 to the most north-westerly angle of the said lot 20 being a point on the aforesaid southern boundary of a Permanent Reserve on the left bank of Fish Creek; thence generally north-easterly along the said southern boundary of a Permanent Reserve to the point of commencement.

All of which boundaries are shown on plans marked "A" and "B" approved by the Governor in Council and deposited in the office of the State Rivers and Water Supply Commission, Melbourne.—(Corres. 1957/23185.)

6. That the principal works to be constructed or carried out by the Trust shall consist of Reservoir, Main Pipeline, Service Basin and reticulation of the township of Fish Creek.

7. The name of the Trust shall be Fish Creek Waterworks Trust.

And the Honorable Wilfred John Mibus, Her Majesty's Minister of Water Supply for the State of Victoria, shall give the necessary directions herein accordingly.

A. MAHLSTEDT,  
Clerk of the Executive Council.

APOLLO BAY WATERWORKS TRUST.

At Government House, Melbourne, the fourteenth  
day of January, 1958.

PRESENT:

His Excellency the Governor of Victoria.  
Mr. McArthur | Mr. Porter.  
Mr. Fraser |

AMENDMENT OF ORDER.

UNDER the powers conferred by the Water Acts and all other powers enabling him in that behalf, His Excellency the Governor of the State of Victoria, by and with the advice of the Executive Council of the said

State, doth hereby amend as follows the Order in Council constituting the Apollo Bay Waterworks Trust, made on the 15th day of January, 1924 and published in the *Victoria Government Gazette* of the 23rd January, 1924.

In Clause (2) for the words "East Riding" there shall be substituted the words "Apollo Bay Riding".

And the Honorable Wilfred John Mibus, Her Majesty's Minister of Water Supply for the State of Victoria, shall give the necessary directions herein accordingly.

A. MAHLSTEDT,  
Clerk of the Executive Council.

#### BALLARAT WATER COMMISSIONERS.

*At Government House, Melbourne, the fourteenth day of January, 1958.*

PRESENT:

His Excellency the Governor of Victoria.  
Mr. McArthur | Mr. Porter.  
Mr. Fraser

#### ADDITIONAL LOAN OF £16,000.

UNDER the powers conferred by the Water Acts and all other powers enabling him in that behalf, His Excellency the Governor of the State of Victoria, by and with the advice of the Executive Council of the said State, doth hereby grant an additional loan of Sixteen thousand pounds (£16,000) to the Ballarat Water Commissioners for the construction of pipe mains and the purchase and installation of meters as set forth in the detailed statement bearing date the 9th day of January, 1958, and verified under the seal of the State Rivers and Water Supply Commission.

The loan hereby granted shall be subject to the provisions of the Water Acts.

And the Honorable Wilfred John Mibus, Her Majesty's Minister of Water Supply for the State of Victoria, shall give the necessary directions herein accordingly.

A. MAHLSTEDT,  
Clerk of the Executive Council.

#### BENDIGO SEWERAGE AUTHORITY.

*At Government House, Melbourne, the fourteenth day of January, 1958.*

PRESENT:

His Excellency the Governor of Victoria.  
Mr. McArthur | Mr. Porter.  
Mr. Fraser

#### POWER TO BORROW £10,000.

UNDER the powers conferred by the Sewerage Districts Acts and all other powers enabling him in that behalf, His Excellency the Governor of the State of Victoria, by and with the advice of the Executive Council of the said State, doth hereby consent to the Bendigo Sewerage Authority borrowing at interest an additional sum of Ten thousand pounds (£10,000) subject to the provisions of the Sewerage Districts Acts and for the carrying out of works in accordance with the provisions of Sections 91, 126 and 133 of the *Sewerage Districts Act* 1928, No. 3772, the said sum to be borrowed by way of overdraft from the Commonwealth Trading Bank of Australia. All moneys received by the said Authority in repayment of costs and expenses of the said works, or any of them, shall be set aside for the purpose of and applied in repayment of the said sum so borrowed.

And the Honorable Wilfred John Mibus, Her Majesty's Minister of Water Supply for the State of Victoria, shall give the necessary directions herein accordingly.

A. MAHLSTEDT,  
Clerk of the Executive Council.

#### DANDENONG SEWERAGE AUTHORITY.

*At Government House, Melbourne, the fourteenth day of January, 1958.*

PRESENT:

His Excellency the Governor of Victoria.  
Mr. McArthur | Mr. Porter.  
Mr. Fraser

#### CONSENT TO BORROWING £40,000.

UNDER the powers conferred by the Sewerage Districts Acts and all other powers enabling him in that behalf, His Excellency the Governor of the State of Victoria, by and with the advice of the Executive Council of the said State, doth hereby consent to the Dandenong Sewerage Authority borrowing by the issue of debentures, a sum of Forty thousand pounds (£40,000) in two amounts of Fifteen thousand pounds (£15,000) and Twenty-five thousand pounds (£25,000) respectively to meet the cost of sewerage works at Dandenong as set forth in the detailed statement bearing date the 10th day of January, 1958.

And the Honorable Wilfred John Mibus, Her Majesty's Minister of Water Supply for the State of Victoria, shall give the necessary directions herein accordingly.

A. MAHLSTEDT,  
Clerk of the Executive Council.

#### ECHUCA SEWERAGE AUTHORITY.

*At Government House, Melbourne, the fourteenth day of January, 1958.*

PRESENT:

His Excellency the Governor of Victoria.  
Mr. McArthur | Mr. Porter.  
Mr. Fraser

#### CONSENT TO BORROWING £1,000.

UNDER the powers conferred by the Sewerage Districts Acts and all other powers enabling him in that behalf, His Excellency the Governor of the State of Victoria, by and with the advice of the Executive Council of the said State, doth hereby consent to the Echuca Sewerage Authority borrowing, by the issue of debentures, a sum of One thousand pounds (£1,000) to meet the cost of sewerage extensions as set forth in the detailed statement bearing date the 10th day of January, 1958.

And the Honorable Wilfred John Mibus, Her Majesty's Minister of Water Supply for the State of Victoria, shall give the necessary directions herein accordingly.

A. MAHLSTEDT,  
Clerk of the Executive Council.

#### ECHUCA SEWERAGE AUTHORITY.

*At Government House, Melbourne, the fourteenth day of January, 1958.*

PRESENT:

His Excellency the Governor of Victoria.  
Mr. McArthur | Mr. Porter.  
Mr. Fraser

#### AMENDMENT OF ORDER.

UNDER the powers conferred by the Sewerage Districts Acts and all other powers enabling him in that behalf, His Excellency the Governor of the State of Victoria, by and with the advice of the Executive Council of the said State, doth hereby amend as follows the Order in Council proclaiming the Sewerage District and constituting the Echuca Sewerage Authority made the 18th October, 1927, as amended by Orders in Council made the 22nd December, 1939, 29th July, 1952, and 13th March, 1956, and published in the *Victoria Government Gazettes* dated the 26th October, 1927, 29th December, 1939, 6th August, 1952 and 21st March, 1956.

In Clause (a) for the expression "Two thousand pounds (£2,000)" there shall be substituted the expression "Six thousand pounds (£6,000)".

And the Honorable Wilfred John Mibus, Her Majesty's Minister of Water Supply for the State of Victoria, shall give the necessary directions herein accordingly.

A. MAHLSTEDT,  
Clerk of the Executive Council.

#### INVERLOCH WATERWORKS TRUST.

At Government House, Melbourne, the fourteenth day of January, 1958.

##### PRESENT:

His Excellency the Governor of Victoria.  
Mr. McArthur | Mr. Porter.  
Mr. Fraser |

#### AMENDMENT OF ORDER.

UNDER the powers conferred by the Water Acts and all other powers enabling him in that behalf, His Excellency the Governor of the State of Victoria, by and with the advice of the Executive Council of the said State, doth hereby amend as follows the Order in Council consenting to the Inverloch Waterworks Trust borrowing by the issue of debentures the sum of Five thousand pounds (£5,000) made on the 13th day of August, 1957, and published in the *Victoria Government Gazette* of the 14th October, 1957.

For the expression "bearing interest at the rate of 55 per centum per annum" there shall be substituted the expression "bearing interest at the rate of 55 10s. per centum per annum".

And the Honorable Wilfred John Mibus, Her Majesty's Minister of Water Supply for the State of Victoria, shall give the necessary directions herein accordingly.

A. MAHLSTEDT,  
Clerk of the Executive Council.

#### LORNE WATERWORKS TRUST.

At Government House, Melbourne, the fourteenth day of January, 1958.

##### PRESENT:

His Excellency the Governor of Victoria.  
Mr. McArthur | Mr. Porter.  
Mr. Fraser |

#### REPEAL OF ORDERS.

UNDER the powers conferred by the Water Acts and all other powers enabling him in that behalf, His Excellency the Governor of the State of Victoria, by and with the advice of the Executive Council of the said State, doth hereby repeal the Orders made by the Governor in Council on the 26th March, 1935, 31st May, 1938 and 16th July, 1940, fixing the limit of the overdraft to be obtained by the Lorne Waterworks Trust from the National Bank of Australasia Limited, Winchelsea, at Five hundred pounds (£500), Six hundred pounds (£600) and One thousand five hundred pounds (£1,500) respectively.

And as on and from the date hereof the said Orders of the Governor in Council shall be deemed to be repealed accordingly.

And the Honorable Wilfred John Mibus, Her Majesty's Minister of Water Supply for the State of Victoria, shall give the necessary directions herein accordingly.

A. MAHLSTEDT,  
Clerk of the Executive Council.

#### APPROACHING LAND SALES.

SALES of Crown lands, in fee-simple, will be held at the under-mentioned places and dates, viz:—

	No. of Gazette
Ballarat.—Tuesday, 18th February, 1958	3
Colac.—Wednesday, 22nd January, 1958	268
Dandenong.—Thursday, 30th January, 1958	269
Foster.—Tuesday, 4th February, 1958	269
Melbourne.—Wednesday, 19th February, 1958	3
Minyip.—Tuesday, 4th February, 1958	269
Stawell.—Wednesday, 22nd January, 1958	268
Warracknabeal.—Tuesday, 4th February, 1958	269
Warragul.—Wednesday, 12th February, 1958	1
Wonthaggi.—Friday, 24th January, 1958	269

#### SALES OF CROWN LANDS BY AUCTION.

The lands will be sold in fee-simple, and subject to the covenants, conditions, exceptions, and reservations directed by the Governor in Council by an Order in Council dated the 5th August, 1930, and published in the *Government Gazette* of the 8th August, 1930, varied as herein.

A deposit of at least twelve and a half per centum of the price at which each lot is sold must be paid by the purchaser at the time of sale, and all such payments shall be made in coin, bank notes or cheques approved by the officer conducting the sale, and the residue of such price will be payable in equal instalments, in accordance with the scale hereunder, on the last day of each successive period of six months from the time of sale, or, if the purchaser choose, at any earlier time or times; and such residue of the purchase money shall bear interest at the rate of Five pounds per centum per annum, to be computed with respect to each instalment for the period which has elapsed between the time of sale and the time of the payment of such instalment. If the residue of the price be paid within thirty days after the time of the sale no interest will be payable thereon.

The Governor in Council may allow a transfer of the purchaser's interest to an approved person at any time before the final payment of the purchase money is made. The fee for transfer shall be One pound and such transfer will be subject to payment of stamp duty.

#### SCALE OF PAYMENTS OF RESIDUE.

£20 and under, 6 instalments.
Over £20, and not exceeding £50, 8 instalments.
Over £50, and not exceeding £100, 10 instalments.
Over £100, and not exceeding £200, 12 instalments.
Over £200, and not exceeding £300, 14 instalments.
Over £300, and not exceeding £400, 16 instalments.
Over £400, and not exceeding £500, 18 instalments.
Over £500, 20 instalments.

#### FEES, ETC.

The amount payable for Assurance Fund (One halfpenny for each £1 of purchase price) and Crown grant fee must be paid with the balance of purchase money. The following is the scale of fees for Crown grants:—

50 acres and under, £1 10s.
Over 50 acres, £2.
Where the purchase money does not exceed £5, the grant fee is £1.

Valuations of improvements (if not purchased by the owner thereof), and charges for survey, must also be paid at the time of sale.

#### KEITH TURNBULL,

Commissioner of Crown Lands and Survey.  
Office of Crown Lands and Survey,  
Melbourne, 13th January, 1958.

**BALLARAT.**—Sale (No. 11329) of Crown lands, in fee-simple, by auction, will be held at the LAND OFFICE, BALLARAT, on TUESDAY, the 18th FEBRUARY, 1958, at a quarter-past TWO o'clock p.m. To be conducted by H. H. DODD, Land Officer.

BALLARAT EAST, PARISH OF BALLARAT, COUNTY OF GRANT.  
*In the South-east of Township.*

Upset price £70 the lot. Charge for survey £7 7s. 6d.

Lot 1. Area 3 acres (subject to survey and any necessary easements disclosed thereby), allotment 3 of section 128. Subject to drainage easement 25 links wide. One month allowed for removal of improvements.

*Fronting Fussell-street.*

Upset price £60 the lot. Charge for survey £5 5s.

Lot 2. Area 37 5/10 perches, allotment 12D of section 12B.

## LINTON, PARISH OF ARGYLE, COUNTY OF GRENVILLE.

*In the north of the Township.*

Upset price £25 the lot. Charge for survey £5 15s.

Lot 3. Area 3 roods (subject to survey and any necessary easements disclosed thereby), allotment A12. One month allowed for removal of improvements.

*Frontages to Gillespie, Adair and York streets.*

Upset price £20 the lot. Charge for survey £5 15s.

Lot 4. Area 2r. 17 6/10p., allotments 7 and 8 of section 12. One month allowed for removal of improvements.

## CRESWICK, PARISH OF CRESWICK, COUNTY OF TALBOT.

*Fronting Gardiner-street.*

Upset price £65 the lot. Charge for survey £5 15s.

Lot 5. Area 3r. 27 6/10p. (subject to remarking of survey), allotment 20 of section 50A. Valuation of improvements, £2,045 (David Smith).

## CLUNES, PARISH OF CLUNES, COUNTY OF TALBOT.

*In the North-west of the Township.*

Upset price £25 per lot. Charge for survey £5 10s. per lot.

Lot 6. Area 1r. 18p. (subject to survey and any necessary easements disclosed thereby), allotment 6 of section A. One month allowed for removal of improvements.

Lot 7. Area 1r. 18p. (subject to survey and any necessary easements disclosed thereby), allotment 6A of section A. One month allowed for removal of improvements.

## EGERTON, PARISH OF BUNGAL, COUNTY OF GRANT.

*Fronting Main-street: In the North of the Township.*

Upset price £30 the lot. Charge for survey £6 12s. 6d.

Lot 8. Area 3r. 16 4/10p. (subject to survey and any necessary easements disclosed thereby), allotment 4 of section 2. Valuation of improvements, £52 10s. fencing (Education Department).

## PARISH OF CARNGHAM, COUNTY OF GRENVILLE AT SNAKE VALLEY.

Upset price £25 the lot. Charge for survey £6 2s. 6d.

Lot 9. Area 2a. 0r. 6p. (subject to survey and any necessary easements disclosed thereby), allotment 44A of section 15. Valuation of improvements, £100 (D. M. Kelly).

Upset price £20 the lot. Charge for survey £5 15s.

Lot 10. Area 3r. 12p. (subject to survey and any necessary easements disclosed thereby), allotment 44B of section 15. One month allowed for removal of improvements.

**MELBOURNE.**—Sale (No. 11330) of Crown lands in fee-simple, by auction will be held at the BOARD ROOM, ROOM No. 10, GROUND FLOOR, TEMPLE COURT, 422 COLLINS-STREET, MELBOURNE, on WEDNESDAY, the 19th FEBRUARY, 1958, at half-past TEN o'clock a.m. To be conducted by C. E. RICE, Land Officer. Auctioneers: BAILLIEU, ALLARD PTY. LTD., 360 Collins-street, Melbourne.

## MACEDON, PARISH OF MACEDON, COUNTY OF BOURKE.

*About 1 mile West of Macedon Railway Station, and about 250 yards East of Calder Highway.*

Upset price £30 per lot. Charge for survey £6 10s. per lot.

Lot 1. Area 1r. 9p., allotment 8 of section 70.

Lot 2. Area 1r. 10p., allotment 9 of section 70.

Note.—The allotment numbers for lots 1 and 2 refer to a recent survey of section 70 and do not accord with the current lithographic plan.

## WARRANTYTE, PARISH OF WARRANTYTE, COUNTY OF EVELYN.

Upset price £100 per lot. Charge for survey £6 per lot.

*Fronting East side of Whipstick Gully.*

Lot 3. Area 31 perches, allotment 22 of section 4.

*Fronting East side of Whipstick Gully at Corner of Brackenbury-street.*

Lot 4. Area 33 perches, allotment 23 of section 4.

*Fronting West side of Magpie-road, at Corner of Mitchell-avenue.*

Upset price £75 the lot. Charge for survey £6 10s.

Lot 5. Area 1r. 18p. (subject to review), allotment 6D of section 15.

*Fronting East side of Magpie-road, South of Brackenbury-street.*

Upset price £100 the lot. Charge for survey £6 10s.

Lot 6. Area 1r. 4p. (subject to review), allotment 24 of section 17.

## KINGLAKE WEST, PARISH OF KINGLAKE, COUNTY OF ANGLESEY.

*Fronting unnamed Government roads. From 100 to 300 yards North of Whittlesea-Kinglake-road.*

Upset price £30 per lot. Charge for survey £8 per lot.

Lot 7. Area 1a. 0r. 13p. (subject to review), allotment 21 of section B.

Lot 8. Area 1a. 1r. 5p. (subject to review), allotment 22 of section B.

Upset price £30 per lot. Charge for survey £7 10s. per lot.

Lot 9. Area 1 acre (subject to review), allotment 23 of section B.

Lot 10. Area 1 acre (subject to review), allotment 24 of section B.

Lot 11. Area 1 acre (subject to review), allotment 25 of section B.

Lot 12. Area 1 acre (subject to review), allotment 26 of section B.

Lot 13. Area 1 acre (subject to review), allotment 27 of section B.

Upset price £30 the lot. Charge for survey £8.

Lot 14. Area 1a. 0r. 22p. (subject to review), allotment 28 of section B.

## PARISH OF TARRAWARRA NORTH, COUNTY OF EVELYN.

*About 1 mile along Toolangi-road from Dixon's Creek Post Office, thence 1 mile East across Paul's Creek.*

Upset price £75 the lot. Charge for survey £12 5s.

Lot 15. Area 20 acres (subject to survey and any necessary easements disclosed thereby), allotment 51A.

Upset price £60 the lot. Charge for survey £12 5s.

Lot 16. Area 13 acres (subject to survey and any necessary easements disclosed thereby), allotment 51B.

## PARISH OF TYABB, COUNTY OF MORNINGTON.

*About 4 miles East of Somerville and about 2 miles South of Pearcedale.*

Upset price £85 the lot. Charge for survey £13 12s. 6d.

Lot 17. Area 24a. 0r. 4p. (subject to survey and any necessary easements disclosed thereby), allotment 28N.

## PROPOSED REVOCATIONS OF TEMPORARY RESERVATIONS OF LANDS BY ORDERS IN COUNCIL.

IN pursuance of the provisions of the *Land Act 1928*, notice is hereby given that it is the intention of the Governor in Council to revoke the temporary reservations of lands by Orders in Council hereunder referred to, viz.:—

*The following Notices were published 1<sup>o</sup> on the 18th December, 1957, pursuant to Orders of the 10th December, 1957.*

**BERROOK.**—The temporary reservations, by Orders in Council of the 11th June, 1940, and the 11th March, 1941, of 5,848 acres 3 roods 12 perches and 3,656 acres 0 roods 10 perches, respectively, of land in the Parish of Berrook, as sites for the Growth of Timber for the purpose of the manufacture or production of eucalyptus oil.—(B.784(1) (09675/141; Rs.5183).

**ELMORE.**—The temporary reservation, by Order in Council of the 16th December, 1913, of 5 acres of land in the Township of Elmore, as a site for a Market.—(E.38(5) (Rs.921).

**SWAN HILL.**—The temporary reservation, by Order in Council of the 29th July, 1940, of 3 roods 26 perches of land in the Township of Swan Hill, as a site for Public Gardens.—(S.464(5) (Rs.5065).

**RICH AVON WEST.**—The temporary reservation, as a site for Affording Access to Water, and the withholding from sale, leasing and licensing, by Order in Council of the 25th August, 1879, of 140 acres, more or less, of land in the Parish of Rich Avon West, situate in section D, revoked as to part by various Orders, so far as the balance thereof, containing 136 acres 22 perches, is concerned.—(R.75(3) (Rs.1664).

**GELLIBRAND.**—The temporary reservation, by Order in Council of the 26th October, 1928, of 10 acres of land in the Township of Gellibrand, as a site for Public Recreation, so far only as the portion containing 2 acres 0 roods 6 perches, indicated by hachure on plan hereunder, is concerned.—(G.237(2) (Rs.3772).

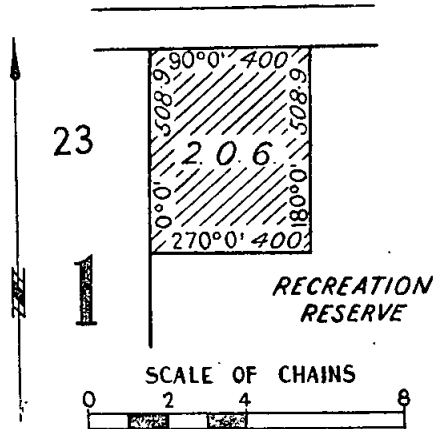

**MARONG.**—The temporary reservation, by Order in Council of the 12th August, 1935, of 312 acres of land in the Parish of Marong, as a site for the Growth of Timber for the purpose of the manufacture or production of eucalyptus oil, so far only as the two separate portions containing 23 acres 3 roods 10 perches, more or less, indicated by hachure on plan hereunder, are concerned.—(M.32(5) (0352/141).

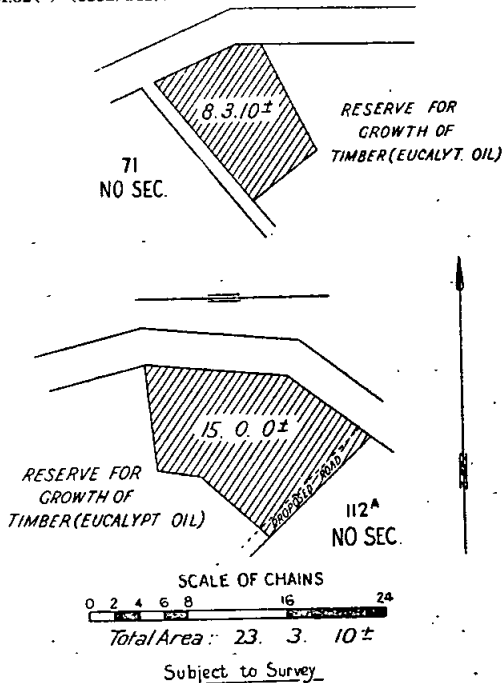

**MILDURA.**—The temporary reservation, by Order in Council of the 10th October, 1932, of 498 acres, more or less, of land in the Parish of Mildura, as a site for Public

Recreation, so far only as the portion containing 12 acres 1 rood 12 perches, indicated by hachure on plan hereunder, is concerned.—(M.556(11) (Rs.4244).

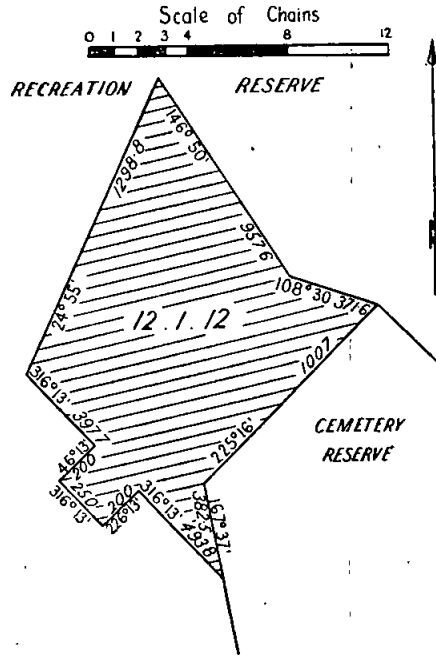

KEITH TURNBULL,  
Commissioner of Crown Lands and Survey.

**PROPOSED REVOCATIONS OF TEMPORARY RESERVATIONS OF LANDS BY ORDERS IN COUNCIL.**

IN pursuance of the provisions of the Land Act 1928, notice is hereby given that it is the intention of the Governor in Council to revoke the temporary reservations of lands by Orders in Council hereunder referred to, viz:—

The following Notices were published 1<sup>o</sup> on the 11th December, 1957, pursuant to Orders of the 3rd December, 1957.

**BARRAKEE.**—The temporary reservation, by Order in Council of the 21st October, 1941, of 236 acres 10 perches of land in the Parish of Barrakee as a site for the Growth of Timber for the purpose of the manufacture or production of eucalyptus oil, so far only as the portion containing 70 acres 2 roods 13 perches, indicated by hachure on plan hereunder, is concerned.—(B.662(4) (0170/141).

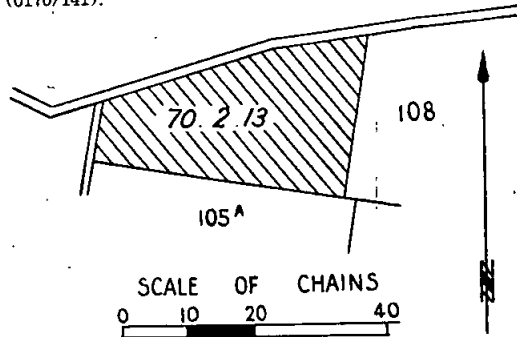

**TIMBOON.**—The temporary reservation, by Order in Council of the 30th September, 1889, of 125 acres, more or less, of land in the Parish of Timboon as a site for Public purposes, revoked as to part by various Orders, so



far only as the portion containing 4 acres 2 roods 17 perches, indicated by hachure on plan hereunder, is concerned.—(T.182(?) (Rs.2617).

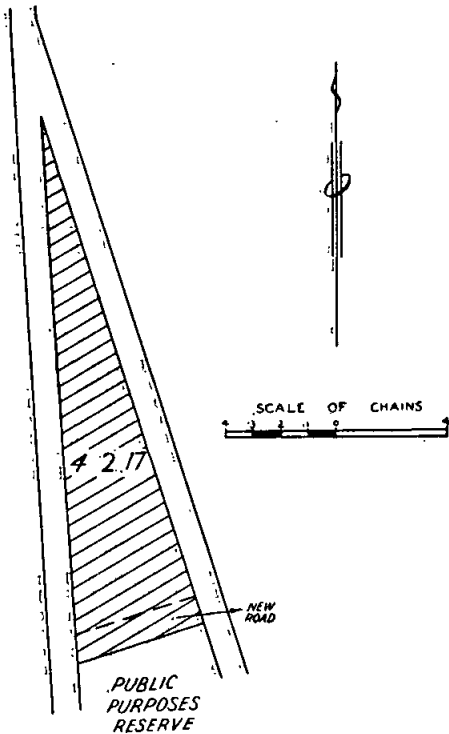

KEITH TURNBULL,  
Commissioner of Crown Lands and Survey.

**PROPOSED REVOCATIONS OF TEMPORARY RESERVATIONS OF LANDS BY ORDERS IN COUNCIL.**

IN pursuance of the provisions of the Land Act 1928, notice is hereby given that it is the intention of the Governor in Council to revoke the temporary reservations of lands by Orders in Council hereunder referred to, viz.:

The following Notices were published 1° on the 8th January, 1958, pursuant to Orders of the 18th December, 1957.

**MUNTHAM.**—The temporary reservation, by Order in Council of the 20th January, 1914, of 1 acre, 3 roods 10 8/10 perches of land in the Parish of Muntham as a site for a State School, is about to be revoked.—(M.288<sup>(s)</sup>) (Rs.2599).

**MARYBOROUGH.**—The temporary reservation, by Order in Council of the 16th October, 1888, of 10 acres 20 6/10 perches of land in the Township of Maryborough as a site for Drainage purposes, revoked as to part by various Orders, so far only as the portion containing 1 rood 5 perches, indicated by hachure on plan hereunder, is concerned.—(M.66<sup>(1b)</sup>) (Rs.2292).

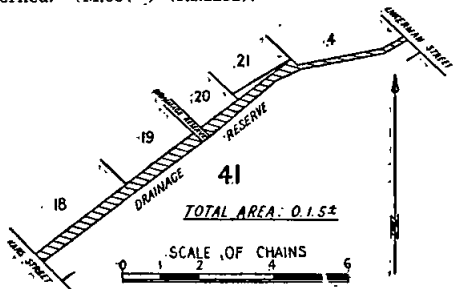

**BENDIGO (WHITE HILLS).**—The temporary reservation, by Order in Council of the 17th January, 1872 (see Government Gazette of the 26th January, 1872, page 187), of 1 acre of land at Bendigo, Parish of Sandhurst, as a

site for Police purposes, so far only as the portion containing 2 roods, indicated by hachure on plan hereunder, is concerned.—(S.372<sup>(ss)</sup>) (C.93654).

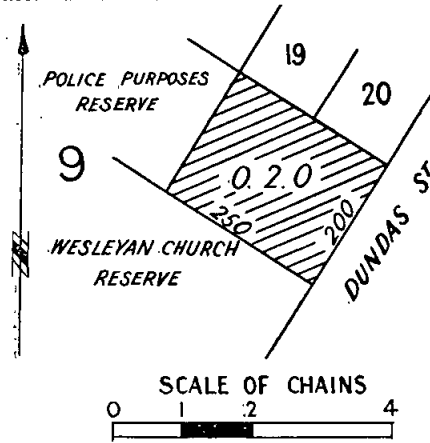

Subject to Survey

KEITH TURNBULL,  
Commissioner of Crown Lands and Survey.

**COMMON ABOUT TO BE DIMINISHED.**

IN pursuance of the provisions contained in the Land Act 1928, notice is hereby given that it is the intention of the Governor in Council to diminish the common hereinafter mentioned, viz.:

The following Notice was published 1° on the 11th December, 1957, pursuant to Order of the 3rd December, 1957.

The Maldon Shire Common, proclaimed as such by the Governor in Council on the 2nd April, 1889, and altered by Order in Council of the 23rd April, 1912, is about to be diminished by the excision therefrom of—

- (1) allotment 15A, section 3, Parish of Maldon, containing 2 acres 3 roods 21 perches;
- (2) the portion in the Parish of Maldon indicated by hachure on plan hereunder.

**TOWNSHIP OF MALDON**

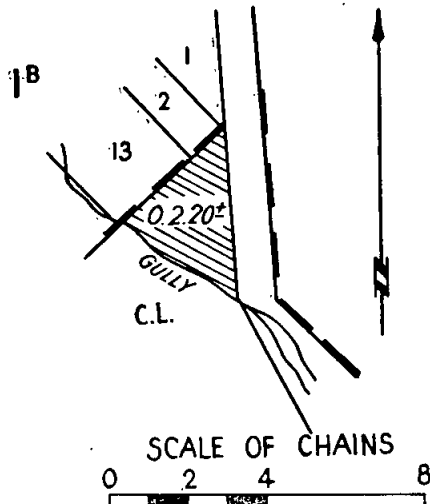

KEITH TURNBULL,  
Commissioner of Crown Lands and Survey.

## COMMITTEES OF MANAGEMENT OF RESERVES.

## APPOINTMENTS.

WHEREAS by section 184 of the *Land Act* 1928 it is provided that it shall be lawful for the Governor in Council or the Board of Land and Works to appoint and remove any number of persons, not less than three, or any municipal council, or the governing body of any corporation, to be a Committee of Management of any specified Crown land reserved either temporarily or permanently for any of the purposes set out in section 14 of the *Land Act* 1928, and not conveyed to or vested in trustees: Now therefore the Board of Land and Works doth hereby appoint the under-mentioned persons to be members of the Committee of Management of the Reserves named:—

## "HAMILTON SHOW GROUNDS RESERVE."

Harold Douglas Young, Andrew Garfield Gardner, and Eric McMurrich Philip as the Committee of Management for a period of three (3) years of the lands in municipal district of Hamilton temporarily reserved by Orders in Council dated 24th April, 1883, and 16th April, 1889, as a site for the Hamilton Pastoral and Agricultural Society's Show Yards and known as "Hamilton Show Grounds Reserve."—(Corres. Rs.3575.)

## "DRY HOLE RECREATION RESERVE."

Basl Leslie Downes, Hugh Percival Pedrazzi, Clarence Walter Atwell, and Leslie Stephen Holmes as a Committee of Management for a period of three (3) years of the land temporarily reserved by Order in Council of 5th October, 1948, as a site for Watering purposes and Public Recreation in the Parish of Gorae, and known as the "Dry Hole Recreation Reserve."—(Corres. Rs.5145.)

## "LANDSBOROUGH MEMORIAL PARK."

Owen Charles Friend, as a member of the Committee of Management for the period ending 11th February, 1960, of the land temporarily reserved by Order in Council dated the 23rd August, 1875, as a site for Recreation purposes in the Township of Landsborough, in the place of John William Hodgetts, deceased.—(Corres. Rs.1230.)

## "LANDSBOROUGH RACECOURSE RESERVE."

William Aston, Maurice Gilbert Davies, John Friend, Owen Charles Friend, Maurice Hodgetts, William Webb Hodgetts, Charles Peacock, Charles J. Turner, and Arthur J. Vance as a Committee of Management for a period of three (3) years of the land temporarily reserved by Orders in Council dated 19th November, 1866, and 10th March, 1903, as sites for a Racecourse in the Parish of Landsborough, and known as the "Landsborough Racecourse Reserve."—(Corres. Rs.646.)

## "ROCHESTER RECREATION RESERVE."

The Council for the Shire of Rochester as the Committee of Management of the land temporarily reserved as a site for Public Recreation in the Township of Rochester by Order in Council dated 10th December, 1957, and known as the "Rochester Recreation Reserve."—(Corres. Rs.2207.)

## "YENDON RECREATION RESERVE."

Norman Thomas Carbury, Roy William Harrison, Bernard Vincent Challis, Leslie Herbert Trigg, Alexander John Walker, John Spruce, and George J. Ryan as a Committee of Management for a period of three (3) years of the land temporarily reserved by Order in Council dated the 21st October, 1872, as a site for Recreation purposes and Cricket Ground in the Town of Buninyong East (now Township of Yendon), and known as the "Yendon Recreation Reserve."—(Corres. Rs.5326.)

## "MAFFRA MUNICIPAL DEPOT."

The Council of the Shire of Maffra as a Committee of Management of the land temporarily reserved as a site for a Municipal Depot by Order in Council dated 10th December, 1957, in the Township of Maffra, Parish of Maffra.—(Corres. Rs.7681.)

## "MAFFRA CHILDREN'S PLAYGROUND."

The Council of the Shire of Maffra as a Committee of Management of the land temporarily reserved as a site for a Children's Playground by Order in Council dated 10th December, 1957, in the Township of Maffra, Parish of Maffra.—(Corres. Rs.2000.)

## "BESSIEBELLE SWIMMING POOL RESERVE."

John Vernon Leaver, Thomas James William Lindsey, and Garth Ray Kelly as a Committee of Management for a period of three (3) years of the Crown land temporarily reserved by Order in Council of 16th July, 1957, as a site for a Swimming Pool situated in the Parish of Broadwater, and known as the "Bessie Belle Swimming Pool."—(Corres. Rs.7645.)

## "BARKER'S CREEK RECREATION RESERVE."

Ronald Edward Pritchard, Thomas Joseph Felstead, and Jeffrey Fredrick Pritchard as the Committee of Management for a period of three (3) years of the land temporarily reserved by Order in Council dated the 29th January, 1889, as a site for Cricket and other purposes of Public Recreation in the Parish of Castlemaine, and known as the "Barker's Creek Recreation Reserve."—(Corres. Rs.3082.)

## "VICTORIA PARK," INVERLEIGH.

John McNaughton, Harold Cecil Hutchins, John Ernest Henry Lubcke, Ian McLean Smyth, Eric T. Peel, Robert Stanley McMillan, and Ivan George Bath as a Committee of Management for a period of three (3) years of the land temporarily reserved by Order in Council dated 27th February, 1900, as a site for a Public Park in the Town of Inverleigh, and known as "Victoria Park."—(Corres. Rs.2141.)

## "BOOLITE PUBLIC RECREATION AND PUBLIC HALL RESERVE."

Ernst Oswald Kelm, Luis Carl Tegelhuter, and Gordon Edward Habel as the Committee of Management for a period of three (3) years from 18th December, 1957, of the land temporarily reserved by Orders in Council dated 26th May, 1902, and 7th September, 1948, as a site for Public Recreation and a Public Hall in the Parish of Dunmunkle, and known as the "Boollite Public Recreation and Public Hall Reserve."—(Corres. Rs.6221.)

## "WHITTLESEA PUBLIC PARK RESERVE."

Reginald Norman Bryson and Charles McDonald as members of the Committee of Management for a period of three (3) years of that portion of the land reserved as a site for a Public Park in the Parish of Toorourrong, at Whittlesea, and that portion of the permanent reservation along the Plenty River, both of which are indicated in yellow and blue colours respectively on plan marked W.A./3.8.39 attached to Lands Department Correspondence Rs.2111, and known as the "Whittlesea Public Park Reserve."—(Corres. Rs.2111.)

## "LLOYD PARK," LANGWARRIN.

Erling Harold Jondahl, Douglas William Nisbet, Albert Edward Hillier Webb, B. J. Bren, Roy Percy Hutton, William John Bosse, H. L. Lloyd, Herbert Edward Murray, and Thomas Reuben Turner as a Committee of Management for a period of three (3) years of the remaining portion of the area in the Parish of Langwarrin reserved as a site for a Public Park and other purposes of Public Recreation by Order in Council dated 27th August, 1907, and also of the area in the said parish reserved for such purposes by Order in Council dated 29th January, 1946, both of which areas are together known as "Lloyd Park."—(Corres. Rs.3660.)

In witness whereof the common seal of the Board of Land and Works was hereunto affixed this ninth day of January, One thousand nine hundred and fifty-eight, in the presence of—

(SEAL)

KEITH TURNBULL, President.  
W. T. LONG, Member.

COMMITTEES OF MANAGEMENT OF RESERVES.  
APPOINTMENTS.

WHEREAS by section 184 of the *Land Act 1928* it is provided that it shall be lawful for the Governor in Council or the Board of Land and Works to appoint and remove any number of persons, not less than three, or any municipal council, or the governing body of any corporation, to be a Committee of Management of any specified Crown land reserved either temporarily or permanently for any of the purposes set out in section 14 of the *Land Act 1928*, and not conveyed to or vested in trustees: Now therefore the Board of Land and Works doth hereby appoint the under-mentioned persons to be members of the Committee of Management of the Reserves named:—

"LAANECOORIE MECHANICS' INSTITUTE AND FREE LIBRARY RESERVE."

Allen Brownbill, Roy Cain, Ernest James Hallett, Horace D. Grimmett, Charles E. Cornwall, Aubrey J. R. Jarry, and Jack Galloway as a Committee of Management for a period of three (3) years of the land temporarily reserved by Order in Council dated the 20th September, 1890, as an extension of the Mechanics' Institute and Free Library Reserve in the Township of Laanecoorie, Parish of Laanecoorie.—(Corres. Rs.7668.)

"DUNKELD MEMORIAL PARK" AND "DUNKELD TOURIST CAMPING RESERVE."

Keith James Crawford, John Stanley Brudenell Young Woodburn, and Kenneth Sleeman (for a period of three (3) years), Reuben George Schache, Donald Stewart Gale, and Ernest John Baxter (for so long only as they continue to be members of and the elect of the Dunkeld Development League), and Charles Thomas Rochfort (for so long only as he continues to be a Councillor and the elect of the Council of the Shire of Mount Rouse) as a Committee of Management of the land in the Township of Dunkeld temporarily reserved as a site for Public Recreation and Gardens by Order in Council dated 19th October, 1954, and known as the "Dunkeld Memorial Park," and also of the land in the Parish of Dunkeld temporarily reserved as a site for Tourist Camping purposes by Order in Council of the same date, and known as the "Dunkeld Tourist Camping Reserve."—(Corres. Rs.7171, Rs.7179.)

"OCEAN GROVE FORESHORE RESERVE."

Reginald Guyett, Gilbert McKeown, Allan Ray, John Parkes, Frederick Gray, Trevor Smith, and E. Scott Inglis as a Committee of Management for a period of three (3) years of such portions of the Reserve for Public purposes in the Parish of Bellarine as are indicated by red colour on plans marked B.25/9/29 and B.16/1/35 with Lands Department correspondence Rs.3922, and of the land temporarily reserved by Order in Council dated 21st March, 1939, as a site for Public purposes in the Parish of Bellarine, all of which lands are together known as the "Ocean Grove Foreshore Reserve."—(Corres. Rs.3922.)

"COLBINABBIN RECREATION RESERVE."

Norman David Wright, Malcolm Gregory Hill, Keith Stewart Vickers, Leslie Murray Weeks, Clement Bertrand Hill, Edward Stanley Weppner, Finlay Starritt Rathjen, David Robert Andrew and John Henry Pook as a Committee of Management for a period of three (3) years from 17th December, 1957, of the land temporarily reserved by Order in Council dated 16th December, 1907, as a site for Public Recreation in the Parish of Colbinabbin and known as the "Colbinabbin Recreation Reserve."—(Corres. Rs.660.)

"WANGARATTA RACECOURSE RESERVE."

Martin Joseph Seymour, Joseph McDonnell, Harry Johnstone Hoysted, John Michael de Vins Purbrick, Arthur Crawford Callander, Vincent Joseph McKenna and Raymond Carlyle Parkinson as a Committee of Management for a period of three (3) years from 17th December, 1957, of the land temporarily reserved by Order in Council dated 8th October, 1907, as a site for a Racecourse and other purposes of Public Recreation in the Parish of Wangaratta South and known as the "Wangaratta Racecourse Reserve."—(Corres. Rs.1886.)

"CASTLEMAINE RECREATION RESERVE."

The Council of the Town of Castlemaine as a Committee of Management of the land in the Parish of Castlemaine temporarily reserved by Order in Council of 3rd December, 1957, in addition to and adjoining the site temporarily

reserved by Order in Council of 13th March, 1957, and together known as the "Castlemaine Recreation Reserve."—(Corres. Rs.4654.)

In witness whereof the common seal of the Board of Land and Works was hereunto affixed this eighteenth day of December, One thousand nine hundred and fifty-seven, in the presence of—

(SEAL) KEITH TURNBULL, President.  
W. T. LONG, Member.

COMMITTEE OF MANAGEMENT OF CERTAIN CROWN RESERVES IN THE NOOJEE DISTRICT.

WHEREAS by section 184 of the *Land Act 1928* it is provided that it shall be lawful for the Governor in Council or the Board of Land and Works to appoint any number of persons not less than three or any municipal council or the governing body of any corporation, to be a Committee of Management of any specified Crown land reserved either temporarily or permanently for any of the purposes set out in section 14 of the *Land Act 1928*, and not conveyed to or vested in trustees, and to remove any or all of the persons so appointed, or revoke the appointment of any such council or body: Now therefore, the Board of Land and Works doth hereby appoint:—

Andrew John Costin, Ronald George Costin, Arthur John Walsh, Sydney Marcus Fox, Ralph Henry Cornwall, Charles William Triffitt, Walter Scott, William George Moule, Harry Christian, Edmund Cornwall, William Whitmore Carlisle Carter, Leslie Grafton Turner and Charles Ernest Wilson as a Committee of Management, for a period of three (3) years from 21st December, 1957, of the under-mentioned reserves:—

1. Such portions of the frontages along both sides of the Latrobe and Toorong Rivers in the Parishes of Neerim, Noojee East and Fumina as are indicated by red colour on plan marked N.E./5.10.22 attached to Lands Department correspondence Rs.2952, and known as "Toorong Valley Reserve."

2. Such portions of the frontages along both sides of the Latrobe and Loch Rivers in the Parishes of Neerim and Noojee East as are indicated by red colour on plan marked N.E./4.10.22 attached to Lands Department correspondence Rs.3630, also the remaining portion of the land in the Township of Noojee, temporarily reserved as a site for Public purposes by Order in Council dated 21st February, 1928, and known as the "Loch Valley Reserve" and the "Noojee Camping Park."—(Corres. Rs.3630.)

3. The lands temporarily reserved by Orders in Council dated 20th January, 1923, as a site for Recreation purposes, and 20th May, 1927, as a site for Public Recreation, in the Township of Noojee, Parish of Neerim, and known as the "Noojee Recreation Reserve."—(Corres. Rs.2660.)

4. The land in the Parish of Noojee temporarily reserved as a site for Public purposes by Order in Council dated 16th May, 1911, and known as the "Myrtle Bower Reserve."—(Corres. Rs.3834.)

5. The land in the Parish of Noojee East temporarily reserved as a site for Public Recreation by Order in Council dated 10th August, 1914, and the land in the said Parish, temporarily reserved as a site for Public purposes by Order in Council dated 24th February, 1915, and together known as the "Loch Valley Recreation Reserve."—(Corres. Rs.1264, Rs.214.)

6. The land in the Parish of Noojee East temporarily reserved as a site for Public purposes by Order in Council dated 26th September, 1910, and known as the "Loch Valley Falls (Prescott's) Reserve."—(Corres. Rs.74.)

In witness whereof the common seal of the Board of Land and Works was hereunto affixed this eighteenth day of December, One thousand nine hundred and fifty-seven, in the presence of—

(SEAL) KEITH TURNBULL, President.  
W. T. LONG, Member.

AMENDMENT OF REGULATIONS FOR THE CARE, PROTECTION, AND MANAGEMENT OF A RESERVE FOR RECREATION AND PUBLIC PURPOSES, PARISH OF MOORPANYAL, AND KNOWN AS "OSBORNE PARK".

THE Board of Land and Works, in pursuance of the powers conferred on it, doth hereby amend the Regulations made on the 8th May, 1933, for the care, protection, and management of the Reserve for Recreation and Public purposes in the Parish of Moorpanyal by the addition to Regulation 13 of the words, "without the permission, in writing, of the Committee of Management being first obtained".—(Corres. Rs.4023.)

The common seal of the Board of Land and Works was hereunto affixed this ninth day of January, 1958, in the presence of—

(SEAL) KEITH TURNBULL, President.  
W. T. LONG, Member.

PUBLIC HEARING BY A PERSON APPOINTED UNDER THE 34TH SECTION OF THE LAND ACT 1928.

NOTICE is hereby given that at the time and place mentioned in the Schedule hereunder, applications for leases and licences under the Land Acts, objections to such applications, objections to proposed proclamations, alterations, additions, diminutions, revocations, or unions of commons, and reasons against forfeiture of any leases or licences under the Land Acts deemed liable to forfeiture, will be publicly heard by the person whose name is set opposite such place in such Schedule, being a person appointed by me, the responsible Minister of the Crown administering the Land Acts, to hear the same and report thereon in writing to me.

KEITH TURNBULL,  
Commissioner of Crown Lands and Survey and  
President of the Board of Land and Works.  
Department of Crown Lands and Survey,  
Melbourne, 14th January, 1958.

SCHEDULE.

LANDS DEPARTMENT OFFICE, BENDIGO, Thursday,  
30th January, 1958, at 10 a.m.—H. J. Henkel, Land  
Officer, Bendigo.

Land Act 1928.

PERMIT CANCELLED.

NOTICE is hereby given that the permit mentioned in the Schedule hereunder has been cancelled.

District.	Corr. No.	Name of Permit Holder.	Parish.	Allotment.	Section.	Area.
Beechworth .. .. .	868/44	R. A. Exell .. .. .	Dondangadale .. .	8	2	A. R. P. (60 0 0)

Department of Crown Lands and Survey,  
Melbourne, 14th January, 1958.

KEITH TURNBULL,  
Commissioner of Crown Lands and Survey.

Land Act 1928.

LICENCES UNDER THE LAND ACTS 1915 AND 1928 DECLARED VOID.

NOTICE is hereby given that the Licences in the Schedule hereunder have been Declared Void for the reason specified in each case.

District.	Corr. No.	Name of Licensee.	Section of Land Act under which Licensed.	Parish.	Allotment.	Section.	Area.	Annual Rental.	Reasons for Voiding.
Geelong ...	2/86	G. J. Lynch ..	86	Durridwarrah	51B	..	A. R. P. 20 0 0	£ s. d. 1 0 0	Licensees request Non-compliance with residence condi- tions
Beechworth ...	265/129	A. Sutton ..	129	Porepukah ..	17D	7	1 2 0	1 0 0	

Department of Crown Lands and Survey,  
Melbourne, 14th January, 1958.

KEITH TURNBULL,  
Commissioner of Crown Lands and Survey.

CLOSER SETTLEMENT ACT 1938.

THE Farm Allotment mentioned in the Schedule hereunder is hereby proclaimed available for application and may be taken up under Closer Settlement Lease.

Parish.	Allotment.	Section.	Area.	Monetary Liability.	Deposit, Including Lease and Registration Fees.	Term of Lease.	Remarks.
Gunamalary ..	40 and 41	..	A. R. P. 602 3 26	£ s. d. 1,492 0 0	£ s. d. 303 5 0	36 years	Yearly instalment £65 9s. (09067/121)

Office of Crown Lands and Survey,  
Melbourne, 14th January, 1958.

KEITH TURNBULL,  
Commissioner of Crown Lands and Survey.

## TENDERS—PUBLIC WORKS DEPARTMENT

**TENDERS** will be received at this office until **TEN a.m.** on the days and for the purposes under-mentioned.

Particulars may be learnt at this Office and also at places shown in parenthesis.

W.O. means: Inspector of Works Office; P.S.—Police Station; T.S.—Technical School; H.E.S.—Higher Elementary School; S.S.—State School; H.S.—High School.

The Board of Land and Works will not necessarily accept the lowest or any tender.

**NOTE.**—No preliminary deposits are to be lodged with tenders, but a deposit, in accordance with the following Schedule, will be required from the successful tenderer:—

For contract amounts exceeding £200 and not exceeding £500 .. .. .	\$ 5
For contract amounts exceeding £500 and not exceeding £1,000 .. .. .	10
For contract amounts exceeding £1,000—1 per cent. of tender .. .. .	500
	(maximum deposit)

All tenders should be on a "firm tender" basis.

**NOTE.**—Plans and specifications will not be available at school buildings from the 19th December, 1957, to 4th February, 1958.

*21st January, 1958.*

Ararat.—Transfer of equipment from Mont Park Hospital to Ararat Mental Hospital.

Ararat.—External sewerage, fire service, and water supply to two standard wards, Mental Hospital. (W.O., Ararat.)

Braybrook.—Supply, delivery, installation, and testing of additions to the heating system. S.S. No. 1102.

Camberwell.—Supply and installation of concrete and stainless steel wash troughs, &c., Girls' Secondary School.

Camberwell.—Rerendering and waterproofing of parapet walls, High School.

Carlton.—Supply and installation of new main cable, Public Offices, Exhibition Buildings, Western Annexe.

Caulfield South.—Complete rewiring and re-designing of electrical installation, S.S. No. 4315.

Coburg.—Installation of an exhaust ventilation system in the cook house, "D" Division, Gaol, Urquhart-street.

Colac.—Erection of out-office block, installation of sanitary fittings and sewer drains, &c., S.S. No. 117. (W.O., Camperdown; P.S., Colac.)

Footscray.—Interior renovations and painting, Girls' Secondary School.

Forrest.—Erection of "Ellinbank" type residence, S.S. No. 2708. (W.O., Camperdown; P.S., Forrest.)

Glenhompson.—Erection of No. 2 (two) new timber shelter pavilions, 20 ft. x 16 ft., S.S. No. 947. (W.O., Hamilton.)

Gnarwarre.—Repairs and painting and provision of display boards, S.S. No. 1491. (W.O., Geelong.)

Kew.—Supply and delivery of one 38-in. hydro extractor, Mental Hospital.

Kew.—Repairs and provision of floor tiles to Wards "C" and "Cl," Mental Hospital. (W.O., Kew Mental Hospital.)

Mont Park.—Central heating service and external steam line to the Administration Block, Mental Hospital. (Mental Hospital, Mont Park.)

Northcote.—Alterations and additions to electrical installation, Police Station. (P.S., Northcote.)

Prahran.—Erection of covered way, Girls' Technical School.

Preston.—Rewire, alterations, and additions to electrical installations of main building, "Pleasant View" Receiving House, Wood-street.

Reservoir East.—Additions to the heating system to two new and two existing class-rooms, S.S. No. 4636.

Royal Park.—Additional lighting in male and female lounges, &c., Park Wards, Mental Hospital, Poplar-road.

Sunbury.—Supply, delivery, and bolting down of laundry machinery, Mental Hospital.

Warragul.—Supply, delivery, installation, and testing of piped oxygen-acetylene welding plant, High School.

Warrnambool.—Erection of Welco garage, 36 ft. x 15 ft., Mental Hospital. (W.O., Warrnambool.)

Woorndoo.—External painting of school and residence, renewal of fencing, S.S. No. 1001. (W.O., Warrnambool.)

*28th January, 1958.*

Ararat.—General repairs and painting to residence and out-buildings, Police Station. (W.O., Ararat.)

Ballan.—Erection of timber residence, Police Station. (W.O., Ballarat; P.S., Bacchus Marsh; Ballan.)

Bendigo.—First and second sections of concrete veneer timber-framed school, Girls' Secondary School. (W.O., Bendigo.)

Bendigo.—Electrical installation in stages 1 and 2, Girls' Secondary School. (W.O., Bendigo.)

Bendigo.—Supply, delivery, installation, and testing of the mechanical services for stages 1 and 2 of building programme, Girls' Secondary School. (W.O., Bendigo.)

Broadford.—Erection of brick veneer residence with timber-framed garage and fuel shed, Soil Conservation Authority. (W.O., Alexandra; P.S., Broadford.)

Brunswick.—Resurfacing of concrete stairs and landings, Girls' Secondary School.

Buninyong.—Renovations and painting, Police Station. (W.O., Ballarat; P.S., Buninyong.)

Carlton.—Supply and installation of automatically operated fire sprinkler system, Exhibition Buildings.

Coatesville.—Extensions to the heating system and conversion of boiler to oil firing, S.S. No. 4712.

Colac.—Erection of No. 2 (two) shelter pavilions, 32 ft. x 16 ft., High School. (W.O., Camperdown; P.S., Colac.)

Dimboola.—Supply, delivery, installation and testing of water filtration plant, High School. (W.O., Horsham; P.S., Dimboola.)

Frankston.—Erection of No. 2 (two) 20 ft. x 40 ft. new shelter pavilions, High School.

Freshwater Creek.—Erection of an additional room and porch, enclosing back verandah, residence, S.S. No. 256. (W.O., Geelong.)

Glen Waverley.—Additional out-office accommodation, S.S. No. 2219.

Hamilton.—External and internal repairs and painting, drainage, and sealing garage floor, residence, 75 King-street, S.S. No. 295. (W.O., Hamilton.)

Heatherston.—Exterior painting to various buildings, Sanatorium. (Sanatorium, Heatherston.)

Heidelberg.—Erection of chain pipe and mesh fence, S.S. No. 4713

Huntingdale.—Extension of existing heating to two additional L.T.C. classrooms, S.S. No. 4716.

Ivanhoe East.—Renewal of water service, S.S. No. 4386.

Mandurang.—Septic closet installation and construction of new out-offices, S.S. 1952. (W.O., Bendigo.)

Maroona.—Repairs and painting to school and residence, S.S. No. 1943. (W.O., Ararat.)

Middle Park.—Complete rewiring of electrical installation in main school building, S.S. No. 2815.

Mildura.—Sawdust extraction installation for the wood-working machine shop, Technical School.

Mont Park.—Alterations and additions to L.T.C. building, Larundel Mental Hospital. (W.O., Mont Park.)

Mornington.—Repairs, internal and external painting to residence, Police Station. (P.S., Mornington.)

Norlane.—Electrical services in five (5) additional L.T.C. class-rooms, S.S. No. 4734. (W.O., Geelong.)

Norlane.—Supply, delivery, installation and testing of a warm-air heating/ventilation system in new wing, S.S. No. 4734. (W.O., Geelong.)

Norlane.—Erection of No. 5 additional classrooms, S.S. No. 4734. (W.O., Geelong.)

Pearcedale.—Erection of "Ellinbank" type residence, S.S. No. 2961.

Port Melbourne.—Installation of fire sprinkler system, Public Works Department Depot, Salmon-street.

Sandringham.—Construction of brick and concrete protective work to basement structure, Hospital.

Traralgon.—Extension of heating to two additional L.T.C. classrooms, High School. (W.O., Traralgon.) (Amended Specification.)

Wantirna.—Installation of septic tank grouping and re-establishment of out-offices, S.S. No. 3709. P.S., Fern-tree Gully.)

Warragul.—Repairs, painting, and installation of heating stove, Police Station. (W.O., Traralgon; P.S., Warragul.)

Warragul.—Electrical installation to and the installation of arc welding equipment, High School. (W.O., Korumburra; P.S., Warragul.)

**NOTE.**—Plans and specifications will not be available at school buildings from the 19th December, 1957, to 4th February, 1958.

*4th February, 1958.*

Alamein.—Erection of party and non-party boundary fences, S.S. No. 4649.

Beaconsfield.—Repairs and painting, S.S. No. 3033. (W.O., Korumburra.)

Beaconsfield.—Erection of non-party boundary, fencing, S.S. No. 3033. (P.S., Berwick.)

Beaufort.—External repairs and painting, Police Station. (W.O., Ballarat; P.S., Beaufort.)

Birchip.—Fencing, H.E.S. No. 2602. (W.O., Warrack-nabeal; P.S., Birchip.)

Burwood.—Erection of brick veneer residence, Presbyterian Ladies' College, "Heatherset".

Chatham.—Completion of repairs and painting, S.S. No. 4314.  
 Collingwood.—Re-surfacing of concrete steps and stairs to ground and first floors, Block 1, Technical School.  
 Diggers Road (Werribee).—Internal and external painting, provision of display boards, S.S., No. 4312.  
 Dimboola.—Renewal of fencing to Government Road, High School. (W.O., Warracknabeal; Horsham; P.S., Dimboola.)  
 Footscray.—External and internal renovations and repairs, Caretaker's residence, S.S. No. 1912, Hyde-street.  
 Glen Waverley.—Provision of one (1) new shelter pavilion, S.S. No. 2219.  
 Horsham.—Repairs and painting to school and Caretaker's quarters, S.S. No. 298. (W.O., Horsham.)  
 Horsham.—Supply, delivery, installation and testing of a piped oxy-acetylene gas supply to welding bays, High School. (W.O., Horsham.)  
 Kew.—Electrical installation for two Children's Cottages, Mental Hospital.  
 Kingsville.—External renovations to all buildings excluding shelter shed, S.S. No. 3988.  
 Langi Kal Kal.—New mess block building, Training Centre, Penal and Gaols. (W.O., Ballarat; Maryborough.)  
 Langi Kal Kal.—Electrical installation in new mess block, Training Centre, Penal and Gaols. (W.O., Ballarat.)  
 Mornington.—Sewerage installation, &c., "Sutton Grange", Children's Welfare Department. (P.S., Mornington.)  
 Princes Hill.—Interior renovations and painting. (Infants' School), S.S. No. 2955.

St. Kilda.—Erection of pipe and chain, mesh boundary fencing, S.S. No. 1479.  
 Tourello.—Internal and external painting and repairs to residence, S.S. No. 740. (W.O., Ballarat.)  
 Warburton East.—Repairs and painting, S.S. No. 2764. (P.S., Warburton.)  
 Wendouree West.—Erection of No. 2 shelter pavilions, 32 ft. x 16 ft., S.S. No. 4701. (W.O. Ballarat; P.S., Wendouree.)  
 West Melbourne.—Supply, delivery, installation and testing of a refrigeration installation in a new section of cool room, Government Cool Store, Dudley-street.  
 Windsor.—Repairs and painting, S.S. No. 1896.  
 Wurruk.—Septic tank installation at school and residence, construction of new out-offices, S.S. No. 2518 (W.O., Traralgon.)  
 Yannathan.—Purchase and removal of school residence, S.S. No. 2422. (P.S., Koo-Wee-Rup.)  
 Yarraville.—Replacement of chalkboards, S.S. No. 1501.

11th February, 1958.

Bendigo.—Erection of lecture wing and physical education wing, plus connecting links, Teachers' Training College. (W.O., Bendigo.)  
 All tenders should be on a "firm tender" basis.  
 Tenders to be addressed to the Honorable the Commissioner of Public Works, and envelope containing tender marked "Tender for \_\_\_\_\_ due \_\_\_\_\_"  
 T. K. MALTBY,  
 Commissioner of Public Works.  
 Public Works Department,  
 Melbourne, 14th January, 1958.

**PUBLIC SERVICE NOTICES**

**PUBLIC SERVICE (PUBLIC SERVICE BOARD) REGULATION 39.—VACANCIES.**

THE Permanent Heads of the Departments shown have recommended the officers named hereunder for appointment to the under-mentioned vacancies.

Office and Classification.	Duties.	Qualifications.	Officer Recommended for Appointment.		
			Name.	Classification.	Date of Classification.

**PROFESSIONAL DIVISION.**

**DEPARTMENT OF LAW.**  
*Office of the Public Trustee.*

Professional Assistant, Class "C2"	To assist in the Conveyancing work and to approve of distributions (testate and intestate) and such other work as may be allocated to him by the solicitor to the Public Trustee, and generally, to act as an assistant solicitor to the Public Trustee	To be a barrister and solicitor of the Supreme Court of Victoria with practical experience in conveyancing and the administration of deceased persons' estates	Taylor, G. R. . .	Professional Assistant, Class "C1"	6.6.57
------------------------------------	---	--	-------------------	------------------------------------	--------

(This advertisement is in lieu of the advertisement inviting applications for a position of Professional Assistant, Class "C2", which appeared on Page 51 of *Government Gazette* No. 1 of the 8th January, 1958.)

**DEPARTMENT OF CROWN LANDS AND SURVEY.**

Cartographic Assistant, Class "C"	To prepare for reproduction final drawings of topographic and cadastral maps and plans from compiled information and to assist in the supervision of sections of the work and staff of the Drawing Office as required	To be a first class penman, thoroughly experienced in all types of mapping techniques and conversant with the various methods of map and plan reproduction	Missen, J. E. . .	Cartographic Assistant, Class "D"	17.9.52
-----------------------------------	---	--	-------------------	-----------------------------------	---------

**TECHNICAL AND GENERAL DIVISION.**

**DEPARTMENT OF STATE FORESTS.**

Forest Overseer, Grade I. (£802-£880)	To supervise operations of forest employees and licensees, and to carry out general fire patrol duties	To possess a good knowledge of the Victorian Forests Act and Regulations and of office procedure and to have extensive practical experience of field methods and operations in the State Forests Department	Gustus, C. J. C.	Forest Overseer, Grade II.	3.9.54
---------------------------------------	--	---	------------------	----------------------------	--------

Appeals against such recommendations should be lodged with the Secretary to the Public Service Board not later than Saturday, the 25th January, 1958.

Office of the Public Service Board,  
 Melbourne, 14th January, 1958.

By order,  
 V. P. SCULLY,  
 Secretary.

## PUBLIC SERVICE (PUBLIC SERVICE BOARD) REGULATION 39.—RECLASSIFICATIONS.

THE Public Service Board has raised the classification of the under-mentioned offices as shown, and the Permanent Heads of the Departments have recommended the officers named for appointment.

Office and Present Classification.	Revised Classification.	Duties.	Qualifications.	Officer Recommended for Appointment.		
				Name.	Classification.	Date of Classification.
<b>TECHNICAL AND GENERAL DIVISION.</b>						
<b>DEPARTMENT OF WATER SUPPLY.</b>						
<i>Central Gippsland Irrigation Project—Heyfield.</i>						
Assistant (Male), Grade I.	Senior Grade II. (£520—£546)	To maintain stocks of construction materials, tools, and equipment as required by the Executive Engineer; to prepare requisitions and local orders for supplies; to supervise preparation of issue dockets and to control operation of the store and storeyard	A sound knowledge of the store requirements for a construction project and of operation of a store; to be conversant with the Commission's system of stores acquisition and accounting; to have ability to control staff	O'Dwyer, P. F.	Assistant (Male), Grade I.	8.12.52
<i>Camperdown Centre.</i>						
Senior Turncock	Inspector (£461—£500)	To attend to general repair and maintenance of pipe mains; operate and maintain motor pumping plant; supervise the installation of service tappings to Commission water mains	Knowledge of, and experience in, general repair and maintenance of pipe mains, including jointing and laying of pipes	Porter, A. J.	Senior Turncock	20.1.53

Appeals against such recommendations should be lodged with the Secretary to the Public Service Board not later than Saturday, the 25th January, 1958.

By order,

V. P. SCULLY,  
Secretary.

Office of the Public Service Board,  
Melbourne, 14th January, 1958.

## PUBLIC SERVICE OF VICTORIA.—VACANCIES.

APPLICATIONS will be received by the Public Service Board up to Wednesday, the 29th January, 1958, from persons employed in the Public Service Board of Victoria, who are eligible and qualified for appointment to the under-mentioned positions:—

## ADMINISTRATIVE DIVISION.

Class "C", State Accident Insurance Office, Department of Chief Secretary.

Yearly Salary.—£940, minimum; £1,030, maximum.

Duties.—To act as personnel and staff training officer; to advise on ways of improving efficiency and to implement approved changes; to assist generally in the work of the Administrative Division and control the Office library.

Qualifications.—To possess a sound knowledge of the Public Service Act and Regulations, and to be experienced in personnel work. Preference will be given to applicants who have specialized knowledge of office Organization and Methods and with a knowledge of and experience in insurance work.

Class "C1", Audit Office, Department of Premier. (Four vacancies.)

Yearly Salary.—£785, minimum; £875, maximum.

Duties.—To conduct audits throughout Victoria as directed by the Auditor General.

Qualifications.—To be a qualified accountant and to have had experience in the practice of governmental and public auditing.

Class "C1", Department of Public Works.

Yearly Salary.—£785, minimum; £875, maximum.

Duties.—Under the Officer in Charge, Works Administration Branch, to assist in the checking and passing of payments in respect of major contracts and in the finalization of files in relation thereto.

Qualifications.—A thorough knowledge of the Regulations respecting Public Accounts and experience in departmental practice and procedure and in dealing with accounts.

Class "C", Department of Agriculture.

Yearly Salary.—£785, minimum; £875, maximum.

Duties.—Under the supervision of the Manager, Rutherglen Research Station, and Manager, Viticultural Station, Rutherglen, to keep all financial records concerning expenditure and revenue; to prepare pay sheets reimbursements and inventories, check accounts, etc., to lodge requisitions and order stores, including foodstuffs and oversee the catering for resident staff; to maintain farm record books, receive and despatch orders and advise consignees; to register and file inward and outward correspondence and prepare miscellaneous returns as required.

Qualifications.—Experience in keeping advance and revenue cash books and preparation of reimbursements; a good knowledge of Regulations respecting public accounts and banking practice; experience in correspondence and general records work.

NOTE.—A residence is available for the successful applicant, if married, for which rental of ten per cent. of standard salary, plus £16 per annum will be charged. Accommodation is available at the farm for a single man at a cost of £3 8s. per week. Particulars available from the Department of Agriculture.

Class "C", Audit Office, Department of Premier. (Four vacancies.)

Yearly Salary.—£598, minimum; £728, maximum.

Duties.—To assist in the audit and examination of accounts as required by the Auditor General.

Qualifications.—To have a knowledge of the Audit Act and the regulations thereunder and to produce evidence of having entered on a course of study in accountancy.

Class "C", State Accident Insurance Office, Department of Chief Secretary.

Yearly Salary.—£598, minimum; £728, maximum.

Duties.—To act as Cashier; to receive all revenue and make cash payments of compensation; to issue certificates of insurance, and to keep remittance books and trust cash book.

*Qualifications.*—A good knowledge of the Workers' Compensation Acts and Regulations with experience of insurance and agency accounts.

**Class "C", Department of Crown Lands and Survey.**

*Yearly Salary.*—£598, minimum; £728, maximum.

*Duties.*—To keep the ledgers for soldier settlers' lease accounts under the general settlement scheme, and to control the accounts for grazing and miscellaneous rents.

*Qualifications.*—To have a knowledge of the Soldier Settlement Acts and the Agreement Relating to War Service Land Settlement; to have had experience of the Department's mechanical accounting system.

**Class "C", Department of State Forests.**

*Yearly Salary.*—£598, minimum; £728, maximum.

*Duties.*—To attend to matters relating to the dedication and excision of forest land and the purchase of land; to make departmental enquiries and to assist generally in the work of the Estates and Occupation Section.

*Qualifications.*—To have a sound knowledge of the relevant provisions of the Forests Act and procedures thereunder; to be a competent draughtsman.

**PROFESSIONAL DIVISION.**

**Professional Assistant Class "G1", Office of the Public Trustee, Department of Law.**

*Yearly Salary.*—£785, minimum; £875, maximum.

*Duties.*—To assist in the conveyancing work and in Court applications in the estates of patients and infirm persons, and such other work as may be allocated to him by the solicitor to the Public Trustee.

*Qualifications.*—To be a barrister and solicitor of the Supreme Court of Victoria with practical experience in conveyancing and the administration of deceased persons' estates.

**Librarian (Female), Classes "E" and "D", Public Library Branch, Department of Chief Secretary. (Four vacancies.)**

*Yearly Salary.*—Junior—At 16 years of age, £156;  
at 17 years of age, £182;  
at 18 years of age, £221;  
at 19 years of age, £260;  
at 20 years of age, £299.  
Adult—£338, minimum; £468, maximum.

*Duties.*—To assist generally in the professional work of the Public Library.

*Qualifications.*—To be under 30 years of age; to hold the Preliminary Certificate of the Library Association of Australia, or at least the Leaving Certificate with a good general knowledge of books and current affairs. Applicants will be submitted to a suitable test to prove their qualifications and aptitude for library work and, upon appointment will be classified in accordance with their qualifications.

**TECHNICAL AND GENERAL DIVISION.**

**Trade Instructor, Penal and Gaols Branch, Department of Chief Secretary.**

*Yearly Salary.*—£580, minimum; £697, maximum.

*Duties.*—To take charge of classes in bricklaying and to instruct prisoners in all aspects of the trade.

*Qualifications.*—To be an experienced bricklayer with ability to instruct in the trade processes and to be able to maintain discipline among prisoners.

**Rental Officer, Grade II, Office of the Housing Commission (Heidelberg Office), Department of Treasurer.**

*Yearly Salary.*—£507, minimum; £546, maximum.

*Duties.*—To engage in the weekly collection of rents on the Commission's metropolitan estate to interview tenants in regard to arrears; and to assist generally in regard to rental collections.

*Qualifications.*—To have had experience in dealing with the public; to be a good penman, capable of handling public moneys and keeping accurate records; to be active and between the ages of 25 and 45 years and to hold a car driver's licence.

**Assistant (Female), Publicity, Department of State Forests.**

*Yearly Salary.*—£390, minimum; £481, maximum.

*Duties.*—Under supervision to arrange the compilation and distribution of all departmental publicity and the preparation of trade and show exhibits, and to design pictorial publicity material.

*Qualifications.*—To have a thorough knowledge of, and to be experienced in, copy writing and design lay-out, and to be able to organize displays.

**General Assistant, Museums, Public Library Branch, Department of Chief Secretary.**

*Yearly Salary.*—£416, minimum; £455, maximum.

*Duties.*—Under the supervision of the Director, to assist generally in museum routine, changing of and attention to exhibits, and the maintenance of the reserve collections and museum stores; to perform such other duties as may be directed.

*Qualifications.*—To possess sound physique, some acquaintance with machinery, and preferably to hold a motor driver's licence.

**Farm Assistant, Agricultural College, Dookie Agricultural College, Department of Agriculture.**

*Yearly Salary.*—£364, minimum; £390, maximum.

*Duties.*—Under the direction of the Principal, to assist in the practical work of the farm and in the control and instruction of students in practical farm work.

*Qualifications.*—To possess a sound practical knowledge of farm machinery, including tractors; ability to handle horses and sound practical experience in farming.

*NOTE.*—Accommodation is available for a single man only. Particulars available from the Department of Agriculture.

*NOTE.*—The salary rates quoted above do not include the additional amounts which are payable under Regulation 77A of the Board's Regulations.

By order,

V. P. SCULLY,  
Secretary.

Office of the Public Service Board,  
Melbourne, 14th January, 1958.

**PUBLIC SERVICE OF VICTORIA.—VACANCIES.**

**DEPARTMENT OF HEALTH.**

**MENTAL HYGIENE BRANCH.**

**TECHNICAL AND GENERAL DIVISION.**

**A**PPPLICATIONS will be received by the Public Service Board up to Wednesday, the 5th February, 1958, from persons employed in the Public Service of Victoria, who are eligible and qualified for appointment to the under-mentioned position:—

**Deputy Charge Nurse (Male).**

Sunbury Mental Hospital—one vacancy.  
Beechworth Mental Hospital—one vacancy.

*Yearly Salary.*—£468, minimum; £494, maximum.

*Duties.*—To be second in charge of a ward and to relieve the Charge Nurse.

*Qualifications.*—To possess the Mental Hygiene Nursing Certificate and to have had experience in a Mental Hospital; to be a registered Mental Nurse.

*NOTE.*—The salary rates quoted above do not include the additional amount which is payable under Regulation 77A of the Board's Regulations.

By order,

V. P. SCULLY,  
Secretary.

Office of the Public Service Board,  
Melbourne, 14th January, 1958.



PUBLIC SERVICE EXAMINATION.—  
ADMINISTRATIVE DIVISION.

At the entrance examination held on the 14th December, 1957, the under-mentioned candidates passed the required standard in the order of merit indicated.

Order of Merit.	Name.	Order of Merit.	Name.
1	Pollard, George Reginald	81	Brodrick, Thomas Clement
2	McNamara, Patrick	82	Hall, John Douglas
3	Clifford, John Dudley	83	Gidley, John Arthur
4	Whitehead, Dennis Frank	84	Lyon, Francis John
5	Johnson, John Leslie	85	Blackman, John William
6	Stafford, Allan Patrick	86	Walker, Bruce Ian
7	Bartels, Thomas Joseph	87	White, William Bayly
8	O'Shannessy, Neil Edward	88	Cleary, Thomas Vincent
9	Lacey, Hugh Matthew	89	Brown, Neil Anthony
10	Martin, Roger Bernard	90	Le Couteur, Richard Adeney
11	Gerber, Paul Gerstel	91	Bedohazy, Thomas
12	Henry, Maurice Cherrington	92	Johnstone, James
13	Altmann, Frederick	93	Oost Lievensse, Willem Frederik Hendrik
14	Maher, Kevin Joseph	94	Burgess, Montague Walter
15	Reddoch, James William	95	Devitt, John Edmund
16	Newman, Lawrence Stanley	96	Camilleri, John Charles
17	Williamson, Sydney Anthony	97	Nugara, Henry Ivor Rienzi Anthony
18	Ferguson, John Thomas	98	Kerslake, Graeme Bruce
19	Hayes, Sidney Harold	99	Lang, John Desmond
20	McCullough, James Stuart	100	Malady, Michael Thomas
21	Holden, Richard Albert	101	Cassar, Francis Xavier James
22	Rose, Donald Campbell	102	Allsop, Francis Frederick
23	Stewart, Donald John	103	McFadden, Gordon Campbell
24	McCarthy, Francis Stanislaus	104	Brown, Don Clissold
25	Oakley, Reginald	105	Magree, Robin Neil
26	Nelson, Anthony	106	Poulter, Sydney James Haylock
27	Fiddian, Ian Tristan Samuel	107	Redman, Barry Gerard
28	Dynan, John Bernard	108	Kishander, James Alfred
29	Daniel, John Walter	109	Matfin, Alan John
30	Gannan, Gerald Howarth	110	Carroll, Paul Manderville
31	Scully, Vincent James	111	Quick, John Stirling
32	Webber, Alan Reid	112	Le Boeuf, John Acton
33	Judge, John Brian	113	Hart, Keith
34	Walter, Christopher Forbes	114	Nagelkerke, Cornelis Jacob
35	Cuddihy, William Lawrence	115	Komives, Alexander Sandor
36	Joss, David Alexander	116	Dawson, John Patrick
37	Weld-Smith, Rupert Arthur Nasmith	117	Collard, Ian John
38	McHugh, Robert John	118	McGregor, Peter John
39	Norman, Henry Julius	119	O'Shannassy, Francis Patrick
40	Burns, Ian Bernard Graham	120	Hunter, Kenneth James
41	Crick, Geoffrey Alan	121	Silber, Stanley Henry Keevill
42	Spottiswood, Arthur Brian	122	Cox, Joseph
43	Sherwood, George Michael	123	O'Connor, John Brian
44	Thick, Graeme Reginald	124	Hamilton, John William
45	Daffey, Terence Francis	125	Drudge, John Reynolds
46	Lamont, Norman	126	Sutherland, Donald Finlay Gordon
47	Michl, Vaclav	127	Byrne, William Edward
48	Morris, John Riviere	128	Jones, Victor Charles
49	Condon, Patrick Charles	129	McGuinness, Robert James
50	Thompson, Ernest John	130	Calnin, John Thomas
51	Williams, Peter John	131	Hannon, Edward James
52	Wilson, John Gilchrist	132	Bateman, Frederick Spencer
53	Green, Ronald Francis Xavier	133	Roberts, David John
54	Higgs, Robert Henry	134	Evans, Michael James John
55	Foenander, George Phillip Cecil	135	Csakfal, Tibor
56	Hunter, Terence Joseph	136	Mayberrv, Kempson John
57	Watts, Eric Eacott	137	Newcombe, Graeme Wilfred
58	Lorkin, James Francis	138	Thomas, Lindsay Robert
59	Sanders, Denis Michael	139	Gilchrist, Francis Lawrence
60	Evans, Christopher Jeffrey Hellier	140	Charles, George Edward
61	Northwood, Kelvin John	141	Dimech, Michael Joseph
62	Ellinghaus, Armin Edmund	142	Davidson, Ernest Albert
63	Williams, Edward Ronald	143	Bergmanis, Olgerts
64	Mackenzie, John Seaforth	144	O'Connell, Thomas Montiford Peter
65	Kehoe, John Edward	145	King, Eugene Augustine
66	Bolza, Geza	146	Crawley, William Edward
67	Mitchell, Tom Rostron	147	Edwards, Geoffrey John
68	Smark, Michael James	148	Williams, Graham Francis
69	Latrobe, Walter Mabe	149	Edmonds, Denis Clive
70	Sach, Ronald Leslie	150	Scott, Leonard Richard
71	Acton, Leslie	151	Dixon, Michael Joseph
72	Tooby, Arthur William	152	Joon, Eric Maurice
73	Flanagan, Gerard Michael	153	Leonard, Geoffrey William
74	Curtain, Michael John	154	Burke, Peter John
75	Leak, George Basil	155	Watson, William John
76	Berry, Timothy Joseph	156	McDonald, Anthony Charles Stephen
77	Graham, Bruce	157	Doolan, Barry John
78	Schiller, Peter Charles Phillip	158	Goggin, Patrick Leo
79	Veenstra, Cornelis	159	Marantelli, Gavin Patrick
80	Hodgkinson, Peter John	160	Rogers, David Wallace
		161	Bath, Charles Graham
		162	Horvath, Charles
		163	Walsh, Richard John
		164	Kirk, Ian Charles
		165	Blackman, Robin Alan
		166	McCrae, John Edward
		167	Treyvaud, David Leigh
		168	Keating, Brian Ignatius
		169	Norris, Robert John
		170	Eversteyn, Theodore John
		171	McKenna, John Charles
		172	Crotty, Kevin Edward
		173	Poll, Franklin Harold

Order of Merit.	Name.
174 ..	Jacobs, Keith William
175 ..	Nielsen, Ian Francis
176 ..	Davis, John Ward
177 ..	Malady, Timothy James
178 ..	Schlitz, Peter John
179 ..	Van Helden, Johan
180 ..	Redmond, Kevin Alan
181 ..	Zsizsmann, Tibor Bela
182 ..	Fulton, Wayne Hilary

Candidates who have not already done so should immediately furnish the Board with documentary evidence of their age and of their educational qualifications.

By order,

V. P. SCULLY,  
Secretary.

Office of the Public Service Board,  
Melbourne, 14th January, 1958.

**PUBLIC SERVICE EXAMINATION.—  
PROFESSIONAL DIVISION.**

AT the entrance examination held on the 14th December, 1957, the under-mentioned candidates passed the required standard in the order of merit indicated.

Order of Merit.	Name.
1 ..	Jeffreys, Arthur Albert
2 ..	Mansfield, Lyle John
3 ..	Hawkes, Edgar Charles
4 ..	Eccleston, Gregory Compton
5 ..	Parish, Arthur
6 ..	Malady, Michael Anthony
7 ..	Burubu, Ruggero Luigi
8 ..	Skelton, Robert John
9 ..	Seeley, Arthur William
10 ..	McKay, Neil John
11 ..	Bryning, Ivan Bertram
12 ..	Hindle, John Charles
13 ..	Powell, Malcolm Hugh
14 ..	King, William Horace
15 ..	Lucy, Anthony
16 ..	Kingsbury Alan
17 ..	Barrett, Kenneth Alexander
18 ..	Gangell, Neil Newton
19 ..	Fry, Lindsay Keith
20 ..	Miller, Kenneth James
21 ..	Davidson, Eric Neil
22 ..	Pivetta, Noli Peter
23 ..	Colledge, Malcolm
24 ..	Knuckey, Ronald Gordon
25 ..	Eddington, Robert Arthur
26 ..	De La Rue, John Russell
27 ..	O'Toole, Laurence Michael
28 ..	Charrett, Peter Lawrence
29 ..	Mears, Terence Leslie
30 ..	Schestopalow, Vladimir
31 ..	Read, Brian Richard
32 ..	Moloney, Raymond Philip
33 ..	Curry, Neil David
34 ..	Woodford, Richard Barrie
35 ..	Dungan, Jeffrey Kevin
36 ..	Hayes, Brian Thomas
37 ..	Opie, Thomas Roy
38 ..	Karnups, Imants Janis
39 ..	Forster, David Croft
40 ..	Blakston, Lynsey Frank
41 ..	Cornish, Ian Ernest
42 ..	Hennessy, Gregory James
43 ..	Elvish, Gregory Ross
44 ..	Frost, Philip
45 ..	Sheehan, Noel Robert
46 ..	Howlett, Gregory John
47 ..	Hughes, Robin John
48 ..	Fennell, Alan James
49 ..	Twigg, Graeme Charles
50 ..	Couttie, Michael John
51 ..	Smitmanis, Ivars Juris
52 ..	Thomas, Trevor Leslie
53 ..	Mathews, Roger Graham
54 ..	Kolpin, Noel William

Candidates who have not already done so should immediately furnish the Board with documentary evidence of their age and of their educational qualifications.

By order,

V. P. SCULLY,  
Secretary.

Office of the Public Service Board,  
Melbourne, 14th January, 1958.

No. 783.

Public Service Act 1946, Section 39.

**REGULATIONS.—PART III.—SALARIES, INCREMENTS,  
AND ALLOWANCES.**

THE Public Service Board, in pursuance of the powers conferred by the Public Service Act 1946, hereby amends its Regulations as shown below :—

**FIRST SCHEDULE.  
PROFESSIONAL DIVISION.  
Offices and Rates of Salaries.**

Office.	Yearly Rate of Salary.	
	Minimum.	Maximum.
DEPARTMENT OF HEALTH.	£	£
MENTAL HYGIENE BRANCH.		
CLASS "C1".		
Add— Bio-chemist (Female) .. .. .	785	875
CLASS "C".		
Delete— Bio-chemist (Female) .. .. .	598	728

This Regulation shall have effect as on and from the 9th December, 1957.

A. GARRAN, Chairman.  
V. P. SCULLY, Secretary.

Office of the Public Service Board,  
Melbourne, 16th December, 1957.

No. 791.

Public Service Act 1946, Section 39.

**REGULATIONS.—PART III.—SALARIES, INCREMENTS,  
AND ALLOWANCES.**

THE Public Service Board, in pursuance of the powers conferred by the Public Service Act 1946, hereby amends its Regulations as shown below :—

**FIRST SCHEDULE.  
PROFESSIONAL DIVISION.  
Offices and Rates of Salaries.**

Office.	Yearly Rate of Salary.	
	Minimum.	Maximum.
DEPARTMENT OF CHIEF SECRETARY.	£	£
CLASS "C2".		
Add— Curator of Molluscs, National Museum ..	940	1,030
CLASS "C1".		
Delete— Curator of Molluscs, National Museum ..	785	875
DEPARTMENT OF TREASURER.		
CLASS "A".		
Add— Senior Architect (Project), Housing Commission .. .. .	1,550	1,650
Senior Architect (Design and Research), Housing Commission .. .. .	1,550	1,650

A. GARRAN, Chairman.  
V. P. SCULLY, Secretary.

Office of the Public Service Board,  
Melbourne, 23rd December, 1957.

No. 787.

Public Service Act 1946, Section 50.

REGULATIONS.—PART III.—SALARIES, INCREMENTS, AND ALLOWANCES.

THE Public Service Board, in pursuance of the powers conferred by the Public Service Act 1946, hereby amends its Regulations as shown below:—

SIXTH SCHEDULE.

TEMPORARY EMPLOYEES.

Designations of Positions and Rates of Salaries.

Department and Designation of Position.	Yearly Rate of Salary.		Increments (Annual).
	Minimum.	Maximum.	
	£	£	
<b>DEPARTMENT OF PUBLIC WORKS.</b>			
<b>PORTS AND HARBOURS.</b>			
<i>Delete—</i>			
Engine Driver of Launches ..	..	\$	..
Master of Launches ..	..	\$	..
§ Rates in accordance with Part I. of The Merchant Service Guild (Bay, Harbor and River Vessels) Award.			
<i>Add—</i>			
Engine Driver of Launch ("Fury") ..	..	570	..
Engine Driver of Launch ("Goudie" and "Victory") ..	..	513	..
Master of Launch ("Fury") ..	..	570	..
Master of Launch ("Goudie" and "Victory") ..	..	513	..
<i>To have effect as on and from the 1st July, 1957.</i>			
<i>Delete—</i>			
Able Seaman ..	323	349† ×	..
Deckhand† ..	297	310† ×	..
Engine Driver of Launch ("Fury") ..	..	570	..
Engine Driver of Launch ("Goudie" and "Victory") ..	..	513	..
Lighterman ..	416	429	..
Master of Launch ("Fury") ..	..	570	..
Master of Launch ("Goudie" and "Victory") ..	..	513	..
Includes an allowance of £13 a year for danger money.			
<i>Add—</i>			
Able Seaman ..	323	349† = ×	..
Deckhand† ..	297	310† = ×	..
Engine Driver of Launch ("Fury") ..	..	570 =	..
Engine Driver of Launch ("Goudie" and "Victory") ..	..	513 =	..
Lighterman ..	403	416 =	..
Master of Launch ("Fury") ..	..	570 =	..
Master of Launch ("Goudie" and "Victory") ..	..	513 =	..
<i>To have effect as on and from the 1st January, 1958.</i>			
† With rations when required to live on the vessel.			
‡ After the completion of two years' satisfactory service as such, will be eligible for progression to Able Seaman.			
= In addition an allowance of five shillings for each day or part thereof while engaged upon either towing or carrying explosives.			
× While serving in the dredging vessel "Matthew Flinders" entitled to an allowance at the rate of £40 a year for hard lying.			

A. GARRAN, Chairman.  
V. P. SCULLY, Secretary.

Office of the Public Service Board,  
Melbourne, 19th December, 1957.

No. 788.

Public Service Act 1946, Section 50.

REGULATIONS.—PART III.—SALARIES, INCREMENTS, AND ALLOWANCES.

THE Public Service Board, in pursuance of the powers conferred by the Public Service Act 1946, hereby amends its Regulations as shown below:—

SECOND SCHEDULE.

TECHNICAL AND GENERAL DIVISION.

Offices and Rates of Salaries.

Department and Office.	Yearly Rate of Salary.		Increments (Annual).
	Minimum.	Maximum.	
	£	£	
<b>DEPARTMENT OF PUBLIC WORKS.</b>			
<b>PORTS AND HARBOURS.</b>			
<i>Delete—</i>			
Engine Driver of Launches ..	..	φ	..
Master of Launches ..	..	φ	..
φ Rates in accordance with Part I. of The Merchant Service Guild (Bay, Harbor and River Vessels) Award.			
<i>Add—</i>			
Engine Driver of Launch ("Fury") ..	..	583	..
Engine Driver of Launch ("Goudie" and "Victory") ..	..	526	..
Master of Launch ("Fury") ..	..	583	..
Master of Launch ("Goudie" and "Victory") ..	..	526	..
<i>To have effect as on and from 1st July, 1957.</i>			
<i>Delete—</i>			
Able Seaman ..	323	349† ×	..
Deckhand† ..	297	319† ×	..
Engine Driver, Marine ..	..	φ†	..
Engine Driver of Launch ("Fury") ..	..	583	..
Engine Driver of Launch ("Goudie" and "Victory") ..	..	526	..
Lighterman, Leading Hand ..	455	481	1 of £26
Lighterman ..	416	429	..
Marine Engine Driver and Greaser ..	450	476†	1 of £26
Master of Launch ("Fury") ..	..	583	..
Master of Launch ("Goudie" and "Victory") ..	..	526	..
Working Officer in Charge, Powder Anchorage ..	554	606	2 of £26
φ Rates in accordance with Part I. of The Merchant Service Guild (Bay, Harbor and River Vessels) Award.			
Includes an allowance of £13 a year for danger money.			
<i>Add—</i>			
Able Seaman ..	323 =	349 = † ×	..
Deckhand† ..	297	310 = † ×	..
Engine Driver of Launch ("Fury") ..	..	583 =	..
Engine Driver of Launch ("Goudie" and "Victory") ..	..	526 =	..
Lighterman, Leading Hand ..	442	468 =	1 of £26
Lighterman ..	403	416 =	..
Master of Launch ("Fury") ..	..	583 =	..
Master of Launch ("Goudie" and "Victory") ..	..	526 =	..
Working Officer in Charge, Powder Anchorage ..	554	606 =	2 of £26
<i>To have effect as on and from the 1st January, 1958.</i>			
† With rations when required to live on the vessel.			
= In addition, an allowance of 5s. for each day or part thereof while engaged upon either towing or carrying explosives.			
‡ After the completion of two years' satisfactory service as such, will be eligible for progression to Able Seaman.			
× While serving in the dredging vessel "Matthew Flinders" entitled to an allowance at the rate of £40 a year for hard lying.			

A. GARRAN, Chairman.  
V. P. SCULLY, Secretary.

Office of the Public Service Board,  
Melbourne, 19th December, 1957.

No. 786

Public Service Act 1946.

REGULATIONS.—PART III.—SALARIES, INCREMENTS, AND ALLOWANCES.

THE Public Service Board, in pursuance of the powers conferred by the Public Service Act 1946, hereby amends its Regulations as shown below:—

FOURTH SCHEDULE.  
ADMINISTRATIVE DIVISION.

Amount or Range of Salary Assigned to Offices in Class "A1", Classes "A" and "A1", and Class "A".

Office.	Yearly Rate of Salary.	
	Minimum.	Maximum.
	£.	£
DEPARTMENT OF CHIEF SECRETARY.		
CLASS "A".		
Add— Registrar, Licensing Court .. .. .	..	1,550
<i>To have effect as on and from the 27th December, 1957.</i>		
DEPARTMENT OF HEALTH.		
CLASS "A".		
Add— Assistant Secretary, Mental Hygiene Authority and Mental Hygiene Branch	1,550	1,750
DEPARTMENT OF LABOUR AND INDUSTRY.		
CLASS "A1".		
Assistant Secretary .. .. .	1,800	2,150
CLASSES "A", and "A1".		
Delete— Assistant Secretary .. .. .	1,550	1,950
<i>To have effect as on and from the 16th December, 1957.</i>		

A. GARRAN, Chairman.  
V. P. SCULLY, Secretary.

Office of the Public Service Board,  
Melbourne, 19th December, 1957.

No. 790.

Public Service Act 1946, Section 50.

REGULATIONS.—PART III.—SALARIES, INCREMENTS, AND ALLOWANCES.

THE Public Service Board, in pursuance of the powers conferred by the Public Service Act 1946, hereby amends its Regulations as shown below:—

SIXTH SCHEDULE.  
TEMPORARY EMPLOYEES.

Designations of Positions and Rates of Salaries.

Department and Designation of Position.	Yearly Rate of Salary.		Increments (Annual).
	Minimum.	Maximum.	
	£	£	
DEPARTMENT OF MINES.			
Add— Drill Assistant, Leading Hand	..	411	..

A. GARRAN, Chairman.  
V. P. SCULLY, Secretary.

Office of the Public Service Board,  
Melbourne, 23rd December, 1957.

No. 785.

Public Service Act 1946, Section 40.

REGULATIONS.—PART III.—SALARIES, INCREMENTS, AND ALLOWANCES.

THE Public Service Board, in pursuance of the powers conferred by the Public Service Act 1946, hereby amends its Regulations as shown below:—

SIXTH SCHEDULE.

TEMPORARY EMPLOYEES.

Designations of Positions and Rates of Salaries.

Department and Designation of Position.	Yearly Rate of Salary.		Increments (Annual).
	Minimum.	Maximum.	
	£	£	
DEPARTMENT OF HEALTH.			
GENERAL HEALTH. Exotic Diseases.			
Add— Cook (Female) .. .. .	..	348	..
DEPARTMENT OF WATER SUPPLY.			
Delete—			
Draughtsman, Assistant (Designing)†—			
At 19 years of age .. .. .	..	468	..
At 20 years of age .. .. .	..	494	..
Adult .. .. .	546	572	1 of £26
Engineer .. .. .	785	1,030	**
Engineer, Assistant .. .. .	598	728	**
Add—			
Draughtsman, Assistant (Designing)†—			
At 19 years of age .. .. .	..	520	..
At 20 years of age .. .. .	..	546	..
Adult .. .. .	598	638	1 of £40
Engineer, Assistant .. .. .	598	1,030	**

† To apply to employees qualified by examination to receive a Diploma in Civil Engineering.  
\*\* Increments in accordance with the scale of rates of salaries as set out in the Third Schedule to these Regulations.

A. GARRAN, Chairman.  
V. P. SCULLY, Secretary.

Office of the Public Service Board,  
Melbourne, 16th December, 1957.

No. 792.

Public Service Act 1946, Section 39.

REGULATIONS.—PART III.—SALARIES, INCREMENTS, AND ALLOWANCES.

THE Public Service Board, in pursuance of the powers conferred by the Public Service Act 1946, hereby amends its Regulations as shown below:—

FIRST SCHEDULE.

PROFESSIONAL DIVISION.

Offices and Rates of Salaries.

Office.	Yearly Rate of Salary.	
	Minimum.	Maximum.
	£	£
DEPARTMENT OF AGRICULTURE.		
CLASS "B".		
Add— Science Master, Agricultural College ..	1,100	1,200

This Regulation shall have effect as on and from the 1st January, 1958.

A. GARRAN, Chairman.  
V. P. SCULLY, Secretary.

Office of the Public Service Board,  
Melbourne, 23rd December, 1957.

No. 782.

Public Service Act 1946, Section 50.

REGULATIONS.—PART III.—SALARIES, INCREMENTS, AND ALLOWANCES.

THE Public Service Board, in pursuance of the powers conferred by the Public Service Act 1946, hereby amends its Regulations as shown below:—

SIXTH SCHEDULE.  
TEMPORARY EMPLOYEES.

Designations of Positions and Rates of Salaries.

Department and Designation of Position.	Yearly Rate of Salary.		Increments (Annual).
	Minimum.	Maximum.	
<b>GENERAL.</b>	£	£	
<i>Delete—</i>			
Assistant (Male), Grade II.—Junior*			
Under 16 years of age ..	..	156	..
At 16 years of age ..	..	182	..
At 17 years of age ..	..	208	..
At 18 years of age ..	..	247	..
At 19 years of age ..	..	286	..
At 20 years of age ..	..	338	..
Adult ..	390	403	..
* Employees must possess the Intermediate Certificate or equivalent.			
<i>Add—</i>			
Assistant (Male), Grade II.—Junior—			
Under 16 years of age ..	..	156	..
At 16 years of age ..	..	182	..
At 17 years of age ..	..	208	..
At 18 years of age ..	..	247	..
At 19 years of age ..	..	286	..
At 20 years of age ..	..	338	..
Adult ..	390	403	..

A. GARRAN, Chairman.  
V. P. SCULLY, Secretary.

Office of the Public Service Board,  
Melbourne, 16th December, 1957.

No. 789.

Public Service Act 1946, Section 50.

REGULATIONS.—PART III.—SALARIES, INCREMENTS, AND ALLOWANCES.

THE Public Service Board, in pursuance of the powers conferred by the Public Service Act 1946, hereby amends its Regulations as shown below:—

SECOND SCHEDULE.

TECHNICAL AND GENERAL DIVISION.

Offices and Rates of Salaries.

Department and Office.	Yearly Rate of Salary.		Increments (Annual).
	Minimum.	Maximum.	
<b>DEPARTMENT OF HEALTH.</b>	£	£	
<b>TUBERCULOSIS.</b>			
State Sanatoria.			
<i>Delete—</i>			
General Hand ..	..	351	..
<i>Add—</i>			
General Hand ..	351	364	..

This Regulation shall have effect as on and from the 28th November, 1957.

A. GARRAN, Chairman.  
V. P. SCULLY, Secretary.

Office of the Public Service Board,  
Melbourne, 23rd December, 1957.

PRIVATE ADVERTISEMENTS

CITY OF SALE.

By-LAW No. 43.

A by-law of the City of Sale made under the Dog Acts and Numbered 43 for fixing registration and other fees thereunder.

IN pursuance of the powers conferred by the Dog Acts and of any and every other power it thereunto enabling the Mayor, Councillors and Citizens of the City of Sale orders as follows:—

- The following fees and sums are hereby fixed pursuant to the Dog Acts—
  - For registration pursuant to Section 5 of the Dog Act 1928 as amended by any Act—Seven shillings and six pence.
  - For particulars of any dog or for the name of the registered owner thereof or for a certified copy of the receipt mentioned in section 10 of the Dog Act 1928 as amended by any Act—Two shillings and six pence.
  - Sum payable to the Registration Officer pursuant to section 13 of the Dog Act 1928 as amended by any Act—Ten shillings.
  - Sum payable to the Registration Officer pursuant to section 14 of the Dog Act 1928 as amended by any Act—Ten shillings.

2. This by-law shall apply to and have operation throughout the whole of the municipal district.

Resolution for passing this by-law agreed to by the council of the City of Sale on the 18th day of November, 1957, and confirmed on the 16th day of December, 1957.

In witness whereof the seal of the said Council was affixed hereto this 16th day of December, 1957, in the presence of—

W. J. STEPHENSON, Mayor.

(SEAL) CHAS. E. CARTLEDGE, Councillor.

141 J. R. RAY, Town Clerk.

CITY OF SUNSHINE.

NOTICE is hereby given that the Council of the City of Sunshine did, at the meeting of the Council held on 16th December, 1957, by Special Order, resolve to borrow the sum of £15,000 by the issue of debentures for such amount on the credit of the Municipality; to pay interest on such loan at the rate of £5 10s. per cent. per annum; to liquidate such loan by twenty (20) half-yearly instalments of approximately £985 1s. 6d. which shall cover principal and interest payable on the first day of February and the first day of August in each year during the currency of the loan at the National Bank of Australasia Limited, Melbourne, or at the Council's Bankers for the time being in Melbourne; that such loan shall be applied for the purpose of defraying part of the cost of the execution of the construction of a group of streets known as the "Yallourn-Maxweld Streets Scheme".

By order of the Council dated 17th December, 1957.

143 T. W. DEUTSCHMANN, Town Clerk.

CITY OF SUNSHINE.

NOTICE is hereby given that the Council of the City of Sunshine did, at the meeting of the Council held on 16th December, 1957, by Special Order, resolve to borrow the sum of £10,000 by the issue of debentures for such amount on the credit of the Municipality; to pay interest on such loan at the rate of £5 10s. per cent. per annum; to liquidate such loan by twenty (20) half-yearly instalments of approximately £656 14s. 6d. which shall cover principal and interest payable on the first day of February and the first day of August in each year during the currency of the loan at the National Bank of Australasia Limited, Melbourne, or at the Council's Bankers for the time being in Melbourne; that such loan shall be applied for the purpose of defraying part of the cost of the execution of the construction of a group of streets known as the "Yallourn-Maxweld Streets Scheme".

By order of the Council dated 17th December, 1957.

142 T. W. DEUTSCHMANN, Town Clerk.

CITY OF PRESTON.

DECLARATION OF PUBLIC HIGHWAY.

A Declaration by the City of Preston Made Under Section 585 (3) of the Local Government Act 1946.

IN pursuance of the powers conferred by the Local Government Act 1946, the Council of the City of Preston, hereby declares Biran-court to be dedicated to the public as a Public Highway.

The location and description of Biran-court is shown by hachure on the plan hereunder.

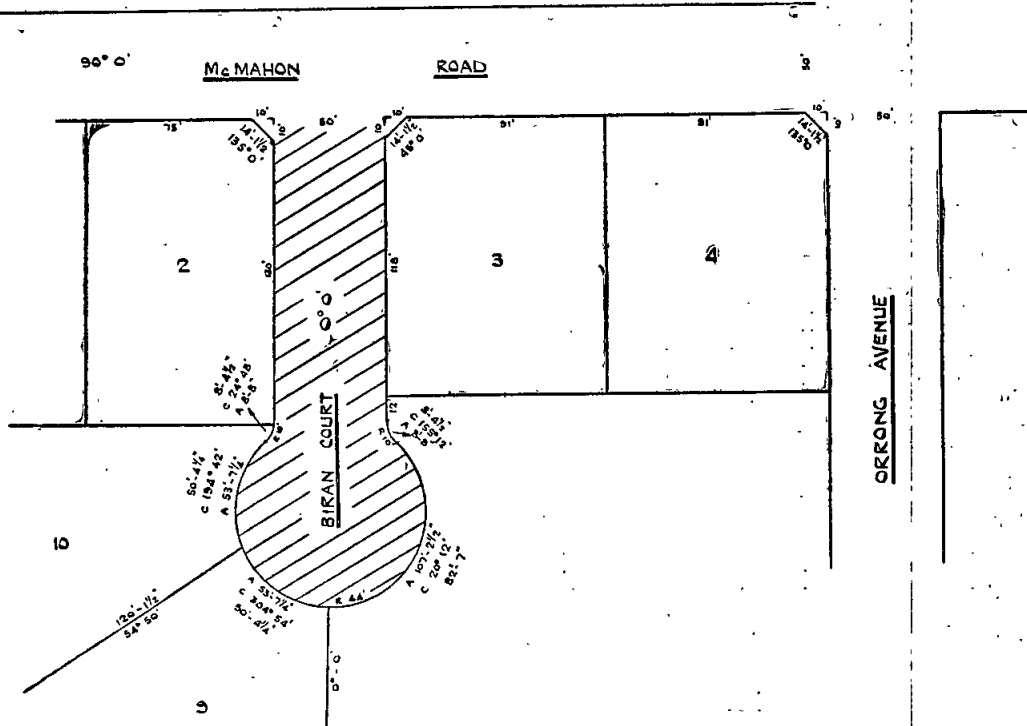

The common seal of the Mayor, Councillors, and Citizens of the City of Preston was affixed hereto this twentieth day of December, 1957, in the presence of—

(SEAL)

C. B. W. KIRBY, Mayor.  
GORDON R. KELLETT, Councillor.  
J. C. DONATH, Town Clerk.

25

CITY OF WARRNAMBOOL.

BY-LAW No. 114.

A By-law of the City of Warrnambool, made under the Dog Acts, and numbered 114, for fixing registration and other fees thereunder.

IN pursuance of the powers conferred by the Dog Acts and of any and every other power enabling it in that behalf and for the purpose of carrying the said Acts into execution, the Mayor, Councillors, and Citizens of the City of Warrnambool hereby order as follows:—

1. The following fees and sums are hereby fixed pursuant to the Dog Acts:—

	s.	d.
(a) For registration pursuant to section 5 of the Dog Act 1928, as amended by any Act .. .. .	10	0
(b) For particulars of any dog or for the name of the registered owner thereof or for a certified copy of the receipt mentioned in section 10 of the Dog Act 1928, as amended by any Act .. .. .	2	6
(c) Sum payable to the Registration Officer pursuant to section 13 of the Dog Act 1928, as amended by any Act .. .. .	10	0
(d) Sum payable to the Registration Officer pursuant to section 14 of the Dog Act 1928, as amended by any Act .. .. .	10	0

2. This By-law shall apply to and have operation throughout the whole of the municipal district.

Resolution for passing this By-law agreed to by the Council of the City of Warrnambool on the 19th day of November, 1957, and confirmed on the 17th day of December, 1957.

The common seal of the Mayor, Councillors, and Citizens of the City of Warrnambool was affixed hereto this 17th day of December, 1957, in the presence of—

(SEAL)

JOHN A. WELSH, Mayor.  
E. P. GIBBONS, Councillor.  
K. L. ARNEL, Town Clerk.

124

BOROUGH OF RINGWOOD.

BY-LAW No. 40.

A By-law of the Borough of Ringwood made under the Dog Acts and numbered 40 for fixing registration and other fees thereunder.

IN pursuance of the powers conferred by the Dog Acts and of any and every other power it thereunto enabling the Mayor, Councillors and Burgesses of the Borough of Ringwood orders as follows:—

1. The following fees and sums are hereby fixed pursuant to the Dog Acts:—

(a) For Registration pursuant to section 5 of the Dog Act 1928 as amended by any Act—Ten shillings.
(b) For particulars of any dog or for the name of the registered owner thereof or for a certified copy of the receipt mentioned in section 10 of the Dog Act 1928 as amended by any Act—Two shillings and six pence.
(c) Sum payable to the Registration Officer pursuant to section 13 of the Dog Act 1928 as amended by any Act—Ten shillings.
(d) Sum payable to the Registration Officer pursuant to section 14 of the Dog Act 1928 as amended by any Act—Ten shillings.

2. This By-law shall apply to and have operation throughout the whole of the municipal district.

Resolution for passing this By-law agreed to by the council of the Borough of Ringwood on the 20th November, 1957, and confirmed on the 19th December, 1957.

The corporate seal of the Borough of Ringwood was hereunto affixed on 19th December, 1957 in the presence of—

(SEAL) A. G. LAVIS, Chairman.  
E. T. PURSER, Councillor.  
ALFRED KELLY, Town Clerk.

134

## SHIRE OF ALTONA.

## LOAN No. 1.

*Notice of Intention to Borrow the Sum of £15,000 for Permanent Works and Undertakings.*

NOTICE is hereby given that the Council of the Shire of Altona proposes to borrow the sum of Fifteen thousand pounds on the credit of the municipal revenues of the President, Councillors, and Ratepayers of the Shire of Altona, such sum to be raised by the issue of debentures in accordance with the provisions of the Local Government Act.

1. The maximum rate of interest that may be paid is Five pounds ten shillings per cent. per annum.

2. The purpose for which the loan is to be applied is for drainage works in West Newport area.

3. The period of the loan shall be ten years.

4. The moneys borrowed shall be repayable by providing out of the Municipal Fund twenty half-yearly instalments of approximately £985 1s. 6d. each, including principal and interest, on the 1st day of April and the 1st day of October during the currency of the loan. The first instalment shall be payable on the 1st day of October, 1958.

5. Such moneys shall be repayable at the Commonwealth Trading Bank of Australia, Melbourne, or at the Council's bankers for the time being in Melbourne.

The plans, specifications, and estimate cost of the proposed work, and a statement showing the proposed expenditure of the moneys to be borrowed, are open for inspection at the Municipal Offices, Altona.

121 JAMES W. WATERS, Shire Secretary.

## SHIRE OF BET BET.

NOTICE is hereby given that First Constable R. Adams, 10136, has been appointed as Prosecuting Officer and Inspector of Nuisances to the Bealiba Riding of the Shire of Bet Bet, in lieu of First Constable R. O'Sullivan, 9322, who has resigned.

138 R. T. CUTTS, Shire Secretary.

## SHIRE OF ELTHAM.

## LOAN No. 30.

*Notice of Intention to Borrow the Sum of £15,000 for Permanent Works and Undertakings.*

NOTICE is hereby given that the Council of the Shire of Eltham proposes to borrow the sum of Fifteen thousand pounds on the credit of the municipal revenues of the President, Councillors, and Ratepayers of the said Shire, such sum to be raised by the issue of debentures in accordance with the provisions of the Local Government Acts.

1. The maximum rate of interest that may be paid is £5 10s. per cent. per annum.

2. The purpose for which the loan is to be applied is construction of part of Mountain View-road, Montmorency.

3. The period of the loan shall be ten years.

4. The moneys borrowed shall be repayable by providing out of the Municipal Fund twenty half-yearly instalments of approximately £985 1s. 6d. each, including principal and interest, on the 1st day of October and the 1st day of April during the currency of the loan. The first instalment shall be payable on the 1st day of October, 1958.

5. Such moneys shall be repayable at The Commercial Bank of Australia Limited, Melbourne, or at the Council's bankers for the time being in Melbourne.

The plans and specifications and the estimate of the cost of the proposed works, and a statement showing the proposed expenditure of the moneys to be borrowed, are open for inspection at the Shire Office, Eltham.

118 R. J. HAM, Shire Secretary.

## SHIRE OF MALDON.

## BY-LAW No. 11.

A by-law of the Shire of Maldon made under the Dog Acts and numbered 11 for fixing registration and other fees thereunder.

IN pursuance of the powers conferred by the Dog Acts and of any and every other power it thereunto enabling the Council of the Shire of Maldon orders as follows:—

1. The following fees and sums are hereby fixed pursuant to the Dog Acts:—

(a) For registration pursuant to section 5 of the *Dog Act 1928* as amended by any Act—Five shillings.

(b) For particulars of any dog or for the name of the registered owner thereof or for a certified copy of the receipt mentioned in section 10 of the *Dog Act 1928* as amended by any Act—Two shillings and six pence.

(c) Sum payable to the Registration Officer pursuant to section 13 of the *Dog Act 1928* as amended by any Act—Ten shillings.

(d) Sum payable to the Registration Officer pursuant to section 14 of the *Dog Act 1928* as amended by any Act—Ten shillings.

2. This by-law shall apply to and have operation throughout the whole of the municipal district.

Resolution for passing this by-law agreed to by the Council of the Shire of Maldon on the 7th day of November, 1957, and confirmed on the 5th day of December, 1957.

The common seal of the President, Councillors and Ratepayers of the Shire of Maldon was hereunto affixed this 5th day of December, 1957, in the presence of—

(SEAL) A. E. WOOD, President.  
J. P. EDWARDS, Councillor.  
M. CLEARY, Shire Secretary.

139

## SHIRE OF MANSFIELD.

## LOAN No. 32.

*Notice of Intention to Borrow the Sum of £4,000 for Permanent Works and Undertakings.*

NOTICE is hereby given that the Council of the Shire of Mansfield proposes to borrow the sum of Four thousand pounds on the credit of the municipal revenues of the President, Councillors, and Ratepayers of the said Shire, such sum to be raised by the issue of debentures in accordance with the provisions of the Local Government Acts.

1. The maximum rate of interest that may be paid is 5½ per cent. per annum.

2. The purpose for which the loan is to be applied is for purchase of road-making machinery, viz., dozer.

3. The period of the loan shall be three years.

4. The moneys borrowed shall be repayable by providing out of the Municipal Fund six half-yearly instalments of approximately £730 15s. each, including principal and interest, on the 1st day of April and the 1st day of October during the currency of the loan. The first instalment shall be payable on the 1st day of October, 1958.

5. Such moneys shall be repayable at the Bank of New South Wales, Melbourne, or at the Council's bankers for the time being in Melbourne.

The plans and specifications and the estimate of the cost of the proposed works, and a statement showing the proposed expenditure of the moneys to be borrowed, are open for inspection at the Shire Office, Mansfield.

135 R. WOMERSLEY, Shire Secretary.

## SHIRE OF MULGRAVE.

NOTICE is hereby given that the Council of the Shire of Mulgrave has altered, under the provisions of the *Local Government Act 1946*, the names of the streets shown hereunder:—

*Old Name; Plan of Subdivision Number; New Name; Locality.*

Edith-street; 22346; Allen-street; Glen Waverley.  
Margot-street; 26919; Bales-street; Mt. Waverley.

123

F. S. BALES, Shire Secretary.

## SHIRE OF WODONGA.

BY-LAW No. 40.

A By-law of the Shire of Wodonga, made under the Health Acts, and numbered 40 for fixing the limits within which it shall be unlawful to keep swine or pig sties.

IN pursuance of the powers conferred by the *Health Act 1928* and all other powers it thereunto enabling, the President, Councillors, and Ratepayers of the Shire of Wodonga order as follows:—

1. By-laws, Shire of Wodonga, numbered 4 and 4A relating to pigs are hereby repealed.

2. This By-law shall apply to and have operation in the following parts of the municipal district:—

Commencing at a point 8 chains south-west of the southern corner of Crown allotment 5, section 24, Parish of Wodonga; thence north-westerly 5 chains; thence north-easterly by a line 5 chains from and parallel to the Murray Valley Highway to the Kiewa River and by a prolongation of that line to a point 5 chains north of the said river; thence generally southerly by a line parallel to and distant 5 chains from that river to the south side of the Murray Valley Highway; thence generally southerly by a line parallel to and 5 chains east of the eastern boundary of Killara Estate subdivision being L.P.29197 to a point 5 chains south-west of the northern boundary of the military area; thence north-westerly by line to the point of commencement.

Commencing at the junction of the Melbourne-Albury Railway Reserve and Carroll's-road on the western boundary of Crown allotment 1, section A11, Parish of Wodonga; thence south-easterly by that reserve to the House Creek; thence by that creek to its junction with the Wodonga Creek; thence by that creek to the Melbourne-Albury Railway Reserve; thence southerly by the said Reserve to the southern boundary of the Wodonga Pre-emptive Right; thence by that boundary to the north-eastern corner of Crown allotment 5, section U; thence south-westerly by the eastern boundary of Crown allotments 5, 6, 7, 8, 9, 10, section U, to the south-eastern corner of the said Crown allotment 10; thence easterly by the southern boundary of Crown allotments 1 and 2, sections XII, allotment 9, section XIIA, and allotment 8, section XII B; thence southerly by the eastern boundaries of Crown allotments 7A, section A8, allotment 7, sections A9, 4, 5, 10, section XI, allotment 9 of 11, 4, 5, section 5; thence westerly by the southern boundary of Crown allotments 5, 6, 7 of section 5 and Crown allotment 3, section H, to the House Creek; thence generally northerly to the north-eastern corner of Crown allotment 2, section M2; thence westerly by the northern boundaries of Crown allotments 2 and 1, section M2, to the road at the north-western corner of the said allotment 1; thence northerly by the western boundaries of Crown allotment 1, section N2, the cemetery and 1, section A11, to the point of commencement.

3. No person shall keep or permit or suffer to be kept any swine or pig sty within the area prescribed.

Resolution adopting this By-law agreed to by the Council on the 2nd October, 1957, and confirmed on the 6th November, 1957.

The common seal of the President, Councillors, and Ratepayers of the Shire of Wodonga was hereunto affixed, in the presence of—

J. S. HORE, President.

(SEAL) R. S. BENSON, Councillor.

H. McK. SILKE, Shire Secretary.

Submitted to the Commission of Public Health on the 26th day of November, 1957.—G. V. STAFFORD, Secretary to the Commission.

Approved by the Governor in Council, 18th December, 1957.—A. MAHLSTEDT, Clerk of the Executive Council. 129

NOTICE is hereby given that Apsley Golf Club, of Box 26, Apsley, has applied for a lease under section 125 of the *Land Act 1928* for a term of 21 years over an area of approximately 100 acres of Crown land, described as allotment 29A, Parish of Murrandarra. 122

Victoria.

## ACT 391.—FIRST SCHEDULE.

I THE MOST REVEREND JOSEPH JOHN BOOTH, of Cathedral Buildings, Flinders-lane, Melbourne, in the State of Victoria, C.M.G., M.C., E.D., B.A., TH. Soc., D.D., Archbishop Administrator of the Church of England Diocese of Melbourne, head or authorized representative of the denomination known as the Church of England, in the Diocese of Melbourne, in Victoria, with the consent of the Church of England Trusts Corporation for the Diocese of Melbourne, of Flinders-lane, Melbourne aforesaid, which is entitled to be registered as the Trustee of the land described in the subjoined statement of trusts, hereby apply to the Governor of the State of Victoria, for leave to dispose of the said land by the means and for the purposes mentioned in the said statement of trusts, and I hereby certify that the said land was promised or reserved as a site for Church of England purposes on the 25th February, 1861.

That the Church of England Trusts Corporation for the Diocese of Melbourne is entitled to be registered as the only trustee of the said land.

That there is no building erected upon the said land.

Dated this 14th day of October, 1957.

JOSEPH BOOTH,

Archbishop Administrator.

The Church of England Trusts Corporation for the Diocese of Melbourne, hereby consents to this application.

The seal of the Church of England Trusts Corporation for the Diocese of Melbourne was hereto affixed by Richard Clayton Wardle, Registrar of the Diocese of Melbourne, in the presence of—

(L.S.) JOSEPH BOOTH, Corporation Trustee.  
H. W. BUCKLEY, Corporation Trustee.  
R. C. WARDLE, Registrar.

## STATEMENT OF TRUSTS.

*Description of Land.*—2 acres, Parish of Mooroolbark, County of Evelyn, being allotment 2e; Commencing at a point bearing south 331 links from the north-eastern angle of allotment 2c; bounded thence by roads bearing south 400 links, and west 500 links; and, thence by allotment 2c, bearing north 400 links, and east 500 links to the point of commencement.

*Names of Trustees.*—The Church of England Trusts Corporation for the Diocese of Melbourne, of Cathedral Buildings, Flinders-lane, Melbourne.

*Power of Disposition.*—Power to sell, lease, mortgage, or exchange all or any part of such land subject to the approval of the Archbishop of Melbourne for the time being, or during the absence of the Archbishop from the Diocese or the vacancy of the see, to the approval of the person for the time being administering the affairs thereof. The land, until otherwise disposed of, to be held for the purposes for which it was granted or reserved by the Crown.

*Purposes to which Proceeds of Disposition are to be Applied.*—To be paid to the Archbishop or administrator aforesaid, to be applied to such purposes of the Church of England in the Diocese of Melbourne as may by such Archbishop or administrator acting under the advice of the Council of the Diocese, be from time to time deemed desirable.

RIGBY & FIELDING, of 60 Market-street, Melbourne, solicitors of the applicant. 178

## THE BALLARAT WATER COMMISSIONERS.

NOTICE is hereby given to owners of tenements in the streets set out in the Schedule hereto and the private streets, lanes, courts, and alleys opening thereto that the main pipes in the said streets being laid down the owners of all tenements situated as above are required to cause proper pipes and stop cocks to be laid so as to supply water within such tenements from the main pipe, and the laying of all such pipes and stop cocks shall be completed in accordance with By-law No. 10 of The Ballarat Water Commissioners on or before the 1st day of February, 1958.

Boronia-grove, from Grevillea-road, northerly 7 chains.  
Oak-street, from Kirk-street, southerly 51 chains.  
Russell-street, from Sturt-street to Alfred-street.  
Cooke-street, from Pleasant-street to Ripon-street.  
Hawthorn-grove, throughout.  
Richards-street, from Wilson-street to York-street.



Poplar-street, from 5 chains west of Dowling-street, to Hawthorn-grove.  
 Suburban-avenue, throughout.  
 Doveton-street north, from Norman-street northerly 40½ chains.  
 Pryor-street, from 6 chains south of Barkly-street to Boundary-road.  
 Heales-street, from Boundary-road northerly 3 chains.  
 Boundary-road, from Pryor-street to Heales-street.  
 Wesley-court, throughout.  
 Reid-street, from 5½ chains west of Thompson-street, westerly to Ainley-street.  
 Belford-street, from York-street, northerly 4½ chains.  
 Williams-street, from 5½ chains west of Dowling-street, westerly 5½ chains.  
 Walker-street, from Havelock-street to Sherrard-street.  
 Ararat-street, from Lydiard-street to Armstrong-street.  
 Victory-avenue, from 4½ chains north of Cuthbert-road, northerly 3 chains.  
 Talbot-street south, from Bell-street to Leith-street.  
 El'Ramleh-avenue, throughout.  
 Little Dods-street, from Callow-street, southerly 2½ chains.  
 Callow-street south, from Larter-street to Main-street.  
 Callow-street north, from Macdonald-street to Montrorse-street.  
 Larter-street, from York-street to Callow-street.  
 Montrorse-street, throughout.  
 Kinnersley-avenue, from Geelong-road easterly 7 chains.  
 Cardigan-avenue, throughout.  
 Iris-avenue, from 8½ chains east of Dowling-street to Essex-street.  
 Dunrobin-court, throughout.  
 Bowden-street, from 4½ chains south of Fisher-street, westerly 3½ chains.  
 Grandview-grove, from Norman-street, northerly 5½ chains.  
 Norman-street, from Forest-street to Gillies-street, from Forest-street easterly 6 chains, and from Havelock-street easterly 8½ chains.  
 Mathilda-street, throughout.  
 Adela-street, throughout.  
 Pevensey-street, throughout.  
 Stamford-street, throughout.  
 Edwin-street, throughout.  
 Hastings-street, throughout.  
 Margaret-street, throughout.  
 Harold-street, from Hastings-street to Stamford-street.  
 Forest-street, from Norman-street to Edwin-street.  
 Dover-street, from Romney-street to Stamford-street.  
 Maude-street, throughout.  
 Romney-street, throughout.  
 Edgar-street, throughout.  
 Grammar-street, from Kirk-street to College-street.  
 College-street, from 4 chains west of Symons-street to Grammar-street.  
 Rowlands-street (Sebastopol), from 5 chains south of Walker-street to Birdwood-avenue.  
 Yarrowee-street (Sebastopol), from Bridge-street, northerly 14 chains.  
 Hill-street (Sebastopol), from Spencer-street to Rowlands-street.  
 Rowlands-street (Sebastopol), from Hill-street northerly 4½ chains.  
 Charlotte-street (Sebastopol), from Bridge-street southerly 15 chains.

C. H. CLAMP,

Secretary of The Ballarat Water Commissioners.

24th December, 1957.

130

#### BENDIGO SEWERAGE AUTHORITY.

##### DECLARATION OF SEWERAGE AREAS.

THE Bendigo Sewerage Authority, having made provision for carrying off the sewage from each and every property which or any part of which is within the sewerage areas hereinafter described, doth hereby declare that on and after the 1st day of February, 1958, each and every property which or any part of which is within the said Sewerage Areas shall be deemed to be a sewered property within the meaning of the Sewerage Districts Acts.

The boundaries of the Sewerage Areas hereinbefore referred to are—

##### SEWERAGE AREA No. 145.

Commencing at the intersection of Byron and Carpenter streets on the boundary of Sewerage Area No. 139; thence southerly along the west side of and across Carpenter-street to the northern boundary of Crown allotment 37, section H1, Parish of Sandhurst; thence easterly along the said northern boundary and across Spring Gully-road to the eastern side of Spring Gully-road; thence northerly

to the north-western corner of Crown allotment 537 of H; thence easterly along the northern boundary of Crown allotments 537 and 537a to the western boundary of Crown allotment 538; thence northerly along the western boundaries of Crown allotments 538 and 539 and by a line across Stanley-street to the southern-most corner of Sewerage Area No. 139; thence generally westerly along the boundaries of Sewerage Area No. 139 to the point of commencement.

##### SEWERAGE AREA No. 146.

Commencing at the intersection of Swan and Plover streets on the boundary of Sewerage Area No. 114; thence south-westerly along Plover-street to the centre line of Holmes-road; thence north-westerly along Holmes-road to the south-eastern side of Anderson-street; thence south-westerly along Anderson-street to the western-most angle of Crown allotment 23k, section K, at Bendigo; thence south-easterly along the south-western boundary of the said Crown allotment and its prolongation to the boundary of Sewerage Area No. 113; thence generally northerly and westerly along the boundaries of Sewerage Areas Nos. 103, 59, 93 and 114 to the point of commencement.

##### SEWERAGE AREA No. 147.

Commencing at the north-western corner of Church of England Reserve, Township of Kangaroo Flat, on the boundary of Sewerage Area No. 88; thence easterly along the northern boundary of the Church Reserve and across Church-street to the eastern side of Church-street; thence northerly along Church-street to the centre line of Kangaroo Gully and northerly along Kangaroo Gully to the centre line of Lansell-street; thence westerly along Lansell-street to the boundary of Sewerage Area No. 88; thence southerly along the Sewerage Area boundary to the point of commencement.

##### SEWERAGE AREA No. 148.

Commencing at the intersection of Camp and Carpenter streets on the boundary of Sewerage Area No. 88; thence westerly along Camp-street to the centre line of the Bendigo Creek; thence southerly along the Bendigo Creek to a point in line with the southern boundary of plan of subdivision of Crown allotment 12 and part of Crown allotment 13, section 10; thence easterly by a line and along the said southern boundary and its eastern prolongation to the boundary of Sewerage Area No. 88; thence northerly along the said Sewerage Area boundary to the point of commencement.

##### SEWERAGE AREA No. 149.

Commencing at the intersection of Bay-street with the Bendigo Creek being a point on the boundary of Sewerage Area No. 50; thence north-westerly along the centre line of Bay-street to its intersection with Mackenzie-street west; thence south-westerly along Mackenzie-street west to a point on the prolongation of the south-western boundary of Crown allotment 8, section 45B, at Bendigo; thence north-westerly across Mackenzie-street west and along the said Crown allotment boundary to the western-most angle of the said Crown allotment 8; thence north-easterly along the north-western boundaries of Crown allotments 8, 7B, 7A, 5, 4, 1, 7 and 6E to the south side of Symonds-street; thence westerly along Symonds-street to the south-eastern side of Aspinall-street; thence north-easterly along Aspinall-street to the northern-most angle of Crown allotment 20A, section 58B; thence south-easterly along the north-eastern boundary of the said Crown allotment 20A to the western-most angle of Crown allotment 18; thence north-easterly along the north-western boundaries of Crown allotments 18, 17 and 16 and the prolongation thereof through Crown allotment 15, through Crown land and across Emmetts-street to the south-western boundary of Crown allotment 58, section L; thence north-westerly and north-easterly along the south-western and north-western boundaries of the said Crown allotment 58 to its most northern angle; thence north-westerly along Pig Sty Gully to a point 1 chain past Aspinall-street; thence north-easterly by a line parallel with Aspinall-street to the eastern side of Specimen Hill-road; thence northerly along Specimen Hill-road to the northern boundary of Residence Licence No. 01692/129; thence easterly and southerly around the boundaries of the said Residence Licence and southerly by a line to the centre line of the realignment of Taylor-street; thence easterly along Taylor-street to the centre line of Illingworth-street; thence southerly along Illingworth-street to the centre line of Reeve-street; thence south-westerly along the centre line of Reeve-street to the eastern side of Specimen Hill-road; thence southerly along Specimen Hill-road to the north-western side of Mackenzie-street west; thence north-easterly along Mackenzie-street west to the southern-most angle of Crown allotment 4, section 34B; thence by a line bearing 156 degrees (true) across

Mackenzie-street west and through Crown land to the boundary of Sewerage Area No. 50; thence south-westerly along the said Sewerage Area boundary to the point of commencement.

By order of the Bendigo Sewerage Authority,

H. W. SNELL, Chairman.  
H. A. MOORS, Secretary.

MUNICIPAL ASSOCIATION OF VICTORIA.

BY-LAW No. 43.

A By-law of the Shire of Cranbourne made under the Dog Acts and numbered 43, for fixing registration and other fees thereunder.

IN pursuance of the powers conferred by the Dog Acts and of any and every other power it thereunto enabling the President, Councillors, and Ratepayers of the Shire of Cranbourne, orders as follows:—

1. The following fees and sums are hereby fixed, pursuant to the Dog Acts:—

- (a) For registration, pursuant to section 5 of the Dog Act 1928, as amended by any Act . . . . . 7 6
- (b) For particulars of any dog or for the name of the registered owner thereof or for a certified copy of the receipt mentioned in section 10 of the Dog Act 1928, as amended by any Act . . . . . 2 6
- (c) Sum payable to the Registration Officer, pursuant to section 13 of the Dog Act 1928, as amended by any Act . . . . . 10 0
- (d) Sum payable to the Registration Officer, pursuant to section 14 of the Dog Act 1928, as amended by any Act . . . . . 10 0

2. This By-law shall apply to and have operation throughout the whole of the municipal district of the Shire of Cranbourne.

Resolution for passing this By-law agreed to by the Council at the meeting on the 13th December, 1957, and confirmed on the 10th day of January, 1958.

The common seal of the President, Councillors, and Ratepayers of the Shire of Cranbourne was hereunto affixed by order of the Council, in the presence of—

(SEAL) L. J. COCHRANE, President.  
W. B. CAMPBELL, Councillor.  
GEORGE F. KNOWLES, Councillor.  
T. W. GRANT, Shire Secretary.

144

GEELONG WATERWORKS AND SEWERAGE TRUST.  
SEWER EXTENSIONS NOS. 258, 258A, 281, 293, AND 296.

PURSUANT to section 55 (2) of the Geelong Waterworks and Sewerage Act 1928 (No. 3692), notice is hereby given of the intention of the Trust to construct sewers to provide for properties in and adjacent to Walter-street, City of Geelong, Church-street and Howcourt, City of Geelong West, and Centreway, Shire of Corio, and more particularly as shown on maps which are open for inspection at this office between the hours of 9 a.m. and 4 p.m. from Monday to Friday inclusive.

Dated this 8th day of January, 1958.

137 B. C. HENSHAW, Secretary.

NOTICE OF DISSOLUTION.

NOTICE is hereby given that the partnership heretofore subsisting between John Maxwell McDonald, of Nicholson-street, Healesville, electrical contractor, and John James Doherty, of 44 Rutland-road, Box Hill, electrical contractor, carrying on business of electrical contractors at Healesville, under the firm of "McDonald and Doherty," has been dissolved as from the 30th day of November, 1957.

J. M. McDONALD.  
J. J. DOHERTY.

153

NOTICE is hereby given that the partnership heretofore subsisting between Rachel Otenstein and Rachel Solenski, under the name of "Otenstein and Solenski," in delicatessan business at 316 Clarendon-street, South Melbourne, has been dissolved by mutual consent. Such business will hereafter be carried on by the former solely, who will meet all commitments of the said business.

Dated the 6th day of January, 1958.

RACHEL OTENSTEIN.  
R. SOLENSKI.

198

NOTICE is hereby given that the partnership heretofore subsisting between the undersigned, Henry Stewart Rickards and John Bertram Rann, carrying on business at 1A Anchor-place, Prahran, under the name of "Foil Pax Co.," has been dissolved by mutual consent as from 8th January, 1958. All debts due to and owing by the late partnership will be received and paid by John Bertram Rann, who will continue to carry on the said business under the same name at the same place, but in partnership with one James Hanger.

Dated at Melbourne this 8th day, of January, 1958.

H. S. RICKARDS.  
J. B. RANN.

Witness—FREDERICK OWEN, solicitor, Melbourne.  
Frederick Owen and Associates, solicitors, 84 William-street, Melbourne, C.L. 191

NOTICE OF DISSOLUTION OF PARTNERSHIP.

NOTICE is hereby given that the partnership heretofore subsisting between the undersigned, Leslie Rosenbloom and Don Rabinov, carrying on business as medical practitioners at 326A South-road, Moorabbin, under the names of "Drs. L. Rosenbloom and D. Rabinov" and of "Moorabbin Clinic," has been dissolved by mutual consent as from the 18th day of December, 1957. All debts due to and owing by the late firm will be received and paid by Dr. Don Rabinov, who will continue to carry on business at the same place.

Dated at Moorabbin the 18th day of December, 1957.

DON RABINOV.  
L. ROSENBLOOM.

Witness to both signatures—B. ROSENBLOOM, housewife,  
Flat 7, 586 Nepean Highway, East Brighton. 175

HENRY GEORGE CLUB LIMITED.

REGISTER of Unclaimed Monies held by the Henry George Club Ltd., 18 George-parade, Melbourne.

Name of Owner on Books.	Total Amount Due to Owner.	Description of Unclaimed Money.	Date of Last Claim.
	£ s. d.		
Anderson, G. S. E. (address unknown)	0 3 0	Dividends	No claim
Barass, W. F. (dead)	0 10 0	"	"
Brown, R. J. (address unknown)	0 5 0	"	"
Chalmers, John (dead)	0 1 0	"	"
Datson, M. (dead)	0 1 0	"	"
Ford, J. (dead)	0 1 0	"	"
Forster, T. W. (dead)	0 1 0	"	"
Johnson, S. A. (gaol)	0 1 0	"	"
Kirkland, A. M. (dead)	0 5 0	"	"
Mathieu, J. A. (address unknown)	0 1 0	"	"
McLoskey, Mrs. Eva (dead)	0 1 0	"	"
Mewkill, E. (dead)	0 5 0	"	"
Murphy, J. J. (address unknown)	0 3 0	"	"
Paling, Mrs. L. (dead)	0 2 0	"	"
Pollard, W. (address unknown)	0 1 0	"	"
Smithson, C. W. (address unknown)	0 2 0	"	"
Spinks, V. (address unknown)	0 1 0	"	"

132

No. of Company: 865/10696.

COMPANIES ACT 1938.

REGISTER of Unclaimed Moneys held by The Perpetua Executors and Trustees Association of Australia Limited.

Name of Owner on Books.	Total Amount Due to Owner.	Description of Unclaimed Money.	Date of Last Claim.
	£ s. d.		
Attenborough, W. (executors)	7 10 0	Dividends Nos. 109 and 110	23.2.12
Cave-Thomas, H. F. . .	0 10 0		

198

The Companies Act 1938, Section 574.—Thirty-second Schedule.

REGISTER of Unclaimed Money held by Goldsbrough, Mort and Company Limited, Melbourne, 1st January, 1958.

## REGISTER OF UNCLAIMED MONEYS—continued.

Name of Owner on Books.	Total Amount Due to Owner.	Description of Unclaimed Money.	Date of Last Claim.	Name of Owner on Books.	Total Amount Due to Owner.	Description of Unclaimed Money.	Date of Last Claim.
	£ s. d.				£ s. d.		
Unknown ..	23 2 9	Proceeds of one sack of wool (no brand) sold 15th February, 1951	Nil	Unknown ..	2 7 3	Proceeds of one cattle sold 22nd May, 1951	Nil
Unknown ..	20 7 2	Proceeds of one sack of wool XYZ sold 7th March, 1951	Nil	S. Clues ..	1 14 10	Cheque No. 8719 issued at Melbourne, 3rd July, 1951, unrepresented	Nil
Unknown ..	36 3 4	Proceeds of one sack of wool branded JM/AMF sold 7th March, 1951	Nil	Lewis Bell ..	8 5	Cheque No. 9710 issued at Melbourne, 29th September, 1951, unrepresented	Nil
Unknown ..	13 17 2	Proceeds of one sack of wool branded McK/Doon sold 7th May, 1951	Nil	S. H. Tomlinson ..	1 16 5	Cheque No. 369 issued at Melbourne, 30th November, 1951, unrepresented	Nil
Unknown ..	18 6 3	Proceeds of one sack of wool (no brand) sold 31st March, 1951	Nil	R. Jones ..	1 13 7	Cheque No. 310 issued at Melbourne, 30th November, 1951 unrepresented	Nil
Unknown ..	267 8 8	Proceeds of one bale of wool branded Bunilla sold 24th April, 1951	Nil	G. H. Crumpton	3 3 0	Cheque No. 383 issued at Melbourne, 30th November, 1951, unrepresented	Nil
Unknown ..	21 19 9	Proceeds of one sack of wool (no brand) sold 24th April, 1951	Nil	N. E. Downing	1 16 8	Cheque No. 388 issued at Melbourne, 30th November, 1951, unrepresented	Nil
Unknown ..	251 15 5	Proceeds of four bales of wool branded AWB sold 21st May, 1951	Nil	G. A. Brightman	5 5 1	Cheque No. 1092 issued at Melbourne, 18th December, 1951, unrepresented	Nil
Unknown ..	12 11	Proceeds of two sacks of wool branded B/Bal sold 12th July, 1951	Nil	Mrs. E. Nicholson	307 19 9	Cheque No. 3560 issued at Alexandra, 28th November, 1951, unrepresented	Nil
Unknown ..	18 19 1	Proceeds of two bales of wool branded JS sold 12th July, 1951	Nil	W. Brown ..	3 10 0	Cheque No. 738 issued at Horsham, 20th November, 1951, unrepresented	Nil
Unknown ..	3 11 11	Proceeds of one sack of wool not branded sold 12th July, 1951	Nil	W. Brant ..	4 3 0	Cheque No. 1093 issued at Melbourne, 30th October, 1951, unrepresented	Nil
Unknown ..	1 1	Proceeds of one sack of wool branded ES sold 16th October, 1951	Nil	L. J. Harrison	3 8	Cheque No. 1159 issued at Melbourne, 30th October, 1951, unrepresented	Nil
Unknown ..	4 0 9	Proceeds of one sack of wool branded AC sold 16th October, 1951	Nil	P. A. Barnes	18 4	Cheque No. 1165 issued at Melbourne, 4th December, 1951, unrepresented	Nil
Unknown ..	6 2 11	Proceeds of one sack of wool branded TGH/W sold 13th December, 1951	Nil	J. McWaters	1 6 9	Cheque No. 5917 issued at Melbourne, 21st February, 1951, unrepresented	Nil
Unknown ..	18 14 11	Proceeds of two sacks of wool branded VZ sold 13th December, 1951	Nil	D. F. Smith	5 2	Cheque No. 6299 issued at Melbourne, 29th March, 1951, unrepresented	Nil
Unknown ..	2 15 9	Proceeds of one skin sold 30th January, 1951	Nil	B. Bishop ..	1 14 3	Cheque No. 6796 issued at Melbourne, 27th April, 1951, unrepresented	Nil
Unknown ..	4 8 3	Proceeds of three skins sold 13th February, 1951	Nil	Altona Meat Supply	6 17 0	Cheque No. 6919 issued at Melbourne, 4th May, 1951, unrepresented	Nil
Unknown ..	1 5 3	Proceeds of one hide sold 13th March, 1951	Nil	W. T. Price	2 2	Cheque No. 7538 issued at Melbourne, 22nd June, 1951, unrepresented	Nil
Unknown ..	6 4	Proceeds of one skin sold 10th April, 1951	Nil	W. Waldorf	3 10	Cheque No. 7596 issued at Melbourne, 22nd June, 1951, unrepresented	Nil
Unknown ..	1 15 4	Proceeds of horse hair sold 24th April, 1951	Nil	L. Beer ..	1 15 4	Cheque No. 9343 issued at Melbourne, 21st September, 1951, unrepresented	Nil
Unknown ..	2 12 4	Proceeds quantity of rabbit skins sold 25th September, 1951	Nil	Kenneth L. Gray	16 1	Cheque No. 10552 issued at Melbourne, 19th December, 1951, unrepresented	Nil
Unknown ..	10 2	Proceeds of one sheep skin sold 9th October, 1951	Nil	W. Coleman	2 10 0	Cheque No. 9233 issued at Wangaratta 9th February, 1951, unrepresented	Nil
Unknown ..	1 5 7	Proceeds of produce incorrectly credited Gross Koondrook, 23rd November, 1951	Nil	Mrs. A. N. Ryan	3 9 0	Cheque No. 1023 issued at Wangaratta, 25th July, 1951, unrepresented	Nil
Unknown ..	2 16 10	Proceeds of produce incorrectly credited Dowling 7th November, 1951	Nil	L. Ashlekov	1 12 1	Cheque No. 10307 issued at Melbourne, 23rd January, 1951, unrepresented	Nil
Unknown ..	7 4	Proceeds of one sheep skin 11th December, 1951	Nil	T. Gleen ..	1 1 6	Cheque No. 2097 issued at Melbourne, 25th October, 1951, unrepresented	Nil
Unknown ..	19 6	Proceeds of one calf 4th September, 1951	Nil	H. Smith ..	32 9 9	Cheque No. 2578 issued at L'field 5th April, 1951, unrepresented	Nil
Unknown ..	18 6	Proceeds of one calf 17th October, 1951	Nil	F. Miller ..	11 4	Cheque No. 1093 issued at Melbourne, 30th October, 1951, unrepresented	Nil
Unknown ..	6 7 6	Proceeds of one lamb 31st March, 1951	Nil	Estate Beer	9 12 6	Commission on stock and wool seasons 1948 and 1949	Nil
H. Robinson	9 13 1	Proceeds of one steer cheque 9569 unrepresented client unknown sold 20th July, 1951	Nil				
Unknown ..	2 12 11	Proceeds of two calves sold 16th August, 1951	Nil		1,154 16 8		
Unknown ..	8 4	Proceeds of one pig sold 2nd May, 1951	Nil				

HOWARD SMITH LIMITED.

REGISTER of Unclaimed Moneys held by Howard Smith Limited.

Name of Owner.	Balance Amount Due to Owner.	Description of Unclaimed Money.	Date Accrued.
	£ s. d.		
W. Allen	0 10 11	Unclaimed labour	Jan., 1951
R. Allen	0 10 0	"	"
A. Burns	0 10 0	"	"
J. Bowden	0 2 8	"	"
T. Brotherwood	0 10 11	"	"
P. Collins	0 9 4	"	"
J. Cory	0 10 11	"	"
W. Christensen	0 3 4	"	"
R. Clarke	1 1 5	"	"
H. Carroll	0 6 8	"	"
M. Erickson	1 3 6	"	"
J. Furness	1 11 2	"	"
A. Hill	0 3 4	"	"
E. Holland	0 9 0	"	"
F. Jensen	1 0 3	"	"
P. Kinnane	0 11 7	"	"
W. Luckey	0 10 11	"	"
E. Lee	0 10 0	"	"
M. Langley	0 3 4	"	"
L. Mullen	0 5 0	"	"
S. Miller	0 5 0	"	"
J. McMinn	0 5 0	"	"
A. McKay	0 3 4	"	"
W. McAllister	0 6 8	"	"
F. Pettiona	0 3 4	"	"
R. Pratt	0 3 4	"	"
A. Phillips	0 10 11	"	"
F. Piggott	0 3 4	"	"
E. Stackpools	0 9 0	"	"
J. Thomas	0 2 8	"	"
J. Timms	0 9 4	"	"
G. Webb	0 6 6	"	"
G. Johnson	0 5 9	"	Mar., 1951
S. Schofield	2 14 8	"	May, 1951
R. Seaborn	0 7 0	"	June, 1951
S. Bulpit	0 3 6	"	"
J. Fulton	0 3 6	"	"
R. Allen	0 3 6	"	"
J. J. Williams	0 6 11	"	"
J. Ross	0 9 1	"	July, 1951
W. Carlton	0 11 3	"	Oct., 1951
F. Bazin	0 11 3	"	"
G. Winchcombe	0 11 3	"	"
H. Brookes	0 1 6	"	Dec., 1951
M. Brown	0 1 6	"	"
W. Browney	0 3 0	"	"
W. Costello	0 1 6	"	"
H. Cairns	0 3 0	"	"
R. Clarke	0 1 6	"	"
C. Collins	0 1 6	"	"
R. Collins	0 1 6	"	"
J. Collins	0 1 6	"	"
F. Fitzgerald	0 4 6	"	"
L. Smith	0 10 0	"	"
R. Fagan	0 1 6	"	"
C. Francis	0 3 0	"	"
G. Graham	0 3 0	"	"
M. Hamilton	0 1 6	"	"
F. Hendy	0 3 0	"	"
G. J. Hagg	0 1 6	"	"
W. Kirkham	0 1 6	"	"
A. Kirkham	0 4 6	"	"
H. Kelly	0 1 6	"	"
J. Kirkham	0 3 0	"	"
R. Lannon	0 1 6	"	"
J. Muldoon	0 1 6	"	"
W. McKenna (deceased)	0 1 6	"	"
J. McKay	0 4 6	"	"
J. McCarthy	0 3 0	"	"
W. Murray	0 3 0	"	"
D. Murray	0 1 6	"	"
A. Olsen	0 1 6	"	"
H. Papworth	0 1 6	"	"
W. Peterson	0 1 6	"	"
H. Robinson	0 1 6	"	"
J. Reed	0 1 6	"	"
C. Sullivan	0 3 0	"	"
A. Stow (deceased)	0 1 6	"	"
H. Stuart	0 1 6	"	"
E. W. Smith	0 1 6	"	"
H. Windcombe	0 3 0	"	"
R. Williams	0 1 6	"	"
H. White	0 1 6	"	"
	25 12 10		

The Companies Act 1938.  
BRUNSWICK PLASTER MILLS PTY. LTD.  
20 Tinning-street, Brunswick.

Thirty-second Schedule.

REGISTER of Unclaimed Money held by Brunswick Plaster Mills Pty. Ltd.

Name of Owner on Books.	Total Amount Due.	Description of Unclaimed Money.	Date Accrued.
	£ s. d.		
D. Beeson	4 2 3	Wages	9.5.51
F. Perry	1 4 9	"	18.7.51
P. Lang	0 7 1	"	8.8.51
L. Tanner	1 18 3	"	15.8.51
R. Ross	1 1 10	"	22.8.51
A. Beck	2 12 8	"	17.10.51
R. Beck	3 2 9	"	17.10.51
J. Beck	3 2 9	"	17.10.51

13th January, 1958.  
122

P. R. HALEY,  
Manager.

SHELL REFINING (AUST.) PTY. LTD.—GEELONG REFINERY.

REGISTER of Unclaimed Monies held by Shell Refining (Aust.) Pty. Ltd.—Geelong Refinery, 31st December, 1957.

Name of Owner on Books.	Total Amount Due to Owner.	Description of Unclaimed Money.
	£ s. d.	
Winsor, W. E.	6 5 8	Wages
Carroll, B. O.	6 5 8	Wages
Richardson, R.	3 14 8	Wages
Borkowski, Mrs. S.	3 16 5	Wages
Nortota, L.	3 12 11	Wages
Van Der Stap, G. W.	2 16 6	Wages
Volkmann, A. C. R.	3 19 5	Wages
Wirstuik, L.	3 5 3	Workers Compensation
Perkins, J. R.	39 5 2	Chemist Account
Kolb, V. C.	0 15 6	Account for supply of Steel
Jones, R.	0 16 6	Workers Compensation
		Chemist Account
		Refund Pension Fund Contributions

133

Companies Act 1938—32nd Schedule.

ORBOST BUTTER AND PRODUCE COY. LTD.

REGISTER of Unclaimed Money held by the Orboast Butter and Produce Company Limited, as at January, 1958.

Name of Owner on Books.	Total Amount Due to Owner.	Description of Unclaimed Money.	Date of Last Claim.
	£ s. d.		
Grambower, A. R.	0 1 3	Dividend	No claim
Harmer, W. S.	0 1 3	"	"
Haycox, W.	0 8 9	"	"
Hooper, C. H.	0 12 6	"	"
Mooney, J.	0 6 3	"	"
Richardson, Jos.	1 5 0	"	"
Cameron, T. C.	0 1 3	"	"

157

J. A. TANNER,  
Secretary.

The Companies Act 1938, Section 245.

THE CHARLTON ELECTRIC LIGHT AND POWER COMPANY LIMITED (IN VOLUNTARY LIQUIDATION).

NOTICE is hereby given that a General Meeting of the company will be held at my office, Shamrock Buildings, Williamson-street, Bendigo, on Monday, 24th February, 1958, at Two p.m., for the purpose of having laid before it an account by the liquidator of the winding up showing how the winding has been conducted and the property of the company has been disposed of.

Dated this 14th day of January, 1958.

E. R. GRELLIS, Liquidator.

DUNLOP RUBBER AUSTRALIA LIMITED.

REGISTER of Unclaimed Money held by Dunlop Rubber Australia Limited., 108 Flinders-street, Melbourne.

Name.	Address.	Amount.	Wages Year Ended—
		£ s. d.	December, 1951
Butchart, Allan .. .. .	72 Clive-street, West Footscray .. .. .	0 9 11	" "
Buchmanis, Irina .. .. .	145 Montague-street, South Melbourne .. .. .	0 4 5	" "
Catania, Josephine .. .. .	155 Drummond-street, Carlton .. .. .	0 12 8	" "
Campbell, Donald Robert .. .. .	110 Inglis-street, Port Melbourne .. .. .	0 8 10	" "
Everton, Fred .. .. .	" Southgate," 7 Milverton-street, Moonee Ponds .. .. .	2 0 1	" "
Flores, Lina .. .. .	115 Alexander-parade, Clifton Hill .. .. .	1 7 7	" "
Fuksa, Kymmer .. .. .	32 Wellington-street, St. Kilda .. .. .	0 1 0	" "
Gaujmalietis, Malgonis .. .. .	12 Church-street, St. Kilda .. .. .	1 15 10	" "
Jedlicka, Gustav .. .. .	59 Morgan-street, Carnegie .. .. .	1 19 10	" "
Kaczmarek, Nadzija .. .. .	20 Burnett-street, St. Kilda .. .. .	0 5 11	" "
Louca, Nich. Michael .. .. .	108 Inglis-street, Port Melbourne .. .. .	1 0 2	" "
Lukasek, Frankisek .. .. .	95 Studley Park-road, Kew .. .. .	1 19 8	" "
Lielups, Ansis .. .. .	98 Richardson-street, Albert Park .. .. .	1 9 0	" "
Morris, Douglas Aubrey .. .. .	15 Goodrich-street, South Oakleigh .. .. .	0 1 6	" "
Morris, Gladys .. .. .	4 Eville-street, South Melbourne .. .. .	1 4 3	" "
Mauridis, Constantinos .. .. .	117 Union-street, Windsor .. .. .	1 18 1	" "
Popazan, George .. .. .	625 St. Kilda-road, St. Kilda .. .. .	2 5 7	" "
Russin, Nick .. .. .	17 Harmarot-street, St. Kilda .. .. .	0 9 10	" "
Rennie, Doreen Louise .. .. .	21 Tanner-street, Richmond .. .. .	1 6 4	" "
Rudiate, Kaze .. .. .	10 Vaucluse-street, Richmond .. .. .	1 9 4	" "
Sova, Bohuslav .. .. .	c/o Peoples' Palace, King-street, Melbourne .. .. .	0 3 1	" "
Seretis, Alexandre .. .. .	12 Dundas-place, Albert Park .. .. .	0 3 4	" "
Snellaars, Mary .. .. .	24 Dandenong-road, Frankston .. .. .	0 19 11	" "
		23 16 2	

Companies Act 1938—Thirty-second Schedule.

SWALLOW AND ARIELL LIMITED.

REGISTER of Unclaimed Money held by Swallow and Ariell Limited.

Name.	Address of Owner on Books.	Total Amount Due to Owner.	Description of Unclaimed Money.	Date of Last Claim.
		£ s. d.		
Bridge, James .. .. .	57 Autumn-street, Geelong West .. .. .	4 0 0	Dividend on ordinary shares..	No claim has been made in respect of such money
Cross, John .. .. .	Hopkins-street, Footscray .. .. .	2 0 0	" " " " " "	" " " "
Dando, Henry (deceased)..	150 Graham-street, Port Melbourne .. .. .	0 10 0	" " " " " "	" " " "
Dando, Edward Cunningham	Colac .. .. .	0 6 0	" " " " " "	" " " "
Mueller, Bertha (deceased)	Burwood-road, Hawthorn .. .. .	1 0 0	" " " " " "	" " " "

COMMONWEALTH AIRCRAFT CORPORATION PTY. LTD.

REGISTER of Unclaimed Moneys held by Commonwealth Aircraft Corporation Pty. Ltd.

Name of Owner on Books.	Last Known Address.	Total Amount Due to Owner.	Description of Unclaimed Money.	Date of Last Claim.
		£ s. d.		
Carmichael, J. (deceased) ..	440 William-street, West Melbourne .. .. .	2 13 11	Unclaimed Wages..	No claim
Millard, J. B. .. .. .	10 Wills-street, Glen Iris .. .. .	0 19 0	" " " "	" "
Lilley, F. B. .. .. .	410 St. Georges-road, Thornbury .. .. .	8 2 9	" " " "	" "
Phillips, W. .. .. .	225 Canterbury-road, St. Kilda .. .. .	8 2 4	" " " "	" "
Crawford, J. E. .. .. .	47 Jolimont-street, Jolimont .. .. .	4 5 10	" " " "	" "
Williams, P. .. .. .	270 Bell-street, East Preston .. .. .	2 4 7	" " " "	" "
Brown, J. W. .. .. .	24 Marine-parade, St. Kilda .. .. .	13 18 2	" " " "	" "
Regardo, P. R. (Miss) .. .. .	71 Langhorne-street, Dandenong .. .. .	2 6 1	" " " "	" "
Allan, K. .. .. .	137 Station-street, Carlton .. .. .	8 19 0	" " " "	" "
Baxter, N. W. .. .. .	16 Dunstan-avenue, East Brunswick .. .. .	1 0 0	" " " "	" "
Boulton, B. S. .. .. .	62 Cromwell-street, Collingwood .. .. .	9 11 0	" " " "	" "
Johnston, W. R. .. .. .	1 Yonga-road, Balwyn .. .. .	1 3 1	" " " "	" "
Clements, E. .. .. .	734 Whitehorse-road, Mont Albert .. .. .	7 14 11	" " " "	" "
Ritchie, J. F. .. .. .	14 Mary-street, St. Kilda .. .. .	5 7 4	" " " "	" "
Brookes, B. (Mrs.) .. .. .	39 Murphy-street, Richmond .. .. .	0 0 8	" " " "	" "
Plumbridge, G. (deceased)	172 Wingrove-street, Alphington .. .. .	0 11 6	" " " "	" "
White, J. .. .. .	40 Howe-crescent, Albert Park .. .. .	4 17 0	" " " "	" "
	Total .. .. .	81 17 2		

THE BALLARAT WOOLLEN AND WORSTED COMPANY LIMITED.

DIVIDEND ACCOUNT 1951—£200 19s. 10d.

REGISTER of Unclaimed Moneys held by The Ballarat Woollen and Worsted Company Limited, Hill-street, Ballarat, 1951.

Name and Address of Owner on Books.	Total Amount Due to Owner.	Description of Unclaimed Money.	Date of Last Claim.
	£ s. d.		
Abbott, Elizabeth P., (Estate of), c/o Mr. I. Abbott, Miller-street, Tongala	2 1 5	Dividends 16 and 17 .. ..	No claim
Armstrong, William (Estate of), Whiting and Aitken, Solicitors, Melbourne	1 3 0	" " " " " "	"
Baker, James C. (Estate of), c/o W. T. Baker, Barkly-street, Footscray ..	1 3 0	" " " " " "	"
Barr, Robert (Estate of), John Barr, Kanyapella .. ..	1 3 0	" " " " " "	"
Bennett, Henry G. (Estate of), 50 Highway, Nedlands, W.A. .. ..	0 13 10	" " " " " "	"
Blythe, Helen (Estate of), Downing and Downing, 39 St. George's-terrace, Perth, W.A.	1 7 7	" " " " " "	"
Brooks, Mrs. Helen F., Hoskins-street, Temora, N.S.W.	0 9 2	" " " " " "	"
Budden, Mrs. Emma, Kedron Park-road, Wooloowin, Q'ld. .. ..	1 16 10	" " " " " "	"
Callaway Julia (Estate of), c/o National Bank, Bairnsdale .. ..	3 4 5	" " " " " "	"
Cannon, Mrs. Catherine, 6 Nelson-street, Windsor .. ..	0 13 10	" " " " " "	"
Carey, Mrs. Bridget A., 2 King-street, Ballarat East .. ..	0 13 10	" " " " " "	"
Cattanach, Mary (Estate of), Miss Margaret Cattanach, Campbell's Forest	0 13 10	" " " " " "	"
Chisholm, John, Miner's Rest .. ..	0 9 2	" " " " " "	"
Clark, Lyndon, 196 Victoria-street, Ballarat .. ..	2 6 0	" " " " " "	"
Cohen, Coleman H., 250 High-street, St. Kilda .. ..	0 13 10	" " " " " "	"
Cook, Percy P., Collins House, 360 Collins-street, Melbourne .. ..	0 18 5	" " " " " "	"
Costello, Ellen (Estate of), Mrs. Mary Clements, Aumann-court, Mont Albert North	2 19 10	" " " " " "	"
Davies, Miss Jane, 59 Phillips-street, Coburg .. ..	11 0 10	" " " " " "	"
Germon, William (Estate of), W. J. Germon, 26 Pearson-street, Brighton ..	0 18 5	" " " " " "	"
Grey, Robert H. (Estate of), Cuthbert, Morrow, Must, and Shaw, Lydiard-street, South Ballarat	2 15 2	" " " " " "	"
Hanlon, Kathleen A. (Estate of), P.O. Box 51, Portland .. ..	3 9 0	" " " " " "	"
Hicks, Louisa (Estate of), Mr. James Hicks, Westgarth-street, Fairfield ..	0 13 10	" " " " " "	"
Hosken, James T., 9 Brougham-street, Ballarat .. ..	0 18 5	" " " " " "	"
James, Edwin H., Wandin Yallock .. ..	0 13 10	" " " " " "	"
Kean, Miss Kate, Leigh Creek .. ..	0 9 2	" " " " " "	"
Kerr, Miss Martha, Victoria-street, Kerang .. ..	0 18 5	" " " " " "	"
Lamont, Charles (Estate of), J. Lamont, 13 Talbot-street, North Ballarat ..	0 18 5	" " " " " "	"
Lawrence, Mrs. Amelia, Drummond-street, South Ballarat .. ..	0 9 2	" " " " " "	"
Levy, Rose (Estate of), c/o Mr. A. Levy, Ballarat .. ..	0 13 10	" " " " " "	"
Marshall, William (Estate of), E. M. Tobin, P.O. Box 192, Ouyen .. ..	0 13 10	" " " " " "	"
Merze, Wilbur M., Hanna-street P.O., South Melbourne .. ..	53 16 5	" " " " " "	"
Mildred, Lindsay, 60 Queen-street, Melbourne .. ..	1 7 7	" " " " " "	"
Mills, George P., 469 Chancery-lane, Melbourne .. ..	13 16 0	" " " " " "	"
Mills, Miss Clara W., 469 Chancery-lane, Melbourne .. ..	5 10 5	" " " " " "	"
Osmond, Stanley, 293 Collins-street, Melbourne .. ..	27 12 0	" " " " " "	"
Plummer, Frederick R., Box 172, Haymarket P.O., Sydney, N.S.W. .. ..	0 18 5	" " " " " "	"
Rainbow Mrs. Matilda, 32 Dendy-street, Middle Brighton .. ..	0 13 10	" " " " " "	"
Rainbow, Joseph (Estate of), J. J. Rainbow, 6 Mt. Pleasant-road, West Preston	0 13 10	" " " " " "	"
Reid, William H. (Estate of), W. L. Reid, 50 Peel-street, South Ballarat ..	13 16 0	" " " " " "	"
Rothacker, Ellen J. (Estate of), "Kelvin Grove," Woodvale .. ..	0 13 10	" " " " " "	"
Rowlands, Owen, Post Office, Sebastopol .. ..	0 9 2	" " " " " "	"
Sayle, Miss Eliza J., Chinaman's Flat, Maryborough .. ..	0 9 2	" " " " " "	"
Settle, Harold W., c/o Mrs. B. Settle, 16 Banole-avenue, East Prahran ..	1 3 0	" " " " " "	"
Sherry, John C., 1 Story-street, Parkville .. ..	2 1 5	" " " " " "	"
Smith, Agnes (Estate of), Peel-street, Ballarat .. ..	0 9 2	" " " " " "	"
Snell, George J., (Estate of), 9 Otway-street North, Ballarat East .. ..	0 18 5	" " " " " "	"
Stephenson, Harold S. G., 100 Linacre-road, Hampton .. ..	2 15 2	" " " " " "	"
Stillman, Christina M., (Estate of), Cohen and Kirby and Co., Victoria Chambers, 117 Pall Mall, Bendigo	2 10 7	" " " " " "	"
Summerscales, Mrs. Mary, 47 Matlock-street, Canterbury .. ..	0 13 10	" " " " " "	"
Tonkin, Mary E., 10 Oak-street, Hawthorn .. ..	2 15 2	" " " " " "	"
Upham, Charles D. (Estate of), 249 Ascot Vale-road, Ascot Vale .. ..	0 13 10	" " " " " "	"
Varcoe, Benjamin (Estate of), Phillip W. Must, Lydiard-street, Ballarat ..	0 13 10	" " " " " "	"
Walters, Mary E. (Estate of), W. A. Walters, 233 Tyler-street, Preston ..	0 13 10	" " " " " "	"
Wise, John M., c/o Mrs. J. McRae, 327 Marmion-street, North Cottesloe, W.A.	1 3 0	" " " " " "	"
Woods, William F., (Estate of), 394 Collins-street, Melbourne .. ..	2 1 5	" " " " " "	"
Young, James (Estate of), 333 Collins-street, Melbourne .. ..	0 9 3	" " " " " "	"
Sundry shareholders (65 in number), particulars of whose names, &c., may be inspected at the registered office of the Company, whose amounts are as follows:—			
65—4s. 7d. each .. ..	14 17 11		
<i>Unpresented Cheques—</i>			
Armstrong, Miss Nora, 22 Kerferd-street, East Malvern .. ..	} 1 16 10		
Armstrong, Miss Iris W., 374 Orrong-road, Caulfield .. ..			
Sheard, Mrs. Blanche V., 28 Woodsome-street, Mt. Lawley, W.A. .. ..			
Chalmers, Thomas (Estate of), Mr. A. S. Chalmers, "Glen Allan," Yarra Junction	0 8 0		
Gray, James (Estate of), Mr. H. K. McCleery, 443 Bourke-street, Melbourne	0 18 0		
Lang, Alan, Borellan, N.S.W. .. ..	} 0 9 7		
Lang, Stuart, Borellan, N.S.W. .. ..			
Padgett, Sylvia (now Mrs. Quast), c/o Messrs. Mansfield and Co., Ocean Building, Singapore, Malaya .. ..		0 6 5	
Sutton, Mrs. Sheila M. B., 14 Gillies-street, Ballarat .. ..	1 4 0		
Taplin, Emma (Estate of), Messrs. E. H. Houen and Co., Govett's Leap-road, Blackheath, Blue Mountains, N.S.W.	1 2 5		
Taplin, Robert (Estate of), Messrs. E. H. Houen and Co., Govett's Leap-road, Blackheath, Blue Mountains, N.S.W.	1 2 5		

## CALTEX OIL (AUSTRALIA) PTY. LTD., MELBOURNE.

REGISTER of Unclaimed Moneys held as at 31st December, 1957, for the year 1957.

Name and Address.	Total Amount Due to Owner.	Description of Unclaimed Money.	Date of Last Claim.
	£ s. d.		
Alberton, Yarram .. .. .	0 11 4	Unpresented cheque .. .. .	25.9.56
Bockmann, G., Ararat .. .. .	0 10 0	" .. .. .	17.10.56
Berryman, A. N., Wonthaggi .. .. .	0 7 4	" .. .. .	24.8.56
Bayliss, G., Deniliquin .. .. .	3 15 8	" .. .. .	18.9.56
Bartalotto, A., Kerang .. .. .	0 2 3	" .. .. .	18.2.57
Bradley, A. H., Ouyen .. .. .	0 4 2	" .. .. .	26.8.57
Cater, W., Violet Town .. .. .	1 0 0	" .. .. .	3.7.56
Chizzenetti, I., Dalyston .. .. .	0 12 0	" .. .. .	24.8.56
Daradassis, G., Melbourne .. .. .	2 16 0	Unclaimed wages cheque .. .. .	23.1.57
Doran, E., Balranald .. .. .	0 2 9	" .. .. .	16.11.57
Dickson, R., Noble Park .. .. .	1 2 0	" .. .. .	31.7.56
Doreen, D., Balranald .. .. .	1 6 7	" .. .. .	11.6.57
Ellis, C. S., Eldorado .. .. .	2 0 0	" .. .. .	9.7.56
Gilwace Partnership, Deniliquin .. .. .	13 1 3	" .. .. .	1.10.56
Gitsham and Son, Kerang .. .. .	0 4 0	" .. .. .	9.11.56
Harte, M., 98 Norris-street, Williamstown .. .. .	2 0 0	" .. .. .	15.6.56
Hewson, A. H., Barham, New South Wales .. .. .	0 11 0	" .. .. .	5.6.57
Love, W., Barham, New South Wales .. .. .	0 7 4	" .. .. .	16.1.57
Mauley, J., Ouyen .. .. .	0 2 3	" .. .. .	18.2.57
Mellows, F., Tungamah .. .. .	0 11 0	" .. .. .	12.7.56
Miller, N., 30 Cochran-street, Camberwell .. .. .	2 0 0	" .. .. .	14.2.57
Moran, T., Quambatook .. .. .	0 19 1	" .. .. .	4.9.56
McLean, R. H., Ballarat .. .. .	0 7 4	" .. .. .	16.7.57
McNeice, L., Peshurst .. .. .	0 2 1	" .. .. .	7.9.56
Neyland, Mark, Patchewollock .. .. .	1 2 0	" .. .. .	9.5.57
Nicholls, T. W. C., Merton .. .. .	0 3 8	" .. .. .	31.7.56
Parkins, C., Shelford .. .. .	1 0 2	" .. .. .	30.9.57
Phillips, D., Willaura .. .. .	0 3 0	" .. .. .	18.9.56
Porter, D., Kenny's-lane, Hamilton .. .. .	0 9 0	" .. .. .	15.5.57
Rentsch, J. M., Hamilton .. .. .	0 8 6	" .. .. .	8.3.57
Russo, G., Cockatoo .. .. .	0 3 8	" .. .. .	28.9.56
Ryan and Sons, J. H., Toolamba .. .. .	28 0 6	" .. .. .	30.4.57
Sanderson, K., Myrtleford .. .. .	0 4 8	" .. .. .	20.9.56
Shand, A., 660 Studd-road, Dandenong .. .. .	0 5 9	" .. .. .	24.10.56
Smith, F. R., Cooma, New South Wales .. .. .	0 7 4	" .. .. .	5.6.57
Sorey Bros., Avoca .. .. .	4 0 6	" .. .. .	23.7.57
Tuena, Jack, Walpeup .. .. .	0 5 6	" .. .. .	23.5.57
Wilson, R., Bulla .. .. .	0 5 0	" .. .. .	20.8.56

154

## HUMES LIMITED.

REGISTER of Unclaimed Moneys as at 1st January, 1958.

Name of Owner on Books and Last Known Address.	Total Amount Due to Owner.	Description of Unclaimed Money.	Date of Last Claim.
	£ s. d.		
George C. Parnham, 107 Beulah-road, Norwood, South Australia	0 14 0	Dividend due on 7 Ordinary Shares— 47th Dividend paid 30.3.51—7s. 48th Dividend paid 8.10.51—7s.	30.9.30
John E. Treloar, c/o W. Dummage, Esq., Kyle-street, Knoxville, South Australia	0 14 0	Dividend due on 7 Ordinary Shares— 47th Dividend paid 30.3.51—7s. 48th Dividend paid 8.10.51—7s.	30.9.30
Eleanor E. B. Wemyss, 70 Howitt-avenue, Rose Park, South Australia	0 14 0	Dividend due on 7 Ordinary Shares— 47th Dividend paid 30.3.51—7s. 48th Dividend paid 8.10.51—7s.	30.9.30
George M. P. McRae, c/o. Noyes Bros., Clarence-street, Sydney, New South Wales	3 14 0	Dividend due on 37 Ordinary Shares— 47th Dividend paid 30.3.51—£1 17s. 48th Dividend paid 8.10.51—£1 17s.	30.9.40
Philip A. Bush, "Kia Ora," Macquarie Plains, Tasmania	1 10 0	Dividend due on 15 Ordinary Shares— 47th Dividend paid 30.3.51—15s. 48th Dividend paid 8.10.51—15s.	7.10.40
Estate of the late Charles A. Fuss, c/o Lawrence R. Fuss, Esq., Box 18, Burra North, South Australia	1 10 0	Dividend due on 15 Ordinary Shares— 47th Dividend paid 30.3.51—15s. 48th Dividend paid 8.10.51—15s.	6.10.47

199

W. J. KERFERD, Public Officer.

**JAMES HARDIE AND CO. -PTY. LTD.**

(Incorporated in New South Wales.)

**R**EGISTER of Unclaimed Money held by James Hardie and Co. Pty. Ltd., 312-City-road, South-Melbourne, S.C.5.

Name of Owner on Books.	Total Amount Due to Owner.	Description of Unclaimed Money.	Date of Last Claim.
	£ s. d.		
H. Dixon, c/o Brooklyn Hostel .. .. .	14 2 7	Unclaimed wages .. .. .	September, 1956
C. Karayannis, 20 Stewart-street, South Yarra .. .. .	0 10 0	" .. .. .	December, 1956
M. Pikoš, 14 Maddon-street, Albert Park .. .. .	3 6 6	" .. .. .	April, 1956
B. Robertson, 19 Kennedy-street, Reservoir .. .. .	3 19 0	" .. .. .	June, 1957
L. Rátopoulos, 33 Clyde-street, Newport .. .. .	1 16 1	" .. .. .	June, 1957
L. Vella, 25 Latrobe-street, Newport .. .. .	4 10 1	" .. .. .	June, 1957
C. Loh, 13 Glendearg-grove, Malvern .. .. .	2 18 1	" .. .. .	June, 1957
C. Wong, 9 Meadow-street, East St. Kilda .. .. .	5 13 0	" .. .. .	June, 1957
	36 15 4		

131

**KIA-ORA INDUSTRIES LIMITED.**

**R**EGISTER of Unclaimed Moneys held by Kia-Ora Industries Limited, 201 High-street, Prahran, S.I, Victoria, as at 31st December, 1957.

Name of Owner on Books.	Total Amount Due to Owner.	Description of Unclaimed Money.	Date of Last Claim.
	£ s. d.		
Belle Bryson, 232 Toorak-road, South Yarra .. .. .	2 0 0	Dividend on shares .. .. .	14.11.51.
Roland E. Harrington (estate), 72 Apollo-street, Bombay, India .. .. .	2 0 0	" .. .. .	" .. .. .
Martha Lydia Hughes, G.P.O., Box 7, Brisbane, Queensland .. .. .	1 4 0	" .. .. .	" .. .. .
Grace Maddox, 64 Carson-street, Studley Park .. .. .	1 0 0	" .. .. .	" .. .. .
Jane Sanderson, Commercial-road, Hobart, Tasmania .. .. .	1 0 0	" .. .. .	" .. .. .
Matthew Smith, Dowling-street, Waterloo, New South Wales .. .. .	2 0 0	" .. .. .	" .. .. .
Thomas Taylor, Bastings-street, Northcote .. .. .	1 0 0	" .. .. .	" .. .. .
Car line Truss, 10 Balmoral-street, Waitara, New South Wales .. .. .	1 0 0	" .. .. .	" .. .. .
Francis James Tully, 8 Ripley-grove, Caulfield .. .. .	0 4 0	" .. .. .	" .. .. .
Jane Beatrice Watson, 67 Orrong-road, Balaclava .. .. .	5 0 0	" .. .. .	" .. .. .
Robert Thompson, Quorn, South Australia .. .. .	5 0 0	" .. .. .	" .. .. .
Sarah A. Jaye, 119 Morgan-street, Wagga, New South Wales .. .. .	1 0 0	" .. .. .	" .. .. .
Total .. .. .	22 8 0		

182

**INTERNATIONAL HARVESTER COMPANY OF AUSTRALIA PTY. LTD.**

LIST OF UNCLAIMED MONIES.

Name.	Amount Due.	Description.	Date of Last Claim.
	£ s. d.		
Brand, D. P. .. .. .	2 18 3	Wages .. .. .	16.12.56
King, S. W. .. .. .	0 18 6	Wages .. .. .	11.11.56
Clark, R. .. .. .	1-0-0	National Savings Contributions .. .. .	30.11.56
McCormack, G. .. .. .	1 7 8	Wages .. .. .	15 10 56
Grzonek, A. .. .. .	0 17 0	Wages .. .. .	29.1 57
Whyte, N. .. .. .	7 16 3	Wages .. .. .	21.2 57
De Gilder, K. .. .. .	8 6 3	Wages .. .. .	4 4.57
Milne, H. A. .. .. .	1 11 8	Wages .. .. .	1.10.57

127

The Companies Act 1938.

**TRUNFULL AND DELANEY PTY. LTD.**

**P**URSUANT to section 238 of the Companies Act 1938, notice is hereby given that a meeting of the creditors of Trunfull and Delaney Pty. Limited will be held at the Board Room, the Institute of Chartered Accountants in Australia, 18 Queen-street, Melbourne, on Friday, the 7th day of February, 1958, at Eleven a.m. for the purpose of nominating a liquidator.

Dated this 13th day of January, 1958.

170 M. TRUNFULL, Director.

**SONAN PROPRIETARY LIMITED (IN VOLUNTARY LIQUIDATION).**

**N**OTICE is hereby given, in pursuance of section 236 of the Companies Act, Victoria, that a General Meeting of the members of the above-named company will be held at the registered office of the company, 256 City-road, South Melbourne, in the State of Victoria, at Twelve o'clock noon, on the 25th February, 1958, for the purpose of receiving the liquidator's account showing how the winding up has been conducted and the company's property disposed of.

Dated this 8th day of January, 1958.

140 HUGO FISCHER, Liquidator.

**THE CARLISLE RIVER DAIRY COMPANY LIMITED.**

NOTICE OF SPECIAL RESOLUTION TO WIND UP, PURSUANT TO SECTION 226.

**A**T an Extraordinary General Meeting of the above-named company, duly convened and held at the Public Hall, Carlisle River, on Friday, the 10th day of January, 1958, the following Resolution was duly passed as a Special Resolution:—

"That the company be wound up voluntarily under the provisions of Part 1 of the Companies Act 1938, and that Ian Alexander MacLeod, of 86 Murray-street, Colac, be and is hereby appointed liquidator for the purpose of such winding up."

Dated the 10th day of January, 1958.

C. C. HARRIS, Chairman.  
Cunningham and Larkins, solicitors, Colac. 197



*Companies Act 1938.*

## DORNAN ENGINEERING CO. PTY. LTD.

PURSUANT to section 238 of the *Companies Act 1938*, notice is hereby given that a meeting of the creditors of Dornan Engineering Co. Pty. Ltd. will be held at the Board Room, Timber Merchants Association, 51 William-street, Melbourne, on Friday, the 24th day of January, 1958, at Eleven a.m. for the purpose of nominating a liquidator.

Dated this 13th day of January, 1958.

169 R. DORNAN, Director.

In the Supreme Court.—In the matter of Part I. of the Companies Acts and in the matter of THE INVESTMENT AND DEVELOPMENT COMPANY PROPRIETARY LIMITED.

NOTICE is hereby given of the registration on the 9th day of January, 1958, by the Registrar-General of the State of Victoria. Firstly, of an Order of the Supreme Court of Victoria made on the 6th day of December, 1957, confirming the reduction of capital of the above-named company from £100,000 divided into 100,000 shares of £1 each, to £70,000 divided into 50,000 shares of £1 each, and 50,000 shares of 8s. each, and that such reduction be effected by returning to the holders of the 50,000 shares which have been issued paid up capital to the extent of 12s. per share as follows:—

1. As to 26,000 shares numbered 17,652 to 43,650 (inclusive) and 49,000—

(a) By the cancellation of the debt of £10,500 owing by the holder of such shares to the company;

(b) by the assignment to the said holder of £5,100 of debts owing to the company.

2. As to 11,500 shares numbered 8,652 to 17,651 (inclusive) and 46,151 to 48,650 (inclusive) by the cancellation of £6,900 being part of the debt owing by the holder of such shares to the company.

3. As to the 11,500 shares numbered 1 to 8,651 (inclusive) 43,651 to 46,150 (inclusive) and 48,651 to 48,999 (inclusive) by the assignment to the holder of £6,900 of debts owing to the company.

4. As to 1,000 shares numbered 49,001 to 50,000 (inclusive) by the assignment to the said holder of £600 of debts owing to the company.

And Secondly, of a Minute approved of by the said Court which is in the following terms:—

That the capital of the company is now £70,000 divided into 50,000 shares of £1 each, and 50,000 shares of 8s. each, reduced from £100,000 divided into 100,000 shares of £1 each. At the time of the registration of this Minute 50,000 shares of 8s. each, numbered 1 to 50,000 (inclusive) have been issued and are deemed to be fully paid up, and the remaining 50,000 shares of £1 each are unissued.

Dated the 10th day of January, 1958.

BLAKE & RIGGALL, 120 William-street, Melbourne, solicitors for the company. 195

*The Companies Act 1938.*

## HENTY TIMBER AND TRADING CO. PTY. LTD. (IN LIQUIDATION).—Notice to Creditors of First Meeting.

(Under the Order for the Winding Up of the above-named Company, dated the 19th August, 1957.)

NOTICE is hereby given that a First Meeting of creditors in the above matter will be held at the Institute of Chartered Accountants (Aust.), Board Room, 18 Queen-street, Melbourne, on Wednesday, the 22nd day of January, 1958, at Eleven o'clock in the forenoon.

Dated this 8th day of January, 1958.

JOHN KENNETH HALL, Official Liquidator, 390 Little Collins-street, Melbourne. 152

## AUSTRAL CREDITS PTY. LTD. (IN LIQUIDATION).

NOTICE is hereby given that the creditors in the above-named company, which is being wound up voluntarily, are required on or before the 31st day of January, 1958, to send their names and addresses and particulars of their debts or claims to the undersigned liquidator of the said company and if so required by notice, in writing, from the said liquidator are to prove their debts or claims at such time and place as may be specified in such notice, or in default thereof they will be excluded from the benefit of any distribution made.

A. B. CURRIE, Liquidator, 454 Collins-street, Melbourne, C.I. 159

CAROLINE KATHERINE WALLACE, late of 12 Canterbury-place, Brighton Beach, widow, DECEASED.

CREDITORS, next of kin, and others having claims in respect of the estate of the deceased (who died on 21st day of July, 1957), are requested by the executor, John Garde, to send particulars thereof to him, addressed care of the under-mentioned solicitors, by the 19th day of March, 1958, after which date he will distribute the assets, having regard only to the claims of which he then has notice.

ADAMS & GARDE, solicitors, 472 Bourke-street, Melbourne. 151

CREDITORS, next of kin, and others having claims in respect of the estate of Mary Anderson Henderson, late of 2A Carmyle-avenue, Toorak, widow, deceased (who died on 30th August, 1957), are to send the particulars of their claims to the Trustees, Executors, and Agency Company Limited, whose registered office is at 401 Collins-street, Melbourne, by 17th March, 1958, after which date it will distribute the assets, having regard only to the claims of which it then has notice.

W. H. FLOOD & PERMEZEL, solicitors, of 379 Collins-street, Melbourne. 158

CREDITORS, next of kin, and others having claims in respect of the estate of Edmund Joseph Mackin, formerly of Riddell, farmer, but late of Castlemaine, retired farmer, deceased (who died on the 28th day of June, 1957, and probate of whose will has been granted to Clarence William Willoughby Webster and Arthur Dean Pearce, both of 430 Little Collins-street, Melbourne, solicitors), are to send in particulars of their claims to the said executors, care of the under-mentioned solicitors, by the 17th day of March, 1958, after which date they will distribute the assets, having regard only to the claims of which they then have notice.

PEARCE & WEBSTER, solicitors, 430 Little Collins-street, Melbourne. 160

CREDITORS, next of kin, and others having claims in respect of the estate of David William Stevens, late of "Braeside," Bacchus Marsh, formerly yardman, late kiosk proprietor, deceased (who died on the 22nd day of November, 1956, and probate of whose will has been granted to Esther Irene Florence Stevens, of "Braeside," Bacchus Marsh, widow), are to send in particulars of their claims to the said executrix, care of the under-mentioned solicitors, by the 17th day of March, 1958, after which date she will distribute the assets, having regard only to the claims of which she then has notice.

PEARCE & WEBSTER, solicitors, 430 Little Collins-street, Melbourne. 161

CREDITORS, next of kin, and others having claims in respect of the estate of Alfred Wambach, late of 28 Centennial-avenue, Brunswick, in the State of Victoria, retired painter, deceased (who died on the 29th day of July, 1957), and probate of whose will was granted to The Perpetual Executors and Trustees Association of Australia Limited, of Nos. 100-104 Queen-street, Melbourne, in the said State, are requested to send particulars of such claims to the said The Perpetual Executors and Trustees Association of Australia Limited, at its address as aforesaid on or before the 16th day of March, 1958, after which date it will proceed to distribute the assets of the said deceased amongst the persons entitled thereto, having regard only to the claims of which it shall then have had notice.

GAIR & BRAHE, of 243 Collins-street, Melbourne. 119

PURSUANT to the *Trustee Act 1928*, all persons having claims against the property or estate of Beryl Jean Weatherhead, late of Flat 3, Bay-street, Rosebud, married woman, deceased, intestate (who died on the 2nd July, 1956, and letters of administration of whose estate were granted by the Supreme Court of Victoria on the 20th December, 1957, to Robert Moore Weatherhead, the widower of the said deceased), are hereby required to send particulars of such claims to the said administrator, addressed to the care of Dudley A. Tregent, 422 Collins-street, Melbourne, on or before the 16th March, 1958, after the expiration of which time the said administrator will proceed to distribute the assets of the said deceased amongst the persons entitled thereto, having regard only to the claims of which he shall have had notice.

DUDLEY A. TREGENT, B.A., LL.M., solicitor, 422 Collins-street, Melbourne. 180

**CREDITORS**, next of kin, and others having claims against the estate of Clara Helen Wildman, late of 17 Albion-street, West Brunswick, widow, deceased (who died on the 20th day of March, 1957), are requested to send particulars of their claims to the executor, John Ward, care of W. E. Pearcey and Ivey, of 90 William-street, Melbourne, by the 17th day of March, 1958, after which date the said executor will proceed to distribute the assets of the said deceased, having regard only to the claims of which he shall then have had notice.

W. E. PEARCEY & IVEY, 90 William-street, Melbourne,  
solicitors for the said John Ward. 162

**CREDITORS**, next of kin, and others having claims in respect of the estate of Sarah Ann Forsyth, late of 8 Mundy-street, Mentone, widow, deceased (who died on the 16th November, 1957), are to send particulars of their claims to The Equity Trustees, Executors, and Agency Company Limited, whose registered office is situate at 472 Bourke-street, Melbourne, by the 15th day of March, 1958, after which date it will distribute the assets, having regard only to the claims of which it then has notice.

WEIGALL & CROWTHER, 459 Little Collins-street,  
Melbourne. 163

FLORENCE KATE DAVIS, late of 267 Warrigal-road, Burwood, widow, DECEASED.

**CREDITORS**, next of kin, and others having claims in respect of the estate of the deceased (who died on 2nd September, 1957), are required by the personal representatives, George Oliver Legg, of 22 Proudfoot-street, Mont Albert, and Keith Erskine Jones, of Mount Pleasant-road, Nunawading, to send particulars to them by the 31st day of March, 1958, after which date the personal representatives may convey or distribute the assets, having regard only to the claims of which they then have notice.

Dated 6th January, 1958.

LEACH & THOMSON, solicitors, 472 Bourke-street,  
Melbourne. 171

MARY ELIZABETH KNIGHT, late of Flat No. 6, 319 Fox Hollies-road, Acoc's Green, Birmingham, 27, England, DECEASED.

**CREDITORS**, next of kin, and others having claims in respect of the estate of the deceased (who died on 24th January, 1957), are required by the trustee, William Slater, of 422 Collins-street, Melbourne, solicitor, to send particulars to him by the 20th day of March, 1958, after which date the trustee may convey or distribute the assets, having regard only to the claims of which he then has notice.

SLATER & GORDON, solicitors, 422 Collins-street,  
Melbourne. 168

ARTHUR SAMUEL DRAKEFORD, late of 69 Park-street, Moonee Ponds, late member of the House of Representatives, DECEASED.

**CREDITORS**, next of kin, and others having claims in respect of the estate of the deceased (who died on 9th June, 1957), are required by the trustee, Ellen Theresa Drakeford, of 69 Park-street, Moonee Ponds, widow, to send particulars to her by the 20th March, 1958, after which date the trustee may convey or distribute the assets, having regard only to the claims of which she then has notice.

SLATER & GORDON, solicitors, 422 Collins-street,  
Melbourne. 167

JOHN CAIN, late of 25 James-street, Northcote, member of the Legislative Assembly, DECEASED.

**CREDITORS**, next of kin, and others having claims in respect of the estate of the deceased (who died on 4th August, 1957), are required by the trustees, Dorothea Vera Marie Cain, of 25 James-street, Northcote, and John Cain, of 261 High-street, Northcote, solicitor, to send particulars to them by the 20th day of March, 1958, after which date the trustees may convey or distribute the assets, having regard only to the claims of which they then have notice.

SLATER & GORDON, solicitors, 422 Collins-street,  
Melbourne. 166

WILLIAM JOHN RAWSON, late of 6 Woodville-avenue, Glenhuntly, stereotyper, DECEASED.

**CREDITORS**, next of kin, and others having claims in respect of the estate of the deceased (who died on 3rd September, 1957), are required by the trustee, Roy Robert Rawson, of Mast Gully-road, Upwey, to send particulars to him by the 20th day of March, 1958, after which date the trustee may convey or distribute the assets, having regard only to the claims of which he then has notice.

SLATER & GORDON, solicitors, 422 Collins-street,  
Melbourne. 163

SUSANNA MAY BOAST (sometimes known as Susie May Boast), late of 6 Springfield-avenue, East St. Kilda, in the State of Victoria, widow, DECEASED.

**CREDITORS**, next of kin, and others having claims in respect of the estate of the deceased (who died on 26th August, 1957), are required by the trustees of the said deceased, namely The Equity Trustees, Executors, and Agency Company Limited, of 472 Bourke-street, Melbourne, and Geoffrey Llewellyn Jones, of 422 Collins-street, Melbourne, to send particulars to them, at 472 Bourke-street, Melbourne, by the 17th March, 1958, after which date the said trustees may convey or distribute the assets, having regard only to the claims of which they then have notice.

Dated the 9th day of January, 1958.

164

HENRIETTA CORNELIA WOOD, late of Thurla-street, Swan Hill, in the State of Victoria, widow, DECEASED.

**CREDITORS**, next of kin, and other persons having claims against the estate of the deceased, are required to send particulars of same to the executrix, Alethea Alice Baker, in care of the undersigned, on or before the 30th March, 1958, after which date she will distribute the assets, having regard only to the claims of which she then has notice.

GERALD E. DELANY & CO., solicitors, 63 Campbell-street, Swan Hill. 172

WALTER PERCIVAL GRAY, formerly of 235 Napier-street, Fitzroy, but late of Rye, maintenance officer, DECEASED.

**CREDITORS**, next of kin, and others having claims against the estate of the deceased (who died on the 9th day of May, 1957), are required by the executors, Linda Shirley Moore, of 549 Beach-road, Mordialloc, married woman, and Roy Champney Lawrence, of 23 Courang-road, Glen Iris, retired hotelkeeper, to send particulars to them, care of the under-mentioned solicitors, by the 18th day of March, 1958, after which date the executors may convey or distribute the assets, having regard only to the claims of which they then have notice.

UPTON & ETTIELSON, solicitors, 395 Collins-street,  
Melbourne. 174

**CREDITORS**, next of kin, and others having claims against the estate of Olive Mary Marguerite Robinson, late of Auckland, New Zealand, spinster, deceased (who died on 19th June, 1957); are to send particulars of their claims to The Union Trustee Company of Australia Limited, the registered office of which is situate at 333 Collins-street, Melbourne, in the State of Victoria, by the 16th day of March, 1958, after which date it will distribute the assets, having regard only to the claims of which it then has notice.

BLAKE & RIGGALL, solicitors, 120 William-street,  
Melbourne. 176

**CREDITORS**, next of kin, and others having claims in respect of Ephraim John Gerrard Tickle, late of 830 Whitehorse-road, Box Hill, in the State of Victoria, retired plasterer, deceased (who died on the 30th day of October, 1957), and probate of whose will was granted to Arthur Alexander Brahe, of 243 Collins-street, Melbourne, in the said State, solicitor, are requested to send particulars of such claims to the said Arthur Alexander Brahe, in care of the undermentioned solicitors, on or before the 16th day of March, 1958, after which date the said Arthur Alexander Brahe will proceed to distribute the assets of the said deceased amongst the persons entitled thereto, having regard only to the claims of which he shall then have had notice.

GAIR & BRAHE, of 243 Collins-street, Melbourne. 120.

EDITH THOMAS, late of Goynes-road, Epsom, in the State of Victoria, spinster, DECEASED.

CREDITORS, next of kin, and all other persons having claims against the estate of the said deceased, are required by Sandhurst and Northern District Trustees, Executors, and Agency Company Limited, of View-street, Bendigo, in the said State, the administrator to whom letters of administration with the will annexed of the estate of the above-named deceased have been granted, to send particulars thereof, in writing, to the said company, on or before the 14th day of March, 1958, after which date it will proceed to distribute the assets of the said deceased, having regard only to the claims of which it shall then have notice.

Dated the 9th day of January, 1958.

WATSON, JAMES, & ROGERS, of Bull-street, Bendigo, solicitors for the administrator. 136

CREDITORS, next of kin, and others having claims in respect of the estate of Catherine Agnes Lynch, formerly of 20 Harding-street, Ascot Vale, but late of 1 Ardmillan-road, Moonee Ponds, married woman, deceased (who died on the 22nd day of August, 1957, and probate of whose will was granted by the Supreme Court of Victoria on the 12th day of December, 1957, to National Trustees, Executors, and Agency Company of Australasia Limited, of 95 Queen-street, Melbourne), are to send particulars of their claim to the said company, at its address above-mentioned, by the 28th March, 1958, after which date the said company will distribute the assets, having regard only to the claims of which it then has notice.

PATRICIA O'DONOGHUE, M.A., LL.B., solicitor, 209 Pascoe Vale-road, Essendon. 155

FRANCESCO PELLEGRINO, late of 203 Peel-street, North Melbourne, in the State of Victoria, fruiterer, DECEASED.

NOTICE is hereby given that all persons having claims upon the estate of the above-named deceased (who died on the 18th day of January, 1957, and an application for probate of whose will have been made to the Supreme Court of Victoria, by National Trustees, Executors, and Agency Company Limited, of 95 Queen-street, Melbourne), are hereby required to send particulars, in writing, of such claims to the applicant company before the 15th day of March, 1958, after which date the executor may convey or distribute the said estate, or any part thereof, to and among the persons entitled thereto, having regard only to the claims of which they shall have had formal notice.

ADAMI, MAHER, & CO., solicitors, 4 Bank-place, Melbourne, solicitors for the said company. 147

STANLEY BURWOOD HOLDER, late of 51 Cookson-street, Camberwell, chartered accountant (Aust.), DECEASED (who died on the 27th day of May, 1957).

CREDITORS, next of kin, and all other persons having claims against the estate of the said deceased, are required by the executor of his will, Kenneth Burwood Holder, of 23 Faversham-road, Canterbury, chartered accountant (Aust.), to send particulars thereof to him, care of the under-mentioned solicitors, on or before the 31st day of March, 1958, after which date he may proceed to distribute the assets of the deceased, having regard only to the claims of which he then has notice.

COLTMAN, WYATT, & ANDERSON, solicitors, 578 Bourke-street, Melbourne. 150

ALEXANDER BENJAMIN HOWITT, late of 2A Queensbridge-street, South Melbourne, motor engineer, DECEASED (who died on the 3rd January, 1957).

CREDITORS, next of kin, and all other persons having claims against the estate of the said deceased, are required by the executors, Edward Charlton Eckersley, of 20 Dumblane-street, Hughesdale, public accountant, and Geoffrey Cheverton Wyatt, of 578 Bourke-street, Melbourne, solicitor, to send particulars thereof to them, care of the under-mentioned solicitors, on or before the 29th day of March, 1958, after which date they may proceed to distribute the assets of the deceased, having regard only to the claims of which they then have notice.

COLTMAN, WYATT, & ANDERSON, solicitors, 578 Bourke-street, Melbourne. 149

*Trustee Act 1928.*

NOTICE TO CLAIMANTS.

PURSUANT to the *Trustee Act 1928*, creditors, next of kin, and all other persons having claims in respect of the deceased person named below are required to send particulars of such claims to the legal personal representatives at the address stated, on or before the date stated, after which date the representatives will distribute the assets, having regard only to the claims of which notice has been received:—

Stephen Patrick Wilson, late of 41 Cox-street, Port Fairy, retired blacksmith, deceased, died 21st November, 1957.—Claims to the executrix, Mary Ann Wilson, of 41 Cox-street, Port Fairy, widow, care of Conlan and Leishman, solicitors, 38 Bank-street, Port Fairy, by 18th March, 1958. 156

ELIZABETH MAUDE DUNCAN ATKINSON, late of 108 Darling-road, East Malvern, married woman, DECEASED (who died on the 3rd day of September, 1957).

CREDITORS, next of kin, and all other persons having claims against the estate of the deceased, are required by the executors of her will, Leonard Malcolm Atkinson, of 108 Darling-road, East Malvern, estate agent, Leonard Earl Atkinson, of 15 Dunbar-avenue, Caulfield, insurance manager, Malcolm Earl Atkinson, of Mount Royal, Parkville, manager and secretary, and The Equity Trustees, Executors, and Agency Company Limited, of 472 Bourke-street, Melbourne, to send particulars thereof to them, care of the said company, on or before the 31st day of March, 1958, after which date they may proceed to distribute the assets of the deceased, having regard only to the claims of which they then have notice.

COLTMAN, WYATT, & ANDERSON, solicitors, 578 Bourke-street, Melbourne. 148

CREDITORS, next of kin, and others having claims in respect of the estate of Charles Cairns, late of Fingal, Boneo, via Rosebud, farmer, deceased (who died on 14th June, 1957), are to send particulars of their claims to Robert Kenneth Russell Cairns, care of the undersigned, by the 19th March, 1958, after which date he will distribute the assets, having regard only to the claims of which he then has notice.

COOK & McCALLUM, solicitors, 422 Collins-street, Melbourne. 179

CREDITORS, next of kin, and others having claims in respect of the estate of Cecil Rose McClelland, late of 458 Punt-road, South Yarra, widow, deceased (who died on the 25th September, 1957), are to send particulars of their claims to National Trustees, Executors, and Agency Company of Australasia Limited, of 95 Queen-street, Melbourne, by the 20th day of March, 1958, after which date it will distribute the assets, having regard only to the claims of which it then has notice.

GILLOTT, MOIR, & AHERN, solicitors, of 95 Queen-street, Melbourne. 181

MARY MARGARET GORDON MAXWELL, formerly of "Carnsworth," Studley-avenue, Kew, but late of "Ravenswood," Glenferrie-road, Kew, gentlewoman, DECEASED.

CREDITORS, next of kin, and others having claims against the estate of the deceased (who died on the 4th day of September, 1957), are required by the executors, Phillip Windmiller Ettelson, of 395 Collins-street, Melbourne, solicitor, and Cecil Watts, of High-street, Northcote, bank manager, to send particulars to them, care of the under-mentioned solicitors, by the 18th day of March, 1958, after which date the executors may convey or distribute the assets, having regard only to the claims of which they then have notice.

UPTON & ETTIELSON, solicitors, 395 Collins-street, Melbourne. 184

DOROTHEA STELLA GRAY, late of 35 Park-road, Surrey Hills, widow, DECEASED.

CREDITORS, next of kin, and others having claims against the estate of the deceased (who died on the 19th day of July, 1957), are required by the executor, Phillip Windmiller Ettelson, of 395 Collins-street, Melbourne, to send particulars to him, care of the under-mentioned solicitors, by the 18th day of March, 1958, after which date the executor may convey or distribute the assets, having regard only to the claims of which he then has notice.

UPTON & ETTIELSON, solicitors, 395 Collins-street, Melbourne. 185

DORIS MARY MOUNTJOY, formerly of Bedford-road, Ringwood, but late of 15 Marian-street, Hawthorn, gentlewoman, DECEASED.

CREDITORS, next of kin, and others having claims against the estate of the deceased (who died on the 2nd day of June, 1957), are required by the executrix, Myra Gladys Mountjoy, of 15 Marian-street, Hawthorn, aforesaid, gentlewoman, to send particulars to her, care of the under-mentioned solicitors, by the 18th day of March, 1958, after which date the executrix may convey or distribute the assets, having regard only to the claims of which she then has notice.

UPTON & ETTIELSON, solicitors, 395 Collins-street, Melbourne. 186

STELLA CONSTANCE GUDE, late of 3 Stawell-street, Kew, widow, DECEASED.

CREDITORS, next of kin, and others having claims against the estate of the deceased (who died on the 10th day of May, 1955), are required by the executrix, Eleanor Constance Pendlebury, of 74 Balwyn-road, Balwyn, married woman, to send particulars to her, care of the under-mentioned solicitors, by the 18th day of March, 1958, after which date the executrix may convey or distribute the assets, having regard only to the claims of which she then has notice.

UPTON & ETTIELSON, solicitors, 395 Collins-street, Melbourne. 187

JOHN PATRICK ROY PAXTON, formerly of Hotel Esplanade, Perth, in Western Australia, but late of 24 Mount-street, Perth aforesaid, company director and hotel proprietor, DECEASED.

CREDITORS, next of kin, and others having claims against the estate of the deceased (who died on 3rd June, 1957), are required by the executors, Elaine Gertrude Paxton, Elsie May Plowman, and The Perpetual Executors, Trustees, and Agency Company (W.A.) Limited, of 89 St. George's-terrace, Perth aforesaid, to send particulars to them by the 16th March, 1958, after which date the executors may convey and distribute the assets, having regard only to the claims of which they then have notice.

BLAKE & RIGGALL, solicitors, 120 William-street, Melbourne. 194

HERBERT GATE HANSON, late of 66 Rose-street, Armadale, company director.

CREDITORS, next of kin, and others having claims against the estate of the deceased (who died on the 27th day of August, 1957), are required by the executors, Arthur Godfrey Hanson and Harold Clive Hanson, both of Cobaw, graziers, to send particulars to them, care of the under-mentioned solicitors, by the 18th day of March, 1958, after which date the executors may convey or distribute the assets, having regard only to the claims of which they then have notice.

UPTON & ETTIELSON, solicitors, 395 Collins-street, Melbourne. 188

DORIS MCKINNON, late of 245 Buckley-street, Essendon, married woman, DECEASED.

CREDITORS, next of kin, and others having claims against the estate of the deceased (who died on the 23rd day of May, 1957), are required by the executor, John McKinnon, of 245 Buckley-street, Essendon aforesaid, accountant, to send particulars to him, care of the under-mentioned solicitors, by the 18th day of March, 1958, after which date the executor may convey or distribute the assets, having regard only to the claims of which he then has notice.

UPTON & ETTIELSON, solicitors, 395 Collins-street, Melbourne. 189

LIONEL GEORGE GRAY, late of 4 Strabane-avenue, Box Hill, telephone technician, DECEASED.

CREDITORS, next of kin, and others having claims against the estate of the deceased (who died on the 21st day of June, 1957), are required by the executrix, Nancy May Gray, of 4 Strabane-avenue, Box Hill, aforesaid, widow, to send particulars to her, care of the under-mentioned solicitors, by the 18th day of March, 1958, after which date the executrix may convey or distribute the assets, having regard only to the claims of which she then has notice.

UPTON & ETTIELSON, solicitors, 395 Collins-street, Melbourne. 190

PERCY ALFRED TATHAM, of Currie, King Island, in the State of Tasmania, grazier, and The Perpetual Executors and Trustees Association of Australia Limited, whose registered office is situate at Nos. 100-104 Queen-street, Melbourne, in the State of Victoria, the executors of the will of Mary Tatham (who died on the 18th day of September, 1957), require all creditors, next of kin, and others having claims against the property or estate of the said deceased, to send to the said executors, in the care of the said association, on or before the 24th day of March, 1958, particulars, in writing, of such claims, after which date the said executors intend to convey or distribute such property or estate to or among the persons entitled thereto, having regard only to the claims of which they shall have had notice.

Dated the 9th day of January, 1958.

MALLESON, STEWART, & CO., solicitors, 105 King-street, Melbourne. 192

GAVIN WILSON WATSON, late of 46 Barrow-street, Coburg, licensed grocer, DECEASED.

CREDITORS, next of kin, and others having claims in respect of the estate of the deceased (who died on 19th April, 1957), are required by the executors of the deceased's will, Agnes Eliza Watson, of 46 Barrow-street, Coburg, widow, and George Bryce McIndoe, of 7A Orrong-road, Armadale, chartered accountant (Aust.), to send particulars to them, care of the undersigned, by the 24th March, 1958, after which date the executors may convey or distribute the assets, having regard only to the claims of which they then have notice.

Dated this 13th day of January, 1958.

WHITING & BYRNE, 166 Queen-street, Melbourne, solicitors for the executors. 196

## MINING NOTICE

### ASSOCIATED AUSTRALIAN OILFIELDS NO LIABILITY.

NOTICE is hereby given that all shares in default of Call No. 6 of Six pence per share are forfeited, and will be sold by public auction at 12 noon on Wednesday, 22nd January, 1958, in the vestibule of the Stock Exchange of Melbourne, 422 Little Collins-street, Melbourne, unless previously redeemed.

By order of the Board,

R. R. SANDERSON, Legal Manager.

13th January, 1958.

177

## IMPOUNDINGS

**BANNOCKBURN.**—Impounded in Bannockburn Pound, by Ranger Mason.

1 silver-grey Jersey cow, big star on off hip, dropped hip on near side, no visible brand

If not claimed and expenses paid, to be sold on 27th January, 1958.

J. L. DAVIES,

Poundkeeper.

205—12/

**ECHUCA.**—Impounded in Echuca Pound.

1 red-roan Shorthorn bull, small notch off ear, no visible brand

If not claimed and expenses paid, to be sold on 24th January, 1958.

W. A. BOAL,

Poundkeeper.

202—10/6

**HEIDELBERG.**—Impounded in Diamond Creek Pound.

1 brindle and white heifer, no visible brand  
1 red-roan heifer, no visible brand

If not claimed and expenses paid, to be sold on 29th January, 1958.

F. PHILLIPS,

Town Clerk.

201—10/6

**K**EILOR.—Impounded in Kellor Pound.

1 chestnut pony mare, fire brand on near shoulder and neck  
 1 bay pony mare, no visible brand  
 1 bay pony gelding, no visible brand  
 1 black pony gelding, no visible brand  
 If not claimed and expenses paid, to be sold on 30th January, 1958.  
 D. PASCOE,  
 Poundkeeper.  
 207—15/

**L**ARA.—Impounded from Bell Park.

1 strawberry colour steer, nick in left ear, no visible brand  
 If not claimed and expenses paid, to be sold on 1st February, 1958.  
 RONALD W. ELLIS,  
 Poundkeeper.  
 206—9/

**M**ILDURA.—Impounded in Lake Benetook Pound.

1 red and white cow, Red Poll cross, near ear split, no visible brand  
 1 brindle and white cow, no visible brand  
 1 brindle and white heifer, no visible brand  
 1 red and white heifer, Red Poll cross, no visible brand  
 If not claimed and all expenses paid, to be sold on 30th January, 1958.  
 S. C. JESSOP,  
 Poundkeeper.  
 204—15/

**M**ORTLAKE.—Impounded in Mortlake Pound, on 9th January, 1958.

1 Corriedale 2-tooth ram, no visible brand  
 If not claimed and expenses paid, to be sold on 14th February, 1958.  
 GEO. ROBERTSON,  
 Poundkeeper.  
 209—10/6

**S**HEPPARTON.—Impounded in Shire of Shepparton Pound.

1 bay delivery mare, open bridle, no visible brand  
 1 Jersey steer, no visible brand (from saleyards)  
 If not claimed and expenses paid, to be sold on 30th January, 1958.  
 W. DANIEL,  
 Poundkeeper.  
 208—12/

**W**ARRAGUL.—Impounded in Warragul Pound, from property of Mr. Slater, Sea View.

1 brown dehorned cow, dark points, no visible brand  
 If not claimed and expenses paid, to be sold on 30th January, 1958.  
 L. A. HEMLEY,  
 Shire Secretary.  
 203—10/6

**W**ARRNAMBOOL.—Impounded in Warrnambool Pound.

1 black yearling heifer, no visible brand  
 If not claimed and expenses paid, to be sold on 22nd January, 1958.  
 V. MCKAY,  
 Poundkeeper.  
 200—9/

STATE ACTS, 1954—continued.

No.	Price. s. d.
5784. Melbourne and Metropolitan Tramways (Board)	0 9
5785. Consolidated Revenue	0 6
5786. Consolidated Revenue	0 6
5787. Consolidated Revenue	0 6
5788. Auditor-General's Salary	0 6
5789. Corneal Grafting	0 6
5790. Totalizator (Amendment)	0 6
5791. Country Roads and Level Crossings Funds	0 6
5792. Entertainments Tax (Amendment)	0 6
5793. Finance (Racing)	1 0
5794. Bellarine Water Supply	0 6
5795. Melbourne and Metropolitan Board of Works (Amendment)	0 6
5796. Apprenticeship (Amendment)	0 6
5797. Judges (Powers)	0 6
5798. Goods (Amendment)	0 6
5799. Police Offences (Female Offenders)	0 6
5800. Friendly Societies (Amendment)	0 6
5801. Portland Harbor Trust (Amendment)	0 6
5802. Public Service (Amendment)	0 6
5803. Geelong and District Cultural Institute	0 9
5804. Vermin and Noxious Weeds (Amendment)	0 9
5805. Surplus Revenue	0 6
5806. Gas Regulation (Amendment)	0 9
5807. Parking of Vehicles (Amendment)	0 6
5808. Parliamentary Salaries and Allowances	0 9
5809. County Court (Judges)	0 6
5810. Swan Hill Lands Exchange	0 6
5811. Miners' Phthisis (Treasury Allowances) Amendment	0 6
5812. Gas and Fuel Corporation (Kyneton Undertaking)	0 9
5813. Dog Races	1 3
5814. Infectious Diseases Hospitals	1 0
5815. Public Officers Salaries	0 6
5816. Wheat Industry Stabilization	1 3
5817. Children's Welfare	2 0
5818. Consolidated Revenue	0 6
5819. Mental Hygiene (Maintenance)	0 6
5820. Parliamentary Contributory Retirement Fund	0 6
5821. Water Supply Loan Application	1 0
5822. Napier-street Bridge	0 9
5823. Health (Amendment)	1 6
5824. Forests (Amendment)	0 9
5825. Co-operative Housing Societies (Guarantees)	0 6
5826. Midwives (Amendment)	0 6
5827. State Electricity Commission (Borrowing)	0 6
5828. Justices (Amendment)	0 6
5829. Fire Brigades (Amendment)	0 9
5830. Mildura College Lands (Amendment)	0 6
5831. Country Roads (Amendment)	0 6
5832. Soldier Settlement (Financial)	0 6
5833. River Murray Waters	0 9
5834. Town and Country Planning (Metropolitan Area)	1 0
5835. Housing	0 9
5836. Gas and Fuel Corporation (Mornington Undertaking)	0 9
5837. Railways (Commissioners' Salaries)	0 6
5838. Water	0 9
5839. State Forests Loan Application	0 6
5840. Railway Loan Application	1 3
5841. Police Offences (Sports Grounds)	0 6
5842. Transfer of Land	3 9
5843. Local Government (Amendment)	1 9
5844. Land Tax	0 6
5845. Water (Connexions to Mains)	0 6
5846. Statutes Amendment	0 6
5847. Landlord and Tenant	0 9
5848. Transport Regulation (Amendment)	1 0
5849. Judges Salaries	0 6
5850. Public Works Loan Application	0 6
5851. Adoption of Children (Amendment)	0 6
5852. Hide and Leather Industries (Suspension)	0 6
5853. Appropriation of Revenue	4 0

W. M. HOUSTON,  
 Government Printer.

**STATE ACTS, 1954**

COPIES of the following Acts of Parliament of Victoria may be obtained at the Government Printing Office, or from any bookseller, at the price set opposite to each:—

No.	Price. s. d.
5773. Coal Mine Workers Pensions (Amendment)	0 6
5774. Police Offences (Unlawful Games)	0 6
5775. Local Government (City of Sunshine)	0 6
5776. State Savings Bank (Deposits)	0 6
5777. Chandler Highway and Bridge	0 6
5778. Town and Country Planning	1 0
5779. Police Offences (Obscene Publications)	0 9
5780. Health (Infectious Diseases)	0 6
5781. Melbourne Cricket Ground (Guarantee)	0 6
5782. Superannuation (Female Officers)	0 6
5783. Crimes	0 6

**STATE ACTS, 1955**

COPIES of the following Acts of Parliament of Victoria may be obtained at the Government Printing Office, or from any bookseller, at the price set opposite to each:—

No.	Price. s. d.
5854. Consolidated Revenue	0 6
5855. Statute Law Revision Committee (Amendment)	0 6
5856. Consolidated Revenue	0 6
5857. Auditor-General's Salary	0 6

STATE ACTS, 1955—continued.

No.	Price. s. d.
5858. Consolidated Revenue	0 6
5859. Hide and Leather Industries (Repeal)	0 3
5860. Teaching Service (Amendment)	0 6
5861. Maintenance (Enforcement of Orders)	0 6
5862. Companies (Names)	0 6
5863. Legal Profession Practice (Amendment)	0 9
5864. Newport "A" Power Station	0 6
5865. Adoption of Children	0 6
5866. Geelong Waterworks and Sewerage (Amendment)	0 f
5867. Parliamentary Elections (State Servants) Amendment	0 6
5868. Firearms (Olympic Games)	0 6
5869. Justices (Amendment)	0 9
5870. Country Fire Authority (Financial)	0 6
5871. Supreme Court and County Court (Judges)	0 6
5872. Railway Deviations	0 9
5873. State Savings Bank (Amendment)	0 6
5874. Crown Proceedings	0 6
5875. Gas and Fuel Corporation (Financial)	0 6
5876. Children's Welfare (Amendment)	0 6
5877. Evidence (Amendment)	0 9
5878. Land Tax (Exemptions and Rates)	0 6
5879. Health (Offensive Trades)	0 6
5880. Dietitians Registration (Amendment)	0 6
5881. Medical (Pharmacy Board Fees)	0 6
5882. Benefit Associations (Amendment)	0 6
5883. Surplus Revenue	0 6
5884. Landlord and Tenant (Amendment)	1 3
5885. Police Offences (Valueless Cheques)	0 6
5886. Dairy Produce (Cheese)	0 6
5887. Coal Mine Workers Pensions (Amendment)	0 6
5888. Parking of Vehicles (Amendment)	0 6
5889. Public Service (Amendment)	0 6
5890. Police Regulation (Junior Trainees)	0 6
5891. Wonthaggi Railway Land	0 6
5892. Licensing	0 9
5893. Stock Medicines (Amendment)	0 6
5894. Marine (Temporary Exemptions)	0 6
5895. Administration and Probate (Estates)	0 9
5896. Statute Law Revision	0 9
5897. Police Regulation (Pensions)	0 6
5898. Bailiffs	0 6
5899. Housing	1 0
5900. Soldier Settlement (Amendment)	0 9
5901. Old Colonists' Association	0 6
5902. Supreme Court (Officers)	0 6
5903. Co-operative Housing Societies (Amendment)	0 6
5904. Dog Races	0 6
5905. Olympic Games	0 6
5906. Water Supply Loan Application	1 0
5907. Friendly Societies (Amendment)	0 6
5908. Licensing (Amendment)	1 0
5909. Revocation and Excision of Crown Reservations	1 3
5910. Forests (Amendment)	0 6
5911. Superannuation	1 3
5912. Fisheries (Proclamation)	0 6
5913. Melbourne Market and Park Lands	0 6
5914. Limitation of Actions	1 9
5915. Motor Car (Amendment)	0 9
5916. Milk Board (Amendment)	0 6
5917. Crimes (Amendment)	0 9
5918. Railways (Amendment)	0 9
5919. Labour and Industry (Long Service Leave)	0 6
5920. Home Finance	0 6
5921. Public Works Loan Application	0 6
5922. State Forests Loan Application	0 6
5923. Mental Hygiene (Amendment)	0 9
5924. Local Government (Amendment)	0 9
5925. Mines (Petroleum)	1 0
5926. Geelong Market Site	0 6
5927. Railway Loan Application	1 3
5928. Lang Lang Land	0 6
5929. Geelong Harbor Trust (Amendment)	0 6
5930. Transport Regulation	1 9
5931. Commercial Goods Vehicles	1 6
5932. Motor Car (Road Safety)	0 6
5933. Public Officers Salaries	0 6
5934. Property Law and Transfer of Land	0 9
5935. Companies	1 6
5936. Crimes (Driving Offences)	0 9
5937. Labour and Industry (Shops)	0 9
5938. Mines (Uranium and Thorium)	0 9
5939. Railways Dismantling	0 9
5940. Appropriation of Revenue	4 3

STATE ACTS, 1956

COPIES of the following Acts of Parliament of Victoria may be obtained at the Government Printing Office, or from any bookseller, at the price set opposite to each:—

No.	Price. s. d.
5941. Limitation of Actions (Extension)	0 6
5942. Serviceton Public Hall	0 6
5943. Keilor (Unimproved Rating Poll)	0 6
5944. Portland Harbor Trust (Land)	0 6
5945. Motor Car (Third-Party Insurance)	0 6
5946. Local Government (Broadmeadows)	0 6
5947. Melbourne Harbor Trust (Amendment)	0 6
5948. Returned Servicemen's Badges	0 f
5949. Grain Elevators (Financial)	0 6
5950. Workers' Compensation (Police)	0 6
5951. North Carlton Land	0 6
5952. Superannuation (Amendment)	0 6
5953. Country Fire Authority (Borrowing)	0 t
5954. Operation Gratitude Race Meeting	0 6
5955. Rural Finance Corporation (Amendment)	0 6
5956. Melbourne College of Divinity (Amendment)	0 6
5957. Supreme Court (Wards of Court)	0 6
5958. Stamps (Amendment)	0 6
5959. Cancer Institute (Loan Movies)	0 6
5960. The Victoria Racing Club	0 6
5961. Penal Reform	1 9
5962. Police Offences (Control of Raffles)	0 6
5963. Process Servers and Inquiry Agents	1 3
5964. Consolidated Revenue	0 6
5965. Medical (Registration)	0 6
5966. Gas and Fuel Corporation (Castlemaine Undertaking)	0 9
5967. Home Finance	0 9
5968. Police Offences (Amendment)	0 6
5969. Judges Salaries and Allowances	0 6
5970. Public Officers Salaries and Allowances	0 9
5971. Motor Car (Registration Fees)	0 6
5972. Melbourne Subways (Borrowing)	0 6
5973. Railways (Commissioners)	0 6
5974. Game (Destruction)	0 6
5975. Boilers Inspection (Amendment)	0 6
5976. The Geelong Gas Company's	0 6
5977. St. Kilda and Brighton Electric Street Railway (Partial Dismantling)	0 9
5978. Country Roads	1 0
5979. Health (Narcotics)	0 6
5980. Water (Compensation)	0 9
5981. Land (Improvement Purchase Lease)	0 9
5982. Melbourne and Metropolitan Board of Works	1 3
5983. Road Traffic	1 0
5984. Housing (Slum Research Officer)	0 6
5985. Firearms (Industrial Tools)	0 6
5986. Hospitals and Charities (Liability of Patients)	0 6
5987. The Constitution Act Amendment (Committee of Public Accounts)	0 6
5988. Local Government (Building Regulations)	0 9
5989. Estate Agents	2 3
5990. Freedom of the City of Melbourne	0 6
5991. Subordinate Legislation Committee	0 6
5992. Local Authorities Superannuation	0 6
5993. West Melbourne Market Land	0 6
5994. Consolidated Revenue	0 6
5995. Juries	1 9
5996. Administration and Probate	0 6
5997. Consolidated Revenue	0 6
5998. Amendments Incorporation	3 6
5999. Labour and Industry (Long Service Leave)	0 6
6000. Melbourne Racing Club	1 3
6001. State Electricity Commission	0 6
6002. Gas and Fuel Corporation (Acquisition)	0 6
6003. Land (Unused Roads)	0 6
6004. Police Regulation (Retirement)	0 6
6005. Labour and Industry (Wages Boards)	0 6
6006. The Constitution Act Amendment	8 6
6007. Sheep (Foot Rot)	0 9
6008. The Ballarat Gas Company's	0 6
6009. Veterinary Surgeons (Amendment)	0 6
6010. Gas Regulation (Amendment)	0 9
6011. Land Tax (Rates)	0 6
6012. Registrar-General's Fees	1 0
6013. Instruments (Amendment)	0 9
6014. Entertainments Tax (Rates)	0 6
6015. Soldier Settlement (Amendment)	0 6
6016. Electoral	1 6
6017. Police Regulation (Reservists)	0 9
6018. Police Pensions Fund (Investment)	0 6
6019. Revenue Deficit Funding	0 6
6020. Portland Harbor Trust (Borrowing Powers)	0 6
6021. Stamps (Cheques and Receipts)	0 6
6022. Motor Car (Driving Licences)	0 6
6023. National Parks	1 0
6024. Health	7 9

STATE ACTS, 1956.—continued.

No.	Price s. d.
6025. National Art Gallery and Cultural Centre ..	0 9
6026. Youth Organizations Assistance ..	0 6
6027. Appleton Dock Railway Construction ..	0 6
6028. Co-operative Housing Societies (Guarantees and Indemnities) ..	0 6
6029. Education (Kindergarten Teachers) ..	0 6
6030. Teaching Service (Married Women) ..	1 0
6031. Workers Compensation (Supplementary Board) ..	0 6
6032. Hospital Benefits (Amendment) ..	0 6
6033. Railways (Malvern Subways) ..	0 6
6034. Water Supply Loan Application ..	1 3
6035. Nurses ..	1 9
6036. Housing (Land) ..	1 0
6037. Police Offences (Trespass to Farms) ..	0 6
6038. Motor Car (Fees) ..	0 6
6039. Police Offences (Cruelty to Animals) ..	0 6
6040. State Forests Loan Application ..	0 6
6041. Melbourne and Metropolitan Board of Works (Borrowing Powers) ..	0 6
6042. Racing (Finance) ..	0 6
6043. Railway Loan Application ..	1 3
6044. Gas and Fuel Corporation (Frankston and Dandenong Undertakings) ..	1 9
6045. Stamps (Hire-Purchase Agreements) ..	0 6
6046. Forests (Masonite Agreement) ..	1 3
6047. Companies (Unit Trusts) ..	0 9
6048. Local Government (Amendment) ..	0 6
6049. Public Works Loan Application ..	0 9
6050. Marriage (Property) ..	0 9
6051. Parliamentary Contributory Retirement Fund (Amendment) ..	0 6
6052. Housing (Broadmeadows Land) ..	0 6
6053. Children's Court ..	2 0
6054. Housing (Staff) ..	0 6
6055. Appropriation of Revenue ..	4 3
6056. Governor's Salary ..	0 6

W. M. HOUSTON,  
Government Printer.

STATE ACTS, 1957

COPIES of the following Acts of Parliament of Victoria may be obtained at the Government Printing Office, or from any bookseller, at the price set opposite to each:—

No.	Price s. d.
6057. Trinity College ..	0 6
6058. Vermin and Noxious Weeds (Financial) ..	0 6
6059. Victorian Inland Meat Authority (Financial) ..	0 6
6060. Melbourne and Metropolitan Board of Works (Contributions) ..	0 6
6061. Moorabbin Land ..	0 6
6062. Pounds (Fees) ..	0 6
6063. Dried Fruits (Amendment) ..	0 6
6064. Public Account (Amendment) ..	0 6
6065. Rabbit (Biological Destruction) ..	0 6
6066. Public Works Loan Application ..	0 6
6067. Game (Destruction) ..	0 6
6068. Coal Mine Workers Pensions (Amendment) ..	0 6
6069. Police Offences ..	5 6
6070. Racing ..	3 3
6071. Yinnar Lands ..	0 6
6072. Sandringham to Black Rock Electric Street Railway (Dismantling) ..	0 9
6073. Forests ..	3 0
6074. Wodonga (Unimproved Rating Poll) ..	0 6
6075. Housing (Commonwealth and State Agreement) ..	1 3
6076. Cemeteries (Financial) ..	0 6
6077. Consolidated Revenue ..	0 6
6078. Masseurs (Registration) ..	0 6
6079. Country Roads (Amendment) ..	0 6
6080. Maintenance ..	1 0
6081. Stamps (Hire-Purchase Agreements) Amendment ..	0 6
6082. Justices ..	8 0
6083. Mornington Land ..	0 6
6084. Medical (Registration) ..	0 9
6085. Soil Conservation and Land Utilization (River Flats) ..	0 6
6086. Aborigines ..	0 9
6087. Grain Elevators (Border Railways) ..	0 6
6088. Barley Marketing (Amendment) ..	0 6
6089. Administration and Probate (Amendment) ..	0 6
6090. Housing ..	0 9
6091. Police Regulation (Amendment) ..	0 6
6092. Trotting Races ..	1 0
6093. Weights and Measures (Amendment) ..	0 6
6094. Benefit Associations (Amendment) ..	0 6

STATE ACTS, 1957—continued.

No.	Price s. d.
6095. Transport (Westernport Bay) ..	0 6
6096. Labour and Industry (Amendment) ..	0 6
6097. Game (Amendment) ..	0 6
6098. Landlord and Tenant (Control) ..	3 3
6099. Consolidated Revenue ..	0 6
6100. Wangaratta (Rating on Unimproved Values) ..	0 6
6101. Railways (Furlough) Amendment ..	0 6
6102. Consolidated Revenue ..	0 6
6103. Crimes ..	9 0
6104. Stamps ..	1 9
6105. Port Melbourne Lagoon Lands ..	0 6
6106. Solicitor-General (Pension) ..	0 6
6107. Justices (Amendment) ..	0 9
6108. Dog ..	0 6
6109. Trustee Companies ..	0 9
6110. Coal Mine Workers Pensions (Amendment) ..	0 6
6111. Audit ..	2 0
6112. Statute Law Revision ..	0 6
6113. Judicial Proceedings (Regulation of Reports) ..	0 6

W. M. HOUSTON,  
Government Printer.

THE VICTORIA GOVERNMENT GAZETTE is published on WEDNESDAY EVENING in each week, and Notices for insertion will be received by the Government Printer at or before Two p.m. at ordinary rates, and late advertisements between Two p.m. and Five p.m. at double rates on the day preceding the day of publication.

Single copies of the VICTORIA GOVERNMENT GAZETTE are One shilling, posted One shilling and three pence.

No GAZETTES prior to January, 1950, in stock.

\*\*\*ALL PAYMENTS ARE REQUIRED IN ADVANCE.—Remittances should be made by postal note, money order, or draft in favour of the Government Printer. Advertisements unaccompanied by a remittance sufficient to cover the cost of insertion will be returned unpublished.

SUBSCRIPTIONS.—The subscription, including postage, is £2 15s. per annum, £1 7s. 6d. half-yearly, or 13s. 9d. per quarter, payable in advance.

Subscriptions are required to commence and terminate with a month.

A lesser period than three months cannot be subscribed for.

Subscribers do not receive the Acts of Parliament with the GAZETTE.

ADVERTISEMENTS are charged at the rate of 1s. 6d. per line single column, and 3s. per line double column.

The title (£5 Reward, Dissolution of Partnerships, &c.) forms one or more lines as a heading.

On an average, ten words make a line.

Every signature must likewise be counted as a line.

The final words of a paragraph, though only portion of a line, must be counted as one line.

SIGNATURES (in particular) and proper names must be written very plainly in the text; ONE SIDE ONLY of each slip of paper should be WRITTEN UPON.

ALL COMMUNICATIONS should be addressed to "The Government Printer, Melbourne."

ALL DOCUMENTS illegibly written will be returned unpublished, and, where brands occur unprovided for by the ordinary letters of the alphabet, a worded explanatory description must be furnished.

THE "VICTORIA GOVERNMENT GAZETTE."

ATTENTION is invited to the following procedure in relation to the publication of official matter in the Government Gazette:—

1. Matter submitted to the Executive Council.

Matter submitted to the Executive Council which requires gazettal will normally be published in the issue of the following week.

Where urgent gazettal is required, special arrangements should be made with the Gazette Officer.

Publication will be facilitated by the submission of carbon copies for the use of the Gazette Officer.

2. Other matter.

(a) All other matter duly certified by a responsible officer for publication should be lodged with the Gazette Officer not later than half-past Ten a.m. on Tuesday.

(b) Lengthy or involved notices should be forwarded several days before publication.

(c) Proofs, which will be supplied only when specifically requested, or at the direction of the *Gazette* Officer, should be returned promptly to avoid delay in publication.

(d) No additions or amendments to matter for publication will be accepted by telephone.

AGENTS FOR THE "VICTORIA GOVERNMENT GAZETTE."

THE following have been appointed agents to receive Advertisements and Subscriptions for the *Victoria Government Gazette*:—

ARMSTRONG'S AGENCY, 143 Queen-street, Melbourne.

ARMSTRONG BROS., Kyneton.

MESSRS. ARNALL & JACKSON, 115 Barkly-street, West Brunswick.

BERRY, ANDERSON, & CO., 207 Sturt-street, Ballarat.

MR. WM. DAVIS, Mildura.

A. J. DIGBY (B. S. and N. W. Cash), Main-street, Bairnsdale.

EDGAR'S NEWS AGENCY, Hargreaves-street, Bendigo.

MESSRS. HENRY FRANKS & CO., Booksellers and Stationers, Market-square, Geelong.

MESSRS. GORDON & GOTCH, News Agents, 511 Little Collins-street, Melbourne; and corner Barrack and Clarence streets, Sydney.

A. C. HAMPTON, 243 Mitchell-street, Bendigo.

MESSRS. HARSTON, PARTRIDGE, & CO., 455 Little Collins-street, Melbourne.

MR. C. F. LATIMER, News Agent, Casterton.

MCARTHUR'S AUTHORIZED NEWSAGENCY, 345 Wyndham-street, Shepparton.

MESSRS. R. H. & W. M. PETTY, News Agent, Wangaratta.

MESSRS. POWELL & DIXON, 89 Firebrace-street, Horsham.

J. PURDIE & CO., 138 Moorabool-street, Geelong.

F. W. RASHLEIGH & SON, Nunn-street, Benalla.

ROBERTSON & MULLENS LTD., Elizabeth-street, Melbourne.

SALE AUTHORIZED NEWS AGENTS, Sale.

SKINNER'S AUTHORIZED NEWSAGENCY, 49-51 Franklin-street, Traralgon.

MESSRS. SMITH & DUNNON, Hamilton.

THE MERCANTILE EXCHANGE, 380 Collins-street, Melbourne.

F. D. & J. R. TRAINOR, 246 Wyndham-street, Shepparton.

C. F. & H. J. VERNON, 162 Bridge-road, Richmond.

VIEW POINT AUTHORIZED NEWSAGENCY, 4 View Point, Bendigo.

E. W. B. WELSH, Hogan-street, Tatura.

A copy of the *Gazette* filed at each place for public reference.

CONTENTS

	PAGE
Acts of Parliament on sale at the Government Printing Office .. .. .	129
Appointments .. .. .	95
Auction Sales Act .. .. .	88
Bank Holidays .. .. .	87
Contracts .. .. .	92
Country Roads Board .. .. .	92
Courts .. .. .	88
Government Notices .. .. .	88
Impoundings .. .. .	128
Lands .. .. .	98
Mining .. .. .	88, 128
Money Lenders Act 1938—Supplementary List .. .. .	88
Orders in Council .. .. .	96
Police Sale .. .. .	92
Private Advertisements .. .. .	113
Proclamations .. .. .	85
Public Holidays .. .. .	87
Public Holiday—Australia Day .. .. .	88
Public Service Notices .. .. .	106
Tenders .. .. .	105
Transport Regulation Board—Public Hearings .. .. .	89
Waterworks Trusts .. .. .	93