



VICTORIA GOVERNMENT GAZETTE

Published by Authority

[Registered at the General Post Office, Melbourne, for transmission by post as a newspaper.]

No. 98]

WEDNESDAY, NOVEMBER 12

[1958

ACTS OF PARLIAMENT.

PROCLAMATION

By His Excellency the Governor of the State of Victoria and its Dependencies in the Commonwealth of Australia, &c., &c., &c.

I, THE Governor of the State of Victoria, in the Commonwealth of Australia, do hereby declare that I have this day assented, in Her Majesty's name, to the Bills passed by the Parliament of the said State, the titles whereof are hereunder set forth, that is to say:—

- No. 6431. "A Act to apply out of the Consolidated Revenue the sum of Two million three hundred and forty-three thousand eight hundred and nineteen pounds to the service of the year One thousand nine hundred and fifty-seven and One thousand nine hundred and fifty-eight."
 No. 6432. "An Act to amend Sections Three and Thirty of the 'Fences Act 1928'.
 No. 6433. "An Act relating to payments by Cheque under Contracts for the Sale of Land."
 No. 6434. "An Act to re-enact Section Five and to amend Section Seven of the 'Metropolitan Fire Brigades Act 1958'.
 No. 6435. "An Act to provide for the Registration of Hire-Purchase Repossession Agents."

Given under my Hand and the Seal of the State of Victoria aforesaid, at Melbourne, this twenty-eighth day of October, in the year of our Lord, One thousand nine hundred and fifty-eight, and in the seventh year of the reign of Her Majesty Queen Elizabeth II.

(L.S.)

DALLAS BROOKS.

By His Excellency's Command,

HENRY E. BOLTE,
Premier.

GOD SAVE THE QUEEN!

ACTS OF PARLIAMENT.

PROCLAMATION

By His Excellency the Governor of the State of Victoria and its Dependencies in the Commonwealth of Australia, &c., &c., &c.

I, THE Governor of the State of Victoria, in the Commonwealth of Australia, do hereby declare that I have this day assented, in Her Majesty's name, to the Bills passed by the Parliament of the said State, the titles whereof are hereunder set forth, that is to say:—

- No. 6436. "An Act relating to certain land owned by the Housing Commission in the City of Broadmeadows."
 No. 6437. "An Act to apply out of the Consolidated Revenue the sum of Nineteen million seven hundred and seventy-eight thousand five hundred and ninety-two pounds to the service of the year One thousand nine hundred and fifty-eight and One thousand nine hundred and fifty-nine."

Given under my Hand and the Seal of the State of Victoria aforesaid, at Melbourne, this twenty-ninth day of October, in the year of our Lord, One thousand nine hundred and fifty-eight, and in the seventh year of the reign of Her Majesty Queen Elizabeth II.

(L.S.)

DALLAS BROOKS.

By His Excellency's Command,

HENRY E. BOLTE,
Premier.

GOD SAVE THE QUEEN!

ACTS OF PARLIAMENT.

PROCLAMATION

By His Excellency the Governor of the State of Victoria and its Dependencies in the Commonwealth of Australia, &c., &c., &c.

I, THE Governor of the State of Victoria, in the Commonwealth of Australia, do hereby declare that I have this day assented, in Her Majesty's name, to the Bills passed by the Parliament of the said State, the titles whereof are hereunder set forth, that is to say:—

No. 6438. "An Act to amend Part VI of the 'Instruments Act 1958'."

No. 6439. "Act to incorporate First Church of Christ, Scientist, Melbourne and to provide for the Incorporation of other Churches of Christ, Scientist, in the State of Victoria and for other purposes."

Given under my Hand and the Seal of the State of Victoria aforesaid, at Melbourne, this fifth day of November, in the year of our Lord One thousand nine hundred and fifty-eight, and in the seventh year of the reign of Her Majesty Queen Elizabeth II.

(L.S.) DALLAS BROOKS.

By His Excellency's Command,
HENRY E. BOLTE,
Premier.

GOD SAVE THE QUEEN!

FLORAL EMBLEM
FOR
THE STATE OF VICTORIA.

PROCLAMATION

I, THE Governor of the State of Victoria, in the Commonwealth of Australia, by and with the advice of the Executive Council of the said State, do by this my Proclamation declare that the Pink Form of the Common Heath, *Epacris impressa* Labill., be adopted as the Floral Emblem for the State of Victoria.

Given under my Hand and the Seal of the State of Victoria aforesaid, at Melbourne, this eleventh day of November, in the year of our Lord One thousand nine hundred and fifty-eight, and in the seventh year of the reign of Her Majesty Queen Elizabeth II.

(L.S.) DALLAS BROOKS.

By His Excellency's Command,
HENRY E. BOLTE,
Premier.

GOD SAVE THE QUEEN!

NOTE.—A coloured picture of the Floral Emblem, together with a description of the flower, will be published in the *Government Gazette* towards the end of this year.

Game Acts.

REVOCATION OF PROCLAMATION RESPECTING PROTECTION OF NATIVE GAME AT "HILTONWOOD", CLYDE.

PROCLAMATION

By His Excellency the Governor of the State of Victoria and its Dependencies in the Commonwealth of Australia, &c., &c., &c.

I, THE Governor of the State of Victoria, in the Commonwealth of Australia, by and with the advice of the Executive Council of the said State, and in pursuance of the provisions of the Game Acts and all other powers me enabling in that behalf, do by this my Proclamation revoke the Proclamation made the nineteenth day of October, 1915, and published in the *Government Gazette* of twenty-seventh day of October, 1915, respecting protection of native game at "Hiltonwood", Clyde.

Given under my Hand and the Seal of the State of Victoria aforesaid, at Melbourne, this eleventh day of November, in the year of our Lord, One thousand nine hundred and fifty-eight, and in the seventh year of the reign of Her Majesty Queen Elizabeth II.

(L.S.) DALLAS BROOKS.

By His Excellency's Command,
L. H. S. THOMPSON,
for Chief Secretary.

GOD SAVE THE QUEEN!

ROAD TRAFFIC ACT 1956.

PROCLAMATION

By His Excellency the Governor of the State of Victoria and its Dependencies in the Commonwealth of Australia, &c., &c., &c.

WHEREAS by the *Road Traffic Act 1956* it is amongst other things enacted that Part II. of the said Act shall apply only in respect of infringements occurring in any area or circumstance specified for the purpose of such Part by Proclamation of the Governor in Council published in the *Government Gazette* and occurring after the date of such Proclamation:

And whereas it is also enacted in the said Act that any such Proclamation may provide that such Part of the said Act shall apply only in respect of parking infringements or in respect of traffic infringements or in any particular area or circumstance:

And whereas it is further enacted that no such Proclamation shall be made in relation to parking infringements unless the council of any municipality the municipal district or any part of the municipal district of which is specified therein has requested the Governor in Council to extend the application of such Part to such municipal district or part thereof:

And whereas the Council of the Shire of Korumburra has requested the Governor in Council to extend the application of such Part in respect only of parking infringements to the Shire of Korumburra:

Now therefore I, the Governor of the State of Victoria, in the Commonwealth of Australia, by and with the advice of the Executive Council of the said State, do by this my Proclamation specify the Shire of Korumburra as an area in which Part II. of the *Road Traffic Act 1956* shall apply in respect only of parking infringements occurring after the date hereof.

Given under my Hand and the Seal of the State of Victoria aforesaid, at Melbourne, this eleventh day of November, in the year of our Lord, One thousand nine hundred and fifty-eight, and in the seventh year of the reign of Her Majesty Queen Elizabeth II.

(L.S.) DALLAS BROOKS.

By His Excellency's Command,
L. H. S. THOMPSON,
for Chief Secretary.

GOD SAVE THE QUEEN!

ROAD TRAFFIC ACT 1956.

PROCLAMATION

By His Excellency the Governor of the State of Victoria and its Dependencies in the Commonwealth of Australia, &c., &c., &c.

WHEREAS by the *Road Traffic Act 1956* it is amongst other things enacted that Part II. of the said Act shall apply only in respect of infringements occurring in any area or circumstance specified for the purpose of such Part by Proclamation of the Governor in Council published in the *Government Gazette* and occurring after the date of such Proclamation:

And whereas it is also enacted in the said Act that any such Proclamation may provide that such Part of the said Act shall apply only in respect of parking infringements or in respect of traffic infringements or in any particular area or circumstance:

And whereas it is further enacted that no such Proclamation shall be made in relation to parking infringements unless the council of any municipality the municipal district or any part of the municipal district of which is specified therein has requested the Governor in Council to extend the application of such Part to such municipal district or part thereof:

And whereas the Council of the Shire of Alexandra has requested the Governor in Council to extend the application of such Part in respect only of parking infringements to the Shire of Alexandra:

Now therefore I, the Governor of the State of Victoria, in the Commonwealth of Australia, by and with the advice of the Executive Council of the said State, do by this my Proclamation specify the Shire of Alexandra

as an area in which Part II. of the *Road Traffic Act 1956* shall apply in respect only of parking infringements occurring after the date hereof.

Given under my Hand and the Seal of the State of Victoria aforesaid, at Melbourne, this eleventh day of November, in the year of our Lord, One thousand nine hundred and fifty-eight, and in the seventh year of the reign of Her Majesty Queen Elizabeth II.

(L.S.) DALLAS BROOKS.

By His Excellency's Command,
L. H. S. THOMPSON,
for Chief Secretary.

GOD SAVE THE QUEEN!

PUBLIC HIGHWAY.—SHIRE OF MULGRAVE.

PROCLAMATION

By His Excellency the Governor of the State of Victoria and its Dependencies in the Commonwealth of Australia, &c., &c., &c.

WHEREAS by the *Local Government Act 1946* (No. 5203), section 518, it is amongst other things enacted that it shall be lawful for the Governor in Council at any time, and from time to time, upon the request of the council of any municipality, by notice in the *Government Gazette*, to declare any land reserved, used or by purchase or exchange acquired for a street, road, highway, thoroughfare, bridge, square, court, alley or right-of-way to be a public highway, and that such land shall thereupon and thenceforth from the date of such Proclamation become and be absolutely dedicated to the public as a public highway within the meaning of any law then or thereafter in force:

And whereas the Council of the Shire of Mulgrave has requested that the land hereinafter mentioned, which has been used for a street within the said Shire, be so declared to be a public highway:

Now, therefore, I, the Governor of the State of Victoria in the Commonwealth of Australia, by and with the advice of the Executive Council of the said State, do by this Proclamation declare that all that piece of land used for a street, being part of Crown Portion 15, Parish of Mulgrave, and being the land shown as Fairland Avenue on lodged Plan of Subdivision No. 11232 shall be a public highway within the meaning of the said Act.

Given under my Hand and the Seal of the State of Victoria aforesaid, at Melbourne, this fifth day of November, in the year of our Lord One thousand nine hundred and fifty-eight, and in the seventh year of the reign of Her Majesty Queen Elizabeth II.

(L.S.) DALLAS BROOKS.

By His Excellency's Command,
T. K. MALBY,
Commissioner of Public Works.

GOD SAVE THE QUEEN!

PUBLIC HIGHWAY.—SHIRE OF FRANKSTON AND HASTINGS.

PROCLAMATION

By His Excellency the Governor of the State of Victoria and its Dependencies in the Commonwealth of Australia, &c., &c., &c.

WHEREAS by the *Local Government Act 1946*, section 518, it is amongst other things enacted that it shall be lawful for the Governor in Council at any time, and from time to time, upon the request of the council of any municipality, by notice in the *Government Gazette*, to declare any land reserved, used or by purchase or exchange acquired for a street, road, highway, thoroughfare, bridge, square, court, alley or right-of-way to be a public highway, and that such land shall thereupon and thenceforth from the date of such Proclamation become and be absolutely dedicated to the public as a public highway within the meaning of any law then or thereafter in force:

And whereas the Council of the Shire of Frankston and Hastings has requested that the land hereinafter mentioned, which has been used for a street within the said Shire, be so declared to be a public highway:

Now, therefore, I, the Governor of the State of Victoria in the Commonwealth of Australia, by and with the advice of the Executive Council of the said State, do, by this Proclamation, declare that all that piece of land, used for a street, being part of Crown allotment 11, section 2, Parish of Frankston, and being the land described hereunder shall be a public highway within the meaning of the said Act, namely:—

THE CREST (PORTION OF).

Commencing at the south-eastern angle of Lot 37 shown on lodged Plan of Subdivision No. 11579, bounded thence by lines bearing respectively north 46 degs. 6 mins. east 232 feet 10½ inches, north 10 degs. 57 mins. east 786 feet 2½ inches, south 79 degs. 3 mins. east 50 feet, south 10 degs. 57 mins. west 802 feet 0½ inch, south 46 degs. 6 mins. west 248 feet 8½ inches and north 43 degs. 54 mins. west 50 feet to the point of commencement.

Given under my Hand and the Seal of the State of Victoria aforesaid, at Melbourne, this fifth day of November, in the year of our Lord One thousand nine hundred and fifty-eight, and in the seventh year of the reign of Her Majesty Queen Elizabeth II.

(L.S.) DALLAS BROOKS.

By His Excellency's Command,
T. K. MALBY,
Commissioner of Public Works.

GOD SAVE THE QUEEN!

PUBLIC HIGHWAY.—SHIRE OF SPRINGVALE AND NOBLE PARK.

PROCLAMATION

By His Excellency the Governor of the State of Victoria and its Dependencies in the Commonwealth of Australia, &c., &c., &c.

WHEREAS by the *Local Government Act 1946* (No. 5203), section 518, it is amongst other things enacted that it shall be lawful for the Governor in Council at any time, and from time to time, upon the request of the council of any municipality, by notice in the *Government Gazette*, to declare any land reserved, used or by purchase or exchange acquired for a street, road, highway, thoroughfare, bridge, square, court, alley or right-of-way to be a public highway, and that such land shall thereupon and thenceforth from the date of such Proclamation become and be absolutely dedicated to the public as a public highway within the meaning of any law then or thereafter in force:

And whereas the Council of the Shire of Springvale and Noble Park has requested that the land hereinafter mentioned, which has been used for a road within the said Shire, be so declared to be a public highway:

Now, therefore, I, the Governor of the State of Victoria in the Commonwealth of Australia, by and with the advice of the Executive Council of the said State, do by this Proclamation declare that all that piece of land used for a road, being part of Crown Portion 22, Parish of Dandenong, and being the land shown as Mons Parade between Beatty Grove and Chandler Road on lodged Plan of Subdivision No. 6870, shall be a public highway within the meaning of the said Act.

Given under my Hand and the Seal of the State of Victoria aforesaid, at Melbourne, this fifth day of November, in the year of our Lord One thousand nine hundred and fifty-eight, and in the seventh year of the reign of Her Majesty Queen Elizabeth II.

(L.S.) DALLAS BROOKS.

By His Excellency's Command,
T. K. MALBY,
Commissioner of Public Works.

GOD SAVE THE QUEEN!

PUBLIC HIGHWAY.—SHIRE OF SPRINGVALE AND NOBLE PARK.

PROCLAMATION

By His Excellency the Governor of the State of Victoria and its Dependencies in the Commonwealth of Australia, &c., &c., &c.

WHEREAS by the *Local Government Act* 1946, section 518, it is amongst other things enacted that it shall be lawful for the Governor in Council at any time, and from time to time, upon the request of the Council of any municipality, by notice in the *Government Gazette*, to declare any land reserved, used or by purchase or exchange, acquired for a street, road, highway, thoroughfare, bridge, square, court, alley or right-of-way to be a public highway, and that such land shall thereupon and thenceforth from the date of such Proclamation become and be absolutely dedicated to the public as a public highway within the meaning of any law then or thereafter in force:

And whereas the Council of the Shire of Springvale and Noble Park has requested that the land hereinafter mentioned, which has been reserved for a street within the said Shire, be declared to be a public highway:

Now, therefore, I, the Governor of the State of Victoria, in the Commonwealth of Australia, by and with the advice of the Executive Council of the said State, do, by this Proclamation declare that all that piece of land reserved for a street, being part of Crown Allotment 3, Section 12, Parish of Mordialloc, and being shown as Clapham Avenue on lodged Plan of Subdivision No. 12159, shall be a public highway within the meaning of the said Act.

Given under my Hand and the Seal of the State of Victoria aforesaid, at Melbourne, this fifth day of November, in the year of our Lord One thousand nine hundred and fifty-eight, and in the seventh year of the reign of Her Majesty Queen Elizabeth II.

(L.S.)

DALLAS BROOKS.

By His Excellency's Command,

T. K. MALTBY,
Commissioner of Public Works.

GOD SAVE THE QUEEN!

MALDON SHIRE COMMON DIMINISHED.

PROCLAMATION

By His Excellency the Governor of the State of Victoria and its Dependencies in the Commonwealth of Australia, &c., &c., &c.

WHEREAS by Division 10 of Part I. of the *Land Act* 1928 it is amongst other things enacted that the Governor in Council may from time to time increase, and, after one month's notice in the *Government Gazette*, diminish, alter, or abolish any common, and may from time to time re-proclaim the whole or any part of any such common for any of the purposes and subject to the provisions of the said Part of the said Act, and that nothing therein contained shall prevent the exercise of the powers conferred by the said Part of the said Act with respect to the leasing or licensing of any land comprised in any common: And whereas notice of the intention to diminish the Maldon Shire Common has been duly published in the *Government Gazette* for one month:

Now therefore I, the Governor of the State of Victoria in the Commonwealth of Australia, by and with the advice of the Executive Council of the said State, do hereby diminish the Maldon Shire Common by deducting therefrom 11 acres 1 rood more or less of land in the Parish of Maldon comprised within the boundaries as defined by description published in the *Government Gazette* of 17th September, 1958.

Given under my Hand and the Seal of the State of Victoria aforesaid, at Melbourne, this fifth day of November, in the year of our Lord One thousand nine hundred and fifty-eight, and in the seventh year of the reign of Her Majesty Queen Elizabeth II.

(L.S.)

DALLAS BROOKS.

By His Excellency's Command,

KEITH TURNBULL,
Commissioner of Crown Lands and Survey.

GOD SAVE THE QUEEN!

MALDON SHIRE COMMON DIMINISHED.

PROCLAMATION

By His Excellency the Governor of the State of Victoria and its Dependencies in the Commonwealth of Australia, &c., &c., &c.

WHEREAS by Division 10 of Part I. of the *Land Act* 1928 it is amongst other things enacted that the Governor in Council may from time to time increase, and, after one month's notice in the *Government Gazette*, diminish, alter, or abolish any common, and may from time to time re-proclaim the whole or any part of any such common for any of the purposes and subject to the provisions of the said Part of the said Act, and that nothing therein contained shall prevent the exercise of the powers conferred by the said Part of the said Act with respect to the leasing or licensing of any land comprised in any common: And whereas notice of the intention to diminish the Maldon Shire Common has been duly published in the *Government Gazette* for one month:

Now therefore I, the Governor of the State of Victoria in the Commonwealth of Australia, by and with the advice of the Executive Council of the said State, do hereby diminish the Maldon Shire Common by deducting therefrom the portion of land in the Township of Maldon comprised within the boundaries as defined by description, published in the *Government Gazette* of 8th October, 1958.

Given under my Hand and the Seal of the State of Victoria aforesaid, at Melbourne, this fifth day of November, in the year of our Lord One thousand nine hundred and fifty-eight, and in the seventh year of the reign of Her Majesty Queen Elizabeth II.

(L.S.)

DALLAS BROOKS.

By His Excellency's Command,

KEITH TURNBULL,
Commissioner of Crown Lands and Survey.

GOD SAVE THE QUEEN!

BANK HOLIDAYS.

PROCLAMATION

By His Excellency the Governor of the State of Victoria and its Dependencies in the Commonwealth of Australia, &c., &c., &c.

IN pursuance of the provisions of the Banks and Currency Acts, I, the Governor of the State of Victoria, in the Commonwealth of Australia, do by this my Proclamation appoint the days and dates named hereunder special days to be observed as Bank Holidays or Bank Half-Holidays (as the case may be) at the places respectively mentioned, that is to say:—

Bank Holiday:—

SATURDAY, THE 6TH DECEMBER, 1958, at Timboon.

Bank Half-Holidays from the Hour of Eleven a.m.

WEDNESDAY, THE 26TH NOVEMBER, 1958, at Creswick.

THURSDAY, THE 13TH NOVEMBER, 1958, at Glenthompson.

Given under my Hand and the Seal of the State of Victoria aforesaid, at Melbourne, this eleventh day of November, in the year of our Lord, One thousand nine hundred and fifty-eight, and in the seventh year of the reign of Her Majesty Queen Elizabeth II.

(L.S.)

DALLAS BROOKS.

By His Excellency's Command,

L. H. S. THOMPSON,
for Chief Secretary.

GOD SAVE THE QUEEN!

PUBLIC HALF-HOLIDAY.

PROCLAMATION

By His Excellency the Governor of the State of Victoria and its Dependencies in the Commonwealth of Australia, &c., &c., &c.

IN pursuance of the provisions contained in Part III. of the *Public Service Act* 1946, I, the Governor of the State of Victoria, in the Commonwealth of Australia, by and with the advice of the Executive Council of the said

State, do by this my Proclamation appoint the day and date hereunder mentioned to be observed as a Public Half-Holiday at the place specified, viz.:—

Public Half-Holiday from the Hour of Twelve o'clock noon:—

THURSDAY, THE 13TH NOVEMBER, 1958, throughout the City of Hamilton.

Given under my Hand and the Seal of the State of Victoria aforesaid, at Melbourne, this fifth day of November, in the year of our Lord One thousand nine hundred and fifty-eight, and in the seventh year of the reign of Her Majesty Queen Elizabeth II.

(L.S.) DALLAS BROOKS.

By His Excellency's Command,
L. H. S. THOMPSON,
for Chief Secretary.

GOD SAVE THE QUEEN!

ENGINEERS OF WATER SUPPLY—EXAMINATIONS, 1958.

THE under-mentioned candidates have passed examinations conducted by the Board of Examiners of Engineers of Water Supply, and on payment of the prescribed fees may obtain certificates of qualification:—

Borley, K. D.	Long, A. A.
Bramham, R. B.	Paul, A. C.
Clegg, A. H.	Strom, A. G.
Dickson, R. S.	Tadgell, J. F.
Fisher, J. D.	Taylor, F. G.
Kermode, G. W. D.	Thompson, D. E.
Kibby, R.	Willersdorf, B. K.
Little, D. J.	Wood, K. H.

K. E. FINDLAY,
Secretary, Board of Examiners.

State Rivers and Water Supply Commission,
Melbourne, 7th November, 1958.

REGISTER OF DISTRIBUTORS OF PRINTED MATTER.

THE following is a copy of the Register corrected to the end of October, 1958, and is published in accordance with the requirements of sub-section (3) of Section 182 of *Police Offences Act 1957*.

Name.	Address.	Date of Registration.
Hyde Distributing Company Pty. Ltd.	247 Collins-street, Melbourne, C.I.	18.8.54
Victorian Magazine Distributors Pty. Ltd.	247 Collins-street, Melbourne, C.I.	18.8.54
Australian Musical Productions Pty. Ltd.	Princess Theatre, Spring-street, Melbourne, C.I.	2.9.54
Consolidated Press Limited	247 Collins-street, Melbourne, C.I.	2.9.54
Shakespeare Head Press Pty. Ltd.	247 Collins-street, Melbourne, C.I.	2.9.54
Robertson and Mullens Limited	107-113 Elizabeth-street, Melbourne, C.I.	7.9.54
J. Ewins and Sons Pty. Ltd.	111 Sturt-street, Ballarat	7.9.54
Moe Books and Stationery Pty. Ltd.	46A George-street, Moe	7.9.54
Burns, Oates, and Washbourne (Australia) Pty. Ltd.	72-74 Bourke-street, Melbourne, C.I.	7.9.54
The Argus and Australasian Ltd.	28 Flinders-street, Melbourne, C.I.	8.9.54
Gordon and Gotch (Australasia) Ltd.	511 Little Collins-street, Melbourne, C.I.	13.9.54
Larry Cleland Pty. Ltd.	125 Swanston-street, Melbourne, C.I.	13.9.54
The Book Depot	o/o The Methodist Conference of Victoria and Tasmania, 288 Little Collins-street, Melbourne, C.I.	15.9.54
L. J. M. Hodder and Company	328 Flinders-street, Melbourne, C.I.	21.9.54
Strautins, Janis Arturs	573 Flinders-lane, Melbourne, C.I.	21.9.54
B. H. Walsh, and Son	34 Queen-street, Melbourne, C.I.	23.9.54
Stanley Young Pty. Ltd.	244 Swanston-street, Melbourne, C.I.	23.9.54
Associated Newspapers Limited	247 Collins-street, Melbourne, C.I.	23.9.54
Hicks Smith and Sons Pty. Ltd.	23 McKillop-street, Melbourne, C.I.	27.9.54
Lothian Publishing Co. Pty. Ltd.	1 Fleming-place, Melbourne, C.I.	27.9.54
Whitcombe and Tombs Pty. Ltd.	332 Collins-street, Melbourne, C.I.	4.10.54
Spicers (Australia) Pty. Ltd.	377 Lonsdale-street, Melbourne, C.I.	4.10.54
W. Ramsay (Surgical) Limited	340 Swanston-street, Melbourne, C.I.	7.10.54
William Heinemann Limited	317 Collins-street, Melbourne, C.I.	12.10.54
Edwards Dunlop and Co. Ltd.	382 Lonsdale-street, Melbourne, C.I.	13.10.54
Alex. Cowan (Australia) Pty. Ltd.	500 Collins-street, Melbourne, C.I.	14.10.54
F. W. Cheshire Pty. Ltd.	338 Little Collins-street, Melbourne, C.I.	20.10.54
Longmans Green and Co. Ltd.	531 Little Collins-street, Melbourne, C.I.	22.10.54
Angus and Robertson Limited	68-68 Elizabeth-street, Melbourne, C.I.	25.10.54
Shepson and Company	109 Swanston-street, Melbourne, C.I.	29.10.54
Southdown Press Pty. Ltd.	51 Queen-street, Melbourne, C.I.	29.10.54
G. J. Coles and Company Limited	282 Little Collins-street, Melbourne, C.I.	1.11.54
Technical Book and Magazine Co.	297-299 Swanston-street, Melbourne, C.I.	3.11.54
Cassell and Company Limited	210 Queen-street, Melbourne, C.I.	4.11.54
Harding Publicity	5 Davey-street, Mordialloc	5.11.54
The Herald and Weekly Times	44-74 Flinders-street, Melbourne, C.I.	5.11.54
H. & S. Publications	Bringingly-road, Austral, New South Wales	10.11.54
Davies, Cyril Victor	66 McBride-avenue, Wonthaggi	10.11.54
Berry, Anderson and Company	207 Sturt-street, Ballarat	16.11.54
William Collins (Overseas) Ltd.	527-531 Little Collins-street, Melbourne, C.I.	16.11.54
MacMillan and Company Limited	32 Flinders-street, Melbourne, C.I.	25.11.54
Thompson, James Walter	137 Gloucester-street, Sydney, New South Wales	2.12.54
Oxford University Press, Australian Branch	346 Little Collins-street, Melbourne, C.I.	2.12.54
De Dion Publishing Company	Sassafras, Victoria	11.1.55
B. J. Ball Limited	401 Post Office Place, Melbourne, C.I.	21.2.55
N.S.W. Bookstall Co. Pty. Ltd.	112 Castlereagh-street, Sydney, New South Wales	22.2.55
Robert Burns Book Club	17 Railway-avenue, Caulfield	1.3.55
Georgian House Pty. Ltd.	296 Beaconsfield-parade, Middle Park	9.3.55
Colorgrave Publications	44-74 Flinders-street, Melbourne, C.I.	24.3.55
United Press Book Division	44-74 Flinders-street, Melbourne, C.I.	24.3.55
Herald-Sun Readers Book Club	44-74 Flinders-street, Melbourne, C.I.	24.3.55
"Truth" and "Sportsman" Limited	Hosking House, Hosking-place, 84½ Pitt-street, Sydney, New South Wales	29.3.55
The Legend Press Pty. Ltd.	31 Macquarie-place, Sydney, New South Wales	27.4.55
Commercial Publications Pty. Ltd.	262 Queen's Parade, Clifton Hill	28.5.55
Unification Pty. Ltd.	497 Collins-street, Melbourne, C.I.	27.9.57
Horwitz Publications Inc. Pty. Ltd.	400 Sussex-street, Sydney, New South Wales	9.5.57
Brian Vincent Casey—Distribution in Victoria on behalf of Adult Educational Publications, Pelican-street, Surrý Hills, New South Wales	572 Lonsdale-street, Melbourne, C.I.	1.9.58

Police Regulation Act 1946.

POLICE FORCE OF VICTORIA.

DETERMINATION NO. 71 OF THE POLICE CLASSIFICATION BOARD.

THE Police Classification Board, in pursuance of the powers in that behalf conferred by the *Police Regulation Act 1946*, hereby makes the following Determination, that is to say:—

1. The Determination No. 59 of the Police Classification Board of 23rd July, 1956, and published in the *Government Gazette* of the 21st August, 1956, as amended, is hereby further amended in paragraph 9 as follows:—

f s. d.

- (a) By inserting immediately after the expression and figures "Sub-Officer in Charge of Radio Technicians, Information Bureau, being the holder of at least a Second Class Commercial Operator's Certificate of Proficiency (inclusive of any other Special Duties allowance) 63 18 6." the expression and figures "Editor, Police Life 63 18 6."
- (b) By inserting immediately after the expression and figures "Shadowers, Criminal Investigation Branch 36 10 6." the expression and figures "Assistant Editor, Police Life 36 10 6."

2. This Determination shall come into operation on the 7th day of November, 1958.

Dated at Melbourne this 7th day of November, 1958.

J. F. MULVANY,

A Judge of the County Court of
Victoria, Chairman and Member of the Police
Classification Board.

D. S. RAMAGE,

Member of the Police Classification Board.

F. G. HOLLAND,

Member of the Police Classification Board.

RULES OF THE SUPREME COURT.

IN pursuance of the powers conferred by the Supreme Court Acts and all other powers hereunto enabling, the following amendment to Chapter I. of the Rules of the Supreme Court is made and shall take effect from the date of publication in the *Government Gazette*:—

In Rule 5 of Order LXVIIA for the words "licensed house or premises" there shall be substituted the words "premises licensed for the sale of intoxicating liquor unless such premises be the place of levy."

Dated this 29th day of October, 1958, at Judges' Chambers, Supreme Court, Melbourne.

E. F. HERRING, C.J.

CHARLES J. LOWE, J.

NORMAN O'BRYAN, J.

JOHN V. BARRY, J.

ARTHUR DEAN, J.

R. R. SHOLL, J.

T. W. SMITH, J.

E. H. HUDSON, J.

R. V. MONAHAN, J.

G. A. PAPE, J.

A. D. G. ADAM, J.

LAW DEPARTMENT.

COURTS OF PETTY SESSIONS—DAYS AND HOURS APPOINTED.

HIS Excellency the Governor of the State of Victoria by and with the advice of the Executive Council thereof, doth by Order made on the 5th day of November, 1958, pursuant to the provisions of Section 64 of the *Justices Act 1957*, appoint the days and hours contained in the Schedule below for the holding of Courts of Petty Sessions at the places named in such Schedule in lieu of the days and hours heretofore appointed—to take effect as from the dates shown.

SCHEDULE.

Place.	Days and Hours.
Birchip	Every Tuesday at 2.30 p.m., as from and inclusive of the 6th January, 1959
Donald	Every Wednesday at 10 a.m., as from and inclusive of the 7th January, 1959
Elmore	Every Friday at 10 a.m., as from and inclusive of the 12th December, 1958

N. G. WISHART,
Acting Clerk of the Executive Council.

At the Executive Council Chamber,
Melbourne, 5th November, 1958.

LAW DEPARTMENT.

SITTINGS OF THE SUPREME COURT AT SALE.

HIS Excellency the Governor of the State of Victoria, by and with the advice of the Executive Council thereof, doth by Order made on the 11th day of November, 1958, appoint Tuesday, the 18th November, 1958, for the Sittings of the Supreme Court in its criminal jurisdiction at Sale, in addition to the days heretofore appointed.

N. G. WISHART,
Acting Clerk of the Executive Council.

At the Executive Council Chamber,
Melbourne, 11th November, 1958.

WALWA WATERWORKS TRUST.

THE Walwa Waterworks Trust, in pursuance of and in exercise of the powers conferred by the Water Acts, doth hereby make a rate for the supply of water for domestic purposes of Three shillings and six pence (3s. 6d.) in the pound on the annual municipal valuation of lands and tenements liable to be rated in the Walwa Urban District.

Provided that in no case shall the amount of the rate payable per annum in respect of any tenement (other than land on which there is no building) be less than Six pounds fifteen shillings (£6 15s.), and in respect of any block of land on which there is no building less than One pound (£1).

Such rates are made and shall be levied upon the occupiers or owners of the said land and tenements for the year commencing the 1st day of January, 1958, and shall be payable on the 17th day of November, 1958, at the office of the said Trust.

(a) The maximum quantity of water to be supplied in any one year without further charge to any property rated by the Trust is hereby fixed at the quantity which, at a charge of Four shillings (4s.) per 1,000 gallons, would produce an amount equal to the amount of the rate levied on such property for the said year.

(b) The charge for water supplied by measure to any property rated by the Trust in excess of such maximum quantity computed, as in the last preceding clause, is hereby fixed at Two shillings (2s.) per 1,000 gallons.

(c) The charge for water supplied by measure to any property not rated by the Trust is hereby fixed at Two shillings and six pence (2s. 6d.) per 1,000 gallons and the minimum charge where water is supplied shall be Five pounds (£5) per annum.

(d) The charge for water supplied by measure shall be payable on demand at the office of the Trust.

Passed on this 17th day of October, 1958.

(SEAL) JAS. H. HARVEY, Chairman.
WALTER D. RYLAH, Secretary.

Approved, 10th November, 1958.—W. J. MIBUS, Minister of Water Supply.

MEENIYAN WATERWORKS TRUST.

RATING BY-LAW FOR THE YEAR 1958.

THE Meeniyon Waterworks Trust, in pursuance and exercise of the powers conferred by the Water Acts, doth hereby make a rate for the supply of water for domestic purposes of Three shillings and sixpence in the pound on the annual municipal valuation of lands and tenements liable to be rated within the Meeniyon Urban District.

Provided that in no case shall the amount of rate payable per annum in respect of any tenement (other than land on which there is no building) be less than Six pounds fifteen shillings, and in respect of any land on which there is no building less than Twenty shillings.

Such rates are made and shall be levied upon the occupiers or owners of the said lands and tenements for the year commencing the 1st day of January, 1958, and shall be payable on the 19th November, 1958, at the office of the said Trust, Meeniyon.

The maximum quantity of water to be supplied in any one year without further charge to any property rated by the Trust is hereby fixed at the quantity which, at a charge of Two shillings per 1,000 gallons, would produce an amount equal to the amount of the rate levied on such property for the said year.

The charge for water supplied by measure to any property rated by the Trust in excess of such maximum quantity, computed as in the last preceding clause, is hereby fixed at Two shillings per 1,000 gallons.

The charge for water supplied by measure to any property not rated by the Trust is hereby fixed at Two shillings per 1,000 gallons, and the minimum quantity of water to be charged for in cases where water is so supplied is hereby fixed at 10,000 gallons.

The charge for water supplied by measure shall be payable, on demand, at the office of the Trust, Meeniyon.

Passed this 13th day of October, 1958.

(SEAL) W. T. JONES, Chairman.
J. R. THOMPSON, Secretary.

Approved, 28th October, 1958.—W. J. MIBUS, Minister of Water Supply.

SHIRE OF SPRINGVALE AND NOBLE PARK.

ORDER CONFIRMED.

THE Minister of the Crown administering the *Local Government Act 1946*, on the 31st day of October, 1958, confirmed the Order hereinafter referred to, in pursuance of section 513 of the said Act, viz.:—

An Order of the Council of the Shire of Springvale and Noble Park, made on the 15th day of September, 1958, for the purpose of providing places of public resort and recreation, and for acquiring for such purpose all that piece of land, being part of Crown allotment C, section 23, Parish of Dandenong, commencing at a point bearing 180 deg. 1 min. 18 1/10 links from the intersection of the eastern alignment of Springvale-road with the southern alignment of Mackay-street; thence bounded by lines bearing respectively 89 deg. 53 1/2 min. 3,000 links, 180 deg. 1 min. 159 6/10 links, 269 deg. 20 1/2 min. 3,000 links, and 0 deg. 1 min. 188 3/10 links to the point of commencement.

T. K. MALTBY,
Commissioner of Public Works.

Marriage Act 1928.

MINISTERS OF RELIGION REGISTERED TO CELEBRATE MARRIAGES IN VICTORIA.

IT is hereby notified that in pursuance of the provisions of the *Marriage Act 1928*, 19 Geo. V. No. 3726, Sec. 11, the undermentioned Officiating Ministers of Religion have been registered at this Office for the celebration of marriages in Victoria:—

Number in Register.	Name.	Designation	Denomination.	Residence.	Date of Registration.
11880	Baker, Albert Oliver Strawson	Preacher	Churches of Christ ..	11 Erica Crescent, Heathmont ..	7.10.58
11881	Hammond, Terence Anthony	Priest ..	Roman Catholic ..	St. Francis' Monastery, Lonsdale-street, Melbourne	7.10.58
11882	O'Shaughnessy, John ..	Priest ..	Roman Catholic ..	St. Ignatius, Richmond ..	7.10.58
11883	Murphy, Kevin Joseph ..	Priest ..	Roman Catholic ..	Sacred Heart Presbytery, Mildura ..	7.10.58
11884	Murray, Ronald Joseph ..	Priest ..	Roman Catholic ..	53 Mont Victor-road, Kew ..	10.10.58
11885	Johnson, Kenneth Barry ..	Pastor ..	Assemblies of God in Australia	Eastern Hostel, Yallourn East ..	10.10.58
11886	Boyazoglu, Chrystostom Michael	Priest ..	Greek Orthodox ..	14 Kooyong-road, Armadale ..	16.10.58
11887	Jewell, William Ernest ..	Brigadier..	Salvation Army ..	120 Errard-street, Ballarat ..	17.10.58
11888	Gilchrist, Joseph Charles ..	Priest ..	Roman Catholic ..	St. Patrick's College, Cathedral-place East Melbourne ..	22.10.58
11889	Bartholomeusz, Samuel Douglas	Priest ..	Church of England ..	St. Matthew's Rectory, Broadford ..	28.10.58

Office of the Government Statist,
Melbourne, 3rd November, 1958.

S. H. E. HOLLOW,
Assistant Government Statist.

STATE RIVERS AND WATER SUPPLY COMMISSION.

LICENCES TO DIVERT WATER AND CUT RACES, PURSUANT TO THE PROVISIONS OF THE WATER ACTS.

LICENCES as detailed hereunder for the term of years from the date specified in each case have been granted by the Governor in Council to the persons named in the following Schedule:—

Licence No.	Term of Licence and Commencing Date.	Name and Address of Person to Whom Licence is to be Granted.	Source of Supply.	Area Authorized to be Irrigated per Annum.	Volume of Water Authorized to be Diverted Per Annum.
				acres.	ac. ft.
187	Fifteen years from 1.7.58 ..	Benjamin Lesley Bramley, Gunbower ..	Gunbower Creek	47	94
235	Fifteen years from 1.7.58 ..	Joseph Stanley Bernasochi, Brighton ..	Pyramid Creek	100	200
283	Fifteen years from 1.7.58 ..	Albert Francis Tanner and Joyce Tanner, Kerang	Pyramid Creek ..	100	200
831/202	Fifteen years from 1.7.58 ..	Hannah Elizabeth Reed, Gunbower ..	Gunbower Creek	95	190
834/202	Fifteen years from 1.7.58 ..	Francesco Cunsolo, Gunbower ..	Gunbower Creek	31	62
1189	Fifteen years from 1.7.58 ..	Charles Tempest George Morris, Rutherglen	River Murray ..	100	200
1190	Fifteen years from 1.7.58 ..	Reginald William Morris and Esther Elizabeth Morris, Robinvale	Narcooyia Creek	100	300
1191	Fifteen years from 1.7.58 ..	Stanley Bruce Jones and Beatrice May Jones, Robinvale	Narcooyia Creek	100	300
1192	Fifteen years from 1.7.58 ..	M. and J. McLeish, Yea ..	Goulburn River	40	80
1193	Fifteen years from 1.7.58 ..	Joseph Alphonsus Daniel, Salisbury West	Loddon River ..	5	10

Office of the State Rivers and Water Supply Commission,
Melbourne, 28th October, 1958.

E. BROWN, Secretary,
State Rivers and Water Supply Commission.

MONEY LENDERS ACT 1938.

IN accordance with the provisions of the above-mentioned Act, the following is published for general information.

List of persons to whom Money Lenders' Licences have been issued for the year ending 30th June, 1959.

Name.	Authorized Name.	Authorized Address.	Date of Issue.
Amalgamated Retailers (Vic.) Ltd. (S. J. J. Gilkes, appointee)	Amalgamated Retailers (Vic.) Ltd. ..	239 Elizabeth-street, Melbourne ..	21.10.58
Green, P. M. ..	P. M. Green ..	95 Bluff-road, Black Rock ..	8.10.58
Green, R. J. ..	R. J. Green ..	95 Bluff-road, Black Rock ..	8.10.58
Lensworth Finance Ltd. (B. W. B. Ruffels, appointee)	Lensworth Finance Ltd. ..	339 Collins-street, Melbourne ..	30.9.58
Lombard (Australia) Ltd. (H. W. Quilty, appointee)	Lombard (Australia) Ltd. ..	53 Queen-street, Melbourne ..	29.9.58

State Treasury,
Melbourne, 3rd November, 1958.

M. A. R. SYNNOT,
Registrar.

AUCTION SALES ACT 1928.

LIST of persons to whom Auctioneers' Licences have been issued during the month of September, 1958.

Name.	Address.	Date of Issue.
Balestra, V.	344 St. George's-road, North Fitzroy	16.9.58
Doherty, E. J.	177 Sydney-road, Coburg	23.9.58
*Spain, A. R.	Walnut-avenue, Mildura	25.9.58
Stephen, D.	River-road, Swan Hill	24.9.58
Thomas, K. J.	Darling-street, Wentworth, N.S.W.	25.9.58
Tilley, W. B.	34 Service-street, Bairnsdale	19.9.58
Wright, K. I.	251 Deakin-avenue, Mildura	18.9.58

* By Transfer from R. J. Burke.

The Treasury,
Melbourne, 3rd November, 1958.

A. T. SMITHERS,
Director of Finance.

CONTRACTS ACCEPTED.—(Series 1958-59.)

FIREWOOD—METROPOLITAN, ETC.

Period—From 1st October, 1958, to 30th September, 1959.

Item No.	Security.	Particulars.	Kinds of Firewood.	Rate per Cord of 128 cubic feet.	Name of Contractor.	Charge against Vote or Fund.
	£	FIREWOOD—		£ s. d.		
		Supply of Firewood, in such quantities as may be ordered, from 1st October, 1958, to 30th September, 1959, at the under-mentioned places.				
1	20	Ararat— For the various Government Offices including Mental Hospital, in 2-ft. billets	½ Red Gum, ½ Box	8 11 0	<i>A. Storti, Banfield-street, Ararat (A)</i>	Contingencies, 1958-59 and 1959-60.
1	3	Ballarat— For the various Government Offices, in 2-ft. billets	Gum, Peppermint, and Messmate	5 8 0	<i>H. O'Callaghan, 1119 Howitt-street, Ballarat</i>	
2	25	For the Mental Hospital only, in 2-ft. billets	Gum, Peppermint, and Messmate	4 12 3		
3	25	For the Mental Hospital, in 5-ft. lengths	Stringybark, Gum and Peppermint	3 11 0		
4	5	For the Gaol only, in 5-ft. lengths		3 17 0	<i>W. P. Tuddenham and Sons, Ross Creek (A)</i>	
1	25	Beechworth— For the Mental Hospital and Government Offices, in 2-ft. billets	Stringybark, Red Gum, Red Box, Messmate, and Apple Box	4 15 0	<i>F. C. Jensen, Beechworth (A)</i>	
2	25	For the Mental Hospital, in 5-ft. lengths		3 7 0		
1	..	Dookie— For Agricultural College— 1-ft. billets			Purchase by agreement	
2	..	2-ft. billets				
1	..	Glenormiston— For Dairy College— 5-ft. lengths (50 cubic feet per ton)			Purchase by agreement	
1	..	Horsham— For Longerenong Agricultural College, in 4 or 8-ft. lengths				
1	10.	Stawell— For Government Offices in 2-ft. billets	Box	7 0 0	<i>D. H. Repper, Illawarra, via Stawell (A)</i>	
2	5	For the Pleasant Creek Special School, in 5-ft. lengths		3 10 0		
1	..	Sunbury— For Mental Hospital, in 2-ft. billets	Mixed Wood	Order from Forests Commission	
1	..	Werribee— For Research Farm— 1-ft. billets	Mixed Wood	Order from Forests Commission	
2	..	2-ft. billets		

Where the name of the supplier is shown in italics, with the sign (A), no contract has been executed, and supplies are to be purchased from the persons named, under Tender Board Agreement.

28th October, 1958.

W. H. RUTHERFORD,
Secretary to the Tender Board.

CONTRACTS ACCEPTED.—(Series 1958-59.)

FIREWOOD.—COUNTRY TOWNS, ETC.

Period—From 1st October, 1958, to 30th September, 1959.

Contract No.	Place.	Kinds of Firewood.	Rate per Cord of 128 Cubic Feet.				Name of Contractor.	Charge against Vote or Fund.
			In 1-ft. Billets.	In 2-ft. Billets.	In 4-ft. Lengths.	In 5-ft. Lengths.		
1722	Alexandra	<i>s. d.</i>	<i>s. d.</i>	<i>s. d.</i>	<i>s. d.</i>	Purchase by agreement	
1723	Bacchus Marsh	Gum, Peppermint, Stringybark, Messmate, and Apple Box	115 0	C. G. Bourke, Bullengarook ..	
1724	Bairnsdale ..	Box, Ironbark, Stringybark	230 0	200 0	A. Petruccelle, Mt. Taylor ..	
1725	Benalla	Purchase by agreement	
1726	Bendigo ..	Grey Box	216 0	C. Rohde, 56 Mitchell-street, Bendigo	
1727	" ..	Grey or Red Box	192 0	..	106 0	R. J. Bradley, Church-street, Kangaroo Flat	
1728	Camperdown ..	Messmate	169 0	145 0	L. L. Grayland, Cobden ..	
1729	Casterton	Purchase by agreement	
1730	Castlemaine ..	Peppermint and Box	77 0	R. L. Maltby, Taradale	
1731	" ..	Grey Box	209 6	209 6	J. H. Jones, Princes-street, Campbells Creek	
1732	Colac ..	Stringybark and Messmate	125 0	110 0	Forests Commission of Victoria, Otway West District	
1733	Corryong	Purchase by agreement	
1734	Dandenong ..	Red Gum and Box	180 0	180 0	Woodlands Fuel Supply, 28 Joffroad, Pascoe Vale	
1735	Daylesford ..	Gum, Peppermint, Stringybark, Messmate, and Apple Box	115 0	C. G. Bourke, Bullengarook ..	
1736	Dimboola ..	White Gum and Box	175 0	160 0	R. N. Warner, 11 Denham-street, Dimboola	
1737	Echuca ..	Red Gum	128 0	128 0	N. A. Backway, 20 Eyre-street, Echuca	
1738	Foster	Purchase by agreement	
1739	Frankston ..	Messmate, Peppermint, Box, and Gum	197 6	187 6	A. Stephenson, Emerald-road, Narro Warren East	
1740	Geelong ..	Gum and Messmate	110 0	110 0	..	J. H. McColl, Wallace-street, Meredith	
1741	Hamilton	Purchase by agreement	
1742	Horsham ..	White Gum and Box	170 0	160 0	R. N. Warner, 11 Denham-street, Dimboola	
1743	Korang	Purchase by agreement	
1744	Kyneton ..	Gum, Peppermint, Stringybark, Messmate, and Apple Box	115 0	C. G. Bourke, Bullengarook ..	
1745	Leongatha	Purchase by agreement	
1746	Lilydale ..	Peppermint, Messmate, and Silvertop	177 6	177 6	R. A. Symonds, "Spring Grove Farm," Hoddles Creek	
1747	Maryborough ..	Box	200 0	180 0	} A. E. Cleary and Sons, 154 Magnolia-avenue, Mildura	
1748	Mildura ..	Box	200 0	180 0		
1749	Nhill ..	Box and White Gum	195 0	185 0	R. N. Warner, 11 Denham-street, Dimboola	
1750	Numurkah	} Purchase by agreement	
1751	Orbost		
1752	Ouyen		
1753	Portland	} A. E. Cleary and Sons, 154 Magnolia-avenue, Mildura	
1754	Red Cliffs ..	Box	200 0	180 0		
1755	St. Arnaud	Purchase by agreement	
1756	Sale ..	Red Gum	150 0	150 0	K. F. Fyfe, 9 Turnbull-street, Sale	
1757	Seymour	} Purchase by agreement	
1758	Shepparton		
1759	Swan Hill		
1760	Terang		
1761	Traralgon	} A Stephenson, Emerald-road, Narro Warren East	
1762	Upwey ..	Box, Messmate, Peppermint, and Gum	197 6	187 6		
1763	Wangaratta ..	Red Gum	120 0	120 0	R. S. Dunstan, Murdoch-road, Wangaratta	
1764	Warracknabeal	Box and White Gum	190 0	180 0	R. N. Warner, 11 Denham-street, Dimboola	
1765	Warragul ..	Peppermint	150 0	135 0	J. G. Treadwell, Topiram ..	
1766	Warrnambool ..	White Gum	174 0	140 0	J. C. D. French, 28 Mickle-street, Warrnambool	
1767	Wodonga ..	Red Box and Gum	130 0	130 0	Wodonga Woodyard, Box 149, Post Office, Wodonga	
1768	Yallourn ..	Messmate and Stringybark	135 0	135 0	E. V. Broberg, 17 Broadway West, Yallourn	
1769	Yarram	Purchase by agreement	

Contingencies, 1958-59 and 1959-60.

CONTRACTS ACCEPTED.—(Series 1958-59.)

PUBLIC WORKS.

1613. South Yarra, Police Officers College, (3) electrical installation, original contract, £246 10s., additional, £412 10s., £659.—J. Newall.
1614. Dookie, Agricultural College, (1) re-construction and sealing of various internal roads, £1,572.—Country Roads Board.
1615. Royal Park, Mental Hospital, (3) sealing of parking areas, £471 6s.—Fowler Road Constructions Pty. Ltd.
1616. Brighton, High School, (3) installation of equipment in sheet metal shop, original contract, £248 6s., additional, £48, £296 6s.—W. E. Tuck.
1617. Hawthorn, Swinburne Technical College, (1) provision of gas heating to new class-rooms, £373.—Gas and Fuel Corporation of Victoria.
1618. Ferntree Gully North, State School No. 4718, (1) excavation works and earth moving, £435.—A. V. Jennings Construction Co. Pty. Ltd.
1619. Essendon, State School No. 483, (4) repairs and painting, &c., original contract, £220, additional, £50, £270.—A. Sidari.
1620. Lilydale, High School, (1) temporary electrical restoration after fire, £602.—J. Speedy.
1621. Kew, Mental Hospital, (2) alterations to X-ray rooms, original contract, £135, additional, £257, £392.—Barron Bros.
1622. Mildura, State School No. 2915, (1) site works, £1,126.—City of Mildura.
1623. Royal Park, Mental Hospital, (1) maintenance of communication system, £331 14s.—Communication Systems of Australia Pty. Ltd.
1624. Melbourne, Police Headquarters, Russell-street, (3) re-plastering, &c., original contract, £248 10s., additional, £65, £313 10s.—C. H. Taylor.
1625. Fawkner, High School, (1) new gas service, &c., £314 3s.—Gas and Fuel Corporation of Victoria.
1626. Murrumbidgee, State School No. 3449, (1) supply and installation of gas space heating equipment, £1,176 17s. 11d.—Colonial Gas Association Ltd.
1627. Ascot Vale West, State School No. 4025, (1) supply and installation of gas space heating equipment, £968.—Gas and Fuel Corporation of Victoria.
1628. Rutherglen, Research Station, (6) supply and erection of hay and crusher shed, £565.—Delarne (Sales) Pty. Ltd.
1629. Strathmore, High School, (1) sewer extension, £1,200 3s. 4d.—Melbourne and Metropolitan Board of Works.
1630. Larundel, Mental Hospital, (1) supply and lay underground cable, £620 4s. 8d.—Postmaster-General.
1631. Melbourne, Titles Office, (1) removal of cold cathode lighting and installation of hot cathode in lieu, £264.—J. Newall.
1632. Corryong, State School No. 1309, (1) electrical installation, original contract, £248 10s., extras, £59 10s., £308.—R. G. Clarke.
1633. Williamstown, Lighter *Boonah*, (1) vessel docked, chipped, cleaned, and painted, £324.—Hobson's Bay Dock and Engineering Co. Pty. Ltd.
1634. Carlton, Visual Aid Centre, (3) supply and installation of fluorescent units, original contract, £217 10s., extras, £48, £265 10s.—J. Newall.
1635. Alexandra, Shire, (1) site works for provision of toilet block at Jerusalem Creek, £277 17s. 4d.—Forests Commission of Victoria.
1636. Seymour, Inspector's Residence, (4) internal renovations, original contract, £185, additional, £90, £275.—C. J. Bates.
1637. Flemington, Girl's Secondary School, (4) hot-water service, original contract, £172 12s., additional, £94 2s., £266 14s.—W. R. Davis.
1638. Extras on contract, serial No. 4685/57-58.—£203 10s.
1639. Extras on contract, serial No. 4640/56-57.—£238.
1640. Extras on contract, serial No. 4870/55-56.—£4,591.
1641. Extras on contract, serial No. 1053/58-59.—£15 10s.
1642. Extras on contract, serial No. 3563/54-55.—£435 1s.
1643. Extras on contract, serial No. 871/56-57.—£2,114 0s. 2d.
1644. Extras on contract, serial No. 2493/57-58.—£645 10s.
1645. Extras on contract, serial No. 3930/57-58.—£871 9s.
1646. Extras on contract, serial No. 1783/56-57.—£7,411 16s. 6d.
1647. Extras on contract, serial No. 4522/57-58.—£55 10s.
1648. Extras on contract, serial No. 2319/57-58.—£1,036 8s. 11d.
1649. Extras on contract, serial No. 3585/57-58.—£1,340.
1650. Extras on contract, serial No. 3680/57-58.—£2,296 18s. 5d.
1651. Extras on contract, serial No. 2999/57-58.—£193 15s.
1652. Extras on contract, serial No. 1946/57-58.—£111 11s. 6d.
1653. Extras on contract, serial No. 3496/53-54.—£36,236 3s. 2d.
1654. Extras on contract, serial No. 4824/56-57.—£49 4s. 1d.
1655. Extras on contract, serial No. 2585/57-58.—£154.
1656. Extras on contract, serial No. 2320/57-58.—£690 10s.
1657. Extras on contract, serial No. 2320/57-58.—£870 10s.
1658. Extras on contract, serial No. 751/57-58.—£510 12s. 6d.
1659. Extras on contract, serial No. 4358/57-58.—£118.
1660. Extras on contract, serial No. 4630/56-57.—£395.
1661. Extras on contract, serial No. 790/48-49.—£27,194 0s. 6d.
1662. Extras on contract, serial No. 4266/57-58.—£40 6s. 10d.
1663. Extras on contract, serial No. 4282/57-58.—£204.
1664. Extras on contract, serial No. 1802/57-58.—£1,786.
1665. Extras on contract, serial No. 4631/57-58.—£59.
1666. Extras on contract, serial No. 4197/57-58.—£808 12s.
1667. Extras on contract, serial No. 2507/57-58.—£1,114 2s. 1d.
1668. Extras on contract, serial No. 1670/57-58.—£5,854 19s. 7d.
1669. Extras on contract, serial No. 3488/57-58.—£1,516 8s.
1670. Extras on contract, serial No. 4636/57-58.—£444 10s.
1671. Extras on contract, serial No. 807/58-59.—£494 8s. 3d.
1672. Extras on contract, serial No. 4640/57-58.—£2,060 10s. 6d.
1673. Extras on contract, serial No. 4637/57-58.—£219 5s. 3d.
1674. Extras on contract, serial No. 3369/57-58.—£81 19s. 10d.
1675. Extras on contract, serial No. 4240/57-58.—£19.
1676. Extras on contract, serial No. 2007/57-58.—£282 18s.
1677. Extras on contract, serial No. 3459/57-58.—£493.
1678. Extras on contract, serial No. 3040/57-58.—£50.
1679. Extras on contract, serial No. 780/56-57.—£1,691 4s. 9d.
1680. Extras on contract, serial No. 2488/57-58.—£914.
1681. Extras on contract, serial No. 4635/57-58.—£943 3s. 11d.
1682. Extras on contract, serial No. 495/58-59.—£48.
1683. Extras on contract, serial No. 3634/57-58.—£794 15s. 6d.
1684. Extras on contract, serial No. 3597/57-58.—£190 10s.
1685. Extras on contract, serial No. 2993/57-58.—£199.
1686. Extras on contract, serial No. 4166/57-58.—£455.
1687. Extras on contract, serial No. 2411/57-58.—£396 14s.
1688. Extras on contract, serial No. 7269/56-57.—£92 4s.
1689. Extras on contract, serial No. 1715/57-58.—£4,090.
1690. Extras on contract, serial No. 4707/56-57.—£356 9s.
1691. Extras on contract, serial No. 3450/55-56.—£794.
1692. Extras on contract, serial No. 2334/57-58.—£324 12s. 11d.
1693. Extras on contract, serial No. 4640/57-58.—£473 0s. 3d.
1694. Extras on contract, serial No. 1133/58-59.—£48.
1695. Extras on contract, serial No. 3411/57-58.—£106 1s.
1696. Extras on contract, serial No. 1086/58-59.—£31 10s.
1697. Extras on contract, serial No. 6196/56-57.—£364 13s.
1698. Extras on contract, serial No. 2486/57-58.—£333 9s. 9d.
1699. Extras on contract, serial No. 1209/58-59.—£116 17s. 6d.
1700. Extras on contract, serial No. 746/58-59.—£20 8s.
1701. Extras on contract, serial No. 7180/56-57.—£3,154 5s.
1702. Extras on contract, serial No. 807/58-59.—£928 14s.
1703. Extras on contract, serial No. 807/58-59.—£565 18s. 7d.

1704. Extras on contract, serial No. 2311/57-58.—£997 16s. 6d.
 1705. Extras on contract, serial No. 3494/57-58.—£893 8s.
 1706. Extras on contract, serial No. 549/58-59.—£171.
 T. K. MALTBY, Commissioner of Public Works. 6.11.58.

ORDERS IN COUNCIL.—(Series 1958-59.)

PUBLIC WORKS DEPARTMENT.

1707. French Island Penal Settlement, overhaul and repair of two (2) diesel engines, £332 18s. 5d.—Southern Cross Windmills and Engines Pty. Ltd. (S.E. 149141 "A").
 1708. Government House, Melbourne, supply, making and laying on underfelt, of carpets, £377 9s.—W. P. Murison. (M. 191583.)
 1709. Government House, Melbourne, supply of furnishings, £666 13s. 6d.—The Myer Emporium Ltd. (M. 193125.)
 1710. High School, Hampton, supply and installation of bench assemblies, £340 5s. 10d.—Gas and Fuel Corporation. (S.E. 177214.)
 1711. Kew Mental Hospital, supply and installation of one (1) operating theatre light, £383.—Allen and Hanburys (Australasia) Ltd. (M. 191365.)
 1712. Mont Park Mental Hospital, supply of X-ray equipment, £11,058 14s. 6d.—Stanford X-ray (Vic.) Pty. Ltd. (N.E. 199559.)
 1713. Mont Park Mental Hospital, supply of two (2) theatre trolleys, £262.—P. E. Hayward. (N.E. 198643.)
 1714. Mont Park Mental Hospital, conversion of Pyrox projectors for use of cinemascope films, £508 10s.—Pyrox Limited. (N.E. 196283.)
 1715. State School No. 1896, Windsor, site works carried out, £295.—Pahran City Council. (M. 152636.)
 1716. State School No. 1366, Kialla, supply and erection of one (1) standard P.S/3 prefabricated residence, £4,272 16s.—W. Phelan and Sons Pty. Ltd. (N.E. 193465.)
 1717. S.S. Rip.—(a) Docking vessel, general repairs, painting &c, £6,279 17s. 7d.—Hobsons' Bay Dock and Engineering Co. Pty. Ltd; and (b) repairs and renewal of oil lines, lavatories and soil lines, engine room maintenance &c., £973 13s. 6d.—V. F. Harris Pty. Ltd. (L.G. 56/1207.)
 1718. Sunbury Mental Hospital, supply of boot and shoe finishing machine, £352 5s.—Johnson and Sons Pty. Ltd. (N. 192017.)
 1719. State School No. 1480, Charlton, resurfacing of asphalt area, £494 19s.—Charlton Shire Council. (N. 165719.)
 1720. Tottenham Technical School, supply of piano, £265. Allan and Co. Pty. Ltd. (W. 197874.)
 1721. Tallangatta Hospital, construction of roads, £2,229 11s. 7d.—Towong Shire Council. (N.E. 182995.)
 Approved by the Governor in Council, 5th November, 1958.—N. G. WISHART, Acting Clerk of the Executive Council.

EDUCATION DEPARTMENT.

1595. One only electric duplicating machine, for Moorabbin Technical School, £179.—Roneo Co. (Melbourne) Pty. Ltd.
 1596. One only sound level meter, for Royal Melbourne Technical College, £453 13s.—Warburton Franki (Melb.) Ltd.
 1597. One only Hounsfield tensometer and attachments, for Warrnambool Technical School, £120.—Wm. Adams and Co. Ltd.
 1598. One only Orsatt apparatus, for Warrnambool Technical School, £29.—H. B. Selby and Co. Pty. Ltd.
 1599. One only Proctor needle apparatus, for Warrnambool Technical School, £45 10s.—H. B. Selby and Co. Pty. Ltd.
 1600. One only liquid limit, for Warrnambool Technical School, £32 10s.—H. B. Selby and Co. Pty. Ltd.
 1601. One only Proctor compaction cylinder, for Warrnambool Technical School, £25 10s.—H. B. Selby and Co. Pty. Ltd.
 1602. One only Proctor hammer, for Warrnambool Technical School, £8 15s.—H. B. Selby and Co. Pty. Ltd.
 Approved by the Governor in Council, 5th November, 1958.—N. G. WISHART, Acting Clerk of the Executive Council.

STATE ELECTRICITY COMMISSION OF VICTORIA.

1603. The hire of two Mack trucks for construction work at Rocky Valley Dam, Kiewa Hydro-Electric Scheme, for period ending 30th April, 1959, to Quotation No. 1380, at schedule rates.—Deacon's Transport Services Pty. Ltd.

1604. The supply of 60,000 junction boxes for consumers' services for a period of twelve months, to Specification No. 48/58-59, at schedule rates.—G. W. Engineering Pty. Ltd.

1605. The supply and installation of six flue gas analysers for boilers, Morwell Project (including £645 9s. for installation, subject to variations in costs of labour and materials), to Quotation No. 8, £5,044 10s. 1d.—Geo. Kent (Australia) Pty. Ltd.

1606. The supply of two cubicle-type switchboards and associated rectifiers for System Control Centre, Richmond, to Specification No. 28/58-59, £5,050.—McKenzie and Holland (Aust.) Pty. Ltd.

1607. The construction of swimming pool at Yallourn, to Specification No. 11A/58-59, £21,548.—J. J. Marr and Sons Pty. Ltd.

1608. The supply of indoor wall mounting current transformers for metering of consumers' installations for a period of twelve months, to Specification No. 46/58-59, at schedule rates.—O. J. Nilsen and Co. Pty. Ltd.

1609. The construction of buildings and facilities associated with new swimming pool at Yallourn, to Specification No. 11A/58-59, £10,241.—L. R. Parrick Pty. Ltd.

1610. The supervision of dismantling, repair and re-assembly of No. 6 bucket wheel dredger at Yallourn, at schedule rates.—Pyrox Ltd.

1611. The supply and delivery of ready mixed concrete for construction work at Morwell Power Station and Briquette factory for period ending 30th June, 1959, to Quotation No. 1314, at schedule rates.—Ready Mixed Concrete (Vic.) Pty. Ltd.

1612. The supply of two vacuum tanks for drying out electrical equipment, Transformer Repair Depot, Fishermen's Bend, subject to variations in cost of labour and materials, to Specification No. 212/57-58, £6,150.—John Thompson Combustion Engineering Pty. Ltd.

Approved by the Governor in Council, 21st October, 1958.—N. G. WISHART, Acting Clerk of the Executive Council.

1770. The supply of 6,400 disc insulators for transmission lines (including estimated £1,626 13s. 5d. customs duty), to Quotation No. 1503, £7,146 13s. 5d.—A.F.C.A. Pty. Ltd., c/o John Joseph.

1771. The construction of Switchhouse and Associated Works, Briquette Handling Power Distribution Centre, Morwell Project, plus estimated £500, at schedule rates, to Specification No. 88/58-59, £8,780.—L. R. Parrick Pty. Ltd.

Approved by the Governor in Council, 28th October, 1958.—N. G. WISHART, Acting Clerk of the Executive Council.

Hospitals and Charities Act 1948.

APPOINTMENT AMENDED.

HIS Excellency the Governor of the State of Victoria, by and with the advice of the Executive Council thereof, doth by Order made on the 5th day of November, 1958, amend the Order made on the 14th day of October, 1958, in respect of the appointment of a Government Representative on the Committee of Management of Morwell and District Hospital, by the deletion of the name of "Octavius Paget Palmer" and the substitution therefor of the name of "Octavius Paget Palmer", and by the deletion of the words "Morwell and" and the substitution therefor of the words "The Mortlake".

N. G. WISHART,

Acting Clerk of the Executive Council.

At the Executive Council Chamber,
Melbourne, 5th November, 1958.

DEPARTMENT OF LABOUR AND INDUSTRY.

DETERMINATION OF THE CARPENTERS BOARD.

ATTENTION is drawn to the fact that a notice of appeal to the Industrial Appeals Court has been lodged against clause 3 (xi) of the Determination of the Carpenters Board made on the 21st October, 1958.

Section 45 (b) of Act 5771, provides that, when an appeal is made in accordance with that Act, the part of the Determination appealed against shall not come into operation until the appeal has been dealt with by the Court.

H. N. JONES,
Secretary.

Transport Regulation Acts.

TRANSPORT REGULATION BOARD.

NOTICES OF PUBLIC HEARINGS.

NOTICE is hereby given that the applications made by the persons named below for licences to operate commercial passenger vehicles on the route or routes, or in the manner set out opposite their names, will be heard at a time and place to be communicated to the parties.

Name and Address; Nature of Application.

SOUTH WESTERN ROADWAYS PTY. LTD., 205 Raglan-parade, Warrnambool; 1 commercial passenger vehicle, with seating capacity for eight persons, to operate as follows:—(a) As an additional stage omnibus under the same terms and conditions as all "C.O." licences at present held by the applicant company, (b) as a special service omnibus subject to all regulations appertaining to such operations and subject also to the condition that all journeys undertaken commence within a radius of ten (10) miles of the Warrnambool Post Office.

McKENZIE'S TOURIST SERVICES PTY. LTD., 53 Barkers-road, Kew; application for variation of all "C.O." licences to include the ability to operate the following day tour:—Commencing from 100 Flinders-street, Melbourne, to Healesville (including Sanctuary and/or Maroondah Dam); thence to Toolangi, Silvia Creek, Murrindindi Falls, Murrindindi, Devlin's Bridge, Glenburn, Mount Slide, Yarra Glen; thence to Melbourne.

TIME-TABLE.

Depart Melbourne	9.00 a.m.
Return Melbourne	5.30 p.m.

FARE.

35s., including meals. Lunch Toolangi; afternoon tea Mount Slide.

CORIO BUSLINES PTY. LTD., 23 Catherine-street, Geelong West; 1 commercial passenger vehicle, with seating capacity for 37 persons, to operate as an additional stage omnibus under the same terms and conditions as all "U.O." licences at present held by the applicant company.

HAYRES, H. J., 35 Canberra-avenue, Dandenong; 1 commercial passenger vehicle, with seating capacity for five persons, to operate under the same terms and conditions as existing taxi-cabs licensed at Noble Park, subject to the cancellation of licence No. C.H.298.

THE SACRED HEART SCHOOL, Heathcote; application for renewal of licence No. T.P.27, expiring 26th February, 1959, authorizing operations under the same terms and conditions.

FLOOD'S MOTOR SERVICE PTY. LTD., Arnold-street, Bendigo; application for renewal of licence Nos. C.O.448, C.O.449, C.O.450, C.O.453, C.O.455, C.O.456, C.O.457, C.O.459, C.O.460, C.O.461, expiring 7th February, 1959, authorizing operations as stage omnibuses under the same terms and conditions.

WALKERS HIRE CARS, 247 Charman-road, Cheltenham; application for renewal of licence No. C.T.43, expiring 7th February, 1959, authorizing operations as a country taxi-cab from Cheltenham.

MILLS, F., 46 Petrie-street, Frankston; application for renewal of licence No. C.T.59, expiring 7th February, 1959, authorizing operations as a country taxi-cab from Frankston.

FISHER, L. J., (trading as Western Port Road Lines), Main-street, Lang Lang; application for renewal of licence Nos. T.S.157, T.S.425, and T.S.428, expiring 31st January, 1959, authorizing operations under the same terms and conditions.

ORGAN'S BUS SERVICE PTY. LTD., 32 Yaldwin-street, West Kyneton; application for renewal of licence No. T.S.328, expiring 7th February, 1959, authorizing operations under the same terms and conditions.

COLE, J. H., Wood-street, Beaconsfield; application for renewal of licence No. C.H.318, expiring 21st December, 1958, authorizing operations as a country private hire car from Beaconsfield.

WALKER, S. A., 5 High-street, Mordialloc; application for renewal of licence No. C.T.30, expiring 7th February, 1959, authorizing operations as a country taxi-cab from Mordialloc.

MAY, C. W., 6 Higgins-street, Wangaratta; 1 commercial passenger vehicle, with seating capacity for eight persons, to operate for the carriage of passengers and parcels between Benalla and Wangaratta.

TIME-TABLE.

Daily.

Depart Benalla	8.30 a.m.
Arrive Wangaratta	9.15 a.m.
Depart Wangaratta	4.30 p.m.
Arrive Benalla	5.15 p.m.

WAY, N. D., 40 Adeney-street, Kingsville; 1 commercial passenger vehicle, with seating capacity for five persons, to operate as a metropolitan private hire car under composite conditions from an approved depot in Zone "K".

WITHAM, A. D., 182 Spring-street, Regent; application for variation of Route 137A (Greensborough—Montmorency—Eltham) to operate an extension of service from the corner of Rattray and Para roads, Montmorency, via Para-road to the corner of Para-road and Main Eltham-road as soon as road conditions permit.

(Sections, fares, and time-tables to be determined.)

NOTICE is hereby given that the applications made by the persons named below for licences to operate the commercial goods vehicles on the route or routes, or in the manner set out opposite their names, will be heard at a time and place to be communicated to the persons concerned:—

Name and Address; Nature of Application.

BAKER, W. W., 10 Pearse-street, Nathalia; 1 commercial goods vehicle (100 cwt.) to operate within the Benalla Division of the Country Roads Board—road-contracting plant and materials.

BARNES PANEL BEATING WORKS, 32 Yarra Bank-road, South Melbourne; 1 commercial goods vehicle (tow truck) to operate throughout the State of Victoria for the purpose of repairing or towing disabled or wrecked vehicles.

BARNSTABLE, R. A., 31 The Avenue, Hampton; 1 commercial goods vehicle (80 cwt.) to operate within the Dandenong Division of the Country Roads Board as a water tanker.

BILLS, A., Day-street, Bairnsdale; 1 commercial goods vehicle (257 cwt.) to operate from Cuthbertson and Richards' sawmill at Glen Willis to the Bairnsdale Railway Station—sawn timber.

BOON SPA PTY. LTD., 264 Geelong-road, West Footscray; 1 commercial goods vehicle (129 cwt.) to operate within a radius of 50 miles of own premises at West Footscray, but excluding operations between Melbourne and Geelong, in the course of business as "aerated waters and cordial manufacturers"—own aerated waters and cordials.

BRAY, W. D. & O. E., 36 Dudley-street, Rochester; 1 commercial goods vehicle (97 cwt.) to operate—(a) within a radius of 20 miles of the post office at Rochester—general goods, (b) within a radius of 50 miles of the post office at Rochester—road-contracting plant and materials.

CHALK, A. B., 103 Mary-street, Morwell; variation of licence No. D.A.32615 by the addition of the ability to operate within a radius of 20 miles of the post office at Morwell—general goods.

CITY GUIDE SYSTEM (VIC.) PTY. LTD., 328 Flinders-street, Melbourne; 1 commercial goods vehicle (13 cwt.) to operate throughout the State of Victoria for the purpose of repairing, servicing, and installing City Guide Systems—tools of trade, city guides for repair or having been repaired for installation.

CLARKE, B. E. & L. M., 34 Telford-street, Yarrowonga; 1 commercial goods vehicle (145 cwt. low loader) to operate within a radius of 50 miles of Yarrowonga in the course of business as "contractors"—own bulldozer.

COATE'S MOTORS PTY. LTD., 80 Main-street, Bairnsdale; 1 commercial goods vehicle (100 cwt.) to operate throughout the Shires of Bairnsdale, Stratford, Omeo, Tambo, and Orbost in the course of business as "vehicle and instrument, distributors"—tractors, farm machinery, and goods in connexion with own business.

CUMMINS, D. F., P.O., Ouyen; 1 commercial goods vehicle (90 cwt.) to operate—(a) within a radius of 20 miles of the post office at Ouyen—general goods, (b) within the Shires of Walpeup, Swan Hill, Wycheproof, and Karkarook—road-contracting plant and materials.

DANDENONG CAR WRECKERS, 131 Lonsdale-street, Dandenong; 1 commercial goods vehicle (30 cwt.) to operate within a radius of 100 miles of Dandenong as a tow truck for the purpose of repairing or towing disabled or wrecked vehicles.

- GORDON, J., c/o Bonnie Doon Post Office; 1 commercial goods vehicle (91 cwt.) to operate within the Shire of Mansfield—road-contracting plant and materials.
- HUXTABLE, K. J. & M. V., 202 Station-street, Koo-Wee-Rup; 1 commercial goods vehicle (107 cwt.) to operate—(a) within a radius of 20 miles of the Koo-Wee-Rup Post Office—general goods, (b) within a radius of 50 miles of the Koo-Wee-Rup Post Office—road-contracting plant and materials.
- HUXTABLE, K. J. & M. V., 202 Station-street, Koo-Wee-Rup; 1 commercial goods vehicle (105 cwt.) to operate from and to the City of Melbourne, to and from places within a radius of 20 miles of the post office at Koo-Wee-Rup—general goods.
- LAMONT, H. J., 10 Lucerne-street, Ashburton; 1 commercial goods vehicle (8 cwt.) to operate within a radius of 100 miles of the premises of E.I.L. Service Pty. Ltd., 100 Leicester-street, Carlton, for the servicing and maintenance of television sets under contract to aforesaid company—tools of trade and incidental spare parts.
- LA ROSA, J., 378 Francis-street, Yarraville; 1 commercial goods vehicle (99 cwt.) to operate—(a) within a radius of 25 miles of the G.P.O., Melbourne—general goods, (b) from pits at Cranbourne to places within a radius of 25 miles of the G.P.O., Melbourne—sand.
- MCGRATH, F. W., 40 Kars-street, Frankston; 1 commercial goods vehicle (86 cwt.) to operate—(a) within a radius of 25 miles of the G.P.O., Melbourne—general goods, (b) within a radius of 50 miles of the post office at Frankston—second-hand household furniture.
- MCPHERSON, D. W., 69 Airlie-road, Montmorency; variation of licence No. D.A.33779 by deleting present conditions and adding in lieu the ability to operate throughout the State of Victoria for the purpose of servicing and repairing Turner washing machines—tools of trade, spare parts, and materials incidental to such work.
- NATIONAL TYRE SERVICE (HORSHAM) PTY. LTD., 103 Fire-brace-street, Horsham; 3 commercial goods vehicles (14, 8, and 71 cwt.) to operate within a radius of 70 miles of own premises at Horsham in the course of business as "tire retreaders and distributors"—new and second-hand tires and tubes, tires and tubes for repair or having been repaired, batteries, oil, and motor car accessories.
- PETERS ICE CREAM (VIC.) PTY. LTD., 171-183 Burnley-street, Richmond; 1 commercial goods vehicle (20 cwt.) to operate throughout the State of Victoria for the purpose of installing, servicing, and maintaining commercial refrigerators—own refrigerators for installation and replacement, spare parts, tools of trade and materials incidental to trade.
- TOLEDO BERKEL PTY. LTD., 59 Bourke-street, Melbourne; 1 commercial goods vehicle (8 cwt.) to operate—(a) throughout the State of Victoria in the course of business as "scale makers and food preparing machinery distributors"—weighing machines, food-preparing distributors, meat and food-slicing machines, (b) throughout the State of Victoria for the purpose of servicing and maintaining the aforesaid machines—tools of trade, spare parts, and test weights.
- VICTORIAN INDUSTRIAL SALES & SERVICE PTY. LTD., corner Power and Kavanagh streets, South Melbourne; 4 commercial goods vehicles (12, 12, 12, and 8 cwt.) to operate throughout the State of Victoria for the purpose of servicing and maintaining tractors and allied equipment—tools of trade, spare parts, and materials incidental to such work.
- WILCOCK, L. G., 28 Lillian-street, Stawell; 1 commercial goods vehicle (8 cwt.) to operate within a radius of 100 miles of own premises at Stawell in the course of business as "building contractor"—tools of trade and small quantities of building materials incidental to the completion of own contracts.
- WILMOT, J. E., 57A Kangaroo-road, Murrumbidgee; variation of licence No. D.A.6136 by deleting paragraph (b) and adding in lieu the ability to operate within a radius of 70 miles of the premises of the Oakleigh Brick Co. Pty. Ltd., at Oakleigh—bricks on behalf of the said company.

NOTICE is hereby given that the application made by the persons named below for renewal of licence with variation to operate the commercial goods vehicle on the route or routes, or in the manner set out opposite their names, will be heard at a time and place to be communicated to the persons concerned:—

Name and Address; Present Franchise; Amended Conditions; Licence; Expiry Date.

- POWER, T. J. & N., 26 Meredith-road, Reservoir; 1 commercial goods vehicle (100 cwt.) to operate—(a) within a radius of 25 miles from the G.P.O., Melbourne

—general goods, (b) within a radius of 40 miles of the G.P.O., Melbourne, and to the City of Geelong on behalf of the Northcote Brick Co. Ltd., at Northcote—bricks; deleting paragraph (b) and adding in lieu—a radius of 70 miles; D.A.18588; 24th January, 1959.

Notice of any objection should be forwarded to reach the Secretary of the Board not later than Wednesday, 26th November, 1958.

E. V. FIELD,
Secretary.

Exhibition Buildings, Rathdown-street, Carlton, N.3,
12th November, 1958.

SHIRE OF ALTONA.

TOWN AND COUNTRY PLANNING ACTS.

Interim Development Order.

BY virtue of the powers conferred by the Town and Country Planning Acts and of every other power enabling it in that behalf, the President, Councillors, and Ratepayers of the Shire of Altona (hereinafter referred to as the Responsible Authority) having commenced the preparation of a Planning Scheme in accordance with the said Act on the 12th day of December, 1957, hereby makes the following Interim Development Order for the purpose of regulating, restricting, restraining, or prohibiting the use or development of any land or the erection, construction, or carrying out of any building or works on any land within the area described or shown on the map as the Schedule hereto.

1. After the coming into operation of this Interim Development Order no person shall use or develop any land or erect, construct, or carry out any buildings or works on any land within the area included in the Schedule, except in accordance with the provisions of a permit issued by the Responsible Authority.

2. Any application for a permit to use or develop any land or to erect, construct, or carry out any buildings or works, shall be accompanied by a sketch plan or copy of certificate or title of the land and a description of the proposed use or development, and type and construction of any buildings or works proposed to be erected, constructed or carried out, and such other particulars relating to the application as the Responsible Authority may require.

3. This Interim Development Order shall not prevent the continuance of the use of any land or buildings for the purposes for which such land or buildings were lawfully used immediately before the coming into operation of this Order.

4. *Schedule.*—That portion of the municipal district of the Shire of Altona within the area bounded by Railway-street south, Bent-street, The Esplanade, and Sargood-street, Altona.

R. LOGAN, President.
(SEAL) R. J. COOPER, Councillor.
JAMES W. WATERS, Shire Secretary.

Report by the Town and Country Planning Board on the 23rd October, 1958. Recommended for approval.—FRED. C. COOK, Chairman.

Approved by the Governor in Council on the 5th day of November, 1958.—N. G. WISHART, Acting Clerk of the Executive Council.

4 GEORGE VI. No. 4755, SECTION 6.

I HEREBY give notice that, on the 17th October, 1958, the Public Trustee filed an election to administer the following deceased person's estate, in accordance with section 6 of the *Public Trustee Act 1940*:—

*RAYNER, MICHAEL JOSEPH, also known as Michael Joseph Raynor, late of 11 Pohlman-avenue, North Fitzroy, retired textile worker, died 4th August, 1958.

*According to the provisions of the will.

I HEREBY give notice that, on the 20th October, 1958, the Public Trustee filed an election to administer the following deceased person's estate, in accordance with section 6 of the *Public Trustee Act 1940*:—

*DALTON, JOHN LEO, late of 208 Station-street, North Carlton, french polisher, died 18th August, 1958.

*According to the provisions of the will.

I HEREBY give notice that, on the 30th October, 1958, the Public Trustee filed elections to administer the following deceased persons' estates, in accordance with section 6 of the *Public Trustee Act 1940*:—

BURNELL, HAROLD, late of Lawson-street, Spring Gully, Bendigo, war pensioner, died 23rd June, 1958, intestate.

*ELDER, FLORENCE AUGUSTA, formerly of Y.M.C.A. Hostel, City-road, South Melbourne, but late of Prince Henry's Hospital, Melbourne, widow, died 15th September, 1958.

*ELDRIDGE, PERCY BADEN, late of 108A Eglinton-street, Moonee Ponds, storeman, died 17th August, 1958.

*PEINEMAN, JAMES WILLIAM, also known as James William Perneman, late of 905 Talbot-street, Ballarat, labourer, died 24th May, 1958.

*PERUGINI, MAY ROSABEL, formerly of 12 Robert-street, Elwood, but late of 139 New-street, Brighton, widow, died 7th June, 1958.

*RYAN, MICHAEL VICTOR, late of 255 Victoria-street, Abbotsford, postal employee, died 2nd July, 1958.

*SMITH, ETHEL MAUD, formerly of 36 Denbigh-road, Armadale, but late of "Garoopna", 14 A'Beckett-street, Kew, spinster, died 21st September, 1958.

*WALLACE, RACHEL, late of Holland Park, Brisbane, Queensland, spinster, died 7th February, 1956.

*WERNICKE, OTTO BISMARCK, formerly of 146 Blyth-street, East Brunswick, but late of 214 Arden-street, North Melbourne, pensioner, died 19th August, 1958.

* According to the provisions of the will.

I HEREBY give notice that, on the 31st October, 1958, the Public Trustee filed elections to administer the following deceased persons' estates, in accordance with section 6 of the *Public Trustee Act 1940*:—

DOYLE, MARY JOSEPHINE, formerly of 441 Royal-parade, Parkville, but late of Mount Royal, Parkville, pensioner, died 28th August, 1958, intestate.

*FULTON, WILLIAM, formerly of 542 Burwood-road, Hawthorn, but late of 6 Churchill-street, Glenferrie, retired gardener, died 24th August, 1958.

MOORES, ANDREW GARDINER, late of 342 Beaconsfield-parade, St. Kilda, painter, died 27th April, 1957, intestate.

MURRIHY, THOMAS PILKINGTON, late of Mount Royal, Parkville, pensioner, died 14th July, 1957, intestate.

McPHERSON, LESLIE DUNCAN, late of Ouyen, water ranger, died 27th June, 1958, intestate.

WILLIAMS, ELIZABETH SANKEY, late of 68 James-street, Northcote, pensioner, died 23rd August, 1958, intestate.

* According to the provisions of the will.

A. D. DUNCAN,
Acting Public Trustee.

601 Little Collins-street, Melbourne, C.1, 5th November, 1958.

NOTICE.

ADMINISTRATION of the estate of each of the under-mentioned deceased persons has been granted to the Public Trustee, and creditors, next of kin, and all others having claims against the estate of any of the persons so mentioned are required to send particulars of their claims to the Public Trustee, 7th Floor, 601 Little Collins-street, Melbourne, on or before the 15th January, 1959, or they will be excluded from the distribution of the estate when the assets are being distributed:—

*BURDEU, PERCIVAL CHARLES GORDON, also known as Percival Charles Burdeu, late of 180 Bell-street, Coburg, retired public servant, died 1st July, 1958.

BURNELL, HAROLD, late of Lawson-street, Spring Gully, Bendigo, war pensioner, died 23rd June, 1958, intestate.

†DALTON, JOHN LEO, late of 208 Station-street, North Carlton, french polisher, died 18th August, 1958.

DOYLE, MARY JOSEPHINE, formerly of 441 Royal-parade, Parkville, but late of Mount Royal, Parkville, pensioner, died 28th August, 1958, intestate.

†ELDER, FLORENCE AUGUSTA, formerly of Y.M.C.A. Hostel, City-road, South Melbourne, but late of Prince Henry's Hospital, Melbourne, widow, died 15th September, 1958.

†ELDRIDGE, PERCY BADEN, late of 108A Eglinton-street, Moonee Ponds, storeman, died 17th August, 1958.

FOCK, JUSTUS DANIEL, temporarily of Hargaon District Sitapur, India, but late of 26 Glover-street, South Oakleigh, sugar technologist, died 5th June, 1958, intestate.

†FULTON, WILLIAM, formerly of 542 Burwood-road, Hawthorn, but late of 6 Churchill-street, Glenferrie, retired gardener, died 24th August, 1958.

*HEAD, FREDERICK GEORGE, late of 28 Carrington-grove, East St. Kilda, retired builder, died 7th June, 1958.

MOORES, ANDREW GARDINER, late of 342 Beaconsfield-parade, St. Kilda, painter, died 27th April, 1957, intestate.

MURRIHY, THOMAS PILKINGTON, late of Mount Royal, Parkville, pensioner, died 14th July, 1957, intestate.

McPHERSON, LESLIE DUNCAN, late of Ouyen, water ranger, died 27th June, 1958, intestate.

†PEINEMAN, JAMES WILLIAM, also known as James William Perneman, late of 905 Talbot-street, Ballarat, labourer, died 24th May, 1958.

†PERUGINI, MAY ROSABEL, formerly of 12 Robert-street, Elwood, but late of 139 New-street, Brighton, widow, died 7th June, 1958.

RAMSDEN, JOSEPH EDWARD, late of 36 Young-street, Kew, engineering inspector, died 18th July, 1958, intestate.

†RAYNER, MICHAEL JOSEPH, also known as Michael Joseph Raynor, late of 11 Pohlman-avenue, North Fitzroy, retired textile worker, died 4th August, 1958.

RUNNBERG, GUNNAR HJALMAR, late of 22 Gladstone-parade, Elsternwick, retired manufacturer, died 4th August, 1958, intestate.

†RYAN, MICHAEL VICTOR, late of 255 Victoria-street, Abbotsford, postal employee, died 2nd July, 1958.

†SMITH, ETHEL MAUD, formerly of 36 Denbigh-road, Armadale, but late of "Garoopna", 14 A'Beckett-street, Kew, spinster, died 21st September, 1958.

*TIPPETT, MARY ELIZA (in the will called May Eliza Tippett), late of 14 Stevenson-street, South Kingsville, widow, died 1st September, 1958.

†WERNICKE, OTTO BISMARCK, formerly of 146 Blyth-street, East Brunswick, but late of 214 Arden-street, North Melbourne, pensioner, died 19th August, 1958.

WILLIAMS, ELIZABETH SANKEY, late of 68 James-street, Northcote, pensioner, died 23rd August, 1958, intestate.

* With the will annexed.

† According to the provisions of the will.

A. D. DUNCAN,
Acting Public Trustee.

Melbourne, 5th November, 1958.

Country Fire Authority Acts.

PERMISSION TO HOLD FIRE BRIGADE DEMONSTRATION.

I N pursuance with the provisions of section 79 (1) and (2) of the *Country Fire Authority Act 1944*, the Country Fire Authority has granted permission for the holding of a fire brigade demonstration as under:—

RURAL FIRE BRIGADES.

At Wycheproof, on Saturday, 21st March, 1959.

G. G. SINCLAIR,
Secretary.

10th November, 1958.

DEPARTMENT OF MINES.

APPLICATIONS FOR LEASES DECLARED ABANDONED.

9178, Ballarat; John Hearn; 20 acres, Parish of Moorarbool East.

9185, Castlemaine; Victor Maxwell Jones and Denis George Bates; 19 acres, Parish of Bulla Bulla.

CONSENT GRANTED TO TRANSFER MINING LEASE.

7118, Mineral; from Albert Ernest Rodda to Joseph Pincini.

MINERAL SEARCH LICENCES EXPIRED.

68, Mineral Search Licence; Norman Campbell Madden; Parish of Jan Juc.

76, Mineral Search Licence; W. R. Hume Proprietary Limited; Parish of Boola Boola.

W. J. MIBUS,
Minister of Mines.

MINING LEASES AND LICENCE DECLARED VOID.

7247, Mineral; Ceramic Kaolin Mines Proprietary Limited; 10a. 2r. 0p., Parish of Wodonga.

7412, Mineral; Reginald Walter Bartholomew; 15 acres, Parish of Langi Ghiran.

2756, Tailings Licence; John Liddy; Parish of Sandhurst.

J. B. TILLEY,
Secretary for Mines.

DEPARTMENT OF CROWN LANDS AND SURVEY.

ACT 391.—SECOND SCHEDULE.

A STATEMENT of trusts having been submitted by the head or authorized representative of the denomination of the Church of England, under the provisions of the "Act to provide for the Abolition of State Aid to Religion", for allowance by the Governor, the same was allowed by him on the fifth day of November, 1958, and the following is the form in which such statement of trusts has been allowed:—

Statement of Trusts.

Description of Land.—1 acre 1 rood, Township of Yea, Parish of Yea, County of Anglesey, being allotment 1, section 11: Commencing at the junction of the south-eastern boundary of Pelissier-street and the north-eastern boundary of The Parade; bounded thence by Pelissier-street bearing N. 59 deg. 48 min. E. 625 links; by Lyons-street bearing S. 30 deg. 12 min. E. 200 links; by allotment 2 bearing S. 59 deg. 48 min. W. 625 links; and thence by The Parade bearing N. 30 deg. 12 min. W. 200 links to the commencing point.

Names of Trustees.—The Church of England Trusts Corporation for the Diocese of Wangaratta.

Powers of Disposition.—Power to sell, lease, mortgage or exchange all or any part of such land subject to the approval of the Bishop of Wangaratta for the time being, or during the absence of the Bishop from the Diocese or the vacancy of the see, to the approval of the person for the time being administering the affairs thereof. The land, until otherwise disposed of, to be held for the purposes for which it was granted or reserved by the Crown.

Purposes to which Proceeds of Disposition are to be Applied.—To be paid to the Bishop or administrator aforesaid to be applied to such purposes of the Church of England in the Diocese of Wangaratta as may by such Bishop or administrator acting under the advice of the Council of the Diocese be from time to time deemed desirable.

S. H. AUSTIN, EMBLING, & JACKSON, solicitors, Yea.

As witness the hand of the Governor of the State of Victoria, this fifth day of November, 1958—

DALLAS BROOKS,
Governor of the State of Victoria.

APPOINTMENTS.

HIS Excellency the Governor of the State of Victoria, by and with the advice of the Executive Council thereof, has, by Orders made on the 5th day of November, 1958, been pleased to make the under-mentioned appointments, viz.:—

DEPARTMENT OF CROWN LANDS AND SURVEY.

Trustee of Site.

ROBERT SOUTHBY, M.D., B.S., F.R.A.C.P.,

to be a Trustee of the land permanently reserved on the 14th March, 1882, as a site for a Hall and Library for the use of the Medical Society of Victoria and for other Scientific purposes at East Melbourne, in the place of Thomas Ernest Victor Hurley, deceased.

DEPARTMENT OF HEALTH.

Government Representatives on Hospital Committees.

KEITH HAROLD LOVETT

to be Government Representative on the Committee of Management of Wimmera Base Hospital, Horsham, pursuant to the provisions of section 48 of the *Hospitals and Charities Act 1948*, for a further term of three years from the 15th November, 1958; and

ARTHUR NOEL YOUNG

to be Government Representative on the Committee of Management of Morwell and District Community Hospitals, pursuant to the provisions of section 48 of the *Hospitals and Charities Act 1948*, for a term of three years.

LAW DEPARTMENT.

Justices of the Peace.

ANDREW JOHN KNOX WILSON, 104 Tramway-parade, Beaumaris, and

GEORGE WILLIAM NEWMAN, 12 Appleton-street, Richmond,

to Keep the Peace in the Central Bailiwick of the State of Victoria.

Commissioners for Taking Declarations &c.

CHARLES MCPHERSON HARDY, Superintendent, The Temperance and General Life Assurance Society Limited, corner of Russell and Collins streets, Melbourne, and

STANLEY WILLIAM BELCHER, Officer of the Commonwealth Bank of Australia, 225 Bourke-street, Melbourne,

to be Commissioners for taking Declarations and Affidavits, pursuant to the provisions of the *Evidence Act 1928*, to resign upon ceasing to occupy their present positions; and

LESLIE GEORGE PRING, 214A Eureka-street, Ballarat, JOSEPH WILLIAM BYRNE, 327 St. George's-road, North Fitzroy, and

DOUGLAS GEORGE BLACKIE, 23 Durham-street, East Richmond,

to be Commissioners for taking Declarations and Affidavits, pursuant to the provisions of the *Evidence Act 1928*, to resign upon removing from the neighbourhood of the addresses stated.

Probation Officers of Children's Courts.

GEORGE HENRY FLETCHER, 8 Malcolm-street, Bendigo, to be a Probation Officer for the Children's Court at Bendigo, pursuant to the provisions of the *Children's Court Act 1956*;

JOHN HOLDSWORTH SHIELDS, The Rectory, King Edward-street, Cohuna, to be a Probation Officer for the Children's Court at Cohuna, pursuant to the provisions of the *Children's Court Act 1956*;

WILLIAM GEORGE KENNEDY, 27 Church-street, Dimboola, to be a Probation Officer for the Children's Court at Dimboola, pursuant to the provisions of the *Children's Court Act 1956*; and

DENIS JOSEPH HEENAN, 60 Craig-avenue, Warracknabeal, to be a Probation Officer for the Children's Court at Warracknabeal, pursuant to the provisions of the *Children's Court Act 1956*.

Sworn Valuers.

MALDWIN ANGOVE ROBERTS, 667 High-street, Thornbury, to be a Sworn Valuator for the Counties of Bourke, Evelyn and Mornington, pursuant to the provisions of the *Transfer of Land Act 1954*; and

KENNETH FITCH KEMP, care of Doepel, Lilley, and Taylor, corner of Sturt and Lydiard streets, Ballarat,

to be a Sworn Valuator for the Counties of Grant, Grenville, Ripon and Talbot, pursuant to the provisions of the *Transfer of Land Act 1954*.

Clerk of Petty Sessions.

NORMAN MAURICE THOMPSON

to be Clerk of Petty Sessions at Brunswick and Coburg during the absence of A. E. Thompson on sick leave, to take effect from the date of commencement of duty.

DEPARTMENT OF PUBLIC WORKS.

Commissioner of the Geelong Harbor Trust.

ERNEST WESLEY MCCANN,

pursuant to the provisions of the Geelong Harbor Trust Acts, to be a Commissioner of the Geelong Harbor Trust for the period of three (3) years ending on the 31st December, 1961.

Wharf Managers, &c.

Senior Constable SAMUEL CROMWELL SMITH, No. 9213, to be Wharf Manager and Collector of Slip Dues at Hastings, to carry out that portion of Part II. of the *Marine Act 1928* which relates to the management of Public Wharfs, and to be an officer under section 19 of such Act to levy and collect wharfage rates thereat, at a remuneration of £20 per annum, *vice* Senior Constable James Bernard Bramwell, No. 9162, transferred;

First Constable WILLIAM ROBERT CLAUD WATSON, No. 10100,

to be Wharf Manager at Mallacoota and Gipsy Point, to carry out that portion of Part II. of the *Marine Act 1928* which relates to the management of Public Wharfs, and to be an officer under section 19 of such Act, to levy and collect wharfage rates thereat, at a remuneration of £12 10s. per annum, *vice* First Constable Robert Stanley Johnson, No. 10171, transferred; and

First Constable KENNETH ROWE, No. 8441, to be Wharf Manager at San Remo and Corinella, to carry out that portion of Part II. of the *Marine Act 1928* which relates to the management of Public Wharfs, and to be an officer under section 19 of such Act, to levy and collect wharriage rates thereat, at a remuneration of £20 per annum, *vice* First Constable Sidney Ivan Porter, No. 9796, transferred.

Collector of Imposts.

ERIC VERNON NICHOLLS FIELD to act temporarily as Collector of Imposts, Transport Regulation Board, *vice* B. P. Kay;

CLARENCE NORMAN ROSCHOLLER to act temporarily as Collector of Imposts, Department of Labour and Industry, during the absence of R. H. Williams, on leave; and

WILLIAM LETHBRIDGE CLIFFORD HALL to act temporarily as Collector of Imposts, Chief Secretary's Office, during the absence of D. H. McDermott, on leave.

Receiver of Revenue.

GREGORY FRANCIS MEEHAN to act temporarily as Receiver of Revenue, Wodonga, during the absence of D. L. Croft, on leave.

N. G. WISHART,
Acting Clerk of the Executive Council.

At the Executive Council Chamber,
Melbourne, 5th November, 1958.

APPOINTMENTS.

HIS Excellency the Governor of the State of Victoria, by and with the advice of the Executive Council thereof, has, by Orders made on the 11th day of November, 1958, been pleased to make the under-mentioned appointments, viz.:—

LAW DEPARTMENT.

Stipendiary Magistrate.

HARRY WILLIAM PASCOE to be a Stipendiary Magistrate, pursuant to the provisions of the *Justices Act 1957*; a Coroner for the State of Victoria, pursuant to the provisions of the *Coroners Act 1928*; and a Warden of the Goldfields in and for the State of Victoria, pursuant to the provisions of the *Mines Act 1928*, to take effect from the date of commencement of duty.

Registrar of Probates and Administrations.

JOHN DAVENPORT JOSE to act as Registrar of Probates and Administrations during the absence of G. E. Wilson on annual leave, to take effect from the date of commencement of duty.

Assistant Registrar of Probates and Administrations.

DANIEL WALTER KENNEDY to act as Assistant Registrar of Probates and Administrations during the period J. D. Jose is acting as Registrar of Probates and Administrations, to take effect from the date of commencement of duty.

N. G. WISHART,
Acting Clerk of the Executive Council.

At the Executive Council Chamber,
Melbourne, 11th November, 1958.

LAW DEPARTMENT.

APPOINTMENTS REVOKED.

HIS Excellency the Governor of the State of Victoria, by and with the advice of the Executive Council thereof, doth by Order made on the 5th day of November, 1958, revoke the appointments of the under-mentioned persons as Commissioners for taking Declarations and Affidavits, pursuant to the provisions of the *Evidence Act 1928*:—

ALAN FREDERICK CORNELL, HAROLD VICTOR FRECKELTON, ROBERT DUNCAN HATCH, ALAN WALTER KING, ALEXANDER FRANCIS RIZZOLI, EDWARD BRIAN WALL, ROBERT GLADSTONE BARRETT, STANLEY GEORGE BATES, NORMAN LINDSAY BURCHELL, ALBERT ERNEST BROWN, JOHN ANDREW HOOPER, WILLIAM LESLIE HUGHES, ROBERT WILLIAM LAMONT, ROBERT JOHN DAWSON LONEY, RONALD MOUNTFORD, ALISON STEWART O'BRIEN, ROBERT LESLIE PONSFORD, STANLEY GODFREY ROSE, FREDERICK CHARLES SIDES, RUBEN FRANCIS WELLINGTON, WILLIAM ROY WELCHMAN, LAWRENCE FREDERICK WILLIAMS, DENNIS RAYMOND ZINN, and DAVID GLADSTONE GILL.

N. G. WISHART,
Acting Clerk of the Executive Council.

At the Executive Council Chamber,
Melbourne, 5th November, 1958.

No. 98.—10559/58.—2

RESIGNATIONS.

HIS Excellency the Governor of the State of Victoria, by and with the advice of the Executive Council thereof, has, by Orders made on the 5th day of November, 1958, accepted the resignations of the persons named hereunder of the offices mentioned, viz.:—

LAW DEPARTMENT.

ESTHER KENNEDY, from the Commission of the Peace for the Central Bailiwick of the State of Victoria.

ANDREW JOHN KNOX WILSON, from the Commission of the Peace for the Eastern Bailiwick of the State of Victoria.

JOSEPH PATRICK KEALY, as a Probation Officer, pursuant to the provisions of the *Children's Court Act 1956*, for the Children's Court at Frankston.

N. G. WISHART,
Acting Clerk of the Executive Council.

At the Executive Council Chamber,
Melbourne, 5th November, 1958.

DEPARTMENT OF CROWN LANDS AND SURVEY.

At the Executive Council Chamber, Melbourne, the fifth day of November, 1958.

PRESENT:

HIS Excellency the Governor of Victoria.
Mr. Cameron | Mr. Thompson.

UNUSED AND UNMADE ROADS CLOSED.

HIS Excellency the Governor of the State of Victoria, by and with the advice of the Executive Council thereof, doth hereby direct that, in pursuance of the provisions of section 304 of the *Land Act 1928*, the unused and unmade roads referred to hereunder be closed, viz.:—

Township of Smith's Gully, Parish of Queenstown, County of Evelyn, being the road between allotments 8 and 9.—(Q.22(4) (Misc. 3051).

Township of Korumburra, Parish of Korumburra, County of Mornington, being the road indicated by hachure on plan hereunder.—(K.172(12) (C.91184).

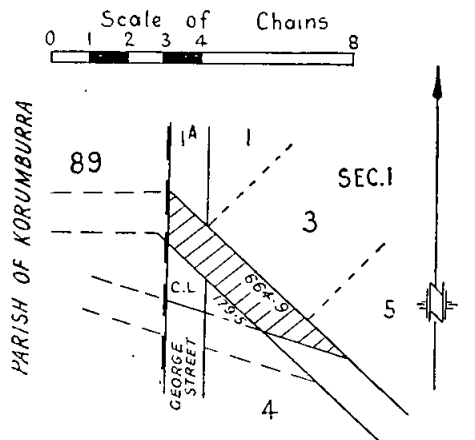

And the Honorable Keith Hector Turnbull, Her Majesty's Commissioner of Crown Lands and Survey for the State of Victoria, shall give the necessary directions herein accordingly.

N. G. WISHART,
Acting Clerk of the Executive Council.

MARKETING OF PRIMARY PRODUCTS ACT 1935 (No. 4337).

*At the Executive Council Chamber, Melbourne, the
fifth day of November, 1958.*

PRESENT:

His Excellency the Governor of Victoria.
Mr. Cameron | Mr. Thompson.

REGULATIONS.

IN pursuance of the powers conferred by sections 23 (1) and 43 (1) of the *Marketing of Primary Products Act 1935* (No. 4337), His Excellency the Governor of the State of Victoria, by and with the advice of the Executive Council thereof, and on the recommendation of the Onion Marketing Board, doth hereby make the following Regulation (that is to say):—

The forty-seventh period of time in respect of which the computation of or accounting for the net proceeds of the sale of onions may be made by the Onion Marketing Board shall be from the 16th November, 1957, to the 15th November, 1958 (both dates inclusive).

And the Honorable Gilbert Lawrence Chandler, Her Majesty's Minister of Agriculture for the State of Victoria, shall give the necessary directions herein accordingly.

N. G. WISHART,
Acting Clerk of the Executive Council.

ROAD TRAFFIC ACT 1956.

*At the Executive Council Chamber, Melbourne, the
fifth day of November, 1958.*

PRESENT:

His Excellency the Governor of Victoria.
Mr. Cameron | Mr. Thompson.

REGULATIONS.

IN pursuance of the powers conferred by the *Road Traffic Act 1956* and all other powers him thereunto enabling, His Excellency the Governor of the State of Victoria, in the Commonwealth of Australia, by and with the advice of the Executive Council of the said State, doth hereby further amend the Road Traffic Regulations 1958 as follows (that is to say):—

Regulation 1502 shall be revoked and the following Regulation substituted therefor:—

"1502. Notwithstanding anything in these Regulations any provision of a by-law whether made before or after the commencement of these Regulations in pursuance of the powers contained in paragraph XXII. of sub-section (1) of section 197 of the *Local Government Act 1946* shall have in relation to any standing place for motor cars appointed under the said paragraph XXII.—

- (a) which is also a parking area constituted under these Regulations, and
 - (b) in respect of which there is inscribed on every parking sign associated therewith particulars of the days and hours during which and the period of time for which such standing place may be occupied by motor cars and of the fee if any for the occupation by a motor car of a position on such standing place, and
 - (c) in the case of a parking area in which angle parking is permitted or directed by the by-law, the parking signs associated with the parking area have been erected with the consent of the Traffic Commission,
- the same force and effect as if these Regulations had not been promulgated."

And the Honorable Arthur Gordon Rylah, Her Majesty's Chief Secretary for the State of Victoria, shall give the necessary directions herein accordingly.

N. G. WISHART,
Acting Clerk of the Executive Council.

COUNTRY ROADS BOARD.

At the Executive Council Chamber, Melbourne, the fifth day of November, 1958.

PRESENT:

His Excellency the Governor of Victoria.
Mr. Cameron | Mr. Thompson.

ORDER APPROVING OF WIDENING AN EXISTING MAIN ROAD IN THE SHIRE OF BERWICK.

WHEREAS the Country Roads Board constituted under the *Country Roads Act 1928* (No. 3662) has represented to His Excellency the Governor in Council that it appears to it desirable that the existing Woori Yallock-Pakenham-Koo-Wee-Rup road in the Shire of Berwick (declared to be a main road under the said Act which declaration was confirmed by the Order in Council published in the *Government Gazette* of the 14th January, 1914, on page 91) should be widened by the said Board: And whereas the said Board in accordance with the requirements of section 19 of the said cited Act, as amended by the *Country Roads Act 1956* (No. 5978) has caused to be prepared a map plan and estimate showing the points between which and on and through what land the said widening is proposed to be made and the cost of acquiring the land: And whereas on an inspection of the said map and plan and a consideration of the said estimate His Excellency the Governor in Council is satisfied that there are funds legally available for acquiring the land: Now therefore be it known by this present Order that His Excellency the Governor of the State of Victoria with the advice of the Executive Council thereof doth hereby approve of the said road being widened, that is to say:—

All that piece of land in the Parish of Gembrook, the boundaries of which are as follow:—Commencing at a point on the southern boundary of allotment 19A of the said parish distant 108 deg. 9 min. 365 links, 95 deg. 2 min. 362 links and 89 deg. 55 min. 1,842.7 links from the south-western angle of the said allotment; thence by lines bearing respectively 359 deg. 54 min. 394 links, 19 deg. 35 min. 234.5 links, 41 deg. 0 min. 235.4 links, 55 deg. 52 min. 623 links, 25 deg. 52 min. 231.7 links, 89 deg. 55 min. 44.6 links, 206 deg. 1 min. 238.3 links, 236 deg. 57 min. 459.8 links, 230 deg. 40 min. 308.3 links, 209 deg. 21 min. 165.5 links, 198 deg. 16 min. 160.4 links, 180 deg. 21 min. 394.5 links and 269 deg. 55 min. 32.3 links to the point of commencement—which said piece of land is particularly delineated and shown coloured red on survey plan numbered 6961, lodged in the office of the Country Roads Board.

And the Honorable Sir Thomas Karran Maltby, Her Majesty's Commissioner of Public Works for the State of Victoria, shall give the necessary directions herein accordingly.

N. G. WISHART,
Acting Clerk of the Executive Council.

COUNTRY ROADS BOARD.

At the Executive Council Chamber, Melbourne, the fifth day of November, 1958.

PRESENT:

His Excellency the Governor of Victoria.
Mr. Cameron | Mr. Thompson.

ORDER APPROVING OF WIDENING AN EXISTING MAIN ROAD IN THE SHIRE OF ROSEDALE.

WHEREAS the Country Roads Board constituted under the *Country Roads Act 1928* (No. 3662) has represented to His Excellency the Governor in Council that it appears to it desirable that the existing Rosedale-Heyfield road in the Shire of Rosedale (declared to be a main road under the said Act which declaration was confirmed by the Order in Council published in the *Government Gazette* of the 30th March, 1938, on page 1081, and amended in the *Government Gazette* of the 4th May, 1938, on page 1387), should be widened by the said Board: And whereas the said Board in accordance with the requirements of section 19 of the said cited Act, as amended by the *Country Roads Act 1956* (No. 5978), has caused to be prepared a map plan and estimate showing

the points between which and on and through what land the said widening is proposed to be made and the cost of acquiring the land: And whereas on an inspection of the said map and plan and a consideration of the said estimate His Excellency the Governor in Council is satisfied that there are funds legally available for acquiring the land: Now therefore be it known by this present Order that His Excellency the Governor of the State of Victoria with the advice of the Executive Council thereof doth hereby approve of the said road being widened, that is to say:—

All that piece of land in the Parish of Winnindoo, the boundaries of which are as follow:—Commencing at a point on the eastern boundary of allotment 3B, section 17, of the said parish distant 165 deg. 41 min. 5,875 links from the north-eastern angle of allotment 3A of the said section; thence by lines bearing respectively 165 deg. 41 min. 559 links, 188 deg. 4 min. 371 links and 354 deg. 35 min. 913 links to the point of commencement—which said piece of land is particularly delineated and shown coloured red on survey plan numbered 6965, lodged in the office of the Country Roads Board.

And the Honorable Sir Thomas Karran Maltby, Her Majesty's Commissioner of Public Works for the State of Victoria, shall give the necessary directions herein accordingly.

N. G. WISHART,
Acting Clerk of the Executive Council.

COUNTRY ROADS BOARD.

At the Executive Council Chamber, Melbourne, the fifth day of November, 1958.

PRESENT:

His Excellency the Governor of Victoria.
Mr. Cameron | Mr. Thompson.

ORDER APPROVING OF WIDENING AN EXISTING MAIN ROAD IN THE SHIRE OF BET BET.

WHEREAS the Country Roads Board constituted under the *Country Roads Act 1928* (No. 3662) has represented to His Excellency the Governor in Council that it appears to it desirable that the existing Bridgewater-Dunolly road in the Shire of Bet Bet (declared to be a main road under the said Act which declaration was confirmed by the Order in Council published in the *Government Gazette* of the 21st September, 1938, on page 2912) should be widened by the said Board: And whereas the said Board in accordance with the requirements of section 19 of the said cited Act, as amended by the *Country Roads Act 1956* (No. 5978), has caused to be prepared a map plan and estimate showing the points between which and on and through what land the said widening is proposed to be made and the cost of acquiring the land: And whereas on an inspection of the said map and plan and a consideration of the said estimate His Excellency the Governor in Council is satisfied that there are funds legally available for acquiring the land: Now therefore be it known by this present Order that His Excellency the Governor of the State of Victoria with the advice of the Executive Council thereof doth hereby approve of the said road being widened, that is to say:—

All that piece of land in the Parish of Tarnagulla, the boundaries of which are as follow:—Commencing at a point on the western boundary of allotment 1, section G, of the said parish distant 350 deg. 44 min. 625.7 links from the south-western angle of the said allotment; thence by lines bearing respectively 350 deg. 44 min. 342.3 links, 6 deg. 39 min. 353 links, 30 deg. 55 min. 447.6 links, 199 deg. 22 min. 527 links and 184 deg. 4 min. 576.7 links to the point of commencement—which said piece of land is particularly delineated and shown coloured red on survey plan numbered 6948, lodged in the office of the Country Roads Board.

And the Honorable Sir Thomas Karran Maltby, Her Majesty's Commissioner of Public Works for the State of Victoria, shall give the necessary directions herein accordingly.

N. G. WISHART,
Acting Clerk of the Executive Council.

COUNTRY ROADS BOARD.

At the Executive Council Chamber, Melbourne, the
fifth day of November, 1958.

PRESENT:

His Excellency the Governor of Victoria,
Mr. Cameron | Mr. Thompson.

ORDER APPROVING OF A NEW ROAD IN THE SHIRE
OF SEYMOUR.

WHEREAS the Country Roads Board constituted under the *Country Roads Act 1928* (No. 3662) has represented to His Excellency the Governor in Council that it appears to it desirable that the new Police Access road in the Shire of Seymour should be made by the said Board: And whereas the said Board in accordance with the requirements of section 4 of the *Country Roads Act 1936* (No. 4458) and of section 19 of the said first cited Act has caused to be prepared a map plan and estimate showing the points between which and on and through what land the said new road is proposed to be made and the cost of acquiring the land: And whereas on an inspection of the said map and plan and a consideration of the said estimate His Excellency the Governor in Council is satisfied that there are funds legally available for acquiring the land: Now therefore be it known by this present Order that His Excellency the Governor of the State of Victoria with the advice of the Executive Council thereof doth hereby approve of the said road being made, that is to say:—

All that piece of land in the Parish of Seymour, the boundaries of which are as follow:—Commencing at the southern angle of allotment 9, section X, of the said parish; thence by lines bearing respectively 350 deg. 45 min. 1,040 links, 136 deg. 45 min. 134.1 links, 170 deg. 45 min. 859.3 links and 217 deg. 53 min. 102.3 links to the point of commencement—which said piece of land is particularly delineated and shown coloured red on survey plan numbered 6964, lodged in the office of the Country Roads Board.

And the Honorable Sir Thomas Karran Maltby, Her Majesty's Commissioner of Public Works for the State of Victoria, shall give the necessary directions herein accordingly.

N. G. WISHART,
Acting Clerk of the Executive Council.

COUNTRY ROADS BOARD.

At the Executive Council Chamber, Melbourne, the
fifth day of November, 1958.

PRESENT:

His Excellency the Governor of Victoria,
Mr. Cameron | Mr. Thompson.

ORDER APPROVING OF A NEW ROAD IN THE CITY
OF WILLIAMSTOWN.

WHEREAS the Country Roads Board constituted under the *Country Roads Act 1928* (No. 3662) has represented to His Excellency the Governor in Council that it appears to it desirable that the new Newport Subway road in the City of Williamstown should be made by the said Board: And whereas the said Board in accordance with the requirements of section 4 of the *Country Roads Act 1936* (No. 4458) and of section 19 of the said first cited Act has caused to be prepared a map plan and estimate showing the points between which and on and through what land the said new road is proposed to be made and the cost of acquiring the land: And whereas on an inspection of the said map and plan and a consideration of the said estimate His Excellency the Governor in Council is satisfied that there are funds legally available for acquiring the land: Now therefore be it known by this present Order that His Excellency the Governor of the State of Victoria with the advice of the Executive Council thereof doth hereby approve of the said road being made, that is to say:—

All that piece of land in the Parish of Cut Paw Paw, the boundaries of which are as follow:—Commencing at a point on the western boundary of allotment 12, portion 2, of the said parish, the said point being at the intersection of the south side of North-road and the said

western boundary; thence by lines bearing 90 deg. 0 min. 248 ft. 1½ in. and 238 deg. 10 min. 64 ft. 6¼ in.; thence by the arc of a circle of radius of 50 feet a distance of 36 ft. 6 in. the chord of which arc bears 217 deg. 15 min.; thence by a line bearing 196 deg. 20 min. 70 ft. 6¼ in.; thence south-easterly by the arc of a circle of radius of 40 feet a distance of 55 ft. 7½ in.; thence by lines bearing respectively 116 deg. 40 min. 40 ft. 11½ in., 270 deg. 0 min. 65 ft. 9 in. and 323 deg. 47 min. 243 ft. 2 in. to the point of commencement—which said piece of land is particularly delineated and shown coloured red on survey plan numbered 6963, lodged in the office of the Country Roads Board.

And the Honorable Sir Thomas Karran Maltby, Her Majesty's Commissioner of Public Works for the State of Victoria, shall give the necessary directions herein accordingly.

N. G. WISHART,
Acting Clerk of the Executive Council.

COUNTRY ROADS BOARD.

At the Executive Council Chamber, Melbourne, the
fifth day of November, 1958.

PRESENT:

His Excellency the Governor of Victoria,
Mr. Cameron | Mr. Thompson.

ORDER APPROVING OF WIDENING AN EXISTING
STATE HIGHWAY IN THE CITY OF WARRNAMBOOL.

WHEREAS the Country Roads Board constituted under the *Country Roads Act 1928* (hereinafter called "the principal Act") has in exercise of its powers under the *Country Roads Act 1948* for the purpose of widening the Princes Highway in the City of Warrnambool (declared to be a State highway under the principal Act, which declaration was confirmed by an Order in Council published in the *Government Gazette* of the 8th day of July, 1925, on pages 2371-3), by Resolution dated the 14th day of October, 1957, fixed new alignments for the north and south sides of the said highway: And whereas by sub-section (3) of section 2 of the *Country Roads Act 1948* it is provided (*inter alia*) that the widening of any State highway pursuant to such Act shall for all purposes be deemed to be the making of such State highway pursuant to the principal Act: And whereas by sub-section (2) of section 2 of the *Country Roads Act 1948* it is provided (*inter alia*) that no State highway shall be widened pursuant to that Act unless the Governor in Council has by Order published in the *Government Gazette* approved such widening: And whereas the said Board in accordance with the requirements of section 19 of the principal Act has caused to be prepared a map plan and estimate showing the points between which and on and through what land the said highway is proposed to be made and the cost of acquiring the land: And whereas on an inspection of the said map and plan and a consideration of the said estimate His Excellency the Governor in Council is satisfied that there are funds legally available for acquiring the land which it is necessary to acquire for the purpose: Now therefore be it known by this present Order that His Excellency the Governor of the State of Victoria with the advice of the Executive Council thereof doth hereby for the purposes of the *Country Roads Act 1948*, approve of the said highway being widened so as to include therein the land described in the Schedule hereto and doth hereby for the purposes of the principal Act approve of the said highway being made over the land described in the said Schedule.

SCHEDULE.

All those pieces of land in the Parish of Wangoom, the boundaries of which are as follow:—

- (a) Commencing at the south-eastern angle of allotment 114 of the said parish; thence by lines bearing respectively 270 deg. 0 min. 120 links, 360 deg. 0 min. 22.2 links, 290 deg. 16 min. 1,436.7 links, 360 deg. 0 min. 64 links, 110 deg. 16 min. 1,564.6 links and 180 deg. 0 min. 42 links to the point of commencement.

(b) Commencing at the north-western angle of lot 9 on plan of subdivision numbered 2007, lodged in the Office of Titles, and being part of allotment 113 of the said parish; thence by lines bearing respectively 110 deg. 16 min. 479.6 links, 180 deg. 0 min. 64 links, 290 deg. 16 min. 403.6 links, 235 deg. 8 min. 86.9 links and 360 deg. 0 min. 140 links to the point of commencement.

(c) Commencing at a point on the eastern boundary of lot 31 on plan of subdivision numbered 19047, lodged in the Office of Titles, and being part of allotment 114 of the said parish the said point being distant 179 deg. 59 min. 90 ft. 11 in. from the north-eastern angle of the said lot; thence by lines bearing respectively 179 deg. 59 min. 40 feet, 235 deg. 14 min. 11 ft. 5 in., 290 deg. 29 min. 40 feet and 55 deg. 14 min. 57 feet to the point of commencement—

which said pieces of land are particularly delineated and shown coloured red on survey plans numbered 6697 and 6698, lodged in the office of the Country Roads Board.

And the Honorable Sir Thomas Karran Maltby, Her Majesty's Commissioner of Public Works for the State of Victoria, shall give the necessary directions herein accordingly.

N. G. WISHART,
Acting Clerk of the Executive Council.

COUNTRY ROADS BOARD.

At the Executive Council Chamber, Melbourne, the fifth day of November, 1958.

PRESENT:

His Excellency the Governor of Victoria.
Mr. Cameron | Mr. Thompson.

ORDER APPROVING OF WIDENING AN EXISTING STATE HIGHWAY IN THE SHIRE OF CORIO.

WHEREAS the Country Roads Board constituted under the *Country Roads Act 1928* (No. 3662) has represented to His Excellency the Governor in Council that it appears to it desirable that the existing Princes Highway in the Shire of Corio (declared to be a State highway under the said Act which declaration was confirmed by the Order in Council published in the *Government Gazette* of the 30th December, 1947, on page 6281/2) should be widened by the said Board: And whereas the said Board in accordance with the requirements of section 19 of the said cited Act, as amended by the *Country Roads Act 1956* (No. 5978), has caused to be prepared a map plan and estimate showing the points between which and on and through what land the said widening is proposed to be made and the cost of acquiring the land: And whereas on an inspection of the said map and plan and a consideration of the said estimate His Excellency the Governor in Council is satisfied that there are funds legally available for acquiring the land: Now therefore be it known by this present Order that His Excellency the Governor of the State of Victoria with the advice of the Executive Council thereof doth hereby approve of the said highway being widened, that is to say:—

SCHEDULE.

All that piece of land in the Parish of Moorpanyal, the boundaries of which are as follow:—Commencing at the south-eastern angle of allotment 67 of the said parish; thence by lines bearing respectively 270 deg. 0 min. 100 feet, 360 deg. 0 min. 71 ft. 6 in., 359 deg. 40 min. 20 feet, 89 deg. 15 min. 100 ft. 6 in. and 180 deg. 0 min. 91 ft. 6 in. to the point of commencement—which said piece of land is particularly delineated and shown coloured red on survey plan numbered 6996, lodged in the office of the Country Roads Board.

And the Honorable Sir Thomas Karran Maltby, Her Majesty's Commissioner of Public Works for the State of Victoria, shall give the necessary directions herein accordingly.

N. G. WISHART,
Acting Clerk of the Executive Council.

COUNTRY ROADS BOARD.

At the Executive Council Chamber, Melbourne, the fifth day of November, 1958.

PRESENT:

His Excellency the Governor of Victoria.
Mr. Cameron | Mr. Thompson.

DECLARATION OF THE WIDENING OF THE CAVENDISH-COLERAINE ROAD, THE Kelfeera ROAD AND THE AVIATION ROAD, IN THE SHIRE OF DUNDAS AND SHIRE AND BOROUGH OF BENALLA AND SHIRE OF WERRIBEE RESPECTIVELY.

WHEREAS by section 21 of the *Country Roads Act 1928* (No. 3662), as amended by the *Country Roads Act 1956* (No. 5978), it is amongst other things enacted that when the Country Roads Board under the provisions of the Country Roads Act has taken the land necessary for constructing the road or deviation or widening it shall as soon as it thinks such road or deviation or widening is fit to be used as a public highway by Resolution declare the road or deviation or widening to be a main road or part thereof and that upon publication in the *Government Gazette* of the Order of the Governor in Council confirming such Resolution such road or deviation or widening shall thereupon be a main road or a part thereof within the meaning of the said Act: And whereas the said Board has by Resolution declared the roads on the land described in the Schedules to such Resolution to be parts of main roads: Now therefore His Excellency the Governor of the State of Victoria by and with the advice of the Executive Council thereof doth hereby confirm the said Resolution.

Resolution for Declaration of the Widening of Main Roads under the Country Roads Act.

Whereas the land the site of the roads the courses of which are below set out was taken by the Board under the provisions of the Country Roads Act for the purpose of widening the main roads aforesaid which widenings have now been laid out and formed on the same: And whereas the said Board (being the Country Roads Board incorporated under the said Act) thinks that the widenings aforesaid are fit to be used as parts of public highways such Board at a meeting now holden doth by this Resolution hereby declare the same as described in the Schedules hereto with the commencing and terminating points thereof respectively specified to be parts of the main roads within the meaning and for the purposes of the Country Roads Act.

SCHEDULE.

Shire of Dundas.

14. *Cavendish-Coleraine road* (4914).—All those pieces of land in the Parish of Urangara, the boundaries of which are as follow:—

- (a) Commencing at the north-western angle of allotment 22, section B, of the said parish; thence by lines bearing respectively 83 deg. 46 min. 137.9 links, 232 deg. 12 min. 242.6 links and 22 deg. 13 min. 144.4 links to the point of commencement.
- (b) Commencing at the northern angle of allotment 23, section B, of the said parish; thence by lines bearing respectively 134 deg. 23 min. 378.8 links, 297 deg. 23 min. 173.9 links, 280 deg. 22 min. 295.4 links, 263 deg. 22 min. 173.9 links and 66 deg. 22 min. 378.8 links to the point of commencement—

which said pieces of land are particularly delineated and shown coloured red on survey plans numbered 6149 and 6150, lodged in the office of the Country Roads Board.

SCHEDULE.

Shire and Borough of Benalla.

9. *Kelfeera-road* (1809).—All those pieces of land in the Parish of Benalla, the boundaries of which are as follow:—

- (a) Commencing at the eastern angle of allotment 15, section 7, of the said parish; thence by lines bearing respectively 180 deg. 0 min. 27 ft. 3 in., 329 deg. 5 min. 44 feet and 115 deg. 0 min. 24 ft. 11 in. to the point of commencement.

- (b) Commencing at the north-western angle of allotment 1, section H, of the said parish; thence by lines bearing respectively 90 deg. 0 min. 40 feet, 225 deg. 0 min. 56 ft. 7 in. and 360 deg. 0 min. 40 feet to the point of commencement—

which said pieces of land are particularly delineated and shown coloured red and blue on survey plan numbered 6033, lodged in the office of the Country Roads Board.

SCHEDULE.

Shire of Werribee.

7. *Aviation-road* (18007).—All those pieces of land in the Parish of Deutgam, the boundaries of which are as follow:—

- (a) Commencing at the south-eastern angle of allotment 14, section C, of the said parish; thence by lines bearing respectively 273 deg. 9 min. 87.1 links, 95 deg. 38 min. 300 links, 67 deg. 24 min. 420 links, 38 deg. 6 min. 396.5 links, 10 deg. 37 min. 300 links and 188 deg. 11 min. 87.1 links to the point of commencement.
- (b) Commencing at a point in allotment 13e, section C, of the said parish, distant 188 deg. 11 min. 100 links and 97 deg. 51 min. 100 links from the north-western angle of the said allotment; thence by lines bearing respectively 97 deg. 51 min. 926.5 links, 273 deg. 55 min. 281.7 links, 250 deg. 30 min. 378.2 links, 226 deg. 38 min. 298.8 links, 209 deg. 47 min. 314.9 links, 190 deg. 25 min. 229.1 links and 8 deg. 11 min. 947 links to the point of commencement.
- (c) Commencing at the south-eastern angle of allotment 13d, section C, of the said parish; thence by lines bearing respectively 277 deg. 51 min. 960 links, 95 deg. 23 min. 284 links, 66 deg. 42 min. 485.4 links, 38 deg. 52 min. 482.2 links, 10 deg. 12 min. 284 links and 187 deg. 50 min. 960 links to the point of commencement—

which said pieces of land are particularly delineated and shown coloured red on survey plans numbered 5346 and 5537, lodged in the office of the Country Roads Board.

The common seal of the Country Roads Board was hereto affixed at Carlton this twenty-seventh day of October, One thousand nine hundred and fifty-eight, in the presence of—

D. V. DARWIN, Chairman.
(SEAL) W. H. NEVILLE, Member.
R. E. V. DONALDSON, Secretary.

And the Honorable Sir Thomas Karran Maltby, Her Majesty's Commissioner of Public Works for the State of Victoria, shall give the necessary directions herein accordingly.

N. G. WISHART,
Acting Clerk of the Executive Council.

YARRAM WATERWORKS TRUST.

At the Executive Council Chamber, Melbourne, the fifth day of November, 1958.

PRESENT:

His Excellency the Governor of Victoria.
Mr. Cameron | Mr. Thompson.

ADDITIONAL LOAN OF £13,338.

UNDER the powers conferred by the Water Acts and all other powers enabling him in that behalf, His Excellency the Governor of the State of Victoria, by and with the advice of the Executive Council of the said State, doth hereby grant an additional loan of Thirteen thousand three hundred and thirty-eight pounds (£13,338) to the Yarram Waterworks Trust for the construction of pipe mains and the purchase and installation of meters, as set forth in the detailed statement bearing date the 30th October, 1958, and verified under the seal of the State Rivers and Water Supply Commission.

The loan hereby granted shall be subject to the provisions of the Water Acts.

And the Honorable Wilfred John Mibus, Her Majesty's Minister of Water Supply for the State of Victoria, shall give the necessary directions herein accordingly.

N. G. WISHART,
Acting Clerk of the Executive Council.

MIRBOO NORTH WATERWORKS TRUST.

At the Executive Council Chamber, Melbourne, the fifth day of November, 1958.

PRESENT:

His Excellency the Governor of Victoria.
Mr. Cameron | Mr. Thompson.

ADDITIONAL LOAN OF £400.

UNDER the powers conferred by the Water Acts and all other powers enabling him in that behalf, His Excellency the Governor of the State of Victoria, by and with the advice of the Executive Council of the said State, doth hereby grant an additional loan of Four hundred pounds (£400) to the Mirboo North Waterworks Trust for the construction of pipe mains and the purchase and installation of meters, as set forth in the detailed statement bearing date the 30th October, 1958, and verified under the seal of the State Rivers and Water Supply Commission.

The loan hereby granted shall be subject to the provisions of the Water Acts.

And the Honorable Wilfred John Mibus, Her Majesty's Minister of Water Supply for the State of Victoria, shall give the necessary directions herein accordingly.

N. G. WISHART,
Acting Clerk of the Executive Council.

TOORA WATERWORKS TRUST.

At the Executive Council Chamber, Melbourne, the fifth day of November, 1958.

PRESENT:

His Excellency the Governor of Victoria.
Mr. Cameron | Mr. Thompson.

ADDITIONAL LOAN OF £7,992.

UNDER the powers conferred by the Water Acts and all other powers enabling him in that behalf, His Excellency the Governor of the State of Victoria, by and with the advice of the Executive Council of the said State, doth hereby grant an additional loan of Seven thousand nine hundred and ninety-two pounds (£7,992) to the Toora Waterworks Trust for the construction of new town water supply works at Welshpool and Port Welshpool, as set forth in the detailed statement bearing date the 30th October, 1958, and verified under the seal of the State Rivers and Water Supply Commission.

The loan hereby granted shall be subject to the provisions of the Water Acts.

And the Honorable Wilfred John Mibus, Her Majesty's Minister of Water Supply for the State of Victoria, shall give the necessary directions herein accordingly.

N. G. WISHART,
Acting Clerk of the Executive Council.

HAMILTON WATERWORKS TRUST.

At the Executive Council Chamber, Melbourne, the fifth day of November, 1958.

PRESENT:

His Excellency the Governor of Victoria.
Mr. Cameron | Mr. Thompson.

ADDITIONAL LOAN OF £14,199.

UNDER the powers conferred by the Water Acts and all other powers enabling him in that behalf, His Excellency the Governor of the State of Victoria, by and with the advice of the Executive Council of the said State, doth hereby grant an additional loan of Fourteen thousand one hundred and ninety-nine pounds (£14,199) to the Hamilton Waterworks Trust for the construction of pipe mains and the purchase and installation of meters,

as set forth in the detailed statement bearing date the 30th October, 1958, and verified under the seal of the State Rivers and Water Supply Commission.

The loan hereby granted shall be subject to the provisions of the Water Acts.

And the Honorable Wilfred John Mibus, Her Majesty's Minister of Water Supply for the State of Victoria, shall give the necessary directions herein accordingly.

N. G. WISHART,
Acting Clerk of the Executive Council.

MURTOA WATERWORKS TRUST.

At the Executive Council Chamber, Melbourne, the fifth day of November, 1958.

PRESENT:
His Excellency the Governor of Victoria.
Mr. Cameron | Mr. Thompson.

ADDITIONAL LOAN OF £556.

UNDER the powers conferred by the Water Acts and all other powers enabling him in that behalf, His Excellency the Governor of the State of Victoria, by and with the advice of the Executive Council of the said State, doth hereby grant an additional loan of Five hundred and fifty-six pounds (£556) to the Murtoa Waterworks Trust for the construction of pipe mains and the purchase and installation of meters, as set forth in the detailed statement bearing date the 30th October, 1958, and verified under the seal of the State Rivers and Water Supply Commission.

The loan hereby granted shall be subject to the provisions of the Water Acts.

And the Honorable Wilfred John Mibus, Her Majesty's Minister of Water Supply for the State of Victoria, shall give the necessary directions herein accordingly.

N. G. WISHART,
Acting Clerk of the Executive Council.

GEELONG WATERWORKS AND SEWERAGE TRUST.

At the Executive Council Chamber, Melbourne, the fifth day of November, 1958.

PRESENT:
His Excellency the Governor of Victoria.
Mr. Cameron | Mr. Thompson.

CONSENT TO THE GEELONG WATERWORKS AND SEWERAGE TRUST COMPULSORILY ACQUIRING LAND.

UNDER the powers conferred by the Geelong Waterworks and Sewerage Acts and all other powers enabling him in that behalf, His Excellency the Governor of the State of Victoria, by and with the advice of the Executive Council of the said State, doth hereby consent to the compulsory acquisition by the Geelong Waterworks and Sewerage Trust of approximately one and one-quarter perches of land, being part of Crown allotment 9, section XI, Parish of Moorpanyal, County of Grant, as shown by red colour on a plan approved by the Governor in Council and deposited in the office of the State Rivers and Water Supply Commission, Melbourne. (Corres. 58/13520.)

And the Honorable Wilfred John Mibus, Her Majesty's Minister of Water Supply for the State of Victoria, shall give the necessary directions herein accordingly.

N. G. WISHART,
Acting Clerk of the Executive Council.

GEELONG WATERWORKS AND SEWERAGE TRUST.

At the Executive Council Chamber, Melbourne, the fifth day of November, 1958.

PRESENT:
His Excellency the Governor of Victoria.
Mr. Cameron | Mr. Thompson.

CONSENT TO BORROWING £75,000.

UNDER the powers conferred by the Geelong Waterworks and Sewerage Acts and all other powers enabling him in that behalf, His Excellency the Governor of the State of Victoria, by and with the advice of the Executive Council of the said State, doth hereby consent to the Geelong Waterworks and Sewerage Trust borrowing at interest, subject to the Geelong Waterworks and Sewerage Acts, the sum of Seventy-five thousand pounds (£75,000) to meet the cost of water supply works.

And the Honorable Wilfred John Mibus, Her Majesty's Minister of Water Supply for the State of Victoria, shall give the necessary directions herein accordingly.

N. G. WISHART,
Acting Clerk of the Executive Council.

KERANG SEWERAGE AUTHORITY.

At the Executive Council Chamber, Melbourne, the fifth day of November, 1958.

PRESENT:
His Excellency the Governor of Victoria.
Mr. Cameron | Mr. Thompson.

CONSENT TO BORROWING £5,700.

UNDER the powers conferred by the Sewerage Districts Acts and all other powers enabling him in that behalf, His Excellency the Governor of the State of Victoria, by and with the advice of the Executive Council of the said State, doth hereby consent to the Kerang Sewerage Authority borrowing by the issue of debentures a sum of Five thousand seven hundred pounds (£5,700) for the conversion of Loan No. 4 maturing on 1st December, 1958.

And the Honorable Wilfred John Mibus, Her Majesty's Minister of Water Supply for the State of Victoria, shall give the necessary directions herein accordingly.

N. G. WISHART,
Acting Clerk of the Executive Council.

TRARALGON SEWERAGE AUTHORITY.

At the Executive Council Chamber, Melbourne, the fifth day of November, 1958.

PRESENT:
His Excellency the Governor of Victoria.
Mr. Cameron | Mr. Thompson.

POWER TO BORROW £20,000.

UNDER the powers conferred by the Sewerage Districts Acts, and all other powers enabling him in that behalf, His Excellency the Governor of the State of Victoria, by and with the advice of the Executive Council of the said State, doth hereby consent to the Traralgon Sewerage Authority borrowing at interest an additional sum of Twenty thousand pounds (£20,000), subject to the provisions of the Sewerage Districts Acts, for the carrying out of works in accordance with the provisions of sections 91, 126, and 133 of the *Sewerage Districts Act 1928*, No. 3772, the said sum to be borrowed by way of overdraft from the Commonwealth Trading Bank of Australia. All moneys received by the said Authority in repayment of costs and expenses of the said works, or any of them, shall be set aside for the purpose of and applied in repayment of the said sum so borrowed.

And the Honorable Wilfred John Mibus, Her Majesty's Minister of Water Supply for the State of Victoria, shall give the necessary directions herein accordingly.

N. G. WISHART,
Acting Clerk of the Executive Council.

BENEFIT ASSOCIATIONS ACTS.

*At the Executive Council Chamber, Melbourne, the
fifth day of November, 1958.*

PRESENT:

His Excellency the Governor of Victoria.
Mr. Cameron | Mr. Thompson.

IN pursuance of the provisions of the Benefit Associations Acts, His Excellency the Governor of the State of Victoria, in the Commonwealth of Australia, by and with the advice of the Executive Council of the said State, after consideration by the Minister of reports in writing made by the Registrar of Sickness, Hospital, Medical and Funeral Benefit Associations and the Government Statist, doth by this Order amend the Order made on the eighteenth day of December, 1957, declaring the Hospital Benefits Association of Victoria to be exempt from the provisions of the said Acts, by inserting after condition No. 10 the following condition:—

"11. Upon the approval by the Commonwealth Minister of Health of the establishment of a 'Special Account' as provided in the Commonwealth National Health Act, conditions numbered 2 (b), 3, 4 and 5 above shall not apply with respect to the particular medical and/or hospital fund or funds associated with such Special Account."

And the Honorable Arthur Gordon Rylah, Her Majesty's Chief Secretary for the State of Victoria, shall give the necessary directions herein accordingly.

N. G. WISHART,
Acting Clerk of the Executive Council.

BENEFIT ASSOCIATIONS ACTS.

*At the Executive Council Chamber, Melbourne, the
fifth day of November, 1958.*

PRESENT:

His Excellency the Governor of Victoria.
Mr. Cameron | Mr. Thompson.

IN pursuance of the provisions of the Benefit Associations Acts, His Excellency the Governor of the State of Victoria, in the Commonwealth of Australia, by and with the advice of the Executive Council of the said State, after consideration by the Minister of reports in writing made by the Registrar of Sickness, Hospital, Medical and Funeral Benefit Associations and the Government Statist, doth by this Order amend the Order made on the eighteenth day of December, 1957, declaring the Latrobe Valley Hospitals and Health Services Association to be exempt from the provisions of the said Acts, by inserting after condition No. 10 the following condition:—

"11. Upon the approval by the Commonwealth Minister of Health of the establishment of a 'Special Account' as provided in the Commonwealth National Health Act, conditions numbered 2 (b), 3, 4 and 5 above shall not apply with respect to the particular medical and/or hospital fund or funds associated with such Special Account."

And the Honorable Arthur Gordon Rylah, Her Majesty's Chief Secretary for the State of Victoria, shall give the necessary directions herein accordingly.

N. G. WISHART,
Acting Clerk of the Executive Council.

BENEFIT ASSOCIATIONS ACTS.

*At the Executive Council Chamber, Melbourne, the
fifth day of November, 1958.*

PRESENT:

His Excellency the Governor of Victoria.
Mr. Cameron | Mr. Thompson.

IN pursuance of the provisions of the Benefit Associations Acts, His Excellency the Governor of the State of Victoria, in the Commonwealth of Australia, by and with the advice of the Executive Council of the said State, after consideration by the Minister of reports in writing made by the Registrar of Sickness, Hospital, Medical and Funeral Benefit Associations and the Government Statist, doth by this Order amend the Order made on the

eighteenth day of December, 1957, declaring the Mildura District Hospital and Medical Fund to be exempt from the provisions of the said Acts, by inserting after condition No. 10 the following condition:—

"11. Upon the approval by the Commonwealth Minister of Health of the establishment of a 'Special Account' as provided in the Commonwealth National Health Act, conditions numbered 2 (b), 3, 4 and 5 above shall not apply with respect to the particular medical and/or hospital fund or funds associated with such Special Account."

And the Honorable Arthur Gordon Rylah, Her Majesty's Chief Secretary for the State of Victoria, shall give the necessary directions herein accordingly.

N. G. WISHART,
Acting Clerk of the Executive Council.

BENEFIT ASSOCIATIONS ACTS.

*At the Executive Council Chamber, Melbourne, the
fifth day of November, 1958.*

PRESENT:

His Excellency the Governor of Victoria.
Mr. Cameron | Mr. Thompson.

IN pursuance of the provisions of the Benefit Associations Acts, His Excellency the Governor of the State of Victoria, in the Commonwealth of Australia, by and with the advice of the Executive Council of the said State, after consideration by the Minister of reports in writing made by the Registrar of Sickness, Hospital, Medical and Funeral Benefit Associations and the Government Statist, doth by this Order amend the Order made on the eighteenth day of December, 1957, declaring the South-Western District Hospital Benefits Fund to be exempt from the provisions of the said Acts, by inserting after condition No. 10 the following condition:—

"11. Upon the approval by the Commonwealth Minister of Health of the establishment of a 'Special Account' as provided in the Commonwealth National Health Act, conditions numbered 2 (b), 3, 4 and 5 above shall not apply with respect to the particular medical and/or hospital fund or funds associated with such Special Account."

And the Honorable Arthur Gordon Rylah, Her Majesty's Chief Secretary for the State of Victoria, shall give the necessary directions herein accordingly.

N. G. WISHART,
Acting Clerk of the Executive Council.

BENEFIT ASSOCIATIONS ACTS.

*At the Executive Council Chamber, Melbourne, the
fifth day of November, 1958.*

PRESENT:

His Excellency the Governor of Victoria.
Mr. Cameron | Mr. Thompson.

IN pursuance of the provisions of the Benefit Associations Acts, His Excellency the Governor of the State of Victoria, in the Commonwealth of Australia, by and with the advice of the Executive Council of the said State, after consideration by the Minister of reports in writing made by the Registrar of Sickness, Hospital, Medical and Funeral Benefit Associations and the Government Statist, doth by this Order amend the Order made on the eighteenth day of December, 1957, declaring the Geelong and District Contributory Association for Public and Private Hospitals to be exempt from the provisions of the said Acts, by inserting after condition No. 10 the following condition:—

"11. Upon the approval by the Commonwealth Minister of Health of the establishment of a 'Special Account' as provided in the Commonwealth National Health Act, conditions numbered 2 (b), 3, 4 and 5 above shall not apply with respect to the particular medical and/or hospital fund or funds associated with such Special Account."

And the Honorable Arthur Gordon Rylah, Her Majesty's Chief Secretary for the State of Victoria, shall give the necessary directions herein accordingly.

N. G. WISHART,
Acting Clerk of the Executive Council.

BENEFIT ASSOCIATIONS ACTS.

*At the Executive Council Chamber, Melbourne, the
fifth day of November, 1958.*

PRESENT:

His Excellency the Governor of Victoria.
Mr. Cameron | Mr. Thompson.

IN pursuance of the provisions of the Benefit Associations Acts, His Excellency the Governor of the State of Victoria, in the Commonwealth of Australia, by and with the advice of the Executive Council of the said State, after consideration by the Minister of reports in writing made by the Registrar of Sickness, Hospital, Medical and Funeral Benefit Associations and the Government Statist, doth by this Order amend the Order made on the eighteenth day of December, 1957, declaring the Seymour Hospital Benefit Scheme to be exempt from the provisions of the said Acts, by inserting after condition No. 10 the following condition:—

"11. Upon the approval by the Commonwealth Minister of Health of the establishment of a 'Special Account' as provided in the Commonwealth National Health Act, conditions numbered 2 (b), 3, 4 and 5 above shall not apply with respect to the particular medical and/or hospital fund or funds associated with such Special Account."

And the Honorable Arthur Gordon Rylah, Her Majesty's Chief Secretary for the State of Victoria, shall give the necessary directions herein accordingly.

N. G. WISHART,
Acting Clerk of the Executive Council.

BENEFIT ASSOCIATIONS ACTS.

*At the Executive Council Chamber, Melbourne, the
fifth day of November, 1958.*

PRESENT:

His Excellency the Governor of Victoria.
Mr. Cameron | Mr. Thompson.

IN pursuance of the provisions of the Benefit Associations Acts, His Excellency the Governor of the State of Victoria, in the Commonwealth of Australia, by and with the advice of the Executive Council of the said State, after consideration by the Minister of reports in writing made by the Registrar of Sickness, Hospital, Medical and Funeral Benefit Associations and the Government Statist, doth by this Order amend the Order made on the eighteenth day of December, 1957, declaring the Wonthaggi and District Hospital Benefit Fund to be exempt from the provisions of the said Acts, by inserting after condition No. 10 the following condition:—

"11. Upon the approval by the Commonwealth Minister of Health of the establishment of a 'Special Account' as provided in the Commonwealth National Health Act, conditions numbered 2 (b), 3, 4 and 5 above shall not apply with respect to the particular medical and/or hospital fund or funds associated with such Special Account."

And the Honorable Arthur Gordon Rylah, Her Majesty's Chief Secretary for the State of Victoria, shall give the necessary directions herein accordingly.

N. G. WISHART,
Acting Clerk of the Executive Council.

BENEFIT ASSOCIATIONS ACTS.

*At the Executive Council Chamber, Melbourne, the
fifth day of November, 1958.*

PRESENT:

His Excellency the Governor of Victoria.
Mr. Cameron | Mr. Thompson.

IN pursuance of the provisions of the Benefit Associations Acts, His Excellency the Governor of the State of Victoria, in the Commonwealth of Australia, by and with the advice of the Executive Council of the said State, after consideration by the Minister of reports in writing made by the Registrar of Sickness, Hospital, Medical and Funeral Benefit Associations and the Government Statist, doth by this Order amend the Order made on the

eighteenth day of December, 1957, declaring the Yallourn Medical and Hospital Society to be exempt from the provisions of the said Acts, by inserting after condition No. 10 the following condition:—

"11. Upon the approval by the Commonwealth Minister of Health of the establishment of a 'Special Account' as provided in the Commonwealth National Health Act, conditions numbered 2 (b), 3, 4 and 5 above shall not apply with respect to the particular medical and/or hospital fund or funds associated with such Special Account."

And the Honorable Arthur Gordon Rylah, Her Majesty's Chief Secretary for the State of Victoria, shall give the necessary directions herein accordingly.

N. G. WISHART,
Acting Clerk of the Executive Council.

BENEFIT ASSOCIATIONS ACTS.

*At the Executive Council Chamber, Melbourne, the
fifth day of November, 1958.*

PRESENT:

His Excellency the Governor of Victoria.
Mr. Cameron | Mr. Thompson.

IN pursuance of the provisions of the Benefit Associations Acts, His Excellency the Governor of the State of Victoria, in the Commonwealth of Australia, by and with the advice of the Executive Council of the said State, after consideration by the Minister of reports in writing made by the Registrar of Sickness, Hospital, Medical and Funeral Benefit Associations and the Government Statist, doth by this Order amend the Order made on the eighteenth day of March, 1958, declaring the Diamond Valley Community Hospital to be exempt from the provisions of the said Acts, by inserting after condition No. 10 the following condition:—

"11. Upon the approval by the Commonwealth Minister of Health of the establishment of a 'Special Account' as provided in the Commonwealth National Health Act, conditions numbered 2 (b), 3, 4 and 5 above shall not apply with respect to the particular medical and/or hospital fund or funds associated with such Special Account."

And the Honorable Arthur Gordon Rylah, Her Majesty's Chief Secretary for the State of Victoria, shall give the necessary directions herein accordingly.

N. G. WISHART,
Acting Clerk of the Executive Council.

BENEFIT ASSOCIATIONS ACTS.

*At the Executive Council Chamber, Melbourne, the
fifth day of November, 1958.*

PRESENT:

His Excellency the Governor of Victoria.
Mr. Cameron | Mr. Thompson.

IN pursuance of the provisions of the Benefit Associations Acts, His Excellency the Governor of the State of Victoria, in the Commonwealth of Australia, by and with the advice of the Executive Council of the said State, after consideration by the Minister of reports in writing made by the Registrar of Sickness, Hospital, Medical and Funeral Benefit Associations and the Government Statist, doth by this Order amend the Order made on the eighteenth day of March, 1958, declaring the Kiewa Works Medical Society to be exempt from the provisions of the said Acts, by inserting after condition No. 10 the following condition:—

"11. Upon the approval by the Commonwealth Minister of Health of the establishment of a 'Special Account' as provided in the Commonwealth National Health Act, conditions numbered 2 (b), 3, 4 and 5 above shall not apply with respect to the particular medical and/or hospital fund or funds associated with such Special Account."

And the Honorable Arthur Gordon Rylah, Her Majesty's Chief Secretary for the State of Victoria, shall give the necessary directions herein accordingly.

N. G. WISHART,
Acting Clerk of the Executive Council.

BENEFIT ASSOCIATIONS ACTS.

At the Executive Council Chamber, Melbourne, the fifth day of November, 1958.

PRESENT:

His Excellency the Governor of Victoria.
Mr. Cameron | Mr. Thompson.

IN pursuance of the provisions of the Benefit Associations Acts, His Excellency the Governor of the State of Victoria, in the Commonwealth of Australia, by and with the advice of the Executive Council of the said State, after consideration by the Minister of reports in writing made by the Registrar of Sickness, Hospital, Medical and Funeral Benefit Associations and the Government Statist, doth by this Order amend the Order made on the eighteenth day of March, 1958, declaring the Hospital Benefit Fund, Red Cliffs, to be exempt from the provisions of the said Acts, by inserting after condition No. 10 the following condition:—

"11. Upon the approval by the Commonwealth Minister of Health of the establishment of a 'Special Account' as provided in the Commonwealth National Health Act, conditions numbered 2 (b), 3, 4 and 5 above shall not apply with respect to the particular medical and/or hospital fund or funds associated with such Special Account."

And the Honorable Arthur Gordon Rylah, Her Majesty's Chief Secretary for the State of Victoria, shall give the necessary directions herein accordingly.

N. G. WISHART,
Acting Clerk of the Executive Council.

BENEFIT ASSOCIATIONS ACTS.

At the Executive Council Chamber, Melbourne, the fifth day of November, 1958.

PRESENT:

His Excellency the Governor of Victoria.
Mr. Cameron | Mr. Thompson.

IN pursuance of the provisions of the Benefit Associations Acts, His Excellency the Governor of the State of Victoria, in the Commonwealth of Australia, by and with the advice of the Executive Council of the said State, after consideration by the Minister of reports in writing made by the Registrar of Sickness, Hospital, Medical and Funeral Benefit Associations and the Government Statist, doth by this Order amend the Order made on the eighteenth day of March, 1958, declaring the Altona Community Hospital Benefits Fund to be exempt from the provisions of the said Acts, by inserting after condition No. 10 the following condition:—

"11. Upon the approval by the Commonwealth Minister of Health of the establishment of a 'Special Account' as provided in the Commonwealth National Health Act, conditions numbered 2 (b), 3, 4 and 5 above shall not apply with respect to the particular medical and/or hospital fund or funds associated with such Special Account."

And the Honorable Arthur Gordon Rylah, Her Majesty's Chief Secretary for the State of Victoria, shall give the necessary directions herein accordingly.

N. G. WISHART,
Acting Clerk of the Executive Council.

BENEFIT ASSOCIATIONS ACTS.

At the Executive Council Chamber, Melbourne, the fifth day of November, 1958.

PRESENT:

His Excellency the Governor of Victoria.
Mr. Cameron | Mr. Thompson.

IN pursuance of the provisions of the Benefit Associations Acts, His Excellency the Governor of the State of Victoria, in the Commonwealth of Australia, by and with the advice of the Executive Council of the said State, after consideration by the Minister of reports in writing made by the Registrar of Sickness, Hospital, Medical and Funeral Benefit Associations and the Government Statist, doth by this Order amend the Order made on the

eighteenth day of March, 1958, declaring the National Independent Order of Oddfellows Medical Services Fund to be exempt from the provisions of the said Acts, by inserting after condition No. 10 the following condition:—

"11. Upon the approval by the Commonwealth Minister of Health of the establishment of a 'Special Account' as provided in the Commonwealth National Health Act, conditions numbered 2 (b), 3, 4 and 5 above shall not apply with respect to the particular medical and/or hospital fund or funds associated with such Special Account."

And the Honorable Arthur Gordon Rylah, Her Majesty's Chief Secretary for the State of Victoria, shall give the necessary directions herein accordingly.

N. G. WISHART,
Acting Clerk of the Executive Council.

Water Acts.

STATE RIVERS AND WATER SUPPLY COMMISSION.

At the Executive Council Chamber, Melbourne, the fifth day of November, 1958.

PRESENT:

His Excellency the Governor of Victoria.
Mr. Cameron | Mr. Thompson.

RED CLIFFS URBAN DISTRICT.—DISTRICT EXTENDED.

UNDER the powers conferred by the Water Acts and all other powers enabling him in that behalf, His Excellency the Governor of the State of Victoria, with the advice of the Executive Council of the said State, on the recommendation of the State Rivers and Water Supply Commission, doth hereby declare, order, and direct as follows:—

That the Red Cliffs Urban District be extended by adding to the same the lands set out and described in the Schedule hereto and as on and from the date of this order such district shall be deemed to be so extended.

SCHEDULE.

Commencing at a point in the north-eastern boundary of allotment 240, section B, Parish of Mildura in line with the south-eastern boundary of allotment 33A; thence north-easterly by a line and generally north-easterly by the northern boundaries of a road adjoining the southern boundaries of allotments 33A, 33, 34, 35, 36, 38A, 52c, 52B, 52, 50A, 50, 48 and a line in continuation of that portion of the road adjoining the south-eastern boundary of allotment 48 to a point in the southern boundary of allotment 45B; thence easterly by the southern boundaries of allotments 45B and 45c to the south-eastern angle of the last-mentioned allotment; thence generally northerly by the south-eastern boundary of allotment 45c and the north-eastern boundaries of allotments 45c and 45A to the south-eastern boundary of allotment 45; thence north-easterly by the last-mentioned boundary of said allotment 45, section B, and a line in continuation thereof to a point in line with the north-eastern boundary of allotment 11, section B1; thence south-easterly by a line and the north-eastern boundaries of allotments 11, 10, 9, 8, 7, 6 to the most eastern angle of the last-mentioned allotment; thence south-westerly by the south-eastern boundary of allotment 6 to the most southern angle thereof; thence generally south-westerly by the eastern boundaries of a road to a point in line with the northern boundary of allotment 51B; thence generally westerly by the southern boundary of a road adjoining the northern boundaries of allotments 51B, 51, 51A and 53 to 58 inclusive, section B, to the most western angle of allotment 58; thence south-easterly by a line in continuation of the north-western boundary of said allotment 58 to the north-eastern boundary of allotment 240 aforesaid; thence north-westerly by the north-eastern boundary of the last-mentioned allotment to the point of commencement.

The lands described in the foregoing Schedule are shown on a plan approved by the Governor in Council, and deposited in the Office of the State Rivers and Water Supply Commission, Melbourne.—(Corres. No. 58/4494.)

And the Honorable Wilfred John Mibus, Her Majesty's Minister of Water Supply for the State of Victoria, shall give the necessary directions herein accordingly.

N. G. WISHART,
Acting Clerk of the Executive Council.

MINES ACT 1928.

At the Executive Council Chamber, Melbourne, the
eleventh day of November, 1958.

PRESENT:

His Excellency the Governor of Victoria.
Mr. Cameron | Sir Thomas Maltby.
Mr. Porter

LAND EXCEPTED FROM OCCUPATION FOR MINING PURPOSES.

HIS Excellency the Governor of the State of Victoria, by and with the advice of the Executive Council thereof, doth hereby, in pursuance of the provisions of the *Mines Act 1928*, except from occupation for mining purposes under any miner's right, or from being leased under a mining lease, the lands on which are situated the mining dams hereinafter described:—

Briseis Dredge Hole, situated south of and east of allotment 7A, section 10, in the Parish of Tangambalanga, and adjoining Sandy Creek.

Cocks Pioneer Dredge Hole, situated south of allotment 12H, section A2, in the Parish of Byawatha, and adjoining Reedy Creek.

Cocks Eldorado Dredge Hole, situated south of the Public Park Reserve in the western portion of the Township of Eldorado, Parish of Byawatha, and adjoining Reedy Creek.

Woolshed Valley Dam, situated near the junction of Snakes Head Creek and Reedy Creek, in the Parish of Eldorado.

Chappells Gully Dam, situated near the junction of Chappells Creek and Reedy Creek, in the Parish of Eldorado.

Rowdy No. 1 Dam, situated east of the Township of Yackandandah, in the Parish of Yackandandah, on Rowdy Flat, and adjoining Yackandandah Creek.

Staghorn Dam, situated south-west of the Township of Allan's Flat, in the Parish of Yackandandah, and adjoining Yackandandah Creek.

Ovens River Flats Dredge Hole, situated near the Ovens River, approximately 20 chains upstream from allotment 11, section 10, in the Parish of Freeburgh.

Baranduda Dredge Hole, situated north-west of allotments 3B and 4C, section 7, in the Parish of Yackandandah, and adjoining Yackandandah Creek.

Fletchers Dam, situated in the Parish of Stanley, being 1 mile south and approximately 1½ mile east of the north-west corner of the parish boundary.

And the Honorable Wilfred John Mibus, Her Majesty's Minister of Mines for the State of Victoria, shall give the necessary directions herein accordingly.

N. G. WISHART,
Acting Clerk of the Executive Council.

COUNTRY FIRE AUTHORITY ACTS.

At the Executive Council Chamber, Melbourne, the
eleventh day of November, 1958.

PRESENT:

His Excellency the Governor of Victoria.
Mr. Cameron | Sir Thomas Maltby.
Mr. Porter

AMENDMENT OF REGULATIONS.

WHEREAS by the Country Fire Authority Acts it is amongst other things enacted that the Governor in Council may make Regulations for regulating the duties and conduct of officers and employees of the Country Fire Authority:

And whereas Regulations were made under the *Country Fire Authority Act 1944* on the twenty-ninth day of May, 1945, and published in the *Government Gazette* of the thirtieth day of May, 1945, and such Regulations have been amended from time to time:

Now therefore His Excellency the Governor of the State of Victoria, in the Commonwealth of Australia, by and with the advice of the Executive Council of the said State and in pursuance of the provisions of the Country Fire Authority Acts, doth hereby further amend the said Regulations (that is to say):—

Clause 5 is amended as follows:—

- (1) In sub-clause (6) for the expression "£1,300" there shall be substituted the expression "£1,500".
- (2) In sub-clause (7) for the expression "£970" there shall be substituted the expression "£1,100".
- (3) Sub-clause (8) shall be revoked.
- (4) In sub-clause (10) for the expression "not more than Seven shillings and six pence" there shall be substituted the expression "not more than Eight shillings".

And the Honorable Lindsay Hamilton Simpson Thompson, for and on behalf of Her Majesty's Chief Secretary for the State of Victoria, shall give the necessary directions herein accordingly.

N. G. WISHART,
Acting Clerk of the Executive Council.

WEIGHTS AND MEASURES ACTS.

At the Executive Council Chamber, Melbourne, the
- eleventh day of November, 1958.

PRESENT:

His Excellency the Governor of Victoria.
Mr. Cameron | Sir Thomas Maltby.
Mr. Porter |

REGULATIONS.

IN pursuance of the powers conferred by the Weights and Measures Acts, His Excellency the Governor of the State of Victoria, in the Commonwealth of Australia, by and with the advice of the Executive Council of the said State, doth make the Regulations following (that is to say):—

The Weights and Measures Regulations 1952 as amended are hereby further amended as follows:—

1. In Regulation 3, the following definition is hereby inserted after the definition of "Personal weighing machine":—

"'Public weighing' means any weighing made on a public weighbridge for any purpose other than the weighing of—

- (a) vehicles which are owned by the owner of the weighbridge; or
- (b) goods of which the owner of the weighbridge is either the owner, seller or intending seller, or purchaser or intending purchaser (including where necessary the determination of the tare weight of any vehicle in connexion with the weighing of any such goods)."

2. Paragraph (d) of Regulation 19 is hereby revoked and the following paragraph is substituted therefor:—

"(d) any instrument which is not of a pattern approved under section 32 of the Acts or Regulations 25 and 26 hereof, unless such instrument was in use for trade before the twenty-ninth day of October, 1957."

3. The following paragraph is hereby added at the end of Regulation 86:—

"(c) A weighing instrument which is—
(i) of approved pattern;
(ii) used only in sales by wholesale; and
(iii) is prominently marked 'For Use in Measuring Cows' Milk Only',
may, in addition to graduations in terms of weight, be marked in terms of Imperial liquid measure, for which purpose 1 gallon of milk shall be deemed to weigh 10.32 pounds."

4. In paragraph (a) of Regulation 118, the words "or other approved material" are hereby inserted after the word "metal".

5. The following proviso is hereby added after paragraph (d) of Regulation 193:—

"Provided that this paragraph shall—
(a) not prohibit any Government Department or municipality from using any weighbridge not registered as a public weighbridge in the administration of any Act or any Regulations made under any Act, relating to the weights of vehicles or to the wheel-loads or axle-loads of vehicles on public highways; and
(b) be subject to any permit which the Superintendent may issue if he thinks fit, permitting a Government Department to use a weighbridge not registered as a public weighbridge, for purposes specified in such permit."

6. The following paragraph is hereby added at the end of the proviso to Regulation 236:—

“(d) the owner of a public weighbridge which is of ticket-printing type and is used for weighing goods of which he is the owner, seller or intending seller, or purchaser or intending purchaser (including any necessary determinations of the tare weights of vehicles in connexion with such weighings) may for such purposes provide weight tickets which are in other style and not bound in books but so that—

(i) no reference is made in any such ticket to the fact that the weighbridge is a public weighbridge; and

(ii) each such ticket has prominently printed on it ‘This Ticket Not Valid for Public Weighing.’”

7. The following proviso is hereby added at the end of Regulation 242:—

“Provided that paragraphs (e), (f), (g), (h), (l) and (r) of this Regulation shall not apply in any case where tickets of other than the prescribed form are used pursuant to paragraph (d) of the proviso to Regulation 236 hereof.”

8. The following paragraph is hereby inserted after paragraph (h) of Regulation 243:—

“(i) use for any public weighing any weight ticket not of the form prescribed in paragraph (c) of Regulation 236 hereof.”

And the Honorable Lindsay Hamilton Simpson Thompson, for and on behalf of Her Majesty's Chief Secretary for the State of Victoria, shall give the necessary directions herein accordingly.

N. G. WISHART,
Acting Clerk of the Executive Council.

RACING ACT 1957.

*At the Executive Council Chamber, Melbourne, the
eleventh day of November, 1958.*

PRESENT:

His Excellency the Governor of Victoria.

Mr. Cameron
Mr. Porter

Sir Thomas Maltby.

DOG RACING CONTROL BOARD REGULATIONS 1958.

IN pursuance of the powers conferred by the Racing Acts and all other powers him thereunto enabling, His Excellency the Governor of the State of Victoria, in the Commonwealth of Australia, by and with the advice of the Executive Council of the said State, doth hereby make the Regulations following (that is to say):—

1. These Regulations may be cited as the “Dog Racing Control Board Regulations 1958” and shall come into operation on the date of publication thereof in the *Victoria Government Gazette*.

2. The Chairman of the Dog Racing Control Board shall be entitled to receive—

- (a) a travelling allowance of One hundred and twenty-five pounds a year; and
- (b) a fee of Two hundred and fifty pounds a year.

And the Honorable Arthur Gordon Rylah, Her Majesty's Chief Secretary for the State of Victoria, shall give the necessary directions herein accordingly.

N. G. WISHART,
Acting Clerk of the Executive Council.

COURTS OF GENERAL SESSIONS OF THE PEACE FOR THE YEAR 1959.

At the Executive Council Chamber, Melbourne, on the 11th day of November, 1958.

PRESENT:

His Excellency the Governor of Victoria.
 Mr. Cameron | Sir Thomas Maltby.
 Mr. Porter

IN pursuance of the provisions of the *Justices Act 1957*, His Excellency the Governor of the State of Victoria, by and with the advice of the Executive Council thereof, doth by this present Order direct that the dates for holding Courts of General Sessions of the Peace during the year 1959 be appointed as specified in the subjoined Schedule, viz:—

SCHEDULE.

Ararat	Tuesday, 19th May
Bairnsdale	Tuesday, 27th October
	Tuesday, 12th May
	Tuesday, 6th October
Ballarat	Tuesday, 3rd February
	Tuesday, 5th May
	Tuesday, 4th August
	Wednesday, 4th November
Bendigo	Tuesday, 3rd February
	Tuesday, 19th May
	Tuesday, 11th August
	Tuesday, 13th October
Colac	Tuesday, 24th March
	Tuesday, 21st July
	Tuesday, 15th December
Geelong	Tuesday, 3rd March
	Tuesday, 2nd June
	Tuesday, 1st September
	Wednesday, 4th November
Hamilton	Tuesday, 24th February
	Tuesday, 2nd June
	Tuesday, 17th November
Horsham	Tuesday, 3rd March
	Tuesday, 9th June
	Tuesday, 15th December
Kerang	Tuesday, 14th April
	Tuesday, 18th August
	Tuesday, 24th November
Korumburra	Tuesday, 5th May
	Tuesday, 25th August
	Tuesday, 24th November
Maryborough	Tuesday, 24th March
	Tuesday, 13th October
Melbourne	Monday, 19th January
	Monday, 2nd February
	Monday, 2nd March
	Wednesday, 1st April
	Friday, 1st May
	Monday, 1st June
	Wednesday, 1st July
	Monday, 3rd August
	Tuesday, 1st September
	Thursday, 1st October
	Monday, 2nd November
	Tuesday, 1st December
Mildura	Tuesday, 3rd March
	Tuesday, 4th August
	Tuesday, 24th November
Morwell	Tuesday, 26th May
	Tuesday, 25th August
	Tuesday, 27th October
Sale	Wednesday, 11th March
	Tuesday, 21st July
	Tuesday, 1st December
Shepparton	Tuesday, 21st April
	Tuesday, 15th September
	Tuesday, 1st December
Wangaratta	Tuesday, 17th February
	Tuesday, 16th June
	Tuesday, 1st September
	Tuesday, 20th October
Warragul	Wednesday, 11th March
	Tuesday, 21st July
	Wednesday, 4th November
Warrnambool	Tuesday, 7th April
	Tuesday, 28th July
	Tuesday, 6th October

And the Honorable Arthur Gordon Rylah, Her Majesty's Attorney-General for the State of Victoria, shall give the necessary directions herein accordingly.

N. G. WISHART,
 Acting Clerk of the Executive Council.

BENDIGO SEWERAGE AUTHORITY.

At the Executive Council Chamber, Melbourne, the eleventh day of November, 1958.

PRESENT:

His Excellency the Governor of Victoria.
 Mr. Cameron | Sir Thomas Maltby.
 Mr. Porter

CONSENT TO BORROWING £35,000.

UNDER the powers conferred by the Sewerage Districts Acts and all other powers enabling him in that behalf, His Excellency the Governor of the State of Victoria, by and with the advice of the Executive Council of the said State, doth hereby consent to the Bendigo Sewerage Authority borrowing by the issue of debentures the sum of Thirty-five thousand pounds (£35,000) in two amounts of Twenty thousand pounds (£20,000) and Fifteen thousand pounds (£15,000) respectively to meet the cost of sewerage works at Bendigo, as set forth in the detailed statement bearing date the 5th November, 1958.

And the Honorable Wilfred John Mibus, Her Majesty's Minister of Water Supply for the State of Victoria, shall give the necessary directions herein accordingly.

N. G. WISHART,
 Acting Clerk of the Executive Council.

LEONGATHA SEWERAGE AUTHORITY.

At the Executive Council Chamber, Melbourne, the eleventh day of November, 1958.

PRESENT:

His Excellency the Governor of Victoria.
 Mr. Cameron | Sir Thomas Maltby.
 Mr. Porter

POWER TO BORROW £10,000.

UNDER the powers conferred by the Sewerage Districts Acts and all other powers enabling him in that behalf, His Excellency the Governor of the State of Victoria, by and with the advice of the Executive Council of the said State, doth hereby consent to the Leongatha Sewerage Authority borrowing by the issue of debentures a sum of Ten thousand pounds (£10,000), subject to the provisions of the Sewerage Districts Acts, and for the carrying out of works in accordance with the provisions of sections 91, 126 and 133 of the *Sewerage Districts Act 1928*, No. 3772. All moneys received by the said Authority in repayment of costs and expenses of the said works, or any of them, shall be set aside for the purpose of and applied in repayment of the said sum so borrowed.

And the Honorable Wilfred John Mibus, Her Majesty's Minister of Water Supply for the State of Victoria, shall give the necessary directions herein accordingly.

N. G. WISHART,
 Acting Clerk of the Executive Council.

HOUSING ACTS.

At the Executive Council Chamber, Melbourne, the eleventh day of November, 1958.

PRESENT:

His Excellency the Governor of Victoria.
 Mr. Cameron | Sir Thomas Maltby.
 Mr. Porter

DECLARATION OF A RECLAMATION AREA AT PORT MELBOURNE.

WHEREAS within an area in the City of Port Melbourne described in the Schedule hereto there are houses which—

- (a) are unfit for human habitation and
- (b) are in the opinion of the Housing Commission insanitary or unhealthy by reason of—
 - (1) the excessive number of buildings within the area;

- (ii) the bad arrangement of buildings within the area; and
 (iii) the bad arrangement or narrowness of streets within the area:

And whereas the Housing Commission considers that housing conditions within the area cannot satisfactorily be dealt with unless the said area is dealt with under Part III. of the *Slum Reclamation and Housing Act 1938* (No. 4568) as a Reclamation Area and has recommended that the said area should be constituted a Reclamation Area:

And whereas the Housing Commission having duly complied with the provisions of sub-section (3) of section 19 of the said Act, has submitted to the Governor in Council its recommendation that the said area should be constituted a Reclamation Area:

Now therefore I, the Governor of the State of Victoria, in the Commonwealth of Australia, by and with the advice of the Executive Council of the said State, do hereby declare the said area to be a Reclamation Area.

SCHEDULE.

All that land situate within the municipal district of the City of Port Melbourne, being section 46 in the City of Port Melbourne, in the Parish of Melbourne South, and being the land bounded by a line, commencing at the intersection of the south-westerly alignment of Ingles-street with the south-easterly alignment of Crockford-street; thence south-easterly by the said south-westerly alignment of Ingles-street to the intersection of same with the north-westerly alignment of Esplanade East; thence south-westerly by the said north-westerly alignment of Esplanade East to the intersection of same with the north-easterly alignment of Raglan-street; thence north-westerly by the said north-easterly alignment of Raglan-street to the intersection of same with the said south-easterly alignment of Crockford-street; thence north-easterly by the said south-easterly alignment of Crockford-street to the point of commencement.

And the Honorable Horace Rostill Petty, Her Majesty's Minister of Housing for the State of Victoria, shall give the necessary directions herein accordingly.

N. G. WISHART,
Acting Clerk of the Executive Council.

HOUSING ACTS.

At the Executive Council Chamber, Melbourne, the
eleventh day of November, 1958.

PRESENT:

His Excellency the Governor of Victoria.
 Mr. Cameron | Sir Thomas Maltby.
 Mr. Porter |

DECLARATION OF A RECLAMATION AREA AT PORT MELBOURNE.

WHEREAS within an area in the City of Port Melbourne described in the Schedule hereto there are houses which—

- (a) are unfit for human habitation and
 (b) are in the opinion of the Housing Commission insanitary or unhealthy by reason of—
 (i) the excessive number of buildings within the area;
 (ii) the bad arrangement of buildings within the area; and
 (iii) the bad arrangement or narrowness of streets within the area:

And whereas the Housing Commission considers that housing conditions within the area cannot satisfactorily be dealt with unless the said area is dealt with under Part III. of the *Slum Reclamation and Housing Act 1938* (No. 4568) as a Reclamation Area and has recommended that the said area should be constituted a Reclamation Area:

And whereas the Housing Commission having duly complied with the provisions of sub-section (3) of section 19 of the said Act, has submitted to the Governor in Council its recommendation that the said area should be constituted a Reclamation Area:

Now therefore I, the Governor of the State of Victoria, in the Commonwealth of Australia, by and with the advice of the Executive Council of the said State, do hereby declare the said area to be a Reclamation Area.

SCHEDULE.

All that land situate within the municipal district of the City of Port Melbourne, and being Crown allotments 15, 16 and 17, and parts of Crown allotments 14, 18 and 19, all of section 9 in the City of Port Melbourne, in the Parish of Melbourne South, and being the land bounded by a line commencing at a point being the most southerly angle of the land comprised in certificate of title, volume 3054, folio 610, which said point is the intersection of the north-westerly alignment of Nott-street with the north-easterly alignment of a road 20 feet wide; thence north-westerly by the said north-easterly alignment of the said road 20 feet wide to the intersection of same with the north-western boundary of the said Crown portion 14; thence north-easterly by portion of the said north-western boundary of Crown portion 14 and by the north-western boundaries of the said Crown portions 15, 16 and 17, and by portion of the north-western boundary of the said Crown portion 18 to a point being the intersection of the said north-western boundary of Crown portion 18 with the south-western boundary of a road 12 feet wide, which last-mentioned point is the most northerly angle of the land comprised in certificate of title, volume 1574, folio 748; thence south-easterly by the said south-western boundary of the said road 12 feet wide to a point being the most westerly angle of lot 3 on plan of subdivision No. 40367, lodged in the Office of Titles; thence further south-easterly by the south-western boundary of the said lot 3 to the most southerly angle thereof; thence north-easterly by the south-easterly boundary of the said lot 3 to a point thereon being the most westerly angle of the land comprised in certificate of title, volume 6731, folio 067; thence south-easterly by the south-western boundary of the land comprised in the said certificate of title, volume 6731, folio 067, to a point being the most southerly angle thereof, which last-mentioned point is situate on the said north-westerly alignment of Nott-street; thence south-westerly by the said north-westerly alignment of Nott-street to the point of commencement.

And the Honorable Horace Rostill Petty, Her Majesty's Minister of Housing for the State of Victoria, shall give the necessary directions herein accordingly.

N. G. WISHART,
Acting Clerk of the Executive Council.

APPROACHING LAND SALES.

SALES of Crown lands, in fee-simple, will be held at the under-mentioned places and dates, viz.:

	No. of Gazette.
Bairnsdale.—Monday, 15th December, 1958 ..	96
Bendigo.—Thursday, 13th November, 1958 ..	91
Castlemaine.—Thursday, 20th November, 1958 ..	91
Kaniva.—Wednesday, 26th November, 1958 ..	94
Kerang.—Thursday, 4th December, 1958 ..	94
Kyneton.—Thursday, 20th November, 1958 ..	91
Piangil.—Thursday, 4th December, 1958 ..	94
Queenscliff.—Saturday, 22nd November, 1958 ..	94
Rochester.—Thursday, 4th December, 1958 ..	94
Swan Hill.—Thursday, 4th December, 1958 ..	94
Swift's Creek.—Friday, 14th November, 1958 ..	91
Yarrowonga.—Friday, 12th December, 1958 ..	98

SALE OF CROWN LANDS BY AUCTION.

The lands will be sold in fee-simple, and subject to the covenants, conditions, exceptions, and reservations directed by the Governor in Council by an Order in Council dated the 5th August, 1930, and published in the *Government Gazette* of the 8th August, 1930, varied as herein.

A deposit of at least twelve and a half per centum of the price at which each lot is sold must be paid by the purchaser at the time of sale, and all such payments shall be made in coin, bank notes or cheques approved by the officer conducting the sale, and the residue of such price will be payable in equal instalments, in accordance with the scale hereunder, on the last day of each successive period of six months from the time of sale, or, if the purchaser choose, at any earlier time or times; and such residue of

the purchase money shall bear interest at the rate of Five pounds per centum per annum, to be computed with respect to each instalment for the period which has elapsed between the time of sale and the time of the payment of such instalment. If the residue of the price be paid within thirty days after the time of the sale no interest will be payable thereon.

The Governor in Council may allow a transfer of the purchaser's interest to an approved person at any time before the final payment of the purchase money is made. The fee for transfer shall be One pound and such transfer will be subject to payment of stamp duty.

SCALE OF PAYMENTS OF RESIDUE.

£20 and under, 6 instalments.
 Over £20, and not exceeding £50, 8 instalments.
 Over £50, and not exceeding £100, 10 instalments.
 Over £100, and not exceeding £200, 12 instalments.
 Over £200, and not exceeding £300, 14 instalments.
 Over £300, and not exceeding £400, 16 instalments.
 Over £400, and not exceeding £500, 18 instalments.
 Over £500, 20 instalments.

FEES, ETC.

The amount payable for Assurance Fund (One halfpenny for each £1 of purchase price) and Crown grant fee must be paid with the balance of purchase money. The following is the scale of fees for Crown grants:—

50 acres and under, £1 10s.
 Over 50 acres, £2.

Where the purchase money does not exceed £5, the grant fee is £1.

Valuations of improvements (if not purchased by the owner thereof), and charges for survey, must also be paid at the time of sale.

KEITH TURNBULL,
 Commissioner of Crown Lands and Survey.
 Office of Crown Lands and Survey,
 Melbourne, 11th November, 1958.

YARRAWONGA.—Sale (No. 11393) of Crown lands in fee-simple, by auction, will be held at the LAND INSPECTOR'S OFFICE, YARRAWONGA, on FRIDAY, the 12th DECEMBER, 1958, at TEN o'clock a.m. To be conducted by L. GIBNEY, Land Officer, Wangaratta.

PARISH OF BURRAMINE, COUNTY OF MOIRA.

Fronting North side of Murray Valley Highway about 10 miles West of Yarrawonga.

Upset price £30 the lot. Charge for survey £7 7s. 6d.

Lot 1. Area 2a. 2r., subject to survey and any necessary easements disclosed thereby, allotment 3b.

Also,

The following freehold land, offered for and on behalf of the Minister of Education.

PARISH OF STRATHMERTON, COUNTY OF MOIRA.

In South of Parish, being the old Strathmerton School site, formerly S.S. 2440.

Upset price £60 the lot.

Lot 2. Area 2 acres, allotment 16A of section D, and being the land more particularly described in Crown grant volume 1804, folio 697, subject to State Rivers and Water Supply Commission easement along northern boundary.

Sale of lot 2 is subject to the following conditions:—

- (a) The purchaser shall pay the purchase money in full at the sale.
- (b) The preparation and registration of the transfer under the Transfer of Land Act shall be attended to by the purchaser or his solicitor, and all costs relating thereto shall be borne by the purchaser.

AERIAL PHOTOGRAPHY CONTRACTS 1958-59.

THE approval of the Honorable the Minister of Lands has been given to an agreement being entered into with Adastra Airways Pty. Ltd., to effect the Aerial Photography of the Dergholm-Casterton Drainage Area Project for the quotation as received of £1,750.

G. L. WOOD,
 Secretary for Lands.

PROPOSED REVOCATION OF TEMPORARY RESERVATION, AND THE WITHHOLDING FROM SALE, LEASING, AND LICENSING, OF LAND BY ORDER IN COUNCIL.

IN pursuance of the provisions of the Land Act 1928, notice is hereby given that it is the intention of the Governor in Council to revoke the temporary reservation, and the withholding from sale, leasing, and licensing, of land by Order in Council hereunder referred to, viz:—

The following Notice was published 1° on the 29th October, 1958, pursuant to Order of the 21st October, 1958.

BELLELEN.—The temporary reservation as a Pipe Track in connexion with the Stawell Water Supply, and the withholding from sale, leasing, and licensing, by Order in Council of the 20th November, 1876, of certain Crown land in the municipal district of Stawell and the Parishes of Stawell, Illawarra, Mokepilly, Bellellen, and Jallukar, revoked as to part by Order of the 4th July, 1906, so far only as a strip 50 links in width along the north-western boundary of the various portions in the Parish of Bellellen is concerned.—(B.571(*) (C.93570).

KEITH TURNBULL,
 Commissioner of Crown Lands and Survey.

PROPOSED REVOCATIONS OF TEMPORARY RESERVATIONS OF LANDS BY ORDERS IN COUNCIL.

IN pursuance of the provisions of the Land Act 1928, notice is hereby given that it is the intention of the Governor in Council to revoke the temporary reservations of lands by Orders in Council hereunder referred to, viz:—

The following Notices were published 1° on the 29th October, 1958, pursuant to Orders of the 21st October, 1958.

BOROKA.—The temporary reservation, by Order in Council of the 22nd October, 1907, of 8 acres of land in the Parish of Boroka as a site for Railway purposes.—(B.678(*) (Rs.4037).

LANCEFIELD.—The temporary reservation, by Order in Council of the 15th December, 1890, of 2 acres 1 rood 4 8/10 perches of land in the Township of Lancefield as a site for Municipal purposes.—(L.15(*) (Rs.1213).

LORNE.—The temporary reservation, by Order in Council of the 30th September, 1958, of 350 acres, more or less, of land in the Parish of Lorne as a site for Public purposes.—(L.147(*) (Rs.7771).

PORTLAND.—The temporary reservation, by Order in Council of the 7th December, 1891 (see Government Gazette of the 11th December, 1891, page 4994) of 73 acres, more or less, of land in the Township of Portland as a site for Public purposes, revoked as to part by Order of the 26th August, 1958, so far as the balance thereof, containing 8 acres 3 roods 38 perches, more or less, is concerned.—(P.69(†) (Rs.6150).

BENDIGO.—The temporary reservation, by Order in Council of the 21st January, 1931, of 2 acres 1 rood 17 perches of land at Bendigo, Parish of Sandhurst, as a site for Recreation purposes, revoked as to part by various Orders, so far only as the portion containing 23 perches, more or less, indicated by hachure on plan hereunder, is concerned.—(S.372(*) (Rs.4088).

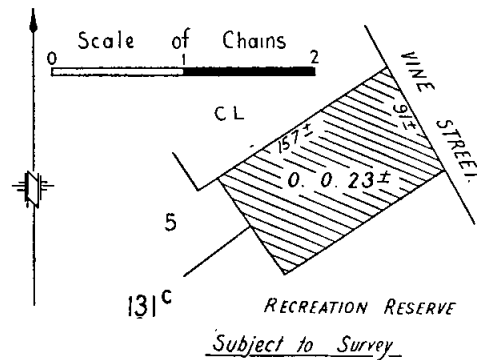

KEITH TURNBULL,
 Commissioner of Crown Lands and Survey.

PROPOSED REVOCATION OF TEMPORARY RESERVATION OF LAND BY ORDER IN COUNCIL (AS TO PORTION).

IN pursuance of the provisions of the *Land Act 1928*, notice is hereby given that it is the intention of the Governor in Council to revoke portion of the temporary reservation of land by the Order in Council hereunder referred to, viz.:—

The following Notice was published 1° on the 12th November, 1958, pursuant to Order of the 5th November, 1958.

MARYSVILLE.—The temporary reservation, by Order in Council of the 27th December, 1865, of 3 roods 24 perches of land at Marysville as a site for Police purposes, revoked as to part by Order of the 13th September, 1950, so far only as the portion containing 27 perches, more or less, indicated by hachure on plan hereunder, is concerned.—(M.431^(a)) (Rs. 5793).

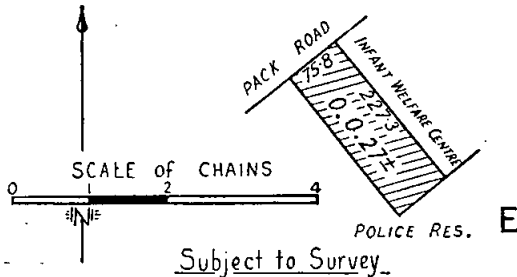

KEITH TURNBULL,
Commissioner of Crown Lands and Survey.

PROPOSED REVOCATION OF TEMPORARY RESERVATION OF LAND BY ORDER IN COUNCIL.

IN pursuance of the provisions of the *Land Act 1928*, notice is hereby given that it is the intention of the Governor in Council to revoke the temporary reservation of land by Order in Council hereunder referred to, viz.:—

The following Notice was published 1° on the 22nd October, 1958, pursuant to Order of the 14th October, 1958.

CHILTERN WEST.—The temporary reservations, by Orders in Council of the 20th May, 1913, of 6 acres 1 rood 5 perches, 11 acres 3 roods 24 perches, and 8 acres of land in the Parish of Chiltern West as sites for the Supply of Gravel.—(C.381^(a)) (Rs.7579).

KEITH TURNBULL,
Commissioner of Crown Lands and Survey.

PROPOSED REVOCATION OF TEMPORARY RESERVATION OF LAND BY ORDER IN COUNCIL.

IN pursuance of the provisions of the *Land Act 1928*, notice is hereby given that it is the intention of the Governor in Council to revoke the temporary reservation of land by Order in Council hereunder referred to, viz.:—

The following Notice was published 1° on the 5th November, 1958, pursuant to Order of the 28th October, 1958.

GRINGEGALGONA.—The temporary reservation, by Order in Council of the 29th January, 1935, of 4 acres 3 roods 25 perches of land in the Parish of Gringegalgon as a site for a State School.—(G.150^(A2)) (Rs.4432).

KEITH TURNBULL,
Commissioner of Crown Lands and Survey.

COMMON ABOUT TO BE DIMINISHED.

IN pursuance of the provisions contained in the *Land Act 1928*, notice is hereby given that it is the intention of the Governor in Council to diminish the common hereinafter mentioned, viz.:—

The following Notice was published 1° on the 29th October, 1958, pursuant to Order of the 21st October, 1958.

The Ballarat West Town Common, proclaimed as such by the Governor in Council on the 28th January, 1861, is about to be diminished by the excision therefrom of the

portion in the Parish of Dowling Forest containing 12 acres, more or less, indicated by hachure on plan hereunder.

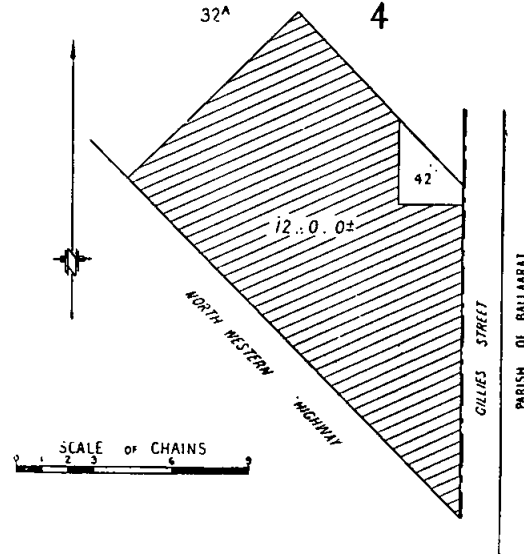

KEITH TURNBULL,
Commissioner of Crown Lands and Survey.

COMMON ABOUT TO BE DIMINISHED.

IN pursuance of the provisions contained in the *Land Act 1928*, notice is hereby given that it is the intention of the Governor in Council to diminish the common hereinafter mentioned, viz.:—

The following Notice was published 1° on the 22nd October, 1958, pursuant to Order of the 14th October, 1958.

The Inverleigh and Teesdale United Town and Farmers Common, proclaimed as such by the Governor in Council on the 14th May, 1884, is about to be diminished by the excision therefrom of all land within the boundaries of the Common, except the portion of Crown land indicated by red colour on plan marked "C" over 24.9.1958 attached to Lands Department correspondence Rs.313.

KEITH TURNBULL,
Commissioner of Crown Lands and Survey.

PUBLIC HEARINGS BY PERSONS APPOINTED UNDER THE 34TH SECTION OF THE LAND ACT 1928.

NOTICE is hereby given that at the times and places mentioned in the Schedule hereunder, applications for leases and licences under the *Land Acts*, objections to such applications, objections to proposed proclamations, alterations, additions, diminutions, revocations, or unions of commons, and reasons against forfeiture of any leases or licences under the *Land Acts* deemed liable to forfeiture, will be publicly heard by the persons whose names are set opposite such places respectively in such Schedule, being persons appointed by me, the responsible Minister of the Crown administering the *Land Acts*, to hear the same and report thereon in writing to me.

KEITH TURNBULL,
Commissioner of Crown Lands and Survey, and
President of the Board of Land and Works.

Department of Crown Lands and Survey,
Melbourne, 10th November, 1958.

SCHEDULE.

COURT HOUSE, HEALESVILLE, Tuesday, 25th and Thursday, 27th November, 1958, at 10.30 a.m. each day.—C. E. Slade and J. A. Murphy.

LANDS DEPARTMENT, MELBOURNE, Wednesday, 26th November, 1958, Monday, 1st and Wednesday, 3rd December, 1958, at 9 a.m. each day.—C. E. Slade and J. A. Murphy.

Soldier Settlement Acts.
LEASES SURRENDERED.

NOTICE is hereby given that the Soldier Settlement Commission, pursuant to the powers conferred upon it by the Soldier Settlement Acts, has accepted the surrender of the leases mentioned in the Schedule hereunder for the reasons specified.

SCHEDULE.

Corr. No.	Name.	Section of Act No. 5179 under which Leased.	Parish.	Allotment.	Area.	Reason.
					A. R. P.	
1595/27	J. W. Coop	27	Nar-nar-noon	75c	164 3 8	New lease to issue
1596/27	H. T. W. Leach	27	Nar-nar-noon	75b	166 0 18	New lease to issue
1597/27	R. H. Templeton	27	Nar-nar-noon	74d	186 2 6	New lease to issue
1598/27	J. H. Murdoch	27	Nar-nar-noon	74c	165 3 21	New lease to issue

Soldier Settlement Commission,
Melbourne, 7th November, 1958.

I. K. MORTON,
Secretary.

Land Act 1928.

LICENCES UNDER THE LAND ACTS 1915 AND 1928 DECLARED VOID.

NOTICE is hereby given that the Licence in the Schedule hereunder has been declared void for the reason specified.

District.	Corr. No.	Name of Licensee.	Section of Land Act under which Licensed.	Parish.	Allotment.	Section.	Area.	Annual Rental.	Reason for Voiding.
							A. R. P.	£ s. d.	
Bairnsdale	125/129	R. P. Richardson	129	Suggan Buggan	3	..	0 1 30	1 0 0	Licence expired

Department of Crown Lands and Survey,
Melbourne, 10th November, 1958.

KEITH TURNBULL,
Commissioner of Crown Lands and Survey.

COMMITTEES OF MANAGEMENT OF RESERVES.
APPOINTMENTS.

WHEREAS by section 184 of the *Land Act 1928* it is provided that it shall be lawful for the Governor in Council or the Board of Land and Works to appoint and remove any number of persons, not less than three, or any municipal council, or the governing body of any corporation, to be a Committee of Management of any specified Crown land reserved either temporarily or permanently for any of the purposes set out in section 14 of the *Land Act 1928*, and not conveyed to or vested in trustees: Now therefore the Board of Land and Works doth hereby appoint the under-mentioned persons to be members of the Committee of Management of the Reserves named:—

"KILCUNDA MECHANICS' INSTITUTE AND FREE LIBRARY RESERVE."

John Wylie (the younger), Robert Ramage, Allan R. Hamilton, John William Carew, William James Price, Francis Alice Carew, Dorothy E. Burns, Roda Vera Carew, and Peter Dwyer as a Committee of Management for a period of one (1) year of the land temporarily reserved by Order in Council dated the 8th October, 1901, as a site for a Mechanics' Institute and Free Library in the Township of Kilcunda, and known as the "Kilcunda Mechanics' Institute and Free Library Reserve."—(Corres. Rs.3158.)

"PACHEWOLLOCK RACECOURSE AND RECREATION RESERVE."

George Alexander Cummings, Archibald Jackson, Matthew John Walsh, Neil Alex Walsh, and Alan Edward Grigg as a Committee of Management for a period of three (3) years of the land temporarily reserved by Order in Council dated 25th October, 1927, as a site for Racecourse, Public Recreation and Showgrounds in the Parish of Patchewollock, and known as the "Patchewollock Racecourse and Recreation Reserve."—(Corres. Rs.3563.)

"FERNVALE SOLDIERS' MEMORIAL RESERVE."

John Michael O'Farrell, Thomas Daniel Ronan, Andrew Paton, James Gordon Paton, Ian Archibald Paton, William Geoffrey Paton, and William John Ronan as a Committee of Management for a period of three (3) years of the land temporarily reserved by Order in Council dated 13th June, 1933, as a site for Public purposes in the Parish of Bolga, and known as the "Fernvale Soldiers' Memorial Reserve."—(Corres. Rs.3155.)

"PIRRON YALLOCK MECHANICS' INSTITUTE RESERVE."

Neil Vagg, Charles Harold Gore, Fred Newcombe, Neil George Mathieson, George Cobbedick, and S. S. Lamb as a Committee of Management for a period of three (3) years of the land temporarily reserved by Order in Council dated 19th April, 1898, as a site for a Mechanics' Institute in the Township of Pirron Yallock, and known as the "Pirron Yallock Mechanics' Institute Reserve."—(Corres. Rs.4908.)

"CALLAWADDA MECHANICS' INSTITUTE RESERVE."

Andrew Raymond Cheyne, Arthur Thomas Erwin, Allan Thomas Hutchings, Chilvers James Hutchings, Charles Edmond Squire, and William John Byron as a Committee of Management for a period of three (3) years from 13th October, 1958, of the land in the Parish of Callawadda temporarily reserved by Order in Council dated the 19th December, 1893, as a site for a Mechanics' Institute, and known as the "Callawadda Mechanics' Institute Reserve."—(Corres. Rs.5841.)

"DOOEN PUBLIC HALL RESERVE."

Wilfrid Howard Hobbs, Rupert Albert Levitzke, Arthur Allen Bodey, Alpin Johns, Frederick George Mills, William Francis Cromarty, Cecil John Hobbs, Roy Clarence Mills, Arthur Ernest Woolman, and David Harold Johns as a Committee of Management for a period of three (3) years of the land temporarily reserved by Order in Council of 11th January, 1949, as a site for a Public Hall in the Parish of Dooen, and known as the "Dooen Public Hall Reserve."—(Corres. Rs.6095.)

"MOUNT DANDENONG RESERVES."

John Neville Hodgskiss as a member of the Committee of Management for the period ending 29th November, 1960, in the room of Eric Lancelot Singleton, deceased, of the Crown Reserves at Mount Dandenong in the Parish of Mooroolbark as are indicated by red tint on plan marked M/31.8.37 with Lands Department correspondence Rs.310, and also the lands temporarily reserved by Order in Council dated the 3rd July, 1956, as a site for the Preservation of Native Flora and for Scenic purposes, and by Order in Council dated 11th September, 1957, as a site for Public Recreation, and known as the "Mount Dandenong Reserves."—(Corres. Rs.310.)

"DANYO RECREATION RESERVES."

Jock Etherton, Edward Albert Harley, Albert Alexander McKee, William Henry Harley, R. E. Beer, E. A. Etherton, C. W. Crane, and Ralph John Pritchard as the Committee of Management for a period of three (3) years of the lands in the Parish of Danyo reserved by Orders in Council dated 27th September, 1922, and 5th August, 1929, as sites for Recreation purposes and Public Recreation respectively, and known as the "Danyo Recreation Reserves."—(Corres. Rs.2578, Rs.3886.)

"WOOSANG RECREATION RESERVE."

Joseph Moore Gould, John McGurk, James William Stuart, William Neil Gould, Cyril Round, and Mathew Raymond Donaldson as a Committee of Management for a period of three (3) years of the land in the Parish of Woosang temporarily reserved by Order in Council dated the 23rd April, 1894, as a site for Public Recreation, and known as the "Woosang Recreation Reserve."—(Corres. Rs.4644.)

"BALNARRING FORESHORE AND TULUM PARK RESERVES."

William Graham Myers for so long only as he continues to be a councillor and the elect of the Council of the Shire of Flinders, and Bert Anderson, Edward Arthur Hillman, Tom Haselgrove, George Edward Hansen, William Harris Brown, Charles Albert James Temby, Frederick James Thistlethwaite, and John Everett Wrouth as members of the Committee of Management for a period of three (3) years of the under-mentioned Crown reserves, known as the "Balnarring Foreshore and Tulum Park Reserves."—

- (a) The land permanently reserved by Order in Council dated 31th March, 1927, as a site for Public Recreation in the Township of Balnarring Beach, Parish of Balnarring.—(Rs.3424.)
- (b) The land temporarily reserved by Order in Council dated 16th March, 1914, as a site for the Recreation, Convenience or Amusement of the people in the Township of Balnarring Beach.—(Rs.490.)
- (c) Such portion of the Reserve for Public purposes in the Parishes of Balnarring and Bittern as is indicated by pink tint on plan marked B/10.10.29 with Lands Department correspondence Rs.2091.
- (d) The remaining portion of the land temporarily reserved by Order in Council dated 2nd June, 1891, as a site for a Public Park and Watering purposes in the Township of Balnarring Beach.—(Rs.491.)—(Corres. Rs.2091.)

"WYE RIVER FORESHORE RESERVE."

David John Morrison, Douglas Mitchell, Neville Hunter, Patrick Warrington, Roy Stanway, Lulu Toomath, and Arthur Joseph Jonas as a Committee of Management for a period of three (3) years of the reserved Crown land in the Parishes of Kaanglang and Wongarra, shown by pink colour on the plan marked W/29.8.58, attached to Lands Department correspondence Rs.3989, and known as the "Wye River Foreshore Reserve."—(Corres. Rs.3989.)

"VINIFERA RECREATION RESERVE."

Harold William Bailey, Ian Wallace McLean, Bohdan Nazar, Alan Leslie Shadboit, Kenneth William Phelan, Frederick Lawrence Boulton, Leslie Bernath, Albert William Roberts, and Herbert Hosking as a Committee of Management for a period of three (3) years of the land in the Parish of Tyntynder West reserved by Order in Council of the 22nd March, 1949, as a site for Public Recreation, and known as the "Vinifera Recreation Reserve."—(Corres. Rs.6335.)

"GORMANDALE RECREATION RESERVE."

Victor Thomas Morley in the room of Colin Randle Missen, deceased, as a member of the Committee of Management for the period ending the 11th June, 1960, of the land in the Parish of Willung temporarily reserved as a site for Public Recreation by Orders in Council dated the 21st November, 1950, and 18th March, 1952, and known as the "Gormandale Recreation Reserve."—(Corres. Rs.6595.)

"BRADVALE PUBLIC HALL RESERVE."

Edgar Albert Coad (the younger), Douglas Alan Smith, Henry Peter Crist, Charles Gillespie, Alfred John Nicol, William George Smith, Philip Thomas Smith, and Colin John Grist as a Committee of Management for a period of three (3) years of the land temporarily reserved by Order in Council of 3rd May, 1949, as a site for a Public Hall in the Parish of Galla, and known as the "Bradvale Public Hall Reserve."—(Corres. Rs.6342.)

"BARJARG PUBLIC HALL RESERVE."

Stanley F. Warren, Keith B. Cleeland, S. Cleeland, V. Petherd, Rex A. Cleeland, Rupert Cleeland, Alan P. McCashney, R. L. Peel, Arthur A. Warren, J. D. Dinan, and A. J. Peers as the Committee of Management of the land in the Parish of Nillahcootie temporarily reserved by Order in Council dated the 23rd September, 1958, as a site for a Public Hall, and known as the "Barjarg Public Hall Reserve."—(Corres. Rs.7743.)

"PUBLIC RECREATION RESERVE."

The Council of the City of Melbourne as the Committee of Management of the land in the Parish of Dousta Galla, temporarily reserved as a site for Public Recreation by Order in Council dated the 23rd September, 1958.—(Corres. Rs.7719.)

In witness whereof the common seal of the Board of Land and Works was hereunto affixed this twenty-ninth day of October, One thousand nine hundred and fifty-eight, in the presence of—

(SEAL) KEITH TURNBULL, President.
G. L. WOOD, Member.

TENDERS—PUBLIC WORKS DEPARTMENT

TENDERS will be received at this office until TEN a.m. on the days and for the purposes under mentioned. Particulars may be learnt at this Office and also at places shown in parenthesis.

W.O. means Inspector of Works Office; P.S.—Police Station; T.S.—Technical School; H.E.S.—Higher Elementary School; S.S.—State School; H.S.—High School.

The Board of Land and Works will not necessarily accept the lowest or any tender.

NOTE.—No preliminary deposits are to be lodged with tenders, but a deposit, in accordance with the following Schedule, will be required from the successful tenderer:—

	£
For contract amounts exceeding £200 and not exceeding £500	5
For contract amounts exceeding £500 and not exceeding £1,000	10
For contract amounts exceeding £1,000—1 per cent. of tender	500
	(maximum deposit)

All tenders should be on a "firm tender" basis.

18th November, 1958.

Ascot Vale.—Renewal of floors in Infant Section, S.S. No. 2608. (S.S., Ascot Vale.)

Ballarat.—Erection of bicycle shelter, Teachers' Training College. (W.O., Ballarat; Teachers' Training College, Ballarat.)

Balmoral.—Septic tank installation and alterations to water supply, &c., Consolidated School. (W.O., Hamilton; Consolidated School, Balmoral.)

Bamawm Settlement.—Purchase and removal from site of old school building, out-offices, &c., S.S. No. 3726. (W.O., Bendigo.)

Beechworth.—Erection of two (2) brick-veneer residences for Medical Officers, Mental Hospital. (W.O., Wangaratta; P.S., Beechworth.)

Beechworth.—Supply and installation of electric hot-water services in two brick-veneer residences, Mental Hospital. (W.O., Wangaratta; P.S., Beechworth.)

Belmont (Geelong).—Joinery consisting of coat racks, benches, tool racks, &c., High School.

Brunswick South-west.—Resurfacing of concrete paving in corridors, &c., S.S. No. 4304. (S.S., Brunswick South-west.)

Brunswick South-west.—Electrical installation, additional light and power, S.S. No. 4304. (S.S., Brunswick South-west.)

Bungador.—Repairs, painting, and new window, &c., S.S. No. 4255. (W.O., Warrnambool, Camperdown; S.S., Bungador.)

Byrneside.—Internal and external painting and general repairs to school, S.S. No. 1680. (W.O., Shepparton; S.S., Byrneside.)

Caulfield.—Conversion of boiler to oil firing, S.S. No. 773. (S.S., Caulfield.)

Coburg.—Electrical installation, south gate building, Pentridge Gaol.

Gardiner, Repairs and painting, boys' and girls' toilets, S.S. No. 3888.

Glenferrie.—Remodelling of boys' toilet block, Swinburne Technical College. (Swinburne Technical College, Glenferrie.)

Glen Forbes.—Repairs and painting, S.S. No. 4008. (W.O., Korumburra; S.S., Glen Forbes.)

Kyabram.—Erection of second section in concrete veneer L.T.C., High School. (W.O., Shepparton, Benalla; H.S., Kyabram.)

Kyabram.—Electrical installation, stage 2, High School. (W.O., Shepparton; H.S., Kyabram.)

Kyabram.—Mechanical services for stage 2 of building programme, High School. (W.O., Shepparton; H.S., Kyabram.)

Kyneton.—Purchase and removal from site of old residence and detached washhouse, Police Station. (W.O., Kyneton.)

Lilydale.—Repairs, external and internal painting, additional warmray stoves, High School (old site). (H.S., Lilydale.)

Lilydale.—Party and non-party fencing, S.S. No. 876. (S.S., Lilydale.)

Maryborough.—New toilet at teacher's residence, Gladstone-street, and connexion to town sewerage, S.S. No. 404. (W.O., Maryborough.)

Melbourne.—Supply of doors, Peter MacCallum Clinic, Cancer Institute. (Peter MacCallum Clinic, Cancer Institute, Melbourne.)

Mildura South.—Erection of staff-room, S.S. No. 4389. (W.O., Mildura; S.S., Mildura South.)

Mont Park.—Extension of existing central heating system in Wards M.2, M.3, and F.2, and F.3, Larundel Mental Hospital.

Mornington.—Supply and delivery of timber piles for Mornington Pier, Public Works Department.

Nangiloc.—Erection of new out-office block and septice closets, S.S. No. 4184. (W.O., Mildura; S.S., Nangiloc.)

Newbridge.—Internal and external painting, renovations, fencing, residence, S.S. No. 457. (W.O., Bendigo; S.S., Newbridge.)

Officer.—Repairs and painting to residence, drinking trough to the school, S.S. No. 2742. (S.S., Officer.)

Ormond.—Replacement of chalkboards, S.S. No. 3074. (S.S., Ormond.)

Pakenham.—Extension of heating system to Infants' Block, Consolidated School. (Consolidated School, Pakenham.)

Port Melbourne.—Supply of sawn hardwood, Storeyard, Public Works Department, Salmon-street. (W.O., Bairnsdale.)

Port Melbourne.—Supply of 50 couches for school staff-rooms, Public Works Department Depot, Salmon-street.

Port Melbourne.—Supply of 222 tables for 74 miscellaneous High and Secondary Schools, Public Works Department Depot, Salmon-street.

Preston.—Supply of stackable tubular steel chairs for Assembly Hall, S.S. No. 4316.

Queenscliff.—Electrical installation, Lighthouse Keeper's Residence, Ports and Harbors, Public Works Department.

Richmond.—Additions to spray painting workshop, Technical School.

Richmond.—Supply, delivery, installation, and testing of humidifying and ventilation equipment in spray painting workshop, Technical School. (T.S., Richmond.)

Richmond.—Electrical installation in junior turning and fitting shop, and junior woodwork shop, Technical School. (T.S., Richmond.)

Richmond.—Electrical installation in spray-painting workshop, Technical School. (T.S., Richmond.)

Ringwood.—Repairs and painting, S.S. No. 2997. (S.S., Ringwood.)

Ringwood East.—Repairs and painting, S.S. No. 4180. (S.S., Ringwood East.)

Robinvale.—Erection of brick cell block, store-room, and provision of exercise yard, Police Station. (W.O., Swan Hill, Mildura; P.S., Robinvale.)

Royal Park.—Erection of brick-veneered residence, "Turana", Children's Welfare Department.

Rosebud.—Internal and external painting, Police Station. (P.S., Rosebud.)

Rupanyup.—Construction of new toilet block at school and new water closet at residence, erection of septic tank, and connexion of school and residence to town-sewerage system, &c., S.S. No. 1595. (W.O., Warracknabeal; S.S., Rupanyup.)

Seymour.—Erection of third section, High School. (W.O., Alexandra; H.S., Seymour.)

Seymour.—Electrical installation third section, High School. (W.O., Alexandra, Shepparton; H.S., Seymour.)

Seymour.—Repairs and painting, Court House. (W.O., Alexandra; Police Station, Seymour.)

Somers.—Repairs and alterations to hot-water services, and supply, installation, and testing of exhaust fan to kitchen, Health and Recreation Camp, Education Department. (Health and Recreation Camp, Somers.)

Various.—Erection of fourteen (14) additional classrooms to various concrete-veneered timber-framed primary schools, various schools.

Werribee.—Provision and delivery of stainless-steel sinks, Research Farm.

25th November, 1958.

Acheron.—Repairs and painting and new flooring to school, out-offices, and shelter shed, S.S. No. 1449. (W.O., Alexandra; S.S., Acheron.)

Ballarat.—Laying of barred floor tiles to the floor of the kitchen and food preparation area of the Mess Room, Mental Hospital. (W.O., Ballarat; Mental Hospital, Ballarat.)

Ballarat.—Blackout curtains for aids and social studies rooms, Teachers College. (W.O., Ballarat.)

Ballarat.—Supply and installation of stainless steel equipment for meal service units, Ward F.7, Mental Hospital.

Ballarat.—Supply and delivery of steam heated tilting kettles for main kitchen, Mental Hospital.

Beechworth.—Supply and delivery of steam heated cooking equipment, Mental Hospital.

Bendigo.—New front fence and internal renovations and painting to Residence, 76 Russell-street, High School. (W.O., Bendigo.)

Box Hill.—External and internal repairs and painting, Court House. (Amended specification.)

Buchan.—Provision of a garage, fuel store, and extension to office, Buchan Caves, Lands Department. (W.O., Bairnsdale; Lands Department, Buchan Caves.)

Camberwell.—Internal and external painting, High School.

Carrum Downs.—Repairs, painting, and fencing, S.S. No. 3613. (S.S., Carrum Downs.)

Caulfield.—Enclosure of balcony on first floor and repairs, &c., S.S. No. 773.

Colac.—Supply of workshop equipment 9-in. swing lathes, High School. (Revised specification.)

Dandenong.—Supply and installation of gas heated hot-water service and gas heating system, Police Station.

Dandenong.—New central Police Station. (P.S., Dandenong.)

Dandenong.—Electrical installation, New Police Station.

East Oakleigh.—Electrical installation, rewiring, and additional light and power, S.S. No. 4327.

Elwood.—Erection of two (2) shelter pavilions, High School.

Epsom.—Painting, repairs, provision of new chalkboards and room heater, cupboards and fencing, &c., S.S. No. 2367. (W.O., Bendigo; S.S., Epsom.)

Ferntree Gully.—Repairs and painting, S.S. No. 1307. (S.S., Ferntree Gully.)

Gisborne.—Repairs and painting and new fencing, Police Station. (W.O., Kyneton; P.S., Gisborne.)

Greythorn.—Erection of two (2) shelter pavilions, High School.

Heatherton.—Supply and installation of refrigeration plant for two new cool rooms in remodelled kitchen, Sanatorium. (Amended specification.)

Kew.—Supply and installation of stainless-steel equipment for meal service units for two (2) Cottages, Mental Hospital.

Langi Kal Kal.—Supply and installation of kitchen equipment, Training Centre, Penal and Gaols Department.

Leongatha.—Repairs, internal and external painting, Residence, 16 Brumley-street, High School. (W.O., Korumburra; H.S., Leongatha.)

Meadow Creek.—Repairs and painting, S.S. No. 3431. (W.O., Benalla; S.S., Meadow Creek.) (Amended specification.)

Melbourne.—Repairs to floor and laying rubber tiles, Central Chest Clinic.

Melbourne.—Supply and lay linoleum, rubber and vinyl floor coverings, Cancer Institute, Lonsdale-street.

Melbourne.—New lighting installation in registration and checking offices, Titles Office.

Melbourne.—Supply of No. 2 executive desks, No. 2 bookcases to details and specifications, Public Offices, 61 Spring-street.

Melbourne.—Supply and erection of steel cupboards, Titles Office, Queen-street.

Modella.—Internal renovations and painting, &c., S.S. No. 3456. (W.O., Traralgon; S.S., Modella.)

Mont Park.—Supply of sawn timber, Mental Hospital.

Mont Park.—Conversion of coke boilers to oil firing, and modifications to the existing central heating and hot-water services, Janefield Mental Hospital.

Mont Park.—Supply and installation of one flush-mounted platform scale in the laundry, Larundel Mental Hospital.

Mont Park.—Electrical installation for Secretary's Residence, Plenty Mental Hospital.

Moorabbin West.—Replacement of doors, S.S. No. 4643. (S.S., Moorabbin West.)

Murtoa.—Internal repairs and painting, &c., S.S. No. 1549. (W.O., Warracknabeal, Horsham; S.S., Murtoa.)

Port Melbourne.—External and internal repairs and renovations to Caretaker's Residence, S.S. No. 1427.

Red Hill.—Supply, delivery, installation, and testing of extension of heating to six existing classrooms and conversion of two boilers to oil firing, Consolidated School. (Consolidated School, Red Hill.)

Royal Park.—Electrical installation to L.T.C. extension, Research Clinic, Mental Hospital.

Sandringham.—Erection of two new shelter pavilions (32 ft. x 16 ft.), Girls' Technical School. (Girls' Technical School, Sandringham.)

Sandringham.—Conversion of cloak recess to form a female staff room, S.S. No. 267. (S.S., Sandringham.)

Scoresby.—Removal of the house purchased from Mrs. Legge and re-erection at the Horticultural Station. (Horticultural Station, Scoresby.)

Seymour.—Supply, delivery, installation, and testing of mechanical services to new Manual Arts and Combined Arts Wings, High School. (W.O., Benalla; H.S., Seymour.)

Shepparton.—Erection of two (2) 16 ft. x 32 ft. shelter pavilions, S.S. No. 4742. (W.O., Shepparton; S.S., Shepparton.)

Sunbury.—Supply and installation of central heating and hot-water services to Administration Block, Mental Hospital. (Mental Hospital, Sunbury.)

Sunbury.—Aerial reticulation to residential area, Mental Hospital. (Mental Hospital, Sunbury.)

Tarnagulla.—New out-office block and septic tank installation, S.S. No. 1023. (W.O., Maryborough; S.S., Tarnagulla.)

Toorak.—Provision of window guards, &c., S.S. No. 3016.

Upper Ferntree Gully.—Renovations to residence and provision of windows to rear porch, Hill top-road, S.S. No. 3926. (S.S., Upper Ferntree Gully.)

Warrnambool.—Supply of sawn timber, Mental Hospital. (W.O., Warrnambool.)

Warrnambool.—Supply and delivery of portable plate warmers, Mental Hospital.

Williamstown.—Recharging, acetoning, and inspection of acetylene navigation light cylinders from 1st January, 1959, to 31st December, 1959, Ports and Harbors, Dredging Depot, Public Works Department.

2nd December, 1958.

Ballarat.—Staff toilets, internal painting, &c., S.S. No. 1256, Ballarat Orphanage. (W.O., Ballarat; S.S., Ballarat Orphanage.)

Ballarat.—Erection of a new brick Mortuary and demolition of existing Mortuary Building, Court House. (W.O., Ballarat.)

Balwyn North.—Heating of additional L.T.C. classroom, S.S. No. 4638. (S.S., Balwyn North.)

Brunswick East.—Erection of sub-station office at south-east corner of Methven Park, Police Station.

Brunswick North.—Repairs, enclosing of sleepout, renewals and painting, &c., Residence, 4 Sheffield-street, S.S. No. 3585.

Castlemaine North.—Extension of shelter pavilion to provide woodshed, &c., S.S. No. 2051. (W.O., Kyneton; S.S., Castlemaine North.)

Cobains.—Erection of one 20 ft. x 16 ft. shelter pavilion, S.S. No. 4387. (W.O., Bairnsdale; S.S., Cobains.)

Coburg.—Supply and delivery of sawn timber (Kauri Pine), Pentridge Gaol.

Dandenong.—Repairs and painting, S.S. No. 1403. (S.S., Dandenong.) (Amended specification.)

Geelong.—Erection of one (1) 32 ft. x 16 ft. shelter pavilion, Gordon Institute of Technology. (W.O., Geelong; Gordon Institute of Technology, Geelong.)

Glen Waverley.—Erection of two (2) classroom building and sundry additional work, "Mandalay", Jells-road, Wheeler's Hill, Children's Welfare Department. ("Mandalay", Glen Waverley.)

Goornong.—Internal and external renovation to all buildings, Police Station. (W.O., Bendigo; P.S., Goornong.)

Gravel Hill.—Installation of heating stoves, S.S. No. 1566. (W.O., Bendigo.)

Heatherton.—Remodelling kitchen, &c., Sanatorium.

Hexham.—Repairs and painting to school and residence, S.S. No. 296. (W.O., Warrnambool; S.S. Hexham.)

Kananook.—Erection of two (2) 32 ft. x 16 ft. shelter pavilions, S.S. No. 4783. (S.S., Kananook.)

Kolora.—External painting and repairs of school and residence and out-buildings, &c., S.S. No. 883. (W.O., Camperdown; S.S., Kolora.)

Lalbert.—Erection of new block of out-offices and septic tank system, S.S. No. 2990. (W.O., Swan Hill; S.S., Lalbert.)

Leongatha.—Internal and external painting and minor repairs to residence, 18 Brumley-street, High School. (W.O., Korumburra; H.S., Leongatha.)

Maryborough.—Erection of new brick laundry and toilet, connexion to town sewerage, Police Station. (W.O., Maryborough.)

Melbourne.—External repairs and painting, Public Offices, 55-61 Spring-street.

Melbourne.—Heating of wool school, Royal Melbourne Technical School.

Mildura.—Painting, repairs, louvres to sleep-out, new bath, &c., at residence, 4 Sarnia-avenue, High School. (W.O., Mildura; H.S., Mildura.)

Mont Albert.—Installation of eight heating stoves and repairs to one stove, S.S. No. 3943.

Mortlake.—External painting of school, out-buildings, and fences, S.S. No. 397. (W.O., Warrnambool; S.S., Mortlake.)

Myola East.—Reblocking, repairs and painting, S.S. No. 2407. (W.O., Shepparton; S.S., Myola East.)

Nelson.—External and internal repairs and painting, &c., S.S. No. 1615. (W.O., Warrnambool; Police Station, Portland; S.S., Nelson.)

Norlane.—Erection of two (2) 32 ft. x 16 ft. shelter pavilions, High School. (W.O., Geelong; H.S., Norlane.)

Ringwood East.—Erection of boundary fences, S.S. No. 4180.

Sandringham.—Erection of a brick garage, &c., Police Station. (P.S., Sandringham.)

Shepparton.—Erection of plant room for air conditioning plant, Court House. (W.O., Shepparton.)

Skipton.—Erection of new "A" type office, Police Station. (W.O., Camperdown; P.S., Skipton.)

Sunshine.—Internal and external painting and minor repairs to caretaker's residence, Technical School. (T.S., Sunshine.)

Sunbury.—External painting of Administrative Buildings, Mental Hospital. (Mental Hospital, Sunbury.)

Tongala.—Purchase and removal of residence and out-buildings, Consolidated School. (W.O., Shepparton.)

Various.—Supply of ten (10) fitted wardrobes and ten (10) shoe tidies, to be delivered to ten various suburban sites, Children's Cottages, Children's Welfare Department.

Wantirna South.—External and internal repairs and painting, S.S. No. 4582.

Wonthaggi.—External and internal painting and replacements, residence, Drysdale-street, S.S. No. 3650. (W.O., Korumburra; S.S., Wonthaggi.)

Woodside.—External painting, repairs, replacement of tank, S.S. No. 1176. (W.O., Traralgon; S.S., Woodside.)

Tenders to be addressed to the Honorable the Commissioner of Public Works, and envelope containing tender marked "Tender for _____".

T. K. MALTBY,
Commissioner of Public Works.

Public Works Department,
Melbourne, 11th November, 1958.

PUBLIC SERVICE NOTICES

PUBLIC SERVICE (PUBLIC SERVICE BOARD) REGULATION 39.—RECLASSIFICATIONS.

THE Public Service Board has raised the classification of the under-mentioned offices as shown, and the Permanent Heads of the Departments have recommended the officers named for appointment.

Office and Present Classification.	Revised Classification.	Duties.	Qualifications.	Officer Recommended for Appointment.		
				Name.	Classification.	Date of Classification.
ADMINISTRATIVE DIVISION.						
DEPARTMENT OF TREASURER.						
<i>Probate Duties Office.</i>						
Class "C1"	Class "C2"	To check assessments and refunds prepared by assessors; to supervise the operation of the provisions of Section 14 of the <i>Administration and Probate (Estates) Act 1951</i>	To possess a thorough knowledge of the Administration and Probate (Estates) Acts, the Statutory Rules and legal decisions relating thereto, and practical experience in their application; to have experience in dealing with matters arising under Section 14	Ward, T. C.	Class "C1"	2.5.55
DEPARTMENT OF HEALTH.						
<i>General Health Branch.</i>						
Class "E"	Class "C"	To act as Proprietary Medicines Registrar and to assist the Chief Health Officer as required with records, files, and correspondence	To have a knowledge of Division 3 of Part XIV. of the <i>Health Act 1956</i> and the Proprietary Medicines Regulations and to have the ability to prepare accurate précis and conduct correspondence	Curley, R. G.	Class "E"	16.2.54
PROFESSIONAL DIVISION.						
DEPARTMENT OF PREMIER.						
<i>Soil Conservation Authority.</i>						
Assistant Conservation Officer (Technical and General Division) (three offices)	Conservation Officer, Class "C" (three offices)	To advise landholders on soil conservation measures; to carry out surveys for contour layout; to assist in the carrying out of soil conservation works	To have a thorough knowledge of the characteristics and use of land; experience in the practice of agriculture, and a knowledge of the principles and application of soil conservation methods; to be qualified in accordance with the provisions of Public Service (Public Service Board) Regulation 43	Ebbs, G. B...	Assistant Conservation Officer	16.3.55
				Huffam, D. J.	Assistant Conservation Officer	26.4.56
				Langford, J. C. W.	Assistant Conservation Officer	9.10.55
TECHNICAL AND GENERAL DIVISION.						
DEPARTMENT OF WATER SUPPLY.						
Assistant (Male), Grade II.	Assistant (Male), Grade I. (£481-£507)	To assist with the maintenance of office records and the preparation of pay sheets, stores returns, financial statements and costing work	To possess a good knowledge of accounting work and to have had experience of the preparation of pay sheets and the maintenance of office records	Hoefman, A.	Assistant (Male), Grade II.	15.8.54

Appeals against such recommendations should be lodged with the Secretary to the Public Service Board not later than Saturday, the 22nd November, 1958.

Office of the Public Service Board,
Melbourne, 11th November, 1958.

By order,
J. F. HALL,
Acting Secretary.

PUBLIC SERVICE OF VICTORIA.—VACANCIES.

APPLICATIONS will be received by the Public Service Board up to Wednesday, the 26th November, 1958, from persons employed in the Public Service of Victoria, who are eligible and qualified, for appointment to the under-mentioned positions:—

ADMINISTRATIVE DIVISION.

Class "C2", Office of the Registrar of Probates, Department of Law.

Yearly Salary.—£1,000, minimum; £1,100, maximum.

Duties.—To have charge of the Records Room and staff; be responsible for the maintenance, custody, registration and searches of the records, the supervision of the photo-copying section and the collection of all fees payable thereon. To

deal with all correspondence, to examine Bonds and Sureties and advise Solicitors and their clerks in connexion therewith; to relieve the Chief Clerk as required.

Qualifications.—A sound knowledge of the *Administration and Probate Act 1928* and amendments thereof, the Rules of the Supreme Court (Probate) and Supreme Court Office fees regulations under the Administration and Probate Act and the functions of the Registrar of Probates; to be experienced in the settling of Orders of the Supreme Court in its Probate Jurisdiction.

Class "C2", Department of Crown Lands and Survey.

Yearly Salary.—£1,000, minimum; £1,100, maximum.

Duties.—To supervise the keeping of the Estate accounts for land purchased by the Soldier Settlement Commission and the costing records of the

development thereof; and of the personal accounts and other assistance granted to ex-servicemen.

Qualifications.—To be a qualified accountant. To have a satisfactory knowledge of the Soldier Settlement Acts and of the Agreement and other arrangements entered into with the Commonwealth Government in relation to War Service Land Settlement, and of departmental procedure. To have a wide experience in the control of ledgers under a mechanized accounting system.

Class "C2" (District Accounting Officer), Castlemaine Branch, Department of Water Supply.

Yearly Salary.—£1,000, minimum; £1,100, maximum.

Qualifications.—A good knowledge of the Water Acts, a knowledge of the incidence of rating, and experience in rate collecting; ability to conduct negotiations and correspondence, to represent the Commission in proceedings for recovery of rates, and to carry out such specialized duties as are associated with a district in the Coliban Area.

NOTE.—A residence is available for the successful applicant, if married, for which rental of 10 per cent. of standard salary, plus £16 per annum, will be charged. Particulars available from the Department of Water Supply.

Classes "C"—"C1", Office of the Public Trustee, Department of Law.

Yearly Salary.—£624, minimum; £920, maximum.

Duties.—To act as Assistant Trust Officer (Deceased Estates).

Qualifications.—A general knowledge of the Public Trustee Acts and the Regulations thereunder and the law affecting the administration of estates of deceased persons, agencies and trust estates; experience in the management and conduct of estates.

Class "C", Premier's Office, Department of Premier.

Yearly Salary.—£624, minimum; £759, maximum.

Duties.—To act as Salaries Clerk; keep salaries, superannuation and taxation records; to prepare reimbursements; to assist in the preparation of estimates of revenue and expenditure of the Department.

Qualifications.—To have a good knowledge of the Public Accounts and Stores Regulations and the Regulations under the Public Service Act, and preferably a good knowledge of the activities of the various branches of the Department of Premier.

PROFESSIONAL DIVISION.

District Engineer, Classes "B"—"A1", Geelong Centre, Department of Water Supply.

Yearly Salary.—£1,180, minimum; £1,850, maximum.

Duties.—To supervise the construction and maintenance of all water supply works in the Bellarine and Otway Waterworks Districts and to control staff at a district office.

Qualifications.—To possess a Degree or Diploma in Civil Engineering and to be qualified as an Engineer of Water Supply together with extensive experience in construction and maintenance of town water supply services; to have administrative ability.

Inspecting Clerk of Courts, Class "B1", Courts Branch, Department of Law.

Yearly Salary.—£1,390, minimum; £1,500, maximum.

Qualifications.—To have had at least ten years' experience as a Clerk of Courts and to possess a thorough knowledge of the duties of such office and those of the office of Receiver and Paymaster.

Senior Draughtsman, Class "C2", Ports and Harbors Branch, Department of Public Works.

Yearly Salary.—£1,000, minimum; £1,100, maximum.

Duties.—To prepare hydrographic charts, compute tidal predictions and astronomical phenomena, and to carry out marine surveys for charts, deepening operations, and marine marks and structures.

Qualifications.—To be a competent draughtsman well versed in hydrographic survey and capable of effecting calculations in connexion therewith. To be familiar with the methods of maintenance of channels and marine demarcation in Victorian ports.

NOTE.—The recommended applicant will be required to reside at Queenscliff—no quarters are available.

Draughtsman, Classes "C"—"C1", Department of Water Supply.

Yearly Salary.—£624, minimum; £920, maximum.

Duties.—To prepare working drawings for the construction of pumping stations, and the installation of steam, diesel and electric motor-driven pumping plant.

Qualifications.—To have had Technical School or other approved training in mechanical draughting and approved practical experience in general drawing office work; to possess the pre-requisite qualifications prescribed in paragraphs (a) and (b) of Public Service (Public Service Board) Regulation 23.

TECHNICAL AND GENERAL DIVISION.

Senior Inspector of Land Settlement (Horsham), Department of Crown Lands and Survey.

Yearly Salary.—£806, minimum; £884, maximum.

Duties.—To supervise the work of a group of Inspectors and to instruct them in the proper use and maintenance of power equipment; to inspect and furnish reports and valuations of land and improvements as required under the provisions of the Acts administered by the Department.

Qualifications.—To have a sound knowledge of the Vermin and Noxious Weeds Act and to be familiar with other Acts administered by the Department; to have had experience with modern power equipment and the latest fumigants and weedicides used by the Department for the control of vermin and noxious weeds; a sound knowledge of land valuations essential; ability to advise on farming methods generally.

Drill Foreman, Grade I, Department of Mines.

Yearly Salary.—£689, minimum; £728, maximum.

Duties.—Under the direction of the Drill Superintendent to take charge of Departmental drilling unit; to keep weekly diaries and determine strata; to collect and classify samples of cores; to be responsible for all stores and equipment attached to the drill; to carry out welding work and dressing of bits.

Qualifications.—To have a thorough knowledge of drilling practice; to be capable of assembling and repairing engines, pumps and all parts of a drilling plant; to be capable of controlling a drilling crew.

Drill Sub-Foreman, Grade I, Department of Mines.

Yearly Salary.—£572.

Duties.—Under the direction of the Foreman to take charge of the operation of a drill.

Qualifications.—To have a sound knowledge of drilling practice and the operation of a drilling plant; to be capable of controlling the work of a shift.

Shorthand Writer and Typist (Female), Senior, Crown Solicitor's Office, Department of Law.

Yearly Salary.—£494, minimum; £520, maximum.

Duties.—To act as a Shorthand Writer and Typist to members of the Common Law and Conveyancing Branches of the Crown Solicitor's Office.

Qualifications.—To have satisfied the Public Service Board, by test, of her ability to write shorthand at the rate of 120 words a minute and to have had experience in the setting out of legal documents particularly those relating to Court proceedings and conveyancing matters.

Motor Mechanic, Office of the Chief Commissioner of Police, Department of Chief Secretary.

Yearly Salary.—£455, minimum; £494, maximum.

Qualifications.—To have had at least six years' experience in general repairs to modern cars and trucks. The possession of an "A" grade Motor Mechanic's Certificate is desirable.

Inspector of Gas Meters, Office of the Chief Inspector of Explosives and Gas Examiner, Department of Chief Secretary.

Yearly Salary.—£429, minimum; £455, maximum.

Duties.—To inspect and test gas meters in accordance with the requirements of the Gas Regulation Act in Melbourne and country centres, and to perform other duties as directed by the Gas Examiner.

Qualifications.—To be of good character and address and of sound health and physique; to be an experienced driver and to hold a current licence to drive a motor car; to have had satisfactory training preferably at a technical school and suitable trade experience; to be not less than 21 years and preferably not over 40 years of age.

Watchman, Department of Public Works.

Yearly Salary.—£325, minimum; £338, maximum.

Duties.—To carry out night-watching duties at the State Public Offices, 61 Spring-street and other State Government offices within the Treasury Reserve, Melbourne, C.2.

Qualifications.—To be active and in good health and to have a knowledge of the workings of the watchman's clock and fire alarm system.

NOTE.—The salary rates quoted above do not include the additional amounts which are payable under Regulation 77A of the Board's Regulations.

By order,

J. F. HALL,
Acting Secretary.

Office of the Public Service Board,
Melbourne, 11th November, 1958.

PUBLIC SERVICE OF VICTORIA.—VACANCIES.

DEPARTMENT OF HEALTH.

MENTAL HYGIENE BRANCH.

TECHNICAL AND GENERAL DIVISION.

APPLICATIONS will be received by the Public Service Board up to Wednesday, the 3rd December, 1958, from persons employed in the Public Service of Victoria, who are eligible and qualified, for appointment to the under-mentioned positions:—

Trade Instructor, Grade I, Ballarat Mental Hospital.

Yearly Salary.—£572, minimum; £624, maximum.

Duties.—Under direction of the Psychiatrist Superintendent to take charge of classes in Carpentry, Joinery, and Cabinet Making and to instruct patients in all aspects of the work.

Qualifications.—To be a qualified Carpenter and Joiner with ability to instruct patients in the trade processes.

Tailor, Grade I, Mont Park Mental Hospital.

Yearly Salary.—£455, minimum; £494, maximum.

Duties.—To be in charge of Tailor's Shop; to manufacture and repair clothing, &c.

Qualifications.—To be a qualified tailor and to possess ability to cut, draft and manufacture the types of male clothing in use for mental patients.

NOTE.—The salary rates quoted above do not include the additional amounts which are payable under Regulation 77A of the Board's Regulations.

By order,

J. F. HALL,
Acting Secretary.

Office of the Public Service Board,
Melbourne, 11th November, 1958.

PRIVATE ADVERTISEMENTS

CITY OF COBURG.

LOAN No. 68.

Notice of Intention to Borrow the Sum of £10,000 for Permanent Works and Undertakings.

NOTICE is hereby given that the Council of the City of Coburg proposes to borrow the sum of Ten thousand pounds (£10,000) on the credit of the municipal revenues of the Mayor, Councillors, and Citizens of the said City, such sum to be raised by the issue of debentures, in accordance with the provisions of the Local Government Acts.

1. The maximum rate of interest that may be paid is 5½ per cent. per annum.

2. The purpose for which the loan is to be applied is road and drainage works.

3. The period of the loan shall be twenty years.

4. The moneys borrowed shall be repayable by providing out of the Municipal Fund forty (40) equal half-yearly instalments of £415 6s. 4d., including principal and interest, on the 1st day of March and the 1st day of September during the currency of the loan. The first instalment shall be payable on the 1st day of September, 1959.

5. Such moneys shall be repayable at the Commonwealth Trading Bank of Australia, Melbourne, or at the Council's bankers for the time being in Melbourne.

The plans and specifications and the estimate of the cost of the proposed works, and a statement showing the proposed expenditure of the moneys to be borrowed, are open for inspection at the Town Hall, Coburg, during office hours.

3790

G. A. BRIDGES, Acting Town Clerk.

CITY OF HEIDELBERG.

LOAN No. 88 (PRIVATE STREET CONSTRUCTION).

NOTICE is hereby given that at the Meeting of the Council of the City of Heidelberg held at the Town Hall, Ivanhoe, on 6th October, 1958, the said Council did agree to the following Resolution, that is to say:

"That the Council do by Special Order and it does hereby resolve to borrow the sum of £15,000 by the issue of debentures on the credit of the Mayor, Councillors, and Citizens of the City of Heidelberg, in accordance with the provisions of the *Local Government Act 1946.*"

The rate of interest to be paid shall be £5 10s. per centum per annum, and the said loan shall be liquidated by twenty half-yearly repayments of principal and interest at the Commonwealth Trading Bank of Australia, or at the Council's bankers for the time being in the City of Melbourne.

The purposes for which the said loan shall be applied are for the construction of private streets under the provisions of Division 10 of Part XIX. of the *Local Government Act 1946*, and the loan shall be liquidated from the receipts of money payable under schemes under the said Division.

Notice is hereby further given that at the Meeting of the said Council held at the Town Hall, Ivanhoe, on 3rd November, 1958, the said Resolution was confirmed.

3760

F. PHILLIPS, Town Clerk.

CITY OF HEIDELBERG.

LOAN No. 87B (PRIVATE STREET CONSTRUCTION).

NOTICE is hereby given that at the Meeting of the Council of the City of Heidelberg held at the Town Hall, Ivanhoe, on 6th October, 1958, the said Council did agree to the following Resolution, that is to say:

"That the Council do by Special Order and it does hereby resolve to borrow the sum of £6,000 by the issue of debentures on the credit of the Mayor, Councillors, and Citizens of the City of Heidelberg, in accordance with the provisions of the *Local Government Act 1946.*"

The rate of interest to be paid shall be £5 10s. per centum per annum, and the said loan shall be liquidated by twenty half-yearly repayments of principal and interest at the Commonwealth Trading Bank of Australia, or at the Council's bankers for the time being in the City of Melbourne.

The purposes for which the said loan shall be applied are for the construction of private streets under the provisions of Division 10 of Part XIX. of the *Local*

Government Act 1946, and the loan shall be liquidated from the receipts of money payable under schemes under the said Division.

Notice is hereby further given that at the Meeting of the said Council held at the Town Hall, Ivanhoe, on 3rd November, 1958, the said Resolution was confirmed.

3761 F. PHILLIPS, Town Clerk.

CITY OF NORTHCOTE.

LOAN No. 50.

Notice of Intention to Borrow.

NOTICE is hereby given that the Council of the City of Northcote proposes to borrow the sum of £10,000 on the credit of the Mayor, Councillors, and Ratepayers of the said City by an issue of debentures, in accordance with the provisions of the Local Government Acts. In connexion therewith the following information is stated:—

- (a) The amount of the principal moneys which it is proposed to borrow is £10,000.
- (b) The maximum rate of interest that may be paid is 5½ per cent. per annum.
- (c) The times which the moneys borrowed are to be repayable are the 1st day of October, 1959, and the 1st days of April and October during the years 1960–1968, inclusive, and the 1st day of April, 1969, and that the place such moneys shall be repayable is at the Commonwealth Trading Bank of Australia, Melbourne, or at the Council's bankers for the time being in Melbourne.
- (d) The purpose for which the loan is to be applied is for—
Road construction.
Provision of furnishings and equipment for Town Hall.
Construction and purchase of Plant and Machinery for the disposal of refuse.
- (e) The manner in which the loan is to be liquidated is by provision out of the Municipal Fund in each half-year during the currency of the loan of the sum of £656 14s. 4d., which includes principal and interest.

The plans and specifications and estimate of the cost of the works, and a statement showing the proposed expenditure of the moneys to be borrowed, are open for inspection at the Municipal Office.

Dated the 11th day of November, 1958.

3752 E. MASON, Town Clerk and City Manager.

CITY OF SANDRINGHAM.

LOAN No. 61.

Notice of Intention to Borrow the Sum of Ten Thousand pounds (£10,000) for Permanent Works and Undertakings in the City of Sandringham.

NOTICE is hereby given that the Council of the City of Sandringham proposes to borrow on the credit of the municipal revenues of the Mayor, Councillors, and Citizens of the City of Sandringham the sum of Ten thousand pounds (£10,000), such sum to be raised by the issue of debentures, in accordance with the provisions of the Local Government Acts.

The maximum rate of interest that may be paid is £5 10s. per centum per annum.

The money borrowed shall be repayable, together with interest, at the National Bank of Australasia Limited, Melbourne, or the Council's bankers for the time being, by half-yearly instalments on the 1st days of March and September in each year, the loan to have a currency of twenty years, the first payment to be made on the 1st September, 1959, and the final payment on the 1st March, 1979.

The purpose for which the loan is to be applied shall be—

- (1) Road works £9,000
 - (2) Provision of places of public resort and recreation 1,000
- £10,000

The loan is to be liquidated by appropriating out of the municipal fund forty (40) half-yearly payments of approximately £415 6s. 4d. each, covering principal and interest, during the term of the loan.

The plans, specifications, and estimates of cost of the works referred to above, and statement showing the proposed expenditure of the money to be borrowed, are open for inspection during office hours of the Council, Town Hall, Sandringham.

Dated this 31st day of October, 1958.
3772 F. G. TRICKS, Town Clerk.

CITY OF SHEPPARTON.

LOAN No. 27.

Notice of Intention to Borrow the Sum of £7,000 for Permanent Works and Undertakings.

NOTICE is hereby given that the Council of the City of Shepparton proposes to borrow the sum of Seven thousand pounds on the credit of the municipal revenues of the Mayor, Councillors, and Citizens of the said City, such sum to be raised by the issue of debentures, in accordance with the provisions of the Local Government Acts.

- 1. The maximum rate of interest that may be paid is 5½ per cent. per annum.
- 2. The purpose for which the loan is to be applied is—
Street Construction £7,000
- 3. The period of the loan shall be fifteen years.
- 4. The moneys borrowed shall be repayable by providing out of the municipal fund 30 half-yearly instalments of approximately £345 13s. 10d. each, including principal and interest, on the 1st day of December and the 1st day of June during the currency of the loan. The first instalment shall be payable on the 1st day of June, 1959.
- 5. Such moneys shall be repayable at the Commonwealth Trading Bank of Australia, Melbourne, or at the Council's bankers for the time being in Melbourne.

The plans and specifications and the estimate of the cost of the proposed works, and a statement showing the proposed expenditure of the moneys to be borrowed, are open for inspection at the Town Hall, Shepparton.

3756 R. WEST, Town Clerk.

CITY OF SHEPPARTON.

LOAN No. 28.

Notice of Intention to Borrow the Sum of £8,000 for Permanent Works and Undertakings.

NOTICE is hereby given that the Council of the City of Shepparton proposes to borrow the sum of Eight thousand pounds (£8,000) on the credit of the Mayor, Councillors, and Citizens of the said City, by the issue of debentures, in accordance with the provisions of the Local Government Acts. In connexion therewith the following information is stated:—

- 1. The amount of the principal moneys which it is proposed to borrow is Eight thousand pounds (£8,000).
- 2. The maximum rate of interest that may be paid is 5½ per cent. per annum.
- 3. The purposes for which the loan is to be applied are:—

Street Construction	£1,520
Drain Construction	4,500
The provision of places of Public Resort and Recreation	1,980
	£8,000

- 4. The period of the loan shall be ten (10) years.
- 5. The moneys borrowed shall be repayable by providing out of the municipal fund twenty half-yearly instalments of £525 7s. 6d. each, including principal and interest, on the 1st day of September and the 1st day of March during the currency of the loan. The first instalment shall be payable on the 1st day of September, 1959.
- 6. Such moneys shall be repayable at the Commonwealth Trading Bank of Australia, Melbourne, or at the Council's bankers for the time being in Melbourne.

The plans, specifications and estimate of the cost of the works, and a statement showing the proposed expenditure of the moneys to be borrowed, are open for inspection at the Town Hall, Shepparton.

Dated the 7th day of November, 1958.
3750 R. WEST, Town Clerk.

BOROUGH OF PORT FAIRY.

ESTABLISHMENT OF POUND.

NOTICE is hereby given that the Council of the Borough of Port Fairy has appointed a pound for the purposes of the Pounds Act in Southcombe Park, situate off the southern extension of William-street, Port Fairy, and

being part of lot 114, L.P. 1035, Port Fairy Special Survey; and notice is further given that the said Council has revoked the appointment of the pound situate at the south-east corner of Campbell and William streets, Port Fairy.

3759 F. F. BERKERY, Town Clerk.

SHIRE OF SEYMOUR.

LOAN No. 11.

Notice of Intention to Borrow the Sum of £10,000 for Permanent Works and Undertakings.

NOTICE is hereby given that the Council of the Shire of Seymour proposes to borrow the sum of Ten thousand pounds, on the credit of the municipal revenues of the President, Councillors, and Ratepayers of the said Shire, such sum to be raised by the issue of debentures, in accordance with the provisions of the Local Government Acts.

1. The maximum rate of interest that may be paid is 5½ per cent. per annum.
2. The purpose for which the loan is to be applied is—
 - (a) Purchase of diesel power grader, track dozer, and hot bituminous spray unit—£6,350.
 - (b) Construction of kerb and channelling and sealing of streets in the Township of Seymour—£3,650.
3. The period of the loan shall be ten years.
4. The moneys borrowed shall be repayable by providing out of the municipal fund twenty half-yearly instalments of approximately £656 14s. 6d. each, including principal and interest, on the 1st day of August and the 1st day of February during the currency of the loan. The first instalment shall be payable on the 1st day of August, 1959.

5. Such moneys shall be repayable at The Commercial Banking Company of Sydney Limited, Melbourne, or at the Council's bankers for the time being in Melbourne.

The plans and specifications and the estimate of the cost of the proposed works, and a statement showing the proposed expenditure of the moneys to be borrowed, are open for inspection at the Shire Hall, Seymour.

3773 H. E. CLAREY, Shire Secretary.

SHIRE OF SPRINGVALE AND NOBLE PARK.

LOAN No. 66.

Special Order to Borrow the Sum of £5,000.

NOTICE is hereby given that the Council, at an Ordinary Meeting held on Monday, 3rd November, 1958, at 7 p.m., passed the following Resolution as a "Special Order":—

"That—

1. (a) This Council borrow moneys by the issue of debentures upon the credit of the municipality, pursuant to section 583 of the *Local Government Act 1946*.
- (b) The amount of the principal moneys to be borrowed be £5,000.
- (c) The rate of interest to be paid be £5 10s. per annum.
- (d) The moneys borrowed be repayable by twenty equal instalments payable respectively on the 1st day of February and on the 1st day of August of each year, the first such instalment being repayable on the 1st day of August, 1959.
- (e) The moneys borrowed be repayable at the Commercial Bank of Australia Limited, No. 337 Collins-street, Melbourne, or at the Council's bankers for the time being in Melbourne.
- (f) The loan be applied for the purposes of liquidating or of partly liquidating the amount due on overdraft of current account to the Council's bankers in respect of the execution of private street construction schemes, pursuant to Division 10 of Part XIX. of the *Local Government Acts*.
- (g) The loan be liquidated by providing out of the municipal fund on the 1st day of February and on the 1st day of August of each year the sum necessary to pay the half-yearly instalment and the interest then due in respect of the loan."

2. The Council directs that this Resolution be brought forward for confirmation as a Special Order at a Meeting of the Council to be held on the 1st day of December, 1958, at 7 o'clock in the afternoon.

Notice is hereby further given that the said Resolution will be submitted for confirmation at the Ordinary Meeting of the Council to be held on Monday, 1st December, 1958, at 7 p.m., in the Council Chambers, Shire Offices, Springvale.

3755 H. L. WILLIAMS, Shire Secretary.

DIOCESE OF WANGARATTA.

DIOCESAN SYNOD.

NOTICE is hereby given that the Vicar-General of the Diocese of Wangaratta has convened the Diocesan Synod for Thursday, 18th day of December, 1958, at 10 a.m., at the Parish Hall, Wangaratta.

3775 J. J. WHEATLEY, Registrar.

KORUMBURRA WATERWORKS TRUST.

NOTICE is hereby given, in accordance with section 230 of the *Water Act 1928*, as amended by the *Water (Amendment) Act 1957*, that the Catchment Areas of the following Reservoirs are to be kept free from contamination or pollution:—

1. Old Reservoir.
2. New Reservoir.
3. Bellview Creek Reservoir.

By order of the Trust,

3751 M. H. GARDNER, Trust Secretary.

NOTICE OF INTENTION TO APPLY FOR A LICENCE TO DIVERT WATER (RE-ISSUE) FROM THE THOMSON RIVER, AT COWWARR.

I HEREBY give notice that I intend to apply for a licence empowering me to divert water for a term of fifteen years to the extent of 30 acre-feet per annum at a maximum rate of 1 acre-foot per day of 24 hours for the irrigation of 20 acres, being part of allotments L4, L9, L10, section 90, Parish of Glenmaggie, and to occupy certain Crown lands for works of diversion, and to cut a race thereon.

Any objection to such application must be forwarded, in writing, to reach the State Rivers and Water Supply Commission, Melbourne, before 11th December, 1958, being 30 days from the first publication of this notice.

GEORGE MARTIN DOWNING.

Heyfield.

3793

NOTICE OF INTENTION TO APPLY FOR A LICENCE TO DIVERT WATER AND CUT RACES FROM THE THOMSON RIVER AT DAWSON.

WE hereby give notice that we intend to apply for a licence empowering us to divert water for a term of fifteen years to the extent of 60 acre-feet per annum at a maximum rate of 3 acre-feet per day of 24 hours for the irrigation of 30 acres, being part of allotments 83c, 83d, and 84A, Parish of Glenmaggie, and to occupy certain Crown lands for works of diversion, and to cut a race thereon.

Any objection to such application must be forwarded, in writing, to reach the State Rivers and Water Supply Commission, Melbourne, before 30th November, 1958, being 30 days from the first publication of this notice.

JOHN EDWARD & ENID BERYL HOLLONDS.

Dawson-road, via Heyfield.

3764

NOTICE OF INTENTION TO APPLY FOR A LICENCE TO DIVERT WATER AND CUT RACES FROM THE THOMSON RIVER AT COWWARR.

WE hereby give notice that we intend to apply for a licence empowering us to divert water for a term of fifteen years to the extent of 60 acre-feet per annum at a maximum rate of 4 acre-feet per day of 24 hours for the irrigation of 30 acres, being part of allotments D2, D3, D4, Parish of Winnindoo, and to occupy certain Crown lands for works of diversion, and to cut a race thereon.

Any objection to such application must be forwarded, in writing, to reach the State Rivers and Water Supply Commission, Melbourne, before 25th November, 1958, being 30 days from the first publication of this notice.

ESTATE OF J. D. FOGARTY.

10 Pearson-street, Heyfield.

3763

NOTICE OF INTENTION TO APPLY FOR A LICENCE TO DIVERT WATER AND CUT RACES FROM THE THOMSON RIVER AT COWWARR.

WE hereby give notice that we intend to apply for a licence empowering us to divert water for a term of fifteen years to the extent of 100 acre-feet per annum

at a maximum rate of 4 acre-feet per day of 24 hours for the irrigation of 50 acres, being part of allotment Q, sections 7A, 8A, 9A, Parish of Toongabbie North, and to occupy certain Crown lands for works of diversion, and to cut a race thereon.

Any objection to such application must be forwarded, in writing, to reach the State Rivers and Water Supply Commission, Melbourne, before 3rd December, 1958, being 30 days from the first publication of this notice.

JOHNSTON BROS.

Cowwarr, Gippsland.

3794

NOTICE OF INTENTION TO APPLY FOR A LICENCE TO DIVERT WATER AND CUT RACE FROM THE TAYLOR'S CREEK AT GUNBOWER (RE-ISSUE).

I HEREBY give notice that I intend to apply for a licence empowering me to divert water for a term of fifteen years to the extent of 80 acre-feet per annum at a maximum rate of 5 acre-feet per day of 24 hours for the irrigation of 40 acres by gravitation, being part of allotments 15 and 15E, section C, Parish of Patho, and to occupy certain Crown lands for works of diversion, and to use a race thereon.

Any objection to such application must be forwarded, in writing, to reach the State Rivers and Water Supply Commission, Melbourne, within 30 days from the publication of this notice.

REGINALD FREDERICK TOLL.

"Kanowna," Gunbower.

3776

NOTICE OF INTENTION TO APPLY FOR A LICENCE TO DIVERT WATER AND CUT RACE FROM THE KOW SWAMP AT GUNBOWER (RE-ISSUE).

I HEREBY give notice that I intend to apply for a licence empowering me to divert water for a term of fifteen years to the extent of 100 acre-feet per annum at a maximum rate of 5 acre-feet per day of 24 hours for the purpose of irrigating 50 acres by pumping, being part of allotment 15E, section C, Parish of Patho, and to occupy certain Crown lands for works of diversion, and to use a race thereon.

Any objection to such application must be forwarded, in writing, to reach the State Rivers and Water Supply Commission, Melbourne, within 30 days from the publication of this notice.

REGINALD FREDERICK TOLL.

"Kanowna," Gunbower.

3777

NOTICE OF INTENTION TO APPLY FOR A LICENCE TO DIVERT WATER AND CUT RACE FROM THE TAYLOR'S CREEK AT GUNBOWER (RE-ISSUE).

I HEREBY give notice that I intend to apply for a licence empowering me to divert water for a term of fifteen years to the extent of 100 acre-feet per annum at a maximum rate of 4 acre-feet per day of 24 hours for the irrigation of 50 acres by gravitation, being part of allotments 17, 18 and 19, section C, Parish of Patho; and to occupy certain Crown lands for works of diversion, and to cut a race thereon.

Any objection to such application must be forwarded, in writing, to reach the State Rivers and Water Supply Commission, Melbourne, within 30 days from the publication of this notice.

FREDERICK CHARLES TOLL.

Main-street, Gunbower.

3778

NOTICE OF INTENTION TO APPLY FOR A LICENCE TO DIVERT WATER AND CUT RACE FROM THE THOMSON RIVER AT COWWARR.

I HEREBY give notice that I intend to apply for a licence empowering me to divert water for a term of fifteen years to the extent of 200 acre-feet per annum at a maximum rate of 8 acre-feet per day of 24 hours for the irrigation of 100 acres, being part of allotments F1 and F2, section X1, Parish of Toongabbie North, and to occupy certain Crown lands for works of diversion, and to cut a race thereon.

Any objection to such application must be forwarded, in writing, to reach the State Rivers and Water Supply Commission, Melbourne, before 30th November, 1958, being 30 days from the first publication of this notice.

GEORGE COLLINS MORGAN.

22 Fowler-street, Moe.

3762

NOTICE OF INTENTION TO APPLY FOR A LICENCE TO DIVERT WATER FROM THE MITCHELL RIVER AT WALPA.

I HEREBY give notice that I intend to apply for a licence empowering me to divert water for a term of fifteen years to the extent of 140 acre-feet per annum at a maximum rate of 3 acre-feet per day of 24 hours for irrigation of 70 acres, being lots 9, 12, 13 and 14 on plan of subdivision 4224, subdivisions A and B of Crown allotments 49 and 50, Parish of Coongulmerang, and to occupy certain Crown lands for works of diversion.

Any objection to such application must be forwarded, in writing, to reach the State Rivers and Water Supply Commission, Melbourne, before 6th December, 1958, being 30 days from the first publication of this notice.

DORIS ELAINE RODERICK.

P.O. Box 11, Bairnsdale.

3768

NOTICE OF INTENTION TO APPLY FOR A LICENCE TO DIVERT WATER AND CUT RACE (RE-ISSUE) FROM THE THOMSON RIVER, AT HEYFIELD.

I HEREBY give notice that I intend to apply for a licence empowering me to divert water for a term of fifteen years to the extent of 50 acre-feet per annum at a maximum rate of 3 acre-feet per day of 24 hours for the irrigation of 25 acres of pastures, being part of allotments 5, 6, 7, 8, 9, and 10, Parish of Tinamba, and to occupy certain Crown lands for works of diversion, and to cut a race thereon.

Any objection to such application must be forwarded, in writing, to reach the State Rivers and Water Supply Commission, Melbourne, before 27th November, 1958, being 30 days from the first publication of this notice.

HAROLD JAMES JENNINGS.

Commercial-road, Heyfield.

3746

NOTICE OF INTENTION TO APPLY FOR A LICENCE TO DIVERT WATER AND CUT RACE FROM THE THOMSON RIVER, AT COWWARR.

I HEREBY give notice that I intend to apply for a licence empowering me to divert water for a term of fifteen years to the extent of 120 acre-feet per annum at a maximum rate of 3 acre-feet per day of 24 hours for the irrigation of 60 acres of pastures, being part of allotments Nos. 116, 117, and 132, Parish of Toongabbie North, and to occupy certain Crown lands for works of diversion, and to cut a race thereon.

Any objection to such application must be forwarded, in writing, to reach the State Rivers and Water Supply Commission, Melbourne, before 1st December, 1958, being 30 days from the first publication of this notice.

ANDREW FRANCIS MUNRO.

"Florida," Cowwarr, Gippsland.

3747

NOTICE OF INTENTION TO APPLY FOR A LICENCE TO DIVERT WATER FROM THE THOMSON RIVER, AT HEYFIELD.

I HEREBY give notice that I intend to apply for a licence empowering me to divert water for a term of fifteen years to the extent of 100 acre-feet per annum at a maximum rate of 4 acre-feet per day of 24 hours for the irrigation of 60 acres, being part of allotments 34B, 35A, 35B, 35D, Parish of Glenmaggie, and to occupy certain Crown lands for works of diversion, and to cut a race thereon.

Any objection to such application must be forwarded, in writing, to reach the State Rivers and Water Supply Commission, Melbourne, before 12th December, 1958, being 30 days from the first publication of this notice.

MICHAEL JOSEPH HIGGINS.

Heyfield.

3757

NOTICE is hereby given that the partnership heretofore subsisting between the undersigned Donald Joseph Fraser, of 15 McPherson-street, Dandenong, in the State of Victoria, hairdresser, and Brian Robert Fraser, of 1 Exeter-court, Dandenong, in the said State, driver, and carrying on business as hairdressers and tobacconists at 9-11 Langhorne-street, Dandenong, in the name of "Brydon Saloon", has been dissolved by mutual consent as from the 31st day of October, 1958, after which date the said Donald Joseph Fraser shall carry on the said business, and who has taken over all liabilities and all debts due and owing to the said late firm.

Dated the 30th day of October, 1958.

D. J. FRASER.

BRIAN R. FRASER.

Robert J. McMahon, LL.B., solicitor, Nepean Highway, Rosebud.

3745

THE partnership carried on by Lindsay Gordon Redgrave and Adolphus Grasso as medical practitioners at 261 Heatherton-road, Noble Park, was dissolved by mutual consent on 31st August, 1958. The practice will be carried on by Adolphus Grasso and John Graham Downes at the same address.

L. G. REDGRAVE.
A. GRASSO.

W. B. and O. McCutcheon, solicitors, 31 Queen-street, Melbourne. 3781

NOTICE is hereby given that the partnership heretofore subsisting between the undersigned Jack Gerard Varley Hudson and Victor Ray Sedgwick, carrying on business as real estate agents and auctioneers at 101 Ryrie-street, Geelong, under the name of "Norman Belcher & Co.", has been dissolved by mutual consent as from the 10th day of October, 1958. All debts due to and owing by the said late firm will be received and paid by the said Jack Gerard Varley Hudson, who will continue to carry on the business at the same place under the said name of Norman Belcher and Co.

Dated at Geelong this 15th day of October, 1958.

J. G. V. HUDSON.
V. RAY SEDGWICK.

Witness—M. W. KROGER.

Harwood and Pincott, solicitors, 77 Moorabool-street, Geelong, solicitors for both parties. 3789

NOTICE is hereby given that the partnership heretofore subsisting between the undersigned James Dunne and Edward Henderson McLeod, carrying on business as machinery merchants, under the name of Dunne and McLeod, and as panel beaters, under the name of Benteleigh Panel Beaters, both of which businesses have heretofore been carried on at corner of Crosbie Park-avenue and North-road, East Benteleigh, has been dissolved by mutual consent as from 1st July, 1958. All debts (if any) due to and owing by the former partnership will be received and paid by James Dunne, who will continue to carry on such businesses under the same names at the same place.

Dated at Melbourne, the 20th day of October, 1958.

E. H. MCLEOD.
J. DUNNE.

Witness to both signatures—ARTHUR DICK.

Frederick Owen and Associates, solicitors, 84 William-street, Melbourne. 3815

NOTICE is hereby given that the business heretofore managed by Kenneth Gordon Spicer, on behalf of the owner, Inez Beryl Appleyard, known as Paramount Used Cars, conducted at 340 Nicholson-street, Fitzroy, has been sold on the 16th day of October, 1958. The said business has been acquired and will be carried on at the same address by John Arthur Hart.

G. C. HANNAN & RYAN, solicitors, 472 Bourke-street, Melbourne. 3782

The Companies Act 1938.

G. H. CHOMLEY & SONS PTY. LTD. (IN VOL. LIQ.).
NOTICE CONVENING FINAL MEETING (PURSUANT TO SECTION 236).

NOTICE is hereby given, in pursuance of section 236 of the *Companies Act 1938*, that a General Meeting of the members of the above-named company will be held at the office of the liquidator, 128 William-street, Melbourne, on 15th December, 1958, at 2.30 p.m., for the purpose of having an account laid before them showing the manner in which the winding up has been conducted and the property of the company disposed of, and of hearing any explanation that may be given by the liquidator.

Dated at Melbourne, this 7th day of November, 1958.
3800 G. W. CHENOWETH, Liquidator.

In the matter of CLAYTON FLOORING & RUBBER COMPANY PROPRIETARY LIMITED (in Voluntary Liquidation), Creditors' Winding Up, and in the matter of the *Companies Act 1938*.

NOTICE is hereby given that, in pursuance of section 245, Final Meetings will be held at 180 Elgin-street, Carlton, on the 12th day of December, 1958—

of shareholders at 4 o'clock,
of creditors at 3 o'clock,

for the purpose of laying before such meetings an account showing how the winding up of the above-named company has been conducted and the property of the company disposed of, and of giving any explanation thereof.

Dated this 5th day of November, 1958.

3799 M. E. WITHEROW, Liquidator.

JALAN KEBUN RUBBER COMPANY LIMITED (IN VOLUNTARY LIQUIDATION).

NOTICE is hereby given that at an Extraordinary Meeting of the shareholders of the above-named company, held at the registered office, 84 William-street, Melbourne, on the 5th day of November, 1958, the following Resolution was carried as a Special Resolution:—

"That the sale of the plantation of the Jalan Kebun Rubber Company Limited, situated within the Federation of Malaya, which sale was made by the directors of the said company, be and is hereby confirmed and approved and that the company be now wound up voluntarily, such being a members' voluntary winding up."

Sherrard Roy Warnock, a secretary of the company, was appointed liquidator. An immediate distribution of Seven shillings and six pence per share will be made to all shareholders on surrender of their scrip for marking, and a further distribution of Two shillings and six pence at least on receipt of balance of purchase money.

3787 SHERRARD R. WARNOCK, Liquidator.

Companies Act 1938.

NOTICE OF INTENTION TO APPLY TO ATTORNEY-GENERAL FOR LICENCE.

PURSUANT TO SECTION 18 (1).

I, JESSIE MARY VASEY, of 117 Walsh-street, South Yarra, on behalf of The Vasey Housing Auxiliary (War Widows' Guild), about to be formed for the purpose of promoting charity and other useful objects, hereby give notice of intention to apply to the Attorney-General for a licence directing that the said association be registered as a company with limited liability without the addition of the word "Limited" to its name.

Dated this 30th day of October, 1958.

J. M. VASEY, Director.

Abbott, Stillman, and Wilson, solicitors, 422 Little Collins-street, Melbourne. 3758

COMMANDO INDUSTRIES LTD. (IN LIQUIDATION).

NOTICE CONVENING FINAL MEETING.

NOTICE is hereby given that the Final Meeting of the company will be held on Tuesday, 16th December, 1958, at 9.45 a.m., at the Board Room, Third Floor, 18 Queen-street, Melbourne, in accordance with the provisions of section 245 of the *Companies Act 1938*.

Dated this 7th day of November, 1958.

ERIC A. KELLAM, Liquidator.

Digby and Kellam, chartered accountants (Aust.), 14 Queen-street, Melbourne, C.I. 3809

JOHN BUNCLE & SON LTD. (IN LIQUIDATION).

NOTICE OF ANNUAL MEETING.

NOTICE is hereby given that, in accordance with section 235 of the *Companies Act 1938*, a General Meeting of members will be held in the Board Room, 3rd Floor, 18 Queen-street, Melbourne, on Wednesday, 17th December, 1958, at 2.15 p.m.

Dated this 7th day of November, 1958.

ERIC A. KELLAM, Liquidator.

Digby and Kellam, chartered accountants (Aust.), 14 Queen-street, Melbourne, C.I. 3810

JOHN BUNCLE COMMANDO LTD. (IN LIQUIDATION).

NOTICE CONVENING FINAL MEETING.

NOTICE is hereby given that the Final Meeting of the company will be held on Wednesday, 17th December, 1958, at 10 a.m., at the Board Room, Third Floor, 18 Queen-street, Melbourne, in accordance with the provisions of section 245 of the *Companies Act 1938*.

Dated this 7th day of November, 1958.

ERIC A. KELLAM, Liquidator.

Digby and Kellam, chartered accountants (Aust.), 14 Queen-street, Melbourne, C.I. 3808

BARKLAMB BROS. PTY. LTD., 23 Eumeralla-road, Caulfield.

ON the 5th November, 1958, at an Extraordinary Meeting duly held, it was resolved by Special Resolution that the company be voluntarily wound up.

FRANK NOLAN, of 959 Nepean Highway, Moorabbin, appointed liquidator. 3817

Notice of Intention to Make a First and Final Return of Capital.—In the matter of APEX GOLD MINES NO LIABILITY (in Liquidation), and in the matter of the Companies Act 1934-1956.

NOTICE is hereby given of my intention to make a First and Final Return of Capital by way of payment of not more than 213d. per share in the above matter. Any creditor who has not yet proved his debit is required to lodge his proof with the liquidator by the 15th day of December, 1958, and to establish his claim by that date otherwise his claim will be expunged and I shall proceed to make a First and Final Return of Capital without regard to such claim.

Dated this 12th day of November, 1958.

K. L. MILNE, Liquidator.

Proofs must be delivered or forwarded to the liquidator at the offices of Milne and Burgess, 108 Gawler-place, Adelaide. 3749

CREDITORS, next of kin, and all others having claims in respect of the estate of Ethel Bolitho, late of 4 Booth-street, Golden Square, in the State of Victoria, widow, deceased (who died on the 10th day of May, 1958), are required by Farmers and Citizens Trustees Company Bendigo Limited, of Charing Cross, Bendigo aforesaid, the executor of the will of the said deceased, to send particulars thereof, in writing, to the said company, on or before the 31st day of December, 1958, after which date the said company will distribute the assets of the said deceased, having regard only to the claims of which it then has notice.

Dated the 5th day of November, 1958.

WATSON, JAMES, & ROGERS, of Bull-street, Bendigo, solicitors for the executor. 3774

PETER WETTON, formerly of 4 Ibis-court, Norlane, but late of S.S. *Strathaird*, at Sea, an infant, DECEASED, intestate.

CREDITORS, next of kin, and others having claims in respect of the estate of the said deceased (who died 8th March, 1958) are required by the applicant for letters of administration of the estate, Roy Lindsay Bockholt, of 189 Moorabool-street, Geelong, solicitor, to send particulars to him, care of the undersigned solicitors, by 7th January, 1959, after which date the said applicant may convey or distribute the assets, having regard only to the claims of which he then has notice.

WIGHTON & McDONALD, solicitors, 189-191 Moorabool-street, Geelong. 3771

HARRY JOSEPH CULLEN, late of 1146 Nepean Highway, Cheltenham, in the State of Victoria, gentleman, DECEASED (who died on the 3rd day of September, 1958).

CREDITORS, next of kin, and all other persons having claims against the estate of the deceased are required by the executor of the will, John Douglas Cullen, of Swan Hill, in the said State, accountant, to send particulars to him, care of the undersigned, on or before the 5th day of February, 1959, after which date he will distribute the assets, having regard only to the claims of which he then has notice.

GARDEN & GREEN, solicitors, McCallum-street, Swan Hill. 3792

CREDITORS, next of kin, and others having claims in respect of the estate of Charles Edward Hunter, late of 30 Richardson-street, Essendon, printer, deceased, intestate (who died on the 23rd day of January, 1958), are to send particulars of their claims to the administratrix of the said estate, Sybil Hunter, care of the undersigned solicitor, on or before the 24th day of January, 1959, after which date she will distribute the assets, having regard only to the claims of which she then has notice.

LOUIS P. LE GRAND, solicitor, 660 Sydney-road, Brunswick. 3795

CLARA SCHOOLING CLARK, late of Norwich Hall Hospital, 221 Union-road, Surrey Hills, widow, DECEASED.

CREDITORS, next of kin, and others having claims in respect of the estate of the deceased (who died on 8th July, 1958) are required by the trustees, The Equity Trustees, Executors, and Agency Co. Ltd., of 472 Bourke-street, Melbourne, and Phyllis Edith Luxton Grey, of 33 Silvermines-road, St. Arnaud, to send particulars to the said company, at 472 Bourke-street, Melbourne, by the 15th day of January, 1959, after which date the trustees may convey or distribute the assets, having regard only to the claims of which it and she then have notice.

Dated 4th day of November, 1958.

WEIGALL & CROWTHER, 459 Little Collins-street, Melbourne, solicitors. 3779

CREDITORS, next of kin, and others having claims in respect of the estate of David Thomas Carson, formerly of Dixie, farmer, but late of 39 Mitchell-street, Bentleigh, in the State of Victoria, storeman, deceased (who died on the 4th day of May, 1958), are to send particulars of their claims to The Equity Trustees, Executors, and Agency Company Limited, of 472 Bourke-street, Melbourne, in the said State, by the 22nd day of January, 1959, after which date it will distribute the assets, having regard only to the claims of which it then has notice.

FRANK C. HULLS, LL.B., barrister and solicitor, of 203 Queen-street, Melbourne, and 322 Centre-road, Bentleigh. 3780

KATHLEEN ELMA HIGGINS, late of 64 Beavers-road, Northcote, married woman, DECEASED.

CREDITORS, next of kin, and others having claims in respect of the estate of the said deceased (who died on 11th day of August, 1957) are required by deceased's personal representative, Hugh Thomas Higgins, of 64 Beavers-road aforesaid, retired public servant, to send particulars to him, care of the under-mentioned solicitors, by the 21st day of January, 1959, after which date the personal representative may convey or distribute the assets, having regard only to the claims of which he then has notice.

HEFFEY & BUTLER, 369 Lonsdale-street, Melbourne, solicitors for the said Hugh Thomas Higgins. 3783

CREDITORS, next of kin, and others having claims in respect of the estate of Keith Ormond McCabe, late of 201 Arthur-street, Fairfield, packer, deceased (who died on the 18th May, 1958), are to send particulars of their claims to the executors, Rex Hugh McCabe and Hazel Joyce Ferguson, care of the under-mentioned solicitor, on or before the 12th day of January, 1959, after which date the executors will proceed to distribute the assets, having regard only to the claims of which they then have notice.

ROYSTON T. CAHIR, of 108 Queen-street, Melbourne, solicitor. 3784

CREDITORS, next of kin, and others having claims in respect of the estate of Vincent Gedye, late of 20 Grattan-street, Prahran, manufacturer, deceased (who died on the 4th November, 1957), are to send particulars of their claims to Richard Lorimer Gedye, of 27A Central Park-road, East Malvern, manufacturer, and George Alan Bitcon, of 330 Wattletree-road, East Malvern, company director, by the 14th January, 1959, after which date they will distribute the assets, having regard only to the claims of which they then have notice.

CORR & CORR, solicitors, 104 Queen-street, Melbourne. 3785

PURSUANT to the *Trustees Act* 1928, notice is hereby given that all persons having claims against the estate of Catherine Mary Griffin, formerly of 41 Riversdale-road, Hawthorn, but late of 7 Moffat-street, Brighton Beach, spinster, deceased (who died on the 9th day of September, 1958), are hereby required to send particulars, in writing, of such claims to National Trustees, Executors, and Agency Company of Australasia Limited, of 95 Queen-street, Melbourne, the executor of the will of the said deceased, on or before the 20th day of January, 1959, after which date the executor will proceed to convey or distribute the said estate, to or among the persons entitled thereto, having regard only to the claims of which they shall then have had notice.

DAVIS, COOKE, & CUSSEN, solicitors, Temple Court, 422 Collins-street, Melbourne. 3769

Trustees Act 1953.

NOTICE TO CLAIMANTS.

PURSUANT to the *Trustees Act 1953*, creditors, next of kin, and all other persons having claims in respect of the deceased person named below are required to send particulars of such claims to the legal personal representatives at the address stated, on or before the date stated, after which date the representatives will distribute the assets, having regard only to the claims of which notice has been received:—

Jessie Margaret Buchan, formerly of 2 Guthrie-avenue, Geelong West, but late of Queen Elizabeth Home, Ballarat, in the State of Victoria, spinster, died on the 27th day of July, 1958.—Claims to John William Buchan, Jane Annie Buchan, and Stuart John Buchan, care of Doyle and Kerr, solicitors, 187 Rynie-street, Geelong, by the 21st day of January, 1959. 3753

CREDITORS, next of kin, and others having claims against the estate of Frederica Cashen, late of Atkinson-street, Templestowe, widow, deceased, intestate (who died on 9th January, 1958), are required by John Francis Cashen, the administrator of the estate of deceased, to send to him, addressed to the care of the undersigned solicitors, particulars thereof, on or before 28th February, 1959, after which date he will distribute the assets, having regard only to the claims of which he shall then have notice.

GAVAN DUFFY & KING, solicitors, 95 Queen-street, Melbourne. 3788

SID BHUGWANA, late of Swan Hill, in the State of Victoria, carrier, DECEASED (who died on the 19th day of December, 1957).

CREDITORS, next of kin, and all other persons having claims against the estate of the deceased, are required by the executors of the will, Sandhurst and Northern District Trustees, Executors and Agency Company Limited, of View-street, Bendigo, in the said State, to send particulars to it, care of the undersigned, on or before the 4th day of February, 1959, after which date it will distribute the assets, having regard only to the claims of which it then has notice.

GARDEN & GREEN, solicitors, McCallum-street, Swan Hill. 3765

CREDITORS, next of kin, and others having claims against the estate of Isabella Agnes Simmonds (in the will called Isabella Simmonds), late of 24 Canterbury-street, Brown Hill, Ballarat, in the State of Victoria, widow, deceased (who died on the 27th day of June, 1958), are to send particulars of their claims to the executors, care of The Fidelity Trustee Company Limited, of 101 Lydiard-street north, Ballarat, in the said State, by the 31st day of January, 1959, after which date they will distribute the assets, having regard only to the claims of which they then have notice.

CUTHBERT, MORROW, MUST, & SHAW, solicitors, Ballarat. 3770

CREDITORS, next of kin, and others having claims against the estate of Margaret White, late of Miners Rest, in the State of Victoria, widow, deceased (who died on the 26th day of June, 1958), are required to send particulars of their claims to the executor, The Fidelity Trustee Company Limited, of 101 Lydiard-street north, Ballarat, in the said State, by the 21st day of January, 1959, after which date it will distribute the assets, having regard only to the claims of which it then has notice.

CUTHBERT, MORROW, MUST, & SHAW, solicitors, Ballarat. 3767

HANNIBAL COY, late of 16 Byrne-avenue, Elwood, gentleman, DECEASED.

CREDITORS, next of kin, and others having claims in respect of the estate of the said deceased (who died on the 17th July, 1958), are required by the personal representative, The Trustees Executors and Agency Company Limited, whose registered office is situate at 401 Collins-street, Melbourne, to send particulars to it, at the office of the said company, by the 29th day of January, 1959, after which date the personal representative may convey or distribute the assets, having regard only to the claims of which it then has notice.

Dated this 11th day of November, 1958.

LEACH & THOMSON, solicitors, 472 Bourke-street, Melbourne. 3797

CREDITORS, next of kin, and others having claims in respect of the estate of Catherine Orr, late of Dunnstown, in the State of Victoria, widow, deceased, intestate (who died on the 24th day of April, 1958), are to send particulars of their claims to The Fidelity Trustee Company Limited, of 101 Lydiard-street north, Ballarat, in the said State, by the 13th day of January, 1959, after which date it will distribute the assets, having regard only to the claims of which it then has notice.

CUTHBERT, MORROW, MUST, & SHAW, solicitors, Ballarat. 3754

CREDITORS, next of kin, and others having claims in respect of the estate of Robert Wicks, late of 5 Edmond-street, East Brunswick, labourer, deceased (who died on the 3rd day of September, 1957), are to send particulars of their claims to the executor of the said estate, Francis Frederick Quinn, care of the undersigned solicitor, on or before the 24th day of January, 1959, after which date he will distribute the assets, having regard only to the claims of which he then has notice.

LOUIS P. LE GRAND, solicitor, 660 Sydney-road, Brunswick. 3796

CREDITORS, next of kin, and others having claims against the estate of Eric Carl Fiedler, late of "Springbank," Ruby, farmer, deceased, are required to send particulars to the administrator of the said estate, care of the under-mentioned solicitors, on or before the 12th January, 1959. After the said date the administrator will distribute the assets, having regard only to the claims of which it then has notice.

BIRCH, ROSS, & ATKINSON, solicitors, Leongatha. 3798

EMILY ALICE PALMER, late of 457 Wattletree-road, East Malvern, widow, DECEASED.

CREDITORS, next of kin, and others having claims against the estate of the above-named deceased (who died on the 10th day of November, 1957) are required to send particulars of such claims to the executrix, Violet Eva Denehy, of 457 Wattletree-road, Malvern, married woman, care of the undersigned, at the address given hereunder, on or before the 15th day of January, 1959, after which date the said executrix will distribute the assets, having regard only to the claims of which she shall then have had notice.

SLATER & GORDON, solicitors, 422 Collins-street, Melbourne. 3786

FREDERICK WILLIAM GEPHART, late of Mernda, gentleman, DECEASED.

CREDITORS, next of kin, and others having claims in respect of the the estate of the deceased (who died on 27th July, 1958), are required by the executrix of the will, Mavis Farrington, of 7 Oxford-street, East Brighton, married woman, to send particulars of such claims, in writing, to the said executrix, in the care of Dugdale, Simmons, and Stevens, of 486 Bourke-street, Melbourne, by the 20th day of January, 1959, after which date the executrix may convey or distribute the assets, having regard only to the claims of which she then has notice.

DUGDALE, SIMMONS, & STEVENS, solicitors, 486 Bourke-street, Melbourne. 3803

CREDITORS, next of kin, and others having claims in respect of the estate of Elizabeth Spratt, late of 430 Clarke-street Northcote, in the State of Victoria, spinster, deceased (who died on the 20th day of March, 1958), are required to send particulars of their claims to National Trustees, Executors, and Agency Company of Australasia Limited, of 95 Queen-street, Melbourne, by the 20th day of January, 1959, after which date it will distribute the assets, having regard only to the claims of which it then has notice.

JOHN B. PLANT, LL.B., solicitor, 368 Collins-street, Melbourne. 3804

CREDITORS, next of kin, and others having claims in respect of the estate of Antony Jacono Eden, late of Bluff-road, Moorabbin, nurseryman, deceased (who died on the 30th day of May, 1958), are to send particulars of their claims to The Trustees, Executors, and Agency Company Limited, at its registered office, 401 Collins-street, Melbourne, by the 15th day of January, 1959, after which date it will distribute the assets, having regard only to the claims of which it then has notice.

PRICE & CHAMBERLIN, solicitors, 443 Little Collins-street, Melbourne. 3820

CREDITORS, next of kin, and others having claims in respect of the estate of Edward Russell Mockridge, late of 93 Page-street, Albert Park, in the State of Victoria, professional cyclist, deceased (who died on the 13th day of September, 1958), are required by the administratrix, Irene Mockridge, of 93 Page-street, Albert Park, in the said State, widow, to send particulars of their claims to her, care of Rogers and Gaylard, solicitors, of 281 Collins-street, Melbourne, by the 21st day of January, 1959, after which date the said administratrix will distribute the assets of the deceased, having regard only to the claims of which she then shall have had notice.

ROGERS & GAYLARD, solicitors, 281 Collins-street, Melbourne. 3805

GEORGE ERNEST RICHARDS, late of "Nyala," Sutton Grange, in the State of Victoria, gentleman, DECEASED.

CREDITORS, next of kin, and others having claims in respect of the estate of the deceased (who died on the 29th day of May, 1958), are required by the personal representatives, Ernest Avonsleigh Richards, of Sutton Grange, grazier, and Donald George Richards, of 25 Rusden-street, Elsternwick, comptroller of Stamps, both in the said State, to send particulars to them, by the 30th day of January, 1959, after which date the personal representatives may convey or distribute the assets, having regard only to the claims of which they then have notice.

HEDDERWICK, FOKES, & ALSTON, solicitors, 103 William-street, Melbourne. 3807

HELEN NICOLL HANSEN, late of 43 O'Shannessy-street, North Melbourne, widow, DECEASED.

CREDITORS, next of kin, and others having claims against the estate of the above-named deceased (who died on the 22nd day of June, 1958), are required to send such particulars of such claims to the executor, Harold Francis Speak, of 155 Errol-street, North Melbourne, care of the undersigned, at the address given hereunder, on or before the 6th day of January, 1959, after which date the said executor will distribute the assets, having regard only to the claims of which he shall then have had notice.

IRVING S. PLOTKIN solicitor, 379 Collins-street, Melbourne. 3811

LILLIAN MABEL DUNN, late of 377 Victoria-street, West Melbourne, widow, DECEASED.

CREDITORS, next of kin, and others having claims against the estate of the above-named deceased (who died on the 10th day of June, 1958), are required to send particulars of such claims to the executor, Francis James O'Grady, of 377 Victoria-street, West Melbourne, care of the undersigned, at the address given hereunder, on or before the 6th day of January, 1959, after which date the said executor will distribute the assets, having regard only to the claims of which he shall then have had notice.

IRVING S. PLOTKIN solicitor, 379 Collins-street, Melbourne. 3812

FRANCIS HENRY MANSELL, late of 40A Brougham-street, North Melbourne, hairdresser, DECEASED.

CREDITORS, next of kin, and others having claims against the estate of the above-named deceased (who died on the 13th day of July, 1958), are required to send particulars of such claims to the executor, Irving Samuel Plotkin, of 379 Collins-street, Melbourne, on or before the 6th day of January, 1959, after which date the said executor will distribute the assets, having regard only to the claims of which he shall then have had notice.

IRVING S. PLOTKIN solicitor, 379 Collins-street, Melbourne. 3813

PURSUANT to the *Trustees Act 1928*, creditors, next of kin, and all other persons having claims in respect of the estate of John Fenwick Crosby, late of 362 Glenferrie-road, Hawthorn, company director (who died on the 19th day of May, 1958), are required to send particulars of their claims to The Union Trustee Company of Australia Limited, the registered office of which is situate at 333 Collins-street, Melbourne, and Florence Maude Crosby, of 362 Glenferrie-road, Hawthorn, widow, care of the said company, by the 14th day of January, 1959, after which date they will distribute the assets, having regard only to the claims of which they shall then have had notice.

OSWALD, BURT, & CO., solicitors, 178 William-street, Melbourne. 3814

CREDITORS, next of kin, and others having claims in respect of the estate of Phillip Rice, late of 10 Broomfield-road, Auburn, retired labourer, deceased, intestate (who died on the 25th February, 1958), are requested to send particulars of their claims to the administratrix of the estate Mavis Peers, care of the under-mentioned solicitor, by the 16th day of January, 1959, after which date the administratrix will distribute the assets, having regard only to the claims of which she then has notice.

K. P. REES, B.A., LL.B., solicitor, 314 Collins-street, Melbourne. 3806

JOHN HENRY WATSON SMITH, late of 1 Ilma-grove, Northcote, in the State of Victoria, gentleman, DECEASED.

CREDITORS, next of kin, and others having claims in respect of the said deceased (who died on the 4th day of March, 1958) are to send particulars of their claims to John Lancelot Hewison, the executor of the will of the said deceased, care of the under-mentioned solicitors, by the 1st day of February, 1959, after which date the said executor will distribute the assets in the said estate, having regard only to the claims of which he then has notice.

ELLISON, HEWISON, & WHITEHEAD, solicitors, 352 Collins-street, Melbourne. 3816

PURSUANT to the Trustee Acts, all persons having claims against the property or estate of Stojan Pejic, late of 35 Adam-street, Burnley, in Victoria, railway employee, deceased (who died on 15th October, 1957, and probate of whose will was granted by the Supreme Court of Victoria, on 4th March, 1958, to Edna Wood, of 35 Adam-street, Burnley, in Victoria, home duties, the executrix named therein), are hereby required to send particulars of such claim to the said executrix, care of the under-mentioned solicitors, on or before the 31st day of January, 1959, after the expiration of which time the said executrix will proceed to distribute the assets of the said deceased amongst the persons entitled thereto, having regard only to the claims of which she has then had notice.

L'ESTRANGE & KENNEDY, solicitors, of 291 Bridge-road, Richmond. 3819

In the Supreme Court of the State of Victoria.
SALE BY THE SHERIFF.

ON Wednesday, the 17th day of December, 1958, at 11 a.m., at Police Station, 188 High-street, Kew (unless process be stayed or satisfied):—

All the estate and interest (if any) of David Michael Kott, school teacher, of 9 Laver-street, Kew, as proprietor of an estate, in fee-simple, in the land described in certificate of title, volume 5066, folio 1013073, upon which is erected a brick villa, situate and known as 9 Laver-street, Kew.

Registered mortgage No. A22461 for £4,800 affects the said estate and interest.

Terms: Cash only.

D. K. PARK, Sheriff's Officer.

10th November, 1958.

3818

IMPOUNDINGS

KYABRAM.—Impounded in Kyabram Pound.

1 bay draught mare, white blaze, hind feet white, no visible brand

If not claimed and expenses paid, to be sold on 21st November, 1958.

W. G. GREAVES,

3766—10/6

Poundkeeper.

OXLEY.—Impounded in Oxley Pound, from Redcamp, by Mrs. Evans.

12 wethers, 1 ewe, and 1 lamb, no visible brand

If not claimed and expenses paid, to be sold on 27th November, 1958.

M. J. WARREN,

3801—10/6

Poundkeeper.

TUNGAMAH.—Impounded in Tungamah Pound, by T. O'Kane.

1 brindle Shorthorn bull, no visible brand
 If not claimed and expenses paid, to be sold on 26th November, 1958.
 M. L. TAIT,
 Poundkeeper.
 3748—10/6

WEDDERBURN.—Impounded in Wedderburn Pound.

1 Comeback ewe, no visible brand
 If not claimed and expenses paid, to be sold on 19th November, 1958.
 R. EASON,
 Poundkeeper.
 3802—9/

YARRAM.—Impounded in Yarram Pound, by Shire Herdsman, from Pound-road, 27th October, 1958.

1 yellow heifer, no visible brand
 1 white heifer, full ears, no visible brand
 1 brown Jersey heifer, full ears, like CR on right rump
 If not claimed and expenses paid, to be sold on 21st November, 1958.
 L. MITCHELL,
 Poundkeeper.
 3821—13/6

EDGAR'S NEWS AGENCY, Hargreaves-street, Bendigo.
 MESSRS. HENRY FRANKS & CO., Booksellers and Stationers, Market-square, Geelong.

MESSRS. GORDON & GOTCH, News Agents, 511 Little Collins-street, Melbourne; and corner Barrack and Clarence streets, Sydney.

GULLAN'S NEWSAGENCY, 88 Bridge-street, Ballarat.

A. C. HAMPTON, 243 Mitchell-street, Bendigo.

MESSRS. HARSTON, PARTRIDGE, & CO., 455 Little Collins-street, Melbourne.

MR. C. F. LATIMER, News Agent, Casterton.

MCARTHUR'S AUTHORIZED NEWSAGENCY, 345 Wyndham-street, Shepparton.

MESSRS. R. H. & W. M. PETTY, News Agent, Wangaratta.

MESSRS. POWELL & DIXON, 89 Firebrace-street, Horsham.

J. PURDIE & CO., 138 Moorabool-street, Geelong.

F. W. RASHLEIGH & SON, Nunn-street, Benalla.

ROBERTSON & MULLENS LTD., Elizabeth-street, Melbourne.

SALE AUTHORIZED NEWSAGENCY, 142 Raymond-street, Sale.

SKINNER'S AUTHORIZED NEWSAGENCY, 49-51 Franklin-street, Traralgon.

MESSRS. SMITH & DUNNON, Hamilton.

THE MERCANTILE EXCHANGE, 380 Collins-street, Melbourne.

TUFF'S SHEPPARTON NEWSAGENCY, 246 Wyndham-street, Shepparton.

C. F. & H. J. VERNON, 162 Bridge-road, Richmond.

VIEW POINT AUTHORIZED NEWSAGENCY, 4 View Point, Bendigo.

E. W. B. WELSH, Hogan-street, Tatura.

A copy of the Gazette filed at each place for public reference.

W. M. HOUSTON,
 Government Printer.

THE VICTORIA GOVERNMENT GAZETTE is published on WEDNESDAY EVENING in each week, and Notices for insertion will be received by the Government Printer at or before Two p.m. at ordinary rates, and late advertisements between Two p.m. and Five p.m. at double rates on the day preceding the day of publication.

Single copies of the VICTORIA GOVERNMENT GAZETTE are One shilling, posted One shilling and three pence.

No GAZETTES prior to January, 1950, in stock.

***ALL PAYMENTS ARE REQUIRED IN ADVANCE.—Remittances should be made by postal note, money order, or draft in favour of the Government Printer. Advertisements unaccompanied by a remittance sufficient to cover the cost of insertion will be returned unpublished.

SUBSCRIPTIONS.—The subscription, including postage, is £2 15s. per annum, £1 7s. 6d. half-yearly, or 13s. 9d. per quarter, payable in advance.

Subscriptions are required to commence and terminate with a month.

A lesser period than three months cannot be subscribed for.

Subscribers do not receive the Acts of Parliament with the GAZETTE.

ADVERTISEMENTS are charged at the rate of 1s. 6d. per line single column, and 3s. per line double column.

The title (£5 Reward, Dissolution of Partnerships, &c.) forms one or more lines as a heading.

On an average, ten words make a line.

Every signature must likewise be counted as a line.

The final words of a paragraph, though only portion of a line, must be counted as one line.

SIGNATURES (in particular) and proper names must be written very plainly in the text; ONE SIDE ONLY of each slip of paper should be WRITTEN UPON.

ALL COMMUNICATIONS should be addressed to "The Government Printer, Melbourne".

ALL DOCUMENTS illegibly written will be returned unpublished, and where brands occur unprovided for by the ordinary letters of the alphabet, a worded explanatory description must be furnished.

AGENTS FOR THE "VICTORIA GOVERNMENT GAZETTE".

THE following have been appointed agents to receive Advertisements and Subscriptions for the Victoria Government Gazette:—

ARMSTRONG'S AGENCY, 143 Queen-street, Melbourne.

ARMSTRONG BROS., Kyneton.

MESSRS. ARNALL & JACKSON, 115 Barkly-street, West Brunswick.

MR. WM. DAVIS, Mildura.

A. J. DIGBY (B. S. and N. W. Cash), Main-street, Bairnsdale.

CONTENTS

	PAGE
Acts of Parliament	3571
Appointments	3586
Auction Sales Act	3579
Bank Holidays	3574
Bank Half-Holidays	3574
Contracts	3579
Country Roads Board	3589
Courts	3577
Estates of Deceased Persons	3584
Government Notices	3575
Impoundings	3617
Lands	3601
Mining	3585
Ministers of Religion Registered to Celebrate Marriages in Victoria	3578
Money Lenders Act 1938—Supplementary List	3578
Orders in Council	3587
Private Advertisements	3610
Proclamations	3571
Public Half-Holiday	3574
Public Service Notices	3608
Resignations	3587
State Rivers and Water Supply Commission	3578
Tenders	3605
Transport Regulation Board—Public Hearings	3583
Waterworks Trusts	3577