



VICTORIA GOVERNMENT GAZETTE

Published by Authority

[Registered at the General Post Office, Melbourne, for transmission by post as a newspaper.]

No. 110]

WEDNESDAY, DECEMBER 13

[1961

Land Act 1958.

UNALIENATED CROWN LAND AVAILABLE FOR SETTLEMENT UNDER IMPROVEMENT PURCHASE LEASES.

PROCLAMATION

By His Excellency the Governor of the State of Victoria and its Dependencies in the Commonwealth of Australia,
&c., &c., &c.

IN pursuance of the provisions of section 153 of the *Land Act 1958*, I, the Governor of the State of Victoria, in the Commonwealth of Australia, by and with the advice of the Executive Council of the said State, do by this Proclamation declare the unalienated Crown lands mentioned in the subjoined Schedule, to be available for settlement under improvement purchase leases.

SCHEDULE.

County.	Parish.	Allotment.	Section.	Area.	Land Valuation.
				A. R. P.	
Tambo	Nowa Nowa South	7	A	186 2 36	£1 per acre

Given under my Hand and the Seal of the State of Victoria aforesaid, at Melbourne, this fifth day of December, in the year of our Lord One thousand nine hundred and sixty-one, and in the tenth year of the reign of Her Majesty Queen Elizabeth II.

(L.S.)

DALLAS BROOKS.

By His Excellency's Command,

KEITH TURNBULL,
Commissioner of Crown Lands and Survey.

GOD SAVE THE QUEEN!

PUBLIC HIGHWAY.—CITY OF MOORABBIN.

PROCLAMATION

By His Excellency the Governor of the State of Victoria and its Dependencies in the Commonwealth of Australia, &c., &c., &c.

WHEREAS by the *Local Government Act* 1958, as amended, section 519, it is amongst other things enacted that it shall be lawful for the Governor in Council at any time, and from time to time, upon request of the council of any municipality, by notice in the *Government Gazette* to proclaim any land reserved, used or by purchase or exchange acquired for a street, road, highway, thoroughfare, bridge, square, court, alley or right-of-way to be a public highway, and that such land shall thereupon and thenceforth from the date of such Proclamation become and be absolutely dedicated to the public as a public highway within the meaning of any law then or thereafter in force:

And whereas the Council of the City of Moorabbin requested that the land hereinafter mentioned, which has been used for a street within the said City, be so declared to be a public highway:

Now therefore, I, the Governor of the State of Victoria in the Commonwealth of Australia, by and with the advice of the Executive Council of the said State, do by this Proclamation declare that all that part of Crown portion 37, Parish of Moorabbin, being the street known as Monamie-avenue indicated by hatching on the plan hereunder, shall be a public highway within the meaning of the said Act.

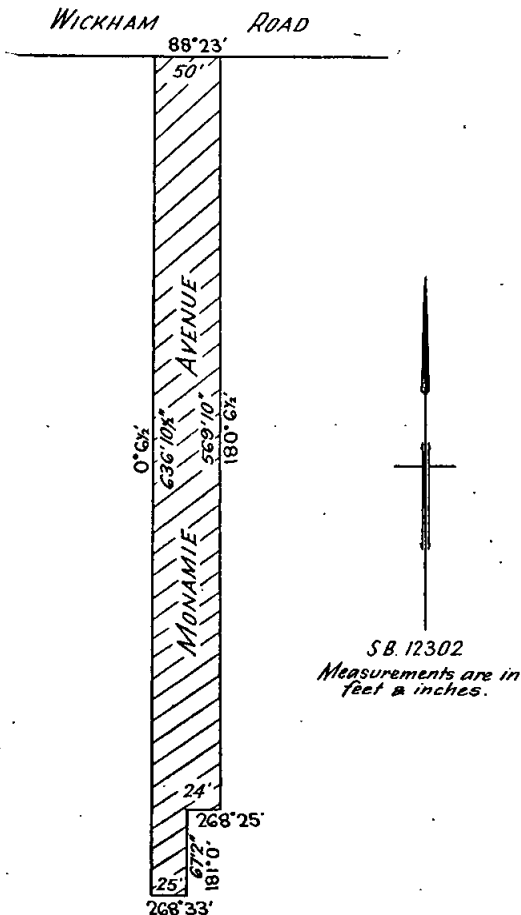

S.B. 12302
Measurements are in feet & inches.

Given under my Hand and the Seal of the State of Victoria aforesaid, at Melbourne, this fifth day of December, in the year of our Lord One thousand nine hundred and sixty-one, and in the tenth year of the reign of Her Majesty Queen Elizabeth II.

(L.S.) DALLAS BROOKS.
By His Excellency's Command,
MURRAY PORTER,
Minister for Local Government.
GOD SAVE THE QUEEN!

PUBLIC HOLIDAYS.

PROCLAMATION

By His Excellency the Governor of the State of Victoria and its Dependencies in the Commonwealth of Australia, &c., &c., &c.

IN pursuance of the provisions contained in Part III. of the *Public Service Act* 1946, I, the Governor of the State of Victoria, in the Commonwealth of Australia, by and with the advice of the Executive Council of the said State, do by this my Proclamation appoint the days and dates hereunder mentioned to be observed as Public Holidays at the places respectively specified, viz.:-

Public Holidays:—

SATURDAY, THE 10TH FEBRUARY, 1962, throughout the Shire of Whittlesea.

SATURDAY, THE 30TH DECEMBER, 1961, throughout the Borough of Benalla.

Given under my Hand and the Seal of the State of Victoria aforesaid, at Melbourne, this twelfth day of December, in the year of our Lord One thousand nine hundred and sixty-one, and in the tenth year of the reign of Her Majesty Queen Elizabeth II.

(L.S.) DALLAS BROOKS.
By His Excellency's Command,
A. G. RYLAH,
Chief Secretary.
GOD SAVE THE QUEEN!

Forests Act 1958 (No. 6254).

PROCLAMATION OF PROHIBITED PERIOD.

PROCLAMATION

By His Excellency the Governor of the State of Victoria and its Dependencies in the Commonwealth of Australia, &c., &c., &c.

IN pursuance of the powers conferred by section 3 of the *Forests Act* 1958, I, the Governor of the State of Victoria in the Commonwealth of Australia, by and with the advice of the Executive Council of the said State, do by this my Proclamation proclaim the period commencing at midnight between the fifteenth and sixteenth days of December, 1961, and ending at midnight between the fifteenth and sixteenth days of April, 1962, to be the prohibited period in respect to any fire protected area other than a State forest or national park in the State of Victoria situated in such municipalities as are specified in the Schedule hereto.

SCHEDULE.

The Shires of Bairnsdale, Omeo, Orbost, Tambo.

Given under my Hand and the Seal of the State of Victoria aforesaid, at Melbourne, this twelfth day of December, in the year of our Lord One thousand nine hundred and sixty-one, and in the tenth year of the reign of Her Majesty Queen Elizabeth II.

(L.S.) DALLAS BROOKS.
By His Excellency's Command,
L. H. S. THOMPSON,
Minister of Forests.
GOD SAVE THE QUEEN!

ACTS OF PARLIAMENT.

PROCLAMATION

By His Excellency the Governor of the State of Victoria and its Dependencies in the Commonwealth of Australia, &c., &c., &c.

I, THE Governor of the State of Victoria, in the Commonwealth of Australia, do hereby declare that I have this day assented, in Her Majesty's name, to the Bills passed by the Parliament of the said State, the titles whereof are hereunder set forth, that is to say:—

- No. 6802. An Act to amend the *University Act* 1958 in relation to the Appointment of Pro-Vice-Chancellors and Deans of Faculties.
- No. 6803. An Act to permit the purchase of Lands or Buildings for the purposes of or for the Efficient Working of the State Accident Insurance Office, and for other purposes.

No. 6804. An Act to vest portion of the Bed Soil and Banks of the Yarra River in the Melbourne and Metropolitan Board of Works and for other purposes.

No. 6805. An Act to make Provision with respect to the Establishment of a Scheme for Providing Legal Assistance for Poor Persons.

No. 6806. An Act to amend the *Crimes Act 1958*.

No. 6807. An Act to apply out of the Consolidated Revenue the sum of Four million four hundred and sixteen thousand five hundred and ninety-five pounds to the service of the year One thousand nine hundred and sixty and One thousand nine hundred and sixty-one.

Given under my Hand and the Seal of the State of Victoria aforesaid, at Melbourne, this fifth day of December, in the year of our Lord One thousand nine hundred and sixty-one, and in the tenth year of the reign of Her Majesty Queen Elizabeth II.

(L.S.)

DALLAS BROOKS.

By His Excellency's Command,

HENRY E. BOLTE,
Premier.

GOD SAVE THE QUEEN!

CHRISTMAS AND NEW YEAR HOLIDAYS.

IT is hereby notified that on—

MONDAY, THE 25TH DECEMBER, 1961,
TUESDAY, THE 26TH DECEMBER, 1961,
MONDAY, THE 1ST JANUARY, 1962, and
TUESDAY, THE 2ND JANUARY, 1962,

the Public Offices will be closed, such days having been appointed by the *Public Service Act 1953* to be observed as holidays in the Public Offices throughout the State of Victoria.

This notice relates only to the closing of the State Public Offices. All inquiries regarding holidays in other offices and in shops and industry should be directed to the Department of Labour and Industry, Old Treasury Building, Spring-street, Melbourne, C.1. (Telephone 63 0321, Extension 6158 or 6382.)

A. G. RYLAH,
Chief Secretary.Chief Secretary's Office,
Melbourne, C.1, 28th November, 1961.

PUBLICATION OF THE "VICTORIA GOVERNMENT GAZETTE."

IT is hereby notified that, owing to the Christmas and New Year Holidays, the last issue of the *Victoria Government Gazette* for the year 1961 will be published on Wednesday, the 20th December, except if special circumstances shall require otherwise.

The next *Gazette* after the 20th December, 1961, will be published on Friday, the 5th January, 1962, and thereafter on each Wednesday, as usual.

A. C. BROOKS,
Government Printer.*Country Fire Authority Act 1958.*

SUMMER PERIOD IN RESPECT OF SPECIFIED PARTS OF THE COUNTRY AREA OF VICTORIA.

WHEREAS by section 4 of the *Country Fire Authority Act 1958* it is enacted that the Chief Secretary of Victoria, after consultation with the Minister of Forests, may, from time to time by declaration published in the *Government Gazette* declare any period to be the summer period in respect of the country area of Victoria, or any specified part or parts thereof and, without affecting the generality of the foregoing, may declare different periods to be the summer period in respect of different parts of the said country area:

And whereas the Chief Secretary and the Minister of Forests have consulted accordingly:

Now therefore I, Arthur Gordon Rylah, the Chief Secretary of Victoria, do hereby declare the period commencing at midnight on the fifteenth day of December, 1961, and ending at midnight on the fifteenth day of April, 1962, to be the summer period in respect of the parts hereinafter specified of the country area of Victoria, that is to say:—

The Fifth Fire Control Region comprising the municipal districts of the Cities of Hamilton and Warrnambool, the Boroughs of Koroiit and Port Fairy and the Shires of Belfast, Dundas, Minhamite, Mortlake, Mount Rouse and Warrnambool;

the Sixth Fire Control Region comprising the municipal districts of the City of Colac, the Town of Camperdown and the Shires of Colac, Hampden, Heytesbury and Otway, except those portions of the said Sixth Fire Control Region comprising the land under the control of the Soldier Settlement Commission, which the Governor in Council has consented to being used for settlement under the *Land Settlement Act 1959* and being all such land situated—

(a) in the Parishes of Wiridjil, Waarre and Paaratte, County of Heytesbury;

(b) in such portion of the Parish of Coradjil, County of Heytesbury as lies to the south-west of the Cobden-Kennedy's Creek road;

(c) in such portions of the Parish of Latrobe as lie (i) to the west of the Old Princetown-road; and (ii) to the east of the Old Princetown-road and within 3 miles from such road;

the Eleventh Fire Control Region comprising the municipal districts of the Shires of Bairnsdale, Omeo, Orbost and Tambo; and

those portions of the Ninth Fire Control Region comprised by the Shires of Buln Buln, Korumburra, Mirboo, Narracan, South Gippsland, Warragul and Woorayl.

A. G. RYLAH,
Chief Secretary.Chief Secretary's Office,
Melbourne, 12th December, 1961.

NOTICE TO MARINERS.

[No. 21 of 1961.]

AUSTRALIA.—VICTORIA.

THE following Notice to Mariners, which has been received from the Harbor Master, Geelong, is published for general information.

C. O'MALLEY,
Port Officer.Ports and Harbors Branch,
Department of Public Works,
Melbourne, C.2, 11th December, 1961.

GEELONG HARBOR TRUST COMMISSIONERS.

PORT OF GEELONG.

1. *Refinery Pier—Construction of New Berthing Head Completed.**Former Notice.*—No. 4 of 1960.

Position.—Fixed Red Light—south-eastern extremity Refinery Pier. Lat. 38 deg. 05 min. 28 sec. S.; Long. 144 deg. 23 min. 24 sec. E. (approx.).

Details.—A new berthing head has been completed to the southward of the existing Refinery Pier. Commencing at a point 315 degrees distant 1,141 feet from the above position, proceeding in a 225 degrees direction for a distance of 506 feet; thence in a 150 degrees direction for 957 feet to its seaward extremity.

Lighting.—During the hours of darkness the seaward extremity of the New Pier is marked by two Red lights vertically disposed, 3 feet apart, the lowest light being at a height of 18 feet above high water level.

Dredged Area.—The new berthing head is dredged to a depth of 36 feet over the following area. From a position 109 deg. 14 min. 35.6 sec. distant 45 feet from No. 9 beacon, Corio Channel, in a 351 deg. 38 min. 06.3 sec. direction for a distance of 1,160 feet; thence in a 060 deg. 00 min. 00 sec. direction for a distance of 750 feet; thence in a 107 deg. 22 min. 42.6 sec. direction for a distance of 308 feet to merge with the dredged cut inner limit of the northern berthing head.

Numbering of Berths.—In future berths will be designated by numbers commencing with No. 1 on the north side of the most northerly berth; and thence No. 2, No. 3 and No. 4 berth on the south side of the south berthing head.

2. *Dangerous Wreck Removed.**Former Notice.*—No. 17 of 1961 hereby cancelled.

Position.—Point Wilson Beacon. Lat. 38 deg. 05 min. 36 sec. S.; Long. 144 deg. 30 min. 27 sec. E. (approx.).

Details.—The dangerous wreck 098 degrees distant 13,270 feet from the above position has been removed.

Remarks.—Area is now clear of obstructions.

Transport Regulation Acts.

TRANSPORT REGULATION BOARD.

NOTICES OF PUBLIC HEARINGS.

NOTICE is hereby given that the applications made by the persons named below for licences to operate the commercial goods vehicles on the route or routes, or in the manner set out opposite their names, will be held at a time and place to be communicated to the persons concerned:—

Name and Address; Nature of Application.

- BEAMAN, A. J., 472 Wilson-street, Albury, N.S.W.; 1 commercial goods vehicle (101 cwt.) to operate—(a) within a radius of 90 miles of the post office at Wangaratta (Benalla Division of the Country Roads Board)—plant the property of a contractor and required for use in connexion with the construction or maintenance of some specific, existing or proposed road, street, footpath, bridge, wharf, pier, weir or channel, (b) within a radius of 20 miles from site of construction or maintenance work performed pursuant to paragraph (a) above, or from the railway station nearest thereto—metal, stones, screenings, ashes, gravel, sand, earth and any other materials required for such work.
- CANNY, W., & SON PTY. LTD., Roy-street, Wangaratta; 1 commercial goods vehicle (191 cwt.) to operate—(a) within a radius of 20 miles of the post office at Wangaratta—general goods, (b) within a radius of 50 miles from B.P. Australia Ltd. Depot at Benalla—petroleum products in prescribed types of containers and empty return containers.
- CASEY, L. M., 3 Dundas-street, St. Arnaud; application to vary the conditions of existing licence No. D.A.44462, by adding as paragraph (c) "between St. Arnaud and Doobobetic, mail and two (2) passengers".
- CHENHALL, E. G., 69 Station-street, Arncliffe, N.S.W.; 3 commercial goods vehicles (approximately 120 cwt. each) to operate throughout the State of Victoria, in the course of business as a "travelling showman"—own equipment and novelty prizes.
- COFFEY, J. G., 94 Chum-street, Golden Square; 1 commercial goods vehicle (12 cwt.) to operate within a radius of 100 miles from the chief post office in the City of Bendigo, but excluding operations to or from the City of Melbourne or the metropolitan area—refrigerators, washing machines, television sets and aerials, and electrical fittings for installation, also tools of trade, spare parts and materials incidental to the maintenance and servicing of electrical equipment, in the course of business as "electrical retailer".
- COOPER, J. E., Brandey Creek-road, Warragul; 1 commercial goods vehicle (100 cwt.) to operate—(a) throughout the State of Victoria, in the course of business as "marine collector"—marine goods as designated in the *Marine Stores and Old Metals Act 1958*, No. 6303, but excluding the carriage of any such goods to wharves, docks or ships for shipment or export purposes, (b) within a radius of 20 miles of Warragul—general goods.
- CROCKFORD & ROBERTSON PTY. LTD., 15 Abbott-street, Fairfield; 1 commercial goods vehicle (8 cwt.) to operate throughout the State of Victoria, in the course of business as "air control engineers"—tools of trade, spare parts and materials incidental to the servicing and installation of heating and air conditioning systems.
- DOOLAN, P. J., Lumsden-street, Kilmore; 2 commercial goods vehicles (98 cwt. each) to operate within a radius of 5 miles of the post office at Kilmore and between Kilmore and Melbourne via the Hume Highway serving places *en route* and places within a radius of 2 miles of such highway—general goods.
- FYSH, G. W. & G. A., 509 Belmore-road, Box Hill South; 1 commercial goods vehicle (65 cwt.) to operate throughout the State of Victoria, in the course of business as a "marine collector"—marine goods as designated in the *Marine Stores and Old Metals Act 1958*, No. 6303.
- GORDON BROTHERS PTY. LTD., 120 Union-street, Brunswick; 1 commercial goods vehicle (17 cwt.) to operate throughout the State of Victoria, in the course of business as "refrigeration engineers" for the purpose of servicing and supervision of installation of refrigeration and air conditioning plant—tools of trade, spare parts, refrigeration and air conditioning equipment for repair or having been repaired and for specialized installation and materials incidental thereto.
- GREEN, S. R., 237 Maribyrnong-road, Ascot Vale; 1 commercial goods vehicle (16 cwt.) to operate within a radius of 50 miles of Four'n Twenty Pies Pty. Ltd. at Ascot Vale, solely on behalf of such company—pies, pasties, sausage rolls and fruit drinks in waxed paper containers.
- HARDMAN, R. R., 3 Moroney-street, Boronia; 1 commercial goods vehicle (7 cwt.) to operate throughout the State of Victoria, in the course of business as "contract blind fitter"—tools of trade, canvass and other type blinds, screens and awnings for fitting, and materials incidental thereto.
- HEDLEY, J. G., Flat 4, Kennedy-street, Morwell; 1 commercial goods vehicle (10 cwt.) to operate throughout the State of Victoria on behalf of Graham Evans and Co., construction contractors, as a supervising foreman—tools of trade and a small quantity of material incidental to the repair or completion of a particular contract.
- HORNBUCKLE, E., Briagalong; 1 commercial goods vehicle (254 cwt.) to operate—(a) from forest landings in the Dargo area to Milner's sawmill at Stratford—logs, (b) from forest and private landings in the Briagalong and Dargo areas to the S.E.C. at Bairnsdale—poles, (c) within a radius of 20 miles of the post office at Stratford—sawn timber.
- LENON, A. J., 61 Archer-street, Shepparton; 1 commercial goods vehicle (74 cwt.) to operate within a radius of 40 miles of the post office at Shepparton, in the course of business as "wood merchant and fencing post supplier"—own firewood and fencing posts.
- LICKA, A., Pearce-street, Wodonga; 1 commercial goods vehicle (109 cwt.) to operate—(a) within a radius of 50 miles from the post office at Wodonga—plant the property of a contractor and required by him for use in connexion with the construction or maintenance of some specific, existing or proposed road, street, footpath, bridge, pier, wharf, weir or channel, and also the following materials, viz., metal, stones, screenings, ashes, gravel, sand and earth, (b) within a radius of 20 miles from the site of any construction or maintenance work performed pursuant to paragraph (a) above, or from the railway station nearest thereto—any other materials required for such work, (c) within a radius of 20 miles from the post office at Wodonga—general goods excluding any plant or materials carried or to be carried pursuant to paragraphs (a) and (b) above.
- MASSEY FERGUSON (AUST.) LTD., 3 Devonshire-road, Sunshine; 1 commercial goods vehicle (21 cwt.) to operate throughout the State of Victoria, in the course of business as "farm machinery manufacturer" for the purpose of testing agricultural machinery—tools of trade, testing equipment and machinery for testing.
- MATTHEWS, S. T., 46 Robinson-street, Morwell; 1 commercial goods vehicle (187 cwt.) to operate—(a) within a radius of 50 miles from the post office at Morwell—plant the property of a contractor and required by him for use in connexion with the construction or maintenance of some specific, existing or proposed road, street, footpath, bridge, pier, wharf, weir or channel, and also the following materials, viz., metal stones, screenings, ashes, gravel, sand and earth, (b) within a radius of 20 miles from the site of any construction or maintenance work performed pursuant to paragraph (a) above, or from the railway station nearest thereto—any other materials required for such work, (c) within a radius of 20 miles from the post office at Morwell—general goods excluding any plant or materials carried or to be carried pursuant to paragraphs (a) and (b) above.
- MEYERS, T. W., Lot 23-24, Upper Glen Park-road, Eltham North; 1 commercial goods vehicle (113 cwt.) to operate—(a) within a radius of 25 miles of Melbourne—general goods, (b) within a radius of 70 miles of L.S.D. Brick Co. (Vic.) Pty. Ltd., at Bundoora, solely on behalf of the said company—concrete bricks.
- MORE QUARRIES, Harrow; 1 commercial goods vehicle (219 cwt.) to operate—(a) within the Shire of Kowree—plant the property of a contractor and required by him for use in connexion with the construction or maintenance of some specific, existing or proposed road, street, footpath, bridge, pier, wharf, weir or channel, and also the following materials, viz., metal stones, screenings, ashes, gravel, sand and earth, (b) within a radius of 20 miles from the site of any construction or maintenance work performed pursuant to paragraph (a) above, or from the railway station nearest thereto—any other materials required for such work, (c) within a radius of 20 miles from the post office at Harrow—general goods, excluding any plant or materials carried or to be carried, pursuant to paragraphs (a) and (b) above.

- MOTOR SPARES LTD., 547 Elizabeth-street, Melbourne; 1 commercial goods vehicle (7 cwt.) to operate within a radius of 75 miles from the chief post office at Shepparton in the course of business as "radio and television engineers" for the purpose of installing and servicing air conditioners, refrigerators, television sets and radio sets—air conditioners, television sets, radio sets and refrigerators for specialized installation, repair or having been repaired, and tools of trade, equipment and materials incidental to installation and servicing.
- McMULLEN, A. H., & Co., Salisbury-street, Orbost; 3 commercial goods vehicles (135, 127 and 144 cwt.) to operate—(a) within a radius of 20 miles of the post office at Orbost—general goods, (b) to and from places within a radius of 50 miles of the post office at Orbost from and to places within paragraph (a)—livestock, (c) within a radius of 50 miles of the post office at Orbost—second-hand household furniture, fish and cream and empty return containers, (d) from B.P. Australia Ltd.'s depot at the aforesaid places within a radius of 50 miles of the aforesaid depot—petroleum products in prescribed types of containers and empty return containers.
- McMULLEN, A. H., & Co., Salisbury-street, Orbost; 2 commercial goods vehicles (233 and 238 cwt.) to operate from Legge's sawmill at Genoa, Cann River sawmills at Cann River, Henry's timber mill and J. R. De Ross and Sons' sawmill at Club-terrace, Henderson and Bell's sawmill and Pow's timber mill at Cabbage Tree to Orbost Railway Station—sawn timber.
- PATTINSON, R. J., Yarram-street, Yarram; application to vary the conditions of existing licence No. D.A.44291 by adding as paragraph (c) "from State Electricity Commission at Morwell to Yarram and District Co-op. Society Ltd. and Permewan Wright Ltd. at Yarram—briquettes".
- PRITCHARD, G. E., 40 Bradbury-street, Ballarat; 1 commercial goods vehicle (132 cwt.) to operate from bush sites in the Daylesford and Sailor's Falls areas to the C.S.R. factory at Bacchus Marsh—pulpwood.
- RAVEN, W. G., 227 Smith-street, Fitzroy; 1 commercial goods vehicle (10 cwt.) to operate throughout the State of Victoria in the course of business as "funeral director" as a mortuary vehicle.
- REDBENBACH, W. & M., 2 Stanley-street, Bairnsdale; application to vary the conditions of existing licence No. T.T.D.2103 by deleting present conditions and adding in lieu—(1) logs from forest landings within a radius of 40 miles of the post office at Stratford to sawmills at Stratford and Dargo, (2) sawn timber from sawmills at Stratford to railhead at Stratford and consignees between Sale and Bairnsdale, (3) sawn timber from sawmills at Dargo to railhead at Fernbank and consignees between Sale and Bairnsdale".
- ROBINSON, H., 10 Dunlop-avenue, Ormond; 1 commercial goods vehicle (approximately 100 cwt.) to operate—(a) within a radius of 25 miles of the G.P.O., Melbourne—general goods, (b) from pits in the Cranbourne area to places within paragraph (a) above—sand.
- UTAH AUSTRALIA LTD., 505 St. Kilda-road, Melbourne; 1 commercial goods vehicle (198 cwt.) to operate throughout the State of Victoria in the course of business as "civil and constructional engineers" as a specially constructed water tanker for the purpose of spraying own contracts.
- WHITE, K. W., 34 Princess-street, Warrnambool; 1 commercial goods vehicle (110 cwt.) to operate—(a) within a radius of 75 miles of the post office at Peshurst (Warrnambool Division of the Country Roads Board)—plant the property of a contractor and required for use in connexion with the construction or maintenance of some specific, existing or proposed road, street, footpath, bridge, wharf, pier, weir or channel, (b) within a radius of 20 miles from site of construction or maintenance work performed pursuant to paragraph (a) above, or from the railway station nearest thereto—metal, stones, screenings, ashes, gravel, sand, earth and any other materials required for such work, (c) within a radius of 20 miles of the post office at Warrnambool—general goods.
- WILLIAMSON, W. J., 17 Oak-street, Seymour; 1 commercial goods vehicle (145 cwt.) to operate—(a) within a radius of 50 miles from the post office at Seymour—plant the property of a contractor and required by him for use in connexion with the construction or maintenance of some specific, existing or proposed road, street, footpath, bridge, pier, wharf, weir or channel, and also the following materials, viz., metal, stones, screenings, ashes, gravel, sand and earth, (b) within a radius of 20 miles from the site of any

construction or maintenance work performed pursuant to paragraph (a) above, or from the railway station nearest thereto—any other materials required for such work, (c) within a radius of 20 miles from the post office at Seymour—general goods excluding any plant or materials carried or to be carried pursuant to paragraphs (a) and (b) above.

NOTICE is hereby given that the applications made by the persons named below for renewal of licences to operate the commercial goods vehicles, on the route or routes or in the manner set out opposite their names, will be heard at a time and place to be communicated to the persons concerned:—

Name and Address; Present Franchise; Licence No.; Date of Expiry.

- BEAUEPEAIRE TYRE SERVICE PTY. LTD., 83-95 Franklin-street, Melbourne; 1 commercial goods vehicle (8 cwt.) to operate within a radius of 50 miles from licensee's branch store situate in the Township of Warragul, in the course of business as "tire retreaders and distributors"—tires and tubes for sale and delivery, used tires for repair and retreading or having been repaired or retreaded, batteries, oil and car accessories; D.A.629/28; 10th February, 1962.
- CARLTON & UNITED BREWERIES LTD., 16 Bouverie-street, Carlton; 2 commercial goods vehicles (7 and 15 cwt.) to operate—(a) within a radius of 50 miles from the post office situate at the corner of Bourke and Elizabeth streets in the City of Melbourne, in the course of business as "brewers"—own goods, (b) throughout the State of Victoria for the purpose of undertaking maintenance and servicing work at hotels and canteens—tools of trade, plumbers' equipment and incidental materials to such servicing and maintenance; D.A.808/1; 22nd March, 1962.
- E.I.L. SERVICE PTY. LTD., 161-173 Sturt-street, South Melbourne; 1 commercial goods vehicle (8 cwt.) to operate throughout the State of Victoria in the course of licensee's business as "electrical engineers" for the purpose of installing, servicing and maintaining electrical appliances—electrical appliances for installation, tools of trade, spare parts and materials incidental to licensee's own contracts; D.A.30374/7; 24th March, 1962.
- EMOLEUM (AUST.) LTD., Arden-street, North Melbourne; 1 commercial goods vehicle (184 cwt.) to operate from the premises of the licensee at North Melbourne direct to spraying sites within the State of Victoria in the course of its business as a "manufacturer of bitumen emulsion"—licensee's own emoleum in bulk tanker; D.A.1042/4; 24th March, 1962.
- NATIONAL TYRE SERVICE (HAMILTON) PTY. LTD., corner of French and Cox streets, Hamilton; 1 commercial goods vehicle (9 cwt.) to operate within a radius of 80 miles from the premises of the licence holder at Hamilton, in the course of business as "tire dealers and retreaders"—new tires for delivery to clients and second-hand tires for retreading and recapping or having been retreaded or recapped; D.A.2374/3; 30th January, 1962.
- NORTON, F., PTY. LTD., 22 Sargood-street, Altona; 3 commercial goods vehicles (40, 8 and 10 cwt.) to operate throughout the State of Victoria—tools of trade and equipment incidental to own contracts entered into by the holder of this licence in the course of his business as "master plumber"; D.A.31887; D.A.31887/1; D.A.31887/3; 17th February, 1962.
- TROFIN, F., 74 Kinnon-avenue, Belmont, Geelong; 1 commercial goods vehicle to operate—(a) within a radius of 95 miles from the post office at Cohuna and/or within a radius of 100 miles from the post office at Merbein (Bendigo Division of the Country Roads Board)—plant the property of a contractor and required for use in connexion with the construction or maintenance of some specific, existing or proposed road, street, footpath, bridge, wharf, pier, weir or channel, (b) within a radius of 20 miles from site of construction or maintenance work performed pursuant to paragraph (a) above, or from the railway station nearest thereto—metal, stones, screenings, ashes, gravel, sand, earth and any other materials required for such work; D.A.31807; 10th February, 1962.
- SUNBEAM CORPORATION LTD., Sloane-street, Maribyrnong; 2 commercial goods vehicles (9 and 8 cwt.) to operate throughout the State of Victoria in the course of licensee's business as "manufacturers of electrical and farm appliances"—electrical and farm appliances for installation and demonstration purposes, tools of trade, spare parts and materials incidental to the servicing and maintenance of such appliances; D.A.14579/26, D.A.14579/27; 24th March, 1962.

YOUNG, G. G., 67 Kent-road, Pascoe Vale; 1 commercial goods vehicle (55 cwt.) to operate—(a) complete new motor cars from the premises of the Ford Motor Co. of Australia Pty. Ltd., at Broadmeadows, direct to the premises of consignees throughout the State of Victoria, (b) complete second-hand motor cars from the premises of distributors and dealers to consignees throughout the State of Victoria; T.D.A.41262; 20th February, 1962.

NOTICE is hereby given that the application made by the person named below for renewal with variation of licence to operate the commercial goods vehicle, on the route or routes or in the manner set out opposite his name, will be heard at a time and place to be communicated to the person concerned:—

Name and Address; Present Franchise; Variation.

CHISELETT, W. A. R., PTY. LTD., 154 Commercial-street, Merbein; 1 commercial goods vehicle (102 cwt.) to operate in the course of licensee's business as "manufacturers of aerated waters"—licensee's own manufactured aerated waters and empty returns only in the under-mentioned areas:—(a) Within a radius of 20 miles from the post office at Merbein, (b) from and to licensee's premises at Merbein to and from the Township of Murrayville and townships *en route*, via the Calder Highway, to the Township of Ouyen, and thence via the Ouyen-Pinnaroo Highway *en route* to the Township of Murrayville; by deleting paragraph (a) and adding in lieu: Within a radius of 60 miles from the post office at Merbein.

NOTICE is hereby given that the applications made by the persons named below for licences to operate commercial passenger vehicles, on the route or routes or in the manner set out opposite their names, will be heard at a time and place to be communicated to the parties:—

Name and Address; Nature of Application.

MURRUMBEENA BUS SERVICES, 12 Castlebar-road, Oakleigh; 1 commercial passenger vehicle, with seating capacity for 35 persons, to operate as a metropolitan route omnibus on Route 77A (Murrumbena) under the same terms and conditions as all M.O. licences at present held by the applicant and interchangeably on Route 132A (Moorabbin-Moorabbin East).

GLENROY BUS SERVICE CO. PTY. LTD., 492 Pascoe Vale-road, Pascoe Vale; application for variation of Route 48A (Part C—Glenroy-Broadmeadows) to extend service via Pascoe Vale-road and Camp-road to Widford-street.

NORTHERN BUS LINES PTY. LTD., 352 Bell-street, Preston; 1 commercial passenger vehicle, with large seating capacity, to be purchased, to operate as a metropolitan route omnibus on the following route:—

Broadmeadows Railway Station—Broadmeadows Military Camp.

Description of Route: Commencing in Railway-parade, adjacent to Broadmeadows Railway Station, via Railway-parade, Cuthbert and Martell streets, Camp-road to Broadmeadows Military Camp (return trips to be operated via Camp-road and Railway-parade).

Fares to be Charged: Any one section, 6d. Any two sections, 9d.

Sections on Route: To be determined.

Time-table to be Observed: Minimum service—week days, 30 minutes 6.15 a.m. to 7 p.m. Saturdays, 30 minutes 7 a.m. to 1 p.m. No service Sundays or public holidays.

PRIDHAM, W., PTY. LTD., 11 Evans-street, Braybrook; application for renewal of licence No. T.P.12 (expiring 31st December, 1961) authorizing the carriage of employees only, free of charge, between the Sunshine and Footscray Railway Stations and the company premises in Evans-street, Braybrook, via Ballarat-road.

DYSONS, L. C., BUS SERVICE PTY. LTD., 753 Plenty-road, East Preston; application for variation of permit authority authorizing the carriage of school children from Fairfield North State School to East Preston Technical School, to extend service via Speight-street to the corner of Speight and St. David streets (to serve new pupils from Wales-street State School) and to charge the following weekly fares only as an alternative to separate and distinct fares where so required—(1) corner of Jones and Dundas streets—school, 4s. 6d. weekly, 6d. single, (2) Fairfield North

State School—school, 5s. weekly, 7d. single, (3) corner of St. David and Speight streets—school, 6s. 6d. weekly, 9d. single.

DYSONS, L. C., BUS SERVICE PTY. LTD., 753 Plenty-road, East Preston; application for variation of Route 263A (Regent-Whittlesea-Kinglake) to extend service on Sundays only—(a) to Melbourne: service to operate from Wights Tourist Bureau, via Flinders, Russell, Bourke and Nicholson streets, Alexandra-parade, Queens-parade, High-street, Tyler-street, and thence via normal route, (b) into Tourourrong Reservoir, via Jacks Creek-road, from corner of Jacks Creek-road and Old Yea-road.

Time-table (Sundays only):

Depart Whittlesea 9 a.m. Arrive City 10 a.m.
Depart City 10 a.m. (via Tourourrong). Arrive Kinglake 11.45 a.m.

Depart Kinglake 5 p.m. (via Tourourrong). Arrive City 6.45 p.m.

Depart City 6.45 p.m. Arrive Whittlesea 7.45 p.m.

Fares to be Charged: Kinglake-Melbourne, 18s. return, 10s. single. Kinglake West-Melbourne, 14s. return, 8s. single. Tourourrong-Melbourne, 12s. return, 7s. single. Whittlesea-Melbourne, 9s. return, 5s. 6d. single. Yan Yean-Melbourne, 8s. return, 4s. 6d. single. Mernda-Melbourne, 7s. return, 4s. single. South Morang-Melbourne, 6s. return, 3s. 6d. single.

APPPLICATIONS for metropolitan taxi-cab licences by the persons listed hereunder in respect of commercial passenger vehicles with seating capacity for five persons:—

Name and Address.

ALLAN, C. A., Flat 1, "Lowestoft", Henry-street, Windsor.
PROCTOR, R. H. E., 24 St. Vincent-place, Albert Park.
GUY, E. L., Liverpool-road, Kilsyth.
LEWIS, N. J. C., 36 Sandown-road, Ascot Vale.
ANDREWS, T., 21 Chatham-road, Canterbury.
SANCO, G., 141 Gertrude-street, Fitzroy.
FREEMAN, G., 65 O'Connor-street, Reservoir.
PIPER, H. A., 16 Wattle-avenue, Glenhuntly.
ALLCHIN, S. V., 15 Lalor-street, Port Melbourne.
KING, P. G., 52 Rosamond-street, Balacivava.
TOWNSEND, P. D., 64 Shoobra-road, Elsternwick.
LANGFORD, M. A., 36 Cope-street, Coburg.
ARMSTRONG, S., 26 Sunderland-avenue, Ashburton.
PARKER, W. V., 4 Roosevelt-street, Coburg.
CHARLES, J. N., 7 Bessell-court, Jacana.
KELL, D. M., Flat 1, 62 Harold-street, Middle Park.
YENDALL, O. L., 405 St. Georges-road, North Fitzroy.
ROOK, T. B., 422 Queens-parade, Clifton Hill.
STAPLETON, A. T., 180 Donald-street, East Brunswick.
HENSHALL, H., Flat 1, 32 Lawn-crescent, Braybrook.
SCHIPP, R. L., 57 Beverley-street, East Doncaster.
JOSEPH, B., 12 Greville-road, Rosanna.
HARRIS, S., 9 Moore-street, Elwood.
BARKER, D. E., 34 Avocet-street, East Doncaster.
DAYNES, R. S. K., 16 Skeffington-street, West Heidelberg.
BRIGHT, P. G., 195 Clarendon-street, South Melbourne.
SOUMILAS, G., 1 Buxton-street, Elsternwick.
FRANGOUDIS, L., 263 Coventry-street, South Melbourne.
LANDY, E. G., 40 Gloucester-road, Ashburton.
CRAWFORD, F. L., 44 Williams-road, Windsor.
CUNNINGHAM, G. V., 88 Nelson-road, South Melbourne.
APSITE, J., 3 Patterson-street, East Coburg.
JEACLE, R. W., 429 Dorcas-street, South Melbourne.
RASMUSSEN, N. A. R., 46 Baker-street, Richmond.
SPARKS, C. C., 28A Queens-avenue, Carnegie.
HAYES, R. A. S., 48 Kangaroo-road, Murrumbena.
UREN, E., 176 Brunswick-road, East Brunswick.
ZEMEL, T., 4 Campbell-street, East Kew.
CLARK, R., Warrandyte-road, Research.
ALDER, R. N., 57 Andrew-street, Windsor.
VAN DER KRANS, W., 50 Mary-street, Kew.
ERIKSEN, O. M., 4 Peter-street, South Yarra.
FREESTONE, L. A., 19 Lahinch-street, Broadmeadows.
KIRBY, N. G., 27 Acacia-avenue, Huntingdale.
WEBBER, J. W., 100 Buncle-street, North Melbourne.
NOTMAN, R. C., 175 Sycamore-street, South Caulfield.
BARON, F. J., 899 Plenty-road, Kingsbury.
RICHARDS, J. D., 15 Commercial-road, South Yarra.
LAWRENCE, H. T., 29 Alfred-street, North Melbourne.
GOULD, P. J., 10 Glencoe-street, Caulfield.
WHELAN, J. G., 17 O'Grady-street, Albert Park.
YOUNG, R. D., "Lindisfarne", Springvale-road, Donvale.
THOMAS, G. E., 12 Greville-road, Rosanna.
BURKE, J. T., Gordon's-lane, South Morang.
FELDGAIER, I., Flat 9, 39 Acland-street, St. Kilda.
CARBIS, A. E., 16 Boyne-street, East Coburg.
GELBHARDT, L., 5 Boyd-street, Thornbury.
BERRY, W. J., 11 Clarke-street, Prahran.
CHRYSAL, R. M., 41 Elgin-street, Hawthorn.

BATTY, F. B., 9 Oakover-road, Preston.
 PRODROMOU, T., 4 McCrory-street, Coburg.
 DAY, E., Block 7, 158 Arnold-street, North Carlton.
 WALTERS, D., 5 Audley-street, Coburg.
 KELLEHR, H., 4 Bellevue-street, Coburg.
 KLEIN, T. S., 1 Wattle-grove, Moreland.
 ZWEIFEL, T., 18 Normanby-place, Richmond.
 SCRIMGEOUR, K. J., 9 Kathryn-street, Fawkner.
 WILSON, H. J. L., 207 Spring-street, Reservoir.
 MESSER, W. H., 1270 Nepean Highway, Cheltenham.

Notice of any objection should be forwarded to reach the Secretary to the Board not later than Wednesday, 27th December, 1961.

B. P. KAY,
 Secretary.

Exhibition Buildings, Rathdowne-street, Carlton, N.3,
 Wednesday, 13th December, 1961.

Local Government Act 1958 (Part 48).

RENEWAL OF UNUSED ROAD AND WATER FRONTAGE LICENCES.

ALL Unused Road and Water Frontage Licences expiring on 31st December, 1961 (excepting those cancelled or terminated) are hereby renewed for a further term of three years.

KEITH TURNBULL,
 Minister of Lands.

Department of Crown Lands and Survey,
 Melbourne, 12th December, 1961.

SHIRE OF SOUTH GIPPSLAND.—PUBLIC HIGHWAY.

PURSUANT to the provisions of sections 522 and 526 of the *Local Government Act 1958*, the Council of the Shire of South Gippsland hereby directs that the land in the Parish of Wonga Wonga South indicated by hatching on the diagram annexed hereto, which has been purchased, taken or acquired by it, shall be a public highway on and from the date of publication of this Order in the *Government Gazette* and declares that such land shall be a public highway in lieu of the land indicated by cross-hatching on the said diagram.

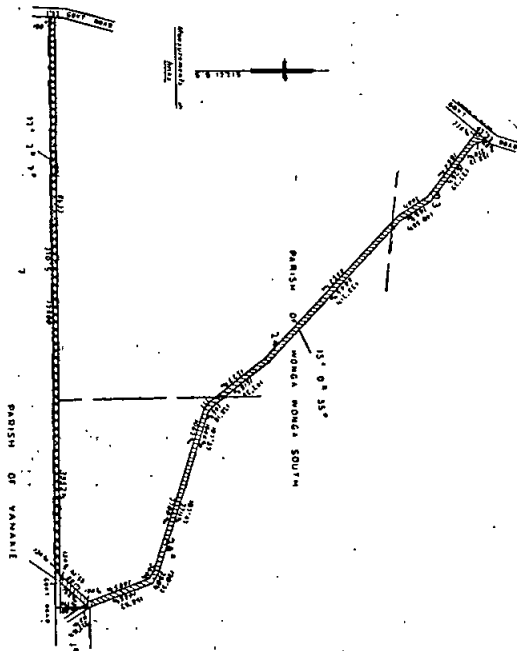

The common seal of the President, Councillors and Ratepayers of the Shire of South Gippsland was hereunto affixed this tenth day of August, 1961—

(SEAL) W. E. COOK, President.
 J. H. McDONALD, Councillor.
 J. RENNICK, Shire Secretary.

Approved by the Governor in Council,
 5th December, 1961.

N. G. WISHART,
 Acting Clerk of the Executive Council.

PUBLIC TRUSTEE ACT 1958 (No. 6350).—SECTION 17.

I HEREBY give notice that on the 29th November, 1961, the Public Trustee filed elections to administer the following deceased persons' estates, in accordance with section 17 of the *Public Trustee Act 1958*:—

BAKER, MARY POWELL, also known as Mary Baker, late of 9 George-street, Dimboola, married woman, died 28th August, 1961.

BROOKE, BARBARA MARY, late of 462 St. Kilda-road, Melbourne, married woman, died 26th June, 1961.

ELLIS, ISABEL MARGARET, late of 212 Pascoe Vale-road, Essendon, clerk, died 30th July, 1961.

HOWDEN, ELSIE JANE, formerly of "Heatherlie", Belgrave, late of Kew, spinster, died 30th September, 1961.

THORNE, CHARLES EDWARD, late of Mount Royal, Parkville, pensioner, died 11th August, 1961.

WISEMAN, CATHERINE, late of Benevolent Home, Ballarat, spinster, died 24th June, 1961.

A. D. DUNCAN,
 Public Trustee.

601 Little Collins-street, Melbourne, 6th December, 1961.

NOTICE.

CREDITORS, next of kin and others having claims against the estate of any of the under-mentioned deceased persons, are required to send particulars of their claims to the Public Trustee, 7th Floor, 601 Little Collins-street, Melbourne, the personal representative, on or before the 16th February, 1962, after which date the Public Trustee may convey or distribute the assets, having regard only to the claims of which the Public Trustee then has notice:—

BAKER, MARY POWELL, also known as Mary Baker, late of 9 George-street, Dimboola, married woman, died 28th August, 1961.

BARTLETT, SELINA, late of 3 Beena-avenue, Murrumbena, widow, died 9th April, 1961.

BROOKE, BARBARA MARY, late of 462 St. Kilda-road, Melbourne, married woman, died 26th June, 1961.

ELLIS, ISABEL MARGARET, late of 212 Pascoe Vale-road, Essendon, clerk, died 30th July, 1961.

FEARON, ROGER ST. CLAIR, late of 25 Main-street, Blackburn, insurance agent, died 30th May, 1961.

GINN, HERBERT STANLEY, late of 26 Allambee-avenue, East Camberwell, retired public servant, died 12th September, 1961.

GOW, NORMAN LESLIE, late of 31 Edwards-avenue, Garden City, painter, died 22nd August, 1961.

HOWDEN, ELSIE JANE, formerly of "Heatherlie", Belgrave, late of Kew, spinster, died 30th September, 1961.

LYMBERY, ROBERT, late of 24 Farm-street, Newport, retired dockyard employee, died 13th September, 1961.

MAGUIRE, JOAN EILEEN, late of 29 Richardson-street, Albert Park, married woman, died 6th September, 1961.

NORTHEY, MARGARET LYLE, also known as Margaret Northey, late of 6 Ferry-crescent, West Brunswick, widow, died 23rd August, 1961.

PARDY, ALFRED, late of 240 Lygon-street, Carlton, retired accountant, died 14th September, 1961.

SMITH, ALFRED EBER, formerly of 39 Gordon-grove, East Preston, late of 85 Cheddar-road, Reservoir, clerk, died 16th September, 1961.

SMITH, MARDI FRANCIS, also known as Mardi Smith, late of 30 Scott-street, Elwood, clerk, died 24th August, 1961.

STONE, HAROLD, formerly serving under regimental No. 1038, in the 13th Australian Light Horse of the A.I.F., late of 4 Union-street, Malvern, retired clerk, died 5th April, 1961.

THORNE, CHARLES EDWARD, late of Mount Royal, Parkville, pensioner, died 11th August, 1961.

WEBSTER, HARRY JOSEPH, late of 62 Henty-street, Reservoir, pensioner, died 21st June, 1961.

WISEMAN, CATHERINE, late of Benevolent Home, Ballarat, spinster, died 24th June, 1961.

A. D. DUNCAN,
 Public Trustee.

Melbourne, 6th December, 1961.

RULES UNDER THE JUSTICES ACT.

SELECTION BY A LAW OFFICER OF THE PLACES AND DAYS AND HOURS FOR HOLDING COURTS (WITHIN THE MEANING OF THE SAID RULES).

I, THE undersigned, ARTHUR GORDON RYLAH, a Law Officer of the State of Victoria, in pursuance of the powers conferred upon me by Rule 2 of the Justices Act 1936 (No. 2), do hereby select for the year 1962, from the places appointed by the Governor in Council for holding Courts of Petty Sessions referred to in Rule 1 of the said Rules, the places named in the list hereto annexed as places for holding Courts within the meaning of the said Rule 2: And I do hereby with respect to each place named in the said list from the days and hours appointed by the Governor in Council for holding Courts of Petty Sessions further select the days and hours set forth in the said list opposite the name and the said places respectively as the days and hours at which the said Courts shall be held.

Signed at Melbourne, this 1st day of December, 1961.

A. G. RYLAH, Law Officer.

COURTS, DAYS AND HOURS FOR THE HEARING OF SPECIAL COMPLAINTS DURING 1962.

Court.	Day.	Hour.	January.	February.	March.	April.	May.	June.	July.	August.	September.	October.	November.	December.
ALEXANDRA	Fri.	11 a.m.	26	23	23	..	18	15	18	10	7	5	2, 30	..
ARARAT	Fri.	10 a.m.	12, 26	9, 23	9, 23	6	4, 18	1, 15, 29	13, 27	10, 24	7, 21	5, 19	2, 16, 30	14, 28
AVENEL	Thur.	1 p.m.	1	..	24	16	8	3
AVOCA	Mon.	2 p.m.	21	18	16	13	10
BACCHUS MARSH	Wed.	2 p.m.	31	28	28
BACCHUS MARSH	Fri.	10 a.m.	5, 19	2, 16	2, 16, 30	13, 27	11, 25	8, 22	6, 20	3, 17, 31	14, 28	12, 26	9, 23	7, 21
BAIRNSDALE	Thur.	10 a.m.	18	1, 15	1, 15, 29	12, 26	10, 24	7, 21	5, 19	2, 9, 23	13, 27	11, 25	8, 22	6, 20
BALLAN	Mon.	10 a.m.	12, 26	9, 23	9, 23	6	4, 18	1, 15, 29	13, 27	10, 24	7, 21	5, 19	2, 16, 30	14
BALLARAT	Tue.	10 a.m.	Every	Tuesday	and Thursday	except Public	Holidays.
BEAUFORT	Mon.	10 a.m.	22	19	19	16	14	11	9	6	3	1, 29	26	24
BEECHWORTH	Thur.	10 a.m.	25	22	22	19	17	14	12	9	6	4	1, 29	..
BENALLA	Wed.	10 a.m.	17, 31	14, 28	14, 28	11	9, 23	6, 20	4, 18	1, 15, 29	12, 26	10, 24	7, 21	5, 19
BENDIGO	Mon.	10 a.m.	22	19, 26	19, 26	16	14, 21	11, 18	9, 16	6, 13	3, 10	1, 8, 29	5, 26	3
"	Tue.	10 a.m.	9, 23	6, 20	6, 20	3, 17	1, 15, 29	12, 26	10, 24	7, 21	4, 18	2, 16, 30	13, 27	11
"	Wed.	10 a.m.	3, 17, 31	14, 28	14, 28	11	9, 23	6, 20	4, 18	1, 15, 29	12, 26	10, 24	7, 21	5, 19
"	Thur.	10 a.m.	4, 18, 25	1, 15, 22	1, 15, 22	12, 10,	10, 17,	7, 14, 21	5, 12, 19	2, 9, 16,	6, 13, 27	4, 11, 25	18, 22	6, 20
"	Fri.	10 a.m.	5, 12, 19	2, 9, 16	2, 9, 16,	6, 13, 27	4, 11, 25	1, 8, 22,	6, 20, 27	3, 17, 24,	14, 21,	12, 19,	9, 16, 23	7, 14, 21
BERWICK	Tue.	10 a.m.	9	8	8	1	29	31	28
BIRCHIP	Tue.	2.30 p.m.	16	13	13	10	8	5	3, 31	21	25	16	..	11
BOORT	Thur.	10 a.m.	4	..	1	26	..	21	..	16	6
BOX HILL	Mon.	10 a.m.	8, 22	5, 19	5, 19	2, 16, 30	14, 28	11, 25	9, 23	6, 20	3, 17	1, 15, 29	12, 26	10, 24
BRIGHT	Fri.	10 a.m.	Every	Friday	except Public	Holidays.
BRIGHTON	Fri.	10 a.m.	23	20	20	17	15	12	10	7	4	2, 30	27	..
BROADFORD	Thur.	10.30 a.m.	11, 25	8, 22	8, 22	5, 19	3, 17, 31	14, 28	12, 26	9, 23	6, 20	4, 18	1, 15, 29	13
BRUNSWICK	Mon.	10 a.m.
"	Wed.	10 a.m.	Every	Monday,	Wednesday	and Friday	except Public	Holidays.
BUNGAREE	Fri.	10 a.m.	9	5	5	2, 30	28	25	23	20	17	15	12	10
BUNVIE	Mon.	10 a.m.	3, 31	28	28	18	15
CAMBERWELL	Mon.	10 a.m.	Every	Monday	and Thursday	except Public	Holidays.
CAMBERWELL	Thur.	10 a.m.
CAMPERDOWN	Thur.	10 a.m.	4	1	1, 20	26	24	21	19	16	13	11	8	6
CARLTON	Tue.	10 a.m.	Every	Tuesday	and Thursday	except Public	Holidays.
CASTERTON	Thur.	10 a.m.	18	15	15	12	10	7	5	2, 30	27	25	22	20
CASTLEMAINE	Thur.	10 a.m.	4, 18	1, 15	1, 15, 29	12, 26	10, 24	7, 21	5, 19	2, 16, 30	13, 27	11, 25	8, 22	6, 20
CHARLTON	Thur.	10 a.m.	18	15	15	12	10	7	5	2, 30	27	25	22	20
CHELSEA	Mon.	10 a.m.	Every	Monday	except Public	Holidays.
CHELTENHAM	Mon.	10 a.m.	Every	Friday	except Public	Holidays.
CHILTERN	Mon.	10 a.m.	3
CLUNES	Wed.	10 a.m.	17	14	14	11	9	6	4	1, 29	26	24	21	19
COBRAM	Wed.	10 a.m.	17	14	14	11	9	6	4	1, 29	26	24	21	19
COBURG	Tue.	10 a.m.	Every	Tuesday	and Thursday	except Public	Holidays.
COHUNA	Thur.	10 a.m.	11	8	8	5	3, 31	28	26	23	20	18	15	13
COLAC	Mon.	10 a.m.	15	12, 26	26	9	7, 21	18	2, 16, 30	13, 27	10, 24	8, 22	5, 19	3, 17
COLERAINE	Fri.	10 a.m.	19	16	16	13	11	8	6	3, 31	28	26	23	21
COLLINGWOOD	Thur.	10 a.m.	Every	Thursday	except Public	Holidays	(Civil cases on Thursday only).
CORRYONG	Thur.	10 a.m.	11	8	8	5	3, 31	28	26	23	20	18	15	13
COWES	Thur.	10 a.m.	18	15	15	12	10	7	5	2, 30	27	25	22	20
CRANBOURNE	Mon.	10 a.m.	3, 31	28	28	18	16	12	10	7
CRISWICK	Mon.	10 a.m.	18	16	13	10	8
DANDENONG	Mon.	10 a.m.	Every	Monday	and Friday	except Public	Holidays.
"	Fri.	10 a.m.
DAYLESFORD	Wed.	10 a.m.	10, 17	7, 14	7, 14	4, 11	2, 9, 30	6, 27	4, 25	1, 22, 29	19, 26	17, 24	14, 21	12, 19
DIMBOOLA	Tue.	10 a.m.	9, 23	6, 20	6, 20	3, 17	1, 15, 29	12, 26	10, 24	7, 21	4, 18	2, 16, 30	13, 27	11
DONALD	Wed.	10 a.m.	3, 31	28	28	18	16	12	10	7
DROMANA	Wed.	10 a.m.	17	14	14	11	9	6	4	1, 29	26	24	21	19
DROUIN	Thur.	10 a.m.	4, 18	1, 15	1, 15, 29	12, 26	10, 24	7, 21	5, 19	2, 16, 30	13	11, 25	8, 22	6, 20
DUNOLLY	Thur.	10 a.m.	25	22	22	19	17	14	12	9	6	4	1, 29	..
EALBEEHAWK	Wed.	10 a.m.	3, 31	28	28	18	16	12	10	7
ECHUCA	Thur.	10 a.m.	11, 25	8, 22	8, 22	5, 19	3, 17, 31	14, 28	12, 26	9, 23	6, 20	4, 18	1, 15, 29	13
ECHUCA	Tue.	10 a.m.	16, 30	13, 27	13, 27	10	8, 22	5, 19	3, 17, 31	14, 28	11, 25	9, 23	6, 20	4, 18
EDENHOPE	Wed.	11 a.m.
ELMORE	Fri.	10 a.m.	26	23	23	11	9	6	4	1, 29	26	24	21	19
ELSTERNWICK	Thur.	10 a.m.	Every	Thursday	except Public	Holidays.
ELTHAM	Wed.	10 a.m.	17	14	14	11	9	6	4	1, 29	26	24	21	19
EURGA	Fri.	10 a.m.	19	16	16	13	11	8	6	3, 31	28	26	23	21
FERNTREE GULLY	Mon.	10.15 a.m.	Every	Monday	except Public	Holidays.
"	Mon.	10 a.m.	Every	Monday	and Thursday	except Public	Holidays.
FITZROY	Thur.	10 a.m.
"	Wed.	10 a.m.	3, 17, 31	14, 28	14, 28	11	9, 23	6, 20	4, 18	1, 15, 29	12, 26	10, 24	7, 21	5, 19
"	(Civil cases only)
FLEMINGTON	Mon.	10 a.m.	Every	Monday	except Public	Holidays.
FOOTSCRAY	Wed.	10 a.m.	Every	Monday,	Wednesday	and Thursday	except Public	Holidays	(Wednesday reserved for Civil Matters only).
FOSTER	Thur.	10 a.m.
FOSTER	Tue.	10.30 a.m.	23	20	20	15	15	10
FRANKSTON	Tue.	10 a.m.	Every	Tuesday	and Friday	except Public	Holidays.
FRANKSTON	Fri.	10 a.m.
GEELONG	Tue.	10 a.m.	Every	Tuesday	and Friday	except Public	Holidays.
GEELONG	Fri.	10 a.m.
GISBORNE	Mon.	10 a.m.	15	12	2, 30	27	24	22	19
GLENROY	Wed.	10 a.m.	Every	Wednesday	except Public	Holidays.
HAMILTON	Thur.	10 a.m.	11, 25	1, 8, 22	1, 8, 22,	5, 19, 26	3, 17, 31	14, 21,	12, 10,	9, 16, 23	6, 13, 20	4, 11, 18	1, 8, 15,	6, 13
"	Wed.	10 a.m.	17	14	14	11	9	6	4	1, 29	26	24	21	19
HASTINGS	Wed.	10 a.m.	Every	Wednesday	except Public	Holidays.
HAWTHORN	Wed.	10 a.m.	10, 24	7, 21	7, 21	4, 18	2, 16, 30	13, 27	11, 25	8, 22	5, 19	3, 17, 31	14, 28	12
HEALESVILLE	Wed.	10 a.m.	12	9	9	6	4	1, 29	26					

COURTS, DAYS, AND HOURS FOR THE HEARING OF SPECIAL COMPLAINTS DURING 1962—continued.

Court.	Day.	Hour.	January.	February.	March.	April.	May.	June.	July.	August.	September.	October.	November.	December.
HORSHAM	Mon.	10 a.m.				2, 30								
	Wed.	10 a.m.	10, 24	7, 21	7, 21	18	16, 30	13, 27	11, 25	8, 22	5, 19	3, 17, 31	14, 28	12
INGLEWOOD	Tue.	10 a.m.	9	6	6	3	1, 29	26	24	21	18	16	13	11
JAMIESON	Mon.	11 a.m.		26	26		21	18	16	13	10	8	5	3
JEPARIT	Tue.	2 p.m.	30		27		22		17		11		6	
KANIVA	Tue.	10 a.m.	2	27		4	2, 30	19		14		9		4
KERANG	Wed.	10 a.m.		7	7		2, 30	27	25	22	19	17	14	12
KEW	Mon.	10 a.m.	Every	Monday	and Thursday	except	Public	Holidays.						
KILMORE	Tue.	10.30 a.m.	13, 27	13, 27	13, 27	10	8, 22	5, 19	3, 17, 31	14, 28	11, 25	9, 23	20	4, 18
KOROIT	Fri.	10 a.m.		2	2	27	25	22	20	17	14	12	9	7
KORUMBURRA	Thur.	10 a.m.		1	1, 29	26	24	21	19	16	13	11	8	6
KYABRAM	Fri.	10 a.m.	19	16	16	13	11	8	6	3, 31	28	26	23	21
KYNETON	Wed.	10 a.m.	8, 17, 31	14, 28	14, 28	11	9, 23	6, 20	4, 18	1, 15, 29	12, 26	10, 24	7, 21	5, 19
LAKES ENTRANCE	Thur.	10 a.m.		8	8	5	3, 31	28	26	23	20	18	15	13
LANCFIELD	Fri.	10.30 a.m.	26		23		18		13		7		2	
LANG LANG	Wed.	10 a.m.	24	21	21	18	16	13	11	8	5	3, 31	28	
LEONGATHA	Wed.	10 a.m.	31	28	28		23	20	18	15	12	10	7	5
LILYDALE	Fri.	10 a.m.	12, 26	9, 23	9, 23	6	4, 18	1, 15, 29	13, 27	10, 24	7, 21	5, 19	2, 16, 30	14
MAFFRA	Wed.	10 a.m.	24	21	21	18	16	13	11	8	5	3, 31	28	
MALDON	Mon.	10 a.m.	22	19	19	16	14	11	9		3	1, 29	26	24
MALVERN	Wed.	10 a.m.	Every	Tuesday,	Wednesday	and Friday	except	Public	Holidays.					
	Fri.	10 a.m.		1	29		24		19		13		8	
MANANGATANG	Thur.	10 a.m.		21	18	16	13	11	8	5	3, 31	28		
MANSFIELD	Wed.	11 a.m.	4	1	1, 29	26	24	21	19	16	13	11	8	6
MARYBOROUGH	Thur.	10 a.m.		1	1, 29	26	24	21	19	16	13	11	8	6
MELBOURNE	Mon.	10 a.m.	Every	Monday,	Wednesday	and Friday	except	Public	Holidays.					
	Fri.	10 a.m.		1	29		24		19		13		8	
MELBOURNE WEST	Wed.	10 a.m.	Every	Monday,	Wednesday	and Friday	except	Public	Holidays.					
	Fri.	10 a.m.		1	29		24		19		13		8	
MELTON	Mon.	10.30 a.m.		26	26		21	18	16	13	10	8	5	3
MERINO	Wed.	11 a.m.		14	14		11	8	6	3	1			19
	Mon.	10 a.m.	8, 22	5, 19, 26	5, 19, 26	2, 16, 30	14, 28	11, 25	9, 23	6, 20	3, 17	1, 15, 29	12, 26	10, 24
MILDURA	Wed.	10 a.m.	10, 24	7, 21	7, 21	4, 18	2, 16, 30	13, 27	11, 25	8, 22	5, 19	3, 17, 31	14, 28	12
	Thur.	10 a.m.	25	22	22	19	17	14	12	9	6	4	2, 30	27
MINYIP	Mon.	2 p.m.	15	12	9	7	7	4	2, 30	24	21	18	15	13
MIRBOO NORTH	Wed.	1.30 p.m.	17	14	14	11	9	6	4	1, 29	26	24	21	19
MITTA MITTA	Wed.	11 a.m.	10		7		2	27		22		17		12
MOE	Thur.	10.30 a.m.	4, 11, 18	1, 8, 15	1, 8, 15	5, 12, 26	3, 10, 24, 31	7, 21, 28	5, 19, 26	2, 16, 30	13, 20, 27	11, 18, 25	8, 15, 22	6, 13, 20
MOONEE PONDS	Tue.	10 a.m.	Every	Tuesday,	Wednesday	and Friday	except	Public	Holidays.					
	Wed.	10 a.m.		1	29		24		19		13		8	
MORDIALLOC	Thur.	10 a.m.	Every	Thursday	except	Public	Holidays.							
MORNINGTON	Thur.	10 a.m.	8, 22	8, 22	8, 22	5, 19	3, 17, 31	14, 28	12, 26	9, 23	6, 20	4, 18	1, 15, 29	13, 27
MORTLAKE	Wed.	2 p.m.	10	7	7	4	2, 30	27	25	22	19	17	14	12
MORWELL	Tue.	10.30 a.m.	Every	Tuesday	except	Public	Holidays.							
MURCHISON	Tue.	10 a.m.	9	6	3	1, 29	28	24	21	18	16	13	11	11
MURRAYVILLE	Thur.	2.30 p.m.	11	8	8	5	3, 31	28	26	23	20	18	15	13
MURTOA	Tue.	10 a.m.	23	20	20	17	15	12	10	7	4	2, 30	27	
MYRTLEFORD	Wed.	10 a.m.	24	21	21	18	16	13	11	8	5	3, 31	28	
NAGAMBIE	Fri.	10 a.m.	5		2	27	7		22		17		9	
NATHALLA	Mon.	10 a.m.	16	12		3	29		2, 30	27	24	22	19	17
NATIMUK	Tue.	10 a.m.		6		3	29		24		20		18	
NEWTSTEAD	Mon.	10 a.m.	8	5	2, 30	28	25	23	20	17	15	12	10	8
NHILL	Thur.	10 a.m.	4	1	1, 29	26	24	21	19	16	13	11	8	6
NORTHCOTE	Tue.	10 a.m.	Every	Tuesday	and Friday	except	Public	Holidays.						
	Fri.	10 a.m.		1	29		24		19		13		8	
NORTH MELBOURNE	Mon.	10 a.m.	Every	Monday	and Thursday	except	Public	Holidays.						
	Thur.	10 a.m.		1	29		24		19		13		8	
NUMBUKAH	Tue.	10 a.m.	16	13	13	10	8	5	3, 31	28	25	23	20	18
NYAH WEST	Wed.	10 a.m.	24	21	21	18	16	13	11	8	5	3, 31	28	
OAKLEIGH	Fri.	10 a.m.	Every	Friday	except	Public	Holidays.							
OMEO	Wed.	10 a.m.	14		14		23		20		12		10	6
ORBOST	Wed.	10 a.m.	10, 31	7, 28	7, 28	11	2, 9, 30	6, 27	4, 18	1, 22, 29	19, 26	17, 24	7, 14	12, 19
OUYEN	Thur.	10 a.m.	11	8	5	3, 31	28	26	23	20	18	15	13	11
PAKENHAM	Thur.	10 a.m.	11	8	5	3, 31	28	26	23	20	18	15	13	11
PENSHURST	Mon.	10 a.m.		26	26		21	18	16	13	10	8	5	3
PORT FAIRY	Wed.	10 a.m.	31	28	28		23	20	18	15	12	10	7	5
PORTLAND	Wed.	10 a.m.	10, 24	7, 21	7, 21	4, 18	2, 16, 30	13, 27	11, 25	8, 22	5, 19	3, 17, 31	14, 28	12
PORT MELBOURNE	Mon.	10 a.m.	8, 22	5, 19	5, 19	2, 16, 30	14, 28	11, 25	9, 23	6, 20	3, 17	1, 15, 29	12, 26	10
	Thur.	10 a.m.	Every	Thursday	except	Public	Holidays.							
PRAHRAN	Mon.	10 a.m.	Every	Monday	and Friday	except	Public	Holidays.						
	Fri.	10 a.m.		1	29		24		19		13		8	
PRESTON	Mon.	10 a.m.	15	12, 26	26	9	7, 21	18	2, 16, 30	13, 27	10, 24	8, 22	5, 19	3, 17
	Thur.	10 a.m.	Every	Thursday	except	Public	Holidays.							
	Tue.	9.30 a.m.	30	27	27	24	21	17			11		6	
RAINBOW	Tue.	9.30 a.m.	30	27	27	24	21	17			11		6	
REDCLIFFS	Tue.	10 a.m.	9, 23	6, 20	6, 20	3, 17	1, 15, 29	12, 26	10, 24	7, 21	4, 18	2, 16, 30	13, 27	11
	Tue.	10 a.m.	Every	Tuesday	and Friday	except	Public	Holidays.						
RICHMOND	Fri.	10 a.m.		1	29		24		19		13		8	
	Wed.	10 a.m.	10, 24	7, 21	7, 21	4, 18	2, 16, 30	13, 27	11, 25	8, 22	5, 19	3, 17, 31	14, 28	12
	Tue.	10 a.m.	Every	Tuesday	and Thursday	except	Public	Holidays.						
RINGWOOD	Fri.	10 a.m.	5, 19	2, 16	2, 16, 30	13, 27	11, 25	8, 22	6, 20	3, 17, 31	14, 28	12, 26	9, 23	7, 21
	Tue.	10 a.m.	30	27	27		22	19	17	14	11	9	6	4
ROBINVALE	Wed.	10 a.m.	24	21	21	18	16	13	11	8	5	3, 31	28	
ROCHESTER	Wed.	10 a.m.	30	27	27		22	19	17	14	11	9	6	4
ROSBY	Fri.	10.30 a.m.		23		4	2, 30	15		10		5	30	
RUSHWORTH	Wed.	10 a.m.	10	7	7	4	2, 30	27	25	22	19	17	14	12
RUTHERGLEN	Tue.	10 a.m.	30	27	27		22	19	17	14	11	9	6	4
SALE	Tue.	10 a.m.	9, 23, 30	6, 13, 20, 27	6, 20, 27	10, 17	18, 15, 22, 29	5, 12, 19, 26	3, 10, 17, 24	14, 21, 28	4, 11, 25	2, 9, 16, 30	6, 13, 27	4, 18
SANDRINGHAM	Wed.	10 a.m.	Every	Wednesday	except	Public	Holidays.							
SEA LAKE	Wed.	10.30 a.m.	16	13	13	10	8	5	3, 31	28	25	23	20	18
SEYMOUR	Mon.	10 a.m.	8, 22	5, 19	5, 19	2, 16, 30	14, 28	11, 25	9, 23	6, 20	3, 17	1, 15, 29	12, 26	10, 24
SHEPPARTON	Thur.	10 a.m.	4, 11, 18	1, 8, 15	1, 8, 15	5, 12, 19, 26	3, 10, 17, 24	7, 14, 21, 28	5, 12, 19, 26	2, 9, 16, 23, 30	6, 13, 20, 27	4, 11, 18, 25	1, 8, 15, 22	6, 13, 20
SMYTHSDALE	Mon.	10 a.m.	15	12		9								

COURTS, DAYS, AND HOURS FOR THE HEARING OF SPECIAL COMPLAINTS DURING 1962—continued.

Court.	Day.	Hour.	January.	February.	March.	April.	May.	June.	July.	August.	September.	October.	November.	December.
VIOLET TOWN	Thur.	10 a.m.	4	1	1, 29	26	24	21	19	16	13	11	8	6
WALWA	Wed.	11 a.m.	15, 22	12, 19, 26	10, 26	9, 16	7, 14, 21	11, 18	2, 9, 16, 23	6, 13, 20, 27	3, 10, 24	1, 8, 22, 29	5, 19, 26	3, 17, 24
WANGARATTA	Mon.	11 a.m.	15, 22	12, 19, 26	10, 26	9, 16	7, 14, 21	11, 18	2, 9, 16, 23	6, 13, 20, 27	3, 10, 24	1, 8, 22, 29	5, 19, 26	3, 17, 24
WARBURTON	Wed.	11 a.m.	31	28	28	..	23	20	18	15	12	10	7	5
WARRACKNABEAL	Wed.	10 a.m.	17	14	14	11	9	6	4	1, 20	28	24	21	19
WARRAGUL	Fri.	10 a.m.	Every	Friday except Public Holidays.
WARRNAMBOOL	Tue.	10 a.m.	Every	Tuesday except Public Holidays.
WERRIEBE	Mon.	10.30 a.m.	8	5	5	2, 30	28	25	23	20	17	15	12	10
WHITTLESEA	Mon.	11 a.m.	15	12	..	0	7	..	2, 30	27	24	22	19	17
WILLAURA	Fri.	10.30 a.m.	..	2	30	..	25	..	20	..	14	..	9	..
WILLIAMSTOWN	Wed.	10 a.m.	Every	Wednesday except Public Holidays.
WODONGA	Tue.	10 a.m.	9, 16	6, 15	6, 15	3, 12	1, 10, 29	7, 26	5, 24	2, 21, 30	18, 27	16, 25	13, 22	11, 20
WONTHAGGI	Thur.	10 a.m.
WOODEND	Tue.	10 a.m.	16, 30	13, 27	13, 27	10	8, 22	5, 19	3, 17, 31	14, 28	11, 25	9, 23	6, 20	4, 18
WOOMELANG	Mon.	10 a.m.	..	20	25	..	21	18	16	13	10	8	5	3
WYCHEPROOF	Thur.	2.30 p.m.	..	8	..	5	31	26	20	..	20	..	15	..
YACKANDANDAH	Wed.	10 a.m.	17	14	14	11	9	6	4	1, 20	28	24	21	19
YALLOURN	Fri.	10 a.m.	26	23	23	..	15	13	10	7	5	2	30	..
YARRAM	Wed.	10.30 a.m.	10, 24	7, 21	7, 21	4, 18	2, 16, 30	13, 27	11, 25	8, 22	5, 19	3, 17, 31	14, 28	12
YARRAWONGA	Wed.	10 a.m.	24	21	21	18	16	13	11	8	5	3, 31	28	..
YEA	Tue.	11 a.m.	16	13	13	10	8	5	3, 31	28	25	23	20	18
YEA	Tue.	11 a.m.	23	20	20	17	15	12	10	7	4	2, 30	27	..

Melbourne and Metropolitan BOARD OF WORKS.

GENERAL NOTICE.

THE Melbourne and Metropolitan Board of Works, having made sewers for carrying off the sewage from each and every property which, or any part of which, abuts on the streets or parts of streets in which such sewers are laid, and which are included within the sewerage areas hereinafter described, do hereby declare that on and after the 13th January, 1962, each and every property which, or any part of which, abuts on the said streets or parts of streets, shall be deemed to be a sewer property within the meaning of the Melbourne and Metropolitan Board of Works Act 1958.

The Sewerage Areas hereinbefore referred to are:—

Sewerage Area No. 1730.

City of Nunawading.—Commencing at the junction of Whitehorse-road and Alfred-street on the boundary of Sewerage Area No. 974; thence southerly, easterly and southerly following the said boundary to the Ringwood railway line, easterly along the said railway line to Springvale-road, northerly along Springvale-road, westerly along Whitehorse-road to a point 190 feet east of the eastern boundary of Moncrief-road, southerly by a subdivisional line to the north-eastern angle of lot 6 Moncrief-road, westerly along the northern boundaries of the said lot 6 and lot 7 Moncrief-road, northerly along the western boundaries of lots 8 to 12 Moncrief-road, westerly along Whitehorse-road to the commencing point.

Sewerage Area No. 1731.

City of Nunawading.—Commencing at a point in Springfield-road 150 feet west of the western boundary of Springvale-road; thence southerly along the eastern boundaries of lots 6 Springfield-road and 15 Esdale-street, westerly along Esdale-street, southerly along the eastern boundary of lot 5 Esdale-street, westerly along the southern boundaries of the said lot 5 and lots 10 and 4 Mark-place, further westerly along Sandy-street, northerly along the western boundaries of lots 31 Sandy-street and 26 Esdale-street, westerly along Esdale-street, northerly along the western boundaries of lots 16 Esdale-street and 5 Springfield-road, easterly along Springfield-road to the commencing point.

Sewerage Area No. 1732.

City of Footscray.—Commencing at the junction of The Avenue and Vernon-street; thence southerly along Vernon-street and a line in continuation to the Newport-Sunshine railway line, north-westerly along the said railway line, northerly by a line to and along the western boundaries of lots 125 to 118 Strong-street, easterly along the northern boundaries of lots 118 and 117 Strong-street, 100 and 99 Abbot-street, 82 and 81 Steel-street, and 64 Ferguson-street to the boundary of Sewerage Area No. 1472, southerly, generally easterly, and northerly following the said boundary to the junction of Le Fevre-street and Fiddian-street, easterly along Fiddian-street to Stony Creek, south-easterly along Stony Creek to Melbourne-road, southerly along Melbourne-road, westerly along The Avenue to the commencing point.

Sewerage Area No. 1733.

City of Box Hill.—Commencing at the junction of Gillard-street and Highbury-road; thence easterly along Highbury-road, northerly and westerly along the eastern and portion of the northern boundaries of lot 2 Highbury-road to the southern extremity of Bennett-street, northerly along Bennett-street to the boundary of Sewerage Area No. 1545, generally westerly, southerly, and generally westerly following the said boundary to Gardiners Creek, generally southerly along Gardiners Creek to Highbury-road, easterly along Highbury-road to the commencing point.

Sewerage Area No. 1734.

City of Heidelberg.—Commencing at the junction of Longstaff-street and Streeton-crescent on the boundary of Sewerage Area No. 1683; thence easterly, northerly, and north-easterly following the said boundary to McCubbin-street, north-westerly and generally westerly along McCubbin-street, southerly along the western boundary of lot 150 Streeton-crescent, westerly along the northern boundary of lot 142 Mackenel-street, north-westerly along the north-eastern boundary of lot 138 Keam-street, south-westerly and westerly along Keam-street, southerly along Burke-road north, south-easterly along Longstaff-street to the commencing point.

Sewerage Area No. 1735.

Cities of Williamstown and Footscray and Shire of Altona.—Commencing at the junction of Hansen-street and Mason-street; thence easterly along Mason-street, northerly along Leslie-street, north-westerly along Margaret-street, northerly along Graham-street, easterly along the southern boundary of No. 14 Graham-street, northerly along the eastern boundaries of Nos. 14 to 60 Graham-street, south-easterly and easterly along Percy-street, south-easterly and easterly along Bruce-street to its eastern extremity, northerly by a line to and along the western boundary of Sewerage Area No. 746 to Blackshaws-road, westerly along Blackshaws-road, northerly along Truman-street, westerly along the northern boundaries of lots 10 Truman-street and 9 Saitley-street, northerly along Saitley-street, westerly along the northern boundaries of lots 16 Saitley-street and 15 New-street, northerly along New-street, westerly along the northern boundary of lot 12 New-street, southerly along the western boundaries of lots on the western side of New-street and lot 1 Blackshaws-road, easterly along Blackshaws-road, southerly along Hansen-street to the commencing point.

Further particulars regarding the streets or parts of streets in which sewers have been laid may be ascertained on inquiry at the Board's office.

By order of the Board,

H. J. SNADDEN,
Secretary.

CONTRACTS ACCEPTED.—(Series 1961-62.)

PROVISIONS.—MEAT.

No. of Contract.	Particulars of Each Tender Accepted.	Amount.	Name of Contractor.	Charge Against Vote or Fund.
	PROVISIONS—			
	Supply of Meat, in such quantities as may be ordered, from 1st January, 1962, to 31st March, 1962			
	Schedule No. 1.—Melbourne District—			
1832	Kew Mental Hospital	Rates as per annex	F. Watkins Pty. Ltd. ..	General Expenses 1961-62
1833	Pentridge Penal Establishment and "Fairlea" Female Prison, Fairfield	" "	Oscar Mayer Pty. Ltd. ..	
1834	Children's Welfare Depot, Royal Park, and Travancore Developmental Centre, Flemington	" "	J. H. Cooke Pty. Ltd. ..	
1835	"Winstan" Juvenile School, 186 Springvale-road, Nunawading	" "	J. H. Cooke, Pty. Ltd.	
1836	Royal Park Mental Hospital and Receiving House	" "	J. H. Cooke Pty. Ltd. ..	
	Schedule No. 2.—Mont Park, Bundoora, Larundel, Janefield, Gresswell, and Pleasant View, Wood-street, Preston—			
1837	Mont Park District	" "	W. Angliss and Co. (Aust.) Pty. Ltd.	
1838	Preston	" "		
1839	Gresswell Sanatorium	" "		
1840	Schedule No. 3.—SS. Rip and Dredges	" "	G. K. & M. Reynolds Bros. Pty. Ltd.	
1841	Schedule No. 4.—Teachers' College and Hostels at Grattan-street, 93 Drummond-street, Carlton; 470 and 481 St. Kilda-road, Melbourne; 19 Queens-road, Melbourne; 152 Toorak-road west, South Yarra; Frank Tate House, 373 Dandenong-road, Armadale; "Redcourt" 6 and "Lar-nook," 13 Ororong-road Armadale; 11 Patterson-street, Hawthorn; 174 Punt-road, Prahran; 221 Burwood-road, Burwood; John Cannon House, 32 Belmont-avenue, Kew; 17 Moule-avenue, Brighton; Police Hospital, St. Kilda-road, Melbourne; and Mental Hygiene Clinic, 321 Glenferrie-road, Malvern	" "		
1842	Schedule No. 5.—Heatherton Sanatorium, Cheltenham	" "	J. H. Cooke Pty. Ltd. ..	
			W. Angliss and Co. (Aust.) Pty. Ltd.	
1843	Schedule No. 6.—Ararat District	" "	H. A. Morris	
1844	Schedule No. 7.—Ballarat District— Gaol and Mental Hospital	" "	Victorian Inland Meat Authority	
1845	Teachers' Hostels	" "	H. A. Morris	
1846	Schedule No. 8.—Beechworth District	" "	E. Spencer	
	Schedule No. 9.—Bendigo District—			
1847	Gaol	" "	Alan H. Gittins	
1848	Sandhurst Boys' Centre	" "	Alan H. Gittins	
1849	Teachers' Hostels	" "	L. K. and M. P. Marchioni	
1850	Schedule No. 10.—Castlemaine District	" "	McQueen Bros.	
1851	Schedule No. 11.—School of Forestry, Creswick	" "	H. J. Symons Pty. Ltd.	
1852	Schedule No. 13.—McLeod Settlement, French Island	" "	George Hayman	
	Schedule No. 14.—Geelong District—			
1853	Gaol	" "	A. Bubb	
1854	Teachers' Hostels	" "	A. C. Knight	
1855	Schedule No. 15.—Coorimungie Prison Camp, Heytesbury Forest	" "	Heytesbury Butchery	
1856	Schedule No. 17.—Langi Kal Kal Training Centre	" "	F. P. Haintz and Son	
1857	Schedule No. 20.—Sale Gaol	" "	T. L. Webster Pty. Ltd.	
1858	Schedule No. 21.—Pleasant Creek Special School, Stawell	" "	H. A. Morris	
1859	Schedule No. 22.—Sunbury District	" "	F. Watkins Pty. Ltd.	
1860	Schedule No. 23.—Warrnambool District	" "	P. and L. Collins Pty. Ltd.	

Approved H. E. BOLTE, Treasurer.—7.12.1961.

SCHEDULE NO. 1.—MELBOURNE DISTRICT.

ANNEX TO CONTRACT No. 1962/1832.

F. Watkins Pty. Ltd., 184 Bourke-street, Melbourne.

Sub-schedule No. 9.

MEAT FOR MENTAL HOSPITAL, KEW.

Security, £35.

	£	s.	d.
Fresh Beef—			
1. Rolled Roast boneless (Brisket excluded) per cntl.	11	13	4
2. Buttocks	do.	11	5
3. Shin and Gravy Beef (boneless)	do.	11	5
4. Corned Beef—Rolled or Round, as ordered, without bone or cartilage	do.	12	10
5. Fresh Mutton—(Whole Sheep) (Kidney fat to be removed)	do.	3	15
6. Veal—boned	per lb.	0	2
7. Sausages—Mixed	do.	0	1
8. Livers—Sheep	do.	0	2
9. " Ox	do.	0	1
10. Kidneys, Ox	do.	0	2
11. " Sheep	do.	0	2
12. Tripe, Fresh	do.	0	1
13. Tongues—Ox	do.	0	1
" Sheep	each	0	0

SCHEDULE No. 1.—MELBOURNE DISTRICT—continued.

	per lb.	per doz.	per set	per lb.	per lb.
14. Sausage—Belgium	0	2	4		
15. Beef Loaf	do.	0	2	6	
16. Ham Loaf	do.	0	3	3	
17. Veal Loaf	do.	0	3	3	
18. Saveloys	per doz.	0	3	6	
19. Brains, Sheep	per set	0	0	7	
20. Fowls, First quality	per lb.	0	5	6	
21. Bacon Sides	do.	0	4	6	

ANNEX TO CONTRACT No. 1962/1833.

Oscar Mayer Pty. Ltd., P.O. Box 163, Footscray.

Sub-schedule No. 10.

MEAT FOR PENTRIDGE PENAL ESTABLISHMENT, COBURG; AND "FAIRLEA" FEMALE PRISON, FAIRFIELD.

Security, £35.

	per cntl.	do.	do.	per lb.
Fresh Beef—				
1. Fore-quarters	6	13	4	
2. Minced	do.	9	3	4
3. Corned Beef—Rolled or Round, as ordered, without bone or cartilage	do.	11	13	4
4. Fresh Mutton (whole sheep)	do.	3	19	2
5. Sausages—Mixed—thin	per lb.	0	1	6

SCHEDULE No. 1.—MELBOURNE DISTRICT—*continued.*

		£	s.	d.
6. Fresh Suet—Kidney	per lb.	0	0	7
7. Saveloys	do.	0	1	10
8. Sausage—Beef German	do.	0	2	2
9. Sausage Mince	do.	0	1	1
10. Dripping, Beef	do.	0	1	2
11. Frankfurts	do.	0	2	0
12. Livers—Sheep	do.	0	1	6
13. Ham Loaf	do.	0	3	0

ANNEX TO CONTRACT No. 1962/1834.

J. H. Cooke Pty. Ltd., 378 Queen's-parade, Clifton Hill.

Sub-schedule No. 11.

MEAT FOR CHILDREN'S WELFARE DEPOT, ROYAL PARK, AND TRAVANCORE DEVELOPMENTAL CENTRE, FLEMINGTON.

		£	s.	d.
Security, £8.				
1. Fresh Beef—Rolled Roast Sirloin—Boneless	per lb.	0	2	8
2. Beef—Corned—Silverside	do.	0	3	2
Fresh Mutton—				
3. Legs	do.	0	1	4
4. Legs (Two tooth)	do.	0	1	5
5. Chops—Mid Loin (Two tooth)	do.	0	1	3
6. Rib Chops as Cutlets (Two tooth)	do.	0	1	4
Steak—				
7. Rump	do.	0	3	6
8. Blade	do.	0	2	9
9. Minced	do.	0	1	9
10. Veal—Fillet, boneless	do.	0	3	3
11. Pickled Pork	do.	0	2	0
12. Sausages—Mixed	do.	0	1	8
13. Sausage—Straasburg, Pork	do.	0	3	3
14. Tripe—Fresh	do.	0	0	9
15. Frye—Lamb	do.	0	1	9
16. Ox Tongue	per lb.	0	1	6
17. Frankfurts	do.	0	2	5
18. Rabbits—Fresh	do.	0	3	0

ANNEX TO CONTRACT No. 1962/1835.

J. H. Cooke Pty. Ltd., 378 Queen's-parade, Clifton Hill.

Sub-schedule No. 12.

FOR "WINLATON" JUVENILE SCHOOL, 186 SPRINGVALE-ROAD, NUNAWADING.

		£	s.	d.
Security, £5.				
Fresh Beef—				
1. Rolled Roast Sirloin, Boneless	per lb.	0	2	6
2. Corned—Silverside	do.	0	3	2
3. Mutton Fresh—Fore-quarters	do.	0	0	11
4. " " Legs	do.	0	1	6
5. " " Chops—Mid Loin (Two tooth)	do.	0	1	6
6. " " Forequarter	do.	0	1	1
7. Steak—Topside	do.	0	3	2
8. Steak—Rump	do.	0	3	9
9. " Stewing	do.	0	2	9
10. " Minced	do.	0	2	2
11. " Blade	do.	0	2	9
12. Sausages—Mixed	do.	0	1	8
13. Sausage Meat	do.	0	0	10
14. Frye—Lamb	do.	0	1	9
15. Veal—Fillet—Boneless	do.	0	3	3
16. Veal—T bone	do.	0	3	3
17. " Leg, boned	do.	0	2	11
18. Pork—Pickled	do.	0	2	0
19. Pressed Ham Loaf	do.	0	7	3
20. Tongues—Ox	do.	0	1	6
21. Dripping beef	do.	0	1	0
22. Brains—Sheep	per set	0	0	5
23. Sausage—Straasburg—Pork	per lb.	0	3	2
24. Frankfurts	do.	0	2	5
25. Rabbits—Fresh	do.	0	3	3

ANNEX TO CONTRACT No. 1962/1836.

J. H. Cooke Pty. Ltd., 378 Queen's-parade, Clifton Hill.

Sub-schedule No. 13.

MEAT FOR RECEIVING HOUSE AND MENTAL HOSPITAL, ROYAL PARK.

		£	s.	d.
Security, £10.				
Fresh Beef—				
1. Rolled Roast, boneless (Brisket excluded)	per lb.	0	2	8
2. Thick Flank	do.	0	2	7
3. Fresh Mutton (Legs)	do.	0	1	5
4. Chops—Fore-quarter	do.	0	0	11
5. Sausages—Thin	do.	0	1	8
6. Sausage—Mince	do.	0	0	9
7. Rabbits—Fresh	do.	0	3	3
8. Fowls—First quality	do.	0	5	3
9. Sausage, beef german	do.	0	2	6
10. Beef—Corned Silverside	do.	0	2	11
11. Liver—Ox	do.	0	1	6

SCHEDULE No. 2.—MONT PARK AND SANATORIUM GRESSWELL, ETC.

ANNEX TO CONTRACT No. 1962/1837.

W. Angliss and Co. (Aust.) Pty. Ltd., 42 Bourke-street, Melbourne.

Sub-schedule No. 4.

MEAT.

(For Mont Park Mental Hospital, &c.)

		£	s.	d.
Security, £35.				
Fresh Beef—				
1. Buttocks	per cwt.	10	0	0
2. Topside, pieces	do.	15	16	8
3. Rolled Roast—Boneless (Brisket excluded)	do.	12	10	0
Beef, Corned—				
4. Rolled or Round, as ordered, without bone or cartilage	do.	11	5	0
5. Corned—Silverside	do.	16	13	4
Mutton, Fresh—				
6. Carcass or Sides (Kidney fat to be removed)	do.	3	15	0
7. Legs	per lb.	0	1	4
Chops—				
8. Loin	do.	0	1	4
9. Forequarter	do.	0	1	0
Steak—				
10. Minced	do.	0	2	3
11. Buttock, sliced	do.	0	3	4
12. Sausage—Meat	do.	0	1	2
13. Sausages—Mixed	do.	0	1	9
14. Shanks—Sheep	each	0	0	6
15. Tripe—Fresh	per lb.	0	0	8½
16. Brains—Sheep	per set	0	0	6
17. Kidneys—Ox	per lb.	0	2	6
18. Livers—Sheep	do.	0	1	8
19. Livers—Calves	do.	0	1	3
20. Sausage—Beef German	do.	0	2	4
21. Rabbits—Fresh	do.	0	3	0
22. Ham Loaf	per lb.	0	3	1
23. Fillet Veal	do.	0	2	6
24. Fowls—First quality	do.	0	5	0
25. Lamb Chops	do.	0	2	9
26. Bones—Beef	do.	0	0	0½
27. Bacon—Sides	do.	0	4	0
28. Sweetbreads	per box	0	4	0

ANNEX TO CONTRACT No. 1962/1838.

W. Angliss & Co. (Aust.) Pty. Ltd., 42 Bourke-street, Melbourne.

Sub-schedule No. 5.

MEAT.

(For Pleasant View Receiving House, Wood-street, Preston.)

		£	s.	d.
Security, £5.				
Fresh Beef—Sirloin—Boneless (Brisket excluded)				
1. Fresh Beef—Sirloin—Boneless (Brisket excluded)	per lb.	0	3	0
2. Corned Beef—Silverside	do.	0	3	3
3. Fresh Lamb—Legs	do.	0	2	6
Chops—				
4. Loin—Lamb	do.	0	3	3
5. Fore-quarter—Lamb	do.	0	1	3
6. Livers—Lamb	do.	0	2	0
7. Sausages—Pork	do.	0	1	9
8. Dripping—Beef	do.	0	1	0
9. Tongues—Sheep	do.	0	1	6
10. Brains—Sheep	per set	0	0	7
11. Frankfurts	per doz.	0	5	0
12. Sausage—Straasburg—Pork	per lb.	0	3	4
13. Rabbits—Fresh	do.	0	3	0
14. Capons	do.	0	5	0
15. Tripe	do.	0	0	9
16. Ham, tinned, 2lb. tin	do.	0	10	0
17. Pork—Fresh—Legs	do.	0	3	6
18. Steak—Buttock	do.	0	2	9
19. " Fillet	do.	0	5	0
20. " Minced	do.	0	2	3
21. Mutton—Legs (boiling)	do.	0	1	6

ANNEX TO CONTRACT No. 1962/1839.

W. Angliss and Co. (Aust.) Pty. Ltd. 42 Bourke-street, Melbourne.

Sub-schedule No. 6.

MEAT.

(For Gresswell Sanatorium.)

Security £15.

	per lb.	£	s.	d.
1. Fresh Beef—Rolled Roast Sirloin (Boneless)	per lb.	0	3	6
2. Beef—Corned Silverside	do.	0	3	3
3. Lamb—Fresh Legs	do.	0	2	6
4. " Chops Mid-loin	do.	0	3	0
5. " " Chump	do.	0	2	6
6. " " Fore-quarter	do.	0	1	4
7. " " Cutlets	do.	0	3	6
8. " " Rolled	do.	0	1	6
9. Pork—Fresh Legs	do.	0	3	9
10. " Chops	do.	0	3	9
11. " Pickled	do.	0	2	9
12. Mutton—Leg Chops	do.	0	1	6
13. Veal—Fresh, Shoulder	do.	0	1	3
14. " " Cutlets	do.	0	3	6
15. " " Fillet	do.	0	2	6
16. Steak—Rump	do.	0	3	9
17. " " Topside	do.	0	3	3
18. " " Blade	do.	0	2	6
19. " " Porterhouse	do.	0	3	9
20. " " Fillet	do.	0	5	0
21. " " Minced	do.	0	2	0
22. Brains—Sheep	per set	0	0	7
23. Fowls—First quality	per lb.	0	5	0
24. Frankfurts	do.	0	2	6
25. Ham Loaf	do.	0	3	3
26. " Pressed Leg	do.	0	7	9
27. " Pressed Shoulder	do.	0	6	9
28. Kidneys—Ox	do.	0	2	9
29. " " Sheep	do.	0	2	6
30. Livers—Sheep	do.	0	1	8
31. " " Lamb	do.	0	1	8
32. " " Calves	do.	0	1	3
33. Rabbits—Fresh	do.	0	3	0
34. Sausages—Mixed	do.	0	1	9
35. " " Pork	do.	0	1	9
36. Sausage Meat	do.	0	1	2
37. " " Strasbourg—Pork	do.	0	3	4
38. Shanks—Sheep	each	0	0	6
39. Tripe—Fresh	per lb.	0	0	8½
40. Tongues—Ox	do.	0	1	9
41. " " Sheep	do.	0	1	0
42. Veal and Pork Loaf—Pressed	do.	0	3	3
43. Savoury Loaf—Pressed	do.	0	3	3
44. Ham—Leg—Raw	do.	0	5	0

SCHEDULE No. 3.—S.S. "Rip" AND DREDGES.

ANNEX TO CONTRACT No. 1962/1840.

G. K. & M. Reynolds Bros. Pty. Ltd., 4 Blackwood-street, North Melbourne.

Sub-schedule No. 3.

MEAT.

(Delivery at Yarra River Wharves.)

Security, £5.

	per lb.	£	s.	d.
1. Fresh Beef—Roast	per lb.	0	2	2
Beef—Corned—				
2. Silverside	do.	0	3	3
3. Rolled	do.	0	2	3
Fresh Mutton—				
4. Fore-quarter	do.	0	0	10½
5. Legs	do.	0	1	4½
Chops—				
6. Forequarter	do.	0	1	4½
7. Loin	do.	0	1	9½
Steak—				
8. Rump	do.	0	4	4
9. Stewing	do.	0	2	1
10. Topside	do.	0	3	3
11. Sausages—Mixed	do.	0	1	8½
12. Tripe—Fresh	do.	0	1	0
13. Livers—Sheep	do.	0	1	10
14. Suet—Kidney	do.	0	0	6
15. Rabbits—Fresh	do.	0	2	4
16. Ice	per cwt.	0	1	1

SCHEDULE No. 4.—TEACHERS' COLLEGES, HOSTELS, POLICE HOSPITAL, ETC.

(Delivery at Institutions.)

TEACHERS' COLLEGES AND HOSTELS AT GRATTAN-STREET, 93 DRUMMOND-STREET, CARLTON; 470 AND 481 ST. KILDA-ROAD, MELBOURNE; 19 QUEENS-ROAD, MELBOURNE; 152 TOORAK-ROAD WEST, SOUTH YARRA; TATE HOUSE, 373 DANDENONG-ROAD, ARMADALE; "REDCOURT" NO. 6, AND "LARNOOK," 13 ORRONG-ROAD, ARMADALE; 11 PATTERSON-STREET, HAWTHORN; 174 PUNT-ROAD, PRAHRAN, 221 BURWOOD-ROAD, BURWOOD; JOHN CANNON HOUSE, 32 BELMONT-AVENUE, KEW; 17 MOULE-AVENUE, BRIGHTON; POLICE HOSPITAL, ST. KILDA-ROAD, MELBOURNE; AND MENTAL HYGIENE CLINIC, 321 GLENFERRIE-ROAD, MALVERN.

ANNEX TO CONTRACT No. 1962/1841.

J. H. Cooke Pty. Ltd., 378 Queen's-parade, Clifton Hill.

Sub-schedule No. 2.

MEAT.

Security, £15.

	per lb.	£	s.	d.
Fresh Beef—				
1. Rolled Prime Ribs, boneless	per lb.	0	2	7
2. Topside	do.	0	3	2
3. Sirloin, boneless	do.	0	2	9
Fresh Mutton—				
4. Legs	do.	0	1	5
5. Legs, pickled	do.	0	1	4
6. Sides, Two-tooth	do.	0	1	1
7. Legs, Two-tooth	do.	0	1	6
8. Cutlets	do.	0	1	6
9. Chops, Middle Loin	do.	0	1	3
10. Chops, Forequarter	do.	0	0	11
11. Chops, Chump	do.	0	1	3
12. Beef—Corned, Silverside	do.	0	3	1
Veal—				
13. Shoulder, boned	do.	0	2	0
14. Fillet, boneless	do.	0	3	6
Steak—				
15. Blade	do.	0	2	10
16. Minced Blade	do.	0	2	0
17. Stewing	do.	0	2	10
18. Rump	do.	0	3	11
19. Fillet	do.	0	6	0
20. Sausages—Mixed	do.	0	1	8
21. Sausage—Meat	do.	0	0	11
22. " " Beef, German	do.	0	2	9
23. " " Strasburg	do.	0	3	0
24. Livers—Sheep	do.	0	2	0
25. Kidneys—Sheep	do.	0	1	6
26. " " Ox	do.	0	2	6
27. Tongues—Ox	do.	0	1	3
28. Ox Tails	do.	0	1	6
29. Brains—Sheep	per set	0	0	5
30. Tripe—Fresh	per lb.	0	0	9
31. Frankfurts	do.	0	2	4
32. Bones—Soup	do.	no	charge	
33. Suet—Kidney	do.	0	0	6
34. Rabbits—Fresh	do.	0	3	3
35. Fowls—First quality	do.	0	5	3
36. Pork—Legs	do.	0	3	11
37. " " Loin	do.	0	3	9
38. Lamb, Legs	do.	0	2	8
39. Ham—Pressed	do.	0	7	0
40. Dripping—Beef	do.	0	1	0

SCHEDULE No. 5.—HEATHERTON SANATORIUM.

ANNEX TO CONTRACT No. 1962/1842.

W. Angliss and Co. (Aust.) Pty. Ltd., 42 Bourke-street, Melbourne, C.I.

Sub-schedule No. 3.

MEAT.

Security, £5.

	per lb.	£	s.	d.
1. Beef, Fresh Roast—Rump	per lb.	0	3	9
2. " " Corned—Silverside	do.	0	3	3
3. Lamb, Fresh—Legs	do.	0	2	6
4. " " " Shoulder—Rolled	do.	0	1	3
5. " " " Chops Mid. Loin	do.	0	3	3
6. " " " Chops, Chump	do.	0	2	6
7. " " " Chops, Forequarter	do.	0	1	4
8. " " " Cutlets	do.	0	3	3
9. Pork, Fresh—Legs	do.	0	3	9
10. " " " Chops	do.	0	3	9
11. " " " Minced	do.	0	2	3
12. Veal—Shoulder—Boned	do.	0	1	3
13. " " " Cutlets	do.	0	3	3
14. Steak—Rump	do.	0	4	0
15. " " " Blade	do.	0	2	9
16. " " " Topside	do.	0	3	0
17. " " " Minced	do.	0	2	3
18. " " " Porterhouse	do.	0	3	9
19. " " " Fillet	do.	0	5	0

SCHEDULE No. 5.—HEATHERTON SANATORIUM—*continued.*

		£	s.	d.
20. Mutton, Pumped Leg	per lb.	0	1	4
21. Tripe—Fresh	do.	0	0	10
22. Brains—Sheep	per set	0	0	7
23. Lambs Fry	per lb.	0	2	0
24. Tongues—Sheep	do.	0	1	6
25. Kidneys—Ox	do.	0	3	0
26. „ Sheep	do.	0	2	6
27. Tails—Ox	do.	0	1	6
28. Sausages—Pork	do.	0	1	9
29. Frankfurts—Vienna	do.	0	3	4
30. Beef German—Sausage	do.	0	2	4
31. Ham—Loaf	do.	0	3	3
32. „ Pressed Shoulder	do.	0	6	9
33. Rabbits, Fresh	do.	0	3	0
34. Capons, First quality	do.	0	5	0
35. Dripping, Beef	do.	0	1	0

SCHEDULE No. 7.—BALLARAT DISTRICT—*continued.*

		£	s.	d.
7. Mid Loin Chops	per lb.	0	2	4
Veal—				
8. Shoulder, Boned	do.	0	3	6
9. Fillet, Boneless	do.	0	4	0
Steak—				
10. Blade	do.	0	4	5
11. Rump	do.	0	6	0
12. Minced	do.	0	3	5
13. Sausages—Mixed	do.	0	2	0
14. Sausage Meat	do.	0	1	6
15. Livers—Calves	do.	0	1	0
16. Kidneys—Ox	do.	0	1	3
17. Frankfurts	do.	0	2	0
18. Ham Loaf	do.	0	3	0
19. Dripping—Beef	do.	0	1	3
20. Shanks—sheep	each	0	0	6
21. Beef Luncheon	per lb.	0	2	2

SCHEDULE No. 6.—ARARAT DISTRICT.

ANNEX TO CONTRACT No. 1962/1843.
H. A. Morris, 107 Victoria-street, Ballarat.

Sub-schedule No. 4.

MEAT.

Security, £30.

		£	s.	d.
Fresh Beef—				
1. Rolled Roast (Boneless, brisket excluded)	per cntl.	11	5	0
2. Buttocks	do.	11	5	0
3. Fresh Mutton—Kidney fat to be removed	do.	4	3	4
4. „ Middle Loin Chops	do.	5	0	0
5. Corned Beef—Rolled or Round, as ordered, without bone or cartilage	do.	11	5	0
6. Kidney—Ox	per lb.	0	2	0
7. Veal—Fillet	do.	0	1	10
8. Sausages—Mixed	do.	0	1	11
9. Steak—Topside	do.	0	3	3
10. Beef Luncheon Loaf	do.	0	1	10
11. Sausage Meat	do.	0	1	3
12. Saveloys	do.	0	1	11

SCHEDULE No. 8.—BEECHWORTH DISTRICT.

ANNEX TO CONTRACT No. 1962/1846.
E. Spencer, Camp-street, Beechworth.

Sub-schedule No. 4

MEAT.

Security, £30.

		£	s.	d.
1. Fresh Beef (Gaol)	per cntl.	12	1	8
2. Fresh Beef—Rolled Roast, boneless, brisket excluded	do.	12	18	4
3. Corned Beef, Rolled or Round as ordered, without bone or cartilage	do.	12	18	4
4. Mutton—Fresh (kidney fat to be removed for Mental Hospitals)	do.	4	11	8
5. Beef Steak, minced	do.	12	10	0
6. Sausage Meat	per lb.	0	1	4
7. Sausages—Mixed	do.	0	1	10
8. Sausage—German	do.	0	2	7
9. Tripe—Fresh	do.	0	1	3
10. Veal—Boned	do.	0	2	6
11. Livers—Sheep	do.	0	1	9
12. Kidneys—Ox	do.	0	1	9

SCHEDULE No. 7.—BALLARAT DISTRICT.

ANNEX TO CONTRACT No. 1962/1844.
Victorian Inland Meat Authority, 522 Little Collins-street, Melbourne.

Sub-schedule No. 4.

MEAT.

(For Gaol and Mental Hospital.)

Security, £35.

		£	s.	d.
Fresh Beef—				
1. Buttocks	per cntl.	15	0	0
2. Roast—Rolled (Brisket excluded)	do.	11	13	4
3. Beef, Corned, Rolled or Round, as ordered, without bone or cartilage	do.	13	6	8
Mutton—Fresh—				
4. Kidney fat removed (Mental Hospital)	do.	5	0	0
5. Mince-meat	per lb.	0	3	2
6. Sausages	do.	0	2	0
7. Sausage, Beef, German	do.	0	2	4
8. Tripe	do.	0	1	0
9. Veal	do.	0	3	5
10. Sausage Meat	do.	0	1	4

SCHEDULE No. 9.—BENDIGO DISTRICT.

ANNEX TO CONTRACT No. 1962/1847.
Alan H. Gittins, 350 Hargreaves-street, Bendigo.

Sub-schedule No. 7.

MEAT.

For Gaol.

Security, £5.

		£	s.	d.
1. Fresh Beef	per lb.	0	2	0
2. Corned Beef—Rolled, without bone or cartilage	do.	0	1	10
3. Fresh Mutton	do.	0	1	0
4. Sausages—Mixed	do.	0	1	9
5. Mince-meat	do.	0	1	2

ANNEX TO CONTRACT No. 1962/1845.

Alan H. Gittins, 350 Hargreaves-street, Bendigo.

Sub-schedule No. 8.

MEAT.

For Sandhurst Boys' Centre, Bendigo.

Security, £5.

		£	s.	d.
1. Fresh Beef—Rolled Roast, boneless, brisket excluded	per lb.	0	3	3
2. Fresh Beef—Buttocks	do.	0	2	8
3. Corned Beef—Rolled or round, as ordered, without bone or cartilage	per lb.	0	2	6
4. Corned Silverside	do.	0	3	3
5. Fresh Mutton—Legs	do.	0	1	10
6. „ „ Chops, Mid-Loin	do.	0	1	10
7. Steak—Rump	do.	0	5	0
8. „ Stewing	do.	0	3	6
9. Sausage Meat	do.	0	1	2
10. Sausages—Mixed	do.	0	1	9
11. Sausage—Beef German	do.	0	2	6
12. Bacon, Rashers, Shoulder	per lb.	0	6	2
13. Dripping—Beef	per tin	1	5	0
14. Shin—Beef	per lb.	0	2	0
15. Lamb Chops	do.	0	3	11
16. „ Legs	do.	0	3	2

ANNEX TO CONTRACT No. 1962/1845.

H. A. Morris, 107 Victoria-street, Ballarat.

Sub-schedule No. 5.

MEAT.

For delivery to Teachers' Hostels as under:—

Gillies-street, Ballarat
Beaufort House, Beaufort-avenue, Ballarat
1415 Sturt-street, Ballarat.
130 Victoria-street, Ballarat
126 Webster-street, Ballarat

Security, £5.

		£	s.	d.
1. Fresh Beef—Sirloin	per lb.	0	4	0
2. Beef—Corned—Silverside	do.	0	4	9
Fresh Mutton—				
3. Legs	do.	0	2	6
4. Forquarter Chops	do.	0	1	4
5. Legs Pickled	do.	0	2	6
Two Tooth—				
6. Chump Chops	do.	0	2	6

SCHEDULE No. 9.—BENDIGO DISTRICT—continued.

ANNEX TO CONTRACT No. 1962/1849.

L. K. and M. P. Marchioni, Cnr. Killians-walk and Queen-street, Bendigo.

Sub-schedule No. 9.

MEAT.

For Teachers' College Hostels as under—

Osborne-street, Pleasant Vale, Bendigo.
"Lanewood," McLaren-street, Bendigo.
"Comersdale," Panton-street, Golden Square, Bendigo.

Security, £5.		£	s.	d.
Fresh Beef—				
1. Topside	per lb.	0	3	6
2. Corned Beef—Rolled or Round, as ordered, without bone or cartilage	do.	0	2	3
3. Corned Silverside	do.	0	3	6
4. Fresh Mutton—Carcase	do.	0	1	0
Steak—				
5. Blade (Minced)	do.	0	2	9
6. Chuck	do.	0	2	8
7. Rump	do.	0	5	6
8. Sausages—Mixed	do.	0	1	9
9. Sausage Meat	do.	0	1	4
10. Livers—Sheep	do.	0	0	9
11. Veal, Fillet—boneless	do.	0	4	6
12. Brains—Sheep	per set	0	0	6
13. Kidneys—Ox	per lb.	0	1	3
14. Ox Tails	do.	0	1	6
15. Sausage, Strasburg	do.	0	3	7
16. Salad Loaf	do.	0	3	5
17. Bacon, Middle Rashers	do.	0	6	0

SCHEDULE No. 10.—CASTLEMAINE GAOL.

ANNEX TO CONTRACT No. 1962/1850.

McQueen Brothers, Hargreaves-street, Castlemaine.

Sub-schedule No. 2.

MEAT.

Security, £5.		£	s.	d.
1. Fresh Beef				
2. Fresh Mutton	per lb.	0	1	11
3. Corned Beef—Rolled or Round, as ordered, without bone or cartilage	do.	0	1	3
4. Minced Meat—Beef	do.	0	2	3
5. Sausage Meat	do.	0	1	3
6. Sausages—Mixed	do.	0	1	6
7. Saveloys	per doz.	0	4	6

SCHEDULE No. 11.—SCHOOL OF FORESTRY, CRESWICK

ANNEX TO CONTRACT No. 1962/1851.

H. J. Symons, Pty. Ltd., 1015 Macarthur-street, Ballarat.

Sub-schedule No. 4.

MEAT.

Security, £3.		£	s.	d.
1. Fresh Beef—Topside				
2. " " Sirloin, boneless	per lb.	0	4	3
3. Corned, Silverside	do.	0	4	3
4. Mutton—Fresh, sides	do.	0	1	0
5. Pork—Fresh, leg	do.	0	4	6
6. Steak—Stewing	do.	0	3	8
7. " Minced	do.	0	2	6
8. Sausages—Mixed	do.	0	2	0
9. Sausage—Beef German	do.	0	3	0
10. Kidney—Ox	do.	0	2	0
11. Liver—Sheep	do.	0	1	0
12. Saveloys	per doz.	0	4	0

SCHEDULE No. 13.—MCLEOD SETTLEMENT, FRENCH ISLAND.

ANNEX TO CONTRACT No. 1962/1852.

George Hayman, Lang Lang.

Sub-schedule No. 3.

MEAT.

Security, £5.		£	s.	d.
1. Fresh Beef				
2. Mutton	per lb.	0	2	4
3. Sausages—Mixed	do.	0	1	2
	do.	0	2	3

SCHEDULE NO. 14.—GEEELONG DISTRICT.

ANNEX TO CONTRACT No. 1962/1853.

A. Bubb, 147 Moorabool-street, Geelong.

Sub-schedule No. 3.

MEAT.

For Gaol.

Security, £5.		£	s.	d.
1. Fresh Beef				
2. Corned Beef—Rolled or Round, without bone or cartilage	per lb.	0	2	0
3. Fresh Mutton—Forequarters	do.	0	0	11
4. " " —Legs	do.	0	1	2
5. Beef—Minced	do.	0	2	0
6. Sausages—Mixed	do.	0	1	6
7. Sausage Meat	do.	0	0	10
8. " Beef German	do.	0	2	2
9. Dripping, Beef	do.	0	0	10

ANNEX TO CONTRACT No. 1962/1854.

A. C. Knight, 27 Melbourne-road, North Geelong.

Sub-schedule No. 4.

MEAT.

For delivery to Teachers' Hostels as under—

"Lauriston," 23 Aberdeen-street, Geelong.
"Forty-Five," The Esplanade, Western Beach, Geelong.
"Hawthorn," Aberdeen-street, Geelong
"Ariston," Packington-street, Geelong.
"Warrain," 56 Western Beach, Geelong.

Security, £5.		£	s.	d.
Fresh Beef—				
1. Sirloin, boneless	per lb.	0	3	3
2. Topside Roast	do.	0	3	3
3. Corned Beef—Rolled or Round, as ordered, without bone or cartilage	do.	0	3	3
Mutton—				
4. Legs, Two-tooth	do.	0	1	6
5. Forequarters, boned, rolled, and pickled	do.	0	1	0
6. Chops, Forequarter	do.	0	1	1
7. Chops, Cutlets	do.	0	1	8
Steak—				
8. Chuck	do.	0	2	11
9. Bladebone	do.	0	3	0
10. Minced	do.	0	2	2
11. Fillet—Veal	do.	0	1	0
12. Tongues—Ox	do.	0	1	0
13. Kidneys—Ox	do.	0	1	8
Sausages—				
14. Mixed, thin	do.	0	1	7
15. Pork, thick	do.	0	1	7
16. Sausage—Pork, German	do.	0	3	3
17. Sausage Mince	do.	0	0	11
18. Bacon—Shoulder	do.	0	4	6

SCHEDULE No. 15.—COORLEMUNGLE PRISON CAMP, HEYTESBURY FOREST.

ANNEX TO CONTRACT No. 1962/1855.

Heytesbury Butchery, Timboon.

Sub-schedule No. 3.

MEAT.

Security, £4.		£	s.	d.
1. Fresh Beef				
2. Corned Beef—Rolled or Round, as ordered, without bone or cartilage	per lb.	0	3	9
3. Sausages—Mixed	do.	0	3	5
4. Sausage Mince	do.	0	2	5
5. Dripping—Beef	do.	0	1	1

SCHEDULE No. 17.—LANGI KAL KAL TRAINING CENTRE

ANNEX TO CONTRACT No. 1962/1856.

F. P. Haintz and Son, Havelock-street, Beaufort.

Sub-schedule No. 2.

MEAT.

Security, £5.		£	s.	d.
1. Fresh Beef—Boneless				
2. Sausages—Mixed	per lb.	0	4	0
3. Mince Meat	do.	0	2	0
	do.	0	1	6

**SCHEDULE No. 20.—SALE GAOL,
ANNEX TO CONTRACT No. 1962/1857.
T. L. Webster Pty. Ltd., 80 Raymond-street, Sale.**

Sub-schedule No. 2.

MEAT.

Security, £3.

		£	s.	d.
1. Fresh Beef	per lb.	0	2	7
2. Fresh Mutton, Chops—Forequarter	do.	0	1	3
3. " " Legs	do.	0	1	5
4. Corned Beef—Rolled or Round, as ordered, without bone or cartilage	do.	0	2	7
5. Sausage—Meat	do.	0	1	6

**SCHEDULE No. 21.—PLEASANT CREEK SPECIAL SCHOOL,
STAWELL.**

**ANNEX TO CONTRACT No. 1962/1858.
H. A. Morris, 107 Victoria-street, Ballarat.**

Sub-schedule No. 3.

MEAT.

Steak— Security, £3.

		£	s.	d.
1. Rump	per lb.	0	5	0
2. Stewing (Minced when required)	do.	0	2	5
3. Fresh Mutton—Leg	do.	0	1	8
4. Chops—Middle Loin	do.	0	1	0
5. Sausages—Pork	do.	0	1	10
6. Livers—Sheep	do.	0	0	6
7. Sausage—Meat	do.	0	1	2
8. " —Pork German	do.	0	2	9
9. Bacon	do.	0	6	9
10. Beef—Rolled Roast	do.	0	3	0
11. Tripe—Fresh	do.	0	1	0
12. Kidney—Ox	do.	0	2	0

SCHEDULE No. 22.—SUNBURY DISTRICT.

**ANNEX TO CONTRACT No. 1962/1859.
F. Watkins Pty. Ltd., 150 Lonsdale-street, Melbourne.**

Sub-schedule No. 5.

MEAT.

Security, £40.

		£	s.	d.
1. Rolled Roast, boneless, (brisket excluded)	per centl.	12	10	0
2. Buttocks	do.	11	5	0
3. Fresh Mutton—Kidney fat to be removed	do.	4	3	4
4. Corned Beef—Rolled or Round, as ordered, without bone or cartilage	do.	12	10	0
5. Sausages—Mixed	per lb.	0	1	9
6. Sausage Meat	do.	0	1	4
7. Sausage—Beef—German	do.	0	2	4
8. Veal—Boneless	do.	0	2	3
9. Tripe—Fresh	do.	0	1	2
10. Ox Kidney	do.	0	3	0

SCHEDULE No. 23.—WARRNAMBOOL DISTRICT.

**ANNEX TO CONTRACT No. 1962/1860.
P. and L. Collins Pty. Ltd., 8 Nicholson-street, Warrnambool.**

Sub-schedule No. 4.

MEAT.

Security, £15.

		£	s.	d.
1. Fresh Beef—Rolled Roast (brisket excluded)	per lb.	0	2	6
2. Corned Beef—Rolled or Round, as ordered	do.	0	2	4
Fresh Mutton—				
3. Forequarters	do.	0	0	10
4. Legs	do.	0	1	4
5. Chops—Middle Loin	do.	0	1	2
Steak—				
6. Topside	do.	0	2	10
7. Stewing	do.	0	2	3
8. Sausage—Beef German	do.	0	2	9
9. Livers—Sheep	do.	0	1	0
10. Sausage Meat	do.	0	1	6
11. Sausages—Beef	do.	0	2	0
12. " —Pork	do.	0	2	3
13. Beef—Minced	do.	0	2	6
14. Kidneys—Ox	do.	0	2	6

CONTRACTS ACCEPTED.—(Series 1961-62.)

PUBLIC WORKS.

1721. Ararat, Mental Hospital, demolition of chimney stack at Engineer's workshop, £250.—H. Barlow.
1722. Ascot Vale, Showgrounds, Government Pavilion, alterations and electrical installations; original, £198 15s.; additional, £220 17s., £419 12s.—R. G. Harris Pty. Ltd.
1723. Warracknabeal, Inspector of Works Residence, repairs and painting to residence; original, £229; additional, £34 15s., £263 15s.—J. G. Shaw and Sons.
1724. Heidelberg West, State School No. 4267, electrical services and installation; original, £233; additional, £225, £458.—J. and B. Ranking.
1725. Westbreen, State School No. 4158, external painting to old school building; original, £232; additional, £18 15s., £250 15s.—L. W. Friezer.
1726. Toolamba South, State School No. 2728, re-blocking of part of floor; original, £203 15s.; additional, £69 14s., £273 9s.—W. J. Pryde.
1727. Bairnsdale, Fisheries and Wildlife Residence, internal and external repairs and painting; original, £129; additional, £170, £299.—F. W. Merlo.
1728. Extras on contract, serial No. 60-61/3100.—£2,963 1s. 6d.
1729. Extras on contract, serial No. 60-61/3093.—£130 0s. 9d.
1730. Extras on contract, serial No. 60-61/2130.—£305.
1731. Extras on contract, serial No. 60-61/4110.—£409 8s.
1732. Extras on contract, serial No. 60-61/3094.—£326.
1733. Extras on contract, serial No. 61-62/569.—£2,749.
1734. Extras on contract, serial No. 60-61/3154.—£139 15s.
1735. Extras on contract, serial No. 60-61/1733.—£52 5s. 6d.
1736. Extras on contract, serial No. 60-61/3688.—£330 14s. 1d.
1737. Extras on contract, serial No. 60-61/2849.—£26 18s. 11d.
1738. Extras on contract, serial No. 60-61/3098.—£1,871 7s.
1739. Extras on contract, serial No. 60-61/3046.—£12 4s. 8d.
1740. Extras on contract, serial No. 60-61/4177.—£80.
1741. Extras on contract, serial No. 60-61/1408.—£151 8s.
1742. Extras on contract, serial No. 60-61/4056.—£124.
1743. Extras on contract, serial No. 60-61/2384.—£283 13s.
1744. Extras on contract, serial No. 60-61/3492.—£25 5s.
1745. Extras on contract, serial No. 61-62/570.—£827.
1746. Extras on contract, serial No. 61-62/1023.—£143.
1747. Extras on contract, serial No. 60-61/3093.—£665.
1748. Extras on contract, serial No. 60-61/4227.—£1,186 9s.
1749. Extras on contract, serial No. 61-62/980.—£95 14s.
1750. Extras on contract, serial No. 59-60/3810.—£428.
1751. Extras on contract, serial No. 61-62/584.—£160 8s.
1752. Extras on contract, serial No. 60-61/4183.—£1,498.
1753. Extras on contract, serial No. 61-62/104.—£353 4s.
1754. Extras on contract, serial No. 61-62/577.—£226.
1755. Extras on contract, serial No. 61-62/823.—£44 13s.
1756. Extras on contract, serial No. 60-61/3414.—£73 10s.
1757. Extras on contract, serial No. 60-61/2533.—£513 9s. 3d.
1758. Extras on contract, serial No. 60-61/4235.—£182 5s.
1759. Extras on contract, serial No. 59-60/4178.—£115 5s.
1760. Extras on contract, serial No. 61-62/755.—£316 16s. 6d.
1761. Extras on contract, serial No. 58-59/3762.—£175 8s.
1762. Extras on contract, serial No. 61-62/1213.—£85.
1763. Extras on contract, serial No. 56-57/5067.—£506 16s. 6d.
1764. Extras on contracts, serial No. 60-61/3096.—£460 0s. 8d.
1765. Extras on contract, serial No. 61-62/563.—£369 16s.
1766. Extras on contract, serial No. 60-61/3038.—£92 10s.
1767. Extras on contract, serial No. 61-62/842.—£65 10s.
1768. Extras on contract, serial No. 60-61/2285.—£75 15s. 9d.
1769. Extras on contract, serial No. 61-62/942.—£118 15s. 6d.
1770. Extras on contract, serial No. 61-62/575.—£305 9s. 7d.
1771. Extras on contract, serial No. 61-62/1392.—£28.
1772. Extras on contract, serial No. 59-60/1850.—£41 7s. 4d.
1773. Extras on contract, serial No. 61-62/578.—£726.
1774. Extras on contract, serial No. 60-61/2366.—£1,534.
1775. Extras on contract, serial No. 60-61/1409.—£101 16s.
1776. Extras on contract, serial No. 60-61/4244.—£575.

1777. Extras on contract, serial No. 60-61/2274.—
£684 12s. 6d.
1778. Extras on contract, serial No. 60-61/4154.—£79 10s.
1779. Extras on contract, serial No. 60-61/3271.—
£202 0s. 6d.
1780. Extras on contract, serial No. 60-61/810.—£340 9s.
1781. Extras on contract, serial No. 60-61/3110.—
£646 9s. 5d.
1782. Extras on contract, serial No. 60-61/3720.—
£2,261 16s. 6d.
1783. Extras on contract, serial No. 60-61/4266.—
£220 11s. 3d.
1784. Extras on contract, serial No. 60-61/3107.—
£476 16s.
1785. Extras on contract, serial No. 61-62/570.—£1,648.
1786. Extras on contract, serial No. 60-61/3168.—
£53 19s. 7d.
1787. Extras on contract, serial No. 60-61/2755.—
£232 13s. 9d.
1788. Extras on contract, serial No. 60-61/1074.—
£1,974 15s. 9d.
1789. Extras on contract, serial No. 60-61/2236.—
£328 2s. 6d.
1790. Extras on contract, serial No. 61-62/814.—£243 15s.
1791. Extras on contract, serial No. 59-60/3371.—
£56 17s. 4d.
1792. Extras on contract, serial No. 60-61/1057.—£79 10s.
1793. Extras on contract, serial No. 61-62/961.—£60.
1794. Extras on contract, serial No. 61-62/583.—
£248 7s. 7d.
1795. Extras on contract, serial No. 61-62/792.—£158.
1796. Extras on contract, serial No. 60-61/3514.—£63 15s.
1797. Extras on contract, serial No. 55-56/6843.—
£11,692 14s. 1d.
1798. Extras on contract, serial No. 61-62/929.—£76 15s.
1799. Extras on contract, serial No. 61-62/568.—
£1,593 7s. 3d.
1800. Extras on contract, serial No. 59-60/1861.—
£707 12s. 6d.
1801. Extras on contract, serial No. 60-61/3103.—
£317 17s. 6d.
1802. Extras on contract, serial No. 60-61/1831.—£284 9s.
1803. Extras on contract, serial No. 60-61/3418.—£319.
1804. Extras on contract, serial No. 60-61/1379.—£787.
1805. Extras on contract, serial No. 59-60/5034.—
£7,552 2s. 7d.
1806. Extras on contract, serial No. 60-61/2370.—
£33 7s. 6d.
1807. Extras on contract, serial No. 61-62/1223.—£172 3s.
1808. Extras on contract, serial No. 60-61/3396.—
£412 10s. 6d.
1809. Extras on contract, serial No. 61-62/577.—£860 15s.
1810. Extras on contracts, serial No. 60-61/4280.—
£155 6s. 6d.
1811. Extras on contract, serial No. 60-61/3093.—
£266 15s. 4d.
1812. Extras on contract, serial No. 60-61/1413.—£132 3s.
1813. Extras on contract, serial No. 60-61/1413.—£207.
H. R. PETTY, Commissioner of Public Works.
1.12.61.

GENERAL STORES.

Gazette No. 9, 1st February, 1961, Schedule No. 52, Tools (General).—All contracts under this Schedule have been extended to 31st March, 1962.

CONTRACT CANCELLED.

Gazette No. 83, 27th September, 1961, Schedule No. 69, Stationery (General).—Item No. 249, Typewriters, policy size, Remington Rand, Chartres Pty. Ltd., is hereby cancelled.

CONTRACT ACCEPTED.

1861. Item No. 249, Typewriters, policy size, £39 10s. each, Olivetti Australia Pty. Ltd., as from 28th November, 1961.

H. COUTTS, Secretary to the Tender Board. 11.12.61.

ORDERS IN COUNCIL.—(Series 1961-62.)

PUBLIC WORKS.

1814. Ashwood High School Development Co-operative Society Ltd., special grant authorized by Education Department as contribution towards site works and ground improvements at the school. (S.E.258857.)

1815. Beaumaris State School No. 3899, removal of fourteen pine trees, £438.—D. M. Reed. (S.E.266377.)

1816. Ports and Harbors Branch, supply of marine lighting equipment as follows:—Apparatus for installation of new navigation lights, £1,718 4s. 6d.—Marine and Industrial Power Pty. Ltd.; navigation lights, £718 14s.—M. E. Mack and Co. Pty. Ltd. (M.42558.)

No. 110.—10641/61.—2

1817. Yallourn Technical College, urgent repairs to roof damaged by storm, £696 12s. 8d.—M. Marley. (S.E.259417.)

1818. Yallourn Technical College, renewal of fibrous plaster and acoustic panels to damaged ceilings, Trade Wing, £440.—W. G. Campbell. (S.E.259417.)

Approved by the Governor in Council, 5th December, 1961.—N. G. WISHART, Acting Clerk of the Executive Council.

STATE ELECTRICITY COMMISSION.

1819. For the supply of polyvinyl chloride coats, trousers and leggings for a period of two years, to Specification No. 61-62/143, at Schedule Rates.—Bramac Ltd.

1820. For the supply of galvanized forged suspension hooks for transmission lines for a period of two years, to Specification No. 61-62/105, at Schedule Rates.—Cyclone Forgings Pty. Ltd.

1821. For construction of civil engineering works, comprising foundations, floors, walls, roofs, slot bunker, paving, turbo-generator blocks, drainage and ancillary works for Hazelwood Power Station, to Specification No. 61-62/77, £1,113,530 (plus items at Schedule Rates).—S. Haunstrup and Co. Pty. Ltd.

1822. For the supply of galvanized forged mild steel pole steps for a period of two years, to Specification No. 61-62/76, at Schedule Rates.—Mark Rollinson and Sons Pty. Ltd.

1823. For the supply and delivery of galvanized structural steelwork for 220 kV switchyard at Geelong Terminal Station, to Specification No. 61-62/163, £5,440.—W. H. and S. Massey Pty. Ltd.

1824. For the erection of electrical plant and equipment at Redcliffs Terminal Station, to Specification No. 61-62/119, £19,064 (plus work at Schedule Rates).—T. A. Mellen Pty. Ltd.

1825. For the excavation of pole, guy and earth pin holes and earthing trenches, for the extension of supply in the metropolitan area for a period of two years, to Specification No. 61-62/70, at Schedule Rates.—J. J. and I. L. Mitchell.

1826. For the supply of 38,000 feet of paper-insulated supervisory control cable for installation between the System Control Centre and Malvern Terminal Station, to Specification No. 61-62/82, £37,840.—Siemens Henley Pty. Ltd.

1827. For the supply of one 22/11 kV transformer and spares for Morwell Power Station, to Specification No. 61-62/87, £33,487.—Wilson Electric Transformer Co. Pty. Ltd.

1828. For the erection of brick offices, show-room, garage and store at Wodonga, to Specification No. 61-62/64, £13,361 10s. 6d.—Rudolf Zauner.

1829. For the supply of four 230 kV circuit breakers and associated equipment, for installation at Templestowe Terminal Station, to Specification No. 61-62/27, £120,180.—A.S.E.A. Electric (Aust.) Pty. Ltd.

1830. For the supply of nine 230 kV circuit breakers and associated equipment for installation at Rowville Terminal Station and Yallourn Power Station, to Specification No. 61-62/27, £232,757.—Australian Electrical Industries Pty. Ltd.

1831. For the supply of seventeen 230 kV circuit breakers and associated equipment for installation at Keilor and Thomastown Terminal Stations, to Specification No. 61-62/27, £377,181.—Australian General Electric Pty. Ltd.

Approved by the Governor in Council, 28th November, 1961.—N. G. WISHART, Acting Clerk of the Executive Council.

Auction Sales Act 1958.

PAYMENT OF FEES FOR AUCTIONEERS' LICENCES.

—TIME EXTENDED.

HIS Excellency the Governor of the State of Victoria, by and with the advice of the Executive Council thereof, doth by Order made on the 12th December, 1961, under the powers conferred by section 16 of the *Auction Sales Act 1958* (No. 6202), extend the time for making payment of fees for Auctioneers' Licences granted at the General Meeting of Justices, held on the fourth Tuesday in November, 1961, for the licensing of Auctioneers, to and inclusive of the tenth day of January, 1962.

N. G. WISHART,
Acting Clerk of the Executive Council.

At Government House,
Melbourne, 12th December, 1961.

Audit Act 1958.

DESIGNATION OF CERTIFYING OFFICERS.

PUBLIC ACCOUNTS AND STORES REGULATIONS.—REGULATION 3.
HIS Excellency the Governor of the State of Victoria, by and with the advice of the Executive Council thereof, doth by Order made on the 28th November, 1961, revoke the Order made on the 2nd July, 1958, pursuant to Regulation 3 of the Public Accounts and Stores Regulations 1958, designating certain offices as being offices, the occupiers of which shall certify accounts for payment in respect of the several departments and services specified in the Order, in so far as it relates to the State Accident Insurance Office and Funds and the State Motor Car Insurance Office and Funds under the Division of the Honorable the Chief Secretary, and in lieu thereof doth designate the undernamed offices as such offices under the said Division in respect of the undernamed Branch and services as shown:—

State Accident Insurance Office and Funds, State Motor Car Insurance Office and Funds,	}	The Insurance Commissioner or the Deputy Insurance Commissioner or the Accountant or the Assistant Accountant.
---	---	--

N. G. WISHART,
 Acting Clerk of the Executive Council.

At Government House,
 Melbourne, 12th December, 1961.

MINES DEPARTMENT.

SUBJECT to any necessary excisions, &c., it is proposed to grant the following mining leases:—

- 7827, Mineral; George William Rowland; 17a. 3r. 7p., Parish of Eldorado.
- 7971, Mineral; Percival Alfred Mowat; 21a. 0r. 6p., Parish of Holey Plains.
- 7972, Mineral; Percival Alfred Mowat; 27a. 3r. 10p., Parish of Holey Plains.
- 8006, Mineral; Percival Alfred Mowat; 3r. 36 7/10p., Parish of Holey Plains.

APPLICATIONS FOR LEASES REFUSED.

- 9216, Castlemaine; George Heywood and Frank Sturgess; 10 acres, Parish of Maldon.
- 7660, Mineral; McKenzie Creek Quarrying Co. Pty. Ltd.; 27 acres, Parish of Bungallally.
- 8014, Mineral; Frederick Thomas Webb; 8 acres, Parish of Corinella.

MINING LEASES GRANTED.

- 5602, Gippsland; Stewart Crouch; 14a. 0r. 21p., Parishes of Waratah and Waratah North.
- 8008, Mineral; Australian Plaster Industries Proprietary Limited; 24a. 3r. 18p., Parish of Woatwoara.
- 8009, Mineral; Australian Plaster Industries Proprietary Limited; 27a. 0r. 11p., Parish of Woatwoara.
- 8010, Mineral; Australian Plaster Industries Proprietary Limited; 24a. 1r. 12p., Parish of Pirro.

W. J. MIBUS,
 Minister of Mines.

CO-OPERATION ACT 1958.

STATEMENT showing the amounts paid by the Registrar of Co-operative Societies during the half-year ended 30th November, 1961, into Court under the provisions of section 78 of the *Co-operation Act 1958*, and subdivision (5) of Division 4 of Part VI. of the *Companies Act 1958*.

Name of Society and Last Address of Registered Office.	Date when Society dissolved.	Amount paid into Court.
		£ s. d.
Co-operative Wholesalers of Victoria Limited, 1287 Nepean-highway, Cheltenham ..	7.1.60	36 12 1

Dated the fourth day of December, 1961.

E. T. EBBELS,
 Registrar of Co-operative Societies.

179 Queen-street, Melbourne, C.1.

EDUCATION DEPARTMENT.

SUMMONING OFFICER.

UNDER section 5 of the *Education Act 1958*, I hereby appoint—

First Constable KENNETH WILLIAM READ
 to summon parents within the State of Victoria.

JOHN BLOOMFIELD,
 Minister of Education.

Melbourne, 7th December, 1961.

EDUCATION DEPARTMENT.

SUMMONING OFFICERS.

UNDER section 5 of the *Education Act 1958*, I hereby appoint—

First Constable JOHN ALOYSIUS OWENS and
 First Constable IVAN VICTOR JOHNS
 to summon parents within the State of Victoria.

JOHN BLOOMFIELD,
 Minister of Education.

Melbourne, 5th December, 1961.

Co-operative Housing Societies Act 1958.

APPOINTMENT.

PURSUANT to the provisions of section 49 of the *Co-operative Housing Societies Act 1958*, I am pleased to approve the appointment of—

CHARLES OLAF WINTER
 as a Director of Vaccinscol No. 1 Co-operative Housing Society Limited for the period 1st January, 1962, to 31st December, 1963, both dates inclusive.

H. E. BOLTE,
 Treasurer.

Land Act 1958.

APPOINTMENTS REVOKED.

HIS Excellency the Governor of the State of Victoria, by and with the advice of the Executive Council thereof, doth by Order made on the 5th December, 1961, revoke the appointment of the under-mentioned persons as Bailiffs of Crown Lands:—

LESLIE JOSEPH VINCENT,
 CLIFTON READ STEVENSON, and
 ALFRED ERNEST JONES.

N. G. WISHART,
 Acting Clerk of the Executive Council.

At Government House,
 Melbourne, 5th December, 1961.

LATROBE RIVER IMPROVEMENT TRUST.

BY-LAW No. 11.

THE Latrobe River Improvement Trust, in pursuance and exercise of the powers conferred by the *River Improvement Act 1958*, doth hereby make the By-law following:—

1. The following rates, to be called the "Latrobe River Improvement District River Improvement Rate", are hereby made, and shall be levied upon the occupiers or owners of all properties within the Latrobe River Improvement District which are rateable to any municipality:—

A rate of Twelve shillings and six pence (12s. 6d.) in the pound on the net annual value of all properties in the First Division, being those properties coloured orange on the plan of the Latrobe River Improvement District, titled the "Latrobe River Improvement District Rating Divisions, 1961", approved by the Governor in Council and lodged at the office of the State Rivers and Water Supply Commission at Melbourne.

A rate of Two shillings and six pence (2s. 6d.) in the pound on the net annual value of all properties in the Second Division, being those properties shown coloured purple on the said plan.

A rate of Two shillings and three pence (2s. 3d.) in the pound on the net annual value of all properties in the Third Division, being those properties shown coloured red on the said plan.

A rate of Two shillings (2s.) in the pound on the net annual value of all properties in the Fourth Division, being those properties shown coloured brown on the said plan.

A rate of One shilling and six pence (1s. 6d.) in the pound on the net annual value of all properties in the Fifth Division, being those properties shown coloured blue on the said plan.

A rate of One shilling (1s.) in the pound on the net annual value of all properties in the Sixth Division, being those properties shown coloured yellow on the said plan.

A rate of Nine pence (9d.) in the pound on the net annual value of all properties in the Seventh Division, being those properties coloured green on the said plan.

A rate of Six pence (6d.) in the pound on the net annual value of all properties in the Eighth Division, being those properties shown coloured pink on the said plan.

A rate of Three pence (3d.) in the pound on the net annual value of all properties in the Ninth Division, being those properties shown coloured grey on the said plan.

2. In respect of all those properties within the Tenth Division, being all those properties uncoloured on the said plan, no rate is made or levied for the period beginning with the 1st day of January, 1961, and ending with the 31st day of December, 1961.

3. In respect of any rateable property other than those included in the Tenth Division the minimum amount payable shall be Five shillings.

4. Such rates are made and shall be levied for the period beginning with the 1st day of January, 1961, and ending with the 31st day of December, 1961, and shall be payable on the 7th day of December, 1961, at the office of the Latrobe River Improvement Trust at Traralgon.

5. Such person or persons as the Latrobe River Improvement Trust may from time to time appoint for the purpose shall be and is or are hereby authorized to demand, receive, collect and recover the said rate.

The foregoing By-law was made by the Latrobe River Improvement Trust on the 23rd day of November, 1961, and the common seal of the said Trust was hereunto affixed this 23rd day of November, 1961, in the presence of—

(SEAL) A. G. BURNET, Chairman.
R. E. TANNER, Commissioner.
N. M. SMITH, Secretary.

Approved by the Governor in Council, 5th December, 1961.—N. G. WISHART, Acting Clerk of the Executive Council.

THE BALLARAT WATER COMMISSIONERS.

RATING BY-LAW FOR THE YEAR 1962.

No. 65.

THE Ballarat Water Commissioners, in pursuance and exercise of the powers conferred by the Water Acts, doth hereby make a rate for the supply of water for domestic purposes of One shilling and one penny in the pound of the annual municipal valuation of lands and tenements liable to be rated within the Ballarat Water Supply District.

Provided that in no case shall the amount of water rate payable annually be less than One pound ten shillings in respect of any rateable property.

Such rates are made and shall be levied upon the occupiers or owners of the said lands and tenements for the year commencing the first day of January, 1962, and shall be payable on the thirty-first day of March, 1962, at the office of The Ballarat Water Commissioners.

The maximum quantity of water to be supplied in any one year, without further charge to any property rated by the Commissioners, is hereby fixed at the quantity which, at a charge of One shilling and four pence per 1,000 gallons, would produce an amount equal to the amount of the rate levied on such property for the said year.

The charge for water supplied by measure to any property rated by the Commissioners in excess of such maximum quantity, computed as in the last preceding clause, is hereby fixed at One shilling and four pence per 1,000 gallons.

The charge for water supplied by measure shall be payable, on demand, at the office of the Commissioners.

Passed this ninth day of November, 1961.

(SEAL) ARTHUR W. NICHOLSON, Chairman.
A. GUYE, Commissioner.
CHAS. H. CLAMP, Secretary.

Approved, 30th November, 1961.—W. J. MIBUS, Minister of Water Supply.

AVENEL WATERWORKS TRUST.

AUTHORITY TO OBTAIN BANK OVERDRAFT.

HIS Excellency the Governor of the State of Victoria, by and with the advice of the Executive Council thereof, doth by Order made on the 12th December, 1961, authorize the Avenel Waterworks Trust to obtain in pursuance of the provisions of section 286 of the *Water Act 1958* (No. 6413) an advance or advances during the year 1961 from the Commercial Bank of Australia Limited, Nagambie, by overdraft of the Trust's current account thereat, such overdraft not to exceed at any one time the sum of Five hundred pounds (£500).

N. G. WISHART,
Acting Clerk of the Executive Council.

At Government House,
Melbourne, 12th December, 1961.

NHILL WATERWORKS TRUST.

RATING BY-LAW FOR THE YEAR 1962.

THE Nhill Waterworks Trust, in pursuance and exercise of the powers conferred by the Water Acts, doth hereby make a rate for the supply of water used for domestic purposes of Two shillings and six pence in the pound on the annual municipal valuation of lands and tenements liable to be rated within the Nhill Urban District.

1. Provided that in no case shall the amount of rate payable per annum in respect to any tenement (other than land on which there is no building) be less than Forty shillings, and in respect of land on which there is no building less than Fifteen shillings.

2. Such rates are made and shall be levied upon the occupiers or owners of the said lands and tenements for the year commencing 1st January, 1962, and shall be payable on the 1st day of February, 1962, at the office of the said Trust.

3. The maximum quantity of water to be supplied in any one year without further charge shall be the quantity which, at a rate of Twenty pence per 1,000 gallons, would produce an amount equal to the amount of rate levied on such property for the said year.

4. The charge for water supplied by measure to any property rated by the Trust in excess of such maximum quantity, computed as in the last preceding clause, is hereby fixed at Fifteen pence per 1,000 gallons.

5. The charge for water supplied by measure to any property not rated by the Trust is hereby fixed at Two shillings and six pence per 1,000 gallons.

6. The charge for water supplied by measure shall be payable, on demand, at the office of the said Trust.

7. *Public Institutions and Others.*—Water supplied to the Government Departments, charitable or other institutions, religious denominations, shall be by measure at One shilling and three pence per 1,000 gallons or by special arrangement.

8. *Water Troughs.*—Private water troughs will be charged for at the rate of Thirty shillings per annum each, except where, in the opinion of the Trust, a meter shall be necessary, in which case the minimum charge shall be for 24,000 gallons at One shilling and three pence per 1,000 gallons.

Such person or persons as the Commissioners of the Trust may from time to time appoint for that purpose shall be authorized to demand and receive and collect and recover the said rates and charges.

Passed this 7th day of November, 1961.

(SEAL) F. E. BOUND, Chairman.
H. L. BOND, Secretary.

Approved, 4th December, 1961.—W. J. MIBUS, Minister of Water Supply.

DONALD WATERWORKS TRUST.

RATING BY-LAW FOR THE YEAR 1962.

THE Donald Waterworks Trust, in pursuance and exercise of the powers conferred by the Water Acts, doth hereby make a rate for the supply of water for domestic purposes of Two shillings in the pound (£1) of the net annual value of lands and tenements liable to be rated within the Donald Urban District.

Provided that in no case shall the amount of rates payable for annum in respect of any tenement (other than land upon which there is no building) be less than Twenty shillings, and in respect of any land upon which there is no building less than Ten shillings.

Such rates are made and shall be levied upon the occupiers or owners of the said lands and tenements for the year commencing on the 1st day of January, 1962, and shall be payable on the 28th day of February, 1962, at the office of the Trust.

The maximum quantity of water to be supplied in any one year without further charge to any property rated by the Trust is hereby fixed at the quantity which, at a charge of One shilling and three pence per 1,000 gallons, would produce an amount equal to the amount of the rate levied on such property for the said year.

The charge for water supplied by measure to any property rated by the Trust in excess of such maximum quantity, computed as in the last preceding clause, is hereby fixed at One shilling and three pence per 1,000 gallons.

The charge for water supplied by measure shall be payable on demand.

The foregoing By-law was made by the Donald Waterworks Trust on the 13th day of November, 1961, and the common seal of the Trust was affixed on the 13th day of November, 1961, in the presence of—

(SEAL) G. M. BOLDEN, Chairman.
B. M. BASSETT, Commissioner.
H. C. SMALE, Secretary.

Approved, 4th December, 1961.—W. J. MIBUS, Minister of Water Supply.

MOUNT BEAUTY WATERWORKS TRUST.

RATING BY-LAW FOR THE YEAR ENDING 31ST DECEMBER, 1962.

THE Mount Beauty Waterworks Trust, in pursuance and exercise of the powers conferred by the Water Acts, doth hereby make a rate for the supply of water for domestic purposes of One shilling and five pence (1s. 5d.) in the pound on the annual valuation of lands and tenements liable to be rated within the Mount Beauty Urban District.

Provided that in no case shall the amount of rate payable per annum in respect of any tenement (other than land on which there is no building) be less than £4 5s., and in respect of any land on which there is no building be less than One pound (£1).

Such rates are made and shall be levied upon the occupiers or owners of the said lands and tenements for the period commencing the 1st day of January, 1962, and ending on the 31st day of December, 1962, and shall be payable on the 1st day of May, 1962, at the office of the said Trust.

Passed this seventeenth day of October, 1961.

(SEAL) S. A. CLARKE, Chairman.
A. J. MCCULLOUGH, Commissioner.
N. W. ALEXANDER, Secretary.

Approved, 30th November, 1961.—W. J. MIBUS, Minister of Water Supply.

LAKES ENTRANCE WATERWORKS TRUST.

RATING BY-LAW No. 5.

THE Lakes Entrance Waterworks Trust, in pursuance and exercise of the powers conferred by the Water Acts, doth hereby make the following rate on lands and tenements liable to be rated in the Lakes Entrance Waterworks Trust District.

On such lands and tenements a rate of Two shillings in the pound on the amount of the annual municipal valuation not exceeding Seventy-five pounds, and where the annual municipal valuation exceeds Seventy-five pounds a rate of Two shillings in the pound for the first Seventy-five pounds, and One shilling in the pound for every pound exceeding Seventy-five pounds of such valuation.

Such rates are made and shall be levied upon the occupiers or owners of the said lands and tenements for the year commencing on the 1st day of January, 1962, and shall be payable on the 12th day of January, 1962, at the offices of the said Trust.

Passed this 9th day of October, 1961.

(SEAL) IAN R. BULMER, Chairman.
G. W. RIDSDALE, Secretary.

Approved, 30th November, 1961.—W. J. MIBUS, Minister of Water Supply.

MERRIGUM WATERWORKS TRUST.

RATING BY-LAW FOR THE YEAR 1962.

THE Merrigum Waterworks Trust, in pursuance and exercise of the powers conferred by the Water Acts, doth hereby make a rate for the supply of water for domestic purposes of Two shillings in the pound on the net annual valuation of lands and tenements liable to be rated within the Merrigum Urban District.

Provided that in no case shall the amount of rate payable per annum in respect of any tenement (other than land on which there is no building) be less than Two pounds ten shillings, and in respect of any land on which there is no building less than One pound.

Garden Licence.

The charge for the supply of water for watering gardens for the year commencing 1st January, 1962, shall be at the rate of Ten shillings per 100 square yards of garden with a minimum annual charge of One pound. Such charge shall be payable, on demand, to the Secretary of the Trust.

Such rates are made and shall be levied upon the occupiers or owners of the said lands and tenements for the year commencing 1st January, 1962, and shall be payable on the 30th day of April, 1962, to the Secretary of the said Trust, resident at Merrigum.

Passed this 18th day of October, 1961.

(SEAL) WALTER R. GORMAN, Chairman.
JOHN S. MANLEY, Secretary.

Approved, 4th December, 1961.—W. J. MIBUS, Minister of Water Supply.

MURCHISON WATERWORKS TRUST.

RATING BY-LAW FOR THE YEAR 1962 (No. 80).

THE Murchison Waterworks Trust, in pursuance and exercise of the powers conferred by the Water Acts, doth hereby make a rate for the supply of water for domestic purposes of Two shillings and nine pence in the pound on the annual municipal valuations of lands and tenements liable to be rated within the Murchison Urban District.

Provided that in no case shall the amount of rate payable per annum in respect of any tenement (other than on land on which there is no building) be less than Five pounds, and in respect of any land on which there is no building be less than Three pounds.

Such rates are made and levied on the occupiers or owners of the said lands and tenements for the year commencing on the 1st day of January, 1962, and shall be payable on the 9th day of January, 1962, at the office of the Trust.

The maximum quantity of water to be supplied in any one year without further charge to any property rated by the Trust is hereby fixed at the quantity which, at a charge of Two shillings and nine pence per 1,000 gallons, would produce an amount equal to the amount of the rate levied on such property for the said year.

The charge for water supplied by measure to any property rated by the Trust in excess of such maximum quantity, computed as in the last preceding clause, is hereby fixed at One shilling and six pence per 1,000 gallons.

The charge for water supplied by measure shall be payable, on demand, at the office of the Trust.

Passed this 14th day of November, 1961.

(SEAL) EDWD. E. HAMMOND, Chairman.
A. HARRIS, Secretary.

Approved, 4th December, 1961.—W. J. MIBUS, Minister of Water Supply.

MURTOA WATERWORKS TRUST.

RATING BY-LAW FOR THE YEAR 1962.

THE Murtoa Waterworks Trust, in pursuance and exercise of the powers conferred by the Water Acts, doth hereby make a rate for the supply of water for domestic purposes of Sixteen pence in the pound on the annual municipal valuation of lands and tenements liable to be rated within the Murtoa Urban District.

Provided that in no case shall the amount of rate payable per annum in respect of any tenement (other than land on which there is no building) be less than Two pounds ten shillings (£2 10s.), and in respect of any land on which there is no building less than One Pound (£1).

Such rates are made and shall be levied upon the occupiers or owners of the said lands and tenements for the year commencing the 1st day of January, 1962, and shall be payable on the 4th day of January, 1962, at the office of the said Trust.

The maximum quantity of water to be supplied in any one year, without further charge to any property rated by the Trust, is hereby fixed at the quantity which, at a charge of Sixteen pence per 1,000 gallons, would produce an amount equal to the amount of the rate levied on such property for the said year.

The charge for water supplied by measure to any property rated by the Trust in excess of such maximum quantity, computed as in the last preceding clause, is hereby fixed at One shilling per 1,000 gallons.

The charge for water supplied by measure shall be payable, on demand, at the office of the Trust.

Passed this 23rd day of October, 1961.

(SEAL) W. W. SCHODDE, Chairman.
G. R. GELLATLY, Commissioner.
H. W. A. MILLER, Commissioner.
H. G. CRAM, Secretary.

Approved, 30th November, 1961.—W. J. MIBUS, Minister of Water Supply.

BRUTHEN WATERWORKS TRUST.

RATING BY-LAW No. 10.

THE Bruthen Waterworks Trust, in pursuance and exercise of the powers conferred by the Water Acts, doth hereby make the following rates for the supply of water for domestic purposes on lands and tenements liable to be rated in the Bruthen Urban District.

On such lands and tenements a rate of Three shillings and six pence in the pound on the amount of the annual municipal valuation not exceeding Sixty pounds, and where the annual municipal valuation exceeds Sixty pounds a rate of Three shillings and six pence in the pound for the first Sixty pounds, and Six pence in the pound for every pound exceeding Sixty pounds of such valuation.

Provided that in no case shall the amount of rate payable per annum in respect of any tenement (other than land on which there is no building) be less than Two hundred and ten shillings, and in respect of land on which there is no building less than Thirty shillings.

Such rates are made and shall be levied upon the occupiers or owners of the said lands and tenements for the year commencing the 1st day of January, 1962, and shall be payable on the 5th day of January, 1962, at the office of the said Trust.

The maximum quantity of water to be supplied in any one year, without further charge to any property rated by the Trust, is hereby fixed at the quantity which, at the charge of Eighteen pence per 1,000 gallons would produce an amount equal to the amount of the rate levied on such property for the said year. The charge for water supplied by measure to any property rated by the Trust in excess of such maximum quantity, computed as in the last preceding clause, is hereby fixed at One shilling per 1,000 gallons.

The charge for water supplied by measure shall be payable, on demand, at the office of the Trust.

Passed this 26th day of October, 1961.

(SEAL) R. RAWLINGS, Chairman.
G. W. RIDSDALE, Secretary.

Approved, 30th November, 1961.—W. J. MIBUS, Minister of Water Supply.

HAMILTON WATERWORKS TRUST.

RATING BY-LAW FOR THE YEAR 1962.

By-law No. 78.

THE Hamilton Waterworks Trust, the Waterworks District of which Trust has been proclaimed an Urban District for the purpose of the Water Acts (hereinafter referred to as "the Trust"), in pursuance and exercise of the powers conferred by the Water Acts, doth hereby make this By-law for such Urban District for determining the rate to be paid in respect of the several lands and tenements to be supplied with water for domestic purposes, and directs as follows:—

1. The said Hamilton Waterworks Trust doth hereby make a rate for the supply of water for domestic purposes of Twelve pence halfpenny in the pound on the

annual municipal valuation of lands and tenements liable to be rated within the Hamilton Waterworks Urban District. Provided that in no case shall the amount of rate payable in respect of any land on which there is a building be less than Seven pounds ten shillings, and in respect of any land on which there is no building less than Three pounds.

Such rates are made and shall be levied upon the occupiers or owners of the said lands and tenements for the year commencing on the first day of January, 1962, and shall be payable on the first day of February, 1962, at the office of the said Trust.

2. The maximum quantity of water to be supplied in any one year without further charge to any property rated by the Trust is hereby fixed at the quantity which, at a charge of Two shillings per 1,000 gallons, would produce an amount equal to the amount of the rate levied on such property for the said year.

3. Except where water is supplied by special agreement, and except as provided by By-law No. 30 of the Trust—

- (a) The charge for water supplied by measure to any property rated by the Trust in excess of such maximum quantity, computed as in the last preceding clause, is hereby fixed at One shilling per 1,000 gallons.
- (b) The charge for water supplied by measure to any property not rated by the Trust is hereby fixed at Two shillings per 1,000 gallons, and the minimum quantity of water to be charged for in cases where water is so supplied is hereby fixed at 10,000 gallons.

4. The charge for water supplied by measure shall be payable, on demand, at the office of the Trust.

5. Such person or persons as the Trust may from time to time appoint for the purposes shall be authorized to demand, receive, collect and recover the rates and charges aforesaid and each of them. And in the absence of such appointment the Secretary and/or Rate Collector of the Trust shall be deemed to have been appointed for the purpose aforesaid and every one of them.

Passed the twenty-third day of November, 1961.

The common seal of the Hamilton Waterworks Trust was hereto affixed this 23rd day of November, 1961, in the presence of—

(SEAL) F. K. HEWETT, Chairman.
W. F. HEWETT, Commissioner.
H. F. DONALD, Secretary.

Approved, 4th December, 1961.—W. J. MIBUS, Minister of Water Supply.

SHIRE OF TUNGAMAH WATERWORKS TRUST.

RATING BY-LAW FOR 1962 IN THE URBAN DISTRICT OF TUNGAMAH.

By-law No. 250.

THE Shire of Tungamah Waterworks Trust, in pursuance and exercise of the powers conferred by the Water Acts, doth hereby make a rate for the supply of water for domestic purposes of Twenty-four pence in the pound on the annual municipal valuation of lands and tenements liable to be rated within the Tungamah Urban District.

Provided that in no case shall the amount of the rate payable in respect of any tenement (other than land on which there is no building) be less than Five pounds, and in respect of land on which there is no building less than Twenty shillings.

Such rates are made and shall be levied upon the occupiers or owners of the said lands and tenements for the year commencing on the 1st day of January, 1962, and shall be payable on the 10th day of April, 1962, at the office of the Trust.

For every trough a minimum sum of Forty shillings per annum shall be charged.

The aforesaid charges shall be payable, on demand.

Passed this 20th day of November, 1961.

The seal of the Trust was hereto affixed this 20th day of November, 1961, in the presence of—

(SEAL) N. McCORMACK, Chairman.
GEORGE R. SYMONS, Commissioner.
M. CLEARY, Secretary.

Approved, 4th December, 1961.—W. J. MIBUS, Minister of Water Supply.

TRENTHAM WATERWORKS TRUST.

RATING BY-LAW FOR THE YEAR 1962.

THE Trentham Waterworks Trust, in pursuance and exercise of the powers conferred by the Water Acts, doth make and levy a rate for the supply of water for domestic purposes of Twenty-three pence in the pound on the net annual municipal valuation of lands and tenements within the Trentham Urban District.

Provided that in no case shall the amount of rate payable in respect of any tenement (other than land on which there is no building) be less than Thirty shillings per annum.

Such rate shall be for the year commencing the 1st day of January, 1962, and shall be due and payable at the office of the Trust, Kyneton, on the 19th day of January, 1962.

Passed this 25th day of October, 1961.

(SEAL) J. G. ROTHE, Chairman.
S. G. PORTER, Secretary.

Approved, 4th December, 1961.—W. J. MIBUS, Minister of Water Supply.

SHIRE OF TUNGAMAH WATERWORKS TRUST.

RATING BY-LAW FOR 1962 IN THE RURAL DISTRICT OF TUNGAMAH.

By-law No. 251.

THE Shire of Tungamah Waterworks Trust, in pursuance and exercise of the powers conferred by the Water Acts, doth hereby make a rate for the supply of water for stock and domestic purposes of Ten pence in the pound on the annual municipal valuation of lands and tenements liable to be rated within the Tungamah Rural District.

Provided that in no case shall the amount of the rate payable in respect of any tenement or vacant land be less than Two shillings.

For the supply of water to gardens and special plots of land, the charge shall be by agreement.

The above-mentioned rate and charges are hereby made for the year commencing on the 1st day of January, 1962, and are due and payable on the 10th day of April, 1962, at the office of the Trust.

Passed this 20th day of November, 1961.

The seal of the Trust was hereto affixed this 20th day of November, 1961, in the presence of—

(SEAL) N. McCORMACK, Chairman.
GEORGE R. SYMONS, Commissioner.
M. CLEARY, Secretary.

Approved, 4th December, 1961.—W. J. MIBUS, Minister of Water Supply.

SHIRE OF TUNGAMAH WATERWORKS TRUST.

RATING BY-LAW FOR 1962 IN THE URBAN DISTRICT OF ST. JAMES.

By-law No. 252.

THE Shire of Tungamah Waterworks Trust, in pursuance and exercise of the powers conferred by the Water Acts, doth hereby make a rate for the supply of water for domestic purposes of Twenty-four pence in the pound on the annual municipal valuation of lands and tenements liable to be rated within the St. James Urban District.

Provided that in no case shall the amount of the rate payable in respect of any tenement (other than land on which there is no building) be less than Five pounds, and in respect of any land on which there is no building less than Twenty shillings.

Such rates are made and shall be levied upon the occupiers or owners of the said lands and tenements for the year commencing on the 1st day of January, 1962, and shall be payable on the 10th day of April, 1962, at the office of the Trust.

For every water trough a minimum sum of Forty shillings per annum shall be charged.

The aforesaid charges shall be payable, on demand.

Passed this 20th day of November, 1961.

The seal of the Trust was hereto affixed this 20th day of November, 1961, in the presence of—

(SEAL) N. McCORMACK, Chairman.
GEORGE R. SYMONS, Commissioner.
M. CLEARY, Secretary.

Approved, 4th December, 1961.—W. J. MIBUS, Minister of Water Supply.

WARRAGUL WATERWORKS TRUST.

RATING BY-LAW FOR THE YEAR 1962—No. 54.

THE Warragul Waterworks Trust, in pursuance of the powers conferred by the Water Acts, doth hereby make a rate for the supply of water for domestic purposes of Fifteen pence (1s. 3d.) in the pound on the annual municipal valuation of lands and tenements liable to be rated within the Warragul Urban District.

1. Provided that in no case shall the amount of the rate payable per annum in respect of any tenement (other than land on which there is no building) be less than Twenty-six shillings (26s.), and in respect of any land on which there is no building be less than Twelve shillings and six pence.

2. Such rates are made and shall be levied upon the occupiers or owners of the said lands and tenements for the year commencing on the 1st day of January, 1962, and shall be due and payable on the 2nd day of March, 1962, at the office of the Trust, Queen-street, Warragul.

3. The maximum quantity of water to be supplied in any one year without further charge to any property rated by the Trust is hereby fixed at the quantity which, at a charge of Fifteen pence (1s. 3d.) per 1,000 gallons, would produce an amount equal to the amount of rates levied on such property for the said year.

4. The charge for water supplied by measure to any property rated by the Trust in excess of such maximum quantity, computed as in the last preceding clause, is hereby fixed at Fifteen pence (1s. 3d.) per 1,000 gallons.

5. The minimum charge per annum for the supply of water to Government premises shall be Ninety shillings (90s.), and for excess water over 60,000 gallons, the charge shall be Fifteen pence (1s. 3d.) per 1,000 gallons.

6. The charge for water supplied by measure shall be payable, on demand, at the office of the Trust.

Passed this 21st day of November, 1961.

(SEAL) C. W. PEDERSEN, Chairman.
R. W. LEASK, Secretary.

Approved, 4th December, 1961.—W. J. MIBUS, Minister of Water Supply.

YARRAWONGA URBAN WATERWORKS TRUST.

RATING BY-LAW FOR THE YEAR 1962.

THE Yarrowonga Urban Waterworks Trust, in pursuance and exercise of the powers conferred by the Water Acts, doth hereby make the following rates for the supply of water on lands and tenements liable to be rated within the Yarrowonga Urban District.

On such lands and tenements a rate of One shilling and six pence in the pound on the amount of the annual municipal valuation.

Provided that in no case shall the amount of rate payable per annum in respect of any tenements (other than land on which there is no building) be less than Three pounds, and in respect of land on which there is no building less than Thirty shillings.

Such rates are made and shall be levied upon the occupiers or owners of the said lands and tenements for the year commencing on the 1st day of January, 1962, and shall be payable on the 1st day of February, 1962, at the office of the said Trust.

The maximum quantity of water to be supplied in any one year without a further charge to any property rated by the Trust is hereby fixed at the quantity which, at a charge of One shilling per 1,000 gallons, would produce an amount equal to the amount of the rate levied on such property for the said year.

The charge for water supplied by measure to any property rated by the Trust in excess of such maximum quantity, computed as in the last preceding clause, is hereby fixed at One shilling per 1,000 gallons.

The charge for water supplied by measure shall be payable, on demand, at the office of the said Trust.

Passed this 17th day of October, 1961.

(SEAL) L. PIERCE, Chairman.
J. WALKER, Secretary.

Approved, 4th December, 1961.—W. J. MIBUS, Minister of Water Supply.

SEYMOUR WATERWORKS TRUST.

RATING BY-LAW FOR THE YEAR 1962.

THE Seymour Waterworks Trust, in pursuance and exercise of the powers conferred by the Water Acts, doth hereby make a rate for the supply of water for domestic purposes of One shilling in the pound of the annual municipal valuation of lands and tenements liable to be rated within the Seymour Urban District.

Provided that in no case shall the amount of rate payable per annum in respect of any tenement (other than land on which there is no building) be less than Twenty-five shillings, and in respect of any land on which there is no building less than Ten shillings.

Such rates are made and shall be levied upon the occupiers or owners of the said lands and tenements for the year commencing the 1st day of January, 1962, and shall be payable on the 1st day of March, 1962, at the office of the said Trust.

The maximum quantity of water to be supplied in any one year without further charge to any property rated by the Trust is hereby fixed at the quantity which, at a charge of One shilling per 1,000 gallons, would produce an amount equal to the amount of the rate levied on such property for the said year.

The charge for water supplied by measure to any property rated by the Trust in excess of such maximum quantity, computed as in the last preceding clause, is hereby fixed at One shilling and six pence per 1,000 gallons.

The charge for water supplied by measure shall be payable, on demand, at the office of the said Trust.

Dated this 16th day of October, 1961.

(SEAL) T. G. WILKINSON, Chairman.
F. TRAINOR, Commissioner.
M. E. COUGHLIN, Commissioner.
P. WILSON, Commissioner.
J. W. ELLIOTT, Commissioner.
W. E. HEYWOOD, Commissioner.
H. CLYDESDALE, Secretary.

Approved, 30th November, 1961.—W. J. MIBUS, Minister of Water Supply.

CHARLTON WATERWORKS TRUST.

RATING BY-LAW FOR THE YEAR 1962 (No. 77).

THE Charlton Waterworks Trust, in pursuance and exercise of the powers conferred by the Water Acts, doth hereby make a rate for the supply of water for domestic purposes of Two shillings and six pence in the pound on the amount of the annual municipal valuation of the lands and tenements liable to be rated within the Charlton Urban District.

Provided that in no case shall the amount of rate payable per annum in respect of any tenement (other than land on which there is no building) be less than Three pounds, and in respect of any land on which there is no building less than One pound ten shillings.

Such rates are made for the year commencing on the 1st day of January, 1962, and ending on the 31st day of December, 1962, and shall be payable on the 1st day of March, 1962, at the office of the said Trust.

The maximum quantity of water to be supplied in any one year without further charge to any property rated by the Trust is hereby fixed at the quantity which, at a charge of One shilling and six pence per thousand (1,000) gallons, would produce an amount equal to the amount of rate levied on such property for the said year.

The charge for water supplied by measure to any property rated by the Trust in excess of such maximum quantity, computed as in the last preceding clause, is hereby fixed at One shilling and six pence per thousand (1,000) gallons.

The charge for water supplied by measure shall be payable, on demand, at the office of the said Trust.

The charge for water supplied from any stand pipe on the Trust's water mains is hereby fixed at Two shillings per thousand (1,000) gallons, and shall be payable, on demand, at the office of the said Trust.

The foregoing By-law No. 77 was made by the Charlton Waterworks Trust on the 9th day of October, 1961, and the seal of the Trust was hereto affixed, in our presence—

(SEAL) C. FANNING, Chairman.
W. H. WOOD, Commissioner.
IAN SCOTT, Secretary.

Approved, 4th December, 1961.—W. J. MIBUS, Minister of Water Supply.

APOLLO BAY WATERWORKS TRUST.

RATING BY-LAW FOR THE YEAR 1962.

THE Apollo Bay Waterworks Trust, in pursuance and exercise of the powers conferred by the Water Acts, doth hereby make a rate for the supply of water for domestic purposes of One shilling and four pence (1s. 4d.) in the pound of the annual municipal valuation of lands and tenements liable to be rated within the Apollo Bay Urban District.

Provided that in no case shall the amount of rate payable per annum in respect of any tenement (other than land on which there is no building) be less than Eighty shillings (80s.), and in respect of any land on which there is no building less than Forty shillings (40s.).

Such rates are made and shall be levied upon the occupiers or owners of the said lands and tenements for the year commencing on the 1st day of January, 1962, and shall be payable on the 2nd day of April, 1962, at the office of the said Trust.

The maximum quantity of water to be supplied in any one year without further charge to any property rated by the said Trust is hereby fixed at the quantity which, at a charge of One shilling and six pence (1s. 6d.) per 1,000 gallons, would produce an amount equal to the amount of the rate levied on such property for the said year.

The charge for water supplied by measure to any property rated by the Trust in excess of such maximum quantity, computed as in the last preceding clause, is hereby fixed at One shilling and six pence (1s. 6d.) per 1,000 gallons.

Water supplied to cricket, tennis, or bowling clubs, and to Government Departments, showgrounds, and similar properties shall be charged for at the rate of One shilling and six pence (1s. 6d.) per 1,000 gallons, provided that the minimum quantity to be charged for shall not be less than 15,000 gallons.

The charge for water supplied by measure shall be payable, on demand, at the office of the Trust.

Passed this 22nd day of November, 1961.

(SEAL) MALCOLM M. THOMSON, Chairman.
J. TRESEDER, Secretary.

Approved, 4th December, 1961.—W. J. MIBUS, Minister of Water Supply.

APPOINTMENTS.

HIS Excellency the Governor of the State of Victoria, by and with the advice of the Executive Council thereof, has, by Orders made on the 5th day of December, 1961, been pleased to make the under-mentioned appointments, viz.:

LAW DEPARTMENT.

Justices of the Peace.

WILLIAM EDWARD TAINSH, Clydesdale, and
MERVYN NOEL MURPHY, 89 Piper-street, Kyneton,
to Keep the Peace in the Midland Bailiwick of the State of Victoria; and

HENRY JOSEPH DOWD, 40 Cromwell-street, Glenroy,
EDWARD COLIN HILL, 22 Albert Hill-road, Lilydale, and
JOHN THOMAS SMITH, 4 Ulm-street, North Coburg,
to Keep the Peace in the Central Bailiwick of the State of Victoria.

Commissioners for Taking Declarations, &c.

DAVID JOHN ALLAN TREDINNICK, Marketing Manager,
Black and Decker (A/Asia) Pty. Ltd., Croydon,
and

GEORGE SEGER, Credit Officer, Pye Pty. Ltd., Clarinda-
road, Clayton,

to be Commissioners for taking Declarations and Affidavits, pursuant to the provisions of the *Evidence Act 1958*, to resign upon ceasing to occupy their present positions; and

NORMAN WILLIAM HOPKINSON, 4 Cape-street, Heidelberg,

WILLIAM ROBERT MORRIS, Molesworth,
JOHN NORMAN FANNING, 33 Langford-street, Surrey
Hills,

CARLISLE VICTOR IRVINE BARNDEN, 71 Deakin-avenue,
Mildura, and

JOHN PATRICK ANDERSON, 192 Hilton-street, Glenroy,
to be Commissioners for taking Declarations and Affidavits, pursuant to the provisions of the *Evidence Act 1958*, to resign upon removing from the neighbourhood of the addresses stated.

Deputy Prothonotary, &c.

BRYAN JAMES COSGRIFF
to be also Deputy Prothonotary and Clerk of the Children's Court at Wangaratta and Clerk of the Children's Court at Yarrowonga, during the absence of M. A. Tuohy on annual leave, to take effect from the date of commencement of duty.

Deputy Clerk of the Peace, &c.

MICHAEL JAMES TERENCE QUIRK
to be Deputy Clerk of the Peace, Registrar of the County Court, Clerk of the Court of Mines, Clerk of Petty Sessions and Clerk of the Children's Court at Maryborough, and Clerk of Petty Sessions and Clerk of the Children's Court at Avoca, Bealiba, Dunolly and Tarnagulla, during the absence of V. G. Stafford on annual leave, to take effect from the date of commencement of duty.

Clerks of Children's Courts.

DONALD ROBERT WALKER
to be Clerk of the Children's Court at Melbourne, during the absence of E. L. Ross on annual leave, to take effect from the date of commencement of duty; and

GREGORY FRANCIS MEEHAN
to be Clerk of the Children's Court at Charlton, Culgoa, Sea Lake, Wedderburn and Wycheproof, during the absence of D. L. Croft on annual leave, to take effect from the date of commencement of duty.

DEPARTMENT OF AGRICULTURE.

Member of the Onion Marketing Board.

JOHN EDWARD TRUETT,
pursuant to the provisions of the *Marketing of Primary Products Act 1958*, to be a Member of the Onion Marketing Board for a period of two (2) years.

DEPARTMENT OF CROWN LANDS AND SURVEY.

Bailiffs of Crown Lands.

LEO BRISCO SHEILS, Attendant, Public Offices Reserve,
DAVID KEITH PARK, Custodian of Metropolitan Buildings, and
ROGER HENRY PETTYFOR, Gardener,
to be Bailiffs of Crown Lands without additional salary.

DEPARTMENT OF THE TREASURER.

Receivers of Revenue.

IRWIN MATTHEW GREEN
to act temporarily as Receiver of Revenue, Taxation Office, 179 Queen-street, Melbourne, during the absence of S. V. Morriss on leave; and

BRUCE VAUGHT MCDONALD
to act temporarily as Receiver and Paymaster, Melbourne, vice T. V. Crozier, from and inclusive of 4th December, 1961.

Collector of Imposts.

BENJAMIN PATRICK KAY
to act temporarily as Collector of Imposts, Transport Regulation Board, during the absence of A. V. C. Cook on leave.

N. G. WISHART,
Acting Clerk of the Executive Council.

At Government House,
Melbourne, 5th December, 1961.

RESIGNATION.

HIS Excellency the Governor of the State of Victoria, by and with the advice of the Executive Council thereof, has, by Order made on the 5th day of December, 1961, accepted the resignation of the person named hereunder of the office mentioned, viz.:—

LAW DEPARTMENT.

LEONARD MAXWELL KELLETT, as a Commissioner for taking Declarations and Affidavits, pursuant to the provisions of the *Evidence Act 1958*.

N. G. WISHART,
Acting Clerk of the Executive Council.

At Government House,
Melbourne, 5th December, 1961.

LATROBE VALLEY ACT 1958.

At Government House, Melbourne, the fifth day of December, 1961.

PRESENT:

His Excellency the Governor of Victoria.
Mr. Chandler | Mr. Reid.
Mr. Thompson |

RE-APPOINTMENT OF MEMBERS AND VICE-CHAIRMAN OF THE LATROBE VALLEY DEVELOPMENT ADVISORY COMMITTEE.

IN pursuance of the powers conferred by section 4 of the *Latrobe Valley Act 1958*, His Excellency the Governor of the State of Victoria, by and with the advice of the Executive Council thereof, doth by this Order—

(a) Re-appoint the following to be Members of the Latrobe Valley Development Advisory Committee for a period of three years, as from and inclusive of the 19th December, 1961, viz.:—

THOMAS FORRISTAL, A.A.S.A.,
FREDERICK CHARLES COOK, C.E., L.S., M.I.S., Aust.,
A.M.T.P.I., F.A.P.I.,
RONALD ALLEN KING PALMER, M.M.E., B.E.E., Dip.Com.,
A.M.I.E. Aust., and
JACK HURTLE GREER, L.S., M.I.S. Aust.

(b) Re-appoint the said THOMAS FORRISTAL to be Vice-Chairman of the Committee.

And the Honorable Henry Edward Bolte, Her Majesty's Premier for the State of Victoria, shall give the necessary directions herein accordingly.

N. G. WISHART,
Acting Clerk of the Executive Council.

LOCAL GOVERNMENT DEPARTMENT.

At Government House, Melbourne, the fifth day of December, 1961.

PRESENT:

His Excellency the Governor of Victoria.
Mr. Chandler | Mr. Reid.
Mr. Thompson |

VARIATION OF SPECIFICATIONS, ETC., FOR PRIVATE STREET CONSTRUCTION SCHEME—SHIRE OF WARRACKNABEAL.

IN pursuance of the provisions of section 592 of the *Local Government Act 1958*, as amended, the Governor of the State of Victoria, by and with the advice of the Executive Council thereof, being satisfied that the works provided for in a scheme for the construction of the "War Service Estate" group of private streets cannot be satisfactorily executed in accordance with the specifications, maps, plans, sections and elevations in the scheme, hereby authorizes the Council of the Shire of Warracknabeal to execute the work with such variation of the said specifications, maps, plans, sections and elevations as are necessary to permit construction of Menin-avenue with the following variations, namely:—

(a) Existing proposal: Carriageway of 25 feet with the southern side thereof distant 20 ft. 6 in. from the southern alignment of Menin-avenue.

(b) Amended proposal: Carriageway 24 ft. 10 in. with the southern side thereof distant 19 feet from the southern alignment of Menin-avenue.

And the Honorable Murray Victor Porter, Her Majesty's Minister for Local Government for the State of Victoria, shall give the necessary directions herein accordingly.

N. G. WISHART,
Acting Clerk of the Executive Council.

AUDIT ACT 1958 (No. 6203).

At Government House, Melbourne, the fifth day of December, 1961.

PRESENT:

His Excellency the Governor of Victoria.
 Mr. Chandler | Mr. Reid.
 Mr. Thompson |

PUBLIC ACCOUNTS AND STORES REGULATIONS 1958.

IN pursuance of the provisions of the *Audit Act* 1958 (No. 6203) and all other powers in that behalf him enabling, His Excellency the Governor of the State of Victoria, by and with the advice of the Executive Council thereof, doth hereby make the following additional Regulations under the Public Accounts and Stores Regulations 1958 in the manner shown, such Regulations to have effect from and inclusive of the 1st January, 1962:—

31. Except in accordance with this Part, no officer shall be authorized to incur any liability or shall have any authority to make any contract on behalf of the Crown or of the Government or of any Department or its branches without the authority in writing of the responsible Minister.

31A. Regulation 31 in its present form under the Public Accounts and Stores Regulations 1958 is amended to read 31A.

37A. The general conditions and forms of specification and of contracts which may from time to time be authorized or adopted for any Department or Authority shall be strictly adhered to and no alteration shall be made thereto, unless approved in writing by the responsible Minister or Authority.

161A. Officers in charge of public buildings shall, in the event of repairs being required, promptly report to the Permanent Head of the Department, the necessity for such repairs being effected.

And the Honorable Henry Edward Bolte, Her Majesty's Treasurer for the State of Victoria, shall give the necessary directions herein accordingly:

N. G. WISHART,
 Acting Clerk of the Executive Council.

TOURIST ACT 1958.

At Government House, Melbourne, the fifth day of December, 1961.

PRESENT:

His Excellency the Governor of Victoria.
 Mr. Chandler | Mr. Reid.
 Mr. Thompson |

REGULATIONS.

IN pursuance of the powers conferred by section 5A of the *Tourist Act* 1958, as amended by the *Tourist (Amendment) Act* 1961, and section 12 of the *Tourist Act* 1958, His Excellency the Governor of the State of Victoria, by and with the advice of the Executive Council thereof, doth hereby make the following Regulations:—

FEES.

1. These Regulations may be cited as the Tourist Development Authority (Fees) Regulations.

2. Each of the appointed members and the nominee of the Minister shall, unless he is engaged in full-time employment as an officer of the Crown or the Public Service or as a member or officer of any public statutory corporation, be entitled to be paid a fee of £5 5s. in respect of each day on which such appointed member or nominee of the Minister attends a meeting of the Tourist Development Authority, an inspection made by the Tourist Development Authority, a meeting of a Committee or Sub-committee of the Tourist Development Authority of which Committee or Sub-committee he is a member or a meeting of another Commonwealth or State Tourist Authority as the representative of the Victorian Authority:

Provided that no appointed member or nominee of the Minister shall be entitled to receive more than one fee in respect of any one day notwithstanding that he may attend more than one meeting and/or inspection on that day.

And the Honorable Henry Edward Bolte, Her Majesty's Premier for the State of Victoria, shall give the necessary directions herein accordingly.

N. G. WISHART,
 Acting Clerk of the Executive Council.

DEPARTMENT OF CROWN LANDS AND SURVEY.

At Government House, Melbourne, the fifth day of December, 1961.

PRESENT:

His Excellency the Governor of Victoria.
 Mr. Chandler | Mr. Reid.
 Mr. Thompson

LANDS TEMPORARILY RESERVED AS SITES.

HIS Excellency the Governor of the State of Victoria, by and with the advice of the Executive Council thereof, doth hereby, in pursuance of the provisions of the Land Act 1958, reserve, temporarily, and also except from occupation for mining purposes, under any miner's right, the lands hereinafter described:—

BONEGILLA.—Site for Camping purposes in addition to and adjoining the site temporarily reserved therefor by Order in Council of the 15th November, 1937, 3 acres 2 roods 16 perches, Parish of Bonegilla, County of Bogong, as indicated by hachure on plan hereunder.—(B.575^(*)) (Rs.4742).

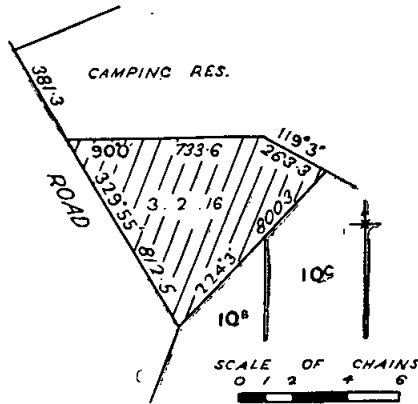

BONEGILLA.—Site for Camping purposes in addition to and adjoining the site temporarily reserved therefor by Order in Council of the 12th December, 1938, 6 acres 2 roods 35 perches, Parish of Bonegilla, County of Bogong, as indicated by hachure on plan hereunder.—(B.575^(*)) (Rs.4742).

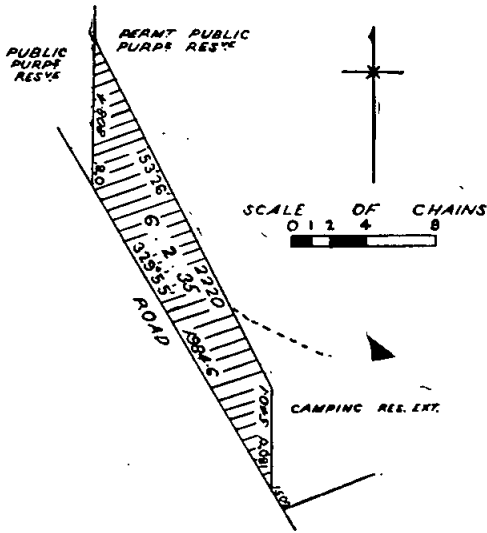

BOOROOPIKI.—Site for Public purposes, 9 acres more or less, Parish of Boorookpi, County of Lowan, as indicated by hachure on plan hereunder.—(B.664^(*)) (Rs.8101).

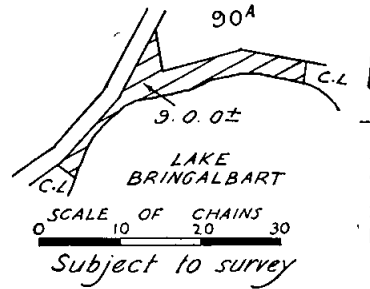

BAEL BAEI.—Site for Water Supply purposes in addition to and adjoining the site temporarily reserved therefor by Order in Council of the 21st September, 1896, 14 acres 20 perches more or less, Parish of Bael Bael, County of Tatchera, as indicated by hachure on plan hereunder.—(B.640^(*)) (Rs.6039).

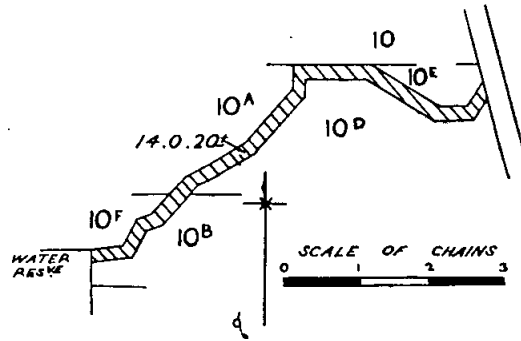

And the Honorable Keith Hector Turnbull, Her Majesty's Commissioner of Crown Lands and Survey for the State of Victoria, shall give the necessary directions herein accordingly.

N. G. WISHART,
 Acting Clerk of the Executive Council.

DEPARTMENT OF CROWN LANDS AND SURVEY.

At Government House, Melbourne, the fifth day of December, 1961.

PRESENT:

His Excellency the Governor of Victoria.
 Mr. Chandler | Mr. Reid.
 Mr. Thompson

REVOCATIONS OF TEMPORARY RESERVATIONS OF LANDS BY ORDERS IN COUNCIL.

HIS Excellency the Governor of the State of Victoria, by and with the advice of the Executive Council thereof, doth hereby, in pursuance of the provisions of the Land Act 1958, revoke the temporary reservations of lands by Orders in Council hereinafter referred to, viz.:—

MYRTLEFORD.—Order in Council of 21st June, 1897, of 1 acre 1 rood 22 perches of land in the Parish of Myrtleford, as a site for a State School.—(C.21278.)

HOWQUA.—Order in Council of 13th April, 1874, of 5 acres of land in the Parish of Howqua, as a site for State School purposes.—(C.20539.)

ALEXANDRA.—Order in Council of 31st October, 1932, of 100 acres of land in the Parish of Alexandra, as a site for Public Recreation.—(Rs.4258.)

And the Honorable Keith Hector Turnbull, Her Majesty's Commissioner of Crown Lands and Survey for the State of Victoria, shall give the necessary directions herein accordingly.

N. G. WISHART,
 Acting Clerk of the Executive Council.

DEPARTMENT OF CROWN LANDS AND SURVEY.

At Government House, Melbourne, the fifth day of December, 1961.

PRESENT:

His Excellency the Governor of Victoria.
Mr. Chandler | Mr. Reid.
Mr. Thompson

REVOCATION OF ORDER IN COUNCIL WITHHOLDING CERTAIN LAND FROM SALE, LEASING, AND LICENSING.

HIS Excellency the Governor of the State of Victoria, by and with the advice of the Executive Council thereof, doth hereby, in pursuance of the provisions of the *Land Act 1958*, revoke the withholding from sale, leasing, and licensing of the land mentioned hereunder:—

AWONGA.—Order in Council of 27th May, 1878, of 5 acres of land in the Parish of Awonga as a site for Public purposes (State School).—(C.96829.)

And the Honorable Keith Hector Turnbull, Her Majesty's Commissioner of Crown Lands and Survey for the State of Victoria, shall give the necessary directions herein accordingly.

N. G. WISHART,
Acting Clerk of the Executive Council.

COUNTRY ROADS BOARD.

At Government House, Melbourne, the fifth day of December, 1961.

PRESENT:

His Excellency the Governor of Victoria.
Mr. Chandler | Mr. Reid.
Mr. Thompson

ORDER APPROVING OF WIDENING AN EXISTING MAIN ROAD IN THE SHIRE OF BET BET.

WHEREAS the Country Roads Board constituted under the *Country Roads Act 1958* (No. 6229) has represented to His Excellency the Governor in Council that it appears to it desirable that the existing Avoca-Bealiba road in the Shire of Bet Bet (declared to be a main road under the said Act which declaration was confirmed by the Order in Council published in the *Government Gazette* of the 14th July, 1915, on page 2616) should be widened by the said Board: And whereas the said Board in accordance with the requirements of section 19 of the said cited Act has caused to be prepared a map plan and estimate showing the points between which and on and through what land the said widening is proposed to be made and the cost of acquiring the land: And whereas on an inspection of the said map and plan and a consideration of the said estimate His Excellency the Governor in Council is satisfied that there are funds legally available for acquiring the land: Now therefore be it known by this present Order that His Excellency the Governor of the State of Victoria with the advice of the Executive Council thereof doth hereby approve of the said road being widened, that is to say:—

All those pieces of land in the Parish of Archdale, the boundaries of which are as follow:—

- (a) Commencing at the south-eastern angle of allotment 38 of the said parish; thence by lines bearing respectively 270 deg. 0 min. 353.7 links, 338 deg. 38 min. 1,172.9 links and 144 deg. 26 min. 1,342.8 links to the point of commencement.
- (b) Commencing at the north-eastern angle of allotment 39A of the said parish; thence by lines bearing respectively 180 deg. 0 min. 1,150 links, 340 deg. 47 min. 1,776.1 links and 132 deg. 3 min. 787 links to the point of commencement—

which said pieces of land are particularly delineated and shown coloured red on survey plan numbered 8163, lodged in the office of the Country Roads Board.

And the Honorable Horace Rostill Petty, Her Majesty's Commissioner of Public Works for the State of Victoria, shall give the necessary directions herein accordingly.

N. G. WISHART,
Acting Clerk of the Executive Council.

COUNTRY ROADS BOARD.

At Government House, Melbourne, the fifth day of December, 1961.

PRESENT:

His Excellency the Governor of Victoria.
Mr. Chandler | Mr. Reid.
Mr. Thompson

ORDER APPROVING OF WIDENING AN EXISTING MAIN ROAD IN THE SHIRE OF NARRACAN.

WHEREAS the Country Roads Board constituted under the *Country Roads Act 1958* (No. 6229) has represented to His Excellency the Governor in Council that it appears to it desirable that the existing Trafalgar-Thorpdale road in the Shire of Narracan (declared to be a main road under the said Act which declaration was confirmed by the Order in Council published in the *Government Gazette* of the 10th May, 1916, on page 1841) should be widened by the said Board: And whereas the said Board in accordance with the requirements of section 19 of the said cited Act has caused to be prepared a map plan and estimate showing the points between which and on and through what land the said widening is proposed to be made and the cost of acquiring the land: And whereas on an inspection of the said map and plan and a consideration of the said estimate His Excellency the Governor in Council is satisfied that there are funds legally available for acquiring the land: Now therefore be it known by this present Order that His Excellency the Governor of the State of Victoria with the advice of the Executive Council thereof doth hereby approve of the said road being widened, that is to say:—

All those pieces of land in the Parish of Moe, the boundaries of which are as follow:—

- (a) Commencing at an angle in the western boundary of the existing Trafalgar-Thorpdale road, through allotment 72 of the said parish, formed by the intersection of lines bearing 5 deg. 59 min. and 331 deg. 45 min.; thence by lines bearing respectively 185 deg. 59 min. 254.5 links, 347 deg. 1 min. 233.3 links, 336 deg. 51 min. 182.7 links, 314 deg. 7 min. 405.3 links, 118 deg. 36 min. 150 links, 129 deg. 42 min. 283.2 links, and 151 deg. 45 min. 194.8 links to the point of commencement.
- (b) Commencing at an angle in the southern boundary of the existing Trafalgar-Thorpdale road, through allotment 64 of the said parish, formed by the intersection of lines bearing 278 deg. 38 min. and 255 deg. 57 min.; thence by lines bearing respectively 98 deg. 38 min. 52.6 links, 238 deg. 19 min. 270.5 links, 190 deg. 53 min. 243.2 links, 163 deg. 52 min. 283.9 links, 333 deg. 12 min. 306.8 links, 359 deg. 49 min. 192 links, 36 deg. 28 min. 190 links, and 75 deg. 57 min. 176.5 links to the point of commencement.
- (c) Commencing at an angle in the western boundary of the existing Trafalgar-Thorpdale road, through allotment 64 of the said parish, formed by the intersection of lines bearing 38 deg. 49 min. and 55 deg. 41 min.; thence by lines bearing respectively 36 deg. 25 min. 374.3 links, 6 deg. 5 min. 502.9 links, 341 deg. 58 min. 472.5 links, 153 deg. 12 min. 318.3 links, 95 deg. 55 min. 38.6 links, 105 deg. 41 min. 331.8 links, 179 deg. 7 min. 68.7 links, 211 deg. 21 min. 152.8 links, 229 deg. 53 min. 279.8 links, 183 deg. 28 min. 137.9 links, 218 deg. 39 min. 368.4 links, and 235 deg. 41 min. 120.7 links to the point of commencement.
- (d) Commencing at an angle in the eastern boundary of the existing Trafalgar-Thorpdale road, through allotment 64 of the said parish, formed by the intersection of lines bearing 55 deg. 41 min. and 37 deg. 50 min.; thence by lines bearing respectively 220 deg. 33 min. 355.2 links, 223 deg. 48½ min. 120.1 links, 228 deg. 16 min. 259.7 links, 38 deg. 49 min. 520.3 links, and 55 deg. 41 min. 220 links to the point of commencement—

which said pieces of land are particularly delineated and shown coloured red on survey plan numbered 8323, lodged in the office of the Country Roads Board.

And the Honorable Horace Rostill Petty, Her Majesty's Commissioner of Public Works for the State of Victoria, shall give the necessary directions herein accordingly.

N. G. WISHART,
Acting Clerk of the Executive Council.

COUNTRY ROADS BOARD.

At Government House, Melbourne, the fifth day of December, 1961.

PRESENT:

His Excellency the Governor of Victoria.
Mr. Chandler | Mr. Reid.
Mr. Thompson

DECLARATION OF THE WIDENING OF ARCHIES CREEK-ROAD IN THE SHIRE OF BASS.

WHEREAS by section 21 of the *Country Roads Act* 1958 (No. 6229) it is amongst other things enacted that when the Country Roads Board under the provisions of the Country Roads Act has taken the land necessary for constructing the road or deviation or widening it shall as soon as it thinks such road or deviation or widening is fit to be used as a public highway by Resolution declare the road or deviation or widening to be a main road or part thereof and that upon publication in the *Government Gazette* of the Order of the Governor in Council confirming such Resolution such road or deviation or widening shall thereupon be a main road or a part thereof within the meaning of the said Act: And whereas the said Board has by Resolution declared the road on the land described in the Schedule to such Resolution to be part of a main road: Now therefore His Excellency the Governor of the State of Victoria by and with the advice of the Executive Council thereof doth hereby confirm the said Resolution.

Resolution for Declaration of the Widening of a Main Road under the Country Roads Act.

Whereas the land the site of the road the course of which is below set out was taken by the Board under the provisions of the Country Roads Act for the purpose of widening the main road aforesaid which widening has now been laid out and formed on the same: And whereas the said Board (being the Country Roads Board incorporated under the said Act) thinks that the widening aforesaid is fit to be used as part of a public highway such Board at a meeting now holden doth by this Resolution hereby declare the same as described in the Schedule hereto with the commencing and terminating points thereof respectively specified to be part of the main road within the meaning and for the purpose of the Country Roads Act.

SCHEDULE.

Shire of Bass.

12. *Archies Creek-road* (812).—All those pieces of land in the Parish of Wonthaggi North, the boundaries of which are as follow:—

- (a) Commencing at the north-western angle of allotment 115A of the said parish; thence by lines bearing respectively 90 deg. 27 min. 596 links, 250 deg. 7 min. 580.8 links, 237 deg. 29 min. 192.9 links, 219 deg. 11 min. 263.7 links and 28 deg. 42 min. 581.9 links to the point of commencement.
- (b) Commencing at the south-eastern angle of allotment 113 of the said parish; thence by lines bearing respectively 270 deg. 27 min. 339.7 links, 59 deg. 48 min. 248.6 links, 42 deg. 35 min. 257.6 links, 36 deg. 43 min. 361.7 links and 203 deg. 38 min. 663 links to the point of commencement—

which said pieces of land are particularly delineated and shown coloured red and blue on survey plan numbered 7413, lodged in the office of the Country Roads Board.

The common seal of the Country Roads Board was hereto affixed at Kew, this twenty-seventh day of November, One thousand nine hundred and sixty-one, in the presence of—

(SEAL) D. V. DARWIN, Chairman.
W. H. NEVILLE, Member.
R. E. V. DONALDSON, Secretary.

And the Honorable Horace Rostill Petty, Her Majesty's Commissioner of Public Works for the State of Victoria, shall give the necessary directions herein accordingly.

N. G. WISHART,
Acting Clerk of the Executive Council.

COUNTRY ROADS BOARD.

At Government House, Melbourne, the fifth day of December, 1961.

PRESENT:

His Excellency the Governor of Victoria.
Mr. Chandler | Mr. Reid.
Mr. Thompson

ORDER APPROVING OF WIDENING AN EXISTING MAIN ROAD IN THE SHIRE OF McIVOR.

WHEREAS the Country Roads Board constituted under the *Country Roads Act* 1958 (No. 6229) has represented to His Excellency the Governor in Council that it appears to it desirable that the existing Seymour-Toorborac road in the Shire of McIvor (declared to be a main road under the said Act which declaration was confirmed by the Order in Council published in the *Government Gazette* of the 16th July, 1947, on pages 3851-55) should be widened by the said Board: And whereas the said Board in accordance with the requirements of section 19 of the said cited Act has caused to be prepared a map plan and estimate showing the points between which and on and through what land the said widening is proposed to be made and the cost of acquiring the land: And whereas on an inspection of the said map and plan and a consideration of the said estimate His Excellency the Governor in Council is satisfied that there are funds legally available for acquiring the land: Now therefore be it known by this present Order that His Excellency the Governor of the State of Victoria with the advice of the Executive Council thereof doth hereby approve of the said road being widened, that is to say:—

All that piece of land in the Parish of Panyule, the boundaries of which are as follow:—Commencing at the southern angle of allotment 7, section B, of the said parish; thence by lines bearing respectively 305 deg. 29 min. 354.3 links, 101 deg. 11 min. 372.2 links, 88 deg. 13 min. 423.3 links, and 253 deg. 39 min. 520.8 links to the point of commencement—which said piece of land is particularly delineated and shown coloured red on survey plan numbered 8155, lodged in the office of the Country Roads Board.

And the Honorable Horace Rostill Petty, Her Majesty's Commissioner of Public Works for the State of Victoria, shall give the necessary directions herein accordingly.

N. G. WISHART,
Acting Clerk of the Executive Council.

COUNTRY ROADS BOARD.

At Government House, Melbourne, the fifth day of December, 1961.

PRESENT:

His Excellency the Governor of Victoria.
Mr. Chandler | Mr. Reid.
Mr. Thompson

ORDER APPROVING OF WIDENING AN EXISTING MAIN ROAD IN THE SHIRE OF EUROA.

WHEREAS the Country Roads Board constituted under the *Country Roads Act* 1958 (No. 6229) has represented to His Excellency the Governor in Council that it appears to it desirable that the existing Euroa-Arcadia road in the Shire of Euroa (declared to be a main road under the said Act which declaration was confirmed by the Order in Council published in the *Government Gazette* of the 9th May, 1923, on page 1240) should be widened by the said Board: And whereas the said Board in accordance with the requirements of section 19 of the said cited Act has caused to be prepared a map plan and estimate showing the points between which and on and through what land the said widening is proposed to be made and the cost of acquiring the land: And whereas on an inspection of the said map and plan and a consideration of the said estimate His Excellency the Governor in Council is satisfied that there are funds legally available for acquiring the land: Now therefore be it known by this present Order that His Excellency the Governor of the State of Victoria with the advice of the Executive Council thereof doth hereby approve of the said road being widened, that is to say:—

All that piece of land in the Parish of Mlepoll, the boundaries of which are as follow:—Commencing at the eastern angle of allotment 60A of the said parish; thence

by lines bearing respectively 180 deg. 0 min. 222.3 links, 344 deg. 54 min. 410.3 links and 148 deg. 25 min. 204 links to the point of commencement—which said piece of land is particularly delineated and shown coloured red on survey plan numbered 8170, lodged in the office of the Country Roads Board.

And the Honorable Horace Rostill Petty, Her Majesty's Commissioner of Public Works for the State of Victoria, shall give the necessary directions herein accordingly.

N. G. WISHART,
Acting Clerk of the Executive Council.

COUNTRY ROADS BOARD.

At Government House, Melbourne, the fifth day of
December, 1961.

PRESENT:

His Excellency the Governor of Victoria.
Mr. Chandler | Mr. Reid.
Mr. Thompson |

DECLARATION OF THE WIDENING OF NEPEAN HIGHWAY IN THE CITIES OF BRIGHTON AND MOORABBIN.

WHEREAS by sections 21 and 74 of the *Country Roads Act 1958* (No. 6229) it is amongst other things enacted that when the Country Roads Board under the provisions of the Country Roads Act has taken the land necessary for constructing the highway or deviation or widening it shall as soon as it thinks such highway or deviation or widening is fit to be used as a public highway by Resolution declare the highway or deviation or widening to be a State highway or part thereof and that upon publication in the *Government Gazette* of the Order of the Governor in Council confirming such Resolution such highway or deviation or widening shall thereupon be a State highway or a part thereof within the meaning of the said Act: And whereas the said Board has by Resolution declared the highway on the land described in the Schedule to such Resolution to be part of a State highway: Now therefore His Excellency the Governor of the State of Victoria by and with the advice of the Executive Council thereof doth hereby confirm the said Resolution.

Resolution for Declaration of the Widening of a State Highway under the Country Roads Act.

Whereas the land the site of the highway the course of which is below set out was taken by the Board under the provisions of the Country Roads Act for the purpose of widening the State highway aforesaid which widening has now been laid out and formed on the same: And whereas the said Board (being the Country Roads Board incorporated under the said Act) thinks that the widening aforesaid is fit to be used as part of a public highway such Board at a meeting now holden doth by this Resolution hereby declare the same as described in the Schedule hereto with the commencing and terminating points thereof respectively specified to be part of the State highway within the meaning and for the purposes of the Country Roads Act.

SCHEDULE.

Cities of Brighton and Moorabbin.

16. *Nepean Highway*.—All those pieces of land in the Parish of Moorabbin, the boundaries of which are as follow:—

- (a) Commencing at the north-western angle of lot 31 on plan of subdivision numbered 9892, lodged in the Office of Titles, and being part of Dendy's Crown Special Survey in the said parish; thence by lines bearing respectively 90 deg. 5 min. 138 ft. 3 in., 134 deg. 25 min. 181 ft. 9 in., 302 deg. 25 min. 71 ft. 6 in., 298 deg. 18½ min. 166 ft. 6½ in. and 279 deg. 23 min. 61 ft. 10½ in. to the point of commencement.
- (b) Commencing at a point on the southern boundary of lot 1 on plan of subdivision numbered 12549, lodged in the Office of Titles, and being part of Dendy's Crown Special Survey in the said parish, the said point being distant 90 deg. 10½ min. 113 ft. 6 in. from the western angle of the said lot; thence by lines bearing respectively 18 deg. 26 min. 32 feet, 317 deg. 36½ min. 141 feet, 327 deg. 8 min. 22 ft. 9½ in., 134 deg.

21½ min. 200 feet, 202 deg. 16 min. 15 ft. 0½ in. and 270 deg. 10½ min. 40 feet to the point of commencement.

- (c) Commencing at the western angle of lot 10, section C, on plan of subdivision numbered 529, lodged in the Office of Titles, and being part of Dendy's Crown Special Survey in the said parish; thence by lines bearing respectively 114 deg. 25½ min. 39 feet, 130 deg. 41 min. 120 feet, 63 deg. 58½ min. 32 ft. 3 in., 4 deg. 22½ min. 45 ft. 0½ in., 180 deg. 31½ min. 103 feet, 247 deg. 32 min. 13 ft. 3½ in. and 314 deg. 32½ min. 204 ft. 5 in. to the point of commencement.
- (d) Commencing at the more westerly of the south-western angles of lot 1 on plan of subdivision numbered 13749, lodged in the Office of Titles, and being part of Dendy's Crown Special Survey in the said parish; thence by lines bearing respectively 0 deg. 30 min. 26 feet, 135 deg. 47½ min. 44 ft. 0½ in., 271 deg. 5 min. 26 feet and 225 deg. 47½ min. 7 ft. 1½ in. to the point of commencement.
- (e) Commencing at the western angle of lot 2 on plan of subdivision numbered 10096, lodged in the Office of Titles, and being part of Dendy's Crown Special Survey in the said parish; thence by lines bearing respectively 43 deg. 39 min. 3 feet, 138 deg. 57½ min. 40 ft. 2 in. and 314 deg. 40½ min. 40 feet to the point of commencement—

which said pieces of land are particularly delineated and shown coloured red on survey plan numbered 5783, lodged in the office of the Country Roads Board.

The common seal of the Country Roads Board was hereto affixed at Kew, this twenty-seventh day of November, One thousand nine hundred and sixty-one, in the presence of—

(SEAL) D. V. DARWIN, Chairman.
W. H. NEVILLE, Member.
R. E. V. DONALDSON, Secretary.

And the Honorable Horace Rostill Petty, Her Majesty's Commissioner of Public Works for the State of Victoria, shall give the necessary directions herein accordingly.

N. G. WISHART,
Acting Clerk of the Executive Council.

COUNTRY ROADS BOARD.

At Government House, Melbourne, the fifth day of
December, 1961.

PRESENT:

His Excellency the Governor of Victoria.
Mr. Chandler | Mr. Reid.
Mr. Thompson |

ORDER APPROVING OF WIDENING AN EXISTING STATE HIGHWAY IN THE SHIRE OF HEYTESBURY.

WHEREAS the Country Roads Board constituted under the *Country Roads Act 1958* (No. 6229) has represented to His Excellency the Governor in Council that it appears to it desirable that the existing Princes Highway in the Shire of Heytesbury (declared to be a State highway under the said Act which declaration was confirmed by the Order in Council published in the *Government Gazette* of the 8th July, 1925, on pages 2371-3) should be widened by the said Board: And whereas the said Board in accordance with the requirements of section 19 of the said cited Act has caused to be prepared a map plan and estimate showing the points between which and on and through what land the said widening is proposed to be made and the cost of acquiring the land: And whereas on an inspection of the said map and plan and a consideration of the said estimate His Excellency the Governor in Council is satisfied that there are funds legally available for acquiring the land: Now therefore be it known by this present Order that His Excellency the Governor of the State of Victoria with the advice of the Executive Council thereof doth hereby approve of the said highway being widened, that is to say:—

All that piece of land in the Parish of Pomborneit, the boundaries of which are as follow:—Commencing at a point on the eastern boundary of allotment 23B, section

A, of the said parish distant 185 deg. 7 min. 30 links from the north-eastern angle of the said allotment; thence by lines bearing respectively 256 deg. 56 min. 743.7 links, 64 deg. 38 min. 61 links, 74 deg. 17 min. 450 links and 85 deg. 7 min. 237 links to the point of commencement—which said piece of land is particularly delineated and shown coloured red on survey plan numbered 8263, lodged in the office of the Country Roads Board.

And the Honorable Horace Rostill Petty, Her Majesty's Commissioner of Public Works for the State of Victoria, shall give the necessary directions herein accordingly.

N. G. WISHART,
Acting Clerk of the Executive Council.

COUNTRY ROADS BOARD.

At Government House, Melbourne, the fifth day of December, 1961.

PRESENT:

His Excellency the Governor of Victoria.
Mr. Chandler | Mr. Reid.
Mr. Thompson

ORDER APPROVING OF WIDENING AN EXISTING STATE HIGHWAY IN THE SHIRE OF TAMBO.

WHEREAS the Country Roads Board constituted under the *Country Roads Act 1958* (No. 6229) has represented to His Excellency the Governor in Council that it appears to it desirable that the existing Princes Highway in the Shire of Tambo (declared to be a State highway under the said Act which declaration was confirmed by the Order in Council published in the *Government Gazette* of the 8th July, 1925, on pages 2371-3) should be widened by the said Board: And whereas the said Board in accordance with the requirements of section 19 of the said cited Act has caused to be prepared a map plan and estimate showing the points between which and on and through what land the said widening is proposed to be made and the cost of acquiring the land: And whereas on an inspection of the said map and plan and a consideration of the said estimate His Excellency the Governor in Council is satisfied that there are funds legally available for acquiring the land: Now therefore be it known by this present Order that His Excellency the Governor of the State of Victoria with the advice of the Executive Council thereof doth hereby approve of the said highway being widened, that is to say:—

All those pieces of land in the Parish of Colquhoun, the boundaries of which are as follow:—

- (a) Commencing at a point on the eastern boundary of allotment 100 of the said parish distant 322 deg. 57 min. 1,368 links and 19 deg. 33 min. 819.5 links from the south-eastern angle of the said allotment; thence by lines bearing respectively 345 deg. 21 min. 593.6 links, 319 deg. 14 min. 632 links, 119 deg. 48 min. 180.1 links, 139 deg. 19 min. 473.6 links, 162 deg. 38 min. 490 links, and 199 deg. 33 min. 145 links to the point of commencement.
- (b) Commencing at a point on the western boundary of allotment 92 of the said parish distant 322 deg. 57 min. 781.5 links from the southern angle of the said allotment; thence by lines bearing respectively 322 deg. 57 min. 94.8 links, 353 deg. 9 min. 315 links, 2 deg. 55 min. 140.4 links and 350 deg. 36 min. 535.8 links to the point of commencement—

which said pieces of land are particularly delineated and shown coloured red on survey plan numbered 7958, lodged in the office of the Country Roads Board.

And the Honorable Horace Rostill Petty, Her Majesty's Commissioner of Public Works for the State of Victoria, shall give the necessary directions herein accordingly.

N. G. WISHART,
Acting Clerk of the Executive Council.

COUNTRY ROADS BOARD.

At Government House, Melbourne, the fifth day of December, 1961.

PRESENT:

His Excellency the Governor of Victoria.
Mr. Chandler | Mr. Reid.
Mr. Thompson

ORDER APPROVING OF WIDENING AN EXISTING MAIN ROAD IN THE SHIRE OF BERWICK.

WHEREAS the Country Roads Board constituted under the *Country Roads Act 1958* (No. 6229) has represented to His Excellency the Governor in Council that it appears to it desirable that the existing Beaconsfield-Emerald road in the Shire of Berwick (declared to be a main road under the said Act which declaration was confirmed by the Order in Council published in the *Government Gazette* of the 6th August, 1930, on page 2061) should be widened by the said Board: And whereas the said Board in accordance with the requirements of section 19 of the said cited Act has caused to be prepared a map plan and estimate showing the points between which and on and through what land the said widening is proposed to be made and the cost of acquiring the land: And whereas on an inspection of the said map and plan and a consideration of the said estimate His Excellency the Governor in Council is satisfied that there are funds legally available for acquiring the land: Now therefore be it known by this present Order that His Excellency the Governor of the State of Victoria with the advice of the Executive Council thereof doth hereby approve of the said road being widened, that is to say:—

All those pieces of land in the Parish of Pakenham, the boundaries of which are as follow:—

- (a) Commencing at an angle in the western boundary of allotment 72 of the said parish formed by the intersection of lines bearing 193 deg. 45 min. and 160 deg. 55 min.; thence by lines bearing respectively 13 deg. 45 min. 88 links, 50 deg. 19 min. 239 links, 220 deg. 43 min. 210 links, 207 deg. 4 min. 124.7 links and 340 deg. 55 min. 34 links to the point of commencement.
- (b) Commencing at a point on the eastern boundary of allotment 59b, distant 160 deg. 3 min. 80 links from the north-eastern angle of the said allotment; thence by lines bearing respectively 160 deg. 3 min. 420 links, 190 deg. 42 min. 560 links, 3 deg. 48 min. 150 links, 351 deg. 18 min. 502.4 links and 5 deg. 7 min. 300 links to the point of commencement—

which said pieces of land are particularly delineated and shown coloured red on survey plan numbered 8093, lodged in the office of the Country Roads Board.

And the Honorable Horace Rostill Petty, Her Majesty's Commissioner of Public Works for the State of Victoria, shall give the necessary directions herein accordingly.

N. G. WISHART,
Acting Clerk of the Executive Council.

COUNTRY ROADS BOARD.

At Government House, Melbourne, the fifth day of December, 1961.

PRESENT:

His Excellency the Governor of Victoria.
Mr. Chandler | Mr. Reid.
Mr. Thompson

ORDER APPROVING OF WIDENING AN EXISTING MAIN ROAD IN THE SHIRE OF BASS.

WHEREAS the Country Roads Board constituted under the *Country Roads Act 1958* (No. 6229) has represented to His Excellency the Governor in Council that it appears to it desirable that the existing Korumburra-Wonthaggi road in the Shire of Bass (declared to be a main road under the said Act which declaration was confirmed by the Order in Council published in the *Government Gazette* of the 13th May, 1914, on page 2049) should be widened by the said Board: And whereas the said Board in accordance with the requirements of

section 19 of the said cited Act has caused to be prepared a map plan and estimate showing the points between which and on and through what land the said widening is proposed to be made and the cost of acquiring the land: And whereas on an inspection of the said map and plan and a consideration of the said estimate His Excellency the Governor in Council is satisfied that there are funds legally available for acquiring the land: Now therefore be it known by this present Order that His Excellency the Governor of the State of Victoria with the advice of the Executive Council thereof doth hereby approve of the said road being widened, that is to say:—

All those pieces of land in the Parish of Wonthaggi, the boundaries of which are as follow:—

- (a) Commencing at an angle in the eastern boundary of allotment 28 of the said parish, formed by the intersection of lines bearing 307 deg. 44 min. and 319 deg. 5 min.; thence by lines bearing respectively 314 deg. 17 min. 346.6 links, 325 deg. 34 min. 256.9 links and 139 deg. 5 min. 600.6 links to the point of commencement.
- (b) Commencing at an angle in the western boundary of allotment 28A of the said parish, formed by the intersection of lines bearing 202 deg. 3 min. and 166 deg. 55 min.; thence by lines bearing respectively 22 deg. 3 min. 523 links, 192 deg. 4 min. 231 links, 172 deg. 39 min. 421.8 links, 156 deg. 58 min. 411.5 links, 319 deg. 5 min. 495.9 links and 346 deg. 55 min. 168 links to the point of commencement—

which said pieces of land are particularly delineated and shown coloured red on survey plan numbered 8139, lodged in the office of the Country Roads Board.

And the Honorable Horace Rostill Petty, Her Majesty's Commissioner of Public Works for the State of Victoria, shall give the necessary directions herein accordingly.

N. G. WISHART,
Acting Clerk of the Executive Council.

COUNTRY ROADS BOARD.

At Government House, Melbourne, the fifth day of
December, 1961.

PRESENT:

His Excellency the Governor of Victoria.
Mr. Chandler | Mr. Reid.
Mr. Thompson |

DECLARATION OF THE WIDENING OF HEIDELBERG-KINGLAKE ROAD IN THE SHIRE OF ELTHAM.

WHEREAS by section 21 of the *Country Roads Act* 1958 (No. 6229) it is amongst other things enacted that when the Country Roads Board under the provisions of the *Country Roads Act* has taken the land necessary for constructing the road or deviation or widening it shall as soon as it thinks such road or deviation or widening is fit to be used as a public highway by Resolution declare the road or deviation or widening to be a main road or part thereof and that upon publication in the *Government Gazette* of the Order of the Governor in Council confirming such Resolution such road or deviation or widening shall thereupon be a main road or a part thereof within the meaning of the said Act: And whereas the said Board has by Resolution declared the road on the land described in the Schedule to such Resolution to be part of a main road: Now therefore His Excellency the Governor of the State of Victoria by and with the advice of the Executive Council thereof doth hereby confirm the said Resolution.

Resolution for Declaration of the Widening of a Main Road under the Country Roads Act.

Whereas the land the site of the road the course of which is below set out was taken by the Board under the provisions of the *Country Roads Act* for the purpose of widening the main road aforesaid which widening has now been laid out and formed on the same: And whereas the said Board (being the Country Roads Board incorporated under the said Act) thinks that the widening aforesaid is fit to be used as part of a public highway such Board at a meeting now holden doth by this Resolution hereby declare the same as described in the Schedule

hereto with the commencing and terminating points thereof respectively specified to be part of the main road within the meaning and for the purposes of the *Country Roads Act*.

SCHEDULE.

Shire of Eltham.

1. *Heidelberg-Kinglake road* (5601).—All those pieces of land in the Parish of Greensborough, the boundaries of which are as follow:—

- (a) Commencing at the north-western angle of allotment 13, section C, of the said parish; thence by lines bearing respectively 90 deg. 3 min. 130 links, 213 deg. 24 min. 274.4 links, 5 deg. 17 min. 230 links, 270 deg. 3 min. 50 links, 0 deg. 51 min. 92.2 links, 58 deg. 0 min. 247.7 links, 224 deg. 40 min. 156.9 links and 204 deg. 33 min. 123 links to the point of commencement.
- (b) Commencing at the north-western angle of allotment 15A, section C, of the said parish; thence by lines bearing respectively 58 deg. 33 min. 347 links, 219 deg. 3 min. 150 links, 223 deg. 55 min. 582.8 links, 31 deg. 48 min. 207 links and 27 deg. 35 min. 202.2 links to the point of commencement.
- (c) Commencing at the south-eastern angle of allotment 18A, section C, of the said parish; thence by lines bearing respectively 21 deg. 50 min. 977 links, 65 deg. 30 min. 430.2 links, 69 deg. 53 min. 310 links, 239 deg. 5 min. 845.7 links, 201 deg. 33 min. 759.9 links and 219 deg. 8 min. 65.3 links to the point of commencement.
- (d) Commencing at the north-western angle of allotment 35A of the said parish; thence by lines bearing respectively 112 deg. 17 min. 75 links, 229 deg. 10 min. 67.8 links and 346 deg. 3 min. 75 links to the point of commencement.
- (e) Commencing at a point on the north-western boundary of allotment 35, section C, of the said parish, distant 58 deg. 12 min. 1,042 links from the western angle of the said allotment; thence by lines bearing respectively 58 deg. 12 min. 60 links, 93 deg. 31 min. 243 links, 112 deg. 35 min. 413 links, 241 deg. 15 min. 42 links, 291 deg. 20 min. 380 links and 274 deg. 48 min. 285.1 links to the point of commencement.
- (f) Commencing at an angle in the northern boundary of the existing Heidelberg-Kinglake road, distant 335 deg. 23 min. 119.2 links from the northern angle of allotment 37, section C, of the said parish; thence by lines bearing respectively 212 deg. 24 min. 408.2 links, 241 deg. 15 min. 845 links, 12 deg. 8 min. 40.3 links, 52 deg. 34 min. 334 links, 46 deg. 36 min. 393.6 links, 59 deg. 11 min. 465.4 links, 92 deg. 42 min. 210 links, 104 deg. 2 min. 210 links and 278 deg. 22 min. 417.9 links to the point of commencement.
- (g) Commencing at the northern angle of allotment 37, section C, of the said parish; thence by lines bearing respectively 147 deg. 1 min. 75 links, 269 deg. 43 min. 81 links and 32 deg. 24 min. 75 links to the point of commencement.
- (h) Commencing at the north-western angle of allotment 39, section C, of the said parish; thence by lines bearing respectively 98 deg. 22 min. 171 links, 150 deg. 25 min. 299 links, 108 deg. 9 min. 336 links, 87 deg. 56 min. 927 links, 266 deg. 8 min. 953 links, 288 deg. 9 min. 257.1 links, 317 deg. 35 min. 398.8 links, 253 deg. 30 min. 60 links and 327 deg. 1 min. 75 links to the point of commencement—

which said pieces of land are particularly delineated and shown coloured red on survey plans numbered 6455, 6504, 6505 and 7007, lodged in the office of the Country Roads Board.

The common seal of the Country Roads Board was hereto affixed at Kew, this twenty-seventh day of November, One thousand nine hundred and sixty-one, in the presence of—

(SEAL) D. V. DARWIN, Chairman.
W. H. NEVILLE, Member.
R. E. V. DONALDSON, Secretary.

And the Honorable Horace Rostill Petty, Her Majesty's Commissioner of Public Works for the State of Victoria, shall give the necessary directions herein accordingly.

N. G. WISHART,
Acting Clerk of the Executive Council.

COUNTRY ROADS BOARD.

At Government House, Melbourne, the fifth day of December, 1961.

PRESENT:

His Excellency the Governor of Victoria.
 Mr. Chandler | Mr. Reid.
 Mr. Thompson |

ORDER APPROVING OF A DEVIATION FROM A MAIN ROAD IN THE SHIRE OF RODNEY.

WHEREAS the Country Roads Board constituted under the *Country Roads Act 1958* (No. 6229) has represented to His Excellency the Governor in Council that it appears to it desirable that the deviation herein-after referred to from the existing Lancaster-Mooroopna road in the Shire of Rodney (declared to be a main road under the said Act which declaration was confirmed by the Order in Council published in the *Government Gazette* of the 2nd July, 1947, on page 3354) should be made by the said Board: And whereas the said Board in accordance with the requirements of section 19 of the said cited Act has caused to be prepared a map plan and estimate showing the points between which and on and through what land the said deviation is proposed to be made and the cost of acquiring the land: And whereas on an inspection of the said map and plan and a consideration of the said estimate His Excellency the Governor in Council is satisfied that there are funds legally available for acquiring the land: Now therefore be it known by this present Order that His Excellency the Governor of the State of Victoria with the advice of the Executive Council thereof doth hereby approve of the said road being made, that is to say:—

All that piece of land in the Parish of Mooroopna, the boundaries of which are as follow:—Commencing at a point on the eastern boundary of allotment 88B of the said parish, distant 359 deg. 54 min. 592.1 links from the south-eastern angle of the said allotment; thence by lines bearing respectively 307 deg. 28 min. 218.4 links, 270 deg. 3 min. 227.3 links, 216 deg. 51 min. 905.1 links, 270 deg. 3 min. 960.4 links, 77 deg. 3 min. 732.5 links, 47 deg. 24 min. 797.2 links, 36 deg. 51 min. 1,002.7 links and 179 deg. 54 min. 915.5 links to the point of commencement—which said piece of land is particularly delineated and shown coloured red on survey plan numbered 8189, lodged in the office of the Country Roads Board.

And the Honorable Horace Rostill Petty, Her Majesty's Commissioner of Public Works for the State of Victoria, shall give the necessary directions herein accordingly.

N. G. WISHART,
 Acting Clerk of the Executive Council.

COUNTRY ROADS BOARD.

At Government House, Melbourne, the fifth day of December, 1961.

PRESENT:

His Excellency the Governor of Victoria.
 Mr. Chandler | Mr. Reid.
 Mr. Thompson |

ORDER APPROVING OF WIDENING AN EXISTING MAIN ROAD IN THE SHIRE OF MYRTLEFORD.

WHEREAS the Country Roads Board constituted under the *Country Roads Act 1958* (No. 6229) has represented to His Excellency the Governor in Council that it appears to it desirable that the existing Happy Valley-road in the Shire of Myrtleford (declared to be a main road under the said Act which declaration was confirmed by the Order in Council published in the *Government Gazette* of the 5th July, 1939, on page 2512) should be widened by the said Board: And whereas the said Board in accordance with the requirements of section 19 of the said cited Act has caused to be prepared a map plan and estimate showing the points between which and on and through what land the said widening is proposed to be made and the cost of acquiring the land: And whereas on an inspection of the said map and plan and a consideration of the said estimate His Excellency

the Governor in Council is satisfied that there are funds legally available for acquiring the land: Now therefore be it known by this present Order that His Excellency the Governor of the State of Victoria with the advice of the Executive Council thereof doth hereby approve of the said road being widened, that is to say:—

All those pieces of land in the Parish of Barwidgee, the boundaries of which are as follow:—

- (a) Commencing at the northern angle of allotment 16, section A, of the said parish; thence by lines bearing respectively 135 deg. 41 min. 139.6 links, 258 deg. 43 min. 238.2 links, 250 deg. 58 min. 325 links, and 60 deg. 20 min. 510.2 links to the point of commencement.
- (b) Commencing at a point on the northern boundary of allotment 16, section A, of the said parish, distant 81 deg. 57 min. 44 links from the north-western angle of the said allotment; thence by lines bearing respectively 81 deg. 57 min. 792 links, 242 deg. 20 min. 547.3 links, 226 deg. 22 min. 314.4 links, 207 deg. 14 min. 430.6 links, 6 deg. 19 min. 649.2 links, 96 deg. 3 min. 42 links, and 6 deg. 43 min. 102.9 links to the point of commencement—

which said pieces of land are particularly delineated and shown coloured red on survey plans numbered 8201 and 8202, lodged in the office of the Country Roads Board.

And the Honorable Horace Rostill Petty, Her Majesty's Commissioner of Public Works for the State of Victoria, shall give the necessary directions herein accordingly.

N. G. WISHART,
 Acting Clerk of the Executive Council.

COUNTRY ROADS BOARD.

At Government House, Melbourne, the fifth day of December, 1961.

PRESENT:

His Excellency the Governor of Victoria.
 Mr. Chandler | Mr. Reid.
 Mr. Thompson |

ORDER APPROVING OF WIDENING AN EXISTING MAIN ROAD IN THE SHIRE OF WARRNAMBOOL.

WHEREAS the Country Roads Board constituted under the *Country Roads Act 1958* (No. 6229) has represented to His Excellency the Governor in Council that it appears to it desirable that the existing Peterborough-road in the Shire of Warrnambool (declared to be a main road under the said Act which declaration was confirmed by the Order in Council published in the *Government Gazette* of the 7th December, 1932, on page 2756) should be widened by the said Board: And whereas the said Board in accordance with the requirements of section 19 of the said cited Act has caused to be prepared a map plan and estimate showing the points between which and on and through what land the said widening is proposed to be made and the cost of acquiring the land: And whereas on an inspection of the said map and plan and a consideration of the said estimate His Excellency the Governor in Council is satisfied that there are funds legally available for acquiring the land: Now therefore be it known by this present Order that His Excellency the Governor of the State of Victoria with the advice of the Executive Council thereof doth hereby approve of the said road being widened, that is to say:—

All that piece of land in the Township of Peterborough, Parish of Narraturk, the boundaries of which are as follow:—Commencing at the north-eastern angle of allotment 2, section 3, of the said township; thence by lines bearing respectively 180 deg. 0 min. 15 feet, 315 deg. 0 min. 21 ft. 2½ in., and 90 deg. 0 min. 15 feet to the point of commencement—which said piece of land is particularly delineated and shown coloured red on survey plan numbered 8180, lodged in the office of the Country Roads Board.

And the Honorable Horace Rostill Petty, Her Majesty's Commissioner of Public Works for the State of Victoria, shall give the necessary directions herein accordingly.

N. G. WISHART,
 Acting Clerk of the Executive Council

COUNTRY ROADS BOARD.

At Government House, Melbourne, the fifth day of December, 1961.

PRESENT:

His Excellency the Governor of Victoria.
Mr. Chandler | Mr. Reid.
Mr. Thompson |

ORDER APPROVING OF A DEVIATION FROM A MAIN ROAD IN THE SHIRE OF KORUMBURRA.

WHEREAS the Country Roads Board constituted under the *Country Roads Act 1958* (No. 6229) has represented to His Excellency the Governor in Council that it appears to it desirable that the deviation herein-after referred to from the existing Fairbank-road in the Shire of Korumburra (declared to be a main road under the said Act which declaration was confirmed by the Order in Council published in the *Government Gazette* of the 5th October, 1932, on page 2256) should be made by the said Board: And whereas the said Board in accordance with the requirements of section 19 of the said cited Act has caused to be prepared a map plan and estimate showing the points between which and on and through what land the said deviation is proposed to be made and the cost of acquiring the land: And whereas on an inspection of the said map and plan and a consideration of the said estimate His Excellency the Governor in Council is satisfied that there are funds legally available for acquiring the land: Now therefore be it known by this present Order that His Excellency the Governor of the State of Victoria with the advice of the Executive Council thereof doth hereby approve of the said road being made, that is to say:—

All those pieces of land in the Parish of Korumburra, the boundaries of which are as follow:—

- (a) Commencing at an angle in the northern boundary of the existing Fairbank-road through allotment 59 of the said parish, formed by the intersection of lines bearing 109 deg. 51 min. and 57 deg. 17 min.; thence by lines bearing respectively 289 deg. 51 min. 318.4 links, 299 deg. 23 min. 428.9 links, 111 deg. 30 min. 500 links, 83 deg. 57 min. 549.5 links, 129 deg. 15 min. 639.1 links, 276 deg. 42 min. 145.6 links, 308 deg. 16 min. 154 links, 335 deg. 52 min. 115.1 links, 316 deg. 9 min. 116.7 links, 303 deg. 55 min. 176 links and 237 deg. 17 min. 348.6 links to the point of commencement.
- (b) Commencing at an angle in the southern boundary of the existing Fairbank-road through allotment 59 of the said parish, formed by the intersection of lines bearing 56 deg. 42 min. and 92 deg. 22 min.; thence by lines bearing respectively 92 deg. 22 min. 214.3 links, 154 deg. 30 min. 110.6 links and 292 deg. 33 min. 283.4 links to the point of commencement.
- (c) Commencing at an angle in the northern boundary of allotment 59 of the said parish, formed by the intersection of lines bearing 255 deg. 20 min. and 229 deg. 20 min.; thence by lines bearing respectively 75 deg. 20 min. 75 links, 118 deg. 51 min. 227 links, 273 deg. 0 min. 249.5 links, 260 deg. 5 min. 600 links, 246 deg. 0 min. 320 links, 222 deg. 32 min. 164.9 links, 28 deg. 31 min. 135.6 links, 50 deg. 34 min. 239.6 links, 84 deg. 18 min. 154.6 links, 84 deg. 28 min. 449.4 links and 49 deg. 50 min. 159 links to the point of commencement.
- (d) Commencing at a point on the western boundary of allotment 82 of the said parish, distant 360 deg. 0 min. 103 links from the south-western angle of the said allotment; thence by lines bearing respectively 360 deg. 0 min. 43.5 links, 29 deg. 42 min. 40.6 links, 57 deg. 0 min. 270 links, 230 deg. 29 min. 291.9 links and 208 deg. 4 min. 45.5 links to the point of commencement.
- (e) Commencing at the south-eastern angle of allotment 83 of the said parish; thence by lines bearing respectively 229 deg. 50 min. 80 links, 29 deg. 42 min. 123.4 links and 180 deg. 0 min. 55.6 links to the point of commencement.
- (f) Commencing at an angle in the northern boundary of the existing Fairbank-road through allotment 60 of the said parish, formed by the intersection of lines bearing 118 deg. 34 min. and 89 deg. 25 min.; thence by lines bearing respectively 298 deg. 34 min. 292.3 links, 278 deg.

57 min. 210.1 links, 266 deg. 14 min. 211.9 links, 268 deg. 24 min. 66.9 links, 68 deg. 5 min. 339.3 links, 95 deg. 32 min. 185.8 links, 111 deg. 56 min. 468.6 links, 78 deg. 0 min. 135.9 links, 207 deg. 39 min. 79.5 links, 241 deg. 52 min. 98 links and 269 deg. 25 min. 201.5 links to the point of commencement—

which said pieces of land are particularly delineated and shown coloured red on survey plan numbered 7960, lodged in the office of the Country Roads Board.

And the Honorable Horace Rostill Petty, Her Majesty's Commissioner of Public Works for the State of Victoria, shall give the necessary directions herein accordingly.

N. G. WISHART,
Acting Clerk of the Executive Council.

NATIONAL PARKS ACT 1958.

At Government House, Melbourne, the twelfth day of December, 1961.

PRESENT:

His Excellency the Governor of Victoria.
Mr. Bloomfield | Mr. Petty.

PURSUANT to the powers conferred by the *National Parks Act 1958* (No. 6326) and all other powers thereunto enabling, His Excellency the Governor of the State of Victoria, by and with the advice of the Executive Council thereof, hereby makes the following Regulations (that is to say):—

1. These Regulations may be cited as the Fraser National Park (Fees, Tolls and Charges) Regulations 1961.
2. The following fees, tolls and charges are to be paid by persons using amenities provided in the Fraser National Park:—

(a) For Admission to the National Park—

- (i) 2s. per car per day.
- (ii) 10s. per bus per day.

(b) For Camping—

2s. per night per person (no charge for car).

And the Honorable Henry Edward Bolte, Her Majesty's Premier for the State of Victoria, shall give the necessary directions herein accordingly.

N. G. WISHART,
Acting Clerk of the Executive Council.

ROAD TRAFFIC ACT 1958.

At Government House, Melbourne, the twelfth day of December, 1961.

PRESENT:

His Excellency the Governor of Victoria.
Mr. Bloomfield | Mr. Petty.

ORDER EXTENDING APPLICATION OF ACT TO CERTAIN LAND OR PREMISES VESTED IN OR UNDER THE CONTROL OF THE SHIRE OF KORUMBURRA.

IN pursuance of the powers conferred by the *Road Traffic Act 1958* and all other powers him thereunto enabling, His Excellency the Governor of the State of Victoria, in the Commonwealth of Australia, by and with the advice of the Executive Council of the said State, and at the request of the Council of the Shire of Korumburra, doth by this Order extend the application of the provisions of the said Act to the following land or premises vested in or under the control of the Shire of Korumburra, namely:—

Korumburra Public Park, Township of Korumburra, Parish of Korumburra, County of Buln Buln, comprising 24 acres 0 roods 15 perches, and situate adjacent to Crown allotments 47 and 48, section VI., Parish and County aforesaid.

And the Honorable Arthur Gordon Rylah, Her Majesty's Chief Secretary for the State of Victoria, shall give the necessary directions herein accordingly.

N. G. WISHART,
Acting Clerk of the Executive Council.

ROAD TRAFFIC ACT 1958.

At Government House, Melbourne, the twelfth day of December, 1961.

PRESENT:

His Excellency the Governor of Victoria.
Mr. Bloomfield | Mr. Petty.

ORDER EXTENDING APPLICATION OF ACT TO CERTAIN LAND OR PREMISES VESTED IN OR UNDER THE CONTROL OF THE SHIRE OF FRANKSTON.

IN pursuance of the powers conferred by the *Road Traffic Act* 1958 and all other powers him thereunto enabling, His Excellency the Governor of the State of Victoria, in the Commonwealth of Australia, by and with the advice of the Executive Council of the said State, and at the request of the Council of the Shire of Frankston, doth by this Order extend the application of the provisions of the said Act to the following land or premises vested in or under the control of the Shire of Frankston, namely:—

1. An area situated in the Township of Frankston bounded on the north by Wells-street, on the east, south-east and south by the lane known as Park-lane and on the west by Thompson-street, including Park-lane itself.

2. An area situated in the Township of Frankston at the western end of Balmoral-street as created on plan of subdivision numbered 1090 and bounded on the east by the western boundary of plan of subdivision numbered 1090, on the south by the Gas and Fuel Corporation's storage yard, on the west by the western boundary of Keys-street and on the north by the southern boundary of plan of subdivision numbered 27373.

3. An area of land situated in the Township of Frankston, fronting Wells-street and bounded as follows:—Commencing at the south-eastern corner of lot 5, plan of subdivision numbered 33932; thence north 19 deg. 22 min. east for 130 ft. 10½ in., east 19 deg. 25 min. south for 50 feet, south 19 deg. 22 min. west for 130 ft. 9 in. and westerly by the northern building line of Wells-street for 50 feet to the point of commencement.

And the Honorable Arthur Gordon Rylah, Her Majesty's Chief Secretary for the State of Victoria, shall give the necessary directions herein accordingly.

N. G. WISHART,
Acting Clerk of the Executive Council.

ROAD TRAFFIC ACT 1958.

At Government House, Melbourne, the twelfth day of December, 1961.

PRESENT:

His Excellency the Governor of Victoria.
Mr. Bloomfield | Mr. Petty.

ORDER EXTENDING APPLICATION OF ACT TO CERTAIN LAND OR PREMISES VESTED IN OR UNDER THE CONTROL OF THE CITY OF BALLAARAT.

IN pursuance of the powers conferred by the *Road Traffic Act* 1958 and all other powers him thereunto enabling, His Excellency the Governor of the State of Victoria, in the Commonwealth of Australia, by and with the advice of the Executive Council of the said State, and at the request of the Council of the City of Ballaarat, doth by this Order extend the application of the provisions of the said Act to the following land or premises vested in or under the control of the City of Ballaarat, namely:—

1. The whole of the area known as the "Botanical and Public Gardens Reserve" and the "Site for Public Park and Gardens" in the vicinity of Lake Wendouree, Township and City of Ballaarat, County of Grenville, and shown delineated and hachured on the plan marked "A" annexed hereto.

2. The area comprising the site for a Public Hall and portion of the adjoining land bounded on the north by Market-street, on the east by Armstrong-street, on the south by Main-street and on the west by Doveton-street, Township and City of Ballaarat, County of Grenville, and being the land shown delineated and hachured on the plan marked "B" annexed hereto.

3. Portion of the area bounded on the north by Field-street, on the east by Lowe-street, on the south by Curtis-street, and on the west by Grenville-street, Township of Ballaarat East, City and Parish of Ballaarat, County of Grenville, and being the land shown delineated and hachured on the plan marked "C" annexed hereto.

4. The whole of section S, Township of Ballaarat East, City of Ballaarat, County of Grant, and bounded by Scott-parade, Ebdon-street and Davies-street.

And the Honorable Arthur Gordon Rylah, Her Majesty's Chief Secretary for the State of Victoria, shall give the necessary directions herein accordingly.

N. G. WISHART,
Acting Clerk of the Executive Council.

LANDLORD AND TENANT ACT 1958.

At Government House, Melbourne, the twelfth day of December, 1961.

PRESENT:

His Excellency the Governor of Victoria.
Mr. Bloomfield | Mr. Petty.

ORDER EXTENDING APPLICATION OF PART V. OF THE LANDLORD AND TENANT ACT 1958 TO CERTAIN PREMISES AND EXCLUDING CERTAIN PREMISES FROM THE OPERATION OF CERTAIN PROVISIONS OF THAT PART.

IN pursuance of the powers conferred by section 44 of the *Landlord and Tenant Act* 1958, His Excellency the Governor of the State of Victoria, by and with the advice of the Executive Council thereof, doth hereby declare that the application of Part V. of the *Landlord and Tenant Act* 1958, shall extend to the premises known as No. 21 Harrison-street, Ringwood:

And doth hereby further declare that each of the following premises, namely Nos. 11 and 11A Normanby-road, Caulfield, shall be excluded from the operation of the whole of the provisions contained in Divisions 2 and 3 of Part V. of the Act.

And the Honorable Arthur Gordon Rylah, Her Majesty's Attorney-General in and for the State of Victoria, shall give the necessary directions herein accordingly.

N. G. WISHART,
Acting Clerk of the Executive Council.

MOTOR CAR ACT 1958.

At Government House, Melbourne, the twelfth day of December, 1961.

PRESENT:

His Excellency the Governor of Victoria.
Mr. Bloomfield | Mr. Petty.

MOTOR CAR TRIALS OF SPEED WITHIN THE BOROUGH OF CAMPERDOWN AND THE SHIRE OF HAMPDEN.

WHEREAS it is enacted by sub-section (2) of section 83 of the *Motor Car Act* 1958 that, if a motor car is used on a highway for purposes of racing or of trial of speed, the driver or the person in charge thereof shall be liable to a penalty of not more than Fifty pounds, provided that the said sub-section (2) shall not apply to a motor car used as aforesaid on any highway or portion thereof specified by Order in Council published in the *Government Gazette* and on such days and during such hours as are specified in the Order:

And whereas the Camperdown Motor Sports Club has requested that such an Order be made so as to enable motor car trials of speed to be conducted by the said club on Old Timboon-road on Monday, the twenty-ninth day of January, 1962, and Sunday, the eighteenth day of March, 1962:

Now therefore His Excellency the Governor of the State of Victoria, by and with the advice of the Executive Council thereof, and in pursuance of the powers conferred by the *Motor Car Act* 1958, doth by this Order specify that portion of Old Timboon-road within the Borough of Camperdown and the Shire of Hampden,

lying between the rail crossing and the Old Geelong-road as a highway in respect of which any motor car may, without being subject to the application of the said sub-section (2) of section 83 of the *Motor Car Act 1958*, be used for purposes of trials of speed under the control and supervision of the said Camperdown Motor Sports Club on Monday, the twenty-ninth day of January, 1962, and Sunday, the eighteenth day of March, 1962, between the hours of Ten o'clock in the forenoon and Five o'clock in the afternoon on each day, provided that the officer in charge of police in attendance is satisfied that such highway is in a satisfactory condition for racing purposes and that adequate arrangements have been made for the safety of the public.

And the Honorable Arthur Gordon Rylah, Her Majesty's Chief Secretary for the State of Victoria, shall give the necessary directions herein accordingly.

N. G. WISHART,
Acting Clerk of the Executive Council.

LEONGATHA SEWERAGE AUTHORITY.

*At Government House, Melbourne, the
twelfth day of December, 1961.*

PRESENT:

His Excellency the Governor of Victoria.
Mr. Bloomfield | Mr. Petty.

REPEAL OF ORDER.

UNDER the powers conferred by the Sewerage Districts Acts, and all other powers enabling him in that behalf, His Excellency the Governor of the State of Victoria, by and with the advice of the Executive Council of the said State, doth hereby repeal the Order made by the Governor in Council on the 21st November, 1961, consenting to the Leongatha Sewerage Authority borrowing the sum of Five thousand pounds (£5,000) by the assignment of the general fund to meet the cost of sewerage works.

And as on and from the date hereof the said Order of the Governor in Council shall be deemed to be repealed accordingly.

And the Honorable Wilfred John Mibus, Her Majesty's Minister of Water Supply for the State of Victoria, shall give the necessary directions herein accordingly.

N. G. WISHART,
Acting Clerk of the Executive Council.

LEONGATHA SEWERAGE AUTHORITY.

*At Government House, Melbourne, the
twelfth day of December, 1961.*

PRESENT:

His Excellency the Governor of Victoria.
Mr. Bloomfield | Mr. Petty.

POWER TO BORROW £5,000.

UNDER the powers conferred by the Sewerage Districts Acts, and all other powers enabling him in that behalf, His Excellency the Governor of the State of Victoria, by and with the advice of the Executive Council of the said State, doth hereby consent to the Leongatha Sewerage Authority borrowing at interest by the assignment of the general fund a sum of Five thousand pounds (£5,000) for the carrying out of works in accordance with the provisions of sections 95, 130 and 137 of the *Sewerage Districts Act 1958*. All moneys received by the said Authority in repayment of costs and expenses of the said works, or any of them, shall be set aside for the purpose of and applied in repayment of the said sum so borrowed.

And the Honorable Wilfred John Mibus, Her Majesty's Minister of Water Supply for the State of Victoria, shall give the necessary directions herein accordingly.

N. G. WISHART,
Acting Clerk of the Executive Council.

BALLARAT SEWERAGE AUTHORITY.

*At Government House, Melbourne, the
twelfth day of December, 1961.*

PRESENT:

His Excellency the Governor of Victoria.
Mr. Bloomfield | Mr. Petty.

CONSENT TO BORROWING £50,000.

UNDER the powers conferred by the Sewerage Districts Acts, and all other powers enabling him in that behalf, His Excellency the Governor of the State of Victoria, by and with the advice of the Executive Council of the said State, doth hereby consent to the Ballarat Sewerage Authority borrowing by the assignment of the general fund the sum of Fifty thousand pounds (£50,000) (in two amounts of Twenty-five thousand pounds (£25,000)) to meet the cost of sewerage works, as set forth in the detailed statement bearing date the 8th December, 1961.

And the Honorable Wilfred John Mibus, Her Majesty's Minister of Water Supply for the State of Victoria, shall give the necessary directions herein accordingly.

N. G. WISHART,
Acting Clerk of the Executive Council.

WODONGA SEWERAGE AUTHORITY.

*At Government House, Melbourne, the
twelfth day of December, 1961.*

PRESENT:

His Excellency the Governor of Victoria.
Mr. Bloomfield | Mr. Petty.

CONSENT TO BORROWING £20,000.

UNDER the powers conferred by the Sewerage Districts Acts, and all other powers enabling him in that behalf, His Excellency the Governor of the State of Victoria, by and with the advice of the Executive Council of the said State, doth hereby consent to the Wodonga Sewerage Authority borrowing by the assignment of the general fund the sum of Twenty thousand pounds (£20,000) to meet the cost of sewerage works, as set forth in the detailed statement bearing date the 8th December, 1961.

And the Honorable Wilfred John Mibus, Her Majesty's Minister of Water Supply for the State of Victoria, shall give the necessary directions herein accordingly.

N. G. WISHART,
Acting Clerk of the Executive Council.

WODONGA SEWERAGE AUTHORITY.

*At Government House, Melbourne, the
twelfth day of December, 1961.*

PRESENT:

His Excellency the Governor of Victoria.
Mr. Bloomfield | Mr. Petty.

CONSENT TO COMPULSORY ACQUISITION OF LAND FOR PUMPING STATION.

UNDER the powers conferred by the Sewerage Districts Acts, and all other powers enabling him in that behalf, His Excellency the Governor of the State of Victoria, by and with the advice of the Executive Council of the said State, doth hereby consent to compulsory acquisition by the Wodonga Sewerage Authority of the land being described in the Schedule hereto, being the site for a sewage pumping station.

SCHEDULE.

Commencing at a point on the western boundary of Crown allotment 4, section C2, Township of Wodonga, County of Bogong, being a point on a line parallel to and distant 13 ft. 6 in. north-easterly from the north-eastern boundary of Melbourne-Wodonga Railway Reserve; thence south-easterly by the said line parallel to the north-eastern boundary of the Railway Reserve through the said Crown allotment 4 for a distance of 704 feet; thence north-easterly by a line at right angles

to the said north-eastern boundary of the Railway Reserve for a distance of 150 feet; thence north-westerly by a line parallel to and distant 163 ft. 6 in. north-easterly from north-eastern boundary of the said Railway Reserve for a distance of 180 feet; thence south-westerly by a line at right angles to the said north-eastern boundary of the Railway Reserve for a distance of 117 feet; thence north-westerly by a line parallel to and distant 46 ft. 6 in. north-easterly from the said north-eastern boundary of the Railway Reserve to a point on the western boundary of the said Crown allotment 4; thence southerly along the said western boundary of Crown allotment 4 to the point of commencement.

All of which land is shown by red colour on a plan approved by the Governor in Council and deposited in the office of the State Rivers and Water Supply Commission, Melbourne.—(Corres. No. 59/1670/136.)

And the Honorable Wilfred John Mibus, Her Majesty's Minister of Water Supply for the State of Victoria, shall give the necessary directions herein accordingly.

N. G. WISHART,
Acting Clerk of the Executive Council.

FISH CREEK WATERWORKS TRUST.

*At Government House, Melbourne, the
twelfth day of December, 1961.*

PRESENT:

His Excellency the Governor of Victoria.
Mr. Bloomfield | Mr. Petty.

EXTENT OF URBAN DISTRICT INCREASED.

UNDER the powers conferred by the Water Acts and all other powers enabling him in that behalf, His Excellency the Governor of the State of Victoria, by and with the advice of the Executive Council of the said State, doth hereby declare, order and direct as follows:—

That the extent of the urban district of the Fish Creek Waterworks Trust be increased by adding to the same the land comprised within the boundaries described

in the Schedule hereto, and as on and from the date hereof, the extent of such district shall be deemed to be increased accordingly.

SCHEDULE.

Commencing at the intersection of the south-eastern boundary of lot 15 on lodged plan of subdivision No. 4377, Parish of Doomburrim, County of Buln Buln, with the southern boundary of a Reserve on the left bank of Fish Creek being also a point on the boundary of the existing waterworks district and being a point on the north-western boundary of Falls-road; thence north-easterly along the north-western boundary of Falls-road to the south-eastern angle of an area of 4 acres 3 roods 35½ perches of land, described in certificate of title, volume 7886, folio 105; thence generally north-westerly along the north-eastern boundary of a reserve on the right bank of Fish Creek to the westernmost angle of the said lands described in certificate of title, volume 7886, folio 105; thence north-easterly along the north-western boundary of the said land described in certificate of title, volume 7886, folio 105, and by a line being the continuation thereof across a road through Crown allotment 23c to a point in line with the north-eastern boundary of lot 3 on lodged plan of subdivision No. 52983; thence south-easterly by a line through the said Crown allotment 23c to the north-eastern angle of lot 3; thence south-easterly along the north-eastern boundary of the said lot 3 and by a line being the continuation thereof across a road to a point on the north-western boundary of Crown allotment 23b, being a point on the south-eastern boundary of Falls-road; thence generally south-westerly along the said south-eastern boundary of Falls-road to a point on the boundary of the existing waterworks district; thence generally north-westerly along the boundary of the existing waterworks district to the point of commencement.

All of which boundaries are shown on a plan approved by the Governor in Council and deposited in the office of the State Rivers and Water Supply Commission, Melbourne.—(Corres. No. 59/2233/29.)

And the Honorable Wilfred John Mibus, Her Majesty's Minister of Water Supply for the State of Victoria, shall give the necessary directions herein accordingly.

N. G. WISHART,
Acting Clerk of the Executive Council.

WEIGHTS AND MEASURES ACT 1958.

At Government House, Melbourne, the twelfth day of December, 1961.

PRESENT:

His Excellency the Governor of Victoria.
Mr. Bloomfield | Mr. Petty.

AMENDMENT OF REGULATIONS.

IN pursuance of the powers conferred by the *Weights and Measures Act 1958* and all other powers him thereunto enabling, His Excellency the Governor of the State of Victoria, in the Commonwealth of Australia, by and with the advice of the Executive Council of the said State, doth hereby further amend the *Weights and Measures Regulations 1959* as follows (that is to say):—

In paragraph (b) of Regulation 177 for the expression "1962", there shall be substituted the expression "1963".

And the Honorable Arthur Gordon Rylah, Her Majesty's Chief Secretary for the State of Victoria, shall give the necessary directions herein accordingly.

N. G. WISHART,
Acting Clerk of the Executive Council.

POLICE REGULATION ACT 1958.

At Government House, Melbourne, the twelfth day of December, 1961.

PRESENT:

His Excellency the Governor of Victoria.

Mr. Bloomfield | Mr. Petty.

AMENDMENT OF REGULATIONS.

HIS Excellency the Governor of the State of Victoria, in the Commonwealth of Australia, by and with the advice of the Executive Council of the said State, and in pursuance of the powers conferred by the *Police Regulation Act 1958* and all other powers him thereunto enabling, doth hereby further amend the Police Regulations 1957 as follows (that is to say):—

1. In sub-regulation (1) of Regulation 5 for the sub-heading "Sub-officers and Constables", there shall be substituted the sub-heading "Sub-officers, First Constables and Constables".
2. In sub-regulation (1) of Regulation 7 for the words "officers or sub-officers", there shall be substituted the words, "officers, sub-officers or first constables".
3. In Regulation 25 for the words "officers, sub-officers and constables", there shall be substituted the words "officers, sub-officers, first constables and constables".
4. In Regulation 48 for the word "constables", there shall be substituted the words "first constables and constables".
5. In Regulation 52 for the word "constables", there shall be substituted the words "first constables and constables".
6. In Regulation 56 for the word "constable", there shall be substituted the words "first constable or constable".
7. In Regulation 59 for the word "constables", there shall be substituted the words "first constables or constables".
8. In Regulation 60—
 - (a) for the word "constables", there shall be substituted the words "first constables and constables";
 - (b) for the word "constable", there shall be substituted the words "first constable or constable".
9. In Regulation 61 for the word "constable" (where twice appearing), there shall be substituted the words "first constable or constable".
10. In Regulation 62 for the word "constable" (where twice appearing), there shall be substituted the words "first constable or constable".
11. For the heading immediately preceding Regulation 63, there shall be substituted the heading "First Constables and Constables".
12. In Regulation 63 for the word "Constables", there shall be substituted the words "First Constables and Constables".
13. In Regulation 65 for the word "constable", there shall be substituted the words "first constable or constable".
14. In Regulation 69 for the word "constable", there shall be substituted the words "first constable or constable".
15. In Regulation 70 for the word "Constables", there shall be substituted the words "First Constables or Constables".
16. In Regulation 74 for the word "constables", there shall be substituted the words "first constables and constables".
17. In sub-regulation (2) of Regulation 167 for the words "officer, sub-officer or constable", there shall be substituted the words "officer, sub-officer, first constable or constable".
18. In Regulation 177 after the words "first constables", there shall be inserted the word "constables".
19. In sub-regulation (1) of Regulation 347 for the word "constable", there shall be substituted the words "escorting member".
20. In paragraph (a) of sub-regulation (1) of Regulation 365 after the word "Melbourne" (where first occurring), there shall be inserted the following words:—

"Except as hereinafter provided, a member of the Force may present himself at any one examination for not less than two of the prescribed subjects."

21. In Regulation 395 for the words "sub-officers and constables", there shall be substituted the words "sub-officers, first constables and constables".

22. In sub-regulation (1) of Regulation 398 for the words "sub-officers and constables", there shall be substituted the words "station officers, sub-officers, first constables and constables".

23. In Regulation 405—

(a) for the sub-heading "Station Officers, Sub-officers and Constables (Foot Police)", there shall be substituted the heading "Station Officers, Sub-officers, First Constables and Constables (Foot Police)";

(b) for the sub-heading "Sub-officers and Constables (Mounted Police)", there shall be substituted the sub-heading "Sub-officers, First Constables and Constables (Mounted Police)";

(c) for the sub-heading "Sub-officers and Constables (Mobile Traffic Police, Members of the Force performing Motor Cycle or Motor Car Duty, Motor Testing Police and such Other Members as are authorized by the Chief Commissioner)", there shall be substituted the sub-heading "Sub-officers, First Constables and Constables (Mobile Traffic Police, Members of the Force performing Motor Cycle or Motor Car Duty, Motor Testing Police and such Other Members as are authorized by the Chief Commissioner)".

24. In Regulation 406—

(a) in sub-regulation (1) for the words "Officers, Sub-officers and Constables", there shall be substituted the words "Officers, Sub-officers, First Constables and Constables";

(b) in sub-regulation (2) for the words "Station Officers, Sub-officers and Constables", there shall be substituted the words "Station Officers, Sub-officers, First Constables and Constables".

25. In Regulation 407 for the words "Station Officers, Sub-officers and Constables", there shall be substituted the words "Station Officers, Sub-officers, First Constables and Constables".

26. In Regulation 412 for the sub-heading "Station Officers, Sub-officers and Constables", there shall be substituted the sub-heading "Station Officers, Sub-officers, First Constables and Constables".

27. In Regulation 418 for the words "Mounted Constables", there shall be substituted the words "Mounted First Constables and Constables".

28. In sub-regulation (3) of Regulation 422 for the words "station officers, sub-officers and constables", there shall be substituted the words "station officers, sub-officers and first constables".

29. In Regulation 423 for the words "Station Officers, Sub-officers and Constables" (wherever appearing as a sub-heading or otherwise), there shall be substituted the words "Station Officers, Sub-officers, First Constables and Constables".

30. In the Twenty-first Schedule for the words "Station Officers, Sub-officers and Constables (Foot Uniform)" (wherever those words appear), there shall be substituted the words "Station Officers, Sub-officers, First Constables and Constables (Foot Uniform)".

31. In the Twenty-second Schedule for the words "Sub-officers and Constables (Mounted Uniform)" (wherever those words appear), there shall be substituted the words "Sub-officers, First Constables and Constables (Mounted Uniform)".

32. In the Twenty-third Schedule for the words "Sub-officers and Constables (Mobile Traffic Police, Members of the Force performing Motor Cycle or Motor Car Duty, Motor Testing Police and such Other Members as are authorized by the Chief Commissioner—Uniform)" (wherever those words appear), there shall be substituted the words "Sub-officers, First Constables and Constables (Mobile Traffic Police, Members of the Force performing Motor Cycle or Motor Car Duty, Motor Testing Police and such Other Members as are authorized by the Chief Commissioner—Uniform)".

And the Honorable Arthur Gordon Rylah, Her Majesty's Chief Secretary for the State of Victoria, shall give the necessary directions herein accordingly.

N. G. WISHART,
Acting Clerk of the Executive Council.

Apprenticeship Act 1958.

APPRENTICESHIP COMMISSION OF VICTORIA.

At Government House, Melbourne, the twelfth day of December, 1961.

PRESENT:

His Excellency the Governor of Victoria.

Mr. Bloomfield

Mr. Petty.

AMENDMENT OF HAIRDRESSING TRADES APPRENTICESHIP REGULATIONS.

IN pursuance of the powers conferred by the *Apprenticeship Act 1958*, His Excellency the Governor of the State of Victoria, by and with the advice of the Executive Council thereof, doth hereby amend the Hairdressing Trades Apprenticeship Regulations as follows, that is to say:—

(1) Sub-clause (1) (c) of Regulation 4 shall be rescinded as from the first day of April, 1962.

(2) Regulation 8, shall be rescinded, and the following substituted therefor:—

“Minimum Rates of Wages for Apprentices.”

8. As from the beginning of the first pay period to commence on or after the 1st day of November, 1961, the minimum rates of wages to be paid to apprentices in the said trades shall be as follows:—

(a) *Ladies' Hairdressing*—

1st year—at the rate of £4 0 0 per week

2nd year—at the rate of £5 5 0 per week

3rd year—at the rate of £7 10 0 per week

4th year—at the rate of £10 10 0 per week

(b) *Men's Hairdressing*—

1st year—at the rate of £5 3 0 per week

2nd year—at the rate of £7 2 0 per week

3rd year—at the rate of £10 10 0 per week

4th year—at the rate of £15 13 0 per week

(c) *Ladies' and Men's Hairdressing*—

1st year—at the rate of £5 3 0 per week

2nd year—at the rate of £7 2 0 per week

3rd year—at the rate of £10 10 0 per week

4th year—at the rate of £15 13 0 per week

5th year—at the rate of £17 12 0 per week

(3) Regulation 10 shall be rescinded and the following substituted therefor:—

“Proportion of Apprentices to Journeymen.”

10. (1) Subject to sub-regulation (2) of this Regulation—

(a) the number of apprentices who may be employed by any employer at any time in the trade of Ladies' Hairdressing shall not exceed the proportion of one apprentice to each journeyman employed by such employer in such trade;

(b) the number of apprentices who may be employed by any employer at any time in the trade of Men's Hairdressing and Ladies' and Men's Hairdressing shall not exceed the proportion of one apprentice to every three or fraction of three journeymen employed by such employer in such trades.

(2) With the consent of the Commission and upon satisfying the Commission that he has the training facilities deemed adequate by the Commission for the training of each apprentice concerned, an employer may employ in the said trades such number of apprentices as the Commission may determine in excess of the proportion prescribed by sub-regulation (1) hereof. Any apprentice employed pursuant to this sub-regulation shall not be included for the purpose of ascertaining the number of apprentices who may otherwise be employed in accordance with the provisions of sub-regulation (1) hereof.

(3) For the purposes of this Regulation—

(a) an employer working at the trades shall be deemed to be a journeyman;

(b) the number of journeymen employed at any time shall be deemed to be the average per working day of the number of journeymen employed in the said trades by such employer during the period of six months immediately preceding such time;

(c) 'apprentices' means apprentices or probationers and 'journeymen' means journeymen or journeywomen."

And the Honorable George Oswald Reid, Her Majesty's Minister of Labour and Industry for the State of Victoria, shall give the necessary directions herein accordingly.

N. G. WISHART,
Acting Clerk of the Executive Council.

Apprenticeship Act.
APPRENTICESHIP COMMISSION OF VICTORIA.

At Government House, Melbourne, the twelfth day of December, 1961.

PRESENT:

His Excellency the Governor of Victoria.
Mr. Bloomfield | Mr. Petty.

AMENDMENT OF BREAD TRADE APPRENTICESHIP REGULATIONS.

IN pursuance of the powers conferred by the *Apprenticeship Act 1958*, His Excellency the Governor of the State of Victoria, by and with the advice of the Executive Council thereof, doth hereby rescind Regulation 8 of the Bread Trade Apprenticeship Regulations and substitute therefor the following:—

"Minimum Rates of Wages of Apprentices.

8. From and including the 31st day of August, 1961, the minimum weekly wage rates to be paid to apprentices in the said trade shall be the under-mentioned percentages of the rate prescribed from time to time for 'All others engaged in the making and/or baking of bread' in the Determination of the Bread Trade Board:—

(a) With respect to the term of apprenticeship of five years—

Year of Apprenticeship.	Percentage.
1st year—	
1st six months	31.8
2nd six months	34.4
2nd year—	
1st six months	37
2nd six months	39.5
3rd year—	
1st six months	44.6
2nd six months	49.8
4th year—	
1st six months	57.4
2nd six months	65
5th year—	
1st six months	75.3
2nd six months	85.4

(b) With respect to the term of apprenticeship of four years—

1st year—	
1st six months	37
2nd six months	39.5
2nd year—	
1st six months	44.6
2nd six months	49.8
3rd year—	
1st six months	57.4
2nd six months	65
4th year—	
1st six months	75.3
2nd six months	85.4

The total wages of apprentices shall be calculated to the nearest 6d., half or less than half of 6d. to be disregarded."

And the Honorable George Oswald Reid, Her Majesty's Minister of Labour and Industry for the State of Victoria, shall give the necessary directions herein accordingly.

N. G. WISHART,
Acting Clerk of the Executive Council.

APPROACHING LAND SALES.

SALES of Crown lands, in fee-simple, will be held at the under-mentioned places and dates, viz.:-

Leongatha.—Monday, 18th December, 1961 ..	No. of Gazette. 102
---	---------------------------

REGULATIONS FOR THE CARE, PROTECTION AND MANAGEMENT OF THE "YEUNGROON CAMPING AND WATERING RESERVE".

WHEREAS by section 218 of the *Land Act 1958*, power is given to the Board of Land and Works to make Regulations in respect of the care, protection and management of any Crown land which has been reserved under the Land Acts for any public purpose whatsoever and which has not been conveyed to or vested in trustees, and for the further purposes as enacted: Now therefore the Board of Land and Works in pursuance of the power conferred aforesaid, doth hereby make the following Regulations in respect of the remaining portion of the land in the Parish of Yeungroon, temporarily reserved by Order in Council dated 4th February, 1878, as a site for Camping and Watering purposes, hereinafter referred to as the "Reserve".

The Reserve has been placed under the control of a Committee of Management (hereinafter referred to as the "Committee"), with power and authority to enforce these Regulations.

REGULATIONS.

1. No person shall enter or remain in the Reserve who may offend against decency as regards dress, language or conduct.
2. No person shall bathe from the Reserve unless decently attired in a suitable bathing costume.
3. No person shall climb on or in any manner deface, damage or interfere with any buildings, fences, gates, structures, fixtures, equipment, posts, trees, shrubs or flowers in the Reserve.
4. No person shall remove from the Reserve any gravel, stone, sand or loam.
5. No person shall cut, saw, dig, move or displace any tree, bough, live or dead timber, wood or other material which may be in or around the Reserve without the consent, in writing, of the Committee.
6. No person shall discharge any firearm or air-gun in the Reserve.
7. No person shall bring into the Reserve any cattle, horses, goats, pigs, or other animals except sheep, without the permission, in writing, of the Committee.
8. No person shall throw or cause to be thrown any stone or other substance in the Reserve.
9. No person shall on the Reserve—
 - (a) Light a fire or burn any material except with the consent of the Committee, or in the places set apart for the purpose, by the Committee.
 - (b) Break glass of any kind or leave or deposit any matter or thing injurious to persons.
 - (c) Deposit or leave any bottles, glass, tin, can, waste paper, garbage or litter of any kind, except in the receptacles provided for that purpose by the Committee.
10. No person shall enter or remain in the Reserve while in a state of intoxication.
11. No person shall offer for sale or hire any article within the Reserve or within any tent, booth or other structure thereon, without the permission, in writing, of the Committee.
12. The Committee shall have the right to refuse the entry of caravans.
13. No person shall remain in the Reserve at any time when lawfully directed by any officer or employee of the Committee or by any member of the Police Force to leave the Reserve.—(Rs.8099.)

The common seal of the Board of Land and Works was hereto affixed this seventh day of December, 1961, in the presence of—

(SEAL) KEITH TURNBULL, President.
F. KLENNER, Member.

Every person who contravenes or fails to comply with these Regulations shall, in accordance with the provisions of section 218 of the *Land Act 1958*, for each offence be liable to a penalty of not more than Five pounds, and every person who contravenes or fails to comply with any such Regulations, and who, after he has been warned by any bailiff of Crown lands or by any member of the Police Force, does not desist therefrom, may be forthwith apprehended by such bailiff or member of the Police Force and taken before some justice to be dealt with according to law, and shall be liable to a penalty of not more than Ten pounds.

ADDITIONAL REGULATIONS FOR THE CARE, PROTECTION AND MANAGEMENT OF THE "JAMIESON RIVER FRONTAGE RESERVE".

THE Board of Land and Works, in pursuance of the powers conferred on it, doth hereby make the following additional Regulations in respect of the land temporarily reserved by Order in Council dated 27th December, 1901, as a site for Public Recreation, and of such portion of the Reserve for Public purposes as is indicated by blue colour on plan marked J/21 1.1937, attached to Lands Department correspondence Rs. 3459, both areas being situated in the Township of Jamieson, hereinafter referred to as the "Reserve".

REGULATIONS.

9. (a) An additional charge of Three shillings per day shall be made for each site to which electricity is supplied on that portion of the Reserve set apart for camping.
- (b) No person, other than the hirer of the site, shall connect to any of the electrical outlets provided to the site.
- (c) No person shall use any electrical leads or equipment except in conformity with State Electricity Commission requirements.—(Rs.3459.)

The common seal of the Board of Land and Works was hereto affixed this seventh day of December, 1961, in the presence of—

(SEAL) KEITH TURNBULL, President.
F. KLENNER, Member.

Every person who contravenes or fails to comply with these Regulations shall, in accordance with the provisions of section 218 of the *Land Act 1958*, for each offence be liable to a penalty of not more than Five pounds, and every person who contravenes or fails to comply with any such Regulations, and who, after he has been warned by any bailiff of Crown lands or by any member of the Police Force, does not desist therefrom, may be forthwith apprehended by such bailiff or member of the Police Force and taken before some justice to be dealt with according to law, and shall be liable to a penalty of not more than Ten pounds.

PROPOSED REVOCATIONS OF TEMPORARY RESERVATIONS AND THE WITHHOLDING FROM SALE, LEASING, AND LICENSING OF LANDS BY ORDERS IN COUNCIL.

IN pursuance of the provisions of the *Land Act 1958*, notice is hereby given that it is the intention of the Governor in Council to revoke the temporary reservations, and the withholding from sale, leasing, and licensing of lands by Orders in Council hereunder referred to, viz.:-

The following Notices were published 1^o on the 13th December, 1961, pursuant to Orders of the 5th December, 1961.

BUNGALALLY.—The temporary reservation as a site for a Quarry and the withholding from sale, leasing, and licensing, by Order in Council of the 23rd December, 1879, of 22 acres 3 roods 11 perches of land in the Parish of Bungalally.—(B.93^(a)) (Rs.220).

JAN JUC.—The temporary reservation as a site for Public purposes and the withholding from sale, leasing, and licensing, by Order in Council of the 17th October, 1881 (see *Government Gazette*, 21st October, 1881, page 2900), of 280 acres, more or less, of land in the Parish of Jan Juc, revoked as to part by Order of the 19th February, 1889, so far as the balance thereof containing 105 acres, more or less, is concerned.—(J.7^(e)) (C.68014).

BONEGILLA.—The temporary reservation as a site for Public purposes and the withholding from sale, leasing, and licensing, by Order in Council of the 8th October, 1877 (see *Government Gazette*, 12th October, 1877, page 1925), of 78 acres, more or less, of land in the Parish of

Bonegilla, so far only as the portion containing 6 acres 2 roods 20 perches, more or less, indicated by hachure on plan hereunder, is concerned.—(B.575(4) (Rs.44).

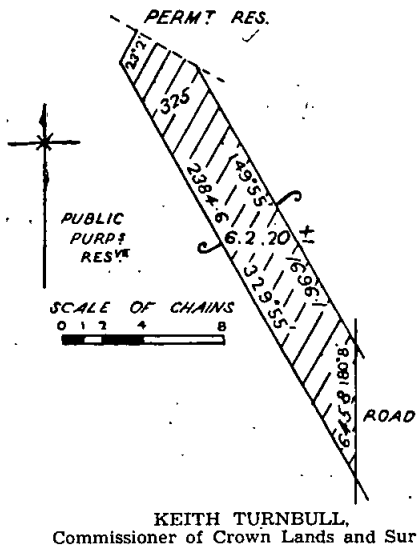

MULLROO (LAKE CULLULLERAIN).—The temporary reservation, by Order in Council of the 12th December, 1930, of 1,435 acres 2 roods 36 perches of land in the Parish of Mullroo, as a site for Water Supply purposes, revoked as to part by various Orders, so far only as the portion, containing 12 acres 0 roods 32 perches, more or less, indicated by hachure on plan hereunder, is concerned.—(M.499(1) (Rs.4076).

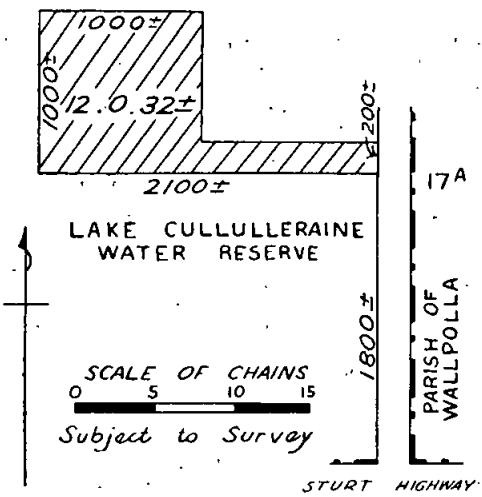

PROPOSED REVOCATIONS OF TEMPORARY RESERVATIONS OF LANDS BY ORDERS IN COUNCIL.

IN pursuance of the provisions of the Land Act 1958, notice is hereby given that it is the intention of the Governor in Council to revoke the temporary reservations of lands by Orders in Council hereunder referred to, viz.:

The following Notices were published 1° on the 22nd November, 1961, pursuant to Orders of the 14th November, 1961.

DUCHEMBEGAARRA.—The temporary reservation, by Order in Council of the 13th October, 1903, of 2 roods of land in the Parish of Duchembegarra, as a site for State School purposes.—(D.185(5) (C.22760).

TALLANGATTA.—The temporary reservation, by Order in Council of the 29th April, 1941, of 2 acres 1 rood 30 perches of land in the Township of Tallangatta, as a site for Camping purposes.—(T.74(d1) (Rs.5075).

TALLANGATTA.—The temporary reservation, by Order in Council of the 30th January, 1893, of 27 acres 2 roods 23 perches of land in the Township of Tallangatta, as a site for Show Yards.—(T.74(d1) (Rs.1929).

BENALLA.—The temporary reservation, by Order in Council of the 3rd September, 1860 (see Government Gazette of 14th September, 1860, page 1723), of 1 acre 3 roods 32 perches of land in the Township of Benalla, as a site for Public Buildings, revoked as to part by Order of the 10th November, 1927, so far as the balance thereof, containing 1 acre 0 roods 22 perches, is concerned.—(B.390(3) (Rs.5411).

TALLANGATTA.—The temporary reservation, by Order in Council of the 22nd January, 1889, of 12 acres 1 rood 3 perches of land in the Township of Tallangatta, as a site for Public Recreation, revoked as to part by Order of the 29th April, 1941, so far as the balance thereof, containing 11 acres 0 roods 24 3/10 perches, is concerned.—(T.74(d1) (Rs.4174).

GREENSBOROUGH (QUEENSTOWN).—The temporary reservation, by Order in Council of the 14th May, 1866, of 5 acres of land in the Parish of Greensborough, as a site for a Cricket Ground, so far only as the portion, containing 1 rood 27 perches, indicated by hachure on plan hereunder, is concerned.—(G.179(6) (Rs.1460).

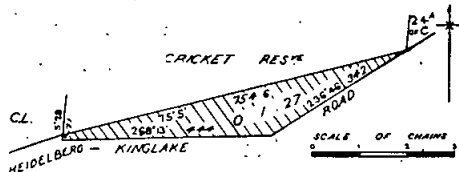

NEERIM.—The temporary reservation, by Order in Council of the 7th January, 1890, of 6 acres 0 roods 1 perch of land in the Township of Neerim, as a site for Cricket and other purposes of Public Recreation and the temporary reservation by Order of the 21st January, 1897 of 1 acre 1 rood 20 perches of land as an extension thereto, so far only as the respective portions, containing 17 perches and 1 rood 14 perches, indicated by hachure on plan hereunder, are concerned.—(N.121(10) (Rs.2270).

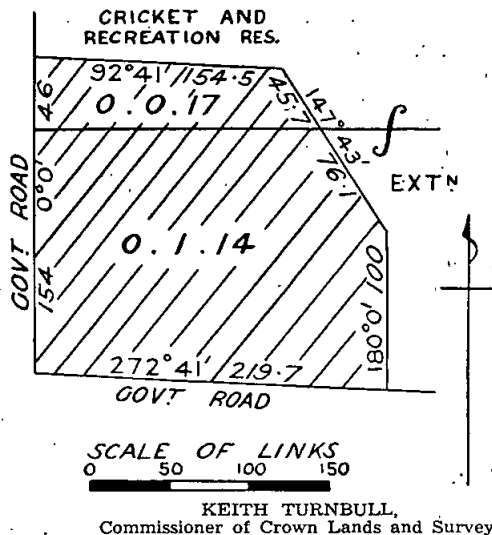

PROPOSED REVOCATIONS OF TEMPORARY RESERVATIONS OF LANDS BY ORDERS IN COUNCIL.

IN pursuance of the provisions of the Land Act 1958, notice is hereby given that it is the intention of the Governor in Council to revoke the temporary reservations of lands by Orders in Council hereunder referred to, viz.:

The following Notices were published 1° on the 6th December, 1961, pursuant to Orders of the 28th November, 1961.

WERRIMULL.—The temporary reservation, by Order in Council of the 22nd May, 1928, of 3 acres 2 roods of land in the Parish of Werrimull as a site for a State School.—(W.423(2) (Rs.3681).

BIRREGURRA.—The temporary reservation, by Order in Council of the 21st December, 1868, of 3 acres 2 roods 28 perches of land in the Parish of Birregurra as a site for the Supply of Stone, so far only as the portion containing 3 roods 15 perches, more or less, indicated by hachure on plan hereunder, is concerned.—(B.395⁽²⁾) (Rs.8027).

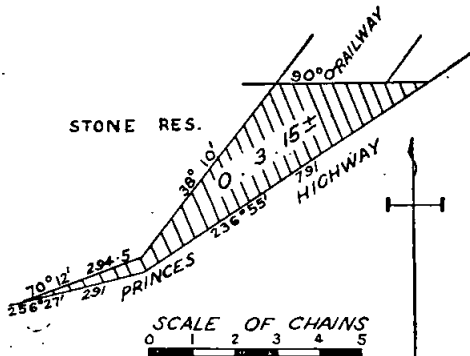

GLENALBYN.—The temporary reservation, by Order in Council of the 6th August, 1903, of 1,660 acres, more or less, of land in the Parishes of Glenalbyn, Salisbury West, and the Township of Inglewood as a site for Water Supply purposes, revoked as to part by various Orders, so far only as the portion in the Parish of Glenalbyn containing 5 acres, more or less, indicated by hachure on plan hereunder, is concerned.—(G.161⁽³⁾) (Rs.1328).

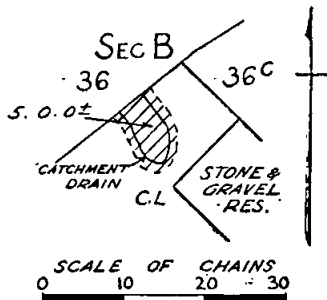

KEITH TURNBULL,
Commissioner of Crown Lands and Survey.

PROPOSED REVOCATION OF TEMPORARY RESERVATION AND THE WITHHOLDING FROM SALE, LEASING, AND LICENSING OF LAND BY ORDER IN COUNCIL.

IN pursuance of the provisions of the *Land Act 1958*, notice is hereby given that it is the intention of the Governor in Council to revoke the temporary reservation, and the withholding from sale, leasing, and licensing of land by Order in Council hereunder referred to, viz.:

The following Notice was published 1° on the 22nd November, 1961, pursuant to Order of the 14th November, 1961.

KERANG.—The temporary reservation, as a site for Water Supply purposes, and the withholding from sale, leasing and licensing by Order in Council of the 16th July, 1883, of 5 acres of land in the Township of Kerang.—(K.19⁽⁵⁾) (Rs.5954).

KEITH TURNBULL,
Commissioner of Crown Lands and Survey.

PROPOSED REVOCATION OF TEMPORARY RESERVATION AND THE WITHHOLDING FROM SALE, LEASING AND LICENSING OF LAND BY ORDER IN COUNCIL.

IN pursuance of the provisions of the *Land Act 1958*, notice is hereby given that it is the intention of the Governor in Council to revoke the temporary reservations, and the withholding from sale, leasing and licensing of lands by Order in Council hereunder referred to, viz.:

The following Notice was published 1° on the 29th November, 1961, pursuant to Order of the 21st November, 1961.

KURRACA.—The temporary reservation as a site for Public purposes (State School) and the withholding from sale, leasing and licensing by Order in Council of the 3rd

October, 1881 (see *Government Gazette*, 7th October, 1881, page 2787), of 2 acres of land in the Parish of Kurraca.—(K.140(A²)) (C.98635).

KEITH TURNBULL,
Commissioner of Crown Lands and Survey.

PROPOSED REVOCATIONS OF TEMPORARY RESERVATIONS OF LANDS BY ORDERS IN COUNCIL.

IN pursuance of the provisions of the *Land Act 1958*, notice is hereby given that it is the intention of the Governor in Council to revoke the temporary reservations of lands by Orders in Council hereunder referred to, viz.:

The following Notices were published 1° on the 29th November, 1961, pursuant to Orders of the 21st November, 1961.

COLIBAN.—The temporary reservation, by Order in Council of the 15th June, 1915, of 53 acres of land in the Parish of Coliban, as a site for Forest purposes.—(C.252⁽³⁾) (C.62481).

MUCKLEFORD.—The temporary reservation, by Order in Council of the 23rd July, 1877 (see *Government Gazette*, 27th July, 1877, page 1423), of 5 acres of land in the Parish of Muckleford as a site for Public purposes (State School).—(M.259⁽⁵⁾) (C.98634).

KEITH TURNBULL,
Commissioner of Crown Lands and Survey.

PROPOSED REVOCATIONS OF TEMPORARY RESERVATIONS AND THE WITHHOLDING FROM SALE, LEASING, AND LICENSING OF LANDS BY ORDERS IN COUNCIL.

IN pursuance of the provisions of the *Land Act 1958*, notice is hereby given that it is the intention of the Governor in Council to revoke the temporary reservations, and the withholding from sale, leasing, and licensing of lands by Orders in Council hereunder referred to, viz.:

The following Notices were published 1° on the 13th December, 1961, pursuant to Orders of the 5th December, 1961.

BONEGILLA.—The temporary reservation, by Order in Council of the 15th November, 1937, of 7 acres 0 roods 27 perches of land in the Parish of Bonegilla as a site for Camping purposes, and the temporary reservation, by Order of the 12th December, 1938, of 3 acres of land as an extension thereto, so far only as the respective portions containing 2 roods 8 perches and 10 perches, indicated by hachure on plan hereunder, are concerned.—(B.575⁽⁴⁾) (Rs.4742).

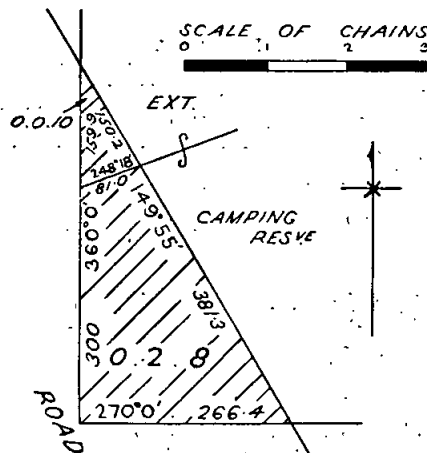

THE CLOSER SETTLEMENT ACT 1938.

THE Farm Allotment mentioned in the Schedule hereunder is hereby proclaimed available for application, and may be taken up under Closer Settlement Lease.

Parish.	Allotment.	Section.	Area.	Monetary Liability.	Deposit, Including Lease and Registration Fees.	Term of Lease.	Remarks.
			A. R. P.	£ s. d.	£ s. d.		
Nypo	41	..	769 0 38	1,427 14 0	288 19 0	36 years	Yearly Instalment £62 14s. 0d. Survey fee £66 17s. 6d. 9½ miles to Yaapeet. 14½ miles to Hopetoun. Improvements Crown £47 14s. 0d. Lessees £66 15s. 0d. (A. L. Moyle)

Department of Crown Lands and Survey.
Melbourne, 12th December, 1961.

KEITH TURNBULL,
Commissioner of Crown Lands and Survey.

COMMITTEES OF MANAGEMENT OF RESERVES.

APPOINTMENTS.

WHEREAS by section 221 of the *Land Act 1958* it is provided that it shall be lawful for the Governor in Council or the Board of Land and Works to appoint and remove any number of persons, not less than three, or any municipal council, or the governing body of any corporation, to be a Committee of Management of any specified Crown land reserved either temporarily or permanently for any of the purposes set out in section 14 of the *Land Act 1958*, and not conveyed to or vested in trustees: Now therefore the Board of Land and Works doth hereby appoint the under-mentioned persons to be members of the Committee of Management of the Reserves named:—

"LAKE BOGA WATER SUPPLY AND PUBLIC PARK RESERVES."

Arthur Charles Routley in the place of Reginald Harry Priestly (resigned) as a member of the Committee of Management for the period ending 17th July, 1964, of the reserved Crown lands shown coloured red and bordered red on plan marked KB over 4.8.60, attached to Lands Department correspondence Rs.6286, and known as the "Lake Boga Water Supply and Public Park Reserves".—(Corres. Rs.6286, Rs.2824.)

"BULGA PUBLIC HALL RESERVE."

Alan Percival Currie, Keith Woodburn, John Anderson, Michael Kevin Kelly and Martin O'Connor as a Committee of Management for a period of three (3) years of the land temporarily reserved by Order in Council dated 21st October, 1902, as a site for Public purposes in the Parish of Woorinen, and known as the "Bulga Public Hall Reserve".—(Corres. Rs.3639.)

"WARATAH BAY AND WALKERVILLE FORESHORE RESERVE."

Robert H. Holt, Charles A. Nicoll, George T. Buckland, Michael A. Griffin, Clarence Gordon Landy, Anthony Gordon Landy, Frank Oldfield, Robert Gleaming, Geoffrey S. Gair, Ronald Thorn, H. N. Jackson and A. Metzke as a Committee of Management for the period ending 16th February, 1963, of the reserved Crown lands in the Township of Walkerville and the Parish of Waratah, as is indicated by red colour on plan marked "W" over 23.11.61, attached to Lands Department correspondence Rs.6547, and known as the "Waratah Bay and Walkerville Foreshore Reserve".—(Corres. Rs.6547.)

This appointment is in lieu of all previous appointments in respect of the said land which are hereby revoked.

"WOOSANG RECREATION RESERVE."

John McGurk, Mathew Ramage Donaldson, Cyril Round, William Neil Gould and Joseph Moore Gould as a Committee of Management for a period of three (3) years of the land in the Parish of Woosang temporarily reserved by Order in Council dated the 23rd April, 1894, as a site for Public Recreation, and known as the "Woosang Recreation Reserve".—(Corres. Rs.4644.)

"PATCHEWOLLOCK RACECOURSE AND RECREATION RESERVE."

James Alexander Jolly, George Alexander Cummings, Alan Edward Grigg, Neil Alex Walch, Raymond Keith Loxton and Archibald Jackson as a Committee of Management for a period of three (3) years of the land temporarily reserved by Order in Council dated 25th October, 1927, as a site for Racecourse, Public Recreation and Showgrounds, in the Parish of Patchewollock, and known as the "Patchewollock Racecourse and Recreation Reserve".—(Corres. Rs.3563.)

"KATAMATITE SWIMMING POOL RESERVE."

Leonard Leslie Kilgour, William Ewart Garside, Harry Arthur Watt, John Pendlebury, Thomas Howard Robison, Kenneth Bruce Bryant, Leslie Alexander Young, Kevin Martin Ryan and William Barker Trewin as a Committee of Management for a period of three (3) years from 27th November, 1961, of the land in the Township of Katamatite, Parish of Katamatite temporarily reserved as a site for a Swimming Pool by Order in Council dated the 2nd September, 1958, and known as the "Katamatite Swimming Pool Reserve".—(Corres. Rs.7763.)

"MOSTANK RECREATION RESERVE."

Albert Herman Haeusler, Francis Ray Walker, James Leslie McQueen, Lindah Vincent Storer, Ivy Irene Brown and Lindsay John Storer as a Committee of Management for a period of three (3) years of the land in the Parish of Annuello temporarily reserved by Order in Council dated the 1st July, 1930, as a site for Public Recreation, and known as the "Mostank Recreation Reserve".—(Corres. Rs.4018.)

"UPPER BEACONSFIELD RECREATION RESERVE."

Keith Donald Ferguson, James Alexander Foster Robson, Clive Joseph Thompson, Kenneth David Hudson, Eric Harold David Morton, Ernest Edward Lang, John Boulton Hudson, Gregory Bernard Adcock and Marshall James Jessep as a Committee of Management for a period of three (3) years of the remaining portion of the land temporarily reserved by Order in Council dated 17th June, 1941, as a site for Public Recreation in the Parish of Gembrook at Beaconsfield Upper, and known as the "Upper Beaconsfield Recreation Reserve".—(Corres. Rs.5219.)

"HOTSPUR RECREATION RESERVE."

Albert Cameron, M. E. Woodford, N. E. Spencer, Alfred Leonard Edge, Leslie Arthur Woodford, Raymond William Gough, Charles Gordon Brown, Reuben Nicholas Saunders, William Bardell and Eric Storer as a Committee of Management for a period of three (3) years from 29th November, 1961, of the land in the Township of Hotspur temporarily reserved by Order in Council of 2nd September, 1895, as a site for Public Recreation, and known as the "Hotspur Recreation Reserve".—(Corres. Rs.2442.)

"DOWER RECREATION RESERVE."

Henry David Barbour, Albert Otto Herman Moller, Andrew James Edward Dawson, Neil Browning, Andrew McHarg Hay, Eric Clarence Lanyon, Thomas Lionel McMahon, Robert Albert Brown, Frederick Honeychurch, George Austin Edwards, George Duncan Miller and Edward Stanislaus Mullen as a Committee of Management for a period of three (3) years of the land in the Township of Kangaroo Flat, Parish of Sandhurst, temporarily reserved by Orders in Council dated 10th March, 1873, and 31st January, 1950, as a site for Public Recreation, and known as the "Dower Recreation Reserve".—(Corres. Rs.2233.)

"DUNKELD PUBLIC HALL."

Linden Arthur Cameron, Ann Rosemary Woodburn, Peter Charles Tustin Armytage and Catherine Anne Funk as members of the Committee of Management for the period ending 14th September, 1963, of the land in the Township of Dunkeld temporarily reserved by Order in Council dated 14th May, 1957, as a site for a Public Hall, and known as the "Dunkeld Public Hall".—(Corres. Rs.7553.)

"BLACKWOOD MECHANICS' INSTITUTE RESERVE."

Kenneth Kendall Matheson, in the place of Kenneth Rendall, as a member of the Committee of Management for the period ending 25th October, 1964, of the land temporarily reserved by Orders in Council dated 7th March, 1890, and 27th April, 1880, as a site for a Mechanics' Institute at Blackwood, and known as the "Blackwood Mechanics' Institute Reserve".—(Corres. Rs.4711.)

"PUBLIC PURPOSES RESERVE," FRANKSTON.

The Council of the Shire of Frankston as a Committee of Management of the land in the Township of Frankston temporarily reserved by Order in Council dated 14th November, 1961, as a site for Public purposes.—(Corres. Rs.3396.)

"BELVOIR PARK," WODONGA.

The Council of the Shire of Wodonga as a Committee of Management of the remaining portion of the land in the Township and Parish of Wodonga temporarily reserved as a site for a Public Park by Orders in Council dated 27th February, 1878, 11th June, 1903, 11th March, 1904, and 8th November, 1961, and known as "Belvoir Park", Wodonga.—(Corres. Rs.4548.)

This appointment is in lieu of all previous appointments which are hereby revoked.

"MUNICIPAL GOLF LINKS," FRANKSTON.

The Council of the Shire of Frankston as a Committee of Management of the land in the Township of Frankston temporarily reserved by Order in Council dated 14th November, 1961, as a site for Public Recreation, and known as the "Municipal Golf Links".—(Corres. Rs.4823.)

"FRANKSTON COMMUNITY HOSPITAL RESERVE."

The Committee of Management of the Frankston Community Hospital as a Committee of Management of the land in the Township of Frankston temporarily reserved by Order in Council dated 14th November, 1961, as a site for Hospital purposes.—(Corres. Rs.8088.)

"SPRINGDALE RECREATION RESERVE."

Mervyn George Packer, Norman Keith Nichol, Gordon Lindly Prichard, Geoffrey William Yea, William Paul McFarland, Norman Francis Packer, William Percival Nichol and Leo John Packer as a Committee of Management for a period of three (3) years of the land in the Parish of Tatonga temporarily reserved by Order in Council dated 30th September, 1958, as a site for Public Recreation, and known as the "Springdale Recreation Reserve".—(Corres. Rs.4176.)

"BRADVALE PUBLIC HALL RESERVE."

Alick Archibald McKinnon, Arthur Leslie Welfare, Charles Gillespie, Noel Richard Gillespie, Edgar Albert Coad, Philip Thomas Smith, Alfred John Nichol and Charles Willoughby Grist as a Committee of Management for a period of three (3) years of the land temporarily reserved by Order in Council of 3rd May, 1949, as a site for a Public Hall in the Parish of Galla, and known as the "Bradvale Public Hall Reserve".—(Corres. Rs.6342.)

"RUSHWORTH WILDFLOWER SANCTUARY RESERVE."

James Service, Albert Ronald Hawking, Herbert James Hawking, Thomas McKenzie King, Ollov George Risstrom, Edgar Allan Bertram, Robert Fleming, Francis James Miller and Leonard Charles Coyle as a Committee of Management for a period of three (3) years of the land in the Parish of Moora temporarily reserved by Order in Council dated the 1st July, 1952, as a site for Public Park and the Preservation of Native Flora, and known as the "Rushworth Wildflower Sanctuary Reserve".—(Corres. Rs.6955.)

"NUNGA RECREATION RESERVE."

Lance Dunkley as a member of the Committee of Management for the period ending 8th November, 1964, of the land in the Parish of Boulka, temporarily reserved by Order in Council dated the 29th May, 1928, as a site for Public Recreation, and known as the "Nunga Recreation Reserve".—(Corres. Rs.3684.)

"MOUNT BUNINYONG AND LAL LAL PUBLIC PARKS."

Richard Vincent, for so long only as he continues to be a Councillor and the elect of the Council of the Shire of Buninyong, as a member of the Committee of Management of the Mount Buninyong and Lal Lal Public Parks, in the place of Wilfred Bennetts Harbour, who has ceased to be a Councillor.—(Corres. Rs.65557.)

In witness whereof the common seal of the Board of Land and Works was hereunto affixed this twenty-ninth day of November, One thousand nine hundred and sixty-one, in the presence of—

(SEAL)

KEITH TURNBULL, President.
F. KLENNER, Member.

TENDERS—PUBLIC WORKS DEPARTMENT

TENDERS will be received at this Department until **TEN** a.m. on the days, and for the purposes, under mentioned.

Particulars may be learnt at the Department and also at places shown in parenthesis.

W.O. means Inspector of Works Office; P.S.—Police Station; T.S.—Technical School; H.E.S.—Higher Elementary School; S.S.—State School; H.S.—High School; C.S.—Consolidated School.

Tenders should be submitted on the Department's printed Tender Form. All tenders must be on a "Firm Tender" basis. The Board of Land and Works will not necessarily accept the lowest or any tender.

Tenders to be addressed to the Hon. the Commissioner of Public Works, and envelope containing tender to be marked "Tender for _____, closing _____".

NOTE—No preliminary deposit is to be lodged with any tender, but a deposit in accordance with the prescribed Schedule may be required from each successful tenderer.

NOTE—Plans and specifications will not be available at school buildings from 20th December, 1961, to 5th February, 1962.

Tuesday, 19th December, 1961.

Amphitheatre.—Septic tank installation and water supply extension, school and residence, S.S. 1637. (W.O., Maryborough; S.S., Amphitheatre.)

Apollo Bay.—Supply and delivery of 12,800 tons of spalls to breakwaters, Ports and Harbors.

Ararat.—Exhaust system to servery and staff kitchen. Mental Hospital. (W.O., Ballarat.)

Ballarat.—New toilets for male and female staff, School of Mines. (W.O., Ballarat; School of Mines, Ballarat.)

Ballarat.—Erection of additional toilets, S.S. 2022. (W.O., Ballarat; S.S., Ballarat.)

Banyule.—First and second sections in concrete veneer timber-framed construction, High School.

Banyule.—Electrical installation in non-standard stages 1 and 2, High School.

Banyule.—Supply, delivery, installation and testing of mechanical services, High School.

Bayswater.—Additional toilets, washing facilities and fire service, S.S.2163.

Belgrave South.—Water supply and septic tank installation, school and residence, S.S. 3551. (S.S., Belgrave South.)

Bell Post Hill.—Supply and delivery of 60 tons of graded $\frac{1}{2}$ -in. bituminous premix, S.S. 4804.

Bethanga.—New out-office block, septic tank and water supply installation, S.S. 1883. (W.O., Wangaratta; P.S., Wodonga; S.S., Bethanga.)

Brunswick.—Provision of additional sinks and basins, Girls' Technical School.

Carlton.—Supply of eight six-drawer steel filing cabinets, Motor Registration Branch, Exhibition Buildings.

Carlton.—Supply and delivery of 260 cubic yards of 2½-in. metal and 260 cubic yards of 2-in. metal (basalt), Secondary Teachers' Training College, Swanston-street.

Clayton West.—Supply and installation of an effluent pump for septic tank, S.S. 4840.

Coburg.—Supply and delivery of trichlorethylene degreasing plant, Pentridge Gaol.

Coburg North.—Provision of new garage and concrete drive, Family Group Home, 27 Jackson-parade.

Cressy.—New out-office block, septic tanks and water supply installations, S.S. 731, and residence. (W.O., Camperdown; S.S., Cressy.)

Culgoa.—Septic tank installation and resiting of existing out-office buildings, S.S. 3246. (W.O., Swan Hill; S.S., Culgoa.)

Dooen.—Supply of timber, Longerenong Agricultural College.

- Dooen.—Supply of timber (additional supply), Longerenong Agricultural College.
- Dumbalk.—Exterior renovations and painting, S.S. 3415. (W.O., Korumburra; S.S., Dumbalk.)
- Elliminyt.—Septic tank installation and water supply, S.S. 2028. (W.O., Camperdown; S.S., Elliminyt.)
- Emu.—Internal and external painting to school and residence, S.S. 2011. (W.O., Maryborough; S.S., Emu.)
- Fern Tree Gully.—Supply and installation of effluent pump for septic tank, S.S. 1307.
- Flemington.—Installation of thermostatic and manual fire alarm system, Travancore Developmental Centre.
- Glenroy.—Connexion to sewer, installation of fire service, abolishing septic tank system, &c., High School.
- Glenroy.—Supply and lay approximately 250 square yards "A" quality lino tiles to specified areas, Court House.
- Hesket.—Repairs, external and internal painting to school and residence, S.S. 1004. (W.O., Kyneton; S.S., Hesket.)
- Jordanville North.—Six class-rooms, concrete veneer timber-framed primary school, S.S. 4903.
- Jordanville North.—Electrical installation, new school of six (6) L.T.C. class-rooms, S.S. 4903.
- Jordanville North.—Plenum heating in new six class-room unit, S.S. 4903.
- Lake Tyers.—New out-office block and septic tank installation, S.S. 1319. (W.O., Bairnsdale; S.S., Lake Tyers.)
- Linton.—New out-office block, install septic tank, S.S. 880. (W.O., Ballarat.)
- Maryborough East.—Provision of additional external door in Infant Block, S.S. 2828. (W.O., Maryborough.)
- Melbourne.—Supply and delivery of a single-screw diesel survey launch, Ports and Harbors.
- Mont Park.—100 yards Bradana awning duck, foam green, 100 yards Bradana awning duck, savannah yellow, Mental Hospital.
- Myrning.—Repairs and painting, S.S. 487. (W.O., Ballarat; S.S., Myrning.)
- Pascoe Vale South.—Erection of Library and Visual Aids Building, S.S. 4704.
- Pascoe Vale South.—Electrical installation in new Library and Visual Aids Room, S.S. 4704.
- Preston.—Minor repairs and external painting to the caretaker's residence, Technical School.
- Preston East.—Supply and delivery of one 24-in. thickener and one radial arm saw, Technical School.
- Sebastopol.—Supply and delivery of 20 cub. ft. refrigerator, Girls' Technical School. (W.O., Ballarat.)
- Sebastopol.—Connexion town sewerage, fire service, &c., S.S. 1167. (W.O., Ballarat; S.S., Sebastopol.)
- Seymour.—Septic tank installation, &c., S.S. 547, Tallarook-street. (W.O., Alexandra; S.S., Seymour.)
- Silvan.—Installation of septic tank at school and residence, S.S. 1801. (S.S., Silvan.)
- Sunbury.—Alterations and extensions to Wards M.1 and F.1, Mental Hospital. (Mental Hospital, Sunbury.)
- Sunbury.—Electric light and power installation in new Day Room and Meal Service Unit in Wards M.1 and F.1, Mental Hospital.
- Sunbury.—Electrical installation for control of hot-water systems in Wards F.1, F.2 and F.3, and M.1, M.2 and M.3, Mental Hospital.
- Tarranyurk.—New out-office block, septic closets, S.S. 3000. (W.O., Warracknabeal.)
- Traralgon.—Supply and delivery of 150 tons of graded ½-in. bituminous premix grit, Technical School.
- Underbool.—Installation of septic tank, S.S. 3819. (W.O., Mildura; S.S., Underbool.)
- Walwa.—Septic tank installation at school and residence, S.S. 2806. (W.O., Wangaratta.)
- Werribee.—Internal and external renovations, S.S. 649. (S.S., Werribee.)
- Whittlesea.—Installation of septic tank, S.S. 2090. (S.S., Whittlesea.)
- Wonthaggi.—Supply and delivery of 260 tons of graded bituminous premix grit, S.S. 3650.
- Wonthaggi.—Supply and delivery of 200 cubic yards of ½-in. metal screenings, S.S. 3650.
- Woodleigh.—Repairs and painting of residence, S.S. 2463. (W.O., Korumburra; S.S., Woodleigh.)
- Tuesday, 9th January, 1962.**
- Alexandra.—Repairs and painting to residence, 13 Myrtle-street, S.S. 912. (W.O., Alexandra.)
- Ararat.—Supply and delivery as required, 500 cubic yards of surface gravel, 100 cubic yards of ½-in. screenings, 100 cubic yards of garden soil, 50 cubic yards concrete sand, Mental Hospital.
- Ashwood.—Repairs to roof, S.S. 4698.
- Benalla East.—New shelter pavilion, S.S. 2256. (W.O., Benalla; S.S., Benalla East.)
- Bendigo.—General repairs, renovations and painting, Technical School. (W.O., Bendigo.)
- Bona Vista.—Internal and external painting and repairs, S.S. 3612. (W.O., Warragul; S.S., Bona Vista.)
- Brimpaen.—Purchase and removal of old school, S.S. 2525. (W.O., Horsham.)
- Bunyip.—Renovations and painting, S.S. 2229. (S.S., Bunyip.)
- Cheitenham North.—Supply and delivery of 52 tons of ½-in. premixed bituminous screenings and 16 tons of ½-in. premixed bituminous toppings, S.S. 4763, Bernard-street.
- Coburg.—External repairs and painting, Technical School.
- Coburg North.—Electrical rewiring of main building and Army hut and improvements to public address system, S.S. 4543.
- Colac.—Renovations of exterior and interior painting of kitchen, Police Inspector's residence. (W.O., Camperdown; P.S., Colac.)
- Connewirricoo.—Purchase and removal of old building, S.S. 1543. (W.O., Horsham.)
- Douglas.—Purchase and removal of old school, S.S. 2044. (W.O., Horsham.)
- Doveton.—Erection of office and residence, &c., Police Station.
- Doveton.—Electrical installation in new brick veneer police station and residence.
- Frankston.—Supply and delivery of woodwork shop equipment, Technical School.
- Frankston.—Junior and senior fitting and turning equipment, Technical School.
- Gembrook.—Septic tank and water supply installation, S.S. 2506. (S.S., Gembrook.)
- Glenhuntly.—Erection of a two-story brick and brick veneer residence, Police Station.
- Glenhuntly.—Electrical installation, residence, Police Station.
- Glenroy.—Electrical installation in new sports pavilion, Technical School. (T.S., Glenroy.)
- Glenroy.—Supply and delivery and installation of H.W.S. to dressing pavilion, Technical School.
- Hawkesdale.—New concrete veneer L.T.C. school building, High School. (W.O., Warrnambool.)
- Hawkesdale.—Electrical installation in new type "300", High School. (W.O., Warrnambool; H.E.S. and S.S., Hawkesdale.)
- Hawkesdale.—Mechanical services for L.T.C. "300", High School.
- Hawthorn.—Supply and delivery of 160 cubic yards ready-mixed concrete, Milk Board, Domville-avenue.
- Horsham.—Repairs and painting, Public Works Department Inspector's residence. (W.O., Horsham.)
- Keon Park.—Supply of two 9-in. swing lathes and one 14-in. shaper, Technical School.
- Kerang.—External repairs and painting of school building, S.S. 1410. (W.O., Swan Hill; S.S., Kerang.)
- Melbourne.—Sealing of cornice molds, Public Works Department, New Treasury Building.
- Melbourne.—Repairs and painting of office, Hairdressing School of C.R.T.S. Annex.
- Mont Park.—Bedsides, tubular steel, Mental Hospital.
- Murtoa.—Repairs, external painting, &c., Police Station. (W.O., Warracknabeal; P.S., Murtoa.)
- Numurkah.—Renewal of water service at school and residence, S.S. 2134. (W.O., Shepparton; S.S., Numurkah.)
- Richmond.—External repairs and painting to residence, S.S. 1567.
- Rochester.—Renovations and painting, Police Station and residence. (W.O., Bendigo; P.S., Rochester.)
- Royal Park.—Supply and installation of aluminium windows to Administration Building, Mental Hospital. (W.O., Royal Park Mental Hospital.)
- Swan Hill.—Provision of internal toilet and wash room for female staff, S.S. 1142. (W.O., Swan Hill; S.S., Swan Hill.)
- The Basin.—Supply and installation of an effluent pump for septic tank, S.S. 2329.
- Toolangi.—External painting and repairs, S.S. 3237. (W.O., Alexandra; S.S., Toolangi.)
- White Hills.—Supply of various timber furniture items, Technical School. (W.O., Bendigo.)
- Windsor.—Repairs to roofs, S.S. 1896.
- Yallourn North.—Repairs to floors, S.S. 3967. (W.O., Traralgon; S.S., Yallourn North.)
- Yan Yean.—Renovations to school and residence, S.S. 697. (S.S., Yan Yean.)
- Yarra Park.—Internal and external renovations, S.S. 1406.
- Tuesday, 16th January, 1962.**
- Branxholme.—Internal and external painting, S.S. 1978. (W.O., Warrnambool; S.S., Branxholme.)
- Coleraine.—Installation of hot-water service in new residence, Police Station. (W.O., Hamilton; P.S., Coleraine.)
- Dandenong.—Supply of 1-in. or 1½-in. drilling machine, Technical School.

Dennington.—Internal and external painting and repairs to school and residence, S.S. 182. (W.O., Warrnambool; S.S., Dennington.)

Derrinallum.—New concrete veneer L.T.C. school building, Higher Elementary School. (W.O., Camperdown.)

Derrinallum.—Electrical installation in type "300" new school, Higher Elementary School. (W.O., Ballarat, Hamilton, Warrnambool and Camperdown.)

Derrinallum.—Supply, delivery, installation and testing of the mechanical services, Higher Elementary School. (W.O., Camperdown.)

Echuca.—Flooring in Engineering Workshop and construction of welding bays in Motor Mechanics' Shop, Technical School. (W.O., Shepparton; T.S., Echuca.)

Eltham North.—Installation of septic tank water supply, fire service and drinking facilities, S.S. 4212.

Eltham North.—Supply and installation of an effluent pump for septic tank, S.S. 4212.

Frankston.—Motor mechanics' equipment, Technical School.

Frankston.—Supply of redgum piles, Pier, Public Works Department.

Fulton.—Six class-room concrete veneer timber-framed Primary School, S.S. 4907.

Fulton.—Electrical installation in new school of six L.T.C. class-rooms, S.S. 4907.

Fulton.—Plenum heating in new six class-room unit, S.S. 4907.

Geelong East.—Erection of new residence, Police Inspector's residence. (W.O., Geelong.)

Glenrowan.—Extension of class-room, provision of partition and various works with painting, S.S. 1742. (W.O., Benalla; S.S., Glenrowan.)

Hawthorn.—Supply of ten science benches, 15 ft. x 2 ft. x 2 ft. 9 in., for new Junior School, Swinburne Technical College.

Huntingdale.—Non-party fencing, High School.

Kew.—Supply and installation of three passenger lifts for main building, Mental Hospital.

Maryborough.—Repairs and painting, S.S. 404. (W.O., Maryborough.)

Mont Park.—Supply and installation of plenum heating system for Wards F.11 and M.8, Mental Hospital.

Murrayville.—Extension of cookery room and alterations, Consolidated School. (W.O., Mildura; C.S., Murrayville.)

Numurkah.—Electrical installation, exterior lighting, High School. (W.O., Wangaratta; H.S., Numurkah.)

Oakleigh.—Alteration to electrical reticulation and electrical installation for heating in two glasshouses, S.S. Nursery 4214.

Rosebud.—Repairs and painting to school and residence, High School.

Royal Park.—Supply and delivery of 50 tons of stone-filled sheet asphalt, 100 tons of 1½-in. premixed bituminous metal, 50 tons of ½-in. graded premixed bituminous screenings, 20 tons of ½-in. premixed bituminous toppings, Quamby, Social Welfare Department.

Royal Park.—Central heating extension to treatment room in female convalescent ward "A", Mental Hospital.

Sebastopol.—Erection of No. 2 shelter pavilions and store, Technical School. (W.O., Ballarat.)

Sunbury.—Repairs and renovations to foreman gardener's residence, Mental Hospital. (Mental Hospital, Sunbury.)

Tatong.—Erection of one (1) new timber shelter pavilion, S.S. 3006. (W.O., Benalla; S.S., Tatong.)

Timboon.—Electrical installation in sports pavilion, Consolidated School. (W.O., Warrnambool; C.S., Timboon.)

Traralgon.—Connexion to sewer, installation of fire service, S.S. 4652. (W.O., Traralgon.)

Warragul.—Modified first section, Technical School. (W.O., Warragul.)

Warragul.—Electrical installation in new class-room block, Technical School. (W.O., Warragul; T.S., Warragul.)

Warragul.—Supply, delivery, installation and testing of heating system and hot-water service for new building, Technical School. (W.O.; Warragul.)

Warrandyte.—Installation of septic tank, fire service, water supply, drinking and ablution facilities, new out-office block for boys and new woodshed, S.S. 12.

Wesburn.—Supply and installation of an effluent pump for septic tank, S.S. 3466.

Whittlesea.—Repairs and painting, Court House. (P.S., Whittlesea.)

Whittlesea.—Supply and installation of an effluent pump for septic tank, S.S. 2090.

Tuesday, 23rd January, 1962.

Bridgewater.—External and internal repairs and painting, Police Station. (W.O., Bendigo; P.S., Bridgewater.)

Burnley.—Erection of wheat root rot glasshouse (stage one), Horticultural Gardens.

Douglas.—Erection of shelter pavilion, S.S. 2044. (W.O., Horsham.)

Glen Park.—Erection of shelter pavilion, S.S. 1135. (W.O., Ballarat.)

Grenville.—Installation of septic closets, new out-offices, S.S. 1153. (W.O., Ballarat.)

Koo-Wee-Rup.—Septic tank and fire service installations, High School. (H.S., Koo-Wee-Rup.)

Lake Burrumbeet.—Purchase and removal of old school building, S.S. 368. (W.O., Ballarat.)

Lake Charm.—Erection of new standard toilet block and installation of septic closets, S.S. 2122. (Amended specification.) (W.O., Swan Hill; S.S., Lake Charm.)

Morwell.—Connexion to sewer and installation of fire service, &c., S.S. 4692. (W.O., Traralgon.)

Murtoa.—Erection of shelter pavilion and store, High School. (W.O., Warracknabeal.)

Ouyen.—Septic tank installation, S.S. 3615 and residence. (W.O., Mildura; S.S., Ouyen.)

Redcliffs.—Internal and external repairs and renovations to office, residence and outbuildings, Police Station. (W.O., Mildura; P.S., Redcliffs.)

South Yarra.—Part internal renovations, Melbourne High School.

Tuesday, 29th May, 1962.

Melbourne.—Design, construction and delivery of a twin-screw trailing and cutter suction hopper dredger, Ports and Harbors, Public Works Department.

NOTE.—Plans and specifications will not be available at school buildings from 20th December, 1961, to 5th February, 1962.

H. R. PETTY,

Commissioner of Public Works.

Public Works Department,
Melbourne, 12th December, 1961.

PUBLIC SERVICE NOTICES

PUBLIC SERVICE OF VICTORIA.—VACANCY.

(TEMPORARY APPOINTMENT.)

APPLICATIONS will be received by the Public Service Board up to Wednesday, 27th December, 1961, from persons who are qualified for appointment to the under-mentioned position:—

Assistant (Male), Grade I, Mines Department (Cobden).

Yearly Salary.—£478, minimum; £510, maximum.

Duties.—Under the direction of the Foreman, to attend to the local administration of the camp including keeping time sheets, preparing wages sheets and making payments to staff, requisitioning for an accounting for stores and spare parts, catering for camp, organizing transport in connexion with the drill, attending to sick leave applications and performing other duties as required.

Qualifications.—Capable of keeping the records of the drill, and compiling wages sheets; ability to arrange camp catering and control staff. A driver's licence is an advantage.

The salary rates quoted above do not include the additional amount which is payable under Regulation 77A of the Boards Regulations.

By order,

V. P. SCULLY,
Secretary.

Office of the Public Service Board,
Melbourne, 12th December, 1961.

PUBLIC SERVICE OF VICTORIA.—VACANCY.

DEPARTMENT OF HEALTH.

MENTAL HYGIENE BRANCH.

TECHNICAL AND GENERAL DIVISION.

APPLICATIONS will be received by the Public Service Board up to Wednesday, the 3rd January, 1962, from persons employed in the Public Service of Victoria, who are eligible and qualified for appointment to the under-mentioned position:—

Deputy Charge Nurse (Male), Ararat Mental Hospital.
(Two vacancies.)

Yearly Salary.—£542, minimum; £574, maximum.

Duties.—To be second in charge of a ward.

Qualifications.—A current practising certificate for mental nursing and approved experience.

NOTE.—The salary rates quoted above do not include the additional amount which is payable under Regulation 77A of the Board's Regulations.

By order,

V. P. SCULLY,
Secretary.

Office of the Public Service Board,
Melbourne, 12th December, 1961.

PUBLIC SERVICE OF VICTORIA.—VACANCIES.

APPPLICATIONS will be received by the Public Service Board up to Wednesday, the 27th December, 1961, from persons employed in the Public Service of Victoria, who are eligible and qualified for appointment to the under-mentioned positions:—

ADMINISTRATIVE DIVISION.

Secretary, Class "A1", Department of Agriculture.

Yearly Salary.—£2,425.

Duties.—Subject to the Director, to administer the Department.

Qualifications.—Administrative and organizing ability. A knowledge of the Acts and Regulations administered by the Department and of its organization would be an advantage.

Assistant Secretary, Office of the Chief Commissioner of Police, Class "A", Chief Secretary's Department.

Yearly Salary.—£1,920, minimum; £2,060, maximum.

Duties.—To be Assistant Secretary and to assist in the administrative work of the Police Department, and to act as Staff Officer.

Qualifications.—Organizing ability with experience in administration and control and direction of staff, and preferably, a good knowledge of the organization of the Police Department and its activities and procedures.

Class "B1", Superannuation Board and Pensions Office, Treasury.

Yearly Salary.—£1,630, minimum; £1,770, maximum.

Duties.—To act as Assistant Secretary and Accountant and to be responsible for the proper recording of the income and expenditure of the Superannuation Board; to conduct interviews and to carry out any of the duties of the Secretary as circumstances require.

Qualifications.—A good knowledge of the Superannuation Act and of Division 2 of Part III. of the Teaching Service Act; experience in dealing with accounts and banking; ability to conduct interviews and correspondence.

Class "C2", Office of the Government Statist, Chief Secretary's Department.

Yearly Salary.—£1,170, minimum; £1,280, maximum.

Duties.—To act as Accountant and Staff Clerk to the Branch.

Qualifications.—A qualified Accountant with a good knowledge of the Public Service Acts and Regulations, the Superannuation Acts and the Regulations respecting Public Accounts.

Class "C2", Registry of Co-operative Housing Societies and Co-operative Societies, Treasury.

Yearly Salary.—£1,170, minimum; £1,280, maximum.

Duties.—To inspect the books and accounts of and report on the administration of co-operative housing societies and co-operative societies; to assist the Registrar generally.

Qualifications.—A qualified Accountant, preferably with a good knowledge of the Co-operative Housing Societies Act and the Co-operation Act and of the operations of co-operative housing societies and co-operative societies.

Class "C1", Department of Agriculture.

Yearly Salary.—£960, minimum; £1,060, maximum.

Duties.—To be responsible for the receipt and collection of public moneys, the storage, sale and distribution of Departmental publications, and the keeping of relevant records.

Qualifications.—Experience in revenue procedures and a good knowledge of the Public Accounts and Stores and Public Service Regulations.

Class "C1", Department of Crown Lands and Survey.

Yearly Salary.—£960, minimum; £1,060, maximum.

Duties.—To report on applications affecting the disposal of Crown lands and to record dealings on locality plans.

Qualifications.—A good knowledge of the various Acts and Regulations administered by the Department; to be qualified as a Clerk and Draughtsman.

Class "C1", Public Solicitor's Office, Law Department.

Yearly Salary.—£960, minimum; £1,060, maximum.

Duties.—To assist the Officer in Charge of the Criminal Branch of the office of the Public Solicitor, and general administrative duties.

Qualifications.—A good knowledge of criminal law and the law of procedure and evidence.

Class "C1", Premier's Office, Premier's Department.

Yearly Salary.—£960, minimum; £1,060, maximum.

Duties.—To act as Secretary and executive officer of the Government Motor Transport Committee.

Qualifications.—Preferably some experience in the keeping of statistical and other records, the handling of correspondence and the preparation of agenda and minutes of meetings. A knowledge of Government motor transport requirements would be an advantage.

Class "C1", Tourist Development Authority, Premier's Department.

Yearly Salary.—£960, minimum; £1,060, maximum.

Duties.—To be Officer in Charge of the Shipping and Airways Section of the Victorian Government Tourist Bureau, Melbourne; to arrange reservations and prepare itineraries for interstate and overseas shipping and airways travel; to supervise keeping of fare and time-tables and sailing schedules; to maintain liaison with shipping and airways companies.

Qualifications.—A good knowledge of the booking and associated procedures in regard to sea and air travel; to be able to deal with the public and answer inquiries, and supervise staff.

NOTE.—The successful applicant will be required to work a five and a half day week—Monday to Friday plus Saturday morning—for which an additional allowance will be paid.

Class "C1", Registry of Co-operative Housing Societies and Co-operative Societies, Treasury.

Yearly Salary.—£960, minimum; £1,060, maximum.

Duties.—To examine applications for registration of Co-operative Housing Societies and Co-operative Societies; to draft rules and special resolutions for such societies.

Qualifications.—A knowledge of the operations of Co-operative Housing Societies and Co-operative Societies; ability to draft rules and resolutions.

Class "C", Accounts Branch, Education Department.

Yearly Salary.—£710, minimum; £860, maximum.

Duties.—To pass teachers' salaries for payment, including the computation of increments, and allowances payable under the Teaching Service Regulations; to deal with correspondence and inquiries relating to salaries.

Qualifications.—A knowledge of the relevant portions of the Public Service and Teaching Service Acts and Regulations.

Class "C", Public Works Department.

Yearly Salary.—£710, minimum; £860, maximum.

Duties.—To be responsible for the preparation of wages sheets and maintaining relevant records, and to supervise personnel engaged thereon; to pay wages in the field.

Qualifications.—To be competent in the preparation of wages sheets, the payment of wages, and keeping of records. Ability to control staff. A knowledge of the Public Accounts and Stores Regulations and preferably of Commonwealth Arbitration Commission Awards and Wages Board Determinations.

Class "C", Accounts Branch, Treasury.

Yearly Salary.—£710, minimum; £860, maximum.

Duties.—To keep account of the daily transactions of the Public Account with the Banks and to prepare daily statements of balances; check returns from Receivers of Revenue and prepare reconciliations statements of Treasury and bank balances.

Qualifications.—A good knowledge of the Treasury system of accounting for moneys in the Public Account and the Public Accounts and Stores Regulations 1958 and to be conversant with the provisions of the Audit Act.

Class "C", Taxation (Land Tax) Office, Treasury.

Yearly Salary.—£710, minimum; £860, maximum.

Duties.—To make searches at the Office of Titles; to prepare sketches for identification of lands by assessors, valuers and others, and draw plans as required; to obtain particulars necessary for the preparation of charges under the Land Tax Act and lodge charges for registration.

Qualifications.—A good knowledge of transfer of land dealings, Titles Office procedure, and Land Tax Act and Regulations. A knowledge of draughting is desirable.

PROFESSIONAL DIVISION.

Senior Medical Officer, Sanatoria, Class "A1", Tuberculosis Branch, Department of Health.

Yearly Salary.—£2,850.

Duties.—To undertake the medical care and treatment of tuberculosis patients; to perform other medical duties as directed.

Qualifications.—A legally qualified medical practitioner of Victoria with at least one year of post-graduate hospital experience; experience in the treatment of persons suffering from pulmonary tuberculosis.

NOTE.—The successful applicant will be required to "live in". Board and quarters will be provided for a single appointee at a deduction of £205 a year. A residence is available for the successful applicant, if married, for which a rental of 10 per cent. of standard salary, plus £16 a year, will be charged. Particulars available from the Department of Health.

Assistant Examiner of Titles, Class "A1", Office of Titles, Law Department.

Yearly Salary.—£2,300.

Qualifications.—A Barrister and Solicitor of the Supreme Court of Victoria with satisfactory practical experience in conveyancing.

Superintendent, "Allambie", (Female), Class "B1", Social Welfare Branch, Family Welfare Division, Chief Secretary's Department.

Yearly Salary.—£1,573, minimum; £1,713, maximum.

Duties.—To be Superintendent of "Allambie" Reception Centre, Burwood; to be responsible for the custody, care, training and activities of children; and to assist in their assessment and placement; to supervise a large staff.

Qualifications.—An appropriate degree or diploma, organizing ability, qualities of leadership and aptitude for work with children; experience in institutional management.

Technical Officer, Class "B", Free Library Service Board, Chief Secretary's Department.

Yearly Salary.—£1,390, minimum; £1,500, maximum.

Duties.—To act as deputy to the Secretary; to be responsible for technical advisory services related to general library practice, book selection, and library planning, offered by the Board to Municipal Libraries; to administer the Central Cataloguing Service, and to prepare and issue the Board's Monthly Book List.

Qualifications.—A good knowledge of standard library practice and procedure; some experience in book selection especially for Municipal Libraries; to have passed the Registration Certificate Examination of the Library Association of Australia or its equivalent; alternatively to be a graduate of a recognized University in Arts, Science or Education, and to have passed the Preliminary Certificate examination of the Library Association of Australia.

Chemist, Classes "C"—"C2", Department of Agriculture.

Yearly Salary.—£860, minimum; £1,280, maximum.

(Commencing salary according to experience.)

Duties.—To carry out analyses of a range of agricultural products and materials.

Qualifications.—A science degree or approved diploma, with chemistry as a major subject, and preferably some experience in analytical chemistry.

Scientific Officer (Chemist), Classes "C"—"C2", General Health Branch, Department of Health.

Yearly Salary.—£860, minimum; £1,280, maximum—
Science Graduate or Diplomat
in Chemistry.

£960, minimum; £1,280, maximum—
Pharmaceutical Chemist.

(Commencing salary according to experience.)

Duties.—To be responsible for the management of the Department of Health Poisons Information Centre at the Royal Children's Hospital and subject to the direction of the Medical Director of the Hospital to answer inquiries on accidental poisoning; to collate information on poisons and substances containing poisons.

Qualifications.—A degree in science or diploma in chemistry, preferably with a knowledge of pharmacology or to be a qualified and registered pharmaceutical chemist.

Assistant, Class "C", National Gallery, Chief Secretary's Department.

Yearly Salary.—£710, minimum; £860, maximum.

Duties.—To assist in the routine work of the National Gallery, particularly the Print Department, and to assist the Curator of Prints and Drawings and the public in matters of general and specialized research and information; to develop the research section of this collection and to assist in publications and to lecture; to assist in planning of exhibitions.

Qualifications.—A Degree of Fine Arts of the University of Melbourne or the equivalent; a comprehensive knowledge of the history of art especially in relation to prints and drawings, and a working knowledge of the standard literature of this subject.

Clerk of Courts, Grade III, Class "C", City Court, Courts Branch, Law Department.

Yearly Salary.—£710, minimum; £860, maximum.

Qualifications.—As prescribed by Public Service

(Public Service Board) Regulation 46.

TECHNICAL AND GENERAL DIVISION.

Claims Investigator, State Accident Insurance Offices, Chief Secretary's Department. (Two vacancies.)

Yearly Salary.—£894, minimum; £990, maximum.

Duties.—To investigate and report on Motor Car and Workers Compensation Claims.

Qualifications.—A practical knowledge of Motor Car and Workers Compensation Insurance and experience in investigation and reporting on claims. A person with a good knowledge of the Motor Car and Workers Compensation Acts and the law of negligence is preferred.

Horticultural Assistant (Male), Burnley Horticultural College, Department of Agriculture.

Yearly Salary.—£622, minimum; £718, maximum.

Duties.—To take charge of a section of the gardens; to lecture and demonstrate to students; other duties as required.

Qualifications.—Diploma of a recognized Agricultural or Horticultural College, alternatively the Certificate of Competency in Horticulture or equivalent qualifications; a good knowledge of the cultivation of ornamental plants and horticultural crops under Victorian conditions; ability to teach students.

NOTE.—To be eligible for appointment, applicants who do not possess the Diploma or Certificate must pass the prescribed examination to be held on a date to be fixed which will be notified to all applicants. Particulars as to the nature and scope of the examination may be obtained from the office of the Public Service Board.

Assistant (Materials and Testing), Grade I, Water Supply Department.

Yearly Salary.—£542, minimum; £606, maximum.
Duties.—To be responsible for carrying out tests of engineering materials and for the accuracy of the results. To operate and maintain equipment and to make the necessary calculations for testing data sheets.
Qualifications.—Experience in testing materials and ability to carry out such tests.

Assistant (Male), Grade I, Motor Registration Branch, Office of the Chief Commissioner of Police, Chief Secretary's Department.

Yearly Salary.—£542, minimum; £574, maximum.
Duties.—To be in charge of the Number Plates and Labels Counter.
Qualifications.—A good knowledge of the Regulations regarding the issue of number plates and labels; experience in dealing with the public.

NOTE.—To be eligible to apply for this position, temporary employees or officers of the Technical and General Division other than Assistants (Male), must have passed the Board's examination for registration for appointment as Assistant (Male), Grade II., Technical and General Division.

Chauffeur, Departmental, Crown Law Offices, Law Department.

Yearly Salary.—£430, minimum; £446, maximum.

Duties.—To transport Judges on country circuits and Senior Officers of the Department and other duties as required.

Qualifications.—An experienced licensed driver with a good mechanical knowledge of motor cars and able to effect minor repairs; a good knowledge of the roads of the State.

Lift Attendant, Public Works Department.

Yearly Salary.—£366, minimum; £382, maximum.

Photographic Assistant (Male), Junior, Department of Crown Lands and Survey.

Yearly Salary.—Under 16 years of age, £140;
 at 16 years of age, £179;
 at 17 years of age, £197;
 at 18 years of age, £210;
 at 19 years of age, £267;
 at 20 years of age, £316.

Duties.—To assist in all types of photographic work.
Qualifications.—Some experience in a photographic laboratory, and a Junior Technical School Certificate or equivalent.

NOTE.—The salary rates quoted above do not include the additional amount which is payable under Regulation 77A of the Board's Regulations.

By order,
 V. P. SCULLY,
 Secretary.

Office of the Public Service Board,
 Melbourne, 12th December, 1961.

PUBLIC SERVICE (PUBLIC SERVICE BOARD) REGULATION 39.—RECLASSIFICATIONS.

THE Public Service Board has raised the classification of the under-mentioned offices as shown, and the Permanent Heads of the Departments have recommended the officers named for appointment.

Office and Present Classification.	Revised Classification.	Duties.	Qualifications.	Officer Recommended for Appointment.		
				Name.	Classification.	Date of Classification.
PROFESSIONAL DIVISION.						
DEPARTMENT OF AGRICULTURE.						
Senior Technical Executive Officer, Class "A1" (£2,300)	Senior Executive Officer, Class "A1" (£2,600)	To assist in professional aspects of the Central Administration of the Department, to examine and report on agricultural research and extension projects	Degree in Agricultural Science or Veterinary Science; a detailed knowledge of the functions of the Department of Agriculture and a wide knowledge of Victorian Agriculture	McKeon, B. F.	Senior Technical Executive Officer, Class "A1" (£2,300)	29.6.58
CHIEF SECRETARY'S DEPARTMENT.						
<i>National Gallery Branch.</i>						
Guide Lecturer, Class "C1"	Curator of Australian Art, Class "C2"	As Curator of Australian Art, to advise on the acquisition of works for, and to be responsible for the conservation storage study, display and recording of the Gallery's collections of Australian Art	Academic qualifications in the Fine Arts appropriate to the duties and experience in the fields of Australian painting and sculpture; a working knowledge of the Australian collections in the National Gallery and experience in an Art Gallery	Finemore, B. J.	Guide Lecturer, Class "C1"	11.3.59
PREMIER'S DEPARTMENT.						
<i>Soil Conservation Authority.</i>						
Assistant Research Officer, Class "C1" (two offices)	Research Officer, Class "B"	Conservation research and ecological investigations as directed	A degree in Agricultural Science, Science or equivalent degree	Rowe, R. K. Sibley, G. T.	Assistant Research Officer, Class "C1"	8.1.60 16.7.60

Appeals against such recommendations should be lodged with the Secretary to the Public Service Board not later than Saturday, the 23rd December, 1961.

Office of the Public Service Board,
 Melbourne, 12th December, 1961.

By order,
 V. P. SCULLY,
 Secretary.

PUBLIC SERVICE (PUBLIC SERVICE BOARD) REGULATION 39.—VACANCY.

THE Permanent Head of the Department shown has recommended the officer named hereunder for appointment to the under-mentioned vacancy.

Office and Classification.	Duties.	Qualifications.	Officer Recommended for Appointment.		
			Name.	Classification.	Date of Classification.
PROFESSIONAL DIVISION.					
DEPARTMENT OF HEALTH.					
<i>Maternal and Child Welfare Branch.</i>					
Superintending School Medical Inspector, Class "A1" (£3,018)	To assist the Director of Child Health (Medical) in the administration and organization of the School Medical Services	A legally qualified medical practitioner of Victoria preferably with a higher qualification in medicine or child health; experience in medical inspection of children	Jones, Lorna D.	Superintending Medical Inspector (Surveys), Class "A1" (£2,793)	25.1.61

Appeals against such recommendation should be lodged with the Secretary to the Public Service Board not later than Saturday, the 23rd December, 1961.

Office of the Public Service Board,
Melbourne, 12th December, 1961.

By order,
V. P. SCULLY,
Secretary.

Teaching Service Act 1958.

TEACHING SERVICE (CLASSIFICATION, SALARIES AND ALLOWANCES) REGULATIONS.

AMENDMENT No. 25.

THE Teachers Tribunal, in pursuance of the powers conferred by the *Teaching Service Act 1958*, hereby amends the Teaching Service (Classification, Salaries and Allowances) Regulations in the manner following, that is to say:—

PART II.—SECONDARY SCHOOLS DIVISION.

In sub-clause 4 (b), immediately before the word "Camberwell", insert the word "Balwyn".

(To take effect from and including the 1st January, 1962.)

PART III.—TECHNICAL SCHOOLS DIVISION.

In sub-clause 5 (b), immediately before the words "Caulfield" and "Yallourn", insert the words "Brighton" and "Warrnambool", respectively.

(To take effect from and including the 1st January, 1962.)

PART V.—PROFESSIONAL OFFICERS.

In clause 12, under the sub-heading "(b) Principals and Staffs of Teachers' Colleges and Training Institutions",

- (i) delete the expression "Principal, Burwood and Toorak Teachers' Colleges" and the salary rates shown therefor;
- (ii) for the expression "Principal, Melbourne and Secondary Teachers' Colleges", substitute the expression "Principal, Burwood, Melbourne, Secondary and Toorak Teachers' Colleges".

(To take effect from and including the 1st January, 1962.)

PART XII.—ALLOWANCES.

1. After sub-clause 37 (e), insert the following new sub-clause:—

"(f) Where a student in training is required to live away from his home and is unable to secure accommodation in a Teachers' College Hostel, the Tribunal may authorize payment of an allowance equal to one-half of the excess of the cost of his private board over £3 5s. a week, provided that in no case shall the weekly allowance exceed 10s."

2. Sub-clauses (f) and (g) to be re-lettered (g) and (h) respectively.

(To take effect from and including the 1st January, 1962.)

LOUIS F. C. GARLICK, Chairman.

G. FENNELL, Secretary.

Office of the Teachers Tribunal,
Melbourne, 4th December, 1961.

PRIVATE ADVERTISEMENTS**CITY OF BROADMEADOWS.****BY-LAW No. 33.**

A By-law of the City of Broadmeadows, made under the provisions of Part VII. and Part XXXV. of the *Local Government Act 1958*, and numbered 33, for the control and management of public reserves, pleasure grounds or places of public resort or recreation within the said City.

IN pursuance of the powers conferred by the *Local Government Act 1958*, the Mayor, Councillors and Citizens of the City of Broadmeadows order as follows:—

1. This By-law shall come into operation and have effect immediately upon its publication in the *Government Gazette*.

2. That By-law 21 be amended by the following alterations in clause 2:—

That the name of:—

Lahinch Reserve be changed to Anderson Reserve.
Broadmeadows East Reserve to Roper Reserve.
Middle-street Reserve to Gould Reserve.

And the inclusion of:—

Emu-parade Reserve, corner of Gavin-street, Jacana.
Pascoe Vale Reserve, corner of Sunset Boulevard, Jacana.
Lorica-avenue Reserve, Broadmeadows, through to Avalon-street, Broadmeadows.
Smiley-road Reserve, corner of Trethowan-street, Broadmeadows.
Kitchener-street Reserve.

Resolution for passing this By-law agreed to by the Council of the City of Broadmeadows on 11th September, 1961, and confirmed on the 9th October, 1961.

The common seal of the Mayor, Councillors and Citizens of the City of Broadmeadows was hereunto affixed, in the presence, by order of the Council—

(SEAL) A. POPE, Mayor.
H. PAYNE, Councillor.
E. F. SMILEY, Town Clerk.

Approved by the Governor in Council, 28th November, 1961.—N. G. WISHART, Acting Clerk of the Executive Council. 16578

CITY OF COBURG.**PRIVATE STREETS LOAN No. 16.**

NOTICE is hereby given that at a Meeting of the Council of the City of Coburg, held on Monday, 6th November, 1961, the Council did pass a Special Order for the borrowing of Fifteen thousand pounds (£15,000) on the credit of the Mayor, Councillors and Citizens of the City of Coburg, such sum to be raised by the grant of a mortgage, in accordance with the provisions of the *Local Government Act 1958*.

1. The rate of interest to be paid is Five pounds seventeen shillings and six pence (£5 17s. 6d.) per centum per annum.

2. The moneys borrowed shall be repayable by 30 equal half-yearly instalments of Seven hundred and fifty-nine pounds two shillings and five pence (£759 2s. 5d.), including principal and interest, by providing out of the receipts of moneys payable under schemes of private street construction and advances from the municipal fund, should such receipts be insufficient, the required amounts, on the 1st day of February and the 1st day of August during the currency of the loan; the first instalment shall be payable on the 1st day of August, 1962.

3. The period of the loan shall be fifteen years.

4. Such moneys shall be repayable at the Commonwealth Savings Bank of Australia, Sydney-road, Coburg, or at the Council's bankers for the time being in Melbourne.

5. The purpose for which the loan is to be applied is the defraying of the cost of the execution of schemes of private street construction.

And notice is hereby further given that the Council, at its Meeting held on Monday, 4th December, 1961, did confirm such Special Order.

16563

G. A. BRIDGES, Town Clerk.

CITY OF ESSENDON.**LOAN No. 43.**

Notice of Intention to Borrow the Sum of £25,000 for Permanent Works and Undertakings.

NOTICE is hereby given that the Council of the City of Essendon proposes to borrow the sum of Twenty-five thousand pounds on the credit of the municipal revenues of the Mayor, Councillors and Citizens of the said Municipality, such sum to be raised by the grant of a mortgage, in accordance with the provisions of the *Local Government Act 1958*.

1. The maximum rate of interest that may be paid is £5 17s. 6d. per cent. per annum.

2. The purpose for which the loan is to be applied is the construction of roads and streets in the Municipality.

3. The period of the loan shall be ten years.

4. The moneys borrowed shall be repayable by providing out of the municipal fund twenty half-yearly instalments of approximately £1,670 14s. each, including principal and interest, on the 1st day of October and the 1st day of April during the currency of the loan. The first instalment shall be payable on the 1st day of October, 1962.

5. Such moneys shall be repayable at The State Savings Bank of Victoria, Melbourne.

The plans and specifications and the estimate of the cost of the proposed works and a statement showing the proposed expenditure of the moneys to be borrowed, are open for inspection at the Town Hall, Moonee Ponds, during office hours.

K. LISTER, Town Clerk.

1st December, 1961.

16585

CITY OF ESSENDON.**LOAN No. 44.**

Notice of Intention to Borrow the Sum of £25,000 for Permanent Works and Undertakings.

NOTICE is hereby given that the Council of the City of Essendon proposes to borrow the sum of Twenty-five thousand pounds on the credit of the municipal revenues of the Mayor, Councillors and Citizens of the said Municipality, such sum to be raised by the grant of a mortgage, in accordance with the provisions of the *Local Government Act 1958*.

1. The maximum rate of interest that may be paid is £5 17s. 6d. per cent. per annum.

2. The purpose for which the loan is to be applied is the construction of roads and streets in the Municipality.

3. The period of the loan shall be fifteen years.

4. The moneys borrowed shall be repayable by providing out of the municipal fund thirty half-yearly instalments of £1,265 4s. each, including principal and interest, on the 1st day of October and the 1st day of April during the currency of the loan. The first instalment shall be payable on the 1st day of October, 1962.

5. Such moneys shall be repayable at The Commonwealth Savings Bank of Australia, Melbourne.

The plans and specifications and the estimate of the cost of the proposed works and a statement showing the proposed expenditure of the moneys to be borrowed, are open for inspection at the Town Hall, Moonee Ponds, during office hours.

K. LISTER, Town Clerk.

1st December, 1961.

16586

CITY OF FOOTSCRAY.**LOAN No. 55.**

Notice of Intention to Borrow the Sum of £25,000 for Permanent Works and Undertakings.

NOTICE is hereby given that the Council of the City of Footscray proposes to borrow the sum of Twenty-five thousand pounds on the credit of the municipal revenues of the Mayor, Councillors and Citizens of the said City, such sum to be raised by the grant of a mortgage, in accordance with the provisions of the *Local Government Acts*.

1. The maximum rate of interest that may be paid is 5½ per cent. per annum.

2. The purpose for which the loan is to be applied is for capital expenditure for the electricity undertaking.

3. The period of the loan shall be fifteen years.

4. The moneys borrowed shall be repayable by providing out of the municipal fund thirty half-yearly instalments of £1,265 4s. each, including principal and interest, on the 1st day of March and the 1st day of

September, during the currency of the loan. The first instalment shall be payable on the 1st day of September, 1962.

5. Such moneys shall be repayable at the Commonwealth Trading Bank of Australia, Footscray.

The plans and specifications and the estimate of the cost of the proposed works and a statement showing the proposed expenditure of the moneys to be borrowed, are open for inspection at the Municipal Offices, Napier-street, Footscray.

Dated the 5th day of December, 1961.

16566

E. J. SMITH, Town Clerk.

CITY OF FOOTSCRAY.

By-LAW No. 268.

IN pursuance of the powers conferred by the Health Act, the Council of the City of Footscray has made By-law No. 268, repealing By-laws Nos. 34, 81, 192 and 237, providing for the collection and removal from households of refuse, regulating the type and fixing the maximum size of receptacles, and for the disposal of refuse and for other purposes.

The By-law was approved by the Governor in Council on the 21st November, 1961.

Notice is hereby given that a copy of the By-law is open for inspection, free of charge, during office hours, at the offices of the Council, at the Town Hall, corner of Napier and Hyde streets, Footscray.

16567

E. J. SMITH, Town Clerk.

CITY OF HEIDELBERG.

WHEREAS the Council of the municipality of Heidelberg has received an application from the owner of so many of the premises fronting on the under-mentioned streets as in rateable value are the greater part of all premises so fronting, the Council hereby declares the same to be dedicated to the public as public highways:—

Liberty-parade (Tobruk-avenue to Dougharty-road).
Bardia-street.
Killerton-crescent.
Larissa-street.
Barce-place.
Carbeena-parade (Oriell-road to Blackwood-parade).

The common seal of the Mayor, Councillors and Citizens of the City of Heidelberg was hereto affixed by me,

E. C. JACK, Acting Town Clerk.

in the presence of—

(SEAL) CHARLES A. MARTIN, Mayor,
FRANK T. ROJO, Councillor.

16587

CITY OF MELBOURNE.

By-LAW No. 420.

NOTICE is hereby given that at meetings of the Council of the City of Melbourne held on the 16th day of October, 1961, and the 13th day of November, 1961, the said Council did make, pass and confirm a By-law intitled "A By-law of the City of Melbourne made under Part VII, Division I, of the *Local Government Act 1958*, and section 36 of the *Hawkers and Pedlars Act 1958*, and numbered 420 for regulating the use of streets, roads and public places in the City of Melbourne by street hawkers and itinerant traders and for other purposes" and prescribing the limits as to time and place within the said City within which any person holding a metropolitan hawker's licence under the provisions of the *Hawkers and Pedlars Act 1958*, may sell or offer or expose for sale any articles specified in his licence, summary of which is set out hereunder:—

The By-law provides:—

- For the repeal and consolidation of all existing By-laws relating to the sale of goods on streets, roads and public places within the City;
- for the appointment of street stands within the City of Melbourne;
- for the issue of permits under certain conditions for the operation of kerbside cafés, fruit stalls, flower kiosks and food kitchens;
- for the issue of permits for periods not exceeding twelve hours to allow the sale of goods from positions other than duly appointed street stands;
- for the area within which the holders of metropolitan hawkers' licences may sell goods specified in such licences;

(f) that no person other than the holder of a permit under the By-law or a metropolitan hawker's licence may sell any goods in any street, road or public place within the City.

Copy of the By-law is open for inspection, free of charge, at the Town Clerk's Department, Town Hall, Melbourne, during office hours, viz., from 8.25 a.m. to 4.45 p.m. daily from Monday to Friday, both inclusive.

The By-law will come into operation on 14th December, 1961.

F. H. ROGAN, Town Clerk.

Town Hall, Melbourne, 12th December, 1961. 16609

CITY OF MORDIALLOC.

LOAN No. 49 P.S.—£25,000.

Special Order for Borrowing Money for the Purpose of Constructing Private Streets.

NOTICE is hereby given that at an Ordinary Meeting of the Council of the City of Mordialloc, held on the 13th November, 1961, the said Council did agree to the following Resolution, that is to say:—

1. That the Council do by Special Order and it does hereby resolve to borrow the sum of Twenty-five thousand pounds (£25,000) for a period of ten years by the grant of a mortgage for such amount on the credit of the Mayor, Councillors and Citizens of the City of Mordialloc, in accordance with the provisions of section 585 of the *Local Government Act 1958* (as amended).

2. That the rate of interest to be paid shall be £5 17s. 6d. per centum per annum.

3. That the moneys borrowed shall be repaid by twenty (20) half-yearly instalments of approximately £1,670 14s. each, including principal and interest, on the 1st day of July and the 1st day of January during the currency of the loan. The first instalment shall be payable on the 1st day of July, 1962.

4. Such moneys shall be repayable at the State Savings Bank of Victoria, Melbourne.

5. The purpose for which the loan is to be applied is the construction of private streets, in accordance with the provisions of Division 10, Part XIX., of the *Local Government Act*.

6. The loan to be liquidated by providing out of receipts from owners made liable under the schemes or in case such receipts are insufficient then by providing from the Municipal Fund in each half-year during the currency of the loan, the sum of approximately £1,670 14s., which sum includes principal and interest.

And notice is hereby further given that at the meeting of the said Council held at the Council Chambers, Mentone, on the 11th December, 1961, the said Resolution was confirmed.

16385

J. GRUT, Town Clerk.

CITY OF PRESTON.

LOAN No. 52.

Notice of Intention to Borrow the Sum of £50,000 for Permanent Works and Undertakings.

NOTICE is hereby given that the Council of the City of Preston proposes to borrow the sum of £50,000 (Fifty thousand pounds) on the credit of the municipal revenues of the Mayor, Councillors and Citizens of the said City, such sum to be raised by the grant of a mortgage, in accordance with the provisions of the *Local Government Act 1958*.

1. The maximum rate of interest that may be paid is £5 17s. 6d. per centum per annum.

2. The purposes for which the loan is to be applied are:—

Construction of Reservoir Swimming Pool (part cost)	£36,500
Electricity Department—Capital expenditure—	
Meters	£1,600
Services	3,400
Substations	4,100
Transmission lines	4,400
	<hr/>
	13,500
	<hr/>
	£50,000

3. The period of the loan shall be forty (40) years.

4. The loan shall be repaid by the establishment and accumulation of a sinking fund, pursuant to the provisions of section 428A of the *Local Government Act 1958*, by provision out of the municipal fund of an appropriate amount in each half-year during the period of the loan.

5. The loan shall be repaid in one amount at maturity at the Office of the Local Authorities Superannuation Board, Rigby House, 15 Queens-road, Melbourne, or at such other place as the Board may require.

6. Interest shall be payable at the Office of the Board or such other place as the Board may require in half-yearly payments of £1,468 15s. each, on the 1st day of October and the 1st day of April in each year during the period of the loan, the first of such payments being made on the 1st day of October, 1962.

The plans, specifications and the estimate of the cost of the proposed works and a statement showing the proposed expenditure of the moneys to be borrowed, are open for inspection at the Municipal Offices, High-street, Preston, during office hours.

J. C. DONATH, Town Clerk.

4th December, 1961.

16568

CITY OF PRESTON.

LOAN No. 51.

Notice of Intention to Borrow the Sum of £25,000 for Permanent Works and Undertakings.

NOTICE is hereby given that the Council of the City of Preston proposes to borrow the sum of £25,000 (Twenty-five thousand pounds) on the credit of the municipal revenues of the Mayor, Councillors and Citizens of the said City, such sum to be raised by the grant of a mortgage, in accordance with the provisions of the Local Government Act 1958.

1. The maximum rate of interest that may be paid is £5 17s. 6d. per centum per annum.

2. The purposes for which the loan is to be applied are:—

Reconstruction of Edwards-street, west of Edgar's Creek	£5,100
Reconstruction of Gilbert-road, west flank, from Oakover-road to Burgess-street	5,150
Drainage, Bond-street	1,000
Construction of footpaths, kerbs and channels in James-street, from Murray-road to Bruce-street	1,750
Construction of west flank in Epping-road	5,500
Reconstruction of the west flank in Plenty-road, from Bell-street to Gower-street	3,000
Electricity Department—Capital expenditure—	
Meters	£600
Services	950
Substations	950
Transmission lines	1,000
	<u>3,500</u>
	£25,000

3. The period of the loan shall be ten (10) years.

4. The moneys borrowed shall be repayable by providing out of the municipal fund twenty (20) half-yearly instalments of approximately £1,670 14s. each, including principal and interest, on the 1st day of October and the 1st day of April in each year during the currency of the loan. The first instalment shall be payable on the 1st day of October, 1962.

5. Such moneys shall be repayable at The State Savings Bank of Victoria, Melbourne.

The plans and specifications and the estimate of the cost of the proposed works and a statement showing the proposed expenditure of the moneys to be borrowed, are open for inspection at the Municipal Offices, High-street, Preston, during office hours.

J. C. DONATH, Town Clerk.

4th December, 1961.

16570

CITY OF SPRINGVALE.

BY-LAW No. 154.

A By-law of the City of Springvale made under section 197 of the Local Government Act 1958, and numbered 154, for prohibiting, regulating or controlling excavating operations.

IN pursuance of the powers conferred by the Local Government Acts, the Mayor, Councillors and Citizens of the City of Springvale order as follows:—

1. In this By-law unless inconsistent with or repugnant to the context—

“Council” means the Council of the City of Springvale.

“Excavating Operations” means excavating operations other than quarrying or blasting operations.

“Minister” means the person for the time being administering the provisions of the Local Government Acts.

2. By-law No. 153 of the City of Springvale is hereby repealed.

3. (1) No person shall commence or carry on excavating operations for the removal of rock, stone, gravel, clay, soil or sand from land, unless he is the holder of a written permit from the Council.

(2) No permit to commence or carry on excavating operations shall authorize the carrying on of any such operations for any period in excess of two years from a date to be specified in the permit as being the date of commencement of such permit.

4. Any permit granted by the Council for the carrying on of excavating operations for the removal of rock, stone, gravel, clay, soil or sand from land may, if the Council thinks fit, be renewed by the Council from time to time, but no such renewal shall be for a period in excess of one year from the expiration of the permit or any renewal thereof, as the case may be.

5. Notwithstanding anything hereinbefore contained clauses 3 and 4 of this By-law shall not apply to any land in which any excavating operations were commenced before the 10th day of November, 1938, and have since that date continued without substantial interruption nor to any other land on which excavating operations were being carried on at the commencement of the Local Government (Amendment) Act 1954, unless the Minister, in writing, approves of the application of this By-law to such other land.

6. Any person guilty of a wilful breach of this By-law shall be liable to a penalty of not less than £5 or more than £20 and a further penalty of not more than £5 for each day on which an offence against this By-law is continued after a conviction or order of any Court.

7. This By-law shall apply to and have operation throughout the whole of the municipal district of the City of Springvale.

Resolution for passing this By-law agreed to by the Council on the 19th day of September, 1961, and confirmed the 16th day of October, 1961.

The common seal of the Mayor, Councillors and Citizens of the City of Springvale was hereto affixed, in the presence of—

A. B. SOUTTER, Councillor.
F. WACHTER, Councillor.
H. L. WILLIAMS, Town Clerk.

Approved by the Governor in Council on the 28th day of November, 1961.—N. G. WISHART, Acting Clerk of the Executive Council. 16590

SHIRE OF ALTONA.

NOTICE is hereby given that the Altona Shire Council has applied for a lease under section 134, Land Act 1958, for a term of 21 years, of the area of 190 acres in the Parish of Truganina, known as the Altona Sports Park, for the purposes of amusement and recreation.

16287 JAMES W. WATERS, Shire Secretary.

SHIRE OF ALTONA.

STREET NAMES ALTERED.

NOTICE is hereby given that the Council of the Shire of Altona by Resolution adopted at a meeting on 28th November, 1961, orders in accordance with provisions of the Local Government Act 1958, that the following street name be altered as follows:—

Former Name; Description of Section Altered; New Name.
Ernhurst-road; between lots 126 and 127 of L.P.29991; Scullin-street.

16557 JAMES W. WATERS, Shire Secretary.

SHIRE OF BACCHUS MARSH.

NOTICE is hereby given that the Council of the Shire of Bacchus Marsh intends to borrow the sum of £15,000 at £5 17s. 6d. per cent. interest, repayable at Melbourne, in twenty equal amounts of principal and interest, on the 1st day of March and the 1st day of September each year, for the purpose of constructing main drainage works at Bacchus Marsh.

Plans and specifications, estimate of the cost, and statement showing the proposed expenditure, are open for inspection at the office of the Council.

16637 A. W. BOND, Shire Secretary.

SHIRE OF BEECHWORTH.

BY-LAW No. 13.

A By-law of the Shire of Beechworth made under section 197 of the *Local Government Act 1958*, and numbered 13, for regulating the driving of cattle in or along roads in the municipal district, and for maintaining the good rule and government of the Municipality.

IN pursuance of the powers conferred by the *Local Government Act 1958*, the President, Councillors and Ratepayers of the Shire of Beechworth order as follows:—

1. This By-law shall come into operation on the day after the day of the publication thereof in the *Victoria Government Gazette*.

2. This By-law shall apply to and have operation throughout the whole of the Shire of Beechworth.

3. No person shall cause or permit or suffer any cattle to graze or wander upon any land not enclosed by a substantial fence.

4. Every person who drives any cattle upon or along any such street or road shall drive such cattle:

- (a) In a direct route as far as practicable having regard to the point of the commencement of the driving of such cattle and their destination;
- (b) where the route mentioned in paragraph (a) of this clause is of a greater distance than the respective distances hereinafter mentioned. Drives such cattle a distance of not less than 6 miles each day in the case of sheep and of not less than 10 miles each day in the case of other cattle.

And any person who contravenes any of the foregoing provisions of this clause shall be guilty of an offence.

5. Every person who drives any cattle from any point not within the said Shire into, onto, or along any street or road within the Shire shall prior to so doing give notice to the Secretary of the Shire for the time being of his intention so to do and shall simultaneously therewith furnish to the said Secretary the particulars following, that is to say:—

- (i) The number and kind of such cattle;
- (ii) The names and addresses of the drover or drovers of such cattle;
- (iii) The intended point of entry into the Shire;
- (iv) The route proposed to be traversed with such cattle if within the Shire and the destination of such cattle and, if such destination be not within the Shire the intended point of exit from the said Shire.

Every person who, having failed to give notice as aforesaid or having failed to furnish all or any of the aforesaid particulars, drives any cattle into, onto, or along any street or road within the Shire shall be guilty of an offence.

The Resolution for passing this By-law was agreed to by the Council on the 6th day of October, 1961, and confirmed by the Council on the 3rd day of November, 1961.

The common seal of the President, Councillors and Ratepayers of the Shire of Beechworth was hereunder affixed, in our presence, this 3rd day of November, 1961—

(SEAL) J. J. MACAULAY, President.
D. A. MCKENZIE MCHARG, Councillor.
16558 G. T. GRAY, Shire Secretary.

SHIRE OF BIRCHIP.

LOAN No. 23.

Notice of Intention to Borrow the Sum of £15,000 for Permanent Works and Undertakings.

NOTICE is hereby given that the Council of the Shire of Birchip proposes to borrow the sum of Fifteen thousand pounds (£15,000) on the credit of the municipal revenues of the President, Councillors and Ratepayers of the said Shire of Birchip, such sum to be raised by the grant of a mortgage, in accordance with the provisions of the *Local Government Act 1958*.

1. The maximum rate of interest that may be paid is 5½ per centum per annum.

2. The purposes for which the loan is to be applied are:—

The construction of new Municipal Chambers and Offices.

3. The period of the loan shall be twenty years.

4. The loan is to be liquidated by the creation of a sinking fund, pursuant to section 420 of the *Local Government Act 1958*.

5. The moneys borrowed shall be repayable in one amount on the maturity date of the loan at the Offices of the Local Government Superannuation Board, 15 Queens-road, Melbourne, or at such other place as the Board may require.

6. The plans and specifications and the estimate of cost of the proposed works and a statement of the proposed expenditure of the moneys to be borrowed, are open for inspection at the Shire Offices, Birchip.

Dated this 11th day of December, 1961.

16577

A. HIBBERD, Shire Secretary.

SHIRE OF ELTHAM.

LOAN No. 42.

Notice of Intention to Borrow.

NOTICE is hereby given that the Council of the Shire of Eltham intends to borrow Four thousand pounds (£4,000) on the credit of the President, Councillors and Ratepayers of the said Shire by the grant of a mortgage in accordance with the provisions of the *Local Government Acts*.

In connexion therewith the following information is stated:—

- (a) The amount of the principal moneys which it is proposed to borrow is Four thousand pounds.
- (b) The maximum rate of interest that may be paid is £5 17s. 6d. per centum per annum.
- (c) The times at which the moneys borrowed are to be repayable are the first day of October, 1962, the first days of April and October during the years 1963-1971 inclusive, and the first day of April, 1972. The place at which such moneys shall be repayable is the Bank of New South Wales, Greensborough.
- (d) The purposes for which the loan is to be applied are:—

Part cost of Infant Welfare and Pre-School Centre at Montmorency.

Purchase of land for parking of vehicles.

Purchase of land for road widening.

- (e) The manner in which the loan is to be liquidated is by provision out of the Municipal Fund in each half-year during the currency of the loan of the sum of £267 6s. 3d., which includes principal and interest.

The plans and specifications and estimate of the cost of the works and a statement showing the proposed expenditure of the money to be borrowed, are open for inspection at the Shire Offices, Eltham.

Dated this 12th day of December, 1961.

16589

M. B. WATSON, Shire Secretary.

SHIRE OF FERN TREE GULLY.

DECLARATION OF NEW ALIGNMENT, DORSET-ROAD, BORONIA.

NOTICE is hereby given that the Council of the Shire of Fern Tree Gully has fixed a new alignment for the western side of Dorset-road, Boronia, from a point 107 ft. 9½ in. north of its intersection with Boronia-road northwards a distance of 1,250 ft. 9½ in. to its intersection with William-street. Copies of the plan of the new alignment prepared in accordance with the provisions of section 622 of the *Local Government Act 1958*, are lodged in the offices of the Council, the Registrar of Titles and the Registrar-General, and are open for inspection, without fee, at any time at which the said offices are open for business.

16580

D. J. BAKER, Shire Secretary.

SHIRE OF FLINDERS.

LOAN No. 29.

Notice of Intention to Borrow £10,000 for Permanent Works and Undertakings.

NOTICE is hereby given that the Council of the Shire of Flinders proposes to borrow the sum of Ten thousand pounds upon the credit of the municipal revenues of the President, Councillors and Ratepayers of the Shire of Flinders, such sum to be raised by the grant of a mortgage in accordance with the provisions of the *Local Government Act 1958*.

1. The maximum rate of interest that may be paid is £5 17s. 6d. per centum per annum.

2. The purpose for which the loan is to be applied is Road Construction.

3. The period of the loan shall be ten years.

4. The money borrowed shall be repayable by providing out of the Municipal Fund twenty half-yearly instalments of £668 5s. 7d., including principal and interest on the 1st day of March and 1st day of September during the currency of the loan. The first instalment shall be payable on 1st September, 1962.

5. Such moneys shall be repayable at the National Bank of Australasia Limited, Melbourne.

Plans and specifications and the estimate of the cost of the proposed works, and a statement showing the proposed expenditure of the moneys to be borrowed, are open for inspection at the Shire Office, Dromana.

16565

S. WILLIAMS, Shire Secretary.

SHIRE OF MINHAMITE.

NOTICE is hereby given that First Constable Kenneth William Read, No. 10932, has been appointed Prosecuting Officer to the Shire of Minhamite, in lieu of First Constable A. H. C. Allen, V.A., No. 9057, resigned.

16579

ALAN J. BOWES, Shire Secretary.

SHIRE OF NATHALIA.

LOAN No. 32.

Notice of Intention to Borrow the Sum of £5,000 for Permanent Works and Undertakings.

NOTICE is hereby given that the Council of the Shire of Nathalia proposes to borrow the sum of Five thousand pounds on the credit of the municipal revenues of the President, Councillors and Ratepayers of the said shire, such sum to be raised by the grant of a mortgage in accordance with the provisions of the *Local Government Act 1958*.

1. The maximum rate of interest that may be paid is 5½ per cent. per annum.

2. The purposes for which the loan is to be applied are:—

- (a) Reconstruction and sealing of streets.
- (b) Concreting footpaths and channels.

3. The period of the loan shall be ten years.

4. The moneys borrowed shall be repayable by providing out of the municipal fund twenty half-yearly instalments of approximately £334 3s. each, including principal and interest on the first day of March and the first day of September during the currency of the loan. The first instalment shall be payable on the first day of September, 1962.

5. Such moneys shall be repayable at The State Savings Bank of Victoria, Melbourne.

The plans and specifications and the estimate of the cost of the proposed works, and a statement showing the proposed expenditure of the moneys to be borrowed, are open for inspection at the Shire Office, Nathalia.

J. K. DANCOCKS, Shire Secretary.

6th December, 1961.

16561

SHIRE OF NUMURKAH.

DECLARATION OF PUBLIC HIGHWAY.

NOTICE is hereby given that, pursuant to the provisions of section 587 (3) of the *Local Government Act 1958*, the Council of the Shire of Numurkah has declared Denson-street, in the Strathmerton Housing Commission Estate, a public highway.

16478

J. W. REED, Shire Secretary.

Dog Act 1958.

SHIRE OF SOUTH BARWON.

IN pursuance of the powers conferred by section 18 of the *Dog Act 1958*, the Council of the Shire of South Barwon doth order that the whole of the municipal district shall be the area specified for the purposes of the section afore-mentioned.

In witness whereof the common seal of the Shire of South Barwon was affixed hereto this 5th day of December, 1961.

16581

(SEAL) L. A. G. ROBERTS, President.
K. F. BONNEY, Councillor.
E. T. CORNISH, Shire Secretary.

SHIRE OF STAWELL.

ORDER DECLARING PUBLIC HIGHWAYS.

IN pursuance of the powers conferred by section 522 of the *Local Government Act 1958*, the Council of the Shire of Stawell does hereby order: That the lands hereinafter described, which have been purchased by it, shall be public highways, viz:—

All that piece of land, being part of Crown allotment 19, Parish of Joel Joel, as described in certificate of title, volume 8210, folio 741.

All that piece of land, being part of Crown allotment 18, Parish of Wallaloo, as described in certificate of title, volume 8110, folio 519.

All that piece of land, being part of Crown allotment K, Parish of Bellaura, as described in certificate of title, volume 8226, folio 081.

The common seal of the Council of the President, Councillors and Ratepayers of the Shire of Stawell was hereto affixed this 5th day of December, 1961, in the presence of—

(SEAL) E. W. GILES, President.
L. J. CAMPBELL, Councillor.
V. C. NIELSEN, Secretary.

16583

SHIRE OF STAWELL.

LOAN No. 7.

Notice of Intention to Borrow the Sum of £10,000 for Permanent Works and Undertakings.

NOTICE is hereby given that the Council of the Shire of Stawell proposes to borrow the sum of Ten thousand pounds on the credit of the municipal revenues of the President, Councillors and Ratepayers of the said Shire, such sum to be raised by the grant of a mortgage, in accordance with the provisions of the *Local Government Act 1958*.

1. The maximum rate of interest that may be paid is 5½ per cent. per annum.

2. The purposes for which the loan is to be applied are:—

Installation of new weighbridge, Great Western (part cost)	£1,000
Township drainage construction, Marnoo (part cost)	4,000
Township drainage construction, Hall's Gap (part cost)	500
Township drainage construction, Great Western (part cost)	4,500
	£10,000

3. The period of the loan shall be ten years.

4. The moneys borrowed shall be repayable by providing out of the municipal fund twenty half-yearly instalments of approximately £668 5s. 6d. each, including principal and interest, on the 1st day of April and the 1st day of October during the currency of the loan. The first instalment shall be payable on the 1st day of October, 1962.

5. Such moneys shall be repayable at the State Savings Bank of Victoria, Melbourne.

The plans and specifications and the estimate of the cost of the proposed works and a statement showing the proposed expenditure of the moneys to be borrowed, are open for inspection at the Shire Office, Stawell.

Dated 6th December, 1961.

16562

V. C. NIELSEN, Shire Secretary.

SHIRE OF WINCHELSEA.

BY-LAW No. 56.

A By-law, No. 56, made under Division 7 of Part IV. of the *Health Act 1958*, for extending the operation of By-law No. 45 relating to the collection, deposit and disposal of rubbish and refuse and the removal, replacement, cleansing and disinfecting of receptacles to the Wye River area.

IN pursuance of the powers conferred by the *Health Act 1958*, the President, Councillors and Ratepayers of the Shire of Winchelsea order as follows:—

(1) By-law No. 45 of the Shire of Winchelsea shall apply to and have operation over the area set out in the schedule hereto and unless exempted shall apply to every house, building and premises therein.

SCHEDULE.

Crown allotments Numbers 29D, 29E, 29F, 29G, 29H, 29J, 29K, and 29M, Parish of Kaanglang, County of Polwarth.

Resolution for passing this By-law agreed to by the Council on the 11th day of August, 1961, and confirmed on the 13th day of September, 1961.

The common seal of the President, Councillors and Ratepayers of the Shire of Winchelsea was hereunto affixed the 13th day of September, 1961, in the presence of—

(SEAL) J. S. CALDOW, President.
R. C. TUNE, Councillor.
W. W. WESTHORPE, Shire Secretary.

Submitted to the Commissioner of Public Health, on the 31st day of October, 1961.—A. T. GARDNER, Secretary, Commission of Public Health.

Approved by the Governor in Council, the 21st day of November, 1961.—N. G. WISHART, Acting Clerk of the Executive Council. 16582

THE BALLARAT SEWERAGE AUTHORITY.

GENERAL NOTICE.

THE above-mentioned Sewerage Authority having made provision for carrying off the sewage from each and every property which or any part of which is within the Sewerage Areas hereinafter described, doth hereby declare that on and after the first day of January, 1962, each and every property which or any part of which is within the said Sewerage Areas shall be deemed to be a sewerer property within the meaning of the *Sewerage Districts Act 1958*.

The boundaries of the Sewerage Areas hereinbefore referred to are:—

Sewerage Area No. 207.

City of Ballarat.—Commencing at the south-east corner of No. 23 Clayton-street west, being a point on the boundary of Sewerage Area No. 173; thence southerly to a point about 142 feet from Grant-street and about 109 feet from Wainwright-street west and being the north-east corner of No. 8 Wainwright-street west, easterly to a point on the western boundary of No. 2 Wainwright-street west about 80 feet from Wainwright-street west, northerly by a line parallel to and about 162 feet from Geelong-road to the centre line of the Canadian Creek Channel, south-easterly along the centre line of the Canadian Creek Channel to the north building line of Wainwright-street east, south-easterly along the north building line of Wainwright-street east and Larter-street, southerly along the west building line of Larter-street to the north-east corner of No. 230 Larter-street, south-easterly to the north-west corner of No. 235 Larter-street, easterly to the north-east corner of the said No. 235, southerly to the north-east corner of No. 25 Lal Lal-street, easterly to the north-east corner of No. 43 Lal Lal-street, north-easterly across Murphy-street to the north-west corner of No. 45 Lal Lal-street, being about 209 feet from Lal Lal-street, easterly and southerly along the northern and eastern boundaries of the said No. 45 to a point on the north building line of Lal Lal-street about 107 feet east of Murphy-street, westerly along the north building line of Lal Lal-street to the north-east corner of Lal Lal-street and Geelong-road, westerly across Geelong-road to the north-west corner of Geelong-road and Stephens-street, westerly to the south-west corner of No. 26 Geelong-road, generally northerly along the western boundaries of Nos. 26, 22, 20, 18, 16, 14, 12, 10 and 8 Geelong-road to the south building line of Wainwright-street west, north-easterly to the south-west corner of No. 2 Wainwright-street west, westerly along the north building line of Wainwright-street west to the east building line of Grant-street, south-westerly to the north-west corner of Grant-street and Wainwright-street west, westerly about 286 feet along the north building line of Wainwright-street west to the north-east corner of Wainwright-street west and Bagge-street; thence north-westerly, north-easterly, northerly, north-easterly, south-easterly, north-easterly, south-easterly and easterly along the boundaries of Sewerage Area No. 173 to the point of commencement.

Sewerage Area No. 208.

Borough of Sebastopol.—Commencing at the north-west corner of the Redan State School grounds being a point on the boundary of Sewerage Area No. 145; thence northerly along the east building line of Alfred-street to the north-east corner of Alfred and Rubicon streets; thence easterly, southerly, westerly, southerly, south-westerly, north-westerly and south-westerly along the boundaries of Sewerage Areas Nos. 118 and 145 to the point of commencement.

Sewerage Area No. 209.

Shire of Ballarat.—Commencing at the north-east corner of Grevillea-road and Banksia-road; thence north-westerly along the east building line of Banksia-road to the south-east corner of Banksia-road and Willow-grove, north-easterly along the south building line of Willow-grove to the south-west corner of Willow-grove and Marigold-street, south-easterly along the west building line of Marigold-street to the north-west corner of Marigold-street and Grevillea-road; thence westerly along the north building line of Grevillea-road to the point of commencement.

Further particulars regarding the streets or parts of streets in which sewers have been laid may be ascertained on inquiry at the Authority's office.

By order of the said Sewerage Authority,

16584 A. W. NICHOLSON, Chairman.
CHAS. H. CLAMP, Secretary.

NOTICE is hereby given that the Wodonga Bowling Club has applied for a lease for a term of 21 years under section 134 of the *Land Act 1958* of part of the Recreation and Plantation Reserve, Township and Parish of Wodonga, containing approximately 3 acres, as a site for the purposes of Amusement and Recreation (Bowling Club). 16612

Sewerage Districts Acts.

PROPOSED SEWERAGE AUTHORITY.

NOTICE is hereby given that the Seymour Waterworks Trust has made application to the Honorable the Minister of Water Supply for the Proclamation of a Sewerage District at Seymour, and for the construction, maintenance and continuance of sewerage works within that district under the provisions of the *Sewerage Districts Acts*.

A general plan and description of the proposed works have been submitted with the application, and copies of same may be seen at Waterworks Trust Office.

Dated at Seymour the 21st day of November, 1961.

16375 H. CLYDESDALE, Secretary.

NOTICE is hereby given that Hardbar Proprietary Limited has applied for a lease under section 134, *Land Act 1958*, for a term of 48 years from 16th February, 1962, of allotment 6B, section 59, City of Port Melbourne, as a site for a warehouse and engineering workshop. 16371

NOTICE is hereby given that Henry Berry and Company (Australasia) Limited has applied for a lease under section 134 of the *Land Act 1958*, for a term of 59 years from 12th March, 1962, of allotment 8, section 55F, City of Port Melbourne, Parish of Melbourne South, containing about 3 acres, as a site for Warehouse and Factory purposes. 16479

I, LORNA MAY WOOD, of 46 The Avenue, Coburg, in the State of Victoria, nurse, heretofore called and known by the name of Lorna May Hope, hereby give public notice that by a deed poll dated the 20th day of November, 1961, duly executed and attested and deposited with the Registrar-General of the said State, on the 8th day of December, 1961, I formally and absolutely renounced and abandoned the said name of Lorna May Hope and declared that I had assumed and adopted and intended thenceforth upon all occasions whatsoever to use and subscribe the name of Lorna May Wood instead of the said name of Lorna May Hope and so as to be at all times thereafter called, known and described by the said name of Lorna May Wood.

16602

L. M. WOOD.

PARTNERSHIP ACT 1958.

NOTICE is hereby given that the partnership heretofore subsisting between Gilbert Kearley Patrick and Thomas Lockland McGregor, carrying on business under the name of Ronlach Cycle and Sports Stores, at 1193 Glenhantly-road, Glenhantly, was dissolved on the first day of December, 1961, on which date the said Gilbert Kearley Patrick retired from the said firm and Gwenyth Eleanor McGregor became a member thereof. The said partnership will henceforth be carried on by the said Thomas Lockland McGregor and Gwenyth Eleanor McGregor under

the said name at the said address, and they will receive all moneys due to, and pay all moneys due by, the said former partnership.

G. PATRICK.
T. MCGREGOR.
G. E. MCGREGOR.

Hulbert A. Greening and Bennett, of 422 Collins-street, Melbourne, and at 7A Royal-avenue, Glenhuntly, solicitors. 16607

NOTICE is hereby given that the partnership heretofore subsisting between Donald Robert Fraser and Browning Elliott Mummery, carrying on business as "Kingspring Roller Co.", at Room 3, Lees Buildings, Main-street, Croydon, has been dissolved as from the 28th day of November, 1961, so far as concerns the said Browning Elliott Mummery, who retires from the said firm, and John Douglas Harry has been admitted as a partner in his place and stead.

Dated this first day of December, 1961.

D. R. FRASER.
B. E. MUMMERY.
J. D. HARRY.
16576

1961, No. 6535.

In the Supreme Court of Victoria.—In the matter of Part VI. of the *Companies Act 1958*.—In the matter of HOPE BUILDING & CONSTRUCTION COMPANY PROPRIETARY LIMITED.

NOTICE is hereby given that a petition for the winding up of the above-named company by the Supreme Court was on the 29th day of November, 1961, presented to the said Court by Fowler Road Constructions Proprietary Limited and the said petition is directed to be heard before the Court sitting at Melbourne, on the 12th day of February, 1962, and any creditor or contributory of the said company desirous to support or oppose the making of an Order on the said petition may appear at the time of hearing by himself or counsel for that purpose; and a copy of the petition will be furnished to any creditor or contributory of the said company requiring the same by the undersigned on payment of the regulated charge for the same.

The petitioner's address is, 269 Williamstown-road, Port Melbourne.

The petitioner's solicitors are Evans, Masters and Gilbert, of 34 Queen-street, Melbourne.

EVANS, MASTERS & GILBERT, solicitors for the petitioner.

NOTE.—Any person who intends to appear on the hearing of the said petition must serve on or send by post to the above-named solicitors, notice, in writing, of his intention so to do. The notice must state the name and address of the person, or if a firm, the name and address of the firm, and must be signed by the person or firm, or his or their solicitor (if any) and must be served, or, if posted, must be sent by post in sufficient time to reach the above-named not later than Four o'clock in the afternoon of the 10th day of February, 1962.

16559

1961, No. 6537.

In the Supreme Court of Victoria.—In the matter of Part VI. of the *Companies Act 1958*.—In the matter of STYLE-RITE HOMES PROPRIETARY LIMITED.

NOTICE is hereby given that a petition for the winding up of the above-named company by the Supreme Court was, on the 5th day of December, 1961, presented to the said Court by Broons Timbers Proprietary Limited, and the said petition is directed to be heard before the Court sitting at Melbourne on the 12th day of February, 1962, and any creditor or contributory of the said company desirous to support or oppose the making of an Order on the said petition may appear at the time of hearing by himself or counsel for that purpose; and a copy of the petition will be furnished to any creditor or contributory of the said company requiring the same by the undersigned on payment of the regulated charge for the same.

The petitioner's address is, Geelong-road, Brooklyn.

The petitioner's solicitors are Evans, Masters and Gilbert, of 34 Queen-street, Melbourne.

EVANS, MASTERS & GILBERT, solicitors for the petitioner.

NOTE.—Any person who intends to appear on the hearing of the said petition must serve on or send by post to the above-named solicitors, notice, in writing, of his

intention so to do. The notice must state the name and address of the person, or if a firm, the name and address of the firm, and must be signed by the person or firm, or his or their solicitor (if any) and must be served, or, if posted, must be sent by post in sufficient time to reach the above-named not later than Twelve o'clock noon, of the 10th day of February, 1962. 16560

NOTICE OF FORFEITED SHARE SALE.

NOTICE is hereby given that all contributing shares in the capital of the company on which the First and or Sixth Call of Six pence per share, due on 8th November, 1961, has not been paid, are forfeited and will be offered for sale at public auction at 11.45 a.m. on Wednesday, 20th December, 1961. The sale will take place in the vestibule of the Stock Exchange of Melbourne.

By order of the Board,

16573 REES B. WITHERS, Secretary.

The *Companies Act 1958*.

ROBERT MORTON & SONS PROPRIETARY LIMITED
(IN VOLUNTARY LIQUIDATION).

PURSUANT to section 195 (3) of the *Companies Act 1958*, notice is hereby given that, at an Extraordinary General Meeting of the company, duly convened and held on 6th December, 1961, the following Resolution was passed as a Special Resolution:—

"That the company be wound up voluntarily".

And at such meeting William Reynolds Pearson, chartered accountant, of 90 Queen-street, Melbourne, was appointed liquidator for the purposes of the winding up.

Dated the 6th day of December, 1961.

R. S. MORTON, Chairman.

Pearson and Tatnall, public accountants, 90 Queen-street, Melbourne. 16556

The *Companies Act 1958*.—In the matter of WEBB DICKENSON PROPRIETARY LIMITED, of 127 Acland-street, St. Kilda.—Notice to Creditors of Meeting, Pursuant to Section 201 (2).

NOTICE is hereby given that a Meeting of Creditors of the above-named company will be held at the offices of Kennedy, Smail and Middlemiss, 31 Queen-street, Melbourne, on Monday, the 18th day of December, 1961, at 2.30 p.m., pursuant to the provisions of section 201, a meeting of members of the company having been convened on the same day for the purpose of considering, and if thought fit, passing a resolution that the company be wound up voluntarily.

Dated this 11th day of December, 1961.

J. A. KOOPMAN, Director.

Kennedy, Smail and Middlemiss, 31 Queen-street, Melbourne. 16623

The *Companies Act 1958*.—In the matter of W. D. HUGHES & COMPANY PROPRIETARY LIMITED.—Notice re Meeting of Creditors, Pursuant to Section 201 (2).

NOTICE is hereby given that a Meeting of Creditors of the above-named company will be held at the offices of Kennedy, Smail and Middlemiss, 31 Queen-street, Melbourne, on Thursday, the 14th day of December, 1961, at 3.30 p.m., the company having convened a meeting of its members for the same day for the purpose of considering a Resolution that the company be wound up voluntarily.

Dated this 7th day of December, 1961.

W. D. HUGHES, Director.

Kennedy, Smail and Middlemiss, 31 Queen-street, Melbourne. 16619

The *Companies Act 1958*.—In the matter of CENTRAL VIDEO FILM SERVICE PROPRIETARY LIMITED, 441 St. Kilda-road, Melbourne.—Notice re Meeting of Creditors, Pursuant to Section 201 (2).

NOTICE is hereby given that a Meeting of Creditors of the above-named company will be held at the Board Room, Timber Merchants' Association, 51 William-street, Melbourne, at 10.30 a.m., on Friday, 15th December, 1961, the company having convened a meeting of its members for the same day for the purpose of considering a Resolution that the company be wound up voluntarily.

Dated this 5th day of December, 1961.

D. H. LEE, Director.

A. B. Goslin, Lewis Luckins and Co., accountants, 397 Little Collins-street, Melbourne. 16620

Companies Act 1958.

J. L. D. INVESTMENTS PROPRIETARY LIMITED
(IN VOLUNTARY LIQUIDATION).

NOTICE is hereby given in pursuance of section 210 of the *Companies Act 1958*, that a General Meeting of the members of the above-named company will be held at the office of the liquidator, Suite 27, "Stanhill", 34 Queens-road, Melbourne, on Thursday, the 18th day of January, 1962, at Ten o'clock in the forenoon, for the purpose of receiving the liquidator's account showing how the winding up has been conducted and the company's property disposed of, and of hearing any explanation that may be given by the liquidator.

Dated this 6th day of December, 1961.

16621 R. A. STEVENSON, Liquidator.

Companies Act 1958.—In the matter of BLITS TRADING CO. PTY. LTD. (in Liquidation).—Under the Order for Winding Up the Above-named Company on 26th February, 1961.

NOTICE is hereby given that a First Meeting of Creditors in the above matter will be held in the Board Room of A. J. Irwin, 4th floor, 366 Bourke-street, Melbourne, on Wednesday, the 20th day of December, 1961, at 10.30 o'clock in the forenoon. To entitle creditors to vote thereat, a proof of debt must be lodged with the official liquidator not later than 4 p.m. on the 19th day of December, 1961. Proxies to be used at the meeting must be lodged with the official liquidator not later than 4 p.m. on the 19th day of December, 1961.

Dated this 5th day of December, 1961.

A. J. IRWIN, official liquidator and liquidator, 366 Bourke-street, Melbourne. 16618

Companies Act 1958.—In the matter of DAVID ALLEN & CO. PTY. LTD., of 71 Little Lonsdale-street, Melbourne.—And in the matter of the *Companies Act 1958*.

NOTICE is hereby given that, pursuant to section 201, that a Meeting of Creditors of the above-named company will be held at the office of A. J. Irwin, 4th Floor, 366 Bourke-street, Melbourne, on Friday, the 8th day of December, 1961, at 10.30 a.m., for the purposes set out in sections 201, 202 and 203 of the above Act.

By order of the Board,

R. G. COFFIN, Director.

Dated this 5th day of December, 1961.

A. J. Irwin, public accountant, 366 Bourke-street, Melbourne. 16616

GIPPSLAND SPEED COURSING CLUB PTY. LTD.

AT a General Meeting of the above company, held in Sale, on 28th November, 1961, it was resolved by Special Resolution to voluntarily wind up the company.

The undersigned was appointed liquidator, and any claims against the company should be submitted forthwith to my office, situate 149A Raymond-street, Sale.

16575 R. W. MATTHEWS, Liquidator.

ALL STATES MOTOR PARTS PTY. LIMITED.

AT a General Meeting of members of all States Motor Parts Pty. Limited, held at the registered office, 191 Riversdale-road, Camberwell, on 4th day of December, 1961, the following Special Resolution was passed:—

"That the company be wound up voluntarily."

At a General Meeting of members held on the same day it was resolved "that Kenneth David Humphries, of 191 Riversdale-road, Camberwell, in the State of Victoria, be appointed liquidator for the purpose of winding up the affairs and distributing the assets of the company."

Dated the 5th day of December, 1961.

16588 K. D. HUMPHRIES, Liquidator.

AEGIS MANUFACTURING CO. PTY. LTD. (IN LIQUIDATION.)

NOTICE is hereby given that the Final General Meeting of the company will be held at the company's registered office, 208 Little Lonsdale-street, Melbourne, on Monday, 15th January, 1962, at Ten a.m., to receive the final report of the conduct of the liquidation.

Signed this 8th day of December, 1961.

16635 JAMES H. MAGRATH, Liquidator.

The Companies Act 1958.

D. R. ANSTEE HOLDINGS PROPRIETARY LIMITED.

AT an Extraordinary General Meeting of the members of the above company, duly convened and held at 20 Blackburn-road, Blackburn, on Wednesday, 6th December, 1961, the following Special Resolution was duly passed:—

"That the company be wound up voluntarily and that the secretary take the necessary steps for this purpose in accordance with the company's Articles of Association and the *Companies Act 1958*."

Dated this 8th day of December, 1961.

J. REZAK, Liquidator.

John Rezak and Co., public accountants, First Floor, 222 Queen-street, Melbourne. 16597

Companies Act 1958.—In the matter of FEDERAL ELECTRICS PTY LTD., of 1431 Malvern-road, Malvern, and in the matter of the *Companies Act 1958*.

NOTICE is hereby given that, pursuant to section 201, that a Meeting of Creditors of the above-named company will be held at the office of A. J. Irwin, Fourth Floor, 366 Bourke-street, Melbourne, on Thursday, the 14th day of December, 1961, at half-past Ten a.m., for the purposes set out in sections 201, 202 and 203 of the above Act.

By Order of the Board,

S. SPACKMAN, Director.

Dated this 8th day of December, 1961.

A. J. Irwin, public accountant, 366 Bourke-street, Melbourne. 16631

Companies Act 1958.—In the matter of DAVID ALLEN & COMPANY PTY. LTD. (in Liquidation).

NOTICE is hereby given that an Extraordinary General Meeting of the above-named company, duly convened and held at the office of A. J. Irwin, Fourth Floor, 366 Bourke-street, Melbourne, on Friday, the 8th day of December, 1961, at quarter-past Ten o'clock in the forenoon, the following Special Resolution was duly passed:—

"That it has been proved to the satisfaction of this meeting that the company cannot, by reason of its liabilities, continue in business, and that it is advisable to wind up, and accordingly by that the company be wound up voluntarily and that Melton Kenzie, of Fourth Floor, 366 Bourke-street, Melbourne, be appointed liquidator for the purpose of the winding up.

Dated this 8th day of December, 1961.

M. KENZIE, Liquidator.

Fourth Floor, 366 Bourke-street, Melbourne. 16632

P. PAGE PRINTING & DISTRIBUTING CO. PTY. LTD.
(IN LIQUIDATION).

NOTICE CONVENING FINAL MEETING, PURSUANT TO SECTION 210 OF THE "COMPANIES ACT" 1958.

NOTICE is hereby given, in pursuance of section 210 of the *Companies Act 1958*, that a General Meeting of the members of the above-named company will be held in the office of the liquidator, 422 Collins-street, Melbourne, on Thursday, 25th January, 1962, at ten o'clock in the forenoon, for the purpose of having an account laid before them showing the manner in which the winding up has been conducted and the property of the company disposed of and of hearing any explanation that may be given by the liquidator.

Dated the 7th day of December, 1961.

16636 L. A. LARGE, Liquidator.

The Companies Act 1958.

SPICER SHOE COMPANY PROPRIETARY LIMITED
(IN VOLUNTARY LIQUIDATION).

NOTICE is hereby given that, in accordance with section 210 (1) of the *Companies Act 1958*, a Final Meeting of the creditors of the above-named company will be held at the offices of Fuller, King and Co., Fifth Floor, 83 William-street, Melbourne, on Tuesday, 23rd January, 1962, at half-past Twelve p.m., for the purpose of having before the meeting an account of the joint liquidators showing how the winding up has been conducted and the property of the company disposed of.

Dated this 12th day of December, 1961.

16633 K. H. VIAL, Joint Liquidator.

Companies Act 1958.

REDEVELOPMENT CORPORATION LIMITED (IN VOLUNTARY LIQUIDATION—MEMBERS WINDING UP).

NOTICE is hereby given, pursuant to section 195 of the *Companies Act 1958*, that at a General Meeting of the company, held at the registered office of the company, 5 Palmer-street, Jolimont, on 7th December, 1961, the following Special Resolution was duly passed:—

"That the company be wound up voluntarily and that John Grattan Ryan, of 422 Collins-street, Melbourne, be nominated as liquidator for the purpose of winding up."

Dated this 11th day of December, 1961.

J. G. RYAN, Liquidator.
422 Collins-street, Melbourne, C.1. 16630

The Companies Act 1958.

SPICER SHOE COMPANY PROPRIETARY LIMITED (IN VOLUNTARY LIQUIDATION).

NOTICE is hereby given that, in accordance with section 210 (1) of the *Companies Act 1958*, a Final Meeting of the members of the above-named company will be held at the offices of Fuller, King and Co., Fifth Floor, 83 William-street, Melbourne, on Tuesday, 23rd January, 1962, at a quarter-past Twelve p.m., for the purpose of laying before the meeting an account of the joint liquidators showing how the winding up has been conducted and the property of the company disposed of.

Dated this 12th day of December, 1961.

16629 K. H. VIAL, Joint Liquidator.

No. of Company: 18037.

Companies Act 1958.

J. J. RAYBOULD SERVICE PROPRIETARY LIMITED. COPY RESOLUTION, PURSUANT TO SECTION 16 (2) AND 121 (1).

At a General Meeting of the members of J. J. Raybould Service Proprietary Limited, duly convened and held at the office of J. J. Raybould Service Proprietary Limited, Room No. 4, Third Floor, 37 Swanston-street, Melbourne, Victoria, on the 4th day of December, 1961, the following Special Resolution was duly passed:—

"That the company be wound up voluntarily."

It was also resolved that W. A. McDonald, of 37 Swanston-street, Melbourne, be and is hereby appointed liquidator for the purposes of the winding up.

Dated this 5th day of December, 1961.

16627 W. A. McDONALD, Liquidator.

FREDERICK NEWMAN, late of 355 Yarra Boulevard, East Ivanhoe, in the State of Victoria, engineer, DECEASED.

CREDITORS, next of kin and others having claims against the estate of the above-named deceased (who died on the 28th day of April, 1961), are required to send particulars of their claims to Leonard Charles Naismith and Leslie George Lanyon, the executors of the will of the said deceased, care of the under-mentioned solicitors, by the 23rd day of February, 1962, after which date the said executors will distribute the assets in the said estate, having regard only to the claims of which they then have notice.

PAVEY, WILSON, COHEN & CARTER, solicitors, 390 Lonsdale-street, Melbourne. 16601

CREDITORS, next of kin and others having claims in respect of the estate of Richard Charles Lee, formerly of Maitland-street, East Malvern, but late of 10 Creswick-street, Glen Iris (who died on the 7th June, 1961, and probate of whose will was granted to Flora Isa Lee, of 10 Creswick-street, Glen Iris, the executrix named in the said will) are to send particulars of their claims to the executrix, care of the undersigned at his address mentioned hereunder, by the 5th February, 1962, after which date the said executrix will distribute the assets, having regard only to the claims of which she then has notice.

K. G. CRANAGE, solicitor, 273A Glenferrie-road, Malvern. 16592

CREDITORS, next of kin and others having claims in respect of the estate of Thomas Dent Barrett, late of Kars-street, Frankston, contractor, deceased (who died on the 1st December, 1960), are to send particulars of their claims to Thomas Dent Barrett Junior, care of the undersigned by the 19th day of February, 1962, after which date he will distribute the assets, having regard only to the claims of which he then has notice.

COOK & McCALLUM, solicitors, 422 Collins-street, Melbourne. 16622

CREDITORS, next of kin and others having claims in respect of the estate of Rupert Harold Harding, formerly of Elizabeth-street, West Geelong, railway employee, but late of 22 Ann-street, West Geelong, retired railway employee, deceased (who died on the 17th day of May, 1961), are asked to send particulars of their claims to the executor, care of the undersigned, by the 15th day of February, 1962, after which date it will distribute the assets, having regard only to the claims of which it then has notice.

F. R. APTED, solicitor, 63 Yarra-street, Geelong. 16610

LYLE MARIE CAREY, late of Marton, in the Dominion of New Zealand, widow, DECEASED.

CREDITORS, next of kin and others having claims in respect of the estate of deceased (who died on the 25th day of May, 1961), are required to send particulars of their claims to The Union Trustee Company of Australia Limited, of 333 Collins-street, Melbourne, by the 20th day of February, 1962, after which date it will distribute the assets, having regard only to claims of which it then has notice.

OAKLEY, THOMPSON & CO., solicitors, 443 Little Collins-street, Melbourne. 16594

CREDITORS, next of kin and others having claims against the estate of Isabella Marie Hannah McCarthy, late of 22 Batman-street, Essendon, in the State of Victoria, widow, deceased (who died on the 16th day of September, 1961), are required to send particulars of their claims to The Perpetual Executors and Trustees Association of Australia Limited, of 100 Queen-street, Melbourne, by the 15th day of February, 1962, after which date the said company will distribute the assets of the said estate, having regard only to claims of which it then has notice.

WILLIAM HARRISON & SON, solicitors, 11 Bank-place, Melbourne. 16595

CREDITORS, next of kin and others having claims in respect of the estate of Sheila Ida Lemmon, late of 26 Doncaster-road North Balwyn, married woman, deceased (who died on the 4th day of March, 1961), are to send particulars of their claims to The Equity Trustees, Executors and Agency Company Limited, of 472 Bourke-street, Melbourne, by the 27th day of March, 1962, after which date the said company will distribute the assets, having regard only to the claims of which it then has notice.

LYNCH & MACDONALD, of 360 Collins-street, Melbourne. 16624

CREDITORS, next of kin and others having claims in respect of the estate of Herbert Royston Kershaw, late of Gisborne-road, Bacchus Marsh, gentleman, deceased (who died on the 12th day of August, 1961, and probate of whose will has been granted to Norma Stewart, of Gisborne-road, Bacchus Marsh, married woman), are to send particulars of their claims to the said executrix, care of the under-mentioned solicitors, by the 15th day of February, 1962, after which date she will distribute the assets, having regard only to the claims of which she then has notice.

PEARCE & WEBSTER, solicitors, 430 Little Collins-street, Melbourne. 16598

CREDITORS, next of kin and others having claims in respect of the estate of Edward Byrne, late of Flinders-road, Shoreham, in the State of Victoria, retired farmer, deceased, intestate (who died on the 5th day of July, 1961), are to send particulars of their claims to The Equity Trustees, Executors and Agency Company Limited, of 472 Bourke-street, Melbourne, by the 16th day of February, 1962, after which date it will distribute the assets, having regard only to the claims of which it then has notice.

RIVERS, DICKINSON & STIRLING, 17 Queen-street, Melbourne, solicitors. 16604

CREDITORS, next of kin and others having claims in respect of the estate of George Frederick Thompson, late of 16 Gould-street, Burwood, gentleman, deceased (who died on the 1st day of October, 1961), are required to send particulars of their claims to the executor, Percy Charles Mostyn Loughhead, care of the undersigned, by the 15th day of February, 1962, after which date the said executor will distribute the assets, having regard only to the claims of which he then has notice.

TOLHURST, DRUCE & EMMERSON, 357 Little Collins-street, Melbourne, solicitors. 16615

CREDITORS, next of kin and others having claims in respect of the estate of Noel Archibald Daley, of 102 Marlborough-street, East Bentleigh, in the State of Victoria, general manager, deceased (who died on the 6th day of June, 1961), are to send particulars of their claims to National Trustees, Executors and Agency Company of Australasia Limited, of 95 Queen-street, Melbourne, in the State of Victoria, the executor named in the said will, at its registered office at the address above-mentioned by the 15th day of February, 1962, after which date the said executor will distribute the assets, having regard only to the claims of which it then shall have notice.

R. G. DUNLOP, solicitor, 108 Queen-street, Melbourne.
16634

CREDITORS, next of kin and others having claims in respect of the estate of Marion Elizabeth Saunders, formerly wife of William Alfred Saunders, of Dunedin, in the Provincial District of Otago and Dominion of New Zealand, journalist, but latterly of Balclutha, in the Provincial District of Otago, aforesaid, widow, deceased (who died on the 8th day of November, 1960), are to send particulars of their claims to The Trustees, Executors and Agency Company Limited, at its registered office, 401 Collins-street, Melbourne, by the 16th day of February, 1962, after which date the said company will distribute the assets, having regard only to the claims of which it then has notice.

EUSTACE L. J. MURPHY, solicitor, 40 Queen-street, Melbourne.
16628

CREDITORS, next of kin, and others having claims in respect of the estate of Carmine Di Rosato, also known as Charles Rosato, late of 53 Chapman-street, North Melbourne, pensioner, deceased (who died on the 19th day of March, 1961), are required to send the particulars of their claims to the National Trustees, Executors and Agency Company of Australasia Limited, of 95 Queen-street, Melbourne, by the 22nd day of February, 1962, after which date it will distribute the assets, having regard only to the claims of which it then has notice.

ANTHONY J. LOPES, solicitor, 1 Birdwood-street, South Oakleigh.
16572

CREDITORS, next of kin, and others having claims in respect of the estate of Mary Stewart Jane Wilson, late of 34 Victoria-street, Elsternwick, widow, deceased, are requested to send particulars of their claims to Leslie Walker and Kenneth John Clements, of 269 Glenhuntly-road, Elsternwick, solicitor, the executors appointed by the will of the said deceased, by the 20th day of February, 1962, after which date the executors will distribute the assets, having regard only to the claims of which they have notice.

KENNETH J. CLEMENTS, solicitor, 269 Glenhuntly-road, Elsternwick.
16571

Re Estate ERNEST EDMUND ROOKE, DECEASED

CREDITORS, next of kin, and others having claims in respect of the estate of Ernest Edmund Rooke, late of Portland, tank maker, deceased (who died on the 17th February, 1961), are to send particulars of their claims to Ernest Alan Rooke, care of the under-mentioned solicitor, the executor appointed by the deceased's will, by the 28th day of February, 1962, after which date the said Ernest Alan Rooke will distribute the assets, having regard only to the claims of which he then has notice.

DOUGLAS R. GREY, LL.B., 18 Henty-street, Portland.
16564

CREDITORS, next of kin, and others having claims against the estate of Anna Constance Oddie, late of Chepstowe, in the State of Victoria, widow, deceased (who died on the 10th day of August, 1961), are required to send particulars of their claims to the executor, The Fidelity Trustee Company Limited, of 101 Lydiard-street north, Ballarat, in the said State, by the 20th day of February, 1962, after which date it will distribute the assets, having regard only to the claims of which it then has notice.

CUTHBERT, MORROW, MUST & SHAW, solicitors, Ballarat.
16591

CREDITORS, next of kin, and others having claims against the estate of Margaret Smyth, late of Caritas Christi Hospice, 104 Studley Park-road, Kew, widow, deceased (who died on the 9th day of September, 1961), are required to send particulars of their claims to John Harold Donovan and Elizabeth Donovan, the executors of the

deceased, care of John Ginnane, solicitor, of 153A Barkly-street, Footscray, by the 23rd day of February, 1962, after which date the said executors may transfer or distribute the assets, having regard only to the claims of which they then have notice.

JOHN GINNANE, solicitor, 153A Barkly-street, Footscray.
16600

CREDITORS, next of kin and all others having claims in respect of the estate of Thomas Shuttleworth, formerly of 704 Inkerman-road, Caulfield, surgeon dentist, but late of Karana Baptist Home, 55 Walpole-street, Kew, retired surgeon dentist, deceased (who died on the 22nd day of February, 1961), are to send particulars of their claims to the executors, Allan Leigh Hughes and Alec Hall McKay, care of their solicitors, whose name and address is set out below, by the 15th day of February, 1962, after which date the executors will distribute the assets, having regard only to the claims of which they then have notice.

H. S. W. LAWSON, HUGHES & CO., 357 Little Collins-street, Melbourne, solicitors.
16596

CREDITORS, next of kin and others having claims in respect of the estate of Alfred Marcus Chalmers, late of 59 Glyndon-road, Camberwell, nursery hand, deceased (who died on the 19th day of August, 1961), are required by the executor, Sidney William Murray, of 188 Separation-street, Northcote, retired, to send particulars to him, care of the undersigned, before the 16th day of February, 1962, after which date he will distribute the assets, having regard only to the claims of which he then has notice.

GORDON, RENNICK & GAYNOR, solicitors, 473 Bourke-street, Melbourne.
16625

PAUL GAUCI, late of 72 Junction-street, Newport, in the State of Victoria, cleaner, DECEASED.

CREDITORS, next of kin and others having claims in respect of the estate of the deceased (who died on the 18th day of July, 1961), are required by the administrator, Charles Gauci, of 72 Junction-street, Newport, in the said State, electrical fitter, to send particulars to him, in care of the under-mentioned solicitor, by the 14th day of February, 1962, after which date the administrator may convey or distribute the assets, having regard only to the claims of which he then has notice.

Dated this 13th day of December, 1961.

F. J. CORDER, solicitor, of 470 Bourke-street, Melbourne.
16626

HAROLD CLIFFORD ALLEN, formerly of 57 Beach-road, Hampton, but late of 434 Beach-road, Beaumaris, manager, DECEASED.

CREDITORS, next of kin and others having claims in respect of the estate of the deceased (who died on the 20th day of March, 1961), are required by the executors, Ronald Clifford Allen, of 2 Orlando-street, Hampton, sales manager, and John Horatio Allen, of 160 Gaffney-street, Coburg, sheet metal worker, to send particulars to them, care of the undersigned by the 28th day of February, 1962, after which date the executors may convey or distribute the assets, having regard only to the claims of which they then have notice.

PURVES & PURVES, solicitors, 90 William-street, Melbourne.
16613

CREDITORS, next of kin and all others having claims in respect of the estate of Alice Flavell MacKenzie, late of 10 Mitford-street, St. Kilda, in the State of Victoria, spinster, deceased (who died on the 8th day of July, 1961), and probate of whose will was granted by the Supreme Court of Victoria, in its probate jurisdiction, on the 16th day of November, 1961, to Arthur Alexander Brahe, of 243 Collins-street, Melbourne, in the said State, solicitor, one of the executors of the will of the said deceased, are required to send particulars in writing of such claims to the said executor, at his above-mentioned address, on or before the 14th day of February, 1962, after which date the said executor will proceed to distribute the assets of the said deceased amongst the persons entitled thereto, having regard only to the claim or claims of which the said executor shall then have had notice.

GAIR & BRAHE, 243 Collins-street, Melbourne, solicitors for the executor.
16614

CREDITORS, next of kin and others having claims in respect of the estate of Frank Ernest Boyd, late of 41 Margarita-street, Hampton, retired teacher, deceased (who died on the 25th day of July, 1961), are to send particulars of their claims to the executor, Frank Ernest Daniell Boyd, care of the under-mentioned solicitors, on or before the 14th day of February, 1962, after which date the said executor will distribute the assets, having regard only to the claims of which notice has been received.

IRVING S. PLOTKIN, LL.B., solicitor, 379 Collins-street, Melbourne. 16611

CREDITORS, next of kin and others having claims in respect of the estate of William Charles Lee, late of 23 Mt. Ida-avenue, Hawthorn (who died on the 24th March, 1961, and probate of whose will was granted to Narcissus Violet Lee, of 23 Mt. Ida-avenue, Hawthorn, the executrix named in the said will) are to send particulars of their claims to the executrix, care of the undersigned at his address mentioned hereunder, by the 5th February, 1962, after which date the said executrix will distribute the assets, having regard only to the claims of which she then has notice.

K. G. CRANAGE, solicitor, 273A Glenferrie-road, Malvern. 16593

CREDITORS, next of kin and others having claims in respect of the estate of Keith Hocknell Dawson, formerly of "Greystones", Rowsley, station manager, but late of 281 Main-street, Bacchus Marsh, real estate employee, deceased (who died on the 12th day of May, 1960, and probate of whose will has been granted to Doris McBean Dawson, of 281 Main-street, Bacchus Marsh, widow), are to send in particulars of their claims to the said executrix, care of the under-mentioned solicitors, by the 15th day of February, 1962, after which date she will distribute the assets, having regard only to the claims of which she then has notice.

PEARCE & WEBSTER, solicitors, 430 Little Collins-street, Melbourne. 16599

CREDITORS, next of kin and others having claims in respect of the estate of Florence May Mary Robinson, late of St. Helier's Bay, in the City of Auckland, New Zealand, widow, deceased (who died on the 29th day of December, 1960), are to send particulars of their claims to The Trustees, Executors and Agency Company Limited, of 401 Collins-street, Melbourne, by the 16th day of February, 1962, after which date it will distribute the assets, having regard only to the claims of which it then has notice.

RIVERS, DICKINSON & STIRLING, 17 Queen-street, Melbourne, solicitors. 16605

CREDITORS, next of kin and others having claims against the estate of Eliza Craig, late of "Laura Dell," Rockbank, in the State of Victoria, widow, deceased (who died on 1st June, 1961), are required by the executors, Cyril Thomas Ryan, of 24 Amery-street, Ashburton, draftsman, and Hector Garfield Fraser, of 33 Coppin-grove, Hawthorn, piano repairer, to send particulars to them, care of the under named, by the 20th February, 1962, after which date the said executors will distribute the assets, having regard only to the claims of which they then have notice.

R. E. LEWIS, ORR & GIBSON, solicitors, 406 Lonsdale-street, Melbourne. 16639

CREDITORS, next of kin and others having claims against the estate of Philip John Richard Venten, late of 300 Tucker-road, Ormond, in the State of Victoria, window cleaner, deceased (who died on 18th February, 1961), are required by the executrix, Elizabeth Venten, of 300 Tucker-road, Ormond, widow, to send particulars to her, care of the under named, by the 20th February, 1962, after which date the said executrix will distribute the assets, having regard only to the claims of which she then has notice.

R. E. LEWIS, ORR & GIBSON, solicitors, 406 Lonsdale-street, Melbourne. 16606

CREDITORS, next of kin and all others having claims in respect of the estate of Espine Robert Fitzherbert Batty, late of care of Aitken, Walker and Strachan, of 123 William-street, Melbourne, in the State of Victoria, gentleman, deceased (who died on the 3rd day of September, 1961), are required by the executors, James Ford Strachan and Robert Russell Aitken, both of 123 William-street, Melbourne, aforesaid solicitors, to send particulars

to them, care of the under-mentioned solicitors, by the 14th day of February, 1962, after which date they may convey or distribute the assets, having regard only to the claims of which they then have notice.

AITKEN, WALKER & STRACHAN, solicitors, 123 William-street, Melbourne. 16608

In the Supreme Court of the State of Victoria.

SALE BY THE SHERIFF.

ON Thursday, the 1st of February, 1962, at Three p.m., at the Police Station, Springvale (unless process be stayed or satisfied):—

All the estate and interest (if any) of Style Rite Homes Pty. Ltd., of 75A Bourke-street, Melbourne, as proprietor of an estate in fee-simple in the land described in certificate of title, volume 3280, folio 500, upon which is erected a brick dwelling-house of five rooms known as No. 18 Dowling-avenue, Springvale.

Registered mortgage No. A997620 (for approximately £2,750) affects the said estate and interest.

Terms: Cash only.

N. FROGLEY, Sheriff's officer.

7th December, 1961.

16608

MINING NOTICE

OIL DEVELOPMENT N. L.

NOTICE is hereby given that all issued contributing shares in the capital of the company on which the call of Sixpence per share, due on Wednesday, 8th November, 1961, was not paid, were forfeited on Thursday, 23rd November, 1961, and will be sold at Twelve noon, on Wednesday, 20th December, 1961, in the Vestibule of The Stock Exchange of Melbourne *without postponement*.

By Order of the Board,

A. T. MOLLOY, Secretary.

6th Floor, 100 Collins-street, Melbourne, C.1, 6th December, 1961. 16617

IMPOUNDINGS

LARA.—Impounded in Lara Pound, from Corio.

5 Border Leicester sheep, no visible brand

If not claimed and expenses paid, to be sold on 23rd December, 1961.

RONALD W. ELLIS,
Poundkeeper.

16574—9/

MELBOURNE.—Impounded in Arden-street Pound by A. Thomas.

1 wether, red brand on back

If not claimed and expenses paid, to be sold on 28th December, 1961.

R. HAMILTON,
Poundkeeper.

16638—10/6

YARRA JUNCTION.—Impounded in Yarra Junction Pound.

2 brindle Hereford heifers, no visible brand

If not claimed and expenses paid, to be sold on 23rd December, 1961.

M. BERUDE,
Poundkeeper.

16569—10/6

ACTS REPRINTED IN ACCORDANCE WITH THE AMENDMENTS INCORPORATION ACT 1958 (No. 6422).

No.	Price.
	s. d.
6191. Administration and Probate Act	4 9
6225. Co-operation Act	4 0
6246. Evidence Act	3 6
6283. Labour and Industry Act	7 3
6285. Landlord and Tenant Act	4 6
6293. Licensing Act	9 3
6299. Local Government Act	25 0
6328. Nurses Act	2 0
6363. Second-hand Dealers Act	1 3
6875. Stamps Act	6 0
6399. Transfer of Land Act	5 0
6401. Trustee Act	4 0
6419. Workers Compensation Act	4 9
6455. Companies Act (2nd reprint)	15 0

A. C. BROOKS,
Government Printer.

AGENTS FOR THE "VICTORIA GOVERNMENT GAZETTE".

THE following have been appointed agents to receive Advertisements and Subscriptions for the *Victoria Government Gazette*:—

- ARMSTRONG'S AGENCY, 205 Queen-street, Melbourne, C.I.
- ARMSTRONG BROS., Kyneton.
- ARNALL & JACKSON, 115 Barkly-street, West Brunswick.
- BAIRNSDALE AUTHORIZED NEWSAGENCY, Main-street, Bairnsdale.
- COOKE, F. R. & E. M., 69 Bridge-street, Benalla.
- DAVIS, WM. (MILDURA) PTY. LTD., 126 Eighth-street, Mildura.
- DIXON'S NEWSAGENCY, 89 Firebrace-street, Horsham.
- EDGAR'S NEWSAGENCY, 293 Hargreaves-street, Bendigo.
- FRANKS, HENRY, & CO., Booksellers and Stationers, 184 Ryrie-street, Geelong.
- GORDON & GOTCH, News Agents, 511 Little Collins-street, Melbourne, C.I.; and corner of Barrack and Clarence streets, Sydney.
- GULLAN'S NEWSAGENCY, 88 Bridge-street, Ballarat.
- HALES, D. & N., Henty-street, Casterton.
- HAMPTON, A. C., 243 Mitchell-street, Bendigo.
- HARSTON, PARTRIDGE & CO. PTY. LTD., 455 Little Collins-street, Melbourne, C.I.
- MERCANTILE EXCHANGE, 380 Collins-street, Melbourne, C.I.
- PETTY, R. H. & W. M., 83 Murphy-street, Wangaratta.
- PURDIE, J., & CO., 138 Moorabool-street, Geelong.
- SALE AUTHORIZED NEWSAGENCY, 142 Raymond-street, Sale.
- SKINNER'S AUTHORIZED NEWSAGENCY, 49-51 Franklin-street, Traralgon.
- SMITH & DUNNON, 112 Gray-street, Hamilton.
- TUFF'S SHEPPARTON NEWSAGENCY, 246 Wyndham-street, Shepparton.
- VERNON, C. F. & H. J., 162 Bridge-road, Richmond.
- VIEW POINT NEWSAGENCY, 4 View Point, Bendigo.

A copy of the *Gazette* filed at each place for public reference.

THE "VICTORIA GOVERNMENT GAZETTE".

SUBSCRIPTIONS.—The subscription, including postage, is £2 15s. per annum, £1 7s. 6d. half-yearly, or 13s. 9d. per quarter, payable in advance.

Subscriptions are required to commence and terminate with a month.

A lesser period than three months cannot be subscribed for.

Subscribers do not receive the Acts of Parliament with the GAZETTE.

ADVERTISEMENTS are charged at the rate of 1s. 6d. per line single column, and 3s. per line double column.

The title (£5 Reward, Dissolution of Partnerships, &c.) forms one or more lines as a heading.

On an average, ten words make a line.

Every signature must likewise be counted as a line.

The final words of a paragraph, though only portion of a line, must be counted as one line.

SIGNATURES (in particular) and proper names must be written very plainly in the text; ONE SIDE ONLY of each slip of paper should be WRITTEN UPON.

ALL COMMUNICATIONS should be addressed to "The Government Printer, Melbourne".

ALL DOCUMENTS illegibly written will be returned unpublished, and where brands occur unprovided for by the ordinary letters of the alphabet, a worded explanatory description must be furnished.

THE VICTORIA GOVERNMENT GAZETTE is published on WEDNESDAY EVENING in each week, and Notices for or before ONE p.m. at ordinary rates, and late advertisements between ONE p.m. and FOUR p.m. at double rates on the day preceding the day of publication.

Single copies of the VICTORIA GOVERNMENT GAZETTE are One shilling, posted One shilling and five pence.

No GAZETTES prior to January, 1950, in stock.

***ALL PAYMENTS ARE REQUIRED IN ADVANCE.—Remittances should be made by postal note, money order, or draft in favour of the Government Printer. Advertisements unaccompanied by a remittance sufficient to cover the cost of insertion will be returned unpublished.

CONTENTS

	PAGE
Acts of Parliament	4256
Appointments	4277
Christmas and New Year Holidays	4257
Contracts	4265
Courts	4262
Estates of Deceased Persons	4261
Government Notices	4257
Impoundings	4317
Lands	4295
Melbourne and Metropolitan Board of Works—	
Notice	4264
Mining	4272, 4317
Notice to Mariners	4257
Orders in Council—	
Acts—Latrobe Valley; Local Government	4278
Land; Country Roads; National Parks;	4280
Road Traffic; Landlord and Tenant;	et seq
Motor Car; Sewerage Districts; Water.	
Private Advertisements	4307
Proclamations	4255
Public Holidays	4256
Publication of the "Victoria Government Gazette"	4257
Public Service Notices	4302
Regulations—	
Acts—Audit; Tourist	4279
Weights and Measures; Police Regula-	4290
tion; Apprenticeship.	et seq
Resignation	4278
Tenders	4300
Transport Regulation Board—Public Hearings	4258
Waterworks Trusts	4273