



VICTORIA GOVERNMENT GAZETTE

Published by Authority

[Registered at the General Post Office, Melbourne, for transmission by post as a newspaper.]

No. 211

WEDNESDAY, MARCH 22

[1961

Land Act 1958.

UNALIENATED CROWN LAND AVAILABLE FOR SETTLEMENT UNDER IMPROVEMENT PURCHASE LEASES.

PROCLAMATION

By His Excellency the Administrator of the Government of the State of Victoria and its Dependencies in the Commonwealth of Australia, &c., &c., &c.

IN pursuance of the provisions of Section 153 of the *Land Act 1958*, I, the Administrator of the Government of the State of Victoria, in the Commonwealth of Australia, by and with the advice of the Executive Council of the said State, do by this Proclamation declare the unalienated Crown lands mentioned in the sub-joined schedule, to be available for settlement under improvement purchase leases.

SCHEDULE.

County.	Parish.	Allotment.	Section.	Area.	Land Valuation.
				A. R. P.	
Buln Buln	Narracan South	77D	..	47 0 0	£7 10s. per acre

Given under my Hand and the Seal of the State of Victoria aforesaid, at Melbourne, this fifteenth day of March, in the year of our Lord One thousand nine hundred and sixty-one, and in the tenth year of the reign of Her Majesty Queen Elizabeth II.

CHARLES J. LOWE.

(L.S.)

By His Excellency's Command,

KEITH TURNBULL,
Commissioner of Crown Lands and Survey.

GOD SAVE THE QUEEN!

Milk and Dairy Supervision Act 1958 (No. 6317).
MUNICIPALITIES DEFINED AS URBAN DISTRICTS.

PROCLAMATION

By His Excellency the Administrator of the Government of the State of Victoria and its Dependencies in the Commonwealth of Australia, &c., &c., &c.

IN pursuance of the provisions contained in Part III. of the *Milk and Dairy Supervision Act 1958 (No. 6317)*, I, the Administrator of the Government of the State of Victoria in the Commonwealth of Australia by and with the advice of the Executive Council, do by this my Proclamation hereby define for the purposes of the said Act the Municipal Districts whose names appear in the Schedule hereto as urban districts as on and from the first day of April, One thousand nine hundred and sixty-one.

SCHEDULE.

City of Wangaratta.	Shire of Euroa.
Shire of Wangaratta.	Shire of Warragul.
Borough of Benalla.	Shire of Buln Buln.
Shire of Oxley.	

Given under my Hand and the Seal of the State of Victoria aforesaid, at Melbourne, this twenty-first day of March, in the year of our Lord One thousand nine hundred and sixty-one, and in the tenth year of the reign of Her Majesty Queen Elizabeth II.

(SEAL)

CHARLES J. LOWE.

By His Excellency's Command,

G. L. CHANDLER,
Minister of Agriculture.

GOD SAVE THE QUEEN!

**DUMBALK WATERWORKS TRUST.—DISTRICT
PROCLAIMED AN URBAN DISTRICT.**

PROCLAMATION

By His Excellency the Administrator of the Government of the State of Victoria and its Dependencies in the Commonwealth of Australia, &c., &c., &c.

UNDER the powers conferred by the Water Acts and all other powers enabling him in that behalf, I, the Administrator of the Government of the State of Victoria, in the Commonwealth of Australia, by and with the advice of the Executive Council of the said State do hereby proclaim that on and from the date hereof the whole of the Waterworks District of the Dumbalk Waterworks Trust shall be and become an Urban District for the purpose of and within the meaning of the said Acts.

Given under my Hand and the Seal of the State of Victoria aforesaid, at Melbourne, this fifteenth day of March, in the year of our Lord One thousand nine hundred and sixty one, and in the tenth year of the reign of Her Majesty Queen Elizabeth II.

(L.S.) CHARLES J. LOWE.

By His Excellency's Command,

W. J. MIBUS,
Minister of Water Supply.

GOD SAVE THE QUEEN!

Public Service Act 1958.

**ALTERATION OF DAY APPOINTED FOR PUBLIC
HALF-HOLIDAY.**

PROCLAMATION

By His Excellency the Administrator of the Government of the State of Victoria and its Dependencies in the Commonwealth of Australia, &c., &c., &c.

WHEREAS by a Proclamation issued on the twenty-eighth day of February, 1961, and published in the *Government Gazette* of the first day of March, 1961, Monday, the twenty-first day of March, 1961, was appointed, under the provisions of sub-section (2) of section 67 of the *Public Service Act 1958*, for a public half-holiday throughout the Shire of Ballan:

And whereas it is made to appear to me expedient that the said Monday, the twenty-first day of March, 1961, should not be a public half-holiday throughout such municipality:

Now therefore I, the Administrator of the Government of the State of Victoria, by and with the advice of the Executive Council thereof, and in pursuance of the provisions of section 67 of the *Public Service Act 1958*, do by this my Proclamation declare that the said day shall not be a public half-holiday throughout such municipality, and appoint Monday, the twenty-seventh day of March, 1961, to be a public half-holiday throughout such municipality.

Given under my Hand and the Seal of the State of Victoria aforesaid, at Melbourne, this fifteenth day of March, in the year of our Lord One thousand nine hundred and sixty-one, and in the tenth year of the reign of Her Majesty Queen Elizabeth II.

(L.S.) CHARLES J. LOWE.

By His Excellency's Command,

L. H. S. THOMPSON,
for Chief Secretary.

GOD SAVE THE QUEEN!

BANK HALF-HOLIDAYS.

PROCLAMATION

By His Excellency the Administrator of the Government of the State of Victoria and its Dependencies in the Commonwealth of Australia, &c., &c., &c.

IN pursuance of the provisions of the *Bank Holidays Act 1958*, I, the Administrator of the Government of the State of Victoria, in the Commonwealth of Australia, do

by this my Proclamation appoint the day and date named hereunder as a special day to be observed as a Bank Half-Holiday at the place mentioned, that is to say:—

Bank Half-Holiday from the Hour of Eleven a.m.

THURSDAY, THE 23RD MARCH, 1961, at Corryong.

Given under my Hand and the Seal of the State of Victoria aforesaid, at Melbourne, this fifteenth day of March, in the year of our Lord One thousand nine hundred and sixty-one, and in the tenth year of the reign of Her Majesty Queen Elizabeth II.

(L.S.) CHARLES J. LOWE.

By His Excellency's Command,

A. G. RYLAH,
Chief Secretary.

GOD SAVE THE QUEEN!

EASTER HOLIDAYS.

IT is hereby notified that on—

FRIDAY, THE 31ST MARCH,
SATURDAY, THE 1ST APRIL,
MONDAY, THE 3RD APRIL, and
TUESDAY, THE 4TH APRIL, 1961,

the Public Offices will be closed, such days being appointed by the *Public Service Act 1958*, to be observed as holidays in the Public Offices throughout Victoria.

This notice relates only to the closing of the State Public Offices. All inquiries regarding holidays in other offices and in shops and industry should be directed to the Department of Labour and Industry, Old Treasury Building, Spring-street, Melbourne, C.1. (Telephone 63 0321, Extension 6158 or 6382.)

A. G. RYLAH,

Chief Secretary's Office,
Melbourne, C.1, 9th March, 1961.

**PUBLICATION OF THE "VICTORIA GOVERNMENT
GAZETTE".**

EASTER HOLIDAYS.

BECAUSE of the Easter Holidays, the *Victoria Government Gazette* will be published on—

FRIDAY, THE 7TH APRIL, 1961,
instead of Wednesday, the 5th April, 1961.

All official matter for publication therein should be lodged with the *Gazette* Officer, Chief Secretary's Department (Telephone Extension 6282), not later than 10.30 a.m. on Thursday, the 6th April, 1961. Private advertisements will be received at the Government Printing Office up to 2 p.m. on Thursday, the 6th April, 1961.

A. C. BROOKS,
Government Printer.

DEPARTMENT OF MINES.

SUBJECT to any necessary excisions, &c., it is proposed to grant the following mining leases:—

- 7634, Mineral, James Colin Stedman; 10a. 3r. 19p., Parish of Mullungdung.
- 7636, Mineral; James Colin Stedman; 9a. 0r. 23p., Parish of Mullungdung.
- 7789, Mineral; Sulphates Limited; 3a. 0r. 12p., Parish of Allambee East.
- 7845, Mineral; John Mabilia; 112a. 1r. 8p., Parish of Korumburra.
- 7885, Mineral; James Colin Stedman; 8a. 1r. 19p., Parish of Mullungdung.
- 7934, Mineral; Henry Allan Green; 106a. 2r. 34p., Parish of Lynchfield.

MINERAL SEARCH LICENCES GRANTED.

- 288, Mineral Search Licence; Industrial Rock Mines Pty. Ltd.; 4,590 acres, Parishes of Whitfield South, Wabonga, Toombullup and Cambatong.
- 289, Mineral Search Licence; Industrial Rock Mines Pty. Ltd.; 4,860 acres, Parishes of Toombullup, Whitfield South, Dueran East and Cambatong.

W. J. MIBUS,
Minister of Mines.

MONEY LENDERS ACT 1958.

IN accordance with the provisions of the above-mentioned Act the following is published for general information.

List of persons to whom Money Lenders Licences have been issued for the year ending 30th June, 1961.

Name.	Authorized Name.	Authorized Address.	Date of Issue.
Alrama Pty. Ltd. (B. A. MacKay, appointee)	Alrama Pty. Ltd.	221 Balaclava-road, Caulfield . .	15.2.61
*Capital Credit Corp. Pty. Ltd. (N. Baron, appointee)	Capital Credit Corp. Pty. Ltd. . .	185 Flinders-lane, Melbourne . .	20.12.60
Clayton Finance Pty. Ltd. (N. E. MacKinnon, appointee)	Clayton Finance Pty. Ltd.	14 Centre-road, Clayton	20.1.61
Craig Davis Homes Pty. Ltd. (W. C. Craig, appointee)	Craig Davis Homes Pty. Ltd. . . .	108 Queen-street, Melbourne . . .	1.1.61
Credits Pty. Ltd. (R. A. Disber, appointee)	Credits Pty. Ltd.	161-173 Sturt-street, South Melbourne	10.11.60
†Custom Credit Corp. Ltd. (A. J. Rodd, appointee)	Custom Credit Corp. Ltd.	Cnr. Leeds and Byron streets, Footscray	20.1.61
†Custom Credit Corp. Ltd. (A. J. Rodd, appointee)	Custom Credit Corp. Ltd.	67 Riversdale-road, Camberwell . .	19.1.61
†Custom Credit Corp. Ltd. (A. J. Rodd, appointee)	Custom Credit Corp. Ltd.	14 Walker-street, Dandenong . . .	1.2.61
*Custom Credit Corp. Ltd. (A. J. Rodd, appointee)	Custom Credit Corp. Ltd.	14 Walker-street, Dandenong . . .	1.2.61
†Custom Credit Corp. Ltd. (A. J. Rodd, appointee)	Custom Credit Corp. Ltd.	568 St. Kilda-road, Melbourne . . .	6.2.61
†Custom Credit Corp. Ltd. (A. J. Rodd, appointee)	Custom Credit Corp. Ltd.	327 Sturt-street, Ballarat	17.2.61
Darbyshire, John William	John William Darbyshire	510 Kooyong-road, South Caulfield . .	4.1.61
Dresdon Credits Pty. Ltd. (J. F. Wickens, appointee)	Dresdon Credits Pty. Ltd.	132 Gardenvale-road, Gardenvale . .	4.1.61
Invesco Finance Corp. Pty. Ltd. (C. J. Lowe, appointee)	Invesco Finance Corp. Pty. Ltd. . .	11 Lygon-street, East Brunswick . .	17.11.60
Johnson, Richard Leslie	Richard Leslie Johnson	47 Ballarat-road, Maidstone	24.2.61
Land Finance Properties Ltd. (A. G. Hanson, appointee)	Land Finance Properties Ltd.	14-22 Commercial-road, Melbourne . .	24.1.61
Reid Murray Acceptance Ltd. (D. K. Fidge, appointee)	Reid Murray Acceptance Ltd.	827 Burke-road, Camberwell	1.12.60
Reid Murray Acceptance Ltd. (D. K. Fidge, appointee)	Reid Murray Acceptance Ltd.	260 Hampshire-road, Sunshine . . .	18.1.61
Reid Murray Acceptance Ltd. (D. K. Fidge, appointee)	Reid Murray Acceptance Ltd.	399 Clayton-road, Clayton	3.2.61
Sarovich, Theoder Harold	Theoder Harold Sarovich	412 Whitehorse-road, Surrey Hills . .	21.2.61
South Gate Investments Pty. Ltd. (L. J. Billing, appointee)	South Gate Investments Pty. Ltd. . .	396 High-street, St. Kilda	20.1.61

* New Authorised Address. † Transfer of Appointee. M. A. R. SYNNOT, Registrar.

STATE RIVERS AND WATER SUPPLY COMMISSION.

APPLICATION FOR A LICENCE TO DIVERT WATER AND CUT A RACE PURSUANT TO THE PROVISIONS OF THE WATER ACT 1958.

LICENCE as detailed hereunder to divert water and cut race has been revoked by the Governor in Council, as from the date shown:—

Licence No.	Name of Person to whom Licence has been Granted.	Source of Supply.	Date of Revocation.
837	D. Curtain	Loddon River	1.7.60

Office of the State Rivers and Water Supply Commission, Melbourne, 15th March, 1961. E. BROWN, Secretary, State Rivers and Water Supply Commission.

Water Acts.

STATE RIVERS AND WATER SUPPLY COMMISSION. RAINBOW AND PAKENHAM URBAN DISTRICTS.

NOTICE to owners of tenements in the under-mentioned streets in the Rainbow and Pakenham Urban Districts and the private streets, lanes, courts and alleys opening thereto.

RAINBOW URBAN DISTRICT.

Winifred-street, from end of existing main opposite allotment 12 to a point opposite allotment 10, about 2 chains easterly.

PAKENHAM URBAN DISTRICT.

Baldhill-road, from Racecourse-road to a point opposite lot 5, about 1 chain south-easterly from Station-street.
Racecourse-road, from end of existing main opposite lot 4 on lodged plan of subdivision No. 21709, to a point opposite lot 5 on said lodged plan, about 1 chain northerly.
Thomas-street, from Henty-street to a point opposite lot 3, about 2 chains southerly from Acacia-street.

The main pipe in the said streets being laid down, the owners of all tenements situated as above are hereby required, on or before the 24th day of April next, to cause proper pipes and stop cocks to be laid, so as to supply water within such tenements from the main pipe.

E. BROWN, Secretary, State Rivers and Water Supply Commission. Melbourne, 17th March, 1961.

CO-OPERATION ACT 1958.

NOTICE is hereby given that Lake Wallace Co-operative Dairymen's Society Limited, which was registered under the Industrial and Provident Societies Act 1928, has this day been registered under the Co-operation Act 1958, under the name of Edenhope Co-operative Society Limited, by virtue of which registration the society became incorporated thereunder.

Dated at Melbourne this sixteenth day of March, 1961. E. T. EBBELS, Registrar of Co-operative Societies.

Transport Regulation Acts.
TRANSPORT REGULATION BOARD.
NOTICES OF PUBLIC HEARINGS.

NOTICE is hereby given that the applications made by the persons named below for licences to operate the commercial goods vehicles, on the route or routes or in the manner set out opposite their names, will be heard at a time and place to be communicated to the persons concerned:—

Name and Address; Nature of Application.

- BOOTS PURE DRUG Co. (AUST.) PRY. LTD.**, 33 Stewart-street, Richmond; 1 commercial goods vehicle (8 cwt.) to operate in the course of business as "drug manufacturers and distributors"—(a) within a radius of 50 miles of own premises at Richmond—own goods, (b) throughout the State of Victoria—samples and display materials, with the ability to leave a sample if required.
- ADAMS, WILLIAM, TRACTORS PTY. LTD.**, Post Office, Box 35, Oakleigh; 14 commercial goods vehicles (9, 9, 10, 10, 9, 8, 8, 8, 8, 8, 8 and 12 cwt.) to operate throughout the State of Victoria in the course of business as "earth-moving and industrial equipment distributors" for the sole purpose of servicing and repairing such equipment—tools of trade, spare parts and materials incidental to servicing.
- BOESCH, H. J.**, 31 Queens-road, Melbourne; 1 commercial goods vehicle (128 cwt.) to operate within a radius of 50 miles of the post office at Alexandra—road-contracting plant and materials.
- BOOTH, R. M.**, 110 Eureka-street, Ballarat; 1 commercial goods vehicle (approximately 100 cwt.) to operate—(a) within a radius of 25 miles of the chief post office at Ballarat—general goods, (b) within a radius of 55 miles of the post office at Beaufort (Ballarat Division of the Country Roads Board)—road-contracting plant and materials.
- BOYER, L. E. E.**, 6 Warren-street, Kyneton; 1 commercial goods vehicle (109 cwt.) to operate—(a) within a radius of 20 miles of the post office at Kyneton—general goods, (b) within a radius of 95 miles of the post office at Cohuna and/or within a radius of 100 miles of the post office at Merbein (Bendigo Division of the Country Roads Board)—road-contracting plant and materials.
- BOYER, L.**, 111 Piper-street, Kyneton; 1 commercial goods vehicle (174 cwt.) to operate—(a) within a radius of 20 miles of the post office at Kyneton—general goods, (b) within a radius of 95 miles of the post office at Cohuna and/or within a radius of 100 miles of the post office at Merbein (Bendigo Division of the Country Roads Board)—road-contracting plant and materials.
- BURGESS BROS.**, 73-77 Wilson-street, Horsham; 1 commercial goods vehicle (approximately 200 cwt.) to operate—(a) within a radius of 20 miles of the post office at Horsham—general goods, (b) within a radius of 80 miles of the post office at Dimboola (Horsham Division of the Country Roads Board)—road-contracting plant and materials.
- CAUCHI, J., & G. CINI**, 84 Hertford-road, Sunshine; application to vary the conditions of existing licence No. D.A.14186 by deleting present conditions and adding in lieu: "(a) within a radius of 25 miles of the G.P.O., Melbourne—general goods, (b) from pits in the Cranbourne, Langwarrin area to places within paragraph (a)—sand".
- CRONIN, P. D.**, Daylesford; 1 commercial goods vehicle (142 cwt.) to operate from bush sites in the Daylesford area to the C.S.R. factory at Bacchus Marsh—pulpwood.
- CUTCHIE, A. E. & M. E.**, 10 Doeen-road, Horsham; 1 commercial goods vehicle (168 cwt.) to operate—(a) within a radius of 20 miles of the post office at Horsham—general goods, (b) within a radius of 80 miles of the post office at Dimboola (Horsham Division of the Country Roads Board)—road-contracting plant and materials.
- DYERS TRANSPORT PTY. LTD.**, Sale; 1 commercial goods vehicle (240 cwt.) to operate—(a) from the Yallourn North Extension to the Gippsland Base Hospital at Sale—brown coal and briquettes, (b) within a radius of 20 miles of the post office at Sale—general goods, (c) within a radius of 50 miles of the post office at Sale—superphosphate, such superphosphate having been initially consigned to Sale by rail.
- GOTH, J., & Co. PTY. LTD.**, 66 Railway-terrace, Merrylands, New South Wales; 2 commercial goods vehicles (149 and 234 cwt.) to operate—(a) from quarry at Barnawatha to places along the rail standardization project between Wodonga and Bowser, New South Wales—rail ballast, (b) from quarry at Barnawatha to places within a radius of 50 miles of such quarry—metal dust.
- HALL, G. W.**, 24 Callen-street, Seymour; 1 commercial goods vehicle (267 cwt.) to operate—(a) within a radius of 20 miles of the post office at Seymour—general goods, (b) within a radius of 50 miles of the post office at Seymour—petroleum products in prescribed types of containers and empty return containers.
- HANCOCK, G. R.**, 9 Smyth-street, Mount Waverley; application to vary the conditions of existing licence No. D.A.41780 by adding to paragraph (b) "and on behalf of Clarke Strickland Pty. Ltd."
- HARLOW, D. W.**, 45 Ross-street, Dandenong; application to vary the conditions of existing licence No. D.A.39016 by deleting "Monbulk" and adding in lieu: "Dandenong".
- HASSETT, J.**, 18 Horn-street, Leongatha; application to vary the conditions of existing licence No. D.A.40022 by deleting paragraph (b) and adding in lieu as paragraph (b): "(i) from Yallourn and Morwell to the Leongatha Butter Factory at Leongatha—briquettes, (ii) from Yallourn and Morwell to J. T. Knox's quarry at Leongatha—briquettes, (iii) from Yallourn and Morwell to the premises of Rocla Pipes Ltd. at Traralgon—briquettes".
- HUNT, R. S.**, 16 Perry-street, Orbost; 1 commercial goods vehicle (113 cwt.) to operate—(a) within a radius of 20 miles of the post office at Orbost—general goods, (b) within a radius of 50 miles of the post office at Orbost—petroleum products in prescribed types of containers and empty return containers, (c) to and from places within a radius of 50 miles of the post office at Orbost from and to places as described in paragraph (a) above—livestock.
- KEOGH, P., PTY. LTD.**, 303 Ascot Vale-road, Moonee Ponds; 2 commercial goods vehicles (274 and 279 cwt.) to operate—(a) within a radius of 25 miles of Melbourne—general goods, (b) throughout the State of Victoria as "erection engineers"—tools of trade and erection equipment incidental to own contracts.
- LINDORS, W. J.**, 14 Francis-street, Heidelberg; application to vary the conditions of existing licences Nos. T.D.3606 and T.D.3607 by deleting present conditions and adding in lieu: "within a radius of 50 miles of the post office at Kerang—road-contracting plant and materials".
- MANN'S TRANSPORT PTY. LTD.**, Heyfield; application to vary the conditions of existing licence No. D.A.37473/2 by deleting paragraph (b) and adding in lieu: "within a radius of 75 miles from Rocla Pipes Ltd. at Traralgon—concrete pipes".
- MITCHELL, C.**, 122 Thompson-street, Hamilton; 1 commercial goods vehicle (10 cwt.) to operate—(a) within a radius of 20 miles of the post office at Hamilton—general goods, (b) from and to places situate within a radius of 50 miles of Hamilton to and from places situate within paragraph (a) above—second-hand household furniture.
- NATIONAL TYRE SERVICE (MILDURA) PTY. LTD.**, 124 Langtree-avenue, Mildura; application to vary the terms of existing licence No. D.A.2374/14 by deleting present conditions and adding in lieu: "within a radius of 100 miles from the chief post office in the City of Mildura and to and from the Townships of Robinvale and Wentworth in the course of business as 'tire reconditioners'—new and second-hand tires and tubes and batteries for delivery to and collection from own clients".
- NORTON, N. D.**, Melton; 1 commercial goods vehicle (140 cwt.) to operate from colliers situate at Bacchus Marsh to consignees at Ballarat and Melbourne—brown coal.
- RILEY DODDS AUSTRALIA LTD.**, 636 Swanston-street, Carlton; 1 commercial goods vehicle (9 cwt.) to operate throughout the State of Victoria in the course of business as "steam generating engineers" for the purpose of servicing steam generating plants—tools of trade, spare parts and materials incidental thereto.
- SEAFOODS (MELBOURNE) PTY. LTD.**, 18 Fish Market, Footscray-road, Footscray; 3 commercial goods vehicles (55, 13 and 16 cwt.) to operate throughout the State of Victoria in the course of business as "fish and frozen food distributors" in a specially-constructed and insulated vehicle—fresh and frozen fish, frozen processed vegetables, frozen chicken rolls and dim sims and mussels in glass containers.
- SOUTH WANGARATTA SAWMILLING Co.**, Sandford-road, Wangaratta; 1 commercial goods vehicle (87 cwt.) to operate in the course of business as "sawmillers"—(a) within a radius of 20 miles of own premises at Wangaratta—mill ends, (b) from own premises at Wangaratta to places within a radius of 50 miles of the post office at Wangaratta—sawn timber.

VICTORIAN OATGROWERS POOL AND MARKETING CO. LTD., 420 St. Kilda-road, Melbourne; 1 commercial goods vehicle (8 cwt.) to operate in the course of business as "grain merchant"—(a) within a radius of 50 miles of own premises at Melbourne—own goods, (b) throughout the State of Victoria for the purpose of servicing own installations—tools of trade, spare parts and materials incidental thereto, with the ability to carry a small quantity of grain samples.

NOTICE is hereby given that the applications made by the persons named below for renewal of licences to operate the commercial goods vehicles on the route or routes, or in the manner set out opposite their names, will be heard at a time and place to be communicated to the persons concerned:—

Name and Address; Present Franchise; Licence No.; Date of Expiry.

- AUSTRALIA & NEW ZEALAND BANK LTD., 394 Collins-street, Melbourne; 1 commercial goods vehicle (7 cwt.) to operate throughout the State of Victoria—own used accounting machines, typewriters, office equipment and office furniture from and to licensee's store situated in the City of Melbourne, to and from own branch offices, also tools, spare parts and materials incidental to the servicing and maintenance of typewriters, accounting machines and own office equipment; D.A.4106; 23rd June, 1961.
- B.C.X. PURE FRUIT DRINKS PTY. LTD., Allingham-street, Golden Square; 1 commercial goods vehicle (100 cwt.) to operate—(a) aerated waters, cordials and empty bottles and/or other containers for return and also fresh citrus fruits in season for processing, in the course of licensee's business as "aerated water manufacturers and fruit processors" in the following area only, namely:—within a radius of 100 miles from the chief post office in the City of Bendigo, but subject to the condition that no goods whatsoever shall be carried from or to any place situated within the metropolitan area of Melbourne as defined in the *Commercial Goods Vehicles Act 1955*, (b) from and to the premises of the holders of this licence at Golden Square, Bendigo, to and from the premises of Murray Breweries Pty. Ltd. at Beechworth—licensee's own manufactured cordials and milk bar syrups in glass containers and empty glass containers; D.A.3576/2; 11th May, 1961.
- BEAUREPAIRE TYRE SERVICE PTY. LTD., 83-95 Franklin-street, Melbourne; 1 commercial goods vehicle (15 cwt.) to operate within a radius of 75 miles from the post office at Sale, in the course of business as "tire retreaders and distributors"—tires and tubes for sale and delivery, used tires for repair or retread or having been repaired or retreaded, batteries, oil and car accessories; D.A.629/24; 24th June, 1961.
- BEAUREPAIRE TYRE SERVICE PTY. LTD., 83-95 Franklin-street, Melbourne; 1 commercial goods vehicle (24 cwt.) to operate within an area bounded by the following townships:—Boundary Bend, Manangatang, Speed, Woomelang, Quambatook, Kerang, Koondrook and Murrabit, in the course of business as "tire retreaders and distributors"—tires and tubes for sale and delivery, used tires for repair or retread or having been repaired or retreaded, batteries, oil and car accessories. Goods to be forwarded by rail from the City of Melbourne to the Township of Swan Hill and distributed in the aforementioned area; D.A.629/25; 27th June, 1961.
- BONELLO, M., 12 Westmoreland-road, Sunshine; 1 commercial goods vehicle (196 cwt.) to operate from collieries situate at Bacchus Marsh to the Cities of Melbourne, Ballarat and Geelong—brown coal only; D.A.26363; 27th June, 1961.
- DAVIS, W. J., 19 Mitchell-street, Belmont, Geelong; 1 commercial goods vehicle (116 cwt.) to operate—(a) within a radius of 50 miles from the chief post office in the City of Geelong—road-contracting plant and materials, (b) within a radius of 25 miles from the chief post office in the City of Geelong—general goods; D.A.29807; 20th May, 1961.
- EVANS, J. C., Walker-street, Anglesea; 1 commercial goods vehicle to operate within a radius of 75 miles of chief post office at Geelong (Geelong Division of the Country Roads Board)—road-contracting plant and materials; D.A.29357; 13th May, 1961.
- GORDON BROTHERS PTY. LTD., 110-120 Union-street, Brunswick; 1 commercial goods vehicle (7 cwt.) to operate throughout the State of Victoria for the maintenance of food processing and refrigeration equipment—tools of trade, spare parts and materials incidental to the maintenance of such equipment; D.A.1172/3; 2nd June, 1961.
- HALL, G. W. T. PTY. LTD., 482 Bourke-street, Melbourne; 1 commercial goods vehicle (8 cwt.) to operate throughout the State of Victoria, in the course of business of the holders of this licence as "engineering contractors"—tools of trade and equipment incidental to licensee's own contracts; D.A.24525/1; 24th June, 1961.
- HALSE, H. C., 40 Bent-street, Moonee Ponds; 1 commercial goods vehicle (62 cwt.) to operate throughout the State of Victoria for the purpose of repairing or towing disabled or wrecked vehicles—tools, spare parts and materials incidental to trade; D.A.4297; 28th June, 1961.
- For JONES, D. W. PTY. LTD., 126 Cecil-street, Williamstown; 2 commercial goods vehicles (115 and 110 cwt.) to operate—(a) within a radius of 25 miles from the post office situate at the corner of Bourke and Elizabeth streets, in the City of Melbourne—general goods, (b) within a radius of 50 miles from the post office situate at the corner of Bourke and Elizabeth streets in the City of Melbourne—petroleum products in prescribed types of containers and empty containers on behalf of the Shell Co. of Aust. Ltd.; D.A.1392/4, D.A.1392/5; 24th June, 1961.
- KENT, W. F., Irrewillipe East; 1 commercial goods vehicle (approximately 140 cwt.) to operate—(a) within a radius of 20 miles from the post office at Irrewillipe East—general goods, (b) from and to places within the radius described in paragraph (a) above, to and from places within a radius of 50 miles from the post office at Irrewillipe East—livestock, (c) from Corio to Irrewillipe East—petroleum products and empty returns on behalf of Neptune Oil Co. Pty. Ltd.; D.A.28242; 15th April, 1961.
- KING, R. J., Hawkesdale; 2 commercial goods vehicles (100 and 237 cwt.) to operate—(a) within a radius of 20 miles from the post office at Hawkesdale—general goods, (b) from and to places situate within the radius as described in paragraph (a) above, to and from places situate within a radius of 50 miles from the post office at Hawkesdale—livestock, (c) between the Shell Co. of Australia Ltd.'s depot at Portland and licensee's premises at Hawkesdale—petroleum products in prescribed types of containers and empty containers on behalf of the said company; D.A.7503/1, D.A.7503/2; 6th May, 1961.
- MAWSON, E. B., Box 66, Post Office, Cohuna; 2 commercial goods vehicles (120 and 239 cwt.) to operate within a radius of 95 miles of the post office at Cohuna and/or within a radius of 100 miles of the post office at Merbein (Bendigo Division of the Country Roads Board)—road-contracting plant and materials; D.A.29719, D.A.29719/1; 6th May, 1961.
- MAWSON, E. B. & SONS, Box 66, Post Office, Cohuna; 2 commercial goods vehicles (72 and 95 cwt.) to operate within a radius of 95 miles of the post office at Cohuna and/or within a radius of 100 miles of the post office at Merbein (Bendigo Division of the Country Roads Board)—road-contracting plant and materials; D.A.30119/7, D.A.30119/8; 6th May, 1961.
- MOOROODUC CO-OPERATIVE TRADING SOCIETY, Moorooduc; 1 commercial goods vehicle (108 cwt.) to operate within a radius of 20 miles from the post office at Moorooduc and to and from the City of Melbourne, in the course of business as "general merchants"—own storekeeper goods; D.A.9889/1; 24th June, 1961.
- OAKLEY, GEORGE & ROBERT (trading as Oakley Bros.), 322 High-street, Windsor; 1 commercial goods vehicle (90 cwt.) to operate within a radius of 50 miles from the post office situate at the corner of Bourke and Elizabeth streets in the City of Melbourne, in the course of business as "jute merchants"—own second-hand bags; D.A.30163; 24th June, 1961.
- PETERS ICE CREAM (VIC.) LTD., 171-183 Burnley-street, Richmond; 2 commercial goods vehicles (8 and 17 cwt.) to operate throughout the State of Victoria for the purpose of installing, servicing and maintaining refrigerators—own refrigerators for installation and replacement, spare parts, tools of trade and materials incidental to trade; D.A.1813/8, D.A.1813/9; 23rd June, 1961.
- SOLLY, J., corner of Barwon-terrace and Yarra-street, Geelong; 1 commercial goods vehicle (161 cwt.) to operate—(a) from and to the City of Geelong to and from the Cities of Melbourne and Ballarat—second-hand bottles, broken glass and empty cases on return journeys, (b) within a radius of 25 miles from the chief post office in the City of Geelong—marine goods as designated in the *Marine Stores and Old Metals Act 1958* (No. 6303); D.A.6759/2; 20th May, 1961.
- WALES, J., 13 Balmoral-avenue, North Essendon; 1 commercial goods vehicle (40 cwt.) to operate throughout the State of Victoria, in the course of business as

"monumental mason"—masonry, tools of trade and equipment used only for the erection of memorials at cemeteries; D.A.2214; 27th June, 1961.

WHITE, H. C., Orford; 1 commercial goods vehicle (254 cwt.) to operate—(a) within a radius of 20 miles from the post office at Orford—general goods, (b) from and to places situate within the radius as described in paragraph (a) above and to and from Portland, Hamilton and Warrnambool and to and from places situate on the railway lines between Portland and Hamilton, Warrnambool and Hamilton, and Port Fairy and Warrnambool—general goods; D.A.2278; 15th April, 1961.

NOTICE is hereby given that the applications made by the persons named below for the renewal of licences with variation to operate the commercial goods vehicles on the route or routes, or in the manner set out opposite their names, will be heard at a time and place to be communicated to the persons concerned:—

Name and Address; Present Franchise; Variation; Licence No.; Date of Expiry.

MILNES, J. B., Pymble-avenue, Inverloch; 1 commercial goods vehicle (126 cwt.) to operate—(a) within a radius of 20 miles from the post office at Morwell—general goods, (b) within a radius of 50 miles from the post office at Morwell—road-contracting plant and materials; deleting present conditions and adding in lieu—(a) within a radius of 20 miles of the post office at Inverloch—general goods, (b) within a radius of 50 miles of the post office at Wonthaggi—road-contracting plant and materials; D.A.29530; 6th May, 1961.

RABIN, J., 23 Konrad-street, East Bentleigh; 1 commercial goods vehicle (12 cwt.) to operate within a radius of 50 miles from the post office at Brighton and to and from the Township of Warragul, in the course of business as "stallholder and shopkeeper"—drapery, frocks and coats; deleting Brighton and adding in lieu—East Bentleigh; D.A.4104; 23rd June, 1961.

NATIONAL TIRE SERVICE (MILDURA) PTY. LTD., 124 Langtree-avenue, Mildura; 1 commercial goods vehicle (14 cwt.) to operate within a radius of 100 miles from the chief post office in the City of Mildura and to and from the Township of Pinnaroo, via Ouyen, in the course of licensee's business as "tire reconditioners"—new and second-hand tires and tubes and batteries for delivery to and collection from own clients; deleting present conditions and adding in lieu—within a radius of 100 miles from the chief post office in the City of Mildura, and to and from the Townships of Robinvale and Wentworth, in the course of business as "tire reconditioners"—new and second-hand tires and tubes, and batteries for delivery to and collection from own clients; D.A.2374/12; 2nd March, 1961.

NOTICE is hereby given that the applications made by the persons named below for licences to operate commercial passenger vehicles on the route or routes, or in the manner set out opposite their names, will be heard at a time and place to be communicated to the parties:—

Name and Address; Nature of Application.

WICKHAM, K. G., Wedderburn; 1 commercial passenger vehicle, with seating capacity for 27 persons, to operate for the carriage of school children only between Korong Vale and Wedderburn, under contract to the Education Department.

SORENSEN, C., 69 Seaford-road, Seaford; 1 commercial passenger vehicle, with seating capacity for five persons, to operate under the same terms and conditions as existing taxi-cabs licensed at Seaford.

ANDERSON, P. E. (trading as Gordon Anderson), Box 80, Cobram; 1 commercial passenger vehicle, with seating capacity for 27 persons, to operate as follows:—(a) For the carriage of school children only between Cobram and Numurkah High School, under contract to the Education Department, (b) as a country special service omnibus from Cobram.

BRIEN, J. H., & Co. PTY. LTD., 130 Moreland-street, Footscray; 2 commercial passenger vehicles, one with seating capacity for 33 passengers and one to be purchased, to operate as metropolitan special service omnibuses, in accordance with the provisions of the Transport Consolidated Regulations.

BROADMEADOWS BUS SERVICE PTY. LTD., Queens-parade, Fawkner; application for variation of Route No. 104A (North Coburg—Broadmeadows) to delete operations between the corner of Sydney-road and Queens-parade, via Queens-parade, Albert, Marlborough, Derby and McBryde streets and Lynch-road, to the corner of Lynch-road and Bruce-street, and instead to

operate from the corner of Sydney-road and Queen's parade, via Sydney-road, Lorne, McBryde and Tyrell streets and Lynch-road to the corner of Bruce-street and Lynch-road, thence via normal route, with the ability in the meantime to operate from the corner of Sydney-road and Queens-parade, via Sydney-road, Lorne, Lesleigh, Argyle and McBryde streets, Lynch-road, to the corner of Bruce-street and Lynch-road to normal route only until such time as Tyrell-street and Lorne-street between Lesleigh and McBryde streets is constructed.

TREZISE, A. R., & Co. PTY. LTD., corner Gordon and Barkly streets, Footscray; application for variation of all "M.O." licences, Route No. 110A (Footscray—Sunshine) to operate a deviation of service from the corner of Ballarat-road and Churchill-avenue, via Churchill-avenue, Churchill Highway to the corner of Duke-street and Devonshire-road, thence via normal route.

Time-table.

60 minutes frequency—7.00 a.m.—6.00 p.m.

(Detailed time-table, sections and fares to be determined.)

Notes.—(i) Subject to construction of Devonshire-road between Darnley-street and Dobson-crescent.

(ii) No alteration to frequency in Ballarat-road.

BUTLER, W. T., 145 Geelong-road, Footscray; 1 commercial passenger vehicle, with seating capacity for 31 persons, to operate for the carriage of employees only of Thomas Borthwick and Sons between the Footscray Railway Station and the company's premises in Francis-street, Brooklyn, via Barkly-street, Geelong-road, and Francis-street, under contract to Thomas Borthwick and Sons.

VENTURA MOTORS PTY. LTD., 17 Centre-road, Oakleigh; 1 commercial passenger vehicle, with seating capacity for 39 persons, to operate as an additional metropolitan stage omnibus on Route No. 208A (Box Hill—Mordialloc) under the same terms and conditions as "M.O." licences at present held by the applicant.

PLUMMER, W. S., 11 Whyte-grove, Mont Albert; application for permit authority to operate vehicle holding licence No. M.C.518, for the carriage of school children only from the corner of Pigdon and Lygon streets, via Studley Park-road, Studley-avenue, Stawell-street, Yarravale-street, Willis-street, Barry-street, Ratten-avenue, Hale-street, Irymple-avenue, Doncaster-road, Wattle-avenue, Maleela-avenue, Narrak-road and Burwood-road to Mount Scopus College.

Time-table.

Monday—Friday.

Depart Carlton 7.00 a.m.

APPLICATIONS for metropolitan private hire car licences by the persons listed hereunder in respect of commercial passenger vehicles with seating capacity for five persons:—

Name and Address; Proposed Operational Address.

SPIRASON, T., 26B Ellerslie-place, Toorak; Luxury Hire Cars, 18-20 Swan-street, Richmond.

LEHMANN, A. R., 6 Peacock-street, West Brunswick; Luxury Hire Cars, 18-20 Swan-street, Richmond.

HOUGH, H. W., 8 Sunnyside-grove, Bentleigh; Luxury Hire Cars, 18-20 Swan-street, Richmond.

CREA, P. J., 111A Station-street, Fairfield; Luxury Hire Cars, 18-20 Swan-street, Richmond.

CHAMBERLAIN, H. W., 16 Conifer-avenue, Brooklyn; Luxury Hire Cars, 18-20 Swan-street, Richmond.

NUTTALL, S. A., 34 Cain-avenue, Northcote; Luxury Hire Cars, 18-20 Swan-street, Richmond.

APPLICATIONS for metropolitan private hire car licences by the persons listed hereunder in respect of commercial passenger vehicles with seating capacity for five persons, to operate under composite conditions from an approved depot in zone set out opposite their names:—

Name and Address; Zone.

LUPONE, OLINDO, 103 Rennie-street, Coburg; "G", "J".

CARLISLE, H. T., 29 Glencara-street, Avondale Heights; "J", "K".

MILLS, N. E., 19 Combermere-street, Essendon; "J".

EGAN, A. J., 27 Hampden-street, Braybrook; "K".

MCLAUGHLIN, A. M., 34 Inneilan-road, Murrumbena; "A".

FREESTONE, G. H., 31 Buckingham-street, North Richmond; "J".

ILIAS, V., 26 Nelson-road, South Melbourne; "E", "A".

KOLLNER, G. W., 65 Morrah-street, Parkville; 1 commercial passenger vehicle, with seating capacity for five persons, to operate as a metropolitan taxi-cab, subject to the cancellation of metropolitan private hire car licence No. M.H.407, held by the applicant.

WARBRICK, A., 9 Beths-street, Bentleigh; 1 commercial passenger vehicle, with seating capacity for five persons, to operate as a metropolitan taxi-cab, subject to the cancellation of metropolitan private hire car licence No. M.H.763, held by the applicant.

WARBRICK, A., 9 Beths-street, Bentleigh; 1 commercial passenger vehicle, with seating capacity for five persons, to operate as a metropolitan taxi-cab, subject to the cancellation of metropolitan private hire car licence No. M.H.870, held by the applicant.

FORD MOTOR CO. OF AUSTRALIA PTY. LTD., Melbourne-road, Norlane, Geelong; application for renewal of licence No. T.P.55, expiring 8th May, 1961, authorizing operations under the same terms and conditions.

LUNDBERG, M. G. & G., 37 Barkly-street, Box Hill; application for renewal of licence No. T.P.68, expiring 4th July, 1961, authorizing operations under the same terms and conditions.

Notice of any objection should be forwarded to reach the Secretary to the Board not later than Wednesday, 5th April, 1961.

E. V. FIELD,
Secretary.

Exhibition Buildings, Rathdown-street, Carlton, N.3, Wednesday, 22nd March, 1961.

Housing Acts.
HOUSING COMMISSION.
VICTORIA.

Copy of Declaration of the Housing Commission, pursuant to Section 8 of Act No. 4568, as amended by Section 3 of Act No. 5328.

THE Housing Commission, after making due inquiries and obtaining all necessary reports, is satisfied that the house situate at and known as Number 56 Princes-street, Korumburra, does not comply with the regulations made under section 8 of the Slum Reclamation and Housing Act No. 4568, as amended, and the Housing Commission hereby declares such house to be unfit for human habitation.

Dated the 24th day of October, 1960.

The common seal of Housing Commission was hereto affixed, in the presence of—

(SEAL) J. P. GASKIN, Deputy Director.
G. G. BOLWELL, Secretary.

NOTE.—Any owner of a house or registered mortgagee of the land on which the house is situate, who feels aggrieved by any declaration of the Commission that such house is unfit for human habitation may, within fourteen days after the service of the declaration (endorsed hereon) that such house is unfit for human habitation, appeal therefrom to a Court of Petty Sessions consisting of a Police Magistrate sitting without any other justice or justices—see sub-section 6 of section 8 of Act No. 4568 as amended aforesaid.

Housing Acts.
MUNICIPALITY OF KORUMBURRA.

DIRECTION, PURSUANT TO SECTION 8 (2) OF THE SLUM RECLAMATION AND HOUSING ACT NO. 4568, AS AMENDED BY SECTION 3 OF ACT NO. 5328, REQUIRING A HOUSE TO BE DEMOLISHED.

To Mrs. Margaret Ann Kroeger,
Executrix of Estate of Mary Margaret Egan.

TAKE notice that the Housing Commission, being of the opinion that it is impracticable to make the house or land described in the Schedule hereto comply with the regulations under section 8 of the Slum Reclamation and Housing Act No. 4568, as amended aforesaid hereby directs you to demolish such house within sixty (60) days after the date of service of this notice.

Dated the 13th day of February, 1961.

For and on behalf of the Housing Commission,

A. W. TAYLOUR,
An Officer of the Commission duly authorized to sign this notice.

SCHEDULE.

The house situate at Korumburra, and known as number 56 Princes-street, Korumburra, erected on land having a frontage of 40 feet or thereabouts to the said street.

NOTE.—Any owner who fails to comply with the direction above within the time specified shall be guilty of an offence against the above-mentioned Act.

If an owner fails to comply with the direction above within the time specified the Commission may—

- (a) demolish the house;
- (b) recover from the owner any expenses incurred;
- (c) sell or dispose of any material taken from the house;
- (d) apply proceeds of sale towards expenses of Commission and pay surplus (if any) to owner.
(See sub-section 5 of section 8 of Act 4568 as amended aforesaid.)

Housing Acts.

MUNICIPALITY OF KORUMBURRA.

NOTICE, PURSUANT TO SECTION 8 (2) OF THE SLUM RECLAMATION AND HOUSING ACT NO. 4568, AS AMENDED BY SECTION 3 OF ACT NO. 5328, OF A DECLARATION BY THE HOUSING COMMISSION THAT A HOUSE IS UNFIT FOR HUMAN HABITATION.

To Mrs. Margaret Ann Kroeger,
Executrix of Estate of Mary Margaret Egan.

TAKE notice that the Housing Commission (hereinafter called "the Commission"), after making due inquiries and obtaining all necessary reports, is satisfied that the House (and/or land) described in the Schedule hereto does not comply with the Regulations made under section 8 of the above-mentioned Act as amended, and accordingly the Commission has declared such house to be unfit for human habitation.

A copy of the said declaration of the Commission is endorsed hereon and is served herewith: And take further notice that the following is a statement in writing setting out the particulars in respect of which the house or the land on which it is situated fails to comply with such Regulations, namely:

PARTICULARS.

Stump timbers decayed and defective. Sub-floor and structural timbers decayed and defective. Walls sagging out of line. Weatherboards split, decayed and defective. Cap and barge boards decayed and defective. Roof leaks, roof iron corroded, loose and out of shape. Spouting corroded, holed and missing. Downpipes corroded, defective and missing. Ridging corroded. Floors sunken, decayed and out of level. Flooring at ground level. T. and G. linings defective. T. and G. ceilings sagging and defective. Window frames, sashes and sills decayed and defective. Window sashes missing. Window glass fractured and missing. Glazing putty decayed. Doors missing and out of position. Evidence of weather damp. W.C. structure in disrepair. No stormwater or sullage water drains provided. Verandah structure in disrepair. Flooring boards decayed and missing, sub-floor timbers decayed. Walls and ceilings stained and discoloured. Fire place and stone hearths fractured and defective. Fuel stove defective. Cast iron copper defective, no flue provided. No troughs installed. No bath installed. No sink installed. Galvanized sheet iron chimney corroded and holed. Yard paving inadequate. Site overgrown with vegetation. Paintwork and putty perished. Fences in disrepair.

The Commission relies on each particular item of non-compliance separately as supporting its said declaration.

Dated the 13th day of February, 1961.

For and on behalf of the Housing Commission,

A. W. TAYLOUR,

An Officer of the Commission duly authorized to sign this notice.

SCHEDULE.

The house situate at Korumburra, and known as number 56 Princes-street, Korumburra, erected on land having a frontage of 40 feet or thereabouts to the said street.

YARRA RIVER IMPROVEMENT TRUST.

RATING BY-LAW 1961.

THE Yarra River Improvement Trust, in pursuance and exercise of the powers conferred by the *River Improvement Act 1958*, doth hereby make the By-law following:—

1. The following rate, to be called the "Yarra River Improvement District River Improvement Rate", is hereby made and shall be levied upon the occupiers or owners of all properties within the Yarra River Improvement District which are rateable to any municipality:—

A rate of Six pence (6d.) in the pound on the net annual municipal value of such properties. Provided that the sum of One shilling shall be the minimum amount of rate in respect of any property liable to be rated in the said district.

2. Such rate is made and shall be levied for the year beginning with the 1st January, 1961, and ending with the 31st day of December, 1961, and shall be payable on the 30th day of March, 1961, at the office of the Yarra River Improvement Trust, at Healesville.

3. Such person or persons as the Yarra River Improvement Trust may from time to time appoint for that purpose shall be and is or are hereby authorized to demand, receive, collect and recover the said rate.

The foregoing By-law was made by the Yarra River Improvement Trust on the 2nd day of March, 1961, and the common seal of the said Trust was hereunto affixed this 2nd day of March, 1961, in the presence of—

(SEAL) W. V. HOUGHTON, Chairman.
W. M. OLIVER, Secretary.

Approved by the Governor in Council,
15th March, 1961.

A. MAHLSTEDT,
Clerk of the Executive Council.

MITCHELL RIVER IMPROVEMENT TRUST.

BY-LAW No. 4.

THE Mitchell River Improvement Trust, in pursuance and exercise of the powers conferred by the *River Improvement Act 1958*, doth hereby make the By-law following:—

1. The following rate, to be called the "Mitchell River Improvement District River Improvement Rate", is hereby made and shall be levied upon the occupiers or owners of all properties within the Mitchell River Improvement District which are rateable to any Municipality, a rate of Eight pence in the £1 on the Annual Municipal value of such properties. Provided that the sum of One shilling shall be the minimum amount of rate in respect of any property liable to be rated in the said District.

2. Such rate is made and shall be levied for the year beginning with the 1st day of January, 1961, and ending with the 31st day of December, 1961, and shall be payable on the 1st day of May, 1961, at the office of the Mitchell River Improvement Trust, Nicholson-street, Bairnsdale.

3. Such person or persons as the Mitchell River Improvement Trust may from time to time appoint for that purpose shall be and is or are hereby authorized to demand, receive, collect and recover the said rate.

The foregoing By-law was made by the Mitchell River Improvement Trust on the 27th day of February, 1961, and the common seal of the said Trust was hereunto affixed on the 27th day of February, 1961.

(SEAL) W. H. DUMARESQ, Chairman.
T. H. PEART, Commissioner.
J. B. NEALE, Secretary.

Approved by the Governor in Council,
15th March, 1961.

A. MAHLSTEDT,
Clerk of the Executive Council.

MACALISTER RIVER IMPROVEMENT TRUST.

BY-LAW No. 5.

THE Macalister River Improvement Trust, in pursuance and exercise of the powers conferred by the *River Improvement Act 1958*, doth hereby make the By-law following:—

1. The following rate, to be called the "Macalister River Improvement District River Improvement Rate", is hereby made and shall be levied upon the occupiers or

owners of all the properties within the Macalister River Improvement District which are rateable to any municipality a rate of Three pence in the pound on the annual municipal value of such properties. Provided that the sum of One shilling shall be the minimum amount of rate in respect of any property liable to be rated in the said district.

2. Such rate is made and shall be levied for the year beginning with the 1st day of January, 1961, and ending with the 31st day of December, 1961, and shall be payable on the 2nd day of May, 1961, at the office of the Macalister River Improvement Trust at Maffra.

3. Such person or persons as the Macalister River Improvement Trust may from time to time appoint for that purpose shall be, and is or are, hereby authorized to demand, collect, and recover the said rate.

The foregoing By-law was made by the Macalister River Improvement Trust on the 16th day of February, 1961, and the common seal of the said Trust was hereunto affixed on the 16th day of February, 1961.

(SEAL) G. A. GRAY, Chairman.
J. GANNON, Commissioner.
M. H. McMAHON, Secretary.

Approved by the Governor in Council,
15th March, 1961.

A. MAHLSTEDT,
Clerk of the Executive Council.

BROKEN RIVER IMPROVEMENT TRUST.

FIXING THE LIMIT OF A BANK OVERDRAFT.

HIS Excellency the Administrator of the Government of the State of Victoria, by and with the advice of the Executive Council thereof, doth by Order made on the 15th March, 1961, in pursuance of the provisions of section 288 of the *Water Act 1958* (No. 6413), fix the limit of the overdraft to be obtained by the Broken River Improvement Trust from the National Bank of Australasia Limited, Benalla, at an amount not to exceed at any one time the sum of One thousand five hundred pounds (£1,500).

A. MAHLSTEDT,
Clerk of the Executive Council.

At the Executive Council Chamber,
Melbourne, 15th March, 1961.

SHIRE OF KOWREE WATERWORKS TRUST.

AUTHORITY TO OBTAIN BANK OVERDRAFT.

HIS Excellency the Administrator of the Government of the State of Victoria, by and with the advice of the Executive Council thereof, doth by Order made on the 15th March, 1961, authorize the Shire of Kowree Waterworks Trust to obtain, in pursuance of the provisions of section 286 of the *Water Act 1958* (No. 6413), an advance or advances during the year 1961 from the National Bank of Australasia Limited, Edenhope, by overdraft of the Trust's current account thereat, such overdraft not to exceed at any one time the sum of Two thousand pounds (£2,000).

A. MAHLSTEDT,
Clerk of the Executive Council.

At the Executive Council Chamber,
Melbourne, 15th March, 1961.

Motor Car Act 1958.

APPROVAL OF PROTECTIVE HELMETS FOR MOTOR CYCLISTS.

NOTICE is hereby given that the under-mentioned protective helmet has been approved by me as complying with Section 31 (1) (f) of the *Motor Car Act 1958*.

Trade Name.	Submitted By	Approval No.
Italian AGV X60 ..	Protector Goggle Co. Pty. Ltd., 17 Church-street, Middle Brighton	H.3

S. H. PORTER,
Chief Commissioner.

LAW DEPARTMENT.

COURTS OF PETTY SESSIONS—DAYS AND HOURS APPOINTED.

HIS Excellency the Administrator of the Government of the State of Victoria by and with the advice of the Executive Council thereof, doth by Order made on the 15th March, 1961, pursuant to the provisions of Section 64 of the *Justices Act 1958*, appoint the days and hours contained in the Schedule below for the holding of Courts of Petty Sessions at the places named in such Schedule in lieu of the days and hours heretofore appointed—to take effect as from the dates shown.

SCHEDULE.

Place.	Days and Hours.
Werriboe..	Every Monday at 10.30 a.m. as from and inclusive of 10th April, 1961
Lorne ..	Every Friday at 1 p.m. from 7th April, 1961, to April 28th, 1961, both dates inclusive, and every alternate Friday at 1 p.m. from 12th May, 1961, to 27th October, 1961, both dates inclusive.

A. MAHLSTEDT,
Clerk of the Executive Council.

At the Executive Council Chamber,
Melbourne, 15th March, 1961.

PUBLIC TRUSTEE ACT 1958 (No. 6350).—SECTION 17.

I HEREBY give notice that on the 7th March, 1961, the Public Trustee filed elections to administer the following deceased persons' estates, in accordance with section 17 of the *Public Trustee Act 1958*:—

*COSWAY, EDITH MATILDA, late of Stradbroke-road, Montrose, married woman, died 28th November, 1960.

DALPINO, SILVANO, late of Carisbrook, labourer, died 18th December, 1960, intestate.

DAWES, EDGAR BARNETT, late of 43 James-street, Guildford, Western Australia, railway employee, died 16th October, 1955, intestate.

NASH, JAMES LEO, late of 462 Little Lonsdale-street, Melbourne, watchman, died 31st December, 1960, intestate.

REEVES, FRANCIS JOSEPH, late of 128 Chestnut-street, Richmond, council employee, died 17th January, 1961, intestate.

*REIDY, KATHLEEN MARY, late of 4 Aberdeen-grove, Northcote, spinster, died 20th December, 1960.

* According to the provisions of the will.

I HEREBY give notice that on the 9th March, 1961, the Public Trustee filed elections to administer the following deceased persons' estates, in accordance with section 17 of the *Public Trustee Act 1958*:—

ARCHIBALD, JAMES EMILE BREDEBERG, formerly of War Veterans' Home, Cheltenham, but late of Bundoora, clerk, died 9th January, 1961, intestate.

BOOTHBY, WILLIAM ARTHUR, late of Methodist Mission, Arden-street, North Melbourne, pensioner, died 11th August, 1960, intestate.

A. D. DUNCAN,
Public Trustee.

601 Little Collins-street, Melbourne, C.1, 15th March, 1961.

NOTICE..

ADMINISTRATION of the estate of each of the under-mentioned deceased persons has been granted to the Public Trustee, and creditors, next of kin and all others having claims against the estate of any of the persons so mentioned are required to send particulars of their claims to the Public Trustee, 7th Floor, 601 Little Collins-street, Melbourne, on or before the 25th May, 1961, or they will be excluded from the distribution of the estate when the assets are being distributed:—

ARCHIBALD, JAMES EMILE BREDEBERG, formerly of War Veterans' Home, Cheltenham, but late of Bundoora, clerk, died 9th January, 1961, intestate.

BOOTHBY, WILLIAM ARTHUR, late of Methodist Mission, Arden-street, North Melbourne, pensioner, died 11th August, 1960, intestate.

*COSWAY, EDITH MATILDA, late of Stradbroke-road, Montrose, married woman, died 28th November, 1960.

DALPINO, SILVANO, late of Carisbrook, labourer, died 18th December, 1960, intestate.

DAWES, EDGAR BARNETT, late of 43 James-street, Guildford, Western Australia, railway employee, died 16th October, 1955, intestate.

NASH, JAMES LEO, late of 462 Little Lonsdale-street, Melbourne, watchman, died 31st December, 1960, intestate.

†NELSON, HENRIETTA ANN, late of 2 Wheatland-road, Malvern, widow, died 5th January, 1961.

REEVES, FRANCIS JOSEPH, late of 128 Chestnut-street, Richmond, council employee, died 17th January, 1961, intestate.

*REIDY, KATHLEEN MARY, late of 4 Aberdeen-grove, Northcote, spinster, died 20th December, 1960.

†STEPHENS, EDITH MARY, formerly of 65 St. Georges-road, Elsternwick, but late of 15 Narrawong-road, South Caulfield, widow, died 24th October, 1960.

* According to the provisions of the will.

† With the will annexed.

A. D. DUNCAN,

Public Trustee.

Melbourne, 15th March, 1961.

SHIRE OF BERWICK.

PUBLIC HIGHWAY.

IN pursuance of the powers conferred by sections 522 and 526 of the *Local Government Act 1958*, the Council of the Shire of Berwick doth hereby direct that the land in the Parish of Koo-Wee-Rup East shown hatched on the plan hereunder, which has been taken, purchased or acquired by it, shall be a public highway from and after the date of publication of this Order in the *Government Gazette*, and doth declare that such land shall be a public highway in lieu of the land in the said parish shown cross-hatched on the said plan.

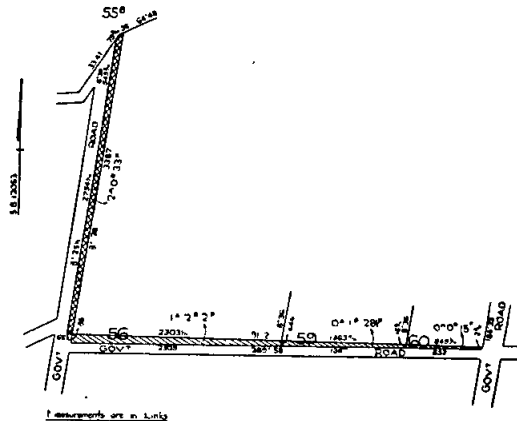

The common seal of the President, Councillors and Ratepayers of the Shire of Berwick was hereunto affixed this 19th day of September, 1960, in the presence of—

R. H. TEMPLETON, President.
P. B. RONALD, Councillor.
BEATRICE THOMAS, Secretary.

Approved by the Governor in Council,
15th March, 1961.

A. MAHLSTEDT,
Clerk of the Executive Council.

SHIRE OF SWAN HILL.

SEPARATE RATE.—ORDER AMENDED.

THE Order made by the Governor in Council on the 24th January, 1961, confirming a separate rate of Five pence (5d.) in the pound, made by the Council of the Shire of Swan Hill, and published in the *Government Gazette* of the 1st February, 1961, at page 264, was amended at a meeting of the Executive Council held on the 15th March, 1961, by the substitution of the words "net annual value" for the words "unimproved capital value".

A. MAHLSTEDT,
Clerk of the Executive Council.

Local Government Department,
Melbourne.

Town and Country Planning Act 1958, as Amended.
OCEAN-ROAD PLANNING SCHEME 1955 (SHIRE OF SOUTH BARWON).—AMENDMENT No. 2, 1961.

NOTICE THAT A PLANNING SCHEME HAS BEEN PREPARED AND IS AVAILABLE FOR INSPECTION.

NOTICE is hereby given that the Town and Country Planning Board, in pursuance of its powers under the *Town and Country Planning Act 1958*, as amended, has prepared a Planning Scheme for the area of land defined in the Second Schedule to the *Barwon Heads Lands Exchange Act 1960*, being generally described as Crown allotment 12 of section B, Township of Barwon Heads, and for the purpose of enabling the continuance of the use of such lands as a golf course.

All maps, plans, descriptions and other data fully setting out and explaining the Planning Scheme have been deposited at the office of the Shire of South Barwon, Shire Hall, Belmont, and at the office of the Town and Country Planning Board, 61 Spring-street, Melbourne, and will be open for inspection without payment of any fee by all persons affected, during office hours, on all days of the week except Saturdays, Sundays and public holidays, until and including the 22nd day of June, 1961.

Any persons affected by the Planning Scheme are required to set forth in writing all objections they may have, addressed to the Secretary, Town and Country Planning Board, 61 Spring-street, Melbourne, on or before the 22nd day of June, 1961.

W. H. CRAIG, Secretary,
 Town and Country Planning Board.

Town and Country Planning Act 1958, as Amended.
SHIRE OF BULLA.

INTERIM DEVELOPMENT ORDER.

BY virtue of the powers conferred by the *Town and Country Planning Act 1958*, as amended, and of every other power enabling it in that behalf, the Council of the Shire of Bulla (hereinafter referred to as "the responsible Authority") having commenced the preparation of planning schemes in accordance with the said Act, hereby makes the following Interim Development Order, for the purpose of regulating, restricting, restraining or prohibiting the use or development of any land or the erection, construction or carrying out of any buildings or works on any land within the area described or shown on the map as the Schedule hereto.

1. After the coming into operation of this Interim Development Order, no person shall use or develop any land or erect, construct or carry out any buildings or works on any land within the area included in the Schedule, except in accordance with the provisions of a permit issued by the responsible authority.

2. Any application for a permit to use or develop any land or to erect, construct or carry out any buildings or works, shall be accompanied by a sketch, plan or copy of certificate of title of the land and a description of the proposed use or development and type and construction of any buildings or works proposed to be erected, constructed or carried out and such other particulars relating to the application as the responsible authority may require.

3. This Interim Development Order shall not prevent the continuance of the use of any land or buildings for the purposes for which such land or buildings were lawfully used immediately before the coming into operation of this Order.

SCHEDULE.

4. All that area of land contained within the following boundary:—Commencing on the Hume Highway where it intersects the northern boundary of the Parish of Kal Kallo; thence westerly by that boundary and the northern boundary of the Parish of Micklehem to Deep Creek; thence southerly by that Creek to the northern boundary of the Parish of Bollinda; thence westerly by that boundary to the Country Roads Board road (known as the Konagaderra Developmental road); thence north-westerly, south-westerly, north-westerly and south-westerly by that road to the Melbourne-Lancefield road; thence southerly by that road to the north boundary of allotment 1, section 19, Parish of Bollinda; thence westerly by a line in continuation of that boundary to the eastern boundary of the Parish of Buttlerjorck; thence northerly by that boundary, westerly and southerly by the northern and western boundaries of that parish to the Calder Highway; thence south-easterly by that highway to the north boundary of the Parish of Maribyrrong; thence easterly

by that boundary to the north boundary of section 9, Parish of Tullamarine; thence easterly by that boundary and the northern boundaries of sections 8 and 7 to the Melbourne-Lancefield road; thence south-easterly by that road to the western boundary of section 6; thence northerly by that boundary and a line to the Moonee Ponds Creek; thence easterly by that Creek to the western boundary of the Township of Broadmeadows; thence northerly and easterly by the western and northern boundaries of that township to the western boundary of the land contained in certificate of title, volume 5534, folio 765; thence northerly by that boundary to the southern boundary of Crown portion 9, Parish of Will-Will-Rook; thence easterly by that boundary and northerly by the eastern boundaries of the said portion and allotment F, section 3, Parish of Yuroke to Somerton-road; thence easterly by that road to the Hume Highway; and thence northerly by that highway to the point of commencement.

(SEAL) N. J. CLIFF, President.
 T. A. ALSTON, Councillor.
 J. M. KELLY, Shire Secretary.

Report by the Town and Country Planning Board on the 7th day of March, 1961, recommended for approval.—FRED. C. COOK, Chairman.

Approved by the Governor in Council on the 15th day of March, 1961.—A. MAHLSTEDT, Clerk of the Executive Council.

Town and Country Planning Act 1958.
CITY OF MALVERN.

INTERIM DEVELOPMENT ORDER.

BY virtue of the powers conferred by the *Town and Country Planning Act 1958* and of every other power enabling it in that behalf, the Council of the City of Malvern (hereinafter referred to as the Responsible Authority) having commenced the preparation of a planning scheme in accordance with the said Act, hereby makes the following Interim Development Order for the purpose of regulating, restricting, restraining or prohibiting the use or development of any land or the erection, construction or carrying out of any buildings or works on any land within the area described or shown on the map as the Schedule hereto.

1. After the coming into operation of this Interim Development Order no person shall use or develop any land or erect, construct or carry out any buildings or works on any land within the area included in the Schedule, except in accordance with the provisions of a permit issued by the Responsible Authority.

2. Any application for a permit to use or develop any land or to erect, construct or carry out any buildings or works, shall be accompanied by a sketch, plan or copy of certificate of title of the land and a description of the proposed use or development and type of construction of any buildings or works proposed to be erected, constructed or carried out and such other particulars relating to the application as the Responsible Authority may require.

3. This Interim Development Order shall not prevent the continuance of the use of any land or buildings for the purposes for which such land or buildings were lawfully used immediately before the coming into operation of this Order.

SCHEDULE.

4. The whole of the municipal district of the City of Malvern.

(SEAL) J. JOHNSON, Mayor.
 S. E. STEVENS, Councillor.
 D. W. LUCAS, Town Clerk.

Report by the Town and Country Planning Board on the 25th day of February, 1960, recommended for approval.—FRED. C. COOK, Chairman.

Approved by the Governor in Council on the 22nd day of March, 1960.—A. MAHLSTEDT, Clerk of the Executive Council.

Report by the Town and Country Planning Board on the 21st day of February, 1961, recommended for approval.—FRED. C. COOK, Chairman.

Approved by the Governor in Council on the 15th day of March, 1961.—A. MAHLSTEDT, Clerk of the Executive Council.

CONTRACTS ACCEPTED.—(Series 1960-61.)**PRISONERS' MEALS IN LOCK-UPS.****CONTRACT ACCEPTED.**

For the supply of prisoners' meals at Bourke-street West, from 12th March, 1961, to 30th June, 1961: Breakfast and Tea, 3s.; Hot Dinner, 4s.—Sam Yick.

H. COUTTS, Secretary to the Tender Board. 21.3.61.

CONTRACTS ACCEPTED.—(Series 1961-62.)**VICTORIAN RAILWAYS.**

129. Flashing light signals for £16,559 6s. (Contract 61687).—McKenzie and Holland (Aust.) Pty. Ltd. 130. Erection of stockyards at Coleraine Junction for £5,921 6s. (Contract 61704).—Noske Bros. (Hamilton). 131. Erection of Works Depot at Spencer-street for £18,084 (Contract 61782).—Eric Rhind Pty. Ltd. 132. Telephone cable, at rates (Contract 61813).—Austral Standard Cables Pty. Ltd. 133. 2,200-volt cable for £1,567 4s. (Contract 61866).—Vealls Electrical and Radio Pty. Ltd. 134. Wooden poles, at rates (Contract 61878).—Messrs. Donchi Bros.

By order of the Victorian Railways Commissioners,

W. WALKER, Secretary. 17.3.61.

ORDERS IN COUNCIL.—(Series 1960-61.)**STATE ELECTRICITY COMMISSION.**

2926. The loading, transportation and unloading of poles from Bairnsdale Pole Depot to dumps and peg sites in Gippsland, for a period of twelve months, to Quotation No. 3278, at Schedule rates.—Kennedy and McDiarmid.

2927. The supply of ten 400-h.p. induction motors for overburden conveyors system at Yallourn Open Cut and fixed conveyors to raw coal bunkers at Morwell Open Cut, to Specification No. 60-61/196, £44,435.—McColl Electric Works Ltd.

2928. The supply of safety boots and shoes, for a period of two years, to Specification No. 60-61/198, at Schedule rates.—C. H. Morris.

2929. The supply of 850 miles of steel-cored aluminium conductor for 220 kV transmission line—Kerang to Redcliffs—to Specification No. 60-61/190, £369,325.—Olympic Cables Pty. Ltd.

2930. The supply of jointing sleeves and trolley wire for transmission and distribution lines, for a period of two years, to Specification No. 60-61/101A, at Schedule rates.—British Insulated Callenders Cables (Aust.) Pty. Ltd.

2931. The supply of copper conductor for transmission and distribution lines, for a period of two years, to Specification No. 60-61/101A, at Schedule rates.—Olympic Cables Pty. Ltd.

2932. The supply of 10,000 22 kV pin-type insulators, to Specification No. 60-61/153, £7,616 13s. 4d.—A.F.C.A. Pty. Ltd.

2933. The supply of 5,000 22 kV pin-type insulators, to Specification No. 60-61/153, £7,750.—Australian Porcelain Sales and Trading Pty. Ltd.

2934. The supply of 15,000 22 kV pin-type insulators, to Specification No. 60-61/153, £15,065 15s.—R. M. Hall Pty. Ltd.

2935. The supply of 200/250 volt mercury type electric discharge lamps, for public lighting, for a period of twelve months, to Specification No. 60-61/170, at Schedule rates.—British General Electric Co. Pty. Ltd.

2936. The supply of 200/250 volt sodium type electric discharge lamps, for public lighting, for a period of twelve months, to Specification No. 60-61/170, at Schedule rates. Condor Lamps (A'asia) Pty. Ltd.

Approved by the Governor in Council, 7th March, 1961.—A. MAHLSTEDT, Clerk of the Executive Council.

EDUCATION DEPARTMENT.

2937. One only smoke density indicator, for Royal Melbourne Technical College, £160.—Bell's Asbestos and Engineering (Australia) Ltd.

Approved by the Governor in Council, 15th March, 1961.—A. MAHLSTEDT, Clerk of the Executive Council.

HOSPITALS AND CHARITIES ACT 1958 (No. 6274).

IT is hereby notified for general information that the Hospitals and Charities Commission has, under the provisions of section 50 of the above-mentioned Act, approved the corporate name of the Gippsland Benevolent Home being changed to:—

"THE GIPPSLAND HOME AND HOSPITAL."

Dated at Melbourne, this fourteenth day of March, One thousand nine hundred and sixty-one.

JOHN LINDELL,
Chairman.

Local Government Act 1958.**CITY OF NUNAWADING.****ORDER CONFIRMED.**

THE Minister of the Crown administering the *Local Government Act 1958*, on the 14th day of March, 1961, confirmed the Order hereinafter referred to, in pursuance of section 514 of the said Act:—

An Order of the Council of the City of Nunawading, made on the 21st July, 1959, for the purpose of increasing the width of portion of Percy-street, Nunawading, and for acquiring for such purpose all those pieces of land described hereunder, viz.:—

Firstly.—All that piece of land being part of Crown portion 77, Parish of Nunawading, County of Bourke, and being part of the land more particularly described in certificate of title, volume 6483, folio 498, lodged in the Office of Titles, Melbourne, and being the land contained within a boundary line commencing at the south-east corner of the land described in the said certificate of title, volume 6483, folio 498; thence on a bearing of 269 deg. 57½ min. for a distance of 50 ft. 3½ in.; thence on a bearing of 353 deg. 57 min. for a distance of 269 ft. 4 in.; thence on a bearing of 89 deg. 57½ min. for a distance of 50 ft. 3½ in.; thence on a bearing of 173 deg. 57 min. for a distance of 269 ft. 4 in. to the point of commencement.

Secondly.—All that piece of land being part of Crown portion 77, Parish of Nunawading, County of Bourke, and being part of the land more particularly described in certificate of title, volume 6104, folio 1220799, lodged in the Office of Titles, Melbourne, and being the land contained within a boundary line commencing at the north-east corner of the land described in the said certificate of title, volume 6104, folio 1220799; thence on a bearing of 178 deg. 24 min. for a distance of 174 ft. 11 in.; thence on a bearing of 269 deg. 59 min. for a distance of 8 ft. 10 in.; thence on a bearing of 358 deg. 11½ min. for a distance of 175 feet; thence on a bearing of 90 deg. 20 min. for a distance of 9 ft. 6 in. to the point of commencement.

M. V. PORTER,

Minister for Local Government.

Local Government Act 1958.**SHIRE OF FRANKSTON—ORDER CONFIRMED.**

THE Minister of the Crown administering the *Local Government Act 1958*, on the 15th day of March, 1961, confirmed the Order hereinafter referred to, in pursuance of section 514 of the said Act, namely:—

An Order of the Council of the Shire of Frankston made on the 14th December, 1958, for the purpose of increasing the width and improving the alignment of Overport-road, Frankston, and for acquiring for such purpose all that piece of land described hereunder, viz.:—

All that piece of land commencing at the south-east corner of the land described in certificate of title, volume 7986, folio 099, being part of lot 1 on plan of subdivision No. 4750 lodged in the Office of Titles, and being part of Crown allotment 8, section 4, Parish of Frankston, County of Mornington, such point being on the southern boundary of Sweetwater Creek; thence by lines bearing respectively north 80 deg. 28 min. west 141 ft. 11 in., north 65 deg. 41 min. west 50 feet, south 88 deg. 29 min. east 110 ft. 3½ in. to the southern boundary of Sweetwater Creek; thence in a south-easterly direction by the southern boundary of the said creek to the point of commencement.

M. V. PORTER,

Minister for Local Government.

APPOINTMENTS.

HIS Excellency the Administrator of the Government of the State of Victoria, by and with the advice of the Executive Council thereof, has, by Orders made on the 15th day of March, 1961, been pleased to make the under-mentioned appointments, viz.:—

CHIEF SECRETARY'S DEPARTMENT.

Electoral Returning Officer.

WILLIAM CHARLES JAMESON

to be Returning Officer for the Electoral District of Fitzroy, *vice* Edward Bruce Cullen, resigned.

Electoral Registrars (Acting).

NORMAN RUSSELL ARNOLD

to be Electoral Registrar (Acting) for the Drysdale, Geelong, Newtown and Chilwell, and Queenscliff Subdivisions of the Electoral District of Geelong; and for

the Bannockburn, Geelong North, Geelong West, Meredith and Sutherland Subdivisions of the Electoral District of Geelong West, to take effect on and from the 27th February, 1961, during the absence on leave of Michael Francis McSherry;

WILLIAM DOUGLAS ARCH
to be Electoral Registrar (Acting) for the Bendigo, Eaglehawk, Elmore, Raywood, and Sandhurst East Subdivisions of the Electoral District of Bendigo; and for the Castlemaine, Golden Square, Heathcote, Kyneton, Maldon, Marong, Seymour, and Strathfieldsaye Subdivisions of the Electoral District of Midlands, to take effect on and from the 6th March, 1961, during the absence on leave of William Frederick Bridger;

NORMAN DONALD PUNIARD
to be Electoral Registrar (Acting) for the Bairnsdale, Bruthen, Lindenow, Lucknow, Maffra, Omeo, Orbost, Rosedale, Stratford, Toongabbie, and Walhalla Subdivisions of the Electoral District of Gippsland East; and for the Foster, Leongatha, Mirboo North, Sale, Traralgon, and Yarram Subdivisions of the Electoral District of Gippsland South, to take effect on and from the 6th March, 1961, during the absence on leave of John Henry Page;

ROBERT ALEXANDER MATHER
to be Electoral Registrar (Acting) for the Blyth, Edward, and Fitzroy North Subdivisions of the Electoral District of Brunswick East; and for the Carlton, Clifton Hill, Collingwood North, and Fitzroy Subdivisions of the Electoral District of Fitzroy, to take effect on and from the 6th March, 1961, during the absence on leave of William Charles Jameson;

JAMES THOMAS MCALLEN
to be Electoral Registrar (Acting) for the Burnley, Hawthorn, and Richmond South Subdivisions of the Electoral District of Hawthorn; and for the Abbotsford, Collingwood, and Richmond Subdivisions of the Electoral District of Richmond, to take effect on and from the 14th March, 1961, during the absence on leave of Leonard John Lubcke; and

JOHN RONALD GEOFFREY HAYES
to be Electoral Registrar (Acting) for the Drouin, Koo-Wee-Rup, Korumburra, Loch, Pakenham, Warragul, and Wonthaggi Subdivisions of the Electoral District of Gippsland West; and for the Morwell, Neerim South, Trafalgar, Warragul North, and Yellourn Subdivisions of the Electoral District of Morwell, to take effect on and from the 3rd March, 1961, during the absence on leave of Owen Patrick Griffin.

Inspector of Explosives.

NORMAN ERNEST MCKENDRICK,
pursuant to the provisions of section 32 of the *Explosives Act 1958*, to be an Inspector for the purposes of Part I. of the said Act.

Stipendiary Probation Officers.

NEIL THOMAS HEARN BEGGS and
GEOFFREY THOMAS CUDDIHY,
pursuant to the provisions of section 507 (1) of the *Crimes Act 1958*, to be Stipendiary Probation Officers.

Inspectors of Totalizators.

ALISTER VINCENT ALLAN and
KEVIN WILKINS,
pursuant to the provisions of Part V. of the *Racing Act 1958*, to be Inspectors of Totalizators.

DEPARTMENT OF HEALTH.

Members of Dental Board.

BENJAMIN KEITH RANK, M.B., B.S., and
JOHN MCFARLANE WARK, L.D.S., D.D.Sc.,
to be Members of the Dental Board of Victoria, pursuant to the provisions of section 46 of the *Medical Act 1958*, for the period ending 28th February, 1964.

Medical Officers.

GERTRUDE SPENCER, M.B., B.S.,
to be Medical Officer (Female), Grade I, Mental Hygiene Branch, Department of Health, pursuant to the provisions of section 20 of the *Mental Hygiene Act 1958*, as from and inclusive of the 14th February, 1961;

RODERICK ALAN WESTERMAN, M.B., B.S.,
to be Medical Officer, Grade II, Mental Hygiene Branch, Department of Health, pursuant to the provisions of section 20 of the *Mental Hygiene Act 1958*, as from and inclusive of the 20th February, 1961;

DENNIS WILLIAM MAGINN, M.B., B.S., M.D.,
to be Medical Officer, Grade II, Mental Hygiene Branch, Department of Health, pursuant to the provisions of section 20 of the *Mental Hygiene Act 1958*; and

JOHN MARCUS WOODFORDE, M.B., B.S., D.P.M.,
to be Medical Officer (Male), Grade I, Mental Hygiene Branch, Department of Health, pursuant to the provisions of section 20 of the *Mental Hygiene Act 1958* (No. 6314), as from and inclusive of the 13th February, 1961.

Secretary of Mental Hospital.

GORDON READ SLEEMAN
to be Secretary, Mental Hospital, Beechworth, pursuant to the provision of section 39 of the *Mental Hygiene Act 1958* (No. 6314), as from and inclusive of the 4th March, 1961, vice J. T. Garvey.

LAW DEPARTMENT.

Justices of the Peace.

HAROLD THOMAS GRIFFITHS, 34 Hodgkinson-street,
Bendigo,

to Keep the Peace in the Midland Bailiwick of the State of Victoria;

CHRISTOPHER STONEY, Mirboo,
to Keep the Peace in the Eastern Bailiwick of the State of Victoria; and

JAMES STANLEY BOUGHTON, 369 Glenferrie-road, Malvern,

GEOFFREY WILLIAM BARRY, care of New Zealand Loan and Mercantile Agency Co. Ltd., Dandenong, and
WILLIAM DYSON LEE FARRAR, care of Footscray and District Hospital, 25 Eleanor-street, Footscray,
to Keep the Peace in the Central Bailiwick of the State of Victoria.

Commissioners for Taking Declarations, &c.

DESMOND THOMAS O'CALLAGHAN, Stamp Duties Office,
Melbourne,

to be a Commissioner for taking Declarations and Affidavits, pursuant to the provisions of the *Evidence Act 1958*, to refrain from charging fees and to resign upon ceasing to be an officer of the Stamp Duties Office.

Clerk of Children's Courts.

LAWRENCE ROSS OEHMS
to be Clerk of the Children's Court at Mansfield, Alexandra, Jamieson, Woods Point and Yea, during the absence of J. B. Ries on annual leave, to take effect from the date of commencement of duty.

Clerk of Petty Sessions.

LAWRENCE ROSS OEHMS
to be Clerk of Petty Sessions at Port Melbourne and Williamstown, and Clerk of Petty Sessions and Clerk of the Children's Court at Lilydale and Werribee, during the absence of L. E. Breen on annual leave, to take effect from the date of commencement of duty.

Deputy Prothonotary, &c.

WILLIAM EDWARD GUY
to be Deputy Prothonotary and Clerk of the Children's Court at Ballarat, during the absence of E. N. Kinchington on annual leave, to take effect from the date of commencement of duty; and

GREGORY JAMES FINDLAY
to be Deputy Prothonotary, Clerk of the Peace for the Northern Bailiwick, Registrar of the County Court, Clerk of Petty Sessions and Clerk of the Children's Court at Shepparton, and Clerk of Petty Sessions and Clerk of the Children's Court at Dookie, Murchison, Rushworth and Tatura, during the absence of A. E. Thompson on annual leave, to take effect from the date of commencement of duty.

DEPARTMENT OF THE TREASURER.

Collectors of Imposts.

MAURICE VINCENT HAMMOND
to be Collector of Imposts, State Accident Insurance Office and State Motor Car Insurance Office, vice J. P. Dynon; and

GRAEME RITCHIE BROWN
to be Collector of Imposts, Audit Office, Department of Premier, vice St. Q. G. Raymond.

Receiver of Revenue.

GREGORY FRANCIS MEEHAN
to act temporarily as Receiver of Revenue, Colac, during the absence of A. R. Penfold, on leave.

DEPARTMENT OF WATER SUPPLY.

Commissioner of River Improvement Trust.

RONALD ALBERT RODWELL
to be a Commissioner of the Tambo River Improvement Trust for a period of four years from the date hereof, subject to the provisions of the *River Improvement Act 1958*.

A. MAHLSTEDT,
Clerk of the Executive Council.

At the Executive Council Chamber,
Melbourne, 15th March, 1961.

DEPARTMENT OF CROWN LANDS AND SURVEY.

At the Executive Council Chamber, Melbourne, the seventh day of March, 1961.

PRESENT:

His Excellency the Administrator of the Government of Victoria.

Mr. Chandler | Mr. Thompson.

REVOCATION OF TEMPORARY RESERVATION OF LAND BY ORDER IN COUNCIL.

HIS Excellency the Administrator of the Government of the State of Victoria, by and with the advice of the Executive Council thereof, doth hereby, in pursuance of the provisions of the *Land Act 1958*, revoke the temporary reservation of land by Order in Council hereinafter referred to, viz.:

GLENMONA.—Order in Council of 8th December, 1873, of 2 acres of land in the Parish of Glenmona as a site for State School purposes.—(Rs.6375.)

And the Honorable Keith Hector Turnbull, Her Majesty's Commissioner of Crown Lands and Survey for the State of Victoria, shall give the necessary directions herein accordingly.

A. MAHLSTEDT,
Clerk of the Executive Council.

DEPARTMENT OF CROWN LANDS AND SURVEY.

At the Executive Council Chamber, Melbourne, the fifteenth day of March, 1961.

PRESENT:

His Excellency the Administrator of the Government of Victoria.

Mr. Bloomfield | Mr. Petty.
Mr. Turnbull

UNUSED ROADS CLOSED.

HIS Excellency the Administrator of the Government of the State of Victoria, by and with the advice of the Executive Council thereof, doth hereby direct that, in pursuance of the provisions of section 349 of the *Land Act 1958*, the unused roads referred to hereunder be closed, viz.:

Parish of Yarrowee, County of Grenville, being the road between allotment A42 and allotment A9d.—(Y2^(*)) (J.30040).

Township of Lucknow, Parish of Wy-Yung, County of Dargo, being the portion of the width of the Princes Highway indicated by hachure on plan hereunder.—(W.236⁽¹⁵⁾) (Rs.3789).

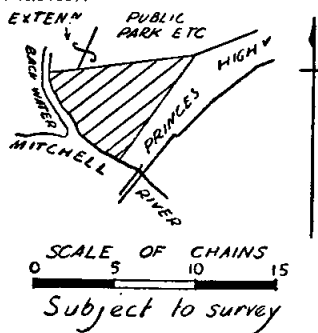

Parish of Glenpatrick, County of Kara Kara, being the road indicated by hachure on plan hereunder.—(G.74⁽⁸⁾) (J.27060).

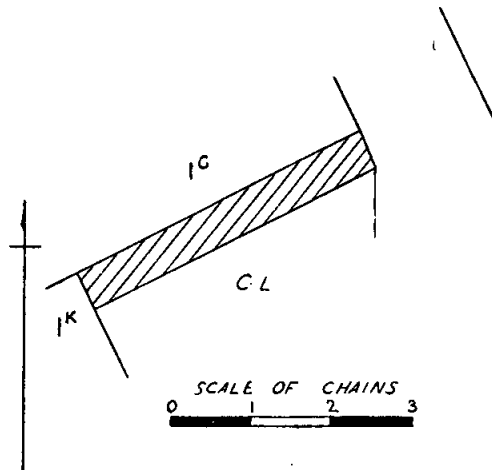

And the Honorable Keith Hector Turnbull, Her Majesty's Commissioner of Crown Lands and Survey for the State of Victoria, shall give the necessary directions herein accordingly.

A. MAHLSTEDT,
Clerk of the Executive Council.

DEPARTMENT OF CROWN LANDS AND SURVEY.

At the Executive Council Chamber, Melbourne, the fifteenth day of March, 1961.

PRESENT:

His Excellency the Administrator of the Government of Victoria.

Mr. Bloomfield | Mr. Petty.
Mr. Turnbull

LANDS TEMPORARILY RESERVED AS SITES.

HIS Excellency the Administrator of the Government of the State of Victoria, by and with the advice of the Executive Council thereof, doth hereby, in pursuance of the provisions of the *Land Act 1958*, reserve, temporarily, and also except from occupation for mining purposes under any miner's right, the land hereinafter described:—

SANDHURST (BENDIGO).—Site for Public Baths, in addition to and adjoining the site temporarily reserved therefor by Order in Council of the 25th April, 1881, 8 perches, more or less, at Bendigo, Parish of Sandhurst, County of Bendigo, as indicated by hachure on plan hereunder.—(S.372⁽²⁴⁾) (Rs.6114).

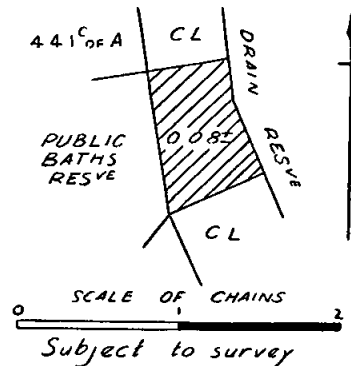

BALMORAL.—Site for a Rubbish Depot, 6 acres 2 roods 39 perches, Parish of Balmoral, County of Dundas, as indicated by hachure on plan hereunder.—(B.44(G) (Rs.3216).

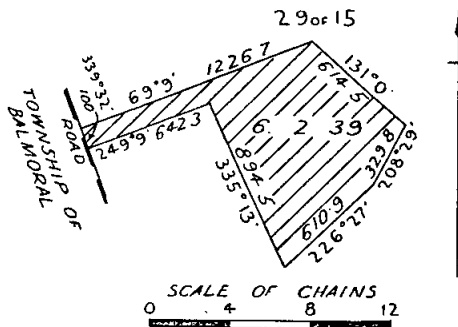

RUTHERGLEN.—Site for State School purposes, 21 acres 2 roods 30 perches, more or less, Township of Rutherglen, Parish of Lilliput, County of Bogong, as indicated by hachure on plan hereunder.—(R.50(2) (Rs.8030).

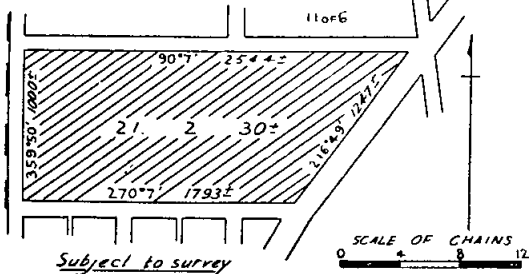

And the Honorable Keith Hector Turnbull, Her Majesty's Commissioner of Crown Lands and Survey for the State of Victoria, shall give the necessary directions herein accordingly.

A. MAHLSTEDT,
Clerk of the Executive Council.

COAL MINES ACT 1958 (No. 6221).—PART III.

At the Executive Council Chamber, Melbourne, the fifteenth day of March, 1961.

PRESENT:

His Excellency the Administrator of the Government of Victoria.

Mr. Bloomfield | Mr. Petty.
Mr. Turnbull

PURSUANT to the provisions of section 116 of the *Coal Mines Act 1958* (No. 6221), Part III., His Excellency the Administrator of the Government of the State of Victoria, by and with the advice of the Executive Council thereof, doth by this Order—

- (a) Re-appoint CYRIL HENRY EVANS, nominated by the Victorian Railways Commissioners; and
 - (b) Appoint GIOVANNI MABILIA, nominated by owners of coal mines other than the State Coal Mine in Victoria—to be representative of such owners; and
 - (c) Re-appoint JOSEPH SOPPITT; and
- Appoint ALBERT FARMER, being the names submitted by the body known as the Powlett River Branch of the Australasian Coal and Shale employees' Federation—to be representatives of the employees in the coal mining industry of Victoria,

as members of the said Tribunal for a period of three years from and inclusive of the 22nd February, 1961.

And the Honorable Wilfred John Mibus, Her Majesty's Minister of Mines for the State of Victoria, shall give the necessary directions herein accordingly.

A. MAHLSTEDT,
Clerk of the Executive Council.

PORTLAND HARBOR TRUST ACT.

At the Executive Council Chamber, Melbourne, the fifteenth day of March, 1961.

PRESENT:

His Excellency the Administrator of the Government of Victoria.

Mr. Bloomfield | Mr. Petty.
Mr. Turnbull

APPOINTMENT OF COMMISSIONERS AND CHAIRMAN AND DEPUTY CHAIRMAN OF THE PORTLAND HARBOR TRUST.

IN accordance with the provisions of the Portland Harbor Trust Act, His Excellency the Administrator of the Government of the State of Victoria, by and with the advice of the Executive Council thereof, doth by this Order appoint THEODORE CUYLER JARRETT, as Commissioner and Chairman; RALPH BRYANT ANDERSON, as Commissioner and Deputy Chairman; and WILLIAM SILVESTER NORTON, as Commissioner, of the Portland Harbor Trust for a period of three years ending 31st March, 1964, and doth hereby determine that the salary payable to the said Theodore Cuyler Jarrett shall be £850 per annum, and the salary payable to each of Ralph Bryant Anderson and William Silvester Norton shall be £300 per annum.

And the Honorable Sir Thomas Karran Maltby, Her Majesty's Commissioner of Public Works for the State of Victoria, shall give the necessary directions herein accordingly.

A. MAHLSTEDT,
Clerk of the Executive Council.

TOORA WATERWORKS TRUST.

At the Executive Council Chamber, Melbourne, the fifteenth day of March, 1961.

PRESENT:

His Excellency the Administrator of the Government of Victoria.

Mr. Bloomfield | Mr. Petty.
Mr. Turnbull

APPROVAL OF PLAN SHOWING SITE OF PIPE-LINE.

HIS Excellency the Administrator of the Government of the State of Victoria, by and with the advice of the Executive Council thereof, doth hereby approve, in accordance with the provisions of the Water Acts, a plan showing the site for a pipe-line to be constructed by the Toora Waterworks Trust on the land as described in the Schedule hereto.

SCHEDULE.

Site of Pipe-line from Welshpool to Port Welshpool.
Commencing at a point on the eastern boundary of the Welshpool Reticulation Area being a point on the Midland Highway near the north-eastern angle of allotment 16a of section A, Parish of Welshpool, County of Buln Buln, and being a point on the centre-line of the pipe-line; thence by a strip of land 50 links in width, being 25 links on each side of the centre-line of the pipe-line, generally south-easterly along the Midland Highway to a point on the western boundary of allotment 17, Township of Port Welshpool; thence south-easterly along a deviation of the Midland Highway through allotments 17, 16 and 15, across a road and through allotment 14, in the said township, to a point on the Midland Highway near the north-eastern angle of the said allotment 14; thence southerly along the Midland Highway to a point on the centre-line of the Port Welshpool pipe-line.

All of which lands are shown on a plan approved by the Governor in Council, and deposited in the office of the State Rivers and Water Supply Commission, Melbourne.—(Corres. 59/5998/13.)

And the Honorable Wilfred John Mibus, Her Majesty's Minister of Water Supply for the State of Victoria, shall give the necessary directions herein accordingly.

A. MAHLSTEDT,
Clerk of the Executive Council.

MORNINGTON SEWERAGE AUTHORITY.

At the Executive Council Chamber, Melbourne, the
fifteenth day of March, 1961.

PRESENT:

His Excellency the Administrator of the Government of
Victoria.

Mr. Bloomfield | Mr. Petty.
Mr. Turnbull |

AMENDMENT OF ORDER.

UNDER the powers conferred by the Sewerage Districts Acts and all other powers enabling him in that behalf, His Excellency the Administrator of the Government of the State of Victoria, by and with the advice of the Executive Council of the said State, doth hereby amend as follows the Order in Council made on the 20th day of September, 1960, and published in the *Government Gazette* dated 21st September, 1960, consenting to the Mornington Sewerage Authority borrowing the sum of Fifty thousand pounds (£50,000):—

For the expression "borrowing by the issue of a debenture the sum of Fifty thousand pounds (£50,000)" there shall be substituted the expression "borrowing by the assignment of rates and charges the sum of Fifty thousand pounds (£50,000)".

And the Honorable Wilfred John Mibus, Her Majesty's Minister of Water Supply for the State of Victoria, shall give the necessary directions herein accordingly.

A. MAHLSTEDT,
Clerk of the Executive Council.

STRATHDOWNIE DRAINAGE TRUST.

At the Executive Council Chamber, Melbourne, the
fifteenth day of March, 1961.

PRESENT:

His Excellency the Administrator of the Government of
Victoria.

Mr. Bloomfield | Mr. Petty.
Mr. Turnbull |

LOAN OF £5,000.

IN pursuance of the powers conferred by section 43 of the *River Improvement Act 1958* and all other powers enabling him in that behalf, His Excellency the Administrator of the Government of the State of Victoria, by and with the advice of the Executive Council of the said State, doth by this Order:—

1. Make advance by way of loan to the Strathdownie Drainage Trust of a sum of Five thousand pounds (£5,000); and

2. Apply the following terms and conditions:—

(a) That the said sum shall be used for the carrying out of approved river improvement works within the boundary of the Strathdownie Drainage District;

(b) that the Strathdownie Drainage Trust shall, in respect to such advance by way of loan, be subject to the powers, rights, duties and obligations conferred and imposed by—

(i) the provisions of sections 284, 285 and 287 to 294 of Part VII. of the *Water Act 1958*, so adapted that the word "Authority" therein shall mean "the Strathdownie Drainage Trust";

(ii) the provisions of section 295 of the said Part VII. of the *Water Act 1958*, so adapted as if for the expressions "any waterworks trust or local governing body" and "such waterworks trust or local governing body" there were substituted the expression "Strathdownie Drainage Trust".

And the Honorable Wilfred John Mibus, Her Majesty's Minister of Water Supply for the State of Victoria, shall give the necessary directions herein accordingly.

A. MAHLSTEDT,
Clerk of the Executive Council.

GEELONG WATERWORKS AND SEWERAGE TRUST.

At the Executive Council Chamber, Melbourne, the
fifteenth day of March, 1961.

PRESENT:

His Excellency the Administrator of the Government of
Victoria.

Mr. Bloomfield | Mr. Petty.
Mr. Turnbull |

CONSENT TO BORROWING £100,000.

UNDER the powers conferred by the Geelong Waterworks and Sewerage Acts and all other powers enabling him in that behalf, His Excellency the Administrator of the Government of the State of Victoria, by and with the advice of the Executive Council of the said State, doth hereby consent to the Geelong Waterworks and Sewerage Trust borrowing at interest, subject to the Geelong Waterworks and Sewerage Acts, the sum of One hundred thousand pounds (£100,000) to meet the cost of water supply works.

And the Honorable Wilfred John Mibus, Her Majesty's Minister of Water Supply for the State of Victoria, shall give the necessary directions herein accordingly.

A. MAHLSTEDT,
Clerk of the Executive Council.

ST. ARNAUD SEWERAGE AUTHORITY.

At the Executive Council Chamber, Melbourne, the
fifteenth day of March, 1961.

PRESENT:

His Excellency the Administrator of the Government of
Victoria.

Mr. Bloomfield | Mr. Petty.
Mr. Turnbull |

CONSENT TO THE ST. ARNAUD SEWERAGE AUTHORITY PURCHASING LANDS SITUATED WITHOUT ITS SEWERAGE DISTRICT.

UNDER the powers conferred by the Sewerage Districts Acts and all other powers enabling him in that behalf, His Excellency the Administrator of the Government of the State of Victoria, by and with the advice of the Executive Council of the said State, doth hereby consent to the purchase by the St. Arnaud Sewerage Authority of the lands comprised within the boundaries described in the Schedule hereto, which lands are situated without the Sewerage District of the said Authority.

SCHEDULE.

Commencing at the southernmost angle of Crown allotment 27, section A, Parish of St. Arnaud, County of Kara Kara; thence easterly along the southern boundaries of the said Crown allotment 27 and of Crown allotments 26, 25 and 24 to the easternmost angle of the said Crown allotment 24; thence northerly and westerly along the eastern and northern boundaries of the said Crown allotment 24 to its westernmost angle; thence northerly along the eastern boundary of Crown allotment 10 a distance of 650 links; thence through the said Crown allotment 10 by lines bearing south 59 deg. 3 min. west a distance of 400 links and north 80 deg. 18 min. west a distance of approximately 237 links to a point on the western boundary of the said Crown allotment 10; thence northerly along the western boundary of the said Crown allotment 10 to its westernmost angle; thence westerly along the northern boundary of Crown allotments 9, 8 and 7 to the westernmost angle of the said Crown allotment 7; thence generally southerly along the western boundary of the said Crown allotment 7 and of Crown allotment 27 to the point of commencement.

All of which lands are shown on a plan approved by the Governor in Council, and deposited in the office of the State Rivers and Water Supply Commission, Melbourne.—(Corres. 59/1245/29.)

And the Honorable Wilfred John Mibus, Her Majesty's Minister of Water Supply for the State of Victoria, shall give the necessary directions herein accordingly.

A. MAHLSTEDT,
Clerk of the Executive Council.

WODONGA SEWERAGE AUTHORITY.

*At the Executive Council Chamber, Melbourne, the
fifteenth day of March, 1961.*

PRESENT:

His Excellency the Administrator of the Government of
Victoria.

Mr. Bloomfield
Mr. Turnbull

Mr. Petty.

CONSENT TO COMPULSORY ACQUISITION OF LAND
SITUATED OUTSIDE THE SEWERAGE DISTRICT.

UNDER the powers conferred by the Sewerage Districts
Acts and all other powers enabling him in that behalf,
His Excellency the Administrator of the Government of
the State of Victoria, by and with the advice of the
Executive Council of the said State, doth hereby consent
to the compulsory acquisition by the Wodonga Sewerage
Authority of land situated outside the Sewerage District,
being Crown allotment 4, section B2, Township of
Wodonga, Parish of Wodonga, County of Bogong, as
shown by red colour on a plan approved by the Governor
in Council, and deposited in the office of the State Rivers
and Water Supply Commission, Melbourne.—(Corres.
1959/1670/74.)

And the Honorable Wilfred John Mibus, Her Majesty's
Minister of Water Supply for the State of Victoria, shall
give the necessary directions herein accordingly.

A. MAHLSTEDT,
Clerk of the Executive Council.

OVENS RIVER IMPROVEMENT TRUST.

*At the Executive Council Chamber, Melbourne, the
fifteenth day of March, 1961.*

PRESENT:

His Excellency the Administrator of the Government of
Victoria.

Mr. Bloomfield
Mr. Turnbull

Mr. Petty.

CONSENT TO BORROWING £8,000.

UNDER the powers conferred by the *River Improve-
ment Act 1958* and all other powers enabling him in
that behalf, His Excellency the Administrator of the
Government of the State of Victoria, by and with the
advice of the Executive Council of the said State, doth
hereby consent to the Ovens River Improvement Trust
borrowing at interest, at the rate of Five pounds seventeen
shillings and six pence per centum per annum, the sum
of Eight thousand pounds (£8,000), subject to the pro-
visions of the *River Improvement Act 1958*, to meet the
cost of new plant.

And the Honorable Wilfred John Mibus, Her Majesty's
Minister of Water Supply for the State of Victoria, shall
give the necessary directions herein accordingly.

A. MAHLSTEDT,
Clerk of the Executive Council.

BROKEN RIVER IMPROVEMENT TRUST.

*At the Executive Council Chamber, Melbourne, the
fifteenth day of March, 1961.*

PRESENT:

His Excellency the Administrator of the Government of
Victoria.

Mr. Bloomfield
Mr. Turnbull

Mr. Petty.

LIMIT OF BORROWING POWER.

UNDER the powers conferred by the *River Improve-
ment Act 1958* and all other powers enabling him in
that behalf, His Excellency the Administrator of the
Government of the State of Victoria, by and with the
advice of the Executive Council of the said State, doth
hereby specify that the amount of money which may be

borrowed by the Broken River Improvement Trust, pur-
suant to the *River Improvement Act 1958* (No. 6358), shall
not exceed in the whole the sum of Twenty thousand
pounds (£20,000).

And the Honorable Wilfred John Mibus, Her Majesty's
Minister of Water Supply for the State of Victoria, shall
give the necessary directions herein accordingly.

A. MAHLSTEDT,
Clerk of the Executive Council.

BENDIGO SEWERAGE AUTHORITY.

*At the Executive Council Chamber, Melbourne, the
fifteenth day of March, 1961.*

PRESENT:

His Excellency the Administrator of the Government of
Victoria.

Mr. Bloomfield
Mr. Turnbull

Mr. Petty.

CONSENT TO COMPULSORY ACQUISITION OF LANDS
SITUATED OUTSIDE THE SEWERAGE DISTRICT.

UNDER the powers conferred by the Sewerage Districts
Acts and all other powers enabling him in that behalf,
His Excellency the Administrator of the Government of
the State of Victoria, by and with the advice of the
Executive Council of the said State, doth hereby consent
to the compulsory acquisition by the Bendigo Sewerage
Authority of lands situated outside the Sewerage District,
being the whole of Crown allotments 3, 12 and 16, no
section, Parish of Huntly, County of Bendigo, as shown
by red colour on a plan approved by the Governor in
Council, and deposited in the office of the State Rivers
and Water Supply Commission, Melbourne.—(Corres.
1959/1673/59.)

And the Honorable Wilfred John Mibus, Her Majesty's
Minister of Water Supply for the State of Victoria, shall
give the necessary directions herein accordingly.

A. MAHLSTEDT,
Clerk of the Executive Council.

COUNTRY ROADS BOARD.

*At the Executive Council Chamber, Melbourne, the
fifteenth day of March, 1961.*

PRESENT:

His Excellency the Administrator of the Government of
Victoria.

Mr. Bloomfield
Mr. Turnbull

Mr. Petty.

ORDER APPROVING THE WIDENING OF AN
EXISTING STATE HIGHWAY IN THE SHIRE
OF MORNINGTON.

WHEREAS:

I. Section 114 of the *Country Roads Act 1958* (herein
called "the Act") provides (*inter alia*) in—

- (a) Sub-section (1) thereof that the powers conferred
upon municipal councils by Division fourteen of
Part XIX, of the *Local Government Act 1958*
shall so far as applicable be conferred upon
the Country Roads Board (herein called "the
Board") so far as relates to the declaration of
the alignment the widening and opening up of
State highways and that the provisions of
the said Division shall with certain modifications
extend and apply accordingly;
- (b) sub-section (2) thereof that no State highway
shall be widened or opened up pursuant to the
said section unless the Governor in Council has
by Order published in the *Government Gazette*
approved such widening or opening up;

II. The Board has—

- (a) in exercise of the powers conferred upon it by
the said section 114 and for the purpose of
widening the Nepean Highway in the Shire of
Mornington (declared by the Board pursuant
to the Act or some corresponding previous
enactment to be a State highway which declara-
tion was confirmed by an Order of the Governor

in Council published in the *Government Gazette* of the 29th October, 1947, at pages 5573-5 thereof) by Resolution dated the fifteenth day of December, 1952, fixed a new alignment for the east side of the said highway;

(b) in accordance with the provisions of section 19 of the Act caused to be prepared a map plan and estimate showing—

- (i) the points between which and the lands on and through which the said widening is proposed to be made; and
- (ii) the cost of acquiring the land:

III. The Governor in Council is satisfied that there are funds legally available for acquiring the said land:

Now therefore His Excellency the Administrator of the Government of the State of Victoria with the advice of the Executive Council thereof by this Order approves for the purposes of sections 20, 74 and 114 of the Act—

- (a) the widening of the said Nepean Highway so as to include therein the land described in the Schedule hereto; and
- (b) the acquisition of the land so described.

SCHEDULE.

All that piece of land in the Parish of Moorooduc, the boundaries of which are as follow:—Commencing at a point on the northern boundary of Crown portion 12 of the said parish distant 48 deg. 38½ min. 132 feet from the northern angle of lot 1 on plan of subdivision numbered 17357, lodged in the Office of Titles; thence by lines bearing respectively 48 deg. 32½ min. 147 ft. 3 in., 138 deg. 48½ min. 84 ft. 7½ in., 220 deg. 41 min. 148 ft. 10 in., 318 deg. 51½ min. 28 ft. 2½ in., 319 deg. 5½ min. 40 feet and 318 deg. 35½ min. 36 ft. 9½ in. to the point of commencement—which said piece of land is particularly delineated and shown coloured red on survey plan numbered 5642, lodged in the office of the Country Roads Board.

And the Honorable Sir Thomas Karran Maltby, Her Majesty's Commissioner of Public Works for the State of Victoria, shall give the necessary directions herein accordingly.

A. MAHLSTEDT,
Clerk of the Executive Council.

COUNTRY ROADS BOARD.

At the Executive Council Chamber, Melbourne, the fifteenth day of March, 1961.

PRESENT:

His Excellency the Administrator of the Government of Victoria.

Mr. Bloomfield		Mr. Petty.
Mr. Turnbull		

ORDER APPROVING OF WIDENING AN EXISTING MAIN ROAD IN THE SHIRE OF KARKAROOC.

WHEREAS the Country Roads Board constituted under the *Country Roads Act* 1958 (No. 6229) has represented to His Excellency the Governor in Council that it appears to it desirable that the existing Hopetoun-Patchewollock road in the Shire of Karkaroc (declared to be a main road under the said Act which declaration was confirmed by the Order in Council published in the *Government Gazette* of the 19th March, 1941, on page 1325) should be widened by the said Board: And whereas the said Board in accordance with the requirements of section 19 of the said cited Act has caused to be prepared a map plan and estimate showing the points between which and on and through what land the said widening is proposed to be made and the cost of acquiring the land: And whereas on an inspection of the said map and plan and a consideration of the said estimate His Excellency the Governor in Council is satisfied that there are funds legally available for acquiring the land: Now therefore be it known by this present Order that His Excellency the Administrator of the Government of the State of Victoria with the advice of the Executive Council thereof doth hereby approve of the said road being widened, that is to say:—

All that piece of land in the Parish of Patchewollock, the boundaries of which are as follow:—Commencing at the south-western angle of allotment 6 of the said parish; thence by lines bearing respectively 340 deg. 10 min. 195 links, 52 deg. 0 min. 37.5 links, 134 deg. 16 min. 295.8 links and 270 deg. 0 min. 175.2 links to the point

of commencement—which said piece of land is particularly delineated and shown coloured red on survey plan numbered 7812, lodged in the office of the Country Roads Board.

And the Honorable Sir Thomas Karran Maltby, Her Majesty's Commissioner of Public Works for the State of Victoria, shall give the necessary directions herein accordingly.

A. MAHLSTEDT,
Clerk of the Executive Council.

COUNTRY ROADS BOARD.

At the Executive Council Chamber, Melbourne, the fifteenth day of March, 1961.

PRESENT:

His Excellency the Administrator of the Government of Victoria.

Mr. Bloomfield		Mr. Petty.
Mr. Turnbull		

ORDER APPROVING OF WIDENING AN EXISTING STATE HIGHWAY IN THE SHIRE OF NARRACAN.

WHEREAS the Country Roads Board constituted under the *Country Roads Act* 1958 (No. 6229) has represented to His Excellency the Governor in Council that it appears to it desirable that the existing Princes Highway in the Shire of Narracan (declared to be a State highway under the said Act which declaration was confirmed by the Order in Council published in the *Government Gazette* of the 8th July, 1925, on pages 2371-3, and *Government Gazette* of the 13th December, 1944, on pages 3083-4) should be widened by the said Board: And whereas the said Board in accordance with the requirement of section 19 of the said cited Act has caused to be prepared a map plan and estimate showing the points between which and on and through what land the said widening is proposed to be made and the cost of acquiring the land: And whereas on an inspection of the said map and plan and a consideration of the said estimate His Excellency the Governor in Council is satisfied that there are funds legally available for acquiring the land: Now therefore be it known by this present Order that His Excellency the Administrator of the Government of the State of Victoria with the advice of the Executive Council thereof doth hereby approve of the said highway being widened, that is to say:—

All those pieces of land in the Parish of Moe, the boundaries of which are as follow:—

- (a) Commencing at the north-eastern angle of allotment 8, section 6, Township of Trafalgar in the said parish; thence by lines bearing respectively 189 deg. 47 min. 28 feet, 314 deg. 45½ min. 32 ft. 1½ in., and 79 deg. 44 min. 28 feet to the point of commencement.
- (b) Commencing at the north-eastern angle of lot 1 on plan of subdivision numbered 10709, lodged in the Office of Titles, and being part of allotment 159 of the said parish; thence by lines bearing respectively 189 deg. 47 min. 28 ft. 5½ in., 246 deg. 49 min. 81 ft. 10 in., 231 deg. 16 min. 74 feet, 225 deg. 30 min. 44 feet, 9 deg. 47 min. 82 ft. 10 in., 67 deg. 48 min. 131 ft. 9 in., and 79 deg. 44 min. 33 ft. 7 in. to the point of commencement.
- (c) Commencing at a point on the boundary of the Railway Reserve in the Parish of Moe the said point being distant 259 deg. 44 min. 28 feet, and 352 deg. 50 min. 133 ft. 6½ in. from the north-eastern angle of allotment 8, section 6, Township of Trafalgar in the said parish; thence by lines bearing respectively 231 deg. 2 min. 140 ft. 2½ in., 259 deg. 44 min. 189 ft. 8½ in., 69 deg. 41 min. 190 ft. 3½ in., and 64 deg. 30 min. 129 ft. 10½ in. to the point of commencement—

which said pieces of land are particularly delineated and shown coloured red on survey plan numbered 7819, lodged in the office of the Country Roads Board.

And the Honorable Sir Thomas Karran Maltby, Her Majesty's Commissioner of Public Works for the State of Victoria, shall give the necessary directions herein accordingly.

A. MAHLSTEDT,
Clerk of the Executive Council.

COUNTRY ROADS BOARD.

At the Executive Council Chamber, Melbourne, the
fifteenth day of March, 1961.

PRESENT:

His Excellency the Administrator of the Government of
Victoria.

Mr. Bloomfield
Mr. Turnbull

Mr. Petty.

ORDER APPROVING OF A DEVIATION FROM A
MAIN ROAD IN THE SHIRE OF KERANG.

WHEREAS the Country Roads Board constituted under the *Country Roads Act 1958* (No. 6229) has represented to His Excellency the Governor in Council that it appears to it desirable that the deviation hereinafter referred to from the existing Kerang-Quambatook road in the Shire of Kerang (declared to be a main road under the said Act which declaration was confirmed by the Order in Council published in the *Government Gazette* of the 19th February, 1941, on page 908) should be made by the said Board: And whereas the said Board in accordance with the requirements of section 19 of the said cited Act has caused to be prepared a map plan and estimate showing the points between which and on and through what land the said deviation is proposed to be made and the cost of acquiring the land: And whereas on an inspection of the said map and plan and a consideration of the said estimate His Excellency the Governor in Council is satisfied that there are funds legally available for acquiring the land: Now therefore be it known by this present Order that His Excellency the Administrator of the Government of the State of Victoria with the advice of the Executive Council thereof doth hereby approve of the said road being made, that is to say:—

All that piece of land in the Parish of Budgerum East, the boundaries of which are as follow:—

Commencing at a point on the northern boundary of allotment 4, section 1 of the said parish, distant 236 deg. 1 min. 350 links from the north-eastern angle of the said allotment; thence by lines bearing respectively 149 deg. 7 min. 555.6 links, 275 deg. 53 min. 865.6 links and 56 deg. 1 min. 694.4 links to the point of commencement.

Also, all those pieces of land in the Parish of Budgerum West, the boundaries of which are as follow:—

(a) Commencing at the north-western angle of allotment 3A, section E of the said parish; thence by lines bearing respectively 81 deg. 6 min. 453.6 links, 234 deg. 36 min. 666.5 links and 16 deg. 46 min. 330 links to the point of commencement.

(b) Commencing at a point on the eastern boundary of allotment 3, section E of the said parish distant 196 deg. 46 min. 1,225 links and 234 deg. 36 min. 1,802 links from the north-eastern angle of the said allotment; thence by lines bearing respectively 214 deg. 36 min. 810 links, 266 deg. 34 min. 523.3 links and 54 deg. 36 min. 1,205.1 links to the point of commencement.

(c) Commencing at a point on the southern boundary of allotment 3, section E of the said parish distant 90 deg. 0 min. 5,351.1 links from the south-western angle of the said allotment; thence by lines bearing respectively 54 deg. 36 min. 750 links, 218 deg. 37 min. 463.9 links, 255 deg. 31 min. 288 links and 270 deg. 0 min. 42.9 links to the point of commencement.

(d) Commencing at the south-eastern angle of allotment 10, section E of the said parish; thence by lines bearing respectively 245 deg. 10 min. 1,225.2 links, 43 deg. 5½ min. 2,092.7 links and 197 deg. 24 min. 1,062.3 links to the point of commencement.

(e) Commencing at an angle in the western boundary of the Public Purposes Reserve in the said parish, the said angle being formed by the intersection of lines bearing 266 deg. 34 min. and 218 deg. 37 min.; thence by lines bearing respectively 86 deg. 34 min. 88.8 links, 234 deg. 36 min. 239.4 links and 38 deg. 37 min. 170.7 links to the point of commencement.

(f) Commencing at an angle in the western boundary of the Public Purposes Reserve in the said parish, the said angle being formed by the intersection of lines bearing 255 deg. 31 min. and 223 deg. 5 min.; thence by lines bearing

respectively 75 deg. 31 min. 677.8 links, 234 deg. 36 min. 1,820.8 links and 43 deg. 5 min. 1,212.1 links to the point of commencement.

(g) Commencing at a point on the western boundary of the Public Purposes Reserve in the said parish, the said point being distant 235 deg. 28 min. 691.8 links from an angle in the said boundary formed by the intersection of lines bearing 223 deg. 5 min. and 235 deg. 28 min.; thence by lines bearing respectively 222 deg. 57 min. 1,756.8 links, 17 deg. 24 min. 347.8 links, 42 deg. 57 min. 767.4 links and 55 deg. 28 min. 692.1 links to the point of commencement.

(h) Commencing at a point on the western boundary of the Public Purposes Reserve in the said parish, the said point being distant 245 deg. 10 min. 1,699.4 links from an angle in the said boundary formed by the intersection of lines bearing 197 deg. 24 min. and 245 deg. 10 min.; thence by lines bearing respectively 223 deg. 5½ min. 1,150.5 links, 26 deg. 46 min. 533.7 links, 43 deg. 5½ min. 268.5 links and 65 deg. 10 min. 399.1 links to the point of commencement—

which said pieces of land are particularly delineated and shown coloured red on survey plans numbered 7787 and 7788, lodged in the office of the Country Roads Board.

And the Honorable Sir Thomas Karran Maltby, Her Majesty's Commissioner of Public Works for the State of Victoria, shall give the necessary directions herein accordingly.

A. MAHLSTEDT,
Clerk of the Executive Council.

COUNTRY ROADS BOARD.

At the Executive Council Chamber, Melbourne, the
fifteenth day of March, 1961.

PRESENT:

His Excellency the Administrator of the Government of
Victoria.

Mr. Bloomfield
Mr. Turnbull

Mr. Petty.

ORDER APPROVING OF WIDENING AN EXISTING
STATE HIGHWAY IN THE SHIRE OF FLINDERS.

WHEREAS the Country Roads Board constituted under the *Country Roads Act 1958* (No. 6229) has represented to His Excellency the Governor in Council that it appears to it desirable that the existing Princes Highway in the Shire of Flinders (declared to be a State highway under the said Act which declaration was confirmed by the Order in Council published in the *Government Gazette* of the 29th October, 1947, on pages 5573-5) should be widened by the said Board: And whereas the said Board in accordance with the requirement of section 19 of the said cited Act has caused to be prepared a map plan and estimate showing the points between which and on and through what land the said widening is proposed to be made and the cost of acquiring the land: And whereas on an inspection of the said map and plan and a consideration of the said estimate His Excellency the Governor in Council is satisfied that there are funds legally available for acquiring the land: Now therefore be it known by this present Order that His Excellency the Administrator of the Government of the State of Victoria with the advice of the Executive Council thereof doth hereby approve of the said highway being widened, that is to say:—

All that piece of land in the Parish of Nepean, the boundaries of which are as follow:—Commencing at the south-western angle of allotment 65A of the said parish; thence by the arc of a circle of radius of 1,086 links, a distance of 336 links, the chord of which arc bears 349 deg. 28 min.; thence by lines bearing respectively 155 deg. 58 min. 201.5 links, 131 deg. 36 min. 222.9 links, 121 deg. 13 min. 46.2 links and 276 deg. 41 min. 228.6 links to the point of commencement—which said piece of land is particularly delineated and shown coloured red on survey plan numbered 7867, lodged in the office of the Country Roads Board.

And the Honorable Sir Thomas Karran Maltby, Her Majesty's Commissioner of Public Works for the State of Victoria, shall give the necessary directions herein accordingly.

A. MAHLSTEDT,
Clerk of the Executive Council.

COUNTRY ROADS BOARD.

At the Executive Council Chamber, Melbourne, the
fifteenth day of March, 1961.

PRESENT:

His Excellency the Administrator of the Government of
Victoria.

Mr. Bloomfield
Mr. Turnbull

Mr. Petty.

ORDER APPROVING OF WIDENING AN EXISTING
STATE HIGHWAY IN THE SHIRE OF TAMBO.

WHEREAS the Country Roads Board constituted under the *Country Roads Act 1958* (No. 6229) has represented to His Excellency the Governor in Council that it appears to it desirable that the existing Princes Highway in the Shire of Tambo (declared to be a State highway under the said Act which declaration was confirmed by the Order in Council published in the *Government Gazette* of the 8th July, 1925, on pages 2371-3) should be widened by the said Board: And whereas the said Board in accordance with the requirements of section 19 of the said cited Act has caused to be prepared a map plan and estimate showing the points between which and on and through what land the said widening is proposed to be made and the cost of acquiring the land: And whereas on an inspection of the said map and plan and a consideration of the said estimate His Excellency the Governor in Council is satisfied that there are funds legally available for acquiring the land: Now therefore be it known by this present Order that His Excellency the Administrator of the Government of the State of Victoria with the advice of the Executive Council thereof doth hereby approve of the said highway being widened, that is to say:—

All those pieces of land in the Parish of Colquhoun, the boundaries of which are as follow:—

- (a) Commencing at the north-western angle of allotment 110 of the said parish; thence by lines bearing respectively 128 deg. 9 min. 29 ft. 2½ in., 276 deg. 4 min. 24 ft. 9 in. and 6 deg. 4 min. 15 ft. 6 in. to the point of commencement.
- (b) Commencing at a point on the eastern boundary of allotment 101A of the said parish, distant 0 deg. 7 min. 447.4 links from the south-eastern angle of the said allotment; thence by lines bearing respectively 338 deg. 3 min. 330.1 links, 320 deg. 39 min. 421.7 links, 123 deg. 26 min. 256.9 links, 142 deg. 49 min. 197 links, 159 deg. 30 min. 164.7 links and 180 deg. 7 min. 179.5 links to the point of commencement—

which said pieces of land are particularly delineated and shown coloured red and blue on survey plans numbered 7773 and 7824, lodged in the office of the Country Roads Board.

And the Honorable Sir Thomas Karran Maltby, Her Majesty's Commissioner of Public Works for the State of Victoria, shall give the necessary directions herein accordingly.

A. MAHLSTEDT,
Clerk of the Executive Council.

COUNTRY ROADS BOARD.

At the Executive Council Chamber, Melbourne, the
fifteenth day of March, 1961.

PRESENT:

His Excellency the Administrator of the Government of
Victoria.

Mr. Bloomfield
Mr. Turnbull

Mr. Petty.

ORDER APPROVING OF A DEVIATION FROM A
MAIN ROAD IN THE SHIRE OF TOWONG.

WHEREAS the Country Roads Board constituted under the *Country Roads Act 1958* (No. 6229) has represented to His Excellency the Governor in Council that it appears to it desirable that the deviation hereinafter referred to from the existing Tallangatta Creek-road in the Shire of Towong (declared to be a main road under the said Act which declaration was confirmed by the Order in Council published in the *Government Gazette* of the 4th June, 1947, on page 2821) should be made by the said

Board: And whereas the said Board in accordance with the requirements of section 19 of the said cited Act has caused to be prepared a map plan and estimate showing the points between which and on and through what land the said deviation is proposed to be made and the cost of acquiring the land: And whereas on an inspection of the said map and plan and a consideration of the said estimate His Excellency the Governor in Council is satisfied that there are funds legally available for acquiring the land: Now therefore be it known by this present Order that His Excellency the Administrator of the Government of the State of Victoria with the advice of the Executive Council thereof doth hereby approve of the said road being made, that is to say:—

All those pieces of land in the Parish of Wagra, the boundaries of which are as follow:—

- (a) Commencing at the north-eastern angle of allotment 5, section 12 of the said parish; thence by lines bearing respectively 120 deg. 53 min. 131.6 links, 285 deg. 43 min. 250 links and 90 deg. 5 min. 127.7 links to the point of commencement.
- (b) Commencing at a point on the eastern boundary of allotment 5, section 12 of the said parish, distant 343 deg. 9 min. 882.8 links from the south-eastern angle of the said allotment; thence by lines bearing respectively 338 deg. 11 min. 591 links, 327 deg. 6 min. 151.5 links, 311 deg. 4 min. 232.8 links, 120 deg. 53 min. 322.1 links and 163 deg. 9 min. 693.2 links to the point of commencement.
- (c) Commencing at the south-eastern angle of allotment 5, section 12 of the said parish; thence by lines bearing respectively 270 deg. 5 min. 50 links, 165 deg. 18 min. 238 links, 179 deg. 17 min. 653.6 links, 353 deg. 1 min. 890.4 links, 357 deg. 41 min. 341.4 links and 163 deg. 9 min. 356.5 links to the point of commencement.
- (d) Commencing at the north-eastern angle of allotment 8, section 16 of the said parish; thence by lines bearing respectively 214 deg. 51 min. 31 links, 280 deg. 17 min. 519.3 links, 320 deg. 22 min. 594 links, 329 deg. 49 min. 768.4 links, 359 deg. 6 min. 267.2 links, 151 deg. 11 min. 305 links, 151 deg. 15 min. 1,212 links and 102 deg. 32 min. 582 links to the point of commencement.

Also, all that piece of land in the Parish of Wyeboob, the boundaries of which are as follow:—

Commencing at a point on the western boundary of allotment 6, section 1A of the said parish, distant 163 deg. 9 min. 211 links and 181 deg. 47 min. 1,160.3 links from the north-western angle of the said allotment; thence by lines bearing respectively 167 deg. 30 min. 514.5 links, 331 deg. 20 min. 250.5 links and 1 deg. 47 min. 282.7 links to the point of commencement—

which said pieces of land are particularly delineated and shown coloured red on survey plans numbered 7610, 7611 and 7612, lodged in the office of the Country Roads Board.

And the Honorable Sir Thomas Karran Maltby, Her Majesty's Commissioner of Public Works for the State of Victoria, shall give the necessary directions herein accordingly.

A. MAHLSTEDT,
Clerk of the Executive Council.

COUNTRY ROADS BOARD.

At the Executive Council Chamber, Melbourne, the
fifteenth day of March, 1961.

PRESENT:

His Excellency the Administrator of the Government of
Victoria.

Mr. Bloomfield
Mr. Turnbull

Mr. Petty.

ORDER APPROVING OF A DEVIATION FROM A
MAIN ROAD IN THE SHIRE OF PORTLAND.

WHEREAS the Country Roads Board constituted under the *Country Roads Act 1958* (No. 6229) has represented to His Excellency the Governor in Council that it

appears to it desirable that the deviation hereinafter referred to from the existing Portland-Nelson road in the Shire of Portland (declared to be a main road under the said Act which declaration was confirmed by the Order in Council published in the *Government Gazette* of the 9th July, 1947, on pages 3628-9) should be made by the said Board: And whereas the said Board in accordance with the requirements of section 19 of the said cited Act has caused to be prepared a map plan and estimate showing the points between which and on and through what land the said deviation is proposed to be made and the cost of acquiring the land: And whereas on an inspection of the said map and plan and a consideration of the said estimate His Excellency the Governor in Council is satisfied that there are funds legally available for acquiring the land: Now therefore be it known by this present Order that His Excellency the Administrator of the Government of the State of Victoria with the advice of the Executive Council thereof doth hereby approve of the said road being made, that is to say:—

All those pieces of land in the Parish of Mouzie, the boundaries of which are as follow:—

- (a) Commencing at the north-eastern angle of allotment 38, section 7 of the said parish; thence by lines bearing respectively 188 deg. 24 min. 913.8 links, 339 deg. 41 min. 475 links, 316 deg. 56 min. 551.6 links, 288 deg. 50 min. 789.9 links and 97 deg. 59 min. 1,436.6 links to the point of commencement.
- (b) Commencing at a point on the western boundary of allotment 13b, section 8 of the said parish, distant 188 deg. 24 min. 2,869 links from the north-western angle of the said allotment; thence by lines bearing respectively 158 deg. 42 min. 493.2 links, 135 deg. 44 min. 506.3 links, 291 deg. 47 min. 384.3 links, 330 deg. 3 min. 440 links and 8 deg. 24 min. 301.5 links to the point of commencement.
- (c) Commencing at a point on the southern boundary of allotment 13b, section 8 of the said parish, distant 278 deg. 23 min. 808 links from the south-eastern angle of the said allotment; thence by lines bearing respectively 278 deg. 23 min. 190 links, 322 deg. 18 min. 140 links and 116 deg. 50 min. 306.6 links to the point of commencement.
- (d) Commencing at a point on the northern boundary of allotment 1B, section 9 of the said parish, distant 278 deg. 23 min. 1,179 links and 322 deg. 17 min. 449 links from the north-eastern angle of the said allotment; thence by lines bearing respectively 303 deg. 54 min. 289.9 links, 111 deg. 46 min. 180 links and 142 deg. 17 min. 120 links to the point of commencement—

which said pieces of land are particularly delineated and shown coloured red on survey plan numbered 7791, lodged in the office of the Country Roads Board.

And the Honorable Sir Thomas Karran Maltby, Her Majesty's Commissioner of Public Works for the State of Victoria, shall give the necessary directions herein accordingly.

A. MAHLSTEDT,
Clerk of the Executive Council.

COUNTRY ROADS BOARD.

At the Executive Council Chamber, Melbourne, the
fifteenth day of March, 1961.

PRESENT:

His Excellency the Administrator of the Government of
Victoria.

Mr. Bloomfield | Mr. Petty.
Mr. Turnbull

DECLARATION OF THE WIDENING OF THE WESTERN HIGHWAY IN THE SHIRE OF MELTON.

WHEREAS by sections 21 and 74 of the *Country Roads Act 1958* (No. 6229) it is amongst other things enacted that when the Country Roads Board under the provisions of the Country Roads Act has taken the land necessary for constructing the highway or deviation or widening it shall as soon as it thinks such highway or deviation or widening is fit to be used as a public highway by Resolution declare the highway or deviation or

widening to be a State highway or part thereof and that upon publication in the *Government Gazette* of the Order of the Governor in Council confirming such Resolution such highway or deviation or widening shall thereupon be a State highway or a part thereof within the meaning of the said Act: And whereas the said Board has by Resolution declared the highway on the land described in the Schedule to such Resolution to be part of a State highway: Now therefore His Excellency the Administrator of the Government of the State of Victoria by and with the advice of the Executive Council thereof doth hereby confirm the said Resolution.

Resolution for Declaration of the Widening of a State Highway under the Country Roads Act.

Whereas the land the site of the highway the course of which is below set out was taken by the Board under the provisions of the Country Roads Act for the purpose of widening the State highway aforesaid which widening has now been laid out and formed on the same: And whereas the said Board (being the Country Roads Board incorporated under the said Act) thinks that the widening aforesaid is fit to be used as part of a public highway such Board at a meeting now holden doth by this Resolution hereby declare the same as described in the Schedule hereto with the commencing and terminating points thereof respectively specified to be part of the State highway within the meaning and for the purposes of the Country Roads Act.

SCHEDULE.

Shire of Melton.

2. *Western Highway*.—All that piece of land in the Parishes of Djerriwarrh and Kororoit, the boundaries of which are as follow:—Commencing at the northern angle of the south-western portion of Crown portion A, section 14, of the parish last named, the said angle being formed by the intersection of the eastern boundary of the Toolern Creek and the southern boundary of the existing Western Highway; thence by lines bearing respectively 124 deg. 41 min. 652.4 links, 293 deg. 56 min. 315.2 links, 283 deg. 57 min. 625.1 links, 272 deg. 40 min. 361.2 links, 78 deg. 6 min. 638.1 links and 124 deg. 41 min. 109.6 links to the point of commencement—which said piece of land is particularly delineated and shown coloured red and yellow on survey plan numbered 6403, lodged in the office of the Country Roads Board.

The common seal of the Country Roads Board was hereto affixed at Kew, this sixth day of March, One thousand nine hundred and sixty-one, in the presence of—

(SEAL) D. V. DARWIN, Chairman.
W. H. NEVILLE, Member.
N. L. ALLANSON, Acting Secretary.

And the Honorable Sir Thomas Karran Maltby, Her Majesty's Commissioner of Public Works for the State of Victoria, shall give the necessary directions herein accordingly.

A. MAHLSTEDT,
Clerk of the Executive Council.

COUNTRY ROADS BOARD.

At the Executive Council Chamber, Melbourne, the
fifteenth day of March, 1961.

PRESENT:

His Excellency the Administrator of the Government of
Victoria.

Mr. Bloomfield | Mr. Petty.
Mr. Turnbull

DECLARATION OF A DEVIATION FROM THE WILLAURA-WICKLIFFE ROAD IN THE SHIRE OF ARARAT.

WHEREAS by sections 21 and 58 of the *Country Roads Act 1958* (No. 6229) it is amongst other things enacted that when the Country Roads Board under the provisions of the Country Roads Act has by Resolution declared a deviation to be a main road the said Board may also declare that such deviation shall be in lieu of any existing road or part thereof named in such Resolution and that on publication in the *Government Gazette*

of the Order confirming such Resolution the existing road or part thereof shall cease to be a main road or be discontinued as provided in the Resolution: And whereas the said Board has by Resolution declared the deviation on the land described in the First Schedule to such Resolution to be a main road and has also declared that such deviation shall be in lieu of the part of the existing road being the land described in the Second Schedule to the said Resolution and that such part of the said existing road shall be discontinued: Now therefore His Excellency the Administrator of the Government of the State of Victoria by and with the advice of the Executive Council thereof doth hereby confirm the said Resolution.

Resolution for Declaration of a Deviation of a Main Road under the Country Roads Act.

Whereas the land the site of the road the course of which is below set out was taken by the Board under the provisions of the *Country Roads Act 1958* for the purpose of constructing such road deviation which road deviation has now been laid out and formed on the same: And whereas the said Board (being the Country Roads Board incorporated under the said Act) thinks that the road aforesaid is fit to be used as a public highway such Board at a meeting now holden acting under the authority conferred upon it by sections 21 and 58 of the said Act doth by this present Resolution hereby declare the said road deviation the course of which is described in the First Schedule hereto with the commencing and terminating points thereof respectively specified to be part of a main road within the meaning and for the purposes of the *Country Roads Act 1958*: And the said Board doth also declare that such deviation shall be in lieu of the existing road or part thereof described in the Second Schedule hereto and that such part of the said existing road shall be discontinued.

FIRST SCHEDULE.

Shire of Ararat.

12. *Willaura-Wickliffe road* (412).—All that piece of land in the Parish of Wickliffe North, the boundaries of which are as follow:—Commencing at the south-western angle of allotment 3, section 14, of the said parish; thence by lines bearing respectively 331 deg. 12 min. 1,341.3 links, 351 deg. 21 min. 249 links, 0 deg. 56 min. 455.9 links, 31 deg. 55 min. 797.1 links, 192 deg. 0 min. 574.7 links, 180 deg. 56 min. 550 links, 171 deg. 21 min. 500 links and 159 deg. 18 min. 776.2 links to the point of commencement—which said piece of land is particularly delineated and shown coloured red on survey plan numbered 6553A, lodged in the office of the Country Roads Board.

SECOND SCHEDULE.

Shire of Ararat.

12. *Willaura-Wickliffe road* (412).—All that piece of land in the Parish of Wickliffe North, the boundaries of which are as follow:—Commencing at a point on the western boundary of allotment 3, section 14, of the said parish distant 331 deg. 12 min. 1,341.3 links from the south-western angle of the said allotment; thence by lines bearing respectively 171 deg. 21 min. 531.9 links, 159 deg. 18 min. 829.1 links, 331 deg. 12 min. 1,783.5 links, 31 deg. 55 min. 1,189.2 links, 192 deg. 0 min. 656.4 links, 180 deg. 56 min. 148.3 links, 211 deg. 55 min. 269.1 links and 151 deg. 12 min. 287.7 links to the point of commencement—which said piece of land is particularly delineated and shown coloured blue on survey plan numbered 6553A, lodged in the office of the Country Roads Board.

The common seal of the Country Roads Board was hereto affixed at Kew, this sixth day of March, One thousand nine hundred and sixty-one, in the presence of—

D. V. DARWIN, Chairman.
(SEAL) W. H. NEVILLE, Member.
N. L. ALLANSON, Acting Secretary.

And the Honorable Sir Thomas Karran Maltby, Her Majesty's Commissioner of Public Works for the State of Victoria, shall give the necessary directions herein accordingly.

A. MAHLSTEDT,
Clerk of the Executive Council.

LANDLORD AND TENANT ACT 1958.

At the Executive Council Chamber, Melbourne, the twenty-first day of March, 1961.

PRESENT:

His Excellency the Administrator of the Government of Victoria.

Sir Thomas Maltby | Mr. Porter.
Mr. Thompson

ORDER EXTENDING APPLICATION OF PART V. OF THE LANDLORD AND TENANT ACT 1958 TO CERTAIN PREMISES.

IN pursuance of the powers conferred by section 44 of the *Landlord and Tenant Act 1958*, His Excellency the Administrator of the Government of the State of Victoria, by and with the advice of the Executive Council thereof, doth hereby declare that the application of Part V. of the *Landlord and Tenant Act 1958* shall extend to each of the following premises:—

1. The premises known as No. 76 Peel-street, Windsor.
2. The premises known as Flat No. 5, "Sherwood Court", at Nos. 18-20 Burton-avenue, Hawthorn.
3. The premises known as No. 42 Barry-street, Carlton.
4. That part of the premises known as Lot 54, Howell-street, Research, which on the 21st March, 1961, was let to one T. J. Marmion.
5. The premises known as No. 23 Hodgson-terrace, Richmond.
6. The premises known as No. 7 Hodgkinson-street, Clifton Hill, and all premises forming part of such premises.
7. The premises known as No. 145 Amess-street, North Carlton.
8. The premises known as No. 350 St. Georges-road, North Fitzroy.

And the Honorable Arthur Gordon Rylah, Her Majesty's Attorney-General in and for the State of Victoria, shall give the necessary directions herein accordingly.

A. MAHLSTEDT,
Clerk of the Executive Council.

ELECTRIC LIGHT AND POWER ACT 1958 AND STATE ELECTRICITY COMMISSION ACTS.

At the Executive Council Chamber, Melbourne, the twenty-first day of March, 1961.

PRESENT:

His Excellency the Administrator of the Government of Victoria.

Sir Thomas Maltby | Mr. Porter.
Mr. Thompson

REVOCATION OF THE SHIRE OF KERANG ELECTRIC LIGHTING ORDER No. 132—1917.

WHEREAS on the 12th day of February, 1918, the Council of the municipality of the President, Councillors and Ratepayers of the Shire of Kerang (hereinafter called "the undertakers") was granted an Order under the *Electric Light and Power Act 1915*, cited as the Shire of Kerang Electric Lighting Order No. 132—1917 (hereinafter called "the said Order"), authorizing the supply of electricity within the Township of Kerang and land adjacent thereto, more particularly described in the First Schedule annexed to the said Order, commencing on the 12th day of February, 1918: And whereas the undertakers have made application for the revocation of the said Order: Now therefore His Excellency the Administrator of the Government of the State of Victoria, by and with the advice of the Executive Council thereof, and under the powers in that behalf contained in the said Order and by and with the consent and concurrence of the said undertakers as expressed in their application addressed to the Secretary of the State Electricity Commission of Victoria, doth hereby revoke the said Order, such revocation to date from the 1st day of February, 1961.

And the Honorable George Oswald Reid, Her Majesty's Minister of Electrical Undertakings for the State of Victoria, shall give the necessary directions herein accordingly.

A. MAHLSTEDT,
Clerk of the Executive Council.

ELECTRIC LIGHT AND POWER ACT 1958 AND STATE ELECTRICITY COMMISSION ACTS.

At the Executive Council Chamber, Melbourne, the twenty-first day of March, 1961.

PRESENT:

His Excellency the Administrator of the Government of Victoria.

Sir Thomas Maltby | Mr. Porter.
Mr. Thompson

REVOCATION OF THE KERANG (DISTRICT) ELECTRIC LIGHTING ORDER No. 256-1947.

WHEREAS on the 17th day of February, 1947, the Council of the municipality of the President, Councillors and Ratepayers of the Shire of Kerang (hereinafter called "the undertakers") was granted an Order under the *Electric Light and Power Act 1928*, cited as the Kerang (District) Electric Lighting Order No. 256-1947 (hereinafter called "the said Order"), authorizing the supply of electricity in portions of the Parishes of Kerang, Gannawarra, Murrabit and Murrabit West, more particularly described in the First Schedule annexed to the said Order, commencing on the 17th day of February, 1947: And whereas the undertakers have made application for the revocation of the said Order: Now therefore His Excellency the Administrator of the Government of the State of Victoria, by and with the advice of the Executive Council thereof, and under the powers in that behalf contained in the said Order and by and with the consent and concurrence of the said undertakers as expressed in their application addressed to the Secretary of the State Electricity Commission of Victoria, doth hereby revoke the said Order, such revocation to date from the 1st day of February, 1961.

And the Honorable George Oswald Reid, Her Majesty's Minister of Electrical Undertakings for the State of Victoria, shall give the necessary directions herein accordingly.

A. MAHLSTEDT,
Clerk of the Executive Council.

STATE ELECTRICITY COMMISSION ACTS.

At the Executive Council Chamber, Melbourne, the twenty-first day of March, 1961.

PRESENT:

His Excellency the Administrator of the Government of the State of Victoria.

Sir Thomas Maltby | Mr. Porter.
Mr. Thompson

ELECTRICAL APPROVALS REGULATIONS—APPROVAL OF EQUIPMENT, 1953, APPLIANCES TO BE SUBMITTED FOR APPROVAL:

PURSUANT to Section 51 of the *State Electricity Commission Act 1958*, His Excellency the Administrator of the Government of the State of Victoria, by and with the advice of the Executive Council thereof, and on the recommendation of the State Electricity Commission of Victoria, doth hereby prescribe the following class and type of electrical appliance and apparatus intended, suggested, or designed for use in, or for the purpose of, or for connexion to, any electrical installation, and that electrical appliances or apparatus of the said class or type shall not after the 2nd day of April, 1962, be sold, hired or exposed for sale or hire, or advertised for sale or hire, unless the appliance or apparatus has been approved by the State Electricity Commission of Victoria, and is stamped or labelled as prescribed, that is to say:—

Electric Blankets—

An electric blanket being a flexible electric heating appliance for operation at low or extra low voltage and primarily intended for the general application of heat to a bed and having a projected surface area exceeding six square feet, such surface area being the projected area (projected on to a horizontal plane on which the blanket is laid out flat) of that portion of the blanket containing the heating element; it shall not include the area of any marginal hems or flaps surrounding the portion in which the heating element is contained,

and further orders and prescribes that the fees for examining, testing and reporting to be paid to the State Electricity Commission of Victoria on application for approval of any article shall be the respective fees set out in the Table hereunder; and, moreover, that any person applying for approval of any article shall deliver

to the State Electricity Commission of Victoria, with his application for approval for the purpose of examination and testing, such number of samples of each articles for which approval is sought as is set out in the said Table and such further samples of unassembled parts as the Commission may by notice in writing require, which samples shall be labelled in compliance with the Electrical Approvals Regulations—Approval of Equipment, 1953.

TABLES ABOVE REFERRED TO.

Article.	Testing Fee.	Number of Samples to be Delivered to Commission.
	£ s. d.	
Electric Blanket	17 0 0	2 (two)
Electric Blanket with thermostats ..	22 10 0	2 (two)
Plastic covering of heating element—an additional	7 0 0	2 (two)
Where a device is included in an electric blanket and has not been approved under some other application—		
For each E.L.V. transformer—an additional	3 0 0	2 (two)
For each flexible cord—an additional ..	15 0 0	50 yards

And the Honorable George Oswald Reid, Her Majesty's Minister of Electrical Undertakings for the State of Victoria, shall give the necessary directions herein accordingly.

A. MAHLSTEDT,
Clerk of the Executive Council.

APPROACHING LAND SALES.

SALES of Crown lands, in fee-simple, will be held at the under-mentioned places and dates, viz.:—

	No. of Gazette.
Ararat.—Thursday, 6th April, 1961 ..	17
Bendigo.—Thursday, 13th April, 1961 ..	17
Echuca.—Monday, 17th April, 1961 ..	20
Manangatang.—Wednesday, 19th April, 1961 ..	20
Merino.—Friday, 28th April, 1961 ..	21

SALE BY AUCTION OF RIGHT TO LEASE CROWN LAND.

Melbourne.—Wednesday, 29th March, 1961 .. 13

SALE OF FREEHOLD LAND BY AUCTION.

Cohuna.—Monday, 17th April, 1961 .. 20
Koo-wee-rup.—Friday, 28th April, 1961 .. 21

SALE OF CROWN LAND BY AUCTION.

The land will be offered for sale in fee-simple, and subject to the provisions of the Land Act and Regulations thereunder.

The upset price is the sum at which bidding will start, and no bid below that sum can be accepted. The highest bidder at or above that sum shall be the purchaser, subject to signature of contract and any necessary payment.

TERMS:

A deposit of at least 12½% of the purchase price must be paid at the sale, either in cash or by cheque.

The residue is payable in half-yearly instalments, in accordance with the following scale, or may be paid off at any earlier time.

- £20 and under, 6 instalments.
- Over £20, and not exceeding £50, 8 instalments.
- Over £50, and not exceeding £100, 10 instalments.
- Over £100, and not exceeding £200, 12 instalments.
- Over £200, and not exceeding £300, 14 instalments.
- Over £300, and not exceeding £400, 16 instalments.
- Over £400, and not exceeding £500, 18 instalments.
- Over £500, 20 instalments.

Interest at the rate of 5% per annum is payable with all payments of residue, and is computed for each instalment from the date of sale to the date of such payment. Additional interest is charged if any instalment is not paid on or before the due date.

If paid off within 30 days of sale, no interest is payable.
FEES, ETC.:

Also payable at the sale, in addition to the deposit, are the survey fee and the valuation of improvements (if purchaser be not the owner thereof).

Payable with balance of purchase money—

Crown Grant fee—50 acres and under .. £1 10s.
 Over 50 acres £2
 Purchase money £5 or under £1

Assurance Fund contribution—One halfpenny for each £1 of purchase price. (This is a fund established to guarantee the validity of freehold titles.)

Transfer of interest prior to completion of payment may be allowed on payment of £1 fee and subject to stamp duty.

If unable to attend personally, a prospective purchaser may arrange for another person to bid as his agent.

KEITH TURNBULL,
 Commissioner of Crown Lands and Survey.
 Office of Crown Lands and Survey,
 Melbourne, 22nd March, 1961.

MERINO.—Sale (No. 11542) of Crown land in fee-simple, by auction, will be held at the COURT HOUSE, MERINO, on FRIDAY, the 28th APRIL, 1961, at THREE o'clock p.m. To be conducted by H. E. MICHELL, Land Officer, Hamilton.

TOWNSHIP OF MERINO, PARISH OF MERINO, COUNTY OF NORMANBY.

At the North-west corner of Burke and Annesley streets, being former Police Purposes Reserve.

Upsét price £200 the lot. Survey fee £6 12s. 6d.

Area 3 roods, allotment 10 of section 3. Valuation of improvements, £387 (six-roomed timber house, outbuildings, tanks, fencing, &c.). (Crown.)—(J.30530.)

SALE OF FREEHOLD LAND BY AUCTION.

KOO-WEE-RUP.—A sale, by auction, of freehold property, for and on behalf of the Minister of Education, will be held at the LAND INSPECTOR'S OFFICE, KOO-WEE-RUP, on FRIDAY, the 28th APRIL, 1961, at ELEVEN o'clock a.m. To be conducted by J. A. MURPHY, Land Officer, Melbourne.
 Lot 1.

PARISH OF YANNATHAN, COUNTY OF MORNINGTON.
 At Catani, fronting South-east side of Main-street, being Site and Buildings of Old Education Department Residence.

Upsét price, £1,248 the lot.

Area 1 rood, part of allotment 74, being lot 13 on plan of subdivision No. 9055, lodged in the Office of Titles, and being the land described in freehold certificate of title, volume 7115, folio 894, together with all improvements thereon.

CONDITIONS.

Deposit of at least 12½ per cent. payable at sale and balance within 60 days. Purchaser to arrange for, and bear costs of, registration of transfer of title.

Note.—Improvements on this property comprise a weatherboard dwelling of four rooms, plus bathroom, veranda, and detached washhouse.—(C.91335.)

PROPOSED REVOCATIONS OF TEMPORARY RESERVATIONS OF LANDS BY ORDERS IN COUNCIL.

IN pursuance of the provisions of the Land Act 1958, notice is hereby given that it is the intention of the Governor in Council to revoke the temporary reservations of lands by Orders in Council hereunder referred to, viz.:

The following Notices were published 1° on the 1st March, 1961, pursuant to Orders of the 21st February, 1961.

ECHUCA NORTH.—The temporary reservation, by Order in Council of the 13th January, 1930, of 20 acres of land in the Parish of Echuca North, as a site for Cattle Yards and Abattoirs.—(E.96(8) (Rs.3944).

ST. ARNAUD.—The temporary reservation, by Order in Council of the 14th December, 1926, of 27 2/10 perches of land in the Township of St. Arnaud, as a site for Drainage purposes.—(S.206(10) (Rs.3398).

KEITH TURNBULL,
 Commissioner of Crown Lands and Survey,

PROPOSED REVOCATIONS OF TEMPORARY RESERVATIONS OF LAND BY ORDERS IN COUNCIL.

IN pursuance of the provisions of the Land Act 1958, notice is hereby given that it is the intention of the Governor in Council to revoke the temporary reservations of land by Orders in Council hereunder referred to, viz.:

The following Notices were published 1° on the 15th March, 1961, pursuant to Orders of the 7th March, 1961.

ECHUCA.—The temporary reservation by Order in Council of the 21st December, 1921, of 7 acres 1 rood 17 perches of land in the Township of Echuca, as a site for Public purposes, revoked as to part by various Orders, so far only as the portion containing 21 perches indicated by hachure on plan hereunder are concerned.—(E3(8) (Rs.6175).

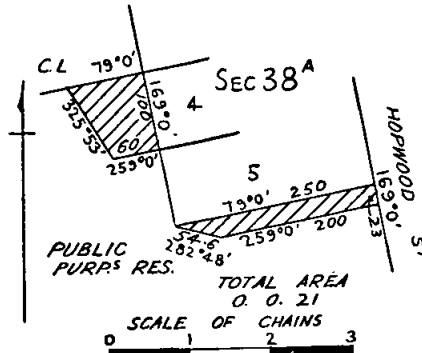

GLENMONA.—The temporary reservation, by Order in Council of the 18th August, 1908, of 44 acres 3 roods 13 perches of land in the Parish of Glenmona as a site for Watering purposes and for Supply of Gravel, revoked as to part by Order of the 14th April, 1915, so far only as the portion containing 1 rood 13 perches, indicated by hachure on plan hereunder, is concerned.—(G.155(8) (Rs.8026).

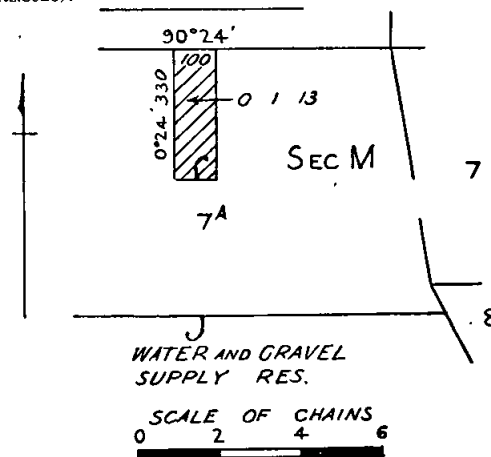

KEITH TURNBULL,
 Commissioner of Crown Lands and Survey.

PROPOSED REVOCATIONS OF TEMPORARY RESERVATIONS OF LANDS BY ORDERS IN COUNCIL.

IN pursuance of the provisions of the Land Act 1958, notice is hereby given that it is the intention of the Governor in Council to revoke the temporary reservations of lands by Orders in Council hereunder referred to, viz.:

The following Notices were published 1° on the 8th March, 1961, pursuant to Orders of the 28th February, 1961.

NOORILIM.—The temporary reservation, by Order in Council of the 15th December, 1899, of 2 roods of land in the Parish of Noorilim, as a site for a Public Hall.—(N.73(4) (Rs.5865).

SANDHURST.—The temporary reservation, by Order in Council of the 7th September, 1926, of 310 acres, more or less, of land in the Parishes of Huntly and Sandhurst,

as a site for Public purposes (Sewerage), revoked as to part by Order of the 24th July, 1945, so far only as the portion in the Parish of Sandhurst, containing 1 rood 30 perches, more or less, indicated by hachure on plan hereunder, is concerned.—(S.371⁽¹⁰⁾) (Rs.5790).

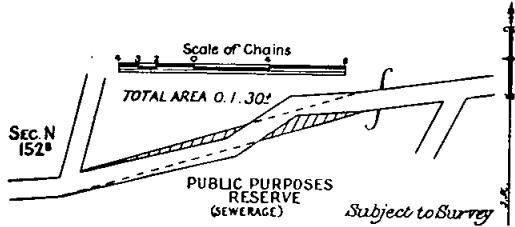

KEITH TURNBULL,
Commissioner of Crown Lands and Survey.

PROPOSED PERMANENT RESERVATION OF LAND AS A SITE.

IN pursuance of the provisions of the *Land Act 1958*, notice is hereby given that it is the intention of the Governor in Council to permanently reserve as a site the land hereunder referred to:—

The following Notice was published 1° on the 8th March, 1961, pursuant to Order of the 28th February, 1961.

MOOROOLBARK (Mt. DANDENONG).—Land to be permanently reserved as a site for an Arboretum, 3 acres 1 rood 22 perches, Parish of Mooroolbark, County of Evelyn, as indicated by hachure on plan hereunder.—(M.152⁽⁶⁾) (Rs.8024).

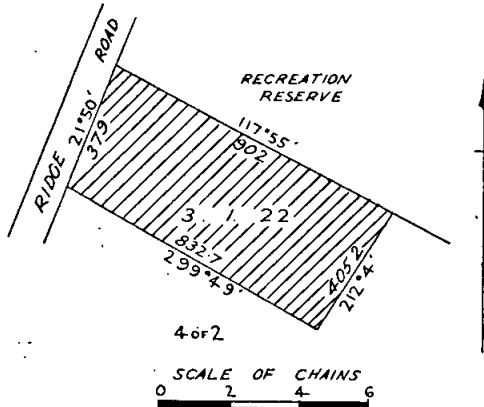

KEITH TURNBULL,
Commissioner of Crown Lands and Survey.

PROPOSED REVOCATION OF THE SETTING APART OF LAND BY ORDER IN COUNCIL.

IN pursuance of the provisions of the *Land Act 1958*, notice is hereby given that it is the intention of the Governor in Council to revoke the setting apart of land by Order in Council hereunder referred to, viz.:—

The following Notice was published 1° on the 22nd March, 1961, pursuant to Order of the 7th March, 1961.

AVOCA.—The setting apart, by Order in Council of the 9th January, 1860, of 2 acres of land in the Township of Avoca as a site for Market purposes.—(A.86⁽⁹⁾) (Rs.5711).

KEITH TURNBULL,
Commissioner of Crown Lands and Survey.

PROPOSED REVOCATION OF THE TEMPORARY RESERVATION, AND THE WITHHOLDING FROM SALE, LEASING, AND LICENSING OF LAND BY ORDER IN COUNCIL.

IN pursuance of the provisions of the *Land Act 1958*, notice is hereby given that it is the intention of the Governor in Council to revoke the temporary reservation, and the withholding from sale, leasing and licensing, of land by Order in Council hereunder referred to, viz.:—

The following Notice was published 1° on the 22nd March, 1961, pursuant to Order of the 7th March, 1961.

INGLEWOOD.—The temporary reservation as a site for Municipal purposes and Public Gardens and the withholding from sale, leasing and licensing by Orders in

Council of the 18th September, 1882, and 29th May, 1883 (see *Government Gazettes* 1882, page 2319, and 1883, page 1117) of 1 acre 2 roods 3½ perches of land in the Township of Inglewood, are about to be revoked.—(14⁽⁴⁾) (Rs.8006).

KEITH TURNBULL,
Commissioner of Crown Lands and Survey.

LOCAL LAND BOARDS.

IN pursuance of the provisions of section 34 of the *Land Act 1958*, notice is hereby given that public hearings at the following places and times, will be conducted by the persons respectively mentioned, being duly appointed in that behalf.

KEITH TURNBULL,
Commissioner of Crown Lands and Survey,
Department of Crown Lands and Survey,
Melbourne, 21st March, 1961.

SCHEDULE.

- MELBOURNE BOARD ROOM, 2ND FLOOR, TREASURY BUILDINGS, Friday, 7th April, 1961, at 10.30 a.m.—R. A. Walker, J. A. Murphy.
- BAIRNSDALE LAND OFFICE, Monday, 10th April, 1961, at 10 a.m.—W. C. Harry.
- ORBOST LAND INSPECTOR'S OFFICE, Wednesday, 12th April, 1961, at 10.30 a.m.—W. C. Harry.
- CANN RIVER PUBLIC HALL, Thursday, 13th April, 1961, at 11 a.m.—W. C. Harry.
- MALLACOOTA PUBLIC HALL, Thursday, 13th April, 1961, at 3 p.m.—W. C. Harry.
- BUCHAN LAND INSPECTOR'S OFFICE, Monday, 17th April, 1961, at 11 a.m.—W. C. Harry.

LAND AVAILABLE UNDER THE SOLDIER SETTLEMENT ACT.

NOTIFICATION is hereby given in accordance with Section 50 of the *Soldier Settlement Act 1958*, that the under-mentioned holdings are available for settlement.

Any discharged serviceman who has applied to the Commission on or before the 22nd March, 1961, for classification in the required class or classes of primary production for which the holdings are made available and whose application has been accepted but not necessarily finalized, or any discharged serviceman who has been classified as suitable in such class of primary production, may apply on the prescribed form for settlement on the holdings.

The prescribed application forms, plans and further particulars may be obtained from the Enquiry Branch, Soldier Settlement Commission, State Public Offices, Melbourne. The closing date for the receipt of completed applications for settlement on these holdings is the 10th April, 1961, such applications to be in the hands of the Secretary, Soldier Settlement Commission, on or before that date.

I. K. MORTON,
Secretary.

Soldier Settlement Commission,
Melbourne, 20th March, 1961.

SCHEDULE OF ALLOTMENTS.

PORTION OF "WEERANGOURT" ESTATE.

PARISH OF WEERANGOURT, COUNTY OF NORMANBY.

Suitable for Grazing (Sheep) and Mixed Farming with some Dairying.

Lot Number on Plan of Subdivision.	Area.
	A. B. P.
8	330 3 30

PORTION OF HORSHAM IRRIGATION SETTLEMENT AREA.

PARISH OF BUNGALALLY, COUNTY OF BORUNG.

Suitable for Establishment of Lucerne and Pasture Under Irrigation for Dairying.

Lot Number on Plan of Subdivision.	Area.
	A. B. P.
91c	101 2 20

Land Settlement Act 1959.

LAND AVAILABLE FOR APPLICATION.

NOTIFICATION is hereby given in accordance with Section 7 of the *Land Settlement Act 1959*, that the under-mentioned holdings are available for settlement.

Any male person who is not less than 21 years of age and who is a British subject may apply on the prescribed form for settlement on any holding or holdings, indicating where he applies in respect of more than one holding his order of preference therefor.

Prescribed application forms, plans and further details may be obtained from the Enquiry Branch, Soldier Settlement Commission, Public Offices, Melbourne, C.2. Closing date for receipt of completed application forms for settlement on these holdings is the 10th April, 1961. Such applications to be in the hands of the Secretary, Soldier Settlement Commission, on or before that date.

I. K. MORTON,
Soldier Settlement Commission, Secretary,
Melbourne, C.2, 14th March, 1961.

SCHEDULE OF ALLOTMENTS.

SUBDIVISION OF FIRST PORTION OF EAST GOULBURN IRRIGATION SETTLEMENT AREA.

PARISH OF DUNBULBALANE—COUNTY OF MOIRA.

Suitable for the Growing of Soft Fruits under Irrigation.

Lot Number on Plan of Subdivision.	Approximate Area in Acres (Subject to Survey).
4	49
5	55
6	45
7	48
8	52
9	64
10	50
11	51
12	52
13	46
14	45
15	45
16	45
17	45
18	47
19	51
20	52
21	48
22	59
23	62
24	50
25	61

REVOCATION OF THE APPOINTMENT OF THE COMMITTEE OF MANAGEMENT OF THE "KALLISTA PUBLIC PARK".

WHEREAS by section 221 of the *Land Act 1958* it is provided that it shall be lawful for the Governor in Council or the Board of Land and Works to appoint any number of persons, not less than three, or any municipal council, or the governing body of any corporation, to be a Committee of Management of any specified Crown land reserved either temporarily or permanently for any of the purposes set out in section 14 of the *Land Act 1958*, and not conveyed to or vested in trustees, and to remove any or all of the persons so appointed, or revoke the appointment of any such Council or body: Now therefore the Board of Land and Works doth hereby revoke the appointment of the Council of the Shire of Fern Tree Gully as a Committee of Management of the land in the Parish of Monbulk temporarily reserved by Order in Council of the 14th August, 1956, as a site for a Public Park, and known as the "Kallista Public Park"—(Corres. Rs.7462.)

In witness whereof the common seal of the Board of Land and Works was hereunto affixed this ninth day of March, One thousand nine hundred and sixty-one, in the presence of—

(SEAL) KEITH TURNBULL, President.
F. H. KLENNER, Member.

COMMITTEES OF MANAGEMENT OF RESERVES.

APPOINTMENTS.

WHEREAS by section 221 of the *Land Act 1958* it is provided that it shall be lawful for the Governor in Council or the Board of Land and Works to appoint and remove any number of persons, not less than three, or any municipal council, or the governing body of any corporation, to be a Committee of Management of any specified Crown land reserved either temporarily or permanently for any of the purposes set out in section 14 of the *Land Act 1958*, and not conveyed to or vested in trustees: Now therefore the Board of Land and Works doth hereby appoint the under-mentioned persons to be members of the Committee of Management of the Reserves named:—

"WODONGA RACECOURSE AND RECREATION RESERVE."

Jack Stanley Hore, Keith Chapman, Gerald Thomas Tanner, Desmond Martin, Daniel Joseph Goonan, Arthur Bligh Smith Collins, Arthur Gordon Richardson, James Morgan Harvey, James Wilfred McGrath, Neil Joseph O'Keeffe, Ernest Barrett Mann, Charles Felix Pollard, Keith Hartwig, John Maher, Thomas Gordon Seymour White, Robert Richardson, Cyril Anthony Collins and Dudley John Schubert, as a Committee of Management for a period of three (3) years of the land temporarily reserved for a Racecourse, Showground and Public Recreation Ground in the Parish of Wodonga, and known as the "Wodonga Racecourse and Recreation Reserve".—(Corres. Rs.1734.)

"MILLOO RECREATION RESERVE."

Robert Starritt Rankin, George Marshall, Maurice Brendan Tuohy, Thomas Henry Appleby, Samuel Appleby, William Gilbert Elliott, Reginald Thomas Harry, John Archibald Wilson, and Edmund Paul Mitchell as a Committee of Management for a period of three (3) years from 27th March, 1961, of the lands temporarily reserved by Orders in Council dated the 13th September, 1880, and 29th May, 1894, for Cricket and Other purposes of Public Recreation in the Parish of Milloo, and known as the "Milloo Recreation Reserve".—(Corres. Rs.4236.)

"WENDON PARK TOURIST CAMP RESERVE."

Folmer Charles Jensen, George McKinnell, Dugald McIntyre, Walter John Gray and Arthur William Fraser as a Committee of Management for a period of three (3) years of the land temporarily reserved by Order in Council dated 18th December, 1947, as a site for Tourist Camping purposes in the Parish of Goolengook, together with the adjoining permanent reservation along the Bemm River, as shown coloured red and blue on plan "G" 8.12.47, attached to Lands Department Correspondence Rs.6087, and known as "Wendon Park Tourist Camp Reserve".—(Corres. Rs.6087.)

"COMBIENBAR PUBLIC RECREATION AND PUBLIC HALL RESERVE."

Samuel Albert Clay in the place of William Michael Shiels (resigned) as a member of the Committee of Management for the period ending the 23rd March, 1963, of the land in the Parish of Combiensbar, temporarily reserved by Orders in Council dated the 20th July, 1925, and the 22nd December, 1953, as a site for Public Recreation and Public Hall.—(Corres. Rs.3150.)

"LAH RECREATION RESERVE."

Colin Thewlis, Frederick Lewis Dart, Allan Walter Vaughan, Bruce Kennedy, D. P. Dunn, Walter Lyndon Vaughan, R. J. Lang, Thomas Archer Harrop and Peter Thewlis as a Committee of Management for a period of three (3) years of the land temporarily reserved by Order in Council dated 6th February, 1929, as a site for Public Recreation in the Parish of Warracknabeal, and known as the "Lah Recreation Reserve".—(Corrs. Rs.3798.)

"CONCONGELLA HALL SITE."

Allan G. Holden, Charles F. Oliver, Albert E. Thomas, Doris C. Chapman and Thomas G. Shirreff as a Committee of Management for a period of three (3) years of the land in the Parish of Stawell, temporarily reserved by Order in Council dated the 16th August, 1960, as a site for a Public Hall, and known as the "Concongella Hall Site".—(Corres. Rs.7965.)

"THE STAWELL SEWERAGE RESERVE."

The Stawell Sewerage Authority, as a Committee of Management of the land temporarily reserved by Order in Council dated the 14th February, 1961, as a site for Sewerage purposes in the Parish of Illawarra.—(Corres. Rs.8013.)

"PRINCETOWN PUBLIC HALL RESERVE."

Jasmine Queenie Currell, Margaret Winsome Bowker, Dorothy May Webber, Bridget Mary Till, Kezia Maude Grace Till, Frederick Henry Ford and William John Till as a Committee of Management for a period of three (3) years of the land temporarily reserved by Order in Council of the 13th July, 1885, as a site for a Public Hall in the Township of Princetown, and known as the "Princetown Public Hall Reserve".—(Corres. Rs.1898.)

"DUNKELD MEMORIAL PARK" AND "DUNKELD TOURIST CAMPING RESERVE."

Kenneth Sleeman, John Stanley Brudenell Young Woodburn and Keith James Crawford (for a period of three (3) years), and Ernest John Baxter, Donald Stewart Gale and Reuben George Schache (for so long only as they continue to be members and the elect of the Dunkeld Development League), and Charles Thomas Rochfort (for so long only as he continues to be a Councillor and the elect of the Council of the Shire of Mount Rouse) as a Committee of Management of the land in the Township of Dunkeld temporarily reserved as a site for Public Recreation and Gardens by Order in Council dated the 19th October, 1954, and known as the "Dunkeld Memorial Park", and also of the land in the Parish of Dunkeld temporarily reserved as a site for Tourist Camping purposes of the same date together with the abutting reserved frontage to the Wannan River, and known as the "Dunkeld Tourist Camping Reserve".—(Corres. Rs.7171, Rs.7179.)

"ST. HELEN'S RECREATION RESERVE."

Alfred Sherlock, Otto James Carter, Victor Charles Humphrys, Kevin Alfred Humphrys and Alec Victor Edward Edwards as a Committee of Management for a period of three (3) years of the land in the Parish of St. Helen's temporarily reserved by Order in Council dated the 21st June, 1960, as a site for Public Recreation, and known as the "St. Helen's Recreation Reserve".—(Corres. Rs.2006.)

"THOMSON PUBLIC RECREATION RESERVE."

Ronald Henry Robertson, Henry Albert Harvey, Frank Lindsay Bradhurst, James Albert Hussey, Herbert Charles Barnes, George Mills Brew and Donald Bentley as a Committee of Management for a period of three (3) years of the land in the City of Geelong temporarily reserved as a site for Public Recreation by Order in Council dated the 3rd August, 1954, and known as the "Thomson Public Recreation Reserve".—(Corres. Rs.7240.)

"PERONNE MEMORIAL HALL."

William Hans Roy Stehn, Carl Ernest Block, Albert Ernest Stehn, William Albert Burns and Matthew John Cuming as a Committee of Management for a period of three (3) years of the land in the Parish of Mortat temporarily reserved as a site for a Public Hall by Order in Council dated 2nd February, 1955, and known as the "Peronne Memorial Hall Reserve".—(Corres. Rs.7331.)

"BALLARAT SHOWGROUNDS AND RECREATION RESERVE."

C. R. James in the place of Harold Richard Milne (resigned) for so long only as he continues to be the representative of the Ballarat and District Trotting Club as a member of the Committee of Management of the land permanently reserved by Order in Council dated the 9th September, 1935, as a site for Show-yards and Public Recreation in the Parish of Ballarat, and known as the "Ballarat Showgrounds and Recreation Reserve".—(Corres. Rs.2348.)

"HAMILTON SHOWGROUNDS."

Andrew Garfield Gardner, James Alexander Hanson and James Simpson Young as a Committee of Management for a period of three (3) years of the lands in the municipal district of Hamilton temporarily reserved by Orders in Council dated 24th April, 1883, and 16th April, 1889, as a site for the Hamilton Pastoral and Agricultural Society's Show-yards, and known as "Hamilton Showgrounds Reserve".—(Corres. Rs.3575.)

In witness whereof the common seal of the Board of Land and Works was hereunto affixed this ninth day of March, One thousand nine hundred and sixty-one, in the presence of—

(SEAL) KEITH TURNBULL, President.
F. H. KLENNER, Member.

Land Act 1958.

LEASES SURRENDERED.

NOTICE is hereby given that the Governor in Council has accepted the surrender of the Lease mentioned in the schedule hereunder for the reason specified.

District.	Corr No.	Name.	Section of Land Act under which Leased.	Parish.	Allotment.	Section.	Area.	Class.	Reason.
Melbourne	0550/125	Henry Berry and Company (Australia) Limited	125	Melbourne South	Balance allot. 8	55F	A. R. P. 2 3 39 ¹ / ₁₀	..	Surrendered as from 12th January, 1961 (New lease to issue)

Department of Crown Lands and Survey,
Melbourne, 14th March, 1961.

KEITH TURNBULL,
Commissioner of Crown Lands and Survey.

THE CLOSER SETTLEMENT ACT 1958.

THE Farm Allotment mentioned in the Schedule hereunder is hereby proclaimed available for application, and may be taken up under Closer Settlement Lease.

Parish.	Allotment.	Section.	Area.	Monetary Liability.	Deposit, Including Lease and Registration Fees.	Term of Lease.	Remarks.
Borwick	2	4	A. R. P. 21 2 9	£ s. d. 5,822 0 0	£ s. d. 583 5 0	35½ years	Quarterly Instalment £72 1s. 0d. Survey fee £13 12s. 6d. Improvements £132 to be paid for in addition. Subject to Drainage Easements 20 links wide on North, West and East boundaries. Subject to residue and non-assignment conditions

Department of Crown Lands and Survey,
Melbourne, 21st March, 1961.

KEITH TURNBULL,
Commissioner of Crown Lands and Survey.

LIST OF CROWN LANDS AVAILABLE.

THE under-mentioned areas are available for application as provided by various sections of the Land Act 1958, and all applications received on or before Wednesday, 19th April, 1961, will be deemed to have been made simultaneously, but any application lodged after such date may be considered if received in time for inclusion in the advertisement of the cases to be heard at the Local Land Board. Applications on proper form, accompanied by 5s. duty stamp uncancelled (registration fee), may be delivered or forwarded by post to the Local Land Officer or to any Crown Lands Office in Victoria. Subject to the approval of the Secretary for Lands, when the survey fee exceeds £25 but does not exceed £50, a deposit of £25 may be paid, and when the fee exceeds £50, a deposit of 50 per cent. of the fee, the balance in either case being payable over six years in half-yearly instalments.

Marked plans of any particular area, application forms, and any further information may be obtained from the Crown Lands Department, Melbourne, and Land Office, Bendigo.

Department of Crown Lands and Survey,
Melbourne, 21st March, 1961.

KEITH TURNBULL,
Commissioner of Crown Lands and Survey.

* Improvements may be subject to re-valuation after land has been granted to an applicant.

Local Land Office.	County.	Parish.	Allotment.	Section.	Area.	How Available.		Survey Fee.	Valuation of improvements (if any).	Location of Land, &c.	Nearest Railway Station or Township and Distance in miles therefrom.	How Accessible.	Water Supply.	General Description of Land—Soil, Timber, Suitability (Grazing, &c.).			
						Classification.	Value per Acre.										
						A.	B.	F.									
						£	s.	d.	£	s.	d.	£	s.	d.			
Bendigo (a), (b).	Talbot	Drummond	15, 15A, 15B, & 15C	2	19 0 0±	3rd	3 10 0	30 7 6	—	In the south-east of the Parish adjoining State Forest	Mainsbury township 3 miles	By road	To be conserved	Undulating sandstone and shale with thin soil, covered with gorse and native grass. Timber cover is of yellow box, messmate and manna gum of firewood quality.			

AGRICULTURAL AND GRAZING LANDS—SELECTION PURCHASE ALLOTMENTS.

DIVISION 4, PART I, LAND ACT 1958.

(a) Subject to survey. (b) Subject to mining condition.

PUBLIC SERVICE NOTICES

PUBLIC SERVICE (PUBLIC SERVICE BOARD) REGULATION 39.—RECLASSIFICATIONS.

THE Public Service Board has raised the classification of the under-mentioned offices as shown, and the Permanent Heads of the Departments have recommended the officers named for appointment.

Office and Present Classification.	Revised Classification.	Duties.	Qualifications.	Officer Recommended for Appointment.		
				Name.	Classification.	Date of Classification.

PROFESSIONAL DIVISION.

DEPARTMENT OF AGRICULTURE.

Potato Expert, Class "B1"	Class "A"	To advise on potato culture; to supervise the development and operation of the State Potato Research Station, Healesville, and the planning and conduct of potato experimental projects and the Potato Seed Certification Scheme; to lecture and prepare radio scripts, journal and press articles, and demonstrations	A Diploma of an Agricultural College; sound knowledge of the theory and practice of potato growing; extensive experience in the conduct of potato experimental and advisory work; experience in lecturing and the preparation of articles for publication	Mattingley, G. H.	Potato Expert, Class "B1"	3.2.55
---------------------------	-----------	--	---	-------------------	---------------------------	--------

TECHNICAL AND GENERAL DIVISION.

TREASURY.

Taxation (Land Tax) Office.

Assistant (Male), Grade II., Grades 16-21 inclusive (two offices)	Assistant (Male), Grade I., Grades 23-25 inclusive (two offices)	To assist Valuers in the keeping and filing of records, particularly in regard to sales information; to prepare plans and deal with correspondence	To be capable of preparing plans for identification of lands; a good knowledge of and experience in office procedure; a sound knowledge of the metropolitan area and the State of Victoria is desirable	Clark-Troy, S. H. N.	Assistant (Male), Grade II. Assistant (Male), Grade II.	26.8.57 2.9.60
				Vink, G. E.		

DEPARTMENT OF CROWN LANDS AND SURVEY.

Machinist (Female), Grade III., Grades F19-F21 inclusive	Machinist (Female), Senior, Grades F24-F26 inclusive	To draw cheques and post the Cash Book and Expenditure Journal of the Soldier Settlement Loan Account; to post accounts for salaries, wages, and allowances	To be an efficient and experienced Remington and Burroughs Accounting Machines operator	Micklethwait, Muriel G. (Mrs.)	Machinist (Female), Grade III.	1.2.55
--	--	---	---	--------------------------------	--------------------------------	--------

Appeals against such recommendations should be lodged with the Secretary to the Public Service Board not later than Saturday, the 1st April, 1961.

Office of the Public Service Board,
Melbourne, 21st March, 1961.

By order,
V. P. SCULLY,
Secretary.

PUBLIC SERVICE (PUBLIC SERVICE BOARD) REGULATION 39.—VACANCY.

THE Permanent Head of the Department shown has recommended the officer named hereunder for appointment to the under-mentioned vacancy.

Office and Classification.	Duties.	Qualifications.	Officer Recommended for Appointment.		
			Name.	Classification.	Date of Classification.

TECHNICAL AND GENERAL DIVISION.

DEPARTMENT OF CROWN LANDS AND SURVEY.

Photographer, Grade II., Grades 24-30 inclusive	To carry out all types of photographic work, particularly copying maps, plans, documents, aerial photographs, mosaics, and other subjects, and prepare contact prints and enlargements; to assist in the training of juniors	A competent photographer with a good knowledge of all branches of photography and skill in copying, printing, and enlarging	Thomas, W. T.	Photographic Assistant (Male), Grades 13-20 inclusive	15.1.58
---	--	---	---------------	---	---------

Appeals against such recommendation should be lodged with the Secretary to the Public Service Board not later than Saturday, the 1st April, 1961.

Office of the Public Service Board,
Melbourne, 21st March, 1961.

By order,
V. P. SCULLY,
Secretary.

PUBLIC SERVICE OF VICTORIA.—VACANCIES.

APPLICATIONS will be received by the Public Service Board up to Wednesday, the 5th April, 1961, from persons employed in the Public Service of Victoria, who are eligible and qualified, for appointment to the under-mentioned positions:—

ADMINISTRATIVE DIVISION.

Class "B", Department of Crown Lands and Survey.

Yearly Salary.—£1,390, minimum; £1,500, maximum.

Duties.—To be responsible for the payment of expenditure incurred by the Department and the Soldier Settlement Commission and to control the receipt and banking of moneys received by both Authorities. To prepare estimates of revenue and expenditure.

Qualifications.—A qualified accountant with a good knowledge of the financial provisions of the Acts administered by the Department and the Commission and of the regulations governing departmental accounts.

Class "C2", Water Supply Department.

Yearly Salary.—£1,170, minimum; £1,280, maximum.

Duties.—To control stores materials for the Goulburn Valley Channel Enlargement works; to keep appropriate records; to control the transport of men, materials and plant engaged on the project.

Qualifications.—To be conversant with the various types of stores, materials, tools, &c., used on a large construction project, and to have a good knowledge of the operation of a large store containing stocks of building materials, timber, iron and steel, workshop requirements, machinery parts and electrical fittings.

NOTE.—A house is available for the successful applicant, if married, for which a rental of 10 per cent. of standard salary, plus £16 a year, will be charged. Particulars available from the Department of Water Supply.

Class "C1", Office of the Chief Commissioner of Police, Chief Secretary's Department.

Yearly Salary.—£960, minimum; £1,060, maximum.

Duties.—To maintain continuous stock checks and reconciliations of ledger records and physical stocks at the General Store, Transport Store, and Radio Store. To examine requisitions from Police Stations for stores and inspect receipt and issue vouchers.

Qualifications.—Administrative ability and a good knowledge of Part V. of the Public Accounts and Stores Regulations 1958. Some practical stores experience is desirable.

Class "C", Office of the Housing Commission, Treasury.

Yearly Salary.—£710, minimum; £860, maximum.

Duties.—To be responsible for the control and maintenance of the Commission's vehicles and the keeping of relevant records.

Qualifications.—Capacity to control a large transport fleet and ability to maintain the necessary records. Experience in transport work desirable.

Class "C", Accounts Branch, Education Department.

Yearly Salary.—£710, minimum; £860, maximum.

Duties.—To pass teachers' salaries for payment, including the computation of increments, and allowances payable under the Teaching Service Regulations; to deal with correspondence and inquiries relating to salaries.

Qualifications.—A knowledge of the relevant portions of the Public Service and Teaching Service Acts and regulations.

Class "C", Education Department.

Yearly Salary.—£710, minimum; £860, maximum.

Duties.—To arrange for the medical examination of members of the Teaching Service and applicants for appointment; to deal with reports submitted by the School Medical Officers.

Qualifications.—Ability to conduct correspondence and interviews. A knowledge of the Superannuation Board's requirements relating to medical examinations is desirable.

Class "C", Department of Agriculture.

Yearly Salary.—£710, minimum; £860, maximum.

Duties.—To be responsible for the collection of Agricultural College students' fees and to keep the relevant accounts; to keep staff and students'

records and prepare statistical returns as required, check salaries and wages sheets and requisitions for stores; to perform other duties as required.

Qualifications.—A good knowledge of and experience in Public Accounts procedure and a knowledge of the Public Service Act and Regulations.

Class "C", Burnley Horticultural College, Department of Agriculture.

Yearly Salary.—£710, minimum; £860, maximum.

Duties.—Under the Principal to be responsible for the supervision and control of the College office; the collection and banking of Revenue, the recording of Expenditure; the keeping of the Pupils' Account, the maintenance of inventories of assets and the accounting of the receipt and issue of stores and materials; to prepare pay-sheets and tax records; to perform clerical duties as required.

Qualifications.—A good knowledge of the Public Accounts and Stores Regulations; to be conversant with relevant sections of the Public Service Act and Regulations; ability to control staff. Experience in the procedures applicable to an educational institution is desirable.

PROFESSIONAL DIVISION.

Stipendiary Magistrate, Grade I, Class "A1", Courts Branch, Law Department.

Yearly Salary.—£3,075.

Qualifications.—As prescribed by Public Service (Public Service Board) Regulation 45.

Stipendiary Magistrate, Grade II, Class "A1", Courts Branch, Law Department.

Yearly Salary.—£2,850.

Qualifications.—As prescribed by Public Service (Public Service Board) Regulation 45.

School Dental Officer, Classes "A"—"A1", Maternal and Child Welfare Branch, Department of Health. (Eight vacancies.)

Yearly Salary.—£1,920, minimum; £2,600, maximum.

Duties.—To perform Dental duties as directed at School Dental Centres and Children's Institutions and to visit country areas with Mobile Dental Units.

Qualifications.—A legally qualified dentist, registered in Victoria, with appropriate dental experience.

Senior Psychologist, Classes "B"—"A", Royal Park Research Centre, Mental Hygiene Branch, Department of Health.

Yearly Salary.—£1,390, minimum; £2,060, maximum. (Commencing salary in accordance with qualifications and experience.)

Duties.—Under the Chief Clinical Officer, to carry out research.

Qualifications.—A degree of an approved University with honours in Psychology (double major) and preferably an appropriate post-graduate degree. Experience in research and social psychology.

Draughtsman, Classes "C"—"C1", Public Works Department.

Yearly Salary.—£710, minimum; £1,060, maximum.

Duties.—To prepare, under direction, plans and specifications of electrical installations in all types of public buildings.

Qualifications.—A sound technical training in electrical engineering and several years' drawing office experience in the design and layout of electric light and power installation, &c.; the pre-requisite qualifications prescribed in paragraphs (a) and (b) of Public Service (Public Service Board) Regulation 23.

TECHNICAL AND GENERAL DIVISION.

Orchard Supervisor, Grade I, Department of Agriculture.

Yearly Salary.—£846, minimum; £894, maximum.

Duties.—To inspect, pursuant to the Vegetation and Vine Diseases and Fruit and Vegetables Acts 1958, orchards, nurseries, markets, &c., to advise fruit growers on all phases of orchard work; and to take charge of a Grade 1 supervision district.

Qualifications.—A wide knowledge of Victorian orcharding; experience in orchard supervision; a thorough knowledge of insect and fungous pests and of the Acts and Regulations administered by the Horticultural Division of the Department; and to have passed the prescribed examination.

Orchard Supervisor, Grade II, Department of Agriculture.

Yearly Salary.—£718, minimum; £846, maximum.
Duties.—To inspect, pursuant to the Vegetation and Vine Diseases and Fruit and Vegetables Acts 1958, orchards, nurseries, markets, &c., and to advise fruit growers on all phases of orchard work.
Qualifications.—A good practical knowledge of fruit growing; a sound knowledge of insect and fungous diseases and the Acts and Regulations administered by the Horticultural Division of the Department; and to have passed the prescribed examination.

Field Officer, Department of Agriculture.

Yearly Salary.—
 Junior—at 17 years of age, £241;
 at 18 years of age, £324;
 at 19 years of age, £368;
 at 20 years of age, £420.
 Adult—£654, minimum; £798, maximum.
 (Commencing salary will be determined within this initial range according to experience, but advancement is not limited to the maximum quoted.)
Duties.—To assist with the experimental work conducted by the Biology Branch and any other work required by the Chief Biologist.
Qualifications.—Diploma of an Agricultural or Horticultural College or equivalent.

Note.—Field Officers are eligible for appointment to the position of Field Officer, Senior—salary range £846-£942—and on passing a qualifying examination for appointment to the Professional Division as Experimental Officer—salary range £810-£1,280.

Crier, Sheriff's Office, Law Department.

Yearly Salary.—£398, minimum; £510, maximum.
Duties.—To attend in Court, to administer oaths in connexion with the business of the Court, to clean the Courts and to carry out the instructions of the presiding Judge.

Storeman, Grade II, Office of the Chief Commissioner of Police, Chief Secretary's Department. (Three vacancies.)

Yearly Salary.—£382, minimum; £398, maximum.
POSITION No. 1.
Duties.—To drive the delivery truck operated by the General Store, and deliver and collect goods, and to assist generally in the Store as required.
Qualifications.—To hold a current driver's licence, to be energetic and capable of handling heavy parcels.

POSITION No. 2.

Duties.—To assemble and pack stores for distribution to Police Stations and assist generally in the General Store as required.
Qualifications.—To be energetic and capable of handling heavy parcels. Some previous experience in the handling of stores would be an advantage.

POSITION No. 3.

Duties.—To serve motor vehicle parts and accessories over the counter of the Transport Store to mechanics and assist generally in the Store as required.
Qualifications.—Some knowledge of modern motor vehicle parts and accessories and capable of keeping neat and accurate records.

Labourer, Senior (Bendigo Public Offices), Public Works Department.

Yearly Salary.—£350, minimum; £382, maximum.
Duties.—To perform cleaning and labouring duties and take charge of labourers as required; to act as storeman in the Departmental store.
Qualifications.—Experience in the maintenance and cleaning of public buildings and in the care of stores.

Note.—The salary rates quoted above do not include the additional amount which is payable under Regulation 77A of the Board's Regulations.

By order,
 V. P. SCULLY,
 Secretary.

Office of the Public Service Board,
 Melbourne, 21st March, 1961.

PUBLIC SERVICE OF VICTORIA.—VACANCIES.

(TEMPORARY APPOINTMENTS.)

APPLICATIONS will be received by the Public Service Board up to Wednesday, the 5th April, 1961, from persons who are qualified for appointment to the under-mentioned positions:—

Carpenter, Public Works Department. (Two vacancies.)

Yearly Salary.—£510.
Duties.—To undertake carpentering duties as required.
Qualifications.—A qualified carpenter and joiner, competent to carry out repairs to office and school furniture.

Note.—The salary rate quoted above does not include the additional amount which is payable under Regulation 77A of the Board's Regulations.

By order,
 V. P. SCULLY,
 Secretary.

Office of the Public Service Board,
 Melbourne, 21st March, 1961.

PUBLIC SERVICE OF VICTORIA.—VACANCY.

DEPARTMENT OF HEALTH.

MENTAL HYGIENE BRANCH.

TECHNICAL AND GENERAL DIVISION.

APPLICATIONS will be received by the Public Service Board up to Wednesday, the 12th April, 1961, from persons employed in the Public Service of Victoria, who are eligible and qualified for appointment to the under-mentioned position:—

General Assistant, Kew Mental Hospital.

Yearly Salary.—£382, minimum; £414, maximum.
Duties.—To give general assistance in the various artisan activities connected with the Hospital services and maintenance.
Qualifications.—To be a semi-skilled worker in good physical condition. Knowledge of some trade desirable.

Note.—The salary rates quoted above do not include the additional amount which is payable under Regulation 77A of the Board's Regulations.

By order,
 V. P. SCULLY,
 Secretary.

Office of the Public Service Board,
 Melbourne, 21st March, 1961.

No. 1098.

Public Service Act 1958, Section 50.

REGULATIONS.—PART III.—SALARIES, INCREMENTS AND ALLOWANCES.

THE Public Service Board, in pursuance of the powers conferred by the *Public Service Act 1958*, hereby amends its Regulations as shown below:—

SIXTH SCHEDULE.

TEMPORARY EMPLOYEES.

Designations of Position and Rates of Salaries.

Department and Designation of Position.	Yearly Rate of Salary.		Increments (Annual).
	Minimum.	Maximum.	
	£	£	
DEPARTMENT OF AGRICULTURE.			
<i>Delete</i> — Film Editor (Female) ..	572	636	2 of £32
<i>Add</i> — Film Editor (Female) ..	588	684	3 of £32

A. GARRAN, Chairman.
 V. P. SCULLY, Secretary.

Office of the Public Service Board,
 Melbourne, 6th March, 1961.

Teaching Service Act 1958.

TEACHING SERVICE (TEACHERS TRIBUNAL) REGULATIONS.

AMENDMENT No. 9.

THE Teachers Tribunal, in pursuance of the powers conferred by the *Teaching Service Act 1958*, hereby amends Regulation 1 of the Teaching Service (Teachers Tribunal) Regulations in the manner following, that is to say:—

REGULATION 1.

Rescind clause 10 and substitute therefor the following clause:—

10. The following shall be the scale of commuted reimbursements to cover personal expenses of District Inspectors using their own or Government-owned motor cars on official business:—

Inspectorate.	Own Car. £'s a year.	Government-owned Car. £'s a year.
Balwyn	140	Nil
Broadmeadows	150	Nil
Brunswick	140	Nil
Camberwell	130	Nil
Carlton	140	Nil
Caulfield	120	Nil
Collingwood	130	Nil
Dandenong	150	Nil
Essendon	150	Nil
Footscray	140	Nil
Hawthorn	140	Nil
Heidelberg	150	Nil
Malvern	120	Nil
Mentone	130	Nil
Moorabbin	130	Nil
Oakleigh	130	Nil
Preston	130	Nil
Reservoir	150	Nil
Ringwood	150	Nil
St. Kilda	120	Nil
Sunshine	160	Nil
Bairnsdale	600	90
Ballarat	160	Nil
Beechworth	560	100
Benalla	425	Nil
Bendigo	275	10
Castlemaine	450	60
Colac	425	30
Corio	380	5
Echuca	420	60
Frankston	260	5
Geelong	105	Nil
Hamilton	480	80
Horsham	525	60
Leongatha	425	40
Lilydale	260	40
Maryborough	400	10
Mildura	430	80
Pakenham	360	Nil
Seymour	600	100
Shepparton	390	Nil
Stawell	525	60
Swan Hill	500	110
Traralgon	400	20
Warragul	325	Nil
Warrnambool	390	Nil

(To take effect from and including the 19th March, 1961.)

LOUIS F. C. GARLICK, Chairman.

G. FENNELL, Secretary.

Office of the Teachers Tribunal,
Melbourne, 17th March, 1961.

TENDERS—PUBLIC WORKS DEPARTMENT

TENDERS will be received at this Department until **TEN a.m.**, on the days and for the purposes under mentioned.

Particulars may be learnt at the Department and also at places shown in parenthesis.

W.O. means Inspector of Works Office; P.S.—Police Station; T.S.—Technical School; H.E.S.—Higher Elementary School; S.S.—State School; H.S.—High School; C.S.—Consolidated School.

Tenders should be submitted on the Department's printed Tender Form. All tenders must be on a "Firm Tender" basis. The Board of Land and Works will not necessarily accept the lowest or any tender.

Tenders to be addressed to the Secretary, Public Works Department, and envelope containing tender to be marked **Tender for** , closing

NOTE—No preliminary deposit is to be lodged with any tender, but a deposit in accordance with the prescribed Schedule, may be required from each successful tenderer.

Tuesday, 28th March, 1961.

Ararat.—Internal and external repairs and painting, S.S. 800. (W.O., Ararat; S.S., Ararat.)

Ballarat North.—Extension to existing Trades Wing, Technical School. (W.O., Ballarat; T.S., Ballarat North.)

Bennettswood.—Electrical installation of four additional L.T.C. class-rooms, &c., S.S. 4693. (S.S., Bennettswood.)

Birchip.—Erection of timber-framed residence and "A" type office, &c., Police Station. (W.O., Warracknabeal; P.S., Birchip.)

Brighton.—Rewiring of electrical installation, Melbourne Teachers' College Hostel, 23 Moule-street.

Broken Creek.—Purchase and removal of timber school and residence, S.S. 862. (W.O., Benalla.)

Caulfield.—Supply and fix curtains, Technical School.

Charlton.—Repairs and painting, Clerk of Courts residence. (W.O., Bendigo; P.S., Charlton.)

Cobden.—Installation of Warmray No. 3 heaters, S.S. 864. (W.O., Warrnambool; S.S., Cobden.)

Euroa.—Purchase and removal of class-rooms, S.S. 1706. (W.O., Benalla; S.S., Euroa.)

Glen Waverley Heights.—Electrical installation and public address system in additional L.T.C. class-rooms, &c., S.S. 4836. (S.S., Glen Waverley Heights.)

Kew.—Electrical installation in remodelled Wards B.1 and B.3, Mental Hospital. (Amended specification.) (W.O., Kew Mental Hospital.)

Landsborough.—Erection of new office, Police Station. (Amended specification.) (W.O., Maryborough; P.S., Landsborough.)

Leongatha.—Renovations to residence, 15 Bellingham-street, High School. (W.O., Korumburra; H.S., Leongatha.)

Lucydale.—Purchase and removal old school buildings, S.S. 3604. (W.O., Wangaratta.)

Maryborough.—Electrical installation in two prefabricated class-room units, Technical School. (W.O., Maryborough; T.S., Maryborough.)

Melbourne.—Roof repairs, Index Room, Titles Office.

Merbein.—Electrical installation in new school, High School. (W.O., Mildura.)

Merbein.—Mechanical services for new school, High School. (W.O., Mildura and Bendigo.)

Murrumbeena.—Erection of Police Station and residence.

Murrumbeena.—Gas hot-water service and gas heating, Police Station and residence. (P.S., Murrumbeena.)

Port Fairy.—Supply and delivery of 2,500 tons of spalls to foreshore at Eastern Beach, Ports and Harbors. (P.W.D., Harbor Office, Port Fairy.)

Royal Park.—New stainless steel urinal and C.I.P.E. basin, &c., "Turana", Social Welfare Department.

Sale.—Electrical installation, rewiring of Mechanics' Institute, Technical School. (W.O., Bairnsdale; T.S., Sale.)

Sebastopol.—Supply of sheet metal machinery, Technical School.

Upper Yarra.—New High School building.

Wangaratta.—Supply of refrigerator for Canteen, High School. (W.O., Wangaratta.)

Werribee.—Erection of two grain silos, Research Station. (Research Station, Werribee.)

Werribee.—Internal painting and repairs of residences Nos. 16 and 20, Research Farm. (Research Farm, Werribee.)

Wonthaggi.—Remodelling Workshop Block, Technical School. (Amended specification.) (W.O., Korumburra; T.S., Wonthaggi.)

Wednesday, 5th April, 1961.

Ballarat.—Supply of drop-side cots, Mental Hospital. (W.O., Ballarat.)

Blackburn.—Erection of No. 2 shelter pavilions and storeroom, Technical School. (T.S., Blackburn.)

Brunswick.—Supply and erection of steelwork for car washes, Police Transport Depot.

Carlton.—Supply, delivery and fixing of stainless steel benchwork for new kitchen, Secondary Teachers' Training College.

Coleraine.—Reconstruction of entrance porch, S.S. 2118. (W.O., Hamilton; S.S., Coleraine.)

Corryong.—Internal renovations, provision of new office and Sandilux fitting, residence, High School. (W.O., Wangaratta; H.S., Corryong.)

Cranbourne North.—Plenum heating in new school, S.S. 4887.

Cranbourne North.—Electrical installation in new school, S.S. 4887.

Dartmoor.—Erection of toilet block and woodshed, and installation of septic tank, S.S. 1035. (W.O., Warrnambool; S.S., Dartmoor.) (Amended specification.)

Dartmoor.—Electrical installation, Police Station (W.O., Hamilton; P.S., Dartmoor.)

Derrinallum.—Replacement of roofing with galvanized iron, S.S. 2050. (W.O., Camperdown; S.S., Derrinallum.)

Doutta Galla.—Sewerage, &c., S.S. 4708. (S.S., Doutta Galla.) (Amended specification.)

East Loddon.—Chalkboards and blinds, Consolidated School. (W.O., Bendigo; C.S., East Loddon.)

Frankston.—Supply of equipment for kitchen, Teachers' College Hostel.

Geelong.—Supply tables and cupboard, Gordon Institute of Technology. (W.O., Geelong.)

Hamilton.—Electrical installation, Pastoral Research Station residence. (W.O., Hamilton.)

Kyabram.—Renewal of electrical installation, S.S. 2902. (Amended specification.) (W.O., Shepparton; S.S., Kyabram.)

Laverton.—Additional class-rooms to school, S.S. 4765.

Melbourne.—Electrical installation, rewire of building, Crown Law Offices, Lonsdale-street.

Mont Park.—Supply, delivery and fixing on site of S.S. benchwork, Larundel Mental Hospital. (W.O., Mont Park Mental Hospital.)

Niddrie.—Erection of No. 2 shelter pavilions, S.S. 4849. (S.S., Niddrie.) (Amended specification.)

North Melbourne.—Supply and installation of public address system, Government Printing Office.

Parkmore.—Electrical installation of light, power and public address system for new school of eight L.T.C. class-rooms, &c., S.S. 4881.

Purnim West.—Erection of shelter pavilion, S.S. 2905. (W.O., Warrnambool; S.S., Purnim West.)

Redcliffs.—Electrical installation in new school, High School. (W.O., Mildura.)

St. Arnaud.—Supply of refrigerator for Canteen, High School. (W.O., Bendigo.)

Sale.—Electrical installation, residence, Police Station. (Amended specification.) (W.O., Bairnsdale; P.S., Sale.)

South Melbourne.—Renewal of roofing over Assembly Hall, MacRobertson Girls' High School.

South Melbourne.—Alterations to showers, Teachers' Hostel, 19 Queens-road.

Stawell.—Erection class-room wing in concrete veneer timber-framed construction, High School. (W.O., Ararat and Ballarat; H.S., Stawell.)

Sunbury.—Electrical installation in new school, High School.

Sunbury.—Supply, delivery, installation and testing of mechanical services for High School.

Sunshine Heights.—Plenum heating system to four additional class-rooms, S.S. 4744.

Sunshine North.—Erection of No. 2 32-ft. x 16-ft. shelter pavilions and 16-ft. x 8-ft. store, Girls' Technical School.

Toolangi.—Installation of septic system to three cottages, Potato Research Farm. (Research Farm, Toolangi.)

Upper Yarra.—Electrical installation, new school, High School.

Walpeup.—Erection of toilet block, Mallee Research Station. (W.O., Mildura; Research Station, Walpeup.)

Warrnambool South.—Replacement of shelter shed, new ridding on school roof, S.S. 1902. (W.O., Warrnambool; S.S., Warrnambool South.)

Tuesday, 11th April, 1961.

Ballarat North.—Electrical installation in extensions to Manual Arts Wing, Technical School. (W.O., Ballarat; T.S., Ballarat North.)

Belmont.—Internal and external renovations to residence, 40 Fyans-street, Chilwell, High School. (W.O., Geelong; H.S., Belmont.)

Beulah.—Repairs and painting, Police Station. (Amended specification.) (W.O., Warracknabeal; P.S., Beulah.)

Burnley.—Erection of Canteen and Recreation Room, Horticultural Gardens.

Camberwell.—New cupboards under chalkboards, S.S. 888.

Carlton.—Alteration to watchhouse with repairs and painting to all buildings, Police Station.

Carranballac.—Erection of timber-framed residence and garage, S.S. 3876. (W.O., Ararat and Ballarat; S.S., Carranballac.)

Frankston Heights.—Erection of new Primary School, S.S. 4815.

Hamilton.—Non-party fencing, S.S. 4777. (W.O., Hamilton; S.S., Hamilton.)

Hawthorn.—Repairs and painting, Court House.

Kangaroo Flat.—Erection of new combined out-office and laundry block, S.S. 4728. (W.O., Bendigo; S.S., Kangaroo Flat.)

Korong Vale.—New combined out-office block and septic tank installation, S.S. 1800. (W.O., Bendigo; S.S., Korong Vale.)

Manangatang.—Internal and external renovations, renewal of roof, repairs, &c., Consolidated School. (W.O., Swan Hill; C.S., Manangatang.)

Melbourne.—Alterations to store and provision of fire-escape exits, Head Office, Fisheries and Wildlife Department.

Melbourne.—Electrical installation, including new switchboards, &c., and rewiring of portion of First Floor, Titles Office, 283 Queen-street.

Melbourne.—Fire service, Supreme Court. (Amended specification.)

Mildura.—Erection of hostel and amenities block, Girls' High School Hostel. (W.O., Mildura.)

Mont Park.—Modifications to pipes, pumps, valves, &c., on soap and soda services, laundry, Larundel Mental Hospital. (W.O., Mont Park Mental Hospital.)

Moorabbin.—Repairs and painting to residence, S.S. 1111. (S.S., Moorabbin.)

Murrayville.—Repairs, internal and external painting, Court House. (W.O., Mildura; P.S., Murrayville.)

Neerim South.—New tapping from main and replacement of existing internal service and installation of new sinks in Science Room, Higher Elementary School and S.S. 2432. (W.O., Warragul; H.E.S. and S.S., Neerim South.)

Nhill.—Repairs and painting, Court House. (W.O., Horsham; P.S., Nhill.)

Redcliffs.—Mechanical services for new school, High School. (W.O., Mildura.)

Ringwood.—Additional lavatory accommodation, S.S. 2997. (S.S., Ringwood.)

Smythesdale.—Erection of out-office and woodshed block, install septic closets, S.S. 978. (Amended specification.) (W.O., Ballarat; S.S., Smythesdale.)

Tottenham North.—Electrical installation in new classrooms, &c., S.S. 4703. (S.S., Tottenham North.)

Warrnambool.—Provision of new toilet and connexion of residence to town sewerage system, High School. (W.O., Warrnambool.)

T. K. MALTBY,
Commissioner of Public Works.

Public Works Department,
Melbourne, 21st March, 1961.

TENDERS FOR THE SERVICE, 1961-62.—PRINTING AND WRITING PAPERS, ENVELOPES, ETC.

TENDERS will be received until Eleven a.m. on Friday, 19th May, 1961, from persons willing to supply, at Melbourne, Paper, Envelopes, &c., for the Victorian Government, as per Schedule No. 1, in the quantities and at the time stated therein.

The rates tendered must not include Sales Tax.

Forms of tender, conditions of tendering, schedule, conditions of contract, and samples, may be obtained from the Secretary to the Tender Board, Macarthur-street, Melbourne, C.2.

Security will be required, as provided in the tender form, either in Commonwealth Treasury Bonds, or approved bank guarantee, bank deposit receipt, Savings Bank deposit book, or non-negotiable cheque in favour of the Secretary to the Tender Board, as the tenderer may elect.

The security must be completed and the contract signed within five days of acceptance of the tender, failing which the contract may be again advertised, or another tender accepted.

No. 21.—2068/61.—3

The lowest or any tender will not necessarily be accepted.

In the event of tenderers withdrawing or attempting to withdraw their tenders before notification of acceptance of same, or failing to take up their accepted tenders within the prescribed period after notification of acceptance, they may be disqualified from tendering or holding any future contracts for Government supplies for a period of twelve months, such disqualification to date from the notification of acceptance of tender. It is also stipulated that, if a tenderer be a member of a firm and such firm be interested in the contract, the tender shall be in the name of the firm and not in that of the individual and that, for a breach of this condition, the tender will be declared informal.

Preference will be given by the Tender Board, provided the quality of the articles offered is satisfactory and the rates tendered are considered reasonable—

- (a) to tenders for articles manufactured within the Commonwealth;
- (b) to tenders for articles manufactured within any other part of the British Empire.

Rates tendered must include T.T. exchange ruling at time of tendering.

Tenders enclosed in a separate envelope, and having the words, "Tender for Supplies to the Government Printer" written thereon, must be deposited in the Tender Box at the Tender Board Offices, Macarthur-street, Melbourne, or, if sent by post, postage must be prepaid, and the tenders addressed to the Chairman of the Tender Board, Tender Board Offices, Macarthur-street, Melbourne, C.2, which office they must reach not later than by first post on the date of closing of tenders.

CONDITIONS OF CONTRACT.

1. In these conditions and in the form of contract and Schedule hereto annexed the words "Government Printer" shall include the officer bearing or acting under that title, or such other officer as the Government may from time to time appoint to perform the duty in the manner in relation to which the expression is used. The word "Storekeeper" shall mean the officer (or officers) of the Government who inspects and takes delivery of the stores. The word "Schedule" shall mean and embrace the Schedule or Schedules hereunto annexed.

2. Under no circumstances will a contractor be permitted to abandon his contract. In the event of the contractor failing to carry on the contract, the contract security money will in that case be absolutely forfeited; and, in addition, the contractor will be held liable for any loss which the Government may sustain in consequence of such failure.

3. The Government will order from the contractor those articles enumerated in the Schedule for which his tender is accepted.

4. The first delivery under this contract, equal to one-half the quantity contracted for, shall be made not later than 30th November, 1961, and the remainder shall be delivered not later than 28th February, 1962. Should the contractor so desire, the whole quantity contracted for may be delivered by the date first specified.

5. The supplies are to be in accordance with Schedule conditions where so stated, and of the particular manufacture indicated in the Schedule.

6. Bales are to be supplied in standard mill packs, i.e., 4 bales to the ton. The number of reams in each bale to be consistent for each item. Number of each bale and number of reams in each bale to be clearly marked on the outside.

7. All packages, cases, wrappings, &c., whether bulk be broken or not, shall be considered the property of the Government and no charges or expenses whatsoever beyond the price tendered and set out in the Schedule will be allowed to the contractor. The net weight only will be paid for. Contractors must provide, without extra charge, whatever labour, &c., may be required in the packing and delivery of the supplies.

8. All supplies shall be made to the Government Printer. The goods shall be delivered as may be directed by that officer in terms of contract. At the time of delivering the supplies, the contractor shall produce an invoice and specification showing the number and contents of each package in duplicate to the officer authorized to accept delivery, and such officer shall give an acknowledgment to the contractor of the receipt of the stores delivered by him.

9. All papers supplied, excepting Item 38, must be supplied in reams, and must be according to the specification as set out in the Schedule, and cut to the true size ordered. Each ream must contain 500 sheets, and must be supplied flat (unless otherwise specified). No creased, damaged or retree paper will be accepted.

10. The acceptance of the supplies shall be subject to the approval of the Government Printer, whose decision shall be final. If, after the delivery of the supplies has been taken, any deficiency or defect is discovered therein, such deficient or defective stores may be returned to the contractor. All rejected goods must be removed by the contractor within forty-eight hours after notice has been given to him by the Government Printer of such rejection, and if not so removed the Government Printer is hereby empowered to send same to any store in Melbourne, there to be stored at the contractor's risk and expense, such expenses to be deducted as in clause 10. Delivery will not be deemed to have been made until the goods have been approved. In the case of the rejection or return of any supplies the contractor shall bear the whole cost of replacing the supplies rejected or returned, otherwise purchases will be effected at the contractor's risk, and the extra expense deducted as in clause 10.

11. In the event of the goods not being delivered within the time stated the Government Printer may, on giving the contractor twenty-four hours' notice, purchase the supplies, or any like supplies that are suitable for the service, at the contractor's risk, and the extra expense incurred over and above the contract price (if any) will be deducted from the contractor's account or from the security money.

12. A refusal to execute orders, irregularity in the quantity or quality of the supplies or delay in delivering or replacing them when required, will subject the contractor, upon report from the Government Printer to the Tender Board, to such mulct, not exceeding One hundred pounds, for each and every default, as the Treasurer may direct, and the amount may be deducted as set out in clause 10. It will also be in the power of the Treasurer, upon such refusal, irregularity, or delay, to terminate the contract forthwith, and declare forfeit the whole or any portion of the security money; and, in addition, the contractor may be disqualified from tendering or holding any future contract or contracts for a period of twelve months from the date of such disqualification.

13. Contractors are not at liberty to transfer their contracts under cover of power of attorney, coupled with an interest or otherwise, and no such transfer will be recognized by the Government.

14. In the event of any alteration in the duty of Customs or Telegraphic Transfer Exchange, which may affect any of the items included in the contract, the Government or the contractor, as the case may be, will make a proportionate allowance by way of deduction from or increase of the price of the item so affected, and the contractor shall, if called upon, submit such documentary evidence as may be required by the Government to permit of the calculation of any such allowance.

15. The contractor shall not insure the material against war risk. Provided the material is consigned on a separate bill of lading to the Government of Victoria, any loss or damage in transit occasioned by any war risks to which the material may be subject whilst on board ship shall be to Victorian Government account, subject to the production by the contractor of documentary evidence satisfactory to the Tender Board.

16. Each package shall be branded "O.H.M.S., The Government of Victoria, The Government Printer, Melbourne," and numbered consecutively, and each package shall also be marked with the number of the contract and contents of same for identification purposes.

17. All goods forwarded under this contract shall, wherever railway facilities are available, be consigned by rail.

18. Every account shall be in prescribed form, setting out the contract and item numbers, and shall furnish full details of how it is made up.

19. Payment for supplies will be made in Melbourne when same have been accepted.

H. E. BOLTE,
Treasurer.

The Treasury,
Melbourne, 20th March, 1961.

PRIVATE ADVERTISEMENTS

CITY OF ARARAT.

LOAN No. 46.

Notice of Intention to Borrow.

NOTICE is hereby given that the Council of the City of Ararat proposes to borrow the sum of £3,000, on the credit of the Mayor, Councillors and Citizens of the said City by a grant of mortgage, in accordance with the provisions of the *Local Government Act 1958*. In connexion therewith the following information is stated:—

1. The amount of the principal moneys which it is proposed to borrow is Three thousand pounds (£3,000).

2. The maximum rate of interest that may be paid is Five pounds seventeen shillings and six pence (£5 17s. 6d.) per centum per annum.

3. The moneys borrowed shall be repayable by providing out of the municipal fund twenty half-yearly instalments of approximately £200 9s. 9d. each, including principal and interest, on the 1st day of December and the 1st day of June during the currency of the loan. The first instalment shall be payable on the 1st day of December, 1961, and the place such moneys shall be repayable is at the Commonwealth Savings Bank of Australia, Melbourne.

4. The purpose for which the loan is to be applied is for capital works in respect of the Council's electrical undertaking.

The plans and specifications and estimate of the cost of the works, and a statement showing the proposed expenditure of the moneys to be borrowed, are open for inspection, during office hours, at the Town Hall, Ararat.
13218 J. I. GRENFELL, Town Clerk.

CITY OF OAKLEIGH.

NOTICE OF INTENTION TO BORROW.

LOAN No. 69.

NOTICE is hereby given that the Council of the City of Oakleigh intends to borrow Twenty-five thousand pounds (£25,000) on the credit of the Mayor, Councillors and Citizens of the said City by the grant of a mortgage, in accordance with the provisions of the *Local Government Acts*.

In connexion therewith the following information is stated:—

(a) The amount of the principal moneys which it is proposed to borrow is Twenty-five thousand pounds.

(b) The maximum rate of interest that may be paid is £5 17s. 6d. per centum per annum.

(c) The times which the moneys borrowed are to be repayable are the 1st day of January, 1962, and the first days of July and January during the years 1962-1971, inclusive, and that the place such moneys shall be repayable is at The Commercial Banking Company of Sydney Ltd., Oakleigh.

(d) The purpose for which the loan is to be applied is—Construction of roads and footways.

(e) The manner in which the loan is to be liquidated is by the provision out of the municipal fund in each half-year during the currency of the loan of the sum of £1,670 14s. (One thousand six hundred and seventy pounds fourteen shillings), which includes principal and interest.

The plans and specifications and estimate of the cost of the works and a statement showing the proposed expenditure of the moneys to be borrowed, are open for inspection at the Council Chambers.

Dated this 21st day of March, 1961.

13262

A. E. RAVEN, Town Clerk.

CITY OF RINGWOOD.

BY-LAW No. 46.

A By-law of the City of Ringwood, made under the *Uniform Building Regulations, Victoria, and the Local Government Act 1958*, for adopting the minimum area, depth and width of frontage specified in columns 3, 4 and 5 of Table 804 of the *Uniform Building Regulations, Victoria*.

IN pursuance of the powers conferred by the *Uniform Building Regulations, Victoria, and the Local Government Acts*, the Mayor, Councillors and Citizens of the City of Ringwood order as follows:—

1. By-law No. 30 of the Borough of Ringwood is hereby repealed.

2. (a) The minimum area, depth and width of frontage specified in column 3 of Table 804 of the Uniform Building Regulations, Victoria, as amended by the Uniform Building Regulations Amending Regulations No. 2, are hereby adopted as the minimum area, depth and width of frontage of land on which a building of Class I. or Class II. occupancy shall be constructed in that portion of the municipal district set out and described in the First Schedule hereto.

(b) The minimum area, depth and width of frontage specified in column 4 of Table 804 of the Uniform Building Regulations, Victoria, as amended by the Uniform Building Regulations Amending Regulations No. 2 are hereby adopted as the minimum area, depth and width of frontage of land on which a building of Class I. or Class II. occupancy shall be constructed in that portion of the municipal district set out and described in the Second Schedule hereto.

(c) The minimum area, depth and width of frontage specified in column 5 of Table 804 of the Uniform Building Regulations, Victoria, as amended by the Uniform Building Regulations Amending Regulations No. 2 are hereby adopted as the minimum area, depth and width of frontage of land on which a building of Class I. or Class II. occupancy shall be constructed in that portion of the municipal district set out and described in the Third Schedule hereto.

THE SCHEDULES HEREINBEFORE REFERRED TO.

First Schedule.

The whole of the municipal district, excluding those areas set out and described in the Second and Third Schedules hereto.

Second Schedule.

(a) Commencing at a point on the eastern alignment of Heatherdale-road at its intersection with the southern alignment of Canterbury-road; thence easterly along the southern alignment of Canterbury-road to the eastern municipal boundary; thence southerly along the eastern municipal boundary to the southern municipal boundary, which boundary also being the Dandenong Creek; thence westerly along the southern boundary to the eastern alignment of Heatherdale-road; thence northerly along the eastern alignment of Heatherdale-road to the commencing point.

(b) Commencing at a point on the eastern municipal boundary at the southern alignment of Plymouth-road; thence southerly along the eastern municipal boundary to the northern alignment of Mt. Dandenong-road; thence westerly along the northern alignment to the north-eastern alignment of Carcoola-road; thence north-easterly along the north-eastern alignment to the western alignment of Old Lilydale-road; thence southerly along the western alignment to the northern alignment of Holland-road; thence westerly along the northern alignment, which boundary also being the southern boundary of Crown allotment 22A, section D, Township of Ringwood, Parish of Ringwood, to the south-western corner of the same Crown allotment; thence north-westerly along the south-western boundary to the north-western alignment of Maroondah Highway; thence south-westerly along the north-western alignment to the south-eastern corner of lot 4 on L.P. 36419; thence north-westerly along the north-eastern boundary of lot 4 and continuing north-westerly along the north-eastern boundary of lots 89 to 75 on L.P. 11019 to the Mullum Mullum Creek; thence south-westerly along the Mullum Mullum Creek to the eastern corner of lot 14 on L.P. 41695; thence north-westerly along the north-eastern boundaries of lots 14 to 3 on L.P. 41695 to the north-western alignment of Mullum Mullum-road; thence north-easterly along the north-western alignment to the eastern corner of lot 13 on L.P. 17967; thence north-westerly along the north-eastern boundaries of lots 13 to 5 on L.P. 17967 and continuing north-westerly along the south-western boundary of lot L.P. 15698 to the north-western alignment of Wonga-road; thence south-westerly along the north-western alignment to the eastern alignment of Warrandyte-road; thence northerly along the eastern alignment to the eastern projection of the northern boundary of lots 1 to 9 on L.P. 13604; thence westerly along the northern boundary and continuing along the northern boundary of lots 13 and 14 on L.P. 9882 to the north-western corner of lot 14; thence southerly along the western boundary of lots 14 to 17 on L.P. 9882 to the south-eastern corner of lot 4 on L.P. 5295; thence westerly along the southern boundary of lot 4 to the western boundary; thence northerly along the western boundary of lot 4 to the northern boundary; thence easterly along the northern boundary of lot 4 to the north-eastern corner of lot 4; thence northerly along the southern

projection of the eastern boundary of lot 2 on L.P. 20399 and continuing northerly along the eastern boundary of lots 2 and 1 on L.P. 20399 to the northern alignment of Oban-road; thence easterly along the northern alignment to the eastern alignment of Warrandyte-road; thence northerly along the eastern alignment to the northern boundary of allotment application No. 44262 in the Titles Office; thence easterly along the northern boundary to the eastern boundary of the same allotment; thence southerly along the eastern boundary of the same allotment and partly along the eastern boundary of allotment application No. 38142 in the Titles Office to the south-western corner of allotment application No. 40917 in the Titles Office; thence easterly along the southern boundary of allotment application No. 40917 in the Titles Office to the eastern alignment of Wonga-road; thence north-easterly along the eastern alignment to the south-western corner of allotment application No. 19902 in the Titles Office; thence easterly along the southern boundary of allotment application No. 19902 in the Titles Office to the eastern boundary of the same allotment; thence northerly along the eastern boundary of allotment application No. 19902 in the Titles Office and continuing northerly along the eastern boundary of allotments application Nos. 20887 and 28074 in the Titles Office, the last-mentioned boundary also being the western alignment of Kalinda-road and continuing northerly along the western alignment of Kalinda-road to the southern alignment of Plymouth-road; thence easterly along the southern alignment to the commencing point.

Third Schedule.

(a) Commencing at a point at the intersection of the northern municipal boundary and the western alignment of Kalinda-road, which point also being the north-eastern corner of lot 3 on L.P. 19426; thence southerly along the western alignment of Kalinda-road and continuing southerly along the eastern boundaries of allotments application Nos. 20887 and 19902 in the Titles Office to the south-eastern corner of allotment application No. 19902 in the Titles Office; thence westerly along the southern boundary of the same allotment to the south-western corner of the same allotment, which point also being on the eastern alignment of Wonga-road; thence south-westerly along the eastern alignment to the eastern projection of the southern boundary of allotment application No. 40917 in the Titles Office; thence westerly along the southern boundary to the eastern boundary of allotment application No. 38142 in the Titles Office; thence northerly along the eastern boundary and continuing northerly along the eastern boundary of allotment application No. 44262 in the Titles Office to the north-eastern corner of the same allotment; thence westerly along the northern boundary of the same allotment application No. 44262 in the Titles Office to the eastern alignment of Warrandyte-road; thence northerly along the eastern alignment to the northern municipal boundary; thence easterly along the northern municipal boundary to the commencing point.

(b) Commencing at a point at the intersection of the eastern alignment of Glenvale-road and the southern alignment of Oban-road; thence easterly along the southern alignment of Oban-road to the eastern boundary of lot 1 on L.P. 20399; thence southerly along the same eastern boundary and continuing southerly along the eastern boundary and southern projection of the eastern boundary of lot 2 on L.P. 20399 to the north-eastern corner of lot 4 on L.P. 5295; thence westerly along the northern boundary of lot 4 to the western boundary; thence southerly along the western boundary of lot 4 and continuing southerly along the western boundary of lots 83 to 87 on L.P. 20559 to the northern alignment of Burlock-avenue; thence westerly along the northern alignment to the western alignment; thence southerly along the western alignment of Burlock-avenue to the northern alignment of Felix-crescent; thence westerly along the northern alignment to the south-eastern corner of lot 413 on L.P. 14956; thence northerly along the eastern boundary of lot 413 to the northern boundary; thence westerly along the northern boundary to the north-western corner of lot 413; thence northerly along the eastern boundaries of lots 415 and 416 on L.P. 14956 to the north-eastern corner of lot 416; thence westerly along the northern boundary of lot 416 to the eastern alignment of Glenvale-road; thence northerly along the eastern alignment to the commencing point.

Resolution for passing this By-law was agreed to by the Council of the City of Ringwood on the 24th day of November, 1960, and confirmed on the 20th day of December, 1960.

The corporate seal of the Mayor, Councillors and Citizens of the City of Ringwood was hereunto affixed, in the presence of—

(SEAL) R. C. HORMAN, Mayor.
A. G. LAVIS, Councillor.
F. P. DWERRYHOUSE, Town Clerk.

Approved by the Governor in Council, on the 28th day of February, 1961.—A. MAHLSTEDT, Clerk of the Executive Council. 13198

CITY OF SALE.

LOAN No. 25.

Notice of Intention to Borrow the Sum of £11,000 for Permanent Works and Undertakings.

NOTICE is hereby given that the Council of the City of Sale proposes to borrow the sum of Eleven thousand pounds, on the credit of the municipal revenues of the Mayor, Councillors and Citizens of the said City, such sum to be raised by the grant of a mortgage, in accordance with the provisions of the *Local Government Act 1958*.

1. The maximum rate of interest that may be paid is 5½ per cent. per annum.

2. The purposes for which the loan is to be applied are:—

- (a) The purchase of land for a new Olympic swimming pool and for off-street parking areas under town planning .. £5,000
- (b) The construction of a depot .. £3,000
- (c) Purchase of front-end loader .. £3,000

3. The period of the loan shall be five years.

4. The moneys borrowed shall be repayable by providing out of the municipal fund ten half-yearly instalments of approximately £1,281 6s. 5d. each, including principal and interest, on the 1st day of January and the 1st day of July during the currency of the loan. The first instalment shall be payable on the 1st day of January, 1962.

5. Such moneys shall be repayable at the State Savings Bank of Victoria, Melbourne.

The plans and specifications and estimate of the cost of the proposed works, and a statement showing the proposed expenditure of the moneys to be borrowed, are open for inspection at the City Council Chambers, Sale.

Dated 22nd March, 1961.

13215

J. R. RAY, Town Clerk.

BOROUGH OF ECHUCA.

BY-LAW No. 54.

NOTICE is hereby given that at a meeting of the Borough of Echuca held on the 14th day of November, 1960, the said Council did confirm a Special Order made for—

- (a) Repealing By-law No. 53;
- (b) prescribing brick areas;
- (c) adapting the minimum area, depth and width of frontage specifications in column 3 of Table 804 of the Uniform Building Regulations, Victoria; and
- (d) dispensing with the requirements of clause 813 of the said Regulations.

The said By-law was approved by the Governor in Council on the 28th day of February, 1961.

A copy of such By-law is open for inspection, free of charge, during office hours at the Town Hall, Echuca.

13219

K. F. McCARTNEY, Town Clerk.

BOROUGH OF ECHUCA.

LOAN No. 37.

Notice of Intention to Borrow.

NOTICE is hereby given that the Council of the Borough of Echuca intends to borrow Five thousand pounds (£5,000) on the credit of the Mayor, Councillors and Burgesses of the said Borough by the grant of a mortgage in accordance with the provisions of the *Local Government Acts*.

In connexion therewith the following information is stated:—

- (a) The amount of the principal moneys which it is proposed to borrow is Five thousand pounds.
- (b) The maximum rate of interest that may be paid is £5 17s. 6d. per centum per annum.
- (c) The times which the moneys borrowed are to be repayable are the 15th day of December, 1961, and the 15th days of December and June during

the years 1961-1976 inclusive, and that the place such moneys shall be repayable is at the Bank of New South Wales.

(d) The purpose for which the loan is to be applied is:—

Improvements to municipal sale-yards.

(e) The manner in which the loan is to be liquidated is by provision out of the municipal fund in each half-year during the currency of the loan of the sum of £253 0s. 10d., which includes principal and interest.

The plans and specifications and estimate of the cost of the works and a statement showing the proposed expenditure of the moneys to be borrowed, are open for inspection at the Town Hall.

Dated this 17th day of March, 1961.

13232

K. F. McCARTNEY, Town Clerk.

SHIRE OF ALBERTON.

LOAN No. 14.

Notice fo Intention to Borrow the Sum of £6,000 for Permanent Works and Undertakings.

NOTICE is hereby given that the Council of the Shire of Alberton proposes to borrow the sum of Six thousand pounds on the credit of the municipal revenues of the President, Councillors and Ratepayers of the said Shire, such sum to be raised by the grant of a mortgage, in accordance with the provisions of the *Local Government Act 1958*.

1. The maximum rate of interest that may be paid is 5½ per cent. per annum.

2. The purpose for which the loan is to be applied is:—

Purchase of aerodrome site at Yarram and erection of storage shed and amenities block at Shire Hall, Yarram.

3. The period of the loan shall be ten years.

4. The moneys borrowed shall be repayable by providing out of the municipal fund twenty half-yearly instalments of approximately £400 19s. 4d. each, including principal and interest, on the 1st day of June and the 1st day of December during the currency of the loan. The first instalment shall be payable on the 1st day of December, 1961.

5. Such moneys shall be repayable at The State Savings Bank of Victoria, Melbourne.

The plans and specifications and the estimate of the cost of the proposed works and a statement showing the proposed expenditure of the moneys to be borrowed, are open for inspection at the Shire Hall, Yarram.

Dated 17th March, 1961.

13240

A. W. CURRY, Shire Secretary.

SHIRE OF BACCHUS MARSH.

LOAN No. 7.

Notice of Intention to Borrow the Sum of £15,000 for Permanent Works and Undertakings.

NOTICE is hereby given that the Council of the Shire of Bacchus Marsh proposes to borrow the sum of Fifteen thousand pounds on the credit of the municipal revenues of the President, Councillors and Ratepayers of the said Shire, such sum to be raised by the grant of a mortgage in accordance with the provisions of the *Local Government Act 1958*.

1. The maximum rate of interest that may be paid is £5 17s. 6d. per cent. per annum.

2. The purposes for which the loan is to be applied are to pay the Council's proportion of a main drainage scheme for the Town of Bacchus Marsh.

3. The period of the loan shall be ten years.

4. The moneys borrowed shall be repayable by providing out of the municipal fund twenty half-yearly instalments of approximately £1,002 8s. 4d. each, including principal and interest on the 1st day of July and the 1st day of January during the currency of the loan. The first instalment shall be payable on the 1st day of January, 1962.

5. Such moneys shall be repayable at the State Savings Bank of Victoria, Melbourne.

The plans and specifications and the estimate of the cost of the proposed works and a statement showing the proposed expenditure of the moneys to be borrowed, are open for inspection at the Shire Office, Bacchus Marsh.

Dated 17th March, 1961.

13231

A. W. BOND, Shire Secretary and Engineer.

SHIRE OF BALLARAT.

LOAN No. 24.

Notice of Intention to Borrow the Sum of £26,000 for Permanent Works and Undertakings.

NOTICE is hereby given that the Council of the Shire of Ballarat proposes to borrow the sum of £26,000 on the credit of the President, Councillors, and Ratepayers of the said Shire by the grant of the mortgage, in accordance with the provisions of the Local Government Acts.

In connexion therewith the following information is stated:—

- The amount of the proposed moneys it is proposed to borrow is £26,000.
- The maximum amount of interest to be paid is £5 17s. 6d. per centum per annum.
- The times which the moneys borrowed are to be repayable are the first days of July and January during the years 1962 to 1971 inclusive, and the first payment shall be payable on the first day of January, 1962, and that the place at which such moneys shall be repayable is the National Bank of Australasia Limited, Melbourne.
- The purpose for which the loan is to be applied is drainage works.
- The manner in which the loan is to be liquidated is by provision out of the municipal fund each half year during the currency of the loan of the sum of £1,737 10s. 6d., which includes principal and interest.

The plans and specifications and estimate of the cost of the works, and the statement showing the proposed moneys to be borrowed, are open for inspection at the Shire Offices, Wendouree.

Dated this 16th day of March, 1961.

13220 H. R. TRUEMAN, Shire Secretary.

SHIRE OF BEECHWORTH.

LOAN No. 7.

Notice of Intention to Borrow.

NOTICE is hereby given that the Council of the Shire of Beechworth intends to borrow Three thousand five hundred pounds (£3,500) on the credit of the President, Councillors and Ratepayers of the said Shire by the grant of a mortgage in accordance with the provisions of the Local Government Acts.

In connexion therewith the following information is stated:—

- The amount of the principal moneys which it is proposed to borrow is £3,500 (Three thousand five hundred pounds).
- The maximum rate of interest that may be paid is £5 17s. 6d. (Five pounds seventeen shillings and six pence) per centum per annum.
- The times which the moneys borrowed are to be repayable are the 1st day of December, 1961, and the 1st days of June and December during the years 1962-1971 inclusive, and that the place such moneys shall be repayable is at the Bank of New South Wales, Beechworth.
- The purpose for which the loan is to be applied is:—

For part cost of erecting Football Club Rooms £3,000
Part cost of building Kindergarten £ 500

- The manner in which the loan is to be liquidated is by provision out of the municipal fund in each half-year during the currency of the loan of the sum of £233 18s., which includes principal and interest.

The plans and specifications and estimate of the cost of the works and a statement showing the proposed expenditure of the moneys to be borrowed, are open for inspection at the Shire Offices.

Dated this 16th day of March, 1961.

13229 G. T. GRAY, Shire Secretary.

SHIRE OF BENALLA.

LOAN No. 26.

Notice of Intention to Borrow the Sum of £7,000 for Permanent Works and Undertakings (Road Plant).

NOTICE is hereby given that the Council of the Shire of Benalla proposes to borrow the sum of Seven thousand pounds for the purchase of road plant, on the credit of the municipal revenues of the Shire

President, Councillors and Ratepayers of the Shire of Benalla by the issue of debentures carrying interest at a rate not to exceed 5½ per cent. per annum.

Such loan will be liquidated over a period of five years by periodical half-yearly payments of £815 7s. 9d., being principal, together with interest, from time to time accruing due on so much of the total amount of the said loan as is unpaid, and payable at the head office of The National Bank of Australasia Ltd., Melbourne.

Dated this 14th day of March, 1961.

13238 E. C. BATES, Shire Secretary.

SHIRE OF BERWICK.

ALTERATION OF STREET NAMES.

NOTICE is hereby given that the Council of the Shire of Berwick has, in pursuance of the powers conferred by the *Local Government Act 1958*, made orders changing the names of the following streets:—

Old Name: Cemetery-road.

New Name: Thewlis-road.

Location: Commencing at the Princes Highway west of Crown allotment 46, continuing northerly to Brown-road at the south-west corner of Crown allotment 48, Parish of Pakenham.

Old Name: Unnamed.

New Name: Weatherhead-road.

Location: From Tynong-Gembrook road easterly through Crown allotment 23, Parish of Tonimbuk, Council title, volume 5924, folio 1184782.

Old Name: Webb-street.

New Name: Shrives-road.

Location: Commencing at the south-west corner of Crown allotment 23A Parish of Berwick, and continuing easterly along the southern boundary of the said allotment; and thence north-easterly along the eastern boundaries of Crown allotments 22K, 22D and 22C to the Gippsland railway line; and thence through Crown allotment 11c to the Princes Highway.

13207 BEATRICE THOMAS, Shire Secretary.

SHIRE OF COBRAM.

BY-LAW No. 6.

NOTICE is hereby given that at a meeting of the Cobram Shire Council, held on 3rd March, 1961, the Council of the Shire of Cobram did confirm a Special Order made for the purposes of adopting By-law No. 6, made under the provisions of the *Local Government Act 1958*, for the management and control of the Cobram Corporation Sale-yards.

A true copy of the By-law is open for inspection by any person during normal office hours.

13201 RONALD T. CUTTS, Shire Secretary.

SHIRE OF COBRAM.

BY-LAW No. 7.

NOTICE is hereby given that at a meeting of the Cobram Shire Council, held on 3rd March, 1961, the Council of the Shire of Cobram did confirm a Special Order made for the purpose of adopting By-law No. 7, made under the provisions of the *Dog Act 1957*, for the purpose of fixing registration fees for dogs and for other purposes relating to the said Act.

A true copy of the By-law is open for inspection by any person during normal office hours.

13202 RONALD T. CUTTS, Shire Secretary.

SHIRE OF CORIO.

NOTICE is hereby given that Senior Constable Jack James West, No. 9185, has been appointed Prosecuting Officer to the Shire of Corio, in place of Senior Constable B. T. J. Fletcher, No. 8815.

13210 H. W. MYERS, Shire Secretary.

SHIRE OF FRANKSTON.

BY-LAW No. 102.

NOTICE is hereby given that a By-law has been made under the provisions of sub-section (4) of section 4 of the *Police Offences Act 1958* and of any and every power thereunto it enabling, for extending to the Shire of Frankston all the provisions of Part I. of the said Act (other than section 6 thereof).

Notice is further given that a copy of the above By-law is open for inspection, free of charge, during office hours, at the office of the Council, Davey-street, Frankston.

G. C. PENTLAND, Shire Secretary.

Shire Office, Frankston. 13214

SHIRE OF FRANKSTON.

NAME OF ROAD CHANGED.

IN accordance with the provisions of the *Local Government Act 1958*, notice is hereby given of the change of the road names as follows:—

Old Name; New Name; Location.

- Melbourne-road or Nepean Highway; Nepean Highway; south from Crown allotment 25, section D, Parish of Frankston, to Crown allotment 6, section D (Wells-street).
- Bay-street; Nepean Highway; south from Wells-street to Davey-street, Township of Frankston.
- Bay-street; Nepean Highway; south from Davey-street, lower level, west side of road reserve, abutting Crown allotment 1 and Police Reserve.
- Bay-street or Bay-street South; Bay-street South; south from Davey-street to High-street, upper level, east side of road reserve abutting Crown allotments 2 and 1, section 1, and public park.
- Bay-street South or The Esplanade; The Esplanade; south from High-street, upper level, east side of road reserve, abutting sections 7 and 8, Township of Frankston.
- Long-road; Lindrum-road; from Cranbourne-road northerly for its full length.

By order of the Council,

G. C. PENTLAND, Shire Secretary.

Shire Office, Frankston. 13216

Local Government Act 1958, Part XVIII, Division 4.

SHIRE OF FRANKSTON.

NOTICE OF INTENTION TO TAKE LAND COMPULSORILY.

WHEREAS the Council of the Shire of Frankston deems it expedient to execute a permanent work or undertaking for the purpose whereof it is in the opinion of the said Council necessary and desirable that the said Council exercise its power of taking land compulsorily as provided by the *Local Government Act 1958*, and the said Council has caused to have prepared such specifications, maps, plans, sections, and elevations of such work or undertaking as are necessary, and in which are expressed the nature and extent of such work or undertaking, and on and through what land the said work or undertaking is proposed to be placed, and the names of the owners or reputed owners, lessees or reputed lessees, and the occupiers, of such land as far as can be ascertained, and the said specifications, maps, plans, sections, and elevations so prepared have been approved by the said Council.

In pursuance of the provisions of the *Local Government Act 1958*, the said Council hereby gives notice that the description shortly of the purport of the said specifications, maps, and other papers is as follows:—

"To provide an off-street car parking area by the acquisition of all that land comprised in lots 24 and 25 on plan of subdivision No. 1090, lodged in the Office of Titles, and being part of Crown allotment 12, section B, Township and Parish of Frankston, County of Mornington, being the whole of the land more particularly described in certificates of title, volume 8231, folio 764, and volume 8210, folio 234."

And the said Council hereby gives further notice that the said specifications, maps and other papers are deposited at the Shire Office, Davey-street, Frankston, and are there open for inspection and perusal by all persons interested on all the days and between the hours the municipal offices are appointed to be open, for the space of 40 clear days after the publication of this notice in the *Government Gazette*.

And the said Council does hereby call upon all persons interested in or affected by the proposed work or undertaking to set forth, in writing, addressed to the said Council or the Shire Secretary, Shire Office, Davey-street, Frankston, within 40 clear days from the publication of this notice in the *Government Gazette*, all objections which they may have to the proposed work or undertaking.

By order of the Council,

G. C. PENTLAND, Shire Secretary.

13263

SHIRE OF KANIVA.

LOAN No. 14.

Notice of Intention to Borrow the Sum of £3,000 for Permanent Works and Undertakings.

NOTICE is hereby given that the Council of the Shire of Kaniva proposes to borrow the sum of Three thousand pounds on the credit of the municipal revenues of the President, Councillors and Ratepayers of the said

Shire, such sum to be raised by the grant of a mortgage, in accordance with the provisions of the *Local Government Act 1958*.

1. The maximum rate of interest that may be paid is £5 17s. 6d. per cent. per annum.
2. The purpose for which the loan is to be applied is:—
Construction of power lines in Township of Kaniva.
3. The period of the loan shall be ten years.
4. The moneys borrowed shall be repayable by providing out of the municipal fund twenty half-yearly instalments of approximately £200 each, including principal and interest, on the 1st day of December and the 1st day of June during the currency of the loan. The first instalment shall be payable on the 1st day of November, 1961.
5. Such moneys shall be repayable at The State Savings Bank of Victoria, Melbourne.

The plans and specifications and the estimate of the cost of the proposed works and a statement showing the proposed expenditure of the moneys to be borrowed, are open for inspection at the Shire Office, Kaniva.

13241

N. G. HAYNES, Shire Secretary.

SHIRE OF WARRAGUL.

LOAN No. 27.

Notice of Intention to Borrow the Sum of £10,000 for Permanent Works and Undertakings.

NOTICE is hereby given that the Council of the Shire of Warragul proposes to borrow the sum of £10,000 on the credit of the municipal revenues of the President, Councillors and Ratepayers of the Shire, such sum to be raised by the grant of a mortgage, in accordance with the provisions of the *Local Government Act 1958*.

The maximum rate of interest that may be paid is £5 17s. 6d. per centum per annum.

The purpose for which the loan is to be applied is the construction of private streets, in accordance with the provisions of Division 10 of Part XIX. of the *Local Government Act*.

The period of the loan shall be for ten years.

The loan shall be repaid by twenty (20) half-yearly instalments of approximately £668 5s. 7d., including principal and interest on the 1st day of November and the 1st day of May in each year, at The Australian and New Zealand Savings Bank, Warragul, or at the Council's bankers for the time being in Melbourne.

The plans and specifications and the estimate of cost of the proposed works, and a statement showing the proposed expenditure of the moneys to be borrowed, are open for inspection at the Shire Hall, Warragul.

13261

D. MCADIE, Shire Secretary.

SHIRE OF WERRIBEE.

BY-LAW No. 45.

A By-law of the Shire of Werribee made under section 198 of the *Local Government Act 1958*, and numbered 45 for declaring streets and roads within the municipal district to be roads of limited access and for other purposes.

IN pursuance of the powers conferred by the *Local Government Act 1958*, and of any and every other power it thereunto enabling the President, Councillors and Ratepayers of the Shire of Werribee order as follows:—

1. The streets or roads within the municipal district specified in the Schedule hereto are hereby declared to be roads of limited access.
2. No person shall without the consent of the Council of the Shire of Werribee provide any further facilities for vehicles to enter or leave any land which abuts on such road of limited access and to which reasonable alternative means of vehicular access are or can be available.
3. No person shall enter or leave with a vehicle or permit any person to enter or leave with a vehicle any such land as aforesaid except by a passage in regular use before the commencement of this By-law or subsequently approved by Resolution of the said Council.

Penalties.

4. The penalties for offences are—

<i>Offence.</i>	<i>Penalty.</i>
First offence	maximum £20
Second (or more) similar offence ..	minimum £10
	maximum £20

Continuing offence—

For each day on which the offence is continued after a conviction or order of any court . . . maximum £5 a day

THE SCHEDULE HEREINBEFORE REFERRED TO.

The Princes Highway west from the eastern boundary of the Shire of Werribee to the commencement of the Werribee by-pass and from the western end of the said by-pass to the western boundary of the said Shire.

The Resolution for passing this By-law was agreed to by the Council on the 8th day of December, 1960, and confirmed on the 19th day of January, 1961.

The common seal of the President, Councillors and Ratepayers of the Shire of Werribee was hereto affixed in the presence of—

(SEAL) J. D. BELLIN, Councillor.
F. JONES, Councillor.
N. G. MINNS, Secretary.

Approved by the Governor in Council on the 28th day of February, 1961.—A. MAHLSTEDT, Clerk of the Executive Council. 13223

NOTICE is hereby given that Philips Electrical Industries Pty. Limited has applied for a lease under section 134, *Land Act 1958*, for a term of 50 years from 1st June, 1961, of allotments 16 and 17 of section E, City of South Melbourne, Parish of Melbourne South, containing 3 roods 24 perches, as a site for offices, warehouse, and electrical merchandising. 13305

NOTICE is hereby given that the trustees of the Wonthaggi Golf Club have applied for a lease, under section 134, *Land Act 1958*, for a term of 21 years, of allotment 3, section 117, Township of Wonthaggi, containing 107 acres 3 roods 4 perches, as a site for amusement and recreation. 12998

GILBERT & RAHILLY, solicitors, Wonthaggi. 12998

NOTICE is hereby given that the Lalbert Golf Club has applied for a lease for a term of 21 years, under section 134 of the *Land Act 1958*, in respect of an area of Crown lands containing approximately 70 acres, being portion of a Public Purposes Reserve abutting Lake Lalbert and west of allotment 15, section A, Parish of Lalbert, as a site for purposes of Amusement and Recreation. 12995

Water Acts.**PROPOSED COHUNA WATERWORKS TRUST.**

NOTICE is hereby given that the Cohuna Shire Council has made application to the Honorable the Minister of Water Supply for the constitution of a Waterworks Trust, and for the proclamation of a Waterworks District at Cohuna, and the construction, maintenance, and continuance of water supply works within that district, under the provisions of the Water Acts.

A general plan and description of the proposed works have been submitted with the application, and copies of same may be seen at the Shire Office, at Cohuna.

Dated at Cohuna, the 27th day of February, 1961.
13016 R. E. KNOWLES, Shire Secretary.

THE BALLARAT SEWERAGE AUTHORITY.**GENERAL NOTICE.**

THE above-mentioned Sewerage Authority, having made provision for carrying off the sewage from each and every property which or any part of which is within the sewerage area hereinafter described, doth hereby declare that, on and after the first day of April, 1961, each and every property which, or any part of which, is within the said sewerage area shall be deemed to be a seweraged property within the meaning of the *Sewerage Districts Act 1958*.

The boundaries of the sewerage area hereinbefore referred to are:—

Sewerage Area No. 203.

City of Ballarat.—Commencing at the south-east corner of Eureka and Richards streets, being a point on the boundary of Sewerage Area No. 200; thence northerly across Eureka-street to the south-west corner of No. 203 Eureka-street, north-easterly about 116 feet along the western boundary of the said No. 203, easterly about 154 feet to the north-east corner of No. 205 Eureka-street, easterly to the north-east corner of No. 217 Eureka-street, northerly about 38 feet along a fence, easterly about 209 feet by a line parallel to and about 165 feet from Eureka-street, easterly to the north-west corner of No. 233 Eureka-street, easterly to the north-east corner of No. 237 Eureka-street, northerly about

10 feet along the western boundary of No. 10 Fussell-street, easterly to the north-east corner of the said No. 10, south-easterly to the north-west corner of No. 247 Eureka-street, easterly to the north-east corner of No. 253 Eureka-street, easterly about 65 feet along a fence, easterly about 232 feet by a line to a point on the eastern boundary of No. 265 Eureka-street about 196 feet from Eureka-street, easterly about 105 feet on the prolongation of the last-mentioned line, southerly to a point on the north building line of Eureka-street about 98 feet from the south-west corner of No. 265 Eureka-street, south-easterly across Eureka-street to the north-east corner of No. 264 Eureka-street, north-westerly along the boundary of Sewerage Area No. 200 to the point of commencement.

Further particulars regarding the streets or parts of streets in which sewers have been laid may be ascertained on inquiry at the Authority's office.

By order of the said Sewerage Authority,
A. W. NICHOLSON, Chairman.
CHAS. H. CLAMP, Secretary.

13209

HAMILTON SEWERAGE AUTHORITY.**GENERAL NOTICE.**

THE above-mentioned Sewerage Authority, having made provision for carrying off the sewage from each and every property which, or any part of which, is within the sewerage areas hereinafter described, doth hereby declare that on and after the 27th day of March, 1961, each and every property which, or any part of which, is within the said sewerage areas shall be deemed to be a seweraged property within the meaning of the *Sewerage Districts Act 1958*.

The boundaries of the sewerage areas hereinbefore referred to are published in *Government Gazette*, No. 18, 8th March, 1961, on pages 868 and 869, and described under heading of Sewerage Areas, Nos. 7, 8, 9, 10, and 11.

By order of Sewerage Authority,

J. J. JORDAN, Chairman.
H. F. DONALD, Secretary.

13245

NOTICE OF INTENTION TO APPLY FOR A LICENCE TO DIVERT WATER AND CUT RACE FROM THE GOULBURN RIVER ANABRANCH, AT TABILK.

I HEREBY give notice that I intend to apply for a licence empowering me to divert water for a term of fifteen years to the extent of 200 acre-feet per annum at a maximum rate of 6 acre-feet per day of 24 hours for the irrigation of 100 acres of lucerne pasture, being part of allotments 47A, 47B, 48A, and 48B, Parish of Tabilk, and to occupy certain Crown lands for works of diversion, and to cut a race thereon.

Any objection to such application must be forwarded, in writing, to reach the State Rivers and Water Supply Commission, Melbourne, before 30th April, 1961, being 30 days from the first publication of this notice.

GEOFFREY ARMSTRONG.

Islay Vale, Tabilk.

13235

In the matter of a transfer between RICHARD GREY SELICK, JOHN DAVIES, RICHARD BURROWS, GEORGE FLACK, THOMAS FELLOW, WILLIAM THOMAS TWEDDLE, THOMAS ARMSTRONG, ADOLPHUS PATTERSON and JOHN SEWARD MORTIMER to THE CHURCH OF ENGLAND TRUSTS CORPORATION FOR THE DIOCESE OF WANGARATTA of the whole of the land described in certificate of title, volume 2605, folio 942, and in the matter of Act No. 797 of 1884.

PURSUANT to section 7 of Act No. 797, I, Thomas Makinson Armour, Bishop of Wangaratta, consent to the transfer of the whole of the land described in certificate of title, volume 2605, folio 942, to The Church of England Trusts Corporation for the Diocese of Wangaratta, such consent to be in place of the consent of the said Richard Grey Selick, John Davies, Richard Burrows, George Flack, Thomas Fellow, William Thomas Tweddle, Thomas Armstrong, Adolphus Patterson and John Seward Mortimer.

Dated the 10th day of March, 1961.

13205 THOMAS WANGARATTA, Bishop of Wangaratta.

NOTICE is given that the partnership between Henry Sprague, of 10 Yawla-street, Bentleigh, and Robert Grant, of 56 Ardyne-street, Murrumbeena, carried on at corner of Male-street and Durrant-street, Brighton, under the name of Durrant Service Station, has been dissolved by mutual consent as from the 30th November, 1959. All debts owing by the said firm will be paid by Henry Sprague, who will continue to carry on the business at the same place.

Dated 17th February, 1961.

13206

HENRY SPRAGUE.
ROBERT GRANT.

NOTICE is hereby given that the partnership heretofore subsisting between the undersigned, Marion Muirhead and Marjorie Yvonne Jones, carrying on business as ladies' hairdressers, at 75 Dunloe-avenue, North Box Hill, under the firm name of Deirdri Phillips Beauty Salon, has been dissolved by mutual consent as from the 10th day of March, 1961. All debts due to and owing by the said late firm will be received and paid by the said Marjorie Yvonne Jones, who will continue to carry on the business at the same place under the name Marjorie Y. Jones.

Dated at North Box Hill, the 10th day of March, 1961.

M. MUIRHEAD.
M. Y. JONES.

Witness—P. H. PIPPEY, solicitor, 1 Watts-street, Box Hill.
13267

NOTICE is hereby given that the partnership heretofore subsisting between us, the undersigned, William Charles McLister and Keith Charles McLister, carrying on the business of a poultry farm and hatchery, at 176 Hall-street, Spotswood, under the style or firm name of "Yallambee Estate Poultry Farm and Hatchery", has been dissolved by mutual consent as from the 1st day of March, 1961, and as from that date the said Keith Charles McLister will carry on the said business on his own account under the name of "Yallambee Hatchery", at Campbell-road, Portsea.

Dated the 15th day of March, 1961.

WM. C. McLISTER.
KEITH C. McLISTER.

Witness to both signatures—A. BIRCH.

Henderson and Ball, of 430 Little Collins-street, Melbourne, solicitors for both parties.
13273

NOTICE is hereby given that the partnership heretofore subsisting between Donald Gordon Ranson and Barbara June Ranson, carrying on business as plumbers, at 154 Banksia-street, West Heidelberg, under the style or firm of "D. G. Ranson", has been dissolved as from the 31st day of December, 1960.

Dated this 17th day of March, 1961.

D. G. RANSON.
B. J. RANSON.

13307

The Companies Act 1958.—Section 153.
YOUNGHUSBAND LIMITED.

REGISTER of Unclaimed Moneys held by Youngusband Limited as at 1st March, 1961.

Name and Address of Owner on Books.	Total Amount due to Owner.	Description of Unclaimed Money.	Date of Last Claim.
	£ s. d.		
Lilley, B. M., Melbourne	3 0 0	Dividend ..	No Claim
Finlayson, Est. R. J., Adelaide	37 12 0	" ..	"
Goldsbrough Mort and Co., Melbourne	4 5 10	Proceeds ..	"
Jackson, T., East Malvern	11 1 7	" ..	"
Upton, A. W., Corowa ..	1 7	" ..	"
Clarke, Miss L., Cobram	8 11	" ..	"
Clarke, Mrs. A. J., Cobram	7 6 1	" ..	"
Clarke, A. M., Cobram ..	17 11	" ..	"
Coppock, R. D., Piangil	2 19 5	" ..	"
	67 13 4		

13117

D. & W. MURRAY LIMITED.

REGISTER of Unclaimed Moneys held by D. and W. Murray Limited on 28th February, 1961.

Name and Address of Owner on Books.	Total Amount Due to Owner.	Description of Unclaimed Money.	Date of Last Claim.
	£ s. d.		
T. D. Davidson, 7 Hartley-road, Brighton, S.A.	0 9 3	Dividend ..	Nil

13204

Companies Act 1958.

BRUNSWICK PLASTER MILLS PTY. LTD.

REGISTER of Unclaimed Moneys held by Brunswick Plaster Mills Pty. Ltd.

Name of Owner on Books.	Total Amount Due to Owner.	Description of Unclaimed Money.	Date Accrued.
	£ s. d.		
K. Johnson ..	2 12 11	Wages ..	10.2.54
E. Hawley ..	5 11 4	" ..	17.3.54
R. Freer ..	5 2 9	" ..	24.3.54
R. Freer ..	0 10 9	" ..	7.4.54
A. Pace ..	2 17 9	" ..	28.4.54
E. Kumar ..	0 2 2	" ..	28.4.54
E. Howe ..	2 9 7	" ..	26.5.54
G. Coco ..	5 19 2	" ..	26.5.54
A. Capocchi ..	1 5 4	" ..	30.6.54
F. Paino ..	5 13 9	" ..	30.6.54
C. Koefea ..	3 17 4	" ..	22.9.54
R. Tripodi ..	0 10 3	" ..	29.9.54
G. Russo ..	0 14 10	" ..	29.9.54
R. Denman ..	0 14 10	" ..	20.10.54
J. Morran ..	5 6 8	" ..	1.12.54
K. Stewart ..	0 4 3	" ..	1.12.54
R. Burman ..	3 1 2	" ..	15.12.54
G. Moder ..	2 6 4	" ..	15.12.54
J. Morran ..	0 4 3	" ..	15.12.54
T. Whittle ..	1 11 0	" ..	5.1.55
	50 16 5		

13179

THE GEELONG AND CRESSY TRADING CO. LTD.

REGISTER of Unclaimed Moneys held by the Geelong and Cressy Trading Co. Ltd.

Name of Owner on Books.	Total Amount Due to Owner.	Description of Unclaimed Money.	Date of Last Claim.
	£ s. d.		
King, F. ..	2 12 1	Proceeds of produce	1.10.54
Allin, B. A., Junior	0 15 0	Dividend 1954	4.10.54
Boddington Bros.	0 15 0	" ..	"
Brocklebank, Mary	1 10 0	" ..	"
Downs, D. P. ..	0 7 6	" ..	"
Denning, Edward	0 13 6	" ..	"
Ford, Frank ..	0 13 6	" ..	"
Hucker, Peter ..	1 1 0	" ..	"
Hoare, F. E. ..	3 9 0	" ..	"
Heal, V. G. ..	0 13 6	" ..	"
Light, R. A. ..	0 6 0	" ..	"
Morriss, Frederick (Estate)	0 13 6	" ..	"
Rainey, Sarah ..	2 3 6	" ..	"
Venters, J. R. ..	0 15 0	" ..	"
Koily, N. ..	0 18 0	Proceeds of produce	7.1.55
	17 6 1		

13225

THE ADELAIDE STEAMSHIP COMPANY LIMITED.

(Incorporated in South Australia.)

REGISTER of Unclaimed Moneys held by The Adelaide Steamship Company Limited as at 7th March, 1961.

Name of Owner on Books.	Total Amount due to Owner.	Description of Unclaimed Money.	Date of Claim.
	£ s. d.		
C. Henriksen ..	0 14 6	Wages ..	Jan., 1954
E. Clark ..	0 10 10	" ..	April, 1954

13109

Tenth Schedule.

WOODSIDE (LAKES ENTRANCE) OIL CO. N.L.

REGISTER of Unclaimed Moneys held by the Woodside (Lakes Entrance) Oil Co. N.L., 792 Elizabeth-street, Melbourne.

Name and Address of Owner on Books.	Total Amount Due to Owner.	Description of Unclaimed Money.	Certificate Number.	Date of Last Claim.
G. H. Burnell, P.O., Box 11, Killara, New South Wales	£ 1 1 0	Proceeds of Forfeiture Sale (to be paid on surrender of scrip)	46937	20. 7. 59
J. K. Cameron, 668 Brighton-road, Seacliff, South Australia	0 19 3	" " " "	41035	"
J. B. Craven c/o J. Craven and Co. Ltd., Rundle-street, Adelaide, South Australia	1 9 2	" " " "	30236	"
R. B. Craven, c/o J. Craven and Co. Ltd., Rundle-street, Adelaide, South Australia	1 9 2	" " " "	30381	"
William A. R. Crouch, c/o E. S. and A. Bank, Mt. Gambier, South Australia	0 9 4	" " " "	42242	"
Donlyn Nominees, 90 Queen-street, Melbourne, C.1	20 8 4	" " " "	21180-21184, 21123-21125, 29521-29522	"
Charles H. Dunning, 482 North-road, Ormond	17 10 0	" " " "	25648-25649, 25768, 25754, 25974, 26647	"
G. Eisfelder, 68 Bull-street, Bendigo	2 18 4	" " " "	51880	"
Gillon and Sharp Nominees, 360 Collins-street, Melbourne	0 19 10	" " " "	42513, 42504	"
Mrs. Lilian Greenhill, Winchelsea, Victoria	5 16 8	" " " "	62542-62543	"
Linden Skardon Greenhill, Winchelsea, Victoria	5 16 8	" " " "	62544-62545	"
C. O. Harrop, 3 Edward-street, South Tamworth, New South Wales	1 1 0	" " " "	75270	"
L. J. Harvey, Box 1281L, G.P.O., Adelaide, South Australia	0 0 7	" " " "	45883	"
W. H. Harvey, 28 Pirie-street, Adelaide, South Australia	11 13 4	" " " "	32494, 46231, 19673-19675, 44168	"
L. R. Hicks, 25 Gronfell-street, Adelaide, South Australia	0 9 4	" " " "	45878	"
Norton Jackson, 13 Windermere-street, Blackburn	1 8 0	" " " "	46847	"
Cecil W. Jago, 12 Eyre-street, Matraville, New South Wales	20 8 4	" " " "	47002-47006, 47014-47015	"
Mrs. Marie Kaufman, 207 King William-road, Hyde Park, South Australia	1 9 2	" " " "	32374	"
Allan Keith Lawson, Padthaway Station, Padthaway, South Australia	5 16 8	" " " "	66980, 66981	"
A. T. Leete, 277 Victoria-street, Abbotsford	2 18 4	" " " "	48372	"
A. M. Moffat, 28 Pirie-street, Adelaide, South Australia	0 14 7	" " " "	75029	"
A. A. Murray, cr. Lygon and Pigdon-streets, North Carlton, N.4	6 14 2	" " " "	79947, 50878, 50888	"
C. H. McArthur, 31 Gronfell-street, Adelaide, South Australia	0 4 1	" " " "	46154	"
Jeffrey Nahum, 30 Bridgo-street, Lane Cove, Sydney, New South Wales	0 11 8	" " " "	75138	"
A. G. Pearson, 24 Bowmore-street, Hughesdale, S.E.12	5 16 8	" " " "	25688, 25928	"
Ernest H. Plueckhahn, 37 Glongyle-terrace, Glandore, South Australia	1 9 2	" " " "	32948	"
David McC. Portley, 36 Oxlade-drive, New Farm, Brisbane, Queensland	0 17 6	" " " "	46782	"
Lizzie A. Rischbieth, 7 William-street, Hawthorn, South Australia	2 18 4	" " " "	16094	"
N. G. Simpson, 66 Pitt-street, Sydney, New South Wales	8 15 0	" " " "	49902-49906, 47783-47785	"
V. E. Smith, 14 Cabana Wyldc-street, Potts Point, Sydney, New South Wales	0 4 8	" " " "	75665	"
William Stanic, Box 650E, G.P.O., Melbourne	20 8 4	" " " "	63587-63588, 63591-63595	"
S. P. Stocker, 213 Williamson-street, Bendigo	2 18 4	" " " "	22031	"
H. G. Sutton, Box 14, Northcote, N.16	8 15 0	" " " "	26172-26173, 13545	"
Leslie Sutton, Box 14, Northcote	11 13 4	" " " "	13546, 26170-26171, 26462-26463	"
C. G. Tolhurst, 28 Pirie-street, Adelaide, South Australia	3 10 0	" " " "	75034, 6632	"
R. F. Vellender, 1 Rodborough-avenue, North Sydney, New South Wales	2 18 4	" " " "	66633	"
R. Walton, 66 Pitt-street, Sydney, New South Wales	11 13 4	" " " "	47594-47596, 47665-47666, 47680, 52285	"
Harriette M. Alexander, 66 Toorak-road, South Yarra	8 15 0	" " " "	60203-60205	"
Miss Mary J. Allan, 14 Straught-street, Burwood, Victoria	5 16 8	" " " "	41865, 17437, 31884, 43973	"
Mrs. Daphne M. Aplin, 1 Jalan Bungah Hinai Tahjong Garden Estate, Penang, Malaya	1 18 6	" " " "	30279, 40260	"
Malcolm Bruce Assheton, 4 Lavinia-street, Hove, South Australia	2 18 4	" " " "	29845	"
Arthur William Banks, 29 Weston-street, Brunswick, N.10	10 4 9	" " " "	2995-2996, 40052, 12495, 40786	"
Mrs. Elaine C. Basheer, 3 West-terrace, Kensington Gardens, South Australia	7 15 2	" " " "	10363-10364, 31332, 42668	"
Max Rafeek Basheer, 24 Waymouth-street, Adelaide, South Australia	11 13 4	" " " "	10365-10367, 15382	"
Percy Norman Battaini, 35 Loch-street, St. Kilda	0 11 8	" " " "	40035	"
Andrew Hamilton Becher, 40 Kooyong-Koot-road, Hawthorn	5 16 8	" " " "	61600-61601	"
Leslie Gilbert Binns, 20 Dalgety-road, Beaumaris	8 15 0	" " " "	21786-21788	"

REGISTER OF UNCLAIMED MONEYS—continued.

Name and Address of Owner on Books.	Total Amount Due to Owner.	Description of Unclaimed Money.	Certificate Number.	Date of Last Claim.
	£ s. d.			
Robert Vivian Blatchford, 188 St. Georges-terrace, Perth, Western Australia	1 18 6	Proceeds of Forfeiture Sale (to be paid on surrender of scrip)	30910, 41591	20.7.59
Mrs. Catherine J. Brownell, 20 Stanhope-grove, Camberwell	6 15 4	" " " "	15039, 31170, 42124, 30189, 45344	"
Horace B. V. Butler, Flat 5, 15 Kembala-street, Hawthorn	2 18 4	" " " "	2759, 30645, 41008	"
George Leslie Bullen, 27 Danluce-avenue, Brighton, South Australia	3 4 2	" " " "	15288, 42397	"
Isabel Jean Cairns, 23 Winifred-street, Pascoe Vale South	2 18 4	" " " "	26287	"
Mrs. Lonie R. Campbell, 11 Wolsley-grove, Brighton Beach	11 13 4	" " " "	2422-2425, 20808-20809, 32112, 44598	"
George Shell Cleghorn, 214 Portrush-road, St. Georges, South Australia	0 9 4	" " " "	41162	"
Brian Matthew V. Condon, 59 Bagot-avenue, Hilton, South Australia	0 19 3	" " " "	41375	"
Charles Henry Cornish, Flat 1, 24 Burns-street, Elwood	2 18 4	" " " "	22643	"
William Couch, 314 Mitcham-road, Mitcham	4 16 10	" " " "	1554, 30253, 40216	"
Alfred Ernest Crocos, 40 Honeysuckle-street, Bendigo	29 3 4	" " " "	63637-63646	"
John Joseph Dempsey, 3 Radnor-street, Rosanna	0 19 3	" " " "	43057	"
John William Dunn, 99 Carlisle-street, St. Kilda	9 14 3	" " " "	2428-2429, 11859, 40192	"
Brian E. Fitzpatrick, c/o Newman College, University of Melbourne, Carlton	1 1 0	" " " "	75466	"
James Spraggon Forrest, 5 Lonsdale-avenue, Pymble, Sydney, New South Wales	9 14 3	" " " "	13395-13397, 41417	"
Mrs. Marie Grundy, 154 North-road, Brighton, Victoria	0 19 3	" " " "	43180	"
Cyril Gunn, 361 Collins-street, Melbourne	0 19 3	" " " "	—	"
Gordon William Harris, S. A. Stevedoring Co. Ltd., Lipson-street, Pt. Adelaide, South Australia	7 15 2	" " " "	13093-13094, 30746, 41219	"
Mrs. Ellen Rose Hart, 39 Park-road, Middle Park	2 18 4	" " " "	19573	"
Francis Owen Hart, 39 Park-road, Middle Park	2 18 4	" " " "	19572	"
Mrs. Winifred Helme, 11 Williams-road, Windsor	5 16 8	" " " "	11498-11499	"
Frank A. Herde, 1 Pembroke-street, Kensington Park, South Australia	0 9 4	" " " "	31120, 42018	"
Frank Hoffman, 228 Pitt-street, Sydney, New South Wales	14 11 8	" " " "	—	"
John Paton Hume, 121 Gordon-street, Balwyn, E.S.	2 15 5	" " " "	30011, 40019	"
Allan W. S. Huntington, 38 Mary-street, Surrey Hills, New South Wales	58 6 8	" " " "	66600-66619	"
Margaret E. A. and Arthur C. M. Jupp, 68 Glenferrie-road, Kew	0 19 3	" " " "	75714	"
John D. Kahlbetyer, c/o Heinz Bros. A/sia Pty. Ltd., 271 Pitt-street, Sydney	1 18 6	" " " "	41231, 45083	"
Charles Keeler, Orange-grove, Bayswater	0 19 3	" " " "	41230	"
Mrs. Dorothea A. Kelly, 22 Arcadia-avenue, Oakleigh	2 18 4	" " " "	17506	"
Frederick R. Kimber, Acorn-avenue, Bolair Estate, South Australia	0 19 3	" " " "	41823	"
Charalambos N. Klonaris, c/o E. J. Galanos, 65 Canning-highway, South Perth, Western Australia	1 18 6	" " " "	31481-42957	"
George Murray Knowles, Post Office, Gawler Rail, South Australia	0 19 3	" " " "	44151	"
Sam Komesarook, 279 Alma-road, Caulfield, S.E.S.	1 18 6	" " " "	15633, 42887	"
Shirley Alice Kusman, c/o Mr. Martin, Canterbury-road, Heathmont	2 18 4	" " " "	28483	"
Raymond Vincent Kyatt, 4 Reserve-road, Ringwood	1 18 6	" " " "	31239, 42271	"
Albert Ernest Layther, 26 Kilby-road, North Kew, E.S.	0 19 3	" " " "	42795	"
John M. Lohrman, 28 Hillsley-avenue, Everard Park, South Australia	2 18 4	" " " "	65170	"
Michael R. C. Long, c/o 122 Carpenter-street, Brighton, S.5	0 19 3	" " " "	40572	"
George A. H. Lynch, 20 Kinross-avenue, Caulfield, S.E.7	2 0 10	" " " "	32941, 75212	"
Miss Ruby M. Lynch, 20 Kinross-avenue, Caulfield, S.E.7	1 9 2	" " " "	32942	"
Mrs. Margaret Manners, 7 Harrow-road, St. Peters, South Australia	4 16 10	" " " "	53488, 33191, 75686	"
Mrs. Frederick W. Marshall, 3 Winchester-street, St. Peters, South Australia	5 14 4	" " " "	62043, 75132	"
Ronald Merkel, 9 Redcourt-avenue, Armadale, S.E.3	0 15 9	" " " "	46764	"
Pearce Herbert Morgan, 815 Armstrong-street North, Ballarat	0 19 3	" " " "	40611	"
Clifford M. Mortal, 128 Victoria Park-road, Kelvin Grove, Queensland	1 18 6	" " " "	31622, 43270	"
Nerida Joy Mosley, 48 Thomas-street, East Brighton	1 18 6	" " " "	31450, 42905	"
Mrs. Laurel M. McBeath, 35 Kidman-avenue, Kidman Park, South Australia	1 18 6	" " " "	30609, 40945	"
Keith Robert McCance, c/o Leonard G. May and Son, 99 Queen-street, Melbourne	2 18 4	" " " "	—	"
John Burgess Mackay, Dept. of Immigration, Canberra, Australian Capital Territory	0 19 3	" " " "	42218	"
Douglass, McMillan (Estate of), 67 Waterloo-street, Joondanna Heights, Western Australia	0 19 3	" " " "	42830	"
Albert W. Nancarrow, c/o Tolhurst Healy Munckton and Co., 401 Collins-street, Melbourne	0 9 4	" " " "	31067, 41911	"
James Arthur Neale, 3 Golf Links-avenue, Oakleigh, S.E.12	1 18 6	" " " "	31947, 43002	"

REGISTER OF UNCLAIMED MONEYS—*continued.*

Name and Address of Owner on Books.	Total Amount Due to Owner.	Description of Unclaimed Money.	Certificate Number	Date of Last Claim.
	£ s. d.			
Norman Victor Nicholls, 29 Grattan-street, Carlton, N.3 ..	5 16 8	Proceeds of Forfeiture Sale (to be paid on surrender of scrip)	—	20.7.59
Brian Scott Noblett, c/o Goldsbrough Mort and Co., Adelaide, South Australia	0 8 9	" " " "	45958, 31642	"
Mrs. Margaret M. Noonan, c/o F. A. Maides, 422 Little Collins-street, Melbourne	29 3 4	" " " "	48884-48893	"
Dr. Horace J. Perkins, 44 Marlborough-street, Brighton, South Australia	2 12 6	" " " "	32804, 46906	"
Hugh S. Ramsay, c/o Mrs. Jean S. Ramsay, 70 Riversdale-Road, Hawthorn, E.2	0 19 3	" " " "	44050	"
Mrs. Jean S. Ramsay, 70 Riversdale-road, Hawthorn, E.2	2 18 4	" " " "	13614	"
Charles C. Rasmussen, 5 James-street, East Oakleigh ..	2 18 4	" " " "	623	"
Victor C. Rethus, Lorquon, Victoria ..	2 18 4	" " " "	16146	"
Edward Wilfred Rice, 31 Derby-street, Highgate, Brisbane, Queensland	1 18 6	" " " "	30688, 41109	"
Mrs. Rose Rothfield, 11 Carmyle-avenue, Toorak, S.E.2 ..	0 9 4	" " " "	43717	"
Mrs. Eva May Ryan, 10 Ravenswood-avenue, East Ivanhoe	2 18 4	" " " "	13167, 41256	"
Thomas Henry Ryan, 10 Ravenswood-avenue, East Ivanhoe	3 17 7	" " " "	13164-13166, 41255	"
Mrs. Florence J. Scurry, 66 Burke-drive, Attadale, Western Australia	6 15 11	" " " "	2326, 15426, 42704	"
Mrs. I. C. F. Simmons, 9 Sutton-street, North Balwyn ..	1 18 6	" " " "	30694, 41116	"
Percy Charles Sparke, 6 Burns-road, Mahroonga, New South Wales	1 18 6	" " " "	44813, 45899, 45900	"
Henry C. J. Spencer, 22 Queens-court, Adelaide, South Australia	2 0 10	" " " "	32874, 75078,	"
Miss Myra A. Stevenson, Treasury Lodge, c/o New Treasury Buildings, Melbourne	2 18 4	" " " "	5159	"
Reginald S. Tasker, 25 Gilbert-street, Gilberton, South Australia	0 19 3	" " " "	43454	"
David Allan Thomas, 288 Sussex-street, Sydney, New South Wales	22 6 10	" " " "	61525-61529	"
Mrs. Irene W. Townley, 7 Waiema-avenue, Sandy Bay, Tasmania	1 18 6	" " " "	32731, 46630	"
James A. L. Viney, 87 Kyama-avenue, Cumberland-Park, South Australia	1 18 6	" " " "	31661, 43355	"
Terence M. Walcott (Estate of), c/o Boys and Ellis, Box 66 P.O., Bombala, New South Wales	4 16 10	" " " "	19266, 31927, 44074	"
Albert H. Ward, 138 Williams-road, East Prahran ..	2 18 4	" " " "	63150	"
Lionel Edward Wark, 85 Prospect-road, Prospect, South Australia	2 18 4	" " " "	61080	"
Paul John Watson, 52 Elwood-street, Brighton ..	1 9 2	" " " "	-32327	"
Mrs. Elizabeth M. E. Wellington, 12 Nora-street, Maylands, South Australia	0 9 4	" " " "	30990, 41740	"
Stanley John White, 81 Princes-highway, Sylvania, New South Wales	18 13 4	" " " "	52172, 75417	"
Eric R. Whitworth, 28 Robert-street, Collie, Western Australia	0 11 8	" " " "	—	"
Frank D. Wisdom, 51 Durham-road, Surrey Hills ..	0 19 3	" " " "	45497	"
Miss N. M. Young, 4 Melrose-street, Newport ..	2 18 4	" " " "	92574	"
Miss Margaret M. Noonan, c/o F. A. Maides, 422 Little Collins-street, Melbourne	2 10 0	" " " "	33457	"
Charles Henry Dunning, 482 North-road, Ormond ..	20 0 0	" " " "	91512-91515	"
	654 3 10			

13212

Tenth Schedule.

BEAU MONDE (AUSTRALIA) LIMITED.

REGISTER of Unclaimed Moneys held by Beau Monde (Australia) Limited.

Name and Address of Owner on Books.	Total Amount Due to Owner.	Description of Unclaimed Money.	Date of Last Claim.
	£ s. d.		
Martin, Keston William, Post Office Store, Pottsville Beach, Murwillumbah, Queensland	3 12 0	Interim Dividend paid 23rd April, 1959, on 48 Ordinary Shares	16.10.59
Martin, Keston William, Post Office Store, Pottsville Beach, Murwillumbah, Queensland	3 12 0	Interim Dividend paid 14th April, 1960 on 48 Ordinary Shares	16.10.59
Martin, Keston William, Post Office Store, Pottsville Beach, Murwillumbah, Queensland	2 17 7	Final Dividend paid 21st October, 1960 on 48 Ordinary Shares	16.10.59
Campbell, Stewart, 38 Tooronga-road, East Malvern	5 0 10	Final Dividend paid 21st October, 1960 on 84 Ordinary Shares	14.4.60

13213

WESTERN DISTRICT CO-OPERATIVE CO. LTD.

REGISTER of Unclaimed Moneys held by Western District Co-operative Co. Ltd., 14-20 King-street, Melbourne, C.1.

Name and Address of Owner on Books.	Total Amount Due to Owner.	Description of Unclaimed Money.	Date of Last Claim.
	£ s. d.		
Adams, William John, 11 Evans-street, Port Melbourne	0 5 0	Dividend for year 1954	No claim
Albury Co-operative Butter Factory Co. Ltd.	9 5 0	" " "	"
Barr, Ann Maria, Ormond-road, Geelong	0 5 0	" " "	"
Bell Bros. (James and Angus), Cororooke	0 10 0	" " "	"
Bond, Henry, (Deceased), c/o Excc. Mr. I. Bond, 30 Henham-street, Hawthorn East	0 10 0	" " "	"
Bourke, Martin, Cororooke	0 5 0	" " "	"
Brown, George Fynney, Post Office, Yambuk	0 5 0	" " "	"
Cain, Vernon George Lionel, (Deceased), c/o Nicol, Silvester and Culhane, Percy-street, Portland	0 5 0	" " "	"
Carter, Edwin John, 138 Koroit-street, Warrnambool	0 5 0	" " "	"
Chandley, William, Eurack	0 5 0	" " "	"
Clarke, John T., Noorat	0 10 0	" " "	"
Cooke, Henry Matthew, Coleraine	0 5 0	" " "	"
Crowe, Albert Ernest, Western Reserve, Warrnambool	0 10 0	" " "	"
Dowling, Kevin Francis, Panmure	0 15 0	" " "	"
Eldridge, Thomas Henry, Jnr.,	0 5 0	" " "	"
Eldridge, Thomas, Snr., (Estate of), Alvie	0 5 0	" " "	"
Fahey, Mrs. Catherine, c/o Mrs. Jas. Pekin, Learmonth-street, Moonee Ponds	0 15 0	" " "	"
French, James, Garvoc	0 5 0	" " "	"
French, John, 4 Wilson-street, Colac	0 5 0	" " "	"
Gent, Gordon McD. and Dorothy E., Malop-street, Geelong	0 10 0	" " "	"
Gleeson, Thomas, 50 John-street, East Brunswick	1 0 0	" " "	"
Good, Estate of William H., c/o J. S. Tait and Son, Warrnambool	2 10 0	" " "	"
Hallyburton, Estate of George, Pomborneit	0 10 0	" " "	"
Harney, Robert P., Garvoc	2 5 0	" " "	"
Hill, Joseph (Estate of), Post Office, Nullawarre	0 10 0	" " "	"
Horne, William, (Deceased), c/o J. G. R. Horne, "Iluka", Yulong, via Colac	1 5 0	" " "	"
Inglis, George, Cororooke	0 5 0	" " "	"
Inglis, James Thomas, Cororooke	0 10 0	" " "	"
Kelly, Michael Ambrose, Koroit	0 10 0	" " "	"
Laidlaw, David Thomas, (Deceased), c/o J. S. Tait, 125 Kepler-street, Warr- nambool	1 5 0	" " "	"
Lester, William, (Estate of), c/o Ruth Lester, Ararat	0 5 0	" " "	"
Luke, James, 14 King-street, Warrnambool	0 10 0	" " "	"
Mackay, Andrew, Warrion	0 5 0	" " "	"
McCabe, C., (Estate of), c/o Gavin Duffy, Camperdown	1 5 0	" " "	"
McCarthy, Robert Thomas, (Estate of), c/o Mrs. Mary McCarthy, Coragulae, via Colac	0 10 0	" " "	"
McComb, William James, Nalangil	0 10 0	" " "	"
McCosker, Thomas Dennington	1 0 0	" " "	"
McDonald, Mrs. Mary, 141 Clarke-street, Northcote	0 5 0	" " "	"
McKenzie, Alex., "Hillside", Donnybrook	0 5 0	" " "	"
McKenzie, William, (Deceased), c/o Excc. Mr. J. A. McKenzie, Glengarry	0 10 0	" " "	"
McLeod, Malcolm, (Estate of), c/o Mrs. Edie McLeod, Thorpdale	1 0 0	" " "	"
Meredith, Mrs. Roberta Jane, 16 Fitzroy-street, Geelong East	0 15 0	" " "	"
Mibus, Adolfe Gustave, c/o Eric Uebergang, Penshurst	1 5 0	" " "	"
Moodie, Stephen L., Hyne-street, Lilydale	0 5 0	" " "	"
Moore, Geo. S., Axfords Private Bag, Terang	0 5 0	" " "	"
Muir, Robert Archibold, Cudgee	0 5 0	" " "	"
Noonan, T., Penshurst	0 10 0	" " "	"
O'Leary, Miss Margaret, 15 Lansdown-street, East Melbourne	0 5 0	" " "	"
O'Leary, Mathew, 157 Nicholson-street, East Coburg	1 0 0	" " "	"
O'Shea, William (Deceased), c/o J. J. Kervin, Pirron Yallock	0 5 0	" " "	"
Parish, John Foster, Russells Creek, via Warrnambool	0 5 0	" " "	"
Read, Oliver Lyle, Barwon Heads	2 10 0	" " "	"
Richards, William Henry, Cororooke	0 5 0	" " "	"
Ryan, Mrs. Katherine, Cororooke	0 5 0	" " "	"
Sadler, Joseph, (Estate of), c/o David E. Trickett, Terang	0 10 0	" " "	"
Seale, George, Cororooke	0 5 0	" " "	"
Simpkin, Mrs. Elizabeth L., Becac	0 5 0	" " "	"
Smith, Mrs. Bernard Cyril, 21 Lansdown-street, East Melbourne	0 5 0	" " "	"
Smith, John, Alvie	0 10 0	" " "	"
Stanton, James, Penshurst	0 10 0	" " "	"
Stephens, Henry, Warrion	0 5 0	" " "	"
Trust, George, 45 Vale-street, St. Kilda	0 5 0	" " "	"
Warburton, Francis W., Private Bag, Kerang	0 5 0	" " "	"
Westlake, William, Ottway-street, Portland	2 10 0	" " "	"
Whiting, John, Kolora	0 10 0	" " "	"
Williams, James, Garvoc	0 5 0	" " "	"
Wilson, Richard, Grasmere	0 10 0	" " "	"
Wilson, Richard, O., (Estate of), c/o R. O. and A. F. Wilson, Private Bag 66, Colac	0 10 0	" " "	"
	48 5 0		

GUNBOWER CO-OPERATIVE BUTTER FACTORY AND TRADING CO. LTD.

REGISTER of Unclaimed Moneys held by the Gunbower Co-operative Butter Factory and Trading Co. Ltd.

Name and Address of Owner on Books.	Total Amount Due to Owner.	Description of Unclaimed Money.	Date of Last Claim.
	£ s. d.		
Easton, A. A. (Estate of), Macorna	0 2 2	Dividend..	Nil
Hawken, H. C., Leitchville	0 6 0	"	"
Major, T. F., McMillans	0 6 0	"	"
McLennon, A. J., Cohuna	0 7 2	"	"
Pettigrove Bros., Macorna	1 4 11	"	"
Pettigrove, H. G., Macorna	0 17 4	"	"
Reid, A. S., Gunbower	0 6 0	"	"
Simoni, D., Leitchville	0 6 0	"	"
Storm, E. A. (Estate of), Cohuna	0 6 0	"	"
Sutherland Bros., McMillans	0 6 0	"	"
Bonshon, Mrs. J., Fitzgerald-road, Essendon	0 6 0	Retros. Pay, Rebates and Dividend	"
Brewer, F. E., P.O. Box 48, Cohuna	1 5 2	"	"
Easton, A. A. (Estate of), Cohuna	0 12 0	"	"
Fletcher, C. E., c/o Mrs. D. Hetherington, Koroop	0 6 0	"	"
Fletcher, J. H., Teal Point, via Kerang	0 19 2	"	"
Gibbon, F. W., c/o J. F. O. Gibbon, Gunbower	1 13 6	"	"
Hawker, H. C., Leitchville	0 6 0	"	"
Hall, A. E., 39 Chatham-road, Canterbury	6 13 2	"	"
Harris, J. C., Box 87, Lilydale	2 9 2	"	"
Opie, T., c/o Mrs. G. Yates, Cohuna	1 4 0	"	"
Randall, F. W. E., P. B., Cohuna	1 7 7	"	"
Riley, D. E., Warburton-road, Woori Yallock	0 5 7	"	"
Simoni, D., Leitchville	0 6 0	"	"
Storm, E. A. (Estate of), Cohuna	0 6 0	"	"
West, K. H., 53 Neale-street, Kennington, Bendigo	0 6 1	"	"
Goulding, J. F., Leitchville	0 6 3	"	"
Keath, J. W., unknown	3 8 11	"	"
Peacock, K., unknown	0 10 4	"	"
Howells, D., unknown	0 6 9	"	"
Bonshor, Mrs. J., Fitzgerald-road, Essendon	0 6 0	"	"
Bowman, C. (Estate of Late), c/o R. A. I. M. Quinlan, Wayside Delivery, Cohuna	0 10 9	"	"
Bray, W. T., Jr., and Maxwell, D. R., "Lockslea," Cohuna	0 12 0	"	"
Brown, J. G., Leitchville	0 6 0	"	"
Brown, L. G., Leitchville	0 6 0	"	"
Dripps, S. J. (Estate of), 13 Myrall-street, Quarry Hill, Bendigo	1 1 7	"	"
Fletcher, C. E. (Estate of), c/o Mrs. D. Hetherington, Koroop	2 5 6	"	"
Gibbon, F. W., c/o J. F. O. Gibbon, Cohuna	2 2 3	"	"
Gray, Mrs. C. M., Box 49, Cohuna	0 16 9	"	"
Hawken, H. C., Leitchville	0 6 0	"	"
Heath, G. R. (Estate of), unknown	0 8 4	"	"
Khan, N. (deceased), Leitchville	0 16 9	"	"
Parry, C., 8 Hume-street, Armadale	0 14 5	"	"
Reid, A. S., Kerang P.O.	0 6 0	"	"
Simoni, D., Leitchville	0 6 0	"	"
Storm, E. A. (Estate of), Cohuna	0 6 0	"	"
Bowman, Chas. (Estate of), c/o A. A. M. Quinlan, Wayside Delivery, Cohuna	0 13 6	"	"
Shanahan, F. M. and R. A., Leitchville	3 8 7	"	"
Fletcher, C. E. (Estate of), Mrs. Hetherington, Koroop	0 7 6	"	"
Fletcher, D., unknown	1 17 6	"	"
Francis, W. C. (Estate of), unknown	0 7 6	"	"
Gray, C. M., unknown	1 1 0	"	"
Grass, W., unknown	3 1 1	"	"
Hawker, H. C., Leitchville	0 7 6	"	"
Lyons, W. A. (Estate of), unknown	0 18 0	"	"
Lake, A. M., unknown	1 3 0	"	"
Moore, Mrs. I. M. (Estate of), unknown	0 16 6	"	"
Norman, W. J. (Estate of), unknown	0 7 6	"	"
Opie, Mrs. T., c/o Mrs. G. Yates, Cohuna	1 10 0	"	"
Olsen, J. C., unknown	7 4 2	"	"
Reid, Alex., unknown	0 7 6	"	"
Simoni, D., Leitchville	0 7 6	"	"
Twigg, L. R., unknown	0 7 6	"	"
Twigg, K. R., unknown	0 7 6	"	"
Scott, N. W., unknown	0 5 8	Dividend and Revolving Fund	"
Mansfield, W. (Estate of), unknown	0 3 2	"	"
Love, M., unknown	1 15 8	"	"
Peacock, K., unknown	1 3 9	"	"
McLean, K., unknown	0 15 2	"	"
Borton, G. N., unknown	1 2 10	"	"
Major, D. S., unknown	1 14 3	"	"
Stagg, W., unknown	1 11 2	"	"
	72 0 7		

DENNYS, LASCELLES LIMITED.

REGISTER of Unclaimed Moneys held by Dennys, Lascelles Limited, as at 1st March, 1961.

Name of Owner on Books.	Total Amount Due to Owner.	Description of Unclaimed Money.	Date of Last Claim.
	£ s. d.		
<i>Casterton Branch.</i>			
Unknown	4 0 0	Cheque 236, 30.6.54
Unknown	0 15 0	Cheque 2198, 30.6.54
<i>Cobden Branch</i>			
Cobden Hospital Committee	0 5 0	Cheque 5464
Unknown	0 4 5	Cheque 5430
McConnell, L., Cobden	0 5 11	N/P. Stock Cheque 5206
Trigg, J.	0 17 10	Cheque 5254
Austin, T., Camperdown	0 8 11	N/P. Stock Cheque 5238
Andrews, A. J., Elingamite	0 2 11	N/P. Stock Cheque 5183
Unknown	1 9 9	Cheque 4919
Unknown	0 7 11	Cheque 4115
Sinnott, J., Elingamite North	0 4 11	N/P. Stock Cheque 7694
<i>Hamilton Branch.</i>			
Brandt, A.	0 1 10	N/P. Calf, Cheque 5569, 4.5.54
Bartsch, O.	0 4 8	N/P. Calf, Cheque 5665, 11.5.54
Wakfer, J.	1 0 0	Wages, Cheque 3915, 21.12.53
Cameron, W.	10 10 8	Agistment, Cheque 3290, 8.2.54
Nash, Jas.	0 11 0	Manure Rebate, Cheque 9077, 31.3.54
Dyson, N.	9 9 2	N/P. Stock, Cheque 2812, 17.12.54
Unknown	4 5 1	N/P. 1 Wether, 13.8.54
<i>Geelong Branch.</i>			
Barbera, N.	1 3 1	Wages, 7.5.54
McCabe, J.	2 15 0	Wages, 31.12.54
Smith, A.	2 7 0	Wages, 31.12.54
Warren, C.	2 6 6	Wages, 31.12.54
Wilson, D.	2 7 0	Wages, 31.12.54
Arnott, L.	4 6 8	Wages, Bonus, 31.12.54
Benvenega, G.	1 7 1	Wages, Bonus, 31.12.54
Connelly, N.	6 4 7	Wages, Bonus, 31.12.54
Connor, A.	8 18 3	Wages, Bonus, 31.12.54
Daffy, M.	1 1 3	Wages, Bonus, 31.12.54
Leeson, R.	2 2 10	Wages, Bonus, 31.12.54
Mulvahill, J.	3 2 8	Wages, Bonus, 31.12.54
McCabe, J.	1 16 3	Wages, Bonus, 31.12.54
O'Brien, T.	0 14 6	Wages, Bonus, 31.12.54
Reid, S.	6 14 1	Wages, Bonus, 31.12.54
Seanlon, J.	0 17 9	Wages, Bonus, 31.12.54
Vespo, S.	1 4 0	Wages, Bonus, 31.12.54
Anderson, L.	0 15 6	Wages, Bonus, 30.6.54
Brown, J.	1 9 6	Wages, Bonus, 30.6.54
Carroll, A.	5 4 5	Wages, Bonus, 30.6.54
Farrelly, N.	1 2 0	Wages, Bonus, 30.6.54
Hosking, Arthur G., Deniliquin, N.S.W.	44 4 0	Dividend, Cheque 3345, 26.8.54
Hosking, Arthur G., Deniliquin, N.S.W.	13 0 0	Dividend, Cheque 4751, 28.2.55
	150 8 11		

13224

COMMONWEALTH AIRCRAFT CORPORATION PTY. LTD.

REGISTER of Unclaimed Moneys held by Commonwealth Aircraft Corporation Pty. Ltd. as at 9th March, 1961.

Name of Owner on Books.	Last Known Address.	Total Amount due to Owner.	Description of Unclaimed Money.	Date of Last Claim.
		£ s. d.		
H. Brown	21 Young-street, Moonee Ponds	14 5 4	Unclaimed wages	No Claim
H. Oldridge	47 Doncaster-road, Box Hill	7 8 2	"	"
C. B. Sutherland	45 Dalgetty-road, Beaumaris	8 17 5	"	"
N. Kerr	214 Nott-street, Port Melbourne	3 3 1	"	"
G. E. Brown (Mrs.)	Lot 689 Hotham-road, East Keilor	2 4 3	"	"
R. G. Berry	98 Collins-street, Thornbury	2 17 2	"	"
W. F. Wood (deceased)	299 Johnstone-street, Abbotsford	36 9 2	"	"
W. Prochniewicz	142 Kerford-road, Albert Park	11 18 2	"	"
W. Przychodzki	9 Walter-street, Footscray	17 2	"	"
K. Smith (Miss)	48 Wilgah-street, East St. Kilda	2 11 6	"	"
F. J. Murphy	274 High-street, Windsor	3 4	"	"
J. S. Murray (Mrs.)	33 Kerford-road, Albert Park	1 1 0	"	"
G. Yiannitsarou	19 Victoria-avenue, Albert Park	4 1 6	"	"
A. P. Jinks	127 Gipps-street, East Melbourne	13 4	"	"
J. F. O'Brien	259 Williamstown-road, Yarraville	17 11 1	"	"
M. Colgan	c/o S. Leighton, Yardley-street, Maidstone	2 8 1	"	"
J. Janousky	69 King William-street, Regent	7 14 4	"	"
	Total	124 4 1		

13148

THE AUSTRALIAN ESTATES COMPANY LTD.

(Incorporated in England.)

REGISTER of Unclaimed Moneys held by The Australian Estates Company Limited.

Name and Address of Owner on Books.	Total Amount Due to Owner.	Description of Unclaimed Moneys.	Date of Last Claim.	Name and Address of Owner on Books.	Total Amount Due to Owner.	Description of Unclaimed Moneys.	Date of Last Claim.
	£ s. d.				£ s. d.		
C. J. R. Simmonds (address unknown)	0 2 6	Cheque ..	11.8.54	W. Prezybleck, 56 Collins-street, Melbourne	7 4 4	Wages ..	30.6.54
N. J. Watt, Lubeck ..	0 1 6	" ..	2.5.54	H. Sweeney, Fairfield ..	2 0 2	" ..	30.6.54
V. McReilly, Jerildere, N.S.W.	763 2 5	" ..	6.10.54	R. Kozel, West Footscray	14 18 6	" ..	30.6.54
V. McReilly, Jerildere, N.S.W.	59 6 0	" ..	20.12.54	D. Sinapoli, South Yarra	5 15 11	" ..	30.6.54
W. D. and R. L. Murrell, Ensay	0 8 4	" ..	8.10.54	C. Flaim, West Melbourne	9 0 0	" ..	30.6.54
A. Lee, Frankston ..	3 3 9	" ..	7.2.55	W. Townsing, Braybrook	5 2 7	" ..	30.6.54
F. Beavis, 68 Charles-street, Ascot Vale	1 19 2	Wages ..	16.7.54	P. Pearse, Moonee Ponds	4 17 8	" ..	30.6.54
E. Bedford, 20 McPherson-street, Footscray	8 5 0	" ..	23.12.54	E. Bedford, Footscray ..	0 13 2	" ..	30.6.54
J. Osborn, Altona ..	2 14 6	" ..	26.9.54	D. Adams, West Footscray	4 9 10	" ..	30.6.54
T. Synster (address unknown)	2 14 9	" ..	4.11.54	R. Maxwell, Yimta, S.A.	2 16 4	" ..	30.6.54
H. Pollock, West Footscray	2 14 9	" ..	13.1.55	J. C. Simpson, Kew ..	6 16 10	" ..	30.6.54
J. Drysdale, West Footscray	4 1 3	" ..	24.2.55	H. Bayley, East Brunswick	0 6 8	" ..	15.12.54
G. Williams, West Footscray	8 19 8	" ..	1.7.54	A. Moxon, East Brunswick	0 6 8	" ..	15.12.54
H. Pollock, West Footscray	5 17 10	" ..	1.7.54	K. Duke, Malvern ..	0 4 9	" ..	15.12.54
S. Cardona, Ascot Vale ..	7 10 3	" ..	1.7.54	W. Mallia, West Melbourne	1 0 8	" ..	15.12.54
N. Hodges, Maidstone ..	11 8 3	" ..	1.7.54	N. Bray, North Melbourne	4 12 1	" ..	15.12.54
L. McKay, Yarraville ..	10 1 0	" ..	1.7.54	C. Ord, A'Beckett-street, Melbourne	2 10 9	" ..	15.12.54
D. Harper, Footscray ..	3 17 10	" ..	1.7.54	J. Wright, Little Lonsdale-street, Melbourne	0 1 8	" ..	15.12.54
J. Edwards, Footscray ..	5 5 2	" ..	1.7.54	M. Grubic, Footscray ..	4 15 8	" ..	15.12.54
F. Beavis, Ascot Vale ..	1 1 11	" ..	16.12.54	F. Oarisi, West Melbourne	0 13 7	" ..	15.12.54
D. Sharpe, West Footscray	0 3 10	" ..	16.12.54	W. Buckhorn, Maribyrnong	3 14 11	" ..	15.12.54
H. Serpell, Tottenham ..	0 6 8	" ..	16.12.54	E. Windmeeller, Maribyrnong	8 10 11	" ..	15.12.54
J. Speechley, Yarraville	5 3 7	" ..	16.12.54	B. Hadicke, Footscray ..	4 5 11	" ..	15.12.54
S. Appedisano, Yarraville	0 5 0	" ..	16.12.54	A. Floramo, East Brunswick	1 13 0	" ..	15.12.54
V. Guastallgnome, West Footscray	0 16 6	" ..	16.12.54	A. Rubusa, East Brunswick	1 13 0	" ..	15.12.54
G. Fraser, West Footscray	1 19 7	" ..	16.12.54	S. Freeth, Braybrook ..	2 9 6	" ..	15.12.54
R. Wilson, West Footscray	1 12 7	" ..	16.12.54	E. Goetze, Maribyrnong	2 14 0	" ..	15.12.54
K. Greenough, Yarraville	3 5 0	" ..	16.12.54	H. Jusofovic, Ascot Vale	3 12 10	" ..	15.12.54
L. Males, Sunshine ..	0 16 9	" ..	16.12.54	J. Hamer, Ascot Vale ..	2 8 5	" ..	15.12.54
P. Pearse, Moonee Ponds	1 13 0	" ..	16.12.54	I. Kimek, Ascot Vale ..	0 6 7	" ..	15.12.54
E. Kinneburgh, Footscray	0 11 8	" ..	16.12.54	S. Jurcic, Footscray ..	4 10 4	" ..	15.12.54
S. Bawdykes, Sunshine ..	0 6 8	" ..	16.12.54	F. Hander, Sunshine ..	2 9 6	" ..	15.12.54
T. Calautte, Footscray ..	5 8 9	" ..	16.12.54	D. Brooker, Sunshine ..	2 2 11	" ..	15.12.54
P. Myhalchyslyn, Brooklea	2 3 3	" ..	16.12.54	W. Magain, West Footscray	1 6 5	" ..	15.12.54
V. Gramadakis, Windsor	2 0 7	" ..	16.12.54	J. Maricic, West Footscray	2 14 4	" ..	15.12.54
A. O'Connor, South Melbourne	2 10 6	" ..	30.6.54	D. Forbes, West Footscray	3 5 3	" ..	15.12.54
J. May, Carnegie ..	21 0 8	" ..	30.6.54	E. Smot, Yarraville ..	2 16 1	" ..	15.12.54
N. Sosto, North Melbourne	5 13 4	" ..	30.6.54	T. Izynski, West Sunshine	0 3 4	" ..	15.12.54
G. Lopreado, West Footscray	6 11 8	" ..	30.6.54	S. Mallia, Brooklyn ..	1 19 2	" ..	15.12.54
D. Hull, Ascot Vale ..	6 13 2	" ..	30.6.54	J. Osborn, Altona ..	0 3 4	" ..	15.12.54
L. Polmear, Y.M.C.A., Melbourne	1 5 2	" ..	30.6.54	K. Kerr, Braybrook ..	0 17 7	" ..	15.12.54
R. Morehead, Beaumaris	7 17 0	" ..	30.6.54	C. Malluccio, Yarraville	4 11 11	" ..	15.12.54
W. Mahor (deceased), West Brunswick	10 1 9	" ..	30.6.54	W. Winnell (address unknown)	0 5 0	Cheque ..	4.11.54
					1,128 4 7		

13118

Companies Act 1958—Section 153 (1).

MARYBOROUGH KNITTING MILLS (CUTTLE) LTD.

REGISTER of Unclaimed Moneys held by Maryborough Knitting Mills (Cuttle) Ltd.

Name of Owner on Books.	Total Amount Due to Owner.	Description of Unclaimed Money.	Date of Last Claim.
	£ s. d.		
J. A. Miller ..	9 15 0	Dividend Nos. 8 to 20 ..	No claim ever made. Unable to trace
Executors of C. L. Williams (deceased) ..	9 15 0	Dividend Nos. 8 to 20 ..	Unable to trace Executors

13192

The Companies Act 1958.

THE COLONIAL SUGAR REFINING COMPANY LIMITED.

REGISTER of Unclaimed Moneys held by the Colonial Sugar Refining Company Limited.

Name of Owner on Books.	Total Amount Due to Owner.		Description of Unclaimed Money.	Date Accrued.
	£	s. d.		
L. Portelli	5	0 5	Wages	6.1.54
G. Cerillo	2	15 8	"	13.1.54
F. Postnett	0	7 5	Workers Compensation	13.1.54
I. Teleczuk	2	8 2	Wages	20.1.54
P. Costigan	2	16 4	"	20.1.54
L. Gingo	2	16 4	"	3.2.54
J. Lajsic	7	12 7	"	3.2.54
G. H. F. Scott	2	11 1	"	3.2.54
G. Harper	4	8 0	"	3.3.54
J. Naumowecy	2	15 7	"	24.3.54
L. Geryina	2	15 5	"	24.3.54
T. Cotranei	1	2 11	"	24.3.54
G. Gattellou	0	1 6	"	24.3.54
G. Maraluto	0	6 0	"	24.3.54
G. Agastino	0	4 6	"	24.3.54
J. Smith	3	6 7	"	7.4.54
A. Nastopolous	3	10 11	"	28.4.54
G. Mellos	2	11 4	"	5.5.54
Miss A. Conti	1	17 8	"	19.5.54
A. H. Wilson	0	1 9	"	3.6.54
W. Turnbull	0	1 9	"	3.6.54
H. Chojnicki	2	10 11	"	9.6.54
G. Mercuri	2	12 6	"	16.6.54
D. Christ	1	0 2	"	18.8.54
C. Gianelli	2	10 11	"	18.8.54
C. Scott	2	14 6	"	18.8.54
Brereton Bros. and Wass	1	14 10	Overpayment for Sugar	19.8.54
E. Mugliett	0	11 8	Wages	15.9.54
M. Panagintidis	2	11 2	"	6.10.54
P. Genco	0	1 0	"	20.10.54
J. Kirkham	0	9 1	"	12.1.55
G. Mangion	2	10 9	"	19.1.55
D. Clements	0	3 1	"	9.2.55
J. Saleba	2	0 10	"	23.2.55
	71	3 4		

13199

ROCHESTER CO-OPERATIVE BUTTER AND CANNING CO. LTD.

REGISTER of Unclaimed Moneys held by the Rochester Co-operative Butter and Canning Co. Ltd.

Name and Address of Owner on Books.*	Total Amount Due to Owner.		Description of Unclaimed Money.	Date of Last Claim.
	£	s. d.		
Allan, George, Bendigo	0	6 0	Dividend, 30th June, 1954..	31.12.48
Emery, R. C., Camberwell	0	12 0	"	31.12.51
Fletcher, David, Lancashire, England	0	6 0	"	31.12.53
Gibbs, Harry F., Bamawm Extension	0	12 0	"	31.12.48
Green, William H., Ballondella	0	6 0	"	31.12.49
Haley, Alexander Leslie, Ballondella	0	12 0	"	31.12.53
Hamilton, Albert Jas., Tongala	0	6 0	"	31.12.49
Jellicoe, Felix St. H., Guildford, Surrey, England	0	12 0	"	31.12.48
Jellicoe, Katherine E., Guildford, Surrey, England	0	12 0	"	31.12.48
Johnstone, William, Nanneella	0	6 0	"	31.12.52
Kelly, Edward J., Rochester	0	6 0	"	31.12.48
Keogh, Patrick J., Albert Park	0	6 0	"	31.12.48
Kerlin, Edward, Ivanhoe	0	6 0	"	31.12.50
King, L. C., Rochester	0	12 0	"	31.12.48
Murdoch, Robert Jnr., Nanneella	0	6 0	"	31.12.53
Murphy, Lilian, Canterbury	0	7 2	"	31.12.53
Paynter, George H. W., West Footscray	0	6 0	"	31.12.49
Patrick, H. D., Nanneella	2	18 10	"	31.12.50
Smith, Arthur C., Injune, via Roma, Q'ld.	0	6 0	"	31.12.48
Sweatman, Elizabeth, Longwarry	0	6 0	"	31.12.48
Sweatman, Thomas, Longwarry	0	6 0	"	31.12.48
Sharp, Thomas (deceased), Nanneella	0	6 0	"	31.12.48
Slattery, John Joseph, Tennyson	1	5 2	"	31.12.52
Smith, Mary Jane, Rochester	1	10 0	"	31.12.53
Warden, Henry F., Camberwell	0	18 0	"	31.12.53
Whinfield, John Loddon, Lockington	0	6 0	"	31.12.53
Williams, George, Lockington	0	12 0	"	31.12.48
Wilson, Mary, Albert Park	0	6 0	"	31.12.50
	15	19 2		

13227

Tenth Schedule.

HOADLEY'S CHOCOLATES LIMITED.

REGISTER of Unclaimed Moneys held by Hoadley's Chocolates Limited, Coventry-street, South Melbourne.

Name of Owner on Books.	Last Known Address.	Total Amount Due to Owner.	Description of Unclaimed Money.	Date of Last Claim.
		£ s. d.		
Allbone, Hanna Isabel	39 Glebe-street, Glebe, N.S.W.	3 15 0	Dividend on :— 60 Ordinary shares	1923
Ashworth, James	139 Ryrie-street, Geelong	7 10 0	120 " " "	"
Carroll, Mary	51 Ashworth-street, Middle Park	7 10 0	120 " " "	"
Davies, Oliver George	18 Church-street, Balmain, N.S.W.	3 15 0	60 " " "	"
Hunn, Frank Edward	175 Burke-road, Canterbury	7 10 0	120 " " "	"
Lynch, Rose Mary	89 High-street, Prahran	7 10 0	120 " " "	"
McGillicuddy, Elizabeth	10 Cecil-street, Williamstown	1 17 6	30 " " "	"
O'Loughlin, Catherine (deceased)	240 Maribyrnong-road, Moonee Ponds	7 10 0	120 " " "	"
Ransley, Eva Annie	10 Jeffrey-street, Canterbury, N.S.W.	3 15 0	60 " " "	"
Raven, Helen	31 Blair-street, Moreland	1 17 6	30 " " "	"
Rigbye, Margaret	38 Bowen-street, Moonee Ponds	1 17 6	30 " " "	"
Thornton, Thomas F.	55 Glebe-road, Glebe, N.S.W.	3 15 0	60 " " "	"
Warne, Alice Orpah	178 North-road, Brighton	7 10 0	120 " " "	"
Wright, Agnes	159 Cecil-street, South Melbourne	7 10 0	120 " " "	"
Woodlands, Frederick W.	40 Smith-street, Collingwood	1 17 6	30 " " "	"
Reid, Catherine Francis	Main-street, Mordialloc	1 17 6	30 " " "	"
Barnard, Bryan	22 Carrington-avenue, Mosman, N.S.W.	0 12 6	50 " " "	1959
Stokes, Jean	c/o Mr. D. M. Taylor, 55 Huntingtower-road, Malvern, S.E.4	4 0 0	100 Preference shares	"
Young, Jessie Mary Violet	427 Dryburgh-street, North Melbourne	3 15 0	60 Ordinary shares	"
Rothwell, Walter (deceased)	Barkell and Peacock, 11c Castlereagh-street, Sydney, N.S.W.	3 0 0	60 " " "	"
Alentorn, Benjamin (deceased)	Hefley and Butler, 369 Lonsdale-street, Melbourne	4 0 0	100 Preference shares	"
King, Eleanor Lily	16 Glyndeburn-avenue, Toorak	4 0 0	100 " " "	"
Wilson, Beulah	Morrison, Teare and Purnell, 164 Flinders-street, Melbourne	2 0 0	50 " " "	"
		98 5 0		

13193

KYNETON DISTRICT BUTTER AND CHEESE CO. LTD.

REGISTER of Unclaimed Moneys held by the Kyneton District Butter and Cheese Co. Ltd.

Name and Address of Owner on Books:	Total Amount Due to Owner.	Description of Unclaimed Money.	Date of Last Claim.
	£ s. d.		
Cook, E. F., unknown	0 10 0	Dividend, 1954	Nil
Dean, A., 13 Errard-street, North Ballarat	0 5 0	" " "	"
Hughes, B. J. (ded.), c/o Mrs. G. Mottingham, 11 Smith-st., Thornbury	0 5 0	" " "	"
Morgan, H. (deceased), c/o M. Morgan, Emberton P.O.	0 5 0	" " "	"
Mullins, E., Chunes P.O.	0 3 0	" " "	"
McRae, D. (deceased), c/o E. W. Tulloh, Kilmore	0 10 0	" " "	"
McCreery, T. (deceased), unknown	0 15 0	" " "	"
O'Meara Bros., c/o Mrs. J. O'Meara, Malmsbury	1 0 0	" " "	30.8.52
O'Sullivan, J., c/o R. Weston, 10 William-street, Dandenong	0 5 0	" " "	30.8.51
Reynolds, C., c/o O. Marshall, 486 Hawthorn-road, Caulfield	0 10 0	" " "	Nil
	4 8 0		

13228

THE DIMBOOLA STORES LIMITED.

REGISTER of Unclaimed Moneys held by The Dimboola Stores Limited.

Name and Address of Owner on Books.	Total Amount Due to Owner.	Description of Unclaimed Money.	Date of Last Claim.
	£ s. d.		
Schultz, Bernhard (deceased Estate), Rippon-road, Hamilton	1 5 0	Dividend for year ended 30th June, 1954	No claim
Moller, Peter W., 92 Wirraway-street, Moe	1 17 6	Dividend for year ended 30th June, 1954	"
	3 2 6		

13164

No. 21.—2068/61.—4

KYABRAM AND DISTRICT CO-OPERATIVE DAIRY COMPANY LIMITED.

REGISTER of Unclaimed Moneys held by Kyabram and District Co-operative Dairy Company Limited.

Name and Address of Owner on Books.	Total Amount Due to Owner.	Description of Unclaimed Money.	Date of Last Claim.
	£ s. d.		
Dobinson, George, 125 Ormond-road, Elwood	0 12 0	Dividend, 4th December, 1954	12.11.52
Dickson, Robert, Tongala	0 12 0	" " " "	1.4.40
Dowey, William Henry, 76 The Grove, Moreland	0 18 0	" " " "	21.11.47
Eyles, P. J., Girgarre	0 12 0	" " " "	1.4.40
Glover, Alfred James, Poowong	0 6 0	" " " "	27.11.51
Gardiner, Joseph, Kyabram	0 6 0	" " " "	18.12.42
Grosvenor, Ronald Walter, Kyabram	0 15 0	" " " "	4.12.53
Hawker, Edith Alberta, Private Bag, Kyabram	0 6 0	" " " "	4.12.53
Hamilton, Keith, Myrtleford	0 19 3	" " " "	1.4.40
Kerlin, James Patrick, 510 Albert-street, East Melbourne	1 16 0	" " " "	24.11.49
Kappler, Miriam, Cora Lynn	0 6 0	" " " "	29.3.41
Lancaster, Thomas Bartram, and John Wilkinson, Lancaster	1 10 0	" " " "	27.11.51
Mustey, Martha, Bonn, Rochester	0 6 0	" " " "	4.12.53
McDonald, Mary Elizabeth, 38 Bealiba-road, Caulfield	1 4 0	" " " "	1.4.40
McNiff, Daniel A., Kyabram	0 12 0	" " " "	22.11.50
Spiers, William, Marathon, via Echua	0 12 0	" " " "	22.11.50
Tebble, Charles Henry, Cooma, via Tatura	0 16 6	" " " "	4.12.53
Tooley, Alice May, Girgarre	0 8 5	" " " "	12.11.52
	12 17 2		

13265

Companies Act 1958.—Tenth Schedule.

MILK BOTTLES RECOVERY LIMITED.

REGISTER of Unclaimed Moneys held by the Milk Bottles Recovery Limited.

Name of Owner on Books.	Total Amount Due to Owner.	Description of Unclaimed Money.	Date of Last Claim.
	£ s. d.		
Bradshaw, R.	3 14 11	Dividend on Shares	Unclaimed
Barr, M.	6 5 0	" " " "	"
Christensen and Francisco	7 10 0	" " " "	"
Kennedy, C. A.	3 8 8	" " " "	"
Nargoan Cream Co.	3 14 11	" " " "	"
Pearce, K. W.	3 14 11	" " " "	"
Pollock, R. A.	3 14 11	" " " "	"
Ray, T.	3 14 11	" " " "	"
Ragg, T. A.	3 14 11	" " " "	"
Ragg, A.	3 14 11	" " " "	"
Westmoreland, W.	4 1 2	" " " "	"

13127

AUSTRALIAN, MERCANTILE, LAND AND FINANCE COMPANY LIMITED.

REGISTER of Unclaimed Moneys held by Australian, Mercantile, Land and Finance Company Limited, for period 1st January, 1954 to 31st December, 1954.

Name of Owner in Books.	Last Known Address.	Total Amount due to Owner.	Description of Unclaimed Money.	Date of Last Claim.
		£ s. d.		
Cameron, H. P.	Orbost	1 19 1	Cartage	31.8.54
Carol, W. L.	Stawell	0 10 0	Cartage	28.8.54
Davis, G.	Balook	2 1 0	Stock proceeds	24.6.54
Dudley, S. J.	Longwood	6 18 6	Cartage	3.8.54
Formosa, N.	35 Lothian-street, North Melbourne	1 19 7	Wages bonus	20.6.54
Green, G.	Unknown	3 17 6	Stock proceeds	5.7.54
Hunt, J.	72 Mellon-street, Brunswick	1 6 5	Wages	3.3.54
Hunt, J.	72 Mellon-street, Brunswick	0 17 5	Wages bonus	20.6.54
Johnson, W.	Currie, King Island	5 1 10	Stock proceeds	13.4.54
McDonald, A.	8 Clarendon-street, Malvern	3 18 7	Wages bonus	20.6.54
Mears, M.	Western Australia	7 19 8	" "	20.6.54
Morgan, T.	Foster	11 0 7	Produce proceeds	20.9.54
Peteri, E.	87 Delbridge-street, Fitzroy	5 1 10	Wages bonus	20.6.54
Turner, W.	52 Reynard-street, Coburg	2 10 9	" "	20.6.54
		55 2 9		

13131

Companies Act 1958.

THE PERPETUAL EXECUTORS AND TRUSTEES ASSOCIATION OF AUSTRALIA LIMITED.

REGISTER of Unclaimed Moneys held by The Perpetual Executors and Trustees Association of Australia Limited.

Name of Owner on Books.	Total Amount Due to Owner.	Description of Unclaimed Money.	Date of Last Claim.
	£ s. d.		
Attenborough, Executors of W.	7 10 0	Dividends Nos. 115 and 116 . . .	23.2.12
Cave-Thomas, H. F.	0 10 0		

13150

FORD MOTOR COMPANY OF AUSTRALIA PTY. LTD.

REGISTER of Unclaimed Moneys, held by Ford Motor Company of Australia Pty. Ltd., as at 31st December, 1954.

Name and Address of Owner on Books.	Total Amount Due to Owner.	Description of Unclaimed Money.	Date of Last Claim.
	£ s. d.		
Schkiezi, Anton, 49 Yarra-street, Geelong	5 18 8	Wages	No claim
Lozyck, J., Address Unknown	2 17 4		
Rubnic, Milan, Norlane Hostel	6 3 10		
Schkiezi, Anton, 49 Yarra-street, Geelong	5 9 1		
Riis, Ada Maria, 229 Malop-street, Geelong	3 19 4		
Palanca, Luigi, 20 Brownbill-street, East Geelong	5 4 9		
Hobbs, Austin Edward, 23 Dudley-street, Newtown	5 8 0		
Rudolph, Osmond William, Nicholas-street, Geelong	2 10 2		
O'Tools, Ronald John, 3 Read-street, Newtown	1 19 4		
	39 10 6		

13135

FORD MANUFACTURING COMPANY OF AUSTRALIA PTY. LTD.

REGISTER of Unclaimed Moneys held by Ford Manufacturing Company of Australia Pty. Ltd., as at December, 31st, 1954

Name and Address of Owner on Books.	Total Amount Due to Owner.	Description of Unclaimed Money.	Date of Last Claim.
	£ s. d.		
Depta, Cyril, 41 Fyans-street, Chilwell	2 13 6	Wages	No claim
Alsop, Robert Maxwell, 193 Malop-street, Geelong	3 3 5		
McCarthy, Timothy Ronald, 19 Aberdeen-street, Geelong	2 13 11		
Schaefer, Karl, 44 Richmond-street, North Geelong	10 8 9		
Tomys, Seigfried, Railway Hostel, Pakington-street, West Geelong	5 18 8		
Briggs, Jack, 77 Prospect-road, Newtown	6 0 0		
Schyic, Anton, 13 Victoria-street, North Geelong	10 18 9		
Sarovic, Marko, 17 Woodstock-street, Chilwell	4 17 11		
Oliver, John, 69 Clarence-street, West Geelong	1 6		
	46 16 5		

13136

TATURA BUTTER FACTORY AND FARMERS' PRODUCE CO. LTD.

REGISTER of Unclaimed Moneys held by the Tatura Butter Factory and Farmers' Produce Co. Ltd.

Name and Address of Owner on Books.	Total Amount Due to Owner.	Description of Unclaimed Money.	Date of Last Claim.
	£ s. d.		
Baker, Thomas, North Mooropna	1 0 0	Dividend, 30th June, 1954 . . .	30.11.52
Zeqir, Shefik, Tatura	0 15 0		
	1 15 0		

13264

CORIO (HOLDINGS) LIMITED.

REGISTER of Unclaimed Moneys held by Corio (Holdings) Limited.

Name and Address of Owner on Books.	Total Amount Due to Owner.	Description of Unclaimed Money.	Date of Last Claim.
	£ s. d.		
Berger, John Joseph, 137 Hedderwick-street, Essendon	0 1 8	Proceeds of sale of 1 Share due to takeover ..	Unknown
Bisgrove, Ricard, 525 Flinders-lane, Melbourne ..	3 6 6	Dividend on 133 shares	"
Christensen, Doris Edith Evelyn, 56 Ninth-avenue, St. Lucia, Brisbane	0 1 8	Proceeds of sale of 1 share due to takeover ..	"
Christensen, Doris Edith Evelyn, 56 Ninth-avenue, St. Lucia, Brisbane	3 6 6	Dividend on 133 shares	"
Dennett, John Eric Stephen, R.A.A.F. Station, Schofield, N.S.W.	1 5 0	Dividend on 50 shares	"
Leahy, Dorothy May, 107 Main-street, Stawell ..	24 2 0	Dividend on 964 shares	"
Lehnan, Sidney, Box 25, East Caulfield	0 7 0	Dividend on 14 shares	"
Meredith, Earnest Raymond, 74 Alma-road, St. Kilda	0 3 4	Proceeds of sale of 2 shares due to takeover ..	"
Montague, Everett William, Young-street, Drouin, Vic.	0 3 4	Proceeds of sale of 2 shares due to takeover ..	"
Montague, Everett William, Young-street, Drouin, Vic.	5 14 0	Dividend on 228 shares	"
Moodie, James Bunyan, 9 Stradbroke-avenue, East Brighton	1 13 0	Dividend on 66 shares	"
McCarthy, Margaret Veronica, c/o Box 25, Collins-street, P.O., Melbourne	0 1 8	Proceeds of sale of 1 share due to takeover ..	"
McCarthy, Margaret Veronica, c/o Box 25, Collins-street, P.O., Melbourne	0 16 6	Dividend on 33 shares	"
Potter, Charles William, No. 4 Budo Mansions, 162 Charing Cross-road, London, W.C.2., England	2 10 0	Dividend on 100 shares	"

13152

Companies Act 1958—Tenth Schedule.

THE MARYBOROUGH DISTRICT CO-OPERATIVE BUTTER FACTORY COMPANY LIMITED.

REGISTER of Unclaimed Moneys held by The Maryborough District Co-operative Butter Factory Limited, of Railway-street, Maryborough, on the First day of March 1961.

Name of Owner on Books.	Total Amount Due to Owner.	Description of Unclaimed Money.	Date of Last Claim.
	£ s. d.		
Mrs. J. E. Dromey	4 0	28th Dividend on 2-£1 shares	28.8.46
Miss Georgina Farquharson	10 0	" " " 5- "	27.8.43
Mr. H. Harbour	2 0	" " " 1- "	27.8.52
Mr. Thomas Mold	2 0	" " " 1- "	28.8.46
Mrs. E. Schmidt	10 0	" " " 5- "	31.8.50
Mr. John H. Smith	10 0	" " " 5- "	28.8.51
Mrs. Ellen Wiseman	4 0	" " " 2- "	29.8.44
Total	2 2 0		

13134

D. & W. MURRAY (AUSTRALIA) LIMITED.

REGISTER of Unclaimed Moneys held by D. and W. Murray (Australia) Limited on 28th February, 1961.

Name and Address of Owner on Books.	Total Amount Due to Owner.	Description of Unclaimed Money.	Date of Last Claim.
	£ s. d.		
Mental Hygiene Dept., Sunbury	92 10 0	Overpayment of account	..
J. I. Mitchell, address unknown	39 0 10	Cash received	..

13203

The Companies Act 1958.—In the matter of HOUSE OF FASHION HARMONY PTY. LTD. (IN LIQUIDATION).

NOTICE is hereby given that a Fourth and Final Dividend is intended to be declared in this matter. Creditors who have not proved their debts by the 10th day of April, 1961, will be excluded from the dividend.

Dated this 20th day of March, 1961.

E. R. SMAIL, Liquidator.

Kennedy, Smail and Middlemiss, 31 Queen-street, Melbourne. 13298

Companies Act 1958.—In the matter of CAHILL'S PAINTERS PROPRIETARY LIMITED, Pursuant to Section 195 (3).

AT an Extraordinary General Meeting of the above-named company held at 302 Melbourne-road, Newport, on the 10th day of March, 1961, the following Resolution was passed as a Special Resolution:—

"That the company be liquidated voluntarily, and that Geoffrey Robert Orr, public accountant, of 266 Swan-street, Richmond, be appointed liquidator."

Dated this 20th day of March, 1961.

13242

R. H. CAHILL, Director.

The Companies Act 1958.—In the matter of POWER TOOL COMPANY OF AUSTRALIA PROPRIETARY LIMITED.—Notice re Meeting of Creditors, Pursuant to Section 201 (2).

NOTICE is hereby given that a Meeting of Creditors of the above-named company will be held at the offices of Kennedy, Smail and Middlemiss, Lower Ground Floor, 31 Queen-street, Melbourne, on Friday, the 24th day of March, 1961, at 11 a.m., the company having convened a meeting of its members for the same day for the purpose of considering a Resolution that the company be wound up voluntarily.

Dated this 17th day of March, 1961.

C. F. LACEY, Director.

Kennedy, Smail and Middlemiss, 31 Queen-street, Melbourne, C.I. 13296

The Companies Act 1958.

L. R. W. MOSS PTY. LTD. (IN LIQUIDATION).

NOTICE is hereby given that a First Dividend is intended to be declared in the above matter and that creditors who have not proved their debt by the 12th day of April may be excluded from this distribution.

Dated this 20th day of March, 1961.

J. K. HALL, Official Liquidator.

Hall and Rose, chartered accountants (Aust.), 390 Little Collins-street, Melbourne, C.I. 13274

The Companies Act 1958.

NAPKIN SUPPLY SERVICE PROPRIETARY LIMITED (IN LIQUIDATION).

NOTICE CONVENING FINAL MEETING OF MEMBERS, PURSUANT TO SECTION 210.

NOTICE is hereby given, in pursuance of section 210 of the *Companies Act 1958*, that a General Meeting of the members of the above-named company will be held on the 21st day of April, 1961, at the offices of Hall and Rose, chartered accountants, 390 Little Collins-street, Melbourne at 2.45 p.m., in the afternoon, for the purpose of having an account laid before them showing the manner in which the winding up has been conducted and the property of the company disposed of, and of hearing any explanations that may be given by the liquidator.

Dated this 16th day of March, 1961.

JOHN KENNETH HALL, Liquidator.

Hall and Rose, 390 Little Collins-street, Melbourne. 13266

The Companies Act 1958.

NAPKIN SUPPLY SERVICE PROPRIETARY LIMITED (IN LIQUIDATION).

NOTICE CONVENING FINAL MEETING OF CREDITORS, PURSUANT TO SECTION 210.

NOTICE is hereby given, in pursuance of section 210 of the *Companies Act 1958*, that a General Meeting of the creditors of the above-named company will be held on the 21st day of April, 1961, at the offices of Hall and Rose, chartered accountants, 390 Little Collins-street, Melbourne, at 3.00 p.m., in the afternoon, for the purpose of having an account laid before them showing the manner in which the winding up has been conducted and the property of the company disposed of, and of hearing any explanations that may be given by the liquidator.

Dated this 16th day of March, 1961.

JOHN KENNETH HALL, Liquidator.

Hall and Rose, 390 Little Collins-street, Melbourne. 13272

No. of company—30523.

CARRICK INVESTMENTS PROPRIETARY LIMITED.

NOTICE OF MEMBERS VOLUNTARY WINDING UP OF A COMPANY REGISTERED UNDER THE COMPANIES ACT 1958.

Special Resolution.

AT an Extraordinary General Meeting of members of Carrick Investments Proprietary Limited, duly convened and held at 422 Little Collins-street, Melbourne, on the 18th day of March, 1961, the following Special Resolution was duly passed:—

"That the company be wound up voluntarily under the provisions of the *Companies Act 1958*."

Walter Summerton, of 422 Little Collins-street, Melbourne, was duly appointed liquidator.

A. R. T. HUNTER, Chairman of Directors, Carrick Investments Proprietary Limited. 13285

FARMERS AND CITIZENS TRUSTEES COMPANY BENDIGO LIMITED.

AT an Extraordinary General Meeting of the above-named company, duly convened and held at the registered office of the company, Charing Cross, Bendigo, on Friday, the 10th day of March, 1961, the following Resolution was duly passed as a Special Resolution:—

"That the company be wound up voluntarily."

And at such last-mentioned meeting Victor George Southall, Joseph Aloysius Costigan, and John Reginald Tredinnick were appointed liquidators for the purposes of the winding up.

Dated the 10th day of March, 1961.

13302

F. K. HILL, Chairman.

No. 6412 of 1960.

In the Supreme Court of Victoria.—In the matter of Part 1 of the *Companies Act 1958*; and in the matter of ACE PACKING COMPANY PROPRIETARY LIMITED.—Before His Honour Mr. Justice Adam the 2nd day of March, 1961.

UPON the petition of Composite Buyers Proprietary Limited a creditor of the above-named company on the 6th day of December, 1960, preferred unto the court and upon hearing Mr. Paterson of counsel for the petitioner and upon reading the said petition an affidavit of Ronald James Ward sworn the 12th day of December, 1960, verifying the said petition, affidavits of Peter Duhan Garretty sworn the 14th day of December, 1960, and the 2nd day of March, 1961, respectively, the *Government Gazette* of the 15th day of February, 1961, and the *Age* newspaper of the 15th day of February, 1961, each containing an advertisement of the said petition, this court doth order that the time for swearing the affidavit verifying the petition be extended until the 13th day of December, 1960; and that the said Ace Packing Company Proprietary Limited be wound up by this court under the provisions of the *Companies Act 1958*; and that John Kenneth Hall, of 390 Little Collins-street, Melbourne, official liquidator, be named official liquidator in this winding up; and it is further ordered that the official liquidator pay any moneys received by him into the National Bank of Australasia Limited, 271 Collins-street, Melbourne, in the name of "Ace Packing Company Proprietary Limited (in liquidation)"; and it is further ordered that the petitioning creditor's costs of this petition be taxed and paid out of the assets of the company, and it is directed that this Order be passed and entered forthwith.

By the court,

E. H. COGHILL, Master.

Entered the 14th day of March, 1961.

ARTHUR PAYNE, Prothonotary.

NOTE.—It will be the duty of such of the persons as are liable to make out or concur in making out a statement of affairs as the official liquidator may require to attend on the official liquidator at such time and place as the official liquidator may appoint and to give him all information he may require.

Pavey, Wilson, Cohen and Carter, solicitors, 390 Lonsdale-street, Melbourne. 13275

No. of company—23889.

UNITED SHAREHOLDERS PROPRIETARY LIMITED (IN VOLUNTARY LIQUIDATION).

NOTICE CONVENING FINAL MEETING, PURSUANT TO SECTION 210, COMPANIES ACT 1958.

NOTICE is hereby given that the Final General Meeting of United Shareholders Proprietary Limited will be held at the registered office, 21 Court-street, Box Hill, Victoria, at Eleven a.m., on Monday, 24th April, 1961, to receive the final accounts and liquidator's report.

13303

HARRIE F. GOUGH, Liquidator.

WAYDEN AND COMPANY PROPRIETARY LIMITED (IN VOLUNTARY LIQUIDATION).

NOTICE is hereby given that, in pursuance of section 210 of the *Companies Act 1958*, the Final Meeting of shareholders will be held at the offices of Godden and Vale, 20 Queen-street, Melbourne, on Thursday, 27th April, 1961, at Ten a.m.

BUSINESS.

To receive and consider the liquidator's final statement of account.

Dated this 16th day of March, 1961.

13304

J. W. DANBY, Liquidator.

CREDITORS, next of kin and others having claims in respect of the estate of Ethel Violet Tuomy, late of 691 High-street, East Prahran, widow, deceased (who died on the 30th June, 1960), are to send particulars of their claims to Linda St. Ledger Chandler, of 504 Dandenong-road, Caulfield, Desmond Ernest Tuomy, of 89 Marshall-street, Ivanhoe, Garnette St. Leger Galvin, of 113 High-street, Kew, and Gertrude Kent Varcoe, of Terang, the executrices and executor named in the said will, care of the under-mentioned proctors, by the 24th May, 1961, after which date they will distribute the assets, having regard only to the claims of which they then have notice.

CORR & CORR, solicitors, 290 Latrobe-street, Melbourne. 13311

Trustee Act 1958.

PURSUANT to the *Trustee Act 1958*, creditors, next of kin, and all other persons having claims in respect of the estates of the deceased persons named below are required to send particulars to the legal personal representative or representatives, at the address stated, after which date the representative or representatives will distribute the assets, having regard only to the claims of which notice has been received:—

James Henry Brownbill, late of Arnold West, farmer, deceased, who died on the 21st day of September, 1960.—Claims to the executors, Lindsay Brownbill, of Arnold West; farmer, in care of the undersigned solicitors, not later than the 20th day of June, 1961. Tatchell, Dunlop, Smalley and Balmer, solicitors, 290 Williamson-street, Bendigo. 13208

Ellen Gapphen Spilsbury (also known as Ellen Jessiper Spilsbury and Ellen Coman Spilsbury), late of 4 Rupert-street, Newport, widow, deceased, died on 10th January, 1960.—Claims to the executor, Norman Alexander Spilsbury, of 99 Mason-street, Newport, fuel and produce merchant, care of John F. Carroll, of 4 Paisley-street, Footscray, solicitor, by the 25th day of May, 1961. John F. Carroll, LL.B., solicitor, 4 Paisley-street, Footscray. 13282

Timothy Walsh, late of 73 Thompson-street, Williamstown, grocer, deceased, died on 3rd December, 1959.—Claims to the executor, Francis James Walsh, of 63 Challis-street, Newport, grocer, care of John F. Carroll, of 4 Paisley-street, Footscray, solicitor, by the 25th day of May, 1961. John F. Carroll, LL.B., solicitor, 4 Paisley-street, Footscray. 13283

CREDITORS, next of kin, and others having claims in respect of the estate of Florine Ernestine Burow, formerly of Kilgour-street, Geelong, in the State of Victoria, but late of Ocean Grove, in the said State, spinster, deceased (who died on the 3rd day of December, 1959), are to send the particulars of their claims to The Fidelity Trustee Company Limited, at its office at 8 Malop-street, Geelong aforesaid, by the 1st day of June, 1961, after which date it will distribute the assets, having regard only to the claims of which it then has notice.

FREEMAN & FALLOW, solicitors, 41 Yarra-street, Geelong. 13221

DORENDA MAY ROGERS, late of 61 Fyans-street, South Geelong, married woman, DECEASED.

CREDITORS, next of kin, and others having claims in respect of the estate of the said deceased (who died 6th December, 1960), are required by the applicants for grant of probate of the will, Doris Marion Somer, married woman, and Arthur Henry Henningsen, salesman, both of 62 Wyena-street, Camp Hill, Brisbane, Queensland, to send particulars to them, care of the undersigned solicitors, by 24th May, 1961, after which date the said applicants may convey or distribute the assets, having regard only to the claims of which they then have notice.

WIGHTON & McDONALD, solicitors, 189-191 Moorabool-street, Geelong. 13222

MARY EUNICE GIBSON, late of 42 Berkeley-street, Hawthorn, married woman, DECEASED.

CREDITORS, next of kin and others having claims in respect of the estate of the above-named deceased (who died on the 19th day of October, 1960) are required by James Samuel Gibson, of 42 Berkeley-street, Hawthorn, solicitor, to send particulars to him, care of the under-mentioned solicitors, by the 20th day of May, 1961, after which date he may convey or distribute the assets, having regard only to the claims of which he then has notice.

Dated the 7th day of March, 1961.

R. E. LEWIS ORR & GIBSON, solicitors, 825 Burke-road, Camberwell. 13174

CREDITORS, next of kin and others having claims in respect of the estate of Winifred Jessie Nicoll, late of 109 Mathoura-road, Toorak, spinster, deceased (who died on the 30th October, 1960), are to send particulars of their claims to The Union Trustee Company of Australia Limited, of 333 Collins-street, Melbourne, by the 23rd May, 1961, after which date it will distribute the assets, having regard only to the claims of which it then has notice.

MILLS & OAKLEY, solicitors, 10 Powlett-street, East Melbourne. 13200

ELIZABETH MAY STEPHENSON, late of 187 Francis-street, Yarraville, widow, DECEASED.

CREDITORS, next of kin, and others having claims in respect of the estate of the deceased (who died on the 30th day of October, 1960), are required by the applicant for grant of probate, Allan Harry Woods, of 10 Fehon-street, Yarraville, managing director, to send particulars to him, care of the undersigned, by the 31st day of May, 1961, after which date the applicant for probate may convey or distribute the assets, having regard only to the claims of which he then has notice.

Dated the 16th day of March, 1961.

ARTHUR SECOMB & CO., 128 William-street, Melbourne, solicitors for the applicant for probate. 13233

JOHN FRANCIS STACEY, late of Sea Lake, in the State of Victoria, farmer, DECEASED.

CREDITORS, next of kin, and others having claims in respect of the estate of the deceased (who died on the 2nd day of October, 1960), are required by the executors, Gordon Francis Stacey, formerly of Nyah, in the State aforesaid, but now of Beverford, in the State aforesaid, and Graham Hugh Stacey, of Sea Lake, in the State aforesaid, farmers, to send particulars to them, care of the undersigned, by the 5th day of June, 1961, after which date the executors may convey or distribute the assets, having regard only to the claims of which they then have notice.

Dated this 17th day of March, 1961.

ALEC M. HAYES, solicitor, 199 Campbell-street, Swan Hill. 13234

ALBERT FREDERICK CLUGG, late of Springhurst, farmer, DECEASED.

CREDITORS, next of kin, and others having claims in respect of the estate of the deceased (who died on the 5th day of March, 1960), are required by the trustees, William George Just, of 71 Reid-street, Wangaratta, and The Perpetual Executors and Trustees Association of Australia Limited, of 100-104 Queen-street, Melbourne, to send particulars to them, addressed care of their solicitor, W. G. Just, 71 Reid-street, Wangaratta, by the 18th day of May, 1961, after which date the trustees may convey or distribute the assets, having regard only to the claims of which they then have notice.

Dated the 8th day of March, 1961.

W. G. JUST, B.A., LL.B., solicitor, Wangaratta. 13236

CREDITORS, next of kin, and others having claims in respect of the estate of Sydney John Missen, late of Hiamdale, in the State of Victoria, farmer (who died on the 16th September, 1960, and probate of whose will was granted by the Supreme Court of Victoria on the 24th February, 1961, to Lyla Jessie Missen, widow, and Joseph Missen, farmer, both of Hiamdale, the executrix and executor named in said will), are to send particulars of their claims to the said executrix and executor, care of the below-mentioned solicitors, by the 31st May, 1961, after which date they will distribute the assets of the said deceased, having regard only to the claims of which they then have notice.

Dated 17th March, 1961.

BRUCE & LITTLETON, solicitors, Traralgon. 13239

AGNES LILLIAN LAMONT, late of 36 Glenbrook-avenue, Clayton, widow, DECEASED.

CREDITORS, next of kin and others having claims against the estate of the deceased (who died on 27th November, 1960), are required by the administrator, Alfred Dudley Boxall, to send particulars to him, care of 120 William-street, Melbourne, by the 25th May, 1961, after which date he may convey and distribute the assets, having regard only to the claims of which he then has notice.

BLAKE & RIGGALL, 120 William-street, Melbourne, solicitors. 13295

CREDITORS, next of kin and others having claims in respect of the estate of David Fraser Milne, late of 27 Simpson's-road, Box Hill, retired manufacturer (who died on the 12th day of July, 1960), are required to send particulars of their claims to the executors, care of the under-mentioned solicitor, by the 31st day of May, 1961, after which date the executors will distribute the assets, having regard only to the claims of which they then have notice.

K. P. REES, B.A., LL.B., solicitor, 89 Queen-street, Melbourne. 13297

CREDITORS, next of kin, and others having claims in respect of the estate of Miloslav Kollross, late of 81 Cromwell-road, South Yarra, in the State of Victoria, electrician, deceased (who died on the 29th day of July, 1958), are to send particulars of their claims to Josef Kollross, the attorney under power of Frantiska Frances Radova, mother of the deceased, care of the under-mentioned solicitors, on or before the 10th day of May, 1961, after which date the said attorney under power will distribute the assets, having regard only to the claims of which notice has been received.

Dated the 9th day of March, 1961.

A. L. C. FLINT & MARRIE, of 578 Bourke-street, Melbourne, solicitors for the attorney under power. 13256

EMILY COX, late of 14 Seymour-street, Ballarat, in the State of Victoria, married woman, DECEASED (who died on the 24th December, 1960).

CREDITORS, next of kin, and all other persons having claims against the estate of the said deceased are required by the executor, The Fidelity Trustee Company Limited, of 101 Lydiard-street north, Ballarat, to send detailed particulars of their claims in respect of the said property to the said executor on or before the 22nd day of June, 1961, after which date it will proceed to distribute the said estate, having regard only to the claims of which it then has notice.

Dated this 17th day of March, 1961.

R. H. RAMSAY & GAUNT, 41 Lydiard-street, Ballarat, solicitors for the said executor. 13258

CREDITORS, next of kin and others having claims in respect of the estate of George William Rutherford Noble, formerly of Fairfield West-road, Newcastle-upon-Tyne, England, but late of 21 Collingwood-street, Sandringham, Victoria, gentleman, deceased (who died on the 5th day of October, 1960), are to send particulars of their claims to National Trustees, Executors and Agency Company of Australasia Limited, and Winifred Noble, to the registered office of the said company, 95 Queen-street, Melbourne, by the 7th day of June, 1961, after which date they will distribute the assets, having regard only to the claims of which they then have notice.

LYNCH & MACDONALD, 360 Collins-street, Melbourne, solicitors for the executors. 13299

CREDITORS, next of kin and others having claims in respect of the estate of Daisy Elizabeth Williams, formerly of "Willdene", Gould-street, Frankston, but late of Thursday Island, gentilewoman, deceased (who died on 1st September, 1960), are to send particulars of their claims to the trustees, The Perpetual Executors and Trustees Association of Australia Limited, of 100-104 Queen-street, Melbourne, and Phillip Windmiller Ettelson, now of 100 Queen-street, Melbourne, solicitor, by 25th day of May, 1961, after which date they will distribute the estate, having regard only to the claims of which they then have notice.

UPTON & ETTELSON, solicitors, 100 Queen-street, Melbourne. 13301

CREDITORS, next of kin and others having claims in respect of the estate of Frederick Herman Jencke, late of Buln Buln East, in the State of Victoria, farmer, deceased (who died on the 4th day of December, 1960), are required by the Public Trustee for Victoria, the executor to whom probate of the will of the said Frederick Herman Jencke, deceased was granted, to send particulars to him, at 601 Little Collins-street, Melbourne, by the 29th day of May, 1961, after which date the executor may convey or distribute the assets, having regard only to claims of which he may then have notice.

Dated the 17th day of March, 1961.

J. T. STRACHAN, solicitor, 3 Smith-street, Warragul. 13308

FREDERICK OTTLEY WARR, formerly of Westall-road, Springvale, but late of 14 Buckingham-avenue, Bentleigh, estate agent, DECEASED.

CREDITORS, next of kin and others having claims in respect of the estate of the above-named deceased (who died on the 26th day of November, 1959), are required by the executrix, Elizabeth Brodie Warr, of 14 Buckingham-avenue, Bentleigh, widow, to send particulars to her, care of the undersigned, by the 5th day of June, 1961, after which date the executrix may convey or distribute the assets, having regard only to the claims of which she then has notice.

S. W. MISSON & BARTLEY, solicitors, 59 Waverley-road, East Malvern. 13309

CREDITORS, next of kin, and all other persons having claims against the estate of Edward Gould Norris, late of 1035 Mount Alexander-road, Essendon, in the State of Victoria, chemist, deceased (who died on the 1st day of February, 1961, probate of whose will was approved by the Supreme Court of the said State, in its probate jurisdiction, to Roy Leonard Yelland, of 37 Swanston-street, Melbourne, solicitor), are requested to send particulars of their claims, in writing, to the said Roy Leonard Yelland, at his above-mentioned address, on or before the 24th day of May, 1961, after which date the said Roy Leonard Yelland will distribute the assets, having regard only to the claims of which he then will have had notice. And notice is hereby further given that the said Roy Leonard Yelland will not be liable for the assets so distributed, or any part thereof, to any person of whose claim he shall not have had notice as aforesaid.

ROY L. YELLAND, solicitor, of 37 Swanston-street, Melbourne. 13287

GRACE VINTER PIKE, formerly of "Vinterfield", Vinter-avenue, Croydon, in the State of Victoria, but late of 6 Park-street, Malvern, in the said State, spinster, DECEASED.

CREDITORS, next of kin, and others having claims in respect of the estate of the deceased (who died on the 1st July, 1960), are required by The Equity Trustees, Executors, and Agency Company Limited, of 472 Bourke-street, Melbourne, in the said State, the applicant for probate of the will of the deceased to send particulars to the said company by the 31st day of May, 1961, after which date the said company may convey or distribute the assets, having regard only to the claims of which he then has notice.

LYNCH & MACDONALD, solicitors, 360 Collins-street, Melbourne. 13288

NELLIE ROFF WALKER, late of 99 Park-street, South Yarra, spinster, DECEASED.

CREDITORS, next of kin, and others having claims in respect of the estate of the deceased (who died on the 10th day of October, 1960), are required by the trustee, Joseph James Kenny, of 360 Collins-street, Melbourne, the executor to whom probate of the will and codicil of the said deceased was granted by the Supreme Court of Victoria to send particulars to him by the 31st day of May, 1961, after which date the said executor may convey or distribute the assets, having regard only to the claims of which he then has notice.

LYNCH & MACDONALD, solicitors, 360 Collins-street, Melbourne. 13289

GRACE MARY STEWART, late of "Cliveden Mansions", 192 Wellington-parade, East Melbourne, in the State of Victoria, widow, DECEASED.

CREDITORS, next of kin, and others having claims in respect of the estate of the deceased (who died on the 19th December, 1960), are required by the personal representatives, The Trustees, Executors, and Agency Company Limited, of 401 Collins-street, Melbourne; James Cuming Stewart, of 1 Kenley-court, Toorak, medical practitioner, and Alexander William Stewart, of 6 Heyington-place, Toorak, company director, to send particulars to them, in the care of the said company, by the 26th June, 1961, after which date they may convey or distribute the assets, having regard only to the claims of which they then have notice.

HEDDERWICK, FOOKES & ALSTON, solicitors, 103 William-street, Melbourne. 13290

THE PERPETUAL EXECUTORS AND TRUSTEES ASSOCIATION OF AUSTRALIA LIMITED, whose registered office is situate at Nos. 100-104 Queen-street, Melbourne, in the State of Victoria, and Henry Campbell Rathie, of Maryvale, Yalleroi, in the State of Queensland, grazier, and Grace Constance Dawborn, of "Bushfield", Berrigan, in the State of New South Wales, married woman, the executors and executrix of the will of Margaret Lester Rathie (who died on the 20th day of December, 1959), require all creditors, next of kin, and others having claims against the property or estate of the said deceased to send to the said executors, in the care of the said association, on or before the 24th day of May, particulars, in writing, of such claims, after which date the said executors intend to convey or distribute such property or estate to or among the persons entitled thereto, having regard only to the claims of which they shall have had notice. 13251

GEORGE ERNEST WILSON STEWART, late of Sutcliffe-street, Sea Lake, pensioner, DECEASED.

CREDITORS, next of kin and other persons having claims against the estate of the deceased, are required to send particulars of same to the executrix, Vera Caldwell, in care of the undersigned, on or before the 26th day of May, 1961, after which date she will distribute the assets, having regard only to the claims of which she then has notice.

GERALD E. DELANY & CO., solicitors, 270 Campbell-street, Swan Hill. 13268

CREDITORS, next of kin, and others having claims in respect of the estate of Muriel Norris Holton, late of 33 Ferndale-road, Glen Iris, married woman, deceased (who died on the 19th day of July, 1960), are to send particulars of their claims to the executors, Harold Holton, sworn valuer, and Phillip Windmiller Ettelson, solicitor, in care of the under-mentioned solicitors, by the 31st day of May, 1961, after which date the executors may distribute the assets of the estate, having regard only to the claims of which they then have notice.

UPTON & ETTIELSON, solicitors, 100 Queen-street, Melbourne. 13292

CREDITORS, next of kin, and others having claims in respect of the estate of Catherine Jane Nicholson Dummett, late of 19 Lorne-street, Carnegie, widow, deceased (who died on the 10th day of November, 1960), are to send particulars to the executors, Elva Jean Dummett, hairdressing attendant, and Frederick George Dummett, timber worker, in care of the under-mentioned solicitors, by the 31st day of May, 1961, after which date the executors may distribute the assets of the estate, having regard only to the claims of which they then have notice.

UPTON & ETTIELSON, solicitors, 100 Queen-street, Melbourne. 13293

CREDITORS, next of kin, and others having claims in respect of the estate of Joseph Nicholson, late of 16 Ovens-street, Yarraville, retired gatekeeper, deceased (who died on the 28th day of September, 1960), are to send particulars of their claims to The Union Trustee Company of Australia Limited, care of 333 Collins-street, Melbourne, by the 5th day of June, 1961, after which date it will distribute the assets of the said deceased, having regard only to the claims of which it then has notice.

RYMER, LANGFORD & RITCHIE, solicitors, of 346 Little Collins-street, Melbourne. 13284

JANE EDITH HAYES, late of 30 Caroline-street, South Yarra, widow, DECEASED.

CREDITORS, next of kin, and others having claims against the estate of deceased (who died on the 19th day of November, 1960), are required to send particulars thereof to Nellie Coates, of 150 Tucker-road, East Bentleigh, married woman, care of the undersigned solicitor, by the 10th day of May, 1961, after which date she will distribute the assets of the deceased, having regard only to the claims of which she then has notice.

E. K. O'DONNELL, solicitor, 173 Greville-street, Prahran. 13253

CREDITORS, next of kin, and others having claims in respect of the estate of Violet Cameron McIntyre, late of 573 Toorak-road, Toorak, in the State of Victoria, spinster, deceased (who died on the 21st December, 1960), are to send particulars of their claims to the executors, James Ford Strachan and Robert Russell Aitken, solicitors, both of 123 William-street, Melbourne, by the 26th day of May, 1961, after which date the executors will distribute the assets, having regard only to the claims of which they then have notice.

AITKEN, WALKER & STRACHAN, solicitors, 123 William-street, Melbourne. 13248

CREDITORS, next of kin and others having claims in respect of the estate of Emily Harrip, late of Nyora, in the State of Victoria, widow, deceased (who died on the 6th day of December, 1960), are to send particulars of their claims to The Trustees, Executors, and Agency Company Limited, of 401 Collins-street, Melbourne, in the said State, by the 1st day of June, 1961, after which date it will distribute the assets of the deceased, having regard only to the claims of which it has notice.

ABBOTT, STILLMAN & WILSON, solicitors, 422 Little Collins-street, Melbourne. 13246

LILIAN MARY EVA, formerly of Earl-terrace, Windsor, Brisbane, Queensland, but late of 12 Manor-street, Middle Brighton, spinster, DECEASED.

CREDITORS, next of kin, and others having claims against the estate of the deceased (who died on 13th August, 1960), are required by the executor, Richard Theodore Harold Eva, to send particulars to him, care of 120 William-street, Melbourne, by the 25th May, 1961, after which date the executor may convey and distribute the assets, having regard only to the claims of which he then has notice.

BLAKE & RIGGALL, solicitors, 120 William-street, Melbourne. 13291

CREDITORS, next of kin, and others having claims in respect of the estate of Ada Elizabeth Dod, late of 373 Elgar-road, Box Hill, in the State of Victoria, widow, deceased (who died on the 26th day of July, 1960), are required by the executor, Murray Hopetoun Rawlings, of 390 Elgar-road, Box Hill, in the said State, accountant, to send particulars of their claims to him, care of Rogers and Gaylard, solicitors, of 281 Collins-street, Melbourne, by the 31st day of May, 1961, after which date the said executor will distribute the assets of the deceased, having regard only to the claims of which he then shall have had notice.

ROGERS & GAYLARD, solicitors, 281 Collins-street, Melbourne. 13286

CREDITORS, next of kin, and others having claims in respect of the estate of Athol John Sinnbeck, late of Leongatha, in the State of Victoria, butter factory employee, deceased (who died on the 3rd day of October, 1960), are to send particulars of their claims to the executor, Athol Noel Sinnbeck, care of the under-mentioned solicitors, on or before the 10th day of May, 1961, after which date the said executor will distribute the assets, having regard only to the claims of which notice has been received.

Dated the 9th day of March, 1961.

A. L. C. FLINT & MARRIE, of 578 Bourke-street, Melbourne, solicitors for the executor. 13255

CREDITORS, next of kin, and others having claims in respect of the estate of Thomas Johnson, formerly of 25 Westgarth-street, East Malvern, in the State of Victoria, builder and contractor, late of 4 Silver-street, Malvern, in the State of Victoria, sub-estate agent, deceased (who died on the 21st day of May, 1960), are to send particulars of their claims to the executrix, Elinor Elizabeth Johnson, care of the under-mentioned solicitors, on or before the 10th day of May, 1961, after which date the said executrix will distribute the assets, having regard only to the claims of which notice has been received.

Dated the 9th day of March, 1961.

A. L. C. FLINT & MARRIE, of 578 Bourke-street, Melbourne, solicitors for the executrix. 13254

CREDITORS, next of kin and others having claims in respect of the estate of John Matthew Jones, late of North Boorhaman, in the State of Victoria, farmer, deceased (who died on the 22nd day of December, 1960), are to send particulars of their claims to the executors, Margaret Alice Jones, of Rutherglen, widow, William Joseph Jones, of North Boorhaman, farmer, and John Desmond Jones, of Koondrook, farmer, to care of Frank B. Lethbridge, solicitor, Main-street, Rutherglen, by the 22nd day of May, 1961, after which date the said executors will distribute the assets, having regard only to the claims of which they shall then have had notice.

Dated the 15th day of March, 1961.

FRANK B. LETHBRIDGE, solicitor, of Main-street, Rutherglen, solicitor for the executors. 13280

CREDITORS, next of kin and others having claims in respect of the estate of Clyde Belmont Olholm, late of "River Range", Wodonga West, in the State of Victoria, grazier, deceased (who died on the 10th day of February, 1961), are to send particulars of their claims to the executors, Valerie Claire Fisher, of Barnawartha, married woman, and Kevin Belmont Olholm, formerly of Kyabram, but now of Chiltern, farmer, to care of Frank B. Lethbridge, solicitor, Main-street, Rutherglen, by the 22nd day of May, 1961, after which date the said executors will distribute the assets, having regard only to the claims of which they shall then have had notice.

Dated the 15th day of March, 1961.

FRANK B. LETHBRIDGE, solicitor, of Main-street, Rutherglen, solicitor for the executors. 13281

CREDITORS, next of kin and others having claims in respect of the estate of Herman Ernest Beissel, late of 109 Barkly-street, Mordialloc, in the State of Victoria, retired printer, deceased (who died on the 27th day of October, 1960), are requested by the executor, The National Trustees, Executors and Agency Company of Australasia Limited, of 95 Queen-street, Melbourne, to send to it particulars of their claim, by the 23rd day of May, 1961, after which date it will distribute the assets, having regard only to the claims of which it then has notice.

A. G. ALLAWAY, solicitor, 386 Flinders-lane, Melbourne. 13269

CREDITORS, next of kin and others having claims in respect of the estate of Charles Frederick Shurey, formerly of 717 High-street, Armadale, traveller, but late of 9 Alandale-avenue, Balwyn, manager, deceased (who died on the 29th day of June, 1960, and probate of whose will has been granted to Constance May Shurey, of 9 Alandale-avenue, Balwyn, widow), are to send in particulars of their claims to the said executrix, care of the under-mentioned solicitors, by the 25th day of May, 1961, after which date she will distribute the assets, having regard only to the claims of which she then has notice.

PEARCE & WEBSTER, solicitors, 430 Little Collins-street, Melbourne. 13270

CREDITORS, next of kin and others having claims in respect of the estate of Ivy May Winter, late of 141 Cochrane-street, Gardenvale, widow, deceased (who died on the 1st day of January, 1961), are to send particulars of their claims to The Equity Trustees, Executors and Agency Company Limited, of 472 Bourke-street, Melbourne, by the 9th day of June, 1961, after which date it will distribute the assets, having regard only to the claims of which it then has notice.

DAVID THOMAS, of 140 Queen-street, Melbourne, solicitors for the said company. 13271

CREDITORS, next of kin and others having claims in respect of the estate of Charles George Carter, formerly of 47 Winchester-street, Moonee Ponds, but late of 68 Clarendon-street, East Melbourne, gentleman, deceased (who died on the 29th day of September, 1959), are required to send particulars of their claims to Charles Leonard Carter and Irma May McDonald, the executors of the will of the said deceased, care of the undersigned solicitors, by the 24th day of May, 1961, after which date the executors will distribute the assets, having regard only to the claims of which they then have notice.

SEWELL & SEWELL, solicitors, 422 Collins-street, Melbourne. 13277

CHARLES HILTON BACON, late of 92 Gamon-street, Yarraville, retired railwayman, DECEASED.

CREDITORS, next of kin and others having claims in respect of the estate of deceased (who died on the 17th day of May, 1959), are required by the executor, David Roy Bacon, of 92 Gamon-street, Yarraville aforesaid, to send particulars to him, care of the under-named solicitor, by the 15th day of June, 1961, after which date the executor may convey or distribute the assets, having regard only to the claims of which he then has notice.

JOHN GINNANE, solicitor, 153A Barkly-street, Footscray. 13278

FREDERICK WILLIAM GREEN, formerly of 34 Gordon-street, Hampton, but late of Malaluka-road, Leopold, near Geelong, company director, DECEASED.

CREDITORS, next of kin, and others having claims in respect of the estate of the above-named deceased (who died on the 26th day of October, 1958), are required by the representatives, Anthony William Baxter, formerly of 17 Sinclair-avenue, Glen Iris, but now of 331 Union-road, Balwyn, company general manager, Lindsay Archibald McConchie, formerly of 7 Napier-street, Mentone, in Victoria, but now of 84 Raglan-street, Manly, New South Wales, company manager, and William George Campbell, of 480 Bourke-street, Melbourne, solicitor, to send particulars to them, care of the under-mentioned solicitors, by the 31st day of May, 1961, after which date the personal representatives may convey or distribute the assets, having regard only to the claims of which they then have notice.

Dated the 21st day of March, 1961.

J. M. SMITH & EMMERTON, solicitors, 480 Bourke-street, Melbourne. 13250

No. 21.—2068/61.—5

CREDITORS, next of kin, and others having claims in respect of the estate of Alexander Herbert Fraser, late of "Kinross", 59 Queens-road, Melbourne, in the State of Victoria, gentleman, deceased (who died on the 3rd day of January, 1961), are required by the executors, James Ford Strachan and Robert Russell Aitken, both of 123 William-street, Melbourne, in the said State, solicitors, to send particulars to them, care of the under-mentioned solicitors, by the 17th day of May, 1961, after which they may convey or distribute the assets, having regard only to the claims of which they then have notice.

AITKEN, WALKER & STRACHAN, solicitors, of 123 William-street, Melbourne. 13252

CREDITORS, next of kin, and all others having claims in respect of the estate of Robert Walter Delves, late of Flat 4, 110 Martin-street, Gardenvale, in the State of Victoria, retired manufacturer's agent, deceased (who died on the 17th day of August, 1960), are required to send particulars of their claims to Alan Stawell Brett, of 3 Bretani-avenue, Elsternwick, in the State of Victoria, Commonwealth public servant, the executor to whom probate of the will of the said deceased has been granted by the Supreme Court of Victoria, care of the undersigned, by the 24th day of May, 1961, after which date he will distribute the assets of the said deceased, having regard only to the claims of which he shall have had notice.

J. M. SMITH & EMMERTON, solicitors, 480 Bourke-street, Melbourne. 13249

INSOLVENCY NOTICE

COMMONWEALTH OF AUSTRALIA.

The *Bankruptcy Act 1924-1959*.

THE ASSIGNED ESTATE OF HALIL ALI.

No. 53 of 1961.

NOTICE is hereby given that a First Dividend is intended to be declared in the above matter. Creditors who have not proved their debts by the 12th day of April, 1961, will be excluded from this dividend.

Dated this 21st day of March, 1961.

13276

J. K. HALL, Trustee.

MINING NOTICE

THE undersigned, hereby make application to register Baldwin Bell Mining Corporation, No Liability, as a company under the provisions of Part II. of the *Companies Act 1958*.

1. The name of the company is to be Baldwin-Bell Mining Corporation, No Liability.
2. The place of operations and intended operations is at Corryong, Victoria.
3. The registered office of the company will be situated at Corryong, Victoria.
4. The value of the company's property including leased ground and machinery is £1,937 10s.
5. The number of shares in the company is 50,000 (Fifty thousand) of £1 each.
6. The number of shares subscribed for is 15,000, being not less than twenty-five per centum of the entire number of shares in the company.
7. The amount of subscribed capital which is paid up is £1,250, being not less than five per centum of the subscribed capital.
8. The name of the manager is Ronald Brian Bell, of Corryong, but also of 104 Alexander-street, Crow's Nest, Sydney, New South Wales.
9. The names and addresses and occupations of at least two shareholders who have subscribed for shares in the company and the number of shares subscribed for by each of them at this date are as follows:—
E. H. Baldwin, Showground-road, Castle Hill, New South Wales, engineer, 7,500 shares.
Ronald Brian Bell, 104 Alexander-street, Crow's Nest, Sydney, engineer, 7,500 shares.

R. BRIAN BELL, Managing Director.

Dated this 10th day of March, 1961.

Witness to signature—J. A. EVANS, J.P.

I, Ronald Brian Bell, do solemnly and sincerely declare that:—

1. I am the manager of the said intended company.

2. That the above statement is to the best of my belief and knowledge true in every particular. And I make this solemn declaration conscientiously believing the same to be true, and by virtue of the provisions of an Act of the Parliament of Victoria rendering persons making a false declaration punishable for wilful and corrupt perjury.

Taken before me at Sydney, this 10th day of March, 1961.

13310

J. A. EVANS, J.P.

IMPOUNDINGS

MULGRAVE.—Impounded in Shire of Mulgrave Pound.

1 white nanny goat, no visible brand

If not claimed and expenses paid, to be sold at Dandening Market, on 10th April, 1961.

13312—9/

P. C. CONLEN,
Poundkeeper.

SOUTH BARWON.—Impounded in South Barwon Shire Pound, on 13th March, 1961, by Ranger.

1 nanny goat, black with white points, no visible brand

If not claimed and expenses paid, to be sold on 29th March, 1961.

13211—10/6

E. MASON,
Poundkeeper.

STATE ACTS, 1959.

COPIES of the following Acts of Parliament of Victoria may be obtained at the Government Printing Office, or from any bookseller, at the price set opposite to each:—

No.	Price.
	s. d.
6490. Water (Contracts)	0 6
6491. Property Law (Amendment)	0 6
6492. Agricultural Education (Amendment)	0 6
6493. Swan Hill Railway Land	0 6
6494. Stamps (Amendment)	0 6
6495. Justices (Amendment)	0 6
6496. Consolidated Revenue	0 6
6497. State Electricity Commission (Tourist Areas)	0 6
6498. Aborigines (Houses)	0 6
6499. Superannuation (Amendment)	0 6
6500. Country Roads (Amendment)	0 6
6501. Bendigo Land	0 6
6502. University (Honorary Degrees)	0 6
6503. Melbourne and Metropolitan Board of Works (Reconstitution)	0 9
6504. Land (Charges)	0 6
6505. Statute Law Revision	1 0
6506. Legal Profession Practice (Amendment)	0 6
6507. Health	0 9
6508. Fisheries (Amendment)	0 6
6509. Water (Irrigation Districts)	0 6
6510. Broadmeadows (Rating on Unimproved Values)	0 6
6511. Trustee (Amendment)	0 6
6512. Nurses	0 6
6513. Hairdressers Registration (Amendment)	0 6
6514. Labour and Industry (Retail Trading Hours)	0 6
6515. Milk Board (Amendment)	0 6
6516. Stock Diseases (Amendment)	0 9
6517. Hepburn Springs Land	0 9
6518. Vermin and Noxious Weeds	1 0
6519. The Constitution Act Amendment (Parliamentary Salaries)	0 9
6520. Public Works Committee (Amendment)	0 6
6521. Land (Plantation Areas)	0 6
6522. National Art Gallery and Cultural Centre (Amendment)	0 6
6523. Portland Harbor Trust (Amendment)	0 6
6524. Revocation and Excision of Crown Reservations	1 9
6525. Tourist (Amendment)	0 6
6526. Town and Country Planning (Amendment)	0 6
6527. Vegetation and Vine Diseases (Amendment)	0 6
6528. Medical	0 9
6529. Bread Industry	1 0
6530. Cemeteries	0 9
6531. Hire-Purchase	2 3
6532. Motor Car (Amendment)	0 9
6533. Motor Car (Hours of Driving)	0 6
6534. Land Settlement	1 9
6535. Local Government (Amendment)	1 6
6536. Melbourne and Metropolitan Board of Works (Amendment)	1 3
6537. Consolidated Revenue	0 6

STATE ACTS, 1959—continued.

No.	Price.
	s. d.
6538. War Veterans' Homes Trust	1 3
6539. Frustrated Contracts	0 6
6540. Evidence (Amendment)	0 6
6541. Amendments Incorporation (Extension)	0 6
6542. Melbourne and Richmond Lands	0 9
6543. Local Government (Councillors' Declarations)	0 6
6544. Transfer of Land (Amendment)	0 6
6545. State Savings Bank (Amendment)	0 6
6546. Country Roads (Offices and Buildings)	0 6
6547. Statute Law Revision	0 6
6548. Marriage (Fees)	0 6
6549. State Electricity Commission (Hazelwood Power Station)	0 6
6550. Fences (Amendment)	0 6
6551. Coroners (Amendment)	0 6
6552. Stamps	0 6
6553. Motor Car (Insurance Surcharge)	0 6
6554. Entertainments Tax (Reduction)	0 6
6555. Melbourne and Metropolitan Tramways (Amendment)	0 9
6556. Local Government (Municipalities Assistance Fund)	0 6
6557. Police Offences (Penalties)	0 6
6558. Consolidated Revenue	0 6
6559. Road Traffic (Infringements)	0 9
6560. Superannuation	0 6
6561. Crimes (Penalties)	0 6
6562. Alphington to East Preston Railway Construction (Housing)	0 6
6563. Motor Car	1 0
6564. Registration of Births, Deaths and Marriages	2 3
6565. Coal Mines (Pensions)	0 6
6566. Water Supply Loan Application	1 3
6567. Game (Amendment)	0 6
6568. Metropolitan Fire Brigades (Borrowing Powers)	0 6
6569. Health (Amendment)	0 6
6570. Police Regulation (Delegation of Powers)	0 6
6571. Imprisonment of Fraudulent Debtors (Depositions)	0 6
6572. Crimes (Sentences and Parole)	0 6
6573. Gas and Fuel Corporation (Colonial Gas Association Undertakings)	1 3
6574. Racing (Meetings)	0 6
6575. Landlord and Tenant (Amendment)	0 6
6576. Distribution of Population (Joint Committee)	0 6
6577. Lifts and Cranes	1 0
6578. Cemeteries (Investment of Funds)	0 6
6579. Public Service (Amendment)	0 6
6580. Trustee (Mortgages)	0 6
6581. Justices (Amendment)	0 6
6582. Water (Irrigation)	1 9
6583. Country Fire Authority (Amendment)	0 6
6584. Milk Board (Milk Shops)	0 6
6585. Forests (Pulpwood Agreement)	1 3
6586. Police Offences (Betting)	0 6
6587. Revenue Deficit Funding	0 6
6588. Geelong Trades Hall Council (Trustees)	0 6
6589. Melbourne Harbor Trust (Commissioners)	0 6
6590. Railway Loan Application	1 3
6591. State Forests Loan Application	0 6
6592. Land Tax (Rates)	0 6
6593. Teaching Service (Amendment)	0 6
6594. Land (Special Grants)	0 9
6595. Labour and Industry (Motor Car Shops)	0 6
6596. Home Finance (Financial)	0 6
6597. Dromana Land (Arthur's Seat Public Park)	0 6
6598. Money Lenders (Amendment)	0 6
6599. Landlord and Tenant (Fair Rents)	0 6
6600. Labour and Industry (Amendment)	0 6
6601. Local Government	0 9
6602. Public Works Loan Application	0 6
6603. Soldier Settlement (Amendment)	0 6
6604. Water (Land Reclamation)	0 6
6605. Mental Health	4 3
6606. Appropriation of Revenue	7 0

Table of Acts and Enactments passed date of operation, &c. 0 6

A. C. BROOKS,
Government Printer.

STATE ACTS, 1960.

COPIES of the following Acts of Parliament of Victoria may be obtained at the Government Printing Office, or from any bookseller, at the price set opposite to each:—

No.	Price.
	s. d.
6607. Anzac Day	1 0

STATE ACTS, 1960.—*continued.*

No.	Price.
	s. d.
6608. Agricultural Lime (Amendment) ..	0 6
6609. Motor Car (Commencement) ..	0 6
6610. Fisheries (Change of Title) ..	0 6
6611. Stamps (Amendment) ..	0 6
6612. Land (Public Authorities) ..	0 6
6613. Coal Canal Bridge ..	0 6
6614. Metropolitan Fire Brigades (Borrowing Powers) ..	0 6
6615. Wodonga Lands Exchange ..	0 6
6616. Licensing (Fees) ..	0 6
6617. Home Finance (Loans to Minors) ..	0 6
6618. Co-operative Housing Societies (Amendment) ..	0 6
6619. Racing (Totalizators Extension) ..	1 0
6620. Companies ..	0 6
6621. Judges Salaries and Allowances ..	0 6
6622. Coal Mines (Pensions Contributions) ..	0 6
6623. Landlord and Tenant (Further Amendment) ..	0 6
6624. Public Officers Salaries and Allowances ..	0 9
6625. Legal Profession Practice (Amendment) ..	0 6
6626. Church of England in Australia Constitution ..	1 9
6627. Companies (Fees) ..	0 6
6628. Motor Car (Amendment) ..	1 0
6629. Geelong Waterworks and Sewerage (Amendment) ..	0 6
6630. Latrobe Valley (Financial) ..	0 6
6631. Labour and Industry (Amendment) ..	0 6
6632. Acts Interpretation ..	0 6
6633. Children's Court (Enforcement of Awards) ..	0 6
6634. Supreme Court (Proceedings before Master) ..	0 6
6635. Melbourne and Metropolitan Board of Works (Borrowing Powers) ..	0 6
6636. Electoral Provinces ..	0 9
6637. Town and Country Planning (Amendment) ..	0 6
6638. Racing (Dog Races) ..	0 6
6639. Industrial Safety Advisory Council ..	0 6
6640. Administration and Probate (Offices) ..	0 6
6641. Justices (Bail) ..	0 6
6642. National Parks (Amendment) ..	0 9
6643. Medical (Amendment) ..	0 6
6644. Melbourne Harbor Trust Lands ..	1 0
6645. Weights and Measures (Penalties) ..	0 6
6646. Transfer of Land (Stratum Estates) ..	0 6
6647. Local Government (Preston Streets Agreement) ..	0 9
6648. John Storey Memorial Fund ..	0 6
6649. Police Offences (Amendment) ..	0 6
6650. Motor Car (Third-Party Insurance) ..	0 6
6651. Social Welfare ..	2 9
6652. City of Melbourne Underground Railway Construction ..	1 0
6653. Valuation of Land ..	1 3
6654. Milk Board (Amendment) ..	0 6
6655. Victoria Racing Club (Amendment) ..	0 6
6656. Consolidated Revenue ..	0 6
6657. Consolidated Revenue ..	0 6
6658. Motor Car (Driving) ..	0 6
6659. Licensing (Amendment) ..	1 0
6660. Consolidated Revenue ..	0 6
6661. Consolidated Revenue ..	0 6
6662. Friendly Societies (Dental Clinics) ..	0 6
6663. Cancer (Amendment) ..	0 6
6664. Dried Fruits (Amendment) ..	0 6
6665. Barwon Heads Lands Exchange ..	0 6
6666. Revocation of Crown Reservations ..	0 6
6667. The Constitution Act Amendment (Expenses) ..	0 6
6668. Supreme Court (Orders) ..	0 6
6669. Gippsland Railway Deviation ..	0 9
6670. Hamilton Stockyards Railway Construction ..	0 6
6671. Nurses (Amendment) ..	0 6
6672. Ministry of Transport (Railway Officers) ..	0 6
6673. Fruit and Vegetables (Road Barriers) ..	0 6
6674. Transport Regulation (Qualifications of Chairman) ..	0 6
6675. Motor Car (Insurance Surcharge Continuance) ..	0 6
6676. Geelong Harbor Trust (Freezing Works Agreement) ..	0 9
6677. Western Metropolitan Market (Amendment) ..	0 6
6678. Racing (Trotting Races) ..	0 6
6679. Wattle Park Land ..	0 6
6680. Surplus Revenue ..	0 6
6681. Milk and Dairy Supervision (Research Contributions) ..	0 6
6682. Tourist (Amendment) ..	0 6
6683. Fisheries (Crayfish) ..	0 6
6684. Audit (Amendment) ..	0 6
6685. Sale of Allotments of Land (Amendment) ..	0 6
6686. Cattle Compensation (Amendment) ..	0 6
6687. Co-operative Housing Societies (Guarantees) ..	0 6
6688. State Library National Gallery National Museum and Institute of Applied Science ..	1 3
6689. Medical (Blood Transfusion) ..	0 6
6690. The Constitution Act Amendment (Treating) ..	0 6

STATE ACTS, 1960.—*continued.*

No.	Price.
	s. d.
6691. State Forests Loan Application ..	0 6
6692. Local Authorities Superannuation (Amendment) ..	0 9
6693. Local Government (Disqualification) ..	1 0
6694. Superannuation (Additions to Pensions) ..	0 6
6695. Police Regulation (Pensions) ..	0 6
6696. Trustee Companies (Amalgamation) ..	0 6
6697. Geelong and Colac Railway (Deviation) ..	0 6
6698. University Colleges Lands ..	0 6
6699. Local Government (Private Street) ..	0 6
6700. Northcote School ..	0 6
6701. Public Works Loan Application ..	0 9
6702. Tower Hill and Malmsbury Lands ..	0 6
6703. Coal Mines (Pensions) ..	0 6
6704. Vermin and Noxious Weeds (Financial) ..	0 6
6705. Navigable Waters (Oil Pollution) ..	1 0
6706. Business Names (Public Borrowings) ..	0 6
6707. Health (Tuberculosis Arrangement) ..	0 6
6708. Water Supply Loan Application ..	1 3
6709. Railway Loan Application ..	1 0
6710. Land Tax (Relief) ..	0 6
6711. Land Tax (Rates) ..	0 6
6712. Monash University (Amendment) ..	0 6
6713. National Fitness Council of Victoria ..	1 0
6714. Local Government (Keilor Waverley and Springvale) ..	0 6
6715. Explosives ..	2 3
6716. Statute Law Revision ..	0 9
6717. Motor Car (Abolition of Owners' Certificates) ..	0 6
6718. Road Traffic (Amendment) ..	0 6
6719. Milk Board (Powers) ..	0 6
6720. Marketing of Primary Products (Members) ..	0 6
6721. Melbourne and Geelong Mortgages ..	0 9
6722. Building Societies (Amendment) ..	0 9
6723. Local Government (Scaffolding Inspection) ..	0 9
6724. State Electricity Commission (Borrowing) ..	0 6
6725. Labour and Industry (Butchers' Shops) ..	0 6
6726. Country Fire Authority (Sawmill Burners) ..	0 6
6727. Sewerage Districts (Amendment) ..	1 0
6728. Water (Amendment) ..	1 3
6729. Housing (Powers) ..	0 6
6730. Entertainments Tax (Amendment) ..	0 6
6731. Crimes (Kidnapping) ..	0 6
6732. Health (Amendment) ..	0 6
6733. Game (Licences) ..	0 6
6734. Estate Agents (Amendment) ..	0 6

A. C. BROOKS,
Government Printer.

THE "VICTORIA GOVERNMENT GAZETTE".

SUBSCRIPTIONS.—*The subscription, including postage, is £2 15s. per annum, £1 7s. 6d. half-yearly, or 13s. 9d. per quarter, payable in advance.*

Subscriptions are required to commence and terminate with a month.

A lesser period than three months cannot be subscribed for.

Subscribers do not receive the Acts of Parliament with the GAZETTE.

ADVERTISEMENTS are charged at the rate of 1s. 6d. per line single column, and 3s. per line double column.

The title (£5 Reward, Dissolution of Partnerships, &c.) forms one or more lines as a heading.

On an average, ten words make a line.

Every signature must likewise be counted as a line.

The final words of a paragraph, though only portion of a line, must be counted as one line.

SIGNATURES (in particular) and proper names must be written very plainly in the text; ONE SIDE ONLY of each slip of paper should be WRITTEN UPON.

ALL COMMUNICATIONS should be addressed to "The Government Printer, Melbourne".

ALL DOCUMENTS illegibly written will be returned unpublished, and where brands occur unprovided for by the ordinary letters of the alphabet, a worded explanatory description must be furnished.

THE VICTORIA GOVERNMENT GAZETTE is published on WEDNESDAY EVENING in each week, and Notices for insertion will be received by the Government Printer at or before Two p.m. at ordinary rates, and late advertisements between Two p.m. and Five p.m. at double rates on the day preceding the day of publication.

Single copies of the VICTORIA GOVERNMENT GAZETTE are One shilling, posted One shilling and five pence.

No GAZETTES prior to January, 1950, in stock.

***ALL PAYMENTS ARE REQUIRED IN ADVANCE.—Remittances should be made by postal note, money order, or draft in favour of the Government Printer. Advertisements unaccompanied by a remittance sufficient to cover the cost of insertion will be returned unpublished.

PUBLICATION OF OFFICIAL MATTER.

ATTENTION is invited to the following procedure in relation to the publication of official matter in the *Government Gazette*:—

1. Matter submitted to the Executive Council.

Matter submitted to the Executive Council which requires gazettal will normally be published in the issue of the following week.

Where urgent gazettal is required, special arrangements should be made with the *Gazette* Officer.

Publication will be facilitated by the submission of carbon copies for the use of the *Gazette* Officer.

2. Other matter.

(a) All other matter duly certified by a responsible officer for publication should be lodged with the *Gazette* Officer not later than half-past Ten a.m. on Tuesday.

(b) Lengthy or involved notices should be forwarded several days before publication.

(c) Proofs, which will be supplied only when specifically requested, or at the direction of the *Gazette* Officer, should be returned promptly to avoid delay in publication.

(d) No additions or amendments to matter for publication will be accepted by telephone.

AGENTS FOR THE "VICTORIA GOVERNMENT GAZETTE".

THE following have been appointed agents to receive Advertisements and Subscriptions for the *Victoria Government Gazette*:—

ARMSTRONG'S AGENCY, 205 Queen-street, Melbourne.

ARMSTRONG BROS., Kyneton.

MESSRS. ARNALL & JACKSON, 115 Barkly-street, West Brunswick.

MR. WM. DAVIS, Mildura.

A. J. DIGBY (B. S. and N. W. Cash), Main-street, Bairnsdale.

EDGAR'S NEWSAGENCY, Hargreaves-street, Bendigo.

MESSRS. HENRY FRANKS & CO., Booksellers and Stationers, Market-square, Geelong.

MESSRS. GORDON & GOTCH, News Agents, 511 Little Collins-street, Melbourne; and corner Barrack and Clarence streets, Sydney.

GULLAN'S NEWSAGENCY, 88 Bridge-street, Ballarat.

A. C. HAMPTON, 243 Mitchell-street, Bendigo.

MESSRS. HARSTON, PARTRIDGE, & CO., 455 Little Collins-street, Melbourne.

MR. C. L. LATIMER, News Agent, Casterton.

MCCARTHUR'S AUTHORIZED NEWSAGENCY, 345 Wyndham-street, Shepparton.

MESSRS. R. H. & W. M. PETTY, News Agents, Wangaratta.

MESSRS. POWELL & DIXON, 89 Firebrace-street, Horsham.

J. PURDE & CO., 138 Moorabool-street, Geelong.

SALE AUTHORIZED NEWSAGENCY, 142 Raymond-street, Sale.

SKINNER'S AUTHORIZED NEWSAGENCY, 49-51 Franklin-street, Traralgon.

MESSRS. SMITH & DUNNON, Hamilton.

THE MERCANTILE EXCHANGE, 380 Collins-street, Melbourne.

A. C. THOMAS, 69 Bridge-street, Benalla.

TUFF'S SHEPPARTON NEWSAGENCY, 246 Wyndham-street, Shepparton.

C. F. & H. J. VERNON, 162 Bridge-road, Richmond.

VIEW POINT AUTHORIZED NEWSAGENCY, 4 View Point, Bendigo.

E. W. B. WELSH, Hogan-street, Tatura.

A copy of the *Gazette* filed at each [] for public reference.

CONTENTS

	PAGE
Acts of Parliament on sale at the Government Printing Office	1004
Appointments	957
Bank Half-Holidays	948
Contracts	957
Country Roads Board	962
Courts	955
Easter Holidays	948
Estates of Deceased Persons	955
Government Notices	949
Impoundings	1004
Insolvency Notice	1003
Lands	968
Mining	948, 1003
Money Lenders Act 1958—Supplementary List ..	949
Orders in Council—	
Acts—Crown Lands; Coal Mines; Portland Harbor Trust; Waterworks Trusts. <i>et seq</i>	959
Landlord and Tenant; Electric Light and Power; State Electricity Commission. <i>et seq</i>	967
Private Advertisements	980
Proclamations	947
Public Service Notices	974
Public Half-Holidays	948
Publication of the <i>Victoria Government Gazette</i> ..	948
State Rivers and Water Supply Commission ..	949
Tenders	978
Transport Regulation Board—Public Hearings ..	950
Waterworks Trusts	954