



# VICTORIA GOVERNMENT GAZETTE

Published by Authority

[Registered at the General Post Office, Melbourne, for transmission by post as a newspaper.]

No. 831

WEDNESDAY, SEPTEMBER 27

[1961

## JUSTICES ACT 1958.

### PROCLAMATION

By His Excellency the Governor of the State of Victoria and its Dependencies in the Commonwealth of Australia, &c., &c., &c.

WHEREAS by an Act of Parliament of the State of Victoria intituled the *Justices Act 1958*, it is provided in sub-section (2) of section 24 thereof that the Governor in Council may by Proclamation published in the *Government Gazette* specify municipal districts for the purpose of section 24 of the said Act: And whereas it is considered desirable that the municipal districts named in the Schedule hereto be so specified: Now therefore I, the Governor of the said State of Victoria, by and with the advice of the Executive Council thereof, do by this my Proclamation hereby specify for the purpose of the said section 24 of the said Act the municipal districts whose names appear in the said Schedule—to take effect as on and from the 16th October, 1961.

SCHEDULE.  
CITY OF COLAC.  
Shire of Colac.

Given under my Hand and the Seal of the State of Victoria aforesaid, at Melbourne, this eighteenth day of September, One thousand nine hundred and sixty-one, and in the tenth year of the reign of Her Majesty Queen Elizabeth II.

(L.S.) DALLAS BROOKS.

By His Excellency's Command,  
E. R. MEAGHER,  
for Attorney-General.

GOD SAVE THE QUEEN!

### PUBLIC HIGHWAY.—CITY OF NUNAWADING.

#### PROCLAMATION

By His Excellency the Governor of the State of Victoria and its Dependencies in the Commonwealth of Australia, &c., &c., &c.

WHEREAS by the *Local Government Act 1958*, section 519, it is amongst other things enacted that it shall be lawful for the Governor in Council at any time, and

from time to time, upon request of the council of any municipality, by notice in the *Government Gazette* to proclaim any land reserved, used or by purchase or exchange acquired for a street, road, highway, thoroughfare, bridge, square, court, alley or right-of-way to be a public highway, and that such land shall thereupon and thenceforth from the date of such Proclamation become and be absolutely dedicated to the public as a public highway within the meaning of any law then or thereafter in force:

And whereas the Council of the City of Nunawading requested that the land hereinafter mentioned, which has been used for a street within the said City, be so declared to be a public highway:

Now, therefore, I, the Governor of the State of Victoria in the Commonwealth of Australia, by and with the advice of the Executive Council of the said State, do by this Proclamation declare that all that part of Crown portion 119 Parish of Nunawading being the portion of the street known as Victoria-avenue indicated by hatching on the plan hereunder, shall be a public highway within the meaning of the said Act.

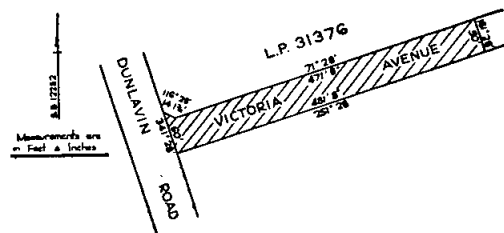

Given under my Hand and the Seal of the State of Victoria aforesaid, at Melbourne, this eighteenth day of September, in the year of our Lord One thousand nine hundred and sixty-one, and in the tenth year of the reign of Her Majesty Queen Elizabeth II.

(L.S.) DALLAS BROOKS.

By His Excellency's Command,  
MURRAY PORTER,  
Minister for Local Government.

GOD SAVE THE QUEEN!

*Land Act 1958.*

## UNALIENATED CROWN LAND AVAILABLE FOR SETTLEMENT UNDER IMPROVEMENT PURCHASE LEASES.

## PROCLAMATION

By His Excellency the Governor of the State of Victoria and its Dependencies in the Commonwealth of Australia,  
&c., &c., &c.

IN pursuance of the provisions of section 153 of the *Land Act 1958*, I, the Governor of the State of Victoria, in the Commonwealth of Australia, by and with the advice of the Executive Council of the said State, do by this Proclamation declare the unalienated Crown lands mentioned in the subjoined Schedule, to be available for settlement under improvement purchase leases.

## SCHEDULE.

County.	Parish.	Allotment.	Section.	Area.	Land Valuation.
				A. B. P.	
Buln Buln .. .. .	Bruthen .. .. .	25	..	354 2 8	£5 per acre

Given under my Hand and the Seal of the State of Victoria aforesaid, at Melbourne, this eighteenth day of September, in the year of our Lord One thousand nine hundred and sixty-one, and in the tenth year of the reign of Her Majesty Queen Elizabeth II.

DALLAS BROOKS.

(L.S.)

By His Excellency's Command,

KEITH TURNBULL,

Commissioner of Crown Lands and Survey.

GOD SAVE THE QUEEN!

## BANK HOLIDAY.

## PROCLAMATION

By His Excellency the Governor of the State of Victoria and its Dependencies in the Commonwealth of Australia, &c., &c., &c.

IN pursuance of the provisions of the Banks and Currency Acts, I, the Governor of the State of Victoria, in the Commonwealth of Australia, do by this my Proclamation appoint the day and date named hereunder a special day to be observed as a Bank Holiday at the place mentioned, that is to say:—

*Bank Holiday:—*

WEDNESDAY, THE 27TH SEPTEMBER, 1961, at Trentham.

Given under my Hand and the Seal of the State of Victoria aforesaid, at Melbourne, this eighteenth day of September, in the year of our Lord One thousand nine hundred and sixty-one, and in the tenth year of the reign of Her Majesty Queen Elizabeth II.

(L.S.)

DALLAS BROOKS.

By His Excellency's Command,

E. R. MEAGHER,

for Chief Secretary.

GOD SAVE THE QUEEN!

Given under my Hand and the Seal of the State of Victoria aforesaid, at Melbourne, this twenty-sixth day of September, in the year of our Lord One thousand nine hundred and sixty-one, and in the tenth year of the reign of Her Majesty Queen Elizabeth II.

(L.S.)

DALLAS BROOKS.

By His Excellency's Command,

A. G. RYLAH,

Chief Secretary.

GOD SAVE THE QUEEN!

## PUBLIC HOLIDAYS.

## PROCLAMATION

By His Excellency the Governor of the State of Victoria and its Dependencies in the Commonwealth of Australia, &c., &c., &c.

IN pursuance of the provisions contained in Part III. of the *Public Service Act 1958*, I, the Governor of the State of Victoria, in the Commonwealth of Australia, by and with the advice of the Executive Council of the said State, do by this my Proclamation appoint the days and dates hereunder mentioned to be observed as Public Holidays or Public Half-Holidays (as the case may be) at the places respectively specified, viz.:—

*Public Holidays:—*

TUESDAY, THE 7TH NOVEMBER, 1961, throughout the west portion of the Loddon Valley Highway in the Shire of Gordon.

\*SATURDAY, THE 7TH OCTOBER, 1961, throughout the Shire of Nathalia.

TUESDAY, THE 7TH NOVEMBER, 1961, throughout the City of Bendigo.

*Public Half-Holiday from the Hour of Eleven a.m.:—*  
SATURDAY, THE 11TH NOVEMBER, 1961, throughout the South and West Ridings of the Shire of Dimboola.

*Public Half-Holidays from the Hour of Twelve o'clock noon:—*

\*THURSDAY, THE 12TH OCTOBER, 1961, throughout the North Riding of the Shire of Wimmera.

WEDNESDAY, THE 22ND NOVEMBER, 1961, throughout the City of Bendigo.

\*THURSDAY, THE 19TH OCTOBER, 1961, throughout the Shire of Lowan.

\*TUESDAY, THE 17TH OCTOBER, 1961, throughout the North Riding of the Shire of Dimboola.

\* Agricultural Show.

Given under my Hand and the Seal of the State of Victoria aforesaid, at Melbourne, this twenty-sixth day of September, in the year of our Lord

## BANK HOLIDAYS.

## PROCLAMATION

By His Excellency the Governor of the State of Victoria and its Dependencies in the Commonwealth of Australia, &c., &c., &c.

IN pursuance of the provisions of the *Bank Holidays Act 1958*, I, the Governor of the State of Victoria, in the Commonwealth of Australia, do by this my Proclamation appoint the days and dates named hereunder special days to be observed as Bank Holidays or Bank Half-Holidays (as the case may be) at the places respectively mentioned, that is to say:—

*Bank Holidays:—*

TUESDAY, THE 7TH NOVEMBER, 1961, at Maryborough.

WEDNESDAY, THE 27TH SEPTEMBER, 1961, at Kilmore.

SATURDAY, THE 7TH OCTOBER, 1961, at Nathalia.

*Bank Half-Holidays from Eleven a.m.:—*

WEDNESDAY, THE 11TH OCTOBER, 1961, at Kerang.

FRIDAY, THE 13TH OCTOBER, 1961, at Woomelang.

TUESDAY, THE 17TH OCTOBER, 1961, at Rainbow.

WEDNESDAY, THE 27TH SEPTEMBER, 1961, at Alexandra.

WEDNESDAY, THE 29TH NOVEMBER, 1961, at Ballarat.

One thousand nine hundred and sixty-one, and in the tenth year of the reign of Her Majesty Queen Elizabeth II.

(L.S.)

DALLAS BROOKS.

By His Excellency's Command,

A. G. RYLAH,  
Chief Secretary.

GOD SAVE THE QUEEN!

## SHIRE OF BULN BULN.—PUBLIC HIGHWAY.

IN pursuance of the powers conferred by sections 522 and 526 of the *Local Government Act 1958*, the Council of the Shire of Buln Buln doth hereby direct that the land in the Parish of Drouin West shown hatched on the plan hereunder, which has been taken, purchased or acquired by it, shall be a public highway from and after the date of publication of this Order in the *Government Gazette*, and doth declare that such land shall be a public highway in lieu of the land in the said parish shown cross-hatched on the said plan.

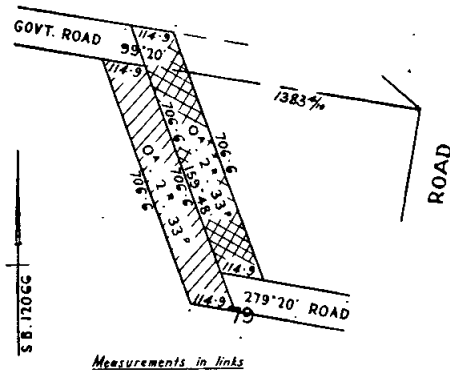

The common seal of the President, Councillors and Ratepayers of the Shire of Buln Buln was heretofore affixed this 18th day of July, 1960, in the presence of—

(SEAL) W. REA, President.  
A. E. BERTRAM, Councillor.  
K. A. PRETTY, Secretary.

Approved by the Governor in Council,  
12th September, 1961.

N. G. WISHART,  
Acting Clerk of the Executive Council.

## MELBOURNE AND METROPOLITAN BOARD OF WORKS.

NOTICE TO THE OWNERS OF TENEMENTS IN THE UNDER-MENTIONED STREETS, AND THE PRIVATE STREETS, LANES, COURTS AND ALLEYS OPENING THERETO.

THE main pipe in the said streets being laid down, the owners of all tenements situated as under are hereby required, on or before the 30th October, 1961, to cause a proper pipe and stop cocks to be laid, so as to supply water within such tenements from the main pipe.

H. J. SNADDEN,  
Secretary.

19th September, 1961.

## STREET AND POSITION.

*Altona.*

Cyclamen-avenue, from Millers-road eastwards 16 chains.  
Mahon-avenue, from Cyclamen-avenue to Blackshaws-road.  
Marion-street, from Millers-road eastwards 22½ chains.

*Broadmeadows.*

Maffra-street, from Barry's-road north-westwards 21 chains.

*Dandenong.*

Alexander-avenue, from 2 chains south of Elray-avenue to Wallace-avenue.  
Wallace-avenue, from Alexander-avenue to King George-parade.  
Crawford-avenue, from Gardiner-avenue to Barbara-avenue.  
Stevenson-avenue, from Crawford-avenue to Marcella-avenue.  
Edna-avenue, from Stevenson-avenue to Barbara-avenue.  
Barbara-avenue, from Edna-avenue northwards 3½ chains.

*Doncaster.*

Robert-street, from Manningham-road to Mangan-street.  
Avon-street, from 7 chains east of Bulleen-road to Austin-street.  
Austin-street, from Avon-street south-eastwards 2 chains.  
Marcus-road, from Manningham-road northwards 8½ chains.  
Marcedon-road, from Manningham-road northwards 19½ chains.  
Lionel-street, from 3½ chains south of Maggs-street further southwards 5 chains.  
Dianne-street, from 4 chains south of Maggs-street further southwards 2 chains.

*Eltham.*

Rosehill-road, from Bolton-street eastwards 9 chains.

*Heidelberg.*

Decathlon-street, from Olympic-avenue to Nooroong-avenue.

*Keilor.*

Ridley-avenue, from Deutscher-avenue to Stanley-street.  
Hanley-street, from Ridley-avenue to Mountain View-avenue.

*Malvern.*

Bromley-court, from Albany-road westwards 4½ chains.

*Moorabbin.*

Botany-court, from Springs-road westwards 10 chains.  
Bunny-road, from Springs-road westwards 9½ chains.  
Voltri-street, from Alice-street eastwards 3½ chains.

*Nunawading.*

Denis-street, from Scott-street to Purches-street.  
Barbara-street, from Denis-street to Canterbury-road.  
Adele-street, from Denis-street to Canterbury-road.  
Andrew-street, from Denis-street to Canterbury-road.  
Held-street, from Adele-street to Andrew-street.  
Canterbury-road, from Adele-street eastwards 14 chains.  
Marie-street, from Adele-street to Andrew-street.  
Purches-street, from Canterbury-road northwards 14½ chains.  
Kett-street, from Junction-road to Tasman-avenue.  
Tasman-avenue, from Kett-street eastwards 5½ chains.  
Van Diemen-avenue, from Kett-street eastwards 5½ chains.

*Preston.*

O'Connell-street, from Plenty-road to Curtain-street.  
Curtain-street, from O'Connell-street westwards 2 chains.  
Cash-street, from Plenty-road to Maryborough-avenue.  
Dunne-street, from 5½ chains west of Plenty-road to Maryborough-avenue.

*Ringwood.*

Fremont-road, from 5½ chains south of Bedford-road to Tudor-court.  
Tudor-court, from Fremont-road eastwards 5 chains.

*Springvale and Noble Park.*

Edinburgh-road, from Police-road southwards 22 chains.  
Eye-court, from Edinburgh-road eastwards 7½ chains.  
Neville-court, from Edinburgh-road eastwards 7½ chains.  
Alward-avenue, from Clayton-road to Elizabeth-street.  
Charlotte-street, from Alward-street southwards 3 chains.  
Tallawantia-street, from Alward-street southwards 3 chains.  
Loama-street, from Heatherton-road to Myrtle-street.  
Myrtle-street, from Loama-street eastwards and westwards 9 chains.  
Larry-court, from Myrtle-street northwards 5½ chains.

*Waverley.*

Tricks-court, from Blackburn-road eastwards 3½ chains.  
Gwynne-street, from 6½ chains east of Charles-street further westwards 4½ chains.  
Garrisson-drive, from Darien-street eastwards 14½ chains.  
Rolls-avenue, from Garrisson-drive southwards 4½ chains.  
Wolseley-avenue, from Garrisson-drive southwards 4½ chains.  
Poplar-avenue, from Vannam-drive to Mountain Ash-drive.  
Vannam-drive, from Poplar-avenue southwards 8½ chains.  
Silver Ash-drive, from Poplar-avenue northwards 14 chains.  
Mountain Ash-drive, from Poplar-avenue northwards 14 chains.  
Parkhill-drive, from Mountain Ash-drive eastwards 2 chains.

*Whittlesea.*

Mount View-road, from Pleasant-road to Chappell-street.  
Chappell-street, from Mount View-road to Thomas-street.  
Thomas-street, from Chappell-street to Travers-street.  
Travers-street, from Thomas-street to Mount View-road.

CONTRACTS ACCEPTED.—(Series 1961-62.)

PROVISIONS.—MEAT.

No. of Contract.	Particulars of Each Tender Accepted.	Amount.	Name of Contractor.	Charge Against Vote or Fund.
	<b>PROVISIONS—</b>			
	Supply of Meat, in such quantities as may be ordered, from 1st October, 1961, to 31st December, 1961.			
	<b>Schedule No. 1.—Melbourne District—</b>			
1044	Kew Mental Hospital .. .. .	Rates as per annex	F. Watkins Pty. Ltd. ..	General Expenses 1961-62
1045	Pentridge Penal Establishment and "Fairlea" Female Prison, Fairfield .. .. .	" "	Oscar Mayer Pty. Ltd. ..	
1046	Children's Welfare Depot, Royal Park, and Travancore Developmental Centre, Flemington .. .. .	" "	J. H. Cooke Pty. Ltd. ..	
1047	"Winton" Juvenile School, 186 Springvale-road, Nunawading .. .. .	" "	J. H. Cooke, Pty. Ltd.	
1048	Royal Park Mental Hospital and Receiving House .. .. .	" "	J. H. Cooke Pty. Ltd. ..	
	<b>Schedule No. 2.—Mont Park, Bundoora, Larundel, Janefield, Gresswell, and Pleasant View, Wood-street, Preston—</b>			
1049	Mont Park District .. .. .	" "	Thomas Borthwick & Sons (A/Asia) Ltd.	
1050	Preston .. .. .	" "	W. Anglias and Co. (Aust.) Pty. Ltd.	
1051	Gresswell Sanatorium .. .. .	" "	G. K. & M. Reynolds Bros. Pty. Ltd.	
1052	<b>Schedule No. 3.—SS. Rip and Dredges .. .. .</b>			
1053	<b>Schedule No. 4.—Teachers' College and Hostels at Grattan-street, 93 Drummond-street, Carlton; 470 and 481 St. Kilda-road, Melbourne; 19 Queens-road, Melbourne; 152 Toorak-road west, South Yarra; Frank Tate House, 373 Dandenong-road, Armadale; "Redcourt" 6 and "Lar-nook," 13 Orrong-road Armadale; 11 Patterson-street, Hawthorn; 174 Punt-road, Prahran; 221 Burwood-road, Burwood; John Cannon House, 32 Belmont-avenue, Kew; 17 Moule-avenue, Brighton; Police Hospital, St. Kilda-road, Melbourne; and Mental Hygiene Clinic, 321 Glenferrie-road, Malvern .. .. .</b>			
1054	<b>Schedule No. 5.—Heatherton Sanatorium, Cheltenham .. .. .</b>			
1055	<b>Schedule No. 6.—Ararat District .. .. .</b>			
1056	<b>Schedule No. 7.—Ballarat District—</b> Gael and Mental Hospital .. .. .			
1057	Teachers' Hostels .. .. .			
1058	<b>Schedule No. 8.—Beechworth District .. .. .</b>			
	<b>Schedule No. 9.—Bendigo District—</b>			
1059	Gael .. .. .			
1060	Sandhurst Boys' Centre .. .. .			
1061	Teachers' Hostels .. .. .			
1062	<b>Schedule No. 10.—Castlemaine District .. .. .</b>			
1063	<b>Schedule No. 11.—School of Forestry, Creswick .. .. .</b>			
1064	<b>Schedule No. 13.—McLeod Settlement, French Island .. .. .</b>			
	<b>Schedule No. 14.—Geelong District—</b>			
1065	Gael .. .. .			
1066	Teachers' Hostels .. .. .			
1067	<b>Schedule No. 15.—Coorimungle Prison Camp, Heytesbury Forest .. .. .</b>			
1068	<b>Schedule No. 17.—Langi Kal Kal Training Centre .. .. .</b>			
1069	<b>Schedule No. 20.—Sale Gael .. .. .</b>			
1070	<b>Schedule No. 21.—Pleasant Creek Special School, Stawell .. .. .</b>			
1071	<b>Schedule No. 22.—Sunbury District .. .. .</b>			
1072	<b>Schedule No. 23.—Warrnambool District .. .. .</b>			

Approved H. E. BOLTE, Treasurer.—11.9.61.

SCHEDULE NO. 1.—MELBOURNE DISTRICT.

ANNEX TO CONTRACT NO. 1961/1044.

F. Watkins Pty. Ltd., 184 Bourke-street, Melbourne.

Sub-schedule No. 9.

MEAT FOR MENTAL HOSPITAL, KEW.

Security, £35.

	£	s.	d.
<b>Fresh Beef—</b>			
1. Rolled Roast boneless (Brisket excluded) per cwt.	12	10	0
2. Buttocks .. .. .	11	5	0
3. Shin and Gravy Beef (boneless) .. .. .	11	13	4
4. Corned Beef—Rolled or Round, as ordered, without bone or cartilage .. .. .	12	10	0
5. Fresh Mutton—(Whole Sheep) (Kidney fat to be removed) .. .. .	4	11	8
6. Veal—boned .. .. .	0	2	2
7. Sausage Meat .. .. .	0	1	4
8. Sausages—Mixed .. .. .	0	1	10
9. Livers—Sheep .. .. .	0	2	3
10. " Ox .. .. .	0	1	8
11. Kidneys, Ox .. .. .	0	2	10
12. " Sheep .. .. .	0	2	2
13. Tripe, Fresh .. .. .	0	1	1
14. Tongues—Ox .. .. .	0	1	10
" Sheep .. .. .	0	0	8

SCHEDULE No. 1.—MELBOURNE DISTRICT—continued.

	£	s.	d.
15. Sausage—Belgium .. .. .	0	2	4
16. Beef Loaf .. .. .	0	2	6
17. Ham Loaf .. .. .	0	3	3
18. Veal Loaf .. .. .	0	3	3
19. Saveloys .. .. .	0	3	6
20. Brains, Sheep .. .. .	0	0	7
21. Fowls, First quality .. .. .	0	5	6
22. Bacon Sides .. .. .	0	5	2
23. Rabbit Fillets .. .. .	0	4	0

ANNEX TO CONTRACT NO. 1961/1045.

Oscar Mayer Pty. Ltd., P.O. Box 163, Footscray.

Sub-schedule No. 10.

MEAT FOR PENTRIDGE PENAL ESTABLISHMENT, COBURG; AND "FAIRLEA" FEMALE PRISON, FAIRFIELD.

Security, £35.

	£	s.	d.
<b>Fresh Beef—</b>			
1. Fore-quarters .. .. .	8	6	8
2. Minced .. .. .	10	0	0
3. Corned Beef—Rolled or Round, as ordered, without bone or cartilage .. .. .	11	13	4
4. Fresh Mutton (whole sheep) .. .. .	4	3	4
5. Sausages—Mixed—thin .. .. .	0	1	6

SCHEDULE No. 1.—MELBOURNE DISTRICT—*continued.*

	£	s.	d.	
6. Fresh Suet—Kidney .. .. .	per lb.	0	0	7
7. Saveloys .. .. .	do.	0	1	10
8. Sausage—Beef German .. .. .	do.	0	2	2
9. Sausage Mince .. .. .	do.	0	1	1
10. Dripping, Beef .. .. .	do.	0	1	2
11. Frankfurts .. .. .	do.	0	2	0
12. Livers—Sheep .. .. .	do.	0	1	6
13. Ham Loaf .. .. .	do.	0	3	0

ANNEX TO CONTRACT No. 1961/1046.

*J. H. Cooke Pty. Ltd., 378 Queen's-parade, Clifton Hill.*

Sub-schedule No. 11.

MEAT FOR CHILDREN'S WELFARE DEPOT, ROYAL PARK, AND TRAVANCORE DEVELOPMENTAL CENTRE, FLEMINGTON.

	£	s.	d.	
Security, £8.				
1. Fresh Beef—Rolled Roast Sirloin—Boneless	per lb.	0	2	9
2. Beef—Corned—Silverside .. .. .	do.	0	3	3
Fresh Mutton—				
3. Legs .. .. .	do.	0	1	6
4. Legs (Two tooth) .. .. .	do.	0	1	7
5. Chops—Mid Loin (Two tooth) .. .. .	do.	0	1	5
6. Rib Chops as Cutlets (Two tooth) .. .. .	do.	0	1	6
Steak—				
7. Rump .. .. .	do.	0	3	6
8. Blade .. .. .	do.	0	3	0
9. Minced .. .. .	do.	0	1	11
10. Veal—Fillet, boneless .. .. .	do.	0	3	3
11. Pickled Pork .. .. .	do.	0	2	0
12. Sausages—Mixed .. .. .	do.	0	1	8
13. Sausage—Strasbourg, Pork .. .. .	do.	0	3	4
14. Tripe—Fresh .. .. .	do.	0	0	9
15. Frys—Lamb .. .. .	do.	0	1	10
16. Ox Tongue .. .. .	per lb.	0	1	6
17. Frankfurts .. .. .	do.	0	2	6
18. Rabbits—Fresh .. .. .	do.	0	3	0

ANNEX TO CONTRACT No. 1961/1047.

*J. H. Cooke Pty. Ltd., 378 Queen's-parade, Clifton Hill.*

Sub-schedule No. 12.

FOR "WINLATON" JUVENILE SCHOOL, 186 SPRINGVALE-ROAD, NUNAWADING.

	£	s.	d.	
Security, £5.				
Fresh Beef—				
1. Rolled Roast Sirloin, Boneless	per lb.	0	2	6
2. Corned—Silverside .. .. .	do.	0	3	3
3. Mutton Fresh—Fore-quarters .. .. .	do.	0	0	11
4. Legs .. .. .	do.	0	1	6
5. " " Chops—Mid Loin (Two tooth)	do.	0	1	6
6. Steak—Topside .. .. .	do.	0	3	3
7. Steak—Rump .. .. .	do.	0	3	11
8. " Stewing .. .. .	do.	0	2	11
9. " Minced .. .. .	do.	0	2	3
10. " Blade .. .. .	do.	0	2	11
11. Sausages—Mixed .. .. .	do.	0	1	9
12. Sausage Meat .. .. .	do.	0	1	0
13. Frys—Lamb .. .. .	do.	0	2	0
14. Veal—Fillet—Boneless .. .. .	do.	0	3	3
15. Veal—T bone .. .. .	do.	0	3	3
16. " Leg, boned .. .. .	do.	0	3	0
17. Pork—Pickled .. .. .	do.	0	2	0
18. Pressed Ham Loaf .. .. .	do.	0	7	6
19. Tongues—Ox .. .. .	do.	0	1	6
20. Dripping beef .. .. .	do.	0	1	1
21. Brains—Sheep .. .. .	per set	0	0	5
22. Sausage—Strasbourg—Pork .. .. .	per lb.	0	3	2
23. Frankfurts .. .. .	do.	0	2	3
24. Rabbits—Fresh .. .. .	do.	0	3	3

ANNEX TO CONTRACT No. 1961/1048.

*J. H. Cooke Pty. Ltd., 378 Queen's-parade, Clifton Hill.*

Sub-schedule No. 13.

MEAT FOR RECEIVING HOUSE AND MENTAL HOSPITAL, ROYAL PARK.

	£	s.	d.	
Security, £10.				
Fresh Beef—				
1. Rolled Roast, boneless (Brisket excluded)	per lb.	0	2	9
2. Thick Flank .. .. .	do.	0	2	8
3. Fresh Mutton (Legs) .. .. .	do.	0	1	6
4. Corned Beef—Rolled or Round, as ordered, without bone or cartilage	do.	0	3	0
5. Chops—Fore-quarter .. .. .	do.	0	1	0
6. Sausages—Mixed .. .. .	do.	0	1	8
7. Sausage—Mince .. .. .	do.	0	0	10
8. Rabbits—Fresh .. .. .	do.	0	3	3
9. Fowls—First quality .. .. .	do.	0	5	3
10. Sausage, beef german .. .. .	do.	0	2	6

SCHEDULE No. 2.—MONT PARK AND SANATORIUM GRESSWELL, ETC.

ANNEX TO CONTRACT No. 1961/1049.

*Thomas Borthwick & Sons (A/Asia) Ltd., Francis-street, Brooklyn.*

Sub-schedule No. 4.

MEAT.

(For Mont Park Mental Hospital, &c.)

	£	s.	d.	
Security, £50.				
Fresh Beef—				
1. Buttocks .. .. .	per cwtl.	10	16	8
2. Topside, pieces .. .. .	do.	15	16	8
3. Rolled Roast—Boneless (Brisket excluded)	do.	12	18	4
Beef, Corned—				
4. Rolled or Round, as ordered, without bone or cartilage	do.	11	5	0
5. Corned—Silverside .. .. .	do.	16	13	4
Mutton, Fresh—				
6. Carcass or Sides (Kidney fat to be removed)	do.	4	11	8
7. Legs .. .. .	per lb.	0	1	6
Chops—				
8. Loin .. .. .	do.	0	1	6
9. Lamb—Loin .. .. .	do.	0	2	9
Steak—				
10. Thick Flank .. .. .	do.	0	3	4
11. Rump .. .. .	do.	0	3	9
12. Minced .. .. .	do.	0	2	4
13. Topside .. .. .	do.	0	3	4
14. Bullock, sliced .. .. .	do.	0	3	5
15. Sausage—Meat .. .. .	do.	0	1	2
16. Sausages—Mixed .. .. .	do.	0	1	9
17. Shanks—Sheep .. .. .	each	0	0	6
18. Tripe—Fresh .. .. .	per lb.	0	0	10
19. Brains—Sheep .. .. .	per set	0	0	6
20. Kidneys—Ox .. .. .	per lb.	0	2	6
21. Livers—Sheep .. .. .	do.	0	1	8
22. Livers—Calves .. .. .	do.	0	1	8
23. Sausage—Strasbourg, Pork .. .. .	do.	0	3	3
24. Beef—German .. .. .	do.	0	2	4
25. Rabbits—Fresh .. .. .	do.	0	3	0
26. Saveloys .. .. .	per doz.	0	4	0
27. Ham Loaf .. .. .	per lb.	0	3	1
28. Fillet Veal .. .. .	do.	0	2	9
29. Fowls—First quality .. .. .	do.	0	5	6
30. Lamb Chops .. .. .	do.	0	2	9
31. Veal .. .. .	do.	0	2	6
32. Bones—Beef .. .. .	do.	0	0	0½

ANNEX TO CONTRACT No. 1961/1050.

*W. Angliss & Co. (Aust.) Pty. Ltd., 42 Bourke-street, Melbourne.*

Sub-schedule No. 5.

MEAT.

(For Pleasant View Receiving House, Wood-street, Preston.)

	£	s.	d.	
Security, £5.				
Fresh Beef—				
1. Fresh Beef—Sirloin—Boneless (Brisket excluded)	per lb.	0	3	3
2. Corned Beef—Silverside .. .. .	do.	0	3	3
3. Fresh Lamb—Legs .. .. .	do.	0	2	9
Chops—				
4. Loin—Lamb .. .. .	do.	0	4	0
5. Fore-quarter—Lamb .. .. .	do.	0	1	6
6. Livers—Lamb .. .. .	do.	0	2	0
7. Sausages—Pork .. .. .	do.	0	1	11
8. Dripping—Beef .. .. .	do.	0	1	1½
9. Tongues—Sheep .. .. .	do.	0	1	10
10. Brains—Sheep .. .. .	per set	0	0	7
11. Frankfurts .. .. .	per doz.	0	5	0
12. Sausage—Strasbourg—Pork .. .. .	per lb.	0	3	4
13. Rabbits—Fresh .. .. .	do.	0	3	0
14. Capons .. .. .	do.	0	5	0
15. Tripe .. .. .	do.	0	0	9
16. Ham, tinned, 2lb. tin .. .. .	do.	0	10	0
17. Bacon, boned .. .. .	do.	0	5	6

ANNEX TO CONTRACT No. 1961/1051.

W. Angliss and Co. (Aust.) Pty. Ltd., 42 Bourke-street, Melbourne.

Sub-schedule No. 6.

MEAT.

(For Gresswell Sanatorium.)

Security £15.		£	s.	d.
1. Fresh Beef—Rolled Roast Sirloin (Boneless)	per lb.	0	3	6
2. Beef—Corned Silverside	do.	0	3	3
3. Lamb—Fresh Legs	do.	0	2	9
4. " Chops—Mid-loin	do.	0	3	0
5. " " Chump	do.	0	2	6
6. " " Fore-quarter	do.	0	1	4
7. " " Cutlets	do.	0	3	6
8. " " Rolled	do.	0	1	9
9. Pork—Fresh Legs	do.	0	4	0
10. " " Chops	do.	0	3	6
11. " " Pickled	do.	0	2	9
12. Mutton—Leg Chops	do.	0	1	6
13. Veal—Fresh, Shoulder	do.	0	1	3
14. " " Cutlets	do.	0	3	6
15. " " Fillet	do.	0	2	6
16. Steak—Rump	do.	0	4	0
17. " " Topside	do.	0	3	3
18. " " Blade	do.	0	2	6
19. " " Porterhouse	do.	0	4	6
20. " " Fillet	do.	0	5	0
21. " " Minced	do.	0	2	0
22. Brains—Sheep	per set	0	0	7
23. Fowls—First quality	per lb.	0	5	0
24. Frankfurts	do.	0	2	6
25. Ham Loaf	do.	0	3	3
26. " " Pressed Leg	do.	0	7	9
27. " " Pressed Shoulder	do.	0	6	9
28. Kidneys—Ox	do.	0	2	9
29. " " Sheep	do.	0	2	6
30. Livers—Sheep	do.	0	2	0
31. " " Lamb	do.	0	2	0
32. " " Calves	do.	0	1	3
33. Rabbits—Fresh	do.	0	3	0
34. Sausages—Mixed	do.	0	1	11
35. " " Pork	do.	0	2	0
36. Sausage Meat	do.	0	1	4
37. " " Strasbourg—Pork	do.	0	3	4
38. Shanks—Sheep	each	0	0	6
39. Tripe—Fresh	per lb.	0	0	8½
40. Tongues—Ox	do.	0	1	9
41. " " Sheep	do.	0	1	0
42. Veal and Pork Loaf—Pressed	do.	0	3	3
43. Savoury Loaf—Pressed	do.	0	3	5
44. Ham—Leg—Raw	do.	0	6	0

SCHEDULE No. 3.—S.S. "Rip" AND DREDGES.

ANNEX TO CONTRACT No. 1961/1052.

G. K. & M. Reynolds Bros. Pty. Ltd., 4 Blackwood-street, North Melbourne.

Sub-schedule No. 3.

MEAT.

(Delivery at Yarra River Wharves.)

Security, £5.		£	s.	d.
1. Fresh Beef—Roast	per lb.	0	2	10
Beef—Corned—				
2. Silverside	do.	0	3	3
3. Rolled	do.	0	2	3
Fresh Mutton—				
4. Fore-quarter	do.	0	0	10½
5. Legs	do.	0	1	4½
Chops—				
6. Forequarter	do.	0	1	4½
7. Loin	do.	0	1	9½
Steak—				
8. Rump	do.	0	4	4
9. Stewing	do.	0	2	1
10. Topside	do.	0	3	3
11. Sausages—Mixed	do.	0	1	8½
12. Tripe—Fresh	do.	0	1	0
13. Livers—Sheep	do.	0	1	11
14. Suet—Kidney	do.	0	0	6
15. Rabbits—Fresh	do.	0	2	4
16. Ice	per cwt.	0	4	1

SCHEDULE No. 4.—TEACHERS' COLLEGES, HOSTELS, POLICE HOSPITAL, ETC.

(Delivery at Institutions.)

TEACHERS' COLLEGES AND HOSTELS AT GRATTAN-STREET, 93 DRUMMOND-STREET, CARLTON; 470 AND 481 ST. KILDA-ROAD, MELBOURNE; 19 QUEENS-ROAD, MELBOURNE; 152 TOORAK-ROAD WEST, SOUTH YARRA; TATE HOUSE, 373 DANDENONG-ROAD, ARMADALE; "REDCOURT" NO. 6, AND "LARNOOK," 13 ORBONG-ROAD, ARMADALE; 11 PATTERSON-STREET, HAWTHORN; 174 PUNT-ROAD, PRAHRAN, 221 BURWOOD-ROAD, BURWOOD; JOHN CANNON HOUSE, 32 BELMONT-AVENUE, KEW; 17 MOULE-AVENUE, BRIGHTON; POLICE HOSPITAL, ST. KILDA-ROAD, MELBOURNE; AND MENTAL HYGIENE CLINIC, 321 GLENFERRIE-ROAD, MALVERN.

ANNEX TO CONTRACT No. 1961/1053.

J. H. Cooke Pty. Ltd., 378 Queen's-parade, Clifton Hill.

Sub-schedule No. 2.

MEAT.

Security, £15.

Security, £15.		£	s.	d.
1. Fresh Beef—				
Rolled Prime Ribs, boneless	per lb.	0	2	7
2. Topside	do.	0	3	3
3. Sirloin, boneless	do.	0	2	9
Fresh Mutton—				
4. Legs	do.	0	1	6
5. Legs, pickled	do.	0	1	6
6. Sides, Two-tooth	do.	0	1	2
7. Legs, Two-tooth	do.	0	1	7
8. Cutlets	do.	0	1	7
9. Chops, Middle Loin	do.	0	1	3
10. Chops, Forequarter	do.	0	1	0
11. Chops, Chump	do.	0	1	4
12. Beef—Corned, Silverside	do.	0	3	3
Veal—				
13. Shoulder, boned	do.	0	2	3
14. Fillet, boneless	do.	0	3	6
Steak—				
15. Blade	do.	0	3	0
16. Minced Blade	do.	0	2	3
17. Stewing	do.	0	2	11
18. Rump	do.	0	3	11
19. Fillet	do.	0	7	0
20. Sausages—Mixed	do.	0	1	8
21. Sausage—Meat	do.	0	1	0
22. " " Beef, German	do.	0	2	9
23. " " Strasbourg	do.	0	3	0
24. Livers—Sheep	do.	0	2	0
25. Kidneys—Sheep	do.	0	1	6
26. " " Ox	do.	0	2	6
27. Tongues—Ox	do.	0	1	3
28. Ox Tails	do.	0	1	6
29. Brains—Sheep	per set	0	0	5
30. Tripe—Fresh	per lb.	0	0	9
31. Frankfurts	do.	0	2	4
32. Bones—Soup	do.	no	charge	
33. Suet—Kidney	do.	0	0	6
34. Rabbits—Fresh	do.	0	3	3
35. Fowls—First quality	do.	0	5	3
36. Pork—Legs	do.	0	4	0
37. " " Loin	do.	0	4	0
38. Lamb, Legs	do.	0	2	10

SCHEDULE No. 5.—HEATHERTON SANATORIUM.

ANNEX TO CONTRACT No. 1961/1054.

W. Angliss and Co. (Aust.) Pty. Ltd., 42 Bourke-street, Melbourne, C.I.

Sub-schedule No. 3.

MEAT.

Security, £5.

Security, £5.		£	s.	d.
1. Beef, Fresh Roast—Rump	per lb.	0	4	0
2. " " Corned—Silverside	do.	0	3	6
3. Lamb, Fresh—Legs	do.	0	2	9
4. " " " Shoulder—Rolled	do.	0	1	3
5. " " " Chops Mid. Loin	do.	0	4	0
6. " " " Chops, Chump	do.	0	2	3
7. " " " Chops, Forequarter	do.	0	1	4
8. " " " Cutlets	do.	0	3	9
9. Pork, Fresh—Legs	do.	0	4	0
10. " " " Chops	do.	0	3	6
11. " " " Minced	do.	0	2	6
12. Veal—Shoulder—Boned	do.	0	1	3
13. " " " Cutlets	do.	0	3	3
14. Steak—Rump	do.	0	4	6
15. " " " Blade	do.	0	2	9
16. " " " Topside	do.	0	3	0
17. " " " Minced	do.	0	2	5
18. " " " Porterhouse	do.	0	4	0
19. " " " Fillet	do.	0	5	0

SCHEDULE No. 5.—HEATHERTON SANATORIUM—continued.

20. Mutton, Pumped Leg .. .. .	per lb.	0 1 6
21. Tripe—Fresh .. .. .	do.	0 0 10
22. Brains—Sheep .. .. .	per set	0 0 7
23. Lambs Fry .. .. .	per lb.	0 2 0
24. Tongues—Sheep .. .. .	do.	0 1 10
25. Kidneys—Ox .. .. .	do.	0 3 0
26. " Sheep .. .. .	do.	0 2 6
27. Tails—Ox .. .. .	do.	0 1 6
28. Sausages—Pork .. .. .	do.	0 1 11
29. Frankfurts—Vienna .. .. .	do.	0 3 4
30. Beef Gorman—Sausage .. .. .	do.	0 2 6
31. Ham—Loaf .. .. .	do.	0 3 3
32. " Pressed Shoulder .. .. .	do.	0 6 9
33. Rabbits, Fresh .. .. .	do.	0 3 0
34. Capons, First quality .. .. .	do.	0 5 0
35. Dripping, Beef .. .. .	do.	0 1 1½

SCHEDULE No. 7.—BALLARAT DISTRICT—continued.

7. Mid Loin Chops .. .. .	per lb.	0 2 6
Veal—		
8. Shoulder, Boned .. .. .	do.	0 3 6
9. Fillet, Boneless .. .. .	do.	0 4 0
Steak—		
10. Blade .. .. .	do.	0 4 6
11. Rump .. .. .	do.	0 6 0
12. Minced .. .. .	do.	0 3 6
13. Sausages—Mixed .. .. .	do.	0 2 0
14. Sausage Meat .. .. .	do.	0 1 6
15. Livers—Calves .. .. .	do.	0 1 3
16. Kidneys—Ox .. .. .	do.	0 1 3
17. Frankfurts .. .. .	do.	0 2 1
18. Ham Loaf .. .. .	do.	0 3 0
19. Dripping—Beef .. .. .	do.	0 1 3
20. Shanks—sheep .. .. .	each	0 0 6
21. Beef Luncheon .. .. .	per lb.	0 2 2

SCHEDULE No. 6.—ARARAT DISTRICT.

ANNEX TO CONTRACT No. 1961/1055.  
H. A. Morris, 107 Victoria-street, Ballarat.

Sub-schedule No. 4.

MEAT.		Security, £30.	£ s. d.
Fresh Beef—			
1. Rolled Roast (Boneless, brisket excluded) per ontl.			12 18 4
2. Buttocks .. .. .	do.		12 1 8
3. Fresh Mutton—Kidney fat to be removed .. .. .	do.		5 16 8
4. " Middle Loin Chops .. .. .	do.		5 16 8
5. Corned Beef—Rolled or Round, as ordered, without bone or cartilage .. .. .	do.		12 18 4
6. Kidney—Ox .. .. .	per lb.	0 2 0	
7. Veal—Filleted .. .. .	do.	0 2 0	
8. Sausages—Mixed .. .. .	do.	0 2 0	
9. Steak—Topside .. .. .	do.	0 3 5	
10. Beef Luncheon Loaf .. .. .	do.	0 1 11	
11. Sausage Meat .. .. .	do.	0 1 4	
12. Saveloys .. .. .	do.	0 2 0	

SCHEDULE No. 8.—BEECHWORTH DISTRICT.

ANNEX TO CONTRACT No. 1961/1058.  
E. Spencer, Camp-street, Beechworth.

Sub-schedule No. 4.

MEAT.		Security, £30.	£ s. d.	
1. Fresh Beef (Gaol) .. .. . per ontl.				12 1 8
2. Fresh Beef—Rolled Roast, boneless, brisket excluded .. .. .				do. 12 18 4
3. Corned Beef, Rolled or Round as ordered, without bone or cartilage .. .. .				do. 12 18 4
4. Mutton—Fresh (kidney fat to be removed for Mental Hospitals) .. .. .				do. 4 11 8
5. Beef Steak, minced .. .. .				do. 12 10 0
6. Sausage Meat .. .. .				per lb. 0 1 4
7. Sausages—Mixed .. .. .				do. 0 1 10
8. Sausage—German .. .. .				do. 0 2 7
9. Tripe—Fresh .. .. .				do. 0 1 4
10. Veal—Boned .. .. .				do. 0 2 6
11. Livers—Sheep .. .. .				do. 0 1 10
12. Mutton Chops .. .. .				do. 0 1 4
13. Saveloys .. .. .				do. 0 1 2
14. Kidneys—Ox .. .. .				do. 0 2 0
15. Dripping—Beef .. .. .				do. 0 1 0

SCHEDULE No. 7.—BALLARAT DISTRICT.

ANNEX TO CONTRACT No. 1961/1056.  
H. A. Morris, 107 Victoria-street, Ballarat.

Sub-schedule No. 4.

MEAT.		(For Gaol and Mental Hospital.)	Security, £35.	£ s. d.
Fresh Beef—				
1. Buttocks .. .. .	per ontl.			14 11 8
2. Roast—Rolled (Brisket excluded) .. .. .	do.			12 18 4
3. Beef, Corned, Rolled or Round, as ordered, without bone or cartilage .. .. .	do.			12 18 4
Mutton—Fresh—				
4. Kidney fat removed (Mental Hospital) .. .. .	do.			5 0 0
5. Minced .. .. .	per lb.	0 3 2		
6. Sausages .. .. .	do.	0 2 0		
7. Sausage, Beef, German .. .. .	do.	0 2 3		
8. Tripe .. .. .	do.	0 1 0		
9. Saveloys .. .. .	do.	0 2 0		
10. Veal .. .. .	do.	0 3 5		
11. Suet .. .. .	do.	0 0 5		
12. Sausage Meat .. .. .	do.	0 1 4		

SCHEDULE No. 9.—BENDIGO DISTRICT.

ANNEX TO CONTRACT No. 1961/1059.  
Alan H. Gittins, 350 Hargreaves-street, Bendigo.

Sub-schedule No. 5.

MEAT.		For Gaol.	Security, £5.	£ s. d.	
1. Fresh Beef .. .. .					per lb. 0 2 3
2. Corned Beef—Rolled, without bone or cartilage .. .. .					do. 0 1 11
3. Fresh Mutton .. .. .					do. 0 1 0
4. Sausages—Mixed .. .. .					do. 0 1 9
5. Minced .. .. .					do. 0 1 3

ANNEX TO CONTRACT No. 1961/1060.

Alan H. Gittins, 350 Hargreaves-street, Bendigo.

Sub-schedule No. 6.

MEAT.		For Sandhurst Boys' Centre, Bendigo.	Security, £5.	£ s. d.	
1. Fresh Beef—Rolled Roast, boneless, brisket excluded .. .. .					per lb. 0 3 3
2. Fresh Beef—Buttocks .. .. .					do. 0 2 9
3. Corned Beef—Rolled or round, as ordered, without bone or cartilage .. .. .					per lb. 0 2 6
4. Corned Silverside .. .. .					do. 0 3 3
5. Fresh Mutton—Legs .. .. .					do. 0 1 10
6. " " Chops, Mid-Loin .. .. .					do. 0 1 10
7. " " Chops, Forequarter .. .. .					do. 0 1 6
8. Steak—Rump .. .. .					do. 0 5 0
9. Veal—Fillet, boneless .. .. .					do. 0 3 3
10. Sausage Meat .. .. .					do. 0 1 3
11. Livers—Sheep .. .. .					do. 0 0 11
12. Kidney—Ox .. .. .					do. 0 1 6
13. Sausages—Mixed .. .. .					do. 0 1 9
14. Sausage—Beef German .. .. .					do. 0 2 6
15. Saveloys .. .. .					per doz. 0 3 9
16. Bacon, Rashers, Shoulder .. .. .					per lb. 0 6 3
17. Dripping—Beef .. .. .					do. 0 0 8
18. Tripe, Fresh .. .. .					do. 0 1 3
19. Lamb Chops .. .. .					do. 0 3 11
20. " Legs .. .. .					do. 0 3 3

ANNEX TO CONTRACT No. 1961/1057.

Victorian Inland Meat Authority, 522 Little Collins-street, Melbourne.

Sub-schedule No. 5.

MEAT.		For delivery to Teachers' Hostels as under:—	Security, £5.	£ s. d.	
Gillies-street, Ballarat					
Beaufort House, Beaufort-avenue, Ballarat					
1415 Sturt-street, Ballarat.					
130 Victoria-street, Ballarat					
126 Webster-street, Ballarat					
1. Fresh Beef—Sirloin .. .. .					per lb. 0 4 0
2. Beef—Corned—Silverside .. .. .					do. 0 5 0
Fresh Mutton—					
3. Legs .. .. .					do. 0 2 6
4. Forequarter Chops .. .. .					do. 0 1 6
5. Legs Pickled .. .. .					do. 0 2 6
Two Tooth—					
6. Chump Chops .. .. .					do. 0 2 6

**SCHEDULE No. 9.—BENDIGO DISTRICT—continued.**

ANNEX TO CONTRACT No. 1961/1061.

Frank Wade, 193 Williamson-street, Bendigo.

**Sub-schedule No. 7.**

MEAT.

For Teachers' College Hostels as under—

Osborne-street, Pleasant Vale, Bendigo.  
"Lancewood," McLaren-street, Bendigo.  
"Comersdale," Pantton-street, Golden Square, Bendigo.

Security, £5.		£	s.	d.
Fresh Beef—				
1. Topside .. .. .	per lb.	0	3	6
2. Corned Beef—Rolled or Round, as ordered, without bone or cartilage .. .. .	do.	0	2	6
3. Corned Silverside .. .. .	do.	0	3	6
4. Fresh Mutton—Carcase .. .. .	do.	0	1	2
Steak—				
5. Blade (Minced) .. .. .	do.	0	2	10
6. Chuck .. .. .	do.	0	2	8
7. Rump .. .. .	do.	0	5	6
8. Sausages—Mixed .. .. .	do.	0	1	10
9. Sausage Meat .. .. .	do.	0	1	5
10. Livers—Sheep .. .. .	do.	0	0	8
11. Veal, Fillet—boneless .. .. .	do.	0	4	6
12. Brains—Sheep .. .. .	per set	0	0	6
13. Kidneys—Ox .. .. .	per lb.	0	1	6
14. Ox Tails .. .. .	do.	0	1	6
15. Sausage, Strasburg .. .. .	do.	0	3	7
16. Salad Loaf .. .. .	do.	0	3	6
17. Bacon, Middle Rashers .. .. .	do.	0	7	0

**SCHEDULE No. 10.—CASTLEMAINE GAOL.**

ANNEX TO CONTRACT No. 1961/1062.

McQueen Brothers, Hargreaves-street, Castlemaine.

**Sub-schedule No. 2.**

MEAT.

Security, £5.		£	s.	d.
1. Fresh Beef .. .. .	per lb.	0	1	11
2. Fresh Mutton .. .. .	do.	0	1	3
3. Corned Beef—Rolled or Round, as ordered, without bone or cartilage .. .. .	do.	0	2	2
4. Minced Meat—Beef .. .. .	do.	0	2	3
5. Sausage Meat .. .. .	do.	0	1	3
6. Sausages—Mixed .. .. .	do.	0	1	6
7. Saveloys .. .. .	per doz.	0	4	6

**SCHEDULE No. 11.—SCHOOL OF FORESTRY, CRESWICK**

ANNEX TO CONTRACT No. 1961/1063.

H. J. Symons, Pty. Ltd., 1015 Macarthur-street, Ballarat.

**Sub-schedule No. 4.**

MEAT.

Security, £3.		£	s.	d.
1. Fresh Beef—Topside .. .. .	per lb.	0	4	6
2. " " Sirloin, boneless .. .. .	do.	0	4	6
3. Corned, Silverside .. .. .	do.	0	4	6
4. Mutton—Fresh, sides .. .. .	do.	0	1	3
5. Pork—Fresh, leg .. .. .	do.	0	5	0
6. Steak—Stewing .. .. .	do.	0	4	0
7. " Minced .. .. .	do.	0	2	9
8. Sausages—Mixed .. .. .	do.	0	2	0
9. Sausage—Beef German .. .. .	do.	0	3	0
10. Kidney—Ox .. .. .	do.	0	2	0
11. Liver—Sheep .. .. .	do.	0	1	0
12. Saveloys .. .. .	per doz.	0	4	0

**SCHEDULE No. 13.—McLEOD SETTLEMENT,**

FRENCH ISLAND.

ANNEX TO CONTRACT No. 1961/1064.

George Hayman, Lang Lang.

**Sub-schedule No. 3.**

MEAT.

Security, £5.		£	s.	d.
1. Fresh Beef .. .. .	per lb.	0	2	4
2. Mutton .. .. .	do.	0	1	3
3. Sausages—Mixed .. .. .	do.	0	2	2

**SCHEDULE NO. 14.—GEEELONG DISTRICT.**

ANNEX TO CONTRACT No. 1961/1065.

Jackson's (Corio) Meat Packing Co. Pty. Ltd., P.O. Box 163, Footscray.

**Sub-schedule No. 3.**

MEAT.

For Gaol.

Security, £5.

Security, £5.		£	s.	d.
1. Fresh Beef .. .. .	per lb.	0	2	1
2. Corned Beef—Rolled or Round, without bone or cartilage .. .. .	do.	0	2	4
3. Fresh Mutton—Forequarters .. .. .	do.	0	1	2
4. " "—Legs .. .. .	do.	0	1	3
5. Beef—Minced .. .. .	do.	0	2	0
6. Sausages—Mixed .. .. .	do.	0	1	8
7. Sausage Meat .. .. .	do.	0	1	1
8. " Beef German .. .. .	do.	0	2	4
9. Dripping, Beef .. .. .	do.	0	1	1

ANNEX TO CONTRACT No. 1961/1066.

Jackson's (Corio) Meat Packing Co. Pty. Ltd., P.O. Box 163, Footscray.

**Sub-schedule No. 4.**

MEAT.

For delivery to Teachers' Hostels as under—

"Lauriston," 23 Aberdeen-street, Geelong.  
"Forty-Five," The Esplanade, Western Beach, Geelong.  
"Hawthorn," Aberdeen-street, Geelong.  
"Ariston," Packington-street, Geelong.  
"Warrain," 56 Western Beach, Geelong.

Security, £5.

Security, £5.		£	s.	d.
Fresh Beef—				
1. Sirloin, boneless .. .. .	per lb.	0	3	3
2. Topside Roast .. .. .	do.	0	3	6
3. Corned Beef—Rolled or Round, as ordered, without bone or cartilage .. .. .	do.	0	3	6
Mutton—				
4. Legs, Two-tooth .. .. .	do.	0	1	7
5. Forequarters, boned, rolled, and pickled .. .. .	do.	0	1	1
6. Chops, Forequarter .. .. .	do.	0	1	1
7. Chops, Cutlets .. .. .	do.	0	1	10
Steak—				
8. Chuck .. .. .	do.	0	3	0
9. Bladebone .. .. .	do.	0	3	3
10. Minced .. .. .	do.	0	2	3
11. Fillet—Veal .. .. .	do.	0	1	0
12. Tongues—Ox .. .. .	do.	0	1	0
13. Kidneys—Ox .. .. .	do.	0	1	8
Sausages—				
14. Mixed, thin .. .. .	do.	0	1	8
15. Pork, thick .. .. .	do.	0	1	8
16. Sausage—Pork, German .. .. .	do.	0	3	4
17. Sausage Mince .. .. .	do.	0	0	11
18. Bacon—Shoulder .. .. .	do.	0	4	6

**SCHEDULE No. 15.—COORIE MUNGLE PRISON CAMP, HEYTESBURY FOREST.**

ANNEX TO CONTRACT No. 1961/1067.

Heytesbury Butchery, Timboon.

**Sub-schedule No. 3.**

MEAT.

Security, £4.

Security, £4.		£	s.	d.
1. Fresh Beef .. .. .	per lb.	0	4	0
2. Corned Beef—Rolled or Round, as ordered, without bone or cartilage .. .. .	do.	0	3	5
3. Sausages—Mixed .. .. .	do.	0	2	5
4. Sausage Mince .. .. .	do.	0	1	8
5. Dripping—Beef .. .. .	do.	0	1	1

**SCHEDULE No. 17.—LANGI KAL KAL TRAINING CENTRE**

ANNEX TO CONTRACT No. 1961/1068.

F. P. Haintz and Son, Havelock-street, Beaufort.

**Sub-schedule No. 2.**

MEAT.

Security, £5.

Security, £5.		£	s.	d.
1. Fresh Beef—Boneless .. .. .	per lb.	0	4	0
2. Sausages—Mixed .. .. .	do.	0	2	0
3. Mince Meat .. .. .	do.	0	1	6



**SCHEDULE No. 20.—SALE GAOL.**  
ANNEX TO CONTRACT No. 1961/1069.  
*T. L. Webster Pty. Ltd., 80 Raymond-street, Sale.*

**Sub-schedule No. 2.**

**MEAT.**  
Security, £3.

		£	s.	d.
1. Fresh Beef	per lb.	0	2	0
2. Fresh Mutton, Chops—Forequarter	do.	0	1	4
3. " " Legs	do.	0	1	6
4. Corned Beef—Rolled or Round, as ordered, without bone or cartilage	do.	0	2	9
5. Sausage—Meat	do.	0	1	8

**SCHEDULE No. 21.—PLEASANT CREEK SPECIAL SCHOOL, STAWELL.**

ANNEX TO CONTRACT No. 1961/1070.  
*H. A. Morris, 107 Victoria-street, Ballarat.*

**Sub-schedule No. 3.**

**MEAT.**  
Security, £3.

Steak—		£	s.	d.
1. Rump	per lb.	0	5	6
2. Stewing (Minced when required)	do.	0	2	7
3. Beef, Corned Silverside	do.	0	3	6
4. Fresh Mutton—Leg	do.	0	1	9
5. Chops—Middle Loin	do.	0	1	2
6. Sausages—Pork	do.	0	1	11
7. Livers—Sheep	do.	0	0	10
8. Sausage—Meat	do.	0	1	3
9. Saveloys—First quality	do.	0	1	11
10. Bacon	do.	0	7	3

**SCHEDULE No. 22.—SUNBURY DISTRICT.**

ANNEX TO CONTRACT No. 1961/1071.  
*F. Watkins Pty. Ltd., 150 Lonsdale-street, Melbourne.*

**Sub-schedule No. 5.**

**MEAT.**  
Security, £40.

Fresh Beef—		£	s.	d.
1. Rolled Roast, boneless, (brisket excluded)	per cntl.	12	18	4
2. Buttocks	do.	11	13	4
3. Fresh Mutton—Kidney fat to be removed	do.	4	15	10
4. Corned Beef—Rolled or Round, as ordered, without bone or cartilage	do.	13	6	8
5. Sausages—Mixed	per lb.	0	1	10
6. Sausage Meat	do.	0	1	5
7. Sausage—Beef—German	do.	0	2	4
8. Veal—Boneless	do.	0	2	3
9. Tripe—Fresh	do.	0	1	2
10. Livers—Sheep	do.	0	2	0
11. Ox Kidney	do.	0	3	0
12. Saveloys	per doz.	0	3	6

**SCHEDULE No. 23.—WARRNAMBOOL DISTRICT.**

ANNEX TO CONTRACT No. 1961/1072.  
*Thomas Borthwick and Sons (A/asia) Ltd., P.O. Box 150, Portland.*

**Sub-schedule No. 4.**

**MEAT.**  
Security, £5.

		£	s.	d.
1. Fresh Beef—Rolled Roast (brisket excluded)	per lb.	0	2	3
2. Corned Beef—Rolled or Round, as ordered	do.	0	2	4
<b>Fresh Mutton—</b>				
3. Forequarters	do.	0	0	10
4. Legs	do.	0	1	4
5. Chops—Middle Loin	do.	0	1	2
<b>Steak—</b>				
6. Topside	do.	0	2	10
7. Stewing	do.	0	2	3
8. Sausage—Beef German	do.	0	2	9
9. Livers—Sheep	do.	0	1	4
10. Sausage Meat	do.	0	1	6
11. Sausages—Beef	do.	0	2	2
12. " Pork	do.	0	2	4
13. Beef—Minced	do.	0	2	6
14. Kidneys—Ox	do.	0	2	6
15. Tripe—Fresh	do.	0	1	8
16. Saveloys	do.	0	2	3

**CONTRACTS ACCEPTED.—(Series 1961-62.)**  
**PUBLIC WORKS.**

1001. Dingwall, State School No. 3183, new out-offices and septic closets, school and residence, £602 5s.—C. R. Wilson and Son.

1002. Doncaster, Police Station, erection of office, £1,138 16s.—R. J. Griffiths and A. R. Jones.

1003. Elwood, State School No. 3942, pipe and chain mesh fencing, £328 15s.—A. Arnolds Fences Pty. Ltd.

1004. Glen Waverley, High School, erection of two 32-ft. x 16-ft. shelter pavilions and storeroom, £1,090.—J. Nieuwboer.

1005. Hawthorn, Social Welfare, Headquarters Training Division, supply and fix Vermiculite ceilings, £593.—W. H. Cockram and Sons Pty. Ltd.

1006. Hopetoun, High School, supply and erection of one (1) "Plymouth" P8-3 type residence, £5,186 18s. 6d.—W. Phelan and Sons Pty. Ltd.

1007. Horsham West, State School No. 4697, electrical installation in four additional class-rooms, &c., £1,237 15s.—J. W. McDowell.

1008. Horsham West, State School No. 4697, plenum heating, £1,985.—Lonsdale Sheet Metal and Steel Co. Pty. Ltd.

1009. Kew, Mental Hospital, farm fencing, £280.—R. W. Lee.

1010. Lake Bolac, Police Station, erection of timber residence and "A" type police office, £7,052.—B. F. Schotte.

1011. Lakeside, State School No. 4882, erection of two 32-ft. x 16-ft. shelter pavilions, £1,060.—G. Chalmers and E. Broome.

1012. Leongatha, State School No. 2981, installation of sewerage, &c., £903 2s.—A. J. Avage and Son Pty. Ltd.

1013. Lilydale, Police Department Offices and residence, electrical installation, £903 10s. 11d.—M. K. Amos.

1014. Lyndale, High School, erection of two shelter pavilions and store, £1,180.—G. Chalmers and E. Broome.

1015. Melbourne, Parliament House, installation of new main switchboard, distribution board, sub-boards and sub-mains in basement and ground floor, £8,690.—A. W. Cole Pty. Ltd.

1016. Melbourne, Police Headquarters, Russell-street, renewal of feed line from booster pump to roof, overhaul of pump, &c., £496.—Wm. Kean Industries.

1017. Melbourne, Legislative Council Chamber, improved lighting, £1,490.—Marshall and Camerino.

1018. Mildura, Technical School, residence, internal and external painting and repairs, £256.—J. P. Abrey.

1019. Nathalia, Lands and Survey Department, erection of timber-framed residence and garage, £4,021 10s.—D. J. McDonald.

1020. Portland South, State School No. 4750, plenum heating in eight class-room unit, £2,298.—Lonsdale Sheet Metal and Steel Co. Pty. Ltd.

1021. Roslyn, State School No. 4663, painting toilet block, Morrison units and L.T.C. block, £639 10s. 6d.—H. De Vries.

1022. Rushworth, State School No. 1057, plenum heating in six class-room unit, £2,300.—Gray and Wood.

1023. Sale, State School No. 545, residence 44 Lansdowne-street, internal painting and painting front fence and garage, £261.—P. Sheehy and P. Casey.

1024. St. James, Police Station, renovations and provision of septic closet, £995.—G. E. Currey.

1025. Scoresby, State School No. 1028, septic tank installations at school and residence, &c., £1,108 19s. 3d.—L. V. Dickson.

1026. Sebastopol, Girls' Technical School, electrical installation, £9,483 8s. 2d.—W. M. McKnight and Sons.

1027. Traralgon, Mental Hospital, supply and installation of exhaust ventilation, 180°F. hot water, steam supply and heating systems in kitchen and cafeteria, £4,996.—Belsair Pty. Ltd.

1028. Traralgon, State School No. 3584, residence 56 Lafayette-street, reblocking, repairs and painting, £650.—John Corser Pty. Ltd.

1029. Upper Yarra, High School, supply and installation of an effluent pump for septic tank, £310 17s.—W. E. Tuck.

1030. Wallacedale North, State School No. 3332, residence, new out-office and sanitary installation, £776.—W. J. Coates.

1031. Wangaratta, Junior Technical School, external painting and repairs, £1,440 15s. 6d.—L. Cooper.

1032. Werribee, Research Farm, remodelling and additions to toilet blocks at staff quarters, £2,369 11s. 6d.—J. Hopkins.

1033. Werribee, Research Farm, residences Nos. 16 and 20, internal painting and repairs, £495.—J. P. McElligott and Co. Pty. Ltd.

1034. Yaapeet, State School No. 3976, erection of out-office, woodshed block, install septic closets at school and residence, £682 14s.—L. G. McKenzie.

H. R. PETTY, Commissioner of Public Works. 22.9.61.

CONTRACTS ACCEPTED.—(Series 1961-62.)

REQUISITES FOR EDUCATION DEPARTMENT.

SCHEDULE No. 1.

REQUISITES (JUNIOR SCHOOL), EDUCATION DEPARTMENT.

Contract from 1st September, 1961, to 31st August, 1962.

1961/1073.— <i>Art and Craft Supply Co. Pty. Ltd.</i>	.. .. .	Security, £100.
1961/1074.— <i>Belco Pty. Ltd.</i>	.. .. .	Security, £250.
1961/1075.— <i>A. E. Flanders and Co.</i>	.. .. .	Security, £25.
1961/1076.— <i>Rexall Products</i>	.. .. .	Security, £100.
1961/1077.— <i>Sands and McDougall Pty. Ltd.</i>	.. .. .	Security, £100.
1961/1078.— <i>School Aids</i>	.. .. .	Security, £100.

Where the name of the supplier opposite any item is shown in italics, with the sign (A), no contract has been executed nor security lodged, requirements of such items are to be purchased from the supplier named, under Tender Board Agreement.

Item No.	Description of Articles.	Rate.			Name of Contractor.
		£	s.	d.	
1	Powder, colours in, 1-lb. cardboard boxes			per doz.	} Rexall Products
	Red .. .. .	1	5	9*	
	Blue .. .. .	1	5	9*	
	Yellow .. .. .	1	5	9*	
	Sea Green .. .. .	1	5	9*	
	Purple .. .. .	1	5	9*	
	Turquoise .. .. .	1	5	9*	
	Orange .. .. .	1	5	9*	
	Leaf green .. .. .	1	5	9*	
	Black .. .. .	1	1	9*	
White .. .. .	0	17	9*		
2	Brushes (hair), No. 8—				} Art and Craft Supply Co. Pty. Ltd.
	(a) $\frac{1}{2}$ " round .. .. .	0	19	0	
	(b) $\frac{1}{4}$ " flat .. .. .	0	19	0	
3	Newsprint, white, 15" x 11", in packets of 100 sheets			per doz. packets	Obtain from Government Printer.
4	Chalkboards (Temper Plate), green, size 16" x 12"	1	13	0	School Aids
5	Chalk, white, in boxes of 1 gross "Belco"	0	2	9	Belco Pty. Ltd.
6	Chalk, coloured, in boxes of 1 gross "Belco"—				} Belco Pty. Ltd.
	(a) Yellow .. .. .	0	6	3	
	(b) Mixed—ratio per box as follows:—				
	24 sticks—Bright yellow .. .. .				
	18 " Terracotta brown .. .. .				
	24 " Orange .. .. .				
	12 " Bright red .. .. .				
	12 " Blue .. .. .				
	12 " Dark green .. .. .				
	18 " Leaf-green .. .. .				
12 " Purple .. .. .					
12 " Black .. .. .					
7	Surface Paper, Squares, mixed colours in packets of 360 squares—			per doz. packets	} Sands and McDougall, Pty. Ltd.
	(a) 5" squares (pkt. of 360) .. .. .	1	9	0	
	(b) 10" squares (pkt. of 360) .. .. .	5	11	0	
	Each packet of 360 squares to contain colours collated in following ratio:—				
	60 squares each—Red, blue, yellow, sea-green				
	20 " " Purple, turquoise, orange, leaf-green				
	10 " " White, black, grey, brown				
8	Plain White Card, 4-sheet paste board—				} Sands and McDougall Pty. Ltd.
	(a) 8" squares in pkts. of 50 .. .. .	1	11	0	
	(b) sheets 20" x 12 $\frac{1}{2}$ " in pkts. of 50 sheets	5	10	6	
9	Scissors, Metal Kindergarten, No. 100-3 $\frac{1}{4}$ "	3	3	0	A. E. Flanders and Co.
10	Beads, Plastic, $\frac{1}{8}$ " coloured in boxes of 100 beads. Each box to contain 20 beads of the following colours:—Red, green, blue, yellow, white	1	13	6	Art and Craft Supply Co. Pty. Ltd.
11	Laces, Plastic, for threading 20 beads $\frac{1}{8}$ ". To be in equal numbers of colours, red, green, blue, yellow, white	0	8	6	Art and Craft Supply Co. Pty. Ltd.
12	Tablets, Plastic, reversible, blue, yellow, 1" squares by $\frac{1}{4}$ " deep; in packets of 100	3	7	0	Art and Craft Supply Co. Pty. Ltd.
13	Sticks, Plastic, Coloured, in packets of 100. Each packet to contain 20 sticks of the following colours:—Red, green, blue, yellow, white:—				} Art and Craft Supply Co. Pty. Ltd.
	(a) Size 2" .. .. .	0	16	6	
	(b) Size 4" .. .. .	1	6	6	
	(c) Size 6" .. .. .	1	15	0	

\* Less 3 $\frac{1}{2}$  per cent.—14 days.

## CONTRACTS ACCEPTED.—(Series 1961-62)—continued.

## REQUISITES FOR EDUCATION DEPARTMENT.

## SCHEDULE No. 2.

## EXERCISE BOOKS AND REQUISITES, EDUCATION DEPARTMENT.

Contract from 1st September, 1961, to 31st August, 1962.

1961/1079.—Cardboard Containers Manufacturing Co. Pty. Ltd.	Security, £15.
1961/1080.—Corrugated Fibre Container Pty. Ltd.	Security, £20.
1961/1081.—Alex. Cowan (Aust.) Pty. Ltd.	Security, £50.
1961/1082.—William Irving	Security, £30.
1961/1083.—Johnell Containers Pty. Ltd.	Security, £5.
1961/1084.—R. F. Mustow	Security, £60.
1961/1085.—Redmond Inglis and Co. Pty. Ltd.	Security, £25.
1961/1086.—Sands and McDougall Pty. Ltd.	Security, £60.
1961/1087.—R. B. Shankley Pty. Ltd.	Security, £25.
1961/1088.—Spicers (Aust.) Pty. Ltd.	Security, £10.

All supplies under this Schedule will be ordered by the Stores Officer, Education Department, and must be delivered as directed by him.

Item No.	Description of Articles.	Rate.	Name of Contractor.	
		£ s. d.		
1	Compasses, 4" legs "Tokin" .. .. . per doz.	.. .. .	Purchase (Clause 109)	
2	" " wooden, 12" legs rubber tip .. .. . "	4 2 9	Sands and McDougall Pty. Ltd.	
3	Erasers, blackboard, Felt .. .. . "	1 7 6		
4	Pastels, 12 in a box "Reeves" .. .. . per doz.	0 10 2	R. E. Mustow	
5	Rulers, box, flat, 12", marked in inches, eights, and metric per gross measures	1 3 0	Sands and McDougall Pty. Ltd.	
6	Rulers, Blackboard, graduated .. .. . each	0 5 6	William Irving	
7	Squares, set, 45°, 6" side, calibrated .. .. . per doz.	0 6 8	Sands and McDougall Pty. Ltd.	
8	" " 60°, 8" side, calibrated .. .. . "	0 6 8		
9	" " Blackboard { 45° .. .. . each	0 4 5	William Irving	
	60° .. .. . "	0 4 5		
10	" " T. 18", oiled .. .. . per doz.	2 5 0	Purchase (Clause 109)	
11	" " T. 24", oiled .. .. . "	"		
12	" " T. 42", oiled .. .. . "	"		
13	Ink wells (plastic), covered, to fit 1½" hole .. .. . per gross	2 6 0	Spicers (Aust.) Pty. Ltd.	
14	Slate cloth, on rollers, 52" x 36" .. .. . each	.. .. .	Purchase (Clause 109)	
15	Protractors, Blackboard .. .. . "	0 5 3	William Irving	
16	Resurfacers, Blackboard .. .. . per tin	.. .. .	Purchase (Clause 109)	
17	Forks, Tuning, "C", C.512, 125 c.m. length .. .. . each	.. .. .		
18	Books, Exercise, 4 sheet, foolscap quarto, 8" x 6½", plain sheet. Quality of the paper to be Cream wove, 18 lb. large post 16½" x 21" 500 sheets to the ream, hard engine sized. Cover to be of white chip-board, green marbled, .014-.015, printed "Exercise Book, Grades I. and II.", and may bear a trade symbol	per gross	3 4 7	Redmond Inglis and Co. Pty. Ltd.
19	Books, Exercise, 6 sheet, size 9" x 7", with faint ruling 18 m.m. from line to line. Quality of paper to be cream wove, 18 lb. large post 16½" x 21", 500 sheets to ream, hard engine sized. Cover to be of white chip-board, .014-.015 printed in green to an approved typographical design "Exercise Book, Grade III. with 18 m.m. rulings," and may bear a trade symbol	"	3 9 6	Alex Cowan (Aust.) Pty. Ltd.
20	Books, Exercise, 6 sheet, size 9" x 7", with faint ruling 14m.m. from line to line. Quality of paper to be cream wove 18 lb. large post 16½" x 21", 500 sheets to ream, hard engine sized. Cover to be of white chip-board, .014-.015 printed in green to an approved typographical design "Exercise Book, Grade IV. with 14 m.m. rulings" and may bear a trade symbol	"	3 8 6	Alex Cowan (Aust.) Pty. Ltd.
21	Books, Exercise, 12 sheet, 1 section stapled, size 9" x 7", with faint ruling, 9m.m. from line to line. Quality of paper to be cream wove, 18 lb. large post 16½" x 21", 500 sheets to ream, hard engine sized. Cover to be of white chip-board .014-.015 printed in bronze blue to an approved typographical design "Exercise Book", and may bear a trade symbol	"	7 12 6	Alex Cowan (Aust.) Pty. Ltd.
22	Books, Exercise, 24 sheet, size 9" x 7", section sewn, quarto bound, ruling, quality of paper and cover to be as prescribed for Item 21, cover to be printed "Exercise Book", and may bear a trade symbol	"	17 12 0	Spicers (Aust.) Pty. Ltd.
23	Books, Exercise, Mapping, 8 sheet, 9" x 7", Burnie cream wove paper, plain—cover to be of marble chip-board, printed "Exercise Book—Mapping", and may bear a trade symbol	"	5 7 9	R. B. Shankley Pty. Ltd.
24	Books, Exercise, Science, 8 sheet, 9" x 7", quality of paper and cover to be as prescribed for Item 21, cover to be red, printed "Science Book." The leaves to be lithographed, faint ruled on one side, and in tenths on the reverse side, the tenths to appear on the right hand side when the book is opened, the inch ruling to be slightly thicker to show the inch lines distinctly. Each page to contain 48 1" squares, 8 down, 6 across, and may bear a trade symbol	"	7 17 0	
25	Books, Drawing, line, 8 leaves, 10½" x 7½", stapled along longer side, white cartridge paper, Imperial, 56 lb., 480 sheets, smooth, wood free, opaque. Cover to be blue pressings, Quad. Cap., 72 lb., 480 sheets, printed "Drawing Book", and may bear a trade symbol	"	2 8 0	Alex Cowan (Aust.) Pty. Ltd.
26	Containers, cardboard, corrugated fibre, 16" x 12" x 12" .. .. . each	.. .. .	Purchase (Clause 109)	
27	Containers, cardboard, corrugated fibre, 12" x 12" x 12" .. .. . "	.. .. .		
28	Containers, cardboard, corrugated fibre, 12" x 9" x 12" .. .. . "	.. .. .		
29	Containers, cardboard, corrugated fibre, 15" x 9½" x 12" .. .. . "	0 1 7½		
30	Containers, cardboard, corrugated fibre, 15" x 9½" x 4" .. .. . "	.. .. .		
31	Containers, cardboard, corrugated fibre, 20" x 15" x 12" .. .. . "	0 2 9½		
32	Containers, cardboard, corrugated fibre, 24" x 15" x 12" .. .. . "	0 3 1½		
33	Containers, cardboard, corrugated fibre, 42" x 8" x 8" .. .. . "	0 2 7½	Johnell Containers Pty. Ltd.	

CONTRACTS ACCEPTED.—(Series 1961-62)—*continued*.  
REQUISITES FOR EDUCATION DEPARTMENT.

- Schedule No. 3 .. .. . Chemicals for Science Classes for District High Schools and Higher Elementary Schools, &c.  
Schedule No. 4 .. .. . Requisites for Science Classes for District High Schools and Higher Elementary Schools, &c.  
Schedule No. 5 .. .. . Utensils and Requisites for Girls' Schools, Cookery and Needlework Centres.  
Requirements under the above-mentioned Schedules for the period from 1st September, 1961, to 31st August, 1962, are to be obtained in accordance with the provisions of Regulation 109, Part V., Public Accounts and Stores Regulations, 1958.

H. COURTTS,  
Secretary to the Tender Board.

15th September, 1961.

GENERAL STORES.  
SCHEDULE No. 69.  
STATIONERY, GENERAL.

Contract from 1st September, 1961, to 31st August, 1962.

- 1961/1089.—Angus and Co. Pty. Ltd. . . . . Security, £25.  
1961/1090.—Arnold Ribbon Co. . . . . Security, £10.  
1961/1091.—B. J. Ball Ltd. . . . . Security, £10.  
1961/1092.—Behr-Manning (Aust.) Pty. Ltd. . . . . Security, £20.  
1961/1093.—W. & G. Dean . . . . . Security, £10.  
1961/1094.—Dunlop Rubber Australia Ltd. . . . . Security, £15.  
1961/1095.—Dunlopillo Pty. Ltd. . . . . Security, £7.  
1961/1096.—Edwards Dunlop and Co. Ltd. . . . . Security, £100.  
1961/1097.—Gollin and Co. Ltd. . . . . Security, £25.  
1961/1098.—Len Houghton and Co. . . . . Security, £10.  
1961/1099.—S. H. Isaacs . . . . . Security, £10.  
1961/1100.—John Jackson and Co. Pty. Ltd. . . . . Security, £18.  
1961/1101.—R. E. Mustow . . . . . Security, £210.  
1961/1102.—Olivetti Australia Pty. Ltd. . . . . Security, £100.  
1961/1103.—Ormiston Rubber Co. Pty. Ltd. . . . . Security, 10.  
1961/1104.—Perth Stationers . . . . . Security, £10.  
1961/1105.—Ponsford Newman and Benson Ltd. . . . . Security, £25.  
1961/1106.—Ramsay and Hall Pty. Ltd. . . . . Security, £5.  
1961/1107.—Remington Rand Chartres Pty. Ltd. . . . . Security, £50.  
1961/1108.—Robertson and Mullens Pty. Ltd. . . . . Security, £10.  
1961/1109.—Sands and McDougall Pty. Ltd. . . . . Security, £100.  
1961/1110.—Sellotape (Australia) Pty. Ltd. . . . . Security, £100.  
1961/1111.—Shepson and Co. Pty. Ltd. . . . . Security, 20.  
1961/1112.—Spicers (Australia) Pty. Ltd. . . . . Security, £36.  
1961/1113.—Tomasetti and Son Pty. Ltd. . . . . Security, £10.  
1961/1114.—Tucker Industries Pty. Ltd. . . . . Security, £30.  
1961/1115.—John Withers and Son Pty. Ltd. . . . . Security, £45.

All supplies under this Schedule will be ordered by the Stores Officer, Education Department, and must be delivered as directed by him.

Item No.	Description of Articles.	Rate.	Name of Contractor.	
		£ s. d.		
1	Balances, Letter, with weights, $\frac{1}{4}$ oz. to 8 oz. . . . each	1 12 0	R. E. Mustow	
2	Bands, elastic, $0\frac{1}{2}$ , $2'' \times \frac{1}{2}'' \times \frac{1}{2}''$ , in boxes of 1 gross . . . per box	0 1 9 $\frac{1}{2}$ *	Dunlop Rubber Australia Ltd.	
3	" elastic, $0\frac{1}{2}$ , $2\frac{1}{2}'' \times \frac{1}{2}'' \times \frac{1}{2}''$ , in boxes of 1 gross . . . "	0 1 10 $\frac{1}{2}$ *		
4	" elastic, $0\frac{1}{2}$ , $3'' \times \frac{1}{2}'' \times \frac{1}{2}''$ , in boxes of 1 gross . . . "	0 2 3 $\frac{1}{2}$ *		
5	" elastic, $0\frac{1}{2}$ , $3\frac{1}{2}'' \times \frac{1}{2}'' \times \frac{1}{2}''$ , in boxes of 1 gross . . . "	0 2 5*		
6	" elastic, flat, $4\frac{1}{2}'' \times \frac{1}{2}'' \times \frac{1}{2}''$ , in boxes of 1 gross . . . "	0 14 0*		
7	" elastic, flat, $6'' \times \frac{1}{2}'' \times \frac{1}{2}''$ , in boxes of 1 gross . . . "	0 15 9*		
8	" elastic, thread, grey, $1\frac{1}{8}'' \times \frac{1}{8}'' \times \frac{1}{2}''$ , in boxes of 1 gross, per doz. boxes	0 5 9 $\frac{1}{2}$		
9	" elastic, thread, grey, $1\frac{1}{8}'' \times \frac{1}{8}'' \times \frac{1}{2}''$ , in boxes of 1 gross, No. 12	0 7 4		Sands and McDougall Pty. Ltd.
10	" elastic, thread, grey, $2'' \times \frac{1}{8}'' \times \frac{1}{2}''$ , in boxes of 1 gross, No. 14	0 7 4		
11	" elastic, thread, grey, $3'' \times \frac{1}{8}'' \times \frac{1}{2}''$ , in boxes of 1 gross, No. 18	0 8 0		
12	Baskets, document, wire, foolscap . . . . . each	0 1 9 $\frac{1}{2}$	Purchase (Clause 109)	
13	" waste paper, top $11\frac{1}{4}''$ in diameter, bottom $7\frac{1}{2}''$ diameter height $10\frac{1}{2}''$ , metal, bucket type	0 7 11		Edwards Dunlop and Co. Ltd.
14	Books—Bibles, Church of England, Ruby . . . . . "	..	Sands and McDougall Pty. Ltd.	
15	Binders, metal fasteners, with washers, No. 641, in boxes of 1 gross	0 3 8*		
16	" metal fasteners, with washers, No. 642, in boxes of 1 gross	0 3 6 $\frac{1}{2}$		
17	" metal fasteners, with washers, No. 643, in boxes of 1 gross, "Koala"	0 3 10		
18	" metal fasteners, with washers, No. 644, in boxes of 1 gross, "Koala"	0 4 5		
19	" metal fasteners, with washers, No. 645, in boxes of 1 gross	0 4 10		
20	" metal fasteners, with washers, No. 646, in boxes of 1 gross	0 5 4		
21	" screw, brass, $1''$ . . . . . per doz.	0 3 0		Ponsford Newman and Benson Ltd.
22	" screw, brass, $1\frac{1}{4}''$ . . . . . "	0 3 3		
23	" screw, brass, $2''$ . . . . . "	0 3 6		
24	" screw, brass, $2\frac{1}{2}''$ . . . . . "	0 3 9		
25	Bodkins, with eye, riveted through handle, $4\frac{1}{4}''$ blade . . each	0 3 0*	Edwards Dunlop and Co. Ltd.	
26	" with eye, " " " " " " " " " " "	0 5 9		
27	Bowls, glass, Bankers, $3\frac{1}{4}''$ diameter at top . . . . . "	0 0 6 $\frac{1}{2}$	Sands and McDougall Pty. Ltd.	
28	Boxes, cloth covered, for ledger cards, $4'' \times 6''$ . . . . . "	0 3 6		
29	" cloth covered, for ledger cards, $6'' \times 8''$ . . . . . "	0 5 0	Enterprise Boxes	
30	" cash, $8''$ , with trays . . . . . "	0 15 6 $\frac{1}{2}$		Robertson and Mullens Pty. Ltd.
31	" cash, $12''$ , with trays . . . . . "	1 0 3	R. E. Mustow	
32	" cash, $14''$ , with trays . . . . . "	1 17 6		
	Brushes, Artists—			
33	Sable (red), crow, finest, in quills, Winsor and Newton's . . per doz.	..	Purchase (Clause 109)	
34	Sable (red), duck, finest, in quills, Winsor and Newton's . . "	..		
35	Sable (red), goose, finest, in quills, Winsor and Newton's . . "	..		
36	Sable (red), large swan, finest, in quills, Winsor and Newton's each	..	W. & G. Dean Pty. Ltd.	
37	Sable (red), small swan, finest, in quills, Winsor and Newton's "	1 16 0		

\* Less  $2\frac{1}{2}$  per cent.—30 days.

CONTRACTS ACCEPTED.—(Series 1961-62)—continued.

Item No.	Description of Articles.	Rate.	Name of Contractor.
SCHEDULE No. 69—continued.			
		£ s. d.	
38	Brushes, damping, felt and rubber, 3½" .. .. .	each	Purchase (Clause 109)
39	" litho., sable, Series 152, No. 0 .. .. .	per doz.	
40	" litho., sable, Series 152, No. 1 .. .. .	"	
41	" litho., sable, Series 152, No. 2 .. .. .	"	
42	" litho., sable, Series 152, No. 3 .. .. .	"	
43	" litho., sable, Series 152, No. 4 .. .. .	"	
44	" litho., sable, Series 152, No. 5 .. .. .	"	
45	" litho., sable, Series 152, No. 6 .. .. .	"	
46	" litho., sable, Series 152, No. 7 .. .. .	"	
47	" paste and gum, ½", flat .. .. .	"	
48	" paste and gum, ¾", flat .. .. .	"	
49	" typewriter, tooth brush type, 6" overall .. .. .	"	
50	" typewriter, wire handle, bottle type .. .. .	"	
51	Cans Oil for Typewriters .. .. .	"	Tomasetti and Son Pty. Ltd.
52	Cards, playing .. .. .	per doz.	
53	Cases, attache, solid leather, with one X tin plate enamelled frame clamped into body of case, two Australian locks; lined with leather cloth, round leather covered metal handle, best make and finish, metal protected corners riveted on lid	per inch	Purchase (Clause 109)
54	Stationery head for previous item, to be of best leather cloth throughout, well sown, best make and finish, pockets fastened with leather flap	each	
55	Satchels, black leather, zip folio, zip 3 sides full, reinforced metal back	"	J. Jackson and Co. Pty. Ltd.
56	Clag— In 10-oz. bottles, with brushes .. .. .	per doz. bottles	W. Pocknall (A)
57	In 20-oz. bottles, without brushes .. .. .	"	
58	Office paste Powder—3-oz. packets .. .. .	per gross	Angus and Co. Pty. Ltd.
59	Clips, bulldog, 2½", No. 1910 .. .. .	per doz.	
60	" bulldog, small, No. 1895 .. .. .	"	Purchase (Clause 109)
61	" glider or equal thereto, large, in boxes of 100 .. .. .	per doz. boxes	
62	" glider or equal thereto, small, in boxes of 100 .. .. .	"	Perth Stationers
63	" letter, side, foolscap size .. .. .	each	
64	" letter, end, foolscap size .. .. .	"	
65	Colours, water, moist, whole cakes in pans, Winsor and Newton's— Series No. 1.—Burnt Sienna, Burnt Umber, Chinese White, Chrome Yellow, Emerald Green, Indian Red, Mauve, Neutral Tint, Payne's Grey, Prussian Blue, Raw Sienna, Raw Umber, Vandyke Brown, Venetian Red, Yellow Ochre	per doz. pans	R. E. Mustow
66	Series No. 2.—Gamboge; Hooker's Green, No. 1; Hooker's Green, No. 2; Indigo; Purple Lake; Scarlet Lake; Sepia	"	
67	Series No. 3.—Cobalt Blue, French Blue, French Ultramarine, Crimson Lake	"	
68	Series No. 4.—Aurora Yellow, Carmine, Violet Carmine, Vermillion	"	
69	Colours, liquid, Chinese White, Winsor and Newton's, in bottles	per doz. bottles	Purchase (Clause 109)
70	Covers, typewriter, foolscap size, oilcloth .. .. .	each	
71	" typewriter, brief size, oilcloth .. .. .	"	W. & G. Dean Pty. Ltd.
72	" typewriter, policy size, oilcloth .. .. .	"	
73	Correctors, blue and red print, in 1-oz. bottles .. .. .	per doz.	
74	Crayons, solid marking, coloured .. .. .	per gross	John Withers and Son Pty. Ltd.
75	Cushions, chair, rubber .. .. .	each	
76	Damper, label, 4", roller, bakelite .. .. .	"	Purchase (Clause 109)
77	Diaries, Australian, various, pocket series .. .. .	"	
78	" Australian, various, cloth series .. .. .	"	R. E. Mustow
79	" Australian, various, rough series .. .. .	"	
80	Directories, municipal, ¼-bound or library, latest edition .. .. .	"	Dunlopillo Ltd.
81	" Victorian, latest edition .. .. .	"	
82	Dispenser tape Cellulose to take 1296" .. .. .	"	Purchase (Clause 109)
83	" " " " 2592" .. .. .	"	
84	Erasers, circular, typewriter .. .. .	per doz.	John Withers and Son Pty. Ltd.
85	" combined, 2½", ink and pencil .. .. .	"	
86	" draughtsmen .. .. .	"	Ormiston Rubber Co. Pty. Ltd.
87	" pliable, pencil .. .. .	per lb.	
88	Eyelets, short—600 in box .. .. .	per box	R. E. Mustow
89	" medium .. .. .	"	
90	" long .. .. .	"	
91	Fasteners paper, ¾", R.O., 1 gross in box .. .. .	per doz. boxes	Purchase (Clause 109)
92	" paper, ½", S.1 and R.1, 1 gross in box .. .. .	"	
93	" paper, ¾", R.2, 1 gross in box .. .. .	"	Purchase (Clause 109)
94	" paper, ¾", S.3 and R.3, 1 gross in box .. .. .	"	
95	" paper, ¾", S.4, 1 gross in box .. .. .	"	John Withers and Son Pty. Ltd.
96	" paper, 1", S.5, 1 gross in box .. .. .	"	
97	" paper, 1¼", R.6, 1 gross in box .. .. .	"	Purchase (Clause 109)
98	" paper, 1¼", S.7 and R.7, 1 gross in box .. .. .	"	
99	" paper, 2", S.8 and R.8, 1 gross in box .. .. .	"	Shepson and Co. Pty. Ltd.
100	" paper, 2½", R.10, 1 gross in box .. .. .	"	
101	" paper, "Ty-tite", 1 gross in box .. .. .	per box	Purchase (Clause 109)
			Ty-tite Products (A)

CONTRACTS ACCEPTED.—(Series 1961-62)—continued.

Item No.	Description of Articles.	Rate.	Name of Contractor.
SCHEDULE NO. 69—continued.			
		£ s. d.	
102	Files box, indexed, foolscap, with clip, 15" x 11½" x 3" .. each	0 9 5½	Robertson and Mullens Pty. Ltd.
103	" box, foolscap, not indexed, 14½" x 9½" x 2" .. ..	0 5 1	R. E. Mustow
104	" concertina, manila, foolscap .. ..	0 9 11	Purchase (Clause 109)
105	Files, concertina, manila, quarto .. ..	.. ..	
106	" foolscap, with index .. ..	.. ..	John Withers and Son Pty. Ltd.
107	" springback, foolscap .. ..	0 5 5	
108	" springback, music size .. ..	0 7 3	R. E. Mustow
109	" springback, octavo .. ..	.. ..	Purchase (Clause 109)
110	" springback, large quarto, 11½" x 9" .. ..	0 5 4	John Withers and Son Pty. Ltd.
111	" springback, small quarto .. ..	.. ..	Purchase (Clause 109)
112	Glue, "Seccotine" .. .. per doz. tubes	.. ..	
113	Grips, { Finger and Thumb-¾" .. .. per doz.	0 1 1*	Dunlop Rubber Australia Ltd.
	" " " " ¾" .. ..	0 1 2½*	
114	" finger, thimble style, large .. ..	0 1 10*	
115	" finger, thimble style, medium .. ..	0 1 7*	
116	" finger, thimble style, small .. ..	0 1 7*	
117	Gum, art, blocks, 2½" x 1½" x 1½", "Radiant" .. ..	0 8 9	R. E. Mustow
118	" dry, arabic .. .. per lb.	.. ..	Purchase (Clause 109)
119	" liquid, 4-oz. bottles with cap and brush .. .. per doz.	0 13 6	Angus and Co. Pty. Ltd.
120	" obliterating, I.R., stamp .. .. per bot.	.. ..	Purchase (Clause 109)
121	" obliterating, metal stamp .. ..	.. ..	
122	Inkstands, glass, with tray, two holes and caps .. .. each	0 7 9	Sands and McDougall Pty. Ltd.
123	" glass, square, 3½", glass top with pen tray .. ..	.. ..	Purchase (Clause 109)
124	Knives, desk erasers .. .. each	0 4 2	Sands and McDougall Pty. Ltd.
125	Labels, gummed, 2½" x 1½", with border, pads of 100 .. .. per pad	.. ..	Purchase (Clause 109)
126	" gummed, 1" x ¾" with border, box of 100 .. .. per box	.. ..	
127	Machines, eyelet, hand punches .. .. each	1 5 9	Sands and McDougall Pty. Ltd.
128	" numbering, "Velos" 900, 6 figure .. ..	2 9 0	
129	" stapling, "Celco-80" enamelled .. ..	1 0 8	Lin Houghton and Co.
130	Oil, for typewriters, 2-oz. bottles .. ..	0 0 9	Ramsay and Hall Pty. Ltd.
131	Openers, letter, steel .. ..	0 2 0	Sands and McDougall Pty. Ltd.
132	Pads, self-inking, I.R. stamp, 2½" x 4½", red, blue, purple, black, per doz. green No. 1	1 5 6	
133	" self-inking, I. R., stamp 3½" x 6", green, black, blue, red, purple, No. 2 .. ..	1 14 0	R. E. Mustow
134	Paper, rolls, for adding machines, 3 7/16" x 3 3/4", in 80-yd. rolls .. per roll	0 1 8†	Edwards Dunlop and Co. Ltd.
135	" rolls for adding machines, 2½" x 3½", in 80-yd. rolls ..	0 1 6†	
136	" rolls for adding machines, 2½" x 3½" .. ..	0 0 11†	
137	" rolls, for cash register, size "Y" .. ..	.. ..	
138	Pencil, lengthener .. .. per doz.	.. ..	Purchase (Clause 109)
139	Pencils, coloured, hexagonal, blue .. ..	.. ..	
140	" coloured, blue, round .. ..	.. ..	
141	" coloured, hexagonal, green .. ..	0 2 6	R. E. Mustow
142	" coloured, green, round .. ..	0 2 8½	
143	" coloured, hexagonal, red .. ..	0 2 6	Purchase (Clause 109)
144	" coloured, red, round .. ..	0 2 8½	
145	" coloured, round, combined red and blue .. ..	.. ..	
146	" coloured, violet, round .. ..	.. ..	
147	" crayon, coloured, in boxes of 12 colours .. ..	1 8 6½	Robertson and Mullens Ltd.
148	" drawing .. ..	0 2 7½	Shepson and Co. Pty. Ltd.
149	" office, H. B., "Popular" .. ..	0 1 4½	R. E. Mustow
150	" indelible, "Puma" .. ..	0 2 3	
151	" refills, for propellers, black .. .. per doz. boxes	.. ..	Purchase (Clause 109)
152	" refills, for propellers, coloured .. ..	.. ..	
153	" waterproof .. .. per doz.	.. ..	
154	Pens, Ball Point, Bic Crystal, "Throwaway" .. ..	0 5 0	Gollin and Co. Pty. Ltd.
155	" refills .. ..	.. ..	
156	" drawing, large, "Harling's", B.E. 2 .. ..	.. ..	
157	" drawing, small, "Harling's", B.E. 12 .. ..	.. ..	
158	" stylo, "Conway Stewart", No. 115 .. .. each	.. ..	Purchase (Clause 109)
Pen Nibs, in boxes of one gross—			
159	Anchor, Nos. 1, 2, 3 .. .. per box	.. ..	
160	Australian, No. 9 .. ..	0 5 6	B. J. Ball Ltd.
161	Journal .. ..	.. ..	
162	Ball-pointed, grey, graded .. ..	.. ..	
163	" First class", No. 9 .. ..	.. ..	
164	Gillots, No. 170 .. ..	.. ..	
165	" No. 290 .. ..	.. ..	
166	" No. 292 .. ..	.. ..	
167	" No. 293 .. ..	.. ..	
168	" No. 303 .. ..	.. ..	Purchase (Clause 109)
169	" Nos. 404m, 404f .. ..	.. ..	
170	" mapping .. ..	.. ..	
171	" J", black .. ..	.. ..	
172	" J", black .. ..	.. ..	
173	" J", elongated, black, "Gilt" .. ..	.. ..	
174	" J", black, "Gilt" .. ..	.. ..	
175	Magazine, Brandauer and Co. .. ..	.. ..	

\* Rates less 2½% for payment by end of month following month of delivery

† Less 2½%—30 days.

CONTRACTS ACCEPTED.—(Series 1961-62)—continued.

Item No.	Description of Articles.	Rate.	Name of Contractor.
SCHEDULE No. 69—continued.			
£ s. d.			
176	Pen Nibs, in boxes of one gross—continued—		
177	Mail, No. 2134 .. .. . per box	.. .. .	Purchase (Clause 109)
178	Manifolding, No. 0505 .. .. .	.. .. .	
179	Probate, Esterbrook .. .. .	.. .. .	
180	Relief .. .. .	.. .. .	
181	Review, Brandauer and Co. .. .. .	.. .. .	
182	Scribbler, No. 147. "Ariel" .. .. .	0 3 6	
183	Times .. .. .	.. .. .	
184	Waverley .. .. .	.. .. .	
185	Lawson .. .. .	.. .. .	
186	Leicester .. .. .	.. .. .	
187	Dawson, No. 9 .. .. .	.. .. .	Purchase (Clause 109)
188	Mitchell .. .. .	.. .. .	Purchase (Clause 109)
189	Kopinib .. .. .	.. .. .	
190	Latem .. .. .	.. .. .	
191	Pedigree .. .. .	.. .. .	
192	Penholders Wooden, rubber grip, assorted colours .. .. . per gross	2 7 6	
193	Pins, drawing, 1/4" diameter 144 in box .. .. . per box	0 1 8	
194	Pounce .. .. .	.. .. .	
195	Protractors 6" celluloid .. .. . per lb.	.. .. .	
196	" circular celluloid, 5", full circle, 1/8" thick, 1/4" top .. .. . each	0 8 6	
197	" bevel, two-way reading .. .. .	.. .. .	
198	Punches, for files, two holes, c to c, small 3 3/8" .. .. .	0 4 7	
199	Refills, for table calendars, "Pioneer" .. .. .	0 2 3†	
200	" " "Invicta" .. .. .	Published price less 50%	
201	Stands for table calendars, "Pioneer" .. .. . per doz.	2 0 0†	
202	" " "Invicta" .. .. . each	0 3 9	
203	Rulers, ebony, round, 15" .. .. .	.. .. .	
204	Rulers, flat, 15", brass edge .. .. . per doz.	0 12 11	
205	" flexible, metal, 15" .. .. .	.. .. .	
206	Scissors, office, 6" .. .. .	2 6 11	
207	" surgical, 6" .. .. .	3 2 6	
208	Scales, draughtsmen's, boxwood, engine-divided— 1/8" and 1/4"; 1/4" and 1/2"; 3/8" and 1/2"; 1/2" and 1"; Armstrong .. .. .	.. .. .	
209	" survey, boxwood, engine-divided, 10/20, 20/40, 30/60, 40/80, 40/160, 50/100—double sided .. .. .	.. .. .	
210	Seals, gummed, notarial, No. 3 (packet of 100) .. .. . per pkt.	0 0 8	
211	Sharpener, pencil, rotary, adjustable .. .. . each	1 0 4	
212	Silencers, mats, for typewriter, 12" x 12" .. .. .	0 9 9	
213	Sponges, to fit bowls .. .. .	.. .. .	
214	Squares, set, 45°, celluloid, 6" .040 .. .. .	.. .. .	
215	" set, 45°, celluloid, 8" .040 .. .. .	.. .. .	
216	" set, 45°, celluloid, 10" .040 .. .. .	.. .. .	
217	" set, 60°, celluloid, 8" .040 .. .. .	.. .. .	
218	" set, 60°, celluloid, 10" .050 .. .. .	.. .. .	
219	" set, 60°, celluloid, 12" .060 .. .. .	.. .. .	
220	Stamps, dating, medium, No. 2, "Dominion" .. .. .	0 2 5	
221	" small, No. 1 1/2 .. .. .	0 1 8	
222	Rests for stamps, metal, to take ten stamps .. .. .	0 6 0	
223	Staples for stapling machines—		
224	Velos (1,000) in box .. .. . per box	.. .. .	
225	Hotchkiss No. 1 or Velos (5,000 in box) .. .. .	.. .. .	
226	Hotchkiss No. 1A or Velos (5,000 in box) .. .. .	.. .. .	
227	Bostitch or Velos (5,000 in box) .. .. .	.. .. .	
228	Comet Mark V. (5,000 in box), "Celco" 2616 .. .. .	0 4 2	
229	Velos Crown C., No. 350 (5,000 in box) .. .. .	0 4 7	
230	Koala, No. 60 (3,000 in box) .. .. .	0 2 8	
231	" No. 80 (5,000 in box) .. .. .	0 4 2 1/2	
232	Rexel Universal (5,000 in box) .. .. .	0 4 7	
233	Straps, cotton, 2 ft., 1-in. wide, with buckle .. .. . per doz.	0 5 9	
234	" cotton, 3 ft., 1-in. wide, with buckle .. .. .	0 7 6	
235	" cotton, 4 ft., 1-in. wide, with buckle .. .. .	0 9 5	
236	Tape, Cellulose, 1/2 in. x 72 yards .. .. . per roll	0 4 5	
237	" 1/2 in. x 72 yards .. .. .	0 6 2	
238	" 1 in. x 72 yards .. .. .	0 7 10	
239	" 1/2 in. x 36 yards .. .. .	0 2 7	
240	" 1 in. x 36 yards .. .. .	0 3 4	
241	" 1 in. x 36 yards .. .. .	0 4 3	
242	" 1/2 in. x 225 in. (and dispenser) .. .. . each	0 0 10	
243	" 1/2 in. x 300 in. (and dispenser) .. .. . per roll	0 1 4 1/2	
244	" Paper, brown, gummed, 1 in. No. 60 .. .. .	0 3 0†	
245	" " " " 2 in. No. 80 .. .. .	0 6 0†	
246	" adhesive, opaque, linen, 1 1/2 in. .. .. .	.. .. .	
247	" " " " 1/2 in. .. .. .	.. .. .	
248	Trays, pen, glass, 9 1/2 in. x 3 in. .. .. . each	0 2 11	
249	Type Cleaner .. .. .	0 1 7	
250	Typewriters, foolscap size .. .. .	32 10 0	
251	" brief size .. .. .	33 10 0	
252	" policy size .. .. .	39 0 0	
253	Wax, sealing, red, packed in 1-lb. boxes .. .. . per lb.	0 3 6	
254	Weights, paper, glass, 4 in. x 2 1/2 in. x 1 in. .. .. . each	0 3 9†	

† Less 2 1/2 per cent.—30 days.

**CONTRACTS ACCEPTED.—(Series 1961-62.)**

SCHEDULE No. 68.

**GENERAL STORES—STAMPS, RUBBER.**

Contract from 1st September, 1961, to 31st August, 1962.

1961/1116.—M. G. King's Rubber Stamp Co. .. Security, £13.

*Delivery to be made at the Education Department stationery Store, within 7 days of receipt of order.*

Item No.	Description of Articles.	Rate.	Name of Contractor.
		<i>s. d.</i>	
	Stamps, rubber, wooden handle and mount, any length up to 5", type up to $\frac{1}{4}$ " high—		
1	One line .. .. . each	4 0	M. G. King's Rubber Stamp Co.
2	Two lines .. .. . "	4 9	
3	Three lines .. .. . "	5 6	
4	Four lines .. .. . "	6 9	
5	Over four lines .. .. . line extra	1 6	
	Stamps, rubber, wooden handle and mount, circular, oval, or square, any wording not exceeding—		
6	2" x 1 $\frac{1}{2}$ " .. .. . each	7 6	Purchase (Clause 100)
7	3" x 2" .. .. . "	9 6	
8	4" x 3" .. .. . "	..	

Approved—H. E. BOLTE, Treasurer. 14.9.61.

**CONTRACTS ACCEPTED.—(Series 1961-62.)**

**CEREALS.**

Requirements under Sub-Schedule No. 7 of Schedule No. 1 for the month of October, 1961, are to be purchased from the under-mentioned firms at the rates per cwt. respectively indicated, viz.:—Robert Harper and Co. Ltd., Oatmeal—flaked, 45s., Peas—split, yellow, 60s. Rice—dressed, 82s., Rice—unpolished, 82s., Tapioca—seed, 8d. per lb., less 3 per cent. fourteen days or 2 $\frac{1}{2}$  per cent. 30 days; H. S. K. Ward Pty. Ltd., Barley—pearl, 38s. 3d., Oatmeal—plain, 42s.

H. COUTTS, Secretary to the Tender Board. 25.9.61.

**ORDERS IN COUNCIL.—(Series 1961-62.)**

**EDUCATION DEPARTMENT.**

999. One only three-phase variable speed 415-volt 50-cycle motor and starting contactor, for Castlemaine Technical College, £178 4s. 6d.—Electric Guarantee and Trading Co. Pty. Ltd.

1000. Four oscilloscopes (£57 10s. each), for Collingwood Technical School, £230.—Electronic Industries Pty. Ltd.

Approved by the Governor in Council, 18th September, 1961.—N. G. WISHART, Acting Clerk of the Executive Council.

**STATE ELECTRICITY COMMISSION.**

1035. The supply of motor spirit for a period of one year to Quotation Nos. 5444 and 5445, at Schedule Rates.—Ampol Petroleum (Vic.) Pty. Ltd.

1036. The supply of motor spirit for a period of one year to Quotation Nos. 5444 and 5445, at Schedule Rates.—Atlantic Union Oil Co. Pty. Ltd.

1037. The supply of motor spirit for a period of one year to Quotation Nos. 5444 and 5445, at Schedule Rates.—B.P. Australia Pty. Ltd.

1038. The supply of motor spirit for a period of one year to Quotation Nos. 5444 and 5445, at Schedule Rates.—Caltex Oil (Aust.) Pty. Ltd.

1039. The supply of motor spirit for a period of one year to Quotation Nos. 5444 and 5445, at Schedule Rates.—H. C. Sleigh Ltd.

1040. The supply of motor spirit for a period of one year to Quotation Nos. 5444 and 5445, at Schedule Rates.—Total Oil Products (Aust.) Pty. Ltd.

1041. The supply of motor spirit and cleaning agent for a period of one year to Quotation Nos. 5444 and 5445, at Schedule Rates.—Vacuum Oil Co. Pty. Ltd.

Approved by the Governor in Council, 5th September, 1961.—N. G. WISHART, Acting Clerk of the Executive Council.

1042. The supply and delivery of milk for messes and tea-rooms in Yallourn Area for a period of two years, to Specification No. 61-62/65, at Schedule Rates.—J. S. Dwyer.

1043. The supply of grey combination overalls for a period of two years, to Specification No. 61-62/44, at Schedule Rates.—Sterling Clothing Co. Pty. Ltd.

Approved by the Governor in Council, 12th September, 1961.—N. G. WISHART, Acting Clerk of the Executive Council.

*Cemeteries Act 1958.*

**SCALE OF FEES OF THE MANANGATANG PUBLIC CEMETERY.**

IN pursuance of the powers conferred upon them by the Cemeteries Acts the trustees of the Manangatang Public Cemetery hereby make the following scale of fees, which shall come into operation upon publication in the *Government Gazette*, and from and after such publication every scale of fees heretofore made by the said trustees shall be and is hereby rescinded to the extent to which it conflicts with this scale.

*Land for Private Graves.*

	<i>£ s. d.</i>
8 ft. x 4 ft. selected by Trustees for adult body	3 0 0
8 ft. x 4 ft. selected by applicant	.. 3 0 0
Grave for child	.. 1 10 0

W. BLENKHORN, Trustee.  
J. M. CURRAN, Trustee.  
L. J. McQUEEN, Trustee.

Approved by the Governor in Council, 18th September, 1961.

N. G. WISHART,  
Acting Clerk of the Executive Council.

*Cemeteries Act 1958.*

**SCALE OF FEES OF THE BOX HILL PUBLIC CEMETERY.**

IN pursuance of the powers conferred upon them by the Cemeteries Acts the trustees of the Box Hill Public Cemetery hereby make the following scale of fees, which shall come into operation upon publication in the *Government Gazette*, and from and after such publication every scale of fees heretofore made by the said trustees shall be and is hereby rescinded to the extent to which it conflicts with this scale.

*Land for Private Graves.*

	<i>£ s. d.</i>
Special plots, 8 ft. x 4 ft.	.. 20 0 0

*Private Graves.*

Sinking grave 7 feet	.. 12 0 0
Sinking grave 8 feet	.. 14 0 0
Re-opening grave, any compartment	.. 11 0 0

*Maintenance of Graves.*

Establishment and maintenance first year	.. 3 0 0
Each succeeding year	.. 2 0 0

A. R. ALLINGHAM, Trustee.  
E. V. DATE, Trustee.  
K. PATTERSON, Trustee.

Approved by the Governor in Council, 18th September, 1961.

N. G. WISHART,  
Acting Clerk of the Executive Council.



THE PORTLAND HARBOR TRUST COMMISSIONERS.

REGULATIONS—AMENDMENT No. 12.

IN pursuance of the *Portland Harbor Trust Act 1958*, the Portland Harbor Trust Commissioners make the following Regulations:—

1. Regulation 6 is amended by deleting the last sentence and substituting in lieu thereof:—

“No money shall be drawn out of the bank save by cheque signed by any one Commissioner and countersigned by the Secretary or Accountant.”

SCHEDULE No. 19.

2. Schedule No. 19.—Charges under Regulation 289 are repealed and the following are substituted in lieu thereof:—

SCHEDULE No. 19.

*Charges under Regulation 289.*

<i>Wharfage Rates.</i>	<i>s. d.</i>
Ballast consisting of sand, shingle or stone .. .. .	1 0
Ammonia Liquor .. .. .	5 6
Coal .. .. .	5 6
Crude Oil .. .. .	5 6
Empty returns, being drums, casks, cases, boxes, crates, baskets, biscuit and lolly tins and bags .. .. .	5 6
Phosphatic Rock .. .. .	2 6
Sand (carried as cargo) and shell .. .. .	5 6
All other goods .. .. .	8 4
Goods exempt.—Passenger's luggage only.	

*Provided.*

(a) That goods which have been produced or manufactured within the Commonwealth, and which arrive at this Port from any other Port in the Commonwealth shall pay the following rates:—

	<i>s. d.</i>
Ballast consisting of sand, shingle or stone .. .. .	0 9
Ammonia Liquor .. .. .	4 2
Coal .. .. .	2 9
Crude Oil .. .. .	4 2
Empty returns, being drums, casks, cases, boxes, crates, baskets, biscuit and lolly tins and bags .. .. .	4 2
Phosphatic Rock .. .. .	2 6
Sand (carried as cargo) and shell .. .. .	4 2
All other goods .. .. .	5 6

(b) That goods arriving from any Port within the Commonwealth, but not produced or manufactured within the Commonwealth, shall pay the same rate as they would be liable to if imported direct from outside the Commonwealth.

(c) That the rates specified in the Schedule hereto at per ton may be calculated by the Commissioners by weight or by measure at their option.

3. The following Regulation is included immediately after Regulation 280:—

“Regulation 280A. When the Master, owner, or agent of a vessel requires tug or motor launch assistance in the Port of Portland, and such assistance is provided by the Commissioners, such Master, owner or agent shall pay the charges as set out in Schedule No. 20.”

SCHEDULE No. 20.

*Charges under Regulation 280A.*

*Removals, Berthing, Mooring or Unberthing by Tug Assistance. Calculated on Gross Tonnage:—*

*For Each Service.*

	Ordinary Work Period.			Week Day Overtime.			Sat., Sun. and Public Holidays.		
	£	s.	d.	£	s.	d.	£	s.	d.
Under 7,500 tons .. .. .	34	10	0	49	10	0	55	0	0
7,500 tons—10,000 tons .. .. .	37	10	0	52	10	0	58	0	0
Over 10,000 tons .. .. .	42	10	0	57	10	0	63	0	0

Provided that when the cargo tonnage loaded or discharged does not exceed 200 tons the specified rates will be reduced by 20 per cent.

*Waiting Time.*

In the event of a vessel not being ready for departure or arrival at the appointed time the foregoing rates cover the first half-hour of attendance after which an additional rate per hour or part thereof of £19 will be made.

*Performing Work Not Specified Above.*

	£	s.	d.	£	s.	d.	£	s.	d.
Hourly Rate .. .. .	29	15	0	44	15	0	50	5	0

*Use of Motor Launches* per hour or part thereof to be calculated from time of appointment.

	£	s.	d.	£	s.	d.	£	s.	d.
Hourly Rate .. .. .	5	5	0	6	15	0	7	7	0

*Use of Mooring Launch Running Lines.*

	£	s.	d.	£	s.	d.	£	s.	d.
For each service .. .	4	4	0	4	15	0	5	5	0

Dated at Portland this 19th day of July, 1961.

Given under the common seal of the Portland Harbor Trust Commissioners by order of the Commissioners, in the presence of—

(SEAL)

T. C. JARRETT, Chairman.  
W. S. NORTON, Commissioner.  
L. C. MOULTON, Secretary.

Approved by the Governor in Council,  
18th September, 1961.

N. G. WISHART,  
Acting Clerk of the Executive Council.

**RULES OF THE SUPREME COURT.**

**I**n pursuance of the powers conferred by the *Supreme Court Act 1958* and all other powers hereunto enabling Chapter VII. of the Rules of the Supreme Court is herewith amended as follows:—

- (a) In Sub-rule (1) of Rule 27 for the words "forthwith on" there shall be substituted the words "within seven days of."
- (b) In Rule 101 for the words "twenty-one days" there shall be substituted the words "one month," and for the words "one month" there shall be substituted the words "six weeks".
- (c) In Rule 102 for the words "fourteen clear days" there shall be substituted the words "seven days".

Dated this 18th day of September, 1961, at Judges' Chambers, Supreme Court, Melbourne.

E. F. HERRING, C.J.  
NORMAN O'BRYAN, J.  
JOHN V. BARRY, J.  
ARTHUR DEAN, J.  
R. V. MONAHAN, J.  
G. A. PAPE, J.  
A. D. G. ADAM, J.  
D. M. LITTLE, J.  
GREGORY GOWANS, J.

**AUCTION SALES ACT 1958.**

**L**IST of Persons to whom Auctioneers' Licences have been issued during the month of August, 1961.

Name.	Address.	Date of Issue.
Beynon, Frederick Roy	35 Rose-street, McKinnon	22.8.61
Christensen, Raymond Alfred	75 Airlie-road, Montmorency	15.8.61
Lock, Gordon	380 McKinnon-road, McKinnon	17.8.61
Malcolm, Ralph Morton	14 Delville-avenue, Mordialloc	16.8.61
O'Brien, Gerald	13 Collegian-street, Strathmore	8.8.61
Pitard, Maurice Sydney	1 Head-street, Balwyn	15.8.61
Sanders, Maurice Edgar	14 Joyce-street, Elwood	3.8.61
Shillito, John Richard	10 Watson-grove, Glenhuntly	21.8.61
Smith, Claud William	32 William-street, Warragul	14.8.61
Wright, George Albert	4 Fairy-street, Ivanhoe	8.8.61

The Treasury,  
Melbourne, C.2, 22nd September, 1961.

E. W. COATES,  
Director of Finance.

## Local Government Act 1958, Part 48, Section 904.

## LICENCES TO OCCUPY UNUSED ROADS.

NOTICE is hereby given that Licences to occupy Unused Roads have been issued to the following approved applicants, and that the Licence Fee specified in each case has been received by the Accountant, Department of Crown Lands and Survey, Melbourne, C.2.

Number of Licence.	Name and Address of Licensee.	Municipality.	Parish.	Abutting— Allotments and Sections.	Area.	Fee for Licence.	Date of Issue of Licence.	Date of Expiry of Licence.
42361	Schuster, Mrs. H., and H. Gibson, Howqua Hills, c/o Merrijig P.O., via Mansfield	Mansfield	Changue	Spring-street, and part Lovick-street (Township of Howqua)	1 2 0	1 0 0	1.1.61	31.12.63
42362	Freeman, R. Tallarook	Yea	Yea	North and north-west of 187L and 187	10 0 0	1 10 0	1.1.61	31.12.63
42363	Nelson, J., Box 161, P.O., Benalla	Benalla	Winton	West of 45 and 49	12 0 0	6 0 0	1.1.61	31.12.63
42364	Wilson, J. J., "Adavilla", Thurgroona, N.S.W.	Yaokandandah	Gundowring	East of A, section 6	6 0 0	1 12 6	1.1.61	31.12.63
42365	Stuckey, H. R., "Leawood", Flynn	Rosedale	Rosedale	South of 3A, section B	7 2 0	3 0 0	1.1.61	31.12.63
42366	McFeeters, D. H., Reid's Creek, via Beechworth	Beechworth	Beechworth	Between 1 and 8, section 2	0 3 0	1 0 0	1.1.61	31.12.63
42367	Pickering, A. L., "Acheron Lea," Maroonah Highway, Buxton	Healesville	Buxton	South of 42B and east of south part 42A	5 1 0	3 0 0	1.1.61	31.12.63
42368	Wiaken, I. H., State School 3633, Bruarong, via Yaokandandah	Yaokandandah	Bruarong	Adjoining the Bruarong State School and 10 on one side and part 3 and part 4 on other side	2 0 0	5 0 0	1.1.61	31.12.63
42369	Fulford, J. W., Melbourne-road, Wodonga West	Chiltern	Chiltern	North of 6, section 5	2 0 0	1 0 0	1.1.61	31.12.63
42370	Long, H. S., "Larnoo," Yea	Yea	Ghin Ghin	Between 19, 47, 56, 57 and 55	26 0 0	1 19 0	1.1.61	31.12.63

Department of Crown Lands and Survey,  
Melbourne, 13th September, 1961.

KEITH TURNBULL,  
Commissioner of Crown Lands and Survey.

## MONEY LENDERS ACT 1958.

IN accordance with the provisions of the above-mentioned Act the following is published for general information.

List of persons to whom Money Lenders' Licences have been issued for the year ending 30th June, 1962.

Name.	Authorized Name.	Authorized Address.	Date of Issue.
Auer, Lawrence Gilbert	Gilbert Auer	7A Nolan-street, Maryborough	24.7.61
Bird, Jack Aubrey	J. A. Bird	166 Springfield-road, Blackburn	3.7.61
Bo-Tim Investments Ltd. (L. H. Jackman, Appointee)	Bo-Tim Investments Ltd.	125 Mollison-street, Bendigo	12.9.61
Building Guarantee and Discount Co. Ltd. (H. E. Levy, Appointee)	Building Guarantee and Discount Co. Ltd.	225 Collins-street, Melbourne	1.8.61
Clare Constructions Pty. Ltd. (L. M. Glynn, Appointee)	Clare Constructions Pty. Ltd.	28 Elizabeth-street, Melbourne	5.9.61
Commercial and General Acceptance Ltd. (R. G. Overell, Appointee)	Commercial and General Acceptance Ltd.	24 The Esplanade, St. Kilda	24.8.61
Fulton, William Keford	W. K. Fulton	30 Bennett-parade, East Kew	27.7.61
McErvale, Alexander Albert	A. A. McErvale	103 Havlin-street, Bendigo	11.9.61
Nevon Pty. Ltd. (N. K. Cuthbert, Appointee)	Nevon Pty. Ltd.	Suite 4, 67 Queens-road, Melbourne	30.8.61
Nichleborough Estate Pty. Ltd. (J. E. Dimelow, Appointee)	Nichleborough Estate Pty. Ltd.	422 Collins-street, Melbourne	22.8.61
Reid Murray Acceptance Ltd. (D. K. Fidge, Appointee)	Reid Murray Acceptance Ltd.	c/o Paynes Bon Marche Pty. Ltd., 144 Baloolme-road, Mentone	24.8.61
Reid Murray Acceptance Ltd. (D. K. Fidge, Appointee)	Reid Murray Acceptance Ltd.	c/o Paynes Bon Marche Pty. Ltd., 201 Lonsdale-street, Dandenong	21.8.61
Reid Murray Acceptance Ltd. (D. K. Fidge, Appointee)	Reid Murray Acceptance Ltd.	145 Smith-street, Fitzroy	22.8.61
Tilley, George Leonard	G. L. Tilley	356 Sydney-road, Coburg	8.9.61
Wilcray Credits Pty. Ltd. (C. Wilson, Appointee)	Wilcray Credits Pty. Ltd.	Railway-parade, Croydon	15.8.61

State Treasury,  
Melbourne, C.2, 22nd September, 1961.

M. A. R. SYNNOT,  
Registrar.

## HOSPITALS AND CHARITIES ACT No. 6274 (1952).

IT is hereby notified for general information that the Hospitals and Charities Commission, under the provisions of section 50 of the above-mentioned Act, has approved the corporate name of The Gippsland Hospital at Sale being changed to:—

"GIPPSLAND BASE HOSPITAL."

Dated at Melbourne, this 18th day of September, 1961.

JOHN LINDELL,  
Chairman.

## Landlord and Tenant Act 1958.

## ORDER EXTENDING APPLICATION OF PART V. OF THE ACT TO CERTAIN PREMISES, ETC.

ERRATUM.—The premises referred to in item 7 of the Order published on page 3186 of the *Government Gazette* dated 20th September, 1961, as "Number 69 Moorah-street, Parkville", should read "Number 69 Morrah-street, Parkville".

R. BURNS,  
Acting Secretary, Law Department.

## NOTICE.

**CREDITORS**, next of kin and others having claims against the estate of any of the under-mentioned deceased persons are required to send particulars of their claims to the Public Trustee, 7th Floor, 601 Little Collins-street, Melbourne, the personal representative, on or before the 30th November, 1961, after which date the Public Trustee may convey or distribute the assets, having regard only to the claims of which the Public Trustee then has notice:—

**AMIGUET, ALFRED THOMAS LOUIS**, known as Thomas Amiguët, formerly of 4 Admiral-street, Footscray, but late of Repatriation General Hospital, Heidelberg, pensioner, died 28th June, 1961.

**ANGUS, MAY LOUISE**, late of 3 Barnes-avenue, Burwood, widow, died 20th July, 1961.

**BLEAZBY, MARGARET NOBLE**, also known as Madge Bleazby and Margaret Noble, formerly of 51 Bell-street, Fitzroy, and 45 Woolton-avenue, Thornbury, but late of 216 Wood-street, East Preston, retired hosiery mender, died 19th July, 1961.

**BONE, ELIZA JANE NEWELL**, late of Prestonia Private Hospital, Hotham-street, Northcote, widow, died 15th July, 1961.

**BOWDITCH, LIZZIE**, late of 39 Tennyson-street, East Malvern, widow, died 14th June, 1961.

**BRICKNELL, WILLIAM**, late of 463 New-street, Elwood, pensioner, died 1st March, 1961.

**BRUCE, ERNEST NEIL**, late of residence at Bank of New South Wales, 190 Bourke-street, Melbourne, caretaker, died on or about 21st September, 1960.

**BUNTING, IAN ADOLPHUS GEORGE**, formerly of "Clovelly", Frankston-road, Cranbourne, but late of 10 Elizabeth-street, East Bentleigh, retired farmer, died 30th November, 1960.

**CORBETT, PETER JOSEPH**, also known as Peter Corbett, late of Woorinen South, pensioner, died 22nd June, 1961.

**COWAN, EMBLEM**, late of 6 Ryland-street, Ashburton, widow, died 9th July, 1961.

**DONALDSON, JAMES**, late of Maldon Hospital, Adair-street, Maldon, pensioner, died 13th July, 1961.

**ENGELMAN, ALICE**, late of 28 Dunlop-avenue, Ascot Vale, widow, died 8th July, 1961.

**FROUD, MAUD**, also known as Maud Simpkins, late of 5 Bungalow-court, Queen-street, Humber Bay, Ontario, Canada, widow, died 19th October, 1941.

**GRIFFEN, KATE**, also known as Kate Griffin, late of Lyndhurst-street, Richmond, married woman, died 29th May, 1888.

**HOLLAND, THOMAS ROY**, late of 27 Peel-street, Kew, salesman, died 28th February, 1961.

**KENNEDY, WALTER HERBERT**, late of St. Andrews Guest House, Dawson-street, Ballarat, journalist, died 24th June, 1961.

**MATHESON, WILLIAM**, late of 1 Narvick-crescent, Heidelberg West, pensioner, died 21st May, 1961.

**MUDGE, LIONEL**, late of 12 Anderson-street, Surrey Hills, salesman, died 5th October, 1960.

**MCCABE, OWEN**, formerly of 32 Richlieu-street, Maidstone, but late of 21 Reid-street, Northcote, retired railway employee, died 10th June, 1961.

**O'CONNELL, MICHAEL DANIEL**, late of 13 Olive-grove, Pascoe Vale, boilermaker, died 30th June, 1961.

**PENBERTHY, FREDERICK HAROLD**, formerly of 218 Queensberry-street, North Melbourne, but late of 18 Herbert-street, Ringwood, retired engineer, died 30th July, 1961.

**PHILLIPS, EDIS ANNIE**, late of 1 Somerville-street, Coburg, married woman, died 13th July, 1961.

**PIERCE, FREDERICK HERBERT**, late of 40 Brougham-street, Kew, pensioner, died 29th July, 1961.

**PIPER, WILLIAM GEORGE**, late of 31 Cecil-street, Fitzroy, brewery employee, died 3rd July, 1961.

**POLLOCK, LETITIA CONSTANCE VICTORIA**, late of 6 Percy-street, St. Albans, widow, died 20th September, 1959.

**PORCORATO, GIOVANNI**, formerly of 575 Kellor-road, Niddrie, but late of 115 Wellington-street, Femington, sheet metal worker, died 14th July, 1961.

**ROBERTS, ALVIN EDGAR**, formerly of 24 Birdwood-street, Box Hill South, but late of 46 Stott-street, Box Hill South, retired clerk, died 11th June, 1961.

**ROBINSON, ENRICA**, late of 45 Marriott-street, Parkdale, pensioner, died 4th August, 1961.

**SAWYERS, VICTOR CHARLES**, also known as Charles Victor Sawyers, formerly of 51 Bank-street, South Melbourne, but late of 19 Service-street, Hampton, retired clerk, died 22nd May, 1961.

**STRINGER, JOSEPH BERNARD**, late of Flat 8, 84 Nicholson-street, Fitzroy, manager, died 3rd August, 1959.

**UTTERIDGE, EMILY JANE**, late of 148 Power-street, Hawthorn, spinster, died 1st August, 1961.

**VESSEY, FRANK STANLEY**, late of 13 Best-street, Reservoir, car painter, died 4th July, 1961.

**WEST, WILLIAM GEORGE EDWARD**, formerly of Market-street, Benalla West, but late of Nymagee, New South Wales, contractor, died 14th December, 1958.

**WILLIAMS, FREDERICK JAMES**, late of 26 Hunter-street, Malvern, medical practitioner, died 15th June, 1961.

A. D. DUNCAN,

Public Trustee.

Melbourne, 20th September, 1961.

## PUBLIC TRUSTEE ACT 1958, No. 6350, SECTION 17.

**I HEREBY** give notice that on the 22nd August, 1961, the Public Trustee filed an election to administer the following deceased person's estate, in accordance with section 17 of the *Public Trustee Act 1958*:—

**BRICKNELL, WILLIAM**, late of 463 New-street, Elwood, pensioner, died 1st March, 1961.

**I HEREBY** give notice that on the 7th September, 1961, the Public Trustee filed an election to administer the following deceased person's estate, in accordance with section 17 of the *Public Trustee Act 1958*:—

**FROUD, MAUD**, also known as Maud Simpkins, late of 5 Bungalow-court, Queen-street, Humber Bay, Ontario, Canada, widow, died 19th October, 1941.

**I HEREBY** give notice that on the 12th September, 1961, the Public Trustee filed an election to administer the following deceased person's estate, in accordance with section 17 of the *Public Trustee Act 1958*:—

**BUNTING, IAN ADOLPHUS GEORGE**, formerly of "Clovelly", Frankston-road, Cranbourne, but late of 10 Elizabeth-street, East Bentleigh, retired farmer, died 30th November, 1960.

**I HEREBY** give notice that on the 13th September, 1961, the Public Trustee filed elections to administer the following deceased persons' estates, in accordance with section 17 of the *Public Trustee Act 1958*:—

**BLEAZBY, MARGARET NOBLE**, also known as Madge Bleazby and Margaret Noble, formerly of 51 Bell-street, Fitzroy, and 45 Woolton-avenue, Thornbury, but late of 216 Wood-street, East Preston, retired hosiery mender, died 19th July, 1961.

**CORBETT, PETER JOSEPH**, also known as Peter Corbett, late of Woorinen South, pensioner, died 22nd June, 1961.

**DONALDSON, JAMES**, late of Maldon Hospital, Adair-street, Maldon, pensioner, died 13th July, 1961.

**KENNEDY, WALTER HERBERT**, late of St. Andrews Guest House, Dawson-street, Ballarat, journalist, died 24th June, 1961.

**MATHESON, WILLIAM**, late of 1 Narvick-crescent, Heidelberg West, pensioner, died 21st May, 1961.

**I HEREBY** give notice that on the 14th September, 1961, the Public Trustee filed elections to administer the following deceased persons' estates, in accordance with section 17 of the *Public Trustee Act 1958*:—

**PENBERTHY, FREDERICK HAROLD**, formerly of 218 Queensberry-street, North Melbourne, but late of 18 Herbert-street, Ringwood, retired engineer, died 30th July, 1961.

**PIERCE, FREDERICK HERBERT**, late of 40 Brougham-street, Kew, pensioner, died 29th July, 1961.

**PIPER, WILLIAM GEORGE**, late of 31 Cecil-street, Fitzroy, brewery employee, died 3rd July, 1961.

**PORCORATO, GIOVANNI**, formerly of 575 Kellor-road, Niddrie, but late of 115 Wellington-street, Femington, sheet metal worker, died 14th July, 1961.

**ROBINSON, ENRICA**, late of 45 Marriott-street, Parkdale, pensioner, died 4th August, 1961.

**UTTERIDGE, EMILY JANE**, late of 148 Power-street, Hawthorn, spinster, died 1st August, 1961.

**WEST, WILLIAM GEORGE EDWARD**, formerly of Market-street, Benalla West, but late of Nymagee, New South Wales, contractor, died 14th December, 1958.

**I HEREBY** give notice that on the 19th September, 1961, the Public Trustee filed an election to administer the following deceased person's estate, in accordance with section 17 of the *Public Trustee Act 1958*:—

**STRINGER, JOSEPH BERNARD**, late of Flat 8, 84 Nicholson-street, Fitzroy, manager, died 3rd August, 1959.

A. D. DUNCAN,

Public Trustee.

601 Little Collins-street, Melbourne, C.1, 20th September, 1961.

## PUBLIC TRUSTEE ACT 1958.

NOTICE is hereby given that on the 18th day of May, 1961, an order was made by a Judge of the Supreme Court, pursuant to section 25 of the *Public Trustee Act 1958*, on the grounds that the whereabouts are unknown of Una Winifred Symonds, formerly of 7 Gordon-street, Hampton, widow, the owner of real and personal estate, authorizing the Public Trustee to exercise certain powers affecting the said estate; and that the Public Trustee intends to exercise such of the powers conferred on him by the said order as becomes necessary.

A. D. DUNCAN,  
Public Trustee.

## CITY OF PRESTON.

Town and Country Planning Acts.

## INTERIM DEVELOPMENT ORDER.

BY virtue of the powers conferred by the Town and Country Planning Acts and of every other power enabling it in that behalf the City of Preston (hereinafter referred to as the Responsible Authority), having commenced the preparation of a planning scheme in accordance with the said Act on the 18th day of February, 1952, hereby makes the following Interim Development Order for the purpose of regulating, restricting, restraining or prohibiting the use or development of any land or the erection, construction or carrying out of any buildings or works on any land within the area described or shown on the map as the Schedule hereto.

1. After the coming into operation of this Interim Development Order no person shall use or develop any land or erect, construct or carry out any buildings or works on any land within the area included in the Schedule, except in accordance with the provisions of a permit issued by the Responsible Authority.

2. Any application for a permit to use or develop any land or to erect, construct or carry out any buildings or works, shall be accompanied by a sketch plan or copy of certificate of title of the land and a description of the proposed use or development, and type and construction of any buildings or works proposed to be erected, constructed or carried out and such other particulars relating to the application as the Responsible Authority may require.

3. This Interim Development Order shall not prevent the continuance of the use of any land or buildings for the purpose for which such land or buildings were lawfully used immediately before the coming into operation of this Order.

4. SCHEDULE.—The whole of the municipal district of the City of Preston.

(SEAL)

C. P. W. KIRBY, Mayor.  
A. H. CAPP, Councillor.  
J. C. DONATH, Town Clerk.

Report by the Town and Country Planning Board on the 12th day of September, 1957. Recommended for approval.—FRED C. COOK, Chairman.

Approved by the Governor in Council on the 17th day of September, 1957.—A. MAHLSTEDT, Clerk of the Executive Council.

Report by the Town and Country Planning Board on the 4th day of September, 1958. Recommended for approval pursuant to section 5 of the *Town and Country Planning (Metropolitan Area) Act 1954* (No. 5834).—FRED C. COOK, Chairman.

Approved by the Governor in Council pursuant to section 5 of the *Town and Country Planning (Metropolitan Area) Act 1954* (No. 5834). Dated this 17th day of September, 1958.—N. G. WISHART, Acting Clerk of the Executive Council.

Report by the Town and Country Planning Board on the 26th day of August, 1959. Recommended for approval, pursuant to section 34 of the *Town and Country Planning Act 1958*.—FRED C. COOK, Chairman.

Approved by the Governor in Council, pursuant to section 34 of the *Town and Country Planning Act 1958*. Dated this 15th day of September, 1959.—A. MAHLSTEDT, Clerk of the Executive Council.

Report by the Town and Country Planning Board on the 9th day of September, 1960. Recommended for approval, pursuant to section 34 of the *Town and Country Planning Act 1958*, as amended.—FRED C. COOK, Chairman.

Approved by the Governor in Council, pursuant to section 34 of the *Town and Country Planning Act 1958*, as amended. Dated this 20th day of September, 1960.—A. MAHLSTEDT, Clerk of the Executive Council.

Report by the Town and Country Planning Board on the 4th day of September, 1961. Recommended for approval, pursuant to section 34 of the *Town and Country Planning Act 1958*, as amended.—FRED C. COOK, Chairman.

Approved by the Governor in Council, pursuant to section 34 of the *Town and Country Planning Act 1958*, as amended. Dated this 18th day of September, 1961.—N. G. WISHART, Acting Clerk of the Executive Council.

*Town and Country Planning Act 1958, as Amended.*  
MELBOURNE AND METROPOLITAN BOARD OF WORKS.

## INTERIM DEVELOPMENT ORDER.

*Notice of Approval.*

IN pursuance of the powers conferred by the *Town and Country Planning Act 1958*, as amended, the Governor of the State of Victoria, by and with the advice of the Executive Council thereof, having taken into consideration a report of the Town and Country Planning Board, on the twenty-sixth day of September, One thousand nine hundred and sixty-one, approved an Interim Development Order by the said Melbourne and Metropolitan Board of Works for the whole of the metropolitan area.

The Interim Development Order provides that the use or development of any land and the erection, construction or carrying out of any buildings or works on any land within the whole of the metropolitan area is prohibited, except in so far as such Order or the Melbourne and Metropolitan Board of Works, pursuant to such Order, permits (absolutely or subject to any condition or conditions) the use or development of such land and the erection, construction or carrying out thereon of buildings or works.

Copies of the said Interim Development Order are available for inspection, free of charge, at the office of the Melbourne and Metropolitan Board of Works, at the office of the Town and Country Planning Board and as to so much of the said Order as relates to land in the municipal district of any municipality at the office of such municipality.

H. J. SNADDEN,  
Secretary.

*Hospitals and Charities Act 1958* (No. 6274).—Section 46.  
PETITION TO INCORPORATE FAIRVIEW HOMES FOR THE AGED.

IT is notified, in accordance with the provisions of section 46 of Act No. 6274, that the Hospitals and Charities Commission has received a petition signed by not less than 25 contributors to Fairview Homes for the Aged praying that that institution be incorporated under the provisions of the said Act. The institution established in Warragul will have for its objects—

- the erection, management, maintenance and administration of Homes for the Aged in the Shire of Warragul, Buln Buln and Narracan;
- the purchase or acquisition of any real and personal property, and the construction of homes for the aged and other buildings for that purpose, and the doing of all such other things as are incidental or conducive to the attainment of the above objects, but in the premises for which a grant under the Commonwealth Aged Persons Homes Act is received, only aged persons as defined in the said Act shall be admitted;
- doing such other things which, in the Committee's opinion, will provide for the economic, social and recreational well-being of the residents;
- the assets and income of the organization shall be applied solely in furtherance of these objects and no portion shall be distributed directly or indirectly to its members except as bona fide compensation for services rendered or expenses incurred on behalf of the organization, and is capable of being incorporated.

If a counter petition signed by an equal or greater number of contributors is not lodged with the aforesaid Commission at No. 1 Nicholson-street, Melbourne, within one calendar month of the publication of this notice, the Governor in Council may, by order made pursuant to Act No. 6274, declare the contributors for the time being to Fairview Homes for the Aged to be a body corporate by the name set forth in such Order.

R. W. MACK,  
Minister of Health.

Department of Health,  
Melbourne, 21st September, 1961.

Transport Regulation Acts.  
TRANSPORT REGULATION BOARD.  
NOTICES OF PUBLIC HEARINGS.

NOTICE is hereby given that the applications made by the persons named below for licences to operate commercial passenger vehicles on the route or routes, or in the manner set out opposite their names, will be heard at a time and place to be communicated to the parties concerned:—

*Name and Address; Nature of Application.*

- L. C. DYSON BUS SERVICE PTY. LTD., 753 Plenty-road, Reservoir; 1 commercial passenger vehicle, with seating capacity for 35 persons, to operate under the same terms and conditions as licence Nos. C.O.158 and C.O.166.
- GEELONG COLLEGE, Talbot-street, Newtown, Geelong; 1 commercial passenger vehicle, with seating capacity for ten persons, to operate for the carriage of college students and staff on education excursions within a radius of 50 miles of Geelong, free of charge, as and when required.
- MENLYN, E., 6 Young-street, Bacchus Marsh; 1 commercial passenger vehicle, with seating capacity for 33 persons, to operate under the same terms and conditions as licence No. T.S.312.
- MOORE, M. J., Greenvale, via Heywood; 1 commercial passenger vehicle, with seating capacity for 31 persons, to operate as follows:—(1) For the carriage of school children only between Whittlebury and Heywood under contract to the Education Department, (2) to operate as a special service omnibus from Greenvale, (3) to operate under special traffic conditions from Greenvale.
- KRAFT FOODS LTD., Salmon-street, Port Melbourne; 1 commercial goods vehicle, with seating capacity for eight persons, to operate for the carriage of employees only free of charge between Port Melbourne and the City, via Salmon-street, Williamstown-road, Normanby-road, Yarra Bank-road, over Queen's Bridge, returning via Queen's Wharf-road, King-street Bridge, Yarra Bank-road, &c., to premises in Salmon-street, Port Melbourne.
- MOLESWORTH, E. M., 529 St. George's-road, Thornbury; 1 commercial passenger vehicle, with seating capacity for five persons, to operate for the carriage of children free of charge between their homes and the kindergarten of 529 St. George's-road, Thornbury.
- DRIVER BROS. PTY. LTD., 108 Glen Iris-road, Glen Iris; 1 commercial passenger vehicle, with seating capacity for 37 persons, to operate as an additional metropolitan stage omnibus on Route 81A (Chadstone-Glen Iris-Camberwell Junction) under the same terms and conditions as M.O. licences at present held by the applicant.
- WILLIAMSON, E. N. (trading as Whitehorse Bus Service), 494 Elgar-road, Box Hill; application for variation of Route 108A (North Balwyn-Mont Albert-Box Hill) to extend all service to the Greythorn shopping centre, Doncaster-road, from the existing terminus at the corner of Doncaster and Greythorn roads instead of only those shopping trips authorized at the moment by permit authority.
- TURNER, K. & T. M., 35 Woonah-street, Chadstone; application for renewal of licence No. T.P.18 and T.P.47, expiring 10th February, 1962, to be operated under the same terms and conditions.
- VICTORIA HALL SUNDAY SCHOOL, 11 Coronation-street, West Footscray; application for renewal of licence No. T.P.22, expiring 12th February, 1962, to be operated under the same terms and conditions.
- QANTAS EMPIRE AIRWAYS LTD., Beach-road, Avalon; application for renewal of licence Nos. T.P.61, T.P.97, and T.P.111, expiring 28th February, 1962, to be operated under the same terms and conditions.
- WOODBURN, T. Mrs., "Addistone", Wulgulmerang, via Buchan; application for renewal of licence No. T.P.41, expiring 3rd January, 1962, to be operated under the same terms and conditions.
- REV. FATHER HOGAN, Holy Rosary School, Heathcote; application for renewal of licence No. T.P.27, expiring 26th February, 1961, to be operated under the same terms and conditions.
- DANDENONG & DISTRICT MENTALLY RETARDED CHILDREN'S WELFARE ASSOCIATION, Scout Hall, Melbourne-road, Dandenong; application for renewal of licence No. T.P.124, expiring 3rd January, 1962, to be operated under the same terms and conditions.
- WALLS, J., 32A Jasper-street, Noble Park; application for renewal of licence No. C.T.279, expiring 27th February, 1962, authorizing operations as a country taxi-cab from Dandenong.

APPLICATIONS for metropolitan private hire car licences by the persons listed hereunder in respect of commercial passenger vehicles, with seating capacity for five persons, to operate under composite conditions from an approved depot in zone set out opposite their names:—

*Name and Address; Zone.*

- LAMONT, R. H., 11 Mattea-court, East Preston; "C", "N", "H", "J", and "K".
- ANDREWS, T., 21 Chatham-road, Canterbury; "E".
- CURTIN, J. C., 25 Boyne-street, East Coburg; "N", "A", "E", and "G".
- LAMONT, R. H., 11 Mattea-court, East Preston; 1 commercial passenger vehicle, with seating capacity for five persons, to operate as a metropolitan taxi-cab.
- ANDREWS, T., 21 Chatham-road, Canterbury; 1 commercial passenger vehicle, with seating capacity for five persons, to operate as a metropolitan taxi-cab.

NOTICE is hereby given that the applications made by the persons named below for licences to operate the commercial goods vehicles on the route or routes, or in the manner set out opposite their names, will be held at a time and place to be communicated to the persons concerned:—

*Name and Address; Nature of Application.*

- PERRY, A. G. (trading as Alberto's Circus), care of Mrs. Morton, Princes Highway, Narre Warren; 5 commercial goods vehicles (108, 15, 76, 31 and 64 cwt.) to operate throughout the State of Victoria in the course of business as a "circus proprietor"—own circus equipment.
- PERRY, A. G. (trading as Alberto's Circus), care of Mrs. Morton, Princes Highway, Narre Warren; 2 commercial goods vehicles (58 and 68 cwt.) to operate throughout the State of Victoria in the course of business as a "circus proprietor"—own circus livestock and equipment.
- ALBION QUARRYING CO. PTY. LTD., corner of Arden and Laurens-streets, North Melbourne; 1 commercial goods vehicle (222 cwt.) to operate within a radius of 50 miles from own premises at North Melbourne in the course of business as "road construction contractors"—roadmaking plant and materials, hot asphalt and pre-mix.
- ALLEN, M. J., Reillys-road, Nerrena, via Leongatha; 1 commercial goods vehicle (30 cwt.) to operate—(a) within a radius of 20 miles of Nerrena—general goods, (b) to and from places within a radius of 50 miles of Nerrena from and to places within paragraph (a) above—livestock.
- GRAHAM, R. B. & M. J. (trading as Applan Service Station), 228-234 High-street, Shepparton; 1 commercial goods vehicle (15 cwt.) to operate throughout the State of Victoria for the purpose of towing or repairing wrecked and disabled vehicles—tools of trade, spare parts and materials incidental thereto.
- BENSLEY, P. & B. (trading as Bensley Bros.), Alumatta-street, Wangaratta; 1 commercial goods vehicle (approximately 200 cwt.) to operate within a radius of 150 miles of the Post Office at Wangaratta for the purpose of towing and/or repairing wrecked and disabled vehicles—tools of trade, spare parts and materials incidental thereto.
- BRIGGS, A. S. & E. K., 69 Burnell-street, West Brunswick; 3 commercial goods vehicles (97, 69 and 191 cwt.) to operate throughout the State of Victoria in the course of business as a "travelling showman"—own equipment and novelty prizes.
- BRUST, I., 291 Alma-road, Caulfield; 1 commercial goods vehicle (7 cwt.) to operate—(a) within a radius of 25 miles of the G.P.O., Melbourne, for the purpose of delivering foodstuffs solely on behalf of Tasty Products Pty. Ltd., Box Hill, (b) throughout the State of Victoria solely on behalf of Tasty Products Pty. Ltd., Box Hill, for the purpose of booking orders with the ability to leave a sample when required.
- CARTER, J. W., Napier-street, Stawell; application to vary the conditions of existing licence No. D.A.37184 by deleting the present conditions and adding in lieu—(a) within a radius of 55 miles of the post office at Beaufort (Ballarat Division of the Country Roads Board)—plant the property of a contractor and required for use in connexion with the construction or maintenance of some specific, existing or proposed road, street, footpath, bridge, wharf, pier, weir or channel, (b) within a radius of 20 miles from site of construction or maintenance work performed pursuant to paragraph (a) above, or from the railway station nearest thereto—metal, stones, screenings, ashes, gravel, sand, earth and any other materials required for such work, (c) within a radius of 20 miles of the post office at Stawell—general goods.

- COLE, J. C., Princes Highway, Garfield; 1 commercial goods vehicle (8 cwt.) to operate throughout the State of Victoria as a repossession agent solely on behalf of Lintons Engineering Agency—repossessed articles.
- CONSOLIDATED METAL PRODUCTS LTD., 140 Forrest-street, Sunshine; 2 commercial goods vehicles (11 and 7 cwt.) to operate throughout the State of Victoria in the course of business as "agricultural machinery manufacturers and agents" for the purpose of servicing and maintaining agricultural machinery—tools of trade, spare parts and materials incidental to such servicing and maintenance work.
- DOYLE, R. E. & W. E. (trading as Doyle's Valley Transport), 130 Mary-street, Morwell; 1 commercial goods vehicle (252 cwt.) to operate—(a) within a radius of 20 miles of the post office at Morwell—general goods, (b) from Caltex Oil (Aust.) Pty. Ltd. depot at Warragul to consignees at Traralgon—petroleum products in prescribed types of containers and empty return containers.
- DOYLE, R. E., 130 Mary-street, Morwell; 1 commercial goods vehicle (134 cwt.) to operate—(a) within a radius of 20 miles of the post office at Morwell—general goods, (b) from Caltex Oil (Aust.) Pty. Ltd. depot at Warragul to consignees at Traralgon—petroleum products in prescribed types of containers and empty return containers.
- EASTERN POWER LINES PTY. LTD., 30 Aurum-crescent, Ringwood; application to vary the conditions of existing licence No. T.D.4684 by deleting "20 miles radius of own premises" and adding in lieu "25 miles radius of own premises".
- ELDRIDGE, S. A., 25 Widdop-crescent, Moorabbin; 1 commercial goods vehicle (7 cwt.) to operate throughout the State of Victoria in the course of business as a Television Antenna Engineer for the purpose of testing television reception areas and antennas—tools of trade, antennas for testing purposes, specialized installation and materials incidental thereto.
- GRIFFIN, R., 342 Barnard-street, Bendigo; 1 commercial goods vehicle (131 cwt.) to operate—(a) within a radius of 95 miles of the post office at Cohuna and/or within a radius of 100 miles of the post office at Merbein; (Bendigo, Division of the Country Roads Board)—plant, the property of a contractor and required for use in connexion with the construction or maintenance of some specific, existing or proposed road, street, footpath, bridge, wharf, pier, weir or channel, (b) within a radius of 20 miles from site of construction or maintenance work performed pursuant to paragraph (a) above, or from the railway station nearest thereto—metal, stones, screenings, ashes, gravel, sand, earth and any other materials required for such work, (c) within a radius of 25 miles of the post office at Bendigo—general goods.
- HANSEN, J. S. & E. L., Weeragua, via Noorinbee; application to vary the conditions of existing licence No. D.A.4284/1 by adding—"Between the Vacuum Oil Co.'s depot at Bairnsdale and places within a radius of 20 miles of Weeragua—petroleum products and empty containers".
- HIGGINBOTHAM, W. J. & B. I., 2 Elm-street, East Ivanhoe; 1 commercial goods vehicle (16 cwt.) to operate as "radio and television wholesalers and servicemen"—(a) within a radius of 50 miles of own premises at East Ivanhoe—own goods, (b) throughout the State of Victoria for the purpose of demonstrating radio and television component parts, aerials, television boosters and public address systems and for servicing radios, television sets and public address systems, radio and television component parts, aerials, television boosters and public address systems for demonstration, tools of trade, spare parts and materials incidental to servicing with the ability to make an urgent incidental delivery of a particular component part.
- HILDER, J. W., Gembrook; application to vary the conditions of existing licence No. T.T.D.1812 by deleting from paragraph (a) "J. D. Pearce and A. Briely and the Metropolitan Area" and adding in lieu—"T. K. & J. Williams and within a radius of 25 miles of the G.P.O., Melbourne".
- THE HOFFMAN BRICK & POTTERIES LTD., Dawson-street, Brunswick; application to vary the conditions of existing licence No. D.A.35003/3 by deleting "Brunswick" and adding in lieu "Yallourn".
- HOSE, F., Powell-street, Ocean Grove; 2 commercial goods vehicles (120 and 97 cwt.) to operate—(a) within a radius of 25 miles from the chief post office in the City of Geelong—general goods, (b) from places situated within a radius of 10 miles of Wallington to City of Melbourne—market garden and orchard produce, but excluding the carriage of potatoes in bags and brown onions.
- JEFFS, I. F., Lawler-street, Yarram; 1 commercial goods vehicle (106 cwt.) to operate—(a) within a radius of 20 miles of the post office at Yarram—general goods, (b) within a radius of 50 miles of the post office at Yarram—petroleum products in prescribed types of containers and empty return containers.
- KEATH, ROBIN, PTY. LTD., Box 128, Horsham; 1 commercial goods vehicle (12 cwt.) to operate throughout the State of Victoria in the course of business as "earth-moving contractors" for the purpose of servicing and maintaining own earth-moving equipment—tools of trade, spare parts and materials incidental to such work.
- LAWES, L. E. J., 59 Stawell-road, Horsham; 1 commercial goods vehicle (100 cwt.) to operate—(a) within a radius of 80 miles of the post office at Dimboola (Horsham division of the Country Roads Board)—plant, the property of a contractor and required for use in connexion with the construction or maintenance of some specific, existing or proposed road, street, footpath, bridge, wharf, pier, weir or channel, (b) within a radius of 20 miles from site of construction or maintenance work performed pursuant to paragraph (a) above, or from the railway station nearest thereto—metal, stones, screenings, ashes, gravel, sand, earth and any other materials required for such work, (c) within a radius of 20 miles of the post office at Horsham—general goods.
- LEAHY, J. J., 82 Fairy-street, Warrnambool; 1 commercial goods vehicle (10 cwt.) to operate throughout the State of Victoria as a mortuary vehicle in the course of business as funeral directors.
- LEECH, E. M., Landseer-street, Castlemaine; 1 commercial goods vehicle (169 cwt.) to operate—(a) within a radius of 95 miles of the post office at Cohuna and/or within a radius of 100 miles of the post office at Merbein (Bendigo division of the Country Roads Board)—plant, the property of a contractor and required for use in connexion with the construction or maintenance of some specific, existing or proposed road, street, footpath, bridge, wharf, pier, weir or channel, (b) within a radius of 20 miles from site of construction or maintenance work performed pursuant to paragraph (a) above, or from the railway station nearest thereto—metal, stones, screenings, ashes, gravel, sand, earth and any other materials required for such work, (c) within a radius of 20 miles of the post office at Castlemaine—general goods.
- MARRICKVILLE MARGARINE PTY. LTD., corner Ballarat-road and Lacey-street, Braybrook; 1 commercial goods vehicle (11 cwt.) to operate in course of business as margarine distributors—(a) throughout the State of Victoria for the purpose of advertising and demonstrating own goods—samples, display and advertising materials, (b) within a radius of 50 miles of Eta Food Pty. Ltd. depots at Ballarat, Bendigo, Wangaratta, Warrnambool, Horsham, Swan Hill, Geelong and Morwell for the purpose of supplying storekeepers with replacement stock—own margarine not exceeding 1½ cwt. in weight and having been initially railed to the particular depot from which the vehicle is operating.
- MOBILE EARTH DRILLING PTY. LTD., 342 King-street, Mascot, New South Wales; 2 commercial goods vehicles (182 and 150 cwt.) to operate within a radius of 50 miles of the post office at Wangaratta in the course of business as "boring contractors"—tools of trade, boring equipment and materials, also to operate for the purpose of towing complete drilling machines incidental to own contracts.
- MOORE ROAD MACHINERY (VIC.) PTY. LTD., Williamstown-road, Port Melbourne; 1 commercial goods vehicle (15 cwt.) to operate throughout the State of Victoria in the course of business as "engineers" for the purpose of repairing and servicing farm and industrial machinery—tools of trade, spare parts and materials incidental to such work.
- MURRAY VALLEY BY-PRODUCTS PTY. LTD., Osboldstone-road, Wangaratta; 1 commercial goods vehicle (46 cwt.) to operate within a radius of 70 miles of own premises at Wangaratta in the course of business as "stockfeed, tallow and fertilizer manufacturers" for the collection of butchers' and abattoirs' waste, dead stock, offal, bones and fat.
- MYERS, B. & G., PTY. LTD., 40 Water-street, Ballarat; 1 commercial goods vehicle (15 cwt.) to operate throughout the State of Victoria in the course of business as "milking machine manufacturers" for the purpose of installing and servicing milking machines—milking machines for installation or repair, rubberware, tools of trade and materials incidental to own contracts.

- McGREGOR, P. E., & SON, Benalla-road, Shepparton; 1 commercial goods vehicle (15 cwt.) to operate throughout the State of Victoria in the course of business as "motor wreckers and second-hand dealers" for the purpose of attending sales and disposal sales, with the ability to carry on return journeys to Shepparton—wrecks or loose disposal parts not exceeding 10 cwt. in any one load.
- MCKENZIE, J. & D., PTY. LTD., 159 Sparks-road, Norlane. Geelong; 1 commercial goods vehicle (409 cwt.) to operate throughout the State of Victoria in the course of business as "excavation contractors"—tools of trade, own earth-moving equipment and a small quantity of materials incidental to the completion of own contracts.
- QUICK PLUMBING PTY. LTD., 635 Waterdale-road, West Heidelberg; 1 commercial goods vehicle (30 cwt.) to operate—(a) within a radius of 50 miles of the G.P.O., Melbourne, in the course of business as "general plumbers"—own goods, (b) throughout the State of Victoria for the purpose of supervising own building contracts—tools of trade, equipment and small quantities of materials incidental to the completion of own contracts.
- PRAZNOVSZKY, D. & J. (trading as Praznovszky Carriers), 798 Warrigal-road, Oakleigh; 1 commercial goods vehicle (approximately 150 cwt.) to operate—(a) within a radius of 25 miles of Melbourne—general goods, (b) from pits at Cranbourne to places within paragraph (a) above—sand.
- RICHARDSON, A. N., 2 Edinburgh-street, South Blackburn; 1 commercial goods vehicle (6 cwt.) to operate throughout the State of Victoria in the course of business as an "electronic engineer" for the purpose of servicing and repairing electronic equipment—tools of trade, spare parts, second-hand electronic equipment for repair or having been repaired and materials incidental thereto.
- SANDHURST BRICK Co. LTD., Broadcasting House, View Point, Bendigo; 2 commercial goods vehicles (124 cwt. each) to operate—(a) within a radius of 25 miles from the chief post office in the City of Bendigo—general goods, (b) within a radius of 70 miles from the chief post office in the City of Bendigo—bricks the property of the applicant in the course of business as "brick manufacturers".
- STERNE, K. A., 488 Toorak-road, Toorak; 1 commercial goods vehicle (8 cwt.) to operate within a radius of 50 miles of the G.P.O., Melbourne, and to and from the Warragul Market in the course of business as a "drapery and knitwear stallholder"—own drapery and knitwear.
- STOREY, R. A., Main Ocean-road, Laver's Hill; application to vary the conditions of existing licence No. D.A.30454 by adding "from Princetown to Colac, via Hordern Vale, Laver's Hill, Beech Forest, Gellibrand and Colac—farm produce and returning from Geelong with superphosphate".
- THIESS BROS. PTY. LTD., New Footscray-road, Footscray; 2 commercial goods vehicles (53 and 52 cwt.) to operate—(a) within a radius of 25 miles of Melbourne in the course of business as "civil engineering and building contractors"—own goods, (b) throughout the State of Victoria—tools of trade and equipment incidental to own contracts, (c) within a radius of 20 miles of any project currently engaged upon or from the nearest railway station thereto—materials for use on such projects and any excavated material and earth.
- THIESS BROS. PTY. LTD., New Footscray-road, Footscray; 6 commercial goods vehicles (17, 7, 7, 3, 17 and 8 cwt.) to operate throughout the State of Victoria in the course of business as "excavation specialists"—tools of trade, spare parts and materials incidental to the servicing and maintenance of own excavation equipment.
- WEBB, FRED, PTY. LTD., 197 Graham-street, Wonthaggi; 1 commercial goods vehicle (10 cwt.) to operate within a radius of 25 miles of Broadford Quarries, Broadford, in the course of business as "quarry masters" for the purpose of servicing and maintaining own bulldozers, quarrying equipment and vehicles—tools of trade, spare parts and materials incidental to such servicing and maintenance work.
- WET MIX & PRECAST CONCRETE PTY. LTD., 53-59 Hoddle-street, Collingwood; 3 commercial goods vehicles (171, 170 and 175 cwt.) to operate within a radius of 20 miles of own branch works at Morwell—pre-mixed concrete.
- routes or in the manner set out opposite their names, will be heard at a time and place to be communicated to the persons concerned:—
- Name and Address; Present Franchise; Licence No.; Date of Expiry.*
- BOYLE, W. C., 24 Dalmahoy-street, Bairnsdale; 1 commercial goods vehicle (125 cwt.) to operate licensee's own goods in the course of his business as "general storekeeper and greengrocer" on the following routes:—(a) Between the Townships of Benambra and Wodonga, via Glen Wills, Mitta Mitta and Tallangatta, (b) between the Townships of Benambra and Bairnsdale, via Omeo; D.A.18185; 7th December, 1961.
- BRIDGES, W. G. & B. (trading as W. G. Bridges and Co.), Havelock-street, Beaufort; 1 commercial goods vehicle (79 cwt.) to operate within a radius of 50 miles of the post office at Beaufort in the course of business as "hardware retailers"—own goods; D.A.31349; 17th December, 1961.
- BROWN MOTORS PTY. LTD., 10 Queen-street, Bendigo; 1 commercial goods vehicle (12 cwt.) to operate throughout the State of Victoria for the demonstration, repair and servicing of tractors and farm implements—tools of trade, spare parts and materials incidental to such work; D.A.31348; 9th December, 1961.
- FROST, W. E., Box 4, Omeo; 1 commercial goods vehicle (107 cwt.) to operate—(a) within a radius of 20 miles from licensee's store at Omeo and to and from Bairnsdale, in the course of business of the licence holder as "general storekeeper"—own goods, (b) from and to Bairnsdale to and from Omeo and places situate within a radius of 20 miles from licensee's store at Omeo—petroleum products in prescribed types of containers and empty containers; D.A.33092; 17th December, 1961.
- FURNAM, J., 44 Stockdale-avenue, East Bentleigh; 1 commercial goods vehicle (25 cwt.) to operate throughout the State of Victoria in the course of business as "hawker"—own clothing. Special condition.—It is also a condition of this licence that any of the goods carried for resale shall not be supplied to retail stores; D.A.10766; 21st December, 1961.
- GARDNER & NAYLOR PTY. LTD., 192 Burwood-road, Hawthorn; 1 commercial goods vehicle (48 cwt.) to operate throughout the State of Victoria in the course of business as "engineers and manufacturers" for the purpose of installation and servicing and heating, ventilating, air conditioning and steam plants—tools of trade, spare parts and materials incidental to such installation and servicing work; D.A.1128/3; 18th December, 1961.
- LAWRENCE, K. S., 21 Goleen-street, North Coburg; 1 commercial goods vehicle (221 cwt.) to operate from collieries situate at Bacchus Marsh to the City of Melbourne—brown coal only; D.A.6361; 12th October, 1961.
- MAYFAIR DISTRIBUTORS PTY. LTD., Box 90, Post Office, Bendigo; 1 commercial goods vehicle (72 cwt.) to operate throughout the State of Victoria as a refrigerated vehicle—pressed and canned meats, bacon, fresh meat, dressed poultry, smoked hams, canned hams and small sterile packs not exceeding 1 ton in weight in any one week, such goods being the property of Intercontinental Packers Pty. Ltd.; D.A.28159/2; 17th December, 1961.
- MURRAY BREWERIES PTY. LTD., Last-street, Beechworth; 2 commercial goods vehicles (100 and 102 cwt.) to operate within a radius of 50 miles from the post office at Beechworth and to and from the Townships of Shelley and Corryong, via Cudgawa, in the course of business as "brewers of aerated waters and cordials and wine and spirit merchants"—aerated waters, cordials, wines and spirits; D.A.1641, D.A.1641/1; 5th December, 1961.
- NICHOLLS, A. R., 54 Swallow-crescent, Norlane, Geelong; 1 commercial goods vehicle (8 cwt.) to operate—(a) within a radius of 25 miles from the chief post office in the City of Geelong, in the course of licensee's business as "fencing contractor"—own goods, (b) throughout the State of Victoria, in the course of licensee's business as "fencing contractor"—tools of trade incidental to own contracts; D.A.31376; 17th December, 1961.
- PEDEN'S PTY. LTD., 128 Henty-street, Casterton; 1 commercial goods vehicle (100 cwt.) to operate within a radius of 50 miles from the post office at Casterton, in the course of business as "builders and timber merchants"—own goods; D.A.3631; 26th October, 1961.
- RODDA PTY. LTD., 65 Beach-street, Port Melbourne; 1 commercial goods vehicle (128 cwt.) to operate—(a) within a radius of 25 miles from the post office situate at the corner of Bourke and Elizabeth streets in the

NOTICE is hereby given that the applications made by the persons named below for renewal of licences to operate the commercial goods vehicles, on the route or



City of Melbourne, in the course of business as "suppliers of industrial earths"—own goods, (b) throughout the State of Victoria—earth-moving and milling equipment and plant for use at sites of excavation in connexion with the carrying out of licensees' own contracts, (c) from any such site of excavation as aforesaid to the nearest and most convenient railway station—mineral earth for consignment by rail to Melbourne, (d) from any such site of excavation as aforesaid on the return journey to Melbourne upon completion of a contract—one pay load of mineral earth, (e) (1) from pits at Gordon to licensees' premises at Port Melbourne—white clay for fillers, (2) from pits at Redesdale to licensees' premises at Port Melbourne—magnesium carbonate, (3) from pits at Lillieur and Moranding to licensees' premises at Port Melbourne—diatomaceous earth; D.A.1942/3; 18th October, 1961.

DONALDSON BROS. & TIPPETT LTD., Creswick-road, Ballarat; 1 commercial goods vehicle (8 cwt.) to operate throughout the State of Victoria for the purpose of servicing and maintaining agricultural machinery and lighting plants—tools of trade, spare parts and materials incidental to such servicing and maintenance work; D.A.1947/4; 5th December, 1961.

SQUIRES, C. T. & M. C., High-street, Avoca; 1 commercial goods vehicle (100 cwt.) to operate—(a) within a radius of 20 miles from the post office at Avoca—general goods, (b) from and to the City of Ballarat, to and from the following places:—(i) the Town of Avoca, (ii) places en route between Ballarat and Avoca via Lexton, including places not more than 5 miles distant from any point along the said route—general goods; provided that no such goods as aforesaid shall be carried for consignment to the railhead at Ballarat and no such goods as aforesaid consigned to the railhead at Ballarat shall be carried from the Ballarat Railway Station to any place situate within a radius of 7 miles from the post office at Avoca; D.A.2089; 18th December, 1961.

THOMPSON, A. J., Kinglake West; 1 commercial goods vehicle (203 cwt.) to operate—(a) from and to Melbourne or Yarra Glen or Whittlesea, to and from places on or reached from the road between Kinglake West and Yea, via Flowerdale—general goods excluding wool, subject to the condition that no goods whatsoever shall be carried to or from any place within a radius of 5 miles from the post office at Yea, (b) from and to Melbourne or Yarra Glen or Whittlesea, to and from places on or reached from the road between Mt. Slide and Yea, via Glenburn—general goods subject to the condition that no goods whatsoever shall be carried to or from any place within a radius of 5 miles from the post office at Yea, (c) from and to places on or reached from the road between Kinglake West and Mt. Slide, to and from Melbourne—general goods, (d) from and to places on or reached from the road between Mt. Slide and Yea, via Glenburn, to and from the railway stations at either Yarra Glen or Whittlesea—wool only provided that no goods whatsoever shall be carried to or from any place within a radius of 5 miles from the post office at Yea, (e) between Kinglake and Melbourne, via Whittlesea and South Morang—general goods; D.A.2150; 18th December, 1961.

WALSH, P. E., 47 Melbourne-road, Ballarat; 1 commercial goods vehicle (260 cwt.) to operate from collieries situate at Bacchus Marsh to the Cities of Melbourne and Ballarat—brown coal only; D.A.2225/2; 21st December, 1961.

WATTS, R. A., 2 Shaw-street, Richmond; 1 commercial goods vehicle (109 cwt.) to operate—(a) from quarries in the Avoca, Castlemaine and Chewton districts to the City of Melbourne—own paving and veneer slate, (b) from the Ballan district to the City of Melbourne—own rock spalls for landscape work; D.A.24012/1; 17th December, 1961.

NOTICE is hereby given that the application made by the person named below for renewal with variation of licence to operate the commercial goods vehicle, on the route or routes, or in the manner set out opposite the name, will be heard at a time and place to be communicated to the person concerned:—

Name and Address; Present Franchise; Variation; Licence No.; Date of Expiry.

LAMSON ENGINEERING CO. LTD., 30-32 Lexton-road, Box Hill; 1 commercial goods vehicle (12 cwt.) to operate—(a) within a radius of 50 miles from the post office, situate at the corner of Bourke and Elizabeth streets in the City of Melbourne, in the course of business as "engineers"—Lamson pneumatic tube

and conveyor belts, dictograph telephone instruments and parts being the property of the holder of this licence, (b) from and to the City of Melbourne, to and from the City of Ballarat—tools of trade and spare parts incidental to the installation and servicing of specialized systems; deleting paragraph (b) and adding in lieu as paragraph (b) "throughout the State of Victoria—tools of trade, equipment and spare parts incidental to the servicing and installation of communication systems"; D.A.1466; 5th December, 1961.

NOTICE is hereby given that the applications made by the persons named below for renewal of temporary licences for a period of twelve months to operate the commercial goods vehicles on the route or routes, or in the manner set out opposite their names, will be heard at a time and place to be communicated to the parties concerned:—

Name and Address; Present Franchise; Licence Number; Date of Expiry.

ACLER, G., Cann River; 1 commercial goods vehicle (352 cwt.) to operate from sawmills in the Cann River area to the railway station and consignees at Orbost—sawn timber; T.T.D.3123; 12th December, 1961.

ADAMS, J., Powelltown; 1 commercial goods vehicle (180 cwt.) to operate for the carriage of logs from Foresta's landing in the Matlock area to Foresta's sawmill at North Fitzroy; T.T.D.1685; 6th December, 1961.

ARMSTRONG, E. M. & R., 13 Mill-street, Heyfield; 1 commercial goods vehicle (261 cwt.) to operate for the carriage of logs from any forest landings in the Licola area to sawmills at Heyfield; T.T.D.518; 20th December, 1961.

BABBINGTON, E. N. & E. C. (trading as Babbington Bros.), Benwerrin, via Lorne; 1 commercial goods vehicle (246 cwt.) to operate for the carriage of logs, sawn timber and own sawmill requisites within a radius of 20 miles of the post office at Benwerrin and to and from Geelong and Colac; T.T.D.2182; 14th December, 1961.

Box, W., Forrest, via Colac; 1 commercial goods vehicle (205 cwt.) to operate for the carriage of—(1) logs from forest landings at Mt. Sabine and Gerangamete to Hancock Bros.' sawmill at Barramunga and Gerangamete, (2) sawn timber from Hancock Bros.' sawmills at Barramunga and Gerangamete to consignees at Geelong, (3) sawn timber from Hamill and Mulgrew sawmills at Barramunga and Hancock Bros.' at Gerangamete to consignees at Colac and the railway station at Birregurra; T.T.D.1888; 9th December, 1961.

BRENDA, J. F., Nicholas-street, Lilydale; 1 commercial goods vehicle (220 cwt.) to operate for the carriage of—(1) logs from any forest landing in the Niagaroon and Upper Yarra forestry district and the North Big River area to the railway station at Healesville and to any mill or dump which is located within the radius of 20 miles of such landings or of the railway station at Healesville or to any mill or timber yard situated within a radius of 25 miles of the G.P.O., Melbourne, (2) sawn timber from sawmills at Marysville to any timber yard or building site within a radius of 25 miles of the G.P.O., Melbourne; T.T.D.1615; 21st December, 1961.

COLLINS, J., & BROS. PTY. LTD., Rodger-street, Yarram; 1 commercial goods vehicle (179 cwt.) to operate for the carriage of—(1) logs from forest landings within a radius of 50 miles of Yarram to own sawmill at Yarram, (2) sawn timber from own sawmill at Yarram to consignees within a radius of 50 miles of Yarram; T.T.D.2098; 1st December, 1961.

CROWE BROS. TRANSPORT PTY. LTD., Buchan; 1 commercial goods vehicle (280 cwt.) to operate for the carriage of sawn timber from Crowe Bros.' sawmill at Buchan to the railway station at Nowa Nowa and to consignees at Bairnsdale; T.T.D.1621; 14th December, 1961.

DE VRIES, W., Lakes Entrance; 1 commercial goods vehicle (approximately 200 cwt.) to operate for the carriage of—(1) from forest landings in the Orbost and Nowa Nowa areas to sawmills at Orbost and Nowa Nowa—logs, (2) from sawmills at Orbost and Nowa Nowa to the railway station at Orbost—sawn timber; T.T.D.3124; 20th December, 1961.

DOWNY, W. D., & CO. PTY. LTD., 79 Lorimer-street, South Melbourne; 1 commercial goods vehicle (357 cwt.) to operate for the carriage of—(1) logs from forest landings within a radius of 50 miles of Dargo to sawmills at Dargo, (2) sawn timber from sawmills at Dargo to the railhead at Fernbank or Stratford and to consignees at Stratford and Sale; T.T.D.3102; 12th December, 1961.

- DUNNING, G. & D., PTY. LTD., Forest-road, Orbost; 3 commercial goods vehicles (264, 238 and 225 cwt.) to operate for the carriage of—(1) sawn timber from Errimundra Timber Co.'s mills at Club Terrace to the Orbost railway station, (2) general goods within a radius of 20 miles from the post office at Orbost; T.T.D.1889, T.T.D.1890, T.T.D.1891; 9th December, 1961.
- EVANS, C., Club Terrace; 1 commercial goods vehicle (335 cwt.) to operate for the carriage of—(1) from forest landings in the Lind Park area to sawmills at Club Terrace—logs, (2) from timber yards at Club Terrace to the railway station at Orbost—sawn timber; T.T.D.3114; 20th December, 1961.
- HAMPSHIRE, E. & C., Bros., Winchelsea; 1 commercial goods vehicle (263 cwt.) to operate for the carriage of—(1) logs from forest landings in the Benwerrin and Deans Marsh areas to own sawmill at Deans Marsh, (2) sawn timber from own sawmill at Deans Marsh to consignees at Colac and Geelong; T.T.D.2100; 1st December, 1961.
- HARRIS, W., Yarra Junction; 1 commercial goods vehicle (133 cwt.) to operate for the carriage of sawn timber from Parkinson Bros. and Piper's sawmill at Hazeldene to building sites in the metropolitan area; T.T.D.2107; 15th December, 1961.
- HILDER, J., Main-road, Gembrook; 1 commercial goods vehicle (approximately 120 cwt.) to operate for the carriage of—(1) battens, fencing rails, palings and scantlings from J. D. Pearse, Hilder and Sons, Goodie and Atkinson, F. Fielder and A. Briely sawmills at Gembrook to consignees in the metropolitan area, (2) sawn timber and palings from W. D. Hilder and Sons sawmill at Fumina South to J. W. Hilder and Sons yards at Gembrook; T.T.D.1812; 17th December, 1961.
- KEITH, G., 12 Tambo-avenue, Reservoir; 1 commercial goods vehicle (135 cwt.) to operate for the carriage of—(1) loose palings battens (3 ft. to 9 ft. long, 2 in. to 4 in. wide,  $\frac{1}{2}$  in. to 1 in. thick) from Jackson's sawmill at Yea to A.P.M. yards at Fairfield, (2) loose palings battens (3 ft. to 9 ft. long, 2 in. to 4 in. wide,  $\frac{1}{2}$  in. to 1 in. thick) from Murrindindi sawmills at Murrindindi to the A.P.M. yards at Broadford and Fairfield, (3) general goods within a radius of 20 miles of the G.P.O., Melbourne; T.T.D.1896; 17th December, 1961.
- LEWANDOWSKI, E., care of St. Clair Timber Co., Heyfield; 1 commercial goods vehicle (242 cwt.) to operate for the carriage of logs from forest landings in Licola area to sawmills at Heyfield; T.T.D.3122; 20th December, 1961.
- MAHER, J., 12 Jamieson-street, Daylesford; 1 commercial goods vehicle (109 cwt.) to operate for the carriage of sawn timber from own sawmill at Spargo Creek to building sites or timber yards at Geelong; T.T.D.1680; 6th December, 1961.
- MATTHEWS, J., 85 Mt. Dandenong-road, East Ringwood; 1 commercial goods vehicle (249 cwt.) to operate for the carriage of sawn timber from Charles Bros.' sawmill at Woods Point, via Warburton or Eildon Weir, to dry kiln seasoning company's timber yards at Port Melbourne; T.T.D.1611; 21st December, 1961.
- MCCONACHY, L., Three Bridges; 1 commercial goods vehicle (204 cwt.) to operate for the carriage of sawn timber from McConachy's sawmill at Three Bridges to consignees in the metropolitan area; T.T.D.2101; 1st December, 1961.
- MORMILL SAWMILLING CO. PTY. LTD., Marysville-road, Buxton; 1 commercial goods vehicle (261 cwt.) to operate for the carriage of—(1) from own forest landings in the Narbethong, Buxton and Taggerty areas to own mill at Buxton—logs, (2) from own mill at Buxton to consignees within a radius of 20 miles of Buxton and to the railway station at Healesville—sawn timber, (3) from own mill at Buxton to timber yards and direct on to building sites within a radius of 25 miles of Melbourne—sawn timber; T.T.D.555; 14th December, 1961.
- MURATORE, G., Main-road, Gilderoy; 2 commercial goods vehicles (102 and 258 cwt.) to operate for the carriage of—(1) within a radius of 50 miles of own premises at Poweltown in the course of business as "primary producer"—own goods, (2) from own sawmill at Poweltown to consignees at Bayswater, Box Hill and Melbourne—own sawn timber; T.T.D.3103, T.T.D.3104; 5th December, 1961.
- MURRAY VALLEY SAWMILLS PTY. LTD., Blake-street, Nathalia; 1 commercial goods vehicle (108 cwt.) to operate for the carriage of—(1) sawn timber from own sawmills at Nathalia or Licola to consignees within a radius of 50 miles of each mill, (2) sawn timber from sawmills at Mansfield to consignees within a radius of 20 miles of Mansfield; T.T.D.3009; 21st December, 1961.
- POLDME, J., care of St. Clair Timber Co., Heyfield; 1 commercial goods vehicle (259 cwt.) to operate for the carriage of logs from forest landings in the Licola area to sawmills at Heyfield; T.T.D.3121; 20th December, 1961.
- REDENBACH, W. & M., 2 Stavely-street, Bairnsdale; 1 commercial goods vehicle (270 cwt.) to operate for the carriage of—(1) logs from forest landings within a radius of 50 miles from the post office at Cann River to sawmills at Cann River, (2) sawn timber from sawmills at Cann River to the railway station and consignees at Orbost; T.T.D.2103; 15th December, 1961.
- SAXTON TIMBER & TRADING CO. PTY. LTD., 26 Albert-street, Moe; 1 commercial goods vehicle (288 cwt.) to operate for the carriage of—(1) sawn timber from the Saxton Timber and Trading Co.'s sawmill at Licola to Saxton Timber and Trading Co.'s timber yards at Moe, (2) sawmilling equipment from Saxton Timber and Trading Co.'s timber yards at Moe to Saxton Timber and Trading Co.'s sawmill at Licola, (3) building materials from Saxton Timber and Trading Co.'s timber yards at Moe to consignees at Traralgon and to consignees en route to Licola, (4) precut timber from Saxton Timber and Trading Co.'s timber yards at Moe to Saxton Timber and Trading Co.'s employee's housing project at Licola, (5) transport of sawmilling equipment from company's sawmill at Licola to company engineering shop at Moe, (6) transport of equipment and timber between the company's mill at Licola and Moe and the company's pine plantations at Longford and Moondarra (Victoria); T.T.D.1629; 14th December, 1961.
- SHARPE, J., & SONS PTY. LTD., 37 Lorimer-street, South Melbourne; 1 commercial goods vehicle (154 cwt.) to operate for the carriage of—(1) within a radius of 25 miles of Melbourne in the course of business as "timber and hardware merchants"—own goods, (2) from private properties within a radius of 50 miles of Melbourne to own mill at South Melbourne—pine logs; T.T.D.3098; 5th December, 1961.
- STILES, R., 14 Windsor-avenue, Moe; 1 commercial goods vehicle (247 cwt.) to operate for the carriage of logs from forest landings in the Licola area to sawmills at Heyfield; T.T.D.3113; 12th December, 1961.

Notice of any objection should be forwarded to reach the Secretary of the Board not later than 11th October, 1961.

B. P. KAY,  
Secretary.

Exhibition Building, Rathdown-street, Carlton, N.3.  
27th September, 1961.

#### DIMBOOLA SEWERAGE AUTHORITY.

##### BY-LAW No. 3.

THE Dimboola Sewerage Authority, in pursuance and exercise of the powers conferred by the *Sewerage Districts Act 1958*, and the *Sewerage Districts (Amendment) Act 1960*, doth hereby make the By-law following for its Sewerage District.

##### Minimum Sewerage Rate.

1. The minimum amount of rate to be paid annually by the owner or occupier of any rateable sewered property on which there is a building or by the owner or occupier of any rateable sewered property on which there is no building shall be Seven pounds ten shillings and Three pounds respectively.

2. The minimum amount of rate as set out in clause 1 hereof shall take effect on the 1st day of October, 1961.

The foregoing By-law was made and passed by the Dimboola Sewerage Authority on the 7th day of August, 1961, and confirmed on the 4th day of September, 1961.

In witness whereof the common seal of the Dimboola Sewerage Authority was hereto affixed on the 4th day of September, 1961.

The common seal of the Dimboola Sewerage Authority was hereunto affixed, in the presence of—

(SEAL) BENJAMIN C. WARD, Chairman.  
L. W. A. POLACK, Commissioner.  
T. MICHIE, Secretary.

Approved by the Governor in Council, 18th September, 1961.—N. G. WISHART, Acting Clerk of the Executive Council.

## LOUGH CALVERT DRAINAGE TRUST.

RATING BY-LAW 1961.

**T**HE Lough Calvert Drainage Trust, in pursuance and exercise of the powers conferred by the *River Improvement Act 1948*, doth hereby make the By-law following:—

1. The following rate to be called the Lough Calvert Drainage District Drainage Rate is hereby made and shall be levied upon the occupiers or owners of all properties in the Lough Calvert Drainage District which are rateable to any municipality:—

- (a) A rate of Eleven pence in the pound on the net annual municipal value of all properties in the First Division of the Lough Calvert Drainage District shown coloured green on the plan titled "Lough Calvert Drainage District Rating Divisions 1958", approved by the Governor in Council and deposited at the office of the State Rivers and Water Supply Commission at Melbourne.
- (b) A rate of Ten pence in the pound on the net annual municipal value of all properties in the Second Division of the Lough Calvert Drainage District shown coloured brown on the said plan.
- (c) A rate of Nine pence in the pound on the net annual municipal value of all properties in the Third Division of the Lough Calvert Drainage District shown coloured yellow on the said plan.
- (d) A rate of Five pence half-penny in the pound on the net annual municipal value of all properties in the Fourth Division of the Lough Calvert Drainage District shown coloured grey on the said plan.
- (e) A rate of Four pence in the pound on the net annual municipal value of all properties in the Fifth Division of the Lough Calvert Drainage District shown coloured violet on the said plan.
- (f) A rate of Two pence in the pound on the net annual municipal value of all properties in the Sixth Division of the Lough Calvert Drainage District shown coloured pink on the said plan.
- (g) No rate is made or levied in respect of any property within the Seventh Division of the Lough Calvert Drainage District comprising all those lands not included in the First, Second, Third, Fourth, Fifth or Sixth Divisions.

Provided that in no case shall the amount of rate payable in respect of any rateable property within the Lough Calvert Drainage District be less than One shilling.

2. Such rate is made and shall be levied for the period beginning with the 1st day of January, 1961, and ending on the 31st day of December, 1961, and shall be payable on the 2nd day of October, 1961, at the office of the Lough Calvert Drainage Trust, at Colac.

3. Such person or persons as the Lough Calvert Drainage Trust may from time to time appoint for that purpose shall be and is or are hereby authorized to demand, receive, collect and recover the said rate.

The foregoing By-law was made by the Lough Calvert Drainage Trust on the 14th day of August, 1961, and the seal of the said Trust was hereby affixed this 14th day of August, 1961, in the presence of—

T. A. BARNARD, Chairman.  
 (SEAL) ARTHUR F. POTTER, Commissioner.  
 A. C. THEODORE, Secretary.

Approved by the Governor in Council,  
 26th September, 1961.

N. G. WISHART,  
 Acting Clerk of the Executive Council.

## LOCAL GOVERNMENT DEPARTMENT.

## SHIRE OF ALTONA.—ORDER CONFIRMED.

**T**HE Minister of the Crown administering the *Local Government Act 1958*, as amended, on the 15th day of September, 1961, confirmed the Order hereinafter referred to, in pursuance of section 514 of the said Act, namely:—

An Order of the Council of the Shire of Altona made on the 8th August, 1961, for the purpose of providing land for the Housing Commission of Victoria for the erection of low-rental housing units and for acquiring for that purpose all that piece of land being lot 100 on lodged plan of subdivision No. 7931, and being the balance of the land in certificate of title, volume 4115, folio 985.

MURRAY PORTER,  
 Minister for Local Government.

## LOCAL GOVERNMENT DEPARTMENT.

## SHIRE OF MORNINGTON.—ORDER CONFIRMED.

**T**HE Minister of the Crown administering the *Local Government Act 1958*, as amended, on the 12th day of September, 1961, confirmed the Order hereinafter referred to, in pursuance of section 514 of the said Act, namely:—

An Order of the Council of the Shire of Mornington made on the 11th August, 1961, for the purpose of providing municipal storeyards and for acquiring for that purpose all that piece of land being part of Crown allotment 9 of section 22, Parish of Moorooduc, commencing at a point on the north-eastern boundary of Gordon-street distant 287 feet from the north corner of the intersection of Gordon-street and Barkly-street; thence north along the said boundary for 50 feet; thence bearing 232 deg. 2 min. for 175 ft. 10 in. to the south-west boundary of a drainage reserve; thence south-east along that boundary for 50 feet; thence bearing 52 deg. 0 min. for 174 ft. 8 in. to the commencing point.

MURRAY PORTER,  
 Minister for Local Government.

## Country Roads Acts.

## COUNTRY ROADS BOARD.

## NOTICE OF FIXING NEW ALIGNMENTS OF THE HUME HIGHWAY IN THE CITY OF WANGARATTA.

**N**OTICE is hereby given that the Country Roads Board, under the powers conferred upon it by the *Country Roads Act 1958* (No. 6229), has fixed an alignment for each side of a new State highway (under the nomenclature "Hume Highway") in the City of Wangaratta, as described hereunder, that is to say:—

- (a) Commencing at the south-eastern angle of allotment 3, section 66, Township of Wangaratta, Parish of Wangaratta North; thence by lines bearing respectively 17 deg. 0 min. 462 feet, 287 deg. 0 min. 19 ft. 5½ in. and 7 deg. 27½ min. 1,635 ft. 0½ in. to a point on the eastern boundary of allotment 16A, section 11, of the said parish distant 344 deg. 55 min. 154 ft. 10 in. from the south-eastern angle of the allotment last named;
- (b) Commencing at a point on the southern boundary of allotment 3, section 66, Township of Wangaratta, Parish of Wangaratta North, distant 287 deg. 0 min. 115 feet from the south-eastern angle of the said allotment; thence by lines bearing respectively 57 deg. 14 min. 19 ft. 4½ in., 7 deg. 27½ min. 371 ft. 6½ in., 327 deg. 14 min. 22 ft. 10½ in., 107 deg. 0 min. 15 feet, 7 deg. 27½ min. 1,785 ft. 2½ in. and 13 deg. 7 min. 220 feet to a point in allotment 16A, section 11, of the said parish distant 344 deg. 55 min. 505 ft. 8½ in. from the south-eastern angle of the allotment last named—

which said new alignments are shown on survey plan numbered 8083, lodged in the office of the Country Roads Board.

Copies of the said survey plan are lodged in the offices of the Country Roads Board, the municipality of the City of Wangaratta, the Registrar of Titles and the Registrar-General, respectively, and may be inspected by any person, without a fee, at any time at which such offices are open for business.

Dated the nineteenth day of September, 1961.

R. E. V. DONALDSON,  
 Secretary.

Country Roads Board, 60 Denmark-street, Kew, E.4.

## STATE FORESTS DEPARTMENT.

## APPOINTMENT OF COMMITTEE OF MANAGEMENT OF "JERUSALEM CREEK CAMPING AREA".

**W**HEREAS by section 50 of the *Forests Act 1958* (No. 6254) it is provided that the Minister of Forests may, on the recommendation of the Forests Commission, appoint any number of persons, not less than three, to be a Committee of Management of any land forming part of any reserved forest, such land being a place of natural beauty or interest or a health resort, and may remove any of such persons: Now, therefore, I, Lindsay Hamilton Simpson Thompson, Her Majesty's Minister of Forests in the State of Victoria, on the recommendation of the Forests Commission, do hereby appoint—

RONALD GEORGE STEVENSON

in lieu of R. O. Boese as a Member of the Committee of Management until the 5th November, 1963, of the land forming part of the Reserved Forest in the Parish of

Thornton, County of Anglesey, described in the accompanying Schedule, and known as Jerusalem Creek Camping Area, such being a place of natural beauty and interest.

## SCHEDULE ABOVE REFERRED TO.

Parish of Thornton, County of Anglesey, 52 acres, more or less, being the area shown by pink colour on plan marked A.57/526 over 28.10.60 in file of correspondence No. 57/526 of the Forests Department.

Dated at Melbourne, the twenty-fifth day of September, 1961.

L. H. S. THOMPSON,  
Minister of Forests.

## LAW DEPARTMENT.

SITTINGS OF SUPREME COURT, BENDIGO—  
REVOCATION.

HIS Excellency the Governor of the State of Victoria, by and with the advice of the Executive Council thereof, doth by Order made on the 18th September, 1961, revoke the appointment of a day for the Sittings of the Supreme Court at Bendigo, on Monday, the 25th September, 1961.

N. G. WISHART,  
Acting Clerk of the Executive Council.

At Government House,  
Melbourne, 18th September, 1961.

## STAMPS ACT.

IN pursuance of the powers contained in the Stamps Act, I hereby certify that, until further notice, Victorian Oil No Liability is a company engaged solely or principally in the search or mining for petroleum.

Dated the 27th day of September, 1961.

D. G. RICHARDS,  
Comptroller of Stamps.

## DEPARTMENT OF MINES.

SUBJECT to any necessary excisions, etc., it is proposed to grant the following mining lease:—

7950, Mineral; Douglas James Wade; 9a. 2r. 20p., Parish of Tarrawarra North.

APPLICATION FOR LEASE DECLARED  
ABANDONED.

2822, Ararat; Norman Albert Bucknall, deceased; 143 acres, Parish of Moyston.

CONSENT GRANTED TO TRANSFER MINING LEASES  
AND WATER RIGHT LICENCES.

9143, Castlemaine; from Ernest Godfrey Derrick to Duncan Robert McLean and Keith Milner Chugg.  
8319, Beechworth; from Alec William Kohn to the estate of Anthony Collins, deceased, and from the estate of Anthony Collins, deceased, to Ray Draper.  
7372, Mineral; from Alfred Edward Argent to Leonard Edward Warner.  
1200, Water Right Licence; from Henry Lewis Rigbye and Kenneth Wright to Kenneth Wright.  
1230, Water Right Licence; from Henry Lewis Rigbye and Kenneth Wright to Kenneth Wright.

## TAILINGS LICENCES GRANTED.

3127, Tailings Licence; the President, Councillors and Ratepayers of the Shire of Ballan; at Egerton (in lieu of Tailings Licence No. 2869, expired).  
3128, Tailings Licence; the President, Councillors and Ratepayers of the Shire of Avoca; at Homebush (in lieu of Tailings Licence No. 2877, expired).  
3129, Tailings Licence; John Doyle and Robert Leo Doyle; at Eaglehawk (in lieu of Tailings Licence No. 3046, expired).  
3130, Tailings Licence; John Doyle and Robert Leo Doyle; at California Gully (in lieu of Tailings Licence No. 3047, expired).  
3131, Tailings Licence; John Doyle and Robert Leo Doyle; at Bendigo (in lieu of Tailings Licence No. 3048, expired).  
3132, Tailings Licence; John Doyle and Robert Leo Doyle; at Bendigo (in lieu of Tailings Licence No. 3049, expired).  
3133, Tailings Licence; John A. Bain; Parish of Lilliput (in lieu of Tailings Licence No. 3040, expired).  
3134, Tailings Licence; John Doyle and Robert Leo Doyle; at Huntly (in lieu of Tailings Licence No. 3045, expired).

## MINERAL SEARCH LICENCES GRANTED.

335, Mineral Search Licence; J. Parkinson, M. Parkinson and C. Parkinson; 50 acres, Parish of Brimbonga.  
336, Mineral Search Licence; J. Parkinson, M. Parkinson and C. Parkinson; 50 acres, Parish of Brimbonga.

## MINING LEASE EXPIRED.

8971, Castlemaine; George Heywood and Francis Grant Sturgess; 31a. 3r. 2p., Parish of Maldon.

TERM OF PETROLEUM PROSPECTING LICENCES  
EXTENDED.

196, Petroleum Prospecting Licence; Oilco Limited; 191 square miles, Parishes of Maffra, Stratford, Woundallah, Denison, Winnindoo, Tinamba, Toongabbie North, Glenmaggie, Coongulla, Wa-de-lock and Bundalaguah.  
197, Petroleum Prospecting Licence; Oilco Limited; 195 square miles, Parishes of Coongulla, Wa-de-lock, Briagalong, Bow-Worrung, Narrang, Glenaladale, Koorool, Marlooh, Nindoo and Stratford.  
201, Petroleum Prospecting Licence; Oilco Limited; 96 square miles, Parishes of Tong Bong, Loy Yang, Callignee, Bulga, Carrajung, Boodyarn, Wonwron and Mullungdung.

W. J. MIBUS,  
Minister of Mines.

## STATE RIVERS AND WATER SUPPLY COMMISSION.

BY-LAW No. 5358.

*Interest on Unpaid Rates.*

THE State Rivers and Water Supply Commission, in pursuance and exercise of the powers conferred by the Water Acts, doth hereby make the By-law following:—

All general rates levied by the Commission in the year commencing 1st July, 1961, in respect of the Bacchus Marsh, Campaspe, Goulburn-Murray, Macalister, Merbein, Nyah, Redcliffs, Robinvale, Tresco and Werribee Irrigation Districts shall bear interest at the rate of 6 per centum per annum from the date when such rates become payable until the said rates are paid, but interest shall not be payable in respect of any such rates if such rates are paid within six months after they have become payable.

The foregoing By-law was made by the State Rivers and Water Supply Commission on the 18th day of September, 1961, and the common seal of the said Commission was hereunto affixed the 22nd day of September, 1961, in the presence of—

(SEAL) L. R. EAST, Commissioner.  
A. L. TISDALL, Commissioner.

Approved by the Governor in Council, 26th September, 1961.—N. G. WISHART, Acting Clerk of the Executive Council.

## Water Acts.

STATE RIVERS AND WATER SUPPLY COMMISSION.  
DROMANA—PORTSEA URBAN DISTRICT.

NOTICE to owners of tenements in the under-mentioned streets in the Dromana-Portsea Urban District, and the private streets, lanes, courts and alleys opening thereto:—

*Rosebud.*

Brendel-street, from end of existing main opposite lot 195 to Ella-crescent.  
Ella-crescent, from Rae-street to Brendel-street.  
Eastbourne-road, from end of existing main opposite lot 147 to a point opposite lot 161, about 5½ chains easterly.

Ronlyn-street, from end of existing main opposite lot 28 to Ella-crescent.  
Whyte-street, from end of existing main opposite lot 144 to a point opposite lot 160, about 6½ chains easterly.

*McCrae.*

Coburn-avenue, from Wonga-grove to Cornell-street.  
Ford-lane.  
Howitt-street, from Burton-street to Ford-lane, and south-west from Ford-lane to a point opposite lot 94, about 3 chains south-westerly.  
Wonga-grove, from The Eyrie to Coburn-avenue.

The main pipe in the said streets being laid down, the owners of all tenements situated as above are hereby required, on or before the 31st day of October next, to cause proper pipes and stop cocks to be laid, so as to supply water within such tenements from the main pipe.

E. BROWN, Secretary.  
State Rivers and Water Supply Commission.  
Melbourne, 22nd September, 1961.

Country Fire Authority Act.  
 PERMISSION TO HOLD FIRE BRIGADE  
 DEMONSTRATION.

IN pursuance with the provisions of section 103 of the *Country Fire Authority Act 1958*, the Country Fire Authority has granted permission for the holding of a fire brigade demonstration as under:—

URBAN FIRE BRIGADES.

At Korumburra, on Saturday, 25th November, 1961.

J. L. ALLEN,  
 Secretary.

21st September, 1961.

Country Fire Authority Act.  
 PERMISSION TO HOLD FIRE BRIGADE  
 DEMONSTRATION.

IN pursuance with the provisions of section 103 of the *Country Fire Authority Act 1958*, the Country Fire Authority has granted permission for the holding of a fire brigade demonstration as under:—

URBAN FIRE BRIGADES.

At Portland, on Saturday, 2nd December, 1961.

J. L. ALLEN,  
 Secretary.

20th September, 1961.

Country Fire Authority Act.  
 PERMISSION TO HOLD FIRE BRIGADE  
 DEMONSTRATION.

IN pursuance with the provisions of section 103 of the *Country Fire Authority Act 1958*, the Country Fire Authority has granted permission for the holding of a fire brigade demonstration as under:—

RURAL FIRE BRIGADES.

At Keysborough, on Saturday, 31st March, 1962.

J. L. ALLEN,  
 Secretary.

20th September, 1961.

Dairy Products Acts.  
 QUOTAS FOR BUTTER AND CHEESE.  
 BUTTER QUOTA.

I, GILBERT LAWRENCE CHANDLER, Minister of Agriculture in the State of Victoria, after consultation with the Victorian Dairy Products Board, and after ascertaining that the supply and distribution of butter at reasonable prices to consumers thereof in Victoria will be ensured, hereby determine a quota for butter as follows:—

The proportion shall be forty-two point nought five per cent.

The period for which this quota is to operate shall be the month of October, 1961.

CHEESE QUOTA.

I, GILBERT LAWRENCE CHANDLER, Minister of Agriculture in the State of Victoria, after consultation with the Victorian Dairy Products Board, and after ascertaining that the supply and distribution of cheese at reasonable prices to consumers thereof in Victoria will be ensured, hereby determine a quota for cheese as follows:—

The proportion shall be thirty point three per cent.

The period for which this quota is to operate shall be the month of October, 1961.

G. L. CHANDLER,  
 Minister of Agriculture.

25th September, 1961.

*Electric Light and Power Act 1958.*

ORDER GRANTED BY THE GOVERNOR IN COUNCIL.

IT is hereby notified that an Order, pursuant to the provisions of the *Electric, Light and Power Act 1958* (No. 6241), as hereunder mentioned, has been granted by His Excellency the Governor in Council, viz.:—

Order No. 323.—Order under section 10 of the above-mentioned Act granted to the City of Ararat in respect of a defined area in the Shire of Ararat.

G. O. REID,  
 Minister of Electrical Undertakings.

State Electricity Commission of Victoria,  
 26th September, 1961.

LAW DEPARTMENT.  
 APPOINTMENT REVOKED.

HIS Excellency the Governor of the State of Victoria, by and with the advice of the Executive Council thereof, doth by Order made on the 18th September, 1961, revoke the appointment of Ferdinando Joseph Vignano as a Commissioner for taking declarations and affidavits pursuant to the provisions of the *Evidence Act 1958*.

N. G. WISHART,  
 Acting Clerk of the Executive Council.

At Government House,  
 Melbourne, 18th September, 1961.

APPOINTMENTS.

HIS Excellency the Governor of the State of Victoria, by and with the advice of the Executive Council thereof, has, by Orders made on the 18th day of September, 1961, been pleased to make the under-mentioned appointments, viz.:—

CHIEF SECRETARY'S DEPARTMENT.

*Officer in Charge of Prison.*

JAMES HENRY FELLOWS,  
 pursuant to the provisions of the *Goals Act 1958*, to be Officer in Charge of Her Majesty's Prison Camp, Coorremungle, as from and inclusive of the 14th September, 1961, *vice* John Eddy Dihm, transferred.

*Member of Street Traders Licences Board.*

JOHN WILLIAM ROBINSON (an officer of the Education Department),  
 pursuant to the provisions of section 5 of the *Street Trading Act 1958*, to be a member of the Street Traders Licences Board, for a period of two years, *vice* William Richard Stevenson, retired.

DEPARTMENT OF HEALTH.

*Trustees of Cemeteries.*

EDWIN ALBERT CHAPPEL  
 to be a Trustee, Pannoobamawm Public Cemetery, *vice* O. Chappel (deceased);

ROBERT ERNEST AIRD  
 to be a Trustee, Pannoobamawm Public Cemetery, *vice* F. R. Lowrie (deceased);

GRAHAM BUCHANAN SINCLAIR, and  
 VICTOR FREDERICK DRUCE  
 to be Trustees, Pannoobamawm Public Cemetery, as additional trustees;

HENRY CATIONS  
 to be a Trustee, Teesdale Public Cemetery, *vice* J. A. Cations (deceased); and

BARRY GEORGE ROWE  
 to be a Trustee, Sandon Public Cemetery, *vice* J. Rowe (deceased).

*Public Vaccinator.*

ARNOLD FREDERICK COOPER, M.B., B.S.,  
 to be Public Vaccinator for the municipality of Port Melbourne.

LAW DEPARTMENT.

*Justices of the Peace.*

JOHN FRANKLIN BARNES, Kathryn-road, Scoresby,  
 LEON MENDEL SHEEZEL, 185 Bourke-street, Melbourne,  
 ARTHUR NOEL GRIBBIN, 4 Brettonneux-square, East

Malvern,  
 KEITH NORMAN GEORGE RIAL, 77 Fitzroy-street, St.

Kilda, and  
 BASIL WALTER ROY TUTTON, 24 Adeney-avenue, East Kew,  
 to Keep the Peace in the Central Bailiwick of the State of Victoria.

*Commissioner for Taking Declarations, &c.*

CHARLES DOUGLAS POWELL, 31 McGrath-street, Castlemaine,  
 to be a Commissioner for taking Declarations and Affidavits, pursuant to the provisions of the *Evidence Act 1958*, to resign upon removing from the neighbourhood of the address stated.

*Special Magistrate of the Children's Court.*

BARBARA, THE BARONESS WOOTTON OF ABINGER,  
 to be a Special Magistrate, pursuant to section 5 of the *Children's Court Act 1958*, for the Petty Sessions District

of Melbourne (that is to say)—That continuous area made up of all places therein whereat any matter justiciable by a Court of Petty Sessions arising, the Court of Petty Sessions duly appointed to be held at Melbourne aforesaid and there sitting would, were an information or complaint founded on such matter laid or made, be the proper Court to deal therewith by reason of such Court being holden at the place most easy of access from the place where the subject-matter arose.

*Clerk of the Children's Court, &c.*

BRYAN JOHN COSGRIFF  
to be Clerk of the Children's Court at Mordialloc and Clerk of Petty Sessions at Cheltenham, Chelsea and Mordialloc, during the absence of K. G. Pummeroy on annual leave, to take effect from the date of commencement of duty.

*Clerk of Petty Sessions, &c.*

WILLIAM DESMOND MARTIN  
to be Clerk of Petty Sessions and Clerk of the Children's Court at Eltham, *vice* P. J. Rodda, relieved, to take effect from the date of commencement of duty.

N. G. WISHART,  
Acting Clerk of the Executive Council.

At Government House,  
Melbourne, 18th September, 1961.

RESIGNATIONS.

HIS Excellency the Governor of the State of Victoria, by and with the advice of the Executive Council thereof, has, by Orders made on the 18th day of September, 1961, accepted the resignations of the persons named hereunder of the offices mentioned, viz.:—

LAW DEPARTMENT.

GORDON FORBES LATIMER, from the Commission of the Peace for the Western Bailiwick of the State of Victoria.

NORMAN REID, from the Commission of the Peace for the Central Bailiwick of the State of Victoria.

HAROLD ROBERT POULSEN, as a Commissioner for taking Declarations and Affidavits, pursuant to the provisions of the *Evidence Act 1958*.

RAYMOND THOMAS EDWARD HATTON, as a Commissioner for taking Declarations and Affidavits, pursuant to the provisions of the *Evidence Act 1958*.

JAMES HARVEY JAMIESON, as a Commissioner for taking Declarations and Affidavits, pursuant to the provisions of the *Evidence Act 1958*.

N. G. WISHART,  
Acting Clerk of the Executive Council.

At Government House,  
Melbourne, 18th September, 1961.

SITTINGS OF THE SUPREME COURT FOR THE HEARING OF CRIMINAL TRIALS AND FOR THE TRIAL OF CAUSES ELSEWHERE THAN IN MELBOURNE FOR THE YEAR 1962.

*At Government House, Melbourne, the twelfth day of September, 1961.*

PRESENT:

His Excellency the Governor of Victoria.

Mr. Petty  
Mr. Reid

Mr. Turnbull.

WHEREAS by the *Supreme Court Act 1958*, the Sittings of the Supreme Court for the hearing of Criminal Trials and also for the Trial of Causes elsewhere than in Melbourne are to be held on such days as the Governor in Council shall from time to time appoint: Now therefore His Excellency the Governor of the State of Victoria, by and with the advice and consent of the Executive Council thereof, doth by this present Order appoint that the Sittings of the said Supreme Court for the hearing of Criminal Trials and also for the Trial of Causes elsewhere than in Melbourne, shall during the year 1962, be held at the places hereinafter mentioned in that behalf on the days and dates indicated in connexion therewith in the Schedule following, that is to say:—

SCHEDULE.

Places.	Days and Dates, 1962.										
	February.	March.	April.	May.	June.	July.	August.	September.	October.	November.	December.
BALLARAT .. ..	..	Mon. 5 to Fri. 23	..	..	Mon. 4 to Fri. 22	..	..	Mon. 3 to Fri. 21	..	..	Mon. 3
BENDIGO .. ..	..	Mon. 26	..	..	Mon. 25	..	Mon. 27	..	Mon. 22	..	Mon. 10
GEELONG .. ..	Mon. 5	..	..	Mon. 30 April	..	..	Wed. 1	..	..	Wed. 7	..
HAMILTON .. ..	..	Tue. 6	..	..	..	..	..	Tue. 25	..	..	..
HORSHAM .. ..	..	..	Tue. 3	..	..	..	..	..	Tue. 9	..	..
MILDURA .. ..	..	..	..	Mon. 21	..	..	..	..	Mon. 1	..	..
SALE .. ..	..	Tue. 13	..	..	..	..	Tue. 7	..	..	..	..
SHEPPARTON .. ..	..	Tue. 20	..	..	..	..	Tue. 14	..	..	..	Tue. 4
WANGARATTA .. ..	..	..	Tue. 10	..	..	..	Tue. 21	..	..	..	..
WARRNAMBOOL .. ..	..	Tue. 27	..	..	..	Tue. 17	..	..	Tue. 16	..	..
CRIMINAL COURT ..	Mon. 12	Wed. 14	Wed. 11	Mon. 14	Wed. 13	Mon. 16	Mon. 13	Wed. 12	Mon. 15	Mon. 12	Mon. 10

And the Honorable Edward Raymond Meagher for and on behalf of Her Majesty's Attorney-General for the State of Victoria, shall give the necessary directions herein accordingly.

N. G. WISHART,  
Acting Clerk of the Executive Council.

DEPARTMENT OF CROWN LANDS AND SURVEY.

DEPARTMENT OF CROWN LANDS AND SURVEY.

At Government House, Melbourne, the eighteenth day of September, 1961.

At Government House, Melbourne, the eighteenth day of September, 1961.

PRESENT:

His Excellency the Governor of Victoria.

Mr. Bolte	Mr. Rylah
Mr. Mibus	Mr. Petty
Mr. Turnbull	Mr. Reid
Mr. Porter	Mr. Fraser
Mr. Thompson	Mr. Mack.
Mr. Meagher	

PRESENT:

His Excellency the Governor of Victoria.

Mr. Bolte	Mr. Rylah
Mr. Mibus	Mr. Petty
Mr. Turnbull	Mr. Reid
Mr. Porter	Mr. Fraser
Mr. Thompson	Mr. Mack.
Mr. Meagher	

UNUSED ROADS CLOSED.

HIS Excellency the Governor of the State of Victoria, by and with the advice of the Executive Council thereof, doth hereby direct that, in pursuance of the provisions of section 349 of the *Land Act 1958*, the unused roads referred to hereunder be closed, viz:—

Township of Moe, Parish of Yarragon, County of Buln Buln, being the road between allotment 21 and allotment 21A, section 1.—(M.498(10) (G.60627).

Parish of Eurambeen, County of Ripon, being the road indicated by hachure on plan hereunder.—(E.94(3) (J.29312).

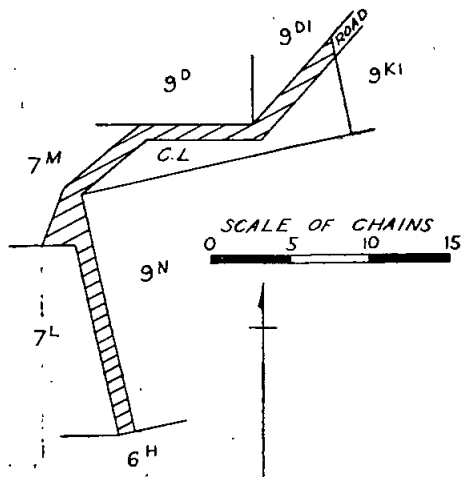

Parish of Jeeralang, County of Buln Buln, being the road indicated by hachure on plan hereunder.—(J.48(6) (H.021870).

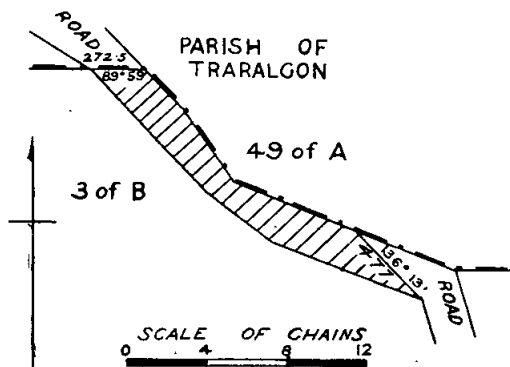

And the Honorable Keith Hector Turnbull, Her Majesty's Commissioner of Crown Lands and Survey for the State of Victoria, shall give the necessary directions herein accordingly.

N. G. WISHART,  
Acting Clerk of the Executive Council.

LAND TEMPORARILY RESERVED AS A SITE.

HIS Excellency the Governor of the State of Victoria, by and with the advice of the Executive Council thereof, doth hereby, in pursuance of the provisions of the *Land Act 1958*, reserve, temporarily, and also except from occupation for mining purposes, under any miner's right, the land hereinafter described:—

HAMILTON.—Site for Public purposes, 1 acre 0 roods 15 perches, Township of Hamilton, Parish of North Hamilton, County of Dundas, as indicated by hachure on plan hereunder.—(H.45(2) (Rs.8068).

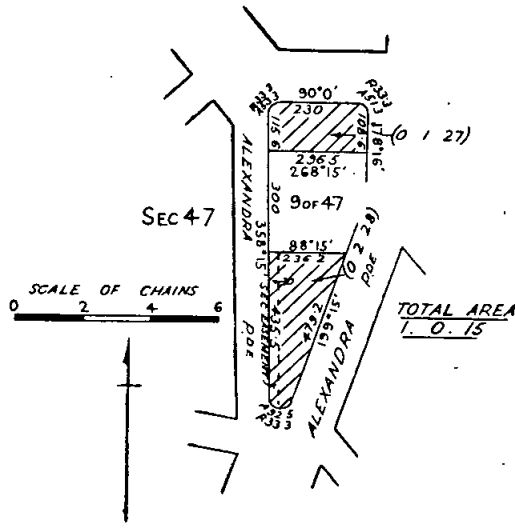

And the Honorable Keith Hector Turnbull, Her Majesty's Commissioner of Crown Lands and Survey for the State of Victoria, shall give the necessary directions herein accordingly.

N. G. WISHART,  
Acting Clerk of the Executive Council.

DEPARTMENT OF CROWN LANDS AND SURVEY.

At Government House, Melbourne, the eighteenth day of September, 1961.

PRESENT:

His Excellency the Governor of Victoria.

Mr. Bolte	Mr. Rylah
Mr. Mibus	Mr. Petty
Mr. Turnbull	Mr. Reid
Mr. Porter	Mr. Fraser
Mr. Thompson	Mr. Mack.
Mr. Meagher	

REVOCATIONS OF TEMPORARY RESERVATIONS OF LANDS BY ORDERS IN COUNCIL.

HIS Excellency the Governor of the State of Victoria, by and with the advice of the Executive Council thereof, doth hereby, in pursuance of the provisions of the *Land Act 1958*, revoke the temporary reservations of lands by Orders in Council hereinafter referred to, viz:—

NEWLINGROOK.—Order in Council of 30th November, 1914, of 26 acres 0 roods 22 perches of land in the Parish of Newlingrook as a site for Public Recreation.—(Rs.364.)

**SEBASTOPOL.**—Order in Council of 3rd October, 1938, of 1 acre 2 roods 17 perches of land in the Township of Sebastopol as a site for a Rubbish Depot.—(Rs.4299.)

**WODONGA.**—Order in Council of 9th July, 1918, of 1 acre 0 roods 19 8/10 perches of land in the Township of Wodonga as a site for Recreation purposes, so far only as regards the portion thereof comprised within the boundaries published in the *Government Gazette* of 23rd August, 1961, and containing 2 roods 20 perches, more or less.—(Rs.743.)

And the Honorable Keith Hector Turnbull, Her Majesty's Commissioner of Crown Lands and Survey for the State of Victoria, shall give the necessary directions herein accordingly.

N. G. WISHART,  
Acting Clerk of the Executive Council.

**FORESTS ACT 1958.**

At Government House, Melbourne, the eighteenth day of September, 1961.

PRESENT:

His Excellency the Governor of Victoria.  
Mr. Bolte | Mr. Rylah  
Mr. Mibus | Mr. Petty  
Mr. Turnbull | Mr. Reid  
Mr. Porter | Mr. Fraser  
Mr. Thompson | Mr. Mack  
Mr. Meagher

**ALIENATED LAND ACQUIRED BY EXCHANGE, ETC. AND DEDICATED AS PERMANENT FOREST.**

WHEREAS by section 42, sub-section 8, of the *Forests Act 1958*, it is prescribed that the Governor in Council may acquire by exchange of land dedicated as permanent forest—

- (a) any alienated land or Crown land licensed or leased with an inchoate right of purchase; or
- (b) any land, public or private, and whether vested in trustees or otherwise,

and may by Order published in the *Government Gazette* dedicate the same as permanent forest:

Now, therefore, His Excellency the Governor of the State of Victoria, by and with the advice of the Executive Council of the said State, and in pursuance of the provisions of section 42, sub-section 8, of the *Forests Act 1958*, doth by this Order—

- (1) acquire the alienated land described in Schedule "A" hereto by exchange of land dedicated as permanent forest described in Schedule "B" hereto;
- (2) excise from the Forest Reserve the area described in the aforesaid Schedule "B", such excision to take effect 30 days from date hereof;
- (3) dedicate the land described in Schedule "A" aforementioned as permanent forest, such dedication to take effect 30 days from date hereof.

THE SCHEDULE ABOVE REFERRED TO.

**Schedule "A"—Dedication Schedule No. 165.**

Alienated land acquired from Myles Thomas Edward Atkins and Stella Jessie Atkins, both of Mirboo North, in exchange for an area of permanent forest described in Schedule "B" and dedicated as permanent forest, being part of Crown allotment 147, Parish of Mirboo, County of Buln Buln, comprising 51 acres 1 rood 36 perches.

**Schedule "B"—Excision Schedule No. 133.**

Land excised from the permanent forest reserve for Myles Thomas Edward Atkins and Stella Jessie Atkins, both of Mirboo North, in exchange for the land described in Schedule "A", being 51 acres 1 rood 36 perches of State Forest Reserve, Parish of Mirboo, County of Buln Buln, being the land shown on plan marked S.748 over 58/121 in the file of correspondence No. 58/121 in the Forests Department.

And the Honorable Lindsay Hamilton Simpson Thompson, Her Majesty's Minister of Forests for the State of Victoria, shall give the necessary directions herein accordingly.

N. G. WISHART,  
Acting Clerk of the Executive Council.

**LOCAL GOVERNMENT DEPARTMENT.**

At Government House, Melbourne, the eighteenth day of September, 1961.

PRESENT:

His Excellency the Governor of Victoria.  
Mr. Bolte | Mr. Rylah  
Mr. Mibus | Mr. Petty  
Mr. Turnbull | Mr. Reid  
Mr. Porter | Mr. Fraser  
Mr. Thompson | Mr. Mack  
Mr. Meagher

**ROAD DISCONTINUED.—SHIRE OF ALTONA.**

WHEREAS it is provided in section 528 (2) of the *Local Government Act 1958*, as amended, that where a road (whether or not a public highway but not being a road set out on land of the Crown) or any part thereof is not required for public use, the Governor in Council, on the request of the council of the municipality in which such road is situated, made not less than one month after publishing in a newspaper generally circulating in the district and posting to the registered proprietor (if any) of the land and any person known to have an interest in the land, notice of intention to make such a request, may by Order published in the *Government Gazette*, direct that such road or part shall be discontinued and thereupon such road or part shall be discontinued accordingly:

And whereas the Council of the Shire of Altona requested that the Governor in Council direct that Herbert-street, Altona, be discontinued, and has published in a newspaper circulating in the district and posted to the registered proprietor of the land in the street and to all persons known to have an interest in the street notice of intention to make such request:

Now, therefore, His Excellency the Governor of the State of Victoria, by and with the advice of the Executive Council thereof, hereby directs that the said road, which is shown by hachure on the plan hereunder, shall be discontinued.

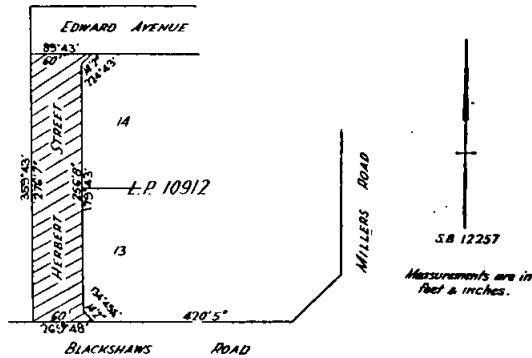

And the Honorable Murray Victor Porter, Her Majesty's Minister for Local Government for the State of Victoria, shall give the necessary directions herein accordingly.

N. G. WISHART,  
Acting Clerk of the Executive Council.

**LOCAL GOVERNMENT DEPARTMENT.**

At Government House, Melbourne, the eighteenth day of September, 1961.

PRESENT:

His Excellency the Governor of Victoria.  
Mr. Bolte | Mr. Rylah  
Mr. Mibus | Mr. Petty  
Mr. Turnbull | Mr. Reid  
Mr. Porter | Mr. Fraser  
Mr. Thompson | Mr. Mack  
Mr. Meagher

**CONFIRMATION OF SEPARATE RATE.—CITY OF ST. KILDA.**

IN pursuance of the provisions of section 287 of the *Local Government Act 1958*, as amended, His Excellency the Governor of the State of Victoria, by and



with the advice of the Executive Council thereof, hereby confirms a separate rate not exceeding Twenty four pence in the pound on the net annual value of the properties described hereunder, which rate was made by the Council of the City of St. Kilda on the 24th July, 1961, to be levied for a period of sixteen years for the purpose of providing parking facilities:—

- (a) The properties situate at and fronting the north side of Carlisle-street and bounded on the west by Chapel-street and on the east by the Melbourne-Sandringham railway line and numbered from 192 to 288 Carlisle-street inclusive;
- (b) The properties situate at and fronting the south side of Carlisle-street and bounded on the west by Chapel-street and on the east by the Melbourne-Sandringham railway line and numbered from 103 to 207 Carlisle-street inclusive.

And the Honorable Murray Victor Porter, Her Majesty's Minister for Local Government for the State of Victoria, shall give the necessary directions herein accordingly.

N. G. WISHART,  
Acting Clerk of the Executive Council.

LOCAL GOVERNMENT DEPARTMENT.

At Government House, Melbourne, the eighteenth day of September, 1961.

PRESENT:

His Excellency the Governor of Victoria.	
Mr. Bolte	Mr. Rylah
Mr. Mibus	Mr. Petty
Mr. Turnbull	Mr. Reid
Mr. Porter	Mr. Fraser
Mr. Thompson	Mr. Mack.
Mr. Meagher	

ROAD DISCONTINUED.—CITY OF CAMBERWELL.

WHEREAS it is provided in section 528 (2) of the *Local Government Act 1958*, that where a road (whether or not a public highway but not being a road set out on land of the Crown) or any part thereof is not required for public use, the Governor in Council, on the request of the council of the municipality in which such road is situated, made not less than one month after publishing in a newspaper generally circulating in the district and posting to the registered proprietor (if any) of the land and any person known to have an interest in the land, notice of intention to make such a request, may, by Order published in the *Government Gazette*, direct that such road or part shall be discontinued and thereupon such road or part shall be discontinued accordingly:

And whereas the Council of the City of Camberwell requested that the Governor in Council direct that a right-of-way between Dempster-avenue and Frank-street, North Balwyn, be discontinued, and has published in a newspaper circulating in the district and posted to the registered proprietor of the land in the street and to all persons known to have an interest in the street notice of intention to make such request:

Now, therefore, His Excellency the Governor of the State of Victoria, by and with the advice of the Executive Council thereof, hereby directs that the said right-of-way which is shown by hachure on the plan hereunder, shall be discontinued and that the land and soil thereof may be sold by the Council of the City of Camberwell by agreement.

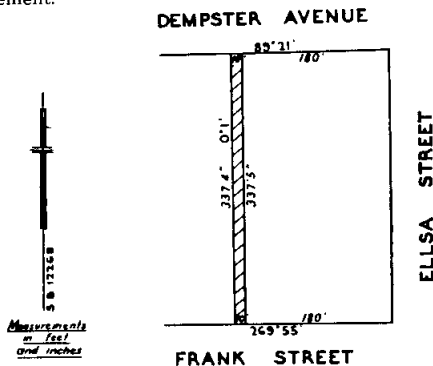

And the Honorable Murray Victor Porter, Her Majesty's Minister for Local Government for the State of Victoria, shall give the necessary directions herein accordingly.

N. G. WISHART,  
Acting Clerk of the Executive Council.

LOCAL GOVERNMENT DEPARTMENT.

At Government House, Melbourne, the eighteenth day of September, 1961.

PRESENT:

His Excellency the Governor of Victoria.	
Mr. Bolte	Mr. Rylah
Mr. Mibus	Mr. Petty
Mr. Turnbull	Mr. Reid
Mr. Porter	Mr. Fraser
Mr. Thompson	Mr. Mack.
Mr. Meagher	

ROAD DISCONTINUED.—CITY OF SOUTH MELBOURNE.

WHEREAS it is provided in section 528 (2) of the *Local Government Act 1958*, as amended, that where a road (whether or not a public highway but not being a road set out on land of the Crown) or any part thereof is not required for public use, the Governor in Council, on the request of the council of the municipality in which such road is situated, made not less than one month after publishing in a newspaper generally circulating in the district and posting to the registered proprietor (if any) of the land and any person known to have an interest in the land notice of intention to make such a request, may, by Order published in the *Government Gazette*, direct that such road or part shall be discontinued and thereupon such road or part shall be discontinued accordingly:

And whereas the Council of the City of South Melbourne has requested that the Governor in Council direct that portion of Little Moray-place, South Melbourne, be discontinued, and, not less than one month previously, has published in a newspaper generally circulating in the district and posted to the registered proprietor of the land in the road and to all persons known to have an interest in the said road notice of intention to make such request:

Now, therefore, His Excellency the Governor of the State of Victoria, by and with the advice of the Executive Council thereof, hereby directs that the portion of the said road which is shown by hachure on the plan hereunder shall be discontinued and that the land and soil thereof may be sold by the Council of the City of South Melbourne by agreement:

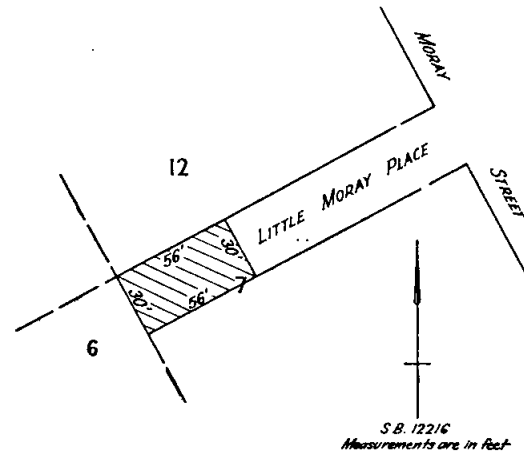

And the Honorable Murray Victor Porter, Her Majesty's Minister for Local Government for the State of Victoria, shall give the necessary directions herein accordingly.

N. G. WISHART,  
Acting Clerk of the Executive Council.

COURTS OF GENERAL SESSIONS OF THE PEACE  
FOR THE YEAR 1962.

At Government House, Melbourne, the eighteenth day of  
September, 1961.

PRESENT:

His Excellency the Governor of Victoria.	
Mr. Bolte	Mr. Rylah
Mr. Mibus	Mr. Petty
Mr. Turnbull	Mr. Reid
Mr. Porter	Mr. Fraser
Mr. Thompson	Mr. Mack.
Mr. Meagher	

IN pursuance of the provisions of the *Justices Act 1958*, His Excellency the Governor of the State of Victoria, by and with the advice of the Executive Council thereof, doth by this present Order direct that the dates for holding Courts of General Sessions of the Peace during the year 1962 be appointed as specified in the subjoined Schedule, viz.:—

	SCHEDULE.
ARARAT .. .. .	Tuesday, 27th March. Wednesday, 1st August.
BAIRNSDALE .. .. .	Tuesday, 6th February. Tuesday, 28th August.
BALLARAT .. .. .	Monday, 5th February. Tuesday, 1st May. Wednesday, 1st August. Wednesday, 7th November.
BENDIGO .. .. .	Tuesday, 10th April. Tuesday, 17th July. Tuesday, 18th September. Tuesday, 20th November.
COLAC .. .. .	Tuesday, 10th April. Tuesday, 14th August. Tuesday, 13th November.
GEELONG .. .. .	Thursday, 1st March. Tuesday, 5th June. Monday, 3rd September. Monday, 3rd December.
HAMILTON .. .. .	Tuesday, 20th February. Tuesday, 5th June. Tuesday, 23rd October.
HORSHAM .. .. .	Tuesday, 13th March. Tuesday, 17th July. Tuesday, 4th December.
KERANG .. .. .	Tuesday, 13th February. Tuesday, 12th June. Tuesday, 2nd October.
KORUMBURRA .. .. .	Tuesday, 3rd April. Tuesday, 21st August. Thursday, 1st November.
MARYBOROUGH .. .. .	Tuesday, 27th March. Tuesday, 22nd May. Tuesday, 16th October.
MELBOURNE .. .. .	Monday, 15th January. Thursday, 1st February. Thursday, 1st March. Monday, 2nd April. Tuesday, 1st May. Friday, 1st June. Monday, 2nd July. Wednesday, 1st August. Monday, 3rd September. Monday, 1st October. Thursday, 1st November. Monday, 3rd December.
MILDURA .. .. .	Monday, 19th March. Monday, 18th June. Monday, 20th August. Monday, 19th November.
MORWELL .. .. .	Thursday, 1st March. Tuesday, 5th June. Tuesday, 23rd October.
SALE .. .. .	Tuesday, 3rd April. Tuesday, 18th September. Tuesday, 11th December.
SHEPPARTON .. .. .	Tuesday, 6th February. Tuesday, 17th July. Wednesday, 7th November.
WANGARATTA .. .. .	Tuesday, 6th February. Tuesday, 15th May. Tuesday, 2nd October. Tuesday, 4th December.
WARRAGUL .. .. .	Monday, 19th February. Tuesday, 1st May. Monday, 8th October.

SCHEDULE—continued.

WARRNAMBOOL .. .. .  
Tuesday, 10th April.  
Tuesday, 19th June.  
Tuesday, 4th September.  
Tuesday, 4th December.

And the Honorable Arthur Gordon Rylah, Her Majesty's Attorney-General in and for the State of Victoria, shall give the necessary directions herein accordingly.

N. G. WISHART,  
Acting Clerk of the Executive Council.

HEALTH ACT 1958 (No. 6270).

At Government House, Melbourne, the eighteenth  
day of September, 1961.

PRESENT:

His Excellency the Governor of Victoria.	
Mr. Bolte	Mr. Rylah
Mr. Mibus	Mr. Petty
Mr. Turnbull	Mr. Reid
Mr. Porter	Mr. Fraser
Mr. Thompson	Mr. Mack.
Mr. Meagher	

DIVISION 1 OF PART V. OF THE HEALTH ACT 1958  
(No. 6270). RELATING TO PIGGERIES, EXTENDED  
TO THE WHOLE OF THE MUNICIPAL DISTRICT  
OF THE SHIRE OF WARANGA.

UNDER the powers conferred by the *Health Act 1958* (No. 6270), His Excellency the Governor of the State of Victoria, by and with the advice of the Executive Council thereof, on the request of the Council of the Shire of Waranga, and on the recommendation of the Commission of Public Health, doth hereby order that the provisions of Division 1 of Part V. of the said Act, so far as those provisions are applicable to piggeries, shall be extended to the whole of the municipal district of the Shire of Waranga.

And the Honorable Ronald William Mack, Her Majesty's Minister of Health for the State of Victoria, shall give the necessary directions herein accordingly.

N. G. WISHART,  
Acting Clerk of the Executive Council.

HEALTH ACT 1958 (No. 6270).

At Government House, Melbourne, the eighteenth  
day of September, 1961.

PRESENT:

His Excellency the Governor of Victoria.	
Mr. Bolte	Mr. Rylah
Mr. Mibus	Mr. Petty
Mr. Turnbull	Mr. Reid
Mr. Porter	Mr. Fraser
Mr. Thompson	Mr. Mack.
Mr. Meagher	

ESTABLISHMENT OF A GARBAGE DEPOT BY THE  
BOROUGH OF SWAN HILL.

UNDER the powers conferred by section 48 (1) (e) of the *Health Act 1958* (No. 6270), His Excellency the Governor of the State of Victoria, by and with the advice of the Executive Council of the said State, doth hereby consent to the provision by the Borough of Swan Hill of suitable places, works, buildings, plant, machinery, and appliances for the inoffensive disposal or destruction of refuse and rubbish on an area of land containing 5 acres or thereabout in centre of Crown allotment 30, section B, Parish of Castle Donnington, County of Taichera, in the Municipal District of the Shire of Swan Hill.

And the Honorable Ronald William Mack, Her Majesty's Minister of Health for the State of Victoria, shall give the necessary directions herein accordingly.

N. G. WISHART,  
Acting Clerk of the Executive Council.

## COUNTRY ROADS BOARD.

At Government House, Melbourne, the  
eighteenth day of September, 1961.

## PRESENT:

His Excellency the Governor of Victoria.

Mr. Bolte	Mr. Rylah
Mr. Mibus	Mr. Petty
Mr. Turnbull	Mr. Reid
Mr. Porter	Mr. Fraser
Mr. Thompson	Mr. Mack.
Mr. Meagher	

ORDER APPROVING OF WIDENING AN EXISTING  
MAIN ROAD IN THE SHIRE OF GLENLYON.

WHEREAS the Country Roads Board constituted under the *Country Roads Act 1958* (No. 6229) has represented to His Excellency the Governor in Council that it appears to it desirable that the existing Hepburn-Newstead road in the Shire of Glenlyon (declared to be a main road under the said Act which declaration was confirmed by the Order in Council published in the *Government Gazette* of the 19th July, 1939, on page 2645) should be widened by the said Board: And whereas the said Board in accordance with the requirements of section 19 of the said cited Act has caused to be prepared a map plan and estimate showing the points between which and on and through what land the said widening is proposed to be made and the cost of acquiring the land: And whereas on an inspection of the said map and plan and a consideration of the said estimate His Excellency the Governor in Council is satisfied that there are funds legally available for acquiring the land: Now therefore be it known by this present Order that His Excellency the Governor of the State of Victoria with the advice of the Executive Council thereof doth hereby approve of the said road being widened, that is to say:—

All that piece of land in the Parish of Yandoit, the boundaries of which are as follow:—Commencing at the northern angle of allotment 7<sup>o</sup>, section 1A, of the said parish; thence by lines bearing respectively 130 deg. 0 min. 195 links, 166 deg. 31 min. 147.7 links and 325 deg. 39 min. 325.8 links to the point of commencement— which said piece of land is particularly delineated and shown coloured red on survey plan numbered 7927, lodged in the office of the Country Roads Board.

And the Honorable Horace Rostill Petty, Her Majesty's Commissioner of Public Works for the State of Victoria, shall give the necessary directions herein accordingly.

N. G. WISHART,  
Acting Clerk of the Executive Council.

## COUNTRY ROADS BOARD.

At Government House, Melbourne, the  
eighteenth day of September, 1961.

## PRESENT:

His Excellency the Governor of Victoria.

Mr. Bolte	Mr. Rylah
Mr. Mibus	Mr. Petty
Mr. Turnbull	Mr. Reid
Mr. Porter	Mr. Fraser
Mr. Thompson	Mr. Mack.
Mr. Meagher	

ORDER APPROVING OF WIDENING AN EXISTING  
MAIN ROAD IN THE SHIRE OF ALTONA AND CITY  
OF WILLIAMSTOWN.

WHEREAS the Country Roads Board constituted under the *Country Roads Act 1958* (No. 6229) has represented to His Excellency the Governor in Council that it appears to it desirable that the existing Kororoit Creek-road in the Shire of Altona and City of Williamstown (declared to be a main road under the said Act which declaration was confirmed by the Order in Council published in the *Government Gazette* of the 23rd July, 1952, on page 3936) should be widened by the said Board: And whereas the said Board in accordance with the requirements of section 19 of the said cited Act has caused to be prepared a map plan and estimate showing the points between which and on and through what land the said widening is proposed to be made and the cost of acquiring the land: And whereas on an inspection

of the said map and plan and a consideration of the said estimate His Excellency the Governor in Council is satisfied that there are funds legally available for acquiring the land: Now therefore be it known by this present Order that His Excellency the Governor of the State of Victoria with the advice of the Executive Council thereof doth hereby approve of the said road being widened, that is to say:—

All those pieces of land in the Parish of Cut-paw-paw, the boundaries of which are as follow:—

- (a) Commencing at the south-western angle of lot 190 on plan of subdivision numbered 1316, lodged in the Office of Titles, and being part of allotment C<sup>2</sup>, section 3, of the said parish; thence by lines bearing respectively 0 deg. 9 min. 20 ft. 11½ in., 102 deg. 8½ min. 100 ft. 9½ in. and 270 deg. 9 min. 98 ft. 7 in. to the point of commencement.
- (b) Commencing at the north-western angle of allotment D<sup>1</sup>, section 3, of the said parish; thence by lines bearing respectively 90 deg. 10 min. 1,363 ft. 9½ in., 89 deg. 58 min. 66 ft. 4 in., 89 deg. 58½ min. 5,036 ft. 8 in., 180 deg. 17½ in. 40 ft. 8½ in., 270 deg. 0½ min. 1,194 ft. 11½ in., 269 deg. 2 min. 600 ft. 0½ in., 269 deg. 58 min. 3,241 ft. 7½ in., 269 deg. 58 min. 66 ft. 4 in., 270 deg. 9 min. 1,192 ft. 1 in., 282 deg. 8½ min. 243 feet and 90 deg. 10 min. 66 feet to the point of commencement.
- (c) Commencing at a point on the northern boundary of allotment C<sup>1</sup>, section 4, of the said parish, distant 102 deg. 4 min. 13 ft. 5½ in. from the north-western angle of the said allotment; thence by lines bearing respectively 102 deg. 4 min. 476 ft. 9 in., 141 deg. 6½ min. 32 feet, 278 deg. 11 min. 677 ft. 3 in., 269 deg. 59 min. 701 ft. 10 in., 257 deg. 33 min. 314 ft. 1 in., 239 deg. 22 min. 297 ft. 3 in., 37 deg. 7 min. 134 ft. 10½ in., 54 deg. 20 min. 110 ft. 9½ in., 67 deg. 25 min. 156 ft. 10½ in., 77 deg. 33 min. 160 ft. 11 in., 84 deg. 53 min. 157 ft. 2½ in. and 92 deg. 21 min. 819 ft. 0½ in. to the point of commencement.
- (d) Commencing at a point on the southern boundary of allotment F<sup>1</sup>, section 4, of the said parish, distant 102 deg. 4 min. 688 ft. 9½ in. from the south-western angle of the said allotment; thence by lines bearing respectively 98 deg. 11 min. 647 ft. 1½ in., 49 deg. 9½ min. 39 ft. 4 in., 180 deg. 7½ min. 34 ft. 0½ in., 231 deg. 6 min. 53 ft. 11 in. and 282 deg. 4 min. 642 ft. 5½ in. to the point of commencement.
- (e) Commencing at the south-eastern angle of allotment E<sup>1</sup>, section 4, of the said parish; thence by lines bearing respectively 282 deg. 10½ min. 1,333 ft. 8½ in., 321 deg. 10 min. 54 ft. 0½ in., 102 deg. 10½ min. 1,557 ft. 7 in., 104 deg. 49½ min. 734 ft. 2 in. and 282 deg. 10½ min. 915 ft. 2½ in. to the point of commencement.
- (f) Commencing at the south-eastern angle of lot 387 on plan of subdivision numbered 1316, lodged in the Office of Titles, and being part of allotment H<sup>1</sup>, section 3, of the said parish; thence by lines bearing respectively 282 deg. 7 min. 15 feet, 51 deg. 8 min. 18 ft. 10½ in. and 180 deg. 9 min. 15 feet to the point of commencement.
- (g) Commencing at the south-eastern angle of allotment H<sup>2</sup>, section 3, of the said parish; thence by lines bearing respectively 282 deg. 7 min. 1,270 ft. 2 in., 100 deg. 34 min. 455 feet, 50 deg. 22 min. 19 ft. 2½ in., 180 deg. 9 min. 15 feet, 100 deg. 34 min. 381 ft. 8 in., 50 deg. 22 min. 19 ft. 2½ in., 180 deg. 9 min. 15 feet, 100 deg. 34 min. 381 ft. 8 in., 50 deg. 22 min. 19 ft. 2½ in., and 180 deg. 9 min. 49 ft. 11½ in. to the point of commencement.
- (h) Commencing at the north-eastern angle of allotment E<sup>2</sup>, section 3, of the said parish; thence by lines bearing respectively 280 deg. 34 min. 1,274 ft. 3½ in., 282 deg. 11 min. 637 ft. 10½ in., 231 deg. 11 min. 18 ft. 10½ in., 282 deg. 11 min. 61 ft. 4½ in., 321 deg. 11 min. 23 ft. 4 in., 282 deg. 11 min. 342 ft. 6 in., 278 deg. 22 min. 150 ft. 4 in., 282 deg. 11 min. 200 feet, 231 deg. 8 min. 88 feet, 0 deg. 5 min. 73 ft. 11 in., 51 deg. 6 min. 50 ft. 4 in., 102 deg. 7 min. 1,524 ft. 3½ in., 102 deg. 8 min. 529 ft. 4 in., and 102 deg. 8½ min. 681 ft. 1½ in. to the point of commencement.

- (i) Commencing at the north-eastern angle of allotment D<sup>2</sup>, section 4, of the said parish; thence by lines bearing respectively 180 deg. 8½ min. 33 ft. 11½ in., 282 deg. 11 min. 64 ft. 6½ in., 284 deg. 49½ min. 278 ft. 2½ in., 232 deg. 31 min. 18 ft. 4 in., 284 deg. 49½ min. 62 feet, 322 deg. 31 min. 23 ft. 9 in., 284 deg. 49½ min. 329 ft. 7 in., 232 deg. 31 min. 18 ft. 4 in., 0 deg. 11½ min. 15 feet and 102 deg. 10 min. 771 ft. 6 in. to the point of commencement.
- (j) Commencing at the north-eastern angle of lot 9 on plan of subdivision numbered 966, lodged in the Office of Titles, and being part of allotment D<sup>2</sup>, section 4, of the said parish; thence by lines bearing respectively 180 deg. 11½ min. 15 feet, 321 deg. 11 min. 23 ft. 3½ in. and 102 deg. 10 min. 15 feet to the point of commencement.
- (k) Commencing at the north-eastern angle of allotment C<sup>2</sup>, section 4, of the said parish; thence by lines bearing respectively 102 deg. 10½ min. 196 ft. 5½ in., 279 deg. 7 min. 300 ft. 5 in., 282 deg. 10½ min. 300 feet, 51 deg. 10 min. 20 ft. 7 in. and 102 deg. 10½ min. 390 ft. 7 in. to the point of commencement.

Also, all that piece of land in the Parish of Truganina, the boundaries of which are as follow:—

Commencing at the north-western angle of allotment F, section 9, of the said parish; thence by lines bearing respectively 90 deg. 26½ min. 173 ft. 10½ in., 264 deg. 50½ min. 661 ft. 6½ in., 270 deg. 26½ min. 1,797 ft. 3½ in., 64 deg. 43 min. 148 ft. 7½ in. and 90 deg. 26½ min. 2,147 ft. 11½ in. to the point of commencement—

which said pieces of land are particularly delineated and shown coloured red and yellow on survey plans numbered 7797, 7798, 7843 and 7844, lodged in the office of the Country Roads Board.

And the Honorable Horace Rostill Petty, Her Majesty's Commissioner of Public Works for the State of Victoria, shall give the necessary directions herein accordingly.

N. G. WISHART,  
Acting Clerk of the Executive Council.

COUNTRY ROADS BOARD.

At Government House, Melbourne, the eighteenth day of September, 1961.

PRESENT:

His Excellency the Governor of Victoria.	
Mr. Bolte	Mr. Rylah
Mr. Mibus	Mr. Petty
Mr. Turnbull	Mr. Reid
Mr. Porter	Mr. Fraser
Mr. Thompson	Mr. Mack.
Mr. Meagher	

ORDER APPROVING OF THE MAKING OF A NEW BY-PASS ROAD IN THE SHIRES OF ALTONA AND WERRIBEE.

WHEREAS:

I. Country Roads Board incorporated by the *Country Roads Act 1958* has represented to His Excellency the Governor in Council that it appears to the said Board that a new by-pass road (Princes Highway By-pass Road) in the Shires of Altona and Werribee should be made.

II. The said Board in accordance with sections 19 and 101 of the said Act has caused to be prepared a map plan and estimate showing—

- (a) the points between which and the land on and through which the said new by-pass road is proposed to be made;
- (b) the cost of acquiring the said land.

III. On inspection of the said map and plan and consideration of the said estimate His Excellency the Governor in Council is satisfied that there are funds legally available for acquiring the said land.

Now therefore His Excellency the Governor of the State of Victoria by and with the advice of the Executive Council thereof doth hereby approve of the said land (being the land described in the Schedule hereunder) being acquired and the said road being made.

SCHEDULE.

All that piece of land in the Parishes of Truganina and Tarneit, the boundaries of which are as follow:—

Commencing at the south-eastern angle of allotment 5, section 21, Parish of Truganina, on the western bank of the Kororoit Creek; thence by the said bank bearing 141 deg. 44½ min. 711 ft. 9 in.; thence generally south-westerly through allotments 6, 7, 5, 3 and 1, section 20 and 6, section 19, of the parish last named, by lines bearing respectively 255 deg. 8 min. 1,229 ft. 1 in., 237 deg. 19 min. 55 ft. 4 in., 219 deg. 29½ min. 433 ft. 6½ in., 225 deg. 31 min. 638 feet, 221 deg. 11 min. 405 ft. 9 in., 223 deg. 52½ min. 167 ft. 4½ in., 218 deg. 50 min. 670 feet, 206 deg. 0 min. 168 feet, 193 deg. 30 min. 130 feet, 182 deg. 0 min. 215 feet, 96 deg. 8 min. 260 ft. 3 in., 186 deg. 8 min. 66 feet, 267 deg. 15 min. 190 feet, 204 deg. 30 min. 198 feet, 244 deg. 30 min. 65 feet, 267 deg. 0 min. 66 feet, 290 deg. 30 min. 268 feet, 276 deg. 8 min. 345 feet, 260 deg. 30 min. 58 feet, 250 deg. 0 min. 68 feet, 239 deg. 20 min. 165 feet, 252 deg. 25 min. 241 feet, 329 deg. 23 min. 50 feet, 239 deg. 22½ min. 7,837 ft. 6 in., 230 deg. 0 min. 268 feet, 213 deg. 45 min. 172 feet, 195 deg. 20 min. 153 feet, 187 deg. 55 min. 212 ft. 6 in., 141 deg. 40 min. 84 feet, 97 deg. 26½ min. 200 feet, 195 deg. 40 min. 133 ft. 4 in. and 277 deg. 26 min. 200 feet; thence through portion 11, allotments 4 and 3, section A, 3A and 4, section 3, and allotments 7, 8, 9 and 10, section A, Parish of Truganina, by lines bearing respectively 214 deg. 30 min. 194 feet, 248 deg. 20 min. 144 feet, 289 deg. 0 min. 326 feet, 287 deg. 10 min. 174 feet, 278 deg. 10 min. 178 feet, 265 deg. 15 min. 190 feet, 251 deg. 30 min. 262 feet, 239 deg. 16½ min. 239 ft. 1½ in., 239 deg. 15 min. 197 ft. 3 in., 234 deg. 44½ min. 220 ft. 10 in., 228 deg. 50½ min. 184 ft. 4 in., 221 deg. 41 min. 222 ft. 3½ in., 214 deg. 10 min. 117 ft. 9½ in., 209 deg. 34 min. 178 ft. 9 in., 200 deg. 7 min. 418 ft. 11 in., 190 deg. 50 min. 5,204 ft. 9 in., 161 deg. 35 min. 66 feet, 200 deg. 13 min. 529 ft. 10 in., 208 deg. 46 min. 326 ft. 10 in., 215 deg. 45 min. 328 ft. 1 in., 225 deg. 2 min. 327 ft. 11 in., 231 deg. 55 min. 326 feet, 239 deg. 52 min. 326 ft. 8 in., 247 deg. 20 min. 326 ft. 4 in., 255 deg. 5 min. 324 ft. 8 in., 261 deg. 37 min. 284 ft. 3 in., 263 deg. 16 min. 2,261 ft. 11 in., 222 deg. 30 min. 98 ft. 7 in., 231 deg. 45 min. 93 ft. 7 in., 319 deg. 22 min. 73 ft. 7 in., 229 deg. 41 min. 110 ft. 11 in., 203 deg. 52 min. 52 ft. 6 in., 207 deg. 35 min. 71 feet, 179 deg. 15 min. 217 ft. 6 in., 186 deg. 7 min. 28 ft. 4 in., 217 deg. 10 min. 163 ft. 1 in., 276 deg. 7 min. 111 ft. 11 in., 186 deg. 7 min. 75 ft. 3 in., 352 deg. 40 min. 77 ft. 5 in., 276 deg. 7 min. 98 ft. 6½ in., 336 deg. 40 min. 145 ft. 9 in., 357 deg. 2 min. 175 ft. 8 in., 325 deg. 0 min. 115 ft. 7 in., 315 deg. 40 min. 64 ft. 10 in., 292 deg. 50 min. 122 ft. 2 in., 263 deg. 16 min. 2,117 ft. 7½ in., 252 deg. 21 min. 3,225 ft. 1 in., 246 deg. 40 min. 347 feet, 221 deg. 20 min. 161 feet, 192 deg. 0 min. 147 feet, 165 deg. 40 min. 184 feet, 197 deg. 0 min. 86 feet, 233 deg. 40 min. 155 feet, 188 deg. 11 min. 76 feet, 278 deg. 11 min. 66 feet, 8 deg. 11 min. 18 ft. 6 in., 305 deg. 10 min. 175 ft. 6 in., 340 deg. 0 min. 201 feet and 313 deg. 20 min. 148 feet; thence through allotments 14, 14A, 13 and 10, section B, Parish of Tarneit, by lines bearing respectively 285 deg. 55 min. 129 feet, 270 deg. 0 min. 101 feet, 252 deg. 21 min. 6,717 ft. 9 in., and 342 deg. 21 min. 198 feet; thence generally north-easterly along the railway reserve and through allotments 8 and 7, section A, and allotments 4 and 3A, section 3, Parish of Truganina, by lines bearing respectively 72 deg. 21 min. 11,198 ft. 4 in., 83 deg. 16 min. 2,098 ft. 1 in., 67 deg. 39 min. 448 ft. 9 in., 35 deg. 31 min. 63 ft. 2 in., 5 deg. 14 min. 232 ft. 11 in., 327 deg. 51 min. 59 ft. 11 in., 72 deg. 21 min. 105 feet, 162 deg. 21 min. 147 ft. 10½ in., 186 deg. 7 min. 60 feet, 175 deg. 17 min. 91 ft. 2½ in., 134 deg. 40 min. 82 feet, 95 deg. 28 min. 253 ft. 10 in., 42 deg. 30 min. 11 ft. 7½ in., 50 deg. 46 min. 95 ft. 1 in., 140 deg. 3 min. 121 ft. 5½ in., 96 deg. 7 min. 62 ft. 9½ in., 83 deg. 16 min. 2,119 ft. 10 in., 81 deg. 37 min. 270 feet, 75 deg. 5 min. 300 feet, 67 deg. 20 min. 300 feet, 59 deg. 52 min. 300 feet, 51 deg. 55 min. 300 feet, 45 deg. 2 min. 300 feet, 35 deg. 45 min. 300 feet, 28 deg. 46 min. 300 feet and 20 deg. 13 min. 361 ft. 1 in.; thence generally northerly through allotments 3, 4 and 16, section A, Parish of Truganina, by lines bearing respectively 2 deg. 55 min. 70 ft. 6 in., 10 deg. 50 min. 6,272 ft. 9 in., 66 deg. 38 min. 354 ft. 5 in., and 199 deg. 9 min. 758 ft. 11 in.; thence generally north-easterly through allotment 1, section 19, along the southern boundaries of allotments 1, 3 and 4, section 19, through allotments 1 and 4, section 21, and along the southern boundaries of allotments 4 and 5, section 21, all of the Parish of Truganina, by lines bearing

respectively 76 deg. 8 min. 106 ft. 4 in., 12 deg. 48 min. 181 ft. 3 in., 45 deg. 8 min. 110 feet, 69 deg. 8 min. 92 feet, 105 deg. 8 min. 122 feet, 115 deg. 8 min. 231 ft. 6 in., 103 deg. 37 min. 192 feet, 90 deg. 48 min. 208 ft. 6 in., 80 deg. 58 min. 185 feet, 59 deg. 24 min. 8,333 ft. 8 in., 48 deg. 30 min. 143 feet, 33 deg. 30 min. 162 feet, 16 deg. 30 min. 136 feet, 4 deg. 30 min. 108 ft. 3 in., 276 deg. 10½ min. 509 ft. 2 in., 6 deg. 10½ min. 66 feet, 87 deg. 10 min. 178 ft. 6 in., 80 deg. 30 min. 270 feet, 19 deg. 10 min. 130 feet, 48 deg. 15 min. 93 feet, 91 deg. 15 min. 84 feet, 108 deg. 5 min. 236 feet, 99 deg. 20 min. 231 feet, 91 deg. 56 min. 176 feet, 83 deg. 21 min. 150 feet, 70 deg. 27 min. 178 ft. 5 in., 51 deg. 17 min. 1,353 ft. 8 in., 41 deg. 11 min. 1,450 ft. 8 in., and 52 deg. 8 min. 1,236 ft. 2 in. to the point of commencement.

Also, all that piece of land in the Parish of Truganina, the boundaries of which are as follow:—

Commencing at a point on the southern boundary of allotment 11, section A, of the said parish, distant 252 deg. 21 min. 2,796 ft. 1½ in. from the south-eastern angle of the said allotment; thence by lines bearing respectively 252 deg. 21 min. 170 feet, 348 deg. 24 min. 331 ft. 10 in., 72 deg. 21 min. 100 feet and 156 deg. 18 min. 331 ft. 10 in. to the point of commencement—

which said pieces of land are particularly delineated and shown coloured red, green and yellow on survey plans numbered 7561, 7562, 7564, 7565 and 7597, lodged in the office of the Country Roads Board.

And the Honorable Horace Rostill Petty, Her Majesty's Commissioner of Public Works for the State of Victoria, shall give the necessary directions herein accordingly.

N. G. WISHART,  
Acting Clerk of the Executive Council.

#### COUNTRY ROADS BOARD.

*At Government House, Melbourne, the  
eighteenth day of September, 1961.*

PRESENT:

His Excellency the Governor of Victoria.

Mr. Bolte	Mr. Rylah
Mr. Mibus	Mr. Petty
Mr. Turnbull	Mr. Reid
Mr. Porter	Mr. Fraser
Mr. Thompson	Mr. Mack.
Mr. Meagher	

#### ORDER APPROVING OF WIDENING AN EXISTING MAIN ROAD IN THE CITY OF WAVERLEY.

WHEREAS the Country Roads Board constituted under the *Country Roads Act 1958* (No. 6229) has represented to His Excellency the Governor in Council that it appears to it desirable that the existing Springvale-road in the City of Waverley (declared to be a main road under the said Act which declaration was confirmed by the Order in Council published in the *Government Gazette* of the 30th September, 1936, on page 2596) should be widened by the said Board: And whereas the said Board in accordance with the requirements of section 19 of the said cited Act has caused to be prepared a map plan and estimate showing the points between which and on and through what land the said widening is proposed to be made and the cost of acquiring the land: And whereas on an inspection of the said map and plan and a consideration of the said estimate His Excellency the Governor in Council is satisfied that there are funds legally available for acquiring the land: Now therefore be it known by this present Order that His Excellency the Governor of the State of Victoria with the advice of the Executive Council thereof doth hereby approve of the said road being widened, that is to say:—

All that piece of land in the Parish of Mulgrave, the boundaries of which are as follow:—Commencing at the south-eastern angle of portion 73 of the said parish; thence by lines bearing respectively 181 deg. 23 min. 45 ft. 11 in., 181 deg. 0 min. 587 ft. 8 in., 270 deg. 3 min. 45 feet, 45 deg. 31½ min. 42 ft. 9 in., 1 deg. 0 min. 557 ft. 9½ in., 359 deg. 49½ min. 1,836 ft. 4 in., 174 deg. 14 min. 105 feet, 89 deg. 49½ min. 6 feet and 179 deg. 49½ min. 1,686 ft. 2 in. to the point of commencement—which said piece of land is particularly delineated and shown coloured red and yellow on survey plan numbered 8219, lodged in the office of the Country Roads Board.

And the Honorable Horace Rostill Petty, Her Majesty's Commissioner of Public Works for the State of Victoria, shall give the necessary directions herein accordingly.

N. G. WISHART,  
Acting Clerk of the Executive Council.

#### COUNTRY ROADS BOARD.

*At Government House, Melbourne, the  
eighteenth day of September, 1961.*

PRESENT:

His Excellency the Governor of Victoria.

Mr. Bolte	Mr. Rylah
Mr. Mibus	Mr. Petty
Mr. Turnbull	Mr. Reid
Mr. Porter	Mr. Fraser
Mr. Thompson	Mr. Mack.
Mr. Meagher	

#### ORDER APPROVING OF WIDENING AN EXISTING MAIN ROAD IN THE SHIRE OF BUNINYONG.

WHEREAS the Country Roads Board constituted under the *Country Roads Act 1958* (No. 6229) has represented to His Excellency the Governor in Council that it appears to it desirable that the existing Colac-Ballararat road in the Shire of Buninyong (declared to be a main road under the said Act which declaration was confirmed by the Order in Council published in the *Government Gazette* of the 12th May, 1948, on pages 2927-8) should be widened by the said Board: And whereas the said Board in accordance with the requirements of section 19 of the said cited Act has caused to be prepared a map plan and estimate showing the points between which and on and through what land the said widening is proposed to be made and the cost of acquiring the land: And whereas on an inspection of the said map and plan and a consideration of the said estimate His Excellency the Governor in Council is satisfied that there are funds legally available for acquiring the land: Now therefore be it known by this present Order that His Excellency the Governor of the State of Victoria with the advice of the Executive Council thereof doth hereby approve of the said road being widened, that is to say:—

All that piece of land in the Parish of Yarrowee, the boundaries of which are as follow:—Commencing at a point on the southern boundary of allotment A of the said parish, distant 269 deg. 0 min. 512.4 links from the south-eastern angle of the said allotment; thence by lines bearing respectively 269 deg. 0 min. 50.6 links, 7 deg. 55 min. 1,716.3 links, 27 deg. 41 min. 1,795 links, 200 deg. 50 min. 419.2 links, 207 deg. 41 min. 1,370.1 links and 187 deg. 55 min. 1,699.8 links to the point of commencement—which said piece of land is particularly delineated and shown coloured red on survey plan numbered 8192, lodged in the office of the Country Roads Board.

And the Honorable Horace Rostill Petty, Her Majesty's Commissioner of Public Works for the State of Victoria, shall give the necessary directions herein accordingly.

N. G. WISHART,  
Acting Clerk of the Executive Council.

#### COUNTRY ROADS BOARD.

*At Government House, Melbourne, the  
eighteenth day of September, 1961.*

PRESENT:

His Excellency the Governor of Victoria.

Mr. Bolte	Mr. Rylah
Mr. Mibus	Mr. Petty
Mr. Turnbull	Mr. Reid
Mr. Porter	Mr. Fraser
Mr. Thompson	Mr. Mack.
Mr. Meagher	

#### ORDER APPROVING OF WIDENING AN EXISTING STATE HIGHWAY IN THE SHIRES OF BUNGAREE AND BUNINYONG.

WHEREAS the Country Roads Board constituted under the *Country Roads Act 1958* (No. 6229) has represented to His Excellency the Governor in Council that it appears to it desirable that the existing Western Highway in the Shires of Bungaree and Buninyong (declared to be a State highway under the said Act which declaration

was confirmed by the Order in Council published in the *Government Gazette* of the 8th July, 1925, on pages 2371-3) should be widened by the said Board: And whereas the said Board in accordance with the requirements of section 19 of the said cited Act has caused to be prepared a map plan and estimate showing the points between which and on and through what land the said widening is proposed to be made and the cost of acquiring the land: And whereas on an inspection of the said map and plan and a consideration of the said estimate His Excellency the Governor in Council is satisfied that there are funds legally available for acquiring the land: Now therefore be it known by this present Order that His Excellency the Governor of the State of Victoria with the advice of the Executive Council thereof doth hereby approve of the said highway being widened, that is to say:—

All those pieces of land in the Parish of Warrenheip, the boundaries of which are as follow:—

- (a) Commencing at a point on the southern boundary of allotment 2, section 2A, of the said parish, distant 248 deg. 56 min. 392.3 links from the south-eastern angle of the said allotment; thence by lines bearing respectively 248 deg. 56 min. 240 links, 275 deg. 31 min. 260 links and 82 deg. 46 min. 486.6 links to the point of commencement.
- (b) Commencing at the north-western angle of allotment 4, section 2A, of the said parish; thence by lines bearing respectively 73 deg. 55 min. 440 links, 95 deg. 31 min. 1,075.2 links, 267 deg. 33½ min. 1,678.2 links and 73 deg. 55 min. 191.2 links to the point of commencement—

which said pieces of land are particularly delineated and shown coloured red on survey plan numbered 8245, lodged in the office of the Country Roads Board.

And the Honorable Horace Rostill Petty, Her Majesty's Commissioner of Public Works for the State of Victoria, shall give the necessary directions herein accordingly.

N. G. WISHART,  
Acting Clerk of the Executive Council.

#### COUNTRY ROADS BOARD.

At Government House, Melbourne, the  
eighteenth day of September, 1961.

##### PRESENT:

His Excellency the Governor of Victoria.

Mr. Bolte	Mr. Rylah
Mr. Mibus	Mr. Petty
Mr. Turnbull	Mr. Reid
Mr. Porter	Mr. Fraser
Mr. Thompson	Mr. Mack.
Mr. Meagher	

#### DECLARATION OF THE WIDENING OF WEDDERBURN-BOORT ROAD IN THE SHIRE OF KORONG.

WHEREAS by section 21 of the *Country Roads Act* 1958 (No. 6229) it is amongst other things enacted that when the Country Roads Board under the provisions of the Country Roads Act has taken the land necessary for constructing the road or deviation or widening it shall as soon as it thinks such road or deviation or widening is fit to be used as a public highway by Resolution declare the road or deviation or widening to be a main road or part thereof and that upon publication in the *Government Gazette* of the Order of the Governor in Council confirming such Resolution such road or deviation or widening shall thereupon be a main road or a part thereof within the meaning of the said Act: And whereas the said Board has by Resolution declared the road on the land described in the Schedule to such Resolution to be part of a main road: Now therefore His Excellency the Governor of the State of Victoria by and with the advice of the Executive Council thereof doth hereby confirm the said Resolution.

#### Resolution for Declaration of the Widening of a Main Road under the Country Roads Act.

Whereas the land the site of the road the course of which is below set out was taken by the Board under the provisions of the Country Roads Act for the purpose of widening the main road aforesaid which widening has now been laid out and formed on the same: And whereas the said Board (being the Country Roads Board incorporated under the said Act) thinks that the widening aforesaid is fit to be used as part of a public highway,

such Board at a meeting now holden doth by this Resolution hereby declare the same as described in the Schedule hereto with the commencing and terminating points thereof respectively specified to be part of the main road within the meaning and for the purposes of the Country Roads Board.

##### SCHEDULE.

#### Shire of Korong.

8. *Wedderburne-Boort road* (8708).—All that piece of land in the Parish of Mysia, the boundaries of which are as follow:—Commencing at the north-eastern angle of a Railway Reserve, formerly part of allotment 152 of the said parish; thence by lines bearing respectively 179 deg. 53 min. 909 links, 343 deg. 51 min. 945.8 links and 89 deg. 52 min. 261.3 links to the point of commencement— which said piece of land is particularly delineated and shown coloured red on survey plan numbered 7119, lodged in the office of the Country Roads Board.

The common seal of the Country Roads Board was hereto affixed, at Kew, this eleventh day of September, One thousand nine hundred and sixty-one, in the presence of—

D. V. DARWIN, Chairman.  
C. G. ROBERTS, Deputy Chairman.  
R. E. V. DONALDSON, Secretary.

And the Honorable Horace Rostill Petty, Her Majesty's Commissioner of Public Works for the State of Victoria, shall give the necessary directions herein accordingly.

N. G. WISHART,  
Acting Clerk of the Executive Council.

#### COUNTRY ROADS BOARD.

At Government House, Melbourne, the  
eighteenth day of September, 1961.

##### PRESENT:

His Excellency the Governor of Victoria.

Mr. Bolte	Mr. Rylah
Mr. Mibus	Mr. Petty
Mr. Turnbull	Mr. Reid
Mr. Porter	Mr. Fraser
Mr. Thompson	Mr. Mack.
Mr. Meagher	

#### DECLARATION OF THE WIDENING OF BEAUFORT-LEXTON ROAD IN THE SHIRE OF RIPON.

WHEREAS by section 21 of the *Country Roads Act* 1958 (No. 6229) it is amongst other things enacted that when the Country Roads Board under the provisions of the Country Roads Act has taken the land necessary for constructing the road or deviation or widening it shall as soon as it thinks such road or deviation or widening is fit to be used as a public highway by Resolution declare the road or deviation or widening to be a main road or part thereof and that upon publication in the *Government Gazette* of the Order of the Governor in Council confirming such Resolution such road or deviation or widening shall thereupon be a main road or a part thereof within the meaning of the said Act: And whereas the said Board has by Resolution declared the road on the land described in the Schedule to such Resolution to be part of a main road: Now therefore His Excellency the Governor of the State of Victoria by and with the advice of the Executive Council thereof doth hereby confirm the said Resolution.

#### Resolution for Declaration of the Widening of a Main Road under the Country Roads Act.

Whereas the land the site of the road the course of which is below set out was taken by the Board under the provisions of the Country Roads Act for the purpose of widening the main road aforesaid which widening has now been laid out and formed on the same: And whereas the said Board (being the Country Roads Board incorporated under the said Act) thinks that the widening aforesaid is fit to be used as part of a public highway such Board at a meeting now holden doth by this Resolution hereby declare the same as described in the Schedule hereto with the commencing and terminating points thereof respectively specified to be part of the main road within the meaning and for the purposes of the Country Roads Act.

## SCHEDULE.

*Shire of Ripon.*

5. *Beaufort-Lexton road* (14105).—All that piece of land in the Parish of Raglan, the boundaries of which are as follow:—Commencing at the south-eastern angle of allotment 1E, section 3, of the said parish; thence by lines bearing respectively 343 deg. 51 min. 623 links, 118 deg. 9 min. 8.4 links, 156 deg. 32 min. 625.7 links and 256 deg. 10 min. 85.8 links to the point of commencement—which said piece of land is particularly delineated and shown coloured red on survey plan numbered 7654, lodged in the office of the Country Roads Board.

The common seal of the Country Roads Board was hereto affixed, at Kew, this eleventh day of September, One thousand nine hundred and sixty-one, in the presence of—

(SEAL) D. V. DARWIN, Chairman.  
C. G. ROBERTS, Deputy Chairman.  
R. E. V. DONALDSON, Secretary.

And the Honorable Horace Rostill Petty, Her Majesty's Commissioner of Public Works for the State of Victoria, shall give the necessary directions herein accordingly.

N. G. WISHART,  
Acting Clerk of the Executive Council.

## MOUNT BEAUTY WATERWORKS TRUST.

*At Government House, Melbourne, the  
twenty-sixth day of September, 1961.*

## PRESENT:

His Excellency the Governor of Victoria.  
Mr. Fraser | Mr. Mack.

## AMENDMENT OF ORDER.

UNDER the powers conferred by the Water Acts and all other powers enabling him in that behalf, His Excellency the Governor of the State of Victoria, by and with the advice of the Executive Council of the said State, doth hereby amend as follows the Order in Council constituting the Mount Beauty Waterworks Trust made on the 17th March, 1959, and published in the *Victoria Government Gazette* dated 18th March, 1959.

In clause 3 for the expression "South Riding of the Shire of Bright" there shall be substituted the expression "Mount Beauty Riding of the Shire of Bright".

And the Honorable Wilfred John Mibus, Her Majesty's Minister of Water Supply for the State of Victoria, shall give the necessary directions herein accordingly.

N. G. WISHART,  
Acting Clerk of the Executive Council.

## MOUNT BEAUTY SEWERAGE AUTHORITY.

*At Government House, Melbourne, the  
twenty-sixth day of September, 1961.*

## PRESENT:

His Excellency the Governor of Victoria.  
Mr. Fraser | Mr. Mack.

## AMENDMENT OF ORDER.

UNDER the powers conferred by the *Sewerage Districts Act 1958* and all other powers enabling him in that behalf, His Excellency the Governor of the State of Victoria, by and with the advice of the Executive Council of the said State, doth hereby amend as follows the Order in Council proclaiming the Sewerage District and constituting the Mount Beauty Sewerage Authority made on the 25th May, 1960, and published in the *Victoria Government Gazette* dated 1st June, 1960.

In clause (d) for the expression "South Riding of the Shire of Bright" there shall be substituted the expression "Mount Beauty Riding of the Shire of Bright".

And the Honorable Wilfred John Mibus, Her Majesty's Minister of Water Supply for the State of Victoria, shall give the necessary directions herein accordingly.

N. G. WISHART,  
Acting Clerk of the Executive Council.

## LEONGATHA WATERWORKS TRUST.

*At Government House, Melbourne, the  
twenty-sixth day of September, 1961.*

## PRESENT:

His Excellency the Governor of Victoria.  
Mr. Fraser | Mr. Mack.

## ALTERATION IN THE CONSTITUTION OF THE TRUST.

WHEREAS by an Order in Council bearing date the 6th day of March, 1905, the Leongatha Waterworks Trust was duly constituted and by a further Order dated the 18th day of May, 1915, the constitution was amended to provide that the Trust shall consist of seven Commissioners to be elected for such Trust.

And whereas the Trust has now requested that the constitution be further amended to provide for seven Commissioners, six of whom shall be elected by the ratepayers and one appointed by the Governor in Council and that one-third of the elected Commissioners shall retire annually.

Now therefore His Excellency the Governor of the State of Victoria, by and with the advice of the Executive Council of the said State, and in pursuance of the powers conferred upon him by the Water Acts, doth hereby declare that the persons holding office as Commissioners of the Leongatha Waterworks Trust shall after the 25th day of October, 1961, cease to hold office as such Commissioners accordingly, and shall, after such day, be succeeded by seven Commissioners, six of whom shall be elected by the ratepayers on the 26th day of October, 1961, and one other person appointed by the Governor in Council.

And doth hereby direct that as from the 26th day of October, 1961, one-third of the Commissioners elected by the ratepayers shall retire and be elected annually and the Commissioners shall go out of office in the order of the number of votes obtained by each at his election commencing with the smallest number and proceeding upwards, and, in all such cases if the votes given for any Commissioners of whom a number less than the whole are to go out of office at any one time have been equal, or if such Commissioners have been elected without a poll, the Trust fourteen days at least previously to the day hereby appointed for the going out of office, and in its default, the Governor in Council, shall for such occasion determine in what order and which of such Commissioners shall go out of office.

And the Honorable Wilfred John Mibus, Her Majesty's Minister of Water Supply for the State of Victoria, shall give the necessary directions herein accordingly.

N. G. WISHART,  
Acting Clerk of the Executive Council.

## BALLARAT SEWERAGE AUTHORITY.

*At Government House, Melbourne, the  
twenty-sixth day of September, 1961.*

## PRESENT:

His Excellency the Governor of Victoria.  
Mr. Fraser | Mr. Mack.

## CONSENT TO BORROWING £45,000.

UNDER the powers conferred by the *Sewerage Districts Act 1958* and all other powers enabling him in that behalf, His Excellency the Governor of the State of Victoria, by and with the advice of the Executive Council of the said State, doth hereby consent to the Ballarat Sewerage Authority borrowing the sum of Forty-five thousand pounds (£45,000) in two amounts of Twenty-five thousand pounds (£25,000) and Twenty thousand pounds (£20,000) respectively by the assignment of the General Fund to meet the cost of sewerage works at Ballarat, as set forth in the detailed statement bearing date the 21st September, 1961.

And the Honorable Wilfred John Mibus, Her Majesty's Minister of Water Supply for the State of Victoria, shall give the necessary directions herein accordingly.

N. G. WISHART,  
Acting Clerk of the Executive Council.

## GEELONG WATERWORKS AND SEWERAGE TRUST.

*At Government House, Melbourne, the  
twenty-sixth day of September, 1961.*

PRESENT:

His Excellency the Governor of Victoria,  
Mr. Fraser | Mr. Mack.

## CONSENT TO BORROWING £50,000.

UNDER the powers conferred by the Geelong Waterworks and Sewerage Acts, and all other powers enabling him in that behalf, His Excellency the Governor of the State of Victoria, by and with the advice of the Executive Council of the said State, doth hereby consent to the Geelong Waterworks and Sewerage Trust borrowing at interest, subject to the Geelong Waterworks and Sewerage Acts, the sum of Fifty thousand pounds (£50,000) to meet the cost of sewerage works.

And the Honorable Wilfred John Mibus, Her Majesty's Minister of Water Supply for the State of Victoria, shall give the necessary directions herein accordingly.

N. G. WISHART,  
Acting Clerk of the Executive Council.

## GEELONG WATERWORKS AND SEWERAGE TRUST.

*At Government House, Melbourne, the  
twenty-sixth day of September, 1961.*

PRESENT:

His Excellency the Governor of Victoria,  
Mr. Fraser | Mr. Mack.

## COMPULSORY ACQUISITION OF EASEMENT.

UNDER the powers conferred by the Geelong Waterworks and Sewerage Acts, and all other powers enabling him in that behalf, His Excellency the Governor of the State of Victoria, by and with the advice of the Executive Council of the said State, doth hereby consent to the compulsory acquisition by the Geelong Waterworks and Sewerage Trust of an easement for water supply purposes, such land being part of Crown allotment 8, Parish of Barrarbool, County of Grant, as shown by red colour on plans marked "A" and "B" approved by the Governor in Council and deposited in the office of the State Rivers and Water Supply Commission, Melbourne.—(Corres. Rs.59/1021/166.)

And the Honorable Wilfred John Mibus, Her Majesty's Minister of Water Supply for the State of Victoria, shall give the necessary directions herein accordingly.

N. G. WISHART,  
Acting Clerk of the Executive Council.

## SNOWY RIVER IMPROVEMENT TRUST.

*At Government House, Melbourne, the twenty-sixth day  
of September, 1961.*

PRESENT:

His Excellency the Governor of Victoria,  
Mr. Fraser | Mr. Mack.

## LOAN OF £10,000.

IN pursuance of the powers conferred by section 43 of the *River Improvement Act 1958* and all other powers enabling him in that behalf, His Excellency the Governor of the State of Victoria, by and with the advice of the Executive Council of the said State, doth by this Order—

1. Make advance by way of loan to the Snowy River Improvement Trust of a sum of Ten thousand pounds (£10,000); and

2. Apply the following terms and conditions:—

(a) That the said sum shall be used for the carrying out of approved river improvement works within the boundaries of the Snowy River Improvement District;

(b) that the Snowy River Improvement Trust shall, in respect of such advance by way of loan, be subject to the powers, rights, duties and obligations conferred and imposed by—

- (i) the provisions of sections 284, 285 and 287 to 294 of Part VII. of the *Water Act 1958*, so adapted that the word "Authority" therein shall mean "the Snowy River Improvement Trust", and
- (ii) the provisions of section 295 of the said Part VII. of the *Water Act 1958*, so adapted as if for the expressions "any waterworks trust or local governing body" and "such waterworks trust or local governing body" there were substituted the expression "the Snowy River Improvement Trust".

And the Honorable Wilfred John Mibus, Her Majesty's Minister of Water Supply for the State of Victoria, shall give the necessary directions herein accordingly.

N. G. WISHART,  
Acting Clerk of the Executive Council.

## MOOROOPNA WATERWORKS TRUST.

*At Government House, Melbourne, the twenty-sixth day  
of September, 1961.*

PRESENT:

His Excellency the Governor of Victoria,  
Mr. Fraser | Mr. Mack.

## REPEAL OF ORDER.

UNDER the powers conferred by the Water Acts and all other powers enabling him in that behalf, His Excellency the Governor of the State of Victoria, by and with the advice of the Executive Council of the said State, doth hereby repeal the Order made by the Governor in Council on 24th November, 1954, fixing the limit of the overdraft to be obtained by the Moorooopna Waterworks Trust from the Commercial Bank of Australia Limited, Moorooopna, at an amount not to exceed at any one time the sum of One thousand pounds (£1,000).

And as on and from the date hereof the said Order of the Governor in Council shall be deemed to be repealed accordingly.

And the Honorable Wilfred John Mibus, Her Majesty's Minister of Water Supply for the State of Victoria, shall give the necessary directions herein accordingly.

N. G. WISHART,  
Acting Clerk of the Executive Council.

## TARWIN RIVER IMPROVEMENT TRUST.

*At Government House, Melbourne, the twenty-sixth day  
of September, 1961.*

PRESENT:

His Excellency the Governor of Victoria,  
Mr. Fraser | Mr. Mack.

## LOAN OF £10,000.

IN pursuance of the powers conferred by section 43 of the *River Improvement Act 1958* and all other powers enabling him in that behalf, His Excellency the Governor of the State of Victoria, by and with the advice of the Executive Council of the said State, doth by this Order—

1. Make advance by way of loan to the Tarwin River Improvement Trust of a sum of Ten thousand pounds (£10,000); and

2. Apply the following terms and conditions:—

(a) That the said sum shall be used for the carrying out of approved river improvement works within the boundaries of the Tarwin River Improvement District;

(b) that the Tarwin River Improvement Trust shall, in respect of such advance by way of loan, be subject to the powers, rights, duties and obligations conferred and imposed by—

- (i) the provisions of sections 284, 285 and 287 to 294 of Part VII. of the *Water Act 1958*, so adapted that the word



- "Authority" therein shall mean "the Tarwin River Improvement Trust", and
- (ii) the provisions of section 295 of the said Part VII. of the *Water Act* 1958, so adapted as if for the expressions "any waterworks trust or local governing body" and "such waterworks trust or local governing body" there were substituted the expression "the Tarwin River Improvement Trust".

And the Honorable Wilfred John Mibus, Her Majesty's Minister of Water Supply for the State of Victoria, shall give the necessary directions herein accordingly.

N. G. WISHART,  
Acting Clerk of the Executive Council.

#### KIEWA RIVER IMPROVEMENT TRUST.

At Government House, Melbourne, the twenty-sixth day of September, 1961.

PRESENT:

His Excellency the Governor of Victoria.  
Mr. Fraser | Mr. Mack.

#### LOAN OF £5,000.

IN pursuance of the powers conferred by section 43 of the *River Improvement Act* 1958 and all other powers enabling him in that behalf, His Excellency the Governor of the State of Victoria, by and with the advice of the Executive Council of the said State, doth by this Order—

1. Make advance by way of loan to the Kiewa River Improvement Trust of a sum of Five thousand pounds (£5,000).

2. Apply the following terms and conditions:—

- (a) That the said sum shall be used for the carrying out of approved river improvement works within the boundaries of the Kiewa River Improvement District;
- (b) that the Kiewa River Improvement Trust shall, in respect of such advance by way of loan, be subject to the powers, rights, duties and obligations conferred and imposed by—
- (i) the provisions of sections 284, 285 and 287 to 294 of Part VII. of the *Water Act* 1958, so adapted that the word "Authority" therein shall mean "the Kiewa River Improvement Trust", and
- (ii) the provisions of section 295 of the said Part VII. of the *Water Act* 1958, so adapted as if for the expressions "any waterworks trust or local governing body" there were substituted the expression "the Kiewa River Improvement Trust".

And the Honorable Wilfred John Mibus, Her Majesty's Minister of Water Supply for the State of Victoria, shall give the necessary directions herein accordingly.

N. G. WISHART,  
Acting Clerk of the Executive Council.

#### TOWN AND COUNTRY PLANNING ACT 1958, AS AMENDED.

At Government House, Melbourne, the twenty-sixth day of September, 1961.

PRESENT:

His Excellency the Governor of Victoria.  
Mr. Fraser | Mr. Mack.

#### REVOCATION IN PART OF THE TALLANGATTA PLANNING SCHEME 1956.

WHEREAS it is provided under the *Town and Country Planning Act* 1958, as amended, that the Governor in Council, upon application of the Town and Country Planning Board or the responsible authority or of any other person or body of persons appearing to him to be interested, may revoke the whole or any part of any planning scheme if he thinks that, under the special circumstances of the case, it should be so revoked: Now, therefore, the Governor in Council, by and with the advice

of the Executive Council and on the recommendation of the Town and Country Planning Board, doth hereby revoke the Tallangatta Planning Scheme 1956, in so far as it applies to all that land being lot 11A on the plan of subdivision No. 51860, lodged at the Office of Titles, being part of Crown allotment 7, section 11, Parish of Beethang, County of Bogong.

And the Honorable Murray Victor Porter, Her Majesty's Minister for Local Government for the State of Victoria, shall give the necessary directions herein accordingly.

N. G. WISHART,  
Acting Clerk of the Executive Council.

#### TOWN AND COUNTRY PLANNING ACT 1958, AS AMENDED.

At Government House, Melbourne, the twenty-sixth day of September, 1961.

PRESENT:

His Excellency the Governor of Victoria.  
Mr. Fraser | Mr. Mack.

#### REVOCATION OF AN INTERIM DEVELOPMENT ORDER.—MELBOURNE AND METROPOLITAN BOARD OF WORKS.

IN pursuance of the powers conferred by the *Town and Country Planning Act* 1958, as amended, the Governor of the State of Victoria, by and with the advice of the Executive Council thereof, at the request of the Melbourne and Metropolitan Board of Works, supported by the recommendation of the Town and Country Planning Board, hereby revokes the Interim Development Order for the whole of the metropolitan area other than such part thereof as lies within the municipal district of the Shire of Fern Tree Gully made by the Melbourne and Metropolitan Board of Works on the 19th day of October, 1959, approved by the Governor in Council on the 1st day of March, 1960, and notice of approval of which was published in the *Government Gazette* on the 16th day of March, 1960, and subsequently republished in accordance with the *Town and Country Planning Act* 1958, as amended, in the *Government Gazette* on the 24th day of May, 1961.

And the Honorable Murray Victor Porter, Her Majesty's Minister for Local Government for the State of Victoria, shall give the necessary directions herein accordingly.

N. G. WISHART,  
Acting Clerk of the Executive Council.

#### HOUSING ACT 1958.

At Government House, Melbourne, the twenty-sixth day of September, 1961.

PRESENT:

His Excellency the Governor of Victoria.  
Mr. Fraser | Mr. Mack.

#### DECLARATION OF A RECLAMATION AREA AT CARLTON.

WHEREAS within an area situated in the City of Melbourne (which area is described in the Schedule hereto) there are houses which—

- (a) are unfit for human habitation; and
- (b) are in the opinion of the Housing Commission unsanitary or unhealthy by reason of—
- (i) the excessive number of buildings within the area;
- (ii) the bad arrangement of buildings within the area;
- (iii) the bad arrangement or narrowness of streets within the area.

And whereas Housing Commission considers that housing conditions within the said area cannot be satisfactorily dealt with unless the said area is dealt with, pursuant to Division 2 of Part III. of the *Housing Act* 1958, as a Reclamation Area:

And whereas Housing Commission, having duly compiled with the provisions of sub-section (3) of section 67 of the

*Housing Act 1958*, has submitted to the Governor in Council its recommendation that the said area should be constituted as a Reclamation Area:

Now therefore, I, the Governor of the State of Victoria, in the Commonwealth of Australia, by and with the advice of the Executive Council of the said State and in pursuance of the powers conferred by the said Act, and upon such recommendation doth by this Order declare the area described in the Schedule hereto to be a Reclamation Area.

## SCHEDULE.

All that piece of land situate within the municipality of the City of Melbourne, being the whole of Crown allotments 1, 2, 3, 8, 9, 10, 11, 12, 13, 14, 15, 16, 22, 23 and 24, all of sections 69A, at Carlton, Parish of Jika Jika, County of Bourke, and so much of Crown allotments 4, 5, 6 and 7, section 69A, at Carlton, Parish of Jika Jika, County of Bourke, as lies within an area bounded as follows:—

Commencing at a point on the eastern alignment of Drummond-street being the north-western corner of the said Crown allotment 4; thence easterly along the northern boundary of Crown allotment 4 to the north-eastern corner of the land described in certificate of title, volume 8117, folio 334; thence southerly by the eastern boundaries of the lands described in certificates of title, volume 8117, folio 334, volume 8117, folio 333 and volume 754, folio 773, and by the southerly prolongation of the eastern boundary of the land comprised in certificate of title, volume 754, folio 773, to a point on the northern boundary of the land comprised in certificate of title, volume 8182, folio 372; thence easterly by the said northern boundary of the land comprised in certificate of title, volume 8182, folio 372, to the north-eastern corner of such land; thence southerly by the eastern boundaries of the lands comprised in certificates of title, volume 8182, folio 372, volume 825, folio 955, volume 8248, folio 961 and volume 8275, folio 033, to the south-eastern corner of the land comprised in the said certificate of title, volume 8275, folio 033; thence southerly across Reeves-street to the north-eastern corner of the land comprised in certificates of title, volume 8123, folio 782, volume 8096, folio 759, volume 8109, folio 785, volume 4412, folio 319 and volume 4412, folio 318, to a point on the southern boundary of the said Crown allotment 7; thence westerly by the said southern boundary of Crown allotment 7 to the south-western corner thereof being a point on the eastern alignment of Drummond-street; and thence northerly by the said eastern alignment of Drummond-street to the point of commencement.

And the Honorable Lindsay Hamilton Simpson Thompson, Her Majesty's Acting Minister of Housing for the State of Victoria, shall give the necessary directions herein accordingly.

N. G. WISHART,  
Acting Clerk of the Executive Council.

## LANDLORD AND TENANT ACT 1958.

At Government House, Melbourne, the  
twenty-sixth day of September, 1961.

## PRESENT:

His Excellency the Governor of Victoria.  
Mr. Fraser | Mr. Mack.

ORDER EXTENDING APPLICATION OF PART V. OF THE LANDLORD AND TENANT ACT 1958, TO CERTAIN PREMISES AND EXCLUDING CERTAIN PREMISES FROM THE OPERATION OF CERTAIN PROVISIONS CONTAINED IN PART V.

IN pursuance of the powers conferred by section 44 of the *Landlord and Tenant Act 1958*, His Excellency the Governor of Victoria, by and with the advice of the Executive Council thereof, doth hereby declare that the application of Part V. of the *Landlord and Tenant Act 1958* shall extend to each of the following premises:—

1. The premises known as No. 5 Miller-street, Box Hill.
2. The premises known as No. 441 Swan-street, Richmond.

And doth hereby further declare that the premises known as Flat No. 2 at No. 28 Neerim-road, Caulfield, shall be excluded from the operation of the whole of the provisions contained in divisions 2 and 3 of Part V. of the Act.

And the Honorable Arthur Gordon Rylah, Her Majesty's Attorney-General, in and for the State of Victoria, shall give the necessary directions herein accordingly.

N. G. WISHART,  
Acting Clerk of the Executive Council.

## SEEDS ACT 1958 (No. 6364).

At Government House, Melbourne, the  
twenty-sixth day of September, 1961.

## PRESENT:

His Excellency the Governor of Victoria.  
Mr. Fraser | Mr. Mack.

## REGULATIONS.

UNDER the powers conferred by the *Seeds Act 1958* (No. 6364) to make Regulations for or with respect to the carrying out of Victorian seed certification schemes including the conditions under which certificates in accordance with such schemes may be granted, His Excellency the Governor of the State of Victoria, by and with the advice of the Executive Council of the said State, doth hereby make the following Regulations, that is to say:—

The Regulations made on the 14th December, 1936, and amended on 13th December, 1937, 9th December, 1947, 14th June, 1955, 28th August, 1956, and 27th September, 1960, are hereby further amended as follows:—

(a) at the end of Regulation 10 there shall be inserted the following:—

"(IX.) Nangeela Subterranean Clover 14 lb.";

(b) at the end of the Second Schedule there shall be inserted the following:—

"(IX.) Nangeela Subterranean Clover—

Three pence for every 20 lb. or part thereof";

(c) at the end of the Third Schedule there shall be inserted the following:—

"(IX.) Nangeela Subterranean Clover—

One penny half penny for every 20 lb. or part thereof";

(d) at the end of the Fourth Schedule there shall be inserted the following:—

"(IX.) Nangeela Subterranean Clover—

One penny half penny for every 20 lb. or part thereof".

And the Honorable Gilbert Lawrence Chandler, Her Majesty's Minister of Agriculture for the State of Victoria, shall give the necessary directions herein accordingly.

N. G. WISHART,  
Acting Clerk of the Executive Council.

## APPROACHING LAND SALES.

SALES of Crown lands, in fee-simple, will be held at the under-mentioned places and dates, viz:—

	No. of Gazette.
Ararat.—Friday, 29th September, 1961	75
Avoca.—Friday, 13th October, 1961	79
Ballarat.—Tuesday, 3rd October, 1961	75
Bendigo.—Thursday, 5th October, 1961	77
St. Arnaud.—Thursday, 12th October, 1961	79
Sale.—Tuesday, 3rd October, 1961	75
Wedderburn.—Monday, 16th October, 1961	79

## LOCAL LAND BOARDS.

IN pursuance of the provisions of section 34 of the *Land Act 1958*, notice is hereby given that public hearings at the following places and times will be conducted by the persons respectively mentioned, being duly appointed in that behalf.

KEITH TURNBULL,  
Commissioner of Crown Lands and Survey.

Department of Crown Lands and Survey,  
Melbourne, 26th September, 1961.

BENDIGO LAND OFFICE, Thursday, 12th October, 1961,  
at 9.30 a.m.—G. E. HARPIN.

LIST OF CROWN LANDS AVAILABLE.

THE under-mentioned areas are available for application as provided by various sections of the *Land Act 1958*, and all applications received on or before Wednesday, 25th October, 1961, will be deemed to have been made simultaneously, but any application lodged after such date may be considered if received in time for inclusion in the advertisement of the cases to be heard at the Local Land Board.

Applications on proper form, accompanied by 5s. duty stamp uncancelled (registration fee), may be delivered or forwarded by post to the Local Land Officer or to any Crown Lands Office in Victoria. Subject to the approval of the Secretary for Lands, when the survey fee exceeds £25 but does not exceed £50, a deposit of £25 may be paid, and when the fee exceeds £50, a deposit of 50 per cent. of the fee, the balance in either case being payable over six years in half-yearly instalments.

Marked plans of any particular area, application forms, and any further information may be obtained from the Crown Lands Department, Melbourne, and Land Offices, Redcliffs and Ballarat.

Department of Crown Lands and Survey,  
Melbourne, 26th September, 1961.

KEITH TURNBULL,  
Commissioner of Crown Lands and Survey.

\* Improvements may be subject to re-valuation after land has been granted to an applicant

Local Land Office.	County.	Parish.	Allotment.	Section.	Area.	How Available.		Survey Fee.	Valuation of Improvements (if any).	Location of Land, &c.	Nearest Railway Station or Township and Distance in miles therefrom.	How Accessible.	Water Supply.	General Description of Land—Soil, Timber, Suitability (Grazing, &c.).	
						Classification.	Value per Acre.								
				A. R. P.		£ s. d.		£ s. d.							
AVAILABLE UNDER SECTION 138 OF THE LAND ACT 1958.															
Redcliffs (a)	Karkaroc	Mournpoul	21c	..	2 2 0	..	Rental to be fixed	7 7 6	To be valued	Fronting Calder Highway $\frac{1}{4}$ a mile north of Hattah Railway Station	Hattah R.S., $\frac{1}{4}$ mile	By road ..	To be conserved	Suitable for residence	
Ballarat (a)	Talbot	Creswick	H3	..	0 2 0	..	..	6 0 0	Nil	Fronting north side of main C.R.B. road, approx. $\frac{2}{4}$ miles north-east of the township of Creswick	Creswick R.S., approx. $\frac{2}{4}$ miles	.. ..	..	Suitable for dwelling and garden	

(a) Subject to survey.

**PROPOSED REVOCATIONS OF TEMPORARY RESERVATIONS OF LANDS BY ORDERS IN COUNCIL.**

**I**N pursuance of the provisions of the *Land Act 1958*, notice is hereby given that it is the intention of the Governor in Council to revoke the temporary reservations of lands by Orders in Council hereunder referred to, viz.:—

The following Notices were published 1° on the 13th September, 1961, pursuant to Orders of the 5th September, 1961.

**SALE.**—The temporary reservation, by Order in Council of the 13th June, 1916, of 1 rood 23 perches of land in the Township of Sale, as a site for Railway purposes.—(S.239(a) (Rs.1068).

**TURRUMBERRY.**—The temporary reservation, by Order in Council of the 15th September, 1941, of 2 acres of land in the Parish of Turrumberry, as a site for State School purposes.—(T.208(4) (Rs.5273).

**STAWELL.**—The temporary reservation, by Order in Council of the 20th April, 1874, of 5 acres of land in the Parish of Stawell, as a site for a Manure Depot, and the temporary reservation by Order of the 31st July, 1899, of 32 acres 1 rood 31 perches of land, as an extension thereto.—(S.329(1a) (C.86065).

**WOMBAT (DAYLESFORD).**—The temporary reservation, by Order in Council of the 3rd August, 1874 (see *Government Gazette* 1874, page 1470), of 1 acre 2 roods, more or less, of land in the Parish of Wombat, as a site for the Supply of Gravel, so far only as the portion containing 20 perches, more or less, indicated by hachure on plan hereunder, is concerned.—(W.179(27) (W.68737).

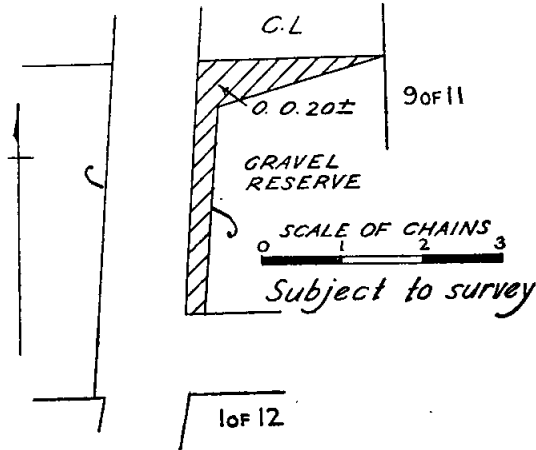

**HORSHAM.**—The temporary reservation, by Order in Council of the 8th March, 1932, of 8 acres 2 roods 25 7/10 perches of land in the Township of Horsham, as a site for Public Recreation, and the temporary reservation by Order of the 27th April, 1954, of 2 roods 36 perches of land as an extension thereto, so far only as the respective portions containing 1 rood 15 perches and 23 perches, indicated by hachure on plan hereunder, are concerned.—(H.91(3) (Rs.2496).

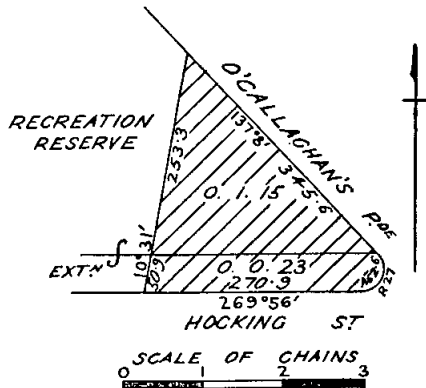

KEITH TURNBULL,  
Commissioner of Crown Lands and Survey.

**PROPOSED REVOCATIONS OF TEMPORARY RESERVATIONS OF LAND BY ORDERS IN COUNCIL.**

**I**N pursuance of the provisions of the *Land Act 1958*, notice is hereby given that it is the intention of the Governor in Council to revoke the temporary reservations of land by Orders in Council hereunder referred to, viz.:—

The following Notices were published 1° on the 6th September, 1961, pursuant to Orders of the 29th August, 1961.

**CANNUM (AUBREY).**—The temporary reservation, by Order in Council of the 16th September, 1929, of 30 acres 3 roods 32 perches of land in the Parish of Cannum, as a site for Public Recreation.—(C.417(6) (Rs.3890).

**KEILOR.**—The temporary reservation, by Order in Council of the 17th August, 1874, of 4 acres 1 rood 38 1/2 perches of land in the Township of Keilor, as a site for State School purposes.—(K.24(2) (C.83971).

**NHILL.**—The temporary reservation, by Order in Council of the 28th September, 1920, of 27/10 perches of land in the Township of Nhill, as a site for a Free Library, and the temporary reservation, by Order of the 10th November, 1927, of 5/10 perch of land, as an extension thereto.—(N.102(4) (Rs.2212).

**ORBOST.**—The temporary reservation, by Order in Council of the 1st September, 1924, of 10 acres of land in the Parish of Orbost, as a site for a Rubbish Depot.—(O.23(10) (Rs.2982).

**RUSHWORTH.**—The temporary reservation, by Order in Council of the 9th June, 1890, of 1 acre 2 roods 8 perches of land in the Township of Rushworth, as a site for Municipal Sale Yards, revoked as to part by Order of the 26th March, 1957, so far only as the portion containing 28 perches, indicated by hachure on plan hereunder, is concerned.—(R.47(6) (Rs.5952).

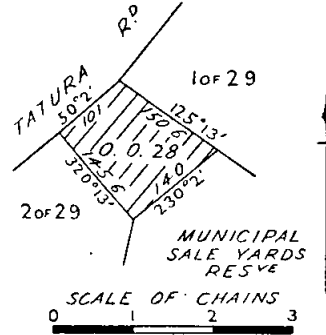

KEITH TURNBULL,  
Commissioner of Crown Lands and Survey.

**PROPOSED REVOCATIONS OF TEMPORARY RESERVATIONS OF LANDS BY ORDERS IN COUNCIL.**

**I**N pursuance of the provisions of the *Land Act 1958*, notice is hereby given that it is the intention of the Governor in Council to revoke the temporary reservations of lands by Orders in Council hereunder referred to, viz.:—

The following Notices were published 1° on the 20th September, 1961, pursuant to Orders of the 12th September, 1961.

**CORINDHAP.**—The temporary reservation, by Order in Council of the 13th October, 1931, of 20 acres 2 roods 35 perches of land in the Township of Corindhap as a site for the Supply of Gravel, revoked as to part by Order of the 23rd May, 1939, so far as the balance thereof, containing 20 acres 0 roods 6 perches, is concerned.—(C.269(6) (Rs.4158).

**BENALLA.**—The temporary reservation, by Order in Council of the 27th April, 1868, of 166 acres 1 rood 15 perches of land in the Parish of Benalla, as a site for Police purposes.—(B.392(3) (Rs.5496).

**HOWQUA.**—The temporary reservation, by Order in Council of the 8th April, 1885, of 2 acres of land in the Parish of Howqua, as a site for a State School.—(H.111(11) (Rs.8070).

**MILLOO.**—The temporary reservation, by Order in Council of the 12th June, 1876 (see *Government Gazette*, 16th June, 1876, page 1148) of 5 acres of land in the Parish of Milloo, as a site for Public purposes (State School), and the temporary reservation, by Order of the 17th April, 1924, of 2 acres 1 rood of land as an extension thereto.—(M.455(2) (Rs.2915).

WANNAEUE (ROSEBUD).—The temporary reservation, by Order in Council of the 21st April, 1959, of 6 acres 3 roods 9 perches of land in the Parish of Wannaeue, as a site for Hospital purposes.—(W.32<sup>(3)</sup>) (Rs.7816).

UPOTIPOPON.—The temporary reservation, by Order in Council of the 3rd October, 1887, of 1 acre of land in the Parish of Upotipotpon, as a site for a State School.—(U.53<sup>(3)</sup>) (C.96950).

HEALESVILLE.—The temporary reservation, by Order in Council of the 21st August, 1865 (see *Government Gazette*, 29th August, 1865, page 1939), of 1 acre 1 rood 9 perches of land in the Township of Healesville, as a site for Police purposes, so far only as the portion containing 3 perches, indicated by hachure on plan hereunder, is concerned.—(H.113<sup>(4)</sup>) (Rs.109).

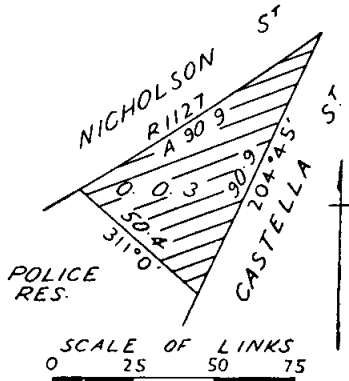

YACKANDANDAH.—The temporary reservation, by Order in Council of the 20th January, 1868, of 11 acres 2 roods 20 perches of land in the Township of Yackandandah, as a site for Police purposes, revoked as to part by various Orders, so far only as the portion containing 2 roods 20 perches, more or less, indicated by hachure on plan hereunder, is concerned.—(Y.45<sup>(12)</sup>) (Rs.1590).

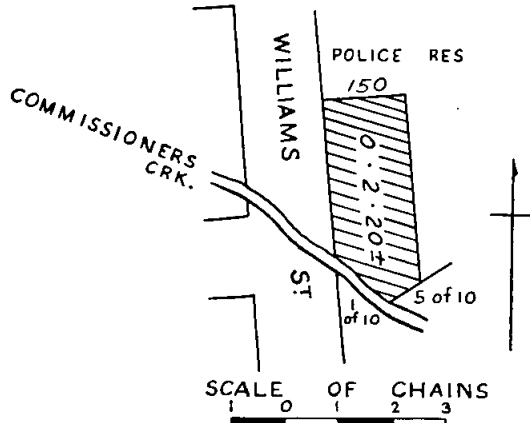

Subject to Survey

KEITH TURNBULL,  
Commissioner of Crown Lands and Survey.

PROPOSED REVOCATIONS OF TEMPORARY RESERVATIONS AND THE WITHHOLDING FROM SALE, LEASING, AND LICENSING OF LANDS BY ORDERS IN COUNCIL.

IN pursuance of the provisions of the *Land Act 1958*, notice is hereby given that it is the intention of the Governor in Council to revoke the temporary reservations, and the withholding from sale, leasing, and licensing of lands by Orders in Council hereunder referred to, viz.:—  
The following Notices were published 1° on the 20th September, 1961, pursuant to Orders of the 12th September, 1961.

DIMBOOLA.—The temporary reservation as a site for the use of the Police Department and the withholding from sale, leasing and licensing, by Order in Council of the 18th September, 1882, of 6 acres 1 rood 1 perch of land in the Township of Dimboola, revoked as to part by various Orders, so far only as the portion containing 32 perches, indicated by hachure on plan hereunder, is concerned.—(D.150<sup>(9)</sup>) (Rs.5081).

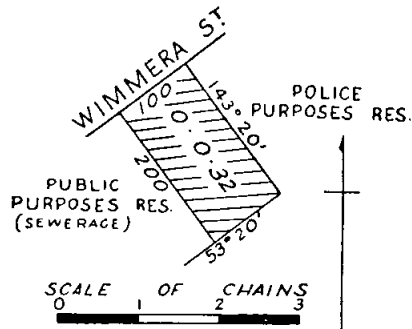

JERUK.—The temporary reservation as a site for Water Supply purposes and the withholding from sale, leasing and licensing, by Order in Council of the 12th June, 1882, of 10 acres of land in the Parish of Jeruk, so far only as the portion containing 1 acre, indicated by hachure on plan hereunder, is concerned.—(J.35<sup>(2)</sup>) (W.84704).

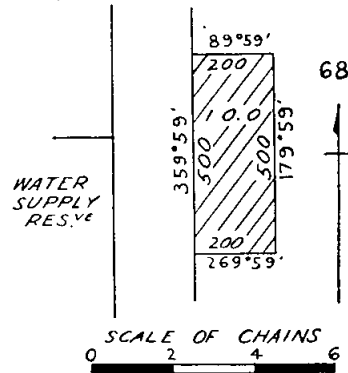

KEITH TURNBULL,  
Commissioner of Crown Lands and Survey.

PROPOSED REVOCATION OF PORTION OF TEMPORARY RESERVATION OF LAND BY ORDER IN COUNCIL.

IN pursuance of the provisions of the *Land Act 1958*, notice is hereby given that it is the intention of the Governor in Council to revoke portion of the temporary reservation of land by Order in Council hereunder referred to, viz.:—

The following Notice was published 1° on the 27th September, 1961, pursuant to Order of the 18th September, 1961.

BALLAARAT EAST.—The temporary reservation, by Order in Council of the 12th January, 1900 (see *Government Gazette*, 19th January, 1900, page 222), of 3 roods 18 perches, more or less, of land in the Township of Ballarat East as a site for an Ornamental Plantation, so far only as the portion containing 20 perches, more or less, indicated by hachure on plan hereunder, is concerned.—(B.128<sup>(4)</sup>) (Rs.8048).

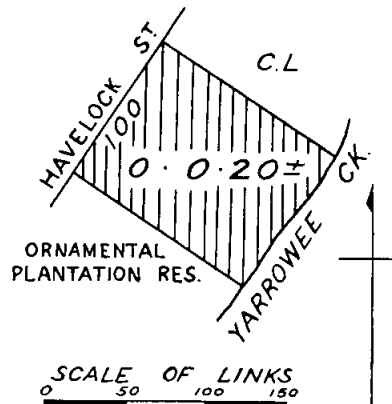

Subject to Survey

KEITH TURNBULL,  
Commissioner of Crown Lands and Survey.

## COMMITTEES OF MANAGEMENT OF RESERVES.

## APPOINTMENTS.

WHEREAS by section 221 of the *Land Act* 1958 it is provided that it shall be lawful for the Governor in Council or the Board of Land and Works to appoint and remove any number of persons, not less than three, or any municipal council, or the governing body of any corporation, to be a Committee of Management of any specified Crown land reserved either temporarily or permanently for any of the purposes set out in section 14 of the *Land Act* 1958, and not conveyed to or vested in trustees: Now therefore the Board of Land and Works doth hereby appoint the under-mentioned persons to be members of the Committee of Management of the Reserves named:—

## "BELGRAVE CENTRAL PARK RESERVE."

Lewis Jaques Newstead, Graham Alexander Connan, George Forsyth Christie, Alexander Wynnum King, James Ignatius Luby, Wilfred Osborne and Gerald Irish as a Committee of Management for the period ending 28th June, 1963, of that part of the public purposes reserve in the Parish of Narree Worrان as is indicated by blue colour on plan marked N over 6.9.61 attached to Lands Department correspondence Rs.4028, such land being part of the "Belgrave Central Park Reserve".—(Corres. Rs.4028.)

## "BELGRAVE CENTRAL PARK RESERVE."

The Council of the Shire of Fern Tree Gully as a Committee of Management of that part of the public purposes reserve in the Parish of Narree Worrان as is indicated by red colour on plan marked N over 6.9.61 attached to Lands Department correspondence Rs.4028, such land being part of the "Belgrave Central Park Reserve".—(Corres. Rs.4028.)

This appointment is in lieu of all previous appointments in respect of the said land, which are hereby revoked.

## "HILDA SWIMMING POOL RESERVE."

Ivan O'Donnell, Norman Cowling, George Walker, John Stephen Dunstan, Robert Augustine Kronk, Edward Robert Scott and John McKay Cannon as a Committee of Management for a period of three (3) years of the land temporarily reserved by Order in Council dated 25th January, 1949, as a site for Public Recreation (Swimming Pool) in the City of Bendigo, Parish of Sandhurst, and known as the "Hilda Swimming Pool Reserve", Kennington.—(Corres. Rs.6320.)

## "MALDON ATHENAEUM RESERVE."

Vera M. Somers, A. E. Edhouse, Ivan Clyde Park and W. A. Woodlock as a Committee of Management for a period of three (3) years from 9th September, 1961, of the land in the Township of Maldon permanently reserved by Order in Council of 12th March, 1889, as a site for an Athenaeum, Mining Museum and Free Library and adjoining land temporarily reserved by Order in Council of 10th December, 1946, as a site for Athenaeum and Free Library purposes, together known as the "Maldon Athenaeum Reserve".—(Corres. Rs.3060.)

## "ROBINVALE RECREATION RESERVE."

Henry Scott Ray, Ronald Cook, James Kennedy, Percy Lawrence Kimpton, Walter William Scott, Leonard James Arnott, Leslie John Neyland, Thomas Roy Jones, Norman Leslie Ginn and William Noel Chirgwin as a Committee of Management for the period of three (3) years of the land in the Township of Robinvale, Parish of Bumbang, temporarily reserved by Order in Council dated the 9th December, 1940, as a site for Public Recreation, and known as the "Robinvale Recreation Reserve".—(Corres. Rs.5139.)

## "BOORHAMAN RECREATION RESERVE."

Francis Michael O'Keefe, Michael McKenzie, Thomas Patrick Fogarty, Eric James Sammon, William Kenneth McDonald, Laurence John O'Keefe, John Patrick O'Keefe, Patrick Thomas Naughtin and Edmond Barthold Duffus as a Committee of Management for a period of three (3) years of the land permanently reserved by Order in Council dated the 28th January, 1927, as a site for Public Recreation in the Parish of Boorhaman, and known as the "Boorhaman Recreation Reserve".—(Corres. Rs.3404.)

## "YELLINGBO JUNCTION PARK."

Gordon Derrick Logan, Leonard Henry Staff, Christopher Ian Parslow, Darrel Gordon Lunson and Francis Edward Quigley as a Committee of Management for a period of three (3) years of the reserved lands in the

Parish of Wandin Yallock indicated by red colour on plan marked "W" 14.4.54 attached to Lands Department correspondence Rs.7213, and known as the "Yellingbo Junction Park".—(Corres. Rs.7213.)

In witness whereof the common seal of the Board of Land and Works was hereunto affixed this thirteenth day of September, One thousand nine hundred and sixty-one, in the presence of—

(SEAL) KEITH TURNBULL, President.  
L. B. MERCER, Member.

## ADDITIONAL REGULATIONS FOR THE CARE, PROTECTION AND MANAGEMENT OF THE "COHUNA RECREATION RESERVE".

THE Board of Land and Works, in pursuance of the powers conferred on it by section 218 of the *Land Act* 1958, doth hereby make the following additional Regulations in respect of the reserved Crown lands in the Parish of Cohuna as indicated by red and blue colours on plan marked C/8.3.1946, attached to Lands Department correspondence Rs.5312, and known as the "Cohuna Recreation Reserve".

## REGULATIONS.

24. The Committee of Management may set apart a portion or portions of the Reserve as and for the purposes of a Caravan Park and may make, fix and collect fees or other charges for entering and use of any such area or the buildings thereon.

25. In the area set aside by the Committee as a Caravan Park the following Regulations shall apply:—

1. In these Regulations, unless inconsistent with the context or subject-matter—

"Camping" includes the parking of a vehicle on the camping site.

"Camping site" means an individual site set apart by the Committee for the parking of vehicles and for the erection of tents.

"Caretaker" shall mean the Manager or Deputy Caretaker appointed by the Committee.

"Occupier" includes each and every person in charge of a vehicle parked on a camping site and the person in charge of any tent thereon.

"Refuse" includes food and all discarded matter.

"Sanitary conveniences" includes urinals, water closets, showers, water taps, gully traps, wash troughs, washing machines, wash coppers, wash basins, refuse bins and receptacles provided by the Committee for depositing therein of refuse.

"Vehicle" includes—

(a) motor cars within the meaning of the *Motor Car Act* 1958; and

(b) caravans and trailers.

*Parking of Vehicles.*

2. The person in charge of a vehicle and who desires to park the same in the Caravan Park shall park it on a camping site as directed by the Caretaker or, in his absence, on a vacant camping site in the said park and shall pay to the Caretaker the fees prescribed in accordance with these Regulations.

3. No occupier or other person shall park any vehicle and/or erect any tent or annexe so that any part thereof shall extend beyond the limits of the camping site occupied by him.

*Time Limit on Camping.*

4. No person other than a person desirous of holidaying in the Caravan Park shall bring a caravan therein and then only for a period of not more than three weeks at any one time save that under exceptional circumstances the Committee may extend the period of time upon receipt of a request, in writing, from the person or persons concerned.

*Sub-letting.*

5. No person shall sub-let any vehicle within the Caravan Park without the permission, in writing, of the Committee first obtained.

*Animals.*

6. No animals other than dogs shall be permitted in the Caravan Park and then only if confined to camping sites occupied by their owners or persons in charge of such dogs, or on a leash, or within the enclosure set apart for dogs.

7. If, in the opinion of the Caretaker, any dog is causing annoyance or disturbance to persons within the Caravan Park the owner or person for the time being in charge of such animal shall forthwith remove it from the Caravan Park.

*Conduct in the Caravan Park.*

8. No occupier shall deposit or cause to be deposited refuse in or on any part of the Caravan Park other than in receptacles provided for that purpose by the Committee.

9. Each occupier shall keep the camping site allocated to him clean and tidy.

10. Waste water shall be placed in or directed into receptacles provided by the Committee and under no circumstances shall waste water be deposited on or allowed to overflow on to the grounds of the Caravan Park. Occupiers shall be responsible for the emptying of such receptacles as directed by the Caretaker and then only into gully traps provided for that purpose.

11. The digging of trenches around vehicles or tents is prohibited.

12. No fires shall be lighted in the Caravan Park, except in such places as may be appointed by the Committee.

13. No person shall erect any building or structure in the Caravan Park other than annexes made of canvas or similar material which shall be deemed to be part of a vehicle and any tent or similar structure approved by the Caretaker.

14. No person shall—

(a) mark, write on or deface, or in any way damage any building, post, fence, railing, pillar or any other structure or property within the Caravan Park;

(b) affix any bill, sign or notice board to any tree or structure within the Caravan Park without permission, in writing, of the Committee first obtained.

15. No person shall without permission, in writing, of the Committee first obtained and subject to such conditions as the Committee thinks fit within the Caravan Park—

(a) sell or offer for sale any article or commodity whatsoever or distribute any bill or like thing or place any chair, seat or other item for hire;

(b) erect or place therein any building, booth, shed, stand, screen, post, rail, fence, swing, or seat or other erection or obstruction of any kind whatsoever, or in any way enclose any part of the Caravan Park;

(c) preach, declaim, harangue or deliver any address of any kind to members of the public;

(d) carry, use, or discharge any fireworks, firearms, air-gun or other lethal weapons.

16. No person shall without permission, in writing, of the Committee first obtained, operate or use any loud-speaker, amplifier, or broadcasting equipment (mechanical or electrical) for broadcasting music, speech, or other noises or sound within the Caravan Park.

17. No person shall spit or expectorate on any path or in any building or erection on the Caravan Park.

18. No person shall remove or displace any board, plate or fitting for the exhibition of any Regulations, neither shall any person remove or displace any notice fixed or set up in the Caravan Park by the Committee.

19. No person shall wilfully obstruct, disturb, interrupt or annoy any officer or employee of the Committee in the proper execution of his work and duty.

20. No person shall wilfully obstruct, disturb or annoy any other person in the proper use of the Caravan Park.

21. No person shall play, practise or engage in any game or sport within the Caravan Park without the consent of the Committee.

22. No male over the age of six years shall enter or use any place, room, convenience or building set apart for the use of females, and no females shall enter or use any place, room, convenience or building set apart for the use of males.

23. No person shall offend against decency as regards dress, language or conduct, or the use of unnecessarily loud talking, or by any unnecessary noise disturbing or otherwise annoying persons in the Caravan Park.

24. No person over the age of fourteen years shall use playground equipment erected within the Caravan Park.

25. No person shall cut, saw, dig, move or displace any tree, bough, live or dead timber, wood, or other material which may be in or around the Caravan Park without the consent, in writing, of the Committee.

26. No person shall remove any stone, soil, sand or loam from the Caravan Park without the consent, in writing, of the Committee.

*Boats.*

27. No person shall launch or moor any boat within the Caravan Park except at or from such places as are set apart for such purposes by the Committee, and the Committee may demand such fees as it from time to time determines for the use by any person of facilities or structures provided for these purposes.

28. No person shall drive any vehicle within the Caravan Park at a greater speed than 5 miles per hour.

*Fees.*

29. Every occupier shall pay to the Caretaker the respective fees prescribed from time to time by the Committee.

*General.*

30. Every person holding or purporting to hold any receipt or permission, in writing, issued by the Committee shall, on demand by any members of the Committee or any officer thereof or any member of the Police Force, produce such receipt or permission.

31. Any person who shall offend against any of these Regulations may be requested to leave the Caravan Park forthwith, and his refusal or failure to leave when so requested by the Caretaker or any duly authorized officer of the Committee or any member of the Police Force shall constitute a further offence against these Regulations. —(Rs.5312.)

The common seal of the Board of Land and Works was hereto affixed this 21st day of September, 1961, in the presence of—

(SEAL) KEITH TURNBULL, President.  
F. KLENNER, Member.

Every person who contravenes or fails to comply with these Regulations shall, in accordance with the provisions of section 218 of the *Land Act 1958*, for each offence be liable to a penalty of not more than Five pounds, and every person who contravenes or fails to comply with any such Regulations, and who, after he has been warned by any bailiff of Crown lands or by any member of the Police Force, does not desist therefrom, may be forthwith apprehended by such bailiff or member of the Police Force and taken before some justice to be dealt with according to law, and shall be liable to a penalty of not more than Ten pounds.

**RESCISSION OF REGULATION FOR THE CARE, PROTECTION AND MANAGEMENT OF THE RESERVE IN THE CITY OF MELBOURNE FOR THE RECREATION, CONVENIENCE AND AMUSEMENT OF THE PEOPLE AND FOR A CHILDREN'S PLAYGROUND.**

THE Board of Land and Works, in pursuance of the powers conferred on it, doth hereby rescind Regulation 17 of the Regulations made on 28th April, 1910, for the care, protection and management of the land in the City of Melbourne temporarily reserved by Order in Council dated, 24th August, 1909, as a site for the Recreation, Convenience and Amusement of the people and for a Children's Playground.—(Rs.525.)

The common seal of the Board of Land and Works was hereto affixed this twenty-first day of September, 1961, in the presence of—

(SEAL) KEITH TURNBULL, President.  
F. KLENNER, Member.

Every person who contravenes or fails to comply with these Regulations shall, in accordance with the provisions of section 218 of the *Land Act 1958*, for each offence be liable to a penalty of not more than Five pounds, and every person who contravenes or fails to comply with any such Regulations, and who, after he has been warned by any bailiff of Crown lands or by any member of the Police Force, does not desist therefrom, may be forthwith apprehended by such bailiff or member of the Police Force and taken before some justice to be dealt with according to law, and shall be liable to a penalty of not more than Ten pounds.

**APPLICATION OF THE REGULATIONS FOR THE CARE, PROTECTION AND MANAGEMENT OF THE "KING RESERVE", QUEENSCLIFF.**

WHEREAS by section 218 of the *Land Act 1958*, power is given to the Board of Land and Works to make Regulations in respect of the care, protection and management of any Crown land which has been reserved under the Land Acts for any public purpose whatsoever and which has not been conveyed to or vested in trustees, and for the further purposes as enacted, and whereas by sub-section 1 (e) of the said section 218 of

the *Land Act 1958*, power is given to the Board of Land and Works to apply all or any of the Regulations so made to any other land reserved aforesaid and not conveyed to or vested in trustees, in any case where the persons, Council or body comprising the Committee of Management of such first-mentioned land, are or is also appointed to the Committee of Management of such other land: Now therefore the Board of Land and Works, in pursuance of the powers conferred, doth hereby make the following Regulations:—

The Regulations made by the Board of Land and Works on 4th September, 1961, in respect of the reserved land in the Parish of Paywit, at Queenscliff as is indicated by

blue colour on plan Q.12.8.31 attached to Lands Department correspondence Rs.4110, and known as "King Reserve", are hereby applied to the land in the Township of Queenscliff, temporarily reserved by Order in Council dated 29th August, 1961, as a site for Public purposes.—(Rs.4110.)

The common seal of the Board of Land and Works was hereto affixed this twenty-first day of September, 1961, in the presence of—

(SEAL) KEITH TURNBULL, President.  
F. KLENNER, Member.

**PUBLIC SERVICE NOTICES**

**PUBLIC SERVICE (PUBLIC SERVICE BOARD) REGULATION 39.—RECLASSIFICATION.**

THE Public Service Board has raised the classification of the under-mentioned office as shown, and the Permanent Head of the Department has recommended the officer named for appointment.

Office and Present Classification.	Revised Classification.	Duties.	Qualifications.	Officer Recommended for Appointment.		
				Name.	Classification.	Date of Classification.

**PROFESSIONAL DIVISION.**

**TREASURY.**

*Office of the Housing Commission.*

Section Leader Draughtsman, Class "B"	Property Dealings Officer, Class "B1"	To direct and supervise the operation of the Draughting Section of the Property Control Division, and supervise various land dealings; to be responsible for the overall activities involved in Slum Reclamation, for the submission of Orders in Council and the preparation and service of notices to treat and for the supply of information required by the Division where legal and technical decisions regarding property are involved	A competent survey draughtsman with ability to control staff, and a good knowledge of the activities of the Division, conversant with procedure regarding land and property dealings, and aspects of title procurement involving the compulsory acquisition and re-subdivision of land for large housing projects, particularly as applied to Slum Reclamation projects; a knowledge of relevant sections of Housing Act, the Lands Compensation Act, and the Transfer of Land Act	Creighton, W.	Section Leader Draughtsman, Class "B"	15.10.56
---------------------------------------	---------------------------------------	--	--	---------------	---------------------------------------	----------

Appeals against such recommendation should be lodged with the Secretary to the Public Service Board not later than Saturday, the 7th October, 1961.

Office of the Public Service Board,  
Melbourne, 26th September, 1961.

By order,  
N. J. SIMMANCE,  
Acting Secretary.

**PUBLIC SERVICE OF VICTORIA.—VACANCIES.**

APPLICATIONS will be received by the Public Service Board up to Wednesday, the 11th October, 1961, from persons employed in the Public Service of Victoria, who are eligible and qualified for appointment to the under-mentioned positions.

**ADMINISTRATIVE DIVISION.**

**Assistant Accountant, Class "A", Education Department.**

*Yearly Salary.*—£1,920, minimum; £2,060, maximum.

*Duties.*—To be responsible under the Accountant for the direction and supervision of staff and the preparation of estimates and financial statements.

*Qualifications.*—A qualified Accountant with a good knowledge of the Public Accounts and Stores Regulations and Treasury and Audit practice.

**Public Service Inspector, Class "B", Office of the Public Service Board, Premier's Department.**

*Yearly Salary.*—£1,390, minimum; £1,500, maximum.

*Duties.*—As prescribed by section 44 (2) of the *Public Service Act 1958*.

*Qualifications.*—A good knowledge of the Public Service Act and Regulations and of the general organization of Departments; to be competent to carry out investigations in Departments and compile reports. A Diploma in Public Administration or other appropriate qualification will be an advantage.

**Class "C2", Division of State Development, Premier's Department.**

*Yearly Salary.*—£1,170, minimum; £1,280, maximum.

*Duties.*—To assist in the general administrative work of the Division; to compile and maintain information necessary for the use of the Division in advising manufacturers on aspects of industrial development in Victoria; to perform other duties as directed.

*Qualifications.*—A good administrative background preferably with experience in secretarial work and in compiling reports. A knowledge of industrial development in Victoria would be an advantage.

**Class "C1", Public Works Department.**

*Yearly Salary.*—£960, minimum; £1,060, maximum.

*Duties.*—To be responsible for the operation of the Port Melbourne and South Melbourne storeyards involving the control of a large staff engaged on the receipt, stowage, issue and transport of stores to work sites. To assist as required in the control of other storeyards operated by the Department.

*Qualifications.*—To be familiar with the various types of stores used on building and general engineering construction work and with office furniture and fittings; a good knowledge of stores organization and methods and of the Public Accounts and Stores Regulations 1958, and capable of controlling a large staff. Accountancy qualifications would be an advantage.



**Class "C1" Tuberculosis Branch, Department of Health.**

*Yearly Salary.*—£960, minimum; £1,060, maximum.  
*Duties.*—To supervise the Survey activities of the Mass X-ray Section.

*Qualifications.*—A knowledge of the Public Service Act and Regulations; of the Public Accounts and Stores Regulations 1958 and of the operations of the Mass X-ray Section. A knowledge of the installation and operation of electrical and X-ray equipment is desirable.

**Class "C1", Frankston Centre, Water Supply Department.**

*Yearly Salary.*—£960, minimum; £1,060, maximum.

*Duties.*—To maintain cost records under various heads of expenditure and to prepare financial records as required; to supervise preparation of time and wages sheets and to assist in the payment of wages; to examine claims under contracts or agreements or for supplies and services and to charge them under various funds; to supervise preparation of various returns.

*Qualifications.*—A knowledge of accounts work and of costing and wages requirements.

**Class "C", Superannuation Board and Pensions Office, Treasury.**

*Yearly Salary.*—£710, minimum; £860, maximum.

*Duties.*—To examine and check returns of contributions under the Superannuation Acts and make the necessary records; to ensure that officers contribute to the Fund on a correct basis, and generally to assist in the administration of the Superannuation Acts.

*Qualifications.*—A good knowledge of the provisions of the Superannuation Acts is desirable.

**Class "C", Stores Branch, Education Department.**

*Yearly Salary.*—£710, minimum; £860, maximum.

*Duties.*—To attend to insurance of motor vehicles and school equipment; to pass miscellaneous accounts; to handle cash sales of departmental publications.

*Qualifications.*—Experience in dealing with accounts and a knowledge of the relevant sections of the Public Accounts and Stores Regulations.

**Class "C", Water Supply Department.**

*Yearly Salary.*—£710, minimum; £860, maximum.

*Duties.*—To examine travelling allowance and overtime claims; to record and submit claims lodged in accordance with the Workers Compensation Acts; to arrange furniture removals of officers on transfer.

*Qualifications.*—A knowledge of the Public Accounts and Stores Regulations 1958 and of the relevant provisions of the Public Service Regulations and of the Workers Compensation Act.

**PROFESSIONAL DIVISION.****Chief Stipendiary Magistrate, Class "A1", Courts Branch, Law Department.**

*Yearly Salary.*—£3,525.

*Qualifications.*—As prescribed by Public Service (Public Service Board) Regulation 45.

**Metropolitan Stipendiary Magistrate, Class "A1", Courts Branch, Law Department.**

*Yearly Salary.*—£3,300.

*Qualifications.*—As prescribed by Public Service (Public Service Board) Regulation 45.

**Stipendiary Magistrate, Grade I, Class "A1", Courts Branch, Law Department.**

*Yearly Salary.*—£3,075.

*Qualifications.*—As prescribed by Public Service (Public Service Board) Regulation 45.

**Stipendiary Magistrate, Grade II, Class "A1", Courts Branch, Law Department.**

*Yearly Salary.*—£2,850.

*Qualifications.*—As prescribed by Public Service (Public Service Board) Regulation 45.

**Second in Charge, Motor Car Branch, Class "B1", Crown Solicitor's Office, Law Department.**

*Yearly Salary.*—£1,630, minimum; £1,770, maximum.

*Duties.*—To be second in charge of the Motor Car Branch, Crown Solicitor's Office.

*Qualifications.*—A Barrister and Solicitor of the Supreme Court of Victoria with adequate Common Law experience for the performance of the duties of the position.

**Draughtsman, Classes "C"—"C1", Public Works Department. (Two vacancies.)**

*Yearly Salary.*—£710, minimum; £1,060, maximum. (Commencing salary according to experience.)

*Duties.*—Planning water supply, sewerage and septic installations in public buildings and institutions and detailing, specifying and estimating in connexion therewith.

*Qualifications.*—To be suitably qualified for and experienced in the preparation of plans and specifications for water supply and sewerage and septic installations, house connexions, sanitary plumbing and drainage, with a good knowledge of the by-laws of the Melbourne and Metropolitan Board of Works and Country Sewerage Authorities; to possess the pre-requisite qualifications prescribed in paragraphs (a) and (b) of Public Service (Public Service Board) Regulation 23. Partial completion of a Civil Engineering course would be an advantage.

**TECHNICAL AND GENERAL DIVISION.****Draughting Assistant, Grade II, Department of Crown Lands and Survey.**

*Yearly Salary.*—£686, minimum; £750, maximum.

*Duties.*—To assist in the preparation of topographical maps from aerial photographs using second order Stereo-Plotting equipment.

*Qualifications.*—A good knowledge of the use of aerial photographs for topographical mapping, and conversant with the principles of A.6 Stereo-Plotting and Multiplex equipment.

**Real Estate Officer, Grade II, Office of the Housing Commission, Treasury.**

*Yearly Salary.*—£654, minimum; £750, maximum.

*Duties.*—To negotiate settlements with owners of land; to advise prospective purchasers of terms and conditions under which Commission houses may be sold, and to conduct interviews with prospective tenants of shop premises owned by the Commission.

*Qualifications.*—A good knowledge of Real Estate transactions; ability to deal with the public and to conduct negotiations.

**Estate Officer, Grade IV. (Resident Metropolitan Area), Office of the Housing Commission, Treasury.**

*Yearly Salary.*—£590, minimum; £654, maximum.

*Duties.*—To perform housing estate duties, as required, in respect of a high-density section of a district including revenue collection, interviewing tenants regarding rental arrears, advising tenants on matters affecting their tenancy and inspecting and reporting on dwellings and various phases of estate management.

*Qualifications.*—To be educated to Intermediate Certificate standard or to be already an Estate Officer. Ability to make investigations and prepare reports. Experience in dealing with the public and capable of handling public moneys; to be active, married, and between the ages of 25 and 45 years. A current motor driver's licence.

*NOTE.*—(1) After completing three years' satisfactory service as Estate Officer, Grade IV, will be eligible for progression to Estate Officer, Grade III. (£686—£718).

(2) The person appointed must be prepared to reside in a Housing Commission flat, and to work at nights, week-ends and public holidays as may be required. Rent free accommodation will be provided in a two-bedroom flat.

**Blacksmith—Instructor, Dookie Agricultural College, Department of Agriculture.**

*Yearly Salary.*—£606.

*Duties.*—To be responsible for the operation of the College Blacksmith's Shop, to undertake maintenance and repair of College equipment and to conduct demonstrations; to carry out other duties as required.

*Qualifications.*—An experienced Blacksmith able to demonstrate to students in general blacksmithing, the treatment of metals, and the care and use of tools and equipment; a competent oxy-acetylene and electric welder.

*NOTE.*—Accommodation is available for a single man only.

**Machinist (Female), Senior, Office of the Housing Commission, Treasury.**

*Yearly Salary.*—£572, minimum; £604, maximum.

*Duties.*—To operate an accounting machine for the posting of House Purchasers' personal and/or collections accounts and control accounts.

*Qualifications.*—Ability to operate a Remington or Mercedes accounting machine. A knowledge of Housing Commission procedure of posting of Collection and Ledger Account cards is desirable.

**Fisheries and Wildlife Officer, Grade II, Fisheries and Wildlife Branch, Chief Secretary's Department.**

*Yearly Salary.*—£478, minimum; £574, maximum.

*Duties.*—To enforce the provisions of the Fisheries and Game Acts and regulations and generally to assist in the outside work of the Branch.

*Qualifications.*—To be strong, healthy and active, able to drive a motor vehicle and to manage a motor boat. A good knowledge of and ability to effect running repairs to motor vehicles and marine engines. A knowledge of all classes of fish and native game and the methods of fishermen and shooters would be an advantage. An education to intermediate standard is desirable. Applicants should be under forty (40) years of age.

*NOTE.*—An allowance of £150 a year for overtime and week-end duty is payable, plus an additional week's leave.

*NOTE.*—The salary rates quoted above do not include the additional amount which is payable under Regulation 77A of the Board's Regulations.

By order,

N. J. SIMMANCE,  
Acting Secretary.

Office of the Public Service Board,  
Melbourne, 26th September, 1961.

**PUBLIC SERVICE OF VICTORIA.—VACANCY.**

(TEMPORARY APPOINTMENT.)

APPLICATIONS will be received by the Public Service Board up to Wednesday, the 11th October, 1961, from persons who are qualified for appointment to the under-mentioned position:—

**Mechanic, Senior, Water Supply Department.**

*Yearly Salary.*—£590.

*Duties.*—To supervise and work on maintenance of vehicles at Central Administrative Offices, Armadale. To service, adjust and tune motor vehicles.

*Qualifications.*—Extensive experience in the maintenance and repair of vehicles, testing of vehicles for roadworthiness, and supervision of staff. Ability to keep records of stores and fuel issues. To be a qualified tradesman.

The salary rate quoted above does not include the additional amount which is payable under Regulation 77A.

By order,

N. J. SIMMANCE,  
Acting Secretary.

Office of the Public Service Board,  
Melbourne, 26th September, 1961.

**APPOINTMENT OF A DEPUTY TO A MEMBER OF THE PUBLIC SERVICE BOARD.**

WHEREAS in the manner prescribed by the Regulations and at an election held in conjunction with the election of Frederick Charles McArdle as the public service representative on the Public Service Board, George William Rogan was elected to be his deputy in the case of his suspension, illness or absence.

And whereas the said Frederick Charles McArdle is unable by reason of illness to attend meetings of the Board during the period from the 25th September, 1961, to the 3rd October, 1961, both dates inclusive.

Now therefore, at the request of the said Frederick Charles McArdle, and in pursuance of the powers conferred by section two of the *Public Service (Amendment) Act 1959*, No. 6573, I do hereby appoint the said George William Rogan to be the deputy of Frederick Charles McArdle during the above-mentioned period.

Given under my hand at Melbourne this twenty-fifth day of September, 1961.

A. GARRAN,  
Chairman.

**PUBLIC SERVICE OF VICTORIA.**

QUALIFYING TESTS—TYPISTS (FEMALE).

THE under-mentioned candidates passed in the order of merit indicated the typing test at 42 words a minute, held on 16th September, 1961:—

Order of Merit.	Candidates.
1	Woloshen, Vera (Mrs.)
2	Galletly, Frances Julie (Mrs.)
3	Lavey, Denise Theresa
4	Scanlan, Marlene Denise
5	Scott, Joy Beverley
6	Sheldon, Marlene Lucy
7	Phelan, Carol Frances
8	Dunstan, Glenda Irene
9	Jamroz, Willemina Pietje (Mrs.)
10	McCausland, Joan Mary
11	Pyke, Margaret Joan
12	Cortissos, Catherine
13	Griffith, Beverley Ann
14	McKeown, Patricia
15	Mitchell, Judith Anne
16	Priest, Maureen Alice
17	Baxter, Constance (Mrs.)
18	O'Reilly, Gillian
19	Wilson, Jillian Ivy
20	Burt, Ursula Margaret
21	Dicks, Patricia
22	Neuhaus, Tia Johanna Alide (Mrs.)
23	Radtke, Elfriede
24	Austin, Elva Minnie
25	Fitch, Judith Anne
26	Pooley, Heather Patricia
27	Stewart, Pamela Alison
28	Blake, Gay Dorothea
29	Jakutis, Ona (Mrs.)
30	Powlesland, Florence Mirian
31	Pund, Margaret Elizabeth
32	Reid, Mavis Alma (Mrs.)
33	Robertson, Wendy Elaine
34	Rowan, Veronica Kathleen
35	Williams, Pamela Bromfield (Mrs.)
36	Turner, Barbara Lorraine (Mrs.)
37	Valke, Pieternella Hendarika
38	Weissenfeld, Bernice Jane
39	Willy, Hilda May
40	Nicholls, Mavis Marjorie
41	Urquijo, Dolores Angela
42	Savas, Atchenoulla
43	Vallance, Annette

By order,

N. J. SIMMANCE,  
Acting Secretary.

Office of the Public Service Board,  
Melbourne, 26th September, 1961.

*Public Service Act 1958.*

**PUBLIC SERVICE (PUBLIC SERVICE BOARD).—REGULATION 46.**

EXAMINATION—CLERK OF COURTS.

NOTICE is hereby given that the candidates named hereunder qualified for promotion to Class "C", Professional Division, as Clerks of Courts, at the examination held on the 10th and 11th August, 1961:—

*Name.*

Meehan, Wallace Gervase  
McMahon, Kevin George  
O'Farrell, Lawrence  
Smith, Lionel Cedric Winton  
Stocks, Bernard James  
Wilson, Robert Ractliffe  
Denahy, John Gerald  
Dunlop, Anthony Ronald John  
Drummond, David Alexander  
Gidley, John Arthur

The following candidates passed in the subjects shown:—

*Introduction to Law and Practice.*

Mann, Maurice Howard  
Meehan, Russell John  
Meldrum, Ronald Keith John  
Mornane, James Stanislaus  
Stocks, Bernard James  
Willis, Ian Richard  
Bennett, Ian James  
Dalton, Geoffrey Bryan  
Drummond, David Alexander  
Evely, Martin Thomas  
Hutchins, John Sydney

*Statute Law No. 1.*

Meehan, Wallace Gervase  
McMahon, Kevin George  
Ryan, Michael Augustus  
Smith, John James Xavier  
Wilson, Robert Ractliffe  
Denahy, John Gerald  
Dennis, James Barrie  
Docking, Barry Francis  
Dunlop, Anthony Ronald John  
Drummond, David Alexander  
Gidley, John Arthur

*Statute Law No. 2.*

Mackie, Stewart Gordon  
McMahon, Kevin George  
O'Farrell, Lawrence  
Gemmell, James Sloan  
Smith, John James Xavier  
Smith, Lionel Cedric Winton  
Stocks, Bernard James  
Street, Patrick Denis  
Bailey, Ronald Keith  
Collard, Ian John  
Docking, Barry Francis  
Dunlop, Anthony Ronald John  
Drummond, David Alexander  
Emerson, Edwin Alexander  
Gunn, John Caldwell

By order,  
N. J. SIMMANCE,  
Acting Secretary.

Office of the Public Service Board,  
Melbourne, 26th September, 1961.

Tenders to be addressed to the Hon. the Commissioner of Public Works, and envelope containing tender to be marked "Tender for \_\_\_\_\_, closing \_\_\_\_\_".

NOTE.—No preliminary deposit is to be lodged with any tender, but a deposit in accordance with the prescribed Schedule may be required from each successful tenderer.

**Tuesday, 3rd October, 1961.**

Allansford.—Repairs and painting to residence, S.S. 3. (W.O., Warrnambool; S.S., Allansford.) (Amended specification.)

Bairnsdale.—Supply and delivery of 20 cub. ft. refrigerator, High School.

Ballarat.—Electrical services in new Occupational Therapy Centre, Mental Hospital. (W.O., Ballarat; Mental Hospital, Ballarat.)

Ballarat.—Erection of L.T.C. building with office, toilet "Norwood" Hospital, Mental Hygiene Authority. (W.O., Ballarat.)

Ballarat.—Renovations and painting to residence, 224 Dowling-street, High School. (W.O., Ballarat.)

Beaumaris North.—Erection of additional class-rooms, S.S. 4803.

Beechworth.—Construction of four additional out-offices for girls and septic tank installation, S.S. 1560. (W.O., Wangaratta; S.S., Beechworth.)

Boundary Bend.—Erection of a new out-office block and septic tanks, S.S. 4089. (Amended specification.) (W.O., Swan Hill; S.S., Boundary Bend.)

Briar Hill.—Installation of septic tank, filter bed and fire service, S.S. 4341.

Broadford.—Alterations and renovations to assistant's residence, Hamilton-street, S.S. 1125. (W.O., Alexandra; S.S., Broadford.)

Bundoora.—Replacement of existing heat exchangers, headers and pipework, Larundel Mental Hospital, Plenty-road.

Camberwell South.—Internal and external renovations to cleaner's residence, S.S. 4170.

Caulfield.—Mechanical services for three-story classroom block and single-story Trades Block, Technical School.

Clarinda.—Additional out-offices, septic tank installation, water supply and fire service, S.S. 3336.

Corio.—Connexion to sewer, Technical School. (W.O., Geelong; T.S., Corio.)

Corop.—Provision of flywire screens with internal and external painting, S.S. 1021. (W.O., Shepparton; S.S., Corop.)

Heatherton.—Supply, delivery, installation and testing of equipment in the laundry, Sanatorium, Kingston-road.

Kew.—Kitchen equipment for two cottage blocks, No. 40 and No. 41, Children's Cottages, Mental Hospital. (Two specifications.)

Kilcunda-road.—General repairs, internal and external painting, &c., S.S. 3337. (W.O., Korumburra; S.S., Kilcunda-road.)

Koonung Heights.—Connexion to sewer and abolishing septic tank, drains, &c., S.S. 4727.

Melbourne.—Supply and lay vinyl tiles, Secondary Teachers' College Hostel, 572 St. Kilda-road. (Amended specification.)

Mitcham.—Concrete veneer timber-framed special Primary School, Special School 4871.

Mont Park.—Supply, delivery and fixing on site of new stainless steel benchwork for new kitchen, Central Mess-room, Mental Hospital.

Mont Park.—Dining room furniture, Mental Hospital.

Mont Park.—Hot-water systems and central heating in Isolation Block, Mental Hospital.

Mooroolbark.—Erection of first section, Technical School.

Mooroolbark.—Mechanical services to stage 1, Technical School.

Mooroolbark.—Electrical installation in stage 1, Technical School.

Nanneella South.—Repairs and painting, &c., to residence, S.S. 1857. (Amended specification.) (W.O., Shepparton; P.S., Echuca; S.S., Nanneella South.)

Normanville.—Removal of Budgerum East State School and re-erection/restoration, plus provision of new sheltered and out-offices, S.S. 4189. (W.O., Swan Hill; S.S., Normanville.)

Oak Park.—Electrical installation in extended stage 3, Standard High School. (H.S., Oak Park.)

Orbost.—Electrical installation in modified type "300" (additional wing), High School. (W.O., Bairnsdale; High School, Orbost.)

Orbost.—Mechanical services new L.T.C. block, High School. (W.O., Bairnsdale.)

Parktone.—Electrical installation of four (4) additional L.T.C. class-rooms, S.S. 4843.

Parktone.—Erection of additional class-rooms, S.S. 4843.

No. 1153.

*Public Service Act 1958, Section 50.*

**REGULATIONS.—PART III.—SALARIES, INCREMENTS AND ALLOWANCES.**

THE Public Service Board, in pursuance of the powers conferred by the *Public Service Act 1958*, hereby amends its Regulations as shown below:—

**SIXTH SCHEDULE.**

**TEMPORARY EMPLOYEES.**

*Designations of Positions and Rates of Salaries.*

Department and Designation of Position.	Yearly Rate of Salary.		Increments (Annual).
	Minimum.	Maximum.	
	£	£	
DEPARTMENT OF TREASURER.			
HOUSING COMMISSION.			
<i>Add—</i> Assistant (Civil Engineering Design), Senior ..	1,182	1,285	1 of £48 and 1 of £55

*This Regulation shall have effect as on and from the 3rd September, 1961.*

A. GARRAN, Chairman.  
N. J. SIMMANCE, Acting Secretary.

Office of the Public Service Board,  
Melbourne, 15th September, 1961.

**TENDERS—PUBLIC WORKS DEPARTMENT**

TENDERS will be received at this Department until TEN a.m. on the Tuesdays, and for the purposes, under mentioned.

Particulars may be learnt at the Department and also at places shown in parenthesis.

W.O. means Inspector of Works Office; P.S.—Police Station; T.S.—Technical School; H.E.S.—Higher Elementary School; S.S.—State School; H.S.—High School; C.S.—Consolidated School.

Tenders should be submitted on the Department's printed Tender Form. All tenders must be on a "Firm Tender" basis. The Board of Land and Works will not necessarily accept the lowest or any tender.

Port Melbourne.—Supply and delivery of one (1) only 20-ton low loader machinery float, Depot, Public Works Department, Salmon-street.

St. Albans.—Installation of septic tank and fire service, S.S. 2969.

St. Albans.—Supply of workshop equipment, Technical School.

St. Albans East.—Installation of septic tanks, storm-water drains and fire service, partition walls for staff toilets, S.S. 4741.

Sale.—Renovations of Assembly Hall, Technical School. (T.S., Sale.)

Sebastopol.—Electrical installation, stage 1, Technical School. (W.O., Ballarat.)

Springvale North.—Additional out-offices and drinking and ablution troughs, S.S. 1658. (S.S., Springvale North.)

Syndal.—Septic tank installation, fire service and extension of water supply, S.S. 4714.

Tallangatta.—Supply, delivery, installation and testing of the mechanical services, High School. (W.O., Wangaratta.)

Walpeup.—Electrical installation, Research Station. (Research Station, Walpeup.)

Wangaratta.—Erection of new timber shelter pavilion, S.S. 643. (W.O., Wangaratta.)

Wendouree.—Electrical installation, two additional classrooms, S.S. 1813, Howitt-street. (W.O., Ballarat; S.S., Wendouree.)

Wilkur South.—Erection of shelter pavilion, S.S. 4010. (W.O., Warracknabeal; S.S., Wilkur South.)

Wonthaggi.—Repairs and painting, S.S. 3650, residence, 31 Broome-crescent. (W.O., Korumburra.)

#### Tuesday, 10th October, 1961.

Antonio Park.—Fencing, S.S. 4844.

Ararat.—Modifications to ventilation in kitchen of "J" Ward, Mental Hospital. (W.O., Ballarat, Ararat.)

Ararat.—Additions to heating system and hot-water service for new day room in "J" Ward, Mental Hospital. (W.O., Horsham, Ararat, Ballarat.)

Ashwood.—Fencing, S.S. 4698.

Ballarat.—Sawdust extraction unit in carpenters' shop, Mental Hospital. (W.O., Ballarat.)

Balwyn.—Renewal of galvanized corrugated iron roof gutters, &c., S.S. 1026.

Beaufort.—Supply and delivery of 20 cub. ft. refrigerator, High School. (W.O., Ballarat.)

Benalla.—Purchase and removal, detached timber laundry, fuel shed and bathroom unit, including a timber garage, High School. (W.O., Benalla; H.S., Benalla.)

Broadford.—Additional toilets and filtration system, S.S. 1125. (W.O., Alexandra; S.S., Broadford.)

Burwood East.—Additional toilet accommodation and septic tank installation, fire service, S.S. 454.

Castlemaine.—Electrical installation, provision of sanitary incinerators, High School, Forest-street, Wheeler-street. (W.O., Bendigo; H.S., Castlemaine.)

Clifton Hill.—External repairs and painting, S.S. 3146.

Echuca.—Provision of slow combustion heaters, Technical School. (W.O., Shepparton; T.S., Echuca.)

Footscray.—Electrical installation, S.S. 253.

Frankston Forest.—Erection of chain mesh and pipe post and wire fencing, S.S. 4872. (S.S., Frankston Forest.)

Geelong East.—Supply of workshop machines, Technical School.

Glengarry West.—Resiting existing woodshed and closet, repairs to closets, septic tank and water supply, installations at residence, S.S. 4426. (W.O., Traralgon; S.S., Glengarry West.)

Hamilton.—Supply and installation of heating system to new wings, High School. (W.O., Hamilton.)

Hamilton.—Additions in concrete veneer, L.T.C., High School. (W.O., Hamilton.)

Hampton.—Repairs, painting and installation of demonstration bench, High School. (H.S., Hampton.)

Hastings.—Reblocking to class-room No. 2 and vestibule, S.S. 1098. (S.S., Hastings.)

Hawthorn.—Supply and delivery of woodworking equipment for new junior school, Swinburne Technical School.

Healesville.—Erection of 1,440 feet post and wire fencing (non-party), S.S. 849. (S.S., Healesville.)

Huntingdale.—Electrical installation in extended stage 3, High School. (H.S., Huntingdale.)

Huntingdale.—Heating and hot-water service for stage 3 and three class-rooms to Arts and Music Wing, High School.

Huntingdale.—Erection of third (3rd) section of building, High School.

Kew.—Rubber mattresses, Mental Hospital.

Koo-Wee-Rup.—Supply and installation of oil-firing equipment and modifications to existing heating system, High School. (H.S., Koo-Wee-Rup.)

Maryborough.—New staff toilets, sewerage and drainage, Technical School. (W.O., Maryborough.)

Melbourne.—Electrical installation, rewiring and additions, Dental Clinic, 448 St. Kilda-road.

Melbourne.—Air-conditioning and ventilation installations, William Angliss Food Trades School, Latrobe-street.

Mitcham.—Electrical installation of new special L.T.C. school, Special School No. 4871.

Mitcham.—Plenum heating and hot-water service, Special School No. 4871.

Mont Park.—Supply of equipment for staff mess, Mental Hospital.

Mont Park.—Upholstered lounge-room furniture, Mental Hospital.

Mont Park.—Staff location and paging system, Larundel Mental Hospital.

Mornington.—Erection of chain mesh and pipe post and wire fencing, High School. (H.S., Mornington.)

Myrtleford.—Supply and delivery of approximately 1,150 cub. yds. of granite sand, New High School. (W.O., Wangaratta, Benalla; Police Station, Myrtleford.)

Noble Park.—Erection of brick veneer residence, office and garage, and fuel shed, Police Station.

Numurkah.—New internal toilet and septic tank, repairs, internal and external painting, Court House. (W.O., Shepparton; Police Station, Numurkah.)

Oakleigh.—Electrical installation, extensions to Trades Wing, Technical School. (Technical School, Oakleigh.)

Oakleigh.—Heating for trades wing extension, Technical School.

Oberon.—External painting of eight class-rooms, office, staff-room and toilet block, S.S. 4735. (W.O., Geelong; S.S., Oberon.)

Parkton.—Plenum heating to four additional classrooms, S.S. 4843.

Rutherglen.—Internal repairs and painting, S.S. 522. (W.O., Wangaratta; S.S., Rutherglen.)

Stawell.—New toilet and connexion of residence to town sewerage, High School. (W.O., Ararat; H.S., Stawell.)

Swan Hill.—Electrical installation in Domestic Arts Wing, High School. (W.O., Swan Hill, Bendigo, Horsham; H.S., Swan Hill.)

Swan Hill.—Supply and installation of heating and hot-water service systems to Domestic Arts Wing, High School. (W.O., Swan Hill.)

Syndal.—Installation of electric light and power for Tuck Shop, Technical School. (T.S., Syndal.)

Tallangatta.—Electrical installation for type (300) school, New High School. (W.O., Wangaratta, Benalla; P.S., Beechworth, Rutherglen.)

Traralgon.—Kitchen equipment for main kitchen, Mental Hospital.

Vermont.—Installation of septic tank, &c., and fire service, S.S. 1022.

Warragul.—Erection of 20 ft. x 20 ft. storage unit, Agriculture Department. (W.O., Warragul.)

#### Tuesday, 17th October, 1961.

Baumaris North.—Extension of plenum heating to four additional class-rooms, S.S. 4803.

Blackburn.—External painting to L.T.C. building, S.S. 2923.

Boolite.—Renovations and repairs, S.S. 2170. (W.O., Warracknabeal; S.S., Boolite.)

Bunyip.—New out-office block and septic tank installation, S.S. 2229. (S.S., Bunyip.)

Burnley Gardens.—Conversion of hot-water boiler to oil firing, Burnley Horticultural college.

Coburg West.—Additional toilets, new spouting, &c., S.S. 3941.

Dennington.—Septic tank installation at school and residence, S.S. 182. (W.O., Warrnambool.)

Echuca.—Repairs and renovations, Technical School. (W.O., Shepparton; Technical School, Echuca.)

Fawkner.—Additional sanitary accommodation and connexion of school to Melbourne and Metropolitan Board of Works sewer, S.S. 3590.

Greenslopes.—New Primary School, S.S. 4891.

Greenslopes.—Electrical installation—new school of twelve (12) L.T.C. class-rooms, S.S. 4891.

Greenslopes.—Plenum heating to new twelve class-room unit, S.S. 4891.

Heathmont East.—New Primary School, S.S. 4819.

Heathmont East.—Electrical installation—new school of six (6) L.T.C. class-rooms, S.S. 4819.

Heathmont East.—Plenum heating in new six class-room unit, S.S. 4819.

Horsham.—Repairs to Bristol prefabs, and external painting to out-office block, Technical School. (W.O., Horsham; T.S., Horsham.)

Melbourne.—Supply and delivery to Melbourne, Victoria, of one 12-in. Cutter Suction Dredge, together with floating and shore discharge pipe-lines, Ports and Harbors, Public Works Department.

Merrilands.—Plenum heating to four additional classrooms, S.S. 4826.

Port Campbell.—Erection of timber-framed residence, "A" type office, garage and fuel store, Police Station. (W.O., Warrnambool.)

Ruby.—Exterior repairs and painting to residence, S.S. 3208. (W.O., Korumburra; S.S., Ruby.)

Sea Lake.—Sewerage installation, Higher Elementary School, 3273. (W.O., Swan Hill; Higher Elementary School, Sea Lake.)

Skipton.—Installation of septic tank at school and residence, S.S. 582. (W.O., Camperdown; S.S., Skipton.)

Sunbury.—New electrical reticulation (stage 4), including street lighting, Mental Hospital.

Tyers.—New out-office block, septic tanks and water supply installation, S.S. 2182. (W.O., Traralgon.)

Underbool.—Erection of new out-offices and provision of septic tanks, residence and depot, Lands and Survey Department. (W.O., Mildura.)

Various.—Erection of fifty (50) timber class-rooms, staff-rooms and stores in 22 Sub-district Contracts, comprising one to seven class-rooms respectively, Schools. (W.O., Bairnsdale, Ballarat, Benalla, Bendigo, Camperdown, Horsham, Geelong, Maryborough, Mildura, Shepparton, Traralgon, Warracknabeal and Warragul.)

West Melbourne.—Supply and delivery of corkboard insulation, fourth section, Government Cool Stores.

Yallourn.—Provision of washing and drinking facilities, S.S. 4085. (W.O., Traralgon; S.S., Yallourn.)

Yallourn.—Electrical installation new trades block, Technical College. (W.O., Traralgon; Technical School (Junior), Yallourn.)

#### NOTICE.

The Department of Public Works gives notice that tenders, based on specified bills of quantities, are being invited for the erection of steel and reinforced concrete High School, Caulfield.

Plans are available at the Department of Public Works for reference purposes, and potential tenderers are requested for the purpose of obtaining specified bills of quantities to register their names with the Consulting Quantity Surveyors, namely—

W. J. P. TILLYARD, 240 Victoria-parade, East Melbourne.

Telephone: JA 3328.

H. R. PETTY,

Commissioner of Public Works.

Public Works Department,

Melbourne, 26th September, 1961.

## PRIVATE ADVERTISEMENTS

### Local Government Acts.

#### CITY OF CAMBERWELL.

##### DECLARATION OF STREETS AS PUBLIC HIGHWAYS.

**WHEREAS** it is provided in section 587 (3) of the *Local Government Act 1958* that where any private street being more than 15 feet in width is constructed to the satisfaction of the Council, but not so constructed under Part XIX., Division 10 or Part XLII. of the said Act or any previous enactment—

- (a) on the application of the greater part of the owners of so many of the premises fronting on such street as in rateable value are the greater part of all the premises so fronting, the Council shall by writing under the common seal of the municipality declare the same to be dedicated to the public as a Public Highway and
- (b) upon the publication of such declaration in the *Government Gazette* the said street shall become dedicated to the public as a Public Highway and shall thereafter be under the care and management of the Council which shall notwithstanding anything in the said Division 10 be liable for the cost of any reconstruction thereof.

And whereas the Council of the City of Camberwell is of the opinion that—

Ambon-street, Alamein-avenue, Anson-court, Bardia-avenue, Beaufort-court, Benghazi-avenue, Buna-court, Catalina-avenue, Crete-avenue, Derna-road, Gona-court, Gloucester-road, Halifax-court, Hudson-court, Huon-grove, Lae-court, Liberator-street, Markham-avenue, Mitchell-street, Morotai-avenue, Mustang-court, Ramu-grove, Samarinda-avenue, Sunderland-avenue, Tarakan-avenue, Tobruk-road, Victory-Boulevard, Warner-avenue, Wewak-road, Wirraway-court, private streets set out on the Ashburton Housing Estate Subdivision, Parish of Boroondara by the

Housing Commission within the municipality of the Council of the City of Camberwell have been so constructed to its satisfaction.

And whereas the owners of the greater part of all premises fronting on the said private streets have requested the said Council to declare the same dedicated to the public as Public Highways under the provision of the said section.

Now therefore the Council of the City of Camberwell hereby declares—

Ambon-street, Alamein-avenue, Anson-court, Bardia-avenue, Beaufort-court, Benghazi-avenue, Buna-court, Catalina-avenue, Crete-avenue, Derna-road, Gona-court, Gloucester-road, Halifax-court, Hudson-court, Huon-grove, Lae-court, Liberator-street, Markham-avenue, Mitchell-street, Morotai-avenue, Mustang-court, Ramu-grove, Samarinda-avenue, Sunderland-avenue, Tarakan-avenue, Tobruk-road, Victory-Boulevard, Warner-avenue, Wewak-road, Wirraway-court, set out as aforesaid to be dedicated to the public as Public Highways.

Dated this 18th day of September, 1961.

The common seal of the Mayor, Councillors and Citizens of the City of Camberwell was hereto affixed, in the presence of—

NEVILLE C. LEE, Mayor.

ERIC W. RAVEN, Councillor.

H. L. POLGLASE, Acting Town Clerk.

15625

#### CITY OF DANENONG.

##### BY-LAW No. 23.

A By-law of the City of Dandenong made under the provisions of sections 197 and 198 of the *Local Government Act 1958*, and the Uniform Building Regulations Victoria for—

- (a) prescribing areas in which buildings of Class II. and III. occupancy shall not be constructed to contain more than two storeys;
- (b) specifying the minimum distance of outer walls of any buildings of Class I. or II. occupancy from the frontage of any land; and
- (c) regulating, restricting, restraining or prohibiting the erection, construction use, occupation, conversion as alteration of and any addition to buildings or erections.

**I**N pursuance of the powers conferred by the *Local Government Act 1958*, and the Uniform Building Regulations Victoria and every other power it thereunto enabling, the Mayor, Councillors and Citizens of the City of Dandenong orders as follows:—

1. (1) In this By-law unless inconsistent with the subject or context matter—

"Building" has the same meaning as in the Regulations.

"Council" means the Council of the City of Dandenong.

"Consent of the Council" means the consent of the Council by a proper resolution duly passed at a properly constituted meeting.

"Dwelling house" has the same meaning as in section 198 (6) of the *Local Government Act 1958*.

"Frontage" has the same meaning as in the Regulations.

"Ground storey" has the same meaning as in the Regulations.

"Municipal district" means the municipal district of the Council.

"Regulations" mean the Uniform Building Regulations Victoria.

(2) The classification of buildings by occupation set out in clause 601 and clause 602 of the Regulations shall apply *mutatis mutandis* for the purpose of this By-law wherever a building is referred to in this By-law as being of a specified class.

2. Clause 5 of By-law No. 103 of the Shire of Dandenong (now the City of Springvale) so far as it relates to the City of Dandenong is hereby repealed.

3. (1) No person shall construct within the municipal district—

(a) any building of Class II. occupancy containing more than two storeys including the ground storey; or

(b) any building of Class II. occupancy unless—

(i) if the building contains 8 or less flats then every such flat shall contain a minimum area of 800 square feet;

(ii) if the building contains nine or more flats then at least 80 per cent. of the number of flats shall contain a

minimum area of not less than 800 square feet per flat and the remainder not less than 600 square feet per flat;

(2) No person shall construct any building of Class III. occupancy in any area within the municipal district other than an area zoned for residential purposes as defined under By-law No. 103 of the Shire of Dandenong (now City of Springvale) which is still in force so far as it relates to the City of Dandenong and any such building of Class III. occupancy shall not contain more than two storeys including the ground storey.

(3) Nothing in sub-clauses (1) and (2) hereof shall preclude the erection of a building of Class II. or III. occupancy containing three storeys including the ground storey where such ground storey is entirely used for the purpose of providing space for parking of vehicles.

4. No person shall construct, erect, alter or convert any building to be used as a dwelling house unless such building when constructed, erected, altered or converted—

- (a) covers a minimum area of 900 square feet if it consists of a single unit; or
- (b) covers a minimum area of 800 square feet for each unit if it consists of 8 or less separate units; or
- (c) covers a minimum area of 800 square feet per unit for 80 per cent. of the number of units and 600 square feet for the remainder if it contains nine or more separate units.

5. (1) The minimum distance of the outer wall of any building of Class I. or II. occupancy from the frontage of any land is hereby specified as 25 feet.

(2) No person shall erect or construct any building of Class I. or II. occupancy or erect or construct any additions to any such building closer to the frontage of any land than 25 feet.

6. Every person guilty of a wilful act or default contrary to the provisions of this By-law shall be liable to a penalty of not less than £5 nor more than £20 and to a further penalty of not more than £5 for each day such an offence is continued after a conviction or order by any Court.

7. This By-law shall apply to and have operation throughout the whole of the municipal district.

Resolution for passing this By-law agreed to by the Council the 24th day of July, 1961, and confirmed the 28th day of August, 1961.

The common seal of the Mayor, Councillors and Citizens of the City of Dandenong was hereunto affixed in the presence of—

(SEAL) R. A. JEFFERS, Mayor.  
K. A. FALCONER, Councillor.  
R. BOOTH, Town Clerk.

Confirmed by the Governor in Council the 12th day of September, 1961.—N. G. WISHART, Acting Clerk of the Executive Council. 15630

#### CITY OF GEELONG WEST.

##### LOAN No. 47.

*Notice of Intention to Borrow the Sum of £10,000 for Permanent Works and Undertakings.*

NOTICE is hereby given that the Council of the City of Geelong West proposes to borrow the sum of Ten thousand pounds, on the credit of the municipal revenues of the Mayor, Councillors and Citizens of the said City, such sum to be raised by the grant of a mortgage, in accordance with the provisions of the *Local Government Act 1958*.

1. The maximum rate of interest that may be paid is 5½ per cent. per annum.

2. The purpose for which the loan is to be applied is:—  
Street construction and underground drainage works.

3. The period of the loan shall be ten years.

4. The moneys borrowed shall be repayable by providing out of the municipal fund twenty half-yearly instalments of approximately £668 5s. 6d. each, including principal and interest, on the 1st day of June and the 1st day of December during the currency of the loan. The first instalment shall be payable on the 1st day of June, 1962.

5. Such moneys shall be repayable at the State Savings Bank of Victoria, Melbourne.

The plans and specifications and the estimate of the cost of the proposed works, and a statement showing the proposed expenditure of the moneys to be borrowed, are open for inspection at the Town Hall, Geelong West.

Dated 18th September, 1961.

15610 R. J. HAMMETT, Town Clerk.

#### CITY OF HAMILTON.

##### BY-LAW No. 89.

A By-law of the City of Hamilton, made under section 65 of the *Health Act 1958*, as amended by the *Health (Amendment) Act 1960*, and numbered 89, for fixing a fee for the examination of plans, specifications, particulars and descriptions of proposed septic tank systems, and any inspection of sites and installations.

IN pursuance of the powers of the *Health Act 1958* and of any and every other power it thereunto enabling, the Council of the City of Hamilton order as follows:—

1. The following fee is hereby fixed:—

For the examination of plans, specifications, particulars and descriptions of the proposed septic tank systems, and any inspection of sites and installations of septic tank systems—£2 (Two pounds).

2. This By-law shall apply to and have operation throughout the whole of the municipal district of the City of Hamilton.

3. This By-law shall come into full force and effect immediately after its publication in the *Government Gazette*.

Resolution for passing this By-law No. 89 was agreed to by the Council of the City of Hamilton on the 13th day of July, 1961, and confirmed on the 24th August, 1961.

The common seal of the Mayor, Councillors and Citizens of the City of Hamilton was hereunto affixed, in the presence of—

(SEAL) E. C. DEMPSTER, Mayor.  
J. E. RILEY, Councillor.  
H. F. DONALD, Town Clerk.

15611

#### CITY OF MELBOURNE.

##### BY-LAW No. 418.

NOTICE is hereby given that at meetings of the Council of the City of Melbourne, held on the 24th day of July, 1961, and the 21st day of August, 1961, the said Council did make, pass and confirm a By-law intitled "A By-law of the City of Melbourne made under Part VII. Division I. of the *Local Government Act 1958*" and section 91 of an Act of the Governor and Legislative Council of New South Wales 6, Victoria No. 7 intitled "An Act to incorporate the inhabitants of the Town of Melbourne" and numbered 418 for suppressing nuisances and for other purposes", summary of which is set out hereunder, viz:—

The By-law provides for—

- (a) the amendment and consolidation of By-law No. 250 as amended;
- (b) the repeal of all By-laws and Regulations relating to traffic which have been superseded by the Road Traffic Regulations;
- (c) the repeal of By-laws relating to street parking;
- (d) the re-enactment of the nuisances provisions of By-law No. 250 and certain other nuisance By-laws.

Copy of the By-law is open for inspection free of charge at the Town Clerk's Office, Town Hall, Melbourne, during office hours, namely from 8.25 a.m. to 4.45 p.m. daily from Monday to Friday both inclusive.

The By-law will come into operation on the 28th day of September, 1961.

15627 F. H. ROGAN, Town Clerk.

#### CITY OF MOORABBIN.

##### LOAN No. 115.

*Notice of Intention to Borrow the Sum of £25,000 for Permanent Works and Undertakings.*

NOTICE is hereby given that the Council of the City of Moorabbin proposes to borrow the sum of Twenty-five thousand pounds, on the credit of the municipal revenues of the Mayor, Councillors and Citizens of the said City, such sum to be raised by the grant of a mortgage, in accordance with the provisions of the *Local Government Act 1958*.

1. The maximum rate of interest that may be paid is £5 17s. 6d. per centum per annum.

2. The purposes for which the loan is to be applied are:—

Construction and widening of roads	£21,700
Construction of concrete channels and foot-paths	1,800
Construction of parking area at Moorabbin	1,500
	<hr/>
	£25,000

3. The period of the loan shall be ten years.

4. The moneys borrowed shall be repayable by providing out of the municipal fund twenty half-yearly instalments of approximately £1,670 14s. each, including principal and interest, on the 1st day of January and the 1st day of July during the currency of the loan. The first instalment shall be payable on the 1st day of July, 1962.

5. Such moneys shall be repayable at the State Savings Bank of Victoria, Melbourne.

The plans and specifications and the estimate of the cost of the proposed works, and a statement showing the proposed expenditure of the moneys to be borrowed, are open for inspection at the Municipal Offices, Nepean Highway, Moorabbin, during office hours.

Dated the 20th day of September, 1961.  
15609 V. A. SMITH, Town Clerk.

## CITY OF WILLIAMSTOWN.

## LOAN No. 34.

*Notice of Intention to Borrow the Sum of £10,000 for Permanent Works and Undertakings.*

NOTICE is hereby given that the Council of the City of Williamstown proposes to borrow the sum of Ten thousand pounds (£10,000) on the credit of the municipal revenues of the Mayor, Councillors and Citizens of the City, such sum to be raised by the grant of a mortgage, in accordance with the provisions of the *Local Government Act 1958*.

The maximum rate of interest that may be paid is £5 17s. 6d. per centum per annum.

The purpose for which the loan is to be applied is:—

Extensions to Electricity Supply Undertaking £10,000

The period of the loan shall be fifteen years.

The moneys borrowed shall be repayable by providing out of the municipal fund thirty half-yearly instalments of approximately £506 1s. 8d. each, including principal and interest, on the first day of July and the first day of January during the currency of the loan. The first instalment shall be payable on the first day of July, 1962.

Such moneys shall be repayable at the Commonwealth Trading Bank of Australia, Melbourne, or at the Council's Bankers for the time being in Melbourne.

The plans and specifications and the estimate of the cost of the proposed works, and a statement showing the proposed expenditure of the moneys to be borrowed are, open for inspection at the Town Hall, Ferguson-street, Williamstown.

15622 J. E. MORLEY, Town Clerk.

*Local Government Act 1958 and Health Act 1958.*

## BOROUGH OF ECHUCA.

NOTICE is hereby given that it is the intention of the Council of the Borough of Echuca, in exercise of the powers conferred upon it by the *Local Government Act 1958* and the *Health Act 1958* and all other powers it enabling to execute upon those pieces of land being Crown Suburban allotments 4A and 13A, Township of Echuca, Parish of Echuca North, County of Rodney and being the whole of the land comprised in certificates of title, volume 8126, folio 983, and volume 3917, folio 215, being the land situate at the corner of McKenzie-street and Eyre-street in the Borough of Echuca, the following work or undertakings:—

The providing of a suitable place within the said Borough for the disposal of refuse and rubbish.

The Council has caused to be prepared specifications, maps, plans and elevations showing the nature and extent of the said work or undertaking and the exact site and measurements thereof and the land upon which the same is proposed to be placed and stating that the name of the owner and occupier so far as can be ascertained by the Council is Dorothy Evelyn Hore, formerly of 76 High-street, Echuca, and now of 4 Gower-avenue, Camberwell, in the State of Victoria, married woman. The said specification, maps, plans and elevations have been approved by the Council and are now deposited for inspection by all persons interested, at the offices of the Council, situate at the corner of Hare and Heygarth streets, Echuca, and may be inspected there during office hours.

All persons affected by the proposed work or undertaking are hereby called upon to set forth, in writing, addressed to the Council or to its Town Clerk within forty (40) clear days from the date of the publication of this notice in the *Government Gazette*, all objections which they may have to such work or undertaking.

Dated this 21st day of September, 1961.  
15632 K. F. McCARTNEY, Town Clerk.

## SHIRE OF CRANBOURNE.

## NOTICE OF INTENTION TO BORROW £10,000.

NOTICE is hereby given that the Council of the Shire of Cranbourne proposes to borrow the sum of Ten thousand pounds (£10,000), on the credit of the municipal revenues of the President, Councillors and Ratepayers of the Shire of Cranbourne, such sum to be raised by the grant of a mortgage, in accordance with the provisions of the *Local Government Act 1958*.

1. The maximum rate of interest that may be paid is £5 17s. 6d. per cent. per annum, payable half-yearly, the first of such payments is to be made on 1st July, 1962.

2. The purposes for which the loan is to be applied are:—

Purchase of land for Recreation Ground ..	£2,700
Purchase of land for road-widening purposes ..	4,800
Erection of Infant Welfare/Pre-school Centre ..	1,500
Erection of Pre-school Centre ..	1,000

£10,000

3. The period of the loan shall be forty (40) years.

4. The loan is to be liquidated by the creation of a sinking fund, pursuant to the provisions of section 428A of the *Local Government Act*.

5. Such moneys to be repayable at the Local Authorities Superannuation Board, Melbourne.

The plans and specifications and the estimate of the cost of the proposed works, and a statement showing the proposed expenditure of the moneys to be borrowed, are open for inspection at the Shire Offices, Cranbourne.

15612 T. W. GRANT, Shire Secretary.

## SHIRE OF EUROA.

## LOAN No. 23.

*Notice of Intention to Borrow the Sum of Three Thousand Pounds for Permanent Works and Undertakings.*

TAKE notice that the Council of the Shire of Euroa proposes to borrow on the credit of the President, Councillors and Ratepayers of the said Shire the sum of Three thousand pounds (£3,000), such sum to be raised by the issue of debentures, in accordance with the provisions of the *Local Government Act 1946*.

The maximum rate of interest that may be paid is £5 16s. 3d. per centum per annum.

Such moneys shall be repayable by fourteen half-yearly instalments, each of £263 17s. 8d., including principal and interest, by providing out of the municipal fund such amounts on the 1st day of June and the 1st day of December in each respective year during the currency of the loan.

Such money shall be repayable at Melbourne at the National Bank of Australasia Limited, or at the Council's bankers for the time being in Melbourne.

The purpose for which the loan is to be applied is—

Erection of Infant Welfare Centre.

The plans, specifications and estimates of the works referred to above, and a statement showing the proposed expenditure of the money to be borrowed, are open for inspection at the Shire Office, Euroa.

Dated this 25th day of September, 1961.  
15687 R. L. MANLEY, Shire Secretary.

## SHIRE OF FRANKSTON.

## LOAN No. 67.—£25,000.

*Special Order.*

NOTICE is hereby given that the Council of the Shire of Frankston did at a meeting held on Monday, 28th August, 1961, agree to the following Resolution:—

1. That this Council borrow the sum of £25,000 by the grant of mortgage for such amount secured on the credit of the President, Councillors and Ratepayers of the municipality, in accordance with the provisions of section 585 of the *Local Government Act 1958*, as amended.

2. That the rate of interest to be paid be £5 17s. 6d. per centum per annum.

3. That the period of the Loan be ten (10) years and that the moneys borrowed be repayable by half-yearly instalments of £1,671 approximately, including principal and interest on the 1st day of April and the 1st day of October during the currency of the loan, the first instalment being payable on the 1st day of April, 1962.

4. That such moneys be repayable at the State Savings Bank of Victoria, Melbourne.

5. That the loan be applied for the purpose of constructing private streets within the Shire of Frankston, in pursuance of and in accordance with the provisions of Division 10 of Part XIX. of the *Local Government Act 1958*.

And notice is hereby further given that the said Council did at a meeting held on Monday, 25th September, confirm the Special Order.

G. C. PENTLAND, Shire Secretary.  
Shire Office, Frankston. 15533

## SHIRE OF FRANKSTON.

## BY-LAW No. 101.

NOTICE is hereby given that a By-law has been made, under the provisions of section 193 (1) (j) of the *Local Government Act 1958*, for the purpose of—

- (a) Prohibiting the provision of further vehicular access facilities between limited access roads and abutting lands;
- (b) prohibiting the entry or leaving of the limited access road by vehicles except by passages—
  - (1) in regular use before the commencement of this By-law, or
  - (2) subsequently approved by Council Resolution;
- (c) prohibiting and regulating the presence of animals on limited access roads;
- (d) regulating traffic; and
- (e) prescribing penalties for breaches of this By-law and for other purposes.

Notice is further given that a copy of the above By-law is open for inspection, free of charge, during office hours, at the office of the Council, Davey-street, Frankston.

G. C. PENTLAND, Shire Secretary.  
Shire Office, Frankston. 15604

## SHIRE OF HASTINGS.

## BY-LAW No. 2.

A By-law of the Shire of Hastings, made under section 65 of the *Health Act 1958*, as amended by the *Health Act (Amendments) Act 1960*, numbered No. 2 for fixing fee for the examination of plans, specifications, particulars and description of proposed septic tank systems and any inspection of sites and installations.

THE President, Councillors and Ratepayers of the Shire of Hastings, pursuant of the power conferred by the *Health Act 1958*, and of any and every other power enabling in that behalf order as follows:—

That the following fee is hereby fixed for the examination of plans, specifications, particulars and descriptions of proposed septic tank systems and any inspection of site and installation of septic tank systems—£4.

Resolution for passing this By-law agreed to by the Council of the Shire of Hastings on the 1st day of August, 1961, and was confirmed on the 5th day of September, 1961.

The common seal of the President, Councillors and Ratepayers of the Shire of Hastings was affixed hereto in the presence of—

(SEAL) W. G. MYERS, President.  
J. A. BABINGTON, Councillor.  
L. A. WALKER, Secretary.  
15689

## SHIRE OF HASTINGS.

NOTICE is hereby given that Senior Constable L. R. McMenomy has been appointed as Prosecuting Officer to the Shire of Hastings.

L. A. WALKER, Shire Secretary.  
Shire Office, Hastings, 20th September, 1961. 15628

## SHIRE OF KORUMBURRA.

*Notice of Intention to Acquire Land Compulsorily.*

WHEREAS the Council of the Shire of Korumburra deems it expedient to execute a certain work or undertaking for the purpose whereof it is in the opinion of the said Council necessary or desirable that it exercise its powers of taking land compulsorily as provided by the *Local Government Acts*, and the said Council has caused to have prepared such plans of the work or undertaking as are necessary and in which are set out the lands on which the said work or undertaking is proposed to be effected and the names of the owners or reputed owners, lessees or reputed lessees and the occupiers of such land as far as can be ascertained, and the said plans have been approved by the Council.

In pursuance of the provisions of the *Local Government Acts*, the said Council hereby gives notice:—

1. That it intends to compulsorily acquire the land described hereunder in the parish of Jumbunna East for the purpose of construction of a deviation of the Outtrim-Moyarra road:

Land to be acquired: Part Crown allotments 58b, 58f, 59, 59c, 59d, 63d, all in the Parish of Jumbunna East.

2. That the plans of the proposal, adopted by the Council on the 20th day of September, 1961, are open for inspection at the Shire Office, Korumburra, during normal office hours.

3. That all persons affected by the proposed work or undertaking are hereby called upon to set forth, in writing, addressed to the Council or the Shire Secretary within 40 clear days from the publication of this notice in the *Government Gazette*, all objections they may have to the work or undertaking.

Dated this 22nd day of September, 1961.

15682 W. O. CLARK, Shire Secretary.

## SHIRE OF MORTLAKE.

## LOAN No. 6.

*Notice of Intention to Borrow.*

NOTICE is hereby given that the Council of the Shire of Mortlake intends to borrow the sum of £10,000 on the credit of the municipal revenues of the President, Councillors and Ratepayers of the said Shire, such sum to be raised by the grant of a mortgage in accordance with the provisions of the *Local Government Act 1958*.

1. The maximum rate of interest that may be paid is £5 17s. 6d. per cent. per annum.

2. The purpose for which the loan is to be applied shall be the construction of an Olympic standard swimming pool and the provision of a water filtration plant for such, at Mortlake.

3. The period of the loan shall be fifteen years.

4. The moneys borrowed shall be repayable by providing out of the municipal fund, 30 half-yearly instalments of £506 1s. 9d. each, including principal and interest on the 1st day of June and the 1st day of December during the currency of the loan. The first instalment shall be payable on the 1st day of June, 1962.

5. Such moneys shall be repayable at the C.B.C. Savings Bank Limited, Melbourne.

Plans and specifications and estimate of the cost of the proposed works and a statement showing the proposed expenditure of the moneys to be borrowed, are open for inspection at the Shire Office, Mortlake.

15631 W. J. GRAY, Shire Secretary.

## SHIRE OF PORTLAND.

## LOAN No. 21.

*Notice of Intention to Borrow the Sum of £2,400 for Permanent Works and Undertakings.*

NOTICE is hereby given that the Council of the Shire of Portland proposes to borrow the sum of Two thousand four hundred pounds, on the credit of the municipal revenues of the President, Councillors and Ratepayers of the said Shire, such sum to be raised by the grant of a mortgage, in accordance with the provisions of the *Local Government Act 1958*.

1. The maximum rate of interest that may be paid is 5½ per cent. per annum.

2. The purpose for which the loan is to be applied is:—  
Concrete footpaths construction in the Town of Heywood—£2,400.

3. The period of the loan shall be five years.

4. The moneys borrowed shall be repayable by providing out of the municipal fund ten half-yearly instalments of approximately £279 11s. 3d. each, including principal and interest, on the 1st day of January and the 1st day of July during the currency of the loan. The first instalment shall be payable on the 1st day of July, 1962.

5. Such moneys shall be repayable at the State Savings Bank of Victoria, Melbourne.

The plans and specifications and the estimate of the cost of the proposed works, and a statement showing the proposed expenditure of the moneys to be borrowed, are open for inspection at the Shire Office, Heywood, during office hours.

M. D. ALLARDICE, Shire Secretary.  
12th September, 1961. 15602



## SHIRE OF RODNEY.

## LOAN No. 46.

*Notice of Intention to Borrow the Sum of £5,000 for Permanent Works and Undertakings.*

NOTICE is hereby given that the Council of the Shire of Rodney proposes to borrow the sum of Five thousand pounds, on the credit of the municipal revenues of the President, Councillors and Ratepayers of the said Shire, such sum to be raised by the grant of a mortgage, in accordance with the provisions of the *Local Government Act 1958*.

1. The maximum rate of interest that may be paid is £5 17s. 6d. per cent. per annum.
2. The purposes for which the loan is to be applied are:—

Construction of concrete footpaths, kerbing and channelling, drainage works and street construction in the Township of Tatura.

3. The period of the loan shall be ten years.
4. The moneys borrowed shall be repayable by providing out of the municipal fund twenty half-yearly instalments of approximately £334 3s. each, including principal and interest, on the 1st day of January and the 1st day of July during the currency of the loan. The first instalment shall be payable on the 1st day of July, 1962.

5. Such moneys shall be repayable at the State Savings Bank of Victoria, Melbourne.

The plans and specifications and the estimate of the cost of the proposed works, and a statement showing the proposed expenditure of the moneys to be borrowed, are open for inspection at the Shire Office, Tatura.

15601

R. PERRY, Shire Secretary.

## SHIRE OF SOUTH BARWON.

## LOAN No. 49.

*Notice of Intention to Borrow.*

NOTICE is hereby given that the Council of the Shire of South Barwon intends to borrow Twenty-three thousand pounds (£23,000) on the credit of the President, Councillors and Ratepayers of the said Shire, by the grant of a mortgage, in accordance with the provisions of the *Local Government Acts*.

In connexion therewith the following information is stated:—

- (a) The amount of the principal moneys which it is proposed to borrow is Twenty-three thousand pounds.
- (b) The maximum rate of interest that may be paid is £5 17s. 6d. per annum.
- (c) The times which the moneys borrowed are to be repayable are on the 30th day of June and the 31st day of December during the years 1962 to 1971 inclusive, and that the place such moneys shall be repayable is at the Bank of New South Wales, Belmont.
- (d) The purposes for which the loan is to be applied are:—

1. Installation of pedestrian traffic lights, Belmont	£700
2. Construction of underground drains, Golf-avenue, Barwon Heads	1,300
3. Construction of footpaths, South Valley-road, Highton	1,100
4. Construction of underground drains and channels, Bailey and Francis streets	1,500
5. Construction of underground drains, Fischer-street and Zeally Bay-road	3,500
6. Purchase of Highton Recreation Reserve	2,000
7. Construction of kerbs, channels, footpaths and secondary drains—Belmont and Highton	2,000
8. Construction of road pavements, kerbs, channels, footpaths and secondary drains—Barwon Riding	2,000
9. Construction of underground drains in Roslyn-road, Brocka-avenue to Kardinia Creek	4,300
10. Land acquisition and road construction, Barwon Heads	3,100
11. Construction main drain—Zeally Bay-road	1,250
12. Portion of cost of Grovedale Infant Welfare Centre	250
	£23,000

(e) The manner in which the loan is to be liquidated is by provision out of the municipal fund in each half-year during the currency of the loan of the sum of £1,537 0s. 10d., which includes principal and interest.

The plans and specifications and estimate of the cost of the works and a statement showing the proposed expenditure of the moneys to be borrowed, are open for inspection at the Shire Office, Belmont.

Dated this 20th day of September, 1961.

15619

E. T. CORNISH, Shire Secretary.

## SHIRE OF TUNGAMAH.

## BY-LAW No. 53.

A By-law of the Shire of Tungamah made under section 65 of the *Health Act 1958*, as amended by the *Health (Amendment) Act 1960*, and numbered 53, for fixing a fee for the examination of plans, specifications, particulars and description of proposed septic tank systems and any inspections of site and installations.

IN pursuance of the powers of the *Health Act 1958*, and of any and every other power it thereunto enabling, the President, Councillors and Ratepayers of the said Shire order as follows:—

- (1) The following fee is hereby fixed:—

For the examination of plans, specifications, particulars and descriptions of the proposed septic tank systems and any inspections of sites and installations of septic tank systems—1 (one pound).

(2) This By-law shall apply and have operation throughout the whole of the municipal district.

Resolution for passing this By-law was agreed to by the Council of the Shire of Tungamah on the 21st day of August, 1961, and confirmed on the 18th day of September, 1961.

The seal of the President, Councillors and Ratepayers of the Shire of Tungamah was hereunto affixed this 18th day of September, 1961, in the presence of—

D. F. LANE, President.

(SEAL)

GEORGE R. SYMONS, Councillor.

M. CLEARY, Secretary.

15621

## SHIRE OF UPPER MURRAY.

## BY-LAW No. 23.

A By-law of the Shire of Upper Murray, made under the *Local Government Acts* and the *Uniform Building Regulations, Victoria*, and numbered 23, for determining, applying, dispensing with or regulating such matters or things as are left to be determined, applied, dispensed with or regulated by the Council of the said Shire of Upper Murray under the *Uniform Building Regulations, Victoria*.

IN pursuance of the powers conferred by the *Local Government Acts* and the *Uniform Building Regulations, Victoria*, and of any and every power it thereunto enabling, the President, Councillors and Ratepayers of the Shire of Upper Murray order as follows:—

*Minimum Area, Depth and Width of Frontage.*

1. The minimum area, depth and width of frontage specified in column 3 of Table 804 of the *Uniform Building Regulations, Victoria* (hereinafter called the *Regulations*) are hereby adopted as the minimum area, depth and width of frontage of land on which a building shall be constructed throughout those portions of the municipal district set out and described in clause 5 of this By-law.

2. The minimum area, depth and width of frontage specified in column 3 of Table 804 of the *Uniform Building Regulations, Victoria* (hereinafter called the *Regulations*) are hereby adopted as the minimum area, depth and width of frontage of land on which a building shall be constructed throughout those portions of the municipal district set out and described in clause 6 of this By-law.

3. Notwithstanding the provision of clause 1 of this By-law, the Council may permit the construction of a building of Class I. occupancy on land having a lesser area, depth or width of frontage or at a lesser distance from boundaries than those specified in column 3 of Table 804, or the construction of a building in Classes III., V., VI., VII. or VIII. occupancy or a building to which a building of Class IV. occupancy is attached on land having an area, depth or width of frontage less than that prescribed in clause 809 in any case where, on the date of commencement of this By-law, such land existed as a separate allotment and had not been reduced in area or was shown on any plan of subdivision approved by the Council and lodged in the Office of Titles.

4. The By-law of the Shire of Upper Murray, numbered 19, is hereby repealed.

5. Clauses 1 and 3 of this By-law shall apply to and have operation throughout those portions of the municipal district of the Shire of Upper Murray which are situated within 2 miles of the post offices at, Towong, Cudgewa and Tintalra and within the proclaimed Corryong Town Planning Area, excepting that portion of the municipal district referred to in clause 6 below.

6. Clause 2 of this By-law shall apply to and have operation throughout that portion of the municipal district of the Shire of Upper Murray purchased by the Housing Commission, Victoria, and known as the Police Reserve.

7. This By-law shall come into operation on its approval by the Governor in Council and after proclamation published in the *Victoria Government Gazette*.

Resolution for the passing of this By-law was agreed to by the Council of the Shire of Upper Murray on the 9th day of May, 1960, and confirmed on the 15th day of June, 1960..

The common seal of the President, Councillors and Ratepayers of the Shire of Upper Murray was hereunto affixed this 15th day of June, 1961—

(SEAL) E. H. NICHOLAS, Shire President.  
A. J. FINDLAY, Councillor.  
G. H. TATE, Shire Secretary.

Approved by the Governor in Council, 18th July, 1961.  
—A. MAHLSTEDT, Clerk of the Executive Council. 15608

SHIRE OF UPPER YARRA.

ORDER CHANGING NAMES OF ROADS.

NOTICE is hereby given that the Council of the Shire of Upper Yarra, in pursuance of the provisions of the Local Government Act, has, by resolution dated 5th September, 1961, made an Order changing the names of the roads set out hereunder:—

Old Name.	New Name.	Township or District.	Description.
Blackwood-avenue and part of Brisbane-parade	Blackwood-avenue ..	Warburton ..	From eastern end of Damman's-road to end of Blackwood-avenue at intersections with Acheron Way
Willis-road .. ..	Worley-road .. ..	Hoddles Creek ..	Along northern boundaries of Crown allotments 67b and 27, and on eastern boundaries of Crown allotments 23 and 23a, Parish of Woori Yallock
Symonds-road .. ..	Staves-road .. ..	Hoddles Creek ..	Between Crown allotments 73a and 73b, Parish of Woori Yallock
River-road .. ..	Richards-street ..	Warburton .. ..	Between Brett and Brisbane Hill roads
Not named .. ..	Thomas-avenue .. .	Warburton .. ..	Along southern bank of Yarra River between Brisbane Bridge and Warburton Tennis Courts
Old Beenak .. ..	Elvian-road .. ..	Woori Yallock ..	From Warburton Highway to Church-road

15683

J. N. EDDY, Shire Secretary.

SHIRE OF WANNON.  
GRAZING BY-LAW No. 32.

NOTICE is hereby given that the Council did, on the 11th day of September, 1961, confirm the Resolution passed on the 14th day of August, 1961, repealing By-law No. 32, made under the provisions of sections 197 and 545 of the *Local Government Act* 1946, for regulating the conditions under which cattle may be driven on to any road for the purpose of grazing thereon with the Council's consent.

Dated this 15th day of September, 1961.  
15603 V. J. WHARTON, Shire Secretary.

SHIRE OF WARRAGUL.  
BY-LAW No. 69.

A By-law of the Shire of Warragul made under the provisions of the *Health Act* 1958, for examining and branding carcasses, parts of carcasses or meat by or under the direction of the meat inspector in that portion of the Warragul Meat Area, situated in the municipal district of the Shire of Warragul.

IN pursuance of the powers conferred by the Health Act, and every other power thereunto enabling the President, Councillors and Ratepayers of the Shire of Warragul order as follows:—

1. Clause 9 (b) of By-law No. 59 is hereby repealed and the following clause substituted therefore:—

9. (b) For examining and branding any carcass of or meat derived from any— s. d.

- (i) Bull, cow, calf (other than a bobby calf) heifer, ox or steer .. 3 10
- (ii) Bobby calf, goat, kid, lamb or sheep .. 1 4
- (iii) Swine .. .. 1 10

Resolution for passing this By-law agreed to by the Council of the Shire of Warragul on the 11th day of April, 1961, and confirmed on the 9th day of May, 1961.

The common seal of the President, Councillors and Ratepayers of the Shire of Warragul was affixed hereto this 9th day of May, 1961—

(SEAL) W. A. GREEN, President.  
A. R. MCKAY, Councillor.  
D. MCADIE, Shire Secretary.

Submitted to the Commission of Public Health on the 25th day of July, 1961.—A. T. GARDNER, Secretary, Commission of Public Health.

Approved by the Governor in Council on the 29th day of August, 1961.—A. H. MAHLSTEDT, Clerk of the Executive Council. 15624

SHIRE OF YACKANDANDAH.

EXTENSION OF TIME TO MAKE A REVALUATION.

PLEASE take notice that it is the intention of the Council at its next meeting to be held on Thursday, 5th October, 1961, to confirm the following Resolution:—

That application be made to the Local Government Department for an extension of time of four years to have a revaluation of the Shire as it is considered that there has been no general appreciable change in values of properties since the return of the last valuation.

15623 L. KRUTLI, Shire Secretary.

MURTOA WATERWORKS TRUST.

NOTICE TO THE OWNERS OF TENEMENTS IN THE UNDERMENTIONED STREETS AND ROADS.

THE main pipes in the said streets being laid down, the owners of all tenements situated as under are hereby required on or before the 6th day of November, 1961, to cause a proper pipe and stop cocks to be laid, so as to supply water within such tenements from the main pipes.

STREET AND POSITION.

- Breen-street, from Gulbin-street to McDonald-street; from Hamilton-street eastward 390 feet.
- Friend-street, from Lloyd-street eastward 416 feet.
- Lloyd-street, from Munro-street to 160 feet south Friend-street.
- Lake-street, from Munro-street southward 800 feet.
- Miller-street, from Marma-street to Breen-street.
- Hatchett-street, from Breen-street northward 325 feet.

H. G. CRAM, Secretary of The Murtoa Waterworks Trust. 15629

NOTICE is hereby given that the Provisional Committee of the Mountain District Bush Nursing Centre has applied for a lease under section 134, *Land Act* 1958, for a term of 21 years as a site for a Bush Nursing Centre situate at Cockatoo. 15532

NOTICE is hereby given that Macintosh and Company Proprietary Limited has applied for a lease, under section 134, *Land Act* 1958, for a term of ten years from 11th December, 1961, of allotment 14, section E, City of South Melbourne, containing 35 8/10 perches, as a site for a general engineering works. 15568

## DANDENONG SEWERAGE AUTHORITY.

## GENERAL NOTICE.

THE above-mentioned Sewerage Authority, having made provision for carrying off the sewage from each and every property which or any part of which is within the Sewerage Areas hereinafter described, doth hereby declare that on and after the 1st day of October, 1961, each and every property which or any part of which is within the said Sewerage Areas shall be deemed to be a sewered property within the meaning of the *Sewerage Districts Act 1958*.

The boundaries of the Sewerage Areas hereinbefore referred to are:—

*Sewerage Area No. 51.*

Commencing at a point being the intersection of the western side of Cyril-grove and the southern side of Claudia-street; thence westerly along the southern side of Claudia-street a distance of 334 ft. 7 in.; thence northerly by a line perpendicular to Claudia-street a distance of 150 feet; thence easterly by a line parallel to Claudia-street to the western side of Cyril-grove; thence southerly along the western side of Cyril-grove to the point of commencement.

*Sewerage Area No. 52.*

Commencing at a point being the intersection of the eastern side of Liege-avenue and the north-eastern side of Joffre-street; thence northerly along the eastern side of Liege-avenue a distance of approximately 172 feet; thence north-westerly across Liege-avenue by a line parallel to Joffre-street a distance of approximately 195 feet; thence northerly by a line parallel to Liege-avenue a distance of approximately 352 feet; thence easterly by a line perpendicular to Liege-avenue to the eastern side of Liege-avenue; thence southerly along the eastern side of Liege-avenue a distance of approximately 214 feet; thence easterly by a line parallel to Claudia-street a distance of 198 feet; thence southerly by a line parallel to Liege-avenue a distance of 250 feet; thence westerly by a line parallel to Claudia-street a distance of approximately 59 feet; thence southerly by a line parallel to Liege-avenue to the north-eastern side of Joffre-street; thence north-westerly along the north-eastern side of Joffre-street to the point of commencement.

*Sewerage Area No. 53.*

Commencing at a point being the intersection of the south-western side of Carmen-street and the western side of Maurice-street; thence south-easterly along the south-western side of Carmen-street a distance of approximately 262 feet; thence southerly by a line parallel to Maurice-street a distance of approximately 308 feet; thence westerly by a line perpendicular to Maurice-street to the western side thereof; thence northerly along the western side of Maurice-street a distance of 150 feet; thence westerly by a line perpendicular to Maurice-street a distance of 162 feet; thence northerly by a line parallel to Maurice-street a distance of 300 feet; thence easterly by a line perpendicular to Maurice-street to the western side thereof; thence northerly along the western side of Maurice-street to the point of commencement.

*Sewerage Area No. 54.*

Commencing at a point being the intersection of the southern side of Garside-street and the eastern side of Ross-street; thence easterly along the southern side of Garside-street a distance of 980 feet; thence southerly by a line parallel to Ross-street a distance of 90 feet; thence westerly by a line parallel to Garside-street to the eastern side of Ross-street; thence northerly along the eastern side of Ross-street to the point of commencement.

*Sewerage Area No. 55.*

Commencing at a point being the intersection of the western side of King George-parade and the northern side of Goldlang-street; thence northerly along the western side of King George-parade to its intersection with the south-western side of Carmen-street; thence south-easterly across King George-parade and along the south-western boundary of lot 5 on lodged plan of subdivision No. 32081 to its southern angle; thence northerly along the eastern boundaries of the said lot 5 and lots 4, 3, 2 and 1 on the said lodged plan to the south-western side of Princes Highway; thence south-easterly along the south-western side of Princes Highway to the eastern angle of lot 1 on lodged plan of subdivision No. 18938; thence south-westerly along the south-eastern boundary of the said lot 1 to its southern angle; thence north-westerly along the north-eastern boundary of lot 61 on the lodged plan of subdivision No. 8766 a distance of 70 ft. 8 1/2 in.; thence south-westerly by a line parallel to Edgewood-road a distance of 79 ft. 4 in.; thence southerly by a line parallel to the western boundary of lot 62 on the said lodged plan to

the north-eastern side of Ray-street; thence south-easterly along the north-eastern side of Ray-street and the south-easterly prolongation thereof to the south-eastern side of Edgewood-road; thence south-westerly along the south-eastern side of Edgewood-road to the north-western angle of lot 14 on lodged plan of subdivision No. 42249; thence southerly along the western boundary of the said lot 14 and the southerly prolongation thereof to the eastern angle of lot 8 on lodged plan of subdivision No. 41586; thence westerly along the southern boundaries of the said lot 8 and lots 9 and 10 on the said lodged plan to the south-eastern angle of lot 12 on the said lodged plan; thence north-westerly along the north-eastern boundary of the said lot 12 to its north-eastern angle; thence westerly along the northern boundary of the said lot 12 to the eastern side of King George-parade; thence south-westerly across King George-parade to the point of commencement.

*Sewerage Area No. 56.*

Commencing at a point being the intersection of the north-eastern side of Princes Highway and the north-western side of Waverley-drive; thence north-westerly along the north-eastern side of Princes Highway to its intersection with the south-eastern side of Elonera-road; thence north-easterly along the south-eastern side of Elonera-road to its intersection with the north-eastern side of Camellia-avenue; thence south-easterly along the north-eastern side of Camellia-avenue to the western angle of lot 29 on lodged plan of subdivision No. 52510; thence north-easterly along the north-western boundaries of the said lot 29 and lot 30 on the said lodged plan and the north-easterly prolongation thereof to the north-eastern side of Smale-court; thence south-easterly along the north-eastern side of Smale-court to the western angle of lot 37 on the said lodged plan; thence north-easterly along the north-western boundary of the said lot 37 to its northern angle; thence north-easterly across a drainage reserve to the western angle of lot 57 on the said lodged plan; thence north-westerly along the south-western boundaries of the said lot 57 and lots 56, 55, 54, 53, 52, 51, 50 and 48 on the said lodged plan and the north-westerly prolongation thereof to the northern side of Oakwood-avenue; thence easterly along the northern side of Oakwood-avenue to the western angle of lot 390 on lodged plan of subdivision No. 51450; thence north-easterly along the north-western boundaries of the said lot 390 and lot 433 on lodged plan of subdivision No. 52538 across Kingswood-crescent and along the north-western boundaries of lots 434, 437, 438, 439, 440, 441 and 442 on the said lodged plan to the southern side of Wallis-road; thence easterly along the southern side of Wallis-road to its intersection with the western side of Heyington-crescent; thence southerly and south-westerly along the western and north-western sides of Heyington-crescent to its intersection with the southern side of Mollison-street; thence westerly along the southern side of Mollison-street to the north-eastern angle of lot 161 on lodged plan of subdivision No. 50962; thence southerly along the eastern boundary of the said lot 161 to its south-eastern angle; thence westerly and north-westerly along the southern and south-western boundaries of the said lot 161 and lots 162, 163, 164 and 165 on the said lodged plan to the south-eastern side of Waverley-drive; thence westerly across Waverley-drive to the north-western side thereof; thence south-westerly along the north-western side of Waverley-drive to the point of commencement.

*Sewerage Area No. 57.*

Commencing at a point being the intersection of the south-eastern side of Orchid-avenue and the north-eastern side of Pinewood-avenue; thence south-easterly along the north-eastern side of Pinewood-avenue to the western angle of lot 31 on a plan of subdivision No. 5125, lodged with the City of Dandenong; thence generally north-easterly along the irregular north-western boundary of the said lot 31 to its northern angle; thence south-easterly along the north-eastern boundaries of the said lot 31 and lots 30, 29, 28, 27, 26, 25, 24 and 22 on the said lodged plan and the south-easterly prolongation thereof to the south-eastern side of Boronia-avenue; thence south-westerly along the south-eastern side of Boronia-avenue to its intersection with the north-eastern side of Pinewood-avenue; thence south-easterly along the north-eastern side of Pinewood-avenue to its intersection with the south-eastern side of Holly-avenue; thence south-westerly along the south-eastern side of Holly-avenue to its intersection with the north-eastern side of Oakwood-avenue; thence south-easterly along the north-eastern side of Oakwood-avenue and the south-easterly prolongation thereof to the eastern side of Gladstone-road; thence southerly along the eastern side of Gladstone-road to its intersection with the south-easterly prolongation of the south-western side of Mulgoa-avenue; thence north-westerly across Gladstone-road and along

the south-western side of Mulgoa-avenue to its intersection with the south-eastern side of Bentley-avenue; thence south-westerly along the south-eastern side of Bentley-avenue a distance of approximately 185 feet; thence south-easterly by a line parallel to Mulgoa-avenue a distance of approximately 234 feet; thence southerly by a line parallel to Gladstone-road a distance of approximately 310 feet; thence westerly by a line parallel to Heatherton-road a distance of approximately 265 feet; thence southerly by a line parallel to Gladstone-road to the northern side of Heatherton-road; thence westerly along the northern side of Heatherton-road to the south-eastern angle of lot 2 on lodged plan of subdivision No. 41778; thence northerly along the eastern boundary of the said lot 2 to its north-eastern angle; thence westerly along the southern boundaries of lots 28 and 29 on lodged plan of subdivision No. 43075 to the most western angle of lot 29; thence north-easterly along the north-western boundary of the said lot 29 to the southern side of Crawford-avenue; thence generally northerly across Crawford and Barbara avenues to the southern angle of lot 35 on the said lodged plan; thence north-westerly along the south-western boundary of the said lot 35 to its western angle; thence north-easterly by a line parallel to Barbara-avenue to a point on the south-western boundary of lot 151 on lodged plan of subdivision No. 50961; thence north-westerly along the south-western boundaries of the said lot 151 and lot 152 on the said lodged plan to the south-eastern angle of lot 153 on the said lodged plan; thence westerly along the southern boundary of the said lot 153 to its south-western angle; thence northerly along the western boundary of the said lot 153 to the southern side of Mollison-street; thence north-easterly across Mollison-street to the intersection of the northern side thereof with the south-eastern side of Irving-road; thence north-easterly along the south-eastern side of Irving-road and the north-easterly prolongation thereof to the north-eastern side of Oakwood-avenue; thence south-easterly along the north-eastern side of Oakwood-avenue to its intersection with the south-eastern side of Orchid-avenue; thence north-easterly along the south-eastern side of Orchid-avenue to the point of commencement.

*Sewerage Area No. 58.*

Commencing at a point on the northern side of Heatherton-road such point being distant 150 feet east from the eastern side of Hillside-avenue; thence northerly by a line parallel to Hillside-avenue a distance of approximately 149 feet; thence easterly by a line parallel to Heatherton-road a distance of approximately 119 feet; thence southerly by a line parallel to Hillside-avenue to the northern side of Heatherton-road; thence westerly along the northern side of Heatherton-road to the point of commencement.

For the purposes of these descriptions the streets herein described shall be taken as those similarly designated on the Official Plans of Dandenong Sewerage Authority.

Unless otherwise specified the lodged plans of subdivisions herein referred to are those lodged with the Office of Titles, Melbourne.

By order of the Dandenong Sewerage Authority.

VICTOR R. THARLE, Chairman.  
A. R. EDWARDS, Secretary.

15635

SPRINGVALE AND NOBLE PARK SEWERAGE  
AUTHORITY.

GENERAL NOTICE.

THE above-mentioned Sewerage Authority, having made provision for carrying off the sewage from each and every property which or any part of which is within the Sewerage Areas hereinafter described, doth hereby declare that on and after the 1st day of October, 1961, each and every property which or any part of which is within the said Sewerage Areas shall be deemed to be a sewered property within the meaning of the *Sewerage Districts Act 1958*.

The boundaries of the Sewerage Areas hereinbefore referred to are:—

*Sewerage Area No. 41—Springvale.*

Commencing at a point being the intersection of the eastern side of Springvale-road and the southern side of Virginia-street; thence southerly along the eastern side of Springvale-road to its intersection with the south-easterly prolongation of the south-western boundary of lot 401 on lodged plan of subdivision No. 9636; thence north-westerly across Springvale-road and along the south-western boundary of the said lot 401 to its south-western angle; thence northerly along the western boundary of the said lot 401 and the northerly prolongation thereof to the southern side of Newcomen-road;

thence easterly along the southern side of Newcomen-road to the western side of Springvale-road; thence easterly across Springvale-road to the point of commencement.

*Sewerage Area No. 42—Noble Park.*

Commencing at a point on the eastern side of Simpson-street such point being distant 200 feet north from the northern side of Noble-street; thence westerly by a line parallel to Noble-street a distance of approximately 220 feet; thence northerly by a line parallel to Simpson-street a distance of approximately 386 feet; thence westerly by a line parallel to Myrtle-street a distance of approximately 50 feet; thence northerly by a line parallel to Simpson-street a distance of approximately 200 feet to the northern side of Myrtle-street; thence westerly along the northern side of Myrtle-street a distance of approximately 123 feet; thence northerly along the southerly prolongation of the eastern side of Avon-street and the eastern side thereof a distance of approximately 307 feet; thence easterly by a line parallel to Heatherton-road a distance of approximately 177 feet; thence northerly by a line parallel to Simpson-street a distance of approximately 7 feet; thence easterly by a line parallel to Heatherton-road a distance of 168 feet to the western side of Simpson-street; thence easterly across Simpson-street to the north-western angle of lot 54 on lodged plan of subdivision No. 10933; thence easterly along the northern boundaries of the said lot 54 and lots 53 and 52 on the said lodged plan to the north-eastern angle of the said lot 52; thence southerly along the eastern boundary of the said lot 52 and the southerly prolongation thereof to the southern side of Walsh-street; thence westerly along the southern side of Walsh-street a distance of 53 feet; thence southerly by a line parallel to Simpson-street a distance of 150 feet; thence westerly by a line parallel to Walsh-street to the eastern side of Simpson-street; thence southerly along the eastern side of Simpson-street to the point of commencement.

*Sewerage Area No. 43—Noble Park.*

Commencing at a point being the intersection of the northern side of Norris-street and the western side of Shepreth-avenue; thence easterly across Shepreth-avenue and along the northern side of Norris-street to the south-western angle of lot 44 on lodged plan of subdivision No. 33542; thence northerly along the western boundaries of the said lot 44 and lot 42 on the said lodged plan and the northerly prolongation thereof to the northern side of Griffith-street; thence easterly along the northern side of Griffith-street to its intersection with the western side of Arnold-street; thence south-easterly along the north-eastern side of Arnold-street and southerly along the eastern side of Arnold-street to its intersection with the south-easterly prolongation of the north-eastern boundary of lot 7 on lodged plan of subdivision No. 11206; thence north-westerly across Arnold-street and along the north-eastern boundary of the said lot 7 to its north-western angle; thence southerly along the eastern boundary of lot 6 on the said lodged plan of subdivision and the southerly prolongation thereof to the southern side of Norris-street; thence westerly along the southern side of Norris-street to the north-eastern angle of lot 46 on lodged plan of subdivision No. 33542; thence southerly along the eastern boundary of the said lot 46 to its south-eastern angle; thence westerly along the southern boundary of the said lot 46 to the north-eastern angle of lot 6 on lodged plan of subdivision No. 43281; thence southerly along the eastern boundary of the said lot 6 to its south-eastern angle; thence westerly along the southern boundary of the said lot 6 to the north-eastern side of the eastern court of Shepreth-avenue; thence south-westerly across the said eastern court of Shepreth-avenue to the north-eastern angle of lot 9 on the said lodged plan of subdivision; thence southerly along the eastern boundary of the said lot 9 to its south-eastern angle; thence westerly along the southern boundaries of the said lot 9, a recreation reserve, and lot 3 on the said lodged plan of subdivision to its south-western angle; thence southerly along the eastern boundary of lot 5 on lodged plan of subdivision No. 43282 to its south-eastern angle; thence westerly along the southern boundary of the said lot 5 to the eastern side of Bloomfield-road; thence northerly along the eastern side of Bloomfield-road to its intersection with the easterly prolongation of the northern side of Rich-street; thence westerly across Bloomfield-road and along the northern side of Rich-street to the south-western angle of lot 9 on lodged plan of subdivision No. 20058; thence northerly along the western boundary of the said lot 9 to its north-western angle; thence easterly along the northern boundaries of the said lot 9 and lots 10 and 11 on the said lodged plan of subdivision and the easterly prolongation thereof to the eastern side of Bloomfield-road; thence easterly along the northern boundaries of lots 1 and 4 on lodged plan of subdivision No. 43281 to the

south-western angle of lot 31 on lodged plan of subdivision No. 33542; thence northerly along the western boundaries of the said lot 31 and lots 30 and 29 on the said lodged plan and the northerly prolongation thereof to the northern side of Norris-street; thence easterly along the northern side of Norris-street to the point of commencement.

*Sewerage Area No. 44—Noble Park.*

Commencing at a point being the intersection of the eastern side of Cumberland-avenue and the southern side of Heatherton-road; thence easterly along the southern side of Heatherton-road to its intersection with the eastern side of Briggs-crescent; thence southerly along the eastern side of Briggs-crescent to the south-western angle of lot 1 on lodged plan of subdivision No. 16219; thence westerly across Briggs-crescent to the western side thereof; thence southerly along the western side of Briggs-crescent to the north-eastern angle of lot 4 on lodged plan of subdivision No. 11406; thence westerly along the northern boundary of the said lot 4 to its north-western angle; thence southerly along the western boundary of the said lot 4 to its south-western angle; thence westerly along the southern boundary of lot 12 on the said lodged plan to the eastern side of Cumberland-avenue; thence northerly along the eastern side of Cumberland-avenue to the point of commencement.

*Sewerage Area No. 45—Noble Park.*

Commencing at a point being the intersection of the southern side of Heatherton-road and the western side of Chandler-road; thence southerly along the western side of Chandler-road a distance of 157 ft. 10½ in.; thence westerly by a line parallel to Heatherton-road a distance of approximately 205 feet; thence northerly by a line perpendicular to Heatherton-road to the southern side thereof; thence easterly along the southern side of Heatherton-road to the point of commencement.

*Sewerage Area No. 46—Springvale.*

Commencing at a point being the intersection of the western side of Springvale-road and the south-western side of Lightwood-road; thence south-easterly across Springvale-road and along the south-western side of Lightwood-road to its intersection with the western side of Warwick-avenue; thence southerly along the western side of Warwick-avenue a distance of approximately 25 feet; thence westerly by a line perpendicular to Warwick-avenue to the western side of Springvale-road; thence northerly along the western side of Springvale-road to the point of commencement.

*Sewerage Area No. 47—Springvale.*

Commencing at a point being the intersection of the western side of Buckingham-avenue and the northern side of Balmoral-avenue; thence northerly along the western side of Buckingham-avenue a distance of 119 feet; thence easterly by a line parallel to Balmoral-avenue a distance of 150 feet; thence southerly by a line parallel to Buckingham-avenue to the northern side of Balmoral-avenue; thence westerly along the northern side of Balmoral-avenue to the point of commencement.

For the purposes of these descriptions the streets herein described shall be taken as those similarly designated on the official plans of the Springvale and Noble Park Sewerage Authority.

By order of the Springvale and Noble Park Sewerage Authority,

A. A. ERICKSEN, Chairman.  
H. L. WILLIAMS, Secretary.

15633

NOTICE is hereby given that the partnership heretofore carried on by Motel Gersovitz, of 100 Balaclavara-road, North Caulfield, and Josip Hoich, of 20 Crimea-street, St. Kilda, under the name of "P.E.R.", at 76 McIlwraith-street, North Carlton, as plumbers, builders and contractors, has been dissolved as from the 1st day of September, 1961.

ARNOLD BLOCH, M.A., LL.B., solicitor, 150 Queen-street, Melbourne, solicitor for the said Motel Gersovitz.

15626

NOTICE is hereby given that the partnership hitherto existing between Geoffrey Rutter Clarke, Kenneth Harry Taylor, Alastair Robin Clarke and Norman Lees, carrying on business as stock and sharebrokers under the name of Clarke and Co., at 422 Little Collins-street, Melbourne, will dissolve by mutual agreement on 30th September, 1961. Geoffrey Rutter Clarke, Alastair Robin Clarke and Edward Douglas Moden will form a partnership and trade as Clarke and Co., at 450 Little Collins-street, Melbourne, and Kenneth Harry Taylor and Norman

Lees will trade in partnership as Taylor Lees and Co., at 422 Little Collins-street, Melbourne. All outstanding transactions of the old partnership will be finalized by the firm of Clarke and Co., at 450 Little Collins-street, Melbourne.

15662

No. 6496

In the Supreme Court of Victoria.—In the matter of Part VI. of the *Companies Act 1958*.—And in the matter of PRIMARY EXPORT CORPORATION OF AUSTRALIA PROPRIETARY LIMITED.

NOTICE is hereby given that a petition for the winding up of the above-named company by the Supreme Court was on the 25th day of September, 1961, presented to the said court by Avis Rent a Car System Proprietary Limited, and the said petition is directed to be heard before the court sitting at Melbourne on the 25th day of October, 1961, and any creditor or contributory of the said company desirous to support or oppose the making of an Order on the said petition may appear at the time of hearing by himself or counsel for that purpose; and a copy of the petition will be furnished to any creditor or contributory of the said company requiring the same by the undersigned on payment of the regulated charge for same.

The petitioner's address is 60 Riley-street, Sydney.

The petitioner's solicitors are Messrs. Evans, Masters and Gilbert, of 34 Queen-street, Melbourne.

EVANS, MASTERS & GILBERT, solicitors for the petitioner.

NOTE.—Any person who intends to appear on the hearing of the said petition must serve on or send by post to the above-named solicitors notice in writing of his intention so to do. The notice must state the name and address of the person, or, if a firm, the name and address of the firm, and must be signed by the person or firm, or his or their solicitor (if any), and must be served, or, if posted, must be sent by post in sufficient time to reach the above-named not later than Four o'clock in the afternoon on the 24th day of October, 1961.

15691

*Companies Act 1958*.—In the matter of D. R. McDONALD PROPRIETARY LIMITED.

NOTICE is hereby given that at an Extraordinary General Meeting of the above-named company duly convened and held at Suite 16, 553 St. Kilda-road, Melbourne, at half past Three o'clock in the afternoon, on the 14th day of September, 1961, the following Special Resolution was duly passed:—

"That it has been proved to the satisfaction of this meeting that the company cannot by reason of its liabilities continue in business and that it is advisable to wind up and accordingly that the company be wound up voluntarily and that Allan John Irwin, of 366 Bourke-street, Melbourne, be appointed liquidator for the purpose of the winding up.

Dated this 20th day of September, 1961.

A. J. IRWIN, Liquidator.

4th Floor, 366 Bourke-street, Melbourne. 15670

In the matter of THE BENDIGO SUN PROPRIETARY LIMITED (in Voluntary Liquidation), Creditors Voluntary Winding Up.—And in the matter of the *Companies Act 1958*.—Notice of Final Meeting of Creditors in Creditors' Voluntary Winding Up.

NOTICE is hereby given that, in pursuance of section 210 (1) of the *Companies Act 1958*, the final meeting of the creditors of the above-named company will be held at the Lyric Buildings, Charing Cross, Bendigo, on the 2nd day of November, 1961, at Eleven o'clock in the forenoon for the purpose of laying before such meeting an account showing how the winding up of the above-named company has been conducted and the property of the company disposed of and of giving any explanation thereof.

Dated the 23rd day of September, 1961.

15688 W. M. L. SUTHERLAND, Liquidator.

The *Companies Act 1958*.—In the matter of G. C. DICKSON & YORSTON (BUILDERS) PTY. LTD. (in Liquidation).

AT an Extraordinary General Meeting of Shareholders held at the registered office, 139 Boundary-road, North Melbourne, on Wednesday, 20th September, 1961, the following Special Resolution was passed:—

"That the company be wound up voluntarily and that Clyde Young, of 55 William-street, Melbourne, in the State of Victoria, chartered accountant, be appointed liquidator for the purposes of such winding up."

15678 C. B. FERGUSON, Secretary.

In the matter of BRAXLEY INDUSTRIES PROPRIETARY LIMITED.

**W**INDING UP Order made the 25th day of September, 1961.

Name and address of official liquidator: Magnus Victor Anderson, 377 Little Collins-street, Melbourne.

GARRETT, DAVIDSON & MATTHEY PTY. LIMITED, Petitioner.

Pearce and Webster, solicitors, 430 Little Collins-street, Melbourne. 15642

The *Companies Act 1958*.—In the matter of R. H. C. SOUND SYSTEMS PTY. LIMITED, of 182 Nepean Highway, Gardenvale.—Notice *re* Meeting of Creditors, pursuant to section 201 (2).

**N**OTICE is hereby given that a Meeting of Creditors of the above-named company will be held at the Chartered Institute of Accountants, 23 McKillop-street, Melbourne, on Friday, the 29th day of September, 1961, at half past Three o'clock p.m., the company having convened a meeting of its members for the same day for the purpose of considering a Resolution that the company be wound up voluntarily.

Dated this 19th day of September, 1961.

R. H. CATHERALL, Director.

A. B. Goslin, Lewis Luckins and Co., 397 Little Collins-street, Melbourne, MU 3451. 15676

*Companies Act 1958*.—In the matter of K. REES EMPORIUMS LIMITED.

**N**OTICE is hereby given that an Extraordinary General Meeting of the above-named company duly convened and held at Kelvin Hall, Collins-place, Melbourne, on 1st day of September, 1961, the following Special Resolution was duly passed:—

"That it has been proved to the satisfaction of this meeting that the company cannot by reason of its liabilities continue in business and that it is advisable to wind up and accordingly that the company be wound up voluntarily and that Ronald Dennis Widdows, of 366 Bourke-street, Melbourne, be appointed liquidator for the purpose of the winding up.

Dated this 4th day of September, 1961.

R. D. WIDDOWS, Liquidator.

366 Bourke-street, Melbourne. 15675

*Companies Act 1958*.—In the matter of J. A. SHERRIN CONSTRUCTIONS PROPRIETARY LIMITED, of 266 McKinnon-road, McKinnon.—Under the order for winding up the above-named company on 29th August, 1961.

**N**OTICE is hereby given that a First Meeting of Creditors in the above matter will be held in the Board Room of the Chartered Institute of Accountants, 23 McKillop-street, Melbourne, on Tuesday, the 10th day of October, 1961, at half past Three o'clock in the afternoon.

To entitle creditors to vote thereat, a proof must be lodged with the Official Liquidator not later than 10 a.m. on the 10th day of October, 1961.

Proxies to be used at the meeting must be lodged with the Official Liquidator not later than 10 a.m. on the 10th day of October, 1961.

Dated this 19th day of September, 1961.

A. J. IRWIN, Official Liquidator.

366 Bourke-street, Melbourne. 15672

*Companies Act 1958*.—In the matter of S. & N. LEIGH PROPRIETARY LIMITED, of 9 Cremorne-street, Richmond.—Under the order for winding up the above-named company on 27th July, 1961.

**N**OTICE is hereby given that a First Meeting of Creditors in the above matter will be held in the Board Room of the Chartered Institute of Accountants, 23 McKillop-street, Melbourne, on Tuesday, the 10th day of October, 1961, at half past Ten o'clock in the forenoon.

To entitle creditors to vote thereat, a proof must be lodged with the Official Liquidator not later than 4 p.m. on the 9th day of October, 1961.

Proxies to be used at the meeting must be lodged with the Official Liquidator not later than 4 p.m. on the 9th day of October, 1961.

Dated this 19th day of September, 1961.

A. J. IRWIN, Official Liquidator.

366 Bourke-street, Melbourne. 15671

SOUTHDOWN KNITTING MILLS PTY. LTD.  
(IN VOLUNTARY LIQUIDATION).

**N**OTICE is hereby given, pursuant to section 210 (2) of the *Companies Act 1958*, that a General Meeting of the above-named company will be held at the office of N. R. Macaw, chartered accountant, 31 Queen-street, Melbourne, on Friday the 27th day of October, 1961, at Two o'clock in the afternoon, for the purpose of having an account laid before them, showing the manner in which the winding up has been conducted and the property of the company disposed of, and of hearing any explanation that may be given by the liquidator.

Dated this 14th day of September, 1961.

15663 N. R. MACAW, Liquidator.

The *Companies Act 1958*.—In the matter of MADISON AVENUE INTERNATIONAL (AUST.) PTY. LIMITED, of 321 William-street, Melbourne.—Notice *re* Meeting of Creditors, Pursuant to Section 201 (2).

**N**OTICE is hereby given that a Meeting of Creditors of the above-named company will be held at the Board Room of the Honorary Justices Association, 6th floor, 34 Queen-street, Melbourne, on Friday, the 6th day of October, 1961, at 2.30 p.m. The company having convened a meeting of its members for the same day for the purpose of considering a resolution that the company be wound up voluntarily.

Dated this 26th day of September, 1961.

N. WEARNE, Director.

John P. Hyman, public accountant, 475 Collins-street, Melbourne. Telephone 61-2122. 15659

The *Companies Act 1958*.—In the matter of HENRY KOPEL'S FURNISHINGS PTY. LTD. (in Liquidation).

**N**OTICE is hereby given that pursuant to section 210 of the *Companies Act 1958*, a Final Meeting of the creditors of the above company will be held at the offices of Kennedy, Small and Middlemiss, 31 Queen-street, Melbourne, on Wednesday, 25th October, 1961, at Ten a.m.

Business.—To receive liquidator's accounts.

Dated this 27th day of September, 1961.

E. R. SMAIL, Liquidator.

Kennedy, Small and Middlemiss, 31 Queen-street, Melbourne. 15657

The *Companies Act 1958*.—In the Supreme Court of Victoria.—ACE PACKING COMPANY PROPRIETARY LIMITED.—Notice to Creditors and Contributors of First Meeting (under the Order for Winding Up of the Above-named company dated the 2nd day of March, 1961).

**N**OTICE is hereby given that the first Meeting of Creditors in the above matter will be held at the offices of Hall and Rose, chartered accountants, 163 William-street, Melbourne, on the 9th day of October, 1961, at 11 o'clock in the forenoon and that the first Meeting of Contributors will be held at the same place and on the same day at 10.45 o'clock in the forenoon.

Dated this 21st day of September, 1961.

A statement of the company's affairs has been lodged.

**NOTE**.—At the first Meeting of the Creditors and Contributors they may amongst other things—

1. By resolution determine whether or not an application is to be made to the court to appoint a liquidator in place of the official liquidator.

2. By Resolution determine whether or not an application shall be made to the court for the appointment of a Committee of Inspection to act with the liquidator, and who are to be the members of the Committee if appointed.

**NOTE**.—If a liquidator is not appointed by the court the official liquidator will be the liquidator.

15646 J. KENNETH HALL, Official Liquidator.

*Companies Act 1958*.

NOEL P. ROBINSON & CO. PROPRIETARY LIMITED  
(IN VOLUNTARY LIQUIDATION).

**N**OTICE is hereby given that, pursuant to section 210 of the *Companies Act 1958*, a meeting of the members of the above-named company will be held at my office, at 82 Somerville-road, Yarraville, at Ten o'clock a.m., on Monday, the 6th day of November, 1961, for the purpose of having an account laid before it showing how the winding up of the company has been conducted and the property of the company disposed of.

15679

B. VASSILIADIS, Liquidator.

The *Companies Act 1958*.—In the matter of L. C. K. ELECTRICS PROPRIETARY LIMITED.—Notice re Meeting of Creditors, Pursuant to Section 201 (2).

NOTICE is hereby given that a Meeting of Creditors of the above-named company will be held at 56 Kemp-avenue, Mount Waverley, on Friday, 29th day of September, 1961, at Ten a.m., the company having convened a meeting of its members for the same day for the purpose of considering a Resolution that the company be wound up voluntarily.

Dated the 26th day of September, 1961.

15634 K. RUSSELL, Director.

The *Companies Act 1958*.

CLASSIC HATCHERY PROPRIETARY LIMITED (IN LIQUIDATION).

NOTICE is hereby given that a First and Final Dividend is intended to be declared in the above matter.

Creditors who have not proved their debts by the 12th day of October, 1961, may be excluded from this Dividend.

J. K. HALL, Liquidator.

Dated this 25th day of September, 1961.

Hall and Rose, chartered accountants, 163 William-street, Melbourne. 15641

The *Companies Act 1958*.

HARVEY BILSON PROPRIETARY LIMITED (IN LIQUIDATION).

NOTICE is hereby given that a First and Final Dividend is intended to be declared in the above matter.

Creditors who have not proved their debts by the 12th day of October, 1961, may be excluded from this Dividend.

J. K. HALL, Liquidator.

Dated this 25th day of September, 1961.

Hall and Rose, chartered accountants, 163 William-street, Melbourne. 15640

HARRY EDWARD NOLTENIUS, late of Woodend, in the State of Victoria, retired, clerk in Holy Orders, DECEASED.

CREDITORS, next of kin and others having claims in respect of the estate of the deceased (who died on the 6th day of January, 1961), are required by the executors, The Perpetual Executors and Trustees Association of Australia Limited, of Nos. 100-104 Queen-street, Melbourne, in the said State, and Harry Eric Charles Noltenius, of 21 Broadway, Bonbeach, in the said State, accountant, and Arthur Brian Noltenius, of The State Savings Bank of Victoria, of 358 Mont Albert-road, Mont Albert, in the said State, bank manager, to send particulars, in writing, to them, at the offices of The Perpetual Executors and Trustees Association of Australia Limited, at 100-104 Queen-street, Melbourne, by the 1st day of December, 1961, after which date the executors may convey or distribute the assets, having regard only to the claims of which they then have notice.

H. HURRY & SON, solicitors, Kyneton, and at Wood-end and Gisborne. 15685

CREDITORS, next of kin and others having claims in respect of the estate of Lucy Mary Bellew, late of 7 Flete-avenue, Malvern, in the State of Victoria, widow, deceased (who died on the 29th day of June, 1961), are to send particulars of their claims to The Trustees Executors and Agency Company Limited, of 401 Collins-street, Melbourne, in the said State, by the 11th day of December, 1961, after which date it will distribute the assets of the deceased, having regard only to the claims of which it then has notice.

ABBOTT, STILLMAN & WILSON, solicitors, 422 Little Collins-street, Melbourne. 15686

CREDITORS, next of kin and others having claims in respect of the estate of Blanche Mitchell, late of "Akarana", Lilydale, in the State of Victoria, widow, deceased (who died on the 26th day of April, 1961), are to send particulars of their claims to National Trustees, Executors and Agency Company of Australasia Limited, of 95 Queen-street, Melbourne, and Thomas Mitchell, care of 95 Queen-street, Melbourne, the executors thereof, by the 27th day of November, 1961, after which date the said company and the said Thomas Mitchell will distribute the estate of the said deceased, having regard only to the claims of which it then has notice.

GILLOTT, MOIR & AHERN, solicitors, 95 Queen-street, Melbourne. 15674

WILLIAM THOMPSON ELLIS, late of 2 Murray-street, Ballarat, in the State of Victoria, retired, DECEASED (who died on the 22nd June, 1961).

CREDITORS, next of kin and all other persons having claims against the estate of the said deceased, are required by the executor, The Fidelity Trustee Company Limited, of 101 Lydiard-street north, Ballarat, to send detailed particulars of their claims in respect of the said property to the said executor, care of the said company, on or before the 20th day of December, 1961, after which date it will proceed to distribute the said estate, having regard only to the claims of which it then has notice.

Dated this 19th day of September, 1961.

R. H. RAMSAY & GAUNT, 41 Lydiard-street, Ballarat, solicitors for the executor. 15684

LILIAN ESSINGTON OFFICER, formerly of 62 Grange-road, Toorak, but late of Swallow-street, Shepparton, in the State of Victoria, widow, DECEASED.

CREDITORS, next of kin and others having claims in respect of the estate of the deceased (who died on the 16th day of May, 1961), are required by the personal representative, Gordon Stuart Russell, acting manager of The Union Trustee Company of Australia Limited, of 333 Collins-street, Melbourne, to send particulars to him by the 30th day of November, 1961, after which date the personal representative may convey or distribute the assets, having regard only to the claims of which he then has notice.

Dated the 25th day of September, 1961.

R. G. B. SKINNER, solicitor, 111 Charles-street, Prahran. 15677

GEORGE RICHARD RICH NICHOLAS, late of "Homeden", Lansell-road, Toorak, and of Macedon, both in the State of Victoria, company director, DECEASED.

CREDITORS, next of kin and others having claims in respect of the estate of the above-named deceased (who died on the 20th day of September, 1960), are required by the trustees, National Trustees, Executors and Agency Company of Australasia Limited, of 95 Queen-street, Melbourne, Francis James Howells, of 199 Nepean Highway, Aspendale, company director, Lindsay George Currell Nicholas, of "Cooring Yering", Lilydale, grazier, and Hilton John Nicholas, of "Yarrowee", Rosehill-road, Lower Plenty, company director, to send particulars to the above-named company, by the 30th day of November, 1961, after which date the trustees may convey or distribute the assets, having regard only to the claims of which the said company then has notice.

Dated the 26th day of September, 1961.

OSWALD BURT & CO., 178 William-street, Melbourne, solicitors for the applicants. 15660

LETITIA STELLA MAY LEVENS, late of 7 Isabella-street, Parkdale, in the State of Victoria, widow, DECEASED.

CREDITORS, next of kin and others having claims in respect of the estate of the deceased (who died on the 25th day of June, 1961), are required by the executor, The Fidelity Trustee Company Limited, to send particulars to its Branch Office, at 50 Market-street, Melbourne, by the 30th day of November, 1961, after which date the executor may convey or distribute the assets, having regard only to the claims of which it then has notice.

A. S. PAYNE, solicitor, 345 Punt-road, Richmond. 15669

JEANNIE HOLDEN POOLMAN, late of 945 Punt-road, South Yarra, in the State of Victoria, widow, deceased (who died on the 1st day of September, 1960).

CREDITORS, next of kin and all other persons having claims against the estate of the deceased, are required by the executors of the will of the deceased Audrey Holden Mann, of Brie Brie, Glenthompson, in the said State, married woman, John Frederick Honey Poolman, of 219 Orrong-road, Toorak, in the said State, medical practitioner, and Vernon Francis Wilcox, of 20 Queen-street, Melbourne, in the said State, solicitor, to send particulars to them, care of the undersigned, on or before the 1st day of December, 1961, after which date they will distribute the assets, having regard only to the claims of which they then have notice.

HALL & WILCOX, solicitors, 20 Queen-street, Melbourne. 15668

ETHEL MARY WOOLCOCK, late of 26 McDonald-street, Mordialloc, in the State of Victoria, spinster, DECEASED.

CREDITORS, next of kin and others having claims in respect of the estate of the deceased (who died on the 9th day of October, 1959), are required by the executor, Hedley Vivian Jenkin, of The Manse, Donald, in the State of Victoria, minister of religion, to send particulars to him by the 30th day of November, 1961, after which date the executor may convey or distribute the assets, having regard only to the claims of which he then has notice.

A. S. PAYNE, of 345 Punt-road, Richmond, solicitor for the executor. 15665

IVAN LEWIS BARTLETT, late of 32 Couche-street, Sunshine, welder and window fitter, DECEASED, intestate.

CREDITORS, next of kin and others having claims in respect of the estate of the deceased (who died on 13th May, 1961), are required by Raymond Henry Bartlett, of 8 Silverwood-grove, Wangaratta, electrical contractor (the administrator to whom letters of administration were granted on 25th September, 1961), to send particulars to him, in care of the undersigned solicitor, by the 28th day of November, 1961, after which date the administrator may convey or distribute the assets, having regard only to the claims of which he then has notice.

DUDLEY A. TREGENT, B.A., LL.M., solicitor, of 422 Collins-street, Melbourne. 15664

MAY LILIAN HENTY, late of 22 Sargood-street, Toorak, widow, DECEASED.

CREDITORS, next of kin and others having claims against the estate of the deceased (who died on 27th July, 1961), are required by the executors, June Roxeth Henty and Bernard Gore Brett, to send particulars to them, care of 120 William-street, Melbourne, by the 1st December, 1961, after which date they may convey and distribute the assets, having regard only to the claims of which they then have notice.

BLAKE & RIGGALL, solicitors, 120 William-street, Melbourne. 15661

JESSIE MARY CUMING, late of Goroke, grazier, DECEASED.

CREDITORS, next of kin and others having claims in respect of the estate of the deceased (who died on 5th November, 1959) are required by the personal representative, Matthew John Cuming, of care of Stewart F. Brown and Proudfoot, 74 Wilson-street, Horsham, to send particulars to him, by the 29th day of November, 1961, after which date the personal representative may convey or distribute the assets, having regard only to the claims of which he then has notice.

Dated the 15th day of September, 1961.

STEWART F. BROWN & PROUDFOOT, 74 Wilson-street, Horsham, solicitors for the personal representative. 15600

#### TRUSTEE ACT 1958.

CREDITORS, next of kin and others having claims against any of the estates specified below are required to send particulars, in writing, of such claims to the personal representative of such estate, in care of Morrison and Teare, solicitors, Numurkah, on or before 29th November, 1961, after which date the assets of the estate will be conveyed or distributed among the persons entitled thereto, having regard only to the claims to which the representatives shall then have had notice:—

James Blair Purdie, late of Wunghnu, farmer, deceased (died 26th May, 1961).

Annie Bitcon, late of 764 Canterbury-road, Surrey Hills, widow, deceased (died 8th January, 1961).

James Cremin, late of Numurkah, Catholic clergyman, deceased (died 22nd April, 1961).

Walter Isaac Fowler, late of Katamatite, retired farmer, deceased (died 16th September, 1960).

Sidney Harry Scott, late of Cobram, retired orchardist, deceased (died 9th May, 1960).

Edith McClusky, late of Cobram, married woman, deceased (died 13th May, 1961).

James Alexander McClusky, late of Cobram, orchardist, deceased (died 23rd May, 1961).

Margaret Marcus, late of Numurkah, widow, deceased (died 18th September, 1960).

Roy Ellis Hicks, late of Nathalia, farmer, deceased (died 7th June, 1961).

Ross Breen, late of Yarroweyah, dairy farmer, deceased (died 8th January, 1961). 15605

CREDITORS, next of kin and others having claims in respect of the estate of Hannah Louisa Sheppard, late of 49 Claremont-avenue, Malvern, widow, deceased (who died on the 1st day of August, 1961), are required to send particulars of their claims to the executrix, care of the undersigned, by the 30th day of November, 1961, after which date she will distribute the assets, having regard only to the claims of which she then has notice.

FREDERICK, OWEN & ASSOCIATES, solicitors, 84 William-street, Melbourne. 15673

MARY JANE ELLIS, late of 4 Monash-street, Footscray, widow, DECEASED.

CREDITORS, next of kin and others having claims in respect of the estate of the deceased (who died on the 5th day of May, 1961), are required by the trustee, Frederick Richard Ellis, to send particulars to him, care of J. A. Redmond and Co., solicitors, 358 Collins-street, Melbourne, by the 30th day of November, 1961, after which date the trustee may convey or distribute the assets, having regard only to the claims of which he then has notice.

Dated the 25th day of September, 1961.

J. A. REDMOND & CO., solicitors, 358 Collins-street, Melbourne. 15667

CREDITORS, next of kin and others having claims against Bruno Alfred Fischer, late of 5 Belford-road, Kew, painter and decorator, deceased (who died on the 26th April, 1960), are required to send particulars thereof to Lina Elisabeth Fischer, care of T. W. Brennan, B.A., LL.B., solicitor, of 441 Law Courts Place, Melbourne, on or before the 26th December, 1961, otherwise they may be excluded when the assets are being distributed.

Dated this 26th day of September, 1961.

T. W. BRENNAN, B.A., LL.B., barrister and solicitor, 441 Law Courts Place, Melbourne, C.I. 15666

CREDITORS, next of kin and all others having claims against the estate of Leonard Michael McGrath, late of Sutherland, in Victoria, farmer, deceased, intestate (who died on the 1st August, 1961), are required by the administratrix of his estate, Patricia Margaret Cooper, of Coimadai, married woman, to send particulars thereof to her, care of the undersigned, on or before the 1st December, 1961, after which date the said administratrix will distribute the assets, having regard only to the claims of which she then has notice.

J. K. SPARK, solicitor, St. Arnaud. 15655

CREDITORS, next of kin and others having claims in respect of the estate of Mary Julia Proud, late of Travelyan-street, Caulfield, widow, deceased (who died on the 9th day of December, 1960), are to send particulars of their claims to The National Trustees, Executors and Agency Company of Australasia Limited (Farmers and Citizens Division), of Charing Cross, Bendigo, on or before the 28th day of November, 1961, after which date it will distribute the assets, having regard only to the claims of which it then has notice.

MARTIN & MARTIN, solicitors, 37 Queen-street, Melbourne. 15658

CREDITORS, next of kin and others having claims in respect of the estate of Eileen Ryan (also known as Aileen Maria Ryan and Eileen Maria Ryan), late of Ararat, in the State of Victoria, spinster, deceased (who died on the 26th day of June, 1961), are to send particulars of their claims to The National Trustees, Executors and Agency Company of Australasia Limited, of 95 Queen-street, Melbourne, the executor of the will of the said deceased, by the 5th day of December, 1961, after which date it will distribute the assets, having regard only to the claims of which it then has notice.

BRIGGS & O'DRISCOLL, solicitors, 94 Barkly-street, Ararat. 15654

CREDITORS, next of kin and others having claims in respect of the estate of Matilda Corbett, late of Portland, in the State of Victoria, widow, deceased (who died on the 10th day of June, 1961), are required to send particulars of their claims to National Trustees, Executors and Agency Company of Australasia Limited, of 95 Queen-street, Melbourne, in the said State, by the 27th November, 1961, after which date the said company will distribute the estate of the said deceased, having regard only to the claims of which it then has notice.

NICOL, SILVESTER & CULHANE, solicitors, Percy-street, Portland. 15653



## Trustee Act 1958.

## NOTICE TO CLAIMANTS.

**P**URSUANT to the Trustee Act 1958, creditors, next of kin, and all other persons having claims in respect of the estates of the deceased persons named below are required to send particulars to the legal personal representative or representatives, at the addresses stated, after which date the representative or representatives will distribute the assets, having regard only to the claims of which notice has been received:—

Lawrence Leonard Stephens, late of 121 Mason-street, Newport, retired fitter, deceased, died on 24th July, 1952.—Claims to the administratrix, Emma Caroline Stephens, of 121 Mason-street, Newport, widow, care of John F. Carroll, of 4 Paisley-street, Footscray, solicitor, by the 29th day of November, 1961. John F. Carroll, LL.B., solicitor, 4 Paisley-street, Footscray. 15681

Pranas Bienkevicius, late of 87 Challis-street, Newport, labourer, deceased, died 19th June, 1961.—Claims to the executor, Frank Binkus, of 87 Challis-street, Newport, labourer, care of John F. Carroll, of 4 Paisley-street, Footscray, solicitor, by the 30th day of November, 1961. John F. Carroll, LL.B., solicitor, 4 Paisley-street, Footscray. 15680

Ellen Teresa Kinane, also known as Ellen Kinane, formerly of Koroit, but late of Nazareth House, Ballarat, spinster, deceased, died 27th June, 1961.—Claims to the executor, Martin Joseph Bourke, of Koroit, secretary, care of Conlan and Leishman, solicitors, 38 Bank-street, Port Fairy, by 5th December, 1961. 15616

**C**REDITORS, next of kin and others having claims in respect of the estate of Frederick Donald Herbert Blois Lawton, late of 26 Inverness-way, Balwyn North, physician, deceased (who died on the 16th July, 1961), are to send particulars of their claims to The Union Trustee Company of Australia Limited, of 333 Collins-street, Melbourne, by the 30th November, 1961, after which date it will distribute the assets, having regard only to the claims of which it then has notice.

WEIGALL & CROWTHER, solicitors, 459 Little Collins-street, Melbourne. 15652

FREDERICK WILLIAM LOCKYER, late of 34 Stewart-street, Ormond, investigating officer, DECEASED.

**C**REDITORS, next of kin and others having claims in respect of the estate of the deceased (who died on the 11th day of June, 1961), are required by Edward Lambert a Beckett and Stephen George Alley, both of 224 Queen-street, Melbourne, solicitors, to send particulars thereof to them, care of the under-mentioned solicitors, on or before the 29th November, 1961, after which date they may proceed to distribute the assets of the deceased, having regard only to the claims of which they then have notice.

MOULE, HAMILTON & DERHAM, solicitors, 224 Queen-street, Melbourne. 15648

HECTOR ODESSA HARRIS, late of 81 Glass-street, Essendon, gentleman, DECEASED.

**C**REDITORS, next of kin and others having claims in respect of the estate of the deceased (who died on the 1st May, 1961), are required by the trustees, The Equity Trustees, Executors and Agency Company Limited, of 472 Bourke-street, Melbourne, and Florence Ivy Harris, of 81 Glass-street, Essendon, widow, to send particulars of their claims to The Equity Trustees, Executors and Agency Company Limited, by the 30th day of November, 1961, after which date the trustees may convey or distribute the assets, having regard only to the claims of which they shall then have had notice.

DUGDALE, DIMMICK & STEVENS, "Peacock House", 486 Bourke-street, Melbourne, solicitors. 15649

**C**REDITORS, next of kin and others having claims in respect of the estate of Charles Henry Johnstone, late of Clark-road, Springvale, process worker, deceased (who died on the 2nd day of July, 1960), are hereby required to send particulars of such claims, in writing, to Joseph Fieldman, care of F. J. Barlow and Fieldman, of Halsbury Chambers, Walker-street, Dandenong, solicitors, the executor of the deceased's will, on or before the 30th day of November, 1961, after which date he will proceed to distribute the assets of the said deceased which shall have come to his hands, among the persons entitled thereto, having regard only to the claims of which he then shall have had notice.

F. J. BARLOW & FIELDMAN, solicitors, Halsbury Chambers, Walker-street, Dandenong. 15656

WILLIAM FRANKLIN WATSON, late of 4 Second-avenue, Brunswick, in the State of Victoria, retired licensed victualler, DECEASED.

**C**REDITORS, next of kin, and others having claims in respect of the estate of the deceased (who died on the 19th day of March, 1961), are required by National Trustees, Executors and Agency Company of Australasia Limited, of 95 Queen-street, Melbourne, the executor to whom probate of the will of the deceased was granted on the 5th day of September, 1961, to send particulars to it by the 29th day of November, 1961, after which date the said company may convey or distribute the assets, having regard only to the claims of which it then has notice.

Dated the 27th day of September, 1961.

LUKE MURPHY & CO., solicitors, 422 Bourke-street, Melbourne. 15636

FANNIE SCOTT ATCHISON, late of Darlington, spinster, DECEASED.

**C**REDITORS, next of kin, and others having claims in respect of the estate of the deceased (who died on the 14th day of September, 1942), are required by the executors, Evelyn Charles Chicheley Tucker and Edward John Wilson Chapple, to send particulars to them, care of the under-mentioned solicitors, by the 6th day of December, 1961, after which date they may convey or distribute the assets, having regard only to the claims of which they then have notice.

BUCKLAND & NEVETT, solicitors, Camperdown.

15695

**C**REDITORS, next of kin, and others having claims in respect of the estate of Florence May Skinner, late of 13 Station-street, Blackburn, widow, deceased (who died on the 25th day of January, 1960), are required to send particulars of their claims to Albert Carlyle Skinner, of 43 Lytton-street, Glenroy, foreman engineer, and George Walter Skinner, of Spring Gully-road, Spring Gully, via Bendigo, clerk, care of Lawrence Rostron and Son, solicitors, 118 Queen-street, Melbourne, by the 1st day of December, 1961, after which date they will distribute the assets, having regard only to the claims of which they then have notice.

LAWRENCE ROSTRON & SON, solicitors, 118 Queen-street, Melbourne. 15692

**C**REDITORS, next of kin, and others having claims in respect of the estate of Daniel Henri Joseph Blomme, late of 42 Hotham-street, East St. Kilda, retired wool buyer, deceased (who died on the 22nd October, 1958), are required to send particulars of their claims to Lucy Agness Blomme, of 10 Ash-grove, Toorak, widow, and Daniel Joseph Maurice Blomme, of 42 Hotham-street, East St. Kilda, barrister at law, care of Lawrence Rostron and Son, solicitors, 118 Queen-street, Melbourne, by the 1st day of December, 1961, after which date they will distribute the assets, having regard only to the claims of which they then have notice.

LAWRENCE ROSTRON & SON, solicitors, 118 Queen-street, Melbourne. 15693

**C**REDITORS, next of kin, and others having claims in respect of the estate of Antonio Virgona, late of 313 Dandenong-road, Armadale, retired wine merchant, deceased (who died on the 29th day of December, 1960), are required to send particulars of their claims to Mario Antonio Virgona, of 231 Brunswick-street, Fitzroy, wine merchant, care of Lawrence Rostron and Son, solicitors, 118 Queen-street, Melbourne, by the 1st day of December, 1961, after which date they will distribute the assets, having regard only to the claims of which they then have notice.

LAWRENCE ROSTRON & SON, solicitors, 118 Queen-street, Melbourne. 15694

**C**REDITORS, next of kin and others having claims in respect of the estate of Frances Ellen Dickinson, late of 28 Hoffmans-road, West Essendon, in the State of Victoria, married woman, deceased (who died on the 20th day of February, 1961), are required by the executor, The Perpetual Executors and Trustees Association Limited, of 100-104 Queen-street, Melbourne, to send particulars to it, by the 6th day of December, 1961, after which date the executor may convey or distribute the assets of the deceased, having regard only to the claims of which it then has notice.

T. R. MACKENZIE, M.A., LL.B., solicitor, 37 Swanston-street, Melbourne, C.I. 15615

**CREDITORS**, next of kin and others having claims in respect of the estate of James William Crawford, formerly of 16 Levien-street, Essendon, but late of Mont Park Mental Home, bootmaker, deceased (who died on the 25th October, 1960), are required to send written particulars of their claims to Mona Teresa Crawford, care of the undersigned by the 19th December, 1961, after which date she will distribute the assets, having regard only to the claims of which she then has notice.

McLAUGHLIN, EAVES & JOHNSTON, of 343 Little Collins-street, Melbourne, solicitors for the administratrix. 15650

RACHEL JANE LOWRIE, formerly of 69 Bridge-street, Northcote (but late of 260 Albury-road, Corowa, in the State of New South Wales, spinster, DECEASED.

**CREDITORS**, next of kin and others having claims in respect of the estate of the deceased (who died on the 16th day of May, 1961), are required by National Trustees, Executors and Agency Company of Australasia Limited, of 95 Queen-street, Melbourne, to send particulars to them by the 6th day of December, 1961, after which date the trustee may convey or distribute the assets, having regard only to the claims of which they then have notice.

ARTHUR SECOMB & CO., solicitors, 128 William-street, Melbourne. 15647

**CREDITORS**, next of kin and others having claims in respect of the estate of Flora Talbot, late of 18 Macgregor-street, East Malvern, widow, deceased (who died on the 17th day of May, 1961, and probate of whose will has been granted to Florence Mary Bishop, of 18 Macgregor-street, East Malvern, married woman), are to send in particulars of their claims to the said executrix, care of the under-mentioned solicitors, by the 30th day of November, 1961, after which date she will distribute the assets, having regard only to the claims of which she then has notice.

PEARCE & WEBSTER, solicitors, 430 Little Collins-street, Melbourne. 15645

**CREDITORS**, next of kin and others having claims in respect of the estate of Winifred Louisa Watt, late of 17 Stanley-avenue, Auburn, spinster, deceased (who died on the 8th day of March, 1961, and probate of whose will has been granted to Francis Henry Parr, of 129 Darling-road, East Malvern, public accountant), are to send in particulars of their claims to the said executor, care of the under-mentioned solicitors, by the 30th day of November, 1961, after which date he will distribute the assets, having regard only to the claims of which he then has notice.

PEARCE & WEBSTER, solicitors, 430 Little Collins-street, Melbourne. 15644

**CREDITORS**, next of kin and others having claims in respect of the estate of Beatrice Alice De Beer, late of Flat 14, 76 Campbell-road, Hawthorn East, widow, deceased (who died on the 21st July, 1961), are to send the particulars of their claims to The Equity Trustees, Executors and Agency Company Limited, whose registered office is situate at 472 Bourke-street, Melbourne, by 30th November, 1961, after which date it will distribute the assets, having regard only to the claims of which it then has notice.

E. W. OLLEY, solicitor, 450 Little Collins-street, Melbourne. 15643

**CREDITORS**, next of kin and others having claims against the estate of Eva May Butcher, late of 155 Dandenong-road, Oakleigh, gentlewoman, deceased (who died on the 8th day of June, 1960), are required by her executrix, Wetah Victoria Butcher, of 153 Dandenong-road, Oakleigh, to send particulars of their claims to her, in care of the undersigned solicitors, by the 7th day of December, 1961, after which date she will distribute the assets, having regard only to the claims of which she shall then have had notice.

STRONGMAN & CROUCH, solicitors, 118 Queen-street, Melbourne. 15639

WILHELMINA MAYO PATIENCE WATSON, late of "Kinross", Broughton-road, Surrey Hills, gentlewoman, DECEASED.

**CREDITORS**, next of kin and others having claims in respect of the estate of the above-named deceased (who died on the 1st day of May, 1961), are required by The Equity Trustees, Executors and Agency Company Limited, of 472 Bourke-street, Melbourne, to send particulars to it by the 27th day of November, 1961, after

which date the company may convey or distribute the assets, having regard only to the claims of which it then has notice.

WISEWOULD, DUNCAN & HANGER, solicitors, 11 Bank-place, Melbourne. 15638

**CREDITORS**, next of kin and others having claims in respect of the estate of Cecil Barrington Hearn, C.B.E., late of 69 Walsh-street, South Yarra, company director, deceased (who died on the 3rd day of July, 1960), are to send particulars of their claims to the executors, Lomer John Heale and Cecil William Over, care of their solicitors, whose name and address is set out below, by the 30th day of November, 1961, after which date the executors will distribute the assets, having regard only to the claims of which they then have notice.

H. S. W. LAWSON, HUGHES & CO., 357 Little Collins-street, Melbourne, solicitors. 15637

ANNIE MIDDLEBROOK, late of Seymour, widow, DECEASED, intestate.

**CREDITORS**, next of kin and others having claims in respect of the estate of the deceased (who died on the 2nd day of December, 1960) are required by the administratrix, Elsie Lillian Watts, to send particulars to the undersigned solicitors, by the 30th day of November, 1961, after which date the administratrix may convey or distribute the assets, having regard only to the claims of which they then have had notice.

WILFRID J. OSBORNE & OSBORNE, solicitors, Seymour. 15613

WILLIAM ALFRED MOLESWORTH JEFFERY, late of Seymour, formerly of Caramut, grazier, formerly post-master, DECEASED.

**CREDITORS**, next of kin and others having claims in respect of the estate of the deceased (who died on the 3rd day of December, 1960) are required by the executrix, Edith Miriam Jeffery, to send particulars to the undersigned solicitors, by the 30th day of November, 1961, after which date the executrix may convey or distribute the assets, having regard only to the claims of which they then have had notice.

WILFRID J. OSBORNE & OSBORNE, solicitors, Seymour. 15614

In the Supreme Court of the State of Victoria.

SALE BY THE SHERIFF.

ON Tuesday, the 31st day of October, 1961, at Eleven a.m., at the Police Station, Carpenter-street, Brighton (unless process be stayed or satisfied):—All the estate and interest (if any) of Selwyn Stanton Phillips, of 900 Hampton-street, North Brighton, contractor, as proprietor of an estate in fee simple in the land described in certificate of title, volume 6133, folio 515, upon which is erected a weatherboard residence and garage, known as No. 900 Hampton-street, North Brighton. Registered mortgage No. A606502 for approximately £4,000 and caveat No. B240665 affect the said estate and interest.

Terms—Cash only.

DAVID J. JOHNSTON, Sheriff's Officer. 19th September, 1961. 15651

## IMPOUNDINGS

**BOORT**.—Impounded in Boort Pound on 20th September, 1961.

1 red poll steer, two notches in each ear, no visible brand  
1 roan steer, no visible brand

If not claimed and expenses paid, to be sold on 5th October, 1961.

15620—12/ J. HUDSON, Poundkeeper.

**DROUIN**.—Impounded in Drouin Pound, from Mountain View, near Ronald's Corner, by Shire Ranger.

1 Guernsey cross cow, seven years, dehorned, M out of right ear, branded L.O.

1 Jersey cow, three years, dehorned, branded L

1 brown steer, five months, no visible brand

1 Jersey cow, three years, "U" reversed out of right ear, no visible brand

If not claimed and expenses paid, to be sold on 13th October, 1961.

15690—18/ FRED P. JONES, Poundkeeper.

**MELBOURNE.**—Impounded in Arden-street Pound, by L. Mewmab, of South Melbourne City Council.  
1 sheep, no visible brand  
If not claimed and expenses paid, to be sold on 12th October, 1961.

15618—10/6 R. HAMILTON,  
Poundkeeper.

**STATE ACTS, 1960.**

COPIES of the following Acts of Parliament of Victoria may be obtained at the Government Printing Office, or from any bookseller, at the price set opposite to each:—

No.	Price. s. d.
6607. Anzac Day .. .. .	1 0
6608. Agricultural Lime (Amendment) .. .. .	0 6
6609. Motor Car (Commencement) .. .. .	0 6
6610. Fisheries (Change of Title) .. .. .	0 6
6611. Stamps (Amendment) .. .. .	0 6
6612. Land (Public Authorities) .. .. .	0 6
6613. Coal Canal Bridge .. .. .	0 6
6614. Metropolitan Fire Brigades (Borrowing Powers) .. .. .	0 6
6615. Wodonga Lands Exchange .. .. .	0 6
6616. Licensing (Fees) .. .. .	0 6
6617. Home Finance (Loans to Minors) .. .. .	0 6
6618. Co-operative Housing Societies (Amendment) .. .. .	0 6
6619. Racing (Totalizators Extension) .. .. .	1 0
6620. Companies .. .. .	0 6
6621. Judges Salaries and Allowances .. .. .	0 6
6622. Coal Mines (Pensions Contributions) .. .. .	0 6
6623. Landlord and Tenant (Further Amendment) .. .. .	0 6
6624. Public Officers Salaries and Allowances .. .. .	0 9
6625. Legal Profession Practice (Amendment) .. .. .	0 6
6626. Church of England in Australia Constitution .. .. .	1 9
6627. Companies (Fees) .. .. .	0 6
6628. Motor Car (Amendment) .. .. .	1 0
6629. Geelong Waterworks and Sewerage (Amendment) .. .. .	0 6
6630. Latrobe Valley (Financial) .. .. .	0 6
6631. Labour and Industry (Amendment) .. .. .	0 6
6632. Acts Interpretation .. .. .	0 6
6633. Children's Court (Enforcement of Awards) .. .. .	0 6
6634. Supreme Court (Proceedings before Master) .. .. .	0 6
6635. Melbourne and Metropolitan Board of Works (Borrowing Powers) .. .. .	0 6
6636. Electoral Provinces .. .. .	0 9
6637. Town and Country Planning (Amendment) .. .. .	0 6
6638. Racing (Dog Races) .. .. .	0 6
6639. Industrial Safety Advisory Council .. .. .	0 6
6640. Administration and Probate (Offices) .. .. .	0 6
6641. Justices (Bail) .. .. .	0 6
6642. National Parks (Amendment) .. .. .	0 9
6643. Medical (Amendment) .. .. .	0 6
6644. Melbourne Harbor Trust Lands .. .. .	1 0
6645. Weights and Measures (Penalties) .. .. .	0 6
6646. Transfer of Land (Stratum Estates) .. .. .	0 6
6647. Local Government (Preston Streets Agreement) .. .. .	0 9
6648. John Storey Memorial Fund .. .. .	0 6
6649. Police Offences (Amendment) .. .. .	0 6
6650. Motor Car (Third-Party Insurance) .. .. .	0 6
6651. Social Welfare .. .. .	2 9
6652. City of Melbourne Underground Railway Construction .. .. .	1 0
6653. Valuation of Land .. .. .	1 3
6654. Milk Board (Amendment) .. .. .	0 6
6655. Victoria Racing Club (Amendment) .. .. .	0 6
6656. Consolidated Revenue .. .. .	0 6
6657. Consolidated Revenue .. .. .	0 6
6658. Motor Car (Driving) .. .. .	0 6
6659. Licensing (Amendment) .. .. .	1 0
6660. Consolidated Revenue .. .. .	0 6
6661. Consolidated Revenue .. .. .	0 6
6662. Friendly Societies (Dental Clinics) .. .. .	0 6
6663. Cancer (Amendment) .. .. .	0 6
6664. Dried Fruits (Amendment) .. .. .	0 6
6665. Barwon Heads Lands Exchange .. .. .	0 6
6666. Revocation of Crown Reservations .. .. .	0 6
6667. The Constitution Act Amendment (Expenses) .. .. .	0 6
6668. Supreme Court (Orders) .. .. .	0 6
6669. Gippsland Railway Deviation .. .. .	0 9
6670. Hamilton Stockyards Railway Construction .. .. .	0 6
6671. Nurses (Amendment) .. .. .	0 6
6672. Ministry of Transport (Railway Officers) .. .. .	0 6
6673. Fruit and Vegetables (Road Barriers) .. .. .	0 6
6674. Transport Regulation (Qualifications of Chairman) .. .. .	0 6
6675. Motor Car (Insurance Surcharge Continuance) .. .. .	0 6

STATE ACTS, 1960.—continued.

No.	Price. s. d.
6676. Geelong Harbor Trust. (Freezing Works Agreement) .. .. .	0 9
6677. Western Metropolitan Market (Amendment) .. .. .	0 6
6678. Racing (Trotting Races) .. .. .	0 6
6679. Wattle Park Land .. .. .	0 6
6680. Surplus Revenue .. .. .	0 6
6681. Milk and Dairy Supervision (Research Contributions) .. .. .	0 6
6682. Tourist (Amendment) .. .. .	0 6
6683. Fisheries (Crayfish) .. .. .	0 6
6684. Audit (Amendment) .. .. .	0 6
6685. Sale of Allotments of Land (Amendment) .. .. .	0 6
6686. Cattle Compensation (Amendment) .. .. .	0 6
6687. Co-operative Housing Societies (Guarantees) .. .. .	0 6
6688. State Library National Gallery National Museum and Institute of Applied Science .. .. .	1 3
6689. Medical (Blood Transfusion) .. .. .	0 6
6690. The Constitution Act Amendment (Treating) .. .. .	0 6
6691. State Forests Loan Application .. .. .	0 6
6692. Local Authorities Superannuation (Amendment) .. .. .	0 9
6693. Local Government (Disqualification) .. .. .	1 0
6694. Superannuation (Additions to Pensions) .. .. .	0 6
6695. Police Regulation (Pensions) .. .. .	0 6
6696. Trustee Companies (Amalgamation) .. .. .	0 6
6697. Geelong and Colac Railway (Deviation) .. .. .	0 6
6698. University Colleges Lands .. .. .	0 6
6699. Local Government (Private Street) .. .. .	0 6
6700. Northcote School .. .. .	0 6
6701. Public Works Loan Application .. .. .	0 9
6702. Tower Hill and Malmsbury Lands .. .. .	0 6
6703. Coal Mines (Pensions) .. .. .	0 6
6704. Vermin and Noxious Weeds (Financial) .. .. .	0 6
6705. Navigable Waters (Oil Pollution) .. .. .	1 0
6706. Business Names (Public Borrowings) .. .. .	0 6
6707. Health (Tuberculosis Arrangement) .. .. .	0 6
6708. Water Supply Loan Application .. .. .	1 3
6709. Railway Loan Application .. .. .	1 0
6710. Land Tax (Relief) .. .. .	0 6
6711. Land Tax (Rates) .. .. .	0 6
6712. Monash University (Amendment) .. .. .	0 6
6713. National Fitness Council of Victoria .. .. .	1 0
6714. Local Government (Keilor Waverley and Springvale) .. .. .	0 6
6715. Explosives .. .. .	2 3
6716. Statute Law Revision .. .. .	0 9
6717. Motor Car (Abolition of Owners' Certificates) .. .. .	0 6
6718. Road Traffic (Amendment) .. .. .	0 6
6719. Milk Board (Powers) .. .. .	0 6
6720. Marketing of Primary Products (Members) .. .. .	0 6
6721. Melbourne and Geelong Mortgages .. .. .	0 9
6722. Building Societies (Amendment) .. .. .	0 9
6723. Local Government (Scaffolding Inspection) .. .. .	0 9
6724. State Electricity Commission (Borrowing) .. .. .	0 6
6725. Labour and Industry (Butchers' Shops) .. .. .	0 6
6726. Country Fire Authority (Sawmill Burners) .. .. .	0 6
6727. Sewerage Districts (Amendment) .. .. .	1 0
6728. Water (Amendment) .. .. .	1 3
6729. Housing (Powers) .. .. .	0 6
6730. Entertainments Tax (Amendment) .. .. .	0 6
6731. Crimes (Kidnapping) .. .. .	0 6
6732. Health (Amendment) .. .. .	0 6
6733. Game (Licences) .. .. .	0 6
6734. Estate Agents (Amendment) .. .. .	0 6
6735. Appropriation of Revenue .. .. .	8 6

A. C. BROOKS,  
Government Printer.

THE "VICTORIA GOVERNMENT GAZETTE".

SUBSCRIPTIONS.—The subscription, including postage, is £2 15s. per annum, £1 7s. 6d. half-yearly, or 13s. 9d. per quarter, payable in advance.

Subscriptions are required to commence and terminate with a month.

A lesser period than three months cannot be subscribed for.

Subscribers do not receive the Acts of Parliament with the GAZETTE.

ADVERTISEMENTS are charged at the rate of 1s. 6d. per line single column, and 3s. per line double column.

The title (£5 Reward, Dissolution of Partnerships, &c.) forms one or more lines as a heading.

On an average, ten words make a line.

Every signature must likewise be counted as a line.

The final words of a paragraph, though only portion of a line, must be counted as one line.

SIGNATURES (in particular) and proper names must be written very plainly in the text; ONE SIDE ONLY of each slip of paper should be WRITTEN UPON.

ALL COMMUNICATIONS should be addressed to "The Government Printer, Melbourne".

ALL DOCUMENTS illegibly written will be returned unpublished, and where brands occur unprovided for by the ordinary letters of the alphabet, a worded explanatory description must be furnished.

THE VICTORIA GOVERNMENT GAZETTE is published on WEDNESDAY EVENING in each week, and Notices for insertion will be received by the Government Printer at or before ONE p.m. at ordinary rates, and late advertisements between ONE p.m. and FOUR p.m. at double rates on the day preceding the day of publication.

Single copies of the VICTORIA GOVERNMENT GAZETTE are One shilling, posted One shilling and five pence.

No GAZETTES prior to January, 1950, in stock.

\*\*\*ALL PAYMENTS ARE REQUIRED IN ADVANCE.—Remittances should be made by postal note, money order, or draft in favour of the Government Printer. Advertisements unaccompanied by a remittance sufficient to cover the cost of insertion will be returned unpublished.

#### PUBLICATION OF OFFICIAL MATTER.

ATTENTION is invited to the following procedure in relation to the publication of official matter in the *Government Gazette*:—

##### 1. Matter submitted to the Executive Council.

Matter submitted to the Executive Council which requires gazettal will normally be published in the issue of the following week.

Where urgent gazettal is required, special arrangements should be made with the *Gazette* Officer.

Publication will be facilitated by the submission of carbon copies for the use of the *Gazette* Officer.

##### 2. Other matter.

(a) All other matter duly certified by a responsible officer for publication should be lodged with the *Gazette* Officer not later than half-past Ten a.m. on Tuesday.

(b) Lengthy or involved notices should be forwarded several days before publication.

(c) Proofs, which will be supplied only when specifically requested, or at the direction of the *Gazette* Officer, should be returned promptly to avoid delay in publication.

(d) No additions or amendments to matter for publication will be accepted by telephone.

#### AGENTS FOR THE "VICTORIA GOVERNMENT GAZETTE".

THE following have been appointed agents to receive Advertisements and Subscriptions for the *Victoria Government Gazette*:—

ARMSTRONG'S AGENCY, 205 Queen-street, Melbourne, C.1.

ARMSTRONG BROS., Kyneton.

ARNALL & JACKSON, 115 Barkly-street, West Brunswick.

BAIRNSDALE AUTHORIZED NEWSAGENCY, Main-street, Bairnsdale.

COOKE, F. R. & E. M., 69 Bridge-street, Benalla.

DAVIS, WM. (MILDURA) PTY. LTD., 126 Eighth-street, Mildura.

DIXON'S NEWSAGENCY, 89 Firebrace-street, Horsham.

EDGAR'S NEWSAGENCY, 293 Hargreaves-street, Bendigo.

FRANKS, HENRY, & CO., Booksellers and Stationers, 184 Ryrie-street, Geelong.

GORDON & GOTCH, News Agents, 511 Little Collins-street, Melbourne, C.1.; and corner of Barrack and Clarence streets, Sydney.

GULLAN'S NEWSAGENCY, 88 Bridge-street, Ballarat.

HALES, D. & N., Henty-street, Casterton.

HAMPTON, A. C., 243 Mitchell-street, Bendigo.

HARSTON, PARTRIDGE & CO. PTY. LTD., 455 Little Collins-street, Melbourne, C.1.

MERCANTILE EXCHANGE, 380 Collins-street, Melbourne, C.1.

PETTY, R. H. & W. M., 83 Murphy-street, Wangaratta.

PURDIE, J., & CO., 138 Moorabool-street, Geelong.

SALE AUTHORIZED NEWSAGENCY, 142 Raymond-street, Sale.

SKINNER'S AUTHORIZED NEWSAGENCY, 49-51 Franklin-street, Traralgon.

SMITH & DUNNON, 112 Gray-street, Hamilton.

TUFF'S SHEPPARTON NEWSAGENCY, 246 Wyndham-street, Shepparton.

VERNON, C. F. & H. J., 162 Bridge-road, Richmond.

VIEW POINT NEWSAGENCY, 4 View Point, Bendigo.

A copy of the *Gazette* filed at each place for public reference.

#### CONTENTS

	PAGE
Acts of Parliament on sale at the Government Printing Office .. .. .	3277
Appointments .. .. .	3239
Auction Sales Act .. .. .	3228
Bank Holidays .. .. .	3212
Cemeteries—Scale of Fees .. .. .	3226
Contracts .. .. .	3214
Country Roads Board .. .. .	3237
Courts .. .. .	3228, 3238
Estates of Deceased Persons .. .. .	3230
Government Notices .. .. .	3213
Impoundings .. .. .	3276
Lands .. .. .	3252
Licences to Occupy Unused Roads .. .. .	3229
Melbourne and Metropolitan Board of Works—Notices .. .. .	3213, 3231
Mining .. .. .	3238
Money Lenders Act 1958—Supplementary List .. .. .	3229
Orders in Council—	
Acts—Supreme Court; Land; Forests; Local Government; Justices; Health; Country Roads; Water; Sewerage Districts; Leongatha Waterworks Trust; Geelong Waterworks and Sewerage; River Improvement; Town and Country Planning; Housing; Landlord and Tenant; Seeds.	3240 <i>et seq</i>
Private Advertisements .. .. .	3263
Proclamations .. .. .	3211
Public Holidays .. .. .	3212
Public Service Notices .. .. .	3258
Regulations—	
Acts—Portland Harbor Trust .. .. .	3227
Resignations .. .. .	3240
State Rivers and Water Supply Commission .. .. .	3238
Tenders .. .. .	3261
Transport Regulation Board—Public Hearings .. .. .	3232