



# VICTORIA GOVERNMENT GAZETTE

Published by Authority

[Registered at the General Post Office, Melbourne, for transmission by post as a newspaper.]

No. 112]

WEDNESDAY, OCTOBER 17

[1962

ROAD PROCLAIMED.

PROCLAMATION

By His Excellency the Governor of the State of Victoria and its Dependencies in the Commonwealth of Australia, &c., &c., &c.

IN pursuance of the provisions of section 25 of the *Land Act 1958*, I, the Governor of the State of Victoria, by and with the advice of the Executive Council of the said State, do hereby proclaim as a road the land in the Parish of Maribyrnong, County of Bourke, as indicated by hachure on plan hereunder.—(C.98808) (M.46<sup>(\*)</sup>).

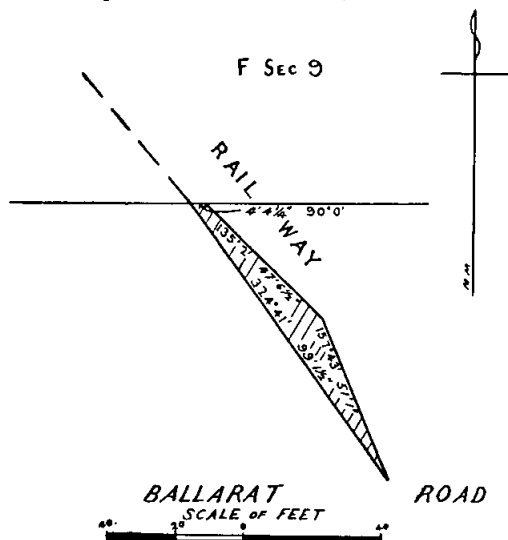

Given under my Hand and the Seal of the State of Victoria aforesaid, at Melbourne, this 9th day of October, in the year of our Lord One thousand nine hundred and sixty-two, and in the eleventh year of the reign of Her Majesty Queen Elizabeth II.

(L.S.)

DALLAS BROOKS.

By His Excellency's Command,

KEITH TURNBULL,  
Commissioner of Crown Lands and Survey.

GOD SAVE THE QUEEN!

PUBLIC HIGHWAY.—CITY OF BOX HILL.

PROCLAMATION

By His Excellency the Governor of the State of Victoria and its Dependencies in the Commonwealth of Australia, &c., &c., &c.

WHEREAS by the *Local Government Act 1958*, as amended, section 519, it is amongst other things enacted that it shall be lawful for the Governor in Council at any time, and from time to time, upon request of the Council of any municipality, by notice in the *Government Gazette*, to proclaim any land reserved, used or by purchase or exchange acquired for a street, road, highway, thoroughfare, bridge, square, court, alley or right-of-way or any street, road, lane or passage made or laid out or proposed to be made or laid out on any land of which a plan delineating that street, road, lane or passage has been lodged with the Registrar of Titles pursuant to subsection (11) of section 569 of the said Act to be a public highway, and that such land shall thereupon and thenceforth from the date of such Proclamation become and be absolutely dedicated to the public as a public highway within the meaning of any law then or thereafter in force:

And, whereas the Council of the City of Box Hill has requested that the land hereinafter mentioned, which has been used for a street within the said city, be so declared to be a public highway:

Now, therefore, I, the Governor of the State of Victoria in the Commonwealth of Australia, by and with the advice of the Executive Council of the said State, do by this Proclamation declare that all that piece of land, being the street known as Sinnott-street, indicated by hatching on the plan hereunder shall be a public highway within the meaning of the said Act.

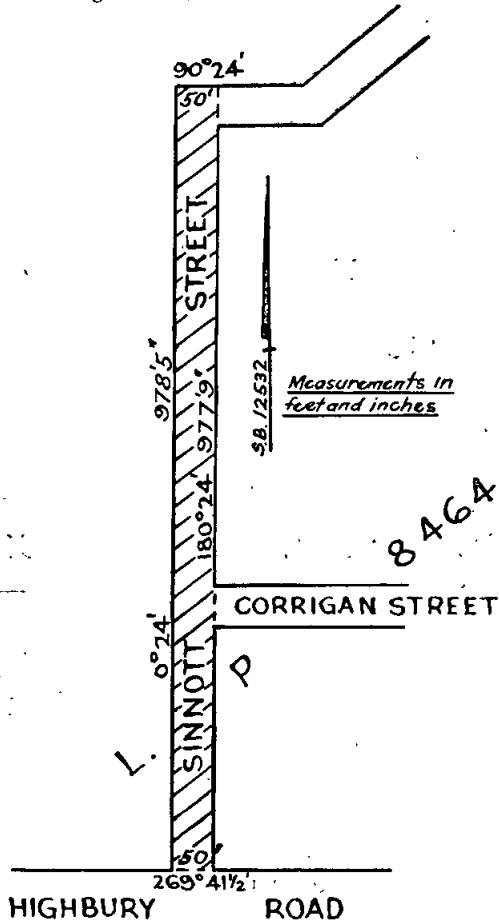

Given under my Hand and the Seal of the State of Victoria aforesaid, at Melbourne, this 9th day of October, in the year of our Lord One thousand nine hundred and sixty-two, and in the eleventh year of the reign of Her Majesty Queen Elizabeth II.

(L.S.) DALLAS BROOKS.  
By His Excellency's Command,  
MURRAY PORTER,  
Minister for Local Government.  
GOD SAVE THE QUEEN!

PUBLIC HIGHWAY.—CITY OF RINGWOOD.

PROCLAMATION

By His Excellency the Governor of the State of Victoria and its Dependencies in the Commonwealth of Australia, &c., &c., &c.

WHEREAS by the *Local Government Act 1958*, as amended, section 519, it is amongst other things enacted that it shall be lawful for the Governor in Council at any time, and from time to time, upon request of the Council of any municipality, by notice in the *Government Gazette*, to proclaim any land reserved, used or by purchase or exchange acquired for a street, road, highway, thoroughfare, bridge, square, court, alley or right-of-way

or any street, road, lane or passage made or laid out or proposed to be made or laid out on any land of which a plan delineating that street, road, lane or passage has been lodged with the Registrar of Titles pursuant to subsection (11) of section 569 of the said Act to be a public highway, and that such land shall thereupon and thenceforth from the date of such Proclamation become and be absolutely dedicated to the public as a public highway within the meaning of any law then or thereafter in force:

And whereas the Council of the City of Ringwood has requested that the land hereinafter mentioned, which has been used for a street within the said city, be so declared to be a public highway:

Now, therefore, I, the Governor of the State of Victoria in the Commonwealth of Australia, by and with the advice of the Executive Council of the said State, do by this Proclamation declare that all that piece of land, being Felix-crescent, as shown on plans of subdivision Nos. 11378 and 11392 lodged in the Office of Titles and thereon coloured brown extending from the northern boundary of Aurum-crescent to the western boundary of Evelyn-road, shall be a public highway within the meaning of the said Act.

Given under by Hand and the Seal of the State of Victoria aforesaid, at Melbourne, this 9th day of October, in the year of our Lord One thousand nine hundred and sixty-two, and in the eleventh year of the reign of Her Majesty Queen Elizabeth II.

(L.S.) DALLAS BROOKS.  
By His Excellency's Command,  
MURRAY PORTER,  
Minister for Local Government.  
GOD SAVE THE QUEEN!

PUBLIC HIGHWAY.—SHIRE OF DONCASTER AND TEMPLESTOWE.

PROCLAMATION

By His Excellency the Governor of the State of Victoria and its Dependencies in the Commonwealth of Australia, &c., &c., &c.

WHEREAS by the *Local Government Act 1958*, as amended, section 519, it is amongst other things enacted that it shall be lawful for the Governor in Council at any time, and from time to time, upon request of the Council of any municipality, by notice in the *Government Gazette*, to proclaim any land reserved, used or by purchase or exchange acquired for a street, road, highway, thoroughfare, bridge, square, court, alley or right-of-way or any street, road, lane or passage made or laid out or proposed to be made or laid out on any land of which a plan delineating that street, road, lane or passage has been lodged with the Registrar of Titles pursuant to subsection (11) of section 569 of the said Act to be a public highway, and that such land shall thereupon and thenceforth from the date of such Proclamation become and be absolutely dedicated to the public as a public highway within the meaning of any law then or thereafter in force:

And, whereas the Council of the Shire of Doncaster and Templestowe has requested that the land hereinafter mentioned, which has been used for a street within the said shire, be so declared to be a public highway:

Now, therefore, I, the Governor of the State of Victoria in the Commonwealth of Australia, by and with the advice of the Executive Council of the said State, do by this Proclamation declare that all that piece of land, being Outlook-drive as shown on plan of subdivision No. 42202 lodged in the Office of Titles and thereon coloured brown, shall be a public highway within the meaning of the said Act.

Given under my Hand and the Seal of the State of Victoria aforesaid, at Melbourne, this ninth day of October, in the year of our Lord One thousand nine hundred and sixty-two, and in the eleventh year of the reign of Her Majesty Queen Elizabeth II.

(L.S.) DALLAS BROOKS.  
By His Excellency's Command,  
MURRAY PORTER,  
Minister for Local Government.  
GOD SAVE THE QUEEN!

PUBLIC HIGHWAYS.—SHIRE OF DONCASTER AND  
TEMPLESTOWE.

## PROCLAMATION

By His Excellency the Governor of the State of Victoria and its Dependencies in the Commonwealth of Australia, &c., &c., &c.

WHEREAS by the *Local Government Act* 1958, as amended, section 519, it is amongst other things enacted that it shall be lawful for the Governor in Council at any time, and from time to time, upon request of the Council of any municipality, by notice in the *Government Gazette*, to proclaim any land reserved, used or by purchase or exchange acquired for a street, road, highway, thoroughfare, bridge, square, court, alley or right-of-way or any street, road, lane or passage made or laid out or proposed to be made or laid out on any land of which a plan delineating that street, road, lane or passage has been lodged with the Registrar of Titles pursuant to subsection (11) of section 569 of the said Act to be a public highway, and that such land shall thereupon and thenceforth from the date of such Proclamation become and be absolutely dedicated to the public as a public highway within the meaning of any law then or thereafter in force:

And, whereas the Council of the Shire of Doncaster and Templestowe has requested that the land hereinafter mentioned, which has been used for streets within the said shire, be so declared to be public highways:

Now, therefore, I, the Governor of the State of Victoria in the Commonwealth of Australia, by and with the advice of the Executive Council of the said State, do by this Proclamation declare that all those pieces of land being Florence-avenue, The Glen, William-street and Adelyn-avenue, as shown on plan of subdivision No. 40387 lodged in the Office of Titles and thereon coloured brown, shall be public highways within the meaning of the said Act.

Given under my Hand and the Seal of the State of Victoria aforesaid, at Melbourne, this ninth day of October, in the year of our Lord One thousand nine hundred and sixty-two, and in the eleventh year of the reign of Her Majesty Queen Elizabeth II.

(L.S.) DALLAS BROOKS.

By His Excellency's Command,  
MURRAY PORTER,  
Minister for Local Government.  
GOD SAVE THE QUEEN!

PUBLIC HIGHWAYS.—SHIRE OF DONCASTER AND  
TEMPLESTOWE.

## PROCLAMATION

By His Excellency the Governor of the State of Victoria and its Dependencies in the Commonwealth of Australia, &c., &c., &c.

WHEREAS by the *Local Government Act* 1958, as amended, section 519, it is amongst other things enacted that it shall be lawful for the Governor in Council at any time, and from time to time, upon request of the Council of any municipality, by notice in the *Government Gazette*, to proclaim any land reserved, used or by purchase or exchange acquired for a street, road, highway, thoroughfare, bridge, square, court, alley or right-of-way or any street, road, lane or passage made or laid out or proposed to be made or laid out on any land of which a plan delineating that street, road, lane or passage has been lodged with the Registrar of Titles pursuant to subsection (11) of section 569 of the said Act to be a public highway, and that such land shall thereupon and thenceforth from the date of such Proclamation become and be absolutely dedicated to the public as a public highway within the meaning of any law then or thereafter in force:

And, whereas the Council of the Shire of Doncaster and Templestowe has requested that the land hereinafter mentioned, which has been used for streets within the said shire, be so declared to be public highways:

Now, therefore, I, the Governor of the State of Victoria in the Commonwealth of Australia, by and with the advice of the Executive Council of the said State, do by this Proclamation declare that all those pieces of land being Harcourt-street, Finlayson-street, Gray-street, Ruda-street, McLeod-street, Massey-street, Hender-street and part of Doncaster-road as shown on plan of subdivision No. 21103 lodged in the Office of Titles and being the

roads coloured brown and yellow on the said plan of subdivision excepting therefrom the "Pathway" 20 feet wide which abuts on McLeod-street and lots 132, 133, 143 and 147 to 152 inclusive on the said plan of subdivision, shall be public highways within the meaning of the said Act.

Given under my Hand and the Seal of the State of Victoria aforesaid, at Melbourne, this ninth day of October, in the year of our Lord One thousand nine hundred and sixty-two, and in the eleventh year of the reign of Her Majesty Queen Elizabeth II.

(L.S.) DALLAS BROOKS.

By His Excellency's Command,  
MURRAY PORTER,  
Minister for Local Government.  
GOD SAVE THE QUEEN!

LINTON WATERWORKS TRUST.—PORTION OF  
DISTRICT PROCLAIMED AN URBAN DISTRICT.

## PROCLAMATION

By His Excellency the Governor of the State of Victoria and its Dependencies in the Commonwealth of Australia, &c., &c., &c.

UNDER the powers conferred by the Water Acts and all other powers enabling me in that behalf, I, the Governor of the State of Victoria, in the Commonwealth of Australia, by and with the advice of the Executive Council of the said State do hereby proclaim that on and from the date hereof, that portion of the Waterworks District of the Linton Waterworks Trust comprised within the boundaries described in the Schedule of the Order in Council dated the 19th day of February, 1957, shall be and become an Urban District for the purposes of and within the meaning of the said Acts, and shall be known as the Linton Urban District.

Given under my Hand and the Seal of the State of Victoria aforesaid, at Melbourne, this sixteenth day of October, in the year of our Lord One thousand nine hundred and sixty-two, and in the eleventh year of the reign of Her Majesty, Queen Elizabeth II.

(L.S.) DALLAS BROOKS.

By His Excellency's Command,  
W. J. MIBUS,  
Minister of Water Supply.  
GOD SAVE THE QUEEN!

## MENTAL HEALTH ACT 1959 (No. 6605).

## DAY OF COMING INTO OPERATION.

## PROCLAMATION

By His Excellency the Governor of the State of Victoria and its Dependencies in the Commonwealth of Australia, &c. &c. &c.

WHEREAS it is provided by section one of the *Mental Health Act* 1959 that the said Act shall come into operation on a day to be fixed by Proclamation of the Governor in Council published in the *Government Gazette*:

Now therefore I, the Governor of the State of Victoria, by and with the advice of the Executive Council thereof, do by this my Proclamation fix the first day of November, 1962, as the day on which the said Act shall come into operation.

Given under my Hand and the Seal of the State of Victoria aforesaid, at Melbourne, this ninth day of October, in the year of our Lord One thousand nine hundred and sixty-two and in the eleventh year of the reign of Her Majesty Queen Elizabeth II.

(L.S.) DALLAS BROOKS.

By His Excellency's Command,  
R. W. MACK,  
Minister of Health.  
GOD SAVE THE QUEEN!

## BANK HOLIDAYS.

## PROCLAMATION

By His Excellency the Governor of the State of Victoria and its Dependencies in the Commonwealth of Australia, &c., &c., &c.

IN pursuance of the provisions of the *Bank Holidays Act 1958*, I, the Governor of the State of Victoria, in the Commonwealth of Australia, do by this my Proclamation appoint the days and dates named hereunder special days to be observed as Bank Holidays or Bank Half-Holiday (as the case may be) at the places respectively mentioned, that is to say:—

*Bank Holidays:—*

WEDNESDAY, 17TH OCTOBER, 1962, at Dookie.  
TUESDAY, 6TH NOVEMBER, 1962, at Ouyen.

*Bank Half-Holiday from the Hour of Eleven a.m.:—*

TUESDAY, 6TH NOVEMBER, 1962, at Mildura, Red Cliffs and Merbein.

Given under my Hand and the Seal of the State of Victoria aforesaid, at Melbourne, this sixteenth day of October, in the year of our Lord One thousand nine hundred and sixty-two, and in the eleventh year of the reign of Her Majesty Queen Elizabeth II.

(L.S.) DALLAS BROOKS.

By His Excellency's Command,  
R. J. HAMER,  
for Chief Secretary.

GOD SAVE THE QUEEN!

## PUBLIC HOLIDAYS.

## PROCLAMATION

By His Excellency the Governor of the State of Victoria and its Dependencies in the Commonwealth of Australia, &c., &c., &c.

IN pursuance of the provisions contained in Part III. of the *Public Service Act 1958*, I, the Governor of the State of Victoria, in the Commonwealth of Australia, by and with the advice of the Executive Council of the said State, do by this my Proclamation appoint the days and dates hereunder mentioned to be observed as Public Holidays or Public Half-Holiday (as the case may be) at the places respectively specified, viz.:—

*Public Holidays:—*

\*TUESDAY, THE 6TH NOVEMBER, 1962, throughout the Ouyen Riding of the Shire of Walpeup.  
TUESDAY, THE 6TH NOVEMBER, 1962, throughout the City of Bendigo.

*Public Half-Holiday from the Hour of Twelve o'clock noon:—*

WEDNESDAY, THE 21ST NOVEMBER, 1962, throughout the Shire of Bungaree.

\* Agricultural Show.

Given under my Hand and the Seal of the State of Victoria aforesaid, at Melbourne, this sixteenth day of October, in the year of our Lord One thousand nine hundred and sixty-two, and in the eleventh year of the reign of Her Majesty Queen Elizabeth II.

(L.S.) DALLAS BROOKS.

By His Excellency's Command,  
R. J. HAMER,  
for Chief Secretary.

GOD SAVE THE QUEEN!

## HOLIDAY.—MELBOURNE CUP DAY.

NOTICE is hereby given that on—

TUESDAY, THE 6TH NOVEMBER, 1962,

the Public Offices in the municipalities mentioned hereunder will be closed, that day being appointed by the *Public Service Act 1958* to be observed as a holiday in the Public Offices:—

The Cities of Box Hill, Brighton, Broadmeadows, Brunswick, Camberwell, Caulfield, Chelsea, Coburg, Collingwood, Dandenong, Essendon, Fitzroy, Footscray, Hawthorn, Heidelberg, Kellor, Kew, Malvern,

Melbourne, Moorabbin, Mordialloc, Northcote, Nunawading, Oakleigh, Port Melbourne, Prahran, Preston, Richmond, Ringwood, St. Kilda, Sandringham, South Melbourne, Springvale, Sunshine, Waverley and Williamstown; the Shires of Altona, Bacchus Marsh, Berwick, Bulla, Cranbourne, Croydon, Doncaster and Templestowe, Eltham, Fern Tree Gully, Frankston, Gisborne, Hastings, Lillydale, Melton, Morningson, Romsey, Werribee and Whittlesea.

This notice relates only to the closing of the State Public Offices. All inquiries regarding holidays in other offices and in shops and industry should be directed to the Department of Labour and Industry, Old Treasury Building, Spring-street, Melbourne. (Telephone 63-0321, Extension 6158 or 6382.)

A. G. RYLAH,

Chief Secretary.

Chief Secretary's Office,  
Melbourne, 8th October, 1962.

*Fisheries Act 1958.*

## NOTICE OF INTENTION RESPECTING NETTING RESTRICTIONS IN TAMBOON INLET.

IT is hereby notified for general information that it is intended, after the expiration of one month from the date of publication of this notice in the *Government Gazette*, to move His Excellency the Governor in Council to make a Proclamation revoking the Proclamation made the third day of August, 1948, and published in the *Government Gazette* of the eleventh day of August, 1948, respecting netting restrictions in Tamboon Inlet and providing as follows:—

1. For the purposes of the Proclamation "Director" means the Director of Fisheries and Wildlife; "Deputy Director" means the Deputy Director of Fisheries and Wildlife; "Officer" means Fisheries and Wildlife Officer.

2. The use of nets of any kind or engines, whether fixed or unfixd, to be employed in fishing, shall be prohibited in Tamboon Inlet within an imaginary line running from the extreme seaward or outward point where the waters of such inlet enter the ocean, from the fifteenth day of October in each year to the thirtieth day of April in the following year (both days inclusive) provided that a seine or hauling net not exceeding 400 fathoms in length may be used during such period for the sole purpose of taking Australian salmon when in a large school in the said inlet, under the following conditions:—

- (a) Any licensed fisherman intending to net or attempt to net such fish when in a large school shall notify the Director or in his absence the Deputy Director of his intention at least 24 hours before netting operations commence.
- (b) On receipt of any such notification the Director or in his absence the Deputy Director shall arrange for an officer to supervise any netting operations and shall cause all such notifications to be placed in the departmental file.
- (c) Not under any circumstances whatever are any netting operations to commence unless an officer is present and has authorized the netting to proceed.
- (d) In the interests of the preservation of good order amongst fishermen, the Director or in his absence the Deputy Director shall determine the time and manner in which netting may be carried out and shall cause such determination to be placed in the departmental file.
- (e) A special return shall be submitted to the Director showing the total quantity of Australian salmon taken in any such netting operation and details as to the disposal of such fish. Such return shall be lodged at the office of the Director at Melbourne within a period of one month from the date on which such fish were netted.

3. The use of nets to be employed in fishing between the first day of May in each year and the fourteenth day of October next following (both days inclusive) shall be restricted in the above-mentioned inlet as follows:—

No person shall—

- (a) Use a "seine" or "hauling" net exceeding in length 400 fathoms.
- (b) Use a "mesh" or "set" net of any kind.

A. G. RYLAH,

Chief Secretary.

A. DUNBAVIN BUTCHER,  
Director of Fisheries and Wildlife.

## Marriage Act 1958.

## MINISTERS OF RELIGION REGISTERED TO CELEBRATE MARRIAGES IN VICTORIA.

It is hereby notified that in pursuance of the provisions of the *Marriage Act 1958* (No. 6306), Sec. 11, the undermentioned Officiating Ministers of Religion have been registered at this Office for the celebration of marriages in Victoria:—

Number in Register.	Name.	Designation.	Denomination.	Residence.	Date of Registration.
12731	Borriero, Tobia .. ..	Priest ..	Roman Catholic ..	378 Nicholson-street, North Fitzroy ..	20.9.62
12732	Kennedy, Henry Joseph ..	Priest ..	Roman Catholic ..	St. Patrick's Cathedral, Melbourne ..	20.9.62
12733	Harewood, Bramwell Milner ..	Major ..	Salvation Army ..	14 Woolten-avenue, Thornbury ..	3.10.62
12734	Mulveney, Ronald Roy ..	Minister ..	Presbyterian ..	Dookie ..	3.10.62
12735	Purcell, John Arthur ..	Priest ..	Roman Catholic ..	345 Burwood-road, Hawthorn ..	3.10.62
12736	Duffus, John Dennis ..	Priest ..	Roman Catholic ..	St. Patrick's Presbytery, Wangaratta ..	3.10.62
12737	Kurien, Vadakumkara Thomas ..	Priest ..	Church of England ..	286 Glenferrie-road, Malvern ..	3.10.62
12738	Naylor, Frederick Edward ..	Elder ..	Re-organized Church of Jesus Christ of Latter Day Saints ..	54 Panorama-street, Clayton ..	10.10.62
12739	Burgess, Colin Gordon ..	Priest ..	Church of England ..	Bright ..	12.10.62

Office of the Government Statist,  
Melbourne, 12th October, 1962.

F. W. CORRIE,  
Assistant Government Statist.

## STATE RIVERS AND WATER SUPPLY COMMISSION.

## LICENCE TO DIVERT WATER AND CUT RACE, PURSUANT TO THE PROVISIONS OF THE WATER ACTS.

THE Licence as detailed hereunder to divert water and cut race has been revoked by the Governor in Council as from the date shown:—

Licence No.	Name and Address of Person to Whom Licence has been Granted.	Source of Supply.	Date of Revocation.
708	C. W. Gardner of Yarroweyah North .. .. .	Torgannah Lagoon	30.6.62

Office of the State Rivers and Water Supply Commission,  
Melbourne, 16th October, 1962.

M. T. IRONSIDE, Secretary,  
State Rivers and Water Supply Commission

## STATE RIVERS AND WATER SUPPLY COMMISSION.

## LICENCES TO DIVERT WATER AND CUT RACES, PURSUANT TO THE PROVISIONS OF THE WATER ACTS.

LICENCES as detailed hereunder for the term of years from the date specified in each case have been granted by the Governor in Council to the persons named in the following Schedule:—

## SCHEDULE.

Licence No.	Term of Licence and Commencing Date.	Name and Address of Person to Whom Licence is to be Granted.	Source of Supply.	Area Authorized to be Irrigated Per Annum.	Volume of Water Authorized to be Diverted Per Annum.
				acres.	ac. ft.
383	Fifteen years from 1.7.62 ..	James Morgan and Daisy Edna Morgan, Strathmerton	River Murray ..	45	90
389	Three years from 1.7.62 ..	Robert James Hampton, Kerang ..	Loddon River ..	65	130
785	Three years from 1.7.62 ..	Bridget Ann Gilmore, Swan Hill ..	River Murray ..	141	282
1626/1018	Nine years from 1.7.62 ..	R. W. and P. E. Eyles, Beverford ..	River Murray ..	10	30
1644	Fifteen years from 1.7.62 ..	Gilguy Pty. Ltd., Bairnsdale ..	Mitchell River ..	15	30
1645	Fifteen years from 1.7.62 ..	Gilguy Pty. Ltd., Bairnsdale ..	Mitchell River ..	4	8

Office of the State Rivers and Water Supply Commission,  
Melbourne, 16th October, 1962.

M. T. IRONSIDE, Secretary,  
State Rivers and Water Supply Commission.

## STATE RIVERS AND WATER SUPPLY COMMISSION.

## LICENCE TO DIVERT WATER, PURSUANT TO THE PROVISIONS OF THE WATER ACTS.

THE licence as detailed hereunder for the term of years from the date specified has been granted by the Governor in Council:—

## SCHEDULE.

Licence No.	Term of Licence and Commencing Date.	Name and Address of Person to Whom Licence is to be Granted.	Source of Supply.	Area Authorized to be Irrigated Per Annum.	Volume of Water Authorized to be Diverted Per Annum.
				acres.	ac. ft.
1646/263	Eleven years from 1.7.62 ..	Eric L. Munzel, Gunbower .. .. .	Taylor's Creek ..	30	60

Office of the State Rivers and Water Supply Commission,  
Melbourne, 16th October, 1962.

M. T. IRONSIDE, Secretary,  
State Rivers and Water Supply Commission.

SHIRE OF PORTLAND.

ORDER FOR THE DEVIATION OF A PUBLIC HIGHWAY.

IN pursuance of the powers conferred by sections 522 and 526 of the *Local Government Act 1958*, the Council of the municipality of the Shire of Portland doth hereby direct that the land in the Parish of Branholme, County of Normanby, shown hatched on the plan attached hereto which said land has been taken purchased or acquired by it shall be a public highway from and after the date of publication of this Order in the *Government Gazette* and doth hereby declare that such land shall be a public highway in lieu of the land in the said parish shown cross-hatched on the said plan.

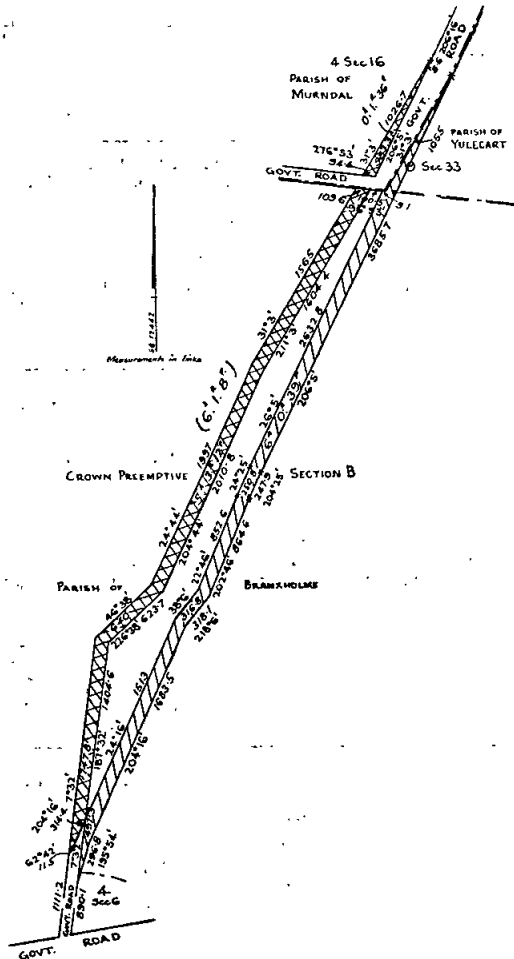

The corporate seal of the President, Councillors and Ratepayers of the Shire of Portland was hereunto affixed this 13th day of July, 1962, in the presence of—

(SEAL) KEITH McLEAN, President.  
M. McL. AYLMER, Councillor.  
M. D. ALLARDICE, Secretary.

Approved by the Governor in Council, 9th October, 1962.—N. G. WISHART, Clerk of the Executive Council.

SHIRE OF DUNDAS.

ORDER FOR THE DEVIATION OF A PUBLIC HIGHWAY.

IN pursuance of the powers conferred by sections 521 and 525 of the *Local Government Act 1958*, the Council of the Shire of Dundas doth hereby direct that the land in the Parish of Yulecart, shown hatched on the plan annexed hereto which has been taken purchased or acquired by it shall be a public highway from and after the date of publication of this Order in the *Government Gazette* and doth declare that such land shall be

a public highway in lieu of the land in the Parish of Murrndal shown cross-hatched on the said plan.

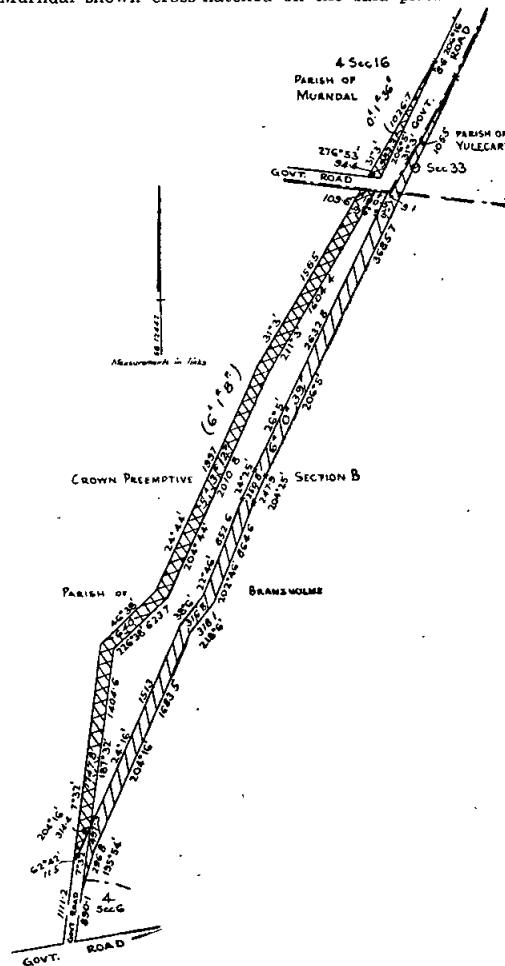

The common seal of the President, Councillors and Ratepayers of the Shire of Dundas was hereunto affixed this 5th day of July, 1962, in the presence of—

(SEAL) L. KIRKWOOD, President.  
MARTIN J. HYNES, Councillor.  
JOSEPH B. NEAL, Shire Secretary.

Approved by the Governor in Council, 9th October, 1962.—N. G. WISHART, Clerk of the Executive Council.

NOTICE TO MARINERS.

[No. 10 of 1962] T.

AUSTRALIA.—VICTORIA.

WESTERN PORT.—EASTERN ENTRANCE.

Beacon Destroyed.—Buoy Established.

Position.—Red Point white beacon, Lat. 38 deg. 33 min. 09 sec. S.; Long. 145 deg. 21 min. 45 sec. S. (approx.).

Details.—Black Reef beacon, stationed 5.85 cables 318 deg. from Red Point beacon, has been destroyed, and is replaced by a buoy in approximately the same position.

Chart Affected.—B.A. 1707; . . . . .

Publications.—*Sailing Directions, Victoria, 1959*, page 416. *Australia Pilot, Vol. 11, 1956*, page 115.

C. O'MALLEY,  
Port Officer.

Ports and Harbors Branch,  
Department of Public Works,  
Melbourne, C.2, 9th October, 1962.

Transport Regulation Acts.  
TRANSPORT REGULATION BOARD.  
NOTICES OF PUBLIC HEARINGS.

NOTICE is hereby given that the applications made by the persons named below for licences to operate commercial passenger vehicles on the route or routes, or in the manner set out opposite their names, will be heard at a time and place to be communicated to the parties:—

*Name and Address; Nature of Application.*

- GLOVER, L. T. & M. C., Hunter-street, Mansfield; 1 commercial passenger vehicle, with seating capacity for five persons, to operate under private hire conditions from Mansfield.
- OLIVER, N. C., 50 Costello-street, Lilydale; 1 commercial passenger vehicle, to be purchased, with seating capacity for five persons, to operate as a country taxi-cab at Mooroolbark.
- STOKES, G. P., 48 McDonald-street, East Geelong; application for one commercial passenger vehicle, with seating capacity for five persons, to operate as an urban taxi-cab within the urban district of Geelong.
- ROYENA MOTORS PTY. LTD., 96 McKinnon-road, McKinnon; 1 commercial passenger vehicle, with seating capacity for 29 passengers, to operate as an additional metropolitan route omnibus on Route 25A (Gardiner-McKinnon) under the same terms and conditions as licences already held in the applicant's name.
- MCNAMEE, B. R., 34 Moylan-street, East Ormond; 1 commercial passenger vehicle, with seating capacity for five passengers, to operate for the carriage of kindergarten children, free of charge, to and from the kindergarten situated at 34 Moylan-street, East Ormond, from and to the children's home addresses, situated in the Ormond, Bentleigh districts.
- DORF TAPS PTY. LTD., Buckland-street, Clayton; 1 goods type vehicle (Bedford van) to operate for the carriage of company employees only, free of charge, from the Clayton Railway Station, via Carinish-road, Centre-road, and Buckland-street to the factory.

*Time-table (Weekdays Only).*

Depart Clayton—7.30 a.m.  
Depart Factory—4.30 p.m., 5.15 p.m.

- SHAVE, O. C., Estate of the late, 1964 Malvern-road, East Malvern; 1 commercial passenger vehicle, with seating capacity for 31 passengers, to operate as an additional metropolitan route omnibus on Route No. 27A (Glen Waverley—St. Kilda), under the same terms and conditions as licences already held in the applicant's name.
- THOMSON'S ROADLINERS, 260 Racecourse-road, Newmarket; application for authority to operate vehicles, licence Nos. M.C.4, 162, 603 and 161 in substitution for, but not in addition to, any of the applicant's M.C. licensed vehicles which hold metropolitan sporting rights.  
NOTE.—Vehicles licence Nos. M.C.4, 162, 603 and 161 do not hold sporting rights.
- FERGUSON, S. V., 151 Raymond-street, Sale; application for renewal of licence No. T.S.290, expiring 1st January, 1963, authorizing operations under the same terms and conditions.

APPLICATIONS for metropolitan private hire car licences by the persons listed hereunder in respect of commercial passenger vehicles, with seating capacity for five persons, to operate under composite conditions from an approved depot in zone set out opposite their names:—

*Name and Address; Zone.*

- ATKINS, J. W., 4 Strabane-avenue, North Box Hill; "T".
- HEDGER, E. S., 6 Ambon-street, Ashburton; "D", "T".
- ANKER, J. M., Flat 5, 86 Blessington-street, St. Kilda; "A", "B", "C", "D".
- THORPE, J. B., 27 Somers-street, Burwood; "D".
- BENNETT, G. A., 271 Flinders-street, Sunbury; "J".

Commercial Goods Vehicles Acts.  
TRANSPORT REGULATION BOARD.  
NOTICES OF PUBLIC HEARINGS.

NOTICE is hereby given that the applications made by the persons named below for licences to operate the commercial goods vehicles on the route or routes, or in the manner set out opposite their names, will be held at a time and place to be communicated to the persons concerned:—

*Name and Address; Nature of Application.*

- ART-CRAFT DECORATORS & UPHOLSTERERS PTY. LTD., 392 Chapel-street, South Yarra; application to vary the conditions of existing licence No. D.A.45126 by deleting

"within a radius of 50 miles of own premises at South Yarra" and adding in lieu "throughout the State of Victoria".

- AUSTRAL SMALLGOODS (E. GROBECKER) PTY. LTD., 60 Stubbs-street, Flemington; 1 commercial goods vehicle (7 cwt.) to operate throughout the State of Victoria in course of business as "smallgoods manufacturers" for the purpose of repairing own vehicles on the road in an emergency—tools of trade, spare parts and materials incidental thereto.
- BATH, B. R., Wireless-road, Kangaroo Flat; 1 commercial goods vehicle (30 cwt.) to operate throughout the State of Victoria in the course of business as "travelling showman"—own plant and equipment and novelty prizes.
- BAUM, H. E., 3 Tahala-road, Toorak; 1 commercial goods vehicle (6 cwt.) to operate within a radius of 50 miles of the G.P.O., Melbourne, in the course of business as "Manager of Austral Cigarette Supply Pty. Ltd.", Malvern, for the purpose of servicing, maintaining and installing cigarette dispensers—tools of trade, cigarette dispensers for installation, repair or having been repaired and a small quantity of stock for replacement and replenishing of cigarette dispensers.
- BROOKES, G. T. & E. S. LEACH, Commercial-road, Koroit; 1 commercial goods vehicle (110 cwt.) to operate within a radius of 50 miles of own premises at Koroit in the course of business as "fuel merchants, plumbers and boring contractors"—own goods.
- COXALL, D. L., Forrest-street, Buninyong; 1 commercial goods vehicle (102 cwt.) to operate within a radius of 50 miles of own premises at Buninyong in the course of business as a "building contractor"—tools of trade, scaffolding and sufficient materials for the completion of own contracts.
- DAY, W. K., 107 Comas-street, Morwell; application to vary the conditions of existing licence No. T.T.D.576 by adding—(a) from private landings at Jeeralang Junction to McMillan & Pyle's sawmill, at Morwell—logs, (b) within a radius of 20 miles of the post office at Morwell—own tractor.
- DE JONG, W. F. & S. CORNILISSON, Broomfield; 1 commercial goods vehicle (140 cwt.) to operate throughout the State of Victoria in the course of business as "marine collectors"—marine goods as designated in the *Marine Stores and Old Metals Act 1953* (No. 6303), but excluding the carriage of any such goods to wharves, docks or ships for shipment or export purposes.
- DOUTHIE, R. A., PTY. LTD., Centre-road, Bentleigh; 3 commercial goods vehicles (221, 138 and 147 cwt.) to operate—(a) within a radius of 25 miles of G.P.O., Melbourne—general goods, (b) from pits in the Cranbourne and Langwarrin area to places within paragraph (a)—sand.
- FITZGERALD, J. W., 27 Adeline-street, Greensborough; 1 commercial goods vehicle (8 cwt.) to operate within a radius of 50 miles of own premises at Ivanhoe for the purpose of installing television sets and antennae—television sets and antennae for installation and tools of trade and equipment incidental to own contracts.
- FRIGRITE LTD., Graham-street west, Port Melbourne; 1 commercial goods vehicle (8 cwt.) to operate throughout the State of Victoria in the course of business as "refrigeration engineers"—refrigerators for installation, also tools of trade, spare parts and materials incidental to the installation and maintenance of such refrigerators.
- GEE, R. F., 48 Hider-street, Warrnambool; 1 commercial goods vehicle (8 cwt.) to operate—(a) within a radius of 20 miles of the post office at Warrnambool—general goods, (b) from places within a radius of 50 miles of the post office at Warrnambool for delivery to the Warrnambool Abattoirs—dead and maimed stock.
- HEMINGWAY & SONS PTY. LTD., 330 Sydney-road, Brunswick; 1 commercial goods vehicle (10 cwt.) to operate within a radius of 50 miles of own branch premises at Bairnsdale in the course of business as "wholesale distributors" and in the area east of a north/south line drawn through Bairnsdale—cigarettes, tobacco and hairdressers supplies subject to the condition that any of the goods so carried shall only be those initially consigned to Bairnsdale by rail.
- JEFFREY, J. & SONS, PTY. LTD., Post Office Box 125, Morwell; application to vary the conditions of existing licence No. D.A.32735/5 by adding "and earthmoving machinery on behalf of other contractors".
- KALMS, A. A., Box 73, Murrayville; 1 commercial goods vehicle (127 cwt.) to operate—(a) within the Shires of Mildura, Walpeup, Swan Hill and Karkaroc—plant the property of a contractor and required for use in connexion with the construction or maintenance of some specific, existing or proposed road, street, footpath, bridge, wharf, pier, weir or channel, (b) within

- a radius of 20 miles from site of construction or maintenance work performed pursuant to paragraph (a) above, or from the railway station nearest thereto.—metal, stones, screenings, ashes, gravel, sand, earth and any other materials required for such work, (c) within a radius of 20 miles of the post office at Murrayville—general goods.
- MARSHALL, I. J., Mount Wallace; 1 commercial goods vehicle (121 cwt.) to operate—(a) within a radius of 20 miles from the post office at Mt. Wallace—general goods, (b) from the premises of B.P. Aust. Ltd., at Geelong to own depot at Mt. Wallace and to places within paragraph (a) above—petroleum products in prescribed types of containers and empty return containers.
- McKINNON, H. J., Caramut-road, Warrnambool; 1 commercial goods vehicle (253 cwt.) to operate—(a) within a radius of 20 miles of post office at Warrnambool—general goods. (b) from Thomas's sawmill at Portland to Ponting Bros., Vic. Sellars Pty. Ltd. and Fotheringham Bros. Warrnambool—sawn timber, (c) from Benbow's Mill, Heywood to Ponting Bros., Vic. Sellars Pty. Ltd. and Fotheringham Bros., Warrnambool—sawn timber, (d) within a radius of 75 miles of the post office at Peshurst (Warrnambool Division of the Country Roads Board) on behalf of the Country Roads Board—concrete and steel bridge piles and girders and heavy machinery.
- O'DONNELL, R., PTY. LTD., 23 Henry-street, Traralgon; 1 commercial goods vehicle (63 cwt.) to operate within a radius of 65 miles of own premises at Traralgon in the course of business as "builders"—tools of trade, builder's equipment and materials incidental to the completion of own contracts.
- PARKINSON, H., 13 Stewart-road, Clayton; 1 commercial goods vehicle (110 cwt.) to operate—(a) within a radius of 25 miles of the G.P.O., Melbourne—general goods, (b) within a radius of 70 miles of the Glen Iris Brick, Tile & Terra Cotta Co. Pty. Ltd. at Oakleigh—bricks on behalf of the said company.
- PATTE, J., Mill-road, Toora; 1 commercial goods vehicle (133 cwt.) to operate—(a) within a radius of 70 miles of the post office at Yarram (Traralgon Division of the Country Roads Board)—plant the property of a contractor and required for use in connexion with the construction or maintenance of some specific, existing or proposed road, street, footpath, bridge, wharf, pier, weir or channel, (b) within a radius of 20 miles from site of construction or maintenance work performed pursuant to paragraph (a) above, or from the railway station nearest thereto—metal, stones, screenings, ashes, gravel, sand, earth and any other materials required for such work, (c) within a radius of 20 miles of the post office at Toora—general goods.
- PETERSON, B. W., 5 Edith-street, Horsham; 1 commercial goods vehicle (11 cwt.) to operate throughout the State of Victoria in the course of business as a "household pest exterminator"—tools of trade and equipment incidental to the completion of own contracts.
- PRIZEY, GEO., & SON LTD., 131 Johnston-street, Fitzroy; 1 commercial goods vehicle (8 cwt.) to operate throughout the State of Victoria in the course of business as "tanners and leather merchants" for the carriage of samples of sole leather for exhibition to prospective purchasers, with the ability to leave up to four sides of leather where urgently required.
- RICHARDSON, JAMES, PTY. LTD., 14 Corr's-lane, Melbourne; 1 commercial goods vehicle (19 cwt.) to operate within a radius of 25 miles of the chief post office at Geelong and to Apollo Bay and places *en route*, returning via Colac and places *en route* in the course of business as "cigarette and tobacco merchants"—cigarettes, tobacco and fancy goods.  
NOTE.—All goods to be initially consigned to Geelong by rail.
- R.M.C. TRANSPORT (N.S.W.) PTY. LTD., 501 Swanston-street, Melbourne; application to vary the conditions of existing licence No. D.A.39437/7 by deleting "Ballarat" and adding in lieu "North Melbourne".
- SAVILLE, R. F., Beverford; 1 commercial goods vehicle (120 cwt.) to operate from Howard Jackett & Co. Pty. Ltd.'s flour mill at Swan Hill to Leitchville—flour mill produce on behalf of the said company.
- SEEAR, W. K., 18 Gillingham-street, Preston; 1 commercial goods vehicle (6 cwt.) to operate throughout the State of Victoria in the course of business as a "refrigeration mechanic" on behalf of Pioneer Refrigeration Pty. Ltd. for the purpose of servicing refrigeration equipment—tools of trade, spare parts, refrigeration equipment for repair or having been repaired.
- SELLARS, W. A., 211 Don-street, Bendigo; 1 commercial goods vehicle (36 cwt. and trailer) to operate within a radius of 100 miles of the post office at Bendigo, excluding all operations to or from the Melbourne metropolitan area in the course of business as an "electrical and refrigeration serviceman" for the purpose of servicing, maintaining and installing television sets, electrical appliances and commercial refrigeration plant—tools of trade, spare parts, television sets, electrical appliances and commercial refrigeration plant for repair or having been repaired and for installation, with the ability to return to own premises at Bendigo with second-hand electrical appliances being trade-in equipment.
- STAWELL TIMBER INDUSTRIES PTY. LTD., Lake-road, Stawell; application to vary the conditions of existing licences Nos. D.A.13328/3 and D.A.13328/4 by deleting present conditions, and adding in lieu "throughout the State of Victoria for the purpose of supervising own contracts in the course of business as 'prefabricated and precut house manufacturers'—tools of trade and small quantities of materials incidental to the repair and completion of own contracts".
- SENNITT, J. P., & SON PTY. LTD., 615 Warrigal-road, Holmesglen; 6 commercial goods vehicles (7 cwt. each) to operate—(a) within a radius of 50 miles of own premises at Holmesglen in the course of business as "ice-cream manufacturers"—own goods, (b) throughout the State of Victoria as a traveller's vehicle—advertising, display materials, ice-cream and ice-cream cones.
- TRENFIELD, R. J., Giffords-road, Warburton; 1 commercial goods vehicle (114 cwt.) to operate—(a) within a radius of 70 miles of the post office at Healesville (Dandenong Division of the Country Roads Board)—plant the property of a contractor and required for use in connexion with the construction or maintenance of some specific, existing or proposed road, street, footpath, bridge, wharf, pier, weir or channel, (b) within a radius of 20 miles from site of construction or maintenance work performed pursuant to paragraph (a) above, or from the railway station nearest thereto—metal, stones, screenings, ashes, gravel, sand, earth and any other materials required for such work, (c) within a radius of 20 miles of the post office at Warburton—general goods.
- TUTT BRYANT (VIC.) PTY. LTD., 383 Williamstown-road, Yarraville; 3 commercial goods vehicles (8 cwt. each) to operate throughout the State of Victoria for the purpose of servicing and maintaining tractors, earth-moving and farm machinery—tools of trade, spare parts and materials incidental to own service and sales contracts.
- WADE, P. F., 254 Hargreaves-street, Bendigo; 1 commercial goods vehicle (14 cwt.) to operate—(a) within a radius of 50 miles from own premises at Bendigo in the course of business as "primary producer and electrical retailer"—own goods, (b) within a radius of 100 miles from own premises at Bendigo, but excluding any operations to or from the City of Melbourne for the purpose of servicing and installing electrical appliances—tools of trade, spare parts and materials incidental thereto, electrical appliances for installation, for repair or having been repaired.
- WARREN, A. P., 42 Volum-street, Manifold Heights; application to vary the conditions of existing licence No. D.A.2238 by adding as paragraph (c) "within a radius of 25 miles of the chief post office at Geelong for the carriage of washed sand and granitic gravels to municipal councils, building contractors and private users for construction purposes".
- WHITTEN, M., Geelong-road, Brooklyn; 1 commercial goods vehicle (155 cwt.) to operate within a radius of 50 miles of the plant of Ready Mixed Concrete (Victoria) Pty. Ltd. at Brooklyn as a specially constructed agitator vehicle—premixed concrete.
- WOODLAND, E. T., 46 Wilgah-street, East St. Kilda; 1 commercial goods vehicle (12 cwt.) to operate throughout the State of Victoria in the course of business as "waste bag collector" for the purpose of collecting household textile waste on behalf of Melbourne Waste Industries Pty. Ltd.
- YORK, HENRY H., & CO. PTY. LTD., 376 Whitehorse-road, Nunawading; 1 commercial goods vehicle (7 cwt.) to operate—(a) within a radius of 50 miles of own branch premises at Numurkah in the course of business as "general merchants and importers"—own goods, (b) within the area bounded by and including Cobram, Kyabram, Tatura, Mooroonna, Shepparton, Yarrowonga and Seymour for the purpose of demonstrating agricultural and horticultural chemicals—agricultural and horticultural chemicals for demonstration with the ability to leave chemicals with a prospective purchaser in an emergency.



YORK, HENRY H., & Co. PTY. LTD., 376 Whitehorse-road, Nunawading; 1 commercial goods vehicle (9 cwt.) to operate—(a) within a radius of 50 miles of own branch premises at Albury in the course of business as "general merchants and importers"—own goods, (b) within the area bounded by and including Wodonga, Rutherglen, Wangaratta, Benalla, Mansfield and Myrtleford for the purpose of demonstrating agricultural and horticultural chemicals—agricultural and horticultural chemicals for demonstration with the ability to leave chemicals with a prospective purchaser in an emergency.

YORK, HENRY H., & Co. PTY. LTD., 376 Whitehorse-road, Nunawading; 1 commercial goods vehicle (7 cwt.) to operate—(a) within a radius of 50 miles of own premises at Beaufort in the course of business as "general merchants and importers"—own goods, (b) within the area bounded by and including Ararat, Stawell, Coleraine, Horsham, Hamilton, Camperdown and Colac for the purpose of demonstrating agricultural and horticultural chemicals—agricultural and horticultural chemicals for demonstration with the ability to leave chemicals with a prospective purchaser in an emergency.

## TOW TRUCKS.

*Name and Address; Nature of Application.*

BAILEY, C. T. & G. A. (trading as Bailey Motors and Motor Cycles), 134 Beach-street, Frankston; 1 commercial goods vehicle (90 cwt.) to operate throughout the State of Victoria as a tow truck for the purpose of lifting and carrying or towing and/or repairing wrecked or disabled vehicles—tools of trade, spare parts and materials incidental thereto.

BOWMAN'S PANEL BEATING WORKS PTY. LTD., 830 High-street, Armadale; 1 commercial goods vehicle (70 cwt.) to operate within a radius of 25 miles of the G.P.O. Melbourne as a tow truck for the purpose of lifting and carrying or towing and/or repairing wrecked or disabled vehicles—tools of trade, spare parts and materials incidental thereto.

BROWN, J. K. & W. E. (trading as Brown's Motors and Bodyworks), 147 High-street, Echuca; 1 commercial goods vehicle (25 cwt.) to operate within a radius of 50 miles of the post office at Echuca as a tow truck for the purpose of lifting and carrying or towing and/or repairing wrecked or disabled vehicles—tools of trade, spare parts and materials incidental thereto.

BURNHAM, F. A. (trading as Burnham Motors), corner of Centre Dandenong and Warrigal roads, Cheltenham; 1 commercial goods vehicle (82 cwt.) to operate within a radius of 20 miles of the post office at Cheltenham as a tow truck for the purpose of lifting and carrying or towing and/or repairing wrecked or disabled vehicles—tools of trade, spare parts and materials incidental thereto.

CLARKE, WALTER J., 89-93 Cecil-street, South Melbourne; 1 commercial goods vehicle (20 cwt.) to operate within a radius of 25 miles of the G.P.O. Melbourne as a tow truck for the purpose of lifting and carrying or towing and/or repairing wrecked or disabled vehicles—tools of trade, spare parts and materials incidental thereto.

HUTSON, F. & R. MEURANT (trading as Yackandandah Motors), Yackandandah; 1 commercial goods vehicle (70 cwt.) to operate within a radius of 100 miles of the post office at Yackandandah as a tow truck for the purpose of lifting and carrying or towing and/or repairing wrecked or disabled vehicles—tools of trade, spare parts and materials incidental thereto.

LYON, D. A. (trading as Lyon Bros.), 283-287 Main-road, Eltham; 1 commercial goods vehicle (30 cwt.) to operate throughout the State of Victoria as a tow truck for the purpose of lifting and carrying or towing and/or repairing wrecked or disabled vehicles—tools of trade, spare parts and materials incidental thereto.

MODERN TOWING & SALVAGE PTY. LTD., 378 Barkly-street, Footscray; 1 commercial goods vehicle (27 cwt.) to operate throughout the State of Victoria as a tow truck for the purpose of lifting and carrying or towing and/or repairing wrecked or disabled vehicles—tools of trade, spare parts and materials incidental thereto.

MCDUGALL, ARCHIE, 301 Barkly-street, West Brunswick; 1 commercial goods vehicle (39 cwt.) to operate throughout the State of Victoria as a tow truck for the purpose of lifting and carrying or towing and/or repairing wrecked or disabled vehicles—tools of trade, spare parts and materials incidental thereto.

STRAUSS BROS. PTY. LTD., Federal-street, Rainbow; 1 commercial goods vehicle (60 cwt.) to operate—(a) within a radius of 50 miles of the post office at Rainbow as a tow truck for the purpose of lifting and carrying or towing and/or repairing wrecked or disabled vehicles—tools of trade, spare parts and materials incidental thereto, (b) within a radius of 50 miles of the post office at Rainbow as a mobile crane.

NOTICE is hereby given that the applications made by the persons named below for renewal of licences to operate the commercial goods vehicles on the route or routes, or in the manner set out opposite their names, will be heard at a time and place to be communicated to the persons concerned:—

*Name and Address; Present Franchise; Licence No.; Date of Expiry.*

JAS. BROWN'S CLEANING CO. PTY. LTD., 367 High-street, Kew; 1 commercial goods vehicle (8 cwt.) to operate—(a) within a radius of 50 miles from the premises of the holder of this licence at Kew—goods in connexion with licensee's business as "dry cleaners", (b) throughout the State of Victoria for the purpose of cleaning rugs and carpets, and cleansing gear and equipment incidental to such work; D.A.750/15; 28th January, 1963.

JONES, D. W., PTY. LTD., 126 Cecil-street, Williamstown; 1 commercial goods vehicle (114 cwt.) to operate—(a) within a radius of 25 miles from the post office situate at the corner of Bourke and Elizabeth streets in the City of Melbourne—general goods, (b) within a radius of 50 miles from the post office situate at the corner of Bourke and Elizabeth streets in the City of Melbourne on behalf of the Shell Company of Australia Ltd.—petroleum products in prescribed types of containers and empty containers; D.A.1392; 24th January, 1963.

NIELSEN, FREDERICK W., PTY. LTD., Chesterville-road, Moorabbin; 1 commercial goods vehicle (70 cwt.) to operate throughout the State of Victoria in the course of business of the holders of this licence as "heating, steam, ventilation and plumbing engineers"—tools of trade, plant and equipment and assembled ductwork required for the installation of air-conditioning and warm-air plants; D.A.4341/2; 1st December, 1962.

PATERSONS PTY. LTD., 152 Bourke-street, Melbourne; 1 commercial goods vehicle (49 cwt.) to operate within a radius of 50 miles from the post office at Traralgon in the course of business as "home furnishers"—furniture and furnishings being the property of the licensee; D.A.1782/6; 24th January, 1963.

PETERS, W. E. M., Tallandoo; 1 commercial goods vehicle (160 cwt.) to operate—(a) within a radius of 50 miles from the post office at Tallandoo—livestock, (b) from Wodonga to primary producers within a radius of 20 miles from the post office at Tallandoo—farm requisites, as return loading on which livestock has been carried for such primary producers, (c) within a radius of 50 miles from the post office at Tallandoo—second-hand furniture; D.A.31358; 15th December, 1962.

PETERS ICE CREAM (VIC.) LTD., Burnley-street, Richmond; 1 commercial goods vehicle (17 cwt.) to operate throughout the State of Victoria for the purpose of maintaining and servicing the licence holder's own heavy refrigeration plants—tools of trade, spare parts and materials incidental to such servicing and maintenance; D.A.1813; 6th December, 1962.

PETERS ICE CREAM (VIC.) LTD., Burnley-street, Richmond; 1 commercial goods vehicle (20 cwt.) to operate throughout the State of Victoria for the purpose of installing, servicing and maintaining commercial refrigerators—licensee's own refrigerators for installation and replacement, spare parts, tools of trade and materials incidental thereto; D.A.1813/12; 28th January, 1963.

PETERS ICE CREAM (VIC.) LTD., Burnley-street, Richmond; 2 commercial goods vehicles (72 and 73 cwt.) to operate throughout the State of Victoria as a specially constructed insulated and refrigerated van for the purpose of supplying own shops and distributors with ice cream and frozen foods at a temperature not exceeding 10 degrees Fahrenheit; T.D.A.1813/21, T.D.A.1813/22; 8th January, 1963.

PETERS ICE CREAM (VIC.) LTD., Burnley-street, Richmond; 2 commercial goods vehicles (71 and 72 cwt.) to operate throughout the State of Victoria as a specially constructed, insulated and refrigerated van for the purpose of supplying own

distributors with ice cream and frozen foods at a temperature not exceeding 10 degrees Fahrenheit; T.D.A.1813/24, T.D.A.1813/25; 22nd January, 1963.

**STAUNTON CONSOLIDATED INDUSTRIES PTY. LTD.**, 75-77 Buckhurst-street, South Melbourne; 1 commercial goods vehicle (8 cwt.) to operate throughout the State of Victoria in the course of business as "advertising contractors"—tools of trade and materials incidental to licensees' own contracts; D.A.2101/1; 8th January, 1963.

**TUTT BRYANT (Vic.) PTY. LTD.**, 383 Williamstown-road, Yarraville; 1 commercial goods vehicle (8 cwt.) to operate throughout the State of Victoria for the purpose of servicing and maintaining tractors, earth-moving and farm machinery—tools of trade, spare parts and materials incidental to licensee's own servicing and sales contracts; D.A.2187/9; 25th October, 1962.

**NOTICE** is hereby given that the applications made by the persons named below for renewal of licences with variation to operate the commercial goods vehicles on the route or routes, or in the manner set out opposite their names, will be heard at a time and place to be communicated to the persons concerned:—

*Name and Address; Present Franchise; Variation.*

**HARRIS BROS. TRANSPORTS PTY. LTD.**, Emerald-road, Beaconsfield Upper; 1 commercial goods vehicle (149 cwt.) to operate from and to the City of Melbourne to and from places situate within a radius of 7 miles from the Upper Beaconsfield Post Office—general goods; by adding as paragraph (b): from and to the depot of the Vacuum Oil Co. Pty. Ltd. at Dandenong to and from places situate within a radius of 20 miles from the post office at Upper Beaconsfield—petroleum products in prescribed types of containers and empty return containers; D.A.1254/7; 15th December, 1962.

**HARRIS BROS. TRANSPORTS PTY. LTD.**, Emerald-road, Beaconsfield Upper; 1 commercial goods vehicle (230 cwt.) to operate—(a) from and to the City of Melbourne to and from places situate within a radius of 7 miles from the Upper Beaconsfield Post Office—general goods, (b) from and to the Depot of the Vacuum Oil Co. Pty. Ltd. at Dandenong to and from places situate within a radius of 20 miles from the post office at Upper Beaconsfield—petroleum products in prescribed types of containers and empty return containers; by deleting paragraph (b); D.A.1254/8; 15th December, 1962.

**WARREN, A. P.**, 42 Volum-street, Manifold Heights; 1 commercial goods vehicle (110 cwt.) to operate—(a) within a radius of 75 miles of the chief post office in the City of Geelong—plant the property of a contractor and required for use in connexion with the construction or maintenance of some specific, existing or proposed road, street, footpath, bridge, wharf, pier, weir or channel, (b) within a 20 miles radius from site of construction or maintenance work performed pursuant to paragraph (a) above or from the railway station nearest thereto—metal, stones, screenings, ashes, gravel, sand, earth and any other materials required for such work; by adding as paragraph (c) within a radius of 25 miles of the chief post office in the City of Geelong for the carriage of washed sand and granitic gravels to municipal councils, building contractors and private users for construction purposes; D.A.2238/1; 15th December, 1962.

Notice of any objection should be forwarded to reach the Secretary to the Board not later than Wednesday, 31st October, 1962.

A. V. C. COOK,  
Acting Secretary.

Exhibition Buildings, Rathdowne-street, Carlton, N.3,  
Wednesday, 17th October, 1962.

*State Savings Bank Act 1958, Section 30.*

THE STATE SAVINGS BANK OF VICTORIA.

ESTABLISHMENT OF BRANCHES.

**THE** Commissioners of the State Savings Bank of Victoria hereby give notice of their intention to establish Branches of the Bank, as under, on 24th October, 1962:—

Box Hill Station.  
Deer Park.

T. E. HALL,  
General Manager.

CONTRACTS ACCEPTED.—(Series 1962-63.)

VICTORIAN RAILWAYS.

48. Cleaning windows of V.R. Administrative Offices, &c., Spencer-street, for £872 (Contract 62248).—Power Cleaning Service Pty. Ltd. 49. Cleaning windows, &c., Inwards Parcels Spencer-street, for £112 (Contract 62251).—Ace Window & General Cleaning Service. 50. Bituminous concrete, at rates (Contract 62257).—Albion Quarrying Co. Pty. Ltd. 51. Wooden poles, at rates (Contract 62271).—Alex. Sturrock & Sons Pty. Ltd. as agents for K. and B. Varney.

By order of the Victorian Railways Commissioners,  
W. WALKER, Secretary. 12.10.62.

SOIL CONSERVATION AUTHORITY.

1493. Glenelg River Catchment Project, erection of concrete structures, Group 1, £2,650.—L. W. Jennings, Hamilton.

PUBLIC WORKS.

1501. Croxton, Special School No. 4679, erection of additional wing and new Administration Section, &c., £29,300.—John P. Wolbers.

1502. Kew, High School, supply, delivery, installation and testing of the mechanical services, £21,140.—Frederick W. Nielsen Pty. Ltd.

1503. St. Albans, Technical School, site works covering asphaltting, drainage and landscaping, £12,146 15s.—R. Lambert.

1504. Abbotsford, State School No. 1886, repairs and painting, £5,400.—A. La Rovere.

1505. Albert Park, State School No. 1181, renewals of rainheads and repairs to plaster, &c., £333.—R. B. Hallett & Sons Pty. Ltd.

1506. Aspendale, Technical School, erection of chain mesh fencing, £958.—Diamond Fence & Gate Co. Pty. Ltd.

1507. Ballarat, State School No. 33, external painting and repairs, £353 5s.—J. & W. & K. Walsh.

1508. Balwyn, State School No. 4675, Yooralla Hospital, supply and installation of P.A.X. telephone system, £939.—Standard Telephones & Cables Pty. Ltd.

1509. Carlton, Melbourne Teachers' College, internal renovations to Art Block, £1,391.—J. & H. Contractors.

1510. Carlton, Exhibition Buildings, maintenance cleaning, 9th September, 1962 to 31st August, 1963, £8,640.—Utility Office Cleaning Services Pty. Ltd.

1511. Ceres, State School No. 1602, painting and repairs to school and residence, £443.—B. A. Warry.

1512. Chatham, State School No. 4314, renewing timber fire-escape stairs, £335.—A. V. Steele.

1513. Connewarre, State School No. 2088, erection of No. (1) shelter pavilion, £374.—A. P. Van Dort & Sons.

1514. Corinella, Penal and Gaols Staff Residences, provision of additional tanks and stands and installation, £278.—G. J. Mountney.

1515. Croydon West, State School No. 4879, erection of two (2) 32 ft. x 16 ft. shelter pavilions, £1,025.—H. I. Johnson & W. H. Johnson.

1516. Croxton, Special School No. 4679, electrical installation of alterations, extensions and new L.T.C. Block, £1,692.—P. J. Lynch.

1517. Donald, Higher Elementary School No. 1465, repairs to school and residence, £348 7s. 6d.—H. J. & K. M. Onley.

1518. Doncaster, Police Station, repairs and painting, £279.—L. J. Jessop.

1519. Euroa, Higher Elementary School No. 1706, installation of underground piping, £387 5s.—Levy Bros.

1520. Freshwater Creek, State School No. 256 and residence, new out-offices, and septic closets, £1,147 6s.—Peter McBride & Co.

1521. Glenroy, State School No. 3118, repairs and painting to school, £1,752.—C. B. Bramich.

1522. Hawksburn, State School No. 1467, demolition of existing canteen and provision of new canteen and store, £3,027.—R. G. Dew.

1523. Hawthorn, Immigration Hostel, 41 Kinkora-road, supply, delivery and installation of briquette-fired hot water service and exhaust system, £2,600.—R. L. & P. P. Baldwin.

1524. Korong Vale, State School No. 1800, internal painting and general repairs to residence, £578 15s. 6d.—B. F. & B. M. Geyer.

1525. Korrine, State School No. 4558, renovations and drinking facilities, £503.—Strykert & Bellingham.

1526. Langl Kal Kal, Social Welfare Department Training Centre, electrical installation in reconstructed homestead building, £1,430.—J. F. Martin.

1527. McKinnon, High School, installation of fire service, £1,470.—Egeberg Building & Plumbing Service.
1528. Macorna, State School No. 2909, external repairs and painting, £335 17s.—R. House.
1529. Melbourne, Agriculture Department, Head Office, maintenance cleaning 9th September, 1962 to 31st August, 1963, £5,025.—Linglow Cleaning Service.
1530. Melbourne, Titles Office, partitioning part of main hall, painting to rooms on first floor, £885 15s.—V. Laizans & Son.
1531. Melbourne, Lands and Survey Department, First Floor, New Treasury Buildings, electrical installation, £338.—W. J. Hardstaff.
1532. Mernda, State School No. 488, construction of out-office block for school and septic tanks for school and residence, £1,593.—Neerim Plumbers Pty. Ltd.
1533. Moe, High School, attention to external windows, £1,490 16s.—Walker & Bennie.
1534. Mont Park, Mental Hospital, supply and installation of materials for re-location of steam, heating and hot water mains to male wards, £1,240.—R. J. Weeks.
1535. Napoleon, State School No. 1072, installation septic tank, &c., £1,510.—A. C. Dawes.
1536. Newborough East, State School No. 4670, provision of shelter sheds and resiting of drinking troughs and washing basins, £548.—E. W. Gravett.
1537. Northcote, High School, internal painting to all buildings and replacements to chalkboards, £4,540.—A. La Rovere.
1538. Numurkah, High School, internal and external painting and repairs.—£9,200.—A. La Rovere.
1539. Nunawading, High School, external renovations, £1,532.—Chromas Paint Manufacturing Co.
1540. Overport, State School No. 4780, electrical installation in new Recreation Hall, £359 18s. 6d.—D. Prout.
1541. Royal Park, Mental Hospital, remodelling of electrical installation in central kitchen, £912 8s.—H. N. Butcher.
1542. Sandringham, State School No. 267, repairs and painting, £3,112.—Donovan & Brown.
1543. St. Arnaud, Police Station, electrical installation, residence, £255 15s.—J. L. Arnold.
1544. Springvale, High School, external painting, &c., £1,418.—Bulleen Constructions Pty. Ltd.
1545. Warrnambool, Technical College, painting of roof and new flooring, £1,285 10s.—Hose & Schultz.
1546. Welton, State School No. 4041, new out-office block and septic tank installations, &c., £661.—R. House.
1547. Wendouree West, State School No. 4701, connexion to town sewerage, &c., £3,789 15s.—J. & W. & K. Walsh.
1548. West Melbourne, Agriculture Department, Government Cool Stores, manufacture, supply and delivery of six (6) steel roof trusses (Section 5), £350.—A. G. Miers Pty. Ltd.
1549. Whittlesea, Police Station, erection of brick veneer residence, office and double garage, £8,639.—Gallagher & Power.
1550. Yarra Glen, State School No. 956, installation of septic tanks, fire service and water supply school and residence, £2,289.—John S. Oram.
1551. Appollo Bay, Consolidated School, erection of Domestic Arts Wing, £18,554.—A. V. Jennings Industries (Aust.) Ltd.
1552. Bulleen, State School No. 4869, extension of school buildings by additional six class-rooms, &c., £14,465.—A. V. Jennings Industries (Aust.) Ltd.
1553. Carlton, University of Melbourne, extensions to existing Hydraulics Laboratory, Stage 2, £133,950.—A. R. P. Crow & Sons Pty. Ltd.
1554. Carlton, University of Melbourne, supply, delivery, installation and testing of plenum heating, exhaust and electric H.W.S. systems for extensions to new Hydraulics Laboratory, £11,061.—Belsair Pty. Ltd.
1555. Fawkner, High School; Fawkner North, State School No. 4779, septic tank installations, building extensions and alterations to toilet blocks, £24,800.—R. W. Wood.
1556. Thomastown, High School, First and Second sections of new school in concrete veneer, timber framed construction, £84,320.—P. M. Versteegen & Sons Pty. Ltd.
1557. Thomastown, High School, installation and testing of the mechanical service for Stages 1 and 2, £11,138.—Mechanical Engineering Pty. Ltd.
1558. Trafalgar, High School, Type "300" High School, £67,760.—A. E. Petch & Son.
1559. Trafalgar, High School, supply, delivery, installation and testing of mechanical services, £10,480.—Thermic Heating & Ventilation.
1560. Appollo Bay, Consolidated School, supply and installation of heating and H.W.S. systems, £9,956.—Mechanical Engineering Pty. Ltd.
1561. Ararat, Mental Hospital, supply and installation of lagging and supports to existing hot water lines between Wards M.9 and M.11, £416 14s.—L. & M. M. Keenan.
1562. Athlone, State School No. 3623, septic tank and water supply installations, &c., £1,005.—J. White.
- 1563.—Ballarat, "Ewing House", Children's School for Deaf No. 4843, erection of No. 3 class-rooms, &c., £9,400.—S. C. Ludbrook & Son.
1564. Brunswick, Girls' Secondary School, external and internal painting and repairs, £3,350.—G. J. Little.
1565. Bulleen, State School No. 4869, Electrical installation of six (6) L.T.C. class-room extension, £560.—J. & B. Ranking.
1566. Burnley, State School No. 2853, installation of new water service, £400.—B. W. Cooper.
1567. Bylands, State School No. 1105, repairs and painting to school and residence, £700.—J. Cruise & Sons.
- H. R. PETTY, Commissioner of Public Works. 10.10.62.
1568. Kew, Mental Hospital, supply beds and patients washing trolley, £2,691 10s. 6d.—Namco Products Pty. Ltd.
1569. Kew, Mental Hospital, supply metal and asphalt, £293 14s.—Albion Quarrying Co. Pty. Ltd.
1570. Coburg, H.M. Gaol, Pentridge, supply mercury vapour lamp, £280.—Edmunds Bros. Pty. Ltd.
1571. Blackburn, Blackburn South High School, supply screenings, metal and toppings, £2,370 6s.—Associated Quarries Pty. Ltd.
1572. Port Melbourne, Mines Department Drill Store, supply steel shelves and erect, £1,349 2s. 6d.—E. T. Brown Ltd.
1573. Orbost, High School, supply refrigerator, £256 11s. 6d.—Pioneer Refrigeration Pty. Ltd.
1574. Royal Park, "Turana", supply floor coverings, £494.—Flor-Lyfe Pty. Ltd.
1575. Merbein, High School, supply road base material, £341 5s.—B. A. Allen.
1576. Merbein, High School, supply screenings, £728 10s.—P. Rocca.
1577. Niddrie, Technical School, supply lathes and shaping machine, £559.—McPhersons Ltd.
1578. Niddrie, Technical School, supply high speed shaping machine, £673 4s.—Westeel's (Vic.) Pty. Ltd.
1579. Echuca, Technical School, supply joinery, £836 7s. 6d.—Johnstone & Morrison Pty. Ltd.
1580. Kangaroo Flat, Technical School, supply guillotine and drilling machine, £274.—Goodall & Co. Pty. Ltd.
1581. Kangaroo Flat, Technical School, supply circular saw bench, £265.—A. & S. Wolfenden.
1582. Kangaroo Flat, Technical School, supply planing machine, £352 10s.—Charles Wolfenden & Co. Pty. Ltd.
1583. Port Melbourne, P.W.D. Storeyard, supply garbage bins, £537 10s.—Wilson Bros. Pty. Ltd.
1584. Burnley, Plant Research Laboratory, supply temperature cabinet, £389.—J. Davey.
1585. Beechworth, Mental Hospital, supply timber.—£420 15s.—Les. Grace.
1586. Mildura, Public Works Department, supply road base material, £433 6s. 8d.—Fraser & Adams.
1587. Bundoora, Mental Hospital, supply mattresses and covers, £1,189 9s.—Seafom Pty. Ltd.
1588. The Basin, State School, 2329, supply hardwood weatherboards, £268 3s. 9d.—James Wright & Sons Pty. Ltd.
1589. Port Melbourne, Mines Department Drill Store, supply shelving, £749 14s.—Steelbit (Vic.) Pty. Ltd.
1590. Burwood, "Allambie", supply electric stoves, £255 10s.—R. R. Wickers Pty. Ltd.
1591. Burwood, "Allambie", supply electrically heated press, £440.—E. G. A. (S. Cunningham) Pty. Ltd.
1592. Royal Park, "Turana" Welfare Centre, supply tables and chairs, £1,358 11s.—Sebal Sales Ltd.
1593. Brunswick, Transport Store, Police Department, supply unistrut type rack and R.U.T. shelving, £811 6s. 3d.—E. T. Brown Ltd.
1594. Beechworth, Mental Hospital, supply granite, gravel and sand, £281 5s.—Arthur Edward West.
1595. Sunshine North, Girls Technical School, supply sewing machines, £500.—Singer Sewing Machine Co.
1596. West Melbourne, Government Cool Stores, supply timber, £1,067 6s. 8d.—Millars Timber & Trading Co. Ltd.
1597. West Melbourne, Government Cool Stores, supply timber, £727 17s. 1d.—Mathews Timber Pty. Ltd.
1598. Melbourne, City Courts, supply furniture, £499 16s.—Emerson Bros. Pty. Ltd.
1599. Hawkesdale, High School, supply refrigerator, £252.—Warburton Franki Industries.
1600. Caulfield, Technical College, supply various items of joinery, £2,256 8s.—Kennett Bros. & Rayner Pty. Ltd.
1601. Warragul, Technical School, supply various items of joinery, £406.—Bera Cabinet Works.

1602. Sebastapol, Boys Technical School, supply furniture, £1,071 15s.—A. R. Dobbin.

1603. Mont Park, Gresswell Sanatorium, supply steam jacketed kettle.—£525.—J. Curtain & Son Pty. Ltd.

1604. Mont Park, Mental Hospital, "Larundel", supply sheeting and cotton moleton, £1,233 6s. 8d.—Hardie Trading Limited.

1605. Cheltenham, Heatherton Sanatorium, supply curtains.—£1,175 5s. 2d.—Hickman & Fisher Pty. Ltd.

1606. Port Melbourne, P.W.D. Storeyard, supply timber hardwood, £294.—Dwyer's Sawmills Pty. Ltd.

1607. Melbourne, Titles Office, supply and install shelving, £582 18s.—E. T. Brown Ltd.

1608. Langi Kal Kal, Training Centre, supply steel fence posts, £590 12s. 6d.—A. Arnold's Fences Pty. Ltd.

1609. Mildura, Public Works Department, supply screenings.—£1,057 10s.—P. Rocca.

H. R. PETTY, Commissioner of Public Works. 12.10.62.

#### ORDERS IN COUNCIL.—(Series 1962-63.)

##### EDUCATION DEPARTMENT.

1494. One only D.C. Dynamometer for Footscray Technical College, £402.—A. N. I. Perkins Pty. Ltd.

1495. One only Vickers Hardness Testing Machine for Royal Melbourne Institute of Technology, £595.—A. E. Supplies Pty. Ltd.

1496. One only Shear Box for Caulfield Technical College, £292.—J. J. Masur & Co. Pty. Ltd.

1497. One only Compression Test Machine for Caulfield Technical College, £955.—Westees (Vic.) Pty. Ltd.

1498. One only Consolidometer, £163 7s. 6d.; one only Triaxial Machine, £593; and one only Automatic Level, £201 for Caulfield Technical College.—Industrial and Scientific Supply Co.

1499. One only Mirror Stereoscope for Caulfield Technical College, £127 10s.—A. G. Barker and Associates Pty. Ltd.

1500. One only Balance for Caulfield Technical College, £118 11s.—W. & T. Avery (Aust.) Pty. Ltd.

Approved by the Governor in Council, 9th October, 1962.—N. G. WISHART, Clerk of the Executive Council.

##### STATE ELECTRICITY COMMISSION.

1610. For the construction of ancillary buildings, Hazelwood Power Station, to Specification No. 62-63/2, £345,394, plus additional work at Schedule rates.—Lewis Construction Co. Pty. Ltd.

1611. For the supply of copper to aluminium tee clamps for transmission lines, for a period of two years, to Specification No. 62-63/7, at Schedule rates.—Metal Products Pty. Ltd.

Approved by the Governor in Council, 18th September, 1962.—N. G. WISHART, Clerk of the Executive Council.

1612. For the supply of earthing electrodes and accessories for distribution system, for a period of two years, to Specification No. 62-63/28, at Schedule rates.—British Tube Mills (Aust.) Pty. Ltd.

1613. For the supply of linemen's rubber mats and protective sleeving, for a period of two years, to Specification No. 62-63/18, at Schedule rates.—Dunlop Rubber Australia Ltd.

1614. For the supply of indoor fuse boxes, for consumer installations, for a period of two years, to Specification No. 61-62/345, at Schedule rates.—Gordon Faine and Sons Pty. Ltd.

1615. For the supply of four rubber-tracked crawler tractors and attachments, Yallourn, to Specification No. 62-63/96, £18,462 7s. 7d.—Heytrack (Aust.) Pty. Ltd.

1616. For the supply of eleven 240-volt battery chargers for metropolitan terminal stations and sub-stations, to Specifications No. 62-63/47, £5,478.—McKenzie and Holland (Aust.) Pty. Ltd.

1617. For the supply of ten 22-kV voltage regulators and spare parts for distribution system, to Specification No. 61-62/280, £13,191.—Noyes Bros. Pty. Ltd.

1618. For the supply and installation of supervisory control cable between Telecommunication Workshop, South Melbourne, and Sub-station "AP", Albert Park, to Specification No. 62-63/69, at Schedule rates.—Siemens Henley Pty. Ltd.

1619. For the supply of pressure-treated pinus radiata timber, for fencing at Yallourn, to Quotation No. 423, £6,006 19s. 1d.—Strahan and Davies Pty. Ltd.

1620. For the supply of standard brackets and accessories for public lighting, for a period of one year, to Specification No. 61-62/344, at Schedule rates.—James Lyall.

1621. For the supply of standard brackets and accessories for public lighting, for a period of one year, to Specification No. 61-62/344, at Schedule rates.—Mitchell and Co. Pty. Ltd.

Approved by the Governor in Council, 25th September, 1962.—N. G. WISHART, Clerk of the Executive Council.

1622. For the supply of standard fittings for fire-fighting equipment, for a period of two years, to Specification No. 61-62/343, at Schedule rates.—Alloycraft Pty. Ltd.

1623. For preservative treatment of cooling tower timbers, Yallourn Power Station, to Quotation No. 851, £9,500.—Email Ltd.

1624. For the supply of 66 kV disconnecting switches and operating gear assemblies for metropolitan and country terminal stations and sub-stations, for a period of two years, to Specification No. 62-63/41, at Schedule rates.—Switchgear Pty. Ltd.

Approved by the Governor in Council, 2nd October, 1962.—N. G. WISHART, Clerk of the Executive Council.

#### COLAC WATERWORKS TRUST.

##### BY-LAW No. 4.

##### Colac Waterworks District—Fixing Charges for Water.

THE Colac Waterworks Trust, in pursuance and exercise of the powers conferred by the Water Acts, doth hereby make the By-law following:—

1. This By-law shall apply to and have force in the Waterworks District of the Colac Waterworks Trust except within any Urban District thereof and except to any property within such District to which, in the opinion of the Trust, water is supplied primarily for industrial or commercial purposes.

2. This By-law shall have effect after 30th day of September, 1962, and shall remain in force until expressly revoked.

3. Minimum annual charges for water supplied by measure from the works of the Trust, except in cases of special agreement with the Trust, shall be as set out in the Schedule hereto. Such charges shall be payable, on demand, at the office of the Colac Waterworks Trust, 2 Rae-street, Colac.

##### SCHEDULE.

Land on which there is a House.	Vacant Land.	Minimum Annual Charge.
Area not exceeding 1 acre	Area not exceeding 25 acres	£ 7 10 0
Area greater than 1 acre and not exceeding 25 acres	Area greater than 25 acres and not exceeding 75 acres	12 10 0
Area greater than 25 acres and not exceeding 75 acres	Area greater than 75 acres and not exceeding 150 acres	20 0 0
Area greater than 75 acres and not exceeding 150 acres	Area greater than 150 acres and not exceeding 300 acres	25 0 0
Area greater than 150 acres	Area greater than 300 acres	30 0 0

The minimum charges provide for one tapping only of the Trust's water main, and for each additional tapping there shall be a minimum annual charge of £5, except that in all cases where there is more than one residence upon the holding concerned there shall be an additional minimum annual charge of £7 10s. 0d. for each additional residence supplied, and that in such cases, if required, a further tapping to serve each additional house will be allowed without further increase in the annual charge.

4. The maximum allowance of water to be supplied per annum in respect of the minimum annual charge shall in each case be the quantity which, if charged for at Two shillings (2s.) per 1,000 gallons, would give an amount equal to such minimum annual charge, and for all water supplied in excess of such allowance the charge shall be Two shillings (2s.) per 1,000 gallons.

The foregoing By-law was made and passed by the Colac Waterworks Trust and the common seal of the said Trust affixed on the 24th day of September, 1962, in the presence of—

ARTHUR F. POTTER, Chairman.  
A. O. BILSON, Commissioner.  
E. J. ROBBINS, Secretary.

Approved by the Governor in Council, 16th October, 1962.—N. G. WISHART, Clerk of the Executive Council.

*Town and Country Planning Act 1961.*

## SHIRE OF SOUTH GIPPSLAND.

## INTERIM DEVELOPMENT ORDER.

*Notice of Approval.*

IN pursuance of the powers conferred by the *Town and Country Planning Act 1961*, the Governor in Council by and with the advice of the Executive Council thereof, on the 16th day of October, 1962, approved an Interim Development Order by the Council of the Shire of South Gippsland.

The Interim Development Order provides that the use or development of approximately the whole of the Shire of South Gippsland south of the South Gippsland Highway excluding the Wilson's Promontory National Park and the area covered by the Interim Development Order for Waratah Bay area which was approved by the Governor in Council on the 28th day of March, 1962, and the erection, construction and carrying out of any buildings or other works thereon is prohibited except that the responsible authority may permit such uses, development, erection, constructions or other works as provided in the order.

A copy of the Interim Development Order and a map showing the areas affected may be inspected free of charge at the office of the Council of the Shire of South Gippsland, at Foster, and at the Office of the Town and Country Planning Board, 61 Spring-street, Melbourne.

J. RENNICK, Shire Secretary.

*Town and Country Planning Act 1961.*

## SHIRE OF BASS.

## INTERIM DEVELOPMENT ORDER.

BY virtue of the powers conferred by the *Town and Country Planning Act 1961* and of every other power enabling it in that behalf, the Shire of Bass (hereinafter referred to as the Responsible Authority) having commenced the preparation of a planning scheme in accordance with the said Act on the 10th day of August, 1962, hereby makes the following Interim Development Order for the purpose of regulating, restricting, restraining or prohibiting the use or development of any land or the erection, construction or carrying out of any buildings or works, that is to say:—

1. Except in accordance with the provision of a permit issued by the Responsible Authority, no person shall use, subdivide or otherwise develop any land or erect, construct or carry out any buildings or works on any land within the area described in the First and Second Schedules hereto.

2. After the coming into operation of this Interim Development Order—

(a) No person shall subdivide any land in that part of the Shire of Bass described in the First Schedule hereto into allotments having an area of less than ten acres.

(b) No person shall subdivide into allotments any land in that part of the Shire of Bass described in the Second Schedule hereto except in accordance with the provisions of a permit issued by the Responsible Authority.

3. Notwithstanding the provisions of Clause 2 (a) hereof the Responsible Authority may permit a parcel of land lesser in area than is prescribed to be excised for the purpose of—

- (a) increasing the area of an existing allotment;
- (b) erecting one only additional dwelling house;
- (c) erecting a hall, church and building principally used for religious purposes;
- (d) erecting a school and buildings principally used for educational purposes; and
- (e) erecting a utility service structure, depot or works, constructed by a Government Department or Public Authority.

4. Nothing in this Interim Development Order shall prevent—

- (a) the continuance of the use of any land or of any existing building or works for the purposes for which the land, building or works was or were being lawfully used immediately before the coming into operation of this Order;
- (b) any dealing or the registration of any dealing with any land in any subdivision of which a plan has been sealed by the Council of the Shire of Bass and lodged with the Registrar of Titles, pursuant to section 569 of the *Local Government Act 1958*, before the coming into operation of this Order.

5. Every application for a permit under the provisions of this Order shall be made on the prescribed form, copies of which may be obtained from the Office of the Responsible Authority at Dalyston.

## FIRST SCHEDULE.

All land in the municipal district of the Shire of Bass, except the areas of land described in the Second Schedule hereto.

## SECOND SCHEDULE.

All land in the municipal district of the Shire of Bass, comprising the Townships of Grantville, Corinella, Bass, San Remo and Kilcunda.

In witness whereof, the Common Seal of the President, Councillors and Ratepayers of the Shire of Bass, was hereto affixed this 17th day of August, 1962, in the presence of—

(SEAL) V. R. LOVE, President.  
JOHN W. HOWARD, Councillor.  
H. BUTTERWORTH, Shire Secretary.

Report by the Town and Country Planning Board on the 22nd day of August, 1962. Recommended for approval. —FRED. C. COOK, Chairman.

Approved by the Governor in Council, pursuant to section 17 of the *Town and Country Planning Act 1961*, on the 16th day of October, 1962.

N. G. WISHART,  
Clerk of the Executive Council.

*Town and Country Planning Act 1961.*

## CITY OF SHEPPARTON PLANNING SCHEME 1953.

## AMENDMENT No. 6, 1962.

*Notice of Amendment.*

IN pursuance of the powers conferred by sub-section 6 of section 32 of the *Town and Country Planning Act 1961*, the Governor in Council, by and with the advice of the Executive Council thereof, on the 16th October, 1962, amended the City of Shepparton Planning Scheme 1953 to include skin-drying sheds in the permissible uses in the Industrial "C" Zone.

A copy of the amendment may be inspected during office hours at the office of the Town and Country Planning Board, 61 Spring-street, Melbourne; at the office of the council of the City of Shepparton; and when available, at the Office of Titles, Melbourne; and at the Central Plan Office of the Department of Crown Lands and Survey, Melbourne.

W. H. CRAIG, Secretary,  
Town and Country Planning Board.

## Town and Country Planning Acts.

## CITY OF PRESTON.

## INTERIM DEVELOPMENT ORDER.

BY virtue of the powers conferred by the *Town and Country Planning Acts* and of every other power enabling it in that behalf, the City of Preston (hereinafter referred to as the responsible authority), having commenced the preparation of a planning scheme in accordance with the said Act on the 18th day of February, 1952, hereby makes the following Interim Development Order for the purpose of regulating, restricting, restraining or prohibiting the use or development of any land or the erection, construction or carrying out of any buildings or works on any land within the area described or shown on the map as the Schedule hereto.

1. After the coming into operation of this Interim Development Order no person shall use or develop any land or erect, construct or carry out any buildings or works on any land within the area included in the Schedule, except in accordance with the provisions of a permit issued by the responsible authority.

2. Any application for a permit to use or develop any land or to erect, construct or carry out any buildings or works, shall be accompanied by a sketch, plan or copy of certificate of title of the land, and a description of the proposed use or development, and type and construction of any buildings or works proposed to be erected, constructed or carried out and such other particulars relating to the application as the responsible authority may require.

3. This Interim Development Order shall not prevent the continuance of the use of any land or buildings for the purpose for which such land or buildings were lawfully used immediately before the coming into operation of this order.

4. *Schedule*.—The whole of the municipal district of the City of Preston.

(SEAL) C. P. W. KIRBY, Mayor.  
A. H. CAPP, Councillor.  
J. C. DONATH, Town Clerk.

Report by the Town and Country Planning Board on the 12th day of September, 1957. Recommended for approval.—FRED C. COOK, Chairman.

Approved by the Governor in Council on the 17th day of September, 1957.—A. MAHLSTEDT, Clerk of the Executive Council.

Report by the Town and Country Planning Board on the 4th day of September, 1958. Recommended for approval pursuant to section 5 of the *Town and Country Planning (Metropolitan Area) Act 1954* (No. 5834).—FRED C. COOK, Chairman.

Approved by the Governor in Council pursuant to section 5 of the *Town and Country Planning (Metropolitan Area) Act 1954* (No. 5834). Dated this 17th day of September, 1958.—N. G. WISHART, Acting Clerk of the Executive Council.

Report by the Town and Country Planning Board on the 26th day of August, 1959. Recommended for approval pursuant to section 34 of the *Town and Country Planning Act 1958*.—FRED C. COOK, Chairman.

Approved by the Governor in Council pursuant to section 34 of the *Town and Country Planning Act 1958*. Dated this 15th day of September, 1959.—A. MAHLSTEDT, Clerk of the Executive Council.

Report by the Town and Country Planning Board on the 9th day of September, 1960. Recommended for approval pursuant to section 34 of the *Town and Country Planning Act 1958*, as amended.—FRED C. COOK, Chairman.

Approved by the Governor in Council pursuant to section 34 of the *Town and Country Planning Act 1958*, as amended. Dated this 20th day of September, 1960.—A. MAHLSTEDT, Clerk of the Executive Council.

Report by the Town and Country Planning Board on the 4th day of September, 1961. Recommended for approval pursuant to section 34 of the *Town and Country Planning Act 1958*, as amended.—FRED C. COOK, Chairman.

Approved by the Governor in Council pursuant to section 34 of the *Town and Country Planning Act 1958*, as amended. Dated this 18th day of September, 1961.—N. G. WISHART, Acting Clerk of the Executive Council.

Report by the Town and Country Planning Board on the 19th day of September, 1962. Recommended for approval pursuant to section 55 of the *Town and Country Planning Act 1961*.—FRED C. COOK, Chairman.

Approved by the Governor in Council pursuant to section 55 of the *Town and Country Planning Act 1961*. Dated this 9th day of October, 1962.—N. G. WISHART, Clerk of the Executive Council.

#### Melbourne and Metropolitan BOARD OF WORKS.

**NOTICE** is hereby given that after the publication of this advertisement in the *Government Gazette* and once in not less than two daily newspapers published in the metropolis, the Melbourne and Metropolitan Board of Works will proceed to compulsorily take (unless the same is in the meantime acquired by the Board from the owner or owners or other person interested by mutual agreement) the land mentioned and described in the Schedule hereto.

The nature of the works in respect of which the land is proposed to be taken is for the purposes in connexion with a proposed sewer.

A plan of the proposed works will be open for inspection at the offices of the Board, 110 Spencer-street, Melbourne, from the date hereof until the 31st October, 1962, during office hours.

The quantity of land which the Board requires for the purpose of such works and other particulars are set forth below.

The consent of the Governor in Council was duly obtained in terms of the Board's principal Act (No. 6310), on the 18th September, 1962.

#### SCHEDULE.

All that piece of land, being part of Crown allotment 7, section 1, Parish of Mordialloc, County of Bourke, commencing at a point in the northern boundary of the said allotment 187 ft. 2½ in. west of the western boundary of Cameron-avenue; thence further westerly along the first-mentioned boundary for 114 ft. 2 in.; thence southerly by a line bearing 179 deg. 13½ min. for 124 ft. 8 in.; thence easterly by lines bearing 89 deg. 36 min. for 55 feet and 113 deg. 24 min. for 64 ft. 8 in.; thence northerly by a line bearing 359 deg. 12 min. for 149 ft. 6 in. to the commencing point and containing an area of 2 roods 29 6/10 perches.

Dated the 8th day of October, 1962.

H. J. SNADDEN, Secretary.

#### Victorian Railways.

#### VICTORIAN RAILWAYS COMMISSIONERS.

BY-LAW No. 386.

*Amendments to By-law No. 351.*

**THE** Victorian Railways Commissioners in the exercise of the powers conferred upon them by the Railways Act, do hereby amend By-law No. 351, as follows:—

#### PART II.—PROVISIONS RELATING TO TICKETS

By inserting the following additional clause:—

12A. A person in possession of a ticket entitling him to suburban travel only shall not take a seat or travel in a first-class carriage of a country train notwithstanding that passengers for suburban travel are conveyed by that train.

Penalty: Twenty pounds.

In witness whereof the common seal of The Victorian Railways Commissioners was affixed hereto this thirteenth day of September, One thousand nine hundred and sixty-two, in the presence of—

(SEAL) E. H. BROWNBILL } Victorian  
E. P. ROGAN } Railways  
Commissioners.

Approved by the Governor in Council, 9th October, 1962.—N. G. WISHART, Clerk of the Executive Council.

#### AUCTION SALES ACT.

**CHARLTON**.—Notice is hereby given that the Annual Meeting of Justices for the licensing of auctioneers will be held at the Court House, at Charlton, on Tuesday, the 27th day of November, 1962, at the hour of Ten o'clock in the forenoon. Dated the 12th day of October, 1962.—ROBIN N. COURTS, Clerk of Petty Sessions.

**HORSHAM**.—Notice is hereby given that the Annual Meeting of Justices for the licensing of auctioneers will be held at the Court House, Horsham, on Tuesday, the 27th day of November, 1962, at the hour of Ten o'clock in the forenoon. Dated the 12th day of October, 1962.—J. M. DUFFY, Clerk of Petty Sessions.

**KERANG**.—Notice is hereby given that the Annual Meeting of Justices for the licensing of auctioneers will be held at the Court House, Kerang, on Tuesday, the 27th day of November, 1962, at Ten o'clock in the forenoon. Dated the 9th October, 1962.—R. J. CANNING, Clerk of Petty Sessions.

**KYNETON**.—Notice is hereby given that the Annual Meeting of Justices for the licensing of auctioneers will be held at the Court House, Kyneton, on Tuesday, the 27th day of November, 1962, at Ten o'clock in the forenoon.—G. W. THOMPSON, Clerk of Petty Sessions.

**MARYBOROUGH**.—Notice is hereby given that the Annual Meeting of Justices for the licensing of auctioneers will be held at the Court House, Maryborough, on Tuesday, the 27th November, 1962, at Ten o'clock in the forenoon. Dated the 4th day of October, 1962.—V. G. STAFFORD, Clerk of Petty Sessions.

**MELBOURNE.**—Notice is hereby given that the Annual Meeting of Justices for the licensing of auctioneers will be held at the City Court, Russell-street, Melbourne, on Tuesday, the 27th November, 1962, at Ten o'clock in the forenoon. Dated the 8th day of October, 1962.—W. H. JOHNSTON, Clerk of Petty Sessions.

**SEA LAKE.**—Notice is hereby given that the Annual Meeting of Justices for the licensing of auctioneers will be held at the Court House, at Sea Lake, on Tuesday, the 27th day of November, 1962, at the hour of Ten-thirty o'clock in the forenoon. Dated the 12th day of October, 1962.—ROBIN N. COURTS, Clerk of Petty Sessions.

**WEDDERBURN.**—Notice is hereby given that the Annual Meeting of Justices for the licensing of auctioneers will be held at the Court House, at Wedderburn, on Tuesday, the 27th day of November, 1962, at the hour of Ten o'clock in the forenoon. Dated the 12th day of October, 1962.—ROBIN N. COURTS, Clerk of Petty Sessions.

**WYCHEPROOF.**—Notice is hereby given that the Annual Meeting of Justices for the licensing of auctioneers will be held at the Court House, at Wycheproof, on Tuesday, the 27th day of November, 1962, at the hour of Ten o'clock in the forenoon. Dated the 12th day of October, 1962.—ROBIN N. COURTS, Clerk of Petty Sessions.

*Marketing of Primary Products Act 1958.*

**ELECTION NOTICE—MAIZE MARKETING BOARD.**

NOTICE is hereby given that I have appointed Friday, the 2nd November, 1962, as the day for nominations of candidates for election as producers' representatives of the Maize Marketing Board.

Nominations in the prescribed form must be lodged before noon on the day of nomination with the Returning Officer, Mr. H. E. Job, Commercial Officer, Department of Agriculture, Melbourne.

G. L. CHANDLER,  
Minister of Agriculture.

**NAGAMBIE WATERWORKS TRUST.**

**RATING BY-LAW FOR 1962.**

**THE Nagambie Waterworks Trust**, in pursuance and exercise of the powers conferred by the Water Acts, doth hereby make a rate for the supply of water for domestic purposes of One shilling and six pence in the pound of the annual municipal valuation of lands and tenements liable to be rated within the Nagambie Urban District.

Provided that in no case shall the amount of rate payable per annum in respect of any tenements (other than land on which there is no building) be less than Fifty shillings, and in respect of any land on which there is no building less than Thirty shillings.

Such rates are made and shall be levied upon the occupiers or owners of the said land and tenements for the year commencing the 1st day of January, 1962, and shall be payable on the 1st day of November, 1962, at the office of the said Trust.

The maximum quantity of water to be supplied in any one year without further charge to any property rated by the Trust is hereby fixed at the quantity which, at a charge of One shilling and six pence per 1,000 gallons, would produce an amount equal to the amount of rate levied on such property for the said year.

The charge for water supplied by measure to any property rated by the Trust in excess of such maximum quantity, computed as in the last preceding clause, is hereby fixed at One shilling and six pence per 1,000 gallons.

The charge for water supplied by measure to any property not rated by the Trust is hereby fixed at One shilling and six pence per 1,000 gallons, and the minimum quantity of water to be charged for in cases where water is so supplied is hereby fixed at 140,000 gallons.

The charge for water supplied by measure shall be payable, on demand, at the office of the Trust.

Passed the 1st day of October, 1962.

(SEAL) D. H. COULTER, Chairman.  
F. M. CHAPMAN, Secretary.

Approved, 10th October, 1962.—W. J. MIBUS, Minister of Water Supply.

**LEARMONTH WATERWORKS TRUST.**

**RATING BY-LAW FOR THE YEAR 1962.**

**THE Learmonth Waterworks Trust**, in pursuance and exercise of the powers conferred by the Water Acts, doth hereby make a rate for the supply of water for domestic purposes of Two shillings and eleven pence in the pound of the annual municipal valuation of lands and tenements liable to be rated within the Learmonth Water Supply District.

Provided that in no case shall the amount of rate payable per annum in respect of any tenement (other than land on which there is no building) be less than Five pounds sixteen shillings and eight pence, and in respect of any land on which there is no building less than Sixteen shillings and eight pence.

Such rates are made and shall be levied upon the occupiers or owners of the said lands and tenements for the period commencing on the 1st day of March, 1962, and ending on the 31st day of December, 1962, and shall be payable on the 15th day of November, 1962, at the office of the said Trust.

The maximum quantity of water to be supplied in any one year without further charge to any property rated by the Trust is hereby fixed at the quantity which, at a charge of Two shillings and six pence per 1,000 gallons, would produce an amount equal to the amount of rate levied on such property for the said period.

The charge for water supplied by measure to any property rated by the Trust in excess of such maximum quantity, computed as in the last preceding clause, is hereby fixed at Two shillings and six pence per 1,000 gallons.

The charge for water supplied by measure to any property not rated by the Trust is hereby fixed at Two shillings and six pence per 1,000 gallons, and the minimum quantity of water to be charged for in cases where water is so supplied is hereby fixed at 46,000 gallons.

The charge for water supplied by measure shall be payable, on demand, at the office of the Trust.

Passed this 24th day of September, 1962.

(SEAL) E. EDWARDS, Chairman.  
J. B. DEAN, Commissioner.  
F. S. MCGRAW, Secretary.

Approved, 9th October, 1962.—W. J. MIBUS, Minister of Water Supply.

**WARRACKNABEAL WATERWORKS TRUST.**

**ANNUAL BALANCE.**

**HIS Excellency the Governor of the State of Victoria**, by and with the advice of the Executive Council thereof, doth, by Order made on the 16th day of October, 1962, in pursuance of the provisions of the Water Acts, fix the 30th day of September in each year, as from the 1st January, 1963, as the day to which the accounts of the Warracknabeal Waterworks Trust shall be balanced.

N. G. WISHART,  
Clerk of the Executive Council.

At Government House,  
Melbourne, 16th October, 1962.

**HAMILTON WATERWORKS TRUST.**

**ANNUAL BALANCE.**

**HIS Excellency the Governor of the State of Victoria**, by and with the advice of the Executive Council thereof, doth, by Order made on the 16th day of October, 1962, in pursuance of the provisions of the Water Acts, fix the 30th day of September in each year, as from 1st January, 1963, as the day to which the accounts of the Hamilton Waterworks Trust shall be balanced.

N. G. WISHART,  
Clerk of the Executive Council.

At Government House,  
Melbourne, 16th October, 1962.

**MINERS REST WATERWORKS TRUST.**

**FIXING THE LIMIT OF BANK OVERDRAFT.**

**HIS Excellency the Governor of the State of Victoria**, by and with the advice of the Executive Council thereof, doth, by Order made on the 16th October, 1962, in pursuance of the provisions of section 288 of the Water Act 1958 (No. 6413), fix the limit of the overdraft to be



obtained by the Miners Rest Waterworks Trust from the National Bank of Australasia Limited, Learmonth, at an amount not to exceed at any one time the sum of Six thousand pounds (£6,000).

N. G. WISHART,  
Clerk of the Executive Council.

At Government House,  
Melbourne, 16th October, 1962.

WODONGA WATERWORKS TRUST.  
AUTHORITY TO OBTAIN BANK OVERDRAFT.

HIS Excellency the Governor of the State of Victoria, by and with the advice of the Executive Council thereof, doth by Order made on the 16th day of October, 1962, authorize the Wodonga Waterworks Trust to obtain, in pursuance of the provisions of section 286 of the *Water Act 1958* (No. 6413) an advance or advances during the year ending 30th September, 1963, from the Commercial Banking Company of Sydney Limited, Wodonga, by overdraft of the Trust's current account thereat, such overdraft not to exceed at any one time the sum of Five thousand pounds (£5,000).

N. G. WISHART,  
Clerk of the Executive Council.

At Government House,  
Melbourne, 16th October, 1962.

LAW DEPARTMENT—ATTORNEY-GENERAL.  
COURT OF PETTY SESSIONS AT HARROW.—DAYS  
AND HOURS APPOINTED.

HIS Excellency the Governor of the State of Victoria, by and with the advice of the Executive Council thereof, doth by Order made on the 16th day of October, 1962, pursuant to the provisions of section 64 of the *Justices Act 1958*, appoint the days and hours contained in the Schedule below for the holding of the Court of Petty Sessions at the place named in such Schedule, in lieu of the days and hours heretofore appointed, to take effect as from the dates shown.

SCHEDULE.

Place.	Days and Hours.
Harrow .. .. .	every Tuesday at 2 p.m. and every fourth Wednesday at 2 p.m., as from 24th October, 1962.

N. G. WISHART,  
Clerk of the Executive Council.

At Government House,  
Melbourne, 16th October, 1962.

LAW DEPARTMENT.  
APPOINTMENT OF ARBITRATOR.

HIS Excellency the Governor of the State of Victoria, by and with the advice of the Executive Council thereof, doth by Order made on the 16th day of October, 1962, appoint His Honour Judge Benjamin James Dunn, a Judge of the County Court, to be an Arbitrator, pursuant to the provisions of section 840 of the *Local Government Act 1958*, as applied by sub-section 2 of section 27 of the *Town and Country Planning Act 1958*, to determine the compensation payable, pursuant to the said section 27, to Violet Mary Phillips, of 258 Warrigal-road, South Oakleigh, in respect of all that piece of land being lot 17 on plan of subdivision No. 8490, lodged in the Office of Titles, and being the land described in certificate of title, volume 6795, folio 813.

N. G. WISHART,  
Clerk of the Executive Council.

At Government House,  
Melbourne, 16th October, 1962.

Country Fire Authority Act.  
PERMISSION TO HOLD FIRE BRIGADE  
DEMONSTRATION.

IN pursuance with the provisions of section 103 of the *Country Fire Authority Act 1958*, the Country Fire Authority has granted permission for the holding of a fire brigade demonstration as under:—

URBAN FIRE BRIGADES.

At Warragul, on Saturday, 24th November, 1962.

J. L. ALLEN,  
Secretary.

Country Fire Authority Act.  
PERMISSION TO HOLD FIRE BRIGADE  
DEMONSTRATION.

IN pursuance with the provisions of section 103 of the *Country Fire Authority Act 1958*, the Country Fire Authority has granted permission for the holding of a fire brigade demonstration as under:—

URBAN FIRE BRIGADES.

At Springvale, on Saturday, 1st December, 1962.

J. L. ALLEN,  
Secretary.

12th October, 1962.

SHIRE OF YARRAWONGA.

ORDER CONFIRMED.

THE Minister of the Crown administering the *Local Government Act 1958*, as amended, on the third day of October, 1962, confirmed the Order hereinafter referred to in pursuance of section 514 of the said Act, namely:—

An order of the Council of the Shire of Yarrawonga made on the 3rd July, 1962, for the purpose of the opening and making of a new road 1 chain wide through Crown allotment 9, section B, Parish of Pelluebla, and for acquiring for that purpose all that piece of land situate in the Parish of Pelluebla, County of Moira, being part of Crown allotment 9, section B, commencing at a point on the southern boundary of the said Crown allotment 9, distant 1,935 9/10 links from the south-western corner of the said Crown allotment and bounded thence on the west by a line bearing 0 deg. 05 min. 40 sec. 6,798 1/10 links; thence on the north by a line forming part of a northern boundary of the said Crown allotment bearing 90 deg. 0 min. 100 links on the east by a line bearing 180 deg. 05 min. 40 sec. 6,798 1/10 links and on the south by part of the southern boundary of the said Crown allotment bearing 270 deg. 02 min. 100 links to the point of commencement, and containing an area of 6 acres 3 roods 7 7/10 perches, or thereabouts.

M. V. PORTER,  
Minister for Local Government.

LOCAL GOVERNMENT DEPARTMENT.

SHIRE OF BACCHUS MARSH.—ORDER CONFIRMED.

THE Minister of the Crown administering the *Local Government Act 1958*, as amended, on the 9th day of October, 1962, confirmed the Order hereinafter referred to in pursuance of section 514 of the said Act, namely:—

An Order of the Council of the Shire of Bacchus Marsh made on the 10th September, 1962, for providing certain lands for the dual purpose of draining adjoining lands and for use as places of public resort and recreation and for acquiring for those purposes the land described in certificates of title, volume 4602, folio 353, and volume 4432, folio 396.

M. V. PORTER,  
Minister for Local Government.

Local Government Department.  
Melbourne.

LOCAL GOVERNMENT DEPARTMENT.

CITY OF HEIDELBERG.—ORDER CONFIRMED.

THE Minister of the Crown administering the *Local Government Act 1958*, as amended, on the 8th day of October, 1962, confirmed the Order hereinafter referred to in pursuance of section 514 of the said Act, namely:—

An Order of the Council of the City of Heidelberg made on the 3rd September, 1962, for the purpose of providing a place of public resort and recreation at Diamond Creek and for acquiring for that purpose all that piece of land being the land described in certificate of title, volume 2857, folio 207.

M. V. PORTER,  
Minister for Local Government.

Local Government Department.  
Melbourne.



## DEPARTMENT OF MINES.

**SUBJECT** to any necessary excisions, &c., it is proposed to grant the following mining leases:—

- 8348, Beechworth; Ronald Brian Bell; 33a. 2r. 27p., Parish of Malkara.  
7111, Maryborough; Welcome Sutton; 667a. 2r. 20p., Parishes of Tchuterr and Wehla.

## MINING LEASE GRANTED.

- 8076, Mineral; Arthur Vincent Marshall; 6a. 3r. 6p., Parish of Glennaggie.

## TERM OF PETROLEUM PROSPECTING LICENCE EXTENDED.

- 248, Petroleum Prospecting Licence; Arco Limited and Oilco Limited; 141 square miles, Parishes of Bumberrah, Colquhoun, Tambo, Sarsfield and Wy Yung.

## TAILINGS LICENCES GRANTED.

- 3194, Tailings Licence; The President, Councillors and Ratepayers of the Shire of Chiltern; Parishes of Chiltern and Chiltern West (in lieu of Tailings Licence No. 2977, expired).  
3195, Tailings Licence; John Doyle and Robert Leo Doyle; Parish of Huntly (in lieu of Tailings Licence No. 3101, expired).  
3196, Tailings Licence; John Doyle and Robert Leo Doyle; at Eaglehawk (in lieu of Tailings Licence No. 3129, expired).  
3197, Tailings Licence; John Doyle and Robert Leo Doyle; at California Gully (in lieu of Tailings Licence No. 3130, expired).  
3198, Tailings Licence; John Doyle and Robert Leo Doyle; at Bendigo (in lieu of Tailings Licence No. 3131, expired).  
3199, Tailings Licence; John Doyle and Robert Leo Doyle; at Bendigo (in lieu of Tailings Licence No. 3132, expired).  
3200, Tailings Licence; John Doyle and Robert Leo Doyle; north of Huntly (in lieu of Tailings Licence No. 3134, expired).  
3201, Tailings Licence; The Mayor, Councillors and Citizens of the City of Bendigo; Parish of Sandhurst (in lieu of Tailings Licence No. 2979, expired).  
3203, Tailings Licence; The President, Councillors and Ratepayers of the Shire of Maldon (in lieu of Tailings Licence No. 2965, expired).

W. J. MIBUS,  
Minister of Mines.

## MINING LEASE DECLARED VOID.

- 7600, Mineral; Henry Bowers; 1a. 1r. 37p., Parish of Bulla Bulla.

E. CONDON,  
Secretary for Mines.

## PUBLIC TRUSTEE ACT 1958 (No. 6350), SECTION 17.

**I** HEREBY give notice that on the 1st October, 1962, the Public Trustee filed elections to administer the following deceased persons' estates in accordance with section 17 of the *Public Trustee Act 1958*:—

BROMLEY, HENRY DAVID, late of 80 Wilson-street, North Carlton, plasterer, died 28th July, 1956.

CHENU, VERA EILEEN, also known as Vera Eileen Chenn, late of 33 Bromby-street, South Yarra, widow, died 6th July, 1962.

CORKE, THOMAS, late of 529 King-street, West Melbourne, no occupation, died 5th August, 1962.

**I** HEREBY give notice that on the 3rd October, 1962, the Public Trustee filed elections to administer the following deceased persons' estates in accordance with section 17 of the *Public Trustee Act 1958*:—

BAILLIE, JAMES WILLIAM, late of Warrnambool and District Base Hospital, Warrnambool, pensioner, died 24th May, 1962.

CALLAGHAN, HELENA, late of 2A Moonga-road, Toorak, pensioner, died 21st July, 1962.

EVANS, FRANCES MAUDE, late of Mont Park, widow, died 14th May, 1962.

GRANT, WILLIAM, formerly of 2 Ferndale-road, Upper Fern Tree Gully, but late of 15 McCully-street, Ascot Vale, retired blacksmith, died 20th August, 1962.

SILK, EDWIN KEMPTON, formerly of 25 Thames-street, Box Hill, but late of Irvine-street, Mount Evelyn, retired master baker, died 17th July, 1962.

SMITH, MARY AGNES, late of Mount Royal, Parkville, pensioner, died 9th May, 1962.

SOLAZZO, MARY, also known as Maria Solazzo, late of 18 Davies-street, West Preston, married woman, died 21st April, 1962.

SOLOMON, ROY PHILLIP, formerly of New Treasury Hotel, Spring-street, Melbourne, but late of 12 Parliament-place, East Melbourne, retired motor engineer, died 24th March, 1962.

WILLIAMS, JOHN, late of 34 Little Bourke-street, Melbourne, handyman, died 20th June, 1962.

ZUPCIC, JOSEPH, also known as Joseph Zupcac, late of Walker's Mill, Shelley, via Walwa, sawmill hand, died 5th January, 1962.

A. D. DUNCAN,  
Public Trustee.

21 Degraives-street, Melbourne, 10th October, 1962.

## NOTICE.

**CREDITORS**, next of kin and others having claims against the estate of any of the under-mentioned deceased persons are required to send particulars of their claims to the Public Trustee, 21 Degraives-street, Melbourne, the personal representative, on or before the 20th December, 1962, after which date the Public Trustee may convey or distribute the assets, having regard only to the claims of which the Public Trustee then has notice:—

BAILEY, HENRY STEPHEN, late of "Risdon", 62 Alma-road, St. Kilda, retired manager, died 26th July, 1962.

BAILLIE, JAMES WILLIAM, late of Warrnambool and District Base Hospital, Warrnambool, pensioner, died 24th May, 1962.

BALL, MARGARET FRANCES, late of 51 Napier-street, Footscray, school teacher, died 15th July, 1962.

BARROWS, RICHARD THOMAS, late of Melbourne Home and Hospital for Aged, Cheltenham, pensioner, died 13th July, 1962.

BELLAMY, ADA MAY, late of 6 Newington-grove, Caulfield, widow, died 5th August, 1962.

BOAL, GEOFFREY THOMAS, late of 53 Grange-road, Sandringham, inspector of police, died 14th July, 1962.

BROMLEY, HENRY DAVID, late of 80 Wilson-street, North Carlton, plasterer, died 28th July, 1956.

CALLAGHAN, HELENA, late of 2A Moonga-road, Toorak, pensioner, died 21st July, 1962.

CHENU, VERA EILEEN, also known as Vera Eileen Chenn, late of 33 Bromby-street, South Yarra, widow, died 6th July, 1962.

CORKE, THOMAS, late of 529 King-street, West Melbourne, no occupation, died 5th August, 1962.

CROMPTON, MADELINE WILLENA, late of 30 Empire-street, Footscray, public servant, died 30th June, 1962.

DONOHUE, ELLEN, late of 41 Charles-street, Burwood, widow, died 27th June, 1962.

EVANS, FRANCES MAUDE, late of Mont Park, widow, died 14th May, 1962.

GRANT, WILLIAM, formerly of 2 Ferndale-road, Upper Fern Tree Gully, but late of 15 McCully-street, Ascot Vale, retired blacksmith, died 20th August, 1962.

HUMPHRIES, MINNIE EMELINE, late of 23 Beaconsfield-road, Briar Hill, spinster, died 16th June, 1962.

LAILEY, BERTHA, late of 21 Alexandra-street, East St. Kilda, widow, died 3rd March, 1962.

MARSHALL, ALFRED GEORGE, late of 22 Alfreton-street, Southwark, London, England, widower, died 2nd December, 1955.

MARSHALL, HENRY OLIVER, late of 36 Ponsonby-place, London, S.W.1, widower, died 9th February, 1951.

MCDONALD, DONALD, late of 411 Riversdale-road, Hawthorn, retired public servant, died 18th July, 1962.

MACKINNON, JOHN FRANCIS NORMAN, late of 97 Latrobe-terrace, Geelong, pensioner, died 25th May, 1962.

MENEIL, MARY MURRAY, in the will called Mary McNeil, formerly of 8 Victory-street, Mitcham, and 13 Freeman-street, Ringwood East, but late of 494 Gilbert-road, West Preston, widow, died 18th July, 1962.

NIGHTINGALE, RAY JOHN, late of Wellington, New Zealand, organizer, died 26th November, 1961.

PREST, THOMAS LESLIE, formerly of 30 George-street, North Hobart, Tasmania, but late of 17 Atkins-street, Kew, carpenter, died 26th January, 1962.

SHARP, FRED, also known as Frederick Sharp, formerly of Ocean View-avenue, Kallista, and 20 Golf Links-road, Glenroy, but late of 32 Mutton-grove, Fawkner, pensioner, died 23rd April, 1962.

SILK, EDWIN KEMPTON, formerly of 25 Thames-street, Box Hill, but late of Irvine-street, Mount Evelyn, retired master baker, died 17th July, 1962.

SMITH, MARY AGNES, late of Mount Royal, Parkville, pensioner, died 9th May, 1962.

SOLAZZO, MARY, also known as Maria Solazzo, late of 18 Davies-street, West Preston, married woman, died 21st April, 1962.

SOLOMON, ROY PHILLIP, formerly of New Treasury Hotel, Spring-street, Melbourne, but late of 12 Parliament-place, East Melbourne, retired motor engineer, died 24th March, 1962.

TREZISE, ISABELLA, formerly of 16 Sydenham-street, West Footscray, but late of Mount Royal, Parkville, widow, died 19th June, 1962.

TURNER, JOHN RIGBY, formerly of care of Geelong Grammar School, Corio, but late of McLelland-avenue, Lara, retired storeman, died 27th June, 1962.

UNDERWOOD, THOMAS KERR, late of 59 Tennyson-street, Moonee Ponds, retired butcher, died 14th July, 1962.

WARBURTON, FLORENCE VIOLET, late of 50 Ebdon-street, Elsternwick, married woman, died 1st July, 1962.

WHITLEY, ALFRED, late of Ferndale-road, Upper Fern Tree Gully, retired policeman, died 14th July, 1962.

WILLIAMS, JOHN, late of 34 Little Bourke-street, Melbourne, handyman, died 20th June, 1962.

ZUPCIC, JOSEPH, also known as Joseph Zupcac, late of Walker's Mill, Shelley, via Walwa, sawmill hand, died 5th January, 1962.

A. D. DUNCAN,  
Public Trustee.

Melbourne, 10th October, 1962.

#### SEWERAGE AUTHORITIES.

##### APPOINTMENT OF AUDITORS.

HIS Excellency the Governor of the State of Victoria, by and with the advice of the Executive Council thereof, doth by Order made on the 16th day of October, 1962, pursuant to the provisions of the *Sewerage Districts Act 1958* (No. 6368), appoint the persons named in the Schedule attached, being Auditors holding certificates of competency from the Municipal Auditors' Board under the *Local Government Act 1958*, to audit and report on the accounts of the Sewerage Authority set opposite their names, for the years as shown.

##### SCHEDULE.

#### SEWERAGE AUTHORITY AUDITS.

Auditors appointed to conduct an audit of the accounts of Sewerage Authorities for the years as shown hereunder.

Authority.	Year Ended.	Name of Auditor.
Camperdown ..	30.9.62	V. Clayton, 77 Kennedy-street, Hamilton
Werribee ..	30.9.62	L. M. Hickman, 45 Wonga-road, Ringwood
	<i>Year Ending.</i>	
Corryong ..	31.12.62	I. K. MacKinnon, 455 Toorak-road, Toorak
St. Arnaud ..	31.12.62	P. Pescod, c/o C. Marquand & Son, 51 Queen-street, Melbourne
Tallangatta ..	31.12.62	I. K. MacKinnon, 455 Toorak-road, Toorak
Tatura ..	31.12.62	R. H. Sullivan, 42 Berry-street, East Melbourne
Yarram ..	31.12.62	E. A. Faulkner, Box 47, Yarram

N. G. WISHART,  
Clerk of the Executive Council.

At Government House,  
Melbourne, 16th October, 1962.

#### APPOINTMENTS.

HIS Excellency the Governor of the State of Victoria, by and with the advice of the Executive Council thereof, has, by Orders made on the 9th day of October, 1962, been pleased to make the under-mentioned appointments, viz.:

##### CHIEF SECRETARY'S DEPARTMENT.

##### *Electoral Registrars (Acting).*

WILLIAM DAVID MILLAR  
to be Electoral Registrar (Acting) for the Caulfield West, Elsternwick North, Ripponlea and St. Kilda North Subdivisions of the Electoral District of Ripponlea; and for

the St. Kilda, St. Kilda Park and St. Kilda West Subdivisions of the Electoral District of St. Kilda, to take effect on and from the 8th October, 1962, during the absence on leave of Edward Joseph Goodwin.

##### PETER CARL SCAMMELL

to be Electoral Registrar (Acting) for the Bentleigh and Moorabbin Subdivisions of the Electoral District of Moorabbin; and for the Highett and Sandringham Subdivisions of the Electoral District of Sandringham, to take effect on and from the 5th September, 1962, during the absence, on leave, of Nicholas Michael O'Donnell; and

##### VICTOR ERNEST SPARK

to be Electoral Registrar (Acting) for the Footscray and Footscray North Subdivisions of the Electoral District of Footscray; and for the Kingsville, Newport, Yarraville and Yarraville West Subdivisions of the Electoral District of Yarraville, to take effect on and from the 24th September, 1962, during the absence on leave of Douglas Stamler Taylor.

#### HEALTH DEPARTMENT.

##### *Secretary of Mental Hospital.*

##### KELVIN CHARLES TURNER

to be Secretary, Mental Hospital and Receiving House, Ballarat, pursuant to the provisions of sections 39 and 45 of the *Mental Hygiene Act 1958*, as from and inclusive of 15th October, 1962, vice Allan Bayne, retired.

#### HOSPITALS AND CHARITIES COMMISSION.

##### *Government Representative on Hospital Committee.*

##### GEORGE HAYES LIMB

to be Government Representative on the Committee of Management of Austin Hospital, Heidelberg, pursuant to the provisions of section 48 of the *Hospitals and Charities Act 1958* for a further period of three years from the 8th November, 1962.

#### LAW DEPARTMENT.

##### *Assistant Registrar of Probates, &c.*

##### DANIEL WALTER KENNEDY

to be Assistant Registrar of Probates and Administration, to take effect from the date of commencement of duty.

##### *Assistant Registrar of County Court.*

##### ANTHONY RONALD DUNLOP

to be Assistant Registrar, pursuant to the provisions of sections 20 and 21 of the *County Court Act 1958*, for the County Court at Mildura, vice P. J. Rodda, relieved, to take effect from the date of commencement of duty.

##### *Clerks of Petty Sessions, &c.*

##### ANTHONY RONALD DUNLOP

to be Clerk of Petty Sessions and Clerk of the Children's Court at Ouyen and Murrayville, vice P. J. Rodda, relieved, to take effect from the date of commencement of duty.

##### DENIS BRIAN DENNIS

to be Clerk of Petty Sessions and Clerk of the Children's Court at Beech Forest, Birregurra, Cressy and Rokewood, vice A. R. Ellis, relieved, to take effect from the date of commencement of duty.

##### *Commissioners for Taking Declarations, &c.*

JOHN HENRY BEETON, Partner, C. W. Stirling and Co., 420 St. Kilda-road, Melbourne,

HARRY CECIL RUSSELL POMEROY, Field Representative, Australian Mutual Provident Society, 425 Collins-street, Melbourne, and

THOMAS ENDREY, Treasurer, Hungarian-Australian Society, 326 Flinders-lane, Melbourne,

to be Commissioners for taking Declarations and Affidavits pursuant to the provisions of the *Evidence Act 1958*, to resign upon ceasing to occupy their present positions; and

CONSTANCE CRAWFORD WILSON, care of Barker and Park Pty. Ltd., Red Cliffs,

CLAUDE WILLIAM COOKE, 89 The Boulevard, Ivanhoe, TERRENCE WILLIAM O'CONNOR, 37 Woornack-road, Carnegie,

GEORGE EDWARD JENNINGS, 86 Fawkner-street, West Essendon, and

FRANCIS JOHN BELL, 40 Lauriston-street, Kyneton, to be Commissioners for taking Declarations and Affidavits pursuant to the provisions of the *Evidence Act 1958*, to resign upon removing from the neighbourhood of the addresses stated.





DEPARTMENT OF CROWN LANDS AND SURVEY.

At Government House, Melbourne, the ninth day of October, 1962.

PRESENT: o

His Excellency the Governor of Victoria.

Mr. Rylah  
Mr. Porter

Mr. Reid  
Mr. Hamer.

LANDS TEMPORARILY RESERVED AS SITES.

HIS Excellency the Governor of the State of Victoria, by and with the advice of the Executive Council thereof, doth hereby, in pursuance of the provisions of the Land Act 1958, reserve, temporarily, and also except from occupation for mining purposes, under any miner's right, the lands hereinafter described:—

BRANJEE.—Site for Sewerage purposes, 21 acres 2 roods 20 perches, more or less, Parish of Branjee, County of Delatite, as indicated by hachure on plan hereunder.—(B.589(4) (Rs.7063).

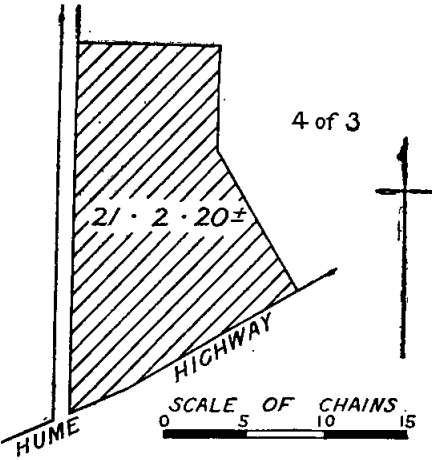

NHILL.—Site for Public Recreation, 18 acres, more or less, Township of Nhill, Parish of Balrootan, County of Lowan, as indicated by hachure on plan hereunder.—(N.102(4) (Rs.8166).

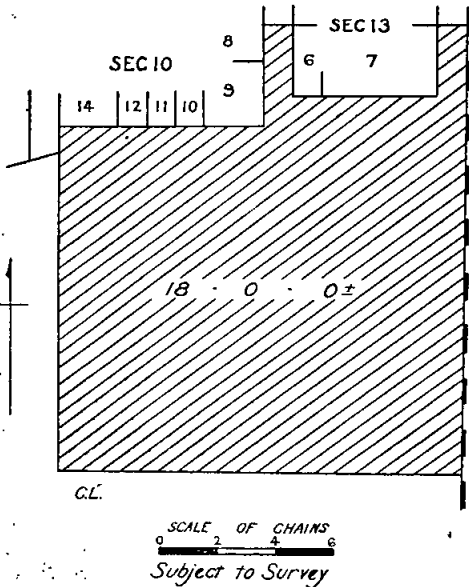

SOUTH MELBOURNE.—Site for Public Gardens, 1 acre 0 roods 29 perches, City of South Melbourne, Parish of Melbourne South, County of Bourke, as indicated by hachure on plan hereunder.—(M.333(32) (Rs.1179).

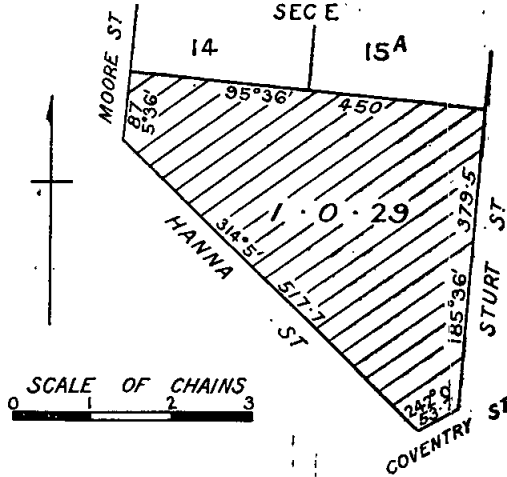

BUMBANG (BANNERTON NORTH).—Site for Public Recreation, 35 acres, more or less, Parish of Bumbang, County of Karkaroo, as indicated by hachure on plan hereunder.—(B.660(L) (Rs.7810).

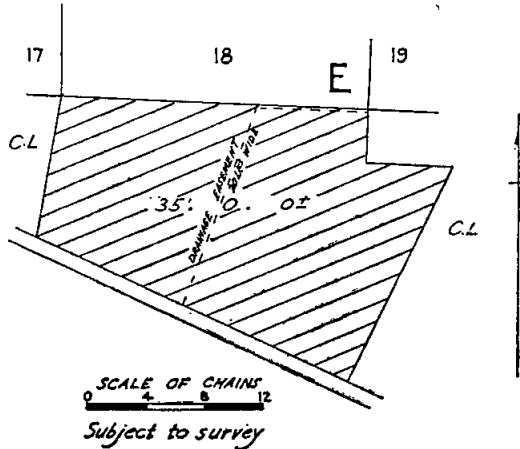

And the Honorable Keith Hector Turnbull, Her Majesty's Commissioner of Crown Lands and Survey for the State of Victoria, shall give the necessary directions herein accordingly.

N. G. WISHART,  
Clerk of the Executive Council.

DEPARTMENT OF CROWN LANDS AND SURVEY.

At Government House, Melbourne, the ninth day of October, 1962.

PRESENT:

His Excellency the Governor of Victoria.

Mr. Rylah  
Mr. Porter

Mr. Reid  
Mr. Hamer.

UNUSED ROADS CLOSED.

HIS Excellency the Governor of the State of Victoria, by and with the advice of the Executive Council thereof, doth hereby direct that, in pursuance of the provisions of section 349 of the Land Act 1958, the unused roads referred to hereunder be closed, viz.:—

Township of Horsham, Parish of Horsham, County of Borung, being the road indicated by hachure on plan hereunder.—(H.91(8) (M.38947).

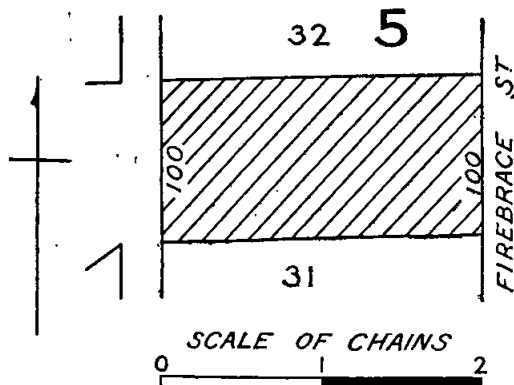

Parish of Dowling Forest, County of Grenville, being the road indicated by hachure on plan hereunder.—(C.102(2) (D.66(2) (J.30416).

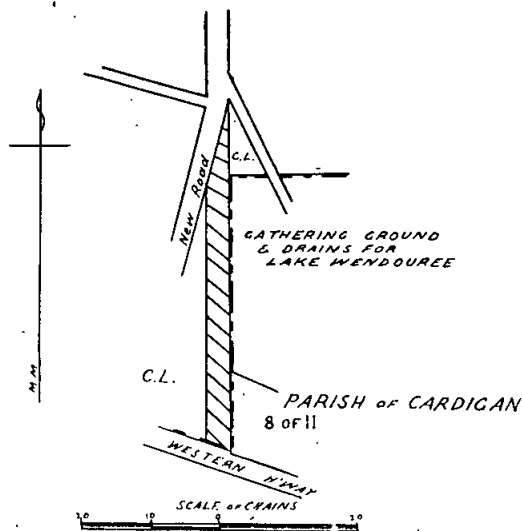

Parish of Neerim, County of Buln Buln, being the road indicated by hachure on plan hereunder.—(N.121(22) (Rs.349).

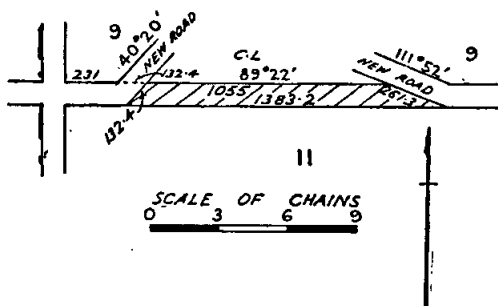

And the Honorable Keith Hector Turnbull, Her Majesty's Commissioner of Crown Lands and Survey for the State of Victoria, shall give the necessary directions herein accordingly.

N. G. WISHART,  
Clerk of the Executive Council.

COUNTRY ROADS BOARD.

At Government House, Melbourne, the ninth day of October, 1962.

PRESENT:

His Excellency the Governor of Victoria.  
Mr. Rylah | Mr. Reid  
Mr. Porter | Mr. Hamer.

ORDER APPROVING OF A NEW ROAD IN THE SHIRE OF HAMPDEN.

WHEREAS the Country Roads Board constituted under the *Country Roads Act 1958* (No. 6229) has represented to His Excellency the Governor in Council that it appears to it desirable that the Collins-lane in the Shire of Hampden should be made by the said Board: And whereas the said Board in accordance with the requirements of section 19 of the said cited Act has caused to be prepared a map plan and estimate showing the points between which and on and through what land the said new road is proposed to be made and the cost of acquiring the land: And whereas on an inspection of the said map and plan and a consideration of the said estimate His Excellency the Governor in Council is satisfied that there are funds legally available for acquiring the land: Now therefore be it known by this present Order that His Excellency the Governor of the State of Victoria with the advice of the Executive Council thereof doth hereby approve of the said road being made, that is to say:—

All that piece of land in the Township of Foxhow, Parish of Struan, the boundaries of which are as follow:— Commencing at the south-western angle of portion 2, allotment F, of the said township; thence by lines bearing respectively 5 deg. 4 min. 117.8 links, 137 deg. 49 min. 373.4 links, 90 deg. 7 min. 1,258.9 links, 205 deg. 46½ min. 508.3 links, 328 deg. 10 min. 422.2 links, 270 deg. 7 min. 1,099.3 links and 5 deg. 4 min. 259.8 links to the point of commencement—which said piece of land is particularly delineated and shown coloured red on survey plan numbered 8552, lodged in the office of the Country Roads Board.

And the Honorable Horace Rostill Petty, Her Majesty's Commissioner of Public Works for the State of Victoria, shall give the necessary directions herein accordingly.

N. G. WISHART,  
Clerk of the Executive Council.

COUNTRY ROADS BOARD.

At Government House, Melbourne, the ninth day of October, 1962.

PRESENT:

His Excellency the Governor of Victoria.  
Mr. Rylah | Mr. Reid  
Mr. Porter | Mr. Hamer.

ORDER APPROVING OF A DEVIATION FROM A MAIN ROAD IN THE SHIRE OF ROSEDALE.

WHEREAS the Country Roads Board constituted under the *Country Roads Act 1958* (No. 6229) has represented to His Excellency the Governor in Council that it appears to it desirable that the deviation hereinafter referred to from the existing Traralgon-Maffra road in the Shire of Rosedale (declared to be a main road under the said Act which declaration was confirmed by the Order in Council published in the *Government Gazette* of the 19th October, 1932, on page 2387) should be made by the said Board: And whereas the said Board in accordance with the requirements of section 19 of the said cited Act has caused to be prepared a map plan and estimate showing the points between which and on and through what land the said deviation is proposed to be made and the cost of acquiring the land: And whereas on an inspection of the said map and plan and a consideration of the said estimate His Excellency the Governor in Council is satisfied that there are funds legally available for acquiring the land: Now therefore be it known by this present Order that His Excellency the Governor of the State of

Victoria with the advice of the Executive Council thereof doth hereby approve of the said road being made, that is to say:—

All those pieces of land in the Parish of Toongabbie North, the boundaries of which are as follow:—

(a) Commencing at the north-eastern angle of allotment E of the said parish; thence by lines bearing respectively 178 deg. 12 min. 627.8 links, 313 deg. 6½ min. 654.6 links, 287 deg. 46 min. 493.8 links and 88 deg. 12 min. 929 links to the point of commencement.

(b) Commencing at the south-western angle of allotment H3 of the said parish; thence by lines bearing respectively 358 deg. 12 min. 199.5 links, 110 deg. 9½ min. 532.8 links and 268 deg. 12 min. 494.1 links to the point of commencement—

which said pieces of land are particularly delineated and shown coloured red on survey plan numbered 8530, lodged in the office of the Country Roads Board.

And the Honorable Horace Rostill Petty, Her Majesty's Commissioner of Public Works for the State of Victoria, shall give the necessary directions herein accordingly.

N. G. WISHART,  
Clerk of the Executive Council.

#### COUNTRY ROADS BOARD.

At Government House, Melbourne, the ninth day of October, 1962.

#### PRESENT:

His Excellency the Governor of Victoria.

Mr. Rylah	Mr. Reid
Mr. Porter	Mr. Hamer.

#### ORDER APPROVING OF A DEVIATION FROM A MAIN ROAD IN THE SHIRE OF MIRBOO.

WHEREAS the Country Roads Board constituted under the *Country Roads Act 1958* (No. 6229) has represented to His Excellency the Governor in Council that it appears to it desirable that the deviation hereinafter referred to from the existing Leongatha-Mirboo road in the Shire of Mirboo (declared to be a main road under the said Act which declaration was confirmed by the Order in Council published in the *Government Gazette* of the 11th March, 1925, on page 822) should be made by the said Board; and whereas the said Board in accordance with the requirements of section 19 of the said cited Act has caused to be prepared a map plan and estimate showing the points between which and on and through what land the said deviation is proposed to be made and the cost of acquiring the land; and whereas on an inspection of the said map and plan and a consideration of the said estimate His Excellency the Governor in Council is satisfied that there are funds legally available for acquiring the land: Now therefore be it known by this present Order that His Excellency the Governor of the State of Victoria with the advice of the Executive Council thereof doth hereby approve of the said road being made, that is to say:—

All those pieces of land in the Parish of Mardan, the boundaries of which are as follow:—

(a) Commencing at a point on the southern boundary of allotment 103 of the said parish, distant 270 deg. 0 min. 1,209 links from the south-eastern angle of the said allotment; thence by lines bearing respectively 270 deg. 0 min. 362 links, 291 deg. 47 min. 193 links, 297 deg. 39 min. 356 links, 106 deg. 25 min. 561.9 links and 103 deg. 48 min. 327 links to the point of commencement.

(b) Commencing at a point in allotment 13D of the said parish, distant 90 deg. 0 min. 1,023.2 links from the south-eastern angle of allotment 103 thereof; thence by lines bearing respectively 77 deg. 16 min. 315.9 links, 244 deg. 38 min. 162.5 links and 270 deg. 0 min. 161.3 links to the point of commencement.

(c) Commencing at a point in allotment 13D of the said parish, distant 90 deg. 0 min. 1,184.5 links, 64 deg. 38 min. 1,367.3 links and 56 deg. 58 min. 124.6 links from the south-eastern angle of allotment 103 thereof; thence by lines bearing respectively 48 deg. 9 min. 399 links,

43 deg. 25 min. 178.4 links, 220 deg. 59 min. 372.7 links and 236 deg. 58 min. 333.8 links to the point of commencement.

(d) Commencing at a point in allotment 13D of the said parish, distant 90 deg. 0 min. 1,207 links, and 64 deg. 38 min. 526.1 links from the north-eastern angle of allotment 15 thereof; thence by lines bearing respectively 64 deg. 38 min. 870.4 links, 56 deg. 58 min. 112.6 links, 230 deg. 25 min. 172.2 links and 246 deg. 33 min. 815.5 links to the point of commencement.

(e) Commencing at a point on the northern boundary of allotment 13 of the said parish, distant 270 deg. 0 min. 64 links from the north-eastern angle of the said allotment; thence by lines bearing respectively 253 deg. 2 min. 608.7 links, 57 deg. 4 min. 326.7 links and 90 deg. 0 min. 308 links to the point of commencement.

(f) Commencing at an angle in the eastern boundary of allotment 5B of the said parish, formed by the intersection of lines bearing 33 deg. 43 min. and 4 deg. 9 min.; thence by lines bearing respectively 213 deg. 43 min. 324.3 links, 16 deg. 41½ min. 736.8 links and 184 deg. 9 min. 437.2 links to the point of commencement.

(g) Commencing at an angle in the western boundary of allotment 6E of the said parish, formed by the intersection of lines bearing 238 deg. 25 min. and 184 deg. 9 min.; thence by lines bearing respectively 58 deg. 25 min. 403 links, 220 deg. 12 min. 556 links and 4 deg. 9 min. 214.2 links to the point of commencement.

(h) Commencing at a point on the eastern boundary of allotment 5B of the said parish, distant 180 deg. 0 min. 1,246.9 links from the north-eastern angle of the said allotment; thence by lines bearing respectively 49 deg. 55 min. 64.4 links, 32 deg. 20 min. 536 links, 18 deg. 19 min. 911.9 links, 166 deg. 28 min. 189.5 links, 198 deg. 19 min. 950.7 links, 212 deg. 20 min. 408.8 links, 263 deg. 39 min. 8.3 links, 249 deg. 44 min. 433 links and 49 deg. 55 min. 346.2 links to the point of commencement.

(i) Commencing at a point on the western boundary of allotment 6B of the said parish; distant 166 deg. 28 min. 322.6 links from the north-western angle of the said allotment; thence by lines bearing respectively 46 deg. 18 min. 171 links, 206 deg. 36 min. 229.4 links and 346 deg. 28 min. 89.5 links to the point of commencement.

Also all those pieces of land in the Parish of Allambee East, the boundaries of which are as follow:—

(a) Commencing at an angle in the western boundary of the existing Leongatha-Mirboo road (through allotment 108 of the said parish, formed by the intersection of lines bearing 43 deg. 28 min. and 7 deg. 21 min.; thence by lines bearing respectively 223 deg. 28 min. 348.2 links, 34 deg. 46 min. 278.5 links, 24 deg. 25 min. 262.6 links and 187 deg. 21 min. 216.9 links to the point of commencement.

(b) Commencing at an angle in the western boundary of the existing Leongatha-Mirboo road through allotment 108 of the said parish, formed by the intersection of lines bearing 21 deg. 31 min. and 353 deg. 34 min.; thence by lines bearing respectively 201 deg. 31 min. 201.5 links, 13 deg. 34 min. 276.1 links and 173 deg. 34 min. 81.5 links to the point of commencement.

(c) Commencing at an angle in the eastern boundary of the existing Leongatha-Mirboo road through allotment 108 of the said parish, formed by the intersection of lines bearing 222 deg. 4 min. and 173 deg. 34 min.; thence by lines bearing respectively 42 deg. 4 min. 230.6 links, 199 deg. 35 min. 234.1 links, 188 deg. 3½ min. 279.8 links and 353 deg. 34 min. 328.4 links to the point of commencement.

(d) Commencing at an angle in the southern boundary of the existing Leongatha-Mirboo road through allotment 108 of the said parish, formed by the intersection of lines bearing 265 deg. 35 min. and 222 deg. 4 min.; thence by lines bearing respectively 85 deg. 35 min. 56 links, 179 deg. 50 min. 18.5 links, 259 deg. 27 min. 84 links and 42 deg. 4 min. 39.8 links to the point of commencement.

(e) Commencing at an angle in the southern boundary of the existing Leongatha-Mirboo road through allotment 108A of the said parish, formed by

the intersection of lines bearing 292 deg. 4 min. and 275 deg. 7 min.; thence by lines bearing respectively 112 deg. 4 min. 392 links, 286 deg. 38 min. 480 links, 9 deg. 22 min. 18.5 links and 95 deg. 7 min. 94 links to the point of commencement.

- (f) Commencing at an angle in the southern boundary of the existing Leongatha-Mirboo road through allotment 108A of the said parish, formed by the intersection of lines bearing 299 deg. 22 min. and 272 deg. 58 min.; thence by lines bearing respectively 119 deg. 22 min. 266.5 links, 288 deg. 26 min. 439 links and 92 deg. 58 min. 183.8 links to the point of commencement—

which said pieces of land are particularly delineated and shown colored red and yellow on survey plans numbered 8583, 8584, 8585 and 8586 lodged in the office of the Country Roads Board.

And the Honorable Horace Rostill Petty, Her Majesty's Commissioner of Public Works for the State of Victoria, shall give the necessary directions herein accordingly.

N. G. WISHART,  
Clerk of the Executive Council.

#### COUNTRY ROADS BOARD.

At Government House, Melbourne, the  
ninth day of October, 1962.

PRESENT:

His Excellency the Governor of Victoria.	
Mr. Rylah	Mr. Reid
Mr. Porter	Mr. Hamer.

#### ORDER APPROVING OF WIDENING AN EXISTING STATE HIGHWAY IN THE SHIRE OF HEYTESBURY.

WHEREAS the Country Roads Board constituted under the *Country Roads Act 1958* (No. 6229) has represented to His Excellency the Governor in Council that it appears to be desirable that the existing Princes Highway in the Shire of Heytesbury (declared to be a State highway under the said Act which declaration was confirmed by the Order in Council published in the *Government Gazette* of the 8th July, 1925, on pages 2371-3) should be widened by the said Board: And whereas the said Board in accordance with the requirements of section 19 of the said cited Act has caused to be prepared a map plan and estimate showing the points between which and on and through what land the said widening is proposed to be made and the cost of acquiring the land: And whereas on an inspection of the said map and plan and a consideration of the said estimate His Excellency the Governor in Council is satisfied that there are funds legally available for acquiring the land: Now therefore be it known by this present Order that His Excellency the Governor of the State of Victoria with the advice of the Executive Council thereof doth hereby approve of the said highway being widened, that is to say:—

All those pieces of land in the Parish of Pombornett, the boundaries of which are as follow:—

- (a) Commencing at the north-western angle of allotment 19A of the said parish; thence by lines bearing respectively 77 deg. 10 min. 275 links, 146 deg. 24 min. 390 links, 102 deg. 16 min. 450 links, 123 deg. 3 min. 95 links, 179 deg. 59 min. 35.5 links, 286 deg. 7½ min. 855.8 links, 270 deg. 2 min. 542.4 links, 47 deg. 45 min. 100.2 links and 63 deg. 48 min. 320 links to the point of commencement.
- (b) Commencing at an angle in the southern boundary of allotment 17, section A, of the said parish, formed by the intersection of lines bearing 87 deg. 30 min and 27 deg. 30 min.; thence by lines bearing respectively 267 deg. 30 min. 411 links, 69 deg. 42 min. 529.9 links and 207 deg. 30 min. 187 links to the point of commencement—

which said pieces of land are particularly delineated and shown coloured red and blue on survey plan numbered 8687, lodged in the office of the Country Roads Board.

And the Honorable Horace Rostill Petty, Her Majesty's Commissioner of Public Works for the State of Victoria, shall give the necessary directions herein accordingly.

N. G. WISHART,  
Clerk of the Executive Council.

#### COUNTRY ROADS BOARD.

At Government House, Melbourne, the ninth day of  
October, 1962.

PRESENT:

His Excellency the Governor of Victoria.	
Mr. Rylah	Mr. Reid
Mr. Porter	Mr. Hamer.

#### ORDER APPROVING OF WIDENING AN EXISTING MAIN ROAD IN THE SHIRE OF PORTLAND.

WHEREAS the Country Roads Board constituted under the *Country Roads Act 1958* (No. 6229) has represented to His Excellency the Governor in Council that it appears to be desirable that the existing Heath-road in the Shire of Portland (declared to be a main road under the said Act which declaration was confirmed by the Order in Council published in the *Government Gazette* of the 26th February, 1930, and 19th February, 1941, on pages 872 and 911 respectively) should be widened by the said Board: And whereas the said Board in accordance with the requirements of section 19 of the said cited Act has caused to be prepared a map plan and estimate showing the points between which and on and through what land the said widening is proposed to be made and the cost of acquiring the land: And whereas on an inspection of the said map and plan and a consideration of the said estimate His Excellency the Governor in Council is satisfied that there are funds legally available for acquiring the land: Now therefore be it known by this present Order that His Excellency the Governor of the State of Victoria with the advice of the Executive Council thereof doth hereby approve of the said road being widened, that is to say:—

All that piece of land in the Parish of Mouzie, the boundaries of which are as follow:—Commencing at a point on the southern boundary of allotment 37, section 9, of the said parish, distant 277 deg. 17 min. 2,766.8 links from the south-eastern angle of the said allotment; thence by lines bearing respectively 277 deg. 17 min. 487 links, 322 deg. 48 min. 140.2 links, 8 deg. 18 min. 648 links, 161 deg. 0 min. 641.2 links and 128 deg. 7 min. 337.4 links to the point of commencement—which said piece of land is particularly delineated and shown coloured red on survey plan numbered 8645, lodged in the office of the Country Roads Board.

And the Honorable Horace Rostill Petty, Her Majesty's Commissioner of Public Works for the State of Victoria, shall give the necessary directions herein accordingly.

N. G. WISHART,  
Clerk of the Executive Council.

#### COUNTRY ROADS BOARD.

At Government House, Melbourne, the ninth day of  
October, 1962.

PRESENT:

His Excellency the Governor of Victoria.	
Mr. Rylah	Mr. Reid
Mr. Porter	Mr. Hamer.

#### ORDER APPROVING OF WIDENING AN EXISTING TOURISTS' ROAD IN THE SHIRE OF OTWAY.

WHEREAS the Country Roads Board constituted under the *Country Roads Act 1958* (No. 6229) has represented to His Excellency the Governor in Council that it appears to be desirable that the existing Ocean-road in the Shire of Otway (declared to be a Tourists' road under the said Act which declaration was confirmed by the Order in Council published in the *Government Gazette* of the 2nd December, 1936, on page 3196) should be widened by the said Board: And whereas the said Board in accordance with the requirements of section 19 of the said cited Act has caused to be prepared a map plan and estimate showing the points between which and on and through what land the said widening is proposed to be made and the cost of acquiring the land: And whereas on an inspection of the said map and plan and a consideration of the said estimate His Excellency the Governor in Council is satisfied that there are funds legally available for acquiring the land: Now therefore be it known by this present Order that His Excellency the Governor of the State of



Victoria with the advice of the Executive Council thereof doth hereby approve of the said road being widened, that is to say:—

All that piece of land in the Parish of Krambruk, the boundaries of which are as follows:—Commencing at a point on the eastern boundary of allotment X of the said parish, distant 356 deg. 31 min. 500 links and 28 deg. 5 min. 1,443.7 links from the south-eastern angle of the said allotment; thence by lines bearing respectively 23 deg. 9½ min. 466 links, 19 deg. 24 min. 1,287.8 links, 73 deg. 28 min. 22.8 links, 20 deg. 23 min. 672.1 links, 31 deg. 7½ min. 384.1 links, 64 deg. 24½ min. 384.1 links, 227 deg. 46 min. 736 links and 194 deg. 58 min. 1,358.4 links to the south bank of the Barham River; thence north-westerly by the said bank; thence by lines bearing respectively 202 deg. 31 min. 623 links, 203 deg. 46 min. 448.2 links and 208 deg. 5 min. 64.3 links to the point of commencement—which said piece of land is particularly delineated and shown coloured red and yellow on survey plan numbered 8781, lodged in the office of the Country Roads Board.

And the Honorable Horace Rostill Petty, Her Majesty's Commissioner of Public Works for the State of Victoria, shall give the necessary directions herein accordingly.

N. G. WISHART,  
Clerk of the Executive Council.

#### COUNTRY ROADS BOARD.

At Government House, Melbourne, the  
ninth day of October, 1962.

PRESENT:

His Excellency the Governor of Victoria.	
Mr. Rylah	Mr. Reid
Mr. Porter	Mr. Hamer.

#### ORDER APPROVING OF WIDENING AN EXISTING STATE HIGHWAY IN THE SHIRE OF GLENLYON.

WHEREAS the Country Roads Board constituted under the *Country Roads Act* 1958 (No. 6229) has represented to His Excellency the Governor in Council that it appears to it desirable that the existing Midland Highway in the Shire of Glenlyon (declared to be a State highway under the said Act which declaration was confirmed by the Order in Council published in the *Government Gazette* of the 10th August, 1960, on pages 2743-8) should be widened by the said Board: And whereas the said Board in accordance with the requirements of section 19 of the said cited Act has caused to be prepared a map plan and estimate showing the points between which and on and through what land the said widening is proposed to be made and the cost of acquiring the land: And whereas on an inspection of the said map and plan and a consideration of the said estimate His Excellency the Governor in Council is satisfied that there are funds legally available for acquiring the land: Now therefore be it known by this present Order that His Excellency the Governor of the State of Victoria with the advice of the Executive Council thereof doth hereby approve of the said highway being widened, that is to say:—

All those pieces of land in the Parish of Holcombe, the boundaries of which are as follow:—

- (a) Commencing at the south-eastern angle of allotment 6, section 10, of the said parish; thence by lines bearing respectively 246 deg. 39½ min. 50.5 links, 335 deg. 54½ min. 1,366.1 links, 289 deg. 21 min. 31.7 links, 62 deg. 52½ min. 23 links, 317 deg. 41 min. 103.6 links, 242 deg. 52½ min. 23 links, 29 deg. 12 min. 38.3 links, 355 deg. 32 min. 1,818.5 links, 355 deg. 28½ min. 869.3 links, 294 deg. 52 min. 22.6 links, 54 deg. 16½ min. 23 links, 167 deg. 5½ min. 906 links, 179 deg. 24 min. 1,596.8 links and 156 deg. 39½ min. 1,710.3 links to the point of commencement.
- (b) Commencing at the south-western angle of allotment 3, section 10, of the said parish; thence by lines bearing respectively 172 deg. 31 min. 628.2 links, 165 deg. 17½ min. 232.1 links, 336 deg. 39½ min. 341.9 links and 359 deg. 26 min. 533.4 links to the point of commencement.
- (c) Commencing at the north-western angle of allotment 3, section 10, of the said parish; thence by lines bearing respectively 2 deg. 54½ min.

242.1 links, 175 deg. 27 min. 1,505.1 links, 347 deg. 5½ min. 716.4 links and 2 deg. 54½ min. 561 links to the point of commencement.

- (d) Commencing at the north-eastern angle of allotment 8, section 10, of the said parish; thence by lines bearing respectively 182 deg. 54½ min. 867.9 links, 356 deg. 29 min. 192 links, 315 deg. 27 min. 26.4 links, 94 deg. 25½ min. 17.5 links, 359 deg. 29 min. 100.9 links, 274 deg. 25½ min. 23 links, 45 deg. 30 min. 30.2 links, 356 deg. 29 min. 825 links and 158 deg. 10½ min. 311.5 links to the point of commencement.
- (e) Commencing at the south-western angle of allotment 4, section 9, Township of Dry Diggings, in the said parish; thence by lines bearing respectively 350 deg. 43½ min. 1,226.7 links, 326 deg. 43 min. 510.6 links, 327 deg. 43½ min. 1,407.3 links, 57 deg. 43½ min. 16.6 links, 147 deg. 31½ min. 1,403.8 links, 146 deg. 35½ min. 144.4 links, 149 deg. 1½ min. 913.7 links, 114 deg. 52 min. 38.1 links, 260 deg. 43½ min. 23 links, 177 deg. 34½ min. 100.5 links, 80 deg. 43½ min. 23 links, 213 deg. 21 min. 31.1 links, 165 deg. 59½ min. 552 links, 174 deg. 1 min. 941.2 links and 338 deg. 29½ min. 931.3 links to the point of commencement.
- (f) Commencing at the north-western angle of allotment 4, section 2, Township of Dry Diggings, in the said parish; thence by lines bearing respectively 103 deg. 58½ min. 534 links, 135 deg. 53½ min. 288.5 links, 147 deg. 37½ min. 100 links, 147 deg. 43½ min. 2,114.9 links, 170 deg. 52 min. 60.7 links, 327 deg. 20 min. 428.9 links, 327 deg. 24 min. 456.8 links, 327 deg. 39½ min. 430 links, 323 deg. 43½ min. 225.5 links, 322 deg. 0½ min. 633 links, 312 deg. 51 min. 103.5 links and 304 deg. 0½ min. 729.9 links to the point of commencement.

Also, all that piece of land in the Parishes of Holcombe and Franklin, the boundaries of which are as follow:—

Commencing at the south-western angle of allotment 1, section 1, Township of Dry Diggings, Parish of Holcombe; thence by lines bearing respectively 285 deg. 6½ min. 1,251.1 links, 279 deg. 44 min. 86.9 links, 279 deg. 27 min. 1,300 links, 320 deg. 12 min. 678.8 links, 121 deg. 9½ min. 937 links, 100 deg. 29½ min. 930.7 links, 89 deg. 26½ min. 1,216.3 links, 109 deg. 38 min. 1,133.2 links and 39 deg. 15½ min. 64.4 links; thence by the arc of a circle of radius 49 links a distance of 109 links, the chord of which arc bears 219 deg. 15½ min.; thence by lines bearing 283 deg. 38 min. 577.6 links and 248 deg. 53 min. 464 links to the point of commencement.

Also, all that piece of land in the Parish of Franklin, the boundaries of which are as follow:—

Commencing at the eastern angle of allotment 3a, Parish of Franklin; thence by lines bearing respectively 316 deg. 52 min. 1,258.6 links, 322 deg. 46 min. 907.3 links, 325 deg. 13½ min. 373.7 links and 140 deg. 12 min. 2,535.2 links to the point of commencement—

which said pieces of land are particularly delineated and shown coloured red and yellow on survey plans numbered 8635, 8636, 8637, 8638 and 8639, lodged in the office of the Country Roads Board.

And the Honorable Horace Rostill Petty, Her Majesty's Commissioner of Public Works for the State of Victoria, shall give the necessary directions herein accordingly.

N. G. WISHART,  
Clerk of the Executive Council.

#### COUNTRY ROADS BOARD.

At Government House, Melbourne, the  
ninth day of October, 1962.

PRESENT:

His Excellency the Governor of Victoria.	
Mr. Rylah	Mr. Reid
Mr. Porter	Mr. Hamer.

#### ORDER APPROVING OF WIDENING AN EXISTING MAIN ROAD IN THE SHIRE OF DONCASTER AND TEMPLESTOWE.

WHEREAS the Country Roads Board constituted under the *Country Roads Act* 1958 (No. 6229) has represented to His Excellency the Governor in Council that it

appears to it desirable that the existing Heidelberg—Warrandyte road in the Shire of Doncaster and Templestowe (declared to be a main road under the said Act which declaration was confirmed by the Order in Council published in the *Government Gazette* of the 1st April, 1914, on page 1545) should be widened by the said Board: And whereas the said Board in accordance with the requirements of section 19 of the said cited Act has caused to be prepared a map plan and estimate showing the points between which and on and through what land the said widening is proposed to be made and the cost of acquiring the land: And whereas on an inspection of the said map and plan and a consideration of the said estimate His Excellency the Governor in Council is satisfied that there are funds legally available for acquiring the land: Now therefore be it known by this present Order that His Excellency the Governor of the State of Victoria with the advice of the Executive Council thereof doth hereby approve of the said road being widened, that is to say:—

All that piece of land in the Parish of Bulleen, the boundaries of which are as follow:—Commencing at a point in allotment 16r of the said parish, distant 234 deg. 20 min. 472 links from an angle in the eastern boundary of the said allotment, formed by the intersection of lines bearing 2 deg. 0 min. and 36 deg. 55 min.; thence by a line bearing 234 deg. 20 min. 616 links; thence by the arc of a circle of radius 152 links a distance of 258 links the chord of which arc bears 287 deg. 40 min.; thence by a line bearing 336 deg. 23 min. 483 links; thence by the arc of a circle of radius 1,089 links a distance of 151.9 links, the chord of which arc bears 332 deg. 23 min.; thence by lines bearing respectively 140 deg. 36 min. 348.5 links, 130 deg. 1 min. 227.1 links, 98 deg. 57 min. 225 links and 65 deg. 51 min. 399.2 links to the point of commencement—which said piece of land is particularly delineated and shown coloured red on survey plan numbered 8370, lodged in the office of the Country Roads Board.

And the Honorable Horace Rostill Petty, Her Majesty's Commissioner of Public Works for the State of Victoria, shall give the necessary directions herein accordingly.

N. G. WISHART,  
Clerk of the Executive Council.

#### COUNTRY ROADS BOARD.

*At Government House, Melbourne, the  
ninth day of October, 1962.*

PRESENT:

His Excellency the Governor of Victoria.	
Mr. Rylah	Mr. Reid
Mr. Porter	Mr. Hamer.

#### ORDER APPROVING OF WIDENING AN EXISTING STATE HIGHWAY IN THE SHIRE OF GRENVILLE.

WHEREAS the Country Roads Board constituted under the *Country Roads Act 1958* (No. 6229) has represented to His Excellency the Governor in Council that it appears to it desirable that the existing Glenelg Highway in the Shire of Grenville (declared to be a State highway under the said Act which declaration was confirmed by the Order in Council published in the *Government Gazette* of the 29th October, 1947, on pages 5573-5) should be widened by the said Board: And whereas the said Board in accordance with the requirements of section 19 of the said cited Act has caused to be prepared a map plan and estimate showing the points between which and on and through what land the said widening is proposed to be made and the cost of acquiring the land: And whereas on an inspection of the said map and plan and a consideration of the said estimate His Excellency the Governor in Council is satisfied that there are funds legally available for acquiring the land: Now therefore be it known by this present Order that His Excellency the Governor of the State of Victoria with the advice of the Executive Council thereof doth hereby approve of the said highway being widened, that is to say:—

All those pieces of land in the Township and Parish of Smythesdale, the boundaries of which are as follow:—

- (a) Commencing at the northern angle of allotment 7, section 24, of the said township; thence by lines bearing respectively 200 deg. 48½ min. 230 links, 0 deg. 30½ min. 84 links and 31 deg. 43½ min. 154 links to the point of commencement.

- (b) Commencing at the north-eastern angle of allotment 6, section 58, of the said township; thence by lines bearing respectively 191 deg. 24½ min. 581.8 links, 252 deg. 59½ min. 854.9 links, 63 deg. 30½ min. 456.6 links, 44 deg. 14 min. 348.2 links, 27 deg. 54 min. 499.3 links, 17 deg. 19½ min. 166.2 links and 180 deg. 30½ min. 187.7 links to the point of commencement—

which said pieces of land are particularly delineated and shown coloured red and yellow on survey plan numbered 8801, lodged in the office of the Country Roads Board.

And the Honorable Horace Rostill Petty, Her Majesty's Commissioner of Public Works for the State of Victoria, shall give the necessary directions herein accordingly.

N. G. WISHART,  
Clerk of the Executive Council.

#### COUNTRY ROADS BOARD.

*At Government House, Melbourne, the  
ninth day of October, 1962.*

PRESENT:

His Excellency the Governor of Victoria.	
Mr. Rylah	Mr. Reid
Mr. Porter	Mr. Hamer.

#### ORDER APPROVING OF WIDENING AN EXISTING MAIN ROAD IN THE SHIRE OF HAMPDEN.

WHEREAS the Country Roads Board constituted under the *Country Roads Act 1958* (No. 6229) has represented to His Excellency the Governor in Council that it appears to it desirable that the existing Foxhow-road in the Shire of Hampden (declared to be a main road under the said Act which declaration was confirmed by the Order in Council published in the *Government Gazette* of the 5th February, 1941, on page 639) should be widened by the said Board: And whereas the said Board in accordance with the requirements of section 19 of the said cited Act has caused to be prepared a map plan and estimate showing the points between which and on and through what land the said widening is proposed to be made and the cost of acquiring the land: And whereas on an inspection of the said map and plan and a consideration of the said estimate His Excellency the Governor in Council is satisfied that there are funds legally available for acquiring the land: Now therefore be it known by this present Order that His Excellency the Governor of the State of Victoria with the advice of the Executive Council thereof doth hereby approve of the said road being widened, that is to say:—

All that piece of land in the Township of Foxhow, Parish of Struan, the boundaries of which are as follow:—Commencing at a point on the southern boundary of portion 10, allotment F, of the said township, distant 41 deg. 44 min. 97.2 links from the south-western angle of the said allotment; thence by lines bearing respectively 25 deg. 46½ min. 1,034 links, 90 deg. 7 min. 380.3 links and 221 deg. 44 min. 1,246.8 links to the point of commencement—which said piece of land is particularly delineated and shown coloured red on survey plan numbered 8552, lodged in the office of the Country Roads Board.

And the Honorable Horace Rostill Petty, Her Majesty's Commissioner of Public Works for the State of Victoria, shall give the necessary directions herein accordingly.

N. G. WISHART,  
Clerk of the Executive Council.

#### COUNTRY ROADS BOARD.

*At Government House, Melbourne, the  
ninth day of October, 1962.*

PRESENT:

His Excellency the Governor of Victoria.	
Mr. Rylah	Mr. Reid
Mr. Porter	Mr. Hamer.

#### ORDER APPROVING OF WIDENING AN EXISTING MAIN ROAD IN THE SHIRE OF MIRBOO.

WHEREAS the Country Roads Board constituted under the *Country Roads Act 1958* (No. 6229) has represented to His Excellency the Governor in Council that it

appears to it desirable that the existing Morwell-Mirboo road in the Shire of Mirboo (declared to be a main road under the said Act which declaration was confirmed by the Order in Council published in the *Government Gazette* of the 5th October, 1932, on page 2256) should be widened by the said Board: And whereas the said Board in accordance with the requirements of section 19 of the said cited Act has caused to be prepared a map plan and estimate showing the points between which and on and through what land the said widening is proposed to be made and the cost of acquiring the land: And whereas on an inspection of the said map and plan and a consideration of the said estimate His Excellency the Governor in Council is satisfied that there are funds legally available for acquiring the land: Now therefore be it known by this present Order that His Excellency the Governor of the State of Victoria with the advice of the Executive Council thereof doth hereby approve of the said road being widened, that is to say:—

All that piece of land in the Township of Mirboo North, Parish of Mirboo, the boundaries of which are as follow:— Commencing at the north-western angle of allotment 30, section 3, of the said township; thence by lines bearing respectively 104 deg. 31 min. 25 feet, 232 deg. 15½ min. 30 ft. 7½ in., and 360 deg. 0 min. 25 feet to the point of commencement—which said piece of land is particularly delineated and shown coloured red on survey plan numbered 8763, lodged in the office of the Country Roads Board.

And the Honorable Horace Rostill Petty, Her Majesty's Commissioner of Public Works for the State of Victoria, shall give the necessary directions herein accordingly.

N. G. WISHART,  
Clerk of the Executive Council.

#### FORESTS ACT 1958.

*At Government House, Melbourne, the  
ninth day of October, 1962.*

PRESENT:

His Excellency the Governor of Victoria.  
Mr. Rylah | Mr. Reid  
Mr. Porter | Mr. Hamer.

WHEREAS the Chairman of the Forests Commission will be absent from the State of Victoria during the period from the fifth day of October to the twenty-eighth day of October, 1962, both dates inclusive,

And whereas by section 17 of the *Forests Act 1958* provision is made in such circumstances for the appointment of a person to act as the deputy of the chairman:

Now therefore in exercise of the powers conferred on him by the said section His Excellency the Governor of the said State by and with the advice of the Executive Council thereof, doth hereby appoint—

HERBERT DUNCAN GALBRAITH  
a Commissioner of the Forests Commission, to act as the deputy of the said Chairman during such period.

And the Honorable Lindsay Hamilton Simpson Thompson, Her Majesty's Minister of Forests for the State of Victoria, shall give the necessary directions herein accordingly.

N. G. WISHART,  
Clerk of the Executive Council.

#### SOIL CONSERVATION AND LAND UTILIZATION ACT.

*At Government House, Melbourne, the  
ninth day of October, 1962.*

PRESENT:

His Excellency the Governor of Victoria.  
Mr. Rylah | Mr. Reid  
Mr. Porter | Mr. Hamer.

#### DISTRICT ADVISORY COMMITTEE—SOUTHERN MALLEE SOIL CONSERVATION DISTRICT.

WHEREAS vacancies exist on the Southern Mallee Soil Conservation District Advisory Committee due to the resignations of Bernard Patrick Foott, being a person

elected to represent grazing, agricultural and other relevant interests in the District, and Richard Fellows Nicolson, being the person representing the State Rivers and Water Supply Commission: Now therefore I, the Governor of the State of Victoria, by and with the advice of the Executive Council thereof, and in pursuance of the provisions of section 15 of the Soil Conservation and Land Utilization Act, do hereby appoint the following persons to such vacancies for a period up to and including the eleventh day of January, 1963:—

JOHN JOSEPH FOOTT  
being a person elected to represent grazing, agricultural and other relevant interests in the District.

KENNETH REGINALD BARLOW  
being the person representing the State Rivers and Water Supply Commission.

And the Honorable Keith Hector Turnbull, Her Majesty's Minister for Conservation for the State of Victoria, shall give the necessary directions herein accordingly.

N. G. WISHART,  
Clerk of the Executive Council.

#### MENTAL HEALTH ACT 1959.

*At Government House, Melbourne, the  
ninth day of October, 1962.*

PRESENT:

His Excellency the Governor of Victoria.  
Mr. Rylah | Mr. Reid  
Mr. Porter | Mr. Hamer.

IN pursuance of the powers conferred by section 5 of the *Mental Health Act 1959*, His Excellency the Governor of the State of Victoria, by and with the advice of the Executive Council of the said State, hereby makes the following appointments:—

ERIC CUNNINGHAM DAX, M.B., B.S., B.Sc., D.P.M. (R.C.P. et S.); L.M.S.S.A. (London), to be a member and chairman of the Mental Health Authority for the period ending 29th November, 1966;

CHARLES RONALD DAVID BROTHERS, M.D., B.S., F.R.A.C.P., to be a member and deputy-chairman of the Mental Health Authority for the period ending 29th November, 1966; and

ALEXANDER HELE RILEY, A.A.S.A., to be administrative member of the Mental Health Authority for the period ending 1st December, 1964.

And the Honorable Ronald William Mack, Her Majesty's Minister of Health for the State of Victoria, shall give the necessary directions herein accordingly.

N. G. WISHART,  
Clerk of the Executive Council.

#### ROYAL COMMISSION INTO KING'S BRIDGE.

*At Government House, Melbourne, the sixteenth  
day of October, 1962.*

PRESENT:

His Excellency the Governor of Victoria.  
Mr. Bloomfield | Mr. Petty.  
Mr. Meagher

HIS Excellency the Governor of the State of Victoria, in the Commonwealth of Australia, by and with the advice of the Executive Council of the said State, and in pursuance of the powers conferred by the Public Accounts and Stores Regulations made under the provisions of the *Audit Act 1958* and all other powers him thereunto enabling, doth by this Order sanction a maximum expenditure of the sum of Twelve thousand eight hundred pounds (£12,800) by the Royal Commission appointed to inquire into the failure of the bridge known as "King's Bridge".

And the Honorable Arthur Gordon Rylah, Her Majesty's Chief Secretary for the State of Victoria, shall give the necessary directions herein accordingly.

N. G. WISHART,  
Clerk of the Executive Council.

## COMPANIES ACT 1961.

At Government House, Melbourne, the  
sixteenth day of October, 1962.

## PRESENT:

His Excellency the Governor of Victoria.  
Mr. Bloomfield | Mr. Petty.  
Mr. Meagher

ORDER UNDER SECTION 318 (3) OF THE  
COMPANIES ACT 1961.

WHEREAS, pursuant to the provisions of sub-section (3) of section 318 of the *Companies Act 1961*, the Governor in Council may by Order published in the *Government Gazette* declare a State or Territory of the Commonwealth to be a proclaimed State for the purposes of the said section 318 if it appears to him that an enactment in force in any such State or Territory contains provisions similar to the said section 318:

And whereas His Excellency the Governor of the State of Victoria, with the advice of the Executive Council thereof, is satisfied that an enactment containing similar provisions to the said section 318 is in force in the State of Western Australia:

Now, therefore, I, the Governor of the State of Victoria, by and with the advice of the Executive Council thereof, do hereby order that the said State of Western Australia shall be a proclaimed State for the purposes of section 318 of the *Companies Act 1961*.

And the Honorable Arthur Gordon Rylah, Her Majesty's Attorney-General for the State of Victoria, shall give the necessary directions herein accordingly.

N. G. WISHART,  
Clerk of the Executive Council.

## COMPANIES ACT 1961.

At Government House, Melbourne, the  
sixteenth day of October, 1962.

## PRESENT:

His Excellency the Governor of Victoria  
Mr. Bloomfield | Mr. Petty.  
Mr. Meagher

ORDER UNDER SECTION 348 (5) OF THE  
COMPANIES ACT 1961.

WHEREAS, pursuant to the provisions of sub-section (5) of section 348 of the *Companies Act 1961*, the Governor in Council may by Order published in the *Government Gazette* declare a class of companies incorporated under the law of another State or Territory of the Commonwealth to be a class of companies of a kind the same or substantially the same as exempt proprietary companies under the *Companies Act 1961*:

And whereas His Excellency the Governor of the State of Victoria, with the advice of the Executive Council thereof, is satisfied that exempt proprietary companies under the laws that are in force in the State of Western Australia are of a class of the same kind as exempt proprietary companies under the *Companies Act 1961*:

Now, therefore, I, the Governor of the State of Victoria, by and with the advice of the Executive Council thereof, do hereby order that exempt proprietary companies under the laws in force in the said State of Western Australia shall be companies of a class of a kind the same as exempt proprietary companies under the *Companies Act 1961*.

And the Honorable Arthur Gordon Rylah, Her Majesty's Attorney-General for the State of Victoria, shall give the necessary directions herein accordingly.

N. G. WISHART,  
Clerk of the Executive Council.

## EXPLOSIVES ACT 1958.

At Government House, Melbourne, the sixteenth  
day of October, 1962.

## PRESENT:

His Excellency the Governor of Victoria.  
Mr. Bloomfield | Mr. Petty.  
Mr. Meagher

## CLASSIFICATION OF EXPLOSIVES.

HIS Excellency the Governor of the State of Victoria, by and with the advice of the Executive Council thereof, and in pursuance of the provisions of section 53 of the *Explosives Act 1958*, doth by this Order classify the under-mentioned explosives as follows:—

## CLASS 3—NITRO-COMPOUND.

## Division 2.

Vibronite-B (Not for General Sale) (ZZ).

## CLASS 6—AMMUNITION.

## Division 2.

Titan 20 Booster (Not for General Sale) (Z).

## Division 3.

Vibrocap SR Electric Blasting Caps (Not for General Sale) (Z).

And the Honorable Arthur Gordon Rylah, Her Majesty's Chief Secretary for the State of Victoria, shall give the necessary directions herein accordingly.

N. G. WISHART,  
Clerk of the Executive Council.

## LABOUR AND INDUSTRY ACT 1958.

At Government House, Melbourne, the sixteenth  
day of October, 1962.

## PRESENT:

His Excellency the Governor of Victoria.  
Mr. Bloomfield | Mr. Petty.  
Mr. Meagher

APPOINTMENT OF DEPUTY-PRESIDENT OF  
INDUSTRIAL APPEALS COURT.

IN pursuance of the powers conferred by the *Labour and Industry Act 1958*, His Excellency the Governor of the State of Victoria, by and with the advice of the Executive Council thereof, doth by this Order appoint for a term of five years from the 16th day of October, 1962—

## NORMAN FREDERICK MITCHELL

to be the Deputy-President of the Industrial Appeals Court, to act in any case where the President is unable to act.

And the Honorable George Oswald Reid, Her Majesty's Minister of Labour and Industry for the State of Victoria, shall give the necessary directions herein accordingly.

N. G. WISHART,  
Clerk of the Executive Council.

## STAMPS ACT 1958 (No. 6375).

At Government House, Melbourne, the sixteenth  
day of October, 1962.

## PRESENT:

His Excellency the Governor of Victoria.  
Mr. Bloomfield | Mr. Petty.  
Mr. Meagher

REVOCATION OF DECLARATION OF APPROVED  
VENDORS.

HIS Excellency the Governor of the State of Victoria, by and with the advice of the Executive Council thereof, doth by this Order made pursuant to section 131c of the *Stamps Act 1958* (No. 6375), revoke the declaration

made on the 21st February, 1961, and published in the *Government Gazette* of the 22nd February, 1961, declaring certain persons to be "approved vendors" for the purposes of subdivision (14) of Division three of Part II. of the *Stamps Act 1958* in so far as the said declaration refers to the under-mentioned person—

175. Delfair Investments Company.

And the Honorable Henry Edward Bolte, Her Majesty's Treasurer for the State of Victoria, shall give the necessary directions herein accordingly.

N. G. WISHART,  
Clerk of the Executive Council.

#### STAMPS ACT 1958 (No. 6375).

*At Government House, Melbourne, the sixteenth day of October, 1962.*

##### PRESENT:

His Excellency the Governor of Victoria.  
Mr. Bloomfield | Mr. Petty.  
Mr. Meagher

#### REVOCATION OF DECLARATION OF APPROVED VENDORS.

HIS Excellency the Governor of the State of Victoria, by and with the advice of the Executive Council thereof, doth by this Order made pursuant to section 131C of the *Stamps Act 1958* (No. 6375), revoke the declaration made on the 16th February, 1960, and published in the *Government Gazette* of the 17th February, 1960, declaring certain persons to be "approved vendors" for the purposes of subdivision (14) of Division three of Part II. of the *Stamps Act 1958* in so far as the said declaration refers to the under-mentioned person—

126. Canberra Television Services Pty. Ltd.

And the Honorable Henry Edward Bolte, Her Majesty's Treasurer for the State of Victoria, shall give the necessary directions herein accordingly.

N. G. WISHART,  
Clerk of the Executive Council.

#### COMPANIES ACT 1961.

*At Government House, Melbourne, on the sixteenth day of October, 1962.*

##### PRESENT:

His Excellency the Governor of Victoria.  
Mr. Bloomfield | Mr. Petty.  
Mr. Meagher

WHEREAS by Proclamation made on the 15th day of August, 1961, pursuant to the provisions of Division 4 of Part V. of the *Companies Act 1958*, the Governor in Council specified—

Credit Endorsement and Guarantee Limited;  
K. Rees Emporiums Limited;  
Credit Advisory Service Pty. Limited;  
Congressional Nominee Company Proprietary Limited;  
K. Rees Slaks Co. of Australia Proprietary Limited;  
Rees Ringwood Emporium Proprietary Limited;  
Tilsworth Development Proprietary Limited; and  
Horsham-Kyosan Engineering Co. Limited,

for the purposes of the said Act: And whereas by Order dated the 17th August, 1961, the Governor in Council appointed JOHN ANGUS NIMMO to be an Inspector to investigate the affairs of the said companies: And whereas such investigation was duly made and the Inspector furnished his report as required by the said Act: Now therefore, having regard to all the circumstances I, the Governor of Victoria, by and with the advice of the Executive Council thereof and under and by virtue of the powers conferred by the provisions of Division 4 of Part VI. of the *Companies Act 1961*, think it proper to direct that the expenses of and incidental to the said investigation, details of which appear in the Schedule hereto, shall be paid by the under-mentioned companies to Her Majesty, and hereby direct accordingly—

Credit Endorsement and Guarantee Limited;  
K. Rees Emporiums Limited;  
Credit Advisory Service Pty. Limited;  
Congressional Nominee Company Proprietary Limited;  
K. Rees Slaks Co. of Australia Proprietary Limited;  
Rees Ringwood Emporium Proprietary Limited; and  
Tilsworth Development Proprietary Limited.

#### SCHEDULE.

	£	s.	d.
Fees of the competent inspector in carrying out the investigation .. .. .	4,649	8	0
Transcript costs—Janet McInnes and Associates .. .. .	477	17	6
Accountant's fees—Brown and Waters .. .. .	544	0	0
Miscellaneous .. .. .	201	3	7

And the Honorable Arthur Gordon Rylah, Her Majesty's Attorney-General for the said State, shall give the necessary directions herein accordingly.

N. G. WISHART,  
Clerk of the Executive Council.

#### WANGARATTA WATERWORKS TRUST.

*At Government House, Melbourne, the sixteenth day of October, 1962.*

##### PRESENT:

His Excellency the Governor of Victoria.  
Mr. Bloomfield | Mr. Petty.  
Mr. Meagher

#### AMENDMENT OF ORDER.

UNDER the powers conferred by the Water Acts and all other powers enabling him in that behalf, His Excellency the Governor of the State of Victoria, by and with the advice of the Executive Council of the said State, doth hereby amend as follows the Order in Council made on the 16th January, 1962, and published in the *Victoria Government Gazette*, dated 17th January, 1962, authorizing the Wangaratta Waterworks Trust to obtain a bank overdraft under the provisions of section 286 of the *Water Act 1958* (No. 6413).

For the expression "Seven thousand five hundred pounds (£7,500)" there shall be substituted the expression "Ten thousand pounds (£10,000)".

And the Honorable Wilfred John Mibus, Her Majesty's Minister of Water Supply for the State of Victoria, shall give the necessary directions herein accordingly.

N. G. WISHART,  
Clerk of the Executive Council.

#### PAYNESVILLE WATERWORKS TRUST.

*At Government House, Melbourne, the sixteenth day of October, 1962.*

##### PRESENT:

His Excellency the Governor of Victoria.  
Mr. Bloomfield | Mr. Petty.  
Mr. Meagher

#### AMENDMENT OF ORDER.

UNDER the powers conferred by the Water Acts and all other powers enabling him in that behalf, His Excellency the Governor of the State of Victoria, by and with the advice of the Executive Council of the said State, doth hereby amend as follows the Order in Council made on the 14th March, 1962, and published in the *Victoria Government Gazette*, dated the 21st March, 1962, fixing the limit of the overdraft to be obtained by the Paynesville Waterworks Trust.

For the expression "at an amount not to exceed at any one time the sum of Ten thousand pounds (£10,000)", there shall be substituted the expression "at an amount not to exceed at any one time the sum of Twenty thousand pounds (£20,000)".

And the Honorable Wilfred John Mibus, Her Majesty's Minister of Water Supply for the State of Victoria, shall give the necessary directions herein accordingly.

N. G. WISHART,  
Clerk of the Executive Council.

## WODONGA SEWERAGE AUTHORITY.

At Government House, Melbourne, the  
sixteenth day of October, 1962.

PRESENT:

His Excellency the Governor of Victoria.  
Mr. Bloomfield | Mr. Petty.  
Mr. Meagher

## POWER TO BORROW £20,000.

UNDER the powers conferred by the *Sewerage Districts Act 1958* and all other powers enabling him in that behalf, His Excellency the Governor of the State of Victoria, by and with the advice of the Executive Council of the said State, doth hereby consent to the Wodonga Sewerage Authority borrowing at interest, a sum of Twenty thousand pounds (£20,000) for the carrying out of works in accordance with the provisions of sections 95, 130 and 137 of the *Sewerage Districts Act 1958*, the said sum to be borrowed by way of overdraft from the Commercial Banking Company of Sydney Limited. All moneys received by the said Authority in repayment of costs and expenses of the said works, or any of them, shall be set aside for the purpose of and applied in repayment of the said sum so borrowed.

And the Honorable Wilfred John Mibus, Her Majesty's Minister of Water Supply for the State of Victoria, shall give the necessary directions herein accordingly.

N. G. WISHART,  
Clerk of the Executive Council.

## BACCHUS MARSH SEWERAGE AUTHORITY.

At Government House, Melbourne, the  
sixteenth day of October, 1962.

PRESENT:

His Excellency the Governor of Victoria.  
Mr. Bloomfield | Mr. Petty.  
Mr. Meagher

## AMENDMENT OF ORDER.

UNDER the powers conferred by the *Sewerage Districts Acts* and all other powers enabling him in that behalf, His Excellency the Governor of the State of Victoria, by and with the advice of the Executive Council of the said State, doth hereby amend as follows the Order in Council proclaiming the Sewerage District and constituting the Bacchus Marsh Sewerage Authority made on the 25th October, 1949, as amended by Orders in Council made on the 20th June, 1961, and 31st January, 1962, and published in the *Victoria Government Gazette*, dated the 2nd November, 1949, 21st June, 1961 and 7th February, 1962, respectively.

In clause (a) for the expression "Two hundred thousand pounds (£200,000)", there shall be substituted the expression "Three hundred thousand pounds (£300,000)".

And the Honorable Wilfred John Mibus, Her Majesty's Minister of Water Supply for the State of Victoria, shall give the necessary directions herein accordingly.

N. G. WISHART,  
Clerk of the Executive Council.

## TRARALGON SEWERAGE AUTHORITY.

At Government House, Melbourne, the  
sixteenth day of October, 1962.

PRESENT:

His Excellency the Governor of Victoria.  
Mr. Bloomfield | Mr. Petty.  
Mr. Meagher

## POWER TO BORROW £30,000.

UNDER the powers conferred by the *Sewerage Districts Acts* and all other powers enabling him in that behalf, His Excellency the Governor of the State of Victoria, by and with the advice of the Executive Council of the said State, doth hereby consent to the

Traralgon Sewerage Authority borrowing at interest an additional sum of Thirty thousand pounds (£30,000) for the carrying out of works in accordance with the provisions of sections 95, 130 and 137 of the *Sewerage Districts Act 1958*, the said sum to be borrowed by way of overdraft from the Commonwealth Trading Bank of Australia. All moneys received by the said Authority in repayment of costs and expenses of the said works, or any of them, shall be set aside for the purpose of and applied in repayment of the said sum so borrowed.

And the Honorable Wilfred John Mibus, Her Majesty's Minister of Water Supply for the State of Victoria, shall give the necessary directions herein accordingly.

N. G. WISHART,  
Clerk of the Executive Council.

## APPROACHING LAND SALES.

SALES of Crown lands, in fee-simple, will be held at the under-mentioned places and dates, viz.:-

	No. of Gazette.
Bendigo.—Thursday, 29th November, 1962 ..	112
Dartmoor.—Monday, 19th November, 1962 ..	111
Foster.—Wednesday, 31st October, 1962 ..	104
Melbourne.—Wednesday, 24th October, 1962 ..	98
Ouyen.—Friday, 19th October, 1962 ..	98
Portland.—Monday, 19th November, 1962 ..	111
Robinvale.—Tuesday, 23rd October, 1962 ..	101
Rochester.—Thursday, 1st November, 1962 ..	104
Seymour.—Friday, 19th October, 1962 ..	101
Tallangatta.—Tuesday, 23rd October, 1962 ..	104
Warragul.—Tuesday, 13th November, 1962 ..	111

## SALE OF CLOSER SETTLEMENT LAND BY AUCTION.

Stanhope.—Thursday, 1st November, 1962 .. 104

## SALE OF CROWN LAND BY AUCTION.

The land will be offered for sale in fee-simple, and subject to the provisions of the Land Act and Regulations thereunder.

The upset price is the sum at which bidding will start, and no bid below that sum can be accepted. The highest bidder at or above that sum shall be the purchaser, subject to signature of contract and any necessary payment.

## TERMS:

A deposit of at least 12½% of the purchase price must be paid at the sale, either in cash or by cheque.

The residue is payable in half-yearly instalments, in accordance with the following scale, or may be paid off at any earlier time.

£20 and under, 6 instalments.

Over £20, and not exceeding £50, 8 instalments.

Over £50, and not exceeding £100, 10 instalments.

Over £100, and not exceeding £200, 12 instalments.

Over £200, and not exceeding £300, 14 instalments.

Over £300, and not exceeding £400, 16 instalments.

Over £400, and not exceeding £500, 18 instalments.

Over £500, 20 instalments.

Interest at the rate of 5% per annum is payable with all payments of residue, and is computed for each instalment from the date of sale to the date of such payment. Additional interest is charged if any instalment is not paid on or before the due date.

If paid off within 30 days of sale, no interest is payable.

## FEES, ETC.:

Also payable at the sale, in addition to the deposit, are the survey fee and, if applicable, the valuation of improvements (if purchaser be not the owner thereof).

## Payable with balance of purchase money—

Crown Grant fee—50 acres and under .. £1 10s.

Over 50 acres .. £2

Purchase money £5 or under £1

Assurance Fund contribution—One halfpenny for each £1 of purchase price. (This is a fund established to guarantee the validity of freehold titles.)

Transfer of interest prior to completion of payment may be allowed on payment of £1 fee and subject to stamp duty.

If unable to attend personally, a prospective purchaser may arrange for another person to bid as his agent.

KEITH TURNBULL,  
Commissioner of Crown Lands and Survey.

Office of Crown Lands and Survey,  
Melbourne, 17th October, 1962.

**BENDIGO.**—Sale (No. 11638) of Crown land in fee-simple, by auction, will be held at the ROOMS OF JAMES ANDREW & CO., 7 QUEEN-STREET, BENDIGO, on THURSDAY, the 29th NOVEMBER, 1962, at TEN o'clock a.m.

To be conducted by G. E. HARPIN, Land Officer, Bendigo. Auctioneers, JAMES ANDREW & CO., 7 Queen-street, Bendigo.

Lot 1.

AT BENDIGO, PARISH OF SANDHURST, COUNTY OF BENDIGO.  
*Fronting the East side of Britain-street, about 2 chains South of Excell-street.*

Upset price £3,225 the lot. Survey fee £6.  
Area 27 perches, allotment 29 of section P.—(W.85129.)

Lot 2.

AT EAGLEHAWK, PARISH OF NERRING, COUNTY OF BENDIGO.  
*At Myers Flat. Fronting the North side of Williams-road, about 1½ miles West of Bendigo-Kulwin railway line.*

Upset price £25 the lot. Survey fee £8 10s.  
Area 2a. 3r., subject to survey, allotment 379B of section A. Subject to water-race easement. One month allowed for removal of fencing.—(W.66336.)

TOWNSHIP OF HUNTLY, PARISH OF HUNTLY, COUNTY OF BENDIGO.

*In the North-east corner of the Township, about 7 chains West of the C.R.B. Main Road.*

Lot 3.

Upset price £50 the lot. Survey fee £7.  
Area 1a. 1r. 19p., allotment 3 of section 18.

Lot 4.

Upset price £90 the lot. Survey fee £7 7s. 6d.  
Area 2a. 0r. 29p., allotment 4 of section 18.—(W.82523.)

Lot 5.

TOWNSHIP OF RAVENSWOOD, PARISH OF RAVENSWOOD, COUNTY OF BENDIGO.  
*In the South of the Township, fronting East side of Calder Highway, about 300 yards South of State School.*

Upset price £95 the lot. Survey fee £9 12s. 6d.  
Area 5a. 1r., subject to survey, allotment 94. One month allowed for removal of improvements.  
*Note.*—Allotment 94 as now offered comprises land hitherto shown on plans as allotments 86, 88, 89, 90, 91 and part of 87.—(W.83892.)

PARISH OF SANDHURST, COUNTY OF BENDIGO.

Lot 6.

*Fronting North side of a road near Sparrowhawk Gully, about 2 chains South-west of Harvey-street.*

Upset price £40 the lot. Survey fee £8 10s.  
Area 1a. 2r. 28p., allotment 73 of section L.—(W.83101.)

Lot 7.

*Fronting the South side of Albert-street, about 3 chains West of Daniel-street.*

Upset price £25 the lot. Survey fee £6.  
Area 1r. 17p., allotment 397G of section A. Subject to drainage easement.—(W.63435.)

Lot 8.

PARISH OF MARONG, COUNTY OF BENDIGO.  
*At Wilson's Hill, fronting South side of a gravel road, about 4 chains East of the State School.*

Upset price £80 the lot. Survey fee £12 5s.  
Area 17a. 2r. 36p., allotment 9 of section 5. Subject to S.E.C. easement near north-eastern corner. One month allowed for removal of improvements.

*Note.*—This allotment surrounds, but does not include, the area occupied by tennis courts, &c.

PARISH OF NEILBOROUGH, COUNTY OF BENDIGO.

Lot 9.

*Fronting North side of a road, about 15 chains East of the Township of Neilborough.*

Upset price £70 the lot. Survey fee £11 5s.

Area 20a. 1r. 10p., allotment 11J of section D. Subject to water-race easement 15 links wide. Grantee shall not be entitled to compensation for any damage to be done by mining (section 81, *Land Act 1958*).—(W.84657.)

Lot 10.

*Fronting South side of a road, about 20 chains East of the Township of Neilborough.*

Upset price £60 the lot. Survey fee £10 2s. 6d.

Area 12a. 2r. 27p., allotment 47B of section G. Grantee shall not be entitled to compensation for any damage to be done by mining (section 81, *Land Act 1958*). One month allowed for removal of improvements.—(W.84656.)

PARISH OF MANDURANG, COUNTY OF BENDIGO.

Lot 11.

*About 1½ miles South of the Township of Kangaroo Flat, fronting the East side of the Western arm of Stanley-crescent.*

Upset price £80 the lot. Survey fee £8 10s.

Area 2a. 1r. 21p., allotment 86C of section D. Subject to a number of water-race easements.—(W.68313.)

Lot 12.

*About ¼ mile North-east of the Township of Mandurang, fronting East side of a gravel road.*

Upset price £160 the lot. Survey fee £10 2s. 6d.

Area 19a. 2r., subject to survey, allotment 8 of section 18. Subject to water-race easements. Grantee shall not be entitled to compensation for any damage to be done by mining (section 81, *Land Act 1958*). One month allowed for removal of improvements.—(W.84396.)

Lot 13.

*About 1 mile North of Township of Mandurang.*

Upset price £35 the lot. Survey fee £7 12s. 6d.

Area 3a. 1r., subject to survey, allotment 6C of section 17. One month allowed for removal of improvements.—(W.62421.)

*Land Settlement Act 1959.*

LAND AVAILABLE FOR APPLICATION.

NOTIFICATION is hereby given in accordance with section 7 of the *Land Settlement Act 1959*, that the under-mentioned holdings are available for settlement.

Any male person who is not less than 21 years of age and who is a British subject may apply on the prescribed form for settlement on any holding or holdings, indicating where he applies in respect of more than one holding his order of preference therefor.

Prescribed application forms, plans, and further details may be obtained from the Settlement Branch, Rural Finance and Settlement Commission, State Public Offices, Melbourne, C.2.

Closing date for receipt of completed application forms for settlement on these holdings is the 5th November, 1962, such applications to be in the hands of the Deputy Secretary, Rural Finance and Settlement Commission, on or before that date.

M. J. CRONIN,  
Deputy Secretary.

Rural Finance and Settlement Commission,  
Melbourne, C.2, 15th October, 1962.

SCHEDULE OF ALLOTMENTS.

SUBDIVISION OF FIFTH PORTION OF YANAKIE ESTATE  
PARISHES OF YANAKIE AND YANARIE SOUTH—COUNTY OF BULN BULN.

*Suitable for Dairying with some Mixed Farming.*

Lot Number on Plan of Subdivision.	Approximate Area in Acres (Subject to Survey).
25	245
26	230
27	235
28	212
29	212
30	200
31	200

LIST OF CROWN LANDS AVAILABLE.

THE under-mentioned areas are available for application as provided by various sections of the Land Act 1958, and all applications received on or before Friday, 15th November, 1962, will be deemed to have been made simultaneously, but any application lodged after such date may be considered if received in time for inclusion in the advertisement of the cases to be heard at the Local Land Board. Applications on proper form, accompanied by 5s. duty stamp uncancelled (registration fee), may be delivered or forwarded by post to the Local Land Officer or to any Crown Lands Office in Victoria. Subject to the approval of the Secretary for Lands, when the survey fee exceeds £25 but does not exceed £50, a deposit of £25 may be paid, and when the fee exceeds £50, a deposit of 50 per cent. of the fee, the balance in either case being payable over six years in half-yearly instalments.

Marked plans of any particular area, application forms, and any further information may be obtained from the Crown Lands Department, Melbourne, and Land Office, Red Cliffs.

Department of Crown Lands and Survey,  
Melbourne, 15th October, 1962.

KEITH TURNBULL,  
Commissioner of Crown Lands and Survey.

\* Improvements may be subject to re-valuation after land has been granted to an applicant.

Local Land Office.	County.	Parish.	Allotment.	Area.	How Available.		Survey Fee.	Valuation of Improvements (if any).	Location of Land, &c.	Nearest Railway Station or Township and Distance in miles therefrom.	How Accessible.	Water Supply.	General Description of Land—Soil, Timber, Suitability (Grazing, &c.).		
					Classification.	Value per Lot									
					A.	R.	F.								
					£	s.	d.								
Red Cliffs.	Karkaroc	Township and Parish of Ouyen	17-24	0 0 32±	..	Rental to be fixed	6 0 0	..	In the East of the township	Ouyen R. S.—½ mile	Gravelled road	To be conserved	Red sandy loam and limestone hilltop; suitable for residence purposes		
			25-26	0 0 22±	..	..	per lot	..	..	..	..	..	..	..	
			27-28	0 0 30±	16	..	..	..	..	..	..	..	..	..	..
			29-30	0 0 22±	..	..	..	..	..	..	..	..	..	..	..
			31-38	0 0 32±	..	..	..	..	..	..	..	..	..		

AVAILABLE UNDER SECTION 138 OF THE LAND ACT 1958.



**PROPOSED REVOCATIONS OF TEMPORARY RESERVATIONS OF LANDS BY ORDERS IN COUNCIL.**

IN pursuance of the provisions of the *Land Act 1958*, notice is hereby given that it is the intention of the Governor in Council to revoke the temporary reservations of lands by Orders in Council hereunder referred to, viz.:-

The following Notices were published 1° on the 10th October, 1962, pursuant to Orders of the 2nd October, 1962.

**CASTLEMAINE (KALIMNA PARK).**—The temporary reservation, by Order in Council of the 10th February, 1910, of 6 acres 0 roods 48/10 perches in the Parish of Castlemaine, as a site for a Public Park, in addition to the site temporarily reserved therefor by Order in Council of the 18th August, 1868 (see *Government Gazette* of the 25th August, 1868, page 1579).—C.100(33) (Rs.178).

**CASTLEMAINE (KALIMNA PARK).**—The temporary reservation, by Order in Council of the 18th August, 1868, (see *Government Gazette* of the 25th August, 1868, page 1579), of 290 acres more or less of land in the Parish of Castlemaine, as a site for a Public Park, revoked as to part by various Orders, is about to be revoked, so far only as the portion containing 20 acres 0 roods 5 perches more or less indicated by hachure on plan hereunder, is concerned.—(C.100(33) (Rs.178).

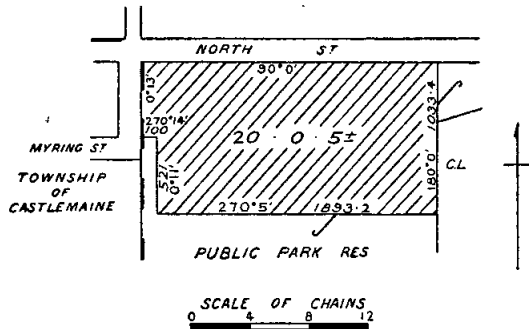

KEITH TURNBULL,  
Commissioner of Crown Lands and Survey.

**PROPOSED REVOCATION OF TEMPORARY RESERVATION, AND THE WITHHOLDING FROM SALE, LEASING, AND LICENSING, OF LAND BY ORDER IN COUNCIL.**

IN pursuance of the provisions of the *Land Act 1958*, notice is hereby given that it is the intention of the Governor in Council to revoke the temporary reservation, and the withholding from sale, leasing, and licensing, of land by Order in Council hereunder referred to, viz.:-

The following Notice was published 1° on the 17th October, 1962, pursuant to an Order of the 9th October, 1962.

**WARRENMANG.**—The temporary reservation as a site for Watering purposes and the withholding from sale, leasing and licensing by Order in Council of the 22nd April, 1879 (see *Government Gazette* 25th April, 1879, page 928), of 10 acres 0 roods 32 perches of land in the Parish of Warrenmang.—(W.42(4) (C.83363).

KEITH TURNBULL,  
Commissioner of Crown Lands and Survey.

**PROPOSED REVOCATIONS OF TEMPORARY RESERVATIONS OF LANDS BY ORDERS IN COUNCIL.**

IN pursuance of the provisions of the *Land Act 1958*, notice is hereby given that it is the intention of the Governor in Council to revoke the temporary reservation of land by Order in Council hereunder referred to, viz.:-

The following Notices were published 1° on the 17th October, 1962, pursuant to Orders of the 9th October, 1962.

**AXEDALE.**—The temporary reservation, by Order in Council of the 17th November, 1874, of 2 acres of land in the Parish of Axedale, as a site for State School purposes.—(A.98(3) (Rs.3664).

No. 112.—8880/62.—3

**CONNEMARREN.**—The temporary reservation, by Order in Council of the 23rd October, 1906, of 50 acres of land in the Parish of Connemarren, as a site for Camping and Watering purposes and the Supply of Gravel, so far only as the portion containing 39 acres 3 roods 36 perches, indicated by hachure on plan hereunder, is concerned.—(C.297(B) (Rs.2078).

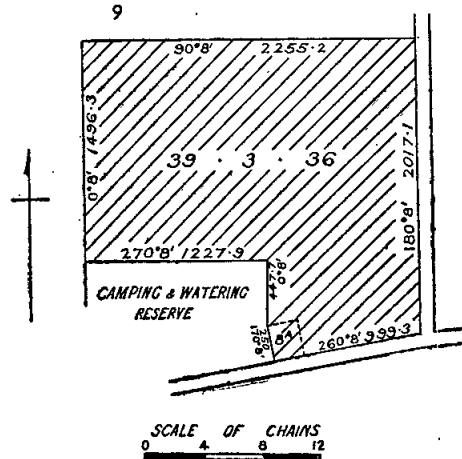

**PYALONG.**—The temporary reservation, by Order in Council of the 13th January, 1868, or 12 acres 1 rood 26 perches of land in the Township of Pyalong, as a site for Police purposes, revoked as to part by Order of the 19th September, 1938, is about to be revoked, so far only as the portion containing 5 perches, indicated by hachure on plan hereunder, is concerned.—(P.113(3) (Rs.1989).

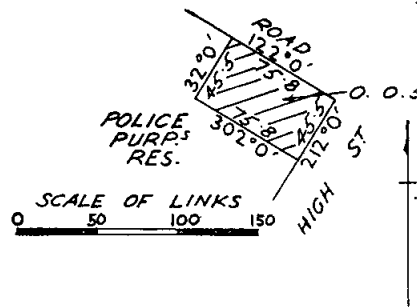

**WALPEUP.**—The temporary reservation, by Order in Council of the 13th November, 1923, of 416 acres 3 roods 19 perches of land in the Parish of Walpeup, as a site for Growth and Preservation of Timber.—(W.406(4) (Rs.2871).

**WOORI YALLOCK.**—The temporary reservation, by Order in Council of the 7th April, 1937, of 5 acres of land in the Parish of Woori Yallock, as a site for the Supply of Gravel.—(W.351(3) (Rs.4675).

KEITH TURNBULL,  
Commissioner of Crown Lands and Survey.

**LOCAL LAND BOARDS.**

IN pursuance of the provisions of section 34 of the *Land Act 1958*, notice is hereby given that a public hearing, at the following place and time, will be conducted by the person respectively mentioned, being duly appointed in that behalf.

KEITH TURNBULL,  
Commissioner of Crown Lands and Survey.

Department of Crown Lands and Survey,  
Melbourne.

**SCHEDULE.**

FOSTER LAND INSPECTOR'S OFFICE, Wednesday,  
31st October, 1962, at 2.30 p.m.—J. A. Murphy.

## Land Act 1958.

## LICENCES UNDER THE LAND ACTS 1928 AND 1958 DECLARED VOID.

NOTICE is hereby given that the Licences in the Schedule hereunder have been Declared Void for the reason specified in each case.

## SCHEDULE.

District.	Corr. No.	Name of Licensee.	Section of Land Act under which Licensed.	Parish.	Allotment.	Section.	Area.		Annual Rental.	Reason for Voiding.
							A. R. P.	£ s. d.		
Castle- maine Melbourne	0416/138	A. R. Woodberry..	138	Castlemaine	4	153	0 1 0	2 10 0	Surrendered—Rent paid to 31.12.61	
	2492/129	Country Roads Board	129	Melbourne South	105	..	1 0 25 $\frac{1}{10}$	390 0 0	Cancelled as at 15.8.62	

Department of Crown Lands and Survey,  
Melbourne, 12th October, 1962.

KEITH TURNBULL,  
Commissioner of Crown Lands and Survey.

## COMMITTEES OF MANAGEMENT OF RESERVES.

## APPOINTMENTS.

WHEREAS by section 221 of the *Land Act 1958* it is provided that it shall be lawful for the Governor in Council or the Board of Land and Works to appoint and remove any number of persons, not less than three, or any municipal council, or the governing body of any corporation, to be a Committee of Management of any specified Crown land reserved either temporarily or permanently for any of the purposes set out in section 14 of the *Land Act 1958*, and not conveyed to or vested in trustees: Now therefore the Board of Land and Works doth hereby appoint the under-mentioned persons to be members of the Committee of Management of the Reserves named:—

## "TOONGABBIE NORTH RACECOURSE AND RECREATION RESERVE."

Albert Hazel Ries, Norman James Goodwin, Patrick McGrath, Robert Henry Mitchell, George Robert Williams, Robert Clyde Andrews, Harold Norman Keith Wood, Archibald Ries, Frederick George Humphrey, John Alexander Farquharson, Alan Anton, Colin Ole Coleman, Allan Bryce Blair and John Armstrong Henderson as a Committee of Management for a period of three (3) years of the land temporarily reserved by Order in Council dated 21st July, 1884, as a site for Racecourse and other purposes of Public Recreation in the Parish of Toongabbie North, and known as the "Toongabbie North Racecourse Reserve".—(Corres. Rs.1752.)

## "ROSEBUD MECHANICS' INSTITUTE."

The Council of the Shire of Flinders as a Committee of Management of the land in the Township of Rosebud, Parish of Wannaeue, permanently reserved by Order in Council dated the 2nd December, 1888, as a site for a Mechanics' Institute and Free Library, and known as the "Rosebud Mechanics' Institute".—(Corres. Rs.2065.)

## "TRENTHAM MECHANICS' INSTITUTE RESERVE."

Albert Stanley Wilson, Edwin Phillip Robson, Kenneth Stanley Andrews, Ralph Herbert Gamble, James Thomson Hutcheson, Russell James Rithie, Kevin Muir, Matthew John Hammond, John William Leslie Groves, Gerard Rahill, John Charles Mayne, Gweneth Wisewould and Jean V. Shaw as a Committee of Management for a period of three (3) years of the land temporarily reserved by Order in Council dated the 17th February, 1879, as a site for a Mechanics' Institute in the Township of Trentham, and known as the "Trentham Mechanics' Institute Reserve".—(Corres. Rs.2874.)

## "QUEENSLIFF RECREATION RESERVE."

Norman Victor Hutchins (for so long only as he continues to be a Councillor and the elect of the Council of the Borough of Queenscliffe) in the place of Robert Fraser (no longer a Councillor) as a member of the Committee of Management of the land in the Township of Queenscliff, Parish of Paywit permanently reserved by Order in Council of 30th March, 1931, as a site for the Recreation of the People, and known as the "Queenscliff Recreation Reserve".—(Corres. Rs.4111.)

## "KERGUNYAH MEMORIAL HALL RESERVE."

Gabriel John Kelly, Alfred George Jarvis, Charles William Cogdell, Thomas Alexander Nisbet, John Charles Reid, Ian Stewart Wallace and Daniel McCarthy Ley as

a Committee of Management for a period of three (3) years of the land temporarily reserved by Orders in Council dated the 12th June, 1923, and 4th July, 1928, as sites for a Public Hall in the Parish of Kergunyah North, and known as the "Kergunyah Memorial Hall Reserve".—(Corres. Rs.2767.)

## "QUAMBATOOK MECHANICS' INSTITUTE RESERVE."

Lewis Arthur Williamson, William Hector Parker, Edmund Alfred Adamthwaite, Keith Williamson and Thomas Vincent Hogan as a Committee of Management for a period of three (3) years of the land temporarily reserved by Order in Council dated 29th August, 1898, as a site for a Mechanics' Institute and Free Library at Quambatook, and known as the "Quambatook Mechanics' Institute Reserve".—(Corres. Rs.2633.)

## "CAPE PATERSON BEACH RESERVE."

Francis Valentine Turner (for so long only as he continues to be a Councillor and the elect of the Council of the Borough of Wonthaggi) in the place of Dominic Dobson (retired) as a member of the Committee of Management of that portion of the reserved Crown lands in the Parish of Wonthaggi as is indicated by red colour on plan marked W/16.8.44 attached to Lands Department correspondence Rs.4057, and known as the "Cape Paterson Beach Reserve".—(Corres. Rs.4057.)

## "KOONYA OCEAN PARK RESERVE."

Walter Edward Davies, Arthur Roy Tapson, Victor George Keating, Victor Arthur Jones, Stanley Gordon Doery, Raymond Christoph Fricke and Seddon John Kirwan as a Committee of Management for a period of three (3) years of the land in the Parish of Nepean indicated by red colour on plan marked "S" over 1.12.53 attached to Lands Department correspondence Rs.7224, and known as the "Koonya Ocean Park Reserve".—(Corres. Rs.7224.)

## "YARRA BANK-ROAD PUBLIC PARK RESERVE."

The Council of the City of South Melbourne as a Committee of Management of the land in the Parish of Melbourne South, City of South Melbourne temporarily reserved by Order in Council dated the 17th July, 1962, as a site for a Public Park.—(Corres. Rs.8136.)

## "YEA RACECOURSE RECREATION RESERVE."

William Anderson Purcell, Douglas Royce Morgan, Daniel Joseph O'Connor, Vernon Neville Sheahan and Frank Victor Slevin as a Committee of Management for a period of three (3) years of the land temporarily reserved by Order in Council dated the 7th September, 1903, as a site for a Racecourse and other purposes of Public Recreation in the Parish of Yea, and known as the "Yea Racecourse and Public Recreation Reserve".—(Corres. Rs.410.)

In witness whereof the common seal of the Board of Land and Works was hereunto affixed this tenth day of October, One thousand nine hundred and sixty-two, in the presence of—

(SEAL) KEITH TURNBULL, President.  
F. KLENNER, Member.

## PUBLIC SERVICE NOTICES

## PUBLIC SERVICE (PUBLIC SERVICE BOARD) REGULATION 52.—RECLASSIFICATIONS.

THE Public Service Board has raised the classification of the under-mentioned offices as shown, and the Permanent Heads of the Departments have recommended the officers named for appointment.

Office and Present Classification.	Revised Classification.	Duties.	Qualifications.	Officer Recommended for Appointment.		
				Name.	Classification.	Date of Classification.
<b>ADMINISTRATIVE DIVISION.</b>						
<b>EDUCATION DEPARTMENT.</b>						
Class "C1"	Class "C2"	To have charge of the Papers Branch; to be responsible for searching for, and the filing and custody of, most of the official correspondence	Good organizing ability; a knowledge of the Department and its filing and registration systems	O'Connell, B. J.	Class "C1"	7.11.57
<b>PROFESSIONAL DIVISION.</b>						
<b>DEPARTMENT OF HEALTH.</b>						
<i>General Health Branch.</i>						
District Health Officer, Grade I., Class "A1" (£3,075)	Senior District Health Officer, Class "A1" (£3,000)	To be a District Health Officer and to undertake when required the following additional duties throughout the State:— (a) To organize demonstrations and give lectures on cancer its early detection and treatment (b) To co-operate with the Cancer Registry of the Anti-Cancer Council of Victoria in recording cancer incidence and assessment of treatment	A legally qualified medical practitioner registered in Victoria, with a Diploma of Public Health, knowledge and experience in medical statistics and experience in public speaking	Rankin, D. W.	District Health Officer, Grade I., Class "A1" (£3,075)	29.6.58
<i>Office of the Housing Commission.</i>						
Valuer Class "B"	Senior Valuer Class "B1"	To be responsible for all valuations made by the Valuation Section of the Commission, to supervise and make valuations in connexion with the acquisition or purchase by the Commission of real estate, to maintain current valuations involved in the sale of houses and land by the Commission, to negotiate, as required, with owners regarding the acquisition of land by private negotiation or compulsory process	To be entitled to an unrestricted certificate of qualification from the Valuers Qualification Board. Experience in negotiating the purchase of land would be an advantage	Swann, J. H.	Valuer, Class "B"	2.3.61
<b>STATE FORESTS DEPARTMENT.</b>						
Forest Entomologist and Research Officer, Class "B"	Class "B1"	To be in charge of the entomology section, to undertake investigations of insect attack on forest trees and timber, and to organize control measures; to carry out miscellaneous technical investigations; to assist the Chief of the Division of Forestry Education and Forestry Research as directed	A graduate of a recognized School of Forestry with a University degree in forestry or science; adequate experience in the investigation of forest entomological problems and the conduct of control measures; ability to organize research projects; a good knowledge of Victorian forests and forestry practice	Irvine, C. J.	Forest Entomologist and Research Officer, Class "B"	30.11.59

Appeals against such recommendations should be lodged with the Secretary to the Public Service Board not later than Saturday, the 27th October, 1962.

Office of the Public Service Board,  
Melbourne, 16th October, 1962.

By order,  
V. P. SCULLY,  
Secretary.

PUBLIC SERVICE (PUBLIC SERVICE BOARD) REGULATION 52.—VACANCIES.

THE Permanent Head of the Department shown has recommended the officers named hereunder for appointment to the under-mentioned vacancies.

Office and Classification.	Duties.	Qualifications.	Officer Recommended for Appointment.		
			Name.	Classification.	Date of Classification.
<b>TECHNICAL AND GENERAL DIVISION.</b>					
<b>STATE FORESTS DEPARTMENT.</b>					
Forest Overseer, Grade I., Grades 34-36 inclusive	To supervise operations of forest employees and licensees, and to carry out general and fire patrol duties	A good knowledge of the Victorian Forests Act and Regulations and of office procedure, and extensive practical experience of field methods and operations in the State Forests Department	Ampt, W. T. . .	Forest Overseer, Grade II., Grades 32-33 inclusive	3.9.54
Forest Overseer, Grade II., Grades 32-33 inclusive	To supervise operations of forest employees and licensees, and to carry out general and fire patrol duties	A knowledge of the Victorian Forests Act and Regulations and of office procedure and practical experience of field methods and operations in the State Forests Department	Evans, H. . .	Staff Foreman, Grades 19-30 inclusive	8.7.52

Appeals against such recommendations should be lodged with the Secretary to the Public Service Board not later than Saturday, the 27th October, 1962.

Office of the Public Service Board,  
Melbourne, 16th October, 1962

By order,  
V. P. SCULLY,  
Secretary.

No. 1247.

Public Service Act 1958, Section 50.

REGULATIONS.—PART IV.—SALARIES AND INCREMENTS.

THE Public Service Board, in pursuance of the powers conferred by the Public Service Act 1958, hereby amends its Regulations as shown below:—

SIXTH SCHEDULE.  
TEMPORARY EMPLOYEES.

Designations of Positions and Rates of Salaries.

Department and Designation of Position.	Yearly Rate of Salary.		Increments (Annual)
	Minimum.	Maximum.	
DEPARTMENT OF CHIEF SECRETARY.	£	£	
SOCIAL WELFARE.			
Youth Welfare Division.			
Add—Seamstresses .. ..	380	396	1 of £16

A. GARRAN, Chairman.  
V. P. SCULLY, Secretary.

Office of the Public Service Board,  
Melbourne, 1st October, 1962.

PUBLIC SERVICE OF VICTORIA.—VACANCIES.

APPLICATIONS will be received by the Public Service Board up to Wednesday, the 31st October, 1962, from persons employed in the Public Service of Victoria, who are eligible and qualified for appointment to the under-mentioned positions:—

ADMINISTRATIVE DIVISION.

Class "B1", Social Welfare Branch (Prisons Division), Chief Secretary's Department.

Yearly Salary.—£1,630, minimum; £1,770, maximum.

Duties.—To be Chief Clerk of the Prisons Division.

Qualifications.—A knowledge of the Social Welfare Act 1960, Goals Act 1958, Crimes Act 1958, Justices Act 1958 and Police Offences Act 1958, and of the Regulations administered by the Division would be an advantage.

Class "B1", Water Supply Department.

Yearly Salary.—£1,630, minimum; £1,770, maximum.

Duties.—To act as Assistant Staff and Industrial Officer.

Qualifications.—A good knowledge of the provisions of the Public Service Acts and Regulations and some knowledge of Industrial Awards and conditions. A knowledge of the works, activities and organization of the Commission and of the Water Acts is desirable.

Class "B", Mental Hygiene Branch, Department of Health.

Yearly Salary.—£1,390, minimum; £1,500, maximum.

Duties.—In charge of the Mental Defectives Section, including management of Hostels, Departmental Clinics, and Portsea Holiday Home and supervisor of expenditure of Mentally Retarded Children's Centres subsidized by the Branch.

Qualifications.—A good knowledge of the Mental Hygiene Acts and Mental Deficiency Requirements, and of the Public Service Acts and Regulations; ability to control staff.

Class "B", Companies Registration Office, Law Department.

Yearly Salary.—£1,390, minimum; £1,500, maximum.

Duties.—To initiate and make inspections under the powers contained in section 7 of the Companies Act 1961, other duties as the Registrar of Companies directs.

Qualifications.—A qualified Accountant, preferably with a good knowledge of the Companies Act and experience in the practice of auditing.

Class "B", Office of the Public Trustee, Law Department.

Yearly Salary.—£1,390, minimum; £1,500, maximum.

Duties.—To act as a Distribution Officer dealing with the larger and more complex estates.

Qualifications.—A qualified Accountant with a good knowledge of accounts relating to deceased estates, of the provisions of the Administration and Probate Acts, the Public Trustee Acts, the Estate Duty Acts and the regulations thereunder, and ability to prepare Estate Duty Returns and assess Probate duty.

Class "C1", Electoral Office, Chief Secretary's Department.

Yearly Salary.—£960, minimum; £1,060, maximum.

Duties.—Under the direction of the Chief Electoral Officer to assist generally in the duties of the Electoral Office.

Qualifications.—Preferably a knowledge of Electoral Law and Administration.

**Class "C1", Education Department.**

*Yearly Salary.*—£960, minimum; £1,060, maximum.

*Duties.*—To assist with correspondence relating to the establishment and conduct of school bus services; to be responsible for the costing work associated with school bus services.

*Qualifications.*—A knowledge of the requirements relating to the conveyance of pupils to school; ability to deal with correspondence.

**Class "C1", Public Works Department.**

*Yearly Salary.*—£960, minimum; £1,060, maximum.

*Duties.*—To draft correspondence in the General Correspondence Branch; to supervise the preparation of letters of acceptance of tenders, the distribution of inwards mail and correspondence, and the Despatch Section; to assist in the preparation of schedules of expenditure.

*Qualifications.*—Experience in drafting correspondence; ability to control and direct staff. A knowledge of the functions of the Board of Land and Works is desirable.

**Class "C", Public Works Department.**

*Yearly Salary.*—£710, minimum; £860, maximum.

*Duties.*—To maintain staff records relating to appointments, promotions, transfers, increments, &c., and other duties as required.

*Qualifications.*—A good knowledge of the Public Service Acts and Regulations and capable of conducting correspondence.

**Class "C", Accounts Branch, Treasury.**

*Yearly Salary.*—£710, minimum; £860, maximum.

*Duties.*—To keep the Appropriation Ledger, prepare detailed statements of expenditure for inclusion in the Treasurer's Finance statement, and undertake relieving duties when required.

*Qualifications.*—A knowledge of the Treasury system of Accounts, the Audit Act and the Public Accounts and Stores Regulations 1958.

**PROFESSIONAL DIVISION.****Geologist, Class "B1", Water Supply Department.**

*Yearly Salary.*—£1,630, minimum; £1,770, maximum.

*Duties.*—To make comprehensive surveys of underground water resources and to prepare reports for publication; to investigate sub-soil conditions affecting drainage problems in irrigation districts; to carry out geological examination of sites for water supply and other engineering projects.

*Qualifications.*—A Degree in Science specializing in Geology, or other approved geological qualification; experience in geological surveys, preferably in connexion with underground water resources.

**Cytologist (Research Geneticist), Class "B", Department of Agriculture.**

*Yearly Salary.*—£1,390, minimum; £1,500, maximum.

*Duties.*—To develop practical breeding and research projects associated with the wheat improvement programme of the Victorian Department of Agriculture, including the investigation of chromosome behaviour in interspecific and intergeneric hybrids, chromosome substitution in relation to breeding for disease resistance, and other characters and gene relationships in wheat. To provide a cytological service for the various breeding programmes.

*Qualifications.*—A degree in Agriculture or Science of an approved University. A sound knowledge of cytological method and interpretation.

**Social Workers, Classes "C"—"C2", Mental Hygiene Branch, Department of Health.**

*Yearly Salary.*—

Male £860, minimum; £1,280, maximum.

Female £803, minimum; £1,223, maximum.

(Commencing salary according to experience.)

*Duties.*—To engage in social work in connexion with patients of mental hospitals or clinics.

*Qualifications.*—Diploma of Social Studies of the University of Melbourne or its equivalent.

**Cadet Valuer, Class "D", Taxation (Land Tax) Office, Treasury. (Two positions.)**

*Yearly Salary.*—£490, minimum; £610, maximum.

*Duties.*—To assist valuers in field and office work in connexion with the valuation of properties for State Land Tax, Probate Duty and Stamp Duty purposes.

*Qualifications.*—The School Leaving Certificate or equivalent qualification (if not a member of the Administrative Division). A general knowledge of the Land Tax Act; competent to make simple plans of buildings and farm holdings.

**NOTE.**—The successful applicants must be prepared to undertake a course of study for the examination prescribed by the Commonwealth Institute of Valuers for admission, or by the Valuers' Qualification Board.

Preference will be given to applicants who have passed subjects for these examinations.

**TECHNICAL AND GENERAL DIVISION.****Construction Inspector, Office of the Housing Commission, Treasury.**

*Yearly Salary.*—£798, minimum; £894, maximum.

*Duties.*—To inspect and report on the quality and standard of works in metropolitan and country areas prior to the Commission's acceptance from contractors; subsequent inspections and reports as required.

*Qualifications.*—Wide practical experience in construction of residential buildings, and ability to perform the duties of the position. Technical school or trade qualifications in building construction are desirable. A car driver's licence.

**Estate Officer, Grade IV., Office of the Housing Commission, Treasury.**

*Yearly Salary.*—£590, minimum; £654, maximum.

*Duties.*—To perform Housing Estate Duties in respect of a section of a district including Revenue Collection, interviewing tenants regarding rental arrears, advising tenants on matters affecting their tenancy, and inspecting and reporting on dwelling and various phases of Estate Management.

*Qualifications.*—To be educated to Intermediate Certificate standard and able to make investigations and prepare reports. Experience in dealing with the public and capable of handling public moneys; a car driver's licence.

**NOTE.**—After completing three years' satisfactory service as Estate Officer, Grade IV., will be eligible for progression to Estate Officer, Grade III. (£686-£718).

**Water Bailiff, Tatura Centre, Water Supply Department.**

*Yearly Salary.*—£430, minimum; £526, maximum.

*Qualifications.*—Ability to control and regulate the supply of water to irrigators and to keep the necessary records and make arithmetical computations; a knowledge of water requirements for crops and grasses grown under irrigation, the methods of preparation of land for irrigation and methods of channel and drain construction and maintenance.

**NOTE.**—A house is available for the successful applicant, if married, for which a rental of 10 per cent. of standard salary plus £16 a year will be charged. Occupancy will be subject to a formal tenancy agreement being entered into. Particulars available from the Water Supply Department.

**Machinist (Female), Grade III., Motor Registration Branch, Office of the Chief Commissioner of Police, Chief Secretary's Department.**

*Yearly Salary.*—£492, minimum; £524, maximum;

*Duties.*—To record, on cash sheets, remittances received for motor vehicle registrations and renewals.

*Qualifications.*—Capable of operating both a Mercedes and a Remington Accounting Machine; a knowledge of the sections of the Motor Car Acts relating to registration fees and Third Party Insurance is desirable.

**Attendant, Office of Titles, Law Department.****Yearly Salary.—**

Junior—under 16 years of age, £166;  
 at 16 years of age, £197;  
 at 17 years of age, £223;  
 at 18 years of age, £254;  
 at 19 years of age, £298;  
 at 20 years of age, £342.

Adult—£398, minimum; £510, maximum.

(Plus an allowance of £48 a year for searching duties.)

**Duties.**—To attend searches by the public and Government Departments of documents registered under the Transfer of Land Act; to advise as to the nature of various dealings on Titles and to sort and replace documents required for searches and dealings.

**Qualifications.**—To be active and tactful in dealing with the public, to have the capacity to assess search fees and to acquire the requisite knowledge of Titles and the various documents evidencing land transactions.

**Typist (Female) Supervising, Office of the Government Statist, Chief Secretary's Department.**

**Yearly Salary.**—£476, minimum; £492, maximum.

**Duties.**—To distribute and supervise the work of the typists in the Registration Section.

**Qualifications.**—A competent typist with ability to control staff.

**Storeman, Grade I, Office of the Chief Commissioner of Police, Chief Secretary's Department.**

**Yearly Salary.**—£430, minimum; £468, maximum.

**Duties.**—To serve at the counter and to undertake clerical work in relation to requisitions from the Vehicle Workshops and to assist generally in the Store.

**Qualifications.**—To be familiar with the different types of motor vehicle parts and accessories and capable of keeping neat and accurate records.

**NOTE.**—As a skeleton staff must always be maintained in the Store, the successful applicant will be rostered for duty on week-ends and public holidays, and paid additional rates under Regulation 110 of the Public Service (Public Service Board) Regulations. He will normally work on day shift but may be rostered, at regular intervals, to work a shift from 2 p.m. to 10.30 p.m.

**Housekeeper, School of Forestry, Creswick, State Forests Department.**

**Yearly Salary.**—£428, minimum; £460, maximum.

**Duties.**—To act as Housekeeper at the School of Forestry, Creswick.

**Qualifications.**—Experience in catering for and managing the domestic affairs of a residential college or other establishment and able to direct and control staff.

**NOTE.**—Board and lodging is available at a charge of £166 a year.

**NOTE.**—The salary rates quoted above do not include the additional amount which is payable under Regulation 74 of the Board's Regulations.

By order,

V. P. SCULLY,  
 Secretary.

Office of the Public Service Board,  
 Melbourne, 16th October, 1962.

**PUBLIC SERVICE OF VICTORIA.—VACANCY.****DEPARTMENT OF HEALTH.****MENTAL HYGIENE BRANCH.****TECHNICAL AND GENERAL DIVISION.**

**APPLICATIONS** will be received by the Public Service Board up to Wednesday, the 7th November, 1962, from persons employed in the Public Service of Victoria, who are eligible and qualified for appointment to the under-mentioned position:—

**Assistant Head Nurse (Male), Ballarat.**

**Yearly Salary.**—£750, minimum; £798, maximum.

**Duties.**—To assist Principal Male Nurse or Head Nurse (Male) in management of male division, and to prepare leave sheets and other records as directed; to relieve senior officers as required, and to give lectures to Student Nurses.

**Qualifications.**—A current practising certificate for Mental Nursing, ability to direct and control staff and patients, and to keep records.

**NOTE.**—The salary rates quoted above do not include the additional amount which is payable under Regulation 74 of the Board's Regulations.

By order,

V. P. SCULLY,  
 Secretary.

Office of the Public Service Board,  
 Melbourne, 16th October, 1962.

**PUBLIC SERVICE OF VICTORIA.—VACANCY.**

(TEMPORARY APPOINTMENT.)

**APPLICATIONS** will be received by the Public Service Board up to Wednesday, the 31st October, 1962, from persons who are qualified for appointment to the under-mentioned position:—

**Topographer, Grade II, Department of Crown Lands and Survey.**

**Yearly Salary.**—£686, minimum; £750, maximum.

**Duties.**—Under direction to be in charge of a survey party engaged on field observations for Geodetic and Topographic surveys, and to assist with Standard Traversing as required.

**Qualifications.**—Experience in obtaining Geodetic and Topographic field survey information and capable of controlling survey assistants.

The salary rates quoted above do not include the additional amount which is payable under Regulation 74 of the Board's Regulations.

By order,

V. P. SCULLY,  
 Secretary.

Office of the Public Service Board,  
 Melbourne, 16th October, 1962.

**EXAMINATION OF APPLICANTS FOR LICENCE AS SHORTHAND WRITER.**

**IT** is hereby notified that an examination of applicants for licence as Shorthand Writer, will be held at the Law Courts (No. 15 Court), Melbourne, on Saturday, 24th November, 1962, at Ten o'clock a.m.

Applications for permission to attend the examination together with an entry fee of Twenty-one shillings (£1 1s.) must be forwarded to reach the Public Service Board's Office, Treasury-place, Melbourne, C.2 (where a copy of the Regulations may be obtained), not later than Saturday, 10th November, 1962.

Satisfactory evidence of—

- (1) Name in full
  - (2) Having attained the age of twenty-one (21) years, and
  - (3) Good moral character
- should be submitted with application.

By order,

V. P. SCULLY,  
 Secretary.

Office of the Public Service Board,  
 Melbourne, 16th October, 1962.

**REPORTER, VICTORIAN PARLIAMENTARY DEBATES.**

**APPLICATIONS** are invited for the position of Reporter on the staff of the Victorian Parliamentary Debates (Hansard).

Full details of duties, salary and conditions of appointment may be obtained from the Chief Reporter.

Applications, stating age, qualifications, and experience, should be lodged with the Chief Reporter, Parliament House, Melbourne, not later than the 27th October, 1962.

A. A. BURNS,  
 Chief Reporter.

**TENDERS—PUBLIC WORKS DEPARTMENT**

**TENDERS** will be received at this Department's Head Office, Treasury-place, Melbourne, until **TEN a.m.** on the Tuesdays, and for the purposes under mentioned.

Particulars may be learnt at the Department and also at places shown in parentheses.

W.O. means Inspector of Works Office; P.S.—Police Station; T.S.—Technical School; H.E.S.—Higher Elementary School; S.S.—State School; H.S.—High School; C.S.—Consolidated School.

Tenders should be submitted on the Department's printed Tender Form and will not be received by telephone. All tenders must be on a "Firm Tender" basis. The Board of Land and Works will not necessarily accept the lowest or any tender.

Tenders to be addressed to the Hon. the Commissioner of Public Works, and envelope containing tender to be marked "Tender for \_\_\_\_\_, closing Tuesday, \_\_\_\_\_".

**NOTE.**—No preliminary deposit is to be lodged with any tender, but a deposit in accordance with the prescribed Schedule may be required from each successful tenderer.

**Tuesday, 23rd October, 1962.**

Ararat.—Installation of area lighting, "J" Ward, Mental Hospital. (W.O., Ballarat.)

Ballarat.—Replacement of urinals, School of Mines. (W.O., Ballarat.)

Beamaris.—Electrical installation, extensions to Manual Arts Wing, High School.

Beamaris.—Supply, delivery, installation and testing of extension of heating to additional class-rooms, High School.

Beechworth.—Renovations to residence, Loch-street, High School. (W.O., Wangaratta; H.S., Beechworth.)

Benalla.—Supply and delivery of woodwork room equipment, Technical School.

Bentleigh.—Electrical installation in extension to Manual Arts Wing, High School.

Bentleigh.—Supply, delivery, installation and testing of extension of heating to additional class-rooms, High School.

Boneo.—Septic tank and bore water installation, S.S. 1184. (S.S., Boneo.)

Box Hill.—Provision of stainless steel troughs, High School.

Blackburn.—Electrical installation in extension to Manual Arts Wing, High School.

Blackburn.—Supply, delivery, installation and testing of extension of heating to additional class-rooms, High School.

Bungaree.—Install septic tanks, S.S. 1960 and residence. (W.O., Ballarat; S.S., Bungaree.)

Burwood.—Repairs and painting to school and residence, S.S. 461.

Carlton.—Maintenance cleaning 1st December, 1962, to 30th November, 1963, State Film Centre, 110 Victoria-street.

Castlemaine.—New external staircase, Technical College. (W.O., Bendigo and Kyneton.)

Croydon.—Electrical installation, extensions to Manual Arts Wing, High School.

Croydon.—Supply, delivery, installation and testing of extension of heating to additional class-rooms, High School.

Donald.—Repairs and painting to Court House. (W.O., Maryborough; P.S., Donald.)

Echuca.—New storeroom attached to existing shelter pavilion, High School. (W.O., Shepparton; H.S., Echuca.)

Ecklin South.—General repairs and painting, S.S. 2647 and residence. (W.O., Warrnambool; S.S., Ecklin South.)

Fitzroy.—Supply and delivery of fluorescent light fittings, High School.

Footscray.—Electrical installation, extensions to Manual Arts Wing, High School.

Footscray.—Supply, delivery, installation and testing of extension of heating to additional class-rooms, High School.

Glenroy.—Electrical installation, extensions to Manual Arts Wing, High School.

Glenroy.—Supply, delivery, installation and testing of extension of heating to additional class-rooms, High School.

Hawkesdale.—Site works, asphalt and concrete paving, drainage and beautification, High School. (W.O., Hamilton and Warrnambool.)

Highett.—Electrical installation in extensions to Manual Arts Wing, High School.

Highett.—Supply, delivery, installation and testing of extension of heating to additional class-rooms, High School.

Kensington.—Part internal renovations, S.S. 2374.

Maribyrnong.—Electrical installation in extensions to Manual Arts Wing, High School.

Maribyrnong.—Supply, delivery, installation and testing of extensions of heating to additional class-rooms, High School.

Melbourne.—Electrical installation, rewiring, alterations and additions to First Floor, Old Treasury Building, Spring-street.

Melbourne.—Supply and installation of an air conditioning system to Second Floor Offices, Fisheries and Wildlife Department, Siddley-street.

Poolajelo.—Construction of new out-office block, installation of septic tank and water supply, S.S. 2978. (W.O., Hamilton; S.S., Poolajelo.)

Port Melbourne.—Supply of squared bluestone 1,000 tons minimum, for Ports and Harbors Branch, Public Works Department Storeyard.

Port Phillip Bay.—Supply of fabricated mild steel tubes, No. 9 Light Structure, South Channel.

Rosanna.—Electrical installation, extensions to Manual Arts Wing, High School.

Rosanna.—Supply, delivery, installation and testing of extension of heating to additional class-rooms, High School.

Rosebud.—Supply and delivery of two 9-in. swing lathes and one 12-in. swing wood-turning lathe, High School.

Seymour.—Erection of one shelter pavilion, S.S. 547. (W.O., Alexandra; S.S., Seymour.)

St. Albans.—Electrical installation, extensions to Manual Arts Wing, High School.

St. Albans.—Supply, delivery, installation and testing of extension of heating to additional class-rooms, High School.

Sunbury.—Provision of heavy-duty asphalt, resurfacing heavy-duty asphalt and road drainage, Mental Hospital. (Mental Hospital, Sunbury.)

Tongala.—Removal of hedge and erection of new fence, Consolidated School residence. (W.O., Shepparton; C.S., Tongala.)

Waverley.—Electrical installation, extensions to Manual Arts Wing, High School.

Waverley.—Supply, delivery, installation and testing of extension of heating to additional class-rooms, High School.

**Tuesday, 30th October, 1962.**

Altona.—Electrical installation in extended stage three, High School. (H.S., Altona.)

Altona.—Mechanical services, stage three, High School.

Ararat.—Supply of steel shelving, Mental Hospital.

Ashens.—Purchase and removal old school building, S.S. 1761. (W.O., Warracknabeal; S.S., Ashens.)

Ballarat.—Supply and fix curtains, Mental Hospital. (W.O., Ballarat.)

Ballarat.—Supply of steel dining furniture, Mental Hospital.

Ballarat.—Supply of Fairfield chairs, Mental Hospital.

Bangholme.—Septic tank and bore-water supply installation, S.S. 3884. (S.S., Bangholme.)

Bentleigh.—General repairs and painting, High School.

Blackburn.—Supply and delivery of (3) three 11 in.-12 in. swing lathes and one 18-in. shaper, Technical School.

Braybrook.—Electrical installation in extended stage three, High School. (H.S., Braybrook.)

Braybrook.—Mechanical services, stage three, High School.

Broadmeadows.—Electrical installation in extended stage three, High School. (H.S., Broadmeadows.)

Broadmeadows.—Mechanical services, stage three, High School.

Cardinia.—Septic tank and bore-water supply installations, S.S. 3689. (S.S., Cardinia.) (Amended specification.)

Carlton.—Supply and fixing precast concrete wall panels, window surrounds, stair treads, landings and parapet cappings, &c., Hydraulics Laboratory Extensions, University of Melbourne.

Carlton.—Supply, installation, glazing of aluminium curtain walling, doors, air intake, louvres, &c., Hydraulics Laboratory Extensions, University of Melbourne.

Carnegie.—Internal and external renovations, State School 2897. (Amended specification.)

Coburg.—Supply and delivery of 1,500 square feet of 14 gauge x ½ inch galvanized wire mesh, 2 ft. 6 in. wide, Pentridge Prison.

Collingwood.—Installation of new hot water systems to laundry and kitchen, Girls' Secondary School.

Corryong.—Erection of new toilet and connexion to Sewerage, Lands and Survey Depot. (W.O., Wangarratta; P.S., Corryong.)

Echuca.—Conversion of art room into science room, High School. (W.O., Shepparton; H.S., Echuca.)

Echuca.—Conversion of locker room to staff room, High School. (W.O., Shepparton; H.S., Echuca.)

French Island.—Supply and delivery of one (1) only diesel-engined pneumatic-tired tractor, McLeod Prison Farm.

Gardenvale.—Internal and external renovations, S.S. 3897.

Geelong.—Repairs and renovations, Gordon Institute of Technology. (W.O., Geelong.)

Hawthorn.—Repairs and painting, attention to roof of Junior Machine Shop, Swinburne Technical College.

Hedley.—Installation of septic tanks and water storage tanks, S.S. 2773, and residence. (W.O., Korumburra; S.S., Hedley.)

Kangaroo Flat.—Supply of machine tools, Technical School.

Kew.—Supplying and laying of vinyl tiles, Children's Cottages, Mental Hospital.

Kyneton.—General repairs and painting to residence, 13 Yaldwin-street, High School. (W.O., Kyneton.)

Lakeside.—Electrical installation in extended stage three, High School. (H.S., Lakeside.)

Lakeside.—Mechanical services, stage three, High School.

Langi Kal Kal.—Supply of pneumatic-tired wheeled tractor with associated farm implements, Social Welfare Department Training Centre. (W.O., Ballarat.)

Lyndale.—External renovations, S.S. 4771.

Maidstone.—External painting and repairs, S.S. 4658.

Mansfield.—Purchase and removal of tank and stand, S.S. 1112. (W.O., Alexandra; S.S., Mansfield.)

Maryborough.—General repairs and painting to all buildings, partly reblocking, refooring, &c., High School. (Amended specification.) (W.O., Maryborough.)

Melbourne.—Renovations to roof of Queens Hall, State Library.

Melbourne.—Reinforced concrete paving, Secondary Teachers' College Hostel, 19 Queens-road.

Melbourne.—Supply of directory boards and signs, Titles Office.

Meredith.—Installation of septic tanks, new toilets and water supply, S.S. 1420, and residence. (W.O., Geelong; S.S., Meredith.)

Mildura.—Supply of one 18-in. shaping machine, Technical School.

Moe.—Repairs to out-offices, S.S. 4662. (W.O., Traralgon; S.S., Moe.)

Mooroopna.—Repairs and painting to residence, Northgate-street, S.S. 1432. (W.O., Shepparton; S.S., Mooroopna.)

Montague.—New accommodation for kitchen and laundry, Special School 2784.

Mont Park.—Supply and delivery of two automatic domestic washing machines, Mental Hospital.

Morwell.—Erection of two additional class-rooms, High School. (W.O., Traralgon.)

Morwell.—Electrical installation, extension to Manual Arts Wing, High School. (W.O., Warragul and Traralgon; H.S., Morwell.)

Morwell.—Supply, delivery, installation and testing of extension of heating to additional class-rooms, High School.

Nareen.—Installation of septic tank and new out-office block, S.S. 2303. (W.O., Hamilton; S.S., Nareen.)

Newcomb.—Two additional class-rooms to concrete veneer timber-framed primary school, S.S. 4776. (W.O., Geelong.)

Northcote.—Repairs and painting to cleaner's residence, High School.

Picola.—Purchase and removal of old school building, S.S. 1989. (W.O., Shepparton; S.S., Picola.)

Preston.—Supply and delivery of equipment for Diploma School, Technical School. (Amended specification.)

Preston North-east.—New office for infant mistress and staff toilet, S.S. 4764.

Pyalong.—Erection of new shelter pavilion, 20 feet x 10 feet, S.S. 2005. (W.O., Kyneton; S.S., Pyalong.)

Rockbank.—Erect out-office block, install septic tank, S.S. 919. (S.S., Rockbank.)

St. Arnaud.—Connexion of school to town sewerage, S.S. 1646. (W.O., Maryborough; S.S., St. Arnaud.)

Sale.—Site works, including earthworks, asphaltting, roadworks, concrete and drainage, High School. (W.O., Traralgon and Bairnsdale; P.S., Sale.)

Sale.—Supply various items of furniture, Technical School. (W.O., Traralgon.)

Sea Lake.—Provision of asphalt areas, drainage, concrete, beautification and associated works, High School. (W.O., Swan Hill; H.S., Sea Lake.)

Shepparton Park.—Purchase and removal of old school building, S.S. 3264. (W.O., Shepparton.)

Sunshine North.—Connexion to sewerage, Boys' Technical School.

Talbot.—Repairs and painting, S.S. 954. (W.O., Maryborough; S.S., Talbot.)

Tongala.—Repairs and painting to school buildings, Consolidated School. (W.O., Shepparton; C.S., Tongala.)

Traralgon.—Renovations, S.S. 4699. (W.O., Traralgon; S.S., Traralgon.)

Various.—Erection of twenty additional class-rooms to concrete veneer timber-framed Primary Schools.

Various.—Extended third sections to four (4) timber-framed High Schools.

Yallourn.—Purchase and removal of old canteen building, Technical School. (W.O., Traralgon.)

### Wednesday, 7th November, 1962.

Alfredton.—Repairs and painting, residence, 93 Gillies-street, Ballarat, S.S. 1091. (Amended specification.) (W.O., Ballarat; S.S., Alfredton.)

Allambee Reserve.—Septic tank installation, S.S. 3501. (W.O., Warragul; S.S., Allambee Reserve.)

Apollo Bay.—General repairs and painting, new toilet with septic tank, Police Station. (Amended specification.) (W.O., Camperdown; P.S., Apollo Bay.)

Ararat.—Supply and erection of chainwire mesh fencing to two tennis courts, Mental Hospital. (W.O., Ballarat and Ararat.)

Ballarat.—Supply, delivery, installation and testing of refrigeration plant for the meat cool room in the main kitchen, Mental Hospital. (W.O., Ballarat.)

Bamawm.—General repairs to residence, new internal lining with internal and external painting, residence, S.S. 1769. (W.O., Bendigo; S.S., Bamawm.)

Bendigo.—Supply of 30 L-shaped typing tables, Technical School.

Bendigo.—Renovations to library, Technical College. (W.O., Bendigo; T.C., Bendigo.)

Cowwarr.—Septic tank installation, S.S. 1967. (W.O., Traralgon; S.S., Cowwarr.)

Drouin West.—Septic tanks and water supply installations, S.S. 1417. (W.O., Warragul; S.S., Drouin West.)

Dumbalk East.—Toilets and septic tank, S.S. 3172. (W.O., Korumburra; S.S., Dumbalk East.)

Elaine.—Erect out-offices, install septic tanks and bore, S.S. 1810. (W.O., Ballarat; S.S., Elaine.)

Eltham.—Additional sanitary accommodation for Girls, High School.

Eltham North.—Repairs and painting, S.S. 4212.

Ensay North.—Septic tank installation, &c., S.S. 3518. (W.O., Bairnsdale; S.S., Ensay North.)

Genoa.—Septic tank installations, S.S. 3112. (W.O., Bairnsdale; S.S., Genoa.)

Glenrowan.—Repairs, painting and new fencing, Police Station. (W.O., Benalla; P.S., Glenrowan.)

Hamilton.—Supply and fix new ply panelling and re-polish court house benches and barriers, Court House. (W.O., Hamilton.)

Hamilton.—Concrete paving and drainage of sheep yards, Research Station. (W.O., Hamilton.)

Hawthorn.—Supply of 24 L-shaped typing tables, Swinburne Technical School.

Inverleigh.—Installation of septic tank and water supply, S.S. 1147. (W.O., Geelong; S.S., Inverleigh.)

Katunga South.—Purchase and removal of old windmill, S.S. 2269. (W.O., Shepparton; S.S., Katunga South.)

Korrine.—Toilet block and septic tank installation, residence and S.S. 4558. (W.O., Korumburra; S.S., Korrine.)

Leongatha North.—New out-offices and woodshed, septic tank and water supply installation, S.S. 4181. (W.O., Korumburra; S.S., Leongatha North.)

Manifold Heights.—Internal painting and repairs, S.S. 4224. (W.O., Geelong; S.S., Manifold Heights.)

Melbourne.—Supply and installation of mobile steel storage units for Criminal Branch, Crown Solicitor's Office, 459 Lonsdale-street.

Mont Park.—Supply, delivery and fixing on site of new stainless steel wall and underbench cupboards for M.S.U.'s, Larundel Mental Hospital.

Mount Moriac.—Septic tank installation at residence and S.S. 1608. (W.O., Geelong; S.S., Mount Moriac.)

Narre Warren East.—Installation of septic tanks, S.S. 3719. (S.S., Narre Warren East.)

Paynesville.—New toilet block, septic tank installations and water supply, S.S. 2343. (W.O., Bairnsdale; S.S., Paynesville.)

Puckapunyal.—Two additional class-rooms to concrete veneer timber-framed primary school, S.S. 1855. (W.O., Alexandra; S.S., Puckapunyal.)



Puckapunyal.—Electrical installation of two (2) additional L.T.C. class-rooms, S.S. 1855. (S.S., Puckapunyal.)

Puckapunyal.—Plenum heating to two (2) additional class-rooms, S.S. 1855. (S.S., Puckapunyal.)

Rosebud.—Additional toilets, drinking and washing facilities, S.S. 2627. (S.S., Rosebud.)

Sale.—Repairs and painting, Technical School residence, 121 MacArthur-street. (W.O., Traralgon; T.S., Sale.)

Seaford.—Septic tank installation at residence, S.S. 3835.

South Yarra.—Attention to balustrade and floor of balcony, Police College.

Various.—Supply and delivery of machine tools and equipment for period 1st December, 1962, to 30th June, 1963, Schools and other Government Buildings.

Wallacedale North.—Renovations to school and residence, S.S., 3332. (W.O., Warrnambool; S.S., Wallacedale North.)

West Melbourne.—Supply of refrigeration system and installation only of six (6) evaporator coils in cool rooms 2B and 8B of section "C" North Raft at Government Cool Stores.

**Tuesday, 13th November, 1962.**

South Melbourne.—Internal and external repairs and painting, Technical School.

H. R. PETTY,  
Commissioner of Public Works.

Public Works Department,  
Melbourne, 16th October, 1962.

## PRIVATE ADVERTISEMENTS

### CITY OF BRIGHTON.

LOAN No. 48.

*Notice of Intention to Borrow the Sum of £25,000 for Permanent Works and Undertakings.*

NOTICE is hereby given that the Council of the City of Brighton proposes to borrow the sum of £25,000 on the credit of the municipal revenues of the Mayor, Councillors and Citizens of the said City, such sum to be raised by the grant of a mortgage, in accordance with the provisions of the *Local Government Act 1958*.

1. The maximum rate of interest that may be paid is 15 10s. per cent. per annum.
2. The purposes for which the loan is to be applied are—  
Reconstruction of Roads and Drainage.
3. The period of the loan shall be ten years.

4. The moneys borrowed shall be repayable by providing out of the municipal fund twenty half-yearly instalments of approximately £1,641 16s. each, including principal and interest, on the 1st day of September and the 1st day of March in each year during the currency of the loan. The first instalment shall be payable on the 1st day of September, 1963.

5. Such moneys shall be repayable at the State Savings Bank of Victoria, Melbourne.

The plans and specifications and the estimate of the cost of the proposed works, and a statement showing the proposed expenditure of the moneys to be borrowed, are open for inspection at the Municipal Offices, Boxshall-street, Brighton.

Dated the 10th October, 1962.

3019 H. C. FERGUSON, Town Clerk.

### CITY OF CAULFIELD.

BY-LAW No. 127.

A By-law of the City of Caulfield number 127 made under the Local Government Acts and particularly under Part VII. of the *Local Government Act 1958* (No. 6299) for prescribing residential areas and for altering By-law No. 66 as altered from time to time.

WHEREAS the Council of the said City of Caulfield has decided to alter the said By-law No. 66 as altered by By-laws numbered respectively 67, 74, 76, 79, 86, 88, 92, 107, 110, 114, 117 and 122 by excluding from Area No. 21 described in the Schedule to the said By-law No. 66 certain land now in pursuance of the powers conferred by the Local Government Acts and of every

other power enabling them in this behalf the Mayor, Councillors and Citizens of the City of Caulfield order as follows:—

1. The Schedule to By-law No. 66 as altered from time to time shall be further altered by adding at the end of the description of Area No. 21 the following words:—

"But not including the land commencing at a point being the north-east corner of North-road and Brett-street; thence easterly along the northern boundary of North-road for a distance of 120 feet; thence northerly along a line 120 feet east of and parallel with the eastern building line of Brett-street for a distance of 220 feet; thence westerly 120 feet to the eastern building line of Brett-street; thence southerly along the eastern building line of Brett-street to the commencing point."

2. The said By-law No. 66 as altered from time to time and as hereby altered is hereby ratified and confirmed.

Resolution for passing this By-law agreed to by the Council on the 19th June, 1962, and confirmed on the 17th July, 1962.

The common seal of the Mayor, Councillors and Citizens of the City of Caulfield was hereunto affixed in the presence of—

(SEAL) A. J. SINCLAIR, Mayor.  
H. G. NELSON, Town Clerk.

Approved by the Governor in Council, 25th September, 1962.—N. G. WISHART, Clerk of the Executive Council.

3037

### CITY OF COBURG.

LOAN No. 19.

*Private Streets.*

NOTICE is hereby given that at a meeting of the Council of the City of Coburg, held on Monday, 10th September, 1962, the Council did pass a Special Order for the borrowing of Twenty-five thousand pounds (£25,000) on the credit of the Mayor, Councillors and Citizens of the City of Coburg, such sum to be raised by the grant of a mortgage in accordance with the provisions of the *Local Government Act 1958*.

1. The rate of interest to be paid is Five pounds ten shillings (£5 10s.) per centum per annum.
2. The moneys borrowed shall be repayable by 30 equal half-yearly instalments of One thousand two hundred and thirty-four pounds twelve shillings and three pence (£1,234 12s. 3d.) including principal and interest, by providing out of the receipts of moneys payable under schemes of private street construction and advances from the municipal fund should such receipts be insufficient, the required amounts on the 1st day of June and the 1st day of December, during the currency of the loan. The first instalment shall be payable on the 1st day of June, 1963.
3. The period of the loan shall be fifteen years.
4. Such moneys shall be repayable at the Commonwealth Savings Bank of Australia, Sydney-road, Coburg.
5. The purpose for which the loan is to be applied is the defraying of the cost of the execution of schemes of private street construction.

And notice is hereby further given that the Council, at its meeting held on Monday, 8th October, 1962, did confirm such Special Order.

3015 G. A. BRIDGES, Town Clerk.

### CITY OF FOOTSCRAY.

LOAN No. 60.

*Notice of Intention to Borrow the Sum of £10,000 for Permanent Works and Undertakings.*

NOTICE is hereby given that the Council of the City of Footscray proposes to borrow the sum of Ten thousand pounds on the credit of the municipal revenues of the Mayor, Councillors and Citizens of the said City, such sum to be raised by the grant of a mortgage, in accordance with the provisions of the Local Government Acts.

1. The maximum rate of interest that may be paid is 5½ per cent. per annum.
2. The purpose for which the loan is to be applied is for road construction in Buckley-street.
3. The period of the loan shall be ten years.
4. The moneys borrowed shall be repayable by providing out of the municipal fund twenty half-yearly instalments of £656 14s. 4d. each, including principal and

interest, on the 1st day of January and the 1st day of July during the currency of the loan. The first instalment shall be payable on the 1st day of July, 1963.

5. Such moneys shall be repayable at the E.S. & A. Savings Bank Limited, in Footscray.

The plans and specifications and the estimate of the cost of the proposed works, and a statement showing the proposed expenditure of the moneys to be borrowed, are open for inspection at the Municipal Offices, Napier-street, Footscray.

Dated this 9th day of October, 1962.

3020

E. J. SMITH, Town Clerk.

## CITY OF FOOTSCRAY.

## LOAN No. 61.

*Notice of Intention to Borrow the Sum of £10,000 for Permanent Works and Undertakings.*

NOTICE is hereby given that the Council of the City of Footscray proposes to borrow the sum of Ten thousand pounds on the credit of the municipal revenues of the Mayor, Councillors and Citizens of the said City, such sum to be raised by the grant of a mortgage, in accordance with the provisions of the Local Government Acts.

1. The maximum rate of interest that may be paid is 5½ per cent. per annum.

2. The purpose for which the loan is to be applied is for road construction in Buckley-street.

3. The period of the loan shall be ten years.

4. The moneys borrowed shall be repayable by providing out of the municipal fund twenty half-yearly instalments of £656 14s. 4d. each, including principal and interest, on the 1st day of January and the 1st day of July during the currency of the loan. The first instalment shall be payable on the 1st day of July, 1963.

5. Such moneys shall be repayable at the C.B.C. Savings Bank Limited, in Melbourne.

The plans and specifications and the estimate of the cost of the proposed works, and a statement showing the proposed expenditure of the moneys to be borrowed, are open for inspection at the Municipal Offices, Napier-street, Footscray.

Dated this 9th day of October, 1962.

3021

E. J. SMITH, Town Clerk.

## CITY OF FOOTSCRAY.

## LOAN No. 62.

*Notice of Intention to Borrow the Sum of £50,000 for Permanent Works and Undertakings.*

NOTICE is hereby given that the Council of the City of Footscray proposes to borrow the sum of Fifty thousand pounds (£50,000) on the credit of the municipal revenues of the Mayor, Councillors and Citizens of the said City, such sum to be raised by the grant of a mortgage, in accordance with the provisions of the Local Government Acts.

1. The maximum rate of interest that may be paid is Five pounds ten shillings (£5 10s.) per centum per annum, payable on the 1st day of January and the 1st day of July in each year during the currency of the loan.

2. The purpose for which the loan is to be applied is as follows:—

Capital Expenditure—Electricity Undertakings—  
Purchase of Transformers .. £50,000

3. The period of the loan shall be forty (40) years.

The loan is to be liquidated by the creation of a sinking fund, pursuant to the provisions of the Local Government Acts, and an amount not less than £467 3s. 2d. will be set aside annually out of the Municipal Fund for such purpose, and the said moneys borrowed shall be repayable on the 1st day of January, 2003, at the office of the State Superannuation Board in Melbourne.

The plans and specifications and the estimate of the cost of the proposed works, and a statement showing the proposed expenditure of the money to be borrowed, are open for inspection at the Municipal Offices, Napier-street, Footscray.

Dated this 9th day of October, 1962.

3022

E. J. SMITH, Town Clerk.

## CITY OF NUNAWADING.

*Notice of Intention to Borrow the Sum of £2,000 for Permanent Works and Undertakings.*

## LOAN No. 58.

NOTICE is hereby given that the Council of the City of Nunawading proposes to borrow the sum of Two thousand pounds (£2,000) on the credit of the municipal revenues of the said City of Nunawading, such sum to be raised by the grant of a mortgage in accordance with the provisions of the Local Government Acts.

1. The maximum rate of interest to be paid is £5 10s. per centum per annum, payable half-yearly.

2. The purpose for which the loan is to be applied is road construction.

3. The period of the loan shall be ten years.

4. The loan is to be liquidated by the creation of a Sinking Fund pursuant to the provisions of section 428A of the Local Government Acts.

5. Such moneys shall be repayable at the office of Olympic Benefits Pty. Ltd., care of V. G. Harrison and Company, 360 Collins-street, Melbourne, or at such other place as the lender may from time to time require at the expiration of the borrowing period.

The plans and specifications and the estimate of the cost of the proposed works and a statement showing the proposed expenditure of the moneys to be borrowed are open for inspection at the Municipal Offices, Nunawading.

3047 A. ROY CHARLESWORTH, Town Clerk.

## CITY OF NUNAWADING.

*Notice of Intention to Borrow the Sum of £2,000 for Permanent Works and Undertakings.*

## LOAN No. 59.

NOTICE is hereby given that the Council of the City of Nunawading proposes to borrow the sum of Two thousand pounds (£2,000) on the credit of the municipal revenues of the said City of Nunawading, such sum to be raised by the grant of a mortgage in accordance with the provisions of the Local Government Acts.

1. The maximum rate of interest to be paid is £5 10s. per centum per annum, payable half-yearly.

2. The purpose for which the loan is to be applied is road construction.

3. The period of the loan shall be ten years.

4. The loan is to be liquidated by the creation of a Sinking Fund pursuant to the provisions of section 428A of the Local Government Acts.

5. Such moneys shall be repayable at the office of Colesanco Superannuation Pty. Ltd., 236 Bourke-street, Melbourne, or at such other place as the lender may from time to time require at the expiration of the borrowing period.

The plans and specifications and the estimate of the cost of the proposed works and a statement showing the proposed expenditure of the moneys to be borrowed are open for inspection at the Municipal Offices, Nunawading.

3048 A. ROY CHARLESWORTH, Town Clerk.

## CITY OF NUNAWADING.

*Notice of Intention to Borrow the sum of £25,000 for Permanent Works and Undertakings.*

## LOAN No. 60.

NOTICE is hereby given that the Council of the City of Nunawading proposes to borrow the sum of Twenty-five thousand pounds (£25,000) on the credit of the municipal revenues of the Mayor, Councillors and Citizens of the said City of Nunawading, such sum to be raised by the grant of a mortgage in accordance with the provisions of the Local Government Acts.

1. The maximum rate of interest that may be paid is £5 10s. per centum per annum.

2. The purposes for which the loan is to be applied are road construction, road channels, kerbing and drainage.

3. The period of the loan shall be ten years.

4. The moneys borrowed shall be repayable by providing out of the municipal fund twenty half-yearly instalments of approximately £1,641 16s. each, including principal and interest, on the 1st day of February and the 1st day of August, during the currency of the loan. The first instalment shall be payable on the 1st day of August, 1963.

5. Such moneys shall be repayable at the State Savings Bank of Victoria, Melbourne.

The plans and specifications and the estimate of the cost of the proposed works and a statement showing the proposed expenditure of the moneys to be borrowed are open for inspection at the Municipal Offices, Nunawading. 3051

A. ROY CHARLESWORTH, Town Clerk.

CITY OF NUNAWADING.

*Notice of Intention to Borrow the Sum of £25,000 for Permanent Works and Undertakings.*

LOAN No. 61.

NOTICE is hereby given that the Council of the City of Nunawading proposes to borrow the sum of Twenty-five thousand pounds (£25,000) on the credit of the municipal revenues of the Mayor, Councillors and Citizens of the said City of Nunawading, such sum to be raised by the grant of a mortgage in accordance with the provisions of the Local Government Acts.

1. The maximum rate of interest that may be paid is £5 10s. per centum per annum.

2. The purposes for which the loan is to be applied are road construction, channel construction, footpath construction, road widening and purchase of plant.

3. The period of the loan shall be fifteen years.

4. The moneys borrowed shall be repayable by providing out of the municipal fund thirty half-yearly instalments of approximately £1,234 12s. 3d. each, including principal and interest, on the 1st day of February and the 1st day of August, during the currency of the loan. The first instalment shall be payable on the 1st day of August, 1963.

5. Such moneys shall be repayable at the Commonwealth Savings Bank of Australia, Melbourne, or at the Council's bankers for the time being in Melbourne.

The plans and specifications and the estimate of the cost of the proposed works and a statement showing the proposed expenditure of the moneys to be borrowed are open for inspection at the Municipal Offices, Nunawading. 3052

A. ROY CHARLESWORTH, Town Clerk.

CITY OF NUNAWADING.

*Notice of Intention to Borrow the Sum of £20,000 for Permanent Works and Undertakings.*

LOAN No. 62.

NOTICE is hereby given that the Council of the City of Nunawading proposes to borrow the sum of Twenty thousand pounds (£20,000) on the credit of the municipal revenues of the Mayor, Councillors and Citizens of the said City of Nunawading, such sum to be raised by the grant of a mortgage in accordance with the provisions of the Local Government Acts.

1. The maximum rate of interest that may be paid is £5 10s. per centum per annum.

2. The purposes for which the loan is to be applied are road construction, channel construction, footpath construction, road widening and highway lighting.

3. The period of the loan shall be ten years.

4. The moneys borrowed shall be repayable by providing out of the municipal fund twenty half-yearly instalments of approximately £1,313 8s. 8d. each, including principal and interest, on the 1st day of March and the 1st day of September, during the currency of the loan. The first instalment shall be payable on the 1st day of September, 1963.

5. Such moneys shall be repayable at the Australia and New Zealand Savings Bank Limited, 394-396 Collins-street, Melbourne.

The plans and specifications and the estimate of the cost of the proposed works and a statement showing the proposed expenditure of the moneys to be borrowed are open for inspection at the Municipal Offices, Nunawading. 3050

A. ROY CHARLESWORTH, Town Clerk.

CITY OF NUNAWADING.

*Notice of Intention to Borrow the Sum of £60,000 for Permanent Works and Undertakings.*

LOAN No. 63.

NOTICE is hereby given that the Council of the City of Nunawading proposes to borrow the sum of Sixty thousand pounds (£60,000) on the credit of the municipal revenues of the said City of Nunawading, such sum to be raised by the grant of a mortgage in accordance with the provisions of the Local Government Acts.

1. The maximum rate of interest to be paid is £5 10s. per centum per annum, payable half-yearly.

2. The purposes for which the loan is to be applied are construction of drain, acquisition of land for Darby and Joan housing units, infant welfare centre, children's playgrounds, provision of bowling club, pre-school centre, Council depot and library.

3. The period of the loan shall be forty years.

4. The loan is to be liquidated by the creation of a Sinking Fund pursuant to the provisions of section 428A of the Local Government Acts.

5. Such moneys shall be repayable at the office of the State Superannuation Board, Treasury Buildings, Melbourne, or at such other place as the lender may from time to time require, at the expiration of the borrowing period.

The plans and specifications and the estimate of the cost of the proposed works and a statement showing the proposed expenditure of the moneys to be borrowed are open for inspection at the Municipal Offices, Nunawading. 3049

A. ROY CHARLESWORTH, Town Clerk.

CITY OF OAKLEIGH.

LOAN No. 80.

*Notice of Intention to Borrow the Sum of £25,000 for Permanent Works and Undertakings.*

NOTICE is hereby given that the Council of the City of Oakleigh proposes to borrow the sum of Twenty-five thousand pounds on the credit of the municipal revenues of the Mayor, Councillors and Citizens of the said City, such sum to be raised by the grant of a mortgage in accordance with the provisions of the Local Government Act 1958.

1. The maximum rate of interest that may be paid is £5 10s. per cent. per annum.

2. The purpose for which the loan is to be applied is:—

Reconstruction of roadways.

3. The period of the loan shall be ten years.

4. The moneys borrowed shall be repayable by providing out of the municipal fund twenty half-yearly instalments of approximately £1,641 16s. each, including principal and interest on the 1st day of August and the 1st day of February, during the currency of the loan. The 1st instalment shall be payable on the 1st day of August, 1963.

5. Such moneys shall be repayable at the State Savings Bank of Victoria, Melbourne.

The plans and specifications and the estimate of the cost of the proposed works and a statement showing the proposed expenditure of the moneys to be borrowed, are open for inspection at the Municipal Offices, Atherton-road, Oakleigh. 3108

A. E. RAVEN, Town Clerk.

CITY OF RINGWOOD.

LOAN No. 45.

*Special Order.*

NOTICE is hereby given that at a meeting of the Council of the City of Ringwood, held in the Council Chambers, Ringwood, on the 13th day of September, 1962, the said Council did agree to the following Resolution, viz.:—

1. That the Council of the City of Ringwood resolves to borrow the sum of Fifty thousand pounds (£50,000) on the credit of the Mayor, Councillors and Citizens of the City of Ringwood, such sum to be secured by the grant of a mortgage in accordance with the provisions of the Local Government Act 1958.

2. The rate of interest to be paid is £5 10s. per centum per annum.

3. The moneys borrowed shall be repayable by twenty half-yearly instalments of approximately £3,283 including principal and interest by providing out of the receipts of moneys payable under schemes of private street construction, and advances from the municipal fund should such receipts be insufficient, the required amounts on the 1st days of March and September, during the currency of the loan. The first instalment shall be payable on the 1st day of March, 1963.

4. The period of the loan shall be ten years.

5. Such moneys shall be repayable at the English, Scottish and Australian Bank Ltd., or at the Council's bankers, for the time being in the City of Melbourne.

6. The purpose for which the loan is to be applied is the defraying of the cost of the execution of schemes of private street construction in accordance with Division 10, Part 19 of the Local Government Act 1958.

Notice is hereby further given that at a meeting of the said Council held in the Council Chambers, Ringwood, on the 11th day of October, 1962, the said Resolution was confirmed.

Town Hall, Ringwood, 15th October, 1962.

3046 F. P. DWERRYHOUSE, Town Clerk.

#### CITY OF RINGWOOD.

##### BY-LAW No. 59.

A By-law of the City of Ringwood, made under section 197 of the *Local Government Act 1958*, and numbered 59 for repealing By-law No. 22, for suppressing nuisances and for other purposes.

IN pursuance of the powers conferred by the *Local Government Act 1958* and of any and every other power it thereunto enabling the Mayor, Councillors and Citizens of the City of Ringwood orders as follows:—

1. By-law No. 13 of the City of Ringwood relating to the suppression of nuisances and By-law No. 22 of the City of Ringwood relating to traffic and parking are hereby repealed.

2. In this By-law the word "Instrument" means any instrument device or thing whatsoever capable of making or being used for making sound or noise and without affecting the generality of the foregoing, includes any loudspeaker amplifier broadcasting set wireless receiving set television set gramophone piano or other instrument or device.

3. No person shall in or upon any land building or place used for the purposes of trade or business make or cause or permit or suffer to be made or caused such a volume or amount of sound or noise as to be an annoyance or nuisance to any other person being in or upon any public highway by using operating controlling sounding or playing any instrument.

4. No person shall in any public highway cause permit or suffer to be caused any noise—

- (a) by shouting calling out haranguing or singing, or
- (b) by using operating controlling sounding or playing any instrument.

5. No person shall obstruct any street or footway by standing or loitering therein or thereon whether for the purpose of selling or offering for sale any goods or otherwise.

6. No person shall throw place or leave upon any public highway any orange peel banana peel or other vegetable matter.

7. No person shall spit or expectorate on any footpath.

8. No person shall cause permit or suffer to be emitted from any land of which he is the owner or occupier any smoke dust grit ash or particles of solid matter the product of the combustion of any material in such quantities as to be an annoyance or nuisance to any other person in or upon any other land or any public highway.

9. This By-law shall apply to and have application throughout the whole of the municipal district.

Resolution for passing this By-law agreed to by the Council of the City of Ringwood on the 13th day of September, 1962, and confirmed on the 11th day of October, 1962.

The corporate seal of the Mayor, Councillors and Citizens of the City of Ringwood was hereto affixed this 12th day of October, 1962, in pursuance of a Resolution of the Council—

(SEAL) M. D. DEUTER, Mayor.  
B. G. CLARKE, Councillor.  
F. P. DWERRYHOUSE, Town Clerk.

3054

#### CITY OF SANDRINGHAM.

##### ALTERATIONS OF STREET NAMES.

NOTICE is hereby given that, in pursuance of the powers conferred by the *Local Government Acts*, the Council of the City of Sandringham did, at a meeting held on the 18th September, 1962, resolve to make the following alterations in street names:—

##### Old Name and Location; New Name.

Holloway-road (from Green Belt to Reserve-road);  
Wangara-road.  
Spring-street (from George-street to Reserve-road);  
Talinga-road.  
George-street (from Ardoyne-street to Balcombe-road);  
Iluka-street.  
Grenville-street (from Beach-road to Railway); Orlando-street.

3018

F. G. TRICKS, Town Clerk.

#### CITY OF SUNSHINE.

##### LOAN No. 47.

##### Notice of Intention to Borrow the Sum of £25,000 for Permanent Works and Undertakings.

NOTICE is hereby given that the Council of the City of Sunshine proposes to borrow the sum of Twenty-five thousand pounds on the credit of the municipal revenues of the Mayor, Councillors and Citizens of the said City, such sum to be raised by the grant of a mortgage in accordance with the provisions of the *Local Government Act 1958*.

1. The maximum rate of interest that may be paid is 5½ per cent. per annum.

2. The purpose for which the loan is required is the following works:—

Construction of Cranwell-street .. ..	£2,000
Completion of construction of Anderson-road .. ..	7,000
Construction of Matthews-street .. ..	11,000
Reconstruction of kerbs and channels in Maribyrnong area .. ..	5,000
	£25,000

3. The period of the loan shall be ten years.

4. The moneys borrowed shall be repayable by providing out of the municipal fund twenty half-yearly instalments of approximately £1,641 16s. each, including principal and interest on the 1st day of January and the 1st day of July, during the currency of the loan. The first instalment shall be payable on the 1st day of July, 1963.

5. Such moneys shall be repayable at the State Savings Bank of Victoria, Melbourne.

The plans and specifications and the estimate of the cost of the proposed works and a statement showing the proposed expenditure of the moneys to be borrowed, are open for inspection at the Town Hall, Sunshine.

5th October, 1962.

3011 T. W. DEUTSCHMANN, Town Clerk.

#### CITY OF WAVERLEY.

##### LOAN No. 53.

##### Notice of Intention to Borrow the Sum of £50,000 for Permanent Works and Undertakings.

NOTICE is hereby given that the Council of the City of Waverley proposes to borrow the sum of Fifty thousand pounds on the credit of the municipal revenues of the Mayor, Councillors and Citizens of the said City of Waverley, such sum to be raised by the grant of a mortgage, in accordance with the provisions of the *Local Government Acts*.

1. The maximum rate of interest that may be paid is £5 10s. per centum per annum.

2. The purpose for which the loan is to be applied is the construction of extensions to the municipal offices.

3. The period of the loan shall be 40 years.

4. The loan shall be repaid by the creation of a sinking fund and an appropriate amount will be set aside annually for the creation of such fund and the said moneys borrowed shall be repayable at the State Superannuation Board, Treasury-place, Melbourne.

The plans and specifications and the estimate of the cost of the proposed works and a statement showing the proposed expenditure of the moneys to be borrowed, are open for inspection at the Municipal Offices, Springvale-road, Glen Waverley, during office hours.

Dated this 17th day of October, 1962.

3038

F. S. BALES, Town Clerk.

#### CITY OF WAVERLEY.

##### NOTICE OF INTENTION TO TAKE LAND COMPULSORILY.

WHEREAS the Council of the City of Waverley deems it expedient to provide the land described in the Schedule hereto as a place of public resort or recreation: And whereas for the purpose thereof the exercise of the compulsory power of taking the said land will in the Council's opinion be necessary and desirable: And whereas the Council has caused to be prepared a map setting out and describing such land and the exact site and admeasurements thereof and the names of the owners or reputed owners, lessees or reputed lessees and the occupiers thereof as far as such names can be ascertained by the Council: And whereas such map is deposited at the office of the Council at Glen Waverley and is and shall be open for inspection by all persons interested

at all reasonable hours for the space of 40 clear days after publication of this notice in the *Government Gazette*, now notice is hereby given to all persons affected by the proposed work and undertaking and they are hereby called upon to set forth, in writing, addressed to the said Council or the Mayor of the City of Waverley within 40 clear days from the publication of this notice in the *Government Gazette* all objections which they may have to the said work or undertaking.

*Schedule Hereinbefore Referred To:*

1. Portion of the land contained in conveyance No. 466, book 190, at the Office of Titles, Melbourne, being more particularly that land having a frontage of 176 feet to the eastern side of Charles-street between Gwynne-street and Regent-street and having a depth of 238 feet to both Gwynne and Regent streets.

2. Portion of the land contained in conveyance No. 466, book 190, at the Office of Titles, Melbourne, being more particularly that land commencing at the south-eastern corner of Gwynne-street and Fleet-street; thence easterly along Gwynne-street a distance of 37 ft. 1 in.; thence southerly by a straight line to a point on the northern alignment of Regent-street 35 ft. 6 in. east of Fleet-street; thence northerly along the eastern alignment of Fleet-street to the point of commencement.

3. All that piece of land described in conveyance No. 845, book 53, at the Office of Titles, Melbourne, and being that land commencing at a point on the southern alignment of Cleveland-street 100 feet east of Charles-street; thence easterly 164 feet along the southern alignment of Cleveland-street; thence southerly a distance of 88 feet; thence westerly a distance of 82 feet; thence southerly a distance of 88 feet to the northern alignment of Hotham-street; thence westerly along the northern alignment of Hotham-street a distance of 182 feet to the eastern alignment of Charles-street; thence northerly along the eastern alignment of Charles-street a distance of 88 feet; thence easterly a distance of 100 feet; thence northerly a distance of 88 feet to the point of commencement.

4. That piece of land described in certificate of titles, volume 2063, folio 412533, under the "Transfer of Land Statute" having a frontage of 82 feet to the south side of Cleveland-street by a depth of 176 feet and commencing 473 feet east of Charles-street.

Dated this 17th day of October, 1962.

3039

F. S. BALES, Town Clerk.

SHIRE OF AVOCA.

LOAN No. 23.

*Notice of Intention to Borrow the Sum of £9,000 for Permanent Works and Undertakings.*

NOTICE is hereby given that the Council of the Shire of Avoca proposes to borrow the sum of £9,000 on the credit of the municipal revenues of the President, Councillors and Ratepayers of the said Shire, such sum to be raised by the grant of a mortgage in accordance with the provisions of the Local Government Acts.

1. The maximum rate of interest that may be paid is £5 8s. 9d. per cent. per annum.

2. The purpose for which the loan is to be applied is for the purchase of road-making plant, viz., a heavy-duty road grader.

3. The period of the loan shall be seven years.

4. The moneys borrowed shall be repayable by providing out of the municipal fund fourteen half-yearly instalments of approximately £781 10s. 10d. each, including principal and interest on the 1st day of January and the 1st day of July, during the currency of the loan. The first instalment shall be payable on the 1st day of July, 1963.

5. Such moneys shall be repayable at C.B.C. Savings Bank Limited, Melbourne.

The plans and specifications and the estimate of the cost of the proposed works and a statement showing the proposed expenditure of the moneys to be borrowed, are open for inspection at the Shire Office, Avoca.

Dated this 2nd day of October, 1962.

3014

F. C. S. EDWARDS, Shire Secretary.

SHIRE OF BASS.

LOAN No. 19.

*Notice of Intention to Borrow.*

NOTICE is hereby given that the Council of the Shire of Bass intends to borrow the sum of Nine thousand five hundred pounds (£9,500) on the credit of the

President, Councillors and Ratepayers of the said Shire, by the granting of a mortgage, in accordance with the provisions of the Local Government Acts.

In accordance therewith the following information is stated:—

1. The amount of the principal moneys which it is proposed to borrow is Nine thousand five hundred pounds (£9,500).

2. The maximum rate of interest that may be paid is £5 8s. 9d. per centum per annum.

3. The time on which the moneys borrowed are to be repayable are the first days of January and July during the years 1963 to 1969 inclusive (the currency of the loan) and that the place such moneys shall be repayable is at the National Bank of Australasia Limited, Savings Bank Branch, Melbourne, or at the office of the Council's bankers for the time being in Melbourne.

4. The purpose for which the loan is to be applied is for the purchase of road-making plant and equipment, viz., two 6-yard trucks, front end loader and sundry items of plant.

5. The manner in which the loan is to be liquidated is by the provision out of the municipal fund each half-year during the currency of the loan the sum of £924 19s. 3d. approximately, which amount includes principal and interest.

The plans, specifications and estimate of the costs of the works and a statement showing the proposed expenditure of the moneys to be borrowed, are open for inspection at the Shire Office, Dalyston.

Dated this 12th day of October, 1962.

3031

H. R. BUTTERWORTH, Shire Secretary.

SHIRE OF BASS.

LOAN No. 20.

*Notice of Intention to Borrow.*

NOTICE is hereby given that the Council of the Shire of Bass intends to borrow the sum of Two thousand one hundred pounds (£2,100) on the credit of the President, Councillors and Ratepayers of the said Shire, by the granting of a mortgage, in accordance with the provisions of the Local Government Acts.

In accordance therewith the following information is stated:—

1. The amount of the principal moneys which it is proposed to borrow is Two thousand one hundred pounds (£2,100).

2. The maximum rate of interest that may be paid is £5 10s. per centum per annum.

3. The time on which the moneys borrowed are to be repayable are the first days of January and July during the years 1963 to 1972 inclusive (the currency of the loan) and that the place such moneys shall be repayable is at the National Bank of Australasia Limited, Savings Bank Branch, Melbourne, or at the office of the Council's bankers for the time being in Melbourne.

4. The purpose for which the loan is to be applied is for the purchase of road-making plant and equipment, viz., two 6-yard trucks, front end loader and sundry items of plant.

5. The manner in which the loan is to be liquidated is by the provision out of the municipal fund each half-year during the currency of the loan the sum of £137 18s. 2d. approximately, which amount includes principal and interest.

The plans, specifications and estimate of the costs of the works and a statement showing the proposed expenditure of the moneys to be borrowed, are open for inspection at the Shire Office, Dalyston.

Dated this 12th day of October, 1962.

3032

H. R. BUTTERWORTH, Shire Secretary.

SHIRE OF BENALLA.

LOAN No. 27.

*Notice of Intention to Borrow the sum of £10,000 for Permanent Works and Undertakings.*

NOTICE is hereby given that the Council of the Shire of Benalla proposes to borrow the sum of Ten thousand pounds on the credit of the municipal revenues of the President, Councillors and Ratepayers of the said Shire, such sum to be raised by the grant of a mortgage, in accordance with the provisions of the *Local Government Act 1958*.

1. The maximum rate of interest that may be paid is 5½ per cent. per annum.

2. The purpose for which the loan is to be applied is for the purpose of road-making machinery.

3. The period of the loan shall be five years.

4. The moneys borrowed shall be repayable by providing out of the municipal fund ten half-yearly instalments of approximately £1,153 13s. 9d. each, including principal and interest, on the 15th day of February and the 15th day of August during the currency of the loan. The first instalment shall be payable on the 15th day of August, 1963.

5. Such moneys shall be repayable at the National Bank of Australasia Ltd., Melbourne.

The plans and specifications and the estimate of the cost of the proposed road-making machinery, and a statement showing the proposed expenditure of the moneys to be borrowed, are open for inspection at the Shire Office, Benalla.

3035 E. C. BATES, Shire Secretary.

SHIRE OF BERWICK.  
ALTERATION OF NAME OF ROAD.

NOTICE is hereby given that the Council of the Shire of Berwick, in pursuance of the powers conferred by the Local Government Acts has re-named the following road:—

Old name—Emerald-Mount Burnett-road.  
New name—Paternoster-road.

*Location.*—A 1-chain road, commencing at the common boundaries of the Shires of Berwick and Fern Tree Gully at the boundary of the Township of Emerald on the western boundary of Crown allotment 44, Parish of Gembrook, and continuing south-easterly across the said allotment and further south-easterly through Crown allotment 1 across a 2-chain Government road to the junction with Ladd-road; and thence northerly to re-join the said 2-chain road; thence a 2-chain road north-easterly through Crown allotment 1 to join the County of Mornington boundary and continuing along the said boundary to the north-west corner of Crown allotment 32B<sup>2</sup>; and thence a 1-chain road along the northern boundary of Crown allotment 32B<sup>3</sup> to rejoin the county boundary at the south-east corner of the said allotment; and thence again a 2-chain road following the county boundary to the junction with the main Healesville-Koo-Wee-Rup road on the northern boundary of Crown allotment A22, Parish of Gembrook.

3013 BEATRICE THOMAS, Shire Secretary.

SHIRE OF CORIO.

NOTICE OF CHANGE OF STREET NAME.

NOTICE is hereby given that in pursuance of the powers conferred by the Local Government Act, the Council of the Shire of Corio, at a meeting on the 26th September, 1962, did resolve to make the following alteration in a street name:—

*Old Name; New Name; Situation.*

Ballarat-street; Coral-street; north of Church-street to Ballarat-road.

W. H. MYERS, Shire Secretary.  
Osborne House, North Geelong. 3042

SHIRE OF ELTHAM.  
CHANGE OF STREET NAMES.

IN accordance with the provisions of the Local Government Acts notice is hereby given of the following change of street names:—

*Old Name; New Name; Location.*

Bonnevue-boulevard; Grand-boulevard; between Eltham-Yarra Glen road and Bolton-street.  
Hogan-avenue; Kirwana-grove; between Grand-boulevard and Bolton-street.

3034 M. B. WATSON, Shire Secretary.

SHIRE OF FERN TREE GULLY.  
BY-LAW No. 126.

A By-law of the Shire of Fern Tree Gully, made under section 197 of the Local Government Act 1958, and every and any other power it thereunto enabling, and numbered 126, for—

- (a) prohibiting the throwing, placing or leaving upon any public highway of orange peel, banana peel or other vegetable matter;
- (b) prohibiting the deposit or leaving of refuse or rubbish on streets, roads, lanes or passages;

(c) prohibiting or regulating the deposit or leaving of refuse or rubbish on any land;

(d) requiring the removal or destruction by the owner or occupier of any land of refuse or rubbish thereon (other than refuse or rubbish the removal of which the Council has undertaken or contracted for under section 48 of the Health Act 1958).

IN pursuance of the powers conferred by the Local Government Act 1958 and of any and every other power it thereunto enabling, the President, Councillors and Ratepayers of the Shire of Fern Tree Gully order as follows:—

1. All By-laws of the Shire of Fern Tree Gully and all parts of any such By-laws inconsistent with or repugnant to any of the provisions hereof and heretofore in force are hereby expressly repealed.

2. No person shall throw, place or leave upon any public highway any orange peel, banana peel, or other vegetable matter.

3. No person shall deposit or leave or cause to be deposited or left any refuse or rubbish on any street, road, lane or passage.

4. No person shall deposit or leave or cause to be deposited or left any refuse or rubbish on any land.

5. The owner or occupier of any land shall remove or destroy all refuse or rubbish thereon (other than refuse or rubbish the removal of which the Council of the Shire of Fern Tree Gully has undertaken or contracted for under section 48 of the Health Act 1958).

6. This By-law shall have operation throughout the whole of the municipal district of the Shire of Fern Tree Gully.

7. Any person who shall wilfully offend against any of the provisions of this By-law shall, on conviction, be liable to a penalty of not more than One hundred pounds and not less than Five pounds.

The resolution for passing this By-law was agreed to by the Council of the Shire of Fern Tree Gully on the 21st day of August, 1962, and confirmed on the 2nd day of October, 1962.

A. H. KLEINERT, President.  
A. ARNOLD, Councillor.

3036 R. B. WEBB, Acting Shire Secretary.

Sewerage Districts Acts.

SHIRE OF FRANKSTON.  
PROPOSED SEWERAGE AUTHORITY.

NOTICE is hereby given that the Council of the Shire of Frankston has made application to the Honorable the Minister of Water Supply for the constitution of a Sewerage Authority and for the proclamation of a Sewerage District at Frankston, Seaford and Mount Eliza and for the construction, maintenance and continuance of sewerage works within that district under the provisions of the Sewerage Districts Acts.

A general plan and description of the proposed works have been submitted with the application and copies of same may be seen at—

- (i) The Shire Office, Davey-street, Frankston;
- (ii) The Offices of the State Rivers and Water Supply Commission, 90 Orrong-road, Armadale;
- (iii) The Offices of the Commission of Public Health, 295 Queen-street, Melbourne.

Dated at Frankston the 13th day of August, 1962.

2869 G. C. PENTLAND, Shire Secretary.

SHIRE OF MINHAMITE.

LOAN No. 5.

*Notice of Intention to Borrow the Sum of £5,000 for Permanent Works and Undertakings.*

NOTICE is hereby given that the Council of the Shire of Minhamite proposes to borrow the sum of Five thousand pounds on the credit of the municipal revenues of the President, Councillors and Ratepayers of the said Shire, such sum to be raised by the grant of a mortgage in accordance with the provisions of the Local Government Act 1958.

1. The maximum rate of interest that may be paid is 5½ per cent. per annum.

2. The purpose for which the loan is to be applied is the acquisition of a dwelling for staff—£5,000.

3. The period of the loan shall be ten years.

4. The moneys borrowed shall be repayable by providing out of the municipal fund, twenty half-yearly instalments of approximately £327 8s. each, including principal

and interest on the 1st day of June and the 1st day of December, during the currency of the loan. The first instalment shall be payable on the 1st day of June, 1963.

5. Such moneys shall be repayable at the State Savings Bank of Victoria, Melbourne.

6. The plans and specifications and the estimate of the cost of the proposed works and a statement showing the proposed expenditure of the moneys to be borrowed, are open for inspection at the Shire Hall, Hawkesdale.

Dated 4th October, 1962.

3012

ALAN J. BOWES, Shire Secretary.

SHIRE OF MYRTLEFORD.

BY-LAW No. 2.

A By-law of the Shire of Myrtleford, made under the Local Government Acts, and numbered 2, for prohibiting the sale of goods from stalls, motor cars, carts, trucks, barrows, boxes, baskets, crates, bags or other vehicles or receptacles standing or placed on any street, road or public place set forth.

IN pursuance of the powers conferred by the Local Government Acts and of any and every other power it therewith enabling the President, Councillors and Ratepayers of the Shire of Myrtleford order as follows:—

No person shall, without the previous consent, in writing, of the Council, sell any goods from any stall, motor car, cart, truck, barrow, box, basket, crate, bag or other vehicle or receptacle standing or placed on any street, road or public place within the municipal district as set out in the Schedule hereto.

THE SCHEDULE HEREINBEFORE REFERRED TO.

Standish-street, from Myrtle Creek to Duke-street.  
Clyde-street, from Myrtle-street to Standish-street.  
Smith-street, from Standish-street to Lawrence-street.  
Myrtle-street, from Alice-street to Lawrence-street.  
Queen-street, from Elgin-street to Clyde-street.  
Albert-street, from Elgin-street to Myrtle-street.

Resolution for passing this By-law was agreed to by the Council of the Shire of Myrtleford on the 7th December, 1961, and confirmed on the 1st February, 1962

The common seal of the President, Councillors and Ratepayers of the Shire of Myrtleford was hereunto affixed on the 1st day of February, 1962, in the presence of—

(SEAL) J. A. JONES, Shire President.  
W. R. SELZER, Councillor.  
K. S. LANE, Shire Secretary.

Approved by the Governor in Council, 25th September, 1962.—N. G. WISHART, Clerk of the Executive Council.

3010

SHIRE OF RODNEY.

LOAN No. 47.

Notice of Intention to Borrow the Sum of £13,000 for Permanent Works and Undertakings.

NOTICE is hereby given that the Council of the Shire of Rodney proposes to borrow the sum of Thirteen thousand pounds on the credit of the municipal revenues of the President, Councillors and Ratepayers of the said Shire, such sum to be raised by the grant of a mortgage, in accordance with the provisions of the *Local Government Act 1958*.

1. The maximum rate of interest that may be paid is £5 10s. per cent. per annum.

2. The purposes for which the loan is to be applied are—

- (a) The erection and equipment of a workshop at Council Depot, Kerford-street, Tatura .. .. . £3,000
- (b) Construction of roads, streets and foot-paths, laying out of gardens and plantation on median strip in the Midland Highway and drainage works—all in the Township of Mooroopna .. 10,000

£13,000

3. The period of the loan shall be ten years.

4. The moneys borrowed shall be repayable by providing out of the municipal fund twenty half-yearly instalments of approximately £853 14s. 6d. each, including principal and interest, on the 1st day of February and the 1st day of August during the currency of the loan. The first instalment shall be payable on the 1st day of August, 1963.

5. Such moneys shall be repayable at the State Savings Bank of Victoria, Melbourne.

The plans and specifications and the estimate of the cost of the proposed works, and a statement showing the proposed expenditure of the moneys to be borrowed, are open for inspection at the Shire Office, Tatura.

Dated the 12th October, 1962.

3029

R. PERRY, Shire Secretary.

SHIRE OF SHEPPARTON.

BY-LAW No. 72.

A By-law of the Shire of Shepparton made under section 781 of the *Local Government Act 1958* and numbered 72 for:—

- (a) regulating the market-place and the buildings, stalls, pens and standings therein and for preventing nuisances or obstructions therein or in the immediate approaches thereto;
- (b) fixing the days and the hours during each day on which the market shall be held;
- (c) licensing yards and premises for the sale of cattle within the municipal district and for fixing (subject to the limitation hereinbefore mentioned) the dues to be paid for such licences; and
- (d) regulating the carriers resorting to the market, and fixing the rates for carrying articles carried therefrom within the limits of the municipal district.

IN pursuance of the powers conferred by the *Local Government Act 1958*, the President, Councillors and Ratepayers of the Shire of Shepparton order as follows:—

1. The Second Schedule of By-law No. 52 as amended by By-laws Nos. 55, 56, 57, 61, 64 and 66 is hereby further amended to read as follows:—

Scale of Stallages, Rents, Tolls and Dues.

(a) Every person exposing or offering for sale or selling in any market provided by the Council, any of the following:—

	s.	d.
Every horse, ass or mule .. .. .	2	6
Every head of neat cattle .. .. .	2	6
Every bull .. .. .	4	0
Every calf (under six months old) .. .. .	0	9
Every sheep or lamb .. .. .	0	4
Every goat .. .. .	0	3
Every pig .. .. .	1	3

For all stock standing in the yards after 10 a.m. on the day following the sale, extra per day:—

	s.	d.
Every horse, ass, mule or pig .. .. .	1	6
Every head of neat cattle .. .. .	0	9
Every sheep or lamb .. .. .	0	6

(b) Every person who—

- (i) Rents or uses any stall or standing place in such market 1 15 0 per day.
- (ii) Sells or exposes for sale without a stall in any market place any article or articles upon which dues have not been otherwise charged or paid .. .. . 0 7 0 per day.

2. The Third Schedule of By-law No. 52 as amended by By-laws Nos. 55, 56, 57, 61, 64 and 66 is hereby further amended to read as follows:—

Every company, firm or person who conducts or arranges the sale by auction of any goods or cattle in any market provided by the Council—

- (i) On appointed market days .. .. . 2 2 0
- (ii) On days other than appointed market days .. .. . 5 5 0

Resolution for passing this By-law was adopted by the Council of the Shire of Shepparton on the 20th day of August, 1962, and confirmed on the 24th day of September, 1962.

In witness whereof the common seal of the President, Councillors and Ratepayers of the Shire of Shepparton was hereto affixed in the presence of—

(SEAL) R. C. JEFFERY, President.  
D. C. CUMMING, Councillor.  
K. LITTLE, Secretary.

3053

SHIRE OF SOUTH BARWON.

LOAN No. 52.

Notice of Intention to Borrow.

NOTICE is hereby given that the Council of the Shire of South Barwon intends to borrow Twenty-five thousand pounds (£25,000) on the credit of the President, Councillors and Ratepayers of the said Shire by the grant of a mortgage in accordance with the provisions of the Local Government Acts.

In connexion therewith the following information is stated:—

(a) The amount of the principal moneys which it is proposed to borrow is Twenty-five thousand pounds.

(b) The maximum rate of interest that may be paid is £5 10s. per annum.

(c) The times which the moneys borrowed are to be repayable are on the 1st day of July and the 1st day of January during the years 1963 to 1978 inclusive, and that the place such moneys shall be repayable is at the Bank of New South Wales, Belmont.

(d) The purposes for which the loan is to be applied are—

1. Purchase of Garbage Collection Unit ..	£3,700
2. Purchase of Mechanical Street Sweeper ..	6,000
3. Main Drain Construction—Highton ..	2,667
4. Construction of North Valley-road (Council contribution to C.R.B. grant) ..	1,120
5. Footpath reconstruction Amundsen-street ..	910
6. Construction of Bus Shelter ..	100
7. Road reconstruction—South Valley-road ..	1,159
8. Purchase of land for Recreational Purposes Kardinia Riding (Portion of cost) ..	2,000
9. Purchase of land for road extension and construction thereof ..	1,932
10. Purchase of land for Recreational Purposes Barwon Riding (Portion of cost) ..	1,000
11. Construction of Francis-street and Reserve-road (Portion of Council contribution to C.R.B. grants) ..	434
12. Road construction and drainage—Esplanade, Torquay ..	1,100
13. Construction of Kerbs, Channels and Drains—Park Land, Torquay ..	850
14. Land acquisition for extension of Clifford-parade, Bostock-avenue, Henty-street and Humble-street, Barwon Heads, and construction thereof ..	1,312
15. Construction of Breamlea-road (Portion of Council contribution to C.R.B. grant) ..	716
	£25,000

(e) The manner in which the loan is to be liquidated is by provision out of the municipal fund in each half-year during the currency of the loan of the sum of £1,234 12s. 3d. which includes principal and interest.

The plans, specifications and estimate of the cost of the works and a statement showing the proposed expenditure of the moneys to be borrowed are open for inspection at the Shire Office, Belmont.

Dated this 16th day of October, 1962.

3030 E. T. CORNISH, Shire Secretary.

Sewerage Districts Acts.

PROPOSED SEWERAGE AUTHORITY.

NOTICE is hereby given that the Shire of Fern Tree Gully has made application to the Honorable the Minister of Water Supply for the constitution of a Sewerage Authority and for the proclamation of a Sewerage District within its municipal boundary and for the construction, maintenance and continuance of sewerage works within that district under the provisions of the Sewerage Districts Acts.

A general plan and description of the proposed works have been submitted with the application and copies of same may be seen at Shire Offices, Fern Tree Gully, Health Department, 295 Queen-street, Melbourne, State Rivers and Water Supply Commission, and 90 Orrong-road, Armadale.

Dated at Fern Tree Gully the 2nd day of October, 1962.

2942 R. B. WEBB, Acting Secretary.

THE BALLARAT SEWERAGE AUTHORITY.

GENERAL NOTICE.

THE above-mentioned Sewerage Authority, having made provision for carrying off the sewage from each and every property, which or any part of which, is within the sewerage area hereinafter described, doth hereby declare that on and after the 1st day of November, 1962, each and every property which, or any part of which, is within the said sewerage area shall be deemed to be a sewered property within the meaning of the *Sewerage Districts Act 1958*.

The boundaries of the sewerage area hereinbefore referred to are:—

Sewerage Area No. 215.

*City of Ballarat.*—Commencing at the south-east corner of No. 5 Killeen-avenue being a point on the boundary of sewerage area No. 184; thence easterly about 152 feet along the north building line of Killeen-avenue to the south-east corner of vacant allotment, No. 11 Killeen-avenue, south-easterly across Killeen-avenue to the north-east corner of No. 26 Killeen-avenue, southerly to the south-east corner of the said No. 26, westerly to the south-west corner of the said No. 26 being a point on the boundary of sewerage area No. 113; thence westerly, northerly and north-easterly along the boundaries of sewerage areas Nos. 113 and 184 to the point of commencement.

Further particulars regarding the streets or parts of streets in which sewers have been laid may be ascertained on enquiry at the Authority's Office.

By Order of the said Sewerage Authority.

A. W. NICHOLSON, Chairman.  
CHAS. H. CLAMP, Secretary.

3040

TRARALGON SEWERAGE AUTHORITY.

THE above-mentioned Sewerage Authority having made provision for the carrying off of sewage from each and every property which or any part of which is within the Sewerage Area hereinafter described, doth hereby declare that on and after the 1st day of October, 1962, each and every property which or any part of which is within the said Sewerage Area shall be deemed to be a sewered property within the meaning of the *Sewerage Districts Act 1958*.

The boundaries of the Sewerage Area hereinbefore referred to are as follows:—

Sewerage Area No. 26.

Commencing at a point on the eastern boundary of Sewerage Area 10, such point being the north-eastern angle of lot 13, lodged plan of subdivision No. 17881, Parish of Traralgon; thence easterly across Liddiard-road to the north-western angle of lot 1, lodged plan of subdivision No. 51881, Parish of Loy Yang, easterly along the northern boundary of lots 1, 3, 4, 5, 6, 7, 8, 9, 10, 33, 34, 35, 36, 37, 38, 39, lodged plan No. 51881, easterly along the northern boundary of lots 75, 76, 77, 78, 86, 85, 84, 150, 151, 152, 154, lodged plan No. 51882, to Lyndon-crescent, southerly along the western building line of Lyndon-crescent to Shakespeare-street, westerly along the northern building line of Shakespeare-street to Liddiard-road; thence northerly along the western building line of Liddiard-road to the point of commencement.

All of which boundaries are shown on a plan which is open for inspection at the office of the Sewerage Authority.

DONALD DUNBAR, Chairman.  
BERNARD LORD, Commissioner.  
ERIC F. TAYLOR, Secretary.

3026

NOTICE OF DISSOLUTION OF PARTNERSHIP.

NOTICE is hereby given that the partnership heretofore carried on by Reginald Charles Burrows, Gwenda Merle Burrows, Kenneth Thomas Burrows and Pauline Anne Frances Burrows at 290 Hope-street, West Brunswick, under the firm name of "Nolco Stainless Products" has been dissolved as from the 1st day of July, 1962. The said business will continue to be carried on by the said Kenneth Thomas Burrows and Pauline Anne Frances Burrows under the same firm name and at the same address.

R. BURROWS.  
G. BURROWS.  
K. BURROWS.  
P. BURROWS.

Peter J. Callahan, solicitor, 422 Collins-street, Melbourne. 3093



**NOTICE** is hereby given by us the undersigned persons that the partnership heretofore subsisting between Percy John Hatwell the elder, of 38 Mentone-parade, Mentone, Percy John Hatwell the younger, of Breakwater-road, East Geelong, and Roy Gorman Hatwell, formerly of Colac, but now of 359 Bluff-road, Hampton, carrying on business at 38 Mentone-parade, Mentone, and at Geelong and Hamilton, under the style or firm name of P. J. Hatwell and Sons, was dissolved as from the 31st day of July, 1960, so far as concerned the said Roy Gorman Hatwell who retired from the said firm on the said date.

P. J. HATWELL, Senior.  
P. J. HATWELL, Junior.  
R. G. HATWELL.

Coltman, Wyatt and Anderson, solicitors, of 578 Bourke-street, Melbourne. 3074

**PURSUANT** to the *Partnership Act 1958*, section 41, notice is hereby given that the medical partnership previously subsisting between Dr. James Augustus Conquest and Dr. James Peter Bird, in practice at 100 Collins-street, Melbourne, has been dissolved as from 22nd June, 1962. All debts due to and owing by the partnership will be received and paid respectively by Dr. Conquest, who will continue the practice in his own name at the same address.

JAMES A. CONQUEST.

Witness—ELIZABETH DEANS.

PETER JAMES BIRD.

Witness—EILEEN M. BIRD.

3072

**NOTICE** is hereby given that the partnership of Warmington and Matthews, architects, of 78 Wellington-parade, East Melbourne, has been dissolved as from 8th October, 1962.

G. STUART WARMINGTON.  
A. W. MATTHEWS.

3028

**NOTICE** is hereby given that the partnership heretofore subsisting between the undersigned, Peter Goumas and John Kokinakis, carrying on business as garage proprietors at 415 Bridge-road, Richmond, under the style or firm name of Richmond Original Garage, has been dissolved by mutual consent as from the 11th day of September, 1962. All debts due and owing by the said late firm will be received and paid by Peter Goumas who will continue to carry on the business at 415 Bridge-road, Richmond, under the said firm name.

Dated this 18th day of September, 1962.

JOHN KOKINAKIS.  
PETER GOUMAS.

Witness—G. KOUVARAS, solicitor, Melbourne.

3027

The *Companies Act 1961*.

JAMES HARE (TEXTILES) PTY. LIMITED.

**AT** a General Meeting of the members of James Hare (Textiles) Pty. Limited duly convened and held at 117 Maling-road, Canterbury, on 3rd October, 1962, the following Special and Ordinary Resolutions respectively were duly passed:—

1. "That the company be wound up voluntarily".
2. "That Robert William Parry, of 44 Queen-street, Melbourne, accountant, be and he is hereby appointed liquidator of the company".

Dated this 10th day of October, 1962.

3086

JOHN RODD, Director.

*Companies Act 1958*.—In the matter of PROVINCIAL BUILDERS & SUPPLIES PROPRIETARY LIMITED (in Voluntary Liquidation).—Creditors Voluntary Winding Up, and in the matter of the *Companies Act 1958*.

**NOTICE** is hereby given that, in pursuance of section 245, the Final Meeting of the members and creditors of the above-named company will be held at the office of A. J. Irwin, 4th Floor, 366 Bourke-street, Melbourne, on Tuesday, the 13th day of November, 1962, at Four o'clock in the afternoon, for the purpose of laying before the meeting an account showing how the winding up of the above-named company has been conducted and the property of the company disposed of, and of giving any explanation thereof.

Dated this 9th day of October, 1962.

A. J. IRWIN, Liquidator.

366 Bourke-street, Melbourne.

3105

No. 112.—8880/62.—4

The *Companies Act 1961*.—In the matter of NEW FOREST TIMBER COMPANY PROPRIETARY LIMITED.—Notice re Meeting of Creditors, Pursuant to Section 260.

**NOTICE** is hereby given that a Meeting of Creditors of the above-named company will be held at the Board Room, Honorary Justices Association of Victoria, 34 Queen-street, Melbourne, on Thursday, the 25th day of October, 1962, at Eleven a.m., the company having convened a meeting of its members for the same day for the purpose of considering a Resolution that the company be wound up voluntarily.

Dated this 16th day of October, 1962.

M. J. BROWN, Director.

Kennedy, Smail and Middlemiss, 31 Queen-street, Melbourne. 3084

*Companies Act 1961*.—In the matter of GAINSBOROUGH FILM & TV PRODUCTIONS PTY. LTD., 18-22 Collins-street, Melbourne.—And in the matter of the *Companies Act 1961*.

**NOTICE** is hereby given that pursuant to section 260 that a Meeting of Creditors of the above-named company will be held at the Institute of Chartered Accountants, 23 McKillop-street, Melbourne, on Wednesday, the 24th day of October, 1962, at 3.30 o'clock in the afternoon, for the purposes set out in sections 260, 261 and 262 of the above Act.

By order of the Board,

B. K. ROGERS, Director.

Dated this 8th day of October, 1962.

J. A. Coakley, public accountant, 125 William-street, Melbourne. 3082

No. of Company 31250.—In the matter of the *Companies Act 1961* and MONALUM JEWELLERY PROPRIETARY LIMITED (in Voluntary Liquidation).

**NOTICE** is hereby given that a General Meeting of the company will be held at Three o'clock in the afternoon on the 16th day of November, 1962, at 205 Greville-street, Prahran, to receive the final account of the liquidator.

3081

R. LOFTUS, Liquidator.

*Companies Act 1961*.

WALKER AND JOY (COUNTRY CONTRACTS) PROPRIETARY LIMITED.

**AT** a General Meeting of members of Walker and Joy (Country Contracts) Proprietary Limited duly convened and held at 20 Nelson-street, Windsor, on the 5th day of October, 1962, the following Special Resolution was duly passed:—

"That it has been proved to the satisfaction of this meeting that the company cannot by reason of its liabilities continue its business and that the company be wound up voluntarily, and that Forbes Yorke Ratray, of 24 Jeffcott-street, Melbourne, in the State of Victoria, chartered accountant, be appointed liquidator of the company".

3065

F. W. WALKER, Director.

In the Supreme Court of Victoria.—In the matter of Part X. of the *Companies Act 1961*.—And in the matter of A. E. BRICKNELL PTY. LTD.—Notice of Winding-Up Order.

**TAKE** notice that a winding-up order was made against A. E. Bricknell Pty. Limited on Thursday, 11th October, 1962. The official liquidator in the said winding up is John Kenneth Hall, 163 William-street, Melbourne.

D. L. CANAVAN, Deputy Commissioner of Taxation of the Commonwealth of Australia, Petitioner. 3061

WEMCO FABRICS PROPRIETARY LIMITED. (IN VOLUNTARY LIQUIDATION).

**NOTICE** is hereby given, in pursuance of section 210 of the *Companies Act 1958*, that the Final Meeting of members of Wemco Fabrics Proprietary Limited will be held at the offices of Flack and Flack, 1st Floor, 128 William-street, Melbourne, on Monday, 19th November, 1962, at Ten a.m., for the purpose of having an account laid before them showing the manner in which the winding up has been conducted and the property of the company disposed of, and of hearing any explanations that may be given by the liquidator.

Dated this 15th day of October, 1962.

3060

W. E. DOBIE, Liquidator.

*Companies Act 1961.*—In the matter of MITCHAM ELECTRIC MOTOR REWINDING COMPANY PROPRIETARY LIMITED.

AT an Extraordinary General Meeting of the above-named company, duly convened and held at 18 Lansell-avenue, Camberwell, on the 15th day of October, 1962, the following Resolution was passed as a Special Resolution:—

“That the company be wound up voluntarily.”

And at such meeting Walter George Suter, of 179 Burwood-road, Hawthorn, was appointed liquidator for the purpose of the winding up.

Dated this 16th day of October, 1962.

3056 W. G. SUTER, Secretary.

*Companies Act 1958.*—In the matter of BIGNELL ESTATES PROPRIETARY LIMITED (in Voluntary Liquidation).—Creditors Voluntary Winding Up, and in the matter of the *Companies Act 1958.*

NOTICE is hereby given that, in pursuance of section 245, the Final Meeting of the members and creditors of the above-named company will be held at the office of A. J. Irwin, 4th Floor, 366 Bourke-street, Melbourne, on the 9th day of November, 1962, at Four o'clock in the afternoon, for the purpose of laying before the meeting an account showing how the winding up of the above-named company has been conducted and the property of the company disposed of, and of giving any explanation thereof.

Dated this 9th day of October, 1962.

A. J. IRWIN, Liquidator.  
366 Bourke-street, Melbourne. 3106

*The Companies Act 1961.*—In the matter of HAMPTON ELECTRICS PTY. LTD.

NOTICE is hereby given that, pursuant to section 210 of the Companies Act, a Final Meeting of the creditors of the above company will be held at the offices of Kennedy, Smail & Middlemiss, 31 Queen-street, Melbourne, on Wednesday, the 7th November, 1962, at Ten o'clock a.m.

*Business.*—To receive the liquidator's accounts.

Dated this 17th day of October, 1962.

E. R. SMAIL, Liquidator.  
Kennedy, Smail & Middlemiss, 31 Queen-street, Melbourne. 3104

*The Companies Act 1961.*

SWANTON & BARRETT ENGINEERING CO. PTY. LTD. (IN LIQUIDATION).

NOTICE is hereby given that a First Dividend is intended to be declared in the above matter, and that creditors who have not proved their debts by the 31st day of October, 1962, will be excluded from this distribution.

Dated this 10th day of October, 1962.

H. V. SAMPSON, A. I. SINCLAIR, Joint Liquidators,  
414 Bourke-street, Melbourne. 3100

*The Companies Act 1961.*—In the matter of TRUSTWORTHY APPLIANCES PROPRIETARY LIMITED (in Liquidation).

NOTICE is hereby given that a First Dividend is intended to be declared in this matter. Creditors who have not proved their debts by the 2nd November, 1962, will be excluded from the dividend.

Dated this 12th day of October, 1962.

E. R. SMAIL, Liquidator.  
Kennedy, Smail & Middlemiss, 31 Queen-street, Melbourne, C.1. 3095

*The Companies Act 1961.*—In the matter of POWER TOOL COMPANY PROPRIETARY LIMITED (in Liquidation).

NOTICE is hereby given that a First and Final Dividend is intended to be declared in this matter. Creditors who have not proved their debts by the 2nd November, 1962, will be excluded from the dividend.

Dated this 12th day of October, 1962.

A. M. HORSBURGH, Liquidator.  
Kennedy, Smail & Middlemiss, 31 Queen-street, Melbourne, C.1. 3094

GORDON VICTOR KEENAN, late of 40 Albert-street, Warragul, gentleman, DECEASED.

CREDITORS, next of kin and others having claims in respect of the deceased (who died on the 7th August, 1962), are required by the trustees, John Henry Handson, and Marjorie Elizabeth Dark, to send particulars to them, care of the undersigned solicitors, by the 17th December, 1962, after which date the trustees may convey or distribute the assets, having regard only to the claims of which they then have notice.

GRAY, FRIEND & LONG, solicitors, Warragul. 3041

STUART GRAHAM MCFARLAND, late of 98 Albert-street, Warragul, retired farmer, DECEASED.

CREDITORS, next of kin and others having claims in respect of the estate of the deceased (who died on the 7th June, 1962), are required by the trustee, the Trustees, Executors and Agency Company, of 401 Collins-street, Melbourne, to send particulars to it by the 14th December, 1962, after which date the trustee may convey or distribute the assets, having regard only to the claims of which it then has notice.

GRAY, FRIEND & LONG, solicitors, Warragul. 3016

ALICE MARY FALLON, late of Neerim South, married woman, DECEASED.

CREDITORS, next of kin and others having claims in respect of the estate of the deceased (who died on the 4th July, 1962), are required by the administrator, William John Fallon, to send particulars to him, care of the under-signed solicitors by the 14th December, 1962, after which date the administrator may convey or distribute the assets, having regard only to the claims of which he then has notice.

GRAY, FRIEND & LONG, solicitors, Warragul. 3017

DUNCAN MCKAY, late of Barwite, in the State of Victoria, farmer, DECEASED.

CREDITORS, next of kin and others having claims in respect of the deceased (who died on the 16th day of April, 1962), are required by his trustees, Charles George Kuhle, agent, and William Gibson Griffiths, farmer, both of Mansfield, to send particulars to them, care of the under-mentioned firm of solicitors, by the 19th day of December, 1962, after which date the trustees may convey and distribute the assets, having regard only to the claims of which they then have notice.

MAL. RYAN & GLEN, High-street, Mansfield, solicitors for the trustees. 3023

MARGARET RYAN, late of Kyabram, in the State of Victoria, spinster, DECEASED.

CREDITORS, next of kin and others having claims in respect of the deceased (who died on the 20th day of April, 1962), are required by her trustee, Thomas Michael Rodney Ryan, of High-street, Mansfield, solicitor, to send particulars to him, care of the under-mentioned firm of solicitors, by the 19th day of December, 1962, after which date the trustee may convey and distribute the assets, having regard only to the claims of which he then has notice.

MAL. RYAN & GLEN, High-street, Mansfield, solicitors for the trustee. 3024

DORIS ELIZABETH BUNTIN, late of 52 Thackeray-road, Reservoir, widow, DECEASED.

CREDITORS, next of kin and others having claims against the estate of the said deceased, are required by the executor, Peter Malcolm Buntin, to send particulars of their claims to the said executor, care of the undersigned solicitors, on or before the 19th day of December, 1962, after which date he will distribute the assets of the said deceased, having regard only to the claims of which he then has notice.

HOME, WILKINSON & LOWRY, solicitors, 401 Collins-street, Melbourne. 3099

CREDITORS, next of kin and all others having claims against the estate of Jessie May Ladson, late of "Atholdell", 273 Danks-street, Middle Park, widow, deceased (who died on the 16th April, 1962), are required to send particulars, in writing, of such claims to the executrix, care of the under-mentioned solicitors, not later than the 22nd December, 1962, after which date she will distribute the assets of the said deceased, having regard only to the claims of which she then has notice.

W. E. PEARCEY & IVEY, solicitors, 90 William-street, Melbourne. 3087

*Trustee Act 1958.*

## NOTICE TO CLAIMANTS.

**P**URSUANT to the *Trustee Act 1958*, creditors, next of kin, and all other persons having claims in respect of the estates of the deceased persons named below are required to send particulars to the legal personal representative or representatives, at the addresses stated, after which date the representative or representatives will distribute the assets, having regard only to the claims of which notice has been received:—

Eleanor Kearney, late of 9 Tait-street, Newport, married woman, deceased, died on the 25th day of August, 1962. Claims to the executor, John Wilkie Kearney, of 9 Tait-street, Newport, retired railway employee, care of John F. Carroll, of 4 Paisley-street, Footscray, solicitor, by the 20th day of December, 1962.—John F. Carroll, LL.B., solicitor, 4 Paisley-street, Footscray. 3055

**C**REDITORS, next of kin and others having claims in respect of the estate of Catherine Croft, late of 29 Fawkner-street, St. Kilda, gentlewoman, deceased (who died on the 5th August, 1962), are to send particulars of their claims to the executors, who have applied for probate of her will dated the 8th April, 1962, namely, the National Trustees, Executors and Agency Company of Australasia Limited, whose registered office is situate at 95 Queen-street, Melbourne, and Virgil Bernard Gill, of 450 Little Collins-street, Melbourne, solicitor, care of National Trustees, Executors and Agency Company of Australasia Limited, at its said office, by the 21st December, 1962, after which date the said executors will distribute the estate, having regard only to the claims of which they then have notice.

VIRGIL B. GILL, solicitor, 450 Little Collins-street, Melbourne. 3071

**C**REDITORS, next of kin and others having claims in respect of the estate of Ethel Brodrick Brodrick, of 173 Fendalton-road, Christchurch, in the Dominion of New Zealand, widow, deceased (who died on the 6th day of April, 1961), are to send particulars of their claims to the executors, The Trustees Executors and Agency Company Limited, care of the under-mentioned solicitors, on or before the 19th day of December, 1962, after which date the said executors will distribute the assets, having regard only to the claims of which notice has been received.

Dated the 17th day of October, 1962.

A. L. C. FLINT & MARRIE, of 578 Bourke-street, Melbourne, solicitors for the executors. 3079

**C**REDITORS, next of kin and other persons having claims against the estate of Thomas Daniel O'Callaghan, late of "Kenilworth Private Hospital", 3 Kenilworth-parade, Ivanhoe, pensioner, deceased (who died on the 30th August, 1962), are to send particulars of their claims to National Trustees, Executors and Agency Company of Australasia Limited, of 95 Queen-street, Melbourne, the executor of the will of the said deceased, by the 21st day of December, 1962, after which date the company will distribute the assets, having regard only to the claims of which it then has notice.

JAMES P. OGGE & CO., solicitors of 165 Greville-street, Prahran. 3080

**C**REDITORS, next of kin and others having claims against the estate of Florence Annie Robinson, late of Keilor-road, Keilor East, widow, deceased (who died on the 17th day of August, 1962), are required to send particulars of their claims to John Francis Carroll, 118 Queen-street, Melbourne, solicitor, the executor of the will of the above deceased, before the 20th day of December, 1962, after which date he will distribute the assets, having regard only to the claims of which he then has notice.

JOHN F. CARROLL, solicitor, 118 Queen-street, Melbourne. 3073

KEITH LAWRENCE BUNTIN, late of 52 Thackeray-road, Reservoir, accountant, DECEASED.

**C**REDITORS, next of kin and others having claims against the estate of the said deceased, are required by the administrator, Peter Malcolm Buntin, to send particulars of their claims to the said administrator, care of the undersigned solicitors, on or before the 19th day of December, 1962, after which date he will distribute the assets of the said deceased, having regard only to the claims of which he then has notice.

HOME, WILKINSON & LOWRY, solicitors, 401 Collins-street, Melbourne. 3098

**C**REDITORS, next of kin and others having claims against the estate of Mary Augusta O'Brien, late of Mont Park, retired nurse, deceased (who died on the 24th November, 1961), are required to send particulars of their claims to Lucy Higgins, of 127 Rowe-street, North Fitzroy, the administratrix of the said estate, care of the under-mentioned proctors, by the 19th December, 1962, after which date she will distribute the assets, having regard only to the claims of which she then has notice.

CORR & CORR, solicitors, 290 Latrobe-street, Melbourne. 3070

JANIE ADAM HIDDLE, late of 16 Forster-street, Williamstown, gentlewoman, DECEASED.

**C**REDITORS, next of kin and others having claims in respect of the estate of the deceased (who died on the 14th day of April, 1962), are required by the personal representative, Elizabeth Swan Hiddle, of 16 Forster-street, Williamstown, secretary, to send particulars to her, care of the under-mentioned solicitors, by the 20th day of December, 1962, after which date the personal representative may convey or distribute the assets, having regard only to the claims of which she then has notice.

PAVEY, WILSON, COHEN & CARTER, solicitors, 390 Lonsdale-street, Melbourne. 3069

WALTER CHRISTIAN HOLT, formerly of 28 Kendall-street, Hampton East, in the State of Victoria, but late of Silvan-road, Mount Evelyn, in the said State, invalid pensioner (who died on the 5th of August, 1962).

**C**REDITORS, next of kin and all others having claims in respect of the estate of the said deceased are required by the executor, Clifford Leslie James, of 405 Riversdale-road, Surrey Hills, in the said State, chartered accountant, to send particulars of such claims to him by the 24th day of December, 1962, after which date he will distribute the assets, having regard only to the claims of which he then has notice.

DAVIES, CAMPBELL & PIESSE, solicitors, 401 Collins-street, Melbourne. 3068

**C**REDITORS, next of kin and others having claims in respect of the estate of Jane Green, late of 15 Burke-road, East Malvern, married woman, who died on the 18th day of July, 1962, are to send particulars of their claims to The Equity Trustees, Executors and Agency Company Limited, of 472 Bourke-street, Melbourne, by the 19th day of December, 1962, after which date it will distribute the assets, having regard only to the claims of which it then has notice.

MACPHERSON & KELLEY, solicitors, 178 Queen-street, Melbourne. 3067

FLORENCE ELIZA STRINGER, late of Lynn Private Hospital, Elgin-avenue, Armadale, spinster, DECEASED (who died 5th August, 1962).

**C**REDITORS, next of kin and all other persons having claims against the estate of the deceased are required by the executors of her will, Florence Catherine Mary Brown, of 19 Denman-avenue, East St. Kilda, married woman, and Frank William James Stringer, of 306 Clayton-road, Clayton, shoe retailer, to send particulars thereof to them, care of the under-mentioned solicitors, before 27th December, 1962, after which date they may distribute the assets of the deceased, having regard only to the claims of which they then have notice.

COLTMAN, WYATT & ANDERSON, solicitors, 578 Bourke-street, Melbourne. 3064

DANIEL JOSEPH GREENE, late of Gordon, retired meat worker, DECEASED.

**C**REDITORS, next of kin and others having claims in respect of the estate of the above-named deceased (who died on 14th December, 1961), are required by the executor, Simon Greene, of Gordon, retired labourer, to send particulars of such claims to him by the 29th day of December, 1962, after which date he may convey or distribute the assets, having regard only to the claims of which he then has notice.

JOHN GINNANE, LL.B., solicitor, 153A Barkly-street, Footscray. 3063

**C**REDITORS, next of kin and others having claims in respect of the estate of Margaret Farrell, formerly of Homebush Hotel, 211 Abbotsford-street, North Melbourne, licensed victualler, but late of 150 Alma-road, East St. Kilda, spinster, deceased (who died on the 24th

day of August, 1962, are to send particulars of their claims to National Trustees Executors and Agency Company of Australasia Limited, at its registered office, 95 Queen-street, Melbourne, by the 21st day of December, 1962, after which date it will distribute the assets, having regard only to the claims of which it then has notice.

DOYLE & KERR, solicitors, 108 Queen-street, Melbourne. 3062

CREDITORS, next of kin and others having claims in respect of the estate of Louis Carver Paul, late of Outtrim, farmer, deceased (who died on the 17th May, 1961), are to send particulars of their claims to Bertha Louise Catherine Thomas, care of the undersigned, by the 13th day of December, 1962, after which date she will distribute the assets, having regard only to the claims of which she then has notice.

BIRCH & ROSS, solicitors, Korumburra. 3059

CREDITORS, next of kin and others having claims in respect of the estate of Mary Margaret Watkin, late of 5 Cross-street, Canterbury, widow, deceased (who died on the 16th day of July, 1962), are to send particulars of their claims to National Trustees, Executors and Agency Company of Australasia Limited, of 95 Queen-street, Melbourne, by the 24th day of December, 1962, after which date it will distribute the assets, having regard only to the claims of which it then has notice.

LEACH & THOMSON, solicitors, 472 Bourke-street, Melbourne. 3058

CREDITORS, next of kin and others having claims in respect of the estate of Flora May McDonald, late of 197 Beach-road, Black Rock, in the State of Victoria, home duties, deceased (who died on the 7th day of December, 1960), are to send particulars of their claims to Charles Wendall Greene, of 527 Balcombe-road, Black Rock, aforesaid, or Leo Clement Hartnett, of 26 Sandringham-road, Sandringham, in the said State (or to the undersigned at their office hereunder mentioned) on or before the 22nd day of January, 1963, after which date the said Charles Wendall Greene and Leo Clement Hartnett will proceed to distribute the assets of the said deceased, having regard only to the claims of which they then have notice.

ADAMS & GARDE, solicitors, 959 Nepean Highway, Moorabbin. 3045

MABEL COLLINS, late of 36 Ferncroft-avenue, East Malvern, gentlewoman, DECEASED.

CREDITORS, next of kin and others having claims in respect of the estate of the above-named deceased (who died on the 24th day of April, 1962), are required by the executors, Trevor Barton Logan, accountant, of 19 Newington-parade, Chelsea, and Albert Yeomans, public servant, of 31 Ferncroft-avenue, East Malvern, to send particulars to them, care of the undersigned by the 21st day of December, 1962, after which date the executors may convey or distribute the assets, having regard only to the claims of which they then have notice.

S. W. MISSON & BARTLEY, solicitors, 59 Waverley-road, East Malvern. 3044

CREDITORS, next of kin and others having claims in respect of the estate of Georgina Mary De Caires, late of 99 Hoddle-street, West Richmond, married woman, deceased (who died on the 10th day of August, 1962), are required by the applicant for a grant of probate, National Trustees, Executors and Agency Company of Australasia Limited, of 95 Queen-street, Melbourne, to send particulars to such company by the 21st day of December, 1962, after which date the said company may convey or distribute the assets, having regard only to the claims of which it then has notice.

LYNCH & MacDONALD, solicitors, 360 Collins-street, Melbourne. 3090

CREDITORS, next of kin and others having claims in respect of the estate of Gertrude Helen Culley, late of Hilton-road, Ferny Creek, spinster, deceased (who died on the 30th day of October, 1961), are to send particulars of their claims to the executors, Helen Esther Lampe and William Manson Jarvie, care of the under-mentioned solicitors, on or before the 18th day of December, 1962, after which date the said executors will distribute the assets, having regard only to the claims of which notice has been received.

MARTIN & MARTIN, solicitors, 37 Queen-street, Melbourne. 3089

CREDITORS, next of kin and others having claims in respect of the estate of Frances Agnes Wilson, formerly of 47 Murray-street, Elsternwick, but late of 33 Seymour-road, Elsternwick, in the State of Victoria, spinster, deceased (who died on the 27th June, 1962), are required to send particulars of their claims to the executor, The Fidelity Trustee Company Limited, at 50 Market-street, Melbourne, by the 21st day of December, 1962, after which date the executor will distribute the assets, having regard only to the claims of which it then has notice.

K. P. REES, B.A., LL.B., solicitor, 89 Queen-street, Melbourne. 3088

CREDITORS, next of kin and others having claims in respect of the estate of Caroline Elizabeth Goodall, late of 88 Orrong-road, Elsternwick, widow, deceased (who died on the 9th day of March, 1962), should send particulars of their claims to The Equity Trustees, Executors and Agency Co. Ltd., of 472 Bourke-street, Melbourne, by the 19th day of December, 1962, after which it will distribute the assets, having regard only to the claims of which it then has notice.

BEST, HOOPER, RINTOUL & SHALLARD, solicitors, 100 Queen-street, Melbourne. 3085

CREDITORS, next of kin and others having claims in respect of the estate of Ada Agnes Thom, late of 418 Glen Eira-road, Caulfield, in the State of Victoria, widow, deceased (who died on the 10th day of October, 1961), are to send particulars of their claims to Ronald Stanwick Thom and John David Thom, care of the under-mentioned solicitors by the 18th day of December, 1962, after which date they will distribute the assets, having regard only to claims of which they have notice.

DARVALL & HAMBLETON, solicitors, 7th Floor, T. & G. Building, cnr. Collins and Russell streets, Melbourne. 3083

EMILY GLEDHILL GLEDHILL, late of Colac, widow, DECEASED.

CREDITORS, next of kin and others having claims in respect of the estate of the deceased (who died 17th June, 1962), are required by the trustees, Cedric Whilton Sewell, of Queens-avenue, Colac, and Colin Crichton Begg, of Gellibrand-street, Colac, solicitors, to send particulars to them by 24th December, 1962, after which date the trustees may convey or distribute the assets, having regard only to the claims of which they then have notice.

SEWELL & SEWELL, solicitors, Colac. 3075

THOMAS EDWARD JAMES, late of 248 Rae-street, North Fitzroy, retired confectioner, DECEASED.

CREDITORS, next of kin and others having claims in respect of the estate of the said deceased (who died on the 17th day of August, 1962), are required to send particulars of their claims to the National Trustees, Executors and Agency Company of Australasia Limited, having its registered office at 95 Queen-street, Melbourne, by the 19th day of December, 1962, after which date it may convey or distribute the assets, having regard only to the claims of which it then has notice.

J. M. SMITH & EMMERTON, 480 Bourke-street, Melbourne. 3076

CREDITORS, next of kin and others having claims in respect of the estate of William Wilson Gay, late of 26 Fairmount-road, East Hawthorn, retired Commissioner of Forests, deceased (who died on the 28th day of July, 1962), are required to send particulars of their claims to the Public Trustee for Victoria, of 21 Degraives-street, Melbourne, by the 19th day of December, 1962, after which date the said Public Trustee will distribute the assets, having regard only to the claims of which he then has notice.

HULBERT A. GREENING & BENNETT, solicitors, 422 Collins-street, Melbourne. 3077

CREDITORS, next of kin and others having claims in respect of the estate of Athol George Munday, late of 144 Kooyong-road, Caulfield, and 108 Collins-street, Melbourne, chartered accountant, deceased (who died on the 5th day of June, 1962), are to send particulars of their claims to the executors, care of the undersigned by the 14th December, 1962, after which date the said executors will distribute the assets, having regard only to the claims of which they then have notice.

HERBERT TURNER & SON, solicitors, of 411 Collins-street, Melbourne. 3097

**CREDITORS**, next of kin and others having claims in respect of the estate of Bernard Store, late of 1 Gardiner-road, Hawthorn, in the State of Victoria, formerly of Jones-street, in the State of Queensland, baker, deceased (who died on the 7th day of July, 1962), are to send particulars of their claims to The Union Trustee Company of Australia Limited, of 333 Collins-street, Melbourne, by the 20th day of December, 1962, after which date it will distribute the assets, having regard only to the claims of which it then has notice.

DOOLAN, KEMP & TOWNSEND, solicitors, 340 Collins-street, Melbourne. 3109

**CREDITORS**, next of kin and others having claims in respect of the estate of Ethel Margaret Culley, late of Hilton-road, Ferny Creek, spinster, deceased (who died on the 2nd day of August, 1961), are to send particulars of their claims to the executors, Helen Esther Lampe and William Manson Jarvie, care of the under-mentioned solicitors on or before the 18th day of December, 1962, after which date the said executors will distribute the assets, having regard only to the claims of which notice has been received.

MARTIN & MARTIN, solicitors, 37 Queen-street, Melbourne. 3107

ROBERT REUBEN BEWSELL, late of 20 Woodvale-road, Boronia, retired orchardist, DECEASED.

**CREDITORS**, next of kin and others having claims in respect of the estate of the said deceased (who died on the 26th day of May, 1962), are required by the executrix, Dorothy Violet Bewsell, to send particulars of their claims to her, care of the under-mentioned solicitors, by the 20th day of December, 1962, after which date she will distribute the assets, having regard only to the claims of which she then has notice.

UPTON & ETTTELSON, solicitors, 100 Queen-street, Melbourne. 3103

HARRY HALL, late of 19 Pascoe-street, Burwood, retired, DECEASED.

**CREDITORS**, next of kin and others having claims in respect of the estate of the said deceased (who died on the 21st day of May, 1962), are required by the executrix, Ailsa Nance Tonkin, to send particulars of their claims to her, care of the under-mentioned solicitors, by the 20th day of December, 1962, after which date she will distribute the assets, having regard only to the claims of which she then has notice.

UPTON & ETTTELSON, solicitors, 100 Queen-street, Melbourne. 3102

**CREDITORS**, next of kin and others having claims in respect of the will of Frank Barstow, late of "Pine Gate", Flat 10, 91 Ormond Esplanade, Elwood, in the State of Victoria, formerly clerk, late company director, deceased (who died on the 6th day of February, 1962), are to send particulars of their claims to Lester, Pearn & Fielden, 443 Little Collins-street, Melbourne, by the 10th day of December, 1962, after which date it will distribute the assets, having regard only to the claims of which it then has notice.

LESTER, PEARN & FIELDEN, solicitors, 443 Little Collins-street, Melbourne. 3101

**CREDITORS**, next of kin and others having claims in respect of the estate of Edward Walter Marsh, late of 14 Victoria-road, Camberwell, in the State of Victoria, retired, deceased (who died on the 15th day of July, 1962), are to send particulars of their claims to the executors, The Equity Trustees, Executors and Agency Company Limited and Frank Gwydyr Marrie, care of the under-mentioned solicitors, on or before the 17th day of December, 1962, after which date the said executors will distribute the assets, having regard only to the claims of which notice has been received.

Dated the 15th day of October, 1962.

A. L. C. FLINT & MARRIE, of 578 Bourke-street, Melbourne, solicitors for the executors. 3078

MARY CONSTANCE MORTON, late of 7 Rothesay-avenue, East Malvern, spinster, DECEASED.

**CREDITORS**, next of kin and others having claims in respect of the estate of the deceased (who died on 21st June, 1962), are required by the applicants for grant of administration, Norman Leopold Morton and Florence May Morton, both of 7 Fell-crescent, East Malvern, gentleman and married woman respectively, and Leo Maxwell Morton, of 11 Newton-street, Lower Fern Tree Gully, apiarist, to send particulars to them, care of the under-mentioned solicitors, by the 19th day of

December, 1962, after which date the applicants for grant of administration may convey or distribute the assets, having regard only to the claims of which they then have notice.

ARTHUR PHILLIPS & JUST, solicitors, 472 Bourke-street, Melbourne. 3096

**CREDITORS**, next of kin and others having claims in respect of the estate of John Mervyn Swallow, formerly of New-street, Eltham, but late of Kew, carpenter, deceased (who died on the 9th day of August, 1962), are to send particulars of their claims to the National Trustees, Executors and Agency Company of Australasia Limited, of 95 Queen-street, Melbourne, by the 20th day of December, 1962, after which date the company will distribute the assets, having regard only to the claims of which it then has notice.

MAHONY O'BRIEN & DUGGAN, solicitors, 20 Queen-street, Melbourne. 3092

**CREDITORS**, next of kin and others having claims in respect of the estate of Thomas Joseph Buzza, formerly of 72 Monash-street, Ascot Vale, but late of 281 North-road, Caulfield South, motor engineer, deceased (who died on the 27th day of May, 1962), are to send particulars of their claims to the executor, National Trustees and Executors Agency Company of Australasia Limited, of 95 Queen-street, Melbourne, by the 24th day of December, 1962, after which date it will distribute the assets, having regard only to the claims of which it then has notice.

GORDON RENNICK & GAYNOR, solicitors, 473 Bourke-street, Melbourne. 3091

## INSOLVENCY NOTICE

The Bankruptcy Act 1924-1961.

COMMONWEALTH OF AUSTRALIA.

THE ASSIGNED ESTATE OF IAN PERCIVAL COX, OF CALULU, VIA HILLSIDE.

No 124 of 1961.

NOTICE is hereby given that a first and final dividend is intended to be declared in the above matter. Creditors who have not proved their debts to the satisfaction of the court on or before the 31st day of October, 1962, or such later date as the court may fix shall be excluded from the distribution.

Dated this 15th day of October, 1962.

J. K. HALL, Trustee.

Hall and Rose, 163 William-street, Melbourne. 3066

## IMPOUNDINGS

**ELTHAM**.—Impounded in Eltham Shire Pound, by Ranger.

3 Hereford bulls, no visible brand

If not claimed and expenses paid, to be sold on 3rd November, 1962.

A. GRAHAM,

3057—10/6

Poundkeeper.

**KANIVA**.—Impounded in Kaniva Pound.

1 full-mouth Corriedale ewe, in full wool, notch in front right ear, no visible brand

If not claimed and expenses paid, will be sold at 2 p.m., on Tuesday, 30th October, 1962.

L. S. CUSHION,

3033—10/6

Poundkeeper.

**NEWSTEAD**.—Impounded in Newstead Pound, by L. Weiss, on 7th October, 1962.

1 brown Jersey heifer, no visible brand

If not claimed and expenses paid, to be sold on 1st November, 1962.

M. GERVASONI,

3025—10/6

Poundkeeper.

**OXLEY**.—Impounded in Oxley Pound, from Markwood, Carboor-road.

1 Shorthorn-Hereford cross steer, 12 months old, 7 under off ear, V under near ear

If not claimed and expenses paid, to be sold on 1st November, 1962.

M. PERKINS,

3043—12/

Poundkeeper.

**STATE ACTS, 1960**

COPIES of the following Acts of Parliament of Victoria may be obtained at the Government Printing Office, or from any bookseller, at the price set opposite to each:—

No.	Price. s. d.
6607. Anzac Day .. .. .	1 0
6608. Agricultural Lime (Amendment) .. .. .	0 6
6609. Motor Car (Commencement) .. .. .	0 6
6610. Fisheries (Change of Title) .. .. .	0 6
6611. Stamps (Amendment) .. .. .	0 6
6612. Land (Public Authorities) .. .. .	0 6
6613. Coal Canal Bridge .. .. .	0 6
6614. Metropolitan Fire Brigades (Borrowing Powers) .. .. .	0 6
6615. Wodonga Lands Exchange .. .. .	0 6
6616. Licensing (Fees) .. .. .	0 6
6617. Home Finance (Loans to Minors) .. .. .	0 6
6618. Co-operative Housing Societies (Amendment) .. .. .	0 6
6619. Racing (Totalizators Extension) .. .. .	1 0
6620. Companies .. .. .	0 6
6621. Judges Salaries and Allowances .. .. .	0 6
6622. Coal Mines (Pensions Contributions) .. .. .	0 6
6623. Landlord and Tenant (Further Amendment) .. .. .	0 6
6624. Public Officers Salaries and Allowances .. .. .	0 9
6625. Legal Profession Practice (Amendment) .. .. .	0 6
6626. Church of England in Australia Constitution .. .. .	1 9
6627. Companies (Fees) .. .. .	0 6
6628. Motor Car (Amendment) .. .. .	1 0
6629. Geelong Waterworks and Sewerage (Amendment) .. .. .	0 6
6630. Latrobe Valley (Financial) .. .. .	0 6
6631. Labour and Industry (Amendment) .. .. .	0 6
6632. Acts Interpretation .. .. .	0 6
6633. Children's Court (Enforcement of Awards) .. .. .	0 6
6634. Supreme Court (Proceedings before Master) .. .. .	0 6
6635. Melbourne and Metropolitan Board of Works (Borrowing Powers) .. .. .	0 6
6636. Electoral Provinces .. .. .	0 9
6637. Town and Country Planning (Amendment) .. .. .	0 6
6638. Racing (Dog Races) .. .. .	0 6
6639. Industrial Safety Advisory Council .. .. .	0 6
6640. Administration and Probate (Offices) .. .. .	0 6
6641. Justices (Ball) .. .. .	0 9
6642. National Parks (Amendment) .. .. .	0 6
6643. Medical (Amendment) .. .. .	1 0
6644. Melbourne Harbor Trust Lands .. .. .	0 6
6645. Weights and Measures (Penalties) .. .. .	0 6
6646. Transfer of Land (Stratum Estates) .. .. .	0 9
6647. Local Government (Preston Streets Agreement) .. .. .	0 6
6648. John Storey Memorial Fund .. .. .	0 6
6649. Police Offences (Amendment) .. .. .	0 6
6650. Motor Car (Third-Party Insurance) .. .. .	2 9
6651. Social Welfare .. .. .	1 0
6652. City of Melbourne Underground Railway Construction .. .. .	1 3
6653. Valuation of Land .. .. .	0 6
6654. Milk Board (Amendment) .. .. .	0 6
6655. Victoria Racing Club (Amendment) .. .. .	0 6
6656. Consolidated Revenue .. .. .	0 6
6657. Consolidated Revenue .. .. .	0 6
6658. Motor Car (Driving) .. .. .	1 0
6659. Licensing (Amendment) .. .. .	0 6
6660. Consolidated Revenue .. .. .	0 6
6661. Consolidated Revenue .. .. .	0 6
6662. Friendly Societies (Dental Clinics) .. .. .	0 6
6663. Cancer (Amendment) .. .. .	0 6
6664. Dried Fruits (Amendment) .. .. .	0 6
6665. Barwon Heads Lands Exchange .. .. .	0 6
6666. Revocation of Crown Reservations .. .. .	0 6
6667. The Constitution Act Amendment (Expenses) .. .. .	0 6
6668. Supreme Court (Orders) .. .. .	0 9
6669. Gippsland Railway Deviation .. .. .	0 6
6670. Hamilton Stockyards Railway Construction .. .. .	0 6
6671. Nurses (Amendment) .. .. .	0 6
6672. Ministry of Transport (Railway Officers) .. .. .	0 6
6673. Fruit and Vegetables (Road Barriers) .. .. .	0 6
6674. Transport Regulation (Qualifications of Chairman) .. .. .	0 6
6675. Motor Car (Insurance Surcharge Continuance) .. .. .	0 6
6676. Geelong Harbor Trust (Freezing Works Agreement) .. .. .	0 9
6677. Western Metropolitan Market (Amendment) .. .. .	0 6
6678. Racing (Trotting Races) .. .. .	0 6
6679. Wattle Park Land .. .. .	0 6
6680. Surplus Revenue .. .. .	0 6
6681. Milk and Dairy Supervision (Research Contributions) .. .. .	0 6
6682. Tourist (Amendment) .. .. .	0 6
6683. Fisheries (Crayfish) .. .. .	0 6
6684. Audit (Amendment) .. .. .	0 6
6685. Sale of Allotments of Land (Amendment) .. .. .	0 6
6686. Cattle Compensation (Amendment) .. .. .	0 6

**STATE ACTS, 1960—continued.**

No.	Price. s. d.
6687. Co-operative Housing Societies (Guarantees) .. .. .	0 6
6688. State Library National Gallery National Museum and Institute of Applied Science .. .. .	1 3
6689. Medical (Blood Transfusion) .. .. .	0 6
6690. The Constitution Act Amendment (Treating) .. .. .	0 6
6691. State Forests Loan Application .. .. .	0 6
6692. Local Authorities Superannuation (Amendment) .. .. .	0 9
6693. Local Government (Disqualification) .. .. .	1 0
6694. Superannuation (Additions to Pensions) .. .. .	0 6
6695. Police Regulation (Pensions) .. .. .	0 6
6696. Trustee Companies (Amalgamation) .. .. .	0 6
6697. Geelong and Colac Railway (Deviation) .. .. .	0 6
6698. University Colleges Lands .. .. .	0 6
6699. Local Government (Private Street) .. .. .	0 6
6700. Northcote School .. .. .	0 6
6701. Public Works Loan Application .. .. .	0 9
6702. Tower Hill and Malmsbury Lands .. .. .	0 6
6703. Coal Mines (Pensions) .. .. .	0 6
6704. Vermin and Noxious Weeds (Financial) .. .. .	1 0
6705. Navigable Waters (Oil Pollution) .. .. .	0 6
6706. Business Names (Public Borrowings) .. .. .	0 6
6707. Health (Tuberculosis Arrangement) .. .. .	1 3
6708. Water Supply Loan Application .. .. .	1 0
6709. Railway Loan Application .. .. .	0 6
6710. Land Tax (Relief) .. .. .	0 6
6711. Land Tax (Rates) .. .. .	0 6
6712. Monash University (Amendment) .. .. .	1 0
6713. National Fitness Council of Victoria .. .. .	0 6
6714. Local Government (Keilor, Waverley and Springvale) .. .. .	2 3
6715. Explosives .. .. .	0 9
6716. Statute Law Revision .. .. .	0 6
6717. Motor Car (Abolition of Owners' Certificates) .. .. .	0 6
6718. Road Traffic (Amendment) .. .. .	0 6
6719. Milk Board (Powers) .. .. .	0 6
6720. Marketing of Primary Products (Members) .. .. .	0 9
6721. Melbourne and Geelong Mortgages .. .. .	0 9
6722. Building Societies (Amendment) .. .. .	0 9
6723. Local Government (Scaffolding Inspection) .. .. .	0 6
6724. State Electricity Commission (Borrowing) .. .. .	0 6
6725. Labour and Industry (Butchers' Shops) .. .. .	0 6
6726. Country Fire Authority (Sawmill Burners) .. .. .	1 0
6727. Sewerage Districts (Amendment) .. .. .	1 3
6728. Water (Amendment) .. .. .	0 6
6729. Housing (Powers) .. .. .	0 6
6730. Entertainments Tax (Amendment) .. .. .	0 6
6731. Crimes (Kidnapping) .. .. .	0 6
6732. Health (Amendment) .. .. .	0 6
6733. Game (Licences) .. .. .	0 6
6734. Estate Agents (Amendment) .. .. .	0 6
6735. Appropriation of Revenue .. .. .	8 6

A. C. BROOKS,  
Government Printer.

**STATE ACTS, 1961**

COPIES of the following Acts of Parliament of Victoria may be obtained at the Government Printing Office, or from any bookseller, at the price set opposite to each:—

No.	Price. s. d.
6736. Public Works Committee (Special Exemption) .. .. .	0 6
6737. Railways (Permanent Service) .. .. .	0 6
6738. Superannuation (Railway Service) .. .. .	0 6
6739. Stamps (Amendment) .. .. .	0 6
6740. Employers and Employés (Attachment of Wages) .. .. .	0 6
6741. St. Kilda (Goldsmith and Shelley Streets) Land .. .. .	0 6
6742. Municipal Association (Amendment) .. .. .	0 6
6743. Wormbete Land .. .. .	0 6
6744. Grain Elevators (Borrowing) .. .. .	0 6
6745. Housing (Amendment) .. .. .	0 9
6746. Land (North-West Mallee Settlement Areas) .. .. .	0 6
6747. Ripon Peace Memorial Hospital Trust .. .. .	0 6
6748. Road Traffic (Parking on Railway and Municipal Property) .. .. .	0 6
6749. Co-operation (Amendment) .. .. .	0 6
6750. Heidelberg and Toolamba Lands Exchange .. .. .	0 6
6751. Town and Country Planning (Amendment) .. .. .	0 6
6752. Janet Clarke Hall .. .. .	0 6
6753. Transport Regulation (Compensation) .. .. .	0 6
6754. Bread Industry (Legal Proceedings) .. .. .	0 6
6755. Milk Pasteurization (Licences) .. .. .	0 6
6756. Health (Proprietary Medicines) .. .. .	0 6
6757. Police Offences (False Reports to Police) .. .. .	0 6
6758. Evidence (Children) .. .. .	0 6
6759. Statute Law Revision .. .. .	0 6
6760. Transport Regulation (Term of Office) .. .. .	0 6
6761. Prostitution .. .. .	0 6

STATE ACTS, 1961.—continued.		Price.
No.		s. d.
6762.	Motor Car (Amendment) .. .. .	1 0
6763.	Game (Amendment) .. .. .	0 6
6764.	The Constitution Act Amendment (Electoral) ..	0 9
6765.	Building Societies (Amendment) .. .. .	1 3
6766.	Juries (Amendment) .. .. .	0 6
6767.	Gas and Fuel Corporation (Borrowing) .. .. .	0 6
6768.	Clean Air (Sub-committees) .. .. .	0 6
6769.	Housing (Home Builders' Account) .. .. .	0 6
6770.	Public Offences (Pinball Machines) .. .. .	0 6
6771.	Fisheries (Commercial Council) .. .. .	0 6
6772.	Consolidated Revenue .. .. .	0 6
6773.	Consolidated Revenue .. .. .	0 6
6774.	Consolidated Revenue .. .. .	0 6
6775.	Game (Black Swans) .. .. .	0 6
6776.	Distribution of Population (Joint Committee) ..	0 9
6777.	Public Works Interim Loan Application .. .. .	0 6
6778.	Legal Profession Practice (Amendment) .. .. .	0 6
6779.	Home Finance (Amendment) .. .. .	0 6
6780.	Cancer (Amendment) .. .. .	0 6
6781.	Tourist (Amendment) .. .. .	0 6
6782.	Water (Ballarat Water Commissioners) .. .. .	0 6
6783.	Commercial Goods Vehicles (Tow Trucks) .. .. .	0 6
6784.	Consolidated Revenue .. .. .	0 6
6785.	Local Government (Municipal Assistance Fund) ..	0 6
6786.	Agricultural Colleges (Leases) .. .. .	0 6
6787.	United Lutheran Church Incorporation .. .. .	1 3
6788.	West Melbourne Market Land (Amendment) .. .. .	0 6
6789.	Portland Harbor Trust (Quarrying) .. .. .	0 6
6790.	Racing (Bookmakers' Course Agents) .. .. .	0 9
6791.	Stamps (Further Amendment) .. .. .	1 0
6792.	North Geelong to Fyansford Railway Deviation ..	0 6
6793.	Apprenticeship (Amendment) .. .. .	0 6
6794.	Land (Unused Roads and Water Frontages) .. .. .	0 9
6795.	Motor Car (Insurance Surcharge) .. .. .	0 6
6796.	Forests (Wood Pulp Agreement) .. .. .	2 0
6797.	Dandenong Lands .. .. .	0 9
6798.	Local Authorities Superannuation (Amendment) ..	0 6
6799.	R.S.L. Welfare Trust Fund .. .. .	0 9
6800.	The Zinc Corporation Limited .. .. .	0 9
6801.	Mines (Explosives) .. .. .	0 6
6802.	University (Officers) .. .. .	0 6
6803.	State Accident Insurance Office .. .. .	0 6
6804.	Melbourne and Metropolitan Board of Works (Yarra River) ..	0 6
6805.	Legal Aid .. .. .	0 9
6806.	Crimes (Breath Test Evidence) .. .. .	0 6
6807.	Consolidated Revenue .. .. .	0 6
6808.	Civil Aviation (Carriers' Liability) .. .. .	0 6
6809.	Sheep Owners Protection .. .. .	1 0
6810.	Entertainments Tax (Amendment) .. .. .	0 6
6811.	Exhibition (Borrowing Powers) .. .. .	0 6
6812.	Children's Welfare (Appeals) .. .. .	0 6
6813.	Pawnbrokers (Amendment) .. .. .	0 6
6814.	Property Law (Loans to Minors) .. .. .	0 6
6815.	Disposal of Uncollected Goods .. .. .	1 0
6816.	Milk and Dairy Supervision (Amendment) .. .. .	0 6
6817.	State Forests Loan Application .. .. .	0 6
6818.	Health (Dangerous Substances) .. .. .	0 6
6819.	Money Lenders (Amendment) .. .. .	0 6
6820.	Water Supply Loan Application .. .. .	1 0
6821.	Co-operative Housing Societies (Amendment) ..	0 6
6822.	Legal Profession Practice (Further Amendment) ..	0 6
6823.	Labour and Industry (Women's Hairdressing) ..	0 6
6824.	Co-operation (Amendment) .. .. .	0 6
6825.	Valuation of Land (Amendment) .. .. .	1 0
6826.	Public Works Loan Application .. .. .	0 6
6827.	Land Tax (Exemptions and Rates) .. .. .	0 9
6828.	Landlord and Tenant (Amendment) .. .. .	0 9
6829.	Mines (Aluminium Agreement) .. .. .	1 3
6830.	Railway Loan Application .. .. .	1 0
6831.	Railways (Funds) .. .. .	0 6
6832.	Motor Boating .. .. .	1 3
6833.	Police Regulation (Amendment) .. .. .	0 6
6834.	Housing (Commonwealth and State Agreement) ..	0 9
6835.	Education (Amendment) .. .. .	0 6
6836.	Racing (Off-course Doubles Totalizators) .. .. .	1 0
6837.	Medical (Amendment) .. .. .	0 6
6838.	Water and Sewerage Authorities (Proceedings and Finances) ..	1 3
6839.	Companies .. .. .	21 0
6840.	The Constitution Act Amendment .. .. .	0 6
6841.	Local Government (Streets and Abattoirs) .. .. .	0 6
6842.	Crown Leases .. .. .	0 6
6843.	Church of England (Greensborough Land) .. .. .	0 6
6844.	Juries (Fees) .. .. .	0 6
6845.	Limitation of Actions (Recovery of Imposts) .. .. .	0 6
6846.	Rural Finance and Settlement Commission .. .. .	1 3
6847.	Marine (Amendment) .. .. .	1 6

STATE ACTS, 1961.—continued.		Price.
No.		s. d.
6848.	Dog .. .. .	0 9
6849.	Town and Country Planning .. .. .	3 3
6850.	Appropriation of Revenue, 1960-61 .. .. .	8 9

A. C. BROOKS,  
Government Printer.

## STATE ACTS, 1962

COPIES of the following Acts of Parliament of Victoria may be obtained at the Government Printing Office, or from any bookseller, at the price set opposite to each:—

No.		Price.
		s. d.
6851.	Racing (Anzac Day) .. .. .	0 6
6852.	Railways (Thomson River Bridge) .. .. .	0 6
6853.	Business Names .. .. .	1 9
6854.	Melbourne Cricket Ground .. .. .	0 6
6855.	Evidence (Amendment) .. .. .	0 6
6856.	Railways (Industrial Awards) .. .. .	0 6
6857.	Children's Welfare (Assistance) .. .. .	0 6
6858.	National Parks .. .. .	0 6
6859.	Consolidated Revenue .. .. .	0 6
6860.	Land (Industrial Grants) .. .. .	0 6
6861.	Revocation and Excision of Crown Reservations .. .. .	1 0
6862.	Standard Insurance Company Limited .. .. .	0 6
6863.	The Constitution Act Amendment (Statute Law Revision Committee) .. .. .	0 6
6864.	Dog (Registration Discs) .. .. .	0 6
6865.	Game (Black Swans) Amendment .. .. .	0 6
6866.	Administration and Probate (Amendment) .. .. .	0 6
6867.	Statute Law Revision .. .. .	0 9
6868.	Tottenham to Brooklyn Railway Construction ..	0 6
6869.	Kerang (Alexandra Park) Land .. .. .	0 6
6870.	Forests (Amendment) .. .. .	0 6
6871.	Melbourne Harbor Trust Lands .. .. .	1 6
6872.	Dried Fruits (Expenses and Finances) .. .. .	0 6
6873.	Housing (Home Builders' Account) .. .. .	0 6
6874.	Supreme Court (Interest on Judgments) .. .. .	0 6
6875.	The Constitution Act Amendment (Postal Voting) .. .. .	0 6
6876.	Melbourne and Metropolitan Board of Works (Government Guarantee) .. .. .	0 6
6877.	Stock (Artificial Breeding) .. .. .	0 9
6878.	Tattooing .. .. .	0 6
6879.	Unclaimed Moneys .. .. .	1 0
6880.	Cancer (Facilities) .. .. .	0 6
6881.	Road Traffic (Traffic Control Items) .. .. .	0 6
6882.	Consolidated Revenue .. .. .	0 6
6883.	Health (Sampling of Foods) .. .. .	0 6
6884.	Crimes (Detention) .. .. .	0 6
6885.	Fisheries (Noxious Fish) .. .. .	0 9
6886.	Subordinate Legislation .. .. .	1 3
6887.	Country Fire Authority (Amendment) .. .. .	0 6
6888.	Local Government (Amendment) .. .. .	1 3
6889.	Poisons .. .. .	3 3
6890.	Probate Duty .. .. .	3 6
	Table of Acts and Enactments passed, date of operation, &c. .. .. .	0 3

A. C. BROOKS,  
Government Printer.

## ACTS REPRINTED IN ACCORDANCE WITH THE AMENDMENTS INCORPORATION ACT 1958 (No. 6422).

No.		Price.
		s. d.
6191.	Administration and Probate Act .. .. .	4 9
6219.	Children's Welfare Act .. .. .	2 6
6225.	Co-operation Act .. .. .	4 0
6246.	Evidence Act .. .. .	3 6
6249.	Fences Act .. .. .	1 3
6251.	Firearms Act .. .. .	2 3
6274.	Hospitals and Charities Act .. .. .	3 6
6283.	Labour and Industry Act .. .. .	7 3
6285.	Landlord and Tenant Act .. .. .	4 6
6293.	Licensing Act .. .. .	9 3
6299.	Local Government Act .. .. .	25 0
6325.	Motor Car Act .. .. .	6 6
6328.	Nurses Act .. .. .	2 0
6330.	Partnership Act .. .. .	1 3
6363.	Second-hand Dealers Act .. .. .	1 3
6375.	Stamps Act .. .. .	6 0
6399.	Transfer of Land Act .. .. .	5 0
6401.	Trustee Act .. .. .	4 0
6419.	Workers Compensation Act .. .. .	4 9
6455.	Companies Act (2nd reprint) .. .. .	15 0

A. C. BROOKS,  
Government Printer.

## THE "VICTORIA GOVERNMENT GAZETTE".

**SUBSCRIPTIONS.**—The subscription, including postage, is £2 15s. per annum, £1 7s. 6d. half-yearly, or 13s. 9d. per quarter, payable in advance.

Subscriptions are required to commence and terminate with a month.

A lesser period than three months cannot be subscribed for.

Subscribers do not receive the Acts of Parliament with the GAZETTE.

ADVERTISEMENTS are charged at the rate of 1s. 6d. per line single column, and 3s. per line double column.

The title (£5 Reward, Dissolution of Partnerships, &c.) forms one or more lines as a heading.

On an average, ten words make a line.

Every signature must likewise be counted as a line.

The final words of a paragraph, though only portion of a line, must be counted as one line.

SIGNATURES (in particular) and proper names must be written very plainly in the text; ONE SIDE ONLY of each slip of paper should be WRITTEN UPON.

ALL COMMUNICATIONS should be addressed to "The Government Printer, Melbourne".

ALL DOCUMENTS illegibly written will be returned unpublished, and where brands occur unprovided for by the ordinary letters of the alphabet, a worded explanatory description must be furnished.

THE VICTORIA GOVERNMENT GAZETTE is published on WEDNESDAY EVENING in each week, and Notices for insertion will be received by the Government Printer at or before ONE p.m. at ordinary rates, and late advertisements between ONE p.m. and FOUR p.m. at double rates on the day preceding the day of publication.

Single copies of the VICTORIA GOVERNMENT GAZETTE are One shilling, posted One shilling and five pence.

No GAZETTES prior to January, 1950, in stock.

\*\*\*ALL PAYMENTS ARE REQUIRED IN ADVANCE.—Remittances should be made by postal note, money order, or draft in favour of the Government Printer. Advertisements unaccompanied by a remittance sufficient to cover the cost of insertion will be returned unpublished.

## PUBLICATION OF OFFICIAL MATTER.

ATTENTION is invited to the following procedure in relation to the publication of official matter in the Government Gazette:—

## 1. Matter submitted to the Executive Council.

Matters submitted to the Executive Council which requires gazettal will normally be published in the issue of the following week.

Where urgent gazettal is required, special arrangements should be made with the Gazette Officer.

Publication will be facilitated by the submission of carbon copies for the use of the Gazette Officer.

## 2. Other matter.

(a) All other matter duly certified by a responsible officer for publication should be lodged with the Gazette Officer not later than half-past Ten a.m. on Tuesday.

(b) Lengthy or involved notices should be forwarded several days before publication.

(c) Proofs, which will be supplied only when specifically requested, or at the direction of the Gazette Officer, should be returned promptly to avoid delay in publication.

(d) No additions or amendments to matter for publication will be accepted by telephone.

## AGENTS FOR THE "VICTORIA GOVERNMENT GAZETTE".

THE following have been appointed agents to receive Advertisements and Subscriptions for the Victoria Government Gazette:—

ANGUS & ROBERTSON LTD., 66-68 Elizabeth-street, Melbourne.

ARMSTRONG BROS. PTY. LTD., Mollison-street, Kyneton.

ARMSTRONG'S AGENCY, 205 Queen-street, Melbourne.

ARNALL & JACKSON, 390 Barkly-street, Brunswick, N.10.

BAIRNSDALE AUTHORIZED NEWSAGENCY, 132 Main-street, Bairnsdale.

COOKE, F. R. & E. M., & SONS, 69 Bridge-street, Benalla.

DAVIS, WM. (MILDURA) PTY. LTD., 126 Eighth-street, Mildura.

DIXON'S NEWSAGENCY, 89 Firebrace-street, Horsham.  
EDGAR'S NEWSAGENCY PTY. LTD., 293 Hargreaves-street, Bendigo.

FRANKS, H., & CO., 184 Ryrie-street, Geelong.

GORDON & GOTCH AUSTRALASIA LTD., 511 Little Collins-street, Melbourne.

GULLAN'S NEWSAGENCY, 88 Bridge-street, Ballarat.

HALES, D. & N., Henty-street, Casterton.

HAMPTON, A. C., 243 Mitchell-street, Bendigo.

HARSTON, PARTRIDGE & CO. PTY. LTD., 455 Little Collins-street, Melbourne.

THE MERCANTILE EXCHANGE, 90 Queen-street, Melbourne.

McGILL'S AUTHORIZED NEWSAGENCY, 183-5 Elizabeth-street, Melbourne.

PETTY, R. H. & W. M., 83 Murphy-street, Wangaratta.

PURDIE, J., & CO., 138 Moorabool-street, Geelong.

SALE AUTHORIZED NEWSAGENCY, 142 Raymond-street, Sale.

SKINNER'S AUTHORIZED NEWSAGENCY, 49-51 Franklin-street, Traralgon.

SMITH & DUNNON, 112-114 Gray-street, Hamilton.

TUFF'S SHEPPARTON NEWSAGENCY, 246 Wyndham-street, Shepparton.

VERNON, C. F. & H. J., 162 Bridge-road, Richmond.

VIEW POINT AUTHORIZED NEWSAGENCY, 4 View Point, Bendigo.

A copy of the Gazette filed at each place for public reference.

## CONTENTS

	PAGE
Acts of Parliament on sale at the Government Printing Office .. .. .	3548
Appointments .. .. .	3512
Auction Sales Act .. .. .	3508
Bank Holidays .. .. .	3498
Contracts .. .. .	3504
Courts .. .. .	3510
Estates of Deceased Persons .. .. .	3511
Government Notices .. .. .	3498
Holiday—Melbourne Cup Day .. .. .	3498
Impoundings .. .. .	3547
Insolvency Notice .. .. .	3547
Lands .. .. .	3524
Melbourne and Metropolitan Board of Works— Notice .. .. .	3508
Mining .. .. .	3511
Ministers of Religion Registered to Celebrate Marriages in Victoria .. .. .	3499
Notice to Mariners .. .. .	3500
Orders in Council— Acts—Local Government; Land; Country Roads; Forests; Soil Conservation and Land Utilization; Mental Health; Audit; Companies; Explosives; Labour and Industry; Stamps; Water.	3513 et seq
Private Advertisements .. .. .	3535
Proclamations .. .. .	3495
Public Holidays .. .. .	3498
Public Service Notices .. .. .	3529
Reporter, Victorian Parliamentary Debates .. .. .	3532
Resignation .. .. .	3513
State Rivers and Water Supply Commission .. .. .	3499
Tenders .. .. .	3533
Transport Regulation Board—Public Hearings .. .. .	3501
Waterworks Trusts .. .. .	3506, 3509