



VICTORIA

GOVERNMENT GAZETTE

Published by Authority

[Registered at the General Post Office, Melbourne, for transmission by post as a newspaper.]

No. 64]

WEDNESDAY, AUGUST 7

[1963

Land Act 1958.

AREA OF LAND COMPRISED IN CERTAIN CLASSES DIMINISHED OR INCREASED.

PROCLAMATION

By His Excellency the Governor of the State of Victoria and its Dependencies in the Commonwealth of Australia, &c., &c., &c.

WHEREAS by the *Land Act 1958* it is amongst other things enacted that the Governor in Council may, by Proclamation to be published in the *Government Gazette*, at any time diminish or increase the area of land comprised in any of the classes mentioned in Part I., Division 1, section 5, of the said *Land Act 1958*, but that the area of lands which may be sold by auction (Class 6), shall not be increased except as in certain cases in the said Act provided: Now therefore I, the Governor of the State of Victoria, in the Commonwealth of Australia, by and with the advice of the Executive Council of the said State, and in accordance with the provisions of sections 94 and 117 of the *Land Act 1958* aforesaid, do hereby diminish or increase (as the case may be) the areas of Crown lands comprised in Classes 3, 6 and 7 of the classes mentioned in section 5 of the *Land Act 1958* aforesaid, to the extent set forth in the subjoined Schedule (that is to say):—

Schedule referred to.

CLASSES DIMINISHED OR INCREASED.

County.	Parish.	Allotment.	Section.	Area.	Diminished.	Increased.	Description.
					Class.	Class.	
				A. R. P.			
Borong	Moyston West ..	22	A	115 1 1±	3	6	In the north of the parish About ¼-mile south of Township of Hepburn
Talbot	Wombat	9A	28A	2 1 1	7	6	

Given under my Hand and the Seal of the State of Victoria aforesaid, at Melbourne, this thirtieth day of July, in the year of our Lord One thousand nine hundred and sixty-three, and in the twelfth year of the reign of Her Majesty Queen Elizabeth II.

ROHAN DELACOMBE.

(L.S.)

By His Excellency's Command,

KEITH TURNBULL,
Commissioner of Crown Lands and Survey.

GOD SAVE THE QUEEN!

MALDON SHIRE COMMON DIMINISHED.

PROCLAMATION

By His Excellency the Governor of the State of Victoria and its Dependencies in the Commonwealth of Australia, &c., &c., &c.

WHEREAS by Division 12 of Part I. of the *Land Act 1958* it is amongst other things enacted that the Governor in Council may from time to time increase, and, after one month's notice in the *Government Gazette*, diminish, alter, or abolish any common, and may from time to time re-proclaim the whole or any part of any such common for any of the purposes and subject to the provisions of the said Part of the said Act, and that nothing therein contained shall prevent the exercise of the powers conferred by the said Part of the said Act with respect to the leasing or licensing of any land comprised in any common: And whereas notice of the intention to diminish the Maldon Shire Common has been duly published in the *Government Gazette* for one month:

Now therefore I, the Governor of the State of Victoria in the Commonwealth of Australia, by and with the advice of the Executive Council of the said State, do hereby diminish the Maldon Shire Common by deducting therefrom the portion in the Township of Maldon being allotment 5, section 6, containing 1 rood 2 perches.—(Rs.353.)

Given under my Hand and the Seal of the State of Victoria aforesaid, at Melbourne, this thirtieth day of July, in the year of our Lord One thousand nine hundred and sixty-three, and in the twelfth year of the reign of Her Majesty Queen Elizabeth II.

(L.S.) ROHAN DELACOMBE.

By His Excellency's Command,
KEITH TURNBULL,
Commissioner of Crown Lands and Survey.
GOD SAVE THE QUEEN!

LICENSING (AMENDMENT) ACT 1960 (No. 6659).

DATE OF COMING INTO OPERATION OF SUB-SECTION (3) OF SECTION 4.

PROCLAMATION

By His Excellency the Governor of the State of Victoria and its Dependencies in the Commonwealth of Australia, &c., &c., &c.

WHEREAS by an Act of Parliament of the State of Victoria passed in the ninth year of the reign of Her Majesty Queen Elizabeth II., intitled the *Licensing (Amendment) Act 1960* (No. 6659), it is enacted that subsection (3) of section 4 of the said Act shall come into operation from and after a day to be fixed by Proclamation of the Governor in Council published in the *Government Gazette*, being a day not less than two years after the commencement of the said Act:

And whereas a period of not less than two years has elapsed since the said *Licensing (Amendment) Act 1960* came into operation on the 11th day of July, 1960, by a Proclamation issued on the 28th day of June, 1960:

Now therefore I, the Governor of the State of Victoria, in the Commonwealth of Australia, by and with the advice of the Executive Council of the said State, do by this my Proclamation fix Wednesday, the first day of January, One thousand nine hundred and sixty-four, as the day upon which sub-section (3) of section 4 of the said *Licensing (Amendment) Act 1960* (No. 6659), shall come into operation.

Given under my Hand and the Seal of the State of Victoria aforesaid, at Melbourne, this sixth day of August, in the year of our Lord One thousand nine hundred and sixty-three and in the twelfth year of the reign of Her Majesty Queen Elizabeth II.

(L.S.) ROHAN DELACOMBE.

By His Excellency's Command,
R. J. HAMER,
Acting Chief Secretary.
GOD SAVE THE QUEEN!

Land Act 1958.
ROAD PROCLAIMED.

PROCLAMATION

By His Excellency the Governor of the State of Victoria and its Dependencies in the Commonwealth of Australia, &c., &c., &c.

IN pursuance of the provisions of section 25 of the *Land Act 1958*, I, the Governor of the State of Victoria, by and with the advice of the Executive Council of the said State, do hereby proclaim as a road the land in the Parish of Bumbang, County of Karkaroc, being the land indicated by hachure on plan hereunder.—(B.660⁽¹⁰⁾) (C.98950).

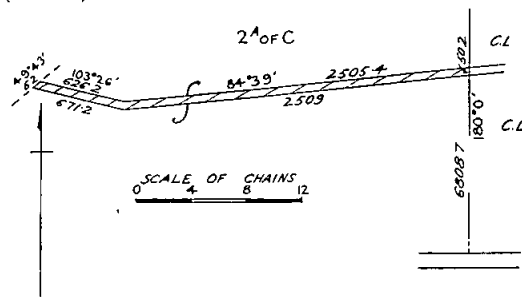

Given under my Hand and the Seal of the State of Victoria aforesaid, at Melbourne, this thirtieth day of July, in the year of our Lord One thousand nine hundred and sixty-three, and in the twelfth year of the reign of Her Majesty Queen Elizabeth II.

(L.S.) ROHAN DELACOMBE.

By His Excellency's Command,
KEITH TURNBULL,
Commissioner of Crown Lands and Survey.
GOD SAVE THE QUEEN!

PUBLIC HALF-HOLIDAYS.

PROCLAMATION

By His Excellency the Governor of the State of Victoria and its Dependencies in the Commonwealth of Australia, &c., &c., &c.

IN pursuance of the provisions contained in Part III. of the *Public Service Act 1958*, I, the Governor of the State of Victoria, in the Commonwealth of Australia, by and with the advice of the Executive Council of the said State, do by this my Proclamation appoint the days and dates hereunder mentioned to be observed as Public Half-Holidays at the places respectively specified, viz.:—

Public Half-Holiday from the Hour of Eleven a.m.:—
*WEDNESDAY, THE 16TH OCTOBER, 1963, throughout the Shire of Rochester.

Public Half-Holiday from the Hour of Twelve o'clock noon:—

*WEDNESDAY, 30TH OCTOBER, 1963, throughout the Shire of Glenelg.

*Agricultural Show.

Given under my Hand and the Seal of the State of Victoria aforesaid, at Melbourne, this sixth day of August, in the year of our Lord One thousand nine hundred and sixty-three and in the twelfth year of the reign of Her Majesty Queen Elizabeth II.

(L.S.) ROHAN DELACOMBE.

By His Excellency's Command,
R. J. HAMER,
for Chief Secretary.

GOD SAVE THE QUEEN!

BANK HOLIDAY.

PROCLAMATION

By His Excellency the Governor of the State of Victoria and its Dependencies in the Commonwealth of Australia, &c., &c., &c.

IN pursuance of the provisions of the *Bank Holidays Act 1958*, I, the Governor of the State of Victoria, in the Commonwealth of Australia, do by this my Proclamation appoint the day and date named hereunder a special day to be observed as a Bank Holiday at the place mentioned, that is to say:—

Bank Holiday:—

WEDNESDAY, THE 7TH AUGUST, 1963, at St. James and Tungamah.

Given under my Hand and the Seal of the State of Victoria aforesaid, at Melbourne, this sixth day of August, in the year of our Lord One thousand nine hundred and sixty-three and in the twelfth year of the reign of Her Majesty Queen Elizabeth II.

(L.S.) ROHAN DELACOMBE.

By His Excellency's Command,
R. J. HAMER,
for Chief Secretary.

GOD SAVE THE QUEEN!

COUNTRY ROADS BOARD.

NOTICE OF FIXING A NEW ALIGNMENT OF MAROONDAH HIGHWAY IN THE CITY OF RINGWOOD.

NOTICE is hereby given that the Country Roads Board under the powers conferred upon it by the *Country Roads Act 1958* (No. 6229), has fixed a new alignment for the east side of Maroondah Highway in the City of Ringwood as described hereunder, that is to say:—

Commencing at a point on the southern boundary of allotment 4, section E, Township and Parish of Ringwood, distant 104 deg. 59 min. 43 feet from the south-western angle of the said allotment; thence by lines bearing respectively 334 deg. 28 min. 19 ft. 6 in., 23 deg. 57 min. 266 feet and 27 deg. 19 min. 246 ft. 10 in. to a point on the north-eastern boundary of lot 1, on plan of subdivision numbered 16612, lodged in the Office of Titles and being part of allotment 9A, section E of the said township, distant 135 deg. 16 min. 19 ft. 2 in. from the northern angle of the said lot—which said new alignment is shown on survey plan numbered 9014, lodged in the Office of the Country Roads Board.

Copy of the said survey plan is lodged in the offices of the Country Roads Board, the municipality of the City of Ringwood, the Registrar of Titles and the Registrar-General respectively and may be inspected by any person without a fee at any time at which such offices are open for business.

Dated the 5th day of August, 1963.

N. L. ALLANSON, Secretary.

Country Roads Board, 60 Denmark-street, Kew, E.4.

DEPARTMENT OF MINES.

SUBJECT to any necessary excisions, &c., it is proposed to grant the following mining lease:—

8075, Mineral; Kenneth Vincent Harris and Clarice Elizabeth Harris; 12a. 1r. 10p., Parish of Buchan.

APPLICATIONS FOR LEASES DECLARED ABANDONED.

8016, Mineral; Bernard Joseph Brennan; 319a. 2r. 3p., Parish of Burgoyne.

8058, Mineral; Percival Alfred Mowat; 26 acres, Parish of Holey Plains.

MINING LEASES GRANTED.

8110, Mineral; Lindsay Gordon McRae and Keith McRae; 18a. 2r., Parish of Colquhoun East.

8119, Mineral; William Gerrard Roache; 5a. 0r. 7 p., Parish of Lorne.

8125, Mineral; Leslie Gordon Newton; 17a. 3r. 7p., Parish of Eldorado.

TAILINGS LICENCES GRANTED.

3235, Tailings Licence; The Department of Agriculture; Parish of Lilliput.

3253, Tailings Licence; The Mayor, Councillors and Citizens of the City of Bendigo; City of Bendigo.

3254, Tailings Licence; The President, Councillors and Ratepayers of the Shire of Bungaree; Parish of Creswick.

3255, Tailings Licence; The Forests Commission of Victoria; Parish of Yarrowee.

3256, Tailings Licence; The President, Councillors and Ratepayers of the Shire of Creswick; at Creswick.

3258, Tailings Licence; The President, Councillors and Ratepayers of the Shire of Creswick; at Creswick.

3260, Tailings Licence; The President, Councillors and Ratepayers of the Shire of Ballarat; at Smythesdale.

3262, Tailings Licence; The Country Roads Board; Parish of Smythesdale.

3263, Tailings Licence; Alfred George Leech; Parishes of Bet Bet and Maryborough.

3265, Tailings Licence; The President, Councillors and Ratepayers of the Shire of Marong; Parish of Nerring.

MINERAL SEARCH LICENCES GRANTED.

446, Mineral Search Licence; Barry Russell Hayes; 50 acres, Parish of Granton.

472, Mineral Search Licence; James Say; 50 acres, Parish of Deddick.

473, Mineral Search Licence; James Say; 50 acres, Parish of Deddick.

474, Mineral Search Licence; James Say; 50 acres, Parish of Deddick.

475, Mineral Search Licence; James Say; 50 acres, Parish of Deddick.

476, Mineral Search Licence; James Say; 50 acres, Parish of Deddick.

477, Mineral Search Licence; James Say; 50 acres, Parish of Deddick.

478, Mineral Search Licence; James Say; 50 acres, Parish of Deddick.

479, Mineral Search Licence; James Say; 50 acres, Parish of Deddick.

480, Mineral Search Licence; James Say; 50 acres, Parish of Deddick.

481, Mineral Search Licence; James Say; 50 acres, Parish of Deddick.

482, Mineral Search Licence; James Say; 50 acres, Parish of Deddick.

483, Mineral Search Licence; James Say; 50 acres, Parish of Deddick.

484, Mineral Search Licence; James Say; 50 acres, Parish of Deddick.

485, Mineral Search Licence; James Say; 50 acres, Parish of Deddick.

486, Mineral Search Licence; James Say; 50 acres, Parish of Deddick.

487, Mineral Search Licence; James Say; 50 acres, Parish of Deddick.

500, Mineral Search Licence; James Say; 50 acres, Parish of Jingallala.

501, Mineral Search Licence; James Say; 50 acres, Parish of Deddick.

502, Mineral Search Licence; James Say; 50 acres, Parish of Deddick.

W. J. MIBUS,
Minister of Mines.

MINING LEASES DECLARED VOID.

9129, Castlemaine; Central Victoria Dredging Company No Liability; 6p., Parish of Strangways.

9159, Ballarat; Maurice O'Connell, Henry Lawrence Higgins and William Thomas Grant; 20a. 3r. 29p., Parish of Coornmill.

E. CONDON,
Secretary for Mines.

Co-operation Act 1958.

CARNEGIE TRADERS CO-OPERATIVE LIMITED.

NOTICE is hereby given in pursuance of section 78 (7) of the *Co-operation Act 1958* and section 308 (2) of the *Companies Act 1961*, that at the expiration of three months from the date hereof, the name of Carnegie Traders Co-operative Limited will, unless cause is shown to the contrary, be struck off the register and the society will be dissolved.

Dated this 31st day of July, 1963.

E. T. EBBELS,
Registrar of Co-operative Societies.

Transport Regulation Act.
TRANSPORT REGULATION BOARD.

NOTICES OF PUBLIC HEARINGS.

NOTICE is hereby given that the applications made by the persons named below for licences to operate commercial passenger vehicles on the route or routes, or in the manner set out opposite their names, will be heard at a time and place to be communicated to the parties.

Applications for metropolitan taxi-cab licences by the persons listed hereunder in respect of commercial passenger vehicles with seating capacity for five persons:—

Name and Address.

- MCINNES, E. J., Flat 11, 2 Blamey-street, Ascot Vale.
WILSON, C. J. P., 1663 Dandenong-road, Oakleigh.
BONMICCI, J., 81 Park-street, Abbotsford.
WHITELAW, I. B., 52 Parkmore-road, Forest Hill.
PASTURA, P., 113 Burnley-street, Richmond.
CAREY, H. B., 37 Clive-street, East Brighton.
CLARKE, J. P., 2 Kurrajong-street, South Oakleigh.
UREN, E., 176 Brunswick-road, East Brunswick.
JONES, R. G., 131 Peel-street, Kew.
DUNSTAN, A. MCD., 28 Tasman-street, West Preston.
FORMAN, H. A., Flat 1, 458 Victoria-parade, East Melbourne.
BARBAGALLO, F., 10 Rupert-street, East Brunswick.
HEANEY, R. S., 47 Paxton-street, South Kingsville.
WALFORD, F. W., 12 Vesper-street, Richmond.
ANASTASIOS, A., 116 Napier-street, South Melbourne.
JOHNSON, V. A., 317 Esplanade East, Port Melbourne.
DORAN, R. T., 36 Donald-street, Footscray.
BRIGHT, P. G., 14 Bridge-street, Port Melbourne.
FERIANCZ, C., 22 Crimea-street, St. Kilda.
RUSSELL, K. S., 20 Royal-avenue, Heathmont.
BLACKLEY, W. C., Flat 12, 3 Cowderoy-street, St. Kilda.
PAPANOTAS, C., 111 Chapel-street, St. Kilda.
KENNEDY, D. R., 17 Peters-street, Niddrie.
TOOKEY, R. D., Flat 8, 34 Park-street, St. Kilda.
D'ALTERIO, L. V., 4 Cullinane-street, Black Rock.
DAY, H. B., 28 Dundas-street, Thornbury.
CHARLES, J. N., 7 Bessell-court, Jacana.
NANCARROW, D. H., 29 Adeney-street, Yarraville.
MCDERMOTT, R. L., 8 Byron-court, West Heidelberg.
CASTLE, J. E., 66 Whitmuir-road, Benteleigh.
BICKFORD, L. J., 30 Lincoln-avenue, Merlynston.
PEERMAN, E., 25 Harbury-street, Reservoir.
ERJAVEC, M., 10 Hamilton-street, Alphington.
BIRD, K. B., 70 Westbury-street, East St. Kilda.
MORTON, L. P., 16 Glyndon-avenue, North Brighton.
DEBON, C., 8 Eagling-street, Keilor.
CAREY, J., 59 Daly-street, West Brunswick.
CANEVA, G. B., 639 Canning-street, North Carlton.
BURGESS, R. J., 25 Devon-avenue, West Coburg.
SPADA, F., 75 Union-street, Northcote.
FRANGOUDIS, L., 452 Coventry-street, South Melbourne.
KEE, L., 781 High-street, Thornbury.
POWER, J. D., 4 Shrimpton-court, North Box Hill.
CLARK, F. J. P., 40 Lawson-street, Essendon.
GUEST, C. V., 1 Winona-grove, Pascoe Vale South.
VICKERS, C. G., 482 Barkers-road, Hawthorn.
MCDONALD, A. M., 63 Park-street, St. Kilda.
HOLLANDER, O., Flat 19, 311 Royal-parade, Parkville.
PARRY, A. V., 19A Powell-street, South Yarra.
FARRELL, L. B., 10 Epstein-street, Reservoir.
ROBERTSON, R. G., 724 Bond-street, Ballarat.
PARKER, W. A., 44 Thompson-street, Avondale Heights.
DOWELL, L. A., 1 Salisbury-road, Ashwood.
BOHLING, R. K., Flat 11, 44 Williams-road, East Prahran.
FICHTENBAUM, M., 193 Fitzroy-street, St. Kilda (2 licences).
ROWE, E. S., 55 Combarton-street, Box Hill.
PEGG, C. A., 79 Southernhay-street, Regent.
MADIGAN, J. H., 5 Bruce-street, East Brighton.
WADE, R. C., Clare Castle Hotel, Exhibition-street, Melbourne.
BARNETT, H., 37 Shelley-street, Elwood.
STEPHENS, E. H., 78 O'Grady-street, Clifton Hill.
MCMILLAN, E. P., 28 Byron-street, Clayton.
GRANARD, P., Flat 3, 5 Avoca-court, Elwood.
PERRY, A. W., 518 High-street, East Prahran.
NITSCHKE, W., 38 Emo-road, East Malvern.
HATEM, J., 4 Langford-street, Williamstown.
MATHESON, R. T. A., 1 Charles-street, Elsternwick.
BAUDAINS, L. A. J., Flat 3, 14 Miller-street, East Prahran.
WOON, A., 11 Keane-street, Coburg.
WALSH, J., 2 Crete-avenue, Ashburton.
PERRI, A. A., 60 Bridge-street, Northcote.
COOKE, J. C., 33 Connolly-avenue, East Coburg.
RECH, A., 131 Keilor-road, Essendon North.
CLOSTER, B. A., Lot 20, Fairlane-court, Blackburn North.
ELIAS, J. V., 8 Curran-street, Huntingdale.
BECK, J. T., 20 Watt-avenue, Pascoe Vale.
CRAVEN, A. E., 21 Letchworth-avenue, East Brighton.
YOUNG, E. C., 3 Greene-avenue, Kingsbury.
NOTMAN, R. C., 175 Sycamore-street, South Caulfield.
RICARDO, A. M., 623 Malvern-road, Toorak.
CRANSTON, W. G., 5 Pamela-grove, Lower Templestowe.
GLEN, J. S., 18 Guthrie-street, West Brunswick.
MCDONALD, E. A., 186 West-street, Glenroy.
FORD, A. R., 4 Black-street, Watsonia.
BALLANTINE, J. K., 452 Mt. Dandenong-road, Kilsyth.
EDWARDS, R. G., 10 Acacia-street, Elsternwick.
RODGERS, W. P. M., 207 Derby-street, Pascoe Vale.
BURGESS, J. C., 3 Foden-street, Brunswick West.
MEYER, C. A., Malcomb-street, Kal Kallo.
JONES, V. R., 90 Carpenter-street, Brighton.
GIBBS, E., 4 Highland-avenue, Clayton.
SMITH, H. W., 13 Wagga-road, Keon Park.
ROACHE, J. J., 3 Warwick-street, Pascoe Vale.
COSTELLO, D. A., 20 Marjorie-street, Preston.
DRISCOLL, K. W., 5 Lloyd-street, Northcote.
TAYLOR, W. P., 24 Hastings-road, East Hawthorn.
MADDEN, F. W., 19 Bell-street, Richmond.
BURNS, T. H., 39 Bixcayne-drive, Mt. Waverley.
GAUDION, H. P. W., 18 Marion-street, North Brighton.
SPILSBURY, G. V., 186 Punt-road, Prahran.
GRIMES, J. V., 29 Peckam-street, Glenroy.
DYSON, J. E., 177 Auburn-road, Hawthorn.
MCWILLIAMS, R. A., 74 Outer-crescent, Brighton.
LEGGO, S. D., Flat 8, 1 Portal-street, Ascot Vale.
WILLMOTT, G. J., 27 Glen-road, Glen Waverley.
HUXTABLE, R. A., 12 Duke-street, St. Kilda.
NEILSON, R. D., 93 Ramu-parade, Heidelberg West.
TIMMS, K. B., 35 Hampshire-road, Forest Hill.
LEGGE, A. J. G., 3 Eileen-street, Glenroy.
CRELLIN, C. D., 19 Midway-street, West Heidelberg.
PRICE, A. W., 45 Scotland-avenue, Greensborough.
LAPTHORNE, A. R., 3 Mulgrave-street, East Reservoir.
NORTH, J., 122 Smith-street, Thornbury.
KROMMYDAS, G., 10 James-street, Fitzroy.
BARRY, I. J., 22 Lothair-street, Pascoe Vale South.
MCBAIN, D. W., 18 Fenacre-street, Strathmore.
HICKEY, L. J., 1651 Malvern-road, Glen Iris.
SHEPPARD, B. F., 6 Well-street, Middle Brighton.
SABLYAK, I., Flat 3, 5 Jackson-street, St. Kilda.
TSAGARIS, C., 4 Gillman-street, East Hawthorn.
ANDRINOPOULIS, G., 13 Barkly-street, East Brunswick.
RYAN, K. J., 36 McColl-street, West Brunswick.
MAGEE, J. L., 107 Landells-road, Pascoe Vale.
GALLAGHER, E., 62 Canterbury-road, Middle Park.
WALTON, S. L., 200 Moor-street, Fitzroy.
MOSES, M. M., 106 Westbury-street, St. Kilda.
CARUANA, H., 86 Juke's-road, Fawkner.
SHURIN, K. R., 166 Barkly-street, St. Kilda.
MULLINS, F., Lot 10 Main-street, Diamond Creek.
MC CARTHY, J. C., 556 Bluff-road, Hampton.
BAMBRIDGE, M. L., 130 Clayton-road, Clayton.
SAMUELSON, J. C., 12 Tuhan-road, Mount Waverley.
MANNING, P. G., 356 Inkerman-road, East St. Kilda.
RAYNOR, N. W., 72 Sycamore-street, South Caulfield.
VALENTINE, N. S., 104 Hambleton-street, Middle Park.
CHARLES, J. L., 332 Punt-road, South Yarra.
HUGHES, H. T., 37 Bath-street, St. Kilda.
SZABO, L., 373 Toorak-road, South Yarra.
FEDELE, G., 146 Capel-street, North Melbourne.
SAGANAKIS, J., 22 Coppin-street, East Malvern.
CLAYTON, E., 850 Toorak-road, East Hawthorn.
PECK, C. R., 20 Parlington-street, Canterbury.
GILL, P. J., 30 Kooyong Koot-road, Hawthorn.
LEWIN, E. C., 4 Peterson-street, Preston.
KROEGER, A. W., 72 Lake-road, Blackburn.
BEGELHOLE, A. L., 12 Quinns-road, East Benteleigh.
RICHARDS, J. W., 28 Howden-crescent, Braybrook.
ZIROS, B. J., 37 Stanhope-street, Broadmeadows.
SPAIN, D. R., 24 Valencia-street, Essendon.
TURNER, I. A., 9 Ramsey-street, East Burwood.
KIRBY, J. V., 60 Whitelaw-street, Reservoir.
MURPHY, I. S., 7 Sinclair-crescent, Macleod.
STEPNELL, O. A., Mont Albert-road, Fern Tree Gully.
OLIVER, W. G., 7 Tennyson-avenue, Highett.
SCHNABEL, J., 3 Edmonds-street, Maidstone.
POWELL, R. E., 12 Mill-street, Aspendale.
LEEK, J. C., 25 Phillip-avenue, Springvale North.
CULLY, J., 2 Woolacott-street, Coburg.
BRIDGE, H. M., Flat 7, Enfield-court, 45 Jackson-street, St. Kilda.
CUNNINGHAM, B. J., 107 Barkly-street, Mordialloc.
TINKER, G. J., 74 Outer-crescent, Brighton.
UTTING, T. G., 16 Outlook-drive, Ivanhoe.
HELD, O., 5 Folkstone-road, Mount Waverley.
CHAN, G., Flat 1, 77 Hotham-street, East St. Kilda.
SMART, J. E., 137 Victoria-street, Brunswick.
MIRENDA, R., 29 Meredith-street, Elwood.
BRUNNER, G., Flat 1, 57 Southey-street, Elwood.
BESI, A., 51 Brunswick-street, Fitzroy.
SMITH, J. C., 181 Cubitt-street, Richmond.
CASSAR, L. J., 88 Halvane-road, Niddrie.
BEARMAN, K. J., Flat 2, 26 Tennyson-street, Elwood.
GURD, D. N., 10 Whittier-street, Kingsbury.
SCHWIND, L. J., 73 Alfred-street, Prahran.

CARROLL, L. J., 10 Mathers-avenue, North Kew.
 TESORIERO, J., 2 Hawsleigh-avenue, East St. Kilda.
 TROLLOPE, N. H., 47 Brunswick-road, East Brunswick.
 MACGREGOR, A. D., 51 Hotham-street, East Melbourne.
 DOWNING, G. T., 29 Diamond-street, Niddrie.
 ELLIOTT, J. McM., 73 Market-street, Kensington.
 BAKER, R. W., 7 Robinson-street, Prahran.
 JESENSEK, L., 95 Severn-street, Yarraville.
 GRAY, B., 57 Alamein-road, West Heidelberg.
 COX, D. W., 13 Bayview-road, East Brighton.
 LEWIS, A. G., 49 Camperdown-street, East Brighton.
 NOTMAN, R. C., 175 Sycamore-street, South Caulfield.
 REED, J. H., 7 Moody-street, North Balwyn.
 CLEMENTS, C. A. J., 8 Olympian-avenue, Mt. Waverley.
 FLEISCHMANN, A. H., 26 North-road, East Reservoir.
 ARMSTRONG, E. R., 2 St. James-street, Glenroy.
 BOOTH, L. P., 29 Cape-street, Heidelberg.
 COATES, L., 102 McCracken-street, Essendon.
 DELIANIS, V., 4 Birch-street, West Preston.
 O'KEEFE, D. M., 18 Moama-street, Braybrook.
 SPENCER, H. J., 366 Mont Albert-road, Mont Albert.
 NICHOLS, J. D., Flat 1, 8a Sydenham-street, Moonee Ponds.
 SEDDON, W. H., 14 Toxeth Park-street, East Coburg.
 PERUGIA, R. E. G., 13 Veronica-street, Northcote.
 WATSON, D. G., 249 Chesterville-road, Moorabbin.
 PALMIERI, A. D., 7 Miller-street, Alphington.
 O'MEARA, J. L., 45 Brunel-street, East Malvern.
 DU-LEE, N. J., 35 Park-road, Surrey Hills.
 KIRK, P. W., 644 Rathdown-street, North Carlton.
 FOLEY, V. P., 35 Bloomfield-road, Ascot Vale.
 KENNY, F. A., 11 Parker-street, Carnegie.
 MACDONALD, R., 94 Holmes-road, Moonee Ponds.
 DAVIES, A., 38 Whyte-street, Brighton Beach.
 PARDY, E., 9 Mincha-street, West Brunswick.
 COBERN, D. J., Flat 2, 86 Blessington-street, St. Kilda.
 NICHOLSON, B. B., 3 Greta-court, Lower Templestowe.
 SMITH, H. F., 1110 Dandenong-road, Carnegie.
 VITOUS, E., 36 Sturdee-street, Reservoir.
 FROSH, H., Flat 1, 89 Addison-street, Elwood.
 BELL, S. G., 22 Middle-road, Maribyrnong.
 SMIT, J., 82 Beaconsfield-parade, Northcote.
 WRIGHT, V. G., 34 Augusta-street, Glenhuntly.
 HART, A. A., Flat 2, 2 Churchill-avenue, Ascot Vale.
 PANDELIU, E., 187 Canterbury-road, St. Kilda.
 BRAVO, S. A., 22 Davern-street, Pascoe Vale.
 MOUNTFORD, J., 2 Hope-street, East Brighton.
 EMIN, A., 672 Rathdowne-street, North Carlton.
 FLETCHER, G. M., Flat 1, 10 Markham-avenue, Ashburton.
 LA ROSE, M. J., 20 Heather-court, Glenroy.
 CONNELLAN, K. G., 117 Peel-street, Windsor.
 KYZINDAS, V. J., 43 Merton-street, Albert Park.
 HODGES, B. F., 14 Bullarto-street, Chadstone.
 DEHIGHDEN, J. V., 88 Waverley-parade, Pascoe Vale South.
 STAPLETON, C. L., 149 Glen Eira-road, East St. Kilda.
 HOLLAND, F. P., 860 Glenhuntly-road, South Caulfield.
 BERNARDS, E. R., 68 Chaucer-street, St. Kilda.
 MORCOM, E. J., 98 Chapman-street, North Melbourne.
 GIOVANNI, A. Di., 67 Barkly-street, North Fitzroy.
 FISHER, D. M., 18 Panorama-avenue, Highett.
 UYT-DEN-BOGAARD, A., 72 McGregor-street, Middle Park.
 URICH, P., 1 Victoria-place, South Melbourne.
 ROOK, T. B., 422 Queens-parade, Clifton Hill.
 KATSIKAS, T., 217 Fitzroy-street, Fitzroy.
 NAUGHTIN, D. T., 43 Chaley-street, East Reservoir.
 PARRY, L. R., 89 Gladstone-road, Dandenong.
 GERKENS, M. P., Flat 28, 61 Kooyong-road, Armadale.
 GORMLEY, K. K., 47 Shower-street, Preston.
 ZUCKER, C. A., 44a Milton-parade, Malvern.
 SHERRIFF, R., 328 Kingsway, South Melbourne.
 McDONALD, B. E., 263 Tyler-street, Preston.
 McNAUGHTON, M. G., 42 Dickinson-street, Glenroy.
 EDEN, F. V., 8 Bethell-avenue, Parkdale.
 RICHARDSON, N. E., 121 Tucker-road, Bentleigh.
 SEARLE, A. R. E., 130 Charles-street, Northcote.
 McLAREN, R., 176 Boundary-road, North Melbourne.
 SAYER, I. R., 22 Wellwood-road, Bonbeach.
 BROWNLEES, C. J., 7 Alfada-street, South Caulfield.
 VERHAGEN, A. J., 66 Kenvinside-road, Noble Park.
 REILLY, N. P., 27 Donald-street, Mt. Waverley.
 WATSON, E. H., Flat 6, 468 Glenferrie-road, Hawthorn.
 COLLINS, E. M., 22 Meadow-crescent, Montmorency.
 PERNELL, J., 436 Victoria-street, North Melbourne.
 KELLY, M. V., 4 McCrae-street, Elwood.
 CRIPPS, R. P., 171 Royal-parade, Parkville.
 DOLPHIN, H. D., 5 Coate-avenue, Alphington.
 NORDEN, J. A., 14 Samuel-road, Blackburn South.
 MORABITO, G., 11 Lawson-street, Moonee Ponds.
 EVERETT, L., 6 Ardmore-street, Mitcham.
 LLEWELLYN, H., Flat 6, Hawsleigh-avenue, East St. Kilda.
 LESLIE, W. E., 5 Separation-street, Alphington.
 WILLIAMS, J., 326 Malvern-road, Prahran East.
 BURNS, G. C., 97 Alexandra-avenue, South Yarra.
 WING-QUAY, R., 24 Gladstone-street, Windsor.
 BERT, A., 81 Alexander-avenue, Thomastown.
 DICKINSON, J. G., 1 Chesterville-drive, East Bentleigh.

FARRIS, G., 26 Lulie-street, Abbotsford.
 DOHERTY, W. C., 1 Melbourne-avenue, Glenroy.
 RODGERS, S., 124 Bellair-street, Kensington.
 TIE, K. S., 26A Seaview-crescent, Black Rock.
 PELLIZZARI, S., 280 Station-street, Carlton.
 BILLING, A. V., 8 Fowler-crescent, Newport.
 FOSSENG, G., 674 Toorak-road, Toorak.
 DIMITRIOS, S., 221 Gore-street, Fitzroy.
 BATT-HALSTEAD, J. T., 17 Hammond-road, Dandenong.
 McINTYRE, R. M., 23 Treloar-crescent, Braybrook.
 LIPSCHITZ, J., Flat 6, 98 Grosvenor-street, St. Kilda.
 CUMMINS, M. R., 77 Kunyung-road, Mt. Eliza.

APPLICATIONS for metropolitan private hire car licences by the persons listed hereunder in respect of commercial passenger vehicles, with seating capacity for five persons, to operate under composite conditions from an approved depot in zone set out opposite their names:—

Name and Address; Zone.

MULLENER, J. W. C., 17 Charlotte-street, Yarraville; "K".
 FARNELL, R. P., 8 Carmichael-road, East Oakleigh; "C".
 MOONEY, J. E., McKinnon-road, McKinnon; "B".
 YOUNG, K. E., 64 Tribuckney-street, Highett; "B".
 VIOLARIS, J., 102A Hoffmans-road, West Essendon; "K".
 BARNES, I. C., 411 Warragul-road, South Oakleigh; "C", "B".
 DICKINSON, J. G., 1 Chesterville-drive, East Bentleigh; "C", "B".
 GIBBS, E., 4 Highland-avenue, Clayton; "A".
 MARTIGNOLES, D., 42 Bardsley-street, Sunshine; "K".
 GASCOIGNE, W. F., 75 King William-street, Fitzroy; "J".
 GASCOIGNE, W. F., 75 King William-street, Fitzroy; "N".
 PAULING, T., 13 Earlstown-road, Oakleigh; "C".
 CASSAR, L. J., 88 Haldane-road, Niddrie; "J".
 WATSON, D. G., 249 Chesterville-road, Moorabbin; "B", "C".
 WINDRAM, G. J., 5 Ambon-court, West Heidelberg; "G".
 O'CONNOR, K. M., Lot 7, Montague-road, Glen Waverley; "C".
 McINTYRE, R. M., 23 Treloar-crescent, Braybrook; "K".
 PYERS, R. S., 21 Deakin-street, West Essendon; "K".
 HODGES, B. F., 14 Bullarto-street, Chadstone; "B".
 HODGES, B. F., 14 Bullarto-street, Chadstone; "C".
 KING, W. J. A., Lot 70, Walter-street, Glen Waverley; "K", "C".
 DOWELL, L. A., 1 Salisbury-road, Ashwood; "A".
 HEANEY, R. S., 47 Paxton-street, South Kingsville; "J".
 HEANEY, R. S., 47 Paxton-street, South Kingsville; "K".
 DORAN, R. T., 36 Donald-street, Footscray; "K".
 KENNEDY, D. R., 17 Peters-street, Niddrie; "N".
 VICKERS, C. G., 482 Barkers-road, Hawthorn; "E".
 COLES, J. M., 39 Kennedy-street, Glen Waverley; "B".
 LECHMERE, R. S., 372 Barkly-street, Elwood; "B", "K", "A".
 COMBEN, R. L., 3 Normanby-avenue, North Caulfield; "B".
 NORTON, J. H., 15 Brentwood-close, Clayton; "B", "C", "A".
 MORGAN, R. W., 17 Ormond-road, Clayton; "B".
 GOLDBERG, P. D., 3 Docker-street, Elwood; "O", "B", "A".
 DEBATTISTA, J., 54 Mount View-road, Thomastown; "H".
 STUBBERFIELD, R. J., 55 Tudor-street, South Oakleigh; "C".
 GILBERT, J., 30 Cleek-avenue, Oakleigh; "C".
 PEPOJONOVIC, L., 89 Thomson-street, South Melbourne; "B".
 ELIAS, J. V., 8 Curran-street, Huntingdale; "E", "B", "C".
 WYNN, H., 29 Foam-street, Elwood; "B".
 McLAUGHLIN, A. M., 34 Innellan-road, Murrumbeena; "C".
 WILLIAMS, R., 82 Para-road, Montmorency; "E".
 SHERRIFF, N. H., 198 Forrest-street, Ardeer; "K".
 SPAIN, D. R., 24 Valencia-street, Essendon; "J".
 PHILLIPS, W. A., 19 Mason-street, Regent; "H".
 LEGGE, A. J. G., 3 Eileen-street, Glenroy; "N".
 OXLADE, J. W., 42 Ashwood-drive, Ashwood; "D".
 HOLLAND, F. P., 860 Glenhuntly-road, South Caulfield; "A", "B".
 GRAHAM, N. A., 117 Peel-street, Windsor; "B", "C".

APPLICATIONS by the persons listed hereunder for metropolitan taxi-cab licences subject to the cancellation of metropolitan private hire car licences held by each applicant, as shown:—

Name and Address; Licence Number.

ELLIS, G., 49 Epsom-road, Ascot Vale; M.H.1815.
 ROWE, J., 72 Wellington-street, St. Kilda; M.H.544.
 FOOTSCRAY DELPHIC TAXIS PTY. LTD., 164 Barkly-street, Footscray; M.H.485.
 FOOTSCRAY DELPHIC TAXIS PTY. LTD., 164 Barkly-street, Footscray; M.H.513.

FOOTSCRAY DELPHIC TAXIS PTY. LTD., 164 Barkly-street, Footscray; M.H.716.
 FOOTSCRAY DELPHIC TAXIS PTY. LTD., 164 Barkly-street, Footscray; M.H.778.
 FOOTSCRAY DELPHIC TAXIS PTY. LTD., 164 Barkly-street, Footscray; M.H.895.
 FOOTSCRAY DELPHIC TAXIS PTY. LTD., 164 Barkly-street, Footscray; M.H.483.
 FOOTSCRAY DELPHIC TAXIS PTY. LTD., 164 Barkly-street, Footscray; M.H.484.
 FOSTER, H., 56 Through-road, Burwood; M.H.445.
 WARBRICK, A., 192 St. Kilda-street, Middle Brighton; M.H.763, M.H.870.
 HOPPER, J. J., 13 Woodville-avenue, Glenhuntly; M.H.2296.
 PERUGIA, R. E. G., 13 Veronica-street, Northcote; M.H.2298.
 GARSON, P. J., 6 Wingara-avenue, East Keilor; M.H.1814.
 MOORE, J. K., 16 Bishop-street, West Footscray; M.H.708.

APPLICATIONS for renewal of licences by persons listed hereunder to operate under the same terms and conditions from the date of expiry:—

Name and Address; Licence Number; Classification; Date of Expiry.

GEELONG ASSOCIATED BUS LINES PTY. LTD., 151 Mercer-street, Geelong; C.O. 386, C.O.445, C.O.568, C.O.947, C.O.948, C.O.949, C.O.952, C.O.953, C.O.954, C.O.955, C.O.956, C.O.957, C.O.958, C.O.959, C.O.960, C.O.961; country omnibus; 30th September, 1963.
 FERGUSON, S. V., 151 Raymond-street, Sale; C.O.1069, C.O.1070; country omnibus; 8th November, 1963.
 CULLEN, J. M. & J. E. (trading as Cullens Bus Lines), 21 Smith-street, Wangaratta; C.O.414; country omnibus; 10th December, 1963.
 KHANCOBAN-SPRING CREEK SCHOOL, care of W. D. Ryland, Box 17, Corryong; C.O.27; country omnibus; 15th September, 1963.
 HOOPER, T. J., Piangil; C.O.34; country omnibus; 29th November, 1963.
 MCPHERSON, R. L. & J. M., 75 Cox-street, Port Fairy; C.O.354; country omnibus; 24th December, 1963.
 SMART, G. V., Camp-street, Beechworth; C.T.206; country taxi-cab, Beechworth; 30th December, 1963.
 CRAWFORD, E. W. H., 8 Moore-street, Wangaratta; C.T.97; country taxi-cab, Wangaratta; 7th December, 1963.
 MORWELL TAXIS PTY. LTD., Denise-street, Morwell; C.T.211; country taxi-cab, Morwell; 23rd December, 1963.
 STEWART, N. M., Glenavon-avenue, Cobram; C.T.204; country taxi-cab, Cobram; 12th December, 1963.
 MYLON, A. G. & E. T., 27 Morrell-street, Mooroopna; C.T.763; country taxi-cab, Mooroopna; 4th December, 1963.
 SHARD, J. H., 198 Balaclava-street, Shepparton; C.T.151; country taxi-cab, Shepparton; 7th December, 1963.
 GODDARD, R. & J. M., 7 Allen-street, Ringwood; C.T.216; country taxi-cab, Ringwood; 13th December, 1963.
 MCHARRY, A. M. & N. J., 43 The Esplanade, Geelong; U.O.482, U.O.484, U.O.420, U.O.473, U.O.409, U.O.476, U.O.478, U.O.479, U.O.480, U.O.481; urban omnibus; 30th September, 1963.
 ARMSTRONG, I. R. & P. M., Cape Otway-road, Moriac; T.S.748; school service; 23rd December, 1963.
 FLORENCE, H. H., 13 Crimea-street, North Caulfield; T.P.134; temporary passenger licence; 13th December, 1963.
 HAYES, L. J. (on behalf of Broadmeadows Sunday School), 87 Victoria-street, Flemington; T.P.444; temporary passenger licence; 3rd December, 1963.
 SMORGAN, NORMAN PTY. LTD., Somerville-road, Brooklyn; T.P.63; temporary passenger licence; 31st December, 1963.
 KELLY, A. L., Toolangi; T.P.50; temporary passenger licence; 4th December, 1963.
 NAGLE, G. P., 105 Raglan-street, South Melbourne; M.T.2610; metropolitan taxi-cab; 6th September, 1963.
 ANSELL, K. R. (on behalf of K. R. Ansell and Mrs. R. E. Boehm), 129 Nepean Highway, Mentone; M.T.1681; metropolitan taxi-cab; 6th September, 1963.
 FOOTSCRAY DELPHIC TAXIS PTY. LTD., 164 Barkly-street, Footscray; M.H.946, M.H.947, metropolitan private hire; 8th September, 1963.
 FOOTSCRAY DELPHIC TAXIS PTY. LTD., 164 Barkly-street, Footscray; M.H.952; metropolitan private hire; 9th September, 1963.
 HOLLANDIA SHOES (AUST.) PTY. LTD., John-street, Lilydale; 1 commercial passenger vehicle, with seating capacity for seventeen persons, to operate as follows—(1) for the carriage of employees only between Lilydale and Healesville, free of charge.

TIME-TABLE.

Monday—Friday.

Dep. Lilydale 7.30 a.m. Arr. Healesville 8.00 a.m.
 Dep. Healesville 4.30 p.m. Arr. Lilydale 5.00 p.m.
 (2) for the carriage of the applicant companies own goods within a radius of 50 miles of Healesville.
 SACRED HEART SCHOOL, Gipson-street, Diamond Creek; 1 commercial passenger vehicle, with seating capacity for 29 passengers, to operate as a temporary passenger vehicle, under the same terms and conditions as licence already held in the applicant's name.
 KENNEDY, J. T., Box 114, Corryong; 1 commercial passenger vehicle, with seating capacity for five persons, to operate under the same terms and conditions as existing taxi-cabs licensed at Corryong.
 FORDAN, W. G. (on behalf of Playtime Day Nursery), 66 Berry-avenue, Chelsea; 1 commercial passenger vehicle, with seating capacity for five passengers, to operate, free of charge, for the carriage of children to and from Berry-avenue to the children's homes situated in Edithvale and Chelsea areas.
 WARRNAMBOOL BUS LINES PTY. LTD., 273 Raglan-parade, Warrnambool; 1 commercial passenger vehicle, with seating capacity for five persons, to operate under the same terms and conditions as licence No. C.O.26, held by the company.
 FLORENCE, H. H., 13 Crimea-street, North Caulfield; 1 commercial passenger vehicle, with seating capacity for five persons, to operate under the same terms and conditions as existing country taxi-cabs licensed at Kyabram.

NOTICE is hereby given that the applications made by the persons named below for licences to operate the commercial goods vehicles on the route or routes or in the manner set out opposite their names, will be held at a time and place to be communicated to the persons concerned:—

Name and Address; Nature of Application.

ORD, W. (trading as A.C.L. Engine Service), 101 Whitehorse-road, Deepdene; 1 commercial goods vehicle (8 cwt.) to operate within a radius of 50 miles of own branch premises at Morwell, in the course of business as "engine reconditioner"—tools of trade, spare parts and materials incidental thereto together with engines for repair or having been repaired.
 KIMPTON, S. MCD., R. D. & B. W. (trading as Barastoc Products), 143 Queen-street, Melbourne; 1 commercial goods vehicle (7 cwt.) to operate throughout the State of Victoria, in the course of business as "flour millers" for the purpose of demonstrating own products—demonstration equipment, including stoves, &c., foodstuffs for demonstration and display materials.
 THE BARKLY BRICK CO. PTY. LTD., 32 Weston-street, Brunswick; 1 commercial goods vehicle (134 cwt.) to operate within a radius of 70 miles of own premises at Brunswick, in the course of business as "brick manufacturers"—bricks.
 BARROW, R. G., 48 Jackson-court, East Doncaster; 1 commercial goods vehicle (180 cwt.) to operate within a radius of 50 miles of the premises of Specified Concrete (Vic.) Pty. Ltd. at Kingston-road, Moorabbin, in a specially constructed agitator vehicle—ready mixed concrete on behalf of the said company.
 CHRISTIAN, J. & D., Cottles Bridge; 1 commercial goods vehicle (approximately 220 cwt.) to operate, in the course of business as "agricultural contractors"—(a) within a radius of 20 miles of the post office at Cottles Bridge—own agricultural equipment, (b) within a radius of 20 miles of the post office at Pyalong—own agricultural equipment.
 CUSTOM TRANSPORT & MOVEMENT ENGINEERS PTY. LTD., 125 Springvale-road, Springvale; 1 commercial goods vehicle (236 cwt.) to operate—(a) within a radius of 20 miles of Springvale—general goods, (b) within a radius of 70 miles of Brick Industries Ltd. at East Burwood—bricks solely on behalf of the said company.
 DEACON, J. V., 28 Irene-crescent, Mitcham; application to vary the conditions of licence No. D.A.49334 (L/C. 136 cwt.) by adding to existing conditions "roof battens and tile fixing materials".
 EZARD, G. & M., 4 Menin-avenue, Warracknabeal; 1 commercial goods vehicle (27 cwt.) to operate—(a) within a radius of 20 miles of the post office at Warracknabeal—general goods, (b) within a radius of 50 miles of the post office at Warracknabeal—milk, cream and empty return containers.

- FIELD & TAYLOR PTY. LTD., 38 Smith-street, Warragul; 2 commercial goods vehicles (14 cwt. and 9 cwt.) to operate throughout the State of Victoria in course of business as "sewerage contractors" for the purpose of supervising own contracts—tools of trade and equipment both own and the property of employees.
- FLICK, W. A., & Co. PTY. LTD., 1008 Sturt-street, Ballarat; application to vary the conditions of licence Nos. D.A.48423 and D.A.48423/1 (L/C. 8 cwt. each) by deleting existing conditions and adding in lieu:—"within that part of Victoria north of a line drawn east and west through the Township of Bacchus Marsh, in the course of business as 'pest exterminators'—tools of trade, spraying equipment and small quantities of materials incidental to own contracts".
- NOTE.—Concentrated chemicals to be forwarded by rail to Ballarat, Horsham, Wedderburn and Shepparton.
- GARLICK, T. C., & M. J., Villeneuve-street, Alexandra; 1 commercial goods vehicle (191 cwt.) to operate—(a) within a radius of 50 miles from the post office at Alexandra—plant the property of a contractor and required by him for use in connexion with the construction or maintenance of some specific, existing or proposed road, street, footpath, bridge, pier, wharf, weir or channel, and also the following materials, viz.: metal, stones, screenings, ashes, gravel and sand, (b) within a radius of 20 miles from the site of any construction or maintenance work performed pursuant to paragraph (a) above, or from the railway station nearest thereto—any other materials required for such work, (c) within a radius of 20 miles from the post office at Alexandra—general goods, excluding any plant or materials carried or to be carried pursuant to paragraphs (a) and (b) above.
- GEPP, G. M. & J. F., Montgomery-street, Skipton; 1 commercial goods vehicle (150 cwt.) to operate within a radius of 50 miles from the post office at Skipton, in the course of business as "timber and hardware merchants and fuel agents"—own goods.
- INGLETON, ALAN S., Cherokee, via Romsey; 1 commercial goods vehicle (100 cwt.) to operate—(a) from private properties in the Cherokee-Kerrie areas to Johnson and Reilly's timber yard at Niddrie—logs, (b) from Forest Commission sites at Mt. Macedon to Every Timber Co., Preston, Hancock Bros., Keon Park and Preston Timber Co., Preston—pine logs.
- KRAFT FOODS LTD., Ocean-road, Allansford; 1 commercial goods vehicle (10 cwt.) to operate within a radius of (100 miles) from the post office at Allansford in the course of business as "cheese manufacturers" for the purpose of maintaining own vehicles—own tools of trade and associated equipment together with spare parts as required.
- LANGSKAILL, A. & N. G. (trading as Langskail Bros.), Buchan; 1 commercial goods vehicle (approximately 150 cwt.) to operate—(a) from and to the Nowa Nowa Railway Station, to and from places on or reached from the road between the Townships of Nowa Nowa and Wuigulmerang—general goods, (b) from and to places situate on the road as defined in paragraph (a) above, to and from the Townships of Bairnsdale and Orbost—general goods, (c) within the Shire of Omeo—livestock.
- LOVE, J. R., Cassilis, via Omeo; application to vary the conditions of licence No. D.A.48267 (L/C. 110 cwt.) by adding to existing conditions—" (a) throughout the Bairnsdale Division of the Country Roads Board—plant the property of a contractor and required for use in connexion with the construction or maintenance of some specific, existing or proposed road, street, footpath, bridge, wharf, pier, weir or channel, (b) within a radius of 20 miles from site of construction or maintenance work performed pursuant to paragraph (a) or from the railway station nearest thereto—metal, stones, screenings, ashes, gravel, sand, earth and any other materials required for such work, (c) within a radius of 20 miles of the post office at Cassilis—general goods".
- HADDEN, J. E., PTY. LTD., 445 Toorak-road, Burwood; application to vary the conditions of licence No. D.A.46051 (L/C. 16 cwt.) by deleting existing conditions and adding in lieu: "within a radius of 50 miles of own depot at Bendigo in course of business as 'cigarette distributors'—own goods".
- NOTE.—All goods to be railed to Bendigo.
- LOWRY, M., Rail-street, Wandong; 1 commercial goods vehicle (92 cwt.) to operate—(a) within a radius of 70 miles of the post office at Healesville (Dandenong Division of the Country Roads Board)—plant the property of a contractor and required for use in connexion with the construction or maintenance of some specific, existing or proposed road, street, footpath, bridge, wharf, pier, weir or channel, (b) within a radius of 20 miles from site of construction or maintenance work performed pursuant to paragraph (a) above, or from the railway station nearest thereto—metal, stones, screenings, ashes, gravel, sand, earth and any other materials required for such work, (c) within a radius of 20 miles of the post office at Wandong—general goods.
- MILLER, B. M., Princes Highway, Drouin; 1 commercial goods vehicle (48 cwt.) to operate—(a) throughout the State of Victoria in the course of business as an "agricultural and fencing contractor"—own agricultural and fencing equipment, (b) within a radius of 20 miles of any current contract or from the nearest railway station thereto—materials for use on such contract.
- MILNER, J. L., 52 Albert-road, Drouin; 1 commercial goods vehicle (117 cwt.) to operate within a radius of 40 miles of Longwarry in course of business as "fuel merchant"—mill ends.
- MORAN, M. P., Snodgrass-street, Broadford; 1 commercial goods vehicle (139 cwt.) to operate—(a) within a radius of 70 miles of the post office at Healesville (Dandenong Division of the Country Roads Board)—plant the property of a contractor and required for use in connexion with the construction or maintenance of some specific, existing or proposed road, street, footpath, bridge, wharf, pier, weir or channel, (b) within a radius of 20 miles from site of construction or maintenance work performed pursuant to paragraph (a) above, or from the railway station nearest thereto—metal, stones, screenings, ashes, gravel, sand, earth and any other materials required for such work, (c) within a radius of 20 miles of the post office at Broadford—general goods.
- SCHMIDT, R. G. & E. G. (trading as Murray Valley Constructions), 35 Auburn-street, Wodonga; 1 commercial goods vehicle (approximately 200 cwt.) to operate—(a) within a radius of 20 miles of the post office at Wodonga—general goods, (b) within a radius of 50 miles of the post office at Wodonga—own road-making plant and equipment.
- JAMES MCEWAN & Co. PTY. LTD., 119 Elizabeth-street, Melbourne; application to vary the conditions of licence No. D.A.16877/1 (L/C. 120 cwt.) by adding to existing conditions; "to and from own garage at Clayton".
- NADASDY, G., 1 Newell-street, Footscray; 1 commercial goods vehicle (8 cwt.) to operate throughout the State of Victoria in the course of business as "marine dealer"—marine goods as designated in the *Marine Stores and Old Metals Act 1958* (No. 6303).
- NATIONAL TYRE SERVICE (WARRNAMBOOL) PTY. LTD., Raglan-parade, Warrnambool; application to vary the conditions of licence Nos. D.A.2374/28, D.A.2374/29, D.A.2374/33 and D.A.2374/49 (L/C. 11, 13, 11 and 8 cwt.) by adding to existing conditions—"polythene piping".
- O'SHANNESY, J. W., Bailey-road, Mt. Evelyn; 1 commercial goods vehicle (28 cwt.) to operate throughout the State of Victoria in course of business as "gas fitter" on behalf of Thermal Traders (Vic.) Pty. Ltd. for the purpose of installing bottled gas appliances—tools of trade, specially coated pipe and fittings not to exceed 3 cwt. and small quantity of materials incidental to installation only, excluding the carriage of appliances.
- PASSLER, P. A., 22 Alexander-avenue, Horsham; 1 commercial goods vehicle (100 cwt.) to operate—(a) within a radius of 80 miles of Dimboola Post Office (Horsham Division of the Country Roads Board)—plant the property of a contractor and required for use in connexion with construction or maintenance of some specific, existing or proposed road, street, footpath, bridge, wharf, pier, weir or channel, (b) within a radius of 20 miles from site of construction or maintenance work performed pursuant to paragraph (a) above, or from the railway station nearest thereto—metal, stones, screenings, ashes, gravel, sand, earth and any other materials required for such work, (c) within a radius of 20 miles of the post office at Horsham—general goods.
- PERMEWAN WRIGHT LTD., 31 King-street, Melbourne; 1 commercial goods vehicle (35 cwt.) to operate within a radius of 50 miles of own branch premises at Benalla in the course of business as "general merchants"—own goods.
- PULLEN, P., Box 157, Casterton; 1 commercial goods vehicle (204 cwt.) to operate—(a) within a radius of 20 miles of the post office at Casterton—general goods, (b) between the Shell Co. of Australia Ltd.'s installation depot at Portland and own depot at Casterton, and from and to the said depot at Casterton to and from places situate within a radius of 20 miles thereof—petroleum products in prescribed types of containers and empty return containers.

REID, J. M. & G. J., 117 Skeen-street, Warrnambool; 2 commercial goods vehicles (4 and 8 cwt.) to operate within a radius of 50 miles of post office at Warrnambool, in the course of business as "electrical contractors"—tools of trade and materials incidental to completion of own contracts, also electrical goods for repair or having been repaired.

REPLACEMENT PARTS PTY. LTD., 618 Elizabeth-street, Melbourne; application to vary the conditions of licence No. D.A.1907/31 (L.C. 8 cwt.) by deleting from existing conditions "the Township of Ararat" and adding in lieu "the City of Ballarat."

ROBERTSON, C. J., Stawell-road, Horsham; 1 commercial goods vehicle (10 cwt.) to operate—(a) within a radius of 20 miles of the post office at Horsham, in course of business as "wrecker"—own goods, (b) within that part of the State of Victoria south of an east-west line drawn through Hopetoun, west of a north-south line drawn through Marnoo and to the South Australian border, north of an east-west line drawn through Balmoral—tools of trade and small parts incidental to own S.E.C. contracts.

SCHWEPPE (AUST.) LTD., 137 Chesterville-road, Highett; 1 commercial goods vehicle (223 cwt.) to operate—(a) within a radius of 50 miles from own premises at Ballarat in course of business as "aerated waters manufacturers"—own goods, (b) within an area west of a north-south line drawn through Ballarat and as far west as a north-south line drawn through Hamilton and south of an east-west line drawn through Warracknabeal—aerated waters in glass containers and open wooden crates for en route delivery only and empty return containers and display and advertising materials.

SCHWEPPE (AUST.) LTD., 137 Chesterville-road, Highett; 1 commercial goods vehicle (223 cwt.) to operate between own factory at Moorabbin and Ballarat for the carriage of bulk deliveries of aerated waters in glass containers and open wooden crates.

SCHWEPPE (AUST.) LTD., 137 Chesterville-road, Highett; 3 commercial goods vehicles (114, 115 and 140 cwt.) to operate between manufacturing point at Moorabbin to Traralgon and Lakes Entrance and return via Yarram and Korumburra for en route delivery only of own manufactured aerated waters in glass containers and in open wooden crates and empty containers.

SERVICE VANS PTY. LTD., 178-196 Normanby-road, South Melbourne; 2 commercial goods vehicles (10 cwt. each) to operate throughout the State of Victoria for the purpose of servicing and maintaining food preservation equipment—tools of trade, spare parts and materials incidental thereto and replacement units.

SINCLAIR, G. M., 4 Kallay-court, Lower Plenty; 1 commercial goods vehicle (200 cwt.) to operate within a radius of 50 miles of the premises of Blue Metal Concrete at Somerton in a specially constructed agitator vehicle—ready mixed concrete.

SMITH, K., "Beulah", Bannockburn; 1 commercial goods vehicle (10 cwt. approximately) to operate—(a) within a radius of 20 miles of the post office at Bannockburn—parcels not exceeding 1 cwt., (b) from and to the Township of Bannockburn to and from the Township of Rokewood and places en route for the collection and delivery of mails under contract to the P.M.G.

HOARE, L. M. & D. F. (trading as James Solly & Co.), corner Yarra-street and Barwon-terrace, Geelong; 1 commercial goods vehicle (126 cwt.) to operate—(a) from and to the City of Geelong to and from the Cities of Melbourne and Ballarat—secondhand bottles, broken glass and empty cases on return journeys, in course of business as a "marine dealer", (b) within a radius of 25 miles from the chief post office in the City of Geelong—marine goods as designated in the *Marine Stores and Old Metals Act 1958* (No. 6303).

STUART, A. C., Mount Taylor, via Bairnsdale; 1 commercial goods vehicle (51 cwt.) to operate—(a) within a radius of 20 miles of the post office at Mount Taylor—general goods, (b) from and to places situated within the radius as defined in paragraph (a) above, to and from places situated within a radius of 50 miles from the post office at Mount Taylor—livestock.

TRANS OTWAY LTD., corner of Ryrie and Fenwick streets, Geelong; 1 commercial goods vehicle (269 cwt.) to operate: General Goods—(a) from and to the metropolitan area of the City of Melbourne as defined in the *Transport Regulation Act 1958*, or from and to the Geelong District as defined in the Second Schedule of the *Commercial Goods Vehicles Act 1958*, to and from: (i) places situated on or accessible only from the Great Ocean-road between the City of Geelong and the Township of Apollo Bay, (ii) places situated within a radius of 10 miles from the post office at Apollo Bay, (iii) places situated within a radius of

5 miles from the post office at Lorne; (b) from and to the Township of Apollo Bay to and from the City of Colac, (c) within a radius of 20 miles from the post office at Apollo Bay, (d) within a radius of 25 miles from the chief post office in the City of Geelong, (e) from and to the Township of Lorne to and from the City of Colac, (f) within a radius of 20 miles from the post office at Lorne.

VICTORIAN INLAND MEAT AUTHORITY, 522 Little Collins-street, Melbourne; 1 commercial goods vehicle (54 cwt.) to operate throughout the State of Victoria in course of business as "abattoir operators and smallgoods manufacturers" in a specially constructed insulated and iced vehicle—meat, bacon, ham, processed meats together with lard and dripping not to exceed 2 cwt.

WOOD, C. M., 5 Normanby-avenue, Thornbury; 1 commercial goods vehicle (108 cwt.) to operate—(a) within a radius of 25 miles of Melbourne—general goods, (b) within a radius of 70 miles of Hoffman Brick and Potteries Pty. Ltd., at Brunswick—bricks solely on behalf of the said company.

ZAMMIT, M., 12 Myers-street, West Sunshine; 1 commercial goods vehicle (140 cwt.) to operate within a radius of 50 miles of the premises of Albion Quarrying Co. Pty. Ltd., at North Melbourne—road-making equipment, hot asphalt, premix and road-making materials.

PULPWOOD CARRIERS.

ADAMS, J. H., Powelltown; 1 commercial goods vehicle (243 cwt.) to operate from logging areas in the vicinity of Noojee to Australian Paper Manufacturers Ltd., at Maryvale—pulpwood.

ADAMS, J. H., Powelltown; 1 commercial goods vehicle (246 cwt.) to operate from logging areas in the vicinity of Powelltown, to Australian Paper Manufacturers Ltd., at Maryvale—pulpwood.

ADAMS, J. H., Powelltown; 1 commercial goods vehicle (223 cwt.) to operate from logging areas in the vicinity of Launching Place and Gembrook to Australian Paper Manufacturers Ltd., at Maryvale—pulpwood.

DUFF, A. R., 48 Kay-street, Traralgon; 1 commercial goods vehicle (221 cwt.) to operate from logging areas situated near Licola, Matlock, Warburton, Boola, Tyers, Balook, Gunya, Langford and Rosedale to Australian Paper Manufacturers Ltd., at Maryvale—pulpwood.

HENRY, J. W., Tyers, via Traralgon; 1 commercial goods vehicle (144 cwt.) to operate from logging areas located within a radius of 20 miles of Tyers and incorporating Tyers, Longford, Boola and Glengarry, to Australian Paper Manufacturers Ltd., at Maryvale—pulpwood.

HORVAT, J., 393 Princes Highway, Morwell; 1 commercial goods vehicle (148 cwt.) to operate from logging areas situated within a radius of 20 miles of Neerim South to Australian Paper Manufacturers Ltd., at Maryvale—pulpwood.

PYE, R. J., 3 Farmer-crescent, Traralgon; 1 commercial goods vehicle (156 cwt.) to operate from logging areas situated near Longford, Coongulla, Gorman-dale, and within a radius of 20 miles of Traralgon to Australian Paper Manufacturers Ltd., at Maryvale—pulpwood.

WASSENAAR, S., 40 Elizabeth-street, Moe; 2 commercial goods vehicles (141 and 153 cwt.) to operate from Healesville and Toolangi logging areas, to Australian Paper Manufacturers Ltd., at Maryvale—pulpwood.

TOW TRUCK.

ENDRESS, E. (trading as St. Albans Towing Service), 29-31 St. Albans-road, St. Albans; 1 commercial goods vehicle (30 cwt.) to operate as a tow truck within a radius of 50 miles of the post office at St. Albans for the purpose of lifting and carrying or towing and/or repairing wrecked or disabled vehicles—tools of trade, spare parts and materials incidental thereto.

NOTICE is hereby given that the applications made by the persons named below for renewal of licences to operate the commercial goods vehicles on the route or routes, or in the manner set out opposite their names from the date of expiry as shown in each case, will be heard at a time and place to be communicated to the persons concerned:—

Name and Address; Nature of Application; Licence No.; Date of Expiry.

KELLAWAY, R. W. H., 12 Glen Iris-road, Camberwell; 1 commercial goods vehicle (8 cwt.) to operate throughout the State of Victoria—licensee's own wire baskets,

cycle and pram baskets and wire goods for exhibition purposes with the ability to make an urgent incidental delivery in the course of business as "manufacturers agent"; D.A.37130; 7th September, 1963.

LIFEGUARD MILK PRODUCTS PTY. LTD., 182 Main-street, Bacchus Marsh; 1 commercial goods vehicle (244 cwt.) to operate—(a) within a radius of 25 miles from the post office situate at the corner of Bourke and Elizabeth streets in the City of Melbourne, and to and from licensees' factory at Bacchus Marsh—goods the property of the licence holders in the course of business as "manufacturers of milk products", (b) from and to places situate within a radius of 25 miles from the chief post office in the City of Ballarat and to and from licensees' factory at Bacchus Marsh—fresh milk in cans and empty milk cans; D.A.1497; 20th June, 1963.

MILLER, W. A., Fern Tree Gully; 1 commercial goods vehicle (189 cwt.) to operate—(a) within a radius of 20 miles from the post office at Fern Tree Gully—general goods, (b) from and to places situate within the radius as defined in paragraph (a) above and to and from places situate within a radius of 50 miles of the aforesaid post office—livestock; D.A.11706; 26th September, 1963.

MCCRACKEN, A. L., 3 Errett-street, Horsham; 1 commercial goods vehicle (109 cwt.) to operate—(a) within a radius of 80 miles of the post office at Dimboola (Horsham Division of the Country Roads Board)—plant the property of a contractor and required for use in connexion with the construction or maintenance of some specific, existing or proposed road, street, footpath, bridge, wharf, pier, weir or channel, (b) within a radius of 20 miles from site of construction or maintenance work performed pursuant to paragraph (a) above, or from the railway station nearest thereto—metal, stones, screenings, ashes, gravel, sand, earth and any other materials required for such work—D.A.36440; 22nd June, 1963.

MCCULLOCH, W. C. & R. W. (trading as W. McCulloch & Son), Holly-street, Golden Square; 1 commercial goods vehicle (15 cwt.) to operate—(a) within a radius of 50 miles of own premises at Bendigo in the course of business as "machinery engineers"—own goods; (b) throughout the State of Victoria in the course of business as a "land grader manufacturer" from own workshop at Bendigo, to farmers and graziers—land-graders; T.D.A.2030; 24th October, 1963.

RAWLINGS, L. A. & R. E., Bruthen; 1 commercial goods vehicle (240 cwt.) to operate—(a) within a radius of 60 miles from the post office at Bruthen, and also within the whole of the area east of a line drawn north and south through the Township of Bruthen as far as the Victorian-New South Wales border—earth-moving and sawmilling equipment on behalf of other contractors, (b) within the area east of a line drawn north and south through the Township of Warragul—own earth-moving, saw-milling and primary production equipment and tools of trade; D.A.36807; 12th October, 1963.

ST. MARY'S CO-OPERATIVE SOCIETY LTD., Maryknoll, via Nar-Nar-Goon; 1 commercial goods vehicle (123 cwt.) to operate within a radius of 50 miles from the post office at Nar-Nar-Goon in the course of business as "builders, farmers, joinery manufacturers, builders' suppliers and general storekeepers"—own goods; D.A.2393; 11th October, 1963.

VOTTA, A., 20 Williams-road, Horsham; 1 commercial goods vehicle (approximately 140 cwt.) to operate—(a) within a radius of 80 miles from the post office at Dimboola (Horsham Division of the Country Roads Board)—plant the property of a contractor and required for use in connexion with the construction or maintenance of some specific, existing or proposed road, street, footpath, bridge, wharf, pier, weir or channel, (b) within a radius of 20 miles from site of construction or maintenance work performed pursuant to paragraph (a) above, or from the railway station nearest thereto—metal, stones, screenings, ashes, gravel, sand, earth and any other materials required for such work; D.A.36354; 22nd June, 1963.

WILLIAMS, T. H., PTY. LTD., 604 High-street, Golden Square; 1 commercial goods vehicle (100 cwt.) to operate within a radius of 50 miles from the post office at Golden Square in the course of business as "produce merchant"—own wheat, bran, pollard, oats and produce; D.A.22671; 17th October, 1963.

or in the manner set out opposite his name, will be held at a time and place to be communicated to the person concerned:—

Name; Present Franchise; Variation.

BAXTER, D. C., 1 Clarendon-avenue, Huntingdale; 1 commercial goods vehicle (147 cwt.) to operate—(a) within a radius of 25 miles from the post office situate at the corner of Bourke and Elizabeth streets in the City of Melbourne—general goods, (b) from Sheldon's sawmill at Pakenham to Whitelaw Monier Pty. Ltd.'s premises at Murrumbena—tile battens, (c) within a radius of 70 miles from the premises of Whitelaw Monier Pty. Ltd. at Murrumbena—tiles, battens and tile fixing materials on behalf of the said company; by deleting from paragraphs (b) and (c) "Murrumbena" and adding in lieu to paragraphs (b) and (c) "Springvale".

Notice of any objection should be forwarded to reach the Secretary of the Board not later than Wednesday, 21st August, 1963.

B. P. KAY,
Secretary.

Exhibition Buildings, Rathdowne-street, Carlton, N.3, 7th August, 1963.

Housing Act 1958.

NOTICE OF RESOLUTION UNDER SECTION 99 (4) OF ACT No. 6275.

NOTICE is hereby given that Housing Commission on the 29th day of July, 1963, resolved as follows:—
"Whereas Housing Commission in respect of the lands described in the Schedule hereto has published a general notice under sub-section (3) of section 99 of the Housing Act 1958, or has given notice to the parties interested under section 9 of the Lands Compensation Act 1958 as incorporated with the Housing Act 1958, Housing Commission hereby resolves that the lands described in the Schedule hereto are finally appropriated for the purposes of the Housing Act 1958."

SCHEDULE.

Firstly.—Crown Statements B, C and F, section 10, Parish of Castle Donnington.

Secondly.—All roads and reserves set out within an area, being part of Crown portions 34 and 35, Parish of Prahran, bounded on the north by Simmons-street, on the east by Surrey-road, on the south by Malvern-road and on the west by Bray-street and Grant-place.

Thirdly.—So much of a street known as Hereford-street, being part of Crown allotment 1, section H, Parish of Wodonga, as is shown hachured on the plan hereunder.

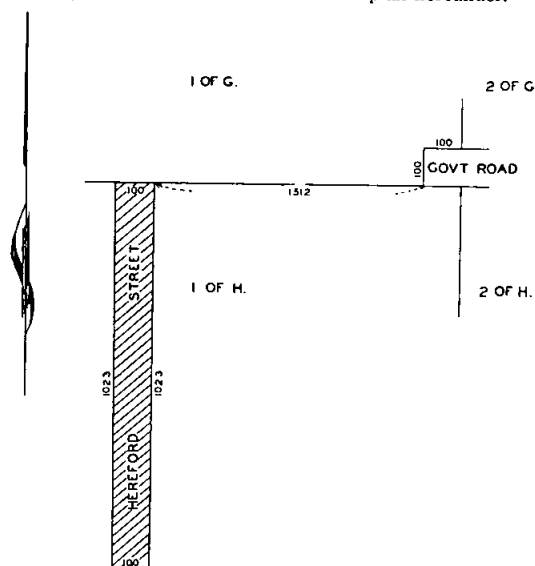

G. G. BOLWELL, Secretary.

NOTICE is hereby given that the application made by the person named below for renewal of licence with variation, licence No. D.A.28582, expiry date 1st October, 1963, to operate the commercial goods vehicle on the route

*Legal Profession Practice Act 1958.***SOLICITORS (AUDIT AND PRACTISING CERTIFICATES) RULES 1963.**

PURSUANT to section 88 of the *Legal Profession Practice Act 1958* and all other provisions in that behalf enabling, the Council of the Law Institute of Victoria doth hereby make the following Rules of the Institute (that is to say):—

Rules published in G.G. 16.6.60 as amended by rules published in G.G. 6.1.61 and G.G. 18.7.62.

1. These Rules may be cited as the Solicitors (Audit and Practising Certificates) Rules 1963 and shall be read and construed with the Solicitors (Audit and Practising Certificates) Rules 1960 and all other Rules amending the same, all of which Rules and these Rules may be cited as the Solicitors (Audit and Practising Certificates) Rules.

2. These Rules shall come into operation on the fifteenth day of August, 1963.

3. Rule 16 is amended—

(a) by inserting the following sub-rule after sub-rule (1) thereof:—

“(1A) For the purpose of making the general test examination referred to in paragraphs (a) and (c) of the last preceding sub-rule, the auditor shall be entitled to examine such number of dealings representative of every phase of the solicitor’s practice as the auditor shall in the circumstances consider reasonable.”;

(b) by inserting the following sub-rule after sub-rule (2) thereof:—

“(2A) The auditor shall report to the Council any deficiency in the trust bank accounts of the solicitor or any substantial illegality or irregularity in relation to his trust accounts as soon as is practicable after the auditor becomes aware of or has reasonable grounds for suspecting the existence thereof.”

4. The following rule is inserted after Rule 29:—

“29A. The register of negotiable securities shall form part of the solicitor’s trust accounts within the meaning of Rule 16 hereof and shall be subject to audit accordingly.”

5. Rule 32 is amended by adding at the end thereof the following words:—

“The solicitor shall not later than the 31st day of October in each year lodge with the Secretary a true copy of the reconciliation statement so kept by him for the month of June in that year duly signed by the solicitor and certified as a true copy by his auditor”.

6. The following rule is inserted after Rule 32A:—

“32B. (1) Every solicitor shall not later than the 31st day of October in each year lodge with the Secretary a statement in writing showing the amount standing to the credit of each account in the solicitor’s trust ledger at the preceding 30th day of June and the total of such amounts together with the name of the person on whose behalf each such amount is respectively held.

(2) Such statement shall be signed by the solicitor and shall be certified as correct by his auditor.

(3) It shall be sufficient compliance with this Rule if, instead of containing the names of the several persons on whose behalf the moneys are held, such persons are clearly identified by reference to the relevant number of the account in the trust ledger or some other easily identifiable symbol.”

Signed for and on behalf of the Council of the Law Institute of Victoria this eleventh day of July, 1963—

P. C. TRUMBLE, President.
ARTHUR HEYMANSON, Secretary.

I approve the above Rules.

Dated this seventeenth day of July, 1963.

E. F. HERRING, Chief Justice.

SHIRE OF WALPEUP.
ROAD DEVIATION ORDER.

PURSUANT to the provisions of sections 522 and 526 of the Local Government Act 1958, the Council of the Shire of Walpeup hereby directs that the land in the Parish of Timberoo, indicated by hatching on the plan hereunder, which has been purchased, taken or acquired by it, shall be a public highway on and from the date of publication of this Order in the Government Gazette, and declares that such land shall be a public highway in lieu of the land indicated by cross-hatching on the said plan.

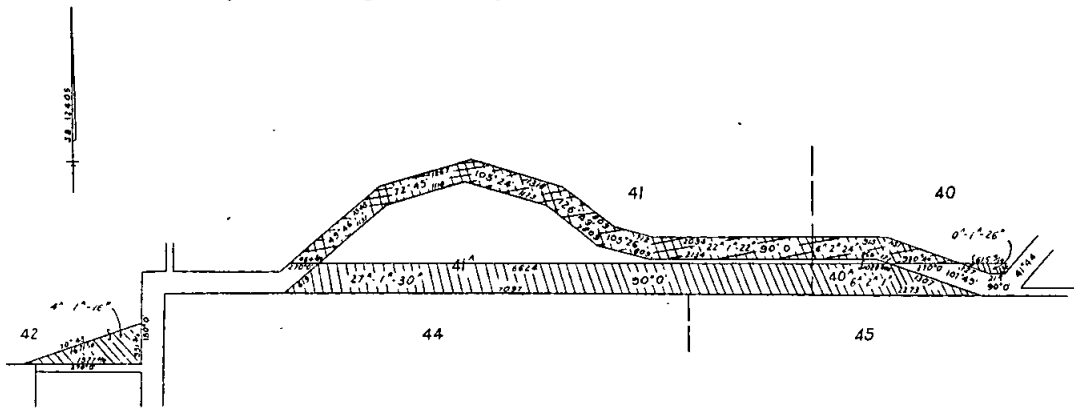

The measurements are in feet

The common seal of the President, Councillors and Ratepayers of the Shire of Walpeup was hereunto affixed this 11th day of April, 1963, in the presence of—

(SEAL)

J. T. LEWIS, President.
L. L. MURPHY, Councillor.
J. W. BALES, Secretary.

Approved by the Governor in Council, 30th July, 1963.—N. G. WISHART, Clerk of the Executive Council.

MONEY LENDERS ACT 1958.

In accordance with the provisions of the above-mentioned Act the following is published for general information.

List of persons to whom Money Lenders' Licences have been issued for the year ended 30th June, 1963.

Name.	Authorized Name.	Authorized Address.	Date of Issue.
*Dresdon Credits Pty. Ltd., (E. Cooper-smith, appointee)	Dresdon Credits Pty. Ltd.	132-134 Gardenvale-road, Garden-vale	25.6.63
Esanda Limited (E. K. Robertson, appointee)	Esanda Limited	588 Station-street, Box Hill ..	7.5.63
Esanda Limited (E. K. Robertson, appointee)	Esanda Limited	13-15 Pultney-street, Dandenong	21.6.63
Esanda Limited (E. K. Robertson, appointee)	Esanda Limited	324 Glenhuntly-road, Elsternwick	25.6.63
Esanda Limited (E. K. Robertson, appointee)	Esanda Limited	9-11 Malop-street, Geelong ..	29.5.63
†Fulton, William Kefford	William Kefford Fulton	377 Johnston-street, Abbotsford ..	27.6.63
†McVitty, Alexander Edwin	Alexander Edwin McVitty	c/o David Bristol, solicitor, 583 Hampton-street, Hampton	7.5.63
Newbay Credit & Investments Pty. Ltd. (J. Fishelson, appointee)	Newbay Credit & Investments Pty. Ltd.	59 Scotchmer-street, North Fitzroy	20.3.63
*Regent Insurance Ltd. (T. Cook, appointee)	Regent Insurance Ltd.	277 William-street, Melbourne ..	4.6.63
*Reid Murray Acceptance Ltd. (B. Hay, appointee)	Reid Murray Acceptance Ltd. ..	58 The Mall, West Heidelberg ..	17.6.63
*Reid Murray Acceptance Ltd. (B. Hay, appointee)	Reid Murray Acceptance Ltd. ..	13 Ferguson-street, Williamstown	18.6.63
*Reid Murray Acceptance Ltd. (B. Hay, appointee)	Reid Murray Acceptance Ltd. ..	302 Wyndham-street, Shepparton	17.6.63
*V. L. Credits Pty. Ltd. (K. M. Malouf, appointee)	V. L. Credits Pty. Ltd.	490 Elizabeth-street, Melbourne ..	4.6.63

State Treasury,
Melbourne, C.2, 30th July, 1963.

* Transfer of Appointee. † New Authorized Address.

W. WATTS,
Registrar.

Water Acts.
STATE RIVERS AND WATER SUPPLY COMMISSION.
NYAH WEST URBAN DISTRICT.

NOTICE to owners of tenements in the under-mentioned street in the Nyah West Urban District and the private streets, lanes, courts and alleys opening thereto:—
Station-street, from end of existing main (opposite allotment 121), about 2 chains south-easterly to a point about 1 chain north-westerly from Elizabeth-street.

The main pipe in the said street being laid down, the owners of all tenements situated as above are hereby required, on or before the 1st day of October next, to cause proper pipes and stop cocks to be laid, so as to supply water within such tenements from the main pipe.

A. H. RIGG, Secretary,
State Rivers and Water Supply Commission.
Melbourne, 2nd August, 1963.

Water Acts.

STATE RIVERS AND WATER SUPPLY COMMISSION.

CRANBOURNE URBAN DISTRICT.

NOTICE to owners of tenements in the under-mentioned streets in the Cranbourne Urban District and the private streets, lanes, courts and alleys opening thereto:—

Cranbourne Urban District.

Bakewell-street, from Codrington-street to a point opposite allotment 5, section 14, about 3½ chains easterly from Russell-street.
 Childers-street, from Russell-street to a point opposite lot 14, about 6½ chains easterly.
 Clarendon-street, from end of existing main (opposite lot 24) to a point opposite lot 11, about 2½ chains westerly from Harry-street.
 Codrington-street, from Lyaal-street to Bakewell-street, and from Childers-street to Sladen-street.
 Cranbourne-drive, from end of existing main (opposite lot 464) to a point opposite lot 79, about 2 chains westerly from McLaren-avenue.
 Dearing-street, from McLaren-avenue to a point opposite lot 634, about 7½ chains westerly.
 Duff-street, from end of existing main (about 11 chains west of High-street) to Tucker-street.
 Greaves-street.
 Lamb-street.
 Lyaal-street, from end of existing main (opposite allotment 7, section 9) to a point opposite lot 8, about ¼ chain westerly from Narre Warren-road.
 McLaren-avenue, from Clarendon-street to Dearing-street, and from Cranbourne-drive to a point opposite lot 415, about 1 chain northerly from Ash-street.
 Mundaring-drive, from end of existing main (opposite lot 35) to Clarendon-street.
 Scott-street, from end of existing main (opposite lot 1) to Sladen-street.
 Sladen-street, from Russell-street to a point opposite lot 10, about ½ chain westerly from Narre Warren-road.
 Tucker-street, from Duff-street to William-street.

The main pipe in the said streets being laid down, the owners of all tenements situated as above are hereby required, on or before the 1st day of October next, to cause proper pipes and stop-cocks to be laid, so as to supply water within such tenements from the main pipe.

A. H. RIGG, Secretary,
 State Rivers and Water Supply Commission.

Melbourne, 2nd August, 1963.

Water Acts.

STATE RIVERS AND WATER SUPPLY COMMISSION.

FRANKSTON-MORNINGTON URBAN DISTRICT.

NOTICE to owners of tenements in the under-mentioned streets in the Frankston-Mornington Urban District and the private streets, lanes, courts and alleys opening thereto:—

Frankston.

Chile-street.
 Coolgardie-street.
 Corsican-street.
 Forest-drive, from end of existing main (opposite lot 555) to Monterey Boulevard.
 Hickory-crescent.
 Lindsay-street.
 Longleaf-street.
 Manna-court.
 Monterey Boulevard, from Frankston-Dandenong road to Radiata-street.
 Moreton-street.
 Norfolk-crescent.
 Radiata-street.
 Stone-street.

Mt. Martha.

Ernest-street, from Taylor-crescent to Victoria-crescent.
 Victoria-crescent, from end of existing main (opposite lot 14) to Ernest-street.

The main pipe in the said streets being laid down, the owners of all tenements situated as above are hereby required, on or before the 1st day of October next, to cause proper pipes and stop-cocks to be laid, so as to supply water within such tenements from the main pipe.

A. H. RIGG, Secretary,
 State Rivers and Water Supply Commission.
 Melbourne, 2nd August, 1963.

Water Acts.

STATE RIVERS AND WATER SUPPLY COMMISSION.

QUEENSLIFF-POINT LONSDALE URBAN DISTRICT.

NOTICE to owners of tenements in the under-mentioned street in the Queenscliff-Point Lonsdale Urban District and the private streets, lanes, courts and alleys opening thereto:—

Point Lonsdale.

Ward-road, from end of existing main (opposite allotment 37) to a point opposite lot 68, about ½ chain south-westerly from Murray-road.

The main pipe in the said street being laid down, the owners of all tenements situated as above are hereby required, on or before the 1st day of October next, to cause proper pipes and stop-cocks to be laid, so as to supply water within such tenements from the main pipe.

A. H. RIGG, Secretary,
 State Rivers and Water Supply Commission.

Melbourne, 2nd August, 1963.

Water Acts.

STATE RIVERS AND WATER SUPPLY COMMISSION.

URBAN DISTRICT SUPPLIED WITH WATER FROM THE COLIBAN SYSTEM OF WATERWORKS.

NOTICE to owners of tenements in the under-mentioned streets in the urban district supplied with water from the Coliban System of Waterworks, and the private streets, lanes, courts and alleys opening thereto:—

Bendigo.

Benghasi-avenue.
 Derna-court.
 Cook-street, from end of existing main (opposite lot 7) to a point opposite lot 11, about 3½ chains easterly.
 Cottle-street, from Belle Vue-road generally south-westerly to a point about 14 chains north-easterly from Wood-ward-road.
 Grace-street, from end of existing main (opposite lot 1) to a point opposite lot 9, about 5½ chains north-westerly from Montgomery-crescent.
 Park-street.
 Putnam-avenue, from end of existing main (opposite lot 27) to a point opposite lot 39, about 1½ chains generally south-easterly from Park-street.
 Taylor-street, from Reeve-street to a point opposite lot 8, about 6½ chains generally north-westerly.
 Towers-street.

Kangaroo Flat.

Alder-street, from end of existing main (opposite lot 3 on lodged plan of subdivision No. 22270) to a point opposite lot 4, about 1½ chains easterly from Broad-court.
 Danson-avenue, from end of existing main (opposite lot 8) to a point opposite lot 11, about ½ chain southerly from Baslar-court.

The main pipe in the said streets being laid down, the owners of all tenements situated as above are hereby required, on or before the 1st day of October next, to cause proper pipes and stop-cocks to be laid, so as to supply water within such tenements from the main pipe.

A. H. RIGG, Secretary,
 State Rivers and Water Supply Commission.

Melbourne, 2nd August, 1963.

Water Acts.

STATE RIVERS AND WATER SUPPLY COMMISSION.

URBAN DISTRICT SUPPLIED WITH WATER FROM THE COLIBAN SYSTEM OF WATERWORKS.

NOTICE to owners of the under-mentioned tenements in the urban district supplied with water from the Coliban System of Waterworks:—
 Baslar-court, lots 17 and 18.

The main pipe being laid down for the supply of water to the above-mentioned tenements, the owners thereof are hereby required, on or before the 1st day of October next, to cause proper pipes and stop-cocks to be laid, so as to supply water within such tenements from the main pipe.

A. H. RIGG, Secretary,
 State Rivers and Water Supply Commission.

Melbourne, 2nd August, 1963.

CONTRACTS ACCEPTED.—(Series 1963-64.)

Contract No.	Particulars.	Amount.	Name of Contractor.	Charge against Vote or Fund.
GOVERNMENT PRINTER.				
	Supply and delivery of Printing Paper, Writing Paper, &c., required by the Government Printer for the year 1963-64.			
512	Schedule No. 1.—Printing Paper, Writing Paper, &c.	Rates as per annex	Australian Paper Manufacturers Ltd.	} General Expenses, 1963-64.
513	" " " "	"	B. J. Ball Ltd.	
514	" " " "	"	Besley and Pike Pty. Ltd.	
515	" " " "	"	E. C. Blackwood Pty. Ltd.	
516	" " " "	"	Bowater Paper Co. Pty. Ltd.	
517	" " " "	"	Brella Pty. Ltd.	
518	" " " "	"	Alex Cowan (Australia) Pty. Ltd.	
519	" " " "	"	Edwards Dunlop and Co. Ltd.	
520	" " " "	"	S. L. Middleton and Co. . .	
521	" " " "	"	R. C. Paterson and Co. Pty. Ltd.	
522	" " " "	"	Sands and McDougall Pty. Ltd.	
523	" " " "	"	R. B. Shankley Pty. Ltd.	
524	" " " "	"	Spicers (Australia) Pty. Ltd.	
525	" " " "	"	L. A. Wade Pty. Ltd. . .	
526	" " " "	"	Wiggins, Teape (Victoria) Pty. Ltd.	
527	" " " "	"	Wiggins, Teape, Shoalhaven Pty. Ltd.	
528	" " " "	"	Max Wurcker Pty. Ltd. . .	

Approved—H. E. Bolte, Treasurer. 10th July, 1963.

ANNEX TO CONTRACTS NOS. 1963/000 TO 1964/000.

Schedule No. 1.

PRINTING PAPER, WRITING PAPER, ETC.

- 1963/512.—*Australian Paper Manufacturers Ltd. (A).*
- 1963/513.—*B. J. Ball Ltd. Security, £1,000.*
- 1963/514.—*Besley and Pike Pty. Ltd. Security, £50.*
- 1963/515.—*E. C. Blackwood Pty. Ltd. Security, £25.*
- 1963/516.—*Bowater Paper Co. Pty. Ltd. Security, £800.*
- 1963/517.—*Brella Pty. Ltd. Security, £40.*
- 1963/518.—*Alex Cowan (Australia) Pty. Ltd. Security, £800.*
- 1963/519.—*Edwards Dunlop and Co. Ltd. Security, £1,000.*
- 1963/520.—*S. L. Middleton and Co. Security, £30.*
- 1963/521.—*R. C. Paterson and Co. Pty. Ltd. Security, £30.*
- 1963/522.—*Sands and McDougall Pty. Ltd. Security, £50.*
- 1963/523.—*R. B. Shankley Pty. Ltd. Security, £75.*
- 1963/524.—*Spicers (Australia) Pty. Ltd. Security, £1,000.*
- 1963/525.—*L. A. Wade Pty. Ltd. Security, £800.*
- 1963/526.—*Wiggins, Teape (Victoria) Pty. Ltd. Security, £1,500.*
- 1963/527.—*Wiggins, Teape, Shoalhaven Pty. Ltd. Security, £300.*
- 1963/528.—*Max Wurcker Pty. Ltd. Security, £75.*

ADJUSTMENT OF CONTRACT RATES.

All rates are subject to adjustment in accordance with the special conditions of the respective contracts. Notification of such adjustments will be published in the *Government Gazette* as required. Contracts for a number of items are subject to special conditions regarding availability of supplies, delivery dates, &c.

AGREEMENTS.

Where the name of the supplier opposite any item is shown in italics, with the sign (A), no contract has been executed nor security lodged; requirements of such items are to be purchased from the supplier named, under Tender Board Agreement.

B. British. C. Commonwealth. F. Foreign.

Item No.	Description.	Quantity.	Rate.	Country of Origin.	Name of Contractor.
WHITE M.F. PRINTING PAPER.					
			f s. d.		
			per ream		
1	Quadruple Foolscap, 35 lb.	3,000 reams	2 15 5	C.	} B. J. Ball Ltd.
4	Double Royal, 38 lb.	3,000 "	3 0 2	C.	
8	33 in. x 44 in., 65½ lb., h.s.	800 "	4 19 3	C.	
9	26½ in. x 40 in., 53 lb. (s/o Quadruple Crown, 60 lb.), h.s.	400 "	4 0 7	C.	

CONTRACTS ACCEPTED—continued.

Item No.	Description.	Quantity.	Rate.	Country of Origin.	Name of Contractor.
PURE WHITE SULPHITE OFFSET PRINTING PAPER.					
			£ s. d.		
			per ream.		
30	Double Medium, 62 lb., 23 in. x 36 in.	500 reams	4 18 10	C.	} Wiggins, Teape, Shoalhaven Pty. Ltd. Bowater Paper Co. Pty. Ltd. Wiggins, Teape, Shoalhaven Pty. Ltd.
31	Double Medium, 80 lb., 23 in. x 36 in.	500 "	6 7 6	C.	
32	Quad Crown, 90 lb., 30 in. x 40 in.	500 "	7 3 5	C.	
33	60½ lb., 29½ in. x 43½ in., guillotine trimmed	1,000 "	5 11 3	C.	
34	81½ lb., 35 in. x 45 in., guillotine trimmed	3,000 "	6 16 3	C.	
35	Quadruple Crown, 116 lb., 30 in. x 40 in.	400 "	9 4 11	C.	
M.G. (LITHO.) PAPER.					
			£		
			per ton.		
38	Quad Crown, 54 lb., 30 in. x 40 in.	50 "	178	C.	Edwards Dunlop and Co. Ltd.
SUPER-CALENDERED PAPER.					
			£ s. d.		
			per ream.		
43	Quad Foolscap, 55 lb.	200 "	4 3 8	C.	} Bowater Paper Co. Pty. Ltd. Alex Cowan (Aus- tralia) Pty. Ltd.
44	Double Demy, 48 lb.	1,200 "	3 13 0	C.	
45	Double Royal, 60 lb.	1,500 "	4 11 3	C.	
46	Quadruple Crown, 72 lb.	1,000 "	5 9 6	C.	
49	Reels, 39 in., s/o Quadruple Crown, 72 lb.	500 reels.	0 1 5.25	C.	
SUPERFINE ART PAPER.					
			per ream.		
56	Double Medium, 56 lb.	100 reams	6 6 0	C.	} Spicers (Australia) Pty. Ltd. Edwards Dunlop and Co. Ltd. L. A. Wade Pty. Ltd.
57	Double Medium, 70 lb.	250 "	7 17 6	C.	
58	Double Medium, 80 lb.	50 "	9 0 0	C.	
59	Double Royal, 70 lb.	100 "	7 17 6	C.	
60	Quadruple Crown, 84 lb.	400 "	9 9 0	C.	
WHITE WOVE BANK.					
			per ream.		
68	Double Medium, 26 lb.	500 "	2 0 1	C.	} Alex Cowan (Aus- tralia) Pty. Ltd.
69	Quad Foolscap, 20 lb.	400 "	1 14 7	C.	
70	Quadruple Foolscap, 29 lb.	2,000 "	2 4 9	C.	
COLOURED BANK PAPER.					
			per ream.		
75	Pink Quadruple Foolscap, 29 lb.	400 "	2 8 4	C.	} Edwards Dunlop and Co. Ltd. Bowater Paper Co. Pty. Ltd. Edwards Dunlop and Co. Ltd.
77	Blue Quad Foolscap, 29 lb.	100 "	2 8 4	C.	
78	Old Gold Quadruple Foolscap, 29 lb.	750 "	2 10 5	C.	
79	Buff Quadruple Foolscap, 29 lb.	100 "	2 8 4	C.	
80	Green Quadruple Foolscap, 29 lb.	1,500 "	2 8 4	C.	
94	Old Gold, 22 lb.	100 "	1 18 3	C.	
95	Buff, 22 lb.	100 "	1 18 3	C.	
WHITE WOVE WRITING PAPER.					
			per ream.		
100	Quadruple Foolscap, 48 lb.	3,000 "	3 12 6	C.	} Edwards Dunlop and Co. Ltd. Alex Cowan (Aus- tralia) Pty. Ltd. Edwards Dunlop and Co. Ltd.
101	Double Large Post, 48 lb.	300 "	3 12 6	C.	
102	Double Large Post, 36 lb.	1,200 "	2 14 5	C.	
103	Quadruple Foolscap, 48 lb., ruled feint blue lines	1,000 "	4 3 4	C.	
104	Double Large Post, 36 lb., Envelope White Wove	2,500 "	2 18 6	C.	
BLUE WOVE WRITING PAPER.					
			per ream.		
109	Quadruple Foolscap, 44 lb.	2,500 "	3 10 7	C.	} Edwards Dunlop and Co. Ltd.
111	Double Large Post, 33 lb.	250 "	2 12 11	C.	
BOND WRITING PAPER—WHITE WOVE—SURFACE SIZED—NOT WATERMARKED.					
			per ream.		
120	Quadruple Foolscap, 48 lb.	5,000 "	3 14 0	C.	} Spicers (Australia) Pty. Ltd. Edwards Dunlop and Co. Ltd.
121	Double Large Post, 36 lb.	1,000 "	2 15 6	C.	
122	Double Medium, 43 lb.	2,000 "	3 6 4	C.	

CONTRACTS ACCEPTED—continued.

Item No.	Description.	Quantity.	Rate.	Country of Origin.	Name of Contractor.
BOND WRITING PAPER—TINTED.					
			£ s. d.		
			per ream.		
135	Old Gold Quad Foolscap, 48 lb.	200 reams	4 3 6	C.	} Spicers (Australia) Pty. Ltd. Bowater Paper Co. Pty. Ltd.
136	Pink Quad Foolscap, 48 lb.	500 "	4 0 0	C.	
137	Green Quadruple Foolscap, 48 lb.	500 "	4 0 0	C.	
139	Canary Quad Foolscap, 48 lb.	200 "	4 0 0	C.	
140	Blue Quadruple Foolscap, 48 lb.	100 "	4 0 0	C.	} L. A. Wade Pty. Ltd.
141	Buff Quadruple Foolscap, 48 lb.	100 "	4 0 0	C.	
145	Pink Double Large Post, 36 lb.	50 "	3 0 0	C.	
146	Green Double Large Post, 36 lb.	100 "	3 0 0	C.	
148	Canary Double Large Post, 36 lb.	100 "	3 0 0	C.	
150	Buff Double Large Post, 36 lb.	200 "	3 0 0	C.	
158	Canary Double Medium, 43 lb.	50 "	3 11 8	C.	
LEDGER PAPER.					
			per lb.		
165	Super Royal, 54 lb.	100 "	0 3 0-375	C.	} Wiggins, Teape (Vic- toria) Pty. Ltd.
167	Double Medium, 68 lb.	200 "	0 3 0-375	C.	
168	Double Demy, 48 lb.	300 "	0 3 0-375	C.	
169	Quadruple Foolscap, 60 lb.	500 "	0 3 0-375	C.	
LOAN - PAPER.					
			per ream.		
188	Double Foolscap, 20 lb.	150 "	12 0 10	B.	Wiggins, Teape (Vic- toria) Pty. Ltd.
DEEDS PARCHMENT PAPER.					
195	Cream Wove White Parchment Paper, 133 lb., 27 in. x 34 in.	50 "	40 11 10	C.	} Wiggins, Teape (Vic- toria) Pty. Ltd.
196	Snow White Parchment Paper, 98 lb., 27 in. x 34 in.	50 "	29 18 3	B.	
GUMMED PAPER.					
			per ream.		
207	White Double Medium	50 "	6 17 1	C.	Spicers (Australia) Pty. Ltd.
			per lb.		
DUPLICATING PAPER.					
212	Quadruple Foolscap, 44 lb.	1,000 "	3 10 2	C.	} Spicers (Australia) Pty. Ltd.
213	Double Large Post, 33 lb.	500 "	2 12 7	C.	
COVER PAPER.					
			per ton.		
219	Wedgewood Blue, 20½ in. x 30½ in., 60 lb.	200 "	185 0 0	C.	} Australian Paper Manufacturers Ltd. (A).
220	Green, 20½ in. x 30½ in., 60 lb.	50 "	185 0 0	C.	
221	Dove Grey, 20½ in. x 30½ in., 60 lb.	400 "	185 0 0	C.	
223	Cream, 20½ in. x 30½ in., 60 lb.	50 "	185 0 0	C.	
BUFF MANILA PAPER.					
263	Quadruple Crown, 240 lb. Short Grain	200 "	168 0 0	C.	} Spicers (Australia) Pty. Ltd.
264	Double Crown, 120 lb., Long Grain	500 "	168 0 0	C.	
CHIPBOARDS.					
279	Single White Lined, 23 in. x 30 in., .014 Long Grain	20,000 boards	131 0 0	C.	Australian Paper Manufacturers Ltd. (A).

CONTRACTS ACCEPTED—continued.

Item No.	Description.	Quantity.	Rate.	Country of Origin.	Name of Contractor.
PASTEBOARDS.					
			£ s. d.		
			per lb.		
297	Betting Ticket Board, 25 in. x 40 in., .010 in.	120,000 boards	0 1 9.75 plus 1½%	C.	B. J. Ball Ltd. Bowater Paper Co. Pty. Ltd. L. A. Wade Pty. Ltd.
MACHINE POSTING LEDGER.					
301	Buff, 25½ in. x 30½ in., 82 lb.	50 reams	0 2 4.44	C.	} Wiggins, Teape (Victoria) Pty. Ltd.
302	White, 23 in. x 36 in., 90 lb.	100 ..	0 2 3.931	C.	
SYSTEM BOARDS.					
			per 100 boards		
316	Salmon, 25½ in. x 30½ in., 6-sheet	2,000 boards	4 0 5½	C.	} Wiggins, Teape, Shoalhaven Pty. Ltd.
317	Buff, 25½ in. x 30½ in., 6-sheet	10,000 "	4 0 5½	C.	
327	Salmon, 25½ in. x 30½ in., 4-sheet	10,000 "	2 11 2½	C.	
328	Buff, 25½ in. x 30½ in., 4-sheet	100,000 "	2 11 2½	C.	
329	Blue, 25½ in. x 30½ in., 4-sheet	5,000 "	2 11 2½	C.	
330	Green, 25½ in. x 30½ in., 4-sheet	40,000 "	2 11 2½	C.	
333	Yellow, 25½ in. x 30½ in., 4-sheet	10,000 "	2 11 2½	C.	
334	White, 25½ in. x 30½ in., 4-sheet	200,000 "	2 9 8½	C.	
337	Salmon, 25½ in. x 30½ in., 3-sheet	5,000 "	2 0 2½	C.	
338	Buff, 25½ in. x 30½ in., 3-sheet	40,000 "	2 0 2½	C.	
339	Blue, 25½ in. x 30½ in., 3-sheet	25,000 "	2 0 2½	C.	
340	Green, 25½ in. x 30½ in., 3-sheet	25,000 "	2 0 2½	C.	
351	White, 27 in. x 34 in., 3-sheet, 26 lb.	10,000 "	2 6 2	C.	
STRAWBOARDS.					
			per ton.		
402	12-oz., 22½ in. x 32 in.	120 ¼-cwt. bundles	81 0 0	C.	} Australian Paper Manufacturers Ltd. (A).
404	20-oz., 22½ in. x 32 in.	80 "	96 0 0	C.	
405	24-oz., 22½ in. x 32 in.	120 "	91 0 0	C.	
406	32-oz., 22½ in. x 32 in.	120 "	91 0 0	C.	
407	64-oz., 22½ in. x 32 in.	80 "	111 0 0	C.	
410	16-oz., 21½ in. x 28½ in.	80 "	86 0 0	C.	
417	16-oz., 20½ in. x 27 in.	120 "	81 0 0	C.	
420	32-oz., 20½ in. x 27 in.	120 "	91 0 0	C.	
423	12-oz., 18½ in. x 23½ in.	120 "	84 0 0	C.	
424	16-oz., 18½ in. x 23½ in.	80 "	89 0 0	C.	
426	24-oz., 18½ in. x 23½ in.	200 "	91 0 0	C.	
427	32-oz., 18½ in. x 23½ in.	120 "	91 0 0	C.	
431	16-oz., 20 in. x 30 in.	120 "	81 0 0	C.	
432	20-oz., 20 in. x 30 in.	80 "	96 0 0	C.	
434	32-oz., 20 in. x 30 in.	80 "	98 0 0	C.	
438	16-oz., 18 in. x 27 in.	160 "	84 0 0	C.	
441	32-oz., 18 in. x 27 in.	80 "	96 0 0	C.	
BOOKBINDERS' CLOTH.					
			per yard.		
460	Red, 36 in. x 36 yd. rolls	24 rolls	0 2 11½	C.	} Brella Pty. Ltd.
461	Green, 36 in. x 36 yd. rolls	24 "	0 2 11½	C.	
462	Brown, 36 in. x 36 yd. rolls	24 "	0 2 11½	C.	
464	Light Blue, 36 in. x 36 yd. rolls	24 "	0 2 11½	C.	
BOOKBINDERS' CANVAS.					
			per sheet.		
472A	Grey, 40 in. x 41 in.	7,000 sheets	0 3 7½	C.	} Brella Pty. Ltd.
474	White, 40 in. x 41 in.	7,000 "	0 3 7½	C.	
BOOKBINDERS' LEATHER—FLAT FINISH.					
			s.f.		
481	Basil Red	72 skins	0 2 6	C.	} S. L. Middleton and Co.
484	Basil Blue	24 "	0 2 6	C.	
485	Sheep, Rough	300 "	0 2 0	C.	
486	Sheep, Smooth	24 "	0 2 0	C.	
487	Roan, Red, Straight Grained	120 "	0 2 0	C.	
488	Roan, Brown, Straight Grained	144 "	0 2 0	C.	
489	Roan, Green, Straight Grained	144 "	0 2 0	C.	
490	Roan, Blue, Straight Grained	144 "	0 2 0	C.	
491	Roan, Black, Straight Grained	96 "	0 2 0	C.	
492	Roan, Maroon, Straight Grained	96 "	0 2 0	C.	

CONTRACTS ACCEPTED—continued.

Item No.	Description.	Quantity.	Rate.	Country of Origin.	Name of Contractor.
ENVELOPES.					
S7	5½ in. x 3½ in., Manilla Pocket	500,000	£ s. d. per 1,000. 0 18 6	C.	Besley and Pike Pty. Ltd.
S11	3½ in. x 5½ in., Window Face, Banker's	1,500,000	1 2 3	C.	Sands and McDougall Pty. Ltd.
S21	3½ in. x 6½ in., Window Face, Banker's	1,000,000	1 4 5	C.	
S25	7 in. x 5 in., Pocket Manilla	250,000	1 11 9	C.	
S36	4 in. x 9 in., Banker's Gummed	1,000,000	1 6 9	C.	
S39	4 in. x 9 in., Window Face	1,000,000	1 17 9	C.	
S44	9 in. x 6 in., Manilla Pocket Gummed	250,000	2 6 6	C.	Besley and Pike Pty. Ltd.
S49	Demy 10½ in. x 4½ in., Manilla Pocket Gummed	500,000	1 14 2½	C.	R. B. Shankley Pty. Ltd.
S55	10½ in. x 7½ in., Pocket Manilla	500,000	3 0 5	C.	Sands and McDougall Pty. Ltd.
S56	10½ in. x 8½ in., Pocket Manilla	500,000	3 9 6	C.	Besley and Pike Pty. Ltd.
S58	12 in. x 6 in., Kraft Brown Pocket	100,000	2 17 0	C.	Spicers (Australia) Pty. Ltd.
S60	14½ in. x 9½ in., Pocket Gummed	500,000	5 11 3	C.	Alex Cowan (Australia) Pty. Ltd.
S61	15 in. x 6 in., Kraft Brown Pocket	100,000	4 13 0	C.	Sands and McDougall Pty. Ltd.
S62	15 in. x 11 in., Kraft Brown Pocket	100,000	7 13 0	C.	Alex Cowan (Australia) Pty. Ltd.
S63	16 in. x 11 in., Kraft Brown Pocket	100,000	9 12 6	C.	Besley and Pike Pty. Ltd.
BLOTTING PAPER.					
S77	White Demy, 38 lb.	1,000 reams	per lb. 0 1 7-5	C.	Wiggins, Teape (Victoria) Pty. Ltd.
BROWN PAPER.					
S82	Kraft, 63 lb., 30 in. x 45 in.	100 "	per ton. 165 0 0	C.	E. C. Blackwood Pty. Ltd.
S83	Kraft, 83 lb., 30 in. x 45 in.	100 "	165 0 0	C.	
S84	Kraft, 166 lb., 45 in. x 60 in., Folded	100 "	163 0 0	C.	
TISSUE PAPER.					
S100	Double Crown White, 7 lb., 20 in. x 30 in.	100 "	per ream 0 2 5-083	F.	Wiggins Teape (Victoria) Pty. Ltd.
GREASEPROOF PAPER.					
S102	18 in. x 28 in, s/o D.C.-13½ lb.	500 "	0 19 9		Spicers (Australia) Pty. Ltd.
WHITE H.S. DUPLICATING PAPER.					
S110	Foolscap, 8½ in. x 13½ in.	100,000 "	0 8 10	C.	L. A. Wade Pty. Ltd.
S111	Quarto, 8½ in. x 10½ in.	25,000 "	0 7 0½	C.	B. J. Ball Ltd.
WHITE WOVE WRITING.					
S122	Foolscap	30,000 "	0 9 1½	C.	B. J. Ball Ltd.
S123	Quarto	5,000 "	0 7 3½	C.	Bowater Paper Co. Pty. Ltd.
SURFACE SIZED WHITE-BOND.					
S125	Foolscap	5,000 "	0 9 4½	C.	Spicers (Australia) Pty. Ltd.
WHITE BANK.					
S129	Foolscap	25,000 "	0 5 11	C.	Bowater Paper Co. Pty. Ltd.
S.131	Quarto	10,000 "	0 4 9	C.	Spicers (Australia) Pty. Ltd.

CONTRACTS ACCEPTED—continued.

Item No.	Description.	Quantity.	Rate.	Country of Origin.	Name of Contractor.
COLOURED BANK.					
S136	Pink Foolscap	5,000 reams	£ s. d. per ream 0 6 3½	C.	Alex Cowan (Aust.) Pty. Ltd.
S137	Old Gold	3,000 "	0 6 6½	C.	} Spicers (Australia) Pty. Ltd.
S139	Blue	1,000 "	0 6 3½	C.	
S140	Pink Quarto, 8¼ in. x 10¼ in.	2,000 "	0 5 1½	C.	
DRAWING PAPER					
S352	15 in. x 22 in.	2,000 "	2 9 5	C.	Bowater Paper Co. Pty. Ltd.
S353	11 in. x 15 in.	5,000 "	1 4 9½	C.	} Spicers (Australia) Pty. Ltd.
S354	7¼ in. x 11 in.	5,000 "	0 12 11	C.	
MANILLA TAGS.					
S71	1 N (in gangs of 4)	50,000	per 1000 0 6 5	C.	} B. J. Ball Ltd.
S72	2 N	50,000	0 7 9	C.	
S73	3 N	50,000	0 8 6	C.	
S74	4 N	50,000	0 9 9	C.	
S75	5 N	250,000	0 11 0	C.	
S76	6 N	100,000	0 13 3	C.	
S77	7 N	100,000	0 15 0	C.	
TRACING PAPER.					
S184	30 in. rolls of 50 yards, Heavyweight	250 rolls	per roll 2 6 3 less 2½ per cent. 30 days	C.	{ Max Wurcker Pty. Ltd. R. C. Paterson and Co. Pty. Ltd.
TRACING CLOTH.					
S185	42 in. (20 yard rolls)	250 rolls	8 5 0		{ Max Wurcker Pty. Ltd. R. C. Paterson and Co. Pty. Ltd.

CONTRACTS ACCEPTED.—(Series 1962-63.)

PRISONERS' MEALS IN LOCK-UPS.

CONTRACT CANCELLED.

Gazette No. 73, 11th July, 1962, Prisoners' Meals, Carlton. Contract No. 99 is hereby cancelled.

CONTRACT ACCEPTED.

For the supply of Prisoners' Meals at Carlton, from 1st June, 1963, to 30th June, 1963, Breakfast and Tea, 2s. 9d.; Hot Dinner; 3s. 9d., V. Bucci.

CONTRACTS ACCEPTED.—(Series 1963-64.)

PRISONERS' MEALS IN LOCK-UPS.

CONTRACT CANCELLED.

Gazette No. 60, 31st July, 1963, Prisoners' Meals, Mt. Evelyn. Contract No. 198 is hereby cancelled.

CONTRACT ACCEPTED.

For the supply of Prisoners' Meals at Mt. Evelyn, from 1st July, 1963, to 30th June, 1964, Breakfast and Tea, 3s.; Hot Dinner, 3s. 6d., B. D. Watts.

GENERAL STORES.

Gazette No. 34, 24th April, 1963, Schedule No. 52, Tools (General).—For the rates shown opposite the following items, substitute the rates as set out hereunder as from 1st July, 1963:—Item No. 38, ¼-in. £1 3s. per dozen; ½-in., £1 6s. per dozen; ¾-in., £1 7s. per dozen; 1-in., £1 9s. per dozen; 1½-in., £1 13s. per dozen; 2-in., £1 18s. per dozen; 1-in., £2 3s. per dozen; Item No. 295, 6-in., 15s. 10d. each; 8-in., £1 each; 10-in., £1 4s. 6d. each; 12-in., £1 9s. 1d. each.

H. COUTTS, Secretary to the Tender Board. 6.8.63.

SOIL CONSERVATION AUTHORITY.

529. Construction of dam and associated earth works, Eppalock Catchment Project, £69.—I. Bunting, Kyneton.

R. D. HALL,
Secretary.

PUBLIC WORKS.

530. Macleod West, Technical School, supply lathes and equipment, £559 19s. 9d.—McPherson's Ltd.

531. Oberon, High School, lay, seal and polish lino, £280.—P. Finn.

532. Melbourne, Government House, supply linen, £255 7s.—Lincot Linen Co. Pty. Ltd.

533. Melbourne, Titles Office, supply plan presses, £1,470.—E. T. Brown Ltd.

534. Ararat, Mental Hospital, supply and lay rubber tiles, £430.—Rasmussen's Floor Covering.

535. Hopetoun, Court House, supply furniture, £716 19s. 3d.—Kennett Bros. and Rayner Pty. Ltd.

536. Mont Park, Mental Hospital, supply mattresses and pillows, £1,477 10s.—Seafoam Pty. Ltd.

537. Kew, Children's Cottages, Mental Hospital, supply chairs, £2,046.—P. Fallshaw.

538. Melbourne, Fisheries and Wildlife Department, supply fibreglass hatching boxes, £570.—Durabild Pty. Ltd.

539. Trafalgar, High School, lay, seal and polish lino, £302 5s.—J. Ellis.

540. Hopetoun, High School, supply tables and chairs, £467 12s.—Stak-N-Fold Furniture Pty. Ltd.

541. South Yarra, Botanic Gardens Kiosk, supply kitchen equipment, £1,971 12s. 9d.—Ahearn, Main and Stott Pty. Ltd.

542. Orbost, High School, supply tables and chairs, £603 1s.—G. A. Whiting Pty. Ltd.
543. Dookie Agricultural College, supply stainless steel refrigerator, £966.—Ahearn, Main and Stott Pty. Ltd.
544. Melbourne, Lands and Survey, supply and install mobile storage, £613 12s.—Steelbilt (Aust.) Pty. Ltd.
545. Caulfield, Technical College, supply of shaping machine, £686 14s.—Frank Vial and Sons Pty. Ltd.
546. Blackburn, Technical School, supply drilling machine, £397.—Frank Vial and Sons Pty. Ltd.
547. Daylesford, Technical School, supply shaping machine, £748 17s. 6d.—McPherson's Ltd.
548. Ballarat, Mental Hospital, supply filing cabinets, £287 11s.—Namco Products Pty. Ltd.
549. Melbourne, Titles Office, supply presses, £986 9s. 6d.—E. T. Brown Ltd.
550. Extras on contract, serial No. 60-61/326, £24 9s.
551. Extras on contract, serial No. 60-61/3808, £15 6s. 4d.
552. Extras on contract, serial No. 60-61/3821, £72.
553. Extras on contract, serial No. 61-62/528, £87 8s. 4d.
554. Extras on contract, serial No. 61-62/2358, £220.
555. Extras on contract, serial No. 61-62/3288, £145 9s. 8d.
556. Extras on contract, serial No. 61-62/3859, £27 10s.
557. Extras on contract, serial No. 62-63/911, £8 2s. 1d.
558. Extras on contract, serial No. 62-63/2302, £167 14s.
559. Extras on contract, serial No. 62-63/3586, £167 14s.
- H. R. PETTY, Commissioner of Public Works. 2.8.63.

ORDERS IN COUNCIL.—(Series 1962-63.)

STATE ELECTRICITY COMMISSION.

5126. For the supply of twelve light sedan motor vehicles, to Quotation No. 4906, £6,900.—Austin Distributors Pty. Ltd.
5127. For the purchase of land in Reserve-road, Cheltenham, being lots 66 and 67 on plan of subdivision No. 11375 to be used for extensions to Cheltenham Substation, £22,500.—C. M. F. Bode.
5128. For the supply of galvanized structural steelwork for 220 kV switchyard, Rowville Terminal Station, to Specification 62-63/376, £25,650.—Johns & Waygood Ltd.
5129. For the purchase of land in Howard-street, Richmond, being part of Crown portion 7, Parish of Jika Jika, to be used for extensions to Central Scientific Laboratory, £36,500.—Newton & Gray Pty. Ltd.
5130. For the supply of safety footwear for a period of one year, to Specification 62-63/359, at Schedule rates.—Oliver & Stevens Pty. Ltd.
5131. For the rebuilding of No. 3 bucket wheel dredger, Morwell Open Cut, to Specification 63-64/4, £67,666, plus items at Schedule rates.—J. R. Pillars Pty. Ltd.
5132. For the construction of extensions to General Service Office at Morwell for additional office accommodation, to Specification 62-63/362, £5,272 10s.—L. Sola Construction Co.
5133. For the supply of grey linesmen's overalls for a period of two years, to Specification 62-63/357, at Schedule rates.—Stirling Henry Ltd.
5134. For the supply of earth wire cover boards for distribution system for a period of two years, to Specification 62-63/338, at Schedule rates.—J. Wright & Sons Pty. Ltd.
5135. For the supply of white and coloured cleaning cloth and white cotton waste for a period of two years, to Specification 62-63/308, at Schedule rates.—Kleen-ware Cotton Waste Pty. Ltd.
5136. For the supply of heavy-weight white stockinette cloth for a period of two years, to Specification 62-63/308, at Schedule rates.—Stanlee (Textiles) Pty. Ltd.
5137. For the supply of public lighting standard brackets and accessories for a period of two years, to Specification 62-63/289, at Schedule rates.—Gamma Welding Constructions.
5138. For the supply of public lighting standard brackets and accessories for a period of two years, to Specification 62-63/289, at Schedule rates.—Viac Products Pty. Ltd.
- Approved by the Governor in Council, 16th July, 1963.—N. G. WISHART, Clerk of the Executive Council.

5139. For the supply and installation of air-conditioning system and water-cooling plant in offices at 238 Flinders-street, Melbourne, to Specification 62-63/291, £7,297.—Alliance Air Conditioning and Refrigeration Co. Pty. Ltd.
5140. For the supply of approximately 117 tons of steel plate for general maintenance; to Quotation No. 79, at Schedule rates.—Broken Hill Pty. Co. Ltd.
5141. For the supply of softwood flooring for a period of two years, to Quotation No. 5015, at Schedule rates.—Mordialloc Timber Co. Pty. Ltd.

5142. For the supply of hardwood flooring for a period of two years, to Quotation No. 5009, at Schedule rates.—Mordialloc Timber Co. Pty. Ltd.

5143. For the purchase of land in Campbell-street, Swan Hill, being Crown allotment 7 and part of Crown allotment 8, section 11, Parish of Castle Donnington, for the erection of offices and showrooms, £8,500.—Piangil Motors Pty. Ltd.

5144. For the supply and installation of 1 gas chromatograph for the Fuel Development Centre, Richmond, and supply of spare parts, to Specification 62-63/110A, £6,161.—H. B. Selby & Co. Pty. Ltd.

5145. For the construction of additions to control building and turbine house, Morwell Power Station, to Specification 62-63/346, £11,755.—Slade Betts Pty. Ltd.

5146. For the supply and erection of 6,600 volt switchgear and supply of spare parts, Hazelwood Power Station, Stage 2, to Specification 62-63/191, £169,502, plus items at Schedule rates.—Australian Electrical Industries Pty. Ltd.

5147. For the supply and erection of 415 volt switchgear, metering, protection and direct current equipment and supply of spare parts, Hazelwood Power Station, Stage 2, to Specification 62-63/191, £238,988 4s. 8d., plus items at Schedule rates.—English Electric Co. of Aust. Pty. Ltd.

- Approved by the Governor in Council, 9th July, 1963.—N. G. WISHART, Clerk of the Executive Council.

ORDERS IN COUNCIL.—(Series 1963-64.)

FORESTS COMMISSION.

- Loan Fund Act No. 6937, Item 6—

560. To the purchase of that portion of Crown allotment 17, Parish of Birregun, containing 5 acres 0 roods 16 perches for forest purposes, £51.—J. T. Phelan.

- Approved by the Governor in Council, 16th July, 1963.—N. G. WISHART, Clerk of the Executive Council.

PUBLIC WORKS.

488. Ballarat, Mental Hospital, supply and installation of four (4) street fire alarms, £797 10s.—May-Oatway Fire Alarms Pty. Ltd. (W.97.)

489. Caulfield, Technical School, supply of electrical equipment, as detailed hereunder:—

- One (1) control desk, and one (1) control cubicle, £488 1s. 6d.—A. V. H. Electrical Engineering Co. Pty. Ltd.

- One (1) control cubicle and seven (7) test panels, £521 13s.—Vealls Electrical and Radio Pty. Ltd.

- Ten (10) test panels, £459.—Elanco Pty. Ltd.

- One (1) Westinghouse rectifier, £310.—McKenzie & Holland (Aust.) Pty. Ltd. (M.1441.)

490. Healesville, High School, special grant authorized by the Education Department towards the cost of ground improvements at the school, £957 17s. 6d.—Healesville High School Advisory Council. (N.E.294324.)

491. Heatherton, Sanatorium, supply and installation of new controls to boilers, £827 7s. 6d.—Landis & Gyr Ltd. (S.E.4165 "A.")

492. Melbourne, Government House, supply of settee and two (2) easy-chairs, £276 10s.—Berkowitz of Collins-street. (M.13514.)

493. Melbourne, Royal Melbourne Institute of Technology, supply and erection of seven (7) distribution panels, new Physics School, £3,332.—Alan C. Hirst & Co. (M.248982 "A.")

494. Mont Park, Mental Hospital, supply of six (6) suspended unit heaters, £287 17s.—L. R. Boag Pty. Ltd. (N.E.11892.)

495. Tatura, Horticultural Research Station, supply and delivery of a Waldor greenhouse and accessories, £1,150 10s.—Banyule Australia Pty. Ltd. (N.E.307513.)

- Approved by the Governor in Council, 30th July, 1963.—N. G. WISHART, Clerk of the Executive Council.

EDUCATION DEPARTMENT.

496. One (1) only upper conditioning unit for Collingwood Technical School, £195.—British United Shoe Machinery Co. of Aust. Pty. Ltd.

497. One (1) only 9-in. hand feed planing and jointing machine (buzzer), for Collingwood Technical School, £198.—Chas. Wolfenden & Co.

498. One (1) only Vane Dumont ignition-scope, for Fern Tree Gully Technical School, £198.—E. A. Machin & Co. Pty. Ltd.

499. One (1) only calculator, for Gordon Institute of Technology, Geelong, £250.—Burrroughs Ltd.

500. One (1) only Analog computer kit, for Gordon Institute of Technology, Geelong, £927.—Warburton Franki Industries (Melb.) Pty. Ltd.

501. One (1) only Roneo electrical duplicator, for Melbourne School of Hairdressing, £185 10s., less trade-in on old machine (£10), £175 10s.—Roneo Co. (Melbourne) Pty. Ltd.

502. One (1) only men's Raynor chair, for Melbourne School of Hairdressing, £114.—Raynor Chairs and Equipment Pty. Ltd.

503. Four (4) only gearboxes, for Richmond Technical School, £120.—E. A. Machin & Co. Ltd.

504. One (1) only International diesel engine, for Richmond Technical School, £200.—Victorian Industrial Sales & Service Pty. Ltd.

505. One (1) only Mayrack frame and body aligning machine, for Richmond Technical School, £1,125.—Repro Automotive Equipment Co. Pty. Ltd.

506. One (1) only Colchester lathe, for South Melbourne Technical School, £1,402 18s.—Herbert Osborne Pty. Ltd.

507. Two (2) only Hercus lathes, for Sunshine Technical School, £433.—McPhersons Ltd.

508. One (1) only centre lathe, for Swinburne Technical College, £895 15s.—Stockdale Newall Machine Tools Pty. Ltd.

509. Two (2) only manually operated calculating machines, for Swinburne Technical College, £124 17s. 6d.—Remington Rand-Charters Pty. Ltd.

510. One (1) only Brunsviga manually operated calculating machine (£69 14s. 4d.) and one (1) only Schubert model manually operated calculating machine (£70 4s.), for Swinburne Technical College, £139 18s. 4d.—Macdougalls Limited.

511. Six (6) only variable D.C. power supplies (£364 10s.) and four (4) only portable laboratory battery supplies (£196 16s.), for Yallourn Technical College, £561 6s.—Moe Armature Rewinding Service.

Approved by the Governor in Council, 30th July, 1963.
—N. G. WISHART, Clerk of the Executive Council.

PUBLIC TRUSTEE ACT 1958 (No. 6350), SECTION 17.

I HEREBY give notice that on the 24th July, 1963, the Public Trustee filed elections to administer the following deceased persons' estates, in accordance with section 17 of the Public Trustee Act 1958:—

ALLIN, ERNEST SAMUEL, late of 72 Hotham-street, East Melbourne, pensioner, died 15th May, 1963.

BAIN, EWEN HERBERT JAMES, late of 25 Ireland-street, Burwood, council employee, died 21st April, 1963.

BARRETT, JAMES EDWARD, formerly of 29 Dalny-road, Murrumbena, late of Flat 7, 102 Truganini-road, Carnegie, retired repatriation official, died 15th May, 1963.

CUTTING, LEONARD HENRY, late of 1 Pall Mall, Bendigo, retort hand, died 16th July, 1962.

FORBES, STANLEY CAMPBELL, late of 29 Lawrence-court, Bayswater, engineer, died 4th November, 1962.

HAGER, ALBERT STANLEY, late of Bungower-road, Somerville, pensioner, died 7th April, 1963.

A. D. DUNCAN,
Public Trustee.

30th July, 1963, 256 Flinders-street, Melbourne, C.1.

NOTICES.

CREDITORS, next of kin and others having claims against the estate of the under-mentioned deceased person are required to send particulars of their claims to the Public Trustee, Mutual Centre, 256-262 Flinders-street, Melbourne, the personal representative, on or before the 7th October, 1963, after which date the Public Trustee may convey or distribute the assets, having regard only to the claims of which the Public Trustee then has notice:—

ROSSA, SELINA MARY ANN, late of 490 Gore-street, Fitzroy, widow, died 3rd May, 1963.

A. D. DUNCAN,
Public Trustee.

Melbourne, 2nd August, 1963.

CREDITORS, next of kin and others having claims against the estate of any of the under-mentioned deceased persons are required to send particulars of their claims to the Public Trustee, Mutual Centre, 256-262 Flinders-street, Melbourne, the personal representative, on or before the 10th October, 1963, after which date the Public Trustee may convey or distribute the assets, having regard only to the claims of which the Public Trustee then has notice:—

ABRAHAMSSON, HENRY RICHARD, also known as Henry Richard Abrahamson, late of 11 Pearson-street, West Brunswick, retired railway employee, died 7th May, 1963.

ALLIN, ERNEST SAMUEL, late of 72 Hotham-street, East Melbourne, pensioner, died 15th May, 1963.

BAIN, EWEN HERBERT JAMES, late of 25 Ireland-street, Burwood, council employee, died 21st April, 1963.

BARRETT, JAMES EDWARD, formerly of 29 Dalny-road, Murrumbena, late of Flat 7, 102 Truganini-road, Carnegie, retired repatriation official, died 15th May, 1963.

CURTIS, JOHN ARTHUR, late of 3 Palm-avenue, North Caulfield, gentleman, died 17th December, 1959.

CUSINI, IVY MAY, late of 6 Violet-grove, Hawthorn, married woman, died 8th May, 1963.

CUTTING, LEONARD HENRY, late of 1 Pall Mall, Bendigo, retort hand, died 16th July, 1962.

FORBES, STANLEY CAMPBELL, late of 29 Lawrence-court, Bayswater, engineer, died 4th November, 1962.

HAGER, ALBERT STANLEY, late of Bungower-road, Somerville, pensioner, died 7th April, 1963.

HUNTER, LILIAN FLORENCE, late of Lot 52, Fortuna-avenue, Croydon, widow, died 9th January, 1963.

KIDDLE, EDGAR, formerly of 26 and 34 Halls-parade, Mitcham, late of 6 Borrowdale-street, Red Hill, Canberra, A.C.T., retired public servant, died 29th December, 1962.

MORRIS, EDITH MAY, late of 12 Fehon-street, Yarraville, widow, died 22nd May, 1963.

RANKIN, WILLIAM JOSEPH, late of 15 Donald-street, Brunswick, pensioner, died 10th April, 1963.

SCOTT, VIOLETTA FLORENCE, late of 19 King-street, Camberwell, married woman, died 2nd March, 1945.

STEWART, HAROLD, late of 27 Mills-street, Hampton, retired draughtsman, died 6th May, 1963.

THRUM, FLORENCE LYDIA, late of 68 Hornby-street, Windsor, married woman, died 20th July, 1962.

TIEFENBACH, MICHAEL, formerly of 19 Cranbourne-avenue, Sunshine, late of 123 Hauptstrasse, Weppersdorf, Burgenland, Austria, labourer, died 22nd November, 1961.

TOOMEY, MARY VERONICA, late of 1 Connelly-street, Brunswick, married woman, died 1st February, 1962.

WALSH, ELLEN MARY, formerly of Albury, New South Wales, late of 57 Thackeray-street, Reservoir, widow, died 10th May, 1963.

A. D. DUNCAN,
Public Trustee.

Melbourne, 2nd August, 1963.

SALE OF LAND ACT 1962.

IN pursuance of the powers conferred by sub-section 3 of section 2 of the Sale of Land Act 1962, I, Rupert James Hamer, the Acting Attorney-General of the State of Victoria and the Minister for the time being administering the said Act, hereby exempt from the provisions of sections 6 and 8 of the said Act each of the allotments of land described in the Schedule hereto.

This exemption is subject to compliance by the mortgagor and the mortgagee in mortgage registered number B406779 in the Office of Titles with the undertakings contained in the application for this exemption dated 25th July, 1963, and shall cease immediately in respect of each of the said allotments.

- (i) upon such allotment becoming subject to any mortgage or charge other than the said mortgage,
or
 - (ii) upon the discharge of such allotment from the said mortgage,
or
 - (iii) upon any variation of the said mortgage other than the variation referred to in the said undertakings or one approved by the Minister,
or
 - (iv) upon the expiration of 12 months from the date hereof,
- whichever shall first occur.

SCHEDULE.

All those allotments of land being lots 5, 7, 18, 20, 21, 22, 23, 25 and 33 to 42 (both inclusive) on plan of subdivision numbered 57745, in the Office of Titles.

Signed at Melbourne this 1st day of August, 1963.

R. J. HAMER,
Acting Attorney-General.

MOOROOPNA SEWERAGE AUTHORITY.
ANNUAL BALANCE.

HIS Excellency the Governor of the State of Victoria, by and with the advice of the Executive Council thereof, doth, by Order made on the 6th August, 1963, pursuant to the provisions of the Sewerage Districts Acts fix the 31st day of December in each year as the day to which the accounts of the Mooroopna Sewerage Authority shall be balanced.

N. G. WISHART,
Clerk of the Executive Council.

At the Executive Council Chamber,
Melbourne, 6th August, 1963.

CASTERTON SEWERAGE AUTHORITY.
FIXING LIMIT OF A BANK OVERDRAFT.

HIS Excellency the Governor of the State of Victoria, by and with the advice of the Executive Council thereof, doth, by Order made on the 6th August, 1963, pursuant to the provisions of section 79 of the Sewerage Districts Act 1958 (No. 6368), fix the limit of the overdraft to be obtained by the Casterton Sewerage Authority from the English, Scottish and Australian Bank Limited, Casterton, at an amount not to exceed at any one time the sum of Thirty thousand pounds (£30,000).

N. G. WISHART,
Clerk of the Executive Council.

At the Executive Council Chamber,
Melbourne, 6th August, 1963.

COMPANIES ACT 1961.

NOTICE is hereby given in pursuance of sections 308 (2) and 308 (3) of the Companies Act 1961, that at the expiration of three months from the date hereof the names of the following companies will, unless cause is shown to the contrary, be struck off the Register and the said companies will be dissolved.

Dated this 2nd day of August, 1963.

T. S. WELSH,
Registrar of Companies.

Companies Registration Office,
Melbourne.

COMPANIES ABOVE REFERRED TO.

Name of Company.	Number of Registration.
Sports & Amusements Proprietary Limited ..	4301
Somerset Investments Proprietary Limited ..	12212
Lawlor & Painter Proprietary Limited ..	15207
H. E. West & Sons Proprietary Limited ..	18980
Automotive Products Manufacturers Association of Australia ..	23428
Electromatic Refrigeration Proprietary Limited ..	23599
Malakoff Alluvial Excavation Proprietary Limited ..	27171
Queensland Guarantee Corporation Proprietary Limited ..	28324
Chippendale Investments Proprietary Limited ..	29143
Ellis Bros. Proprietary Limited ..	32027
Radio Astronomy Trust ..	34596
Paul Hood Investments Proprietary Limited ..	35430
R. Costanzo Proprietary Limited ..	35578
Popular Used Cars Proprietary Limited ..	35784
Austex Sales Company Proprietary Limited ..	36029
H. & W. Auto Repairs Proprietary Limited ..	36134
Bilco Industries Proprietary Limited ..	40054
Pree-Pak Proprietary Limited ..	40789
Frank P. Marett Proprietary Limited ..	41007
Baldovan Investments Proprietary Limited ..	42189
Harold Johnson Proprietary Limited ..	42409
Pree-Pak Industries Proprietary Limited ..	42614
Wrights Trading & Hardware Company Proprietary Limited ..	43203
Andy's Meat Supply Pty. Limited ..	43309
Southern Publications Pty. Limited ..	43336
Schneider Signs Pty. Limited ..	44901
Petroll Constructions Proprietary Limited ..	46244
Nagor Import and Export Corporation Proprietary Limited ..	47137
Park Row Development Corporation Proprietary Limited ..	47139
Grant's Hotel Proprietary Limited ..	48480
Perfect Caterers Proprietary Limited ..	50697
Davis Realty Proprietary Limited ..	52583
Mountson Leaseholds Proprietary Limited ..	52728
Suntan Complexion Proprietary Limited ..	53534

COMPANIES ACT 1961.

NOTICE is hereby given in pursuance of section 308 (2) of the Companies Act 1961, that at the expiration of three months from the date hereof the names of the following companies will, unless cause is shown to the contrary, be struck off the Register.

Dated this 2nd day of August, 1963.

T. S. WELSH,
Registrar of Companies.

Companies Registration Office,
Melbourne.

COMPANIES ABOVE REFERRED TO.

Name of Company.	Number of Registration.
Ray Films Pty. Limited ..	F 3115
Ray T.V. Pty. Limited ..	F 3116
A.A.M. Investments Limited ..	F 3739

LAW DEPARTMENT.

SITTINGS OF SUPREME COURT AMENDED.

HIS Excellency the Governor of the State of Victoria, by and with the advice of the Executive Council thereof, doth, by Order made on the 30th July, 1963, amend the Order in Council approved on the 11th day of September, 1962, appointing certain dates for the holding of the Sittings of the Supreme Court for the hearing of Criminal Trials and for the Trial of Causes elsewhere than in Melbourne for the year 1963, as indicated in the second column of the subjoined Schedule so far as the Court at the place named in the first column of such Schedule is concerned.

SCHEDULE.

Place.	Alteration of Dates.
Criminal Court, Melbourne	From Thursday, 5th September, 1963, to Monday, 2nd September, 1963.

N. G. WISHART,
Clerk of the Executive Council.

At the Executive Council Chamber,
Melbourne, 30th July, 1963.

National Parks Regulations 1959.

APPOINTMENT OF AUTHORIZED OFFICERS.

IN exercise of its powers to protect and maintain national parks and to encourage and regulate their use by the public, the National Parks Authority hereby appoints the under-mentioned persons to be Authorized Officers for the purposes of the National Park Regulations 1959—

TREVOR ELSBURY ARTHUR,
DONALD SYDNEY SAUNDERS, and
ROBERT GORDON MEDLYN YORSTON,
to hold office for so long only as they remain officers of the National Parks Authority;

VICTOR KEVIN ATTRIDGE,
FREDERICK C. W. BARTON,
ALBERT EDWARD GEORGE CAMPBELL,
WILLIAM LINDSAY GARNER,
ALLAN WALTER GOULD,
REGINALD JAMES,
THOMAS CLAUDE JOHNSON,
NORMAN HENRY ERIC McDONALD,
ALEXANDER CHARLES MCGREGOR,
CLAUDE OLIVER,
ROBERT CHARLES TURNER,
RONALD STANLEY TURNER, and
REGINALD RITCHIE TYSON,

to hold office for so long only as they remain National Park Rangers; and

C. D. WILCOCK (Miss),
to hold office for so long only as she remains caretaker of the Tarra Valley National Park.

The common seal of National Parks Authority was hereunto affixed this 31st day of July, 1963, in the presence of—

(SEAL) J. J. STEWART, Member.
L. H. SMITH, Member.
J. T. McDONALD, Secretary.

L. H. SMITH, Director, Office of the National Parks Authority, 276 Collins-street, Melbourne, 31st July, 1963.

FORESTS DEPARTMENT.

APPOINTMENT OF COMMITTEE OF MANAGEMENT OF THE LERDERBERG GORGE FOREST PARK.

WHEREAS by section 50 of the Forests Act 1958 (No. 6254), it is provided that the Minister of Forests may, on the recommendation of the Forests Commission, appoint any number of persons not less than three to be a Committee of Management of any land forming part of any reserved forest, such land being set aside as a forest park, and may remove any of those persons: Now therefore I, Lindsay Hamilton Simpson Thompson, Her Majesty's Minister of Forests for the State of Victoria, on the recommendation of the Forests Commission, do hereby appoint—

E. MOLESWORTH,

as a member of the Committee of Management until the fifth day of June, 1966, of the land forming part of the reserved forest in the Parishes of Blackwood, Coimadai, Coornmill and Myrmiong, County of Bourke, described in the accompanying Schedule, and known as the Lerderberg Gorge Forest Park.

SCHEDULE ABOVE REFERRED TO.

Parishes of Blackwood, Coimadai, Coornmill and Myrmiong, County of Bourke, containing 7,630 acres more or less, being the area shown by yellow border on the plan marked 61/1085 over 25.1.63, on file of correspondence No. 61/1085 of the Forests Department.

Dated at Melbourne the second day of August, 1963.

L. H. S. THOMPSON,
Minister of Forests.

National Parks Act 1958.

APPOINTMENT TO COMMITTEE OF MANAGEMENT.

WILSON'S PROMONTORY NATIONAL PARK.

NOTICE is hereby given that, in pursuance of the powers conferred on it by the National Parks Act 1958, the National Parks Authority has appointed John McNally, Director, National Museum, to be a member, representing national park interests, for three years, from the 1st day of August, 1963, of the Committee appointed to manage the Wilson's Promontory National Park, on behalf of the Authority in accordance with the National Parks Act and Regulations and the powers and functions delegated by the Authority.

L. H. SMITH, Director, Office of the National Parks Authority, 276 Collins-street, Melbourne, 31st July, 1963.

APPOINTMENT OF OFFICIAL LIQUIDATORS.

Notice is hereby given that I, Rupert James Hamer, Her Majesty's Acting Attorney-General for the State of Victoria, under powers conferred by section 11 of the Companies Act 1961 (No. 6839), have appointed the persons named hereunder to be Official Liquidators for the purposes of the aforesaid Companies Act 1961:—

Names of Appointees.

Alexander Wills Ogilvy, care of Edwin V. Nixon & Partners, 401 Collins-street, Melbourne.

Philip Douglas George, care of Edwin V. Nixon & Partners, 401 Collins-street, Melbourne.

Dated at Melbourne, this 5th day of August, 1963.

R. J. HAMER,
Acting Attorney-General.

APPOINTMENTS.

HIS Excellency the Governor of the State of Victoria, by and with the advice of the Executive Council thereof, has, by Orders made on the 30th day of July, 1963, been pleased to make the under-mentioned appointments, viz.:—

CHIEF SECRETARY'S DEPARTMENT.

Electoral Registrars (Acting).

HAROLD BURTON FITZGIBB

to be Electoral Registrar (Acting) for the Drysdale, Geelong, Newtown and Chilwell and Queenscliff Subdivisions of the Electoral District of Geelong, and for the Bannockburn, Geelong North, Geelong West, Meredith and Sutherland Subdivisions of the Electoral District of Geelong West, to take effect on and from the 15th August, 1963, during the absence on leave of Owen Patrick Griffin; and

LESLIE JOHN MAXWELL KING

to be Electoral Registrar (Acting) for the Box Hill, Doncaster, Lilydale, Surrey Hills and Warrandyte Subdivisions of the Electoral District of Box Hill, and for the Diamond

Creek, Eltham, Healesville, Heidelberg and Warburton Subdivisions of the Electoral District of Evelyn, to take effect on and from the 29th July, 1963, during the absence on leave of Herbert William Hodgson.

Honorary Probation Officer.

JAMES DAVID MARTIN, B.A. (the Reverend), The Manse, Noel-street, Apollo Bay, pursuant to the provisions of section 507 (2) of the Crimes Act 1958, to be an Honorary Probation Officer for all Adult Courts in Victoria.

DEPARTMENT OF CROWN LANDS AND SURVEY.

Bailliff of Crown Lands.

PERCY STEPHEN PENDLEBURY
to be a Bailliff of Crown Lands.

MINISTRY OF HEALTH.

Government Representatives on Hospital Committees.

(Pursuant to the Hospitals and Charities Act.)

ARTHUR JOSEPH BAILEY

to be Government Representative on the Committee of Management of Footscray and District Hospital, pursuant to the provisions of section 48 of the Hospitals and Charities Act 1958, for a further period of three years from the 17th August, 1963; and

ARTHUR EWENS SPILLER

to be Government Representative on the Committee of Management of Robinvale and District Hospital, pursuant to the provisions of section 48 of the Hospitals and Charities Act 1958, for a further period of three years from the 20th August, 1963.

LAW DEPARTMENT.

Assistant Registrar of County Court.

PHILIP JOHN RODDA

to be an Assistant Registrar, pursuant to the provisions of sections 20 and 21 of the County Court Act 1958, for the County Court at Bendigo, during the absence of G. W. Thompson on annual leave, to take effect from the date of commencement of duty.

Clerk of Petty Sessions, &c.

PHILIP JOHN RODDA

to be Clerk of the Court of Mines at Kyneton and Clerk of the Children's Court and Clerk of Petty Sessions at Kyneton, Gisborne, Lancefield, Romsey, Sunbury and Woodend, during the absence of G. W. Thompson on annual leave, to take effect from the date of commencement of duty.

Commissioners for Taking Declarations, &c.

MORRIS JOSEPH JACOBS, 457 Centre-road, Bentleigh, and PETER JAMES SALTER, 3 Rishon-avenue, South Blackburn,

to be Commissioners for taking Declarations and Affidavits, pursuant to the provisions of the Evidence Act 1958, to resign upon removing from the neighbourhood of the addresses stated.

Chairman of General Sessions.

JOHN XAVIER O'DRISCOLL, Q.C., B.A., LL.M., a barrister at law of Victoria, who has practised for a period of five years,

to be a Chairman of General Sessions, under the provisions of the Justices Act 1958, to take effect from the date of commencement of duty.

Judge of the County Court.

JOHN XAVIER O'DRISCOLL, Q.C., B.A., LL.M., a barrister at law who has practised as a barrister in Victoria for a period of seven years,

to be a Judge of the County Court and a Judge of Courts of Mines, under the provisions of the County Court Acts, to take effect from the date of commencement of duty.

Justices of the Peace.

WILLIAM PATRICK QUINN, Postmaster-General's Department, Treasury-place, Melbourne, to Keep the Peace in all bailiwicks of the State of Victoria; and

KEITH CHARLES ANDERSON, 35 Truman-street, South Kingsville, and

JAN WILLIAM GAILLARD, 51 Fellow-street, Kew, to Keep the Peace in the Central Bailiwick of the State of Victoria.

N. G. WISHART.

Clerk of the Executive Council.

At the Executive Council Chamber,
Melbourne, 30th July, 1963.

APPOINTMENTS.

HIS Excellency the Governor of the State of Victoria, by and with the advice of the Executive Council thereof, has, by Orders made on the 6th day of August, 1963, been pleased to make the under-mentioned appointments, viz.:

DEPARTMENT OF WATER SUPPLY.
Member of Sewerage Authority.

DOUGLAS HAMILTON MURRELL
to be a Member of the Casterton Sewerage Authority from the date hereof until the 24th October, 1963, subject to the provisions of the Sewerage Districts Acts.

Waterworks Trusts Commissioners.

HENRY ERNEST CLARKE
to be a Commissioner of the Bright Waterworks Trust for a period of four years from the date hereof, subject to the provisions of the Water Acts.

JOHN BERESFORD ELLIOTT
to be a Commissioner of the Wahgunyah Waterworks Trust for a period of four years from the date hereof, subject to the provisions of the Water Acts.

CYRIL ROBERTS HAWKER
to be a Commissioner of the Shire of Nathalia Waterworks Trust to hold office as such from the date hereof until the 22nd April, 1967, subject to the provisions of the Water Acts.

N. G. WISHART,
Clerk of the Executive Council.

At the Executive Council Chamber,
Melbourne, 6th August, 1963.

Township of Boigbeat, Parish of Boigbeat, County of Karkaroc, being the road indicated by hachure on plan hereunder.—(B.747⁽⁸⁾) (M.43098).

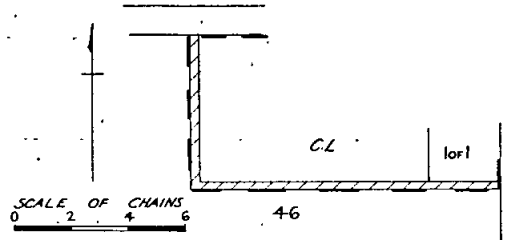

Township of Bung Bong, Parish of Bung Bong, County of Talbot, being the road indicated by hachure on plan hereunder.—(B.539⁽⁶⁾) (W.67116).

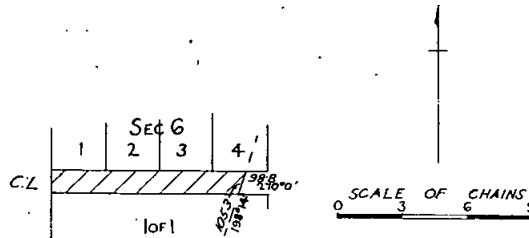

Parish of Elphinstone, County of Talbot, being the road indicated by hachure on plan hereunder.—(E.34⁽²⁾) (W.84423).

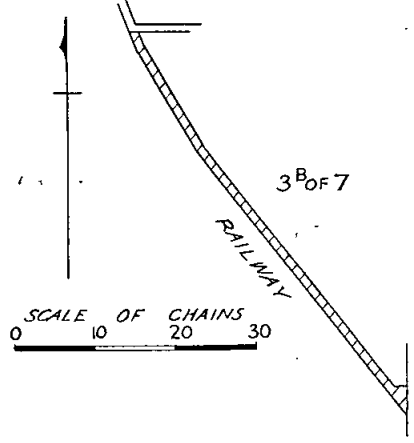

City of Port Melbourne, Parish of Melbourne South, County of Bourke, being the road indicated by hachure on plan hereunder.—(M.334⁽¹⁵⁾) (G.62369).

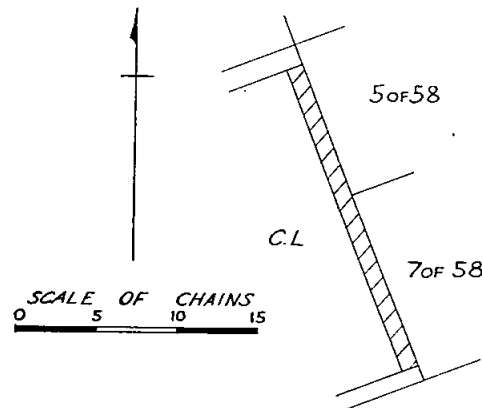

Parish of Rathscar, County of Gladstone, being the road between allotment 14 and allotment 14A, section 5.—(R.65⁽²⁾) (W.81678).

RESIGNATIONS.

HIS Excellency the Governor of the State of Victoria, by and with the advice of the Executive Council thereof, has, by Orders made on the 30th day of July, 1963, accepted the resignations of the persons named hereunder of the offices mentioned, viz.:

LAW DEPARTMENT.

WILLIAM BRUCE JEAVONS, from the Commission of the Peace for the Eastern Bailiwick of the State of Victoria.

FRANCIS WILLIAM RYAN, from the Commission of the Peace for the Northern Bailiwick of the State of Victoria.

N. G. WISHART,
Clerk of the Executive Council.

At the Executive Council Chamber,
Melbourne, 30th July, 1963.

ERRATUM.

IN the Order in Council headed "Revocation of Permanent Reservation of Land", which appeared in the Victoria Government Gazette dated 24th July, 1963 (page 2227), the words "section 3 of the Revocation and Excision of Crown Reservations Act 1959 (No. 6524)" should read "section 5 (1) of the Revocation and Excision of Crown Reservations Act 1959 (No. 6524)".

DEPARTMENT OF CROWN LANDS AND SURVEY.

At the Executive Council Chamber, Melbourne, the thirtieth day of July, 1963.

PRESENT:

His Excellency the Governor of Victoria.
Mr. Bloomfield | Mr. Hamer.

UNUSED ROADS CLOSED.

HIS Excellency the Governor of the State of Victoria, by and with the advice of the Executive Council thereof, doth hereby direct that, in pursuance of the provisions of section 349 of the Land Act 1958, the unused roads referred to hereunder be closed, viz.:

Parish of Bungalally, County of Borung, being the road forming the northern boundary of allotment 235.—(B.93⁽⁴⁾) (1/134).

City of South Melbourne, Parish of Melbourne South, County of Bourke, being the road between allotments 2, 3 and allotment 4, section 57B.—(M.333⁽³⁰⁾); (G.61577).

And the Honorable Keith Hector Turnbull, Her Majesty's Commissioner of Crown Lands and Survey for the State of Victoria, shall give the necessary directions herein accordingly.

N. G. WISHART,
Clerk of the Executive Council.

DEPARTMENT OF CROWN LANDS AND SURVEY.

At the Executive Council Chamber, Melbourne, the thirtieth day of July, 1963.

PRESENT:

His Excellency the Governor of Victoria.
Mr. Bloomfield | Mr. Hamer.

LANDS TEMPORARILY RESERVED AS SITES.

HIS Excellency the Governor of the State of Victoria, by and with the advice of the Executive Council thereof, doth hereby, in pursuance of the provisions of the Land Act 1958, reserve, temporarily, and also except from occupation for mining purposes under any miner's right, the lands hereinafter described:—

BALNARRING.—Site for Public Recreation, 13 acres 3 roods, more or less, Parish of Balnarring, County of Mornington, as indicated by hachure on plan hereunder.—(B.74⁽⁶⁾) (Rs.8237).

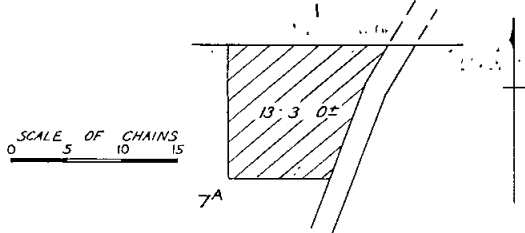

GEELONG.—Site for Public purposes (Car Park), 5 acres 0 roods 6 perches, City of Geelong, Parish of Corio, County of Grant, as indicated by hachure on plan hereunder.—(C.272⁽⁶⁾) (Rs.519).

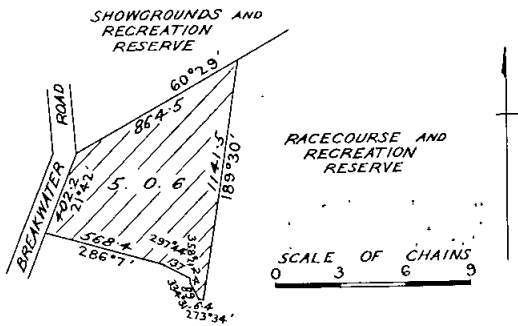

GEELONG.—Site for Public Racecourse and Recreation, 111 acres 1 rood 19 perches, City of Geelong, Parish of Corio, County of Grant, as indicated by hachure on plan hereunder.—(C.272⁽⁶⁾) (Rs.519).

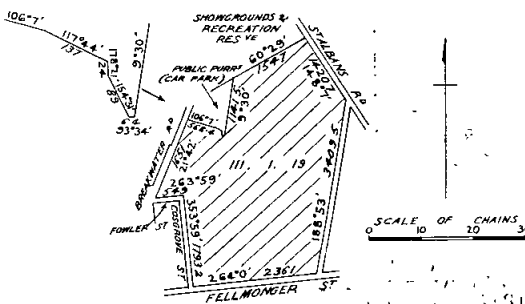

GEELONG.—Site for Agricultural Showgrounds and Public Recreation, 30 acres 3 roods 19 perches, City of Geelong, Parish of Corio, County of Grant, as indicated by hachure on plan hereunder.—(C.272⁽⁶⁾) (Rs.519).

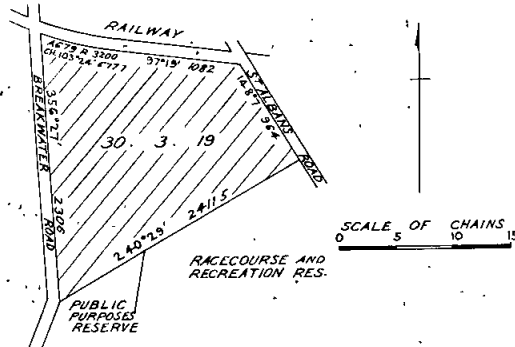

DRUNG DRUNG.—Site for Water Supply purposes, in addition to and adjoining the site temporarily reserved therefor by Order in Council of the 19th March, 1880, 4 acres 3 roods 15 perches, Parish of Drung Drung, County of Borung, as indicated by hachure on plan hereunder.—(D.165⁽²⁾) (Rs.8234).

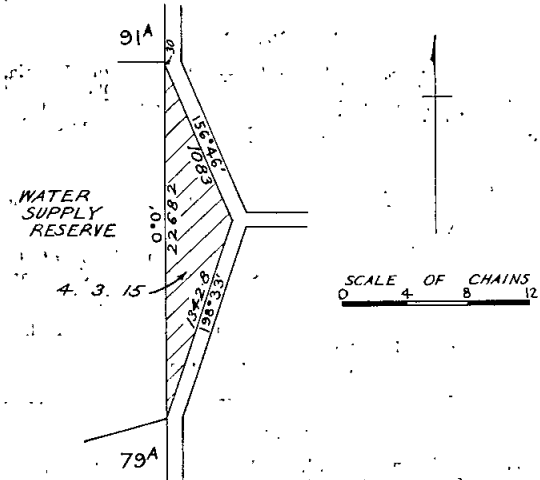

And the Honorable Keith Hector Turnbull, Her Majesty's Commissioner of Crown Lands and Survey for the State of Victoria, shall give the necessary directions herein accordingly.

N. G. WISHART,
Clerk of the Executive Council.

COUNTRY ROADS BOARD.

At the Executive Council Chamber, Melbourne, the thirtieth day of July, 1963.

PRESENT:

His Excellency the Governor of Victoria.
Mr. Bloomfield | Mr. Hamer.

ORDER APPROVING OF WIDENING AN EXISTING MAIN ROAD IN THE SHIRE OF SOUTH BARWON.

WHEREAS the Country Roads Board constituted under the Country Roads Act 1958 (No. 6229) has represented to His Excellency the Governor in Council that it appears to it desirable that the existing Barwon Head-road in the Shire of South Barwon (declared to be a main

road under the said Act which declaration was confirmed by the Order in Council published in the *Government Gazette* of the 1st April, 1914, on page 1547) should be widened by the said Board: And whereas the said Board in accordance with the requirements of section 19 of the said cited Act has caused to be prepared a map plan and estimate showing the points between which and on and through what land the said widening is proposed to be made and the cost of acquiring the land: And whereas on an inspection of the said map and plan and a consideration of the said estimate His Excellency the Governor in Council is satisfied that there are funds legally available for acquiring the land: Now therefore be it known by this present Order that His Excellency the Governor of the State of Victoria with the advice of the Executive Council thereof doth hereby approve of the said road being widened, that is to say:—

All those pieces of land in the Parish of Conewarre, the boundaries of which are as follow:—

- (a) Commencing at the south-eastern angle of allotment G, section 12, of the said parish; thence by lines bearing respectively 270 deg. 0 min. 1,602.5 links, 89 deg. 40 min. 1,086.5 links, 90 deg. 35 min. 516.1 links and 177 deg. 10 min. 1 link to the point of commencement.
- (b) Commencing at the north-eastern angle of allotment E, section 20, of the said parish; thence by lines bearing respectively 90 deg. 0 min. 100.3 links, 112 deg. 30 min. 2,082 links, 130 deg. 55 min. 1,723 links, 301 deg. 49 min. 434.4 links, 308 deg. 26 min. 1,280 links, 294 deg. 24 min. 909 links, 290 deg. 17 min. 1,081.5 links, 318 deg. 10½ min. 1,654 links, 272 deg. 52 min. 437 links and 90 deg. 0 min. 434.1 links to the point of commencement.
- (c) Commencing at the north-western angle of allotment A, section 21, of the said parish; thence by lines bearing respectively 89 deg. 44 min. 666 links, 182 deg. 4 min. 101 links, 270 deg. 6 min. 684.8 links and 12 deg. 44 min. 102.2 links to the point of commencement—

which said pieces of land are particularly delineated and shown coloured red and yellow on survey plan numbered 8858, lodged in the office of the Country Roads Board.

And the Honorable Horace Rostill Petty, Her Majesty's Commissioner of Public Works for the State of Victoria, shall give the necessary directions herein accordingly.

N. G. WISHART,
Clerk of the Executive Council.

COUNTRY ROADS BOARD.

At the Executive Council Chamber, Melbourne, the thirtieth day of July, 1963.

PRESENT:

His Excellency the Governor of Victoria.
Mr. Bloomfield | Mr. Hamer.

ORDER APPROVING OF A DEVIATION FROM A STATE HIGHWAY IN THE BOROUGH OF DAYLESFORD AND SHIRE OF GLENLYON.

WHEREAS the Country Roads Board constituted under the *Country Roads Act 1958* (No. 6229) has represented to His Excellency the Governor in Council that it appears to it desirable that the deviation hereinafter referred

to from the existing Midland Highway in the Borough of Daylesford and Shire of Glenlyon (declared to be a State highway under the said Act which declaration was confirmed by the Order in Council published in the *Government Gazette* of the 10th August, 1960, on pages 2743-8), should be made by the said Board: And whereas the said Board in accordance with the requirements of section 19 of the said cited Act has caused to be prepared a map, plan and estimate showing the points between which and on and through what land the said deviation is proposed to be made and the cost of acquiring the land: And whereas on an inspection of the said map and plan and a consideration of the said estimate His Excellency the Governor in Council is satisfied that there are funds legally available for acquiring the land: Now therefore be it known by this present Order that His Excellency the Governor of the State of Victoria with the advice of the Executive Council thereof doth hereby approve of the said highway being made, that is to say:—

All those pieces of land in the Parish of Wombat the boundaries of which are as follow:—

- (a) Commencing at an angle in the western boundary of the existing Midland Highway through Crown portion 3, section 3, of the said Parish the said angle being formed by the intersection of lines bearing 174 deg. 47 min. and 207 deg. 0 min.; thence by lines bearing respectively 207 deg. 0 min. 562.1 links, 15 deg. 36 min. 843.2 links and 174 deg. 47 min. 312.6 links to the point of commencement.
- (b) Commencing at an angle in the western boundary of allotment 2, section 3, of the said parish, the said angle being formed by the intersection of lines bearing 141 deg. 22 min. and 174 deg. 47 min.; thence by lines bearing respectively 167 deg. 36 min. 1,146.2 links, 184 deg. 2 min. 891.5 links, 201 deg. 55 min. 861.4 links, 259 deg. 16 min. 96.5 links, 27 deg. 0 min. 917 links and 354 deg. 47 min. 2,017.2 links to the point of commencement.
- (c) Commencing at an angle in the eastern boundary of allotment 1, section 3, of the said parish, the said angle being formed by the intersection of lines bearing 141 deg. 22 min. and 174 deg. 47 min.; thence by lines bearing respectively 174 deg. 47 min. 447 links, 337 deg. 52 min. 410.2 links, 329 deg. 23 min. 436.6 links, 323 deg. 40 min. 911 links, 326 deg. 7 min. 484.3 links, 142 deg. 59 min. 278.4 links and 141 deg. 22 min. 1,567.3 links to the point of commencement.
- (d) Commencing at an angle in the western boundary of allotment 6, section 8, of the said parish, the said angle being formed by the intersection of lines bearing 163 deg. 46 min. and 142 deg. 59 min.; thence by lines bearing respectively 343 deg. 46 min. 422.6 links, 149 deg. 14 min. 1,003.3 links, 143 deg. 35 min. 1,107.2 links, 268 deg. 50 min. 36 links and 322 deg. 59 min. 1,688.3 links to the point of commencement.
- (e) Commencing at an angle in the eastern boundary of allotment 4, section 8, of the said parish, the said angle being formed by the intersection of lines bearing 123 deg. 46 min. and 142 deg. 59 min.; thence by lines bearing respectively 336 deg. 40 min. 605 links, 347 deg. 43 min. 495.6 links, 356 deg. 34 min. 732.3 links, 13 deg. 1 min. 1,120.3 links, 184 deg. 40 min. 1,875.3 links and 123 deg. 46 min. 1,034.5 links to the point of commencement.
- (f) Commencing at an angle in the western boundary of allotment 2, section 8, of the said parish, the said angle being formed by the intersection of lines bearing 195 deg. 1 min. and 184 deg. 40 min.; thence by lines bearing respectively 15 deg. 1 min. 1,180.8 links, 26 deg. 29 min. 636.1 links, 196 deg. 2 min. 2,276 links and 4 deg. 40 min. 479.2 links to the point of commencement.
- (g) Commencing at the north-western angle of allotment 1, section 8, of the said parish; thence by lines bearing respectively 350 deg. 36 min. 101.3 links, 351 deg. 28 min. 209.7 links, 158 deg. 50 min. 222.1 links, 154 deg. 40 min. 110.4 links, 168 deg. 7 min. 579.7 links, 179 deg. 35 min. 665.3 links and 350 deg. 36 min. 1,249 links to the point of commencement.
- (h) Commencing at an angle in the eastern boundary of allotment 3, section 8 of the said parish, the said angle being formed by the intersection of lines bearing 170 deg. 36 min. and 206 deg.

29 min.; thence by lines bearing respectively 206 deg. 29 min. 811.6 links, 14 deg. 52 min. 847 links, 6 deg. 12 min. 474.5 links and 170 deg. 36 min. 571.6 links to the point of commencement.

- (i) Commencing at the north-eastern angle of allotment 1F, section 8, of the said parish; thence by lines bearing respectively 153 deg. 14 min. 406.2 links, 171 deg. 31 min. 260 links, 170 deg. 36 min. 52.9 links, 338 deg. 9 min. 724.3 links and 90 deg. 15 min. 39.7 links to the point of commencement.
- (j) Commencing at the north-western angle of allotment 1A, section 8, of the said parish; thence by lines bearing respectively 89 deg. 42 min. 33.8 links, 157 deg. 16 min. 545.2 links, 333 deg. 19 min. 449.1 links and 337 deg. 5 min. 110 links to the point of commencement—

which said pieces of land are particularly delineated and shown coloured red and yellow on survey plans numbered 9113 and 9114, lodged in the office of the Country Roads Board.

And the Honorable Horace Rostill Petty, Her Majesty's Commissioner of Public Works for the State of Victoria, shall give the necessary directions herein accordingly.

N. G. WISHART,
Clerk of the Executive Council.

COUNTRY ROADS BOARD.

At the Executive Council Chamber, Melbourne, the thirtieth day of July, 1963.

PRESENT:

His Excellency the Governor of Victoria.
Mr. Bloomfield | Mr. Hamer.

DECLARATION OF A DEVIATION FROM THE TRARALGON-BALOOK ROAD IN THE SHIRE OF TRARALGON.

WHEREAS by sections 21 and 58 of the Country Roads Act 1958 (No. 6229), it is amongst other things enacted that when the Country Roads Board under the provisions of the Country Roads Act has by resolution declared a deviation to be a main road the said Board may also declare that such deviation shall be in lieu of any existing road or part thereof named in such resolution and that on publication in the *Government Gazette* of the Order confirming such resolution the existing road or part thereof shall cease to be a main road or be discontinued as provided in the resolution: And whereas the said Board has by resolution declared the deviation on the land described in the First Schedule to such resolution to be a main road and has also declared that such deviation shall be in lieu of the part of the existing road being the land described in the Second Schedule to the said resolution and that such part of the said existing road shall be discontinued: Now therefore His Excellency the Governor of the State of Victoria, by and with the advice of the Executive Council thereof doth hereby confirm the said resolution.

Resolution for Declaration of a Deviation of a Main Road under the Country Roads Act.

Whereas the land the site of the road the course of which is below set out was taken by the Board under the provisions of the Country Roads Act 1958 for the purpose of constructing such road deviation which road deviation has now been laid out and formed on the same: And whereas the said Board (being the Country Roads Board incorporated under the said Act) thinks that the road aforesaid is fit to be used as a public highway such

Board at a meeting now holden acting under the authority conferred upon it by sections 21 and 58 of the said Act doth by this present resolution hereby declare the said road deviation the course of which is described in the First Schedule hereto with the commencing and terminating points thereof respectively specified to be part of a main road within the meaning and for the purposes of the Country Roads Act 1958: And the said Board doth also declare that such deviation shall be in lieu of the existing road or part thereof described in the Second Schedule hereto and that such part of the said existing road shall be discontinued.

FIRST SCHEDULE.

SHIRE OF TRARALGON.

4. *Traralgon-Balook road* (16404).—All that piece of land in the Parishes of Callignee and Loy Yang, the boundaries of which are as follow:—

Commencing at a point on the northern boundary of allotment 1B, Parish of Callignee, distant 270 deg. 0 min. 1,511 links from the north-eastern angle of the said allotment; thence by lines bearing respectively 133 deg. 0 min. 550.7 links, 266 deg. 49 min. 180.1 links, 316 deg. 13 min. 534.1 links, 270 deg. 0 min. 154.6 links, 8 deg. 24 min. 225 links, 343 deg. 56 min. 74.8 links and 135 deg. 33 min. 412.5 links to the point of commencement—

Also, all that piece of land in the Parish of Callignee, the boundaries of which are as follow:—

Commencing at an angle in the western boundary of the existing Traralgon-Balook road through allotment 1B of the said parish, formed by the intersection of lines bearing 8 deg. 12 min. and 328 deg. 34 min.; thence by lines bearing respectively 188 deg. 12 min. 130 links, 336 deg. 9½ min. 335 links, 86 deg. 49 min. 43.9 links and 148 deg. 34 min. 211.2 links to the point of commencement—

which said pieces of land are particularly delineated and shown coloured red on survey plan numbered 8450, lodged in the office of the Country Roads Board.

SECOND SCHEDULE.

SHIRE OF TRARALGON.

4. *Traralgon-Balook road* (16404).—All that piece of land in the Parish of Callignee, the boundaries of which are as follow:—Commencing at a point on the northern boundary of allotment 1B of the said parish, distant 270 deg. 0 min. 1,812.2 links from the north-eastern angle of the said allotment; thence by lines bearing respectively 185 deg. 17 min. 178.4 links, 134 deg. 58 min. 277 links, 93 deg. 6 min. 285 links, 86 deg. 49 min. 59.9 links, 136 deg. 13 min. 106.3 links, 156 deg. 9½ min. 20.6 links, 266 deg. 49 min. 141.7 links, 273 deg. 6 min. 328.6 links, 314 deg. 58 min. 362 links, 5 deg. 17 min. 216.2 links and 90 deg. 0 min. 100.4 links to the point of commencement— which said piece of land is particularly delineated and shown coloured blue on survey plan numbered 8450, lodged in the office of the Country Roads Board.

The common seal of the Country Roads Board was hereto affixed, at Kew, this twenty-second day of July, One thousand nine hundred and sixty-three, in the presence of—

(SEAL) I. J. O'DONNELL, Chairman.
F. WEST, Member.
N. L. ALLANSON, Secretary.

And the Honorable Horace Rostill Petty, Her Majesty's Commissioner of Public Works for the State of Victoria, shall give the necessary directions herein accordingly.

N. G. WISHART,
Clerk of the Executive Council.

Forests Act 1958.

EXCHANGE OF FOREST AREAS FOR CROWN LANDS.

At the Executive Council Chamber, Melbourne, the thirtieth day of July, 1963.

PRESENT :

His Excellency the Governor of Victoria.

Mr. Bloomfield | Mr. Hamer.

IN pursuance of the provisions of section 49 of the *Forests Act 1958* (No. 6254) His Excellency the Governor of the State of Victoria, by and with the advice of the Executive Council, doth hereby order that the areas of Reserved Forest situated in the Parishes of Arcadia, Ballyrogan, Barwidgee, Bepcha, Blackwood, Bumbang, Carwarp, Chiltern, Cobboboonee, Heywood, Jeeralang, Mirboo, Monbulk, Murchison North, Myrtleford, Palpara, Sandhurst, Sedgwick, Shepparton, Tarrawarra North, Tooloy, Wangaratta North, Yehrip and Warrak described in the accompanying Excision Schedule No. 139 and comprising 2,340 acres more or less be excised from the Forest Reserves and that the areas of unoccupied Crown lands in the Parishes of Barramunga, Brimbonga, Cobboboonee, Coliban, Eurandelong, Gerangamete, Krambruk, Lillieur, Moorbanool, Trentham and Wombat and described in the accompanying Dedication Schedule No. 172 and comprising 2,380 acres more or less be dedicated as Reserved Forest in exchange in lieu thereof.

Such excisions and dedications to take effect on the fourteenth day after the publication of this order in the *Government Gazette*.

EXCISION SCHEDULE No. 139.

Two thousand three hundred and forty acres more or less of Reserved Forest comprising the areas tabulated hereunder and shown by cross hatched lines in diagrams 1056 to 1079 inclusive on the accompanying plans A and B.

61/191—16th July, 1963.

Diagram.	Correspondence Number.		Parish.	Plan Number.	County.	Area in Acres (More or Less).
	Forests.	Lands.				
1059	61/1109	P06414	Arcadia	11	Moira	2
1070	61/1273	J30795	Ballyrogan	18	Ripon	158
1058	58/989	H027067	Barwidgee	33B	Bogong	50
1075	61/1187	J29054	Bepcha	42c	Dundas	370
1064	60/1808	J30689	Blackwood	49	Bourke	1
1069	63/584	M56040	Bumbang	83A	Karkaroc	1
1072	59/680	M41630	Carwarp	117	Karkaroc	14
1060	59/2087	C98012	Chiltern	119	Bogong	2
1074	62/271	Z27481	Cobboboonee	125	Normanby	70
1066	59/2029	Z31688	Heywood	223A	Normanby	3
1079	62/2032	H028975	Jeeralang	232A	Buln Buln	55
1076	60/540	M3230	Mirboo	304A	Buln Buln	18
1056	62/286	G63830	Monbulk	323D	Evelyn	5
1061	58/984	W81096	Murchison North	335B	Rodney	4
1071	58/332	H027665	Myrtleford	343A	Bogong	15
1068	62/842	C98593	Palpara	202	Follett	24
1067	60/103	W85471	Sandhurst	402c	Bendigo	7
1062	62/1627	W85687	Sedgwick	405	Bendigo	35
1063	60/417	H027643	Shepparton	407A	Moira	1
1077	57/1737	G61592	Tarrawarra North	429	Evelyn	5
1073	61/642	J30650	Tooloy	Cty. 14	Follett	1020
1065	61/1216	H025588	Wangaratta North	470B	Bogong	10
1057	62/1804	W86184	Yehrip	529	Kara Kara	450
1078	59/2752	J28702	Warrak	478	Kara Kara	20

DEDICATION SCHEDULE No. 172.

Two thousand three hundred and eighty acres more or less of unoccupied Crown lands, comprising the areas tabulated hereunder and shown by diagonal hatched lines in diagrams 871 to 882 inclusive shown on the accompanying plan C.

61/191—16th July, 1963.

Diagram.	Correspondence Number.		Parish.	Plan Number.	County.	Area in Acres (More or Less).
	Forests.	Lands.				
871	60/1345	G62156	Barramunga	32	Polwarth	200
872	59/1739	G62136	Barramunga	32	Polwarth	175
873	58/1083	Rs8157	Brimbonga	293B	Evelyn	1
876	62/271	Z27481	Cobboboonee	125	Normanby	10
874	59/2266	W82398	Coliban	132	Talbot	21
875	58/2038	H026882	Eurandelong	187	Delatite	1,500
878	61/1407	G62775	Gerangamete	194	Polwarth	22
879	62/892	J26948	Krambruk	268A	Polwarth	110
877	60/1158	J29951	Lillieur	279	Talbot	1
882	59/1547	4427/47-29	Moorbanool	318	Polwarth	307
881	61/308	W82428	Trentham	456	Dalhousie and Bourke	28
880	60/409	W82417	Wombat	5	Talbot	5

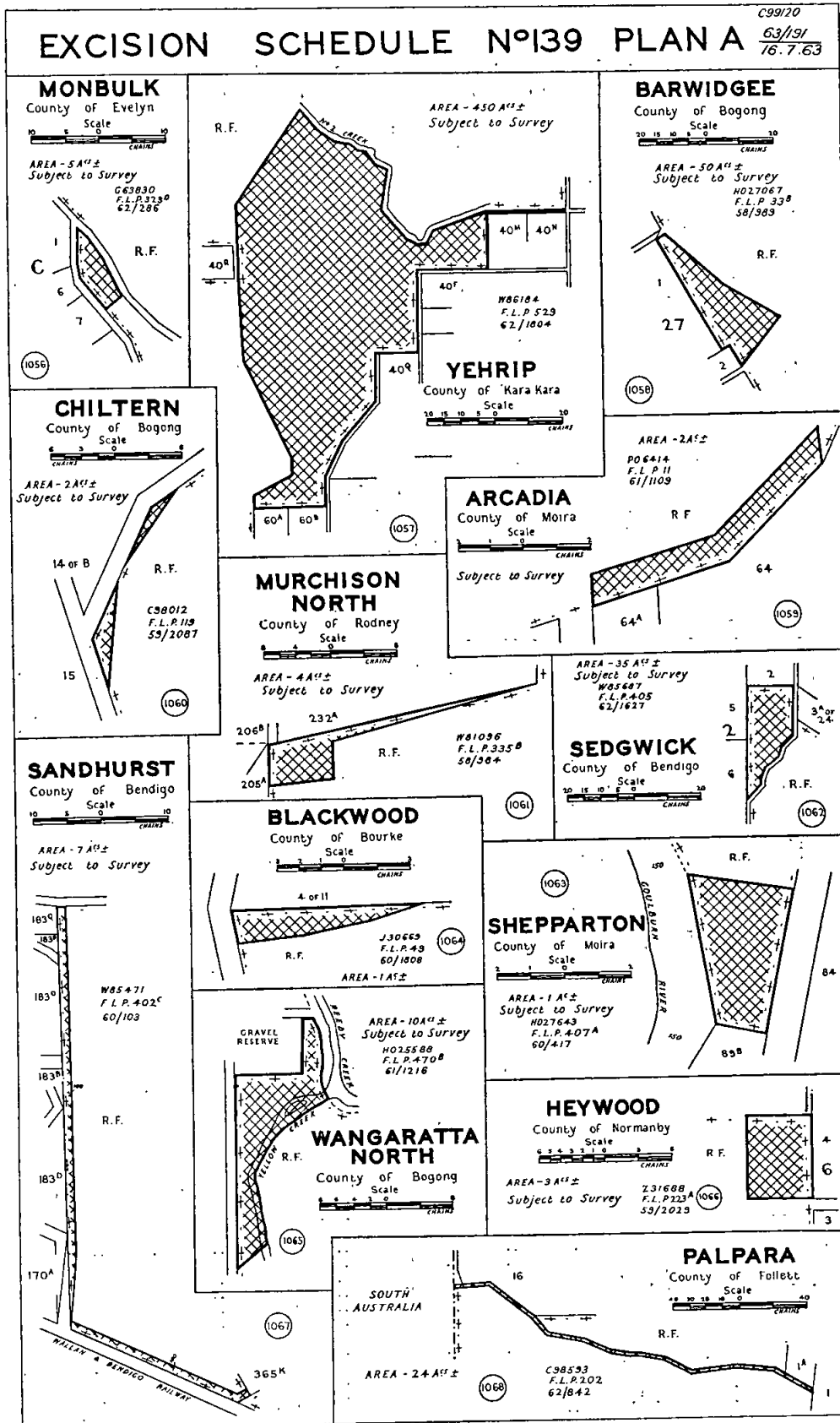

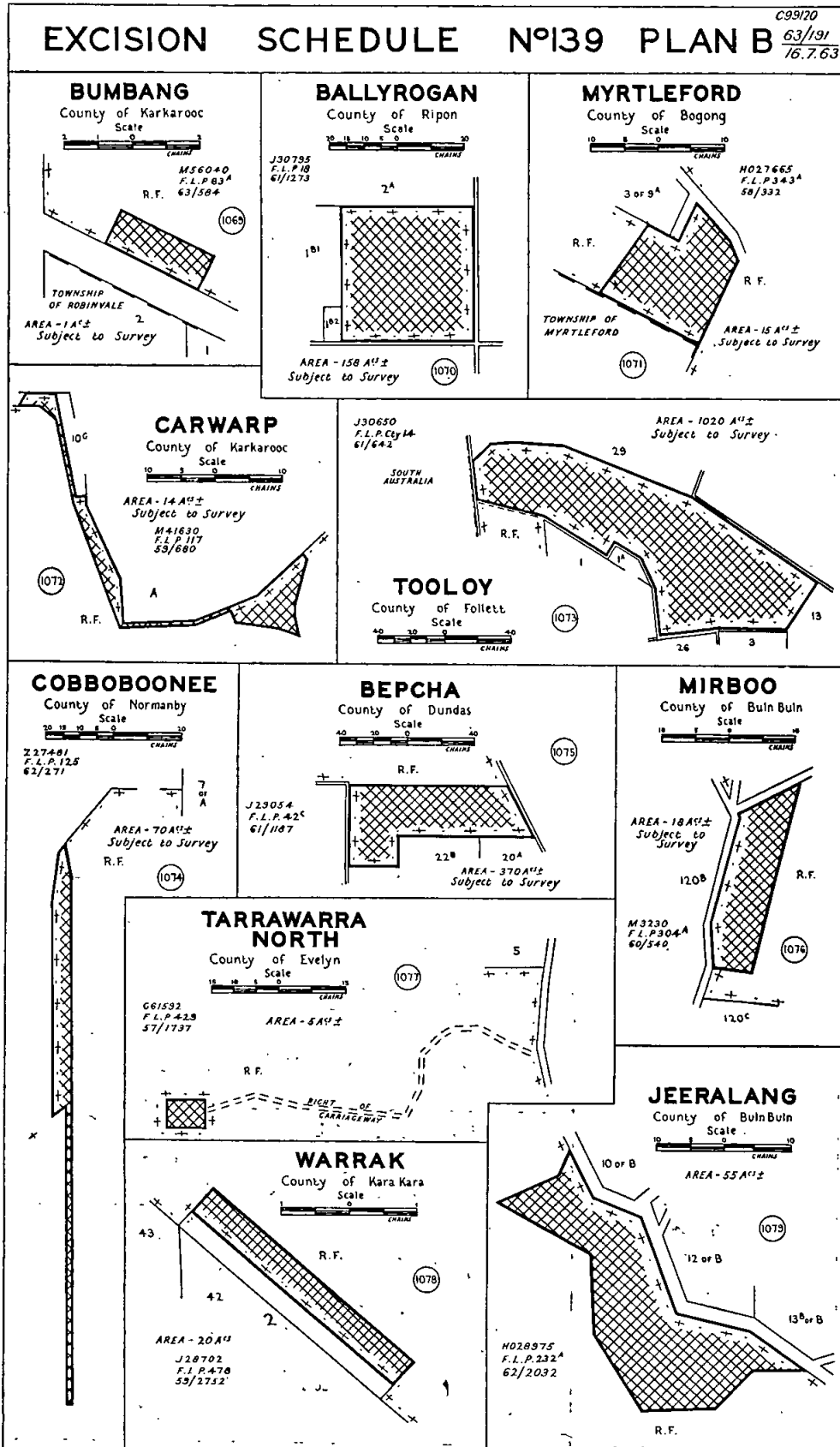

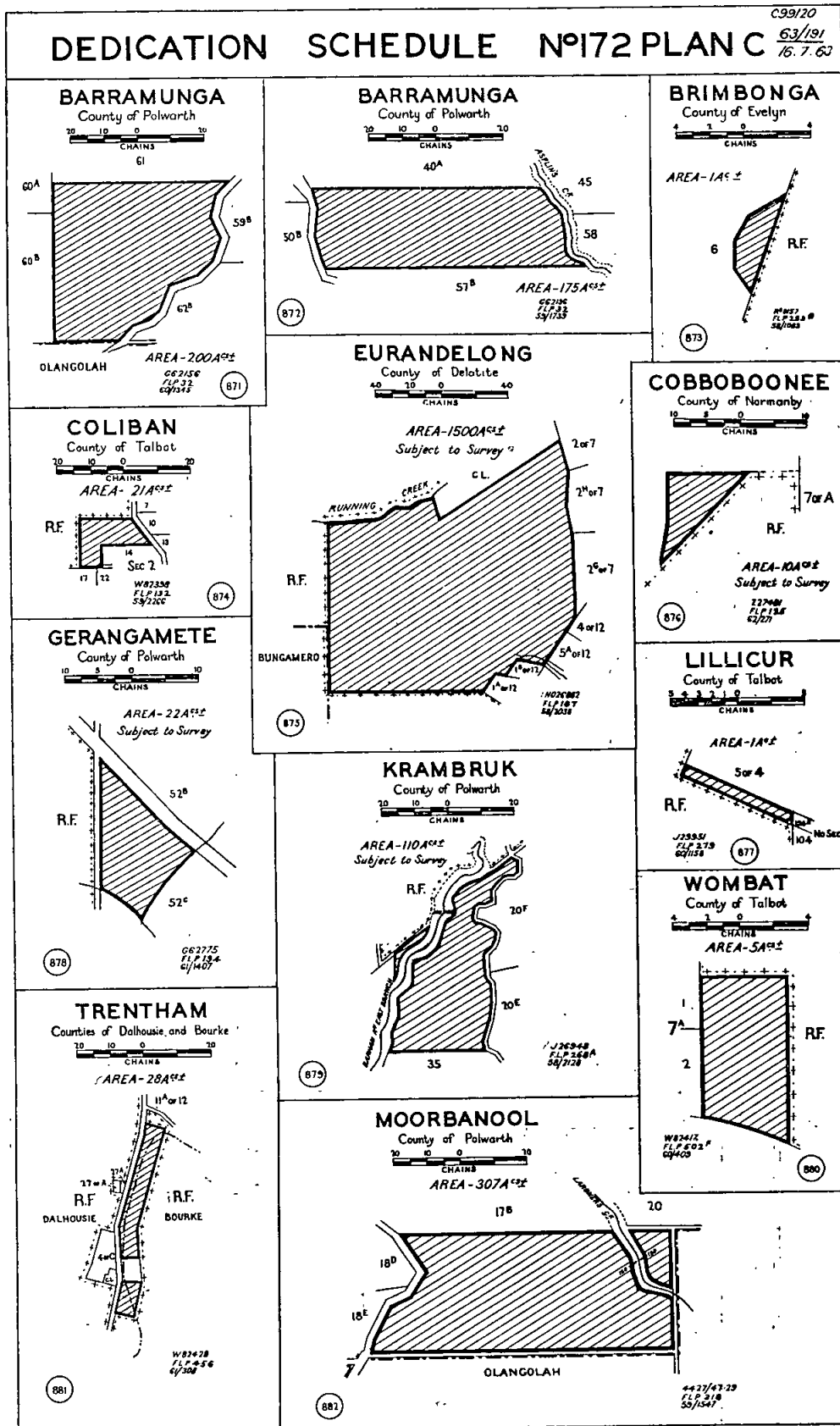

And the Honorable Lindsay Hamilton Simpson Thompson, Her Majesty's Minister of Forests for the State of Victoria, shall give the necessary directions herein accordingly.

N. G. WISHART,
Clerk of the Executive Council.

HOUSING ACT 1958.

At the Executive Council Chamber, Melbourne, the thirtieth day of July, 1963.

PRESENT:

His Excellency the Governor of Victoria.
Mr. Bloomfield | Mr. Hamer.

DECLARATION OF PRIVATE STREETS AS PUBLIC HIGHWAYS WITHIN THE SHIRE OF WERRIBEE.

WHEREAS pursuant to section 107 of the *Housing Act 1958* it is among other things enacted that where works have been carried out in accordance with an Agreement for the full construction of any roads, pavements, culverts or drains made pursuant to the provisions of the said section 107 such roads, pavements, culverts or drains shall be under the care and management of the Municipality which shall be liable for the cost of any maintenance, repair, alteration or reconstruction thereof and the Governor in Council may by order published in the *Government Gazette* declare any road so constructed to be a public highway.

And whereas by Order dated the 16th day of January, 1962, the Governor in Council consented to an Agreement between the Housing Commission and the Shire of Werribee regarding street and drainage construction in Deborah-street, Julian-street, Gavan-court, Glenda-street and Vincent-crescent including the right-of-way and parking bays off Market-road situate in the Municipality of the Shire of Werribee and the carrying out of the works enumerated in the said Agreement.

And whereas the works of road pavement, culvert and drainage construction have now been carried out in accordance with the said Agreement between the Housing Commission and the Shire of Werribee.

Now therefore His Excellency the Governor of the State of Victoria by and with the advice of the Executive Council of the said State and in pursuance of the powers conferred by section 107 of the *Housing Act* and upon the recommendation of the Housing Commission, doth by this Order declare the streets more particularly delineated and shown hatchured on the plan hereunder to be absolutely dedicated to the public as Public Highways within the meaning of any law now or hereafter in force, and that the Council of the Municipality in which the streets are situate shall hereafter be liable for all cost of any maintenance, repair, alteration or reconstruction thereof.

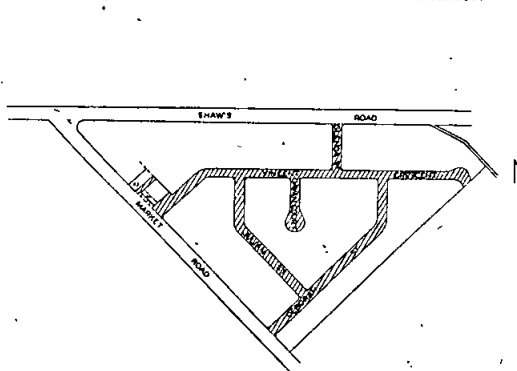

PART OF CROWN ALLOTMENT 6 AND PART OF CROWN ALLOTMENT 7 SECTION 16 PARISH OF DEUTGAM COUNTY OF BOURKE
Scale of Feet

And the Honorable Lindsay Hamilton Simpson Thompson, Her Majesty's Minister of Housing for the State of Victoria, shall give the necessary directions herein accordingly.

N. G. WISHART,
Clerk of the Executive Council.

HOUSING ACT 1958.

At the Executive Council Chamber, Melbourne, the sixth day of August, 1963.

PRESENT:

His Excellency the Governor of the State of Victoria.
Mr. Chandler | Mr. Turnbull.
Mr. Thompson

DECLARATION OF A RECLAMATION AREA AT ST. KILDA.

WHEREAS within an area in the City of St. Kilda described in the Schedule hereto there are houses which;

- (a) are unfit for human habitation, or
- (b) are in the opinion of Housing Commission insanitary or unhealthy by reason of—
 - (i) the excessive number of buildings within the area; and
 - (ii) the bad arrangement of buildings within the area.

And whereas Housing Commission considers that housing conditions within the area cannot satisfactorily be dealt with unless the said area is dealt with under Part III. of the *Housing Act 1958* (No. 6275), as a Reclamation Area and has recommended that the said area should be constituted a Reclamation Area.

And whereas Housing Commission having duly complied with the provisions of sub-section (3) of section 67 of the said Act has submitted to the Governor in Council its recommendation that the said area should be constituted a Reclamation Area.

Now therefore I, the Governor of the State of Victoria in the Commonwealth of Australia, by and with the advice of the Executive Council of the said State, do hereby declare the said area to be a Reclamation Area.

SCHEDULE.

All those pieces of land situate within the municipality of the City of St. Kilda, being part of Crown allotments C and D, portion 70, Parish of Prahran, and being the land described as follows:—

First, the land comprised in Certificates of Title—

Volume.	Folio.
4012	202
4686	042
5284	786
5284	787
5285	812
5285	813
6594	747
6594	748
8370	593

Secondly, the land remaining untransferred in certificates of title, volume 5873, folio 417, and volume 7514, folio 140.

Thirdly, lots numbered 3 and 4 on plan of subdivision number 1392, lodged in the Office of Titles, being part of the land comprised in certificate of title, volume 2251, folio 111.

Fourthly, Rosedale-street, shown on plan of subdivision number 1392, lodged in the Office of Titles, and the reserve 1 foot wide at the northern termination of that street.

Fifthly, the road shown 12 feet wide on plan of subdivision number 1392, lodged in the Office of Titles, and abutting on lots numbered 3, 4, 5, 6, 7 and 16 on the said plan of subdivision.

And the Honorable Lindsay Hamilton Simpson Thompson, Her Majesty's Minister of Housing for the State of Victoria, shall give the necessary directions herein accordingly.

N. G. WISHART,
Clerk of the Executive Council.

COMPANIES ACT 1961.

At the Executive Council Chamber, Melbourne, the sixth day of August, 1963.

PRESENT:

His Excellency the Governor of Victoria.
Mr. Chandler | Mr. Turnbull.
Mr. Thompson

APPOINTMENT OF INSPECTOR.

WHEREAS pursuant to section 172 of the *Companies Act 1961* the Governor in Council has by Proclamation published in the *Government Gazette* declared that the companies the names of which are set forth in the Schedule hereto are companies to which Division 4 of Part VI. of the said Act applies: And whereas it is expedient that a competent Inspector should be appointed to investigate the affairs of the said companies and to report in writing thereon to the Honorable the Attorney-General:

Now therefore, in pursuance of the powers conferred by section 173 of the said Act, His Excellency the Governor of the State of Victoria, by and with the advice of the Executive Council thereof, doth hereby appoint—

PETER MURPHY, one of Her Majesty's Counsel, to be an Inspector to investigate the affairs of the said companies accordingly, and to report in writing thereon to the Honorable the Attorney-General.

SCHEDULE.

Stanhill Consolidated Limited, formerly known as Stanhill Holdings Limited.
Factors Limited, formerly known as The Automobile Finance Company of Australia Limited.
Stanhill Development Finance Limited, formerly known as Stanhill Finance Corporation Limited.
Chevron Sydney Limited.
General Investments & Discounts Proprietary Limited, formerly known as General Investments & Discounts Limited.
Banyule. Australia Pty. Ltd., formerly known successively as Stanhill Limited and Stanhill Pty. Limited.
Park Lane Pty. Limited, formerly known successively as Stanville Limited and Stanville Pty. Limited.
Banyule Pty. Limited.
Stanhill Estates Pty. Limited, formerly known as Stanhill Estates Limited.
Stanhill Development Proprietary Limited, formerly known as Stanhill Development Limited.

And the Honorable Arthur Gordon Rylah, Her Majesty's Attorney-General for the State of Victoria, shall give the necessary directions herein accordingly.

N. G. WISHART,
Clerk of the Executive Council.

COMPANIES ACT 1961.

At the Executive Council Chamber, Melbourne, the sixth day of August, 1963.

PRESENT:

His Excellency the Governor of Victoria.
Mr. Chandler | Mr. Turnbull.
Mr. Thompson

APPOINTMENT OF INSPECTOR.

WHEREAS pursuant to section 172 of the *Companies Act 1961* the Governor in Council has by Proclamation published in the *Government Gazette* declared that the company the name of which is set out in the Schedule hereto is a foreign company to which Division 4 of Part VI. of the said Act applies: And whereas it is expedient that a competent Inspector should be appointed to investigate the affairs of the said foreign company and to report in writing thereon to the Honorable the Attorney-General:

Now therefore, in pursuance of the powers conferred by section 173 of the said Act, His Excellency the Governor of the State of Victoria, by and with the advice of the Executive Council thereof, doth hereby appoint—

PETER MURPHY, one of Her Majesty's Counsel, to be an Inspector to investigate the affairs of the foreign company accordingly, and to report in writing thereon to the Honorable the Attorney-General.

SCHEDULE.

Dominion (Pty.) Ltd.

And the Honorable Arthur Gordon Rylah, Her Majesty's Attorney-General for the State of Victoria, shall give the necessary directions herein accordingly.

N. G. WISHART,
Clerk of the Executive Council.

COMPANIES ACT 1961.

At the Executive Council Chamber, Melbourne, the sixth day of August, 1963.

PRESENT:

His Excellency the Governor of Victoria.
Mr. Chandler | Mr. Turnbull.
Mr. Thompson

APPOINTMENT OF INSPECTOR.

WHEREAS pursuant to section 172 of the *Companies Act 1961* the Governor in Council has by Proclamation published in the *Government Gazette* declared that the company the name of which is set forth in the Schedule hereto is a company to which Division 4 of Part VI. of the Act applies: And whereas it is expedient that a competent Inspector should be appointed to investigate the affairs of the said company and to report in writing thereon to the Honorable the Attorney-General:

Now therefore, in pursuance of the powers conferred by section 173 of the said Act, His Excellency the Governor of the State of Victoria, by and with the advice of the Executive Council thereof, doth hereby appoint—

WILLIAM EVERARD PATERSON, of Counsel, to be an Inspector to investigate the affairs of the said company accordingly, and to report in writing thereon to the Honorable the Attorney-General.

SCHEDULE.

Public Fidelity and Audit Limited, formerly known as Public Fidelity and Audit Proprietary Limited.

And the Honorable Arthur Gordon Rylah, Her Majesty's Attorney-General for the State of Victoria, shall give the necessary directions herein accordingly.

N. G. WISHART,
Clerk of the Executive Council.

LOCAL GOVERNMENT ACT 1958.

At the Executive Council Chamber, Melbourne, the sixth day of August, 1963.

PRESENT:

His Excellency the Governor of Victoria.
Mr. Chandler | Mr. Turnbull.
Mr. Thompson

DIRECTIONS FOR THE PREPARATION OF VOTERS' ROLL FOR THE BERWICK RIDING OF THE SHIRE OF BERWICK.

PURSUANT to the provisions of section 107 of the *Local Government Act 1958*, His Excellency the Governor of the State of Victoria, by and with the advice of the Executive Council thereof, doth by this order direct that a voters' roll for the Berwick Riding of the Shire of Berwick be prepared as follows, that is to say:—

1. A voters' list of the names of all persons who appear to be entitled to be enrolled upon the voters' roll for the Berwick Riding of the Shire of Berwick, shall be made out not later than 12th August, 1963.

2. Public advertisement that such list or a copy thereof may be inspected between the 15th and 17th days of August, 1963, both days inclusive, shall be inserted in a newspaper generally circulating in the neighbourhood not later than 14th August, 1963.

3. Notice of claims of persons to have their names included in such voters' list and notice of objections by persons to the inclusion of any names in such voters' list, shall be given or sent by post to the municipal clerk not later than 17th August, 1963.

4. Lists of claims and objections shall be available at the municipal offices for inspection by any person during office hours on 19th August, 1963.

5. A revision court shall be held on 20th August, 1963.

6. The voters' roll printed and signed by the municipal clerk shall be delivered to the chairman of the municipality not later than 21st August, 1963.

And the Honorable Murray Victor Porter, Her Majesty's Minister for Local Government for the State of Victoria, shall give the necessary directions herein accordingly.

N. G. WISHART,
Clerk of the Executive Council.

WORKERS COMPENSATION ACT 1958.

At the Executive Council Chamber, Melbourne, the sixth day of August, 1963.

PRESENT:

His Excellency the Governor of Victoria.
Mr. Chandler | Mr. Turnbull.
Mr. Thompson

PUBLIC BODY SPECIFIED.

IN pursuance of the powers conferred by the *Workers Compensation Act 1958*, His Excellency the Governor of the State of Victoria, in the Commonwealth of Australia, by and with the advice of the Executive Council of the said State, doth hereby specify the Victorian Licensing Court (excluding the Chairman) for the purposes of section 65 of the said Act.

And the Honorable Arthur Gordon Rylah, Her Majesty's Chief Secretary for the State of Victoria, shall give the necessary directions herein accordingly.

N. G. WISHART,
Clerk of the Executive Council.

LANDLORD AND TENANT ACT 1958.

At the Executive Council Chamber, Melbourne, the sixth day of August, 1963.

PRESENT:

His Excellency the Governor of Victoria.
Mr. Chandler | Mr. Turnbull.
Mr. Thompson

ORDER EXTENDING APPLICATION OF PART V. OF THE LANDLORD AND TENANT ACT 1958 TO CERTAIN PREMISES.

IN pursuance of the powers conferred by section 44 of the *Landlord and Tenant Act 1958*, His Excellency the Governor of Victoria, by and with the advice of the Executive Council thereof, doth hereby declare that the application of Part V. of the *Landlord and Tenant Act 1958* shall extend to the premises known as No. 49 Liddiard-street, Hawthorn.

And the Honorable Arthur Gordon Rylah, Her Majesty's Attorney-General for the State of Victoria, shall give the necessary directions herein accordingly.

N. G. WISHART,
Clerk of the Executive Council.

SWAN HILL SEWERAGE AUTHORITY.

At the Executive Council Chamber, Melbourne, the sixth day of August, 1963.

PRESENT:

His Excellency the Governor of Victoria.
Mr. Chandler | Mr. Turnbull.
Mr. Thompson

CONSENT TO BORROWING £3,000.

UNDER the powers conferred by the Sewerage Districts Acts and all other powers enabling him in that behalf, His Excellency the Governor of the State of Victoria, by and with the advice of the Executive Council of the said State, doth hereby consent to the Swan Hill Sewerage Authority borrowing by the assignment of the General Fund the sum of Three thousand pounds (£3,000) for the conversion of Loan No. 3 which matured on 1st July, 1963.

And the Honorable Wilfred John Mibus, Her Majesty's Minister of Water Supply for the State of Victoria, shall give the necessary directions herein accordingly.

N. G. WISHART,
Clerk of the Executive Council.

MOE SEWERAGE AUTHORITY.

At the Executive Council Chamber, Melbourne, the sixth day of August, 1963.

PRESENT:

His Excellency the Governor of Victoria.
Mr. Chandler | Mr. Turnbull.
Mr. Thompson

CONSENT TO BORROWING £12,000.

UNDER the powers conferred by the Sewerage Districts Acts and all other powers enabling him in that behalf, His Excellency the Governor of the State of Victoria, by and with the advice of the Executive Council of the said State, doth hereby consent to the Moe Sewerage Authority borrowing by the assignment of the General Fund the sum of Twelve thousand pounds (£12,000) to meet the cost of sewerage works as set forth in the detailed statement bearing date the 2nd August, 1963.

And the Honorable Wilfred John Mibus, Her Majesty's Minister of Water Supply for the State of Victoria, shall give the necessary directions herein accordingly.

N. G. WISHART,
Clerk of the Executive Council.

GEELONG WATERWORKS AND SEWERAGE TRUST.

At the Executive Council Chamber, Melbourne, the sixth day of August, 1963.

PRESENT:

His Excellency the Governor of Victoria.
Mr. Chandler | Mr. Turnbull.
Mr. Thompson

CONSENT TO BORROWING £200,000.

UNDER the powers conferred by the Geelong Waterworks and Sewerage Acts and all other powers enabling him in that behalf, His Excellency the Governor of the State of Victoria, by and with the advice of the Executive Council of the said State, doth hereby consent to the Geelong Waterworks and Sewerage Trust borrowing at interest, subject to the Geelong Waterworks and Sewerage Acts, the sum of Two hundred thousand pounds (£200,000) in two amounts of One hundred thousand pounds (£100,000) to meet the cost of water supply works.

And the Honorable Wilfred John Mibus, Her Majesty's Minister of Water Supply for the State of Victoria, shall give the necessary directions herein accordingly.

N. G. WISHART,
Clerk of the Executive Council.

CASTERTON SEWERAGE AUTHORITY.

At the Executive Council Chamber, Melbourne, the sixth day of August, 1963.

PRESENT:
His Excellency the Governor of Victoria.
Mr. Chandler | Mr. Turnbull.
Mr. Thompson |

REPEAL OF ORDER.

UNDER the powers conferred by the Sewerage Districts Acts and all other powers enabling him in that behalf, His Excellency the Governor of the State of Victoria, by and with the advice of the Executive Council of the said State, doth hereby repeal the Order made by the Governor in Council on 30th September, 1958, and published in the *Victoria Government Gazette* on 1st October, 1958, fixing the limit of the overdraft to be obtained by the Casterton Sewerage Authority.

And as on and from the date hereof, the said Order of the Governor in Council shall be deemed to be repealed accordingly.

And the Honorable Wilfred John Mibus, Her Majesty's Minister of Water Supply for the State of Victoria, shall give the necessary directions herein accordingly.

N. G. WISHART,
Clerk of the Executive Council.

AXEDALE WATERWORKS TRUST.

At the Executive Council Chamber, Melbourne, the sixth day of August, 1963.

PRESENT:
His Excellency the Governor of Victoria.
Mr. Chandler | Mr. Turnbull.
Mr. Thompson |

AMENDMENT OF ORDER.

UNDER the powers conferred by the Water Acts and all other powers enabling him in that behalf, His Excellency the Governor of the State of Victoria, by and with the advice of the Executive Council of the said State, doth hereby amend as follows the Order in Council made on the 23rd April, 1963, and published in the *Victoria Government Gazette* dated 24th April, 1963, authorizing the Axedale Waterworks Trust to obtain an overdraft under section 286 of the *Water Act 1958*, No. 6413, during the year 1963.

For the expression "the sum of One hundred and fifty pounds (£150)" there shall be substituted the expression "the sum of Six hundred and fifty pounds (£650)".

And the Honorable Wilfred John Mibus, Her Majesty's Minister of Water Supply for the State of Victoria, shall give the necessary directions herein accordingly.

N. G. WISHART,
Clerk of the Executive Council.

SALE SEWERAGE AUTHORITY.

At the Executive Council Chamber, Melbourne, the sixth day of August, 1963.

PRESENT:
His Excellency the Governor of Victoria.
Mr. Chandler | Mr. Turnbull.
Mr. Thompson |

POWER TO BORROW £30,000.

UNDER the powers conferred by the Sewerage Districts Acts and all other powers enabling him in that behalf, His Excellency the Governor of the State of Victoria, by and with the advice of the Executive Council of the said State, doth hereby consent to the Sale Sewerage Authority borrowing at interest an additional sum of Thirty thousand pounds (£30,000) for the carrying out of works in accordance with the provisions of sections 95, 130 and 137 of the *Sewerage Districts Act 1958*, the said sum to be borrowed by way of overdraft from the Commercial Banking Company of Sydney Limited. All

moneys received by the said Authority in payment of costs and expenses of the said works, or any of them, shall be set aside for the purpose of and applied in repayment of the said sum so borrowed.

And the Honorable Wilfred John Mibus, Her Majesty's Minister of Water Supply for the State of Victoria, shall give the necessary directions herein accordingly.

N. G. WISHART,
Clerk of the Executive Council.

APPROACHING LAND SALES.

SALES of Crown lands, in fee-simple, will be held at the under-mentioned places and dates, viz.:-

	No. of Gazette.
Beechworth.—Wednesday, 4th September, 1963	60
Bright.—Thursday, 5th September, 1963	60
Chiltern.—Wednesday, 4th September, 1963	60
Colac.—Friday, 6th September, 1963	60
Hamilton.—Friday, 9th August, 1963	51
Heathcote.—Friday, 30th August, 1963	57
Tallangatta.—Thursday, 5th September, 1963	60
Yackandandah.—Wednesday, 4th September, 1963	60

PROPOSED REVOCATIONS OF TEMPORARY RESERVATIONS OF LANDS BY ORDERS IN COUNCIL.

IN pursuance of the provisions of the *Land Act 1958*, notice is hereby given that it is the intention of the Governor in Council to revoke the temporary reservations of lands by Orders in Council hereunder referred to, viz.:-

The following Notices were published 1^o on the 31st July, 1963, pursuant to Orders of the 23rd July, 1963.

GIFFARD.—The temporary reservation, by Order in Council of the 19th May, 1891 (see *Government Gazette* of the 22nd May, 1891, page 2167), of 49 acres 1 rood 34 perches of land in the Parish of Giffard as a site for Camping and Watering purposes.—(G.63^(*)) (Ho.28160).

PALLARANG.—The temporary reservation, by Order in Council of 14th December, 1926, of 20 acres 0 roods 1 perch of land in the Parish of Pallarang, as a site for Public Recreation.—P.176^(*) (Rs.3399).

SWAN HILL.—The temporary reservation, by Order in Council of the 19th May, 1896, of 110 acres 3 roods 32 perches of land in the Township of Castle Donnington (now Township of Swan Hill), as a site for a Racecourse, revoked as to part of various Orders, is about to be revoked so far only as the portion containing 1 acre more or less, indicated by hachure on plan hereunder, is concerned.—(S.464⁽⁴⁾) (Rs.1789).

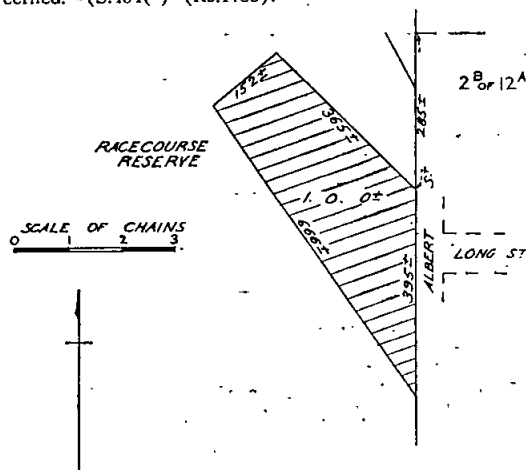

WODONGA.—The temporary reservation, by Order in Council of the 2nd April, 1936, of 5 acres 2 roods 11 1/2 perches of land in the Parish of Wodonga, as a site for Water Supply purposes, revoked as to part by Order of the 15th March, 1943, is about to be revoked so far as the balance thereof, containing 3 acres 0 roods 24 perches, is concerned.—(W.308^(*)) (Rs.4550).

KEITH TURNBULL,
Commissioner of Crown Lands and Survey.

PROPOSED REVOCATION OF TEMPORARY RESERVATION OF LAND BY ORDER IN COUNCIL.

IN pursuance of the provisions of the *Land Act 1958*, notice is hereby given that it is the intention of the Governor in Council to revoke the temporary reservation of land by Order in Council hereunder referred to, viz.:—

The following Notice was published 1° on the 24th July, 1963, pursuant to Order of the 16th July, 1963.

WINIAM.—The temporary reservation by Order in Council of the 11th May, 1886, of 1 acre of land in the Parish of Winiam, as a site for a State School.—(W.324⁽²⁾) (Rs.8230).

KEITH TURNBULL,
Commissioner of Crown Lands and Survey.

PROPOSED REVOCATIONS OF TEMPORARY RESERVATIONS OF LANDS BY ORDERS IN COUNCIL.

IN pursuance of the provisions of the *Land Act 1958*, notice is hereby given that it is the intention of the Governor in Council to revoke the temporary reservations of lands by Orders in Council hereunder referred to, viz.:—

The following Notices were published 1° on the 17th July, 1963, pursuant to Orders of the 9th July, 1963.

BRAYBROOK.—The temporary reservation, by Order in Council of the 1st February, 1961, of 3 acres 1 rood 10 perches of land in the Township of Braybrook as a site for State School purposes, so far only as the portion containing 3 perches, indicated by hachure on plan hereunder is concerned.—(B.439⁽²⁾) (Rs.4425).

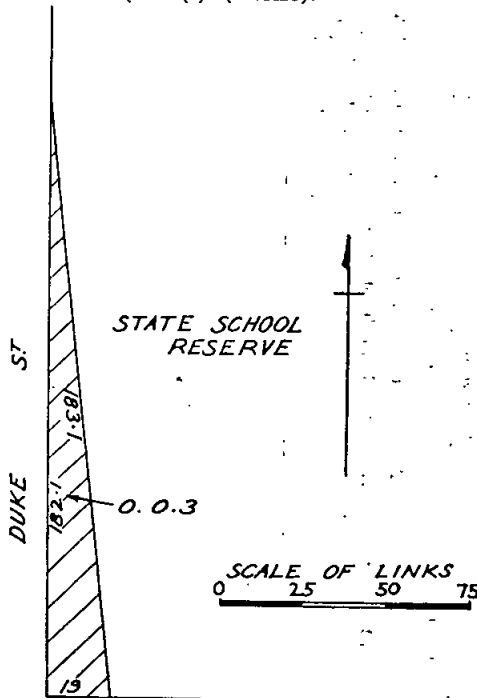

WESTERN HIGHWAY

KOLEYA.—The temporary reservation by Order in Council of the 7th August, 1928, of 3 acres 3 roods 39 perches of land in the Parish of Koley as a site for a State School.—(K.215⁽²⁾) (Rs.3718).

LANDSBOROUGH.—The temporary reservation by Order in Council of the 3rd April, 1894, of 10 acres of land in the Parish of Landsborough as a site for the Supply of Gravel.—(L.119⁽²⁾) (Rs.8231).

MALMSBURY.—The temporary reservation by Order in Council of the 19th October, 1937, of 1 acre 3 roods 28 1/10 perches of land in the Township of Malmsbury as a site for Police purposes, revoked as to part by Order of the 17th February, 1948, is about to be revoked so far as the balance thereof containing 2 roods 38 5/10 perches, is concerned.—(M.65⁽⁴⁾) (Rs.4717).

SPRING HILL.—The temporary reservation by Order in Council of the 21st February, 1911, of 1 acre 0 roods 20 perches of land in the Parish of Spring Hill as a site for a Quarry.—(S.311⁽⁴⁾) (Rs.1240).

KEITH TURNBULL,
Commissioner of Crown Lands and Survey.

PROPOSED REVOCATIONS OF TEMPORARY RESERVATIONS OF LANDS BY ORDERS IN COUNCIL.

IN pursuance of the provisions of the *Land Act 1958*, notice is hereby given that it is the intention of the Governor in Council to revoke the temporary reservations of lands by Orders in Council hereunder referred to, viz.:—

The following Notices were published 1° on the 7th August, 1963, pursuant to Orders of the 30th July, 1963.

ARGYLE.—The temporary reservation, by Order in Council of the 30th October, 1934, of 19 acres 3 roods 35 perches of land in the Parish of Argyle as a site for the Supply of Gravel, so far only as the portion containing 6 acres 3 roods 7 perches, indicated by hachure on plan hereunder, is concerned.—(A.152⁽⁴⁾) (Rs.4410).

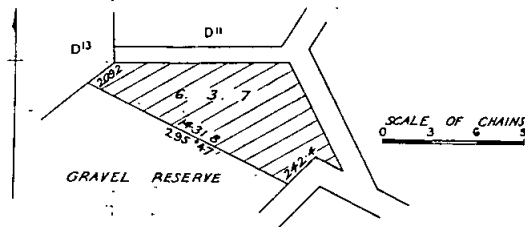

EUMEMMERRING.—The temporary reservation, by Order in Council of the 18th December, 1916, of 20 acres 0 roods 17 perches of land in the Parish of Eumemmerring as a site for Watering purposes, revoked as to part by Order of the 27th April, 1937, is about to be revoked, so far only as the portion containing 1 acre 0 roods 3 perches, indicated by hachure on plan hereunder, is concerned.—(E.78⁽⁴⁾) (Rs. 1337).

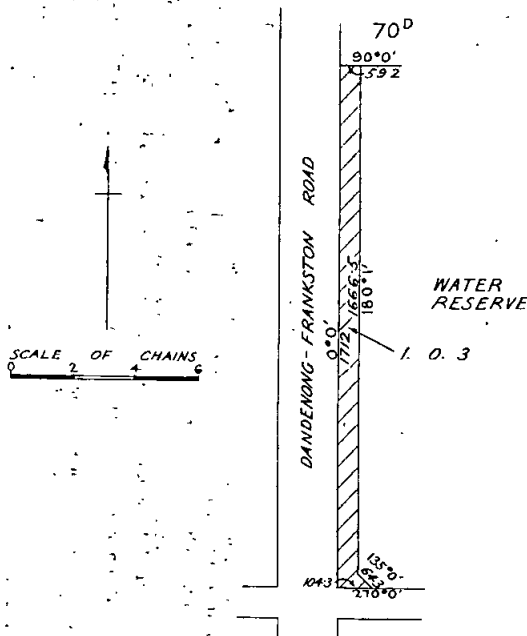

KEITH TURNBULL,
Commissioner of Crown Lands and Survey.

LIST OF CROWN LANDS AVAILABLE.

THE under-mentioned areas are available for application as provided by various sections of the Land Act 1958, and all applications received on or before Thursday, 5th September, 1963, will be deemed to have been made simultaneously, but any application lodged after such date may be considered if received in time for inclusion in the advertisement of the cases to be heard at the Local Land Board. Applications on proper form, accompanied by 5s. duty stamp uncancelled (registration fee), may be delivered or forwarded by post to the Local Land Officer or to any Crown Lands Office in Victoria. Subject to the approval of the Secretary for Lands, when the survey fee exceeds £25 but does not exceed £50, a deposit of £25 may be paid, and when the fee exceeds £50, a deposit of 50 per cent. of the fee, the balance in either case being payable over six years in half-yearly instalments. Marked plans of any particular area, application forms, and any further information may be obtained from the Crown Lands Department, Melbourne, and Land Office, Horsham.

Department of Crown Lands and Survey,
Melbourne, 5th August, 1963.

KEITH TURNBULL,
Commissioner of Crown Lands and Survey.

* Improvements may be subject to re-valuation after land has been granted to an applicant.

Local Land Office.	County.	Parish.	Allotment.	Section.	Area.	How Available.		Survey Fee.	Valuation of Improvements (if any).	Location of Land, &c.	Nearest Railway Station or Township and Distance in miles therefrom.	How Accessible.	Water Supply.	General Description of Land—Soil, Timber, Suitability (Grazing, &c.).	
						Classification.	Value per Acre.								
						A.	B.	C.							
Horsham	Borung	Stawell	9	83	0 1 0±	Rental to be fixed	5 10 0	One month for removal	Fronting south side of Byrme-street about 7 chains south of Gordon-street	Stawell Railway Station ¼ mile	By road	Town water supply	Suitable for residence purposes		

AVAILABLE UNDER SECTION 138 OF THE LAND ACT 1958.

PROPOSED REVOCATION OF TEMPORARY RESERVATION, AND THE WITHHOLDING FROM SALE, LEASING, AND LICENSING, OF LAND BY ORDER IN COUNCIL.

IN pursuance of the provisions of the Land Act 1958, notice is hereby given that it is the intention of the Governor in Council to revoke the temporary reservation, and the withholding from sale, leasing, and licensing, of land by Order in Council hereunder referred to, viz.:

The following Notice was published 1° on the 7th August, 1963, pursuant to Order of the 30th July, 1963.

DALYENONG.—The temporary reservation as a site for State School purposes and the withholding from sale, leasing and licensing, by Order in Council of the 28th June, 1875, of 5 acres of land in the Township of Archdale (now Parish of Dalyenong).—(D.181⁽²⁾) (Rs.6739).

KEITH TURNBULL,

Commissioner of Crown Lands and Survey.

PROPOSED REVOCATION OF TEMPORARY RESERVATION, AND THE WITHHOLDING FROM SALE, LEASING, AND LICENSING OF LAND BY ORDER IN COUNCIL.

IN pursuance of the provisions of the Land Act 1958, notice is hereby given that it is the intention of the Governor in Council to revoke the temporary reservation, and the withholding from sale, leasing and licensing, of land by Order in Council hereunder referred to, viz.:

The following Notice was published 1° on the 24th July, 1963, pursuant to Order of the 16th July, 1963.

COLERAINE.—The temporary reservation as a site for the use of the Police Department and the withholding from sale, leasing and licensing by Order in Council of the 13th October, 1879, of 1 acre of land in the Township of Coleraine.—(C.301⁽³⁾) (Rs.7081).

KEITH TURNBULL,

Commissioner of Crown Lands and Survey.

COMMON ABOUT TO BE DIMINISHED.

IN pursuance of the provisions contained in the Land Act 1958, notice is hereby given that it is the intention of the Governor in Council to diminish the common herein-after mentioned, viz.:

The following Notice was published 1° on the 10th July, 1963, pursuant to Order of the 2nd July, 1963.

The Ballarat West Town Common, proclaimed as such by the Governor in Council on the 28th January, 1861, is about to be diminished by the excision therefrom of the portion containing 13 acres 1 rood 13 perches, indicated by hachure on plan hereunder.—(C.91998).

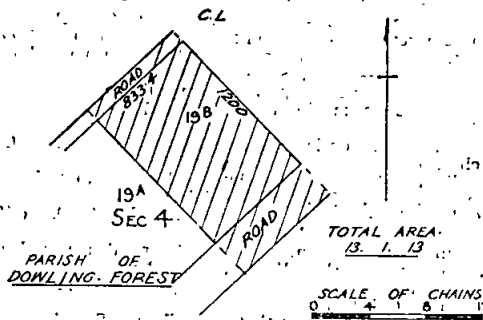

KEITH TURNBULL,

Commissioner of Crown Lands and Survey.

COMMITTEES OF MANAGEMENT OF RESERVES. APPOINTMENTS.

WHEREAS by section 221 of the Land Act 1958 it is provided that it shall be lawful for the Governor in Council or the Board of Land and Works to appoint and remove any number of persons, not less than three, or any municipal council, or the governing body of any corporation, to be a Committee of Management of any specified Crown land reserved either temporarily or permanently for any of the purposes set out in section 14 of the Land Act 1958, and not conveyed to or vested in trustees: Now therefore the Board of Land and Works

doth hereby appoint the under-mentioned persons to be members of the Committee of Management of the Reserves named:—

"FOSTER RECREATION (TENNIS) RESERVE."

James Lewis Wilson in the place of David Ivan Milne (resigned) and Anthony Wilson as members of the Committee of Management for a period ending the 27th March, 1965, of the land in the Parish of Wonga Wonga South temporarily reserved as sites for Public Recreation by Orders in Council dated the 19th November, 1936, and the 20th February, 1951, and known as the "Foster Recreation (Tennis) Reserve".—(Corres. Rs.4631.)

"SARSFIELD RECREATION RESERVE."

Cecil Thomas Filmer, Ian Roland Haggard and Joseph Thomas Coster as a Committee of Management for a period of three years of the land temporarily reserved by Order in Council dated the 24th October, 1892, as a site for Public Recreation in the Township of Sarsfield, and known as the "Sarsfield Recreation Reserve".—(Corres. Rs.1457.)

"MITCHELL GARDENS RESERVE", BAIRNSDALE.

Eric George Pallot in the place of John Kingswell Lloyd (deceased) as a member of the Committee of Management for a period ending the 15th February, 1964, of the land permanently reserved by Order in Council dated the 12th June, 1882, as a site for Recreation purposes in the Town of Bairnsdale; the land temporarily reserved by Order in Council dated the 17th July, 1882, as a site for Recreation purposes in the Town of Bairnsdale and the land temporarily reserved by Order in Council dated the 5th February, 1906, as a site for Public Recreation in the Township of Bairnsdale, which lands are together known as "Mitchell Gardens Reserve".—(Corres. Rs.4821.)

"MIDDLE CREEK PUBLIC HALL RESERVE."

Alfred James Hillman, Colin Bert Peters, John Maxwell Roberts, Claude Edward Waldron and Walter Joseph Roberts as a Committee of Management for a period of three (3) years of the land temporarily reserved by Order in Council dated 11th December, 1876, as a site for Public purposes in the Parish of Buangor, and known as the "Middle Creek Public Hall Reserve".—(Corres. Rs.4883.)

"DIAPUR FREE LIBRARY RESERVE."

William Boadle Hensley, John Mathew Wheeler, William Bruce Hensley, George Albert Cook, Raymond Alfred Voigt, Malcolm David Honeyman, Curtis Henry Honeyman, Edward Mark Cook, Kevin William Marra and William Thomas Cook as a Committee of Management for a period of three (3) years of the land temporarily reserved by Order in Council dated the 24th June, 1889, as a site for a Free Library in the Township of Diapur, and known as the "Diapur Free Library Reserve".—(Corres. Rs.4793.)

"BENJEROOP PUBLIC HALL RESERVE."

Arthur Cyril Henry, Alfred Langdale Nethercote, Arthur Lindsay Morton, Douglas W. Haig, George A. Vistarini, Harold Alfred Davey, William H. Binder and Douglas Walter Wells as a Committee of Management for a period of three (3) years of the land temporarily reserved by Order in Council dated the 18th June, 1888, as a site for a Public Hall in the Township of Benjeroop, and known as the "Benjeroop Public Hall Reserve".—(Corres. Rs.6664.)

"PINE GROVE RECREATION RESERVE."

Richard James Jasper, Percy Thomas Pollock, Raymond Carlyle James, Edwin Albert Chappel, Robert McBeath and Joseph Edwin Chappel as a Committee of Management for a period of three (3) years of the land temporarily reserved by Order in Council dated 15th March, 1887, as a site for Public Recreation in the Parish of Wanurp, and known as the "Pine Grove Recreation Reserve".—(Corres. Rs.1753.)

"DIAPUR RECREATION RESERVE."

William Boadle Hensley, John Mathew Wheeler, William Bruce Hensley, George Albert Cook, Raymond Alfred Voigt, Malcolm David Honeyman, Curtis Henry Honeyman, Edward Mark Cook, Kevin William Marra and William Thomas Cook as a Committee of Management for a period of three (3) years of the land temporarily reserved by Orders in Council dated the 18th April, 1905, and 28th July, 1959, as sites for Public Recreation in the Township of Diapur, and together known as the "Diapur Recreation Reserve".—(Corres. Rs.2724.)

"GARFIELD RECREATION RESERVE."

Albert John Payne, Charles Maceden Styles, Allan R. Payne, Clifford Frederick Butcher, Thomas Patrick Harrison, Leonard John Brenchley, Alfred Henry Bassed, Leonard Claude Austin and Frederick Charles Cox as a Committee of Management for a period of three (3) years of the land temporarily reserved by Order in Council dated the 4th July, 1899, as a site for Public Recreation in the Parish of Koo-Wee-Rup East, and known as the "Garfield Recreation Reserve".—(Corres. Rs.2187.)

"DRUMANURE RECREATION RESERVE."

The Council of the Shire of Numurkah as a Committee of Management of the land temporarily reserved by Order in Council dated the 13th February, 1904, as a site for Public Recreation in the Parish of Drumanure, and known as the "Drumanure Recreation Reserve".—(Corres. Rs.4803.)

"BARKLY RECREATION RESERVE."

Gordon Jonathan Marland, Alan Driscoll, Kenneth Rex Stewart, Neil Alexander Emerson, Malcolm William Herd, Graham John Driscoll, Benjamin Driscoll, Leslie Driscoll and Lawrence Albert Wright as a Committee of Management for a period of three (3) years from 22nd July, 1963, of the land temporarily reserved by Order in Council dated

26th May, 1902, as a site for Public Recreation purposes in the Parish of Barkly, and known as "Barkly Recreation Reserve".—(Corres. Rs.4800.)

"OAKLEIGH MUNICIPAL BUILDINGS RESERVE."

The Council of the City of Oakleigh as a Committee of Management of the land temporarily reserved by Order in Council dated the 30th January, 1963, as a site for Municipal Buildings.—(Corres. Rs.1936.)

"COWWARR PUBLIC PARK RESERVE."

A. O'Brien, Dermot Daniel O'Brien, Herman Floyd Sundermann, Barrett John Houston and John L. O'Brien as a Committee of Management for a period of three (3) years of the land temporarily reserved by Order in Council dated 2nd December, 1879, as a site for Public purposes in the Parish of Toongabbie North, and known as the "Cowwarr Public Park Reserve".—(Corres. Rs.4190.)

In witness whereof the common seal of the Board of Land and Works was hereunto affixed this thirty-first day of July, One thousand nine hundred and sixty-three, in the presence of—

(SEAL) KEITH TURNBULL, President.
L. W. BIRCH, Member.

Land Act 1958.

LEASE SURRENDERED.

NOTICE is hereby given that the Governor in Council has accepted the surrender of the Lease mentioned in the Schedule hereunder for the reason specified.

District.	Corr. No.	Name.	Section of Land Act under which Leased.	Parish.	Allotment.	Section.	Area.	Class.	Reason.
Melbourne	0644/125	Bray Brook Investments Pty. Limited	134	Doutta Galla	13	1A	A. B. P. 4 3 17	..	Surrendered (New lease to issue)

Department of Crown Lands and Survey,
Melbourne, 26th July, 1963.

KEITH TURNBULL,
Commissioner of Crown Lands and Survey.

TENDERS—PUBLIC WORKS DEPARTMENT

TENDERS will be received at this Department's Head office, Treasury-place, Melbourne, until TEN a.m. on the dates, and for the purposes under mentioned.

Particulars may be learnt at the Department and also at places shown in parentheses.

W.O. means Inspector of Works Office; P.S.—Police Station; T.S.—Technical School; H.E.S.—Higher Elementary School; S.S.—State School; H.S.—High School; C.S.—Consolidated School.

Tenders should be submitted on the Department's printed Tender Form and will not be received by telephone. All tenders must be on a "Firm Tender" basis. The Board of Land and Works will not necessarily accept the lowest or any tender.

Tenders to be addressed to the Hon. the Commissioner of Public Works, and envelope containing tender to be marked "Tender for _____, closing Tuesday, _____".

NOTE.—No preliminary deposit is to be lodged with any tender, but a deposit in accordance with the prescribed Schedule may be required from each successful tenderer.

Tuesday, 13th August, 1963.

Building, Electrical and Mechanical Works.

Allambee Estate.—Internal and external repairs and painting, S.S. 3995. (W.O., Warragul; S.S., Allambee Estate.)

Ballarat.—Installation of three (3) steam ovens and two (2) steam kettles in main kitchen, Mental Hospital. (W.O., Ballarat.)

Beaumaris North.—Connexion of residence to sewer, S.S. 4803. (S.S., Beaumaris North.)

Bellfield.—Repairs and internal painting, S.S., 4656.

Benalla.—External and internal renovations to Sergeant's residence, Police Station. (W.O., Benalla.)

Berwick.—Repairs and painting to residence, S.S.40. (S.S., Berwick.)

Blackburn Lake.—Erection of eight (8) class-room, concrete veneer, timber-framed Primary School, S.S. 4860.

Blackburn Lake.—Electrical installation in new school of eight (8) class-rooms, S.S. 4860.

Blackburn Lake.—Supply and installation of a plenum heating system in the new eight (8) class-rooms, S.S. 4860.

Brighton.—Extension of heating to Art Room, Girls' Technical School.

Bullumwaal.—New out-offices and septic tank installation, S.S. 1794. (W.O., Bairnsdale.)

Callawadda.—Repairs and painting, S.S. 2750. (W.O., Ararat; S.S., Callawadda.)

Calulu.—Repairs and painting to residence and out-buildings, S.S. 1821. (W.O., Bairnsdale; S.S., Calulu.)

Carlsruhe.—New toilets and septic tank installation, S.S. 115. (W.O., Kyneton.)

Carrum Downs.—New shelter pavilion, S.S. 3613. (S.S., Carrum Downs.)

Coburg.—Supply and installation of a hot water service for new dormitory block for "D" Division, Pentridge Gaol.

Coleraine.—Additions and renovations, Lands and Survey Department Inspector's residence, McLeod-street. (W.O., Hamilton; P.S., Coleraine.)

Echuca.—External repairs and painting, Technical School. (W.O., Shepparton; T.S., Echuca.)

Evansford.—Sewerage installation, S.S., 801. (W.O., Maryborough; S.S., Evansford.)

Frankston.—Internal renovations, High School. (H.S., Frankston.)

Gannawarra North.—Septic tank installation, S.S. 4547. (W.O., Swan Hill.)

Glenorchy.—Internal repairs and painting, S.S. 263. (W.O., Ararat; S.S., Glenorchy.)

Gorae West.—Repairs and painting to school and residence, install cupboards in school, S.S. 4556. (W.O., Warrnambool; S.S., Gorae West.)

Grenville.—Repairs and painting, S.S. 1153. (W.O., Ballarat; S.S., Grenville.)

Haddon.—Repairs and painting, S.S. 1076 and residence. (W.O., Ballarat; S.S., Haddon.)

Hopetoun.—Repairs and painting, S.S. 3167. (W.O., Warracknabeal; S.S., Hopetoun.)

Iraak.—Installation of septic tank and new toilets, S.S. 4191. (W.O., Mildura; S.S., Iraak.)

Kellalac.—New toilets, install septic tank, S.S. 2358. (W.O., Warracknabeal; S.S., Kellalac.)

Kew.—Supply and installation of gratings and door in main Boiler House, Mental Hospital.

Kew.—Supply and installation of wall type air conditioning units in outpatients room, Surgical Unit, Mental Hospital.

Kingsbury.—Erection of first section of timber-framed concrete veneer school buildings, Technical School.

Kingsbury.—Electrical installation in Stage (1), Technical School.

Kingsbury.—Supply and installation of mechanical services, Stage (1), Technical School.

Lara.—Electrical installation for residence, "Serendip", Fisheries and Wildlife Research Station. (W.O., Geelong.)

Lara.—Electrical installation for Machinery Shed, "Serendip", Fisheries and Wildlife Research Station. (W.O., Geelong.)

Lawler.—New toilets, install septic tank, S.S. 3414. (W.O., Warracknabeal; S.S., Lawler.)

Melbourne.—Dismounting existing and installation of new ductwork and extension to hot water service, State Offices, 179 Queen-street.

Mont Park.—Supply and installation of hot water supply in Wards A, B and C, and Wards M.8, 9, 10 and 11, Larundel Mental Hospital.

Oakleigh.—Internal repairs and painting, High School.

Prahran.—Alterations to residences, Technical School.

Spring Gully.—Connexion to town sewerage system, S.S. 3505. (W.O., Bendigo.)

St. Albans North.—Re-siting of shelter sheds, S.S. 4811.

South Melbourne.—Supply and installation of gas heating equipment, Public Works Department Garage, corner Sturt and Power streets.

Toolangi.—Supply and installation of two (2) evaporative coolers in the Glasshouse, Potato Research Station.

Traralgon.—Entrance porches, Hobson Park Hospital. (W.O., Traralgon.)

Traralgon.—Supply and installation of steam heating in dormitories of Wards F.1 and M.3, Hobson Park Hospital. (W.O., Traralgon.)

Tyabb Railway Station.—Internal and external painting to residence, S.S. 3544. (S.S., Tyabb Railway Station.)

Warragul.—Erection of two (2) shelter pavilions, High School. (W.O., Warragul; H.S., Warragul.)

Waurm Ponds.—Septic tank installation, S.S. 1040 and residence. (W.O., Geelong.)

West Melbourne.—Electrical installation, Section No. 6A, South Raft, Government Cool Stores.

West Melbourne.—Electrical installation, conversion of Cooling Chambers Nos. 1B, 3B, 5B and 7B, "B" Section, South Raft, Government Cool Stores.

Yarram.—Connexion of residence to sewer, Court House. (W.O., Traralgon; P.S., Yarram.)

Yarram.—Connexion of residence—Wesley-street, to sewerage, High School. (W.O., Traralgon; H.S., Yarram.)

Yarram.—Connexion of residence—Commercial-road, to sewerage, High School. (W.O., Traralgon; H.S., Yarram.)

Furniture and Furnishings.

Ballarat.—Supply and lay floor coverings, Teachers' College Hostel. (W.O., Ballarat.)

Ballarat.—Supply and fix curtains, Teachers' College Hostel. (W.O., Ballarat.)

Hopetoun.—Supply and lay lino tiles, Court House. (W.O., Ballarat and Warracknabeal.)

Janefield.—Tubular steel tables and chairs, Mental Hospital.

Melbourne.—Supply and install steel mobile storage, Food Standards Committee, Health Department, 295 Queen-street.

Site Works.

Preston East.—Paving, drainage and associated works, Technical School.

Miscellaneous.

Ararat.—Supply and delivery of one (1) vertical bale loader and one (1) bale stacker, Mental Hospital. (Specifications to be submitted with tender.)

Beechworth.—Supply and delivery of 20,000 bricks, Training Prison. (W.O., Wangaratta.)

Benalla.—Purchase and removal of residence, High School. (W.O., Benalla.)

Carlton.—Maintenance cleaning, 1st September, 1963, to 31st August, 1964, Public Offices, Exhibition Buildings, Rathdown-street.

Coburg.—Supply and delivery of reinforcing steel, Pentridge Gaol.

Melbourne.—Maintenance cleaning, 1st September, 1963, to 31st August, 1964, Agriculture Department, Head Office.

Mont Park.—Supply of blanketing and sheeting for flat ironers, Larundel Mental Hospital. (Samples to be supplied with tender.)

Mont Park.—Supply and delivery of a portable power sifter for the main kitchen, Larundel Mental Hospital.

Plenty.—Supply and delivery of stainless steel bulk food containers for the main kitchen, Mental Hospital.

Port Melbourne.—Supply and delivery of two 100-110 h.p. diesel tractors, Torque converter, pneumatic tires, 4-wheel drive with approximately 2 cubic-yards capacity bucket and dozer blade, Public Works Department Depot, Salmon-street.

Traralgon.—Supply and delivery of stainless steel trays, Hobson Park Hospital.

Tuesday, 20th August, 1963.

Building, Electrical and Mechanical Works.

Allan's Flat.—Internal and external painting and repairs, S.S. 11. (W.O., Wangaratta; S.S., Allan's Flat.)

Bairnsdale.—Alterations, additions, repairs and painting, Clerk of Courts residence. (W.O., Bairnsdale.)

Bayview.—External repairs and painting, S.S. 4752.

Bemm River.—Erection of new out-offices, septic tank and shelter shed, S.S. 4909. (W.O., Bairnsdale.)

Bendigo.—Internal renovations and painting, Technical School. (W.O., Bendigo.)

Betley.—Installation of septic tanks and new toilets, S.S. 774 and residence. (W.O., Maryborough; S.S., Betley.)

Brunswick.—Aluminium windows and entrance doors to new single-story brick Court House.

Burnley.—Electrical installation, automatic thermostatic and Manual Fire Alarm system, Horticultural Gardens.

Colac.—External painting, District School Inspector's residence. (W.O., Camperdown; P.S., Colac.)

Douglas.—New toilets, install septic tank and bore, S.S. 2044. (W.O., Horsham; S.S., Douglas.)

Echuca.—Reblocking and repainting of residence, High School. (W.O., Shepparton; H.S., Echuca.)

Flemington.—Electrical installation, Court House.

Footscray.—Roof repairs, Technical School.

Frankston.—Extension to Physical Education Wing, Teachers' College. (Teachers' College, Frankston.)

Frankston.—Extension of heating to existing buildings, Technical School.

Geelong.—Renovations to out-offices and new water service, S.S. 4398. (W.O., Geelong.)

Gerang Gerung.—Repairs and painting to residence, S.S. 2618. (W.O., Warracknabeal, S.S., Gerang Gerung.)

Goschen.—Septic tank installation and new toilet block, S.S. 3219. (W.O., Swan Hill.)

Gunbower Island.—New shelter pavilion, S.S. 3503. (W.O., Bendigo; S.S., Gunbower Island.)

Hoddles Creek.—New toilets and septic tank installations, S.S. 2541. (S.S., Hoddles Creek.)

Gunbower.—Electrical installation in Leaf storage and Curing Barns, Tobacco Research Station. (W.O., Bendigo; P.S., Cohuna.)

Kangaroo Flat.—Additional toilets, &c., Special School 4728. (W.O., Bendigo.)

Kew.—Strip and replace slate roof of Administration Block, Mental Hospital.

Kialla West.—General repairs, external and internal painting, &c., S.S. 1727. (W.O., Shepparton; S.S., Kialla West.)

Kyabram.—Third section in concrete veneer L.T.C., High School. (W.O., Shepparton and Benalla.)

Kyabram.—Electrical installation in Part Stage 3, High School. (W.O., Shepparton; P.S., Kyabram.)

Kyabram.—Supply and installation of mechanical services, Stage 3 and extensions, High School. (W.O., Bendigo and Shepparton.)

Lake Meran.—Erection of toilet block, installation of septic tank, &c., S.S. 3564. (W.O., Swan Hill; S.S., Lake Meran.)

Maribyrnong.—Repairs and painting, S.S. 3736.

Melbourne.—Electrical installation, Titles Office, 283 Queen-street.

Melbourne.—New lighting installation in stairwells, foyers and main entrances, Police Headquarters, Russell-street.

Meredith.—Repairs and painting to school and residence, S.S. 1420 and residence. (W.O., Geelong; S.S., Meredith.)

Mildura.—Internal painting and repairs, S.S. 2915. (W.O., Mildura.)

Mitiamo.—Internal and external renovations, Police Station and residence. (W.O., Bendigo; P.S., Mitiamo.)

Mount Waverley.—Erection of toilet blocks and connexion to sewer, fire service, water supply and storm-water drains, S.S. 3432.

Nhill.—Repairs and painting, Court House. (W.O., Horsham; P.S., Nhill.)

Nunawading.—Supply and installation of a washer extractor machine, "Winlton", Welfare Centre.

Osborne's Flat.—Septic tank installation, S.S. 1463. (W.O., Wangaratta; S.S., Osborne's Flat.)

Port Melbourne.—Structural steel framework for workshop, Public Works Department Depot.

Prahran.—Demolition and removal of twelve residences and sheds, Malvern-road, Francis and Summers streets, Police Station and Court House-site.

Red Cliffs East.—Repairs and painting to school and residence, S.S. 4123. (W.O., Mildura; S.S., Red Cliffs East.)

Rosanna.—Drinking and washing facilities, sewerage, stormwater drains and water supply, S.S. 4568.

Royal Park.—Supply and installation of new steam and condensate lines to Carpenters' Shop, Mental Hospital.

Royal Park.—Alterations and additions to existing central heating and hot water supply systems in Boys' Classification Centre, "Turana", Remand Centre.

Sale.—Connexion to sewer and installation of fire service, Technical School. (W.O., Traralgon; T.S., Sale.)

Sale.—Additional accommodation, Gaol. (W.O., Bairnsdale and Traralgon.)

Sale.—Supply, delivery and installation of hot water service, gas heaters, laundry equipment and kitchen exhaust system, Gaol. (W.O., Bairnsdale.)

Sale.—Supply and installation of refrigeration system for cool room in the kitchen, Gaol.

Seaford.—Female toilet, S.S. 3835. (S.S., Seaford.)

Somerville.—External painting, S.S. 2656. (S.S., Somerville.)

Stawell.—Repairs and painting residence, 8 Relph-street, Technical School. (W.O., Ararat; T.S., Stawell.)

St. Kilda Park.—New terra cotta tile roof, S.S. 2460.

Sunbury.—Supply and delivery of exhaust ventilation system and piping services to meal service units; Wards M.1, F.1, M.2 and F.2, and modifications to hot water service in M.2 and F.2, Mental Hospital. (W.O., Ballarat.)

Tallandoon.—Renovations to S.S. 2533 and residence. (W.O., Wangaratta.)

Tallangatta.—Renovations to residence and outbuildings, Soil Conservation Authority residence, 19 Queen Elizabeth-drive. (W.O., Wangaratta; P.S., Tallangatta.)

Tatong.—Repairs and painting to school and residence, S.S. 3006. (W.O., Benalla; S.S., Tatong.)

The Brothers.—Septic tank installation, S.S. 2846. (W.O., Bairnsdale; S.S., The Brothers.)

Waitchie.—Septic tank installation, &c., S.S. 3568. (W.O., Swan Hill; S.S., Waitchie.)

Wonthaggi.—General repairs and external painting, Technical School. (W.O., Korumburra; T.S., Wonthaggi.)

Wood Wood.—Provision of toilet blocks and septic tanks, S.S. 3353. (W.O., Swan Hill; S.S., Wood Wood.)

Yannathan.—Septic tanks installation, S.S. 2422. (S.S., Yannathan.)

Yarram.—Connexion to sewer, Forestry Commission residence and office. (W.O., Traralgon; P.S., Yarram.)

Furniture and Furnishings.

Beechworth.—Supply of curtain materials, Mental Hospital.

Kew.—Latex foam rubber mattresses and waterproof covers, Mental Hospital.

Lilydale.—Tubular steel-framed tables and chairs, High School.

Melbourne.—Supply of chairs and tables, Teachers' College.

Melbourne.—Supply of chairs and settees, Teachers' College.

Traralgon.—Supply of 36 bedsteads, Hobson Park Hospital.

Site Works.

Antonio Park.—Asphalting, concrete and drainage, S.S. 4844.

Armadale.—Construction of paving, drainage, and retaining walls with landscaping and fencing, Secondary Teachers' Training Hostel.

Swan Hill.—Provision of asphalt areas, drainage, concrete paving and walls, beautification and associated works, High School. (W.O., Swan Hill.)

Warmambool.—Provision of concrete paving, gravel and heavy duty asphalt roads and drainage, Mental Hospital. (W.O., Camperdown and Warmambool.)

Miscellaneous.

Benalla.—Purchase and removal of old buildings, High School. (W.O., Benalla.)

Coburg.—Supply of 200 cubic yards of pre-mixed concrete, Penridge Gaol.

Tuesday, 27th August, 1963.

Building, Electrical and Mechanical Works.

Ararat.—Erect fire station and annexe to Engineer's Workshop, Mental Hospital. (W.O., Ararat.)

Ballarat.—Renewal of roof to Ward 17, Mental Hospital. (W.O., Ballarat.)

Baringhup.—New toilets and septic tank installation, S.S. 1687. (W.O., Bendigo; S.S., Baringhup.)

Bena.—Internal and external painting and renovations to residence, S.S. 3062. (W.O., Korumburra; S.S., Bena.)

Blackburn South.—Repairs and painting, S.S. 4035. (Amended Specification.)

Burwood.—Internal and external repairs and painting, High School.

Carrum.—Internal renovations, Police Station. (P.S., Carrum.)

Culgoa.—Repairs and external painting, S.S. 3246. (W.O., Swan Hill; S.S., Culgoa.)

Darriman.—Resite boys' out-office and septic tank installation, S.S. 3013. (W.O., Traralgon; S.S., Darriman.)

Dugay's Bridge.—Installation of sewerage, S.S. 1752. (W.O., Wangaratta; S.S., Dugay's Bridge.)

Echuca.—Supply and erection of 70 feet of self-supporting steel Radio Tower, Police Station. (W.O., Shepparton.)

Elmore.—Erection of Court House. (W.O., Bendigo.)

Eltham.—External repairs and painting to all buildings, High School.

Footscray North.—Internal painting and repairs, S.S. 4160.

Hadfield.—1st and 2nd sections of new High School.

Healesville.—Repairs and painting to school and residence, S.S. 849. (S.S., Healesville.)

Horsham East.—Internal and external painting, S.S. 4799. (W.O., Horsham.)

Loch.—Erection of shelter pavilion, S.S. 2912. (W.O., Korumburra; S.S., Loch.)

Lower Plenty.—External and internal renovations, S.S. 1295.

Melbourne.—Repairs and painting—temporary classrooms, Police Depot, St. Kilda-road. (Amended Specification.)

Merrijig.—Sewerage installation, S.S. 1379. (W.O., Alexandra; S.S., Merrijig.)

Montague.—Renewal of roof to main building, Special School 2784.

Moorabbin West.—External renovations, S.S. 4643. (S.S., Moorabbin West.)

Nunawading.—Internal lining to "Warrina", and "Koorringal" Blocks, "Winlton", Social Welfare Department. ("Winlton", Nunawading.)

Nunawading.—Construction of Swimming Pool and incidental works, "Winlton" Training Centre.

Nunawading.—Supply and installation of water treatment plant, "Winlton" Training Centre.

Pascoe Vale.—Internal and external repairs and painting, S.S. 3081.

Piambie.—Erection of combined toilet block, septic tank installations, &c., S.S. 4162. (W.O., Swan Hill, S.S., Piambie.)

Point Lonsdale.—External and internal repairs and painting, Ports and Harbors Quarters. (W.O., Geelong.)

Redbank.—New toilets and septic tank installation, S.S. 896. (W.O., Maryborough; S.S., Redbank.)

Rheola.—Installation of septic tanks, water supply and toilets, S.S. 1059. (W.O., Bendigo; S.S., Rheola.)

Rosebud.—Internal renovations to corridors, High School. (H.S., Rosebud.)

Sale.—Roof repairs, general repairs and external painting, Court House. (W.O., Bairnsdale and Traralgon; P.S., Sale.)

Sale.—Electrical installation, alterations and additions, Gaol. (W.O., Bairnsdale; Gaol, Sale.)

Shepparton.—General repairs and painting to residence, Police Station. (W.O., Shepparton; P.S., Shepparton.)

Somers.—Renovations to the Cinema Children's School Camp, No. 4647. (School Camp, Somers.)

Sunshine.—Supply, delivery and installation of central heating system and circulating fans, Police Station.

Sunshine.—Additional cell block, boiler room, &c., Police Station.

Tallandoon North.—Erection of toilet block and septic tank, S.S. 3682. (W.O., Wangaratta; S.S., Tallandoon North.)

Tatura.—Construction of new Glasshouse, Horticultural Station. (W.O., Shepparton; Horticultural Station, Tatura.)

Terang.—Provision of internal W.C. and connexion of residence to sewerage system, High School, 81 Baynes-street. (Amended Specification). (W.O., Camperdown.)

Torquay.—Internal and external painting and repairs, S.S. 3368. (W.O., Geelong; S.S., Torquay.)

Furniture and Furnishings.

Ballarat.—Supply of steel cabinets, Mental Hospital.

Ballarat.—Supply of 120 hospital beds, Mental Hospital.

Stawell.—Supply of 36 bedside lockers, Pleasant Creek Special School. (W.O., Ballarat.)

Sunshine North.—Supply of benches, Technical School.

Site Works.

Warragul.—Site works, asphalt paving, concrete paving, drainage, &c., Technical School. (W.O., Traralgon and Warragul.)

Miscellaneous.

Ballarat.—Supply and delivery of 5 weighing machines, Mental Hospital.

Dookie.—Supply of timber, hardboard, mouldings, &c., Agricultural College.

Rupanyup.—Purchase and removal of old garage and stable, Police Station. (W.O., Warracknabeal; P.S., Rupanyup.)

H. R. PETTY,
Commissioner of Public Works.

Public Works Department,
Melbourne, 6th August, 1963.

PUBLIC SERVICE NOTICES

PUBLIC SERVICE OF VICTORIA.—VACANCIES.

APPLICATIONS will be received by the Public Service Board up to Wednesday, the 21st August, 1963, from persons employed in the Public Service of Victoria, who are eligible and qualified for appointment to the under-mentioned positions:—

ADMINISTRATIVE DIVISION.

Class "B1" Department of Agriculture.

Yearly Salary.—£2,293, minimum; £2,443, maximum.

Duties.—To act as Senior Clerk of the Livestock Division.

Qualifications.—Organizing and administrative ability and ability to control and direct staff. A knowledge of the Acts and Regulations administered by the Division would be an advantage.

Class "B", Old Children's Hospital, Carlton, Mental Hygiene Branch, Department of Health.

Yearly Salary.—£2,028, minimum; £2,148, maximum.

Duties.—To be secretary of the Hospital.

Qualifications.—Experience in organization of a Mental Hospital, including control of stores, clothing, provisions, &c.; a good knowledge of the Mental Hygiene Acts and the Regulations; ability to control staff.

Class "C2", Office of the Chief Commissioner of Police, Chief Secretary's Department.

Yearly Salary.—£1,788, minimum; £1,908, maximum.

Duties.—To act as personal assistant to the Secretary and Assistant Secretary of the Department; to perform special duties as required.

Qualifications.—Administrative ability and preferably some secretarial experience. A knowledge of the organization and procedure of the Police Department and of the Acts and Regulations administered by the Department would be an advantage.

Inspector of Factories and Shops, Supervising, Class "C2", Department of Labour and Industry. (Two vacancies.)

Yearly Salary.—£1,788, minimum; £1,908, maximum.

Duties.—To supervise inspection work within an inspection district or to carry out the duties of a Supervising Inspector in any other section of the Inspectorate to which he may be assigned. To assist in the general training of recruit Inspectors, and to direct the training of Inspectors "on the job".

Qualifications.—Experience and ability as an Inspector of Factories and Shops and ability to supervise. Willingness to reside, if required, within any district to which he may be assigned.

NOTE.—Applications are also being invited for this position in the Technical and General Division.

Class "C2", Local Government Department.

Yearly Salary.—£1,788, minimum; £1,908, maximum.

Duties.—To examine and report on municipal by-laws and planning schemes. To handle dealings relating to roads, compulsory acquisition, sale and lease of land. To conduct correspondence, prepare Orders in Council and assist senior officers as required.

Qualifications.—A knowledge of the Acts relating to Local Government and Town Planning and the Regulations thereunder, and of municipal affairs; experience in interpreting and administering Acts and regulations; ability to prepare Orders in Council.

Class "C2", State Tender Board; Treasury.

Yearly Salary.—£1,788, minimum; £1,908, maximum.

Duties.—To assist the Secretary to the Tender Board in dealing with tenders and supplies generally and to prepare schedules relating to general stores and provisions; to relieve the Secretary when necessary.

Qualifications.—Experience of stores and merchandise generally as applicable to the Public Service and of commercial practice; a good knowledge of the Public Accounts and Stores Regulations 1958; a knowledge of Customs procedure is desirable.

Class "C1", "Winlaton", Youth Welfare Division, Social Welfare Branch, Chief Secretary's Department.

Yearly Salary.—£1,558, minimum; £1,668, maximum.

Duties.—As Secretary, "Winlaton" Youth Training Centre and "Winbirra" Remand Centre, Nunawading, to be responsible for the control of stores and stocks, accounts, salary payments, staff and inmate records and general clerical duties. To be in charge of artisan staff.

Qualifications.—Experience in the supervision of staff; a knowledge of the Public Service Act and Regulations and of the Public Accounts and Stores Regulations. Experience in accounting and stores procedures is desirable.

Class "C1" Office of the Public Service Board, Premier's Department.

Yearly Salary.—£1,558, minimum; £1,668, maximum.

Duties.—To act as checking and information officer.

Qualifications.—A good knowledge of the Public Service Acts and of the regulations and procedures thereunder. A general knowledge of the organization and staffing of Departments is desirable.

Class "C1", Water Supply Department.

Yearly Salary.—£1,558, minimum; £1,668, maximum.

Duties.—To prepare instructions to the Crown Solicitor relating to the acquisition of land and the creation and surrender of easements; to prepare correspondence to property owners regarding the Commission's entry on to private property for investigation purposes and the provision of bridges; to prepare specialized correspondence regarding land acquisitions.

Qualifications.—A good knowledge of the Commission's activities, the relevant provisions of the Water Act and cognate Acts, and ability to conduct correspondence. A knowledge of conveyancing and of Real Estate practice is desirable.

Class "C", Department of Agriculture.

Yearly Salary.—£1,283, minimum; £1,448, maximum.

Duties.—To be responsible for the collection of Agricultural College students' fees and to keep the relevant accounts; to keep staff and students' records and prepare statistical returns as required, check salaries and wages sheets and requisitions for stores; other duties as required.

Qualifications.—A good knowledge of and experience in Public Accounts procedure and a knowledge of the Public Service Act and Regulations.

Class "C", Department of Crown Lands and Survey.
(Two vacancies.)

Yearly Salary.—£1,283, minimum; £1,448, maximum.

POSITION No. 1.

Duties.—To have charge of the departmental stock of lithographic plans, to be responsible for the supply of plans on requisition to the various branches of the Department and to other departments, to keep necessary stock and accounting records, and to be responsible for the preparation of claims and journal entries for plans supplied.

Qualifications.—A good knowledge of the State and its divisions, of the Closer Settlement Act and the Land Act and of the Regulations. Knowledge of departmental procedure relating to the accounting for money received.

POSITION No. 2.

Duties.—To assist in the preparation of various licences and leases under the Land Act; to deal with applications and correspondence relating to the issue of unused road and water frontage licences under Part 13 of the Land Act 1958.

Qualifications.—A knowledge of the applicable sections of the Land Act and of the Regulations, practice and procedure.

NOTE.—Separate applications must be submitted for the above positions.

Class "C", Department of Health.

Yearly Salary.—£1,283, minimum; £1,448, maximum.

Duties.—To be responsible for the collection, recording and banking of revenue and the preparation of bank reconciliation statements and to assist in the payment of salaries and personal expenses.

Qualifications.—A good knowledge of the Public Accounts and Stores Regulations 1958, Audit requirements, &c.

Class "C", Office of the Public Service Board, Premier's Department.

Yearly Salary.—£1,283, minimum; £1,448, maximum.

Duties.—The preparation and maintenance of officers' record cards.

Qualifications.—A knowledge of the Public Service Acts, Regulations and salary schedules; to be familiar with the structure of Government Departments.

PROFESSIONAL DIVISION.

Valuer, Classes "B"—"B1", Public Works Department.

Yearly Salary.—£2,028, minimum; £2,443, maximum.

Duties.—Under the direction of the Property Officer to make valuations, and perform other duties as required.

Qualifications.—A member of, or qualified for admission to, the Commonwealth Institute of Valuers, or to be entitled to an unrestricted certificate from the Valuers Qualification Board; to have had wide practical experience in valuations of real estate in the Metropolitan (including City properties) and Country areas.

Senior Draughtsman, Class "C2", Department of Crown Lands and Survey. (Two vacancies.)

Yearly Salary.—£1,788, minimum; £1,908, maximum.

POSITION No. 1.

Duties.—To examine and report on Surveyors' plans and field notes, to prepare Certified Plans and Certificates of Adjustment, to perform general survey draughting work as required and assist in the training of Junior Draughtsmen.

Qualifications.—A competent Survey Draughtsman with a good knowledge of survey computations, field practice and preferably the procedure and requirements of the Department in connexion with surveys.

POSITION No. 2.

Duties.—To compile and examine maps and plans for reproduction, to draw plans from Surveyors' field notes, to perform general survey draughting work as required and to assist in the supervision and training of Junior Draughtsmen.

Qualifications.—A competent Survey Draughtsman with a sound knowledge of field practice and of computations necessary for compiling maps and plans, and preferably of departmental procedure and requirements.

NOTE.—Separate applications must be submitted for the above positions.

Farm Survey Research Officer, Classes "C"—"C2", Department of Agriculture.

Yearly Salary.—£1,283, minimum; £1,908, maximum.

(Commencing salary will be determined within this initial career range according to experience.)

Duties.—To conduct business surveys of farm costs in relation to the agricultural industries of the State; to conduct investigations into the economics of different systems of farm management and agricultural practice; other investigations of an economic nature in relation to agricultural commodities as required.

Qualifications.—Degree of Bachelor of Agricultural Science, or its equivalent, with training or experience in the field of Farm Management Economics or a Degree in Agricultural Economics.

TECHNICAL AND GENERAL DIVISION.

Inspector of Factories and Shops, Supervising, Department of Labour and Industry. (Two vacancies.)

Total Emolument.—£1,788, minimum; £1,908, maximum.

Duties.—To supervise inspection work within an inspection district or to carry out the duties of a Supervising Inspector in any other section of the Inspectorate to which he may be assigned. To assist in the general training of recruit inspectors and to direct the training of inspectors "on the job".

Qualifications.—Experience and ability as an Inspector of Factories and Shops and ability to supervise. Willingness to reside, if required, within any district to which he may be assigned.

NOTE.—Applications are also being invited for this position in the Administrative Division.

Farm Supervisor, Assistant, Longerenong Agricultural College, Department of Agriculture.

Yearly Salary.—£1,259, minimum; £1,435, maximum.

Duties.—Under the direction of the Principal to assist the Farm Supervisor in the management of the College farm; to control students and instruct them in practical farm work; other duties as required.

Qualifications.—The Diploma of a recognized Agricultural College and practical experience in general farming.

NOTE.—A house is available for the successful applicant, if married, for which a rental of 10 per cent. of total emolument, less £36 6s. a year will be charged. Accommodation is available for a single man at a charge of £166 a year. Particulars are available from the Department of Agriculture.

Real Estate Officer, Grade I, Office of the Housing Commission, Treasury.

Yearly Salary.—£1,233, minimum; £1,331, maximum.

Duties.—To negotiate settlements with owners of land; to advise prospective purchasers of terms and conditions under which Commission houses may be sold, and to conduct interviews with prospective tenants of shop premises owned by the Commission.

Qualifications.—A good knowledge of Real Estate transactions; ability to deal with the public and to conduct negotiations.

NOTE.—After completing twelve months' service on the maximum salary of Grade I, will be eligible, subject to recommendation of Permanent Head, for progression to Real Estate Officer, Grade II. (£1,383-£1,485).

Trade Instructor, Youth Welfare Division, Social Welfare Branch, Chief Secretary's Department.

Yearly Salary.—£1,223, minimum; £1,295, maximum.

Duties.—To instruct trainees at "Turana" Youth Training Centre, Parkville, in woodwork and in the handling of carpentry and handcraft tools; to assist as directed in maintenance work.

Qualifications.—A qualified and experienced carpenter and joiner, with ability to instruct adolescent youths in trade processes.

Estate Officer, Grade I, Office of the Housing Commission, Treasury.

Yearly Salary.—£1,151, minimum; £1,223, maximum.

(An allowance at the rate of £104 a year will also be paid for duty out of office hours and use of home as an office.)

Duties.—To perform housing estate duties, as required, in respect of a high-density section of a district, including revenue collection, interviewing tenants regarding rental arrears, advising tenants on matters affecting their tenancy, and inspecting and reporting on dwellings and various phases of estate management.

Qualifications.—To be educated to Intermediate Certificate standard or to be already an Estate Officer. Ability to make investigations and prepare reports. Experience in dealing with the public and capable of handling public moneys; to be active; married. A current motor driver's licence.

NOTE.—(1) After completing three years' satisfactory service as Estate Officer, Grade I., will be eligible for progression to Estate Officer, Grade II. (£1,259-£1,295).

(2) The person appointed must be prepared to reside on a Commission Estate and to work at nights, week-ends, and public holidays as may be required. Accommodation will be provided in a three-bedroom flat, for which a rental of 10 per cent. of total emolument, less £36 6s. a year will be charged.

Cheese Maker, School of Dairy Technology, Werribee, Department of Agriculture.

Yearly Salary.—£1,079, minimum; £1,115, maximum.

Duties.—Under direction to undertake the work of manufacture of cheese, and such other dairy products as may be required at the experimental dairy factory at the School of Dairy Technology, Werribee, and to give practical instruction.

Qualifications.—To hold Certificates issued under the Dairy Produce Board for Cheesemaker, Butter-maker, Tester and Grader. Boiler Attendant's Certificate. Practical experience in modern dairy manufacturing particularly cheesemaking and in general dairy factory work. A knowledge of refrigeration is also desirable.

NOTE.—A house is available for the successful applicant, if married, for which a rental of 10 per cent. of total emolument less £36 6s. a year will be charged. Accommodation is available for a single man at a charge of £166 a year. Particulars are available from the Department of Agriculture.

Chief Prison Officer (Female), "Fairlea", Prisons Division, Social Welfare Branch, Chief Secretary's Department.

Yearly Salary.—£953.

Duties.—To relieve the Governor and Deputy Governor as required; to be responsible for the security of the prison in their absence and for control of the clothing store.

Qualifications.—Experience in institutional and staff management and ability to control delinquent females.

Typist (Female), Supervising, Apprenticeship Commission, Department of Labour and Industry.

Yearly Salary.—£899, minimum; £917, maximum.

Duties.—To be responsible, under direction, for the supervision of the typing pool of the Apprenticeship Commission and for the allotment of work thereto; other duties as required.

Qualifications.—A competent typist with ability to control staff.

Motor Truck Driver, Mines Department.

Yearly Salary.—£989, minimum; £1,007, maximum.

Duties.—To drive motorized plant and trucks including semi-trailers and low loaders carrying loads of 30 tons.

Qualifications.—To be capable of handling heavy motorized equipment; to hold a current motor car driver's licence with the necessary endorsement by the Motor Registration Branch to permit the driver to handle articulated vehicles.

Meter Reader, Frankston Centre, Water Supply Department. (Two vacancies.)

Yearly Salary.—£938, minimum; £989, maximum.

Duties.—To assist with the installation and reading of meters in the Mornington Peninsula Area.

Qualifications.—A general knowledge of the mechanism of, and capable of reading various types and sizes of meters; familiar with reticulation work, and able to locate services expeditiously.

By order,
V. P. SCULLY,
Secretary.

Office of the Public Service Board,
Melbourne, 6th August, 1963.

PUBLIC SERVICE OF VICTORIA.—VACANCIES.

DEPARTMENT OF HEALTH.

MENTAL HYGIENE BRANCH.

TECHNICAL AND GENERAL DIVISION.

APPLICATIONS will be received by the Public Service Board up to Wednesday, the 28th August, 1963, from persons employed in the Public Service of Victoria, who are eligible and qualified for appointment to the under-mentioned positions:—

Head Nurse (Male), Warrnambool.

Yearly Salary.—£1,487, minimum; £1,539, maximum.

Duties.—Under direction of the Psychiatrist Superintendent to have charge of staff and patients; to give lectures to Student Nurses and others.

Qualifications.—A current practising certificate for mental nursing. Experience in a senior position in a Mental Hospital; ability to control patients and staff, and compile reports and records; ability to give lectures to Student Nurses and others.

Assistant Head Nurse (Female), Larundel.

Yearly Salary.—£1,115, minimum; £1,187, maximum.

Duties.—To assist Principal Female Nurse in management of Female Division, and to prepare leave sheets and other records as directed; to relieve senior officers as required and give lectures to Student Nurses and others.

Qualifications.—A current practising certificate for Mental Nursing. Ability to direct and control staff and patients and keep records.

NOTE.—Applications from temporary employees who are not eligible for appointment to the Technical and General Division will be accepted.

Charge Nurse (Male), Sunbury.

Yearly Salary.—£1,169, minimum; £1,241, maximum.

Duties.—To take charge or sub-charge of a ward in a Mental Hospital and to assist in the training of Student Nurses and Ward Assistants.

Qualifications.—A current practising Certificate for Mental Nursing and experience as a Deputy Charge Nurse in a Mental Hospital.

Cook (Male), Grade II., Sunbury.

Yearly Salary.—£1,079, minimum; £1,115, maximum.

Duties.—To be in charge of the Kitchen and staff therein.

Qualifications.—A competent cook with experience of large quantity preparation and cooking of foodstuffs, and ability to control a staff of cooks.

Deputy Charge Nurse (Female)—All Institutions.

Yearly Salary.—£881, minimum; £917, maximum.

Duties.—To be second in charge of a ward.

Qualifications.—A current practising certificate for Mental Nursing and approved experience.

Gardener, Grade I., Kew.

Yearly Salary.—Junior—Under 16 years of age—£408
At 16 years of age—£449
At 17 years of age—£523
At 18 years of age—£589
At 19 years of age—£699
At 20 years of age—£806

Adult—£938, minimum; £955, maximum.

Duties.—To carry out general gardening operations in the ornamental grounds.

Qualifications.—Experience in the care of trees, shrubs, hedges and lawns, and in raising and planting out flower seedlings.

NOTE.—Successful applicant shall not be paid a salary in excess of £938 a year unless he has passed a prescribed examination.

General Assistant, Kew.

Yearly Salary.—£921, minimum; £955, maximum.

Duties.—To give general assistance in the various artisan activities connected with the Hospital services and maintenance.

Qualifications.—A semi-skilled worker in good physical condition. Knowledge of some trade desirable.

By order,
V. P. SCULLY,
Secretary.
Office of the Public Service Board,
Melbourne, 6th August, 1963.

PUBLIC SERVICE OF VICTORIA.—VACANCY.
(TEMPORARY APPOINTMENT).

APPLICATIONS will be received by the Public Service Board up to Wednesday, the 21st August, 1963, from persons who are qualified for appointment to the under-mentioned position:—

Draughtsman, Grade II. to Grade V., Water Supply Department.

WATER SUPPLY DEPARTMENT.

Yearly Salary.—£1,079, minimum; £1,643, maximum.
Duties.—The preparation of working drawings for the construction of pumping stations and installation of steam, diesel or electric motor-driven pumping

plant, large pipe-lines and auxiliary mechanical control equipment.

Qualifications.—Technical School or other approved training in mechanical drawing, with practical experience in drawing office work including plant layout and arrangement.

NOTE.—Appointee will be graded according to qualifications and experience.

By order,

V. P. SCULLY,
Secretary.

Office of the Public Service Board,
Melbourne, 6th August, 1963.

PUBLIC SERVICE OF VICTORIA.—RECLASSIFICATIONS.

THE Public Service Board has raised the classification of the under-mentioned offices as shown, and appointed thereto the respective officers named hereunder.

Office and Former Classification.	Revised classification.	Duties.	Qualifications.	Officer Appointed.
-----------------------------------	-------------------------	---------	-----------------	--------------------

ADMINISTRATIVE DIVISION.

LAW DEPARTMENT.

Courts Branch.

Class "E"	Class "D", Administrative Division, (with right of progression to Clerk of Courts, Grade III., Class "C", Professional Division)		As prescribed by Public Service (Public Service Board) Regulation 58	Bonell, E.
-----------	--	--	--	------------

PREMIER'S DEPARTMENT.

Audit Office.

Class "B"	Class "B1"	To perform the duties appropriate to an Auditor, Grade I., including the audit of a Government Department or State Authority and, if required, to be the Deputy to a Senior Auditor responsible for all audits within a district	A qualified accountant with wide experience in the practice of auditing	Tutty, K. J.
-----------	------------	--	---	--------------

TECHNICAL AND GENERAL DIVISION.

CHIEF SECRETARY'S DEPARTMENT.

Fisheries and Wildlife Branch.

Information Officer (Female), F.38	F.39	Under direction to provide an information service for the public, to edit a monthly Newsletter and other departmental publications, to give lectures, to take part in television and radio talks, to prepare press releases	Considerable knowledge of Australian Wildlife and experience in lecturing and the writing of articles; ability to prepare and take part in television and radio talks	Watson, Ina M.
------------------------------------	------	---	---	----------------

DEPARTMENT OF HEALTH.

MENTAL HYGIENE BRANCH.

Repatriation Mental Hospital, Bundoora.

Head Nurse (Male), Grades 37-38 inclusive	Principal Nurse (Male), Grades 40-41 inclusive	Under the direction of the Psychiatrist Superintendent to have charge of staff and patients	Current practising certificate for Mental Nursing. Experience in a senior position in a Mental Hospital, ability to control patients and staff, compile reports and records relating to these duties, and give lectures to Student Nurses and others	Rosengreen, I. J.
---	--	---	--	-------------------

Children's Cottages, Kew.

Head Nurse (Male), Grades 37-38 inclusive	Principal Nurse (Male), Grades 40-41 inclusive	Under direction of the Psychiatrist Superintendent to have charge of Male Division—staff and patients	Current practising certificate for Mental Deficiency Nursing. Experience in a senior position in a Training Hospital, ability to control patients and staff, compile reports and records relating to these duties, and give lectures to Student Nurses and others	Walsh, D.
---	--	---	---	-----------

By order,

V. P. SCULLY,
Secretary.

Office of the Public Service Board,
Melbourne, 6th August, 1963.

PUBLIC SERVICE (PUBLIC SERVICE BOARD) REGULATION 52.—VACANCIES.

THE Permanent Heads of the Departments shown have recommended the officers named hereunder for appointment to the under-mentioned vacancies.

Office and Classification.	Duties.	Qualifications.	Officer Recommended for Appointment.		
			Name.	Classification.	Date of Classification.
TECHNICAL AND GENERAL DIVISION.					
DEPARTMENT OF AGRICULTURE.					
Assistant (Female), Grade II, Grades F11-F12 inclusive	To assist the Senior Female Assistant on Association Herd Test work and perform special duties as required	Preferably a knowledge of the work procedure of the Herd Test Section and of the rules of the Victorian Herd Improvement Association	Whiteoak, Florence R.	Assistant (Female), Grade I., Grades F9-F10 inclusive	27.7.60
DEPARTMENT OF HEALTH.					
MENTAL HYGIENE BRANCH.					
<i>Children's Cottages, Kew.</i>					
Principal Nurse (Female), Grades F38-F39 inclusive	Under direction of the Psychiatrist Superintendent to have charge of Female Division—Staff and Patients	Current practising certificate for Mental Deficiency Nursing. Experience in a senior position in a Training Centre, ability to control patients and staff, compile reports and records relating to these duties, and give lectures to Student Nurses and others	Buckley, Margaret U.	Head Nurse (Female), Grades F35-F36 inclusive	18.11.52

Appeals against such recommendations should be lodged with the Secretary to the Public Service Board not later than Saturday, the 17th August, 1963.

Office of the Public Service Board,
Melbourne, 6th August, 1963.

By order,
V. P. SCULLY,
Secretary.

PRIVATE ADVERTISEMENTS

Town and Country Planning Act 1961 (Twelfth Schedule).

CITY OF BRUNSWICK.—CITY OF BRUNSWICK PLANNING SCHEME 1956.

NOTICE THAT A PLANNING SCHEME HAS BEEN PREPARED AND IS AVAILABLE FOR INSPECTION.
Amendment No. 9, 1963.

NOTICE is hereby given that the Council of the City of Brunswick in pursuance of its powers under the *Town and Country Planning Act 1961*, has prepared a Planning Scheme for the City of Brunswick for—

"All that piece of land in the City of Brunswick commencing at a point which is 292 ft. 3 in. south of the south-east corner of Melville-road and Albion-street thence east a distance of 110 feet thence south a distance of 120 feet thence west a distance of 110 feet thence north a distance of 120 feet along the east side of Melville-road to the point of commencement."

for the purpose of re-zoning land in the described area.

A copy of the scheme has been deposited at the Municipal Offices, Town Hall, Brunswick, and at the office of the Town and Country Planning Board, 61 Spring-street, Melbourne, and will be open for inspection during office hours, by any person, free of charge.

Any persons affected by the Planning Scheme are required to set forth, in writing, all objections they may have, addressed to the Town Clerk, Town Hall, Brunswick, on or before the 7th day of November, 1963, and to state whether they wish to be heard in respect of their objections.

H. W. FOLETTA, Town Clerk.

7th August, 1963. 7079

CITY OF MELBOURNE.

BY-LAW No. 440.

NOTICE is hereby given that at meetings of the Council of the City of Melbourne, held on the 13th day of May, 1963, and the 12th day of June, 1963, the said Council did make, pass and confirm a By-law intitled "A By-law of the City of Melbourne made under Section 91 of an Act of the Governor and Legislative Council of New South Wales 6 Victoria Number 7 Part XV. of the *Health Act, 1958*, and Part VII. Division 1 of the *Local*

Government Act 1958 and numbered 440 for the Regulation of the Abattoirs of the City of Melbourne and for fixing the fees and dues to be charged thereat and for other purposes", summary of which is set out hereunder, viz.—

The By-law which amends and consolidates existing By-laws for the regulation of the City Abattoirs—

- Provides for the use and management of the abattoirs; setting out the days of the year and the hours during which the establishment shall be open.
- Provides for the conditions under which slaughtermen shall be permitted to work at the establishment.
- Provides for the dress and conduct of persons at the establishment and excludes certain persons therefrom.
- Sets out the conditions under which dogs may remain in the establishment.
- Stipulates the fees and dues payable by operators at the establishment.
- Provides for the searching of vehicles by any inspector appointed by the Council under the By-law or member of the Police Force.

The By-law was submitted to the Commission of Public Health on the 23rd day of July, 1963, and approved by the Governor in Council on the 6th day of August, 1963.

F. H. ROGAN, Town Clerk.

Town Hall, Melbourne, 6th August, 1963. 7130

CITY OF NUNAWADING.

No. 705.

LOAN No. 67.

Notice of Intention to Borrow the Sum of £40,000 for Permanent Works and Undertakings.

NOTICE is hereby given that the Council of the City of Nunawading proposes to borrow the sum of Forty thousand pounds (£40,000) on the credit of the municipal revenues of the said City of Nunawading, such sum to be raised by the grant of a mortgage, in accordance with the provisions of the *Local Government Acts*.

1. The maximum rate of interest to be paid is £5 2s. 6d. per centum per annum, payable half-yearly.

2. The purposes for which the loan is to be applied are—
Construction of roads, channels and footpaths.
3. The period of the loan shall be fifteen years.
4. The moneys borrowed shall be repayable by providing out of the municipal fund 30 half-yearly instalments of approximately £1,927 1s. 4d. each, including principal and interest, on the 1st day of April and the 1st day of October, during the currency of the loan. The first instalment shall be payable on the 1st day of April, 1964.
5. Such moneys shall be repayable at the office of the Australian Mutual Provident Society, at 425 Collins-street, Melbourne.

The plans and specifications and the estimate of the cost of the proposed works, and a statement showing the proposed expenditure of the moneys to be borrowed, are open for inspection at the Municipal Offices, Nunawading.

Dated the 1st August, 1963.

7129 J. H. BROWN, Acting Town Clerk.

CITY OF PORT MELBOURNE.

LOAN No. 22.

Notice of Intention to Borrow the Sum of £15,000, for Permanent Works and Undertakings.

NOTICE is hereby given that the Council of the City of Port Melbourne proposes to borrow the sum of Fifteen thousand pounds on the credit of the municipal revenues of the Mayor, Councillors and Citizens of the said City, such sum to be raised by mortgage deed, in accordance with the provisions of the Local Government Acts.

1. The maximum rate of interest that may be paid is 5½ per centum per annum.

2. The purpose for which the loan is to be applied is as follows:—Capital Extensions—Electric Supply Undertaking—£15,000.

3. The period of the loan shall be ten years.

4. The moneys borrowed shall be repayable by providing out of the municipal fund, nineteen equal half-yearly instalments of £603 17s., and a final repayment of £9,961 19s. 8d., including principal and interest on the 15th day of April and the 15th day of October, in each year, during the currency of the loan. The first instalment shall be payable on the 15th day of April, 1964.

5. Such moneys shall be repayable at the Australia and New Zealand Savings Bank Limited, Melbourne, or at the Council's Bankers for the time being in Melbourne.

The plans and specifications and the estimate of the cost of the proposed works and a statement showing the proposed expenditure of the moneys to be borrowed are open for inspection at the Town Hall, Port Melbourne, during office hours.

Dated 1st August, 1963.

7078 J. G. FARROW, Acting Town Clerk.

CITY OF WARRNAMBOOL.

NOTICE is hereby given that the Council of the City of Warrnambool, by Resolution adopted at a meeting held on the 2nd July, 1963, did change the name of a street as follows:—

Old Name; Locality; New Name.

Laverock-road; Princes Highway to Fitzroy-road; Laverock-grove.

7126 K. L. ARNEL, Town Clerk.

CITY OF WAVERLEY.

BY-LAW No. 82.

Fencing of Unightly Land By-law.

A By-law of the City of Waverley made under section 197 of the Local Government Act 1958, and numbered 82, requiring that land which the Council has declared to be unsightly or destructive of the amenity of the neighbourhood shall be enclosed with a sufficient fence.

IN pursuance of the powers conferred by the Local Government Act 1958, and of any and every other power it thereunto enabling the Mayor, Councillors and Citizens of the City of Waverley order as follows:—

1. This By-law shall be known as the Fencing of Unightly Land By-law.

2. (a) The Council may by notice, in writing, to the owner or occupier of any land in the municipal district declare such land to be unsightly or destructive of the amenity of the neighbourhood and may by the same or another notice require such owner or occupier within a time therein limited to cause such land to be enclosed with a sufficient fence of such material and in such manner as is prescribed by the Schedule hereto.

(b) Any owner or occupier on whom any such notice as aforesaid is served shall within the time therein limited comply with the requirements of such notice.

3. Any person guilty of a continuing offence against this By-law shall be liable to a penalty of not more than Five pounds for each day on which an offence against this By-law is continued after a conviction or order by any Court.

4. This By-law shall apply to and have operation throughout the whole of the municipal district.

SCHEDULE.

To be erected in a workmanlike manner in accordance with the provisions hereunder set out—

5 in. x 3 in. red gum posts set at least 2 feet below the natural surface of the ground, soled and strutted at 9 feet centres.

3 in. x 2 in. hardwood top and bottom rails. 3 in. x 1½ in. hardwood centre rail. 6 in. x 1 in. sawn hardwood plinth with 4 in. or 6 in. x 5 ft. 6 in. sawn hardwood palings.

Provided that fences situated at the intersection of two streets shall be erected in compliance with the requirements of By-law No. 87.

Resolution for passing this By-law agreed to by the Council of the City of Waverley, on the 11th day of June, 1963, and confirmed on the 23rd day of July, 1963.

The corporate seal of the Mayor, Councillors and Citizens of the City of Waverley was hereunto affixed, in the presence of—

(SEAL) L. ALLEN, Mayor.
W. MUIR, Councillor.
F. S. BALES, Town Clerk.

7071

CITY OF WAVERLEY.

BY-LAW No. 86.

Mobile Crane By-law.

A By-law of the City of Waverley made under section 197 of the Local Government Act 1958, and numbered 86, for prohibiting or regulating the use as a crane on any road of any mobile crane.

IN pursuance of the powers conferred by the Local Government Act 1958, and of any and every other power it thereunto enabling the Mayor, Councillors and Citizens of the City of Waverley order as follows:—

1. This By-law shall be known as the Mobile Crane By-law.

2. In this By-law the words "mobile crane" shall mean any self-propelled travelling crane having a jib adapted for raising and lowering articles and goods, but shall not include a tow truck while engaged in towing any vehicle.

3. No person shall use as a crane on any road any mobile crane—

(a) without having first obtained from the Council of the City of Waverley a permit for such use.

(b) otherwise than in accordance with the conditions (if any) endorsed on such permit.

4. Any person may make application (in the form set out in the schedule hereto) to the said Council for a permit to use a mobile crane.

5. The Council or any officer authorized in that behalf by the Council shall consider each such application and may grant the same subject to such conditions (if any) as the Council or such officer may in any particular case determine or may refuse to grant the same.

6. This By-law shall apply to and have operation throughout the whole of the municipal district.

THE SCHEDULE HEREBEFORE REFERRED TO.

I, _____ of _____ hereby apply for a permit to use mobile crane registered No. _____ as a crane in _____ street on the _____ day of _____ 19____.
Dated this _____ day of _____ 19____.
Signature.

Resolution for passing this By-law agreed to by the Council of the City of Waverley on the 11th day of June, 1963, and confirmed on the 23rd day of July, 1963.

The corporate seal of the Mayor, Councillors and Citizens of the City of Waverley was hereunto affixed, in the presence of—

(SEAL) L. ALLEN, Mayor.
W. MUIR, Councillor.
F. S. BALES, Town Clerk.

7072

CITY OF WAVERLEY.

BY-LAW No. 87.

Tree and Fence Height By-law.

A By-law of the City of Waverley made under section 197 of the Local Government Act 1958 and numbered 87 for—

- (a) Prohibiting or regulating the use of private property situate at the junction of streets or roads for the growing of trees, shrubs or hedges within certain limits.
- (b) Requiring the removal or lopping of such trees, shrubs or hedges.
- (c) Requiring the reduction in height of any portion of a fence within 30 feet of the junction of any streets or roads.
- (d) Authorizing the Council at the expense of the owner to remove or lop certain trees, shrubs or hedges and to reduce in height certain fences.

IN pursuance of the powers conferred by the Local Government Act 1958, and of any and every other power it thereunto enabling the Mayor, Councillors and Citizens of the City of Waverley order as follows:—

This By-law shall be known as the Tree and Fence Height By-law.

2. By-law No. 76 of the City of Waverley relating to the limitation of the height of trees, shrubs, hedges and fences at the junction of streets or roads is hereby repealed.

3. No person shall use any private property situate at the junction of any streets or roads for the growing of any tree, shrub or hedge abutting on any such street or road or within a distance of thirty feet from the junction of any streets or roads if such tree shrub or hedge exceeds a height of three feet six inches above the level of the portion of the street or road nearest to such tree, shrub or hedge.

4. The Council may at any time by notice, in writing, under the hand of the Town Clerk require the owner of any private property situate at the junction of any streets or roads (within a time specified in such notice) to lop (to a height specified in such notice but not less than three feet six inches above the level of the portion of the street or road nearest thereto) all trees, shrubs or hedges (whether planted before or after the commencement of this By-law) on such private property where such trees, shrubs or hedges abut on or are within ten feet of any such street or road or within a distance of 30 feet from the junction of any streets or roads.

5. The Council may at any time by notice, in writing, under the hand of the Town Clerk require (within a time specified in such notice) the owner of any land to reduce to a height not exceeding three feet six inches any portion of a fence upon such land and within 30 feet of the junction of any streets or roads.

6. Any owner upon whom any notice under clause 4 or clause 5 hereof is served shall comply with the requirements of such notice within the time therein limited.

7. The Council may at the expense of the owner—

- (a) Lop any tree, shrub or hedge growing or being on private property situate at the junction of any streets or roads which is not lopped as required by any such notice as aforesaid.
- (b) Reduce in height any portion of a fence which is not reduced in height as required by any such notice as aforesaid, and the amount of any such expense as aforesaid may be recovered by the Council in a Court of Petty Sessions as a civil debt recoverable summarily.

8. This By-law shall apply to and have operation throughout the whole of the municipal district.

Resolution for passing this By-law agreed to by the Council of the City of Waverley, on the 11th day of June, 1963, and confirmed on the 23rd day of July, 1963.

The corporate seal of the Mayor, Councillors and Citizens of the City of Waverley was hereunto affixed, in the presence of—

(SEAL) L. ALLEN, Mayor.
W. MUIR, Councillor.
F. S. BALES, Town Clerk.

7073

BOROUGH OF BENALLA.

LOAN No. 19.

Notice of Intention to Borrow the Sum of £15,000 for Permanent Works and Undertakings.

NOTICE is hereby given that the Council of the Borough of Benalla proposes to borrow the sum of £15,000 (Fifteen thousand pounds) on the credit of the municipal

revenues of the Mayor, Councillors and Burgesses of the said Borough, such sum to be raised by the grant of a mortgage in accordance with the provisions of the Local Government Act 1958.

1. The maximum rate of interest that may be paid is £5 2s. 6d. per cent. per annum.

2. The purpose for which the loan is to be applied is—

Kerb and channel construction	£4,753
Street construction	10,247
	£15,000

3. The period of the loan shall be ten years.

4. The moneys borrowed shall be repayable by providing out of the municipal fund twenty half-yearly instalments of approximately £967 18s. each, including principal and interest on the 1st day of November and the 1st day May, during the currency of the loan. The first instalment shall be payable on the 1st day of May, 1964.

5. Such moneys shall be repayable at the State Savings Bank of Victoria, Melbourne.

The plans and specifications and the estimate of the cost of the proposed works and a statement showing the proposed expenditure of the moneys to be borrowed, are open for inspection at the Town Hall, Benalla.

7127

L. A. HEMLEY, Town Clerk.

SHIRE OF BIRCHIP.

LOAN No. 25.

Notice of Intention to Borrow the Sum of £7,000, for Permanent Works and Undertakings.

NOTICE is hereby given that the Council of the Shire of Birchip proposes to borrow the sum of Seven thousand pounds on the credit of the municipal revenues of the said Shire, such sum to be raised by the grant of a mortgage in accordance with the provisions of the Local Government Act 1958.

1. The maximum rate of interest that may be paid is £5 per centum per annum.

2. The purpose for which the loan is to be applied is—
Purchase of Road-making Plant and Equipment.

3. The period of the loan shall be six years.

4. The moneys borrowed shall be repayable by providing out of the municipal fund twelve half-yearly instalments of approximately £682 8s. each, including principal and interest, on the 1st day of May and the 1st day of November, during the currency of the loan. The first instalment shall be payable on the 1st day of May, 1964.

5. Such moneys shall be repayable at the State Savings Bank of Victoria, Melbourne.

The plans and specifications and the estimate of the cost of the proposed works and a statement showing the proposed expenditure of the moneys to be borrowed are open for inspection at the Shire Office, Birchip.

1st August, 1963:

7080

A. HIBBERD, Shire Secretary.

SHIRE OF BULLA.

LOAN No. 13.

Notice of Intention to Borrow the Sum of £10,000 for Permanent Works and Undertakings.

NOTICE is hereby given that the Council of the Shire of Bulla proposes to borrow the sum of £10,000 on the credit of the municipal revenue of the President, Councillors and Ratepayers of the said Shire, such sum to be raised by the grant of a mortgage, in accordance with the provisions of the Local Government Act 1958.

1. The maximum rate of interest that may be paid is 5 1/2 per cent. per annum.

2. The purpose for which the loan is to be applied is towards the cost of the construction of the Sunbury Swimming Pool.

3. The period of the loan shall be ten years.

4. The moneys borrowed shall be repayable by providing out of the municipal fund twenty half-yearly instalments of approximately £649 1s. 5d. each, including interest, on the 1st July and the 1st January during the currency of the loan. The first instalment shall be payable on the 1st July, 1964.

5. Such moneys shall be repayable at the Head Office of the National Bank of Australasia Ltd., Melbourne.

The plans and specifications and an estimate of the cost of the proposed works, and a statement showing the proposed expenditure of the moneys to be borrowed, are open for inspection at the Shire Office, Sunbury.

Dated the 1st August, 1963.

7116

JOHN M. KELLY, Shire Secretary.

Local Government Act 1958.
SHIRE OF COBRAM.

DECLARATION OF PRIVATE STREETS AS PUBLIC HIGHWAYS.

IN pursuance of the power conferred by section 587 (3) of the Local Government Act 1958, the Council of the Shire of Cobram on the application of the owners of so many of the premises as in rateable value are the greater part of all the premises fronting on the streets hereinafter mentioned being private streets within the municipal district of the Shire of Cobram more than 15 feet in width constructed to the satisfaction of the Council, but not constructed pursuant to Division 10 of Part XIXI. or Part XLII. of the Local Government Act 1958 or any corresponding previous enactment hereby declares such streets to be dedicated to the public as public highways.

The streets in respect of which this declaration is made are:—

- Ashton-street—full length.
- Charles-street—full length.
- Christie-avenue—full length.
- Elizabeth-street—Wadeson-street to a point 145 feet east of the north-east corner of the intersection of Elizabeth and Wadeson streets.
- Wadeson-street—full length.

In witness whereof the common seal of the President, Councillors and Ratepayers of the Shire of Cobram was hereunto affixed this 17th day of June, 1963, in the presence of—

JOHN E. C. RADCLIFFE, Shire President.

(SEAL) JAMES COX, Councillor.

7113 RONALD T. CUTTS, Shire Secretary.

SHIRE OF CROYDON.

LOAN No. 21.

Notice of Intention to Borrow the Sum of £10,000 for Permanent Works and Undertakings.

NOTICE is hereby given that the Council of the Shire of Croydon, in pursuance of the powers conferred by the Local Government Act, intends to borrow the sum of £10,000 on the credit of the municipal revenues of the President, Councillors and Ratepayers of the said Shire, such sum to be raised by the grant of a mortgage, in accordance with the said Act and states—

- (a) The amount of principal moneys it is proposed to borrow is £10,000.
- (b) The maximum rate of interest that may be paid is £5 2s. 6d. per cent. per annum.
- (c) The period of the loan will be ten years and the time or times at which the moneys borrowed are to be repayable on the 1st day of November and the 1st day of May in each year, during the currency of the loan commencing on the 1st day of May, 1964. The place of repayment will be the State Savings Bank of Victoria, Melbourne.
- (d) The purpose for which the loan is to be applied is for permanent works and undertakings, viz.—

Purchase of road-making plant and machinery.

- (e) The loan is to be liquidated by half-yearly payments of approximately £345 5s. 6d. including principal and interest, payable out of the municipal fund.

Plans and specifications and an estimate of the cost of such works and undertakings, and a statement showing the proposed expenditure of the money to be borrowed, are open for inspection by ratepayers, during office hours, at the Shire Offices, Croydon, for one month after the publication of this notice.

Dated at Croydon this 5th day of August, 1963.

7128 K. A. MCKAY, Shire Secretary.

Town and Country Planning Act 1961 (Twelfth Schedule).

SHIRE OF FLINDERS.—SHIRE OF FLINDERS PLANNING SCHEME.

NOTICE THAT A PLANNING SCHEME HAS BEEN PREPARED AND IS AVAILABLE FOR INSPECTION.

Amendment No. 4.

NOTICE is hereby given that the Shire of Flinders in pursuance of its powers under the Town and Country Planning Act 1961 has prepared a Planning Scheme for McCulloch-street, Dromana, near the corner of Nepean Highway for the purpose of rezoning one block of land from Commercial B to Residential A.

A copy of the Scheme has been deposited at the Shire Office, Dromana, and at the office of the Town and Country Planning Board, 61 Spring-street, Melbourne, and will be open for inspection during office hours by any person, free of charge.

Any persons affected by the Planning Scheme are required to set forth, in writing, all objections they may have addressed to Secretary, Shire of Flinders, Dromana, on or before the 8th day of September, 1963, and state whether they wish to be heard in respect of their objections.

7066

S. WILLIAMS, Shire Secretary.

SHIRE OF HEALESVILLE.

IN pursuance of the powers conferred on it by section 522 of the Local Government Act 1958 the Council of the Shire of Healesville hereby directs that the following land which has been taken purchased or acquired by it shall be a public highway from and after the date of publication of this Order in the Government Gazette.

All of the lands described in certificate of title, volume 8417, folio 943.

By Order made by the Council of the Shire of Healesville, this 30th day of July, 1963.

(SEAL)
7067

R. J. RICHARDS, President.
V. C. MULLETT, Councillor.
W. M. OLIVER, Secretary.

SHIRE OF KYNETON.

NOTICE OF INTENTION TO BORROW THE SUM OF £10,500 FOR PERMANENT WORKS AND UNDERTAKINGS.

NOTICE is hereby given that the Council of the Shire of Kyneton proposes to borrow the sum of Ten thousand five hundred pounds on the credit of the municipal revenue of the President, Councillors and Ratepayers of the said Shire, such sum to be raised by the grant of a mortgage, in accordance with the provisions of the Local Government Act 1958.

1. The maximum rate of interest that may be paid is £5 per centum per annum.
2. The purposes for which the loan is to be applied are—

(1) Purchase of front-end loader and truck ..	£8,000
(2) Purchase of seating for Shire Hall .. .	1,500
(3) Proportion of the cost of Senior Citizen's Club .. .	1,000
	£10,500

3. The period of the loan shall be five years.
4. The moneys borrowed shall be repayable by providing out of the municipal fund ten half-yearly instalments of £1,199 14s. 4d., including principal and interest, on the 1st day of May and the 1st day of November during the currency of the loan. The first instalment shall be repayable on the 1st day of May, 1964.
5. Such moneys shall be repayable at the C.B.C. Savings Bank Limited, Melbourne.

The plans and specifications and the estimate of the proposed works and a statement showing the proposed expenditure of the money to be borrowed, are open for inspection at the Shire Office, Kyneton.

Dated this 30th day of July, 1963.

7108

S. G. PORTER, Shire Secretary.

SHIRE OF MANSFIELD.

LOAN No. 42.

Notice of Intention to Borrow the Sum of £1,500, for Permanent Works and Undertakings.

NOTICE is hereby given that the Council of the Shire of Mansfield proposes to borrow the sum of Fifteen hundred pounds on the credit of the municipal revenues of the President, Councillors and Ratepayers of the said Shire, such sums to be raised by the grant of a mortgage in accordance with the provisions of the Local Government Act 1958.

1. The maximum rate of interest that may be paid is 5 per centum per annum.
2. The purpose for which the loan is to be applied is for purchase of a Motor Truck.
3. The period of the loan shall be three years.
4. The moneys borrowed shall be repayable by providing out of the municipal fund six half-yearly instalments of approximately £272 6s. 6d. each, including principal and interest, on the 1st day of May, and the 1st day of November, during the currency of the loan. The first instalment shall be payable on the 1st day of May, 1964.

5. Such moneys shall be repayable at the State Savings Bank of Victoria, Melbourne.

6. The plans and specifications and the estimate of the cost of the proposed works and a statement showing the proposed expenditure of the moneys to be borrowed are open for inspection at the Shire Office, Mansfield.

Dated the 26th day of July, 1963.

7082

R. WOMERSLEY, Shire Secretary.

SHIRE OF SEYMOUR.

BY-LAW No. 49.

A By-law of the Shire of Seymour made under the Local Government Act and Health Act, Victoria, and numbered 49 for the determining, applying, dispensing with or regulating such matters or things as are left to be determined, applied, dispensed with or regulated by the Council of the said Shire under Local Government and Health Acts, Victoria.

IN pursuance of the powers conferred by the Local Government Act and Health Act, Victoria, and of any and every other power it thereunto enabling the President, Councillors and Ratepayers of the Shire of Seymour order as follows:—

1. This By-law shall apply to all land within the area described in the First Schedule.

2. In this By-law—

“Fowlhouse” means any building or structure for the housing or use of poultry and includes any area of land attached to such building or structure and which is fenced in for the use of such poultry.

“Poultry” includes fowls, ducks, geese and turkeys.

“Kennel” means any building or structure for the housing or use of two or more dogs and includes any area of land attached to such building or structure used as a pen for such dogs.

3. Fowlhouses or kennels or similar structures may be constructed appurtenant to any house or flat provided that such structures:—

- shall be constructed with such materials as may be approved, in writing, by the Council,
- shall have a height not exceeding 8 feet and a total superficial area not exceeding 100 square feet,
- the area of land fenced in for the use of such poultry shall not exceed 200 square feet including structures,
- shall not be within 40 feet of any dwelling, place of living or sleeping,
- shall be distant not less than 4 feet from side and rear boundaries, and
- shall be distant not less than 50 feet of front street frontage and not less than 25 feet of any side street or road of a greater width than 25 feet.

4. The Council may, in writing, permit areas exceeding those specified in clauses 3 (b) and 3 (c) of this By-law.

5. General provisions—

- No person shall keep in any poultry house or similar structure a number of fowls greater than the number produced by dividing the area in square feet of such poultry house or similar structure by four unless confined in approved Battery Cages.
- No person shall keep or store or cause or permit to be kept or stored in any poultry house where poultry is kept any food for consumption by poultry unless such food is kept or stored in rat-proof receptacles or rat-proof buildings.
- The owner or occupier shall cause the poultry house or similar structure to be thoroughly cleaned from time to time as often as may be necessary and shall keep the same in a clean wholesome and sanitary condition at all times.

6. All structures used for the housing of poultry or two or more dogs in use before this By-law is approved and published in the *Government Gazette*, Victoria, shall be brought into conformity with the requirements of this By-law before the expiration of six months after the date of approval and publication in the *Government Gazette*, Victoria.

7. Any person guilty of any contravention of the provisions of this By-law shall be liable on conviction to a penalty not exceeding Twenty pounds and in the case of any offence continuing after such conviction to a further daily penalty of not more than Five pounds but so that the total of such penalties shall not exceed One hundred pounds.

No. 64.—7001/63.—4

FIRST SCHEDULE.

Seymour Area, being the land enclosed in the Township of Seymour and Crown allotments 3, 5, 6, 7, 8 and 9, section X, Parish of Seymour, and Crown allotments 1, 2, 2A, 3, 3A, 4, 5A, 5B, 6, 6A, 7, 7A, 7B, 7C, 8, 8A and 9, section W, Parish of Seymour, and Crown allotments 15, 16, 17, 18, 19, 21, 47, 47A and 47B, section I, Parish of Tallarook, and Crown allotments 48A and 49, section II, Parish of Tallarook, and that part of Crown allotment 52, section II, Parish of Tallarook, north of a direct line between the south-east corner of Crown allotment 49 and the south-west corner of Crown allotment 16, both section II, Parish of Tallarook.

The Resolution for passing this By-law was agreed to by the Council of the Shire of Seymour on the 12th day of March, 1963, and confirmed on the 8th day of April, 1963.

The common seal of the President, Councillors and Ratepayers of the Shire of Seymour was hereunto affixed, in the presence of—

(SEAL) M. E. COUGHLIN, Councillor.
F. TRAINOR, Councillor.
H. E. CLAREY, Shire Secretary.

Submitted to the Commission of Public Health on the 14th May, 1963.—A. T. GARDNER, Secretary, Commission of Public Health.

Approved by the Governor in Council on 16th July, 1963. N. G. WISHART, Clerk of the Executive Council. 7068

SHIRE OF SEYMOUR.

BY-LAW No. 52.

A By-law of the Shire of Seymour made under sections 197 and 228 of the Local Government Act 1958, and numbered 52 to amend By-law No. 45 for—

- Prohibiting the deposit or leaving of refuse or rubbish on streets, roads, lanes, or passages;
- Prohibiting or regulating the deposit or leaving of refuse or rubbish on any land; and
- Requiring the removal or destruction by the owner or occupier of any land of refuse or rubbish thereon (other than refuse or rubbish the removal of which the Council of the Shire of Seymour has undertaken or contracted for under section 48 of the Health Act 1958).

IN pursuance of the powers conferred by the Local Government Act 1958, the President, Councillors and Ratepayers of the Shire of Seymour order as follows:—

1. In clause 3 of By-law No. 45 for the expression “Twenty pounds” substitute the expression “One hundred pounds.”

The Resolution for passing this By-law was agreed to by the Council of the Shire of Seymour, on the 11th day of June, 1963, and confirmed on the 8th day of July, 1963.

The common seal of the President, Councillors and Ratepayers of the Shire of Seymour was hereunto affixed, in the presence of—

(SEAL) M. E. COUGHLIN, Councillor.
F. H. WALLIS, Councillor.
7069 H. E. CLAREY, Shire Secretary.

SHIRE OF SEYMOUR.

ESTABLISHMENT OF POUND.

NOTICE is hereby given that the Council of the Shire of Seymour has established a Pound, on part of allotments 19 and 20, section I, Parish of Seymour, known as the Ammunition Depot, on the Highlands-road.

APPOINTMENT OF POUNDKEEPER.

Notice is hereby given that the Council of the Shire of Seymour has appointed Reginald Vearing, Poundkeeper of the Pound on the Highlands-road, Seymour.

ESTABLISHMENT OF POUND (DOG ACT 1958).

Notice is hereby given that the Council of the Shire of Seymour has appointed as a Dog Pound that piece of land known as the Sanitary Depot, being part of Crown allotment 8A, section W, Parish of Seymour.

7070

H. E. CLAREY, Secretary.

SHIRE OF TRARALGON.

BY-LAW No. 59.

Rubbish and Tips, &c.

A By-law of the Shire of Traralgon made under section 197 of the *Local Government Act 1958*, and section 93 of the *Health Act 1958*, and numbered 59.

IN pursuance of the powers conferred by the above-mentioned Acts the President, Councillors and Ratepayers of the Shire of Traralgon order as follows:—

1. No person shall deposit or leave any refuse or rubbish on streets, roads, lanes or passages other than in authorized tips.

2. No person shall deposit or leave any refuse or rubbish on any land other than a rubbish tip established by the said Shire.

3. The owner or occupier of any land on which any refuse or rubbish is deposited or left on receiving written notice from such Council under the hand of its Shire Secretary, or such other officer of the municipality who may for the time being be acting on behalf of the Shire Secretary requiring such owner or occupier to remove or effectively destroy any such refuse or rubbish shall comply with any such notice within seven days after receipt thereof.

4. No person shall do or suffer to be done any of the following matters at any refuse tip or incinerator under the control of the Council of the Shire of Traralgon:—

- (a) Trespass on any part of such land.
- (b) Obstruct, disturb, interrupt or annoy any person lawfully using such area.
- (c) Neglect or refuse to obey the lawful directions of the Council's Engineer or other officer or employee in charge of any such area.
- (d) Deposit or leave any rubbish, refuse, waste or any other material which in the opinion of the Council's Engineer or other officer in charge of such area is liable to ignite spontaneously or if ignited to cause smoke or fumes of a nature dangerous to the public provided that this prohibition shall apply for only such period of the year as the Council or its Engineer or other officer in charge of any such area shall determine.
- (e) Bring, deposit or leave any refuse or rubbish obtained from any place outside the municipal district of the Shire of Traralgon or Borough of Traralgon without the written authority of the Shire Secretary of the said Shire.
- (f) Light any fire in any part of the tip.
- (g) Interfere with the surface of the tip or with any materials deposited or about to be deposited at the tip.
- (h) Disfigure, damage, destroy or interfere with any notice board, fence, building, appliance, machine, tree, gate or other equipment at the tip.

5. No person in or upon any road, street, footway or public place within the municipal district of the Shire of Traralgon shall drive any vehicle laden with rubbish or refuse which may drop or be blown about unless such vehicle is provided with adequate sides and where necessary enclosed to the satisfaction of the Council.

6. Any person guilty of a contravention of the provisions of this By-law shall be liable on conviction to a penalty not exceeding Twenty pounds and in the case of any offence continuing after such conviction to a further daily penalty of not more than One pound, but so that the total of such penalties shall not exceed One hundred pounds.

7. Clauses 2, 3, and 4 of By-law No. 32 are hereby repealed.

8. This By-law shall apply to and have effect throughout the whole of the municipal district of the Shire of Traralgon.

The Resolution for passing this By-law agreed to by the Council on the 7th March, 1963, and confirmed on the 4th April, 1963.

The common seal of the President, Councillors and Ratepayers of the Shire of Traralgon was hereunto affixed, the 4th day of April, 1963, in the presence of—

(SEAL) H. J. SAUNDERS President.
C. H. JONES, Councillor.
W. TEASDALE, Acting Secretary.

Submitted to the Commission of Public Health on 17th April, 1963.—A. T. GARDNER, Secretary, Commission of Public Health.

Approved by the Governor in Council, 16th July, 1963.—N. G. WISHART, Clerk of the Executive Council.

7081

SHIRE OF WODONGA.

LOAN No. 33.

Notice of Intention to Borrow.

NOTICE is hereby given that the Council of the Shire of Wodonga intends to borrow Five thousand pounds (£5,000) on the credit of the President, Councillors and Ratepayers of the said Shire by the grant of a mortgage in accordance with the provisions of the *Local Government Acts*.

In connexion therewith the following information is stated:—

- (a) The amount of the principal moneys which it is proposed to borrow is £5,000 (Five thousand pounds).
- (b) The maximum rate of interest that may be paid is £5 2s. 6d. per centum per annum.
- (c) The times which the moneys borrowed are to be repayable are the 1st day of June, 1964, and the 1st days of December and June during the years 1964-1973 inclusive, and that the place such moneys shall be repayable is at the Bank of New South Wales, Wodonga.
- (d) The purpose for which the loan is to be applied is:—Sewerage connexions to be made to the following properties—Council Chambers, Swimming Pool, Residence at 23 Stanley-street, Residence at 19 Watson-street, Markets Dining-room, Markets Flats, Infant Welfare and Pre-School Centre, Youth Park, Martin Park, Shire Hall and Library.
- (e) The manner in which the loan is to be liquidated is by provision out of the municipal fund in each half-year during the currency of the loan of the sum of £322 12s. 8d. which includes principal and interest.

The plans and specifications and estimate of the cost of the works and a statement showing the proposed expenditure of the moneys to be borrowed are open for inspection at the Shire Office.

Dated this 7th day of August, 1963.

7110

G. J. MORTON, Shire Secretary.

NOTICE OF INTENTION TO APPLY FOR A LICENCE TO DIVERT WATER AND CUT RACE FROM THE LODDON RIVER AT NEWBRIDGE.

I HEREBY give notice that I intend to apply for a licence empowering me to divert water for a term of fifteen years to the extent of 20 acre-feet per annum at a maximum rate of 2 acre-feet per day of 24 hours for irrigation of 10 acres, being part of allotments S1, 2, 3 and Crown lands adjoining, section 4B, Parish of Tarnagulla, and to occupy certain Crown lands for works of storage and diversion, and to cut a race thereon.

Any objection to such application must be forwarded, in writing, to the State Rivers and Water Supply Commission, Melbourne, within 30 days of the date hereof.

JEFFREY LEONARD KENNEDY.

Newbridge, 5th November, 1962.

7119

NOTICE OF INTENTION TO APPLY FOR A LICENCE TO DIVERT WATER AND CUT RACE FROM THE RIVER MURRAY, AT MILDURA.

WE hereby give notice that we intend to apply for a licence empowering us to divert water for a term of seven years to the extent of 80 acre-feet per annum at a maximum rate of 8 acre-feet per day of 24 hours for the purpose of irrigating 31 acres 3 roods 17 perches, being lot 3 and part of lot 2, section 5, Block F, Parish of Mildura, and to occupy certain Crown lands for works of diversion, and to cut a race thereon.

Any objection to such application must be forwarded, in writing, to reach the State Rivers and Water Supply Commission, Melbourne, before the 31st day of August, 1963, being 30 days from the first publication of this notice.

JERONIM MATOTEK.
MATTHEW VICTOR MATOTEK.
HELEN MATOTEK.

First-street, Nichols Point.

7111

NOTICE OF INTENTION TO APPLY FOR A LICENCE TO DIVERT WATER AND CUT RACE FROM THE RIVER MURRAY, AT MILDURA.

WE hereby give notice that we intend to apply for a licence empowering us to divert water for a term of seven years to the extent of 60 acre-feet per annum at a maximum rate of 2 acre-feet per day of 24 hours for the purpose of irrigating 23 acres 1 rood 18 perches, being lot 8 on plan of subdivision No. 14431, being part of Crown allotment A, Parish of Mildura, and to occupy certain Crown lands for works of diversion, and to cut a race thereon.

Any objection to such application must be forwarded, in writing, to reach the State Rivers and Water Supply Commission, Melbourne, before the 31st day of August, 1963, being 30 days from the first publication of this notice.

ANDY MATOTEK.
HELENA MATOTEK.

Nichols Point.

7112

NOTICE OF INTENTION TO APPLY FOR A LICENCE TO DIVERT WATER AND CUT RACE FROM THE RIVER MURRAY, AT BARNAWARTHA NORTH.

I HEREBY give notice that I intend to apply for a licence empowering me to divert water for a term of seven years to the extent of 50 acre-feet per annum at a maximum rate of 3 acre-feet per day of 24 hours for the irrigation of 25 acres, being parts of allotments B and B2, Parish of Barnawartha North, and to occupy certain Crown lands for works of diversion, and to cut a race thereon.

Any objection to such application must be forwarded, in writing, to reach the State Rivers and Water Supply Commission, Melbourne, before 26th August, 1963, being 30 days from the first publication of this notice.

HERBERT HEINRICH THIELE.

P.O., Box 34, Wodonga.

7076

River Improvement Act 1958.

PROPOSED RIVER IMPROVEMENT DISTRICT.

NOTICE is hereby given that the Council of the Shire of Heytesbury has forwarded to the Minister of Water Supply an application for the constitution of a river improvement district under the jurisdiction and control of a river improvement trust and comprising an area along the Curdies River, under the provisions of the *River Improvement Act 1958*.

Copies of the application and general plan and description of the proposed works have been deposited for inspection at the offices of—

(a) The Minister of Water Supply, State Rivers and Water Supply Commission, 90 Orrong-road, Armadale, S.E.3.

(b) The Shire of Heytesbury, at Cobden.

(c) The Shire of Warrnambool, at Warrnambool.

6887

W. J. HOLTON, Shire Secretary.

GEELONG WATERWORKS AND SEWERAGE TRUST.

THE above-mentioned Trust, having made provision for carrying off the sewage from each and every property which or any part of which is within the sewerage area hereinafter described, doth hereby declare that on and after the 1st day of August, 1963, each and every property which or any part of which is within the said sewerage area shall be deemed and taken to be seweraged property within the meaning of the *Geelong Waterworks and Sewerage Act 1958*.

SEWERAGE AREA No. 277.

Shire of Bellarine, Parish of Moolap, County of Grant.

Commencing at a point being the north-east corner of the intersection of Glover-street and Breadalbane-street, the said point being also on the boundary of Sewerage Area No. 213; thence westerly across Breadalbane-street to a point being the intersection of the prolongation of the north side of Glover-street and the prolongation of the southern boundary of lot No. 37 Breadalbane-street; thence south-westerly along the latter prolongation and continuing south-westerly along the southern boundary of lot No. 37 Breadalbane-street to a point being the south-east corner of lot No. 49 Ivanhoe-court, which is also a point on the boundary of Sewerage Area No. 213; thence north-westerly along the southern boundary of the said lot No. 49 to a point being on the east side of Ivanhoe-court; thence continuing by a line along the periphery of Ivanhoe-court (which is also a boundary of Sewerage Area No. 213) to a point being on the west side of Ivanhoe-court about 276 feet 7½ inches south from the south-west corner of the intersection of Ivanhoe-court and

Ising-street; thence northerly along the west side of Ivanhoe-court to a point being a prolongation of the northern boundary of lot No. 45, Ivanhoe-court, which is also a point on the boundaries of Sewerage Areas Nos. 213 and 237; thence easterly on a straight line across Ivanhoe-court and continuing easterly along the northern boundaries of lots Nos. 45 Ivanhoe-court and 41 Breadalbane-street and crossing Breadalbane-street to a point being on the east side of Breadalbane-street, the said point being also on the boundaries of Sewerage Areas Nos. 237 and 213; thence southerly along the east side of Breadalbane-street to the point of commencement.

SEWERAGE AREA No. 278.

Shire of South Barwon, Parish of Barrarbool, County of Grant.

Commencing at a point being the south-east corner of the intersection of Johnson-street and Summit-avenue, the said point being also on the boundary of Sewerage Area No. 220; thence westerly across Johnson-street and continuing westerly along the south side of Summit-avenue to a point being on the prolongation of the western boundary of lot No. 76 Summit-avenue, the said point being also on the boundaries of Sewerage Areas Nos. 225 and 235; thence northerly on a straight line across Summit-avenue and continuing northerly along the western boundaries of lot No. 76 Summit-avenue and lot No. 105 Apex-avenue and crossing Apex-avenue to a point being on the north side of Apex-avenue; thence easterly along the north side of Apex-avenue and crossing Johnson-street to a point being the north-east corner of the intersection of Apex-avenue and Johnson-street, the said point being also on the boundary of Sewerage Area No. 220; thence southerly across Apex-avenue and continuing southerly along the east side of Johnson-street and crossing Summit-avenue to the point of commencement.

By order of the Commissioners,

7105

(SEAL) J. CARR, Chairman.
B. C. HENSHAW, Secretary.

LEONGATHA SEWERAGE AUTHORITY.

GENERAL NOTICE.

THE above-mentioned Sewerage Authority having made sewers for carrying off the sewage from each and every property which or any part of which abuts on streets or parts of streets in which such sewers are laid and which are included within the sewerage areas hereinafter described doth hereby declare that on and after the 1st day of September, 1963, each and every property which or any part of which abuts on the said streets or parts of streets shall be deemed to be a seweraged property within the meaning of the *Sewerage Districts Act 1958*.

The boundaries of the sewerage areas hereinbefore referred to are:—

Sewerage Area No. 2.

Commencing at a point on the eastern boundary of McDonald-street distant 100 links due east from the north-eastern angle of Crown allotment 9, section 25, Township of Leongatha, Parish of Leongatha, County of Buln Buln, and being a point on the eastern boundary of the existing sewerage district; thence southerly along said boundary of McDonald-street to a point in line with the southern boundary of Crown allotment 6, section 26; thence westerly along the said southern boundary of Crown allotment 6 to its south-western angle; thence south-easterly along the north-eastern boundary of Crown allotment 5 and of Crown allotment 4 to its most easterly angle; thence south-westerly along the south-eastern boundary of the said Crown allotment 4, a distance of 475 links; thence through Crown allotment 3 by a line bearing south 25 deg. 36 min. east a distance of 550 links; thence through Crown allotment 3 and across Crown allotment 8 by a line due east a distance of approximately 690.7 links to a point on the eastern boundary of the said Crown allotment 8; thence southerly along the said eastern boundary of Crown allotment 8 to its south-eastern angle; thence easterly along the southern boundary of Crown allotment 9 and by a line being a continuation thereof across McDonald-street of width 100 links to a point on the easterly boundary of the said road; thence across Parr-street and through Crown allotment 59F, Parish of Leongatha, by a line due south a distance of 400 links; thence by a line due west to a point 300 links due east from the western boundary of the said Crown allotment 59F; thence by lines bearing south 6 deg. 47 min. east, a distance of 500 links, and due west a distance of 300 links to the western boundary of the said Crown allotment 59F; thence southerly along the said western boundary of Crown allotment 59F to a point in line with the southern boundary of Crown allotment 59A; thence westerly by a line across a road to the south-eastern angle of the said Crown allotment 59A, being a point on the South Gippsland Highway and a point on

sewerage area No. 1; thence along the boundary of the said sewerage area No. 1 north-westerly to Parr-street; thence across the South Gippsland Highway to the intersection of the northern boundary of Parr-street and the north-east boundary of the South Gippsland Highway; thence north-westerly along the north-east boundary of the South Gippsland Highway to its intersection with the northern boundary of railway trial survey; thence south-easterly, easterly, and north-easterly by the northern boundary of the said survey to its intersection with a line parallel to the north-east side of Hassett-street and distant 165 feet therefrom; thence by this line north-westerly to its intersection with the northern boundary of Crown allotment 10, section 25 to the western boundary of McDonald-street to the point of commencement.

Sewerage Area No. 3.

Commencing at a point on the eastern boundary of Horn-street distant 100 links due east from the north-eastern angle of Crown allotment 9; section 24; Township of Leongatha; Parish of Leongatha, County of Buln Buln; and being a point in the eastern boundary of the existing sewerage district; thence north-easterly along the said boundary of Horn-street to a point 300 links northerly; thence westerly by a line being a continuation thereof across Horn-street across Crown allotments 26, 25 and 24 to a point 300 feet from the eastern boundary of the said Crown allotment 24; thence southerly to a point on the southern boundary of Crown allotment 24; across Turner-street to a point on the north-eastern corner of Crown allotment 5, section 27; thence southerly along the eastern boundary of the said Crown allotment 5 to its south-eastern angle; thence south-westerly along the boundary of the public park to Hassett-street; thence by a line across Hassett-street to the eastern angle of Crown allotment 25, section 19; thence along the boundary of section 1 to the point of commencement.

Sewerage Area No. 4.

Commencing at a point on the north-eastern boundary of Crown allotment 17, section 9, Township of Leongatha, Parish of Leongatha, County of Buln Buln, and being a point on section 1 of the sewerage area; thence northerly across Gray-street and westerly across Brown-street to the south-eastern angle of Crown allotment 10, section 10; thence westerly along the southern boundary of the said allotment 10 to a point 200 feet from west of Brown-street; thence northerly along a line through Crown allotments 10, 8, 6 and 4, section 10, to a point 200 feet south of the southern side of Shingler-street; thence westerly along a line through Crown allotments 4, 3, 2 and 1 parallel to the southern side of Shingler-street to a point on the western boundary of Crown allotment 1, section 10; thence across a road to its western boundary; thence northerly to Shingler-street and Crown allotment 104, Parish of Leongatha, to a point 245 links north of the southern boundary of the said Crown allotment 104; thence easterly through Crown allotment 104, and Crown allotments 2, 3, and 6, section 11 to the eastern boundary of Crown allotment 6; thence northerly along the eastern boundary of Crown allotment 6 to the south-western angle of Crown allotment 8; thence north-easterly along the boundary of the said Crown allotment 8 along a line being a continuation thereof across the South Gippsland Highway and a railway reserve to a point on the centreline of the south-eastern railway line; thence south-easterly along the said centreline to a point in line with the south-eastern boundary of a drainage reserve being Crown allotment 22, section 18; thence north-easterly by a line across a railway reserve and Hughes-street to the south-eastern angle of the said drainage reserve and along its south-eastern boundary and a line being a continuation thereof across a road to a point on the southern boundary of a recreation reserve distant 1,231.7 links from its south-eastern angle; thence northerly by a line parallel to the eastern boundary of the said reserve to a point in line with the north-western boundary of Crown allotment 1; section 30; thence easterly by a line through a show yard reserve and across a road to the said north-western angle of Crown allotment 1, section 30, and along the north-western boundary of the said Crown allotment 1 to its northern angle; thence south-easterly along the north-eastern boundary of Crown allotment 1 to its eastern angle; thence easterly across a road to the north-western angle of Crown allotment 13, section 28; thence southerly along the western boundaries of Crown allotments 13 and 12; section 28 and by a line being a continuation thereof to a point in line with the south-western boundary of Crown allotment 1, section 27, being a point on the boundary of sewerage area No. 1; thence along that boundary to the point of commencement.

By order of the said Sewerage Authority,

R. H. LESLIE, Chairman.
E. R. HARDING, Secretary.

6999

NOTICE is hereby given that the partnership heretofore subsisting between the undersigned Peter Carson and Acham Walter, carrying on business at the rear of 39 Porter-street, Prahran, under the business name of "C.W. Motors"; and at 17-27 Cotham-road, Kew, under the name of "Kew Garden Motors", has been dissolved by mutual consent as from the 30th day of June, 1963. Peter Carson will continue to carry on "C.W. Motors" and Acham Walter will continue to carry on "Kew Garden Motors."

Dated the 1st day of August, 1963.

P. CARSON.

Witness—J. W. BRENCHELY.

A. WALTER.

Witness—J. W. BRENCHELY.

7097

Partnership Act 1958.

NOTICE OF DISSOLUTION.

NOTICE is hereby given that the partnership heretofore subsisting between the undersigned, Evan John Easton, Robert James Sinclair and John Reginald Sinclair carrying on business as electrical and furniture wholesalers and retailers at 246 High-street, Ashburton, under the firm name of "E. & S. Trading Co." has been dissolved by mutual consent as from the 28th day of July, 1963, so far as concerns the said Evan John Easton who retires from the partnership. All debts due and owing by the said late firm will be received and paid by the continuing partners who shall continue to carry on the business at the same address.

Dated the 28th day of July, 1963.

E. J. EASTON.
R. J. SINCLAIR.
J. SINCLAIR.

Evans, Guss & Holt, solicitors, 406 Lonsdale-street, Melbourne. 7065

AIRDRIE HOLDINGS-PROPRIETARY LIMITED.

AT an Extraordinary General Meeting of the above-named company, duly convened and held at 19 Bruce-street, Toorak, on the 5th day of August, 1963; the following resolution was duly passed as a Special Resolution:—

"That the company be wound up voluntarily."

And at such last-mentioned meeting, John Keshan Maxwell Carroll, of 289 Flinders-lane, Melbourne, was appointed liquidator for the purposes of the winding up.

Dated the 5th day of August, 1963.

EVA W. BLACK, Chairman of the above-mentioned meeting. 7137

Companies Act 1961.

SETTLERS PTY. LTD.

(228 Clarendon-street, East Melbourne).

NOTICE OF MEETING OF CREDITORS.

NOTICE is hereby given that a Meeting of Creditors of the above company will be held in the Board Room Honorary Justice's Association, 34 Queen-street, Melbourne, on Monday, 12th August, 1963, at 2.30 p.m., for the purposes set out in sections 260 to 262 of the above Act, a meeting of the company having been called for the same day to consider and if thought fit to pass a Resolution that the company be wound up voluntarily.

Dated this 29th day of July, 1963.

7095 E. DAWSON, Director.

WOLFENDEN MACHINERY PTY. LTD.

NOTICE is hereby given that an Order of the Supreme Court, dated the 15th day of July, 1963, confirming a reduction of the share capital of the above company has been lodged with the Assistant Registrar of Companies.

ARTHUR SECOMB & CO., solicitors, 128 William-street, Melbourne. 7086

The Companies Act 1961.

FISK CONSTRUCTIONS PTY. LTD. (IN LIQUIDATION).

NOTICE is hereby given that a First and Final Dividend is intended to be declared in the above matter. Creditors who have not proved their debts by the 21st day of August, 1963, may be excluded from this dividend.

Dated this 5th day of August, 1963.

J. K. HALL, Liquidator.

Hall and Rose, chartered accountants, 163 William-street, Melbourne. 7085

Unclaimed Moneys Act 1962.

DAWSON'S (RAINBOW) PTY. LTD.

REGISTER of Unclaimed Money held by Dawson's (Rainbow) Pty. Ltd.

Name of Owner on Books and Last Known Address.	Total Amount Due To Owner.	Description of Unclaimed Money.	Date when Amount first became Payable.
	£ s. d.		
Jacschke, I. E., Tarranyurk	13 0 6	Payment for supply of cream ..	Feb., 1960
Schulze, O. I., Ni Ni Well, via Kiata	5 7 3	" " " " ..	Oct., 1956
Schulze, B. J., Ni Ni Well, via Kiata	5 8 1	" " " " ..	" " " "
Reichenbach, G. M., Gerang Gerung	20 4 10	" " " " ..	Sept., 1959
Lowe, H. F., Propodoolah'	8 1 9	" " " " ..	Jan., 1960
Dahlenburg, F., Winiam, via Nhill	5 15 8	" " " " ..	May, 1960
Peake, F. M., Private Bag 1, Nhill	26 1 6	" " " " ..	Oct., 1961
Roll, I. H., Yaapeet	10 14 4	" " " " ..	Sept., 1959

7114

Companies Act 1961.

SYDNEY, TUCKER (1933) PTY. LIMITED.

NOTICE is hereby given that a meeting of creditors of Sydney, Tucker (1933) Pty. Limited will be held, pursuant to section 260 (1) of the Companies Act 1961, at the registered office of the company, Fourth Floor, Collins House, 360 Collins-street, Melbourne, on Thursday, the 15th August, 1963, at 10.30 o'clock in the forenoon, the company having convened a meeting of the members for the same day for the purpose of considering and, if thought fit, approving a resolution that the company be wound up voluntarily.

Dated this 1st day of August, 1963.

By order of the Board,

SYDNEY E. TUCKER, Secretary:

360 Collins-street, Melbourne. 7088.

Companies Act 1961; Section 254 (2).

CLAYTON FURNISHINGS & FLOOR COVERINGS PROPRIETARY LIMITED.

NOTICE OF RESOLUTION.

AT a General Meeting of the members of Clayton Furnishings & Floor Coverings Proprietary Limited duly convened and held at the Institute of Chartered Accountants, 23 McKillop-street, Melbourne, on the 5th day of August, 1963, the Special Resolution set out below was duly passed:—

"That it has been proved to the satisfaction of this meeting that the company cannot by reason of its liabilities continue in business, and that it is advisable to wind up, and accordingly by that the company be wound up voluntarily, and that J. A. Coakley be appointed liquidator for the purpose of the winding up."

Dated this 5th day of August, 1963.

R. G. BEAZLEY, Director.

John A. Coakley, public accountant; 125 William-street, Melbourne. 7144.

In the matter of VICTORIAN FISHERMENS' ASSOCIATION. WINDING-UP.—Notice of Winding-up Order.

WINDING-UP: Order made the 25th day of June, 1963:

Name and Address of Liquidator, Harold Keith Cartledge, of 1-3 Palmerston-court, South Melbourne.

TREVAKS, HAVYATT & CO, solicitors for the petitioner. 7093

In the Supreme Court.—Co. No. 6732.—In the matter of the Companies Act 1961; and in the matter of THE CLOUDLAND DRIVE-IN THEATRES (PORTLAND) LIMITED.

WINDING-UP Order made the 30th day of July, 1963:

Name and Address of Liquidator, Edward Ronald Small, of 294 Little Lonsdale-street, Melbourne.

EVANS, GUSS & HOLT, solicitors for the petitioner, The Cloudland Drive-in Theatres, Limited. 7104

In the matter of TILLI CRAFT (VIC.) PTY. LTD.—Notice of Winding-up Order.

WINDING-UP: Order made the 26th day of July, 1963:

Name and Address of Liquidator, James Wallace Ross, of 105 Queen-street, Melbourne, C.I.

GILBERT, FIELD & WARNE, solicitors for the petitioner. 7146.

In the matter of the Companies Act 1961; and in the matter of ROBERT McDONOUGH TRADING PROPRIETARY LIMITED OF "COOLIBAH", Heatherdale-road, Vermont.—Form 92 (Regulation 28 (2) (b)).—Notice of Meeting of Creditors (Section 260 (1)).—Robert McDonough Trading Proprietary Limited.

NOTICE is hereby given that a Meeting of Creditors of Robert McDonough Trading Proprietary Limited will be held at the office of R. D. Widdows, Room 49, 2nd Floor, 125 William-street, Melbourne, on Tuesday, the 20th day of August, 1963, at 3.30 p.m. in the afternoon:

Dated this 29th day of July, 1963.

By order of the Board,

7091; R. A. McDONOUGH, Director:

Companies Act 1961.

APEX MOTORS PROPRIETARY LIMITED (IN LIQUIDATION).

NOTICE is hereby given that creditors having claims against the above-named company should lodge proofs of debt with the liquidator, R. C. D. Warne-Smith, 5th Floor, 456 Collins-street, Melbourne. Creditors who have not proved their debts by the 22nd August, 1963, may be excluded from the dividend.

Dated this 5th day of August, 1963:

7143; R. C. D. Warne-Smith, Liquidator.

THE EQUITY TRUSTEES, EXECUTORS AND AGENCY CO. LTD., the registered office of which is situated at 472 Bourke-street, Melbourne, the executor of the will of Jeane Valerie Moore, formerly of 47 Norman-street, Ivanhoe, but late of 5 Gowar-avenue, Camberwell, married woman, deceased (who died on the 23rd day of September, 1962), requires all creditors, next of kin and others having claims against the property or estate of the said deceased to send to the said executor, on or before the 15th day of October, 1963, particulars, in writing, of such claims, after which date the said executor intends to convey or distribute such property or estate to or among the persons entitled thereto, having regard only to the claims of which it shall then have had notice.

ALAN WAINWRIGHT & CO., solicitors, 397 Little Collins-street, Melbourne. 7140

ARTHUR NORMAN ALWIN JONES, of Avondale, Benalla, in the State of Victoria, grazier, Alan Worrall Jones, of Brilliant Estate, Kanumbra, in the said State, grazier, and The Perpetual Executors and Trustees Association of Australia Limited, whose registered office is situate at 100-104 Queen-street, Melbourne, in the State of Victoria, the executors of the will of Mary Ann Jones, late of "Ruskin Hall", Princess-street, Kew, in the said State, widow, deceased (who died on the 28th day of December, 1962), require all creditors, next of kin and others having claims against the property or estate of the said deceased to send to the said executors in the care of the said association on or before the 14th day of October, 1963, particulars, in writing, of such claims, after which date the said executors intend to convey or distribute such property or estate to or among the persons entitled thereto, having regard only to the claims of which they shall have had notice.

ABBOTT, STILLMAN & WILSON, solicitors, 422 Little Collins-street, Melbourne. 7132

ALL persons having claims against the estate of Gordon Verney Gow, late of Walton, New Zealand, farmer, deceased (who died on the 13th December, 1962, and probate of whose will was on the 5th February, 1963, granted by the Supreme Court of New Zealand to The Guardian Trust and Executors Company of New Zealand Limited and application to the Supreme Court of Victoria (Probate Jurisdiction) by The Perpetual Executors and Trustees Association of Australia Limited to seal such probate having been granted on the 29th July, 1963), are hereby required to send particulars of such claims to The Perpetual Executors and Trustees Association of Australia Limited, at its registered office at 100-104 Queen-street, Melbourne, on or before 5th September, 1963, after which date the said company will proceed to transfer, convey or distribute the said estate to or among the persons entitled thereto, having regard only to the claims of which it shall then have had notice, and will not be liable for the assets so transferred, conveyed or distributed to any persons of whose claims it shall not then have had notice.

RYLAH & RYLAH, solicitors, 349 Collins-street, Melbourne. 7094

ANDREW JAMES STEWART, late of Tatura, in the State of Victoria, gentleman, DECEASED.

CREDITORS, next of kin and others having claims in respect of the estate of the said deceased (who died on the 23rd day of October, 1962, and probate of whose will was granted on the 23rd day of April, 1963, to Norman George Starritt, of North-West Mooroopna, and Neil Gordon Stewart, of East Roadside, Tatura, farmers, both in the said State, in care of Stewart and Stewart, solicitors, Tatura), are hereby required to send particulars, in writing, of such claims to the said estate before the 10th day of November, 1963, after which date they will distribute the assets, having regard only to the claims of which they then have notice.

STEWART & STEWART, solicitors, Tatura. 7118

JAMES MORRISON FORSYTH, late of Bulban-road, Little River, farmer, DECEASED (who died on the 7th January, 1963).

CREDITORS and next of kin having claims against the estate of the deceased are requested by the executors, Hazel Margaret Forsyth, Donald Archibald Forsyth and John Morrison Forsyth, to send particulars of their claims to the under-mentioned solicitors, on or before the 7th October, 1963, after which date they will distribute the assets, having regard only to the claims of which they then have notice.

GERALD E. DELANY & CO., solicitors, 452 Lonsdale-street, Melbourne. 7139

RUDOLPH VERNON SEYMOUR, late of 19 Beauview-parade, East Ivanhoe, gentleman, DECEASED.

CREDITORS, next of kin and others having claims in respect of the estate of the deceased (who died on the 2nd day of April, 1963), are required by the executrix, Katie Seymour, of 299 Lower Heidelberg-road, East Ivanhoe, widow, to send particulars to her, care of the under-mentioned solicitor, by the 16th day of October, 1963, after which date the executrix may convey or distribute the assets, having regard only to the claims of which she then has notice.

J. E. SIEVERS, solicitor, 17 Sun-crescent, Sunshine. 7075

CREDITORS, next of kin and others having claims against the estate of John William Porta, late of 49 Doncaster-road, North Balwyn, timber merchant (who died on the 14th day of June, 1961), are to send particulars of their claims to the executors, Robert John Murden and Thelma May Porta, care of the under-mentioned solicitors, by the 15th day of October, 1963, after which date the executors will distribute the assets, having regard only to the claims of which they then have notice.

E. A. ATKYNS & TOOP, solicitors, 422 Little Collins-street, Melbourne. 7133

PERCY JAMES O'BRIEN, formerly of 10 Bourne-road, Glen Iris, distiller, but late of 224 Carrington-road, Coogee, New South Wales, retired, DECEASED (who died on 10th day of February, 1962).

CREDITORS, next of kin and all other persons having claims against the estate of the deceased are required by the executrix of his will, Myrtle Ethel May Johns, formerly of State Savings Bank of Victoria, Bell-street, Coburg, but now of 97 Broughton-road, Surrey Hills, to send particulars thereof to her, care of the under-mentioned solicitors before 21st October, 1963, after which date she may distribute the assets of the deceased, having regard only to the claims of which she then has notice.

COLTMAN, WYATT & ANDERSON, solicitors, of 578 Bourke-street, Melbourne. 7134

CREDITORS, next of kin and others having claims in respect of the estate of Phyllis Irene Clark, late of 12 Mitchell-street, Footscray, widow, deceased (who died on the 26th April, 1963), are to send particulars of their claims to Charles James Clark, of 12 Mitchell-street, Footscray, executor of deceased's will, care of the under-mentioned solicitor, on or before the 16th day of October, 1963, after which date he will distribute the assets, having regard only to the claims of which he then has notice.

JOHN GINNANE, solicitor, 153A Barkly-street, Footscray. 7135

CREDITORS, next of kin and others having claims in respect of the estate of Edward Ernest Smith, late of Morwell, labourer, deceased (who died on 6th May, 1963), are required by the trustee, Sylvia May Smith, of Morwell, to send particulars to her, care of the undersigned, by 20th August, 1963, after which date she will distribute the assets, having regard only to the claims of which she then has notice.

C. H. FORD, LL.M., solicitor, Princes-street, Traralgon. 7122

CREDITORS, next of kin and others having claims against the estate of Annie Margaret Joiner, late of Tongala, in the State of Victoria, married woman, deceased (who died on the 6th day of March, 1963), are required to send particulars of their claims to Ronald James Joiner and Leo James Slattery, care of the undersigned solicitors, by the 20th day of October, 1963, after which date they will distribute the assets, having regard only to the claims of which they then have notice.

MORRISON & SAWERS, solicitors, Kyabram, and at 734 Hawthorn-road, East Brighton. 7123

CREDITORS, next of kin and others having claims in respect of the estate of Thirza Leach Lawrence, late of "Garden Court", Marnie-street, South Yarra, in the State of Victoria, widow, deceased (who died on the 20th day of February, 1963), are required by the executrix, Jean Fermor Lawrence, of "Garden Court", Marnie-street, South Yarra aforesaid, spinster, to send particulars of their claims to her, care of the under-mentioned solicitors, by the 8th day of October, 1963, after which date she may convey or distribute the assets, having regard only to the claims of which she then has notice.

AITKEN, WALKER & STRACHAN, solicitors, 123 William-street, Melbourne. 7100

CREDITORS, next of kin and others having claims in respect of the estate of Simone Gajda, late of 127 Begonia-avenue, Bayswater, married woman, deceased (who died on the 4th day of August, 1962, and probate of whose will has been granted to Julian Gajda, of 127 Begonia-avenue, Bayswater, technician), are to send in particulars of their claims to the said executor, care of the under-mentioned solicitors, by the 10th day of October, 1963, after which date he will distribute the assets, having regard only to the claims of which he then has notice.

PEARCE & WEBSTER, solicitors, 430 Little Collins-street, Melbourne. 7136

CREDITORS, next of kin and others having claims in respect of the estate of Henry Stewart Hogg, late of Korumburra, retired storekeeper, deceased (who died on the 29th day of May, 1963, and probate of whose will has been granted to Ethel Hogg, of 34 Queen-street, Korumburra, widow), are to send in particulars of their claims to the said executrix, care of the under-mentioned solicitors, by the 14th day of October, 1963, after which date she will distribute the assets, having regard only to the claims of which she then has notice.

BIRCH, ROSS & BARLOW, solicitors, Commercial-street, Korumburra. 7138

ELIZABETH ALICE LITTLE, late of 62 Swanston-street, Geelong, widow, DECEASED.

CREDITORS, next of kin and others having claims in respect of the estate of the said deceased (who died 28th March, 1963), are required by the applicants for a grant of probate of the will, The Union-Fidelity Trustee Company of Australia Limited, of 333 Collins-street, Melbourne, and John Lloyd Little, of 6 Kelso-street, Mentone, technical assistant, to send particulars to them, care of The Union-Fidelity Trustee Company of Australia Limited, at its Geelong Office, 8 Malop-street, Geelong, by 16th October, 1963, after which date the said applicants may convey or distribute the assets, having regard only to the claims of which they then have notice.

WIGHTON & McDONALD, solicitors, 189-191 Moorabool-street, Geelong. 7124

EDWIN VICARS KINGWELL, late of 57 Clarence-street, Geelong West, clerk, DECEASED.

CREDITORS, next of kin and others having claims in respect of the estate of the said deceased (who died 14th May, 1963), are required by the applicant for grant of probate of the will, Ivy Emily Bellchambers, of 34 Breakwater-road, East Geelong, stenographer, to send particulars to her, care of the undersigned solicitors, by 16th October, 1963, after which date the said applicant may convey or distribute the assets, having regard only to the claims of which she then has notice.

WIGHTON & McDONALD, solicitors, 189-191 Moorabool-street, Geelong. 7125

ETHEL FLORENCE, late of Swan Hill, in the State of Victoria, married woman, DECEASED.

CREDITORS, next of kin and others having claims in respect of the estate of the deceased (who died on the 19th day of February, 1963), are required by the trustee, The Trustees, Executors and Agency Company Limited, of 401 Collins-street, Melbourne, to send particulars to it, care of the undersigned, by the 15th day of October, 1963, after which date the trustee may convey or distribute the assets, having regard only to the claims of which it then has notice.

Dated this 30th day of July, 1963.

ALEC M. HAYES, solicitor, 199 Campbell-street, Swan Hill. 7117

CREDITORS, next of kin and others having claims in respect of the estate of Therese Zull, late of 135 Brunswick-road, Brunswick, widow, deceased (who died on the 24th day of January, 1963, are required by Walter Frederick McMillan, of 38 Carn-avenue, Ivanhoe, the executor to whom probate of the will of the said deceased was granted on the 31st day of July, 1963), to send particulars of their claims to the said executor, care of the undersigned solicitors, on or before the 16th day of October, 1963, after which date he will distribute the assets of the said deceased among the persons entitled thereto, having regard only to the claims of which he shall then have notice and he will not be liable to any person of whose claim he has not then received notice.

McNAB & McNAB, solicitors, 17 Queen-street, Melbourne. 7099

CREDITORS, next of kin and others having claims in respect of the estate of George Treagus, late of 98 Macpherson-street, Footscray, retired quarryman, deceased (who died on the 14th day of June, 1963), are to send particulars of their claims to the executor, Alexander George Treagus, care of the under-mentioned solicitors, on or before the 9th day of October, 1963, after which date the executor will distribute all assets, having regard only to claims of which notices have been received.

MARTIN & MARTIN, solicitors, 37 Queen-street, Melbourne. 7142

CREDITORS, next of kin and others having claims in respect of the estate of William Henry Doery, late of 20 Tower-street, Mont Albert, director, deceased (who died on the 1st day of February, 1963), are to send particulars of their claims to the executor, George Edward Doery, care of the under-mentioned solicitors, by the 9th day of October, 1963, after which date the executor will distribute the assets, having regard only to the claims of which he then has notice.

MARTIN & MARTIN, solicitors, 37 Queen-street, Melbourne. 7141

MAY LIVINGSTONE LISTON, late of Clivedon Mansions, 192 Wellington-parade, East Melbourne, in the State of Victoria, widow, DECEASED.

CREDITORS, next of kin and others having claims in respect of the estate of the deceased (who died on the 10th May, 1963), are required by the personal representative, National Trustees, Executors and Agency Company of Australasia Limited, of 95 Queen-street, Melbourne, to send particulars to the said company by the 11th October, 1963, after which date it may convey or distribute the assets, having regard only to the claims of which it then has notice.

HEDDERWICK, FOOKES & ALSTON, 103 William-street, Melbourne. 7145

ROBERT GILSON BROOMHEAD, late of 1 Yuille-street, Ashburton, in the State of Victoria, engineer, DECEASED.

CREDITORS, next of kin and others having claims in respect of the estate of the deceased (who died on the 18th of March, 1963), are required by the trustee, James Samuel Gibson, of 825 Burke-road, Camberwell, solicitor, to send particulars to him, care of the undersigned solicitors, by the 14th day of October, 1963, after which date he may convey or distribute the assets, having regard only to the claims of which he then has notice.

Dated the 30th day of July, 1963.

R. E. LEWIS, ORR & GIBSON, solicitors, 825 Burke-road, Camberwell. 7102

CREDITORS, next of kin and others having claims in respect of the estate of Elsie Eleanor Whittle, late of 31 Poath-road, Oakleigh, spinster, deceased (who died on the 28th March, 1963), are to send the particulars of their claims to The Equity Trustees, Executors and Agency Company Limited, of 472 Bourke-street, Melbourne, by the 8th day of October, 1963, after which date it will distribute the assets having regard only to the claims of which it then has notice.

W. G. COLE & CO., solicitors, Oakleigh. 7074

CREDITORS, next of kin and others having claims in respect of the estate of Maria Victoria Moore, late of 63 The Grove, Moreland, spinster, deceased (who died on the 4th day of May, 1962), are required to send particulars of their claims to the executors, Margaret McDonald, of Skipton, and Samuel Henry Moore, of 8 Edro-avenue, Brighton, in care of the undersigned, on or before the 9th day of October, 1963, after which date the executors will distribute the assets, having regard only to the claims of which they then have notice.

WM. MURRAY & SON, solicitors, 117 William-street, Melbourne. 7090

CREDITORS, next of kin and others having claims in respect of the estate of Arthur Hose Bullivant, late of 12 Marne-street, South Yarra, retired grazier, deceased (who died on the 25th day of March, 1963), are to send the particulars of their claims to The Union-Fidelity Trustee Company of Australia Limited, of 333 Collins-street, Melbourne, and Norman Mace, of 88 Clowes-street, South Yarra, public servant, care of the said company, by the 15th day of October, 1963, after which date they will distribute the assets, having regard only to the claims of which they then have notice.

Dated the 1st day of August, 1963.

MADDEN, BUTLER, ELDER & GRAHAM, solicitors, 99 Queen-street, Melbourne. 7089

CREDITORS, next of kin and others having claims in respect of the estate of Herbert William James Elliott, late of 10 Knutsford-street, Balwyn, warehouseman, deceased (who died on 28th January, 1963), are to send particulars of their claims to The Equity Trustees, Executors and Agency Company Limited, 472 Bourke-street, Melbourne, by the 31st day of October, 1963, after which date it will distribute the assets, having regard only to the claims of which it then has notice.

G. A. HILFORD & CO., solicitors, 406 Lonsdale-street, Melbourne. 7083

CREDITORS, next of kin and others having claims in respect of the estate of Albert Henry Tudgey, late of 15 Belgrave-road, East Malvern, retired farmer, deceased (who died on the 21st day of March, 1963, and probate of whose will has been granted to Alan Victor Davis, of 15 Belgrave-road, East Malvern, garage lessee), are to send particulars of their claims to the said executor, care of the under-mentioned solicitors, by the 5th day of October, 1963, after which date he will distribute the assets, having regard only to the claims of which he then has notice.

PEARCE & WEBSTER, solicitors, 430 Little Collins-street, Melbourne. 7087

CREDITORS, next of kin and others having claims in respect of the estate of Ann May Hackett, late of 216 Burke-road, Glen Iris, widow, deceased (who died on the 7th day of November, 1962), are to send particulars of their claims to The Perpetual Executors and Trustees Association of Australia Limited, at 100-104 Queen-street, Melbourne, by the 2nd October, 1963, after which date it will distribute the assets, having regard only to the claims of which it then has notice.

KEITH A. NESS & SON, solicitors, 411 Collins-street, Melbourne. 7092

HENRY THOMAS WILLIAM MORRIS, late of 23 Cadell-street, Swan Hill, tyre fitter, DECEASED (who died on the 3rd March, 1963).

CREDITORS, next of kin and all other persons having claims against the estate of the said deceased are required by the administratrix, Pauline Alice Morris, of 23 Cadell-street, Swan Hill, widow, to send particulars to her, in the care of the undersigned, on or before the 15th October, 1963, after which date she will distribute the assets, having regard only to the claims of which she has notice.

DELANY & DELANY, solicitors, 270 Campbell-street, Swan Hill. 7084

CREDITORS, next of kin and others having claims in respect of the estate of Diana Vernon Smith, late of 9 Illawarra-road, Hawthorn, in Victoria, widow, deceased (who died on the 24th day of October, 1962), are hereby required to send particulars of their claims to Laurence L'Estrange and Roy McIntosh, the executors of her estate, care of the under-mentioned solicitors, by the 15th day of October, 1963, after which date they will distribute the assets, having regard only to the claims of which they then have notice.

L'ESTRANGE & KENNEDY, solicitors, of 291 Bridge-road, Richmond. 7106

CREDITORS, next of kin and others having claims in respect of the estate of Frank Lawther, late of 417 Victoria-street, West Melbourne, in the State of Victoria, clerk, deceased (who died on the 3rd day of February, 1963), are hereby required to send particulars of their claims to Laurence L'Estrange, the executor of the estate, care of the under-mentioned solicitors, by the 15th day of October, 1963, after which date he will distribute the assets, having regard only to the claims of which he then has notice.

L'ESTRANGE & KENNEDY, solicitors, of 291 Bridge-road, Richmond. 7107

STEPHEN SOUTHALL DALDY, late of Arcadia, farmer, DECEASED (who died on the 22nd day of June, 1963).

CREDITORS, next of kin and all others having claims against the estate are required by Florence Emma Daldy, of Arcadia, widow, the sole executrix of his will, to send in particulars to her, on or before the 15th day of October, 1963, after which date the said executrix will distribute the assets, having regard only to the claims of which she then has notice.

Dated the 31st day of July, 1963.

ABERNETHY & TOWERS, 18 High-street, Shepparton, solicitors for Florence Emma Daldy. 7109

In the Supreme Court of the State of Victoria.

SALE BY THE SHERIFF.

ON Wednesday, the 18th day of September, 1963, at Ten a.m. at the Police Station, Hawthorn-road, Caulfield (unless process be stayed or satisfied):—

All the estate and interest (if any) of Zvi Rosenfield and Golda Zahava Rosenfield, manufacturer and married woman respectively, both of 14 Merriwoola-street, Caulfield, as joint proprietors of an estate in fee simple in the land described in certificate of title, volume 5338, folio 426, upon which is erected a brick and rough cast dwelling-house known as No. 14 Merriwoola-street, Caulfield.

Registered mortgage No. B.669971 affects the said estate and interest.

Terms: Cash only.

N. FROGLEY, Sheriff's Officer.

2nd August, 1963.

7098

In the Supreme Court of the State of Victoria.

SALE BY THE SHERIFF.

ON Tuesday, the 17th day of September, 1963, at Eleven a.m. at the Police Station, Brighton (unless process be stayed or satisfied):—

All the estate and interest (if any) of Douglas Whiteford, of 300 St. Kilda-street, Brighton, as joint proprietor with Sylvia Victoria Whiteford, married woman, of an estate in fee simple in the land described in certificate of title, volume 8982, folio 293, upon which is erected a brick dwelling-house known as No. 300 St. Kilda-street, Brighton.

Registered mortgage No. B.54530 (for approximately £6,000), B.59551 (for approximately £3,000) and B.301022 (for approximately £6,000) affect the said estate and interest.

Terms: Cash only.

N. FROGLEY, Sheriff's Officer.

31st July, 1963.

7101

In the Supreme Court of the State of Victoria.

SALE BY THE SHERIFF.

ON Tuesday, the 10th day of September, 1963, at Two p.m. at the Police Station, Portland (unless process be stayed or satisfied):—

All the estate and interest (if any) of William Edwin Longhurst, of Urana (New South Wales), barman, and Ilma Jean Longhurst, married woman, of Queen-street, Nhill (Victoria), as joint proprietors of an estate in fee simple in the land described in certificate of title, volume 7036, folio 132, upon which is erected a weatherboard house known as No. 41 Cape Nelson-road, Portland.

Registered mortgage No. 1109397 affects the said estate and interest.

Terms: Cash only.

G. J. SHEEHAN, Sheriff's Officer.

29th July, 1963.

7103

INSOLVENCY NOTICE

The Insolvency Act, Victoria.—The Insolvent Estate of JAMES KEAMY, formerly of 160 Lygon-street, Carlton, Garage Proprietor.

A FIRST and Final Dividend is about to be declared. Creditors who have not proved their debts on or before the 28th August, 1963, will be excluded. Date of insolvency, 30th April, 1928.

PERCY J. KENT, 33 Mayfield-avenue, Malvern, trustee, 11st August, 1963. 7096

IMPOUNDINGS

FOSTER.—Impounded in Foster Pound, from South Gippsland Highway.

1 brown Jersey cow, nobby, like club right ear, no visible brand

If not claimed and expenses paid, to be sold on 23rd August, 1963.

I. MORRIS,

Poundkeeper.

KANIVA—Impounded in Kaniva Pound.

1 Corriedale weather, 4-tooth, blue tag in ear, KFS, no visible brand
 If not claimed and expenses paid, to be sold on 20th August, 1963.
 L. S. CUSHION,
 Poundkeeper.

MELBOURNE—Impounded in Epsom-road, Newmarket, Pound, by R. Shepherd (ex Carlton Police).

1 white nanny goat, no visible brand
 If not claimed and expenses paid, to be sold on 22nd August, 1963.
 H. G. HERRIS,
 Poundkeeper.

NATHALIA—Impounded in Nathalia Pound.

1 ewe weaner, ear mark left ear, no visible brand
 1 wether, ear mark bottom of right ear, brand blue dot over 5
 1 ewe, ear mark bottom of right ear, top of left ear, no visible brand
 1 ewe, ear mark bottom of right ear, top of left ear, no visible brand
 If not claimed and expenses paid, to be sold on 22nd August, 1963.
 R. D. MORGAN,
 Poundkeeper.

WHITTLESEA—Impounded in Epping Pound, by Ranger.

1 black Friesian heifer, double vee cut bottom of right ear, no visible brand
 If not claimed and expenses paid, to be sold on 23rd August, 1963.
 W. HERD,
 Poundkeeper.

Subordinate Legislation Act 1962.

NOTICE OF MAKING OF STATUTORY RULES.

IN pursuance of the provisions of the *Subordinate Legislation Act 1962* and the Regulations made thereunder, notice is given of the making of the following statutory rules:—

No.	Local Government Act 1958.	Price.
		s. d.
110/1963.	Uniform Building Regulations Amending Regulations No. 3 ..	0 9

Copies of these statutory rules may be purchased at the Sale of Publications Office, Government Printing Office, Macarthur-street, Melbourne.

A. C. BROOKS,
 Government Printer.

STATE ACTS, 1961

COPIES of the following Acts of Parliament of Victoria may be obtained at the Government Printing Office, or from any bookseller, at the price set opposite to each:—

No.		Price.
		s. d.
6736.	Public Works Committee (Special Exemption) ..	0 6
6737.	Railways (Permanent Service) ..	0 6
6738.	Superannuation (Railway Service) ..	0 6
6739.	Stamps (Amendment) ..	0 6
6740.	Employers and Employés (Attachment of Wages) ..	0 6
6741.	St. Kilda (Goldsmith and Shelley Streets) Land ..	0 6
6742.	Municipal Association (Amendment) ..	0 6
6743.	Wormbete Land ..	0 6
6744.	Grain Elevators (Borrowing) ..	0 6
6745.	Housing (Amendment) ..	0 6
6746.	Land (North-West Mallee Settlement Areas) ..	0 9
6747.	Ripon Peace Memorial Hospital Trust ..	0 6
6748.	Road Traffic (Parking on Railway and Municipal Property) ..	0 6
6749.	Co-operation (Amendment) ..	0 6
6750.	Heidelberg and Toolamba Lands Exchange ..	0 6
6751.	Town and Country Planning (Amendment) ..	0 6
6752.	Janet Clarke Hall ..	0 6

STATE ACTS, 1961—continued.

No.		Price.
		s. d.
6753.	Transport Regulation (Compensation) ..	0 6
6754.	Bread Industry (Legal Proceedings) ..	0 6
6755.	Milk Pasteurization (Licences) ..	0 6
6756.	Health (Proprietary Medicines) ..	0 6
6757.	Police Offences (False Reports to Police) ..	0 6
6758.	Evidence (Children) ..	0 6
6759.	Statute Law Revision ..	0 6
6760.	Transport Regulation (Term of Office) ..	0 6
6761.	Prostitution ..	0 6
6762.	Motor Car (Amendment) ..	1 0
6763.	Game (Amendment) ..	0 6
6764.	The Constitution Act Amendment (Electoral) ..	0 9
6765.	Building Societies (Amendment) ..	1 3
6766.	Juries (Amendment) ..	0 6
6767.	Gas and Fuel Corporation (Borrowing) ..	0 6
6768.	Clean Air (Sub-committees) ..	0 6
6769.	Housing (Home Builders' Account) ..	0 6
6770.	Public Offences (Pinball Machines) ..	0 6
6771.	Fisheries (Commercial Council) ..	0 6
6772.	Consolidated Revenue ..	0 6
6773.	Consolidated Revenue ..	0 6
6774.	Consolidated Revenue ..	0 6
6775.	Game (Black Swans) ..	0 6
6776.	Distribution of Population (Joint Committee) ..	0 9
6777.	Public Works Interim Loan Application ..	0 6
6778.	Legal Profession Practice (Amendment) ..	0 6
6779.	Home Finance (Amendment) ..	0 6
6780.	Cancer (Amendment) ..	0 6
6781.	Tourist (Amendment) ..	0 6
6782.	Water (Ballarat Water Commissioners) ..	0 6
6783.	Commercial Goods Vehicles (Tow Trucks) ..	0 6
6784.	Consolidated Revenue ..	0 6
6785.	Local Government (Municipal Assistance Fund) ..	0 6
6786.	Agricultural Colleges (Leases) ..	0 6
6787.	United Lutheran Church Incorporation ..	1 3
6788.	West Melbourne Market Land (Amendment) ..	0 6
6789.	Portland Harbor Trust (Quarrying) ..	0 6
6790.	Racing (Bookmakers' Course Agents) ..	0 9
6791.	Stamps (Further Amendment) ..	1 0
6792.	North Geelong to Fyansford Railway Deviation ..	0 6
6793.	Apprenticeship (Amendment) ..	0 6
6794.	Land (Unused Roads and Water Frontages) ..	0 9
6795.	Motor Car (Insurance Surcharge) ..	0 6
6796.	Forests (Wood Pulp Agreement) ..	2 0
6797.	Dandenong Lands ..	0 9
6798.	Local Authorities Superannuation (Amendment) ..	0 6
6799.	R.S.L. Welfare Trust Fund ..	0 9
6800.	The Zinc Corporation Limited ..	0 9
6801.	Mines (Explosives) ..	0 6
6802.	University (Officers) ..	0 6
6803.	State Accident Insurance Office ..	0 6
6804.	Melbourne and Metropolitan Board of Works (Yarra River) ..	0 6
6805.	Legal Aid ..	0 9
6806.	Crimes (Breath Test Evidence) ..	0 6
6807.	Consolidated Revenue ..	0 6
6808.	Civil Aviation (Carriers' Liability) ..	0 6
6809.	Sheep Owners Protection ..	1 0
6810.	Entertainments Tax (Amendment) ..	0 6
6811.	Exhibition (Borrowing Powers) ..	0 6
6812.	Children's Welfare (Appeals) ..	0 6
6813.	Pawnbrokers (Amendment) ..	0 6
6814.	Property Law (Loans to Minors) ..	0 6
6815.	Disposal of Uncollected Goods ..	1 0
6816.	Milk and Dairy Supervision (Amendment) ..	0 6
6817.	State Forests Loan Application ..	0 6
6818.	Health (Dangerous Substances) ..	0 6
6819.	Money Lenders (Amendment) ..	0 6
6820.	Water Supply Loan Application ..	1 0
6821.	Co-operative Housing Societies (Amendment) ..	0 6
6822.	Legal Profession Practice (Further Amendment) ..	0 6
6823.	Labour and Industry (Women's Hairdressing) ..	0 6
6824.	Co-operation (Amendment) ..	0 6
6825.	Valuation of Land (Amendment) ..	1 0
6826.	Public Works Loan Application ..	0 6
6827.	Land Tax (Exemptions and Rates) ..	0 9
6828.	Landlord and Tenant (Amendment) ..	0 9
6829.	Mines (Aluminium Agreement) ..	1 3
6830.	Railway Loan Application ..	1 0
6831.	Railways (Funds) ..	0 6
6832.	Motor Boating ..	1 3
6833.	Police Regulation (Amendment) ..	0 6
6834.	Housing (Commonwealth and State Agreement) ..	0 9
6835.	Education (Amendment) ..	0 6
6836.	Racing (Off-course Doubles Totalizators) ..	1 0
6837.	Medical (Amendment) ..	0 6

STATE ACTS, 1961—continued.

No.	Price.	
	s.	d.
6838. Water and Sewerage Authorities (Proceedings and Finances)	1	3
6839. Companies	21	0
6840. The Constitution Act Amendment	0	6
6841. Local Government (Streets and Abattoirs)	0	6
6842. Crown Leases	0	6
6843. Church of England (Greensborough Land)	0	6
6844. Juries (Fees)	0	6
6845. Limitation of Actions (Recovery of Imposts)	0	6
6846. Rural Finance and Settlement Commission	1	3
6847. Marine (Amendment)	1	6
6848. Dog	0	9
6849. Town and Country Planning	3	3
6850. Appropriation of Revenue, 1960-61	8	9

A. C. BROOKS,
Government Printer.

STATE ACTS, 1962

COPIES of the following Acts of Parliament of Victoria may be obtained at the Government Printing Office, or from any bookseller, at the price set opposite to each:—

No.	Price.	
	s.	d.
6851. Racing (Anzac Day)	0	6
6852. Railways (Thomson River Bridge)	0	6
6853. Business Names	1	9
6854. Melbourne Cricket Ground	0	6
6855. Evidence (Amendment)	0	6
6856. Railways (Industrial Awards)	0	6
6857. Children's Welfare (Assistance)	0	6
6858. National Parks	0	6
6859. Consolidated Revenue	0	6
6860. Land (Industrial Grants)	0	6
6861. Revocation and Excision of Crown Reservations	1	0
6862. Standard Insurance Company Limited	0	6
6863. The Constitution Act Amendment (Statute Law Revision Committee)	0	6
6864. Dog (Registration Discs)	0	6
6865. Game (Black Swans) Amendment	0	6
6866. Administration and Probate (Amendment)	0	6
6867. Statute Law Revision	0	9
6868. Tottenham to Brooklyn Railway Construction	0	6
6869. Kerang (Alexandra Park) Land	0	6
6870. Forests (Amendment)	0	6
6871. Melbourne Harbor Trust Lands	1	6
6872. Dried Fruits (Expenses and Finances)	0	6
6873. Housing (Home Builders' Account)	0	6
6874. Supreme Court (Interest on Judgments)	0	6
6875. The Constitution Act Amendment (Postal Voting)	0	6
6876. Melbourne and Metropolitan Board of Works (Government Guarantee)	0	6
6877. Stock (Artificial Breeding)	0	9
6878. Tattooing	0	6
6879. Unclaimed Moneys	1	0
6880. Cancer (Facilities)	0	6
6881. Road Traffic (Traffic Control Items)	0	6
6882. Consolidated Revenue	0	6
6883. Health (Sampling of Foods)	0	6
6884. Crimes (Detention)	0	6
6885. Fisheries (Noxious Fish)	0	9
6886. Subordinate Legislation	1	3
6887. Country Fire Authority (Amendment)	0	6
6888. Local Government (Amendment)	1	3
6889. Poisons	3	3
6890. Probate Duty	3	6
6891. County Court (Judges)	0	6
6892. Consolidated Revenue	0	6
6893. Bairnsdale (Unimproved Rating Poll)	0	6
6894. Local Authorities Superannuation (Equipment and Services)	0	6
6895. Melbourne and Metropolitan Board of Works (Borrowing Powers)	0	6
6896. Agricultural Colleges (Financial)	0	6
6897. Portland Harbor Trust (Borrowing Powers)	0	6
6898. Superannuation (Railway Service)	0	6
6899. Railways (Yallourn Tracks)	0	6
6900. Marine Stores and Old Metals (Corporations)	0	6
6901. Judges' Pensions	0	6
6902. Trustee Companies (Amalgamation)	0	9
6903. Entertainments Tax (Partial Abolition)	0	6

STATE ACTS, 1962.—continued.

No.	Price.	
	s.	d.
6904. Adult Education	0	6
6905. Marine (Board Membership)	0	6
6906. Grain Elevators (Borrowing Powers)	0	6
6907. Teaching Service (Residences)	0	6
6908. Brighton (Cramer-street) Land	0	6
6909. Co-operative Housing Societies	0	6
6910. Stamps (Amendment)	0	6
6911. Soil Conservation and Land Utilization	0	6
6912. Beaufort Lands	0	6
6913. Second-hand Dealers (Amendment)	0	6
6914. Agricultural Education (Continuation)	0	6
6915. Trustee (Variation of Trusts)	0	6
6916. Foreign Judgments	1	0
6917. Sale of Human Blood	0	6
6918. Weights and Measures (Amendment)	0	6
6919. Supreme Court (Registrar)	0	6
6920. Administration and Probate (Family Provision)	0	6
6921. Returned Servicemen's Badges	0	6
6922. Shrine of Remembrance Site (Trustees)	0	6
6923. Melbourne Harbor Trust (Port of Melbourne)	0	6
6924. Marriage (Property)	0	6
6925. Superannuation (Pensions)	0	6
6926. Bank Holidays (Saturday)	0	6
6927. Housing Advances and Loans (Procurement Fees)	0	6
6928. Housing Advances and Loans (Improper Commissions)	0	6
6929. Land Tax (Exemptions and Rates)	0	9
6930. Education (School Committees)	0	6
6931. Public Works Loan Application	0	6
6932. Kew and Heidelberg Lands (Amendment)	0	6
6933. Home Finance	1	3
6934. Water Supply Loan Application	1	0
6935. Children's Welfare (Reception Centres)	0	6
6936. Consolidated Revenue	0	6
6937. State Forests Loan Application	0	6
6938. Geelong Waterworks and Sewerage (Amendment)	0	6
6939. Friendly Societies (Amendment)	0	6
6940. Local Government (Further Amendment)	0	9
6941. Railway Loan Application	1	0
6942. Licensing (Temporary Restaurant Licences)	0	6
6943. Country Roads (Amendment)	0	6
6944. Fruit and Vegetables (Amendment)	0	9
6945. Public Works Committee (Special Exemption)	0	6
6946. Coroners (Medical Expenses)	0	6
6947. Land (Special Grants)	0	6
6948. Consolidated Revenue	0	6
6949. Queen's College Land	0	6
6950. Road Traffic (Recovery of Penalties)	0	6
6951. County Court (Amendment)	0	6
6952. Glenaladale National Park	0	6
6953. Young Women's, Christian Association of Australia Incorporation	1	3
6954. Racing (Dog Racing Control Board)	0	6
6955. Barley Marketing (Amendment)	0	6
6956. Country Fire Authority (Amendment)	1	0
6957. Police Regulation	1	3
6958. Justices (Amendment)	1	0
6959. Registration of Births Deaths and Marriages (Amendment)	0	6
6960. The Constitution Act Amendment (Statute Law Revision Committee)	0	6
6961. Statute Law (Further Revision)	0	9
6962. Racing (Amendment)	0	6
6963. Trustee (Mortgages)	0	6
6964. Milk and Dairy Supervision (Amendment)	0	6
6965. Milk Board (Amendment)	0	6
6966. Boilers Inspection (Amendment)	0	6
6967. Health (Amendment)	0	9
6968. Parliamentary Contributory Superannuation	0	9
6969. The Zinc Corporation, Limited (Amendment)	0	6
6970. Probate Duty (Reduction)	0	9
6971. Adoption of Children (Property)	0	6
6972. Mildura Irrigation and Water Trusts (Amendment)	1	0
6973. Building Contracts (Deposits)	0	6
6974. Sewerage Districts (Polls)	0	6
6975. Sale of Land	2	0
6976. Forests (Further Amendment)	1	3
6977. Appropriation of Revenue, 1961-62	8	3

Table of Acts and Enactments passed, date of operation, &c. 0 3

A. C. BROOKS,
Government Printer.

STATE ACTS, 1963

COPIES of the following Acts of Parliament of Victoria may be obtained at the Government Printing Office, or from any bookseller, at the price set opposite to each:—

No.	Price.
s.	d.
6978. Eliza's Restaurant	0 6
6979. Consolidated Revenue	0 6
6980. Solicitor-General (Pensions)	0 6
6981. Racing (Totalizators Percentages)	0 6
6982. Bungaree and Warrenheip Lands Exchange	0 6
6983. State Electricity Commission (Licensing of Electrical Mechanics)	0 6
6984. Drainage Areas (Rates)	0 6
6985. Companies	0 6
6986. Insurance Commissioner (Costs and Expenses)	0 6
6987. Railways Dismantling	0 9
6988. Marine (Amendment)	0 6
6989. Gas Regulation (Amendment)	0 6
6990. Inflammable Liquids	1 3
6991. Railways (Brighton-street Richmond Bridge)	0 6
6992. Hawkers and Pedlers (Amendment)	0 9
6993. Geelong (Market Site) Land	0 6
6994. Parole Board Membership	0 6
6995. Co-operation (Deputy Registrar)	0 6
6996. Landlord and Tenant (Execution of Warrants)	0 6
6997. Justices (Service of Summonses by Post)	0 6
6998. Consolidated Revenue	0 6
6999. Melbourne Harbor Trust (Amendment)	1 0
7000. Racing (Trotting Control)	0 6
7001. Sheep Branding Fluids	0 6
7002. Local Government (Protection from Fire)	0 9
7003. The Metropolitan Transportation Committee	0 6
7004. Fruit and Vegetable Marketing Advisory Committee	0 9
7005. Wholesale Fruit and Vegetable Market (Traders)	0 9
7006. Goods (Title on Execution)	0 6
7007. Companies (Trustees for Debenture Holders)	0 6
7008. Grain Elevators (Border Wheat)	0 6
7009. Revocation and Excision of Crown Reservations	0 9
7010. Housing (Contracts with Minors)	0 6
7011. Rural Finance and Settlement Commission	1 6
7012. Estate Agents (Amendment)	1 9
7013. Local Government	1 0
7014. Local Government (Decentralized Industries)	0 6
7015. Victoria Amateur Turf Club (Incorporating the Melbourne Racing Club)	1 6
7016. North Melbourne Municipal Buildings Site	0 6
7017. Friendly Societies (Building Societies)	0 6
7018. Westernport (Oil Refinery)	1 0
7019. Valuation of Land (Rates)	0 6
7020. Health (Amendment)	0 6
7021. Motor Car (Roadworthiness)	1 0

Table of Acts and Enactments passed, date of operation, &c. 0 3

A. C. BROOKS,
Government Printer.

ACTS REPRINTED IN ACCORDANCE WITH THE AMENDMENTS INCORPORATION ACT 1958 (No. 6422).

No.	Price.
s.	d.
6191. Administration and Probate Act	4 9
6219. Children's Welfare Act	2 6
6225. Co-operation Act	4 0
6229. Country Roads Act	4 0
6231. Crimes Act 1958	13 3
6246. Evidence Act	3 6
6249. Fences Act	1 3
6251. Firearms Act	2 3
6270. Health Act 1958	14 6
6274. Hospitals and Charities Act	3 6
6282. Justices Act 1958	11 3
6283. Labour and Industry Act	7 3
6285. Landlord and Tenant Act	4 6
6293. Licensing Act	9 3
6295. Limitation of Actions Act 1958	1 6
6299. Local Government Act	25 0
6315. Metropolitan Fire Brigades Act 1958	2 9
6325. Motor Car Act	6 6
6328. Nurses Act	2 0
6330. Partnership Act	1 3

ACTS REPRINTED IN ACCORDANCE WITH THE AMENDMENTS INCORPORATION ACT 1958 (No. 6422)—continued.

No.	Price.
s.	d.
6349. Public Service Act 1958	2 9
6350. Public Trustee Act 1958	3 6
6363. Second-hand Dealers Act	1 3
6367. Settled Land Act	4 0
6375. Stamps Act	6 0
6379. State Savings Bank Act 1958	4 3
6399. Transfer of Land Act	5 0
6401. Trustee Act	4 0
6419. Workers Compensation Act	4 9
6455. Companies Act (2nd reprint)	15 0

A. C. BROOKS,
Government Printer.

PUBLICATION OF OFFICIAL MATTER.

ATTENTION is invited to the following procedure in relation to the publication of official matter in the *Government Gazette*:—

1. *Matter submitted to the Executive Council.*
Matters submitted to the Executive Council which requires gazettal will normally be published in the issue of the following week.

Where urgent gazettal is required, special arrangements should be made with the *Gazette Officer*.

Publication will be facilitated by the submission of carbon copies for the use of the *Gazette Officer*.

2. *Other matter.*
- (a) All other matter duly certified by a responsible officer for publication should be lodged with the *Gazette Officer* not later than half-past Ten a.m. on Tuesday.
 - (b) Lengthy or involved notices should be forwarded several days before publication.
 - (c) Proofs, which will be supplied only when specifically requested or, at the direction of the *Gazette Officer*, be returned promptly to avoid delay in publication.
 - (d) No additions or amendments to matter for publication will be accepted by telephone.

THE "VICTORIA GOVERNMENT GAZETTE".

SUBSCRIPTIONS.—The subscription, including postage, is £2 15s. per annum, £1 7s. 6d. half-yearly, or 13s. 9d. per quarter, payable in advance.

Subscriptions are required to commence and terminate with a month.

A lesser period than three months cannot be subscribed for.

Subscribers do not receive the Acts of Parliament with the *GAZETTE*.

ADVERTISEMENTS are charged at the rate of 1s. 6d. per line single column, and 3s. per line double column.

The title (£5 Reward, Dissolution of Partnerships, &c.) forms one or more lines as a heading.

On an average, ten words make a line.

Every signature must likewise be counted as a line.

The final words of a paragraph, though only portion of a line, must be counted as one line.

SIGNATURES (in particular) and proper names must be written very plainly in the text; ONE SIDE ONLY of each slip of paper should be WRITTEN UPON.

ALL COMMUNICATIONS should be addressed to "The Government Printer, Melbourne".

ALL DOCUMENTS illegibly written will be returned unpublished, and where brands occur unprovided for by the ordinary letters of the alphabet, a worded explanatory description must be furnished.

THE VICTORIA GOVERNMENT GAZETTE is published on WEDNESDAY EVENING in each week, and Notices for insertion will be received by the Government Printer at or before ONE p.m. at ordinary rates, and late advertisements between ONE p.m. and FOUR p.m. at double rates on the day preceding the day of publication.

Single copies of the VICTORIA GOVERNMENT GAZETTE are One Shilling, posted One shilling and five pence.

No GAZETTES prior to January, 1950, in stock.

***ALL PAYMENTS ARE REQUIRED IN ADVANCE.—Remittances should be made by postal note, money order, or draft in favour of the Government Printer. Advertisements unaccompanied by a remittance sufficient to cover the cost of insertion will be returned unpublished.

TUFF'S SHEPPARTON NEWSAGENCY, 246 Wyndham-street, Shepparton.

VERNON, C. F. & H. J., 162 Bridge-road, Richmond.

VIEW POINT AUTHORIZED NEWSAGENCY, 4 View Point, Bendigo.

A copy of the Gazette filed at each place for public reference.

AGENTS FOR THE "VICTORIA GOVERNMENT GAZETTE".

THE following have been appointed agents to receive Advertisements and Subscriptions for the Victoria Government Gazette:—

- ARMSTRONG BROS. PTY. LTD., Mollison-street, Kyneton.
- ARMSTRONG'S AGENCY, 205 Queen-street, Melbourne.
- ARNALL & JACKSON, 390 Barkly-street, Brunswick, N.10.
- BAIRNSDALE AUTHORIZED NEWSAGENCY, 132 Main-street, Bairnsdale.
- COOKE, F. R. & E. M., & SONS, 69 Bridge-street, Benalla.
- DAVIES, G. & M. V., 112 Gray-street, Hamilton.
- DAVIS, WM. (MILDURA) PTY. LTD., 126 Eighth-street, Mildura.
- DIXON'S NEWSAGENCY, 89 Firebrace-street, Horsham.
- EDGAR'S NEWSAGENCY PTY. LTD., 293 Hargreaves-street, Bendigo.
- FRANKS, H., & CO., 184 Ryrie-street, Geelong.
- GORDON & GOTCH AUSTRALASIA LTD., 511 Little Collins-street, Melbourne.
- GULLAN'S NEWSAGENCY, 88 Bridge-street, Ballarat.
- HALES, D. & N., Henty-street, Casterton.
- HAMPTON, A. C., 243 Mitchell-street, Bendigo.
- HARSTON, PARTRIDGE & CO. PTY. LTD., 455 Little Collins-street, Melbourne.
- THE MERCANTILE EXCHANGE, 90 Queen-street, Melbourne.
- MCGILL'S AUTHORIZED NEWSAGENCY, 183-5 Elizabeth-street, Melbourne.
- PETTY, R. H. & W. M., 83 Murphy-street, Wangaratta.
- PURDIE, J., & CO., 138 Moorabool-street, Geelong.
- SALE AUTHORIZED NEWSAGENCY, 142 Raymond-street, Sale.
- SKINNER'S AUTHORIZED NEWSAGENCY, 49-51 Franklin-street, Traralgon.

CONTENTS

	PAGE
Acts of Parliament on sale at the Government Printing Office	2469
Appointments	2434
Bank Holiday	2415
Companies Act 1961—Notices	2433
Contracts	2425
Country Roads Board	2415
Courts	2433
Estates of Deceased Persons	2432
Government Notices	2415
Impoundings	2468
Insolvency Notices	2468
Lands	2446
Mining	2415
Money Lenders Act 1958—Supplementary List	2423
Notice of Making of Statutory Rules	2469
Orders in Council—	
Acts—Land, Country Roads; Forests; Housing; Companies; Local Government; Workers Compensation; Landlord and Tenant; Sewerage Districts; Geelong Waterworks and Sewerage; Water.	2435 et seq
Private Advertisements	2457
Proclamations	2413
Public Half-Holidays	2414
Public Service Notices	2453
Regulations—National Parks	2433
Resignations	2435
State Rivers and Water Supply Commission	2423
Tenders	2450
Transport Regulation Board—Public Hearings	2416