



VICTORIA GOVERNMENT GAZETTE

Published by Authority

[Registered at the General Post Office, Melbourne, for transmission by post as a newspaper.]

No. 451

WEDNESDAY, JUNE 16

[1965

Government House,
Melbourne,
12th June, 1965.

ACTS OF PARLIAMENT.

PROCLAMATION

THE QUEEN has been graciously pleased to signify Her Majesty's intention of conferring the following Honours, Decorations and Awards in the Birthday Honours, 1965:—

TO BE KNIGHT BACHELOR.

Councillor (Edward) Leo Curtis.

THE MOST DISTINGUISHED ORDER OF SAINT MICHAEL AND SAINT GEORGE.

To be a Companion of the Civil Division of the said Most Distinguished Order:

Garrett Ernest Fitzgerald, Esquire, B.A., B.Com.

THE MOST EXCELLENT ORDER OF THE BRITISH EMPIRE.

To be a Knight Commander of the Civil Division of the said Most Excellent Order:

The Honourable Sir (Thomas) Chester Manifold.

To be Commanders of the Civil Division of the said Most Excellent Order:

Alick Benson McKay, Esquire.
Judge Albert Leonard Read.

To be Officers of the Civil Division of the said Most Excellent Order:

George Burrigge Leith, Esquire.
Mrs. Beverley Edith Orr.
Councillor Jack Pascoe.

To be Members of the Civil Division of the said Most Excellent Order:

Mrs. Alice Lillian Gertrude Craig.
Harold Thornton Grimwade, Esquire.
Harold Jeffrey Keys, Esquire.
Ivan Edward Layton, Esquire.
Everest Albert Le Page, Esquire.
Mrs. Alma Rogers.
Councillor Henry Lester Smith.

THE IMPERIAL SERVICE ORDER.

To be Companions of the said Order:

William John Price, Esquire.
Roy Edwin Perry Stafford, Esquire.

AWARD OF THE IMPERIAL SERVICE MEDAL.

Henry Clyde Pollock, Esquire.

AWARDS OF THE BRITISH EMPIRE MEDAL.

Alfred George Simmons Hindle, Esquire.
Leslie Thomas Banner, Esquire.

J. COLQUHOUN,
Official Secretary to the Governor.

By His Excellency the Governor of the State of Victoria and its Dependencies in the Commonwealth of Australia, &c., &c., &c.

I, THE Governor of the State of Victoria, in the Commonwealth of Australia, do hereby declare that I have this day assented, in Her Majesty's name, to the Bills passed by the Parliament of the said State, the titles whereof are hereunder set forth, together with the short titles, that is to say:—

- No. 7286. "An Act to amend the *Local Government Act 1958* and for other purposes." (*Local Government (Amendment) Act 1965*.)
No. 7287. "An Act to amend the *Teaching Service Act 1958*." (*Teaching Service (Amendment) Act 1965*.)
No. 7288. "An Act to amend the *Marketing of Primary Products Act 1958* with respect to the Marketing of Eggs and Egg Products and for other purposes." (*Marketing of Primary Products (Egg Marketing) Act 1965*.)
No. 7289. "An Act to consolidate and amend the Law relating to the Making of Orders for Maintenance of Wives Husbands Children and Illegitimate Children and for Confinement, Medical and like Expenses and Funeral Expenses and for the Enforcement of such Orders and of similar Orders made in certain other States, Territories and Countries and for purposes connected therewith." (*Maintenance Act 1965*.)
No. 7290. "An Act to amend the *Veterinary Surgeons Act 1958* with respect to the Qualifications of Veterinary Surgeons and for other purposes." (*Veterinary Surgeons (Amendment) Act 1965*.)
No. 7291. "An Act to constitute a Body Corporate under the Style and Title of the Victoria Institute of Colleges, and to confer on such Body Corporate such Powers as are necessary or expedient to co-ordinate and advance the Provisions of Tertiary Education in certain Institutions." (*Victoria Institute of Colleges Act 1965*.)
No. 7292. "An Act to amend the *Workers Compensation Act 1958*." (*Workers Compensation (Amendment) Act 1965*.)

Given under my Hand and the Seal of the State of Victoria aforesaid, at Melbourne, this ninth day of June, in the year of our Lord One thousand nine hundred and sixty-five, and in the fourteenth year of the reign of Her Majesty Queen Elizabeth II.

(L.S.) ROHAN DELACOMBE.

By His Excellency's Command,
HENRY E. BOLTE,
Premier.

GOD SAVE THE QUEEN!

Land Act 1958.

UNALIENATED CROWN LAND AVAILABLE FOR SETTLEMENT UNDER IMPROVEMENT PURCHASE LEASES.

PROCLAMATION

By His Excellency the Governor of the State of Victoria and its Dependencies in the Commonwealth of Australia, &c., &c., &c.

IN pursuance of the provisions of section 153 of the *Land Act 1958*, I, the Governor of the State of Victoria in the Commonwealth of Australia, by and with the advice of the Executive Council of the said State, do by this Proclamation declare the unalienated Crown lands mentioned in the subjoined Schedule, to be available for settlement under improvement purchase leases.

SCHEDULE.

County.	Parish.	Allotment.	Section.	Area.	Land Valuation.
Bogong	El Dorado	5A	11	A. R. P. 235 0 0±	£3 10s. per acre

Given under my Hand and the Seal of the State of Victoria aforesaid, at Melbourne, this ninth day of June, in the year of our Lord One thousand nine hundred and sixty-five, and in the fourteenth year of the reign of Her Majesty Queen Elizabeth II.

(L.S.)

By His Excellency's Command,

ROHAN DELACOMBE.

JIM BALFOUR,
Minister of Lands.

GOD SAVE THE QUEEN !

Police Offences Act 1958.

APPLICATION OF PROVISIONS OF DIVISION 7 OF PART VII. OF THE POLICE OFFENCES ACT 1958 TO THE SHIRE OF KERANG.

PROCLAMATION

By His Excellency the Governor of the State of Victoria and its Dependencies in the Commonwealth of Australia, &c., &c., &c.

IN PURSUANCE of the powers conferred by the *Police Offences Act 1958*, I, the Governor of the State of Victoria, in the Commonwealth of Australia, by and with the advice of the Executive Council of the said State and on the application of the Council of the Shire of Kerang do by this my Proclamation declare the municipal district of the Shire of Kerang to be a district to which Division 7 of Part VII. of the *Police Offences Act 1958* applies.

Given under my Hand and the Seal of the State of Victoria aforesaid, at Melbourne, this ninth day of June, in the year of our Lord One thousand nine hundred and sixty-five, and in the fourteenth year of the reign of Her Majesty Queen Elizabeth II.

(L.S.)

ROHAN DELACOMBE.

By His Excellency's Command,

V. F. WILCOX,
Acting Chief Secretary.

GOD SAVE THE QUEEN!

Poisons Act 1962 (No. 6889).

PROCLAMATION

By His Excellency the Governor of the State of Victoria and its Dependencies in the Commonwealth of Australia, &c., &c., &c.

WHEREAS by section 4 of the *Poisons Act 1962* it is amongst other things enacted that the Governor in Council may by Proclamation published in the *Government Gazette* amend any of the Schedules One, Two, Three, Four, Five, Six, Seven or Eight to such Act by adding to any such Schedules or removing therefrom any item:

NOW THEREFORE, I, the Governor of the State of Victoria in the Commonwealth of Australia by and with the advice of the Executive Council of the said State do by this Proclamation—

1. Amend Schedule Four to the said Act by removing therefrom the items—

ALLYLISOPROPYLACETYLUREA
AMIDOPYRINE
DIOXYAMIDOPYRIN

2. Amend Schedule Seven to the said Act by adding thereto the following items—

AMIDOPYRINE, derivatives thereof including Dipyron, and substances containing Amidopyrine and derivatives thereof.

METHYL CINCHOPHEN (methyl ester of phenylcinchoninic acid) and substances containing Methyl Cincophen.

ALLYLISOPROPYLACETYLUREA and substances containing Allylisopropylacetylurea.

Given under my Hand and the Seal of the State of Victoria aforesaid, at Melbourne, this ninth day of June, in the year of our Lord One thousand nine hundred and sixty-five, and in the fourteenth year of the reign of Her Majesty Queen Elizabeth II.

(L.S.)

ROHAN DELACOMBE.

By His Excellency's Command,

J. ROSSITER,
Acting Minister of Health.

GOD SAVE THE QUEEN!

Health Act 1958, Section 3.

CERTAIN PRE-SCHOOL CENTRES DECLARED TO BE PUBLIC BUILDINGS.

PROCLAMATION

By His Excellency the Governor of the State of Victoria and its Dependencies in the Commonwealth of Australia, &c., &c., &c.

BY virtue of the powers conferred by sections three and three hundred and eighty-nine of the *Health Act 1958*, I, The Governor of the State of Victoria in the Commonwealth of Australia, by and with the advice of the Executive Council of the said State, do by this Proclamation revoke the Proclamation made on the 2nd day of August, 1950, and published in the *Government Gazette* of the 30th day of August, 1950, and the Proclamation made on the 30th day of October, 1951, and published in the *Government Gazette* of the 7th November, 1951, in which certain Pre-School Centres were declared to be public buildings within the meaning of the *Health Act 1928*, and in lieu thereof do hereby declare to be a "public building" within the meaning of the *Health Act 1958* and Pre-School Centre (including creche, kindergarten, day or residential nursery, or play centre) in which more than five children under the age of six years are received for care or training and which is not required by Part XIA of the *Health Act 1958* to be registered as a child minding centre.

This Proclamation shall take effect on the first day of July One thousand nine hundred and sixty-five:

Given under my Hand and the Seal of the State of Victoria aforesaid, at Melbourne, this ninth day of June, in the year of our Lord One thousand nine hundred and sixty-five, and in the fourteenth year of the reign of Her Majesty Queen Elizabeth II.

(L.S.) ROHAN DELACOMBE.

By His Excellency's Command,

J. ROSSITER,
Acting Minister of Health.

GOD SAVE THE QUEEN!

PUBLIC TRUSTEE ACT 1958 (No. 6350), SECTION 17.

I HEREBY give notice that on the 26th May, 1965, the Public Trustee filed elections to administer the following deceased persons' estates, in accordance with section 17 of the *Public Trustee Act 1958*:—

ARCH, ERIC EDWARD THOMAS, late of Flat 2, 20 Tarakan-street, Heidelberg West, housing officer, died 27th February, 1965.

GRACHAN, SYDNEY GORDON, late of 62 Palmerston-crescent, South Melbourne, labourer, died 21st February, 1961.

HICKEY, MAURICE GEOFFREY, late of lot 7 Heatherton-road, Springvale, plumber, died 23rd January, 1965.

I HEREBY give notice that on the 3rd June, 1965, the Public Trustee filed elections to administer the following deceased persons' estates, in accordance with section 17 of the *Public Trustee Act 1958*:—

BASSETT, WILLIAM, formerly of Tarragindi, Queensland, but late of Queen Elizabeth Home and Hospital for the Aged, Ballarat, retired miner, died 22nd October, 1964.

DONOVAN, HENRY, late of 152 Arnold-street, North Carlton, retired, died 24th April, 1965.

GREENWOOD, JOHN JAMES, late of Melbourne Home and Hospital for the Aged, Cheltenham, pensioner, died 4th September, 1963.

GRUNWALD, ERIC, late of 138 Elizabeth-street, North Richmond, boilermaker, died 1st April, 1965.

HYNDMAN, HELENA ETHEL, formerly of The John Newman Morris Home, 9 Rockingham-street, Kew, but late of "Cransworth", 8 aBeckett-street, Kew, widow, died 28th July, 1964.

MCWILLIAMS, ELIZABETH JOSEPHINE, also known as Elsie McWilliams, late of Bendigo Home and Hospital for the Aged, Bendigo, retired cook, died 17th August, 1964.

WARD, RONALD, late of 195 Abbotsford-street, North Melbourne, waterside worker, died 2nd December, 1963.

WILLIAMS, GEORGE MIFSUD, also known as George Williams, late of Eastern Hostel, Yallourn, labourer, died 19th January, 1965.

GORMLEY, JAMES, late of 25 Kathryn-street, Doveton, fitter, died 12th October, 1964.

A. D. DUNCAN,
Public Trustee.

256 Flinders-street, Melbourne, C.1, 10th June, 1965.

NOTICE.

CREDITORS, next of kin and others having claims against the estate of any of the under-mentioned deceased persons are required to send particulars of their claims to the Public Trustee, 256 Flinders-street, Melbourne, the personal representative, on or before the 17th August, 1965, after which date the Public Trustee may convey or distribute the assets, having regard only to the claims of which the Public Trustee then has notice:—

ARCH, ERIC EDWARD THOMAS, late of Flat 2, 20 Tarakan-street, Heidelberg West, housing officer, died 27th February, 1965.

BARKER, FRANCES VERONICA, late of 12 Victoria-street, St. Kilda, widow, died 18th March, 1965.

BASSETT, WILLIAM, formerly of Tarragindi, Queensland, but late of Queen Elizabeth Home and Hospital for the Aged, Ballarat, retired miner, died 22nd October, 1964.

BAYNES, CHRISTINA ANNIE, late of 2 Pitt-street, Ashburton, married woman, died 2nd April, 1965.

BOYCE, SARAH ALICE, also known as Sarah Boyce, late of 44 North-street, Ascot Vale, home duties, died 21st January, 1965.

BURFORD, DOROTHY ELIZABETH, late of Flat 3, 32 Alma-grove, St. Kilda, married woman, died 26th March, 1965.

CRANSTON, WILLIAM FRANCIS, late of 48 Hammond-street, Thornbury, furrier, died 13th December, 1964.

DONOVAN, HENRY, late of 152 Arnold-street, North Carlton, retired, died 24th April, 1965.

GOODERSON, DENIS GRANTHAM, late of 9 Sinclair-avenue, Gardiner, clerk, died 11th December, 1964.

GORMLEY, JAMES, late of 25 Kathryn-street, Doveton, fitter, died 12th October, 1964.

GRACHAN, SYDNEY GORDON, late of 62 Palmerston-crescent, South Melbourne, labourer, died 21st February, 1961.

GREENWOOD, JOHN JAMES, late of Melbourne Home and Hospital for the Aged, Cheltenham, pensioner, died 4th September, 1963.

GROSS, JEHUDA JOHNNY, late of 77 Willemsmere-road, Kew, retired tailor, died 22nd November, 1964.

GRUNWALD, ERIC, late of 138 Elizabeth-street, North Richmond, boilermaker, died 1st April, 1965.

HALE, SYDNEY ARTHUR ROBERT, also known as Sydney Hale, late of 3 Nevada-avenue, Tecoma, retired building repairer, died 22nd February, 1965.

HICKEY, MAURICE GEOFFREY, late of lot 7 Heatherton-road, Springvale, plumber, died 23rd January, 1965.

HOLLAND, ALBERT EDWARD, late of 26 Griffiths-road, Upwey, retired builder, died 5th April, 1965.

HOSKING, MARY BRIDGET, formerly of Flat 3, 35 Normanby-street, Middle Brighton, and 59 Primrose-street, Essendon, but late of 661 Hampton-street, Brighton, housewife, died 23rd November, 1964.

HYNDMAN, HELENA ETHEL, formerly of The John Newman Morris Home, 9 Rockingham-street, Kew, but late of "Cransworth", 8 aBeckett-street, Kew, widow, died 28th July, 1964.

INIFER, RAYMOND GEORGE GLOUCESTER, late of 31 Old Lilydale-road, East Ringwood, clerk, died 27th December, 1964.

KEMP, EVA CATHERINE, late of Mont Park, unemployed, died 5th February, 1964.

KERR, ARTHUR LAMBERT, late of Union-street, Yarram, retired electrical engineer, died 30th August, 1964.

MCWILLIAMS, ELIZABETH JOSEPHINE, also known as Elsie McWilliams, late of Bendigo Home and Hospital for the Aged, Bendigo, retired cook, died 17th August, 1964.

ROBINSON, GOULBURN HUGH, formerly of 67 St. Vincent-street, Albert Park, but late of 48 Walters-avenue, Niddrie, clerk, died 26th February, 1965.

ROSS, HELEN JEAN, late of Flat 3, 101 Barry-street, Carlton, saleswoman, died 27th February, 1965.

TREANOR, ALMA IRIS, previously known as Alma Iris Dunoon, late of Stanmore, N.S.W., married woman, died 24th June, 1964.

WARD, RONALD, late of 195 Abbotsford-street, North Melbourne, waterside worker, died 2nd December, 1963.

WHIDDETT, MARGARET ETHEL, formerly of 95 Nepean Highway, Elsternwick, but late of Unit 19, 373 South-road, Moorabbin, widow, died 12th April, 1965.

WILLIAMS, GEORGE MIFSUD, also known as George Williams, late of Eastern Hostel, Yallourn, labourer, died 19th January, 1965.

A. D. DUNCAN,
Public Trustee.

Melbourne, 10th June, 1965.

Subordinate Legislation Act 1962 (No. 6886).

DECLARATIONS AS STATUTORY RULES.

WHEREAS sub-section (1) of section 2 of the *Subordinate Legislation Act 1962*, specifies subordinate legislation deemed to be statutory rules pursuant to that Act: And whereas the said sub-section (1) of section 2 provides that where subordinate legislation not so specified comprises of any instrument of a legislative character made pursuant to the provisions of any Act or of any Regulation or Rule made by a local authority or by a person or body of persons having jurisdiction limited to a district or locality the Attorney-General may by notice, in writing, under his hand declare such subordinate legislation to be statutory rules: Now I, the Acting Attorney-General of Victoria, do by such notice hereby declare that the subordinate legislation hereinafter mentioned be statutory rules for the purposes of the said *Subordinate Legislation Act 1962*:—

Railways Act 1958.—By-laws made by the Victorian Railways Commissioners pursuant to the *Railways Act 1958*.

Dated at Melbourne, this 8th day of June, 1965.

V. F. WILCOX,
Acting Attorney-General.

Transport Regulation Act.
TRANSPORT REGULATION BOARD.

HEARING OF APPLICATIONS.

NOTICE is hereby given that the following applications will be considered by the Transport Regulation Board at its offices at Rathdown-street, Carlton, at 10.15 a.m. on Monday, 5th July, 1965.

DEVESON, F. W., 5 Cooper-street, Essendon. Application for variation of Route 16A (Essendon-Niddrie) to operate the 8.10 a.m. trip ex Essendon Railway Station express along Buckley-street to Hoffmans-road, (no passengers to be picked up or set down in Buckley-street).

KANGAROO FLAT BUS LINES PTY. LTD., Station-street, Kangaroo Flat. One commercial passenger vehicle (S/C. 45) to operate under the same terms and conditions as existing "U.O." licences in the name of the applicant company.

NIGHTINGALE J. & M. JOHN, 40 Billingham-road, Deer Park. One commercial passenger vehicle (S/C. 8) to operate for the carriage of passengers between Melbourne and Mt. Buller via Whittlesea on Fridays-Saturdays-Sundays-Mondays.

TIME-TABLE.

Dep. Melbourne	..	7.00 a.m.
Arr. Mt. Buller	..	10.30 a.m.
Dep. Mt. Buller	..	4.30 p.m.
Arr. Melbourne	..	7.30 p.m.

FARES.

To be determined.

NORTHERN BUS LINES PTY. LTD., Walter-street, Glenroy. Application for variation of Route 148A (Broadmeadows-Upfield) to:—(i) Operate a revised timetable in conjunction with Route 147A (Broadmeadows Military Camp-Broadmeadows Railway Station) which provides for increased service on both routes. (ii) Extend service from the Upfield Railway Station via Barry's-road and Sydney-road to the premises of B.F. Goodrich Pty. Ltd., Sydney-road, Somerton, for an initial experimental period of 3 months.

TIME-TABLE ON EXTENSION.

Dep. Broadmeadows	..	8.05 a.m.
Dep. Upfield	..	8.20 a.m.
Dep. Goodrich	..	11.15 a.m.
Dep. Broadmeadows	..	10.45 a.m.
Dep. Upfield	..	11.05 p.m.
Dep. Goodrich	..	4.45 p.m.
Dep. Broadmeadows	..	4.25 p.m.
Dep. Upfield	..	4.40 p.m.

FARES ON EXTENSION.

Broadmeadows-Goodrich	..	1s. 9d.
Upfield-Goodrich	..	1s. 3d.

(iii) To institute an additional section at the corner of Tresco-street and Barry's-road and to amend the existing section to the corner of Lismore and Blair streets.

TAPSCOTT, G. W. & K. T., Winter-street, Buninyong. One commercial passenger vehicle (S/C. 2) to operate for the carriage of passengers, mails and parcels between Buninyong Post Office and Mt. Mercer via Durham Lead, Grenville and Flemings Homestead.

PIERCE, A. L., Lot 15, McMahons-road, East Kinglake. One commercial passenger vehicle (S/C. 5) to operate as a country taxi from Kinglake.

U.S. MOTORS (BELGRAVE) PTY. LTD., Main-road, Belgrave. Application to operate between Belgrave and Fern Tree Gully as an extension of and in association only with those trips authorized by the Board beyond Fern Tree Gully on the Dandenong licensed service.

YOUNG, C. F. W., 5 McDowell-street, Mitcham. Application for permit authority to operate Route 207A, Part A (Mitcham-Vermont) as follows:—Commencing at the Mitcham Railway Station thence via Brunswick-road, Northcote-street, Purches-street, Forster-street to Heatherdale Railway Station thence via Heatherdale-road, Canterbury-road, Purches-street, Churinga-avenue, Langford-avenue, Glenburnie-road, Ferris-street, Ian-crescent, Simpson-street, Creek-road, Brunswick-road to Mitcham Railway Station—with extension from the corner of Canterbury-road and Purches-street, via Canterbury-road, Blanche-drive to Centre-road—Such route to be operated only until Cochrane-street is constructed and capable of carrying omnibus traffic when the service will be operated via Cochrane-street.

Notice is hereby given that the two applications listed hereunder were inadvertently overlooked when gazetting applications for Metropolitan Hire Car Licences, listed in *Government Gazette* No. 28 dated 23rd April, 1965.

APPLICATIONS by the persons listed hereunder for Metropolitan Private Hire Car licence/s in respect of commercial passenger vehicle/s with seating capacity for five (5) persons to operate under composite conditions from approved depots in the zones shown opposite their names.

LAPTHORNE, A. R., 3 Mulgrove-street, East Reservoir—N. SCHERPE, H., Lot 18, Elder-grove, Boronia—T.

The latter application was incorrectly listed in the *Government Gazette* of the 23rd April, 1965, as HELMUTH, S.

APPLICATIONS for renewal of licences as shown, by persons listed hereunder to operate under the same terms and conditions:—

AUSTIN, A. J., 70 Sargood-street, Hampton; M.H.1659.

CALLINAN, W. F., 96 Speight-street, Thornbury; M.T.2872.

CARLISLE, H. T., 29 Glencara-street, Avondale Heights; M.T.2873.

COOLEY, M. R., 47 Spring-street, East Prahran; M.T.2855.

CREEDON, V. M., 11 Mary-street, Clayton; M.T.2871.

CROWE, H. F., 96 Queensberry-street, North Melbourne; M.T.2874.

DASHWOOD, L. L., 39 Glenebor-avenue, Blackburn; C.T.460.

DiBELLA, C., 410 Brunswick-road, West Brunswick; M.T.2861.

DUFTY, T. P., 35 Julia-street, Portland; T.O.7.

DUVIANI, S., 141 Collins-street, Thornbury; M.H.1816.

ERIKSEN, O. M., 4 Peter-street, South Yarra; M.T.2868.

FINNEY, P. B., Hamley Bridge, South Australia; M.T.2733.

GOLD, H., 22 Lincoln-drive, Bulleen; M.T.2869.

GRATTIDGE, R. H., 24 Ashton-street, Reservoir; M.T.2856.

GURVICH, H., 5 Massey-street, Box Hill South; M.T.2854.

HARRIS, C. A., 112 Madden-avenue, Mildura; C.T.622.

HARRISON, F. P., 10 Daphne-street, Pascoe Vale; M.T.2866.

HUME, A. D., 16 Cumming-street, Burwood; M.T.653.

KHANCOBAN SPRING CREEK SCHOOL, Box 17, Coryong; C.O.27.

LAWSON, L., 5 Bungay-street, Watsonia; M.T.2870.

LAWTON, E. A. T., 2 Everett-street, West Brunswick; M.T.2859.

LUXON, F. B., 1 Wilfred-road, Ivanhoe; M.H.1373.

MELLODY, S. R., 932 Canterbury-road, Box Hill; M.H.1374.

MILNER, J. P., 24 Emerald-street, Preston; M.T.2864.

PARSONS, F. W., Flat 1, 20 Victoria-street, Box Hill; M.H.1769.

PRICE, N. F., 21 Perkins-street, Alexandra; C.T.220.

PYERS, R. S., 21 Deakin-street, West Essendon; M.H.1785.

RAYNOR, N. W., 72 Sycamore-street, South Caulfield; M.T.2863.

READ & BRACK PTY. LTD., 6 Nunn-street, Benalla; C.T.585, C.H.393.

ROSS, C. C., 150 Scott-street, Warracknabeal; T.P.173.

ROWLAND, J., 20 Davis-street, Kew; M.T.2858.

SAMUELSON, J. C., 12 Tuhan-road, Mount Waverley; M.T.2875.

SEYMOUR PASSENGER SERVICE PTY. LTD., 7 Wallis-street, Seymour; C.O.867.

SHEERAN, L. H. L., Merricks; T.S.562.

SPILBURG, A. H., 8 Lubrano-street, East Brighton; M.H.1819.

STEVENS, J. J., 1 Surrey-street, Pascoe Vale; M.T.2867.

TRUSCOTT, F. J., 200 Oriel-road, West Heidelberg; M.T.2857.

UTTING, T. E., 16 Outlook-drive, Eaglemont; M.T.438.

WHITTAM, W., 3 Molden-street, East Bentleigh; M.H.1496.

WOOD, E. C., 2 Dart-street, Highett; M.T.2862.

WOODS, A. J., 94 The Boulevard, Thomastown; M.T.2865.

Notice of any objection should be forwarded to reach the Secretary of the Board not later than Wednesday, 30th June, 1965.

Applicants are advised that it will not be necessary to appear on the hearing date specified above, unless advised in writing by the Board.

B. P. KAY,
Secretary.

Exhibition Buildings, Rathdown-street, Carlton, N.3,
Wednesday, 16th June, 1965.

Commercial Goods Vehicles Act.

TRANSPORT REGULATION BOARD.

HEARING OF APPLICATIONS.

NOTICE is hereby given that the following applications will be considered by the Transport Regulation Board at its offices at Rathdown-street, Carlton, at 10.15 a.m., on Monday, 5th July, 1965.

BEAUREPAIRE TYRE SERVICE PTY. LTD., 102 Victoria-street, Carlton. One commercial goods vehicle (L/C. 11 cwt.) to operate within a 50-mile radius of own premises at Mildura and to the Township of Ouyen and places

- on or adjacent to the Pinnaroo-road—tires and tubes for sale and delivery, used tires for repair or retread or having been repaired or retreaded, batteries, oil and motor car accessories in the course of the licensee's business as "Tire Retreaders and Distributors".
- BETTIOL, A. & N.** (trading as A. Bettiol), 43-45 Warrandyte-road, Ringwood. One commercial goods vehicle (L/C. 197 cwt.) to operate within a 50-mile radius of the premises of Pronto Mixed Concrete Co. Pty. Ltd. at Ringwood in a specially constructed agitator vehicle—premixed concrete solely on behalf of the said Co.
- BISHOP, R. A.**, 9 Victory Boulevard, Ashburton. Application to vary the conditions of licence No. D.A.51168 (L/C. 104 cwt.) by deleting from the present conditions "The Oakleigh Brick Co. Pty. Ltd., premises at Oakleigh" and adding in lieu "The City Brick Co. Pty. Ltd., premises at Tooronga-road, Hawthorn East".
- BRUSE, A. H. & J.**, Post Office Box 3, Dromana. One commercial goods vehicle (L/C. 7 cwt.) to operate throughout the State of Victoria in the course of business as "Milking Machine Mechanic"—tools of trade, spare parts and materials incidental to the repair or installation of milking machines.
- BUDGE, L. C.**, 40 Taylor-street, Wangaratta. One commercial goods vehicle (L/C. 264 cwt.) to operate: (a) Within a 50-mile radius of post office at Wangaratta as a "Road Contractor"—road-making plant and materials. (b) Within a 20-mile radius of post office at Wangaratta—general goods.
- BIGGS, H. J. G.** (trading as Contract Sprayers), 10 William-street, Long Gully, Bendigo. One commercial goods vehicle (L/C. 7 cwt.) to operate throughout the State of Victoria in the course of business as "Pest Exterminator"—tools of trade, spray materials and associated equipment subject to the condition that no goods whatsoever shall be carried between the metropolitan area as defined in the *Transport Regulation Act 1958*, and the Bendigo Urban district as also defined in the said *Transport Regulation Act*.
- CROSS, A. H.**, 205 McLeod-street, Bairnsdale. One commercial goods vehicle (L/C. 114 cwt.) to operate: (a) Within a 95-mile radius of the post office at Orbost (Bairnsdale Division of the Country Roads Board) as a "Road Contractor"—road-making plant and materials. (b) Within a 20-mile radius of the post office at Bairnsdale—general goods.
- EATON, W. J.**, Box 8, Orbost. One commercial goods vehicle (L/C. 118 cwt.) to operate: (a) Within a 85-mile radius of post office at Orbost (Bairnsdale Division of the Country Roads Board) as a "Road Contractor"—road-making plant and materials. (b) Within a 20-mile radius of post office at Orbost—general goods.
- EVERY, F. J., PTY. LTD.**, 14 King-street, Bendigo. One commercial goods vehicle (L/C. 15 cwt.) to operate: (a) Within a 20-mile radius of post office at Bendigo in the course of business as "Booksellers and Stationers"—own goods. (b) Throughout the State of Victoria—samples of own goods for display purposes only.
- GARNER, A. J. (JNR.) & N. T.** (trading as Garner Bros.), Post Office Box 60, Coragulac, via Colac. One commercial goods vehicle (L/C. 111 cwt.) to operate: (a) Within a 20-mile radius from the post office at Coragulac—general goods. (b) Within a 50-mile radius of the "A" class depot of the Neptune Oil Co. Pty. Ltd. at Geelong in the course of business as "Agents" of the said company:—(i) petroleum products in prescribed types of containers and empty return containers; (ii) petroleum products in bulk.
- GIBSON, W. W.**, Duke-street, Yarram. Application to vary the conditions of licence No. D.A.18671 (L/C. 138 cwt.) by deleting from the existing conditions "paragraph (c)" and adding in lieu as paragraph (c) "from the S.E.C. at Morwell to consignees at Yarram—briquettes; and (d) from Carrajung to the A.P.M. at Maryvale—pulpwood".
- GLASS, L. C.**, 33 Oakdene-crescent, Murrumbena. One commercial goods vehicle (L/C. 244 cwt.) to operate within a 70-mile radius of the premises of Monier-Besser Pty. Ltd. at Broadmeadows solely on behalf of the said company—bricks.
- HILL, C. T.**, Dundonnell. One commercial goods vehicle (L/C. 115 cwt.) to operate: (a) Within a 75-mile radius of the post office at Peshurst (Warrnambool Division of the Country Roads Board) as a "Road Contractor"—road-making plant and materials. (b) Within a 20-mile radius of the post office at Dundonnell—general goods.
- KEMPEN, C. & A.**, 109 Lava-street, Warrnambool. One commercial goods vehicle (L/C. 16 cwt.) to operate west of a north/south line drawn through Colac and south of an east/west line drawn through Cavendish—tools of trade, boxing and materials incidental to own contracts in the course of business as "Builder and Paving Contractor".
- HECTOR, A. W.** (trading as Major Building and Flooring Service), 171 Blackshaws-road, Spotswood. One commercial goods vehicle (L/C. 23 cwt.) to operate: (a) Within a 50-mile radius of own premises at Spotswood in course of business as "Builders" on behalf of Caltex Oil (Australia) Pty. Ltd.—own goods and goods on behalf of said Co. (b) Throughout the State of Victoria—tools of trade and builders equipment. (c) Within a 20-mile radius of any contract currently engaged upon or from the nearest railway station thereto—materials for use on such project.
- HECTOR, A. W.** (trading as Major Building and Flooring Service), 171 Blackshaws-road, Spotswood. Five commercial goods vehicles (L/C. 9, 8, 8, 8, 10 cwt.) to operate throughout the State of Victoria in course of business as "Maintenance Builders" on behalf of Caltex Oil (Australia) Pty. Ltd. for the purpose of supervising own contracts at service stations and depots—tools of trade and small quantities of materials incidental to the repair or completion of a contract.
- MEYER, R. A.**, Main-street, Fish Creek. One commercial goods vehicle (L/C. 7 cwt.) to operate within that part of the State of Victoria bounded by and including the Townships of Foster, Tidal River, Sandy Point, Walkerville, Fish Creek West, Buffalo, Fish Creek North and Foster aforesaid—mail under contract to the Postmaster-General's Department—parcels and general goods.
- MCCLELLAND, E. C.**, "Pingrove", Bealiba. One commercial goods vehicle (L/C. 76 cwt.) to operate: (a) Within a 50-mile radius from the post office at Bealiba—own goods in the course of trade as "Primary Producer". (b) Within a 50-mile radius from the post office at Bealiba—timber required for cutting and delivery in course of trade as "Timber Merchant". (c) Throughout the State of Victoria—for the carriage of bees, bee-hives, cones, plant and equipment used in connexion with own apiaries—unrefined beeswax, and from the apiary to the home of the apiarist or any depot owned and operated by him, of honey requiring treatment.
- NASH, C. J.**, 39 Purnell-road, Corio. One commercial goods vehicle (L/C. 145 cwt.) to operate within a 50-mile radius from the premises of Hawaiian Australian Concrete Pty. Ltd. at Corio—concrete masonry on behalf of the said company.
- O'ROURKE, J. S. & M. M.** (trading as J. O'Rourke and Co.), Parkinson-grove, Warrnambool. Two commercial goods vehicles (L/C. 10 cwt. each) to operate within a 50-mile radius from the chief post office in the City of Warrnambool for the purposes of installing, repairing and maintaining electrical appliances and television sets in the course of business as "Electrical Retailer"—tools of trade, spare parts and materials incidental thereto, also electrical appliances; television sets and antennae for installation, for repair or having been repaired.
- PLUNKETT, K. R.**, 87 Ardie-street, Warrnambool. One commercial goods vehicle (L/C. 10 cwt.) to operate within an 80-mile radius of post office at Warrnambool in the course of business as "Carpet Laying Contractor"—tools of trade, and materials incidental to own carpet-laying contracts together with carpet and underfelt for laying purposes only.
- ROBINSON, R. D.**, 38 Parkmore-road, Forest Hill. One commercial goods vehicle (L/C. 10 cwt.) to operate throughout the State of Victoria in course of business as "Carpet and Lino Layer"—tools of trade, floor coverings for laying and materials incidental thereto.
- ROSELLA FOODS PTY. LTD.**, 64 Balmain-street, Richmond. Three commercial goods vehicles (L/C. 7, 7, and 6 cwt.) to operate: (a) Within a 50-mile radius from own premises at Richmond—own goods in the course of business as "Food Preservers". (b) Throughout the State of Victoria—tools of trade and advertising materials for the purposes of window dressing, advertising and sales promotion of own products.
- RUSSELL, S. W.**, 19 Ashley-street, Box Hill. One commercial goods vehicle (L/C. 146 cwt.) to operate: (a) Within a 35-mile radius of the premises of Bayview Quarries Pty. Ltd., at Clayton—screenings and stone dust solely on behalf of the said company. (b) From pits within the above radius to the said premises—sand.

SCHMIDT, D. W., 7 Jackson-street, Horsham. One commercial goods vehicle (L/C. 9 cwt.) to operate within a 100-mile radius from the post office at Horsham in the course of business as "Carpet Cleaner and Tiler"—tools of trade and equipment incidental to own contracts.

STEVENS, G., Heyfield. One commercial goods vehicle (L/C. 267 cwt.) to operate from forest landings within a 20-mile radius of the post office at Club Terrace to Errinundra Sawmills Pty. Ltd. at Club Terrace—mill logs.

STRAUB, F. C., 23 High-street, Eaglehawk. One commercial goods vehicle (L/C. 20 cwt.) to operate within an area bounded by the following towns:—Heathcote, Elmore, Echuca, Kerang, City of Swan Hill, Nyah, Chinkapook, Ouyen, Hopetoun, Warracknabeal, St. Arnaud, Maryborough and Castlemaine, in the course of business of the licensee as "Electrician"—un-crated television sets, television aerials and electrical appliances for specialized installation, for repair or having been repaired, tools of trade, spare parts and materials incidental to installation, servicing and maintaining of such appliances and equipment.

TAINSH, H. W., care of Lorraine Knitting Mills Pty. Ltd., 68 Oxford-street, Collingwood. One commercial goods vehicle (L/C. 9 cwt.) to operate solely on behalf of Lorraine Knitting Mills Pty. Ltd. of Melbourne and its branch at Morwell (an approved decentralized secondary industry):—(i) Within a 25-mile radius of the G.P.O., Melbourne. (ii) Between Melbourne and Morwell—partly manufactured and finished materials, manufacturing materials and associated plant.

TEMPLETON, E. L., Tyers, via Traralgon. Application to vary the conditions of licence No. T.T.D.524 (L/C. 143 cwt.) by deleting "paragraph (3) from the existing conditions" and adding in lieu as paragraph (3) "pulpwood within a 25-mile radius of the Australian Paper Mills at Maryvale".

TODOR, K., care of Lorraine Knitting Mills Pty. Ltd., 68 Oxford-street, Collingwood. One commercial goods vehicle (L/C. 9 cwt.) to operate solely on behalf of Lorraine Knitting Mills Pty. Ltd. of Melbourne and its branch at Morwell (an approved decentralized secondary industry):—(i) Within a 25-mile radius of the G.P.O., Melbourne. (ii) Between Melbourne and Morwell—partly manufactured and finished materials, manufacturing materials and associated plant.

TUPPERWARE OF AUSTRALIA PTY. LTD., Lysterfield-road, Fern Tree Gully. One commercial goods vehicle (L/C. 8 cwt.) to operate from retailers in the metropolitan area (as defined in the *Transport Regulation Act 1958*) direct to householders within the State of Victoria in the course of business as "Plastics Manufacturers"—"Tupperware" plastic household goods subject to the condition that the load capacity of the vehicle (8 cwt.) shall not be increased without the Board's prior written permission.

WALSH, M. J., Wyndham-street, Yackandandah. One commercial goods vehicle (L/C. 104 cwt.) to operate: (a) Within a 20-mile radius of the post office at Yackandandah—general goods. (b) From forest landings within a 50-mile radius of post office at Yackandandah to sawmill at Yackandandah—logs. (c) From sawmill at Yackandandah to customers within a 50-mile radius of such mill—sawn timber.

TOW TRUCKS.

A.A.A. TOWING SERVICE PTY. LTD., 67 Poath-road, Hughesdale. One commercial goods vehicle (L/C. 36 cwt.) to operate as a "Tow Truck" throughout the State of Victoria for the purpose of lifting and carrying or towing and/or repairing wrecked or disabled vehicles—tools of trade, spare parts and materials incidental thereto.

ROOTES, W. T., 70-76 Nolan-street, Maryborough. One commercial goods vehicle (L/C. 36 cwt.) to operate throughout the State of Victoria as a "Tow Truck" for the purpose of lifting and carrying or towing and/or repairing wrecked or disabled vehicles—tools of trade, spare parts and materials incidental thereto.

APPLICATION for renewal of licence as shown, by persons listed hereunder, to operate under the same terms and conditions from the date of expiry shown in each case:—

BARTLETT, R. H. & R. I. (trading as Richard H. Bartlett & Son), Mortlake-road, Terang; D.A.44107; 21st August, 1965; 140 cwt.

BURGESS, B. & A., PTY. LTD., Post Office Box 120, Lewis-street, Horsham; D.A.42901/2; 14th August, 1965; 209 cwt.

CRANES & SHOVELS PTY. LTD., 28-32 Cochranes-road, Moorabbin; D.A. 30723/1; 26th August, 1965; 8 cwt.

CRANES & SHOVELS PTY. LTD., 28-32 Cochranes-road, Moorabbin; D.A.30723; 26th August, 1965; 8 cwt.

EASTMOND, R. M., PTY. LTD., 86 Lemon-avenue, Mildura; D.A.23084/11; 14th August, 1965; 139 cwt.

LESKE, T. C., Villiers-street, Port Fairy; D.A.30066/2; 7th August, 1965; 129 cwt.

LIGHTBODY, A. R., Portland-road, Heywood; D.A.44158; 21st August, 1965; 240 cwt.

LOW, J. E., Lake Bolac; D.A.30538; 12th August, 1965; 74 cwt.

MAMOUNEYS PTY. LTD., 339 Hargreaves-street, Bendigo; D.A.31650/2; 28th August, 1965; 22 cwt.

MAAR, H., 24 Ross-street, Niddrie; D.A.29893; 12th August, 1965; 104 cwt.

MILDURA QUARRIES & READY MIXED PTY. LTD., Lots 16-17 Scott-crescent, Box 273, Mildura; D.A.40758/3; 1st August, 1965; 115 cwt.

PARKER, L. & J., Kyabram; D.A.44892; 21st August, 1965; 110 cwt.

PENNEY, F. H., 117 Frank-street, Ballarat; D.A.1805/1; 21st August, 1965; 64 cwt.

ROGERSON, R. D., Derrinallum; D.A.1946/1; 22nd August, 1965; 240 cwt.

VICKEY, A. J. & J. C., Whyte-street, Coleraine; D.A.42350/1; 21st August, 1965; 124 cwt.

WELSH, A., 33 Lava-street, Warrnambool; D.A.13760/4; 21st August, 1965; 140 cwt.

SCHROETER, J. S. & L. A. (trading as Schroeter Bros.), Willis-street, Winchelsea; D.A.1999/1; 10th August, 1965; 77 cwt.

Notice of any objection should be forwarded to reach the Secretary of the Board not later than Wednesday, 30th June, 1965.

Applicants are advised that it will not be necessary to appear on the hearing date specified above, unless advised in writing by the Board.

B. P. KAY,

Secretary.

Exhibition Buildings, Rathdown-street, Carlton, N.3, 16th June, 1965.

LOCAL GOVERNMENT DEPARTMENT.

SHIRE OF CRANBOURNE.—ORDER CONFIRMED.

THE Minister of the Crown administering the *Local Government Act 1958*, as amended, on the 7th day of June, 1965, confirmed the Order hereinafter referred to in pursuance of section 514 of the said Act, namely:

An Order of the Council of the Shire of Cranbourne made on the 14th May, 1965, directing the compulsory taking of the land described in certificate of title, volume 6211, folio 160, for the purpose of providing a place of public resort and recreation.

R. J. HAMER,

Minister for Local Government.

Local Government Department,
Melbourne.

VEGETATION AND VINE DISEASES ACT 1958.— FRUIT AND VEGETABLES ACT 1958.

IN exercise of its powers, the Public Service Board, by Certificate dated the 26th May, 1965, has appointed the under-mentioned persons as Inspectors under the *Vegetation and Vine Diseases Act 1958*, and the *Fruit and Vegetables Act 1958*, without additional salary:—

REGINALD DITCHFIELD, Orchard Inspector.

LEONARD HENRY FREE, Orchard Inspector.

WILLIAM ROBERT MAYBERRY, Horticultural Inspector.

NORMAN GLEN SAINES, Orchard Inspector.

FRANK M. READ,

Director of Agriculture.

CHILDREN'S WELFARE ACT 1958.

DECLARATION OF INSTITUTION AS AN APPROVED HOSTEL.

IN accordance with the provisions of Regulation 42 of Division 1 of the *Social Welfare Regulations 1962*, notice is hereby given that on the tenth day of June, 1965, acting in pursuance of the powers conferred by sub-section (1) of section 14 of the *Children's Welfare Act 1958*, I declared. The Open Door Hostel, 2 Cedric-street, East Ivanhoe, as an approved Hostel for the purposes of the said Act.

V. F. WILCOX,

Acting Chief Secretary.

Chief Secretary's Office,
Melbourne, 10th June, 1965.

Health Act 1958.

VICTORIA—DEPARTMENT OF HEALTH.

NOTICE TO ATTEND FOR RADIOLOGICAL EXAMINATION.

To all persons aged twenty-one years and over enrolled or resident in the Subdivisions specified hereunder in the State Electoral District of Kew.

TAKE notice that you are required to attend at a Department of Health X-ray unit sited in the public street at or as near as possible to the main entrance to the premises specified in this notice, at any time between the hours specified on one of the days specified and during the period specified in respect of those premises, and thereat to submit yourself to radiological examination of the chest for the purpose of ascertaining whether you may be suffering from pulmonary tuberculosis. If you have had a chest X-ray within the last twelve months and for that reason do not wish to be examined now, you should attend the unit as directed and submit particulars of the previous examination.

SPECIFIED SUBDIVISIONS, PREMISES, PERIODS, DAYS AND HOURS.

Subdivision.	Premises.	Period.	Days.	Hours.
Deepondene ..	Cr. Cookson-street and Broadway, Camberwell	Thursday, 24th June, 1965, to Monday, 28th June, 1965 (inclusive)	Each day during the period except Saturday, Sunday and Public Holidays	From 10 a.m. to 8.30 p.m.
	1st Deepondene Scouts Hall, Whitehorse-road, Deepondene	Friday, 25th June, 1965, to Tuesday, 29th June, 1965 (inclusive)	Each day during the period except Saturday, Sunday and Public Holidays	From 10 a.m. to 8.30 p.m.
	Canterbury Dance Hall, Maling-road, Canterbury	Monday, 28th June, 1965, and Tuesday, 29th June, 1965	Monday, 28th June, 1965, Tuesday, 29th June, 1965	From 10 a.m. to 8.30 p.m. From 10 a.m. to 8.30 p.m.
	Cr. Parlington and Woodstock-streets, Canterbury	Tuesday, 29th June, 1965, to Friday, 2nd July, 1965 (inclusive)	Each day during the period except Public Holidays	From 10 a.m. to 8.30 p.m.
	Congregational Church, Hopetoun-avenue, Canterbury	Wednesday, 30th June, 1965, to Friday, 2nd July, 1965 (inclusive)	Each day during the period except Public Holidays	From 10 a.m. to 8.30 p.m.
	Caltex Service Station, cr. Jersey-street, and Whitehorse-road, Balwyn	Wednesday, 30th June, 1965, to Friday, 2nd July, 1965 (inclusive)	Each day during the period except Public Holidays	From 10 a.m. to 8.30 p.m.
	Kew ..	Municipal Library, Walpole-street, Kew	Monday, 26th July, 1965, to Tuesday, 3rd August, 1965 (inclusive)	Each day during the period except Saturday, Sunday and Public Holidays
Cr. Nolan-avenue and Studley Park-road, Kew		Monday, 26th July, 1965, to Thursday, 29th July, 1965 (inclusive)	Each day during the period except Public Holidays	From 10 a.m. to 8.30 p.m.
Church of England, cr. John and Rowland streets, East Kew		Monday, 26th July, 1965, to Friday, 30th July, 1965 (inclusive)	Each day during the period except Public Holidays	From 10 a.m. to 8.30 p.m.
Reserve, cr. Derby-street and Park-crescent, East Kew		Friday, 30th July, 1965, to Thursday, 5th August, 1965 (inclusive)	Each day during the period except Saturday, Sunday and Public Holidays	From 10 a.m. to 8.30 p.m.
B.S. Stillwell Used Cars, cr. Charles-street and Cotham-road, Kew		Monday, 2nd August, 1965, to Thursday, 5th August, 1965 (inclusive)	Each day during the period except Public Holidays	From 10 a.m. to 8.30 p.m.
Reserve, Park Hill-road near Wimba-avenue, East Kew		Wednesday, 4th August, 1965, to Monday, 9th August, 1965 (inclusive)	Each day during the period except Saturday, Sunday and Public Holidays	From 10 a.m. to 8.30 p.m.

NOTE.—Any person to whom this notice applies and who without reasonable excuse fails to comply with the requirements of the notice shall be guilty of an offence, and shall be liable to a penalty of not more than Twenty pounds.

Dated this twenty-fourth day of May, One thousand nine hundred and sixty-five.

KEVIN BRENNAN,
Chief Health Officer.

State Electricity Commission Acts.
ELECTRICAL APPROVALS BOARD.

PURSUANT to Regulation 16 of the Electrical Approvals Regulations—Approval of Equipment, 1953, the State Electricity Commission of Victoria hereby gives notice that it has withdrawn approval of the undermentioned article as from 15th April, 1965 :—

Name of Applicant.	Article and Reference No.	Certificate of Approval No.	Date of Certificate of Approval.
Aeronautical and Industrial Lighting Co. ..	Immersion Heater, Trade Name "Glenleigh", 240 volts, 400 watts, Ref. No. AN/IH/04	1221	16.9.48

Dated the 11th day of June, 1965.

L. G. MORRISON, Secretary.

BAIRNSDALE WATERWORKS TRUST.

BY-LAW No. 2.

THE Bairnsdale Waterworks Trust, in pursuance and exercise of the powers conferred by the Water Acts, doth hereby make the By-law following for its Waterworks District:—

By-law No. 1 made by the Bairnsdale Waterworks Trust on the 9th day of August 1957, is hereby amended as follows:—

1. In Part III., Section 5, for the words "Sections 191 and 194 of the Water Act 1928." There shall be substituted the words "Sections 208 and 211 of the Water Act 1958".
2. In Part IV., Section 14, paragraph (a), after the words "or asbestos cement," shall be added "or other materials approved in writing by the Trust".
3. In Part IV., Section 14, paragraph (d) for the words "tees or fittings", shall be substituted the words, "tees or fittings".
4. At the end of Section 14, Part IV., there shall be added the following paragraphs:—

(f) Copper piping shall comply with the Specification of the Australian Standards Association No. B.158-1961 "Copper Tubes for Water, Gas and Sanitation" and shall be of the following diameters and dimensions:—

(i) Copper Tube suitable for Screwed Connexions:—

Nominal Outside Diameter.	Standard Thickness		Nominal B.S.P. Thread Size.
	Inches.	S.W.G.	
$\frac{1}{8}$	16	0.064	$\frac{1}{8}$
$\frac{1}{4}$	14	0.080	$\frac{1}{4}$
$\frac{3}{8}$	14	0.080	$\frac{3}{8}$
$\frac{1}{2}$	13	0.092	$\frac{1}{2}$
$\frac{5}{8}$	13	0.092	$\frac{5}{8}$
$1\frac{1}{8}$	12	0.104	1
$1\frac{1}{4}$	12	0.104	$1\frac{1}{4}$
$1\frac{1}{2}$	12	0.104	$1\frac{1}{2}$
$2\frac{1}{8}$	11	0.116	2
$2\frac{1}{4}$	11	0.116	$2\frac{1}{4}$
$2\frac{1}{2}$	10	0.128	$2\frac{1}{2}$
$3\frac{1}{8}$	10	0.128	3
$3\frac{1}{4}$	10	0.128	$3\frac{1}{4}$
$4\frac{1}{8}$	10	0.128	4

(ii) Copper Tube suitable for Expanded and other approved Compression fittings and for Capillary and Bronze-welded joints:—

Nominal Outside Diameter.	Standard Thickness.		
	Inches.	S.W.G.	Inches.
$\frac{3}{8}$	18	0.048	$\frac{3}{8}$
$\frac{1}{2}$	18	0.048	$\frac{1}{2}$
$\frac{5}{8}$	18	0.048	$\frac{5}{8}$
$\frac{3}{4}$	17	0.056	$\frac{3}{4}$
1	16	0.064	1
$1\frac{1}{4}$	16	0.064	$1\frac{1}{4}$
$1\frac{1}{2}$	16	0.064	$1\frac{1}{2}$
2	14	0.080	2
$2\frac{1}{2}$	14	0.080	$2\frac{1}{2}$
3	14	0.080	3
$3\frac{1}{2}$	12	0.104	$3\frac{1}{2}$
4	12	0.104	4
5	11	0.116	5
6	10	0.128	6

(g) That part of any service pipe (including any bend elbow or other fitting) which extends in a thoroughfare from a main pipe to and including the stop-tap required to be fixed under Clause 18 of this By-law and all meter connexions shall be of the materials hereinafter set forth:—

(i) Where the diameter of the service pipe is 2 inches or less—copper (with brass fittings).

(ii) Where the diameter of the service-pipe is greater than 2 inches—copper, galvanized wrought-iron, asbestos cement, cast-iron or other materials approved by the Trust.

(h) That part of any service pipe of 2 inches diameter and less which is between the Main Pipe and the meter or where no meter is fixed between the Main Pipe and the building line of the street shall be copper or brass with a wall thickness of not less than 16 S.W.G. in the case of pipes suitable for expanded or other approved compressive fittings and for capillary and bronze welded joints or copper suitable for screwed connexions the wall thickness shall be not less than 13 S.W.G. for $\frac{1}{2}$ in. and $\frac{3}{4}$ in. diameter pipes and for pipes of greater diameter not less than 12 S.W.G.

5. In Part V., Section 17, paragraph (b) for the words "twenty shillings (20s.)", there shall be substituted the words "forty shillings (40s.)".

6. In Part IX., Section 34, paragraph (a) for the words "fifteen shillings (15s.)" as first appearing, there shall be substituted the words "two pounds (£2)".

The foregoing By-law was made by the Bairnsdale Waterworks Trust on the 19th day of May 1965.

IN WITNESS whereof the Common Seal of the Bairnsdale Waterworks Trust was hereto affixed in the presence of—

(SEAL) PHIL. C. KING, Chairman.
K. C. MASON, Commissioner.
J. B. NEALE, Secretary.

Approved by the Governor in Council, 9th June, 1965.—
J. COLQUHOUN, Clerk of the Executive Council.

BARNAWARTHA WATERWORKS TRUST.

AUTHORITY TO OBTAIN BANK OVERDRAFT.

HIS Excellency the Governor of the State of Victoria, by and with the advice of the Executive Council thereof, doth, by Order made on the 9th day of June, 1965, authorize the Barnawartha Waterworks Trust to obtain, in pursuance of the provisions of section 286 of the Water Act 1958 (No. 6413) an advance or advances during the year 1965, from the Bank of New South Wales, Children, by overdraft of the Trust's current account thereat, such overdraft not to exceed at any one time the sum of One thousand pounds (£1,000).

J. COLQUHOUN,
Clerk of the Executive Council.

At the Executive Council Chamber,
Melbourne, 9th June, 1965.

KERANG SEWERAGE AUTHORITY.

RATING BY-LAW FOR THE YEAR 1965.

THE Kerang Sewerage Authority, in pursuance and exercise of the powers conferred by the Sewerage District Acts, doth hereby make a sewerage rate of Two shillings in the pound on the annual municipal valuation of all seweraged properties liable to be rated within the Kerang Sewerage District.

Provided that in no case shall the amount of the rate payable per annum in respect of any tenement (other than land on which there is no building) be less than Five pounds, and in respect of land on which there is no building, Two pounds.

Such rate is to be made and shall be levied upon the occupiers or owners of the said land and tenements for the year commencing on the 1st day of January 1965 and shall be payable on the first day of June 1965 at the office of the said Authority.

The Resolution for passing the foregoing By-law was agreed to by the Kerang Sewerage Authority on the 19th day of February 1965, and was confirmed by the said Authority on the 22nd day of March 1965.

(SEAL) F. J. RYAN, Member.
C. P. LANG, Member.
L. R. RUNDLE, Secretary.

Approved by the Governor in Council, 9th June, 1965.—
J. COLQUHOUN, Clerk of the Executive Council.

CONTRACTS ACCEPTED.—(Series 1964-65.)**VICTORIAN RAILWAYS.**

119. Manufacture, supply, delivery and erection of a gantry crane at Newport Workshops, for £12,373 (Contract 62691).—Johns & Waygood Limited. 120. Erection and completion of brick and concrete signal box, Relay Room and Amenities Building, Princes Bridge Station, for £21,494 (Contract 62777).—Lawson and Laughlin Pty. Ltd. 121. Supply, spreading, grading and compaction of selected filling for proposed Newport, Geelong Duplication between 8M. 22 chains and 10M. 19 chains (Paisley-Galvin) at 14s. per cubic yard (Contract 62798).—Keith Nicholls Pty. Ltd.

By order of the Victorian Railways Commissioners,
W. WALKER, Secretary for Railways.
Melbourne, 11th June, 1965.

SOIL CONSERVATION AUTHORITY.**SUPPLY OF TREATED WOODEN FENCING MATERIALS.**

4029. Posts, 6 ft. x 3 in.—4 in., at £24 a 100, posts, 6 ft. x 4 in.—5 in., at £26 5s. a 100, strainers, 7 ft. 6 in. x 5 in.—6 in., at 12s. each, stays, 10 ft. x 3 in. min., at 10s. each.—Grampians Treated Timber Company, Fisher-street, Stawell.

PUBLIC WORKS.

4030. Carlton, St. Nicholas Hospital, supply lathes and equipment, £1,227 12s. 6d.—L. B. Stockdale Pty. Ltd.
4031. West Parkville, "Turana", supply curtain material, £945.—Frances Burke, Fabrics Pty. Ltd.
4032. Kew, Mental Hospital, supply sterilizers, £629 10s.—K. G. Luke Aust. Pty. Ltd.
4033. Clayton, Secondary Teachers' College, supply kitchen equipment, £1,528.—Brice Scale & Slicer Co. Pty. Ltd.
4034. Clayton, Secondary Teachers' College, supply kitchen equipment, £1,364 16s.—E.G.A. (S. Cunningham) Pty. Ltd.
4035. Clayton, Secondary Teachers' College, supply electric oven, £550.—Thermo Radian Oven Sales Pty. Ltd.
4036. Clayton, Secondary Teachers' College, supply kitchen equipment, £8,168 17s. 6d.—Ahearn Main & Stott Pty. Ltd.
4037. Melbourne, Police Department, supply tables, £698 8s.—D. F. Cowan Sales Pty. Ltd.
4038. Port Melbourne, P.W.D. Depot, supply prime mover, Bedford, £1,817.—G. V. Clarke Motors Pty. Ltd.
4039. Eaglehawk, High School, supply fans, £536 10s.—General Electric Co.
4040. Broadmeadows, Technical School, supply and install furniture, £1,276 18s.—Kennett Bros. & Rayner Pty. Ltd.
4041. Langi Kal Kal, H.M. Training Centre, supply mixing machine, £616 4s. 6d.—The Hobart Manufacturing Co. Pty. Ltd.
4042. Geelong, Gordon Institute of Technology, supply tables and benches, £1,581 12s.—Kennett Bros. & Rayner Pty. Ltd.
4043. Coburg, H.M. Pentridge Prison, supply wire and spooling machines, £16,553.—Bliss & Reels Co. Pty. Ltd.
4044. Port Melbourne, Storeyard, P.W.D., supply pile shoes, £666 13s. 4d.—S. G. Sewell Pty. Ltd.
4045. Werribee, Animal Husbandry Research, supply timber, £1,015 17s. 11d.—J. Wright & Sons (Aust.).
4046. Bundoora, Janefield Training Centre, supply kitchen equipment, £656 1s.—E.G.A. (S. Cunningham) Pty. Ltd.
4047. Bundoora, Janefield Training Centre, supply electric ovens and mixer, £732 10s.—Waldorf Appliances Pty. Ltd.
4048. Bundoora, Janefield Training Centre, supply refrigerator and food bins, £578.—Ahearn Main & Stott Pty. Ltd.
4049. West Parkville, "Turana", supply chairs, £971 12s.—Sebal Sales Ltd.
4050. West Parkville, "Turana", supply mattresses, £796 19s.—Seafoam Pty. Ltd.
4051. West Parkville, "Turana", supply beds, £561.—Namco Furniture Contract Div.

VANCE DICKIE, Acting Minister of Public Works.
8.6.65.

ORDERS IN COUNCIL.—(Series 1964-65.)**PUBLIC WORKS.**

4052. Ararat, High School, special grant authorized by the Education Department towards the cost of construction of a canteen at the school, £1,000 10s.—Ararat High School Advisory Council.—(W.315883.)
4053. Bendigo, Mental Hospital, sewerage works, £1,697 8s. 6d.—Bendigo Sewerage Authority.—(N.W.56105.)

4054. Brunswick East, State School No. 3179, improved lighting, (complete rewire), £865.—P. J. Lynch.—(N.W.64123.)

4055. Coburg, Pentridge Gaol, supply and fitting water pump, main boiler house, £595.—George & George Pty. Ltd.—(N.W.22326.)

4056. Croydon, High School, special grant authorized by the Education Department towards the cost of construction of a sports oval at the school, £2,598 10s.—Croydon High School Advisory Council.—(N.E.63268.)

4057. Ivanhoe, Social Welfare Department, "Larnook", Family Group Home, internal and external renovations, £552.—R. Singer.—(N.E.69954.)

4058. Ivanhoe, Social Welfare Department, "Lentara" Family Group Home, internal and external renovations, £540 15s.—R. Singer.—(N.E.69953.)

4059. Lakes Entrance, Police Station and Residence, supply and installation of electric hot-water services, L.P. gas service and installation of slow combustion stove, £531 10s.—S. Jerkins.—(S.E.265120 "A").

4060. Malmesbury, Social Welfare Department, Youth Training Centre, supply of 7-ft. cut gang mower with hydraulic lift and 24-in. self propelled rotary scythe, £777.—Scott Bonnar Australia Pty. Ltd.—(N.W.68347.)

4061. Melbourne, Emily McPherson College, supply of one (1) Horscroft drying tumbler, £636 17s.—Hardie Trading Limited.—(M.74683.)

4062. Melbourne, Police Headquarters, Russell-street, wiring of new kitchen, £1,302.—R. A. Waldron Trading Co.—(M.292426 "A").

4063. Melbourne, Mines Laboratory, provision of air conditioning, Room 113, £820.—Unit Air Conditioners.—(M.39743.)

4064. Plenty, Mental Hospital, rebuilding of brick flue in boiler house, £652.—J. M. Elton.—(N.E.40151.)

4065. St. Albans North, State School No. 4811, special grant authorized by the Education Department towards the cost of construction of a canteen at the school, £620.—St. Albans North State School No. 4811 Committee.—(W.54771.)

4066. Tower Hill, Fisheries and Wildlife Reserve, concrete footing for stone wall and concrete channel, £800.—J. R. Brown.—(S.W.313084.)

4067. Tower Hill, Fisheries and Wildlife Reserve, sealing of 4,900 square yards of roadway and car park, at rates per estimated cost of £1,020.—J. Keen.—(S.W.313084.)

4068. West Melbourne, Government Cool Stores, "A" Section, rewiring pit lights and sub-mains, £966.—Gellibrand Electric Co.—(M.65801.)

Approved by the Governor in Council, 9th June, 1965.—
J. COLQUHOUN, Clerk of the Executive Council.

EDUCATION DEPARTMENT.

4069. One only Variable Compression Engine for Ballarat School of Mines and Industries, £3,558 18s. 10d.—Tecquipment Ltd.

Approved by the Governor in Council, 9th June, 1965.—
J. COLQUHOUN, Clerk of the Executive Council.

STATE ELECTRICITY COMMISSION.

4070. For the manufacture, supply and delivery of galvanized structural steelwork for 220 and 66-kV switchyards at Heatherston Terminal Station, to Specification No. 64-65/338, £11,520.—Welded Pipelines Pty. Ltd.

4071. For the supply of six lathes for Yallourn Base Workshops, to Specification No. 64-65/207, £9,747 2s.—Wickman (Aust.) Pty. Ltd.

4072. For the supply of terminal clamps for neoprene type neutral screened cable for reticulation services, for a period of two years, to Specification No. 64-65/161, at Schedule rates.—Trojan Ltd.

4073. For the supply of termination clamps for neoprene type neutral screened cable for reticulation services, for a period of two years, to Specification No. 64-65/161, at Schedule rates.—L. Watkins Engineers Pty. Ltd.

Approved by the Governor in Council, 5th May, 1965.—
J. COLQUHOUN, Clerk of the Executive Council.

4074. For the construction of earthworks and site preparation at Substation 'NP' Noble Park, to Specification No. 64-65/327, £10,068 plus items at Schedule rates.—Albara Constructions.

4075. For the supply and erection of two 1,650,000 lb. per hour boilers and associated plant for Stage 4, Hazelwood Power Station, £13,690,890.—Babcock & Wilcox of Aust. Pty. Ltd.

4076. For the supply and erection of two 200 MW turbogenerators and associated plant for Stage 4, Hazelwood Power Station, £4,381,479.—C. A. Parsons & Co. Ltd.

4077. For the supply of aluminium split bolt clamps, for a period of two years, to Specification No. 64-65/205, at Schedule rates.—D. M. Hull & Co. Pty. Ltd.

4078. For the supply and installation of three hydraulically operated truck borers to be fitted on Commission's truck chassis for pole hole digging, to Quotation No. 4161, £12,453.—Tutt Bryant (Vic.) Pty. Ltd.

4079. For the supply of 50,000 super feet of oregon timber for construction and maintenance work, to Quotation No. 4153, at Schedule rates.—J. Wright & Sons (Aust.) Pty. Ltd.

4080. For the purchase by the Commission of land being part of Crown allotment 9, section A, Parish of Hazelwood, County of Buln Buln, and being the whole of land comprised in certificate of title, volume 6647, folio 338, £16,000.—H. G. Williamson.

Approved by the Governor in Council, 11th May, 1965.—J. COLQUHOUN, Clerk of the Executive Council.

LAW DEPARTMENT.

COURTS OF GENERAL SESSIONS.—ALTERATION OF DATES.

HIS Excellency the Governor of the State of Victoria, by and with the advice of the Executive Council thereof, doth, by Order made on the 9th day of June, 1965, amend the Order in Council approved on the 27th October, 1964, appointing certain dates for holding Courts of General Sessions of the Peace during the year 1965, as indicated in the second column of the subjoined Schedule so far as the Courts at the places named in the first column of such Schedule are concerned.

SCHEDULE.

Place; Alteration of Date.

Sale; from Tuesday, the 3rd August, 1965, to Tuesday, the 6th July, 1965.

Ararat; from Tuesday, the 10th August, 1965, to Tuesday, the 13th July, 1965.

Shepparton; from Tuesday, the 17th August, 1965, to Tuesday, the 3rd August, 1965.

Korumburra; from Tuesday, the 24th August, 1965, to Tuesday, the 6th July, 1965.

J. COLQUHOUN, Clerk of the Executive Council.

At the Executive Council Chamber, Melbourne, 9th June, 1965.

LAW DEPARTMENT.

SITTINGS OF SUPREME COURT.—ADDITIONAL DAY.

HIS Excellency the Governor of the State of Victoria, by and with the advice of the Executive Council thereof, doth, by Order made on the 9th day of June, 1965, appoint Tuesday, the 20th day of July, 1965, a day for the Sittings of the Supreme Court at Hamilton, in addition to the days heretofore appointed.

J. COLQUHOUN, Clerk of the Executive Council.

At the Executive Council Chamber, Melbourne, 9th June, 1965.

LAW DEPARTMENT.

CURATOR OF CONVICT'S PROPERTY.

HIS Excellency the Governor of the State of Victoria, by and with the advice of the Executive Council thereof, doth, by Order made on the 9th day of June, 1965, pursuant to the provisions of section 550 of the Crimes Act 1958, commit the custody and management of the property of the convict, Aldo Massola, to Mary Massola, of Kerr-crescent, Montrose, as a curator hereby appointed in that behalf.

J. COLQUHOUN, Clerk of the Executive Council.

At the Executive Council Chamber, Melbourne, 9th June, 1965.

SHIRE OF OTWAY.

ROAD DEVIATION ORDER.

IN pursuance of the powers conferred by sections 522 and 526 of the Local Government Act 1958, the Council of the Shire of Otway doth hereby direct that the land in the Parish of Krambruk, shown hatched on the plan annexed hereto which has been taken, purchased or acquired by it, shall be a public highway from and after the date of publication of this Order in the Government Gazette, and doth declare that such land shall be a public highway in lieu of the land in the said Parish shown cross-hatched on the said plan.

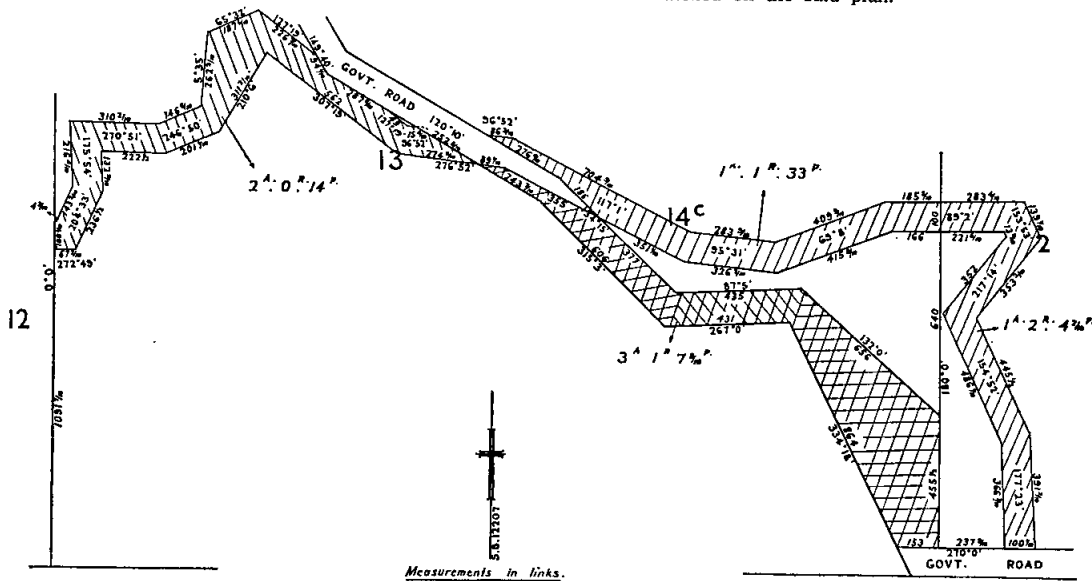

The common seal of the President, Councillors and Ratepayers of the Shire of Otway was hereunto affixed this 17th day of February, 1965, in the presence of—

(SEAL)

W. W. MITCHELL, President.
E. W. MORRIS, Councillor.
T. J. FRY, Secretary.

Confirmed by the Governor in Council, 9th June, 1965.—J. COLQUHOUN, Clerk of the Executive Council.

Town and Country Planning Act 1961.
COBRAM PLANNING SCHEME 1949.
 AMENDMENT No. 5, 1964.

Notice of Approval.

IN pursuance of the powers conferred by the *Town and Country Planning Act 1961*, the Governor in Council, on the 9th June, 1965, approved a planning scheme entitled 'the Cobram Planning Scheme 1949, Amendment No. 5, 1964, in respect of part of the municipal district of the Shire of Cobram.

A copy of the planning scheme as approved may be inspected during office hours at the office of the Town and Country Planning Board, 179 Queen-street, Melbourne; at the office of the Shire of Cobram, at Cobram; and when available, at the Office of Titles, Melbourne, and at the Central Plan Office of the Department of Crown Lands and Survey, Melbourne.

W. H. CRAIG, Secretary,
 Town and Country Planning Board.

Town and Country Planning Act 1961.
WARRAGUL PLANNING SCHEME 1954.
 AMENDMENT No. 5, 1963.

Notice of Approval.

IN pursuance of the powers conferred by the *Town and Country Planning Act 1961*, the Governor in Council, on the 9th June, 1965, approved a planning scheme entitled the Warragul Planning Scheme 1954, Amendment No. 5, 1963, in respect of part of the municipal district of the Shire of Warragul.

A copy of the planning scheme as approved may be inspected during office hours at the office of the Town and Country Planning Board, 179 Queen-street, Melbourne; at the office of the Shire of Warragul, at Warragul; and when available, at the Office of Titles, Melbourne, and at the Central Plan Office of the Department of Crown Lands and Survey, Melbourne.

W. H. CRAIG, Secretary,
 Town and Country Planning Board.

Town and Country Planning Act 1961.
CITY OF CAMBERWELL PLANNING SCHEME 1954.
 AMENDMENT No. 3, 1961.

Notice of Approval.

IN pursuance of the powers conferred by the *Town and Country Planning Act 1961*, the Governor in Council, on the 9th June, 1965, approved a planning scheme entitled the City of Camberwell Planning Scheme 1954, Amendment No. 3, 1961, in respect of part of the municipal district of the City of Camberwell.

A copy of the planning scheme as approved may be inspected during office hours at the office of the Town and Country Planning Board, 179 Queen-street, Melbourne; at the office of the City of Camberwell, at Camberwell; and when available, at the Office of Titles, Melbourne, and at the Central Plan Office of the Department of Crown Lands and Survey, Melbourne.

W. H. CRAIG, Secretary,
 Town and Country Planning Board.

Town and Country Planning Act 1961.
CITY OF BROADMEADOWS PLANNING SCHEME.
 AMENDMENT No. 13, 1964.

Notice of Approval.

IN pursuance of the powers conferred by the *Town and Country Planning Act 1961*, the Governor in Council, on the 9th June, 1965, approved a planning scheme entitled the City of Broadmeadows Planning Scheme, Amendment No. 13, 1964, in respect of part of the municipal district of the City of Broadmeadows.

A copy of the planning scheme as approved may be inspected during office hours at the office of the Town and Country Planning Board, 179 Queen-street, Melbourne; at the office of the City of Broadmeadows, at Broadmeadows; and when available, at the Office of Titles, Melbourne, and at the Central Plan Office of the Department of Crown Lands and Survey, Melbourne.

W. H. CRAIG, Secretary,
 Town and Country Planning Board.

Town and Country Planning Act.
SHIRE OF ROCHESTER.
 INTERIM DEVELOPMENT ORDER.

BY virtue of the powers conferred by the *Town and Country Planning Act 1961*, and of every power enabling it in that behalf, the Shire of Rochester (hereinafter referred

to as the Responsible Authority) having commenced the preparation of a planning scheme in accordance with the said Act on the 3rd day of December, 1964, hereby makes the following Interim Development Order for the purpose of regulating, restricting, restraining or prohibiting the use or development of any land or the erection, construction or carrying out of any buildings or works, that is to say:—

1. Except in accordance with the provisions of a permit issued by the Responsible Authority, no person shall use, subdivide or otherwise develop any land, or erect, construct or carry out any buildings or works on any land within the area described in the Schedule hereto.

2. Every application for a permit under the provisions of this Order shall be made on the prescribed form, copies of which may be obtained from the office of the Responsible Authority at the Shire Office, Rochester.

3. Notwithstanding the provisions of clause 1 hereof, this Interim Development Order shall not prohibit the erection, construction or carrying out of any dwelling-house or ancillary works on any land shown as a separate allotment on a plan of subdivision sealed by the Council of the Shire of Rochester, pursuant to section 569 of the *Local Government Act 1958*, before the coming into operation of this Order.

4. Nothing in this Interim Development Order shall prevent—

- (a) the continuance of the use of any land or any existing building or works for the purpose for which the land or building or works was or were being lawfully used immediately before the coming into operation of this Order;
- (b) any dealing or the registration of any dealing with any land in a subdivision of which a plan has been sealed by the Council of the Shire of Rochester, pursuant to section 569 of the *Local Government Act 1958*, before the coming into operation of this Order.

SCHEDULE.

All that land within the Shire of Rochester, being part of the Parish of Wharparilla, which is technically described hereunder:—

"Commencing at a point being the south-eastern corner of Crown allotment 1A, Parish of Wharparilla, County of Gunbower; thence westerly by a line being the common boundary of the Parishes of Wharparilla and Millewa to the south-western corner of Crown allotment 54, Parish of Wharparilla; thence northerly by the western boundaries of Crown allotments 54, 55, 56, 57, a line across a road, the western boundaries of Crown allotments 58, 59, 60, 61, a line across the Echuca-Serpentine main road, the western boundaries of Crown allotments 103 and 104, and a line across the Murray Valley Highway to a point on the south-western boundary of Crown allotment 114; thence north-westerly by the south-western boundaries of Crown allotment 114 and the Wharparilla pre-emptive right to the south-western corner of the said pre-emptive right; thence northerly by the western boundary of the pre-emptive right, a line across a road, the western boundary of Crown allotment 121 to the north-western corner of Crown allotment 121; thence northerly by a line across a reserve to the intersection of the said line with the left-hand bank of the Murray river; thence easterly and southerly by the said river bank to its intersection with the common boundary between the Shire of Rochester and the City of Echuca; thence southerly and easterly by the said common municipal boundary to its intersection with the left-hand bank of the Campaspe river; thence generally southerly, easterly and southerly along the said river bank to the south-eastern corner of Crown allotment 1A, Parish of Wharparilla, County of Gunbower, being the point of commencement."

In witness whereof the common seal of the President, Councillors and Ratepayers of the Shire of Rochester was hereunto affixed this 14th day of May, 1965, in the presence of—

C. W. W. MACAULEY, Councillor.
 H. A. KEELE, Councillor.
 H. R. WESTCOTT, Shire Secretary.

Report of the Town and Country Planning Board on the 26th day of May, 1965.—Recommended for approval.—FRED. C. COOK, Chairman.

Approved by the Governor in Council on the 9th day of June, 1965.—J. COLQUHOUN, Clerk of the Executive Council.

STATE RIVERS AND WATER SUPPLY COMMISSION.

BY-LAW No. 5489.—BELLARINE PENINSULA, MORNINGTON PENINSULA AND OTWAY WATERWORKS DISTRICTS.—FIXING CHARGES FOR WATER AND REVOKING BY-LAW 5428.

THE State Rivers and Water Supply Commission, in pursuance and exercise of the powers conferred by the Water Acts, doth hereby make the By-law following:—

1. This By-law shall come into operation as on and from the 1st July, 1965, and shall apply to and have force in the Bellarine Peninsula, Mornington Peninsula, and Otway Waterworks Districts, except within any Urban District thereof.
2. By-law No. 5428 made by the State Rivers and Water Supply Commission on the 24th June, 1963, is hereby revoked as from 1st July, 1965.
3. Minimum annual charges for water supplied by measure from the works of the Commission, except in the cases of special agreement with the Commission, shall be as set out in the Schedule hereto. Such charges shall be payable, on demand, at the office of the State Rivers and Water Supply Commission, as follows:—

Name of Waterworks District.	Places at Which Charges for Water shall be Payable.
Bellarine Peninsula	Geelong
Mornington Peninsula	Dandenong or Frankston
Otway	Camperdown

SCHEDULE.

Land on Which there is a House.	Vacant Land.	Minimum Annual Charge.
		£
Area not exceeding 1 acre	Area not exceeding 20 acres	10
Area greater than 1 acre and not exceeding 20 acres	Area greater than 20 acres and not exceeding 40 acres	15
Area greater than 20 acres and not exceeding 40 acres	Area greater than 40 acres and not exceeding 60 acres	20
Area greater than 40 acres and not exceeding 60 acres	Area greater than 60 acres and not exceeding 80 acres	25
Area greater than 60 acres and not exceeding 80 acres	Area greater than 80 acres and not exceeding 100 acres	30
Area greater than 80 acres	Area greater than 100 acres	35

In any case where there is more than one residence upon the holding concerned, the appropriate minimum annual charge set out in the above Schedule shall be increased by £10 for each additional residence supplied. One additional tapping of the Commission's water main will be allowed for each such additional residence.

In all other cases the minimum annual charges set out in the above Schedule provide for one tapping only of the Commission's water main and for each additional tapping there shall be an additional minimum annual charge of £10.

4. The maximum allowance of water to be supplied per annum in respect of the minimum annual charge shall in each case be the quantity which, if charged for at Two shillings per 1,000 gallons, would give an amount equal to such minimum annual charge, and for all water supplied in excess of such allowance the charge shall be Two shillings per 1,000 gallons.

The foregoing By-law was made by the State Rivers and Water Supply Commission on the 7th June, 1965, and the common seal of the said Commission was hereunto affixed on the 7th June, 1965, in the presence of:—

(SEAL)

R. A. HORSFALL, Commissioner.
K. D. GREEN, Commissioner.

Approved by the Governor in Council, 9th June, 1965.—J. COLQUHOUN, Clerk of the Executive Council.

Water Act 1958.

STATE RIVERS AND WATER SUPPLY COMMISSION.
WESTERNPORT URBAN DISTRICT.

NOTICE to owners of tenements in the under-mentioned streets in the Westernport Urban District, and the private streets, lanes, courts and alleys opening thereto:—

Crib Point.

Governor's-road, from Point-road to a point opposite lot 24, about 6½ chains westerly.
Point-road, from Disney-street to Governor's-road.
Tobruk-court.

The main pipe in the said streets being laid down, the owners of all tenements situated as above are hereby required, on or before the 19th day of July next, to cause proper pipes and stop cocks to be laid, so as to supply water within such tenements from the main pipe.

G. W. LEWIS, Acting Secretary,
State Rivers and Water Supply Commission.

Melbourne, 11th June, 1965.

Water Act 1958.

STATE RIVERS AND WATER SUPPLY COMMISSION.
TERANG URBAN DISTRICT.

NOTICE to owners of tenements in the under-mentioned streets in the Terang Urban District, and the private streets, lanes, courts and alleys opening thereto:—

Terang.

Thomson-street (western side), from King-street to a point opposite part of Crown allotment 1, section 16, Parish of Terang, comprised in certificate of title, volume 8012, folio 060, about 14 chains generally north-westerly.

The main pipe in the said streets being laid down, the owners of all tenements situated as above are hereby required, on or before the 19th day of July next, to cause proper pipes and stop cocks to be laid, so as to supply water within such tenements from the main pipe.

G. W. LEWIS, Acting Secretary,
State Rivers and Water Supply Commission.

Melbourne, 11th June, 1965.

*Water Act 1958.*STATE RIVERS AND WATER SUPPLY COMMISSION.
DANDENONG—SPRINGVALE URBAN DISTRICT.

NOTICE to owners of tenements in the under-mentioned streets in the Dandenong—Springvale Urban District, and the private streets, lanes, courts and alleys opening thereto:—

Dandenong.

Civic-drive, from Princes Domain-drive to a point opposite lot 94, about 6½ chains easterly and thence 1 chain southerly.

The main pipe in the said streets being laid down, the owners of all tenements situated as above are hereby required, on or before the 19th day of July next, to cause proper pipes and stop cocks to be laid, so as to supply water within such tenements from the main pipe.

G. W. LEWIS, Acting Secretary,
State Rivers and Water Supply Commission.

Melbourne, 11th June, 1965.

*Water Act 1958.*STATE RIVERS AND WATER SUPPLY COMMISSION.
URBAN DISTRICT SUPPLIED WITH WATER FROM THE
COLIBAN SYSTEM OF WATERWORKS.

NOTICE to owners of tenements in the under-mentioned streets in the urban district supplied with water from the Coliban System of Waterworks, and the private streets, lanes, courts and alleys opening thereto:—

Bendigo.

Gladstone-street, from Mitchell-street to Hoskins-street.
Havlin-street East, from Mundy-street to Stene-street.
Lloyd-street, from Doak-street to a point opposite allotment 248d, about 1½ chains easterly.
Myrmong-court.

Castlemaine.

Dick-street, from Farren-street to Baird-street.

The main pipe in the said streets being laid down, the owners of all tenements situated as above are hereby required, on or before the 19th day of July next, to cause proper pipes and stop cocks to be laid, so as to supply water within such tenements from the main pipe.

G. W. LEWIS, Acting Secretary,
State Rivers and Water Supply Commission.

Melbourne, 11th June, 1965.

DEPARTMENT OF MINES.

SUBJECT to any necessary excisions, &c., it is proposed to grant the following mining lease:—

5614, Gippsland; Cecil Cooper and James Denner; 12a. 2r. 9p., Parish of Wollonaby.

MINING LEASES GRANTED.

8299, Mineral; Standard Quarries Proprietary Limited; 3a. 1r. 6p., Parish of Kangerong.

8342, Mineral; Charles James Dean; 6a. 2r., Parish of Sandhurst.

TERM OF PETROLEUM EXPLORATION LICENCES
EXTENDED.

5, Petroleum Exploration Permit; Frome-Broken Hill Co. Pty. Ltd.; 4,252 square miles, Counties of Dundas, Follett, Hampden, Heytesbury, Normanby and Villiers. Period extended seven months as from 1st June, 1965.

6, Petroleum Exploration Permit; Frome-Broken Hill Co. Pty. Ltd.; 4,383 square miles, Counties of Grant, Grenville, Hampden, Heytesbury, Mornington and Polwarth. Period extended seven months as from 1st June, 1965.

PETROLEUM EXPLORATION PERMITS GRANTED.

53, Petroleum Exploration Permit; Alliance Oil Development Australia No Liability; 637 square miles, County of Buln Buln (in lieu of Petroleum Exploration Permit No. 28 and Petroleum Prospecting Licences Nos. 199 and 210, surrendered).

54, Petroleum Exploration Permit; Alliance Oil Development Australia No Liability; 529 square miles, Counties of Dundas, Follett, Grant and Normanby (in lieu of Petroleum Exploration Permit No. 48 and Petroleum Prospecting Licence No. 256, surrendered).

TAILINGS LICENCES GRANTED.

3348, Tailings Licence; John Lawrence Ward; 40a. 2r. 2p., Parish of Chiltern West (in lieu of Tailings Licence No. 2956, expired).

3378, Tailings Licence; The President, Councillors and Rate-payers of the Shire of Alexandra; Township of Gobur.

3391, Tailings Licence; Robert William Farrell; Township of Maldon.

3392, Tailings Licence; John Doyle and Robert Leo Doyle; Parish of Sandhurst.

3393, Tailings Licence; John Doyle and Robert Leo Doyle; at Bendigo.

3394, Tailings Licence; Guiseppe Mioni and Emilio Mioni; Parish of Korumburra (in lieu of Tailings Licence No. 3312, expired).

3398, Tailings Licence; Albert William Trotter; Parish of Durdidwarrah (in lieu of Tailings Licence No. 3294, expired).

3399, Tailings Licence; Alan Heywood Sutherland; Parish of Toora (in lieu of Tailings Licence No. 3317, expired).

3400, Tailings Licence; The President, Councillors and Rate-payers of the Shire of Buninyong; Parish of Borchonyghurk (in lieu of Tailings Licence No. 3082, expired).

MINERAL SEARCH LICENCES GRANTED.

605, Mineral Search Licence; Edward Arthur Knox and Henry James Evans; 85 acres, Parish of Tarlarn.

608, Mineral Search Licence; Lindsay Gordon McRae and Keith McRae; 50 acres, Parish of Detarka.

612, Mineral Search Licence; Lindsay Gordon McRae and Keith McRae; 890 acres, Parishes of Deddick and Jingallala.

614, Mineral Search Licence; Lindsay Gordon McRae and Keith McRae; 500 acres, Parish of Toonginbooka.

TAILINGS LICENCE EXPIRED.

3322, Tailings Licence; John Doyle and Robert Leo Doyle; Parish of Tarnagulla.

APPLICATION FOR LEASE REFUSED.

8220, Mineral; Harold William Osmand; 27 acres, Parish of Walwa.

CONSENT GRANTED TO TRANSFER MINING LEASE.

9167, Ballarat; from Albert Gordon Russell to Quality Earths Pty. Ltd.

T. A. DARCY,
Minister of Mines.

Melbourne and Metropolitan

BOARD OF WORKS.

NOTICE TO THE OWNERS OF TENEMENTS IN THE UNDER-MENTIONED STREETS, AND THE PRIVATE STREETS, LANES, COURTS, AND ALLEYS OPENING THERETO.

THE main pipe in the said streets being laid down, the owners of all tenements situated as under are hereby required, on or before the 19th July, 1965, to cause a proper pipe and stop cocks to be laid so as to supply water within such tenements from the main pipe.

H. J. SNADDEN,
Secretary.

8th June, 1965.

STREET AND POSITION.

Broadmeadows.

Crowley-court, from Northumberland-road westwards 8½ chains.

Railway-crescent, from 8 chains north of Smeaton-avenue northwards 23½ chains.

Tooradin-crescent, from Railway-crescent to Emerald-street.

Stockdale-avenue, from Railway-crescent to Corinella-crescent.

Rubicon-street, from Stockdale-avenue southwards 10½ chains.

Rye-street, from Railway-crescent to Rubicon-street.

Selby-street, from Tooradin-crescent to Corinella-crescent.

Emerald-street, from Corinella-crescent to Barry-road.

Barry-road, from Emerald-street eastwards 7½ chains.

Barry-road, from Emerald-street westwards 17 chains.

Yinnar-street, from Barry-road to Tooradin-crescent.

Bena-court, from Tooradin-crescent northwards 4½ chains.

Wallan-court, from Tooradin-crescent northwards 6 chains.

Corinella-crescent, from Tara-street westwards and south-westwards 27½ chains.

Dandenong.

Eden-court, from Chandler-road eastwards and south-eastwards 6½ chains.

Doncaster and Templestowe.

Daphne-street, from 4½ chains east of Victoria-street eastwards and northwards 8½ chains.
Acacia-street, from Victoria-street eastwards 11 chains.
William-street, from Mitcham-road southwards and westwards 14½ chains.
Adelyn-avenue, from William-street southwards and westwards 7 chains.
Kevin-court, from William-street westwards 6½ chains.

Heidelberg.

Glenice-street, from Henry-street eastwards 8½ chains.
Meron-court, from Glenice-street southwards 4½ chains.

Malvern.

Kerferd-road, from 5 chains east of Wills-street eastwards 3½ chains.
Alexandra-court, from Kerferd-road northwards and north-eastwards 6 chains.

Melbourne.

Fleming-place, from Little Collins-street southwards 2½ chains.

Nunawading.

Benwerrin-drive, from Dorothy-street south-eastwards 10½ chains.
Bettina-street, from Benwerrin-drive north-eastwards and eastwards 5½ chains.
Mudgee-street, from Benwerrin-drive south-westwards 5½ chains.
Tawarri-place, from Mudgee-street south-eastwards 7½ chains.
Cornish-road, from Dorothy-street to Bettina-street.
Katrina-street, from Koonung-road westwards 33 chains.
Lupin-street, from Katrina-street to Verbena-street.
Verbena-street, from Lupin-street to Koonung-road.
Gerbera-court, from Lupin-street eastwards 9½ chains.
Virgillia-street, from Katrina-street northwards 7½ chains.
Lobelia-court, from Katrina-street northwards 7½ chains.
Caroline-crescent, from Katrina-street northwards and westwards 12½ chains.

Preston.

Graham-court, from Cooper-street northwards and eastwards 8½ chains.

Springvale.

Princes Highway (north-east side), from Elonera-road north-westwards 51 chains.

Sunshine.

Ballarat-road, from Miles-street to Marcellin-court.
Marcellin-court, from Ballarat-road northwards 14½ chains.
Peter Chanel-court, from Marcellin-court westwards 7 chains.
Eymard-street, from Marcellin-court westwards 8½ chains.
Joan-street, from Links-street westwards 18½ chains.
Station-street, from Main-road west to Disraeli-street.
Disraeli-street, from Station-street to Garfield-street.
Garfield-street, from Main-road west to Disraeli-street.

Waverley.

Terama-court, from Madeline-street southwards 6½ chains.
Koonalda-avenue, from Springvale-road westwards 11½ chains.
Merrick-crescent, from Koonalda-avenue southwards and westwards 12 chains.
Newnham-court, from Koonalda-avenue northwards 4½ chains.
Thomas-court, from Koonalda-avenue northwards 4½ chains.
Akuna-avenue, from Westerfield-drive to Samada-street.
Tamala-avenue, from Akuna-avenue to Westerfield-drive.
Wooral-court, from Akuna-avenue north-westwards 5½ chains.
Kala-court, from Akuna-avenue north-westwards 2½ chains.
Dalpura-court, from Tamala-avenue northwards 5 chains.
Bailey-street, from Lawrence-road to Fort-street.
Mackie-road, from Emden-crescent south-westwards 15½ chains.
Woolwich-drive, from Mackie-road north-westwards 9½ chains.
Redfern-crescent, from Mackie-road south-eastwards and eastwards 9½ chains.
Hyde-court, from Mackie-road north-westwards 4½ chains.
Kensington-court, from Redfern-crescent northwards 6 chains.
Baird-street, from Redfern-crescent southwards 3½ chains.
Medoro-grove, from Woolwich-drive south-westwards 2½ chains.

Cemeteries Act 1958.

SCALE OF FEES OF THE HEALESVILLE PUBLIC CEMETERY.

IN pursuance of the powers conferred upon them by the Cemeteries Act the trustees of the Healesville Public Cemetery hereby make the following scale of fees, which shall come into operation upon publication in the *Government Gazette*, and from and after such publication every scale of fees heretofore made by the said trustees shall be and is hereby rescinded to the extent to which it conflicts with this scale.

Public Graves.

	£	s.	d.
Interment in grave without exclusive right—			
stillborn child	3	0	0
Interment in grave without exclusive right—			
others	6	0	0
Number peg or label	0	10	0

Private Graves.

Land, 8 ft. x 4 ft.	6	0	0
Own selection of land (extra)	2	0	0

Sinking Charges for Private Graves.

Sinking grave 6 feet deep	10	0	0
Each additional foot	1	0	0
Sinking oversize grave (extra)	2	0	0
Cancellation of order to sink (if commenced)	1	0	0

Reopening Charges.

Reopening grave (no cover)	8	0	0
Reopening grave (with cover or kerb)	10	0	0

Extra Charges.

Interment outside prescribed hours, or on Saturdays, Sundays or Public Holidays ..	3	0	0
Interment in a private grave without due notice	3	0	0

Miscellaneous Charges.

Certificate of right of burial	0	10	0
Number plate or brick	0	10	0
Permission to erect a headstone or monument—			
2½ per cent. of cost, with a minimum of £2			
Permission to construct a brick grave or to erect any stone kerb, brick tilework or concrete	1	0	0
Exhuming the remains of a body (when authorized)	10	0	0
Interment of ashes in a private grave	2	0	0

EDWARD THOMAS POTTER, Trustee

J. DONOVAN, Trustee.

J. DALTON, Trustee (Chairman).

Approved by the Governor in Council, 9th June, 1965.—
J. COLQUHOUN, Clerk of the Executive Council.

Cemeteries Act 1958.

SCALE OF FEES OF THE KINGOWER PUBLIC CEMETERY.

IN pursuance of the powers conferred upon them by the Cemeteries Act the trustees of the Kingower Public Cemetery hereby make the following scale of fees, which shall come into operation upon publication in the *Government Gazette*, and from and after such publication every scale of fees heretofore made by the said trustees shall be and is hereby rescinded to the extent to which it conflicts with this scale.

	£	s.	d.
Land, 8 ft. x 4 ft.	5	0	0
Sinking grave 6 feet deep	12	0	0
Each additional foot	1	0	0
Sinking grave—stillborn child	5	0	0
Interment fee—stillborn child	1	0	0
Reopening fee	1	0	0
Number plate or brick	0	10	0
Permission to erect a headstone or monument	2	0	0
Interment of ashes in a private grave	2	0	0

J. P. GILMORE, Trustee.

J. H. WALKER, Trustee.

JOHN S. GILLESPIE, Honorary Secretary.

Approved by the Governor in Council, 9th June, 1965.—
J. COLQUHOUN, Clerk of the Executive Council.

Cemeteries Act 1958.

SCALE OF FEES OF THE WARNCOORT PUBLIC CEMETERY.

IN pursuance of the powers conferred upon them by the Cemeteries Act, the trustees of the Warncoort Public Cemetery hereby make the following scale of fees, which shall come into operation upon publication in the *Government Gazette*, and from and after such publication every scale of fees heretofore made by the said trustees shall be and is hereby rescinded to the extent to which it conflicts with this scale.

	£	s.	d.
<i>Public Graves.</i>			
Interment in grave without exclusive right—stillborn child	3	0	0
Interment in grave without exclusive right—others	6	0	0
Number peg or label	0	10	0
<i>Private Graves.</i>			
Land, 8 ft. x 4 ft.	6	0	0
Own selection of land (extra)	2	0	0
<i>Sinking Charges for Private Graves.</i>			
Sinking grave 6 feet deep	10	0	0
Each additional foot	1	0	0
Sinking oversize grave (extra)	2	0	0
Cancellation of order to sink (if commenced)	1	0	0
<i>Reopening Charges.</i>			
Reopening grave (no cover)	8	0	0
Reopening grave (with cover or kerb)	10	0	0
<i>Extra Charges.</i>			
Interment outside prescribed hours, or on Saturdays, Sundays or Public Holidays	3	0	0
Interment in a private grave without due notice	3	0	0
<i>Miscellaneous Charges.</i>			
Certificate of right of burial	0	10	0
Number plate or brick	0	10	0
Permission to erect a headstone or monument— $\frac{2}{3}$ per cent. of cost, with a minimum of £2.			
Permission to construct a brick grave or to erect any stone kerb, brick tilework or concrete	1	0	0
Exhuming the remains of a body (when authorized)	10	0	0
Interment of ashes in a private grave	2	0	0

R. C. DENNIS, Trustee.
F. MOLONEY, Trustee.
A. DIGNAM, Trustee.

Approved by the Governor in Council, 9th June, 1965.—
J. COLQUHOUN, Clerk of the Executive Council.

Cemeteries Act 1958.

SCALE OF FEES FOR WESTERN SUBURBS MEMORIAL PARK LAWN CEMETERY.

IN pursuance of the powers conferred upon them by the Cemeteries Act, the trustees of the Williamstown Public Cemetery hereby make the following scale of fees, which shall come into operation upon publication in the *Government Gazette*, and from and after such publication every scale of fees heretofore made by the said trustees shall be and is hereby rescinded to the extent to which it conflicts with this scale.

	£	s.	d.
<i>Lawn Cemetery.</i>			
Land, 8 ft. x 4 ft. inclusive of first interment	37	10	0
ALEX. W. HICK, Deputy Chairman. WILLIAM L. J. CROFTS, Trustee. D. SMITH, Trustee. C. W. SIDWAY, Manager and Secretary.			

7th May, 1965.

Approved by the Governor in Council, 9th June, 1965.—
J. COLQUHOUN, Clerk of the Executive Council.

Cemeteries Act 1958.

SCALE OF FEES OF THE WONTHAGGI PUBLIC CEMETERY.

IN pursuance of the powers conferred upon them by the Cemeteries Act, the trustees of the Wonthaggi Public Cemetery hereby make the following scale of fees, which shall come into operation upon publication in the *Government Gazette*, and from and after such publication every

scale of fees heretofore made by the said trustees shall be and is hereby rescinded to the extent to which it conflicts with this scale.

	£	s.	d.
<i>Public Graves.</i>			
Interment in a public grave	5	0	0
Interment by Government contractor	4	0	0
Interment of a child under fourteen years	4	0	0
Interment of a stillborn child	3	0	0

	£	s.	d.
<i>Private Graves.</i>			
Adults, 8 ft. x 4 ft. (if allotted by trustees)	10	0	0
Adults, 8 ft. x 4 ft. (if selected)	12	0	0
Children over seven and under fourteen years (if allotted by trustees)	6	0	0
Children seven years of age and under (if allotted by trustees)	4	0	0
Children's graves, if selected (extra)	3	0	0

	£	s.	d.
<i>Sinking Charges.</i>			
Adults grave, 5 ft. 6 in. deep	10	0	0
Each additional foot or part thereof	1	0	0
Sinking oversize grave for American type casket (extra)	4	0	0
Child's grave, under fourteen years	5	10	0
Child's grave, under seven years	4	10	0

	£	s.	d.
<i>Reopening Charges.</i>			
Reopening adult's grave	11	0	0
Reopening grave of child under fourteen years	7	15	0
Reopening vault or tomb	11	0	0
Reopening grave to deposit ashes	2	10	0

	£	s.	d.
<i>Extra Charges.</i>			
Interment in a public grave, without due notice	0	10	6
Interment in a private grave, without due notice	3	0	0
Interments on Saturdays, Sundays or Public Holidays	3	0	0
Removing and replacing slab	2	0	0

	£	s.	d.
<i>Miscellaneous Charges.</i>			
Permission to construct a brick grave	0	15	0
Permission to erect any stone	0	15	0
Permission to erect monument for grave, vault or tomb	1	1	0
Permission to erect name plate	0	5	0
Permission to erect name plate, child	0	1	0
Label	0	5	0
Certificate of right of burial	0	5	0
Copy of rules	0	0	6
Dressing of graves, annual fee	5	0	0
Exhuming the remains of a body (when authorized)	10	0	0
Inspection of plan or register	0	10	0

J. A. QUILFORD, Trustee.
J. ELKIN, Trustee.
JOHN OATES, Trustee.

Approved by the Governor in Council, 9th June, 1965.—
J. COLQUHOUN, Clerk of the Executive Council.

Cemeteries Act 1958.

SCALE OF FEES OF THE YARRAWONGA PUBLIC CEMETERY.

IN pursuance of the powers conferred upon them by the Cemeteries Act, the trustees of the Yarrowonga Public Cemetery hereby make the following scale of fees, which shall come into operation upon publication in the *Government Gazette*, and from and after such publication every scale of fees heretofore made by the said trustees shall be and is hereby rescinded to the extent to which it conflicts with this scale.

	£	s.	d.
<i>Private Graves.</i>			
Land, 8 ft. x 4 ft.	6	0	0
Own selection	2	0	0

	£	s.	d.
<i>Miscellaneous.</i>			
Interment	3	0	0
Monumental mason's fee (flat rate)	3	0	0

FRANK KEENAN, Trustee.
L. HICKS, Trustee.
H. G. OAKLEY, Trustee.

Approved by the Governor in Council, 9th June, 1965.—
J. COLQUHOUN, Clerk of the Executive Council.

Cemeteries Act 1958.

SCALE OF FEES OF THE ORBOST PUBLIC CEMETERY.

IN pursuance of the powers conferred upon them by the Cemeteries Act the trustees of the Orbost Public Cemetery hereby make the following scale of fees, which shall come into operation upon publication in the *Government Gazette*, and from and after such publication every scale of fees heretofore made by the said trustees shall be and is hereby rescinded to the extent to which it conflicts with this scale.

	£	s.	d.
<i>Public Graves.</i>			
Single interment of child under twelve years in ground selected by trustees, including sinking	8	0	0
Single interment of adult in ground selected by trustees, including sinking	12	0	0
Numbered grave peg	0	10	6

Private Graves.

Land, 8 ft. x 4 ft.	8	0	0
---------------------	---	---	---

Sinking and Reopening Charges for Private Graves.

Sinking or reopening grave 5 ft. 3 in. deep	10	0	0
Each additional foot	2	0	0
Sinking or reopening grave 4 feet deep for child under seven years	5	10	0
Sinking or reopening grave 4 feet deep for child over seven years and under twelve years	7	10	0
Sinking oversize grave (extra)	2	0	0

Extra Charges.

Interment on Saturdays, Sundays or Public Holidays	1	0	0
--	---	---	---

Miscellaneous Charges.

Certificate of right of burial	0	10	0
Permission to erect a headstone or monument— 2½ per cent of cost, with a minimum of £2.			
Exhuming the remains of a body (when authorized)	12	0	0
Interment of ashes in a private grave	2	0	0
Numbered grave peg	0	10	6

HENRY A. WHITE, Trustee.

CHARLES W. ROBERTS, Trustee.

C. PERRY, Trustee.

F. J. HEALEY, Trustee.

Approved by the Governor in Council, 9th June, 1965.—
J. COLQUHOUN, Clerk of the Executive Council.

Cemeteries Act 1958.

SCALE OF FEES OF THE SMEATON PUBLIC CEMETERY.

IN pursuance of the powers conferred upon them by the Cemeteries Act the trustees of the Smeaton Public Cemetery hereby make the following scale of fees, which shall come into operation upon publication in the *Government Gazette*, and from and after such publication every scale of fees heretofore made by the said trustees shall be and is hereby rescinded to the extent to which it conflicts with this scale.

	£	s.	d.
<i>Public Graves.</i>			
Interment in grave without exclusive right— stillborn child	3	0	0
Interment in grave without exclusive right— others	6	0	0
Number peg or label	0	10	0

Private Graves.

Land, 8 ft. x 4 ft.	6	0	0
Own selection of land (extra)	2	0	0

Sinking Charges for Private Graves.

Sinking grave 6 feet deep	10	0	0
Each additional foot	1	0	0
Sinking oversize grave (extra)	2	0	0
Cancellation of order to sink (if commenced)	1	0	0

Reopening Charges.

Reopening grave (no cover)	8	0	0
Reopening grave (with cover or kerb)	10	0	0

Extra Charges.

Interment outside prescribed hours, or on Saturdays, Sundays or Public Holidays	3	0	0
Interment in private grave without due notice	3	0	0

Miscellaneous Charges.

Certificate of right of burial	0	10	0
Number plate or brick	0	10	0
Permission to erect a headstone or monument— 2½ per cent of cost, with a minimum of £2.			
Permission to construct a brick grave or to erect any stone kerb, brick tilework or concrete	1	0	0
Exhuming the remains of a body (when authorized)	10	0	0
Interment of ashes in a private grave	2	0	0

H. F. TOOSE, Trustee.

J. ORROCK, Trustee.

G. C. TOOSE, Trustee.

J. CRUM, Trustee.

Approved by the Governor in Council, 9th June, 1965.—
J. COLQUHOUN, Clerk of the Executive Council.

Cemeteries Act 1958.

SCALE OF FEES OF THE MEENIYAN PUBLIC CEMETERY.

IN pursuance of the powers conferred upon them by the Cemeteries Act the trustees of the Meeniyon Public Cemetery hereby make the following scale of fees, which shall come into operation upon publication in the *Government Gazette*, and from and after such publication every scale of fees heretofore made by the said trustees shall be and is hereby rescinded to the extent to which it conflicts with this scale.

	£	s.	d.
<i>Private Graves.</i>			
Land, 8 ft. x 4 ft.	6	0	0
Own selection of land (extra)	2	0	0

Sinking Charges for Private Graves.

Sinking grave 6 feet deep	10	0	0
Each additional foot	2	0	0
Sinking oversize grave (extra)	2	0	0

Reopening Charges.

Reopening grave (no cover)	8	0	0
Reopening grave (with cover or kerb)	10	0	0

Extra Charges.

Interment outside prescribed hours, or on Saturdays, Sundays or Public Holidays	3	0	0
Interment in private grave without due notice	3	0	0

Miscellaneous Charges.

Certificate of right of burial	0	10	0
Number plate or tablet	1	0	0
Permission to erect a headstone or monument— 2½ per cent of cost, with a minimum of £2.			
Exhuming the remains of a body (when authorized)	10	0	0

RONALD RICHARDSON, Trustee.

D. P. MCKITTERICK, Trustee.

W. HANILY, Trustee.

M. J. CONSIDINE, Honorary Secretary.

Approved by the Governor in Council, 9th June, 1965.—
J. COLQUHOUN, Clerk of the Executive Council.

Cemeteries Act 1958.

SCALE OF FEES OF THE MOOROPNA PUBLIC CEMETERY.

IN pursuance of the powers conferred upon them by the Cemeteries Act the trustees of the Mooropna Public Cemetery hereby make the following scale of fees, which shall come into operation upon publication in the *Government Gazette*, and from and after such publication every scale of fees heretofore made by the said trustees shall be and is hereby rescinded to the extent to which it conflicts with this scale.

	£	s.	d.
<i>Public Graves.</i>			
Interment in grave without exclusive right— stillborn child	3	0	0
Interment in grave without exclusive right— others	6	0	0
Number peg or label	0	10	0

Private Graves.

Land, 8 ft. x 4 ft.	10	0	0
Own selection of land (extra)	2	0	0

Sinking Charges for Private Graves.

Sinking grave 6 feet deep	10	0	0
Each additional foot	1	0	0
Sinking oversize grave (extra)	2	0	0
Cancellation of order to sink (if commenced)	1	0	0

Reopening Charges.	
Reopening grave	£ s. d. 10 0 0
Miscellaneous Charges.	
Number plate or brick	0 10 0
Permission to erect a headstone or monument— 2½ per cent. of cost, with a minimum of £2.	
Permission to construct a brick grave or to erect any stone kerb, brick tilework or concrete	1 0 0
Exhuming the remains of a body (when authorized)	10 0 0
Interment of ashes in a private grave	2 0 0
M. G. O'BRIEN, Trustee. H. J. VALE, Trustee. J. PEARSON, Trustee. R. R. RHODES, Trustee.	

Approved by the Governor in Council, 9th June, 1965.—
J. COLQUHOUN, Clerk of the Executive Council.

Cemeteries Act 1958.

SCALE OF FEES OF THE HARCOURT PUBLIC CEMETERY.

IN pursuance of the powers conferred upon them by the Cemeteries Act the trustees of the Harcourt Public Cemetery hereby make the following scale of fees, which shall come into operation upon publication in the Government Gazette, and from and after such publication every scale of fees heretofore made by the said trustees shall be and is hereby rescinded to the extent to which it conflicts with this scale.

Public Graves.	
Interment in grave without exclusive right— stillborn child	£ s. d. 3 0 0
Interment in grave without exclusive right— others	6 0 0
Number peg or label	0 10 0
Private Graves.	
Land, 8 ft. x 4 ft.	6 0 0
Own selection of land (extra)	2 0 0

Sinking Charges for Private Graves.	
Sinking grave 6 feet deep	10 0 0
Each additional foot	1 0 0
Sinking oversize grave (extra)	2 0 0
Cancellation of order to sink (if commenced)	1 0 0

Reopening Charges.	
Reopening grave (no cover)	8 0 0
Reopening grave (with cover or kerb)	10 0 0
Extra Charges.	
Interment outside prescribed hours, or on Saturdays, Sundays or Public Holidays	3 0 0
Interment in a private grave without due notice	3 0 0

Miscellaneous Charges.	
Certificate of right of burial	0 10 0
Number plate or brick	0 10 0
Permission to erect a headstone or monument— 2½ per cent. of cost, with a minimum of £2.	
Permission to construct a brick grave or to erect any stone kerb, brick tilework or concrete	1 0 0
Exhuming the remains of a body (when authorized)	10 0 0
Interment of ashes in a private grave	2 0 0

J. MOYLAN, Trustee.
N. C. FISHER, Trustee.
C. H. JAMES, Trustee.

Approved by the Governor in Council, 9th June, 1965.—J. COLQUHOUN, Clerk of the Executive Council.

Cemeteries Act 1958.

SCALE OF FEES OF THE GOORNONG PUBLIC CEMETERY.

IN pursuance of the powers conferred upon them by the Cemeteries Act the trustees of the Goornong Public Cemetery hereby make the following scale of fees, which shall come into operation upon publication in the

Government Gazette, and from and after such publication every scale of fees heretofore made by the said trustees shall be and is hereby rescinded to the extent to which it conflicts with this scale.

Public Graves.	
Interment in grave without exclusive right— stillborn child	£ s. d. 3 0 0
Interment in grave without exclusive right— others	6 0 0
Number peg or label	0 10 0

Private Graves.	
Land, 8 ft. x 4 ft.	6 0 0
Own selection of land (extra)	2 0 0

Sinking Charges for Private Graves.	
Sinking grave 6 feet deep	10 0 0
Each additional foot	1 0 0
Sinking oversize grave (extra)	2 0 0
Cancellation of order to sink (if commenced)	1 0 0

Reopening Charges.	
Reopening grave (no cover)	8 0 0
Reopening grave (with cover or kerb)	10 0 0
Extra Charges.	
Interment outside prescribed hours, or on Saturdays, Sundays or Public Holidays	3 0 0
Interment in a private grave without due notice	3 0 0

Miscellaneous Charges.	
Certificate of right of burial	0 10 0
Number plate or brick	0 10 0
Permission to erect a headstone or monument— 2½ per cent. of cost, with a minimum of £2.	
Permission to construct a brick grave or to erect any stone kerb, brick tilework or concrete	1 0 0
Exhuming the remains of a body (when authorized)	10 0 0
Interment of ashes in a private grave	2 0 0
W. L. HONEYCHURCH, Trustee. H. LEAMON, Trustee. R. A. RINGE, Trustee.	

Approved by the Governor in Council, 9th June, 1965.—J. COLQUHOUN, Clerk of the Executive Council.

Cemeteries Act 1958.

SCALE OF FEES OF THE FRANKLINFORD PUBLIC CEMETERY.

IN pursuance of the powers conferred upon them by the Cemeteries Act the trustees of the Franklindford Public Cemetery hereby make the following scale of fees, which shall come into operation upon publication in the Government Gazette, and from and after such publication every scale of fees heretofore made by the said trustees shall be and is hereby rescinded to the extent to which it conflicts with this scale.

Public Graves.	
Interment in grave without exclusive right— stillborn child	£ s. d. 3 0 0
Interment in grave without exclusive right— others	6 0 0
Number peg or label	0 10 0

Private Graves.	
Land, 8 ft. x 4 ft.	6 0 0
Own selection of land (extra)	2 0 0

Sinking Charges for Private Graves.	
Sinking grave 6 feet deep	10 0 0
Each additional foot	1 0 0
Sinking oversize grave (extra)	2 0 0
Cancellation of order to sink (if commenced)	1 0 0

Reopening Charges.	
Reopening grave (no cover)	8 0 0
Reopening grave (with cover or kerb)	10 0 0
Extra Charges.	
Interment outside prescribed hours, or on Saturdays, Sundays or Public Holidays	3 0 0
Interment in a private grave without due notice	3 0 0

Miscellaneous Charges.

	£	s	d.
Certificate of right of burial	0	10	0
Number plate or brick	0	10	0
Permission to erect a headstone or monument— 2½ per cent. of cost, with a minimum of £2.			
Permission to construct a brick grave or to erect any stone kerb, brick tilework or concrete	1	0	0
Exhuming the remains of a body (when authorized)	10	0	0
Interment of ashes in a private grave .. .	2	0	0

WILKIE ROBERTSON, Trustee.

WILLIAM STRAWHORN, Trustee.

THOMAS POWELL, Trustee.

Approved by the Governor in Council, 9th June, 1965.—J. COLQUHOUN, Clerk of the Executive Council.

APPOINTMENTS.

HIS Excellency the Governor of the State of Victoria, by and with the advice of the Executive Council thereof, has, by Orders made on the 9th day of June, 1965, been pleased to make the under-mentioned appointments, viz.:—

CHIEF SECRETARY'S DEPARTMENT.

Electoral Registrar (Acting).

THOMAS MICHAEL O'DEA
to be Electoral Registrar (Acting) for the Drouin, Koo-Wee-Rup, Korumburra, Loch, Pakenham, Warragul and Wonthaggi Subdivisions of the Electoral District of Gippsland West; and for the Morwell, Neerim South, Trafalgar, Warragul North and Yallourn Subdivisions of the Electoral District of Morwell, to take effect on and from the 7th June, 1965, during the absence on leave of John Ronald Geoffrey Hayes.

Totalizer Inspector.

PETER JAMES KENYON
to be a Totalizer Inspector, pursuant to the provisions of section 113 (1) of the *Racing Act 1958*.

MINISTRY OF HEALTH.

Members of Committees of Management.

ARTHUR GORDON OLDHAM, C.B.E., E.D.,
to be a Member of the Committee of Management of The Royal Victorian Eye and Ear Hospital, pursuant to proviso (a) to section 48 (1) of the *Hospitals and Charities Act 1958*, for a further term of three years expiring on the 18th June, 1968; and

BRUCE WEMYSS
to be a Member of the Committee of Management of Geelong and District Hospital (Kitchener Memorial), pursuant to proviso (a) to section 48 (1) of the *Hospitals and Charities Act 1958*, for a further term of three years expiring on the 18th June, 1968.

Psychiatrists.

FRED WALTER LUSTIG, M.B., B.S., D.P.M., and
GERRIT JAN WESTERINK, M.B., Ch.B., D.P.M.,
to be Psychiatrists, Mental Hygiene Branch, Department of Health, pursuant to the provisions of section 20 (3) of the *Mental Health Act 1959*.

Trustees of Cemeteries.

SYLVESTER FARRELL
to be a Trustee of the Muckleford Public Cemetery, vice C. Talbot, deceased;

HOWARD RAYMOND LOWE
to be a Trustee of the Wunghnu Public Cemetery, additional Trustee;

JOHN WILLIAM WEBB
to be a Trustee of the Tatura Public Cemetery, vice J. Reilly, resigned;

LEONARD JONES
to be a Trustee of the Bunninyong Public Cemetery, vice C. Eason, resigned;

CLEMENCE ELDRIDGE
to be a Trustee of the Bunninyong Public Cemetery, vice N. Coxhall, resigned;

KEITH GEORGE ALLITT
to be a Trustee of the Narrawong Public Cemetery, vice A. McCubbin, resigned;

CECIL RONALD LEARMONTH
to be a Trustee of the Narrawong Public Cemetery, vice B. Saunders, resigned;

GEORGE ALEXANDER WATSON
to be a Trustee of the Narrawong Public Cemetery, vice J. Melbourne, resigned;

WILBERT HENRY GOODE
to be a Trustee of the Narrawong Public Cemetery, vice L. Hanlon, resigned;

HUGH TAYLOR
to be a Trustee of the Narrawong Public Cemetery, vice S. Melbourne, resigned;

WILLIAM MASON
to be a Trustee of the Narrawong Public Cemetery, vice A. Taylor, resigned;

WALTER JOHN COWAN
to be a Trustee of the Minyip Public Cemetery, vice J. King, deceased;

RICHARD COSGRAVE BAKER
to be a Trustee of the Mount Duneed Public Cemetery, vice J. Russell, deceased;

HERBERT HARPER YOUNG
to be a Trustee of the Malmesbury Public Cemetery, vice L. Swainston, resigned;

ROBERT CONAUGHTON
to be a Trustee of the Ballarat General Cemeteries, vice D. Drohan, resigned;

NEIL WISHART
to be a Trustee of the Maffra Public Cemetery, vice A. Carr, resigned;

MAXWELL WHITE
to be a Trustee of the Fern Tree Gully Public Cemetery, additional Trustee;

ARCHIE LAMBERT EDMONDS
to be a Trustee of the Brighton General Cemetery, vice H. Pascoe, deceased;

THOMAS VARLEY
to be a Trustee of the Green Lake Public Cemetery, vice E. Varley, deceased;

GEORGE FRASER (Jnr.)
to be a Trustee of the Macarthur Public Cemetery, vice G. Fraser, resigned;

CLAUDE KELLY,
THOMAS JOSEPH KELLY,
ROBERT WILLIAM TRIGGER, and
KEITH JOSEPH SHARROCK,
to be Trustees of the Macarthur Public Cemetery, additional Trustees;

THOMAS WILLIAM HARRINGTON, and
NEIL GRAHAM DALEY,
to be Trustees of the Nillumbik Public Cemetery, additional Trustees;

CLYDE FRANCIS MCKENZIE
to be a Trustee of the Flinders Public Cemetery, vice J. West, resigned;

LINDSAY GEORGE MUNN
to be a Trustee of the Minimay Public Cemetery, vice J. Robbie, deceased;

WILLIAM THOMAS LAKEY
to be a Trustee of the Beaufort Public Cemetery, vice N. McLeod, resigned;

JAMES VINCENT CUNNINGHAM
to be a Trustee of the Heywood Public Cemetery, vice A. Stone, resigned;

ARTHUR JOHN HENDER
to be a Trustee of the Sea Lake Public Cemetery, vice N. Bell, resigned;

IAN ANDREW WOOD
to be a Trustee of the Kenmare Public Cemetery, vice W. Wood, deceased;

ARTHUR JAMES CLUGSTON
to be a Trustee of the Kenmare Public Cemetery, vice H. C. Hobson, resigned;

ALEXANDER LAMONT WHITE
to be a Trustee of the Yarra Glen Public Cemetery, vice J. Jensen, deceased;

CHARLES ERNEST BEATTIE
to be a Trustee of the Trentham Public Cemetery, vice W. Stevens, deceased;

MARTIN FRANCIS FLETCHER
to be a Trustee of the Mount Egerton Public Cemetery, vice J. Lillis, resigned;

LESLIE PHILIP WILKINSON
to be a Trustee of the Cudgewa Public Cemetery, vice A. Carkeek, deceased; and

ALEXANDER MCBEATH
to be a Trustee of the Linton Public Cemetery, vice A. Nicol, resigned.

LAW DEPARTMENT.

Commissioners for Taking Declarations, &c.

RAYMOND FRANCIS SHAW, care of Commonwealth Banking Corporation, Parkdale,
 MAXWELL EMERY WOOD, care of The Australian Dried Fruits Association, "Sunraysia House", 24 Jeffcott-street, West Melbourne,
 ERICE AUGUST WILHELM LEDER, care of A. H. McDonald and Co. Pty. Ltd., 566 Bridge-road, Richmond,
 ROBERT HENRY BRANN, care of Fibremakers Ltd., Canterbury-road, Bayswater,
 GORDON DESMOND GASCOYNE, care of Town Hall, Preston,
 BRUCE HACKETT, care of Legal and General Assurance Society Ltd., 392 Little Collins-street, Melbourne, and
 FREDERICK JOHN LACK, care of Plumbers and Gasfitters Employees' Union, 55 Victoria-street, Melbourne, to be Commissioners for taking Declarations and Affidavits, pursuant to the provisions of the Evidence Act 1958, to resign upon ceasing to occupy their present positions; and
 WALTER BERNARD WELCH, 46 Fromer-street, Moorabbin, to be a Commissioner for taking Declarations and Affidavits, pursuant to the provisions of the Evidence Act 1958, to resign upon removing from the neighbourhood of the address stated.

Stipendiary Magistrate, &c.

JAMES MONTEITH STANLEY HUMPHREY to be a Stipendiary Magistrate, pursuant to the provisions of the Justices Act 1958; a Coroner for the State of Victoria, pursuant to the provisions of the Coroner's Act 1958; and a Warden of the Goldfields in and for the State of Victoria, pursuant to the provisions of the Mines Act 1958, to take effect from the date of commencement of duty.

DEPARTMENT OF PUBLIC WORKS.

Wharf Manager and Assistant Wharf Manager.

Senior Constable NORMAN MURRAY McDONALD, No. 9809, to be Wharf Manager, and
 First Constable MALCOLM CLIVE GRANT, No. 12758, to be Assistant Wharf Manager, at Mornington, to carry out that portion of Part II. of the Marine Act 1958, which relates to the management of Public Wharves, and to be officers under section 19 of such Act to levy and collect wharfage rates thereat, both at a remuneration of £50 each, per annum.

DEPARTMENT OF WATER SUPPLY.

Waterworks Trusts Commissioners.

MALCOLM MONCUR THOMSON to be a Commissioner of the Apollo Bay Waterworks Trust for a period of four years from the date hereof, subject to the provisions of the Water Act; and
 LINDSAY GUSTAV DEGENHARDT to be a Commissioner of the Murtoa Waterworks Trust for a period of four years from the date hereof, subject to the provisions of the Water Act.

J. COLQUHOUN,
 Clerk of the Executive Council.

At the Executive Council Chamber,
 Melbourne, 9th June, 1965.

RESIGNATIONS.

HIS Excellency the Governor of the State of Victoria, by and with the advice of the Executive Council thereof, has, by Orders made on the 9th day of June, 1965, accepted the resignations of the persons named hereunder of the offices mentioned, viz.:-

LAW DEPARTMENT.

VICTOR HUGO BAUDINETTE, as a Justice of the Peace for the Western Bailiwick of the State of Victoria.
 VICTOR HUGO BAUDINETTE, as a Deputy Coroner, pursuant to the provisions of the Coroner's Act 1958.
 LAURENCE EDWARD SMITH, as a Commissioner for taking Declarations and Affidavits, pursuant to the provisions of the Evidence Act 1958.

J. COLQUHOUN,
 Clerk of the Executive Council.

At the Executive Council Chamber,
 Melbourne, 9th June, 1965.

DEPARTMENT OF CROWN LANDS AND SURVEY.

At the Executive Council Chamber, Melbourne, the ninth day of June, 1965.

PRESENT:

His Excellency the Governor of Victoria.
 Mr. Chandler | Mr. Bloomfield.
 Mr. Reid

REVOCATION OF TEMPORARY RESERVATION OF LAND BY ORDER IN COUNCIL.

HIS Excellency the Governor of the State of Victoria, by and with the advice of the Executive Council thereof, doth hereby, in pursuance of the provisions of the Land Act 1958, revoke the temporary reservation of land by Order in Council hereinafter referred to, viz.:-

MALDON.—Order in Council of the 11th November, 1868, of 3 acres 0 roods 14 perches of land in the Township of Maldon, as a site for Public Gardens, revoked as to part by Order of the 20th November, 1957, so far as the balance thereof containing 2 acres 3 roods 32 perches, more or less.—(Rs.3677).

And the Honorable James Charles Murray Balfour, Her Majesty's Minister of Lands for the State of Victoria, shall give the necessary directions herein accordingly.

J. COLQUHOUN,
 Clerk of the Executive Council.

DEPARTMENT OF CROWN LANDS AND SURVEY.

At the Executive Council Chamber, Melbourne, the ninth day of June, 1965.

PRESENT:

His Excellency the Governor of Victoria.
 Mr. Chandler | Mr. Bloomfield.
 Mr. Reid

LANDS TEMPORARILY RESERVED AS SITES.

HIS Excellency the Governor of the State of Victoria, by and with the advice of the Executive Council thereof, doth hereby, in pursuance of the provisions of the Land Act 1958, reserve, temporarily, and also except from occupation for mining purposes under any miner's right, the lands hereinafter described:—

ALLAMBEE EAST (CHILDERS).—Site for State School purposes, 32 perches, Parish of Allambee East, County of Buln Buln, as indicated by hachure on plan hereunder.—(A.177⁽¹⁴⁾) (Rs.8131).

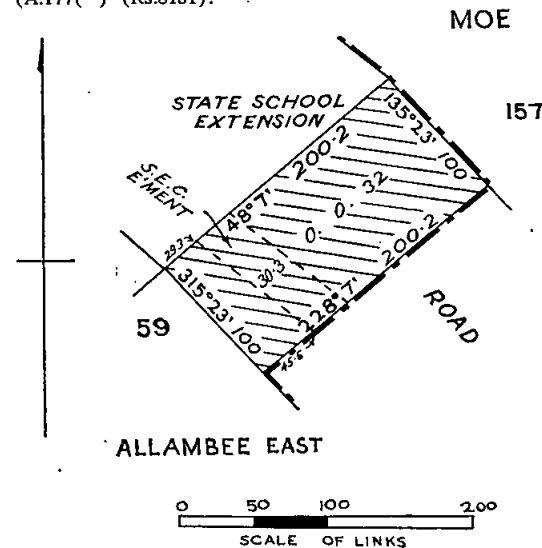

CUT-PAW-PAW (FOOTSCRAY).—Site for Educational purposes, in addition to and adjoining the site temporarily reserved therefor by Order in Council of the 10th June, 1941, 33 perches, Parish of Cut-paw-paw, County of Bourke, as indicated by hachure on plan hereunder.—(C.345⁽¹⁵⁾) (Rs.5215).

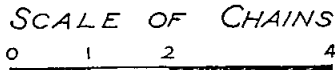
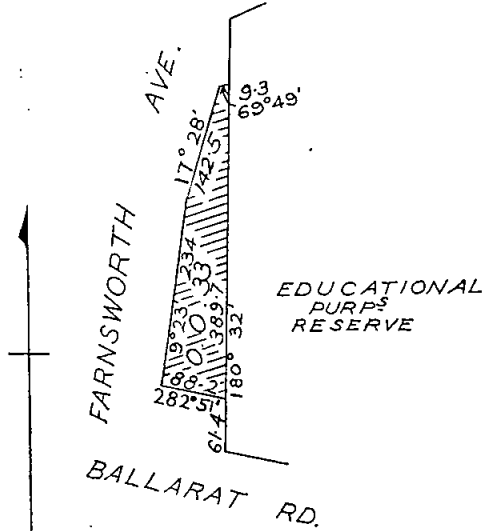

LONGWARRY (ATHLONE).—Site for Public purposes (Public Hall), 3 roods 5 perches, Parish of Longwarry, County of Mornington, as indicated by hachure on plan hereunder.—(L.162⁽⁷⁾) (Rs.8453).

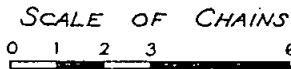
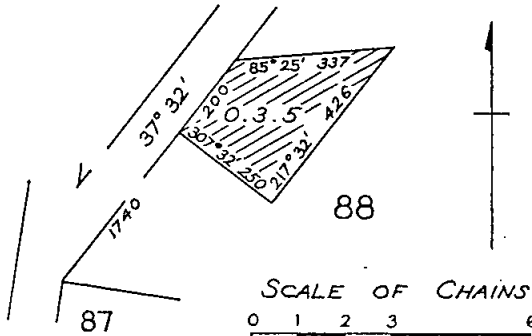

PRAHRAN (GARDENVALE).—Site for Public purposes (Police purposes), 28 perches, East of Elsternwick, Parish of Prahran, County of Bourke, as indicated by hachure on plan hereunder.—(P.81⁽¹¹⁾) (Rs.8459).

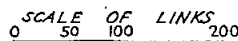
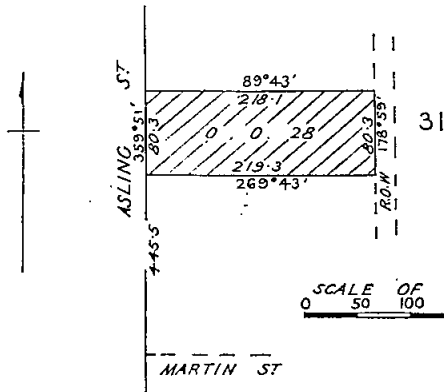

SALE.—Site for Public Park and Public Recreation, in addition to and adjoining the site temporarily reserved therefor by Order in Council of the 6th June, 1956, 26 perches, Township of Sale, Parish of Sale, County of Tanjil, as indicated by hachure on plan hereunder.—(S.239⁽²⁾) (Rs.1321).

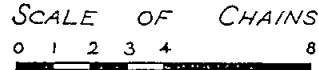
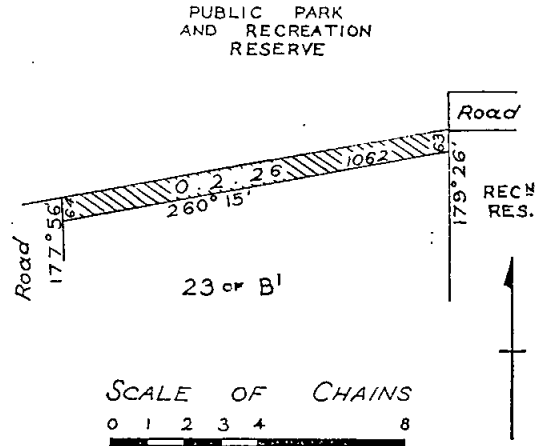

WORMBETE.—Site for Public purposes (Supply of Gravel), 14 acres, more or less, Parish of Wormbete, County of Grant, as indicated by hachure on plan hereunder.—(W.205⁽²⁾) (Rs.8454).

PARISH OF TUTECONG

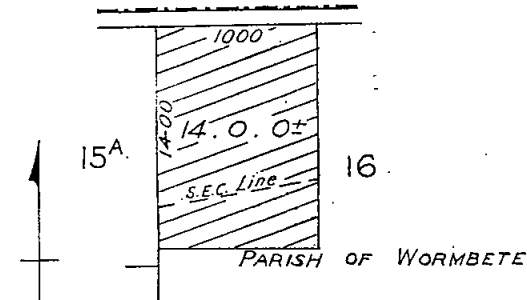

SCALE OF CHAINS

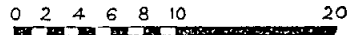

And the Honorable James Charles Murray Balfour, Her Majesty's Minister of Lands for the State of Victoria, shall give the necessary directions herein accordingly.

J. COLQUHOUN,
Clerk of the Executive Council.

DEPARTMENT OF CROWN LANDS AND SURVEY.

At the Executive Council Chamber, Melbourne, the ninth day of June, 1965.

PRESENT:

His Excellency the Governor of Victoria.
Mr. Chandler | Mr. Bloomfield.
Mr. Reid

UNUSED ROADS CLOSED.

HIS Excellency the Governor of the State of Victoria, by and with the advice of the Executive Council thereof, doth hereby direct that, in pursuance of the

provisions of section 349 of the *Land Act 1958*, the unused roads referred to hereunder be closed, viz.:—

Township of Clunes, Parish of Clunes, County of Talbot, being the portion of the width of the road indicated by hachure on plan hereunder.—(C.394^(a)) (J.30597).

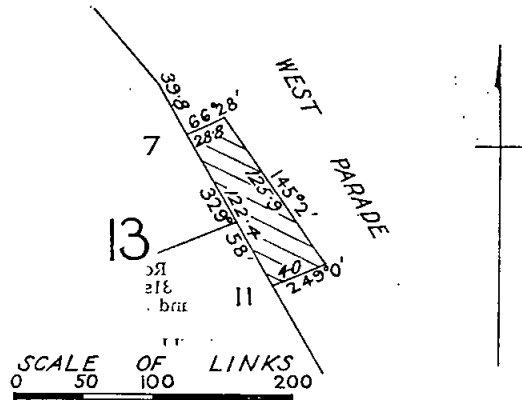

Parish of Moreep, County of Grant, being the road indicated by hachure on plan hereunder.—(M.468⁽³⁾) (Rs.6566).

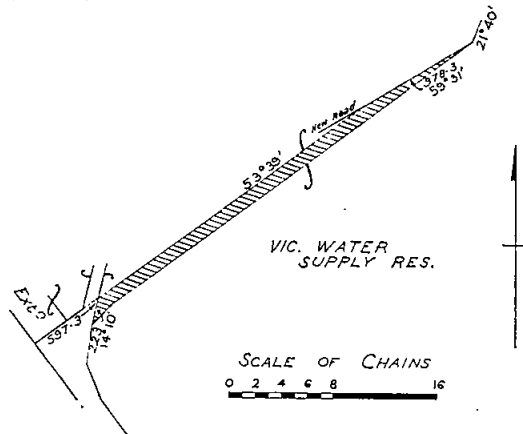

At Bendigo, Parish of Sandhurst, County of Bendigo, being the portion of the width of the road indicated by hachure on plan hereunder.—(S.372⁽¹²³⁾) (0587/138).

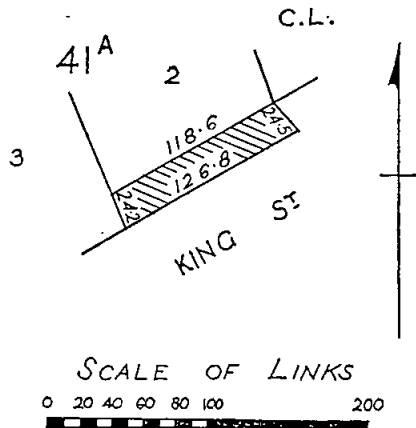

And the Honorable James Charles Murray Balfour, Her Majesty's Minister of Lands for the State of Victoria, shall give the necessary directions herein accordingly.

J. COLQUHOUN,
Clerk of the Executive Council.

COUNTRY ROADS BOARD.

At the Executive Council Chamber, Melbourne, the ninth day of June, 1965.

PRESENT:

His Excellency the Governor of Victoria.
Mr. Chandler | Mr. Bloomfield.
Mr. Reid

DECLARATION OF A DEVIATION FROM DEAN MARSH-LORNE ROAD IN THE SHIRE OF WINCHELSEA.

WHEREAS by sections 58 and 94 of the *Country Roads Act 1958* (No. 6229) it is amongst other things enacted that when the Country Roads Board under the provisions of the Country Roads Act has by Resolution declared a deviation to be a forest road the said Board may also declare that such deviation shall be in lieu of any existing road or part thereof named in such Resolution and that on publication in the *Government Gazette* of the Order confirming such Resolution the existing road or part thereof shall cease to be a forest road or be discontinued as provided in the Resolution: And whereas the said Board has by Resolution declared the deviation on the land described in the First Schedule to such Resolution to be a forest road and has also declared that such deviation shall be in lieu of the part of the existing road being the land described in the Second Schedule to the said Resolution and that such part of the said existing road shall be discontinued: Now therefore His Excellency the Governor of the State of Victoria by and with the advice of the Executive Council thereof doth hereby confirm the said Resolution.

Resolution for Declaration of a Deviation of a Forest Road under the Country Roads Act.

Whereas the land the site of the road the course of which is below set out was taken by the Board under the provisions of the *Country Roads Act 1958* for the purpose of constructing such road deviation which road deviation has now been laid out and formed on the same: And whereas the said Board (being the Country Roads Board incorporated under the said Act) thinks that the road aforesaid is fit to be used as a public highway such Board at a meeting now holden acting under the authority conferred upon it by sections 58 and 94 of the said Act doth by this present Resolution hereby declare the said road deviation the course of which is described in the First Schedule hereto with the commencing and terminating points thereof respectively specified to be part of a forest road within the meaning and for the purposes of the said Act: And the said Board doth also declare that such deviation shall be in lieu of the existing road or part thereof described in the Second Schedule hereto and that such part of the said existing road shall be discontinued.

FIRST SCHEDULE.

Shire of Winchelsea.

Dean Marsh-Lorne road.—All those pieces of land in the Parish of Bambra, the boundaries of which are as follow:—

- (a) Commencing at a point on the western boundary of allotment 34A of the said parish, distant 180 deg. 0 min. 1,200 links and 162 deg. 0 min. 461.7 links from the north-western angle of the said allotment; thence by lines bearing respectively 147 deg. 34 min. 489.2 links, 123 deg. 35 min. 361.5 links, 108 deg. 51 min. 430.6 links, 128 deg. 30 min. 494.4 links, 136 deg. 17 min. 526 links, 293 deg. 42 min. 445.5 links, 333 deg. 46 min. 378.3 links, 311 deg. 21 min. 229.5 links, 283 deg. 35 min. 547.5 links, 306 deg. 48 min. 385 links and 342 deg. 0 min. 431.8 links to the point of commencement.
- (b) Commencing at a point in allotment 34B of the said parish, distant 90 deg. 0 min. 307 links and 321 deg. 27 min. 345.3 links from the south-western angle of the said allotment; thence by lines bearing respectively 313 deg. 17 min. 281.5 links, 113 deg. 42 min. 85.9 links and 141 deg. 27 min. 202.7 links to the point of commencement.
- (c) Commencing at a point on the southern boundary of allotment 34B of the said parish, distant 90 deg. 0 min. 434.9 links from the south-western

angle of the said allotment; thence by lines bearing respectively 321 deg. 27 min. 450.5 links, 132 deg. 18½ min. 274.7 links, 127 deg. 18 min. 276.2 links, 140 deg. 40 min. 195.4 links, 298 deg. 18 min. 289.4 links and 321 deg. 27 min. 17.8 links to the point of commencement.

- (d) Commencing at a point in allotment 37A of the said parish, distant 90 deg. 0 min. 929 links, 141 deg. 27 min. 118 links and 118 deg. 18 min. 244.6 links, from the north-western angle of the said allotment; thence by lines bearing respectively 118 deg. 18 min. 281.4 links, 163 deg. 35 min. 342.3 links, 320 deg. 43 min. 293.7 links, 37 deg. 49 min. 31.8 links and 319 deg. 37 min. 274.8 links to the point of commencement.
- (e) Commencing at an angle in the eastern boundary of the existing Dean Marsh-Lorne road through allotment 37A of the said parish, formed by the intersection of lines bearing 163 deg. 35 min. and 121 deg. 31 min.; thence by lines bearing respectively 343 deg. 35 min. 456.4 links, 150 deg. 32 min. 630.4 links and 301 deg. 31 min. 212.5 links to the point of commencement.
- (f) Commencing at an angle in the western boundary of the existing Dean Marsh-Lorne road through allotment 37A of the said parish, formed by the intersection of lines bearing 10 deg. 48 min. and 321 deg. 51 min.; thence by lines bearing respectively 190 deg. 48 min. 296.4 links, 341 deg. 13 min. 186.1 links, 327 deg. 47 min. 576.8 links, 121 deg. 31 min. 294 links and 141 deg. 51 min. 279 links to the point of commencement.
- (g) Commencing at an angle in the eastern boundary of the existing Dean Marsh-Lorne road through allotment 37A of the said parish, formed by the intersection of lines bearing 190 deg. 48 min. and 155 deg. 21 min.; thence by lines bearing respectively 10 deg. 48 min. 312 links, 174 deg. 0 min. 565.9 links and 335 deg. 21 min. 282 links to the point of commencement.
- (h) Commencing at an angle in the western boundary of the existing Dean Marsh-Lorne road through allotment 37A of the said parish, formed by the intersection of lines bearing 23 deg. 18 min. and 335 deg. 21 min.; thence by lines bearing respectively 203 deg. 18 min. 348 links, 359 deg. 25 min. 633.7 links and 155 deg. 21 min. 345.5 links to the point of commencement.
- (i) Commencing at an angle in the western boundary of allotment 41A of the said parish, formed by the intersection of lines bearing 110 deg. 17½ min. and 140 deg. 15½ min.; thence by lines bearing respectively 290 deg. 17½ min. 31.5 links, 307 deg. 43½ min. 734 links, 349 deg. 28 min. 208 links, 90 deg. 41½ min. 9.8 links, 12 deg. 48 min. 33.9 links, 23 deg. 18 min. 552 links, 181 deg. 57½ min. 542.8 links, 160 deg. 1½ min. 395.1 links, 138 deg. 13½ min. 306.4 links and 124 deg. 1½ min. 111 links to the point of commencement—

which said pieces of land are particularly delineated and shown coloured red on survey plans numbered 9470, 9471 and 9638, lodged in the office of the Country Roads Board.

SECOND SCHEDULE.

Shire of Winchelsea.

Dean Marsh-Lorne road.—All those pieces of land in the Parish of Bamba, the boundaries of which are as follow:—

- (a) Commencing at a point on the southern boundary of allotment 37A of the said parish, distant 90 deg. 0 min. 340 links from the south-western angle of the said allotment; thence by lines bearing respectively 23 deg. 18 min. 547.5 links, 192 deg. 48 min. 548.5 links, 203 deg. 18 min. 35.8 links, 270 deg. 41½ min. 108.3 links and 23 deg. 18 min. 69.3 links to the point of commencement.
- (b) Commencing at an angle in the eastern boundary of the existing Dean Marsh-Lorne road through allotment 37A of the said parish, formed by the intersection of lines bearing 23 deg. 18 min. and 335 deg. 21 min.; thence by lines bearing respectively 203 deg. 18 min. 379.8 links, 10 deg. 50½ min. 288.6 links, 356 deg. 40 min. 315 links and 155 deg. 21 min. 274 links to the point of commencement.

- (c) Commencing at an angle in the western boundary of the existing Dean Marsh-Lorne road through allotment 37A of the said parish, formed by the intersection of lines bearing 190 deg. 48 min. and 155 deg. 21 min.; thence by lines bearing respectively 10 deg. 48 min. 202.6 links, 173 deg. 17 min. 381.6 links and 335 deg. 21 min. 198 links to the point of commencement.
- (d) Commencing at a point in allotment 34B of the said parish, distant 90 deg. 0 min. 434.9 links and 321 deg. 27 min. 450.5 links from the south-western angle of the said allotment; thence by lines bearing respectively 312 deg. 18½ min. 294.5 links, 113 deg. 42 min. 100.5 links and 141 deg. 27 min. 201.9 links to the point of commencement—

which said pieces of land are particularly delineated and shown coloured blue on survey plans numbered 9470, 9471 and 9638, lodged in the office of the Country Roads Board.

The common seal of the Country Roads Board was hereto affixed, at Kew, this 31st day of May, One thousand nine hundred and sixty-five, in the presence of—

I. J. O'DONNELL, Chairman.

(SEAL) F. WEST, Member.

N. L. ALLANSON, Secretary.

And the Honorable James Charles Murray Balfour, Her Majesty's Acting Minister of Public Works for the State of Victoria, shall give the necessary directions herein accordingly.

J. COLQUHOUN,
Clerk of the Executive Council.

COUNTRY ROADS BOARD.

At the Executive Council Chamber, Melbourne, the ninth day of June, 1965.

PRESENT:

His Excellency the Governor of Victoria.
Mr. Chandler | Mr. Bloomfield.
Mr. Reid |

ORDER APPROVING OF WIDENING AN EXISTING STATE HIGHWAY IN THE CITY OF GEELONG.

WHEREAS the Country Roads Board constituted under the *Country Roads Act 1958* (No. 6229) has represented to His Excellency the Governor in Council that it appears to it desirable that the existing Bellarine Highway in the City of Geelong (declared to be a State highway under the said Act which declaration was confirmed by the Order in Council published in the *Government Gazette* of the 10th August, 1960, on page 2743-8) should be widened by the said Board: And whereas the said Board in accordance with the requirements of section 19 of the said cited Act has caused to be prepared a map plan and estimate showing the points between which and on and through what land the said widening is proposed to be made and the cost of acquiring the land: And whereas on an inspection of the said map and plan and a consideration of the said estimate His Excellency the Governor in Council is satisfied that there are funds legally available for acquiring the land: Now therefore be it known by this present Order that His Excellency the Governor of the State of Victoria with the advice of the Executive Council thereof doth hereby approve of the said highway being widened, that is to say:—

All that piece of land in the City of Geelong, Parish of Corio, the boundaries of which are as follow:—Commencing at the southern angle of allotment 2, section 108, of the said City; thence by lines bearing respectively 314 deg. 26 min. 21 feet, 66 deg. 56 min. 16 ft. 1 in. and 179 deg. 26 min. 21 feet to the point of commencement— which said piece of land is particularly delineated and shown coloured red on survey plan numbered 10095 lodged in the office of the Country Roads Board.

And the Honorable James Charles Murray Balfour, Her Majesty's Acting Minister of Public Works for the State of Victoria, shall give the necessary directions herein accordingly.

J. COLQUHOUN,
Clerk of the Executive Council.

COUNTRY ROADS BOARD.

At the Executive Council Chamber, Melbourne, the
ninth day of June, 1965.

PRESENT:

His Excellency the Governor of Victoria.
Mr. Chandler | Mr. Bloomfield.
Mr. Reid

ORDER APPROVING OF A DEVIATION FROM A STATE HIGHWAY IN THE SHIRE OF SOUTH GIPPSLAND.

WHEREAS the Country Roads Board constituted under the *Country Roads Act 1958* (No. 6229) has represented to His Excellency the Governor in Council that it appears to it desirable that the deviation hereinafter referred to from the existing South Gippsland Highway in the Shire of South Gippsland (declared to be a State highway under the said Act which declaration was confirmed by the Order in Council published in the *Government Gazette* of the 23rd November, 1938, on page 3835) should be made by the said Board: And whereas the said Board in accordance with the requirements of section 19 of the said cited Act has caused to be prepared a map plan and estimate showing the points between which and on and through what land the said deviation is proposed to be made and the cost of acquiring the land: And whereas on an inspection of the said map and plan and a consideration of the said estimate His Excellency the Governor in Council is satisfied that there are funds legally available for acquiring the land: Now therefore be it known by this present Order that His Excellency the Governor of the State of Victoria with the advice of the Executive Council thereof doth hereby approve of the said highway being made, that is to say:—

All those pieces of land in the Parish of Wonga Wonga, the boundaries of which are as follow:—

- (a) Commencing at an angle in the western boundary of the existing South Gippsland Highway through allotment 18, section A of the said parish, formed by the intersection of lines bearing 38 deg. 38 min. and 3 deg. 43 min.; thence by lines bearing respectively 218 deg. 38 min. 10.4 links, 250 deg. 51 min. 149.7 links, 274 deg. 21 min. 365.6 links, 320 deg. 19 min. 319.2 links, 100 deg. 24 min. 213.7 links, 75 deg. 41 min. 543.2 links and 183 deg. 43 min. 312.6 links to the point of commencement.
- (b) Commencing at a point on the southern boundary of allotment 18, section A of the said parish, distant 238 deg. 47 min. 150 links, from the south-eastern angle of the said allotment; thence by lines bearing respectively 129 deg. 16 min. 50.6 links, 249 deg. 8 min. 265.1 links, 250 deg. 51 min. 649.2 links, 14 deg. 3 min. 331.8 links, 75 deg. 41 min. 408.6 links, 103 deg. 33 min. 41.8 links, 154 deg. 20 min. 222 links and 58 deg. 47 min. 243.9 links to the point of commencement.

Also all that piece of land in the Parish of Wonga Wonga, the boundaries of which are as follow:—

Commencing at an angle in the northern boundary of allotment 19, section C of the said parish, formed by the intersection of lines bearing 294 deg. 24 min. and 258 deg. 32 min.; thence by lines bearing respectively 114 deg. 24 min. 845 links, 140 deg. 19 min. 269.3 links, 274 deg. 21 min. 43.4 links, 288 deg. 58 min. 435.2 links, 299 deg. 23 min. 541.7 links and 354 deg. 16 min. 146.5 links to the point of commencement.

Also all that piece of land in the Parishes of Wonga Wonga and Wonga Wonga South, the boundaries of which are as follow:—

Commencing at a point on the eastern boundary of allotment 18, section A, Parish of Wonga Wonga, distant 350 deg. 22 min. 73.7 links, from the south-eastern angle of the said allotment; thence by lines bearing respectively 266 deg. 22 min. 211.9 links, 291 deg. 20 min. 47.8 links, 70 deg. 57 min. 827.6 links, 51 deg. 54 min. 254.9 links, 89 deg. 45 min. 622.5 links, 105 deg. 48 min. 621.6 links, 150 deg. 18 min. 609.4 links, 164 deg. 1 min. 387.8 links, 183 deg. 31 min. 832.3 links, 163 deg. 8 min. 407 links, 140 deg. 11 min. 1,291.4 links, 150 deg. 37 min. 742.4 links, 135 deg. 41 min. 1,306.1 links, 92 deg. 43½ min. 43.9 links, 229 deg. 46 min. 30 links, 148 deg. 23 min. 100.8 links, 49 deg. 47 min. 30 links, 189 deg. 5 min. 45.5 links, 148 deg. 23 min. 1,520.1 links, 131 deg.

32 min. 545.2 links, 108 deg. 2 min. 565.9 links, 270 deg. 55 min. 661.8 links, 262 deg. 15 min. 102.8 links, 12 deg. 12 min. 125.5 links, 308 deg. 18 min. 278.8 links, 323 deg. 59 min. 1,817.5 links, 229 deg. 46 min. 65 links, 333 deg. 37 min. 236.7 links, 317 deg. 41 min. 1,118.6 links, 330 deg. 37 min. 107.8 links, 321 deg. 28 min. 1,198.9 links, 329 deg. 36 min. 703.9 links, 320 deg. 11 min. 297.6 links, 349 deg. 0 min. 728.3 links, 4 deg. 41 min. 487.1 links, 347 deg. 3 min. 440.1 links, 303 deg. 25 min. 397.5 links, 330 deg. 50 min. 177 links, 274 deg. 19 min. 666.2 links, 249 deg. 8 min. 451.5 links, 265 deg. 17 min. 36 links, 312 deg. 0 min. 96 links and 266 deg. 22 min. 161 links to the point of commencement—

which said pieces of land are particularly delineated and shown coloured red, yellow and green on survey plans numbered 10078, 10079 and 10080 lodged in the office of the Country Roads Board.

And the Honorable James Charles Murray Balfour, Her Majesty's Acting Minister of Public Works for the State of Victoria, shall give the necessary directions herein accordingly.

J. COLQUHOUN,
Clerk of the Executive Council.

COUNTRY ROADS BOARD.

At the Executive Council Chamber, Melbourne, the
ninth day of June, 1965.

PRESENT:

His Excellency the Governor of Victoria.
Mr. Chandler | Mr. Bloomfield.
Mr. Reid

ORDER APPROVING OF A DEVIATION FROM A STATE HIGHWAY IN THE SHIRE OF WIMMERA.

WHEREAS the Country Roads Board constituted under the *Country Roads Act 1958* (No. 6229) has represented to His Excellency the Governor in Council that it appears to it desirable that the deviation hereinafter referred to from the existing Western Highway in the Shire of Wimmera (declared to be a State highway under the said Act which declaration was confirmed by the Order in Council published in the *Government Gazette* of the 8th July, 1925, on pages 2371-3) should be made by the said Board: And whereas the said Board in accordance with the requirements of section 19 of the said cited Act has caused to be prepared a map plan and estimate showing the points between which and on and through what land the said deviation is proposed to be made and the cost of acquiring the land: And whereas on an inspection of the said map and plan and a consideration of the said estimate His Excellency the Governor in Council is satisfied that there are funds legally available for acquiring the land: Now therefore be it known by this present Order that His Excellency the Governor of the State of Victoria with the advice of the Executive Council thereof doth hereby approve of the said highway being made, that is to say:—

All that piece of land in the Parish of Warung the boundaries of which are as follow:—Commencing at an angle in the northern boundary of the existing Western Highway between allotments 4 and 5 in the said parish, formed by the intersection of lines bearing 117 deg. 59 min. and 108 deg. 9 min.; thence by lines bearing respectively 297 deg. 59 min. 647.8 links, 109 deg. 44 min. 364.8 links, 97 deg. 30½ min. 563.8 links, 87 deg. 49½ min. 1,322.4 links, 106 deg. 17½ min. 798.4 links, 111 deg. 24½ min. 502.2 links and 126 deg. 11½ min. 929 links to the west bank of Mount William creek; thence south-westerly by the said bank; thence by lines bearing respectively 306 degrees 11½ min. 943 links, 291 deg. 24½ min. 449.9 links, 286 deg. 17½ min. 736.2 links, 267 deg. 49½ min. 1,053.1 links and 288 deg. 9 min. 591.5 links to the point of commencement—which said piece of land is particularly delineated and shown coloured red on survey plan numbered 10088 lodged in the office of the Country Roads Board.

And the Honorable James Charles Murray Balfour, Her Majesty's Acting Minister of Public Works for the State of Victoria, shall give the necessary directions herein accordingly.

J. COLQUHOUN,
Clerk of the Executive Council.

COUNTRY ROADS BOARD.

At the Executive Council Chamber, Melbourne, the
ninth day of June, 1965.

PRESENT:

His Excellency the Governor of Victoria.
Mr. Chandler | Mr. Bloomfield.
Mr. Reid

DECLARATION OF A DEVIATION FROM THE MURRAY VALLEY HIGHWAY IN THE SHIRE OF SWAN HILL.

WHEREAS by sections 74 and 58 of the *Country Roads Act 1958* (No. 6229) it is amongst other things enacted that when the Country Roads Board under the provisions of the *Country Roads Act* has by Resolution declared a deviation to be a State highway the said Board may also declare that such deviation shall be in lieu of any existing highway or part thereof named in such Resolution and that on publication in the *Government Gazette* of the Order confirming such Resolution the existing highway or part thereof shall cease to be a State highway or be discontinued as provided in the Resolution: And whereas the said Board has by Resolution declared the deviation on the land described in the First Schedule to such Resolution to be a State highway and has also declared that such deviation shall be in lieu of the part of the existing highway being the land described in the Second Schedule to the said Resolution and that such part of the said existing highway shall be discontinued: Now therefore His Excellency the Governor of the State of Victoria by and with the advice of the Executive Council thereof doth hereby confirm the said Resolution.

Resolution for Declaration of a Deviation of a State Highway under the *Country Roads Act*.

Whereas the land the site of the highway the course of which is below set out was taken by the Board under the provisions of the *Country Roads Act 1958* for the purpose of constructing such highway deviation which highway deviation has now been laid out and formed on the same: And whereas the said Board (being the Country Roads Board incorporated under the said Act) thinks that the highway aforesaid is fit to be used as a public highway such Board at a meeting now holden acting under the authority conferred upon it by sections 74 and 58 of the said Act doth by this present Resolution hereby declare the said highway deviation the course of which is described in the First Schedule hereto with the commencing and terminating points thereof respectively specified to be part of a State highway within the meaning and for the purposes of the *Country Roads Act 1958*: And the said Board doth also declare that such deviation shall be in lieu of the existing highway or part thereof described in the Second Schedule hereto and that such part of the said existing highway shall be discontinued.

FIRST SCHEDULE.

Shire of Swan Hill.

7. *Murray Valley Highway*.—All those pieces of land in the Parish of Narrung, the boundaries of which are as follow:—

- (a) Commencing at a point on the eastern boundary of allotment 12A of the said parish distant 334 deg. 50 min. 441 links from the south-eastern angle of the said allotment; thence by lines bearing respectively 337 deg. 12½ min. 1,966.7 links, 333 deg. 1½ min. 707 links, 321 deg. 11 min. 787.2 links, 318 deg. 31 min. 606.3 links, 116 deg. 3 min. 771.9 links, 141 deg. 18 min. 730.1 links, 153 deg. 0½ min. 743.7 links, 156 deg. 3 min. 610.9 links and 170 deg. 3 min. 1,402.1 links to the point of commencement.
- (b) Commencing at a point on the eastern boundary of allotment 9 of the said parish, distant 180 deg. 9 min. 1,129 links from the north-eastern angle of the said allotment; thence by lines bearing respectively 52 deg. 6 min. 648.9 links, 51 deg. 49½ min. 2,754 links, 69 deg. 59 min. 589.3 links, 97 deg. 41 min. 903.3 links, 258 deg. 20 min. 836.8 links, 244 deg. 57 min. 571.9 links, 234 deg. 57 min. 439.6 links, 232 deg. 14 min. 495.3 links, 231 deg. 52 min. 2,155.6 links, 232 deg. 57½ min. 429 links, 236 deg. 25 min. 213.5 links, 244 deg. 17½ min. 585 links, 256 deg. 17½ min. 591.5 links, 267 deg. 43½ min. 516 links, 278 deg. 13½ min. 514.5 links, 289 deg. 21½ min. 591.3 links, 299

deg. 13½ min. 452 links, 304 deg. 53 min. 6,538.2 links, 110 deg. 23 min. 1,209.8 links, 124 deg. 54½ min. 4,936 links, 122 deg. 5½ min. 836 links, 109 deg. 23½ min. 522.9 links, 98 deg. 8½ min. 463.3 links, 86 deg. 54 min. 524.5 links, 73 deg. 29 min. 654.3 links, 60 deg. 32 min. 476 links and 53 deg. 23 min. 266.6 links to the point of commencement.

- (c) Commencing at an angle in the southern boundary of a State Forest reserve north of allotment 9 of the said parish, formed by the intersection of lines bearing 152 deg. 56 min. and 110 deg. 23 min.; thence by lines bearing respectively 332 deg. 56 min. 1,046.7 links, 141 deg. 7 min. 452.7 links, 134 deg. 40 min. 699.2 links, 124 deg. 44 min. 733 links, 113 deg. 54 min. 118 links and 290 deg. 23 min. 1,083.3 links to the point of commencement—

which said pieces of land are particularly delineated and shown coloured red on survey plans numbered 9570 and 9571, lodged in the office of the Country Roads Board.

SECOND SCHEDULE.

Shire of Swan Hill.

7. *Murray Valley Highway*.—All those pieces of land in the Parish of Narrung, the boundaries of which are as follow:—

- (a) Commencing at the south-western angle of allotment 12 of the said parish; thence by lines bearing respectively 336 deg. 54 min. 1,319.3 links, 350 deg. 3 min. 1,422.9 links, 296 deg. 3 min. 886.1 links, 321 deg. 18 min. 116.7 links, 318 deg. 31 min. 654.3 links, 116 deg. 3 min. 1,750 links, and 170 deg. 3 min. 2,860 links to the point of commencement.
- (b) Commencing at the north-eastern angle of allotment 9 of the said parish; thence by lines bearing respectively 281 deg. 9 min. 1,077 links, 237 deg. 5 min. 1,267 links, 273 deg. 5 min. 1,988 links, 328 deg. 17 min. 1,355 links, 290 deg. 23 min. 2,851.1 links, 304 deg. 5 min. 1,266.8 links, 110 deg. 23 min. 4,184.7 links, 148 deg. 17 min. 1,301.2 links, 93 deg. 5 min. 1,733.7 links, 57 deg. 5 min. 1,290.9 links, 101 deg. 9 min. 1,557.8 links, 53 deg. 0 min. 2,298.5 links, 97 deg. 41 min. 1,834 links, 257 deg. 12 min. 857.3 links, 277 deg. 41 min. 907.7 links, 233 deg. 0 min. 2,309.3 links and 281 deg. 9 min. 493.4 links to the point of commencement—

which said pieces of land are particularly delineated and shown coloured blue on survey plans numbered 9570 and 9571 lodged in the office of the Country Roads Board.

The common seal of the Country Roads Board was hereto affixed at Kew, this thirty-first day of May, One thousand nine hundred and sixty-five, in the presence of—

(SEAL) I. J. O'DONNELL, Chairman.
F. WEST, Member.
N. L. ALLANSON, Secretary.

And the Honorable James Charles Murray Balfour, Her Majesty's Acting Minister of Public Works for the State of Victoria, shall give the necessary directions herein accordingly.

J. COLQUHOUN,
Clerk of the Executive Council.

COUNTRY ROADS BOARD.

At the Executive Council Chamber, Melbourne, the
ninth day of June, 1965.

PRESENT:

His Excellency the Governor of Victoria.
Mr. Chandler | Mr. Bloomfield.
Mr. Reid

DECLARATION OF THE FAIRFIELD-RESERVOIR ROAD IN THE CITY OF PRESTON.

WHEREAS by the Resolution set out below and dated the thirty-first day of May, One thousand nine hundred and sixty-five, the Country Roads Board incorporated under the *Country Roads Act 1958* (No. 6229) being of opinion that the highway in the State of Victoria set out or described in the Schedule to the same is of sufficient importance to be a main road and acting under the powers in that behalf conferred upon it by the said

Act declared such highway to be a main road within the meaning and for the purposes of the Act aforesaid: And whereas the said Act amongst other things provides that the Governor in Council may by Order published in the *Government Gazette* confirm such Resolution whereupon any road mentioned in such Resolution shall be a main road: And whereas it is deemed desirable to confirm the Resolution so made and passed by the said Country Roads Board: Now therefore His Excellency the Governor of the State of Victoria by and with the advice of the Executive Council thereof doth hereby confirm such Resolution and declare upon the publication of this Order in the *Government Gazette* the road mentioned in the Schedule to such Resolution of the Country Roads Board a main road within the meaning and for the purposes of the Country Roads Act 1958.

Resolution for Declaration of a Main Road under the Country Roads Act.

The Country Roads Board incorporated under the Country Roads Act 1958 (No. 6229) at a meeting now holden being of opinion that the highway within the State of Victoria set out or described in the Schedule hereunder written is of sufficient importance to be a main road acting under the powers conferred upon it by the said Act doth by this Resolution hereby declare such highway to be a main road within the meaning and for the purposes of the said Country Roads Act 1958.

SCHEDULE.

City of Preston.

4. *Fairfield-Reservoir road* (13604).—Commencing at its junction with Wood-street, at the north-western angle of lot 103 on the plan of subdivision numbered 10876, lodged in the Office of Titles and being part of allotment 146, Parish of Jika Jika; thence northerly and north-westerly through the said allotment, via Eileen-street and Angliss-street, to and including its several junctions with Whittlesea-road, but excluding the junction of Summerhill and Whittlesea roads.

The common seal of the Country Roads Board was hereto affixed, at Kew, this thirty-first day of May, One thousand nine hundred and sixty-five, in the presence of—

(SEAL) I. J. O'DONNELL, Chairman.
F. WEST, Member.
N. L. ALLANSON, Secretary.

And the Honorable James Charles Murray Balfour, Her Majesty's Acting Minister of Public Works for the State of Victoria, shall give the necessary directions herein accordingly.

J. COLQUHOUN,
Clerk of the Executive Council.

COUNTRY ROADS BOARD.

At the Executive Council Chamber, Melbourne, the ninth day of June, 1965.

PRESENT:

His Excellency the Governor of Victoria.
Mr. Chandler | Mr. Bloomfield.
Mr. Reid

DECLARATION OF A DEVIATION FROM THE COLAC-FORREST ROAD IN THE SHIRE OF OTWAY.

WHEREAS by sections 21 and 58 of the Country Roads Act 1958 (No. 6229) it is amongst other things enacted that when the Country Roads Board under the provisions of the Country Roads Act has by Resolution declared a deviation to be a main road the said Board may also declare that such deviation shall be in lieu of any existing road or part thereof named in such Resolution and that on publication in the *Government Gazette* of the Order confirming such Resolution the existing road or part thereof shall cease to be a main road or be discontinued as provided in the Resolution: And whereas the said Board has by Resolution declared the deviation on the land described in the First Schedule to such Resolution to be a main road and has also declared that such deviation shall be in lieu of the part of the existing road being the land described in the Second Schedule to the said Resolution and that such part of the said existing road shall be discontinued: Now therefore His Excellency the Governor of the State of Victoria by and with the advice of the Executive Council thereof doth hereby confirm the said Resolution.

Resolution for Declaration of a Deviation of a Main Road under the Country Roads Act.

Whereas the land the site of the road the course of which is below set out was taken by the Board under the provisions of the Country Roads Act 1958 for the purpose of constructing such road deviation which road deviation has now been laid out and formed on the same: And whereas the said Board (being the Country Roads Board incorporated under the said Act) thinks that the road aforesaid is fit to be used as a public highway such Board at a meeting now holden acting under the authority conferred upon it by sections 21 and 58 of the said Act doth by this present Resolution hereby declare the said road deviation the course of which is described in the First Schedule hereto with the commencing and terminating points thereof respectively specified to be part of a main road within the meaning and for the purposes of the Country Roads Act 1958: And the said Board doth also declare that such deviation shall be in lieu of the existing road or part thereof described in the Second Schedule hereto and that such part of the said existing road shall be discontinued.

FIRST SCHEDULE.

Shire of Otway.

12. *Colac-Forrest road* (12812).—All that piece of land in the Parish of Yaughner, the boundaries of which are as follow:—Commencing at an angle in the north-eastern boundary of allotment 11c, section A, of the said parish formed by the intersection of lines bearing 249 deg. 17 min. and 258 deg. 27 min.; thence by lines bearing respectively 69 deg. 17 min. 70 links, 107 deg. 20 min. 120 links, 130 deg. 37 min. 266 links, 217 deg. 11 min. 120 links, 308 deg. 56 min. 246 links, 288 deg. 26 min. 292.8 links, and 78 deg. 27 min. 163 links to the point of commencement—which said piece of land is particularly delineated and shown coloured red on survey plan numbered 9357, lodged in the office of the Country Roads Board.

SECOND SCHEDULE.

Shire of Otway.

12. *Colac-Forrest road* (12812).—All that piece of land in the Parish of Yaughner, the boundaries of which are as follow:—Commencing at the south-eastern angle of allotment 11d of the said parish; thence by lines bearing respectively 220 deg. 53 min. 108.9 links, 334 deg. 12 min. 135 links, 279 deg. 9 min. 198 links, 249 deg. 17 min. 157 links, 286 deg. 52 min. 281.4 links, 92 deg. 32 min. 181 links, 69 deg. 17 min. 240 links, 99 deg. 9 min. 277 links and 154 deg. 12 min. 144 links to the point of commencement—which said piece of land is particularly delineated and shown coloured blue on survey plan numbered 9357, lodged in the office of the Country Roads Board.

The common seal of the Country Roads Board was hereto affixed, at Kew, this thirty-first day of May, One thousand nine hundred and sixty-five, in the presence of—

(SEAL) I. J. O'DONNELL, Chairman.
F. WEST, Member.
N. L. ALLANSON, Secretary.

And the Honorable James Charles Murray Balfour, Her Majesty's Acting Minister of Public Works for the State of Victoria, shall give the necessary directions herein accordingly.

J. COLQUHOUN,
Clerk of the Executive Council.

COUNTRY ROADS BOARD.

At the Executive Council Chamber, Melbourne, the ninth day of June, 1965.

PRESENT:

His Excellency the Governor of Victoria.
Mr. Chandler | Mr. Bloomfield.
Mr. Reid

ORDER APPROVING OF WIDENING AN EXISTING ROAD IN THE SHIRE OF HASTINGS.

WHEREAS the Country Roads Board constituted under the Country Roads Act 1958 (No. 6229) has represented to His Excellency the Governor in Council that it appears to it desirable that the existing Wooleys-road, in the Shire of Hastings should be widened by the said Board: And whereas the said Board in accordance with the requirements of sections 19 and 110 of the said Act has caused to be prepared a map plan and

estimate showing the points between which and on and through what land the said widening is proposed to be made and the cost of acquiring the land: And whereas on an inspection of the said map and plan and a consideration of the said estimate His Excellency the Governor in Council is satisfied that there are funds legally available for acquiring the land: Now therefore be it known by this present Order that His Excellency, the Governor of the State of Victoria with the advice of the Executive Council thereof doth hereby approve of the said road being widened, that is to say:—

All those pieces of land in the Parish of Bittern, the boundaries of which are as follow:—

- (a) Commencing at the north-western angle of allotment 85B of the said parish; thence by lines bearing respectively 156 deg. 12½ min. 178 ft. 7½ in., 160 deg. 12 min. 238 ft. 11 in., 151 deg. 23 min. 141 ft. 4½ in., 140 deg. 2 min. 120 ft. 7½ in., 126 deg. 42 min. 131 ft. 9 in., 116 deg. 23 min. 145 ft. 11½ in., 104 deg. 8 min. 134 ft. 10 in., 92 deg. 53 min. 115 ft. 10½ in., 270 deg. 0 min. 497 ft. 7½ in. and 340 deg. 12 min. 836 ft. 6½ in. to the point of commencement.
- (b) Commencing at the south-eastern angle of allotment 86 of the said parish; thence by lines bearing respectively 270 deg. 0 min. 30 feet, 35 deg. 3 min. 34 ft. 5½ in. and 160 deg. 6 min. 30 feet to the point of commencement.
- (c) Commencing at the north-eastern angle of allotment 93B of the said parish; thence by lines bearing respectively 160 deg. 1 min. 20 feet, 304 deg. 55 min. 32 ft. 8½ in. and 89 deg. 50 min. 20 feet to the point of commencement—

which said pieces of land are particularly delineated and shown coloured red and blue on survey plan numbered 10063 lodged in the office of the Country Roads Board.

And the Honorable James Charles Murray Balfour, Her Majesty's Acting Minister of Public Works for the State of Victoria, shall give the necessary directions herein accordingly.

J. COLQUHOUN,
Clerk of the Executive Council.

HEALTH ACT 1958 (No. 6270).

At the Executive Council Chamber, Melbourne, the
ninth day of June, 1965.

PRESENT:

His Excellency the Governor of Victoria.
Mr. Chandler | Mr. Bloomfield.
Mr. Reid

DIVISION 1 OF PART V. OF THE HEALTH ACT 1958 (No. 6270), RELATING TO PIGGERIES, EXTENDED TO CERTAIN TOWNSHIPS IN THE SHIRE OF MARONG.

UNDER the powers conferred by the *Health Act 1958* (No. 6270), His Excellency the Governor of the State of Victoria, by and with the advice of the Executive Council thereof, on the request of the Council of the Shire of Marong, and on the recommendation of the Commission of Public Health, doth hereby order that the provisions of Division 1 of Part V. of the said Act, so far as those provisions are applicable to piggeries, shall be extended to the following townships in the municipal district of the said Shire:—

- (a) the Township of Marong, comprising the area defined as a town in the Proclamation published in the *Government Gazette* dated the 25th February, 1861, on page 406;
- (b) the Township of Bridgewater, comprising the area defined as a town in the Proclamation published in the *Government Gazette* dated the 25th February, 1861, on page 402;
- (c) the Township of Raywood, comprising the area defined in the Proclamation published in the *Government Gazette* dated the 22nd May, 1918, on pages 1596-1597, as amended by the Proclamation published in the *Government Gazette* dated the 10th March, 1920, on page 1281.

And the Honorable John Frederick Rossiter, Her Majesty's Acting Minister of Health for the State of Victoria, shall give the necessary directions herein accordingly.

J. COLQUHOUN,
Clerk of the Executive Council.

HEALTH ACT 1958 (No. 6270).

At the Executive Council Chamber, Melbourne, the
ninth day of June, 1965.

PRESENT:

His Excellency the Governor of Victoria.
Mr. Chandler | Mr. Bloomfield.
Mr. Reid

DIVISION 1 OF PART V. OF THE HEALTH ACT 1958 (No. 6270), RELATING TO PIGGERIES, EXTENDED TO THE WHOLE OF THE MUNICIPAL DISTRICT OF THE SHIRE OF DIAMOND VALLEY.

UNDER the powers conferred by the *Health Act 1958* (No. 6270), His Excellency the Governor of the State of Victoria, by and with the advice of the Executive Council thereof, on the request of the Council of the Shire of Diamond Valley, and on the recommendation of the Commission of Public Health, doth hereby order that the provisions of Division 1 of Part V. of the said Act, so far as those provisions are applicable to piggeries, shall be extended to the whole of the municipal district of the Shire of Diamond Valley.

And the Honorable John Frederick Rossiter, Her Majesty's Acting Minister of Health for the State of Victoria, shall give the necessary directions herein accordingly.

J. COLQUHOUN,
Clerk of the Executive Council.

HEALTH ACT 1958 (No. 6270).

At the Executive Council Chamber, Melbourne, the
ninth day of June, 1965.

PRESENT:

His Excellency the Governor of Victoria.
Mr. Chandler | Mr. Bloomfield.
Mr. Reid

DIVISION 1 OF PART V. OF THE HEALTH ACT 1958 (No. 6270), RELATING TO PIGGERIES, EXTENDED TO THE WHOLE OF THE MUNICIPAL DISTRICT OF THE SHIRE OF CROYDON.

UNDER the powers conferred by the *Health Act 1958* (No. 6270), His Excellency the Governor of the State of Victoria, by and with the advice of the Executive Council thereof, on the request of the Council of the Shire of Croydon, and on the recommendation of the Commission of Public Health, doth hereby order that the provisions of Division 1 of Part V. of the said Act, so far as those provisions are applicable to piggeries, shall be extended to the whole of the municipal district of the Shire of Croydon.

And the Honorable John Frederick Rossiter, Her Majesty's Acting Minister of Health for the State of Victoria, shall give the necessary directions herein accordingly.

J. COLQUHOUN,
Clerk of the Executive Council.

TOWN AND COUNTRY PLANNING ACT 1961.

At the Executive Council Chamber, Melbourne, the
ninth day of June, 1965.

PRESENT:

His Excellency the Governor of Victoria.
Mr. Chandler | Mr. Bloomfield.
Mr. Reid

REVOCATION IN PART OF THE TALLANGATTA PLANNING SCHEME 1956.—REVOCATION No. 2.

WHEREAS it is provided under the *Town and Country Planning Act 1961* that the Governor in Council, upon application of the Town and Country Planning Board or the responsible authority or of any other person or body of persons appearing to him to be interested, may revoke the whole or any part of any planning scheme if he thinks that, under the special circumstances of the case it should be so revoked:

And whereas it is provided under the *Town and Country Planning Act 1961* that the Governor in Council may by the notice of revocation thereof prohibit the use or development of any land to which the revoked scheme or part related except with the consent of the responsible authority which prepared the scheme until such time as a further Interim Development Order is made and any such prohibition shall be deemed to be an Interim Development Order:

Now therefore, His Excellency the Governor of the State of Victoria by and with the advice of the Executive Council and on the recommendation of the Town and Country Planning Board, doth hereby:—

- (i) revoke the Tallangatta Planning Scheme 1956 in so far as it applies to that area of land on the north-western side of Towong-street, Tallangatta, being part of Crown allotments 3 and 7, section 11, Parish of Beethang, County of Bogong, the boundaries of which are as follow:—

Commencing at a point on the north-eastern alignment of Tooma-street, distant 14 feet from the intersection of the said north-eastern alignment with the north-western alignment of Towong-street; thence north-westerly by the said north-eastern alignment for a distance of 132 ft. 1½ in.; thence by lines bearing 49 deg. 49 min. for a distance of 407 ft. 9½ in. and 139 deg. 53½ min. for a distance of 119 ft. 9¼ in. to the north-western alignment of Towong-street; thence south-westerly by the said alignment for a distance of 305 ft. 10 in.; thence by a line bearing 252 deg. 25 min. for a distance of 30 feet to the commencement point;

- (ii) prohibit the use or development of any land described in (i) above except with the consent of the Council of the Shire of Towong.

And the Honorable Rupert James Hamer, Her Majesty's Minister for Local Government for the State of Victoria, shall give the necessary directions herein accordingly.

J. COLQUHOUN,
Clerk of the Executive Council.

Water Act 1958.

STATE RIVERS AND WATER SUPPLY COMMISSION.

At the Executive Council Chamber, Melbourne, the ninth day of June, 1965.

PRESENT:

His Excellency the Governor of Victoria.
Mr. Chandler | Mr. Bloomfield.
Mr. Reid

FRANKSTON-MORNINGTON URBAN DISTRICT— AREA OF DISTRICT INCREASED.

UNDER the powers conferred by the *Water Act 1958* and all other powers enabling him in that behalf, His Excellency the Governor of the State of Victoria, with the advice of the Executive Council of the said State, on the recommendation of the State Rivers and Water Supply Commission, doth hereby declare, order and direct as follows:—

That the area of the Frankston-Mornington Urban District be increased by adding thereto the lands set out and described in the Schedule hereto and as on and from the 30th day of June, 1965, the area of such district shall be deemed to be so increased.

SCHEDULE.

Commencing at the most southern angle of allotment 2, section 5, Parish of Frankston, County of Mornington; thence north-westerly by the north-eastern boundary of Boundary-road to the eastern boundary of Baden Powell-drive; thence generally northerly by the last-mentioned boundary to the northern boundary of Gillards-road; thence westerly by a line to the most southern angle of lot 27 on lodged plan of subdivision No. 26662; thence generally northerly by the left bank of the Kackeraboite Creek to the north-eastern boundary of Stephens-road; thence generally south-easterly by the north-eastern boundaries of that road to the north-western boundary of allotment 1, section 5, Parish of Frankston; thence north-easterly by that allotment boundary, the south-

eastern boundary of allotment 9, section 4, and a line connecting those boundaries to the left bank of Naringaling Creek; thence generally north-easterly by that creek bank to its confluence with Sweetwater Creek; thence generally easterly by the left bank of Sweetwater Creek to the north-western boundary of Overport-road; thence generally easterly by a line and the southern boundary of Sycamore-road to the north-eastern angle of lot 26 on lodged plan of subdivision No. 44139; thence south-westerly by the south-eastern boundary of said lot 26 and a line to the most western angle of lot 29 on lodged plan of subdivision No. 33748; thence generally south-easterly by the south-western boundaries of lots 29 and 28 to the most western angle of lot 3B on lodged plan of subdivision No. 4750; thence generally south-easterly by the south-western boundaries of said lot 3B and lot 4A to the most eastern angle of lot 8B; thence generally westerly by the eastern and southern boundaries of said lot 8B to the eastern boundary of Overport-road; thence generally southerly by the eastern boundaries of that road to the most northern angle of lot 1 on lodged plan of subdivision No. 24339; thence south-easterly by the north-eastern boundaries of said lot 1 and lot 2 and southerly by the eastern boundaries of said lot 2 and lot 3 to the south-eastern angle of the last-mentioned lot; thence easterly by the southern boundary of said lot 3 and southerly by the eastern boundaries of lots 4, 5 and 6 and generally westerly by the southern boundaries of said lot 6 to the eastern boundary of Overport-road; thence southerly by that road boundary to the north-western angle of lot 7; thence generally easterly by the northern boundaries of that lot and southerly by the eastern boundaries of said lot 7 and lots 8 and 9 to the south-eastern angle of the last-mentioned lot; thence westerly by the southern boundary of lot 9 on lodged plan of subdivision No. 24339 aforesaid to the eastern boundary of Overport-road; thence generally southerly by the eastern and south-eastern boundaries of that road to the north-eastern boundary of Armagh-road; thence south-easterly by the last-mentioned road boundary to the most southern angle of lot 6 on lodged plan of subdivision No. 12565; thence south-westerly by a line across Armagh-road to the most northern angle of the land described in certificate of title, volume 7109, folio 647; thence south-easterly and south-westerly by the north-eastern and south-eastern boundaries of the said land to the most southern angle thereof; thence south-easterly by the north-eastern boundary of Humphries-road to the most eastern angle of the land described in certificate of title, volume 7513, folio 005; thence north-easterly and south-easterly by the north-western and north-eastern boundaries of the land described in that certificate of title to the north-western boundary of lot 2 on lodged plan of subdivision No. 39754; thence north-easterly by the last-mentioned lot boundary and the north-western boundaries of lots 43, 42 and 41 on lodged plan of subdivision No. 12904 and a line connecting those boundaries to the most northern angle of the last-mentioned lot; thence south-easterly by the north-eastern boundaries of said lot 41 and of a lane adjoining the north-eastern boundaries of lots 40, 39, 31, 30, 17 and 16, by lines connecting those boundaries, and by a line in continuation of the said north-eastern boundary of that lane across Moorooduc-road to the south-eastern boundary of that road; thence generally south-westerly by the south-eastern boundaries of the said road to a point in line with the south-western boundary of Two Bays-road; thence generally north-westerly by a line across Moorooduc-road and the south-western boundaries of Two Bays-road and of lots 61 and 62 on lodged plan of subdivision No. 13378, to the most western angle of the last-mentioned lot; thence north-easterly by the north-western boundary of said lot 62, westerly by the southern boundary of a reserve, and north-westerly by the south-western boundaries of lots 1 and 2 on lodged plan of subdivision No. 36287 to the most western angle of the last-mentioned lot; thence generally westerly by the southern boundaries of lots 94, 95 and 96 on lodged plan of subdivision No. 13378 and generally south-westerly by the south-eastern boundaries of lots 97, 98 and 99 and by a line in continuation of the last-mentioned lot boundary across Boundary-road to the south-western boundary of that road; thence north-westerly by that road boundary to a point in line with the north-western boundary of lot 136; thence north-easterly by a line and the north-western boundaries of lots 136, 135, 134, 133, 132, 131, 130, 129, 128, 127, 126, 125, 124, 123, 122, 121, 120, 119, 118, 117 and 116 on lodged plan of subdivision No. 13378 to the most southern angle of lot 6 on lodged plan of subdivision No. 23757; thence north-westerly by the south-western boundaries of the last-mentioned lot and lot 13 on lodged plan of subdivision No. 62997 and a line connecting those boundaries to the most western angle of said lot 13; thence south-westerly by the south-eastern boundaries of lots 7 to 13 inclusive on a plan of subdivision of allotment 3, section

5, Parish of Frankston, by Saxil Tuxen, dated 22nd December, 1948 and lodged in the Office of Titles, Melbourne, in correspondence No. 1950/18992, and by a line connecting those boundaries to the most southern angle of the last-mentioned lot; thence north-westerly by the south-western boundaries of said lot 13 and lots 14, 15, 17 and 41 and a line connecting those boundaries to the most western angle of said lot 41; thence north-easterly by the north-western boundaries of the last-mentioned lot and lot 40 on the last-mentioned plan of subdivision to the most southern angle of the land described in certificate of title, volume 7775, folio 085; thence north-westerly by the south-western boundary of the land described in that certificate of title to the south-eastern boundary of Walkers-road; thence south-westerly by that road boundary to the most northern angle of lot 16 on lodged plan of subdivision No. 68076; thence south-easterly by the north-eastern boundary of said lot 16 and south-westerly by the south-eastern boundaries of that lot and lots 15 and 14 to the most southern angle of the last-mentioned lot; thence north-westerly and northerly by the south-western and western boundaries of said lot 14 to the south-eastern boundary of Walkers-road; thence south-westerly by that road boundary to the north-eastern angle of lot 13; thence generally south-easterly by the north-eastern boundaries of that lot and south-westerly by the south-eastern boundaries of said lot 13 and lots 12, 11, 10 and 9 to the most southern angle of the last-mentioned lot; thence north-westerly by the south-western boundary of said lot 9 on lodged plan of subdivision No. 68076 to the south-eastern boundary of Walkers-road aforesaid; thence south-westerly by that road boundary to the most northern angle of lot 6 on lodged plan of subdivision No. 58560; thence south-easterly by the north-eastern boundary of that lot and south-westerly by the south-eastern boundaries of said lot 6 and lots 5, 4, 3, 2 and 1 to the most southern angle of the last-mentioned lot; thence north-westerly by the south-western boundary of said lot 1 and south-westerly by the south-eastern boundary of Walkers-road to the most northern angle of the land described in certificate of title, volume 4020, folio 946; thence south-easterly by the north-eastern boundaries of the land described in that certificate of title and certificate of title, volume 5712, folio 274, and by a line connecting those boundaries to the south-eastern boundary of aforesaid allotment 2, section 5, Parish of Frankston; thence south-westerly by that allotment boundary to the point of commencement.

The lands set out and described in the foregoing Schedule are shown on a plan approved by the Governor in Council, and deposited in the Office of the State Rivers and Water Supply Commission, Melbourne.—(Corres. No. 63/4576).

And the Honorable Thomas Anthony Darcy, Her Majesty's Minister of Water Supply for the State of Victoria, shall give the necessary directions herein accordingly.

J. COLQUHOUN,
Clerk of the Executive Council.

WATER ACT 1958.

STATE RIVERS AND WATER SUPPLY COMMISSION.

At the Executive Council Chamber, Melbourne, the ninth day of June, 1965.

PRESENT:

His Excellency the Governor of Victoria.
Mr. Chandler | Mr. Bloomfield
Mr. Reid.

GOULBURN-MURRAY IRRIGATION DISTRICT—DISTRICT EXTENDED—NORTH SHEPPARTON IRRIGATION AREA—BOUNDARIES VARIED.

UNDER the powers conferred by the *Water Act 1958* and all other powers enabling him in that behalf, His Excellency the Governor of the State of Victoria, with the advice of the Executive Council of the said State, on the recommendation of the State Rivers and Water Supply Commission, doth hereby declare, order, and direct as follows:—

That the Goulburn-Murray Irrigation District be extended and the boundaries of the North Shepparton Irrigation Area be varied by adding to the said District and Area the lands set out and described in the Schedule hereto, and as on and from the 30th day of June, 1965, such District shall be deemed to be so extended and the boundaries of such Area shall be so varied.

SCHEDULE.

1. Commencing at the south-eastern angle of allotment 22, section D, Parish of Mardoona, County of Moira; thence easterly by the northern boundary of a Government road to a point in line with the western boundary of allotment 1, section 19, Township of Wunghnu; thence southerly by a line and the western boundary of said allotment 1 and easterly by the southern boundary of that allotment to the south-eastern angle thereof; thence southerly by the eastern boundary of allotment 6 and a line in continuation thereof to the right bank of the Broken Creek; thence north-westerly and generally south-westerly by that creek bank to the western boundary of a road forming the western boundary of the Township of Wunghnu; thence northerly by the said road boundary to the point of commencement.

2. The whole of allotments 3 and 4, section 18, Township of Wunghnu, Parish of Drumanure.

The lands set out and described in the foregoing Schedule are shown on a plan approved by the Governor in Council, and deposited in the office of the State Rivers and Water Supply Commission, Melbourne. (Corres. No. 63/1001.)

And the Honorable Thomas Anthony Darcy, Her Majesty's Minister of Water Supply for the State of Victoria, shall give the necessary directions herein accordingly.

J. COLQUHOUN,
Clerk of the Executive Council.

DROUIN WATERWORKS TRUST.

At the Executive Council Chamber, Melbourne, the ninth day of June, 1965.

PRESENT:

His Excellency the Governor of Victoria.
Mr. Chandler | Mr. Bloomfield
Mr. Reid.

EXTENT OF WATERWORKS AND URBAN DISTRICTS INCREASED.

UNDER the powers conferred by the *Water Act* and all other powers enabling him in that behalf, His Excellency the Governor of the State of Victoria, by and with the advice of the Executive Council of the said State, doth hereby declare, order and direct as follows:—

That the extent of the Waterworks and Urban Districts of the Drouin Waterworks Trust be increased by adding to the same the land comprised within the boundaries described in the Schedule hereto, and as on and from the date hereof the extent of such District shall be and be deemed to be increased accordingly.

SCHEDULE.

Commencing at the intersection of the southern boundary of lot 33 on lodged plan of subdivision numbered 15870, Parish of Drouin West, County of Buln Buln, and the western boundary of Crown allotment 80, being a point on the boundary of the existing Waterworks District; thence easterly along the southern boundary of the said lot 33 and by a line being the continuation thereof through the said Crown allotment 80 a distance of 300 links; thence due north by a line through the said Crown allotment 80 and across a road reserve to a point on the north-eastern boundary of the said road reserve; thence north-westerly along the said north-eastern boundary of the road reserve to its intersection with the said western boundary of the aforesaid Crown allotment 80, being a point on the boundary of the existing Waterworks District; thence southerly along the boundary of the existing Waterworks District to the point of commencement.

All of which boundaries are shown on a plan approved by the Governor in Council and deposited in the office of the State Rivers and Water Supply Commission, Melbourne.—(Corres. 64/201/48.)

And the Honorable Thomas Anthony Darcy, Her Majesty's Minister of Water Supply for the State of Victoria, shall give the necessary directions herein accordingly.

J. COLQUHOUN,
Clerk of the Executive Council.

SHELL (CORIO TO WILLIAMSTOWN) PIPELINES ACT 1964, NO. 7236.

At the Executive Council Chambers, Melbourne, the ninth day of June, 1965.

PRESENT :

His Excellency the Governor of Victoria.
Mr. Chandler | Mr. Bloomfield.
Mr. Reid

AUTHORIZATION OF DEPTH VARIATION OF THE PIPELINE.

WHEREAS it is provided by the *Shell (Corio to Williamstown) Pipelines Act 1964*, that "the Company" within the meaning of the said Act subject to the said Act may construct a pipeline between its refinery in the Shire of Corio and its storage and manufacturing installations in the City of Williamstown at a depth of approximately three feet along the route shown on the plan laid on the table of the Legislative Council of the Parliament of Victoria on the ninth day of December One thousand nine hundred and sixty-four :

And whereas it is further provided that the Governor in Council may by order published in the *Government Gazette* authorize the laying of the said pipeline with a deviation from the said route or at a depth greater or less than three feet :

Now, therefore, His Excellency the Governor of the State of Victoria by and with the advice of the Executive Council thereof in exercise of the power conferred by Section (5) 2 of the said Act doth hereby authorize the laying of the said pipeline at a depth greater than three feet as set out in the Schedule hereto :

SCHEDULE OF DEPTH VARIATION.
Shire of Corio.

Item.	Location of Variation.	Description of Location.	Maximum Distance from Location of Commencement of variation.	Depth of Pipeline at Location.	Maximum Distance from Location of Termination of variation.
			feet.	feet.	feet.
1	Government road (School-road)	Between Crown allotment 11 and Crown allotment 13, Parish of Moranghurk	100	5	100
2	Government road Bell-road	Between Crown allotment 26 and Crown allotment 38, Parish of Moranghurk	100	5	100
3	Government road..	Between Crown allotment 37 and Crown allotment B, section 14, Parish of Moranghurk	100	5	100
4	Hovells Creek ..	Between Crown allotment 5 of section 14A, Parish of Moranghurk, and Crown allotment 1, section 5A, Parish of Woornyalook	50	6	50
5	Government road..	Between Crown allotment 1., section 5A and Crown allotment 5, section 6A, Parish of Woornyalook	100	5	100
6	Government road..	Between Crown allotment 4, section 6A and Crown allotment B, section 7, Parish of Woornyalook	100	5	100
7	Government road..	Between Crown allotment C, section 10 and Crown allotment A, section 9, Parish of Woornyalook	100	5	100
8	Government road..	Between Crown allotment B1, section 9 and Crown allotment B2, section 9, Parish of Woornyalook	100	5	100
9	Government road..	Between Crown allotment 17 and Crown section 20A, Parish of Murtcaim	100	5	100
10	Government road (Paradise-road)	Between Crown section 21 and Crown section 26A, Parish of Murtcaim	100	5	100
11	Government road (29 mile road)	Between Crown section 26A and Crown allotment A, section 25, Parish of Murtcaim	100	5	100
12	Little River ..	Between Crown allotment B, section 25, Parish of Murtcaim, and Crown allotment B, section 1, Parish of Cocoroc	60	6	60

And the Honourable Vance Oakley Dickie, Her Majesty's Minister of State Development for the State of Victoria, shall give the necessary directions herein accordingly.

J. COLQUHOUN,
Clerk of the Executive Council.

MELBOURNE AND METROPOLITAN TRAMWAYS
ACT 1958 (No. 6311).

At the Executive Council Chamber, Melbourne, the
ninth day of June, 1965.

PRESENT:

His Excellency the Governor of Victoria.
Mr. Chandler | Mr. Bloomfield.
Mr. Reid

WHEREAS His Excellency the Governor of the State of Victoria by and with the advice of the Executive Council thereof has this day consented pursuant to the provisions of section 28 of the *Melbourne and Metropolitan*

Tramways Act 1958, to the Melbourne and Metropolitan Tramways Board raising by way of loan an amount not exceeding Fifty thousand pounds (£50,000): And whereas His Excellency the Governor is satisfied that a sufficient proportion of the loan to be so raised will fall due and be repaid in each year during the currency of the proposed loan: Now therefore it is directed, pursuant to the provisions of section 28 (6) of the said Act, that it shall not be necessary to provide a sinking fund in connexion with such loan.

And the Honourable Henry Edward Bolte, Her Majesty's Treasurer for the State of Victoria, shall give the necessary directions herein accordingly.

J. COLQUHOUN,
Clerk of the Executive Council.

LAND TAX (RATES AND APPEALS) ACT 1963
(No. 7099).

At the Executive Council Chamber, Melbourne, the
ninth day of June, 1965.

PRESENT:

His Excellency the Governor of Victoria.
Mr. Chandler | Mr. Bloomfield.
Mr. Reid |

REAPPOINTMENT OF MEMBERS AND CHAIRMAN OF
THE LAND VALUATION BOARD.

IN pursuance of the powers conferred by section 28 of the Land Tax (Rates and Appeals) Act 1963, His Excellency the Governor of the State of Victoria, by and with the advice of the Executive Council thereof, doth by this Order reappoint—

(a) HUGH LESLIE SIMPSON, Esq., C.B.E.,
KEITH ALEXANDER MORRISON, Esq., LL.B., and
EUGENE O'DWYER, Esq., F.C.I.V.,

to be members of the Land Valuation Board for a period of twelve (12) months from and inclusive of 10th June, 1965; and

(b) the said Hugh Leslie Simpson to be Chairman of the said Board.

And the Honorable Henry Edward Bolte, Her Majesty's Treasurer for the State of Victoria, shall give the necessary directions herein accordingly.

J. COLQUHOUN,
Clerk of the Executive Council.

APPROACHING LAND SALES.

SALES of Crown lands, in fee-simple, will be held at the under-mentioned places and dates, viz.:

	No. of Gazette.
Bendigo.—Thursday, 22nd July, 1965 ..	45
Castlemaine.—Tuesday, 6th July, 1965 ..	38
Maryborough.—Friday, 25th June, 1965 ..	34
Orbost.—Monday, 12th July, 1965 ..	41
St. Arnaud.—Thursday, 24th June, 1965 ..	34

ERRATUM.

IN the notice headed "Sale of Crown Land By Auction" appearing in the Victoria Government Gazette No. 41, dated 9th June, 1965, (pages 1837-8) the words "allotment 31" appearing under Lot 13 should read "allotment 32".

SALE OF CROWN LAND BY AUCTION.

The land will be offered for sale in fee-simple, and subject to the provisions of the Land Act and Regulations thereunder.

The upset price is the sum at which bidding will start, and no bid below that sum can be accepted. The highest bidder at or above that sum shall be the purchaser, subject to signature of contract and any necessary payment.

TERMS:

A deposit of at least 12½% of the purchase price must be paid at the sale, either in cash or by cheque.

The residue is payable in half-yearly instalments, in accordance with the following scale, or may be paid off at any earlier time.

£20 and under, 6 instalments.
Over £20, and not exceeding £50, 8 instalments.
Over £50, and not exceeding £100, 10 instalments.
Over £100, and not exceeding £200, 12 instalments.
Over £200, and not exceeding £300, 14 instalments.
Over £300, and not exceeding £400, 16 instalments.
Over £400, and not exceeding £500, 18 instalments.
Over £500, 20 instalments.

Interest at the rate of 5% per annum is payable with all payments of residue, and is computed for each instalment from the date of sale to the date of such payment. Additional interest is charged if any instalment is not paid on or before the due date.

If paid off within 30 days of sale, no interest is payable.

FEES, ETC.:

Also payable at the sale, in addition to the deposit, are the survey fee and, if applicable, the valuation of improvements (if purchaser be not the owner thereof).

Payable with balance of purchase money—

Crown Grant fee—50 acres and under ..	£1 10s.
Over 50 acres ..	£2
Purchase money £5 or under	£1

Assurance Fund contribution—One halfpenny for each £1 of purchase price. (This is a fund established to guarantee the validity of freehold titles.)

Transfer of interest prior to completion of payment may be allowed on payment of £1 fee and subject to stamp duty.

If unable to attend personally, a prospective purchaser may arrange for another person to bid as his agent.

Attention is drawn to section 95, Land Act 1958, which provides that the purchaser shall be deemed to be the owner for the purposes of other Acts; also to an amendment to the Local Government Act providing for Government roads, in certain circumstances, to be declared "private streets", thus making the purchaser liable to contribute to the cost of street construction.

J. C. M. BALFOUR,
Minister of Lands.

Office of Crown Lands and Survey,
Melbourne, 16th June, 1965.

BENDIGO.—Sale (No. 11782) of Crown land in fee-simple, by auction, will be held at No. 7 QUEEN-STREET, BENDIGO, on THURSDAY, the 22nd JULY, 1965, at TEN o'clock a.m. To be conducted by G. E. HARPIN, Land Officer, Bendigo. Auctioneers: JAMES ANDREW & CO., 48 View-street, Bendigo.

AT BENDIGO, PARISH OF SANDHURST, COUNTY OF BENDIGO.

Lot 1.

Fronting the southern side of Skene-street about 3 chains East of Neale-street.

Upset price £850 the lot. Survey fee £6 10s.

Area 37 perches, allotment 371 of section H. One month allowed for removal of improvements.—(W.87243.)

Lot 2.

At the western corner of Belle Vue-road and Woodward-road.

Upset price £750 the lot. Survey fee £7.

Area 1a. 2r. 17p., allotment 167d of section C. Valuation of improvements £1,050 (fencing and reclamation) (B.C.X. Drinks Pty. Ltd.)—(W.87308.)

Lot 3.

At the southern corner of Woodward-road and Porter-street.

Upset price £296 the lot. Survey fee £5 5s.

Area 1r. 3p., allotment 135c of section C. Valuation of improvements £145 (dwelling, fencing, &c.) (J. E. M. Anderson.)—(W.87573.)

Lot 4.

Fronting the eastern side of Specimen Hill-road about 7 chains north-west of Inglewood-street.

Upset price £200 the lot. Survey fee £7 10s.

Area 2r. 39p., subject to survey, allotment 6b of section L.—(W.80878.)

Lot 5.

Fronting the eastern side of Marble-street about 5 chains south of Marong-road.

Upset price £170 the lot. Survey fee £6.

Area 1 rood, subject to survey, allotment 15 of section 33b.

Lot 6.

Fronting the western side of Pethard-place about 5 chains south of Marong-road.

Upset price £120 the lot. Survey fee £6 10s.

Area 2 roods, subject to survey, allotment 16 of section 33b.

NOTE.—Both lots 5 and 6 are to be sold subject to a special condition that the grantee shall take the land notwithstanding any defects arising from the past use thereof for mining purposes or from any other cause whatsoever.

It is probable that a mine shaft is on lot 6.—(W.82803.)

Lot 7.

At the southern corner of Curnow and Sterry streets.
Upset price £135 the lot. Survey fee £6.

Area 1r. 14p., allotment 7 of section 66B. One month allowed for removal of improvements. Subject to drainage easement 10 links wide.

Lot 8.

Fronting the south side of Curnow-street about 1 chain east of Sterry-street.

Upset price £135 the lot. Survey fee £6.

Area 1r. 16p., allotment 8 of section 66B. One month allowed for removal of improvements. Subject to drainage easement 10 links wide.

Lot 9.

Fronting the east side of Sterry-street about 2 chains south of Curnow-street.

Upset price £100 the lot. Survey fee £6.

Area 1r. 19p., allotment 9 of section 66B. One month allowed for removal of improvements.—(W.81759.)

Lot 10.

At the western corner of the junction of Young, Giudice and Hunter streets.

Upset price £100 the lot. Survey fee £6 12s. 6d.

Area 2 roods, allotment 76A of section C1. Subject to drainage easement 10 links wide.—(W.84224.)

Lot 11.

Fronting the western side of Brazier-street about 3 chains south of Campbell-street.

Upset price £75 the lot. Survey fee £6 10s.

Area 1r. 28p., subject to survey, allotment 543 of section M. One month allowed for removal of improvements.—(W.84719.)

Lot 12.

AT EAGLEHAWK, PARISH OF SANDHURST, COUNTY OF BENDIGO.

Fronting the north side of Victoria-street about 5 chains west of Hicks-street.

Upset price £100 the lot. Survey fee £6 10s.

Area 1 rood, subject to survey, allotment 9 of section 50.

NOTE.—A 6-in. sewer pipe-line is located across the rear of this allotment.—(W.81116.)

Lot 13.

PARISH OF SANDHURST, COUNTY OF BENDIGO.

Fronting the southern side of Marong-road about 20 chains west of Specimen Hill-road.

Upset price £175 the lot. Survey fee £9 12s. 6d.

Area 7a. 1r. 26p., subject to survey, allotment 14U of section L. One month allowed for removal of improvements. Subject to race easement 10 links wide.—(W.84728.)

Lot 14.

Fronting south-eastern side of Empire-road about 13 chains south-west of Saunders-street.

Upset price £20 the lot. Survey fee £7 7s. 6d.

Area 2a. 3r. 34p., subject to survey, allotment 5A of section L. One month allowed for removal of improvements.

Lot 15.

Fronting south-eastern side of Empire-road about 16 chains south-west of Saunders-street.

Upset price £20 the lot. Survey fee £8 10s.

Area 2a. 0r. 27p., subject to survey, allotment 5B of section L. One month allowed for removal of improvements.—(W.85109.)

Lot 16.

Fronting the west side of Butler-street about 11 chains north of Hosken-street.

Upset price £15 the lot. Survey fee £8.

Area 1a. 0r. 32p., allotment 473E of section M.—(W.81163.)

Lot 17.

PARISH OF KNOWSLEY, COUNTY OF RODNEY.

In the south of the Parish.

Upset price £200 the lot. Survey fee £13 2s. 6d.

Area 44a. 3r. 1p., allotment A10.

NOTE.—Attention is drawn to the lack of practical access to this allotment.—(W.87554.)

Lot 18.

PARISH OF MARONG, COUNTY OF BENDIGO.

Fronting the east side of a Government road and about 1½ chains south-east of Marong.

Upset price £100 the lot. Survey fee £12 5s.

Area 16a. 0r. 37p., subject to survey, allotment 43K.—(W.81132.)

Lot 19.

PARISH OF MANDURANG, COUNTY OF BENDIGO.

About 1½ miles north of Mandurang.

Upset price £42 the lot. Survey fee £8 10s.

Area 2a. 3r. 11p., subject to survey, allotment 6E of section 17.—(W.86506.)

Land Settlement Act 1959.

LAND AVAILABLE FOR APPLICATION.

NOTIFICATION is hereby given in accordance with section 7 of the Land Settlement Act 1959, that the under-mentioned holdings are available for settlement. Any male person who is not less than 21 years of age and who is a British subject may apply on the prescribed form for settlement on any holding or holdings, indicating when he applies in respect of more than one holding his order of preference therefor.

Prescribed application forms, plans and further details may be obtained from the Acting Secretary, Rural Finance and Settlement Commission, State Public Offices, Melbourne, C.2.

Closing date for receipt of completed application forms for settlement on these holdings is the 12th July, 1965, such applications to be in the hands of the Acting Secretary, Rural Finance and Settlement Commission, on or before that date.

M. J. CRONIN,
Acting Secretary.

SCHEDULE OF ALLOTMENTS.

SUBDIVISION OF PORTION 11 OF EAST GOULBURN IRRIGATION AREA.

PARISH OF DUNBULBALANE—COUNTY OF MOIRA.

Suitable for the Establishment of Permanent Pastures under Irrigated Culture for Dairying.

Lot Number on Plan of Subdivision.	Approximate Area in Acres.
140	102
141	103
142	103
143	97
144	113
145	101
146	99
147	118
148	103
149	100
150	103
151	105
152	111
153	107
154	109
155	107
156	108
157	123
158	107
159	104
166	130

Rural Finance and Settlement Commission,
Melbourne, C.2, 8th June, 1965.

COMMON ABOUT TO BE DIMINISHED.

IN pursuance of the provisions contained in the *Land Act 1958*, notice is hereby given that it is the intention of the Governor in Council to diminish the common herein-after mentioned, viz.:—

The following Notice was published 1° on the 26th May, 1965, pursuant to Order of the 18th May, 1965.

The United Municipal and Goldfield Common of Clunes, proclaimed as such on the 14th September, 1863, is about to be diminished by the excision therefrom of allotment 12, section 21, Township of Clunes, and containing 1 rood 32 perches.—(Rs.398.)

J. C. M. BALFOUR,
Minister of Lands.

PROPOSED PERMANENT RESERVATION OF LAND AS A SITE.

IN pursuance of the provisions of the *Land Act 1958*, notice is hereby given that it is the intention of the Governor in Council to permanently reserve as a site the land hereunder referred to:—

The following Notice was published 1° on the 9th June, 1965, pursuant to Order of the 1st June, 1965.

MODEWARRE.—Land proposed to be permanently reserved as a site for Public purposes, also excepted from occupation for mining purposes under any miner's right, 1,300 acres, more or less, Parish of Modewarre, County of Grant, as indicated by hachure on plan hereunder.—(M.186⁽²⁾) (Rs.8457.)

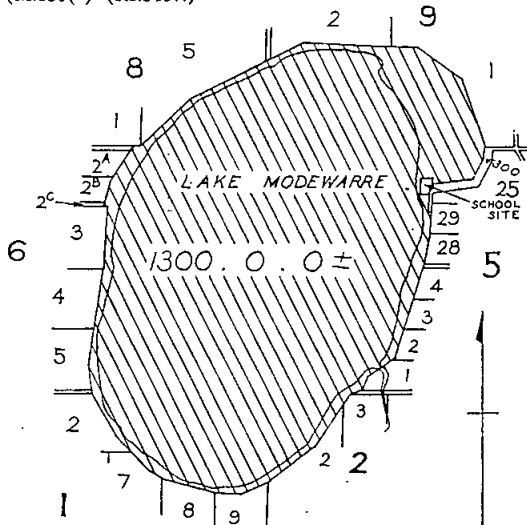

SCALE OF CHAINS.
0 10 20 30 40 80

J. C. M. BALFOUR,
Minister of Lands.

PROPOSED REVOCATION OF TEMPORARY RESERVATION, AND THE WITHHOLDING FROM SALE, LEASING, AND LICENSING, OF LAND BY ORDER IN COUNCIL.

IN pursuance of the provisions of the *Land Act 1958*, notice is hereby given that it is the intention of the Governor in Council to revoke the temporary reservation, and the withholding from sale, leasing, and licensing, of land by Order in Council hereunder referred to, viz.:—

The following Notice was published 1° on the 26th May, 1965, pursuant to Order of the 18th May, 1965.

GLENROWEN.—The temporary reservation as a site for Mechanics' Institute and the withholding from sale, leasing and licensing by Order in Council of the 18th December, 1883, of 1 rood 24 perches of land in the Township of Glenrowen.—(G.92⁽²⁾) (Rs.7044).

J. C. M. BALFOUR,
Minister of Lands.

PROPOSED REVOCATION OF TEMPORARY RESERVATION OF LAND BY ORDER IN COUNCIL.

IN pursuance of the provisions of the *Land Act 1958*, notice is hereby given that it is the intention of the Governor in Council to revoke the temporary reservation of land by Order in Council hereunder referred to, viz.:—

The following Notice was published 1° on the 9th June, 1965, pursuant to Order of the 1st June, 1965.

RATHSCAR.—The temporary reservation, by Order in Council of the 4th May, 1926, of 10 acres 3 roods 18 perches of land in the Parish of Rathscar as a site for Water Supply purposes.—(R.65⁽²⁾) (Rs.3302.)

J. C. M. BALFOUR,
Minister of Lands.

PROPOSED REVOCATIONS OF TEMPORARY RESERVATIONS OF LANDS BY ORDERS IN COUNCIL.

IN pursuance of the provisions of the *Land Act 1958*, notice is hereby given that it is the intention of the Governor in Council to revoke the temporary reservations of lands by Orders in Council hereunder referred to, viz.:—

The following Notices were published 1° on the 16th June, 1965, pursuant to Orders of the 9th June, 1965.

DRUMDLEMARA.—The temporary reservation, by Order in Council of the 4th July, 1922, of 2 roods 23 perches of land in the Parish of Drumdemara as a site for Mechanics' Institute is about to be revoked so far only as the portion containing 11 perches, indicated by hachure on plan hereunder, is concerned.—(D.197⁽⁵⁾) (Rs.2522.)

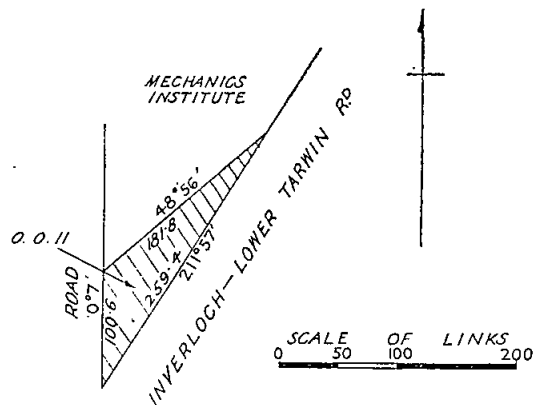

KERANG.—The temporary reservation, by Order in Council of the 8th May, 1951, of 24 acres more or less of land in the Township of Kerang as a site for Public Recreation is about to be revoked so far only as the portion containing 1 acre 1 rood 5 perches, indicated by hachure on plan hereunder, is concerned.—(K.19⁽¹¹⁾) (Rs.6663).

WINDHAM ST

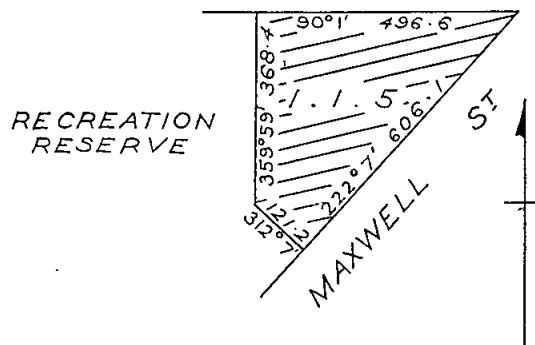

SCALE OF CHAINS
0 1 2 3 6

J. C. M. BALFOUR,
Minister of Lands.

PROPOSED REVOCATION OF TEMPORARY RESERVATION, AND THE WITHHOLDING FROM SALE, LEASING, AND LICENSING OF LAND BY ORDER IN COUNCIL.

IN pursuance of the provisions of the *Land Act 1958*, notice is hereby given that it is the intention of the Governor in Council to revoke the temporary reservation, and the withholding from sale, leasing and licensing of land by Order in Council hereunder referred to, viz.:

The following Notice was published 1° on the 9th June, 1965, pursuant to Order of the 1st June, 1965.

ELMHURST.—The temporary reservation as a site for Police purposes and the withholding from sale, leasing and licensing by Order in Council of the 18th December, 1883 (see *Government Gazette* of the 21st December, 1883, page 3096) of 12 acres 2 roods 33 perches of land in the Township of Elmhurst.—(E.21(°)) (Rs.243.)

J. C. M. BALFOUR,
Minister of Lands.

PROPOSED PERMANENT RESERVATIONS OF LANDS AS SITES.

IN pursuance of the provisions of the *Land Act 1958*, notice is hereby given that it is the intention of the Governor in Council to permanently reserve as sites, and also except from occupation for mining purposes under any miner's right, the lands hereunder referred to:

The following Notices were published 1° on the 26th May, 1965, pursuant to Orders of the 18th May, 1965.

ELTHAM.—Land proposed to be permanently reserved as a site for Public Recreation, 57 acres 3 roods 32 perches, Township of Eltham, Parish of Nillumbik, County of Evelyn, being the site temporarily reserved therefor by Order in Council of the 28th May, 1913, and known as the Eltham Park Reserve.—(E.41(°)) (Rs.932.)

HAWKESDALE.—Land proposed to be permanently reserved as a site for a Racecourse and Public Recreation, 146 acres 0 roods 21 perches, Township of Hawkesdale, Parish of Kangertong, County of Villiers, being the site temporarily reserved therefor by Orders in Council of the 20th December, 1887, and the 26th February, 1957, and known as the Hawkesdale Racecourse and Recreation Reserve.—(H.54(°)) (Rs.1634.)

J. C. M. BALFOUR,
Minister of Lands.

PROPOSED REVOCATIONS OF TEMPORARY RESERVATIONS OF LANDS BY ORDERS IN COUNCIL.

IN pursuance of the provisions of the *Land Act 1958*, notice is hereby given that it is the intention of the Governor in Council to revoke the temporary reservations of lands by Orders in Council hereunder referred to, viz.:

The following Notices were published 1° on the 2nd June, 1965, pursuant to Orders of the 25th May, 1965.

COHUNA.—The temporary reservation, by Order in Council of the 7th October, 1958, of 2 roods of land in the Township of Cohuna, as a site for the purposes of the Forests Act.—(C.424(°)) (Rs.7620.)

DOUTTA GALA (ESSENDON).—The temporary reservation, by Order in Council of the 4th May, 1909, of 3 acres 2 roods 4 perches of land at Essendon, in the Parish of Doutta Gala, as a site for a Public Park and other purposes of Public Recreation, revoked as to part by Order of the 14th January, 1958, is about to be revoked so far only as the portion containing 1 acre 0 roods 34 perches, indicated by hachure on plan hereunder, is concerned.—(E.68(c)) (Rs.2793.)

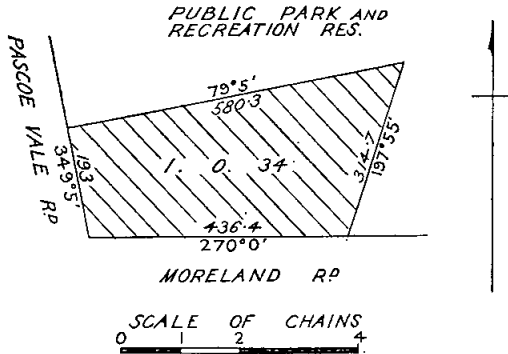

ESKDALE.—The temporary reservation, by Order in Council of the 18th May, 1937, of 1 rood 31 perches of land in the Township of Eskdale, as a site for Camping and Watering purposes.—(E.112(°)) (Rs.4198.)

GEELONG.—The temporary reservation, by Order in Council of the 3rd August, 1954, of 15 acres 1 rood 10 perches, more or less, of land in the City of Geelong, as a site for Public Recreation, is about to be revoked so far only as the portion containing 20 perches, more or less, indicated by hachure on plan hereunder, is concerned.—(G.25(w)) (Rs.7240.)

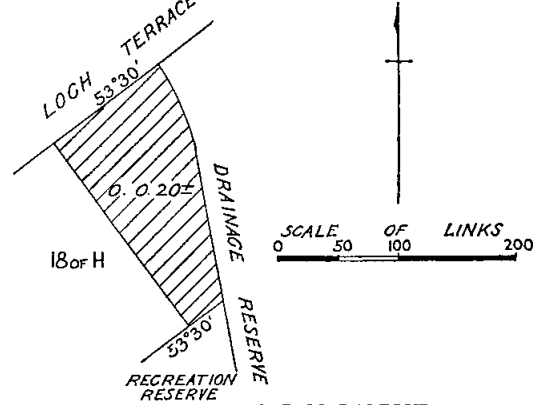

J. C. M. BALFOUR,
Minister of Lands.

PROPOSED REVOCATION OF TEMPORARY RESERVATION, AND THE WITHHOLDING FROM SALE, LEASING, AND LICENSING OF LAND BY ORDER IN COUNCIL.

IN pursuance of the provisions of the *Land Act 1958*, notice is hereby given that it is the intention of the Governor in Council to revoke the temporary reservation, and the withholding from sale, leasing and licensing of land by Order in Council hereunder referred to, viz.:

The following Notice was published 1° on the 16th June, 1965, pursuant to Order of the 9th June, 1965.

JIKA JIKA (NORTH MELBOURNE).—The temporary reservation as a site for Ornamental Plantation and the withholding from sale, leasing and licensing by Order in Council of the 17th July, 1882, of 3 roods 11 perches of land in the Parish of Jika Jika (formerly Town of Hotham).—(M.314(13)) (Rs.8379.)

J. C. M. BALFOUR,
Minister of Lands.

PROPOSED REVOCATIONS OF TEMPORARY RESERVATIONS OF LANDS BY ORDERS IN COUNCIL.

IN pursuance of the provisions of the *Land Act 1958*, notice is hereby given that it is the intention of the Governor in Council to revoke the temporary reservations of lands by Orders in Council hereunder referred to, viz.:

The following Notices were published 1° on the 26th May, 1965, pursuant to Orders of the 18th May, 1965.

BALLARAT EAST.—The temporary reservation, by Order in Council of the 27th June, 1870, of 18½ perches of land in the Township of Ballarat East as a site for a Place of Public Worship in connexion with the Presbyterian Denomination.—(B.128(46)) (C.91802.)

CARWARP.—The temporary reservation, by Order in Council of the 6th November, 1947, of 15 acres of land in the Parish of Carwarp as a site for Public Recreation.—(C.473(°)) (Rs.3288.)

COLVINSBY and WARRAK.—The temporary reservation, by Order in Council of the 7th May, 1877 (see *Government Gazette* of the 11th May, 1877, page 864) of 148 acres 2 roods 28 perches of land in the Parishes of Colvinsby and Warrak as a site for Victorian Water Supply purposes.—(C.367(°)) (C.99359.)

COSTERFIELD.—The temporary reservation, by Order in Council of the 11th January, 1887, of 2 roods 1 perch of land in the Township of Costerfield as a site for Mechanics' Institute, revoked as to part by Order of the 27th February, 1940, is about to be revoked so far as the balance thereof containing 1 rood 15 perches is concerned.—(C.370(c2)) (Rs.1514.)

MOHICAN (BUXTON).—The temporary reservation, by Order in Council of the 13th April, 1965, of 148 acres 2 roods, more or less, of land in the Parish of Mohican as a site for Public purposes (Social Welfare Branch Adventure Camp) is about to be revoked so far only as the portion containing 1 acre 3 roods, more or less, indicated by hachure on plan hereunder, is concerned.—(M.553^(a)) (Rs.8436).

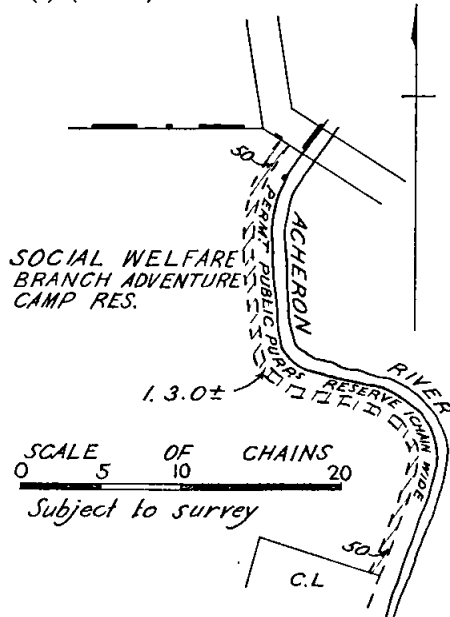

SANDHURST (KENNINGTON).—The temporary reservation, by Order in Council of the 24th September, 1912, of 5 acres 1 rood 9 perches of land in the Parish of Sandhurst as a site for Public Gardens, revoked as to part by Order of the 12th March, 1918, is about to be revoked so far only as the portion containing 1 rood 13 perches, more or less, indicated by hachure on plan hereunder, is concerned.—(S.371⁽²⁰⁾) (Rs.782).

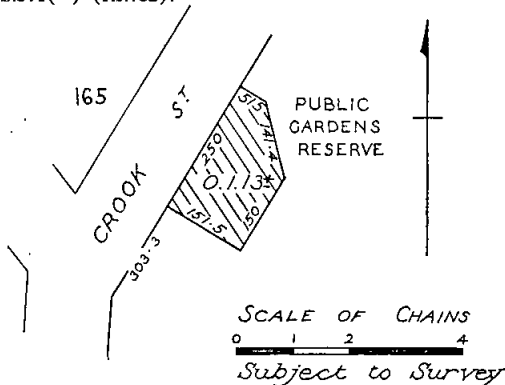

STUARTMILL.—The temporary reservation, by Order in Council of the 29th April, 1921, of 1 acre 2 roods 33 perches of land in the Township of Stuartmill as a site for State School purposes.—(S.355⁽²⁾) (Rs.2126).

WERRAP.—The temporary reservation, by Order in Council of the 27th January, 1920, of 4 acres of land in the Parish of Werrap as a site for State School purposes.—(W.386⁽²⁾) (Rs.2097).

J. C. M. BALFOUR,
Minister of Lands.

LOCAL LAND BOARDS.

IN pursuance of the provisions of section 34 of the Land Act 1958, notice is hereby given that public hearings at the following places and times, will be conducted by the persons respectively mentioned, being duly appointed in that behalf.

J. C. M. BALFOUR,
Minister of Lands.

Department of Crown Lands and Survey,
Melbourne.

SCHEDULE.

BALLARAT PUBLIC OFFICES, Camp-street, Wednesday, 7th July, 1965, at 2.00 p.m.—N. J. Fitzgerald and P. T. Ledger.

OUYEN LAND INSPECTOR'S OFFICE, Wednesday, 14th July, 1965, at 10.30 a.m.—N. J. Fitzgerald.

COMMITTEE OF MANAGEMENT OF RESERVE.

APPOINTMENT.

NOTICE is hereby given that, in pursuance of section 221 of the Land Act 1958, the following appointment of a Committee of Management of Reserved Crown land has been made by the Minister of Lands:—

PUBLIC PURPOSES RESERVE AND THE CAMPING RESERVE IN THE PARISH OF BEULAH.

The Council of the Shire of Karkaroc as a Committee of Management of the reserved Crown land in the Parish of Beulah, shown by hachure on plan hereunder.—(Corres. Rs.8211.)

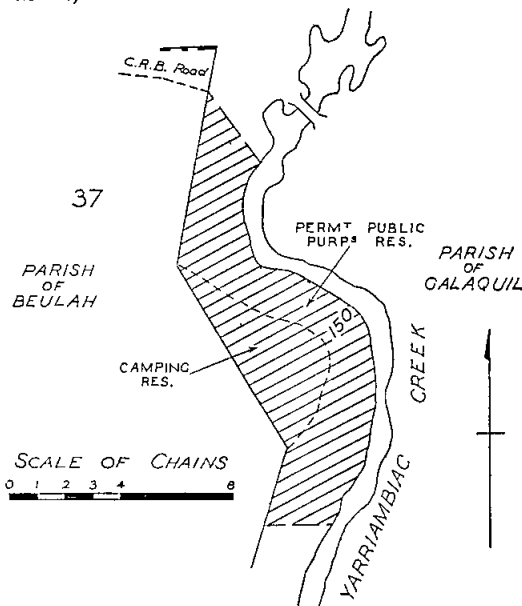

ALAN J. HOLT,
Secretary for Lands.

31st May, 1965.

TENDERS—PUBLIC WORKS DEPARTMENT

TENDERS will be received at the Head Office of the Public Works Department, Treasury-place, Melbourne, until TEN a.m. on the dates shown and for the purposes mentioned hereunder.

Particulars and tender forms may be obtained at the Contracts Office, Room 7, Building Division, Parliament-place, and at the places indicated in brackets after certain items.

The abbreviations shown in the brackets mean the following:—W.O.—Inspector of Works Office; P.S.—Police Station; C.S.—Consolidated School; H.E.S.—Higher Elementary School; H.S.—High School; S.S.—State School; T.S.—Technical School.

Tenders should be submitted on the Department's printed Tender Form and will not be received by telephone. All tenders must be on a "Firm Tender" basis. The lowest or any tender will not necessarily be accepted.

Tenders are to be addressed to the Minister of Public Works, and the envelopes containing the tender is to be clearly marked "Tender for _____, closing Tuesday, _____".

No preliminary deposit is to be lodged with any tender, but a successful tenderer will be required to pay a deposit for any accepted tender of the value of £1,500 or over.

Tuesday, 22nd June, 1965.**Building, Electrical and Mechanical Works.**

Arawata.—Conversion to septic tank, S.S. 2970. (W.O., Korumburra; S.S., Arawata.)

Ellinbank.—Electrical installation in Laboratory and Administration Block, Research Station. (W.O., Warragul.)
Ellinbank.—Erection of brick veneer residence and garage, Dairy Research Station. (W.O., Warragul and Traralgon.)

Geelong.—Electrical installation in Panel Beating Workshop, Gordon Institute of Technology. (W.O., Geelong.)

Hawthorn.—Re-organization of Engineering Laboratories, Swinburne Technical College.

Hawthorn.—Alterations and additions electrical installations, Applied Mechanics, Thermodynamics and Internal Combustion Laboratories, Swinburne Technical College.

Hawthorn.—Supply, installation and testing of Cooling Water, ventilation and exhaust systems and hot-water service for Mechanical Engineering Laboratories, Swinburne Technical College.

Heatherston.—New aluminium glazing to north and south blocks, Sanatorium.

Melbourne.—Installation of P.A.X. system, Agriculture Department, Treasury-place.

Mont Park.—Supply, delivery and fixing on site of new stainless steel benchwork for Meal Service Unit, Ward 6, Mental Hospital. (W.O., Mont Park, Mental Hospital.)

Noradjuha.—New toilet block and install septic tanks, S.S. 1930 and Residence. (W.O., Horsham; S.S., Noradjuha.)

Prahran.—Erection of new High School (Three Storey). (Specified Bills of Quantities.)

Prahran.—Supply and installation of plenum heating, exhaust ventilation and hot-water system, High School.

Preston.—Erection of boiler house, Pleasant View Psychiatric Hospital.

Stawell.—Erection of two Dependent Patients Wards, Pleasant Creek Special School. (W.O., Ararat and Ballarat.) (Bills of Quantities Available.)

Stawell.—Electrical installation for two Dependent Patients Wards, Pleasant Creek Special School. (W.O., Ararat.)

Stawell.—Supply and installation of steam and condensate mains, low and high temperature hot-water systems, plenum and floor heating to two new Dependent Wards, Pleasant Creek Special School. (W.O., Ballarat.)

Viewbank.—Electrical installation in new school of eight L.T.C. class-rooms, &c., S.S. 4892.

Warrnambool West.—New Primary School of eight class-rooms, S.S. 4899. (W.O., Warrnambool.)

Warrnambool West.—Electrical installation, new school of eight L.T.C. class-rooms, &c., S.S. 4899. (W.O., Warrnambool.)

Warrnambool West.—Plenum heating to new eight class-room school, S.S. 4899. (W.O., Warrnambool.)

Werribee.—Erection of residence and garage, Research Farm. (W.O., Geelong.)

Werribee.—Electrical installation in new Dormitory for 27 students, Research Farm.

Furniture and Furnishings.

Melbourne.—Supply of drawing and painting easels, Royal Melbourne Institute of Technology.

Wangaratta.—Supply of benches and display boards, Visual Education Centre, High School. (W.O., Wangaratta.)

Site Works.

Boronia West.—Surface and minor underground drainage, paving (mainly asphalt, some concrete and gravel), and sundry work, S.S. 4908.

Doveton North.—Site works including asphalt paving, concrete paving, drainage and associated works, S.S. 4921. (Police Station, Morwell.)

St. Albans.—New light-duty asphalt, asphalt repairs, drainage works, concreting and gravelling, S.S. 2969.

Wodonga.—Pre-grading of site for proposed Technical School. (W.O., Benalla and Wangaratta; Police Station, Wodonga.)

Miscellaneous.

Carlton.—Maintenance cleaning, 1st July, 1965, to 30th June, 1966, Apprenticeship Commission.

Carlton.—Maintenance cleaning, 1st July, 1965, to 30th June, 1966, State Film Centre, Kelvin-place.

East Melbourne.—Maintenance cleaning, 1st July, 1965, to 30th June, 1966, Mental Health Authority, Clarendon Clinic, 44 Albert-street.

Melbourne.—Maintenance cleaning, 1st July, 1965, to 30th June, 1966, State Offices Annexe, Parliament-place.

Melbourne.—Supply of fire extinguishers from 1st July, 1965, to 30th June, 1966, Public Works Department.

North Fitzroy.—Maintenance cleaning, 1st July, 1965, to 30th June, 1966, School Dental Centre, 658 Nicholson-street.

Prahran.—Maintenance cleaning, 1st July, 1965, to 30th June, 1966, Health Department, Chest Clinic, Clarence-street.

Tuesday, 29th June, 1965.**Building, Electrical and Mechanical Works.**

Back Creek.—Installation of sewerage, S.S. 2025. (W.O., Wangaratta; S.S., Back Creek.)

Baddaginnie.—Bore water supply installation, S.S. 1731 and Residence. (W.O., Benalla; S.S., Baddaginnie.)

Carlton.—New sanitary accommodation and alterations, Residence, Police Station.

Corryong.—Slow combustion stoves to replace open fire-places, Consolidated School. (W.O., Wangaratta; Consolidated School, Corryong.)

Lara.—Electrical installation in Animal House and Banding Shed, Fisheries and Wildlife Reserve, "Serendip". (W.O., Geelong.)

Mordialloc.—Supply, delivery and installation of gas heating, electric sink heaters, circulating fans and removal of existing gas heaters, Police Station.

Nathalia.—Re-roofing Domestic Arts Wing, High School. (W.O., Shepparton.)

Pascoe Vale.—Supply and installation of exhaust system and extensions to heating and hot-water services, Girls' Secondary School.

Pascoe Vale.—Electrical installation, New Art and Music Wing and alterations to existing buildings, Girls' Secondary School.

Royal Park.—Provision and building in, on site, of aluminium door and window frames and glazing at Park Wards, Mental Hospital.

Sandringham.—Electrical installation, lighting improvement and additional power, Technical School.

Traralgon.—Extension of heating system to new classrooms, High School. (W.O., Traralgon.)

Various.—Supply and installation of mechanical services in new Science Blocks, High Schools, Murrumbidgee, McKinnon, Waverley and Mentone.

Various.—Erection of fences at 103 schools in 37 Sub-district contracts, comprising from 1 to 12 schools. The tenderer may tender for all or any of the Sub-district contracts. (W.O., Ballarat, Bendigo, Camperdown, Geelong, Hamilton, Horsham, Maryborough, Mildura, Shepparton, Swan Hill, Traralgon, Wangaratta, Warragul, Warrnambool, Alexandra, Benalla, Kyneton, Korumburra, Ararat and Warracknabeal.)

Wheeler's Hill.—Erection of brick veneer residence and brick garage, Social Welfare Department, "Hillside" Boys' Home.

Furniture and Furnishings.

Preston.—Supply and fix mobile steel shelving in Chemistry Laboratory Store, Technical College.

Site Works.

Cheltenham.—Asphalting, concreting, drainage, asphalt maintenance and associated works, High School.

Lakes Entrance.—Loading and cartage of up to 1,100 cubic yards of stone from the Granite Rock Quarry to the south-west corner of Bullock Island, Ports and Harbors. (W.O., Bairnsdale.)

Lockington.—Construction of new asphalt areas, re-grade asphalt areas, concrete work, drainage and associated works, Consolidated School. (W.O., Bendigo.)

Pinewood.—Earthworks, asphalting, drainage, retaining walls, concreting and associated works, S.S. 4874.

Tongala.—Construction of asphalt and concrete paving, drainage, fire service, beautification and associated works, Consolidated School. (W.O., Bendigo and Shepparton.)

Warrandyte.—Earthworks, asphalting, concreting, drainage and associated works, S.S. 12.

Miscellaneous.

Langi Kal Kal.—Supply of one pneumatic tired wheeled tractor, Training Centre. (W.O., Ballarat.)

Tuesday, 6th July, 1965.**Building, Electrical and Mechanical Works.**

Ararat.—Supply and installation of plenum heating, hot-water system, steam and condensate reticulation for Ward M.6 and Cottage of Ward M.6, Mental Hospital. (W.O., Ararat and Ballarat.)

Benalla.—Modified second and third sections of timber-framed concrete veneer school buildings, Technical School. (W.O., Benalla and Bendigo; P.S., Wodonga.)

Carlton.—Additional storage space to cafeteria and new benches, &c., to kitchen, Melbourne Teachers' College.

Cheltenham.—Repairs and painting, Court House.
 Denison.—Erection of out-offices and septic tank installation, &c., S.S. 4168. (W.O., Traralgon; S.S., Denison.)
 Dookie.—Erection of Chemistry and Biology Laboratory Block, Agricultural College. (W.O., Shepparton; Agricultural College, Dookie.)
 Longerenong.—Erection of Biology and Physics Laboratories, Agricultural College. (W.O., Horsham.)
 Longwarry North.—Conversion to septic tank and bore water supply, S.S. 4272 and Residence. (W.O., Warragul; S.S., Longwarry North.)
 Prahran.—Electrical installation, new three story High School.
 Rutherglen.—Erection of 384 chains of post and wire fencing (labour only), Research Station. (W.O., Wangaratta; Research Station, Rutherglen.)
 Traralgon.—Erection of additional class-rooms, S.S. 4700. (W.O., Traralgon.)
 Traralgon.—Electrical installation in additional six L.T.C. class-rooms, &c., S.S. 4700. (W.O., Traralgon.)
 Various.—Electrical installation in additional Science Wings, High Schools, Balwyn, Macleod, Ashwood and Croydon.

Site Works.

Dandenong.—Site works, including asphalt paving, concrete works, drainage, &c., S.S. 1403. (Police Station, Morwell.)
 Glen Waverley.—Asphalting, concreting, drainage, asphalt maintenance and associated works, S.S. 2219.
 Horsham North.—Construction of asphalt and concrete paving and subsidiary works, S.S. 4926. (W.O., Horsham.)

NOTICE.

The Public Works Department gives notice that tenders based on Drawings and Specified Bills of Quantities will be invited on 16th June, 1965, for construction of the Brunswick High School.

Plans are available at Contracts Office, Room 7, Public Works Department, Parliament-place, Melbourne, for reference purposes, and potential tenderers are requested, for the purpose of obtaining the Specified Bills of Quantities, which will be available on 22nd June, 1965, to register their names before the 22nd June, with the Contracts Clerk.

A further notice will be issued informing tenderers of the date of closing of tenders.

J. C. M. BALFOUR,
 Acting Minister of Public Works.

Public Works Department,
 Melbourne, C.2, 15th June, 1965.

PUBLIC SERVICE NOTICES

No. 1501.

Public Service Act 1958, Section 50.

REGULATIONS.—PART IV.—SALARIES AND INCREMENTS.

THE Public Service Board, in pursuance of the powers conferred by the *Public Service Act 1958*, hereby amends its Regulations as shown below :—

SIXTH SCHEDULE.

TEMPORARY EMPLOYEES.

Designations of Positions and Rates of Salaries.

Department and Designation of Position.	Yearly Rate of Salary.		Increments (Annual).
	Minimum.	Maximum.	
	£	£	
CHIEF SECRETARY'S DEPARTMENT. SOCIAL WELFARE. Youth Welfare Division.			
Add— Cook (Female), Senior ..	881	899	1 of £18

A. GARRAN, Chairman.
 V. P. SCULLY, Secretary.

Office of the Public Service Board,
 Melbourne, 24th May, 1965.

No. 1502.

Public Service Act 1958.

THE Public Service Board, in pursuance of the powers conferred by the *Public Service Act 1958*, hereby amends the Public Service (Public Service Board) Regulations as follows :—

PART VI.—TRAVELLING AND OTHER EXPENSES.

DIVISION II.—MODE OF TRAVELLING.

Regulation 144.

The scale of rates in sub-regulation (1) is deleted and the following scale is inserted in lieu thereof :—

“For cars of 17 h.p. and over .. 5·8d a mile
 For cars under 17 h.p. .. 4·9d a mile.”

DIVISION III.—REIMBURSEMENT FOR USE OF PRIVATE MEANS OF TRANSPORT.

Regulation 145.

The scale of rates in clause (b) of sub-regulation (1) is deleted, and the following scale is inserted in lieu thereof :—

	For the First 5,000 Miles in a Financial Year.	Mileage Over 5,000 Miles in a Financial Year.
	a mile. d.	a mile. d.
Motor Cars—		
17 h.p. and over ..	10·5	5·8
Under 17 h.p. ..	8·9	4·9
Motor Cycles, with side cars ..	4·5	2·5
Motor Cycles ..	3·8	2·2
Bicycles ..	1·3d. a mile irrespective of mileage	

This Regulation shall have effect as on and from the 1st July, 1965.

A. GARRAN, Chairman.
 V. P. SCULLY, Secretary.

Office of the Public Service Board,
 Melbourne, 15th June, 1965.

No. 1500.

Public Service Act 1958, Section 50.

REGULATIONS.—PART IV.—SALARIES AND INCREMENTS.

THE Public Service Board, in pursuance of the powers conferred by the *Public Service Act 1958* hereby amends its Regulations as shown below :—

FIFTH SCHEDULE.

TEMPORARY EMPLOYEES.

DEPARTMENT OF HEALTH.

MENTAL HYGIENE.

Designations of Positions and Rates of Salaries.

Designation of Position.	Yearly Rate of Salary.		Increments (Annual).
	Minimum.	Maximum.	
	£	£	
Delete— Motor Truck Driver ..	989	1,061	2 of £36
Add— Motor Truck Driver— Junior—			
At 18 years of age	703	..
At 19 years of age	800	..
At 20 years of age	910	..
Adult ..	989	1,061	2 of £36

A. GARRAN, Chairman.
 V. P. SCULLY, Secretary.

Office of the Public Service Board,
 Melbourne, 2nd June, 1965.

No. 1499.

*Public Service Act 1958, Section 50.***REGULATIONS.—PART IV.—SALARIES AND INCREMENTS.**

THE Public Service Board, in pursuance of the powers conferred by the *Public Service Act 1958*, hereby amends its Regulations as shown below :—

SIXTH SCHEDULE.**TEMPORARY EMPLOYEES.***Designations of Positions and Rates of Salaries.*

Department and Designation of Position.	Yearly Rate of Salary.		Increments (Annual).
	Minimum.	Maximum.	
	£	£	
GENERAL.			
<i>Delete—</i> Motor Truck Driver ..	989	1,061	2 of £36
<i>Add—</i> Motor Truck Driver— Junior—			
At 18 years of age	703	..
At 19 years of age	800	..
At 20 years of age	910	..
Adult ..	989	1,061	2 of £36

A. GARRAN, Chairman.
V. P. SCULLY, Secretary.

Office of the Public Service Board,
Melbourne, 2nd June, 1965.

PUBLIC SERVICE OF VICTORIA.—VACANCIES.

APPLICATIONS will be received by the Public Service Board up to Wednesday, the 30th June, 1965, from persons employed in the Public Service of Victoria, who are eligible and qualified for appointment to the under-mentioned positions.

ADMINISTRATIVE DIVISION.**Class "B", Education Department.**

Yearly Salary.—£2,028, minimum; £2,148, maximum.

Duties.—Under direction, to supervise the office staff of the Stores Branch; to assist with the preparation of estimates of yearly stock requirements and with the making of recommendations to the Tender Board regarding items to be purchased under contract.

Qualifications.—A knowledge of the Public Accounts and Stores Regulations; a knowledge of departmental regulations and policies regarding the provision of materials and equipment to schools and Government departments would be an advantage.

Class "C1", Motor Registration Branch, Office of the Chief Commissioner of Police, Chief Secretary's Department

Yearly Salary.—£1,558, minimum; £1,668, maximum.

Duties.—To assist in the Cashiers Section in the preparation of the Treasury Statement and the operation of the Dishonored Cheques Account.

Qualifications.—To have a knowledge of accounts and of the Motor Car Acts and Regulations thereunder; to be conversant with the procedures in the various sections of the Branch.

Class "C", State Motor Car Insurance Office, Chief Secretary's Department.

Yearly Salary.—£1,283, minimum; £1,448, maximum.

Duties.—To assist generally in the administration of a section of the Third Party Claims, assess liability and negotiate settlements.

Qualifications.—A good knowledge of Motor Vehicle Insurance and Statute and Common Law relating to Motor Car Claims, ability to conduct correspondence.

Class "C", Motor Registration Branch, Office of the Chief Commissioner of Police, Chief Secretary's Department. (Two vacancies.)

Yearly Salary.—£1,283, minimum; £1,448, maximum.

POSITION No. 1.

Duties.—To assist the Officer in Charge of the subsection dealing with applications for registrations of motor vehicles received from country Police Stations; to check the assessment of fees and Third Party Insurance premiums.

Qualifications.—A knowledge of the Motor Car Acts and Regulations, fees payable thereunder and of the procedures in the various sections of the Branch; ability to control and direct staff.

POSITION No. 2.

Duties.—To assist the Officer in Charge of the Refund Trust Account in the preparation and checking of claims for overpayments and refunds allowable under the Motor Car Acts.

Qualifications.—A knowledge of the Motor Car Acts and Regulations and of fees payable thereunder; ability to control and direct staff.

NOTE.—Separate applications must be submitted for these positions.

Class "C", Department of Crown Lands and Survey.

Yearly Salary.—£1,283, minimum; £1,448, maximum.

Duties.—To assist and relieve the officer in charge of the departmental Expenditure Appropriation Ledger, advances cash book and journal of expenditure. To supervise the registration, charging, checking and passing of accounts for payment by the Treasury.

Qualifications.—A knowledge of the Public Accounts and Stores Regulations, and preferably of those sections of the Acts administered by the Department which authorizes expenditure of public moneys.

Class "C", Division of State Development, Premier's Department.

Yearly Salary.—£1,283, minimum; £1,448, maximum.

Duties.—To collate and prepare statistical information for regional resources surveys and other purposes; to assist in the preparation of reports on the completed surveys and generally.

Qualifications.—Preferably experience in statistical work. Progress towards obtaining an appropriate qualification would be an advantage.

Class "C", Water Supply Department. (Two vacancies.)

Yearly Salary.—£1,283, minimum; £1,448, maximum.

POSITION No. 1.—BENDIGO CENTRE.

Duties.—To assist the District Accounting Officer in Accounting matters including revenue collection.

Qualifications.—A sound knowledge of the incidence of rating and of the Water Act, preferably some experience in rate collecting and a working knowledge of the Public Accounts and Stores Regulations.

POSITION No. 2.—HEAD OFFICE.

Duties.—To assist in the compilation of the records of officers and employees including the preparation of schedules for salary variations; to prepare staff returns as required.

Qualifications.—A good knowledge of Public Service Acts and Regulations.

NOTE.—Separate applications must be submitted for these positions.

PROFESSIONAL DIVISION.**Architect, Classes "B1"—"A", Office of the Housing Commission, Treasury.**

Yearly Salary.—£2,443, minimum; £2,763, maximum.

Duties.—Under the Senior Architect (Supervision) to supervise building construction for the Commission; to control and direct supervisory personnel, District Works Officers and Clerks of Works.

Qualifications.—A qualified Architect with wide practical experience in supervising building construction particularly of a residential nature and in organizing the activities of supervisory personnel.

Clerk of Courts, Grade III., Class "C", Courts Branch, Hamilton, Law Department.

Yearly Salary.—£1,283, minimum; £1,448, maximum.

Qualifications.—As prescribed by Public Service (Public Service Board) Regulation 58.

Cadet Valuer, Class "D", Water Supply Department. (Two vacancies.)

Yearly Salary.—£1,038, minimum; £1,178, maximum.

Qualifications.—A Diploma of Dookie or Longerenong Agricultural Colleges or the Leaving Certificate with—

- The subject, Agricultural Science; or
- progress in the course of study for the examination prescribed by the Commonwealth Institute of Valuers for admission or by the Valuers' Qualification Board; or

(c) three years practical agricultural experience.

Ability to make simple plans of buildings and farms.

NOTE.—The successful applicants must be prepared to undertake a course of study as indicated in (b) above.

TECHNICAL AND GENERAL DIVISION.

Engineering Assessor, State Motor Car Insurance Office, Chief Secretary's Department.

Yearly Salary.—£1,487, minimum; £1,643, maximum.

Duties.—To act as a Motor Car Claims Assessor in the Metropolitan and Country areas.

Qualifications.—An Automotive Engineer with an "A" Grade Certificate of the Victorian Automobile Chamber of Commerce and preferably with practical knowledge of panel beating; ability to assess motor car loss and damage claims and to compile reports. A general knowledge of Motor Car Insurance is desirable.

NOTE.—The successful applicant will be required to carry out both city and country work.

Technical Works Officer, Public Works Department.

Yearly Salary.—£1,331, minimum; £1,435, maximum.

Duties.—To prepare reports, specifications and dimensional sketches for minor alterations and additions, renovations and general maintenance work for various types of buildings. Generally to assist or relieve inspectorial staff as required.

Qualifications.—A qualified and competent tradesman with extensive practical experience in one or more branches of the building industry. Technical certificates in building construction or other trade subjects through technical school courses are desirable.

Technical Assistant (Male), Fisheries and Wildlife Branch, Chief Secretary's Department. (Two vacancies.)

Yearly Salary.—

Junior—At 18 years of age, £703;
at 19 years of age, £800;
at 20 years of age, £910;

Adult—£1,097, minimum; £1,205, maximum.

Duties.—To carry out field and laboratory work associated with wildlife investigations (field work may involve living under rough conditions for periods of several weeks); to carry out other duties as directed.

Qualifications.—To be of good physique and to hold a motor driver's licence; experience of camping; ability to make field observations under rough conditions; to hold the School Intermediate Certificate or equivalent qualification; preferably to have a knowledge of biological laboratory practice and of wildlife, particularly mammals.

Assistant (Male), Grade III., Office of the Chief Commissioner of Police, Chief Secretary's Department.

Yearly Salary.—£1,187, minimum; £1,223, maximum.

Duties.—To be in charge of a section dealing with confidential records and to conduct correspondence.

Qualifications.—Ability to conduct correspondence and to supervise Staff; preferably to be familiar with the organization of the Police Force.

NOTE.—To be eligible to apply for this position, temporary employees or officers of the Technical and General Division other than Assistants (Male), must have passed the Board's examination for registration for appointment as Assistant (Male), Grade I., Technical and General Division.

Water Bailiff, Water Supply Department. (Two vacancies.)

1 vacancy—Red Cliffs Centre.
1 vacancy—Cohuna Centre.

Yearly Salary.—£972, minimum; £1,079, maximum.

Qualifications.—Ability to control and regulate the supply of water to irrigators; keep the necessary records and make arithmetical computations; a knowledge of water supply requirements for crops and grasses grown under irrigation, the methods of preparation of land for irrigation and methods of channel and drain construction and maintenance.

NOTE.—The successful applicant will be required to occupy the official residence provided and vacation of the residence will not be permitted without the express approval of the Water Supply Department. A rental of 10 per cent. of total emolument inclusive of the amount

payable under Regulation 74, less £36 6s. a year will be charged. Occupancy will be subject to a formal tenancy agreement being entered into. Particulars are available from the Water Supply Department.

NOTE.—Separate applications must be submitted for these positions.

Labourer, Public Works Department.

Yearly Salary.—£836, minimum; £853, maximum.

Assistant (Female), Grade II., Motor Registration Branch, Office of the Chief Commissioner of Police, Chief Secretary's Department.

Yearly Salary.—£827, minimum; £845, maximum.

Duties.—To check assessments of registration fees, insurance premiums and applications for drivers' licences, duplicate plates and labels received from country Police Stations.

Qualifications.—A knowledge of the procedure in Inwards Mail Assessment Section and to be conversant with the provisions of the Motor Car Acts relating to registration fees and the Motor Car (Third Party Insurance) Regulations.

NOTE.—The salary rates quoted above do not include the additional amount which is payable under Regulation 74 of the Board's Regulations.

By order,

V. P. SCULLY,

Secretary.

Office of the Public Service Board,
Melbourne, 15th June, 1965.

PUBLIC SERVICE OF VICTORIA.—VACANCIES.

(TEMPORARY APPOINTMENTS.)

APPLICATIONS will be received by the Public Service Board up to Wednesday the 30th June, 1965, from persons who are qualified for appointment to the under-mentioned positions.

Technical Assistant (Male) Department of Crown Lands and Survey.

Yearly Salary.—

Junior—At 17 years of age, £567;
at 18 years of age, £703;
at 19 years of age, £800;
at 20 years of age, £910;

Adult—£1,097, minimum; £1,169, maximum.

Duties.—To assist research workers in field and laboratory work on noxious weeds in Victoria.

Qualifications.—Preferably Intermediate Certificate; an interest in biology, laboratory and field work.

NOTE.—The successful applicant will be required to spend a substantial amount of his time in the field.

Water Bailiff (Relieving), Cobram Centre, Water Supply Department.

Yearly Salary.—£972, minimum; £1,043, maximum.

Duties.—To assist in distribution of water to irrigators and to keep necessary records. To assist in maintenance of irrigation and drainage channels and structures. To relieve water bailiffs as required.

Qualifications.—Physically capable of manual work with ability to carry out clerical work involving keeping of records and preparation of reports. Good personality and preferably some knowledge of irrigation.

Ranger, Birchip Centre, Water Supply Department.

Yearly Salary.—£972, minimum; £1,007, maximum.

Qualifications.—A knowledge of the water requirements and competent to control and regulate the supply of water by channel to landholders; a good knowledge of mechanical equipment used on sand cleaning and other work associated with channel maintenance; ability to carry out repair work to structures of such nature as are provided on a supply channel system. Sufficient clerical ability to prepare time books for men engaged on works. A knowledge of Urban Reticulation Works would be desirable.

Field Assistant (Survey), Grade I., Water Supply Department.

Yearly Salary.—

Junior—Under 16 years of age, £434;
at 16 years of age, £467;
at 17 years of age, £549;
at 18 years of age, £646;
at 19 years of age, £743;
at 20 years of age, £858;

Adult—£938, minimum; £972, maximum.

Duties.—Under the general supervision of a licensed Surveyor to assist in the field duties of a survey party.

Qualifications.—Proved ability in—

- (i) cleaning, ranging and blazing survey lines;
- (ii) plumbing site poles and targets, and/or optically centred targets.
- (iii) measuring by survey tapes, involving the use of plum bob and spring balance;
- (iv) the use of levelling staff;
- (v) the use of optical square, and/or helio, and/or signalling lamp, and/or radio, and/or barometers;
- (vi) accurately placing, making and cutting in position as directed, survey stakes, pegs, trenches, permanent marks, bench marks, and reference marks.

NOTE.—The salary rates quoted above do not include the additional amount which is payable under Regulation 74 of the Board's Regulations.

By order,

V. P. SCULLY,
Secretary.

Office of the Public Service Board,
Melbourne, 15th June, 1965.

PUBLIC SERVICE OF VICTORIA.—VACANCIES.

DEPARTMENT OF HEALTH.
MENTAL HYGIENE BRANCH.

TECHNICAL AND GENERAL DIVISION.

APPLICATIONS will be received by the Public Service Board up to Wednesday, the 7th July, 1965, from persons employed in the Public Service of Victoria, who are eligible and qualified for appointment to the under-mentioned positions:—

Head Nurse (Female), Ballarat.

Yearly Salary.—£1,327 minimum; £1,379 maximum.

Duties.—To assist Principal Nurse in management of female division and to prepare leave sheets and other records as directed by the Principal Nurse; to give lectures to Student Nurses and others.

Qualifications.—A current practising certificate for Mental Nursing. Ability to direct and control staff and patients and to keep records relating thereto.

Charge Nurse (Male). (Three vacancies.)

Sunbury	1 vacancy
Ararat	1 vacancy
Mont Park	1 vacancy

Yearly Salary.—£1,223 minimum; £1,295 maximum.

Duties.—To take charge or sub-charge of a ward in a Mental Hospital and to assist in the training of Student Nurses and others.

Qualifications.—A current practising certificate for Mental Nursing.

NOTE.—Separate applications must be submitted for these positions.

Assistant Head Nurse (Female), Larundel.

Yearly Salary.—£1,187 minimum; £1,275 maximum.

Duties.—To assist Principal Female Nurse in management of Female Division, and to prepare leave sheets and other records as directed; to relieve senior officers as required and give lectures to Student Nurses and others.

Qualifications.—A current practising certificate for Mental Nursing. Ability to direct and control staff and patients and keep records.

Nurse (Male), Senior Surgical Unit, Kew. (Two vacancies.)

Yearly Salary.—£1,223.

Qualifications.—A registered general trained Nurse with surgical and theatre experience.

Deputy Charge Nurse (Male). (Four vacancies.)

Sunbury	1 vacancy
Kew	1 vacancy
Larundel	2 vacancies

Yearly Salary.—£1,151 minimum; £1,187 maximum.

Duties.—To be second in charge of a ward.

Qualifications.—A current practising certificate for Mental Nursing and approved experience.

NOTE.—Separate applications must be submitted for these positions.

Cook (Male), Grade I. (Two vacancies.)

Kew Cottages	1 vacancy
Kew	1 vacancy

Yearly Salary.—£1,025 minimum; £1,079 maximum.

Duties.—To assist in preparation, cooking and serving of meals for patients and staff, and cleanliness of kitchen.

Qualifications.—A knowledge of and experience in large quantity cooking.

NOTE.—Separate applications must be submitted for these positions.

Charge Nurse (Female), Royal Park.

Yearly Salary.—£1,007 minimum; £1,079 maximum.

Duties.—To take charge or sub-charge of a ward in a Psychiatric Hospital and to assist in the training of Student Nurses and others.

Qualifications.—A current practising Certificate for Mental Nursing.

Fireman, Kew.

Yearly Salary.—£972 minimum; £1,025 maximum.

Duties.—To fire boilers and to assist Engineer.

Qualifications.—Boiler Attendant's Certificate or higher qualifications.

Kitchenman, Ballarat.

Yearly Salary.—£904 minimum; £1,007 maximum.

Duties.—To assist Cooks generally, preparation of vegetables and other foodstuffs. Attending to cleanliness of kitchen.

Qualifications.—Some knowledge of cooking is desirable.

Deputy Charge Nurse (Female). (Four vacancies.)

Yearly Salary.—£935 minimum; £971 maximum.

One vacancy—Children's Cottages, Kew.

Duties.—To be second in charge of a ward.

Qualifications.—A current practising certificate for Mental Deficiency Nursing and approved experience.

Three vacancies—Royal Park.

Duties.—To be second in charge of a ward.

Qualifications.—A current practising certificate for Mental Nursing and approved experience.

NOTE.—Separate applications must be submitted for these positions.

Case Aide, (Female). (Eight vacancies.)

Two vacancies—Royal Park;
One vacancy—Mont Park;
One vacancy—Children's Cottages, Kew;
Two vacancies—Larundel;
One vacancy—Kew;
One vacancy—Ballarat.

Yearly Salary—

Junior—Under 16 years of age, £408;
at 16 years of age, £450;
at 17 years of age, £472;
at 18 years of age, £517;
at 19 years of age, £601;
at 20 years of age, £686;

Adult—£810 minimum; £881 maximum.

Duties.—To assist social workers in routine administration and in matters relating to social services, patients' accommodation and personal effects.

Qualifications.—Approved educational standard, mature personality, ability to deal with patients; clerical experience and possession of a driving licence an advantage.

Seamstress, Grade I, Mont Park.

Yearly Salary.—£776 minimum; £827 maximum.

Duties.—To make up and repair clothing and bedding.

Qualifications.—A competent needlewoman and machinist.

The salary rates quoted above do not include the additional amount which is payable under Regulation 74 of the Board's Regulations.

By order,

V. P. SCULLY,
Secretary.

Office of the Public Service Board,
Melbourne, 15th June, 1965.

PUBLIC SERVICE OF VICTORIA.—RECLASSIFICATIONS.

THE Public Service Board has raised the classification of the under-mentioned offices as shown, and appointed thereto the respective officers named hereunder.

Office and Former Classification.	Revised Classification.	Duties.	Qualifications.	Officer Appointed.	
TECHNICAL AND GENERAL DIVISION.					
TREASURY.					
<i>Taxation Office.</i>					
Assistant (Female), Grade I., Grades F9-F12 inclusive	Grade II., F14-F15 inclusive	Grades in-	To count, sort, open and distribute inwards mail; to record registered mail and mail received; to check lists of remittances and prepare them for Cash Register processing	Competent to handle large quantities of mail. A good knowledge of Mail Room and Accounts Branch procedures	Mundy, Mary M.
Assistant (Female), Grade I., Grades F9-F12 inclusive	Grade II., F14-F15 inclusive	Grades in-	To count, sort, open and distribute inwards mail; to check remittances; to operate the daily query list of remittances not readily identifiable	Competent to handle large quantities of mail. A good knowledge of Mail Room and Accounts Branch procedures	Lofthouse, Norma A.
DEPARTMENT OF HEALTH.					
<i>Mental Hygiene Branch—Kew Mental Hospital.</i>					
Farm Assistant, Grades 12-17 inclusive (two offices)	Motor Truck Driver, Grades 17-21 inclusive		To distribute Laundry, Provisions, heavy and light goods, &c., throughout Kew and adjoining Hospitals	To be a licensed Motor Truck Driver	Pickersgill, W. C. Morgan, F. W.

Office of the Public Service Board,
Melbourne, 15th June, 1965.

By order,
V. P. SCULLY,
Secretary.

Teaching Service Act 1958.
TEACHING SERVICE (TEACHERS TRIBUNAL)
REGULATIONS.

AMENDMENT NO. 80.

THE Teachers Tribunal, in pursuance of the powers conferred by the *Teaching Service Act 1985*, hereby amends Regulation 1 of the Teaching Service (Teachers Tribunal) Regulations in the manner following, that is to say:—

Regulation 1.

1. In clause 8, delete the scale of rates and substitute the following scale in lieu thereof:—

	For the First 5,000 Miles in a Financial Year.	Mileage Over 5,000 Miles in a Financial Year.
	pence a mile.	pence a mile.
Motor Cars—		
Over 16 h.p.	10·5	5·8
16 h.p. and under	8·9	4·9
Motor cycles, with side-cars	4·5	2·5
Motor cycles	3·8	2·2
Bicycles	1·3d. a mile irrespective of mileage	

2. In clause 21, delete the scale of rates and substitute the following scale in lieu thereof:—

Motor cars—

Over 16 h.p.	5.8d. a mile.
16 h.p. and under	4.9d. a mile.
Motor cycles	2.2d. a mile.

(To take effect from and including the 1st July, 1965.)

LOUIS F. C. GARLICK, Chairman.
G. FENNELL, Secretary.

Office of the Teachers Tribunal,
Melbourne, 9th June, 1965.

PRIVATE ADVERTISEMENTS

CITY OF BROADMEADOWS.

WHEREAS the Council of the Municipality of Broadmeadows has received an application from the owner of so many of the premises fronting on the under-mentioned streets as in rateable value are the greater part of all premises so fronting, the Council hereby declares the same to be dedicated to the public as public highways:—

All that part of Mascoma-street commencing from a hypothetical line being the westerly extension of the northern boundary of lot 265 on plan of subdivision 66459 then extending in a south-easterly direction and ending at a line bearing 180 deg. 55 min. 30 sec. and 775 ft. 7 in. in length being the eastern boundary of land on plan of subdivision 66459.

All that part of Lockheed-street commencing from a hypothetical line being the easterly extension of the northern boundary of lot 246 on plan of subdivision 66459 then extending in a southerly direction and ending at a hypothetical line being the northern boundary of Mascoma-street on plan of subdivision 66459.

The common seal of the Mayor, Councillors and Citizens of the City of Broadmeadows was hereunto affixed this 7th day of June, 1965.

(SEAL) H. PAYNE, Mayor.
JOHN P. MUTTON, Councillor.
E. F. SMILEY, Town Clerk.

6553

CITY OF FOOTSCRAY.

BY-LAW No. 275.

A By-law of the City of Footscray made under the Local Government Acts and numbered 275 for regulating traffic.

THE Mayor, Councillors and Citizens of the City of Footscray in pursuance of the powers conferred by the Local Government Acts and by every other Act or power enabling it in that behalf order as follows:—

1. "HEAVY TRAFFIC" means and includes motor vehicles ordinarily used in the carriage of goods wares or merchandise (commercial goods) in the course of business and having a load capacity of 3 tons or more, motor vehicles having an unladen weight of 3 tons or more, motor vehicles having an overall length of more than 20 feet but shall not include commercial passenger omnibuses on charter routes or workers trips or motor omnibuses licensed by the Transport Regulation Board travelling with passengers direct to or from terminals. Nothing in this By-law shall be deemed to apply to heavy traffic travelling within the main shopping and business area (hereinafter defined) of the City if and while making bona fide calls to load or unload merchandise or other freight or material of a like nature within such area.

2. "MAIN SHOPPING AND BUSINESS AREA" means the area within the City bounded as follows:—

ON THE WEST by the west side of Albert Street from the north building line of Buckley Street to the south building line of Paisley Street thence west by the south building line of Paisley Street to the east building line of Victoria Street thence north by the east building line of Victoria Street to the south-east building line of Geelong Road.

ON THE NORTH by the rear of allotments of land fronting on the north side of Barkly and Hopkins Streets east from the east building line of Victoria Street to the west building line of Moore Street.

ON THE EAST by the west building line of Moore Street south to a point on the south building line of Hopkins Street opposite the west building line of Moore Street, thence east by the south building line of Hopkins Street to a point on the western alignment of the Melbourne to Williamstown railway easement thence south-west along the said alignment to the north side of Buckley Street.

ON THE SOUTH by the north side of Buckley Street from its eastern end to the west side of Albert Street.

3. During the hours from eight o'clock a.m. to six o'clock p.m. on Mondays, Tuesdays, Wednesdays, Thursdays and Fridays and the hours from eight o'clock a.m. to one o'clock p.m. on Saturdays the driver of heavy traffic shall not proceed through the Main Shopping and Business Area

but shall proceed along any of the following mentioned streets outside the said Area by the most direct route to his destination:—

Victoria Street
Geelong Road
Ballarat Road
Moore Street
Hopkins Street east of Moore Street
Cowper Street
Napier Street
Hyde Street
Buckley Street

Resolution for passing this By-law agreed to by the Council of the City of Footscray on the sixth day of April 1964 and confirmed on the fourth day of May 1964.

The Common Seal of the Mayor, Councillors and Citizens of the City of Footscray was hereunto affixed in our presence by order of the Council.

(SEAL) W. FOGARTY, Mayor.
S. CASSIDY, Councillor.
E. J. SMITH, Town Clerk.

6554

CITY OF HEIDELBERG.

LOAN No. 128.

Construction of Private Streets.

NOTICE is hereby given that at a meeting of the Council of the City of Heidelberg held at the Town Hall, Ivanhoe, on 21st April, 1965, the said Council did agree to the following resolution, that is to say:—

"That the Council do by Special Order and it does hereby resolve to borrow the sum of £50,000 by the grant of a mortgage on the credit of the Mayor, Councillors and Citizens of the City of Heidelberg in accordance with the provisions of the Local Government Act 1958, and Amendments.

The rate of interest to be paid shall be £5 10s. per centum per annum and the said loan shall be liquidated by forty half-yearly repayments of principal together with interest from time to time accruing due on so much thereof as is unpaid at the Commonwealth Savings Bank of Australia, Melbourne.

The purpose for which the said loan shall be applied is for the construction of private streets under the provisions of Division 10 of Part XIX. of the Local Government Act 1958, and Amendments, and the loan shall be liquidated from the receipts of money payable under the schemes under the said Division."

Notice is hereby further given that at the meeting of the said Council, held at the Town Hall, Ivanhoe, on 7th June, 1965, the said resolution was confirmed.

6464 E. C. W. JACK, Town Clerk.

CITY OF MOORABBIN.

BY-LAW No. 267.

NOTICE is hereby given that the Council of the City of Moorabbin has made a By-law under the provisions of the Local Government Act 1958, and numbered 267, for repealing By-law No. 262 and for regulating the conduct of persons using public swimming pools within the municipality.

A copy of the By-law is open for inspection, free of charge, during office hours at the offices of the Council, Nepean Highway, Moorabbin.

Resolution for passing this By-law was agreed to by the Council of the City of Moorabbin on the 3rd May, 1965, and confirmed on the 7th June, 1965.

Dated this 10th day of June, 1965.

6486 V. A. SMITH, Town Clerk.

CITY OF RICHMOND.

LOAN No. 41.

Notice of Intention to Borrow the Sum of £50,000 for Permanent Works and Undertakings.

NOTICE is hereby given that the Council of the City of Richmond proposes to borrow the sum of Fifty thousand pounds on the credit of the municipal revenues of the Mayor, Councillors and Citizens of the said City, such sum to be raised by the grant of a mortgage, in accordance with the provisions of the Local Government Act 1958.

1. The maximum rate of interest that may be paid is £5 15s. per centum per annum.

2. The interest is to be payable half-yearly during the currency of the loan.

3. The period of the loan shall be forty years.

4. The moneys borrowed shall be repayable to State Superannuation Board, Treasury Gardens, Melbourne.

5. The loan is to be liquidated by the creation of a sinking fund pursuant to section 428A of the *Local Government Act 1958*.

6. The purpose for which the loan is to be applied is reconstruction and extension of the Richmond Municipal Abattoirs.

The plans and specifications and the estimate of the cost of the proposed works and a statement showing the proposed expenditure of the moneys to be borrowed are open for inspection at the Town Hall, Richmond, during office hours.

Dated 8th June, 1965.

6465

C. C. EYRES, Town Clerk.

Local Government Act 1958, Part XI, Section 321.

TOWN OF PORTLAND.

RATING ON UNIMPROVED VALUES.

NOTICE is hereby given:

- (i) That the Council of the Town of Portland proposes to rescind the adoption of Part XI. of the *Local Government Act 1958*, relating to "Rating on Unimproved Values";
- (ii) that one-tenth of the persons whose names are inscribed on the municipal roll may by writing under their hands addressed to the chairman or the clerk of the municipality and delivered at the office of the Council within one month after the date of the last publication of the notice, demand that the proposal to rescind the adoption of this Part be submitted to a poll of the ratepayers; and
- (iii) that if no such demand for a poll is made the Council will rescind the adoption of this Part.

By Order of the Council,

E. NOEL T. HENRY, Town Clerk.

10th June, 1965.

6569

SHIRE OF BRIGHT.

LOAN No. 35.

Notice is Intention to Borrow the Sum of £4,400 for Permanent Works and Undertakings.

NOTICE is hereby given that the Council of the Shire of Bright proposes to borrow the sum of Four thousand four hundred pounds on the credit of the municipal revenues of the President, Councillors and Ratepayers of the said Shire of Bright, such sum to be raised by the grant of a mortgage, in accordance with the provisions of the *Local Government Act 1958*.

1. The maximum rate of interest that may be paid is £5 10s. per cent. per annum.

2. The purpose for which the loan is to be applied is the purchase of road plant.

3. The period of the loan shall be six years.

4. The moneys borrowed shall be repayable by providing out of the municipal fund twelve half-yearly instalments of £435 9s. 3d. each, including principal and interest, on the 1st day of March and the 1st day of September during the currency of the loan.

5. Such moneys shall be repayable at the Australia and New Zealand Bank, Melbourne.

The plans and specifications and the estimates of the cost of the proposed works and a statement showing the proposed expenditure of the moneys to be borrowed, are open for inspection at the Municipal Offices, Bright.

Dated 10th June, 1965.

6556

H. G. HAYMES, F.I.M.A., Shire Secretary.

SHIRE OF HEALESVILLE.

LOAN No. 39.

Notice of Intention to Borrow the Sum of £5,750 for Permanent Works and Undertakings.

NOTICE is hereby given that the Council of the Shire of Healesville proposes to borrow the principal sum of Five thousand seven hundred and fifty pounds on the credit of the municipal revenues of the President, Councillors and Ratepayers of the said Shire, such sum to be raised by the grant of a mortgage in accordance with the provisions of the *Local Government Act 1958*.

1. The maximum rate of interest that may be paid is £5 12s. 6d. per cent. per annum.

2. The purpose for which the loan is to be applied is provision of a residence for a council officer.

3. The period of the loan shall be ten years.

4. The moneys borrowed shall be repayable by providing out of the municipal fund twenty half-yearly instalments of approximately £379 16s. 5d. each, including principal and interest, on the 1st day of March and the 1st day of September during the currency of the loan.

The first instalment shall be payable on the 1st day of March, 1966.

5. Such moneys shall be repayable to the Commissioners of the State Savings Bank of Victoria, at the office of the said Commissioners, 139-165 Elizabeth-street, Melbourne.

The plans and specifications and the estimate of the cost of the proposed works and a statement showing the proposed expenditure of the moneys to be borrowed are open for inspection at the office of the Council of the Shire of Healesville, at Healesville.

Dated 8th June, 1965.

6475

W. M. OLIVER, Shire Secretary.

SHIRE OF LILLYDALE.

NOTICE is hereby given that the Council of the Shire of Lillydale has ordered that the following streets and roads shall be named or renamed as set out hereunder:—

Resolution dated 27th February, 1961.

That the deviation road on Lilydale—Montrose road from Leith-road to Mt. Dandenong-road, Montrose be named Swansea-road.

Resolutions dated 24th April, 1961.

That Yering West-road, Yering from Yarra Glen-road westward to Victoria-road be renamed Macintyre-lane.

That Gippsland-road, Lillydale from Cave Hill-road eastward to Anderson-street be renamed Melba-avenue.

Resolution dated 21st August, 1961.

That roads in the Wonga Park area of the West Riding be named as follows:—

Homestead-road from the junction of Yarra-road opposite Bryson-road, easterly, northerly and easterly to the River Yarra.

Yarra-road from the junction of Maroondah Highway northerly to the junction of Jumping Creek-road, (Warrandyte-road) and Dudley-road, thence easterly to the junction of Homestead-road.

Jumping Creek-road from the western boundary of the Shire, easterly to the junction of Yarra-road and Dudley-road.

Reserve-road from Homestead-road in a northerly direction to the River Yarra-road leading in to Witton's Reserve.

Resolution dated 23rd October, 1961.

That Taylor-road, Mooroolbark, from Manchester-road eastward to Hull-road as delineated on plans of subdivision No. 8186 and No. 8906 be renamed Brice-avenue.

Resolution dated 23rd July, 1962.

That the Government road south of allotments 9c and 9H, Parish of Warrandyte, known unofficially as Read's-road be renamed Topping's-road.

Resolution dated the 20th August, 1962.

That Albert-road off Old Gippsland-road, Lillydale on plan of subdivision No. 40721 in the Lillydale Homes Estate be renamed Burton-road.

Resolution dated 19th August, 1963.

That Mountain View-parade in the Sherlock's Hill Estate, Mooroolbark as shown on plan of subdivision No. 19175 within the Shire of Lillydale be renamed Mountview-parade.

Resolution dated 26th October, 1964.

That Ross-road on the southern boundary of Crown allotments 35D, 34c, 33, 31A and 31B, Parish of Gruyere, be renamed Darling-road.

6555

T. H. COWLEY, Shire Secretary.

SHIRE OF MORWELL.

LOAN No. 26.

Notice of Intention to Borrow the Sum of £30,000 for Permanent Works and Undertakings.

NOTICE is hereby given that the Council of the Shire of Morwell proposes to borrow the sum of Thirty thousand pounds on the credit of the municipal revenue of the President, Councillors and Ratepayers of the said Shire, such sum to be raised by the grant of a mortgage in accordance with the provisions of the *Local Government Act 1958*.

1. The maximum rate of interest that may be paid is £5 15s. per centum per annum.

2. The purposes for which the loan is to be applied are:—

Erection of a Municipal Library	£25,000
Part cost of additions and alterations to Municipal Offices	5,000
	£30,000

3. The period of the loan shall be twenty years.

4. The moneys borrowed shall be repayable by providing out of the municipal fund twenty half-yearly instalments of approximately £1,271 15s. 6d. each, including principal and interest, on the 1st day of March and the 1st day of September, during the currency of the loan. The first instalment shall be payable on the 1st day of March, 1966.

5. Such moneys shall be repayable at the National Bank Savings Bank Limited, Melbourne.

The plans and specifications and the estimate of the cost of the proposed works and a statement showing the proposed expenditure of the moneys to be borrowed, are open for inspection at the Shire Office, Morwell.

10th June, 1965.

6495

R. J. LORD, Shire Secretary.

SHIRE OF MORWELL.

LOAN NO. 27.

Notice of Intention to Borrow the Sum of £30,000 for Permanent Works and Undertakings.

NOTICE is hereby given that the Council of the Shire of Morwell proposes to borrow the sum of Thirty thousand pounds on the credit of the municipal revenue of the President, Councillors and Ratepayers of the said Shire, such sum to be raised by the grant of a mortgage in accordance with the provisions of the *Local Government Act 1958*.

1. The maximum rate of interest that may be paid is £5 15s. per centum per annum.

2. The purpose for which the loan is to be applied is:—

Part cost of additions and alterations to Town Hall and Municipal Offices	£30,000
---	---------

3. The period of the loan shall be twenty years.

4. The moneys borrowed shall be repayable by providing out of the municipal fund twenty half-yearly instalments of approximately £1,271 15s. 6d. each, including principal and interest, on the 1st day of March and the 1st day of September, during the currency of the loan. The first instalment shall be payable on the 1st day of September, 1966.

5. Such moneys shall be repayable at the National Bank of Australasia Limited, Melbourne.

The plans and specifications and the estimate of the cost of the proposed works and a statement showing the proposed expenditure of the moneys to be borrowed, are open for inspection at the Shire Office, Morwell.

10th June, 1965.

6498

R. J. LORD, Shire Secretary.

SHIRE OF STAWELL.

ORDER DECLARING PUBLIC HIGHWAY.

IN pursuance of the powers conferred by section 522 of the *Local Government Act 1958*, the Council of the Shire of Stawell doth hereby order that the lands hereinafter described, which have been purchased by it, shall be public highways, viz.:—

All that piece of land being part of Crown allotment 65, Parish of Warra Warra, as described in certificate of title, volume 8417, folio 965.

All that piece of land being parts of Crown allotments 27A, 29, 30A, 31 and 68, Parish of Warra Warra, as described in certificate of title, volume 8424, folio 070.

All that piece of land being part of Crown allotment 46, Parish of Warranook, as described in certificate of title, volume 8430, folio 308.

All that piece of land being part of Crown allotment 14A, Parish of Bellaura, as described in certificate of title, volume 8426, folio 732.

All that piece of land being part of Crown allotment 70, Parish of Wirchilleba, as described in certificate of title, volume 8440, folio 769.

All those pieces of land being parts of Crown allotment 61, Parish of Malakoff, as described in certificate of title, volume 8452, folio 157.

All that piece of land being part of subdivision A of Crown allotment 57, Parish of Bellelen, as described in certificate of title, volume 8481, folio 471.

The common seal of the President, Councillors and Ratepayers of the Shire of Stawell, was hereto affixed this 1st day of June, 1965, in the presence of—

(SEAL) A. H. ELLEN, President.
L. J. CAMPBELL, Councillor.
V. C. NIELSEN, Secretary.

6557

SHIRE OF WERRIBEE.

NOTICE OF INTENTION TO TAKE LAND COMPULSORILY.

NOTICE is hereby given that it is the intention of the Council of the Shire of Werribee, in exercise of the powers conferred on it by the *Local Government Act 1958*, to take compulsorily the following land:—

All that piece of land being part of Crown allotment 1, section 9, in the Parish of Mambourin, and being part of the land described as lot 62 on plan of subdivision No. 5410, lodged in the Office of Titles, Melbourne, the boundaries of which are as follows:—Commencing at a point on the south-east boundary of the said lot 62, distant 2,342 links from the south-west corner of the said lot 62; thence by lines bearing 338 deg. 33 min. 1,127.3 links, 359 deg. 29 min. 334.6 links, 50 deg. 3 min. 319.9 links, 136 deg. 0 min. 189.5 links, 187 deg. 45 min. 478.3 links, 59 deg. 56 min. 231.4 links, 338 deg. 33 min. 906.4 links and 235 deg. 32½ min. 34.2 links to the point of commencement.

The said land is required and being taken for the following work or undertaking by the said Council of providing a site for a depot for the disposal of refuse and rubbish and the erection of an incinerator.

The Council has caused to be prepared maps and other papers showing the nature and extent of such work or undertaking and more particularly describing the said land and the exact site and measurements thereof, and stating that the name of the owner or reputed owner of the said land is Harold Llewellyn Baden Powell, of Market-road, Werribee, Victoria, and the name of the occupier thereof is the said Harold Llewellyn Baden Powell.

The said maps and other papers have been approved by the Council and are now deposited for inspection by all persons interested, at the offices of the Shire of Werribee, situate at Watton-street, Werribee, and may be inspected there, during office hours.

All persons affected by the proposed taking of the land are hereby required to set forth, in writing, addressed to the said Council or to the Municipal Clerk within 40 clear days from the publication of this notice in the *Government Gazette*, all objections which they may have to the taking of the land.

Dated this 11th day of June, 1965.

By order of the Council,

6494

N. G. MINNS, Shire Secretary.

LAND ACT 1958 (No. 6284, AS AMENDED BY ACT No. 7075).

WHEREAS:

I. Application has been made pursuant to sub-section (1) of section 22c of the *Land Act 1958*, by Robert McSparron, formerly of Joel Joel, but now of 240 Forest-street, Ballarat, retired farmer, the trustee for the time being of the Joel Joel Public Hall site, being the land described in the schedule hereto for permission to surrender the said land to Her Majesty Queen Elizabeth the Second.

II. By the said sub-section (1) it is provided that the Attorney-General may by notice published in the *Government Gazette* grant permission to the trustee to surrender the land to Her Majesty, pursuant to the said section 22c and by sub-section (4) of the said section 22c it is further provided that the Attorney-General shall specify the purpose mentioned in section 14 of the *Land Act 1958* for which the land was vested in the trustee or was used or to which the purpose for which it was vested in the trustee or was used is in his opinion substantially similar.

Now I, Vernon Francis Wilcox, as the Minister for the time being acting for or on the behalf of Her Majesty's Attorney-General for the State of Victoria—

(a) Grant permission to the said trustees to surrender the said land to Her Majesty, pursuant to section 22c of the *Land Act 1958*; and

(b) specify pursuant to sub-section (4) of section 22c aforesaid the following purpose mentioned in section 14 of the *Land Act* aforesaid, namely—

“the recreation convenience or amusement of the people”.

SCHEDULE.

All that piece of land being part of Crown allotment 84A, Parish of Joel Joel, and being the whole of the land described in certificate of title, volume 4719, folium 769.

Given under my hand this 28th day of May, One thousand nine hundred and sixty-five—

6547

V. F. WILCOX.

ANY person holding or knowing the whereabouts of original will of Catherine Frances Stow, formerly of 27 McPherson-street, Moonee Ponds, but late of 14 Hoyle-street, Morwell, widow, deceased, kindly contact Patricia O'Donoghue and O'Brien, solicitors, 44 Pascoe Vale-road, Moonee Ponds. 6470

METUNG WATERWORKS TRUST.

BY-LAW No. 1.

NOTICE is hereby given that By-law No. 1 was made by the Metung Waterworks Trust on the 9th day of December, 1964, and was approved by the Governor in Council on 10th March, 1965.

The By-law provides for the following matters:—

1. Interpretation.
2. Licensing of Plumbers.
3. Construction and Arrangement of Works.
4. Materials.
5. Connexions to Mains.
6. Repair.
7. Meters.
8. Misuse and Waste.
9. Private Fire Services.
10. Inspections.
11. Penalties.

The By-law is open for inspection free of charge during normal office hours at the Trust Office, Bruthen.

6502

G. W. RIDSDALE, Secretary.

PORT CAMPBELL WATERWORKS TRUST.

BY-LAW No. 2.

NOTICE is hereby given that By-law No. 2 was made by the Port Campbell Waterworks Trust on the 11th day of February 1965, and approved by the Governor in Council on the 30th day of March 1965.

The By-law provides for the following matters:—

1. Interpretation.
2. Licensing of Plumbers.
3. Construction and Arrangement of Works.
4. Materials.
5. Connexion to Mains.
6. Repair.
7. Meters.
8. Misuse and Waste.
9. Private Fire Services.
10. Inspections.
11. Penalties.

The By-law is open for inspection, free of charge, at the office of the Trust, Shire Offices, at Silvester Street, Cobden.

6477

W. J. HOLTON, Secretary.

GEELONG WATERWORKS AND SEWERAGE TRUST.

PURSUANT to section 60 (2) of the *Geelong Waterworks and Sewerage Act 1958* (No. 6263), notice is hereby given of the intention of the Trust to construct sewers to provide for properties in and adjacent to—

Edol-street and Melbourne-road, North Geelong; Shire of Corio;
 Acacia-street and Downie-crescent, Bell Post Hill; Shire of Corio;
 Greyfern-court and Ferndale-parade, Highton; Shire of South Barwon;
 Thornbury-avenue, Reigate-road, Belle Vue-avenue, Highton; Shire of South Barwon;
 Montpellier-drive, Highton; Shire of South Barwon;
 Montpellier-drive and Lambhill-crescent, Highton; Shire of South Barwon;
 Calder-street, Manifold Heights; City of Geelong West; Portarlington and Wilson roads, Newcomb; Shire of Bellarine;
 Gheringhap-street, Geelong; City of Geelong;

and more particularly as shown on maps which are open for public inspection at the Trust's Offices, Ryrie-street, Geelong, between the hours of 9 a.m. and 4 p.m., daily from Monday to Friday.

Dated this 10th day of June, 1965.

6497

B. C. HENSHAW, Secretary.

SEYMOUR WATERWORKS TRUST.

BY-LAW No. 1.

NOTICE is hereby given that By-law No. 1 was made by the Seymour Waterworks Trust on 15th March 1965, and was approved by the Governor-in-Council on 5th May, 1965.

The By-law provides for the following matters:—

Standing Orders for Regulating and Appointing the Place and Hour of Meetings of the Seymour Waterworks Trust, and Providing for the Management and Conduct of Business Thereat.

The By-law is open for inspection, free of charge, at the office of the Trust, at Tallarook-street, Seymour.

6487

F. D. TRAINOR, Secretary.

Sewerage Districts Acts.

ALEXANDRA WATERWORKS TRUST.

PROPOSED SEWERAGE AUTHORITY.

NOTICE is hereby given that the Alexandra Waterworks Trust has made application to the Honorable the Minister of Water Supply for the constitution of a Sewerage Authority and for the proclamation of a Sewerage District at Alexandra and for the construction, maintenance and continuance of sewerage works within that district under the provisions of the Sewerage Districts Acts.

A general plan and description of the proposed works have been submitted with the application, and copies of same may be seen at the offices of the Trust, Shire Hall, Alexandra, at the offices of the State Rivers and Water Supply Commission, Armadale, and at the offices of the Health Commission, Queen-street, Melbourne.

Dated at Alexandra, the 20th day of May, 1965.

6173

R. G. HATFIELD, Secretary.

NOTICE OF INTENTION TO APPLY FOR A LICENCE TO DIVERT WATER AND CUT RACE (RE-ISSUE) FROM THE BUFFALO RIVER, AT BUFFALO RIVER.

I HEREBY give notice that I intend to apply for a licence empowering me to divert water for a term of eight years to the extent of 47 acre-feet per annum at a maximum rate of 1½ acre-feet per day of 24 hours for the irrigation of tobacco being part of allotment 4A, section 8, Parish of Eurandelong, and to occupy certain Crown lands for works of diversion, and to cut a race thereon.

Any objection to such application must be forwarded, in writing, to reach the State Rivers and Water Supply Commission, Melbourne, before 27th April, 1965, being 30 days from the first publication of this notice.

W. J. MCGUFFIE.

Buffalo River.

6472

NOTICE OF INTENTION TO APPLY FOR A LICENCE TO DIVERT WATER AND CUT RACE (RE-ISSUE) FROM THE BUFFALO RIVER, AT BUFFALO RIVER.

I HEREBY give notice that I intend to apply for a licence empowering me to divert water for a term of eight years to the extent of 24 acre-feet per annum at a maximum rate of 1½ acre-feet per day of 24 hours for the irrigation of tobacco, being part of allotment 3A, section 8, Parish of Eurandelong, and to occupy certain Crown lands for works of diversion, and to cut a race thereon.

Any objection to such application must be forwarded, in writing, to reach the State Rivers and Water Supply Commission, Melbourne, before 27th April, 1965, being 30 days from the first publication of this notice.

W. J. MCGUFFIE.

Buffalo River.

6473

NOTICE OF INTENTION TO APPLY FOR A LICENCE TO DIVERT WATER AND CUT RACE FROM THE OVENS RIVER, AT EVERTON.

I HEREBY give notice that I intend to apply for a licence empowering me to divert eight years to the extent of 27 acre-feet per annum at a maximum rate of 2 acre-feet per day of 24 hours for the irrigation of tobacco, being part of allotments A5 and A20, Parish of Everton, and to occupy certain Crown lands for works of diversion and to cut a race thereon.

Any objection to such application must be forwarded, in writing, to reach the State Rivers and Water Supply Commission, Melbourne, before 11th July, 1965, being 30 days from the first publication of this notice.

GORDON ROBERT HEYWOOD.

Everton, Victoria.

6548

NOTICE OF INTENTION TO APPLY FOR A LICENCE TO DIVERT WATER AND CUT RACE (RE-ISSUE) FROM THE BUFFALO RIVER, AT BUFFALO RIVER.

I HEREBY give notice that I intend to apply for a licence empowering me to divert water for a term of eight years to the extent of 21 acre-feet per annum at a maximum rate of 1½ acre-feet per day of 24 hours for the irrigation of tobacco, being part of allotment 2d, section 7, Parish of Eurandelong, and to occupy certain Crown lands for works of diversion, and to cut a race thereon.

Any objection to such application must be forwarded, in writing, to reach the State Rivers and Water Supply Commission, Melbourne, before 27th April, 1965, being 30 days from the first publication of this notice.

W. J. MCGUFFIE,
Buffalo River. 6474

NOTICE OF INTENTION TO APPLY FOR A LICENCE TO DIVERT WATER AND CUT RACE FROM THE OVENS RIVER, AT BOWMANS FOREST.

WE hereby give notice that we intend to apply for a licence empowering us to divert water for a term of eight years to the extent of 60 acre-feet per annum at a maximum rate of 2 acre-feet per day of 24 hours for the irrigation of 40 acres of tobacco, being part of allotments 4, 1, 1A, 1B, and 14, section 12, and 8c, section N, Parish of Murrungee, and to occupy certain Crown lands for works of diversion, and to cut a race thereon.

Any objection to such application must be forwarded, in writing, to reach the State Rivers and Water Supply Commission, Melbourne, before 7th July, 1965, being 30 days from the first publication of this notice.

W. F. BLAIR & SONS per BRYCE A. BLAIR.
Bowmans Forest, Victoria. 6488

NOTICE OF INTENTION TO APPLY FOR A LICENCE TO DIVERT WATER AND CUT RACE FROM THE OVENS RIVER, AT PEECHELBA.

I HEREBY give notice that I intend to apply for a licence empowering me to divert water for a term of eight years to the extent of 250 acre-feet per annum at a maximum rate of 12 acre-feet per day of 24 hours for the irrigation of 50 acres of lucerne and 150 acres of pasture, being part of allotment 63, Parish of Peechelba, and to occupy certain Crown lands for works of diversion, and to cut a race thereon.

Any objection to such application must be forwarded, in writing, to reach the State Rivers and Water Supply Commission, Melbourne, before 28th June, 1965, being 30 days from the first publication of this notice.

WILLIAM GORE BRETT.
Peechelba. 6489

NOTICE OF INTENTION TO APPLY FOR A LICENCE TO DIVERT WATER AND CUT RACE (RE-ISSUE) FROM THE GOULBURN RIVER, AT THORNTON.

I HEREBY give notice that I intend to apply for a licence empowering me to divert water for a term of fifteen years to the extent of 200 acre-feet per annum at a maximum rate of 5 acre-feet per day of 24 hours for the irrigation of pastures, being part of allotments 32A, 32B and 34, Parish of Eildon, County of Anglesey, and to occupy certain Crown lands for works of diversion, and to cut a race thereon.

Any objection to such application must be forwarded, in writing, to reach the State Rivers and Water Supply Commission, Melbourne, before 17th July, 1965, being 30 days from the first publication of this notice.

THE OAKS FARM.
Private Bag No. 1, Thornton, Vic. 6506

NOTICE OF INTENTION TO APPLY FOR A LICENCE TO DIVERT WATER AND CUT RACE FROM THE OVENS RIVER, AT EUROBIN.

WE hereby give notice that we intend to apply for a licence empowering us to divert water for a term of eight years to the extent of 30 acre-feet per annum at a maximum rate of 1½ acre-feet per day of 24 hours for the irrigation of hops, being part of allotments B8A and part B14b, section 30, Parish of Barwidgee, and to occupy certain Crown lands for works of diversion, and to cut a race thereon.

Any objection to such application must be forwarded, in writing, to reach the State Rivers and Water Supply Commission, Melbourne, before 15th July, 1965, being 30 days from the first publication of this notice.

CARLTON AND UNITED BREWERIES LIMITED.
16 Bouverie-street, Carlton. 6550

NOTICE OF INTENTION TO APPLY FOR A LICENCE TO DIVERT WATER AND CUT RACE (RE-ISSUE) FROM THE OVENS RIVER, AT WHOROLY EAST.

WE hereby give notice that we intend to apply for a licence empowering us to divert water for a term of eight years to the extent of 56½ acre-feet per annum at a maximum rate of 1½ acre-feet per day of 24 hours for the irrigation of 37½ acres of tobacco, being part of allotments 63A and 63B, Parish of Whorouly, and to occupy certain Crown lands for works of diversion, and to cut a race thereon.

Any objection to such application must be forwarded, in writing, to reach the State Rivers and Water Supply Commission, Melbourne, before 15th July, 1965, being 30 days from the first publication of this notice.

CHARLES ERNEST NICOLL.
JANET AGNES NICOLL.
Whorouly East. 6549

TAKE notice that Hilda Wald, of 12 Byrne-avenue, Elwood, and Max Halprin, of 29 Whitmuir-street, Bentleigh, as trustees of the estate of Abraham Wald, deceased, and the said Hilda Wald in her own right, who were partners in the business known as "Swank Styles", have withdrawn from the aforesaid partnership as from the 7th day of March, 1965.

JULIAN MERCER & KIVEN, 224 Queen-street, Melbourne, solicitors for the said Hilda Wald, and Max Halprin. 6551

NOTICE is hereby given that the partnership heretofore subsisting between the undersigned, John Walter Sutton, and Joyce Elma Sutton, carrying on business as butchers, at 712A Skipton-street, Ballarat, under the name of "Sutton's Meat Supply", has been dissolved by mutual consent as from the 3rd day of May, 1965. All debts due to and owing by the said late firm will be received and paid by John Walter Sutton, and Allen Francis Stephens, of 712A Skipton-street, Ballarat, who will continue to carry on the business under the name of "Franklin's Meat Store", at the same place.

Dated at Ballarat the 3rd day of May, 1965.

JOHN W. SUTTON.
J. E. SUTTON.
A. F. STEPHENS.

Witness—MICHAEL SUTTON, solicitor, Ballarat.

DOOLEY-SUTTON & A. W. LONG, solicitors, 43 Lydiard-street south, Ballarat. 6552

Companies Act 1961.—In the matter of MOIR & LOTT PROPRIETARY LIMITED (in Voluntary Liquidation).—Members Winding Up.—Notice of Final Meeting.

NOTICE is hereby given, pursuant to section 272 of the Companies Act 1961, that the Final General Meeting of the members of the above-named company will be held at 44 Queen-street, Melbourne, on the 15th day of July, 1965, at Ten a.m., when I shall lay before the meeting an account how the winding up has been conducted and the property of the company disposed of.

Dated this 10th day of June, 1965.

6490 C. J. WAUGH, Liquidator.

OPAB PROPRIETARY LIMITED,
OF 67 MAUD-STREET, NORTH BALWYN.

NOTICE is hereby given that the shareholders of the above company resolved by a Special Resolution at a General Meeting of Shareholders held at the office of the company, 67 Maud-street, North Balwyn, on the 8th day of June, 1965: "That the company be wound up voluntarily in pursuance of section 254 (1) of the Companies Act 1961".

6484 F. G. COOKE, Secretary.

FANCOURT INVESTMENTS PROPRIETARY LIMITED
(IN VOLUNTARY LIQUIDATION).

NOTICE CONVENING FINAL MEETING OF MEMBERS.

NOTICE is hereby given, in pursuance of section 272 of the Companies Act 1961 that a General Meeting of the members of the company will be held at 8A Church-street, Morwell, on Monday, 19th July, 1965, at Eleven a.m., for the purpose of having an account laid before them, showing the manner in which the winding up has been conducted and the property of the company disposed of, and of hearing any explanation which may be given by the liquidator.

Dated this 7th day of June, 1965.

J. C. BUSH, Liquidator, 8A Church-street, Morwell. 6467

The Companies Act 1961.—In the matter of N. D. PRODUCTS PROPRIETARY LIMITED (in Voluntary Liquidation).—Members Winding Up.

NOTICE is hereby given that at an Extraordinary General Meeting of the above company, duly convened and held at 44 Queen-street, Melbourne, Victoria, on the 8th June, 1965, the following Resolution was proposed and passed as a Special Resolution:—

"That the company be wound up voluntarily and that Charles James Waugh of the firm of Hungerford, Spooner & Kirkhope, chartered accountants, of 44 Queen-street, Melbourne, be appointed liquidator for the purpose of such winding up."

Dated the 8th day of June, 1965.

6492

J. S. SHAW, Secretary.

The Companies Act 1961.—In the matter of GRANCO CONSTRUCTIONS PTY. LTD.—Notice Re Meeting of Creditors, Pursuant to Section 260.

NOTICE is hereby given that a Meeting of Creditors of the above-named company will be held in Room 515, 342 Flinders-street, Melbourne, on Monday, 28th June, 1965, at half-past Ten a.m., the company having convened a meeting of its members for the same day for the purpose of considering a Resolution that the company be wound up voluntarily.

Dated this 7th day of June, 1965.

J. S. GRANT, Director.

Bastian, Bent & Cogle, public accountants, Suite 18, 545 St. Kilda-road, Melbourne, S.C.3. 6468

The Companies Act 1961.—In the matter of BEAUFORT INDUSTRIES PTY. LTD.

NOTICE is hereby given that at an Extraordinary Meeting of the members of the above-named company held on 7th day of June, 1965, it was resolved that the company be wound up voluntarily, and at a meeting of creditors held on the same day, pursuant to section 260, it was resolved that for such purpose Everett Thomson Bent, of Suite 18, 545 St. Kilda-road, Melbourne, accountant, be appointed liquidator.

BASTIAN, BENT & COUGLE, public accountants, Suite 18, 545 St. Kilda-road, Melbourne. 6469

The Companies Act 1961.—In the matter of RED BELL CONSTRUCTION CO. PTY. LTD. (in Voluntary Liquidation).—Members Winding Up.

NOTICE is hereby given that at an Extraordinary General Meeting of the above company, duly convened and held at 44 Queen-street, Melbourne, Victoria, on the 4th day of June, 1965, the following Resolution was proposed and passed as a Special Resolution:—

"That the company be wound up voluntarily and that Ernest Harding Niemann, of 1 Kingston-street, East Malvern, chartered accountant, be appointed liquidator for the purpose of such winding up."

Dated the 4th day of June, 1965.

6491 J. E. MASTWYK, Secretary.

The Companies Act 1961.

J. A. SETEK & COMPANY PROPRIETARY LIMITED.

AT an Extraordinary General Meeting of the members of J. A. Setek & Company Proprietary Limited duly convened and held at 23 Main-road east, St. Albans, on the 8th day of June, 1965, the following Special Resolution was passed:—

"That the declaration of solvency and statement of affairs as submitted by the directors of the company be accepted and this company be now voluntarily wound up."

At the same meeting, Robert Arthur Waters, of 170 Queen-street, Melbourne, was appointed liquidator.

6570

E. SETEK, Secretary.

LEVESON INVESTMENTS PROPRIETARY LIMITED
(IN VOLUNTARY LIQUIDATION).

NOTICE is hereby given that a General Meeting of the company will be held at the offices of H. G. McCutcheon & Co., 34 Queen-street, Melbourne, on Monday, the 21st day of July, 1965, at Twelve o'clock noon, to receive an account showing how the winding up has been conducted and the property of the company disposed of.

Dated this 10th day of June, 1965.

6508

H. W. McCUTCHEON, Liquidator.

NORTHERN BAKERIES (COBURG) PTY. LTD.

(IN VOLUNTARY LIQUIDATION).

NOTICE is hereby given, pursuant to section 272 (2) of the Companies Act 1961, that a General Meeting of the above-named company will be held at the office of Hornemann, Macaw and Oldfield, chartered accountants, 395 Collins-street, Melbourne, on Friday, the 16th day of July, 1965, at 2 o'clock in the afternoon, for the purpose of having an account laid before them, showing the manner in which the winding up has been conducted and the property of the company disposed of and of hearing any explanation that may be given by the liquidator.

Dated this 11th day of June, 1965.

6574

R. W. DAFF, Liquidator.

Companies Act 1961.

W. R. SPEAKMAN & SONS PTY. LTD.

NOTICE OF RESOLUTION.

NOTICE is hereby given that at a General Meeting of the members of W. R. Speakman and Sons Pty. Ltd., duly convened and held at the Institute of Chartered Accountants in Australia, 23 McKillop-street, Melbourne, on the 11th June, 1965, the Special Resolution set out below was duly passed:—

"It is resolved, as a Special Resolution, that the company be wound up by a creditors voluntary winding up, pursuant to section 254 of the Companies Act 1961."

It was also resolved that Kenneth Harold Vial, and Kenneth Conway Keown be appointed to act as liquidators of the company, to act jointly or severally.

Dated this 11th day of June, 1965.

J. MCINTOSH, Secretary.

Fuller, King and Co., 330 Collins-street, Melbourne.

6576

A. R. COMPANY PTY. LTD.

NOTICE is hereby given, pursuant to section 260 of the Companies Act 1961, that a Meeting of the Creditors of the above-named company will be held at the registered office, 295-297 Elizabeth-street, Melbourne, on Wednesday, 30th June, 1965, at Three o'clock in the afternoon, for the purposes mentioned in sections 260, 261 and 262 of the said Act.

Dated the 2nd day of June, 1965.

By order of the Board,

6531

R. W. CULPAN.

The Companies Act 1961.

ALBION QUARRIES LIMITED.

NOTICE OF SPECIAL RESOLUTION, PURSUANT TO SECTION 254 (2).

AT an Extraordinary General Meeting of the members of Albion Quarries Limited, duly convened and held at 141A Arden-street, North Melbourne, on the 10th day of June, 1965, the following Resolution was passed as a Special Resolution:—

"That the company be placed in voluntary liquidation and that Maxwell James Scott of 419 Lonsdale-street, Melbourne, be appointed as liquidator of the company."

6572

D. E. PERKINS, Secretary.

CURNOW HOLDINGS PTY. LTD.

THE following Resolution was passed at an Extraordinary General Meeting of the members of the above-named company held on the 31st day of March, 1965, at 111 Charles-street, Prahran—

"That the company be wound up voluntarily and that Roderick Charles McKenzie be appointed liquidator for the purpose of such winding up and that the assets be distributed in kind, and that the liquidator be authorized at his discretion to make such division of assets as he shall consider fair and equitable between the shareholders entitled thereto."

6514

RODERICK CHARLES MCKENZIE, Liquidator.

The Companies Act 1958.—In the matter of REGAL PLASTICS PROPRIETARY LIMITED (in Liquidation).

NOTICE is hereby given that a First and Final Dividend is intended to be declared in this matter. Creditors who have not proved their debts by the 2nd day of July, 1965, will be excluded from the dividend.

Dated this 11th day of June, 1965.

E. R. SMAIL, Liquidator.

Kennedy, Smail & Middlemiss, 296 Little Lonsdale-street, Melbourne. 6526

WRIGHT STEPHENSON BLOODSTOCK (AUST.)
PROPRIETARY LIMITED (IN VOLUNTARY LIQUIDATION).

NOTICE CONVENING FINAL MEETING OF MEMBERS.

NOTICE is hereby given, in pursuance of section 272 of the Companies Act 1961, that a General Meeting of the members of the company will be held at 330 St. Kilda-road, South Melbourne, on Wednesday, the 21st July, 1965, at 11 a.m., for the purpose of having an account laid before them, showing the manner in which the winding up has been conducted and the property of the company disposed of and of hearing any explanation which may be given by the liquidator.

Dated this 10th day of June, 1965.

A. C. WALLBRIDGE, Liquidator, 330 St. Kilda-road,
South Melbourne. 6501

B. DAVID IMPORT COMPANY PROPRIETARY LIMITED.

NOTICE CONVENING FINAL MEETING, PURSUANT TO
SECTION 272.

NOTICE is hereby given, pursuant to section 272 of the Companies Act 1961, that a General Meeting of the members of the above-named company will be held at 436 St. Kilda-road, Melbourne, on 17th July, 1965, at 10 o'clock in the forenoon, for the purpose of having an account laid before them, showing the manner in which the winding up has been conducted and the property of the company disposed of and of hearing any explanation that may be given by the liquidator.

6503 BRUNO DAVID, Liquidator.

MOORE AND PIZZEY PROPRIETARY LIMITED.

NOTICE OF RESOLUTION.

AT a General Meeting of the members of Moore and Pizzezy Proprietary Limited, held at East Melbourne on the 7th day of June, 1965, the Special Resolution set out below was duly passed:—

"That the company be wound up voluntarily and that F. H. Pizzezy be appointed liquidator for the purpose of winding up."

Dated this 7th day of June, 1965.

6504 FRANK H. PIZZEY, Liquidator.

Companies Act 1961.

JOWETT CARS (AUSTRALIA) PROPRIETARY LIMITED
(IN VOLUNTARY LIQUIDATION).

NOTICE OF FINAL MEETING IN PURSUANCE OF SECTION 272 OF
THE COMPANIES ACT 1961.

NOTICE is hereby given that pursuant to section 272 of the Companies Act 1961 a Final Meeting of the members of the above company will be held at the office of the liquidator, Seventh Floor, 143 Queen-street, Melbourne, on Tuesday, 20th July, 1965, at Ten a.m., for the purpose of presenting the liquidator's account of the winding up and showing how the property of the company has been disposed of.

Dated at Melbourne this 16th day of June, 1965.

J. ARNOLD HANCOCK, Liquidator.

Any shareholder may appoint a proxy to vote on his behalf. A proxy need not be a member of the company.
6562

NOTICE is hereby given in pursuance of section 254 (2) of the Companies Act 1961, that G. R. Emms Proprietary Limited, whose registered office was situated at the office of Hughes, Fincher & Rodda, 290 Latrobe-street, Melbourne, by a Special Resolution passed at a meeting of the shareholders held on the 10th day of June, 1965, agreed that the company be wound up voluntarily.

Dated this 11th day of June, 1965.

6528 N. HARRIS, Liquidator.

The Companies Act 1961.

DIXON BROS. PROPRIETARY LIMITED
(IN VOLUNTARY LIQUIDATION).

NOTICE CONVENING FINAL MEETING OF MEMBERS, PURSUANT
TO SECTION 272.

NOTICE is hereby given, in pursuance of section 272 of the Companies Act 1961, that the Final Meeting of the members of the above-named company will be held at the office of A. H. G. Clarke and Co., 470 Bourke-street, Melbourne, on the 21st day of July, 1965, at 3 p.m., to consider the liquidator's final accounts of the voluntary winding up.

Dated this 11th day of June, 1965.

6500 A. M. LOCKE, Liquidator.

Trustee Act 1958.

NOTICE TO CLAIMANTS.

PURSUANT to the Trustee Act 1958, creditors, next of kin and all other persons having claims in respect of the estate of any deceased person named below are required to send particulars to the legal personal representative or representatives at the address stated, after which date the representative or representatives will distribute the assets, having regard only to the claims of which notice has been received.

Louisa Maggie Harwood, late of Kerang, widow, who died 31st January, 1965.—Claims to the executors, care of Willan & McKenzie, solicitors, Kerang, by 18th August, 1965. 6496

Ada Maria Selina Nolan, late of 7 Johnston-street, Malvern, widow, deceased, who died on the 21st of March, 1965.—Claims to the executor, Reginald Rupert Gray, care of Gray & Gray, solicitors, 188 High-street, Northcote, by the 25th August, 1965. 6573

Robert Arthur, late of Koondrook, farmer, who died on 15th July, 1964.—Claims to the executor, Clive Rupert Arthur, in care of Willan & McKenzie, solicitors, Kerang, by 18th August, 1965. 6541

JESSIE BLANCHE ELLMAN MOORE, formerly of 10 Nott-street, but late of 3 Valley View-road, both East Malvern, in the State of Victoria, widow, DECEASED.

CREDITORS, next of kin and others having claims in respect of the estate of the deceased (who died on the 11th day of March, 1965), are required by the personal representatives, Stanley Lara Caffin, of 43 Allenby-avenue, East Malvern, aforesaid, retired commercial traveller, Allan Warrington Caffin, of 286 Balwyn-road, North Balwyn, in the said State, bank manager, and The Trustees, Executors and Agency Company Limited of 401 Collins-street, Melbourne, in the said State, to send particulars to them, care of the said company, by the 31st day of August, 1965, after which date they will distribute the assets, having regard only to the claims of which they then have notice.

Dated the 10th day of June, 1965.

E. P. JOHNSON & DAVIES, solicitors, 339 Collins-street, Melbourne. 6525

In the will of WILLIAM JAMES DAVIES, late of Fish Point, in the State of Victoria, farmer, DECEASED.

CREDITORS, next of kin and others having claims in respect of the estate of the deceased (who died on the 10th day of March, 1964), are required by the executor, Jack Davies of Fish Point, aforesaid, to send particulars to him, care of the undersigned, by the 25th day of August, 1965, after which date the executor may convey or distribute the assets, having regard only to the claims of which he then has notice.

Dated this 10th day of June, 1965.

ALEC M. HAYES, solicitor, 199 Campbell-street, Swan Hill. 6542

In the will of ROBERT JAMES BRINE, formerly of "Tweedside", Woorinen North, in the State of Victoria, accountant, but late of Swan Hill in the said State, retired accountant, DECEASED.

CREDITORS, next of kin and others having claims in respect of the estate of the deceased (who died on the 18th day of January, 1965), are required by the executor, Cynthia Basingclare Brine of Swan Hill, aforesaid, to send particulars to her, care of the undersigned, by the 25th day of August, 1965, after which date the executor may convey or distribute the assets, having regard only to the claims of which she then has notice.

Dated this 10th day of June, 1965.

ALEC M. HAYES, solicitor, 199 Campbell-street, Swan Hill. 6543

CREDITORS, next of kin and others having claims in respect of the estate of Gordon Leslie Sparkes, late of Murchison, sawmiller, deceased (who died on the 28th day of January, 1964), are hereby required to send particulars of their claims to Phyllis Sparkes, the administratrix of his estate, care of the under-mentioned solicitors, by the 16th day of August, 1965, after which date she will distribute the assets, having regard only to the claim of which they then have notice.

STEWART & STEWART, solicitors, 145 Hogan-street, Tatura. 6505

In the will of HUBERT KILLEEN O'DOHERTY, formerly of Woorinen, in the State of Victoria, but late of Long Gully, in the said State, retired orchardist, DECEASED.

CREDITORS, next of kin and others having claims in respect of the estate of the deceased (who died on the 26th day of May, 1964), are required by the executors, Wilma Frew Wicker and Robert Albert Wicker, both of 42 Lyons-street, White Hills, Bendigo, in the said State, to send particulars to them, care of the undersigned, by the 25th day of August, 1965, after which date the executors may convey or distribute the assets, having regard only to the claims of which they then have notice.

Dated this 10th day of June, 1965.

ALEC M. HAYES, solicitor, 199 Campbell-street, Swan Hill. 6544

In the will of ALLAN GRAHAM HARPER, late of Swan Hill, in the State of Victoria, retired orchardist, DECEASED.

CREDITORS, next of kin and others having claims in respect of the estate of the deceased (who died on the 11th day of December, 1964), are required by the executor, Mary Graham Simpson, of Woorinen, in the said State, to send particulars to her, care of the undersigned, by the 25th day of August, 1965, after which date the executor may convey or distribute the assets, having regard only to the claims of which she then has notice.

Dated this 10th day of June, 1965.

ALEC M. HAYES, solicitor, 199 Campbell-street, Swan Hill. 6545

In the will of LOTTY JENKIN (in the will called Lottie Jenkin), formerly of 8 Maverston-street, Burwood, in the State of Victoria, but late of Woorinen, in the said State, widow, DECEASED.

CREDITORS, next of kin and others having claims in respect of the estate of the deceased (who died on the 7th day of October, 1963), are required by the executors, Hilda Cockroft and David Wallace Cockroft, both of Woorinen, aforesaid, to send particulars to them, care of the undersigned, by the 25th day of August, 1965, after which date the executors may convey or distribute the assets, having regard only to the claims of which they then have notice.

Dated this 10th day of June, 1965.

ALEC M. HAYES, solicitor, 199 Campbell-street, Swan Hill. 6546

GEORGE ALFRED ROSS, late of Euroa, grazier, DECEASED.

CREDITORS, next of kin and others having claims in respect of the estate of the deceased (who died on the 7th day of January, 1964), are required by his trustees, Mary Josephine Ross and Donald George Ross, both of Euroa, widow and grazier respectively, to send particulars to them, care of the under-mentioned firm of solicitors, by the 25th day of August, 1965, after which date the trustees may convey and distribute the assets, having regard only to the claims of which they then have notice.

MAL. RYAN & GLEN, High-street, Mansfield, solicitors for the trustees. 6483

CREDITORS, next of kin and others having claims in respect of the will of Culma Laslett Dawson, late of 1 Errol-street, North Melbourne, service station and garage proprietor, deceased (who died on the 4th day of April, 1962), are required to send the particulars of their claims to the National Trustees, Executors and Agency Co. of Australasia Ltd., of 95 Queen-street, Melbourne, by the 17th day of August, 1965, after which date it will distribute the assets, having regard only to the claims of which it then has notice.

IRVING S. PLOTKIN, SCOTT & OPAT, barristers and solicitors, 379-381 Bourke-street, Melbourne. 6522

JOHN JOSEPH MULLANY, late of 55 Huntingtower road, Armadale, in the State of Victoria, gentleman, DECEASED.

CREDITORS, next of kin and others having claims in respect of the estate of the above-named deceased (who died on the 17th day of April, 1965), are required by the executrix, Mary Monica Mullany, of 55 Huntingtower-road, Armadale, widow, to send particulars to her care of the under-mentioned solicitor, by the 20th day of August, 1965, after which date she may convey or distribute the assets, having regard only to the claims of which she then has notice.

JAMES M. N. MCINTYRE, solicitor, 450 Little Collins-street, Melbourne. 6512

WALTER DENNISTOUN SCOTT, formerly of 317 Beaconsfield-parade, St. Kilda, in the State of Victoria, but late of Tara Hotel, Beach-road, Coogee, in the State of New South Wales, gentleman, DECEASED.

CREDITORS, next of kin and others having claims in respect of the estate of the deceased (who died on the 21st day of August, 1962), are required by the executors, Thomas Graham, and John Stanley Elder, both formerly of 99 Queen-street, Melbourne, in the State of Victoria, but both now of 31 Queen-street, Melbourne, aforesaid, solicitors, to send particulars to them, care of the under-mentioned solicitors by the 21st day of August, 1965, after which date the executors may convey or distribute the assets, having regard only to the claims of which they then have notice.

Dated the 9th day of June, 1965.

MADDEN, BUTLER, ELDER & GRAHAM, solicitors, 31 Queen-street, Melbourne, Victoria. 6523

KATHLEEN DYSON FERGUSON (née BATTINSON), formerly of No. 1 Norfolk-terrace, Rouge Bouillon, St. Helier, but late of the Limes Nursing Home, Green-street, St. Helier, in the Island of Jersey, widow, DECEASED.

CREDITORS, next of kin and others having claims in respect of the estate of the deceased (who died on the 15th day of March, 1965), are required by Perpetual Trustee Company Limited, of 33-39 Hunter-street, Sydney, New South Wales, the attorney under power of the trustee, Midland Bank, Executor and Trustee Company (Channel Islands) Limited, to send particulars to Perpetual Trustee Company Limited, care of Roy Schilling and Co., of 330 Little Collins-street, Melbourne, solicitors, the Melbourne agents for Thomas and Bisley, of 106 Crown-street, Wollongong, solicitors, by the 31st day of August, 1965, after which date the trustee may convey or distribute the assets, having regard only to the claims of which it then has notice.

ROY SCHILLING & CO., solicitors, Hoddle House, 330 Little Collins-street, Melbourne. 6524

CREDITORS, next of kin and others having claims in respect of the estate of Madeleine Allan Downing, late of 77 Roslyn-street, Middle Brighton, widow (who died on the 12th of July, 1964), are to send particulars of their claims to the administrator, The Perpetual Executors and Trustees Association of Australia Limited, at Nos. 100-104 Queen-street, Melbourne, by the 21st August, 1965, after which date it will commence to distribute the assets, having regard only to the claims of which it then has notice.

RENNICK & GAYNOR, solicitors, 473 Bourke-street, Melbourne. 6509

RALPH LEONARD TOFTS, late of lot 3 McGlynn-avenue, South Morang, bricklayer, DECEASED, intestate (who died on the 20th December, 1964).

CREDITORS, next of kin and all other persons having claims against the estate of the deceased, are required by the administratrix, Anita Mary Tofts, to send particulars of their claims to the administratrix, care of the undersigned solicitors, on or before the 18th day of August, 1965, after which date she will distribute the assets, having regard only to the claims of which she then has notice.

HOME, WILKINSON & LOWRY, solicitors, 401 Collins-street, Melbourne. 6510

JOHN STANLEY WILSON GORDON, late of Waubra, in the State of Victoria, farmer, DECEASED (who died on the 10th February, 1965).

CREDITORS, next of kin and all other persons having claims against the estate of the said deceased, are required by the executors The Union-Fidelity Trustee Company of Australia Limited, of 333 Collins-street, Melbourne, and Mary Lauris Gordon, of Waubra, widow, to send detailed particulars of their claims in respect of the said property to the said executors, care of the said company, at 101 Lydiard-street north, Ballarat, on or before the 16th day of August, 1965, after which date it and she will proceed to distribute the said estate, having regard only to the claims of which it and she has notice.

Dated this 16th day of June, 1965.

R. H. RAMSAY & GAUNT, 41 Lydiard-street, Ballarat, solicitors for the executors. 6539

JAMES ALEXANDER CUMING STEWART, late of 1 Kenley-court, Toorak, in the State of Victoria, agricultural scientist, DECEASED.

CREDITORS, next of kin and others having claims in respect of the estate of the deceased (who died on the 8th March, 1965), are required by the personal representatives, James Cuming Stewart, of 1 Kenley-court, aforesaid, company director, and The Trustees, Executors and Agency Company Limited, of 401 Collins-street, Melbourne, in the said State, to send particulars to them, by the 19th August, 1965, after which date the personal representatives may convey or distribute the assets, having regard only to the claims of which they then have notice.

HEDDERWICK FOKES & ALSTON, 103 William-street, Melbourne. 6507

CREDITORS, next of kin and others having claims in respect of the Estate of Violet Madeline Evans, late of 32 Nepean Highway, Mordialloc, married woman, deceased (who died on the 29th April, 1965), are to send their claims to the executors, William Evans and Megam Lewis Evans, care of Allan Moore, LL.B., solicitor, of 406 Lonsdale-street, Melbourne, by the 16th August, 1965, after which date the executors may convey or distribute the assets, having regard only to the claims of which they then have notice.

ALLAN MOORE, LL.B., 406 Lonsdale-street, Melbourne. 6466

CREDITORS, next of kin and others having claims in respect of the estate of Graeme Leslie Kent, late of North Cundare, in the State of Victoria, gentleman, deceased (who died on the 16th day of June, 1964), are to send particulars of their claims to the administratrix, Hanorah Ellen Gordon, care of the under-mentioned solicitors, by the 16th day of August, 1965, after which date the administratrix may convey and distribute the assets, having regard only to the claims of which she then has notice.

P. ARUNDELL & SON, solicitors, Bromfield-street, Colac. 6471

WILLIAM JAMES REDFERN, late of Mansfield, grazier, DECEASED.

CREDITORS, next of kin and others having claims in respect of the deceased (who died on the 1st day of December, 1964), are required by his trustees, Ellen Mary Redfern, of Mansfield, widow, and John William Redfern, of Merton, grazier, to send particulars to them, care of the under-mentioned firm of solicitors, by the 25th day of August, 1965, after which date the trustees may convey and distribute the assets, having regard only to the claims of which they then have notice.

MAL. RYAN & GLEN, High-street, Mansfield, solicitors for the Trustees. 6479

ROBERT WILLIAM ARBUTHNOT, late of Highett-street, Mansfield, motor mechanic.

CREDITORS, next of kin and others having claims in respect of the deceased (who died on the 2nd day of January, 1965), are required by his Administratrix, Susan Brice Arbuthnot, of Highett-street, Mansfield, widow, to send particulars to her, care of the under-mentioned firm of solicitors, by the 25th day of August, 1965, after which date the administratrix may convey and distribute the assets, having regard only to the claims of which she then has notice.

MAL. RYAN & GLEN, High-street, Mansfield, solicitors for the administratrix. 6480

LEILA EVELYN LINDSAY STEEDMAN, late of "Summerlea", Tanti-avenue, Mornington, musician, DECEASED.

CREDITORS, next of kin and others having claims in respect of the estate of Leila Evelyn Lindsay Steedman (who died on the 12th day of September, 1964), are required by the trustees, Edgar Mervyn Harris, of 340 Little Collins-street, Melbourne, and Howard Garnet Alsop, of 7 Moorakynne-avenue, Malvern, to send particulars to them, at care of the office of Harris & McLaren, of 340 Little Collins-street, Melbourne, by the 17th day of August, 1965, after which date the trustees may convey or distribute the assets, having regard only to the claims of which they then have notice.

Dated the 15th day of June, 1965.

OSWALD BURT & CO., solicitors, 178 William-street, Melbourne. 6575

GEORGE ATTA, late of Victoria-street, Mansfield, ambulance station officer.

CREDITORS, next of kin and others having claims in respect of the deceased (who died on the 24th day of December, 1964), are required by his administratrix, Margaret Elizabeth Atta, of Victoria-street, Mansfield, widow, to send particulars to her, care of the under-mentioned firm of solicitors, by the 25th day of August, 1965, after which date the administratrix may convey and distribute the assets, having regard only to the claims of which she then has notice.

MAL. RYAN & GLEN, High-street, Mansfield, solicitors for the administratrix. 6481

WILLIAM JOHN FRANCIS HIGHETT, late of Malcolm-street, Mansfield, retired grazier, DECEASED.

CREDITORS, next of kin and others having claims in respect of the deceased (who died on the 18th day of January, 1965), are required by his trustees, Nellie Highett, of Malcolm-street, Mansfield, widow, and Ian Henry Francis Highett, of "Dalray", Dalray-road, Healesville, grazier, to send particulars to them, care of the under-mentioned firm of solicitors, by the 25th day of August, 1965, after which date the Trustees may convey and distribute the assets, having regard only to the claims of which they then have notice.

MAL. RYAN & GLEN, High-street, Mansfield, solicitors for the trustees. 6482

CREDITORS, next of kin and others having claims in respect of the estate of Elizabeth Jones Connell, late of 39 Belgrave-street, Coburg, in the State of Victoria, married woman (who died on the 2nd day of November, 1964), are required by National Trustees, Executors and Agency Company of Australasia Limited, of 95 Queen-street, Melbourne, (the administrator to which letters of administration with the will dated the 30th day of August, 1946, annexed have been granted by the Supreme Court), to send particulars of their claims to the said company, on or before the 25th day of August, 1965, after which date the said company will distribute the assets, having regard only to the claims of which notice has been received.

M. M. GORMAN, LL.B., solicitor, of 422 Collins-street, Melbourne. 6511

DAVID EDWARD OLIVER, late of 101 Bumbank-street, Ballarat, in the State of Victoria, retired, DECEASED, (who died on the 24th November, 1964).

CREDITORS, next of kin and all other persons having claims against the estate of the said deceased, are required by the executor, William Leslie Henderson, of 112 Gregory-street, Ballarat, manager, to send detailed particulars of their claims in respect of the said property to the said executor, care of R. H. Ramsay & Gaunt, solicitors, Ballarat, on or before the 16th day of August, 1965, after which date he will proceed to distribute the said estate, having regard only to the claims of which he then has notice.

Dated this 16th day of June, 1965.

R. H. RAMSAY & GAUNT, 41 Lydiard-street, Ballarat, solicitors for the executor. 6540

LILY RUTH BARON, formerly of 197 Kooyong-road, Caulfield, late of 11 Fallon-street, Caulfield, spinster, DECEASED.

CREDITORS, next of kin and others having claims in respect of the said deceased, who died 10th day of April, 1965, are required by the executor applying for probate, National Trustees, Executors and Agency Company of Australasia Limited, of 95 Queen-street, Melbourne, to send particulars to it at its address aforesaid, by the 19th day of August, 1965, after which date the executor may convey or distribute the assets, having regard only to the claims of which it then has notice.

BERNARD NOLAN, solicitor, 595 Bourke-street, Melbourne. 6533

WILLIAM ALBERT MINERS, formerly of Launching Place, but late of 657 Waverley-road, Waverley, in the State of Victoria, gentleman, DECEASED.

CREDITORS, next of kin and other persons having claims against the estate of the said deceased, are required to send particulars of same to John Maurice McGarry, the executor of the will of the said deceased, in care of the undersigned, on or before the 23rd day of August, 1965, after which date he will distribute the assets, having regard only to the claims of which he then has notice.

DELANY & DELANY, barristers and solicitors, 270 Campbell-street, Swan Hill. 6534

MONICA BRIDGET BRADY, formerly of Nandaly, but late of Sea Lake, in the State of Victoria, farmer, DECEASED.

CREDITORS, next of kin and other persons having claims against the estate of the said deceased are required to send particulars of same to Thomas Anthony Brady, the executor of the will of the said deceased, in care of the undersigned, on or before the 23rd day of August, 1965, after which date he will distribute the assets, having regard only to the claims of which he then has notice.

DELANY & DELANY, barristers and solicitors, 270 Campbell-street, Swan Hill. 6535

CREDITORS, next of kin and others having claims in respect of the estate of Stanley Richardson, late of 111 Maude-street, Geelong, retired driver, deceased (who died on 13th January, 1965), are to send particulars of their claims to the executors, Ian James Munro, of 20 Herne-street, Geelong West, motor trimmer, and Robert Alexander Richardson, of 4 Exeter-street, Ballarat, factory employee, care of their solicitors, Crawcour & Hollyhoke, whose address appears hereunder, by the 18th day of August, 1965, after which date the said executors will distribute the assets, having regard only to the claims of which they then have notice.

CRAWCOUR & HOLLYHOKE, solicitors, 39 Yarra-street, Geelong. 6536

FLORENCE VICTORIA LEWIS, late of Darmum, married woman, DECEASED.

CREDITORS, next of kin and others having claims in respect of the estate of the deceased (who died on 20th September, 1964), are required by the trustees, Phillip Frank Lewis, veterinary surgeon, and Bessie Edith Lewis, nursing sister, both of 10 Earl's-court, North Balwyn, to send particulars to them care of the undersigned solicitors, by the 19th day of August, 1965, after which date the trustees may convey or distribute the assets, having regard only to the claims of which they then have notice.

GRAY, FRIEND & LONG, solicitors, Warragul. 6537

CREDITORS, next of kin and all others having claims against the estate of Marjorie Elsie Turner, late of 2 Skipton-road, Oakleigh, in the State of Victoria, widow, deceased (who died on the 25th February, 1965), are requested to send particulars of such claims to Lloyd Pym Goode, and Clarence Ernest Arthur Linden, the executors of the above estate, addressed to them at care of Lloyd P. Goode and Company, solicitors, 388 Bourke-street, Melbourne, on or before the expiration of two months from the date of publication hereof, after which date the said executors will distribute the assets, having regard only to the claims of which they shall then have had notice.

LLOYD P. GOODE & CO., solicitors, 388 Bourke-street, Melbourne. 6515

CREDITORS, next of kin and all others having claims against the estate of Frank Ray, late of 213 Orrong-road, Toorak, in the State of Victoria, manufacturer, deceased (who died on 19th May, 1964), are requested to send particulars of such claims to Eric Benson, care of Lloyd P. Goode and Company, solicitors, 388 Bourke-street, Melbourne, the executor of the above estate, at his address on or before the expiration of two months from the date of publication hereof, after which date the said executor will distribute the assets, having regard only to the claims of which he shall then have had notice.

LLOYD P. GOODE & CO., solicitors, 388 Bourke-street, Melbourne. 6516

ANNIE DUNN, formerly of Lancefield, but late of Nazareth House, Cornell-street, East Camberwell, spinster, DECEASED.

CREDITORS, next of kin and others having claims in respect of the estate of the deceased (who died on the 26th day of March, 1965), are required by the personal representative, National Trustees, Executors and Agency Company of Australasia Limited, the registered office of which is at 95 Queen-street, Melbourne, to send particulars to it by the 5th day of September, 1965, after which date the said company may convey or distribute the assets, having regard only to the claims of which it then has notice.

PAUL J. CAREY, solicitor, 396 Little Flinders-street, Melbourne. 6532

CREDITORS, next of kin and all others having claims against the estate of Florence Maria Wale, late of 5 Glass-road, Upper Fern Tree Gully, in the State of Victoria, widow, deceased (who died on the 1st March, 1965), are requested to send particulars of such claims to Andrew Elvin Easton, of 7 Glass-road, Upper Fern Tree Gully, the executor of the above estate, at his address on or before the expiration of two months from the date of publication hereof, after which date the said executor will distribute the assets, having regard only to the claims of which he shall then have had notice.

LLOYD P. GOODE & CO., solicitors, 388 Bourke-street, Melbourne. 6517

MAY VICTORIA BLACK, late of 42 Soudan-street, Coburg, in the State of Victoria, widow, DECEASED.

CREDITORS, next of kin and others having claims in respect of the estate of the deceased (who died on the 3rd day of January, 1965), are to send particulars of their claims to the executor, Henry Joseph Taylor Jones, care of the undersigned solicitors, by the 20th August, 1965, after which date he will proceed to distribute the estate, having regard only to the claims of which he then has notice.

HADEN SMITH & FITCHETT, solicitors, 405 Collins-street, Melbourne. 6518

CREDITORS, next of kin and others having claims in respect of the estate of Bruce George Charles Read, late of 50 Grange-road, Toorak, accountant, deceased (who died on the 26th day of December, 1964), are required by the administratrix, Marie Hunter Read, of Flat 26, 3 Kireep-road, Balwyn, widow, to send particulars of their claims to her, care of Rogers and Gaylard, solicitors, of 281 Collins-street, Melbourne, by the 25th day of August, 1965, after which date the said administratrix will distribute the assets of the deceased, having regard only to the claims of which she then shall have had notice.

ROGERS & GAYLARD, solicitors, 281 Collins-street, Melbourne. 6519

KENNETH CHARLES BONYNGE KELLY, late of 25 Longview-road, North Balwyn, accountant, DECEASED.

CREDITORS, next of kin and others having claims in respect of the estate of the above-named deceased (who died on the 26th day of February, 1965), are required by the executors, National Trustees, Executors and Agency Company of Australasia Limited, of 95 Queen-street, Melbourne, and Marion Edna Kelly, of 25 Longview-road, North Balwyn, widow, to send particulars to the above-named company, by the 16th day of August, 1965, after which date the executors may convey or distribute the assets, having regard only to the claims of which the said company then has notice.

Dated the 14th day of June, 1965.

OSWALD BURT & CO., solicitors, 178 William-street, Melbourne. 6520

CREDITORS, next of kin and others having claims in respect of the estate of Elsie May Low, late of 23 Brindisi-street, Mentone, in the State of Victoria, widow, deceased (who died on 21st March, 1965), are to send the particulars of their claims to the executors, Walter Harold Goodwin, and Albert George Goodwin, in care of Colin Keon-Cohen, 472 Bourke-street, Melbourne, by the 23rd August, 1965, after which date they will distribute the assets, having regard only to the claims of which they then have notice.

Dated the 11th June, 1965.

COLIN KEON-COHEN, solicitor, 472 Bourke-street, Melbourne. 6530

EDWARD CHARLES WORCESTER, late of 16 Howey-street, Gisborne, in the State of Victoria, contractor, DECEASED, intestate.

CREDITORS, next of kin and others having claims in respect of the estate of the said deceased (who died on the 8th day of June, 1964), are required by the administratrix, Beverley Elaine Worcester, of 16 Howey-street, Gisborne, widow, to send particulars in writing to her at the office of the undersigned at Kyneton, by the 31st day of August, 1965, after which date the administratrix, may convey or distribute the assets, having regard only to the claims of which she then has notice.

H. HURRY & SON, solicitors, Kyneton, and at Woodend and Gisborne. 6485

CREDITORS, next of kin and others having claims in respect of the estate of Francis Nankivell, late of Flat 3, 22 Wentworth-avenue, Canterbury, gentleman, deceased (who died on the 18th day of March, 1964), are to send particulars of their claims to the Union-Fidelity Trustee Company of Australia Limited, of 333 Collins-street, Melbourne, by the 17th day of August, 1965, after which date the said company will distribute the assets having regard only to the claims of which it then has notice.

R. WADHAM & DOIG, of 383 Flinders-lane, Melbourne.
6521

LESLIE JOHN RHODES, late of Darnum, farmer,
DECEASED.

CREDITORS, next of kin and others having claims in respect of the estate of the deceased (who died on the 5th February, 1965), are required by the trustee, George Cecil Rhodes, to send particulars to him, care of the undersigned solicitors, by the 31st day of August, 1965, after which date the trustee may convey or distribute the assets, having regard only to the claims of which he then has notice.

GRAY, FRIEND & LONG, solicitors, Warragul. 6538

MARY LUCY ROSS, late of 12 Symonds-street, Hawthorn, in the State of Victoria, widow, DECEASED.

CREDITORS, next of kin and others having claims in respect of the estate of the above-named deceased (who died on the 15th day of April, 1965), are required by the executrix, Alice May Johnston, of 10 Ross-street, Elsternwick, clerk, to send particulars to her, care of the under-mentioned solicitor, by the 20th day of August, 1965, after which date she may convey or distribute the assets, having regard only to the claims of which she then has notice.

JAMES M. N. MCINTYRE, solicitor, 450 Little Collins-street, Melbourne. 6513

CREDITORS, next of kin and others having claims in respect of the estate of Janet Nish Thom, late of 90 Darebin-street, Heidelberg, retired teacher, deceased (who died on the 25th day of March, 1965), are requested to send particulars of such claims to the executor, William James Nish Thom, care of the undersigned, on or before the 26th day of August, 1965, after which date the executor may convey or distribute the assets, having regard only to the claims of which he then has notice.

RONALD STEWART MCINTOSH & CO., of 422 Collins-street, Melbourne; solicitors. 6563

CREDITORS, next of kin and others having claims in respect of Adrian Hope Holloway, late of 36 Mere-weather-avenue, Frankston, in the state of Victoria, gentleman, deceased (who died on 26th day of December, 1963), are required to send written particulars of their claim to Philip Pitt Nind Willis, care of the undersigned, by the 16th day of August, 1965, after which date the executor will distribute the assets, having regard only to claims of which he then has notice.

RALPH FREADMAN, GILES & CO., of 141A Chapel-street, St. Kilda, solicitors for the executor. 6564

CREDITORS, next of kin and others having claims in respect of the estate of Mary Ann Ursula Scarfe, late of 12 Clota-avenue, Box Hill, married woman, deceased (who died on the 17th December, 1954), are to send particulars of their claims to the National Trustees, Executors and Agency Company of Australasia Limited, at 95 Queen-street, Melbourne, by the 19th August, 1965, after which date it will distribute the assets, having regard only to the claims of which it then has notice.

LEACH & THOMSON, solicitors, 472 Bourke-street, Melbourne, 6565

CREDITORS, next of kin and others having claims in respect of the estate of Doris Isabella Caroline Sala, also known as Doris Isabella Sala, late of 3 Blair-road, Glen Waverley, married woman, deceased (who died on the 15th November, 1964), are to send particulars of their claims to The Equity Trustees, Executors and Agency Company Limited, at 472 Bourke-street, Melbourne, by the 19th August, 1965, after which date it will distribute the assets, having regard only to the claims of which it then has notice.

LEACH & THOMSON, solicitors, 472 Bourke-street, Melbourne. 6566

CREDITORS, next of kin and others having claims in respect of the estate of Helen Wilson, formerly of "Bundoran", Glenthompson, but late of Clivedon Mansions, Wellington-parade, East Melbourne, widow, deceased, are required by Brian Russell Martin and Ronald Lowenstern, the executors of the will of the deceased, to send particulars of their claims to the executors at the address shown hereunder, by the 16th day of August, 1965, after which date the executors will distribute the assets, having regard only to the claims of which they have notice.

CAMERON & LOWENSTERN, 62 Thompson-street, Hamilton. 6567

CREDITORS, next of kin and others having claims in respect of the estate of Basil Dundas Wilson, formerly of "Bundoran", Glenthompson, but late of Clivedon Mansions, Wellington-parade, East Melbourne, retired grazier, deceased (who died on the 1st March, 1964), are required by Charles Hector Stamp, the surviving executor of the will of the deceased, to send particulars of their claims to the executor at the address shown hereunder, by the 17th day of August, 1965, after which date the executor will distribute the assets, having regard only to the claims of which he has notice.

CAMERON & LOWENSTERN, 62 Thompson-street, Hamilton. 6568

HAROLD SHAW STUART, late of 175 Melbourne-road, North Williamstown, boilermaker, DECEASED, intestate.

CREDITORS, next of kin and others having claims in respect of the estate of the deceased (who died on the 19th day of May, 1964), are required by the trustee, The Equity Trustees Executors and Agency Company Limited, of 472 Bourke-street, Melbourne, to send particulars to it by the 27th day of August, 1965, after which date the trustee may convey or distribute the assets, having regard only to the claims of which it then has notice.

W. E. PEARCEY & IVEY, 90 William-street, Melbourne, solicitors for the trustee. 6571

CREDITORS and others having claims against the estate of Charles John Frederick Johnston, late of 786 Burwood-road, Hawthorn East, auctioneer, deceased (who died on the 26th day of October, 1964), are required to send particulars in writing of their claims to Oswald Johnston, Agnes Macpherson Bean, Elsie Marion Johnston and Edna May Coulson, in care of the under-mentioned solicitors, the executors of the will of the said deceased, on or before the 17th day of August, 1965, after which date they will distribute the assets, having regard only to the claims of which they shall have had notice.

COOKE & CUSSEN, solicitors, 472 Bourke-street, Melbourne. 6527

CREDITORS, next of kin and others having claims in respect of the estate of Agnes Sarah Shanahan, late of 77 Wright-street, Middle Park, widow, deceased (who died on the 11th day of June, 1964), are required by The Union-Fidelity Trustee Company of Australia Limited, of 333 Collins-street, Melbourne, the administrator, with the will annexed of the estate of the said deceased, to send particulars of their claims to the said company, at its address aforesaid, by the 24th day of August, 1965, after which date the said company will distribute the assets of the estate of the said deceased, having regard only to the claims of which it then has notice.

JOHN MORAN & HAYES, solicitors, 422 Collins-street, Melbourne. 6529

In the Supreme Court of the State of Victoria.

SALE BY THE SHERIFF.

ON Tuesday, the 27th of July, 1965, at 10 a.m., at the Police Station, Beaumaris (unless process be stayed or satisfied):—

All the estate and interest (if any) of David Jarrett, of 19 Woff-street, Beaumaris, salesman, as joint proprietor with Berwyn Frances Burke as tenants-in-common in equal shares of an estate in fee-simple in the land described in certificate of title, volume 7493, folio 081, upon which is erected a 6-roomed brick-veneer dwelling house known as No. 19 Woff-street, Beaumaris.

Registered mortgage No. B.511025 affects the said estate and interest.

Terms: Cash only.

DAVID J. JOHNSTON, Sheriff's Officer.

9th June, 1965.

6560

In the Supreme Court of the State of Victoria.
 SALE BY THE SHERIFF.

ON Friday, the 23rd of July, 1965, at 10 a.m., at the Police Station, Essendon (unless process be stayed or satisfied):—

All the estate and interest (if any) of Horst Creyaufmueller & Dagmar Creyaufmueller, bread carter and married woman respectively, both formerly of 22 Milleara-road, East Keilor, as joint proprietors of an estate in fee-simple in the land described in certificate of title, volume 8358, folio 609, upon which is erected a brick-veneered dwelling house known as No. 22 Milleara-road, East Keilor.

Registered mortgages Nos. B444080 and C129031 affect the said estate and interest.

Terms: Cash only.

N. FROGLEY, Sheriff's Officer.
 10th June, 1965. 6561

IMPOUNDINGS

BEAR'S LAGOON.—Impounded in Bear's Lagoon Pound.

124 Merino wethers, notch on back and front of left ear, green brand on back

If not claimed and expenses paid, to be sold on 23rd June, 1965.

G. TURNER,
 Poundkeeper.
 6493—14/

COBRAM.—Impounded in Cobram Pound.

1 red Shorthorn heifer, slit in right ear, no visible brand

If not claimed and expenses paid, to be sold on 23rd June, 1965.

R. T. CUTTS,
 Shire Secretary.
 6499—12/

COLERAINE.—Impounded in Coleraine Pound by, W. C. Bennett, from Tarrenlea

No. 26. Romney Marsh ram, front notch, back notch, top notch near ear and punch hole near ear, back notch and top notch off ear, indistinct brand

If not claimed and expenses paid, to be sold on 26th June, 1965.

GEO. SPONG,
 Poundkeeper.
 6476—18/

GISBORNE.—Impounded in Gisborne Pound.

5 black heifers, about nine months old, no visible brand
 1 black steer, about nine months old, no visible brand
 1 black and white steer, about nine months old, no visible brand

If not claimed and expenses, paid to be sold on 26th June, 1965.

N. L. TUNSTON,
 Poundkeeper.
 6478—18/

YARRA GLEN.—Impounded in Yarra Glen Pound.

1 Black Polled steer, tag on near ear, no visible brand
 2 black and white heifers, no visible brand

If not claimed and expenses paid, to be sold on 5th July, 1965.

J. A. ELLIS,
 Poundkeeper.
 6577—14/

Subordinate Legislation Act 1962.

NOTICE OF MAKING OF STATUTORY RULES.

IN pursuance of the provisions of the *Subordinate Legislation Act 1962* and the Regulations made thereunder, notice is given of the making of the following statutory rules:—

No.		Price. s. d.
	<i>Teaching Service Act 1958.</i>	
81/1965.	Education Department Regulations 1962 (Amendment No. 5)	1 0
	<i>Melbourne Harbor Trust Act 1958.</i>	
82/1965.	Melbourne Harbor Trust (Amendment of Special Berth Charges) Regulations No. 61	0 6

Copies of these statutory rules may be purchased at the Sale of Publications Section of the Government Printing Office, located at Macarthur-street, Melbourne, C.2. If ordered by mail, remittance should be addressed to "The Government Printer, Box 203, P.O., North Melbourne, N.1.", and should include 6d. extra for postage.

A. C. BROOKS,
 Government Printer.

CONTENTS

	PAGE
Acts of Parliament	1873
Appointments	1890
Cemeteries—Scale of Fees	1886
Contracts	1881
Courts	1882
Estates of Deceased Persons	1875
Government Notices	1875
Impoundings	1924
Lands	1902
Melbourne and Metropolitan Board of Works— Notice	1885
Mining	1885
Notice of Making of Statutory Rules	1924
Orders in Council— Acts—Land; Country Roads; Health; Town and Country Planning; Water; Shell (Corio to Williamstown) Pipelines; Melbourne and Metropolitan Tram- ways; Land Tax (Rates and Appeals).	1891 et seq
Private Advertisements	1913
Proclamations	1873
Public Service Notices	1908
Regulations— Acts—Teaching Service	1912
Resignations	1891
State Rivers and Water Supply Commission	1884
Tenders	1906
Transport Regulation Board—Public Hearings	1876
Waterworks Trusts	1880