



# VICTORIA GOVERNMENT GAZETTE

Published by Authority

[Registered at the General Post Office, Melbourne, for transmission by post as a newspaper.]

No. 561

WEDNESDAY, JULY 14

1965

UNITED MUNICIPAL AND GOLDFIELD COMMON OF  
CLUNES DIMINISHED.

POISONS ACT 1962 (No. 6889).

## PROCLAMATION

By His Excellency the Governor of the State of Victoria and its Dependencies in the Commonwealth of Australia, &c., &c., &c.

WHEREAS by Division 12 of Part 1, of the *Land Act 1958* it is amongst other things enacted that the Governor in Council may from time to time increase, and, after one month's notice in the *Government Gazette*, diminish, alter, or abolish, any common and may from time to time re-proclaim the whole or any part of any such common for any of the purposes and subject to the provisions of the said Part of the said Act, and that nothing therein contained shall prevent the exercise of the powers conferred by the said Part of the said Act with respect to the leasing or licensing of any land comprised in any common: And whereas notice of the intention to diminish the United Municipal and Goldfield Common of Clunes has been duly published in the *Government Gazette* for one month:

Now therefore I, the Governor of the State of Victoria in the Commonwealth of Australia, by and with the advice of the Executive Council of the said State, do hereby diminish the United Municipal and Goldfield Common of Clunes by deducting therefrom 1 rood 32 perches of land being Allotment 12, Section 21, Township of Clunes.—(Rs.398.)

Given under my Hand and the Seal of the State of Victoria aforesaid, at Melbourne, this sixth day of July, in the year of our Lord One thousand nine hundred and sixty-five, and in the fourteenth year of the reign of Her Majesty Queen Elizabeth II.

(L.S.)

ROHAN DELACOMBE.

By His Excellency's Command,

JIM BALFOUR,  
Minister of Lands.

GOD SAVE THE QUEEN!

## PROCLAMATION

By His Excellency the Governor of the State of Victoria and its Dependencies in the Commonwealth of Australia, &c., &c., &c.

WHEREAS by section 4 of the *Poisons Act 1962* it is amongst other things enacted that the Governor in Council may by Proclamation published in the *Government Gazette* amend any of the Schedules One, Two, Three, Four, Five, Six, Seven or Eight to such Act by adding to any such Schedules or removing therefrom any item:

Now therefore, I, the Governor of the State of Victoria in the Commonwealth of Australia by and with the advice of the Executive Council of the said State, by virtue of the provisions of the said section and all other enabling powers, do by this Proclamation—

1. Amend Schedule Four to the said Act by adding thereto the following item—

DIMETHYL SULPHOXIDE for therapeutic use.

2. Amend Schedule Six to the said Act by adding thereto the following item—

DIMETHYL SULPHOXIDE except when included in Schedule Four.

Given under my Hand and the Seal of the State of Victoria aforesaid, at Melbourne, this sixth day of July, in the year of our Lord One thousand nine hundred and sixty-five, and in the fourteenth year of the reign of Her Majesty Queen Elizabeth II.

(L.S.)

ROHAN DELACOMBE.

By His Excellency's Command,

J. ROSSITER,  
Acting Minister of Health.

GOD SAVE THE QUEEN!

## PUBLIC HIGHWAY.—CITY OF NUNAWADING.

## PROCLAMATION

By His Excellency the Governor of the State of Victoria and its Dependencies in the Commonwealth of Australia, &c., &c., &c.

WHEREAS by the *Local Government Act 1958*, as amended, section 519 it is amongst other things enacted that it shall be lawful for the Governor in Council at any time and from time to time upon request of the Council of any municipality by notice in the *Government Gazette* to proclaim any land reserved used or by purchase or exchange acquired for a street road highway thoroughfare bridge square court alley or right-of-way or any street road lane or passage made or laid out or proposed to be made or laid out on any land of which a plan delineating that street road lane or passage has been lodged with the Registrar of Titles to be a public highway and that such land shall thereupon and thenceforth from the date of such proclamation become and be absolutely dedicated to the public as a public highway within the meaning of any law then or thereafter in force:

And whereas the Council of the City of Nunawading has requested that the land hereinafter mentioned, used for a street, be so declared to be a public highway.

Now therefore I, the Governor of the State of Victoria in the Commonwealth of Australia, by and with the advice of the Executive Council of the said State, do by this Proclamation declare that Clare-street coloured brown on plan of subdivision No. 8214 lodged in the Office of Titles shall be a public highway within the meaning of the said Act.

Given under my Hand and the Seal of the State of Victoria aforesaid, at Melbourne, this sixth day of July, in the year of our Lord One thousand nine hundred and sixty-five, and in the fourteenth year of the reign of Her Majesty Queen Elizabeth II.

(L.S.) ROHAN DELACOMBE.

By His Excellency's Command,  
R. J. HAMER,  
Minister for Local Government.

GOD SAVE THE QUEEN!

*Filled Milk Act 1958.*

## NOTICE.

I, GILBERT LAWRENCE CHANDLER, Minister of Agriculture, hereby give notice that I have specified as a product exempted from the operation of the *Filled Milk Act 1958* (No. 6468) the product known as "Fortilac", the composition of which is as follows:—

## Constituents:

Vitamins A, B1, B2, C, D3, E, K3, calcium pantothenate, nicotinic acid, procain penicillin, streptomycin sulphate, calcium chloride, magnesium chloride, iodised sodium chloride, dicalcium phosphate, copper sulphate, zinc sulphate, iron sulphate, cobalt sulphate, skim milk powder, refined coconut oil, refined palm oil, lard, soybean lechithin, mutton tallow, beef oleo.

## Analysis:

|                              |                   |
|------------------------------|-------------------|
| Crude protein (min.)         | 3%                |
| Crude fat (min.)             | 90%               |
| Crude fibre (max.)           | Nil               |
| Added salt (NaCl) (max.)     | 0.4%              |
| Vitamin A                    | 180 I.U. per gram |
| Vitamin D3                   | 75 I.U. per gram  |
| Vitamin B1                   | 25 mcg. per gram  |
| Vitamin B2                   | 45 mcg. per gram  |
| Vitamin C                    | 900 mcg. per gram |
| Vitamin E                    | 540 mcg. per gram |
| Vitamin K3                   | 18 mcg. per gram  |
| Vitamin Nicotinic acid       | 450 mcg. per gram |
| Vitamin Calcium pantothenate | 90 mcg. per gram  |

G. L. CHANDLER,  
Minister of Agriculture.

*State Savings Bank Act 1958, Section 30.*  
THE STATE SAVINGS BANK OF VICTORIA.  
ESTABLISHMENT OF BRANCH.

THE Commissioners of The State Savings Bank of Victoria hereby give notice of the establishment of a Branch of the Bank at 1213c Howitt-street, Wendouree, on 15th July, 1965.

T. E. HALL,  
General Manager.

## MELBOURNE CRICKET GROUND.

## AMENDMENT OF REGULATION.

WHEREAS by section 9 of the *Melbourne Cricket Ground Act 1933* (No. 4149), the trustees appointed thereunder have power from time to time, with the approval of the Governor in Council, to make Regulations as therein provided, and with like approval to repeal or amend such Regulations: And whereas the said Act provides that the Regulations relating to the Metropolitan Cricket Ground in force immediately before the commencement of the said Act shall be deemed to have been made pursuant to the said Act and shall remain in force until repealed under the said Act: And whereas Regulations relating to the Melbourne Cricket Ground have been made from time to time both before and after the commencement of the said Act: And whereas it is in the opinion of the trustees, the Honorable Henry Edward Bolte, Honorable Arthur Augustus Calwell, Honorable Gilbert Lawrence Chandler, Honorable Patrick Leslie Coleman, Honorable Leslie William Galvin, Honorable Thomas Hayes, Honorable Patrick John Kennelly, Alan Judge Holt, Honorable Murray Victor Porter, Sir Kenneth George Luke, Frank Livesey Mauger, Right Honorable Robert Gordon Menzies, Edward Leonard Moran, Honorable John Gladstone Black McDonald, Honorable Arthur Gordon Rylah, Honorable Keith Hector Turnbull, William Joseph Dowling and Samuel John Everett Loxton, necessary and expedient to amend one of such Regulations:

Now therefore, we, the undersigned, a statutory majority of the said trustees for the time being of the land described in the Fifth Schedule to the principal Act as enlarged, pursuant to the provisions of the *Melbourne Cricket Ground Act 1951*, numbered 5614, together with all improvements thereon, do by virtue of all the powers thereunto us enabling hereby amend Regulation No. 20 and substitute therefor the following:—

## REGULATION 20.

The maximum scale of fees which shall be charged and collected by the trustees for admission to the Second and Fourth Divisions of the Reserve on such days as it may be set apart for cricket matches or football matches, or any other outdoor game or sports or amusements, shall (in addition to any tax payable under any law other than the said Act on or in respect of such fees or admissions) be as follows:—

- (a) For admission of every person to the Second Division on any such day such a sum as the trustees may from time to time determine not exceeding Twelve shillings and six pence (12s. 6d.)
- (b) For a reserved seat or reserved accommodation in the Second Division and the booking thereof on any such day such additional sum as the trustees may from time to time determine not exceeding Five shillings (5s.).
- (c) For admission of every person to the Fourth Division on any such day such a sum as the trustees may from time to time determine not exceeding Eight shillings (8s.).
- (d) For a reserved seat or reserved accommodation in the Fourth Division and the booking thereof on any such day such additional sum as the trustees may from time to time determine not exceeding Four shillings (4s.).

Dated at Melbourne, this seventeenth day of May, 1965.

HENRY E. BOLTE.  
ARTHUR A. CALWELL.  
G. L. CHANDLER.  
P. L. COLEMAN.  
T. HAYES.  
P. J. KENNELLY.  
ALAN J. HOLT.  
K. G. LUKE.  
E. L. MORAN.  
KEITH H. TURNBULL.  
W. J. DOWLING.  
S. J. E. LOXTON.

Approved by the Governor in Council, 6th July, 1965.—  
J. COLQUHOUN, Clerk of the Executive Council.

STATE RIVERS AND WATER SUPPLY COMMISSION.  
SECRETARY OF THE COMMISSION.

NOTICE is hereby given that Geoffrey Wilfrid Valentine Lewis has been appointed to the position of Secretary of the State Rivers and Water Supply Commission.

A. L. TISDALL, Chairman,  
State Rivers and Water Supply Commission.  
Melbourne, 9th July, 1965.

Commercial Goods Vehicles Act.  
TRANSPORT REGULATION BOARD.

## HEARING OF APPLICATION.

NOTICE is hereby given that the following applications will be considered by the Transport Regulation Board at its offices at Rathdown-street, Carlton, at 10.15 a.m., on Thursday, 5th August, 1965.

- ANDREWS, R. G. & N. R., 6 Wyuna-road, Caulfield. One commercial goods vehicle (L/C. 198 cwt.) to operate within a 50-mile radius of the premises of The Readymix Group (Vic.) at Huntingdale as a specially constructed agitator vehicle—premixed concrete solely on behalf of the said company.
- ANSELL RUBBER CO. PTY. LTD., corner River and Crown streets, Richmond. Four commercial goods vehicles (L/C. 6, 7, 6 and 6 cwt.) to operate in course of business as "Rubber Goods Manufacturers and Distributors" for the delivery of goods as follows:— (a) Within a 50-mile radius of Melbourne. (b) From any railway station within the State of Victoria to places within a 50-mile radius thereof and between any such railway station and places en route to Melbourne or return journeys to Melbourne in the course of business as "Rubber Goods Manufacturers and Distributors"—own goods.
- BAYVIEW QUARRIES PTY. LTD., 602 St. Kilda-road, Melbourne. One commercial goods vehicle (L/C. 200 cwt. approx.) to operate within a 50-mile radius from own premises at North Melbourne in the course of business as "Pre-mixed Concrete Manufacturers" premixed concrete in a specially constructed agitator vehicle.
- BEAUREPAIRE TYRE SERVICE PTY. LTD., 102 Victoria-street, Carlton. Two commercial goods vehicles (L/C. 6 and 8 cwt.) to operate within a 50-mile radius from own premises at Nhill in the course of business as "Tyre Retreaders and Distributors"—tires and tubes for sale and delivery, used tires for retreading or repair, or having been repaired or retreaded, batteries, oil and motor car accessories.
- BROCKOFF'S BISCUITS PTY. LTD., 53-71 Huntingdale-road, Burwood. One commercial goods vehicle (L/C. 64 cwt.) to operate within a 50-mile radius of own branch premises at Ballarat in the course of business as "Biscuit Manufacturer"—own goods.  
NOTE.—All goods to be initially consigned by rail to Ballarat.
- BROCKOFF'S BISCUITS PTY. LTD., 53-71 Huntingdale-road, Burwood. One commercial goods vehicle (L/C. 61 cwt.) to operate within a 50-mile radius of own branch premises at Morwell in the course of business as "Biscuit Manufacturers"—own goods.  
NOTE.—All goods to be initially consigned by rail to Morwell.
- BROCKOFF'S BISCUITS PTY. LTD., 53-71 Huntingdale-road, Burwood. One commercial goods vehicle (L/C. 64 cwt.) to operate within a 50-mile radius of own branch premises at Shepparton in the course of business as "Biscuit Manufacturers"—own goods.  
NOTE.—All goods to be initially consigned by rail to Shepparton.
- BROCKOFF'S BISCUITS PTY. LTD., 53-71 Huntingdale-road, Burwood. Two commercial goods vehicles (L/C. 56 and 17 cwt.) to operate within a 50-mile radius of own branch premises at Bendigo in the course of business as "Biscuit Manufacturers"—own goods.  
NOTE.—All goods to be initially consigned by rail to Bendigo.
- BROCKOFF'S BISCUITS PTY. LTD., 53-71 Huntingdale-road, Burwood. One commercial goods vehicle (L/C. 59 cwt.) to operate within a 50-mile radius of own premises at Albury, being within that area south of the Victorian N.S.W. border, in the course of business as "Biscuit Manufacturers"—own goods.  
NOTE.—All goods to be initially consigned by rail to Albury.
- BROOK, J. W., 2 Napier-street east, Eaglehawk. One commercial goods vehicle (L/C. 140 cwt.) to operate throughout the State of Victoria in the course of business as "Earth-moving Contractor"—tools of trade, earth-moving plant and equipment incidental to own contracts.
- ELLIS, E. E., 37 Service-road, Moe. One commercial goods vehicle (L/C. 100 cwt.) to operate within a 30-mile radius of post office at Moe in the course of business as "Land and Agricultural Cleaning Contractor and Firewood Merchant"—own agricultural and land cleaning implements and firewood.
- DINNING, C. W., 29 Guild-street, Seymour. One commercial goods vehicle (L/C. 28 cwt.) to operate: (a) Within a 20-mile radius of Seymour in the course of

- business as "Nurseryman"—own goods. (b) From Melbourne to own premises at Seymour—own plants, seedlings, shrubs, ornamental tubs and pots.
- FLOWERS, P. N. & I. J., 20 Fenwick-street, Colac. One commercial goods vehicle (L/C. 15 cwt.) to operate throughout the State of Victoria in the course of business as "Second-hand Dealers" for the purpose of attending auction sales and private households for the purchase of second-hand furniture, antique furniture, second-hand household ornaments and second-hand crockery, excluding the ability to carry to retail stores.
- KOOPMANS, J. A. & A. M. (trading as Garden City Brake Lining Co.), 1142 Norman-street, Ballarat. Two commercial goods vehicles (L/C. 19 cwt. each) to operate west of a north/south line drawn through Shepparton and Sunshine in the course of business as "Automotive Parts and Sales Agents"—automotive parts.
- GUILMARTIN, T. W., 119 Pantom-street, Golden Square. One commercial goods vehicle (L/C. 15 cwt.) to operate within an area bounded by a line joining the Towns of Woodend, Seymour, Shepparton, Cobram; thence the River Murray to Robinvale; then a line joining the Towns of Robinvale, Ouyen, Warracknabeal, Avoca to Woodend in course of business as "Hardware and Timber Wholesaler"—samples and display materials with the ability to leave an urgently required item of hardware.
- HAWKES, L. J., 11 Rothschild-street, Glenhuntingly. One commercial goods vehicle (L/C. 80 cwt.) to operate within a 50-mile radius from the premises of Rockard Fibrous Plaster Co. Pty. Ltd. at Dandenong solely on behalf of the said Co.—fibrous plaster sheets, fixing materials and tools of trade.
- HULSTON, S. B. & M. E. (trading as S. B. Hulston), 10 Byng-avenue, Cheltenham. One commercial goods vehicle (L/C. 195 cwt.) to operate within a 50-mile radius of the premises of Victorian Quarries Ltd. at Dromana in a specially constructed agitator vehicle—premixed concrete solely on behalf of the said company.
- KEATH, ROBIN, PTY. LTD., Post Office Box 128, Horsham. Application to vary the conditions of licence Nos. D.A.22517/17, D.A.22517/19, D.A.22517/21 and D.A.22517/23 (L/C. 240, 240, 240 and 137 cwt.) by deleting the present conditions and adding in lieu:— (a) Within an 80-mile radius of the post office at Dimboola (Horsham Division of the Country Roads Board) plant the property of a contractor and required for use in connexion with the construction or maintenance of some specific existing or proposed road, street, footpath, bridge, wharf, pier, weir or channel. (b) Within a 20-mile radius from site of construction or maintenance work performed pursuant to paragraph (a) above, or from the railway station nearest thereto—metal, stones, screenings, ashes, gravel, sand, earth and any other materials required for such work. (c) Within that part of the State of Victoria west of a line drawn north and south through the City of Ballarat in the course of business of the licensee as "Road-making and Earth-moving Contractor"—own tools of trade, earth-moving and road-making equipment and sufficient fuel only for use in own equipment.
- LATROBE VALLEY METALS PTY. LTD., 43 Princes Highway, Newborough. One commercial goods vehicle (L/C. 144 cwt.) to operate east of a north/south line drawn through the City of Melbourne in the course of business as "Marine Dealer"—marine goods as defined in the *Marine Stores and Old Metals Act 1958* (No. 6303), but excluding the carriage of such goods to wharves, docks, or shipsides for shipment or export purposes.
- MASON, R., 5 Coane-street, Pascoe Vale. One commercial goods vehicle (L/C. 7 cwt.) to operate throughout the State of Victoria in the course of business as "Collection and Repossession Agents"—second-hand refrigerators and second-hand electrical appliances having been repossessed for return to the City of Melbourne.
- MILNE, J. O., Flat 2, 27 Eildon-road, South Melbourne. One commercial goods vehicle (L/C. 45 cwt.) to operate throughout the State of Victoria in the course of business as "Marine Collector"—marine goods and old metals as defined in the *Marine Stores and Old Metals Act 1958* (No. 6303).
- MCCLUSKEY, K. J., 69 Kerr-street, Warrnambool. One commercial goods vehicle (L/C. 136 cwt.) to operate within a 75-mile radius of the Geelong Post Office (Geelong Division of the Country Roads Board) and within a 75-mile radius of the Penshurst Post Office (Warrnambool Division of the Country Roads Board) as a "Road Contractor"—road-making plant and equipment.

- NATIONAL TYRE SERVICE (SHEPPARTON) PTY. LTD.**, 361 Wyndham-street, Shepparton. One commercial goods vehicle (L/C. 9 cwt.) to operate within a 50-mile radius from own branch premises at Shepparton, in the course of business as "Tire Retreaders and Distributors"—tires and tubes for repair or retreading or having been repaired or retreaded, new tires and tubes, batteries, oil, motor car accessories and polythene piping.
- PETERSVILLE AUSTRALIA LTD.**, Wellington-road, Clayton. One commercial goods vehicle (L/C. 11 cwt.) to operate throughout the State of Victoria—own refrigerators for installation also tools of trade, spare parts and materials incidental to the installation, servicing and maintenance of commercial refrigerators.
- PRONK, J. G.**, Duke-street, Boolarra. One commercial goods vehicle (L/C. 256 cwt. approx.) to operate from places within a 25-mile radius of the A.P.M. at Maryvale to the A.P.M. at Maryvale—pulpwood.
- RAND, D. B.**, 307 Gilbert-road, West Preston. One commercial goods vehicle (L/C. 235 cwt.) to operate within a 50-mile radius of the premises of John Sharp & Sons Pty. Ltd. at South Melbourne as an installation contractor, with vehicle fitted with special lifting equipment—prefabricated house roof trusses, tools of trade and special lifting equipment.
- REID, G. H., CONSTRUCTIONS LTD.**, 338 Sydney-road, Coburg. One commercial goods vehicle (L/C. 256 cwt.) to operate: (a) Throughout the State of Victoria in the course of business as "Road Contractors"—own bulldozers, power shovels and earth-moving equipment for use on own contracts. (b) Within a 25-mile radius of G.P.O., Melbourne—bulldozers, power shovels and earth-moving equipment on behalf of other contractors.
- ROWLEY, C. N.**, Wy Yung, via Bairnsdale. Three commercial goods vehicles (L/C. 140, 140 and 127 cwt.) to operate: (a) Within a 95-mile radius of the post office at Orbost (Bairnsdale Division of the Country Roads Board) and within a 70-mile radius of the post office at Yarram (Traralgon Division of the Country Roads Board) as a "Road Contractor"—road-making plant and materials. (b) Within a 20-mile radius of the post office at Bairnsdale—general goods.
- RUSSELL, L. E.**, 55 Kidman-street, Yarraville. One commercial goods vehicle (L/C. 10 cwt.) to operate throughout the State of Victoria in the course of business as "Carpet and Linoleum Layer"—tools of trade and small quantities of carpet and linoleum and floor tiles for laying purposes only.
- SIPSAS, D.**, 24 Chestnut-street, Richmond. Three commercial goods vehicles (L/C. 227, 231, 233 cwt.) to operate: (a) Within a 25-mile radius from the post office situated at the corner of Bourke and Elizabeth streets in the City of Melbourne—general goods. (b) From pits at Cranbourne to places within the radius defined in paragraph (a) above—sand.
- SMITH, V.**, 18 Santon-street, Greensborough. One commercial goods vehicle (L/C. 54 cwt.) to operate: (a) Within a 25-mile radius from the post office situated at the corner of Bourke and Elizabeth streets in the City of Melbourne—general goods. (b) From and to places situated within the radius as defined in paragraph (a) above, to and from places situated within a 50-mile radius from the post office at the corner of Bourke and Elizabeth streets in the City of Melbourne—household furniture being the property or personal effects of a householder or of a member of his family when such goods are being moved:—(i) from residence to residence, (ii) from residence for storage or sale, (iii) from storage to residence, (iv) from a vendor to the residence of the purchaser.
- SUNKIST FROZEN FOODS**, 50 Nott-street, Port Melbourne. One commercial goods vehicle (L/C. 114 cwt.) to operate throughout the State of Victoria in the course of business as "Ice-cream and Frozen Food Distributors"—ice-cream and frozen foods at a temperature not exceeding 10 deg. F.
- TYERS SAND PITS PTY. LTD.**, 8d Church-street, Morwell. One commercial goods vehicle (L/C. 223 cwt.), to operate: (a) Within a 20-mile radius of the Morwell Post Office and to Leongatha—washed sand. (b) Within a 20-mile radius of the Morwell Post Office—gravel, soil, screenings and briquettes.
- WALSH, W. J.**, 16 Grandview-grove, Wendouree. One commercial goods vehicle (L/C. 145 cwt.) to operate: (a) Within a 25-mile radius of the chief post office at Ballarat—general goods. (b) Within a 70-mile radius from the Ballarat premises of Martin Stoneware Pipe Pty. Ltd. solely on behalf of the said company—earthenware pipes and fittings and associated materials.
- YOUNG, T. A. & J. W.** (trading as W. H. Young & Sons), 182 High-street, Shepparton. One commercial goods vehicle (L/C. 150 cwt.), to operate within a 50-mile radius of own premises at Shepparton in the course

of business as "Concrete Manufacturers"—own premixed concrete in a specially constructed agitator vehicle.

#### TOW TRUCK.

- ZERBST, I. K.**, Post Office Box 130, Natimuk. One commercial goods vehicle (L/C. 106 cwt.), to operate as a "Tow Truck" within a 50-mile radius of the Natimuk Post Office for the purpose of lifting and carrying or towing and/or repairing wrecked or disabled vehicles—tools of trade, spare parts and materials incidental thereto.

**APPLICATION** for renewal of licences as shown by persons listed hereunder to operate under the same terms and conditions from the date of expiry shown in each case.

- BINGHAM, J. H.**, Tyabb-road, Mornington; D.A.30519; 12th August, 1965; 30 cwt.
- CASEY, L. M.**, 3 Dundas-street, St. Arnaud; D.A.44462; 17th September, 1965; 7 cwt.
- CHRISTIE, A. McD.**, 32 John-street, Horsham; D.A.30725; 9th September, 1965; 10 cwt.
- FEAKES, J. T.**, 108 Pellatt-street, Beaumaris; T.D.A.46905; 5th August, 1965; 68 cwt.
- FLEETWAYS HAULAWAY PTY. LTD.**, 88-102 Normanby-road, South Melbourne; D.A.48588/6; 16th September, 1965; 185 cwt.; D.A.48588/18; 16th September, 1965; 181 cwt.; D.A.48588/19; 23rd September, 1965; 161 cwt.
- FLEETWAYS HAULAWAY PTY. LTD.**, 88-102 Normanby-road, South Melbourne; D.A.48588/5; 9th September, 1965; 182 cwt.
- FROZEN FREIGHT FORWARDERS PTY. LTD.**, Bertie-street, Port Melbourne; T.D.A.49605/2; 3rd August, 1965; 45 cwt.
- HOWLETT, R. M.**, Dergholm; D.A.44431; 11th September, 1965; 11 cwt.
- KATOS, A. & S.**, 16a Bellarine-street, Geelong; T.D.A.45258/2; 30th September, 1965; 17 cwt.
- LOCKYER, W. R.**, 3 Nelson-street, Sebastopol; D.A.1514; 16th September, 1965; 143 cwt.
- LONERGAN AUTOS PTY. LTD.**, 2 Punt-road, Cobram; D.A.45042; 11th September, 1965; 46 cwt.
- MACDONALD, I. G.**, 373 Sparrowhawk-road, Long Gully, Bendigo; D.A.44379; 4th September, 1965; 134 cwt.
- McKAY MACLEOD PTY. LTD.**, 63-73 Mair-street, Ballarat; D.A.8150; 28th September, 1965; 139 cwt.
- NATIONAL TYRE SERVICE (SHEPPARTON) PTY. LTD.**, 361 Wyndham-street, Shepparton; D.A.2374/40; 4th September, 1965; 18 cwt.
- O'DONNELL BROS. TYRE SERVICE PTY. LTD.**, 90 Kepler-street, Warrnambool; D.A.30833; 16th September, 1965; 13 cwt.
- PARLOUR, D. R. A. & A. R.**, Cudie-street, Cobden; D.A.5050; 21st September, 1965; 148 cwt.
- PHOENIX BISCUIT CO. PTY. LTD.**, Grosvenor-street, Abbotsford; D.A.39491/3; 11th September, 1965; 7 cwt.
- PHOENIX BISCUIT CO. PTY. LTD.**, Grosvenor-street, Abbotsford; D.A.39491/2; 11th September, 1965; 7 cwt.
- RAMAGE BROS. PTY. LTD.**, 8 Ely-street, Wangaratta; D.A.28609/4; 16th September, 1965; 18 cwt.
- ROWE, F. C.**, Katunga; D.A.44441; 11th September, 1965; 112 cwt.
- WHITE, H. L. & S. M.**, Post Office Box 85, Warracknabeal; D.A.51180/3; 23rd September, 1965; 186 cwt.
- WINTER, W. J.**, Main-street, Gordon; D.A.30729; 23rd September, 1965; 116 cwt.

#### TOW TRUCK.

- TAYLOR, J. C.** (trading as Stoneyford Motor Wreckers), Stoneyford; D.A.44376; 4th September, 1965; 8 cwt.

**APPLICATION** by persons listed hereunder for renewal of the licences listed with variation of conditions in the manner set out opposite the name.

- CLARKE, F. W.**, Stonehaven, via Geelong; D.A.42964; 21st August, 1965; Application to renew and vary the conditions of licence No. D.A.42964 (L/C. 194 cwt.) by deleting from the existing conditions "paragraph (b)" and adding in lieu as paragraph (b) "within that part of a 50-mile radius of the aforesaid post office east of a line drawn due north and south through the Township of Stonehaven—own primary produce and livestock and baled hay and straw being obtained on the basis of share agreements".
- KUMMER, I. H.**, 12 John-street, Balwyn; D.A.44487; 17th September, 1965; Application to renew and vary the conditions of licence No. D.A.44487 (L/C. 8 cwt.) by deleting from the existing conditions "within a 50-mile radius from the post office situated at the corner of Bourke and Elizabeth streets in the City of Melbourne" and adding in lieu "to operate throughout the State of Victoria".

MEADE, W. E., 422 Main-street, Bairnsdale; D.A.3617; 21st September, 1965; Application to renew and vary the conditions of licence No. D.A.3617 (L/C. 98 cwt.) by deleting "the existing conditions" and adding in lieu: (a) "from the depot of Brockhoff's Biscuits Pty. Ltd. at Bairnsdale to retailers situated within that part of the State of Victoria east of a north/south line drawn through the Township of Rosedale in the course of business as 'Biscuit Distributors'—biscuits. (b) From the depot of Brockhoff's Biscuits Pty. Ltd. at Morwell to retailers situated within a 50-mile radius of Morwell—biscuits. (c) From the Bairnsdale Railway Station to the depot of Brockhoff's Biscuits Pty. Ltd. at Bairnsdale—biscuits".

MCKENZIE & HOLLAND (AUST.) PTY. LTD., Sutton-street, Newport; D.A.42575/1; 4th September, 1965; Application to renew and vary the conditions of licence No. D.A.42575/1 (L/C. 8 cwt.) by deleting "paragraph (b)" from the existing conditions and adding in lieu: "throughout the State of Victoria—tools of trade, equipment and materials incidental to the installation of signalling equipment along Victorian Railway Lines".

Notice of any objection should be forwarded to reach the Secretary of the Board not later than Wednesday, 28th July, 1965.

Applicants are advised that it will not be necessary to appear on the hearing date specified above unless advised, in writing, by the Board.

B. P. KAY,  
Secretary.

Exhibition Buildings, Rathdown-street, Carlton, N.3, 14th July, 1965.

Transport Regulation Act.

TRANSPORT REGULATION BOARD.

HEARING OF APPLICATIONS.

NOTICE is hereby given that the following applications will be considered by the Transport Regulation Board at its offices at Rathdown-street, Carlton, at 10.15 a.m., on Thursday, 5th August, 1965.

BARNES COACHES (SUNSHINE) PTY. LTD., Station-road, Deer Park. Application for variation of Route 130A (Sunshine-Deer Park) to extend the South Sunshine bus service from the corner of Ardoyne-street and Freeman-street via Ardoyne-street, Boreham-street, Cooper-street, Angus-grove, Mayo-street, Ardoyne-street, thence normal route.

BARNES COACHES (SUNSHINE) PTY. LTD., Station-road, Deer Park. Application for variation of Route 130A (Sunshine-Deer Park) to delete operations via Armstrong-street and Mernda-street and instead to operate via Bardsley-street and Mayne-street to normal route.

CROYDON BUS SERVICE PTY. LTD., Maroondah Highway, Croydon. Application for permit authority to operate an experimental extension of Route 242A (Croydon-Belfast-road) from the corner of Belfast-road and Cardigan-road to the corner of Birmingham and Edinburgh roads via Cardigan and Edinburgh roads.

HICKS, W. A., Albert-street, Footscray. Application for permit authority to operate from—(1) Tullamarine, via Broadmeadows-road, Sharps-road, Bulla-road, Parer-road, McNamara-avenue and Roberts-road to St. Christophers Church, Airport West. (2) East Keilor via Milleara-road, Keilor-road, McNamara-avenue, Roberts-road to St. Christophers Church, Airport West.

Fare: 2s. return.

TIME-TABLE.

(Sundays Only).

Dep. Tullamarine 10.00 a.m. Dep. Church 11.15 a.m.  
Dep. East Keilor 9.10 a.m. Dep. Church 10.15 a.m.

O'CONNELL, D. M., Omeo. Application for variation of licence T.S.71 to include the ability to operate for the carriage of mails under contract to the P.M.G. Department, also parcels and passengers between Omeo and Benambra.

Fares: From Omeo—  
To Hinnomunjie 3s.  
To Benambra .. 6s.

TIME-TABLE.

(Monday to Saturday).

Dep. Omeo .. 5.45 p.m.  
Dep. Hinnomunjie .. 6.10 p.m.  
Arr. Benambra .. 6.30 p.m.  
Dep. Benambra .. 6.35 p.m.  
Dep. Hinnomunjie .. 6.55 p.m.  
Arr. Omeo .. 7.20 p.m.

PERCE, A. L., Lot 15, McMahons-road, East Kinglake. One commercial passenger vehicle (S/C. 5) to operate as a country taxi from Kinglake.

RENNIE, F. H., and SON PTY. LTD., 285 Station-street, Box Hill. Application to operate metropolitan passenger service Route 67A (Box Hill-Burwood) as at present operated under licences held by the applicant with the following amendment to present service:—With extension of deviation (b), Box Hill-Jordanville, from the present terminus at the corner of Huntingdale and Waverley roads to the Chadstone Shopping Centre via Waverley and Warrigal roads, Midlothian-street, Bellevue-avenue, Chadstone-road, through the Chadstone Shopping Centre and returning via Virginia, Capon and Midlothian streets, Warrigal and Waverley roads to normal route. (All trips to be operated express from the corner of Huntingdale and Waverley roads.)

SITCH BUS SERVICES PTY. LTD., Service-street, Sunshine. One commercial passenger vehicle with large seating capacity, to be purchased to operate as an additional metropolitan route omnibus on Route 110A (Footscray-Sunshine) as prescribed.

TRANS OTWAY LIMITED, corner Ryrie and Fenwick streets, Geelong. Application to operate the following day tours from Geelong:—

|   | With Lunch. |        | Without Lunch. |        |
|---|-------------|--------|----------------|--------|
|   | Adult.      | Child. | Adult.         | Child. |
|   | s.          | d.     | s.             | d.     |
| Bellarine Peninsula ..                    | 30          | 0      | 18             | 6      |
| City of Ballarat ..                       | 30          | 0      | 18             | 6      |
| City of Geelong ..                        |             |        | 12             | 6      |
| City of Melbourne ..                      | 35          | 0      | 20             | 0      |
| Dandenong Ranges ..                       | 40          | 0      | 23             | 6      |
| Donna Buang ..                            | 42          | 6      | 25             | 0      |
| Eildon Weir ..                            | 52          | 0      | 30             | 0      |
| Healesville Sanctuary                     | 40          | 0      | 23             | 6      |
| Macedon-Daylesford-<br>Hepburn Springs .. | 40          | 0      | 23             | 6      |
| Marysville-Cumberland<br>-Upper Yarra Dam | 47          | 6      | 27             | 6      |
| Otway Ranges ..                           | 42          | 6      | 25             | 0      |
| Phillip Island ..                         | 52          | 6      | 30             | 0      |

APPLICATIONS for renewal of licences as shown, by persons listed hereunder, to operate under the same terms and conditions:—

ARCHIES CREEK DAIRY PRODUCE CO. LTD., Archies Creek; T.P.4.

BULLUMWAAL TIMBER & TRADING CO. PTY. LTD., Bullumwaal; T.P.234.

HANDLEY, B., Grant-street, Yarram; C.T.587.

MURTAGH, R. J., Elgin-street, Myrtleford; C.T.579.

PLUIM, M. H., 403 Glenfern-road, Upwey; C.T.494.

REARDON, E. J., 5 Marine-avenue, Mornington; C.T.108.

TOTH, A., & B. IVKOVIC, Murray Valley Highway, Bonegilla; C.H.57.

WAILES, J. A. & A. H. (trading as Wailes Bros.), Beach-road, Whittlesea; C.T.523.

Notice of any objection should be forwarded to reach the Secretary of the Board not later than Wednesday, 28th July, 1965.

Applicants are advised that it will not be necessary to appear on the hearing date specified above, unless advised, in writing, by the Board.

B. P. KAY,  
Secretary.

Exhibition Buildings, Rathdown-street, Carlton, N.3, Wednesday, 14th July, 1965.

Transport Regulation Act.

TRANSPORT REGULATION BOARD.

NOTICE is hereby given that, pursuant to powers conferred on the Board by section 29, Transport Regulation Act No. 6400, the Board, having announced a need for a further five (5) metropolitan hire car licences to be allocated to operate in Zone A and two (2) metropolitan hire car licences to be allocated in Zone B to replace hire car licences being converted to taxi-cabs from these zones on 1st September, 1965, will receive up to and including 20th July, 1965, applications in the appropriate form for the seven (7) licences to be issued.

B. P. KAY,  
Secretary.

Exhibition Buildings, Rathdown-street, Carlton, N.3, Wednesday, 14th July, 1965.

Melbourne and Metropolitan  
BOARD OF WORKS.

NOTICE TO THE OWNERS OF TENEMENTS IN THE UNDERMENTIONED STREETS, AND THE PRIVATE STREETS, LANES, COURTS AND ALLEYS OPENING THERETO.

THE main pipe in the said streets being laid down, the owners of all tenements situated as under are hereby required on or before the 16th August, 1965, to cause a proper pipe and stopcocks to be laid so as to supply water within such tenements from the main pipe.

H. J. SNADDEN,  
Secretary.

6th July, 1965.

STREET AND POSITION.

*Caulfield.*

Parton-court, from Grange-road eastwards 8 chains.

*Diamond Valley.*

Scotland-avenue, from Jessop-street south-eastwards and northwards 4½ chains.

*Doncaster and Templestowe.*

Carawatha-street, from 6½ chains east of Caringal-avenue to Rose-street.

Ada-street, from Carawatha-street southwards 5 chains.

Rose-street, from Carawatha-street southwards 6½ chains.

Oregon-drive, from Tunstall-road to Mitcham-road.

Monterey-crescent, from Oregon-drive north-westwards 11½ chains.

Huon-court, from Monterey-crescent south-westwards 5 chains.

Douglas-avenue, from Oregon-drive northwards 4½ chains.

Hotham-street, from Manningham-road to Rooney-street.

Michael-street, from Hotham-street westwards 6½ chains.

Talbot-street, from Hotham-street westwards 6½ chains.

Lauri-Ann-street, from Hotham-street westwards 6½ chains.

Roma-court, from Michael-street northwards 4½ chains.

Coolabah-street, from Church-road eastwards, southwards and eastwards 15½ chains.

Alison-avenue, from Lonsdale-street northwards 7 chains.

*Eltham.*

Virginia-court, from Bolton-road westwards 13½ chains.

*Heidelberg.*

Graham-road, from Eltham-road to Kiers-court.

Eileen-street, from Graham-road to Lyon-road.

Lyon-road, from Eileen-street to Lady Betty-parade.

Lady Betty-parade, Lyon-road to Meyrick-crescent.

Meyrick-crescent, from Lady Betty-parade to Widley-road.

May-street, from Meyrick-crescent to Lascelles-avenue.

Widley-road, from Meyrick-crescent to Rutherford-road.

Rutherford-road, from Widley-road to Lena-street.

Dougharty-road, from Marks-street westwards 1½ chains.

Manton-street, from 19½ chains south of St. James-road southwards 4 chains.

*Keilor.*

Canning-street, from Raglan-street eastwards 6 chains.

Raglan-street, from Canning-street to Riverside-avenue.

Riverside-avenue, from Raglan-street eastwards 6 chains.

Clarendon-street, from 8½ chains west of Lancaster-avenue westwards 6 chains.

Thompson-street, from Clarendon-street north-westwards 6 chains.

Rogerson-street, from Thompson-street north-eastwards 19 chains.

Gordon-street, from Sharps-road to Dalkeith-avenue.

Spring-street, from Gordon-street to Eumarella-street.

Dalkeith-avenue, from Gordon-street to Broadmeadows-road.

Eumarella-street, from Dalkeith-avenue to Sharps-road.

Sharps-road, from Gordon-street westwards 1½ chains.

Sharps-road, from Gordon-street eastwards 3½ chains.

*Malvern.*

Virginia-grove, from Capon-street westwards 11½ chains.

*Melbourne.*

Wreckyn-place, from 1½ chains south-east of Wreckyn-street south-eastwards 1 chain.

*Moorabbin.*

Kilpa-road, from Keys-road to Levanswell-road.

Bignell-road, from Cochranes-road to Corr-street.

Corr-street, from Bignell-road to Alex-avenue.

Alex-avenue, from Bignell-road to South-road.

Joel-court, from Alex-avenue eastwards 5½ chains.

Joyner-street, from Alex-avenue to Cochranes-road.

*Mordialloc.*

Taylor-street, from James-street to Edmond-street.

Edmond-street, from Lower Dandenong-road southwards and eastwards 29½ chains.

Hawke-street, from Edmond-street westwards 11 chains.

St. George-street, from Edmond-street northwards 4 chains.

Ivy-street, from 2½ chains north of Robert-street northwards 3½ chains.

*Nunawading.*

Jessie-street, from Junction-road to Kett-street.

Renfrew-street, from Jessie-street westwards 1½ chains.

Marilyn-court, from Junction-road northwards 17 chains.

Kathleen-street, from Marilyn-court to Jessie-street.

Kett-street, from Jessie-street eastwards 5 chains.

Caversham-court, from Central-road northwards 7 chains.

Rangeview-grove, from Heatherbrae-avenue to Mary-street.

*Oakleigh.*

Valley-street, from Huntingdale-road eastwards 5½ chains.

Wendy-court, from Huntingdale-road eastwards 5½ chains.

Myrtle-court, from Huntingdale-road eastwards 5 chains.

Haughton-road, from 4 chains north-west of Collier-avenue north-westwards 8½ chains.

*Ringwood.*

Rangeview-grove, from Heatherbrae-avenue to Mary-street.

*Springvale.*

Mather-road, from Arnold-street westwards 10 chains.

Black-court, from Mather-road northwards 3½ chains.

Alice-court, from Mather-road northwards 3½ chains.

Arnold-street, from Mather-road northwards 4½ chains.

*Waverley.*

Blackburn-road, from Falconer-street to Seaton-court.

Seaton-court, from Blackburn-road westwards 6 chains.

Rosaline-avenue, from 7 chains north of Holskamp-street northwards 7 chains.

Farquharson-street, from 2 chains north of Bowman-street northwards 7 chains.

Ricketts-road, from Blackburn-road westwards 8½ chains.

Clunies Ross-crescent, from 1½ chains east of Burnet-street eastwards 8½ chains.

Rivett-crescent, from Burnet-street eastwards 7½ chains.

Oliphant-court, from Rivett-crescent northwards 8 chains.

Noble-street, from Clunies Ross-crescent to Florey-crescent.

Waratah-street, from High Street-road to Clematis-street.

High Street-road, from Mimosa-street westwards 1½ chains.

Mimosa-street, from High Street-road to Clematis-street.

Clematis-street, from Mimosa-street westwards 1½ chains.

William-street, from Bruce-street north-eastwards 2½ chains.

Town and Country Planning Act 1961.

TALLANGATTA PLANNING SCHEME 1956.

AMENDMENT No. 1, 1965.

Notice that a Planning Scheme has been Prepared and is Available for Inspection.

NOTICE is hereby given that the Town and Country Planning Board, in pursuance of its powers under the Town and Country Planning Act 1961, has prepared a Planning Scheme for the purpose of—

- (i) Inclusion of land adjacent to the eastern side of Wondah-street, Tallangatta, in the Residential Zone;
- (ii) inclusion of land on the northern side of Towong-street, east of Tooma-street, Tallangatta, in the Residential Zone;
- (iii) reservation of land for Public purposes (School) in Towong-street, Tallangatta;
- (iv) reservation of land for public open space north of Towong-street and east of Queen Elizabeth-drive, Tallangatta; and
- (v) amendments to the Planning Scheme ordinance.

A copy of the scheme has been deposited at the offices of the Town and Country Planning Board, 179 Queen-street, Melbourne, and at the office of the Shire of Towong, at Tallangatta, and will be open for inspection, during office hours, by any person, free of charge.

Any persons affected by the Planning Scheme are required to set forth, in writing, all objections they may have, addressed to the Secretary, Town and Country Planning Board on or before the 14th day of October, 1965, and to state whether they wish to be heard in respect of their objection.

W. H. CRAIG, Secretary.  
Town and Country Planning Board.

**PUBLIC TRUSTEE ACT 1958 (No. 6350).—SECTION 17.**

**I** HEREBY give notice that on the 28th June, 1965, the Public Trustee filed elections to administer the following deceased persons' estates, in accordance with section 17 of the Public Trustee Act 1958:—

- BERGMAN, ERIC OSCAR, late of 25 McIlwraith-street, North Carlton, retired wool classer, died 2nd February, 1965.
- BUCKLEY, JOSEPH EDWARD, late of 75 Vere-street, Collingwood, wharf labourer, died 30th June, 1961.
- DAVENPORT, AGNES, late of 102 Ascot-street, South Ballarat, widow, died 15th March, 1965.
- KEOGH, ALFRED EUSTACE, late of 41 Liddiard-street, Hawthorn, military pensioner, died 5th April, 1965.
- KNIGHT, JAMES CRAIG, late of 235 York-street, South Melbourne, pensioner, died 13th January, 1965.
- MCDONALD, ALBERT, late of Melbourne Home and Hospital for the Aged, Cheltenham, labourer, died 21st November, 1964.
- ROHNER, CORINNA DELORES, late of 55 Park-crescent, Fairfield, spinster, died 20th December, 1956.
- RYAN, THOMAS JOSEPH, late of 226 Wattle Valley-road, Burwood, electrician, died 11th April, 1965.
- SYKES, KATHLEEN AGNES, late of Austin Hospital, Heidelberg, married woman, died 26th May, 1964.
- THOMSON, JOHN WALTER, late of 217 A'Beckett-street, Melbourne, pensioner, died 8th September, 1962.

A. D. DUNCAN,  
Public Trustee.

256 Flinders-street, Melbourne, C.1, 7th July, 1965.

**NOTICE.**

**C**REDITORS, next of kin and others having claims against the estate of any of the under-mentioned deceased persons are required to send particulars of their claims to the Public Trustee, 256 Flinders-street, Melbourne, the personal representative, on or before the 14th September, 1965, after which date the Public Trustee may convey or distribute the assets, having regard only to the claims of which the Public Trustee then has notice:—

- BERGMAN, ERIC OSCAR, late of 25 McIlwraith-street, North Carlton, retired wool classer, died 2nd February, 1965.
- BROWN, JOHN SINCLAIR GORDON, formerly residing in Aden and Woodside, Balmullo, Leuchars, Fife, Scotland, retired master mariner, died 15th December, 1964.
- BUCKLEY, JOSEPH EDWARD, late of 75 Vere-street, Collingwood, wharf labourer, died 30th June, 1961.
- DAVENPORT, AGNES, late of 102 Ascot-street, South Ballarat, widow, died 15th March, 1965.
- FIRTH, WILLIAM (The Elder), late of Somerville, farmer, died 20th December, 1907.
- GREENING, DORA HELEN, late of 37 Robinson-road, Hawthorn, home duties, died 21st March, 1965.
- KEOGH, ALFRED EUSTACE, late of 41 Liddiard-street, Hawthorn, military pensioner, died 5th April, 1965.
- KNIGHT, JAMES CRAIG, late of 235 York-street, South Melbourne, pensioner, died 13th January, 1965.
- LITHERLAND, RALPH, late of Thompsons-road, Bulleen, bricklayer, died 20th July, 1964.
- MCDONALD, ALBERT, late of Melbourne Home and Hospital for the Aged, Cheltenham, labourer, died 21st November, 1964.
- NELSON, FRANCIS HENRY, late of 228 Edward-street, East Brunswick, shoe clicker, died 8th January, 1965.
- O'NEILL, JOHN EDWARD, late of 209 Albert-street, Brunswick, gentleman, died 15th August, 1964.
- PAICE, FREDERICK JOSEPH, commonly known as Frederick Charles Paice, late of 28 Belgrave-street, Coburg, clerk, died 12th April, 1965.
- PINDER, CHARLES WILLIAM, late of De Motts-road, Anakie, retired wood cutter, died 20th March, 1964.
- REDDICK, STELLA HAZEL, late of 22 Alexander-street, Collingwood, spinster, died 9th February, 1965.
- ROBERTS, ROBERT FRANK AUGUSTUS, late of 10 Morgan-street, Glenhantly, retired railway officer, died 21st April, 1965.
- ROHNER, CORINNA DELORES, late of 55 Park-crescent, Fairfield, spinster, died 20th December, 1956.
- RYAN, THOMAS JOSEPH, late of 226 Wattle Valley-road, Burwood, electrician, died 11th April, 1965.
- SHEPHERD, JOHN RODGER, late of Masterton, New Zealand, farm supervisor, died 14th September, 1964.
- SOMMERHALDER, PAUL ROBERT, formerly of 106 Wellington-street, St. Kilda, but late of 11 Moore-street, East Brighton, cabinet maker, died 13th October, 1964.
- SYKES, KATHLEEN AGNES, late of Austin Hospital, Heidelberg, married woman, died 26th May, 1964.
- THOMSON, JOHN WALTER, late of 217 A'Beckett-street, Melbourne, pensioner, died 8th September, 1962.

A. D. DUNCAN,  
Public Trustee.

Melbourne, 7th July, 1965.

**SHIRE OF MORTLAKE.**

**ROAD DEVIATION ORDER.**

**P**URSUANT to the provisions of sections 522 and 526 of the Local Government Act 1958 the Council of the Shire of Mortlake hereby directs that the land in the Parish of Ligar indicated by hatching on the diagram hereunder which has been purchased taken or acquired by it shall be a Public Highway on and from the date of publication of this Order in the Government Gazette and declares that such land shall be a Public Highway in lieu of the land indicated by cross-hatching on the said diagram.

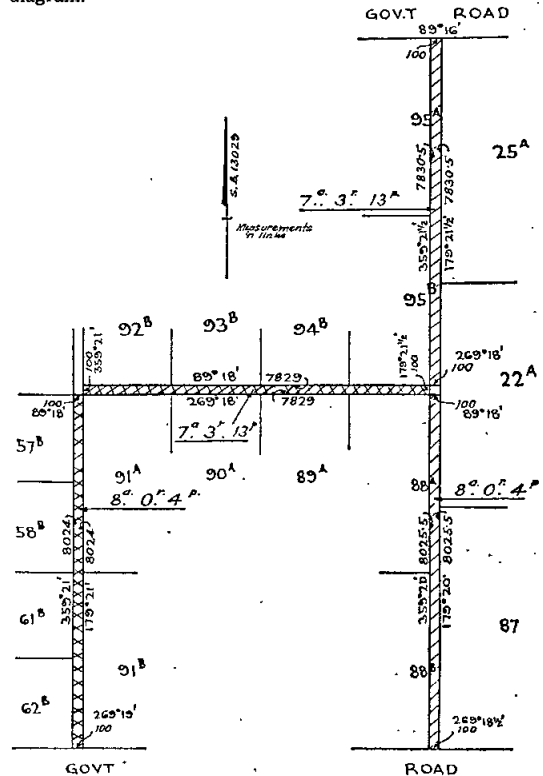

The common seal of the President, Councillors and Ratepayers of the Shire of Mortlake was hereunto affixed, this 15th day of June, 1965, in the presence of—

(SEAL) R. G. BRYANT, President.  
TREVOR O. SMITH, Councillor.  
W. J. GRAY, Secretary.

Confirmed by the Governor in Council, 6th July, 1965.—  
J. COLQUHOUN, Clerk of the Executive Council.

**PUBLIC NOTICE.**

**A**LL persons who as producers of farm produce have any claim against Sun Loong, 46 Wholesale Fruit Market, Melbourne, arising from any failure on his part to pay or account for any moneys payable to them by the said, Sun Loong, for farm produce, are invited to forward particulars and proof of such claims to the Director of Agriculture, Public Offices, Melbourne, C.2, on or before the 31st August, 1965.

FRANK M. READ,  
Director of Agriculture.

**Children's Welfare Act 1958.**

**APPOINTMENT OF CHAIRMAN OF FAMILY WELFARE ADVISORY COUNCIL.**

**I**N pursuance of the powers conferred by the Children's Welfare Act 1958, I, Her Majesty's Acting Chief Secretary for the State of Victoria do hereby appoint Arthur Spencer Colliver to be the Chairman of the Family Welfare Advisory Council for a further period of twelve months commencing on the eighteenth day of July, 1965.

Given under my hand this sixth day of July, 1965.

V. F. WILCOX,  
Acting Chief Secretary.

**CONTRACTS ACCEPTED.—(Series 1965-66.)****VICTORIAN RAILWAYS.**

1. Supply and delivery of 24 circuit V.F. carrier telegraph system equipped for 6 circuits at rates (Contract 62650).—F. Kanematsu (Australia) Pty. Ltd.  
 2. Erection of stockyards at Echuca for £2,525 1s.—(Contract 62788).—C. P. Braine.  
 3. Supply and delivery of bread and bread rolls during period 1st July, 1965 to 30th June, 1967 at rates (Contract 62800).—Associated Bakeries Pty. Ltd.  
 4. Dismantling, removal, &c., of material comprising railway line between 180 M 5 C 79 L near Kerang and Murrabit at rates. (Contract 62815).—G. F. & D. M. Egan.

By order of the Victorian Railways Commissioners,  
 W. WALKER, Secretary for Railways. 9.7.65.

**ORDERS IN COUNCIL.—(Series 1964-65.)****STATE ELECTRICITY COMMISSION.**

4314. For the supply of steel cored aluminium conductor for 330 and 220 kV main transmission lines, to Specification 64-65/141, £297,500.—Cablemakers (A.C.T.) Pty. Ltd.

4315. For the supply of steel cored aluminium conductor for 330 and 220 kV main transmission lines, to Specification 64-65/141, £442,500.—Olympic Cables Pty. Ltd.

Approved by the Governor in Council, 1st June, 1965.—  
 J. COLQUHOUN, Clerk of the Executive Council.

4316. For the supply and delivery of sulphate of alumina, Latrobe Valley area for water purification for a period of two years, to Specification 64-65/368, at Schedule rates.—Aluminates Pty. Ltd.

4317. For the supply and erection of additional steel bracing and concrete foundations for transmission towers on the Dederang-Shepparton, Shepparton-Bendigo and Keilor-Geelong 220kV transmission lines, to Specification 64-65/330, £79,790 plus items at Schedule rates.—Ascom Pty. Ltd.

4318. For the supply of H.V. and L.V. capacitors for power factor correction on the distribution system, to Specification 64-65/273, £72,829.—Ducon Condenser Pty. Ltd.

4319. For the erection of a 220kV transmission line between Templestowe Terminal Station and Doncaster Terminal Station for the augmentation of the metropolitan 220kV system, to Specification 64-65/342, £39,406 plus items at Schedule rates.—Electric Power Transmission Pty. Ltd.

4320. For the supply and installation of air conditioning and fume exhaust systems for regional control building and laboratory, Yallourn Power Station, to Specification 64-65/192, £25,284.—McNiece Bros. Refrigeration Pty. Ltd.

4321. For the supply of one truck-mounted "Gradall" excavator for general construction and maintenance work in the Latrobe Valley, to Quotation 4971, £23,345.—Moore Road Machinery (Vic.) Pty. Ltd.

4322. For the construction of civil engineering works and building for substation "NP" Noble Park, to Specification 64-65/373, £54,548.—T. W. Morris & Son Pty. Ltd.

4323. For the supply of 66kV isolating switches and accessories for metropolitan and country terminal stations and substations for a period of two years, to Specification 64-65/266, at Schedule rates.—Switchgear Pty. Ltd.

4324. For the supply of 10-in. glass disc insulators for use on transmission and distribution lines, to Specification 64-65/222, £54,803.—A.C.I. Glass Insulators Co.

4325. For the supply of 10-in. porcelain disc insulators for use on transmission and distribution lines for a period of one year, to Specification 64-65/222, at Schedule rates.—Nilsen Porcelains (Aust.) Pty. Ltd.

4326. For the supply of 10-in. porcelain disc insulators for use on transmission and distribution lines, to Specification 64-65/222, £33,156.—Australian Porcelain Sales and Trading Pty. Ltd.

Approved by the Governor in Council, 16th June, 1965.—  
 J. COLQUHOUN, Clerk of the Executive Council.

**ORDERS IN COUNCIL.—(Series 1965-66.)****PUBLIC WORKS.**

334. Carlton, Mental Health Authority, St. Nicholas Hospital, supply of three (3) industrial vacuum cleaners, £746 6s. 6d.—Australian Electrical Industries Pty. Ltd. (M.70988.)

335. Kew, Mental Hospital, Wards 30-31, Children's Cottages, repair of ducts, &c., £575 17s. 6d.—Smith and Osborne Pty. Ltd. (M.308256.)

336. Melbourne, Education Department, supply of 3,000 coir mats, £18,600.—Royal Victorian Institute for the Blind. (V.36000.)

337. Melbourne, Parliament House, rectification of faults in ventilation system, £1,996 9s.—Wm. Kean Industries. (M.313158 "B".)

338. Moorabbin, Technical School, special grant authorized by the Education Department towards the cost of additions to the Assembly Hall at the school, £1,838 8s.—Moorabbin Technical School Council. (S.E.45279.)

339. North Brunswick, State School No. 3585, resurfacing of concrete floor, £1,034.—Ian Wilson & Company. (N.W.62569.)

Approved by the Governor in Council, 6th July, 1965.—  
 J. COLQUHOUN, Clerk of the Executive Council.

**EDUCATION DEPARTMENT.**

340. One (1) only Elliott 3A drilling machine, for Bairnsdale Technical School, £387.—Frank Vial & Sons Pty. Ltd.

341. One (1) only air compressor, portable, for Collingwood Technical School, £136 2s.—Brooklands Accessories Pty. Ltd.

342. One (1) only analytical balance, for Royal Melbourne Institute of Technology, £145.—Watson Victor Ltd.

343. One (1) only 16-mm. sound projector, for Royal Melbourne Institute of Technology, £232 10s.—RCA of Australia Pty. Ltd.

344. One (1) only down stroke compression moulding and general purpose hydraulic press, for Royal Melbourne Institute of Technology, £3,960.—Marweight Equipment Pty. Ltd.

345. Five (5) only drawing machines complete with drawing boards, drawing stands and scales, for Royal Melbourne Institute of Technology, £300 14s. 3d.—Harding & Halden Pty. Ltd.

346. Three (3) only calculating machines, for Warragul Technical School, £285.—Sydney Pincombe Pty. Ltd.

347. One (1) only Typetronic tape preparation machine, for Bendigo Technical College, £1,775.—Amalgamated Wireless (A'asia) Ltd.

348. One (1) only generalized electrical machine set, for Bendigo Technical College, £1,259 13s.—English Electric Co. of Aust. Ltd.

349. Sixteen (16) only power factor condensers, for Caulfield Technical College, £974 10s.—Kuga Pty. Ltd.

350. Four (4) only sewing machines, for Emily McPherson College, £282.—Singer Sewing Machine Co.

351. One (1) only single pan automatic chemical balance, for Wodonga Technical School, £145.—Watson Victor Limited.

352. One (1) only Bridge Megger tester, for Frankston Technical School, £190 10s.—H. Rowe & Co. Pty. Ltd.

353. One (1) only Micro-Micro ammeter, for Caulfield Technical College, £297.—Ronald Payne Pty. Ltd.

354. One (1) only gas chromatograph, for Caulfield Technical College, £1,342 2s.—Thomas Optical & Scientific Co.

355. One (1) only wide range oscillator, for Caulfield Technical College, £100.—Sample Electronics Pty. Ltd.

356. One (1) only sound level meter and filter set, for Gordon Institute of Technology, Geelong, £352 6s.—National Instrument Co. Pty. Ltd.

357. One (1) only surface planing machine, for Gordon Institute of Technology, Geelong, £688 15s.—Thomas Robinson & Son Pty. Ltd.

358. One (1) only 16-mm. sound projector, for Melbourne School of Hairdressing, £198.—Sixteen Millimetre Aust. Pty. Ltd.

359. One (1) only automatic electric offset printing machine, for Royal Melbourne Institute of Technology, £825.—Gestetner Pty. Ltd.

360. Two (2) only pH Meter-Millivolt meter, for Royal Melbourne Institute of Technology, £255.—H. B. Selby & Co. Pty. Ltd.

361. One (1) only D.C. Millivolt strip chart recorder, for Royal Melbourne Institute of Technology, £315.—Watson Victor Ltd.

362. One (1) only power oscillator, for Royal Melbourne Institute of Technology, £161.—Simon Gray Pty. Ltd.

363. One (1) only automatic copying centre lathe, for Royal Melbourne Institute of Technology, £6,495.—Qualos Machine Tools Pty. Ltd.

364. Three (3) only monocular microscopes, for Swinburne Technical College, £102.—Watson Victor Ltd.

365. One (1) only regulated power supply, for Swinburne Technical College, £198.—B.W.D. Electronics.

366. One (1) only copying machine (£168 15s.), one (1) only companion unit for same (£88), and one (1) only overhead projector (£110 9s. 9d.), for Warrnambool Technical College, £367 4s. 9d.—Minnesota Mining & Manufacturing Pty. Ltd.

367. One (1) only pH meter (£166), (1) only balance (£175), one (1) only hot plate (£61), and one (1) only spectrophotometer (£450), for Warrnambool Technical College, £852.—Watson Victor Ltd.



368. One (1) only geared stirrer (£52 10s.), and one (1) only centrifuge (£76 10s.), for Warrambool Technical College, £129.—Thomas Optical & Scientific Co. Pty. Ltd.

369. One (1) only refractometer, for Warrambool Technical College, £145.—Drug Houses of Australia.

370. One (1) only infra-red spectrophotometer and accessories, for Ballarat School of Mines, £3,177.—Watson Victor Ltd.

371. One (1) only refractometer, for Bendigo Technical College, £193 10s.—Townson & Mercer Pty. Ltd.

372. One (1) only Artiscopes copying and enlarging machine, for Caulfield Technical College, £180.—Artiscopes Manufacturing Co. Pty. Ltd.

373. One (1) only pottery wheel, hydraulic transmission, for Caulfield Technical College, £225.—Electro-Mechanics Products.

374. One (1) only table type continuous machine for the production of Dyeline prints, for Footscray Technical College, £200.—Max Wurcker Pty. Ltd.

375. One (1) only Electrograph machine, for Melbourne School of Printing and Graphic Arts, £600.—Electrograph Supply Co. Ltd.

376. One (1) only potentiometric titration unit, for Royal Melbourne Institute of Technology, £197.—Austronic Engineering Laboratories.

377. One (1) only spectrophotometer, for Royal Melbourne Institute of Technology, £212 10s.—Watson Victor Ltd.

378. One (1) only top loading balance, for Royal Melbourne Institute of Technology, £165.—Watson Victor Ltd.

Approved by the Governor in Council, 6th July, 1965.—  
J. COLQUHOUN, Clerk of the Executive Council.

#### Notice.

*Labour and Industry Act 1958, Section 45B.*

#### REFERENCE OF A MATTER TO THE INDUSTRIAL APPEALS COURT.

NOTICE is hereby given that, pursuant to the provisions of section 45B of the *Labour and Industry Act 1958*, the Minister of Labour and Industry has referred to the Industrial Appeals Court for determination by it the following matter, viz.:—the effect of the judgment delivered by the Commonwealth Conciliation and Arbitration Commission on the 29th day of June, 1965, in the Metal Trades Cases (C. Nos. 4 and 834 of 1965) on the rates of wages fixed by the determinations of the Wages Boards mentioned in the Schedule hereto.

Notice is also given that the Industrial Appeals Court will deal with the aforesaid matter on Thursday, the 22nd day of July, 1965, at No. 1 Board Room, Workers' Compensation Board Offices, 160 Queen-street, Melbourne.

Dated at Melbourne this 13th day of July, 1965.

C. R. DEDMAN, Registrar.  
Industrial Appeals Court.

#### SCHEDULE.

Aerated Water Trade; Agricultural Implements; Bedsteadmakers; Boarding Houses; Boarding School Employees; Bricklayers; Canteen Workers; Cardboard Box Trade; Country Printers; Cycle Trade; Engravers; Gas Meter; Hospital Executives; Hotel and Restaurant; Jewellers; Marine Stores; Nickelware; Opticians; Ovenmakers; Paper Bag Trade; Port Phillip Seamen's Printers; Stationery; Tinsmiths; Totalizer Employees Watch Cases; Watchmakers; Wireworkers.

#### Co-operation Act 1958.

C.I.G. EMPLOYEES' CO-OPERATIVE LIMITED  
(FORMERLY E.M.F. ELECTRIC COMPANY  
EMPLOYEES CO-OPERATIVE CREDIT SOCIETY  
LIMITED).

#### NOTICE OF CHANGE OF NAME OF SOCIETY.

NOTICE is hereby given that I have this day registered a change of the name of E.M.F. Electric Company Employees Co-operative Credit Society Limited which was incorporated as a Community Advancement Society under the *Co-operation Act 1953* on the twentieth day of December, 1955, and is now incorporated under the name of C.I.G. Employees' Co-operative Limited under the *Co-operation Act 1958*.

Dated at Melbourne this twenty-fourth day of June, 1965.

J. W. JUNGWIRTH,  
Acting Registrar of Co-operative Societies.

#### Housing Act 1958 (Section 99 of Act No. 6275).

GENERAL NOTICE TO PARTIES EMPOWERED BY THE "LANDS COMPENSATION ACT 1958" TO SELL AND CONVEY OR GRANT AND RELEASE, PURSUANT TO SECTION 99 OF ACT 6275.

#### GENERAL NOTICE TO TREAT FOR LAND IN A RECLAMATION AREA AT KENSINGTON.

IN pursuance of the provisions contained in the *Housing Act 1958* and of the *Lands Compensation Act 1958* Housing Commission (hereinafter referred to as the Commission) hereby doth give notice that the lands, tenements and hereditaments described in the Schedule hereto are required for the purpose of the *Housing Act 1958*, and that the Commission is authorized by the provisions of section 68 of the *Housing Act 1958*, to purchase or take compulsorily the said lands.

And the Commission accordingly hereby gives notice to all the parties interested in such lands and to all persons empowered by the *Lands Compensation Act 1958*, to sell and convey or grant and release the lands so required that it requires to take and purchase the lands referred to in the said Schedule hereto and that it is willing to treat with such parties or persons for the purchase thereof and as to the compensation to be made and for the damage that may be sustained by reason of the execution of the works.

And further the Commission hereby requires such parties or persons on or before the expiration of 21 days from the seventeenth day of July, 1965, to deliver to the offices of the Commission, at 179 Queen-street, Melbourne, a statement, in writing, of the particulars of the estate and interest in the said lands, tenements and hereditaments and of the claims made in respect thereof.

Dated the twenty-ninth day of June, 1965.

By order of the Commission,

A. L. BOHN,  
Secretary.

#### SCHEDULE.

All that piece of land situate within the municipality of the City of Melbourne, being part of Crown allotment 19, section 2, Parish of Doutta Galla, and being the land bounded on the north-west by the boundary between Crown allotments 19 and 20, section 2, Parish of Doutta Galla on the north-east by the south-western alignment of Derby-street on the south-east by the north-western alignment of Ormond-street on the south-west by the north-eastern alignment of Altona-street excepting thereout—

First, the land comprised in certificates of title, volume 4645, folio 917 and volume 6086, folio 161.

Secondly, lots numbered 28, 29 and 60 on plan of subdivision No. 2438, lodged in the Office of Titles, being part of the land comprised in certificate of title, volume 6062, folio 346.

Thirdly, so much of the road shown coloured yellow on the map in the margin of certificate of title, volume 6086, folio 161 as lies to the south-west of the north-westerly prolongation of the north-eastern boundary of the land in the said certificate of title.

Fourthly, so much of the road shown 11 feet wide on plan of subdivision No. 2438, lodged in the Office of Titles and adjoining lot No. 28 on the said plan of subdivision, and so much of the reserve, 1 foot wide adjoining such road, as lie to the south-west of the north-westerly prolongation of the north-eastern boundary of the said lot 28.

Plans are available for inspection at the Estates Branch of the Housing Commission situated on the seventh floor, at 179 Queen-street, Melbourne, and forms for the making of claims will also be available on application to the Commission.

#### COMPANIES ACT 1961.

NOTICE is hereby given in pursuance of section 308 (4) of the *Companies Act 1961*, that the names of the companies referred to below, have been struck off the register.

Dated this 9th day of July, 1965.

T. S. WELSH,  
Registrar of Companies.

Companies Registration Office,  
Melbourne.

#### COMPANIES ABOVE REFERRED TO.

| Name of Company.                    | Number of Registration. |
|-------------------------------------|-------------------------|
| Giovenco Constructions Pty. Limited | F 3172                  |
| Giovenco Bros. Pty. Limited         | F 3173                  |

## MONEY LENDERS ACT 1958.

IN accordance with the provisions of the above-mentioned Act the following is published for general information.

List of persons to whom Money Lenders' Licences have been issued for the year ending 30th June, 1965.

| Name.  | Authorized Name.                            | Authorized Address.                          | Date of Issue. |
|--|---|--|----------------|
| *Australian Guarantee Corporation Ltd. (H. A. Smith, Appointee)          | Australian Guarantee Corporation Ltd.       | George-street, Morwell ..                    | 5.5.65         |
| *Commercial Discounters (Victoria) Pty. Ltd. (W. R. Davidson, Appointee) | Commercial Discounters (Victoria) Pty. Ltd. | 330 Collins-street, Melbourne ..             | 13.5.65        |
| *Commercial and General Acceptance Limited (R. G. Overell, Appointee)    | Commercial and General Acceptance Limited   | A.M.P. Building, 51 Hotham-street, Traralgon | 31.5.65        |
| D.D.P. Pty. Limited (R. D. Davidson, Appointee)                          | D.D.P. Pty. Limited .. ..                   | 1 Palmerston-crescent, South Melbourne       | 21.5.65        |
| *G. E. Finance Pty. Ltd. (Joyclyn N. George, Appointee)                  | G. E. Finance Pty. Ltd. .. ..               | 222 Albert-road, South Melbourne             | 1.6.65         |
| †Purchase Credit Corporation Pty. Ltd. (E. Smith, Appointee)             | Purchase Credit Corporation Pty. Ltd.       | 157 Commercial-road, South Yarra             | 24.5.65        |
| *Queen's Bridge Investments Pty. Ltd. (K. L. F. Cook, Appointee)         | Queen's Bridge Investments Pty. Ltd.        | Plummer-street, Port Melbourne..             | 26.3.65        |
| Rechners Ltd. (C. J. Rechner, Appointee)                                 | Rechners Ltd. .. ..                         | 245 Latrobe-street, Melbourne ..             | 7.4.65         |
| Seaboard Finance Co. of Australia Pty. Ltd. (M. J. Feeney, Appointee)    | Seaboard Finance Co. of Australia Pty. Ltd. | 318 Elizabeth-street, Melbourne ..           | 19.5.65        |
| Seaboard Finance Co. of Australia Pty. Ltd. (E. T. Ingram, Appointee)    | Seaboard Finance Co. of Australia Pty. Ltd. | 157 Commercial-road, South Yarra             | 11.5.65        |
| Seaboard Finance Co. of Australia Pty. Ltd. (P. H. Brown, Appointee)     | Seaboard Finance Co. of Australia Pty. Ltd. | 45 Riversdale-road, Camberwell ..            | 24.3.65        |
| *Traders Finance Corporation Ltd. (V. E. Walmsley, Appointee)            | Traders Finance Corporation Ltd. ..         | George-street, Morwell ..                    | 5.5.65         |

\* New authorized address. † Transfer of Appointee.

State Treasury,  
Melbourne, C.2, 5th July, 1965.

W. WATTS, Registrar,  
Money Lenders Act.

## AUCTION SALES ACT.

LIST of Persons to whom Auctioneers' Licences have been issued during the month of May, 1965.

| Name.  | Address.                                   | Date of Issue. |
|--|--|----------------|
| Coady, Peter John .. ..                      | Werril-street, Swan Hill .. ..             | 4.5.65         |
| Cowell, Gerald Joseph .. ..                  | 11 Bowman-street, Aspendale .. ..          | 11.5.65        |
| Creed, Richard Percival .. ..                | 15 Mernda-road, Kooyong .. ..              | 11.5.65        |
| Forbes, John Vincent .. ..                   | 42 Hornby-street, Beaumaris .. ..          | 25.5.65        |
| Foster, Peter William .. ..                  | 74 Desailly-street, Sale .. ..             | 28.5.65        |
| Fryer, Lance William .. ..                   | 74 Main-road, Blackburn .. ..              | 24.5.65        |
| Heerens, Jacobus Hendrick .. ..              | 13 Boronia-road, Boronia .. ..             | 24.5.65        |
| Holloway, Royston Harvey .. ..               | 5 Ascot-street, Malvern .. ..              | 7.5.65         |
| Hoogen-Bosch, Johannes Vitus Cornelius .. .. | Lot 82, Gidgee-court, Wantirna South .. .. | 24.5.65        |
| Jones, Eric Vincent .. ..                    | 2 Mallaluka-avenue, Ocean Grove .. ..      | 25.5.65        |
| McCudden, Joseph .. ..                       | 12 Station-street, Seaholme .. ..          | 21.5.65        |
| Malney, Victor Francis .. ..                 | 545 Mt. Alexander-road, Moonee Ponds .. .. | 7.5.65         |
| Murphy, Keith Desmond .. ..                  | 16 Harrison-street, Benalla .. ..          | 17.5.65        |
| Slee, Murray Wilfred .. ..                   | 72 Corio-street, Shepparton .. ..          | 17.5.65        |
| Sturgess, Leonard Edward .. ..               | 340 Latrobe-street, Melbourne .. ..        | 13.5.65        |
| Young, Kevin James .. ..                     | 12 Penny-avenue, Warragul .. ..            | 14.5.65        |

The Treasury,  
Melbourne, C.2, 5th July, 1965.

E. W. COATES,  
Director of Finance.

State Electricity Commission Acts.  
ELECTRICAL APPROVALS BOARD.

PURSUANT to Regulation 16 of the Electrical Approvals Regulations—Approval of Equipment, 1953, the State Electricity Commission of Victoria hereby gives notice that it has withdrawn approval of the undermentioned articles :—

| Name of Applicant.  | Article and Reference No.   | Date of Certificate of Approval. | Date of Withdrawal. | Approvals Marking. |
|---------------------|---|----------------------------------|---------------------|--------------------|
| Camelec Ltd. ..     | Plug, Trade Name "Camelec", Cat. No. K1-33, 250 volts, 2-pin flat pin Ref. No. AD/OZ/06   | 18.4.63                          | 25.6.65             | S/2                |
| Camelec Ltd. ..     | Plug, Trade Name "Camelec", Cat. No. K1-20-6, 250 volts, 3-pin flat pin Ref. No. AD/OZ/09 | 11.10.63                         | 25.6.65             | S/2                |
| Lemar Industries .. | Blanket, Trade Name "Daydream", Cat. No. ELV, 31.5 volts, 125 watts, Ref. No. BO/A5A/01   | 11.4.62                          | 3.6.65              | N/249              |

Dated the 12th day of July, 1965.

L. G. MORRISON, Secretary.

**VICTORIAN NURSING COUNCIL.**  
INCOME AND EXPENDITURE ACCOUNT FOR THE YEAR ENDED 30TH JUNE, 1964.

|   | £      | s. | d. |   | £      | s. | d. |
|---|--------|----|----|---|--------|----|----|
| Postage .. .. .                                 | 1,845  | 13 | 7  | Profit Sale of Cap Badges .. .. .               | 35     | 17 | 1  |
| Salaries and Wages .. .. .                      | 22,078 | 5  | 4  | Profit on Sale of Badges .. .. .                | 138    | 8  | 0  |
| Printing and Stationery .. .. .                 | 2,519  | 14 | 4  | Profit on Sale of Casebooks .. .. .             | 48     | 2  | 8  |
| Advertising .. .. .                             | 126    | 19 | 6  | Practising Certs.—Initial .. .. .               | 2,155  | 2  | 11 |
| Examination Fees—Final .. .. .                  | 5,099  | 17 | 0  | Practising Certs.—Renewal .. .. .               | 8,624  | 10 | 6  |
| Examination Fees—Entrance and 1st Prof. .. .. . | 1,832  | 17 | 0  | Registration Fees .. .. .                       | 3,863  | 3  | 2  |
| Rent and Cleaning .. .. .                       | 2,915  | 15 | 2  | Examination Fees—Final .. .. .                  | 7,860  | 1  | 0  |
| Telephone Expenses .. .. .                      | 245    | 11 | 6  | Examination Fees—Entrance and 1st Prof. .. .. . | 4,127  | 10 | 0  |
| Electricity .. .. .                             | 266    | 0  | 6  | Sales of Regulations .. .. .                    | 49     | 19 | 11 |
| Travelling Allowance .. .. .                    | 1,266  | 17 | 4  | Sundry Income .. .. .                           | 141    | 7  | 3  |
| Insurance .. .. .                               | 106    | 0  | 4  | Exchange .. .. .                                | 14     | 13 | 2  |
| Sundry Expenses .. .. .                         | 480    | 6  | 8  | Government Grant .. .. .                        | 12,000 | 0  | 0  |
| Maintenance and Repairs .. .. .                 | 153    | 4  | 0  | Interest Received .. .. .                       | 348    | 19 | 5  |
| Refunds—Registration .. .. .                    | 103    | 19 | 6  | Deficit .. .. .                                 | 1,636  | 12 | 10 |
| Refunds—Examination Fees .. .. .                | 39     | 14 | 5  |   |        |    |    |
| Refunds—Practising Certificates .. .. .         | 185    | 4  | 0  |   |        |    |    |
| Audit Fee .. .. .                               | 75     | 0  | 0  |   |        |    |    |
| Payroll Tax .. .. .                             | 280    | 13 | 4  |   |        |    |    |
| Depreciation .. .. .                            | 1,148  | 16 | 5  |   |        |    |    |
| Contribution to Staff Superannuation .. .. .    | 273    | 18 | 0  |   |        |    |    |
|   | 41,044 | 7  | 11 |   | 41,044 | 7  | 11 |

**VICTORIAN NURSING COUNCIL.**  
BALANCE-SHEET AS AT 30TH JUNE, 1964.

|   | £      | s. | d. |   | £      | s. | d. |
|---|--------|----|----|---|--------|----|----|
| Sundry Creditors .. .. .                        | 2,797  | 19 | 0  | Cash Book Balance—No. 1 Account .. .. . | 9,770  | 3  | 7  |
| Practising Certificates Paid in Advance .. .. . | 6      | 0  | 0  | Cash Book Balance—No. 2 Account .. .. . | 860    | 1  | 8  |
|   |        |    |    |   |        |    |    |
|   | £      | s. | d. |   | £      | s. | d. |
| General Fund .. .. .                            | 19,393 | 5  | 1  | Cash on Hand .. .. .                    | 55     | 0  | 0  |
| Less Deficit for year 1963-64 .. .. .           | 1,636  | 12 | 10 | Fixed Deposit .. .. .                   | 5,000  | 0  | 0  |
|   | 17,756 | 12 | 3  | Stock on Hand—Badges .. .. .            | 246    | 14 | 0  |
|   |        |    |    | Stock on Hand—Casebooks .. .. .         | 67     | 10 | 0  |
|   |        |    |    | Furniture and Equipment .. .. .         | 11,649 | 18 | 7  |
|   |        |    |    | Less provision for Depreciation .. .. . | 7,088  | 16 | 7  |
|   | 20,560 | 11 | 3  |   | 4,561  | 2  | 0  |
|   |        |    |    |   | 20,560 | 11 | 3  |

I have audited the books and accounts of the Victorian Nursing Council for the year ended 30th June, 1964. In my opinion, the above Balance-sheet is properly drawn up so as to present a true and fair view of the affairs of the Council as at 30th June, 1964, and the accompanying statement of Income and Expenditure properly summarises the financial operations for the year.

(Sgnd.)  
G. M. HAMILTON,  
Auditor.  
3rd May, 1965.

*Process Servers and Inquiry Agents Act 1958.*  
APPLICATION FOR LICENCES LODGED WITH CLERKS OF COURTS.

BY direction of the Chief Secretary, the subjoined lists of "new" applications for process servers and inquiry agents licences are published for general information.

| Applicant.                             | Address.  | Court.               | Tentative Date of Hearing of Application. |
|--|---|----------------------|---|
| <i>Inquiry Agents Licences.</i>        |   |                      |   |
| Ferguson, John Alfred .. .. .          | c/o Mayne Nickless Ltd., 697 Elizabeth-street, Melbourne                          | South Melbourne ..   | 29.7.65                                   |
| Massarotto, Giovanni .. .. .           | 34 George-street, Brunswick .. .. .   | Brunswick .. .. .    | 30.7.65                                   |
| Murray, Lawrence Arthur .. .. .        | 6 Aitken-street, Clifton Hill .. .. .   | Northcote .. .. .    | 20.7.65                                   |
| Pooles, Robert Harold Francis .. .. .  | 240 Victoria-parade, East Melbourne .. .. .                                       | Moonee Ponds .. .. . | 30.7.65                                   |
| Smith, Aidan Vernon Sunderland .. .. . | Mayne Nickless Ltd., Footscray-road, West Melbourne                               | North Melbourne..    | 29.7.65                                   |
| Staggard, David Keith .. .. .          | Mayne Nickless Ltd., New Footscray-road, West Melbourne                           | North Melbourne..    | 29.7.65                                   |
| Vass, Aris .. .. .                     | 85 Seymour-road, Elsternwick .. .. .  | Elsternwick .. .. .  | 27.7.65                                   |
| <i>Process Servers Licences.</i>       |   |                      |   |
| Jenkins, Donald .. .. .                | { 39 Salmon-street, Deer Park .. .. .<br>414 Lonsdale-street, Melbourne .. .. . } | Sunshine .. .. .     | 23.7.65                                   |
| Jenkins, Peter William .. .. .         | 203 Canterbury-road, St. Kilda .. .. .  | St. Kilda .. .. .    | 28.7.65                                   |
| Murray, Lawrence Arthur .. .. .        | 6 Aitken-street, Clifton Hill .. .. .   | Northcote .. .. .    | 20.7.65                                   |
| Pooles, Robert Harold Francis .. .. .  | 240 Victoria-parade, East Melbourne .. .. .                                       | Moonee Ponds .. .. . | 30.7.65                                   |

Attention is directed to the provisions of the above Act and regulations thereunder relating to the lodgement of objections to applications.

Chief Secretary's Office,  
Melbourne, 13th July, 1965.

C. W. PHILLIPS, Registrar,  
Process Servers and Inquiry Agents.

## Companies Act 1961.

## EXEMPTION BY THE MINISTER PURSUANT TO SECTION 88 (1) OF THE COMPANIES ACT 1961.

## WHEREAS:

I. Darling Management Limited (hereinafter called "the company") is the management company within the meaning of section 76 of the Companies Act 1961 (hereinafter referred to as "the Act") in relation to a Deed constituting the Darling Fund (hereinafter called "the Trust Deed").

II. Permanent Trustee Nominees (Canberra) Limited is the Trustee for the purpose of the Trust Deed.

III. Application has been made by the company for exemption from compliance with the provisions of sub-section (1) of section 84 of the Act in respect of the holders of interests under the Trust Deed who are resident outside the State of Victoria.

Now therefore, I the undersigned, the Minister administering the Act, subject to the terms and conditions set out in the Schedule hereunder, do hereby exempt the company from compliance with the provisions of sub-section (1) of section 84 of the Act in respect of the holders of interests under the Trust Deed who are resident outside Victoria.

## SCHEDULE.

1. The company shall keep in the State of New South Wales, at a place and in the form and manner in which it is required to be kept pursuant to the Companies Act 1961 of that State, a complete register of all holders of interests under the Trust Deed wherever resident.

2. The company shall keep in the State of Victoria a register of the holders of interests under the Trust Deed who are resident in Victoria and the requirements of sub-section (1) of section 84 of the Act shall be complied with in relation to such register.

3. The company shall within fourteen days after receiving a request from any person entitled to inspect the register by virtue of the provisions of sub-section (2) of section 153 of the Act make available to such person for inspection a copy of the register of all holders of interests under the Trust Deed, wherever resident.

Signed at Melbourne, this 9th day of July, 1965.

V. F. WILCOX,  
Acting Attorney-General.

## Marine Act 1958.

## APPOINTMENT OF ASSESSORS FOR COURTS OF MARINE INQUIRY.

HIS Excellency the Governor of the State of Victoria, by and with the advice of the Executive Council thereof, doth by Order made on the 6th day of July, 1965, appoint the following persons to be Assessors for Courts of Marine Inquiry, pursuant to the provisions of section 178 of the Marine Act 1958, for the twelve months ending 30th June, 1966:—

## COURT OF MARINE INQUIRY.

## ASSESSORS.

## Class 1: Masters.

HUGH FITZROY WOOLF  
CEDRIC JAMES HACKWORTH  
GEORGE ARTHUR MOLYNEUX  
DONALD MCLEAN  
JOHN EMSLIE WALKER

## Class 2: Engineers.

GEORGE WILLIAM D'ARCY-EVANS  
JOHN CHARLES ROBERT SUNDERCOMBE.  
GEORGE WINNINGTON MARTIN  
DEREK NORMAN MOORE

## Class 3: Pilots and Exempt Masters.

CEDRIC JAMES HACKWORTH  
GEORGE ARTHUR MOLYNEUX  
DONALD MCLEAN  
JOHN EMSLIE WALKER

## Class 4: Scientific.

GEORGE WILLIAM D'ARCY-EVANS  
JOHN CHARLES ROBERT SUNDERCOMBE.  
ARTHUR MATTHEW COBBETT.

J. COLQUHOUN,  
Clerk of the Executive Council.

At the Executive Council Chamber,  
Melbourne, 6th July, 1965.

## Country Roads Act 1958.

## COUNTRY ROADS BOARD.

## NOTICE OF FIXING NEW ALIGNMENTS OF BURWOOD HIGHWAY IN THE SHIRE OF KNOX.

NOTICE is hereby given that the Country Roads Board, under the powers conferred upon it by the Country Roads Act 1958 (No. 6229) has fixed a new alignment for the north side of Burwood Highway in the Shire of Knox, as described hereunder, that is to say:—

- (a) Commencing at a point on the western boundary of lot 1 on plan of subdivision numbered 18446, lodged in the Office of Titles, and being part of allotment 38B<sup>1</sup>, Parish of Scoresby, distant 22 deg. 34 min. 33.3 links from the south-western angle of the said lot; thence by lines bearing respectively 112 deg. 24 min. 1,483.9 links, 112 deg. 30 min. 2,779.1 links, 112 deg. 26 min. 982.5 links, 67 deg. 25 min. 56.5 links, 202 deg. 24½ min. 40 links, 112 deg. 26 min. 76 links, 22 deg. 24½ min. 40 links, 157 deg. 25 min. 56.6 links, 112 deg. 26 min. 981.5 links, 112 deg. 32 min. 3,489 links and 67 deg. 32½ min. 63.6 links to a point on the eastern boundary of lot 1 on plan of subdivision numbered 7189, lodged in the Office of Titles, and being part of allotment 40, Parish of Scoresby, distant 22 deg. 33 min. 78.3 links from the south-eastern angle of the said lot 1.
- (b) Commencing at a point on the western boundary of lot 2 on plan of subdivision numbered 16690, lodged in the Office of Titles, and being part of allotment 54A, Parish of Scoresby, distant 22 deg. 23 min. 22 feet from the south-western angle of the said lot; thence by a line bearing 112 deg. 23 min. 557 ft. 6½ in. to a point on the eastern boundary of lot 1 on the said plan of subdivision, distant 22 deg. 47 min. 22 feet from the south-eastern angle of the said lot 1.
- (c) Commencing at a point on the western boundary of lot 2 on plan of subdivision numbered 6617, lodged in the Office of Titles, and being part of allotment 54B, Parish of Scoresby, distant 22 deg. 30 min. 37 feet from the south-western angle of the said lot; thence by lines bearing respectively 157 deg. 30 min. 21 ft. 2½ in., 112 deg. 30 min. 469 ft. 5½ in. and 112 deg. 26½ min. 794 ft. 2½ in. to a point on the eastern boundary of lot 16 on plan of subdivision numbered 32239, lodged in the Office of Titles, and being part of allotment 53 of the said parish, distant 22 deg. 37½ min. 22 feet from the south-eastern angle of the said lot 16—

which said new alignment is shown on survey plans numbered 9783, 9784, 9785 and 9786, lodged in the office of the Country Roads Board.

Copies of the said survey plans are lodged in the offices of the Country Roads Board, the municipality of the Shire of Knox, the Registrar of Titles and the Registrar General respectively and may be inspected by any person without a fee at any time at which such offices are open for business.

Dated the 12th day of July, 1965.

N. L. ALLANSON,

Secretary.

Country Roads Board, 60 Denmark-street, Kew, E.A.

## EDUCATION DEPARTMENT.

## APPOINTMENT OF SUMMONING OFFICER.

UNDER section 5 of the Education Act 1958, I hereby appoint—

First Constable HERBERT WILLIAM JOHN EYERS  
to summon parents within the State of Victoria.

JOHN BLOOMFIELD,

Minister of Education.

5th July, 1965.

## DEPARTMENT OF MINES.

**SUBJECT** to any necessary excisions, &c., it is proposed to grant the following mining lease:—

9241, Castlemaine; Wattle Gully Gold Mines No Liability; 77a. 2r. 2p., Parish of Chewton.

## MINING LEASES GRANTED.

5614, Gippsland; Cecil Cooper and James Denner; 12a. 2r. 9p., Parish of Wollonaby.  
8291, Mineral; Percy Ernest Outen and James Charles Outen; 5a. 2r. 9p., Parish of Yehrip.

## CONSENT GRANTED TO TRANSFER MINING LEASE.

8389, Beechworth; from Alan Ambrose Murray to Reedy Creek Tin Company No Liability.

## MINING LEASE EXPIRED.

11317, Bendigo; Ronald Pearce and Bert Pearce; 21a. 2r. 22p., Parish of Moora.

## APPLICATION FOR LEASE DECLARED ABANDONED.

8070, Mineral; John Sydney Mellington and Helen Henderson Mellington; 50 acres, Parish of Wyperfeld.

## EXPLORATION LICENCES GRANTED.

Exploration Licence No. 12; Planet Mining Company Pty. Ltd.; 813 square miles, Counties of Tanjil, Buln Buln, Evelyn, Wonnangatta.  
Exploration Licence No. 13; Planet Mining Company Pty. Ltd.; 825 square miles, Counties of Wonnangatta, Anglesey, Delatite.  
Exploration Licence No. 14; Planet Mining Company Pty. Ltd.; 772 square miles, Counties of Dargo, Wonnangatta, Tambo, Benambra, Bogong.  
Exploration Licence No. 15; Planet Mining Company Pty. Ltd.; 689 square miles, Counties of Dargo, Benambra, Bogong, Wonnangatta.  
Exploration Licence No. 16; Planet Mining Company Pty. Ltd.; 787 square miles, Counties of Delatite, Bogong, Dargo, Wonnangatta.  
Exploration Licence No. 17; Planet Mining Company Pty. Ltd.; 271 square miles, Counties of Talbot, Bourke, Dalhousie, Bendigo.  
Exploration Licence No. 22; Planet Mining Company Pty. Ltd.; 823 square miles, Counties of Bendigo, Rodney, Dalhousie, Bourke, Talbot, Grant.

## MINERAL SEARCH LICENCES GRANTED.

604, Mineral Search Licence; Edward Arthur Knox and Henry James Evans; 427 acres, Parish of Enoch's Point.  
607, Mineral Search Licence; Lindsay Gordon McRae and Keith McRae; 160 acres, Parish of Nowa Nowa.  
613, Mineral Search Licence; Lindsay Gordon McRae and Keith McRae; 4231 acres, Parish of Enano.  
615, Mineral Search Licence; Lindsay Gordon McRae and Keith McRae; 600 acres, Parish of Toonginbooka.

## MINERAL SEARCH LICENCES EXPIRED.

537, Mineral Search Licence; Hilary Fynes-Clinton Nevill and Howard Jarvis; 480 acres, Parish of Dorchapp.  
538, Mineral Search Licence; Hilary Fynes-Clinton Nevill and Howard Jarvis; 480 acres, Parish of Dorchapp.  
566, Mineral Search Licence; James Say; 695 acres, Parishes of Deddick and Jingallalla.

## TAILINGS LICENCES EXPIRED.

3310, Tailings Licence; Nicholas John Ramsay; Parish of Byawatha.  
3329, Tailings Licence; Herbert Claude Cann; Parish of Blackwood.  
3335, Tailings Licence; Thomas Stephen Taylor and John Oswald Krause; Parish of Stawell.

T. A. DARCY,  
Minister of Mines.

## MINING LEASE DECLARED VOID.

5608, Gippsland; David William Hamilton and Dennis Rawson; 21a. Or. 31p., Parish of Tabberabbera.

The applicants for forfeiture of the above-named lease will be granted a new lease under section 57 of the *Mines Act 1958*.

E. CONDON,  
Secretary for Mines.

## FISH CREEK WATERWORKS TRUST.

## RATING BY-LAW FOR THE YEAR 1965, NO. 1.

**T**HE Fish Creek Waterworks Trust, in pursuance and exercise of the powers conferred by the Water Acts, doth hereby make a rate for the supply of water for domestic purposes of Three shillings in the pound of the Net Annual Valuation of the land and tenements liable to be rated within the Fish Creek Urban District.

Provided that in no case shall the amount of rate payable per annum in respect of any tenement (other than land on which there is no building) be less than Six pounds and in respect of land on which there is no building less than One pound per annum. Such rates are made and shall be levied upon the occupiers or owners of the said land and tenements for the year commencing on the 1st day of January, 1965, and shall be due and payable on the 14th day of July, 1965, at the office of the Trust.

The maximum quantity of water to be supplied in any year without further charge to any property rated by the Trust is hereby fixed at the quantity of water which, at a charge of Three shillings per 1,000 gallons, would produce an amount equal to the amount of the rate levied on such property for the said year. The charge for water supplied to a property rated by the Trust in excess of such maximum quantity, computed as in the last preceding clause, is hereby fixed at Three shillings per 1,000 gallons, except that where the quantity of excess water used exceeds 1,000,000 gallons the charge for excess water supplied shall be One shilling and six pence per 1,000 gallons.

The charge for water supplied to any property not rated by the Trust is hereby fixed at Three shillings per 1,000 gallons and the minimum quantity of water to be charged for in cases where water is supplied for domestic purposes only is hereby fixed at 100,000 gallons and in cases where water is supplied for stock and domestic purposes the minimum quantity of water to be charged for is hereby fixed at 200,000 gallons.

Dated this twenty-fourth day of June, 1965.

(SEAL) W. A. GALE, Chairman.  
L. G. HUNT, Commissioner.  
T. E. THORSON, Commissioner.  
G. B. TAYLOR, Secretary.

Approved, 7th July, 1965.—T. A. DARCY, Minister of Water Supply.

## SWAN HILL WATERWORKS TRUST.

## RATING BY-LAW FOR 1965.

**T**HAT the Swan Hill Waterworks Trust, in pursuance and exercise of the powers conferred by the Water Acts, doth hereby make a rate for the supply of water for domestic purposes of Thirteen pence in the pound on the annual municipal valuation of lands and tenements liable to be rated within the Swan Hill Urban District.

Provided that in no case shall the amount of the rate payable per annum in respect of any tenements or land be less than Sixty shillings.

Such rates are made and shall be levied upon the occupiers or owners of the said lands and tenements for the year commencing the 1st day of January, 1965 and shall be payable on the 15th day of July, 1965 at the office of the said Trust.

The maximum quantity of water to be supplied in any one year without further charge to any property rated by the Trust is hereby fixed at the quantity which, at a charge of Twenty pence per one thousand (1,000) gallons would produce an amount equal to the amount of rate levied on such property for the said year.

The charge for water supplied by measure to any property rated by the Trust in excess of such maximum quantity computed as in the last preceding clause is hereby fixed at Twenty pence per one thousand (1,000) gallons.

The charge for water supplied by measure to any property not rated by the Trust is hereby fixed at Twenty pence per one thousand (1,000) gallons, and the minimum

quantity of water to be charged for in cases where water is so supplied is hereby fixed at thirty-six thousand (36,000) gallons.

The charge for water supplied by measure shall be payable, on demand, at the office of the Trust.

Passed on the thirtieth day of June, 1965.

(SEAL) G. K. HARRISON, Chairman.  
R. J. PUGSLEY, Secretary.

Approved, 7th July, 1965.—T. A. DARCY, Minister of Water Supply.

#### LINDENOW WATERWORKS TRUST.

RATING BY-LAW FOR THE PERIOD COMMENCING ON THE 1ST DAY OF JANUARY, 1965, AND ENDING ON THE 31ST DAY OF DECEMBER, 1965.

THE Lindenow Waterworks Trust, in pursuance and exercise of the powers conferred by the Water Acts, doth hereby make a rate for the supply of water for domestic purposes of Three shillings and sixpence in the pound of the annual municipal valuation of lands and tenements liable to be rated within the Lindenow, Waipa, and Lindenow South Urban Districts.

Provided that in no case shall the amount of rate payable for the rating period in respect of any tenement (other than land on which there is no building) be less than Six pounds fifteen shillings, and in respect of any land on which there is no building less than One pound ten shillings.

Such rates are made and shall be levied upon the occupiers or owners of the said lands and tenements for the period commencing on the 1st day of January 1965 and ending on the 31st day of December 1965, and shall be payable on the 15th day of July 1965 at the office of the said Trust.

The maximum quantity of water to be supplied in any one year without further charge to any property rated by the Trust is hereby fixed at the quantity which, at a charge of Three shillings per 1,000 gallons, would produce an amount equal to the amount of the rate levied on such property for the said period.

The charge for water supplied by measure to any property rated by the Trust in excess of such maximum quantity, computed as in the last preceding clause, is hereby fixed at Two shillings and six pence per 1,000 gallons.

The charge for water supplied by measure to any property not rated by the Trust is hereby fixed at Three shillings per 1,000 gallons, and the minimum quantity of water to be charged for in cases where water is so supplied is hereby fixed at 80,000 gallons.

The charge for water supplied by measure shall be payable, on demand, at the office of the Trust.

Passed this 28th day of June, 1965.

(SEAL) E. JOHNSTON, Chairman.  
G. D. MITTON, Commissioner.  
E. LLOYD BRINDLEY, Secretary.

Approved, 7th July, 1965.—T. A. DARCY, Minister of Water Supply.

#### MITCHELL RIVER IMPROVEMENT TRUST.

RATING BY-LAW No. 8.

THE Mitchell River Improvement Trust, in pursuance and exercise of the powers conferred by the River Improvement Act 1958, doth hereby make the By-law following:—

1. The following rate, to be called the "Mitchell River Improvement District River Improvement Rate" is hereby made and shall be levied upon the occupiers or owners of all properties within the Mitchell River Improvement District which are rateable to any municipality:—

A Rate of Seven Pence in the pound on the net Annual Municipal Value of all those properties within the First Division as determined by Order in Council made on the 14th January, 1964, and published in the *Government Gazette* of the 15th January, 1964, being those lands shown coloured green on the plan titled "Mitchell River Improvement Trust Proposed Rating Divisions", approved by the Governor in Council and deposited at the Office of the State Rivers and Water Supply Commission, at Melbourne. (Corres. No. 60/263/25). Provided that the sum of One Shilling shall be the minimum amount payable in respect of any property liable to be rated in the said Division.

A Rate of Five Pence in the pound on the net Annual Municipal Value of all those properties within the Second Division, being those lands shown coloured brown on the said plan. Provided the sum of One Shilling shall be the minimum amount payable in respect of any property liable to be rated in the said Division.

A Rate of Four Pence in the pound on the net Annual Municipal Value of all those properties within the Third Division, being those lands shown coloured yellow on the said plan. Provided that the sum of One Shilling shall be the minimum amount payable in respect of any property liable to be rated in the said Division.

2. Such rates are made and shall be levied for the period beginning on the 1st day of January, 1965, and ending with the 31st day of December, 1965, and shall be payable on the 14th day of July, 1965, at the Office of the Mitchell River Improvement Trust, Nicholson-street, Bairnsdale.

Such person or persons as the Mitchell River Improvement Trust may from time to time appoint for the purpose shall be and is or are hereby authorized to demand, receive, collect and recover the said rate.

The foregoing By-law was made by the Mitchell River Improvement Trust, on the 21st day of June, 1965, and the Common Seal of the said Trust was hereunto affixed, this 21st day of June, 1965—

(SEAL) W. H. DUMARESQ, Chairman.  
G. D. MITTON, Commissioner.  
J. B. NEALE, Secretary.

Approved by the Governor in Council, 6th July, 1965.—J. COLQUHOUN, Clerk of the Executive Council.

#### APPOINTMENTS.

HIS Excellency the Governor of the State of Victoria, by and with the advice of the Executive Council thereof, has, by Orders made on the 6th day of July, 1965, been pleased to make the under-mentioned appointments, viz.:—

##### CHIEF SECRETARY'S DEPARTMENT.

##### Electoral Registrar (Acting).

RONALD JAMES BARBER  
to be Electoral Registrar (Acting) for the Alexandra, Avenel, Benalla, Euroa, Mansfield, Moyhu, Ovens, Violet Town and Yea Subdivisions of the Electoral District of Benalla; and for the Beechworth, Chiltern, Corryong, Tallangatta, Wangaratta, Wodonga and Yackandandah Subdivisions of the Electoral District of Benambra, to take effect on and from the 2nd August, 1965, during the absence, on leave, of Bryant John Murfitt.

##### Honorary Probation Officers.

JOHN HOWARD BARNDEN, State Savings Bank, Mansfield,  
WILLIAM JOHN BILLINGTON, Bruce-street, Box Hill,  
RAYMOND ARNOLD GRAETZ, 248 Scott-street, Warracknabeal,  
WILLIAM VINCENT HOGARTH, The Parade, Mansfield,  
KENNETH DONALD ROWLANDS (the Reverend), 22 Anderson-street, Warracknabeal,  
DONALD ALBERT VERCOE THOMAS, 41 Richelieu-street, Maidstone, and  
FREDERICK WALTERS, 24 Albert-street, Moe,  
pursuant to the provisions of section 507 (2) of the Crimes Act 1958, to be Honorary Probation Officers for all Adult Courts in Victoria; and  
PETER JOHN JEFFREY (the Reverend), St. Mary's Presbytery, Cohuna,  
HARRIET LAURA LAIDLAW LESTER (Mrs.), care of Geelong Grammar School, Corio, and  
HAROLD BRYAN PATTEN, 20 Oak-street, Hawthorn,  
pursuant to the provisions of section 10 (1) of the Children's Court Act 1958, to be Honorary Probation Officers for all Children's Courts in Victoria.

##### Licensing Inspector.

MICHAEL FRANCIS SHARKEY, Chief Inspector of Police, to be a Licensing Inspector for the purposes of the Licensing Act 1958, vice William John Simmons, resigned.

##### DEPARTMENT OF CROWN LANDS AND SURVEY.

##### Member of Committee of Management.

STANLEY JAMES BRYANT  
to be a Member of the Committee of Management, in the place of Graham Allen Brownbill, resigned, of the Recreation Reserve at Dunolly in respect of which a Crown Grant has issued to the Minister of Lands and the President, Councillors and Ratepayers of the Shire of Bet Bet, and known as the Dunolly Recreation Reserve.

MINISTRY OF HEALTH.

Member of Committee of Management of Hospital.

HENRY GASQUOLINE BARROW to be a Member of the Committee of Management of Traralgon and District Hospital, pursuant to proviso (a) to section 48 (1) of the Hospitals and Charities Act 1958 for a further term of three years ending the 23rd July, 1968.

LAW DEPARTMENT.

Commissioners for Taking Declarations, &c.

GEOFFREY FRANCIS XAVIER MILES, care of The Housing Commission, Victoria, 179 Queen-street, Melbourne, and PETER THOMAS STRAW, care of Department of Crown Lands and Survey, Treasury-place, Melbourne, to be Commissioners for taking Declarations and Affidavits, pursuant to the provisions of the Evidence Act 1958, to refrain from charging fees and to resign upon ceasing to occupy their present positions; and

THOMAS RONALD LEEHANE, care of Building Branch, Melbourne and Metropolitan Tramways Board, South Melbourne, DAVID WILLIAM MENZIES, care of Cargo-Rudder's Limited, 28-46 Queensbridge-street, South Melbourne; and

FRANK BRYANT WHITEHEAD, care of Commonwealth Aircraft Corporation, 304 Lorimer-street, Port Melbourne, to be Commissioners for taking Declarations and Affidavits, pursuant to the provisions of the Evidence Act 1958, to resign upon ceasing to occupy their present positions.

Justices of the Peace.

GILBERT ERNEST WOLFE, Commonwealth Crown Solicitor's Office, 440 Little Collins-street, Melbourne, to Keep the Peace in all bailiwicks of the State of Victoria; and

OSWALD GORDON LYLE, 84 Main-street, Bacchus Marsh, KEITH JAMES MUNDAY, 249c Belmore-road, North Balwyn, and

FRANCIS ARTHUR SIMS, care of State Electricity Commission, 22 William-street, Melbourne, to Keep the Peace in the Central Bailiwick of the State of Victoria.

Special Children's Court Magistrates.

JOSEPH WATERS HAYES to be a Special Children's Court Magistrate, pursuant to section 5 of the Children's Court Act 1958, for the City of Mildura and to exercise the jurisdiction of a Children's Court under the said Act, to take effect from the date of commencement of duty; and

KEVIN JOHN BURGESS to be a Special Children's Court Magistrate, pursuant to section 5 of the Children's Court Act 1958, for all places within the State of Victoria where a Court of Petty Sessions is appointed or shall be appointed to be held under the provisions of the Justices Act 1958, and to exercise the jurisdiction of a Children's Court under the Children's Court Act, to take effect from the date of commencement of duty.

DEPARTMENT OF THE TREASURER.

Collector of Imposts.

KEVIN JOHN BURGESS to be Collector of Imposts the Children's Court, Law Department, vice D. B. Scully, transferred.

J. COLQUHOUN, Clerk of the Executive Council.

At the Executive Council Chamber, Melbourne, 6th July, 1965.

RESIGNATION.

HIS Excellency the Governor of the State of Victoria, by and with the advice of the Executive Council thereof, has, by Order made on the 6th day of July, 1965, accepted the resignation of the person named hereunder of the office mentioned, viz.:—

LAW DEPARTMENT.

GILBERT FINLAY BOYLE, as a Justice of the Peace for the Midland Bailiwick of the State of Victoria.

J. COLQUHOUN, Clerk of the Executive Council.

At the Executive Council Chamber, Melbourne, 6th July, 1965.

DEPARTMENT OF CROWN LANDS AND SURVEY.

At the Executive Council Chamber, Melbourne, the sixth day of July, 1965.

PRESENT:

- His Excellency the Governor of Victoria. Mr. Bolte Mr. Bloomfield Mr. Hamer Mr. Darcy Mr. Wilcox Mr. Chandler Mr. Reid Mr. Balfour Mr. Rossiter.

LANDS TEMPORARILY RESERVED AS SITES.

HIS Excellency the Governor of the State of Victoria, by and with the advice of the Executive Council thereof, doth hereby, in pursuance of the provisions of the Land Act 1958, reserve, temporarily, and also except from occupation for mining purposes under any miner's right, the lands hereinafter described:—

BAIRNSDALE.—Site for Public purposes (Police and Public Offices), 2 roods 27 perches, Township of Bairnsdale, Parish of Bairnsdale, County of Tanjil, as indicated by hachure on plan hereunder.—(B.66(11) (Rs.8465).

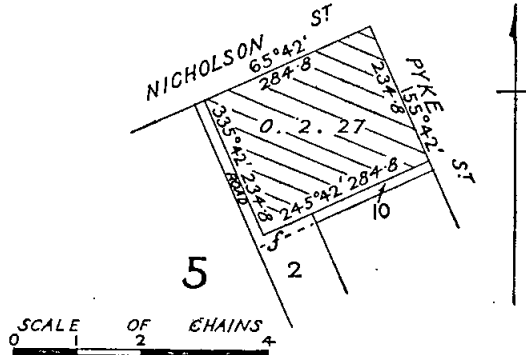

BALLARAT.—Site for Public purposes (Use of the Forests Department), 26 perches, Township of Ballarat, Parish of Ballarat, County of Grenville, as indicated by hachure on plan hereunder.—(B.128(13) (Rs.8481).

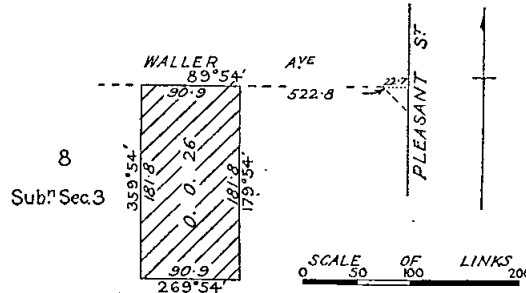

OTWAY.—Site for Public purposes (Public Hall) and Public Recreation in addition to and adjoining the site temporarily reserved therefor by Order in Council of the 15th May, 1956, 3 roods 10 perches, more or less, Parish of Otway, County of Polwarth, as indicated by hachure on plan hereunder.—(O.26(3) (Rs.1705).

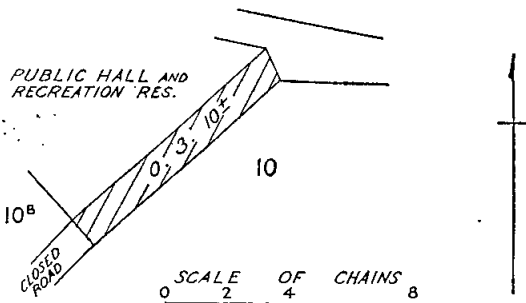





## COUNTRY ROADS BOARD.

At the Executive Council Chamber, Melbourne, the sixth day of July, 1965.

## PRESENT:

|  |               |
|--|---------------|
| His Excellency the Governor of Victoria. |               |
| Mr. Bolte                                | Mr. Chandler  |
| Mr. Bloomfield                           | Mr. Reid      |
| Mr. Hamer                                | Mr. Balfour   |
| Mr. Darcy                                | Mr. Rossiter. |
| Mr. Wilcox                               |               |

## ORDER APPROVING OF A DEVIATION FROM A TOURISTS' ROAD IN THE SHIRE OF OTWAY.

WHEREAS the Country Roads Board constituted under the Country Roads Act 1958 (No. 6229) has represented to His Excellency the Governor in Council that it appears to it desirable that the deviation hereinafter referred to from the existing Ocean-road in the Shire of Otway (declared to be a tourists' road under the said Act which declaration was confirmed by the Order in Council published in the Government Gazette of the 2nd December, 1936, on page 3196) should be made by the said Board: And whereas the said Board in accordance with the requirements of sections 19 and 88 of the said cited Act has caused to be prepared a map plan and estimate showing the points between which and on and through what land the said deviation is proposed to be made and the cost of acquiring the land: And whereas on an inspection of the said map and plan and a consideration of the said estimate His Excellency the Governor in Council is satisfied that there are funds legally available for acquiring the land: Now therefore be it known by this present Order that His Excellency the Governor of the State of Victoria with the advice of the Executive Council thereof doth hereby approve of the said road being made, that is to say:—

All those pieces of land in the Parish of Otway, the boundaries of which are as follow:—

- (a) Commencing at the western angle of allotment 13b of the said parish; thence by lines bearing respectively 314 deg. 8 min. 140.9 links, 121 deg. 29 min. 185.9 links, 115 deg. 39 min. 188.9 links, 104 deg. 48½ min. 267.8 links, 86 deg. 12½ min. 1,316.1 links, 261 deg. 17 min. 485.5 links, 268 deg. 26 min. 1,161.5 links and 316 deg. 31 min. 231 links to the point of commencement.
- (b) Commencing at an angle in the south-western boundary of allotment 13b of the said parish, formed by the intersection of lines bearing 128 deg. 10 min. and 103 deg. 19 min.; thence by lines bearing respectively 308 deg. 10 min. 324 links, 116 deg. 33 min. 310.2 links, 119 deg. 9 min. 238.6 links and 283 deg. 19 min. 237.5 links to the point of commencement.
- (c) Commencing at a point on the eastern boundary of allotment 13c of the said parish, distant 330 deg. 7 min. 237.4 links from the south-eastern angle of the said allotment; thence by lines bearing respectively 304 deg. 43 min. 418.7 links, 103 deg. 19 min. 246.4 links and 150 deg. 7 min. 209.6 links to the point of commencement.
- (d) Commencing at a point on the southern boundary of allotment 13b of the said parish distant 269 deg. 58 min. 680.4 links from the south-eastern angle of the said allotment; thence by lines bearing respectively 134 deg. 34 min. 367.7 links, 147 deg. 5 min. 215.1 links, 315 deg. 12 min. 475.5 links, 289 deg. 30 min. 532.7 links, 330 deg. 7 min. 303.9 links and 119 deg. 9 min. 698.3 links to the point of commencement.
- (e) Commencing at a point on the eastern boundary of lot 3 on plan of subdivision numbered 13562, lodged in the Office of Titles and being part of allotment 11 of the said parish, distant 109 deg. 30 min. 116.8 links and 135 deg. 12 min. 359.6 links from the northern angle of the said lot; thence by lines bearing respectively 135 deg. 12 min. 69.7 links, 161 deg. 31 min. 179.2 links, 193 deg. 51 min. 196.8 links, 358

deg. 30 min. 185.9 links, 351 deg. 10 min. 80.6 links and 344 deg. 1 min. 150.9 links to the point of commencement—

which said pieces of land are particularly delineated and shown coloured red and yellow on survey plan numbered 10024 lodged in the office of the Country Roads Board.

And the Honorable James Charles Murray Balfour, Her Majesty's Acting Minister of Public Works for the State of Victoria, shall give the necessary directions herein accordingly.

J. COLQUHOUN,  
Clerk of the Executive Council.

## COUNTRY ROADS BOARD.

At the Executive Council Chamber, Melbourne, the sixth day of July, 1965.

## PRESENT:

|  |               |
|--|---------------|
| His Excellency the Governor of Victoria. |               |
| Mr. Bolte                                | Mr. Chandler  |
| Mr. Bloomfield                           | Mr. Reid      |
| Mr. Hamer                                | Mr. Balfour   |
| Mr. Darcy                                | Mr. Rossiter. |
| Mr. Wilcox                               |               |

## ORDER APPROVING OF A DEVIATION FROM A TOURISTS' ROAD IN THE SHIRE OF OTWAY.

WHEREAS the Country Roads Board constituted under the Country Roads Act 1958 (No. 6229) has represented to His Excellency the Governor in Council that it appears to it desirable that the deviation hereinafter referred to from the existing Ocean-road in the Shire of Otway (declared to be a tourists' road under the said Act which declaration was confirmed by the Order in Council published in the Government Gazette of the 2nd December, 1936, on page 3196) should be made by the said Board: And whereas the said Board in accordance with the requirements of sections 19 and 88 of the said cited Act has caused to be prepared a map plan and estimate showing the points between which and on and through what land the said deviation is proposed to be made and the cost of acquiring the land: And whereas on an inspection of the said map and plan and a consideration of the said estimate His Excellency the Governor in Council is satisfied that there are funds legally available for acquiring the land: Now therefore be it known by this present Order that His Excellency the Governor of the State of Victoria with the advice of the Executive Council thereof doth hereby approve of the said road being made, that is to say:—

All those pieces of land in the Parish of Aire, the boundaries of which are as follow:—

- (a) Commencing at the western angle of allotment 21b of the said parish; thence by lines bearing respectively 101 deg. 25 min. 128.9 links, 258 deg. 36½ min. 78.8 links and 309 deg. 56 min. 64 links to the point of commencement.
- (b) Commencing at the southern angle of allotment 21c of the said parish; thence by lines bearing respectively 281 deg. 25 min. 141.3 links, 82 deg. 30 min. 230.7 links and 237 deg. 15 min. 107.3 links to the point of commencement.
- (c) Commencing at a point on the north-western boundary of allotment 21b of the said parish, distant 101 deg. 25 min. 219 links and 57 deg. 15 min. 95.9 links from the western angle of the said allotment; thence by lines bearing respectively 57 deg. 15 min. 738.9 links, 227 deg. 16 min. 278.9 links, 236 deg. 36 min. 175.1 links, 240 deg. 51 min. 191.6 links and 258 deg. 36½ min. 105.1 links to the point of commencement.
- (d) Commencing at the southern angle of allotment 21b of the said parish; thence by lines bearing respectively 224 deg. 56 min. 415 links, 237 deg. 15 min. 554.7 links, 43 deg. 16 min. 491.2 links, 49 deg. 12 min. 594.8 links, 55 deg. 57 min. 313.9 links, 23 deg. 25 min. 318 links, 34 deg. 16 min. 289.6 links, 47 deg. 52½ min. 432.9 links, 61 deg. 6 min. 838.5 links, 129 deg. 54 min. 38 links, 243 deg. 29 min. 853 links, 209 deg. 16 min. 648 links and 224 deg. 50 min. 824 links to the point of commencement.

- (e) Commencing at a point on the north-western boundary of allotment 21E of the said parish, distant 44 deg. 50 min. 829 links and 29 deg. 16 min. 243.3 links from the western angle of the said allotment; thence by lines bearing respectively 29 deg. 16 min. 387.7 links, 63 deg. 29 min. 44.1 links and 212 deg. 37 min. 424.9 links to the point of commencement.
- (f) Commencing at a point on the south-eastern boundary of allotment 21A of the said parish, distant 61 deg. 52 min. 27 links, 39 deg. 39 min. 386 links and 46 deg. 40 min. 302.6 links from the southern angle of the said allotment; thence by lines bearing respectively 17 deg. 57 min. 205.5 links, 175 deg. 38 min. 127 links and 226 deg. 40 min. 100.4 links to the point of commencement.

Also all that piece of land in the Parishes of Otway and Aire, the boundaries of which are as follow:—

Commencing at the southern angle of allotment 21F of the said parish; thence by lines bearing respectively 335 deg. 17 min. 172 links, 14 deg. 55 min. 590.3 links, 51 deg. 11 min. 532.9 links, 82 deg. 8 min. 217.2 links, 80 deg. 38½ min. 689.2 links, 73 deg. 43 min. 515 links, 60 deg. 45 min. 141.5 links, 118 deg. 7 min. 157.4 links, 245 deg. 33 min. 574.9 links, 259 deg. 43 min. 335 links, 260 deg. 56 min. 569.6 links, 262 deg. 8 min. 80.9 links, 231 deg. 11 min. 290.6 links, 216 deg. 49 min. 250 links, 194 deg. 55 min. 501.2 links and 218 deg. 15 min. 77 links to the point of commencement.

Also all those pieces of land in the Parish of Otway, the boundaries of which are as follow:—

- (a) Commencing at a point on the southern boundary of allotment 16A of the said parish, distant 118 deg. 7 min. 508.7 links from the south-western angle of the said allotment; thence by lines bearing respectively 60 deg. 45 min. 144.3 links, 71 deg. 12 min. 426.2 links, 74 deg. 43 min. 237.9 links, 94 deg. 46 min. 703 links, 77 deg. 25 min. 225.9 links, 46 deg. 5 min. 213.2 links, 65 deg. 3½ min. 213.2 links, 49 deg. 42 min. 323.9 links, 25 deg. 22½ min. 138.6 links, 52 deg. 54½ min. 298.8 links, 67 deg. 54½ min. 366.6 links, 63 deg. 47 min. 121 links, 343 deg. 11 min. 136.5 links, 53 deg. 35 min. 120.7 links, 85 deg. 49 min. 157.7 links, 120 deg. 4½ min. 136.1 links, 65 deg. 55½ min. 464.9 links, 39 deg. 31 min. 129.8 links, 63 deg. 2 min. 287.7 links, 97 deg. 50 min. 982.3 links, 104 deg. 1½ min. 528.4 links, 88 deg. 11½ min. 129.8 links, 96 deg. 28½ min. 157.8 links, 81 deg. 26 min. 35.9 links, 237 deg. 55 min. 81.9 links, 278 deg. 19 min. 1,792 links, 229 deg. 51 min. 699 links, 250 deg. 34 min. 1,070 links, 222 deg. 25 min. 531 links, 246 deg. 38 min. 404 links, 228 deg. 9 min. 243 links, 269 deg. 7 min. 1,010 links, 240 deg. 57 min. 535.5 links and 298 deg. 7 min. 169.8 links to the point of commencement.
- (b) Commencing at a point on the northern boundary of allotment 19 of the said parish, distant 222 deg. 25 min. 300 links and 246 deg. 38 min. 150.8 links from the north-eastern angle of the said allotment; thence by lines bearing respectively 230 deg. 28 min. 271 links, 244 deg. 44 min. 248.4 links, 48 deg. 9 min. 264 links and 66 deg. 38 min. 258.2 links to the point of commencement.
- (c) Commencing at a point on the northern boundary of allotment 16C of the said parish, distant 70 deg. 34 min. 416.2 links from the north-western angle of the said allotment; thence by lines bearing respectively 70 deg. 34 min. 130.6 links, 235 deg. 22 min. 75.6 links and 269 deg. 35 min. 60.9 links to the point of commencement.
- (d) Commencing at a point on the northern boundary of allotment 16C of the said parish, distant 278 deg. 19 min. 68.7 links from the north-western angle of the said allotment; thence by lines bearing respectively 241 deg. 31 min. 212 links, 49 deg. 51 min. 169.7 links and 98 deg. 19 min. 57.3 links to the point of commencement.
- (e) Commencing at a point on the western boundary of allotment 23 of the said parish, distant 179 deg. 58 min. 51.6 links from the north-eastern angle of the said allotment; thence by lines bearing respectively 63 deg. 19 min. 579.9 links, 100 deg. 45 min. 137.6 links, 82 deg. 29 min. 138 links, 68 deg. 52 min. 159 links, 80 deg. 43 min. 305 links, 92 deg. 40 min. 121 links, 111 deg.

52 min. 210.5 links, 136 deg. 31 min. 24.2 links, 287 deg. 50 min. 309 links, 259 deg. 26½ min. 413.2 links, 243 deg. 59 min. 1,408.2 links, 255 deg. 58½ min. 367.5 links, 54 deg. 45 min. 177.2 links, 57 deg. 55 min. 224.8 links and 63 deg. 19 min. 464.2 links to the point of commencement—

which said pieces of land are particularly delineated and shown coloured red and yellow on survey plans numbered 10020, 10021, 10022 and 10023, lodged in the office of the Country Roads Board.

And the Honorable James Charles Murray Balfour, Her Majesty's Acting Minister of Public Works for the State of Victoria, shall give the necessary directions herein accordingly.

J. COLQUHOUN,  
Clerk of the Executive Council.

COUNTRY ROADS BOARD.

At the Executive Council Chamber, Melbourne, the sixth day of July, 1965.

PRESENT:

His Excellency the Governor of Victoria.  

|                |               |
|----------------|---------------|
| Mr. Bolte      | Mr. Chandler  |
| Mr. Bloomfield | Mr. Reid      |
| Mr. Hamer      | Mr. Balfour   |
| Mr. Darcy      | Mr. Rossiter. |
| Mr. Wilcox     |               |

ORDER APPROVING OF WIDENING AN EXISTING STATE HIGHWAY IN THE SHIRE OF DONALD.

WHEREAS the Country Roads Board constituted under the Country Roads Act 1958 (No. 6229) has represented to His Excellency the Governor in Council that it appears to it desirable that the existing North Western Highway in the Shire of Donald (declared to be a State highway under the said Act which declaration was confirmed by the Order in Council published in the Government Gazette of the 21st January, 1948, on pages 362-3) should be widened by the said Board; and whereas the said Board in accordance with the requirements of section 19 of the said cited Act has caused to be prepared a map plan and estimate showing the points between which and on and through what land the said widening is proposed to be made and the cost of acquiring the land: And whereas on an inspection of the said map and plan and a consideration of the said estimate His Excellency the Governor in Council is satisfied that there are funds legally available for acquiring the land: Now therefore be it known by this present Order that His Excellency the Governor of the State of Victoria with the advice of the Executive Council thereof doth hereby approve of the said highway being widened, that is to say:—

All those pieces of land in the Township of Donald, the boundaries of which are as follow:—

- (a) Commencing at the southern angle of allotment 1A, section 1A of the said township; thence by lines bearing respectively 312 deg. 35 min. 66 feet, 120 deg. 0 min. 27 ft. 6 in., 105 deg. 6 min. 30 ft. 8 in., 75 deg. 20 min. 16 ft. 6 in., 53 deg. 15 min. 16 ft. 3 in. and 222 deg. 35 min. 50 feet to the point of commencement.
- (b) Commencing at the western angle of allotment 11, section 1 of the said township; thence by lines bearing respectively 42 deg. 35 min. 50 feet, 211 deg. 55 min. 16 ft. 3 in., 189 deg. 50 min. 16 ft. 6 in., 160 deg. 4 min. 30 ft. 8 in., 145 deg. 10 min. 27 ft. 6 in. and 312 deg. 35 min. 66 feet to the point of commencement.—

which said pieces of land are particularly delineated and shown coloured red on survey plan numbered 10130, lodged in the office of the Country Roads Board.

And the Honorable James Charles Murray Balfour, Her Majesty's Acting Minister of Public Works for the State of Victoria, shall give the necessary directions herein accordingly.

J. COLQUHOUN,  
Clerk of the Executive Council.

## COUNTRY ROADS BOARD.

At the Executive Council Chamber, Melbourne, the sixth day of July, 1965.

## PRESENT:

|  |               |
|--|---------------|
| His Excellency the Governor of Victoria. |               |
| Mr. Bolte                                | Mr. Chandler  |
| Mr. Bloomfield                           | Mr. Reid      |
| Mr. Hamer                                | Mr. Balfour   |
| Mr. Darcy                                | Mr. Rossiter. |
| Mr. Wilcox                               |               |

## ORDER APPROVING OF WIDENING AN EXISTING STATE HIGHWAY IN THE SHIRE OF NEWSTEAD.

WHEREAS the Country Roads Board constituted under the *Country Roads Act 1958* (No. 6229) has represented to His Excellency the Governor in Council that it appears to it desirable that the existing Midland Highway in the Shire of Newstead (declared to be a State highway under the said Act which declaration was confirmed by the Order in Council published in the *Government Gazette* of the 10th August, 1960, on pages 2743-8) should be widened by the said Board: And whereas the said Board in accordance with the requirements of section 19 of the said cited Act has caused to be prepared a map plan and estimate showing the points between which and on and through what land the said widening is proposed to be made and the cost of acquiring the land: And whereas on an inspection of the said map and plan and a consideration of the said estimate His Excellency the Governor in Council is satisfied that there are funds legally available for acquiring the land: Now therefore be it known by this present Order that His Excellency the Governor of the State of Victoria with the advice of the Executive Council thereof doth hereby approve of the said highway being widened, that is to say:—

All that piece of land in the Parish of Guildford, the boundaries of which are as follow:—Commencing at the south-western angle of allotment 6b, section 6 of the said parish; thence by lines bearing respectively 4 deg. 0 min. 299 links, 16 deg. 30 min. 160 links, 113 deg. 59 min. 223.7 links, 206 deg. 57 min. 132.2 links, 202 deg. 42 min. 145.5 links, 193 deg. 50 min. 121 links and 274 deg. 0 min. 126 links to the point of commencement— which said piece of land is particularly delineated and shown coloured red on survey plan numbered 10145 lodged in the office of the Country Roads Board.

And the Honorable James Charles Murray Balfour, Her Majesty's Acting Minister of Public Works for the State of Victoria, shall give the necessary directions herein accordingly.

J. COLQUHOUN,  
Clerk of the Executive Council.

## COUNTRY ROADS BOARD.

At the Executive Council Chamber, Melbourne, the sixth day of July, 1965.

## PRESENT:

|  |               |
|--|---------------|
| His Excellency the Governor of Victoria. |               |
| Mr. Bolte                                | Mr. Chandler  |
| Mr. Bloomfield                           | Mr. Reid      |
| Mr. Hamer                                | Mr. Balfour   |
| Mr. Darcy                                | Mr. Rossiter. |
| Mr. Wilcox                               |               |

## ORDER APPROVING OF WIDENING AN EXISTING MAIN ROAD IN THE SHIRE OF ROMSEY.

WHEREAS the Country Roads Board constituted under the *Country Roads Act 1958* (No. 6229) has represented to His Excellency the Governor in Council that it appears to it desirable that the existing Kilmore Road in the Shire of Romsey (declared to be a main road under the said Act which declaration was confirmed by the Order in Council published in the *Government Gazette* of the 27th August, 1915, on page 3123) should be widened by the said Board: And whereas the said Board in accordance with the requirements of section 19 of the said cited Act has caused to be prepared a map plan and estimate showing the points between which and on and through what land the said widening is proposed to be made and the cost

of acquiring the land: And whereas on an inspection of the said map and plan and a consideration of the said estimate His Excellency the Governor in Council is satisfied that there are funds legally available for acquiring the land: Now therefore be it known by this present Order that His Excellency the Governor of the State of Victoria with the advice of the Executive Council thereof doth hereby approve of the said road being widened, that is to say:—

All that piece of land in the Parish of Lancefield, the boundaries of which are as follow:—Commencing at the north-eastern angle of allotment 36, section C of the said parish; thence by lines bearing respectively 126 deg. 58 min. 124.5 links, 128 deg. 59 min. 307.7 links, 291 deg. 50 min. 714.9 links and 89 deg. 35 min. 325 links to the point of commencement—which said piece of land is particularly delineated and shown coloured red and yellow on survey plan numbered 10090, lodged in the office of the Country Roads Board.

And the Honorable James Charles Murray Balfour, Her Majesty's Acting Minister of Public Works for the State of Victoria, shall give the necessary directions herein accordingly.

J. COLQUHOUN,  
Clerk of the Executive Council.

## COUNTRY ROADS BOARD.

At the Executive Council Chamber, Melbourne, the sixth day of July, 1965.

## PRESENT:

|  |               |
|--|---------------|
| His Excellency the Governor of Victoria. |               |
| Mr. Bolte                                | Mr. Chandler  |
| Mr. Bloomfield                           | Mr. Reid      |
| Mr. Hamer                                | Mr. Balfour   |
| Mr. Darcy                                | Mr. Rossiter. |
| Mr. Wilcox                               |               |

## ORDER APPROVING OF A DEVIATION FROM A MAIN ROAD IN THE SHIRE OF ALBERTON.

WHEREAS the Country Roads Board constituted under the *Country Roads Act 1958* (No. 6229) has represented to His Excellency the Governor in Council that it appears to it desirable that the deviation hereinafter referred to from the existing Yarram-Traralgon road in the Shire of Alberton (declared to be a main road under the said Act which declaration was confirmed by the Order in Council published in the *Government Gazette* of the 10th September, 1952, on page 5305) should be made by the said Board: And whereas the said Board in accordance with the requirements of section 19 of the said cited Act has caused to be prepared a map plan and estimate showing the points between which and on and through what land the said deviation is proposed to be made and the cost of acquiring the land: And whereas on an inspection of the said map and plan and a consideration of the said estimate His Excellency the Governor in Council is satisfied that there are funds legally available for acquiring the land: Now therefore be it known by this present Order that His Excellency the Governor of the State of Victoria with the advice of the Executive Council thereof doth hereby approve of the said road being made, that is to say:—

All that piece of land in the Parishes of Carrajung and Willung, the boundaries of which are as follow:—

Commencing at a point on the eastern boundary of allotment 31 of the said parish, distant 360 deg. 0 min. 370.3 links from the south-eastern angle of the said allotment; thence by lines bearing respectively 237 deg. 17 min. 459.1 links, 258 deg. 59 min. 640.3 links, 264 deg. 44 min. 891 links, 264 deg. 27 min. 154.5 links, 249 deg. 36 min. 902.7 links, 226 deg. 58½ min. 633 links, 221 deg. 19 min. 285 links, 239 deg. 54 min. 478.8 links, 243 deg. 43½ min. 722.3 links, 247 deg. 42 min. 586.1 links, 243 deg. 28 min. 1,116.9 links, 266 deg. 15 min. 476.9 links, 261 deg. 23½ min. 564.7 links, 263 deg. 15½ min. 405.1 links, 257 deg. 47 min. 655.7 links, 292 deg. 38½ min. 803.7 links, 304 deg. 37 min. 289.4 links, 320 deg. 18 min. 333.9 links, 332 deg. 11 min. 472.4 links, 335 deg. 27 min. 614.8 links, 335 deg. 4 min. 449.1 links, 327 deg. 43 min. 500.5 links, 314 deg. 21 min. 580.2 links, 300 deg. 15½ min. 620.4 links, 278 deg. 4 min. 410.9 links, 311 deg. 12 min. 507.3 links, 298 deg. 57 min. 389 links, 300 deg. 57 min. 964.3 links, 314 deg. 33 min. 636.9 links, 334 deg. 48 min. 231.3 links, 334 deg. 26½ min. 419.1 links, 353 deg. 19 min. 933.2 links, 28 deg. 50 min. 49.4 links, 11 deg. 2 min. 403.9 links, 1 deg. 15 min. 501.1 links, 37 deg. 21 min. 152 links, 55 deg. 8 min. 303.9 links, 195 deg. 28 min.

368 links, 209 deg. 12 min. 406.8 links, 174 deg. 3 min. 807.4 links, 171 deg. 29 min. 650 links, 162 deg. 8 min. 247.6 links, 130 deg. 41 min. 257.9 links, 138 deg. 2½ min. 165 links, 148 deg. 16 min. 406.9 links, 121 deg. 24½ min. 278.5 links, 118 deg. 49½ min. 181.5 links, 119 deg. 11½ min. 984.6 links, 116 deg. 19 min. 580.3 links, 129 deg. 45 min. 301.9 links, 116 deg. 44 min. 302.5 links, 121 deg. 3½ min. 262.1 links, 126 deg. 50 min. 456.3 links, 147 deg. 20½ min. 761.8 links, 159 deg. 11½ min. 635.9 links, 148 deg. 22 min. 164 links, 154 deg. 52 min. 590.4 links, 143 deg. 48 min. 208.2 links, 136 deg. 48 min. 146.7 links, 127 deg. 2½ min. 295.7 links, 116 deg. 22½ min. 344.3 links, 106 deg. 39 min. 295.3 links, 77 deg. 59 min. 1,024.4 links, 86 deg. 28 min. 895.7 links, 63 deg. 12 min. 576.2 links, 62 deg. 37 min. 623 links, 63 deg. 21 min. 567.8 links, 65 deg. 5 min. 699.3 links, 51 deg. 17 min. 922.3 links, 53 deg. 42 min. 239 links, 63 deg. 56½ min. 691.7 links, 84 deg. 27 min. 1,355.1 links, 72 deg. 48 min. 412.1 links, 63 deg. 7 min. 720 links and 180 deg. 0 min. 180 links to the point of commencement— which said piece of land is particularly delineated and shown coloured red and yellow on survey plans numbered 9972, 9973, 9974 and 9987, lodged in the office of the Country Roads Board.

And the Honorable James Charles Murray Balfour, Her Majesty's Acting Minister of Public Works for the State of Victoria, shall give the necessary directions herein accordingly.

J. COLQUHOUN,  
Clerk of the Executive Council.

COUNTRY ROADS BOARD.

At the Executive Council Chamber, Melbourne, the sixth day of July, 1965.

PRESENT:

|  |               |
|--|---------------|
| His Excellency the Governor of Victoria. |               |
| Mr. Bolte                                | Mr. Chandler  |
| Mr. Bloomfield                           | Mr. Reid      |
| Mr. Hamer                                | Mr. Balfour   |
| Mr. Darcy                                | Mr. Rossiter. |
| Mr. Wilcox                               |               |

ORDER APPROVING OF WIDENING AN EXISTING MAIN ROAD IN THE SHIRE OF WOORAYL.

WHEREAS the Country Roads Board constituted under the Country Roads Act 1958 (No. 6229) has represented to His Excellency the Governor in Council that it appears to be desirable that the existing Leongatha-Mirboo road in the Shire of Woorayl (declared to be a main road under the said Act which declaration was confirmed by the Order in Council published in the Government Gazette of the 27th July, 1932 on page 1637) should be widened by the said Board: And whereas the said Board in accordance with the requirements of section 19 of the said cited Act has caused to be prepared a map plan and estimate showing the points between which and on and through what land the said widening is proposed to be made and the cost of acquiring the land: And whereas on an inspection of the said map and plan and a consideration of the said estimate His Excellency the Governor in Council is satisfied that there are funds legally available for acquiring the land: Now therefore be it known by this present Order that His Excellency the Governor of the State of Victoria with the advice of the Executive Council thereof doth hereby approve of the said road being widened, that is to say:—

All those pieces of land in the Parish of Koorooman, the boundaries of which are as follow:—

- (a) Commencing at a point on the eastern boundary of allotment 96E of the said parish, distant 201 deg. 46 min. 103 links from the north-eastern angle of the said allotment; thence by lines bearing respectively 201 deg. 46 min. 4.5 links, 359 deg. 5½ min. 802.3 links, 169 deg. 17 min. 325.9 links and 185 deg. 31 min. 480.1 links to the point of commencement.
- (b) Commencing at the south-western angle of allotment 95 of the said parish; thence by lines bearing respectively 21 deg. 46 min. 137 links, 189 deg. 44½ min. 648 links, 196 deg. 17 min. 591.2 links, 207 deg. 49 min. 241.7 links, 215 deg. 44 min. 763.7 links, 227 deg. 27 min. 462.9 links, 231 deg. 53½ min. 1,650.9 links, 308 deg. 29 min. 68.3 links, 38 deg. 35 min. 230 links, 57 deg. 1 min. 1,087 links, 43 deg. 14 min. 1,145 links and 21 deg. 46 min. 1,719 links to the point of commencement.

- (c) Commencing at the south-western angle of allotment 98A of the said parish; thence by lines bearing respectively 268 deg. 52 min. 219.9 links, 82 deg. 11½ min. 745 links, 70 deg. 18½ min. 404.4 links, 59 deg. 8 min. 439.7 links, 52 deg. 37½ min. 1,117.7 links, 194 deg. 3 min. 266 links, 239 deg. 57 min. 1,732 links and 268 deg. 52 min. 601 links to the point of commencement—

which said pieces of land are particularly delineated and shown coloured red on survey plans numbered 10068 and 10069, lodged in the office of the Country Roads Board.

And the Honorable James Charles Murray Balfour, Her Majesty's Acting Minister of Public Works for the State of Victoria, shall give the necessary directions herein accordingly.

J. COLQUHOUN,  
Clerk of the Executive Council.

COUNTRY ROADS BOARD.

At the Executive Council Chamber, Melbourne, the sixth day of July, 1965.

PRESENT:

|  |               |
|--|---------------|
| His Excellency the Governor of Victoria. |               |
| Mr. Bolte                                | Mr. Chandler  |
| Mr. Bloomfield                           | Mr. Reid      |
| Mr. Hamer                                | Mr. Balfour   |
| Mr. Darcy                                | Mr. Rossiter. |
| Mr. Wilcox                               |               |

DECLARATION OF A DEVIATION FROM THE HEALESVILLE-KOO-WEE-RUP ROAD IN THE SHIRE OF HEALESVILLE.

WHEREAS by sections 21 and 58 of the Country Roads Act 1958 (No. 6229) it is amongst other things enacted that when the Country Roads Board under the provisions of the Country Roads Act has by Resolution declared a deviation to be a main road the said Board may also declare that such deviation shall be in lieu of any existing road or part thereof named in such Resolution and that on publication in the Government Gazette of the Order confirming such Resolution the existing road or part thereof shall cease to be a main road or be discontinued as provided in the Resolution: And whereas the said Board has by Resolution declared the deviation on the land described in the First Schedule to such Resolution to be a main road and has also declared that such deviation shall be in lieu of the part of the existing road being the land described in the Second Schedule to the said Resolution and that such part of the said existing road as is described in the Third Schedule shall be discontinued: Now therefore His Excellency the Governor of the State of Victoria by and with the advice of the Executive Council thereof doth hereby confirm the said Resolution.

Resolution for Declaration of a Deviation of a Main Road Under the Country Roads Act.

Whereas the land the site of the road the course of which is below set out was taken by the Board under the provisions of the Country Roads Act 1958 for the purpose of constructing such road deviation which road deviation has now been laid out and formed on the same: And whereas the said Board (being the Country Roads Board incorporated under the said Act) thinks that the road aforesaid is fit to be used as a public highway such Board at a meeting now holden acting under the authority conferred upon it by sections 21 and 58 of the said Act doth by this present Resolution hereby declare the said road deviation the course of which is described in the First Schedule hereto with the commencing and terminating points thereof respectively specified to be part of a main road within the meaning and for the purposes of the Country Roads Act 1958: And the said Board doth also declare that such deviation shall be in lieu of the existing road or part thereof described in the Second Schedule hereto and that such part of the said existing road as is described in the Third Schedule shall be discontinued.

FIRST SCHEDULE.

Shire of Healesville.

3. Healesville-Koo-Wee-Rup-road (7303).—All that piece of land in the Parish of Gracedale, the boundaries of which are as follow:—Commencing at the intersection

of the eastern boundary of the existing Healesville-Koo-Wee-Rup road through allotment 12A, section B, of the said parish, with the north-eastern boundary of the said allotment; thence by lines bearing respectively 139 deg. 14 min. 200.8 links, 164 deg. 27 min. 1,030.1 links, 187 deg. 55 min. 1,375.9 links, 199 deg. 14 min. 1,592.4 links, 214 deg. 20 min. 980.7 links, 182 deg. 7 min. 909.3 links, 159 deg. 43½ min. 1,043.8 links, 180 deg. 17 min. 492 links, 270 deg. 17 min. 222 links, 251 deg. 38 min. 102.4 links, 354 deg. 3 min. 154.4 links, 19 deg. 16 min. 141 links, 29 deg. 15 min. 154.8 links, 17 deg. 54 min. 67.1 links, 3 deg. 2 min. 75 links, 347 deg. 2 min. 164.5 links, 326 deg. 2 min. 117.3 links, 309 deg. 49 min. 230.1 links, 326 deg. 9 min. 145.7 links, 353 deg. 29 min. 117.4 links, 5 deg. 53 min. 175.4 links, 348 deg. 49½ min. 566 links, 15 deg. 11 min. 572.2 links, 347 deg. 30 min. 135.1 links, 6 deg. 10 min. 200.4 links, 32 deg. 6 min. 184 links, 59 deg. 8 min. 216.2 links, 69 deg. 33½ min. 189.2 links, 29 deg. 26 min. 504.1 links, 19 deg. 14 min. 1,241.2 links, 7 deg. 55 min. 1,123.6 links, 354 deg. 39 min. 464 links, 344 deg. 27 min. 695.1 links, 6 deg. 30 min. 12.4 links and 0 deg. 36 min. 215 links to the point of commencement—which said piece of land is particularly delineated and shown coloured red and yellow on survey plans numbered 9290, 9291, 9292 and 9293, lodged in the office of the Country Roads Board.

SECOND SCHEDULE.

Shire of Healesville.

3. Healesville - Koo-Wee-Rup road (7303).—All those pieces of land in the Parish of Gracedale, the boundaries of which are as follow:—

- (a) Commencing at a point on the southern boundary of allotment 12A, section B, of the said parish, distant 270 deg. 17 min. 843 links from the south-eastern angle of the said allotment; thence by lines bearing respectively 149 deg. 58 min. 106 links, 152 deg. 59 min. 130 links, 165 deg. 9 min. 170 links, 188 deg. 39 min. 166.2 links, 206 deg. 10 min. 176.7 links, 230 deg. 15 min. 161.4 links, 240 deg. 28 min. 273 links, 19 deg. 14 min. 151.7 links, 60 deg. 28 min. 149.9 links, 50 deg. 15 min. 131.2 links, 26 deg. 10 min. 140 links, 8 deg. 39 min. 130 links, 345 deg. 9 min. 138.6 links, 332 deg. 59 min. 116.8 links, 329 deg. 58 min. 94.1 links, 7 deg. 55 min. 202.5 links, 165 deg. 49 min. 89.8 links and 149 deg. 58 min. 64 links to the point of commencement.
- (b) Commencing at an angle in the eastern boundary of the existing Healesville-Koo-Wee-Rup road through allotment 12, section B, of the said parish, formed by the intersection of lines bearing 11 deg. 43 min. and 345 deg. 3 min.; thence by lines bearing respectively 191 deg. 43 min. 170 links, 214 deg. 39 min. 170 links, 238 deg. 18 min. 190 links, 253 deg. 9 min. 180.3 links, 34 deg. 20 min. 159.5 links, 73 deg. 9 min. 42.9 links, 58 deg. 18 min. 156.1 links, 34 deg. 39 min. 128.9 links, 11 deg. 43 min. 126.1 links, 345 deg. 3 min. 165.6 links, 332 deg. 44 min. 79.7 links, 19 deg. 14 min. 171.3 links, 166 deg. 18 min. 103.2 links, 152 deg. 44 min. 108.1 links and 165 deg. 3 min. 200 links to the point of commencement.
- (c) Commencing at an angle in the eastern boundary of the existing Healesville-Koo-Wee-Rup road through allotment 12, section B, of the said parish formed by the intersection of lines bearing 7 deg. 49 min. and 347 deg. 0 min.; thence by lines bearing respectively 187 deg. 49 min. 100 links, 201 deg. 46 min. 90 links, 218 deg. 15 min. 110 links, 237 deg. 56 min. 130 links, 255 deg. 40 min. 250 links, 247 deg. 37 min. 110 links, 2 deg. 7 min. 109.9 links, 67 deg. 37 min. 71.4 links, 75 deg. 40 min. 241.5 links, 57 deg. 56 min. 97.2 links, 38 deg. 15 min. 78.2 links, 346 deg. 46 min. 359.2 links, 293 deg. 45 min. 104 links, 279 deg. 39 min. 70.9 links, 289 deg. 7 min. 124.6 links, 307 deg. 49 min. 51.5 links, 2 deg. 7 min. 123.1 links, 127 deg. 49 min. 106.9 links, 109 deg. 7 min. 100 links, 99 deg. 39 min. 75 links, 113 deg. 45 min. 130 links, 129 deg. 23 min. 110 links, 146 deg. 27 min. 70 links and 167 deg. 0 min. 180 links to the point of commencement—

which said pieces of land are particularly delineated and shown coloured blue on survey plans numbered 9290, 9291 and 9292, lodged in the office of the Country Roads Board.

THIRD SCHEDULE.

Shire of Healesville.

3. Healesville - Koo-Wee-Rup road (7303).—All those pieces of land in the Parish of Gracedale, the boundaries of which are as follow:—

- (a) Commencing at the intersection of the western boundary of the existing Healesville-Koo-Wee-Rup road through allotment 12A, section B, of the said parish with the northern boundary of the said allotment; thence by lines bearing respectively 164 deg. 27 min. 354.9 links, 186 deg. 30 min. 97.6 links, 178 deg. 31 min. 130 links, 162 deg. 35 min. 130 links, 147 deg. 53 min. 166 links, 128 deg. 8 min. 28.1 links, 164 deg. 27 min. 166.8 links, 174 deg. 39 min. 1.6 links, 308 deg. 8 min. 181 links, 327 deg. 53 min. 196.2 links, 342 deg. 35 min. 156.8 links, 358 deg. 31 min. 150.9 links, 6 deg. 30 min. 111.8 links and 0 deg. 36 min. 323.3 links to the point of commencement.
- (b) Commencing at a point in allotment 12A, section B, of the said parish, distant 270 deg. 17 min. 916.8 links and 7 deg. 55 min. 306 links from the south-eastern angle of the said allotment; thence by lines bearing respectively 7 deg. 55 min. 168.3 links, 50 deg. 6 min. 86.6 links, 34 deg. 41 min. 163.7 links, 8 deg. 56 min. 167.9 links, 343 deg. 42 min. 112.6 links, 320 deg. 51 min. 121.4 links, 306 deg. 34 min. 63 links, 344 deg. 27 min. 141 links, 118 deg. 40 min. 97.7 links, 126 deg. 34 min. 90 links, 140 deg. 51 min. 154 links, 163 deg. 42 min. 155 links, 188 deg. 56 min. 213 links, 214 deg. 41 min. 200 links, 230 deg. 6 min. 130 links and 222 deg. 18 min. 95.7 links to the point of commencement—

which said pieces of land are particularly delineated and shown coloured dark-blue on survey plan numbered 9290, lodged in the office of the Country Roads Board.

The common seal of the Country Roads Board was hereto affixed, at Kew, this twenty-eighth day of June, One thousand nine hundred and sixty-five, in the presence of—

(SEAL) I. J. O'DONNELL, Chairman.  
F. WEST, Member.  
N. L. ALLANSON, Secretary.

And the Honorable James Charles Murray Balfour, Her Majesty's Acting Minister of Public Works for the State of Victoria, shall give the necessary directions herein accordingly.

J. COLQUHOUN,  
Clerk of the Executive Council.

STAMPS ACT 1958 (No. 6375).

At the Executive Council Chamber, Melbourne, the sixth day of July, 1965.

PRESENT:

His Excellency the Governor of Victoria.  
Mr. Bolte | Mr. Chandler  
Mr. Bloomfield | Mr. Reid  
Mr. Hamer | Mr. Balfour  
Mr. Darcy | Mr. Rossiter.  
Mr. Wilcox

REVOCATION OF DECLARATION OF APPROVED VENDOR.

HIS Excellency the Governor of the State of Victoria, by and with the advice of the Executive Council thereof, doth by this Order made pursuant to section 131C of the Stamps Act 1958 (No. 6375) revoke the declaration made on the 29th March, 1960, and published in the Government Gazette of the 6th April, 1960, declaring certain persons to be "approved vendors" for the purposes of subdivision (14) of Division three of Part II. of the Stamps Act 1958 in so far as the said declaration refers to the under-mentioned person—

136. Purchase Credit Corporation Pty. Ltd.

And the Honorable Henry Edward Bolte, Her Majesty's Treasurer for the State of Victoria, shall give the necessary directions herein accordingly.

J. COLQUHOUN,  
Clerk of the Executive Council.

MEDICAL ACT 1958.—SECTION 119.

At the Executive Council Chamber, Melbourne, the sixth day of July, 1965.

PRESENT:

|  |               |
|--|---------------|
| His Excellency the Governor of Victoria. |               |
| Mr. Bolte                                | Mr. Chandler  |
| Mr. Bloomfield                           | Mr. Reid      |
| Mr. Hamer                                | Mr. Balfour   |
| Mr. Darcy                                | Mr. Rossiter. |
| Mr. Wilcox                               |               |

PURSUANT to the powers in that behalf conferred by section 119 of the Medical Act 1958 and all other powers enabling him in that behalf, His Excellency the Governor of the State of Victoria, by and with the advice of the Executive Council of the said State, doth by this present notice declare that on and after the first day of January, 1966, the 1964 Addendum to the British Pharmacopoeia 1963 shall have force in Victoria.

And the Honorable John Frederick Rossiter, Her Majesty's Acting Minister of Health for the State of Victoria, shall give the necessary directions herein accordingly.

J. COLQUHOUN,  
Clerk of the Executive Council.

SOIL CONSERVATION AND LAND UTILIZATION ACT.

At the Executive Council Chamber, Melbourne, the sixth day of July, 1965.

PRESENT:

|  |               |
|--|---------------|
| His Excellency the Governor of Victoria. |               |
| Mr. Bolte                                | Mr. Chandler  |
| Mr. Bloomfield                           | Mr. Reid      |
| Mr. Hamer                                | Mr. Balfour   |
| Mr. Darcy                                | Mr. Rossiter. |
| Mr. Wilcox                               |               |

DISTRICT ADVISORY COMMITTEE.—GLENELG SOIL CONSERVATION DISTRICT.

WHEREAS a vacancy exists on the Glenelg Soil Conservation District Advisory Committee due to the death of Cyril Earle Russell Day, being a person elected to represent grazing, agricultural and other relevant interests in the District: Now therefore I, the Governor of the State of Victoria, by and with the advice of the Executive Council thereof, and in pursuance of the provisions of section 15 of the Soil Conservation and Land Utilization Act, do hereby appoint the following person to such vacancy for a period up to and including the twenty-third day of February, 1968:—

ALAN HERBERT BAULCH, being a person elected to represent grazing, agricultural and other relevant interests in the District.

And the Honorable James Charles Murray Balfour, Her Majesty's Minister for Conservation for the State of Victoria, shall give the necessary directions herein accordingly.

J. COLQUHOUN,  
Clerk of the Executive Council.

ROAD TRAFFIC ACT 1958.

At the Executive Council Chamber, Melbourne, the sixth day of July, 1965.

PRESENT:

|  |               |
|--|---------------|
| His Excellency the Governor of Victoria. |               |
| Mr. Bolte                                | Mr. Chandler  |
| Mr. Bloomfield                           | Mr. Reid      |
| Mr. Hamer                                | Mr. Balfour   |
| Mr. Darcy                                | Mr. Rossiter. |
| Mr. Wilcox                               |               |

ORDER EXTENDING THE APPLICATION OF THE ROAD TRAFFIC ACT 1958 TO CERTAIN LAND OR PREMISES VESTED IN OR UNDER THE CONTROL OF THE CITY OF BROADMEADOWS.

IN pursuance of the powers conferred by the Road Traffic Act 1958, His Excellency the Governor of the State of Victoria, in the Commonwealth of Australia, by and

with the advice of the Executive Council of the said State, and at the request of the Council of the City of Broadmeadows, doth by this Order extend the application of the provisions of the said Act to the following land or premises vested in or under the control of the City of Broadmeadows:

All that piece of land the boundaries of which commence at the southern corner of Civic-street and Pascoe Vale-road; thence northerly along Pascoe Vale-road by 500 feet, then westerly by 840 feet; thence southerly by 480 feet; thence easterly to the point of commencement and being the land shown delineated and hachured on the plan hereunder.

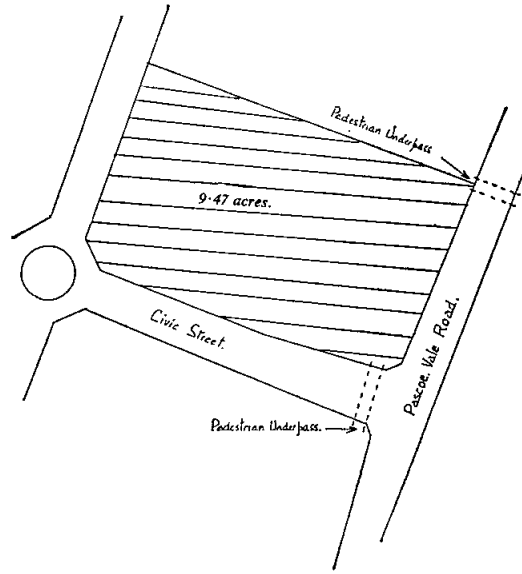

And the Honorable Vernon Francis Wilcox, Her Majesty's Acting Chief Secretary for the State of Victoria, shall give the necessary directions herein accordingly.

J. COLQUHOUN,  
Clerk of the Executive Council.

APPROACHING LAND SALES.

SALES of Crown lands, in fee-simple, will be held at the under-mentioned places and dates, viz.:—

|  | No. of Gazette. |
|--|-----------------|
| Ballarat.—Tuesday, 31st August, 1965 ..    | 56              |
| Beechworth.—Wednesday, 11th August, 1965   | 53              |
| Bendigo.—Thursday, 22nd July, 1965 ..      | 45              |
| Bright.—Thursday, 12th August, 1965 ..     | 53              |
| Colac.—Friday, 20th August, 1965 ..        | 56              |
| Myrtleford.—Thursday, 12th August, 1965 .. | 53              |
| Wodonga.—Wednesday, 11th August, 1965 ..   | 53              |

ERRATUM.

IN the notice headed "SALES OF CROWN LAND BY AUCTION" which was published in the Victoria Government Gazette, No. 53, dated 7th July, 1965 (pages 2191-2192), for the sales listed as "BRIGHT.—Sale (No. 11785), &c." and "MYRTLEFORD.—Sale (No. 11786), &c." substitute the following:—

BRIGHT.—Sale (No. 11785) of Crown land, in fee-simple, by auction, will be held at the COURT HOUSE, BRIGHT, on THURSDAY, the 12th AUGUST, 1965, at 1 o'clock p.m. To be conducted by D. M. O'CONNOR, Land Officer, Beechworth.

TOWNSHIP OF WANDILIGONG, PARISH OF BRIGHT, COUNTY OF DELATTE.

Lot 1.

Fronting the east side of a government road about 4 chains north of the State School reserves.

Upset price £180 the lot. Survey fee £7 17s. 6d.

Area 3a. 0r. 31p., allotment 35a. Valuation of improvements £9 (E. J. Goldsworthy) (Trees). One month allowed for removal of garage and fencing.—(H.011926.)

## Lot 2.

In the north-west of the Township, about 2 chains east of Morses creek.

Upset price £50 the lot. Survey fee £6.

Area 35 perches, allotment 84A. One month allowed for removal of improvements.—(H.026296.)

PARISH OF BRIGHT, COUNTY OF DELATTE.

Abutting the western side of the reservation of Bakers-creek and about  $\frac{1}{2}$  mile south of Bright.

Upset price £75 per lot. Survey fee £6 10s. per lot.

One month allowed for removal of improvements.

## Lot 3.

Area 1r. 7p., allotment 17 of section 6.

## Lot 4.

Area 1r. 7p., allotment 18 of section 6.—(H.027772.)

## Lot 5.

About  $\frac{1}{4}$  mile north of the Township of Wandiligong and about 3 chains east of the Country Roads Board main road.

Upset price £50 the lot. Survey fee £5 5s.

Area 34 perches, allotment 33B of section W. One month allowed for removal of improvements.—(H.029935.)

Abutting the eastern side of the reservation to the Morses creek and about 3 miles south of Wandiligong.

Upset price £45 per lot. Survey fee £9 12s. 6d. per lot.

## Lot 6.

Area 9a. 3r. 14p., allotment S.13A.

## Lot 7.

Area 8a. 2r. 22p., allotment S.13c.—(H.027326.)

**MYRTLEFORD.**—Sale (No. 11786) of Crown land, in fee-simple, by auction, will be held at the LAND INSPECTOR'S OFFICE, MYRTLEFORD, on THURSDAY, the 12th AUGUST, 1965, at ELEVEN o'clock a.m. To be conducted by D. M. O'CONNOR, Land Officer, Beechworth.

## Lot 1.

TOWNSHIP OF MYRTLEFORD, PARISH OF MYRTLEFORD,  
COUNTY OF BOGONG.

Fronting the north side of Elgin-street about 13 chains east of Albert-street.

Upset price £75 the lot. Survey fee £5 5s.

Area 27 perches, allotment 5B of section 13.—(H.026822.)

## SALES OF CROWN LAND BY AUCTION.

The land will be offered for sale in fee-simple, and subject to the provisions of the Land Act and Regulations thereunder.

The upset price is the sum at which bidding will start, and no bid below that sum can be accepted. The highest bidder at or above that sum shall be the purchaser, subject to signature of contract and any necessary payment.

## TERMS:

A deposit of at least 12½% of the purchase price must be paid at the sale, either in cash or by cheque.

The residue is payable in half-yearly instalments, in accordance with the following scale, or may be paid off at any earlier time.

£20 and under, 6 instalments.  
Over £20, and not exceeding £50, 8 instalments.  
Over £50, and not exceeding £100, 10 instalments.  
Over £100, and not exceeding £200, 12 instalments.  
Over £200, and not exceeding £300, 14 instalments.  
Over £300, and not exceeding £400, 16 instalments.  
Over £400, and not exceeding £500, 18 instalments.  
Over £500, 20 instalments.

Interest at the rate of 5% per annum is payable with all payments of residue, and is computed for each instalment from the date of sale to the date of such payment. Additional interest is charged if any instalment is not paid on or before the due date.

If paid off within 30 days of sale, no interest is payable.

## FEES, ETC.:

Also payable at the sale, in addition to the deposit, are the survey fee and, if applicable, the valuation of improvements (if purchaser be not the owner thereof).

## Payable with balance of purchase money—

Crown Grant fee—50 acres and under .. £1 10s.  
Over 50 acres .. £2  
Purchase money £5 or under £1

Assurance Fund contribution—One halfpenny for each £1 of purchase price. (This is a fund established to guarantee the validity of freehold titles.)

Transfer of interest prior to completion of payment may be allowed on payment of £1 fee and subject to stamp duty.

If unable to attend personally, a prospective purchaser may arrange for another person to bid as his agent.

Attention is drawn to section 95, Land Act 1958, which provides that the purchaser shall be deemed to be the owner for the purposes of other Acts; also to an amendment to the Local Government Act providing for Government roads, in certain circumstances, to be declared "private streets", thus making the purchaser liable to contribute to the cost of street construction.

J. C. M. BALFOUR,  
Minister of Lands.

Office of Crown Lands and Survey,  
Melbourne, 14th July, 1965.

**BALLARAT.**—Sale (No. 11787) of Crown land in fee-simple, by auction, will be held at the LAND OFFICE, STATE PUBLIC OFFICES, CAMP-STREET, BALLARAT, on TUESDAY, the 31st AUGUST, 1965, at TWO o'clock p.m. To be conducted by N. J. FITZGERALD, Land Officer, Ballarat.

## Lot 1.

TOWNSHIP OF BALLARAT, PARISH OF BALLARAT,  
COUNTY OF GRENVILLE.

Fronting southern side of Winter-street 320 links west of Adair-street.

Upset price £150 the lot. Survey fee £5 10s.

Area 30 perches, allotment 3 of section 90. One month allowed for removal of improvements.—(J.30923.)

## Lot 2.

TOWNSHIP OF BALLARAT EAST, PARISH OF BALLARAT,  
COUNTY OF GRENVILLE.

Fronting southern side of Chisholm-street about 227 links east of Ida-street.

Upset price £200 the lot. Survey fee £5 10s.

Area 22 perches, allotment 16 of section 88A.

## Lot 3.

Fronting southern side of Chisholm-street about 151 links east of Ida-street.

Upset price £200 the lot. Survey fee £5 10s.

Area 22 perches, allotment 17 of section 88A.

## Lot 4.

Fronting southern side of Chisholm-street about 75 links east of Ida-street.

Upset price £200 the lot. Survey fee £5 10s.

Area 22 perches, allotment 18 of section 88A.

## Lot 5.

At the south-eastern corner of Chisholm and Ida streets.

Upset price £200 the lot. Survey fee £5 10s.

Area 22 perches, allotment 19 of section 88A.

## Lot 6.

Fronting the eastern side of Ida-street 181 links south of Chisholm-street.

Upset price £150 the lot. Survey fee £5 10s.

Area 34 perches, allotment 21 of section 88A.—(J.24929.)

## Lot 7.

PARISH OF BUNINYONG, COUNTY OF GRANT.

At Magpie, fronting the south-west side of a Government road from Ballarat.

Upset price £20 the lot. Survey fee £5 17s. 6d.

Area 1a. 3r. 6p., allotment 9K.—(J.29527.)

NOTE.—Lots 1 to 7 inclusive are within an area covered by the Interim Development Order administered by the Ballarat and District Joint Town Planning Committee.

Lot 8.

PARISH OF BALLARAT, COUNTY OF GRENVILLE.  
At Invermay, fronting the western side of a Government road.

Upset price £6 the lot. Survey fee £7 7s. 6d.

Area 2a. 2r. 26p., allotment 18 of section Q. One month allowed for removal of improvements.—(J.29790.)

Lot 9.

PARISH OF COMMERALGHIP, COUNTY OF GRENVILLE.  
In the north of the Parish.

Upset price £100 the lot. Survey fee £8.

Area 8a. 3r. 7p., allotment 161B. Valuation of improvements £30 (M. Dawkins) (Dam). One month allowed for removal of other improvements.—(J.29758.)

Lot 10.

TOWNSHIP OF BEAUFORT, PARISH OF BEAUFORT, COUNTY OF RIPON.  
Fronting both Becker and Sturt streets west of Speke-street.

Upset price £50 the lot. Survey fee £6.

Area 1r. 30p., subject to survey, allotment 12 of section 60.—(J.30496.)

Lot 11.

PARISH OF CARNNGHAM, COUNTY OF GRENVILLE.  
About 2 miles south of the Township of Carngham.

Upset price £45 the lot. Survey fee £7 12s. 6d.

Area 3a. 0r. 29p., allotment 25. Valuation of improvements £1,000 (E. J. Nunn) (House, garage, fencing, &c.).—(J.25091.)

Lot 12.

TOWNSHIP OF EDGERTON, PARISH OF BUNGAL, COUNTY OF GRANT.  
In the north-west of the Township.

Upset price £30 the lot. Survey fee £6 12s. 6d.

Area 3r. 16p., allotment 5 of section 10.—(J.30754.)

Lot 13.

TOWNSHIP OF BROOMFIELD, PARISH OF CRESWICK, COUNTY OF TALBOT.  
Fronting the western side of the Creswick-road about 11 chains south-west of the State School.

Upset price £15 the lot. Survey fee £7.

Area 1a. 1r. 0p., allotment 23A of section F2. One month allowed for removal of improvements.—(J.22559.)

Lot 14.

PARISH OF CRESWICK, COUNTY OF TALBOT.  
Fronting the west side of a Government road and about 3 chains south of Township of Creswick and about 20 chains east of the Creswick-Ballarat road.

Upset price £10 the lot. Survey fee £6.

Area 2r. 17p., allotment 1G of section T. One month allowed for removal of improvements.—(J.30259.)

Lot 15.

TOWNSHIP OF SMYTHESDALE, PARISH OF SMYTHESDALE, COUNTY OF GRENVILLE.  
Fronting the east side of the main Hamilton to Ballarat road about 10 chains north of Gregory-street.

Upset price £10 the lot. Survey fee £5 10s.

Area 1 rood, allotment 2 of section 2.—(J.29338.)

ALSO THE FOLLOWING FREEHOLD LAND WILL BE OFFERED:—

Lot 16.

NOTE.—This lot is not subject to the provisions of the Land Act as set out above, but comprises freehold land offered on behalf of the Education Department on the following conditions:—

- (a) Deposit of at least 12½ per cent. payable at sale and balance within 60 days.
- (b) Purchaser to arrange for, and bear costs of, registration of transfer of title.

TOWNSHIP OF BALLARAT NORTH, PARISH OF BALLARAT, COUNTY OF RIPON.  
Being Site and Buildings of former Departmental residence known as 210 Forrest-street.  
Upset price £2,950 the lot.

Area 36 perches, being part of allotment 12, section B, and the whole of the land described in freehold certificates of title, vol. 5841, fol. 091 and vol. 5352, fol. 400.—(J.31012.)

COLAC.—Sale (No. 11788) of Crown land in fee-simple, by auction, will be held at the SALE ROOMS, of J. G. JOHNSTONE & CO., 144 MURRAY-STREET, COLAC, on FRIDAY, the 20th AUGUST, 1965, at TWO o'clock p.m. To be conducted by C. G. KNIGHT, Land Officer, Geelong. Auctioneers J. G. JOHNSTONE & CO., 144 Murray-street, Colac.

Lot 1.

PARISH OF GERANGAMETE, COUNTY OF POLWARTH.  
In the south-west corner of the Parish adjoining State Forest.

Upset price £600 the lot. Survey fee £28 7s. 6d.  
Area 119a. 3r. 5p., allotment 52c.—(G.62775.)

PROPOSED REVOCATIONS OF TEMPORARY RESERVATIONS OF LANDS BY ORDERS IN COUNCIL.

IN pursuance of the provisions of the Land Act 1958, notice is hereby given that it is the intention of the Governor in Council to revoke the temporary reservations of lands by Orders in Council hereunder referred to, viz.:—

The following Notices were published 1° on the 7th July, 1965, pursuant to Orders of the 29th June, 1965.

HORSHAM.—The temporary reservation, by Order in Council of the 4th May, 1886, of 8 acres 0 roods 28 perches of land in the Township of Horsham as a site for Municipal purposes, revoked as to part by Order of the 30th March, 1931, is about to be revoked so far as the balance thereof containing 6 acres 3 roods 11½ perches, is concerned.—(H.91<sup>(3)</sup>) (Rs.4204).

MANSFIELD.—The temporary reservation, by Order in Council of the 24th July, 1917, of 1 acre 1 rood 3 perches, more or less, of land in the Township of Mansfield as a site for Swimming purposes.—(M.35<sup>(3)</sup>) (Rs.1647).

MOORPANYAL.—The temporary reservation, by Order in Council of the 30th June, 1866 (see Government Gazette of the 10th August, 1866, page 1721) of 2 acres of land in the Parish of Moorpanyal as a site for the purpose of Affording a Supply of Stone for Road Metal.—(M.199<sup>(b)</sup>) (C.83268).

PARWAN.—The temporary reservation, by Order in Council of the 12th August, 1901, of 2 acres of land in the Parish of Parwan as a site for a State School.—(P.8<sup>(3)</sup>) (O.1681/130).

PROOINGA.—The temporary reservation, by Order in Council of the 27th March, 1917, of 4 acres 2 roods 24 perches of land in the Parish of Prooinga as a site for a State School is about to be revoked so far only as the portion containing 30 perches, indicated by hachure on plan hereunder, is concerned.—(P.179<sup>(a)</sup>) (Rs.1442).

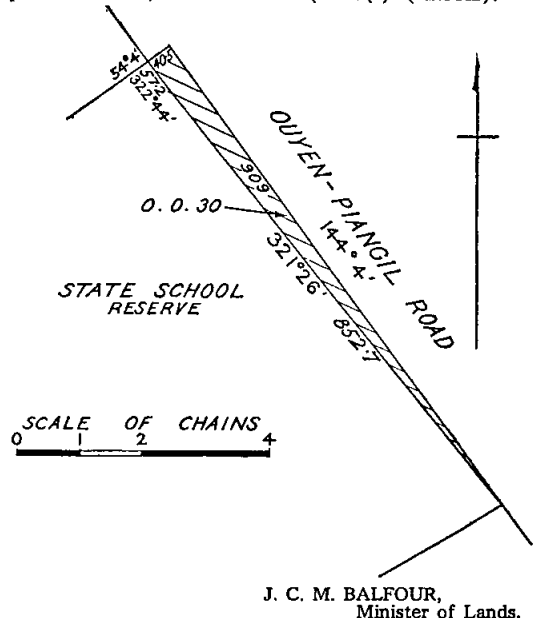



**PROPOSED REVOCATIONS OF TEMPORARY RESERVATIONS OF LANDS BY ORDERS IN COUNCIL.**

IN pursuance of the provisions of the *Land Act 1958*, notice is hereby given that it is the intention of the Governor in Council to revoke the temporary reservations of lands by Orders in Council hereunder referred to, viz.:-

The following Notices were published 1° on the 23rd June, 1965, pursuant to Orders of the 16th June, 1965.

**DIMBOOLA.**—The temporary reservation, by Order in Council of the 20th May 1890 (see *Government Gazette* of the 23rd May, 1890, page 1944), of 173 acres 3 roods 21 perches of land in the Parish of Dimboola, as a site for the Growth and Preservation of Timber, revoked as to part by Order of the 8th July, 1964, is about to be revoked so far only as the portions containing 55 acres more or less, indicated by hachure on plan hereunder, are concerned.—(D.150<sup>(10)</sup>) (Rs.5962).

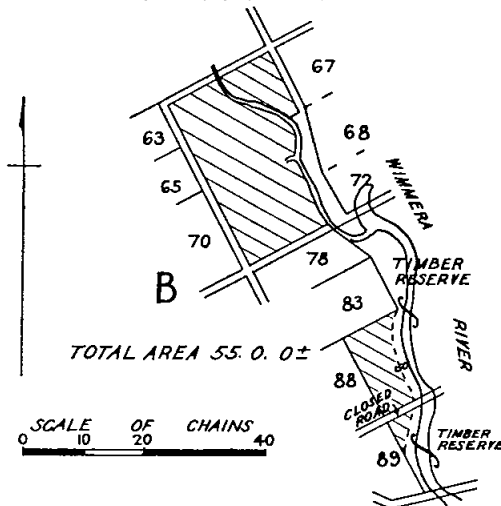

**LEONGATHA.**—The temporary reservation, by Order in Council of the 10th March, 1903, of 2 acres 2 roods of land in the Parish of Leongatha, as a site for Watering purposes, is about to be revoked, so far only as the portion containing 13 perches, indicated by hachure on plan hereunder, is concerned.—(L.167<sup>(8)</sup>) (Rs.8174).

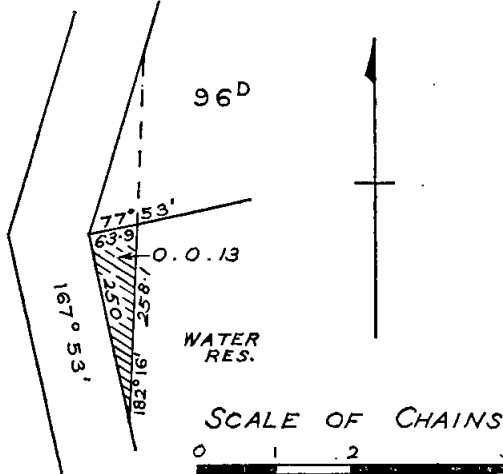

**NATIMUK.**—The temporary reservation, by Order in Council of the 16th April, 1889, of 1 rood 6 5/10 perches of land in the Township of Natimuk (formerly Parish of Natimuk), as a site for a Post and Telegraph Office.—(N.117<sup>(9)</sup>) (C.99635).

**STAWELL.**—The temporary reservation, by Order in Council of the 20th April, 1874, of 5 acres of land in the Parish of Stawell, as a site for a Manure Depot.—(S.329<sup>(16)</sup>) (C.86065).

**STAWELL.**—The temporary reservation, by Order in Council of the 31st July, 1899, of 32 acres 1 rood 31 perches of land in the Parish of Stawell, as a site for a Manure Depot is about to be revoked so far only as the portion containing 8 acres 3 roods more or less, indicated

by hachure on plan hereunder, is concerned.—(S.329<sup>(16)</sup>) (C.86065).

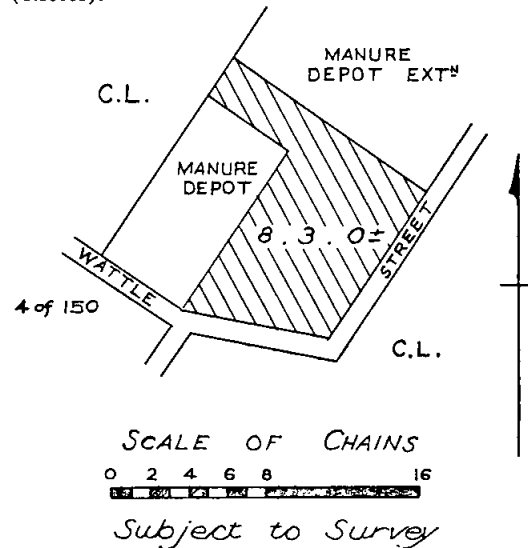

**TANJIL.**—The temporary reservation, by Order in Council of the 28th April, 1964, of 5 acres 1 rood 8 perches of land in the Parish of Tanjil, as a site for Public Recreation.—(T.189<sup>(10)</sup>) (Rs.8317).

J. C. M. BALFOUR,  
Minister of Lands.

**PROPOSED PERMANENT RESERVATIONS OF LANDS AS SITES.**

IN pursuance of the provisions of the *Land Act 1958*, notice is hereby given that it is the intention of the Governor in Council to permanently reserve as sites, and also except from occupation for mining purposes under any miner's right, the lands hereunder referred to:-

The following Notices were published 1° on the 14th July, 1965, pursuant to Orders of the 6th July, 1965.

**BADDAGINNIE.**—Land proposed to be permanently reserved as a site for Public purposes (Public Hall), 1 rood 32 perches, Township of Baddaginnie, Parish of Warrenbayne, County of Delatite, as indicated by hachure on plan hereunder.—(B.71<sup>(3)</sup>) (Rs.8467).

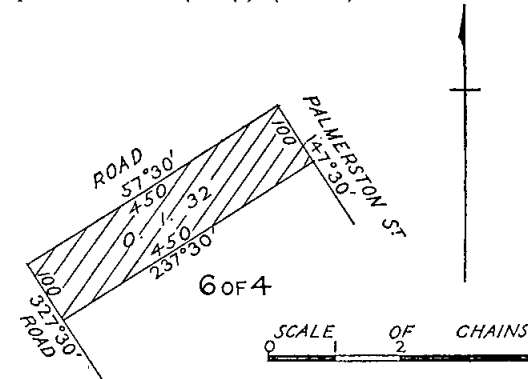

**BOROONDARA AND PRAHRAN (GLEN IRIS).**—Land proposed to be permanently reserved as a site for a Public Park and Watering purposes, 3 acres 2 roods 18 perches, Parish of Boroondara and at Gardiner, Parish of Prahran, County of Bourke, being the remaining portion of the site temporarily reserved therefor by Order in Council of the 3rd May, 1898, and known as the Glen Iris Public Park and Watering purposes Reserve.—(B.415<sup>(3)</sup>, P.81<sup>(10)</sup>) (Rs.2386).

**MIRBOO.**—Land proposed to be permanently reserved as a site for Recreation and Amusement of the People, 7 acres 2 roods 8 perches more or less, Township of Mirboo, Parish of Mirboo South, County of Buln Buln, being the site temporarily reserved therefor by Order in Council of the 21st March, 1934, and known as the Mirboo Recreation Reserve.—(M.517<sup>(15)</sup>) (Rs.4196).

J. C. M. BALFOUR,  
Minister of Lands.

**PROPOSED REVOCATIONS OF TEMPORARY RESERVATIONS OF LANDS BY ORDERS IN COUNCIL.**

IN pursuance of the provisions of the *Land Act 1958*, notice is hereby given that it is the intention of the Governor in Council to revoke the temporary reservations of lands by Orders in Council hereunder referred to, viz.:

The following Notices were published 1° on the 30th June, 1965, pursuant to Orders of the 22nd June, 1965.

**APSELY.**—The temporary reservation by Order in Council of the 8th December, 1873, of 1 acre of land in the Township of Apsley, as a site for State School purposes.—(A.32<sup>(2)</sup>) (Rs.6753.)

**BOROONDARA (KEW).**—The temporary reservation, by Order in Council of the 2nd January, 1945, of 8 acres 0 roods 15 perches of land in the Parish of Boroondara, as a site for Public purposes.—(B.415<sup>(3)</sup>) (Rs.5538.)

**HOMERTON (HEYWOOD).**—The temporary reservation by Order in Council of the 17th November, 1873, of 99 acres 3 roods 37 perches of land in the Parish of Homerton, as a site for Racecourse and General Recreation purposes, and the temporary reservation by Order in Council of the 18th October, 1886, of 49 acres 0 roods 5 perches of land as an extension thereto, are about to be revoked.—(H.109<sup>(4)</sup>) (Rs.383.)

**WAIL.**—The temporary reservation by Order in Council of the 9th July, 1912 (see *Government Gazette* of the 17th July, 1912, page 2870) of 5 acres 1 rood 38 perches of land in the Parish of Wail as a site for Water Supply purposes is about to be revoked, so far only as the portion containing 3 acres 1 rood 32 perches, indicated by hachure on plan hereunder is concerned.—(W.306<sup>(5)</sup>) (M.40949.)

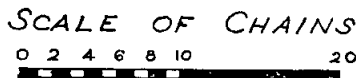
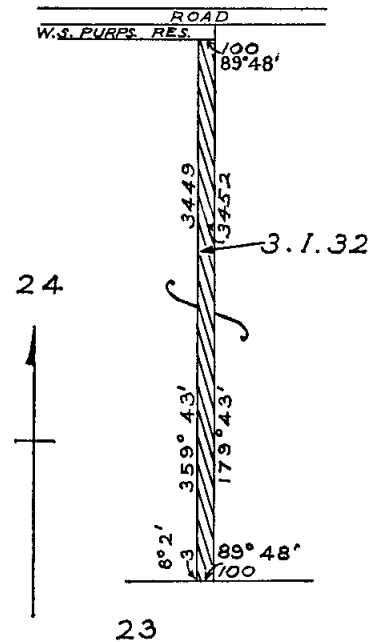

J. C. M. BALFOUR,  
Minister of Lands.

**PROPOSED PERMANENT RESERVATIONS OF LANDS AS SITES.**

IN pursuance of the provisions of the *Land Act 1958*, notice is hereby given that it is the intention of the Governor in Council to permanently reserve as sites the lands hereunder referred to:—

The following Notices were published 1° on the 7th July, 1965, pursuant to Orders of the 29th June, 1965.

**BUNYIP (TYNONG).**—Land proposed to be permanently reserved as a site for Public Recreation also excepted from occupation for mining purposes under any miner's

right, 20 acres 0 roods 35 perches, Parish of Bunyip, County of Mornington, being the site temporarily reserved therefor by Order in Council of the 8th November, 1961, and known as the Tynong Recreation Reserve.—(B.606<sup>(6)</sup>) (Rs.8074).

**YACKANDANDAH.**—Land proposed to be permanently reserved as a site for a Racecourse and other purposes of Public Recreation, also excepted from occupation for mining purposes under any miner's right, 64 acres 3 roods 3½ perches, Parish of Yackandandah, County of Bogong, being the remaining portion of the site temporarily reserved therefor by Order in Council of the 13th February, 1895, and the whole of the site temporarily reserved therefor by Order in Council of the 18th April, 1905, and known as the Yackandandah Racecourse and Recreation Reserve.—(Y.45<sup>(14)</sup>) (Rs.2746).

J. C. M. BALFOUR,  
Minister of Lands.

**PROPOSED REVOCATION OF TEMPORARY RESERVATION, AND THE WITHHOLDING FROM SALE, LEASING, AND LICENSING, OF LAND BY ORDER IN COUNCIL.**

IN pursuance of the provisions of the *Land Act 1958*, notice is hereby given that it is the intention of the Governor in Council to revoke the temporary reservation, and the withholding from sale, leasing, and licensing, of land by Order in Council hereunder referred to, viz.:

The following Notice was published 1° on the 14th July, 1965, pursuant to Order of the 6th July, 1965.

**LEICHARDT.**—The temporary reservation as a site for Public purposes (State School) and the withholding from sale, leasing and licensing by Order in Council of the 28th August, 1876, of 4 acres 3 roods of land in the Township of Leichardt (formerly parish of Leichardt) are about to be revoked, so far only as the portion containing 22 perches, indicated by hachure on plan hereunder, is concerned.—(L.148<sup>(3)</sup>) (C.2598).

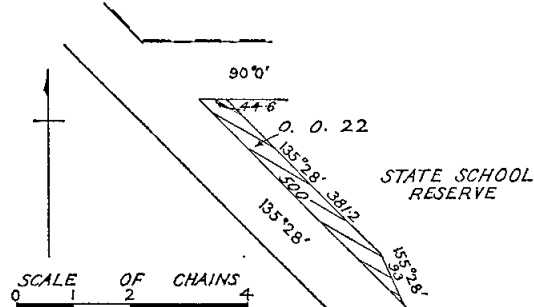

J. C. M. BALFOUR,  
Minister of Lands.

**PROPOSED PERMANENT RESERVATIONS OF LANDS AS SITES.**

IN pursuance of the provisions of the *Land Act 1958*, notice is hereby given that it is the intention of the Governor in Council to permanently reserve as sites the lands hereunder referred to:—

The following Notices were published 1° on the 23rd June, 1965, pursuant to Orders of the 16th June, 1965.

**BRIDGEWATER.**—Land proposed to be permanently reserved as a site for Public Recreation, also excepted from occupation for mining purposes under any miner's right, 12 acres 3 roods 28 perches, Township of Bridgewater, Parish of Bridgewater, County of Bendigo, being the sites temporarily reserved therefor by Orders in Council of the 26th March, 1889, 24th February, 1926, and the 15th March, 1949, and known as the Bridgewater Recreation Reserve.—(B.437<sup>(4)</sup>) (Rs.1932).

**MIRBOO NORTH.**—Land proposed to be permanently reserved as a site for Racecourse, Showground and General Recreation purposes, also excepted from occupation for mining purposes under any miner's right, 49 acres 1 rood 27 perches, Township of Mirboo North, Parish of Mirboo, County of Buln Buln, being the site temporarily reserved therefor by Order in Council of the 19th October, 1910, and known as the Mirboo North Recreation Reserve.—(M.517<sup>(12)</sup>) (Rs.3667).

J. C. M. BALFOUR,  
Minister of Lands.

## Land Act 1958

## PERMIT CANCELLED.

NOTICE is hereby given that the Permit mentioned in the Schedule hereunder has been cancelled.

| District.   | Corr. No. | Name of Permit Holder. | Parish.     | Allotment. | Section. | Area.               |
|-------------|-----------|------------------------|-------------|------------|----------|---------------------|
| Hamilton .. | 630/155   | Ronald Buckley Grey .. | Bullawin .. | 9B         | ..       | A. R. P.<br>950 0 0 |

Department of Crown Lands and Survey,  
Melbourne, 12th July, 1965.

J. C. M. BALFOUR,  
Minister of Lands.

## PROPOSED PERMANENT RESERVATIONS OF LANDS AS SITES.

IN pursuance of the provisions of the *Land Act 1958*, notice is hereby given that it is the intention of the Governor in Council to permanently reserve as sites the lands hereunder referred to:—

The following Notices were published 1° on the 30th June, 1965, pursuant to Orders of the 22nd June, 1965.

MIRBOO NORTH.—Land proposed to be permanently reserved as a site for Tourist Camping purposes, also excepted from occupation for mining purposes under any miner's right, 8 acres 1 rood 10 perches more or less, Township of Mirboo North, Parish of Mirboo, County of Buln Buln, being the remaining portion of the site temporarily reserved therefor by Order in Council of the 22nd November, 1955.—(M.517<sup>(12)</sup>) (Rs.7399).

MIRBOO NORTH.—Land proposed to be permanently reserved as a site for Public Baths, also excepted from occupation for mining purposes under any miner's right, 15 acres 3 roods 13 perches, more or less, Township of Mirboo North, Parish of Mirboo, County of Buln Buln, being the remaining portion of the site temporarily reserved therefor by Order in Council of the 13th August, 1907, and the whole of the sites temporarily reserved therefor by Orders in Council of the 18th August, 1908, 14th October, 1929, 25th February, 1941, 20th January, 1948, 22nd November, 1955, and the 7th April, 1959, and known as the Mirboo North Public Baths Reserve.—(M.517<sup>(12)</sup>) (Rs.3430).

J. C. M. BALFOUR,  
Minister of Lands.

## REGULATIONS FOR THE CARE, PROTECTION AND MANAGEMENT OF THE RUSSELL RESERVE AT LAKE BURRUMBEET.

WHEREAS by section 218 of the *Land Act 1958* power is given to the Minister of Lands to make Regulations in respect of the care, protection and management of any Crown land which has been reserved under the *Land Acts* for any public purpose whatsoever and which has not been conveyed to or vested in trustees, and for further purposes as enacted: Now therefore the Minister of Lands in pursuance of the power conferred aforesaid, doth hereby make the following additional Regulations in respect of the reserved lands in the Parishes of Brewster, Haddon and Burrumbeet shown in pink colour on lithograph plan B over 7.8.58 attached to Lands Department correspondence No. C.70834, and known as the "Russell Reserve" (hereinafter referred to as the "Reserve").

18. The Committee may set apart any portion or portions of the Reserve as a place for parking vehicles.

19. The Committee may fix such fees not exceeding—motor cycles, Two shillings (2s.), motor cars, Four shillings (4s.), buses, Fifteen shillings (15s.), per day, seasons tickets Twenty shillings (20s.), as it thinks fit as fees for parking of vehicles in any place set apart within the Reserve for the parking of vehicles. This fee may be collected on entry to the Reserve or at any other place in the Reserve appointed by the Committee.

20. Every person who parks a vehicle in the place set apart for the parking of vehicles shall pay to the Committee or its authorized representatives on demand such fees as has been fixed by the Committee pursuant to these Regulations as the fee for parking in such place.—(C.70834.)

Given under my hand, at Melbourne, on the 5th day of July, 1965.

JIM BALFOUR,  
Minister of Lands.

Every person who contravenes or fails to comply with these Regulations shall, in accordance with the provisions of section 218 of the *Land Act 1958*, for each offence be liable to a penalty of not more than Five pounds, and every person who contravenes or fails to comply with any such Regulations, and who, after he has been warned by any bailiff of Crown lands or by any member of the Police Force, does not desist therefrom may be forthwith apprehended by such bailiff or member of the Police Force and taken before some justice to be dealt with according to law and shall be liable to a penalty of not more than Ten pounds.

## REGULATIONS FOR THE CARE, PROTECTION AND MANAGEMENT OF THE FRANKSTON AND MOUNT ELIZA FORESHORE RESERVE.

WHEREAS by section 218 of the *Land Act 1958*, the Minister of Lands is empowered to make Regulations with respect to certain land and for extending or applying all or any of those Regulations to certain other land: Now therefore, I, James Charles Murray Balfour, Her Majesty's Minister of Lands in and for the State of Victoria, do hereby make the following Regulation:—

All the Regulations made on the 15th October, 1958, with respect to—

- Such portion of the reserved Crown lands in the Parish of Frankston as is indicated by pink tint on plan marked F/19.5.1937 attached to Lands Department correspondence Rs.3203.
- The land in the Township of Frankston containing 1 acre 1 rood, more or less, temporarily reserved as a site for Public purposes by Order in Council of the 2nd August, 1949, together with that portion of the permanent reserve along the Kananook Creek abutting such land.
- The land in the Township of Frankston containing 1 rood 35 3/10 perches, temporarily reserved as a site for Public purposes by Order in Council of the 2nd August, 1949,

are hereby applied to the land in the Parish of Frankston permanently reserved as a site for Public purposes by Order in Council of the 25th August, 1964.—(Rs.3203.)

Given under my hand, at Melbourne, this 5th day of July, 1965.

JIM BALFOUR,  
Minister of Lands.

## REGULATIONS FOR THE CARE, PROTECTION AND MANAGEMENT OF THE OAKLEIGH PUBLIC PARK AND RECREATION RESERVE.

WHEREAS by section 218 of the *Land Act 1958*, the Minister of Lands is empowered to make Regulations with respect to certain land and for extending or applying all or any of those Regulations to certain other land: Now therefore, I, James Charles Murray Balfour, Her Majesty's Minister of Lands in and for the State of Victoria, do hereby make the following Regulation:—

All the Regulations made on the 1st April, 1942, with respect to the lands temporarily reserved by Orders in Council dated the 21st October, 1940, and the 15th September, 1941, as a site for Public Park and Recreation at Oakleigh are hereby applied to the land at Oakleigh temporarily reserved by Order in Council dated the 1st June, 1965, as a site for Public Park and Recreation.—(Rs.1121.)

Given under my hand, at Melbourne, this 5th day of July, 1965.

JIM BALFOUR,  
Minister of Lands.

REGULATIONS FOR THE CARE, PROTECTION AND MANAGEMENT OF THE RESERVE FOR PUBLIC RECREATION AT CAULFIELD.

WHEREAS by section 218 of the *Land Act 1958*, the Minister of Lands is empowered to make Regulations with respect to certain land and for extending or applying all or any of those Regulations to certain other land: Now therefore, I, James Charles Murray Balfour, Her Majesty's Minister of Lands in and for the State of Victoria, do hereby make the following Regulation:—

All the Regulations made on the 6th May, 1938, and the 2nd August, 1960, with respect to the land at Caulfield in the Parish of Prahran, reserved as a site for Public Recreation by Order in Council dated the 24th January, 1938, are hereby applied to the land at Caulfield in the Parish of Prahran reserved as a site for Public Recreation by Order in Council dated the 25th August, 1964.—(Rs.140.)

Given under my hand, at Melbourne, this 5th day of July, 1965.

JIM BALFOUR,  
Minister of Lands.

REGULATIONS FOR THE CARE, PROTECTION AND MANAGEMENT OF THE "BARNAWARTHA RECREATION RESERVE".

WHEREAS by section 218 of the *Land Act 1958*, the Minister of Lands is empowered to make Regulations with respect to certain land and for extending or applying all or any of those Regulations to certain other land: Now therefore, I, James Charles Murray Balfour, Her Majesty's Minister of Lands in and for the State of Victoria do hereby make the following Regulation:—

All the Regulations made on the 23rd day of July, 1963, with respect to the land in the Township of Barnawartha, temporarily reserved by Orders in Council dated the 4th May, 1891, and the 18th April, 1962, as sites for Public Recreation are hereby applied to the land in the Township of Barnawartha, temporarily reserved by Orders in Council (2) dated the 17th June, 1964, as sites for Public Recreation.—(Rs.246.)

Given under my hand, at Melbourne, on the 5th day of July, 1965.

JIM BALFOUR,  
Minister of Lands.

Every person who contravenes or fails to comply with these Regulations shall, in accordance with the provisions of section 218 of the *Land Act 1958*, for each offence be liable to a penalty of not more than Five pounds, and every person who contravenes or fails to comply with any such Regulations, and who, after he has been warned by any bailiff of Crown lands or by any member of the Police Force, does not desist therefrom may be forthwith apprehended by such bailiff or member of the Police Force and taken before some justice to be dealt with according to law and shall be liable to a penalty of not more than Ten pounds.

COMMITTEES OF MANAGEMENT OF RESERVES.

APPOINTMENTS.

NOTICE is hereby given that, in pursuance of section 221 of the *Land Act 1958*, the following appointments of Committees of Management of reserved Crown Lands have been made by the Minister of Lands:—

"RESERVE FOR PUBLIC PURPOSES (SUPPLY OF GRAVEL) IN THE PARISH OF DURDIDWARRAH."

The Council of Shire of Bannockburn as the Committee of Management of the Crown land temporarily reserved by Order in Council dated the 25th May, 1965, as a site for Public purposes (Supply of Gravel) in the Parish of Durdidwarrah.—(Corres. Rs.8450.)

"FORREST PUBLIC PURPOSES (PUBLIC HALL) RESERVE, PARISH OF YAUGHER."

John William Turner, Arthur Percival Rourke, Clement Norman Peskett, Norman Charles Rourke, Cyril Irvine Lidgerwood, Norman Francis Rourke, Alan Francis Frizon, Alan Maxwell Whelan, Claude Rupert Morrow, Clifford Alfred Frizon and Alexander Newton Dowie as a Committee of Management for a period of three (3) years of the land in the Parish of Yaugher, temporarily reserved as a site for Public purposes (Public Hall) and known as the "Forrest Public Hall".—(Corres. Rs.8431.)

"FRANKSTON AND MOUNT ELIZA FORESHORE RESERVE."

The Council of the Shire of Frankston and Hastings as a Committee of Management of the land in the Parish of Frankston permanently reserved by Order in Council dated the 25th August, 1964, as a site for Public purposes.—(Corres. Rs.3203.)

"GLENPATRICK RECREATION RESERVE."

Margaret Gleisner, Elva Jean Bridson, Harold Amos Bridson, Herbert Edwin Milne and Alan Thomas Pownceby as a Committee of Management for a period of three (3) years of the land temporarily reserved by Order in Council dated the 27th November, 1962, as a site for Public Recreation and of the remaining portion of the land temporarily reserved by Order in Council dated the 24th September, 1883, as a site for Cricket and other purposes of Public Recreation, both in the Parish of Glenpatrick.—(Corres. Rs.2302.)

"HANSONVILLE RECREATION RESERVE."

James Charles Anthony Evans as a member of the Committee of Management for a period ending the 16th May, 1968, of the land temporarily reserved by Orders in Council of the 9th March, 1937, and 15th November, 1955, as a site for Public Recreation in the Parish of Greta and known as the "Hansonville (Greta) Recreation Reserve".—(Corres. Rs.637.)

"KAMAROOKA PUBLIC HALL RESERVE."

B. A. Cail, N. J. McKenzie, R. A. Wilson, W. G. Cail, J. J. Demeo, A. C. Evans, Geoff Pederson, John F. Cail, G. G. Cail, R. M. Ayres, D. J. Aitken and J. H. Hay as a Committee of Management for a period of three (3) years of the land in the Parish of Kamarooka temporarily reserved by Order in Council dated 8th November, 1910, as a site for Public Purposes and known as the "Kamarooka Public Hall Reserve".—(Corres. Rs.5894.)

"KILMANY PUBLIC HALL AND RECREATION RESERVE."

Walter August Schultz, Harold Francis Fox, Charles Edgar Hyatt, Thomas Lyall Robertson, Roy William Wallace, Ian Gavin Tatterson, William Anthony Henebery, Raymond Ian Fox, William James McCann, Thomas William Wallace, Arthur William Macreadie, Noel Derrick Freshwater and John Griffith Atkinson as a Committee of Management for a period of three (3) years of the land temporarily reserved by Order in Council dated the 5th May, 1959, as a site for Public Hall and Public Recreation in the Parish of Wurruk Wurruk and known as the "Kilmany Public Hall and Recreation Reserve".—(Corres. Rs.7808.)

"LAKE SAMBELL RESERVE."

Edmund Bryant Collins, Raymond Alwyn Walls, Kenneth Roy Blake, Rex Walter Norman, Donald Hayes, Thomas Alfred Rossell, Donald Roy Parkinson, Joseph Michael Morley, Harold Raymond Sinclair, John Victor Diffeo, James Jackson Macaulay, Graeme Taylor Gray, Ralph Edwin Boys, Walter Ivan Russell and Ernest Jack Hawking as the Committee of Management for a period ending the 15th July, 1968, of the land in the Township of Beechworth reserved by Orders in Council dated the 14th October, 1929, and the 28th November, 1961, as sites for Public Purposes (excepting that area used for a Rubbish Depot) and known as "Lake Sambell Reserve".—(Corres. Rs.3867.)

"PUBLIC RECREATION RESERVE, TOWNSHIP OF LANCEFIELD."

Raymond Charles Hemphill, Robert Notman, George Leonard Heid, Laurence Henry Green and Keith Joseph Shannon as a Committee of Management for a period ending the 22nd August, 1966, of the land in the Township of Lancefield temporarily reserved by Order in Council dated the 1st September, 1891, as a site for Public Recreation.

This appointment is in lieu of all previous appointments in respect of the said land which are hereby revoked.—(Corres. C.79162.)

"RESERVE FOR WATERING PURPOSES, PARISH OF LANCEFIELD."

Raymond Charles Hemphill, Robert Notman, George Leonard Heid, Laurence Henry Green and Keith Joseph Shannon as a Committee of Management for a period

ending the 22nd August, 1966, of the land in the Parish of Lancefield, temporarily reserved by Order in Council of the 1st August, 1870, as a site for watering purposes.

This appointment is in lieu of all previous appointments in respect of the said land which are hereby revoked.—(Corres. Rs.2148.)

“LEXTON RACECOURSE AND RECREATION RESERVE.”

Angus Henry Fisher, George Henry Impey, John Gerard Briody, Lionel Francis Smith, Daryl John Jolly, Mervyn Bassett Karlslake, Barry Edwin Herbertson, Angus John Fisher, Maxwell Roy Hobson and John William Severino as a Committee of Management for a period of three (3) years of the land temporarily reserved by Orders in Council dated the 13th February, 1893 and 24th September, 1912, for Racecourse and other purposes of Public Recreation in the Township of Lexton and known as the “Lexton Racecourse and Recreation Reserve”.—(Corres. Rs.744.)

“MANSFIELD (LORDS) CRICKET AND RECREATION RESERVE.”

Norman Douglas Pook, Cyril Gordon McMillan and William Charles Oliver as a Committee of Management for a period of three (3) years of the land temporarily reserved by Order in Council dated 28th November, 1887, as a site for Cricket and purposes of Public Recreation in the Town of Mansfield and known as the “Mansfield (Lord's) Cricket and Recreation Reserve”.—(Corres. Rs.2021.)

“OAKLEIGH PUBLIC PARK AND RECREATION RESERVE.”

The Council of the City of Oakleigh as the Committee of Management of the land in the Township of Oakleigh temporarily reserved by Order in Council dated the 1st June, 1965, as a site for Public Park and Recreation.—(Corres. Rs.1121.)

“CROWN LANDS RESERVED FOR PUBLIC RECREATION AT ST. KILDA.”

The Council of the City of St. Kilda as the Committee of Management of the land at St. Kilda temporarily reserved by Order in Council dated the 6th July, 1965, as a site for Public Recreation in addition to and adjoining the site temporarily reserved therefor by Order in Council of the 5th May, 1964.—(Corres. Rs.8333.)

“SEAFORD FORESHORE RESERVE.”

Alfred Watson Read for a period ending the 9th May, 1968, as a member of the Committee of Management of such portions of the Reserves for Public purposes in the Parishes of Frankston and Lyndhurst as are indicated by red colour on plan marked S/29.4.1937 attached to Lands Department correspondence Rs.4674, together with the area between high and low water mark bordering such portions, all of which is known as the “Seaford Foreshore Reserve”.—(Corres. Rs.4674.)

“WEERITE PUBLIC HALL RESERVE.”

William Clarence Sumner, William John Stokes, David G. Rippon, Eric Richard Borthwick and Geoffrey Alexander Boyd as a Committee of Management for a period of three (3) years of the land in Parish of Purrumbete North temporarily reserved by Order in Council dated the 30th September, 1958, as a site for a Public Hall and known as the “Weerite Public Hall Reserve”.—(Corres. Rs.7760.)

“WELSHPOOL RECREATION RESERVE AND MECHANICS' INSTITUTE RESERVE.”

Samuel Cyril Stephens, Pearl Stephens, Jessie Norling, Amelia Busk, Lenore Smith and Kate Lucas as a Committee of Management for a period of three (3) years of the lands temporarily reserved by Orders in Council dated 9th October, 1933 and 23rd January, 1895, as sites for Public Recreation and a Mechanics' Institute and Free Library respectively, in the Parish and Township of Welshpool and known as the “Welshpool Recreation and Mechanics' Institute Reserve”.—(Corres. Rs.4346.)

ALAN J. HOLT,  
Secretary of Lands.

5th July, 1965.

## TENDERS—PUBLIC WORKS DEPARTMENT

TENDERS will be received at the Head Office of the Public Works Department, Treasury-place, Melbourne, until TEN a.m. on the dates shown and for the purposes mentioned hereunder.

Particulars and tender forms may be obtained at the Contracts Office, Room 7, Building Division, Parliament-place, and at the places indicated in brackets after certain items.

The abbreviations shown in the brackets mean the following:—W.O.—Inspector of Works Office; P.S.—Police Station; C.S.—Consolidated School; H.E.S.—Higher Elementary School; H.S.—High School; S.S.—State School; T.S.—Technical School.

Tenders should be submitted on the Department's printed Tender Form and will not be received by telephone. All tenders must be on a “Firm Tender” basis. The lowest or any tender will not necessarily be accepted.

Tenders are to be addressed to the Minister of Public Works, and the envelopes containing the tender is to be clearly marked “Tender for \_\_\_\_\_, closing Tuesday, \_\_\_\_\_”.

No preliminary deposit is to be lodged with any tender, but a successful tenderer will be required to pay a deposit for any accepted tender of the value of £1,500 or over.

Tuesday, 20th July, 1965.

### Building, Electrical and Mechanical Works.

Alberton.—Repairs, painting and additions, S.S. 1 and Residence. (W.O., Traralgon; S.S., Alberton.)

Ararat.—Repairs and painting, Police Station Residence, 3 Tobin-street. (W.O., Ararat; P.S., Stawell.)

Belmont.—Roof repairs, S.S. 26. (W.O., Geelong.)

Brunswick South-West.—Renewal of water supply and additional washing facilities, S.S. 4304.

Brunswick West.—Erection of brick toilet block, S.S. 2890.

Burwood.—Internal repairs and painting, Technical School.

Camperdown.—Erection of additional laundries and toilets and connexion to town sewerage, Teachers' Flats, 3 Hopetoun-street, High School. (W.O., Camperdown.)

Clayton.—Supply and installation of Packaged Sewage Treatment Plant, Monash Secondary Teachers' College.

Coburg.—External renovations, Teachers' College.

Doncaster.—Repair works to swimming pool, S.S. 197.

Dookie.—Electrical installation for new Biology and Chemistry Laboratories, Agricultural College. (W.O., Shepparton and Benalla; Agricultural College, Dookie.)

Echuca West.—Repairs, external painting and erection of fencing, residence, 69 Mitchell-street, S.S. 3916. (W.O., Shepparton; S.S., Echuca West.)

Euroa.—New toilets and renovations to bathroom, residence, S.S. 1706. (W.O., Alexandra; S.S., Euroa.)

Flemington.—New chain mesh fence and gates, &c., S.S. 250.

Glenhompson.—External and internal painting, S.S. 947. (W.O., Hamilton; S.S., Glenhompson.)

Gresswell.—Installation of heaters in residences and Nurses' Hostels, Sanatorium.

Harrierville.—Renovations to school and residence, S.S. 843. (W.O., Wangaratta; S.S., Harrierville.)

Hawksburn.—Gas heating, S.S. 1467.

Inverloch.—Repairs and painting, S.S. 2776. (W.O., Korumburra; S.S., Inverloch.)

Keysborough.—Repairs and painting, S.S. 1466.

Kingsville.—Repairs and painting, Police Station.

Leongatha.—Renovations and painting, High School. (W.O., Korumburra; Police Station, Leongatha.)

Maribyrnong.—Internal renovations, High School.

Middle Park.—Renewal of pans, cisterns, seats and urinals, &c., S.S. 2815.

Morwell.—Addition of concrete veneer Science Wing, High School. (W.O., Traralgon.)

Myrtleford.—Alterations and additions to Leaf Storage Barn, Tobacco Research Station. (W.O., Benalla; Research Station, Myrtleford.)

Newhaven.—Internal and external repairs, renovations and painting, S.S. 3053 and Residence. (W.O., Korumburra; S.S., Newhaven.)

Ormond.—Repairs and painting, Police Station and Residence.

Reservoir West.—Repairs and painting, S.S. 4711.

Seymour.—Repairs and painting to residence and out-buildings, Police Station. (W.O., Alexandra; P.S., Seymour.)

Thornbury.—Repairs, renovations and painting to Family Group Homes "Bunyarra" and "Benwerrin", Social Welfare Department, Clarendon-street.

Trafalgar.—Repairs to roof, external and internal painting, S.S. 2185. (W.O., Warragul; S.S., Trafalgar.)

Wallan Wallan.—Re-blocking, repairs and painting, Police Station and Residence. (W.O., Alexandra; Police Station, Wallan Wallan.)

Waurm Ponds.—Repairs and painting to school and residence, S.S. 1040. (W.O., Geelong; S.S., Waurm Ponds.)

West Melbourne.—Demolition and removal of concrete air raid shelters, William Angliss Food Trades School.

Whorouly East.—Installation of sewerage, S.S. 2478. (W.O., Benalla.)

Youanmite.—Conversion to septic tank, S.S. 3641. (W.O., Benalla; S.S., Youanmite.)

#### Site Works.

Amstel.—Asphalting, concreting, drainage, gravelling and associated works, S.S. 4801.

Ashwood.—Asphalting, concreting, drainage, paving repairs and associated works, S.S. 4698.

Oakleigh.—Asphalting, concreting, drainage and associated works, Technical School.

Various.—Asphalt and concrete paving, re-grading and drainage works at various schools in the Prahran-Caulfield-Ripponlea area.

#### Miscellaneous.

Port Melbourne.—Supply of three Class 6 Crawler Tractors (Australian Standard D4 1964), fitted with ancillary equipment, Public Works Department Depot.

Port Melbourne.—Supply of 3,000 garbage bins, Public Works Department Storeyard, 69 Salmon-street.

### Tuesday, 27th July, 1965.

#### Building, Electrical and Mechanical Works.

Bannockburn.—Internal and external painting and repairs, S.S. 932. (W.O., Geelong.)

Belmont.—Addition of Science Wing, High School. (W.O., Geelong.)

Belmont.—Electrical installation in additional Science Wing, High School. (W.O., Geelong.)

Belmont.—Mechanical services in new Science Wing, High School. (W.O., Geelong.)

Benalla.—Mechanical services to building extensions, Technical School. (W.O., Benalla.)

Bendigo.—Septic tank installations, school and residence, School for the Deaf, S.S. 4726. (W.O., Bendigo.)

Blackburn.—New roof, repairs and painting, S.S. 2923.

Burnley Gardens.—Additions, repairs and renovations to Principal's Residence, Agricultural Department.

Chadstone Park.—Repairs and painting, S.S. 4669.

Cloverlea.—Erection of out-offices, installation of septic tank and bore water supply, S.S. 3520. (W.O., Warragul; S.S., Cloverlea.)

Coburg.—Renovations, Social Welfare Department, Family Group Home "Moonya", 27 Jackson-parade.

Digby.—Renovations, S.S. 2047. (W.O., Warrnambool; S.S., Digby.)

Doon.—Electrical installation for Biology and Physics Laboratories, Longerenong Agricultural College. (W.O., Horsham.)

Echuca.—Electrical installation, re-wiring and improved lighting, Technical School. (W.O., Shepparton; P.S., Echuca.)

Eltham.—Repairs and painting, Court House.

Frankston.—General repairs and painting to Aluminium Pre-fabricated Buildings, Technical School.

Geelong East.—Renovations, S.S. 451. (W.O., Geelong.)

Gnotuk.—New toilet block and septic tank installation, S.S. 3392. (W.O., Camperdown; S.S., Gnotuk.)

Goulburn Weir.—Erection of out-offices and installation of septic tank, S.S. 3358. (W.O., Alexandra; S.S., Goulburn Weir.)

Heathmont.—Repairs and painting, S.S. 4688.

Jancourt East.—Repairs and external painting, provision of new out-offices and tanks and conversion to septic sewerage, S.S. 3783 and Residence. (W.O., Warrnambool; S.S., Jancourt East.)

Jordanville.—Repairs and internal painting, Technical School.

Melbourne.—Internal repairs and painting, Secondary Teachers' College Hostel, "Warwillah", 572 St. Kilda-road.

Melbourne.—External and internal renovations, St. Kilda-road Police Station, Bowen-crescent.

Melton South.—Repairs, painting and installation of septic tank, S.S. 3717, Residence.

Mont Park.—Electrical reticulation and installation for Remodelled Wards F.7, F.8, F.9 and F.10, Mental Hospital.

Morwell.—Electrical installation, Additional Science Wing, High School. (W.O., Traralgon.)

Mount Waverley.—External repairs and painting—internal work to Residence only, Police Station and Residence.

Nathalia.—Re-roofing Domestic Arts Wing, High School. (W.O., Shepparton.)

Point Lonsdale.—Repairs and external painting, S.S. 3322. (W.O., Geelong.)

Queenscliff.—Additions and alterations and brick garage, Police Station. (W.O., Geelong; P.S., Queenscliff.)

Seymour.—Repairs and re-painting to residence and out-buildings, Police Station Residence, 58 Tallarook-street. (W.O., Alexandra; P.S., Seymour.)

Skipton.—New shelter pavilion, repairs and painting, S.S. 582 and Residence. (W.O., Camperdown; S.S., Skipton.)

South Yarra.—Erection of residence for Caretaker, Melbourne High School. (Amended Specification.)

St. Arnaud.—Renovations, S.S. 1646. (W.O., Maryborough; P.S., St. Arnaud; S.S., St. Arnaud.)

Stawell.—Erection of two Dependent Patients Wards, Pleasant Creek Special School. (W.O., Ararat and Ballarat) (Bills of Quantities Available.)

Strathmerton.—Repairs and painting, S.S. 2790. (W.O., Shepparton; S.S., Strathmerton.)

Traralgon.—Plenum heating, new six additional classrooms, S.S. 4700. (W.O., Traralgon.)

Wangaratta.—Addition of Science Wing in cement rendered timber framed construction, High School. (W.O., Wangaratta.)

Wesburn.—New toilet, renovations and painting, S.S. 3466, Residence.

Woodend.—Erection of laundry, W.C. and repairs, Police Station Residence. (W.O., Kyneton; P.S., Woodend.)

Zeerust.—Conversion to septic tank, S.S. 4359. (W.O., Shepparton; S.S., Zeerust.)

Site Works.

Eastmont.—Asphalting, concreting, drainage, gravelling, retaining walls and associated works, S.S. 4789.

Forest Hill.—Asphalt maintenance repairs and other associated works, S.S. 4251.

Ringwood.—Asphalting, asphalt maintenance, drainage, concreting and associated works, S.S. 2997.

Southmoor.—Asphalting, concreting, drainage, grassing and associated works, S.S. 4910.

Miscellaneous.

Port Melbourne.—Supply of fire hose, Public Works Department Storeyard.

Various.—Supply and delivery of A.C.—D.C. Control Cubicles and Bench Type Switchboard Panels for Benalla, Echuca and Horsham Technical Schools.

### Tuesday, 3rd August, 1965.

#### Building, Electrical and Mechanical Works.

Ballarat.—Supply and installation of sawdust extraction system, Mental Hospital. (W.O., Ballarat.)

Beechworth.—Renovations and painting, Clerk of Courts Residence, Victoria-road. (W.O., Wangaratta.)

Brighton.—Repairs and painting, S.S. 1542.

Buangor.—Internal repairs and painting, S.S. 2072 and residence. (W.O., Ararat; S.S., Buangor.)

Chatsworth.—General repairs and painting, S.S. 1382. (W.O., Hamilton; S.S., Chatsworth.)

Dargo.—Renovations, S.S. 1081 and Residence. (W.O., Bairnsdale; S.S., Dargo.)

Dixon's Creek.—Internal painting and repairs, S.S. 1585.

Essendon.—Repairs and painting, S.S. 483.

Framlingham Settlement.—General repairs and painting, S.S. 4532 and Residence. (W.O., Warrnambool; S.S., Framlingham Settlement.)

Geelong.—Provision of acoustic tiles, S.S. 1094. (W.O., Geelong.)

Harrisfield.—Renovations and additional drinking facilities, S.S. 4730.

Horsham.—External renovations, Technical School Residence, 17 Kalimna-avenue. (W.O., Horsham.)

Mannerim.—Repairs and painting, S.S. 3096. (W.O., Geelong; S.S., Mannerim.)

Melbourne.—Internal repairs and painting, Building No. 5, Royal Melbourne Institute of Technology.

Moreland.—Repairs and painting, S.S. 2837.

Niddrie.—External repairs and painting, High School.

South Yarra.—Provision of new steel deck roof, Health Department Offices, 19 Park-street.

Upwey.—Internal and external repairs and painting, High School Residence, 4 High Cliff-road.

Westgarth.—New brick wall, repairs and painting, Caretaker's Residence, S.S. 4177.

Woodleigh.—Repairs and painting, S.S. 2463. (W.O., Korumburra; S.S., Woodleigh.)

#### NOTICE.

The Public Works Department gives notice that tenders based on Drawings, Specifications and Bills of Quantities will be invited in the next few weeks for Alterations and two-story additional wings to the Fitzroy High School.

Plans are available at Contracts Office, Room 7, Public Works Department, Parliament-place, Melbourne, for reference purposes.

A further notice will be issued informing tenderers of the date of closing of tenders.

J. C. M. BALFOUR,  
Acting Minister of Public Works.

Public Works Department,  
Melbourne, C.2, 12th July, 1965.

#### TENDERS FOR THE RIGHT TO REMOVE SALT.

TENDERS will be received up to noon on Wednesday, the 18th August, 1965, for the exclusive right to collect and remove salt from the areas described below for a period of one year from the 1st September, 1965, renewable annually for four years from the 1st September, 1966.

Tenders endorsed "Salt Tender" must reach the Secretary for Lands, State Treasury Buildings, Melbourne, C.2, not later than noon on Wednesday, the 18th August, 1965. Tenderers must supply full names and address and no tender will be received unless the total amount of fee offered for the period, and Ten shillings (10s.) fee for preparation of licence, are enclosed. The licence is subject to a royalty charge of Seven shillings and six pence per ton on all salt collected or removed. Sworn declarations must be furnished to the Secretary for Lands by the licensee when required, setting out the quantity removed.

The successful tenderer will be required to preserve the bottom of the lake or lakes or collecting grounds from injury, in accordance with instructions from any officer authorized by the Minister of Lands.

Plans of all buildings or other structures proposed to be erected on the licensed area must be submitted to and approved of by the Secretary for Lands, who reserves the right of entry for inspection by any officer authorized by him.

The licensee shall not assign, sublet, or part with his interest in the area, or any portion thereof, without the consent of the Minister of Lands.

The licence will be cancelled for non-payment of any annual fees or any royalty charges or breach of any conditions thereof, or if the licensee shall, for a period of twelve (12) months, fail to use the land bona fide for the purposes for which a licence has been issued.

The Governor in Council reserves the right to resume the area, or any part thereof, for public purposes.

Plans may be seen and all information obtained at Department of Crown Lands and Survey, Treasury-place, Melbourne.

The highest or any tender not necessarily accepted.

J. C. M. BALFOUR,  
Minister of Lands.

Office of Crown Lands and Survey,  
Melbourne, 14th July, 1965.

#### Lot 1.

Parish of Mamemgorooch, County of Weeah, being allotments 34, 35 and 36, known as southern portion of "Lake Crosbie" and is situated in the "Pink Lakes" district. Area 218 acres approximately.—(M.60085.)

#### Lot 2.

Parish of Bimbourie, County of Karkaroc, being portion of Lake Tyrrell, abutting allotments 4, 71 and 72. Area 1,200 acres approximately. Formerly held by J. J. Blout.—(01076/138 Mallee.)

#### Lot 3.

Parish of Dartagook, County of Tatchera, being area known as "Swamp", situated west of allotments 2, 3, 3b of section E. Area 284 acres.—(W.87430.)

## PUBLIC SERVICE NOTICES

### APPLICATIONS FOR ADVERTISED VACANCIES.

THE Board is concerned at the growing number of late applications for positions advertised in the *Government Gazette*. It is the practice of the Board to accept applications received in the first mail on the day following the closing date. This practice will continue, but an applicant who, without good reason, leaves the lodgement as late as this is taking a foolish risk with his future career.

An application may be lodged by making use of a Departmental messenger service, by mail, or by placing it in the box in the Board's office. Whatever means is used, it is the responsibility of the applicant to ensure that the application is received in time, and a late application will not be accepted unless a suitable explanation of the delay is furnished.

By order,

V. P. SCULLY,  
Secretary.

Office of the Public Service Board,  
Melbourne, 13th July, 1965.

### PUBLIC SERVICE OF VICTORIA.—VACANCIES.

APPLICATIONS will be received by the Public Service Board up to Wednesday, the 28th July, 1965, from persons employed in the Public Service of Victoria, who are eligible and qualified for appointment to the under-mentioned positions.

#### ADMINISTRATIVE DIVISION.

#### Assistant Secretary, Class "A", Water Supply Department.

Yearly Salary.—£2,613, minimum; £2,763, maximum.

Duties.—To act as Assistant Secretary.

Qualifications.—Administrative ability; preferably a good knowledge of the Acts, By-laws and Regulations administered by the Commission and of its organization and activities.

#### Class "B1", Family Welfare Division, Social Welfare Branch, Chief Secretary's Department.

Yearly Salary.—£2,293, minimum; £2,443, maximum.

Duties.—To be responsible for control and supervision of Records, Maintenance Collection, Child Employment, Street Trading, and other miscellaneous sub-sections of the Family Welfare Division.

Qualifications.—Experience in record systems and general correspondence; a knowledge of the *Social Welfare Act 1960* and *Childrens Welfare Act 1958* is desirable.

#### Class "B", State Accident Insurance Office, Chief Secretary's Department.

Yearly Salary.—£2,028, minimum; £2,148, maximum.

Duties.—To act as Claims Superintendent, State Accident Insurance Office

Qualifications.—A good knowledge of Workers Compensation and Employers' Liability Insurance and of the Workers' Compensation Acts and Regulations and legal decisions thereunder and the law pertaining to Employers Liability; ability to direct and control staff. Practical experience of insurance claims settlements would be an advantage.

#### Class "C1", Dookie Agricultural College, Department of Agriculture.

Yearly Salary.—£1,558, minimum; £1,668, maximum.

Duties.—Under the Registrar, to be responsible for the direct supervision and maintenance of general and stores accountancy at the College; to be responsible for the maintenance of inventories of assets; to act for the Registrar during his absence; other duties as required.

Qualifications.—A good knowledge of the Public Service Act and Regulations and of the Public Accounts and Stores Regulations; ability to control staff. A knowledge of the Agricultural Colleges Act and Regulations is desirable.

NOTE.—A residence will be available at the College for the successful applicant, if married for which a rental of 10 per cent. of total emolument, inclusive of the amount payable under Regulation 74, less £36 6s. a year will be charged.

**Supervising Inspector of Factories and Shops, Class "C2", Department of Labour and Industry.**

*Yearly Salary.*—£1,788, minimum; £1,908, maximum.

*Duties.*—To supervise inspection work within an inspection district or to carry out the duties of a Supervising Inspector in any other section of the Inspectorate to which he may be assigned. To assist in the general training of recruit Inspectors, and to direct the training of Inspectors "on the job".

*Qualifications.*—Experience and ability as an Inspector of Factories and Shops and ability to supervise. Willingness to reside, if required, within any district to which he may be assigned.

**NOTE.**—Applications are also being invited for this position in the Technical and General Division.

**Class "C1", State Motor Car Insurance Office, Chief Secretary's Department.**

*Yearly Salary.*—£1,558, minimum; £1,668, maximum.

*Duties.*—To supervise and control staff, conduct correspondence and assess and negotiate claims.

*Qualifications.*—A good knowledge of Motor Vehicle Insurance, Statute and Common Law relating to injury claims with practical experience in staff control and correspondence.

**Class "C1", Education Department.**

*Yearly Salary.*—£1,558, minimum; £1,668, maximum.

*Duties.*—To have sub-charge of a section of the Buildings Branch dealing with the maintenance of primary school buildings.

*Qualifications.*—A knowledge of the organization and administration of the Branch of the practices followed; a knowledge of the organization of the Public Works Department.

**Class "C1", Stamp Duties Office, Treasury.**

*Yearly Salary.*—£1,558, minimum; £1,668, maximum.

*Duties.*—To have charge of the legal counter, to assess duty on instruments presented for immediate stamping and to deal with enquiries relating to such instruments.

*Qualifications.*—Experience in assessing stamp duty on various instruments chargeable therewith and a good knowledge of the Stamps Act and regulations thereunder.

**Class "C", Social Welfare Branch, Chief Secretary's Department.**

*Yearly Salary.*—£1,283, minimum; £1,448, maximum.

*Duties.*—To arrange purchase and disposal of stores and equipment with particular reference to motor vehicles and office machines. As directed, to handle dealings with the Public Works Department relevant to supply of equipment and building works.

*Qualifications.*—A knowledge of Government purchasing procedures and the Public Accounts and Stores Regulations 1958. Ability to supervise the operation of the Branch's motor vehicle fleet.

**Class "C", Department of Labour and Industry. (Two vacancies.)**

*Yearly Salary.*—£1,283, minimum; £1,448, maximum.

**POSITION NO. 1.—APPRENTICESHIP COMMISSION.**

*Duties.*—To supervise a sub-section of the Industrial Section, dealing with approvals of apprenticeships and transfers and cancellations of indentures. To answer enquiries on such matters and on rates of wages and other conditions of employment of apprentices.

*Qualifications.*—A general knowledge of industrial matters, including apprenticeship. Capacity for supervision and for interviewing.

**POSITION NO. 2.**

*Duties.*—To assist the Assistant Chief Industrial Officer in the investigations of complaints as directed.

*Qualifications.*—A good knowledge of the Labour and Industry Act, Wages Board Determinations and the operation of Federal Awards.

**NOTE.**—Separate applications must be submitted for these positions.

**Class "C", Stamp Duties Office, Treasury.**

*Yearly Salary.*—£1,283, minimum; £1,448, maximum.

*Duties.*—To assist in the assessment of stamp duty on instruments presented for immediate stamping.

*Qualifications.*—Preferably a good knowledge of the Stamps Act and Regulations relative to the assessment of stamp duty on legal documents.

**Class "C", Water Supply Department.**

*Yearly Salary.*—£1,283, minimum; £1,448, maximum.

*Duties.*—To prepare submissions relating to staff appointments, salaries and gratuities. To deal with enquiries regarding the filling of positions and promotions. Other duties as required.

*Qualifications.*—A good knowledge of the Public Service Acts and Regulations; experience in the work outlined would be an advantage.

**Class "E", Tatura, Water Supply Department.**

Applications are invited from Class "E", Administrative Division Officers, who are desirous of transferring to the above position.

**PROFESSIONAL DIVISION.****Assistant Engineer, Class 1, Office of the Housing Commission, Treasury.**

*Yearly Salary.*—£1,461, minimum; £2,293, maximum. (Commencing salary will be determined according to experience and qualifications).

*Duties.*—Preparation of designs for and setting out and supervision of road and drainage construction and site grading on Housing Estates.

*Qualifications.*—Degree or Diploma of Civil Engineering or equivalent qualifications; suitable experience in design and construction of Civil Engineering Works, preferably those associated with earthworks, roads and drainage.

**Inspecting Clerk of Courts, Class "B1", Courts Branch, Law Department.**

*Yearly Salary.*—£2,293, minimum; £2,443, maximum.

*Qualifications.*—At least 10 years' experience as a Clerk of Courts with a good knowledge of the duties of the office, and those of the office of Receiver and Paymaster.

**Clerk of Courts, Grade 1, Class "B", Courts Branch, North Melbourne, Law Department.**

*Yearly Salary.*—£2,028, minimum; £2,148, maximum.

*Qualifications.*—As prescribed by Public Service (Public Service Board), Regulation 58.

**TECHNICAL AND GENERAL DIVISION.****Supervising Inspector of Factories and Shops, Department of Labour and Industry.**

*Total Emolument.*—£1,788, minimum; £1,908, maximum.

*Duties.*—To supervise inspection work within an inspection district or to carry out the duties of a Supervising Inspector in any other section of the Inspectorate to which he may be assigned. To assist in the general training of recruit Inspectors, and to direct the training of Inspectors "on the job".

*Qualifications.*—Experience and ability as an Inspector of Factories and Shops and ability to supervise. Willingness to reside, if required, within any district to which he may be assigned.

**NOTE.**—Applications are also being invited for this position in the Administrative Division.

**Technical Works Officer, Office of the Housing Commission, Treasury.**

*Yearly Salary.*—£1,331, minimum; £1,435, maximum.

*Duties.*—To assist with control of field supervision and the effective employment and technical instruction of Clerks of Works engaged in housing construction contracts.

*Qualifications.*—Extensive practical experience and suitable training in construction of residential buildings. Ability to conduct correspondence and prepare technical reports.



**Radiographer (Male or Female), Tuberculosis Branch, Department of Health.****Yearly Salary.—**

Male—£1,295, minimum; £1,435, maximum.  
Female—£1,061, minimum; £1,223, maximum.

**Duties.**—Under the direction of the Deputy Director of Tuberculosis (Radiology) to carry out radiography work with fixed and mobile X-ray machines and maintain records, filing and storage of X-rays as required.

**Qualifications.**—Experience in chest radiography, the certificate of competency in Radiography of the Conjoint Board of the College of Radiologists of Australasia and the Australasian Institute of Radiography or equivalent.

**Carpenter, Dookie Agricultural College, Department of Agriculture.**

**Yearly Salary.**—£1,061, minimum; £1,187, maximum.

**Duties.**—Under the direction of the Building Instructor to carry out general carpentry constructional and maintenance work; to assist with the supervision of the practical carpentry work of students, other duties as required.

**Qualifications.**—A competent carpenter experienced in timber framing, finishing and fixing, carpentry maintenance and repair work.

**NOTE.**—Accommodation is available for a single man only at a charge of £166 a year.

**Assistant (Male), Grade II., Stamp Duties Office, Treasury.**

**Yearly Salary.**—£1,097, minimum; £1,133, maximum.

**Duties.**—To keep the stores in order, distribute as necessary to the Branches and to check stamped material submitted for refund and distribution.

**Qualifications.**—Experience in Stores procedure; accurate with figures; of good physique.

**NOTE.**—To be eligible to apply for this position temporary employees or officers of the Technical and General Division other than Assistants (Male), must have passed the Board's examination for registration for appointment as Assistant (Male), Grade I., Technical and General Division.

**Senior Ranger, Nyah West Centre, Water Supply Department.**

**Yearly Salary.**—£1,097.

**Duties.**—Supervision, control and regulation of the domestic and stock watering, supervision of repairs and maintenance of channels and structures.

**Qualifications.**—Experience in distribution of water for domestic and stock purposes; capacity for handling men on mechanical plant engaged on channel maintenance and sand clearing, supervising gangs of men on construction and repair of structures; competent to measure piece work.

**Maintenance Assistant, Public Works Department.**

**Yearly Salary.**—£1,061, minimum; £1,097, maximum.

**Duties.**—To carry out maintenance and repairs to furniture and fittings, including metal-framed furniture and metal fittings, in State Government buildings in the metropolitan area.

**Qualifications.**—Ability to repair either wooden or metal furniture, including adjustment of, and minor repairs to, locks and door closers. Ability to use a small arc-welder would be an advantage.

**Photographic Assistant (Male), Department of Crown Lands and Survey.**

**Yearly Salary.—**

Junior—Under 16 years of age—£408;  
at 16 years of age—£448;  
at 17 years of age—£523;  
at 18 years of age—£589;  
at 19 years of age—£699;  
at 20 years of age—£806.

Adult—£921, minimum; £1,043, maximum.

**Duties.**—To assist in photographic work.

**Qualifications.**—Some experience in photographic laboratory; Junior Technical Certificate or equivalent.

No. 56.—5917/65.—3

**Assistant Superintendent, "The Gables", Family Welfare Division, Social Welfare Branch, Chief Secretary's Department.**

**Yearly Salary.**—£971.

**Duties.**—To assist the Superintendent in the care of 25 young children and in the supervision of a small staff.

**Qualifications.**—Good personality and understanding and capacity for the care of emotionally disturbed children. Competent to direct and supervise staff.

**NOTE.**—Quarters and rations provided at a charge of £166 a year.

**Machinist (Female), Grade III., Motor Registration Branch, Office of the Chief Commissioner of Police, Chief Secretary's Department.**

**Yearly Salary.**—£917, minimum; £953, maximum.

**Duties.**—To record, on cash sheets, remittances received for motor vehicle registrations, renewals and transfers.

**Qualifications.**—Capable of operating a Mercedes and a Remington Accounting Machine; a knowledge of the Motor Car Acts relating to registration fees and the Motor Car (Third Party Insurance) Regulations is desirable.

**Clerical Assistant (Female), Grade II., Mordialloch-Chelsea High School, Education Department.**

**Yearly Salary.**—£917, minimum; £935, maximum.

**Duties.**—To assist headmaster in keeping official account and other books of account; to receive, record, and bank money collected by school; to supervise the work of typist; to act as receptionist, and to carry out other clerical duties as directed by headmaster.

**Qualifications.**—Office experience, preferably in one of the larger schools of the Education Department; knowledge of bookkeeping, particularly departmental requirements in connexion with keeping of school accounts; ability to type; tact in dealing with public.

**Machinist (Female), Grade II., Taxation (Land Tax) Office, Treasury.**

**Yearly Salary.**—£863, minimum; £881, maximum.

**Duties.**—To operate an Accounting Machine for the preparation of Land Tax Assessment Notices, Debit Register and for Statistical work; other duties as required.

**Qualifications.**—Competent in the operation of "National" and "Burroughs" Accounting Machines. A knowledge of procedure adopted in the issue of Land Tax Assessment Notices is desirable.

**Housekeeper, Police Officers' College, Office of the Chief Commissioner of Police, Chief Secretary's Department.**

**Yearly Salary.**—£810, minimum; £881, maximum.

**Duties.**—To have charge of catering arrangements and the servicing and cleaning of the premises and to be in control of the kitchen and dining-room.

**Qualifications.**—Experience in the household management of boarding schools or other large establishments; considerable experience in catering; ability to control staff.

**NOTE.**—The salary rates quoted above do not include the additional amount which is payable under Regulation 74 of the Board's Regulations.

By order,

V. P. SCULLY,

Secretary.

Office of the Public Service Board,  
Melbourne, 13th July, 1965.

**PUBLIC SERVICE OF VICTORIA.—VACANCIES.**

(TEMPORARY APPOINTMENTS.)

**A**PPPLICATIONS will be received by the Public Service Board up to Wednesday, the 28th July, 1965, from persons who are qualified for appointment to the under-mentioned positions:—

**Maintenance Supervisor, Assistant, Office of the Housing Commission, Treasury.**

**Yearly Salary.**—£1,383.

**Duties.**—To prepare reports, estimates and specifications regarding painting, renovations and general maintenance of Commission houses; to assist in

supervising the work of maintenance contractors, and issuing work orders and verifying contractors' accounts.

**Qualifications.**—A qualified building tradesman with experience in general house maintenance including external and internal painting renovations; ability to assess and report on house painting and maintenance, and to prepare specifications and estimates. A current car driver's licence.

**Ranger, Birchip Centre, Water Supply Department.**

**Yearly Salary.**—£972, minimum; £1,043, maximum.

**Qualifications.**—A knowledge of the water requirements and competent to control and regulate the supply of water by channel to landholders; a good knowledge of mechanical equipment used on sand cleaning and other work associated with channel maintenance; ability to carry out repair work to structures of such nature as are provided on a supply channel system. Sufficient clerical ability to prepare time books for men engaged on works.

**Water Bailiff, Swan Hill Centre, Water Supply Department. (Two positions.)**

**Yearly Salary.**—£972, minimum; £1,043, maximum.

**Qualifications.**—Ability to control and regulate the supply of water to irrigators; keep the necessary records and make arithmetical computations; a knowledge of water supply requirements for crops and grasses grown under irrigation, the methods of preparation of land for irrigation and methods of channel and drain construction and maintenance.

**NOTE.**—The successful applicant will be required to occupy the official residence provided and vacation of the residence will not be permitted without the express approval of the Water Supply Department. A rental of 10 per cent. of total emolument inclusive of the amount payable under Regulation 74, less £36 6s. a year will be charged. Occupancy will be subject to a formal tenancy agreement being entered into. Particulars are available from the Water Supply Department.

**Water Bailiff (Relieving), Merbein Centre, Water Supply Department.**

**Yearly Salary.**—£972, minimum; £1,043, maximum.

**Duties.**—To assist in distribution of water to irrigators and to keep necessary records. To assist in maintenance of irrigation and drainage channels and structures. To relieve water bailiffs as required.

**Qualifications.**—Physically capable of manual work with ability to carry out clerical work involving keeping of records and preparation of reports. Good personality and preferably some knowledge of irrigation.

**NOTE.**—The salary rates quoted above do not include the additional amount which is payable under Regulation 74 of the Board's Regulations.

By order,  
V. P. SCULLY,  
Secretary.

Office of the Public Service Board,  
Melbourne, 13th July, 1965.

**PUBLIC SERVICE OF VICTORIA.—VACANCIES.**

**DEPARTMENT OF HEALTH.**

**MENTAL HYGIENE BRANCH.**

**TECHNICAL AND GENERAL DIVISION.**

**APPLICATIONS** will be received by the Public Service Board up to Wednesday, the 4th August, 1965, from persons employed in the Public Service of Victoria, who are eligible and qualified for appointment to the under-mentioned positions:—

**Carpenter, Leading Hand, Sunbury.**

**Yearly Salary.**—£1,151, minimum; £1,223, maximum.

**Qualifications.**—A competent and experienced carpenter.

**Deputy Charge Nurse (Male), Traralgon.**

**Yearly Salary.**—£1,151, minimum; £1,187, maximum.

**Duties.**—To be second in charge of a ward.

**Qualifications.**—A current practising certificate for Mental Nursing and approved experience.

**Electrical Mechanic.**

**Yearly Salary.**—£1,061, minimum; £1,187, maximum.

One vacancy—Sunbury.

**Duties.**—Under the direction of the Engineer to maintain electrical installations, to undertake minor installations, and to assist the Engineer generally.

**Qualifications.**—An "A" Grade wiring licence.

One vacancy—Larundel.

**Duties.**—To maintain wiring and electrical equipment, to undertake minor electrical installations, and to assist the Engineer generally.

**Qualifications.**—"A" Grade wiring licence of the State Electricity Commission, or a tradesman electrical fitter.

**NOTE.**—Separate applications must be submitted for these positions.

**Charge Nurse (Female), Sunbury. (Two vacancies.)**

**Yearly Salary.**—£1,007, minimum; £1,079, maximum.

**Duties.**—To take charge or sub-charge of a ward in a Mental Hospital and to assist in the training of Student Nurses and others.

**Qualifications.**—A current practising Certificate for Mental Nursing.

The salary rates quoted above do not include the additional amount which is payable under Regulation 74 of the Board's Regulations.

By order,  
V. P. SCULLY,  
Secretary.

Office of the Public Service Board,  
Melbourne, 13th July, 1965.

No. 1514.

**PUBLIC SERVICE ACT 1958.**

**THE** Public Service Board, in pursuance of the powers conferred by the *Public Service Act 1958*, hereby amends the Public Service (Public Service Board) Regulations as follows:—

**PART X.—LEAVE OF ABSENCE.**

**Division III.—Sick Leave.**

Regulation 168 is deleted and the following Regulation is substituted therefor:—

"168. A public holiday observed between the first and last days of a period of leave of an officer or employee shall not be regarded as part of the leave."

A. GARRAN, Chairman.  
V. P. SCULLY, Secretary.

Office of the Public Service Board,  
Melbourne, C.2, 28th June, 1965.

No. 1513.

*Public Service Act 1958, Section 50.*

**REGULATIONS.—PART IV.—SALARIES AND INCREMENTS.**

**THE** Public Service Board, in pursuance of the powers conferred by the *Public Service Act 1958*, hereby amends its Regulations as shown below:—

**SIXTH SCHEDULE.**

**TEMPORARY EMPLOYEES.**

*Designations of Positions and Rates of Salaries.*

| Department and Designation of Position.     | Yearly Rate of Salary. |          | Increments (Annual). |
|---|------------------------|----------|----------------------|
|   | Minimum.               | Maximum. |                      |
| CHIEF SECRETARY'S DEPARTMENT.               | £                      | £        |                      |
| OFFICE OF THE CHIEF COMMISSIONER OF POLICE. |                        |          |                      |
| Add—Attendant (Female), City Watchhouse ..  | 759                    | 776      | 1 of £17             |

A. GARRAN, Chairman.  
V. P. SCULLY, Secretary.

Office of the Public Service Board,  
Melbourne, 28th June, 1965.

No. 1511.

*Public Service Act 1958, Section 39.*  
REGULATIONS.—PART IV.—SALARIES AND INCREMENTS.

THE Public Service Board, in pursuance of the powers conferred by the *Public Service Act 1958*, hereby amends its Regulations as shown below :—

FIRST SCHEDULE.  
PROFESSIONAL DIVISION.  
*Amount of Salary Assigned to Offices in Class "A1".*

| Office.  | Yearly Rate of Salary. |
|--|------------------------|
| PUBLIC WORKS DEPARTMENT.                                 |                        |
| <i>Delete—</i><br>District Engineer (Electrical) .. .. . | £<br>2,895             |

*This Regulation shall have effect as on and from the 28th February, 1965.*

A. GARRAN, Chairman.  
V. P. SCULLY, Secretary.

Office of the Public Service Board,  
Melbourne, 21st June, 1965.

No. 1512.

*Public Service Act 1958, Section 50.*  
REGULATIONS.—PART IV.—SALARIES AND INCREMENTS.

THE Public Service Board, in pursuance of the powers conferred by the *Public Service Act 1958*, hereby amends its Regulations as shown below :—

SIXTH SCHEDULE.  
TEMPORARY EMPLOYEES.  
*Designations of Positions and Rates of Salaries.*

| Department and Designation of Position. | Yearly Rate of Salary. |          | Increments (Annual).     |
|---|------------------------|----------|--------------------------|
|   | Minimum.               | Maximum. |                          |
| PUBLIC WORKS DEPARTMENT.                |                        |          |                          |
| PORTS AND HARBOURS†‡§//                 |                        |          |                          |
| <i>Delete—</i><br>Steward .. .. .       | 1,025                  | 1,097†θ  | 2 of £36                 |
| <i>Add—</i><br>Steward .. .. .          | 1,025                  | 1,151†θ  | 3 of £36 and<br>1 of £18 |

‡‡ See Regulation 123.  
‡ See Regulation 122.  
// See Regulation 120.  
† With rations when required to live on the vessel.  
θ See Regulation 119.

A. GARRAN, Chairman.  
V. P. SCULLY, Secretary.

Office of the Public Service Board,  
Melbourne, 25th June, 1965.

PUBLIC SERVICE OF VICTORIA.

TESTS FOR SHORTHAND WRITERS AND TYPISTS (FEMALE).  
*Public Service (Public Service Board) Regulations.*

TESTS in shorthand from dictation at the rate of 100 words a minute and 120 words a minute will be held on 28th August, 1965.

Only officers or employees who have previously passed the Board's Shorthand Test at the rate of 100 words a minute, may sit for the test at 120 words a minute.

Applications to sit for the tests should be lodged with the Secretary, Public Service Board, not later than Saturday, the 14th August, 1965.

Candidates will be notified of the time and place of the tests.

By order,  
V. P. SCULLY,  
Secretary.

Office of the Public Service Board,  
Melbourne, 13th July, 1965.

PUBLIC SERVICE OF VICTORIA.

EXAMINATION TO QUALIFY FOR REGISTRATION FOR APPOINTMENT AS ASSISTANT (MALE), GRADE I, TECHNICAL AND GENERAL DIVISION.

*Date of Examination.*—21st August, 1965.

*Eligibility to Enter.*—Officers of the Technical and General Division or employees.

*Subjects of Examination.*—The subjects of the examination, at Proficiency Certificate standard, are—  
English (an Essay and Précis Writing)  
Arithmetic.

*Applications.*—Forms of application, which must be submitted through the Permanent Head of the candidate's Department, are available at the Office of the Public Service Board.

*Closing Date.*—Applications must reach the Secretary, Public Service Board, not later than Saturday, the 31st July, 1965.

Reasonable facilities will be provided for candidates residing in country districts to sit for examination in local centres.

By order,  
V. P. SCULLY,  
Secretary.

Office of the Public Service Board,  
Melbourne, 13th July, 1965.

PUBLIC SERVICE OF VICTORIA.

QUALIFYING TEST—TYPISTS (FEMALE).

AT the test held on the 26th June, 1965, at 42 words a minute, the under-mentioned candidates passed at the required standard:—

METROPOLITAN CANDIDATES.

DEPARTMENT OF AGRICULTURE.

Gunston, Leslee Anne.  
Murphy, Bernadette Frances.  
Huntley, Margaret Anne.

CHIEF SECRETARY'S DEPARTMENT.

Office of the Chief Commissioner of Police.

Kemtj, Anna (Mrs.).  
Dowling, Bernadette Frances.  
Pal, Maria (Mrs.).  
Mills, Jennifer Dianne (Mrs.).  
Cooke, Margaret Lyndon.

Social Welfare Branch.

Bellina, Filippa.

State Library.

Gallina, Adrienne.  
Stawski, Helen.

State Motor Car Insurance Office.  
Deayton, Maureen.

EDUCATION DEPARTMENT.

Day, Joyce Muriel (Mrs.).  
McLennan, Janet.  
Breasley, Jessie Sylvia (Mrs.).  
Rice, Mabel Jean (Mrs.).  
Christensen, Beryl Lorraine (Mrs.).

DEPARTMENT OF HEALTH.

Mass X-Ray Surveys.  
Dunn, Eleanor.

Mental Hygiene Branch.

Thompson, Ellen Lucy (Mrs.).  
Fellows, Inga Emelia Agnes (Mrs.).  
Harris, Margaret.

LAW DEPARTMENT.

Rawlins, Phyllis Lena (Mrs.).  
Eddy, Susan Patricia.

PREMIER'S DEPARTMENT.

Tourist Development Authority.  
Campbell, Yvonne Joan (Mrs.).  
Harris, Rosalind Gaye.

PUBLIC WORKS DEPARTMENT.

Keefe, Patricia.

STATE FORESTS DEPARTMENT.

Forster, Mavis Edna.

TREASURY.

*Housing Commission.*

Morrow, Carmel Theresa (Mrs.).  
 Taxation (*Land Tax*) Office.  
 Clampett, Cherie Muriel.

WATER SUPPLY DEPARTMENT.

Sala, Maureen Imelda.

COUNTRY CANDIDATES.

DEPARTMENT OF AGRICULTURE.

Deary, Marion Jeanette.

CHIEF SECRETARY'S DEPARTMENT.

Office of the Chief Commissioner of Police.  
 Kent, Lola Lorraine.

EDUCATION DEPARTMENT.

Murphy, Linley Isabelle.  
 Blair, Bette Avis.  
 Chivers, Joan Margaret (Mrs.).  
 Richardson, Gwenyth Joan.  
 Huntsman, Catherine Marion (Mrs.).  
 Dowell, Muriel Elva (Mrs.).  
 Douglas, Elizabeth Jean.  
 Judd, Pauline Sandra Finlayson.  
 Williamson, Dorothy May.  
 Scott, Lesley Joan.

HEALTH DEPARTMENT.

*Mental Hygiene Branch.*

Krause, Dorothy Ann.

LAW DEPARTMENT.

Vella, Polly.  
 Byrne, Dianne Joyce.  
 Mansfield, Rhonda Christine.  
 Eunson, Glenda Mary.  
 Phelan, Alice Marguerite.

WATER SUPPLY.

Connor, Ann Shirley.

By order,

V. P. SCULLY,  
 Secretary.

Office of the Public Service Board,  
 Melbourne, 13th July, 1965.

**PRIVATE ADVERTISEMENTS**

CITY OF BALLAARAT.

NOTICE is hereby given that the following previously unnamed street is to be known as follows:—

West of Haines-street, north of Lofven-street, along the north side of section 35, Township of Ballarat East.

Present name: Unnamed.

New Name: Ivey-street.

6965

H. R. MADDERN, Town Clerk.

CITY OF BROADMEADOWS.

PRIVATE STREETS LOAN No. 48—£50,000.

NOTICE is hereby given that the Council of the City of Broadmeadows did at a meeting held on 7th June, 1965, make the following Resolution:—

That this Council, by Special Order, resolves to borrow on the credit of the Mayor, Councillors and Citizens of the City of Broadmeadows the sum of Fifty thousand pounds (£50,000) such sum to be secured by grant of a mortgage in accordance with the provisions of the Local Government Act.

The rate of interest to be paid is £5 12s. 6d. per centum per annum and the said loan shall be liquidated by twenty half-yearly instalments of approximately £3,302 16s., including principal and interest.

The time which the moneys borrowed are to be repayable are on the 1st day of February and on the 1st day of August in each year during the period of ten years. The first payment shall be on 1st February, 1966.

The place the moneys shall be repayable is at the State Savings Bank of Victoria, Melbourne.

The purposes for which the said loan shall be applied are for the construction of private streets under the provisions of Division 10 of Part XIX. of the *Local Government Act* 1958 and amendments, and the loan shall be liquidated from the receipts of money payable under schemes under the said division.

Notice is further given that at a meeting of the said Council held at the Council Chambers, Broadmeadows, on 5th July, 1965, the said Resolution was confirmed.

Dated this 8th day of July, 1965.

6952

E. F. SMILEY, Town Clerk.

CITY OF CAMBERWELL.

STREET NAMING.

NOTICE is hereby given, that in pursuance of the powers conferred by the *Local Government Act* 1958, the Council of the City of Camberwell, at a meeting held on 31st day of May, 1965, did order that the following change in street name be made.

*Old Name; New Name.*

Jason-street; Jason-court.

Such order to take effect from the date of publication in the *Victoria Government Gazette*.

By order,

L. F. CHEFFERS, Chief Administrator.

Civic Centre,

Camberwell, 14th July, 1965.

6955

*Town and Country Planning Act* 1961.

CITY OF CAMBERWELL PLANNING SCHEME 1954.

NOTICE THAT A PLANNING SCHEME HAS BEEN PREPARED AND IS AVAILABLE FOR INSPECTION.

*Amendment No. 24, 1965.*

NOTICE is hereby given that the City of Camberwell in pursuance of its powers under the *Town and Country Planning Act* 1961 has prepared a Planning Scheme for—

“That portion of the Municipality of the City of Camberwell 125 feet north of Whitehorse-road having a frontage of 139 feet to the west side of Balwyn-road and a depth of 114 ft. 6 in. .

A copy of the Scheme has been deposited at the Municipal Offices, Civic Centre, Camberwell and at the Offices of the Town and Country Planning Board, 179 Queen-street, Melbourne, and will be open for inspection during office hours by any person free of charge.

Any persons affected by the Planning Scheme are required to set forth in writing all objections they may have, addressed to the Chief Administrator, Civic Centre, Camberwell, on or before the 16th day of August, 1965, and to state whether they wish to be heard in respect of their objections.

6972

L. F. CHEFFERS, Chief Administrator.

*Town and Country Planning Act* 1961.

CITY OF CAMBERWELL PLANNING SCHEME 1954.

NOTICE THAT A PLANNING SCHEME HAS BEEN PREPARED AND IS AVAILABLE FOR INSPECTION.

*Amendment No. 23, 1965.*

NOTICE is hereby given that the City of Camberwell in pursuance of its powers under the *Town and Country Planning Act* 1961 has prepared a Planning Scheme for—

“The whole of the Municipality of the City of Camberwell”.

A copy of the Scheme has been deposited at the Municipal Offices, Civic Centre, Camberwell and at the Offices of the Town and Country Planning Board, 179 Queen-street, Melbourne, and will be open for inspection during office hours by any person free of charge.

Any persons affected by the Planning Scheme are required to set forth in writing all objections they may have, addressed to the Chief Administrator, Civic Centre, Camberwell, on or before the 16th day of August, 1965, and to state whether they wish to be heard in respect of their objections.

6973

L. F. CHEFFERS, Chief Administrator.

CITY OF FOOTSCRAY.

LOAN No. 72.

*Notice of Intention to Borrow the Sum of £17,500 for Permanent Works and Undertakings.*

NOTICE is hereby given that the Council of the City of Footscray proposes to borrow the principal sum of Seventeen thousand five hundred pounds on the credit of the municipal revenues of the Mayor, Councillors and

Citizens of the said City, such sum to be raised by the grant of a mortgage in accordance with the provisions of the *Local Government Act 1958*.

1. The maximum rate of interest that may be paid is £5 12s. 6d. per cent. per annum.
2. The purposes for which the loan is to be applied are:—

|  |         |
|--|---------|
| Office machines . . . . .                  | £7,125  |
| Roadway construction works—Hyde-street . . | 10,375  |
|  | £17,500 |

3. The period of the loan shall be ten years.
4. The moneys borrowed shall be repayable by providing out of the municipal fund twenty half-yearly instalments of approximately £1,156 each, including principal and interest on the 1st day of April and the 1st day of October during the currency of the loan. The first instalment shall be payable on the 1st day of April, 1966.
5. Such moneys shall be repayable to the Commissioners of the State Savings Bank of Victoria at the office of the said Commissioners, 139–165 Elizabeth-street, Melbourne.

The plans and specifications and the estimate of the cost of the proposed works and a statement showing the proposed expenditure of the moneys to be borrowed are open for inspection at the office of the Council of the City of Footscray, at the Town Hall, Napier-street, Footscray.

E. J. SMITH, Town Clerk.

Dated the 12th day of July, 1965. 6956

*Town and Country Planning Act 1961 (Twelfth Schedule).*

CITY OF NEWTOWN AND CHILWELL.—GEELONG  
PLANNING SCHEME 1959.

NOTICE THAT A PLANNING SCHEME HAS BEEN PREPARED  
AND IS AVAILABLE FOR INSPECTION.

Amendment No. 3.

NOTICE is hereby given that the City of Newtown and Chilwell, in pursuance of its powers under the *Town and Country Planning Act 1961*, has prepared a Planning Scheme for the following areas:—

- (a) Land bounded by Latrobe-terrace, Noble-street, Urana-street, and Bond-street.
- (b) Land known as Nos. 310 and 310A Latrobe-terrace.

for the purpose of varying the zoning of the land from Residential "B" to Commercial "B".

A copy of the scheme has been deposited at the City Hall, Pakington-street, Newtown, and at the office of the Town and Country Planning Board, 179 Queen-street, Melbourne, and will be open for inspection during office hours by any person, free of charge.

Any persons affected by the planning scheme are required to set forth, in writing, all objections they may have, addressed to the Town Clerk, City of Newtown and Chilwell, City Hall, Newtown, Geelong, on or before the 7th August, 1965, and to state whether they wish to be heard in respect of their objections.

1st July, 1965.

6936 J. D. BACKWELL, Town Clerk.

CITY OF NORTHCOTE.

LOAN No. 75.

*Notice of Intention to Borrow the Sum of £50,000 for  
Permanent Works and Undertakings.*

NOTICE is hereby given that the Council of the City of Northcote proposes to borrow the sum of Fifty thousand pounds secured by a charge over the general rates of the municipality of the Mayor, Councillors and Citizens of the said City, such sum to be raised by the grant of a mortgage in accordance with the provisions of the *Local Government Act 1958*.

- (i) The maximum rate of interest that may be paid is £5 15s. per centum per annum.
- (ii) The purpose for which the loan is to be applied is Capital Extensions in the Electricity Supply Undertaking.
- (iii) The period of the loan shall be 40 years.
- (iv) The manner in which the loan is to be liquidated is by the establishment and accumulation of a sinking fund in accordance with the provisions of sections 428A and 432A of the *Local Government Act 1958*. Interest on the amount of the loan shall be payable half-yearly.
- (v) The loan shall be repayable on 1st October, 2005, at the office of the Defence Forces Retirement Benefits Board, Canberra, A.C.T.

The plans and specifications and the estimate of the cost of the proposed works and a statement showing the proposed expenditure of the moneys to be borrowed are open for inspection at the Town Hall, Northcote.

Dated this 30th day of June, 1965.

6963 E. MASON, Town Clerk and City Manager.

No. 955.

CITY OF NUNAWADING.

WHEREAS the Council of the City of Nunawading deems it expedient to exercise its power of taking compulsorily the land described in the Schedule at the foot hereof for the work or undertaking of providing a place of public resort and recreation: And whereas the Council has caused to be prepared a map and other papers setting out the general description of the work or undertaking for which the land proposed to be taken is to be used, the description of the land proposed to be taken, and the names of the owners or reputed owners, lessees or reputed lessees, mortgagees and occupiers of that land so far as those names are known to or can be ascertained by the Council: And whereas the said map and other papers are deposited at the office of the said Council at Nunawading and are and shall be open for inspection by all persons interested at all reasonable hours for the space of 40 clear days after the publication of this notice in the *Government Gazette*: Now notice is hereby given to all persons affected by the proposed taking of the said land to set forth, in writing, addressed to the Council or the Town Clerk, within 40 clear days of the publication of this notice in the *Government Gazette*, all objections which they may have to the taking of the said land.

SCHEDULE HEREINBEFORE REFERRED TO.

All that piece of land, being part of Crown portion 89, Parish of Nunawading, County of Bourke, and being allotment 15 on plan of subdivision No. 9257, and being the whole of the land more particularly described in certificate of title, volume 6156, folio 005, lodged in the Office of Titles, Melbourne, and being the whole of the land contained within a boundary line commencing at a point being the south-east corner of the land described in the said certificate of title; thence on a bearing of 270 deg. 0 min. for a distance of 289 ft. 8½ in.; thence on a bearing of 0 deg. 0 min. for a distance of 90 feet; thence on a bearing of 90 deg. 0 min. for a distance of 252 ft. 2½ in.; thence on a bearing of 163 deg. 16 min. for a distance of 47 ft. 11 in.; thence on a bearing of 151 deg. 45 min. for a distance of 50 ft. 0½ in. to the point of commencement.

Dated the 13th day of July, 1965.

By order of the Council,

7021 J. H. BROWN, Town Clerk.

Local Government Act, Section 512.

CITY OF TRARALGON.

THE Council of the City of Traralgon having deemed it expedient to exercise its power of taking land, as described below, compulsorily, has caused to be prepared maps and papers to show:—

- (a) the general description of the work or undertaking for which the land proposed to be taken is to be used,
- (b) the description of the lands proposed to be taken, and
- (c) the names of the owners or reputed owners, lessees or reputed lessees, mortgagees and occupiers of those lands so far as those names are known to or can be ascertained by the Council.

The same are deposited for inspection at the Municipal Offices, Kay-street, Traralgon.

All persons affected by the proposed taking of the land are to set forth, in writing, addressed to the Council or to me, within forty (40) clear days of the publication of this notice in the *Government Gazette*, all objections which they may have to the taking of the land.

Dated this 6th day of July, 1965.

LESLIE M. HICKMAN, Town Clerk.

Municipal Offices,  
Kay-street, Traralgon.

THE LAND REFERRED TO ABOVE:

Commencing at a point being the south-west corner of Crown allotment 14, section 8, Township and Parish of Traralgon; thence at a bearing of 339 deg. 0 min. for a distance of 26 ft. 0 in.; thence at a bearing of 114 deg. 0 min. for a distance of 21 ft. 2½ in.; thence at a bearing of

69 deg. 0 min. for a distance of 99 ft. 11½ in.; thence at a bearing of 339 deg. 46 min. for a distance of 64 ft. 8 in.; thence at a bearing of 339 deg. 10 min. for a distance of 54 ft. 10 in.; thence at a bearing of 339 deg. 0 min. for a distance of 65 ft. 6 in.; thence at a bearing of 249 deg. 0 min. for a distance of 116 ft. 0 in.; thence at a bearing of 339 deg. 0 min. for a distance of 266 ft. 0 in.; thence at a bearing of 69 deg. 0 min. for a distance of 334 ft. 0 in.; thence at a bearing of 159 deg. 29 min. for a distance of 131 ft. 2½ in.; thence at a bearing of 159 deg. 14½ min. for a distance of 330 ft. 9½ in.; thence on a bearing of 249 deg. 0 min. for a distance of 331 ft. 6 in. to the point of commencement.

(The above land being situate in or near the east side of Peterkin-street, Traralgon, south of Gwalia-street.)

7017

## CITY OF WARRNAMBOOL.

## LOAN No. 64.

Notice of Intention to Borrow the Sum of £5,000 for Permanent Works and Undertakings.

NOTICE is hereby given that the Council of the City of Warrnambool proposes to borrow the sum of Five thousand pounds on the credit of the municipal revenues of the Mayor, Councillors and Citizens of the said City, the sum to be raised by the grant of a mortgage in accordance with the provisions of the Local Government Act 1958.

1. The maximum rate of interest that may be paid is £5 15s. per cent. per annum.
2. The purpose for which the loan is to be applied is part cost of constructing Stadium at Albert Park Reserve £5,000.
3. The period of the loan shall be fifteen years.
4. The moneys borrowed, shall be repayable by providing out of the municipal fund, 30 half-yearly instalments of £250 19s. 10d. each, including principal and interest, on the 1st day of April and the 1st day of October during the currency of the loan. The first instalment shall be payable on the 1st day of April, 1966.
5. Such moneys shall be repayable at The Commercial Savings Bank of Australia Ltd., Warrnambool.

The plans and specifications and the estimate of the cost of the proposed works and a statement showing the proposed expenditure of the moneys to be borrowed are open for inspection at the Town Hall, Warrnambool.

Town Hall, Warrnambool, 9th July, 1965.

6974

K. L. ARNEL, Town Clerk.

## TOWN OF CASTLEMAINE.

## BY-LAW No. 122.

A By-Law of the Town of Castlemaine numbered 122 to amend By-Laws Nos. 99 and 110 for fixing the fees payable to the Council under Part XV. of the Health Act 1958 for the examining and branding of carcasses of animals slaughtered for sale in the Castlemaine Meat Area and for certification with regard to same.

IN pursuance of the powers conferred by the Health Act 1958 and by any and every power enabling it in that behalf, the Mayor, Councillors and Burgesses of the Town of Castlemaine order as follows:—

1. By-Law No. 110 is hereby repealed.
2. For Clause 2, of By-Law No. 99 there shall be substituted the following:—

The Municipality may charge and collect for its own use the following fees and dues in respect of the matters following, that is to say:—

| Fees and dues payable for the examining and branding of any carcass of meat derived from any:— | s. | d. |
|--|----|----|
| (a) Bull, ox, steer, cow or heifer over 300 lbs.   | 3  | 0  |
| (b) Calf to 250 lbs.   | 2  | 6  |
| (c) Sheep, lamb, goat, kid or bobby calf.  | 1  | 2  |
| (d) Swine.   | 1  | 4  |

For every certificate as to an examination by a Meat Inspector—2s. 6d.

Resolution for passing this By-Law was agreed to by the Council of the Town of Castlemaine on the 1st day of April, 1965, and confirmed on the 3rd day of May 1965.

(SEAL) R. J. LANGDON, Mayor.  
JOHN HARCUS, Councillor.  
I. C. SMITH, Town Clerk.

Submitted to the Commission of Public Health on the 25th day of May, 1965.—A. T. GARDNER, Secretary to the Commission.

Approved by the Governor in Council, on the 9th day of June, 1965.—J. COLQUHOUN, Clerk of the Executive Council. 6975

## TOWN OF CASTLEMAINE.

## BY-LAW No. 123.

NOTICE is hereby given that the Council of the Town of Castlemaine has made a By-Law under Part XV. of the Health Act 1958 and numbered 123, for amending By-Laws Nos. 102 and 117, and for fixing the dues and fees payable for services in connexion with the Municipal Abattoirs.

A copy of the By-Law is open for inspection, free of charge, during office hours at the Town Hall, Castlemaine.

Resolution for making this By-Law was agreed to by the Council on the 1st April 1965 and confirmed on the 3rd May 1965.

Submitted to the Commission of Public Health on the 25th May, 1965, and approved by the Governor in Council on the 9th June, 1965.

9th July, 1965.

6976

I. C. SMITH, Town Clerk.

## BOROUGH OF QUEENSLIFFE.

## CHANGE OF NAME OF STREET.

NOTICE is hereby given that the Council of the Borough of Queenscliffe in accordance with the provisions of the Local Government Act 1958 did make an order that the name of a street within the Municipality be changed as set out hereunder.

Old Name; New Name; Location.

Glaneuse-road; Laker-drive; from Ocean-road, Pt. Lonsdale thence northerly for a distance of 577.5 feet thence easterly for a distance of 247.5 feet.

6977

D. F. DREW, Town Clerk.

## BOROUGH OF SEBASTOPOL.

## AMENDMENT OF REGULATIONS.

NOTICE is hereby given that pursuant to section 219 of the Land Act 1958, the Council of the Borough of Sebastopol has amended the regulation for the Care, Protection, and the Management of the Sebastopol Public Gardens and Recreation Reserve, as follows:—

By adding in Regulation 15 after the word "Sundays", the words "without the permission in writing of the Trustees first obtained, and then only subject to such terms and conditions as the Trustees may determine".

7016

E. M. WILLS, Town Clerk.

## Town and Country Planning Act 1961.

## SHIRE OF BALLARAT.—SHIRE OF BALLARAT PLANNING SCHEME.

## Amendment No. 12.

NOTICE THAT A PLANNING SCHEME HAS BEEN PREPARED AND IS AVAILABLE FOR INSPECTION.

NOTICE is hereby given that the Shire of Ballarat in pursuance of its powers under the Town and Country Planning Act 1961 has prepared a plan for the area bounded by Gillies-street, Howitt-street, Burnbank-street and the railway line south of Howitt-street, but excluding the Commercial B zone between Forest-street and Gillies-street for the purpose of re-zoning the area Residential Light Industrial. Also requirements for vehicular parking in Commercial A, Commercial B, and Industrial A, B and C zones have been provided for in the ordinance.

A copy of the scheme has been deposited at the Shire Offices, Gillies-street, Wendouree, and at the Office of the Town and Country Planning Board, 61 Spring-street, Melbourne, and will be open for inspection during office hours by any person free of charge.

Any persons affected by the Planning Scheme are required to set forth, in writing, all objections they may have, addressed to the Shire Secretary, Shire of Ballarat, Shire Offices, Gillies-street, Wendouree, on or before the 16th day of August, 1965, and to state whether they wish to be heard in respect of their objections.

6957

JAMES H. MITCHELL, Shire Secretary.

SHIRE OF BERWICK.  
PAKENHAM POUND.

NOTICE is hereby given that Crown Allotment 12A, Parish of Nar Nar Goon, containing 3 acres 2 roods 2 perches has been appointed as Pakenham Pound and will be used for pound purposes.

6931

BEATRICE THOMAS, Shire Secretary.

SHIRE OF COBRAM.  
SPECIAL ORDER.

NOTICE is hereby given that at a meeting of the Cobram Shire Council, held on Monday 21st June, 1965, it was resolved that the Council do by Special Order, borrow the sum of £5,000 by bank overdraft, from the A.N.Z. Bank, Cobram, for the purpose of financing a private street construction scheme, in Broadway-street.

The rate of interest shall be at 6½ per cent. per annum and the loan will be liquidated by the repayment of amounts due by participating property owners, over a period of ten years.

It is further notified, that the above resolution will be confirmed at a meeting of the Council, to be held on Monday, 19th July, 1965.

6929

R. T. CUTTS, Shire Secretary.

SHIRE OF CROYDON.  
LOAN No. 45.

Notice of Intention to Borrow the Sum of £25,000 (\$50,000) for Permanent Works and Undertakings.

NOTICE is hereby given that the Council of the Shire of Croydon, in pursuance of powers conferred by the Local Government Acts, intends to borrow the sum of £25,000 (\$50,000) on the credit of the municipal revenues of the President, Councillors, and Ratepayers of the said Shire, such sum to be raised by the grant of mortgage, in accordance with the said Acts and states—

(a) The amount of principal moneys it is proposed to borrow is £25,000 (\$50,000).

(b) The maximum rate of interest that may be paid is 5.75 per cent. per annum.

(c) The period of the loan will be 40 years and the time at which the moneys borrowed are to be repayable is 1st day of October, 2005. The place of repayment will be the office of the State Superannuation Board, Melbourne.

(d) The purpose for which the loan is to be applied is for permanent works and undertakings, viz:

Part cost of construction of Offices and Council Chamber.

(e) The loan is to be liquidated by yearly investment of £233 11s. 7d. (\$467.16) in Sinking Fund pursuant Section 428A (2) (b) and interest, payable out of the municipal fund.

Plans and specifications and an estimate of the cost of such works and undertakings, and a statement showing the proposed expenditure of the money to be borrowed, are open for inspection by ratepayers, during office hours, at the Shire Offices, Croydon, for one month after the publication of this Notice.

Dated at Croydon this 5th day of July, 1965.

6930

K. A. McKAY, Shire Secretary.

SHIRE OF CROYDON.  
LOAN No. 44.

Notice of Intention to Borrow the Sum of £10,000 (\$20,000) for Permanent Works and Undertakings.

NOTICE is hereby given that the Council of the Shire of Croydon, in pursuance of powers conferred by the Local Government Acts, intends to borrow the sum of £10,000 (\$20,000) on the credit of the municipal revenues of the President, Councillors, and Ratepayers of the said Shire, such sum to be raised by the grant of mortgage, in accordance with the said Acts and states—

(a) The amount of principal moneys it is proposed to borrow is £10,000 (\$20,000).

(b) The maximum rate of interest that may be paid is 5.625 per cent. per annum.

(c) The period of the loan will be ten years and the time or times at which the moneys borrowed are to be repayable on the 1st day of April and the 1st day of October, in each year during the currency of the loan commencing on the 1st day of April, 1966. The place of repayment will be the National Bank of Australasia Limited, Melbourne.

(d) The purpose for which the loan is to be applied is for permanent works and undertakings, viz:

| Item No. |  |         |
|----------|--|---------|
| 1.       | Croydon-road, traffic islands .. ..                                      | £500    |
| 2.       | Dorset Hall, lining of ceiling .. ..                                     | 550     |
| 3.       | Murray-road — Richards-avenue, asphalt surfacing .. ..                   | 1,000   |
| 4.       | Mountview-street, footpath, east side ..                                 | 650     |
| 5.       | Lacey-street, pavement widening, north side .. ..                        | 2,000   |
| 6.       | Donald-street, reconstruction kerb and channel .. ..                     | 2,000   |
| 7.       | Canterbury-road, Main Drain, south side ..                               | 2,000   |
| 8.       | Bayswater-road, kerb and channel, west side, south Mt. Dandenong-road .. | 1,300   |
|          |  | £10,000 |

(e) The loan is to be liquidated by half-yearly payments of approximately £660 11s. 2d. (\$1321.12) including principal and interest, payable out of the municipal fund.

Plans and specifications and an estimate of the cost of such works and undertakings, and a statement showing the proposed expenditure of the money to be borrowed, are open for inspection by ratepayers, during office hours, at the Shire Offices, Croydon, for one month after the publication of this notice

Dated at Croydon this 5th day of July, 1965.

6932

K. A. McKAY, Shire Secretary.

SHIRE OF FLINDERS.  
SPECIAL ORDER.

Private Streets Construction.

NOTICE is hereby given that at a meeting of the Council held Wednesday, 2nd June, 1965, at the Shire Office, Dromana, the Council did agree to the following Resolution.

That this Council does by special order resolve to borrow the sum of £10,000 by the grant of a mortgage on the credit of the municipal revenues of the Shire of Flinders, such sums to be raised in accordance with the provisions of section 585 of the Local Government Act 1958, as amended.

The maximum rate of interest that may be paid is £5 12s. 6d. per centum per annum.

The money borrowed shall be repayable by twenty half-yearly instalments of approximately £660 11s. 2d., which includes principal and interest, payable on the 1st day of each January and July, the first instalment being due 1st January, 1966, at the office of the National Bank of Australasia Limited Savings Bank, 271 Collins-street, Melbourne.

The purpose for which the loan is to be applied is the construction of private streets in accordance with the provisions of Division 10 of Part XIX. of the Local Government Act and the loan shall be liquidated from the receipts of moneys payable under schemes under this division.

Notice is further given that at a meeting of the Council held in the Shire Office, Dromana, on 7th July, 1965, the said Resolution was confirmed.

6971

S. WILLIAMS, Shire Secretary.

SHIRE OF MARONG.

THE Shire of Marong at its Meeting on 7th July, 1965, did Order that the lane at the rear of High-street, Kangaroo Flat, between Station and Camp streets is henceforth to be named "Dunlop-street".

7013

ROSS M. GRAHAM, Shire Secretary.

SHIRE OF MORNINGTON.

PURSUANT TO SECTION 522 OF THE LOCAL GOVERNMENT ACT 1958.

THE President, Councillors and Ratepayers of the Shire of Mornington order and direct that all that piece or parcel of land being part of Crown allotment 8, section 22, Parish of Moorooduc, County of Mornington, the boundaries of which are more particularly described as follows:—

Commencing at a point on the southern alignment of Barkly-street distant 112 ft. 4½ in. easterly from the eastern alignment of Main-street; thence by lines bearing 106 deg. 56½ min. for 22 ft. 8 in., 151 deg. 51 min. for 89 ft. 8 in., 62 deg. 0 min. for 59 ft. 3 in., 152 deg. 18 min. for 96 ft. 7½ in., 153 deg. 29 min. for 66 ft. 4½ in., 242 deg. 14 min. for 6 ft. 3¼ in., 152 deg. 16 min. for 24 ft. 2 in., 158 deg. 12 min. for 129 ft.

9½ in., 157 deg. 55 min. for 372 ft. 6 in., 109 deg. 29 min. for 13 ft. 3 in., 240 deg. 47 min. for 70 ft. 4½ in., 19 deg. 21 min. for 15 feet, 337 deg. 55 min. for 363 ft. 10½ in., 290 deg. 25½ min. for 6 ft. 9 in., 242 deg. 56 min. for 136 ft. 10 in., 200 deg. 27 min. for 7 ft. 4½ in., 337 deg. 58½ min. for 20 ft. ¼ in., 110 deg. 27 min. for 6 ft. 9 in., 62 deg. 56 min. for 136 ft. 10 in., 20 deg. 34 min. for 7 ft. 4½ in., 338 deg. 12 min. for 122 ft. 3½ in., 332 deg. 16 min. for 21 ft. 6½ in., 331 deg. 35 min. for 67 feet, 62 deg. 40 min. for 50 feet, 331 deg. 51 min. for 186 ft. 2 in., 16 deg. 56½ min. for 22 ft. 7 in., 242 deg. 2 min. for 82 feet home to the point of commencement which piece or parcel of land is contained in part of certificate of title, volume 8544, folio 484, in the register book showing the President, Councillors and Ratepayers of the Shire of Mornington as registered proprietor—

shall be a public highway.

Dated the 30th day of June, 1965.

The common seal of the President, Councillors and Ratepayers of the Shire of Mornington was hereunto affixed, in the presence of—

(SEAL) D. R. MORELL, Shire President.  
J. E. WHITE, Councillor.  
6953 T. MORRISSY, Acting Shire Secretary.

Town and Country Planning Act 1961 (Twelfth Schedule).

SHIRE OF MORWELL.—LATROBE VALLEY SUB-REGIONAL PLANNING SCHEME 1949.

NOTICE THAT A PLANNING SCHEME HAS BEEN PREPARED AND IS AVAILABLE FOR INSPECTION.

Amendment No. 9, 1965.

NOTICE is hereby given that the Council of the Shire of Morwell, in pursuance of its powers under the Town and Country Planning Act 1961, has prepared a Planning Scheme for—

That part of the municipal district of the Shire of Morwell within the Parish of Maryvale shown on the map and described as follows:—

Part of Crown allotment 70, Parish of Maryvale.

The purpose of the scheme is to rezone land from Agricultural "B" to a Special Uses Zone.

A copy of the scheme has been deposited at the Shire Office, Commercial-road, Morwell, and at the office of the Town and Country Planning Board, 179 Queen-street, Melbourne, and will be open for inspection during office hours, by any person, free of charge.

Any persons affected by the planning scheme are required to set forth in writing, all objections they may have, addressed to the Shire Secretary, Shire Office, Commercial-road, Morwell, on or before the 16th day of August, 1965, and state whether they wish to be heard in respect of these objections.

6th July, 1965.

6933 R. J. LORD, Shire Secretary.

SHIRE OF STAWELL.

NOTICE is hereby given that First Constable Ronald Francis William Howden, No. 10094, has been appointed Inspector of Nuisances for the Marnoo District of the Shire of Stawell, vice First Constable G. J. Maxwell, No. 11732.

6970 V. C. NIELSEN, Shire Secretary.

SHIRE OF UPPER YARRA.

LOAN No. 26.

Notice of intention to borrow the sum of £15,400 for Permanent Works and Undertakings.

NOTICE is hereby given that the Council of the Shire of Upper Yarra proposes to borrow the principal sum of Fifteen thousand four hundred pounds on the credit of the municipal revenues of the President, Councillors and Ratepayers of the said Shire, such sum to be raised by the grant of a mortgage in accordance with the provisions of the Local Government Act 1958.

1. The maximum rate of interest that may be paid is £5 15s. per cent. per annum.
2. The purpose for which the loan is to be applied is—  
Part cost of erection of new Municipal Offices and Council Chambers at Yarra Junction . . . . . £15,400
3. The period of the loan shall be twenty years.

4. The moneys borrowed shall be repayable by providing out of the municipal fund 40 half-yearly instalments of £652 16s. 11d. each including principal and interest on the first day of March and the first day of September during the currency of the loan. The first instalment shall be payable on the first day of March, 1966.

5. Such moneys shall be repayable to the Local Authorities Superannuation Board at "Rigby House", 15 Queens-road, Melbourne, or such other place or places as the Board from time to time may require.

The plans and specifications and the estimate of the cost of the proposed works and a statement showing the proposed expenditure of the moneys to be borrowed are open for inspection at the office of the Council of the Shire of Upper Yarra, at Yarra Junction.

Dated 7th July, 1965.

6935 J. N. EDDY, Shire Secretary.

GEELONG WATERWORKS AND SEWERAGE TRUST.

NOTICE to owners of tenements in the under-mentioned streets and private streets, lanes, courts and alleys opening hereto—

City of Geelong.

Denman-street, 59 feet east from existing dead end.

Geelong West.

Clonard-avenue, 170 feet west from lot 19 to Andrew-street.

Newtown and Chilwell.

Ballater-avenue, 123 feet west from Ardlui-drive.

South Barwon.

Kana-street, 1,641 feet between Heyers-road and Peter-street.

Mayrah-court, 501 feet south from Kana-street.

Goyarra-court, 505 feet south from Kana-street.

Burdoo-drive, 794 feet between Heyers-road and Peter-street.

Beltana-street, 153 feet north from Peter-street.

Bieske-road, 266 feet south from Peter-street.

Larcombe-street, 219 feet south from lot 6.

Baums-road, 550 feet west from Scenic-road.

Shoubra-drive, 1,262 feet west from Valley-road South.

Taylor-court, 93 feet south from lot 5 to lot 6.

Ferndale-parade, 409 feet east from Harrison-court.

Maidie-street, 525 feet between Pipe Track Reserve and Scenic-road.

Scenic-road, 249 feet south from Maidie-street, to lot 19.

Desmond-street, 66 feet west from lot 43 to lot 44.

Breakwater-road, 506 feet east from Bailey-street.

Pavo-street, 860 feet east from Colac-grove west to lot 13.

Larcombe-street, 172 feet north from Cuthbert-avenue.

Scenic-road, 293 feet south from existing main to lot 8.

Cedmar-avenue, 162 feet north from Bonsey-road to Cemaloma-court.

Bellarine Shire.

Nobility-street, 1,005 feet south from Drysdale-road.

Bain-court, 213 feet north from Charles-street to lot 4.

Chandos-street, 333 feet west of Wilsons-road.

Corio Shire.

Holmes-street, 302 feet north from lot 21 to lot 40.

Devon-street, 439 feet south from lot 98 to lot 138.

Watson-street, 325 feet between Deakin-street and Bruce-street.

Wolseley-grove, 1,214 feet west from lot 144 to Ward-street.

Ward-street, 694 feet south from Wolseley-grove to lot 132.

Beauford-avenue, 697 feet south from Wolseley-grove to lot 130.

Webber-street, 743 feet between Beauford-avenue and Ward-street.

Hosie-street, 786 feet between Beauford-avenue and Ward-street.

Tilleys-road, 2,650 feet between Heales-road and lot 19.

Frys-road, 2,357 feet between Tilleys-road and Bacchus Marsh-road.

Glengate-road, 452 feet west from Vines-road to lot 144.

Thornburn-street, 93 feet east from Kaunas-street to lot 1.

Forfar-road, 66 feet south from lot 162 to lot 163.

Fairy-street, 274 feet east from Rollins-road to lot 57.

Peacock-avenue, 468 feet north from Darebin-street to lot 92.

Hendy-street, 712 feet north from Plantation-road to lot 14.

Washington-street, 711 feet north from Plantation-road to lot 15.

Coolidge-street, 724 feet north from Plantation-road to lot 90.

Harding-street, 900 feet between Washington-street and Coolidge-street.

Wesley-court, 539 feet north from Harding-street.

Cliveland-court, 532 feet north from Harding-street.



The main pipe in the said streets being laid down the owners of all tenements situated as above are hereby required on or before the 15th day of August, 1965, to cause a proper pipe and stop cocks to be laid so as to supply water within such tenements from the main pipe.

B. C. HENSHAW, Secretary,  
6939 Geelong Waterworks and Sewerage Trust.

#### Water Act.

#### PROPOSED SALE CITY WATER AUTHORITY.

NOTICE is hereby given that the Sale City Council has made application to the Honourable the Minister of Water Supply for the constitution of a Local Governing Body, and for the Proclamation of a Water Supply District at Sale for the purpose of taking over the municipality's waterworks supplying water to the City of Sale, for the construction of new works to augment supplies to the said City, and for the maintenance and continuance of water supply works within the said district under the provisions of the Water Acts.

A general plan and description of the proposal has been submitted with the application, and copies of same may be seen at the Council Chambers, Sale.

Dated at Sale, the 23rd day of June, 1965.

6692 J. R. RAY, Town Clerk.

LAND ACT 1958 (No. 6284, as amended by Act No. 7075).

#### WHEREAS:

- I. Application has been made, pursuant to sub-section (1) of section 22c of the Land Act 1958, by Thomas Peter George Johnson and Raymond Charles Hemphill, the trustees for the time being of Lancefield Mechanics Institute and Free Library site, being the land described in the Schedule hereto, for permission to surrender the said land to Her Majesty Queen Elizabeth the Second.
- II. By the said sub-section (1) it is provided that the Attorney-General may by notice published in the Government Gazette grant permission to the trustees to surrender the land to Her Majesty, pursuant to the said section 22c, and by sub-section (4) of the said section 22c it is further provided that the Attorney-General shall specify the purpose mentioned in section 14 of the Land Act 1958 for which the land was vested in the trustees or was used or to which the purpose for which it was vested in the trustees or was used is in his opinion substantially similar.

Now I, Vernon Francis Wilcox, as the Minister for the time being acting for or on the behalf of Her Majesty's Attorney-General for the State of Victoria—

- (a) grant permission to the said trustees to surrender the said land to Her Majesty pursuant to section 22c of the Land Act 1958; and
- (b) specify pursuant to sub-section (4) of section 22c aforesaid the following purpose mentioned in section 14 of the Land Act aforesaid, namely—  
"A Mechanics Institute and Library".

#### SCHEDULE.

All that piece of land being part of Crown allotment 1, section 63, Township and Parish of Lancefield, and being the whole of the land described in certificate of title, volume 5947, folium 266.

Given under my Hand, this 25th day of June, One thousand nine hundred and sixty-five—

V. F. WILCOX.

Maddock, Lonie and Chisholm, 339 Collins-street, Melbourne. 7024

NOTICE is hereby given that we, Leslie James Cordner, George-street, Dimboola, Laurie Matthew Shippides, High-street, Dimboola, and Clifford Norman Sallmann, Lloyd-street, Dimboola, trustees of the Dimboola Golf Club, have applied for a lease under section 134 of the Land Act 1958 for a term of twenty-one (21) years of an area of Crown land in the Parish of Dimboola, containing 136 acres more or less, for recreation purposes.

L. M. SHIPSIDES.  
L. J. CORDNER.  
C. N. SALLMANN.

6960

NOTICE is hereby given that the North-Western Trotting Club has applied for a lease for a term of 21 years under section 134 of the Land Act 1958, in respect of an area of Crown lands containing 20 acres 2 roods 23 perches, and being allotment 14, section 59A, Parish of Stawell, as a site for amusement and recreation (Trotting Track and Drive-in Theatre).

J. J. JONES, Secretary, North-Western Trotting Club.  
6961

NOTICE is hereby given that the Glenelg District Ambulance Service, of Hamilton, has applied for a lease under section 134, Land Act 1958, for a term of 21 years over portion of the State School reserve in section 4, Township of Edenhope, with frontages of 159 links and 152 links respectively to Wallace and Elizabeth streets, as a site for an ambulance station.

6852 F. WORTH, Superintendent and Secretary.

NOTICE is hereby given that the Wimmera District Ambulance Service has applied for a lease for a term of 21 years, pursuant to section 134 of the Land Act 1958, in respect of an area of Crown lands containing 3 roods 1 perch, being allotment 9, section 19, Township of Warracknabeal, Parish of Werrigar, as a site for an ambulance station.

6853 G. H. BRANSGROVE, Superintendent/Secretary.

NOTICE OF INTENTION TO APPLY FOR A LICENCE TO DIVERT WATER AND CUT RACE FROM THE RIVER MURRAY, AT BOUNDARY POINT.

I HEREBY give notice that I intend to apply for a licence empowering me to divert water for a term of four years to the extent of 300 acre-feet per annum at a maximum rate of 10 acre-feet per day of 24 hours for the irrigation of 100 acres of pasture, being part of sections 2, 2b and 2a, Parish of Olney, and to occupy certain Crown lands for works of diversion, and to cut a race thereon.

Any objection to such application must be forwarded, in writing, to reach the State Rivers and Water Supply Commission, Melbourne, before 13th August, 1965, being 30 days from the first publication of this notice.

NORMAN EDWARD STOECKEL.

Boundary Point Stn., via Renmark. 6946

NOTICE OF INTENTION TO APPLY FOR A LICENCE TO DIVERT WATER AND CUT RACE (RE-ISSUE) FROM THE RIVER MURRAY, AT COBRAM.

I HEREBY give notice that I intend to apply for a licence empowering me to divert water for a term of five years to the extent of 402 acre-feet per annum at a maximum rate of 5 acre-feet per day of 24 hours for the irrigation of 201 acres of lucerne and pasture, being part of allotment 1, Parish of Boosey, and allotments 17 and 18, Parish of Cobram, and to occupy certain Crown lands for works of diversion, and to cut a race thereon.

Any objection to such application must be forwarded, in writing, to reach the State Rivers and Water Supply Commission, Melbourne, before 13th August, 1965, being 30 days from the first publication of this notice.

HUGH CRAIG DICK.

Box 62, Cobram. 6947

NOTICE OF INTENTION TO APPLY FOR A LICENCE TO DIVERT WATER AND CUT RACE (RE-ISSUE) FROM THE GOULBURN RIVER AT MANGALORE.

I HEREBY give notice that I intend to apply for a licence empowering me to divert water for a term of fifteen years to the extent of 200 acre-feet per annum at a maximum rate of 6 acre-feet per day of 24 hours for the irrigating of 100 acres of pastures, being part of allotment 2, Parish of Mangalore, and to occupy certain Crown lands for works of diversion, and to cut a race thereon.

Any objection to such application must be forwarded, in writing, to reach the State Rivers and Water Supply Commission, Melbourne, before 7th July, 1965, being 30 days from the first publication of this notice.

C. G. GRIFFITHS.

"Yamarla", Mangalore West. 6958

**NOTICE OF INTENTION TO APPLY FOR A LICENCE TO DIVERT WATER AND CUT RACE FROM THE KIEWA RIVER AT GUNDOWRING.**

I HEREBY give notice that I intend to apply for a licence empowering me to divert water for a term of fifteen years to the extent of 50 acre-feet per annum at a maximum rate of 2 acre-feet per day of 24 hours for the irrigation of 25 acres of pastures, being part of allotment 2, section 3A, Parish of Tangambalanga, and to occupy certain Crown lands for works of diversion, and to cut a race thereon.

Any objection to such application must be forwarded, in writing, to reach the State Rivers and Water Supply Commission, Melbourne, before 10th August, being 30 days from the first publication of this notice.

MAX REID.

Gundowring.

6959

**PARTNERSHIP ACT 1958.**

NOTICE is hereby given that the partnership heretofore subsisting between Ronald Boston Kitchener Mellier and Thelma May Mellier, at Mincha, under the firm name of "R. B. K. and T. M. Mellier" was dissolved by mutual consent on the 1st day of July, 1965. All debts due by and moneys due to the late firm will be paid or received by the said Ronald Boston Kitchener Mellier, at Mincha aforesaid.

SCHLEIGER & SMALLEY, solicitors, 290 Williamson-street, Bendigo. 7015

NOTICE is hereby given that the partnership heretofore subsisting between Thomas Leslie Primmer, of 24 Brown-street, East Geelong, wrecker, and William Kenneth Wolfenden, of 16 Robertson-street, East Geelong, wrecker, carrying on business at the corner of Portarlington-road, and Sun-street, Moolap, under the style or firm of T. L. Primmer and W. K. Wolfenden, has been dissolved as from the 30th day of June, 1965.

Dated this 6th day of July, 1965.

W. K. WOLFENDEN.  
T. L. PRIMMER.

6949

NOTICE is hereby given that the partnership in the business of retail butchers heretofore carried on at Farnsworth-street, Castlemaine, by John Graham Langridge, of 53 Duke-street, Castlemaine, and Muarice Raymond Nicholls, of 77 Duke-street, Castlemaine, under the name or style of "J. G. Langridge and M. R. Nicholls", has been dissolved by mutual consent. The said Muarice Raymond Nicholls has retired from such business which will hereafter be carried on by the said John Graham Langridge as sole proprietor under the name of "J. G. Langridge".

All accounts owing to or by the said former partnership should be paid to or rendered to the said John Graham Langridge.

Dated the 30th day of June, 1965.

J. G. LANGRIDGE.  
M. R. NICHOLLS.

H. S. W. Lawson & Co., solicitors, Castlemaine. 6938

NOTICE is hereby given that the partnership heretofore subsisting between Ormond Andrews and Frederick Cleve Andrews carrying on business at Nicholson-street, Orbost, under the style or firm of Orme Andrews, has been dissolved as from the 30th day of June, 1965, so far as concerns the said Ormond Andrews who retires from the said firm.

Dated the 6th day of July, 1965.

F. C. ANDREWS.  
O. ANDREWS.

Mosley and Palmer, solicitors, Orbost. 6941

NOTICE is hereby given that the partnership heretofore subsisting between us, the undersigned, Raoul de Crepigny Tunbridge, Frank Russell Braithwaite, Alun Parker Jones, Joseph Leonard Galati and Robert Edward Clayton-Jones, as medical practitioners, at 28 Langhorne-street, Dandenong, and 80 Power-road, Doveton, has been dissolved as from the 6th day of April, 1965, so far as concerns the said Frank Russell Braithwaite, who retires from the said partnership.

Dated the 6th day of April, 1965.

R. DE C. TUNBRIDGE.  
ALUN P. JONES.  
J. GALATI.  
R. CLAYTON-JONES.  
F. R. BRAITHWAITE.

6990

NOTICE is hereby given that the partnership heretofore subsisting between Harold Haven Star, Yvonne Elvie Star and the said Harold Haven Star and Yvonne Elvie Star (as trustees for Terry James Star, Cheryl Anne Star, Malcolm Leigh Star and John Kingsley Star respectively), carrying on business as graziers at Cudgewa, under the style or firm name of H. H. Star and Co., has been dissolved as from the 30th day of June, 1965, so far as concerns the said Harold Haven Star and Yvonne Elvie Star (as trustees for the said Terry James Star, Cheryl Anne Star, Malcolm Leigh Star and John Kingsley Star respectively) who retire from the said firm.

All debts due to and owing by the said firm will be received and paid respectively by the said Harold Haven Star and Yvonne Elvie Star who will continue to carry on the said business in partnership under the style or firm name of H. H. Star and Co.

YVONNE E. STAR.  
H. H. STAR.

(Trustees for Terry James Star.)

YVONNE E. STAR.  
H. H. STAR.

(Trustees for Cheryl Anne Star.)

YVONNE E. STAR.  
H. H. STAR.

(Trustees for Malcolm Leigh Star.)

YVONNE E. STAR.  
H. H. STAR.

(Trustees for John Kingsley Star.)

Witness to all signatures—G. M. ANDERSON. 6942

NOTICE is hereby given that the partnership heretofore subsisting between Wallace Benjamin Elliott and the said Wallace Benjamin Elliott and Ella Mavis Elliott (as trustees for Robert McIntyre Elliott and John Keble Elliott respectively) carrying on business of graziers at Walwa, under the style or firm name of W. B. Elliott & Co. has been dissolved as from the 30th day of June, 1965.

The said Wallace Benjamin Elliott will continue the said business in his own name and will pay all the debts of the said partnership.

W. B. ELLIOTT.

Witness—J. WALTER.

W. B. ELLIOTT.  
E. M. ELLIOTT.

(Trustees for Robert McIntyre Elliott.)

Witness—J. WALTER.

W. B. ELLIOTT.  
E. M. ELLIOTT.

(Trustees for John Keble Elliott.)

Witness—J. WALTER. 6943

NOTICE is hereby given that the partnership heretofore subsisting between Warrick Charles Land, Maggie Land and the said Warrick Charles Land and Maggie Land (as trustees for Bruce Land) carrying on business as farmers, at Cudgewa, under the style or firm name of W. C. Land & Co., has been dissolved as from the 30th day of June, 1965, so far as concerns the said Warrick Charles Land and Maggie Land (as trustees for the said Bruce Land) who retires from the said firm.

All debts due to and owing by the said firm will be received and paid respectively by the said Warrick Charles Land and Maggie Land who will continue to carry on the said business in partnership under the style or firm name of W. C. Land & Co.

W. C. LAND.  
M. LAND.

(Trustees for Bruce Land.)

Witness to both signatures—OWEN D. JEPHCOTT. 6944

NOTICE is hereby given that the partnership heretofore subsisting between Cuyler John Lucas, of 20 Summerhill-road, Black Rock, and Peter Ng, of 157 Elgin-street, Carlton, carrying on business as from the 24th day of March, 1964, at 457 Balcombe-road, Beaumaris, under the name or style of the Chungking Restaurant, has been dissolved as from the 23rd day of December, 1964, and the said Chungking Restaurant, together with its liabilities and assets, has been taken over by the said Cuyler John Lucas as from that date.

CUYLER JOHN LUCAS.  
PETER NG.

Herbert Turner and Son, solicitors, 411 Collins-street, Melbourne. 6997

To whom it may concern, notice is hereby given that the partnership existing heretofore between Stephen Taylor, of Flat 3, 250 Dandenong-road, Windsor, and Leslie Adorjan, of 183 Highfield-road, Camberwell, is hereby dissolved by the retirement of Stephen Taylor from the partnership.

By the solicitor for Stephen Taylor, Julian J. Doyle,  
434A Toorak-road, Toorak. 7027

GOLDSTRAW INDUSTRIES PROPRIETARY LIMITED  
(IN LIQUIDATION).

NOTICE is hereby given that pursuant to section 284 (3) (b) of the Companies Act 1961 a meeting of the members of the above company will be held at 7th Floor, 161-173 Sturt-street, South Melbourne, at 10.45 a.m., on Friday, the 20th August, 1965, to determine the period after which the books and papers of the company and of the liquidator may be destroyed.

Dated the 6th day of July, 1965.

6927 R. W. FOTHERINGHAM, Liquidator.

GOLDSTRAW INDUSTRIES PROPRIETARY LIMITED  
(IN LIQUIDATION).

NOTICE is hereby given that pursuant to section 272 (2) of the Companies Act 1961 a Final Meeting of the members of the above company will be held at 7th Floor, 161-173 Sturt-street, South Melbourne, at 11 a.m., on Friday, the 20th August, 1965, to receive the accounts of the liquidator.

Dated this 6th day of July, 1965.

6928 R. W. FOTHERINGHAM, Liquidator.

DEMIR INVESTMENTS PTY. LIMITED (IN LIQUIDATION).

A GENERAL Meeting of the above company will be held on August 30th, 1965, at 8.30 p.m., at 21 Mitford-street, St. Kilda.

Object.—To lay before the meeting the final account of the liquidator pursuant to section 272 of the Companies Act 1961.

6950 E. SCHINDLER, Liquidator.

The Companies Act 1961.—In the matter of WARRANDYTE PAVING PTY. LTD., trading as SANTONE PAVING Co.—Notice Re Meeting of Creditors, Pursuant to Section 260.

NOTICE is hereby given that a Meeting of Creditors of the above company will be held at the office of M. V. Anderson & Co., 7th Floor, 277 William-street, Melbourne, on Monday, 26th July, 1965, at half-past Ten o'clock in the forenoon, the company having convened a meeting of its members for the same day for the purpose of considering a Resolution that the company be wound up voluntarily.

Dated this 9th day of July, 1965.

6986 A. VITA, Director.

The Companies Act 1961.—In the matter of ELECTRIX (WHOLESALE) PTY. LTD.

NOTICE is hereby given that at an Extraordinary General Meeting of the members of the above-named company held on the 18th day of June, 1965, it was resolved that the company be wound up voluntarily, and at a meeting of creditors held on the same day pursuant to section 260, it was resolved that for such purposes Alan Murray Horsburgh, of 296 Little Lonsdale-street, Melbourne, accountant, be appointed liquidator.

Notice is also given that after 21 days from this date I shall proceed to distribute the assets. All creditors having any claims against the above company should furnish particulars of same by that date, otherwise I shall proceed to distribute the assets, without regard to their claim.

Dated this 5th day of July, 1965.

A. M. HORSBURGH, Liquidator.  
Kennedy, Smail and Middlemiss, 296 Little Lonsdale-street, Melbourne. 6991

Companies Act 1961.

GREYHOUND PARK HOLDINGS PTY. LTD.  
(IN LIQUIDATION).

NOTICE is hereby given that a First and Final Dividend is to be declared to creditors in the above-named matter. Creditors who have not proved their debts by 30th July, 1965, will be excluded from the dividend.

Dated this 8th day of July, 1965.

R. C. D. WARNE-SMITH, Liquidator.  
A. L. Royce and Warne-Smith, 440 Collins-street, Melbourne. 6978

The Companies Act 1961.—In the matter of C. & S. PROPRIETARY LIMITED.

NOTICE is hereby given that at an Extraordinary General Meeting of the members of the above-named company held on the 18th day of June, 1965, it was resolved that the company be wound up voluntarily, and at a meeting of creditors held on the same day pursuant to section 260, it was resolved that for such purposes Alan Murray Horsburgh, of 296 Little Lonsdale-street, Melbourne, accountant, be appointed liquidator.

Notice is also given that after 21 days from this date I shall proceed to distribute the assets. All creditors having any claims against the above company should furnish particulars of same by that date, otherwise I shall proceed to distribute the assets, without regard to their claim.

Dated this 5th day of July, 1965.

A. M. HORSBURGH, Liquidator.  
Kennedy, Smail and Middlemiss, 296 Little Lonsdale-street, Melbourne. 6992

The Companies Act 1961.—In the matter of ELECTRIX (Vic.) PTY. LTD.

NOTICE is hereby given that at an Extraordinary General Meeting of the members of the above-named company held on the 17th day of June, 1965, it was resolved that the company be wound up voluntarily, and at a meeting of creditors held on the same day pursuant to section 260, it was resolved that for such purposes Edward Ronald Smail, of 296 Little Lonsdale-street, Melbourne, accountant, be appointed liquidator.

Notice is also given that after 21 days from this date I shall proceed to distribute the assets. All creditors having any claims against the company should furnish particulars of same by that date, otherwise I shall proceed to distribute the assets, without regard to their claim.

Dated this 5th day of July, 1965.

E. R. SMAIL, Liquidator.  
Kennedy, Smail and Middlemiss, 296 Little Lonsdale-street, Melbourne. 6993

The Companies Act 1961.—In the matter of THE PETER LALOR HOMEBUILDING CO-OPERATIVE SOCIETY LTD. (in Liquidation).

NOTICE is hereby given that a Second and Final Dividend is intended to be declared in this matter. Creditors who have not proved their debts by the 2nd day of August, 1965, will be excluded from the dividend.

Dated this 12th day of July, 1965.

K. D. COURTNEY, Liquidator.  
E. R. SMAIL, Liquidator.  
Kennedy, Smail and Middlemiss, 296 Little Lonsdale-street, Melbourne. 6982

In the matter of the Companies Act 1961; and in the matter of EASYWEAR HOLDINGS PROPRIETARY LIMITED.

NOTICE is hereby given that on the 30th day of June, 1965, an Extraordinary General Meeting of Easywear Holdings Proprietary Limited was duly convened and held at 300 Nicholson-street, Fitzroy, and the following Resolution was duly passed as a Special Resolution:—

“That the company be wound up voluntarily and that Clyde Thomas Young be hereby appointed liquidator for the purposes of such winding up.”

Dated this 2nd day of July, 1965.

K. A. NICHOLLS,  
Secretary of Easywear Holdings Proprietary Limited.  
Herbert Turner & Son, solicitors, 411 Collins-street, Melbourne. 6996

The Companies Act 1961.—In the matter of ANSETT TRAVEL SERVICE PTY. LTD. (in Voluntary Liquidation).—Members winding up.

NOTICE is hereby given that at an Extraordinary General Meeting of the above-named company, duly convened and held at 489 Swanston-street, Melbourne, Victoria, on the 5th day of July, 1965, the following Resolution was proposed and passed as a Special Resolution:—

“That the company be wound up voluntarily.”

Dated this 5th day of July, 1965.

A. FLANDERS, Secretary.  
Alexr. Grant, Dickson & King, solicitors, 119 William-street, Melbourne. 62 2358. 7011

In the Supreme Court of Victoria.—1965 Co. No. 7046.—  
In the matter of the *Companies Act 1961*; and in the matter of TAYGAN PROPRIETARY LIMITED; and in the matter of a petition pursuant to Section 186 of the said Act by Leo Ganas.

NOTICE is hereby given that a petition for the winding up of the above-named company by the Supreme Court was, on the 23rd day of June, 1965, presented by Leo Ganas. And that the said petition is directed to be heard before the Court sitting at Melbourne at the hour of 10.30 a.m., on the 6th day of August, 1965; and any creditor or contributory of the said company desiring to support or oppose the making of an order on the said petition may appear at the time of hearing by himself or his counsel for that purpose, and a copy of the petition will be furnished to any creditor or contributory of the said company requiring the same by the undersigned on payment of the regulated charge for the same.

The petitioner's address is 52 Mooltan-street, Flemington, in the State of Victoria.

The petitioner's solicitors are O'Phelan & Company, of 486 Bourke-street, Melbourne.

O'PHELAN & COMPANY, solicitors for the petitioner.

NOTE.—Any person who intends to appear on the hearing of the said petition must serve on or send by post to the above-named solicitors, notice in writing of his intention so to do. The notice must state the name and address of the person, or, if a firm, the name and address of the firm, and must be signed by the person or firm, or his or their solicitor (if any) and must be served, or, if posted, must be sent by post in sufficient time to reach the above-named not later than four o'clock in the afternoon of the 5th of August, 1965, (the day before the day appointed for the hearing of the petition). 7000

The *Companies Act 1961*.—In the matter of ELECTRIX HOLDINGS PTY. LTD.

NOTICE is hereby given that at an Extraordinary General Meeting of the members of the above-named company, held on the 17th day of June, 1965, it was resolved that the company be wound up voluntarily, and at a meeting of creditors held on the same day, pursuant to section 260, it was resolved that for such purpose Norman Eric Stretton, of 296 Little Lonsdale-street, Melbourne, be appointed liquidator.

Notice is also given that after 21 days from this date I shall proceed to distribute the assets. All creditors having any claims against the company should furnish particulars of same by that date, otherwise I shall proceed to distribute the assets without regard to their claim.

Dated this 5th day of July, 1965.

N. E. STRETTON, Liquidator.

Kennedy, Smail & Middlemiss, 296 Little Lonsdale-street, Melbourne. 6994

In the matter of the *Companies Act 1961*; and in the matter of MORISONS PROPRIETARY LIMITED (in Liquidation).

NOTICE is hereby given that at an Extraordinary General Meeting of members of the above-named company held on Thursday, the 8th day of July, 1965, the following Resolution was passed as a Special Resolution:—

"That it has been proved to the satisfaction of this meeting that the company cannot, by reason of its liabilities, continue its business and that it is therefore advisable to wind up the company forthwith and accordingly the company be wound up as a creditors' voluntary winding up."

Dated this 9th day of July, 1965.

R. T. DICKSON, Secretary.

Weigall & Crowther, solicitors, 83 William-street, Melbourne. 7008

The *Companies Act 1961*.—In the matter of ANSETT ROADLINES OF AUSTRALIA PTY. LTD. (in Voluntary Liquidation).—Members winding up.

NOTICE is hereby given that at an Extraordinary General Meeting of the above-named company, duly convened and held at 489 Swanston-street, Melbourne, Victoria, on the 5th day of July, 1965, the following Resolution was proposed and passed as a Special Resolution:—

"That the company be wound up voluntarily."

Dated this 5th day of July, 1965.

J. W. MURTAGH, Secretary.

Alexr. Grant, Dickson & King, solicitors, 119 William-street, Melbourne. 62 2358. 7010

In the Supreme Court of Victoria.—1965 No. Coy. 7040.—  
In the matter of the *Companies Act 1961*; and in the matter of MORENCO CORPORATION PROPRIETARY LIMITED.

NOTICE is hereby given that a petition for the winding up of the above-named company by the Supreme Court was, on the 9th day of June, 1965, presented by the said company Cine Service Proprietary Limited, and that the said petition is directed to be heard before the court sitting at Melbourne at the hour of 10.30 o'clock in the forenoon on the 30th day of July, 1965; and any creditor or contributory of the said company desiring to support or oppose the making of an order on the said petition may appear at the time of hearing by himself or his counsel for that purpose, and a copy of the petition will be furnished to any creditor or contributory of the said company requiring the same by the undersigned on payment of the regulated charge for the same.

The petitioner's address is 235 Moray-street, South Melbourne.

The petitioner's solicitor is W. M. Bourke, of 191 Greville-street, Prahran.

W. M. BOURKE.

Any person who intends to appear on the hearing of the said petition must serve on or send by post to the above-named solicitor, notice in writing of his intention so to do. The notice must state the name and address of the person, or, if a firm, the name and address of the firm, and must be signed by the person or firm, or his or their solicitor, and must be served, or, if posted, must be sent by post in sufficient time to reach the above named not later than four o'clock in the afternoon of the 29th day of July, 1965. 7026

The *Companies Act 1961*.—In the matter of LYNDBURST POST OFFICE STORE PTY. LTD. (in Voluntary Liquidation).

NOTICE is hereby given that, pursuant to section 272 of the *Companies Act*, a Final Meeting of creditors of the above company will be held at the office of Bruce Fordham, chartered accountant, 50 Toorak-road, South Yarra, on the 16th day of August, 1965, at 10 o'clock in the forenoon.

Business—To receive the liquidator's accounts.

Dated this 9th day of July, 1965.

BRUCE FORDHAM, Liquidator.

50 Toorak-road, South Yarra. 6999

In the matter of the *Companies Act 1961*; and in the matter of PRINCETON HOMES PTY. LTD.

NOTICE is hereby given that at an Extraordinary General Meeting of the above-named company, duly convened and held at the office of Bruce Fordham, 50 Toorak-road, South Yarra, at 11 o'clock in the forenoon, on the 9th day of July, 1965, the following Special Resolution was passed:—

"That the company be wound up voluntarily and that Bruce Edward Fordham, chartered accountant, of 50 Toorak-road, South Yarra, be hereby appointed liquidator for the purposes of such winding up and that pursuant to section 269 of the *Companies Act 1961*, the liquidator be and is hereby authorized to exercise any of the powers given by sub-section (1) of section 236 to a liquidator in a winding up by the court."

Dated this 9th day of July, 1965.

7032

R. J. HARRIS, Chairman.

The *Companies Act 1961*.—Section 272 (1).

THE BEACONSFIELD APARTMENTS PTY. LIMITED (IN LIQUIDATION).

NOTICE is hereby given that a Final Meeting of members of The Beaconsfield Apartments Pty. Limited (in liquidation) will be held at the registered office of the company, 4th Floor, 403 Bourke-street, Melbourne, on Tuesday, the 17th day of August, 1965, at 11 a.m., for the purpose of receiving an account showing how the winding up has been conducted and the property of the company disposed of.

And notice is further hereby given that a Final Meeting of creditors of The Beaconsfield Apartments Pty. Limited (in liquidation) will be held at the registered office of the company, 4th Floor, 403 Bourke-street, Melbourne, on Tuesday, the 17th day of August, 1965, at 11.15 a.m. for the purpose of receiving an account showing how the winding up has been conducted and the property of the company disposed of.

Dated this 8th day of July, 1965.

E. H. NIEMANN, Liquidator.

Hungerford, Spooner and Kirkhope, 44 Queen-street, Melbourne. 6977

Notice of Winding-up Order.—In the matter of ALAN L. JOHNSON PROPRIETARY LIMITED.

**WINDING-UP** Order made on the 9th day of July, 1965.

Name and address of official liquidator: Robert Foster Hughes, 360 Collins-street, Melbourne.

JAMES CANNY, Deputy Commissioner of Taxation of the Commonwealth of Australia, Petitioner. 7031

**NOTICE TO CLAIMANTS.**

**THE PERPETUAL EXECUTORS AND TRUSTEES ASSOCIATION OF AUSTRALIA LIMITED**, whose registered office is situate at Nos. 100-104 Queen-street, Melbourne, in the State of Victoria, Robert Alfred Edgar, of 2 Annetta-avenue, Ashburton South, in the said State, mechanical engineer, and William Stanley Edgar, of 7 Bowman-street, Mount Waverley, in the said State, transport driver, the executors of the will of Robert Halbert Edgar, late of 2 Annetta-avenue, Ashburton South, aforesaid gentleman, deceased (who died on the 12th day of December, 1964), require all creditors, next of kin and others having claims against the property or estate of the said deceased to send to the said executors, in the care of the said association, on or before the 13th day of September, 1965, particulars in writing of such claims, after which date the said executors intend to convey or distribute such property or estate to or among the persons entitled thereto, having regard only to the claims of which they shall have had notice.

Dated the 6th day of July, 1965.

RYLAH & RYLAH, solicitors, 349 Collins-street, Melbourne. 7028

**NOTICE TO CLAIMANTS.**

**THE PERPETUAL EXECUTORS AND TRUSTEES ASSOCIATION OF AUSTRALIA LIMITED**, whose registered office is situate at Nos. 100-104 Queen-street, Melbourne, and John Joseph Natrass, of 80 Balaclava-road, Caulfield, medical practitioner, the executors of the will of Annie Natrass, late of 80 Balaclava-road, Caulfield, widow, deceased (who died on the 7th day of March, 1965), require all creditors, next of kin and others having claims against the property or estate of the said deceased, to send to the said executors, in the care of the said association, on or before the 22nd day of September, 1965, particulars, in writing, of such claims, after which date the said executors intend to convey or distribute such property or estate to or among the persons entitled thereto, having regard only to the claims of which they shall have had notice. Dated the 12th July, 1965. 6979

**CREDITORS**, next of kin and others having claims in respect of the estate of William Ralph Powys Surrey, late of 76 High-street, Hastings, retired wharf labourer, deceased, intestate (who died on the 12th day of November, 1963), are required to send particulars of their claims to William Ralph Powys Rodney Surrey, the administrator of the said estate, care of Lawrence Rostron and Son, 118 Queen-street, Melbourne, solicitors, by the 13th day of September, 1965, after which date the said administrator will distribute the assets, having regard only to the claims of which he then shall have had notice.

**NOTE**.—The said deceased was also known as "William Watson" and "William Smith", and resided at No. 121 Moray-street, South Melbourne, and 48 Emma-street, Carrum, respectively.

LAWRENCE ROSTRON & SON, solicitors, 118 Queen-street, Melbourne. 7004

**CREDITORS**, next of kin and others having claims in respect of the estate of Alfred Andrew Parlett, late of 116 Princes Highway, Dandenong, in the State of Victoria, retired, deceased, intestate (who died on the 28th day of November, 1964), are to send particulars of their claims to the administrator, Norman Christopher Parlett, of Lang Lang, in the said State, baker, by the 18th day of September, 1965, after which date he will distribute the assets, having regard only to the claims of which he then has notice.

S. W. MISSON and BARTLEY, solicitors, 59 Waverley-road, East Malvern. 6951

**CREDITORS**, next of kin and others having claims in respect of the estate of Thomas Edward Sherriff, late of "Sunburst," Old Narre Warren-road, Emerald, in the State of Victoria, retired farmer, deceased (who died on the 8th April, 1965), are required to send particulars of their claims to the executor, The Equity Trustees, Executors and Agency Company Limited, at its registered office, 472 Bourke-street, Melbourne, by the 1st October, 1965, after which date it will distribute the assets, having regard only to the claims of which it then has notice.

J. ERSKINE, solicitor, Belgrave. 7020

**CREDITORS**, next of kin and others having claims in respect of the estate of Elsie Alice Greer, late of 45 Woolton-avenue, Thornbury, widow, deceased (who died on the 4th November, 1964), are to send particulars of their claims to The Equity Trustees, Executors and Agency Company Limited, at its registered office, situate at 472 Bourke-street, Melbourne, by the 30th day of September, 1965, after which date the said company will distribute the estate, having regard only to the claims of which it then has notice.

NORMAN C. PHILLIPS & O'CONNOR, solicitors, 732 High-street, Thornbury. 6945

**CREDITORS**, next of kin and others having claims in respect of the estate of Ethel Walker, late of Flat 19, Manor Court, 146 Power-street, Hawthorn, widow, deceased (who died on the 13th January, 1965), are to send particulars of their claims to National Trustees, Executors and Agency Company of Australasia Limited, at 95 Queen-street, Melbourne, by the 16th day of September, 1965, after which date it will distribute the assets, having regard only to the claims of which it then has notice.

LEACH & THOMSON, solicitors, 472 Bourke-street, Melbourne. 7019

**CREDITORS** and next of kin and others having claims in respect of the estate of Leslie Frank Tout Clarke, late of 6 Koetong-parade, Mt. Eliza, cartage contractor, deceased (who died on the 13th January, 1965), are to send particulars of their claims to The Union-Fidelity Trustee Company of Australia Limited, of 100 Exhibition-street, Melbourne, by the 16th September, 1965, after which date the said company will distribute the assets, having regard only to the claims of which it then has notice.

R. WADHAM & DOIG, solicitors, of 383 Flinders-lane, Melbourne. 6983

**CREDITORS**, next of kin and others having claims in respect of the estate of Kate Mitchell, late of 139 Atherton-road, Oakleigh, spinster (who died on the 9th day of May, 1965), are requested to send particulars of their claims to the executor, Arthur Leslie Park, care of the under-mentioned solicitors, on or before the 17th day of September, 1965, after which date he will distribute the assets, having regard only to the claims of which he then has notice.

McKEAN, PARK & COOPER, solicitors, 84 William-street, Melbourne. 7022

**CREDITORS**, next of kin and others having claims in respect of the estate of Arthur Osborne, late of 21 Lerderberg-street, Bacchus Marsh, retired farmer, deceased (who died on the 28th day of April, 1965, and probate of whose will has been granted to Lillian Osborne, of 21 Lerderberg-street, Bacchus Marsh, teacher, and Arthur Dean Pearce, of 430 Little Collins-street, Melbourne, solicitor), are required to send particulars of their claims to the said executors, care of the under-mentioned solicitors, by the 13th day of October, 1965, after which date they will distribute the assets, having regard only to the claims of which they then have notice.

PEARCE & WEBSTER, solicitors, 430 Little Collins-street, Melbourne. 7002

**CREDITORS**, next of kin and others having claims on or against the estate of Louis Stephen Dubois, late of 155 Power-avenue, Chadstone, in Victoria, leading hand, deceased, intestate, are required to send particulars, in writing, of their claims to the administrator, Eileen Dawn Dubois, of 155 Power-avenue, Chadstone, widow, on or before the 21st October, 1965, after which date the administrator will proceed to distribute the estate, having regard only to such claims as have before then come to her notice.

NORVAL H. DOOLEY & SON, solicitors, 31 Queen-street, Melbourne, C.I. 7025

**CREDITORS**, next of kin and others having claims in respect of the estate of John Andrew Feely, late of 26 Miller-grove, Kew, public servant, deceased (who died on the 5th day of June, 1965), are required to send particulars of their claims to John Adrian Redmond, of 358 Collins-street, Melbourne, solicitor, the executor of the will of the said deceased, care of the under-mentioned solicitors, by the 24th day of September, 1965, after which date he will distribute the assets, having regard only to the claims of which he then has notice.

J. A. REDMOND & CO., solicitors, 358 Collins-street, Melbourne. 7029

MARY MARIA WENDEL, late of 36 High-street, Swan Hill, in the State of Victoria, widow, DECEASED (who died on 16th June, 1964).

CREDITORS, next of kin and all other persons having claims against the estate of the deceased are required by the executors of the will, Edward Wendel and Thomas Bridson Green, to send particulars to them, care of the undersigned, on or before, the 12th day of October, 1965, after which date they will distribute the assets, having regard only to the claims of which they then have notice.

GARDEN & GREEN, solicitors, 4 McCallum-street, Swan Hill. 7014

CREDITORS, next of kin and others having claims against the estate of Sybil Eliza Newell, late of 33 Wheatland-road, Malvern, in the State of Victoria, widow, deceased (who died on 6th April, 1965), are required by the executor, The Equity Trustees, Executors and Agency Company Limited, of 472 Bourke-street, Melbourne, to send to it particulars of their claims by the 22nd day of September, 1965, after which date the said company will distribute the assets, having regard only to claims of which it then has notice.

A. G. ALLAWAY, solicitor, 386 Flinders-lane, Melbourne. 6985

CREDITORS, next of kin and others having claims in respect of the estate of Catharina Blackney, formerly of 17 Steedman-street, Mordialloc, married woman, but late of Melbourne Home and Hospital for the Aged, Cheltenham, widow, deceased (who died on the 7th day of April, 1965), are to send particulars of their claims to the executors, James Huntly Frederick and Bernard Derek Skidmore Batten, care of the under-mentioned solicitors, by the 30th day of September, 1965, after which date the said executors will distribute the assets, having regard only to the claims of which they then have notice.

RODDA, BALLARD & VROLAND, solicitors, 430 Little Collins-street, Melbourne. 6995

CREDITORS, next of kin and others having claims in respect of the estate of Edwin George Rogers, formerly of "Hillcrest," corner Hawthorn and Dandenong roads, Caulfield, but late of 164 Murrumbeena-road, Murrumbeena, retired indentor, deceased (who died on the 12th day of March, 1965), are to send particulars of their claims to The Trustees, Executors and Agency Company Limited, of 401 Collins-street, Melbourne, by the 10th day of September, 1965, after which date it will distribute the assets, having regard only to the claims of which it then has notice.

MOULE, HAMILTON & DERHAM, solicitors, 224 Queen-street, Melbourne. 6998

CREDITORS, next of kin and others having claims in respect of the estate of Henry Deal Howells, late of 26 Sycamore-street, Chadstone, gentleman (who died on the 18th May, 1965), are to send particulars of such claims to National Trustees, Executors and Agency Company of Australasia Limited, at its registered office at 95 Queen-street, Melbourne, by the 29th September, 1965, after which date the assets will be distributed, having regard only to the claims of which it then has notice.

LESTER, PEARN & FIELDEN, solicitors, 14 Haughton-road, Oakleigh. 6940

CREDITORS, next of kin and all other persons having claims against the estate of Michael Griffin, late of 7 St. Georges-road, Elsternwick, gentleman (who died on the 31st day of January, 1965), are to send particulars of such claims to National Trustees, Executors and Agency Co. of Australasia Limited, of 95 Queen-street, Melbourne, by the 22nd day of September, 1965, after which date the company will distribute the assets, having regard only to the claims of which it shall then have notice.

COOKE & CUSSEN, 472 Bourke-street Melbourne, solicitors. 7030

CREDITORS, next of kin and others having claims in respect of the estate of John Peter Leopold McDonald, late of 8 Northcote-road, Armadale, in the State of Victoria, gentleman, deceased (who died on the 23rd day of February, 1965), are to send particulars of their claims to National Trustees, Executors and Agency Company of Australasia Ltd., of 95 Queen-street, Melbourne, by the 15th day of September, 1965, after which date it will distribute the assets, having regard only to the claims of which it then has notice.

GODFREY STEWART & CO., solicitors, 37 Queen-street, Melbourne. 7023

ANNIE SCOTT, late of 4 Ashe-grove, Toorak, in the State of Victoria, spinster, DECEASED.

CREDITORS, next of kin and others having claims in respect of the estate of the deceased (who died on the 3rd day of March, 1965), are required by her personal representative, John Norman Robertson, of 24 Yuille-street, Brighton, in the said State, sharebroker, to send particulars to him, care of the under-mentioned solicitors, by the 17th day of September, 1965, after which date he will distribute the assets, having regard only to the claims of which he then has notice.

Dated the 9th day of July, 1965.

E. P. JOHNSON & DAVIES, solicitors, 339 Collins-street, Melbourne. 6988

ALEXANDER THOMSON, late of Lincoln-road, Croydon, in the State of Victoria, gentleman, DECEASED.

CREDITORS, next of kin and others having claims in respect of the estate of the deceased (who died on the 24th day of January, 1965), are required by the executor, Dudley Alexander Thomson, of 97 Croydon-road, Croydon, in the said State, formerly contractor but now timber worker, to send particulars to him, care of Williams and Matthews, solicitors, 6 McKillop-street, Melbourne, on or before the 20th day of September, 1965, after which date the said executor may convey or distribute the assets, having regard only to the claims of which he shall then have had notice.

WILLIAMS & MATTHEWS, solicitors, 6 McKillop-street, Melbourne. 6981

CREDITORS, next of kin and all others having claims against the estate of James Royce Agnew, late of 58 Shepherd-street, Surrey Hills, in the State of Victoria, electrical engineer, deceased (who died on the 13th December, 1964), are requested to send particulars of such claims to Craig Winnan Agnew, of 8 Bentley-street, Surrey Hills, the executor of the above estate, at his address on or before the expiration of two months from the date of publication hereof, after which date the said executor will distribute the assets, having regard only to the claims of which he shall then have had notice.

LLOYD P. GOODE & CO., solicitors, 388 Bourke-street, Melbourne. 6980

VALERIE FEODORE SMITH, late of 22 Beaconsfield-road, Hawthorn, in the State of Victoria, widow, DECEASED.

CREDITORS, next of kin and others having claims in respect to the estate of the above-named deceased (who died on the 9th day of December, 1964), are required by the executors, Francis Henry Smith and Neville Bruce Smith, to send particulars of their claims to them, care of the under-mentioned solicitors by the 18th day of September, 1965, after which date they will distribute the assets, having regard only to the claims of which they then have notice.

UPTON & ETELSON, solicitors, 100 Queen-street, Melbourne. 6989

ERNEST CARL MUELLER, late of Mollison-street, Bendigo, merchant, DECEASED.

CREDITORS, next of kin and all other persons having claims against the above-mentioned deceased, are required by the executrix, Margaret Ruth Mueller, of 67 Mundy-street, Bendigo, widow, to send particulars thereof to her care of the under-mentioned solicitors on or before the 24th day of September, 1965, after which date she will distribute the assets of the estate, having regard only to the claims for which she then has notice.

Dated the 8th day of July, 1965.

HYETT & HYETT, solicitors, Bendigo. 6964

CREDITORS, next of kin and others having claims in respect of the estate of Victoria Ellen Pynor, late of 38 Marine-parade, St. Kilda, widow (who died on the 17th day of January, 1965, at Melbourne), are to send the particulars of their claims to Marjorie Clare Glover, of 38 Marine-parade, St. Kilda, married woman, Dorothy Beatrice Stahel, of 198 Balcombe-road, Mentone, married woman, and Nancy Vere Field, of 60 Lindens-way, Castle-crag, Sydney, by the 24th day of September, 1965, care of their solicitors, Cole & O'Heare, 465 Collins-street, Melbourne, after which date the said Marjorie Clare Glover, Dorothy Beatrice Stahel and Nancy Vere Field will distribute the assets, having regard only to the claims of which they then have notice.

COLE & O'HEARE, solicitors, 465 Collins-street, Melbourne. 7001

**CREDITORS**, next of kin and all others having claims against the estate of Louisa Maude Chamberlain, late of 524 Lydiard-street north, Ballarat, in the State of Victoria, spinster, deceased (who died on the 12th day of April, 1965), are requested by the executor of the will of the said deceased, The Union-Fidelity Trustee Company of Australia Limited, of 333 Collins-street, Melbourne, in the said State, to send particulars of their claims to the said company, on or before the 30th day of September, 1965, after which date the executor will distribute the assets, having regard only to the claims of which they shall then have had notice.

CUTHBERT, MORROW, MUST & SHAW, solicitors,  
Ballarat. 6968

**CREDITORS**, next of kin and all others having claims against the estate of Lilian Crawford, formerly of 1527 Sturt-street, Ballarat, in the State of Victoria, but late of 3 Russell-street, Ballarat, aforesaid, widow, deceased (who died on the 12th day of April, 1965), are requested by the executor of the will of the said deceased, The Union-Fidelity Trustee Company of Australia Limited, of 100 Exhibition-street, Melbourne, in the said State, to send particulars of their claims to the said company on or before the 30th day of September, 1965, after which date the executor will distribute the assets, having regard only to the claims of which it shall then have had notice.

CUTHBERT, MORROW, MUST & SHAW, solicitors,  
Ballarat. 6966

ANNIE MARY BENNETT, late of 72 Albert-street, Sebastopol, widow, DECEASED (who died on the 31st May, 1965).

**CREDITORS**, next of kin and all persons having claims against the estate of the deceased are required to send particulars to the executors, The Union-Fidelity Trustee Company of Australia Limited, of 101 Lydiard-street north, Ballarat, on or before the 15th September, 1965, after which date it will distribute the assets, having regard only to the claims of which it shall then have notice.

HEINZ & GORDON, solicitors, 209 Dana-street, Ballarat.  
6967

**CREDITORS**, next of kin and others having claims against the estate of Angus Donald Alexander Nimmo, formerly of 37 Anderson-street, Yarraville, but late of Broadway, West Rosebud, retired boot retailer, deceased (who died on the 15th day of December, 1964), are required by the trustee, Vera Hazel Nimmo, of Broadway, West Rosebud, to send particulars of their claims to her, care of the undersigned, by the 22nd day of September, 1965, after which date the trustee may convey or distribute the assets, having regard only to the claims of which she then has notice.

R. E. LEWIS, ORR & GIBSON, solicitors, 406 Lonsdale-street, Melbourne. 7007

**CREDITORS**, next of kin and others having claims against the estate of Winifred Johanna Richardson, formerly of Brown-street, Boronia, but late of 12 Foster-street, Warrnambool, widow, deceased (who died on the 20th day of September, 1964), are required by the trustee, Daniel Thomas Russell, of 6 Jupiter-street, Caulfield, to send particulars of their claims to him care of the undersigned by the 22nd day of September, 1965, after which date the trustee may convey or distribute the assets, having regard only to the claims of which he then has notice.

R. E. LEWIS, ORR & GIBSON, solicitors, 406 Lonsdale-street, Melbourne. 7006

MARGARET ANN TOSHACK HAY, late of 400 Waverley-road, East Malvern, in the State of Victoria, spinster, DECEASED.

**CREDITORS**, next of kin and others having claims in respect of the estate of the deceased (who died on the 15th day of February, 1965), are required by her personal representative, Maurice Howell Davies, of 339 Collins-street, Melbourne, in the said State, solicitor, to send particulars to him by the 17th day of September, 1965, after which date he will distribute the assets, having regard only to the claims of which he then has notice.

Dated the 9th day of July, 1965.

E. P. JOHNSON & DAVIES, solicitors, 339 Collins-street, Melbourne. 6987

**CREDITORS** and next of kin and others having claims in respect of the estate of Edward Stanley Ives, deceased, late of Yarrowonga, in the State of Victoria, shoe repairer (who died on the 16th day of December, 1964), are to send particulars of their claims to the executors of the estate of Edward Stanley Ives, care of G. M. Castles and Middleton, solicitors, of 38 Belmore-street, Yarrowonga, by the 8th day of October, 1965, after which date the said executors will distribute the estate of the said deceased, having regard only to the claims of which they then have notice.

G. M. CASTLES & MIDDLETON, solicitors, 38 Belmore-street, Yarrowonga. 6954

**CREDITORS**, next of kin and others having claims in respect of the estate of Deborah Ann Humphries, late of Plenty Mental Hospital, Mont Park, spinster, deceased, intestate (who died on the 10th day of December, 1964, and letters of administration having been granted to Sarah Portingale, of 203 Nepean Highway, Ascendale, widow), are required to send particulars of their claims to the said administratrix, care of the under-mentioned solicitors, by the 13th day of October, 1965, after which date she will distribute the assets, having regard only to the claims of which she then has notice.

PEARCE & WEBSTER, solicitors, 430 Little Collins-street, Melbourne. 7003

GAVIN JOHN BROWN, formerly of 104 Riversdale-road, Camberwell, late of 21 Sandham-street, Elsternwick, retired clerk, DECEASED (who died on 9th February, 1965).

**CREDITORS**, next of kin and all others having claims in respect of the estate of the said deceased, are requested by the executor, The Trustees, Executors and Agency Company Limited, of 401 Collins-street, Melbourne, to send particulars of such claims to the said company by the 18th September, 1965, after which date it will distribute the assets, having regard only to the claims of which it then has notice.

DAVIES, CAMPBELL & PIESSE, solicitors, 401 Collins-street, Melbourne. 7005

ANNIE MARY WILLIAMS, late of 157 Nott-street, Port Melbourne, in the State of Victoria, married woman, DECEASED, testate.

**CREDITORS**, next of kin and others having claims in respect of the estate of the deceased (who died on the 12th day of March, 1965), are required by The Perpetual Executors and Trustees Association of Australia Limited, of 100-104 Queen-street, Melbourne, to send particulars to it by the 9th day of September, 1965, after which date it may convey or distribute the assets, having regard only to the claims of which it then has notice.

SEPTIMUS, JONES & LEE, solicitors, 327 Collins-street, Melbourne. 6984

RE ELSIE REFFEN MITCHELL, late of Pakington-street, Newtown, Geelong, widow, DECEASED.

**CREDITORS**, next of kin and all persons having claims against the estate of the above named are required by the executors of the will, Roy Davison Birdsey, of Ryrie-street, Geelong, solicitor, and Richard Mason Romney, of Grant-street, Newtown, Geelong, law clerk, to send particulars to them, care of the under-mentioned solicitors, on or before the 14th September, 1965, after which date they will distribute the assets, having regard only to the claims of which they then have notice.

BIRDSEY, DEDMAN & BARTLETT, solicitors, of 166A Ryrie-street, Geelong. 6948

FRANK SHERWOOD SELLAR (usually known as Frank Seller), late of 27 Darling-road, East Malvern, retired jeweller, DECEASED.

**CREDITORS**, next of kin and others having claims in respect of the estate of the deceased (who died on the 30th April, 1965), are required by the personal representative, Alfred Edward Seller, company director, to send particulars to him, at 53 St. George's-road, Toorak, by the 30th day of September, 1965, after which date the personal representative may convey or distribute the assets, having regard only to the claims of which he then has notice.

Dated 9th July, 1965.

LEACH & THOMSON, solicitors, 472 Bourke-street, Melbourne. 7018

In the Supreme Court of the State of Victoria.

SALE BY THE SHERIFF.

ON Friday, the 27th of August, 1965, at 10 a.m., at the Police Station, Croydon (unless process be stayed or satisfied):—

All the estate and interest (if any) of Desmond John Williams, of 15 Yarra-road, Croydon, bread carter, as proprietor of an estate in fee simple in the land described in certificate of title, volume 8288, folio 778, upon which is erected a brick veneer dwelling house, known as No. 15 Yarra-road, Croydon.

Registered mortgage No. B854907 affects the said estate and interest.

Terms: Cash only.

N. FROGLEY, Sheriff's Officer.

12th July, 1965.

7009

**IMPOUNDINGS**

**DONALD.**—Impounded in Donald Pound, from Avon Plains-road, 1½-2 miles from Donald, at 11 a.m., on 11th July, 1965.

2 Border Leicester rams, no visible brand  
2 Dorset Horn rams (dehorned), various ear marks, no visible brand

If not claimed and expenses paid, to be sold on 30th July, 1965.

W. A. CAMERON,

7034—20/

Poundkeeper.

**MORWELL.**—Impounded in Morwell Pound.

2 rams, long tailed, blue dot on shoulder.

If not claimed and expenses paid, to be sold on 3rd August, 1965.

S. HUGUENIN,

6962—12/

Poundkeeper.

**OXLEY.**—Impounded in Oxley Pound from Oxley Flats.

1 black polled cow, M under left ear, no visible brand.

If not claimed and expenses paid, to be sold on 22nd July, 1965.

M. PERKINS,

6969—12/

Poundkeeper.

**SHEPPARTON.**—Impounded in Shepparton Pound.

1 woolly lamb, long tail, no visible brand  
1 woolly two-tooth wether, no visible brand

If not claimed and expenses paid, to be sold on 29th July, 1965.

C. L. MANSELL,

7035—14/

Poundkeeper.

**WARRAGUL.**—Impounded in Warragul Pound, from South-road, Warragul, on 9th July, 1965.

1 Poly Jersey cow, marked and tag left ear, no visible brand

If not claimed and expenses paid, to be sold on 29th July, 1965.

E. McGRATH,

7012—16/

Poundkeeper.

*Subordinate Legislation Act 1962.*

**NOTICE OF MAKING OF STATUTORY RULES.**

IN pursuance of the provisions of the *Subordinate Legislation Act 1962* and the Regulations made thereunder, notice is given of the making of the following statutory rules:—

| No.                        | Sheep Owners Protection Act 1961.   | Price.<br>s. d. |
|----------------------------|---|-----------------|
| 107/1965.                  | Sheep Owners Protection (Sheep Carrier's Licence) Regulations 1965 .. .. .      | 0 9             |
| Local Government Act 1958. |   |                 |
| 108/1965.                  | Unenrolled Voters (Elections of Municipal Councillors) Regulations 1965 .. .. . | 1 0             |
| Road Traffic Act 1958.     |   |                 |
| 109/1965.                  | Road Traffic (Sale of Newspapers) Regulations 1965 .. .. .                      | 0 6             |

| No.  | Marketing of Primary Products Act 1958 (No. 6304)                                     | Price.<br>s. d. |
|--|---|-----------------|
| 110/1965.  | Marketing Boards (Mileage Allowance) Regulations 1965 .. .. .                         | 0 6             |
| Milk Pasteurization Act 1958 (No. 6319).             |   |                 |
| 111/1965.  | Milk Pasteurization Committee (Mileage Allowance) Regulations 1965 .. .. .            | 0 6             |
| Agricultural Colleges Act 1958 (No. 6194).           |   |                 |
| 112/1965.  | Agricultural Colleges Advisory Committee (Mileage Allowance) Regulations 1965 .. .. . | 0 6             |
| Milk and Dairy Supervision Act 1958 (No. 6317).      |   |                 |
| 113/1965.  | Dairy Produce Board (Mileage Allowance) Regulations 1965 .. .. .                      | 0 6             |
| Victorian Inland Meat Authority Act 1958 (No. 6411). |   |                 |
| 114/1965.  | Victorian Inland Meat Authority (Mileage Allowance) Regulations 1965 .. .. .          | 0 6             |
| Dried Fruits Act 1958 (No. 6239).                    |   |                 |
| 115/1965.  | Victorian Dried Fruits Board (Mileage Allowance) Regulations 1965 .. .. .             | 0 6             |
| Social Welfare Act 1960.                             |   |                 |
| 116/1965.  | Social Welfare (Trainees Rates) Regulations 1965 .. .. .                              | 0 6             |
| Road Traffic Act 1958.                               |   |                 |
| 117/1965.  | Road Traffic (Portable Lamps Amendment) Regulations 1965 .. .. .                      | 0 6             |

Copies of these statutory rules may be purchased at the Sale of Publications Section of the Government Printing Office, located at Macarthur-street, Melbourne, C.2. If ordered by mail, remittance should be addressed to "The Government Printer, Box 203, P.O., North Melbourne, N.1.", and should include 6d. extra for postage.

A. C. BROOKS,  
Government Printer.

**CONTENTS**

|  | PAGE           |
|--|----------------|
| Appointments .. .. .   | 2278           |
| Auction Sales Act .. .. .  | 2274           |
| Companies Act 1961—Notice .. .. .  | 2273, 2276     |
| Contracts .. .. .  | 2272           |
| Country Roads Board .. .. .  | 2276           |
| Estates of Deceased Persons .. .. .  | 2271           |
| Government Notices .. .. .   | 2266           |
| Impoundings .. .. .  | 2312           |
| Lands .. .. .  | 2286           |
| Melbourne and Metropolitan Board of Works—<br>Notice .. .. .   | 2270           |
| Mining .. .. .   | 2277           |
| Money Lenders Act 1958—Supplementary List .. .. .  | 2274           |
| Notice of Making of Statutory Rules .. .. .  | 2312           |
| Orders in Council—<br>Acts—Land; Cemeteries; Country Roads;<br>Stamps; Medical; Soil Conservation<br>and Land Utilization; Road Traffic. | 2279<br>et seq |
| Private Advertisements .. .. .   | 2300           |
| Proclamations .. .. .  | 2265           |
| Public Service Notices .. .. .   | 2295           |
| Regulations—<br>Acts—Melbourne Cricket Ground .. .. .  | 2266           |
| Resignation .. .. .  | 2279           |
| State Rivers and Water Supply Commission .. .. .   | 2266           |
| Tenders .. .. .  | 2293           |
| Transport Regulation Board—Public Hearings .. .. .   | 2267           |
| Waterworks Trusts .. .. .  | 2277           |