



VICTORIA
GOVERNMENT GAZETTE

Published by Authority

[Registered at the General Post Office, Melbourne, for transmission by post as a newspaper.]

No. 54]

WEDNESDAY, JULY 20

[1966

PROCLAMATIONS

PUBLIC HIGHWAY—CITY OF OAKLEIGH.

PROCLAMATION

By the Lieutenant-Governor as Deputy for His Excellency the Governor of the State of Victoria and its Dependencies in the Commonwealth of Australia, &c., &c., &c.

WHEREAS by the *Local Government Act 1958*, as amended, section 519, it is amongst other things enacted that it shall be lawful for the Governor in Council at any time and from time to time upon request of the Council of any municipality by notice in the *Government Gazette* to proclaim any land reserved used or by purchase or exchange acquired for a street road highway thoroughfare bridge square court alley or right-of-way or any street road lane or passage made or laid out or proposed to be made or laid out on land of which a plan of subdivision delineating that street road lane or passage has been sealed with the seal of the municipality under subdivision (3) of Division 9 of Part XIX. of the *Local Government Act 1958*, or a corresponding previous enactment to be a public highway and that such land shall thereupon and thenceforth from the date of such Proclamation become and be absolutely dedicated to the public as a public highway within the meaning of any law then or thereafter in force:

And whereas the Council of the City of Oakleigh has requested that the land hereinafter mentioned, being a street made or laid out or proposed to be made or laid out on land of which a plan of subdivision delineating that street has been sealed with the seal of the municipality under subdivision (3) of Division 9 of Part XIX. of the *Local Government Act 1958*, or a corresponding previous enactment, be so declared to be a public highway:

Now therefore I, the Lieutenant-Governor as Deputy for the Governor of the State of Victoria in the Commonwealth of Australia, by and with the advice of the Executive Council of the said State, do by this Proclamation declare that Clarendon Avenue, Oakleigh, shown by hachure on the attached plan shall be a public highway within the meaning of the said Act.

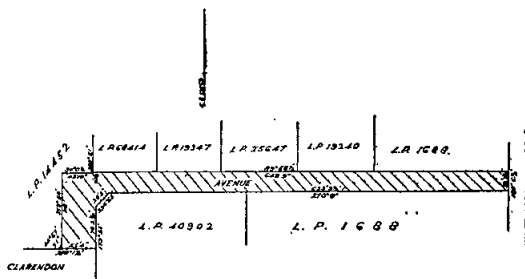

Given under my Hand and the Seal of the State of Victoria aforesaid, at Melbourne, this twelfth day of July, in the year of our Lord, One thousand nine hundred and sixty-six, and in the fifteenth year of the reign of Her Majesty Queen Elizabeth II.

(L.S.)

E. F. HERRING.

By His Excellency's Command,

R. J. HAMER,
Minister for Local Government.

GOD SAVE THE QUEEN!

PUBLIC HIGHWAYS—SHIRE OF DAYLESFORD AND GLENLYON.

PROCLAMATION

By the Lieutenant-Governor as Deputy for His Excellency the Governor of the State of Victoria and its Dependencies in the Commonwealth of Australia, &c., &c., &c.

WHEREAS by the *Local Government Act 1958*, as amended, section 519, it is amongst other things enacted that it shall be lawful for the Governor in Council at any time and from time to time upon request of the Council of any municipality by notice in the *Government Gazette* to proclaim any land reserved used or by purchase or exchange acquired for a street road highway thoroughfare bridge square court alley or right-of-way or any street road lane or passage made or laid out or proposed to be made or laid out on land of which a plan of subdivision delineating that street road lane or passage has been sealed with the seal of the municipality under subdivision (3) of Division 9 of Part XIX. of the *Local Government Act 1958*, or a corresponding previous enactment to be a public highway and that such land shall thereupon and thenceforth from the date of such Proclamation become and be absolutely dedicated to the public as a public highway within the meaning of any law then or thereafter in force:

And whereas the Council of the Shire of Daylesford and Glenlyon has requested that the lands hereinafter mentioned, used for streets, be so declared to be public highways:

Now therefore I, the Lieutenant-Governor as Deputy for the Governor of the State of Victoria in the Commonwealth of Australia, by and with the advice of the Executive Council of the said State, do by this Proclamation declare that Church Avenue, coloured brown on Plan of Subdivision No. 9514 lodged in the Office of Titles, and Radium Street, coloured brown on Plan of Subdivision No. 10220 lodged as aforesaid, shall be public highways within the meaning of the said Act.

Given under my Hand and the Seal of the State of Victoria aforesaid, at Melbourne, this twelfth day of July, in the year of our Lord, One thousand nine hundred and sixty-six, and in the fifteenth year of the reign of Her Majesty Queen Elizabeth II.

(L.S.) E. F. HERRING.

By His Excellency's Command,

R. J. HAMER,
Minister for Local Government.

GOD SAVE THE QUEEN!

PUBLIC HIGHWAY—SHIRE OF BRIGHT.

PROCLAMATION

By the Lieutenant-Governor as Deputy for His Excellency the Governor of the State of Victoria and its Dependencies in the Commonwealth of Australia, &c., &c., &c.

WHEREAS by the *Local Government Act 1958*, as amended, section 519, it is amongst other things enacted that it shall be lawful for the Governor in Council at any time and from time to time upon the request of the Council of any municipality by notice in the *Government Gazette* to proclaim any land reserved used or by purchase or exchange acquired for a street road highway thoroughfare bridge square court alley or right-of-way or any street road lane or passage made or laid out or proposed to be made or laid out on any land of which a plan of subdivision delineating that street road lane or passage has been sealed with the seal of the municipality under subdivision (3) of Division 9 of Part XIX. of the *Local Government Act 1958*, as amended, or a corresponding previous enactment to be a public highway and that such land shall thereupon and thenceforth from the date of such Proclamation become and be absolutely dedicated to the public as a public highway within the meaning of any law then or thereafter in force:

And whereas the Council of the Shire of Bright has requested that the land hereinafter mentioned, being a street road lane or passage made or laid out or proposed to be made or laid out on any land of which a plan of subdivision delineating that street road lane or passage has been sealed with the seal of the municipality under

subdivision (3) of Division 9 of Part XIX. of the *Local Government Act 1958*, as amended, or a corresponding previous enactment, be so declared to be a public highway:

Now therefore I, the Lieutenant-Governor as Deputy for the Governor of the State of Victoria in the Commonwealth of Australia, by and with the advice of the Executive Council of the said State, do by this Proclamation declare that Brooks Street, coloured brown on Plan of Subdivision No. 26884 lodged in the Office of Titles, shall be a public highway within the meaning of the said Act.

Given under my Hand and the Seal of the State of Victoria aforesaid, at Melbourne, this twelfth day of July, in the year of our Lord, One thousand nine hundred and sixty-six, and in the fifteenth year of the reign of Her Majesty Queen Elizabeth II.

(L.S.) E. F. HERRING.

By His Excellency's Command,

R. J. HAMER,
Minister for Local Government.

GOD SAVE THE QUEEN!

LOCAL GOVERNMENT DEPARTMENT.

PROCLAMATION EXTENDING THE OPERATION OF THE UNIFORM BUILDING REGULATIONS

By the Lieutenant-Governor as Deputy for His Excellency the Governor of the State of Victoria and its Dependencies in the Commonwealth of Australia, &c., &c., &c.

WHEREAS section 916A of the *Local Government Act 1958*, as amended, provides—*inter alia*—that the Governor in Council may, by Proclamation published in the *Government Gazette*, at the request of the Council of any municipality (not being a city or town) extend the operation of Part XLIX. of the said Act to the municipal district of such municipality or any part thereof:

And whereas by Proclamation published in the *Government Gazette* on the 4th September, 1946, the operation of the said Part was extended to part of the municipal district of the Shire of McIvor:

Now therefore I, the Lieutenant-Governor as Deputy for the Governor of the State of Victoria by and with the advice of the Executive Council thereof, by this, my Proclamation, do hereby extend the operation of the Regulations made under Part XLIX. of the *Local Government Act 1958*, as amended, to that part of the municipal district of the Shire of McIvor defined hereunder:

Commencing at the south-western corner of allotment 31A¹, Parish of Spring Plains; thence proceeding easterly along the southern boundary of the above allotment and its projection to the south-western corner of allotment 34, Parish of Spring Plains; thence northerly and easterly along the western and northern boundaries of the said allotment and by the projection of the latter to the south-western corner of allotment 38A²; thence northerly to the north-western corner of allotment 38A²; thence easterly by the northern boundaries of allotments 38A², 38B, Parish of Spring Plains, and G, 1A of G; and G, Township of Mia Mia, and the projection of the latter to the south-eastern boundary of the Heathcote-Redesdale road at the most westerly angle of allotment 66, Parish of Spring Plains; thence generally north-easterly by the south-eastern boundary of the said road to a point being the most northerly angle of allotment B11J, Parish of Heathcote; thence northerly across the said road to the most southerly angle of allotment B29B, Parish of Heathcote; thence north-westerly to the most westerly angle of the said allotment B29B; thence north-easterly by the north-western boundaries of allotments B29B and B29 to the western corner of allotment B10; thence north-westerly to the most westerly angle of allotment B36B; thence generally north-easterly by the north-western boundaries of allotments B36B and B36A to the northern corner of allotment B36A; thence south-easterly and north-easterly by the boundary of the State Forest to its junction with the southern boundary of allotment 48, Parish of Heathcote; thence westerly to the most western angle of the said allotment 48; thence north-easterly by a line across the McIvor Highway to the most western angle of allotment 44, Parish of Heathcote; thence easterly by a line across the Northern Highway to the north-western angle of allotment 44A, Parish of Heathcote; thence generally northerly by the eastern boundary of the Northern Highway to the north-western angle of allotment 7 of A, Parish of Knowsley East; thence north-westerly

across the Northern Highway and generally westerly by the southern boundaries of allotments 30, 5b, 60 20g and 20b, to the south-western angle of allotment 20b, Parish of Knowsley East; thence northerly to the south-western angle of allotment 21a, Parish of Knowsley East; thence westerly by the southern boundaries of allotments 21, 22, 9a, 30 and 10a, Parish of Knowsley East, and allotment 7a, Parish of Knowsley, to the eastern boundary of the McIvor Highway; thence generally north-westerly by the said boundary in a straight line across the McIvor Highway to a point on the eastern boundary of allotment 11, Parish of Knowsley; thence southerly by the eastern boundaries of allotments 11 and 11a to the south-eastern corner of allotment 11a; thence westerly along the northern boundary of the Knowsley-Eppalock road to the most south-westerly angle of allotment 12a, Parish of Knowsley; thence generally south-westerly and northerly by the boundary of the State Forest to a point east of and the projection of, the northern boundary of allotment 31 and 32c, Parish of Knowsley; thence westerly by the said northern boundary to the Campaspe River; thence generally southerly along the eastern bank of the Campaspe River to the point of commencement.

And order that the said Regulation shall come into operation in the above described part of the municipal district of the Shire of McIvor on publication of this Proclamation in the *Government Gazette* provided that parts I. and II. of Chapter 8 thereof shall not be deemed to come into operation till the 20th October, 1966, except in so far as may be necessary to enable Council of the said municipality to make by-laws pursuant to the powers conferred by Part III. of the said Chapter and provided further that no such by-law shall come into operation before the 20th October, 1966.

Given under my Hand and the Seal of the State of Victoria aforesaid, at Melbourne, this twelfth day of July, in the year of our Lord, One thousand nine hundred and sixty-six, and in the fifteenth year of the reign of Her Majesty Queen Elizabeth II.

(SEAL) E. F. HERRING.

By His Excellency's Command,
R. J. HAMER,
Minister for Local Government.
GOD SAVE THE QUEEN!

UNITED MUNICIPAL AND GOLDFIELD COMMON OF CLUNES.

PROCLAMATION

By the Lieutenant-Governor as Deputy for His Excellency the Governor of the State of Victoria and its Dependencies in the Commonwealth of Australia, &c., &c., &c.

WHEREAS by Division 12 of Part I of the *Land Act 1958* it is amongst other things enacted that the Governor in Council may from time to time increase, and, after one month's notice in the *Government Gazette*, diminish, alter or abolish any common, and may from time to time re-proclaim the whole or any part of any such common for any of the purposes and subject to the provisions of the said Part of the said Act, and that nothing therein contained shall prevent the exercise of the powers conferred by the said Part of the said Act with respect to the leasing or licensing of any land comprised in any common: And whereas notice of the intention to abolish the United Municipal and Goldfield Common of Clunes has been duly published in the *Government Gazette* for one month: Now therefore I, the Lieutenant-Governor as Deputy for the Governor of the State of Victoria in the Commonwealth of Australia, by and with the advice of the Executive Council of the said State, do hereby abolish the United Municipal and Goldfield Common of Clunes.

Given under my Hand and the Seal of the State of Victoria aforesaid, at Melbourne, this twelfth day of July, in the year of our Lord, One thousand nine hundred and sixty-six, and in the fifteenth year of the reign of Her Majesty Queen Elizabeth II.

(L.S.) E. F. HERRING.

By His Excellency's Command,
JIM BALFOUR,
Minister of Lands.

GOD SAVE THE QUEEN!

Milk and Dairy Supervision Act 1958 (No. 6317).

DECLARING THE TOWNSHIP OF BIRCHIP TO BE A MILK AREA.

PROCLAMATION

By the Lieutenant-Governor as Deputy for His Excellency the Governor of the State of Victoria and its Dependencies in the Commonwealth of Australia, &c., &c., &c.

WHEREAS by section 65 of the *Milk and Dairy Supervision Act 1958* it is provided that on the recommendation of the Minister, any portion of Victoria may be proclaimed a Milk Area by the Governor in Council: And whereas by paragraph (b) of section 55 of the said Act it is provided that Part II. of the said Act shall have effect as regards any Milk Area other than the Metropolitan Milk Area and the Milk Areas of Ballarat, Bendigo, Geelong, Castlemaine and Port Fairy, on such day after the constitution thereof as is fixed by the Governor in Council: Now, therefore, I, the Lieutenant-Governor as Deputy for the Governor of the State of Victoria, by and with the advice of the Executive Council thereof and on the recommendation of the Honorable the Minister of Agriculture, do by this my Proclamation declare that the Township of Birchip together with the whole of the premises of each and every dairy farm or dairy outside such Township, wherever situated, from which milk is sold within such Township shall constitute a Milk Area to be called the Birchip Milk Area: And I do further declare that the 1st day of August, 1966, shall be the day on which Part II. of the said Act and Regulations and Orders made thereunder shall come into operation and be of full force and effect in such Milk Area.

Given under my Hand and the Seal of the State of Victoria aforesaid, at Melbourne, this twelfth day of July, in the year of our Lord, One thousand nine hundred and sixty-six, and in the fifteenth year of the reign of Her Majesty Queen Elizabeth II.

(L.S.) E. F. HERRING.

By His Excellency's Command,
G. L. CHANDLER,
Minister of Agriculture.

GOD SAVE THE QUEEN!

PUBLIC HOLIDAYS.

PROCLAMATION

By His Excellency the Governor of the State of Victoria and its Dependencies in the Commonwealth of Australia, &c., &c., &c.

IN pursuance of the provisions contained in Part III. of the *Public Service Act 1958*, I, the Governor of the State of Victoria, in the Commonwealth of Australia, by and with the advice of the Executive Council of the said State, do by this my Proclamation appoint the days and dates hereunder mentioned to be observed as Public Holidays or Public Half-Holidays (as the case may be) at the places respectively specified, viz.:

Public Holidays:—

WEDNESDAY, THE 21ST SEPTEMBER, 1966, throughout the Shire of Healesville.

Public Half-Holidays from the Hour of Twelve o'clock noon:—

FRIDAY, THE 30TH SEPTEMBER, 1966, throughout the City of Swan Hill.

WEDNESDAY, THE 28TH SEPTEMBER, 1966, throughout the Shire of Seymour.

Given under my Hand and the Seal of the State of Victoria aforesaid, at Melbourne, this nineteenth day of July, in the year of our Lord One thousand nine hundred and sixty-six, and in the fifteenth year of the reign of Her Majesty Queen Elizabeth II.

(L.S.) ROHAN DELACOMBE.

By His Excellency's Command,
JAMES W. MANSON,
Acting Chief Secretary.

GOD SAVE THE QUEEN!

BANK HOLIDAYS.

PROCLAMATION

By His Excellency the Governor of the State of Victoria and its Dependencies in the Commonwealth of Australia, &c., &c., &c.

IN pursuance of the provisions of the *Bank Holidays Act 1958*, I, the Governor of the State of Victoria, in the Commonwealth of Australia, do by this my Proclamation appoint the days and dates named hereunder special days to be observed Bank-Holidays at the places respectively mentioned, that is to say:—

Bank Half-Holidays from the Hour of Eleven a.m.:—

TUESDAY, THE 11TH OCTOBER, 1966, at Cobram, Katamatite and Strathmerton.

Given under my Hand and the Seal of the State of Victoria aforesaid, at Melbourne, this nineteenth day of July, in the year of our Lord One thousand nine hundred and sixty-six, and in the fifteenth year of the reign of Her Majesty Queen Elizabeth II.

(L.S.) ROHAN DELACOMBE.

By His Excellency's Command,

JAMES W. MANSON,
Acting Chief Secretary.

GOD SAVE THE QUEEN!

GOVERNMENT NOTICES

SHIRE OF ARARAT.

ROAD DEVIATION ORDER.

PURSUANT to the provisions of sections 522 and 526 of the *Local Government Act 1958* the Council of the Shire of Ararat hereby directs that the land in the Parish of Jallukar indicated by hatching on the diagram hereunder which has been purchased taken or acquired by it shall be a public highway on and from the date of publication of this Order in the *Government Gazette* and declares that such land shall be a public highway in lieu of the land indicated by cross hatching on the said diagram.

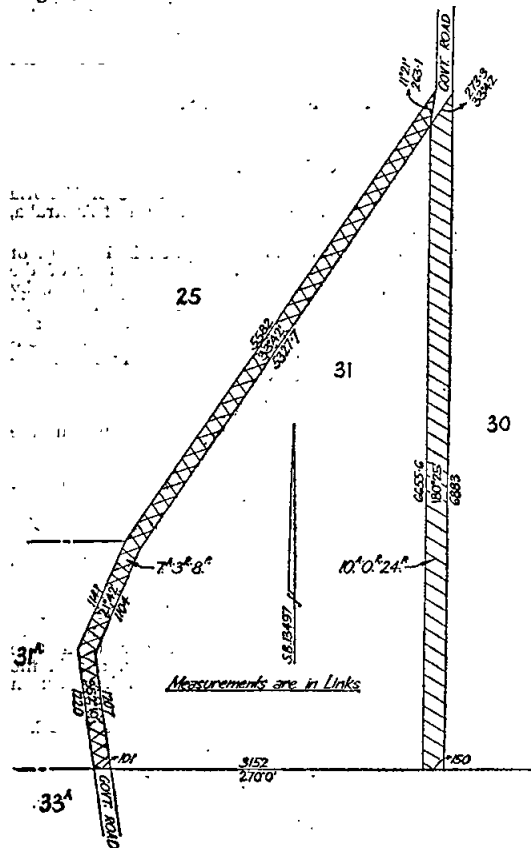

The common seal of the President, Councillors and Ratepayers of the Shire of Ararat was hereunto affixed, this 20th day of June, 1966, in the presence of—

L. K. SHANNON, President.
L. G. WEATHERLY, Councillor.
K. N. BISHOP, Secretary.

Order confirmed by the Governor in Council, 12th July, 1966.—J. COLQUHOUN, Clerk of the Executive Council.

SHIRE OF KOWREE.

ROAD DEVIATION ORDER.

PURSUANT to the provisions of sections 522 and 526 of the *Local Government Act 1958* the Council of the Shire of Kowree hereby directs that the land in the Parish of Neuarpur indicated by hatching on the diagram hereunder which has been purchased taken or acquired by it, shall be a public highway on and from the date of publication of this Order in the *Government Gazette* and declares that such land shall be a public highway in lieu of the land indicated by cross-hatching on the said diagram.

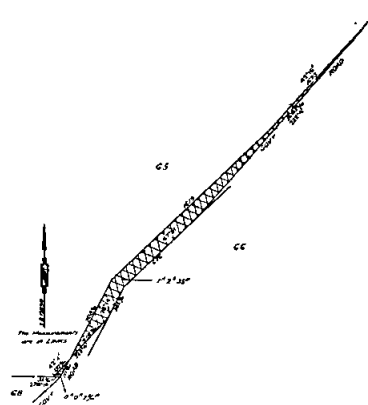

The common seal of the President, Councillors and Ratepayers of the Shire of Kowree was hereunto affixed, this seventh day of September, 1964, in the presence of—

D. A. BULL, President.
RAYMOND L. AMPT, Councillor.
H. ERNEST WALKER, Secretary.

Order confirmed by the Governor in Council, 12th July, 1966.—J. COLQUHOUN, Clerk of the Executive Council.

SHIRE OF ALTONA.

INTERIM DEVELOPMENT ORDER.

Shire of Altona Planning Scheme.

Altona Shopping Area.

BY virtue of the powers conferred by the *Town and Country Planning Act 1961* and of every power enabling it in that behalf, the President, Councillors and Ratepayers of the Shire of Altona, (hereinafter referred to as the Responsible Authority) having commenced the preparation of a planning scheme on the 12th day of December, 1957, in accordance with the *Town and Country Planning Acts* then in force, hereby makes the following Interim Development Order for the purpose of regulating, restricting, restraining or prohibiting the use or development of any land or the erection, construction or carrying out of any building or works on any land within the area described in the Schedule.

1. After the coming into operation of this Interim Development Order no person shall use, subdivide or develop any land or erect, construct or carry out any building or works on any land within the area included in the Schedule, except in accordance with the provisions of a permit issued by the Responsible Authority.

2. Every application for a permit under the provisions of this Order shall be made on the prescribed form, copies of which may be obtained from the office of the Responsible Authority at Altona.

3. This Interim Development Order shall not prevent (a) the continuance of the use of any land or of any existing buildings or works for the purposes for which such land or buildings or works were being lawfully used immediately before the coming into operation of this Order. (b) any dealing or the registration of any dealing with any land in a subdivision of which a plan has been sealed by the Council of the Shire of Altona and lodged with the Registrar of Titles, pursuant to section 569 of the Local Government Act 1958, before the coming into operation of this Order.

4. Schedule—those portions of the Municipal District of the Shire of Altona (a) within the area bounded by Railway-street south, Bent-street, The Esplanade, Pier-street, Queen-street and Sargood-street and (b) the land facing Pier-street between Railway-street north and Civic-parade described, as lots 64 and 63 of LP 7931, and lots 238 to 245 inclusive, lots 152 and 153, and lots 226 to 235 inclusive of LP 2102.

(SEAL) A. W. BOND, President.
W. G. CRESSER, Councillor.
J. W. WATERS, Shire Secretary.

Report by the Town and Country Planning Board on the 29th day of May, 1963. Recommended for approval.—FRED C. COOK, Chairman.

Approved by the Governor in Council on the 18th day of June, 1963.—N. G. WISHART, Clerk of the Executive Council.

Report by the Town and Country Planning Board on the 24th day of June, 1964. Recommended for approval.—FRED C. COOK, Chairman.

Approved by the Governor in Council on the 8th day of July, 1964.—J. COLQUHOUN, Clerk of the Executive Council.

Report by the Town and Country Planning Board on the 7th day of July, 1965. Recommended for approval.—FRED C. COOK, Chairman.

Approved by the Governor in Council on the 20th day of July, 1965.—J. COLQUHOUN, Clerk of the Executive Council.

Report by the Town and Country Planning Board on the 28th day of June, 1966. Recommended for approval.—R. D. L. FRASER, Chairman.

Approved by the Governor in Council on the 12th day of July, 1966.—J. COLQUHOUN, Clerk of the Executive Council.

WURRUK WATERWORKS TRUST.

AUTHORITY TO OBTAIN BANK OVERDRAFT.

HIS Excellency the Governor of the State of Victoria, by and with the advice of the Executive Council thereof, doth by Order made on the 19th day of July, 1966, authorize the Wurruk Waterworks Trust to obtain, in pursuance of the provisions of section 286 of the Water Act 1958 (No. 6413) an advance or advances during the year 1966 from the Australia and New Zealand Bank Limited, Fish Creek, by overdraft of the Trust's current account thereat, such overdraft not to exceed at any one time the sum of Eight hundred dollars (\$800).

J. COLQUHOUN,
Clerk of the Executive Council.

At the Executive Council Chamber,
Melbourne, 19th July, 1966.

MURRAYVILLE WATERWORKS TRUST.

RATING BY-LAW FOR THE YEAR 1966.

THE Murrayville Waterworks Trust, in pursuance and exercise of the powers conferred by the Water Act, doth hereby make a rate for the supply of water for domestic purposes of Seventeen Cents in the dollar on the annual Municipal valuation of lands and tenements liable to be rated within the Murrayville Urban District.

Provided that in no case shall the amount of rate payable per annum in respect of any tenement (other than land on which there is no building) be less than Thirteen Dollars and Fifty Cents and in respect of land on which there is no building be less than Four Dollars.

Such rates are made and shall be levied upon the occupiers or owners of the said lands and tenements for the year commencing on the 1st. day of December, 1966, and shall be payable on the 31st. day of July, 1966, at the Office of the said Trust at the Shire Hall, Ouyen.

The maximum quantity of water to be supplied in any one year without further charge to any property rated by the Trust is hereby fixed at the quantity which, at a charge of Twenty Cents per 1,000 gallons, would produce an amount equal to the amount of rate levied on such property for the said year.

The charge for water supplied by measure to any property rated by the Trust in excess of such maximum quantity, computed as in the last preceding clause, is hereby fixed at Twenty Cents per 1,000 gallons.

The charge for water supplied by measure to any property not rated by the Trust and where no agreement exists, is hereby fixed at Twenty Cents per 1,000 gallons and the minimum quantity of water to be charged for in cases where water is supplied is hereby fixed at 67,500 gallons.

The charge for water supplied by measure shall be payable on demand at the office of the Trust, Ouyen.

Dated this 23rd day of June, 1966.

(SEAL) H. F. HEINTZE, Chairman.
C. C. THURLOW, Commissioner.
J. W. BALES, Secretary.

Approved, 6th July, 1966.—T. A. DARCY, Minister of Water Supply.

COWANGIE WATER SUPPLY DISTRICT.

RATING BY-LAW.

THE Council of the Shire of Walpeup, in pursuance and exercise of the powers conferred by the Water Act; doth hereby make a rate for the supply of water for domestic purposes of TWENTY FIVE CENTS in the DOLLAR on the annual Municipal value of lands and tenements liable to be rated within the Cowangie Water Supply District.

Provided that in no case shall the amount of rate payable per annum in respect to any tenement (other than land on which there is no building) be less than SIXTEEN DOLLARS, and in respect of land on which there is no building be less than FOUR DOLLARS.

Such rates are made and shall be levied upon the occupiers or owners of the said lands and tenements for the year commencing on the 1st. day of October, 1965, and ending on the 30th. day of September, 1966, and shall be payable on the 21st. July, 1966, at the office of the said Council at the Shire Offices, Ouyen.

The maximum quantity of water to be supplied in any one year, without further charge to any property rated by the Council, is hereby fixed at the quantity which, at a charge of TWENTY FIVE CENTS per thousand gallons, would produce an amount equal to the amount of rate levied on such property for the said year.

The charge for water supplied by measure to any property rated by the Council in excess of such maximum quantity, computed as in the last preceding clause, is hereby fixed at TWENTY FIVE CENTS per thousand gallons.

The charge for water supplied by measure to any property not rated by the Council and where no agreement exists is hereby fixed at TWENTY FIVE CENTS per thousand gallons, and the minimum quantity of water to be charged for in cases where water is so supplied is hereby fixed at 30,000 gallons.

The charge for water supplied by measure shall be payable, on demand, at the office of the Council.

The common seal of the President, Councillors and Ratepayers of the Shire of Walpeup was hereto affixed, this Sixteenth day of June, 1966, in the presence of—

(SEAL) J. R. GIBBS, President.
V. J. PEARSON, Councillor.
J. W. BALES, Secretary.

Approved, 18th July, 1966.—T. A. DARCY, Minister of Water Supply.

STATE RIVERS AND WATER SUPPLY COMMISSION.

LICENCES TO DIVERT WATER AND CUT RACES PURSUANT TO THE PROVISIONS OF THE WATER ACT 1958.

THE Governor in Council has approved of the granting by the State Rivers and Water Supply Commission of licences as detailed hereunder for the term of years from the date specified in each case to the persons named in the following Schedule:

SCHEDULE.

Licence No.	Term of Licence and Commencing Date.	Name and Address of Person to Whom Licence is to be Granted.	Source of Supply.	Area Authorized to be Irrigated Per Annum.	Volume of Water Authorized to be Diverted Per Annum.
				acres.	ac. ft.
519	Four years from 1.7.66	Keen Bros., Colignan	River Murray	20	60
7567	Four years from 1.7.66	Lyle James Nickells, Merbein	River Murray	20	60
1184/516	Four years from 1.7.66	Colin James Grant, Nangiloc	River Murray	32	96
2117	Four years from 1.7.66	Kevin James Clarke and Neville Arthur Clarke, Tintaldra	River Murray	20	40
2118	Three years from 1.7.66	Carmelo Conditorio, Koondrook	Gunbower Creek (River Murray Backwater)	14	28
2119	Four years from 1.7.65	Howard John Eggleston, Mildura	River Murray	6	18
2120	Four years from 1.7.66	Alan Efast Leake, Alexandra	Goulburn River	25	50
2121	Four years from 1.7.66	Lockhart Little, Seymour	Goulburn River	50	100
2122	Four years from 1.7.65	Harvey Morgan, Tallangatta	River Murray (Lake Hume)	25	50
2123	Four years from 1.7.66	E. Weeks and Sons, Alexandra	Goulburn River	10	20

Office of the State Rivers and Water Supply Commission, Melbourne, 19th July, 1966.

G. W. LEWIS, Secretary, State Rivers and Water Supply Commission.

STATE RIVERS AND WATER SUPPLY COMMISSION.

LICENCE TO DIVERT WATER, PURSUANT TO THE PROVISIONS OF THE WATER ACT 1958.

THE Licence as detailed hereunder to divert water has been revoked by the Governor in Council as from the date shown:—

Licence No.	Name of Licensee.	Source of Supply.	Term of Licence and Commencing date.	Date of Revocation.
392	Noel Ernest Foster and David Crump McGillivray	Gunbower Creek	Fifteen years from 1.7.58	30.6.66

Office of the State Rivers and Water Supply Commission, Melbourne, 19th July, 1966.

G. W. Lewis, Secretary, State Rivers and Water Supply Commission.

STATE RIVERS AND WATER SUPPLY COMMISSION.

APPLICATIONS FOR LICENCES TO DIVERT WATER AND CUT RACES PURSUANT TO THE PROVISIONS OF THE WATER ACT 1958.

THE Governor in Council has approved of the State Rivers and Water Supply Commission refusing the applications as detailed hereunder for licences to divert water and cut races.

Term of Licence Sought.	Name and Address of Applicant.	Source of Supply.	Area Sought to be Authorized to be Irrigated Per Annum.	Volume of Water Sought to be Authorized to be Diverted Per Annum.
			acres.	ac. ft.
Four years from 14.12.65	Henry Alexander Robert O'Bree, Piangil	River Murray	40	120
Eight years from 1.1.63	James Stanley Pender, Mildura	Wallpolla Creek (River Murray)	50	150

Office of the State Rivers and Water Supply Commission, Melbourne, 19th July, 1966.

G. W. LEWIS, Secretary, State Rivers and Water Supply Commission.

Commercial Goods Vehicles Act.
TRANSPORT REGULATION BOARD.

HEARING OF APPLICATIONS.

NOTICE is hereby given that the following applications will be considered by the Transport Regulation Board at its Offices at Rathdown-street, Carlton at 10.15 a.m., on Wednesday, 10th August, 1966.

- ABBOTT, C. H.**, 6 Tallowwood-street, Frankston. One commercial goods vehicle (L/C. 10 cwt.) to operate throughout the State of Victoria in the course of business as "Serviceman" on behalf of Vulcan Electrics Pty. Ltd., for the purpose of servicing and advising on heating problems—tools of trade, spare parts and appliances for repair and materials incidental to servicing.
- ALBURY BORDER TRANSPORT PTY. LTD.**, 487 Young-street, Albury, N.S.W. One commercial goods vehicle (L/C. 300 cwt. approximately) to operate: (a) From Melbourne to the premises of Lamson Paragon Ltd. being an approved decentralized secondary industry "Printing" at Wodonga—paper and machinery, new and second-hand. (b) From the aforesaid premises at Wodonga to Melbourne—processed and printed paper and machinery.
- ALSTERGREN PTY. LTD.**, 131-141 Queens Bridge-square, South Melbourne. Application to vary the conditions of licence No. D.A. 29856/2 (L/C. 10 cwt.) by deleting the existing conditions and adding in lieu "throughout the State of Victoria in the course of business as Timber Merchants for the purposes of repairing and maintaining own milling equipment—tools of trade, spare parts and materials incidental thereto."
- APPLETON, J. R.**, Stockdale, via Stratford. One commercial goods vehicle (L/C. 217 cwt.) to operate: 1. Within a 20-mile radius from the post office at Stockdale—general goods. 2. Within a 50-mile radius from the post office at Stockdale—sawn timber. This application replaces licence No. T.T.D.462 held by the applicant.
- BAILEY, K. M.**, Little Yarra-road, Yarra Junction. One commercial goods vehicle (L/C. 267 cwt.) to operate: (a) From bush sites within a 20-mile radius of Yarra Junction to Reid Bros. sawmill at Yarra Junction—logs. (b) From bush sites within a 20-mile radius of Yarra Junction to the pole treatment works at Officer and Brooklyn—S.E.C. & P.M.G. poles. (c) From Reid Bros. sawmill at Yarra Junction to timber yards and building sites within a 25-mile radius of Melbourne—sawn timber.
- BARKER, H. & E.** (Trading as Barker Bros.), Yarra Junction. One commercial goods vehicle (L/C. 198 cwt.) to operate from any forest landing in the Upper Yarra Forestry Districts to the Victorian Hardwood Co's sawmill at Powelltown—logs. This application replaces licence No. T.T.D.117/2 held by the applicant.
- BATTEL, A.**, 23 Salisbury-street, Orbost. One commercial goods vehicle (L/C. 264 cwt.) to operate: (a) Throughout that part of the State of Victoria east of the Snowy river—logs. (b) From and to the area defined in paragraph (a) above and from Newmerella and Waygara—logs. (c) From sawmills situated in the area defined in paragraph (a) above and from Newmerella to the Orbost Railway Station—sawn timber. (d) For delivery to customers and building sites within a 20-mile radius of the post office at Orbost—sawn timber. This application replaces licence No. T.T.D.676 held by the applicant.
- BATTY, ALBERT, PTY. LTD.**, 2 Addis-street, Geelong West. Two commercial goods vehicles (L/C. 10 cwt. each plus trailer 30 cwt.) to operate throughout the State of Victoria in the course of business as "Marine Collector"—marine goods as designated in the *Marine Stores and Old Metals Act 1958* (No. 6303), but excluding the carriage of any goods to wharves, docks or ships for shipment or export purposes, with the proviso that the combined load capacities of vehicle and trailer does not exceed 6 tons.
- BAYVIEW QUARRIES PTY. LTD.**, 602 St. Kilda-road, Melbourne. One commercial goods vehicle (L/C. 200 cwt.) to operate within a 50-mile radius of own premises at North Melbourne in the course of business as "Premixed Concrete Manufacturers"—premixed concrete in a specially constructed agitator vehicle.
- BLAIR, I. R.**, 935 Nepean Highway, Mornington. One commercial goods vehicle (L/C. 6 cwt.) to operate throughout the State of Victoria as a "Refrigeration Mechanic" solely on behalf of Pioneer Refrigeration Pty. Ltd.—tools of trade and spare parts incidental to servicing and installation of refrigeration units and replacement units for installation.
- BONNEY, F. L., & Co. (Vic.) PTY. LTD.**, P.O. Box 759, Mildura. Two commercial goods vehicles (L/C. 5 and 10 cwt.) to operate throughout the State of Victoria from own premises in the City of Mildura—tools of trade, equipment and materials incidental to the completion of own contracts in the course of business as "Pest Exterminators."
- BRUHN, F. & V.**, Murray Valley Highway, Cohuna. One commercial goods vehicle (L/C. 71 cwt.) to operate within a 75-mile radius of Cohuna in the course of business as "Septic Tank Cleaners" for the purpose of emptying and cleaning septic tanks, and for disposing of the residue when the tanks have been emptied.
- BUNKER, E. G.**, 18 Robinson-street, Croydon. One commercial goods vehicle (L/C. 76 cwt.) to operate: (a) Within a 25-mile radius of the G.P.O., Melbourne—general goods. (b) Within a 70-mile radius of the plant of Commonwealth Pottery Pty. Ltd. at Blackburn—earthenware pipes and fittings.
- CARLSON, M., PTY. LTD.**, 340 Little Collins-street, Melbourne. One commercial goods vehicle (L/C. 150 cwt.) to operate within a 50-mile radius of the premises of Albion Reid Pty. Ltd. at North Melbourne—road-making plant, hot asphalt and materials solely on behalf of the said company excluding cement from Geelong.
- CHESTER, W. H.**, 48 Pearson-street, Sale. Application to vary the conditions of licence No. D.A.10765 (L/C. 65 cwt.) by deleting "Briagolong" from paragraphs (a), (b) and (c) and adding in lieu "Sale" in paragraphs (a), (b) and (c).
- COOMBS, A. G., PTY. LTD.**, 26 Cochranes-road, Moorabbin. One commercial goods vehicle (L/C. 11 cwt.) to operate throughout the State of Victoria in the course of business as "Heating Engineers"—tools of trade, spare parts and equipment incidental to the installation, servicing and maintenance of air conditioning units and heating systems.
- DALTON, A. K.**, High-street, Macarthur. One commercial goods vehicle (L/C. 46 cwt.) to operate: (a) Within a 50-mile radius of own premises at Macarthur in the course of business as "Hides, Skins and Wool Merchants"—own goods. (b) From own premises at Macarthur to the premises of Apex Wool Co. at Ascot Vale or New Zealand Loan Co. at Brooklyn once per month—own hides, skins, up to ten bales or bags only of wool ends and up to twenty 4-gallon tins of tallow.
- NOTE.—All other wool consigned by rail from Hamilton or Port Fairy.
- DAVIS, D. A.**, 4 Young-street, Springvale. One commercial goods vehicle (L/C. 120 cwt.) to operate within a 50-mile radius of the G.P.O., Melbourne, as a "Marine Collector"—special wares, marine stores or old metals as designated in the *Marine Stores and Old Metals Act 1958* (No. 6303), Part 1, section (3).
- EVETTS, EDWARD, PTY. LTD.**, 357 Heidelberg-road, Northcote. Two commercial goods vehicles (L/C. 133 cwt. each) to operate: (a) Within a 25-mile radius of Melbourne in the course of business as "Sand, Screenings and Stone Suppliers"—own goods. (b) From private properties at Bacchus Marsh to places within paragraph (a)—stone.
- FIELD & TAYLOR PTY. LTD.**, care of Box 19, Warragul. Application to vary the conditions of licence No. D.A.47364 (L/C. 140 cwt.) by deleting "Warragul" and adding in lieu "Cohuna."
- GARDNER, J. W.**, Snake Valley. One commercial goods vehicle (L/C. 79 cwt.) to operate: (a) Within a 20-mile radius from the post office at Linton—general goods. (b) From and to places within the radius as defined in paragraph (a) above, to and from places situated within a 50-mile radius from the post office at Linton and to and from the City of Geelong—livestock.
- HARDIE RUBBER Co. (Vic.) PTY. LTD.**, 33 Lygon-street, Carlton. Two commercial goods vehicles (L/C. 11 and 15 cwt.) to operate within a 50-mile radius of own branch premises at Horsham in the course of business as "Tire Dealers"—new tires and tubes, batteries and tires for repair or having been repaired.
- HARDIE RUBBER Co. (Vic.) PTY. LTD.**, 33 Lygon-street, Carlton. One commercial goods vehicle (L/C. 17 cwt.) to operate within a 50-mile radius of own branch premises at Warragul in the course of business as "Tire Dealers"—new tires and tubes, batteries and tires for repair or having been repaired.
- HARDIE RUBBER Co. (Vic.) PTY. LTD.**, 33 Lygon-street, Carlton. Two commercial goods vehicles (L/C. 11 cwt. each) to operate within a 50-mile radius of own branch premises at Shepparton in the course of business as "Tire Dealers"—new tires and tubes, batteries and tires for repair or having been repaired.

- HARDNER, F. G.**, 201 Waverley-road, Mt. Waverley. One commercial goods vehicle (L/C. 140 cwt.) to operate: (a) Within a 70-mile radius from the premises of the City Brick Works Co. Pty. Ltd. at Hawthorn—bricks on behalf of the said company. (b) Within a 20-mile radius of the Mount Waverley Post Office—general goods.
- KLIPSPRINGER INVESTMENTS PTY. LTD.**, 37 Cranwell-street, Braybrook. One commercial goods vehicle (L/C. 105 cwt.) to operate from own premises at Braybrook to the premises of Jacksons Corio Meat Packing (1965) Pty. Ltd., at North Geelong—animal by-products in bulk containers.
- LONIE, R. L.**, 70 Lincoln-road, Croydon. One commercial goods vehicle (L/C. 200 cwt.) to operate within the Shires of Gordon, East Loddon, Cohuna, Charlton, Kerang and Swan Hill in the course of business as "Cartage Contractor" under contract to E. B. Mawson and Son of Cohuna—road-making plant and materials.
- MASCITTI, N.**, 24 Gezireh-street, Pascoe Vale South. One commercial goods vehicle (L/C. 203 cwt.) to operate within a 50-mile radius of Bayview Quarries Pty. Ltd. plant at North Melbourne in a specially constructed agitator vehicle—pre-mixed concrete.
- MEDHURST, W. D.**, 178 Tenth-street, Mildura. One commercial goods vehicle (L/C. 16 cwt.) to operate throughout the State of Victoria from own premises in the City of Mildura—tools of trade, equipment and materials incidental to the completion of own contracts in the course of business as "Pest Exterminators".
- MCKENZIE, J. & D., PTY. LTD.**, P.O. Box 20, Norlane. One commercial goods vehicle (L/C. 243 cwt.) to operate throughout the State of Victoria as a low loader in the course of business as "Excavation Contractors"—tools of trade, and own plant and equipment incidental to the completion of own contracts.
- NASH, C. J.**, 39 Purwell-road, Corio, Geelong. Application to vary the conditions of licence No. D.A.56485 (L/C. 145 cwt.) by adding to the existing conditions after "Company" . . . "and empty pallets on the return journeys."
- NEW HOLLAND (AUSTRALASIA) PTY. LTD.**, 232 Princes Highway, Dandenong. One commercial goods vehicle (L/C. 7 cwt.) to operate throughout the State of Victoria as a service vehicle in the course of business as "Agricultural Implements Manufacturers"—tools of trade, spare parts, servicing equipment and materials incidental thereto.
- PAVIORS PTY. LTD.**, 21-27 Leicester-street, Fitzroy. One commercial goods vehicle (L/C. 56 cwt.) to operate: (a) Within a 50-mile radius of Fitzroy in the course of business as "Paving and Terrazzo Contractors"—own goods. (b) Throughout the State of Victoria—own tools of trade, plant machines, equipment and terrazzo slabs for installation. (c) Within a 20-mile radius of any contract or from the nearest railway station—materials for use on such contract.
- PERMEWAN WRIGHT LTD.**, 18 Goold-street, Bairnsdale. One commercial goods vehicle (L/C. 223 cwt.) to operate: (a) Within a 50-mile radius from the post office at Bairnsdale—own goods in the course of business as "General and Produce Merchants". (b) Within a 50-mile radius of own premises at Bairnsdale—petroleum products on behalf of H. C. Sleigh Ltd. as an agent for the said company.
Special Condition.—"That all goods so carried shall only be those having been initially consigned to Bairnsdale by rail."
- PEUKER & ALEXANDER PTY. LTD.** and **C. A. BARCLAY, CNR.** William-street and Railway-crescent, Broadmeadows. One commercial goods vehicle (L/C. 135 cwt.) to operate: (a) Within a 25-mile radius of the G.P.O., Melbourne, in the course of business as "Timber and Hardware Merchants"—own goods. (b) From sawmills at Sailor Falls, Trentham and Warburton to own yard at Glenroy and to building sites within a 25-mile radius of the G.P.O., Melbourne—sawn timber. This application replaces licence No. T.T.D.754 held by the applicant.
- QUEENS BRIDGE MOTOR & ENGINEERING CO. PTY. LTD.**, cnr. Smith and Plummer streets, Port Melbourne. One commercial goods vehicle (L/C. 11 cwt.) to operate throughout the State of Victoria in the course of business as "Distributors of Tractors and Farm Machinery" for the purpose of servicing and maintaining agricultural machinery and associated equipment—tools of trade, spare parts and materials incidental thereto.
- ROBSON, D.**, 6 Cadle-street, Dandenong. One commercial goods vehicle (L/C. 84 cwt.) to operate from Longwarry Timber Supplies Pty. Ltd. mill at Longwarry to consignees within a 25-mile radius of Melbourne but only in the area east of a north/south line drawn through Melbourne—sawn timber, pallets and case shooks solely on behalf of the said company.
- ROUNDS, L. L.**, 39 Sheehan-crescent, Shepparton. One commercial goods vehicle (L/C. 7 cwt.) to operate: (a) From Shepparton to Tallygaroopna, and thence via Marungi, Dunbulbalane area, Katandra West and Marionvale—mail and parcels under contract to the P.M.G.'s department. (b) Within a 20-mile radius of Shepparton—general goods.
- ROWLEY, C. N.**, 147 Nicholson-street, Bairnsdale. One commercial goods vehicle (L/C. approximately 140 cwt.) to operate: (a) Within an 85-mile radius of the post office at Orbost (Bairnsdale Division of the Country Roads Board) and within a 70-mile radius of the post office at Yarram (Traralgon Division of the Country Roads Board) as a "Road Contractor"—road-contracting plant used in the construction or maintenance of a road, street, footpath, bridge, wharf, pier, weir or channel. (b) Within a 20-mile radius of the post office at Bairnsdale—general goods.
- RUDD, F. G.**, care of Post Office, Wangaratta. One commercial goods vehicle (L/C. 75 cwt.) to operate between the Townships of Wodonga and Seymour on behalf of the Victorian Railways—tools of trade and equipment incidental to the repair and maintenance of the Standard Gauge Railway Line.
- SAUNDERS, A.**, 232 Grange-road, Glenhuntly. One commercial goods vehicle (L/C. 191 cwt.) to operate within a 70-mile radius of the post office at Healesville (Dandenong Division of the Country Roads Board) as a "Road Contractor"—road-contracting plant used in the construction or maintenance of a road, street, footpath, bridge, wharf, pier, weir or channel.
- SAWYER, W. and J.**, 94 Buckley-street, Footscray. One commercial goods vehicle (L/C. 114 cwt.) to operate within a 70-mile radius of the premises of Clifton Brick Holdings Ltd. at Brunswick solely on behalf of the said company—bricks.
- SCROFANI, M.**, 4 Colin-street, Sunshine. One commercial goods vehicle (L/C. 156 cwt.) to operate within a 50-mile radius of the premises of Albion Reid Pty. Ltd., at Arden-street, North Melbourne, on behalf of the said company—road-making plant, hot asphalt, premix and road-making materials.
- SINGLETON, J. A.**, Phillip-street, Bonnie Doon. One commercial goods vehicle (L/C. 270 cwt.) to operate from Jamieson and Mt. Buller areas to Walker's mill at Mansfield and to Burwood Timber Co. Pty. Ltd. mill at Mansfield—logs. This application replaces licence No. T.T.D.818 held by the applicant.
- STONES, G.**, Hamilton-street, Rutherglen. One commercial goods vehicle (L/C. 53 cwt.) to operate: (a) Within a 20-mile radius of the post office at Rutherglen—general goods. (b) From and to places within the radius described in paragraph (a) above, to and from places situated within a 50-mile radius of the depot of B.P. Australia Ltd. at Wodonga—petroleum products on behalf of the said company.
- TEMPLETON, E. L.**, Tyers, via Traralgon. One commercial goods vehicle (L/C. 143 cwt.) to operate: 1. From forest landings in the Boola Boola area to James Kennedy's mill at Traralgon, McMillan and Pyle sawmill at Morwell, Webb's sawmill at Yarragon, I. M. Burns' sawmill at Darnum, Trafalgar Timber Co., sawmill, Trafalgar—logs. 2. From forest landings in the Boola Boola area to Tyers—pulpwood logs. 3. From places situated within a 25-mile radius of the post office at Maryvale to A.P.M. Ltd. mill at Maryvale—pulpwood. This application replaces licence No. T.T.D.524 held by the applicant.
- TOWT, K. P.**, 25 Frederick-street, Dandenong. One commercial goods vehicle (L/C. 240 cwt.) to operate: (a) From forest landings in the North Garfield and North Bunyip areas to sawmills at Bunyip, Drouin West, Pakenham and Dandenong—logs. (b) Within a 30-mile radius from the post office at Garfield in the course of business as "Logging Contractor"—own logging equipment and associated spare parts.
This application replaces licence No. T.T.D.1077 held by the applicant.
- UNITED TYRE SERVICE (VIC.) PTY. LTD.**, 33 Lygon-street, Carlton. Four commercial goods vehicles (L/C. 8, 10, 11 and 28 cwt.) to operate within a 50-mile radius of own premises at St. Arnaud in the course of business as "Tire Dealers"—new tires and tubes, batteries and tires for repair or having been repaired.
- UNITED TYRE SERVICE (VIC.) PTY. LTD.**, 33 Lygon-street, Carlton. One commercial goods vehicle (L/C. 8 cwt.) to operate within a 50-mile radius of own premises at Horsham in the course of business as "Tire Dealers"—new tires and tubes, batteries and tires for repair or having been repaired.

- UNITED TYRE SERVICE (VIC.) PTY. LTD., 33 Lygon-street, Carlton. Two commercial goods vehicles (L/C. 11 and 15 cwt.) to operate within a 50-mile radius of own premises at Geelong in the course of business as "Tire Dealers"—new tires and tubes, batteries and tires for repair or having been repaired.
- UNITED TYRE SERVICE (VIC.) PTY. LTD., 33 Lygon-street, Carlton. Two commercial goods vehicles (L/C. 11 cwt. each) to operate within a 50-mile radius of own premises at Colac in the course of business as "Tire Dealers"—new tires and tubes, batteries and tires for repair or having been repaired.
- UNITED TYRE SERVICE (VIC.) PTY. LTD., 33 Lygon-street, Carlton. Two commercial goods vehicles (L/C. 11 and 16 cwt.) to operate within a 50-mile radius of own premises at Camperdown in the course of business as "Tire Dealers"—new tires and tubes, batteries and tires for repair or having been repaired.
- UNITED TYRE SERVICE (VIC.) PTY. LTD., 33 Lygon-street, Carlton. Two commercial goods vehicles (L/C. 11 and 14 cwt.) to operate within a 50-mile radius of own premises at Morwell in the course of business as "Tire Dealers"—new tires and tubes, batteries and tires for repair or having been repaired.
- UNITED TYRE SERVICE (VIC.) PTY. LTD., 33 Lygon-street, Carlton. Two commercial goods vehicles (L/C. 11 cwt. each) to operate within a 50-mile radius of own premises at Shepparton in the course of business as "Tire Dealers"—new tires and tubes, batteries and tires for repair or having been repaired.
- UNITED TYRE SERVICE (VIC.) PTY. LTD., 33 Lygon-street, Carlton. One commercial goods vehicle (L/C. 11 cwt.) to operate within a 50-mile radius of own premises at Warragul in the course of business as "Tire Dealers"—new tires and tubes, batteries and tires for repair or having been repaired.

TOW TRUCKS.

- HORE, S. G. & G. O. (trading as B. G. S. Motors), Bunyip. One commercial goods vehicle (L/C. 27 cwt.) to operate within a 100-mile radius from the post office at Bunyip as a "Tow Truck" for the purpose of lifting and carrying or towing and/or repairing wrecked or disabled vehicles—tools of trade, spare parts and materials incidental thereto.
- SMITH, GEOFF, MOTORS, 21 Perkins-street Alexandria. One commercial goods vehicle (L/C. 80 cwt.) to operate throughout the State of Victoria as a "Tow Truck" for the purpose of lifting and carrying or towing and/or repairing wrecked or disabled vehicles—tools of trade, spare parts and materials incidental thereto.

APPLICATIONS for renewal of licences as shown by persons listed hereunder to operate under the same terms and conditions from the date of expiry shown in each case.

- ABERFELDIE QUARRIES & SAND SUPPLY PTY. LTD., Knighton-avenue, East Keilor; D.A.37391/5; 2nd July, 1966; 257 cwt.
- ANDERTON, C., corner Corrigan and Harold roads, Noble Park; D.A.3265; 18th August, 1966; 164 cwt.
- AYTON, F. A. O., Oke-street, Ouyen; D.A.3460/1; 11th August, 1966; 15 cwt.
- DEVANNY BROS. PTY. LTD., 108 Pantom-street, Golden Square; D.A.39639/1; 6th August, 1966; 297 cwt.
- FROST, R. W., Princes Highway, Port Fairy North; D.A.33681; 18th August, 1966; 234 cwt.
- HAMBLIN, J., Poowong; D.A.47097; 27th August, 1966; 60 cwt.
- HESTER, A., Box 65, Warburton; D.A.46505, 11th August, 1966; 8 cwt.
- HINE, L. J., Box 12 R.S.D., Bacchus Marsh; D.A.1303; 7th June, 1966; 137 cwt.
- HUBBARD, G. H., Bendigo; D.A.30962/6; 27th August, 1966; 65 cwt.
- JOCHINKE, G. O., Hindmash-street, Jeparit; D.A.43355/6; 18th August, 1966; 108 cwt.
- KELLY, H. E., 201 Walnut-avenue, Mildura; T.D.A.55562; 9th August, 1966; 131 cwt.
- KINGSLEY INDUSTRIES PTY. LTD., 13 Princes Highway, Springvale; D.A.15317; 23rd August, 1966; 69 cwt.
- LUDLOW, R. P. & N. I., 6 Gravesend-street, Colac; D.A.33519; 18th August, 1966; 100 cwt.
- MACDONALD, N. R., 32 Webster-street, Bendigo; D.A.28292; 18th August, 1966; 235 cwt.
- MARTIN, W. A. & C. E., Havilah, via Myrtleford; D.A.46684; 9th July, 1966; 172 cwt.
- MOORFOOT, P. L., 15 Helmer-crescent, East Geelong; D.A.33542; 11th August, 1966; 134 cwt.
- SHERLOCK, A., 200 Moore-street, Warrnambool; D.A.47045; 27th August, 1966; 10 cwt.

SQUIRES, C. I. & M. C., High-street, Avoca; D.A.2089/1; 31st July, 1966; 109 cwt.

TRARALGON MIXED CONCRETE PTY. LTD., P.O. Box 194, Traralgon; D.A.49231/2; 17th August, 1966; 178 cwt.

BELL, J. F., & C. H. HALL (trading as Western District Boring Co.), 112 Hurd-street, Portland; D.A.46944; 6th August, 1966, 122 cwt.

RENEWALS WITH VARIATION.

APPLICATION by the persons listed hereunder for renewal of the licence listed with variation of conditions in the manner set out opposite the name.

EGAN, J. P., 30 McLean-street, Maffra; D.A.33098; 1st July, 1966; application to renew and vary the conditions of licence No. D.A.33098 (L/C. 146 cwt.) by deleting the existing conditions and adding in lieu. (a) Within an 85-mile radius of the post office at Orbost (Bairnsdale Division of the C.R.B.) and within a 70-mile radius of the post office at Yarram (Traralgon Division of the C.R.B.)—road-contracting plant used in the construction or maintenance of a road, street, footpath, bridge, wharf, pier, weir or channel. (b) Within a 20-mile radius from site of construction or maintenance work pursuant to paragraph (a) above or from a railway station nearest thereto—materials required for such work. (c) Within a 20-mile radius of the post office at Maffra—general goods.

JUKE BOXES OF AUST. PTY. LTD., 13 Sturt-street, Ballarat; D.A.42274/1; 11th August, 1966; application to renew and vary the conditions of licence No. D.A.42274/1 (L/C. 11 cwt.), by deleting the existing conditions and adding in lieu "throughout the State of Victoria in the course of business as 'Amusement and Vending Machine Operators' for the purposes of installing and servicing coin operated amusements or vending machines—machines for installation or repair or having been repaired, tools of trade and materials incidental thereto".

Notice of any objections should be forwarded to reach the Secretary of the Board not later than Wednesday, 3rd August, 1966.

Applicants are advised that it will not be necessary to appear on the hearing date specified above, unless advised in writing by the Board.

B. P. KAY,
Secretary.

Exhibition Buildings, Rathdown-street, Carlton, N.3., 20th July, 1966.

Transport Regulation Act.

TRANSPORT REGULATION BOARD.

HEARING OF APPLICATIONS.

NOTICE is hereby given that the following applications will be considered by the Transport Regulation Board at its offices at Rathdown-street, Carlton, at 10.15 a.m. on Wednesday, 10th August, 1966.

BLAND, W. A., C. P. & L. L., Box 131, Goroke. Three commercial passenger vehicles with large seating capacity to operate under the same terms and conditions as licences T.S.54, T.S.56 and T.S.653, subject to the cancellation of these licences in the name of W. A. Bland.

CUNNINGHAM, N., 60 Unwin-street, Templestowe. One commercial passenger vehicle (S/C. 5) to operate as a country taxi-cab from Templestowe.

GRANGERS BUS SERVICE PTY. LTD., Bath-place, Williamstown. Application for permit authority to operate any one M.O. licensed vehicle for the carriage of employees only of the Victorian Railways Commissioners free of charge between the Footscray Railway Station and the Brooklyn Railway Siding via Williamstown-road and Somerville-road (under contract to Railways).

TIME-TABLE.

(Weekdays only).

Depart Footscray	7.00 a.m.
Depart Brooklyn	3.50 p.m.

LEES, R. G., & K. A. GUY, 19 Bowen-crescent, Mildura. One commercial passenger vehicle (S/C. 8) to operate as a tourist omnibus on a round trip from Mildura via Kulcyne State Forest and Hattah National Park.

FARES.

Mildura-Hattah and return—\$8.00.

TIME-TABLE.

Depart Mildura	9.30 a.m.
Arrive Mildura	5.00 p.m.

LINGARD, S., Birregurra. One commercial passenger vehicle (S/C. 13) to operate as follows: (a) For the carriage of passengers between Birregurra and Colac.

FARES.

\$2.00 weekly return.
40c daily return.
25c single.

TIME-TABLE.

(Monday-Friday).

Leave Birregurra 8.00 a.m.
Leave Colac 5.45 p.m.

(Saturday).

Leave Birregurra 8.00 a.m.
Leave Colac 12.15 p.m.

(b) As a country special service omnibus from Birregurra.

SOUTH WESTERN ROADWAYS PTY. LTD., 146 Koroit-street, Warrambool. One commercial passenger vehicle (S/C. 38) to operate under the same terms and conditions as existing C.O. licences in the name of the applicant company.

THE TRUSTEES OF WESLEY COLLEGE, St. Kilda-road, Melbourne. One commercial goods vehicle (S/C. 6) to operate free of charge for the carriage of students and staff only of Wesley College's Chum Creek Forestry Camp, Healesville as and when required to places of educational interest around the district or to and from Healesville.

WALSHE, E. P., PTY. LTD., Shiel-street, North Melbourne. Application for variation of route 38 (Footscray-East Melbourne) to delete that section of the route between the corner of Moore-street and Byron-street, Footscray via Moore-street, Ryan-street, Leeds-street to the corner of Leeds and Byron streets and instead to operate from the corner of Moore-street and Byron-street via Byron-street to Leeds-street; thence via normal route.

APPLICATION for renewal of licences as shown, by persons listed hereunder to operate under the same terms and conditions:

DOYLE, P., 118 Vaughan-street, Shepparton; C.O.51; C.O.223; C.O.53; C.O.618; C.O.763; C.O.869.

FINLAYSON, P. J. & N., 108 Wilson-street, Horsham; C.T.403; C.T.415.

O'CONNOR, K. M., 7 Agonis-street, Doveton; C.T.299.

PAEGLIS, I., Box 8, Tungamah; T.S.588.

PRATER, S., Broadway, Wycheproof; C.H.164.

TAYLFORTH BROS. PTY. LTD., 7 Lockwood-road, Shepparton; C.O.245.

TREWEEK, W. J., JNR., 105 Evans-street, Sunbury; C.T.102.

Notice of any objection should be forwarded to reach the Secretary of the Board not later than Wednesday, 3rd August, 1966.

Applicants are advised that it will not be necessary to appear on the hearing date specified above, unless advised in writing by the Board.

B. P. KAY,
Secretary.

Exhibition Buildings, Rathdown-street, Carlton, N.3, Wednesday, 20th July, 1966.

Commercial Goods Vehicles Act.

TRANSPORT REGULATION BOARD.

HEARING OF APPLICATION.

NOTICE is hereby given that the following application will be publicly heard by the Transport Regulation Board at its offices at Rathdown-street, Carlton, at 10.15 a.m. on Thursday, 28th July, 1966.

REYNOLDS & COMPANY PTY. LTD., 193 High-street, Prahran. One commercial goods vehicle (L/C. 75 cwt.) to operate from own premises at Prahran for delivery and sale at various country towns, viz.: Beaufort, Ararat, Stawell, Horsham, Dimboola, Nhill, Kaniva, Jeparit, Rainbow, Beulah, Warracknabeal, Casterton, Balmoral, Cavendish, and Serviceton (en route to S.A.) in course of business as "Confectionery Wholesalers and Distributors"—own confectionery.

Notice of any objection should be forwarded to reach the Secretary of the Board not later than Wednesday, 27th July, 1966.

B. P. KAY,
Secretary.

Exhibition Buildings, Rathdown-street, Carlton, N.3, 20th July, 1966.

Stock Diseases Act 1958 (No. 6382).

QUARANTINE DISTRICTS.

THE quarantine restrictions imposed on the following properties and roads have been removed:—

Name; Address.

- Biemans, H. J.; Buffalo.
- Browne, A. J.; Tarwin.
- Browne, D. J.; "Riverslea", Middle Tarwin.
- Buckley, G. E.; Buffalo.
- Buckley, J. B.; "Colls", Buffalo.
- Buckley, J. B.; "The Ranch", Buffalo.
- Buckley, J. B.; "Little Plains", Buffalo.
- Buckley, P.; Meenyan.
- Cope, L. A.; Middle Tarwin.
- Cope, E. F.; Middle Tarwin.
- Cope, J. D.; Middle Tarwin.
- Den Brock, J. W.; Buffalo.
- Dikkenberg, N. & D. J.; Buffalo.
- Doble, M. J.; Buffalo.
- Doble, M. J.; "Spring Plains", Buffalo.
- Dunlop, G.; Middle Tarwin.
- Dunlop, P.; Middle Tarwin.
- Eagle, E. W. & M. I.; Buffalo.
- Emmerson, W. F.; Fish Creek.
- Gardner, P. J.; "Tullaree", Buffalo.
- Hassett, J. E.; Buffalo.
- Haw, F. G. & N. H.; Leongatha.
- Holm, J. L.; Buffalo.
- Holm, J. L. & I. M. M.; Buffalo.
- Jordan, M.; Buffalo.
- Lumsden, N. R.; Fish Creek.
- Murray, Miss M.; "Fairynook", Buffalo.
- O'Loughlin, Est. F. J.; Buffalo.
- O'Loughlin, E. J. & B. F.; Buffalo.
- Poletti, A.; Buffalo.
- Poletti, B.; Buffalo.
- Ray, J. R.; Middle Tarwin.
- Setford, A. G. & R. J.; Buffalo.
- Seuren, G. P. J.; Fish Creek.
- Shire of Woorayl; Buffalo-Tullaree road from junction, south of Buffalo to "Tullaree Gate"; Buffalo-Waratah road from O'Loughlin's Corner to Tarwin Lower-Waratah road; Fish Creek West-road from Buffalo-Waratah road to a point 2½ miles east of Bucklands Track; Conron and Moores road; unnamed road contiguous to the properties of W. Gillingan, R. Cashin, D. Browne, Haw Bros., and J. L. Holm; Stewarts and Dunlops roads, east of Tarwin River; Tarwin Lower-Waratah road from Tarwin Meadows-road junction to Middle Creek.

D. M. FLYNN,
Chief Inspector of Stock.

DEPARTMENT OF MINES.

SUBJECT to any necessary excisions, &c., it is proposed to grant the following mining lease:—

8444, Mineral; Victorian Refining and Smelting Company Proprietary Limited; 31a. Or. 24p., Parish of Sargood.

MINING LEASES GRANTED.

5621, Gippsland; David William Hamilton, John Coyle and Albert Trevor Bruhn; 87a. 2r. 34p., Parish of Jimkee (replacing notice appearing in Government Gazette No. 48, page 2346, 6th July, 1966).

5622, Gippsland; David William Hamilton; 102a. 1r. 21p., Parish of Jimkee (replacing notice appearing in Government Gazette No. 48, page 2346, 6th July, 1966).

EXPLORATION LICENCE DECLARED ABANDONED.

46, Exploration Licence; Gheringhap Pty. Ltd., 100 square miles, County of Dargo.

MINERAL SEARCH LICENCE EXPIRED.

605, Mineral Search Licence; Edward Arthur Knox and Henry James Evans; 85 acres, Parish of Tarildam.

T. A. DARCY,
Minister of Mines.

TAILINGS LICENCE DECLARED VOID.

3264, Tailings Licence; Malcolm Owen Valentine Pritchard; 39a. 3r. 7p., Parish of St. Arnaud.

E. CONDON,
Secretary for Mines.

Health Act 1958.

VICTORIA—DEPARTMENT OF HEALTH.

NOTICE TO ATTEND FOR RADIOLOGICAL EXAMINATION.

To all persons aged twenty-one years and over enrolled or resident in the Subdivisions specified hereunder in the State Electoral District of Ormond.

TAKE notice that you are required to attend at a Department of Health X-ray unit sited in the public street at or as near as possible to the main entrance to the premises specified in this notice, at any time between the hours specified on one of the days specified and during the period specified in respect of those premises, and thereat to submit yourself to radiological examination of the chest for the purpose of ascertaining whether you may be suffering from pulmonary tuberculosis. If you have had a chest X-ray within the last twelve months and for that reason do not wish to be examined now, you should attend the unit as directed and submit particulars of the previous examination.

SPECIFIED SUBDIVISIONS, PREMISES, PERIODS, DAYS AND HOURS.

Subdivision.	Premises.	Period.	Days.	Hours.
Carnegie	Public Hall, Rosstown-road, Carnegie	Monday, 1st August, 1966, to Monday, 8th August, 1966 (inclusive)	Each day during the period except Saturday, Sunday and Public Holidays	From 10 a.m. to 8.30 p.m.
	Public Hall, Royal-avenue, Glenhuntly	Monday, 1st August, 1966, to Tuesday, 9th August, 1966 (inclusive)	Each day during the period except Saturday, Sunday and Public Holidays	From 10 a.m. to 8.30 p.m.
Glenhuntly	Carew's Hardware Store, cnr. Ulupna and North roads, Ormond	Tuesday, 9th August, 1966, to Monday, 22nd August, 1966 (inclusive)	Each day during the period except Saturdays, Sundays and Public Holidays	From 10 a.m. to 8.30 p.m.
	Public Hall, Royal-avenue, Glenhuntly	Monday, 1st August, 1966, to Tuesday, 9th August, 1966 (inclusive)	Each day during the period except Saturday, Sunday and Public Holidays	From 10 a.m. to 8.30 p.m.
	Booran Pharmacy, 187 Booran-road, Glenhuntly	Tuesday, 2nd August, 1966, to Monday, 8th August, 1966 (inclusive)	Each day during the period except Saturday, Sunday and Public Holidays	From 10 a.m. to 8.30 p.m.
Bentleigh North	Hughes' Pharmacy, 441 North-road, Ormond	Tuesday, 9th August, 1966, to Thursday, 18th August, 1966 (inclusive)	Each day during the period except Saturday, Sunday and Public Holidays	From 10 a.m. to 8.30 p.m.
	Carew's Hardware Store, cnr. Ulupna and North roads, Ormond	Tuesday, 9th August, 1966, to Monday, 22nd August, 1966 (inclusive)	Each day during the period except Saturdays, Sundays and Public Holidays	From 10 a.m. to 8.30 p.m.
	Hughes' Pharmacy, 441 North-road, Ormond	Tuesday, 9th August, 1966, to Thursday, 18th August, 1966 (inclusive)	Each day during the period except Saturday, Sunday and Public Holidays	From 10 a.m. to 8.30 p.m.
	Shepherd's Sandwich Bar, 896 North-road, Ormond East	Wednesday, 10th August, 1966 to Monday, 15th August, 1966 (inclusive)	Each day during the period except Saturday, Sunday and Public Holidays	From 10 a.m. to 8.30 p.m.
	Kipen's Drapery, 77 Mackie-road, East Bentleigh	Tuesday, 16th August, 1966, to Wednesday, 24th August, 1966 (inclusive)	Each day during the period except Saturday, Sunday and Public Holidays	From 10 a.m. to 8.30 p.m.
	Northleigh Mobil Service Station, 94 North-road, Oakleigh South	Friday, 19th August, 1966 to Wednesday, 24th August, 1966 (inclusive)	Each day during the period except Saturday, Sunday and Public Holidays	From 10 a.m. to 8.30 p.m.
	Golberg's Self Service Grocery, cnr. Melva-street and North-road, East Bentleigh	Tuesday, 23rd August, 1966, to Thursday, 25th August, 1966 (inclusive)	Each day during the period except Public Holidays	From 10 a.m. to 8.30 p.m.

NOTE.—Any person to whom this notice applies and who without reasonable excuse fails to comply with the requirements of the notice shall be guilty of an offence, and shall be liable to a penalty of not more than Forty dollars.

Dated this 24th day of June, One thousand nine hundred and sixty-six.

KEVIN BRENNAN, Chief Health Officer.

Process Servers and Inquiry Agents Act 1958.

APPLICATIONS FOR LICENCES LODGED WITH CLERKS OF COURTS.

By direction of the Chief Secretary, the subjoined lists of "new" applications for process servers and inquiry agents licences are published for general information.

Applicant.	Address.	Court.	Tentative Date of Hearing of Application.
<i>Inquiry Agents Licences.</i>			
Boyd, Stephen	Flat 1, 34 Vautier-street, Elwood	Elsternwick	9.8.66
Holloway, John Newton	34 Leopold-street, Burwood	Camberwell	4.8.66
Voigt, Trevor Gordon	34 Vautier-street, Elwood	St. Kilda	4.8.66

Attention is directed to the provisions of the above Act and regulations thereunder relating to the lodgement of objections to applications.

Chief Secretary's Office,
Melbourne, 18th July, 1966.

E. L. RICHARDSON, Registrar,
Process Servers and Inquiry Agents.

Apprenticeship Act 1958.

APPRENTICESHIP COMMISSION OF VICTORIA.

NOTICE OF INTENTION TO RECOMMEND THAT THE ELECTROPLATING TRADE BE PROCLAIMED AN APPRENTICESHIP TRADE OUTSIDE THE METROPOLITAN DISTRICT.

NOTICE is hereby given, in pursuance of the provisions of the *Apprenticeship Act 1958*, that it is the intention of the Apprenticeship Commission of Victoria to make a recommendation to the Minister of Labour and Industry that the trade of Electroplater—First Class be proclaimed an apprenticeship trade under the said Act, in so far as it is carried on in the whole of the State of Victoria outside and excepting the Metropolitan District.

It is also notified that the 26th August, 1966, has been fixed as the date before which representations may be made to the said Commission, by or on behalf of employers or employees in the said trade, whether for or against the said recommendation being made.

By order of the Commission,

L. R. BROWN,
Secretary to the Commission.

10 Leicester-street, Carlton, N.3, 13th July, 1966.

Labour and Industry Act 1958, section 45b.

REFERENCE OF A MATTER TO THE INDUSTRIAL APPEALS COURT.

NOTICE is hereby given that, pursuant to the provisions of section 45b of the *Labour and Industry Act 1958*, the Minister of Labour and Industry has referred to the Industrial Appeals Court for determination by it the following matter, viz.:—an application to each of the Wages Boards mentioned in the Schedule hereto to amend its determination by altering the prices and/or rates thereby determined so that they will be in accordance with the judgment of the Commonwealth Conciliation and Arbitration Commission delivered on the 8th day of July, 1966, in the Metal Trades Cases (C. Nos. 1849 and 1855 of 1965; 3 of 1966) and the Pastoral Case (C. No. 80 of 1966).

Notice is also given that the Industrial Appeals Court will deal with the aforesaid matter on Friday, the twenty-second day of July, 1966, at No. 1 Boardroom, Workers' Compensation Board Offices, 160 Queen-street, Melbourne.

Dated at Melbourne, this fifteenth day of July, 1966.

C. R. DEDMAN, Registrar,
Industrial Appeals Court.

SCHEDULE.

Aerated Water Trade; Agricultural and Pastoral Workers; Ambulance Services; Animal Manure; Asbestos Cement Workers; Bagmakers; Biscuit; Boarding Houses; Boarding School Employees; Boilermakers; Boot; Bread Carters; Bread Trade; Bricklayers; Brick Trade; Brushmakers; Builders' Labourers; Building Sheets (Compressed Straw); Bulk Grain Workers; Butter Factories; Canteen Workers; Caretakers; Carpenters; Carters and Drivers; Cement; Cement Articles; Cemetery Employees; Chaffcutters; Cleaners; Clerks (Meat Works); Clothing; Coal and Coke; Commercial Artists; Commercial Clerks; Commercial Travellers; Condenseries; Confectioners; Cork Trade; Cycle Trade; Dairy Farm Workers; Dental Technicians; Draughtsmen; Dress, Shirt, and Underclothing; Dyers and Clothes Cleaners; Electroplaters; Engineers and Brassworkers (Skilled); Engineers and Brassworkers (Unskilled); Engravers; Entertainment Employees (Performers); Excavation or Road Work; Fibrous Plasterers; Filermakers; Fire Brick and Refractories; Fire Brigade Officers; Fire fighters; Flock; Frozen Goods; Fruit Growers; Fruit Packing; Fur Trade; Garden Employees; Hairdressers; Headwear and Straw Hat; Horsehair; Hospital and Benevolent Homes; Hospital Nurses; Hospital Pharmacists; Hotel and Restaurant; Ice; Ice Cream; Industrial Gases; Iron and Steel Rolling; Ironmoulders; Journalists; Knitting Trade; Laundry Workers; Law Clerks; Lift; Limeburners; Manufacturing Chemists; Marine Stores; Meat Preservers; Millet Broom; Mineral Earths; Mothercraft Nurses; Motor Drivers; Nail Makers; Nickelware; Non-ferrous Metals; Nurserymen's; Opticians; Paint and Colour; Painters; Pastrycooks; Photographers; Photographic Goods; Plasterers; Plaster of Paris; Plumbers; Pottery; Poultry Farm Workers; Production Planning; Quarry; Rabbit Processing; Radio Announcers; Retail Dairy; Road Patrolmen's; Roofing Tiles; Saltworkers; Sand Pit; Sausage Casings; Scientific and Technical Workers; Sewage Distribution; Sewer Builders; Shearing Industry; Shops Board No. 1 (Boot Dealers); Shops Board No. 2 (Boot Repairers); Shops Board No. 3 (Butchers); Shops Board No. 7 (Country Shop Assistants);

Shops Board No. 8 (Delicatessens); Shops Board No. 9 (Drapers and Men's Clothing); Shops Board No. 10 (Fish and Poultry); Shops Board No. 12 (Fuel and Fodder); Shops Board No. 13 (Fuel and Fodder—Country); Shops Board No. 14 (Furniture Dealers); Shops Board No. 15 (Grocers); Shops Board No. 16 (Hardware); Shops Board No. 17 (Tobacconists); Shops Board No. 18 (Miscellaneous Shops); Shops Board No. 19 (Confectionery, Pastry, Fruit and Vegetable); Shops Board No. 21 (Booksellers and Newsagents); Shops Board No. 22 (Motor Requisites); Shops Board No. 23 (Electrical and Radio Goods); Slaughtering for Export; Special Service Firemen's; Sports Ground Maintenance; Stonecutters; Storemen, Packers and Sorters; Sugar Refiners; Synthetic Filament Yarn; Tar and Bitumen; Tea Packing; Tennis Strings; Tow Truck Drivers; Underground Clay Mining; Undertakers; Vegetable Growers; Watchmen's; Waterfront Watchmen's; Wharfs and Jetties; Wholesale Grocers; Wire Fence and Tubular Gate; Wire-workers; Woollen and Cotton Trade.

LOCAL GOVERNMENT DEPARTMENT.

ORDER CONFIRMED.—SHIRE OF ROSEDALE.

THE Minister of the Crown administering the *Local Government Act 1958*, as amended on the 11th day of July, 1966, confirmed the Order hereinafter referred to in pursuance of section 514 of the said Act namely:

An Order of the Council of the Shire of Rosedale made on the 21st October, 1965, directing the compulsory taking of the land described hereunder for road purposes:

1. All that piece of land being part of Crown allotment 7, section A, Parish of Wulla Wullock commencing at an angle in the southern boundary of the said allotment formed by lines bearing 89 deg. 21 min. and 332 deg. 46 min.; thence by lines bearing 332 deg. 46 min. 574.8 links; 122 deg. 58 min. 927.8 links and 269 deg. 21 min. 515.9 links to the commencing point.
2. All that piece of land being part of Crown allotment 7, section A, Parish of Wulla Wullock commencing at the south-eastern angle of the said allotment; thence by lines bearing 359 deg. 37 min. 212.4 links; 308 deg. 37 min. 20 secs. 3,042.7 links, 269 deg. 21 min. 47.6 links, 179 deg. 21 min. 219.5 links; 128 deg. 37 min. 30 sec. 2,980.6 links, 152 deg. 5 min. 36.4 links and 89 deg. 18 min. 78 links to the commencing point.

R. J. HAMER,

Minister for Local Government.

Local Government Department,
Melbourne. (3171311)..

Forests Act 1958, No. 6254.

DECLARATION OF LAND NOT TO BE A FIRE PROTECTED AREA.

IN pursuance of the powers conferred by section 3 of the *Forests Act 1958*, I, James Charles Murray Balfour, Her Majesty's Acting Minister of Forests in the State of Victoria, hereby declare that any land which is within one mile of any reserved forest or of any area of unoccupied Crown land proclaimed as a protected forest pursuant to this Act or any corresponding previous enactment or of any national park, and which is situated within the parishes and part parishes specified in the Schedule hereto, shall not be a fire protected area.

SCHEDULE.

The parishes of—Bollinda, Broadford, Bulla Bulla, Chintin, Darraweit Guim, Forbes, Ghin Ghin, Glenaroua, Goldie, Havelock, Holden, Kalkallo, Lancefield, Lowry, Mangalore, Maribyrnong, Merriang, Mickleham, Monegeetta, Moranding, Morang, Pyalong, Seymour, Springfield, Tallarook, Toorourrong, Tuillamarine, Willowmavin, Will-will-rook, Windham, Wollert, Worrourgh, Yan Yean, Yea, Yuroke.

Bylands—that portion west of the North-eastern Railway.
Glenburnie—that portion west of the Broadford-Wandong road.

Kerrisdale—that portion north of the Broadford-Strath Creek road.

Linton—that portion north of Coombes-road and the Melbourne and Metropolitan Board of Works Yan Yean Reserve, and that portion south of the northern boundaries of allotments 3A, 16, 22A and 22B, and the south-eastern boundary of the Melbourne and Metropolitan Board of Works Yan Yean Reserve.

Wallan Wallan—that portion west of the Whittlesea-Wandong road.

JIM BALFOUR,

Acting Minister of Forests.

14th July, 1966.

CONTRACTS ACCEPTED.—(Series 1965-66.)**PUBLIC WORKS.**

3741. Burnley, Horticultural College, supply and installation of heating and hot-water services, soil sterilizer and mist propagation services in the new laboratory and glass-houses, \$13,568.00.—A.F.D.A. Heating & Plumbing Service.
3742. Royal Park, Mental Hospital, modification of central heating systems in female convalescent ward "A" and male convalescent wards "A" and "C", \$7,988.00.—W. S. Atherton & Co. Pty. Ltd.
3743. Sunbury, Mental Hospital, external painting, new nurses' home, \$2,800.00.—R. Bendinelli & E. Carlini.
3744. Sunbury, Mental Hospital, supply and installation of two exhaust hoods in main kitchen, \$2,310.00.—Bruce Sheet Metal Service.
3745. Mooroolbark, State School No. 4417, supply and installation of new copper water supply, \$1,944.00.—P. C. Brewer.
3746. Pascoe Vale, State School No. 3081, new brick toilet block, \$10,875.00.—I. Bulat.
3747. Ringwood, High School, installation of fire service and domestic water supply, \$4,767.00.—C. & J. Plumbing Service.
3748. Melbourne, Little Lonsdale-street, Central Chest Clinic, water and exhaust air systems to film processing machine, \$1,093.00.—S. D. Dawe.
3749. Heatherton, Sanatorium, new sewing room, \$11,500.00.—P. T. Dawes.
3750. Buckley Park, High School, electrical installation—extended stage three, \$7,421.95.—K. J. Dupuy.
3751. Shepparton, State School No. 4943, ten class-room brick veneer primary school plus library, \$104,658.00.—Euroa Building Co.
3752. Caulfield, Technical College, convert store to male toilets, including sewer diversion, &c., \$4,638.00.—N. G. Fleming.
3753. Sunbury, Mental Hospital, supply and installation of briquette fired 14,500 lb./hr. steam boiler and conveyor system for boiler house, \$40,640.00.—George & George Pty. Ltd.
3754. Mont Park, Mental Hospital, repair steam-o-matic boiler, \$2,037.00.—George & George Pty. Ltd.
3755. Larundel, Mental Hospital, supply and installation of 100 radiator hoods, \$1,150.00.—Gray & Wood.
3756. Yallourn, Technical School, part re-roofing, \$6,600.00.—K. H. Helstrup.
3757. Teal Point, State School No. 2486 and Residence, repairs and painting, \$2,100.00.—K. H. Helstrup.
3758. Traralgon, Hobson Park Hospital, steel catwalk and folding doors to boiler house, \$5,800.00.—K. H. Helstrup.
3759. St. Kilda Park, State School No. 2460, renovations to boys' toilet block, \$1,600.00.—K. H. Helstrup.
3760. Manangatang, Consolidated School, renovations, \$20,000.00.—K. H. Helstrup.
3761. Sunbury, Mental Hospital, electrical installation for new industrial therapy building, \$1,876.00.—Jarrett & Crikis.
3762. Various, Schools, maintenance of oil burners and other mechanical equipment for year ending 31st December, 1966, metropolitan area, \$5,557.00.—Keystone General Electric Pty. Ltd.
3763. Various, Schools, North-Eastern Victoria, maintenance of oil burners and other mechanical equipment for year ending 31st December, 1966, inner north-east area, \$4,485.00.—Keystone General Electric Pty. Ltd.
3764. Various, Schools, North-eastern Victoria, maintenance of oil burners and other mechanical equipment for year ending 31st December, 1966, outer north-eastern area, \$2,937.00.—Keystone General Electric Pty. Ltd.
3765. Various, Schools, South-Eastern Victoria, maintenance of oil burners and other mechanical equipment for year ending 31st December, 1966, \$10,415.00.—Keystone General Electric Pty. Ltd.
3766. Various, Schools, Western Victoria, maintenance of oil burners and other mechanical equipment for year ending 31st December, 1966, \$13,049.00.—Keystone General Electric Pty. Ltd.
3767. Mansfield, State School No. 1112, repairs and painting, \$9,935.85.—A. F. Kortum.
3768. Euroa, High School, repairs and painting, \$3,944.00.—A. Kortum.
3769. Viewbank, State School No. 4892, earthworks, asphaltting, concreting, drainage and associated works, \$28,383.75.—Wm. Loud Pty. Ltd.
3770. South Yarra, State School No. 583, external repairs and painting, \$2,662.00.—L. & R. Painting Service.
3771. Kilsyth, State School No. 3645, renewal of urinal, provision of drinking trough and repairs to toilet blocks, \$1,067.00.—C. McCarthy.
3772. Carlton, St. Nicholas Hospital, alterations and additions, administrative branch, \$40,340.00.—McKenzie Constructions Pty. Ltd.
3773. Mitcham, High School, erection of science wing, \$45,584.00.—Marshall Bros. Builders.
3774. Lilydale, State School No. 876, electrical installation, \$1,212.47.—R. N. Murphy.
3775. Burnley Gardens, Horticultural College, supply and installation of mechanical services in the new headhouse of the twin glasshouse, \$1,560.00.—L. C. Osborn Pty. Ltd.
3776. Mont Park, Mental Hospital, erection of three brick veneer residences, \$35,250.00.—E. Osinski Building Co. Pty. Ltd.
3777. Swan Hill, High School, supply and installation of extensions to heating systems, \$28,710.00.—F. A. Petzke & Co.
3778. Tecoma, Melbourne High School, replacement of power line, forestry school, \$1,760.00.—J. & B. Ranking Pty. Ltd.
3779. Burnley Gardens, Horticultural College, alterations to electrical distribution and main switchboard, \$5,200.00.—J. & B. Ranking Pty. Ltd.
3780. Springview, State School No. 4912, asphaltting, concreting, retaining walls, drainage, landscaping and associated works, \$17,345.70.—D. Saathoff & Co.
3781. Montrose, State School No. 2259, earthworks, surface and underground drainage and pavement construction, \$10,398.00.—D. Saathoff & Co.
3782. Seville, State School No. 2820, erection of a store and associated works, supply and installation of heaters, \$3,164.00.—A. V. Steele.
3783. Bon Beach, High School, mechanical services in science wing, \$7,840.00.—Thermic Heating & Ventilation.
3784. Richmond, State School No. 2084, new tile roof, \$4,400.00.—H. & A. Tinsley Pty. Ltd.
3785. Carlton, Secondary Teachers' College, University Grounds, supply and installation of heating and exhaust services to new physics laboratories, \$3,776.00.—Universal Heating & Air Conditioning.
3786. Fitzroy, Mental Health Clinic, 6 Alexander-parade, maintenance cleaning period 1st April, 1966 to 31st May, 1968, \$1,928.00 per year.—Utility Office Cleaning Services Pty. Ltd.
3787. Maribyrnong, Government Printing Office, electrical installation in bulk paper store, \$11,240.00.—J. F. & E. E. Veall.
3788. Mont Park, Gresswell Sanatorium, repairing of steam and hot-water reticulation, \$14,400.00.—R. J. Weekes Pty. Ltd.
3789. Stawell, Pleasant Creek Special School, interior painting to Children's dining room, \$2,284.90.—Wilber Supplies & Service.
3790. Bendoc, Police Station, Court House & Residence, supply and installation of hot-water service and L.P. gas heating, \$1,359.50.—R. K. Williams Pty. Ltd.
3791. Mornington, High School, external renovations, \$4,100.00.—A. Alaimo.
3792. Talbot, State School No. 954, reflooring of classrooms, &c., \$2,349.00.—L. Barry.
3793. Alexandra, Soil Conservation Authority Residence, internal and external repairs and re-painting, \$2,592.00.—L. G. Aldous.
3794. Sale, Technical School, erection of new administration and class-room block, \$281,412.00.—D. Black Pty. Ltd.
3795. Rosanna, High School, renovations, \$3,020.00.—C. B. Bramich.
3796. Merrilands, High School, external renovations, \$3,100.00.—C. B. Bramich.
3797. Glenroy West, State School No. 4809, external repairs and painting, \$2,120.00.—C. B. Bramich.
3798. Broomfield, State School No. 1719, new out-office block, septic tank installation, &c., \$2,390.00.—W. T. Bedson.
3799. Burwood, "Allambie" Children's Home, Elgar-road, supply and installation of central heating and hot-water services for new nurses' home, \$4,556.00.—Belsair Pty. Ltd.
3800. Toongabbie, State School No. 856, Residence, repairs and painting, \$1,093.55.—C. O. Coleman.
3801. Sussex Heights, State School No. 4832, plenum heating in new eight class-room school, \$4,380.00.—Chadstone Air Conditioning Services.
3802. Preston, Technical College, ventilation and engine exhaust system, \$1,110.00.—George H. Curtis & Sons Pty. Ltd.
3803. Koorlong, State School No. 3470 and Residence, new out-offices and septic tank installation, \$2,630.00.—K. P. Collins.
3804. Traralgon, State School No. 4652, connexion to water service, \$1,071.00.—Dunn's Heating & Plumbing Service.
3805. Monbulk, Police Station, erection of brick veneer residence, office and cell block, \$21,927.00.—A. & C. D'Alaisio.
3806. Haven, State School No. 3765 and Residence, conversion to septic tanks, \$1,738.00.—A. C. Dawes.
3807. Everton, State School No. 2031 and Residence, erection of out-offices and installation of septic tanks, \$2,845.10.—A. C. Dawes.

3808. Dean's Marsh, State School No. 1642 and Residence, conversion to septic tank, \$2,141.00.—A. C. Dawes.
3809. Carlisle River, State School No. 3497, new toilet block and septic tank installation, \$2,770.66.—A. C. Dawes.
3810. Campbell's Creek, State School No. 120, conversion of septic sewerage, \$1,375.00.—A. C. Dawes.
3811. Bungador, State School No. 4255, erection of out-offices and installation of septic tank, \$2,636.50.—A. C. Dawes.
3812. Mannerim, State School No. 3096, new toilet block and septic tank installation, \$2,692.00.—R. Dragt.
3813. Springvale North, State School No. 1658, sewerage treatment plant and additional toilets, \$3,750.00.—N. G. Fleming.
3814. Mitcham, High School, mechanical services in science wing, \$7,434.00.—Ford-Swinton Industries Pty. Ltd.
3815. Maffra, State School No. 861, asphalt repairs, \$4,042.50.—G. Frankland.
3816. Drouin, State School No. 1924, supply and installation of central heating, \$6,356.00.—F.I.M.S. Heating.
3817. Rutherglen, Research Station, erection of administration and laboratory block, \$108,500.00.—A. Gathercole & Co. Pty. Ltd.
3818. Hamilton, Research Station, mechanical services to laboratory and administration block, \$13,134.00.—Gray & Wood.
3819. Addington, State School No. 226, external painting, \$1,017.40.—Goodwood Decorating Service.
3820. Stewart, State School No. 4531, internal and external painting and replacement of fibrous plaster sheet, \$1,878.00.—P. Hendricks.
3821. Mont Park, Mental Hospital, alterations to electrical reticulation, \$1,325.00.—M. Harrison.
3822. Maryborough, Technical School, heating system in main school building, \$13,996.00.—J. G. Hibberd Pty. Ltd.
3823. Malvern, "Stonington" Toorak Teachers' College, new assembly hall and lecture block, \$494,471.00.—Hannah Builders Pty. Ltd.
3824. Lilydale, State School No. 876, supply and erection of class-rooms and additional work, \$36,231.00.—R. F. Hosie Pty. Ltd.
3825. Heidelberg, Girl's Secondary School, electrical installation in new art and music wing, &c., \$3,060.50.—R. A. Hexter & Co.
3826. Big Hill, State School No. 1551 and Residence, installation of water supply, \$1,660.00.—J. G. Hibberd Pty. Ltd.
3827. Echuca, Technical School, supply and installation of sawdust extraction plant, \$3,022.75.—J. G. Hibberd Pty. Ltd.
3828. Gardiner, State School No. 3888, fireproofing ceilings, \$1,550.00.—Insulation Materials & Service Pty. Ltd.
3829. Landsborough, State School No. 1862, additional toilet, installation of septic tank, &c., \$1,410.00.—L. A. Johnson.
3830. Buckley Park, High School, erection of third section in concrete veneer L.T.C., \$132,816.00.—A. V. Jennings Industries (Australia) Ltd.
3831. Kew, Mental Hospital, erection of standard school of nursing, \$49,452.00.—A. V. Jennings Industries (Australia) Ltd.
3832. Traralgon, High School, conversion of art rooms and additional rooms, \$48,529.00.—A. V. Jennings Industries (Australia) Ltd.
3833. Warrnambool West, State School No. 4899, asphalt and concrete paving, kerbing, drainage, beautification and associated works, \$11,640.30.—J. Keen.
3834. Hamilton, State School No. 4847, sealing roadway and playing area, \$2,100.00.—J. Keen.
3835. Footscray, Geelong-road, Dental Clinic, supply and installation of air conditioning units, \$1,454.00.—Kelvinator Australia Ltd.
3836. Karingal, High School, erection of assembly hall, \$91,500.00.—W. O. Longmuir & Son Pty. Ltd.
3837. Arnold, State School No. 1664 and Residence, internal repairs and painting, renewal of flooring to classroom, &c., \$1,768.00.—A. L. Lawrence.
3838. Glen Valley, State School No. 3558, erection of out-offices and installation of septic tank, \$1,850.00.—A. K. McCrabb.
3839. Gilderoy, State School No. 3020, septic sewerage, new toilet block, &c., \$2,410.00.—C. McCarthy.
3840. Doncaster East, State School No. 2096, erection of new toilet block and sewerage, demolition of old toilet block and septic tanks, \$20,010.00.—C. McCarthy.
3841. Campmeadows, State School No. 4833, renovations, \$7,094.00.—J. P. McElligott & Co. Pty. Ltd.
3842. Footscray, State School No. 1912, gas heating, \$7,798.00.—D. W. & M. W. McAuslan Pty. Ltd.
3843. Traralgon, High School, modifications to heating and hot-water systems, and installation of exhaust fans, \$4,868.00.—J. & T. Miller Pty. Ltd.
3844. Traralgon, High School, electrical installations, \$4,816.00.—J. R. Martin Pty. Ltd.
3845. Sussex Heights, State School No. 4832, electrical installation in new school of eight (8) L.T.C. class-rooms, &c., \$2,800.00.—R. N. Murphy.
3846. Mitcham, High School, electrical installation in additional science wing, \$2,530.50.—R. N. Murphy.
3847. Gordon, Police Station and Residence, repairs and painting, \$1,020.00.—Mawby & Rixon.
3848. Coromby, State School No. 2082 and Residence, conversion to septic tanks, \$1,340.00.—B. J. Mason.
3849. Castlemaine, High School, construction of concrete and asphalt paving, gravelled areas, drainage and associated works, \$50,887.82.—F. G. Miller.
3850. Burnley Gardens, Horticultural College, electrical installation in plant science laboratory and glasshouse block, \$3,568.00.—H. C. Marshall & Co. Pty. Ltd.
3851. Wurruk, State School No. 2578, external repairs and painting, \$2,856.82.—J. Milnaric.
3852. Boisdale, Consolidated School, external repairs and painting, &c., \$9,467.20.—J. Milnaric.
3853. Malvern, State School 1604, renewal of flooring, \$1,000.00.—R. A. Nash.
3854. Elmhurst, State School No. 959, conversion to septic tanks, \$1,491.00.—P. C. Nicholson.
3855. Albion North, State School No. 4855, connexion to M.M.B.W. sewer, \$1,970.50.—F. Norton Pty. Ltd.
3856. Belmont, State School No. 26, fire service and domestic water supply installation, \$1,261.00.—F. Norton Pty. Ltd.
3857. Tarnagulla, State School No. 1023, external and internal repairs and painting, \$2,318.00.—Oliver's Decorating Service.
3858. Clunes, State School No. 1552, Residence, Bailey-street, internal and external repairs and painting, \$1,188.80.—Oliver's Decorating Service.
3859. Rochester, High School, electrical installation in L.T.C. extension, &c., \$5,762.00.—W. Phelan & Sons Pty. Ltd.
3860. Drysdale, Police Station, supply and erection of a "Plymouth" type residence and resiting of existing office, \$10,938.00.—W. Phelan & Sons Pty. Ltd.
3861. Derrinalum, Lands and Survey Department, Residence, repairs and painting, \$1,664.00.—T. Peperkamp.
3862. Nyah West, Police Station, repairs and painting, \$1,130.00.—Pascoe Vale Painters.
3863. Riverslea, State School No. 3667, internal and external renovations, \$1,985.40.—P. Petroff.
3864. Irymple, Research Station, supply and installation of air conditioning, hot-water and L.P. gas services in the citrus packing shed, \$5,130.00.—F. R. Persson.
3865. Kew, Mental Hospital, plenum heating, hot-water system and steam reticulation for school of nursing, \$12,712.00.—Pacific Sheet Metal Pty. Ltd.
3866. Kew, Mental Hospital, renovations to two nurses' hostels, \$5,996.00.—N. Peshut.
3867. Ocean Grove, erection of Police Station and Residence, \$19,776.00.—L. Poulston & Sons Pty. Ltd.
3868. Portland, State School No. 489, Residence, erection of laundry and toilet, \$1,397.48.—R. K. Patterson.
3869. Laverton, State School No. 2857, internal repairs and painting, \$1,198.22.—C. Ricchetti & P. Sequenzia.
3870. Carlton North, State School No. 1252, repairs to senior school—repairs and painting to residence and out-buildings, \$2,560.00.—C. Ricchetti & P. Sequenzia.
3871. Lara, Serendip, Fisheries and Wildlife Branch, supply and installation of hot-water service and heating system in new service block, \$6,394.00.—R. & H. Rivett.
3872. Sale, Fisheries and Wildlife Branch, erection of steel framed machinery shed, \$1,456.00.—Supa Welds Pty. Ltd.
3873. Mullum, State School No. 4886, asphalt, concreting, drainage, retaining walls and associated works, \$35,845.97.—Sheffield Paving & Construction Co.
3874. Minyip, State School No. 2167, Residence, external and internal repairs and painting, \$3,290.00.—A. Schreuder.
3875. Kerrimuir, State School No. 4816, earthworks, asphalt, drainage, concreting and associated works, \$4,985.00.—Sheffield Paving & Construction Co.
3876. Bendigo, Girls' Secondary School, exhaust system and extensions to heating and hot-water services, \$12,306.00.—D. Smyth & Son Pty. Ltd.
3877. Werribee, Research Farm, completion of mechanical services in new kitchen and dining block, \$1,970.00.—Tempcontrol Engineering Pty. Ltd.
3878. Royal Park, Mental Hospital, supply and installation of steam heating to the chapel, \$2,360.00.—Tempcontrol Engineering Pty. Ltd.
3879. Bon Beach, High School, electrical installation in additional science wing, \$2,688.00.—C. R. Thorn & Sons Pty. Ltd.
3880. Lorne, State School No. 2162, internal toilet for female staff teachers, \$1,192.00.—A. P. Van Dort & Sons.

3881. Altona North, State School No. 4931, electrical installation, new block of eight class-rooms, &c., \$2,080.00.—J. F. & E. E. Veall.

3882. Sussex Heights, State School No. 4832, erection of primary school, \$76,778.00.—J. P. & J. W. Wolbers Pty. Ltd.

3883. Horsham, Boy's Technical School, erection of modified second and third sections, \$163,200.00.—J. P. & J. W. Wolbers Pty. Ltd.

3884. Heidelberg, Girls' Secondary School, erection of new class-room wing and conversion of two existing class-rooms, \$38,748.00.—J. P. & J. W. Wolbers Pty. Ltd.

3885. Jumbunna, State School No. 2954 and Residence, septic tanks, new out-offices, &c., \$2,462.70.—J. White.

3886. Irrewillipe East, State School No. 2357, conversion to septic tanks, \$1,181.50.—N. A. Wooding.

3887. Echuca, High School, electric light and power for additional class-rooms, \$2,760.00.—W. A. D. Electrics Pty. Ltd.

3888. Robinvale, Consolidated School, various repairs to buildings; new stairs to theatre class-room, \$3,002.00.—Welsh & McKay.

3889.—Buln Buln, State School No. 2017, internal and external repairs and painting, \$1,620.00.—T. Webb.

3890. Drouin West, State School No. 1417, repairs and painting, \$1,212.00.—T. T. & J. M. Webb.

JIM BALFOUR, Acting Minister of Public Works.
14.7.66.

CONTRACTS ACCEPTED.—(Series 1966-67.)

CEREALS.

Requirements under Sub-schedule No. 10 of Schedule No. 1 for the period 1st August, 1966, to 31st October, 1966, are to be purchased from the under-mentioned firms at the rates per hundredweight respectively indicated, viz., H. S. K. Ward (Melb.) Pty. Ltd., Barley—pearl, \$4.40; Oatmeal—plain, \$5.35; Oatmeal—flaked, \$5.55; Peas—split—yellow, \$7.85; Robert Harper & Co. Ltd., Rice—dressed, \$9.40; Tapioca—seed, \$7.10.

H. COUTTS, Secretary to the Tender Board. 18.7.66.

ORDERS IN COUNCIL.—(Series 1965-66.)

STATE ELECTRICITY COMMISSION.

3891. For the supply and mounting of four 30 ft. elevating work platforms on truck chassis supplied by the Commission for overhead transmission and distribution work, to Specification No. 65-66/188, \$30,573.08.—Cranes & Shovels (Sales Division) Pty. Ltd.

Approved by the Governor in Council, 10th May, 1966.—J. COLQUHOUN, Clerk of the Executive Council.

3892. For the supply of one rubber fabric conveyor systems at Yallourn and Morwell Open Cuts, to Quotation No. 3831, \$14,232.51.—Goodyear Tyre and Rubber Co. (Aust.) Ltd.

3893. For the general carriage and delivery of goods, machinery and materials for a period of two years, to Specification No. 65-66/327, at Schedule rates.—Yellow Express Carriers Ltd.

Approved by the Governor in Council, 24th May, 1966.—J. COLQUHOUN, Clerk of the Executive Council.

3894. For the payment of compensation due to deferment of belt installation on M.161 conveyor, Morwell Open Cut, as available supplies of beltings were diverted to maintain No. 108 moveable face conveyor, Yallourn Open Cut, supplementary to Specification No. 61-62/141, \$14,210.—Marweight Equipment Pty. Ltd.

3895. For the provision of accommodation and supply of meals at the Ridge Hostel, Morwell, for a period of two years, to Specification No. 60-61/104, at Schedule rates.—B. F. Brown Co. Inc.

3896. For the supply of earthing electrodes for the earthing of substation equipment for a period of two years, to Specification No. 65-66/363, at Schedule rates.—Carter Jones Engineering Company.

Approved by the Governor in Council, 31st May, 1966.—J. COLQUHOUN, Clerk of the Executive Council.

3897. For the supply of one horizontal boring and milling machine with accessories for Yallourn Base Workshops, to Specification No. 65-66/177, \$57,148.—Servian Machine Tools (Australia) Pty. Ltd.

3898. For the supply of one 5 ton mobile crane with telescopic jib for electrical construction work, to Specification No. 65-66/340, \$28,597.—Contracting Plant (Vic.).

3899. For the installation of two 50 pair underground supervisory control cables between Thomastown and South Morang Terminal Stations, to Specification No. 65-66/281, at Schedule rates.—A.E.I. Engineering Pty. Ltd.

3900. For the supply of service fuse cartridges for protection of consumers' services for a period of two years, to Specification No. 65-66/4, at Schedule rates.—Nilsen Cromie Pty. Ltd.

3901. For the supply of service fuse cartridges for protection of consumers' services for a period of two years, to Specification No. 65-66/4, at Schedule rates.—The Scanlan Electric Co. Pty. Ltd.

Approved by the Governor in Council, 7th June, 1966.—J. COLQUHOUN, Clerk of the Executive Council.

3902. For the supply of 1,900 overload relays for system protection, to Specification No. 65-66/252, \$86,755.—English Electric Co. of Aust. Pty. Ltd.

3903. For the supply of 1,300 overload relays for system protection, to Specification No. 65-66/252, \$59,248.—Brown Boveri Aust. Pty. Ltd.

3904. For the supply of liquid petroleum gas for the Latrobe Valley Area for a period of five years, and the erection of associated bulk storage tanks, to Specification No. 65-66/313, at Schedule rates, and \$38,860.—Gas & Fuel Corporation of Victoria.

3905. For the supply of insulated and sheathed supervisory control cable for a period of two years, to Specification No. 65-66/356, at Schedule rates.—Austral Standard Cables Pty. Ltd.

Approved by the Governor in Council, 15th June, 1966.—J. COLQUHOUN, Clerk of the Executive Council.

3906. For the supply of 500 kV transmission line hardware for the Hazelwood-Keilor transmission line, to Specification No. 65-66/56, \$224,518.—Dulmison (Aust.) Pty. Ltd.

3907. For the supply of 500 kV transmission line hardware for the Hazelwood-Keilor transmission line, to Specification No. 65-66/56, \$92,041.—A.N.I. Australia Pty. Ltd.

3908. For the supply of 500 kV transmission line hardware for the Hazelwood-Keilor transmission line, to Specification No. 65-66/56, \$76,204.—Silentbloc (Aust.) Pty. Ltd.

3909. For the supply of 500 kV transmission line hardware for the Hazelwood-Keilor transmission line, to Specification No. 65-66/56, \$18,810.—Alconac Pty. Ltd.

3910. For the supply of pinus radiata and hardwood flooring for construction and general maintenance for a period of one year, to Quotation No. 4399, at Schedule rates.—M. Feigin & Sons Pty. Ltd.

3911. For the supply of 58,000 super feet of imported select grade rough green oregon for construction and general maintenance, to Quotation No. 4423, at Schedule rates.—J. Wright & Sons Aust. Pty. Ltd.

3912. For the supply of power line carrier terminal equipment for communication circuits over 220 kV and 330 kV transmission lines, to Specification No. 65-66/16, \$80,535.20.—Nissho Co. (Aust.) Pty. Ltd.

3913. For the supply of transformer noise enclosure equipment for metropolitan substations, to Specification No. 65-66/333, \$31,242.—Nonoys Pty. Ltd.

3914. For the supply of 800 cast iron tubes for air heaters for Yallourn "C" and "D" power stations, to Specification No. 65-66/416, \$30,320.—Vickers Hoskins Pty. Ltd.

3915. For drilling through earth and brown coal for brown coal investigations, Gippsland area, for a period of twelve months, to Specification No. 65-66/361, at Schedule rates.—K. Cummings.

3916. For drilling through earth and brown coal for brown coal investigations, Gippsland area, for a period of twelve months, to Specification No. 65-66/361, at Schedule rates.—Macdrill Ltd.

3917. For drilling through earth and brown coal for brown coal investigations, Gippsland area, for a period of twelve months, to Specification No. 65-66/361, at Schedule rates.—W. L. Sides & Son Pty. Ltd.

3918. For drilling through earth and brown coal for brown coal investigations, Gippsland area, for a period of twelve months, to Specification No. 65-66/361, at Schedule rates.—Barry & Haire Pty. Ltd.

3919. For the supply of safety footwear for a period of two years, to Specification No. 65-66/359, at Schedule rates.—Morris Shoes (Aust.) Pty. Ltd.

3920. For the supply of safety footwear for a period of two years, to Specification No. 65-66/359, at Schedule rates.—Oliver & Stevens Pty. Ltd.

3921. For the supply of rubber and plastic hose for a period of two years, to Specification No. 65-66/335, at Schedule rates.—Goodyear Tyre & Rubber Co. (Aust.) Ltd.

Approved by the Governor in Council, 21st June, 1966.—J. COLQUHOUN, Clerk of the Executive Council.

3922. For the supply of 330 kV transmission line hardware, to Specification No. 65-66/276, \$53,550.—Alconac Pty. Ltd.

3923. For the supply of 330 kV transmission line hardware, to Specification No. 65-66/276, \$46,641.—Dulmison (Aust.) Pty. Ltd.

3924. For the supply of 330 kV transmission line hardware, to Specification No. 65-66/276, \$14,816.—A.N.I. Pty. Ltd.

3925. For the supply of 330 kV transmission line hardware, to Specification No. 65-66/276, \$14,188.—West Footscray Eng. Pty. Ltd.

3926. For the manufacture, supply, delivery and maintenance of cooling equipment for uprating two 220 kV transformers at Red Cliffs Terminal Station from 30 MVA to 44 MVA, to Quotation No. 653A, \$8,626.—Bruce Peebles (Aust.) Pty. Ltd.

3927. For the supply of high voltage switch fuses, end fittings and fuse clips for mounting powder filled fuses on high voltage distribution system for a period of two years, to Specification No. 65-66/182, at Schedule rates.—Stanger & Co. Ltd.

3928. For the supply of high voltage switch fuses, end fittings and fuse clips for mounting powder filled fuses on high voltage distribution system for a period of two years, to Specification No. 65-66/182, at Schedule rates.—Switchgear Pty. Ltd.

Approved by the Governor in Council, 28th June, 1966.—
J. COLQUHOUN, Clerk of the Executive Council.

ORDERS IN COUNCIL.—(Series 1966-67.)

PUBLIC WORKS.

103. Ararat, Mental Hospital, external painting, \$19,650.00.—J. P. McElligott & Co. Pty. Ltd.—(W.78691.)

104. Karingal, High School, mechanical services to new Assembly Hall, \$5,890.00.—Frederick W. Nielsen Pty. Ltd.—(S.E.89040.)

105. Larundel, Mental Hospital, supply of two (2) Tag-O-Lectric Marking Machines, \$1,980.00.—Laundry and Dry Cleaning Machinery Sales and Service.—(N.E.96312.)

106. Melbourne, Victorian Nursing Council, 437 St. Kilda-road, planning and erection of partitions, \$7,680.00.—Dudley V. Peck Sales Pty. Ltd.—(M.41574.)

107. Mitcham, High School, special grant authorized by the Education Department towards the cost of ground improvements at the school, \$3,000.00.—Mitcham High School Advisory Council.—(E.M.292597.)

108. St. Arnaud, High School, special grant authorized by the Education Department towards the cost of conversion of a shelter shed to a change room at the school, \$2,855.00.—St. Arnaud High School Advisory Council.—(N.W.62497.)

109. Syndal, Technical School, special grant authorized by the Education Department towards the cost of the erection of a gymnasium and shower room at the school, \$3,000.00.—Syndal Technical School Council.—(N.E.59314.)

Approved by the Governor in Council, 12th July, 1966.—
J. COLQUHOUN, Clerk of the Executive Council.

EDUCATION DEPARTMENT.

110. One only bench folder (\$315.00) and one only Cramp folder and bender (\$504.00) for Bairnsdale Technical School, \$819.00.—McPherson's Ltd.

111. One only Treadle guillotine for Essendon Technical School, \$491.40.—McPherson's Ltd.

112. One only 16-mm. projector and ancillary equipment for Gordon Institute of Technology, Geelong, \$863.00.—Hanimex Pty. Ltd.

113. One only electric potter's wheel for Wangaratta Technical School, \$210.00.—W. E. Tuck.

114. Two only Waldown 8SN drilling machines for Collingwood Technical School for \$423.00.—A. & S. Wolfenden.

115. Ten only electric typewriters for Gordon Institute of Technology, Geelong, \$1,775.00.—Sydney Pincombe Pty. Ltd.

116. One only dead weight pressure gauge tester for Royal Melbourne Institute of Technology, \$430.00.—A. E. Supplies Pty. Ltd.

117. Four only oxy-acetylene welding and cutting sets for Wonthaggi Technical & High School, \$390.00.—Commonwealth Industrial Gases.

118. One only Shirley miniature spinning plant for Melbourne School of Textiles, \$6,802.79.—Plattex Agencies Pty. Ltd.

(This is in lieu of Order in Council published in the *Government Gazette*, dated 8th April, 1964, in respect to this item only.)

Approved by the Governor in Council, 12th July, 1966.—
J. COLQUHOUN, Clerk of the Executive Council.

APPOINTMENTS

APPOINTMENTS.

THE Lieutenant-Governor as Deputy for His Excellency the Governor of the State of Victoria, by and with the advice of the Executive Council thereof, has, by Orders made on the 12th day of July, 1966, been pleased to make the under-mentioned appointments, viz.:

MINISTRY OF HEALTH.

Member of Cancer Institute Board.

EDWARD ERIC KEITH BOTTOMLEY, M.B., B.S., M.R.C.P., to be a Member of the Cancer Institute Board, pursuant to section 36 (2) of the *Cancer Act 1958* for the period ending 28th March, 1967, vice S. G. L. Catchlove, resigned.

Member of Hospital Committee of Management.

ERIC ELMORE DIMSEY to be a Member of the Committee of Management of Sandringham and District Memorial Hospital, pursuant to proviso (a) to section 48 (1) of the *Hospitals and Charities Act 1958* for a further period of three years, ending on the 22nd July, 1969.

LAW DEPARTMENT.

Assistant Registrar of Probates, &c., (Acting).

NOEL DRYSDALE MAY to act as Assistant Registrar of Probates and Administrations during the absence of D. W. Kennedy, on annual leave, to take effect from the date of commencement of duty.

Commissioners for Taking Declarations, &c.

ALAN LESLIE TURNER, and
GEORGE HENRY PHAROAH SNEDDON, care of Housing Commission, Victoria, 179 Queen-street, Melbourne, to be Commissioners for taking Declarations and Affidavits, pursuant to the provisions of the *Evidence Act 1958*, to refrain from charging fees and to resign upon ceasing to occupy their present positions, and

ERIC JACK JARRETT, care of The Bank of Adelaide, 267 Collins-street, Melbourne, to be a Commissioner for taking Declarations and Affidavits, pursuant to the provisions of the *Evidence Act 1958*, to resign upon ceasing to occupy his present position.

Justices of the Peace.

WILLIAM JOHNSON, Soldiers-road, Beaconsfield, and
GEORGE THOMAS GAHAN, 4 Cromwell-street, South Yarra, to Keep the Peace in the Central Bailiwick of the State of Victoria, and

NORMAN EDGAR MARKS, "The Grange", Glengarry, to Keep the Peace in the Eastern Bailiwick of the State of Victoria.

Prosecutor.

ALAN ELMSLIE DIXON to be a Prosecutor for the Queen, pursuant to the provisions of section 352 of the *Crimes Act 1958*, to take effect from the date of commencement of duty.

STATE ELECTRICITY COMMISSION OF VICTORIA.

Commissioner.

Sir ADOLF ALEXANDER FITZGERALD, O.B.E., B.Com., F.A.S.A., F.C.A. (Aust.), F.C.I.S., F.C.A.A., as a Commissioner of the State Electricity Commission of Victoria for a period of two years commencing on the 19th day of July, 1966.

DEPARTMENT OF THE TREASURER.

Collector of Imposts.

ERIC STANLEY MARTIN to be Collector of Imposts, Companies Registration Office, Law Department, Melbourne, vice T. S. Welsh, relieved.

J. COLQUHOUN,

Clerk of the Executive Council.

At the Executive Council Chamber,
Melbourne, 12th July, 1966.

APPOINTMENTS.

HIS Excellency the Governor of the State of Victoria, by and with the advice of the Executive Council thereof, has, by Orders made on the 19th day of July, 1966, been pleased to make the under-mentioned appointments, viz.:-

DEPARTMENT OF WATER SUPPLY.

Waterworks Trusts Commissioners.

GRAEME DAVID BERRY

to be a Commissioner of the Longwood Waterworks Trust to hold office as such from the date hereof until the fourth Saturday in November, 1968, subject to the provisions of the Water Act;

LEONARD ABRAM ALLEN

to be a Commissioner of the Lorne Waterworks Trust to hold office as such for a period of four years from the date hereof, subject to the provisions of the Water Act;

LESTER ERNEST HARVEY, and

HERBERT KEITH SLADE

to be Commissioners of the Tongala Waterworks Trust, to hold office as such for a period of four years from the date hereof, subject to the provisions of the Water Act; and

ALEXANDER BRIDGE ELLIOTT

to be a Commissioner of the Underbool Waterworks Trust, to hold office as such for a period of four years from the date hereof, subject to the provisions of the Water Act.

J. COLQUHOUN,

Clerk of the Executive Council.

At the Executive Council Chamber,
Melbourne, 19th July, 1966.

ORDERS IN COUNCIL

HOSPITALS AND CHARITIES ACT 1958.—SECTION 65.

At the Executive Council Chamber, Melbourne, the twelfth day of July, 1966.

PRESENT:

The Lieutenant-Governor as Deputy for His Excellency the Governor of Victoria,

Mr. Bloomfield | Mr. Manson.

AUTHORITY FOR SALE OF LAND BY MOORABBIN COMMUNITY HOSPITAL.

WHEREAS the Moorabbin Community Hospital an institution capable of incorporation under the *Hospitals and Charities Act 1958* and hereafter called "the institution" is the owner of land at 55 McKinnon-road, Moorabbin, more accurately described in the schedule hereto:

And whereas no part of the said land is reserved or set apart for the purposes of the institution:

And whereas the trustees William Meldrum, Walter Edward Schulz and Neil Garnsworthy Wishart for the institution desire that the said land be sold:

Now therefore the Lieutenant-Governor as Deputy for His Excellency the Governor of the State of Victoria by and with the advice of the Executive Council of the said State, by virtue of the powers conferred on him by section 65 of the *Hospitals and Charities Act 1958* and all other powers enabling him in that behalf, hereby consents to the sale of the said land freed and discharged from all trusts affecting the same to Lothar Steen and Betti Steen, of 74 McKinnon-road, Moorabbin, and Walter Eric Webb, of 243 Collins-street, Melbourne, as joint proprietors, for the sum of \$12,500 subject to the payment of a deposit of \$1,500 and payment of the balance by consecutive weekly payments of \$21 each, commencing one week from the date of possession being the 3rd June, 1966, and continuing until the expiration of five years when any outstanding balance shall then be paid with interest at 7 per centum per annum computed quarterly.

And His Excellency, by and with the advice aforesaid, hereby directs that the proceeds of the sale be paid to the said trustees to be held for the Moorabbin Community Hospital.

No. 54.—6514/66.—2

SCHEDULE.

All that piece of land being lot 13 on plan of subdivision No. 8646, lodged in the Office of Titles being part of Dendy's Crown Special Survey, Parish of Moorabbin, and being the whole of the land more particularly described in certificate of title, volume 5523, folio 557. (Subject to all registered and appurtenant easements and the covenant contained in Instrument of Transfer No. 1402482 in the Register Book).

And the Honorable Vance Oakley Dickie, Her Majesty's Minister of Health for the State of Victoria, shall give the necessary directions herein accordingly.

J. COLQUHOUN,

Clerk of the Executive Council.

HOSPITALS AND CHARITIES ACT 1958.—SECTION 65.

At the Executive Council Chamber, Melbourne, the twelfth day of July, 1966.

PRESENT:

The Lieutenant-Governor as Deputy for His Excellency the Governor of Victoria,

Mr. Bloomfield | Mr. Manson.

AUTHORITY FOR SALE OF LAND BY MOORABBIN COMMUNITY HOSPITAL.

WHEREAS the Moorabbin Community Hospital an institution capable of incorporation under the *Hospitals and Charities Act 1958*, and hereafter called "the institution" is the owner of land at 1 Anne-street, Moorabbin, more accurately described in the Schedule hereto:

And whereas no part of the said land is reserved or set apart for the purposes of the institution:

And whereas the trustees William Meldrum, Walter Edward Schulz and Neil Garnsworthy Wishart for the institution desire that the said land be sold:

Now therefore, the Lieutenant-Governor as Deputy for His Excellency the Governor of the State of Victoria by and with the advice of the Executive Council of the said State, by virtue of the powers conferred on him by section 65 of the *Hospitals and Charities Act 1958* and all other powers enabling him in that behalf, hereby consents to the sale of the said land freed and discharged from all trusts affecting the same to Doris Hannah Goldsmith, of 267 Centre-road, Bentleigh, for the sum of \$34,250 subject to the payment of a deposit of \$6,850 and payment of the balance by consecutive annual amounts of \$2,000 each on the 4th May, 1967, and 4th May, 1968, respectively, with the whole of the outstanding balance of purchase money payable on the 4th May, 1969, with interest at 7 per centum per annum computed quarterly.

And His Excellency, by and with the advice aforesaid, hereby directs that the proceeds of the sale be paid to the said trustees to be held for the Moorabbin Community Hospital.

SCHEDULE.

All that piece of land being firstly lots 40, 41, 45 and 46 on plan of subdivision No. 8646, lodged in the Office of Titles being part of Dendy's Crown Special Survey, Parish of Moorabbin, and being the whole of the land more particularly described in certificate of title, volume 4658, folio 581, and secondly part of lots 10, 11, 12 and 13 on plan of subdivision No. 8646, lodged in the Office of Titles, being part of Dendy's Crown Special Survey, Parish of Moorabbin and being the whole of the land more particularly described in certificate of title, volume 5523, folio 558. (Subject to all registered and appurtenant easements and the covenants contained in Instrument of Transfer No. 1402482 in the Register Book.)

And the Honorable Vance Oakley Dickie, Her Majesty's Minister of Health for the State of Victoria, shall give the necessary directions herein accordingly.

J. COLQUHOUN,

Clerk of the Executive Council.

DEPARTMENT OF CROWN LANDS AND SURVEY.

At the Executive Council Chamber, Melbourne, the twelfth day of July, 1966.

PRESENT:

The Lieutenant-Governor as Deputy for His Excellency the Governor of Victoria.

Mr. Bloomfield | Mr. Manson.

LANDS TEMPORARILY RESERVED AS SITES.

THE Lieutenant-Governor as Deputy for His Excellency the Governor of the State of Victoria, by and with the advice of the Executive Council thereof, doth hereby, in pursuance of section 14 of the Land Act 1958, reserve temporarily from sale, from being leased and from having a licence granted in respect thereof, and also except from occupation for mining purposes under any miner's right, the lands hereinafter described:—

SALE.—Site for Public Park and Public Recreation purposes, 1 rood 6 perches, more or less, Township of Sale, Parish of Sale, County of Tanjil, as indicated by hachure on plan hereunder.—(S.239⁽⁵⁾) (Rs.1321).

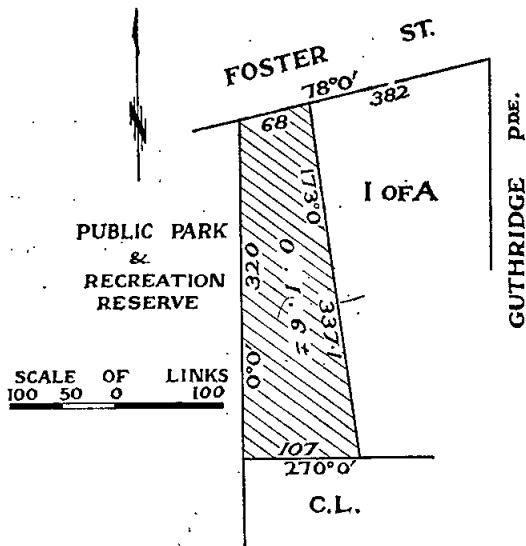

BARWONGEMOONG (LAVERS HILL).—Site for Public Purposes (Forests Department purposes), 3 roods, Parish of Barwongemooing, County of Polwarth, as indicated by hachure on plan hereunder.—(B.742⁽⁵⁾) (Rs.8476).

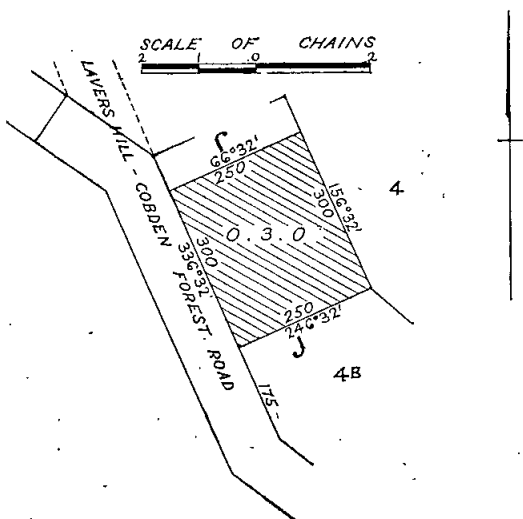

DROUIN.—Site for Public Purposes (Municipal Depot and Storeyard), 1 acre, Township of Drouin, Parish of Drouin West, County of Buln Buln, as indicated by hachure on plan hereunder.—(D.173⁽¹⁸⁾) (Rs.8442).

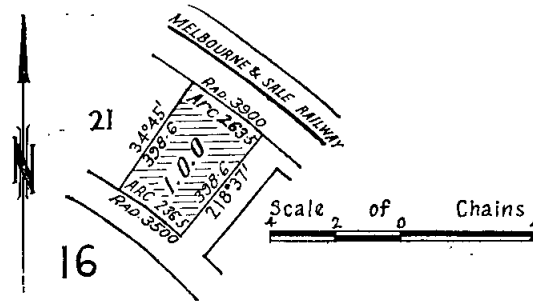

TANJIL.—Site for Public Recreation in addition to and adjoining the site temporarily reserved therefor by Order in Council of the 21st February, 1870, 3 acres, Parish of Tanjil, County of Buln Buln, as indicated by hachure on plan hereunder.—(T.189⁽¹²⁾) (Rs.8214).

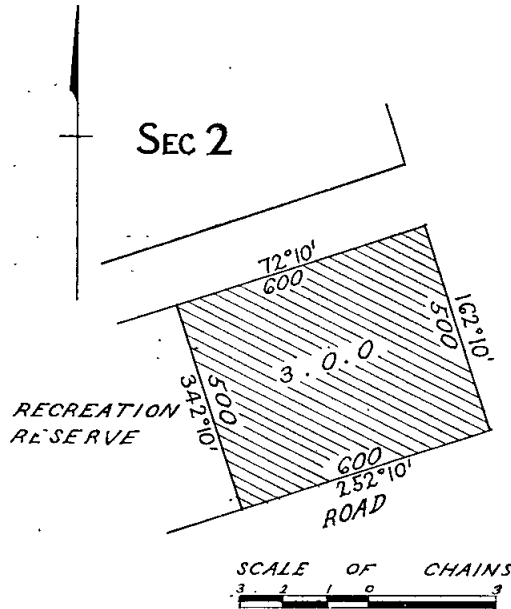

MALDON.—Site for Public Purposes (Municipal Depot), 3 perches, Township of Maldon, Parish of Maldon, County of Talbot, as indicated by hachure on plan hereunder.—(M.449(C)) (Rs.8521).

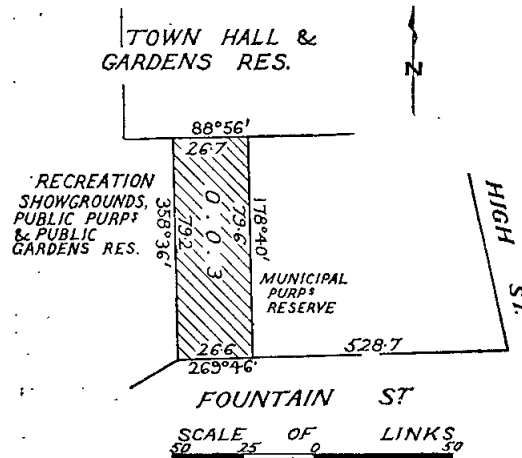

STAWELL.—Site for State School purposes, 3 acres 2 roods 29 perches, Parish of Stawell, County of Borung, as indicated by hachure on plan hereunder.—(S.329⁽¹⁸⁾) (Rs.8626).

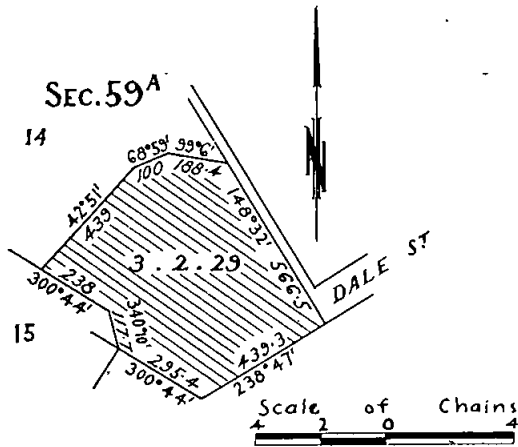

FORREST.—Site for Public Purposes (Forests Department purposes), 1 acre 2 perches, Township of Forrest, Parish of Yaughar, County of Polwarth, as indicated by hachure on plan hereunder.—(F.104⁽²⁾) (Rs.8585).

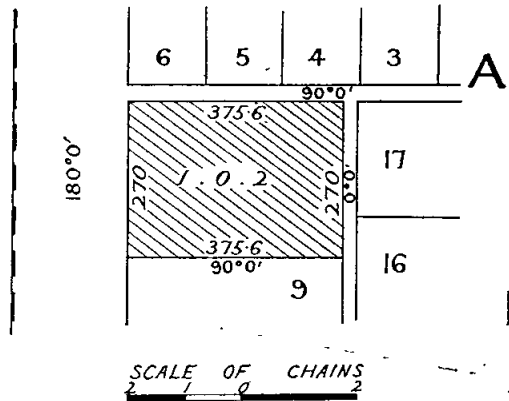

JAN JUC.—Site for Water Supply purposes, 2 acres 3 roods 23 perches, Parish of Jan Juc, County of Grant, as indicated by hachure on plan hereunder.—(J.7⁽⁶⁾) (Rs.8627).

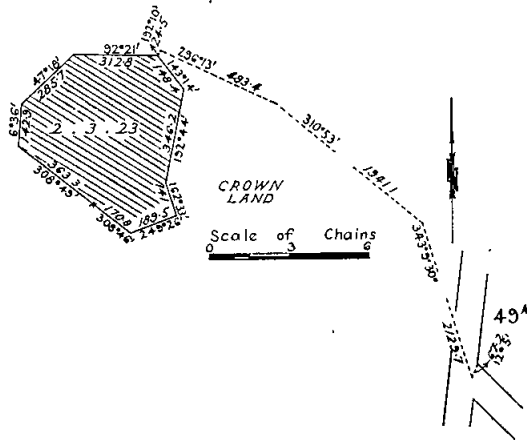

CASTLEMAINE.—Site for Public Purposes (Soil Conservation Authority purposes), 31 perches, Parish of Castlemaine, County of Talbot, as indicated by hachure on plan hereunder.—(C.100(38A & 45A)) (Rs.8606).

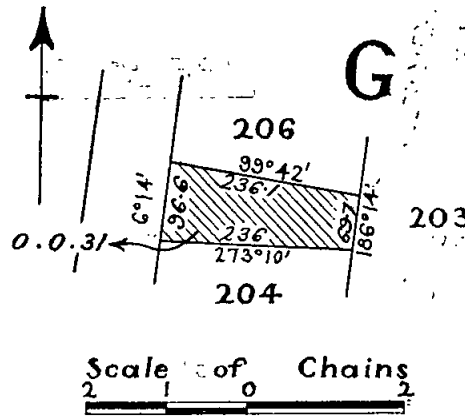

PAYWIT (QUEENSLIFF).—Site for Hospital Purposes 3 acres 3 roods 36 perches, at Queenscliff, Parish of Paywit, County of Grant, as indicated by hachure on plan hereunder.—(P.17⁽⁹⁾) (Rs.8629).

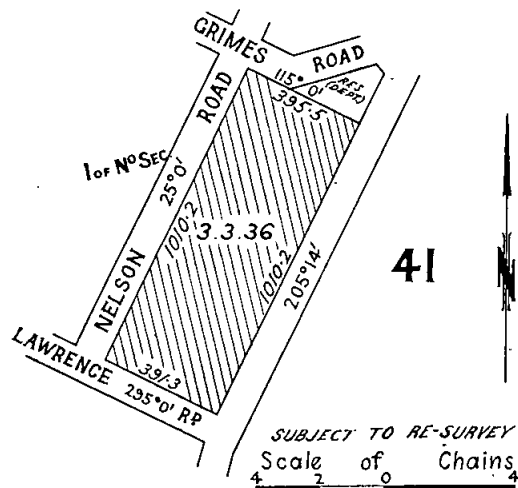

CORRYONG.—Site for Public Park and Recreation, 12 acres 3 roods 36 perches, more or less, Township of Corryong, Parish of Colac Colac, County of Benambra, as indicated by hachure on plan hereunder.—(C.427⁽⁹⁾) (Rs.8611).

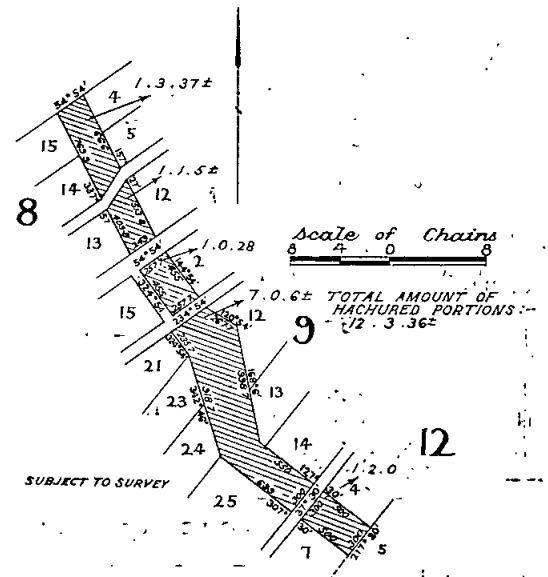

ANAKIE.—Site for Public Purposes (Forests Department purposes), 1 acre, Parish of Anakie, County of Grant, as indicated by hachure on plan hereunder.—(A.31⁽²⁾) (Rs.8480).

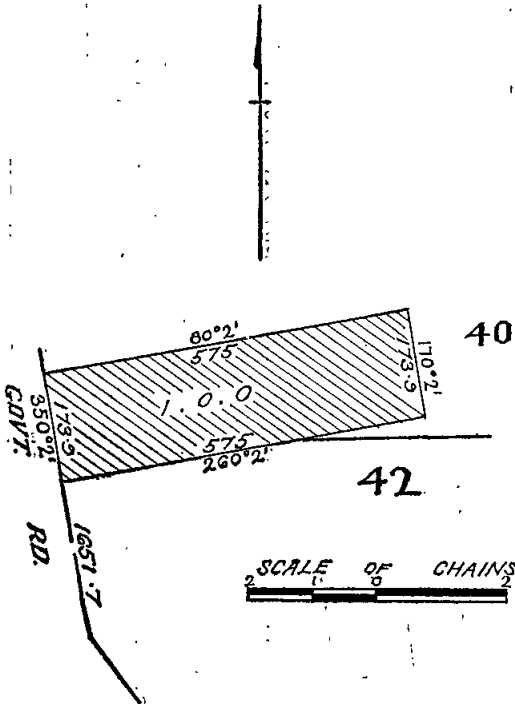

APOLLO BAY.—Site for Public Purposes (Police purposes), 1 rood, Township of Apollo Bay, Parish of Krambruk, County of Polwarth, as indicated by hachure on plan hereunder.—(K.149(A³)) (Rs.8619).

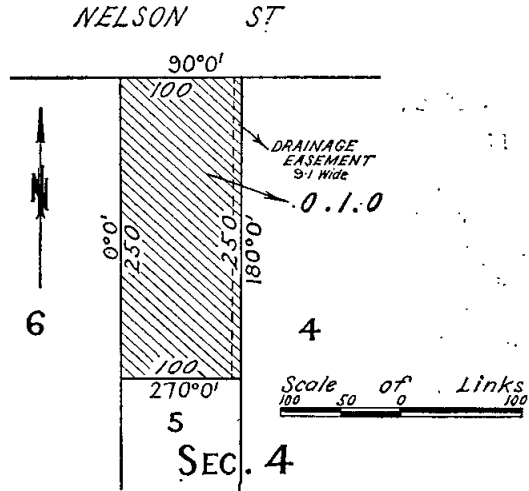

PORTLAND.—Site for Public Purposes (Kindergarten), 39 perches, Township of Portland, Parish of Portland, County of Normanby, as indicated by hachure on plan hereunder.—(P.69⁽¹⁾) (Rs.8622).

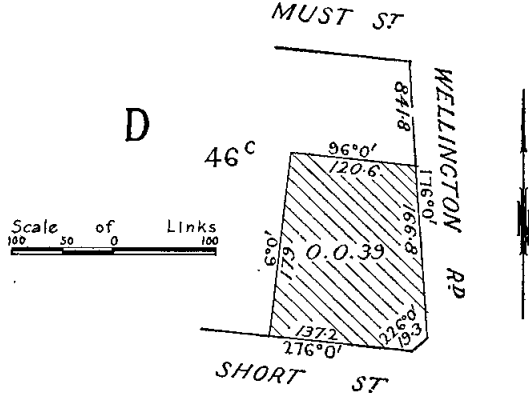

MONIVAE (HAMILTON).—Site for Public Purposes (Agriculture Department purposes), 267 acres 3 roods 4 perches, Parish of Monivae, County of Normanby, as indicated by hachure on plan hereunder.—(M.410⁽²⁾) (Rs.8612).

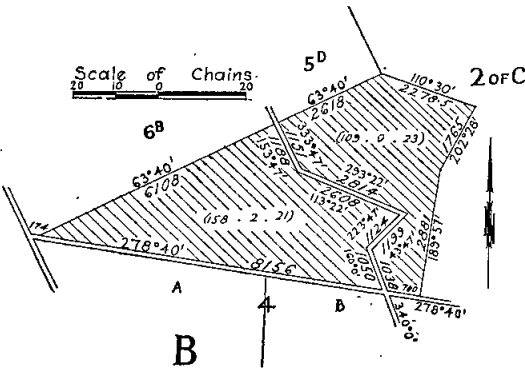

Total Area of Hachured Portions:—267^A 3^R 4^P

BURRUMBEEP.—Site for Water Supply Purposes, 2 acres 1 rood 12 perches, Parish of BurrumbEEP, County of Ripon, as indicated by hachure on plan hereunder.—(B.473⁽⁴⁾) (Rs.8613).

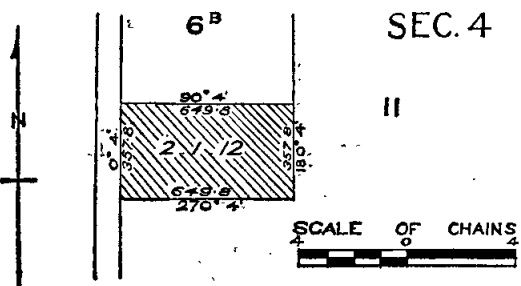

SANDHURST (GOLDEN SQUARE).—Site for Public Purposes (Police purposes), 36 perches, at Bendigo, Parish of Sandhurst, County of Bendigo, as indicated by hachure on plan hereunder.—(S.372⁽¹²²⁾) (Rs.8556).

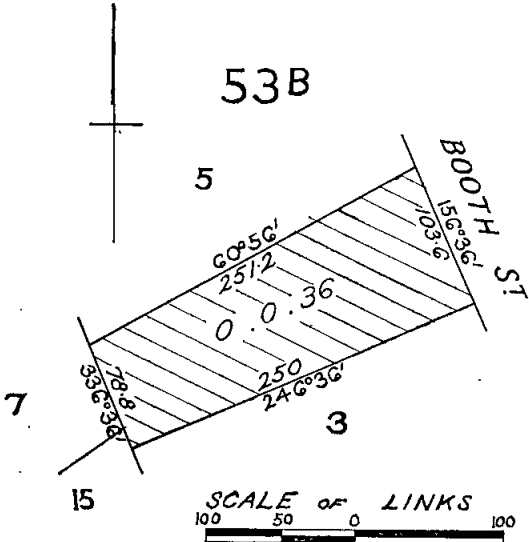

BARONGAROOK.—Site for Public Purposes (Forests Department purposes), 24 perches, Parish of Barongarook, County of Polwarth, as indicated by hachure on plan hereunder.—(B.603⁽⁴⁾) (Rs.8479).

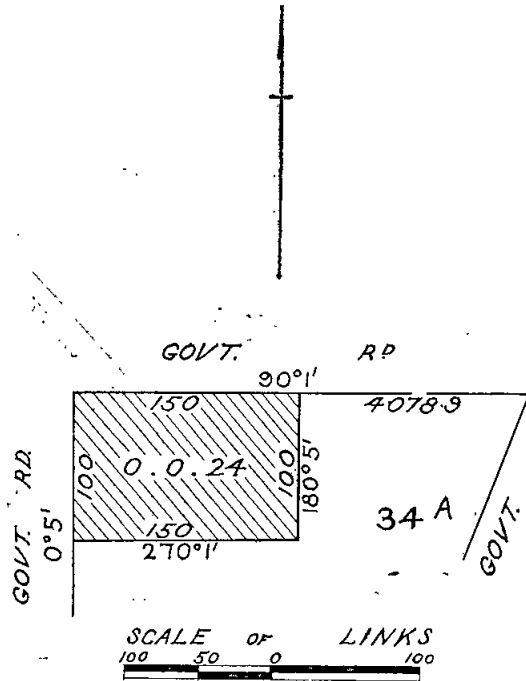

MOLOGA.—Site for Public Recreation, 1 acre 12 perches, more or less, Parish of Mologá, County of Gunbower, as indicated by hachure on plan hereunder.—(M.506⁽³⁾) (Rs.8580).

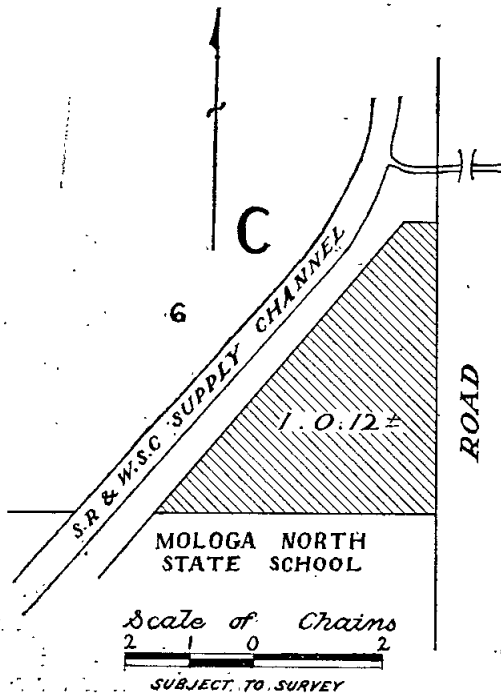

THORNTON (EILDON).—Site for Public Purposes (Forests Department purposes), 2 acres, Parish of Thornton, County of Anglesey, as indicated by hachure on plan hereunder.—(T.180^(A)) (Rs.8511).

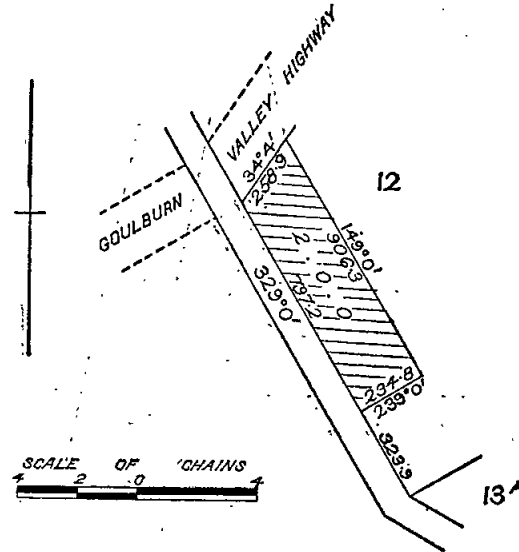

PORTLAND.—Site for Public Purposes and Recreation, 4 acres 3 roods 14 perches, Township of Portland, Parish of Portland, County of Normanby, as indicated by hachure on plan hereunder.—(P.69⁽⁷⁾) (Rs.8614).

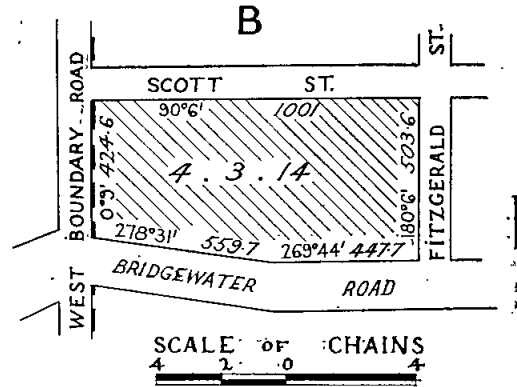

And the Honorable James Charles Murray Balfour, Her Majesty's Minister of Lands for the State of Victoria, shall give the necessary directions herein accordingly.

J. COLQUHOUN,
Clerk of the Executive Council.

DEPARTMENT OF CROWN LANDS AND SURVEY.

At the Executive Council Chamber, Melbourne, the twelfth day of July, 1966.

PRESENT:

The Lieutenant-Governor as Deputy for His Excellency the Governor of Victoria.

Mr. Bloomfield | Mr. Manson.

UNUSED ROADS CLOSED.

THE Lieutenant-Governor as Deputy for His Excellency the Governor of the State of Victoria, by and with the advice of the Executive Council thereof, doth hereby

direct that, in pursuance of the provisions of section 349 of the *Land Act 1958*, the unused roads referred to hereunder be closed, viz.:—

Parish of Wombat, County of Talbot, being the portion of the width of the road indicated by hachure on plan hereunder.—(W.179⁽⁸⁷⁾); (W.82146.)

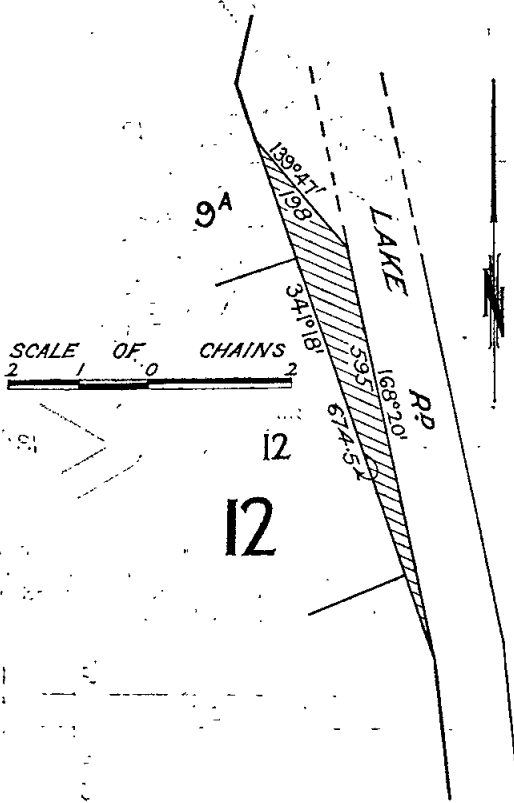

Township of Maryborough, Parish of Maryborough, County of Talbot, being the road indicated by hachure on plan hereunder.—(M.66⁽¹⁵⁾) (W.67421.)

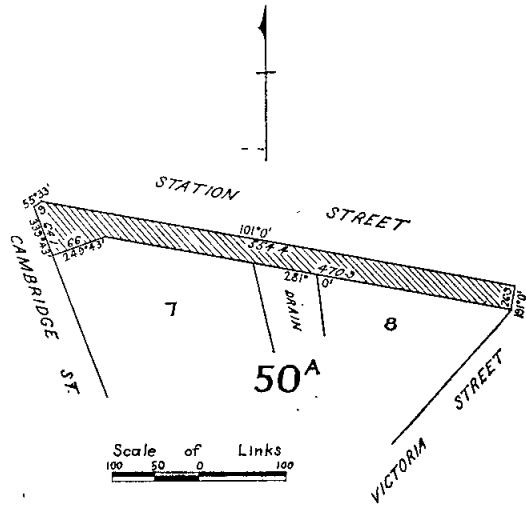

Parish of Boort, County of Tatchera, being the road indicated by hachure on plan hereunder.—(B.654⁽¹¹⁾) (C.97235.)

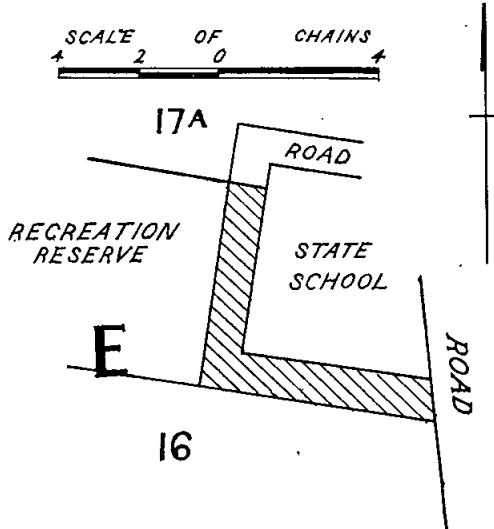

Township of Leichardt, Parish of Leichardt, County of Bendigo, being the portion of the width of the road indicated by hachure on plan hereunder.—(L.148⁽⁸⁾) (W.82550.)

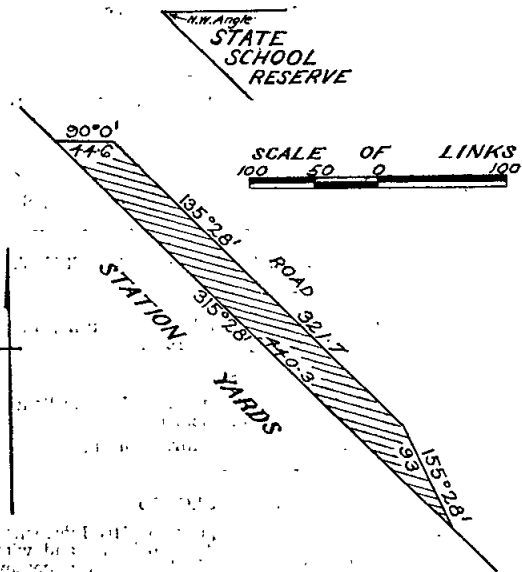

And the Honorable James Charles Murray Balfour, Her Majesty's Minister of Lands for the State of Victoria, shall give the necessary directions herein accordingly.

J. COLQUHOUN,
Clerk of the Executive Council.

DEPARTMENT OF CROWN LANDS AND SURVEY.

At the Executive Council Chamber, Melbourne, the twelfth day of July, 1966.

PRESENT:

The Lieutenant-Governor as Deputy for His Excellency the Governor of Victoria.

Mr. Bloomfield | Mr. Manson.

LAND PERMANENTLY RESERVED AS A SITE.

THE Lieutenant-Governor as Deputy for His Excellency the Governor of the State of Victoria, by and with the advice of the Executive Council thereof, doth hereby, in pursuance of section 14 of the *Land Act 1958*, reserve permanently from sale and from being leased and from

having a licence granted in respect thereof and also except from occupation for mining purposes under any miner's right, the land hereinafter described:—

NAR-NAR-GOON (MARYKNOLL).—As a site for Cemetery Purposes, 2 acres 1 rood 7 perches, Parish of Nar-nar-goan, County of Mornington, as indicated by hachure on plan hereunder.—(N.11⁽⁶⁾) (Rs.8608).

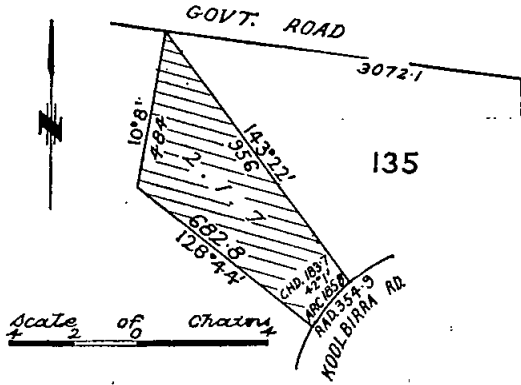

And the Honorable James Charles Murray Balfour, Her Majesty's Minister of Lands for the State of Victoria, shall give the necessary directions herein accordingly.

J. COLQUHOUN,
Clerk of the Executive Council.

DEPARTMENT OF CROWN LANDS AND SURVEY.

At the Executive Council Chamber, Melbourne, the twelfth day of July, 1966.

PRESENT:

The Lieutenant-Governor as Deputy for His Excellency the Governor of Victoria.
Mr. Bloomfield | Mr. Manson.

REVOCATIONS OF TEMPORARY RESERVATIONS OF LAND BY ORDERS IN COUNCIL.

THE Lieutenant-Governor as Deputy for His Excellency the Governor of the State of Victoria, by and with the advice of the Executive Council thereof, doth hereby, in pursuance of the provisions of the Land Act 1958, revoke the temporary reservations of land by Orders in Council hereinafter referred to, viz.:—

YAMBUK.—Order in Council of the 5th October, 1874, of 2 roods of land in the Township of Yambuk as a site for a Temperance Hall.—(Y.39⁽⁴⁾) (Rs.1997.)

CARRARAGARMUNGEE.—Order in Council of the 30th September, 1912, of 2 roods 9 perches of land in the Parish of Carraragarmungee, as a site for a Public Hall.—(C.188⁽³⁾) (Rs.5521.)

BALROOTAN.—Order in Council of the 12th January, 1885, of 5 acres of land in the Parish of Balrootan, as a site for a Cemetery and the temporary reservation by Order in Council of the 5th June, 1917, of 3 acres 16 perches, in two parts as an extension thereto, so far only as the portion containing 3 perches, indicated by hachure on plan hereunder, is concerned.—(B.646⁽²⁾) (Rs.6157.)

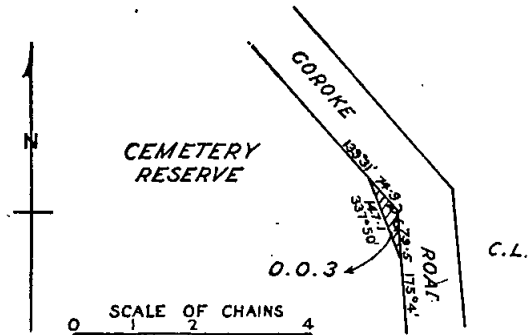

NUNAWADING.—Order in Council of the 11th December, 1882, of 10 acres, more or less, of land in the Parish of Nunawading, as a site for a Quarry.—(N.79⁽⁶⁾) (Rs.1564.)

TARRA TARRA.—Order in Council of the 28th August, 1906, of 1 rood 24 perches of land in the Parish of Tarra Tarra, as a site for a Public Hall.—(Rs.4840.)

TARRA TARRA.—Order in Council of the 28th August, 1906, of 9 acres 2 roods 19 perches of land in the Parish of Tarra Tarra, as a site for Public Recreation.—(Rs.4840.)

SALE.—Order in Council, of the 6th June, 1956, of 92 acres of land in the Township of Sale, as a site for Public Park and Public Recreation, revoked as to part by various Orders, so far only as the portion containing 29 perches more or less, indicated by hachure on plan hereunder, is concerned.—(S.239⁽³⁾) (Rs.1321.)

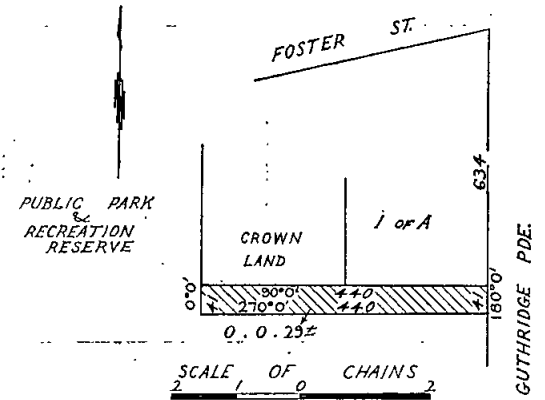

And the Honorable James Charles Murray Balfour, Her Majesty's Minister of Lands for the State of Victoria, shall give the necessary directions herein accordingly.

J. COLQUHOUN,
Clerk of the Executive Council.

LOCAL GOVERNMENT DEPARTMENT.

At the Executive Council Chamber, Melbourne, the twelfth day of July, 1966.

PRESENT:

The Lieutenant-Governor as Deputy for His Excellency the Governor of Victoria.
Mr. Bloomfield | Mr. Manson.

ROAD DISCONTINUED.—CITY OF PRESTON.

WHEREAS it is provided in section 528 (2) of the Local Government Act that where a road (whether or not a public highway but not being a road set out on land of the Crown) or any part thereof is not required for public use, the Governor in Council, on the request of the Council of the municipality in which such road is situated made not less than one month after publishing in a newspaper generally circulating in the district and posted to the registered proprietor (if any) of the land and any person known to have an interest in the land notice of intention to make such a request, may by Order published in the Government Gazette, direct that such road or part shall be discontinued and thereupon such road or part shall be discontinued accordingly.

And whereas the Council of the City of Preston has requested that the Governor in Council direct that portion of Lonsdale-street, Preston, be discontinued, and not less than one month previously, has published in a newspaper generally circulating in the district and posted to the registered proprietor of the land in the road and to all persons known to have an interest in the said road notice of intention to make such request.

Now therefore, the Lieutenant-Governor as Deputy for His Excellency the Governor of the State of Victoria, by and with the advice of the Executive Council thereof, hereby directs:

- (a) that the portion of the said road which is shown by hachure and cross-hachure on the plan hereunder shall be discontinued;
- (b) that notwithstanding such discontinuance the State Electricity Commission of Victoria shall continue to have and possess the same right,

title, power, authority or interest in or in relation to the land shown by cross-hachure on the said plan as it had or possessed prior to such discontinuance with respect to or in connexion with any wires or cables laid or erected in on or over such land for the supply of electricity:

- (c) that, subject to any such right, title, power, authority or interest, the land in the portion of the said road may be sold by the Council of the City of Preston by agreement.

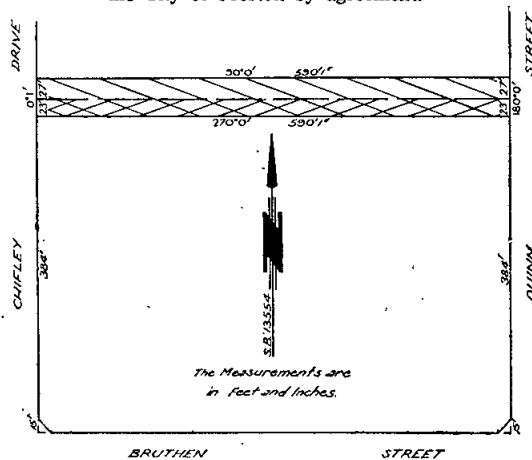

And the Honorable Rupert James Hamer, Her Majesty's Minister for Local Government for the State of Victoria, shall give the necessary directions herein accordingly.

J. COLQUHOUN,
Clerk of the Executive Council.

COUNTRY ROADS BOARD.

At the Executive Council Chamber, Melbourne, the twelfth day of July, 1966.

PRESENT:

The Lieutenant-Governor as Deputy for
His Excellency the Governor of Victoria.
Mr. Bloomfield | Mr. Manson.

ORDER APPROVING OF WIDENING AN EXISTING MAIN ROAD IN THE SHIRE OF SOUTH BARWON.

WHEREAS the Country Roads Board constituted under the Country Roads Act 1958 (No. 6229) has represented to His Excellency the Governor in Council that it appears to it desirable that the existing Barwon Heads-road in the Shire of South Barwon (declared to be a main road under the said Act which declaration was confirmed by the Order in Council published in the Government Gazette of the 1st April, 1914, on page 1547) should be widened by the said Board: And whereas the said Board in accordance with the requirements of section 19 of the said cited Act has caused to be prepared a map plan and estimate showing the points between which and on and through what land the said widening is proposed to be made and the cost of acquiring the land: And whereas on an inspection of the said map and plan and a consideration of the said estimate His Excellency the Governor in Council is satisfied that there are funds legally available for acquiring the land: Now therefore be it known by this present Order that the Lieutenant-Governor as Deputy for His Excellency the Governor of the State of Victoria with the advice of the Executive Council thereof doth hereby approve of the said road being widened, that is to say:—

All that piece of land in the Parishes of Corio and Conewarre, the boundaries of which are as follow:—Commencing at the western angle of land comprised in certificate of title, volume 8485, folio 151, entered in the Register Book and being part of allotment 56, section 2, of the said parish; thence by lines bearing respectively 308 deg. 43 min. 65 ft. 8 in., 309 deg. 38 min. 402 ft. 2½ in., 347 deg. 25 min. 539 ft. 6½ in., 159 deg. 18 min. 195 ft. 1½ in., 153 deg. 5 min. 329 ft. 9½ in., 143 deg. 34 min. 354 ft. 0½ in., 94 deg. 59 min. 19 ft. 10½ in., 226 deg. 24 min. 15 feet, 134 deg. 0 min. 65 ft. 0½ in., 45 deg. 53 min. 15 feet, 178 deg.

22 min. 20 ft. 3¼ in., 130 deg. 52 min. 257 ft. 2¼ in. and 309 deg. 12 min. 273 feet to the point of commencement— which said piece of land is particularly delineated and shown coloured red and yellow on survey plan numbered 10056, lodged in the office of the Country Roads Board.

And the Honorable Murray Victor Porter, Her Majesty's Minister of Public Works for the State of Victoria shall give the necessary directions herein accordingly.

J. COLQUHOUN,
Clerk of the Executive Council.

COUNTRY ROADS BOARD.

At the Executive Council Chamber, Melbourne, the twelfth day of July, 1966.

PRESENT:

The Lieutenant-Governor as Deputy for
His Excellency the Governor of Victoria.
Mr. Bloomfield | Mr. Manson.

ORDER APPROVING OF WIDENING AN EXISTING MAIN ROAD IN THE SHIRE OF GOULBURN.

WHEREAS the Country Roads Board constituted under the Country Roads Act 1958 (No. 6229) has represented to His Excellency the Governor in Council that it appears to it desirable that the existing Heathcote-Nagambie road in the Shire of Goulburn (declared to be a main road under the said Act which declaration was confirmed by the Order in Council published in the Government Gazette of the 23rd July, 1947, on pages 3984-5) should be widened by the said Board: And whereas the said Board in accordance with the requirements of section 19 of the said cited Act has caused to be prepared a map plan and estimate showing the points between which and on and through what land the said widening is proposed to be made and the cost of acquiring the land: And whereas on an inspection of the said map and plan and a consideration of the said estimate His Excellency the Governor in Council is satisfied that there are funds legally available for acquiring the land: Now therefore be it known by this present Order that the Lieutenant-Governor as Deputy for His Excellency the Governor of the State of Victoria with the advice of the Executive Council thereof doth hereby approve of the said road being widened, that is to say:—

All those pieces of land in the Parish of Bailleston, the boundaries of which are as follow:—

- Commencing at the southern angle of allotment 130 of the said parish; thence by lines bearing respectively 242 deg. 8 min. 300.3 links, 49 deg. 33½ min. 585.2 links and 216 deg. 57 min. 299.3 links to the point of commencement.
- Commencing at a point on the eastern boundary of allotment 130 of the said parish, distant 36 deg. 57 min. 1,988.2 links from the southern angle of the said allotment; thence by lines bearing respectively 24 deg. 10½ min. 581.4 links, 191 deg. 31 min. 299.2 links and 216 deg. 57 min. 296.8 links to the point of commencement.
- Commencing at an angle in the western boundary of allotment 132 of the said parish, formed by the intersection of lines bearing 220 deg. 1 min. and 191 deg. 31 min.; thence by lines bearing respectively 40 deg. 1 min. 445.5 links, 200 deg. 49 min. 1,316.6 links and 11 deg. 31 min. 907.8 links to the point of commencement.
- Commencing at an angle in the north-western boundary of allotment 132 of the said parish, formed by the intersection of lines bearing 250 deg. 1 min. and 220 deg. 1 min.; thence by lines bearing respectively 70 deg. 1 min. 551 links, 235 deg. 2½ min. 1,062.8 links and 40 deg. 1 min. 549.3 links to the point of commencement—

which said pieces of land are particularly delineated and shown coloured red on survey plans numbered 10475 and 10476, lodged in the office of the Country Roads Board.

And the Honorable Murray Victor Porter, Her Majesty's Minister of Public Works for the State of Victoria shall give the necessary directions herein accordingly.

J. COLQUHOUN,
Clerk of the Executive Council.

COUNTRY ROADS BOARD.

At the Executive Council Chamber, Melbourne, the
twelfth day of July, 1966.

PRESENT:

The Lieutenant-Governor as Deputy for
His Excellency the Governor of Victoria.
Mr. Bloomfield | Mr. Manson.

ORDER APPROVING OF WIDENING AN EXISTING
MAIN ROAD IN THE SHIRE OF WERRIBEE.

WHEREAS the Country Roads Board constituted under the *Country Roads Act 1958* (No. 6229) has represented to His Excellency the Governor in Council that it appears to it desirable that the existing Duncans-road in the Shire of Werribee (declared to be a main road under the said Act which declaration was confirmed by the Order in Council published in the *Government Gazette* of the 9th November, 1938, on page 3693) should be widened by the said Board: And whereas the said Board in accordance with the requirements of section 19 of the said cited Act has caused to be prepared a map plan and estimate showing the points between which and on and through what land the said widening is proposed to be made and the cost of acquiring the land: And whereas on an inspection of the said map and plan and a consideration of the said estimate His Excellency the Governor in Council is satisfied that there are funds legally available for acquiring the land: Now therefore be it known by this present Order that the Lieutenant-Governor as Deputy for His Excellency the Governor of the State of Victoria with the advice of the Executive Council thereof doth hereby approve of the said road being widened, that is to say:—

All that piece of land in the Parish of Deutgam, the boundaries of which are as follow:—Commencing at the south-eastern angle of allotment 74A, section D, of the said parish; thence by lines bearing respectively 162 deg. 10 min. 26 links, 188 deg. 8 min. 41.7 links, 2 deg. 57 min. 193 links, 357 deg. 12 min. 252.5 links, 352 deg. 14 min. 167.7 links, 347 deg. 10 min. 222.1 links and 162 deg. 10 min. 409.8 links to the point of commencement—which said piece of land is particularly delineated and shown coloured red and blue on survey plan numbered 10499, lodged in the office of the Country Roads Board.

And the Honorable Murray Victor Porter, Her Majesty's Minister of Public Works for the State of Victoria shall give the necessary directions herein accordingly.

J. COLQUHOUN,
Clerk of the Executive Council.

COUNTRY ROADS BOARD.

At the Executive Council Chamber, Melbourne, the
twelfth day of July, 1966.

PRESENT:

The Lieutenant-Governor as Deputy for
His Excellency the Governor of Victoria.
Mr. Bloomfield | Mr. Manson.

ORDER APPROVING OF WIDENING AN EXISTING
MAIN ROAD IN THE SHIRE OF GLENELG.

WHEREAS the Country Roads Board constituted under the *Country Roads Act 1958* (No. 6229) has represented to His Excellency the Governor in Council that it appears to it desirable that the existing Casterton-Apsley road in the Shire of Glenelg (declared to be a main road under the said Act which declaration was confirmed by the Order in Council published in the *Government Gazette* of the 26th May, 1948 on pages 3611-2) should be widened by the said Board: And whereas the said Board in accordance with the requirements of section 19 of the said cited Act has caused to be prepared a map plan and estimate showing the points between which and on and through what land the said widening is proposed to be made and the cost of acquiring the land: And whereas on an inspection of the said map and plan and a consideration of the said estimate His Excellency the Governor in Council is satisfied that there are funds legally available for acquiring the land: Now therefore be it known by this present Order that the Lieutenant-Governor as Deputy for His Excellency the

Governor of the State of Victoria with the advice of the Executive Council thereof doth hereby approve of the said road being widened, that is to say:—

All that piece of land in the Parish of Nangeela the boundaries of which are as follow:—

Commencing at a point on the eastern boundary of allotment 12, section 3, of the said parish, distant 336 deg. 3 min. 988.6 links from the south-eastern angle of the said allotment; thence by lines bearing respectively 314 deg. 6 min. 708.8 links, 117 deg. 14 min. 422.5 links and 156 deg. 3 min. 328.4 links to the point of commencement.

Also, all those pieces of land in the Parish of Casterton, the boundaries of which are as follow:—

(a) Commencing at the intersection of the eastern boundary of the existing Casterton-Apsley road through allotment 1, section 26, of the said parish, with the northern boundary of the said allotment; thence by lines bearing respectively 74 deg. 52 min. 2.8 links, 155 deg. 6 min. 870.8 links, 322 deg. 23 min. 187.5 links and 338 deg. 19 min. 689.5 links to the point of commencement.

(b) Commencing at an angle in the western boundary of the existing Casterton-Apsley road through allotment 3, section 26, of the said parish, formed by the intersection of lines bearing 351 deg. 43 min. and 321 deg. 40 min.; thence by lines bearing respectively 171 deg. 43 min. 492.8 links, 336 deg. 19 min. 975.5 links and 141 deg. 40 min. 517.2 links to the point of commencement.

(c) Commencing at a point on the western boundary of allotment 12 of the said parish, distant 170 deg. 58 min. 1,096.6 links from the north-western angle of the said allotment; thence by lines bearing respectively 166 deg. 52 min. 500.5 links, 341 deg. 53 min. 227 links and 350 deg. 58 min. 275.1 links to the point of commencement.

(d) Commencing at the south-eastern angle of allotment 9 in the said parish; thence by lines bearing respectively 161 deg. 53 min. 74 links, 179 deg. 46 min. 136.6 links, 344 deg. 54 min. 214.3 links, 349 deg. 57 min. 218.8 links and 161 deg. 53 min. 226.7 links to the point of commencement—

which said pieces of land are particularly delineated and shown coloured red on survey plans numbered 10527, 10528 and 10529, lodged in the office of the Country Roads Board.

And the Honorable Murray Victor Porter, Her Majesty's Minister of Public Works for the State of Victoria shall give the necessary directions herein accordingly.

J. COLQUHOUN,
Clerk of the Executive Council.

COUNTRY ROADS BOARD.

At the Executive Council Chamber, Melbourne, the
twelfth day of July, 1966.

PRESENT:

The Lieutenant-Governor as Deputy for
His Excellency the Governor of Victoria.
Mr. Bloomfield | Mr. Manson.

ORDER APPROVING OF WIDENING AN EXISTING
MAIN ROAD IN THE SHIRE OF BERWICK.

WHEREAS the Country Roads Board constituted under the *Country Roads Act 1958* (No. 6229) has represented to His Excellency the Governor in Council that it appears to it desirable that the existing Belgrave-Gembrook road in the Shire of Berwick (declared to be a main road under the said Act which declaration was confirmed by the Order in Council published in the *Government Gazette* of the 3rd May, 1961, on pages 1471-2) should be widened by the said Board: And whereas the said Board in accordance with the requirements of section 19 of the said cited Act has caused to be prepared a map plan and estimate showing the points between which and on and through what land the said widening is proposed to be made and the cost of acquiring the land: And whereas on an inspection of the said map

and plan and a consideration of the said estimate His Excellency the Governor in Council is satisfied that there are funds legally available for acquiring the land: Now therefore be it known by this present Order that the Lieutenant-Governor as Deputy for His Excellency the Governor of the State of Victoria with the advice of the Executive Council thereof doth hereby approve of the said road being widened, that is to say:—

All that piece of land in the Parish of Gembrook, the boundaries of which are as follow:—Commencing at the south-eastern angle of allotment A¹⁷ in the said parish; thence by lines bearing respectively 281 deg. 31 min. 75 links, 33 deg. 35 min. 56.4 links and 145 deg. 39 min. 75 links to the point of commencement—which said piece of land is particularly delineated and shown coloured red on survey plan numbered 10513, lodged in the office of the Country Roads Board.

And the Honorable Murray Victor Porter, Her Majesty's Minister of Public Works for the State of Victoria shall give the necessary directions herein accordingly.

J. COLQUHOUN,
Clerk of the Executive Council.

COUNTRY ROADS BOARD.

At the Executive Council Chamber, Melbourne, the
twelfth day of July, 1966.

PRESENT:

The Lieutenant-Governor as Deputy for
His Excellency the Governor of Victoria.
Mr. Bloomfield | Mr. Manson.

ORDER APPROVING OF WIDENING AN EXISTING TOURISTS' ROAD IN THE SHIRE OF ORBOST.

WHEREAS the Country Roads Board constituted under the *Country Roads Act 1958* (No. 6229) has represented to His Excellency the Governor in Council that it appears to it desirable that the existing Mallacoota-road in the Shire of Orbost (declared to be a Tourists' road under the said Act which declaration was confirmed by the Order in Council published in the *Government Gazette* of the 12th October, 1932, on page 2331) should be widened by the said Board: And whereas the said Board in accordance with the requirements of sections 19 and 88 of the said cited Act has caused to be prepared a map plan and estimate showing the points between which and on and through what land the said widening is proposed to be made and the cost of acquiring the land: And whereas on an inspection of the said map and plan and a consideration of the said estimate His Excellency the Governor in Council is satisfied that there are funds legally available for acquiring the land: Now therefore be it known by this present Order that the Lieutenant-Governor as Deputy for His Excellency the Governor of the State of Victoria with the advice of the Executive Council thereof doth hereby approve of the said road being widened, that is to say:—

All those pieces of land in the Parish of Maramingo, the boundaries of which are as follow:—

- (a) Commencing at an angle in the southern boundary of the existing Mallacoota-road through allotment 9 of the said parish, formed by the intersection of lines bearing 326 deg. 56 min. and 298 deg. 8 min.; thence by lines bearing respectively 146 deg. 56 min. 71.6 links, 303 deg. 32 min. 366.4 links and 118 deg. 8 min. 302.1 links to the point of commencement.
- (b) Commencing at an angle in the northern boundary of the existing Mallacoota-road through allotment 9 of the said parish, formed by the intersection of lines bearing 118 deg. 8 min. and 146 deg. 56 min.; thence by lines bearing respectively 298 deg. 8 min. 1,017.5 links, 109 deg. 2½ min. 356.3 links and 122 deg. 58 min. 668.1 links to the point of commencement.
- (c) Commencing at an angle in the southern boundary of the existing Mallacoota-road through allotment 9 of the said parish, formed by the intersection of lines bearing 298 deg. 8 min. and 282 deg. 8 min.; thence by lines bearing respectively 118 deg. 8 min. 383.1 links, 284 deg. 46 min. 1,327.1 links, 71 deg. 20 min. 157.5 links, 105 deg. 14 min. 113 links, 107 deg. 10 min. 340.7 links and 102 deg. 8 min. 370 links to the point of commencement.

- (d) Commencing at an angle in the northern boundary of the existing Mallacoota-road through allotment 8 of the said parish, formed by the intersection of lines bearing 71 deg. 20 min. and 105 deg. 14 min.; thence by lines bearing respectively 251 deg. 20 min. 246 links, 296 deg. 54 min. 321.6 links, 299 deg. 9 min. 288 links and 105 deg. 1½ min. 798.7 links to the point of commencement.
- (e) Commencing at an angle in the southern boundary of the existing Mallacoota-road through allotment 8 of the said parish, formed by the intersection of lines bearing 273 deg. 3 min. and 241 deg. 6 min.; thence by lines bearing respectively 93 deg. 3 min. 338 links, 119 deg. 9 min. 237 links, 150 deg. 12 min. 24 links, 275 deg. 52 min. 708.5 links and 61 deg. 6 min. 169.4 links to the point of commencement.
- (f) Commencing at an angle in the northern boundary of the existing Mallacoota-road through allotment 8 of the said parish, formed by the intersection of lines bearing 61 deg. 6 min. and 93 deg. 3 min.; thence by lines bearing respectively 241 deg. 6 min. 328 links, 258 deg. 7 min. 589 links, 66 deg. 15 min. 588 links and 82 deg. 28½ min. 328.1 links to the point of commencement.
- (g) Commencing at a point in allotment 7 of the said parish, distant 270 deg. 0 min. 320 links and 27 deg. 13 min. 231.7 links from the south-eastern angle of the said allotment; thence by lines bearing respectively 27 deg. 13 min. 261.3 links, 55 deg. 40 min. 303.5 links, 78 deg. 7 min. 140.5 links and 229 deg. 34 min. 666.9 links to the point of commencement.
- (h) Commencing at a point on the eastern boundary of allotment 4 of the said parish, distant 180 deg. 0 min. 654.1 links from the north-eastern angle of the said allotment; thence by lines bearing respectively 48 deg. 54 min. 228.3 links, 205 deg. 18 min. 493.1 links, 253 deg. 36 min. 438 links, 232 deg. 14 min. 199.1 links and 48 deg. 54 min. 821.4 links to the point of commencement.
- (i) Commencing at an angle in the southern boundary of the existing Mallacoota-road, through allotment 4 of the said parish, formed by the intersection of lines bearing 254 deg. 38 min. and 232 deg. 14 min.; thence by lines bearing respectively 74 deg. 38 min. 74.5 links, 227 deg. 44 min. 485.5 links, 221 deg. 41 min. 646.3 links, 28 deg. 29 min. 177 links, 40 deg. 12 min. 544.5 links and 52 deg. 14 min. 356 links to the point of commencement.—

which said pieces of land are particularly delineated and shown coloured red on survey plans numbered 10389 and 10390, lodged in the office of the Country Roads Board.

And the Honorable Murray Victor Porter, Her Majesty's Minister of Public Works for the State of Victoria shall give the necessary directions herein accordingly.

J. COLQUHOUN,
Clerk of the Executive Council.

COUNTRY ROADS BOARD.

At the Executive Council Chamber, Melbourne, the
twelfth day of July, 1966.

PRESENT:

The Lieutenant-Governor as Deputy for
His Excellency the Governor of Victoria.
Mr. Bloomfield | Mr. Manson.

ORDER APPROVING OF WIDENING AN EXISTING STATE HIGHWAY IN THE CITY OF TRARALGON.

WHEREAS the Country Roads Board constituted under the *Country Roads Act 1958* (No. 6229) has represented to His Excellency the Governor in Council that it appears to it desirable that the existing Princes Highway in the City of Traralgon (declared to be a State highway under the said Act which declaration was confirmed by the Order in Council published in the *Government Gazette* of the 8th July, 1925, on pages 2371-3) should be widened by the said Board: And whereas the said Board in accordance with the requirements of section

19 of the said cited Act has caused to be prepared a map plan and estimate showing the points between which and on and through what land the said widening is proposed to be made and the cost of acquiring the land: And whereas on an inspection of the said map and plan and a consideration of the said estimate His Excellency the Governor in Council is satisfied that there are funds legally available for acquiring the land: Now therefore be it known by this present Order that the Lieutenant-Governor as Deputy for His Excellency the Governor of the State of Victoria with the advice of the Executive Council thereof doth hereby approve of the said highway being widened, that is to say:—

All that piece of land in the Township of Traralgon, Parish of Traralgon, the boundaries of which are as follow:—Commencing at a point distant 114 deg. 15 min. 164 ft. 11½ in. from the south-eastern angle of allotment 5 in the said parish; thence by lines bearing respectively 166 deg. 41 min. 52 ft. 2 in., 249 deg. 9 min. 9 ft. 3½ in., 299 deg. 44 min. 50 ft. 10½ in. and 54 deg. 46 min. 50 feet to the point of commencement—which said piece of land is particularly delineated and shown coloured red on survey plan numbered 10400, lodged in the office of the Country Roads Board.

And the Honorable Murray Victor Porter, Her Majesty's Minister of Public Works for the State of Victoria, shall give the necessary directions herein accordingly.

J. COLQUHOUN,
Clerk of the Executive Council.

COUNTRY ROADS BOARD.

At the Executive Council Chamber, Melbourne, the twelfth day of July, 1966.

PRESENT:

The Lieutenant-Governor as Deputy for
His Excellency the Governor of Victoria.
Mr. Bloomfield | Mr. Manson.

ORDER APPROVING OF WIDENING AN EXISTING STATE HIGHWAY IN THE SHIRE OF BACCHUS MARSH.

WHEREAS the Country Roads Board constituted under the *Country Roads Act 1958* (No. 6229) has represented to His Excellency the Governor in Council that it appears to be desirable that the existing Western Highway in the Shire of Bacchus Marsh (declared to be a State Highway under the said Act which declaration was confirmed by the Order in Council published in the *Government Gazette* of the 8th July, 1925, on pages 2371-3) should be widened by the said Board: And whereas the said Board in accordance with the requirements of section 19 of the said cited Act has caused to be prepared a map plan and estimate showing the points between which and on and through what land the said widening is proposed to be made and the cost of acquiring the land: And whereas on an inspection of the said map and plan and a consideration of the said estimate His Excellency the Governor in Council is satisfied that there are funds legally available for acquiring the land: Now therefore be it known by this present Order that the Lieutenant-Governor as Deputy for His Excellency the Governor of the State of Victoria with the advice of the Executive Council thereof doth hereby approve of the said highway being widened, that is to say:—

All that piece of land in the Parish of Merrimu, the boundaries of which are as follow:—Commencing at a point in portion 9, section 15 of the said parish, distant 0 deg. 21 min. 2,028.8 links, 315 deg. 24 min. 254.7 links and 259 deg. 51 min. 501.5 links from the south-eastern angle of the said portion; thence by lines bearing respectively 261 deg. 17 min. 183.2 links, 235 deg. 24 min. 239.5 links, 251 deg. 35 min. 922.8 links, 305 deg. 53 min. 154.4 links, 71 deg. 25 min. 1,198.6 links, 70 deg. 55 min. 157.6 links and 126 deg. 14½ min. 116.1 links to the point of commencement—which said piece of land is particularly delineated and shown coloured red on survey plan numbered 10547, lodged in the office of the Country Roads Board.

And the Honorable Murray Victor Porter, Her Majesty's Minister of Public Works for the State of Victoria, shall give the necessary directions herein accordingly.

J. COLQUHOUN,
Clerk of the Executive Council.

COUNTRY ROADS BOARD.

At the Executive Council Chamber, Melbourne, the twelfth day of July, 1966.

PRESENT:

The Lieutenant-Governor as Deputy for His Excellency
the Governor of Victoria.
Mr. Bloomfield | Mr. Manson.

DECLARATION OF A DEVIATION FROM THE COLAC-FORREST ROAD IN THE SHIRE OF OTWAY.

WHEREAS by sections 21 and 58 of the *Country Roads Act 1958* (No. 6229) it is amongst other things enacted that when the Country Roads Board under the provisions of the *Country Roads Act* has by Resolution declared a deviation to be a main road the said Board may also declare that such deviation shall be in lieu of any existing road or part thereof named in such Resolution and that on publication in the *Government Gazette* of the Order confirming such Resolution the existing road or part thereof shall cease to be a main road or be discontinued as provided in the Resolution: And whereas the said Board has by Resolution declared the deviation on the land described in the First Schedule to such Resolution to be a main road and has also declared that such deviation shall be in lieu of the part of the existing road being the land described in the Second Schedule to the said Resolution and that such part of the said existing road shall be discontinued: Now therefore the Lieutenant-Governor as Deputy for His Excellency the Governor of the State of Victoria by and with the advice of the Executive Council thereof doth hereby confirm the said Resolution.

Resolution for Declaration of a Deviation of a Main Road Under the Country Roads Act.

Whereas the land the site of the road the course of which is below set out was taken by the Board under the provisions of the *Country Roads Act 1958* for the purpose of constructing such road deviation which road deviation has now been laid out and formed on the same: And whereas the said Board (being the Country Roads Board incorporated under the said Act) thinks that the road aforesaid is fit to be used as a public highway such Board at a meeting now holden acting under the authority conferred upon it by sections 21 and 58 of the said Act doth by this present Resolution hereby declare the said road deviation the course of which is described in the First Schedule hereto with the commencing and terminating points thereof respectively specified to be part of a main road within the meaning and for the purposes of the *Country Roads Act 1958*: And the said Board doth also declare that such deviation shall be in lieu of the existing road or part thereof described in the Second Schedule hereto and that such part of the said existing road shall be discontinued.

FIRST SCHEDULE.

Shire of Otway.

12. Colac-Forrest road (12812).—All those pieces of land in the Parish of Yaughter, the boundaries of which are as follow:—

- (a) Commencing at a point on the eastern boundary of allotment 12, section A of the said parish, distant 141 deg. 12 min. 952 links and 120 deg. 1 min. 944.5 links from the northern angle of the said allotment; thence by lines bearing respectively 120 deg. 1 min. 385.4 links, 143 deg. 58 min. 196.7 links, 170 deg. 41½ min. 806.8 links, 150 deg. 15 min. 328.5 links, 114 deg. 20 min. 28.9 links, 210 deg. 46 min. 144.1 links, 323 deg. 27½ min. 328.4 links, 349 deg. 43½ min. 858.3 links, 332 deg. 26½ min. 279.8 links, and 314 deg. 20 min. 304.1 links to the point of commencement.
- (b) Commencing at the south-western angle of allotment 12A, section A of the said parish; thence by lines bearing respectively 30 deg. 46 min. 176.3 links, 114 deg. 20 min. 415.9 links, 255 deg. 14 min. 174.7 links, and 282 deg. 7 min. 307 links to the point of commencement.
- (c) Commencing at an angle in the northern boundary of allotment 12, section A of the said parish, formed by the intersection of lines bearing 308 deg. 5 min. and 255 deg. 14 min.; thence by lines bearing respectively 128 deg. 5 min. 76.2 links, 280 deg. 41½ min. 71.2 links, 278 deg. 11 min. 77.3 links, and 75 deg. 14 min. 89.4 links to the point of commencement.

- (d) Commencing at an angle in the southern boundary of allotment 12A, section A of the said parish, formed by the intersection of lines bearing 128 deg. 5 min. and 57 deg. 25 min.; thence by lines bearing, respectively 308 deg. 5 min. 164.1 links, 100 deg. 51½ min. 225.2 links and 237 deg. 25 min. 109.2 links to the point of commencement.
- (e) Commencing at the eastern angle of allotment 12, section A of the said parish; thence by lines bearing respectively 303 deg. 11 min. 318.7 links, 282 deg. 52 min. 225.6 links, 280 deg. 41½ min. 493.7 links, 50 deg. 44 min. 110.2 links, 82 deg. 27 min. 101.8 links, 102 deg. 7 min. 357.4 links, 120 deg. 23 min. 412.3 links and 145 deg. 13 min. 141 links to the point of commencement—

which said pieces of land are particularly delineated and shown coloured red on survey plan numbered 10100, lodged in the office of the Country Roads Board.

SECOND SCHEDULE.

Shire of Otway.

12. Colac-Forrest road (12812).—All those pieces of land in the Parish of Yaughter, the boundaries of which are as follow:—

- (a) Commencing at the north-western angle of allotment 12A, section A of the said parish; thence by lines bearing respectively 120 deg. 1 min. 168.5 links, 148 deg. 0 min. 859 links, 173 deg. 17 min. 320 links, 210 deg. 46 min. 295.7 links, 294 deg. 20 min. 100.7 links, 30 deg. 46 min. 274.4 links, 353 deg. 17 min. 264 links, 328 deg. 0 min. 811 links, 300 deg. 1 min. 133.1 links, 323 deg. 58 min. 243.1 links and 120 deg. 1 min. 211.3 links to the point of commencement.
- (b) Commencing at an angle in the northern boundary of allotment 12, section A of the said parish, formed by the intersection of lines bearing 179 deg. 23 min. and 83 deg. 56 min.; thence by lines bearing respectively 359 deg. 23 min. 306 links, 1 deg. 57 min. 295 links, 30 deg. 46 min. 49.5 links, 143 deg. 27½ min. 203 links, 98 deg. 11 min. 476 links, 255 deg. 14 min. 114.1 links, 205 deg. 19 min. 383 links and 263 deg. 56 min. 352 links to the point of commencement.
- (c) Commencing at an angle in the southern boundary of allotment 12A, section A of the said parish; formed by the intersection of lines bearing 308 deg. 5 min. and 255 deg. 14 min.; thence by lines bearing respectively 128 deg. 5 min. 177.9 links, 280 deg. 51½ min. 287.6 links, 294 deg. 20 min. 27.6 links and 75 deg. 14 min. 173.3 links to the point of commencement.
- (d) Commencing at the south-eastern angle of allotment 12A, section A of the said parish; thence by lines bearing respectively 282 deg. 7 min. 191.3 links, 300 deg. 23 min. 195.7 links, 262 deg. 27 min. 182.2 links, 282 deg. 7 min. 100.3 links, 280 deg. 51½ min. 145.3 links, 57 deg. 25 min. 105.8 links, 82 deg. 27 min. 365 links, 122 deg. 44 min. 378 links, and 172 deg. 36 min. 64.7 links to the point of commencement.
- (e) Commencing at an angle in the northern boundary of allotment 12, section A of the said parish, formed by the intersection of lines bearing 128 deg. 5 min. and 50 deg. 44 min.; thence by lines bearing respectively 308 deg. 5 min. 310.8 links, 100 deg. 41½ min. 396.1 links and 230 deg. 44 min. 186.8 links to the point of commencement—

which said pieces of land are particularly delineated and shown coloured blue on survey plan numbered 10100, lodged in the office of the Country Roads Board.

The common seal of the Country Roads Board was hereto affixed, at Kew, this fourth day of July, One thousand nine hundred and sixty-six, in the presence of—

I. J. O'DONNELL, Chairman.
(SEAL) F. WEST, Member,
N. L. ALLANSON, Secretary.

And the Honorable Murray Victor Porter, Her Majesty's Minister of Public Works for the State of Victoria, shall give the necessary directions herein accordingly.

J. COLQUHOUN,
Clerk of the Executive Council.

COUNTRY ROADS BOARD.

At the Executive Council Chamber, Melbourne, the
twelfth day of July, 1966.

PRESENT:

The Lieutenant-Governor as Deputy for His Excellency
the Governor of Victoria.
Mr. Bloomfield | Mr. Manson.

ORDER APPROVING THE WIDENING OF AN EXISTING
MAIN ROAD IN THE SHIRE OF SOUTH BARWON.

WHEREAS:

I. Section 114 of the *Country Roads Act 1958* (herein called "the Act") provides (*inter alia*) in—

- (a) sub-section (1) thereof that the power conferred upon municipal councils by Division fourteen of Part XIX. of the *Local Government Act 1958* shall so far as applicable be conferred upon the Country Roads Board (herein called "the Board") so far as relates to the declaration of the alignment the widening and opening up of main roads and that the provisions of the said Division shall with certain modifications extend and apply accordingly.
- (b) sub-section (2) thereof that no main road shall be widened or opened up pursuant to the said section unless the Governor in Council has by Order published in the *Government Gazette* approved such widening or opening up;

II. The Board has—

- (a) in exercise of the powers conferred upon it by the said section 114 and for the purpose of widening the Barwon Heads-road in the Shire of South Barwon (declared by the Board pursuant to the Act or some corresponding previous enactment to be a main road which declaration was confirmed by an Order of the Governor in Council published in the *Government Gazette* of the 1st April, 1914, at page 1547 thereof) by Resolution dated the 20th day of June, 1966, fixed new alignments for the north and south sides of the said Barwon Heads-road:
- (b) in accordance with the provisions of section 19 of the Act caused to be prepared a map, plan and estimate showing—
- (i) the points between which and the lands on and through which the said widening is proposed to be made; and
- (ii) the cost of acquiring the land.

III. The Governor in Council is satisfied that there are funds legally available for acquiring the said land.

Now therefore the Lieutenant-Governor as Deputy for His Excellency the Governor of the State of Victoria with the advice of the Executive Council thereof by this Order approves for the purposes of sections 20 and 114 of the Act—

- (a) the widening of the said Barwon Heads-road so as to include therein the land described in the Schedule hereto; and
- (b) the acquisition of the land so described.

SCHEDULE.

All those pieces of land in the Parish of Conewarre, the boundaries of which are as follow:—

- (a) Commencing at the south-eastern angle of allotment G, section 12 of the said parish; thence by lines bearing respectively 90 deg. 28 min. 124 links, 103 deg. 54 min. 236.3 links, 112 deg. 4 min. 1,274.5 links, 114 deg. 42 min. 604.6 links, 129 deg. 8 min. 1,162.2 links, 116 deg. 49 min. 645.8 links, 96 deg. 30 min. 670.6 links, 90 deg. 18 min. 2,157.2 links, 108 deg. 18 min. 80.2 links, 270 deg. 0 min. 3,089 links, 310 deg. 55 min. 1,697.9 links, 292 deg. 30 min. 2,126.9 links and 270 deg. 0 min. 124 links to the point of commencement.
- (b) Commencing at the north-western angle of allotment A, section 21 of the said parish; thence by lines bearing respectively 192 deg. 24 min. 102.3 links, 269 deg. 59 min. 2,575.5 links, 280 deg. 48 min. 537 links and 90 deg. 0 min. 3,125 links to the point of commencement.

- (c) Commencing at the north-eastern angle of allotment F, section 23 of the said parish; thence by lines bearing respectively 179 deg. 50 min. 25 links, 316 deg. 31 min. 36.4 links, 273 deg. 12 min. 301.8 links, 281 deg. 53 min. 1,323.3 links, 281 deg. 9½ min. 3,268.1 links, 281 deg. 57½ min. 5,322.7 links, 230 deg. 50 min. 31.4 links, 359 deg. 43 min. 25 links, 283 deg. 35 min. 103 links, 179 deg. 48 min. 25 links, 314 deg. 48 min. 35.4 links, 269 deg. 48 min. 8,351.2 links, 2 deg. 4 min. 101 links, 89 deg. 48 min. 7,972.2 links, 91 deg. 57 min. 375.3 links, 135 deg. 52 min. 36 links, 359 deg. 48 min. 25 links, 102 deg. 56 min. 102.6 links, 179 deg. 43 min. 25 links, 49 deg. 41 min. 32.2 links, 99 deg. 40 min. 340 links, 101 deg. 57½ min. 5,031.1 links, 102 deg. 3 min. 2,839.5 links and 101 deg. 55 min. 2,045.3 links to the point of commencement.
- (d) Commencing at the south-eastern angle of allotment K, section 15 of the said parish; thence by lines bearing respectively 282 deg. 0½ min. 2,815 links, 101 deg. 1½ min. 2,805 links and 179 deg. 40½ min. 49 links to the point of commencement.
- (e) Commencing at the south-eastern angle of allotment L, section 15 of the said parish; thence by lines bearing respectively 282 deg. 10 min. 1,350 ft. 4½ in., 360 deg. 0 min. 29 ft. 6 in., 101 deg. 19 min. 281 ft. 0½ in., 102 deg. 10 min. 900 ft. 11½ in., 97 deg. 25 min. 150 ft. 1½ in., 48 deg. 42 min. 19 ft. 9½ in. and 180 deg. 0 min. 62 ft. 9 in. to the point of commencement—

which said pieces of land are particularly delineated and shown coloured red and yellow on survey plans numbered 9990, 9992, 9993 and 9994, lodged in the office of the Country Roads Board.

And the Honorable Murray Victor Porter, Her Majesty's Minister of Public Works for the State of Victoria, shall give the necessary directions herein accordingly.

J. COLQUHOUN,
Clerk of the Executive Council.

LABOUR AND INDUSTRY ACT 1958.

At the Executive Council Chamber, Melbourne, the twelfth day of July, 1966.

PRESENT:

The Lieutenant-Governor as Deputy for His Excellency the Governor of Victoria.

Mr. Bloomfield | Mr. Manson.

EXTENSION OF THE POWERS OF THE COMMERCIAL CLERKS BOARD.

UNDER the powers in that behalf conferred by the *Labour and Industry Act 1958*, the Lieutenant-Governor as Deputy for His Excellency the Governor of the State of Victoria by and with the advice of the Executive Council thereof doth hereby extend the powers of the Commercial Clerks Board so that in substitution of the powers heretofore conferred upon the said Commercial Clerks Board it shall have power to determine any industrial matter in relation to the process, trade, business or occupation of a person or persons or class or classes of persons (by whatever name called) employed wholly or principally in clerical work in connexion with a trade or business—

- (a) including, without limiting the generality of the foregoing, stenographers, typists, tele-type operators, switchboard attendants and operators of machines used to perform or assist in performing clerical work; but
- (b) excluding any person employed by a banking company, insurance company, trustee company, or barrister or solicitor.
- (c) excluding any person subject to the Determination of the Clerks (Meat Works) Board or the Totalizer Employees Board.

And the Honorable Vernon Francis Wilcox, Her Majesty's Minister of Labour and Industry for the State of Victoria, shall give the necessary directions herein accordingly.

J. COLQUHOUN,
Clerk of the Executive Council.

LANDLORD AND TENANT ACT 1958.

At the Executive Council Chamber, Melbourne, on the nineteenth day of July, 1966.

PRESENT:

His Excellency the Governor of Victoria.
Mr. Wilcox | Mr. Dickie.

ORDER EXTENDING APPLICATION OF PART V. OF THE LANDLORD AND TENANT ACT 1958 TO CERTAIN PREMISES.

IN pursuance of the powers conferred by section 44 of the *Landlord and Tenant Act 1958*, His Excellency the Governor of Victoria, by and with the advice of the Executive Council, doth hereby declare that the application of Part V. of the *Landlord and Tenant Act 1958* shall extend to the following premises—

1. The premises known as Number 175 Cubitt-street, Richmond;
2. The premises known as Number 141 Coppin-street, Richmond.

And the Honorable Vernon Francis Wilcox, Her Majesty's Acting Attorney-General in and for the State of Victoria, shall give the necessary directions herein accordingly.

J. COLQUHOUN,
Clerk of the Executive Council.

LANDLORD AND TENANT ACT 1958.

At the Executive Council Chamber, Melbourne, on the nineteenth day of July, 1966.

PRESENT:

His Excellency the Governor of Victoria.
Mr. Wilcox | Mr. Dickie.

ORDER EXCLUDING CERTAIN PREMISES FROM THE OPERATION OF CERTAIN OF THE PROVISIONS CONTAINED IN PART V. OF THE LANDLORD AND TENANT ACT 1958.

IN pursuance of the powers conferred upon him by the *Landlord and Tenant Act 1958*, His Excellency the Governor of the State of Victoria, by and with the advice of the Executive Council thereof, doth hereby declare that the premises known as Number 3 Ormond-street, Brunswick, shall be excluded from the operation of the whole of the provisions contained in Divisions 2 and 3 of Part V. of the *Landlord and Tenant Act 1958*.

And the Honorable Vernon Francis Wilcox, Her Majesty's Acting Attorney-General in and for the State of Victoria, shall give the necessary directions herein accordingly.

J. COLQUHOUN,
Clerk of the Executive Council.

KYNETON SEWERAGE AUTHORITY.

At the Executive Council Chamber, Melbourne, the nineteenth day of July, 1966.

PRESENT:

His Excellency the Governor of Victoria.
Mr. Wilcox | Mr. Dickie.

SALE OF LAND.

HIS Excellency the Governor of the State of Victoria, by and with the advice of the Executive Council thereof, doth hereby, under the provisions of section 109 of the *Sewerage Districts Act 1958*, approve of the sale by the Kyneton Sewerage Authority of the land described in the Schedule hereto.

SCHEDULE.

All that land comprising Crown allotment 4, section 32A, Township of Kyneton, Parish of Lauriston, County of Dalhousie.

All of which land is shown on a plan approved by the Governor in Council and deposited in the office of the State Rivers and Water Supply Commission, Melbourne (Corr. 59/7544/50).

And the Honorable Thomas Anthony Darcy, Her Majesty's Minister of Water Supply for the State of Victoria, shall give the necessary directions herein accordingly.

J. COLQUHOUN,
Clerk of the Executive Council.

MORNINGTON SEWERAGE AUTHORITY.

At the Executive Council Chamber, Melbourne, the nineteenth day of July, 1966.

PRESENT:
His Excellency the Governor of Victoria.
Mr. Wilcox | Mr. Dickie.

EXTENT OF SEWERAGE DISTRICT INCREASED AND APPROVAL OF SITE OF MAIN SEWER AND LAND TO BE COMPULSORILY ACQUIRED.

UNDER the powers conferred by the Sewerage Districts Act and all other powers enabling him in that behalf, His Excellency the Governor of the State of Victoria, by and with the advice of the Executive Council of the said State, doth hereby declare, order and direct that the extent of the Sewerage District of the Mornington Sewerage Authority be increased by adding to the same the land comprised within the boundaries described in Portion I. of the Schedule hereto and as on and from the date hereof, the extent of such district shall be and be deemed to be increased accordingly, and doth also hereby consent to the construction of a main sewer on the lands described in Portion II. of the Schedule hereto and to compulsory acquisition of the land described in the said Portion II.

SCHEDULE. Portion I.

Commencing at the south-westernmost angle of a Recreation Reserve on lodged plan of subdivision No. 54662, Crown portion 7, Parish of Moorooduc, County of Mornington, being a point on the boundary of the existing Sewerage District; thence south-easterly along the southern boundary of the said Recreation Reserve and by a line across the Nepean Highway to the south-western angle of lot 1 on lodged plan of subdivision No. 53772, Crown portion 14, and along the south-western boundaries of the said lot 1 and of lots 2, 18, 17, 16, 15 and 14 to the southernmost angle of the said lot 14; thence south-westerly by a line across Bungower-road to the easternmost angle of lot 3 on lodged plan of subdivision No. 6505, Crown portion 13, and generally south-westerly and westerly along the south-eastern boundary of the said lot 3 and the southern boundary of lot 1 to the southernmost angle of lot 14A; thence north-easterly and northerly along the south-eastern and eastern boundaries of the said lot 14A and the eastern boundary of lot 15 to the south-eastern angle of lot 16; thence north-westerly along the south-western boundary of the said lot 16 and by a line being the continuation thereof across the Nepean Highway to a point on the south-eastern boundary of Crown section 8, being a point on the boundary of the existing Sewerage District; thence north-easterly along the boundary of the existing Sewerage District to the point of commencement.

Portion II.—Site of Main Sewer.

The site of the main sewer being a strip of land 50 links in width, being 25 links on each side of the centre-line of the said main sewer commencing at a point on the south-eastern boundary of lot 1 on lodged plan of subdivision No. 6762, Crown section 8, Parish of Moorooduc adjacent to its southern angle, being a point on the boundary of the existing Sewerage District; thence generally south-easterly and north-easterly across the Nepean Highway and through lots 14 and 14A on lodged plan of subdivision No. 6505, Crown portion 13, adjacent to the Tanti Creek and the south-eastern boundary of the said lot 14A to a point on the said south-eastern boundary of lot 14A distant approximately 285 links north-easterly from its southernmost angle.

All of which lands are shown on a plan approved by the Governor in Council and deposited in the office of the State Rivers and Water Supply Commission, Melbourne.—(Corr. 63/935/129.)

And the Honorable Thomas Anthony Darcy, Her Majesty's Minister of Water Supply for the State of Victoria, shall give the necessary directions herein accordingly.

J. COLQUHOUN,
Clerk of the Executive Council.

DANDENONG VALLEY AUTHORITY.

At the Executive Council Chamber, Melbourne, the nineteenth day of July, 1966.

PRESENT:
His Excellency the Governor of Victoria.
Mr. Wilcox | Mr. Dickie.

CONSENT TO BORROWING \$100,000.

UNDER the powers conferred by the Dandenong Valley Authority Act and all other powers enabling him in that behalf, His Excellency the Governor of the State of Victoria, by and with the advice of the Executive Council of the said State, doth hereby consent to the Dandenong Valley Authority borrowing by assignment of the Dandenong Valley Authority Fund the sum of One hundred thousand dollars (\$100,000) to meet the cost of river improvement works.

And the Honorable Thomas Anthony Darcy, Her Majesty's Minister of Water Supply for the State of Victoria, shall give the necessary directions herein accordingly.

J. COLQUHOUN,
Clerk of the Executive Council.

River Improvement Act 1958.

LATROBE RIVER IMPROVEMENT TRUST.

At the Executive Council Chamber, Melbourne, the nineteenth day of July, 1966.

PRESENT:
His Excellency the Governor of Victoria.
Mr. Wilcox | Mr. Dickie.

LATROBE RIVER IMPROVEMENT TRUST—EXTENT OF DISTRICT INCREASED.

UNDER the powers conferred by the River Improvement Act 1958 and all other powers enabling him in that behalf, His Excellency the Governor of the State of Victoria, by and with the advice of the Executive Council of the said State of Victoria, doth hereby declare, order and direct as follows:—

That the extent of the Latrobe River Improvement District be increased by adding to the same the lands within the boundaries set out and described in the Schedule hereto, and as on and from the date of this Order the extent of the Latrobe River Improvement District shall be deemed to be so increased.

SCHEDULE.

Commencing at a point in the eastern boundary of allotment 42, section B, Parish of Wurruk Wurruk, 33 chains from the north-eastern angle of allotment 42, being a point on the boundary of the Latrobe River Improvement District as defined on the 25th day of August, 1953; thence northerly by the eastern boundary of allotment 42 and a line in continuation thereof across a road to a point in the southern boundary of allotment 38; thence westerly, northerly and easterly by the southern, western and northern boundaries of allotment 38 to the south-western angle of allotment 36; thence northerly by the western boundary of allotment 36 and a line in continuation thereof across a road to a point in the southern boundary of allotment 29; thence westerly and northerly by the southern and western boundaries of allotment 29 to its north-western angle, being a point in the southern boundary of the Princes Highway; thence generally easterly by the last mentioned boundary to the north-western angle of allotment 22, section E, being a point on the boundary of the Latrobe River Improvement District as defined on the 25th day of August, 1953; thence generally south-westerly by the last mentioned boundary to the point of commencement.

All the lands within the boundaries set forth in the foregoing Schedule are shown coloured green on a plan approved by the Governor in Council, and deposited in the office of the State Rivers and Water Supply Commission, Melbourne.—(Corres. 63/3074.)

And the Honorable Thomas Anthony Darcy, Her Majesty's Minister of Water Supply for the State of Victoria, shall give the necessary directions herein accordingly.

J. COLQUHOUN,
Clerk of the Executive Council.

STAMPS ACT 1958, No. 6375.

At the Executive Council Chamber, Melbourne, the nineteenth day of July, 1966.

PRESENT:

His Excellency the Governor of Victoria.
Mr. Wilcox | Mr. Dickie.

HIS Excellency the Governor of the State of Victoria, by and with the advice of the Executive Council thereof, doth by this Order made pursuant to section 131c of the Stamps Act 1958 (No. 6375) revoke the declaration made on 10th May, 1960, and published in the *Government Gazette* of the 11th May, 1960, declaring certain persons to be "approved vendors" for the purposes of subdivision (14) of Division three of Part II. of the Stamps Act 1958 in so far as the said declaration refers to the under-mentioned person:—

153. Home Credits Pty. Ltd.

And the Honorable Arthur Gordon Rylah, Her Majesty's Acting Treasurer for the State of Victoria, shall give the necessary directions herein accordingly.

J. COLQUHOUN,
Clerk of the Executive Council.

ABORIGINES ACT 1958.

At the Executive Council Chamber, Melbourne, the nineteenth day of July, 1966.

PRESENT:

His Excellency the Governor of Victoria.
Mr. Wilcox | Mr. Dickie.

APPOINTMENT OF CHAIRMAN AND MEMBERS OF THE ABORIGINES WELFARE BOARD.

IN accordance with the provisions of the *Aborigines Act 1958*, His Excellency the Governor of the State of Victoria in the Commonwealth of Australia, by and with the advice of the Executive Council of the said State, doth by this Order—

(a) appoint—

JAMES HENRY DAVEY,
to be Chairman of the Aborigines Welfare Board for the period commencing on the 23rd day of July, 1966, and ending on the 30th day of June, 1967 (both dates inclusive); and

(b) doth appoint—

ALBERT GEORGE BOOTH (nominated by the Chief Secretary),
ROBERT PENN MCLELLAN (nominated by the Minister of Education),
JACK PERCIVAL GASKIN (nominated by the Minister of Housing),
ROBERT SOUTHBY (nominated by the Minister of Health),
COLIN MARTIN TATZ (selected from a panel of three names submitted by the President for the time being of the Aborigines Advancement League),
MARGARET TUCKER (being an Aboriginal),
CORNELIUS EDWARDS (being an Aboriginal),
DONALD FINDLAY FERGUSSON THOMSON (being an expert in anthropology),
DONALD ROBERT HOWE, and
ARTHUR GODFREY HOLDEN,
to be Members of the Aborigines Welfare Board for the period commencing on the 23rd day of July, 1966, and ending on the 30th day of June, 1967 (both dates inclusive).

And the Honorable John Frederick Rossiter, Her Majesty's Acting Minister of Housing for the State of Victoria, shall give the necessary directions herein accordingly.

J. COLQUHOUN,
Clerk of the Executive Council.

LANDS DEPARTMENT NOTICES

APPROACHING LAND SALES.

SALES of Crown lands, in fee-simple, will be held at the under-mentioned places and dates, viz.:—

	No. of Gazette.
Ararat.—Wednesday, 31st August, 1966 ..	50
Ballarat.—Wednesday, 3rd August, 1966 ..	46
Ballarat.—Thursday, 18th August, 1966 ..	50

SALE OF FREEHOLD LAND BY AUCTION.

Geelong.—Tuesday, 30th August, 1966 .. 50

PROPOSED REVOCATIONS OF TEMPORARY RESERVATIONS OF LANDS BY ORDERS IN COUNCIL.

IN pursuance of the provisions of the *Land Act 1958*, notice is hereby given that it is the intention of the Governor in Council to revoke the temporary reservations of lands by Orders in Council hereunder referred to, viz.:—

The following Notices were published 1^o on the 13th July, 1966, pursuant to Orders of the 5th July, 1966.

MELBOURNE SOUTH (ST. KILDA).—The temporary reservation from sale, leasing and licensing by Order in Council of the 28th July, 1911, of 14 acres 3 roods 25 perches of land at St. Kilda, Parish of Melbourne South, as a site for the Recreation, Convenience or Amusement of the People is about to be revoked so far only as the portion containing 2 roods, more or less, indicated by hachure on plan hereunder, is concerned.—(M.333⁽²²⁾) (Rs.50).

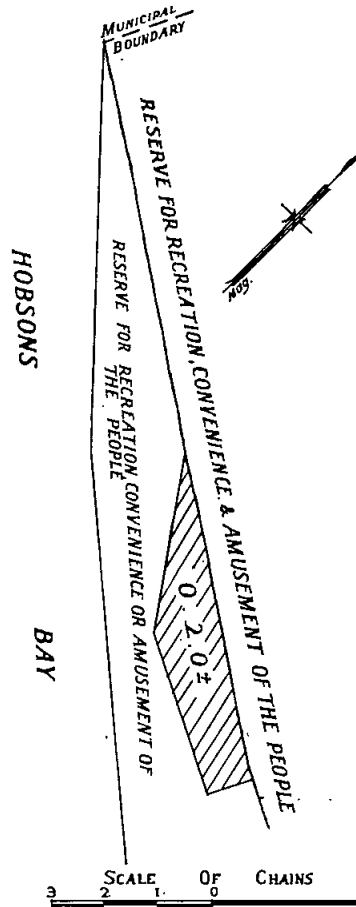

MELBOURNE SOUTH (ST. KILDA).—The temporary reservation from sale, leasing and licensing by Order in Council of the 5th June, 1906, of 19 acres 2 roods 20 perches, more or less, of land at St. Kilda, Parish of Melbourne South, as a site for the Recreation, Convenience and Amusement of the People, revoked as to part by various

Orders, so far only as the portion containing 4 acres, more or less, indicated by hachure on plan hereunder, is concerned.—(M.333⁽²²⁾) (Rs.50).

PROPOSED REVOCATIONS OF TEMPORARY RESERVATIONS OF LANDS BY ORDERS IN COUNCIL.

IN pursuance of the provisions of the Land Act 1958, notice is hereby given that it is the intention of the Governor in Council to revoke the temporary reservations of lands by Orders in Council hereunder referred to, viz.:

The following Notices were published 1° on the 6th July, 1966, pursuant to Orders of the 28th June, 1966.

MILDURA (RED CLIFFS).—The temporary reservation by Order in Council of the 21st February, 1928, of 2 acres 1 rood 37 perches of land at Red Cliffs, Parish of Mildura, as a site for Public purposes, Park and Recreation and Convenience of the People, so far only as the portion containing 25 perches, indicated by hachure on plan hereunder is concerned.—(R.87⁽⁸⁾) (Rs.3631).

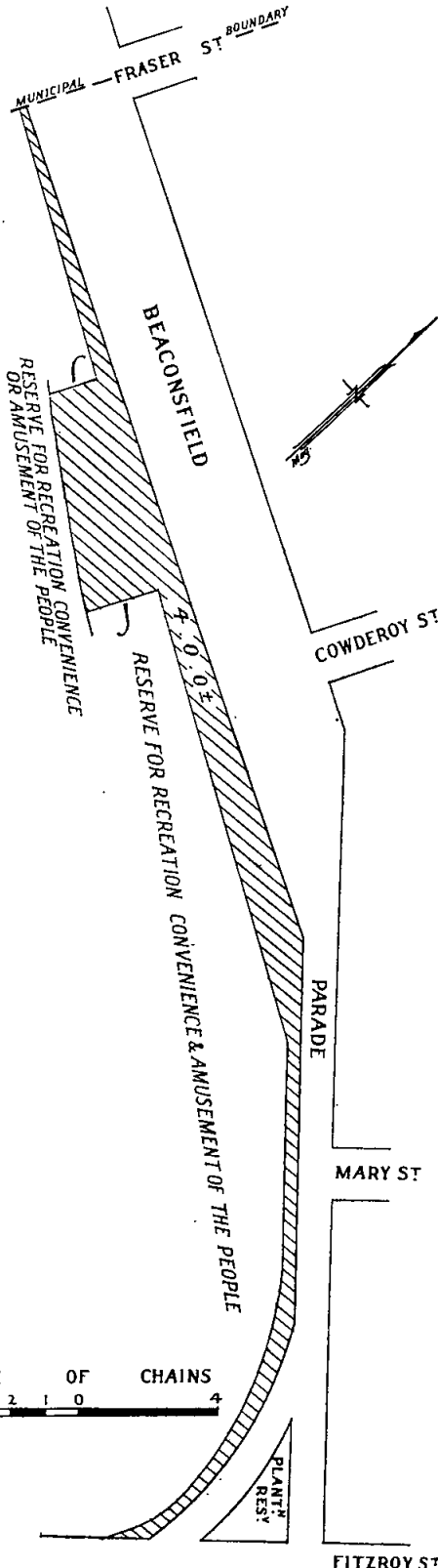

J. C. M. BALFOUR,
Minister of Lands.

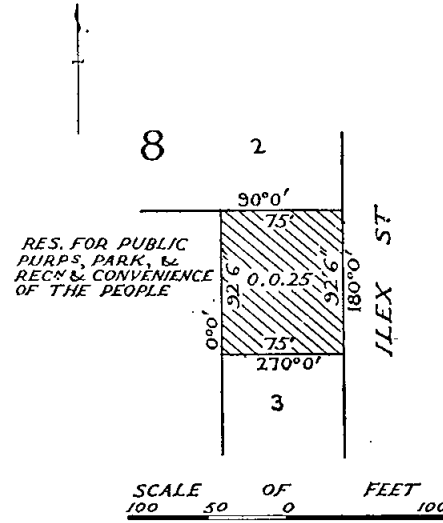

NATIMUK.—The temporary reservation, by Order in Council of the 2nd February, 1874 (see Government Gazette of the 6th February, 1874, page 245), of 2 acres of land in the Township of Natimuk, as a site for State School purposes, revoked as to part by Order of the 28th May, 1963, so far as the balance thereof, containing 1 rood 22 perches is concerned.—(N.117⁽⁹⁾) (C.78598).

JIKA JIKA (ROYAL PARK).—The temporary reservation by Order in Council of the 12th January, 1932, of 60 acres 17 perches of land in the Parish of Jika Jika, as a site for a Mental Hospital, revoked as to part by Order of the 22nd January, 1946, so far only as the portions containing 4 acres 15 perches, indicated by hachure on plan hereunder, are concerned.—(M.314⁽¹⁰⁾) (Rs.4172).

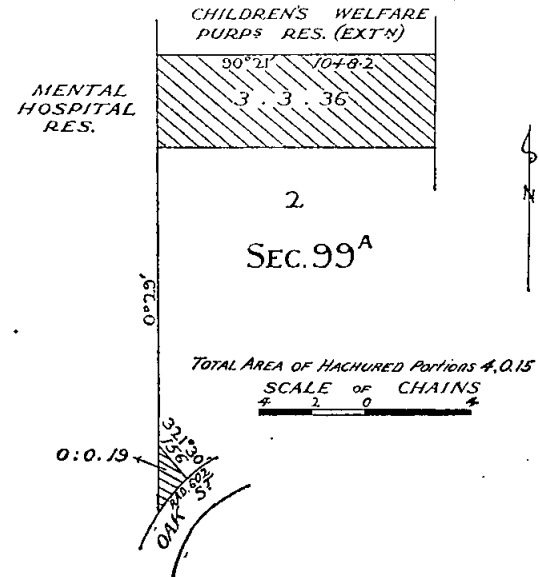

JIKA JIKA (ROYAL PARK).—The temporary reservation by Order in Council of the 2nd April, 1946, of 2 acres 1 rood 14 9/10 perches of land in the Parish of Jika Jika, as a site for Children's Welfare purposes, so far only as the portion containing 1 rood 22 perches, indicated by hachure on plan hereunder, is concerned.—(M.314⁽¹⁵⁾) (Rs.259).

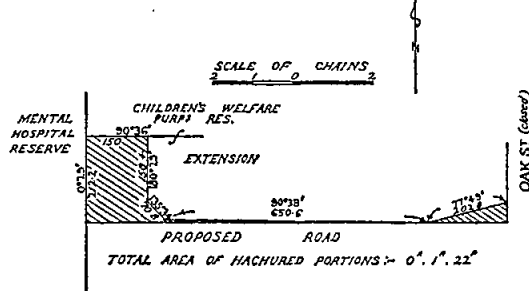

BEYAL.—The temporary reservation, by Order in Council of the 16th April, 1937, of 2 acres 1 rood 24 perches of land in the Parish of Beyal, as a site for State School.—(B.760⁽¹⁾) (Rs.4678).

JIKA JIKA (ROYAL PARK).—The temporary reservation by Order in Council of the 24th December, 1930, of 12 acres 3 roods 15/10 perches of land in the Parish of Jika Jika, as a site for Children's Welfare purposes, so far only as the portion containing 1 acre 3 roods 9 perches, indicated by hachure on plan hereunder, is concerned.—(M.314⁽¹⁵⁾) (Rs.259).

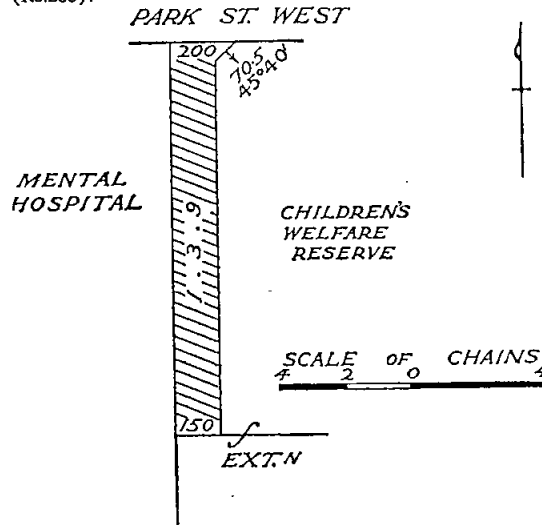

LORNE.—The temporary reservation, by Order in Council of the 21st August, 1917, of 149 acres more or less of land in the Township of Lorne, as a site for Public purposes revoked as to part by various Orders in Council, so far only as the portion containing 2 roods 20 perches more or less, indicated by hachure on plan hereunder, is concerned.—(L.147⁽⁷⁾) (Rs.1690).

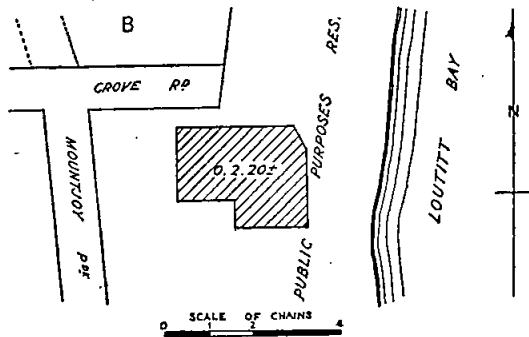

J. C. M. BALFOUR,
Minister of Lands.

PROPOSED REVOCATIONS OF TEMPORARY RESERVATIONS OF LANDS BY ORDERS IN COUNCIL.

IN pursuance of the provisions of the Land Act 1958, notice is hereby given that it is the intention of the Governor in Council to revoke the temporary reservations of lands by Orders in Council hereunder referred to, viz.:—

The following Notices were published 1° on the 20th July, 1966, pursuant to Orders of the 12th July, 1966.

BEULAH.—The temporary reservation, by Order in Council of the 15th May, 1956, of 2 roods 3 perches of land in the Township of Beulah, Parish of Galaquil, as a site for a Children's Playground.—(B.727⁽⁷⁾) (Rs.7115).

BOORT.—The temporary reservation, by Order in Council of the 1st March, 1880, of 2 acres of land in the Parish of Boort as a site for Public Purposes (State School).—(B.654⁽¹¹⁾) (C.97235).

J. C. M. BALFOUR,
Minister of Lands.

PROPOSED PERMANENT RESERVATIONS OF LANDS AS SITES.

IN pursuance of the provisions of the Land Act 1958, notice is hereby given that it is the intention of the Governor in Council to permanently reserve as sites, and also except from occupation for mining purposes under any miner's right, the lands hereunder referred to:—

The following Notices were published 1° on the 20th July, 1966, pursuant to Orders of the 12th July, 1966.

PRAHRAN (CAULFIELD).—As a site for Public Park, Gardens and Public Recreation, 57 acres 1 rood, more or less, Parish of Prahran, at Caulfield, County of Bourke, being the remaining portion of the site temporarily reserved therefor by Order in Council of the 24th April, 1956, and known as "Caulfield Park".—(P.81⁽¹¹⁾) (Rs.215).

PRAHRAN (CAULFIELD).—As a site for Public Purposes (Swimming pool, other associated facilities and car parking), 5 acres 2 perches, Parish of Prahran, at Caulfield, County of Bourke, as indicated by hachure on plan hereunder.—(P.81⁽¹¹⁾) (Rs.8469).

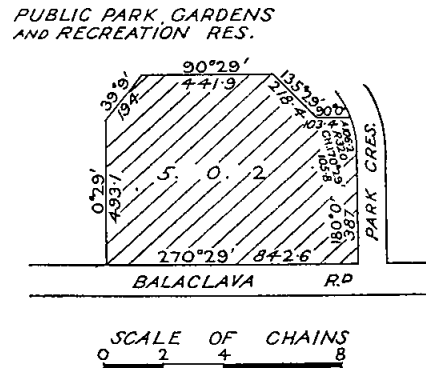

J. C. M. BALFOUR,
Minister of Lands.

AMENDMENT OF REGULATIONS FOR THE CARE, PROTECTION AND MANAGEMENT OF THE "CAULFIELD RACECOURSE RESERVE".

WE, James David Macdonald, the Honourable Sir John Herman Lienhop, the Honourable Sir Herbert John Thornhill Hyland, Joseph Anstice Rafferty, the Honourable Arthur Gordon Rylah, the Honourable Sir Henry Edward Bolte, Edwin James Kennon, Norman de Winton Robinson, John Leslie Davis, Sir Rupert William John Clarke, Robert Alexander Hunter, Thomas Symington Carlyon, Andrew John George Sinclair, Ernest Edwin Gunn and William Richardson Thomson, being the duly appointed Trustees of the land reserved for Racing, Recreation and Public Park purposes and premises, being allotment A, at Caulfield, in the Parish of Prahran, County of Bourke, the subject matter of a Crown grant, volume 7275, folio 1454814, and known as the "Caulfield Racecourse Reserve", in the exercise of the powers conferred on us by the said Crown grant, and by the Land Act 1958 and of any and every other power enabling us so to do, and with the approval of the Governor in Council do hereby amend the Regulations made by the Trustees on the 7th July, 1931, and approved by the Governor in Council on the 13th October, 1931, and as were amended by the Trustees on the 22nd August, 1950, 21st February, 1953, and 30th June, 1965,

respectively and approved by the Governor in Council on the 31st October, 1950, 31st March, 1953, and 24th August, 1965, respectively, by amending the tolls, entrance fees and charges for admission stated in Regulation XVII. to read:—

"For the admission of each person to the first division	\$ 1.15
For the admission of each person to the sixth division from the first division	.35
For the admission of each person to the first and sixth divisions	1.50
For the admission of each person to the fourth division	.50
For the admission of each person to the ninth division	.20
For the admission to the eighth division of every horse, with or without a vehicle, and of every motor car, or motor bicycle, with or without side-car	.30

Dated this 27th day of May, 1966.

J. D. MACDONALD.
J. H. LIENHOP.
H. J. T. HYLAND.
J. A. RAFFERTY.
A. G. RYLAH.
H. E. BOLTE.
E. J. KENNON.
J. L. DAVIS.
R. W. J. CLARKE.
R. A. HUNTER.
T. S. CARLYON.
A. J. G. SINCLAIR.
E. E. GUNN.
W. R. THOMSON.
N. de W. ROBINSON.

Approved by the Governor in Council, 12th July, 1966.—
J. COLQUHOUN, Clerk of the Executive Council.

LOCAL LAND BOARDS.

IN pursuance of the provisions of section 34 of the Land Act 1958, notice is hereby given that public hearings at the following places and times, will be conducted by the persons respectively mentioned, being duly appointed in that behalf.

J. C. M. BALFOUR,
Minister of Lands.

Department of Crown Lands and Survey,
Melbourne.

SCHEDULE.

- MACARTHUR COURT-HOUSE, Monday, 15th August, 1966, at 1.30 p.m., and Tuesday, 16th August, 1966, at 9.30 a.m.—E. Kennedy and K. C. Gittins.
- HAMILTON COURT-HOUSE, Monday, 8th August, 1966, at 2 p.m., and Friday, 12th August, 1966, at 9 a.m.—E. Kennedy and K. C. Gittins.
- CASTERTON COURT-HOUSE, Tuesday, 9th August, 1966, at 9 a.m.—E. Kennedy and K. C. Gittins.
- EDENHOPE COURT-HOUSE, Wednesday, 10th August, 1966, at 9.30 a.m., and Thursday, 11th August, 1966, at 9.30 a.m.—E. Kennedy and K. C. Gittins.
- BALLARAT LAND OFFICE, CAMP-STREET, Wednesday, 17th August, 1966, at 10 a.m.—N. Fitzgerald and P. T. Ledger.

LOCAL LAND BOARDS.

IN pursuance of the provisions of section 34 of the Land Act 1958, notice is hereby given that public hearings at the following places and times, will be conducted by the persons respectively mentioned, being duly appointed in that behalf.

J. C. M. BALFOUR,
Minister of Lands.

Department of Crown Lands and Survey,
Melbourne.

SCHEDULE.

- OMELO LAND OFFICE, 2nd August, 1966, at 11 a.m.—
W. C. Harry.
- ORBOST LAND INSPECTOR'S OFFICE, 4th August, 1966,
at 10.00 a.m.—W. C. Harry.

TENDERS

PUBLIC WORKS DEPARTMENT

TENDERS will be received at Public Works Department, Treasury-place, Melbourne, until TEN a.m. on dates shown and for purposes mentioned hereunder.

Particulars and tender forms available at Contracts Office, Room 7, Building Division, Parliament-place and at places indicated in brackets hereunder.

Abbreviations in brackets mean:—W.O.—Inspector of Works Office; P.S.—Police Station; C.S.—Consolidated School; H.E.S.—Higher Elementary School; H.S.—High School; S.S.—State School; T.S.—Technical School.

Tenders to be submitted on the Department's printed Tender Form and will not be received by telephone. All tenders must be on a "Firm Tender" basis. The lowest or any tender will not necessarily be accepted.

Address tenders to the Minister of Public Works, and endorse the envelope containing the tender "Tender for closing Tuesday,"

No preliminary deposit is required with any tender, but a successful tenderer will be required to pay a deposit for any accepted tender of \$5,000 or over.

Tuesday, 26th July, 1966.

Building, Electrical and Mechanical Works.

Apollo Bay.—External and internal repairs and painting, Residence, 2 Montrose-avenue, Consolidated School. (Amended Specification.) (W.O., Camperdown.)
Balwyn.—Internal repairs, renovations and painting, High School.

Braybrook.—Internal repairs and painting, S.S. 1102.

Burnley.—External repairs and painting, S.S. 2853.

Cardinia.—Septic sewerage, internal and external renovations, Residence, S.S. 3689.

Dandenong.—Internal repairs and painting, Technical School.

Eastmoor.—Repairs and painting, S.S. 4790. (Amended Specification.) (Re-advertised.)

Fairfield North.—General repairs and renovations, S.S. 4329 & Residence.

Footscray North.—Repairs and painting, Special School 4792.

Garfield.—Erection of brick toilet block, Country Roads Board Rest Areas. (W.O., Warragul.)

Hamilton.—Renovations to residence, 28 Bree-road, Technical School. (W.O., Hamilton.)

Hawthorn.—External repairs and painting, Social Welfare Department Hostel, 12 Lissong-grove.

Hopetoun.—Drinking, ablution facilities and water supply installation, S.S. 3167. (W.O., Warracknabeal; S.S., Hopetoun.)

Horsham.—External painting, No. 3 Trade Buildings, Technical School. (W.O., Horsham.)

Horsham West.—Repairs and renovations, S.S. 4691. (W.O., Horsham.) (Re-advertised.)

Kaniva.—Repairs and painting, Residence, 33 Young-street, Consolidated School. (W.O., Horsham; C.S., Kaniva.)

Katamatite East.—Renovations, new porch and new heater, S.S. 3663. (W.O., Benalla; S.S., Katamatite East.)

Koallah.—Erection of out-offices and installation of septic tank, S.S. 4225. (W.O., Camperdown; S.S., Koallah.)

Melbourne.—Internal painting and renovations, School for Deaf Children, St. Kilda-road.

Moyhu.—Additions to residence, new garage, repairs and painting, S.S. 1335 & Residence. (W.O., Benalla; S.S., Moyhu.)

Newbridge.—Electric jet pump, S.S. 457 and Residence. (W.O., Bendigo and Maryborough.)

Nhill.—Erection of new toilet block and demolitions, S.S. 2411. (W.O., Horsham; S.S., Nhill.)

Notting Hill.—Renovations, S.S. 4305.

Oxley.—Repairs and painting, S.S. 1399 & Residence. (W.O., Wangaratta, Benalla; S.S., Oxley.)

Parktone.—External renovations, S.S. 4843.

Prahran.—Internal and external renovations, Secondary Teachers' College, Hostel, 174 Punt-road.

Queenscliff.—Internal and external repairs, renovations, &c., S.S. 1190. (W.O., Geelong, S.S., Queenscliff.)

Richmond.—External renovations and painting, Girls' Secondary School.

St. Albans East.—External repairs and painting, S.S. 4741.

Stony Point.—Supply and erection of chain mesh fencing and gates, Buoy Depot, Ports & Harbours.

Strathdownie.—Repairs and painting, &c., S.S. 2883. (W.O., Hamilton; S.S., Strathdownie.)

Sunshine.—Repairs and painting, S.S. 3113 & Residence.
 Warrnambool.—Erection of standard Manual Arts Blocks, High School. (W.O., Warrnambool.)
 Warrnambool.—Mechanical services in Manual Arts Wing, High School. (W.O., Warrnambool.)
 Werribee.—Erection of mist propagation unit, State Research Farm. (W.O., Geelong.)

Furniture and Furnishings.

Stawell.—Supply of furniture, Technical School.
 Sunshine North.—Supply of furniture, Technical School.

Site Works.

Cheltenham East.—Earthworks, asphaltting, concreting, retaining wall construction, drainage and associated works, S.S. 4754.
 Edithvale.—Site works including asphalt paving, repairs, drainage, &c., S.S. 3790.
 Koonung.—Asphaltting, concreting, drainage, retaining walls, gravelling, landscaping and associated work, High School.
 Ringwood.—Asphaltting, asphalt maintenance, drainage, concreting and associated works, S.S. 2997. (Re-advertised.)
 Studfield.—Surface and underground drainage, asphalt, concrete and gravel pavements, S.S. 4920.

Miscellaneous.

Hamilton.—Supply of treated round fence posts, Pastoral Research Station.
 Hamilton.—Supply of wire fencing, Pastoral Research Station.
 Traralgon.—Supply of electric welding equipment, Technical School.
 Williamstown.—Supply of steel pipes, Dredging Depot, Ports and Harbours. (12-in. Suction Dredge.)

Tuesday, 2nd August, 1966.**Building, Electrical and Mechanical Works.**

Altona East.—Repair and replacement of fencing, S.S. 4805.
 Box Hill.—Electrical installation in alterations and additions, Boys' Technical School.
 Broadford.—Erection of brick veneer office building, Soil Conservation Authority. (W.O., Alexandra and Kyneton.)
 Burwood.—Installation of electric heating, Teachers' College Hostel, 221 Burwood-road.
 Dandenong.—Relining of internal walls and painting, Girls' Secondary School.
 Dimboola.—Toilet facilities, Court House. (W.O., Warracknabeal; P.S., Dimboola.)
 Elwood.—External renovations, High School.
 Fisherman's Bend.—Erection of brick veneer office and steel framed canopy, Licence Testing Station, Police Department.
 Hamilton.—Renovations, Residence, 3 Lewis-street, High School. (W.O., Hamilton.)
 Hampton.—Repairs and painting, High School.
 Hawthorn.—Aluminium soundproofing windows, Applied Science Building, Swinburne Technical College.
 Kaniva.—External repairs and painting all buildings and internal renovations, Infants School, Consolidated School. (W.O., Horsham; C.S., Kaniva.) (Re-advertised.)
 Lalor.—External renovations, S.S. 4709.
 Lang Lang.—Connexion to sewerage, S.S. 2899. (S.S., Lang Lang.) (Re-advertised.)
 Maribyrnong.—Erection of canteen and store, High School.
 Melbourne.—Room air conditioning units, Accounts Branch, Public Works Department, Treasury Place.
 Morwell West.—Internal and external repairs and painting, Residence S.S. 2439. (W.O., Traralgon; S.S., Morwell West.)
 Parklands.—Erection of four additional class-rooms, S.S. 4738.
 Parklands.—Electrical installation in four additional class-rooms, S.S. 4738.
 Parklands.—Plenum heating in four additional class-rooms, S.S. 4738.
 Royal Park.—External repairs and painting, Superintendent's Residence, Psychiatric Hospital.
 Waverley.—Connexion to sewer, High School.
 Somers.—Additions and renewals to septic treatment plant, Children's School Camp 4647.

Furniture and Furnishings.

Beechworth.—Supply and fix curtains to Male Wards 1 to 6, Mental Hospital.
 Mont Park.—Supply of bed spreads, Janefield Mental Hospital.

Mont Park.—Supply of bedside lockers, dining tables and seating forms, Janefield Mental Hospital.

Mont Park.—Supply of Geriatric chairs, Plenty Mental Hospital.

Mont Park.—Supply of wheel chairs, Plenty Mental Hospital.

Site Works.

Lake Bolac.—Pavement repairs and associated works, High School. (W.O., Camperdown, Warrnambool, Geelong, and Hamilton.) (Re-advertised.)
 Rochester.—Construction of concrete and asphalt paving, concrete kerbs and channels, beautification and associated works, High School. (W.O., Bendigo; H.S., Rochester.)
 Shepparton.—Construction of concrete and asphalt paving, gravelled areas, drainage and associated works, S.S. 4943. (C.O., Shepparton.)

Miscellaneous.

Port Melbourne.—Supply and delivery of twelve (12) seven hundredweight vibrating rollers, Public Works Department, Depot, Salmon-street.

Tuesday, 9th August, 1966.**Building, Electrical and Mechanical Works.**

Beechworth.—Provision of staff and patients toilet, &c., Mental Hospital. (Re-advertised.) (W.O., Wangaratta.) (Amended Specification.)
 Beechworth.—External painting of hospital wards and Nursing Administration Buildings, Mental Hospital. (W.O., Wangaratta; Mental Hospital, Beechworth.)
 Boronia.—Renovations to office and residence, Police Station.
 Brunswick West.—Renovations, S.S. 2890 & Residence.
 Burnley Gardens.—Repairs and painting, Curator's Residence, Agriculture Department.
 Ellinbank.—Internal and external repairs and painting, Residence, S.S. 2189. (W.O., Warragul; S.S., Ellinbank.)
 Erica.—Conversion of septic closets and water supply, S.S. 2437 & Residence. (W.O., Warragul.)
 Footscray.—Roof overhaul and renewals, S.S. 253.
 Horsham.—Repairs and painting, Lands & Survey Department, Residence, 36 Stewart-street. (W.O., Horsham.)
 Hurstbridge.—Connexion to town water supply and fire service installation, S.S. 3939.
 Keilor.—External repairs and painting, S.S. 1578.
 Kyabram.—New shelter pavilion and new flooring to cloak room, S.S. 2902. (W.O., Shepparton; S.S., Kyabram.)
 Malmesbury.—Erection of new Education Block, Youth Training Centre. (W.O., Kyneton.) Bills of quantities available.
 Maroona.—Repairs and painting, Residence, S.S. 1943. (W.O., Ararat; S.S., Maroona.)
 Melbourne.—Renovations, Toorak Teachers' College Hostel, 470 St. Kilda-road.
 Melton.—Internal renovations, Residence, S.S. 430. (S.S., Melton.)
 Pascoe Vale.—Remodelling existing buildings for Wool Classing, Melbourne School of Textiles.
 Pascoe Vale South.—Exterior painting and repairs, S.S. 4704.
 Preston.—Repairs and painting, Technical School. (Amended Specification.)
 Stanhope South.—Repairs and painting and new laundry and veranda, Residence, S.S. 4325. (Re-advertised.) (W.O., Shepparton; S.S., Stanhope South.)
 Sunshine North.—Internal renovations, S.S. 4745.
 Swan Hill.—Electrical installation in Fifth Form extensions, Technical School. (W.O., Swan Hill and Bendigo.)
 Traralgon.—Erection of refuse can wash and can store, Hobson Park Hospital. (W.O., Traralgon; Hobson Park Hospital, Traralgon.)
 Won Wron.—Supply and installation of refrigeration system for Cool Room, Reafforestation Prison.

Furniture and Furnishings.

Horsham.—Supply of furniture, Technical School.

Site Works.

Altona North.—Asphaltting, drainage, &c., High School.
 Ballarat.—Asphaltting, concreting, drainage works, brick-work and beautification, S.S. 4936. (W.O., Ballarat.)
 Broadford.—Surface and underground drainage, concrete and asphalt pavements, repairs to sealed pavements and associated work, High School and S.S. 1125. (W.O., Alexandra, Benalla; H.S., Broadford.)
 Colac.—Construction of new asphalt pavements and associated works, S.S. 117. (W.O., Camperdown and Geelong.)
 Glenhuntly.—Repairs to asphalt and concreting, S.S. 3703.

Various.—Earthworks, asphalt, concreting, drainage, asphalt repairs, gravelling, gravel repairs, grouted beaching, grassing and associated works, Section 90, Schools.
 Various.—New light duty asphalt, asphalt repairs, drainage works, concreting and associated works, Section 91, Schools.

Miscellaneous.

Port Melbourne.—Supply of canvas fire hose, Public Works Department Storeyard.

J. C. M. BALFOUR,
 Acting Minister of Public Works.

Public Works Department,
 Melbourne, C.2, 18th July, 1966.

PUBLIC SERVICE NOTICES

No. 1636.

Public Service Act 1958, Section 50.

REGULATIONS.—PART IV.—SALARIES AND INCREMENTS.

THE Public Service Board, in pursuance of the powers conferred by the *Public Service Act 1958*, hereby amends its Regulations as shown below :—

SIXTH SCHEDULE.

TEMPORARY EMPLOYEES.

Designations of Positions and Rates of Salaries.

Department and Designation of Position.	Yearly Rate of Salary.		Increments (Annual).
	Minimum.	Maximum.	
MINES DEPARTMENT.	\$	\$	
<i>Add—Explosives and Gas Examining—Gas Testing Officer ..</i>	2,710	3,046	3 of \$112

F. E. CAHILL, Chairman.
 V. P. SCULLY, Secretary.

Office of the Public Service Board,
 Melbourne, 4th July, 1966.

No. 1637.

Public Service Act 1958, Section 50.

REGULATIONS.—PART IV.—SALARIES AND INCREMENTS.

THE Public Service Board, in pursuance of the powers conferred by the *Public Service Act 1958*, hereby amends its Regulations as shown below :—

FIFTH SCHEDULE.

TEMPORARY EMPLOYEES.

DEPARTMENT OF HEALTH.

MENTAL HYGIENE.

Designations of Positions and Rates of Salaries.

Designation of Position.	Yearly Rate of Salary. £	
	Minimum.	Maximum.
<i>Add—Anaesthetic and Operating Theatre Technician</i>	2,294	2,368

Annual increments shall be in accordance with those prescribed by Sub-Regulations 83 (2) and (83 (3)), provided that in the case of the position of Assistant (Male), Administrative the annual increments shall be in accordance with those prescribed by Part D of the Third Schedule.

F. E. CAHILL, Chairman.
 V. P. SCULLY, Secretary.

Office of the Public Service Board,
 Melbourne, 20th June, 1966.

No. 1638.

Public Service Act 1958.

THE Public Service Board, in pursuance of the powers conferred by the *Public Service Act 1958*, hereby amends the Public Service (Public Service Board) Regulations as follows:—

PART V.—ALLOWANCES.

DIVISION II.—OVERTIME AND STAND-BY ALLOWANCES.
 WATER SUPPLY DEPARTMENT.

Regulation 107 (1).

In column headed "Commutated Overtime Percentage of Total Emolument" the words "of Total Emolument" are deleted.

DIVISION IV.—OTHER ALLOWANCES.
 PREMIER'S DEPARTMENT—TOURIST DEVELOPMENT AUTHORITY.

Regulation 114.

To column headed "Actual Yearly Salary of Officer or Employee" add "6,000–6,399".

To column headed "Yearly Rate of Allowance—5½-Day Week" opposite Actual Yearly Salary range of 6,000–6,399 add "248".

This Regulation shall have effect as on and from the 17th July, 1966.

F. E. CAHILL, Chairman.
 V. P. SCULLY, Secretary.

Office of the Public Service Board,
 Melbourne, C.2, 14th July, 1966.

No. 1639.

Public Service Act 1958, Section 50.

REGULATIONS.—PART IV.—SALARIES AND INCREMENTS.

THE Public Service Board, in pursuance of the powers conferred by the *Public Service Act 1958*, hereby amends its Regulations as shown below :—

SIXTH SCHEDULE.

TEMPORARY EMPLOYEES.

Designations of Positions and Rates of Salaries.

Department and Designation of Position.	Yearly Rate of Salary.		Increments (Annual).
	Minimum.	Maximum.	
CHIEF SECRETARY'S DEPARTMENT.	\$	\$	
STATE LIBRARY, NATIONAL GALLERY, NATIONAL MUSEUM AND INSTITUTE OF APPLIED SCIENCE.			
<i>Add—Librarian (Female) . . .</i>	2,868	3,092	2 of \$112

F. E. CAHILL, Chairman.
 V. P. SCULLY, Secretary.

Office of the Public Service Board,
 Melbourne, 11th July, 1966.

PUBLIC SERVICE OF VICTORIA.—VACANCIES.

APPLICATIONS will be received by the Public Service Board up to Wednesday, the 3rd August, 1966, from persons employed in the Public Service of Victoria, who are eligible and qualified for appointment to the under-mentioned positions.

ADMINISTRATIVE DIVISION.

Class "C", "Winton", Youth Welfare Division, Social Welfare, Chief Secretary's Department.

Yearly Salary.—\$3,026, minimum; \$3,320, maximum.

Duties.—To act as Officer in Charge of Stores at "Winton" Youth Training Centre; to keep records in connexion with trainees' earnings and other duties as directed.

Qualifications.—To be an adult with at least three years service; a knowledge of Regulations under the *Audit Act 1958*; experience in stores control, the ordering of stores and the keeping of financial records.

Class "C", Office of the Government Statist, Chief Secretary's Department.

Yearly Salary.—\$3,026, minimum; \$3,320, maximum.

Duties.—To control searching of indexes and registers and to check complicated searches. To assist the officer in charge of correspondence as required in dealing with postal applications for searches.

Qualifications.—To be an adult with at least three years' service; a knowledge of the various Acts affecting the work of the Branch and of the records and index systems of the office; preferably experience in searching duties; ability to conduct correspondence.

Class "C", Tourist Development Authority, Premier's Department. (Two vacancies.)

Yearly Salary.—\$3,026, minimum; \$3,320, maximum.

Position No. 1

Duties.—Undertake bookings and tour plans by domestic and international airways and by coastal and overseas steamship lines.

Qualifications.—To be an adult with at least three years' service; to be familiar with booking, information and accounting procedures of Victorian Government Tourist Bureaux, and preferably to have had experience in booking airline and shipping passages.

Position No. 2

Duties.—Attend to all correspondence relating to railway bookings in the Victorian Government Tourist Bureau, Melbourne; to undertake rail booking duties and process interstate railway classification sheets.

Qualifications.—To be an adult with at least three years' service; a knowledge of Victorian and interstate railway booking and accounting procedures.

NOTE.—The successful applicants will be required to work a five and a half day week—Monday to Friday and Saturday morning, for which an additional allowance is paid. They may also be required to work shifts and also on Sundays and Public Holidays and to relieve in or accept transfer to Interstate and Provincial City Government Tourist Bureaux.

Separate applications must be submitted for these positions.

PROFESSIONAL DIVISION.**Clinical Tuberculosis Officer, Class "A1", Tuberculosis Branch, Department of Health.**

Yearly Salary.—\$9,000.

Duties.—Under the control of the Director of Tuberculosis, to be in charge of the Northern Suburbs Chest Clinic, Coburg; to undertake clinical duties in relation to the diagnosis, treatment and prevention of tuberculosis, and other duties as directed.

Qualifications.—A legally qualified medical practitioner of Victoria with experience in the diagnosis, treatment and prevention of Tuberculosis.

Senior Engineer, Class 3, Local Government Department.

Yearly Salary.—\$6,028, minimum; \$6,770, maximum.

Duties.—To investigate, inspect, and report on engineering and allied matters submitted by Local Government Authorities; to prepare schedules of allocation of Government funds towards the cost of municipal works; to investigate and report on drainage and flooding problems and on matters associated with the Drainage Areas and River Improvement Acts.

Qualifications.—Degree or diploma in Civil Engineering or other appropriate qualification admitting to Graduate of the Institute of Engineers of Australia, including certificate issued by the Municipal Engineers' Board of Victoria; to be versed in the methods of modern engineering

design and practice and to have experience in the type of engineering works normally undertaken by municipalities.

NOTE.—This advertisement is in lieu of that for Senior Engineer, Class 3, Local Government Department which appeared on page 2456 of the *Government Gazette* dated 13th July, 1966.

Executive Engineer, Class 3, Office of the Housing Commission, Treasury.

Yearly Salary.—\$6,028, minimum; \$6,770, maximum.

Duties.—To be responsible to the Chief Engineer for technical oversight of all work of the engineering staff; preparation of estimates, and analysis of and recommendations regarding tenders for road and drainage construction; preparation of contracts and their administration, including progress certificates and dealings with contractors on major issues.

Qualifications.—A Degree or Diploma in Civil Engineering, or a Municipal Engineer's Certificate or equivalent qualification, considerable experience in both design and construction and the administration of contracts in relation to roads and drainage is essential.

Vice Principal, Dookie Agricultural College, Class "A1", Department of Agriculture.

Yearly Salary.—\$6,550.

Duties.—To assist the Principal generally in the administration of the College and to take charge of it during his absence; to teach one or more subjects of the College curriculum; other duties as directed.

Qualifications.—A University degree in Agricultural Science; Science or Arts, together with a degree or diploma in Education and sound experience on the staff of an Agricultural College.

NOTE.—A house is available for the successful applicant, if married, for which a rental of 10 per cent. of total emolument, inclusive of the amount payable under Regulation 74, less \$72.60 a year, will be charged.

Senior Draughtsman, Class "B", Water Supply Department.

Yearly Emolument.—\$4,714, minimum; \$4,958, maximum.

Duties.—To be responsible to the Chief Estates Officer for the control and work of a section of the Estates Branch; to liaise with the Survey Branch in the preparation of survey plans for the acquisition of land and easements; to prepare instructions to Crown Solicitor covering acquisition of land and easements including lands held under General Law; to prepare orders in Council, statutory declarations and other documents and correspondence connected with land transactions.

Qualifications.—To be a competent Survey Draughtsman with extensive experience in Estates Branch work; to have a thorough knowledge of the Water Act, Sale of Land Act and the relevant sections of cognate acts relating to the acquisition of land and easements required for works and the subdivision of land; to be able to direct the work of other officers.

Cadet Valuer, Class "D", Taxation (Land Tax) Office, Treasury.

Yearly Salary.—\$2,212, minimum; \$2,500, maximum.

Duties.—To assist valuers in field and office work in connexion with the valuation of properties for State Land Tax, Probate Duty and Stamp Duty purposes.

Qualifications.—To have passed the School Leaving Examination (at not more than two examinations), in at least four subjects including English or equivalent qualifications (if not a member of the Administrative Division). A general knowledge of the Land Tax Act; competent to make simple plans of buildings and farm holdings.

NOTE.—The successful applicant must be prepared to undertake a course of study for the examination prescribed for the Commonwealth Institute of Valuers for admission, or by the Valuers' Qualification Board. Preference will be given to applicants who have passed subjects for these examinations, or possess a Diploma from an Agricultural College.

TECHNICAL AND GENERAL DIVISION.

Landscape Designer (Male or Female), Office of the Housing Commission, Treasury.

Yearly Salary.—

Male—\$3,652, minimum; \$3,864, maximum.
Female—\$3,194, minimum; \$3,406, maximum.

Duties.—Under the Chief Architect to be responsible for the landscaping and design of and the preparation of plans for gardens, playgrounds and equipment of Commission Estates and advising as required on the landscaping aspects of proposed estate plans.

Qualifications.—A Diploma of Horticulture from a recognized institution or approved equivalent qualifications, and preferably a Diploma in Landscape Design of either the London or Durham Universities; appropriate experience in the design of gardens.

Hospital Attendant, Pentridge, Prisons Division, Social Welfare Branch, Chief Secretary's Department.

Yearly Salary.—\$2,810, minimum; \$3,122, maximum.

Duties.—To perform duties in the medical treatment of prisoners, and other duties as directed.

Qualifications.—A knowledge of first aid and general male nursing, preferably with the capacity for and experience in managing prisoners.

Technical Assistant (Male), Grade I., Department of Crown Lands and Survey.

Yearly Salary.—

Junior—at 18 years of age, \$1,500;
at 19 years of age, \$1,710;
at 20 years of age, \$1,942;

Adult—\$2,590, minimum; \$2,810, maximum.

Duties.—To assist research workers in field and laboratory work on the control of noxious weeds in Victoria.

Qualifications.—To be educated to Leaving Certificate standard with Biology or Chemistry or Physics as a subject, or to possess equivalent qualifications; to possess a car driving licence, and to be of good physique and be willing and adaptable to living and working in field conditions.

NOTE.—The successful applicant will be stationed at the Department's Research Station, Hopetoun.

Senior Ranger, Nyah West, Water Supply Department.

Yearly Salary.—\$2,554.

Duties.—Supervision, control and regulation of domestic and stock watering; supervision of repairs and maintenance of channels and structures.

Qualifications.—Experience in the distribution of water for domestic and stock purposes; capacity for handling men on mechanical plant engaged on channel maintenance and sand clearing, supervising gangs of men on construction and repair of structures; competent to measure piece work.

NOTE.—There is no house available.

Water Bailiff, Rochester Centre, Water Supply Department.

Yearly Salary.—\$2,294, minimum; \$2,518, maximum.

Qualifications.—Ability to control and regulate the supply of water to irrigators and to keep the necessary records, and make arithmetical computations; a knowledge of water requirements for crops and grasses grown under irrigation; the methods of preparation of land for irrigation and methods of channel and drain construction and maintenance.

NOTE.—*Housing.*—The successful applicant will be required to occupy the official residence provided and vacation of the residence will not be permitted without the express approval of the Water Supply Department. A

rental of 10 per cent. of total emolument, inclusive of the amount payable under Regulation 74, less \$72.60 a year, will be charged. Occupancy will be subject to a formal tenancy agreement being entered into. Particulars are available from the Water Supply Department.

Storeman, Grade II., Education Department.

Yearly Salary.—\$2,114, minimum; \$2,444, maximum.

Duties.—Under the Storekeeper, to act as a section leader in the control and despatch of stores.

Qualifications.—To be active and capable of supervising staff.

Rigger and Sailmaker, Leading, Ports and Harbours Branch, Public Works Department.

Yearly Salary.—\$2,258, minimum; \$2,368, maximum.

Duties.—To take charge of the Rigging Shop at the Williamstown Dredging Depot; to supervise and, as necessary, carry out the sailmaking and rigging work undertaken at the Depot.

Qualifications.—To be experienced in laying out, marking off, cutting, machine and hand sewing of canvas and similar fabrics; to be a capable rigger and splicer.

Shorthand Writer and Typist (Female), Senior, Public Solicitor's Office, Law Department.

Yearly Salary.—\$2,344, minimum; \$2,416, maximum.

Duties.—To perform Shorthand writing and typing duties and to supervise the typing staff of the office.

Qualifications.—A competent Shorthand Writer and Typist who has passed the Shorthand speed test at 100 words a minute.

Machinist (Female), Grade II., Taxation (Land Tax) Office, Treasury.

Yearly Salary.—\$2,012, minimum; \$2,048, maximum.

Duties.—To operate an Accounting Machine for the preparation of Land Tax Assessment Notices and Debit Registers and for Statistical work; other duties as required.

Qualifications.—Competent in the operation of both "National" and "Burroughs" Accounting Machines. A knowledge of procedure adopted in the issue of Land Tax Assessment Notices is desirable.

Shorthand Writer and Typist (Female), Grade I., Shepparton Regional Office, Family Welfare Division, Social Welfare Branch, Chief Secretary's Department.

Yearly Salary.—\$1,976, minimum; \$2,048, maximum.

Duties.—To perform general shorthand, typing and office duties in the Shepparton Regional Office and to take charge of the office in the Regional Inspector's absence.

Qualifications.—Ability to write shorthand at the rate of 80 words a minute and to deal with the public.

NOTE.—The salary rates quoted above do not include the additional amount which is payable under Regulation 74 of the Board's Regulations.

By order,

V. P. SCULLY,
Secretary.

Office of the Public Service Board,
Melbourne, 19th July, 1966.

PUBLIC SERVICE OF VICTORIA.—VACANCIES.

DEPARTMENT OF HEALTH.
MENTAL HYGIENE BRANCH.

TECHNICAL AND GENERAL DIVISION.

APPPLICATIONS will be received by the Public Service Board up to Wednesday, the 10th August, 1966, from persons employed in the Public Service of Victoria, who are eligible and qualified for appointment to the under-mentioned positions:—

Charge Nurse (Female), Ballarat.

Yearly Salary.—\$2,564, minimum; \$2,772, maximum.

Duties.—To take charge of a ward in a Mental Hospital and to assist in the training of Student Nurses and others.

Qualifications.—A current practising Certificate for Mental Nursing.

Electrical Mechanic, Sentor, Mont Park.

Yearly Salary.—\$2,444, minimum; \$2,590, maximum.

Duties.—Under the direction of the Engineer to maintain wiring and electrical equipment, including motors, cookers, urns, radiators, toasters, &c.; to undertake minor electrical installations and to assist the Engineer generally.

Qualifications.—An "A" Grade Wiring Licence.

Assistant Farm Manager, Ballarat.

Yearly Salary.—\$2,444, minimum; \$2,482, maximum.

Duties.—Under direction to assist Farm Manager in farm work and in the management of the farm; to supervise staff and patients in general farming duties and to control farming operations during the absence of the Farm Manager.

Qualifications.—Good knowledge of all branches of farm work and ability to control staff and patients.

NOTE.—The salary rates quoted above do not include the additional amount which is payable under Regulation 74 of the Board's Regulations.

By order,

V. P. SCULLY,
Secretary.

Office of the Public Service Board,
Melbourne, 19th July, 1966.

PUBLIC SERVICE OF VICTORIA.—VACANCIES.

(TEMPORARY APPOINTMENTS.)

APPLICATIONS will be received by the Public Service Board up to Wednesday, the 3rd August, 1966, from persons who are qualified for appointment to the under-mentioned positions:—

Field Officer, Department of Agriculture. (Two positions.)

Yearly Salary.—

Junior—at 18 years of age, \$1,704;
at 19 years of age, \$1,912;
at 20 years of age, \$2,146.

Adult—\$2,914, minimum; \$3,228, maximum.

(Commencing salary according to experience, but advancement is not limited to the maximum quoted.)

POSITION NO. 1 (STATE RESEARCH FARM, WERRIBEE).

Duties.—At the Research Stations of the Agricultural Division, to assist in field experimental work, which includes investigation into problems of soil fertility, varietal improvement, pasture and stock

management; to assist in the maintenance of the Research Stations and other district work as required.

Qualifications.—A Diploma of an Australian Agricultural College or its equivalent.

NOTE.—Accommodation is available for a single man only.

POSITION NO. 2.

Duties.—To assist with the field experimental and other work of the Biology Branch.

Qualifications.—Diploma of an Agricultural or Horticultural College or equivalent.

NOTE.—Field Officers are eligible for progression to Field Officer, Senior, \$3,546–\$3,864 and if they pass a qualifying examination, for appointment to the Professional Division, as Experimental Officer, \$3,734–\$4,466.

Separate applications must be submitted for these positions.

Orchard Inspector, Department of Agriculture.

Yearly Salary.—\$2,914.

Duties.—To assist in fruit fly control and eradication; to inspect fruit in shops, markets and orchards for the presence of pests and diseases; to assist Horticultural Advisers and Inspectors as required.

Qualifications.—A good knowledge of fruit culture and of the pests and diseases affecting fruit trees and preferably experience in fields where good relations with the public are necessary.

NOTE.—The salary rates quoted above do not include the additional amount which is payable under Regulation 74 of the Board's Regulations.

By order,

V. P. SCULLY,
Secretary.

Office of the Public Service Board,
Melbourne, 19th July, 1966.

REPORTER, VICTORIAN PARLIAMENTARY DEBATES.

APPLICATIONS are invited for the position of Reporter on the staff of the Victorian Parliamentary Debates (Hansard).

Full details of duties, salary and conditions of appointment may be obtained from the Chief Reporter, Parliament House, Melbourne.

Applications, stating age, qualifications, and experience, should be lodged with the Chief Reporter, not later than the 10th August, 1966.

A. A. BURNS,
Chief Reporter.

PUBLIC SERVICE OF VICTORIA.—RECLASSIFICATIONS.

THE Public Service Board has raised the classification of the under-mentioned offices as shown, and appointed thereto the respective officers named hereunder.

Office and Former Classification.	Revised Classification.	Duties.	Qualifications.	Officer Appointed
TECHNICAL AND GENERAL DIVISION.				
PUBLIC WORKS DEPARTMENT.				
Draughtsman, Grade IV., Grades 41–44 inclusive (2 offices)	Senior Draughtsman, Grade I., Grades 46–48 inclusive	Under general supervision to plan more important water supply and sewerage installations to public buildings and institutions and to prepare details, specifications and estimates in connexion therewith	Extensive experience in sewerage draughting and capable of preparing working drawings and specifications for water supply and sewerage installations, &c.; to have a comprehensive knowledge of the By-laws of the Melbourne and Metropolitan Board of Works and Country Sewerage Authorities	Daws, N. W. McLeish, J. S. C.
STATE FORESTS DEPARTMENT.				
Welder, Leading Hand, Grades 27–33 inclusive	Welder, Special Class, Leading Hand, Grades 27–34 inclusive	To weld and fabricate components of earth-moving plant; to develop work from drawings or prints and to carry out marking off and oxy-cutting as required; to be responsible to the workshop Supervisor for all work performed by other welders	A qualified or recognized tradesman competent to apply general trade experience in welding mild steel, stainless steel, cast iron, aluminium, copper, brass, die-cast metal and magnesium	Nicoloudiou, M. Y.

Office of the Public Service Board,
Melbourne, 19th July, 1966.

By order,
V. P. SCULLY,
Secretary.

Teaching Service Act 1958.

TEACHING SERVICE (CLASSIFICATION, SALARIES AND ALLOWANCES) REGULATIONS.

AMENDMENT No. 103.

THE Teachers Tribunal, in pursuance of the powers conferred by the *Teaching Service Act 1958*, hereby amends the Teaching Service (Classification, Salaries and Allowances) Regulations in the manner following, that is to say:—

- PART XII.—ALLOWANCES.

1. After clause 45, insert the following new clause:—

“46. Until otherwise determined by the Tribunal, the salaries as prescribed in these Regulations for members of the Teaching Service shall be increased by amounts determined in accordance with the following scale:—

Men Teachers and Professional Officers ..	\$104 a year.
Women Teachers and Professional Officers who are receiving salaries—	
(a) Up to \$4,005 a year	\$83 a year.
(b) \$4,006 a year and up to \$4,490 a year	\$88 a year.
(c) Over \$4,490 a year	\$84 a year.
Students in Training (other than those receiving allowances under clause 37 (g) (ii) of these Regulations) ..	\$52 a year.
Temporary Student Teachers	\$52 a year.
Sewing Mistresses and Temporary Sewing Mistresses	\$42 a year.

Provided that, in the case of a member of the Teaching Service employed part time, the amount payable shall be proportionate to the time actually employed.”

2. Clause 46 to be renumbered 47.

(To take effect from and including the 17th July, 1966.)

LOUIS F. C. GARLICK, Chairman.
G. FENNELL, Secretary.

Office of the Teachers Tribunal,
Melbourne, 13th July, 1966.

PRIVATE ADVERTISEMENTS

NOTICE is hereby given that the National Fitness Council of Victoria has applied for a lease under section 134, *Land Act 1958*, of allotment 33, section 2, Township of Anglesea, for a term of 21 years as a site for amusement and recreation (youth camp). 2404

NOTICE is hereby given that the committee of the Sea Lake Golf Club have applied for a lease under section 134 of the *Land Act 1958* for a term of twenty-one (21) years over Crown land being Water Supply Reserve and former Showgrounds Reserve, Township of Sea Lake, as an extension of their present Golf Course. 2502

NOTICE is hereby given that the Wycheproof Bowling Club has applied for a lease under section 134 of the *Land Act 1958* for a term of 21 years, of allotment 6, section A, Township of Wycheproof, containing approximately 1½ acres and being portion of the Recreation and Showgrounds Reserve fronting Charles-street, as a site for Amusement and Recreation (Bowling Club). 2500

NOTICE is hereby given that the Willaura Golf Club has applied for a lease of allotments 60 and 61, Parish of Lalkaldarno, containing 156 acres 1 rood 28 perches, pursuant to section 134, *Land Act 1958* for the purpose of amusement and recreation for a term of 21 years.

W. A. NICHOLSON, Hon. Secretary.
Willaura Golf Club, Willaura. 2664

DIOCESE OF WANGARATTA.

DIOCESAN SYNOD.

NOTICE is hereby given that the Bishop of Wangaratta has convened the Diocesan Synod for Sunday, 21st August, 1966, at 3 p.m., at the Church Hall, Wangaratta.

2658

J. J. WHEATLEY, Registrar.

NOTICE OF INTENTION TO APPLY FOR A LICENCE TO DIVERT WATER AND CUT RACE FROM MURPHY'S CREEK (RIVER MURRAY), AT GOORAMADDA.

I HEREBY give notice that I intend to apply for a licence empowering me to divert water for a term of four years to the extent of 50-acre feet per annum at a maximum rate of 2 acre-feet per day of 24 hours for the irrigation of 25 acres of pasture and summer crops, being part of allotments 1, 7, 8, section N, Parish of Gooramadda, and to occupy certain Crown lands for works of diversion, and to cut a race thereon.

Any objection to such application must be forwarded, in writing, to reach the State Rivers and Water Supply Commission, Melbourne, before 1st August, 1966, being 30 days from the first publication of this notice.

ALLEN HENRY NOTT.

P.O. Box 35, Rutherglen.

2694

NOTICE OF INTENTION TO APPLY FOR A LICENCE TO DIVERT WATER AND CUT RACE FROM THE GOULBURN RIVER, AT TEN MILE.

I HEREBY give notice that I intend to apply for a licence empowering me to divert water for a term of five years to the extent of 60 acre-feet per annum at a maximum rate of 6 acre-feet per day of 24 hours for the irrigation of 30 acres of potatoes, being allotments 1, 2 and 3, section XIV., Parish of Kevington, and to occupy certain Crown lands for works of diversion.

Any objection to such application must be forwarded, in writing, to reach the State Rivers and Water Supply Commission, Melbourne, before 21st August, 1966, being 30 days from the first publication of this notice.

CLARENCE HENRY GEORGE POOLE.

Kevington Post Office, via Mansfield, Victoria. 2695

NOTICE OF INTENTION TO APPLY FOR A LICENCE TO DIVERT WATER AND CUT RACE (RE-ISSUE) FROM THE RIVER MURRAY, AT YARRAWONGA.

I HEREBY give notice that I intend to apply for a licence empowering me to divert water for a term of fifteen years to the extent of 400 acre-feet per annum at a maximum rate of 15 acre-feet per day of 24 hours for the irrigation of 200 acres of pasture, being allotments 6, 7, 7A and 7B, Parish of Yarrawonga, and to occupy certain Crown lands for works of diversion, and to cut a race thereon.

Any objection to such application must be forwarded, in writing, to reach the State Rivers and Water Supply Commission, Melbourne, before 21st August, 1966, being 30 days for the first publication of this notice.

JAMES BRUCE FORGE.

"Yarramine", Yarrawonga, Victoria. 2689

NOTICE OF INTENTION TO APPLY FOR A LICENCE TO DIVERT WATER AND CUT RACE FROM THE RIVER MURRAY (ULUPNA CREEK), AT MYWEE.

WE hereby give notice that we intend to apply for a licence empowering us to divert water for a term of four years to the extent of 100 acre-feet per annum at a maximum rate of 3 acre-feet per day of 24 hours for the purpose of irrigating 50 acres subclover and rye grass being part of allotment 61D and 61E, section B, Parish of Strathmerton and to occupy certain Crown lands for works of diversion, and to cut a race thereon.

Any objection to such application must be forwarded, in writing, to reach the State Rivers and Water Supply Commission, Melbourne, before the 8th day of August, 1966, being 30 days from the first publication of this notice.

LOUIS CAMPBELL JONES.

LILLIAN JUNE McDONALD.

Rural Delivery, Cobram. 2663

DANDENONG VALLEY AUTHORITY.

NOTICE OF INTENTION TO DECLARE FLOOD-PRONE AREAS.

UNDER section 27 of the Dandenong Valley Authority Act No. 7060, the Dandenong Valley Authority proposes on or after 13th September, 1966, to have proclaimed specified areas along the Centre Swamp Drain from Mordialloc Creek to Carrum Outfall, being within the District of the Dandenong Valley Authority to be within the flood plain of the Dandenong Creek.

Plans specifying the areas to be proclaimed may be inspected at—

The offices of the Authority, 53 Robinson-street, Dandenong.

The State Rivers and Water Supply Commission, 90 Orrong-road, Armadale.

The Municipal Offices of the City of Springvale.

The Municipal Offices of the City of Chelsea.

Any objections to the making of such proclamation made within six weeks of this notice are to be considered by the Dandenong Valley Authority before any such proclamation is made.

Dated the 19th June, 1966.

By direction of the Authority.

K. G. ABBERTON, Secretary.

Dandenong Valley Authority. 2719

CITY OF BOX HILL.

LOAN No. 185.

Notice of Intention to Borrow the Sum of \$100,000 for Permanent Works and Undertakings.

NOTICE is hereby given that the Council of the City of Box Hill proposes to borrow the sum of One hundred thousand dollars secured by a charge over the general rates of the municipality, such sum to be raised by the grant of a mortgage in accordance with the provisions of the Local Government Act 1958.

1. The maximum rate of interest that may be paid is 5½ per cent. per annum.

2. The purpose for which the loan is to be applied is—
Capital Works in the Council's Electric Supply Undertaking.

3. The period of the loan shall be fifteen years.

4. The moneys borrowed shall be repayable by providing out of the municipal fund 30 half-yearly instalments of approximately \$5,019.84 each, including principal and interest, on the 31st day of March and the 30th day of September during the currency of the loan. The first instalment shall be payable on the 31st day of March, 1967.

5. Such moneys shall be repayable at the Australia and New Zealand Savings Bank Limited, Melbourne, or at such other place or places as the lender from time to time may require.

The plans and specifications and the estimate of the cost of the proposed work and a statement showing the proposed expenditure of the moneys to be borrowed are open for inspection at the Town Hall, Box Hill.

Dated this 18th day of July, 1966.

2655

A. N. WALLS, Town Clerk.

CITY OF BROADMEADOWS.

By-Law No. 49.

A By-Law of the City of Broadmeadows made under the Health Act and Numbered 49 for the purpose of prescribing the fees to be charged for the registration of premises and for the renewal and transfer of registration thereof pursuant to such Acts.

THE Mayor, Councillors and Citizens of the City of Broadmeadows, in pursuance of the powers conferred by the Health Acts and every other Act or power enabling it in that behalf doth hereby make the By-Law and Order as follows:—

That By-law No. 18 be amended by the inclusion of Clause (c) in the Schedule referred to in By-Law No. 18.

(c) Food Vending Machines.

Machines operated by	1 cent piece	—	\$0.50
"	"	2 "	0.75
"	"	5 "	1.00
"	"	10 "	2.00
"	"	20 "	3.00
"	"	50 "	4.00

Resolution for passing this By-Law agreed to by the Council of the City of Broadmeadows on the 7th day of March 1966 and confirmed on the 18th day of April 1966.

As witness the common seal of the City of Broadmeadows was hereto affixed on the 18th day of April, 1966, in the presence of—

JOHN CULPIN, Mayor.

(SEAL) H. PAYNE, Councillor.

E. F. SMILEY, Town Clerk.

Submitted to the Commission of Public Health on the 10th day of May, 1966.—A. T. GARDNER, Secretary, Commission of Public Health.

Approved by the Governor in Council, 28th June, 1966.—J. COLQUHOUN, Clerk of the Executive Council. 2640

CITY OF BROADMEADOWS.

WHEREAS the Council of the Municipality of Broadmeadows has received an application from the owner of so many premises fronting on the under-mentioned street as in rateable value are the greater part of all premises so fronting, the Council hereby declares the same to be dedicated to the public as a public highway:—

All that section of Maffra-street between Barry-road and Glenelg-street.

The common seal of the Mayor, Councillors and Citizens of the City of Broadmeadows was hereto affixed this 11th day of July, 1966.

(SEAL) JOHN CULPIN, Mayor.

DAVID H. C. BUCKNELL, Councillor.

E. F. SMILEY, Town Clerk. 2624

CITY OF BROADMEADOWS.

WHEREAS the Council of the Municipality of Broadmeadows has received an application from the owner of so many premises fronting on the under-mentioned streets as in rateable value are the greater part of all premises so fronting, the Council hereby declares the same to be dedicated to the public as a public highway:—

All that section of Kitchener-street between Blair-street and Goulburn-street, Waranga-crescent, part east of Blair-street, Marong-court, Kerang-court, Rodney-court, Deakin-court, part of Joffre-street between Cuthbert-street and Kitchener-street, Charlton-street and Goulburn-street.

The common seal of the Mayor, Councillors and Citizens of the City of Broadmeadows was hereunto affixed this 11th day of July, 1966.

JOHN CULPIN, Mayor.
(SEAL) DAVID H. C. BUCKNELL, Councillor.
E. F. SMILEY, Town Clerk. 2625

CITY OF COLLINGWOOD.

BY-LAW No. 117.

Health Registration Fees Bylaw.

A Bylaw of the City of Collingwood made under Section 368 of the Health Act 1958 and Numbered 117 for prescribing fees for registration and renewal and transfer of registration of premises and food vending machines.

IN pursuance of the powers conferred by the Health Act 1958, and of any and every other power it thereunto enabling the Mayor, Councillors and Citizens of the City of Collingwood orders as follows:—

(1) This Bylaw shall be known as the Health Registration Fees Bylaw.

(2) Bylaw No. 99 of the City of Collingwood prescribing fees for registration and renewal and transfer of registration of premises is hereby repealed.

Nature of Premises. Fees.

(3) The respective fees set out in the second column of the table set out hereunder are hereby prescribed as the fees for the registration and renewal of registration of the respective premises set out in the first column of such table opposite such respective fees namely:—

Offensive trades premises (other than those referred to below)	£5	\$10.00
Offensive trades premises (being fat extracting or melting or rendering works which are conducted at premises occupied principally as a butcher's shop and at which fat is extracted melted or rendered only from materials derived from such shop)	£1	\$2.00
Boarding houses	£2	\$4.00
Common lodging houses	£2	\$4.00
Eating houses	£2	\$4.00
Apartment houses containing not more than one apartment	£1	\$2.00
Apartment houses containing more than one apartment	£2	\$4.00
Food premises		
(i) where not more than five persons including the proprietor and his family are employed	£2	\$4.00
(ii) where more than five such persons are employed, additional for each person in excess of five but not exceeding in any case a maximum fee of	2s. 6d.	\$0.25
Premises at or in any part of which eggs for sale are received or stored for the purpose of being chilled	£2	\$4.00
Hairdressers' shops	£1	\$2.00
Beauty parlors or other like establishments	£1	\$2.00
Chiropodists' establishments	£1	\$2.00
(4) The fees shall be as follows for the granting or the annual renewal of registration of any food vending machine operated by:—		
(i) one or two pennies or one or two cents a sale	10s.	\$1.00
(ii) a coin or coins to the value of three pennies or three cents a sale	10s.	\$1.00
(iii) a coin or coins in excess of three cents but not exceeding sixpence or five cents in value a sale	£1	\$2.00
(iv) a coin or coins in excess of sixpence or five cents in value a sale	£2	\$4.00

(5) Where application for the renewal of registration of any premises or food vending machine is not lodged with the Council until after the last day fixed for the lodging thereof an additional fee of one half of the relevant prescribed fee is hereby prescribed for such renewal of registration, provided that where the fee is paid in decimal currency and the said one half does not consist of a whole number of cents, the additional fee shall be calculated to the next lower whole cent.

(6) A fee of 2s. 6d. or 25 cents is hereby prescribed for the transfer of any registration of premises or food vending machines.

(7) This Bylaw shall apply to and have operation throughout the whole of the municipal district.

Resolution for passing this Bylaw agreed to by the Council of the City of Collingwood on the 21st day of March, 1966, and confirmed on the 2nd day of May, 1966.

The corporate seal of the Mayor, Councillors and Citizens of the City of Collingwood was hereunto affixed in the presence of—

G. H. PEARCE, Mayor.
(SEAL) T. H. MARSHALL, Councillor.
L. D. COOK, Town Clerk.

Submitted to the Commission of Public Health on the 7th day of June, 1966.

Approved by the Governor in Council on the 12th day of July, 1966.—J. COLQUHOUN, Clerk of the Executive Council. 2654

CITY OF ECHUCA.

BY-LAW No. 75.

NOTICE is hereby given that the Mayor, Councillors and Citizens of the City of Echuca have made By-Law No. 75 for regulating and soliciting or collection in any road or street or from house to house adjacent thereto of gifts of money or of subscriptions for any purpose.

A copy of such By-Law is open for inspection free of charge during office hours at the office of the Council, the corner of Hare and Heygarth Streets, Echuca.

2653 K. F. McCARTNEY, Town Clerk.

CITY OF HEIDELBERG.

BY-LAW No. 236.

Prescribing Fees Payable for the Registration of Premises and of Food Vending Machines and Renewal and Transfer of such Registrations.

A BY-LAW of the City of Heidelberg made under the provisions of the Health Act 1958 and amendments and numbered 236, for prescribing the fees payable for the registration of premises and of food vending machines and renewal and transfer of such registrations pursuant to the said Acts.

IN pursuance of the powers conferred by the Health Acts and by every other Act or power enabling it in that behalf, the Council of the City of Heidelberg orders as follows:—

1. That By-Law No. 193 and By-Law No. 215 are hereby repealed.

2. From and after the date of the coming into operation of this By-Law the fees to be charged, received or taken by the Council of the City of Heidelberg for the registration of premises and for annual renewals thereof and for the registration of food vending machines and for annual renewals thereof and for transfers of such registrations shall be as set out in the Schedule hereto.

3. Such fees shall be paid to the Town Clerk by any person making application for any such registration renewal or transfer.

4. This By-Law shall apply to and have operation throughout the whole of the municipality district of the City of Heidelberg.

SCHEDULE.

A. For the granting of annual renewal of registration of premises.

Nature of Premises.	Fees Payable.
Offensive trades premises (other than those referred to below)	Five pounds (or ten dollars)

<i>Nature of Premises.</i>	<i>Fees Payable.</i>
Offensive trades premises (being fat extracting or melting or rendering works which are conducted at premises occupied principally as a butcher's shop and at which fat is extracted melted or rendered only from materials derived from such shop)	One pound (or two dollars)
Boarding Houses	Two pounds (or four dollars)
Common Lodging Houses	Two pounds (or four dollars)
Eating Houses	Two pounds (or four dollars)
Apartment Houses— Containing not more than one apartment	One pound (or two dollars)
Apartment Houses— Containing more than one apartment	Two pounds (or four dollars)
Food Premises—	
(i) where not more than five persons (including the proprietor and his family) are employed	Two pounds (or four dollars)
(ii) where more than five such persons are employed additional for each person in excess of five	Two shillings and sixpence (or twenty-five cents)
Provided that the maximum fee payable shall be	Twenty-five pounds (or fifty dollars)
B. For the granting or annual renewal of registration of food vending machines—	
(i) Machines operated by one or two pennies or one cent per sale	Five shillings (or fifty cents)
(ii) Machines operated by a coin or coins to the value of three pennies or two cents per sale	Ten shillings (or one dollar)
(iii) Machines operated by a coin or coins to the value of four, five or sixpence or three, four or five cents per sale	One pound (or two dollars)
(iv) Machines operated by a coin or coins in excess of sixpence or five cents in value per sale	Two pounds (or four dollars)
C. For any transfer of registration	Two shillings and sixpence (or twenty-five cents)
D. For late fee, where application is not lodged by the prescribed date	Additional fee equal to one half of the registration fee.

The Resolution for passing this By-Law was agreed to by the Council on the 15th day of March, 1966, and confirmed on the 18th day of April, 1966.

The common seal of the Mayor, Councillors and Citizens of the City of Heidelberg was hereto affixed by me—

E. C. W. JACK, Town Clerk,

in the presence of—

(SEAL) J. W. ANDERSEN, Mayor.
T. F. RICH, Councillor.

Submitted to the Commission of Public Health on 19th April, 1966.—A. T. GARDNER, Secretary.

Approved by the Governor in Council on the 28th day of June, 1966.—J. COLQUHOUN, Clerk of the Executive Council. 2652

CITY OF MELBOURNE.

BY-LAW No. 465.

A By-law of the City of Melbourne made under the powers conferred by section 71 of an Act of New South Wales 6 Victoria No. 7, Section 6 of an Act of New South Wales 6 Victoria No. 18 and Section 51 of an Act of Victoria 27 Victoria No. 178 and numbered 465 to amend By-law No. 425.*

IN pursuance of the powers conferred by the above-mentioned enactments and of every other Act or power enabling it in that behalf the Council of the City of Melbourne ORDERS as follows:—

For sub-paragraph (v) of paragraph (a) of sub-clause (1) of Clause 33 of By-law No. 425 there shall be substituted the following sub-paragraph—

	£	s.	d.	\$	c.
“(v) sheep or lamb	0	0	3.6	or	0.03”.

Resolution for passing this By-law agreed to by the Council of the City of Melbourne, the 20th day of June, 1966, and confirmed the 18th day of July, 1966—

(SEAL) IAN F. BEAUREPAIRE, Lord Mayor.
F. H. ROGAN, Town Clerk.

* By-law No. 425, as amended by By-laws Nos. 447 and 456. (66/2191/94C). 2687

CITY OF RINGWOOD.

LOAN No. 69.

Special Order.

NOTICE is hereby given that at a Meeting of the Council of the City of Ringwood held in the Council Chambers on the 15th day of June, 1966, the said Council did agree to the following Resolution, viz:—

1. That the Council of the City of Ringwood resolves to borrow the sum of \$100,000 (One hundred thousand dollars) on the credit of the Mayor, Councillors and Citizens of the City of Ringwood, such sum to be secured by the grant of a mortgage in accordance with the provisions of the *Local Government Act 1958*.

2. The rate of interest to be paid is 5.625 per centum per annum.

3. The moneys borrowed shall be repayable by 20 half-yearly instalments of approximately \$6,605.90 including principal and interest by providing out of receipts of money payable under schemes of private street construction and advances from the municipal fund should such receipts be insufficient, the required amounts on the 1st day of February and August, during the currency of the loan, and the first instalment shall be payable on the 1st day of February, 1967.

4. The period of the loan shall be ten years.

5. Such moneys shall be repayable at the E. S. & A. Savings Bank Ltd., 287 Collins-street, Melbourne.

6. The purpose for which the loan is to be applied is the defraying of the cost of the execution of schemes for private street construction in accordance with Division 10, Part XIX. of the *Local Government Act 1958*.

Notice is hereby further given that at a meeting of the said Council to be held in the Council Chambers on the 11th day of July, 1966, the above Resolution was confirmed.

F. P. DWERRYHOUSE, Town Clerk.

Town Hall, Ringwood, 20th June, 1966. 2690

Town and Country Planning Act 1961.

CITY OF SHEPPARTON.

NOTICE THAT A PLANNING SCHEME HAS BEEN PREPARED AND IS AVAILABLE FOR INSPECTION.

City of Shepparton Planning Scheme 1953, Amendment No. 12, 1966.

NOTICE is hereby given that the Council of the City of Shepparton, in pursuance of its powers under the *Town and Country Planning Act 1961*, has prepared a Planning Scheme for the City of Shepparton for the following purposes—

- (i) Re-zoning land from “Agricultural” to “Residential”;
- (ii) Re-zoning land from “Commercial ‘C’” to “Residential”;
- (iii) Re-zoning land from “Residential” to “Commercial ‘C’”;
- (iv) Deleting a proposed road;
- (v) Permitting the establishment of licensed restaurants in motels in the “Residential Zone”;
- (vi) Permitting the establishment of licensed reception rooms in the “Residential Zone”.

A copy of the scheme has been deposited at the Municipal Offices, Civic Centre, Welsford-street, Shepparton, and at the office of the Town and Country Planning Board, 179 Queen-street, Melbourne, and will be open for inspection during office hours by any person, free of charge.

Any persons affected by the Planning Scheme are required to set forth in writing all objections they may have, addressed to the Town Clerk, City of Shepparton, Municipal Offices, Civic Centre, Shepparton, on or before the 22nd day of August, 1966, and to state whether they wish to be heard in respect of their objections.

2626 R. O'BRIEN, Town Clerk.

Town and Country Planning Act 1961.

CITY OF SHEPPARTON.

NOTICE THAT A PLANNING SCHEME HAS BEEN PREPARED AND IS AVAILABLE FOR INSPECTION.

City of Shepparton Planning Scheme, Amendment No. 13, 1966.

NOTICE is hereby given that the Council of the City of Shepparton, in pursuance of its powers under the *Town and Country Planning Act 1961*, has prepared a Planning Scheme for the City of Shepparton for the following purpose—

- (i) Re-zoning Sites 1 and 4 of the "Special Uses Zone" (Wyndham-street South) to "Residential Zone".

A copy of the scheme has been deposited at the Municipal Offices, Civic Centre, Welsford-street, Shepparton, and at the office of the Town and Country Planning Board, 179 Queen-street, Melbourne, and will be open for inspection during office hours by any person, free of charge.

Any persons affected by the Planning Scheme are required to set forth in writing all objections they may have, addressed to the Town Clerk, City of Shepparton, Municipal Offices, Civic Centre, Shepparton, on or before the 22nd day of August, 1966, and to state whether they wish to be heard in respect of their objections.

2627 R. O'BRIEN, Town Clerk.

BOROUGH OF EAGLEHAWK.

LOAN No. 11.

Notice of Intention to Borrow the Sum of \$11,000 for Permanent Works and Undertakings.

NOTICE is hereby given that the Council of the Borough of Eaglehawk proposes to borrow the sum of Eleven thousand dollars secured by a charge over the general rates of the municipality, such sum to be raised by the grant of a mortgage in accordance with the provisions of the *Local Government Act 1958*.

1. The maximum rate of interest that may be paid is 5.625 per cent. per annum.

2. The purpose for which the loan is to be applied is—

- (a) Construction of Pre-School Centre.
- (b) Council's contribution towards cost of construction of Olympic Swimming Pool at Canterbury Park, Eaglehawk.

3. The period of the loan shall be ten years.

4. The moneys borrowed shall be repayable by providing out of the municipal fund nineteen half-yearly instalments of approximately \$461.57 each, including principal and interest, on the 1st day of April and the 1st day of October during the currency of the loan and one final instalment of outstanding principal moneys owing, and interest. The first instalment shall be payable on the 1st day of April, 1967.

5. Such moneys shall be repayable at C.B.C. Savings Bank Limited, Melbourne.

The plans and specifications and the estimates of the cost of the proposed works, and a statement showing the proposed expenditure of the moneys to be borrowed, are open for inspection at the Town Hall, Eaglehawk.

Dated this 12th day of July, 1966.

2622 D. L. PARKER, Town Clerk.

SHIRE OF AVOCA.

LOAN No. 25.

Notice of Intention to Borrow the Sum of \$11,000 for Permanent Works and Undertakings.

NOTICE is hereby given that the Council of the Shire of Avoca proposes to borrow the sum of Eleven thousand dollars on the credit of the municipal revenues of the President, Councillors and Ratepayers of the said Shire, such sum to be raised by the grant of a mortgage in accordance with the provisions of the *Local Government Acts*.

1. The maximum rate of interest that may be paid is 5.5625 per cent. per annum.

2. The purpose for which the loan is to be applied is for the purchase and installation of plant for the manufacture of reinforced concrete pipes and for building extensions at the R.C. Pipe & Culvert Works.

3. The period of the loan shall be seven years.

4. The moneys borrowed shall be repayable by providing out of the municipal fund fourteen half-yearly instalments of approximately \$961.39 each, including principal and interest, on the 1st day of May and the 1st day of November during the currency of the loan. The first instalment shall be payable on the 1st day of May, 1967.

5. Such moneys shall be repayable at the C.B.C. Savings Bank Limited, Melbourne.

The plans and specifications and the estimate of the cost of the proposed works and a statement showing the proposed expenditure of the moneys to be borrowed are open for inspection at the Shire Office, Avoca.

Dated this 20th day of July, 1966.

2636 F. C. S. EDWARDS, Shire Secretary.

SHIRE OF AVOCA.

BY-LAW No. 30.

NOTICE is given that in pursuance of the provisions of the *Health Act 1958* the Council of the Shire of Avoca has made By-law No. 30 for the purpose of:—

- (1) Repealing By-law No. 29.
- (2) Prescribing fees to be charged for the registration, annual renewal of registration and transfer of registration of food vending machines.

A copy of the By-law is open for inspection free of charge during office hours at the Shire Office, Avoca.

The By-law was passed on the 22nd March, 1966, confirmed on the 20th April, 1966, and approved by the Governor in Council on 28th June, 1966.

2651 F. C. S. EDWARDS, Shire Secretary.

SHIRE OF BIRCHIP.

BY-LAW No. 27.

NOTICE is hereby given that in pursuance with the provisions of the *Health Act 1958*, the Council of the Shire of Birchip has made By-law No. 27 for the purpose of:—

- 1. Repealing By-law No. 19.
- 2. Fixing fees to be charged for the registration, annual renewal of registration and transfer of registration of premises and food vending machines.

A copy of the By-law is open for inspection, free of charge, during office hours at the Shire Office, Cumming Avenue, Birchip.

2650 WALTER J. MCQUILLEN, Shire Secretary.

SHIRE OF CRANBOURNE.

LOAN No. 25.

Notice of Intention to Borrow the Sum of \$6,000 for Permanent Works and Undertakings.

NOTICE is hereby given that the Council of the Shire of Cranbourne proposes to borrow the principal sum of \$6,000 secured by a charge over the general rates of the municipality, such sum to be raised by the grant of a mortgage in accordance with the provisions of the *Local Government Act 1958*.

1. The maximum rate of interest that may be paid is 5.5625 per cent. per annum.

2. The purpose for which the loan is to be applied is—

- The purchase of land in Warrandyte-road, Langwarrin, for Planning Scheme proposals.

3. The period of the loan shall be nine (9) years.

4. The moneys borrowed shall be repayable by providing out of the municipal fund eighteen half-yearly instalments of \$428.22 each including principal and interest on the 1st day of May and the 1st day of November during the currency of the loan. The first instalment shall be payable on the 1st day of May, 1967.

5. Such moneys shall be repayable to the National Savings Bank Limited, Melbourne.

The plans and specifications and the estimate of the cost of the proposed works and a statement showing the proposed expenditure of the moneys to be borrowed are open for inspection at the Office of the Council of the Shire of Cranbourne, at Cranbourne.

T. W. GRANT, Shire Secretary.

20th July, 1966.

SHIRE OF CRANBOURNE.
By-LAW No. 56.

A By-Law of the Shire of Cranbourne made under the *Health Act* 1958 and numbered 56 for prescribing fees to be charged for the registration of premises and food vending machines and for the renewal of such registration and for the transfer of registration thereof, pursuant to the said Act.

IN PURSUANCE of the powers conferred by the *Health Act* 1958, and by every other Act or power enabling it in that behalf, the President, Councillors and Ratepayers of the Shire of Cranbourne order as follows :—

1. By-Law No. 53 of the Shire of Cranbourne is hereby repealed.
2. The fees to be charged, received and taken by the Council of the Shire of Cranbourne, for the registration of premises and food vending machines and for annual renewals thereof, for any transfers of such registrations and additional fees for late application for renewals of the several classes of premises and food vending machines hereunder specified shall be as set out in the Schedule hereto.
3. Any party making application for such registration, renewal or transfer respectively shall pay to the Secretary of the Shire of Cranbourne such fees as are hereby made payable for registration of the premises or food vending machines or annual renewal or transfer of registration thereof (as the case may be) which is the subject-matter of the application.
4. Save as to piggeries, this By-Law shall have force and operation throughout the municipal district of the Shire of Cranbourne, and as to piggeries this By-Law shall have force and operation in so much of the municipal district of the Shire of Cranbourne as is constituted by the Cranbourne and Tooradin Ridings and Crown Allotments 4, 5, 6, 10, 11, 12, 13 and 13A, Parish of Lang Lang, County of Mornington, and the northern part of Crown Allotment 14, said Parish and County, such part being bounded on the south by a prolongation of the southern boundary of the said Crown Allotment 12, bearing S. 80 deg. 5 min. W. to the eastern boundary of the aforesaid Crown Allotment 14.
5. Any party who shall wilfully offend against any of the provisions of this By-Law shall be liable to a penalty of not more than Forty Dollars, and in the case of a continuing offence, to a further penalty of not more than Ten Dollars for each day on which an offence against this By-Law is continued after a conviction or order by any Court in respect thereof against such party.

SCHEDULE ABOVE REFERRED TO.

(a) For every registration and for every annual renewal of registration and additional fee payable when application for renewal lodged after 15th November, in any year.

Nature of Premises and Food Vending Machines.	Fees Payable.	Additional Fees Payable where Application for Renewal Lodged after 15th November in any Year.
		\$
Offensive trades premises (other than those referred to Below)	Ten Dollars ..	5.00
Offensive trades premises (being fat extracting or melting or rendering works which are conducted at premises occupied principally as a butcher's shop and at which fat is extracted melted or rendered only from materials derived from such shop)	Two Dollars ..	1.00
Piggeries, where usual number of pigs does not exceed ten	Four Dollars ..	2.00
Piggeries, where usual number of pigs exceeds ten	Ten Dollars ..	5.00
Cattle Sale Yards	Two Dollars ..	1.00
Boarding Houses	Four Dollars ..	2.00
Common Lodging-houses	Four Dollars ..	2.00
Eating-houses	Four Dollars ..	2.00
Apartment-houses—		
Containing not more than one apartment	Two Dollars ..	1.00
Containing more than one apartment	Four Dollars ..	2.00
Food Premises—Camping areas	Four Dollars ..	2.00
(i) Where not more than five persons (including the proprietor and his family) are employed	Four Dollars ..	2.00
(ii) Where more than five such persons are employed additional for each person in excess of five	Twenty-five Cents ..	0.12
Provided that the maximum fee payable shall be	Fifty Dollars ..	25.00
Premises at or in any part of which eggs for sale are received or stored for the purpose of being chilled	Four Dollars ..	2.00
Premises in which are conducted, Hairdressers' Shops, Beauty Parlours, or other like establishments, or Chiropodists' Establishments	Two Dollars ..	1.00
Food Vending Machines—		
1. Machines operated by one to two cents a sale	Fifty Cents ..	0.25
2. Machines operated by a coin or coins to the value of three cents a sale ..	One Dollar ..	0.50
3. Machines operated by coins in excess of three cents in value but not exceeding five cents	Two Dollars ..	1.00
4. Machines operated by coins in excess of five cents in value	Four Dollars ..	2.00

(b) For any transfer of Registration—Twenty-five Cents.

Resolution for passing this By-Law agreed to by the Council of the Shire of Cranbourne, the 7th April, 1966 and confirmed at a Meeting of the said Council, held the 13th May, 1966.

The Common seal of the President, Councillors and Ratepayers of the Shire of Cranbourne was hereto affixed by order of the Council, this in the presence of—

(SEAL)

P. B. FECHNER, President.
W. THWAITES, Councillor.
W. McL. GREAVES, Councillor.
T. W. GRANT, Shire Secretary.

Submitted to the Commission of Public Health on 7th June, 1966.

A. T. GARDNER, Secretary,
Commission of Public Health.

Approved by the Governor in Council, 12th July, 1966—J. COLQUHOUN, Clerk of the Executive Council.

SHIRE OF CHARLTON.

BY-LAW No. 32.

A By-law of the Shire of Charlton made under the provisions of the Local Government Acts and numbered 32 for amending By-law No. 19 and repealing By-laws Nos. 21, 28 & 29, for prescribing residential areas within the Township of Charlton.

IN pursuance of the powers conferred by the Local Government Act and every other power it thereunto enables the President, Councillors and Ratepayers of the Shire of Charlton to order, as follows:—

The First Schedule of By-law No. 19 shall be amended and the whole of By-laws 21, 28 & 29 repealed, by deleting the whole of clause 1b thereof and substituting therefore the following clause:—

- 1 (b) Being sections 6, 7, Pt. 8 (Lots 1, 1a, 2, 3, 4, 5, 6a, 6b, 7a, 7b, 8a & 8b), 9, 15 & Pts 6A (Lots 11, 12, 13 and part 10 to within a distance of 231 Lin. Ft. 6 Ins., of the boundary between allotments 9 and 10 being the parts of section 6a on the South of the Calder Highway), Township of Charlton, Parish of Charlton East, County of Gladstone.

This By-law shall come into full force and operation immediately after its publication in the Victorian Government Gazette.

The foregoing by-law was passed by Special Order of the Council of the Shire of Charlton on the Twenty-fifth day of January 1966 and was confirmed on the First day of March 1966.

As Witness Thereof the Common Seal of the President, Councillors and Ratepayers of the Shire of Charlton was hereto affixed this First day of March 1966, in the presence of:—

(SEAL) W. H. WOOD, President.
A. J. EDWARDS, Councillor.
A. F. HEYLAR, Secretary.

Approved by the Governor in Council, 21st June, 1966.—
J. COLQUHOUN, Clerk of the Executive Council. 2620

SHIRE OF CRESWICK.

NOTICE OF THE MAKING OF BY-LAWS.

NOTICE is hereby given that the Council of the Shire of Creswick has made the following By-laws:—

By-law No. 26—Road Openings By-law.

A By-law of the Shire of Creswick made under sections 197 (i) (ii), 197 (i) (xiv), 198 (3) (e) (f), 212, 213 (i) and 222 of the Local Government Act 1958, clause 403 and table 401 (h), of the Uniform Building Regulations Victoria and all other powers thereunto enabling and numbered 26 for the purposes of—

- fixing the fees to be paid for road opening permits;
- requiring the adequate boarding and lighting of road opening and the provision of adequate warnings;
- describing the time and manner in which road openings and their refilling are to be carried out;
- prescribing penalties for breaches of this By-law; and for other purposes, as open for inspection at the Office of the Shire Secretary.

By-law No. 27—Crossings By-law.

A By-law of the Shire of Creswick made under sections 197 (i) (ii), 197 (i) (xiv), 212, 213 (i) and 222 of the Local Government Act and all other powers thereunto enabling and numbered 27 for the purposes of—

- requiring the provision of crossings from the roadway to the adjoining property at all points at which access is had from the carriageway;
- providing the form, dimensions and constructional standards;
- providing for cost of, construction, maintenance and repair of crossing to be paid by owners of relevant properties;
- prescribing penalties for breaches of this By-law; and for other purposes as open for inspection at the office of the Shire Secretary.

By-law No. 28—Management of Reserves.

A By-law of the Shire of Creswick made under sections 197 (i) (ii), 197 (i) (xiv), 212, 213 (i) and 222 of the Local Government Act 1958 and all other powers it thereunto enabling and numbered 28, for the purposes of—

- Repealing By-law No. 14;

- Controlling and managing public reserves of which the management is vested in Council;
- regulating the conduct of persons using such public reserves;
- protecting the lawns, plants, shrubs, trees, structures and surrounds in such public reserves;
- prescribing penalties for breaches of this By-law; and for other purposes as open for inspection at the office of the Shire Secretary.

By-law No. 29—Hoardings By-law.

A By-law of the Shire of Creswick made under the provisions of section 198 of the Local Government Act 1958 and all other powers it thereunto enabling and numbered 29, for the purposes of—

- regulating, restraining or prohibiting the erection or construction of hoardings;
- regulating, restricting or preventing the exhibition of advertisements in such places and in such manner or by such means as to affect injuriously the amenities of a public park or to disfigure the natural beauty of the landscape;
- prescribing penalties for breaches of this By-law; and for other purposes as open for inspection at the office of the Shire Secretary.

By-law No. 30—Street Traders and Collectors By-law.

A By-law of the Shire of Creswick made under section 197 of the Local Government Act 1958 and all other powers it thereunto enabling and numbered 30, for the purposes of—

- Regulating the use of streets, roads, and public places by street hawkers and itinerant traders dealing in goods;
- Prohibiting or regulating the sale of goods from any stall, motor car, cart, truck, barrow or other receptacle standing or placed on any street, road, public place or vacant land within the Municipal District;
- Prohibiting or regulating the soliciting or collection in any road or street or from house to house adjacent thereto of gifts of money or of subscriptions for any purpose;
- prescribing penalties for breaches of this By-law; and for other purposes as open for inspection at the office of the Shire Secretary.

By-law No. 31—Caravan By-law.

A By-law of the Shire of Creswick made under section 197 (i) (ix) and 197 (i) (xxxi) (g) of the Local Government Act 1958 and all other powers it thereunto enabling, and numbered 31, for the purposes of—

- Regulating the leaving standing of caravans on streets or roads and the placing and occupying of caravans on private property;
- prescribing penalties for breaches of this By-law; and for other purposes as open for inspection at the office of the Shire Secretary.

By-law No. 33—Unightly Land By-law.

A By-law of the Shire of Creswick made under section 197 (i) (xxxviii) (ba) of the Local Government Act 1958 and all other powers it thereunto enabling, and numbered 33, for the purposes of—

- requiring any land declared by Council to be unsightly or destructive of the amenity of the neighbourhood to be enclosed with a sufficient fence;
- prescribing that every fence shall be of the material and construction specified;
- prescribing penalties for breaches of this By-law; and for other purposes as open for inspection at the office of the Shire Secretary.

By-law No. 34—Proceedings of Council By-law.

A By-law of the Shire of Creswick made under section 197 (i) (i) of the Local Government Act 1958 and all other powers it thereunto enabling, and numbered 34, for the purposes of—

- repealing By-law No. 27 of the Borough of Creswick and By-law No. 1 of the Shire of Creswick;
- adopting the following clauses of Part XI.—Regulation of Proceedings of Council Officers, etc.—of the 15th Schedule to the Local Government Act 1958:—1, 4-30 (Inclusive) 32-39 (Inclusive) 41-44 (Inclusive) 46-51 (Inclusive) 53;

(c) prescribing penalties for breaches of this By-law; and for other purposes as open for inspection at the office of the Shire Secretary.

Notice is also hereby given that the copies thereof are open for inspection, free of charge during office hours, at the office of Council, Town Hall, Creswick.

Dated this 15th day of July, 1966.

2648 K. J. SAUNDERS, Shire Secretary.

SHIRE OF HEALESVILLE.

BY-LAW No. 47.

Health Act Registration Fees By-law.

A By-law of the Shire of Healesville made under Sections 65 and 368 of the Health Act 1958 and Numbered 47 for prescribing the fees to be charged for the registration of premises and food vending machines, and for the renewal or transfer of such registrations pursuant to the provisions of the said Act.

IN pursuance of the powers conferred by the Health Act 1958 and of any and every other power it thereunto enabling the President Councillors and Ratepayers of the Shire of Healesville orders as follows:—

(1) By-laws No. 33 and 41 are hereby repealed.

(2) This By-law may be known as the Health Act Registration Fees By-law.

(3) The fees for the granting or annual renewal of registration of premises shall be as follows:—

Nature of Premises	Fees
APARTMENT HOUSES:	
(i) Containing not more than one apartment	\$2
(ii) Containing more than one apartment	\$4
Boarding Houses	\$4
Camping Areas	\$4
Cattle Sale Yards	\$2
Common lodging houses	\$4
Eating Houses	\$4
Food premises—	
(i) Where not more than five persons (including the proprietor and his family) are employed	\$4
(ii) Where more than five such persons are employed additional for each person in excess of five	\$0.25
Provided that the maximum fee payable shall be	\$50
Offensive trade premises (other than those referred to below)	\$10
Offensive trade premises (being fat extracting or melting or rendering works which are conducted at premises occupied principally as a butcher's shop and at which fat is extracted melted or rendered only from materials derived from such shop)	\$2
Hairdressers' Shops, Beauty Parlors and Chiropractors' establishments	\$2
Premises at or in any part of which eggs for sale are received or stored for the purpose of being chilled	\$4
(4) The fee payable to the Council for the granting or annual renewal of registration of any Food Vending Machine shall be	\$2

(5) Where application for the renewal of registration of any premises or any Food Vending Machine is not lodged with the Council until after the last day fixed for lodging thereof an additional fee of one-half of the relevant prescribed fee is hereby prescribed for such renewal of registration.

(6) A fee of Twenty-five cents is hereby prescribed for the transfer of any registration.

(7) A fee of \$8 is hereby fixed for the examination of plans specifications particulars and descriptions of proposed septic tank systems and any inspection of sites and installation of septic tank systems.

(8) This By-law shall apply to and have operation throughout the whole of the municipal district.

Resolution for passing this By-law agreed to by the Council of the Shire of Healesville on the 26th day of April, 1966, and confirmed on the 31st day of May, 1966.

The common seal of the President, Councillors and Ratepayers of the Shire of Healesville, was herewith affixed, in the presence of—

(SEAL) W. V. HOUGHTON, President.
B. S. WHITWELL, Councillor.
W. M. OLIVER, Shire Secretary.

Submitted to the Commission of Public Health on the 21st June, 1966.—A. T. GARDNER, Secretary, Commission of Public Health.

Approved by the Governor in Council, 12th July, 1966.—J. COLQUHOUN, Clerk of the Executive Council. 2647

SHIRE OF MORNINGTON.

BY-LAW No. 115.

Meat Supervision By-law.

NOTICE is hereby given that the Council of the Shire of Mornington has made a By-law under the Local Government Act 1958 as amended and all other powers it thereunto enabling Numbered 115 for the purposes of:—

(a) The regulation and management of the Meat Area within the Municipal District of the Shire;

(b) Prescribing the conditions on which animals may be received into or supplied or removed from abattoirs;

(c) Fixing the rates of fees or dues payable to the Council under Part XV. of the Health Act 1958;

(d) Prescribing the times for slaughtering animals at private abattoirs;

(e) Providing for the feeding watering and tending and the prevention of cruelty to and overcrowding of animals in abattoirs and the milking of milch animals at abattoirs;

(f) Stopping temporarily the manufacture of and the sale of smallgoods in circumstances in which danger to the consumer is apprehended owing to uncleanness or to the presence of infection on or about the premises where such manufacture or sale is carried out;

(g) Repealing By-laws numbered 50, 63 and 67 of the Shire of Mornington;

(h) Prescribing penalties for breaches of this By-law; and for other purposes.

Notice is also hereby given that a copy of the above-mentioned By-law is open for inspection, free of charge, during office hours, at the office of the said Council, Queen-street, Mornington.

Dated this 15th day of July, 1966.

2643 D. G. COLLINGS, Shire Secretary.

Water Act.

SHIRE OF OXLEY.

PROPOSED WHITFIELD WATERWORKS TRUST.

NOTICE is hereby given that the Shire of Oxley Council has made application to the Honorable the Minister of Water Supply for the constitution of a Waterworks Trust, and for the construction, maintenance, and continuance of water supply works within that District under the provisions of the Water Act.

A general plan and description of the proposed works have been submitted with the application, and copies of same may be seen at Shire Office, at 22 Rowan-street, Wangaratta.

Dated at Wangaratta, the 15th day of July, 1966.

2621 E. F. VAN LEEUWEN, Shire Secretary.

SHIRE OF RODNEY.

LOAN No. 55.

Notice of Intention to Borrow the Sum of \$80,000 for Permanent Works and Undertakings.

NOTICE is hereby given that the Council of the Shire of Rodney proposes to borrow the principal sum of Eighty thousand dollars on the credit of the municipal revenues of the President, Councillors and Ratepayers of the said Shire, such sum to be raised by the grant of a mortgage in accordance with the provisions of the Local Government Act 1958.

1. The maximum rate of interest that may be paid is 5.75 per cent. per annum.

2. The purposes for which the loan is to be applied are:—

(a) Erection of Municipal Offices and Council Chambers, provision of Furnishings and Office Equipment \$78,000

(b) Replacement of Store Sheds required to be moved from the site of the new Municipal Offices and Council Chambers 2,000

\$80,000

3. The period of the loan shall be fifteen years based on a 40-year repayment table.

4. The moneys borrowed shall be repayable by providing out of the municipal fund 29 half-yearly instalments of \$2,565.72 each, including principal and interest, on the 1st day of April and the 1st day of October each year during the currency of the loan, and a final instalment of \$70,176.89 on the 1st day of October, 1981.

The first instalment shall be payable on the 1st day of April, 1967.

The balance of principal outstanding after payment of the twenty-ninth instalment on the 1st April, 1981, shall be met by the raising of a further loan pursuant to section 394 of the Local Government Act.

5. Such moneys shall be repayable at the Commercial Savings Bank of Australia Ltd., Tatura.

The plans and specifications and the estimate of the cost of the proposed works and a statement showing the proposed expenditure of the moneys to be borrowed are open for inspection at the office of the Council of the Shire of Rodney, at Tatura.

2645

R. PERRY, Shire Secretary.

SHIRE OF RODNEY.

LOAN No. 56.

Notice of Intention to Borrow the Sum of \$80,000 for Permanent Works and Undertakings.

NOTICE is hereby given that the Council of the Shire of Rodney proposes to borrow the principal sum of Eighty thousand dollars on the credit of the municipal revenues of the President, Councillors and Ratepayers of the said Shire, such sum to be raised by the grant of a mortgage in accordance with the provisions of the Local Government Act 1958.

1. The maximum rate of interest that may be paid is 5.75 per cent. per annum.

2. The purposes for which the loan is to be applied are:—

- | | |
|---|----------|
| (a) Erection of Municipal Offices and Council Chambers, provision of Furnishings and Office Equipment | \$78,000 |
| (b) Replacement of Store Sheds required to be moved from the site of the new Municipal Offices and Council Chambers | 2,000 |
| | \$80,000 |

3. The period of the loan shall be 40 years.

4. The moneys borrowed shall be repayable by providing out of the municipal fund 80 half-yearly instalments of approximately \$2,565.72 each including principal and interest, on the 1st day of April and the 1st day of October during the currency of the loan.

The first instalment shall be payable on the 1st day of April, 1967.

5. Such moneys shall be repayable at the Commonwealth Savings Bank of Australia, Tatura.

The plans and specifications and the estimate of the cost of the proposed works and a statement showing the proposed expenditure of the moneys to be borrowed are open for inspection at the office of the Council of the Shire of Rodney, at Tatura.

2646

R. PERRY, Shire Secretary.

SHIRE OF RUTHERGLEN.

RUTHERGLEN SHIRE POUND.

Abolition of Pound (Pounds Act 1958, No. 6341).

NOTICE is hereby given that the Council of the Shire of Rutherglen, on 1st July, 1966, abolished the Rutherglen Shire Pound, situated at Eyre-street, Rutherglen, comprising lots 32-49, lodged plan 3957, being parts of Crown allotments 10 and 11, section 1, Township of Rutherglen, Parish of Carlyle, County of Bogong.

Establishment of Pound (Pounds Act 1958, No. 6341).

Notice is hereby given that the Council of the Shire of Rutherglen, on 1st July, 1966, appointed the place at Rutherglen, described hereunder, to be the Rutherglen Shire Pound, viz., Crown allotment 33, section 41, Parish of Carlyle, County of Bogong.

Appointment of Poundkeeper (Pounds Act 1958, No. 6341).

Notice is hereby given that the Council of the Shire of Rutherglen, on 1st July, 1966, appointed Eric Raymond Miller, Poundkeeper for the Rutherglen Shire Pound, in the place of the late Thomas Cullen, deceased.

C. A. RICKETTS, Shire Secretary.

18th July, 1966.

2691

Town and Country Planning Act 1961.

SHIRE OF UPPER MURRAY—CORYYONG PLANNING SCHEME 1960.

NOTICE THAT A PLANNING SCHEME HAS BEEN PREPARED AND IS AVAILABLE FOR INSPECTION.

Amendment No. 2—1966.

NOTICE is hereby given that the Shire of Upper Murray in pursuance of its powers under the *Town and Country Planning Act 1961* has prepared a Planning Scheme for Part of the Shire of Upper Murray for the purpose of amending the Shire of Upper Murray Planning Scheme.

A copy of the scheme has been deposited at the Shire Offices, Hansen-street, Corryong, and at the office of the Town and Country Planning Board, 179 Queen-street, Melbourne, and will be open for inspection during office hours by any person free of charge.

Any persons affected by the Planning Scheme are required to set forth, in writing, all objections they may have, addressed to the Shire Secretary, Shire of Upper Murray, P.O. Box 129, Corryong, on or before the 21st day of October, 1966, and to state whether they wish to be heard in respect of their objections.

Dated this 20th day of July, 1966.

2642

G. H. TATE, Shire Secretary.

ZEEHAN MINES PROPRIETARY LIMITED
(IN LIQUIDATION).

NOTICE is hereby given that, pursuant to section 272 of the *Companies Act 1961*, a meeting of the members of the above-named company will be held at 14th Floor, 447 Collins-street, Melbourne, on Monday, 29th August, 1966, at 11 o'clock in the forenoon, for the purpose of having an account laid before them, showing how the winding up of the company has been conducted and the property of the company disposed of and to decide on the destruction of the books and papers of the company.

Dated this 11th day of July, 1966.

2706

S. S. WALLIS, Liquidator.

Companies Act 1961.—Section 260, Form 92.

VICTORIAN HOUSEWIVES ASSOCIATION.

COMPANIES REGULATIONS—REGULATION 28 (2) (b).

NOTICE OF MEETING OF CREDITORS.

NOTICE is hereby given that a meeting of the creditors of the Victorian Housewives Association will be held at the registered office, 8th Floor, Manchester Unity Building, corner of Collins & Swanston streets, Melbourne, on Friday, 5th day of August, 1966, at 11.30 o'clock in the forenoon.

Agenda.

1. To appoint a chairman.
2. To consider a statement of the Association's affairs.
3. To appoint a liquidator.
4. To consider the appointment of a committee of inspection.
5. To fix the liquidator's remuneration.

Dated this 14th day of July, 1966.

2707

G. DOWNIE, Acting President.

CLENDON COURT PROPRIETARY LIMITED

(IN VOLUNTARY LIQUIDATION).

NOTICE CONVENING FINAL MEETING, PURSUANT TO SECTION 272 OF THE *Companies Act 1961*.

PURSUANT to section 272 of the *Companies Act 1961*, a General Meeting of members of the above-named company will be held at the office of the liquidator, 2nd Floor, 339 Collins-street, Melbourne, on Monday 22nd August, 1966, at 10 a.m., for the purpose of having an account laid before them showing the manner in which the winding up has been conducted and the property of the company disposed of, and of hearing any explanations that may be given by the liquidator.

Dated this 20th day of July, 1966.

2717

E. E. FOKES, Liquidator.

Unclaimed Moneys Act 1962.

REGISTER of Unclaimed Moneys held by the—

Name of Owner on Books and Last Known Address.	Total Amount Due to Owner.	Description of Unclaimed Moneys.	Date when Amount first became Payable.
	\$ c		
VICTORIAN PRODUCERS' CO-OPERATIVE CO. LTD.			
Anderson, Robert M., Elmore	18.00	Dividends	1949
Bailey, Hugh A. (estate of), Ballan	18.00	"	"
Barton, James (estate of), Footscray, W.11	18.00	"	"
Borchard, Johannes H. (estate of), Nyah West	18.00	"	"
Bradley, Patrick J. (estate of), Eldorado	27.00	"	"
Brady, Charles, Kerang	15.00	"	"
Brennan, Andrew J. (estate of), Corack East	40.00	"	"
Christie, Margaret F. Thornton	30.00	"	1954
Cole Bros., Timboon	22.50	"	1950
Curran, Patrick, Wood Wood P.O.	18.00	"	1949
Day, Arthur L. (estate of), Dimboola	22.50	"	1950
Day, Percival J., Dimboola	22.50	"	"
Dunn, Snr. Charles and Sons, Donald	22.50	"	1949
Gee, William T. (estate of), Kangaroo Flat	10.00	"	"
Goldie, James (estate of), Port Fairy	18.00	"	"
Grey, Archibald (estate of), Meathian	13.50	"	"
Galt, Rupert A., Numurkah	30.00	"	1954
Hateley, Reginald L., Natimuk	12.00	"	1949
Hattwell, William (estate of), Box Hill	15.00	"	"
Heath, Henry (estate of), Warracknabeal	18.00	"	"
Hemphill, Johnston (estate of), Lancefield	12.00	"	"
James, Olive, Muckleford Rail	51.00	"	1949
Laverty, James E, Yanac North	36.00	"	"
Lonergan, James (estate of), Quambatook	12.00	"	"
McKee, Edward, Elmore	18.75	"	"
McLennon, Donald M., Marnoo	18.00	"	"
Major Bros., McWilliams	12.00	"	"
Maple, Charles V. (estate of), Nyah West	71.25	"	"
Meyer Bros., Malvern	18.00	"	"
Moll, Frederica B. (estate of), Gerogery, N.S.W.	12.00	"	"
Moreton and Sons, Lake Bolac	36.00	"	"
Morley, James (estate of), Wahgunyah	30.00	"	"
Mues, Charles (estate of), Cohuna	12.00	"	"
McAlpine, Walter T. (estate of), South Caulfield	37.50	"	"
Morton, Murray, Benjeeroop	30.00	"	1954
Park, Josiah (estate of), Lake Bolac	18.00	"	1949
Parker, Jemima (Mrs.), Lindenow	15.00	"	"
Pearson, Robert (estate of), Clyde	15.00	"	"
Perrignon, George H. McC. (estate of), Moulamein, N.S.W.	12.00	"	"
Powell, Alfred F., Thorpdale	30.00	"	1954
Porter, William J., Bobinawarra	22.00	"	1949
Quigley, James (estate of), Harrow	18.00	"	"
Reichelt, Frederick W., Merredin, W.A.	21.50	"	"
Ryan, Timothy, J. (estate of), Myrtleford	18.00	"	"
Scholz, Theodor E., Jindera, N.S.W.	66.00	"	"
Schuller, Edwin A., Edenhope	10.50	"	1950
Schwarz, Gustav T., Melbourne	31.00	"	1949
Sebastian, Robert (estate of), Tocumwal, N.S.W.	18.00	"	"
Sheridan, Michael J., Donald	36.00	"	"
Slaughter, Thomas (estate of), Murtoa	18.00	"	"
Spears Bros. (estate of), Oakleigh	12.00	"	"
Vallance, Neil (estate of), Walpeup	36.00	"	"
Werner, Hanna C. (estate of), Natimuk	13.75	"	"
Walter, Arthur J., Warragamba	12.00	"	"
Zerbst, Alfred, Cowangie	54.00	"	"
Allen, William (estate of), Junortoun	45.00	"	"
Altmann, August, Swan Hill	45.00	"	"
Anders, Alfred A. H., Albert Park	18.00	"	"
Anderson, David, Canterbury	54.00	"	"
Baird, Rupert H., Armadale	18.00	"	"
Baldwin, Sampson H. (estate of), Murrayville	22.50	"	"
Bell, Samuel, Mernda	22.50	"	"
Berry, Edward, Willaura	13.00	"	"
Bickerton, William, Ballarat	27.00	"	"
Binns, Percival E. E.	45.00	"	"
Boucher, Charles, Bendigo	22.50	"	"
Bourchier, William H., Caulfield	18.00	"	"
Boustead Bros., Richavon West	16.00	"	1950
Bowen, Richard Wm., Preston	18.00	"	1949
Bradshaw, Merriott, Mildura	16.25	"	1951
Brown, Arthur W., Speed	31.50	"	1949
Burke, Hurtle, Buckleys	22.50	"	"
Burke, James E., Sydney, N.S.W.	18.00	"	"
Cadgow Bros., Wyalong, N.S.W.	27.00	"	"
Campbell, George A., Rupanyup	45.00	"	"
Carey, William J., Esmond	22.50	"	"
Carmichael, John, Woomelang	18.00	"	"
Childs, Edward E., Kotta	18.00	"	"
Coates, Josiah (estate of), Laen	22.50	"	"
Cox, Walter L., Murchison's Tank	22.50	"	"
Cummins, Thomas, Boree Creek	22.50	"	"
Cunningham, William J. and A. G., Carron	19.50	"	1951
Curnow, Jacob E. (estate of), Sea Lake	13.00	"	"
Dawe, George, Codrington	32.50	"	"

Unclaimed Moneys Act 1962.

REGISTER of Unclaimed Moneys held by the—

Name of Owner on Books and Last Known Address.	Total Amount Due to Owner.	Description of Unclaimed Moneys.	Date when Amount first became Payable.
			\$ c
VICTORIAN PRODUCERS' CO-OPERATIVE COMPANY LIMITED— <i>continued.</i>			
Deed, Ralph H. (estate of), Bendigo	18.00	Dividend	1949
Dickson, David, Pine Lodge	45.00	"	"
Dole, John V., McMillans	11.25	"	1952
Downey, Clifton L., Diamond Creek	18.00	"	1949
Drew, John, Ballarat	18.00	"	"
Duncan, John, Dennington	18.00	"	"
Dunn, Michael (estate of), Essendon	18.00	"	"
Duthie, David (estate of), Jeparit	39.00	"	1951
Fite, Ramon, Marong	11.25	"	1952
Fitzgerald, Edward E., St. Kilda	18.00	"	1949
Flett, John, Warrnambool	22.50	"	"
Ford, Frank, Linton, N.S.W.	13.00	"	1951
Ford, George G., Bunyip	18.00	"	1949
Forsyth, A. (estate of), Mansfield	18.00	"	"
Geilhard, Francis G., Nyah West	18.00	"	"
Gibson, Eric H. M., Wy Yung	13.00	"	1951
Gorman, John J., Gerogery, N.S.W.	22.50	"	1949
Gouldthorp, Robert, Tahara West	18.00	"	"
Guest, Ralph H. B., Willaura	22.50	"	"
Gullett, William, Sydney, N.S.W.	45.00	"	"
Hall Bros., Goorambat	12.50	"	"
Hall, Walter C., Cohuna	18.00	"	1949
Hamilton, William G., Ungarie, N.S.W.	36.00	"	"
Hanson, Harold R., Toora	18.00	"	"
Harbour, Henry and Son, Amphitheatre	18.00	"	"
Harhen, Michael (estate of), Hopetoun	22.50	"	"
Harry, Albert E. (estate of), Bendigo	16.25	"	1951
Hayes, Mary C., Warracknabeal	22.50	"	1949
Heenan, Patricia F., Tandara	18.00	"	"
Henderson, John (estate of), Wilby	36.00	"	"
Heywood, Robert, Canterbury	27.00	"	"
Hickey, William J., Hopetoun West	16.00	"	1950
Hickmott, Joseph (estate of), Pine Grove East	13.50	"	1952
Hildebrand, Ethel J., Katoomba, N.S.W.	12.50	"	1949
Hogan, Edward L., Burramine South	18.00	"	"
Hogan, James C., Daylesford	18.00	"	"
Hole, Richard (estate of), Sea Lake	18.00	"	"
Hopkins, William, Borung	18.00	"	"
Howard, John C., Seymour	18.00	"	"
Howe, Charles, Kangaroo Flat	22.50	"	"
Hunter, Thomas E., Stanhope	12.50	"	"
Issell, Thomas H. G., Bendigo	18.00	"	"
Jager, Albert A., Dingee	13.50	"	1952
Jeitz, Herman, Warracknabeal	54.00	"	1949
Jenkin, Clifford, Croydon	22.50	"	"
Jones, William E., Kerang	18.00	"	"
Kays, Hugh B. (estate of), Nagambie	22.50	"	"
Kelly, Michael J., Garup	24.00	"	1950
Kelly, Patrick W., Tallygaroopna	90.00	"	1949
Kelly, Thomas, Barraport	18.00	"	"
Kelly, Thomas (estate of), Bendigo	18.00	"	"
Kensley, Thomas J. (estate of), Nyah West	22.50	"	"
King, Frank J., Duverney	26.00	"	1951
King, William A., Walpeup	45.00	"	1949
Knowling, William D. (estate of), Ormond	12.50	"	"
Leahy Bros., Bendigo	13.00	"	1951
LeLievre, Edward, Corack East	18.00	"	1949
Lowe, Mary, E., Hayanmi	22.50	"	"
Lucas, Walter L., Yarrowonga	45.00	"	"
Luke, Arthur, Wakool, N.S.W.	18.00	"	"
McAlpine, John, Whitfield	16.25	"	1951
McBean, Bros., Rutherglen	12.50	"	1949
McCauley, James W. (estate of), Pompapiel	13.00	"	1951
McCaw, George, Swan Hill	18.00	"	1949
McClelland, Margaret, Monavale	18.00	"	"
McDonald, Donald, Boosey South	13.00	"	1951
McFarland, S., East Malvern	18.00	"	1949
McIntosh, John H., Woodville, S.A.	22.50	"	"
McIntyre, William B., Ararat	18.00	"	"
McLean, Annie, Ouyen	18.00	"	"
McMahon, John, (estate of), St. Kilda	11.25	"	1952
Maguire, Michael, Youanmite	27.00	"	1949
Maple, Carole B., Mornington	54.00	"	"
Martin, James M., Aubrey	27.00	"	"
Mason, John W., Violet Town	18.00	"	"
Millar, Mary C., Oakvale	22.50	"	"
Ming, Tim Si (estate of), Koondrook	12.50	"	"
Mitchell, David W., Warracknabeal	54.00	"	"
Mitchell, Michael, Northcote	18.00	"	"
Mitchell, Thomas, Stavelly	18.00	"	"
Moore, Charles W., Swan Hill	45.00	"	"
Moore, Christopher, (estate of), Bendigo	22.50	"	"
Murphy, Mary (estate of), Barraport West	18.00	"	"
Netherway, W. F., Doncaster	18.00	"	"

Unclaimed Moneys Act 1962.

REGISTER of Unclaimed Moneys held by the—

Name of Owner on Books and Last Known Address.	Total Amount Due to Owner.	Description of Unclaimed Moneys.	Date when Amount first became Payable.
s c			
VICTORIAN PRODUCERS' CO-OPERATIVE COMPANY LIMITED—continued.			
Newell, Walter D., Galaquil East	54.00	Dividends	1949
Noske, C. T. and O. T., Lancefield Junction	18.00	"	"
O'Brien, Cornelius (estate of), Essendon	16.00	"	1950
O'Gorman Bros., Warracknabeal	18.00	"	1949
Orr, Joseph A. (estate of), Nullawil	18.00	"	"
Painter, William, Gama	18.00	"	"
Parsons, Edwin J., Kew	13.00	"	1951
Paschke, Ernest G., Dimboola	36.00	"	1949
Peck Bros., Koondrook	45.00	"	"
Peebles, Thomas, Matong, N.S.W.	16.00	"	1950
Petersen, Christian M., Ultima	22.50	"	1949
Powell, John M. (estate of), Brentwood	65.00	"	1951
Pumpa, Heinrich A., Balranald, N.S.W.	18.00	"	1949
Quayle, Eliza Jean, Wandin Yallock	22.50	"	"
Quirk, John, Birchip	19.50	"	1951
Rangott, August J., Quambatook	18.00	"	1949
Rankin, Alexander, Mount Albert	18.00	"	"
Rankin, Daniel, Berriwillock	18.00	"	"
Rankin, John H., Watchem	12.50	"	"
Robertson, Hubert C., Alexandra	18.00	"	"
Roig, James (estate of), Spring Gully, Bendigo	90.00	"	"
Ross, William W., Dart Dart	32.50	"	1951
Ryan, James, Kooloonong	18.00	"	1949
Saltmarsh, Eric, Berrigan, N.S.W.	19.50	"	1951
Sambell, Hartley T., Netherby	27.00	"	1952
Schmidt, Ferdinand, Walla Walla, N.S.W.	13.00	"	1951
Schmidt, Rudolph, Flemington	22.50	"	1949
Schmidt, Sydney, Bendigo	18.00	"	"
Schultz, Theodor R., Adelaide, S.A.	54.00	"	"
Scott, Gordon M., Merbein	45.00	"	"
Scroop, Walter J., Pinnaroo, S.A.	45.00	"	"
Simper, Sarah L., Kangaroo Flat	18.00	"	"
Sims, Alexander, Arkona	18.00	"	"
Sinclair, John, Kyneton	279.00	"	"
Smith, Arthur (estate of), Chillingollah	16.25	"	1951
Smith, Charles, Pirita	22.50	"	1949
Smith, Ernest H., Hillston, N.S.W.	22.50	"	"
Smith, John, Prairie	27.00	"	"
Stakelum, William P., Corack East	18.00	"	"
Stanyer, Thomas A., Ouyen	27.00	"	"
Stewart, Alexander C., Murrabit	18.00	"	"
Stewart, Herbert G., Banyena	18.00	"	"
Stott, Gilbert H., Tongala	12.50	"	"
Summers, Charles, Essendon	18.00	"	"
Surridge, George, Carpendeit	18.00	"	"
Taylor Bros., Goornong	22.50	"	1952
Taylor, Charles W., Rushworth	13.00	"	1951
Thompson, James, Kerang	22.50	"	1949
Walsh, Bridget, North Ballarat	22.50	"	"
Watts, William C. L., Grass Flat	32.50	"	1951
Welsh, Neil, Koroop	18.00	"	1949
Wheeler, Herbert C. (estate of), Bunyip	13.00	"	1951
Wicke, Frederick H., Hurstbridge	18.00	"	1949
Wilkinson, Driscella E., Kattanning, W.A.	18.00	"	"
Williams, William and Clark, Thornton	22.50	"	"
Wilson, Frederick G., Perth, W.A.	18.00	"	"
Woldt, Frederick, Willenabrina	22.50	"	"
Wood, William J., Caulfield	13.00	"	1951
Wright, Charles L., Karrawinna	13.50	"	1949
Horne, Denis, Echuca	17.96	Wool Proceeds	1953
Wilson, E., Newbridge	46.54	"	"
Light Bros., Curyo	45.20	"	"
Jardine, F. and K., Rathscar	108.32	"	"
Hepworth, F. J., Woomeelang	19.00	Share Proceeds	"

2615

In the matter of A.M.G. PASTORAL PTY. LIMITED.

At an Extraordinary General Meeting of the above-named company held at 7th Floor, 440 Collins-street, Melbourne, on the 18th day of July, 1966, the following Special Resolution was duly passed:—

"That the company be wound up voluntarily."

And at such last-mentioned meeting Mr. Arthur Neville Davie, of 440 Collins-street, Melbourne, was appointed liquidator for the purpose of the winding up.

E. W. SHEARS, Chairman.

Davies, Campbell & Piesse, solicitors, 401 Collins-street, Melbourne. 2718

The Companies Act 1961.—In the matter of A. NEUHAUS PTY. LTD.

NOTICE is hereby given that pursuant to section 272 of the Companies Act, a final voting of the creditors of the above company will be held at the offices of Bastian, Bent & Cogle, on Tuesday, 9th August, 1966, at 12 p.m., at Suite 18, 545 St. Kilda-road, Melbourne.

Business—To receive the liquidator's accounts.

Dated this 11th day of July, 1966.

E. T. BENT, Liquidator.

Bastian, Bent & Cogle, public accountants, Suite 18, 545 St. Kilda-road, Melbourne, S.C.3. 2633

Victoria.

Companies Act 1961.

BAYLISS & RUSSELL PROPRIETARY LIMITED.

NOTICE OF MEETING OF CREDITORS.

Companies Regulations, Section 262, Regulations 28 (2) (b) and 46 (2).

NOTICE is hereby given that a meeting of the creditors of Bayliss & Russell Pty. Ltd., will be held at Federation House, 342 Flinders-street, Melbourne, on the 27th day of July, 1966, at 11 o'clock in the forenoon.

Agenda.

1. To consider a report from the directors of the company on the financial position of the company and to receive notice that the shareholders have passed a Resolution for the voluntary winding up of the company and the appointment of a liquidator.

2. Pursuant to section 261 of the Companies Act, consider whether to confirm the appointment of the liquidator appointed by the company, or alternatively appoint a person to be liquidator for the purpose of winding up affairs and distribute the assets of the company.

3. To advise the remuneration of the liquidator appointed.

4. To consider the appointment of a Committee of Inspection, pursuant to the provisions of section 262 of the Companies Act.

Dated this 14th day of July, 1966.

On behalf of the Board,

2686 N. G. RUSSELL, Director.

Companies Act 1961.

BROOME INVESTMENTS PTY. LIMITED
(IN VOLUNTARY LIQUIDATION).NOTICE OF CONVENING FINAL MEETING OF MEMBERS,
PURSUANT TO SECTION 272.

NOTICE is hereby given pursuant to section 272 of the Companies Act 1961 that a General Meeting of the members of the above-named company will be held at 414 Collins-street, Melbourne, on Monday, the 22nd day of August, 1966, at 9.30 in the forenoon, for the purpose of having an account laid before them showing the manner, in which the winding up has been conducted and the property of the company disposed of and of hearing any explanation that may be given by the liquidator.

Dated this 14th day of July, 1966.

P. E. AITKEN, Liquidator.

Aitken, Walker & Strachan, solicitors, 414 Collins-street,
Melbourne. 2708

A MEETING of Members of Wilro Pty. Ltd. (in voluntary liquidation) will be held at the offices of the company, Coleraine-road, Hamilton, at 3 p.m., on Tuesday, 26th July, 1966, for the purpose of receiving the account of the liquidation.

2630 R. A. MONTGOMERIE, Liquidator.

Companies Act 1961.

EASTERN GIPPSLAND HARDWARE & SUPPLY CO.
PTY. LTD.

(IN LIQUIDATION).

NOTICE is hereby given, in pursuance of section 272, of the Companies Act 1961, of a General Meeting of members and creditors to be held on Monday, 15th August, 1966, at 11 o'clock in the forenoon, at 130 Commercial-road, Morwell, for the purpose of laying before it the account of the winding up and giving any explanations thereof.

A. G. HOLDEN, Liquidator.

Norman, Cartledge & Holden, 130 Commercial-road,
Morwell. 2635

The Companies Act 1961.

MAIN APPLIANCE SERVICES CO. PTY. LTD.
(IN VOLUNTARY LIQUIDATION).

NOTICE is hereby given that at an Extraordinary Meeting of the members of the above-named company held on Tuesday, the 12th day of July, 1966, it was resolved that the company be wound up voluntarily and at a meeting of creditors held on the same day it was resolved that for such purpose Hudson Pitt, public accountant, of 30 Queens-road, Melbourne, be appointed liquidator.

Dated this 13th day of July, 1966.

H. B. PITT, Liquidator.

Hudson Pitt & Associates, 30 Queens-road, Melbourne,
C.I. 2659

In the Supreme Court of Victoria.—In the matter of the Companies Act 1961, and in the matter of Thirteen Petitions to wind up the companies named hereunder—

ARTISAN BUILDING COMPANY PROPRIETARY LIMITED
(Petition No. 7218 of 1966).ARTISAN INTERIORS PROPRIETARY LIMITED
(Petition No. 7219 of 1966).ARTISAN CORNER PROPRIETARY LIMITED
(Petition No. 7220 of 1966).ARTISAN FRAMERS PROPRIETARY LIMITED
(Petition No. 7221 of 1966).ARTISAN JOINERS PROPRIETARY LIMITED
(Petition No. 7222 of 1966).ARTISAN BRICKLAYERS PROPRIETARY LIMITED
(Petition No. 7223 of 1966).ARTISAN ELECTRICIANS PROPRIETARY LIMITED
(Petition No. 7224 of 1966).ARTISAN SANITATION PROPRIETARY LIMITED
(Petition No. 7225 of 1966).ARTISAN FENCERS PROPRIETARY LIMITED
(Petition No. 7226 of 1966).ARTISAN PLASTERERS PROPRIETARY LIMITED
(Petition No. 7227 of 1966).ARTISAN CONCRETORS PROPRIETARY LIMITED
(Petition No. 7228 of 1966).ARTISAN TILERS PROPRIETARY LIMITED
(Petition No. 7229 of 1966).ARTISAN FRAMERS PROPRIETARY LIMITED
(Petition No. 7230 of 1966).

NOTICE is hereby given that petitions for the winding up of each of the above-named companies by the Supreme Court, were on the 4th day of July, 1966, presented by James Canny, Deputy Commissioner of Taxation of the Commonwealth of Australia. And that each of the said petitions are directed to be heard before the Court, sitting at the Fourteenth Court, Law Courts, William-street, Melbourne, at the hour of 10.30 o'clock, in the forenoon, on the 19th day of August, 1966, and any creditor or contributory of the said companies or of any one of them, desiring to support or oppose, the making of orders on the said petitions, may appear at the time of hearing by himself or his counsel, for that purpose; and copies of the said petitions will be furnished to any creditor or contributory of the said companies, requiring the same by the undersigned, on payment of the regulated charge for the same.

The petitioner's official address is 436 Lonsdale-street, Melbourne.

The petitioner's solicitor is Harold Edward Renfree, Crown solicitor for the Commonwealth, of 440 Little Collins-street, Melbourne.

H. E. RENFREE.

NOTE.—Any person who intends to appear on the hearing of any one or more of the said petitions must serve on or send by post to the above-named H.E. Renfree, notice, in writing, of his intention so to do. The notice must state the name and address of the person, or, if a firm, the name and address of the firm, and must be signed by the person or firm, or his or their solicitor (if any), and must be served or, if posted, must be sent by post in sufficient time to reach the above-named not later than 4 o'clock in the afternoon of the 18th day of August, 1966. 2683

Companies Act 1961.

CENTERCLIME PTY. LTD.

NOTICE OF MEETING OF CREDITORS OR CONTRIBUTORIES.

NOTICE is hereby given that a meeting of the creditors of Centerclime Pty. Ltd. will be held at the office of Bruce Fordham, chartered accountant, 170 Toorak-road, South Yarra, on Monday, the 8th August, 1966, at 10 a.m., for the purpose of considering the company's affairs, the company having convened an Extraordinary General Meeting of its members to be held on the same day and for the purpose of considering and, if thought fit, passing a Special Resolution that the company be wound up voluntarily.

Dated this 8th day of July, 1966.

2675 W. H. SMITH, Director.

In the Supreme Court of Victoria.—1966 Co. No. 7210.—In the matter of the Companies Act 1961, and in the matter of REID MURRAY ACCEPTANCE LIMITED.

NOTICE is hereby given that by an Order dated 28th June, 1966, made in the above matter the Supreme Court of Victoria has directed a separate meeting to be convened of the persons, who on 28th June, 1966, were registered as holders of debenture stock issued by the above-named company and still outstanding for the

purpose of considering and if thought fit approving (with or without modification) a scheme of arrangement proposed to be made between the company and its creditors, and that such meeting will be held at the Town Hall, South Melbourne, on 30th August, 1966, at 10.30 a.m., at which place and time all such persons are requested to attend.

Notice of the said meeting together with—

- (1) copies of the said scheme of arrangement, the statement required to be furnished pursuant to section 182 of the Companies Act, the explanatory statement of the receivers of the company and a statement by The Equity Trustees Executors and Agency Company Limited and Equity Nominees Limited; and
- (2) a form of proxy applicable to the said meeting are being sent to all such persons at the last address of each such person as shown in the register of holders of debenture stock issued by the company but copies of all the documents referred to above including forms of proxy may be inspected and obtained at the registered office of the company, 403 Bourke-street, Melbourne, by any such person.

Every such holder of debenture stock may vote in person at the said meeting or may appoint another person (whether a holder of debenture stock or not) as his proxy to vote in his stead. In the case of joint holders the vote of the senior, who tenders a vote whether in person or by proxy will be accepted to the exclusion of the votes of the other joint holders and for this purpose seniority will be determined by the order in which the names stand in the register of holders of debenture stock.

The form of proxy may be taken by the proxy for a holder of debenture stock to the said meeting. Alternatively if a holder of debenture stock does not arrange that a proxy attend for him the form appointing a proxy should be delivered to or posted to arrive at the registered office of the company, situated at 403 Bourke-street, Melbourne, addressed to the Secretary of the company, not later than 12 noon on 26th August, 1966, or handed to the Chairman, at the meeting at which it is to be used.

By the said Order the Court has appointed Reginald Wilfrid Ellis, or failing him Kenneth Burwood Holder to act as Chairman of the said meeting and has directed the Chairman to report the result of the said meeting to the Court.

The said scheme of arrangement will be subject to the subsequent approval of the Court, which may make such alterations and attach such conditions thereto as it thinks fit.

Dated the 7th day of July, 1966.

Reid Murray Acceptance Limited,
F. G. ROSENBROCK, Secretary.

2684

The Companies Act 1961.

**PLUTO TRADING COMPANY (VICTORIA)
PROPRIETARY LIMITED (IN VOLUNTARY LIQUIDATION).**

NOTICE is hereby given that at an Extraordinary Meeting of the members of the above-named company held on Monday, the 11th day of July, 1966, it was resolved that the company be wound up voluntarily and at a meeting of creditors held on the same day it was resolved that for such purpose John Kenneth Hall, chartered accountant, of 260 Queen-street, Melbourne, be appointed liquidator.

Notice is also given that after 21 days from this date I shall proceed to distribute the assets. All creditors having any claim against the company should furnish particulars of same by that date; otherwise, I shall proceed to distribute the assets, without regard to their claim.

Dated this 18th day of July, 1966.

J. K. HALL, Liquidator.
Hall & Rose, chartered accountants, 260 Queen-street,
Melbourne, C.I. 2672

The Companies Act 1961.—In the matter of RAWLINGS BROS. PRY. LTD.—Notice re Meeting of Creditors, pursuant to Section 260.

NOTICE is hereby given that a Meeting of Creditors of the above-named company will be held at the offices of Kennedy, Small & Middlemiss, 296 Little Lonsdale-street, Melbourne, at 2.30 p.m., on the 8th day of August, 1966, the company having convened a meeting of its members for the same day for the purpose of considering a Resolution that the company be wound up voluntarily.

Dated this 14th day of July, 1966.

M. SACHS, Director.
Kennedy, Small & Middlemiss, 296 Little Lonsdale-street,
Melbourne. 2676

In the Supreme Court of Victoria.—1966 Co. No. 7210.—In the matter of the Companies Act 1961, and in the matter of Reid Murray Acceptance Limited.

NOTICE is hereby given that by an Order dated 28th June, 1966, made in the above matter the Supreme Court of Victoria has directed a separate meeting to be convened of the persons, who are unsecured creditors of the above-named company (other than)—

- (a) persons who are or may be unsecured creditors by virtue of their being holders of debenture stock issued by the company; and
- (b) persons who are or may become creditors in respect of liabilities incurred by the receivers of the company after 10th January, 1963)

for the purpose of considering and if thought fit approving (with or without modification) a scheme of arrangement proposed to be made between the company and its creditors and that such meeting will be held at the Town Hall, South Melbourne, on 30th August, 1966, at 12 noon (or as soon afterwards as the meeting of holders of debenture stock issued by the company to be held at 10.30 a.m. on that day shall have concluded) at which time and place all such persons are requested to attend.

Notice of the said meeting together with—

- (1) copies of the said scheme of arrangement, the statement required to be furnished pursuant to section 182 of the Companies Act and the explanatory statement of the receivers of the company; and
- (2) a form of proxy applicable for the said meeting

are being sent to all such persons at the last address of each such person known to the company, but copies of all the documents referred to above including forms of proxy may be inspected and obtained at the registered office of the company, 403 Bourke-street, Melbourne, by any such person.

Every such unsecured creditor may vote in person at the said meeting or may appoint another person (whether a creditor of the company or not) as his proxy to vote in his stead.

The form of proxy may be taken by the proxy for an unsecured creditor to the said meeting. Alternatively, if an unsecured creditor does not arrange that a proxy attend for him the form appointing the proxy should be delivered or posted to arrive at the registered office of the company, 403 Bourke-street, Melbourne, addressed to the Secretary of the company, not later than 12 noon on 26th August, 1966, or handed to the Chairman at the meeting at which it is to be used.

By the said Order the Court has appointed Reginald Wilfrid Ellis or failing him Kenneth Burwood Holder to act as Chairman of the said meeting and has directed the Chairman to report the result of the said meeting to the Court.

The said scheme of arrangement will be subject to the subsequent approval of the Court, which may make such alterations and attach such conditions thereto as it thinks fit.

Dated the 7th day of July, 1966.

Reid Murray Acceptance Limited,
2685 F. G. ROSENBROCK, Secretary

The Companies Act 1961.

**PLUTO TRADING COMPANY PROPRIETARY LIMITED
(IN VOLUNTARY LIQUIDATION).**

NOTICE is hereby given that at an Extraordinary Meeting of the members of the above-named company held on Monday, the 11th day of July, 1966, it was resolved that the company be wound up voluntarily and at a meeting of creditors held on the same day it was resolved that for such purpose John Kenneth Hall, chartered accountant, of 260 Queen-street, Melbourne, be appointed liquidator.

Notice is also given that after 21 days from this date I shall proceed to distribute the assets. All creditors having any claim against the company should furnish particulars of same by that date; otherwise, I shall proceed to distribute the assets, without regard to their claim.

Dated this 18th day of July, 1966.

J. K. HALL, Liquidator.
Hall & Rose, chartered accountants, 260 Queen-street,
Melbourne, C.I. 2673

NOTICE TO CREDITORS.

PURSUANT to the *Trustee Act 1958*, notice is hereby given that all persons having claims against the estate of George Brady, late of 27 Charlotte-street, Richmond, in the State of Victoria, storeman, deceased (who died on the 14th day of November, 1965, and letters of administration, with the will annexed, of whose estate was granted by the Supreme Court of the said State, in its probate jurisdiction, on the 9th day of June, 1966, to National Trustees, Executors and Agency Company of Australasia Limited, of 95 Queen-street, Melbourne, in the said State), are hereby required to send particulars, in writing, of such claims to Francis Carlisle Madigan, the manager of the said National Trustees, Executors and Agency Company of Australasia Limited, at its above-mentioned address, on or before the 31st day of October, 1966, after which date the said company will proceed to distribute the assets of the said George Brady, deceased, which shall have come to its hands amongst the persons entitled thereto, having regard only to the claims of which it shall then have had notice. And notice is hereby further given that the said company will not be liable for the assets so distributed, or any part thereof, to any person of whose claim it shall not have had notice as aforesaid.

JOSEPH LYNCH & WINDOW, of 299 Bridge-road, Richmond, solicitors for the said National Trustees, Executors and Agency Company of Australasia Limited. 2697

NOTICE is hereby given that all persons having claims against the estate of Leslie Howard Carne, formerly of 26 Mitchell-street, Bentleigh, but late of 11 Galtum-avenue, Bentleigh, in the State of Victoria, accountant, deceased (who died on the 25th day of January, 1965, and probate of whose will was granted by the Supreme Court of the said State in its Probate Jurisdiction on the 16th September, 1965, to Arthur Frederick Carne, formerly of 303 Centre-road, Bentleigh, clerk, but now of 1 George-street, Warragul, in the said State, assistant manager), are hereby required to send particulars, in writing, of such claims to the said Arthur Frederick Carne, care of the under-mentioned solicitors, on or before the 17th day of August, 1966, after which date the said Arthur Frederick Carne will proceed to distribute the assets of the said Leslie Howard Carne, deceased, which shall have come to his hands amongst the persons entitled thereto, having regard only to the claims of which he shall then have had notice.

And notice is hereby further given that the said Arthur Frederick Carne will not be liable for the assets so distributed or any part thereof to any person of whose claim he shall not have had notice as aforesaid.

Dated this 14th day of July, 1966.

REGINALD C. BUTLER & CO., of 312 Centre-road, Bentleigh, proctor for the said Arthur Frederick Carne. 2661

CREDITORS, next of kin and others having claims against the estate of Frederick Martin Herbert, formerly of 5 Cairnes-crescent, Brighton Beach, but late of "Lotus Lodge", Nepean Highway, Rosebud, gentleman, deceased (who died on the 5th day of March, 1966), are required by Fay Elaine Sleeman, of Launching Place, married woman, the administratrix of his estate to send particulars of their claims to her care of the under-mentioned solicitors by the 21st day of September, 1966, after which date she will distribute the assets of his estate, having regard only to claims of which she then has notice.

STRUGNELL & STRUGNELL, solicitors, 106 Bell-street, Coburg. 2688

HUGH VICTOR MCKAY, late of 401 Collins-street, Melbourne, in the State of Victoria, grazier, DECEASED.

CREDITORS, next of kin and others having claims in respect of the estate of the deceased (who died on the 17th January, 1966), are required by The Union-Fidelity Trustee Company of Australia Limited, of 100 Exhibition-street, Melbourne, Cecil Newton McKay, of 401 Collins-street, Melbourne, company director, Hugh Victor McKay, of "Jindalee", Henty, New South Wales, grazier, and Ian Malcolm McKay, of "Bucki", Henty, New South Wales, grazier, the applicants for a grant of administration, to send particulars of their claims to the said applicants, in the care of the said company, by 20th September, 1966, after which date they will convey or distribute the assets having regard only to the claims of which they then have notice.

HEDDERWICK, FOOKES & ALSTON, 103 William-street, Melbourne. 2679

ALFRED BUDD, late of 33 Clive-street, Footscray, in the State of Victoria, retired butcher, DECEASED.

CREDITORS, next of kin and others having claims in respect of the estate of the deceased (who died on the 7th day of November, 1962), are required by the executors, Alfred William Budd, of 33 Clive-street, Footscray, in the said State, bookbinder, and Norman Budd, of 12 Beresford-street, Pascoe Vale South, in the said State, meatworker, to send particulars of them, care of the under-mentioned solicitors, by the 8th day of September, 1966, after which date the executors may convey or distribute the assets, having regard only to the claims of which they then have notice.

MICHAEL NIALL & CO., solicitors, 360 Collins-street, Melbourne. 2681

CREDITORS, next of kin and others having claims in respect of the estate of Mary Goldsmith Neagle, late of 26 Elstone-avenue, Niddrie, widow, deceased (who died on the 17th day of April, 1966), are to send particulars of their claims to the executor, Herbert John Neagle, care of the undersigned, by the 23rd day of September, 1966, after which date he will commence to distribute the assets, having regard only to the claims of which he then has notice.

RENNICK & GAYNOR, solicitors, 473 Bourke-street, Melbourne. 2682

CREDITORS, next of kin and others having claims in respect of the estate of Josephine Florence Moore, late of St. Joseph's Home, St. Georges-road, Northcote, retired clerk, deceased (who died on the 5th day of June, 1966), are to send particulars of their claims to the executor, Hubert O'Brien, of 37 Queen-street, Melbourne, solicitor, by the 23rd day of September, 1966, after which date he will distribute the assets, having regard only to the claims of which he then has notice.

MAHONY, O'BRIEN & DUGGAN, solicitors, 37 Queen-street, Melbourne. 2716

ROBERT EDWARD FLEMING-WATT, late of Eastern Hostel, Yallourn, in the State of Victoria, trades assistant, DECEASED.

CREDITORS, next of kin and others having claims in respect of the estate of the deceased (who died on the 2nd day of April, 1965), are required by the executor, Ewen James Cameron, of 125 North-road, Yallourn North, in the said State, crane driver to send particulars to his solicitors, Messrs. F. X. O'Halloran, Davis & Co., Kirk-street, Moe, by the 20th day of September, 1966, after which date the executor may convey or distribute the assets, having regard only to the claims of which she then has notice.

Dated the 12th day of July, 1966.

F. X. O'HALLORAN, DAVIS & CO., solicitors, Moe.

2616

CREDITORS, next of kin and others having claims in respect of the estate of Amy Frances Lancaster, late of Gracedale Private Hospital, Sefton-place, East Camberwell, in the State of Victoria, pensioner (who died on the 17th day of August, 1963), are to send particulars of their claims to the Perpetual Executors and Trustees Association of Australia Limited, of 100-104 Queen-street, Melbourne, the executor to whom probate of the will of Arthur Henry Stevens, late of 23 Brunswick-street, Fitzroy, in the said State, deceased was granted (the said Arthur Henry Stevens being the executor to whom probate of the will of the said Amy Frances Lancaster was granted), by the 22nd day of September, 1966, after which date it will distribute the assets, having regard only to the claims of which it then has notice.

TREVAKS, HAVYATT & STEWARD, solicitors, 472 Bourke-street, Melbourne. 2628

ROBERT JAMES BURNS, late of Shady Creek-road, Darnum.

CREDITORS, next of kin and others having claims in respect of the estate of the deceased (who died on 30th September, 1965), are required by the trustees, Colin Robert Burns, of Sand-road, Longwarry, railway employee, and Arthur James Burns, of Springvale-road, Springvale South, contractor, to send particulars to their care of the undersigned solicitors, by the 22nd day of September, 1966, after which date the trustees may convey or distribute the assets, having regard only to the claims of which they then have notice.

GRAY, FRIEND & LONG, solicitors, Warragul. 2629

CREDITORS, next of kin and others having claims in respect of the estate of Sydney Horace Seagrave Outtrim, formerly of the Commercial Travellers' Club, Melbourne, but late of Mount Royal Geriatric Home, Royal Park, in the State of Victoria, retired warehouseman, deceased (who died on the 30th day of March, 1966), are to send particulars of their claim to The Union-Fidelity Trustee Company of Australia Limited, of 100 Exhibition-street, Melbourne, or Charles Robert Strangward, of 455 Glen Eira-road, Caulfield, in the said State, by 26th September, 1966, after which date the executors will distribute the assets in the said estate, having regard to the claims of which they then have notice.

ELLISON, HEWISON & WHITEHEAD, solicitors, 421 Bourke-street, Melbourne. 2678

CREDITORS, next of kin and others having claims in respect of the estate of Grace Carrick Bauld, late of 29 Bayview-road, Seddon, widow, deceased (who died on the 18th day of March, 1966), are requested by the executor, John William McCarthy, of 12 Adaleigh-street, Yarraville, electrician, to send particulars of their claims to the executor, care of the undersigned solicitors, by the 21st day of September, 1966, after which he will distribute the assets, having regard only to the claims of which he then has notice.

FREDERICK OWEN AND ASSOCIATES, solicitors, 84 William-street, Melbourne. 2680

THOMAS HENRY CHESSUN, formerly of 18 Bendle-street, East Geelong, but late of 1 April-close, Bitterne, Southampton, gentleman, DECEASED.

CREDITORS, next of kin and others having claims in respect of the estate of the said deceased (who died 5th May, 1965), are required by the executors of the will, Ivan James Lewis, and Charles Vickers-Willis, both of 189 Moorabool-street, Geelong, solicitors, to send particulars to them, care of the undersigned solicitors, by 22nd September, 1966, after which date the said executors may convey or distribute the assets, having regard only to the claims of which they then have notice.

WIGHTON & McDONALD, solicitors, 189-191 Moorabool-street, Geelong. 2631

FRANCIS HENRY KEANE DAVIS, late of 208 Autumn-street, Geelong West, retired office manager, DECEASED.

CREDITORS, next of kin and others having claims in respect of the estate of the said deceased (who died 4th December, 1965), are required by the executrices of the will, Doris Eugene Davis, of 208 Autumn-street, Geelong West, widow, Elizabeth May Wightwick, of 108 Bangaroot-street, North Balgowlah, New South Wales, married woman, and Noreen Margaret Davis, of Flat 4, 29 Fairway Nedlands, Western Australia, spinster, to send particulars to them, care of the undersigned solicitors, by 22nd September, 1966, after which date the said executrices may convey or distribute the assets, having regard only to the claims of which they then have notice.

WIGHTON & McDONALD, solicitors, 189-191 Moorabool-street, Geelong. 2632

CREDITORS, next of kin and others having claims in respect of the estate of John Rohan Walsh, formerly of 52A Burrindi-road, Caulfield, but late of 30 Jean-street, McKinnon, gentleman, deceased (who died on the 8th April, 1966), are required to send particulars of such claims, in writing, to National Trustees Executors and Agency Company of Australasia Limited, at its registered office, at 95 Queen-street, Melbourne, before 20th September, 1966, after which date the said company will distribute the assets, having regard only to the claims of which it then has notice.

DOYLE & KERR, solicitors, 108 Queen-street, Melbourne. 2666

CREDITORS, next of kin and others having claims in respect of the estate of Leslie Clarence Colin Gange (also known as Clarence Leslie Colin Gange, Clarence Gange and Clarrie Gange) late of 193 Tooronga-road, Glen Iris, gentleman, deceased (who died on the 30th day of May, 1964), are to send particulars of their claims to Roy Laurence Ross Gange, in care of Frank C. Hulls & Co., of 414 Bourke-street, Melbourne, the executor to whom probate has been granted, by the 23rd day of September, 1966, after which date he will distribute the assets, having regard only to the claims of which he then has notice.

FRANK C. HULLS & CO., barristers and solicitors, 414 Bourke-street, Melbourne, C.1. 2667

CREDITORS, next of kin and others having claims against the estate of Edward Parker, late of Nilma North, farmer, deceased (who died on 5th day of May, 1966), are requested to send particulars of their claims to The Union-Fidelity Trustee Company of Australia Limited, of 100 Exhibition-street, Melbourne, the executor appointed by deceased's will by the 28th day of September, 1966, after which date it will distribute the assets, having regard only to the claims of which it shall then have had notice.

M. DAVINE & CO., solicitors, Warragul. 2696

JOHN FRANCIS KENNEDY, late of 54 Park-street, Hamilton, in the State of Victoria, garage employee, DECEASED, intestate.

CREDITORS, next of kin, and others having claims in respect of the estate of the deceased, are required by the administratrix, Jean Elizabeth Kennedy, to send particulars to her care of the under-mentioned solicitors, by the 21st September, 1966, after which date the administratrix may convey or distribute the assets, having regard only to the claims of which she then has notice.

CAMERON & LOWENSTERN, solicitors, 62 Thompson-street, Hamilton. 2698

WILLIAM HENRY MATTHEWS, late of Heywood, in the State of Victoria, retired farmer, DECEASED.

CREDITORS, next of kin, and others having claims in respect of the estate of the deceased (who died on the 21st day of November, 1965), are required by the executors, George Richard James Berryman (in the will called George Richard Berryman), and Claude Charles Henry Moore, to send particulars to them, care of the under-mentioned solicitors, by the 21st day of September, 1966, after which date the executors may convey or distribute the assets, having regard only to the claims of which they then have notice.

CAMERON & LOWENSTERN, solicitors, Box 413, Hamilton. 2699

BEATRICE MAY FROST, late of Heywood, in the State of Victoria, widow, DECEASED.

CREDITORS, next of kin, and others having claims in respect of the estate of the deceased (who died on the 5th January, 1966), are required by the executor, Ernest Edward Bond, to send particulars to him, care of the under-mentioned solicitors, by the 21st September, 1966, after which date the executor may convey or distribute the assets, having regard only to the claims of which he then has notice.

CAMERON & LOWENSTERN, solicitors, 62 Thompson-street, Hamilton. 2700

ELIZABETH ATHERTON, formerly of McCrae, but late, of Neerim North, widow.

CREDITORS, next of kin and others having claims in respect of the estate of the deceased (who died on 2nd February, 1966), are required by the trustee William Harvey Atherton, of Neerim North, farmer, to send particulars to him, care of the under-signed solicitors, by the 22nd day of September, 1966, after which date the trustee may convey or distribute the assets, having regard only to the claims of which he then has notice.

GRAY FRIEND & LONG, solicitors, Warragul. 2637

MARY HARRINGTON MANLEY, formerly of Coalville, but late of 31 Earsfield-road, Hampton, widow.

CREDITORS, next of kin and others having claims in respect of the estate of the deceased (who died on 19th September, 1965), are required by the trustee James Gordon MacDonald Manley, of Thorpdale, farmer, to send particulars to him, care of the under-signed solicitors, by the 22nd day of September, 1966, after which date the trustee may convey or distribute the assets, having regard only to the claims of which he then has notice.

GRAY FRIEND & LONG, solicitors, Warragul. 2638

JOHN HART, late of Swan Hill, in the State of Victoria, retired orchardist, DECEASED (who died on 6th May, 1966).

CREDITORS, next of kin and all other persons having claims against the estate of the deceased are required by the executor of the will, Ada May Hart, to send particulars to her care of the undersigned on or before the 14th day of October, 1966, after which date she will distribute the assets, having regard only to the claims of which she then has notice.

GARDEN & GREEN, solicitors, 4 McCallum-street, Swan Hill. 2656

WILLIAM JAMES REID, formerly of Ellenbank, but late of The Manse, St. James, retired farmer.

CREDITORS, next of kin and others having claims in respect of the estate of the deceased (who died on 16th November, 1965), are required by the trustees Dorothy Margaret White, of St. James, married woman, and Maurice William Reid, of 173 Sutton-street, Warragul, retired farmer, to send particulars to them, care of the under-signed solicitors, by the 22nd day of September, 1966, after which date the trustees may convey or distribute the assets, having regard only to the claims of which they then have notice.

GRAY FRIEND & LONG, solicitors, Warragul. 2639

WILLIAM HENRY BORRIDGE, late of Willowvale, grazier, DECEASED.

CREDITORS, next of kin and others having claims in respect of the estate of the deceased (who died on the 17th day of July, 1965), are required by the executor Bertram Mason, to send particulars to him, care of the under-mentioned solicitors, by the 30th day of September, 1966, after which date he may convey or distribute the assets, having regard only to the claims of which he then has notice.

BUCKLAND & NEVETT, solicitors, Camperdown. 2660

VINCENT JOHN HAZLEDINE, late of 27 (in the will shown as 265) Barkly-street East Brunswick, retired Government Servant, DECEASED.

CREDITORS, next of kin and others having claims in respect of the above-named deceased (who died on the 11th March, 1966), are required by the executor National Trustees Executors and Agency Company of Australasia Limited, of 95 Queen-street, Melbourne, to send particulars to the said company, at its address aforesaid, by the 22nd day of September, 1966, after which date the said executor may convey or distribute the assets, having regard only to the claims of which it then has notice.

BERNARD NOLAN, 595 Bourke-street, Melbourne, solicitor. 2665

EDWARD HUDSON, late of 16 Veronica-street, Croxton, in the State of Victoria, engine driver, DECEASED, intestate (who died on the 21st day of October, 1965).

CREDITORS, next of kin and all other persons having claims against the estate of the deceased are required by the administratrix, Margaret Hudson, to send particulars to her care of the undersigned on or before fourteen (14) clear days from the date of the publication of this notice after which date she will distribute the assets, having regard only to the claims of which she then has notice.

GRAEME STEINFORT & CO., solicitors, 580 High-street, Thornbury. 2662

FLORENCE JANE BECK, late of Nyah West, in the State of Victoria, widow, DECEASED (who died on 27th February, 1966).

CREDITORS, next of kin and all other persons having claims against the estate of the deceased are required by the executor of the will, George Frederick Beck, to send particulars to him, care of the undersigned on or before the 14th day of October, 1966, after which date he will distribute the assets, having regard only to the claims of which he then has notice.

GARDEN & GREEN, solicitors, 4 McCallum-street, Swan Hill. 2657

In the will of RUBY ELIZABETH WALTERS, late of 19 Queen-street, Blackburn, married woman, DECEASED.

CREDITORS, next of kin and others having claims in respect of the estate of the deceased (who died on the 2nd day of February, 1966), are required by the trustee, The Equity Trustees, Executors and Agency Company Limited, of 472 Bourke-street, Melbourne, to send particulars to it by the 28th day of September, 1966, after which date the Trustee may convey or distribute the assets, having regard only to the claims of which it then has notice. And notice is hereby given that The Equity Trustees, Executors and Agency Company Limited will not be liable for the assets so distributed or any part thereof to any person of whose claim it shall not have had notice as aforesaid.

Dated the 13th day of July, 1966.

H. E. SHEPHERD, LL.B., of 70 South-parade, Blackburn. The solicitor for The Equity Trustees, Executors and Agency Company Limited. 2668

MARGUERITE IRENE CARTY, formerly of Eventide Lutheran Home for the Aged, Ballarat-road, Hamilton, in the State of Victoria, but late of 36 Skene-street, Hamilton, in the said State, widow, DECEASED.

CREDITORS, next of kin, and others having claims in respect of the estate of the deceased (who died on the 8th September, 1965), are required by the executors, Richard Oliphant Carty, and Thomas David Carty, to send particulars to them, care of the under-mentioned solicitors by the 21st September, 1966, after which date the executors may convey or distribute the assets, having regard only to the claims of which they then have notice.

CAMERON & LOWENSTERN, solicitors, Box 413, Hamilton. 2701

MARIA CECILIA BEATRICE BRIMACOMBE, late of 3 Glead-street, Horsham, in the State of Victoria, spinster, DECEASED.

CREDITORS, next of kin, and others having claims in respect of the estate of the deceased (who died on the 12th February, 1966), are required by the executors, Jean Mary Smith, and Francis Scott Boyle, to send particulars to them, care of the under-mentioned solicitors, by the 21st September, 1966, after which date the executors may convey or distribute the assets, having regard only to the claims of which they then have notice.

CAMERON & LOWENSTERN, solicitors, Box 413, Hamilton. 2702

CREDITORS, next of kin, and others having claims in respect of the estate of Henry Edgar Kimpton, late of 53 Union-street, Northcote, gentleman, deceased (who died on the 3rd May, 1966), are to send particulars of their claims to The Equity Trustees, Executors and Agency Company Limited, of 472 Bourke-street, Melbourne, by the 6th day of October, 1966, after which date it will distribute the assets, having regard only to the claims of which it then has notice.

LEACH & THOMSON, solicitors, 472 Bourke-street, Melbourne. 2703

HORACE COX (also known as Horace Alcock), late of 145 Stawell-street, Richmond, driver, DECEASED.

CREDITORS, next of kin, and others having claims in respect of the estate of the deceased (who died on 27th May, 1966), are required by the trustee, Roy Clive Hopetoun Beattie, of 61 Union-street, Malvern, solicitor, to send particulars to him by 24th September, 1966, after which date he may convey or distribute the assets, having regard only to the claims of which he then has notice.

R. C. H. BEATTIE, solicitor, 509 Collins-street, Melbourne. 2704

CREDITORS, next of kin, and others having claims in respect of the estate of Raszka Cebon, also known as Razka Cebon, late of 444 Dandenong-road, Caulfield, widow, deceased (who died on the 11th day of September, 1965), are requested to send particulars of such claims to the executor, Leon Cebon, care of the undersigned, on or before the 30th day of September, 1966, after which date the said executor may convey or distribute the assets, having regard only to the claims of which he then has notice.

RONALD STEWART, McINTOSH & CO., solicitors, of 422 Collins-street, Melbourne. 2705

CREDITORS, next of kin and all other persons having claims in respect of the estate of Merlyn Selina Cooper, also known as Merline Seline Cooper, late of 191 Rathmines-road, East Hawthorn, in the State of Victoria, widow, deceased (who died on the 10th day of February, 1966), are to send particulars of their claims to The Equity Trustees Executors and Agency Company Limited, of 472 Bourke-street, Melbourne, by the 12th day of October, 1966, after which date it will distribute the assets, having regard only to the claims of which it then has notice.

HAINES, BLAKIE & POLITES, solicitors, 150 Queen-street, Melbourne. 2711

CREDITORS, next of kin, and others having claims in respect of the estate of Edmund Alexander McRae, late of 29 Cascade-street, North Balwyn, manufacturer, deceased (who died on the 19th January, 1966), are required to send particulars of their claims to the executors, care of the under-mentioned solicitor, by the 23rd day of September, 1966, after which date the executors will distribute the assets, having regard only to the claims of which they then have notice.

K. P. REES, B.A., LL.B., solicitor, 89 Queen-street, Melbourne. 2712

CREDITORS, next of kin, and others having claims in respect of the estate of Margaret Mary Weir, late of 405 Mont Albert-road, Mont Albert, in the State of Victoria, spinster, deceased (who died on the 24th day of February, 1966), are to send particulars of their claim to The Union-Fidelity Trustee Company of Australia Limited, of 100 Exhibition-street, Melbourne, or John Munro Whitehead, of 421 Bourke-street, Melbourne, in the said State, by 26th September, 1966, after which date the executors will distribute the assets in the said estate, having regard to the claims of which they then have notice.

ELLISON, HEWISON & WHITEHEAD, solicitors, 421 Bourke-street, Melbourne. 2713

PATRICK JOHN MCGUINNESS, late of 27 Vasey-avenue, Lalor, publisher's assistant, DECEASED (who died on the 21st day of January, 1966).

CREDITORS, next of kin and all other persons having claims against the estate of the deceased are required by the executor, The Trustees, Executors and Agency Company Limited, of 401 Collins-street, Melbourne, to send particulars of their claims to the said company on or before the 21st day of September, 1966, after which date the said company will distribute the assets, having regard only to claims of which it then has notice.

HOME, WILKINSON & LOWRY, solicitors, 401 Collins-street, Melbourne. 2714

ALDYTH BISSET LONGMORE, late of 71 Broadway, East Camberwell, spinster, DECEASED.

CREDITORS, next of kin and others having claims in respect of the estate of the deceased (who died on the 16th day of March, 1966), are required by The Perpetual Executors and Trustees Association of Australia Limited, of 100-104 Queen-street, Melbourne, to send particulars of their claims to the said company by the 21st September, 1966, after which date it will convey or distribute the assets, having had regard only to the claims of which the company then has notice.

TOLHURST, DRUCE & EMMERSON, solicitors, 357 Little Collins-street, Melbourne. 2677

CREDITORS, next of kin and others having claims in respect of the estate of William Orestes Silverlock, late of 35 Downshire-road, Elsternwick, gentleman, deceased (who died on the 13th day of April, 1966, and probate of whose will has been granted to John Orestes Silverlock, of 124 Mount View-road, Briar Hill, tipstaff, and William Lawrence Silverlock, of 313 McKinnon-road, McKinnon, engineer), are required to send particulars of their claims to the said executors, care of the under-mentioned solicitors, by the 22nd day of September, 1966, after which date they will distribute the assets, having regard only to the claims of which they then have notice.

PEARCE & WEBSTER, solicitors, of 430 Little Collins-street, Melbourne. 2669

HILDA LILIAN CAMERON, late of 8 Federal-street, Williamstown, spinster, DECEASED.

CREDITORS, next of kin and others having claims in respect of the estate of the deceased (who died on the 1st day of May, 1966), are required by The Perpetual Executors and Trustees Association of Australia Limited, of 100-104 Queen-street, Melbourne, to send particulars of their claims to the said company by the 28th day of September, 1966, after which date it will convey or distribute the assets, having had regard only to the claims of which the company then has notice.

HENDERSON & BALL, solicitors, 430 Little Collins-street, Melbourne. 2670

MIDGLEY ARTHUR PAGE, formerly of 305 McKinnon-road, McKinnon, but late of Flat 3, No. 271 Grange-road, Ormond, manager, DECEASED.

CREDITORS, next of kin and others having claims in respect of the estate of the deceased (who died on the 14th November, 1965), are required by the executrix of the will of the deceased, Clarice Sylvia Page, of Flat 3, No. 271 Grange-road, Ormond, widow, to send particulars of such claims to the said executrix, addressed to the care of the undersigned, on or before the 28th day of September, 1966, after which date the executrix will proceed to distribute the assets of the said deceased amongst the persons entitled thereto, having regard only to the claims of which she then has notice.

D. CONDON & CO., solicitors, 83 William-street, Melbourne. 2674

CREDITORS, next of kin and others having claims in respect of the estate of Mary Agnes Chalk, late of 8 McPherson-avenue, Carnegie, in the State of Victoria, home duties, deceased, intestate (who died on the 15th February, 1941), are to send particulars of their claims to Mary Ellen Ebstein, of Flat 3, 89 Mathoura-road, Toorak, in the State of Victoria, married woman, the administratrix de bonis non, by the 14th September, 1966, after which date the said administratrix will distribute the assets, having regard only to the claims of which she shall then have notice.

H. L. YUNCKEN & YUNCKEN, solicitors, of 443 Little Collins-street, Melbourne. 2671

CREDITORS, next of kin and others having claims in respect of the estate of Arthur William Frederick Richards, late of 44 Lynch-street, Footscray, rubber worker (who died on the 24th day of March, 1966), are to send particulars of their claims to the administrator, The Equity Trustees, Executors and Agency Company Limited, of 472 Bourke-street, Melbourne, on or before the 22nd day of September, 1966, after which date the administrator will distribute all assets, having regard only to the claims of which notice has been received.

MARTIN & MARTIN, solicitors, 37 Queen-street, Melbourne. 2715

In the Supreme Court of the State of Victoria.

SALE BY THE SHERIFF.

ON Monday, the 29th of August, 1966, at 10 a.m., at the Police Station, Croydon (unless process be stayed or satisfied).

All the estate and interest (if any) of Phyllis Margaret Moyes and Stephen Frank Moyes, both of Mount Dandenong-road, Montrose, engineers, as joint proprietors of an estate in fee-simple in the land described in certificates of title, volume 6903, folio 449; volume 7291, folio 187, and volume 7379, folio 716, upon which is erected a weatherboard dwelling, galvanized iron workshop and single-fronted fibro-cement workshop.

The property, which has a frontage of 239 ft. 6 in., to Mount Dandenong-road, Montrose, commencing on the eastern side of Patricia-avenue, consists of lots 144, 145, 146, 147, 148 and part of lot 143, Mount Dandenong-road.

Registered mortgage No. C.98443 affects the said estate and interest.

Terms: Cash only.

N. FROGLEY, Sheriff's Officer.

13th July, 1966. 2709

In the Supreme Court of the State of Victoria.

SALE BY THE SHERIFF.

ON Monday, the 29th day of August, 1966, at 10 a.m., at the Police Station, Parkdale (unless process be stayed or satisfied).

All the estate and interest (if any) of Giffard Cedric Wyatt, of 32 Clare-street, Mordialloc, film processor, as joint proprietor with Marjorie May Wyatt, married woman, of an estate in fee-simple in the land described in certificate of title, volume 8203, folio 739, upon which is erected a five-roomed weatherboard dwelling house known as No. 32 Clare-street, Mordialloc.

Registered mortgage No. A600417 affects the said estate and interest.

Terms: Cash only.

DAVID J. JOHNSTON, Sheriff's Officer.

12th July, 1966. 2710

In the Supreme Court in the State of Victoria.

SALE BY THE SHERIFF.

ON Monday, the 22nd day of August, 1966, at 3 p.m., at the Police Station, Shepparton (unless process be stayed or satisfied):—

All the estate and interest (if any) of Helen Beaton, of 15 Michel-street, Shepparton, married woman, as proprietor of an estate in fee-simple in the land described in certificate of title, volume 8476, folio 326, upon which is erected a dwelling house, situated at the corner of Michel and Pearce streets, Shepparton. Registered mortgage No. C.169718 affects the said estate and interest.

Terms: Cash only.

R. L. HARRINGTON, Sheriff's Officer.

11th July, 1966. 2634

IMPOUNDINGS

COLERAINE.—Impounded in Coleraine Pound, by Henery McKenery of Coleraine.

No 79. Romney Marsh ram, aged, yoke on neck, no visible brand or ear mark

Impounded by Corinish Partnership, from Austral Park.

No. 80. Merino ewe weaner, tip off near ear, no visible brand

If not claimed and expenses paid, to be sold on 25th July, 1966.

2617—\$2.20
GEO. SPONG,
Poundkeeper.

CUDGEES.—Impounded in Cudgees Pound, on July 11th 1966, by the Shire Ranger, Mr. Pascoe.

1 beige filly, white star on forehead, no visible brand
1 light bay gelding, white on forehead, no visible brand

If not claimed and expenses paid, to be sold on 25th July, 1966.

2641/\$1.60
MORITZ MORRIS,
Poundkeeper.

ECHUCA.—Impounded in Echuca Pound, by A. B. Burtchell, Impounding Officer.

1 billy goat, no visible brand
1 nanny goat, no visible brand

If not claimed and expenses paid, to be sold on 3rd August, 1966.

2623—\$1.60
B. CLEE,
Poundkeeper.

LAKE BENETOOK.—Impounded in Lake Benetook Pound.

1 black and white cow, branded "L" on near side
If not claimed and expenses paid, to be sold on 4th August, 1966.

2644/\$1.20
E. CURTIS,
Poundkeeper.

NUMURKAH.—Impounded in Numurkah Pound.

7 two-tooth wethers, two have notch out of right ear, other five no visible brand
1 six-tooth ewe, no visible brand
4 two-tooth ewes, no visible brand
1 full mouth ewe, no visible brand

If not claimed and expenses paid, to be sold on 5th August, 1966.

2618—\$2
G. A. TAYLOR,
Poundkeeper.

ROCHESTER.—Impounded in Rochester Pound by C.R.B. Stock Inspector from Northern Highway on 17th July, 1966.

1 crossbred wether, red N.M., blue raddle, broken back leg, broken mouth, notch bottom left ear.

If not claimed and expenses paid to be sold on 4th August, 1966.

2720—\$1.80
J. DOBIE,
Poundkeeper.

SUNBURY.—Impounded in Sunbury Pound by Shire Ranger.

2 black and white Friesian heifers, green mark on back, red S on rump

If not claimed and expenses paid, to be sold on 5th August, 1966.

2692/\$1.60
E. PHILLIPS,
Poundkeeper.

TATURA.—Impounded in Tatura Pound.

1 ewe, 1 nick out of right ear, double blue brand on back

If not claimed and expenses paid, to be sold on 28th July, 1966.

2619—\$1.20
J. H. MACTIER,
Poundkeeper.

Subordinate Legislation Act 1962.

NOTICE OF MAKING OF STATUTORY RULES.

IN pursuance of the provisions of the *Subordinate Legislation Act 1962* and the Regulations made thereunder, notice is given of the making of the following statutory rules:—

	<i>Nurses Act 1958 (No. 6328).</i>	
195/1966.	Nurses (Training) Regulations 1966	8c
	<i>Motor Boating Act 1961, Section 15.</i>	
196/1966.	Motor Boating (Shire of Barrabool Authority) Regulations 1966	8c
	<i>Milk Pasteurization Act 1958 (No. 6319).</i>	
197/1966.	Regulations Prescribing Districts	5c
	<i>Motor Car Act 1958.</i>	
198/1966.	Motor Car (Third Party Insurance) Regulations 1966	8c

Copies of these statutory rules may be purchased at the Sale of Publications Section of the Government Printing Office, located off Parliament-place, Melbourne, C.2. If ordered by mail, remittance should be addressed to "The Government Printer, Box 203, P.O., North Melbourne, N.1", and should include 5c extra for postage. If a credit account is held at this Office, no remittance is required with the mail order.

A. C. BROOKS,
Government Printer.

ACTS REPRINTED IN ACCORDANCE WITH THE AMENDMENTS INCORPORATION ACT 1958 (No. 6422), AND FOR SALE AT THE SALE OF PUBLICATIONS BRANCH OF THE GOVERNMENT PRINTING OFFICE, MACARTHUR-STREET, MELBOURNE.

No.		Price.
6189.	Acts Interpretation (Incorporating amendments up to No. 7146)	\$0.15
6191.	Administration and Probate (<i>Second Reprint</i> —Incorporating amendments up to No. 6920)	\$0.35
6194.	Agricultural Colleges Act (<i>Reprint (No. 1)</i> —Incorporating Amendments up to Act No. 7302)	\$0.12
6199.	Apprenticeship (<i>Reprint No. 1</i> , incorporating amendments up to No. 7312)	\$0.25
6209.	Boiler Inspection (Incorporating amendments up to No. 7072)	\$0.18
6210.	Building Societies Act 1958 (Incorporating Amendments up to No. 7125)	\$0.25
6218.	Children's Court (Incorporating amendments up to No. 7084)	\$0.20
6219.	Children's Welfare (Incorporating amendments up to No. 6812)	\$0.25
6220.	Clean Air (Incorporating amendments up to No. 6886)	\$0.10
6222.	Commercial Goods Vehicles (Incorporating amendments up to No. 6886)	\$0.18
6839.	Companies (Incorporating amendments up to No. 7142)	\$2.25
6839.	Companies Act 1961 (<i>Second Reprint</i> —Incorporating amendments up to No. 7332)	\$2.32
6225.	Co-operation (<i>Second Reprint</i> —Incorporating amendments up to No. 7083)	\$0.42
6226.	Co-operative Housing Societies (Incorporating amendments up to No. 7097)	\$0.40
6228.	Country Fire Authority (Incorporating amendments up to No. 7065)	\$0.40
6229.	Country Roads (Incorporating amendments up to No. 6943)	\$0.40
6231.	Crimes (Incorporating amendments up to No. 6958)	\$1.32
6236.	Dog (<i>Second Reprint</i> —Incorporating amendments up to No. 7065)	\$0.15
6242.	Employers and Employés (Incorporating amendments up to No. 6740)	\$0.18
6245.	Estate Agents (<i>Second Reprint</i>)—Incorporating amendments up to No. 7134)	\$0.38
6246.	Evidence (Incorporating amendments up to No. 6758)	\$0.35
6249.	Fences (Incorporating amendments up to No. 6550)	\$0.12
6250.	Fertilizers Act 1958 (Incorporating Amendments up to No. 7142)	\$0.18
6251.	Firearms (Incorporating amendments up to No. 6716)	\$0.22
6916.	Foreign Judgments Act 1962 (<i>Reprint No. 1</i> , including amendments made by Act No. 7332)	\$0.12

ACTS REPRINTED IN ACCORDANCE WITH THE AMENDMENTS INCORPORATION ACT 1958 (No. 6422)— <i>continued</i> .		ACTS REPRINTED IN ACCORDANCE WITH THE AMENDMENTS INCORPORATION ACT 1958 (No. 6422)— <i>continued</i> .	
No.	Price.	No.	Price.
6585. Forests (Pulpwood Agreement) (Incorporating amendments up to No. 6886)	\$0.15	6367. Settled Land (Incorporating amendments up to No. 6505)	\$0.40
6259. Gaols (Incorporating amendments up to No. 6651)	\$0.15	6368. Sewerage Districts Act (Reprint (No. 1) —Incorporating Amendments up to Act No. 7332)	\$0.62
6265. Goods (Third Reprint—Incorporating amendments up to No. 7131)	\$0.28	6651. Social Welfare (Second Reprint—Incorporating amendments up to No. 7084)	\$0.35
6270. Health (Incorporating amendments up to No. 6886)	\$1.45	6372. Soil Conservation and Land Utilization Act 1958 (Incorporating amendments up to No. 6961)	\$0.20
6274. Hospitals and Charities (Incorporating amendments up to No. 6716)	\$0.35	6375. Stamps (Second Reprint—Incorporating amendments up to No. 7142)	\$0.70
6279. Instruments (Second Reprint—Incorporating amendments up to No. 6886)	\$0.38	6375. Stamps (Third Reprint—Incorporating amendments up to No. 7359)	\$0.82
6282. Justices (Incorporating amendments up to No. 6961)	\$1.12	6377. State Electricity Commission (Incorporating amendments up to No. 7054)	\$0.50
6283. Labour and Industry (Second Reprint—Incorporating amendments up to No. 7143)	\$0.75	6379. State Savings Bank (Incorporating amendments up to No. 6886)	\$0.42
6285. Landlord and Tenant (Second Reprint—Incorporating amendments up to No. 6996)	\$0.50	6886. Subordinate Legislation (Incorporating amendments up to No. 6961)	\$0.15
6289. Land Tax (Incorporating amendments up to No. 7099)	\$0.32	6849. Town and Country Planning Act (Reprint (No. 1)—Incorporating Amendments up to Act No. 7276)	\$0.35
6291. Legal Profession Practice (Incorporating amendments up to No. 7065)	\$0.45	6399. Transfer of Land (Second Reprint—Incorporating amendments up to No. 7130)	\$0.52
6293. Licensing Act (Second Reprint—Incorporating Amendments up to No. 7054)	\$0.95	6401. Trustee (Second Reprint—Incorporating amendments up to No. 6963)	\$0.42
6577. Lifts and Cranes (Incorporating amendments up to No. 6886)	\$0.12	6879. Unclaimed Moneys (Incorporating amendments up to No. 6961)	\$0.12
6295. Limitation of Actions (Incorporating amendments up to No. 6845)	\$0.15	6653. Valuation of Land (Incorporating amendments up to No. 7019)	\$0.15
6298. Local Authorities Superannuation (Incorporating amendments up to No. 6894)	\$0.25	6413. Water (Incorporating amendments up to No. 7228)	\$1.42
6299. Local Government (Incorporating amendments up to No. 7052)	\$3.50	6414. Weights and Measures (Including amendments up to No. 6918)	\$0.32
6302. Marine Act (Incorporating Amendments up to Act No. 7350)	\$0.72	6419. Workers Compensation (Incorporating amendments up to No. 7063)	\$0.50
6309. Medical (Incorporating amendments up to No. 6837)	\$0.38		
6310. Melbourne and Metropolitan Board of Works Act 1958 (Incorporating amendments up to No. 7054)	\$0.85		
6312. Melbourne Harbor Trust Act 1958 (Reprint No. 1, incorporating amendments up to Act No. 7356)	\$0.48		
6605. Mental Health (Incorporating amendments up to No. 7135)	\$0.45		
6315. Metropolitan Fire Brigades (Incorporating amendments up to No. 6886)	\$0.28		
6317. Milk and Dairy Supervision (Incorporating amendments up to No. 6964)	\$0.40		
6318. Milk Board Act (Incorporating amendments up to No. 7093)	\$0.22		
6324. Money Lenders (Incorporating amendments up to No. 6886)	\$0.25		
6832. Motor Boating (Incorporating amendments up to No. 6961)	\$0.15		
6325. Motor Car (Incorporating amendments up to No. 6867)	\$0.65		
6326. National Parks Act 1958 (Incorporating Amendments up to No. 7275)	\$0.15		
6328. Nurses (Incorporating amendments up to No. 6716)	\$0.20		
6330. Partnership	\$0.15		
6889. Poisons (Incorporating amendments up to No. 7065)	\$0.35		
6337. Police Offences (Incorporating amendments up to No. 7145)	\$0.82		
6338. Police Regulation (Incorporating amendments up to No. 7081)	\$0.45		
6890. Probate Duty (Incorporating amendments up to No. 6970)	\$0.38		
6343. Process Servers and Inquiry Agents (Incorporating amendments up to No. 7126)	\$0.12		
6344. Property Law (Incorporating amendments up to No. 6867)	\$0.90		
6349. Public Service (Incorporating amendments up to No. 6886)	\$0.28		
6350. Public Trustee (Incorporating amendments up to No. 6961)	\$0.35		
6359. Road Traffic (Incorporating amendments up to No. 6999)	\$0.15		
6359. Road Traffic (Second Reprint—Incorporating amendments up to No. 7332)	\$0.18		
6360. Rural Finance Act (Reprint (No. 1)—Incorporating Amendments up to Act No. 7328)	\$0.12		
6846. Rural Finance and Settlement Commission Act 1961 (Reprint No. 1, incorporating amendments up to No. 7332)	\$0.20		
6975. Sale of Land Act 1962 (Reprint No. 1, incorporating amendments up to No. 7332)	\$0.18		
6363. Second-Hand Dealers	\$0.12		

FIRST NOTIFICATION OF REPRINT—

6282. Justices (Second Reprint—Incorporating amendments up to Act No. 7369)	\$1.23
6325. Motor Car (Second Reprint—Incorporating amendments up to Act No. 7361)	\$0.82

A. C. BROOKS,
Government Printer.

THE "VICTORIA GOVERNMENT GAZETTE".

SUBSCRIPTIONS.—The subscription, including postage, is \$5.50 per annum, or \$2.75 per half year, payable in advance.

Subscriptions are required for whole months, and must cover at least a half year.

Single copies are 10 cents, posted 15 cents. Subscribers do not receive the Acts of Parliament with the GAZETTE.

GAZETTES are held in stock for five years only.

PRIVATE ADVERTISEMENTS.—The charge for insertion is 20 cents per line single column, and 40 cents per line double column. The title forms one or more lines as a heading. On an average ten words make a line of single column. Every signature must likewise be counted as a line. The final words of a paragraph, though only portion of a line, must be counted as one line. Signatures (in particular) and proper names must be written very plainly in the text; ONE SIDE ONLY of each sheet of paper should be WRITTEN UPON.

All documents illegibly written will be returned unpublished, and where brands occur unprovided for by the ordinary letters of the alphabet, a worded explanatory description must be furnished.

THE VICTORIA GOVERNMENT GAZETTE is published on WEDNESDAY EVENING in each week, and Notices for insertion will be received by the Government Printer at or before ONE p.m. at ordinary rates, and late advertisements between ONE p.m. and FOUR p.m. at double rates on the day preceding the day of publication.

PAYMENTS.—Unless the advertiser has a credit account, all payments are required in advance. Remittances should be made by cheque, postal note, or money order payable to "GOVERNMENT PRINTER".

AGENTS FOR THE "VICTORIA GOVERNMENT GAZETTE"

THE following have been appointed agents to receive Advertisements and Subscriptions for the *Victoria Government Gazette*:—

- ARMSTRONG'S AGENCY, 205 Queen-street, Melbourne.
- ARNALL & JACKSON, 390 Barkly-street, Brunswick, N.10.
- BAIRNSDALE AUTHORIZED NEWSAGENCY, 132 Main-street, Bairnsdale.
- COOKE, F. R. & E. M., & SONS, 69 Bridge-street, Benalla.
- DAVIES, G. & M. V., 112 Gray-street, Hamilton.
- DAVIS, WM. (MILDURA) PTY. LTD., 126 Eighth-street, Mildura.
- DIXON'S NEWSAGENCY, 89 Firebrace-street, Horsham.
- EDGAR'S NEWSAGENCY PTY. LTD., 293 Hargreaves-street, Bendigo.
- FRANKS, H., & CO., 184 Ryrrie-street, Geelong.
- GORDON & GOTCH AUSTRALASIA LTD., 511 Little Collins-street, Melbourne.
- GULLAN'S NEWSAGENCY, 88 Bridge-street, Ballarat.
- HALES, D. & N., Henty-street, Casterton.
- HAMPTON, A. C., 243 Mitchell-street, Bendigo.
- HARSTON, PARTRIDGE & CO. PTY. LTD., 455 Little Collins-street, Melbourne.
- KYNETON GUARDIAN PTY. LTD., P.O. Box 18, Kyneton.
- LIVINGSTON'S SHEPPARTON NEWSAGENCY, 246 Wyndham-street, Shepparton.
- THE MERCANTILE EXCHANGE, 90 Queen-street, Melbourne.
- MCGILL'S AUTHORIZED NEWSAGENCY, 183-5 Elizabeth-street, Melbourne.
- PETTY, R. H. & W. M., 83 Murphy-street, Wangaratta.
- PURDIE, J., & CO., 138 Moorabool-street, Geelong.
- R. G. CARTER ADVERTISING SERVICE PTY. LTD., 26-32 King-street, Melbourne.
- SALE AUTHORIZED NEWSAGENCY, 142 Raymond-street, Sale.
- SKINNER'S AUTHORIZED NEWSAGENCY, 49-51 Franklin-street, Traralgon.
- VERNON, C. F. & H. J., 162 Bridge-road, Richmond.
- VIEW POINT AUTHORIZED NEWSAGENCY, 4 View-Point, Bendigo.

A copy of the *Gazette* filed at each place for public reference.

CONTENTS

	PAGE
Acts of Parliament on sale at the Government Printing Office	2658
Appointments	2616
Bank Holidays	2604
Contracts	2613
Government Notices	2604
Impoundings	2658
Lands	2631
Mining	2610
Notice of Making of Statutory Rules	2658
Notice to attend for Radiological Examination	2611
Orders in Council—	
Acts—Hospitals and Charities; Land; Local Government; Country Roads; Labour and Industry; Landlord and Tenant; Sewerage Districts; Dandenong Valley Authority; River Improvement; Stamps; Aborigines.	2617 et seq
Private Advertisements	2640
Proclamations	2601
Public Holidays	2603
Public Service Notices	2636
Regulations—	
Act—Teaching Service	2640
State Rivers and Water Supply Commission	2606
Tenders	2634
Transport Regulation Board—Public Hearings	2607
Waterworks Trusts	2605