



VICTORIA
GOVERNMENT GAZETTE

Published by Authority

[Registered at the General Post Office, Melbourne, for transmission by post as a newspaper.]

No. 59]

WEDNESDAY, AUGUST 10

[1966

PROCLAMATIONS

Land Act 1958.

UNALIENATED CROWN LAND AVAILABLE FOR SETTLEMENT UNDER IMPROVEMENT PURCHASE LEASES.

PROCLAMATION

By His Excellency the Governor of the State of Victoria and its Dependencies in the Commonwealth of Australia &c., &c., &c.

IN pursuance of the provisions of Section 153 of the *Land Act 1958*, I, the Governor of the State of Victoria, in the Commonwealth of Australia, by and with the advice of the Executive Council of the said State, do by this Proclamation declare the unalienated Crown lands mentioned in the subjoined schedule, to be available for settlement under improvement purchase leases.

SCHEDULE.

County.	Parish.	Allotment.	Section.	Area.	Land Valuation.
Grant	Borhoneyghurk	9j	..	A. R. P. 90 0 0 subject to survey	\$2.50 per acre

Given under my Hand and the Seal of the State of Victoria aforesaid, at Melbourne, this second day of August, in the year of Our Lord One thousand nine hundred and sixty-six and in the fifteenth year of the reign of Her Majesty Queen Elizabeth II.

(L.S.)

ROHAN DELACOMBE.

By His Excellency's Command,

JIM BALFOUR,

Minister of Lands.

GOD SAVE THE QUEEN!

Bank Holidays Act 1958.

ALTERATION OF DAY APPOINTED AS A BANK HOLIDAY.

PROCLAMATION

By His Excellency the Governor of the State of Victoria and its Dependencies in the Commonwealth of Australia, &c., &c., &c.

WHEREAS by Section 4 of the *Bank Holidays Act 1958* Thursday, the twenty-ninth day of September, 1966, shall be observed as a bank holiday throughout the municipalities mentioned in the Second Schedule to the said Act:

AND WHEREAS it is made to appear to the Governor in Council expedient that the said day should not be a bank holiday throughout the said municipalities:

NOW THEREFORE I, the Governor of the State of Victoria, in the Commonwealth of Australia, by and with the advice of the Executive Council of the said State, and in pursuance of the powers conferred by Section 7 of the *Bank Holidays Act 1958*, do by this my Proclamation declare that the said day shall not be a bank holiday throughout the said municipalities and appoint—

THURSDAY, THE 22ND DAY OF SEPTEMBER, 1966, to be a bank holiday throughout the municipalities mentioned in the Second Schedule to the *Bank Holidays Act 1958*.

Given under my Hand and the Seal of the State of Victoria aforesaid, at Melbourne, this second day of August, in the year of our Lord One thousand nine hundred and sixty-six, and in the fifteenth year of the reign of Her Majesty Queen Elizabeth II.

(L.S.)

ROHAN DELACOMBE.

By His Excellency's Command,

VANCE DICKIE,
Acting Chief Secretary.

GOD SAVE THE QUEEN!

Vermin and Noxious Weeds Acts.

SIMULTANEOUS DESTRUCTION OF NOXIOUS WEEDS.

PROCLAMATION

By His Excellency the Governor of the State of Victoria and its Dependencies in the Commonwealth of Australia, &c., &c., &c.

WHEREAS by Section 14 of the *Vermin and Noxious Weeds Act 1958*, No. 6409, it is enacted that the Governor in Council may from time to time by Proclamation specify a day being a day not less than thirty days after the publication of such proclamation from and after which any noxious weed specified in such proclamation shall be simultaneously destroyed by every owner and occupier of any land in Victoria or in any part of Victoria described in the proclamation:

Now therefore, I, the Governor of the State of Victoria, in the Commonwealth of Australia, by and with the advice of the Executive Council of the said State, do hereby specify the third day of October, One thousand nine hundred and sixty-six as the day from and after which the noxious weed, *Senecio jacobaea* L.—Ragwort—shall be simultaneously destroyed by every owner and occupier of any land in those parts of Victoria described in the Schedule hereunder.

SCHEDULE

Shire of Alberton	Shire of Traralgon
Shire of Bass	Shire of Upper Yarra
Shire of Buln Buln	Shire of Warragul
Shire of Korumburra	Shire of Woorayl
Shire of Mirboo	Shire of Colac
Shire of Morwell	Shire of Heytesbury
Shire of Narracan	Shire of Otway
Shire of Rosedale	Shire of Winchelsea
Shire of South Gippsland	

Given under my Hand and the Seal of the State of Victoria aforesaid, at Melbourne, this second day of August, in the year of our Lord One thousand nine hundred and sixty-six, and in the fifteenth year of the reign of Her Majesty Queen Elizabeth II.

(L.S.)

ROHAN DELACOMBE.

By His Excellency's Command,

JIM BALFOUR,
Minister of Lands.

GOD SAVE THE QUEEN!

GOVERNMENT NOTICES

LOCAL GOVERNMENT DEPARTMENT.

PETITION FOR PROCLAMATION OF THE SHIRE OF DONCASTER AND TEMPLESTOWE AS A CITY.

IN pursuance of the provisions of the *Local Government Act 1958*, as amended, the substance and prayer of a petition presented to His Excellency the Governor in Council in accordance with section 20 of the said Act, are published viz.:

The petition of the President, Councillors and Ratepayers of the Shire of Doncaster and Templestowe sheweth that the said municipality:

- is substantially urban in character;
- has a population of at least ten thousand inhabitants; and
- in the year ended on the thirtieth day of September last passed, yielded a revenue from general and extra rates of not less than One hundred and sixty thousand dollars (\$160,000.00).

The petitioners therefore pray that His Excellency the Governor in Council, in exercise of the powers and authorities contained in section 18 (1) (k) of the *Local Government Act 1958*, as amended, will proclaim the municipality of the Shire of Doncaster and Templestowe to be a City to be known as the City of Koonarra.

R. J. HAMER,

Minister for Local Government.

Local Government Department,
Melbourne.

LOCAL GOVERNMENT DEPARTMENT.

ORDER CONFIRMED.—CITY OF SANDRINGHAM.

THE Minister of the Crown administering the *Local Government Act 1958*, as amended, on the 1st day of August, 1966, confirmed an Order hereinafter referred to in pursuance of section 514 of the said Act namely:

An Order of the Council of the City of Sandringham made on the 22nd March, 1966, directing the compulsory taking of the land described hereunder for road purposes.

All that piece of land being part of Crown portion 13, Parish of Moorabbin, commencing at a point distant 0 deg. 15½ min. 174 ft. 3 in. and 90 deg. 12½ min. 103 feet from the intersection of the northern building line of Ludstone-street with the eastern building line of Hampton-street, Hampton; thence bearing 45 deg. 14 min. 21 ft. 2½ in., 180 deg. 15½ min. 15 feet and 270 deg. 12½ min. 15 feet to the point of commencement.

R. J. HAMER,

Minister for Local Government.

Local Government Department,
Melbourne.

DEPARTMENT OF MINES.

SUBJECT to any necessary excisions, &c., it is proposed to grant the following mining leases:—

- 8491, Mineral; William Gerrard Roache; 5a. 0r. 7p., Parish of Lorne.
8507, Mineral; Murray Valley Gypsum Pty. Ltd., 198a. 3r. 16p., Parish of Tyalla.

APPLICATIONS FOR LEASES DECLARED ABANDONED.

- 8284, Mineral; Calvin Frederick Broome; Howard Williams, John Smith, Arnold Dean Hadfield; 20a. 1r. 35p., Parish of Bungywarra.
8388, Mineral; Benjamin Freeman; 640a. 0r. 0p., Parish of Mohican.

APPLICATION FOR LEASE REFUSED.

- 8481, Mineral; William Frederick Addinsal; 25 acres, Parish of Norong.

APPLICATION FOR EXPLORATION LICENCES REFUSED.

- 36, Exploration Licence; Roland Walton; 36 square miles, County of Bogong.
44, Exploration Licence; Roland Walton; 20 square miles, Counties of Benambra and Bogong.

E. CONDON,
Secretary for Mines.

Transport Regulation Act.
TRANSPORT REGULATION BOARD.

HEARING OF APPLICATIONS.

NOTICE is hereby given that the following applications will be considered by the Transport Regulation Board at its offices at Rathdown-street, Carlton, at 10.15 a.m. on Wednesday, 24th August, 1966.

PAPPS, S. C., 222 Waverley-road, East Malvern. Two commercial passenger vehicles each with seating capacity for five (5) persons to operate as Metropolitan Taxi-cabs subject to the cancellation of Metropolitan Private Hire Car licences M.H.296 and M.H.297 at present operated from South Suburban Radio Taxis Co-operative Society Ltd. (Zone "A") in the name of the applicant.

PAPPS, R., 222 Waverley-road, East Malvern. One commercial passenger vehicle with seating capacity for five (5) persons to operate as a Metropolitan Taxi-cab subject to the cancellation of Metropolitan Private Hire Car licence M.H.295 operated from South Suburban Radio Taxis Co-operative Society Ltd. (Zone "A") in the name of the applicant.

NOTE.—The date of consideration of these applications is hereby amended from that previously published in *Government Gazette* No. 56, dated 3rd August, 1966.

Notice of any objection should be forwarded to reach the Secretary of the Board not later than Wednesday, 17th August, 1966.

B. P. KAY,
Secretary.

Exhibition Buildings, Rathdown-street, Carlton, N.3, Wednesday, 10th August, 1966.

Transport Regulation Act.
TRANSPORT REGULATION BOARD.

HEARING OF APPLICATIONS.

NOTICE is hereby given that the following applications will be considered by the Transport Regulation Board at its offices at Rathdown-street, Carlton, at 10.15 a.m. on Wednesday, 31st August, 1966.

ALTONA BUS LINES PTY. LTD., 31 Rose-street, Altona. Application for permit authority to operate any one M.O. licensed vehicle over present Route 141A (Footscray-Altona) from the Brooklyn Hostel to Altona with extension from Altona to the Brooklyn Speedway, Derrimut, only on days when small car racing events are held. Time-table and fares to be determined.

HARRISON, A. C., 10 Sheila-street, Rye. One commercial passenger vehicle (S/C. 5) to operate as a country taxi-cab at Rye.

LORD, A. W., 72 Chapman-avenue, Glenroy. Application to operate metropolitan passenger service Route 150A (Broadmeadows-Glenroy) at present operated under M.O. licences held by the applicant with the ability to extend service from the corner of Lytton and William streets, Glenroy, via Tarana-avenue, Pengana-avenue, Loongana-avenue and Kadana-street to the corner of Kadana-street and Tarana-avenue returning to normal route via Tarana-avenue. Extension to constitute one additional section, viz.: Corner Lytton and William-streets—Corner Tarana-avenue and Kadana-street. Fare for six sections to be 14c.

PLOZZA, R. D., 15 Roache-street, Kaniva. One commercial passenger vehicle (S/C. 11) to operate for the carriage of school children between Goroke-road and Kaniva under temporary arrangement with the Education Department.

SCOTCH COLLEGE, Glenferrie-road, Hawthorn. One commercial passenger vehicle with large seating capacity to operate free of charge for the carriage of students to and from inter school sporting fixtures and on excursions as and when required.

WILCOX, L., & B. ENGLISH, Hume Highway, Donnybrook. One commercial passenger vehicle (S/C. 5) to operate under private hire conditions from Donnybrook.

APPLICATION for renewal of licences as shown, by persons listed hereunder to operate under the same terms and conditions:—

BULLUMWAAL TIMBER & TRADING CO. PTY. LTD., Bullumwaal, via Bairnsdale; T.P.234.

CHOWN, B. I., 7 Grandview-avenue, Dandenong; C.T.399.

COKALIS, G., 293 Fitzroy-street, Fitzroy; M.T.4000.

DEPARTMENT OF AGRICULTURE, Dookie Agricultural College, Dookie; T.P.174.

FALLA, D. E., 192 Wood-street, Donald; T.S.209.

HUNTINGTOWER SCHOOL ASSOCIATION, Waimarie-drive, Mount Waverley; T.P.100.

HOLLANDIA SHOES (AUST.) PTY. LTD., John-street, Lilydale; T.P.160.

KRAIF, A., 134 Separation-street, North Geelong; T.P.224.

MCHARRY, N. J. & A., 23 Catherine-street, Geelong West; U.O.418.

READ & BRACK PTY. LTD., 6 Nunn-street, Benalla; C.H.424.

SOUTH WESTERN ROADWAYS PTY. LTD., 205 Raglan-parade, Warrnambool; C.O.1024, C.O.1025.

WARRNAMBOOL BUS LINES PTY. LTD., 273 Raglan-parade, Warrnambool; C.O.26, C.O.46, C.O.299, C.O.1099, C.O.1100.

WAYGARA SAWMILLING CO. PTY. LTD., P.O. Box 255, Orbost; T.P.211.

Notice of any objection should be forwarded to reach the Secretary of the Board not later than Wednesday, 24th August, 1966.

Applicants are advised that it will not be necessary to appear on the hearing date specified above, unless advised in writing by the Board.

B. P. KAY,
Secretary.

Exhibition Buildings, Rathdown-street, Carlton, N.3, Wednesday, 10th August, 1966.

Commercial Goods Vehicles Act.
TRANSPORT REGULATION BOARD.

HEARING OF APPLICATIONS.

NOTICE is hereby given that the following applications will be considered by the Transport Regulation Board at its offices at Rathdown-street, Carlton, at 10.15 a.m. on Wednesday 31st August, 1966.

ATKINSON, R., PTY. LTD., 84 Northern-road, West Heidelberg. One commercial goods vehicle (L/C. 70 cwt.) to operate: (a) Within a 50-mile radius of own premises at West Heidelberg in the course of business as "Builders"—own goods. (b) Throughout the State of Victoria as "Maintenance Contractors" solely on behalf of Moran & Cato Pty. Ltd.—tools of trade, builders' plant and equipment. (c) Within a 20-mile radius of any contract currently engaged upon or from the nearest railway station thereto—materials for use on such contract.

BAYVIEW QUARRIES PTY. LTD., 602 St. Kilda-road, Melbourne. Two commercial goods vehicles (L/C. approximately 200 cwt. each) to operate: (a) From sand pits situated within a 35-mile radius respectively from any one of own premises at Narre Warren, Berwick, Clayton, Springvale, Montrose, St. Helena, North Melbourne, Tullamarine, Lysterfield, Dandenong or Bulla to such premises only—sand. (b) From any one of own premises as defined in paragraph (a) above to consignees situated within a 35-mile radius thereof—screenings, stone dust, sand, hot asphalt and premix. (c) Within a 35-mile radius from any one of own premises as defined in paragraph (a) above—road-making plant and equipment.

BAYVIEW QUARRIES PTY. LTD., 602 St. Kilda-road, Melbourne. One commercial goods vehicle (L/C. approximately 200 cwt.) to operate within a 50-mile radius from own premises at North Melbourne in the course of business as "Premixed Concrete Manufacturers"—premixed concrete in a specially constructed agitator vehicle.

BELL BRYANT (VIC.) PTY. LTD., 352 Macaulay-road, Kensington. One commercial goods vehicle (L/C. 11 cwt.) to operate throughout the State of Victoria in the course of business as "Chemical and Dairy Machinery Manufacturers" for the purpose of installing and servicing machinery and equipment manufactured by the applicants company—tools of trade, spare parts and materials incidental to servicing and maintenance.

BENNETT, W. A., & CO. PTY. LTD., 197 High Street-road, Ashwood. Two commercial goods vehicles (L/C. 125 and 127 cwt.) to operate: (a) Within a 20-mile radius of Ashwood in the course of business as "Garden and Building Suppliers"—own goods. (b) From Castle-maine and Chewton to places within paragraph (a)—own paving slate. (c) From Bacchus Marsh to places within paragraph (a)—own river pebbles. (d) From Geelong to places within paragraph (a)—own crushed stone and honeycomb rock.

BENNETT, W. H., & SONS PTY. LTD., c/- Box 100, Colac. Application to vary the conditions of licence No. D.T. 127 (L/C. 243 cwt.) by deleting paragraph (a) and adding in lieu "from plantation landings in the Otway Forest Area to own sawmill at Deans Marsh—logs."

- BROWN, S. J.**, 16 Danien-street, Glen Waverley. One commercial goods vehicle (L/C. 8 cwt.) to operate throughout the State of Victoria in the course of business as "Sales Representative" solely on behalf of Kraft Foods Ltd.—samples of goods for exhibition to prospective purchasers only with the ability also to carry small quantities of stock display materials in association with the introduction of new products or for the purpose of replacement of obsolete or faulty products or for the interim replenishment of stock at stores subject to the condition that such goods so carried in country areas shall only be those having been initially consigned to said distribution depots by rail.
- CARLILE BROS. PTY. LTD.**, Strickland-road, Bendigo. Application to vary the conditions of licence No. D.A.807 (L/C. 63 cwt.) by adding to paragraph (b) "and the City of Ballarat".
- CENTRE ROAD TIMBER PTY. LTD.**, Peace-street, Springvale. One commercial goods vehicle (L/C. 112 cwt.) to operate within a 50-mile radius of own premises at Springvale in the course of business as "Hardware and Timber Merchants"—own goods.
- CLAVARINO, L. L., & G. N.**, Station-road, Foster. One commercial goods vehicle (L/C. 111 cwt.) to operate within a 20-mile radius of the post office at Foster—general goods.
- DOWDELL, D.**, Box 307, Benalla-road, Shepparton. One commercial goods vehicle (L/C. 134 cwt.) to operate within a 75-mile radius from own premises at Shepparton in the course of business as "House Remover" houses, sheds and outbuildings for removal and re-erection, tools of trade and equipment incidental thereto.
- ELY, A. J.**, 67 Cawkwell-street, Malvern. One commercial goods vehicle (L/C. 102 cwt.) to operate within a 70-mile radius of the premises of "The City Brick Works Pty. Ltd." at Hawthorn—bricks on behalf of the said company.
- FLOWERS, N. J.**, 112 Victoria-street, Eaglehawk. One commercial goods vehicle (L/C. 40 cwt.) to operate. (a) Within a 25-mile radius of Bendigo—general goods. (b) From properties within a 50-mile radius of Eaglehawk to own premises at Eaglehawk in the course of business as "Firewood Merchant"—own firewood.
- HARBOR, A. W., & H. K.**, Nelson-street, Numurkah. Two commercial goods vehicle (L/C. 112 and 147 cwt.) to operate: (a) Within a 25-mile radius of the post office at Numurkah—general goods. (b) From bush sites within a 50-mile radius of Numurkah to own premises at Numurkah—own firewood. (c) From the Rushworth area to own premises at Numurkah—own fence posts, stays, strainer posts, and hay shed poles as fencing supplies.
- HARRISON, R. W.**, Hart-street, Euroa. One commercial goods vehicle (L/C. 241 cwt.) to operate: 1. From forest landings in the Mt. Buller area to sawmills at Benalla—logs. 2. From Strathbogie and Boho area to sawmills at Euroa and Violet Town—logs. 3. Tractors, mill and camping gear and sawmilling equipment within a 20-mile radius of the post office at Euroa. This application replaces licence No. T.T.D.226 held by the applicant.
- HENRY HAYMES PTY. LTD.**, 6-10 Davis-street, Ballarat. One commercial goods vehicle (L/C. 6 cwt.) to operate within a 50-mile radius of own premises at Malvern and to Seymour and places *en route* and to places throughout Gippsland in the course of business as "Paint Manufacturers"—samples, display materials and small quantity of paint to replace damaged or unsaleable paint.
- HENRY'S TIMBER CO. PTY. LTD.**, 549 St. Kilda-road, Melbourne. Two commercial goods vehicles (L/C. 271 and 281 cwt.) to operate: (a) From own sawmills at Club Terrace, Cabbage Tree and Newmerella to Orbost Railway Station—sawn timber. (b) From own sawmill at Newmerella to Nowa Nowa Railway Station—sawn timber. (c) From own timber yard at Clayton to consignees and building sites within a 25-mile radius of G.P.O., Melbourne—sawn timber. (d) In the course of business as "Sawmiller and Timber Merchant" within a 25-mile radius of the G.P.O., Melbourne—own goods. (e) In the course of business as "Sawmiller and Timber Merchant" from and to places within a 25-mile radius of the G.P.O., Melbourne to and from places situated on the Mornington Peninsula own goods. (f) From Dandenong Railway Station for delivery to consignees and building sites within a 20-mile radius of the post office at Dandenong—sawn timber.
- HERON, J.**, Gordon-street, Heyfield. One commercial goods vehicle (L/C. 271 cwt.) to operate from forest landings in the Licola area to sawmills at Heyfield—mill logs. This application replaces licence No. T.T.D.232 held by the applicant.
- HOLLAND, G. A.**, Lockwood South. One commercial goods vehicle (L/C. 240 cwt.) to operate: (a) Within a 20-mile radius of the post office at Lockwood South—general goods. (b) Within a 50-mile radius of the post office specified in part (a) above in the course of business as "Baling Contractor"—tools of trade comprising tractor and baling equipment.
- HOLLOWAY, A. W., C. J., E. G. & E. I.** (trading as Holloway's Building Supplies), 49 Tallangatta-road, Wodonga. One commercial goods vehicle (L/C. 261 cwt.) to operate: (a) Within a 50-mile radius of own timber yard at Wodonga—sawn timber. (b) Within a 20-mile radius of own timber yard at Wodonga in the course of business as "Sawmillers and General Building Suppliers"—own goods. This application replaces licence No. T.T.D.242/1 held by the applicant.
- HOLM, R. C.**, 77 Upper-road, Eaglehawk. Application to vary the conditions of licence No. D.A.33471/1 (L/C. 100 cwt.) by deleting the existing conditions and adding in lieu—" (a) Within a 50-mile radius from the chief post office at Bendigo as a "Road Contractor"—road-making plant and materials. (b) Within a 25-mile radius of the chief post office at Bendigo—general goods."
- HUG, E. L.**, P.O. Box 26, Heyfield. Two commercial goods vehicles (L/C. 249 and 273 cwt.) to operate: 1. From various forest districts via Licola to various mills at Heyfield—logs. 2. Within a 50-mile radius of the post office at Heyfield—plant and equipment, materials, fertilizers, seeds, produce, feed, livestock and all other goods in connexion with primary production and agricultural pursuits. These applications replace licences numbered T.T.D.245 and T.T.D.245/3 held by the applicant.
- HUG, R. E.**, P.O. Box 26, Heyfield. One commercial goods vehicle (L/C. 244 cwt.) to operate: (a) From various forest areas in the MacAlister forest district via Licola to various mills at Heyfield—logs. (b) Within a 50-mile radius of the post office at Heyfield—plant and equipment, materials, fertilizers, seeds, produce, feed, livestock and all other goods in connexion with own primary production and agricultural pursuits. This application replaces licence No. T.T.D.245/4 held by the applicant.
- HYNES, P. & J. C.**, Tawonga South. One commercial goods vehicle (L/C. approximately 340 cwt.) to operate: (a) Within a 25-mile radius of Mt. Beauty Timber Mill at Tawonga South—logs. (b) To consignees within a 50-mile radius of Mt. Beauty Timber Mill at Tawonga South—sawn timber.
- KARI, S. O.**, 139 Williamstown-road, West Footscray. One commercial goods vehicle (L/C. 12 cwt.) to operate throughout the State of Victoria as a "Miner and Prospector"—tools of trade, rock samples, provisions and small quantity of materials incidental to own mining projects.
- KELLY, R. E., & SON**, Pilcher's Bridge, Via Bendigo. One commercial goods vehicle (L/C. 123 cwt.) to operate: (a) In the course of business as "Primary Producers" within a 50-mile radius of Pilcher's Bridge and to and from Melbourne—own goods. (b) For hire or reward within a 50-mile radius of Pilcher's Bridge—livestock. (c) For hire or reward within a 20-mile radius of Pilcher's Bridge—stock food.
- KELVINATOR AUSTRALIA LTD.**, 487 Williamstown-road, Port Melbourne. One commercial goods vehicle (L/C. 10 cwt.) to operate throughout the State of Victoria for the purpose of servicing and installing petrol pumps and petroleum dispensing equipment on behalf of Wayne Pumps Australia Limited—tools of trade, spare parts and materials incidental thereto, pumps and equipment for repair or having been repaired and for installation.
- LACKMANN, B. E.**, 376 Riversdale-road, East Camberwell. One commercial goods vehicle (L/C. 132 cwt.) to operate within a 70-mile radius of the premises of "The City Brick Works Co. Pty. Ltd." at Scoresby—bricks on behalf of the said company.
- LINDEN HAULAGE PTY. LTD.**, 42 Howard-avenue, Mount Waverley. One commercial goods vehicle (L/C. 300 cwt.) to operate under exclusive contract to the Ready Mix Concrete (Vic.) Pty. Ltd.: (a) Within a 25-mile radius from the G.P.O., Melbourne, but no further north than a 12-mile radius of the G.P.O., Melbourne, and to the Township of Bittern—stone and sand for use in the manufacture of concrete. (b) From suppliers situated within a 20-mile radius from the post office at Bittern to own premises at Bittern—sand and screenings. (c) From quarries situated within a 10-mile radius from the post office at Geelong and from pits in the You Yangs area to Ready Mixed Concrete (Vic.) Pty. Ltd., Geelong Plant—sand and screenings.

- LOBB, E., 7 Hall-road, Herne's Oak. One commercial goods vehicle (L/C. 230 cwt.) to operate from forest and private landings in the Noojee, Powelltown, Licola and Yarram areas and within a 25-mile radius of the premises of A.P.M. at Maryvale to the said premises—pulpwood.
- LUKEY-MILLER-MOULDEN AERIAL SERVICES PTY. LTD., Box 42, Derrinalum. Two commercial goods vehicles (L/C. 10 and 21 cwt.) to operate throughout the State of Victoria in the course of business as "Aerial Spraying Contractors"—tools of trade, spare parts, spraying equipment, fuel and chemicals not to exceed 10 cwt.
- MALTBY, A. C. & R. L., Lyell-street, Taradale. One commercial goods vehicle (L/C. 53 cwt.) to operate from own quarry or pits at Taradale to consignees throughout the State of Victoria in the course of business as a "Paving Slate Merchant"—own paving slate.
- MARTINO, C. & E., 474 Belmore-road, Box Hill. One commercial goods vehicle (L/C. 153 cwt.) to operate from bush sites in the Warburton and Powelltown areas which are wholly within a 50-mile radius of the mill of Australian Paper Manufacturers Ltd. at Maryvale—pulpwood to the premises of the said mill. This application replaces licence No. T.T.D.838/1 held by the applicant.
- MILES, B. J., PTY. LTD., Queen and Williamson streets, Bendigo. One commercial goods vehicle (L/C. 7 cwt.) to operate: In the course of business as "Furniture Retailer." (a) Within a 25-mile radius of own premises at Bendigo—own goods and furniture for repair or having been repaired. (b) Within a 25-mile radius of own premises at Niddrie—own goods.
- NUFARM RURAL PRODUCTS PTY. LTD., 100 McBryde-street, Fawkner. One commercial goods vehicle (L/C. 79 cwt.) to operate throughout the State of Victoria in the course of business as "Weed and Pest Control Specialists" as a tanker vehicle for the purpose of spraying at contract sites—tools of trade, spraying equipment and small quantity of chemicals for spraying on site only.
- O'HARA BROS. PLANT HIRE PTY. LTD., 19 Clarke-street, Wangaratta. One commercial goods vehicle (L/C. 8 cwt.) to operate throughout the State of Victoria in the course of business as "Earthmoving Contractors"—tools of trade and equipment incidental to own contracts.
- PEARCE, G. F., Hilgay-road, Coleraine. One commercial goods vehicle (L/C. 130 cwt. approximately) to operate within a 100-mile radius from own premises at Coleraine in the course of business as "House Remover"—houses, sheds and outbuildings for removal and re-erection, tools of trade and equipment incidental thereto.
- PEARCE, J. W., Dandenong-road, Springvale North. One commercial goods vehicle (L/C. 290 cwt.) to operate: (a) From own sawmill at Darnum to own yard at Springvale and to building sites within a 20-mile radius of the said yard at Springvale—sawn timber. (b) From forest landings within a 25-mile radius of Darnum Post Office to own sawmill at Darnum and to own sawmill at Bunyip—logs. (c) From forest landings within a 25-mile radius of Bunyip Post Office to own sawmill at Bunyip—logs. This application replaces licence No. T.T.D.507 held by the applicant.
- THE PORTLAND CO-OPERATIVE DAIRY CO. LTD., Box 260, Portland. Eight commercial goods vehicles (L/C. 73, 76, 77, 78, 101, 109, 173 and 192 cwt.) to operate: (a) From and to own factory at Portland, Heywood and Condah, being an approved secondary decentralized industry, to and from places within a 50-mile radius respectively from factory, and to and from the City of Melbourne—own goods and raw materials used in connexion with own manufacturing and processing of milk products. (b) From factory specified above to suppliers of milk and/or cream situated within a 50-mile radius from factory agency lines.
- ROACHE, W. G., 1 McAdam-crescent, Colac. One commercial goods vehicle (L/C. 147 cwt.) to operate: (a) Within a 20-mile radius of the post office at Lorne—general goods. (b) Within a 50-mile radius of own quarry and pits at Lorne—metal stones, screenings, ashes, gravel, sand, earth and own plant and equipment.
- ROCK PRODUCTS PTY. LTD., McKimmies-lane, Bundoora. One commercial goods vehicle (L/C. 166 cwt.) to operate within a 35-mile radius of own premises at Narre Warren North in the course of business as "Quarry Masters"—own quarry products and quarry plant and equipment.
- READY MIXED CONCRETE (VIC.) PTY. LTD., 501 Swanston-street, Melbourne. One commercial goods vehicle (L/C. 11 cwt.) to operate throughout the State of Victoria in the course of business as "Concrete Manufacturers"—tools of trade and materials incidental to maintenance of own equipment.
- ROWE, GAVIN & Co., 298 Coleraine-road, Hamilton. One commercial goods vehicle (L/C. 169 cwt.) to operate: (a) Within a 20-mile radius from the post office at Hamilton—general goods. (b) From places situated within a 50-mile radius from the post office at Hamilton to Rowe's Pty. Ltd. yard at Hamilton—sawn timber and firewood. This application replaces licence No. T.T.D.860 held by the applicant.
- SAVOY FOOD PRODUCTS PTY. LTD., 31-45 Sunshine-road, West Footscray. Application to vary the conditions of licence No. D.A.52286 (L/C. 43 cwt.) by adding to paragraph (a) "edible fats" and by adding to paragraph (b) "Korumburra, Yarram, Sale, Winchelsea, Camperdown, Warrnambool and Portland."
- SAVOY FOOD PRODUCTS PTY. LTD., 31-45 Sunshine-road, West Footscray. Application to vary the conditions of licence No. D.A.52286/1 (L/C. 43 cwt.) by adding to paragraph (a) "edible fats" and by adding to paragraph (b) "Seymour, Benalla, Wodonga, Kyneton and Echuca."
- SHELLY, P. E., PTY. LTD., Bacchus Marsh. One commercial goods vehicle (L/C. 10 cwt.) to operate from and to points within a 10-mile radius of the post office at Balliang to and from the Townships of Bacchus Marsh and Ballan and the City of Melbourne to the Township of Melton—general goods.
- SHEPHERD, GEO., PTY. LTD., Provost-street, North Melbourne. One commercial goods vehicle (L/C. 180 cwt.) to operate under inclusive contract to Denkavit (Aust.) Pty. Ltd., of 32 Collins-street, Melbourne, for the carriage of bulk premix for the manufacture of "Denkavit" stock feed, from Melbourne, to butter factories at Rochester, Tatura, Cobram, Shepparton, Tongala, Dumbalk and Archie's Creek.
- SIMKUS, K., 101 Coronation-street, West Footscray. One commercial goods vehicle (L/C. 138 cwt.) to operate within a 50-mile radius of the premises of Albion Reid Pty. Ltd., on behalf of the said company—hot asphalt, premix and road-making materials.
- SOUTH-WESTERN CONSTRUCTIONS (HAMILTON) PTY. LTD., Harbour-road, Portland. One commercial goods vehicle (L/C. 187 cwt.) to operate within a 50-mile radius of the post office at Hamilton—plant, the property of a contractor and required by him for use in the construction or maintenance of some specific, existing, or proposed road, street, footpath, bridge, pier, wharf, weir or channel, and also the following materials, viz., metal, stones, screenings, ashes, gravel, sand and earth.
- FITZGERALD, J. T. & V. J. (trading as Suburban Antenna Service), 5 Malta-street, West Ivanhoe. One commercial goods vehicle (L/C. 6 cwt.) to operate within a 50-mile radius from own premises at Ivanhoe in the course of business as "Television Serviceman and Installation Specialist"—television sets for repair or having been repaired, antennae for installation, tools of trade, spare parts and materials incidental thereto.
- SULLIVAN, T. R., Lot 129, Carrara-road, Rowville. One commercial goods vehicle (L/C. 16 cwt.) to operate throughout the State of Victoria as a "Spray Painter" solely on behalf of Lenatex Coatings—tools of trade, spraying equipment and small quantity of materials incidental to the completion of contracts.
- TANDURELLA, G., 7 Downing-street, North Sunshine. One commercial goods vehicle (L/C. 141 cwt.) to operate within a 50-mile radius of the premises of Albion Reid Pty. Ltd., at North Melbourne, solely on behalf of the said company—road-making, plant, hot asphalt, premix and road-making materials.
- TAYLOR, A. J., Patchewollock. One commercial goods vehicle (L/C. 60 cwt.) to operate: (a) Within a 20-mile radius from the post office at Patchewollock—general goods. (b) From and to places within the radius in paragraph (a) above, to and from places situated within a 50-mile radius from the post office at Patchewollock in the course of business as "Firewood Merchant"—own firewood and own tools of trade and equipment.
- TIMOR ENTERPRISES PTY. LTD., 33 Cosham-street, Brighton. Two commercial goods vehicles (L/C. 11 cwt. each) to operate throughout the State of Victoria in the course of business as "Boring Contractor" for the purpose of servicing and maintenance of own equipment—tools of trade, spare parts, equipment and materials incidental to such servicing and maintenance.
- TRANS-WEST HAULAGE PTY. LTD., 45 Ryrie-street, Geelong. One commercial goods vehicle (L/C. 241 cwt.) to operate: (a) From Yallourn to the premises of Australian Paper Manufacturers Ltd. at Maryvale—brown

- coal. (b) From Yallourn North Extension to the State Electricity Commission Open Cut at Yallourn North—brown coal.
- MARKER, C. J., 356 Hargreaves-street, Bendigo. One commercial goods vehicle (L/C. 5 cwt.) to operate within a 100-mile radius from the chief post office in the City of Bendigo in the course of business as "Floor Covering and Carpet Layer"—carpets and floor coverings for laying purposes only—tools of trade and materials incidental thereto, but excluding any operations to or from the City of Melbourne.
- WALKER, N. J. & O. G., Curia-street, Mansfield. One commercial goods vehicle (L/C. 279 cwt.) to operate from forest landings in the Strathbogie and Lima areas to Bamfords Mill at Euroa—logs.
- WHITE, BOB, ELECTRIX PTY. LTD., 42-46 Gordon-avenue, Geelong West. One commercial goods vehicle (L/C. 68 cwt.) to operate within a 50-mile radius of the chief post office in the City of Geelong in the course of business as "Electrical Engineers"—own goods and electrical motors and equipment for repair or having been repaired.

TOW TRUCKS.

- L. DEBON (trading as Elbon Towing Service), New Footscray-road, Footscray. One commercial goods vehicle (L/C. 75 cwt.) to operate throughout the State of Victoria as a "Tow Truck" for the purpose of lifting and carrying or towing and/or repairing wrecked or disabled vehicles—tools of trade, spare parts and materials incidental thereto.
- TRIAD AUTO SERVICE PTY. LTD., 26 Clarice-road, Box Hill South. One commercial goods vehicle (L/C. 64 cwt.) to operate throughout the State of Victoria as a "Tow Truck" for the purpose of lifting and carrying or towing and/or repairing wrecked or disabled vehicles—tools of trade, spare parts and materials incidental thereto.

APPLICATIONS for renewal of licences as shown by persons listed hereunder to operate under the same terms and conditions from the expiry shown in each case.

- ANDERSON, G. D. & D. J., "Idyllwilde", Nirranda; D.A.5215/3; 27th August, 1966; 8 cwt.
- BARASTOC PRODUCTS, 143 Queen-street, Melbourne; D.A.35805/2; 30th July, 1966; 131 cwt.
- BROWN, W. F. & J. M., 120 Latje-road, Robinvale; D.A.37673; 18th August, 1966; 246 cwt.
- D'ABACO & SONS, 6-12 Chandler-road, Noble Park; D.A.46772; 16th July, 1966; 150 cwt.
- MITCHELL & Co. PTY. LTD., 12-36 Cross-street, West Footscray; D.A.6352/2; 23rd August, 1966; 11 cwt.
- POXON, G. J. & A. M., 4 Benga-avenue, Dandenong; D.A.46829/1; 30th July, 1966; 241 cwt.
- SIDES, W. L., & SON PTY. LTD., P.O. Box 228, Clayton; D.A.28601/6; 26th May, 1966; 30 cwt.
- SIDES, W. L., & SON PTY. LTD., P.O. Box 228, Clayton; D.A.28601/7; 18th August, 1966; 74 cwt.
- SIDES, W. L., & SON PTY. LTD., P.O. Box 228, Clayton; D.A.28601/23; 1st May, 1966; 153 cwt.
- STORTI, B., (trading as Westernport Cordials), 303 White-road, Wonthaggi; D.A.2117; 31st July, 1966; 64 cwt.

RENEWAL WITH VARIATION.

MITCHELL & Co. PTY. LTD., 12-36 Cross-street, West Footscray; D.A.6352/1; 9th August, 1966; application to renew and vary the conditions of licence No. D.A.6352/1 (L/C. 7 cwt.) by deleting "Blackstone Diesel Engines" and adding in lieu "Fruit Grading Machinery".

Notice of any objections should be forwarded to reach the Secretary of the Board not later than Wednesday, 24th August, 1966.

Applicants are advised that it will not be necessary to appear on the hearing date specified above, unless advised in writing by the Board.

B. P. KAY,
Secretary.

Exhibition Buildings, Rathdown-street, Carlton, N.3, 10th August, 1966.

ERRATUM.

IN the Victoria Government Gazette No. 56 dated 3rd August, 1966, on page 2745 under the heading "Marine Act 1958 AMENDMENT OF PILOTAGE RATE" the expression "\$0.275" where twice appearing shall read "\$0.0275" and the expression "\$0.104" shall read "\$0.0104".

ERRATUM.

IN Determination No. 128 of the Police Service Board, published in the Victoria Government Gazette of the 3rd August, 1966, page 2733, under the sub-heading "Scale of Annual Salaries—Police Cadets", the expression "At sixteen years (if single)—\$2,052" should read "At sixteen years (if single)—\$1,052".

POLICE OFFENCES ACT 1958.

IN pursuance of the powers conferred upon the Chief Secretary by sub-section (3) of section 184 of the Police Offences Act 1958, I do by this notice grant exemption from compliance with sub-sections (1) and (2) of section 184 of the said Act with respect to the publication "High Citadel", distributed by Colorgrature Publications, 26-30 Flinders-street, Melbourne.

VANCE DICKIE,
Acting Chief Secretary.

Chief Secretary's Office,
Melbourne, 29th July, 1966.

Pounds Act 1958.

TOWN OF CAMPERDOWN.

TABLE of Rates to be charged for the trespass of cattle and their sustenance while impounded, fixed by the Council of the Town of Camperdown.

Description of Cattle Trespassing.	Trespass Rates.		Sustenance Fees. Amounts to be Charged Daily for Sustenance while Impounded.
	Upon Land other than Tillage Land Enclosed by a Substantial Fence.	Upon Tillage Land Enclosed by a Substantial Fence.	
	\$	\$	\$
For every sheep ..	0.03	0.10	0.10
For every goat ..	1.00	2.00	1.00
For every pig ..	1.00	2.00	1.00
For every head of other cattle	1.00	2.00	1.00
For every entire horse, bull or ram	10.00	10.00	1.00

By Order of the Council,
H. D. H. LEARMONTH,
Town Clerk.

Approved by the Governor in Council, 2nd August, 1966.—
J. COLQUHOUN, Clerk of the Executive Council.

Pounds Act 1958.

SHIRE OF SOUTH GIPPSLAND.

TABLE of Rates to be charged for the trespass of cattle and their sustenance while impounded fixed by the Council of the Shire of South Gippsland.

Description of Cattle Trespassing.	Trespass Rates.		Sustenance Fees. Amounts to be Charged Daily for Sustenance while Impounded.
	Upon Land other than Tillage Land Enclosed by a Substantial Fence.	Upon Tillage Land Enclosed by a Substantial Fence.	
	\$	\$	\$
For every sheep ..	0.03	0.10	0.10
For every goat ..	1.00	2.00	0.50
For every pig ..	1.00	2.00	1.00
For every head of other cattle ..	1.00	2.00	0.50

By Order of the Council,
J. RENNICK,
Shire Secretary.

Approved by the Governor in Council, 2nd August, 1966.—
J. COLQUHOUN, Clerk of the Executive Council.

STATE RIVERS AND WATER SUPPLY COMMISSION.

LICENCES TO DIVERT WATER AND CUT RACES, PURSUANT TO THE PROVISIONS OF THE WATER ACTS.

THE Licences as detailed hereunder to divert water and cut races have been revoked by the Governor in Council as from the date shown :—

Licence No.	Term of Licence and Commencing Date.	Name and Address of Person to Whom Licence Granted.	Source of Supply.	Date of Revocation.
60	Fifteen years from 1.7.57	Andrea Pavone, John Pavone and Peter Pavone, Gunbower	Gunbower Creek (Stony Crossing Channel)	30.6.66
141	Fifteen years from 1.7.57	Thomas Henry Forster, Patho	Gunbower Creek (Turner's Lagoon)	30.6.66
162	Fifteen years from 1.7.57	Albert Forster, Moama, N.S.W. (now held by Albert Leslie Forster, Patho)	Gunbower Creek (Turner's Lagoon)	30.6.66
178	Fifteen years from 1.7.58	Andrea Pavone, Gunbower	Gunbower Creek ..	30.6.66
226	Fifteen years from 1.7.58	Walter Douglas Russell, Echuca	Gunbower Creek (Lagoon)	30.6.66
266	Fourteen years from 1.7.59	Ross McGillivray, Gunbower (now held by John William Hunter and Bernice Elizabeth Hunter, Bamawm)	Gunbower Creek ..	30.6.66
278	Fifteen years from 1.7.58	Morton John Garner, Cohuna	Gunbower Creek ..	30.6.66
380	Fifteen years from 1.7.58	Antonio Ciancio, Gunbower	Gunbower Creek ..	30.6.66

Office of the State Rivers and Water Supply Commission, Melbourne, 9th August, 1966.

G. W. LEWIS, Secretary,
State Rivers and Water Supply Commission.

STATE RIVERS AND WATER SUPPLY COMMISSION.

LICENCES TO DIVERT WATER, PURSUANT TO THE PROVISIONS OF THE WATER ACT 1958.

THE Governor in Council has approved of the granting by the State Rivers and Water Supply Commission of licences as detailed hereunder for the term of years from the date specified in each case to the persons named in the following Schedule :—

SCHEDULE.

Licence No.	Term of Licence and Commencing Date.	Name and Address of Person to Whom Licence is to be Granted.	Source of Supply.	Area Authorized to be Irrigated Per Annum.	Volume of Water Authorized to be Diverted Per Annum.
				acres.	ac. ft.
488	Four years from 1.7.66 ..	Estate of late Clarence Arthur Thompson, Cobram	River Murray ..	7	14
549	Four years from 1.7.66 ..	Salvatore Pisasale, North Melbourne	River Murray ..	29	87
553	Four years from 1.7.66 ..	Reginald Percival Underwood and Olive Ellen Underwood, Merbein	River Murray ..	30	90
1233/523	Four years from 1.7.66 ..	Thomas Charles Williams, Torrumberry	River Murray ..	31	93
1665/541	Four years from 1.7.66 ..	Christos Kandris, and Stella Kandris, Robinvale	River Murray ..	25	75
2134/1888	Four years from 1.7.66 ..	Michael Patrick Breen, Kotupna ..	Goulburn River ..	80	160
2135	Four years from 1.7.66 ..	Alan Richard Clement, Toolamba ..	Goulburn River ..	50	100
572	Four years from 1.7.66 ..	Kathleen Margaret Hills, Wentworth, N.S.W.	River Murray (Cowananna Billabong)	3	9
2136	Four years from 1.7.64 ..	Jack Alexander Isaacs, Red Cliffs ..	River Murray ..	80	240

Office of the State Rivers and Water Supply Commission, Melbourne, 9th August, 1966.

G. W. LEWIS, Secretary,
State Rivers and Water Supply Commission.

Water Act 1958.

STATE RIVERS AND WATER SUPPLY COMMISSION.

FRANKSTON-MORNINGTON URBAN DISTRICT.

NOTICE to owners of tenements in the under-mentioned streets in the Frankston-Mornington Urban District and the private streets, lanes, courts and alleys opening thereto:—

Carrum.

- Eel Race-road (southern side), from Chevron-court to—
- (i) a point opposite lot 1, about 2 chains westerly, and
- (ii) a point opposite lot 34, about 3½ chains easterly.

Frankston.

- Alfred-place.
- Burnett-crescent, from end of existing main (opposite lot 21) to a point opposite lot 22, about 3 chains south-easterly; and thence 2 chains north-easterly from Piper-crescent.
- Coral-street, from end of existing main (opposite lot 1) to a point opposite lot 17, about ¼ chain south-easterly from Vermay-avenue.
- Corio-avenue, from Towerhill-road to a point opposite lot 6, about 3 chains north-easterly.
- Culcairn-drive, from end of existing main (opposite lot 21) to a point opposite lot 26, about 34 chains generally westerly from Hastings-road.

- Highview-road, from end of existing main (opposite lot 56) to Valley-road.
- Humphries-road, from a point opposite the north-western boundary of Overport-road to a point opposite lot 3 on lodged plan of subdivision No. 61193, about 10½ chains south-easterly.
- Kandy-court.
- Kent-grove, from Kenilworth-avenue to a point opposite lot 2, about 1½ chains south-westerly.
- Mulgra-street, from end of existing main (opposite lot 32) to a point opposite lot 7, about 6 chains south-easterly from Karina-street.
- New-street, from end of existing main (opposite lot 4) to a point opposite lot 1, about 8½ chains generally south-easterly from Overton-road.
- Nursery-avenue, from end of existing main (opposite lot 1 on plan of subdivision No. 52062) to a point opposite lot 4 on said plan of subdivision, about 8 chains generally south-easterly from Cranbourne-road.
- Overport-road (western side), from end of existing main (opposite lot 12) to a point opposite lot 11, about 6 chains north-westerly from Torrbay-court.
- Sycamore-road, from Trystania-street to a point opposite lot 200, about 8 chains south-westerly.
- Talara-court.
- The Spur, from The Ridge to a point opposite lot 5, about 1 chain southerly.

Trystania-street, from end of existing main (opposite lot 176) to Sycamore-road.

Valley-road.

Vermay-avenue—

(i) from Wangara-road to a point opposite lot 12, about 1 chain southerly, and

(ii) from Coral-street to a point opposite lot 17, about $\frac{1}{2}$ a chain northerly.

Wave-street, from end of existing main (opposite lot 40) to a point opposite lot 36, about 10 chains north-easterly from Bradshaw-street.

Wynden-drive, from end of existing main (opposite lot 10) to a point opposite lot 1 about $7\frac{1}{2}$ chains north-easterly from Bidgee-street.

Yuille-street—

(i) from Pratt-avenue to Marama-drive.

(ii) from Lyons-avenue to Jamboree-avenue.

Mornington.

Armstrong-street, from Tasma-lane to Vancouver-street.

Karina-street, from Bentons-road to a point opposite lot 67, about $13\frac{1}{2}$ chains north-westerly.

Kiandra-street, from Bentons-road to a point opposite lot 38, about 13 chains north-westerly.

Mitchell-street, from Burnett-street to a point opposite lot 58, about 2 chains north-easterly.

Octavia-street, from Empire-street to a point opposite part of Crown allotment 29, section 22, Parish of Moorooduc, about 5 chains south-easterly.

Ruth-road, from Nepean Highway to Maxwell-street.

Tasma-lane, from Armstrong-street to a point opposite lot 7 about 1 chain north-westerly.

Mt. Eliza.

Gillards-road, from Old Mornington-road to Nepean Highway.

Jacksons-road, from end of existing main opposite lot 10 to a point opposite lot 12, about 4 chains south-westerly from Watts-road.

Kenau-avenue, from Nepean Highway to a point opposite lot 4, about $1\frac{1}{2}$ chains easterly.

Kolora-crescent, from end of existing main (opposite lot 722) to a point opposite lot 817, about $7\frac{1}{2}$ chains south-westerly from Koetong-parade.

Leicester-avenue, from Nepean Highway to a point opposite lot 31, about $3\frac{1}{2}$ chains generally south-easterly.

Nepean Highway—

(i) from Stephens-road to a point opposite lot 5, about $3\frac{1}{2}$ chains generally north-easterly, and

(ii) from Gillards-road to a point opposite lot 3, about 15 chains generally north-easterly.

Ocean-grove, from end of existing main (opposite lot 2) to a point opposite lot 29, about $3\frac{1}{2}$ chains generally south-easterly from Harleston-road.

Rodborough-avenue, from end of existing main opposite lot 648 to a point opposite lot 650, about 21 chains south-easterly from Wimbourne-avenue.

Rosedale-grove, from Humphries-road to Violet-avenue.

Rothsay-avenue, from Daveys Bay-road to a point opposite lot 19, about 6 chains south-westerly.

Roy-court.

Seymour-avenue, from end of existing main (opposite lot 30) to Roy-court.

Stephens-road, from Nepean Highway to Ocean-grove.

Vue-road, fronting lots 1, 2, 3 and 4.

Walkers-road, from Humphries-road to a point opposite lot 8, about 25 chains south-westerly.

Wendy-avenue, from Nepean Highway to a point opposite lot 38, about 3 chains generally south-easterly.

Wimbourne-avenue, from end of existing main (opposite lot 462) to Rutland-avenue.

Mt. Martha.

Irvine-avenue, from end of existing main (opposite lot 6) to a point opposite lot 36, about 20 chains generally southerly from Prescott-avenue.

Leggatt-crescent, from end of existing main opposite lot 23 to a point opposite lot 9, about $11\frac{1}{2}$ chains south-westerly; and thence 8 chains south-easterly from Prescott-avenue.

Seaford.

Charles-street, from end of existing main (opposite lot 80) to a point opposite lot 125, about 5 chains easterly from Park-street.

Clovelly-parade, from end of existing main (opposite lot 292) to a point opposite lot 22, about $10\frac{1}{2}$ chains easterly from Wunalla-road.

Florida-way.

Holroyd-street, from Molesworth-street to a point opposite lot 3, about 2 chains southerly.

Lynn-street.

McCulloch-avenue, from Easton-avenue to Bardia-avenue.

Milne-avenue, from end of existing main (opposite lot 1) to a point opposite lot 6, about 4 chains southerly from Moresby-avenue.

Molesworth-street, from Holroyd-street to a point opposite lot 2, about $5\frac{1}{2}$ chains easterly from Barry-street.

Selsey-street, from end of existing main (opposite lot 1) to a point opposite lot 158, about $3\frac{1}{2}$ chains easterly from Torquay-avenue.

Torquay-avenue.

Whitby-way.

Wynnstay-road (to serve lot 111 only), from end of existing main (opposite lot 112) to a point opposite lot 111, about 10 chains easterly from Halifax-street.

The main pipe in the said streets being laid down, the owners of all tenements situated as above are hereby required, on or before the first day of October next, to cause proper pipes and stop cocks to be laid, so as to supply water within such tenements from the main pipe.

G. W. LEWIS, Secretary.

State Rivers and Water Supply Commission.

Melbourne, 29th July, 1966.

Land Settlement Act.

PRELIMINARY NOTICE OF COMPULSORY ACQUISITION.

TAKE notice that by virtue of the powers contained in the Land Settlement Act (No. 6534), the Governor in Council by an Order made on the ninth day of August, 1966, a copy of which appears hereunder, directed that the land described in such Order be acquired compulsorily for the purposes of the said Act.

Copy of Order of the Governor in Council made on the ninth day of August, 1966.

DIRECTION FOR ACQUISITION OF LAND BY COMPULSORY PROCESS.

WHEREAS it is provided by sub-section (1) of section 26 of the Soldier Settlement Act 1958, as extended and applied for the purposes of Part II. of the Land Settlement Act 1959 and of settlement under that Act by sub-section (1) of section 5 of that Act, that where it appears to the Governor in Council that any land proposed to be acquired for the purposes of the Land Settlement Act 1959 cannot be acquired by agreement or cannot be so acquired conveniently or at a reasonable price the Governor in Council may direct that such land be acquired compulsorily: And whereas the Rural Finance and Settlement Commission proposes to acquire for the purposes of the Land Settlement Act 1959 all that piece of land containing 79 acres 3 roods 38 perches more or less being allotment 8, Parish of Coradjiil: And whereas it appears to the Governor in Council that the said land cannot be acquired by the said Commission by agreement at a reasonable price: Now therefore His Excellency the Governor of Victoria by and with the advice of the Executive Council thereof doth by this Order direct that the said land be acquired compulsorily.

Dated at Melbourne, this 9th day of August, 1966.

M. J. CRONIN, Secretary,
Rural Finance and Settlement Commission.

ELECTION OF A MEMBER OF THE COMMITTEE OF CLASSIFIERS FOR THE SECONDARY SCHOOLS DIVISION, EDUCATION DEPARTMENT.

I HEREBY give notice, pursuant to clause 7 of Regulation 2 of the Teaching Service (Teachers Tribunal) Regulations, that it is my intention to proceed to the election of a teacher to the Committee of Classifiers for the Secondary Schools Division for the period commencing on the 1st January, 1967.

Nominations for the said election must be lodged with or delivered by post to me at the Education Department, Treasury-place, Melbourne, before noon on Monday, the 5th September, 1966.

In the event of more candidates than one being duly nominated, the poll for the said election will close at Four o'clock p.m., on Wednesday, 12th October, 1966.

R. H. BIGGS,
Returning Officer.

Treasury Buildings, Treasury-place, Melbourne, C.2, 10th August, 1966.

Hospitals and Charities Act 1958 (No. 6274),
Section forty-six.

PETITION TO INCORPORATE SEYMOUR ELDERLY
CITIZENS' HOSTEL.

IT is hereby notified in accordance with the provisions of section forty-six of Act No. 6274, that the Hospitals and Charities Commission has received a petition signed by not less than 25 contributors to Seymour Elderly Citizens' Hostel praying that the institution be incorporated under the provisions of the said Act.

The institution proposed to be incorporated will have for its objects—

- (a) To provide charitable relief to aged persons by providing permanent facilities for their daily accommodation and care within the institution, stipulating that, in premises for which a grant under the Commonwealth Aged Persons' Homes Act 1954-57 has been received, only aged persons as defined in that Act will be received;
- (b) Doing such other things which, in the Committee's opinion, will provide for the economic, social and recreational well-being of the residents.

If a counter-petition signed by an equal or greater number of contributors is not lodged with the aforesaid Commission at No. 1 Nicholson-street, Melbourne, within one calendar month of the publication of this notice, the Governor in Council may, by Order made pursuant to Act No. 6274, declare the contributors for the time being to Seymour Elderly Citizens' Hostel to be a body corporate by the name set forth in such Order.

VANCE DICKIE,
Minister of Health.

Department of Health,
Melbourne.

COMMITTEE OF ENQUIRY INTO NURSING.

SUBMISSIONS TO ENQUIRY.

THE Committee of Enquiry into Nursing appointed by the Honorable, the Minister of Health, has recently commenced its deliberations. Its terms of reference are:—

1. To assess the needs of Victorian hospitals for nurses—at present and in the immediate future.
2. To relate these needs to the numbers at present available, or likely to become available in the immediate future, considering the growth of secondary education, the entrance qualifications required for training, and the other demands for the services of those in the relevant age groups.
3. To advise on the effects on metropolitan and country hospitals of the curriculum proposed by the Victorian Nursing Council, including financial implications.
4. To recommend ways in which the training needs of nurses and the service needs of hospitals may be reconciled with the least detriment to either.

("Nurses" in this context includes the various categories of trained nurses engaged in administration nursing and teaching, student nurses, nursing aides and student nursing aides, as well as any other categories that may be envisaged;
"hospitals" in the context includes public hospitals, institutions and organizations, and private hospitals.)

As an early step in undertaking its task, the Committee invites any who wish to state their views to the Committee on any of the above matters to first forward a written outline and summary of the case they wish to present to the undersigned, care of Department of Health, 295 Queen-street, Melbourne.

At a later stage, the Committee may invite elaboration of submissions in person and discussion of views with the Committee members at one of its meetings.

J. V. O'DONOGHUE,
Secretary,
Committee of Enquiry into Nursing.

CONTRACTS ACCEPTED.—(Series 1965-66.)

VICTORIAN RAILWAYS.

10. Manufacture, supply and delivery of diesel electric locomotives at rates (Contract 62902).—The Clyde Engineering Co. Pty. Ltd.

11. Manufacture and driving steel and concrete shell piles for No. 1 and No. 2 Bridges over Dudley-street, North Melbourne at rates (Contract 62968).—Westpile Pty. Ltd.

12. Supply and delivery of one No. Yale fork lift truck model G.P.51AT50/74 5,000 lb. capacity for the amount of \$6,190.00 (Contract 62976).—Paul & Gray Pty. Ltd.

By order of the Victorian Railways Commissioners,
N. H. RASHLEIGH, Acting Secretary for Railways. 5.8.66.

PRISONERS' MEALS IN LOCK-UPS.

CONTRACT CANCELLED.

Gazette No. 53, 7th July, 1965, Prisoners' Meals, Kew, Contract No. 304, is hereby cancelled.

CONTRACT ACCEPTED.

4261. For the supply of Prisoners' Meals at Kew, Breakfast and Tea, 35 cents; Hot Dinner, 45 cents, as from 27th March, 1966.—T. J. Fry.

CONTRACTS ACCEPTED.—(Series 1966-67.)

GENERAL STORES.

Gazette No. 55, 27th July, 1966, Schedule No. 1, Printing Papers, &c.—Item Nos. 30, 32-34, 69, 70, 100, 101, 102, 108, 109, 119-122, 135, 136, 140, 146, 154, 156, 297, 319, 327-331, 333, 334, 342, 351, S77. Rates are less 1 per cent., 30 days as from 1st July, 1966. For rates shown opposite the following items, substitute the rates as set out hereunder:—Item No. 101, \$15.50 per thousand; Item No. 102, \$11.62 per thousand; Item No. 122, \$14.26 per thousand, as from 1st July, 1966.

Gazette No. 53, 19th July, 1966, Schedule No. 37, Electric Lamps, &c.—For the rates shown opposite the following items, substitute the rates as set out hereunder:—Item No. 28, \$2.17 each; Item No. 30, \$5.98 each, as from 25th July, 1966.

H. COUTTS, Secretary to the Tender Board. 9.8.66.

ORDERS IN COUNCIL.—(Series 1965-66.)

FORESTS COMMISSION.

Loan Fund Act No. 7367, Item 6, Project P.X.—

4236. To the purchase of that allotments 4, 6, and 7, Parish of Bungil East, and allotments 27b, 27g and 36, Parish of Koetong, comprising 978 acres 3 roods 32 perches, for Forest purposes, \$10,533.40.—Alexander James Müller.

Approved by the Governor in Council, 21st June, 1966.
—J. COLQUHOUN, Clerk of the Executive Council.

STATE ELECTRICITY COMMISSION.

4237. For the supply of enamelled pole danger signs and phase plates for a period of two years, to Specification No. 65-66/303A, at Schedule rates.—Victoria Foundry and Enamelling Works Pty. Ltd.

Approved by the Governor in Council, 28th June, 1966.—
J. COLQUHOUN, Clerk of the Executive Council.

4238. For the supply of mobile belt conveyors and spreaders for Metropolitan fuel depots, to Specification No. 65-66/353, \$46,930.—Munro Engineers Pty. Ltd.

4239. For the supply of galvanised pole steps for distribution poles for a period of two years, to Specification No. 65-66/337, at Schedule rates.—Mark Rollinson & Sons Pty. Ltd.

4240. For the supply of plain and machined non-ferrous castings for general connexions on bus work and equipment in terminal stations and distribution sub-stations for a period of two years, to Specification No. 65-66/247, at Schedule rates.—Specialty Non-Ferrous Foundry.

4241. For the supply of plain and machined non-ferrous castings for general connexions on bus work and equipment in terminal stations and distribution sub-stations for a period of two years, to Specification No. 65-66/247, at Schedule rates.—P. M. Jurss Pty. Ltd.

4242. For the supply of plain and machined non-ferrous castings for general connexions on bus work and equipment in terminal stations and distribution sub-stations for a period of two years, to Specification No. 65-66/247, at Schedule rates.—Johnson's Non-Ferrous Foundry.

4243. For the supply of plain and machined non-ferrous castings for general connexions on bus work and equipment in terminal stations and distribution sub-stations for a period of two years, to Specification No. 65-66/247, at Schedule rates.—Stephen Firman.

Approved by the Governor in Council, 5th July, 1966.—
J. COLQUHOUN, Clerk of the Executive Council.

4244. For the establishment of 220 kV switchgear associated with generators Nos. 7 and 8, Hazelwood Power Station Stage 4, to Specification No. 64-65/127A, \$856,998 plus items at Schedule rates.—A.E.I. Engineering Pty. Ltd.

4245. For the supply of one automatic oscillograph and accessories for fault recording, Hazelwood Power Station, to Quotation No. 3300, \$20,509.—Automatic Accessories Pty. Ltd.

4246. For the construction of concrete roads, drainage and fencing, Ringwood area centre, to Specification No. 65-66/428, at Schedule rates.—Barro's Paving Co. Pty. Ltd.

4247. For the construction of high and/or low voltage distribution lines and sub-stations for a period of two years, to Specification No. 65-66/362, at Schedule rates.—Fernando Bosco & Co.

4248. For the construction of high and/or low voltage distribution lines and sub-stations for a period of two years, to Specification No. 65-66/362, at Schedule rates.—G. M. & P. A. Duncan.

4249. For the construction of high and/or low voltage distribution lines and sub-stations for a period of two years, to Specification No. 65-66/362, at Schedule rates.—Eastern Powerlines Pty. Ltd.

4250. For the construction of high and/or low voltage distribution lines and sub-stations for a period of two years, to Specification No. 65-66/362, at Schedule rates.—N. Elliott Overhead Line Construction Pty. Ltd.

4251. For the construction of high and/or low voltage distribution lines and sub-stations for a period of two years, to Specification No. 65-66/362, at Schedule rates.—J. E. & C. Griffiths Bros.

4252. For the construction of high and/or low voltage distribution lines and sub-stations for a period of two years, to Specification No. 65-66/362, at Schedule rates.—G. Gutschlag.

4253. For the construction of high and/or low voltage distribution lines and sub-stations for a period of two years, to Specification No. 65-66/362, at Schedule rates.—K. M. Joseph & Co. Pty. Ltd.

4254. For the construction of high and/or low voltage distribution lines and sub-stations for a period of two years, to Specification No. 65-66/362, at Schedule rates.—C. J. Robertson & Co.

4255. For the construction of high and/or low voltage distribution lines and sub-stations for a period of two years, to Specification No. 65-66/362, at Schedule rates.—Northern Constructions Pty. Ltd.

4256. For the construction of high and/or low voltage distribution lines and sub-stations for a period of two years, to Specification No. 65-66/362, at Schedule rates.—M. A. Saunders & Son.

4257. For the construction of high and/or low voltage distribution lines and sub-stations for a period of two years, to Specification No. 65-66/362, at Schedule rates.—James E. Spooner.

4258. For the construction of high and/or low voltage distribution lines and sub-stations for a period of two years, to Specification No. 65-66/362, at Schedule rates.—Ian Taylor Constructions Pty. Ltd.

4259. For the supply of diesel fuel oil for stationary engines for a period of two years, to Specification No. 65-66/291, at Schedule rates.—Mobil Oil Australia Ltd.

4260. For the supply of 11,000 volt, 500 amp. single phase outdoor isolators for use in 11,000 volt distribution system for a period of two years, to Specification No. 65-66/284, at Schedule rates.—D. E. Taplin Pty. Ltd.

Approved by the Governor in Council, 12th July, 1966.—J. COLQUHOUN, Clerk of the Executive Council.

ORDERS IN COUNCIL.—(Series 1966-67.)

FORESTS COMMISSION.

Loan Fund Act No. 7367, Item 6—

396. To the purchase of that part of allotment 84, Parish of Scoresby, County of Mornington, containing 15 acres 3 roods 8 perches, for Forest purposes, \$4,000.00.—Giacomo Gargaro.

Approved by the Governor in Council, 5th July, 1966.—J. COLQUHOUN, Clerk of the Executive Council.

EDUCATION DEPARTMENT.

369. Two (2) only direct reading theodolites, for Swinburne Technical College, \$1,193.05.—National Instrument Co. Pty. Ltd.

370. One (1) only weighing scales, for Swinburne Technical College, \$411.86.—W. & T. Avery (Aust.) Pty. Ltd.

371. One (1) only dry copying machine, for Swinburne Technical College, \$312.00.—3M Company.

372. One (1) only dynamometer, for Gordon Institute of Technology, Geelong, \$4,660.00.—Westcoast Industries Pty. Ltd.

373. One (1) only low head pump unit, for Swinburne Technical College, \$480.00.—F. N. Bethune Pty. Ltd.

374. One (1) only temperature humidity recorder for timber drying kiln, for Swinburne Technical College, \$472.00.—Foxall Instruments Pty. Ltd.

375. One (1) only spot welder, for Wonthaggi Technical and High School, \$232.00.—T. Donohue.

376. Fifty-two (52) sets of electronic experimental circuit boards and storage boards, for Footscray Technical College, \$4,952.31.—Plessey Pacific Pty. Ltd., Electronics Group.

(This is in lieu of Order in Council published in the *Government Gazette* dated 6th July, 1966, in respect to this item only.)

377. One (1) only copying machine, for Royal Melbourne Institute of Technology, \$337.50.—3M Company.

378. One (1) only top loading analytical balance (200 grm. capacity), for Ballarat School of Mines, \$340.00.—Watson Victor Ltd.

379. One (1) only recording pH meter, for Ballarat School of Mines, \$527.00.—Warburton Franki Pty. Ltd.

380. One (1) only top loading analytical balance (500 grm. capacity), for Ballarat School of Mines, \$332.40.—Agta Pty. Ltd.

381. One (1) only 16-mm. film projector with external microphone and speaker, for Bendigo Technical College, \$463.48.—Sixteen Millimetre Australia.

382. One (1) only absorptiometer, for Bendigo Technical College, \$379.90.—Thomas Optical & Scientific Co. Pty. Ltd.

383. One (1) only combination epidiascope process camera and photocopier, for Bendigo Technical College, \$500.00.—Artiscope.

384. One (1) only combination saw and buzzer unit, for Melbourne School of Painting, Decorating and Sign Crafts, \$327.50.—Rotary Tools Pty. Ltd.

385. One (1) only portable silk screen drying rack, for Melbourne School of Painting, Decorating and Sign Crafts, \$280.00.—R. Collie & Co. Pty. Ltd.

386. One (1) only overhead projector and accessories, for Swinburne Technical College, \$217.05.—Nairn Audio Visual Activities.

Approved by the Governor in Council, 2nd August, 1966.—J. COLQUHOUN, Clerk of the Executive Council.

PUBLIC WORKS.

387. Belmont, State School No. 26, provision of gas heating, \$2,975.00.—The Geelong Gas Company.—(S.W.81236.)

388. Bundoora, Repatriation Mental Hospital, supply and fitting curtains, \$1,465.40.—Studio of Interiors; supply of chairs and coffee tables, \$1,834.10.—Aristoc Industries Pty. Ltd.—(N.E.89311.)

389. Melbourne, Emily McPherson College of Domestic Science, supply of master and slave clocks, &c., \$1,763.00.—Communication Systems of Australia Pty. Ltd.—(C.D.82882.)

390. Melbourne, National Museum, modifications to ventilation system, \$1,412.00.—Smith & Osborne Pty. Ltd.—(C.D.291681.)

391. Melbourne, State Public Offices Car Park, construction works, \$80,000.00.—John R. & E. Secull Pty. Ltd.—(C.39735.)

392. Melbourne, Treasury Buildings, servicing of boilers, \$1,273.45.—W. S. Atherton & Co. Pty. Ltd.—(M.78573.)

393. Mountain Gate, State School, special grant authorized by the Education Department towards the cost of erection of a canteen at the school, \$1,811.00.—Mountain Gate State School No. 4905 Committee.—(N.E.90471.)

394. Parkdale, High School, erection of party fencing, \$1,323.20.—Messrs. J. Hawkes & Son.—(S.E.50323 "E".)

395. Rosanna, State School, special grant authorized by the Education Department towards the cost of construction of playing fields at the school, \$3,000.00.—Rosanna State School No. 4568 Committee.—(N.E.37224.)

Approved by the Governor in Council, 2nd August, 1966.—J. COLQUHOUN, Clerk of the Executive Council.

Health Act 1958.

VICTORIA—DEPARTMENT OF HEALTH.

NOTICE TO ATTEND FOR RADIOLOGICAL EXAMINATION.

To all persons aged twenty-one years and over enrolled or resident in the Subdivisions specified hereunder in the State Electoral District of Brighton.

TAKE notice that you are required to attend at a Department of Health X-ray unit sited in the public street at or as near as possible to the main entrance to the premises specified in this notice, at any time between the hours specified on one of the days specified and during the period specified in respect of those premises, and thereat to submit yourself to radiological examination of the chest for the purpose of ascertaining whether you may be suffering from pulmonary tuberculosis. If you have had a chest X-ray within the last twelve months and for that reason do not wish to be examined now, you should attend the unit as directed and submit particulars of the previous examination.

SPECIFIED SUBDIVISIONS, PREMISES, PERIODS, DAYS AND HOURS.

Subdivision.	Premises.	Period.	Days.	Hours.
Brighton	(1) D'Anin's Gift Store, 43 Church-street, Brighton	Thursday, 25th August, 1966, to Thursday, 1st September, 1966 (inclusive)	Each day during the period except Saturday, Sunday and Public Holidays	From 10 a.m. to 8.30 p.m.
	(2) Cnr. Male and Church streets, Middle Brighton	Friday, 26th August, 1966 to Friday, 2nd September, 1966 (inclusive)	Each day during the period except Saturday, Sunday and Public Holidays	From 10 a.m. to 8.30 p.m.
	Cnr. Asling and Bay streets, North Brighton	Friday, 2nd September, 1966, to Wednesday, 7th September, 1966 (inclusive)	Each day during the period except Saturday, Sunday and Public Holidays	From 10 a.m. to 8.30 p.m.
	Bathing Box Sportswear, Cnr. Chelsea and St. Kilda streets, Middle Brighton	Friday, 2nd September, 1966, to Friday, 9th September, 1966 (inclusive)	Each day during the period except Saturday, Sunday and Public Holidays	From 10 a.m. to 8.30 p.m.
Hampton	Palm Beauty Salon, 617 Hampton-street, Brighton	Thursday, 8th September, 1966, to Wednesday 14th September, 1966 (inclusive)	Each day during the period except Saturday, Sunday and Public Holidays	From 10 a.m. to 8.30 p.m.
	Shopping Centre, Cnr. Ludstone and Kingston streets, Hampton	Monday, 12th September, 1966, to Wednesday, 14th September, 1966 (inclusive)	Each day during the period except Public Holidays	From 10 a.m. to 8.30 p.m.
	Shopping Centre, Cnr. Sargood-street and Linacre-road, Hampton	Monday, 12th September, 1966, to Wednesday, 21st September, 1966 (inclusive)	Each day during the period except Saturday, Sunday and Public Holidays	From 10 a.m. to 8.30 p.m.
	Municipal Library, Service-street, Hampton			

NOTE.—Any person to whom this notice applies and who without reasonable excuse fails to comply with the requirements of the notice shall be guilty of an offence, and shall be liable to a penalty of not more than Forty dollars.

Dated this twenty-first day of July, One thousand nine hundred and sixty-six.

KEVIN BRENNAN, Chief Health Officer.

Process Servers and Inquiry Agents Act 1958.

APPLICATIONS FOR LICENCES LODGED WITH CLERKS OF COURTS.

BY direction of the Chief Secretary, the subjoined lists of "new" applications for process servers and inquiry agents licences are published for general information.

Applicant.	Address.	Court.	Tentative Date of Hearing of Application.
<i>Process Servers.</i>			
Marzi, Alberto	246 Drummond-street, Carlton	Carlton	22.8.66
Sheppard, Norma Grace	65 Woodcrest-road, Vermont	Ringwood	30.8.66
Thompson, Gordon Ross	George Laurens, Murray-street, Colac	Colac	29.8.66
<i>Inquiry Agent.</i>			
Comer, Frank	Industrial Acceptance Corp. Ltd., 374 Sydney-road, Coburg	Coburg	23.8.66

Attention is directed to the provisions of the above Act and regulations thereunder relating to the lodgment of objections to applications.

Chief Secretary's Office,
Melbourne, 8th August, 1966.

E. L. RICHARDSON, Registrar,
Process Servers and Inquiry Agents.

SHIRE OF SOUTH GIPPSLAND.
ROAD DEVIATION ORDER.

PURSUANT to the provisions of sections 522 and 526 of the Local Government Act 1958, the Council of the Shire of South Gippsland hereby directs that the land in the Parish of Welshpool indicated by hatching in the diagram hereunder, which has been purchased, taken or acquired by it, shall be a public highway on and from the date of publication of this Order in the Government Gazette and declares that such land shall be a public highway in lieu of the land indicated by cross-hatching on the said diagram.

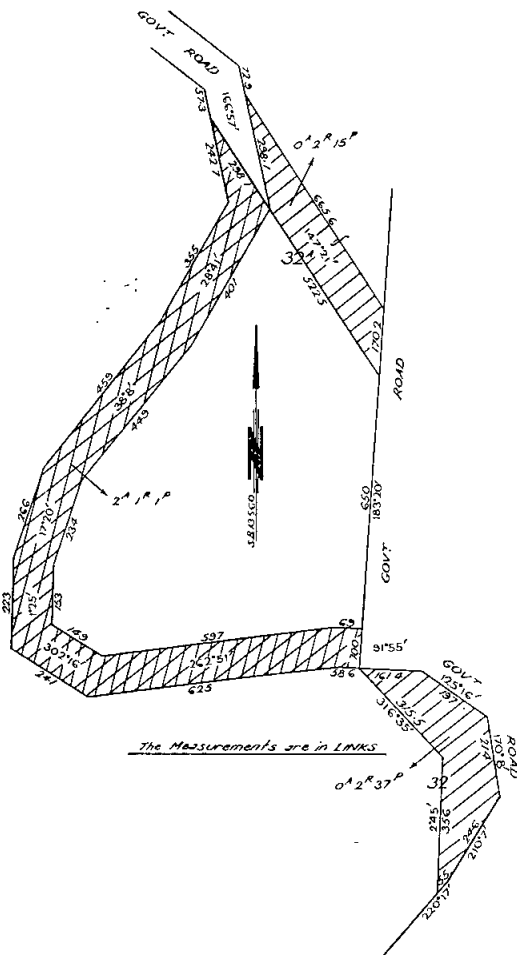

The common seal of the President, Councillors and Ratepayers of the Shire of South Gippsland was hereunto affixed this 14th day of July, 1966—

(SEAL) W. A. GALE, President.
W. B. WOOD, Councillor.
J. RENNICK, Shire Secretary.

Order confirmed by the Governor in Council, 2nd August, 1966.—J. COLQUHOUN, Clerk of the Executive Council.

SHIRE OF GLENELG.—ROAD DEVIATION ORDER.

IN pursuance of the powers conferred by sections 522 and 526 of the Local Government Act 1958 the Council of the Shire of Glenelg doth hereby direct that the land in the Parish of Killara shown hatched on the plan hereunder shall be a public highway from and after the date of publication of this Order in the Government Gazette and

doth hereby declare that such land shall be a public highway in lieu of the land in the said parish shown cross-hatched on the said plan.

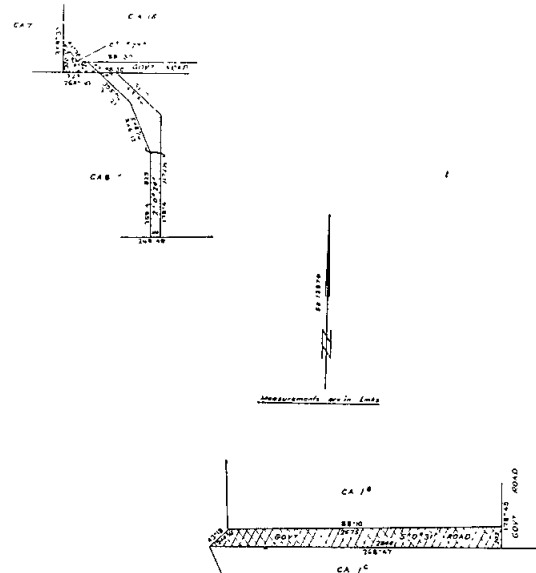

Dated this 18th day of July, 1966.

The common seal of the President, Councillors and Ratepayers of the Shire of Glenelg was hereto affixed in the presence of—

(SEAL) C. M. KOCH, President.
H. W. MITCHELL, Councillor.
J. B. HANSEN, Secretary.

Confirmed by the Governor in Council, the 2nd day of August, 1966.—J. COLQUHOUN, Clerk of the Executive Council.

PUBLIC TRUSTEE ACT 1958 (No. 6350), SECTION 17.

I HEREBY give notice that on the 25th July, 1966, the Public Trustee filed elections to administer the following deceased persons' estates in accordance with section 17 of the Public Trustee Act 1958:—

- ALLAN, DOUGLAS BERTRAM, late of 302 Forest-road, The Basin, salesman, died 19th May, 1966.
- BAKER, EWART GLADSTONE, late of Cohuna, labourer, died 2nd May, 1966.
- ELLIS, ROBERT CHARLES, late of Beechworth, labourer died 8th December, 1965.
- FRANKLIN, KENNETH, late of Stawell, invalid pensioner, died 11th April, 1966.
- MEYER, CARL ALBERT, formerly of Whitlands, but late of Beechworth, farmer, died 22nd November, 1944.
- NEWMAN, THOMAS, late of Elsie-grove, Healesville, timber worker, died 16th March, 1966.
- RICH, WILLIAM, late of 99 The Parade, Ascot Vale, cleaner, died 3rd May, 1965.

A. D. DUNCAN,
Public Trustee.

256 Flinders-street, Melbourne, C.1, 3rd August, 1966.

NOTICE.

CREDITORS, next of kin, and others having claims against the estate of any of the under-mentioned deceased persons are required to send particulars of their claims to the Public Trustee, 256 Flinders-street, Melbourne, the personal representative, on or before the 14th October, 1966, after which date the Public Trustee may convey or distribute the assets, having regard only to the claims of which the Public Trustee then has notice:—

- AITKEN, ANDREW BERTRAM, late of 13 Balmoral-street, Essendon, retired salesman, died 30th March, 1966.
- ALLAN, DOUGLAS BERTRAM, late of 302 Forest-road, The Basin, salesman, died 19th May, 1966.
- ALLIOT, FRANCOIS, formerly of Traralgon, but late of St. Vincent Val d'aosta Italy, farmer and hotel keeper, died 3rd April, 1918.
- BAKER, EWART GLADSTONE, late of Cohuna, labourer, died 2nd May, 1966.

BRETT, WALTER BYRNE, late of 29 South-crescent, South Northcote, gentleman, died 17th January, 1950.

CROMPTON, FREDERICK HUGH, late of 12A Holloway-street, Ormond, greengrocer, died 5th May, 1966.

DOBBS, JOHN JAMES, late of 11 Rutland-street, Newborough, electrical mechanic, died 23rd April, 1966.

DOWNIE, ROBERT MILTON, late of 37 Mooltan-street, Flemington, leading hand, died 4th May, 1966.

DOWNWARD, SYLVIA MARGUERITE, late of 19 Royal-road, Bonbeach, widow, died 19th May, 1966.

ELLIS, ROBERT CHARLES, late of Beechworth, labourer, died 8th December, 1965.

FAULKNER, WALTER EDWARD JOFFRE, late of 94 Kent-road, Pascoe Vale, brass founder, died 23rd April, 1966.

FRANKLIN, KENNETH, late of Stawell, invalid pensioner, died 11th April, 1966.

FRAZER, EDITH MAUDE, late of 245 Albert-street, East Brunswick, widow, died 4th August, 1965.

FROUD, VICTOR CLIFFORD DENNIS, also known as Victor Clifford Dennis Froude, formerly of 45 Selbourne Gardens, Hendon, London, England, but late of 15 Norwich-close, Sarisbury Green, Southampton, England, retired civil servant, died 3rd December, 1962.

KENYON, DAVID JORDON, late of 1 Ivanhoe-street, Glen Waverley, civil engineer, died 4th February, 1966.

MEYER, CARL ALBERT, formerly of Whitlands, but late of Beechworth, farmer, died 22nd November, 1944.

NEWAY, ARTHUR FRANKLIN, late of 99 Shannon-street, Box Hill, retired public servant, died 24th March, 1966.

NEWMAN, THOMAS, late of Elsie-grove, Healesville, timber worker, died 16th March, 1966.

RICH, WILLIAM, late of 99 The Parade, Ascot Vale, cleaner, died 3rd May, 1965.

YOXON, NEIL CRAWFORD, late of 80 Princes-street, North Carlton, carpenter, died 20th April, 1966.

A. D. DUNCAN,
Public Trustee.

Melbourne, 3rd August, 1966.

State Coal Mine Industrial Tribunal Act 1932.

AWARD No. 86.

THE State Coal Mine Industrial Tribunal in pursuance of the powers in that behalf conferred by the provisions of the State Coal Mine Industrial Tribunal Act 1932, No. 4030, and constituted as provided by the said Act and the Order in Council made thereunder hereby determines and awards as follows (that is to say).

That Award No. 78, dated 5th April, 1955, as varied, be further varied as follows:—

1. By deleting from sub-clause (a) of clause 1 the amount "£15 7s." and inserting in lieu thereof the amount "\$32.70".

2. By deleting the table appearing in sub-clause (b) of clause 1 and inserting in lieu thereof the following table:—

Award No.	Classification.	Margin per week.
		\$
1	Car Driver	9.29
2	Caretaker	7.18
3	Deputy	17.13*†
4	Dirt Inspector	14.58
5	Foreman—	
	Surface—	
	First year	24.94
	Second year	26.14
	Thereafter	27.48
	Electrical Fitter—	
	First year	24.94
	Second year	26.14
	Thereafter	27.48
	Fitter—	
	First year	24.94
	Second year	26.14
	Thereafter	27.48
	Stables	19.17
6	Gardener	9.49
7	Oversman	20.71*†
8	Sanitaryman-in-Charge	9.23
9	Storeman	12.24
10	Weighman	11.82
11	Weighbridge attendant	7.36
12	Weighbridge attendant, Railway	10.07
13	Wheeler, Boss	12.15*†

* Includes full compensation for wet pay.

† Plus an underground allowance of 15 cents per shift.

3. In clause 3—Overtime—(i) by deleting from sub-clause (c) the amount "6s." and inserting in lieu thereof the amount "60 cents". (ii) By deleting from sub-clause (d) the amount "6s." and inserting in lieu thereof the amount "60 cents".

4. By deleting from sub-clause (b) of clause 6—Travelling Time and Expenses—the amounts "1s." and "6d.", and inserting in lieu thereof the amounts "10 cents" and "5 cents" respectively.

5. In clause 7—Wet Pay—(i) by deleting from sub-clause (a) the amount "1s." and inserting in lieu thereof the amount "10 cents". (ii) By deleting from sub-clause (b) the amount "1s. 3d." and inserting in lieu thereof the amount "12.5 cents". (iii) By deleting from sub-clause (d) the amounts "1s. 3d." and "2s. 6d.", and inserting in lieu thereof the amounts "12.5 cents" and "25 cents" respectively.

6. By deleting from clause 9—Dirt Allowance—the amount "1s." and inserting in lieu thereof the amount "10 cents".

7. By deleting from clause 10—Heat Allowance—the amount "1s. 6d." and inserting in lieu thereof the amount "15 cents".

8. By deleting from clause 11—Work in Confined Spaces—the amount "3d." and inserting in lieu thereof the amount "2.5 cents".

9. By deleting from sub-clause (e) and (f) of clause 12—Bonus Payment—the amount "£1" wherever appearing and inserting in lieu thereof the amount "\$2.00".

Dated this 28th day of July, 1966.

G. L. DETHRIDGE, Chairman,
State Coal Mine Industrial Tribunal.

Approved by the Governor in Council, 2nd August, 1966.—J. COLQUHOUN, Clerk of the Executive Council.

COMPANIES ACT 1961.

NOTICE is hereby given that, in pursuance of section 308 (4) of the Companies Act 1961, the names of the Companies referred to below have been struck off the Register, and on publication of this notice in the Government Gazette the said Companies will be dissolved.

Dated this 4th day of August, 1966.

E. B. MITCHAM,
Assistant Registrar of Companies.

Companies Registration Office,
Melbourne.

COMPANIES ABOVE REFERRED TO.

Name of Company.	Number of Registration.
Conders Pty. Ltd.	A8283
George R. Ledger Pty. Ltd.	11150
R. & S. Helmer Pty. Ltd.	19353
P. Guiterman Co. (Australasia) Pty. Ltd.	19884
A. W. Dash & Co. Pty. Ltd.	20688
Buninyong Bus Lines Pty. Ltd.	21091
D. C. Plastics Pty. Ltd.	22228
K. B. S. Supplies Pty. Ltd.	27583
Cross Displays (Australia) Pty. Ltd.	30651
Plastic Packaging (Australasia) Pty. Ltd.	32448
Harvey-Bilson Pty. Ltd.	33333
S. M. Wholesalers Pty. Ltd.	33913
G. W. Investments Pty. Ltd.	35621
The Trade & Sales Promotion Company Pty. Ltd.	36867
Commercial Road T.V. Centre Pty. Ltd.	38135
Peter Hand Tobacco Co. Pty. Ltd.	38356
Joblings Investments Pty. Ltd.	38671
British-Asian Equipment Co. (Vic.) Pty. Limited	40099
Et'nea Pty. Ltd.	40101
A. Murray Cameron & Son Pty. Ltd.	41797
Fera Pty. Ltd.	42094
T. S. Southward Pty. Ltd.	42452
J. A. Edward Pty. Ltd.	42616
Rodex of London Pty. Ltd.	43880
J. A. Munday Pty. Ltd.	45037
Howitt Investments Pty. Ltd.	45064
Croydon Equities Pty. Ltd.	45636
Charter Real Estate Pty. Ltd.	48900
Palmata Enterprises Pty. Ltd.	52673
T. L. M. Enterprises Pty. Ltd.	52758
Charter Export Pty. Ltd.	54178
Charter Advisory Services Pty. Ltd.	54253
Gould Bryola Pty. Ltd.	55064
Palmata Enterprises (Lakes Entrance) Pty. Ltd.	55291
L. Fuller Aircraft Engineering Pty. Ltd.	55968
E. W. Gray Holdings Pty. Ltd.	57511
Wiloco Pty. Ltd.	57866
M. R. M. Pty. Ltd.	59015
G. & N. Rubber Pty. Ltd.	60481
Morning Star Mines N.L.	M9939

COMPANIES ACT 1961.

NOTICE is hereby given in pursuance of section 308 (2) and 308 (3) of the Companies Act 1961 that at the expiration of three months from the date hereof the names of the following Companies will, unless cause is shown to the contrary, be struck off the Register and the said Companies will be dissolved.

Dated this 5th day of August, 1966.

E. B. MITCHAM,
Assistant Registrar of Companies.

Companies Registration Office,
Melbourne.

COMPANIES ABOVE REFERRED TO.

Name of Company.	Number of Registration.
J. Hickmer & Sons Pty. Ltd.	13888
Edgcombe & Cross Pty. Ltd.	14625
Viner & Hall Pty. Ltd.	15384
Delheath Pty. Ltd.	18198
Brooklyn Memorials Pty. Ltd.	19996
Dickinson & Carnegie Pty. Ltd.	21755
Barford Holdings Pty. Ltd.	23545
Pounds (Australia) Pty. Ltd.	23970
Whitby Pty. Ltd.	23971
L'Innovation Pty. Ltd.	25925
L. & C. Noble Manufacturing Pty. Ltd.	26782
Rayden Pty. Ltd.	29030
Alexander-Eve Fashions Pty. Ltd.	30463
W. A. Dewhurst & Co. Pty. Ltd.	30720
Triangle Chair Company Pty. Ltd.	31121
A.S.P. (Vic.) Pty. Ltd.	31261
National Guarantee Corporation Pty. Ltd.	32204
Adex Pty. Ltd.	32863
Lemtex Manufacturing Co. Pty. Ltd.	33630
Raytex Manufacturing Co. Pty. Ltd.	33632
Holhamstow Pty. Ltd.	33713
C.B.C. Pty. Ltd.	34298
Alamac Pty. Ltd.	36311
Polypara Pty. Ltd.	37437
Parkside Service Station Pty. Ltd.	37478
Baruna Investments Pty. Ltd.	39073
P. & F. Cabinets Pty. Ltd.	39222
O. & J. Mantle Manufacturers Pty. Ltd.	39488
Checker Investments Pty. Ltd.	39732
F.M.E. Builders Pty. Ltd.	40800
Greenhill Estates Pty. Ltd.	41222
Keron Order Homes Pty. Ltd.	41652
World Meat Traders Pty. Ltd.	41706
Interstate Meat Supplies Pty. Ltd.	41725
Fi-Glass Industries Pty. Ltd.	41903
Multimatic Co. Pty. Ltd.	42098
Sydenham Properties Pty. Ltd.	42128
Moorabbin Squash Pty. Ltd.	42777
E. C. & C. W. Smethurst Pty. Ltd.	43228
Patras Transport Co. Pty. Ltd.	44354
A.A.C. Construction Corporation Pty. Ltd.	44550
Central Victorian Flying Services Pty. Ltd.	44753
Wimmera & Mallee Television Co. Ltd.	44817
Shor Constructions Pty. Ltd.	45151
Lord's Used Cars Pty. Ltd.	45318
Dewhurst Export & Import Co. Pty. Ltd.	45907
Jinnette & White Pty. Ltd.	46100
Multiplex Development Co. (Australia) Pty. Ltd.	46271
Shor Investments Pty. Ltd.	46405
Brighton Credit Corporation Pty. Ltd.	46748
Wholesale Meat Depots Pty. Ltd.	46898
Keron Home Units Pty. Ltd.	46923
Keron Flats Pty. Ltd.	46924
S.B.R. Services Pty. Ltd.	47188
Yurang Court Pty. Ltd.	47259
Adoxa Building Pty. Ltd.	47295
Stuart Middleton Pty. Ltd.	47351
Keron Holdings Pty. Ltd.	48258
R. S. Gillson & Associates Pty. Ltd.	48436
Broad Sites Estates Pty. Ltd.	48842
Harwick Development Co. Pty. Ltd.	48883
Marcus Products Pty. Ltd.	48890
Peter Dennis Estate Agency Pty. Ltd.	49668
I. & M. Exporters Pty. Ltd.	49938
Macman Excavations & Plant Hire Co. Pty. Ltd.	49963
Omega Investments Pty. Ltd.	51267
Blackburn Motor Body Service Pty. Ltd.	51437
Commercial Hotel (Wal Packham) Pty. Ltd.	51618
Gaybon Investments Pty. Ltd.	52401
Australian Discount Retailers Pty. Ltd.	51927
John G. Hutchinson Pty. Ltd.	52684
A.B.C. Sand Supplies Pty. Ltd.	52704
Robert Craig (Machinery) Pty. Ltd.	52803
McCormick Demonstration Units Pty. Ltd.	53232
Fund Raisers Pty. Ltd.	55301
Westvale Electrics Pty. Ltd.	55461

Name of Company.—	Number of Registration.
Border Petroleum Pty. Ltd.	56283
Ballara Investments Pty. Ltd.	56832
Lavanne Pty. Ltd.	57042
Fredland Holdings Pty. Ltd.	58042
Moreno Corporation (Vic.) Pty. Ltd.	58505
C.R.E.C. Pty. Ltd.	58609
R. M. McRostie & Co. Pty. Ltd.	58751
Scientific Advisory Services Pty. Ltd.	58820
Parktone Taxis Pty. Ltd.	58990
Unamit Pty. Ltd.	58998
E. C. & R. B. Dowell Pty. Ltd.	59822
Unamit Development Pty. Ltd.	60036
Kevin Monti Pty. Ltd.	63792
Newton Enterprises Pty. Ltd.	F3915
Phonemasters Distributors Pty. Ltd.	F3941
Dura Face Constructions Pty. Ltd.	F5490
Duraface Marketing Pty. Ltd.	F5495

NOTICE TO MARINERS.

[No 7 of 1966.]

AUSTRALIA.—VICTORIA.

PORT PHILLIP.—ARTIFICIAL REEF ESTABLISHED.

Former Notice.—No. 3 of 1965.

Position.—Mordialloc jetty light, Lat. 38 deg. 01 min. S., Long. 145 deg. 05 min. E. (approx.).

Details.—An artificial reef consisting of reinforced concrete pipes covering an area approximately 200 feet square has been established 1 cable 170 degrees from the 300 gallon red and yellow vertical striped barrel buoy located 4.3 miles 210 degrees from the above position. Depth over reef 55 feet.

Chart Affected.—B.A. 1171.

Publication.—Sailing Directions, Victoria, 1959, page 321.

A. J. WAGGLEN,
Port Officer in Victoria.

Ports and Harbors Branch,
Public Works Department,
Melbourne, C.2, 2nd August, 1966.

NOTICE TO MARINERS.

[No 6 of 1966.]

AUSTRALIA.—VICTORIA.

WESTERNPORT.

1. Lights Established—Crib Point.
2. Lights Established—Stony Point.
3. Light Extinguished—Stony Point.

1. Position.—Crib Point Triangulation Station, Lat. 38 deg. 20 min. 57 sec. S., Long. 145 deg. 12 min. 50 sec. E. (approx.).

Details.—Lights have been established at the Crib Point Refinery Jetty in the following positions from the Crib Point Triangulation Station:—

- (a) Fixed White on No. 1 Mooring Dolphin 091 deg. 26 min. distant 1,882 feet. Elevation 13 ft. 6 in. above high water, visible 2 miles.
- (b) Fixed Red on Walkway south of No. 2 Mooring Dolphin 098 deg. 44 min. distant 1,917 feet. Elevation 15 ft. 0 in. above high water visible 1 mile.
- (c) Fixed Red on No. 1 Berthing Dolphin 104 deg. 36 min. distant 2,177 feet. Elevation 15 ft. 0 in. above high water, visible 1 mile.
- (d) Two Fixed Greens vertically disposed on northern end of No. 1 Berthing Jetty 106 deg. 18 min. 30 sec. distant 2,198 feet. Elevation—Higher 31 ft. 6 in., Lower 25 ft. 6 in. above high water, visible 1 mile.
- (e) Two Fixed Greens vertically disposed on southern end of No. 1 Berthing Jetty 109 deg. 16 min. distant 2,242 feet. Elevation—Higher 31 ft. 6 in., Lower 25 ft. 6 in. above high water, visible 1 mile.

Remarks.—The transit of the two fixed Red lights bears 320 deg. 39 min. and passes eastward of the north-eastern corner of the 42-ft. dredged area a distance of 100 feet approximately normal to the transit.

2. Position.—Stony Point Triangulation Station, Lat. 38 deg. 22 min. 31 sec. S., Long. 145 deg. 13 min. 21 sec. E. (approx.).

Details.—(a) The Rear light, an Isophase White, flash 1 second, eclipse 1 second, has been established on a post on the shore at an elevation of 33 feet (10m1), 304 deg. 31 min. distant 2,721 feet from the above position. Visibility 3 miles.

(b) The Front light, a Flashing White every 6 seconds, thus—flash 2 seconds, eclipse 4 seconds—has been established on a post on the jetty 200 feet from the northern end, at an elevation of 15 feet (4m6), 052 deg. 19 min. distant 929 feet from the above position. Visibility 3 miles.

The lights in line bearing 108 deg. 00 min. lead in to the jetty through the approach channel.

Abridged Description.—

(a) Rear, Iso. 2 sec. 33 feet 3 M.

(b) Front, Fl. ev. 6 sec. 15 feet 3 M.

3. *Position.*—Stony Point Jetty Light, Lat. 38 deg. 22 min. S., Long. 145 deg. 13 min. E. (approx.).

Details.—The former jetty light flashing white every 7½ seconds in the above position is now extinguished.

Charts Affected.—B. A. Nos. 1695B, 1707, 3169, Aus. 144, 156.

Publications.—*Sailing Directions, Victoria, 1959, pages 396 and 397. Australia Pilot, Vol. II., 1956, page 111.*

A. J. WAGGLEN,
Port Officer in Victoria.

Ports and Harbors Branch,
Public Works Department,
Melbourne, C.2, 2nd August, 1966.

Melbourne and Metropolitan
BOARD OF WORKS.

NOTICE TO THE OWNERS OF TENEMENTS IN THE UNDER-
MENTIONED STREETS, AND THE PRIVATE STREETS, LANES,
COURTS AND ALLEYS OPENING THERETO.

THE main pipe in the said streets being laid down, the owners of all tenements situated as under are hereby required on or before the 12th September, 1966, to cause a proper pipe and stop cocks to be laid so as to supply water within such tenements from the main pipe.

H. J. SNADDEN,
Secretary.

2nd August, 1966.

STREET AND POSITION.

Box Hill.

Greenwood-street, from Fulton-crescent southwards 3 chains.

Broadmeadows.

Edmund-street, from King-street eastwards 7½ chains.
Macedon-avenue, from King-street to Edmund-street.
Ambrose-street, from Macedon-avenue eastwards 3 chains.

Diamond Valley.

Lower Glen Park-road, from 15½ chains north-westwards and westwards of Cedar-avenue westwards and southwards 10 chains.
Jan-court, from Plenty-lane southwards 4½ chains.

Doncaster and Templestowe.

Jeffrey-street, from 5½ chains north of Alfred-street northwards 4½ chains.
Hill View-road, from Jeffrey-street eastwards 9½ chains.

Eltham.

Flint-street, from Bolton-street eastwards 7½ chains.

Footscray.

Cain-street, from Nicholson-street westwards 1½ chains.

Heidelberg.

Mark-street, from Martins-lane to Castleton-road.
Castleton-road, from Mark-street eastwards 2½ chains.
Castleton-road, from Mark-street westwards 3 chains.
Lenola-street, from Greensborough-road to Watson-street.
Watson-street, from Lenola-street southwards 1½ chains.

Keilor.

Rose Hill-road, from Rose-avenue south-eastwards 2½ chains.
Rose-avenue, from Rose Creek-road to Rose Hill-road.

Moorabbin.

Blackwood-avenue, from Broome-avenue northwards 7½ chains.
Genoa-street, from Chesterville-road westwards 9½ chains.
Marrbridge-street, from Genoa-street to Hector-court.
Hector-court, from Marrbridge-street westwards 4½ chains.
Ranleigh-court, from Marrbridge-street westwards 4½ chains.
Warrigal-road, from Mills-street to Bernard-street.
Warrigal-road, from McGuire-street to Wren-road.
Chesterville-road, from 6 chains north of Highview-road northwards 4½ chains.

Prahran.

Jubilee-street, from Union-street southwards 2½ chains.

Springvale.

Jacks-avenue, from 4 chains west of Pauline-crescent, westwards 5½ chains.

Sunshine.

Little-street, from 3½ chains north of Laming-road northwards 7½ chains.
Soame-street, from Little-street to Station-street.
Station-street, from Soame-street northwards 1½ chains.
Station-street, from Soame-street southwards 2 chains.

Waverley.

Koonalda-avenue, from 2 chains west of Lochinvar-road to Winmalee-drive.
Winmalee-drive, from Koonalda-avenue north-westwards 8½ chains.
Winmalee-drive, from Koonalda-avenue south-eastwards 4½ chains.
Torbreck-street, from Winmalee-drive westwards 8½ chains.
Fraser-street, from Winmalee-drive northwards 3 chains.
Wilfred-court, from Koonalda-avenue northwards 5½ chains.

Whittlesea.

Sydney-crescent, from Curtin-avenue south-westwards 9 chains.

WILLAURA SEWERAGE AUTHORITY.

BY-LAW No. 2.

THE Willaura Sewerage Authority, in pursuance and exercise of the powers conferred by the Sewerage Districts Act or any other Acts doth hereby make the following By-law:

1. The minimum amount of rate to be paid annually by the owner or occupier of any rateable sewered property within the Willaura Sewerage District on which there is a building shall be fixed at Fifteen dollars (\$15) and in respect of any rateable sewered property on which there is no building shall be fixed at Four dollars (\$4).

The Resolution for passing the foregoing By-law was agreed to by the Willaura Sewerage Authority on 16th May, 1966, and was confirmed by the said Authority on 20th June, 1966.

The common seal of the Willaura Sewerage Authority was affixed hereto on the 20th day of June, 1966, in the presence of—

(SEAL) L. K. SHANNON, Chairman.
RICHARD W. KING, Member.
K. N. BISHOP, Secretary.

Approved by the Governor in Council, 2nd August, 1966.
—J. COLQUHOUN, Clerk of the Executive Council.

MILDURA URBAN WATER TRUST.

CHARGES FOR SERVICE OUTSIDE DISTRICT OF TRUST.

FOR water supplied to properties outside the district of the Mildura Urban Water Trust, for the year ending 30th June, 1967, a minimum charge of Eighteen Dollars (\$18.00) will be made for each connection either directly or indirectly, to the Trust's mains.

This charge is due and payable on the 30th day of September, 1966, and if not paid by the 30th day of November, 1966, will bear interest at the rate of Six per cent. (6%) per annum, from the 30th day of September, 1966 to the date of payment.

For water used in excess of the allowance for any service connection outside the district there shall be a charge of Ten cents (10c) per thousand gallons.

The allowance for any service connection before such charge is made shall be 100,000 gallons for the full year, and shall be on a pro-rata basis for any portion of the year.

H. C. MCKENZIE,
Secretary.

Mildura Urban Water Trust,
7th Street, Mildura, 14th July, 1966.

FIRST MILDURA IRRIGATION TRUST.—MILDURA URBAN WATER TRUST.

PETITIONS UNDER THE MILDURA IRRIGATION AND WATER TRUSTS ACT.

IN pursuance of the provisions of the Mildura Irrigation and Water Trusts Act, the substance and prayer of petitions which have been presented to His Excellency the Governor in Council are published, viz.:—

Petitioners purporting to be the majority of the rate-payers in the areas described in the petitions such areas being described in the Schedule hereto.

Joint petitions from the First Mildura Irrigation Trust and the Mildura Urban Water Trust in respect of the above areas.

The petitioners pray that His Excellency the Governor in Council may be pleased to sever such area from the District of the First Mildura Irrigation Trust and annex the said area to the District of the Mildura Urban Water Trust in accordance with the provisions of the said Act.

Copies of such petitions together with plan showing the area proposed to be severed and annexed may be seen at the office of the Mildura Urban Water Trust, Seventh-street, Mildura.

SCHEDULE.

Parts of allotments 1, 2, 11 and 12, section 43, block F, on lodged plan of subdivision numbered 2637, Parish of Mildura, County of Karkaroc.

T. A. DARCY,
Minister of Water Supply.

TRARALGON WATERWORKS TRUST.

RATING BY-LAW 1966.

THE Traralgon Waterworks Trust, in pursuance and exercise of the powers conferred by the Water Act, doth hereby make a rate for the supply of water for domestic purposes of point five five cents (.55c) in the Dollar on Unimproved Capital Valuation of lands and tenements liable to be rated within the Traralgon Urban District.

1. Provided that in no case shall the amount of rate payable per annum in respect of any tenement, other than land on which there is no building, be less than fifteen dollars (\$15) and in respect of any land on which there is no building be less than eight dollars (\$8).

2. Such rates are made and shall be levied upon the occupiers or owners of the said land and tenements for the year commencing on the first day of January 1966, and shall be payable on the eighth day of October, 1966 at the Office of the said Trust.

3. The maximum quantity of water to be supplied in any one year without further charge to any property rated by the Trust is hereby fixed at a quantity which at a charge of twenty-five cents (25c) per 1,000 gallons, would produce an amount equal to the amount of the rate levied on such property for the said year.

4. The charge for water supplied by measure to any property rated by the Trust in excess of such maximum quantity computed as in the last preceding Clause is hereby fixed at twenty cents (20c) per 1,000 gallons.

5. The charge for water supplied by measure to any property not rated by the Trust will be fixed by special agreement with the Trust provided that in no case shall the amount payable be less than ten dollars (\$10).

6. The charge for water supplied by measure and by special agreement shall be payable on demand at the Office of the said Trust.

Passed this eighth day of June, 1966.

(SEAL) B. F. LORD, Chairman.
C. E. STAMMERS, Commissioner.
L. M. HICKMAN, Secretary.

Approved, 3rd August, 1966.—T. A. DARCY, Minister of Water Supply.

APPOINTMENTS AND RESIGNATIONS

APPOINTMENTS.

HIS Excellency the Governor of the State of Victoria, by and with the advice of the Executive Council thereof, has, by Orders made on the 2nd day of August, 1966, been pleased to make the under-mentioned appointments, viz.:—

CHIEF SECRETARY'S DEPARTMENT.

Licensing Inspector.

CAMPBELL GEORGE THOMAS PAYNE, Chief Inspector of Police, to be a Licensing Inspector for the purposes of the *Licensing Act 1958*.

MINISTRY OF HEALTH.

Members of Committees of Management of Hospitals.

FRANK DAWSON TRAINOR
to be a Member of the Committee of Management of Seymour District Memorial Hospital, pursuant to proviso (a) to section 48 (1) of the *Hospitals and Charities Act 1958*, for a period of three years;

Councillor ALEXANDER JOHN ANNESLEY BRETT
to be a Member of the Committee of Management of Lismore and District Hospital, pursuant to proviso (b) to section 48 (1) of the *Hospitals and Charities Act 1958*, for a period of three years;

Councillor JOHN ROBERT GIBBS, J.P.,
to be a Member of the Committee of Management of the Ouyen and District Hospital, pursuant to proviso (b) to section 48 (1) of the *Hospitals and Charities Act 1958*, for a further period of three years ending the 19th August, 1969;

ARTHUR JOSEPH BAILEY
to be a Member of the Committee of Management of Footscray and District Hospital, pursuant to proviso (a) to section 48 (1) of the *Hospitals and Charities Act 1958*, for a further period of three years ending the 16th August, 1969;

DONALD BRUCE CHAPPELL
to be a Member of the Committee of Management of Ripon Peace Memorial Hospital, pursuant to proviso (a) to section 48 (1) of the *Hospitals and Charities Act 1958*, for a further period of three years ending the 19th August, 1969;

ARTHUR EWENS SPILLER
to be a Member of the Committee of Management of Robinvale and District Hospital, pursuant to proviso (a) to section 48 (1) of the *Hospitals and Charities Act 1958*, for a further period of three years ending the 19th August, 1969; and

JOHN FREDERICK NEVINS
to be a Member of the Committee of Management of The Inglewood Hospital, pursuant to proviso (a) to section 48 (1) of the *Hospitals and Charities Act 1958*, for a period of three years.

LAW DEPARTMENT.

Clerk of Petty Sessions, &c.

BRIAN THOMAS MANSBRIDGE
to be Clerk of Petty Sessions and Clerk of the Children's Court at Koroit, in the place of V. G. Stafford, relieved, to take effect from the date of commencement of duty.

Commissioners for Taking Declarations, &c.

JOSEPH JOHN ANGELO MUSCAT, 9 Vernon-street, South Kingsville, and
RUSSELL JOHN HARDIDGE, 5 Aminga-avenue, Doncaster East,
to be Commissioners for taking Declarations and Affidavits, pursuant to the provisions of the *Evidence Act 1958*, to resign upon removing from the neighbourhood of the addresses stated; and

FRANK PARKIN, care of Bayer Leverkusen Ltd., 1087 High-street, Armadale,
WILLIAM NEIL JAMES, care of Commonwealth Banking Corporation, Dallas, Victoria,
IAN ARTHUR ROBINSON, care of Royal Globe Life Assurance Company Limited, 440 Collins-street, Melbourne, and
VERNON BRUCE MCGREGOR, care of Eagle Star Insurance Co. Ltd., Hamilton,
to be Commissioners for taking Declarations and Affidavits, pursuant to the provisions of the *Evidence Act 1958*, to resign upon ceasing to occupy their present positions.

Justices of the Peace.

ROBERT JOHN DE NEUVILLE PEEL, "Bunburra", Yea, to Keep the Peace in the Central Bailiwick of the State of Victoria; and

WILLIAM FRANCIS DALY, "Warana", Wodonga, to Keep the Peace in the Northern Bailiwick of the State of Victoria.

MINISTRY OF TRANSPORT.

State Coal Mine Industrial Tribunal Member.

WILLIAM ALAN BIRT
pursuant to the provisions of the *State Coal Mine Industrial Tribunal Act 1932*, to be a Member of the State Coal Mine Industrial Tribunal for a period of two (2) years from the 11th day of July, 1966.

J. COLQUHOUN,
Clerk of the Executive Council.

At the Mercy Hospital,
Melbourne, 2nd August, 1966.

APPOINTMENT.

HIS Excellency the Governor of the State of Victoria, by and with the advice of the Executive Council thereof, has, by Order made on the 9th day of August, 1966, been pleased to make the undermentioned appointment, viz.:—

DEPARTMENT OF WATER SUPPLY.

Recreational Area Management Committee.

MORRIS LESLIE PORTINGALE, J.P.,
pursuant to the provisions of the Water (Patterson River Recreational Area) Regulations 1966, to be a member of the Patterson River Recreational Area Management Committee.

J. COLQUHOUN,
Clerk of the Executive Council.

At Government House,
Melbourne, 9th August, 1966.

Vegetation and Vine Diseases Act 1958.—Fruit and Vegetables Act 1958.

APPOINTMENT OF INSPECTORS.

THE Public Service Board, by certificate dated 12th May, 1966, has appointed HAROLD CRAIG-BROWN, and GRAHAM EDGAR CAMERON, as Inspectors under the provisions of the *Vegetation and Vine Diseases Act 1958*, and the *Fruit and Vegetables Act 1958*, without additional salary.

FRANK M. READ,
Director of Agriculture.

FORESTS COMMISSION.

APPOINTMENT OF COMMITTEE OF MANAGEMENT OF THE RHODODENDRON GARDEN, PARISH OF MONBULK.

WHEREAS by section 50 of the *Forests Act 1958* (No. 6254), it is provided that the Minister of Forests may, on the recommendation of the Forests Commission, appoint any number of persons, not less than three, to be a Committee of Management of any land forming part of any reserved forest, such land being set aside as a Rhododendron Reserve, and may remove any of those persons: Now therefore, I, James Charles Murray Balfour, Her Majesty's Acting Minister of Forests for the State of Victoria, on the recommendation of the Forests Commission, do hereby appoint—

R. SANGSTER,

as an additional member of the Committee of Management until the 28th day of February, 1969, of the land forming part of the reserved forest in the Parish of Monbulk, County of Evelyn, described in the accompanying Schedule, and known as the Rhododendron Garden.

SCHEDULE ABOVE REFERRED TO.

Parish of Monbulk, County of Evelyn, comprising 50 acres, more or less, being the area shown by pink colour on plan marked 59/2802 over 28.1.63, on file of correspondence No. 59/2802 of the Forests Department.

Dated at Melbourne the 2nd day of August, 1966.

JIM BALFOUR,
Acting Minister of Forests.

No. 59.—7193/66.—2

RESIGNATIONS.

HIS Excellency the Governor of the State of Victoria, by and with the advice of the Executive Council thereof, has, by Orders made on the 2nd day of August, 1966, accepted the resignations of the persons named hereunder of the offices mentioned, viz.:—

LAW DEPARTMENT.

The persons named in the first column of the Schedule hereto, from the Commission of the Peace for the respective Bailiwicks of the State of Victoria set opposite their names in the second column of the said Schedule.

SCHEDULE.	
Name.	Bailiwick.
FRANCIS JOSEPH MCCRUDDEN ..	Central
ALEXANDER KILLEN ..	Western
ROBERT MANN ..	Midland and Western
JOHN HENRY RYAN ..	Central
RICHARD CLAUDE MCCANN ..	Western
EDMUND PAUL RYAN ..	Southern
LESLIE CLARENCE HALL ..	Western
ROY ALFRED HENRY BRADSHAW ..	Southern
HUMPHREY JAMES CLARE ..	All
PATRICK LOUIS FOLEY ..	Southern
KEITH FRANK ALLISON MYERS ..	All
FREDERICK WILLIAM HOFFMAN ..	Western
HERBERT GLADSTONE PRICE ..	Eastern
THOMAS PATRICK CLIFFORD ..	Midland
WALLACE SUTHERLAND SHARLAND ..	Central
EDWARD GEORGE WILLIAM MARRINER ..	Southern
HUBERT VICTOR CROWTHER ..	Southern
ANDREW WILSON ..	Midland
CHARLES FREDERICK WALSHÉ ..	Central
ARTHUR WILLIAM ATKIN ..	Central
EDGAR LESLIE MORTON ..	Central
KEITH VICTOR HATELEY ..	Western
NEVILLE LOUIS WOLFF ..	Northern
LIONEL EDWARD BALL ..	Central

MALCOLM EARL ATKINSON,
RONALD FRANCIS EVERY, and
DENIS COLIN GERSCHWITZ

as Commissioners for taking Declarations and Affidavits, pursuant to the provisions of the *Evidence Act 1958*.

J. COLQUHOUN,
Clerk of the Executive Council.

At the Mercy Hospital,
Melbourne, 2nd August, 1966.

ORDERS IN COUNCIL

RAILWAYS ACT 1958.

At the Mercy Hospital, Melbourne, the
twenty-seventh day of July, 1966.

PRESENT:

His Excellency the Governor of Victoria.
Mr. Chandler | Mr. Darcy.
Mr. Rossiter

TRANSFER OF SECTIONS OF RAILWAY.

HIS Excellency the Governor of the State of Victoria, by and with the advice of the Executive Council thereof, doth by this Order in pursuance of the provisions of section 39 of the *Railways Act 1958*, transfer the following sections of railway to the Victorian Railway Commissioners, the requisite certificates having been given by the Railway Construction Board and the Chief Engineer of the Board:

1. The deviations on the Wodonga and Tallangatta Railway—

- commencing at 194 miles 59 chains 32 links from Melbourne with a construction length of 72 chains 85 links terminating at 195 miles 48 chains 87 links from Melbourne (original mileage).
- commencing at 197 miles 35 chains 35 links from Melbourne with a construction length of 54 chains 96 links terminating at 198 miles 10 chains 35 links from Melbourne (original mileage).

- (c) commencing at 198 miles 22 chains 12 links from Melbourne with a construction length of 25 chains 48 links terminating at 198 miles 47 chains 43 links from Melbourne (original mileage).
- (d) commencing at 206 miles 33 chains 78 links from Melbourne with a construction length of 1 mile 29 chains 40 links terminating at 207 miles 61 chains 29 links from Melbourne (original mileage).
- (e) commencing at 208 miles 55 chains 21 links from Melbourne with a construction length of 58 chains 49 links terminating at 209 miles 34 chains 01 link from Melbourne (original mileage).
- (f) commencing at 209 miles 61 chains 71 links from Melbourne with a construction length of 1 mile

64 chains 74 links terminating at 211 miles 45 chains 54 links from Melbourne (original mileage).

2. The deviation on the Tallangatta and Cudgewa Railway—

- (a) commencing at 211 miles 74 chains 84 links from Melbourne with a construction length of 2 miles 77 chains 36 links terminating at 214 miles 73 chains 94 links from Melbourne (original mileage).

And the Honorable Rupert James Hamer, Her Majesty's Acting Minister of Transport, shall give the necessary directions herein accordingly.

J. COLQUHOUN,
Clerk of the Executive Council.

DEPARTMENT OF CROWN LANDS AND SURVEY.

At the Mercy Hospital, Melbourne, the second day of August, 1966.

PRESENT:

His Excellency the Governor of Victoria.
Mr. Reid | Mr. Darcy.

LANDS TEMPORARILY RESERVED AS SITES.

HIS Excellency the Governor of the State of Victoria, by and with the advice of the Executive Council thereof, doth hereby, in pursuance of section 14 of the Land Act 1958, reserve temporarily from sale, from being leased and from having a licence granted in respect thereof, and also except from occupation for mining purposes under any miner's right, the lands hereinafter described:—

ARDONACHIE, DUNMORE AND MACARTHUR.—Site for Public purposes (Conservation of Wildlife), 12,780 acres more or less, Parishes of Ardonachie, Dunmore and Macarthur, County of Normanby, as indicated by hachure on plan hereunder.—(A.101(*), D.156(*), M.88(2, 5) (Rs.8664).

ARDONACHIE

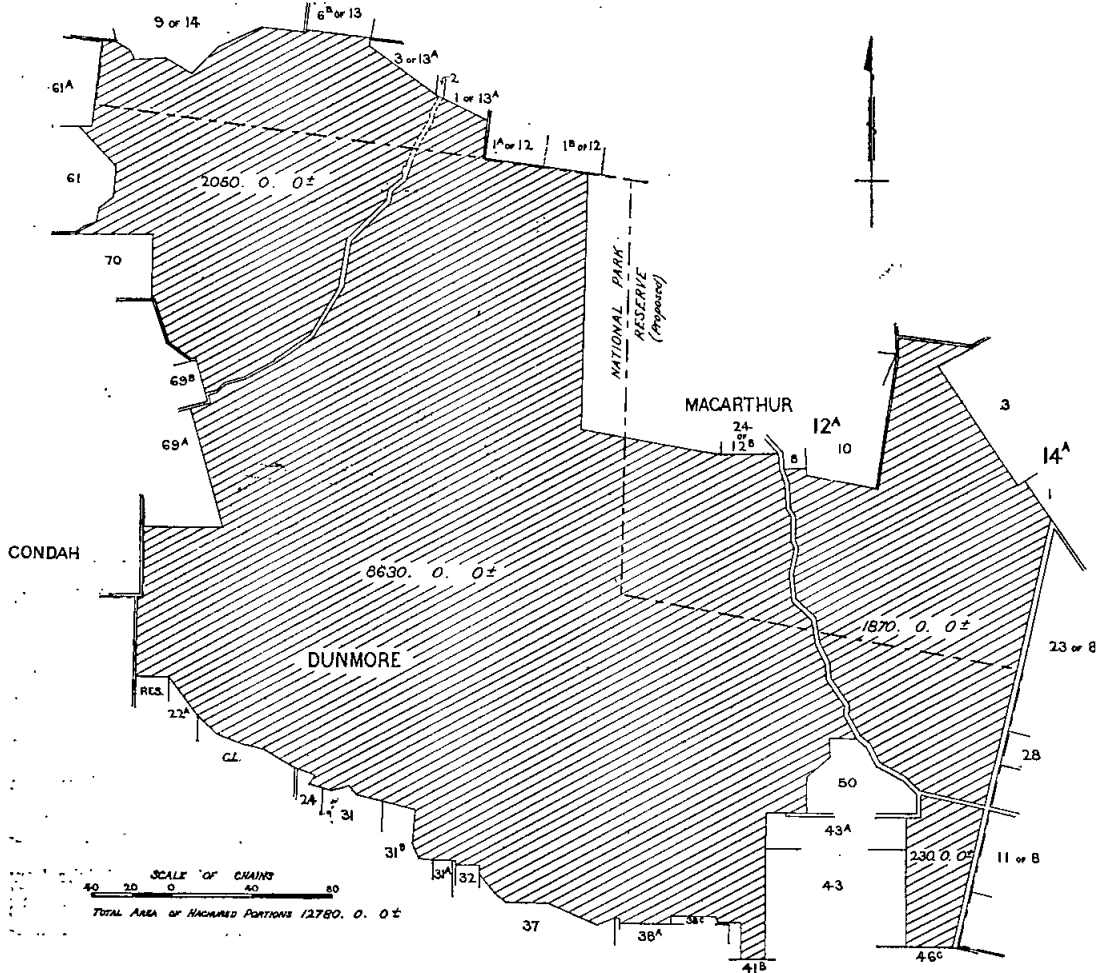

RUSHWORTH.—Site for State School purposes, 6 acres 2 roods more or less, Township of Rushworth, Parish of Moora, County of Rodney, as indicated by hachure on plan hereunder.—(R.47⁽¹⁾) (Rs.2385).

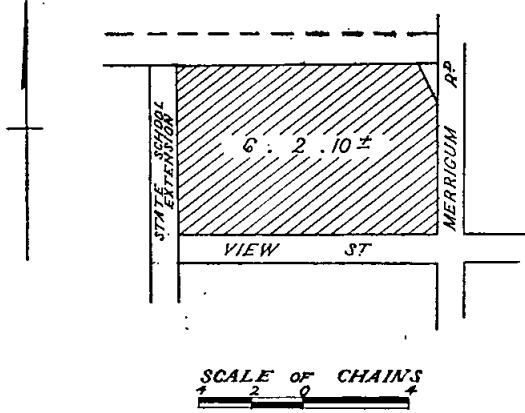

CARLYLE.—Site for Public purposes (Tourist Camping) and Recreation, 7 acres 2 roods more or less, Parish of Carlyle, County of Bogong, as indicated by hachure on plan hereunder.—C.187⁽⁶⁾ (Rs.4517).

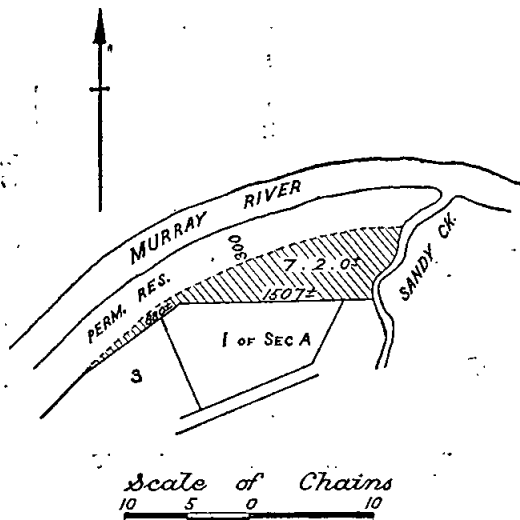

PRAHRAN.—Site for Public purposes (Court House and Police Station), 1 acre 2 perches, Parish of Prahran, County of Bourke, as indicated by hachure on plan hereunder.—(P.81⁽¹³⁾) (Rs.8323).

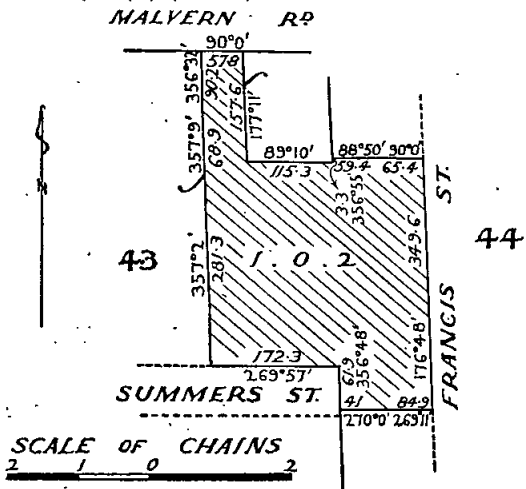

DUNMORE AND MACARTHUR.—Site for National Park, 890 acres more or less, Parishes of Dunmore and Macarthur, County of Normanby, as indicated by hachure on plan hereunder.—(D.156⁽⁴⁾, M.88⁽³⁾) (Rs.3388).

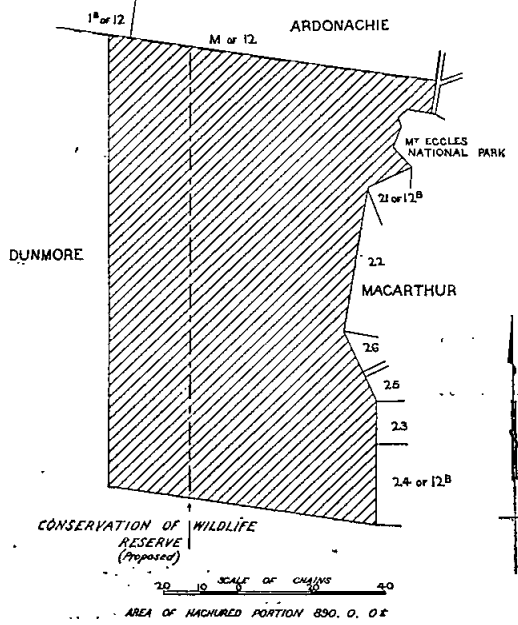

YARRAM YARRAM.—Site for Public purposes (Forests Department purposes), 1 rood 5 perches, Parish of Yarram Yarram, County of Buln Buln, as indicated by hachure on plan hereunder.—(Y.50⁽⁸⁾) (Rs.8565).

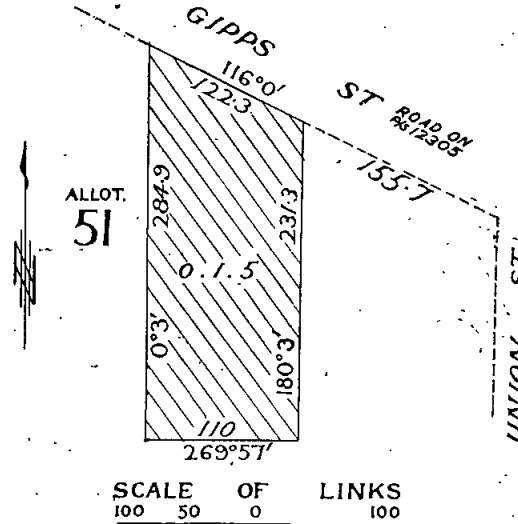

YEA.—Site for Public purposes and Recreation, 3 roods 5 perches more or less, Township of Yea, Parish of Yea, County of Anglesey, as indicated by hachure on plan hereunder.—(Y.56⁽⁸⁾) (Rs.8595).

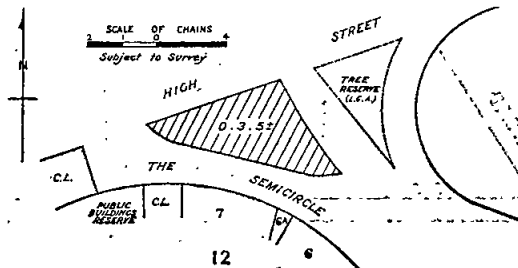

EUROA.—Site for Water Supply purposes, 3 acres 2 roods 13 perches, Parish of Euroa, County of Delatite, as indicated by hachure on plan hereunder.—(E.82^(*)) (Rs.8597).

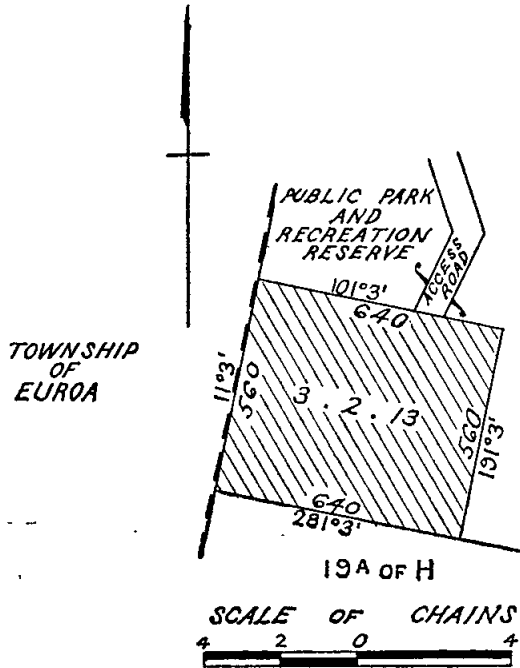

SANDHURST (SPRING GULLY).—Site for State School purposes, 1 acre 10 perches, Parish of Sandhurst, County of Bendigo, as indicated by hachure on plan hereunder.—(S.163(R) (C.99082).

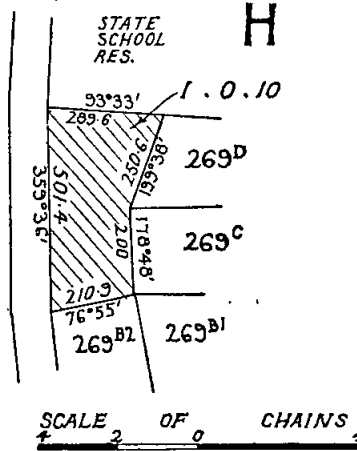

TEMPLESTOWE.—Site for Public purposes (Infant Welfare and Pre-School Centre), 2 roods 39 perches, Township of Templestowe, Parish of Bulleen, County of Bourke, as indicated by hachure on plan hereunder.—(T.76^(*)) (Rs.6387).

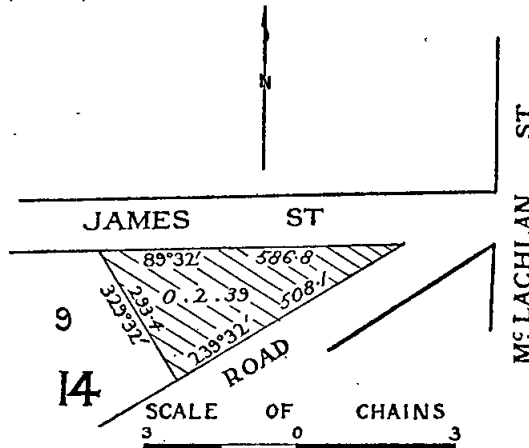

YEA.—Site for Public purposes (Swimming Pool), 3 roods 30 perches more or less, Township of Yea, Parish of Yea, County of Anglesey, as indicated by hachure on plan hereunder.—(Y.56^(*)) (Rs.8596).

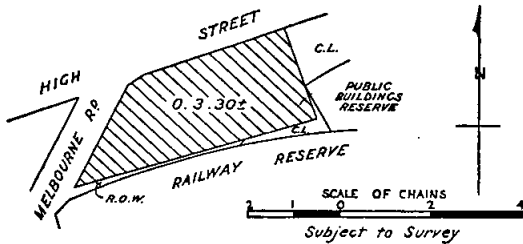

WARBURTON.—Site for Public purposes (Forests Department purposes), 1 acre 27 perches, Parish of Warburton, County of Evelyn, as indicated by hachure on plan hereunder.—(W.348⁽¹³⁾) (Rs.8624).

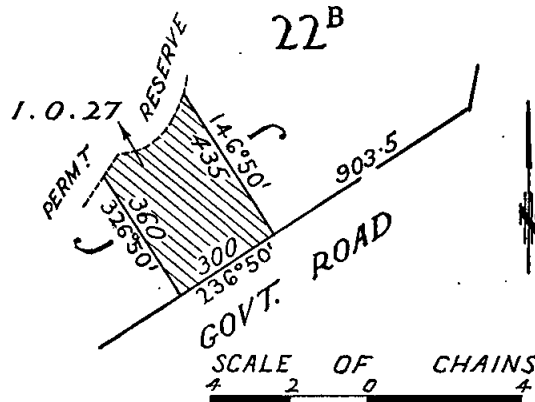

IRREWARRA (WARROWIE).—Site for Public Recreation purposes, 7 acres, Parish of Irrewarra, County of Polwarth, as indicated by hachure on plan hereunder.—(I.12⁽³⁾) (Rs.8594).

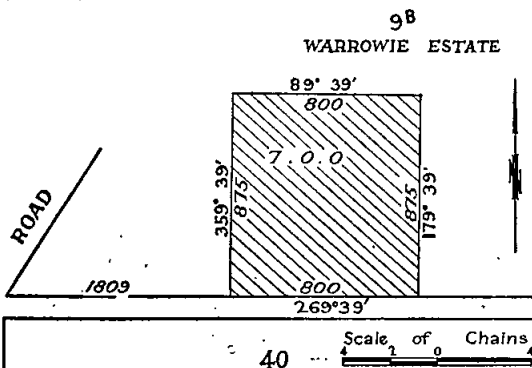

And the Honorable James Charles Murray Balfour, Her Majesty's Minister of Lands for the State of Victoria, shall give the necessary directions herein accordingly.

J. COLQUHOUN,
Clerk of the Executive Council.

DEPARTMENT OF CROWN LANDS AND SURVEY.

At the Mercy Hospital, Melbourne, the second day of August, 1966.

PRESENT:

His Excellency the Governor of Victoria.
Mr. Reid | Mr. Darcy.

UNUSED ROADS CLOSED.

HIS Excellency the Governor of the State of Victoria, by and with the advice of the Executive Council thereof, doth hereby direct that, in pursuance of the provisions of section 349 of the Land Act 1958, the unused roads referred to hereunder be closed, viz.:-

Parish of Branhholme, County of Normanby, being the portion of the width of the road indicated by hachure on plan hereunder.—(B.462⁽²⁾) (J.31701).

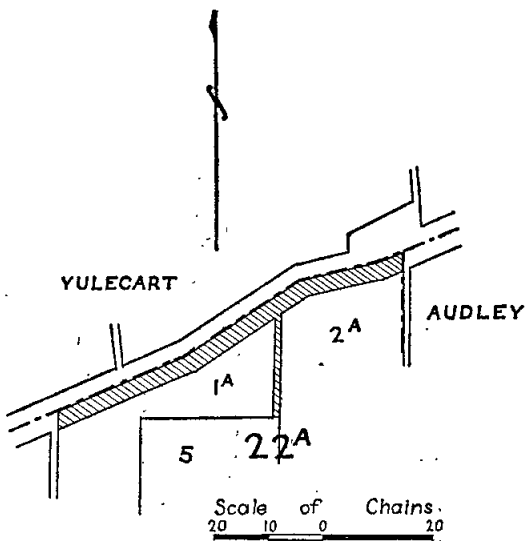

Parish of Bellaura, County of Borung, being the road indicated by hachure on plan hereunder.—(B.572⁽⁴⁾) (O.291/130).

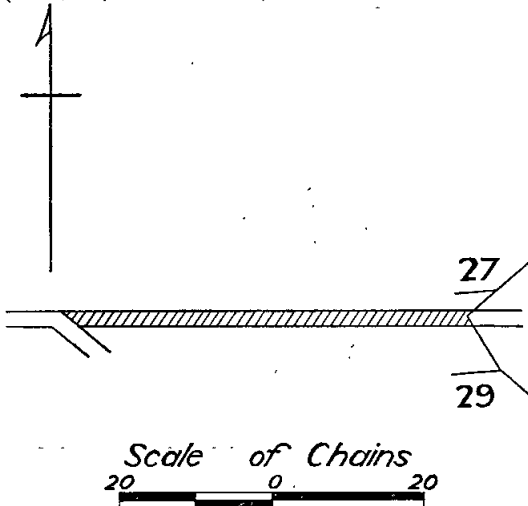

Parish of Clunes, County of Talbot, being the road between allotments 13B and 13C, section 4.—(C.395(L³)) (J.31691).

Parish of Ganoo Ganoo, County of Dundas, being the road between allotments 2A and 2c, section A¹.—(G.190⁽¹⁾) (J.31241).

Parishes of Yalong and Yalong South, County of Gladstone, being the roads indicated by hachure on plan hereunder.—(Y.93⁽⁶⁾) and Y.93⁽⁴⁾) (J.30564).

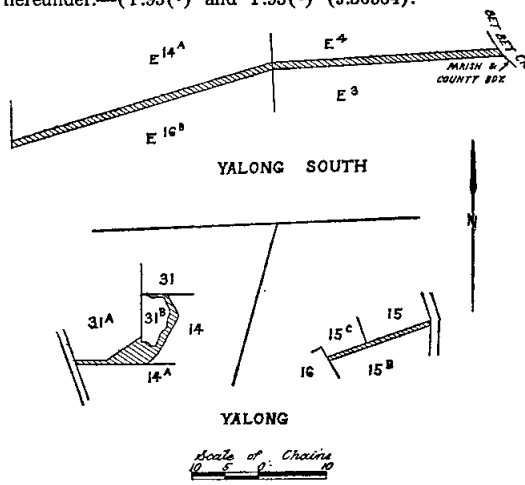

And the Honorable James Charles Murray Balfour, Her Majesty's Minister of Lands for the State of Victoria, shall give the necessary directions herein accordingly.

J. COLQUHOUN,
Clerk of the Executive Council.

DEPARTMENT OF CROWN LANDS AND SURVEY.

At the Mercy Hospital, Melbourne, the second day of August, 1966.

PRESENT:

His Excellency the Governor of Victoria.
Mr. Reid | Mr. Darcy.

REVOCATIONS OF TEMPORARY RESERVATIONS OF LAND BY ORDERS IN COUNCIL.

HIS Excellency the Governor of the State of Victoria, by and with the advice of the Executive Council thereof, doth hereby, in pursuance of the provisions of the Land Act 1958, revoke the temporary reservations of land by Orders in Council hereinafter referred to, viz.:-

BEYAL.—Order in Council of 16th April, 1937, of 2 acres 1 rood 24 perches of land in the Parish of Beyal, as a site for a State School.—(Rs.4678.)

JIKA JIKA.—Order in Council of 12th January, 1932, of 60 acres 0 roods 17 perches of land in the Parish of Jika Jika, as a site for a Mental Hospital, so far only as regards the portion thereof comprised within the boundaries published in the Government Gazette of 6th July, 1966, and containing 4 acres 15 perches.—(Rs.4172.)

JIKA JIKA.—Order in Council of 24th December, 1930, of 12 acres 3 roods 1 5/10 perches of land in the Parish of Jika Jika, as a site for Children's Welfare purposes, so far only as regards the portion thereof comprised within the boundaries published in the Government Gazette of 6th July, 1966, and containing 1 acre 3 roods 9 perches.—(Rs.259.)

JIKA JIKA.—Order in Council of 2nd April, 1946, of 2 acres 1 rood 14 9/10 perches of land in the Parish of Jika Jika, as a site for Children's Welfare purposes, so far only as regards the portion thereof comprised within the boundaries published in the Government Gazette of 6th July, 1966, and containing 1 rood 22 perches.—(Rs.259.)

LORNE.—Order in Council of 21st August, 1917, of 149 acres, more or less, of land in the Township of Lorne as a site for Public Purposes, so far only as regards the portion thereof comprised within the boundaries published in the Government Gazette of 6th July, 1966, and containing 2 roods 20 perches, more or less.—(Rs.1690.)

NATIMUK.—Order in Council of 2nd February, 1874, of 2 acres of land in the Township of Natimuk, as a site for State School purposes.—(C.78598.)

REDCLIFFS.—Order in Council of 21st February, 1928, of 2 acres, 1 rood 37 perches of land at Redcliffs in the Parish of Mildura, as a site for Public Purposes, Park and Recreation and convenience of the people, so far only as regards the portion thereof comprised within the boundaries published in the *Government Gazette* of 6th July, 1966, and containing 25 perches.—(Rs.3631.)

And the Honorable James Charles Murray Balfour, Her Majesty's Minister of Lands for the State of Victoria, shall give the necessary directions herein accordingly.

J. COLQUHOUN,
Clerk of the Executive Council.

BREAD INDUSTRY ACT 1959.

At the Mercy Hospital, Melbourne, the second day of August, 1966.

PRESENT:

His Excellency the Governor of Victoria.
Mr. Reid | Mr. Darcy.

BREAD INDUSTRY ORDER (No. 2) 1966.

WHEREAS it is enacted in section 7 of the *Bread Industry Act 1959* that the Governor in Council on the recommendation of the Minister made after consideration of a report from the Food Standards Committee may, from time to time by Order published in the *Government Gazette* revoke, add to, amend or vary or substitute other provisions for any provisions set out in the Schedule to the Act:

And whereas the Minister after consideration of a report from the said Committee has recommended to the Governor in Council that the Schedule be varied in the manner following:—

Now therefore, in pursuance of the powers conferred by the *Bread Industry Act 1959*, His Excellency the Governor of the State of Victoria, by and with the advice of the Executive Council thereof, doth hereby make the following Order, that is to say:—

1. This Order may be cited as the "Bread Industry Order (No. 2) 1966".
2. In this Order, "Schedule" means Schedule to the *Bread Industry Act 1959*.
3. In clause 11 of the Schedule, the words "two parts per centum of total ash" shall be rescinded and the words "four and three-tenths parts per centum of total ash on a water-free basis" shall be substituted therefor.
4. In sub-clause (2) of clause 13 of the Schedule, the words "two and five-tenths parts per centum of total ash" shall be rescinded and the words "four and eight-tenths parts per centum of total ash on a water-free basis" shall be substituted therefor.

And the Honorable Vernon Francis Wilcox, Her Majesty's Minister of Labour and Industry for the State of Victoria, shall give the necessary directions herein accordingly.

J. COLQUHOUN,
Clerk of the Executive Council.

LOCAL GOVERNMENT DEPARTMENT.

At the Mercy Hospital, Melbourne, the second day of August, 1966.

PRESENT:

His Excellency the Governor of Victoria.
Mr. Reid | Mr. Darcy.

ROAD DISCONTINUED.—CITY OF HEIDELBERG.

WHEREAS, it is provided in section 528 (2) of the Local Government Act that where a road (whether or not a public highway, but not being a road set out on land of the Crown) or any part thereof is not required for public use, the Governor in Council, on the request of the Council of the municipality in which such road is situated, made not less than one month after publishing in a newspaper generally circulating in the district and posting to the registered proprietor (if any) of the land and any person known to have an interest in the land notice of intention to make such a request, may by Order published in the *Government Gazette*, direct that such road or part shall be discontinued and thereupon such road or part shall be discontinued accordingly.

And whereas the Council of the City of Heidelberg has requested that the Governor in Council direct that portion of Birdwood-avenue, Macleod, be discontinued, and not less than one month previously, has published in a newspaper generally circulating in the district and posted to the registered proprietor of the land in the road and to all persons known to have an interest in the said road notice of intention to make such request,

Now therefore, His Excellency the Governor of the State of Victoria, by and with the advice of the Executive Council thereof, hereby directs—

- (a) That the portion of the said road which is shown by hachure and cross-hachure on the plan hereunder shall be discontinued.
- (b) That notwithstanding such discontinuance the Melbourne and Metropolitan Board of Works shall continue to have and possess the same right, title, power, authority or interest in or in relation to the land shown by cross-hachure on the said plan as it had or possessed prior to such discontinuance with respect to or in connexion with any sewers or drains laid or erected in, on or over such land for the purposes of sewerage or drainage.
- (c) That, subject to any such right, title, power, authority or interest, the land in the portion of the said road shall be retained by the Council of the City of Heidelberg for municipal purposes.

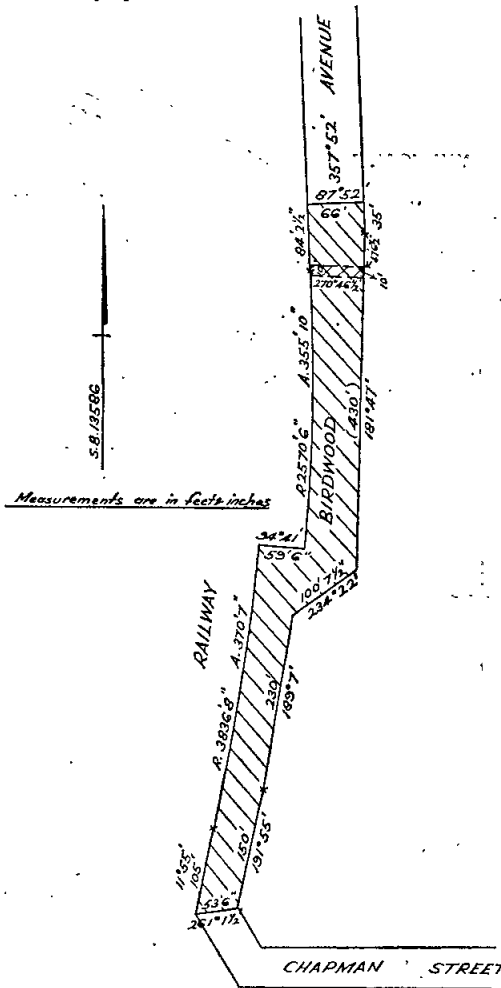

And the Honorable Rupert James Hamer, Her Majesty's Minister for Local Government for the State of Victoria, shall give the necessary directions herein accordingly.

J. COLQUHOUN,
Clerk of the Executive Council.

LOCAL GOVERNMENT DEPARTMENT.

At the Mercy Hospital, Melbourne, this second day of August, 1966.

PRESENT:

His Excellency the Governor of Victoria.
Mr. Reid | Mr. Darcy.

ROAD DISCONTINUED—CITY OF MELBOURNE.

WHEREAS it is provided in section 528 (2) of the Local Government Act 1958, as amended, that where a road (whether or not a public highway but not being a road set out on land of the Crown) or any part thereof is not required for public use the Governor in Council on the request of the council of the municipality in which such road is situated made not less than one month after publishing in a newspaper generally circulating in the district and posting to the registered proprietor (if any) of the land and any person known to have an interest in the land notice of intention to make such request may by Order published in the Government Gazette direct that such road or part shall be discontinued and thereupon such road or part shall be discontinued accordingly:

And whereas the Council of the City of Melbourne has requested that a right-of-way, off Grey-street, East Melbourne, be discontinued and not less than one month previously has published in a newspaper generally circulating in the district and posted to the registered proprietor of the land in the road and to all persons known to have an interest in the said road notice of intention to make such request:

Now therefore His Excellency the Governor of the State of Victoria, by and with the advice of the Executive Council thereof, hereby directs:

- (a) that the said road, which is shown by hachure on the plan hereunder, shall be discontinued;
- (b) that notwithstanding such discontinuance the Melbourne and Metropolitan Board of Works shall continue to have and possess the same right title power authority or interest in or in relation to the land shown by hachure on the said plan as it had or possessed prior to such discontinuance with respect to or in connexion with any sewers or drains laid or erected in on or over such land for the purposes of sewerage or drainage;
- (c) that, subject to any such right title power authority or interest, the land in the said road may be sold by the Council of the City of Melbourne by agreement.

And the Honorable Rupert James Hamer, Her Majesty's Minister for Local Government for the State of Victoria, shall give the necessary directions herein accordingly.

J. COLQUHOUN,
Clerk of the Executive Council.

GAS REGULATION ACT 1958.

At the Mercy Hospital, Melbourne, the second day of August, 1966.

PRESENT:

His Excellency the Governor of Victoria.
Mr. Reid | Mr. Darcy.

FEEES FOR TESTING OF METERS.

WHEREAS, in pursuance of the powers conferred by the Gas Regulation Act 1933, the Governor in Council, by an Order made on the twenty-second day of April, 1952, and published in the Government Gazette of the twenty-third day of April, 1952, did prescribe certain fees for the testing of meters, to take effect from the first day of May, 1952: Now the Governor of the State of Victoria, in the Commonwealth of Australia, by and with the advice of the Executive Council of the said State, and in pursuance of the powers conferred by the Gas Regulation Act 1958, doth by this Order, in lieu of the fees prescribed as aforesaid, prescribe the following fees as the fees payable as on and from the first day of September, 1966, for the testing of meters pursuant to the provisions of section 23 of the said Act (that is to say):—

For every meter of a capacity not exceeding 150 cubic feet per hour	\$1.20
For every meter of a capacity exceeding 150 cubic feet per hour and not exceeding 200 cubic feet per hour	\$1.80
For every meter of a capacity exceeding 200 cubic feet per hour and not exceeding 600 cubic feet per hour	\$2.40
For every meter of a capacity exceeding 600 cubic feet per hour and not exceeding 1,200 cubic feet per hour	\$4.80
For every meter of a capacity exceeding 1,200 cubic feet per hour and not exceeding 3,000 cubic feet per hour	\$9.60
For every meter of a capacity exceeding 3,000 cubic feet per hour	\$12.00

And the Honorable Thomas Anthony Darcy, Her Majesty's Minister of Mines for the State of Victoria, shall give the necessary directions herein accordingly.

J. COLQUHOUN,
Clerk of the Executive Council.

HOSPITALS AND CHARITIES ACT 1958.—SECTION 52.

At the Mercy Hospital, Melbourne, the second day of August, 1966.

PRESENT:

His Excellency the Governor of Victoria.
Mr. Reid | Mr. Darcy.

VARIATION OF THE OBJECTS OR PURPOSES OF BETHANY BABIES' HOME, GEELONG.

WHEREAS Bethany Babies' Home, Geelong, is an incorporated institution within the meaning of the Hospitals and Charities Act 1958:

And whereas the Committee of Management of the said institution has agreed that the objects or purposes of the said institution should be varied:

And whereas the Hospitals and Charities Commission after inquiry has recommended that the objects or purposes should be varied:

Now therefore His Excellency the Governor of the State of Victoria by and with the advice of the Executive Council of the said State, and by virtue of the powers conferred

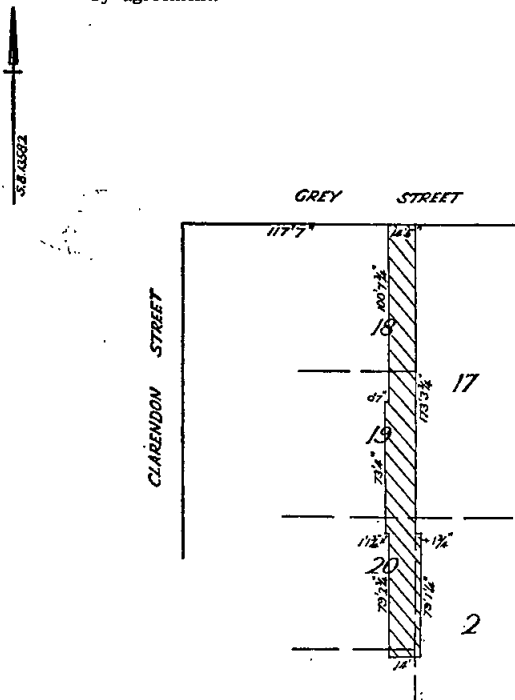

THE MEASUREMENTS ARE IN FEET & INCHES

on him by section 52 of the *Hospitals and Charities Act 1958* and all other powers enabling him in that behalf, hereby varies the objects or purposes of Bethany Babies' Home, Geelong, so that such objects or purposes shall be as follows:—

- (a) to care for unmarried mothers before and after confinement and to instruct them in the proper care of their babies;
- (b) to care for neglected and destitute children up to the age of five years;
- (c) to train and educate and/or to assist in the training and education as mothercraft nurses and/or as infant nurses such person or persons as shall join the staff of the Institution for the purpose of receiving such training and education;
- (d) subject to any law with respect to such adoption, to arrange for the adoption of any children solely in the care of the Institution;
- (e) with the consent of the parent or legal guardian of any child, to arrange a home for such child when discharged from the Institution;
- (f) to do all such other things incidental to or conducive to the attainment of the above objects or any of them.

And the Honorable Vance Oakley Dickie, Her Majesty's Minister of Health for the State of Victoria, shall give the necessary directions herein accordingly.

J. COLQUHOUN,
Clerk of the Executive Council.

HOSPITALS AND CHARITIES ACT 1958.—SECTION 52.

At the Mercy Hospital, Melbourne, the second day of August, 1966.

PRESENT:

His Excellency the Governor of Victoria.
Mr. Reid | Mr. Darcy.

VARIATION OF THE OBJECTS OR PURPOSES OF WEST GIPPSLAND HOSPITAL.

WHEREAS West Gippsland Hospital is an incorporated institution within the meaning of the *Hospitals and Charities Act 1958*:

And whereas the Committee of Management of the said institution has agreed that the objects or purposes of the said institution should be varied:

And whereas the Hospitals and Charities Commission after inquiry has recommended that the objects or purposes should be varied:

Now therefore His Excellency the Governor of the State of Victoria by and with the advice of the Executive Council of the said State, and by virtue of the powers conferred on him by section 52 of the *Hospitals and Charities Act 1958* and all other powers enabling him in that behalf, hereby varies the objects or purposes of West Gippsland Hospital so that such objects or purposes shall be as follows:—

- (a) To afford relief, including maintenance and the treatment or cure of, or attention to, any disease or ailment, or any injury consequent on any accident, medical and/or surgical attendance, medicine, nursing assistance, support or aid of any kind or in any form to such persons as are entitled thereto under the Act;
- (b) to provide facilities for the treatment of intermediate and private patients or either of them;
- (c) to provide facilities for the carrying out of investigations into ailments, diseases, injuries or other matters affecting the human body.

And the Honorable Vance Oakley Dickie, Her Majesty's Minister of Health for the State of Victoria, shall give the necessary directions herein accordingly.

J. COLQUHOUN,
Clerk of the Executive Council.

COUNTRY ROADS BOARD.

At the Mercy Hospital, Melbourne, the second day of August, 1966.

PRESENT:

His Excellency the Governor of Victoria.
Mr. Reid | Mr. Darcy.

DECLARATION OF A DEVIATION FROM THE WALHALLA-ROAD IN THE SHIRE OF NARRACAN.

WHEREAS by sections 21 and 58 of the *Country Roads Act 1958* (No. 6229) it is amongst other things enacted that when the Country Roads Board under the provisions of the *Country Roads Act* has by Resolution declared a deviation to be a main road the said Board may also declare that such deviation shall be in lieu of any existing road or part thereof named in such Resolution and that on publication in the *Government Gazette* of the Order confirming such Resolution the existing road or part thereof shall cease to be a main road or be discontinued as provided in the Resolution: And whereas the said Board has by Resolution declared the deviation on the land described in the First Schedule to such Resolution to be a main road and has also declared that such deviation shall be in lieu of the part of the existing road being the land described in the Second Schedule to the said Resolution and that such part of the said existing road as is described in the Third Schedule shall be discontinued: Now therefore His Excellency the Governor of the State of Victoria by and with the advice of the Executive Council thereof doth hereby confirm the said Resolution.

Resolution for Declaration of a Deviation of a Main Road under the Country Roads Act.

Whereas the land the site of the road the course of which is below set out was taken by the Board under the provisions of the *Country Roads Act 1958* for the purpose of constructing such road deviation which road deviation has now been laid out and formed on the same: And whereas the said Board (being the Country Roads Board incorporated under the said Act) thinks that the road aforesaid is fit to be used as a public highway such Board at a meeting now holden acting under the authority conferred upon it by sections 21 and 58 of the said Act doth by this present Resolution hereby declare the said road deviation the course of which is described in the First Schedule hereto with the commencing and terminating points thereof respectively specified to be part of a main road within the meaning and for the purposes of the *Country Roads Act 1958*: And the said Board doth also declare that such deviation shall be in lieu of the existing road or part thereof described in the Second Schedule hereto and that such part of the said existing road as is described in the Third Schedule shall be discontinued.

FIRST SCHEDULE.

Shire of Narracan.

10. *Walhalla-road* (11810).—All those pieces of land in the Parish of Tanjil, the boundaries of which are as follow:—

- (a) Commencing at an angle in the eastern boundary of allotment 29 of the said parish, formed by the intersection of lines bearing 48 deg. 56 min. and 12 deg. 16 min.; thence by lines bearing respectively 228 deg. 56 min. 80.0 links, 30 deg. 56 min. 151.9 links and 192 deg. 16 min. 80.0 links to the point of commencement.
- (b) Commencing at an angle in the eastern boundary of the existing Walhalla-road, through allotment 30 of the said parish formed by the intersection of lines bearing 198 deg. 32 min. and 181 deg. 2 min.; thence by lines bearing respectively 18 deg. 32 min. 235.2 links, 66 deg. 14 min. 93.0 links, 192 deg. 28 min. 650.3 links, 352 deg. 3 min. 168.0 links and 1 deg. 2 min. 208.1 links to the point of commencement.
- (c) Commencing at a point on the southern boundary of a rubbish depot and gravel reserve distant 248 deg. 15 min. 219.0 links from the south-western angle of allotment 35a of the said parish; thence by lines bearing respectively 227 deg. 22 min. 537.0 links, 358 deg. 53 min. 150.0 links, 117 deg. 38½ min. 48.1 links and 56 deg. 24 min. 426.6 links to the point of commencement.

- (d) Commencing at an angle in the eastern boundary of allotment 1, section D, of the said parish, formed by the intersection of lines bearing 32 deg. 37 min. and 341 deg. 36 min.; thence by lines bearing respectively 212 deg. 37 min. 541.0 links, 242 deg. 15 min. 212.0 links, 37 deg. 3½ min. 463.2 links, 14 deg. 43½ min. 454.1 links and 161 deg. 36 min. 268.2 links to the point of commencement.
- (e) Commencing at the western angle of allotment 2A, section D, of the said parish; thence by lines bearing respectively 50 deg. 43 min. 438.5 links, 203 deg. 35 min. 612.5 links and 341 deg. 36 min. 299.0 links to the point of commencement.
- (f) Commencing at the southern angle of allotment 15, section D, of the said parish; thence by lines bearing respectively 256 deg. 53 min. 46.0 links, 230 deg. 43 min. 215.0 links, 34 deg. 0½ min. 534.3 links and 196 deg. 28 min. 309.0 links to the point of commencement.
- (g) Commencing at an angle on the eastern boundary of allotment 15, section D, of the said parish formed by the intersection of lines bearing 30 deg. 58 min. and 348 deg. 3 min.; thence by lines bearing respectively 210 deg. 58 min. 476.7 links, 16 deg. 39 min. 518.9 links, 359 deg. 0 min. 401.1 links and 168 deg. 3 min. 500.3 links to the point of commencement—

which said pieces of land are particularly delineated and shown coloured red and green on survey plans numbered 10083, 10084 and 10101, lodged in the office of the Country Roads Board.

SECOND SCHEDULE.
Shire of Narracan.

10. *Walhalla-road* (11810).—All that piece of land in the Parish of Tanjil, the boundaries of which are as follow:—Commencing at a point on the north-western boundary of allotment 30 of the said parish, distant 246 deg. 14 min. 402.3 links from the south-western angle of allotment 34 of the said parish; thence by lines bearing respectively 246 deg. 14 min. 202.7 links, 35 deg. 52 min. 395.6 links and 190 deg. 57 min. 243.3 links to the point of commencement—which said piece of land is particularly delineated and shown coloured light-blue on survey plan numbered 10083 lodged in the office of the Country Roads Board.

THIRD SCHEDULE.
Shire of Narracan.

10. *Walhalla-road* (11810).—All those pieces of land in the Parish of Tanjil, the boundaries of which are as follow:—

- (a) Commencing at a point on the north-western boundary of allotment 30 of the said parish, distant 246 deg. 14 min. 402.3 links from the south-western angle of allotment 34 of the said parish; thence by lines bearing respectively 190 deg. 57 min. 408.3 links, 326 deg. 5 min. 292.5 links, 35 deg. 52 min. 94.3 links and 66 deg. 14 min. 202.7 links to the point of commencement.
- (b) Commencing at an angle in the eastern boundary of allotment 1, section D, of the said parish formed by the intersection of lines bearing 230 deg. 43 min. and 161 deg. 36 min.; thence by lines bearing respectively 50 deg. 43 min. 528.8 links, 203 deg. 35 min. 439.5 links, 194 deg. 43½ min. 366.1 links and 341 deg. 36 min. 444.8 links to the point of commencement—

which said pieces of land are particularly delineated and shown coloured dark-blue on survey plans numbered 10083 and 10084, lodged in the office of the Country Roads Board.

The common seal of the Country Roads Board was hereto affixed at Kew this Twenty-fifth day of July, One thousand nine hundred and sixty-six, in the presence of—

(SEAL) I. J. O'DONNELL, Chairman.
F. WEST, Member.
N. L. ALLANSON, Secretary.

And the Honorable Murray Victor Porter, Her Majesty's Minister of Public Works for the State of Victoria, shall give the necessary directions herein accordingly.

J. COLQUHOUN,
Clerk of the Executive Council.

COUNTRY ROADS BOARD.

At the Mercy Hospital, Melbourne, the second day of August, 1966.

PRESENT:

His Excellency the Governor of Victoria.
Mr. Reid | Mr. Darcy.

ORDER APPROVING OF A DEVIATION FROM A STATE HIGHWAY IN THE SHIRE OF WANGARATTA.

WHEREAS the Country Roads Board constituted under the *Country Roads Act 1958* (No. 6229) has represented to His Excellency the Governor in Council that it appears to it desirable that the deviation hereinafter referred to from the existing Hume Highway in the Shire of Wangaratta (declared to be a State highway under the said Act which declaration was confirmed by the Order in Council published in the *Government Gazettes* of the 8th July, 1925, on page 2371, and 26th October, 1932, on page 2439) should be made by the said Board: And whereas the said Board in accordance with the requirements of section 19 of the said cited Act has caused to be prepared a map plan and estimate showing the points between which and on and through what land the said deviation is proposed to be made and the cost of acquiring the land: And whereas on an inspection of the said map and plan and a consideration of the said estimate His Excellency the Governor in Council is satisfied that there are funds legally available for acquiring the land: Now therefore be it known by this present Order that His Excellency the Governor of the State of Victoria with the advice of the Executive Council thereof doth hereby approve of the said highway being made, that is to say:—

All those pieces of land in the Parish of Wangaratta North, the boundaries of which are as follow:—

- (a) Commencing at the northern angle of allotment 1, section B, of the said parish; thence by lines bearing respectively 140 deg. 0 min. 145 ft. 7 in., 210 deg. 14 min. 2,399 ft. 1½ in., 243 deg. 30 min. 235 ft. 7½ in., 320 deg. 0 min. 28 ft. 8½ in., 30 deg. 14 min. 2,531 ft. 6 in., 3 deg. 28 min. 23 ft. 2½ in. and 49 deg. 51 min. 88 ft. 7 in. to the point of commencement.
- (b) Commencing at the northern angle of allotment 1, section H, of the said parish; thence by lines bearing respectively 140 deg. 0 min. 99 feet, 229 deg. 8 min. 1,092 ft. 1½ in., 4 deg. 34 min. 141 ft. 0½ in. and 49 deg. 8 min. 993 ft. 1½ in. to the point of commencement—

which said pieces of land are particularly delineated and shown coloured red and blue on survey plan numbered 10584, lodged in the office of the Country Roads Board.

And the Honorable Murray Victor Porter, Her Majesty's Minister of Public Works for the State of Victoria, shall give the necessary directions herein accordingly.

J. COLQUHOUN,
Clerk of the Executive Council.

COUNTRY ROADS BOARD.

At the Mercy Hospital, Melbourne, the second day of August, 1966.

PRESENT:

His Excellency the Governor of Victoria.
Mr. Reid | Mr. Darcy.

ORDER APPROVING OF WIDENING AN EXISTING MAIN ROAD IN THE SHIRE OF BELFAST.

WHEREAS the Country Roads Board constituted under the *Country Roads Act 1958* (No. 6229) has represented to His Excellency the Governor in Council that it appears to it desirable that the existing Hamilton-road in the Shire of Belfast (declared to be a main road under the said Act which declaration was confirmed by the Order in Council published in the *Government Gazette* of the 25th November, 1914, on page 5287) should be widened by the said Board: And whereas the said Board in accordance with the requirements of section 19 of the said cited Act has caused to be prepared a map plan and estimate showing the points between which and on and through what land the said widening is proposed to be made and the cost of acquiring the land: And whereas

on an inspection of the said map and plan and a consideration of the said estimate His Excellency the Governor in Council is satisfied that there are funds legally available for acquiring the land: Now therefore be it known by this present Order that His Excellency the Governor of the State of Victoria with the advice of the Executive Council thereof doth hereby approve of the said road being widened, that is to say:—

All those pieces of land in the Parish of Belfast, the boundaries of which are as follow:—

- (a) Commencing at an angle in the western boundary of the existing Hamilton-road through Portion 4 of the said parish, formed by the intersection of lines bearing 333 deg. 29 min. and 341 deg. 51 min.; thence by lines bearing respectively 153 deg. 29 min. 1,109.2 links, 155 deg. 11 min. 414.5 links, 160 deg. 7 min. 115 links, 338 deg. 13 min. 99.8 links, 332 deg. 45½ min. 1,355.6 links, 342 deg. 45 min. 469.9 links and 161 deg. 51 min. 284 links to the point of commencement.
- (b) Commencing at an angle in the eastern boundary of the existing Hamilton-road through portion 4 of the said parish, formed by the intersection of lines bearing 155 deg. 11 min. and 160 deg. 7 min.; thence by lines bearing respectively 335 deg. 11 min. 199.5 links, 154 deg. 48½ min. 1,157.3 links, 137 deg. 10 min. 393 links, 124 deg. 42 min. 433.4 links, 290 deg. 8 min. 645.5 links and 340 deg. 7 min. 1,253.6 links to the point of commencement.
- (c) Commencing at a point on the eastern boundary of allotment 4A of the said parish, distant 109 deg. 33 min. 700 links from the northern angle of the said allotment; thence by lines bearing respectively 109 deg. 33 min. 150 links, 130 deg. 34 min. 300 links and 303 deg. 36 min. 443.3 links to the point of commencement.
- (d) Commencing at an angle in the northern boundary of the existing Hamilton-road through Portion 4 of the said parish, formed by the intersection of lines bearing 130 deg. 27 min. and 96 deg. 55 min.; thence by lines bearing respectively 310 deg. 27 min. 360.9 links, 113 deg. 46½ min. 687.5 links and 276 deg. 55 min. 357.1 links to the point of commencement—

which said pieces of land are particularly delineated and shown coloured red on survey plan numbered 10561, lodged in the office of the Country Roads Board.

And the Honorable Murray Victor Porter, Her Majesty's Minister of Public Works for the State of Victoria, shall give the necessary directions herein accordingly.

J. COLQUHOUN,
Clerk of the Executive Council.

COUNTRY ROADS BOARD.

At the Mercy Hospital, Melbourne, the second day of August, 1966.

PRESENT:

His Excellency the Governor of Victoria.
Mr. Reid | Mr. Darcy.

ORDER APPROVING OF WIDENING AN EXISTING MAIN ROAD IN THE SHIRE OF MORNINGTON.

WHEREAS the Country Roads Board constituted under the Country Roads Act 1958 (No. 6229) has represented to His Excellency the Governor in Council that it appears to it desirable that the existing Mornington-Dromana road in the Shire of Mornington (declared to be a main road under the said Act which declaration was confirmed by the Order in Council published in the *Government Gazette* of the 17th April, 1946, on pages 1325-6) should be widened by the said Board: And whereas the said Board in accordance with the requirements of section 19 of the said cited Act has caused to be prepared a map plan and estimate showing the points between which and on and through what land the said widening is proposed to be made and the cost of acquiring the land: And whereas on an inspection of the said map and plan and a consideration of the said estimate His Excellency the Governor in Council is satisfied that there are funds legally available for acquiring the land: Now therefore be it known by this present Order that His Excellency the Governor of

the State of Victoria with the advice of the Executive Council thereof doth hereby approve of the said road being widened, that is to say:—

All those pieces of land in the Parish of Moorooduc, the boundaries of which are as follow:—

- (a) Commencing at a point in allotment 24, section 22, of the said parish, distant 180 deg. 0 min. 323 ft. 8 in. and 89 deg. 51 min. 8 ft. 9 in. from the north-western angle of the said allotment; thence by lines bearing respectively 358 deg. 56 min. 20 feet, 134 deg. 23½ min. 28 ft. 6 in. and 269 deg. 51 min. 20 feet to the point of commencement.
- (b) Commencing at a point in allotment 25, section 22, of the said parish, distant 360 deg. 0 min. 306 ft. 8 in. and 89 deg. 51 min. 9 ft. 5½ in. from the south-western angle of the said allotment; thence by lines bearing respectively 89 deg. 51 min. 20 feet, 224 deg. 23½ min. 28 ft. 0½ in. and 358 deg. 56 min. 20 feet to the point of commencement—

which said pieces of land are particularly delineated and shown coloured red on survey plan numbered 10409, lodged in the office of the Country Roads Board.

And the Honorable Murray Victor Porter, Her Majesty's Minister of Public Works for the State of Victoria, shall give the necessary directions herein accordingly.

J. COLQUHOUN,
Clerk of the Executive Council.

COUNTRY ROADS BOARD.

At the Mercy Hospital, Melbourne, the second day of August, 1966.

PRESENT:

His Excellency the Governor of Victoria.
Mr. Reid | Mr. Darcy.

DECLARATION OF A DEVIATION FROM THE HAZELDEAN-ROAD IN THE SHIRE OF WARRAGUL.

WHEREAS by sections 21 and 58 of the Country Roads Act 1958 (No. 6229) it is amongst other things enacted that when the Country Roads Board under the provisions of the Country Roads Act has by Resolution declared a deviation to be a main road the said Board may also declare that such deviation shall be in lieu of any existing road or part thereof named in such Resolution and that on publication in the *Government Gazette* of the Order confirming such Resolution the existing road or part thereof shall cease to be a main road or be discontinued as provided in the Resolution: And whereas the said Board has by Resolution declared the deviation on the land described in the First Schedule to such Resolution to be a main road and has also declared that such deviation shall be in lieu of the part of the existing road being the land described in the Second Schedule to the said Resolution and that such part of the said existing road shall be discontinued: Now therefore His Excellency the Governor of the State of Victoria by and with the advice of the Executive Council thereof doth hereby confirm the said Resolution.

Resolution for Declaration of a Deviation of a Main Road under the Country Roads Act.

Whereas the land the site of the road the course of which is below set out was taken by the Board under the provisions of the Country Roads Act 1958 for the purpose of constructing such road deviation which road deviation has now been laid out and formed on the same: And whereas the said Board (being the Country Roads Board incorporated under the said Act) thinks that the road aforesaid is fit to be used as a public highway such Board at a meeting now holden acting under the authority conferred upon it by sections 21 and 58 of the said Act doth by this present Resolution hereby declare the said road deviation the course of which is described in the First Schedule hereto with the commencing and terminating points thereof respectively specified to be part of a main road within the meaning and for the purposes of the Country Roads Act 1958: And the said Board doth also declare that such deviation shall be in lieu of the existing road or part thereof described in the Second Schedule hereto and that such part of the said existing road shall be discontinued.

FIRST SCHEDULE.

Shire of Warragul.

9. *Hazeldean road* (17809).—All that piece of land in the Parish of Warragul, the boundaries of which are as follow:—Commencing at a point on the southern boundary of allotment 55 of the said Parish, distant 279 deg. 10 min. 336.4 links from the south-eastern angle of the said allotment; thence by lines bearing respectively 189 deg. 10 min. 100.1 links, 279 deg. 10 min. 1,932.0 links, 321 deg. 09 min. 309.5 links, 317 deg. 37 min. 405.0 links, 123 deg. 39 min. 328.3 links, 118 deg. 57 min. 530.0 links, 103 deg. 52 min. 530.0 links and 99 deg. 10 min. 1,153.5 links to the point of commencement—which said piece of land is particularly delineated and shown coloured red and green on survey plan numbered 9545, lodged in the office of the Country Roads Board.

SECOND SCHEDULE.

Shire of Warragul.

9. *Hazeldean road* (17809).—All that piece of land in the Parish of Warragul, the boundaries of which are as follow:—Commencing at a point on the northern boundary of allotment 57A of the said parish, distant 99 deg. 10 min. 828.0 links from the north-eastern angle of allotment 57C of the said parish; thence by lines bearing respectively 99 degrees 10 min. 149.5 links, 141 deg. 09 min. 133.2 links, 130 deg. 43 min. 797.2 links, 140 deg. 41 min. 305.8 links, 154 deg. 05 min. 293.0 links, 165 deg. 32 min. 192.8 links, 130 deg. 44 min. 115.0 links, 87 deg. 17 min. 143.3 links, 37 deg. 08 min. 213.6 links, 25 deg. 35 min., 915.6 links, 51 deg. 15 min. 121.6 links, 128 deg. 20 min. 102.6 links, 231 deg. 15 min. 121.8 links, 205 deg. 35 min. 902.9 links, 217 deg. 08 min. 270.5 links, 267 deg. 17 min. 230.0 links, 310 deg. 44 min. 186.2 links, 345 deg. 32 min. 214.0 links, 334 deg. 05 min. 271.3 links, 320 deg. 41 min. 285.4 links, 310 deg. 43 min. 797.6 links and 321 deg. 09 min. 253.4 links to the point of commencement—which said piece of land is particularly delineated and shown coloured blue on survey plan numbered 9545, lodged in the office of the Country Roads Board.

The common seal of the Country Roads Board was hereto affixed at Kew this Twenty-fifth day of July, One thousand nine hundred and sixty-six, in the presence of—

(SEAL) I. J. O'DONNELL, Chairman.
F. WEST, Member.
N. L. ALLANSON, Secretary.

And the Honorable Murray Victor Porter, Her Majesty's Minister of Public Works for the State of Victoria, shall give the necessary directions herein accordingly.

J. COLQUHOUN,
Clerk of the Executive Council.

COUNTRY ROADS BOARD.

At the Mercy Hospital, Melbourne, the
second day of August, 1966.

PRESENT:
His Excellency the Governor of Victoria.
Mr. Reid | Mr. Darcy.

DECLARATION OF THE WIDENING OF A ROAD IN THE SHIRE OF PORTLAND.

WHEREAS by section 110 of the *Country Roads Act* 1958 (No. 6229), incorporating section 21 of the said Act it is amongst other things enacted that when the Country Roads Board under the provisions of the *Country Roads Act* has taken the land necessary for constructing a road or deviation or widening it shall as soon as it thinks such road or deviation or widening is fit to be used as a public highway by Resolution declare the road or deviation or widening to be a road or part thereof and that upon publication in the *Government Gazette* of the Order of the Governor in Council confirming such Resolution such road or deviation or widening shall thereupon be a road or part thereof within the meaning of the said Act: And whereas the said Board has by Resolution declared the widening on the land described in the Schedule to such Resolution to be part of a road: Now therefore His Excellency the Governor of the State of Victoria by and with the advice of the Executive Council thereof doth hereby confirm the said Resolution.

Resolution for Declaration of the Widening of a Road under the Country Roads Act.

Whereas the land the site of the road the course of which is below set out was taken by the Board under the provisions of the *Country Roads Act* 1958 for the purpose of widening such road which widening has now been laid out and formed on the same: And whereas the said Board (being the Country Roads Board incorporated under the said Act) thinks that the widening aforesaid is fit to be used as part of a public highway such Board at a meeting now holden acting under the authority conferred upon it by sections 110 and 21 of the *Country Roads Act* 1958 doth by this Resolution hereby declare the same as described in the Schedule hereto with the commencing and terminating points thereof respectively specified to be part of the road within the meaning and for the purposes of the *Country Roads Act*.

SCHEDULE.

Shire of Portland.

Tyrendarra-Ettrick road.—All that piece of land in the Parish of Bessiebelle, the boundaries of which are as follow:—Commencing at the north-eastern angle of allotment 2 of the said parish; thence by lines bearing respectively 168 deg. 44 min. 1,601.8 links, 341 deg. 53 min. 802.8 links, 328 deg. 42 min. 947.2 links and 90 deg. 11 min. 428.7 links to the point of commencement—which said piece of land is particularly delineated and shown coloured red on survey plan numbered 7968, lodged in the office of the Country Roads Board.

The common seal of the Country Roads Board was hereto affixed at Kew this Twenty-fifth day of July, One thousand nine hundred and sixty-six, in the presence of—

(SEAL) I. J. O'DONNELL, Chairman.
F. WEST, Member.
N. L. ALLANSON, Secretary.

And the Honorable Murray Victor Porter, Her Majesty's Minister of Public Works for the State of Victoria, shall give the necessary directions herein accordingly.

J. COLQUHOUN,
Clerk of the Executive Council.

LANG LANG WATERWORKS TRUST.

At Government House, Melbourne, the
ninth day of August, 1966.

PRESENT:
His Excellency the Governor of Victoria.
Mr. Bloomfield | Mr. Rossiter.

EXTENT OF DISTRICT INCREASED.

UNDER the powers conferred by the *Water Act* and all other powers enabling him in that behalf, His Excellency the Governor of the State of Victoria, by and with the advice of the Executive Council of the said State, doth hereby declare, order and direct as follows:—

That the extent of the Waterworks District of the Lang Lang Waterworks Trust be increased by adding to the same the land comprised within the boundaries described in the Schedule hereto, and as on and from the date hereof, the extent of such District shall be and be deemed to be increased accordingly.

SCHEDULE.

Commencing at a point on the right bank of the Lang Lang River, Parish of Yallock, County of Mornington, in line with the south-western boundary of Crown allotment 4, Parish of Lang Lang, being a point on the boundary of the existing Waterworks District; thence generally south-westerly along the said right bank of the Lang Lang River to a point on the north-eastern boundary of the South-eastern Railway Reserve; thence north-westerly along the said north-eastern boundary of the South-eastern Railway Reserve to the westernmost angle of Crown allotment 16, being a point on the boundary of the existing Waterworks District; thence north-easterly, north-westerly, north-easterly, south-easterly and generally south-westerly along the boundary of the existing Waterworks District to the point of commencement.

All of which boundaries are shown on a plan approved by the Governor in Council and deposited in the office of the State Rivers and Water Supply Commission, Melbourne.—(Corres. 64/1822/52).

And the Honorable Thomas Anthony Darcy, Her Majesty's Minister of Water Supply for the State of Victoria, shall give the necessary directions herein accordingly.

J. COLQUHOUN,
Clerk of the Executive Council.

LOCAL GOVERNMENT DEPARTMENT.

At Government House, Melbourne, the
ninth day of August, 1966.

PRESENT:

His Excellency the Governor of Victoria.
Mr. Bloomfield | Mr. Rossiter.

REFUSAL OF APPLICATION FOR SEVERANCE OF PORTION OF THE MUNICIPAL DISTRICT OF THE SHIRE OF PORTLAND AND ANNEXATION THEREOF TO THE TOWN OF PORTLAND.

HIS Excellency the Governor of the State of Victoria, by and with the advice of the Executive Council thereof, and in pursuance of the powers conferred by section 23 (2) of the *Local Government Act 1958*, as amended, hereby refuses to grant an application made by the Council of the Town of Portland for severance of portion of the municipal district of the Shire of Portland and annexation of such portion to the municipal district of the Town of Portland.

And the Honorable Rupert James Hamer, Her Majesty's Minister for Local Government for the State of Victoria, shall give the necessary directions herein accordingly.

J. COLQUHOUN,
Clerk of the Executive Council.

TOWN AND COUNTRY PLANNING ACT 1961.

At Government House, Melbourne, the
ninth day of August, 1966.

PRESENT:

His Excellency the Governor of Victoria.
Mr. Bloomfield | Mr. Rossiter.

REVOCATION IN PART OF THE CITY OF BRUNSWICK PLANNING SCHEME 1956.—REVOCATION No. 2.

WHEREAS it is provided under the *Town and Country Planning Act 1961* that the Governor in Council, upon application of the Town and Country Planning Board or the responsible authority or of any other person or body of persons appearing to him to be interested, may revoke the whole or any part of any planning scheme if he thinks that, under the special circumstances of the case it should be so revoked;

And whereas it is provided under the *Town and Country Planning Act 1961* that the Governor in Council may by notice of revocation thereof prohibit the use or development of any land to which the revoked scheme or part related except with the consent of the responsible authority which prepared the scheme until such time as a further interim development order is made and any such prohibition shall be deemed to be an interim development order;

Now therefore, His Excellency the Governor of the State of Victoria, by and with the advice of the Executive Council and on the recommendation of the Town and Country Planning Board doth hereby:—

- (i) revoke the City of Brunswick Planning Scheme 1956, insofar as it applies to all that land being lot 27, Block B, on plan of subdivision 2111, lodged at the Office of Titles which is more particularly described in certificate of title, volume 4606, folio 068 in the Office of Titles, and being part of Crown portion 97, Parish of Jika Jika, County of Bourke, the boundaries of which are as follows:—

Commencing at a point on the eastern alignment of Grantham-street 34 feet north of the northern alignment of Munro-street;

thence northerly along the eastern alignment of Grantham-street for a distance of 33 feet; thence by a line bearing 89 deg. 54 min. for a distance of 108 feet to a point on the western alignment of a right-of-way; thence southerly along the western alignment of the right-of-way for a distance of 33 feet; thence westerly by a line bearing 269 deg. 54 min. for a distance of 108 feet to the point of commencement; and

- (ii) prohibit the use or development of any land described in (i) above except with the consent of the Council of the City of Brunswick.

And the Honorable Rupert James Hamer, Her Majesty's Minister for Local Government for the State of Victoria, shall give the necessary directions herein accordingly.

J. COLQUHOUN,
Clerk of the Executive Council.

LEONGATHA SEWERAGE AUTHORITY.

At Government House, Melbourne, the
ninth day of August, 1966.

PRESENT:

His Excellency the Governor of Victoria.
Mr. Bloomfield | Mr. Rossiter.

APPROVAL OF SITES OF OUTFALL MAIN, OCEAN OUTFALL, PUMPING STATION, DRAINAGE WORKS, EMERGENCY STORAGES AND RISING MAIN AND EXTENT OF SEWERAGE DISTRICT INCREASED.

UNDER the powers conferred by the Sewerage Districts Act and all other powers enabling him in that behalf, His Excellency the Governor of the State of Victoria, by and with the advice of the Executive Council of the said State doth hereby approve of the sites of Outfall Main, Ocean Outfall, Pumping Station, Drainage Works, Emergency Storages and Rising Main described in portions 1, 2, 3, 4 and 6 of the Schedule hereto and doth hereby declare, order and direct that the extent of the Sewerage District of the Leongatha Sewerage Authority be increased by adding thereto the land comprised within the boundaries described in portion 5 of the Schedule hereto, and as on and from the date hereof the extent of such District shall be and be deemed to be varied accordingly.

SCHEDULE.

PORTION 1.

Site of Outfall Main. (See Plans A to F inclusive.)

The site for the Outfall Main being a strip of land 100 links in width, the centre line of which commences at a point in allotment 8, section 8, Township of Korumburra, Parish of Korumburra, County of Buln Buln; thence north-easterly through the said allotment 8, and allotment 7 and easterly along Stuart-street, generally south-easterly through a Public Park, generally north-easterly along Bridge-road, through allotment 1, section E, along a road reserve adjacent to the south-eastern boundary of allotment 1A; thence generally easterly along the said road reserve, along and across the South-Eastern Railway Reserve, Parish of Korumburra, to the eastern end of the Kardella Railway Station reserve, generally south-easterly along a road reserve adjacent to Crown allotment 32, through the Township of Kardella and along the said road reserve, through Crown allotment 10, across a road and through Crown allotments 51A and 51B, across a road, through Crown allotment 52A, along a road reserve adjacent to the said South-Eastern Railway Reserve, across Coalition Creek, across a railway reserve, across a road, through Crown allotment 53p, Crown allotment 2A, Parish of Koorooman, across Coalition Creek, along a railway reserve, through Crown allotment 64A, Parish of Korumburra, Crown allotments 64B and 64C, across a road, through lots 9, 10, 5 and 4, on lodged plan of subdivision No. 8313, Parish of Leongatha, across a road, through Crown allotment 104A and along a road forming the western boundary of the Township of Leongatha, through allotment 21, section 8, Township of Leongatha, being the site of the existing sewage treatment works, across a road and through Crown allotment 108, Parish of Leongatha, across a road and through Crown allotment 56A, across a road and through Crown allotments 60B and 60C, across a road and through Crown allotment 28 and along the aforesaid South-Eastern Railway Reserve; thence generally southerly across a road and through allotment 7, section I., Township of Koonwarra, allotments 5, 6 and 4,

along a road bounded by the eastern boundaries of allotments 13, 14, 15, 17, 18 and the site for a school, section II; thence south-westerly along a road forming the south-eastern boundary of the school site; thence generally south-easterly through Crown allotment 84d, Parish of Leongatha, Crown allotments 84A, 84E, across a road, through Crown allotments 84E, 87C and 87D, across a road, through Crown allotments 32, 91D and 91C; thence generally southerly through Crown allotment 64A, Parish of Drumdemara, Crown allotments 64B, 65B, 66D and 66A, across a road and through Crown allotment 69C; thence generally south-westerly along a C.R.B. main road; thence generally southerly through Crown allotment 55A, Parish of Tarwin, across a road and through Crown allotment 59, along a road and through Crown allotments 21, 27, 60B and 28B, across the Tarwin River, through Crown allotment 26, across a road, through Crown allotment 28A and along a road; thence south-westerly through Crown allotment 72B and along a road forming the north-western boundary of Crown allotment 72B, Parish of Tarwin South, and across a reserve for public purposes on the coast of Bass Strait to the site of the ocean outfall structure described in portion 2.

PORTION 2.

Site of Ocean Outfall Structure. (See Plan F.)

The site of the Ocean Outfall structure being a strip of land 100 links in width commencing at a point on a reserve for public purposes on the coast of Bass Strait, such point being near Crown allotment 27D, Parish of Tarwin South, County of Buln Buln, and being the termination of the site of outfall main described in portion 1; thence generally south-westerly across the said reserve and into Bass Strait for a distance of 15 chains beyond low water mark.

PORTION 3.

Site of Pumping Station, Storage and Drainage Works. (See Plan C.)

The site for a Pumping Station, Storage and Drainage Works, being land within allotment 19, section 30, Township of Leongatha, Parish of Leongatha, County of Buln Buln, comprising approximately 2 acres 1 rood 3 perches.

PORTION 4.

Sites of Seven Emergency Storage Basins.

The sites for Emergency Storage Basins being:—

- (i) (See Plan B.)—Land in Crown allotment 27, Parish of Korumburra, County of Buln Buln, adjacent to its southern boundary and comprising approximately 1 acre 1 rood 20 perches.
- (ii) (See Plan B.)—Land in allotment 1A, Township of Korumburra, Parish of Korumburra, County of Buln Buln, adjacent to its south-eastern boundary and comprising approximately 16 perches.
- (iii) (See Plan B.)—Land in Crown allotment 53D, Parish of Korumburra, County of Buln Buln, between a railway reserve and Coalition Creek and comprising approximately 36 perches.
- (iv) (See Plan D.)—Land in Crown allotment 3, Parish of Leongatha, County of Buln Buln, adjacent to the western boundary of the South-Eastern Railway Reserve and comprising approximately 1 rood 32 perches.
- (v) (See Plan E.)—Land in Crown allotment 69D, Parish of Drumdemara, County of Buln Buln; adjacent to its eastern boundary and comprising approximately 36 perches.
- (vi) (See Plan F.)—Land in Crown allotment 55A, Parish of Tarwin, County of Buln Buln, adjacent to its north-western boundary and comprising approximately 36 perches.
- (vii) (See Plan F.)—Land in Crown allotment 26, Parish of Tarwin, County of Buln Buln, at its easternmost angle and comprising approximately 3 acres 2 roods 25 perches.

PORTION 5.

Extension of Sewerage District. (See Plan C.)

Commencing at a point on the south-western boundary of allotment 2, section 30, Township of Leongatha, Parish of Leongatha, County of Buln Buln, being distant 470 links from its southernmost angle and being also a point on the existing boundary of the Sewerage District; thence north-easterly by a line parallel to the south-eastern boundary of the said allotment 2, through the said allotment 2 and allotments 3 and 4 and across a road to a point on the south-western boundary of allotment 17; thence generally easterly along the south-western boundary of the said allotment 17 and the southern boundary of allotment 19 to a point in line with the eastern boundary

of allotment 18, section 28; thence southerly by a line across a road and along the said eastern boundary of allotment 18 to a point distant 300 links from its north-eastern angle; thence westerly by a line parallel to the northern boundary of the said allotment 18, through the said allotment 18 and allotment 17 to a point distant 50 links easterly from the eastern boundary of a Drain Reserve; thence generally south-westerly by a line parallel to and distant 50 links from the said boundary of a Drain Reserve through allotments 17, 21, 22, 23 and 24 to a point on the southern boundary of the said allotment 24; thence easterly along the said southern boundary of allotment 24 and by a line being the continuation thereof across a road to a point on the boundary of the existing Sewerage District; thence generally south-westerly and northerly along the boundary of the existing Sewerage District to the point of commencement.

PORTION 6.

Site of Rising Main. (See Plan C.)

The site of the Rising Main, being a strip of land 100 links in width, commencing at a point in the site of Pumping Station, Storage and Drainage Works described in portion 3, being in allotment 19, Township of Leongatha, Parish of Leongatha, County of Buln Buln; thence generally south-westerly through the said allotment 19, across a road and along a Drain Reserve, section 28, to Turner-street; thence westerly along Turner-street; thence generally south-westerly along Milne-street, across Hughes-street, the South-Eastern Railway Reserve, Anderson-street and along Bellingham-street a distance of approximately 4 chains; thence north-westerly along a right-of-way; thence westerly and southerly across Allison-street and along Trease-street to Gooch-street; thence generally westerly along the said Gooch-street; thence southerly along Brown-street; thence generally westerly within and along the southern boundaries of allotments 6 and 5, section 10 to a point on the site of the Outfall Main described in portion 1.

All of which lands and boundaries are shown on plans marked A to F inclusive approved by the Governor in Council and deposited in the office of the State Rivers and Water Supply Commission, Melbourne.—(Corres. 64/5496/54.)

And the Honorable Thomas Anthony Darcy, Her Majesty's Minister of Water Supply for the State of Victoria, shall give the necessary directions herein accordingly.

J. COLQUHOUN,

Clerk of the Executive Council.

LANDS DEPARTMENT NOTICES

APPROACHING LAND SALES.

SALES of Crown lands, in fee-simple, will be held at the under-mentioned places and dates, viz.:—

	No. of Gazette.
Ararat.—Wednesday, 31st August, 1966 ..	50
Ballarat.—Thursday, 18th August, 1966 ..	50

SALE OF FREEHOLD LAND BY AUCTION.

Geelong.—Tuesday, 30th August, 1966 .. 50

PROPOSED REVOCATION OF TEMPORARY RESERVATION OF LAND BY ORDER IN COUNCIL.

IN pursuance of the provisions of the Land Act 1958, notice is hereby given that it is the intention of the Governor in Council to revoke the temporary reservation of land by Order in Council hereunder referred to, viz.:—

The following Notice was published 1° on the 27th July, 1966, pursuant to Order of the 19th July, 1966.

ARARAT.—The temporary reservation by Order in Council of the 10th February, 1953, of 20 perches of land in the Township of Ararat as a site for Government buildings and the temporary reservation by Order in Council of the 14th April, 1953, of 1 rood 20 perches, more or less, as an extension thereto.—(A.148⁽¹⁰⁾) (Rs.5724.)

J. C. M. BALFOUR,

Minister of Lands.

PROPOSED REVOCATIONS OF TEMPORARY RESERVATIONS OF LANDS BY ORDERS IN COUNCIL.

IN pursuance of the provisions of the *Land Act 1958*, notice is hereby given that it is the intention of the Governor in Council to revoke the temporary reservations of lands by Orders in Council hereunder referred to, viz.:—

The following Notices were published 1^o on the 10th August, 1966, pursuant to Orders of the 2nd August, 1966.

BEECHWORTH.—The temporary reservation, by Order in Council of the 17th June, 1935, of 13 acres 1 rood 34 perches of land in the Township of Beechworth as a site for Hospital Purposes, so far only as the portion containing 1 acre 2 roods 29 perches, indicated by hachure on plan hereunder, is concerned.—(B.348⁽²⁾) (Rs.770).

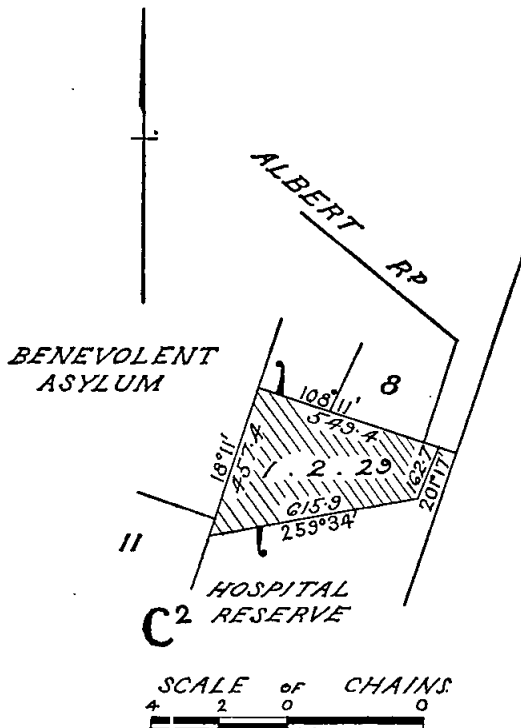

BOCHARA.—The temporary reservation as a site for Camping and Watering and the withholding from sale, leasing and licensing by Order in Council of the 30th October, 1876, (see *Government Gazette* of the 3rd November, 1876, page 2030) of 12 acres 1 rood 20 perches, more or less, of land in the Parish of Bochara.—(B.423⁽²⁾) (Rs.8582).

BOCHARA.—The temporary reservation, by Order in Council of the 4th November, 1953, of 1 acre 2 roods 20 perches, more or less, of land in the Parish of Bochara as a site for a Public Hall.—(B.423⁽²⁾) (Rs.6790).

FOOTSCRAY.—The temporary reservation, by Order in Council of the 9th December, 1902, of 21 3/10 perches of land in the City of Footscray as a site for an Ornamental Plantation.—(F.19⁽²⁾) (C.62029).

JOOP.—The temporary reservation, by Order in Council of the 24th April, 1923, of 6 acres 5 perches of land in the Parish of Joop as a site for Water Supply purposes.—(J.53⁽¹⁾) (Rs.2552).

KIRRAK.—The temporary reservation, by Order in Council of the 18th June, 1888 (see *Government Gazette* of the 22nd June, 1888, page 2033) of 10 acres of land in the Parish of Kirrak as a site for a Cemetery so far only as the portion containing 2 roods 38 perches, indicated by

hachure on plan hereunder, is concerned.—(K.148⁽²⁾) (C.99456).

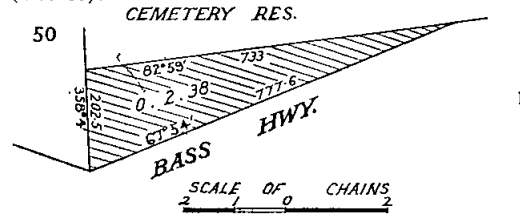

MARYBOROUGH.—The temporary reservation, by Order in Council of the 9th September, 1952, of 1 acre 1 perch of land in the Township of Maryborough as a site for Government and Municipal purposes, so far only as the portion containing 32 perches, indicated by hachure on plan hereunder, is concerned.—(M.66⁽¹⁵⁾) (Rs.5729).

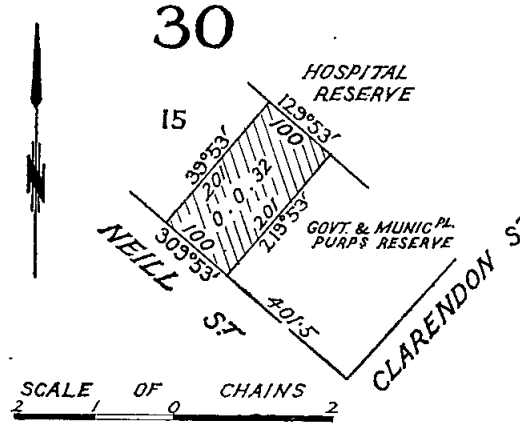

MARYSVILLE.—The temporary reservation, by Order in Council of the 27th December, 1865, of 3 roods 24 perches of land in the Township of Marysville as a site for Police purposes, revoked as to part by various Orders, so far as the balance thereof containing 2 roods 10 perches, more or less is concerned.—(M.431⁽³⁾) (Rs.5793).

TALLYGAROPNA.—The temporary reservation, as a site for Watering purposes and the withholding from sale, leasing and licensing by Order in Council of the 8th May, 1876 (see *Government Gazette* of the 12th May, 1876, page 894) of 39 acres of land in the Parish of Tallygaropna, so far only as the portions containing 31 acres 2 roods, more or less, indicated by hachure on plan hereunder, are concerned.—(T.234⁽³⁾) (C.99924).

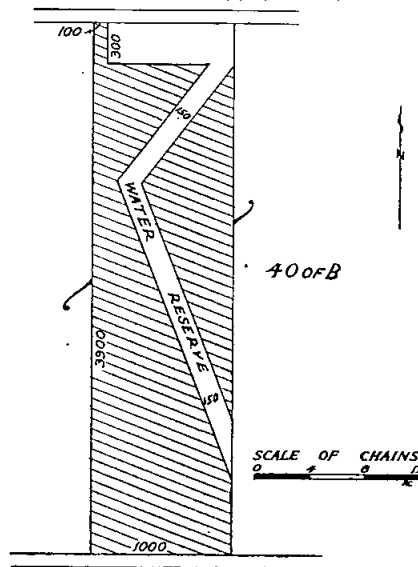

TOTAL AREA OF HACHURED PORTIONS.—31.2.0±

WARRNAMBOOL.—The temporary reservation, by Order in Council of the 16th March, 1960, of 124 acres 18 perches of land in the Township of Warrnambool as a site for Public Park and Public Recreation, so far only as the portion containing 8 acres 1 rood 19 perches, indicated by hachure on plan hereunder, is concerned.—(W.99(6)) (Rs.283).

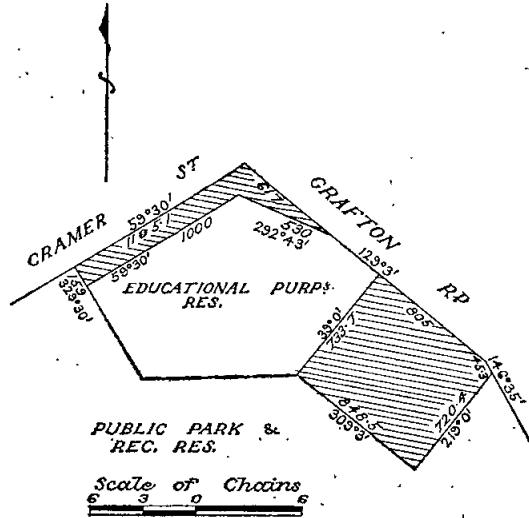

TOTAL AREA OF HACHURED PORTIONS:— 8^a. 1^r. 19^p

WARRNAMBOOL.—The temporary reservation, by Order in Council of the 15th March, 1949, of 10 acres 1 rood 22 perches of land in the Township of Warrnambool as a site for Educational Purposes.—(W.99(9)) (Rs.6333).

J. C. M. BALFOUR,
Minister of Lands.

PROPOSED PERMANENT RESERVATIONS OF LANDS AS SITES.

IN pursuance of the provisions of the Land Act 1958, notice is hereby given that it is the intention of the Governor in Council to permanently reserve as sites, and also except from occupation for mining purposes under any miner's right, the lands hereunder referred to:—

The following Notices were published 1° on the 20th July, 1966, pursuant to Orders of the 12th July, 1966:

PRAHRAN (CAULFIELD).—As a site for Public Park, Gardens and Public Recreation, 57 acres 1 rood, more or less, Parish of Prahran, at Caulfield, County of Bourke, being the remaining portion of the site temporarily reserved therefor by Order in Council of the 24th April, 1956, and known as "Caulfield Park"—(P.81(11)) (Rs.215).

PRAHRAN (CAULFIELD).—As a site for Public Purposes (Swimming pool, other associated facilities and car parking), 5 acres 2 perches, Parish of Prahran, at Caulfield, County of Bourke, as indicated by hachure on plan hereunder.—(P.81(11)) (Rs.8469).

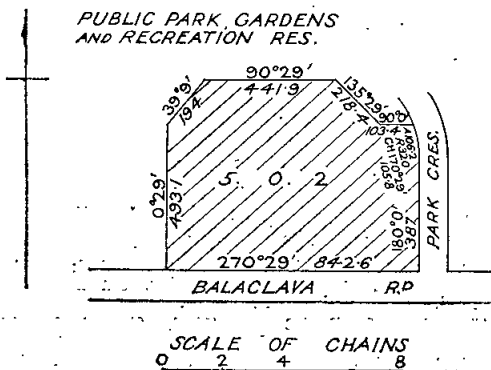

J. C. M. BALFOUR,
Minister of Lands.

PROPOSED REVOCATIONS OF TEMPORARY RESERVATIONS OF LANDS BY ORDERS IN COUNCIL.

IN pursuance of the provisions of the Land Act 1958, notice is hereby given that it is the intention of the Governor in Council to revoke the temporary reservations of lands by Orders in Council hereunder referred to, viz.:—

The following Notices were published 1° on the 3rd August, 1966, pursuant to Orders of the 27th July, 1966.

AVOCA.—The temporary reservation by Order in Council of the 30th July, 1866, of 52 acres 2 roods 2½ perches, more or less, of land (in three separate portions) in the Township of Avoca as sites for Police purposes, revoked as to part by various Orders so far as the balance thereof containing 2 roods 1½ perches is concerned.—(A.86(8)) (Rs.7916).

BALLARAT EAST.—The temporary reservation by Order in Council of the 30th January, 1893, of 8 acres of land in the Township of Ballarat East, as a site for Supply of Gravel, revoked as to part by various Orders, so far as the balance thereof, containing 5 acres 1 rood 7 perches, more or less, is concerned.—(B.128(64)) (Rs.5349).

CARLYLE.—The temporary reservation by Order in Council of 21st January, 1902, of 1 acre 2 roods 16 perches, of land in the Parish of Carlyle, as a site for Drainage purposes, so far only as the portion containing 2 perches, indicated by hachure on plan hereunder is concerned.—(C.187(7)) (Rs.367).

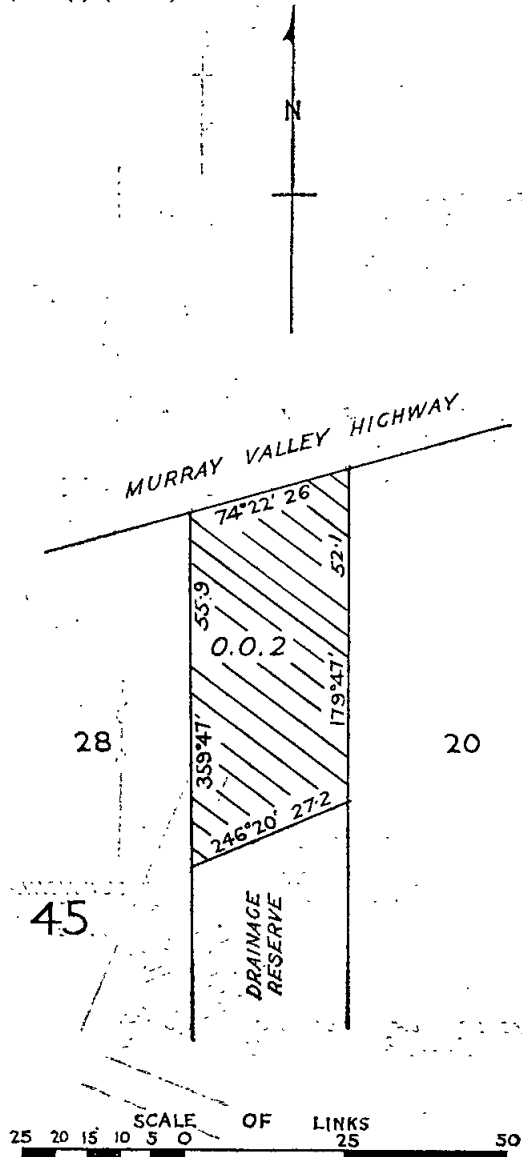

KERANG.—The temporary reservation by Order in Council of the 12th June, 1888, of 1 acre 2 roods of land in the Township of Kerang as a site for the Supply of Material for Road Making Purposes and the temporary reservation by Order in Council of the 10th March, 1891, of 1 rood 3 perches of land as an extension thereto.—(K.19⁽¹¹⁾) (Rs.8578).

KURTING.—The temporary reservation, by Order in Council of the 30th June, 1896, of 6 acres 3 roods 23 perches of land in the Parish of Kurting as a site for Public Recreation.—(K.112⁽²⁾) (Rs.1977).

MULLAGONG.—The temporary reservation, by Order in Council of the 5th December, 1900, of 2 acres of land in the Parish of Mullagong as a site for a State School.—(M.545⁽⁴⁾) (Rs.5873).

Ni Ni.—The temporary reservation, by Order in Council of the 4th November, 1889, of 5 acres of land in the Parish of Ni Ni as a site for a State School.—(N.124⁽²⁾) (Rs.5811).

WARRAQUIL.—The withholding from sale, leasing and licensing by Order in Council of the 25th June, 1877, of 180 acres of land in the Parish of Warraquil, revoked as to part by Order of the 12th March, 1909, so far only as the portion containing 11 acres 32 perches, indicated by hachure on plan hereunder, is concerned.—(W.318⁽⁴⁾) (Rs.8098).

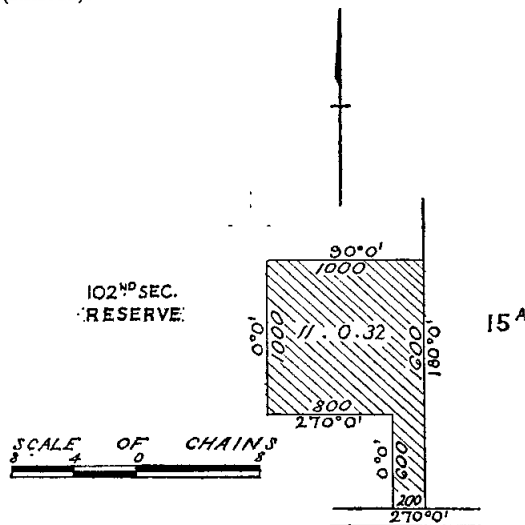

YARRAGON (MOE).—The temporary reservation, as a site for Racecourse and other purposes of Public Recreation and the withholding from sale, leasing and licensing by Order in Council of the 3rd November, 1884, of 118 acres 1 rood 24 perches of land in the Parish of Yarragon, revoked as to part by Order of the 20th February, 1902, so far only as the portion containing 1 acre 22 perches, indicated by hachure on plan hereunder, is concerned.—(Y.109⁽⁹⁾) (Rs.684).

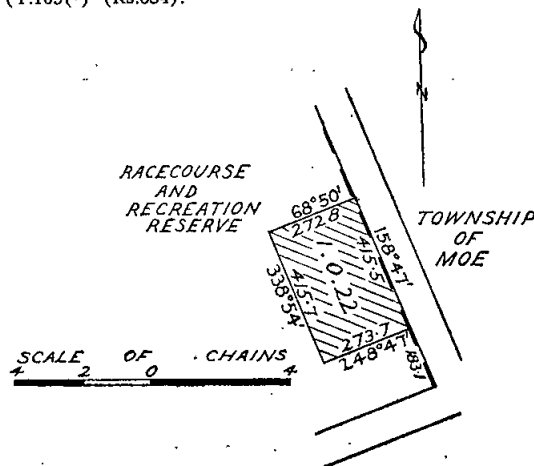

DANDONGADALE (South Buffalo).—The temporary reservation by Order in Council of the 18th September, 1956, of 3 acres, 2 roods, 30 perches, more or less, of land in the Parish of Dandongadale (formerly Dondangadale), as a site for Public Recreation.—(D.196⁽³⁾) (Rs.7497).

GERANGAMETE.—The temporary reservation, by Order in Council of the 5th November, 1941, of 14 acres 2 perches of land in the Parish of Gerangamete as a site for Watering purposes.—(G.170^(c²)) (Rs.5286).

Jil Jil.—The temporary reservation, by Order in Council of the 25th May, 1937, of 1 acre of land in the Parish of Jil Jil as a site for a State school.—J.54⁽⁸⁾) (Rs.4669).

J. C. M. BALFOUR,
Minister of Lands

PROPOSED REVOCATIONS OF TEMPORARY RESERVATIONS OF LANDS BY ORDERS IN COUNCIL.

IN pursuance of the provisions of the *Land Act 1958*, notice is hereby given that it is the intention of the Governor in Council to revoke the temporary reservations of lands by Orders in Council hereunder referred to, viz.:

The following Notices were published 1^o on the 20th July, 1966, pursuant to Orders of the 12th July, 1966.

BEULAH.—The temporary reservation, by Order in Council of the 15th May, 1956, of 2 roods 3 perches of land in the Township of Beulah, Parish of Galaquil, as a site for a Children's Playground.—(B.727⁽⁷⁾) (Rs.7115).

BOORT.—The temporary reservation, by Order in Council of the 1st March, 1880, of 2 acres of land in the Parish of Boort as a site for Public Purposes (State School).—(B.654⁽¹¹⁾) (C.97235).

J. C. M. BALFOUR,
Minister of Lands.

PROPOSED PERMANENT RESERVATIONS OF LANDS AS SITES.

IN pursuance of the provisions of the *Land Act 1958*, notice is hereby given that it is the intention of the Governor in Council to permanently reserve as sites, and also except from occupation for mining purposes under any miner's right, the lands hereunder referred to:

The following Notices were published 1^o on the 3rd August, 1966, pursuant to Orders of the 27th July, 1966.

MOORPANYAL (GEELONG WEST).—Land proposed to be permanently reserved as a site for Public Park and Public Recreation, 9 acres 3 roods 10 perches more or less, Parish of Moorpanyal, County of Grant, being the remaining portion of the site temporarily reserved therefor by Order in Council of the 4th October, 1949, and known as "Western Oval".—(M.199⁽⁹⁾) (Rs.5533).

LAKE ROWAN.—Land proposed to be permanently reserved as a site for Public Recreation, 21 acres 3 roods 21 perches, Township of Lake Rowan (formerly Town of Karrabumet), Parish of Karrabumet, County of Moira, being the site temporarily reserved therefor by Order in Council of the 25th July, 1892, and known as "Lake Rowan Recreation Reserve".—(L.186⁽¹⁾) (Rs.1971).

J. C. M. BALFOUR,
Minister of Lands.

LOCAL LAND BOARDS.

IN pursuance of the provisions of section 34 of the *Land Act 1958*, notice is hereby given that public hearings at the following places and times, will be conducted by the persons respectively mentioned, being duly appointed in that behalf.

J. C. M. BALFOUR,
Minister of Lands.

Department of Crown Lands and Survey,
Melbourne.

SCHEDULE.

GEELONG LAND OFFICE, 123 RYRIE-STREET, GEELONG, Daily at 9.30 a.m., Monday, 22nd August, 1966 to Friday, 26th August, 1966; Monday, 29th August, 1966 to Friday, 2nd September, 1966; Monday, 5th September, 1966 and Tuesday, 6th September, 1966.—E. Kennedy, C. G. Knight.

BOARD ROOM, P.W.D. ANNEXE, STATE PUBLIC OFFICES, TREASURY-PLACE, MELBOURNE. Daily at 9.30 a.m., Wednesday, 7th September, 1966 to Friday, 9th September, 1966.—E. Kennedy, C. G. Knight.

PROPOSED REVOCATIONS OF TEMPORARY RESERVATIONS OF LANDS BY ORDERS IN COUNCIL.

IN pursuance of the provisions of the *Land Act 1958*, notice is hereby given that it is the intention of the Governor in Council to revoke the temporary reservations of lands by Orders in Council hereunder referred to, viz.:—
 The following Notice was published 1° on the 10th August, 1966, pursuant to Orders of the 2nd August, 1966.

MULLROO (LAKE CULLULLERAINE).—The temporary reservation by Order in Council of the 12th December, 1930, of 1,435 acres 2 roods 36 perches of land in the Parish of Mullroo, as a site for Water Supply purposes, revoked as to part by various Orders, is about to be revoked so far only as the portion containing 383 acres 23 perches, indicated by hachure on plan hereunder, is concerned.—(M.499⁽¹⁾) (Rs.4076).

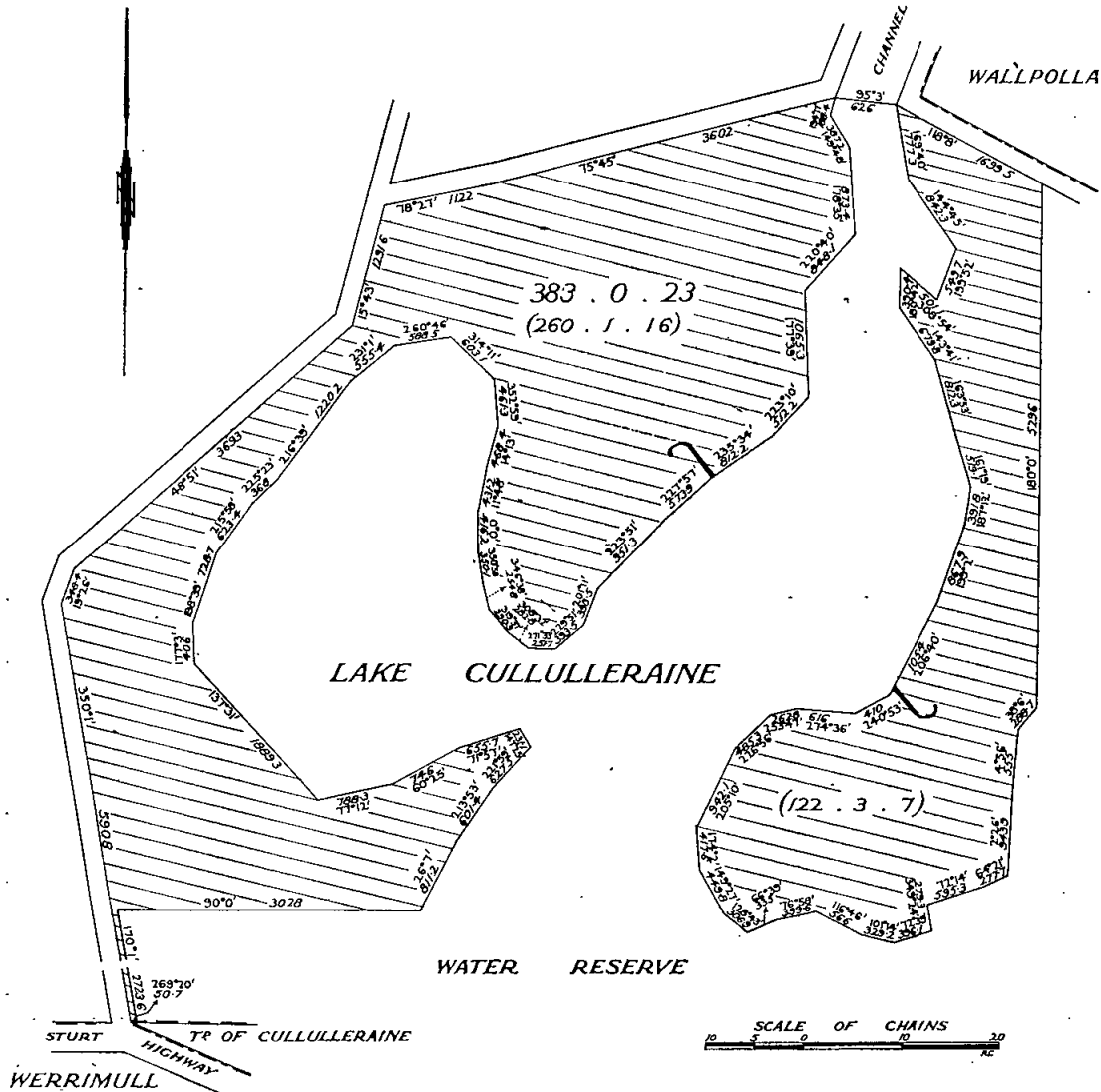

J. C. M. BALFOUR,
 Minister of Lands.

Land Act 1958.
 PERMIT CANCELLED.

NOTICE is hereby given that the Permit in the Schedule hereunder has been cancelled.

District.	Corr. No.	Name of Permit Holder.	Parish.	Allotment.	Section.	Area.
Hamilton ..	670/155	C. N. Venlet	Geerak	32A	..	A. R. P. 168 . 0 . 0

Department of Crown Lands and Survey,
 Melbourne, 4th August, 1966
 No. 59.—7193/66.—3

J. C. M. BALFOUR,
 Minister of Lands.

COMMITTEES OF MANAGEMENT OF RESERVES.

APPOINTMENTS.

NOTICE is hereby given that, in pursuance of section 221 of the Land Act 1958, the following appointments of Committees of Management of reserved Crown lands have been made by the Minister of Lands:—

"BUSHFIELD RECREATION RESERVE."

Geoff Palmer, Roger McKenna, James Conheady, Thomas Edward Davis, Ian McKenzie, James Alfred Grundy, John Francis Lynch as a Committee of Management for a period of three (3) years of the lands temporarily reserved by Order in Council dated the 12th February, 1877, as a site for Recreation and by Order in Council dated 16th October, 1951, as a site for Public Recreation, both sites being in the Parish of Wangoom, and together being known as the "Bushfield Recreation Reserve".—(Corres. Rs.2164.)

"LAL LAL RACECOURSE RESERVE."

The Council of the Shire of Buninyong as the Committee of Management of the land in the Parish of Lal Lal permanently reserved by Order in Council dated the 20th May, 1890, as a site for a Racecourse and known as the "Lal Lal Racecourse Reserve".—(Corres. Rs.2543.)

"LANDING AND PUBLIC PURPOSES RESERVE" PARISH OF YEERUNG.

Leslie Thomas Swan, Neville William C. Bennett, Gary Bernard Tobin, Peter Nowak, Gavan Healy, James S. Farrell, Charles Hollis, Ronald Harry Milner, and Thomas Newton Scott as a Committee of Management for a period of three (3) years of the land in the Parish of Yeerung, temporarily reserved for Landing Purposes, together with the adjoining portion of the public purposes reserve to the Avon River, both areas being shown by red and yellow colour on plan Y/22.7.66 attached to Lands Department correspondence Rs. 8644.—(Corres. Rs.8644.)

"NAPOLEONS RECREATION RESERVE."

Geoffrey Forester McManus, Peter John Nolan, Robert Ian Lightfoot, David Sullivan and James Francis Phelan as the Committee of Management for a period of three (3) years of the remaining portion of the lands temporarily reserved by Orders in Council dated the 18th May, 1874, and 14th March, 1908, for Public Recreation in the Township of Napoleons and known as "Napoleons Recreation Reserve".—(Corres. Rs.2501.)

"PUBLIC PARK AND RECREATION RESERVE", TOWNSHIP OF CORYYONG.

The Council of the Shire of Upper Murray as the Committee of Management of the land in the Township of Coryyong temporarily reserved by Order in Council dated the 12th July, 1966, as a site for Public Park and Recreation Reserve.—(Corres. Rs.8611.)

THE PUBLIC PURPOSES (MUNICIPAL DEPOT AND STOREYARD) RESERVE, DROUIN.

The Council of the Shire of Buln Buln as the Committee of Management of the land in the Township of Drouin, temporarily reserved by Order in Council dated the 12th July, 1966, as a site for Public Purposes (Municipal Depot and Storeyard).—(Corres. Rs.8422.)

PUBLIC PURPOSES (MUNICIPAL DEPOT) RESERVE, TOWNSHIP OF MALDON.

The Council of the Shire of Maldon as the Committee of Management of the land in the Township of Maldon, temporarily reserved by Order in Council dated the 12th July, 1966, as a site for Public Purposes (Municipal Depot).—(Corres. Rs.8521.)

"PUBLIC PURPOSES AND RECREATION RESERVE", TOWNSHIP OF PORTLAND.

The Council of the Town of Portland as the Committee of Management of the land in the Township of Portland temporarily reserved by Order in Council dated the 12th July, 1966, as a site for Public Purposes and Recreation.—(Corres. Rs.8614.)

"STONY CREEK RECREATION AND RACECOURSE RESERVE."

John Rhodes Carmichael, Colin Rhodes Carmichael, Peter Niven Carmichael, George Bengtsson, Turwald Ernest Thorson, Kevin Patrick Dempsey, Frederick Henry Helms, William Frederick Helms, John Meikle, Ian Keppell Greig, Alan John Bell, Joseph Harold Ross, Alan Sutherland Sinclair and William James McGrath as a Committee of Management for a period of three (3) years of the land temporarily reserved by Order in Council dated 14th September, 1910, as a site for a Racecourse and other purposes of Public Recreation in the Township of Dumbalk and known as the "Stony Creek Recreation and Racecourse Reserve".—(Corres. Rs.1371.)

"TALLAROOK RECREATION RESERVE."

William Frederick Schnieder, John William Hedley, Leo Francis Dwyer, Keith Henry Jenkins, Douglas Boulton, Frederick Walter Henry, Joseph Leahy, and William John Jenkin as the Committee of Management for a period of three (3) years of the land temporarily reserved by Order in Council dated the 18th December, 1934, as a site for Public Recreation in the Township of Dabyminga, Parish of Lowry and known as the "Tallarook Recreation Reserve".—(Corres. Rs.4426.)

ALAN J. HOLT,
Secretary for Lands.

9th August, 1966.

TENDERS

PUBLIC WORKS DEPARTMENT

TENDERS will be received at Public Works Department, Treasury-place, Melbourne, until TEN a.m. on dates shown and for purposes mentioned hereunder.

Particulars and tender forms available at Contracts Office, Room 7, Building Division, Parliament-place and at places indicated in brackets hereunder.

Abbreviations in brackets mean:—W.O.—Inspector of Works Office; P.S.—Police Station; C.S.—Consolidated School; H.E.S.—Higher Elementary School; H.S.—High School; S.S.—State School; T.S.—Technical School.

Tenders to be submitted on the Department's printed Tender Form and will not be received by telephone. All tenders must be on a "Firm Tender" basis. The lowest or any tender will not necessarily be accepted.

Address tenders to the Minister of Public Works, and endorse the envelope containing the tender "Tender for , closing Tuesday, ".

No preliminary deposit is required with any tender, but a successful tenderer will be required to pay a deposit for any accepted tender of \$5,000 or over.

Tuesday, 16th August, 1966.

Building, Electrical and Mechanical Works.

Ararat.—Erection of shelter shed, "J" Ward, Mental Hospital. (W.O., Ballarat.) (Re-advertised.)

Ararat.—Repairs and painting, Wards M.8, M.9, M.10 and M.11, Mental Hospital. (W.O., Ararat; P.S., Stawell.) Camp Hill.—Repairs and painting, provision of internal toilet, S.S. 1976. (W.O., Bendigo.)

Diamond Creek.—Renovations to office and residence, Police Station.

Eastmeadows.—Erection of four additional class-rooms, S.S. 4865.

Eastmeadows.—Electrical installation in new block of four (4) L.T.C. class-rooms, S.S. 4865.

Eastmeadows.—Plenum heating in four class-room wing, S.S. 4865.

Echuca.—Repairs and painting, Technical School. (W.O., Shepparton; T.S., Echuca.)

Erica.—Renovations, provision of laundry, S.S. 2437 and Residence. (W.O., Warragul.)

Essendon.—New toilet accommodation, High School. (Re-advertised.)

Essendon.—Extensions to general office, Technical School.

Glenhuntly.—Internal renovations to Senior School Building, S.S. 3703.

Hampton.—Electrical installation in additional Science Wing, &c., High School.

Hampton.—Erection of Science Wing, High School.

Heatherhill.—External repairs and painting, S.S. 4802.

Horsham.—Renovations, S.S. 298 & Residence. (W.O., Horsham.) (Re-advertised.)

Horsham East.—Conversion of septic closets, S.S. 4799. (W.O., Horsham.)
 Kew.—Renovations, S.S. 1075.
 Kialla.—Internal renovations, S.S. 1366 & Residence. (W.O., Shepparton; S.S., Kialla.)
 Koo-Wee-Rup.—Internal renovations, High School. (H.S., Koo-Wee-Rup.)
 Lancaster.—Erection of new store, repairs and re-painting, S.S. 1814 & Residence. (W.O., Shepparton; S.S., Lancaster.) (Re-advertised.)
 Mannibadar.—Conversion to septic sewerage, additional toilet, S.S. 4446. (W.O., Ballarat; S.S., Mannibadar.)
 Maribymong.—External repairs and painting, Police Station & Residence.
 McKinnon.—Roof repairs and renovations, High School & Residence.
 Milawa.—Repairs and painting, S.S. 737 & Residence. (W.O., Wangaratta and Benalla; S.S., Milawa.)
 Monbulk.—Repairs to toilets and water supply, S.S. 3265 & Residence. (S.S., Monbulk.)
 Princes Hill.—External renovations, S.S. 2955.
 Rosebud.—Mechanical services in General Purpose Hall, High School.
 Seymour.—Renovations, High School. (Amended Specification.) (W.O., Alexandra; H.S., Seymour.)
 Strathallan.—Renovations and painting, S.S. 3855. (W.O., Shepparton.) (Re-advertised.)
 Sunbury.—External painting to Mess and Recreation Rooms, Mental Hospital.
 Sunbury.—Internal painting, Ward F.2, Mental Hospital.
 Swan Hill.—Erection of fifth form extensions, Technical School. (Re-advertised.) (W.O., Swan Hill.)
 Yannathan South.—External repairs and painting, Residence, S.S. 3225. (S.S., Yannathan South).

Furniture and Furnishings.

Footscray.—Steel framed tables, Technical College.
 Melbourne.—Steel filing cabinets, cupboards and shelving, Titles Office, Queen-street.
 Melbourne.—Supply and lay welded vinyl, Melbourne School of Hairdressing, Latrobe-street.
 Warrnambool.—Supply and fix stage curtains, Technical College.

Site Works.

Mitcham.—Asphalting, concreting, drainage and associated works, Technical School.

Tuesday, 23rd August, 1966.

Building, Electrical and Mechanical Works.

Balmoral.—Repairs and painting, Consolidated School. (W.O., Hamilton; C.S., Balmoral.)
 Bentleigh West.—Renewal of urinals, pans, cisterns, &c., S.S., 4318.
 Braybrook.—Demolition of slate urinal and renewal with stainless steel urinal, S.S. 1102.
 Broadford.—Renovations, S.S. 1125. (W.O., Kyneton; S.S., Broadford.)
 Carnegie.—Renovations to Senior School, S.S. 2897.
 Caulfield.—Renovations, additional toilet, &c., S.S. 773.
 Dandenong.—External and internal renovations, High School. (Re-advertised.) (H.S., Dandenong.)
 Echuca.—Electrical installation in new L.T.C. Wing, High School. (W.O., Bendigo and Shepparton; H.S., Echuca.)
 Fairfield North.—External and internal repairs and painting, S.S. 4329.
 Fawkner.—Repairs and painting, High School.
 Footscray.—Electrical installation, reticulation of fluorescent lighting, &c., Technical College.
 Footscray.—Sound-proofing of class-rooms, Technical College.
 Footscray.—Supply and installation of plenum heating and modifications to boiler-room, Technical College.
 Geelong.—Roof renewal, internal renovations to Davidson Hall, Gordon Institute of Technology. (Re-advertised.) (W.O., Geelong.)
 Glenormiston North.—Internal and external repairs and painting, S.S. 3207 and Residence. (Re-advertised.) (W.O., Camperdown; S.S. Glenormiston North.)
 Ivanhoe.—Electrical installation, Girls' Hostel, cnr. Maltravers and Marshall streets, Social Welfare Department.
 Longford.—Repairs and painting, S.S. 1694 and Residence. (W.O., Traralgon; S.S. Longford.)
 Macleod.—Connexion to sewer, S.S. 4246.
 Malvern East.—Repairs and painting, S.S. 4139 and residence.
 Moomba Park.—Erection of four additional class-rooms, S.S. 4876.
 Mount View.—Erection of paling fencing, S.S. 4923.

Nathalia.—New ceiling to Domestic Arts Wing, High School. (Re-advertised.) (W.O., Shepparton; H.S. Nathalia.)
 Olinda.—Fencing, S.S. 3494.
 Orbost.—Chain mesh or weld mesh fencing, S.S. 2744. (W.O., Orbost and Bairnsdale; S.S. Orbost.)
 Osborne.—Internal and external renovations, S.S. 2655.
 Point Lonsdale.—Renovations to toilet/store block, S.S. 3322. (W.O., Geelong; S.S. Point Lonsdale.)
 St. Albans.—External repairs and painting, High School.
 Seymour.—Electrical installation in new school of eight (8) class-rooms, &c., S.S. 4957.
 Seymour.—Erection of eight (8) class-room Primary School. S.S. 4957. (W.O., Alexandra; P.S., Seymour.)
 Seymour.—Plenum heating, S.S. 4957. (W.O., Alexandra.)
 South Yarra.—Internal repairs and painting, Melbourne Teachers' College Hostel, 24 Marnie-street.
 Sunny Creek.—General renovations to Residence, S.S. 2908. (W.O., Warragul; S.S. Sunny Creek.)
 Swan Hill.—Extension of mechanical services, Technical School. (W.O., Swan Hill.)
 Thornbury.—Repairs and painting, S.S. 3889 and residence.
 Various.—Disconnexion, transportation and re-erection of approximately 200 (two hundred) existing timber framed pre-fabricated portable class-rooms to various school sites in Victoria.
 Vermont.—Re-stumping of old building, S.S. 1022.
 Warrnambool.—Electrical installation in Manual Arts Wing, &c., High School. (W.O., Warrnambool and Hamilton.)
 Woods Point.—Repairs and painting, S.S. 789 and Residence. (W.O., Alexandra.)

Furniture and Furnishings.

Carlton.—Supply of steel desks, Motor Registration Branch, Lygon-street.
 Melbourne.—Supply of executive chairs, Premiers Department, Cabinet Room, New State Offices, Treasury place. (Yuncken, Freeman Architects Pty. Ltd., 411 King-street, Melbourne.)

Site Works.

Various.—Asphalting, asphalt repairs, gravelling, &c., Altona West, S.S. 4862, Altona East, S.S. 4805, Sunshine North, S.S. 4765 and St. Albans East, S.S. 4721.

Miscellaneous.

Ararat.—Supply of timber, Mental Hospital.
 Beechworth.—Supply and delivery of thicknessing machine, Mental Hospital.
 Melbourne.—Supply of bricks for Day Labour Organization, 1st October, 1966, to 30th September, 1967, Public Works Department.

Tuesday, 30th August, 1966.

Building, Electrical and Mechanical Works.

Ararat.—External renovations to Nurses' Home, Mental Hospital. (W.O., Ararat.)
 Boroondara.—Internal repairs and painting, S.S. 4724.
 Camperdown.—Internal and external repairs and painting, Residence, 56 Bowen-street, S.S. 114. (W.O., Camperdown; S.S., Camperdown.)
 Costerfield.—Erection of out-office and installation of septic tank, S.S. 1187. (Re-advertised.) (W.O., Bendigo; S.S., Costerfield.)
 Elwood.—External renovations, High School. (Re-advertised.)
 Fairfield North.—Renewal of toilet pans, cisterns, urinal and drinking facilities, S.S. 4329.
 Geelong.—Repairs and painting, Technical School (W.O., Geelong.)
 Gerangamete.—New toilet block and laying of drains, &c., S.S. 1243. (W.O., Camperdown; S.S., Gerangamete.)
 Hamilton.—Renovations, Residence, 3 Lewis-street, High School. (Re-advertised.) (W.O., Hamilton.)
 Hamilton.—Renovations, Residence, 28 Bree-road, Technical School. (Re-advertised.) (W.O., Hamilton.)
 Heidelberg Heights.—External repairs and painting, S.S. 4774. (Amended Specification.)
 Leongatha.—Internal and external renovations, Residence, 38 A'Beckett-street, S.S. 2981. (W.O., Korumburra; S.S., Leongatha.)
 Merri.—Repairs and painting, S.S. 3110.
 Portland North.—Roof repairs and renovations, Residence, S.S. 1194. (W.O. Warrnambool; S.S., Portland North.)

Preston East.—Erection of brick veneer Police Station (including electrical services).

Preston West.—Renewal of water service and drinking facilities, S.S. 3885.

South Melbourne.—Repairs and painting, J. H. Boyd Domestic College.

South Melbourne.—Repairs and painting, Caretaker's Residence, MacRobertson Girls' High School.

St. Albans.—External and internal repairs and painting, Technical School.

Strathdownie.—Repairs and painting, &c., S.S. 2883. (Re-advertised.) (W.O., Hamilton; S.S., Strathdownie.)

Victoria Park.—Roof repairs, erection of store, S.S. 2957.

Wallan Wallan.—Re-blocking, repairs and painting, Police Station and Residence. (Re-advertised.) (W.O., Alexandra; P.S., Wallan Wallan.)

Warrnambool.—Connexion of toilet block to sewerage system, Mental Hospital. (W.O., Warrnambool.)

Site Works.

Yarram.—Asphalt paving, grading and gravelling, lawns, &c., S.S. 693. (W.O., Traralgon.)

Miscellaneous.

Port Melbourne.—Supply and delivery of four tons capacity mobile slewing crane, Public Works Department, Depot, Salmon-street.

Port Melbourne.—Supply and delivery of three (3) pneumatic tyred tractor mounted 6 tons cranes, Public Works Department, Depot, Salmon-street.

Port Melbourne.—Supply and delivery of pneumatic tyred tractor mounted eight (8) tons crane, Public Works Department, Depot, Salmon-street.

J. C. M. BALFOUR,

Acting Minister of Public Works.

Public Works Department,
Melbourne, C.2, 8th August, 1966.

TENDERS FOR THE SERVICE, 1966-67.

GENERAL STORES.

TENDERS will be received until Eleven o'clock a.m. on Friday, 26th August, 1966, from persons willing to supply the under-mentioned articles in such quantities as may be ordered by the Victorian Government, from the 1st September, 1966, to the 31st August, 1967:—

Schedules, as above, with full particulars, may be obtained from the Secretary to the Tender Board, by whom also the samples will be shown and any information afforded to persons tendering.

In all cases the total cost of each item must be extended in the columns provided.

Schedule No.

1. Requisites (Junior School).
2. Exercise Books and Requisites.
68. Stamps, Rubber.
69. Stationery (General) and Typewriters. Carbon Papers, Typewriter Ribbons, &c., Typograph Material.

The prices tendered must not include sales tax.

Security.—Five per cent. of total amount of tender accepted, but in no case will security of less than \$6 be received.

Security will be required either in Commonwealth Treasury Bonds, or approved bank guarantee, fixed deposit receipt, Savings Bank deposit book, or non-negotiable cheque in favour of the Secretary to the Tender Board, as the tenderer may elect.

The security must be completed and the contract signed within five days of acceptance of the tender, failing which the contract may be again advertised, or another tender accepted.

The lowest or any tender will not necessarily be accepted.

In the event of tenderers withdrawing or attempting to withdraw their tenders before notification of acceptance of same or failing to take up their accepted tenders within the prescribed period after notification of acceptance, they may be disqualified from tendering or holding any future contracts for Government supplies for a period of twelve months, such disqualification to date from the notification of acceptance of tender. It is also stipulated that, if a tenderer be a member of a firm and such firm be interested in the contract, the tender shall be in the name of the firm and not in that of the individual and that, for a breach of this condition, the tender will be declared informal.

Tenders enclosed in a separate envelope, and having the words "Tender for——" (as the case may be) written thereon, must be deposited in the Tender-box at the Tender Board Offices, 107 Russell-street, Melbourne, or if sent by post, postage must be prepaid, and the tenders addressed to the Chairman of the Tender Board, Tender Board Offices, 107 Russell-street, Melbourne, C.1, which office they must reach not later than by first post on the date of closing of tenders.

The conditions of contract are those published in the Victoria Government Gazette, No. 17, dated 16th March, 1966, pages 868 to 869.

H. E. BOLTE,
Treasurer.

The Treasury,
Melbourne, 9th August, 1966.

PUBLIC SERVICE NOTICES

No. 1645.

Public Service Act 1958, Section 39.

REGULATIONS.—PART IV.—SALARIES AND INCREMENTS.

THE Public Service Board, in pursuance of the powers conferred by the Public Service Act 1958, hereby amends its Regulations as shown below:—

FOURTH SCHEDULE.

ADMINISTRATIVE DIVISION.

Amount of Salary Assigned to Offices in Class "A1".

Office.	Yearly Rate of Salary.
PREMIER'S DEPARTMENT.	\$
Delete— Special Duties Officer, Office of the Public Service Board	9,350

F. E. CAHILL, Chairman.

V. P. SCULLY, Secretary.

Office of the Public Service Board,
Melbourne, 18th July, 1966.

No. 1646.

Public Service Act 1958, Section 39.

REGULATIONS.—PART IV.—SALARIES AND INCREMENTS.

THE Public Service Board, in pursuance of the powers conferred by the Public Service Act 1958, hereby amends its Regulations as shown below:—

FOURTH SCHEDULE.

ADMINISTRATIVE DIVISION.

Amount of Salary Assigned to Offices in Class "A1".

Office.	Yearly Rate of Salary.
PREMIER'S DEPARTMENT.	\$
Add— Senior Public Service Inspector (Staffing and Classification), Office of the Public Service Board	7,900

F. E. CAHILL, Chairman.

V. P. SCULLY, Secretary.

Office of the Public Service Board,
Melbourne, 29th July, 1966.

No. 1647.

Public Service Act 1958, Section 39.

REGULATIONS.—PART IV.—SALARIES AND INCREMENTS.

THE Public Service Board, in pursuance of the powers conferred by the *Public Service Act 1958*, hereby amends its Regulations as shown below:—

FIRST SCHEDULE.

PROFESSIONAL DIVISION.

Amount of Salary Assigned to Offices in Class "A1".

Office.	Yearly Rate of Salary.
CHIEF SECRETARY'S DEPARTMENT.	\$
<i>Delete—</i> Deputy Director, Forensic Science Laboratory, Office of the Chief Commissioner of Police	6,266
<i>Add—</i> Director, Forensic Science Laboratory, Office of the Chief Commissioner of Police	7,200

F. E. CAHILL, Chairman.
V. P. SCULLY, Secretary.

Office of the Public Service Board,
Melbourne, 22nd July, 1966.

PUBLIC SERVICE OF VICTORIA.—VACANCIES.

APPLICATIONS will be received by the Public Service Board up to Wednesday, the 24th August, 1966, from persons employed in the Public Service of Victoria, who are eligible and qualified for appointment to the under-mentioned positions:—

ADMINISTRATIVE DIVISION.

Class "C2", Tourist Development Authority, Premier's Department.

Yearly Salary.—\$4,280, minimum; \$4,560, maximum.

Duties.—To be Accountant to the Tourist Development Authority; to be responsible for the direction and supervision of the accounting procedures of the Authority.

Qualifications.—A qualified Accountant with a good knowledge of the *Audit Act 1958*, the *Public Accounts and Stores Regulations 1958* and preferably the accounting and booking procedures in operation at Victorian Government Tourist Bureaux.

Class "C2", Office of the Housing Commission, Treasury.

Yearly Salary.—\$4,280, minimum; \$4,560, maximum.

Duties.—To supervise all operations within the House Sales Section relating to sub-lettings, assignments of Contracts of Sale and administration of the Housing (House Purchasers' Death Benefits) Regulations. To assist as required in the general supervision and administration of the House Sales Section. To be responsible for records relating to road construction and sewerage installation in so far as these affect properties available for sale.

Qualifications.—A good knowledge of land dealings and of the procedures of the Housing Commission with regard to the sale of houses; ability to conduct correspondence and to control staff.

Class "C1", Office of the Housing Commission, Treasury.

Yearly Salary.—\$3,680, minimum; \$3,960, maximum.

Duties.—To pay staff salaries, and keep taxation records of all officers and employees of the Commission (other than those at the Concrete House Project).

Qualifications.—To be conversant with conditions concerning payment of salaries and allowances under *Public Service Regulations*; a knowledge of the *Superannuation Acts*.

PROFESSIONAL DIVISION.

Superintending Architect (Design and Research), Class "A1", Office of the Housing Commission, Treasury.

Yearly Salary.—\$7,200, minimum; \$7,484, maximum.

Duties.—To be responsible to the Chief Architect for preparation of estate and town plans, site plans, working drawings and details for major housing and shopping projects and slum reclamation areas and to prepare sketch layouts and designs for same having regard to the research and design aspects of the Commission's activities.

Qualifications.—A qualified Architect with wide experience in housing estate, slum reclamation and town planning layouts and house and flat design.

Scientific Officer, Classes "B1"-"A", Weights and Measures Branch, Local Government Department.

Yearly Emolument.—\$4,912, minimum; \$5,714, maximum.

Duties.—Verification and maintenance of standards of weight and measure. Other duties in connexion with the administration of the *Weights and Measures Act*, as directed.

Qualifications.—A Science Degree or approved Diploma in (a) Applied Physics, or (b) Engineering including at least second year Physics, or other equivalent qualification. Laboratory and mechanical experience would be an advantage.

Chemist, Classes "C"-"C2", Coroner's Court, Law Department.

Yearly Emolument.—

\$3,046, minimum; \$4,760, maximum—Science

Degree.

\$2,934, minimum; \$4,760, maximum—Chemistry

Diploma.

(Commencing salary will be determined

according to qualifications and experience.)

Duties.—Under the direction of the Senior Chemist to be responsible for the isolation and identification of a large range of drugs and poisons, and other work of a medico-legal nature as required.

Qualifications.—University Degree in Science, or Technical School Diploma with Chemistry or Biochemistry as a major subject. Applicants should be qualified for submission as Associate of Royal Australian Chemical Institute. A knowledge of modern instrumental techniques would be an advantage.

TECHNICAL AND GENERAL DIVISION.

Technical Works Officer, Public Works Department.

Yearly Salary.—\$3,122, minimum; \$3,334, maximum.

Duties.—To assist in the technical administration of a District Architect's office and prepare reports and specifications for general maintenance work for various types of buildings. Generally to assist or relieve inspectorial staff as required.

Qualifications.—Extensive practical experience in one or more branches of the building industry. Technical certificates in building construction or other trade subjects through technical school courses are desirable.

Technical Works Officer, Office of the Housing Commission, Treasury. (Two vacancies.)

Yearly Salary.—\$3,122, minimum; \$3,334, maximum.

Position No. 1.

Duties.—To assist with control of field supervision and the effective employment and technical instruction of Clerks of Works engaged in housing construction contracts.

Qualifications.—Extensive practical experience and suitable training in construction of residential buildings. Ability to conduct correspondence and prepare technical reports.

Position No. 2.

Duties.—To assist generally in the office in the handling of maintenance works and supply of mechanical equipment in Government buildings; to prepare estimates and minor specifications.

Qualifications.—Training in the theory and practice of a trade associated with mechanical services and equipment in buildings; a good knowledge of machine tools, also office experience in the supply, installation and maintenance of such services and equipment in large buildings; some association with the electrical trade would be an advantage.

NOTE.—Separate applications must be submitted for these positions.

Assistant Superintendent, "Aschdene" Boys' Home, Falls Road, Olinda, Family Welfare Division, Social Welfare Branch, Chief Secretary's Department.

Yearly Salary.—\$3,122, minimum; \$3,228, maximum.

Duties.—To be Assistant Superintendent of a home for approximately 30 school-aged boys; to relieve the Superintendent in his absence.

Qualifications.—A sound education; experience in the care of school-aged boys, including boys with behaviour problems; ability to assist in the management of a home; to be competent in supervising staff and to possess personal flexibility and an interest in learning modern methods of child care.

NOTE.—Quarters and rations provided at \$332 a year. Successful applicant will be required to live-in.

Child Care Officer (Male), Senior, "Aschdene" Boys' Home, Falls Road, Olinda, Family Welfare Division, Social Welfare Branch, Chief Secretary's Department.

Yearly Salary.—\$2,736, minimum; \$2,914, maximum.

Duties.—To assist in the care of school-aged boys and in the supervision of staff; to relieve the Assistant Superintendent as required.

Qualifications.—Experience in the care of school-aged boys and ability to supervise and direct staff; an interest in learning modern methods of caring for boys, including some with behaviour problems. A current motor car driver's licence.

Estate Officer (Male), Grade I, Office of the Housing Commission, Treasury.

Yearly Salary.—\$2,662, minimum; \$2,810, maximum.

(An allowance at the rate of \$208 a year will also be paid for duty out of office hours and use of home as an office.)

Duties.—To perform housing estate duties in respect of a high density section of a district including revenue collection, interviewing tenants regarding rental arrears, advising tenants on matters affecting their tenancy, and inspecting and reporting on dwellings and various phases of estate management.

Qualifications.—To be educated to Intermediate Certificate standard or to be already an Estate Officer. Ability to make investigations and prepare reports. Experience in dealing with the public and capable of handling public moneys; to be active, married. A current motor driver's licence.

NOTE.—(1) After completing three years' satisfactory service as an Estate Officer, Grade I, will be eligible for progression to Estate Officer, Grade II. (\$2,914–\$3,018). (2) The person appointed must be prepared to reside on a Commission Estate and to work at nights and week-ends and public holidays as required. Accommodation will be provided in a three-bedroom flat, for which a rental of 10 per cent. of total emolument, inclusive of the amount payable under Regulation 74, less \$72.60 a year, will be charged.

Laboratory Assistant (Male), Soil Conservation Authority, Premier's Department.

Yearly Salary.—\$2,330, minimum; \$2,554, maximum.

Duties.—To prepare soil samples for analysis and to carry out laboratory analysis as directed including some field testing and sampling in connexion with farm water supplies.

Qualifications.—Experience in routine laboratory analysis or a pass in Chemistry at the Leaving Certificate level or equivalent qualification.

Water Bailiff (Diversions), Boort Centre (Bridgewater), Water Supply Department.

Yearly Salary.—\$2,294, minimum; \$2,518, maximum.

Duties.—To supervise the usage of water by private diverters and to keep the necessary records. To collect data necessary for installation of flow meters and to carry out routine maintenance of meters once installed. To carry out other duties as required.

Qualifications.—Physically capable of manual work and with ability to keep the necessary records and prepare reports. Good personality and preferably some knowledge of irrigation procedures. Ability to estimate areas.

NOTE.—*Housing:* A house will be available for this position in approximately twelve months for which a rental of 10 per cent. of total emolument inclusive of the amount

payable under Regulation 74, less \$72.60 a year, will be charged. Occupancy will be subject to a formal tenancy agreement being entered into. Particulars are available from the Water Supply Department.

Machinist (Female), Grade II, Taxation (Land Tax) Office, Treasury.

Yearly Salary.—\$2,012, minimum; \$2,048, maximum.

Duties.—To operate an Accounting Machine for the preparation of Land Tax Assessment Notices, Debit Register and for Statistical work; other duties as required.

Qualifications.—Competent in the operation of "National" and "Burroughs" Accounting Machines. A knowledge of procedure adopted in the issue of Land Tax Assessment Notices is desirable.

Assistant (Female), Grade II, Maternal and Child Welfare Branch, Department of Health.

Yearly Salary.—\$1,940, minimum; \$1,976, maximum.

Duties.—To be responsible for the filing of records of the medical examinations of school children and supervise staff engaged on this work.

Qualifications.—Experience in the maintenance of medical records and ability to control staff and a knowledge of the activities of the school medical service are desirable.

NOTE.—The salary rates quoted above do not include the additional amount which is payable under Regulation 74 of the Board's Regulations.

By order,

V. P. SCULLY,

Secretary.

Office of the Public Service Board,

Melbourne, 9th August, 1966.

PUBLIC SERVICE OF VICTORIA.—VACANCIES.**DEPARTMENT OF HEALTH.****MENTAL HYGIENE BRANCH.****TECHNICAL AND GENERAL DIVISION.**

APPPLICATIONS will be received by the Public Service Board up to Wednesday, the 31st August, 1966, from persons employed in the Public Service of Victoria, who are eligible and qualified for appointment to the under-mentioned positions:—

Charge Nurse (Female), Sunbury.

Yearly Salary.—\$2,564, minimum; \$2,772, maximum.

(A gratuity of \$104 a year will be payable if both Mental Nursing and Mental Deficiency Certificates are held.)

Duties.—To take charge of a ward in a Mental Hospital and/or Training Centre and to assist in the training of Student Nurses and others.

Qualifications.—A current practising Certificate for Mental Nursing and/or Mental Deficiency Nursing.

Engineer Mechanic, Grade II, Ararat.

Yearly Salary.—\$2,482, minimum; \$2,736, maximum.

Duties.—To assist in the management and maintenance of steam boilers, hot and cold water services, cooking appliances, electrical and sewerage installations.

Qualifications.—A tradesman fitter and turner.

Gardener, Grade II, Royal Park.

Yearly Salary.—\$2,294, minimum; \$2,330, maximum.

Duties.—To carry out general gardening operations in the ornamental grounds.

Qualifications.—Experience in the care of trees, shrubs, hedges and lawns, and in raising and planting out flower seedlings and to hold a current motor driver's licence.

General Assistant, Sunbury.

Yearly Salary.—\$1,974, minimum; \$2,150, maximum.

Duties.—To give general assistance in the various artisan activities connected with the hospital services and maintenance.

Qualifications.—A semi-skilled worker in good physical condition. Knowledge of some trade desirable.

Instructor, Sheltered Workshop (Female), Grade I., St. Nicholas Hospital, Carlton.

Yearly Salary.—\$1,832, minimum; \$1,904, maximum.

Duties.—To assist in the supervision and training of intellectually handicapped adolescents and adults, under the general guidance of the Workshop Supervisor.

Qualifications.—Training experience preferably in a factory setting and interest in the problems of the intellectually handicapped.

Laundress, Grade I., Ballarat.

Yearly Salary.—

- Junior—under 16 years of age, \$854;
- at 16 years of age, \$914;
- at 17 years of age, \$948;
- at 18 years of age, \$1,042;
- at 19 years of age, \$1,220;
- at 20 years of age, \$1,400.
- Adult—\$1,724, minimum; \$1,760, maximum.

Duties.—To assist in Laundry.

Qualifications.—Ability to operate laundry machinery.

The salary rates quoted above do not include the additional amount which is payable under Regulation 74 of the Board's Regulations.

By order,

V. P. SCULLY,
Secretary.

Office of the Public Service Board,
Melbourne, 9th August, 1966.

PUBLIC SERVICE OF VICTORIA.—VACANCY.

(TEMPORARY APPOINTMENT.)

APPLICATIONS will be received by the Public Service Board up to Wednesday, the 24th August, 1966, from persons who are qualified for appointment to the under-mentioned position:—

Technical Works Officer, Public Works Department.
(Three positions.)

Yearly Salary.—\$3,122, minimum; \$3,334, maximum.

Duties.—To assist in the technical administration of a District Architect's office and prepare reports and specifications for general maintenance works for various types of buildings. Generally to assist or relieve inspectorial staff as required.

Qualifications.—Extensive practical experience in one or more branches of the building industry. Technical certificates in building construction or other trade subjects through technical school courses is desirable.

NOTE.—The salary rates quoted above do not include the additional amount which is payable under Regulation 74 of the Board's Regulations.

By order,

V. P. SCULLY,
Secretary.

Office of the Public Service Board,
Melbourne, 9th August, 1966.

AUSTRALIAN ADMINISTRATIVE STAFF COLLEGE.

NOMINATION FOR SESSION NO. 27.

(28th September, 1966—8th December, 1966.)

APPLICATIONS for nomination for Session No. 27 were invited from officers of the Administrative and Professional Divisions in the *Government Gazette* of the 6th July, 1966.

The Board has nominated L. R. Brown, Secretary, Apprenticeship Commission, Department of Labour and Industry, for this Session.

By order,

V. P. SCULLY,
Secretary.

Office of the Public Service Board,
Melbourne, 8th August, 1966.

PUBLIC SERVICE OF VICTORIA.—RECLASSIFICATIONS.

THE Public Service Board has raised the classification of the under-mentioned offices as shown, and appointed thereto the respective officers named hereunder.

Office and Former Classification.	Revised Classification.	Duties.	Qualifications.	Officer Appointed.
-----------------------------------	-------------------------	---------	-----------------	--------------------

PROFESSIONAL DIVISION.

PUBLIC WORKS DEPARTMENT.

Architect, Class "C2"	Classes "B1-A"	To organize, control and co-ordinate the design and works activities of the Prison Labour Works Section; to prepare estimates, plans and specifications and implement departmental policy for prison construction and maintenance works undertaken by contractors; to perform nominated duties as required	A degree or diploma from a recognized Australian School of Architecture or registration under the provisions of the <i>Architects Act 1958</i> ; appropriate experience and capacity for the duties involved	Burville, N. A. G.
-----------------------	----------------	--	--	--------------------

TECHNICAL AND GENERAL DIVISION.

DEPARTMENT OF HEALTH.

Shorthand Writer and Typist (Female), Grade II., Grades F24-F25 inclusive	Senior, Grades F30-F32 inclusive	To act as Stenographer to the Permanent Head and to arrange interviews, deputations and conferences as required	A competent Shorthand Writer and Typist with ability to take shorthand at the rate of 120 words a minute	Williams, Barbara D.
---	----------------------------------	---	--	----------------------

By order,

V. P. SCULLY,
Secretary.

Office of the Public Service Board,
Melbourne, 9th August, 1966.

PRIVATE ADVERTISEMENTS

NOTICE is hereby given that the Willaura Golf Club has applied for a lease of allotments 60 and 61, Parish of Lalkaldarno, containing 156 acres 1 rood 28 perches, pursuant to section 134, *Land Act 1958* for the purpose of amusement and recreation for a term of 21 years.

W. A. NICHOLSON, Hon. Secretary.
Willaura Golf Club, Willaura. 2664

NOTICE is hereby given that White Crystal Chalet Pty. Ltd., has applied for a lease of an area of approximately one acre in the Parish of Yertoo, pursuant to section 134 of the *Land Act 1958* for the purpose of accommodation and facilities for tourists, for a term of 45 years.

FREDERICK OWEN & ASSOCIATES, solicitors, 84 William-street, Melbourne. 2988

LAND ACT 1958, SECTION 134.

NOTICE is hereby given that the Pyramid Hill Golf Club has applied for a lease for a term of twenty-one (21) years under section 134 of the *Land Act 1958*, in respect of an area of Crown land containing approximately 80 acres in the Township of Pyramid Hill and the Parish of Mincha as a site for the purposes of Amusement and Recreation (Golf Links). 2846

LAND ACT 1958 (No. 6284 AS AMENDED BY ACT No. 7075).

WHEREAS:

I. Application has been made pursuant to sub-section (1) of section 22c of the *Land Act 1958* by Alfred Eric Nicholas the trustee for the time being of the Biggara Public Recreation Reserve site being the land described in the schedule hereto for permission to surrender the said land to Her Majesty Queen Elizabeth the Second.

II. By the said sub-section (1) it is provided that the Attorney-General may by notice published in the *Government Gazette* grant permission to the trustee to surrender the land to Her Majesty pursuant to the said section 22c and by sub-section (4) of the said section 22c it is further provided that the Attorney-General shall specify the purpose mentioned in section 14 of the *Land Act 1958* for which the land was vested in the trustee or was used or to which the purpose for which it was vested in the trustee or was used as in his opinion substantially similar.

Now I, the Honorable Vernon Francis Wilcox, in my capacity as Her Majesty's Acting Attorney-General for the State of Victoria—

(a) grant permission to the said trustee to surrender the said land to Her Majesty pursuant to section 22c of the *Land Act 1958*; and

(b) specify pursuant to sub-section (4) of section 22c aforesaid the following purpose mentioned in section 14 of the *Land Act* aforesaid namely—

“the recreation convenience or amusement of the people”.

SCHEDULE.

All that piece of land being Crown allotment 6B, section 2, Parish of Thoughtla, County of Benambra, and being the whole of the land described in certificate of title, volume 6219, folio 771.

Given under my hand this 27th day of July, 1966.

2977 V. F. WILCOX, Acting Attorney-General.

COHUNA SEWERAGE AUTHORITY.

THE Cohuna Sewerage Authority which proposes to compulsorily take the land hereinafter described and which has obtained the consent of the Governor in Council to such proposed compulsory taking hereby publishes the following advertisement, in pursuance of section 111 of the *Sewerage Districts Act 1958*, as re-enacted by section 6 of the *Sewerage Districts Act 1964*, viz.:—

(a) The nature of the works in respect of which such land is proposed to be taken is the building or construction of all necessary and usual works for the operation of Sewerage Treatment Farm thereon and all things or matters appertaining to and incidental to such operation.

(b) A plan or description of the proposed works is open for inspection at the Municipal Offices, Cohuna, between the hours of 9 a.m. and 12 noon and 1 p.m. and 4 p.m. on week days other than public holidays.

(c) The land which is required for the purpose of such works consists of 160 acres or thereabouts, being the land commencing at the most south-eastern angle of Crown allotment 12, section B, Parish of Gunbower West, County of Gunbower; thence westerly along the southern boundary of the said Crown allotment 12 for a distance

of 4,466.4 links; thence by a line bearing north 7 deg. 57 min. east a distance of approximately 6,061.5 links to a point on the northern boundary of the said Crown allotment 12; thence generally easterly and south-easterly along the northern and north-eastern boundaries of the said Crown allotment 12 to the point of commencement, all of which boundaries are shown on a plan approved by the Governor in Council and deposited in the office of the State Rivers and Water Supply Commission, Melbourne.—(Corres. No. 59/1530/15.)

The quantity of land required for the purpose of such works as aforesaid is the whole of the afore-mentioned land and the particulars of the right power or privilege which the Cohuna Sewerage Authority requires for the purpose of such works is an unencumbered estate in fee-simple as owner of the said land.

For and on behalf of the Cohuna Sewerage Authority.

Dated the 26th day of July, 1966.

2859

R. E. KNOWLES, Secretary.

FRANKSTON SEWERAGE AUTHORITY.

COMPULSORY ACQUISITION OF EASEMENTS OF SEWERAGE AND LICENCE TO USE CERTAIN LAND UNDER POWERS GRANTED BY THE SEWERAGE DISTRICTS ACTS.

NOTICE is hereby given that the Frankston Sewerage Authority, for the purpose of constructing an outfall main from Skye-road, Frankston, to the Chelsea Sewerage Treatment Works proposes to compulsorily acquire an easement for sewerage purposes over the land hereinafter described as easement area and a licence over the area hereinafter described as licence area to the Authority and members thereof, its servants and agents, to use for a period of eighteen months from the date of acquisition for the purpose of constructing with such recognized engineering and earth-moving machinery and equipment as may be required for such purpose a sewer main on the land adjacent to the licence area for the purpose of repairing and restoring as far as practicable to its original condition the surface of the said lands after the said work of construction of the sewer main has been completed.

Parish.	Crown Allotment or Lot No.	Easement Area.			Licence Area.		
		A.	R.	P.	A.	R.	P.
Lynnhurst	Lots 13 to 16 inc. LP 4911 part C/A 56.	1	3	17.5	3	2	34.9
..	Lots 20 and 21 LP 4911 part C/A 56		2	30.8	1	1	21.5
..	Lots 1, 2 and 19 LP 65630 part C/A 56	1	0	19.4	2	0	38.8
..	C/A 73 ..		3	21.3	1	3	2.6
..	Part C/A 74A ..		1	10.1	2	2	23.5
..	Part C/A 57 ..			35.2	1		30.4
..	Parts Lots 8, 9 and 3 LP 65024 Parts C/A 55 and 56	1	1	2.7	2	2	5.3
..	Part C/A 57 ..		2	36.7	2	2	9.2

A plan of the proposed works is open for inspection at the office of the Authority, Civic Centre, Davey-street, Frankston, between the hours of 10 a.m. and noon on all week-days on which the Civic Centre is open.

2893

G. C. PENTLAND, Secretary.

GEELONG WATERWORKS AND SEWERAGE TRUST.

PURSUANT to section 60 (2) of the *Geelong Waterworks and Sewerage Act 1958* (No. 6263) notice is hereby given of the intention of the Trust to construct sewers to provide for properties in and adjacent to:—

Cedmar-avenue and Cemaloma-court, Highton—Shire of South Barwon.

Gellibrand-street and Goldsworthy-road, Corio—Shire of Corio.

Marlborough-street, Herne Hill—City of Geelong West.

Riverglen-court, Belmont—Shire of South Barwon.

Melrose-avenue, North Highton—Shire of South Barwon.

Olwen-avenue, East Belmont—Shire of South Barwon.

and more particularly as shown on maps which are open for public inspection at the Trust's Offices, Ryrrie-street, Geelong, between the hours of 9 a.m. and 4 p.m. daily from Monday to Friday.

Dated this 8th day of August, 1966.

3024

B. C. HENSHAW, Secretary.

SPRINGVALE AND NOBLE PARK SEWERAGE
AUTHORITY.

GENERAL NOTICE.

THE above-mentioned Sewerage Authority having made provision for carrying off the sewage from each and every property which, or any part of which is within the Sewerage Areas hereinafter described, doth hereby declare that on and after the 1st day of August, 1966, each and every property which or any part of which is within the said Sewerage Areas shall be deemed to be a seweraged property within the meaning of the *Sewerage Districts Act 1958*.

The boundaries of the Sewerage Areas hereinbefore referred to are:—

Sewerage Area No. 155—Noble Park.

Commencing at a point being the intersection of the northern side of Green-street and the eastern side of Prior-road; thence northerly along the eastern side of Prior-road to its intersection with the southern side of Noble-street; thence easterly along the southern side of Noble-street a distance of 130 feet; thence southerly by a line perpendicular to Noble-street a distance of 150 feet; thence easterly by a line parallel to Noble-street a distance of 20 feet; thence southerly by a line perpendicular to Noble-street to the southern side of Percy-street; thence generally easterly along the southern side of Percy-street to the north-eastern angle of lot 21 on lodged plan of subdivision No. 60068; thence southerly by a line perpendicular to Temple-court to the southern side thereof; thence westerly along the southern side of Temple-court to the north-western angle of lot 45 on lodged plan of subdivision No. 60741; thence southerly along the western boundary of the said lot 45 to its south-western angle; thence easterly along the southern boundary of the said lot 45 to the north-eastern angle of lot 57 on lodged plan of subdivision No. 62004; thence southerly along the eastern boundary of the said lot 57 to the northern side of Green-street; thence generally westerly along the northern side of Green-street to the point of commencement.

Sewerage Area No. 156—Noble Park.

All those pieces of land comprising lots 2 to 7 inclusive and lots 14 and 15 on lodged plan of subdivision No. 72346 and lots 52, 53 and 54 on lodged plan of subdivision No. 72347.

Parts of streets in the above area include Yarraman-road, Bloomfield-road and Kumali-court.

Sewerage Area No. 157—Springvale.

Commencing at a point being the intersection of the northern side of Heatherton-road and the western side of Guildford-avenue; thence westerly along the northern side of Heatherton-road a distance of 240 ft. 7 in.; thence northerly by a line perpendicular to Heatherton-road to the northern side of Hanleth-avenue; thence westerly along the northern side of Hanleth-avenue to the south-western angle of lot 99 on lodged plan of subdivision No. 65685; thence northerly by a line perpendicular to Hanleth-avenue to the northern side of Hilton-avenue; thence easterly along the northern side of Hilton-avenue to its intersection with the eastern side of Upwey-avenue; thence northerly along the eastern side of Upwey-avenue to its intersection with the northern side of Como-court; thence easterly along the northern side of Como-court to the south-western angle of lot 40 on lodged plan of subdivision No. 65682; thence northerly along the western boundary of the said lot 40 to its north-western angle; thence easterly along the northern boundary of the said lot 40 to its eastern angle; thence south-westerly along the south-eastern boundary of the said lot 40 to its south-eastern angle; thence southerly across Como-court to the north-eastern angle of lot 43 on the said lodged plan; thence south-easterly along the north-eastern boundary of the said lot 43 to its eastern angle; thence south-westerly along the south-eastern boundary of lot 49 on lodged plan of subdivision No. 65683 and the south-western prolongation thereof to the western side of Guildford-avenue; thence southerly along the western side of Guildford-avenue to the point of commencement.

For the purposes of these descriptions the lodged plans of subdivision herein referred to shall be taken as those lodged at the Office of Titles, Melbourne.

By Order of the Springvale and Noble Park Sewerage Authority.

W. C. WILSON, Chairman.

H. L. WILLIAMS, Secretary.

2965

NOTICE OF INTENTION TO APPLY FOR A LICENCE
TO DIVERT WATER AND CUT RACE FROM THE
LAGOON (RIVER MURRAY), AT BRIMIN.

WE hereby give notice that we intend to apply for a licence empowering us to divert water for a term of four years to the extent of 170 acre-feet per annum at a maximum rate of 2 acre-feet per day of 24 hours for the irrigation of 85 acres of tobacco and pasture, being part of allotment 11, part 12, section G, Parish of Brimin, and to occupy certain Crown lands for works of diversion, and to cut a race thereon.

Any objection to such application must be forwarded, in writing, to reach the State Rivers and Water Supply Commission, Melbourne, before 5th September, 1966, being 30 days from the first publication of this notice.

BORTOLI BROS. (Per V. BORTOLI).

Brimin, via Rutherglen, Victoria.

2962

NOTICE OF INTENTION TO APPLY FOR A LICENCE
TO DIVERT WATER AND CUT RACE (RE-ISSUE)
FROM THE RIVER MURRAY AND RICHARDSON'S
LAGOON, AT TORRUMBERRY NORTH.

I HEREBY give notice that I intend to apply for a licence empowering me to divert water for a term of four years to the extent of 400 acre-feet per annum, at a maximum rate of 10 acre-feet per day of 24 hours for the irrigation of 200 acres, being allotments 1, 2, 8, 9, 17 and 18, section 8, Parish of Torrumberry North, and to occupy certain Crown lands for works of diversion, and to cut a race thereon.

Any objection to such application must be forwarded, in writing, to reach the State Rivers and Water Supply Commission, Melbourne, before 5th September, 1966, being 30 days from the first publication of this notice.

B. MCK. SCOTT.

Wowonah Estate, Torrumberry.

2954

NOTICE OF INTENTION TO APPLY FOR A LICENCE
TO DIVERT WATER AND CUT RACE FROM THE
RIVER MURRAY AND BURRA CREEK, AT A POINT
DOWNSTREAM FROM NYAH.

WE hereby give notice that we intend to apply for a licence empowering us to divert water for a term of fifteen years to the extent of 300 acre-feet per annum at a maximum rate of 10 acre-feet per day of 24 hours, for the purpose of irrigation of 257 acres 1 rood of all that piece of land being lots 4 and 5 on plan of subdivision No. 50817, lodged in the Office of Titles, being part of allotment 22, Parish of Burra, and to occupy certain Crown lands for works of diversion, and to cut a race thereon.

Any objection to such application must be forwarded, in writing, to reach the State Rivers and Water Supply Commission, Melbourne, before 27th August, 1966, being 30 days from the first publication of this notice.

WILLIAM HUGH PRATT.

LESLIE CAMERON PRATT.

Natya, Victoria.

3041

NOTICE OF INTENTION TO APPLY FOR A LICENCE
TO DIVERT WATER AND CUT RACE FROM THE
RIVER MURRAY AND BURRA CREEK, AT A POINT
DOWNSTREAM FROM NYAH.

WE hereby give notice that we intend to apply for a licence empowering us to divert water for a term of fifteen years to the extent of 300 acre-feet per annum at a maximum rate of 10 acre-feet per day of 24 hours, for the purpose of irrigation of 355 acres 0 roods 7 perches of all that piece of land being lots 2 and 3 on plan of subdivision No. 50817, lodged in the Office of Titles, and being part of allotment 22, Parish of Burra, and to occupy certain Crown lands for works of diversion, and to cut a race thereon.

Any objection to such application must be forwarded, in writing, to reach the State Rivers and Water Supply Commission, Melbourne, before 27th August, 1966, being 30 days from the first publication of this notice.

REGINALD JOHN WILLIAM FORSTER.

JEAN MARY FORSTER.

Kooloonong, Victoria.

3042

FIRST SCHEDULE.

NOTICE OF INTENTION TO APPLY FOR A LICENCE TO DIVERT WATER AND CUT RACE FROM THE RIVER MURRAY AND BURRA CREEK AT A POINT DOWNSTREAM FROM NYAH.

WE hereby give notice that we intend to apply for a licence empowering us to divert water for a term of fifteen years to the extent of 300 acre-feet per annum at a maximum rate of 10 acre-feet per day of 24 hours for the purpose of irrigation of 356 acres, 3 roods, 30 perches, of all that piece of land, being Lot 1 on plan of subdivision No. 50817, lodged in the Office of Titles, and being part of allotment 22, Parish of Burra, and to occupy certain Crown lands for works of diversion, and to cut a race thereon.

Any objection to such application must be forwarded, in writing, to reach the State Rivers and Water Supply Commission, Melbourne, before 27th August, 1966, being 30 days from the first publication of this notice.

PETER AUSTIN GILL and
PATRICIA ROSEMARY GILL.

Kooloonong, Victoria. 2990

CITY OF BRUNSWICK.

LOAN NO. 57.

Notice of Intention to Borrow.

NOTICE is hereby given that the Council of the City of Brunswick intends to borrow \$50,000 on the credit of the Mayor, Councillors and Citizens of the said City by the grant of a mortgage in accordance with the provisions of the Local Government Acts.

In connexion therewith the following information is stated:—

- (a) The amount of the principal moneys which it is proposed to borrow is \$50,000.
- (b) The maximum rate of interest that may be paid is \$5.75 per centum per annum.
- (c) The times which the moneys borrowed are to be repayable are the 1st day of May, 1967, and the 1st days of May and November during the years 1967–1981 inclusive and that the place such moneys shall be repayable is at the Bank of New South Wales.
- (d) The purpose for which the loan is to be applied is:—
Land purchases.
Town Hall renovations.
Reconstruction of various streets.
- (e) The manner in which the loan is to be liquidated is by provision out of the municipal fund in each half-year during the currency of the loan of the sum of \$2,509.92 which includes principal and interest.

The plans and specifications and estimate of the cost of the works and a statement showing the proposed expenditure of the moneys to be borrowed are open for inspection at the Town Hall.

Dated this 10th day of August, 1966.

3020 H. W. FOLETTA, Town Clerk.

CITY OF BRUNSWICK.

LOAN NO. 58.

Notice of Intention to Borrow the Sum of \$50,000 for Permanent Works and Undertakings.

NOTICE is hereby given that the Council of the City of Brunswick proposes to borrow the principal sum of \$50,000 secured by a charge over the general rates of the municipality, such sum to be raised by the grant of a mortgage in accordance with the provisions of the Local Government Act 1958.

- 1. The maximum rate of interest that may be paid is 5.75 per cent. per annum.
- 2. The purpose for which the loan is to be applied is:—
Glenlyon-road—reconstruction.
Park-street east—reconstruction.
Ballarat, Lyle, Fallon, Staley, Peverill, Mincha, and Cohuna streets—reconstruction.
- 3. The period of the loan shall be fifteen years.
- 4. The moneys borrowed shall be repayable by providing out of the municipal fund half-yearly instalments of approximately \$2,510 each including principal and interest on the 1st day of May, and the 1st day of November, during the currency of the loan. The first instalment shall be payable on the 1st day of May, 1967.

5. Such moneys shall be repayable to the Commissioners of the State Savings Bank of Victoria at the office of the said Commissioners, corner Elizabeth and Bourke streets, Melbourne.

The plans and specifications and the estimate of the cost of the proposed works and a statement showing the proposed expenditure of the moneys to be borrowed are open for inspection at the office of the Council of the City of Brunswick, at Town Hall, Sydney-road, Brunswick.

Dated 10th August, 1966.

3021 H. W. FOLETTA, Town Clerk.

CITY OF CHELSEA.

BY-LAW NO. 55.

Buildings.

A By-law No. 55 of the City of Chelsea made pursuant to sections 198 and 926 of the Local Government Act 1958 and Regulations 804 and 815 of the Uniform Building Regulations, Victoria, and every and any other power it thereunto enabling for determining, applying, dispensing with or regulating certain matters or things left to be determined, applied, dispensed with or regulated by the Council of the said City under the Uniform Building Regulations, Victoria.

IN pursuance of the powers conferred by the Local Government Act 1958, and Uniform Building Regulations, Victoria, and of every and any other power it thereunto enabling, the Mayor, Councillors and Ratepayers of the City of Chelsea orders as follows:—

1. This By-law shall come into operation and have effect immediately upon its publication in the Victoria Government Gazette.

2. The whole of the municipal district of the City of Chelsea is hereby prescribed as an area in which no building or buildings of Class II. Occupancy containing more than four flats shall be constructed on any one site comprising an area of 6,500 square feet or more. Provided that for every additional 1,625 square feet of a site over 6,500 square feet one additional flat may be constructed subject to the Uniform Building Regulations, Victoria and any applicable By-laws of the City of Chelsea.

3. In this By-law unless inconsistent with the context or subject-matter:—

- (a) "Building of Class II. Occupancy" has the meaning assigned to that expression in Chapter 6 of the Uniform Building Regulations, Victoria.
- (b) "Flat" has the meaning assigned thereto in Chapter I. of the said Regulations.
- (c) "Site" has the same meaning as is ascribed to this term in the Uniform Building Regulations, Victoria and in determining this meaning regard shall be had to the nature of the plan or plans submitted by or on behalf of the applicant for a permit pursuant to Regulation 503 thereof.

4. Any person wilfully offending against any of the provisions of this By-law shall be guilty of an offence against this By-law.

Resolution for passing this By-law agreed to by the Council of the City of Chelsea on the 21st day of March, 1966, and confirmed on the 2nd day of May, 1966.

The common seal of the Mayor, Councillors and Ratepayers of the City of Chelsea, was hereunto affixed in the presence of—

(SEAL) B. A. HUMMERSTONE, Mayor.
L. F. PAYNE, J.P., Councillor.
F. J. WALSHE, Town Clerk.

Approved by the Governor in Council, 27th June, 1966.
—J. COLQUHOUN, Clerk of the Executive Council. 2964

CITY OF COBURG.

LOAN NO. 99.

Notice of Intention to Borrow the Sum of \$50,000 for Permanent Works and Undertakings.

NOTICE is hereby given that the Council of the City of Coburg proposes to borrow the principal sum of Fifty thousand dollars secured by a charge over the general rates of the municipality, such sum to be raised by the grant of a mortgage in accordance with the provisions of the Local Government Act 1958.

- 1. The maximum rate of interest that may be paid is 5½ per centum per annum.
- 2. The purposes for which the loan is to be applied are:—

Provision of Kindergarten at North-east Coburg	\$30,000
Pascoe Vale Swimming Pool Extensions	20,000
	\$50,000

3. The period of the loan shall be ten years.

4. The moneys borrowed shall be repayable by providing out of the municipal fund twenty half-yearly instalments of approximately \$3,303 each including principal and interest of the 1st day of May and the 1st day of November during the currency of the loan. The first instalment shall be payable on the 1st day of May, 1967.

5. Such moneys shall be repayable to the Commissioners of the State Savings Bank of Victoria, at the office of the said Commissioners, corner Elizabeth and Bourke streets, Melbourne.

The plans and specifications and the estimate of the cost of the proposed works and a statement showing the proposed expenditure of the moneys to be borrowed are open for inspection at the office of the Council of the City of Coburg, at Town Hall, Coburg.

Dated 2nd August, 1966.

2983 G. A. BRIDGES, Town Clerk.

CITY OF GEELONG.

LOAN No. 26.

NOTICE is hereby given that it is the intention of the Council of the City of Geelong to float a loan of \$200,000.00 for permanent works, undertakings and repayment of principal moneys of expiring loans.

2948 L. L. WALTER, Town Clerk.

CITY OF HAWTHORN.

LOAN No. 42.

Notice of Intention to Borrow the Sum of \$150,000 for Permanent Works and Undertakings.

NOTICE is hereby given that the Council of the City of Hawthorn proposes to borrow the sum of One hundred and fifty thousand dollars secured by a charge over the general rates of the municipality, such sum to be raised by the grant of a mortgage in accordance with the provisions of the Local Government Act.

1. The amount of the principal moneys which it is proposed to borrow is \$150,000.

2. The maximum rate of interest that may be paid is 5½ per centum per annum.

3. The period of the loan shall be fifteen years.

4. The moneys borrowed shall be repayable by providing out of the municipal fund 30 half-yearly instalments of approximately \$7,530 each, including principal and interest, on the 1st day of June and the 1st day of December during the currency of the loan. The first instalment shall be payable on the 1st day of June, 1967.

5. Such moneys shall be repayable at the E.S. & A. Savings Bank Ltd., Melbourne, or at the Council's bankers for the time being in Hawthorn.

6. The purposes for which the loan is to be applied are—

Provision of car parking areas and acquiring land for that purposes ..	\$100,000
Rebuilding of Municipal Public Library ..	\$50,000

The plans and specifications and the estimate of the cost of the proposed works, and a statement showing the proposed expenditure of the money to be borrowed, are open for inspection at the Municipal Offices, Town Hall, Hawthorn, during office hours.

Dated this 2nd day of August, 1966.

2949 J. R. JOHNSON, Town Clerk

CITY OF KEILOR.

LOAN No. 66.

Notice of Intention to Borrow the Sum of \$100,000 for Permanent Works and Undertakings.

NOTICE is hereby given that the Council of the City of Keilor proposes to borrow the sum of One hundred thousand dollars (\$100,000) secured by a charge over the general rates of the municipality, such sum to be raised by the grant of a mortgage in accordance with the provisions of the Local Government Act 1958.

1. The maximum rate of interest that may be paid is 5½ per centum per annum.

2. The purposes for which the loan is to be applied are as under:—

(a) Development of Reserves	\$10,000
(b) Office and Laboratory equipment ..	20,000
(c) Purchase of Reserves	20,000
(d) Equipment of Library and purchase of Book-Mobile	26,000
(e) Purchase of Reserves for Public Open Space	24,000
Total	\$100,000

3. The period of the loan shall be 23 years.

4. The moneys borrowed shall be repayable by providing out of the municipal fund of an amount of \$2,568.25 annually for 23 years, to be invested in accordance with the provisions of the Local Government Act 1958 to establish a Sinking Fund, commencing on the 15th October, 1966.

5. The interest on such loan shall be payable half-yearly on the 15th April, and the 15th October of each year, during the currency of the loan, commencing on the 15th April, 1967, at the National Bank of Australasia Limited, 460 Collins-street, Melbourne.

The plans, specifications and the estimates of the cost of the proposed works and a statement showing the proposed expenditure of moneys to be borrowed are open for inspection at the Municipal Offices, Keilor, during office hours.

Dated this 8th day of August, 1966.

3028 N. A. WOODS, Town Clerk.

Town and Country Planning Act (Twelfth Schedule).

MOE-NEWBOROUGH PLANNING SCHEME 1951.

NOTICE THAT A PLANNING SCHEME HAS BEEN PREPARED AND IS AVAILABLE FOR INSPECTION.

Amendment No. 11.

NOTICE is hereby given that the City of Moe, in pursuance of its powers under the Town and Country Planning Act 1961, has prepared a Planning Scheme for the City of Moe for the purpose of changing the name of the scheme to the "City of Moe Planning Scheme 1966" and to amend the ordinance (as amended) for this and other purposes in accordance with the Town and Country Planning Act 1961.

A copy of the scheme has been deposited at the Municipal Offices, Albert-street, Moe, and at the Office of the Town and Country Planning Board, 179 Queen-street, Melbourne, and will be open for inspection during office hours, free of charge.

Any persons affected by the planning scheme are required to set forth, in writing, all objections they may have, addressed to the Town Clerk, City of Moe, Albert-street, Moe, on or before the 12th day of September, 1966, and to state whether they wish to be heard in respect of their objections.

2981 F. E. BARTLETT, Town Clerk.

CITY OF NORTHCOTE.

NAMING OF PRIVATE LANE.

NOTICE is hereby given that at a meeting held on the 1st day of August, 1966, the Council of the City of Northcote resolved that the private lane lying between premises Nos. 25 and 29 Hayes-street, be named—

COMMERCIAL-PLACE.

2970 A. J. HILL, Town Clerk.

CITY OF RINGWOOD.

WHEREAS the Council of the City of Ringwood deems it expedient to acquire all those pieces of land being:—

Part lot 1 Summit-crescent on L.P. 53309; part lot 275 Pine-crescent on L.P. 11392; part lot 293 Panorama-avenue on L.P. 11392; part lot 237 Summit-crescent on L.P. 11392; part lot 1 Burlock-avenue on L.P. 42163; part lot 2 Burlock-avenue on L.P. 42163; part lot 48 Adolphson-avenue on L.P. 20559; part lot 38 Evelyn-road on L.P. 20559; part lot 400 Loughnan-road on L.P. 11524; part lot 59 Aurum-crescent on L.P. 11378; part lot 47 Adolphson-avenue on L.P. 52324; part lot 316 Aurum-crescent on L.P. 11392; part lot 2 Summit-crescent on L.P. 53309; part lot 238 Summit-crescent on L.P. 11392; part lot 253 Summit-crescent on L.P. 11392; part lot 169 Felix-crescent on L.P. 11392; part lot 127 Felix-crescent on L.P. 11378; part lot 114 Aurum-crescent on L.P. 11378; part lot 63 Pine-crescent on L.P. 11378; part lot 276 Pine-crescent on L.P. 11392; part lot 258 Pine-crescent on L.P. 11392; part lot 89 Evelyn-road on L.P. 20559; part lot 208 Summit-crescent on L.P. 11392; part lot 23, Hygeia-parade on L.P. 11378; part lot 54 Adolphson-avenue on L.P. 20559; part lot 38 Montalbo-road, on L.P. 11434; part of lot 39 Montalbo-road on L.P. 11434; part lot 324 Panorama-avenue on L.P. 11392, part lot 355

Cielterre-avenue on L.P. 11392; part lot 321 Aurum-crescent on L.P. 11392; part lot 320 Aurum-crescent on L.P. 11392:—

all land being within the City of Ringwood and being more particularly defined on plans available for inspection at the Ringwood Town Hall,

for the purpose of road and drainage construction works and/or for use by public utilities in conjunction with construction of roads and drains in the Loughnan Hill area, Ringwood; And whereas for the purpose thereof the exercise of the compulsory power of taking such land will in its opinion be necessary and desirable; And whereas the Council has caused to be prepared such specifications, maps and plans as are necessary setting out the nature and extent of such works or undertakings and the exact site and measurements thereof, and has caused the same to be deposited for inspection at the Town Hall, Ringwood.

Now therefore all persons affected by the proposed works or undertakings are called upon to set forth, in writing, addressed to the Council or the Town Clerk within 40 clear days from the publication of this notice in the *Government Gazette*, all objections which they may have to such works or undertakings.

By order,

F. P. DWERRYHOUSE, Town Clerk.

Town Hall,

Ringwood, 8th August, 1966.

3022

CITY OF RINGWOOD.

WHEREAS the Council of the City of Ringwood deems it expedient to acquire easements for drainage over all those pieces of land being:—

Part lot 2 Felix-crescent on L.P. 11434; part lot 417 Burlock-avenue on L.P. 22392; part lot 84 Evelyn-road on L.P. 20559; part lot 1 Montalbo-road on L.P. 43427; part lot 24 Hygeia-parade on L.P. 11378; part lot 3 Loughnan-road on L.P. 11434; part lot 3 Loughnan-road on L.P. 52904; part lot 360 Loughnan-road on L.P. 11392; part lot 236 Summit-crescent on L.P. 11392; part lot 34 Timbertop-road on L.P. 11434; part lot 358 Loughnan-road on L.P. 11392; part lot 4 Avalon-grove on L.P. 44455; part lot 20 Cielterre-avenue on L.P. 11378; part lot 3 Loughnan-road on L.P. 50998; part lot 1 Loughnan-road on L.P. 50998; part lot 4 Loughnan-road on L.P. 52904; part lot 357 Loughnan-road on L.P. 11392; part lot 347 Hygeia-parade on L.P. 11392; part lots 9, 10 and 11 Loughnan-road on L.P. 11434; part lot 359 Loughnan-road on L.P. 11392; part lot 361 Loughnan-road on L.P. 11392; part lots 32 and 33 Loughnan-road on L.P. 11434; part lot 362 Loughnan-road on L.P. 11392; part lot 2 Felix-crescent on L.P. 70214; part lot 24 Glenvale-road on L.P. 11434; part lot 4 Loughnan-road on L.P. 11434:—

all land being within the City of Ringwood and being more particularly defined on plans available for inspection at the Ringwood Town Hall,

for the purpose of constructing drains in conjunction with the construction of roads in the Loughnan Hill area and/or under the provisions of the *Local Government Act 1958*; And whereas for the purpose thereof the exercise of the compulsory power of taking such easements will in its opinion be necessary and desirable; And whereas the Council has caused to be prepared such specifications, maps and plans as are necessary setting out the nature and extent of such works or undertakings and the exact site and measurements thereof, and has caused the same to be deposited for inspection at the Town Hall, Ringwood.

Now therefore all persons affected by the proposed works or undertakings are called upon to set forth, in writing, addressed to the Council or the Town Clerk within 40 clear days from the publication of this notice in the *Government Gazette*, all objections which they may have to such works or undertakings.

By order,

F. P. DWERRYHOUSE, Town Clerk.

Town Hall,

Ringwood, 8th August, 1966.

3023

CITY OF ST. KILDA.

PROSECUTING OFFICER.

THIS is to certify that Richard Harvey, Sergeant of Police, No. 10482, has been appointed Prosecuting Officer for the municipality of the City of St. Kilda, vide Sergeant E. N. Shuey.

3050

A. N. ISAAC, Town Clerk.

CITY OF WAVERLEY.

ABOLITION OF POUND.

NOTICE is hereby given that the Council of the City of Waverley, on 23rd June, 1966, abolished the Pound situated at the Municipal Depot, Fern Tree Gully-road, Notting Hill.

2982

F. S. BALES, Town Clerk.

SHIRE OF BARRABOOL.

CHANGE OF NAME OF STREET.

NOTICE is given that, in pursuance of the powers conferred by the Local Government Act, the Council of the Shire of Barrabool, at a meeting held on the 20th day of July, 1966, did resolve to make the following alteration in a street name:—

Old Name; New Name; Location.

Karrawe-road; Old Coach-road; Moggs Creek, running between Crown allotments 22A, 22B, 22C, 22E, 22F, 22G, and 22H, Parish of Angahook.

G. L. PEARCE, Shire Secretary.

441 Moorabool-street, South Geelong.

2973

SHIRE OF BRIGHT.

LOAN No. 36.

Notice of Intention to Borrow the Sum of \$22,000 for Permanent Works and Undertakings.

NOTICE is hereby given that the Council of the Shire of Bright proposes to borrow the principal sum of \$22,000 secured by a charge over the general rates of the municipality, such sum to be raised by the grant of a mortgage in accordance with the provisions of the *Local Government Act 1958*.

1. The maximum rate of interest that may be paid is \$5.5625 per cent. per annum.

2. The purpose for which the loan is to be applied is the purchase of plant.

3. The period of the loan shall be eight years.

4. The moneys borrowed shall be repayable by providing out of the municipal fund sixteen half-yearly instalments of \$1,722.28 each including principal and interest on the 1st day of May and the 1st day of November during the currency of the loan. The first instalment shall be payable on the 1st day of May, 1967.

5. Such moneys shall be repayable at the Australia and New Zealand Bank, Melbourne.

The plans and specifications and the estimate of the costs of the proposed works and a statement showing the proposed expenditure of the moneys to be borrowed are open for inspection at the office of the Council of the Shire of Bright at Ireland-street, Bright.

11th August, 1966.

2986

H. G. HAYMES, Shire Secretary.

SHIRE OF DIAMOND VALLEY.

CHANGE OF NAME.

NOTICE is hereby given that, pursuant to the provisions of the *Local Government Act 1958*, the Council of the Shire of Diamond Valley doth order that the names of streets within the municipality be changed as set out hereunder:—

Old Name; New Name; Location Referred to.

Latrobe-road; McLennan's-road; shown on lodged plan No. 6039, fronting lots 48 and 46 from River-avenue to Memorial-drive, and on lodged plan No. 22199, from Memorial-drive to Mackelroy-road, and on lodged plan No. 62989, fronting lots 14 and 15, south of Mackelroy-road.

River-avenue; Bella Vista-court; the northern branch of River-avenue, fronting lots 14, 15, 16, 17 and 18 on lodged plan No. 6039, and lots 1, 2, 3, 4 and 5 on lodged plan No. 67173 and lots 6, 7 and 8 on lodged plan No. 69923.

2972

B. J. MORGAN, Shire Secretary.

SHIRE OF ELTHAM.

NOTICE OF INTENTION TO TAKE LAND COMPULSORILY.

NOTICE is hereby given that—

1. The Council of the Shire of Eltham deems it expedient to execute the work or undertaking of extending Sylvan-street, Montmorency, through part of lot 11 on Plan

of Subdivision No. 8968 lodged in the Office of Titles, to provide a connexion with Alban-street, Montmorency.

2. For the purpose of executing the same exercise of its power of taking land compulsorily will, in the opinion of the Council, be necessary.

3. The Council has caused to be prepared maps and other papers describing the proposed work or undertaking and the land proposed to be taken, together with the names of the owners or reputed owners, lessees or reputed lessees and the occupier thereof as far as such names can be ascertained by the Council.

4. Such maps and other papers are deposited at the Shire Offices, Main-road, Eltham, where they are and will remain open for inspection by all persons interested, at all reasonable hours, for the space of 40 clear days after publication of this notice in the *Government Gazette*.

5. All persons affected by the proposed work or undertaking are hereby called upon to set forth, in writing, addressed to the Council, or the Shire Secretary, of the Shire of Eltham, within 40 clear days from the publication of this notice in the *Government Gazette*, all objections which they may have to the said work or undertaking.

Dated this 9th day of August, 1966.

2984 M. B. WATSON, Shire Secretary.

SHIRE OF ELTHAM.

NOTICE OF INTENTION TO TAKE LAND COMPULSORILY.

NOTICE is hereby given that—

1. The Council of the Shire of Eltham deems it expedient to execute the work or undertaking of realigning Fordham's-road, Eltham.

2. For the purpose of executing the same exercise of its power of taking land compulsorily will, in the opinion of the Council, be necessary.

3. The Council has caused to be prepared maps and other papers describing the proposed work or undertaking and the land proposed to be taken, together with the names of the owners or reputed owners, lessees or reputed lessees and the occupier thereof as far as such names can be ascertained by the Council.

4. Such maps and other papers are deposited at the Shire Offices, Main-road, Eltham, where they are and will remain open for inspection by all persons interested, at all reasonable hours, for the space of 40 clear days after publication of this notice in the *Government Gazette*.

5. All persons affected by the proposed work or undertaking are hereby called upon to set forth, in writing, addressed to the Council, or the Shire Secretary, of the Shire of Eltham, within 40 clear days from the publication of this notice in the *Government Gazette*, all objections which they may have to the said work or undertaking.

Dated this 9th day of August, 1966.

2985 M. B. WATSON, Shire Secretary.

SHIRE OF FRANKSTON.

NOTICE UNDER SECTION 513 (1) OF THE LOCAL GOVERNMENT ACT 1958.

NOTICE is hereby given that the Council of the Shire of Frankston has deemed it expedient to exercise its power of taking compulsorily the land described hereunder for the work or undertaking of providing a car parking area as part of the scheme known as the Balmoral Park Scheme for providing car parking facilities in Frankston. The said Council has caused to be prepared and has approved maps and other papers showing the general description of the undertaking for which the land proposed to be taken is to be used, the description of the lands proposed to be so taken, and the names of the owners or reputed owners, lessees or reputed lessees, mortgagees and occupiers of those lands so far as those names are known to or can be ascertained by the Council and such maps and other papers have been deposited at the office of the Council, Civic Centre, Davey-street, Frankston, and are open for inspection by all persons interested at all reasonable hours for 40 clear days after publication of this notice in the *Victoria Government Gazette*.

The purport of the said maps and other papers is the progressive acquisition of lands (including the land hereinafter described) for the establishment of a car parking area known as Balmoral Park, Frankston, which, including internal roads, covers 6½ acres, and will accommodate approximately 1,000 cars. The land to be acquired is delineated and coloured blue on the said map. The land proposed to be taken is all that piece of land commencing at a point on the eastern boundary of Argyle-street (now known as Fletcher-street), Frankston, such point being

located north 19 deg. 14½ min. east 118 feet from the northern boundary of Balmoral-street; thence by lines bearing 19 deg. 14½ min. 89 ft. 10 in., 109 deg. 14 min. 91 feet, 199 deg. 14½ min. 37 feet, 212 deg. 32 min. 9 ft. 3¼ in., 199 deg. 14½ min. 45 feet, 289 deg. 20½ min. 86 feet to the point of commencement, being lots 16 and 17 on plan of subdivision No. 1090, lodged in the Office of Titles, and being the land described in certificate of title, volume 7243, folio 1448465.

Now notice is hereby given to all persons affected by the proposed taking of the said land to set forth, in writing, addressed to the said Council or to its municipal clerk, within 40 clear days of the publication of this notice in the *Victoria Government Gazette*, all objections which they may have to the taking of the said land.

G. C. PENTLAND, Shire Secretary.

Civic Centre, Frankston. 2952

Town and Country Planning Act 1961 (Twelfth Schedule).

SHIRE OF MORNINGTON.—SHIRE OF MORNINGTON PLANNING SCHEME 1959.

NOTICE THAT A PLANNING SCHEME HAS BEEN PREPARED AND IS AVAILABLE FOR INSPECTION.

Amendment No. 19, 1966.

NOTICE is hereby given that the Council of the Shire of Mornington, in pursuance of its powers under the *Town and Country Planning Act 1961*, has prepared a Planning Scheme for—

Land to the north of Forest-drive, at Mount Martha, being portion of the Greenlaw Estate, for the purpose of amending the zoning from Agricultural Zone and Residential "C" Zone to Residential "C" Zone; Public Purpose Reserve—State Rivers and Water Supply Commission Reserve; and Public Open Space Reserves, i.e., Recreation Reserves, Public Park and Golf Course.

A copy of the scheme has been deposited at the Shire Office at Mornington, and at the office of the Town and Country Planning Board, 179 Queen-street, Melbourne, and will be open for inspection during office hours by any person, free of charge.

Any persons affected by the Planning Scheme are required to set forth, in writing, all objections they may have, addressed to the Shire Secretary, Shire of Mornington, Shire Office, Mornington, on or before the 11th day of November, 1966, and to state whether they wish to be heard in respect of their objections.

D. G. COLLINGS, Shire Secretary.

27th July, 1966. 2956

Town and Country Planning Act 1961 (Twelfth Schedule).

SHIRE OF MORNINGTON.—SHIRE OF MORNINGTON PLANNING SCHEME 1959.

NOTICE THAT A PLANNING SCHEME HAS BEEN PREPARED AND IS AVAILABLE FOR INSPECTION.

Amendment No. 18, 1966.

NOTICE is hereby given that the Council of the Shire of Mornington, in pursuance of its powers under the *Town and Country Planning Act 1961*, has prepared a Planning Scheme for—

Land abutting the south-west side of Beluga-street, Mount Eliza, for the purpose of amending the zoning from Residential "D" Zone to Agricultural Zone and Residential "C" Zone.

Land having a frontage of approximately 65 feet to the northern side of Bentons-road, near Moorooduc-road, for the purpose of amending the zoning from Agricultural Zone to Commercial "B" Zone.

A copy of the scheme has been deposited at the Shire Office at Mornington, and at the office of the Town and Country Planning Board, 179 Queen-street, Melbourne, and will be open for inspection during office hours by any person, free of charge.

Any persons affected by the Planning Scheme are required to set forth, in writing, all objections they may have, addressed to the Shire Secretary, Shire of Mornington, Shire Office, Mornington, on or before the 12th day of September, 1966, and to state whether they wish to be heard in respect of their objections.

D. G. COLLINGS, Shire Secretary.

27th July, 1966. 2957

SHIRE OF MORTLAKE.

LOAN NO. 12.

Notice of Intention to Borrow the Sum of \$34,000 for Permanent Works and Undertakings.

NOTICE is hereby given that the Council of the Shire of Mortlake proposes to borrow the sum of Thirty-four thousand dollars (\$34,000) on the credit of the municipal revenues of the President, Councillors and Rate-payers of the said Shire such sum to be raised by the grant of a mortgage in accordance with the provisions of the *Local Government Act 1958*.

1. The maximum rate of interest that may be paid is 5.625 per centum per annum.
2. The purpose for which the loan is to be applied is the purchase of road-making plant.
3. The period of the loan shall be ten years.
4. The moneys borrowed shall be repayable by providing out of the municipal fund twenty half-yearly instalments of \$2,245.90 each, including principal and interest, on the first day of May and the first day of November, during the currency of the loan. The first instalment shall be payable on the first day of May, 1967.
5. Such moneys shall be repayable at the C.B.C. Savings Bank Limited, Melbourne.

The plans and specifications and the estimate of the cost of the proposed works and a statement showing the proposed expenditure of the moneys to be borrowed are open for inspection at the Shire Offices, Mortlake.

Dated this 2nd day of August, 1966.

2950

W. J. CRAY, Shire Secretary.

SHIRE OF SHERBROOKE.

LOAN NO. 103.

Notice of Intention to Borrow the Sum of \$50,000.00 for Permanent Works and Undertakings.

NOTICE is hereby given that the Council of the Shire of Sherbrooke proposes to borrow the principal sum of \$50,000.00 secured by a charge over the general rates of the municipality, such sum to be raised by the grant of a mortgage in accordance with the provisions of the *Local Government Act 1958*.

1. The maximum rate of interest that may be paid is 5½ per cent. per annum.
2. The purposes for which the loan is to be applied are:—
Accounting Machine.
Terry's-avenue Reconstruction.
Rollings-road Main Drain Stage 2.
Toilet Block Baynes Park.
Bayview-road Drain.
Belmont-avenue Construction.
Part Council proportion Edward-street Group and Willow-road Group Private Street Schemes.
Basketball Courts, Kallista.

3. The period of the loan shall be ten years.
4. The moneys borrowed shall be repayable by providing out of the municipal fund half-yearly instalments of approximately \$3,302.33 each, including principal and interest on the first day of November and the first day of May, during the currency of the loan. The first instalment shall be payable on the first day of May, 1967.
5. Such moneys shall be repayable to The Commissioners of the State Savings Bank of Victoria, at the office of the said Commissioners, corner Elizabeth and Bourke streets, Melbourne.

The plans and specifications and the estimate of the cost of the proposed works and a statement showing the proposed expenditure of the moneys to be borrowed are open for inspection at the office of the Council of the Shire of Sherbrooke, Glenfern-road, Upwey.

2951

A. JONES, Shire Secretary.

SHIRE OF SOUTH BARWON.

APPOINTMENT OF PROSECUTING OFFICER.

NOTICE is hereby given that Senior Constable Francis Sylvester Barker has been appointed Prosecuting Officer for all that portion of the Shire of South Barwon situated within the Torquay Police Sub-District.

2961

E. T. CORNISH, Shire Secretary.

PARTNERSHIP ACT 1928

NOTICE is hereby given that the partnership heretofore existing between Ernesta Rubboli and Antonio Pisera in the business known as Italian Cleaning Company was dissolved on the 30th day of June, 1966, on

which date the business was taken over by Antonio Pisera and Karin Pisera. All moneys due by or payable to the partnership may be paid to or obtained from the above-mentioned Antonio Pisera and Karin Pisera at 34 Hall-street, Moonee Ponds.

Dated this 3rd day of August, 1966.

A. B. NATOLI, solicitor and agent for the said Ernesta Rubboli and Antonio and Karin Pisera. 3025

NOTICE is hereby given that the partnership heretofore subsisting between Louis Harvey Sichlau, Maisie Harvey Sichlau, Jack Parker Sichlau and Elsie Ruby Sichlau, carrying on business as drapers and haberdashers at High-street, Yea, under the style or firm of "Country Fashions (Yea)", has been dissolved as from the 1st day of July, 1966, and such business will hereafter be conducted by the said Jack Parker Sichlau and Elsie Ruby Sichlau, who will be responsible for all outstanding debts of the partnership.

Dated the 1st day of August, 1966.

LOUIS H. SICHLAU.
MAISIE HARVEY SICHLAU.
JACK P. SICHLAU.
ELSIE R. SICHLAU.

Witness to Signatures—O. H. M. JACKSON, solicitor, Yea. 3032

NOTICE is hereby given that the partnership existing between Basil Cracknell, Beverley Cracknell and Ian Gordon Cracknell, in the business of laundrers and dry cleaners carried on by them, at 37 Learmonth-street, Queenscliff, under the firm name of "Queenscliff Steam Laundry and Dry Cleaners" has been dissolved by mutual consent. All moneys owing by or to the said partnership business will be received or paid by the said Beverley Cracknell and Ian Gordon Cracknell, who will continue to carry on the said business under the said firm name at the same address.

BEVERLEY CRACKNELL.
BASIL CRACKNELL.
IAN G. CRACKNELL.

Wm. C. Ainsworth & Co., 71 Yarra-street, Geelong, solicitors for the said Basil Cracknell.

W. N. MOONIE & CO., 23 Stokes-street, Queenscliff, solicitors for the said Beverley Cracknell and Ian Gordon Cracknell. 2966

NOTICE is hereby given that the partnership heretofore subsisting between Werner Stern, of 37 McPherson-street, Dandenong, and Brian Ainslie Minto, of 554 Heatherton-road, Dandenong, carrying on the practice of medical practitioners, at 829 Princes Highway, Springvale, has been dissolved by mutual consent as from the 30th day of September, 1965.

Dated this 14th day of June, 1966.

3015

WERNER STERN.

Companies Act 1961.—In the matter of THE VICTORY LIFE REASSURANCE COMPANY OF AUSTRALIA LIMITED.

AT an Extraordinary General Meeting of the above-named company, duly convened and held at 73 King William-street, London, U.K., on the 8th day of August, 1966, the following Resolution was duly passed as a Special Resolution:—

"That the company be wound up voluntarily and that Mr. K. V. Harrison, chartered accountant, be and hereby is appointed liquidator, and that his remuneration for his duties as liquidator be determined in accordance with the scale of fees laid down by the Institute of Chartered Accountants in Australia."

Dated this 8th day of August, 1966.

3027

K. V. HARRISON, Liquidator.

COLAC AND DISTRICT CO-OPERATIVE HOUSING SOCIETY LIMITED.

TAKE notice that the affairs of the above-named society are now fully wound up, and that in pursuance of section 272 (1) of the *Companies Act 1961* and the *Co-operative Housing Societies Act 1958*, a general meeting of the society will be held at the Hi-lite Cafe on the 16th day of September, 1966, at 6.30 o'clock in the afternoon for the purpose of laying before it an account showing how the winding up has been conducted and the property of the society disposed of and giving any explanation thereof.

Dated the 9th day of August, 1966.

D. K. COWAN, Liquidator.

Cowan and Gavens, 45 Gellibrand-street, Colac. 3026

Companies Act 1961.—In the matter of **YOUNG'S HORSHAM GARAGE PTY. LTD.** (in Liquidation).

NOTICE is hereby given that at an Extraordinary Meeting of members of the above-named company, held on 4th August, 1966, it was resolved that the company be wound up voluntarily and at a meeting of creditors held on the same day, pursuant to section 260, it was resolved that for such purpose Harold Keith Cartledge, chartered accountant, of 1 Palmerston-crescent, South Melbourne, be appointed liquidator.

Dated this 5th day of August, 1966.

H. K. CARTLEDGE, Liquidator.

Norman, Cartledge and Browne, chartered accountants,
1 Palmerston-crescent, South Melbourne, S.C.5. 2994

Companies Act 1961, Section 260.
ROOF TOP RENOVATIONS PTY. LTD.

WINDING up Order made 3rd August, 1966.

Name and address of official liquidator: Harold Keith Cartledge, of 1 Palmerston-crescent, South Melbourne.

JAMES CANNY, Deputy Commissioner of Taxation of the Commonwealth of Australia, petitioner. 2997

Companies Act 1961, Section 260.
ROOF TOP RENOVATIONS PTY. LTD.

WINDING up Order made 3rd August, 1966.

Name and address of official liquidator: John Charles Couzens, of 527 Collins-street, Melbourne.

JAMES CANNY, Deputy Commissioner of Taxation of the Commonwealth of Australia, petitioner. 2998

Companies Act 1958.—In the matter of **MULTICASTERS PTY. LTD.** (in Voluntary Liquidation), Creditors Winding Up and in the matter of the Companies Act.

NOTICE is hereby given that a Third and Final Dividend is intended to be declared in the above matter.

Creditors who have not proved their debts by the 2nd day of September, 1966, will be excluded therefrom.

Dated this 3rd day of August, 1966.

R. D. WIDDOWS, Liquidator.

6 Marylin-court, East Bentleigh. 3014

Companies Act 1961.

PURSUANT TO SECTION 254 (2).

RAKAI PROPRIETARY LIMITED.

MEMBERS VOLUNTARY WINDING UP.

AT an Extraordinary General Meeting of the above-named company duly convened and held at the registered office of the company, 422 Collins-street, Melbourne, on the 3rd day of August, 1966, the following Resolution was duly passed as a Special Resolution:—

“That the company be wound up voluntarily”.

And at such last-mentioned meeting, John Ernest McEncroe, of 422 Collins-street, Melbourne, was appointed liquidator for the purposes of the winding up.

Dated this 3rd day of August, 1966.

3017 J. E. McENCROE, Liquidator.

Companies Act 1961.—In the matter of **REGAL CARTONS PTY. LTD.** (in Voluntary Liquidation).—Notice of Final Meeting Pursuant to Section 272 of the Companies Act 1961.

NOTICE is hereby given in pursuance of section 272 of the Companies Act that a General Meeting of the members of the above-named company will be held in the office of Nabisco Pty. Limited, 277 William-street, Melbourne, at 3 o'clock in the afternoon, on Monday, 12th September, 1966, for the purpose of having an account laid before them, showing the manner in which the winding up has been conducted and the property of the company disposed of and hearing any explanation that may be given by the liquidator.

Dated this 3rd day of August, 1966.

3030 H. J. FOSTER, Liquidator.

NOTICE is hereby given that a General Meeting of shareholders of Fomac Pty. Ltd. (in Vol. Liq.), will be held at 11 a.m. on 12th September, 1966, at the office of the liquidator, Clive Thackwray Wilson, 34 Queen-street, Melbourne, for the purpose of showing how the winding up of the company has been disposed of, and to lay before the meeting the account, and to give any explanation thereof. 3040

Companies Act 1961, Section 271.
INTERNATIONAL HOMES CO. PTY. LTD.
(IN LIQUIDATION).

NOTICE is hereby given that pursuant to section 271 of the Companies Act 1961, an Annual Meeting of creditors and members of International Homes Co. Pty. Ltd. (in Liquidation) will be held at the offices of Marquand and Co., 51 Queen-street, Melbourne, on Monday, 12th September, at 11 a.m., for the purpose of laying before the meeting an account of the conduct of the winding up during the year ended 10th May, 1966.

Dated 10th August, 1966.

3049

L. P. SMART, Liquidator.

Companies Act 1961, Section 260.

ROOF TOP RENOVATIONS PTY. LTD.

A MEETING of the company will be held on Thursday, 18th August, 1966, at 3 p.m., for the purpose of placing the company in voluntary liquidation, and a Meeting of Creditors will be held at 3.15 p.m. for the purpose of sections 260, 261 and 262, both meetings will be held in the Board Room of The Institute of Chartered Accountants, 23 McKillop-street, Melbourne.

By order of the Board,

3046

A. WRAY, Director.

Companies Act 1961.

BRITISH THERMAL SUPPLIES (AUST.) PTY. LTD.

NOTICE PURSUANT TO SECTION 254 (2) (b) OF THE COMPANIES ACT 1961.

NOTICE is hereby given that at an Extraordinary General Meeting of the members of the above-named Company, held on Friday, the 29th July, 1966, it was resolved that the company be wound up voluntarily and at a Meeting of Creditors held on the same day pursuant to section 260, it was resolved that for such purposes, Bruce Edward Fordham, of 170 Toorak-road, South Yarra, chartered accountant, be appointed liquidator.

Notice is also given that after 21 days from this date, I shall proceed to distribute the assets. All creditors having any claims against the company should furnish particulars of same by that date, otherwise I shall proceed to distribute the assets without regard to their claim.

Dated this 8th day of August, 1966.

BRUCE FORDHAM, Liquidator.

Bruce Fordham, chartered accountant, 170 Toorak-road, South Yarra. 3047

Companies Act 1961.

BRITISH THERMAL INSULATIONS (AUST.) PTY. LTD.

NOTICE PURSUANT TO SECTION 254 (2) (b) OF THE COMPANIES ACT 1961.

NOTICE is hereby given that at an Extraordinary General Meeting of the members of the above-named Company, held on Friday, the 29th July, 1966, it was resolved that the company be wound up voluntarily and at a Meeting of Creditors held on the same day pursuant to section 260, it was resolved that for such purposes, Bruce Edward Fordham, of 170 Toorak-road, South Yarra, chartered accountant, be appointed liquidator.

Notice is also given that after 21 days from this date, I shall proceed to distribute the assets. All creditors having any claims against the company should furnish particulars of same by that date, otherwise I shall proceed to distribute the assets without regard to their claim.

Dated this 8th day of August, 1966.

BRUCE FORDHAM, Liquidator.

Bruce Fordham, chartered accountant, 170 Toorak-road, South Yarra. 3048

Companies Act 1961.

Re A. E. GATES PTY. LTD. (IN VOLUNTARY LIQUIDATION).

NOTICE TO SHAREHOLDERS AND CREDITORS—FINAL MEETING.

NOTICE is hereby given that a meeting of the shareholders and creditors of the above company will be held on Monday, 5th September, at 10.30 a.m. in the offices of the liquidator for the purposes set out in section 272 of the above Act, of laying before the meeting an account of how the winding up has been conducted and the property of the company disposed of and of giving an explanation thereof.

Dated this 1st day of August, 1966.

2989

JOHN P. HYMAN, Liquidator.

The Companies Act 1961.—In the matter of Y.Q. PTY. LIMITED.

AT an Extraordinary General Meeting of the members of the above-named company duly convened and held at 86 Nicholson-street, Fitzroy, on the 27th day of July, 1966, the Special Resolution set below was duly passed:—

“That the company be wound up voluntarily and that Robert Arthur Jan, public accountant, be appointed liquidator.”

2955

ROBERT ARTHUR JAN, Liquidator.

In the Supreme Court of Victoria.—Co. 7239.—In the matter of the Companies Act 1961; and in the matter of TOWN HOUSE CONSTRUCTION PTY. LTD.

NOTICE is hereby given that a petition for the winding up of the above-named company by the Supreme Court was on the 2nd day of August, 1966, presented by John Sharp and Sons Pty. Limited. And that the said petition is directed to be heard before the court sitting at the Fourteenth Court, Law Courts, William-street, Melbourne, on the 2nd day of September, 1966, at the hour of 10.30 o'clock in the forenoon; and any creditor or contributory of the said company desiring to support or oppose the making of an order on the said petition may appear at the time of hearing by himself or his counsel for that purpose; and a copy of the petition will be furnished to any creditor or contributory of the said company requiring the same by the undersigned on payment of the regulated charge for the same.

The petitioner's address is the corner of Lorimer and Johnston streets, South Melbourne.

The petitioner's solicitors are John J. Cantwell and Co., of 253 Lonsdale-street, Melbourne.

JOHN J. CANTWELL & CO., solicitors for the petitioner.

NOTE.—Any person who intends to appear on the hearing of the said petition must serve or send by post to the above-named solicitors notice, in writing, of his intention to do so. The notice must state the name and address of the person, or if a firm, the name and address of the firm, and must be signed by the person or firm or his or their solicitors (if any) and must be served, or if posted, must be sent by post in sufficient time to reach the above-named not later than Four o'clock in the afternoon on the 1st day of September, 1966.

2974

The Companies Act 1961.—In the matter of READY MIXED ASPHALT PTY. LTD.—Notice re Meeting of Creditors Pursuant to Section 260.

NOTICE is hereby given that a meeting of creditors of the above-named company will be held at Suite 18, 545 St. Kilda-road, Melbourne, on Monday, 29th August, 1966, at 11.30 a.m., the company having convened a meeting of its members for the previous day for the purpose of considering a Resolution that the company be wound up voluntarily.

Dated this 5th day of August, 1966.

BASTIAN, BENT & COUGLE, public accountants, Suite 18, 545 St. Kilda-road, Melbourne.

2975

The Companies Act 1961.—In the matter of B. & D. CONSTRUCTIONS PTY. LIMITED.—Notice re Meeting of Creditors pursuant to Section 260.

NOTICE is hereby given that a meeting of creditors of the above-named company will be held at the offices of Kennedy, Smail and Middlemiss, 296 Little Lonsdale-street, Melbourne, at 3 p.m. on the 22nd day of August, 1966, the company having convened a meeting of its members for the same day for the purpose of considering a Resolution that the company be wound up voluntarily.

Dated this 5th day of August, 1966.

D. KRANJCIC, Director.

Kennedy, Smail and Middlemiss, 296 Little Lonsdale-street, Melbourne.

2995

BALLARAT MAIL PROPRIETARY LIMITED.

AT an Extraordinary General Meeting of the above-named company duly convened and held at 6 Camp-street, Ballarat, on the 29th day of July, 1966, the following Special Resolution was passed:—

“That the company be wound up voluntarily”.

Dated this 4th day of August, 1966.

2979

THOMAS M. MORRIS, Director.

Companies Act 1961, Section 272.

VIC. COTTRILL PTY. LTD. (IN LIQUIDATION).

THE Final Meeting of the company and its creditors will be held on Wednesday, 14th September, 1966, at 9.30 a.m., in the Board Room of the Honorary Justices' Association, 34 Queen-street, Melbourne, to receive the liquidator's final account and report.

3044

C. A. J. TEMPANY, F.C.A., Liquidator.

HENRY MILES COX, formerly of Mount View-road, Rosebud, but late of Boundary-road, Dromana, retired public servant, DECEASED (who died on 5th June, 1966).

CREDITORS, next of kin and all other persons having claims against the estate of the deceased are required by the executor of his will, Alexander Miles Cox, of 11 Queens-avenue, Doncaster, chartered engineer, to send particulars thereof to him care of the under-mentioned solicitors before 12th October 1966, after which date he may distribute the assets of the deceased, having regard only to the claims of which he then has notice.

COLTMAN, WYATT & ANDERSON, solicitors, of 578 Bourke-street, Melbourne.

3035

ROCCO ANTONIO TOCE, late of 60 Foley-street, Kew, in the State of Victoria, retired tailor, DECEASED, intestate.

CREDITORS, next of kin and others having claims in respect of the estate of the deceased (who died on the 8th day of March, 1966), are required by the applicant for grant of administration, Raffaella Toce, of 63 Victoria-street, East Brunswick, in the said State, to send particulars of their claims to her by the 24th day of October, 1966, after which date the applicant for grant of administration may convey or distribute the assets, having regard only to the claims of which she then has notice.

CLARKE, ROWAN & RICHARDS, of 360 La Trobe-street, Melbourne, solicitors for the applicant.

3031

CREDITORS, next of kin and others having claims in respect of the estate of Angus Alexander Gordon, late of Emerald, gentleman, deceased (who died on the 30th day of April, 1966), are to send particulars of their claims to the executor, Alexander William McDonald, care of the under-mentioned solicitors by the 12th day of October, 1966, after which date the executor will distribute the assets, having regard only to the claims of which he then has notice.

GILBERT, FIELD & WARNE, solicitors, 406 Collins-street, Melbourne.

3043

CREDITORS, next of kin and others having claims against the estate of Konstantinos Panias, late of 28 Yambala-street, Clifton Hill, in the State of Victoria, machinist, deceased (who died on the 23rd day of October, 1965), are required to send particulars of their claims to the administrator of his estate, John Panias, care of the under-mentioned solicitors before the 15th day of October, 1966, after which date the said administrator will distribute the estate of the said deceased, having regard only to the claims of which he then has notice.

J. OKNO, PAPAS & CO., solicitors, of 390 Lonsdale-street, Melbourne.

3036

CREDITORS, next of kin and others having claims against the estate of George Pangakis, late of 19 McIlwrick-street, Windsor, in the State of Victoria, labourer, deceased (who died on the 11th day of March, 1964), are required to send particulars of their claims to the administratrix of his estate, Maria Pangakis, care of the under-mentioned solicitors before the 15th day of October, 1966, after which date the said administratrix will distribute the assets of the said deceased, having regard only to the claims of which she then has notice.

J. OKNO, PAPAS & CO., solicitors, of 390 Lonsdale-street, Melbourne.

3037

CREDITORS, next of kin and others having claims against the estate of Cedomir Milosavljevic, late of 101 Mason-street, Newport, in the State of Victoria, labourer, deceased (who died on the 12th day of April, 1966), are required to send particulars of their claims to the administratrix of his estate, Maria Milosavljevic, care of the under-mentioned solicitors before the 15th day of October, 1966, after which date the said administratrix will distribute the estate of the said deceased, having regard only to the claims of which she then has notice.

J. OKNO, PAPAS & CO., solicitors, of 390 Lonsdale-street, Melbourne, C.1.

3038

Trustee Act 1958.

NOTICE TO CLAIMANTS.

PURSUANT to the Trustee Act 1958, creditors, next of kin and all other persons having claims in respect of the estate of any deceased person named below are required to send particulars to the legal personal representative or representatives at the addresses stated, after which date the representative or representatives will distribute the assets, having regard only to the claims of which notice has been received:—

Elaine Marie Poole, late of 9 Cecil-street, Williamstown, widow, deceased, died on the 10th day of June, 1966.—
Claims to the executrix, Ruth Eleanor Stebbings, of 9 Cecil-street, Williamstown, married woman, care of John F. Carroll, of 4 Paisley-street, Footscray, solicitor, by the 12th day of October, 1966. John F. Carroll, LL.B., solicitor, 4 Paisley-street, Footscray. 3029

CREDITORS, next of kin and others having claims in respect of the estate of Clarice Louise Hunt, formerly of "Wakool," Glenfern-road, Upwey, but late of 4 Huongrove, East Bentleigh, in the State of Victoria, widow, deceased (who died on 1st day of October, 1965), are to send particulars of their claims to Heffey & Butler, solicitors, 369 Lonsdale-street, Melbourne, by 4th November, 1966, after which date they will distribute the assets, having regard only to the claims of which they have notice.

HEFFEY & BUTLER, solicitors, 369 Lonsdale-street, Melbourne. 3008

CREDITORS, next of kin and others having claims in respect of the estate of Sylvia Adeline Rolfe, late of 28 Bryson-street, Canterbury, widow, deceased (who died on the 5th June, 1966), are to send particulars of their claims to The Union-Fidelity Trustee Company of Australia Limited, of 100 Exhibition-street, Melbourne, by the 17th October, 1966, after which date it will distribute the assets, having regard only to the claims of which it then has notice.

HENDERSON & BALL, solicitors, 430 Little Collins-street, Melbourne. 3009

CREDITORS, next of kin and others having claims in respect of the will and estate of Selina Jane Mulcahy, formerly of 5 Loch-street, St. Kilda, but late of Flat 8, 4 Loch-street, St. Kilda, in the State of Victoria, married woman, deceased (who died on the 18th day of September, 1965), are required by the administrator Peter Paul Mulcahy, of Flat 4, 43 Melrose-street, North Melbourne, retired, to send particulars of their claims to him, care of Messrs. Strongman and Crouch, solicitors, of 118 Queen-street, Melbourne, by the 15th day of October, 1966, after which date the said administrator will distribute the assets of the deceased, having regard only to the claims of which he then shall have had notice.

STRONGMAN & CROUCH, solicitors, 118 Queen-street, Melbourne. 3010

CREDITORS, next of kin and others having claims in respect of the estate of Joseph Mark Manly, late of Korobeit, retired farmer, deceased (who died on the 13th day of January, 1966), and probate of whose will has been granted to William George Manly, of Korobeit, farmer, and Alexander Joseph Manly, of Rowsley, farmer, are required to send particulars of their claims to the said executors, care of the under-mentioned solicitors, by the 10th day of October, 1966, after which date they will distribute the assets, having regard only to the claims of which they then have notice.

PEARCE & WEBSTER, solicitors, of 430 Little Collins-street, Melbourne. 3011

GLEN WHITELAW HARVIE, late of 7 Riversdale-road, Hawthorn in the State of Victoria, estate agent, DECEASED.

CREDITORS, next of kin and others having claims in respect of the estate of the deceased (who died on the 2nd day of April, 1965), are required by The Perpetual Executors and Trustees Association of Australia Limited, of 100-104 Queen-street, Melbourne, to send particulars of their claims to the said company by the 16th day of October, 1966, after which date it will convey or distribute the assets, having had regard only to the claims of which the company then has notice.

CORR & CORR, solicitors, 290 Latrobe-street, Melbourne. 3012

CREDITORS, next of kin and others having claims in respect of the estate of Henry Redmond Read, late of Rosehill Private Hospital, 265 Centre-road, Bentleigh, gentleman, deceased (who died on the 4th May, 1966), are to send particulars of their claims to The Trustees, Executors and Agency Company Limited, of 401 Collins-street, Melbourne, by the 11th day of October, 1966, after which date the said company will distribute the assets of the said deceased, having regard only to the claims of which it then has notice.

R. WADHAM & DOIG, solicitors, 383 Flinders-lane, Melbourne. 3019

LUCY LEVINUS BURSTON, late of 37 Princess-street, Kew, in the State of Victoria, widow, DECEASED.

CREDITORS, next of kin and others having claims in respect of the estate of the above-named deceased (who died on the 3rd day of July, 1965), are required by the executors, Nelson George Plant and Leonard Clement Liddell, to send particulars of their claims to the executors, care of the office of R. G. Dunlop, of 108 Queen-street, Melbourne, by the 11th day of October, 1966, after which date the executors will convey or distribute the assets of the estate, having had regard only to the claims of which the executors then have notice.

R. G. DUNLOP, of 108 Queen-street, Melbourne, solicitor for the executors. 2991

FLORENCE MIDDLETON MCGIBBONY, formerly of Flat 18, Surrey Hall, No. 564 St. Kilda-road, Melbourne, but late of 14 Sunburst-avenue, North Balwyn, both in the State of Victoria, widow, DECEASED.

CREDITORS, next of kin and others having claims in respect of the estate of the deceased (who died on the 23rd day of March, 1966), are required by the administrator, The Trustees, Executors and Agency Company Limited, of 401 Collins-street, Melbourne, to send particulars to it by the 19th day of October, 1966, after which date the administrator may convey or distribute the assets, having regard to the claims of which it then has notice.

CORNWALL, STODART & CO., 222 Queen-street, Melbourne. 2992

CREDITORS, next of kin and others having claims in respect of the estate of Edwin Reginald Ferber, late of 3 Bambra-road, Caulfield, retired accountant, deceased (who died on the 20th March, 1966), are to send particulars of their claims to The Equity Trustees, Executors and Agency Company Limited and Reginald Keith Ferber, the executors of deceased's will, dated the 7th February, 1966, addressed to the executors, care of The Equity Trustees, Executors and Agency Company Limited, at its address, 472 Bourke-street, Melbourne, by the 15th October, 1966, after which date the said executors will distribute the assets, having regard only to the claims of which it and he then shall have had notice.

HOAD & BONELLA, 114 Hawthorn-road, Caulfield, solicitors for the executors. 3018

PHYLIS JEAN GREEN, late of 36 Clifton-road, Hawthorn East, in the State of Victoria, widow, DECEASED.

CREDITORS, next of kin and others having claims in respect of the estate of the deceased (who died on the 21st April, 1966), are required by the executor, John Donald Green, of 8 Willow-avenue, Cheltenham, driver, to send particulars to him, care of the undersigned solicitors, by the 18th October, 1966, after which date he may convey or distribute the assets, having regard only to the claims of which he then has notice.

Dated 4th August, 1966.

R. E. LEWIS, ORR & GIBSON, solicitors, 825 Burke-road, Camberwell. 2999

CLARICE LYDIA RICKARD, late of 12 Hamilton-avenue, Blackburn, in the State of Victoria, married woman, DECEASED.

CREDITORS, next of kin and others having claims in respect of the estate of the deceased (who died on the 22nd March, 1966), are required by the executor, Neville Gilbert Toyne, of 38 Flowerdale-road, Glen Iris, manufacturer, to send particulars to him, care of the undersigned solicitors, by the 18th October, 1966, after which date he may convey or distribute the assets, having regard only to the claims of which he then has notice.

Dated 4th August, 1966.

R. E. LEWIS, ORR & GIBSON, solicitors, 825 Burke-road, Camberwell. 3000

CREDITORS, next of kin and others having claims in respect of the estate of Beatrice Florence Davis, late of 39 Bedford-street, North Melbourne, married woman, deceased (who died on the 24th day of August, 1965), are requested to send particulars of their claims to the executor, The Equity Trustees, Executors and Agency Company Limited, care of the under-mentioned solicitors, on or before the 12th day of October, 1966, after which date the executor will distribute the assets, having regard only to the claims of which it then has notice.

MCKEAN, PARK & COOPER, solicitors, 84 William-street, Melbourne. 3001

CREDITORS, next of kin and others having claims in the estate of Mabel Cecilia Roberts, late of 100 Manning-road, East Malvern, spinster, deceased (who died on 30th April, 1966), are to send particulars of their claims to Robert Hughes Roberts and Alexander Lowell Pollock, care of the undersigned by the 13th day of October, 1966, after which date they will distribute the assets, having regard only to the claims of which they then have notice.

COOK & Mc CALLUM, solicitors, 422 Collins-street, Melbourne. 2996

HAROLD JOSEPH HARVIE, late of 7 Riversdale-road, Hawthorn, in the State of Victoria, estate agent, DECEASED.

CREDITORS, next of kin and others having claims in respect of the estate of the deceased (who died on the 9th day of February, 1965), are required by The Perpetual Executors and Trustees Association of Australia Limited, of 100-104 Queen-street, Melbourne, to send particulars of their claims to the said company by the 16th day of October, 1966, after which date it will convey or distribute the assets, having had regard only to the claims of which the company then has notice.

CORR & CORR, solicitors, 290 Latrobe-street, Melbourne. 3013

OSWALD ARTHUR PARKER, late of 100 Park-street, North Fitzroy, railway employee, DECEASED.

CREDITORS, next of kin and others having claims in respect of the estate of the deceased (who died on the 21st February, 1965) are required by the executrix, Marie Linda Robinson, of 168 Cotham-road, Kew, spinster, to send particulars to her, care of the under-mentioned solicitor, by the 12th day of October, 1966, after which date the executrix may convey or distribute the assets, having regard only to the claims of which she then has notice.

Dated this 8th day of August, 1966.

NORMA L. JENKINS, L.L.B., solicitor, of 329 St. Georges-road, North Fitzroy. 2976

JAMES WILLIAM HANNAH, late of Minerva-road, Herne Hill, Geelong, manager, DECEASED.

CREDITORS, next of kin and others having claims in respect of the estate of the deceased (who died on the 3rd day of June, 1966), are required by the personal representative, Hugh Laurence Ryan, of 9 Austin-street, Newtown, Geelong, garage proprietor, to send particulars to him care of the under-mentioned solicitors, by the 17th day of October, 1966, after which date the personal representative may convey or distribute the assets, having regard only to the claims of which he then has notice.

WHYTE, JUST & MOORE, solicitors, 27 Malop-street, Geelong. 2978

CATHERINE MAUDE BALL, late of 18 George-street, (formerly known as 10 Fair-street), Geelong West, in the State of Victoria, widow, DECEASED.

CREDITORS, next of kin and others having claims in respect of the estate of the deceased (who died on 6th May, 1966), are required by the personal representatives, The Union-Fidelity Trustee Company of Australia Limited, of 100 Exhibition-street, Melbourne, in the said State, and Ernest Marshall, of 10 Beales-street, Newtown, Geelong, in the said State, retired moulder, to send particulars to them at the office of the said company at 8 Malop-street, Geelong aforesaid, by the 13th day of October, 1966, after which date the personal representatives may convey or distribute the assets, having regard only to the claims of which they then have notice.

FREEMAN & FALLAW, solicitors, 41 Yarra-street, Geelong. 2980

CREDITORS, next of kin and others having claims in respect of the estate of Ruth Sophia Caulfield, late of 224 Prospect Hill-road, Surrey Hills, widow, deceased (who died on the 8th day of April, 1966), are to send particulars of their claims to the executor, Alfred Gordon Bennett, care of the under-mentioned solicitors, on or before the 11th day of October, 1966, after which date the executor will distribute the assets, having regard only to the claims of which he then has notice.

MARTIN & MARTIN, solicitors, 37 Queen-street, Melbourne. 2993

CREDITORS, next of kin and others having claims in respect of the estate of Ewon Roberts McLean, formerly of Glebe-avenue, Cheltenham, but late of 4 Bleazby-street, Bentleigh, in the State of Victoria, formerly carpenter but then retired gentleman, deceased (who died on the 2nd day of May, 1966), are to send particulars of their claims to Vera Gertrude McLean, care of the under-mentioned solicitors by the 11th day of October, 1966, after which date she will distribute the assets, having regard only to the claims to which she then has notice.

Dated this 3rd day of August, 1966.

REGINALD C. BUTLER & CO., solicitors, 312 Centre-road, Bentleigh. 2959

CREDITORS, next of kin and others having claims in respect of the estate of Mary Laura O'Brien, formerly of 149 Canterbury-road, Middle Park, but late of 30 Mavho-street, Bentleigh, in the State of Victoria, widow, deceased (who died on the 9th day of October, 1965), are to send particulars of their claims to Margery Helen Cormick, care of the under-mentioned solicitors, by the 11th day of October, 1966, after which date she will distribute the assets, having regard only to the claims to which she then has notice.

Dated this 3rd day of August, 1966.

REGINALD C. BUTLER & CO., solicitors, 312 Centre-road, Bentleigh. 2960

WILLIAM JOHN KNIGHT, late of 20 Grattan-street, Seymour, retired railway employee, DECEASED.

CREDITORS, next of kin, and others having claims in respect of the estate of the deceased (who died on 28th February, 1966), are required to send particulars of their claims to Colin Callen Knight, and Joyce Adele Knight, the executors in care of the undersigned by the 19th October, 1966, after which date they may convey or distribute the assets, having regard only to the claims of which they then have notice.

WILFRID J. OSBORNE & OSBORNE, solicitors, Seymour. 2971

CREDITORS, next of kin, and others having claims in respect of the estate of Thomas Alfred Gillis, formerly of 64 Douglas-parade, Williamstown, cashier, but late of 56 McKinnon-road, McKinnon, in the State of Victoria, formerly permanent soldier, but then public servant, deceased (who died on the 20th day of August, 1965), are to send particulars of their claims to Reginald Charles Butler, care of the under-mentioned solicitors by the 11th day of October, 1966, after which date he will distribute the assets, having regard only to the claims to which he then has notice.

Dated this 3rd day of August, 1966.

REGINALD C. BUTLER & CO., solicitors, 312 Centre-road, Bentleigh. 2958

CREDITORS, next of kin and all others having claims against the estate of John Joseph Collins, late of 18 Byron-street, Footscray, gentleman, deceased (who died on the 14th day of June, 1964, and probate of whose will was granted by the Supreme Court of Victoria in its probate jurisdiction on the 15th day of July, 1966, to William Charles Collins, of 18 Byron-street, Footscray, gentleman), are required to send particulars, in writing, of such claims to the said William Charles Collins, care of Messrs. Jones and Kennedy, solicitors, 213 Nicholson-street, Footscray, on or before the 15th day of October, 1966, after which date the said William Charles Collins will proceed to distribute the assets of the said John Joseph Collins, deceased, which shall have come to his hands amongst the persons entitled thereto, having regard only to the claims of which he shall then have had notice. And notice is hereby further given that the said William Charles Collins will not be liable for the assets so distributed or any part thereof to any person of whose claim he shall not have had notice as aforesaid.

JONES & KENNEDY, solicitors, 213 Nicholson-street, Footscray. 3045

CHARLES CHRISTOPHER, formerly of Mairdample, but late of Mansfield, farmer, DECEASED.

CREDITORS, next of kin, and others having claims in respect of the deceased (who died on 23rd April, 1966), are required by his trustee, John Joseph Christopher, of Collopy-street, Mansfield, shire overseer, to send particulars to him, care of the under-mentioned solicitors, by the 21st October, 1966, after which date the trustee may convey and distribute the assets, having regard only to the claims of which he then has notice.

MAL. RYAN & GLEN, High-street, Mansfield, solicitors for the trustee. 2953

HECTOR HENRY GLENISTER, late of Winterley-road, Point Lonsdale, retired farmer, DECEASED.

CREDITORS, next of kin and all other persons having claims against the estate of the above-named deceased, are required to send particulars thereof to the undersigned solicitors for the executors, Samuel George Glenister, of Main Lead, Beaufort, farmer, and William Laurence Adamson, of 17 Henry-street, Ringwood, public servant, on or before the 18th day of October, 1966, after which date the said executors will distribute the assets of the said deceased, having regard only to claims of which they shall then have notice.

W. N. MOONIE & CO., solicitors, Queenscliff and Point Lonsdale. 2967

RE DAPHNE RUTH JARDINE, late of 32 Bethune-street, Queenscliff, married woman, DECEASED.

CREDITORS, next of kin and all other persons having claims against the estate of the above-named deceased, are required to send particulars to the undersigned solicitors for the executrix, Myrtle Alice Paul, of 45 Pardy-street, Pascoe Vale, married woman, on or before the 18th day of October, 1966, after which date the said executrix will distribute the assets of the said deceased, having regard only to claims of which she shall then have notice.

W. N. MOONIE & CO., solicitors, Queenscliff and Point Lonsdale. 2968

CREDITORS, next of kin, and others having claims in respect of the estate of William Patrick Coleman, late of Glenmaggie, farmer, deceased (who died on the 6th day of December, 1965), are required to send particulars of their claims to National Trustees, Executors and Agency Company of Australia Limited, of 95 Queen-street, Melbourne, by the 15th day of October, 1966, after which date it will distribute the assets, having regard only to the claims of which it then has notice.

J. CROFTON LEE, solicitor, 69A Raymond-street, Sale. 2969

CREDITORS, next of kin and all others having claims in respect of the estate of Jean Parker Miller, late of 1594 High-street, Glen Iris, in the State of Victoria, widow, deceased (who died on the 17th day of April, 1966), are required by the executor, Alexander Paterson Miller, of 1594 High-street, Glen Iris, aforesaid, retired manager, to send particulars of their claims to him, care of the under-mentioned solicitors, by the 11th day of October, after which date he may convey or distribute the assets, having regard only to the claims of which he then has notice.

AITKEN, WALKER & STRACHAN, solicitors, 414 Collins-street, Melbourne. 3039

EDNA LOWERSON, formerly of 3 Nugent-street, East Preston, late of 6 Grove-street, Eltham, in the State of Victoria, home duties, DECEASED.

CREDITORS, next of kin and others having claims against the estate of the above-named deceased are required to send particulars thereof to National Trustees, Executors and Agency Company, of 95 Queen-street, Melbourne, the executor appointed by the will of the deceased (who died on the 7th May, 1966), addressed to the manager of the said company, by the 15th October, 1966, after which date the said company will distribute the assets of the said deceased, having regard only to those claims of which it shall then have had notice.

HOAD & BONELLA, 114 Hawthorn-road, Caulfield, solicitors for the said company. 3016

LESLIE HERBERT WATKINS, formerly of 9 Rosella-road, Mordialloc, but late of 264 Balcombe-road, Mentone, in the State of Victoria, plasterer, DECEASED.

CREDITORS, next of kin and all other persons having claims against the estate of the deceased are required by his executrix, Ivy Elizabeth Watkins, of 264 Balcombe-road, Mentone, to send particulars to her, care of the under-mentioned solicitors, on or before the 11th day of October, 1966, after which date she will distribute the assets, having regard only to the claims of which she then has notice.

J. ALLAN ANDERSON & SON, solicitors, 472 Bourke-street, Melbourne. 3002

JACK CHAPMAN, late of 30 Wilson-street, Cheltenham, in the State of Victoria, retired market gardener, DECEASED.

CREDITORS, next of kin and all other persons having claims against the estate of the deceased are required by his executor, Kennon Alex. Chapman, of 20 Wedd-street, Cheltenham, to send particulars to him, care of the under-mentioned solicitors, on or before the 11th day of October, 1966, after which date he will distribute the assets, having regard only to the claims of which he then has notice.

J. ALLAN ANDERSON & SON, solicitors, 472 Bourke-street, Melbourne. 3004

HUBERT ALLEN TRANTER, formerly of 25 Hill-street, Box Hill, but late of 1 Warncliffe-road, East Ivanhoe, in the State of Victoria, printer, DECEASED.

CREDITORS, next of kin and all other persons having claims against the estate of the deceased are required by his executrix, Effie Jean Tranter, of 1 Warncliffe-road, East Ivanhoe, to send particulars to her, care of the under-mentioned solicitors, on or before the 11th day of October, 1966, after which date she will distribute the assets, having regard only to the claims of which she then has notice.

J. ALLAN ANDERSON & SON, solicitors, 472 Bourke-street, Melbourne. 3005

CREDITORS, next of kin and others having claims against the estate of Eileen May Bradley, late of 12 Somers-street, Burwood, in the State of Victoria, widow, deceased (who died on the 9th day of June, 1966), are to send particulars of their claims to National Trustees, Executors and Agency Company of Australasia Limited, whose registered office is situate at 95 Queen-street, Melbourne, in the said State, by the 31st day of October, 1966, after which date it will distribute the assets, having regard only to the claims of which it then has notice.

JOHN F. CARROLL, solicitor, 118 Queen-street, Melbourne. 3003

THOMAS GEORGE JOHNSTON, late of Berriwillock, in the State of Victoria, builder, DECEASED.

CREDITORS, next of kin and other persons having claims against the estate of the said deceased (who died on the 11th day of May, 1966), are required to send particulars of same to the executors, William George Johnston and Leo Thomas Johnston, in care of the undersigned, on or before the 21st day of October, 1966, after which date they will distribute the assets, having regard only to the claims of which they then have notice.

DELANY & DELANY, barristers and solicitors, 270 Campbell-street, Swan Hill. 3006

ALISON DOUGLAS DOWLING, late of 347 Beveridge-street, Swan Hill, in the State of Victoria, married woman, DECEASED.

CREDITORS, next of kin and other persons having claims against the estate of the said deceased (who died on the 16th day of May, 1966), are required to send particulars of same to the executor, John Edward Dowling, in care of the undersigned, on or before the 21st day of October, 1966, after which date they will distribute the assets, having regard only to the claims of which they then have notice.

DELANY & DELANY, barristers and solicitors, 270 Campbell-street, Swan Hill. 3007

In the Supreme Court of the State of Victoria.

SALE BY THE SHERIFF.

ON Monday, the 19th of September, 1966, at 2 p.m., at the Police Station, Moonee Ponds (unless process be stayed or satisfied):—

All the estate and interest (if any) of Mary Mifsud, of 16 Canterbury-street, Moonee Ponds, as proprietor of an estate in fee-simple in the land described in certificate of title, volume 8241, folio 919, upon which is erected a weatherboard dwelling-house, known as No. 16, Canterbury-street, Moonee Ponds.

Registered mortgage No. B.454408 affects the said estate and interest.

Terms: Cash only.
N. FROGLEY, Sheriff's Officer.
3rd August, 1966. 3033

In the Supreme Court of the State of Victoria.

SALE BY THE SHERIFF.

ON Tuesday, the 20th of September, 1966, at 10 a.m., at the Police Station, Ascot Vale (unless process be stayed or satisfied):—

All the estate and interest (if any) of J. Bryant, of 64 Mirams-street, Ascot Vale, as joint proprietor with Olive Bryant, married woman, of an estate in fee-simple in the land described in certificate of title, volume 3610, folio 874, upon which is erected a dwelling-house, known as No. 64 Mirams-street, Ascot Vale.

Registered mortgage No. C.441861 affects the said estate and interest.

Terms: Cash only.
DAVID J. JOHNSTON, Sheriff's Officer.
3rd August, 1966. 3034

IMPOUNDINGS

BRANXHOLME.—Impounded in Branhholme Pound.

- 1 Corriedale ewe, two back notches near ear, green tag off ear, no visible brand
 - 2 Corriedale wethers, fork notch off ear, no visible brand
- If not claimed and expenses paid, to be sold on 27th August, 1966.
- V. LATHER,
Poundkeeper.
- 2987—\$1.60

DONALD.—Impounded in Donald Pound from Litchfield, by Shire Ranger, 31st July, 1966.

- 1 Dorset Horn ram, Banyenong tag right ear, no visible brand
 - 1 Border Leicester ram, Black Gate OC 59 tag right ear, red brand on back
- If not claimed and expenses paid, to be sold on 19th September, 1966.
- W. A. CAMERON,
Poundkeeper.
- 2963—\$2.00

DONALD.—Impounded in Donald Pound from private property, Single Tree-road, 4th August, 1966.

- 1 Dorset Horn ram (horns sawn off), about 3 years, no visible brand
- If not claimed and expenses paid, to be sold on 19th September, 1966.
- W. A. CAMERON,
Poundkeeper.
- 3052—\$1.60

SHEPPARTON.—Impounded in Shepparton Pound.

- 6 white pigs, no visible brand
 - 1 black and white pig, no visible brand
- If not claimed and expenses paid, to be sold on 25th August, 1966.
- C. L. MANSELL,
Poundkeeper.
- 3051—\$1.40

Subordinate Legislation Act 1962.

IN pursuance of the provisions of the Subordinate Legislation Act 1962 and the Regulations made thereunder, notice is given of the making of the following statutory rules:—

No.	Description	Price.
	<i>Motor Boating Act 1961, Section 15.</i>	
208/1966.	Motor Boating (Lake Fyans Authority) Regulations 1966	5c
	<i>Mines Act 1958.</i>	
209/1966.	Mines (Survey Fees) Regulations 1966	5c
	<i>Local Government Act 1958.</i>	
210/1966.	Uniform Building Regulations Amending Regulations No. 10	8c
	<i>Health Act 1958 (No. 6270).</i>	
211/1966.	Benzene Regulations 1966	8c
	<i>Labour and Industry Act 1958.</i>	
212/1966.	Labour and Industry (Lead Processes) Regulations 1966	10c
	<i>Public Service Act 1958.</i>	
213/1966.	Public Service (Governor in Council) Regulation No. 30	5c
	<i>Explosives Act 1960.</i>	
214/1966.	Explosives (Amendment No. 3) Regulations 1966	5c
	<i>Weights and Measures Act 1958.</i>	
215/1966.	Weights and Measures (Amendment No. 6) Regulations 1966	12c
	<i>Railways Act 1958.</i>	
216/1966.	Fares and Freights—Increased Charges for Certain Railway Services	8c
	<i>Police Regulation Act 1958.</i>	
217/1966.	Police (Fees) Regulations 1966	8c

Copies of these statutory rules may be purchased at the Sale of Publications Section of the Government Printing Office, located off Parliament-place, Melbourne, C.2. If ordered by mail, remittance should be addressed to "The Government Printer, Box 203, P.O., North Melbourne, N.1", and should include 5c extra for postage. If a credit account is held at this Office, no remittance is required with the mail order.

A. C. BROOKS,
Government Printer.

CONTENTS

	PAGE
Appointments	2992
Companies Act 1961—Notices	2989
Contracts	2985
Erratum	2982
Estates of Deceased Persons	2988
Government Notices	2978
Impoundings	3028
Lands	3005
Melbourne and Metropolitan Board of Works— Notice	2991
Mining	2978
Notices to Mariners	2990
Notice of Making of Statutory Rules	3028
Notice to Attend for Radiological Examination	2987
Orders in Council— Acts—Railways; Land; Bread Industry; Local Government; Gas Regulation; Hos- pitals and Charities; Country Roads; Water; Local Government; Town and Country Planning; Sewerage Districts.	2993 et seq
Private Advertisements	3016
Proclamations	2977
Public Service Notices	3012
Resignations	2993
State Rivers and Water Supply Commission	2983
Tenders	3010
Transport Regulation Board—Public Hearings	2979
Waterworks Trusts	2991