



VICTORIA GOVERNMENT GAZETTE

Published by Authority

[Registered at the General Post Office, Melbourne, for transmission by post as a newspaper.]

No. 771

WEDNESDAY, OCTOBER 12

[1966

PROCLAMATIONS

Land Act 1958.

AREA OF LAND COMPRISED IN CERTAIN CLASSES DIMINISHED OR INCREASED.

PROCLAMATION

By His Excellency the Governor of the State of Victoria and its Dependencies in the Commonwealth of Australia, &c., &c., &c.

WHEREAS by the *Land Act 1958* it is amongst other things enacted that the Governor in Council may, by Proclamation to be published in the *Government Gazette*, at any time diminish or increase the area of land comprised in any of the classes mentioned in Part I., Division 1, Section 5, of the said *Land Act 1958*, but that the area of lands which may be sold by auction (Class 6), shall not be increased except as in certain cases in the said Act provided: Now therefore I, the Governor of the State of Victoria, in the Commonwealth of Australia, by and with the advice of the Executive Council of the said State, and in accordance with the provisions of sections 94 and 117 of the *Land Act 1958* aforesaid, do hereby diminish or increase (as the case may be) the areas of Crown lands comprised in classes 3 and 6 of the classes mentioned in section 5 of the *Land Act 1958* aforesaid, to the extent set forth in the subjoined Schedule (that is to say):—

Schedule referred to.

CLASSES DIMINISHED OR INCREASED.

County.	Parish.	Allotment.	Section.	Area.	Diminished.	Increased.	Description.
					Class	Class	
Tambo	Waygara	2c	A	A. R. P. 4 0 23	3	6	In the north of the Parish

Given under my Hand and the Seal of the State of Victoria, aforesaid, at Melbourne, this fourth day of October, in the year of Our Lord One thousand nine hundred and sixty-six, and in the fifteenth year of the reign of Her Majesty Queen Elizabeth II.

(L.S.)

ROHAN DELACOMBE.

By His Excellency's Command,

JIM BALFOUR,
Minister of Lands.

GOD SAVE THE QUEEN!

Land Act 1958.

UNALIENATED CROWN LAND AVAILABLE FOR SETTLEMENT UNDER IMPROVEMENT PURCHASE LEASES.

PROCLAMATION

By His Excellency the Governor of the State of Victoria and its Dependencies in the Commonwealth of Australia, &c., &c., &c. IN pursuance of the provisions of Section 153 of the *Land Act 1958*, I, the Governor of the State of Victoria, in the Commonwealth of Australia, by and with the advice of the Executive Council of the said State, do by this Proclamation declare the unalienated Crown lands mentioned in the subjoined Schedule, to be available for settlement under improvement purchase leases.

SCHEDULE.

County.	Parish.	Allotment.	Section.	Area.	Land Valuation.
				A. R. P.	
Delatite	Whitfield	9	3	135 1 30	\$10 per acre.

Given under my Hand and the Seal of the State of Victoria aforesaid, at Melbourne this fourth day of October, in the year of Our Lord One thousand nine hundred and sixty-six and in the fifteenth year of the reign of Her Majesty Queen Elizabeth II.

(L.S.)

ROHAN DELACOMBE.
By His Excellency's Command,
JIM BALFOUR,
Minister of Lands.

GOD SAVE THE QUEEN !

ROAD PROCLAIMED.

PROCLAMATION

By His Excellency the Governor of the State of Victoria and its Dependencies in the Commonwealth of Australia, &c., &c., &c.

IN pursuance of the provisions of section 25 of the *Land Act 1958*, I, the Governor of the State of Victoria, by and with the advice of the Executive Council of the said State, do hereby proclaim as a road the land in the Parish of Woodbourne, County of Anglesey, as indicated by hachure on plan hereunder.

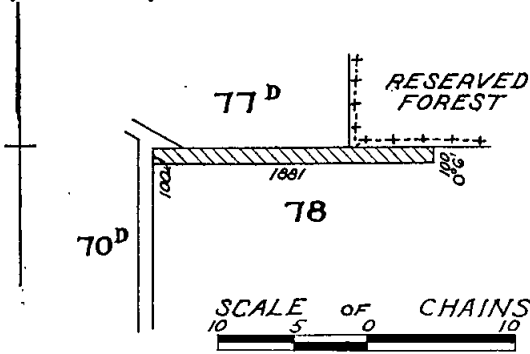

Given under my Hand and the Seal of the State of Victoria aforesaid, at Melbourne, this fourth day of October, in the year of our Lord One thousand nine hundred and sixty-six, and in the fifteenth year of the reign of Her Majesty Queen Elizabeth II.

(L.S.)

ROHAN DELACOMBE.
By His Excellency's Command,
JIM BALFOUR,
Minister of Lands.

GOD SAVE THE QUEEN !

PUBLIC HOLIDAY.

PROCLAMATION

By His Excellency the Governor of the State of Victoria and its Dependencies in the Commonwealth of Australia, &c., &c., &c.

IN pursuance of the provisions contained in Part III. of the *Public Service Act 1958*, I, the Governor of the State of Victoria, in the Commonwealth of Australia, by

and with the advice of the Executive Council of the said State, do by this my Proclamation appoint the day and date hereunder mentioned to be observed as a Public Holiday at the place respectively specified, viz:—

Public Holiday:—

SATURDAY, THE 5TH NOVEMBER, 1966, throughout the Dookie and South Ridings of the Shire of Shepparton.

Given under my Hand and the Seal of the State of Victoria aforesaid, at Melbourne, this fourth day of October, in the year of our Lord One thousand nine hundred and sixty-six and in the fifteenth year of the reign of Her Majesty Queen Elizabeth II.

(L.S.)

ROHAN DELACOMBE.
By His Excellency's Command,
A. G. RYLAH,
Chief Secretary.

GOD SAVE THE QUEEN !

PUBLIC HOLIDAYS.

PROCLAMATION

By His Excellency the Governor of the State of Victoria and its Dependencies in the Commonwealth of Australia, &c., &c., &c.

IN pursuance of the provisions contained in Part III. of the *Public Service Act 1958*, I, the Governor of the State of Victoria, in the Commonwealth of Australia, by and with the advice of the Executive Council of the said State, do by this my Proclamation appoint the days and dates hereunder mentioned to be observed as Public Holidays at the places respectively specified, viz:—

Public Holidays:—

TUESDAY, THE 1ST NOVEMBER, 1966, throughout the City of Ringwood.

TUESDAY, THE 1ST NOVEMBER, 1966, throughout the Shire of Diamond Valley.

Given under my Hand and the Seal of the State of Victoria aforesaid, at Melbourne, this eleventh day of October, in the year of our Lord One thousand nine hundred and sixty-six, and in the fifteenth year of the reign of Her Majesty Queen Elizabeth II.

(L.S.)

ROHAN DELACOMBE.
By His Excellency's Command,
A. G. RYLAH,
Chief Secretary.

GOD SAVE THE QUEEN !

BANK HALF-HOLIDAY.

PROCLAMATION

By His Excellency the Governor of the State of Victoria and its Dependencies in the Commonwealth of Australia, &c., &c., &c.

IN pursuance of the provisions of the *Bank Holidays Act 1958*, I, the Governor of the State of Victoria, in the Commonwealth of Australia, do by this my Proclamation appoint the day and date named hereunder a special day to be observed as a Bank Half-Holiday at the place respectively mentioned, that is to say:—

Bank Half-Holiday from the Hour of 11 a.m.:—

WEDNESDAY, 19TH OCTOBER, 1966, at Jeparit.

Given under my Hand and the Seal of the State of Victoria aforesaid, at Melbourne, this fourth day of October, in the year of our Lord One thousand nine hundred and sixty-six and in the fifteenth year of the reign of Her Majesty Queen Elizabeth II.

(L.S.) ROHAN DELACOMBE.

By His Excellency's Command,

A. G. RYLAH,
Chief Secretary.

GOD SAVE THE QUEEN!

ACTS OF PARLIAMENT.

PROCLAMATION

By His Excellency the Governor of the State of Victoria and its Dependencies in the Commonwealth of Australia, &c., &c., &c.

I, THE Governor of the State of Victoria, in the Commonwealth of Australia, do hereby declare that I have this day assented, in Her Majesty's name, to the Bills passed by the Parliament of the said State, the titles whereof are hereunder set forth together with the short titles, that is to say:—

No. 7435. "An Act to amend the *Firearms Act 1958* with respect to the Possession and Carriage of certain Types of Target Shooting Weapons." (*Firearms (Competition Weapons) Act 1966.*)

No. 7436. "An Act to make Provision with respect to the Incorporation of the Provincial Sewerage Authorities Association of Victoria." (*Provincial Sewerage Authorities Association of Victoria Act 1966.*)

No. 7437. "An Act to make Provision with respect to the Incorporation of the Waterworks Trusts Association of Victoria and for other purposes." (*Waterworks Trusts Association of Victoria Act 1966.*)

No. 7438. "An Act to provide for the Revocation of the Reservations of certain Lands in the Township of Maffra temporarily reserved as Sites for a Municipal Depot and a Children's Playground respectively, for the exchange thereof for certain other Land in the said Township and for the Reservation of that other Land for the Purposes of Public Recreation and a Children's Playground, and for other purposes." (*Maffra Lands Exchange Act 1966.*)

No. 7439. "An Act to provide, upon the Surrender to Her Majesty of certain Land in the Parish of Trewalla, for the Reservation thereof as a Site for Public Purposes and the Grant of certain Crown Land in the said Parish." (*Trewalla Lands Exchange Act 1966.*)

No. 7440. "An Act to amend the *Tattersall Consultations Act 1958.*" (*Tattersall Consultations Act 1966.*)

Given under my Hand and the Seal of the State of Victoria aforesaid, at Melbourne, this eleventh day of October, in the year of our Lord One thousand nine hundred and sixty-six and in the fifteenth year of the reign of Her Majesty Queen Elizabeth II.

(L.S.) ROHAN DELACOMBE.

By His Excellency's Command,

HENRY E. BOLTE,
Premier.

GOD SAVE THE QUEEN!

POISONS ACT 1962 (No. 6889).

PROCLAMATION

By His Excellency the Governor of the State of Victoria and its Dependencies in the Commonwealth of Australia, &c., &c., &c.

WHEREAS by section 4 of the *Poisons Act 1962*, it is amongst other things enacted that the Governor in Council may by Proclamation published in the *Government Gazette* amend any of Schedules One, Two, Three, Four, Five, Six Seven and Eight to such Act by adding to any such Schedule or removing therefrom any item:

Now therefore I, the Governor of the State of Victoria in the Commonwealth of Australia, by and with the advice of the Executive Council of the said State, by virtue of the provisions of the said section and all other enabling powers, do by this Proclamation—

1. Amend Schedule Four to the said Act by removing therefrom the following item:—

LYSERGIC ACID DIETHYLAMIDE.

2. Amend Schedule Five to the said Act by removing therefrom the following item:—

METHOXYCHLOR and substances containing more than 10 per centum of Methoxychlor. Substances containing 10 per centum or less exempt for warning label.

and by adding thereto the following item:—

METHOXYCHLOR except when labelled with a warning label as prescribed by the Regulations for the purposes of Schedule Five.

3. Amend Schedule Six to the said Act by adding thereto the following items:—

ACROLEIN
BROMOXYNIL

4. Amend Schedule Seven to the said Act by adding thereto the following item:—

LYSERGIC ACID DIETHYLAMIDE

Given under my Hand and the Seal of the State of Victoria aforesaid, at Melbourne, this fourth day of October, in the year of our Lord One thousand nine hundred and sixty-six, and in the fifteenth year of the reign of Her Majesty Queen Elizabeth II.

(L.S.) ROHAN DELACOMBE.

By His Excellency's Command,

VANCE DICKIE,
Minister of Health.

GOD SAVE THE QUEEN!

GOVERNMENT NOTICES

LAW DEPARTMENT.

COURT OF PETTY SESSIONS.—ADDITIONAL DAYS.

HIS Excellency the Governor of the State of Victoria by and with the advice of the Executive Council thereof doth by Order made on the 4th day of October, 1966, pursuant to the provisions of section 64 of the *Justices Act 1958*, appoint every Friday, at 10 a.m., as from and inclusive of the 14th October, 1966, for the holding of Courts of Petty Sessions, at Springvale, in addition to the days and hours heretofore appointed.

J. COLQUHOUN,

Clerk of the Executive Council.

At the Executive Council Chamber,
Melbourne, 4th October, 1966.

Adoption of Children Act 1964.

REVOCATION OF APPROVAL OF A PRIVATE ADOPTION AGENCY.

PURSUANT to the provisions of section 21 of the *Adoption of Children Act 1964*, notice is hereby given that, pursuant to provisions of section 20 of the said Act, I have revoked the approval of the following charitable organization as a private adoption agency:—

Charitable Organization.—Warrnambool and District Base Hospital.

Address of Principal Office.—Warrnambool.

Principal Officer.—Stewart Archibald Lindsay.

A. G. RYLAH,
Chief Secretary.

Chief Secretary's Office,
Melbourne, 5th October, 1966.

Transport Regulation Act.
TRANSPORT REGULATION BOARD.

NOTICE is hereby given that previous advice in *Government Gazette* dated Wednesday, 5th October, 1966, that matters for consideration by the Board would be considered on Wednesday, 26th October, 1966, is rescinded and in lieu the matters will be considered on Monday, 24th October, 1966, at 9 a.m.

B. P. KAY,
Secretary.

Exhibition Buildings, Rathdown-street, Carlton, N.3,
Wednesday, 12th October, 1966.

Transport Regulation Act.
TRANSPORT REGULATION BOARD.

Hearing of Applications.

NOTICE is hereby given that the following applications will be considered by the Transport Regulation Board at its offices at Rathdown-street, Carlton, at 10.15 a.m., on Wednesday, 2nd November, 1966.

BEACH TRANSPORT SERVICE PTY. LTD., 1037 Centre-road, South Oakleigh. Application for variation of all C.O. licences, Route 200A (Mordialloc-Chelsea) to operate under charter conditions within a 50-mile radius of the General Post Office, Melbourne, provided that every journey commences within a 2-mile radius of the post office at Edithvale.

NOTE.—This application replaces that previously gazetted on 17th August, 1966.

BROADMEADOWS BUS SERVICE PTY. LTD., 145 Lynch-road, Fawkner. One commercial passenger vehicle to be purchased to operate as an additional metropolitan stage omnibus Route 104A (North Coburg-Broadmeadows Military Camp) under the same terms and conditions as licences already held by the company.

DICKSON, E. H. & W. A., Wattle-street, Manangatang. One commercial passenger vehicle (S/C. 27) to operate under the same terms and conditions as licence No. T.S.502, subject to the cancellation of licence T.S.502 in the name of E. H. Dickson.

DWYER, L. T., 2 Bruce-street, Strathmore and, WILKINSON, A. C., 58 Boumian-avenue, Strathmore. Application for transfer of licence No. M.O.661, current to 30th October, 1966, expiring 30th October, 1969, authorizing Operations on Route 34 (Moonee Ponds-Westgarth) at present authorized in the name of Dajon Investments Pty. Ltd., 8A Raleigh-street, Essendon.

DYSONS, L. C., BUS SERVICE PTY. LTD., 753 Plenty-road, Reservoir. One commercial passenger vehicle (S/C. 35) to operate as an additional metropolitan stage omnibus Route 46A (Regent-Jane-field-Gresswell) under the same terms and conditions as licences already held in the applicant company's name.

EAST PRESTON & EPPING BUS SERVICES HOLDINGS PTY. LTD., 922 High-street, Reservoir. Application for variation of M.O. licences Route 1A Part B (North-East Reservoir-Thornbury-Northland) to operate a loop turning procedure from the corner of Black-street and Rathcowan-road via Rathcowan-road, Borrie-street and Hickford-street to the present terminal at the corner of Hickford-street and Invermay-street. Return journey to Reservoir to be via the same route as now authorized.

NOTE.—No alteration to sections, fares and timetable.

EAST PRESTON & EPPING BUS SERVICES HOLDINGS PTY. LTD., 922 High-street, Reservoir. Application for variation of M.O. licences, Route 152A (North-East Reservoir-Northland) to operate a loop turning procedure from the corner of Black-street and Rathcowan-road, via Rathcowan-road, Borrie-street and Hickford-street to the present terminal at the corner of Hickford-street and Invermay-street. Return journey to Northland to be via the same route as now authorized.

NOTE.—No alteration to sections, fares and timetable.

NEGRAU, G., 52 Bruce-street, Bell Park, Geelong. One commercial passenger vehicle (S/C. 32) to operate for the carriage of bona fide harvesting workers to or from the Geelong urban district from or to their employment at farm properties in the following areas only, namely, within the Shires of South Barwon, Bannockburn, Barrabool, Winchelsea, Leigh and Colac.

STEWART, B. W. & G. S., 57 Bendigo-road, Kerang. One commercial passenger vehicle (S/C. 35) to operate under the same terms and conditions as licence T.S.667 subject to the cancellation of licence T.S.667 in the name of B. W. Stewart.

WARRNAMBOOL BUS LINES PTY. LTD., 273 Raglan-parade, Warrnambool. Application to operate between Wools-thorpe and Warrnambool, via Winslow, Mailor's Flat, Benson's Corner, Cassady's Bridge, Nicholls Corner and Princes Highway extending on week days on the morning and afternoon trips, via Raglan-parade to the factory of Fletcher Jones & Staff Pty. Ltd., in lieu of Winslow, Mailor's Flat, Grasmere depot, Mailor's Flat, Benson's Corner, Woodford, Bushfield and half way extending on week-days on the morning and afternoon trips, via Raglan-parade to the factory of Fletcher Jones and Staff Pty. Ltd.

APPLICATION for renewal of licences as shown, by persons listed hereunder to operate under the same terms and conditions.

ARCHIES CREEK DAIRY PRODUCE CO. LTD., Archies Creek; T.P.4.

DEACON, L. A., 10 Hemming-street, Dandenong; C.T.177.

FLORENCE, H. H., 356 Glen Eira-road, Elsternwick; T.P.134.
GEELONG CHURCH OF ENGLAND GRAMMAR SCHOOL, Corio; T.P.250; T.P.251.

McHARRY, N. J., 23 Catherine-street, Geelong West; U.O.478.

SAULTRY, W., 1350 Dandenong-road, Oakleigh; T.P.89.

Notice of any objection should be forwarded to reach the Secretary of the Board not later than Wednesday, 26th October, 1966.

Applicants are advised that it will not be necessary to appear on the hearing date specified above, unless advised, in writing, by the Board.

B. P. KAY,
Secretary.

Exhibition Buildings, Rathdown-street, Carlton, N.3,
Wednesday, 12th October, 1966.

Transport Regulation Act.
TRANSPORT REGULATION BOARD.

HEARING OF APPLICATIONS.

NOTICE is hereby given that the following applications will be considered by the Transport Regulation Board at its offices at Rathdown-street, Carlton, at 10.15 a.m., on Wednesday, 19th October, 1966.

BELL STREET BUS CO. PTY. LTD., 326 Bell-street, Preston. Application to operate metropolitan stage omnibus service Route 6A (Westbreen-Pascoe Vale-Coburg-Heidelberg) as at present operated under M.O. licences held by the applicant with the following amendments to service. (1) To extend Route 6A from the corner of Bell-street and Plenty-road via Plenty-road to the La Trobe University or alternatively, (2) To extend Route 6A from the corner of Bell-street and Waterdale-road via Waterdale-road to La Trobe University.
(Sections, fares and time-tables to be arranged.)

BELL STREET BUS CO. PTY. LTD., 326 Bell-street, Preston. Application to operate metropolitan stage omnibus service Route 153A (Bell-street-Northland) as at present operated under M.O. licences held by the applicant with the following amendment to service:—
(1) To extend Route 153A from the existing Northland terminus via Albert-street and Plenty-road or other suitable routes to La Trobe University.
(Sections, fares and time-table to be arranged.)

MELBOURNE AND METROPOLITAN TRAMWAYS BOARD, 616 Little Collins-street, Melbourne. Application for authority pursuant to section 33 (1) of the Transport Regulation Act (No. 6400) to operate an extension of the West Heidelberg-City bus route from the corner of Oriel and Southern roads, West Heidelberg, via Southern and Waterdale roads to the La Trobe University,

Sections.

- Oriel and Southern roads to Dougharty-road.
- Dougharty-road to La Trobe University.

Fares.

Through fare: City to Dougharty-road, 28c.; City to La Trobe University, 30c.

Frequency of Service: As required.

NOTE.—The above application is relative to an application previously lodged by the applicant and heard by the Board in February, 1966.

Notice of any objection should be forwarded to reach the Secretary of the Board by Wednesday, 19th October, 1966.

B. P. KAY,
Secretary.

Exhibition Buildings, Rathdown-street, Carlton, N.3,
Wednesday, 12th October, 1966.

Commercial Goods Vehicles Act.
TRANSPORT REGULATION BOARD.

HEARING OF APPLICATIONS.

NOTICE is hereby given that the following applications will be considered by the Transport Regulation Board at its offices at Rathdown-street, Carlton, at 10.15 a.m., on Wednesday, 2nd November, 1966.

ABE, B. H., Exell-street, Eaglehawk. One commercial goods vehicle (L/C. 15 cwt.) to operate within the area bounded by the City of Ballarat, Towns of Maryborough, St. Arnaud, Warracknabeal, Ouyen, Swan Hill, Echuca, Shepparton and Seymour for the purpose of supervising own contracts in the course of business as "Electrical Contractor"—tools of trade, equipment and small quantity of materials incidental to the completion of own contracts.

ALPINE ASH JOINERY & CABINET WORKS & EZARD DISTRIBUTORS PTY. LTD., Mitchell-street, Lucknow via Bairnsdale. One commercial goods vehicle (L/C. 106 cwt.) to operate from own premises at Lucknow for delivery to consignees within a 50-mile radius of Lucknow and to Bairnsdale Railway Station—dressed timber, joinery and flooring boards in the course of trade as timber and joinery merchants.

BABINGTON, E. N. & E. C. (trading as Babington Bros.), Lorne. Application to vary the conditions of licence No. D.T.114/1 (L/C. 147 cwt.) by adding to paragraph (a) after requisites "and own goods in the course of business as "Primary Producers" and by adding as an additional paragraph (c) "from the City of Geelong to own property at Benwerrin—own superphosphate in the course of business as 'Primary Producers'."

BANWELL, H. G., Bullarook. Two commercial goods vehicles (L/C. 141 and 142 cwt.) to operate within the Shire of Bungaree solely on behalf of said Shire—road-making plant and materials.

BEAUREPAIRE TYRE SERVICE PTY. LTD., 102 Victoria-street, Carlton. One commercial goods vehicle (L/C. 11 cwt.), to operate within a 50-mile radius from own premises at Mitcham in the course of business as "Tire Retreaders and Distributors" tires and tubes for sale and delivery, used tires for retreading or repair or having been retreaded or repaired, batteries, oil and motor car accessories.

BREMNER, K. J., 22 Dunbar-avenue, Morwell. Application to vary the conditions of licence No. D.A.51566 (L/C. 141 cwt.), by deleting the existing conditions and adding in lieu "from private landings in the Moe area to J. W. Pearce's mill at Bunyip and J. McGill's mill at Garfield—mill logs."

CAGGIATI, F., 37 Leighton-crescent, Fawkner. One commercial goods vehicle (L/C. 140 cwt.) to operate within a 50-mile radius of the premises of Albion Reid Pty. Ltd., at North Melbourne, solely on behalf of the said company—road-making plant, hot asphalt, premix and road-making materials excluding the carriage of cement and lime ex Geelong.

CANT, W. A. J., Wayside Delivery, Mitiamo. One commercial goods vehicle (L/C. 133 cwt.) to operate: (a) Within a 50-mile radius of the post office at Tennyson in the course of business as "Primary Producer"—own goods. (b) Within a 35-mile radius of the post office at Tennyson—road-making materials. (c) Within a 35-mile radius of the post office at Tennyson—livestock.

CERAMIC TRANSPORT PTY. LTD., 125 Springvale-road, Springvale. One commercial goods vehicle (L/C. 190 cwt., approximately) to operate (a) Within a 20-mile radius of the post office at Springvale—general goods. (b) Within a 70-mile radius of the premises of Brick and Pipe Industries Ltd., at Burwood East—bricks solely on behalf of the said company.

CLARK, B., 165 Scotts-parade, Ballarat. One commercial goods vehicle (L/C. 80 cwt.) to operate throughout the State of Victoria in the course of business as "Marine Collector"—marine stores and old metals as defined in the *Marine Stores and Old Metals Act 1958* (No. 6303), but excluding the carriage of such goods to wharves, docks or ships for shipment or export purposes.

SPECIAL PROVISOR.—That the combined load capacities of both prime mover and any trailer attached thereto, shall not exceed 120 cwt.

COATE, L. W., Lot 9, 373 South-road, Moorabbin. One commercial goods vehicle (L/C. 191 cwt.) to operate within a 50-mile radius of the premises of Specified Concrete (Vic.) Pty. Ltd., at Oakleigh, on behalf of the said company—premixed concrete in a specially constructed agitator vehicle.

DALTON, D. P., Whorouly. One commercial goods vehicle (L/C. 76 cwt.) to operate: (a) Within a 20-mile radius of the post office at Whorouly—general goods. (b) From and to places within the radius defined in paragraph (a) above, to and from places situate within a 50-mile radius from the post office at Whorouly—livestock. (c) Within a 50-mile radius from the post office at Whorouly—petroleum products in prescribed types of containers and empty return containers.

DAVIS, C. S. & A. J. (trading as Davis Bros.), 22 Hunter-street, Heywood. One commercial goods vehicle (L/C. 18 cwt.) to operate within a 50-mile radius of the post office at Heywood in the course of business as "Tire and Battery Resellers"—tires and tubes for sale and delivery, used tires for repair or for return when repaired and also oil, batteries and motor car accessories.

DUNSTAN, R. S., 57 White-street, Wangaratta. One commercial goods vehicle (L/C. 71 cwt.) to operate: (a) Within a 20-mile radius of the post office at Wangaratta—general goods. (b) From and to places in paragraph (a) above, to and from places situated within a 50-mile radius of the post office at Wangaratta—firewood.

EVANS, W. R., 14 Madeline-road, Clayton. One commercial goods vehicle (L/C. 19 cwt.) to operate from the premises of Four'n Twenty Pies Ltd., at Ascot Vale, to the Townships of Cranbourne, Tooradin, Koo-weerup, Lang Lang, Grantville, Kilcunda, Wonthaggi, Inverloch, Koonwarra, Meeniyah, Stoney Creek, Foster, Fish Creek, Leongatha, Korumburra, Loch, Poowong, Pakenham, Officer, Beaconsfield, Berwick and Hallam and thence return to Ascot Vale—pies and pasties in collapsible and/or returnable containers.

FROUD, S. L., Sale-Yarram-road, Stradbroke, via Sale. One commercial goods vehicle (L/C. 113 cwt.) to operate: (1) From the Stradbroke area to Australian Paper Mills at Maryvale—pulpwood. (2) Within a 20-mile radius from the post office at Stradbroke—general goods.

GOODWIN, J. G. & L. T., Omeo Highway, Bruthen. One commercial goods vehicle (L/C. 260 cwt.) to operate from logging areas at Nunnington to Raymond's sawmill at Ensay—sawmill logs.

GREEN, FRED, Standish-street, Myrtleford. One commercial goods vehicle (L/C. 260 cwt. approximately) to operate: (a) Within a 20-mile radius of the post office at Myrtleford—general goods. (b) Within a 50-mile radius of the depot of "Mobil Oil Aust. Pty. Ltd.," at Myrtleford—petroleum products in prescribed types of containers and empty return containers.

GREENBANK, R. N. & J. E., 15 Essex-street, Wendouree. One commercial goods vehicle (L/C. 280 cwt.) to operate throughout the State of Victoria in the course of business as "Earth-moving Contractor"—own tools of trade, equipment and earth-moving machinery and fuel sufficient for the operation of such earth-moving machinery.

GUY, C. C., C. F. & D. J., (trading as C. C. Guy & Co.), Union-road, Albury, N.S.W. One commercial goods vehicle (L/C. 220 cwt.) to operate from the premises of Rocla Pipes Ltd., at Bandiana—lock joint pipes, pressure reinforced concrete pipes and reinforced concrete stock troughs solely on behalf of the said company to the following places:—(a) The City of Echuca and places en route via Murray Valley Highway. (b) The City of Shepparton and places en route via Goulburn Highway. (c) The townships of Myrtleford and Bright and places en route via Owens Highway. (d) The Town of Benalla and places en route via Hume Highway. (e) The State Electricity Commission Depot at Mt. Beauty and places situated on the Mt. Bogong via Tawonga-road.

GUY, J. A., Settlement-road, Cowes, Phillip Island. One commercial goods vehicle (L/C. 140 cwt.) to operate: (a) Within a 20-mile radius from the post office at Cowes—general goods. (b) From and to the Caltex Oil (Aust.) Pty. Ltd., depot at Newport to and from the Township of Cowes—petroleum products in prescribed types of containers and empty return containers. (c) Between the Township of San Remo and the City of Melbourne—fresh fish, empty fish boxes, fisherman's gear for repair or having been repaired and fisherman's requisites.

HOME CRAFTS PTY. LTD., 125 High-street, Wodonga. One commercial goods vehicle (L/C. 15 cwt.) to operate within a 50-mile radius of the post office at Wodonga in the course of business as "Electrical Retailer"—new and secondhand electrical goods, and electrical goods for repair or having been repaired.

- DAVID HOSE PTY. LTD.**, Main-road, Elliminyt. Application to vary the conditions of licence No. D.A.4245/11 (L/C. 230 cwt.) by adding to the existing conditions as an additional paragraph (c) "from Melbourne to Colac solely on behalf of Colac Brick Co. Ltd. of Colac an Approved Decentralized Industry—clay (in bags) and machinery."
- KENNEDY, A. A.**, 10 Esmond-street, Wangaratta. One commercial goods vehicle (L/C. 8 cwt. plus trailer) to operate within a 50-mile radius of the post office at Wangaratta and to Shepparton, Mansfield and Corryong and towns en route in the course of business as "Painting Contractor"—tools of trade scaffolding, air compressors, paint and materials incidental to the completion of own contracts.
- LAZENBY, J. B.**, 23 Havlin-street, Bendigo. One commercial goods vehicle (L/C. 8 cwt.) to operate within a 75-mile radius from the chief post office in the City of Bendigo but excluding any operations to or from the Melbourne Metropolitan Area—washing machines for installation, washing machines, motor mowers and vacuum cleaners and other electrical equipment of repair or having been repaired, tools of trade, spare parts and materials incidental to servicing and maintaining such equipment in the course of business as "Service Mechanic."
- LEGE, JACK, PTY. LTD.**, 43 Thompson-street, Sale. Application to vary the conditions of licence No. D.A.22091/1 (L/C. 40 cwt.) by adding additional paragraphs (b) within a 20-mile radius from site of construction or maintenance work performed pursuant to contracts for earth-moving as held from time to time or from Railway Stations nearest thereto—materials required for such work and (c) Within a 20-mile radius of post office at Sale—general goods.
- MILLS, A.**, Anderson-street, Bairnsdale. One commercial goods vehicle (L/C. 254 cwt.) to operate: (a) Within that part of the State of Victoria east of the Mitchell and Dargo Rivers and west of the Snowy River but excluding any operations to or from Newmerella and Waygara, excluding also, any operations north of a line drawn due east and west through the settlement of Glen Wills or within a 20-mile radius of the post office at Omeo—logs. (b) From any sawmill situated in the area defined in part (a) of this document:—(i) To the railway station nearest to the particular sawmill. (ii) To consignees within a 20-mile radius of the post office at Bairnsdale—sawn timber.
- MOBILE INDUSTRIAL EQUIPMENT LTD.**, 410 Whitehorse-road, Mitcham. Two commercial goods vehicles (9 cwt. each) to operate in the course of business as "Manufacturers of Agricultural Equipment." (a) Within a 50-mile radius from own premises at Mitcham—own goods. (b) Throughout the State of Victoria for the purpose of servicing and demonstrating agricultural appliances for demonstration, for repair or having been repaired also tools of trade, spare parts and materials incidental thereto.
- MCCRAITH REFRIGERATION PTY. LTD.**, 491 Kellor-road, Niddrie. One commercial goods vehicle (L/C. 8 cwt.) to operate throughout the State of Victoria in the course of business as "Refrigeration Engineers" for the purpose of servicing, repairing and maintaining rabbit chillers—tools of trade, spare parts, uncrated refrigeration units and cabinet for repair or having been repaired and for specialized installation and materials incidental thereto.
- O'CONNOR, A. A.**, P.O. Box 507, Morwell. Application to vary the conditions of licence No. T.T.D.1142 (L/C. 160 cwt.) by adding to the existing conditions "from landings in the Morwell area to Ron Andrew's Sawmill at Longwarry—logs".
- O'HARA BROS. PLANT HIRE PTY. LTD.**, 19 Clark-street, Wangaratta. One commercial goods vehicle (L/C. 17 cwt.) to operate throughout the State of Victoria in course of business as "Earth-moving Contractors"—tools of trade, spare parts and equipment incidental to own contracts and fuel only for use in own machinery.
- PERMEWAN WRIGHT LTD.**, Abbotsford. Application to vary the conditions of licence No. D.A.1809/4 (L/C. 78 cwt.) by deleting the existing conditions and adding in lieu: (a) Within a 50-mile radius of the post office at Bairnsdale—own goods in the course of business as "General and Produce Merchants". (b) Within a 50-mile radius of own premises at Bairnsdale—petroleum products on behalf of H. C. Sleigh Ltd. as agent for said company.
- DONALD, N. F. D. & V. L. C.**, (trading as Premier Plumbing Service), 106-108 Hertford-street, Sebastopol. One commercial goods vehicle (L/C. 15 cwt.) to operate in the course of business as "Plumbers and Sewerage Contractors" as follows: (a) Within a 50-mile radius of own premises at Ballarat—own goods. (b) Throughout the State of Victoria—tools of trade and equipment incidental solely to own contracts. (c) Within a 20-mile radius of the site of any project currently engaged upon or from the nearest railway station thereto—materials for use on such project.
- QUICK PLUMBING PTY. LTD.**, 651 Waterdale-road, West Heidelberg. Application to vary the conditions of licence number D.A.44907 (L/C. 55 cwt.) by deleting paragraph (a) and adding in lieu "Within a 50-mile radius of own premises at West Heidelberg in the course of business as 'Plumber'—own goods".
- RAFFERTY, F. J. & R. M.**, 2 Nicholas-street, Lilydale. Application to vary the conditions of licence No. D.T.323 (L/C. 258 cwt.) by adding to the existing condition "from the Australian Milling Company's mill at Molesworth to fencing suppliers in the eastern suburbs of Melbourne—palings and fencing timber".
- ROSS, A. N.**, 1 Peck-street, Bayswater. One commercial goods vehicle (L/C. 19 cwt.) to operate within a 50-mile radius of Four'n' Twenty Pies Pty. Ltd., at Ascot Vale, solely on behalf of such company—pies, pasties, sausage rolls and fruit drinks in waxed paper containers.
- BAILEY, A. J. & D. V.** (trading as Simpson Transport), Block 54, Scotts Creek. Application to vary the conditions of licence No. D.A.57147 (L/C. 138 cwt.) by adding as an additional paragraph (e) "Within a 150-mile radius from the post office at Simpson—live-stock".
- BAILEY, A. J. & D. V.** (trading as Simpson Transport), Block 54, Scotts Creek. One commercial goods vehicle (L/C. 298 cwt.) to operate: (a) Within a 50-mile radius from the post office at Simpson as a "Road Contractor"—road-making plant and materials. (b) Within a 20-mile radius of the post office at Simpson—general goods. (c) Within a 50-mile radius of the post office at Simpson in the course of business as "Primary Producer"—own goods. (d) Within a 150-mile radius of the Simpson Post Office—livestock.
- SOCIETY OF ST. VINCENT DE PAUL WELFARE STORE**, 58 Lydiard-street North, Ballarat. One commercial goods vehicle (L/C. 10 cwt.) to operate throughout the State of Victoria for the purpose of collecting second-hand clothing, empty bottles, second-hand furniture, scrap metal, papers and rags for auctioning, the proceeds of such sales being for distribution to poor and needy persons.
- TONKS (AUSTRALIA) PTY. LTD.**, 485-493 Plenty-road, Preston. One commercial goods vehicle (18 cwt.) to operate throughout the State of Victoria in the course of business as "Manufacturing Engineer"—tools of trade, spare parts and door equipment for repair or having been repaired.
- TULLOCH JENKIN PTY. LTD.**, 287 Main-street, Bairnsdale. One commercial goods vehicle (L/C. 100 cwt.) to operate from own premises at Bairnsdale to consignees within a 50-mile radius of Bairnsdale in the course of business as "Seed, Grain and Fertiliser Agents"—stock and poultry feed, pasture seed and superphosphate.
- VALENTINO, G.**, and **E. RIZZO**, 12 Poplar-street, Thomas-town. One commercial goods vehicle (L/C. 199 cwt.) to operate within a 50-mile radius of the G.P.O. at the corner of Bourke and Elizabeth streets, in the City of Melbourne as a specially constructed agitator vehicle—premixed concrete solely on behalf of Blue Metal Concrete Pty. Ltd.
- VICK, W. F. & A. G.**, Oswald-street, Kyabram. Two commercial goods vehicles (L/C. 99 and 156 cwt.) to operate: (a) Within a 50-mile radius of the post office at Kyabram—road-making plant and materials. (b) Within a 20-mile radius of the post office at Kyabram—general goods. (c) From Finlaysons quarry situated at Pine Lodge and Lake Cooper quarries at Corop to Kyabram—screenings.

TOW TRUCKS.

- A.S.A. TOWING PTY. LTD.** (trading as A.A.A. Towing Service), 46 Connell-road, Oakleigh. One commercial goods vehicle (L/C. 79 cwt.) to operate throughout the State of Victoria as a "Tow Truck" for the purpose of lifting and carrying or towing and/or repairing wrecked or disabled vehicles—tools of trade, spare parts and materials incidental thereto.

SPECIAL CONDITION:

It is also a condition that all goods carried pursuant to paragraph (a) above shall only be those having been initially consigned to Bairnsdale by railway transport.

- CRAWFORD, I. P., Canterbury-road, Bayswater. One commercial goods vehicle (L/C. 66 cwt.) to operate throughout the State of Victoria as a "Tow Truck" for the purpose of lifting and carrying or towing and/or repairing wrecked or disabled vehicles—tools of trade, spare parts and materials incidental thereto.
- DUFF, J., and R. L. POHLMAN (trading as Duff and Pohlman), 2 Preston-street, West Geelong. One commercial goods vehicle (L/C. 54 cwt.) to operate within a 50-mile radius of the chief post office in the City of Geelong as a "Tow Truck" for the purpose of lifting and carrying or towing and/or repairing wrecked or disabled vehicles—tools of trade, spare parts and materials incidental thereto.
- YAL, M., & B. MARTORELLA (trading as Mikes Motor Body Works), 122 Nicholson-street, East Brunswick. One commercial goods vehicle (L/C. 25 cwt.) to operate within a 50-mile radius of the G.P.O., Melbourne, as a "Tow Truck" for the purpose of lifting and carrying or towing and/or repairing wrecked or disabled vehicles—tools of trade, spare parts and materials incidental thereto.
- PANELS, R. & B., PTY. LTD., 60 North-street, Richmond. One commercial goods vehicle (L/C. 47 cwt.) to operate throughout the State of Victoria as a "Tow Truck" for the purpose of lifting and carrying or towing and/or repairing wrecked or disabled vehicles—tools of trade, spare parts and materials incidental thereto.
- TACEY MOTOR CO. PTY. LTD., Hogan-street, Tatura. Application to vary the conditions of licence No. T.D.A.46885 (L/C. 50 cwt.) by deleting "20-mile radius of the post office at Tatura" and adding in lieu "75-mile radius of the post office at Tatura and to and from Melbourne."

APPLICATIONS for renewal of licences as shown by persons listed hereunder to operate under the same terms and conditions from the expiry shown in each case.

- ANSETT TRANSPORT INDUSTRIES (OPERATIONS) PTY. LTD., 489 Swanston-street, Melbourne; D.A.3846/4; 12th November, 1966; 10 cwt.
- ARDMONA FRUIT PRODUCTS CO-OP. PTY. LTD., 55 Crockford-street, Port Melbourne; D.A.47739/2; 10th December, 1966; 65 cwt.
- BAYER LEVERKUSEN LTD., 1087 High-street, Armadale; D.A.48044; 17th December, 1966; 6 cwt.
- BEAUREPAIRE TYRE SERVICE PTY. LTD., 102 Victoria-street, Carlton; D.A.629/31; 15th December, 1966; 11 cwt.
- BEAUREPAIRE TYRE SERVICE PTY. LTD., 102 Victoria-street, Carlton; D.A.629/77; 3rd December, 1966; 11 cwt.
- COX, R. E., Garfield-road, Garfield; T.D.A.37206; 23rd November 1966; 90 cwt.
- ELDRIDGE, L. D., Derrinallum; D.A.40366/7; 26th November, 1966; 268 cwt.
- FEIGLIN, M., & SONS PTY. LTD., Station-street, Nunawading; D.A.1066/18; 6th December, 1966; 15 cwt.
- GIPPSLAND TILE WORKS PTY. LTD., 14 Darling-street, Sale; D.A.1153; 20th November, 1966; 232 cwt.
- HARDING, R. L., Bennett-street, Dandenong; D.A.1241/2; 8th October, 1966; 266 cwt.
- HARRISON, F. & CO., Bridge-street, Benalla; D.A.44181/2; 8th October, 1966; 29 cwt.
- HEMINGWAY, LEO. & PICKETT PTY. LTD., 330 Sydney-road, Brunswick; D.A.39955/11; 10th December, 1966; 66 cwt.; D.A.39955/12; 10th December, 1966; 66 cwt.
- HOLDENSON & NEILSON FRESH FOOD PTY. LTD., 95 Cecil-street, South Melbourne; D.A.47779; 26th November, 1966; 16 cwt.
- KNOWLES, K. C., & J. H. STAPLETON (trading as Knowles and Stapleton), Mount Clear, via Ballarat; D.A.40185/1; 8th October, 1966; 314 cwt.
- LANGSKAILL BROS., BUCHAN; D.A.1470/3; 16th October 1966; 200 cwt.
- FLAHERTY, J. M., & M. M., (trading as M. & J. Distributors), 52 Kepler-street, Warrnambool; T.D.A.44613; 27th November, 1966; 16 cwt.
- NELSON, L. G., 276 Roslyn-street, Highton; D.A.33410; 14th July, 1966; 100 cwt.
- PERMEWAN WRIGHT LTD., 147-179 Alexandra-parade, Abbotsford; D.A.1809/20; 6th November, 1966; 16 cwt.
- PHELAN, W., & SONS PTY. LTD., 157 High-street, Maryborough; D.A.3633/15; 20th November, 1966; 15 cwt.
- RUSSELL, E. J., & R. E. (trading as E. & R. E. Russell (Colac) Pty. Ltd.), 395 Murray-street, Colac; D.A.44337/1; 12th November, 1966; 112 cwt.
- ST. VINCENT DE PAUL WELFARE STORE, 58 Lydiard-street north, Ballarat; D.A.47370; 8th October, 1966; 31 cwt.
- SMITH, R. L., P.O. Box 116, Camperdown; D.A.47802; 26th November, 1966; 5 cwt.
- SUNKIST FOODS PTY. LTD., 50 Nott-street, Port Melbourne; T.D.A.47865/38; 14th October, 1966; 29 cwt.
- WITTINGSLOW, TOM, PTY. LTD., 4 Austin-street, Fairfield; D.A.22859/8; 12th November, 1966; 121 cwt.

TOW TRUCK RENEWALS.

- ALBON, W. R. (trading as Cranbourne Towing Service), South Gippsland Highway, Cranbourne; D.A.34396; 17th November, 1966; 72 cwt.
- CALISTRO T. J., & I. G., & R. L. & H. E. PILMORE (trading as Dimboola Motors), 132 Lloyd-street, Dimboola; D.A.46392; 6th November, 1966; 73 cwt.
- REYNOLDS, L. A., & J. T. LA FONTAINE (trading as Tallangatta Towing Service), Tallangatta; D.A.45965; 6th November, 1966; 73 cwt.
- SAUNDERS, A. R., Main-road, Hurstbridge; D.A.46809; 16th November, 1966; 34 cwt.
- SMASH REPAIRERS PTY. LTD., 77 Bernard-street, Cheltenham; D.A.47001; 6th November, 1966; 40 cwt.

RENEWALS WITH VARIATION.

- APPLICATION by the persons listed hereunder for renewal of the licence listed with variation of conditions in the manner set out opposite the name.
- CHITAKIS, D. N., 1 Newton-street, Shepparton; D.A.33629; 13th October, 1966; Application to renew and vary the condition of licence No. D.A.33629 (L/C. 148 cwt.) by deleting from paragraph (a) "90-mile radius of the post office at Wangaratta" and adding in lieu "50-mile radius of the post office at Shepparton", and by adding as an additional paragraph (c) "Within a 20-mile radius of the post office at Shepparton—general goods."
- HANCOCK, C. F. PTY. LTD., Carpenter-street, Lakes Entrance; D.A.1229/5; 16th October, 1966; D.A.1229/6; 16th October, 1966; D.A.1229/16; 12th November, 1966; Application to renew and vary the conditions of licences numbered D.A.1229/5, D.A.1229/6, and D.A.1229/16 (L/C. 102, 200 approximately, and 230 cwt.) by deleting from paragraph (c) of the existing conditions "and 3."

TOW TRUCK RENEWAL WITH VARIATION.

- STUART & HARRISON PTY. LTD., 31-33 Deakin-avenue, Mildura; D.A.46285; 22nd October, 1966; Application to renew and vary the conditions of licence No. D.A.46285 (L/C. 47 cwt.) by deleting "within a 60-mile radius of the post office at Mildura" and adding in lieu "throughout the State of Victoria."

Notice of any objections should be forwarded to reach the Secretary of the Board not later than Wednesday, 26th October, 1966.

Applicants are advised that it will not be necessary to appear on the hearing date specified above, unless advised, in writing, by the Board.

B. P. KAY,
Secretary.

Exhibition Buildings, Rathdown-street, Carlton, N.3., 12th October, 1966.

Railways Act, 1958.

BOARD OF DISCIPLINE.

NOTICE is hereby given that a vacancy in the office of Deputy to the Officers and Employees' Representative on the Board of Discipline constituted as provided in the Railways Act, 1958, has existed as from the 10th day of July, 1966, and that it is intended to hold an election to fill the said vacancy. In the exercise of the powers vested in me by the Regulations made under the abovementioned Act, I have appointed:—

1. Tuesday, the 25th day of October, 1966, at the hour of 12 o'clock noon, to be the date and hour fixed for the closing of nominations;
2. Room No. 89, Railway Buildings, Spencer-street, Melbourne, to be the place of nomination;
3. Tuesday, the 22nd day of November, 1966, at the hour of 12 o'clock noon, to be the date and the hour for the closing of the poll;
4. Tuesday, the 29th day of November, 1966, to be the latest date upon which the return of the result of the election shall be made by the Returning Officer to me.

Dated this 4th day of October, 1966.

E. R. MEAGHER,
Minister of Transport.

Health Act 1958
VICTORIA—DEPARTMENT OF HEALTH.

NOTICE TO ATTEND FOR RADIOLOGICAL EXAMINATION.

To all persons aged twenty-one years and over enrolled or resident in the Subdivisions specified hereunder in the State Electoral District of Sandringham.

TAKE notice that you are required to attend at a Department of Health X-ray unit sited in the public street at or as near as possible to the main entrance to the premises specified in this notice, at any time between the hours specified on one of the days specified and during the period specified in respect of those premises, and thereat to submit yourself to radiological examination of the chest for the purpose of ascertaining whether you may be suffering from pulmonary tuberculosis. If you have had a Chest X-ray within the last twelve months and for that reason do not wish to be examined now, you should attend the unit as directed and submit particulars of the previous examination.

SPECIFIED SUBDIVISIONS, PREMISES, PERIODS, DAYS AND HOURS.

Subdivision.	Premises.	Period.	Days.	Hours.
Highbett	Maytime Beauty Salon, 332a South-road, Moorabbin	Monday, 24th October, 1966, to Wednesday, 26th October, 1966 (inclusive)	Each day during the period except Public Holidays	From 10 a.m. to 8.30 p.m.
	Larsen's Pharmacy, 17 Spring-road, Highbett	Monday, 24th October, 1966, to Thursday, 27th October, 1966 (inclusive)	Each day during the period except Public Holidays	From 10 a.m. to 8.30 p.m.
	Rolley's T.V. Radio Repair Service, 497 Highbett-road, Highbett	Tuesday, 25th October, 1966, to Friday, 28th October, 1966 (inclusive)	Each day during the period except Public Holidays	From 10 a.m. to 8.30 p.m.
Sandringham	Memorial Hall, Waltham-street, Sandringham	Thursday, 27th October, 1966, to Tuesday, 8th November, 1966 (inclusive)	Each day during the period except Saturdays, Sundays and Public Holidays	From 10 a.m. to 8.30 p.m.
	Derry's Pharmacy, 265A Bluff-road, Sandringham	Friday, 28th October, 1966, to Tuesday, 8th November, 1966 (inclusive)	Each day during the period except Saturdays, Sundays and Public Holidays	From 10 a.m. to 8.30 p.m.
	Top Level Workwear, 279 Bay-road, Cheltenham	Monday, 31st October, 1966, to Friday, 4th November, 1966 (inclusive)	Each day during the period except Public Holidays	From 10 a.m. to 8.30 p.m.
	Cnr. Bluff-road and Royal-avenue, Sandringham	Monday, 7th November, 1966, to Wednesday, 9th November, 1966 (inclusive)	Each day during the period except Public Holidays	From 10 a.m. to 8.30 p.m.
	R. J. Harvey's Estate Agency, 609 Balcombe-road, Black Rock	Wednesday, 9th November, 1966, to Tuesday, 15th November, 1966 (inclusive)	Each day during the period except Saturday, Sunday and Public Holidays	From 10 a.m. to 8.30 p.m.
	Concourse Service Station, Cnr. Reserve-road and North Concourse, Beaumaris	Wednesday, 9th November, 1966, to Tuesday, 15th November, 1966 (inclusive)	Each day during the period except Saturday, Sunday and Public Holidays	From 10 a.m. to 8.30 p.m.
	Personal T.V. Service, Cnr. Balcombe and Haydens roads, Beaumaris	Thursday, 10th November, 1966, to Monday, 14th November, 1966 (inclusive)	Each day during the period except Saturday, Sunday and Public Holidays	From 10 a.m. to 8.30 p.m.
	Cheltenham Auctions, 33-35 Station-road, Cheltenham	Tuesday, 15th November, 1966, to Wednesday, 23rd November, 1966 (inclusive)	Each day during the period except Saturday, Sunday and Public Holidays	From 10 a.m. to 8.30 p.m.
O'Keefe's Hairdressing Salon, 172 Weatherall-road, Cheltenham	Wednesday, 16th November, 1966, to Monday, 21st November, 1966 (inclusive)	Each day during the period except Saturday, Sunday and Public Holidays	From 10 a.m. to 8.30 p.m.	

NOTE.—Any person to whom this notice applies and who without reasonable excuse fails to comply with the requirements of the notice shall be guilty of an offence, and shall be liable to a penalty of not more than Forty dollars.

Dated this 1st day of September, One thousand nine hundred and sixty-six.

R. J. FARNBACH, Chief Health Officer.

Process Servers and Inquiry Agents Act-1958.

APPLICATIONS FOR LICENCES LODGED WITH CLERKS OF COURTS.

BY direction of the Chief Secretary, the subjoined lists of "new" applications for process servers and inquiry agents licences are published for general information.

Applicant.	Address.	Court.	Tentative Date of Hearing of Application.
<i>Process Servers Licences.</i>			
Cooke, Lyell Newsam	5 Bayview-road, East Brigh on	Brighton	28.10.66
Hendrickson, Stanley Maxwell	30 Alma-street, Maryborough	Maryborough	3.11.66
Hirst, Anthony	5 Nicholson-street, Nunawading	Box Hill	28.10.66
<i>Inquiry Agents Licences.</i>			
Cooke, Lyell Newsam	5 Bayview-road, East Brighton	Brighton	28.10.66
Salantri, Vincent	Suite 6, 614 St. Kilda-road, Melbourne	Prahran	27.10.66

Attention is directed to the provisions of the above Act and regulations thereunder relating to the lodgement of objections to applications.

Chief Secretary's Office,
Melbourne, 11th October, 1966.

E. L. RICHARSON, Registrar,
Process Servers and Inquiry Agent

GEELONG WATERWORKS AND SEWERAGE TRUST.

WATER SUPPLY.—BY-LAW No. 104.

Contents.

PART I.

INTERPRETATION AND REPEAL.

Definitions	1
Uniform Building Regulations	2
Repeal provisions	3

PART II.

CHARGES FOR WATER SUPPLY.

General charges	4
Harbor Trust	4 (a)
Parks Gardens etc.	4 (b)
Sports Grounds	4 (c)
Swimming Pools (Public)	4 (d)
Public Benevolent Institutions	4 (e)
Churches	4 (f)
Victorian Railway Commissioners	4 (g)
Special cases	4 (h)
Allowance for Rated Premises	5
Allowance for Sanitary Flushing	6
Estimation of charges (Meter in-operative)	7
Meters—Testing	8
Special Rates and Charges	9
Water Supplies for Rural Purposes	9 (a)
Standpipes—municipalities	9 (b)
Road Consolidation	9 (c)
Hydrants	9 (d)
Tappings	9 (e)
Cast Iron Mains	(e) i
Asbestos cement Mains	(e) ii
Steel Mains	(e) iii
Galvanised Mains	(e) vi

PART III.

GENERAL REGULATIONS RELATING TO WATER SUPPLY.

Licences	10-12
Carrying out of Works—	
Notices and Plans	13-15
Notice of Completion	16
Plumbing Work	17
Service Pipes—	
Size of Service Pipes	18
Depth of Service Pipes	19
Access to Service Pipes	20
Repair of Service Pipes	21-23
One Service per Tenement	24
Trunk Services	25
Connections—	
Tapping Fee	26
Tapping Size	27
Tapping Branches	28
Mains Connections	29
Location of Stop Cocks	30
Insulating Couplings	31
Cross Connections	32
Supply of Water for Particular Purposes—	
Boilers	33
Pumps	34
Cooling	35
Baths	36
Swimming Pools	37
Storage Tanks	38
Cisterns	39
W.C.'s	40
Private Fire Services	41
Materials	42
Meters	43-46
Misuse and Waste—	
Waste of Water	47
Sale of Water	48
Hydrants and Taps	49-50
Street Watering	51
General—	
Inspections	52-53
Consents	54
Variations	55
Penalties	56

GEELONG WATERWORKS AND SEWERAGE TRUST.

By-LAW No. 104.

Water Supply.

THE Geelong Waterworks and Sewerage Trust pursuant to the powers conferred upon it by the *Geelong Waterworks and Sewerage Act 1958*, the *Water Act 1958* and every other power enabling it in that behalf order as follows—

PART I.

INTERPRETATION AND REPEAL.

Definitions.

1. In this By-law unless inconsistent with the context or subject-matter—

- "The Act" means the Geelong Waterworks and Sewerage Act or any other Acts incorporated therewith.
- "Fittings" includes all appliances and things whatsoever, other than pipes, used in connection with the conveying storing or regulation of the flow of water in or derived from a main pipe or service pipe.
- "Main Pipe" means any pipe belonging to or under the control of the Trust and used for the conveying or supplying of water.
- "Person" includes a corporation or company.
- "Private Service" means and includes all pipes and fittings used in connection with the supply of water from a main pipe to a tenement and/or in connection with the use or consumption of such water in or on such tenement.
- "Proper Officer" means any employee of the Trust authorised to execute any function on behalf of the Trust.
- "Service Pipe" means any pipe (not being a main pipe) used for the conveying or supplying of water derived from a main pipe.
- "Trust" means the Geelong Waterworks and Sewerage Trust.
- "Works" means the works of or in connexion with the laying, constructing, altering, disconnecting, removing, repairing, renewing or maintaining of a private service or any part thereof.

All words used in this By-law which are also used in the Act shall have the meanings assigned to them by the Act.

Uniform Building Regulations.

2. All matters affecting the water supply to any building shall conform to the requirements of the Uniform Building Regulations, Victoria, and to this By-law, provided that any provision in this By-law shall, so far as it is or shall become invalid by reason of any provision of the Uniform Building Regulations be of no force or effect.

Repeal of By-laws.

3. By-laws Nos. 36, 65 and 84 relating to Water Supply shall be and the same are hereby revoked as from the date of coming into operation of this By-law, but nothing herein contained shall relieve, discharge, or absolve any person from liability to pay any rate or charge made in accordance with the provisions of the said By-laws; nor abrogate or alter the power of the Trust to recover and enforce payment of any such rate or charge; nor withdraw any permission given, nor cancel any licence granted or order made, nor invalidate any act or thing done, nor annul or stay any proceedings taken, prosecution commenced, or business initiated as in conformity with the provisions of the said By-laws prior to the date of this By-law coming into operation; but the same respectively may be continued and carried to completion, and all offences against any provision of the said By-laws committed before the date of this By-law coming into operation, may be prosecuted for and punished as if this By-law had not been made and passed.

PART II.

CHARGES FOR WATER SUPPLY SERVICE.

Supply by Measure.

General charges.

4. Where pursuant to any Act having application to the Trust or any By-law of the Trust now or hereafter made thereunder the Trust is empowered to charge for water by measure, the amounts to be so charged for the supply of water by measure shall be as follow—

- (a) To the Geelong Harbor Trust for use in shipping other than that owned by the said Trust at the rate of fifty cents per 1,000 gallons.
- (b) For parks (but excluding areas used as football or cricket ovals or sports grounds) gardens and rockeries under municipal control at the rate of ten cents per 1,000 gallons.
- (c) For sports grounds, football and cricket ovals to which no charge for admission is made at the rate of 15 cents per 1,000 gallons provided that the minimum charge in any one year shall in no case be less than ten dollars.
- (d) For swimming pools under municipal or public control at the rate of 15 cents per 1,000 gallons for the first 500,000 gallons consumed, 5 cents per 1,000 gallons for the next 1,500,000 gallons consumed and 15 cents per 1,000 gallons for all consumption above two million gallons in any one year.
- (e) To public benevolent institutions not conducted for private profit but maintained for the charitable care of diseased, aged, infirm, incurable or delinquent persons at the rate of 15 cents per 1,000 gallons for such quantity of water consumed in any one year as shall exceed an agreed allowance free of charge.
- (f) For churches at the rate of 15 cents per 1,000 gallons provided that the minimum charge in any one year shall in no case be less than 10 dollars.
- (g) For the Victorian Railways Commissioners or the Geelong Harbor Trust Commissioners for the use of such Commissioners at the rate of 5 cents per 1,000 gallons as prescribed under Section 52 of the Geelong Waterworks and Sewerage Act Number 6263.
- (h) In all cases other than the foregoing and those dealt with in Clause 9 herein at the rate of 20 cents per 1,000 gallons.

5. In charging the owner or occupier of any lands and tenements for water by measurement supplied thereto such owner or occupier shall be first credited as having paid an amount equal to the amount of water rate charged in respect of such lands and tenements. Allowance for Rated Premises.

6. For the purpose of calculating the amount payable for water supplied by measure a deduction of 7,000 gallons in respect of each water closet installed shall in all cases be made from the annual consumption measured; provided however that the total deduction allowed shall not in any case exceed 21,000 gallons. Allowance for Sanitary Flushing.

7. If any meter stops registering or registers incorrectly the Trust may estimate and charge for the water consumed during the period such meter was not in working order and until it is repaired and refixed as follows— Estimation of charges.

(a) By taking an average of the quantity used during the previous month, 3 months or year or during the corresponding period of the previous year or

(b) On the basis of subsequent consumption after repair.

8. In the event of a consumer being dissatisfied with the registering of a meter he may by notice in writing require the Trust to cause such meter to be removed and tested and together with such notice shall forward a sum of one dollar which if the meter be found to register correctly within a margin of 5 per centum shall be applied in paying the cost of removing, testing and replacing such meter and the balance if any shall be returned to him; but if such meter be found to fail to register or be found to register incorrectly after allowing such margin as aforesaid such meter shall be repaired or replaced or another meter shall be placed instead of it at the cost of the Trust and the amount deposited by the consumer shall be returned to him. Testing Meters.

9. (a) *Water Supplies for Rural Purposes.*—The Trust may grant supplies of water for rural purposes to properties for which the following minimum annual charges shall be payable. Special Rates and charges.

(i) For properties exceeding 1 acre and less than 30 acres—16 dollars.

(ii) For properties exceeding 30 acres and less than 60 acres—32 dollars.

(iii) For properties exceeding 60 acres—48 dollars.

(b) *Standpipes.*—The Trust may grant supplies of water for standpipes to municipalities within its water supply area for which a charge of 20 cents per 1,000 gallons with a minimum annual charge of 10 dollars shall be payable.

(c) The Trust may grant supplies of water for road consolidation purposes for which a charge of 25 cents for each one hundred square yards of road consolidated shall be payable.

(d) The Trust may allow seals on hydrants to be removed in respect of which a charge for replacement of 3 dollars shall be payable.

(e) *Tappings.*—The following charges shall be payable in respect of tappings of the Trust's mains.

(i) Cast Iron mains of all sizes under pressure—4 dollars.

Cast Iron mains not under pressure—

3"—5 dollars 50 cents

4"—5 dollars 50 cents

6"—7 dollars

9"—9 dollars

12"—10 dollars.

(ii) Asbestos Cement mains under pressure—

4"—8 dollars

6"—8 dollars

9"—10 dollars

12"—10 dollars

Asbestos Cement mains not under pressure—

3"—5 dollars 50 cents

4"—5 dollars 50 cents

6"—7 dollars

9"—9 dollars

12"—10 dollars.

(iii) Steel mains under pressure—

6" with tapping saddle—8 dollars

9" with tapping saddle—8 dollars

6" steel plate welded—10 dollars

9" steel plate welded—10 dollars.

(iv) 1½" and 2" Galvanised mains—4 dollars.

PART III.

REGULATING LICENCES CONSTRUCTION MAINTENANCE AND OTHER MATTERS RELATING TO WATER SUPPLY GENERALLY.

Licences.

10. No person shall affix any service pipe to any pipe of the Trust, or alter, repair, or in any manner interfere with any pipe of the Trust, or any service pipe, cock or fitting connected with the pipes of the Trust unless— Unlicensed persons not to interfere with pipes or services.

(a) he is the holder of a "Working Plumber's Licence" under Trust By-law No. 97, or any other By-law, which may now or hereafter be in force within the Drainage Area relating to Sewerage, or

(b) he shall obtain from the Trust a licence in that behalf to execute such work; and any unlicensed person affixing, altering, repairing, or in any manner interfering with any such pipe, service pipe, cock or fitting as aforesaid, shall be liable to a penalty not exceeding One hundred dollars (\$100).

Licences to Plumbers
expiration of.

11. Every such Licence shall expire on the 31st day of December in each year, and may be renewed, but shall be subject to review from time to time, and the Trust may at any time cancel such licence in the event of the holder thereof being adjudged by the Trust to be incompetent, or by himself or his employees committing any breach of the Water Acts or of this By-law, or being guilty of any conduct which the Trust may regard as improper. Application for a renewal of every such licence must be lodged on or before 30th November every year, along with evidence that the applicant has renewed his registration with the Plumbers and Gasfitters Board of Victoria. A minimum charge of One dollar (\$1) will be made on all applications for renewals received after 30th November each year.

12. Before any such licence shall be granted or renewed by the Trust, the person applying for the same shall satisfy the Trust that he is a competent plumber, and that he is thoroughly conversant with the provisions of the By-laws of the Trust relating to Water Supply, and with the Sections of the Water Acts applicable to the Trust; but the Trust may, for any reason it so sees fit, refuse to grant or renew such licence, and shall not be bound to give any reason for such refusal.

Carrying Out of Works.

Notice before
Starting.

13. No person shall carry out any works as herein defined except urgent repairs, without giving the Trust at least two (2) days notice of his intention to do so. Notices shall be in writing and shall specify the work proposed to be done and the time when it is to be carried out. In the event of urgent repairs being required to stop waste or escape of water, notice must be sent to the Trust concurrently with, or immediately after the execution of such urgent repairs.

14. In the case of every private service containing any service pipe of one (1) inch and upwards in diameter, the notice must be accompanied by a properly dimensioned plan of the premises at which the work is to be done showing the location of all buildings and the arrangement of all pipes and fittings proposed to be laid.

Notices to be signed
by Licensed Plumber.

15. Every notice, specification and plan shall be signed by the licensed plumber actually engaged to carry out the works referred to in the notice, or by a licensed plumber employing another licensed plumber to carry out the work under his supervision.

Completion to be
reported.

16. Each licensed plumber shall report to the proper officer of the Trust the completion of any new work, extensions or repairs in connection with any service within twenty-four (24) hours of effecting same.

Carrying out of
plumbing work.

17. Every licensed plumber shall in carrying out any work of water supply—

- (a) execute the work in accordance with the provisions of the Act and any special directions or orders given or issued by the proper officer of the Trust;
- (b) execute the work in a thorough and expeditious manner to the satisfaction of the proper officer;
- (c) use materials of the description, quality, kind and standard prescribed by this By-law;
- (d) employ only competent operatives and assistants;
- (e) obtain permission, where necessary, for the execution of the work on, over or through any private property, or any street, road, park, reserve or other public place or property;
- (f) pay all fees payable to the council of a municipality for the opening of any public road or street or otherwise in connection with the works;
- (g) restore upon completion of the work any part of any public road or street to the satisfaction of the municipal council or other authority having control thereof;
- (h) except where authorised, in writing, by the owner or his agent to omit restoration, restore any other property interfered with by the work to the satisfaction of the proper officer;
- (i) take all proper and necessary precautions so that no accident, damage or unnecessary inconvenience may be directly or indirectly occasioned by the execution of the work and
- (j) exercise at all times immediate supervision over the work.

Service Pipes.

Size of Service Pipe.

18. No service pipe (other than those installed for fire-service purposes and sealed in accordance with the provisions of clause 41 of this By-law) which supplies water otherwise than by measure to any tenement shall have a bore exceeding $\frac{1}{2}$ inch. No person shall connect or affix to the Trust's mains any service pipe (other than those installed for fire service purposes and sealed in accordance with the provisions of clause 41 of this By-law) which has a diameter exceeding the appropriate diameter listed in the Schedule hereunder written corresponding either to the net annual valuation of the property to be served or to the anticipated annual consumption of water at the said property as demonstrated to the satisfaction of the proper officer of the Trust and certified to under his hand, whichever is the larger—

Net Annual Valuation of Property.	Annual Consumption of Water.	Maximum Diameter of Service Pipe Allowed Inches.
Not over \$600	Not over 200,000 gallons	$\frac{3}{4}$
Over \$600 but not over \$1,200	Over 200,000 gallons but not over 500,000 gallons	1
Over \$1,200 but not over \$1,800	Over 500,000 gallons but not over 800,000 gallons	$1\frac{1}{4}$
Over \$1,800 but not over \$3,000	Over 800,000 gallons but not over 1,500,000 gallons	$1\frac{1}{2}$
Over \$3,000 but not over \$5,000	Over 1,500,000 gallons but not over 3,000,000 gallons	2

Provided however, that where the supply of water is in the opinion of the Trust insufficient to meet the normal demands of the properties in the vicinity the sizes of service pipes to be laid to connect such properties to a main pipe will be determined by the Trust irrespective of the valuations or area of such properties.

19. No person shall lay, construct, repair or alter any private service unless every service pipe forming part thereof for such portion of its length as lies in or on private property is securely clipped to a structure or is laid and constructed in such manner that the same is at all points at a depth of not less than twelve (12) inches below the surface of the ground. Every such service pipe for such portion of its length as lies in or on any road, street, lane or right-of-way or where it may be exposed to vehicular traffic shall be laid and constructed in such manner that the same is at all points at a depth of not less than eighteen (18) inches below the surface of the ground or at such greater depth as the Council of the Municipality having control of the said road, street, lane or right-of-way may require.

Depth of Service Pipes.

20. No person shall—

- (a) lay, construct, or alter any private service or any part thereof :
- (b) erect or construct any building, erection or structure—

Access to service pipes.

in such place, position or manner that any part of such private service is not easily accessible for the purposes of inspection, repair and renewal unless such part is comprised of copper piping and copper fittings.

21. Any person using any private service shall at all times keep same in proper repair.

Repair of Service pipes.

22. If any person refuses, neglects or delays to have any private service or any part thereof used by him properly repaired after having been required in writing, by the proper officer of the Trust so to do the Trust by its proper officers, servants or agents may enter into or upon any premises supplied by such private service or any part thereof and may where necessary repair or renew such private service or any part thereof so as to prevent the waste of water and may charge such person with the cost and expense of such repair or renewal and such cost and expense shall be a debt due by such person to the Trust.

Trust can repair Service pipe in certain circumstances.

23. Repair of existing service pipes not laid in accordance with the provision of this section will not be permitted should the repair involve the replacement of more than one pipe length of the service, and all such services must be renewed strictly in accordance with these provisions.

Renewal of Service Pipes.

24. One service pipe only shall be used for domestic supply to each tenement. No extension of private services will be permitted, and not more than one tenement shall be supplied from a single service pipe, except with the approval of the Trust.

One Service Pipe per tenement.

25. A combined or trunk service for the supply of more than one tenement may be allowed, with approval in writing from the Trust, provided it be so arranged that the supply to each tenement shall be independent of the supply to the remaining tenements and that each branch service shall be controlled by a stop cock fixed in a public thoroughfare or right-of-way. The maximum number of branch services of any of the diameters given in the table below that will be allowed from the trunk shall be as follows—

Trunk Services.

Diameter of Trunk Service Inches.	No. of 1 inch Branches only.	No. of ½ inch Branches only.	No. of ¼ inch Branches only.
¾	2
1	..	2	or 5
1¼	2	or 4	or 10
1½	3	or 6	or 15
2	6	or 12	or 30

Connections.

26. No person shall affix or connect or cause to be affixed or connected any service pipe to any main pipe without having first paid to the Trust a tapping fee as from time to time determined to cover the expense of such tapping including the stop cock and ferrule. Should a bossed thimble tapping be required or should repair, removal or replacement of the tapping subsequently become necessary, such work will be carried out by the Trust at cost to the consumer.

Tapping Fee.

27. The maximum diameter of tapping that may be taken shall be ¾ inch provided that permission for a larger tapping may be granted after application, in writing has been made to the Trust.

Size of Tappings.

28. A branch must be inserted in mains of 6" diameter and over for connections of 3" diameter and over and in mains of less than 6" diameter for connections of 2" diameter and over.

Tapping Branches.

29. The service pipe shall be connected to the main pipe with a proper stop cock ferrule which shall be opposite the tenement supplied and in one line at right angles to the main pipe to which such stop cock ferrule is fixed, unless such an arrangement is impracticable.

Connexion to Main.

30. Each water service shall be provided with two (2) high pressure screw down stop cocks, suitably protected and covered with approved cast iron boxes, where ordered. One stop cock shall be fixed to the stop cock ferrule at the main and fitted with a right angle band of copper alloy or brass. The other stop cock shall be located as follows—

Location of Stop Cocks.

- (a) Where the service pipe is in one line at right angles to the main, above ground not more than three (3) feet inside the building line in an accessible position adjacent to the meter site.
- (b) Where the service pipe is not in one line at right angles to the main, underground outside the building line in a position to be fixed by the Proper Officer.

Insulating
Couplings.

31. If required by the Trust a service must be provided with insulating couplings approved by the Trust—one of such couplings must be fixed at the stop cock ferrule on the main, and the other must be fixed at the service crossing the building line, but where a meter is fixed the coupling shall be fixed at the outlet end of the meter connections instead of at the building line.

Cross Connexions.

32. No person shall permit or suffer any fluid, solid or gas, which in the opinion of the Proper Officer of the Trust is capable of polluting water supplied by the Trust, to have means of access to any pipe in communication directly or indirectly with any main pipe of the Trust.

Where any service pipe is connected to any cistern, tank or receptacle used for the storage of water or fluid, there shall be an effective air gap at the outlet of such service pipe and the said outlet shall be not less than one-half ($\frac{1}{2}$) inch above the highest possible water level in the said cistern, tank or receptacle.

*Supply of Water for Particular Purposes.*Connexions to
Steam Boilers.

33. Water supply connections to steam boilers shall be made as follows—

- (a) By direct connection from a service pipe, in which case a screw-down, high pressure stop tap with its spindle vertically upwards shall be fixed on the piping supplying water to a boiler; a vertically acting reflux valve shall be fixed between the stop-tap and the boiler and a half inch ($\frac{1}{2}$) testing ferrule or bit-tap shall be fixed between the reflux valve and the stop-tap; or
- (b) By direct connection from a service pipe together with an injected supply from a storage tank or condensate sump, in which case, in addition to the provisions of paragraph (a) hereof, the injected water to a boiler shall be taken through a separate opening in the wall of the boiler. In no circumstances shall a connection be permitted between any service pipe and the piping from a storage tank or condensate sump.

Water connections may be made through the tops or sides of steam boilers.

Pump Connexions.

34. Pumps for the purpose of increasing pressure in private services shall not be connected without approval in writing from the Trust and then only to cisterns having an effective air gap at the outlet of the service pipe from the main. No person shall fit such a pump to any service pipe communicating directly or indirectly with any main pipe of the Trust unless with the written approval of the Trust where the pump is connected to a service used solely for fire service.

Cooling Water.

35. No person shall use or permit or suffer the use of any private service or any part thereof for the supply of water for cooling purposes unless in accordance with the following requirements—

- (a) any apparatus in which water is used for cooling purposes shall be deemed to be an apparatus within the meaning of this By-law;
- (b) the use of water as aforesaid for any such apparatus shall be subject to the conditions as set out in this By-law;
- (c) No such apparatus shall be installed or used in on or in connection with any property land or tenement unless the Trust shall have first consented thereto in writing;
- (d) Applications for consent to install or use such apparatus shall state the make and type, the minimum and maximum water requirements, and any other information the Trust may require;
- (e) If water used for or in the operation of the said apparatus under full output exceeds one half ($\frac{1}{2}$) gallon per minute it shall not be run to waste unless consent in writing shall have first been obtained from the Trust;
- (f) The quantity of water run to waste shall be limited to the quantity specified in the Trust's consent. Should water in excess of the quantity so specified in the Trust's consent be run to waste the owner or occupier of the property land or tenement or other persons supplied with or using the water so supplied by the Trust who shall permit or allow such excess water to be run to waste shall be guilty of an offence against this By-law;
- (g) The water run to waste shall be recorded by a meter.

Baths.

36. No person shall use or permit or suffer the use of any private services for the purpose of supplying water to any bath capable of containing more than one hundred (100) gallons of water, unless with the approval of the Trust.

Swimming Pools.

37. No person shall use or permit or suffer the use of any private service or any part thereof, for the supply of water to any swimming pool, unless in accordance with the following requirements—

- (a) The supply to the property shall be metered.
- (b) The use of water for any such swimming pool shall be subject to the conditions as set out in this By-law;
- (c) No swimming pool shall be installed or used on any property unless the Trust shall have first consented thereto in writing.
- (d) Application for supply of water to a swimming pool shall state the location and capacity of the pool and give details of any proposed water treatment;
- (e) The pool shall not be emptied into street channels or storm water drains unless consent of the local municipal council has first been obtained and the necessary permission in writing from the municipal council must accompany the application for supply of water.
- (f) The pool shall not be emptied into the Trust's sewer without written approval from the Trust for which a separate application must accompany the application for supply of water.
- (g) The supply to the pool shall be shut off during emptying and the time and rate of supply shall be at the discretion of the Trust;
- (h) An air disconnection to the approval of the Proper Officer shall be provided between the water supply pipe or hose filling the pool and the highest water level of the pool.
- (i) The discharge from the pool may be used for garden watering provided such watering is not carried out during any period that water restrictions are in force.
- (j) Applications shall be made for any alterations or additions to the pool.

38. (a) No person shall fix a storage tank to a service pipe unless in accordance with the following requirements—

- (i) The storage tank shall be provided with a ball tap, overflow pipe and cover.
 - (ii) The storage tank shall be fitted with a stop cock in an accessible position near ground level.
 - (iii) The supply of water to the ball tap shall be controlled by a stop tap connected to the ball-valve by a flexible copper pipe.
 - (iv) The cold water feed into a storage tank shall be at least $\frac{1}{2}$ inch above the top of the overflow from the tank.
 - (v) The overflow pipe shall be of galvanised sheet iron with soldered joints and shall be at least $1\frac{1}{2}$ inch in diameter and all other parts of such tank shall be made of approved materials.
 - (vi) The storage tank and the connections thereto shall be situate in an accessible position.
- (b) Where a storage tank is installed between the roof and the ceiling of any building there shall be fixed beneath such tank a tray constructed of approved material and with an overflow pipe of at least 2 inches in diameter constructed of galvanised sheet iron with soldered joints.

(c) An overflow pipe whether from a storage tank or from a tray or from a storage tank and a tray shall be so constructed as to discharge outside the building in which the storage tank is situate in such a manner that the discharge, if any, therefrom may be readily discernable.

39. No person shall use or permit or suffer the use of any private service or any part thereof for the supply of water to any automatic flushing cisterns unless in accordance with the following requirements—

- (a) A meter shall be fixed solely to record the water used by the cistern;
- (b) The automatic cistern shall be kept under inspection and maintained in proper working order at all times;
- (c) The supply to the automatic cistern shall be shut off at all times when the urinals or other fittings supplied are not made available for use;
- (d) In the event of the Trust at any time ordering the removal of the automatic cistern and its replacement by a hand operated appliance, such order shall be carried out forthwith;
- (e) An agreement in writing containing the said conditions (a) (b) (c) and (d) and such further or other conditions as may be deemed necessary in the circumstances by the Trust shall first be executed by the owner of the premises.

40. No person shall construct, lay or use any service pipe which communicates directly or indirectly with or supplies water to any urinal or water closet or any part thereof save through a cistern or tank so constructed that the water cannot flow continuously and that not more than 3 gallons can escape at one static flush.

41. (a) Private fire services comprising pipes and fittings not exceeding six (6) inches in diameter and without meters may be permitted at the expense of the owner of the premises. Every such fire service shall be sealed. Except in case of fire no person shall, without the authority of the Trust, wilfully break the seal affixed to any private fire service and in the event of any such seal having been broken accidentally or otherwise the occupier of the tenement shall within twenty-four (24) hours thereafter give notice in writing of the fact at the office of the Trust, and shall be liable to pay for all water estimated by the Trust to have been used as a result of the seals having been broken. No water shall be taken from any sealed portion of a private service except for extinguishing fires.

(b) Except as expressly provided in sub-clause (a) of this clause all portions of private services installed for fire service purposes shall comply with all provisions of this By-law.

(c) Every private fire service pipe shall be laid and fixed in a conspicuous position and shall be painted with a distinguishing coating of bright red paint which shall be maintained at all times.

(d) Any application for a fire service shall be made by the owner of the premises and, in writing, to the Trust.

(e) In the event of the owner or occupier committing any offence under the Act or any breach of this By-law or permitting or suffering any such breach or offence to be committed the Trust may by notice, in writing, to the owner withdraw permission for the private fire service and such service shall thereupon be disconnected.

Materials.

42. No person shall use any pipe or fittings in or in connection with a private service unless the same shall comply in all respects with the following specifications—

- (a) The whole of the pipes and fittings shall be of the best quality galvanised wrought-iron, copper, brass, cast iron, welded mild steel or asbestos cement, shall be sound and free from all defects and shall comply with the relevant specifications of the Standards Association of Australia where such specifications have been issued.
- (b) All pipes and pieces shall be true in sectional form, straight longitudinally, clear in bore and (in case of wrought-iron piping) properly galvanised throughout and shall be of equal strength and thickness throughout the entire body of the same.
- (c) Only pipe and fittings which have been tested in accordance with the requirements of the specifications of the Standards Association of Australia will be permitted to be used for services whether inside or outside the tenement.
- (d) All ends of galvanised wrought-iron and brass pipes bends and fittings shall be properly and truly threaded and capable of being screwed into thimbles, tees and fittings.
- (e) All stop taps and bib-taps shall be screw-down, high pressure taps made of hard brass or gun metal.

(f) Copper piping shall comply with AS B158-1961 for copper tubes and any amendments thereto, and shall be of the following diameters and dimensions—

Authorised Nominal bore of Service Pipe.	Equivalent As B158 Tube Type.							
	1		2		3		4	
	Nominal BSP Thread Size.	Nominal Outside Diameter.	Thickness of pipe.	Nominal Outside Diameter.	Thickness of pipe.	Nominal Outside Diameter.	Thickness of pipe.	
in.	in.	in.	SWG.	in.	SWG.	in.	SWG.	
$\frac{1}{2}$	$\frac{1}{2}$	$\frac{1}{2}$	18	$\frac{1}{2}$	19	
$\frac{3}{4}$	$\frac{3}{4}$	$\frac{3}{4}$	17	$\frac{3}{4}$	19	
1	1	1	16	1	18	1	18	
$1\frac{1}{4}$	$1\frac{1}{4}$	$1\frac{1}{4}$	16	$1\frac{1}{4}$	18	$1\frac{1}{4}$	18	
$1\frac{1}{2}$	$1\frac{1}{2}$	$1\frac{1}{2}$	16	$1\frac{1}{2}$	18	$1\frac{1}{2}$	18	
2	2	2	14	2	16	2	18	
$2\frac{1}{2}$	$2\frac{1}{2}$	$2\frac{1}{2}$	14	$2\frac{1}{2}$	16	$2\frac{1}{2}$	18	
3	3	3	14	3	16	3	16	
4	4	4	12	4	14	4	16	

- Type 1. Tubes are suitable for screwed joints.
- Type 2. Tubes are suitable for other types of jointing approved by the Trust.
- Type 3. Tubes are suitable for use above ground only.
- Type 4. Tubes are suitable for use above ground between storage tanks and flush valves supplied therefrom or supplies above ground not connected directly to a main pipe.

(g) Galvanised iron piping shall comply with AS B105-1960 for steel tubes and shall be of heavy gauge tube with the following diameter and dimensions—

Authorised Nominal Bore of Service Pipes in Inches.	Approximate Outside Diameter in Inches.	Thickness.		Sockets.	
		S.W.G.	Inches.	Approximate Outside Diameter in Inches.	Minimum Length in Inches.
$\frac{1}{2}$	$\frac{3}{8}$	10	.128	$1\frac{1}{8}$	$1\frac{1}{2}$
$\frac{3}{4}$	$1\frac{1}{16}$	10	.128	$1\frac{1}{4}$	$1\frac{3}{4}$
1	$1\frac{1}{8}$	8	.160	$1\frac{3}{8}$	$1\frac{7}{8}$
$1\frac{1}{4}$	$1\frac{3}{8}$	8	.160	$2\frac{1}{8}$	$2\frac{1}{4}$
$1\frac{1}{2}$	$1\frac{5}{8}$	8	.160	$2\frac{3}{8}$	$2\frac{1}{2}$
2	$2\frac{1}{8}$	7	.176	$2\frac{5}{8}$	$2\frac{3}{4}$
$2\frac{1}{2}$	3	7	.176	$3\frac{1}{8}$	$2\frac{7}{8}$
3	$3\frac{1}{2}$	6	.192	4	3
$3\frac{1}{2}$	4	6	.192	$4\frac{1}{4}$	$3\frac{1}{4}$
4	$4\frac{1}{2}$	5	.212	$5\frac{1}{8}$	$3\frac{1}{2}$
5	$5\frac{1}{2}$	5	.212	$6\frac{1}{8}$	$3\frac{3}{4}$
6	$6\frac{1}{2}$	5	.212	$7\frac{1}{4}$	$3\frac{3}{4}$

(h) Except with the consent of the Trust all new services of 2 inches internal diameter or under must be of brass, copper, or other materials approved by the Trust.

Meters.

Meters Supplied and Maintained by the Trust.

43. (a) Except as permitted in clause 41 of this By-law no person shall use any private service save for the supply of water solely for domestic purposes exclusive of the watering of any garden or filling of any swimming pool unless the whole of the water supplied to such private service passes through a meter.

(b) Such meters will be provided and maintained by the Trust and every person before installing a private service shall ascertain from the Trust the size of meter to be installed and shall make provision in the arrangement and construction of the private service for connection of such meter in accordance with the following requirements—

- (i) The meter shall be located within the property and not more than three (3) feet from the building line.
- (ii) The meter shall be in an easily accessible position protected from accidental damage.
- (iii) The meter shall be properly and securely affixed to such private service or service pipe by means of connections or quarter bends of brass, copper or copper alloy.
- (iv) The meter shall be fixed truly level on a solid foundation of brick, stone or concrete the top of which foundation is level with or above the surface of the ground.
- (v) All washers used for the connection couplings for meters shall be made of leather.

(c) Pending connection of the said meter the person authorised to install the service pipe shall connect a distance piece in the service pipe in place of the meter.

44. No person shall without the written consent of the Trust construct, place, stack or store or permit or suffer to be constructed, placed, stacked or stored any building, erection or thing over or upon any meter or distance piece in place of any meter connected or affixed to any private service or shall do or permit or suffer to be done any act, matter or thing whereby inspection of such meter or distance piece shall be prevented, obstructed or in any way rendered difficult or interfered with. Restriction of Access to Meter.
45. (a) The Trust may at any time replace or remove for testing any meter attached to any private service. Replacement and Testing of meter.
- (b) Any consumer may at any time request the Trust, in writing, to test any meter attached to his private service and through which water supplied to him passes and shall at the time of the delivery of such request deposit with the Trust a sum of money as from time to time determined by the Trust. The Trust shall thereupon remove and test the meter or cause the same to be tested in such manner as it thinks fit. Fees returned in certain circumstances.
- If such meter is found to be registering correctly the Trust may retain the deposit money in satisfaction of the fee for testing meter hereinbefore prescribed but if such meter is found to be registering incorrectly the deposit shall be returned to such consumer.
46. Every person ceasing to occupy the premises on which such meter is fixed shall give to the Trust, in writing, at least six (6) days' notice of his intention to do so. Consumer Leaving Premises to Notify Trust.
- Misuse and Waste.*
47. No person supplied with water by the Trust shall waste the same or permit or suffer the same to run to waste. Wasting of Water.
48. No person shall take or carry away or permit or suffer any other person to take or carry away any such water from any premises supplied with water by the Trust and no person shall sell any water supplied by the Trust. Sale of Water.
49. No person other than a servant or agent of the Country Fire Authority in the execution of his duty as such servant or agent shall without written permission of the Trust open, close or otherwise interfere with any hydrant attached to any main pipe. Fire Hydrants.
50. No person other than a servant or agent of the Municipality corporation or body having the care and management of a public park, public garden or reserve for public purposes shall without the previous consent of the Trust open, close or otherwise interfere with any tap, valve or other like regulator (except a drinking fountain or other tap provided for public use) in, on or connected with any service pipe used for the supply of water to such park, garden or reserve. Taps in Parks and Reserves.
51. No person shall, without the written permission of the Trust, use fire plugs or hydrants attached to the Trust's mains for the purpose of watering streets or thoroughfares or for road construction purposes. Water for Road Construction Purposes and Street Watering.
- General.*
52. Any person authorised by the Trust in that behalf either generally or for any class of cases or in any particular case may at all reasonable times— Inspections.
- (a) enter into or upon any premises for the purposes of inspecting and may inspect any private service or any part thereof or any works in course of execution therein or thereon; and/or
- (b) enter into or upon any premises for the purpose of superintending the execution of any works in course of execution therein or thereon and may give to the owner or occupier of such premises or any person engaged in executing such works any directions or instructions necessary for the purpose of ensuring that all relevant provisions of this By-law shall be duly complied with and observed during and in connection with the execution of such works;
- (c) for any such purpose as aforesaid may dig or excavate in or upon any such premises.
53. No person shall obstruct, hinder, impede, resist, oppose or refuse admission to any premises by the Proper Officer or any person duly authorised in that behalf by the Trust, or shall fail or neglect to carry out and observe all lawful directions and instructions given by him.
54. Where the sanction, permission, authority, consent, approval, satisfaction, order, direction, opinion, indication, or notice of or from the Trust is necessary, whether special, in writing, or otherwise, with regard to any act, matter or thing mentioned in this By-law, the same may be given by and under the hand of the Secretary, or of the Engineer-in-Chief, personally, or through an inspecting officer appointed under and responsible to him, and authorised on behalf of the Trust, to prescribe any conditions attaching thereto, and subject to and in accordance with which only the same shall be deemed to have been given. Consent etc. of Trust—how same may be given.
55. No variation from the Regulations contained in this By-law will be allowed except by the special written approval of the Trust obtained previously to the proposed variation being carried out. Variations without prior special permit.
56. Any person who commits any breach of any of the provisions of this By-law shall be liable to a penalty of not more than One hundred dollars (\$100). Penalties.

Passed this 25th day of August, 1966.

The common seal of the Geelong Waterworks and Sewerage Trust was hereto affixed in the presence of—

(SEAL)

A. S. THOMPSON, Commissioner.
R. E. GORELL, Commissioner.
B. C. HENSHAW, Secretary.

Approved by the Governor in Council, 13th September, 1966.—J. COLQUHOUN, Clerk of the Executive Council.

COLAC WATERWORKS TRUST.

RATING BY-LAW FOR THE YEAR 1ST OCTOBER, 1966 TO 30TH SEPTEMBER, 1967.

Colac Urban District.

THE Colac Waterworks Trust, in pursuance and exercise of powers conferred by the Water Act, doth hereby make a rate for the supply of water for domestic purposes of Three Cents (3c) in the Dollar on the annual municipal valuations of lands and tenements liable to be rated within the Colac Urban District.

Provided that in no case shall the amount of rate payable per annum in respect of any tenement (other than land on which there is no building) be less than Eight Dollars, and in respect of land on which there is no building less than Four Dollars.

Such rates are made and shall be levied upon the occupiers or owners of the said lands and tenements for the period commencing the 1st day of October, 1966, and shall be payable in one sum on the 31st day of January, 1967, at the office of the said Trust, and if not paid within four months from the date made payable will bear interest at the rate of 6 per cent. per annum from the date made payable until paid.

The maximum quantity of water to be supplied in the aforementioned period, without further charge to any property rated by the Trust, is hereby fixed at the quantity which, at a charge of Twenty Cents per 1,000 gallons, would produce an amount equal to the amount of rate levied on such property for the said period.

The charge for water supplied by measure to any property rated by the Trust in excess of such maximum quantity, computed as in the last preceding clause, is hereby fixed at Twenty Cents per 1,000 gallons.

The above charge for water supplied by measure to any property shall be payable, on demand, at the office of the said Trust.

Signed and sealed this 26th day of September, 1966.

(SEAL) A. O. BILSON, Chairman.
ARTHUR F. POTTER, Commissioner.
E. J. ROBBINS, Secretary.

Approved, 5th October, 1966.—T. A. DARCY, Minister of Water Supply.

COLAC WATERWORKS TRUST.

RATING BY-LAW FOR THE YEAR 1ST OCTOBER, 1966, TO 30TH SEPTEMBER, 1967.

ALVIE, BEEAC, CORAGULAC, COROROKE, CRESSY AND WARRION URBAN DISTRICTS.

THE Colac Waterworks Trust, in pursuance and exercise of powers conferred by the Water Act, doth hereby make a rate for the supply of water for domestic purposes of Twelve and One Half Cents (12.5c) in the Dollar on the annual municipal valuations of lands and tenements liable to be rated within the Alvie, Beeac, Coragulac, Cororoque, Cressy and Warrion Urban Districts.

Provided that in no case shall the amount of rate payable per annum in respect of any tenement (other than land on which there is no building) be less than Fifteen Dollars, and in respect of land on which there is no building less than Four Dollars.

Such rates are made and shall be levied upon the occupiers or owners of the said lands and tenements for the period commencing the 1st day of October, 1966, and shall be payable in one sum on the 31st day of January, 1967, at the office of the said Trust, and if not paid within four months from the date made payable will bear interest at the rate of 6 per cent. per annum from the date made payable until paid.

The maximum quantity of water to be supplied in the aforementioned period, without further charge to any property rated by the Trust, is hereby fixed at the quantity which, at a charge of Twenty Cents per 1,000 gallons, would produce an amount equal to the amount of rate levied on such property for the said period.

The charge for water supplied by measure to any property rated by the Trust in excess of such maximum quantity, computed as in the last preceding clause, is hereby fixed at Twenty Cents per 1,000 gallons.

The above charge for water supplied by measure to any property shall be payable, on demand, at the office of the said Trust.

Signed and sealed this 26th day of September, 1966.

(SEAL) A. O. BILSON, Chairman.
ARTHUR F. POTTER, Commissioner.
E. J. ROBBINS, Secretary.

Approved, 5th October, 1966.—T. A. DARCY, Minister of Water Supply.

LOUGH CALVERT DRAINAGE TRUST.

RATING BY-LAW 1966.

THE Lough Calvert Drainage Trust, in pursuance and exercise of the powers conferred by the River Improvement Act 1958, doth hereby make the By-Law following:—

1. The Following Rate to be called the Lough Calvert Drainage District Drainage Rate is hereby made and shall be levied upon the occupiers or owners of all properties in the Lough Calvert Drainage District which are rateable to any municipality:—

- (a) A rate of four and one half cents in the dollar on the net annual municipal value of all properties in the First Division of the Lough Calvert Drainage District shown coloured green on the plan titled "Lough Calvert Drainage District Rating Divisions 1958", approved by the Governor in Council, and deposited at the Office of the State Rivers and Water Supply Commission at Melbourne.
- (b) A rate of four cents in the dollar on the net annual municipal value of all properties in the Second Division of the Lough Calvert Drainage District shown coloured brown on the said plan.
- (c) A rate of three and three quarters cents in the dollar on the net annual municipal value of all properties in the Third Division of the Lough Calvert Drainage District shown coloured yellow on the said plan.
- (d) A rate of two and one half cents in the dollar on the net annual municipal value of all properties in the Fourth Division of the Lough Calvert Drainage District shown coloured grey on the said plan.
- (e) A rate of one and one half cents in the dollar on the net annual municipal value of all properties in the Fifth Division of the Lough Calvert Drainage District shown coloured violet on the said plan.
- (f) A rate of one cent in the dollar on the net annual municipal value of all properties in the Sixth Division of the Lough Calvert Drainage District shown coloured pink on the said plan.
- (g) No rate is made or levied in respect of any property within the Seventh Division of the Lough Calvert Drainage District comprising all those lands not included in the First, Second, Third, Fourth, Fifth or Sixth Divisions.

Provided that in no case shall the amount of Rate payable in respect of any rateable property within the Lough Calvert Drainage District be less than ten cents.

2. Such rate is made and shall be levied for the period beginning with the 1st day of January 1966, and ending on the 31st day of December 1966, and shall be payable on the 12th day of October, 1966, at the office of the Lough Calvert Drainage Trust at Colac.

3. Such person or persons as the Lough Calvert Drainage Trust may from time to time appoint for that purpose shall be and is or are hereby authorised to demand, receive collect and recover the said rate.

The foregoing By-law was made by the Lough Calvert Drainage Trust on the 8th day of August, 1966, and the seal of the said Trust was hereby affixed this 8th day of August, 1966, in the presence of—

(SEAL) T. A. BARNARD, Chairman.
H. L. ROBERTS, Commissioner.
A. C. THEODORE, Secretary.

Approved by the Governor in Council, 11th October, 1966.
—J. COLQUHOUN, Clerk of the Executive Council.

AUCTION SALES ACT 1958.

BALLARAT.—Notice is hereby given that the Annual Meeting of Justices for the Licensing of Auctioneers will be held at the Court House, Ballarat, on 22nd day of November, 1966, at Ten o'clock in the forenoon. Dated at Ballarat this 7th day of October, 1966.—E. N. KINCHINGTON, Clerk of Petty Sessions.

BENALLA.—Notice is hereby given that the Annual Meeting of Justices for the Licensing of Auctioneers will be held at the Court House, Benalla, on Tuesday, the 22nd day of November, 1966, at the hour of Ten o'clock in the forenoon.—R. F. FREEMAN, Clerk of Petty Sessions.

CAMPERDOWN.—Notice is hereby given that the Annual Meeting of Justices for the Licensing of Auctioneers will be held at the Court House, at Camperdown, on the 22nd day of November, 1966, at Ten a.m., for the Special Purpose of taking into consideration applications for Auctioneers Licences.—M. W. GERKINS, Clerk of Petty Sessions.

EUROA.—Notice is hereby given that the Annual Meeting of Justices for the Licensing of Auctioneers will be held at the Court House, Euroa, on Tuesday, the 22nd day of November, 1966, at the hour of Ten o'clock in the forenoon.—R. F. FREEMAN, Clerk of Petty Sessions.

GEELONG.—Notice is hereby given that the Annual Meeting of Justices for the Licensing of Auctioneers will be held at the Law Courts, Geelong, on Tuesday, the 22nd day of November, 1966, at the hour of Ten o'clock in the forenoon. Dated this 6th day of October, 1966.—J. MILLS, Clerk of Petty Sessions.

SALE.—Notice is hereby given that the Annual Meeting of Justices for the Licensing of Auctioneers will be held at the Court House, Sale, on Tuesday, the 22nd day of November, 1966, at the hour of Ten o'clock in the forenoon. Dated at Sale this 30th day of September, 1966.—D. R. WALKER, Clerk of Petty Sessions, Sale.

TERANG.—Notice is hereby given that the Annual Meeting of Justices for the Licensing of Auctioneers will be held at the Court House, at Terang, on the 22nd day of November, 1966, at Ten a.m., for the special purpose of taking into consideration applications for Auctioneers Licences.—M. W. GERKINS, Clerk of Petty Sessions.

YARRAM.—Notice is hereby given that the Annual Meeting of Justices for the Licensing of Auctioneers will be held at the Court House, Yarram, on Tuesday, the 22nd day of November, 1966, at the hour of Ten o'clock in the forenoon. Dated at Yarram this 30th day of September, 1966.—R. A. ISON, Clerk of Petty Sessions.

HOSPITALS AND CHARITIES ACT 1958 (No. 6274).

IT is hereby notified for general information that the Hospitals and Charities Commission, under the provisions of section 50 of the above-mentioned Act, has approved of the corporate name of Geelong and District Hospital (Kitchener Memorial) being changed to—

“THE GEELONG HOSPITAL”.

Dated at Melbourne, this tenth day of October One thousand nine hundred and sixty-six.

JOHN LINDELL,
Chairman.

PUBLIC TRUSTEE ACT 1958 (No. 6350), SECTION 17.

HEREBY give notice that on the 23rd September, 1966, the Public Trustee filed elections to administer the following deceased persons' estates, in accordance with section 17 of the Public Trustee Act 1958:—

CLARK, GEORGE MCCHESENEY, formerly of 228 Glenlyon-road, East Brunswick, but late of 21 Lowan-street, East Brunswick, retired postal officer, died 20th July, 1966.

DOW, ROBERT, late of 497 Main-street, Mordialloc, retired commercial traveller, died 1st August, 1966.

HUGHES, JOHN STANLEY, late of Puckapunyal, labourer, died 23rd June, 1966.

KENNEDY, ADELAIDE CONSTANCE, formerly of 1045 Burke-road, Hawthorn East, but late of Trewither Private Hospital, 7 Gordon-street, Toorak, widow, died 23rd June, 1966.

KING, PATRICK ALBERT, late of Buronga, N.S.W., retired labourer, died 1st March, 1966.

MARTIN, MARTIN, late of 117 Orange-avenue, Mildura, pensioner, died 21st July, 1966.

VAN DEN BOSSCHE, RAYMOND, late of Flat 4, 262 Beaconsfield-parade, Middle Park, pastrycook, died 21st May, 1966.

WILSON, RONALD, formerly of Erica, but late of Mont Park, sawmill hand, died 31st July, 1966.

HEREBY give notice that on the 20th September, 1966, the Public Trustee filed elections to administer the following deceased persons' estates, in accordance with section 17 of the Public Trustee Act 1958:—

BARBER, ALFRED THOMAS, formerly of Flat 12, Pacific Flats, 102 Grey-street, St. Kilda, but late of 19 Benbrook-avenue, Box Hill, retired law clerk, died 13th July, 1966.

GRIGSBY, PHILLIP, late of Queen Elizabeth Home, Ballarat, pensioner, died 10th March, 1966.

MCCARTHY, FRANCIS, late of 87 Wingate-street, East Bentleigh, timekeeper, died 13th June, 1966.

OLIVER, ERIC DURKIN, late of lot 2, The Glen, Rye, retired accountant, died 28th November, 1965.

A. D. DUNCAN,
Public Trustee.

256 Flinders-street, Melbourne, C.1, 5th October, 1966.

NOTICE.

CREDITORS, next of kin, and others having claims against the estate of any of the under-mentioned deceased persons are required to send particulars of their claims to the Public Trustee, 256 Flinders-street, Melbourne, the personal representative, on or before the 17th December, 1966, after which date the Public Trustee may convey or distribute the assets having regard only to the claims of which the Public Trustee then has notice:—

AIKEN, JAMES, late of 4 Adrienne-crescent, East Oakleigh, retired fitter, died 24th July, 1966.

BARBER, ALFRED THOMAS, formerly of Flat 12, Pacific Flats, 102 Grey-street, St. Kilda, but late of 19 Benbrook-avenue, Box Hill, retired law clerk, died 13th July, 1966.

BARBER, WILLIAM CHARLES, late of 43 Toorak-road, South Camberwell, retired linotype operator, died 20th July, 1966.

BREEN, EILEEN VERONICA, also known as Eileen Breen, late of 41 Carter-street, Albert Park, spinster, died 11th August, 1966.

BROWN, JAMES ALBERT ERNEST, also known as James Ernest Brown, late of 25 Latrobe-street, Caulfield, retired life assurance officer, died 14th July, 1966.

CAIRNS, EVELINE, late of 94 Springvale-road, Springvale, widow, died 21st July, 1966.

CLARK, GEORGE MCCHESENEY, formerly of 228 Glenlyon-road, East Brunswick, but late of 21 Lowan-street, East Brunswick, retired postal officer, died 20th July, 1966.

COFFEY, CATHERINE HANNAH, late of 15 Cheddar-road, Reservoir, widow, died 18th July, 1966.

DAYMOND, GILBERT GEORGE, late of 1 Lacey-street, The Netherlands, Sale, retired woodcarver, died 5th May, 1966.

DOW, ROBERT, late of 497 Main-street, Mordialloc, retired commercial traveller, died 1st August, 1966.

GASSNER, LUDWIG, late of 28 Edward-street, North Geelong, crane driver, died 12th June, 1966.

GRIGSBY, PHILLIP, late of Queen Elizabeth Home, Ballarat, pensioner, died 10th March, 1966.

HORNE, MYRTLE BEATRICE, formerly of 56 Hotham-street, Preston and 538 Toorak-road, Toorak, but late of Flat 49, 208 Middleborough-road, Blackburn, retired domestic, died 17th July, 1966.

HOWLETT, EVA ANNIE MAY, late of 15 Collins-street, Box Hill, married woman, died 8th May, 1966.

HUGHES, JOHN STANLEY, late of Puckapunyal, labourer, died 23rd June, 1966.

KENNEDY, ADELAIDE CONSTANCE, formerly of 1045 Burke-road, Hawthorn East, but late of Trewither Private Hospital, 7 Gordon-street, Toorak, widow, died 23rd June, 1966.

KING, PATRICK ALBERT, late of Buronga, N.S.W., retired labourer, died 1st March, 1966.

MARTIN, MARTIN, late of 117 Orange-avenue, Mildura, pensioner, died 21st July, 1966.

MANZIE, ROYAL RUPERT, also known as Roy Rupert Manzie, late of 27 Esplanade, St. Kilda, retired storeman, died 26th June, 1966.

MCCARTHY, FRANCIS, late of 87 Wingate-street, East Bentleigh, timekeeper, died 13th June, 1966.

OLIVER, ERIC DURKIN, late of lot 2, The Glen, Rye, retired accountant, died 28th November, 1965.

PRATT, JAMES ROBERT, also known as James Pratt, late of 39 Ralston-street, South Yarra, tool storeman, died 29th June, 1966.

RAMAGE, GEORGE, late of 2 Howard-street, Edinburgh, Scotland, retired postman, died 20th February, 1966.

SEABERG, IDILIA MAY CHRISTINA AGNES, also known as Ida May Seaberg and Idalia Seaberg, late of 7 Grattan-street, Prahran, married woman, died 10th June, 1966.

TURNER, ELEANOR FLORENCE PRUDENCE, late of 1 Gallipoli-parade, Croydon, widow, died 27th April, 1966.

VAN DEN BOSSCHE, RAYMOND, late of Flat 4, 262 Beaconsfield-parade, Middle Park, pastrycook, died 21st May, 1966.

WILSON, RONALD, formerly of Erica, but late of Mont Park, sawmill hand, died 31st July, 1966.

A. D. DUNCAN,
Public Trustee.

Melbourne, 5th October, 1966.

NOTICE TO MARINERS.

[No. 10 of 1966.]

AUSTRALIA.—VICTORIA.

WESTERNPORT.

New Bridge Construction.

Date.—On or about 17th October, 1966.

Position.—San Remo Bridge, Lat. 38 deg. 31 min. S., Long. 145 deg. 22 min. E. (Approx.).

Details.—From a position approximately 1,200 feet north-eastward of the San Remo abutment of the existing bridge a new bridge is under construction bearing approximately 305 deg. to Newhaven. White lights, with a visibility of at least one mile upstream and downstream, will be shown at 100 feet centres along the construction work as it proceeds.

Fixed Red and Green lights with the same visibility as above, will be shown from the western and eastern outer extremity respectively of the work as it progresses, and also from the centre fairway piers, visible from upstream only, when these piers are constructed.

Charts Affected.—B.A. 1710. Aust. 144.

Publications.—Sailing Directions, Victoria, 1959, page 409. Australia Pilot, Vol. 11, 1956, page 114.

A. J. WAGGLEN,
Port Officer.

Ports and Harbors Branch,
Public Works Department,
Melbourne, C.2, 6th October, 1966.

DEPARTMENT OF MINES.

SUBJECT to any necessary excisions, &c., it is proposed to grant the following mining lease:—

8364, Mineral; Johannes Eduard Hermann; 12a. Or. 28p., Parish of Minapre.

APPLICATIONS FOR MINING LEASES DECLARED ABANDONED.

8170, Mineral; George Milton; 637 acres, Parish of Buchan.
8171, Mineral; George Milton; 640 acres, Parish of Buchan.
8172, Mineral; George Milton; 640 acres, Parish of Buchan.
8173, Mineral; George Milton; 640 acres, Parish of Buchan.
8174, Mineral; George Milton; 640 acres, Parish of Buchan.
8175, Mineral; George Milton; 640 acres, Parish of Buchan.
8180, Mineral; George Milton; 640 acres, Parish of Buchan.
8182, Mineral; George Milton; 640 acres, Parish of Buchan.
8183, Mineral; George Milton; 640 acres, Parish of Buchan.
8184, Mineral; George Milton; 640 acres, Parish of Buchan.
8185, Mineral; George Milton; 640 acres, Parish of Buchan.
8187, Mineral; George Milton; 640 acres, Parish of Buchan.
8188, Mineral; George Milton; 640 acres, Parish of Buchan.
8256, Mineral; George Milton; 640 acres, Parish of Buchan.
8257, Mineral; George Milton; 640 acres, Parish of Buchan.
8258, Mineral; George Milton; 640 acres, Parish of Buchan.
8259, Mineral; George Milton; 640 acres, Parish of Buchan.
8260, Mineral; George Milton; 640 acres, Parish of Buchan.
8261, Mineral; George Milton; 640 acres, Parish of Buchan.
8262, Mineral; George Milton; 640 acres, Parish of Buchan.
8263, Mineral; George Milton; 640 acres, Parish of Buchan.
8264, Mineral; George Milton; 640 acres, Parish of Buchan.
8266, Mineral; George Milton; 640 acres, Parish of Buchan.
8267, Mineral; George Milton; 640 acres, Parish of Buchan.
8268, Mineral; George Milton; 640 acres, Parish of Buchan.
8269, Mineral; George Milton; 640 acres, Parish of Buchan.
8270, Mineral; George Milton; 640 acres, Parish of Buchan.
8271, Mineral; George Milton; 640 acres, Parish of Buchan.
8290, Mineral; George Milton; 640 acres, Parish of Buchan.
8293, Mineral; George Milton; 640 acres, Parish of Buchan.
8294, Mineral; George Milton; 613 acres, Parish of Buchan.
8295, Mineral; George Milton; 595 acres, Parish of Buchan.
8296, Mineral; George Milton; 633 acres, Parish of Buchan.
8297, Mineral; George Milton; 640 acres, Parish of Buchan.

APPLICATION FOR MINING LEASE REFUSED.

8534, Mineral; Noel Graham Peace, Marion Elaine Peace; 10 acres, Parish of Terrick Terrick West.

CONSENT TO TRANSFER MINING LEASE.

8304, Mineral; from John William Condon to Keith Douglas Sell.

T. A. DARCY,
Minister of Mines.

MINING LEASE DECLARED VOID.

7875, Mineral; Bendigo Brick Company Proprietary Limited; 80a. 3r. Op., Parish of Huntly.

EXPLORATION LICENCES DECLARED VOID.

37, Exploration Licence; I.M.C. Development Corporation; 187 square miles, County of Moira.
66, Exploration Licence; Esso Mineral Company of Australia; 2 square miles, County of Villiers.
67, Exploration Licence; Esso Mineral Company of Australia; 37 square miles, Counties of Dundas, Normanby, Villiers.

E. CONDON,
Secretary for Mines.

LOCAL GOVERNMENT DEPARTMENT.

ORDER CONFIRMED.—CITY OF SALE.

THE Minister of the Crown administering the *Local Government Act 1958*, as amended, on the 30th day of September, 1966, confirmed the Order hereinafter referred to in pursuance of section 514 of the said Act, namely:—

An Order of the Council of the City of Sale made on the 19th September, 1966, directing the compulsory taking of the lands described hereunder for the purposes of an off-street car park, a comfort station and sanitary conveniences:

1. All that piece of land being parts of Crown allotments 1, 2 and 3, section 28, Parish of Sale, commencing at a point being the south-east corner of C.A.1.; thence by a line bearing 258 deg. 0 min. for a distance of 125 feet; thence by a line bearing 348 deg. 0 min. for a distance of 132 feet; thence in a line bearing 258 deg. for a distance of 205 feet; thence on a line bearing 348 deg. for a distance of 132 feet; thence on a line bearing 78 deg. 0 min. for a distance of 330 feet; thence on a line bearing 168 deg. 0 min. for a distance of 12 feet; thence on a line bearing 258 deg. 0 min. for a distance of 155 feet; thence on a line bearing 168 deg. 0 min. for a distance of 86 feet; thence on a line bearing 110 deg. 44 min 07 sec. for a distance of 49 ft. 11 in.; thence on a line bearing 168 deg. for a distance of 139 feet; thence on a line bearing 78 deg. 0 min. for a distance of 113 feet to the point of commencement.

2. All that piece of land being parts of Crown allotments 5, 6, 7, 10, 12, 13 and 14, section 28, Parish of Sale, commencing at the north-west corner of C.A.8; thence by a line bearing 258 deg. 0 min. for a distance of 352 feet; thence on a line bearing 168 deg. 16 min. for a distance of 132 feet; thence on a line bearing 78 deg. 0 min. for a distance of 152 feet, 0 min.; thence on a line bearing 168 deg. 0 min. for a distance of 66 feet; thence on a line bearing 78 deg. 0 min. for a distance of 74 ft. 7½ in.; thence on a line bearing 167 deg. 49 min. for a distance of 121 ft. 7½ in.; thence on a line bearing 258 deg. 05 min. for a distance of 47 ft. 6 in.; thence on a line bearing 170 deg. 43 min. for a distance of 10 ft. 0½ in.; thence on a line bearing 258 deg. 25 min. for a distance of 159 deg. 5 min.; thence on a line bearing 257 deg. 42 min. for a distance of 23 ft. 1½ in.; thence on a line bearing 256 deg. 44½ min. for a distance of 257 ft. 1½ in.; thence on a line bearing 348 deg. 32 min. for a distance of 179 deg. 0½ min.; thence on a line bearing 52 deg. 06 min. for a distance of 42 ft. 10 in.; thence on a line bearing 348 deg. 0 min. for a distance of 132 feet; thence on a line bearing 78 deg. 0 min. for a distance of 373 feet to the point of commencement.

R. J. HAMER,
Minister for Local Government.

Local Government Department,
Melbourne.

CITY OF BRIGHTON PLANNING SCHEME—
14th DECEMBER, 1964.

INTERIM DEVELOPMENT ORDER.

THAT by virtue of the powers conferred by the *Town and Country Planning Act 1961*, as amended, and of every other power enabling it in that behalf, the Council of the City of Brighton (hereinafter referred to as the responsible authority), having commenced the preparation of a planning scheme on the 14th day of December, 1964, in accordance with the *Town and Country Planning Act 1961*, hereby makes the following Interim Development Order for the purpose of regulating, restricting, restraining or prohibiting the use or development of any land or the erection, construction or carrying out of any buildings or works on any land within the area described in the Schedule hereto.

1. After the coming into operation of this Interim Development Order no person shall use or develop any land or erect, construct or carry out any buildings or works on any land within the area included in the Schedule, except in accordance with the provision of a permit issued by the responsible authority.

2. Every application for a permit under the provisions of this Order shall be made on the prescribed form, copies of which may be obtained from the office of the responsible authority at Brighton.

3. This Interim Development Order shall not prevent—

(a) the continuance of the use of any land or buildings or works for the purposes for which such land or buildings or works were lawfully used immediately before the coming into operation of this Order;

(b) any dealing or the registration of any dealing with any land in a subdivision of which a plan has been sealed by the Council of the City of Brighton and lodged with the Registrar of Titles, pursuant to section 569 of the *Local Government Act 1958*, before the coming into operation of this Order.

4. Schedule—The whole of the land within the following boundaries:—Commencing at a point on the west building line of Cochrane-street 652 feet north of Bay-street thence southerly along the west building line of Cochrane-street to Bay-street; thence westerly along the north building line of Bay-street to Berwick-street; thence northerly along the east building line of Berwick-street for a distance of 652 feet; thence easterly by a line to the point of commencement.

In witness whereof the Common Seal of the Mayor, Councillors and Citizens of the City of Brighton was hereunto affixed, this 15th day of December, 1964, in the presence of—

(SEAL) J. E. BOWN, Mayor.
A. R. ROBERTS, Councillor.
C. DE. GARIS, Town Clerk.

Approved by the Governor in Council, pursuant to section 17 of the *Town and Country Planning Act 1961*, on the 4th day of October, 1966.—J. COLQUHOUN, Clerk of the Executive Council.

Town and Country Planning Act 1961.

CITY OF SHEPPARTON PLANNING SCHEME 1953.

AMENDMENT No. 14, 1966.

Notice of Amendment.

IN pursuance of the powers conferred by sub-section 6 of section 32 of the *Town and Country Planning Act 1961*, the Governor in Council, by and with the advice of the Executive Council thereof, on the 11th October, 1966, amended the City of Shepparton Planning Scheme 1953, in respect of the use of land within 20 feet of the road alignment in the Industrial "B" Zone.

A copy of the amendment may be inspected during office hours at the office of the Town and Country Planning Board, 179 Queen-street, Melbourne; at the office of the Council of the City of Shepparton, at Shepparton; and when available, at the Office of Titles, Melbourne; and at the Central Plan Office of the Department of Crown Lands and Survey, Melbourne.

W. H. CRAIG, Secretary,
Town and Country Planning Board.

Town and Country Planning Act 1961.

SHIRE OF CROYDON PLANNING SCHEME 1961.

AMENDMENT No. 5, 1966.

Notice of Amendment.

IN pursuance of the powers conferred by sub-section 6 of section 32 of the *Town and Country Planning Act 1961*, the Governor in Council, by and with the advice of the Executive Council thereof, on the 11th October, 1966, amended the Shire of Croydon Planning Scheme 1961 to provide for a new Special Uses "B" Zone in Dorset-road, Croydon.

A copy of the amendment may be inspected during office hours at the office of the Town and Country Planning Board, 179 Queen-street, Melbourne; at the office of the Council of the Shire of Croydon, at Croydon; and when available, at the Office of Titles, Melbourne; and at the Central Plan Office of the Department of Crown Lands and Survey, Melbourne.

W. H. CRAIG, Secretary,
Town and Country Planning Board.

Town and Country Planning Act 1961.

PORTLAND PLANNING SCHEME 1957.

AMENDMENT No. 5, 1965.

(SHIRE OF PORTLAND.)

Notice of Approval.

IN pursuance of the powers conferred by the *Town and Country Planning Act 1961*, the Governor in Council on the 11th October, 1966, approved a planning scheme entitled the Portland Planning Scheme 1957, Amendment No. 5, 1965 (Shire of Portland), in respect of part of the municipal district of the Shire of Portland.

A copy of the planning scheme as approved may be inspected during office hours at the office of the Town and Country Planning Board, 179 Queen-street, Melbourne; at the office of the Portland Shire Council, at Heywood; and when available, at the Office of Titles, Melbourne; and at the Central Plan Office of the Department of Crown Lands and Survey, Melbourne.

W. H. CRAIG, Secretary,
Town and Country Planning Board.

CONTRACTS ACCEPTED.—(Series 1965-66.)

VICTORIAN RAILWAYS.

26. Supply and delivery of axles for goods wagons, at the rate of \$129.60 each (Contract 62971).—Commonwealth Steel Co. Ltd. 27. Supply, delivery and installation of 2 No. dust collectors for the amount of \$13,376.00 (Contract 63006).—W. G. Crossle & Co. Pty. Ltd. 28. Duplication of the Melbourne to Geelong railway line between Laverton and Werribee, at rates (Contract 63009).—Cook's Construction and Plant Hire Pty. Ltd. 29. Supply and delivery of axles for goods wagons, at the rate of \$81.00 each, F.O.B. Osaka, Japan (Contract 63029).—Sumitomo Shoji (Aust.) Pty. Ltd. 30. Cleaning of windows, general internal and external cleaning of frontage at Spencer-street rail terminal for the amount of \$17,168.00 (Contract 63040).—Niles Cleaning Service. 31. Supply and completion of departmental residence, outbuildings, fencing and services at Goroke, for the amount of \$8,268.15 (Contract 63045).—C. R. Ballinger & Sons.

By order of the Victorian Railways Commissioners,

W. WALKER, Secretary for Railways. 7.10.66.

CONTRACTS ACCEPTED.—(Series 1966-67.)

PUBLIC WORKS.

1159. St. Albans East, State School No. 4741, external repairs and painting, \$1,024.00.—K. J. Haboltd & Son.

1160. Ballarat, Mental Hospital, supply, delivery and installation of one 50-c.f.m. reciprocating air compressor in the laundry, \$1,330.00.—Holman Bros. (Australia) Pty. Ltd.

1161. Maribyrnong, High School, erection of canteen and store, \$7,700.00.—L. J. Jessop.

1162. Pascoe Vale, State School No. 3081, new brick toilet block, \$15,409.00.—D. P. Jessop.

1163. Dandenong, Girls' School, site works, \$4,168.36.—Wm. Loud Pty. Ltd.

1164. Edithvale, State School No. 3790, site works, including asphalt paving and repairs, drainage, &c., \$6,286.05.—Wm. Loud Pty. Ltd.

1165. Eltham East, State School No. 4897, erection of four additional class-rooms, \$30,450.00.—B. M. Morgan.

1166. Parktone, State School No. 4843, external renovations, \$1,879.00.—H. D. & J. McIntyre Bros.

1167. Coburg, Pentridge Gaol, Young Offenders' Building, electrical installation, \$5,290.00.—J. Newell Pty. Ltd.

1168. Keon Park, Technical School and Residence, connexion to sewer, \$14,344.83.—F. Norton Pty. Ltd.

1169. Beechworth, Mental Hospital, external repairs and repainting of three-storey Nurses Quarters, \$4,105.00.—P. M. Painting Service.

1170. Glen Devon, State School No. 4914, erection of eight (8) additional class-rooms, \$62,916.00.—G. & A. Power Pty. Ltd.

1171. Meglin, State School No. 3660, asphalt, asphalt repairs and drainage, \$3,026.00.—Rainbow Construction Company.

1172. Melbourne, Toorak Teachers' College Hostel, 470 St. Kilda-road, installation of electric heating, \$2,470.00.—J. & B. Ranking Pty. Ltd.

1173. Beverley Hills, State School No. 4813, asphaltting, concreting, drainage and associated works, \$9,611.70.—Regent Constructions Pty. Ltd.
1174. Royal Park, Psychiatric Hospital, external repairs and painting, Superintendent's Residence, \$2,772.00.—Frank Robb Painting Company.
1175. Geelong, High School, new pavements, pavement repairs and associated works, \$10,277.33.—Roche Bros. Pty. Ltd.
1176. Spotswood, State School No. 3659, various repairs, renovations and painting, \$2,450.00.—V. Sandic.
1177. Cobram, High School, erection of Manual Arts Wing, class-rooms, library and science rooms, \$148,365.00. J. H. & I. G. Southwell.
1178. Fairfield North, State School No. 4329 and Residence, general repairs and renovations, \$1,488.18.—E. Tabone.
1179. Mont Park, "Larundel" Mental Hospital, installation of steam heating and hot water to new Industrial Therapy Building, \$10,865.00.—Thos. J. Tait Pty. Ltd.
1180. Mont Park, Mental Hospital, installation of steam heating for new Industrial Therapy Building, \$5,000.00.—Thos. J. Tait Pty. Ltd.
1181. Port Melbourne, Mines Store, Cook-street, supply and erection of structural steel framework, concrete footings and floor, \$5,343.00.—Tee Steel Trusses Pty. Ltd.
1182. Ballarat East, State School No. 1998, internal repairs and painting, \$2,684.00.—J. C. & B. J. Thomas.
1183. Warrenheip, State School No. 1591 and Residence, internal and external renovations, \$3,470.00.—J. C. & B. J. Thomas.
1184. Warrong, State School No. 1937, repairs and painting, \$1,405.80.—R. S. Thornton.
1185. North Melbourne, Fruit Inspection Depot, Dynon-street, maintenance cleaning, period 1st July, 1966, to 31st May, 1969, \$840.00 per annum.—Utility Office Cleaning Services Pty. Ltd.
1186. Boronia, High School, external repairs and painting, \$4,090.00.—J. Van Brussel and A. Slenders.
1187. Footscray North, Special School No. 4792, repairs and painting, \$2,410.00.—C. Voet.
1188. Croydon South, State School No. 4890, erection of new primary school of ten (10) class-rooms and library, \$105,240.00.—J. P. & J. W. Wolbers Pty. Ltd.
1189. Bairnsdale, erection of Police Station and Residence, \$57,734.00.—R. J. Barrett & Co.
1190. Burwood, Technical School, repairs and painting, \$8,465.00.—R. Bendinelli & E. Carlini.
1191. Fern Tree Gully, Technical School, repairs and internal painting, \$8,430.00.—R. Bendinelli & E. Carlini.
1192. Norwood, State School No. 4736, external repairs and painting, \$1,618.00.—R. Bendinelli & E. Carlini.
1193. Heidelberg, State School No. 294, Caretaker's Residence, repairs and painting, \$1,794.00.—Bryce & White.
1194. Dandenong, Technical School, internal repairs and painting, \$12,860.00.—I. Bulat.
1195. Beverley Hills, State School No. 4813, mechanical services in new wing, \$7,800.00.—Chadstone Air Conditioning Services.
1196. Mont Park, Mental Hospital, electric installation for Industrial Therapy Unit, \$2,154.00.—Deylen Bros. Electricians.
1197. Diggers Rest, State School No. 2479, repairs and painting of school and erection of a shelter shed, \$2,100.00.—T. G. Donnelly.
1198. Aberfeldie, State School No. 4220, internal and external repairs and painting, \$9,838.00.—A. Dugina.
1199. Glen Devon, State School No. 4914, electrical installation in additional class-rooms, \$2,328.50.—K. J. Dupuy.
1200. Fitzroy, State School No. 450, Residence, repairs and painting, \$798.00.—B. Dwyer.
1201. Hawthorn, Burwood Teachers' College Hostel, Paterson-street, new concrete fire escape stairs, \$3,458.00.—E. G. Constructions.
1202. Overport, State School No. 4780, erection of four additional class-rooms, \$26,914.00.—B. P. Finn Pty. Ltd.
1203. Doveton West, State School No. 4820, repairs and painting, \$6,726.00.—K. & M. Fisher.
1204. Gunbower Island, State School No. 3503, concrete paving and drainage, \$1,379.93.—R. T. Ford & Co.
1205. Fisherman's Bend, Licence Testing Station, erection of brick veneer office and steel framed canopy, \$12,570.00.—M. Gallagher.
1206. Warrambool, High School, erection of standard Manual Arts Blocks, \$58,500.00.—A. Gathercole & Co. (W'bool) Pty. Ltd.
1207. Lalor, State School No. 4709, external renovations, \$1,787.00.—K. J. Haboldt & Son.
1208. Mildura, 4 Valencia-avenue, Technical School Residence, repairs and painting and renovations, &c., \$1,776.40.—O. H. Wynne.
1209. Overport, State School No. 4780, extension of plenum heating, \$3,900.00.—Gray & Wood.
1210. Parklands, State School No. 4738, plenum heating in four class-rooms, \$4,050.00.—Gray & Wood.
1211. Benalla, High School Residence, 11 Salisbury-street, renovations, \$3,096.00.—J. T. Hale.
1212. Silvan South, State School No. 4259, additional toilet accommodation, \$3,420.00.—W. I. & B. C. Hosie.
1213. Mont Park, Mental Hospital, erection of occupational Therapy Building, \$54,616.00.—A. V. Jennings Industries (Australia) Ltd.
1214. Glenroy, Technical School, erection of girls' section of school, \$304,780.00.—A. V. Jennings Industries (Australia) Ltd.
1215. Frankston, High School, science and class-room additions, canteen, &c., \$67,361.00.—A. V. Jennings Industries (Australia) Ltd.
1216. Beverley Hills, State School No. 4813, erection of eight additional class-rooms and library, \$75,188.00.—A. V. Jennings Industries (Australia) Ltd.
1217. Tamleugh North, State School No. 2453, internal and external repairs and painting, \$1,570.00.—M. J. Lear.
1218. Carlton North, State School No. 1252, repairs to senior school, repairs and painting to residence and out-buildings, \$2,586.00.—G. J. Little.
1219. Shepparton, High School, construction of concrete and asphalt paving, drainage and associated works, \$12,079.00.—E. B. Mawson & Sons Pty. Ltd.
1220. East Loddon, Consolidated School, regrading and resurfacing of three tennis courts, \$3,812.00.—E. B. Mawson & Sons Pty. Ltd.
1221. Box Hill, High School, convert two locker rooms to class-rooms, &c., \$1,390.00.—B. J. McCormack.
1222. Ararat, Mental Hospital, Female Division, external painting, \$19,650.00.—J. P. McElligott & Co. Pty. Ltd.
1223. Hawthorn, 12 Lisson-grove, Social Welfare Hostel, external repairs and painting, \$1,280.00.—McKenzie Constructions Pty. Ltd.
1224. Burnley Gardens, Curator's Residence, repairs and painting, \$1,200.00.—A. Newsome and P. Heppleston.
1225. Glenroy, Technical School, extension of mechanical services, \$40,874.00.—Frederick W. Nielsen Pty. Ltd.
1226. Dandenong, Girls' Secondary School, relining of internal walls and painting, \$1,796.00.—A. Alaimo.
1227. Jamieson, State School No. 814, repairs and painting, \$2,772.00.—L. G. Aldous.
1228. Kerang, Police Station, erection of brick veneer office, \$15,700.00.—J. Bakker & W. A. Hayman.
1229. Wendouree, State School No. 1813, erection of two shelter sheds, \$2,550.00.—J. H. Brown & Son Pty. Ltd.
1230. Croydon South, State School No. 4890, plenum heating in new school, \$8,558.00.—Bruce Sheet Metal Service.
1231. Charlton, State School No. 1480, repairs and painting, \$11,230.00.—Bull & Guy.
1232. Bendigo, School for Deaf, No. 4726, Residence, Edwards-road, internal and external repairs and painting, \$1,140.00.—Bull & Guy.
1233. Paynesville, State School No. 2343 and Residence, internal painting to school, repairs to garage, \$1,025.00.—L. Burns.
1234. Poowong, Consolidated School, external painting and repairs, \$4,495.00.—B. M. Carter.
1235. Melbourne, Public Works Department, Accounts Branch, Treasury-place, room air-conditioning units, \$1,205.00.—Chadstone Airconditioning Services.
1236. Mildura, High School, renewal of floors to Science Rooms Nos. 10 and 11, \$1,198.00.—K. L. Cooke.
1237. Boort, High School, electric pump and pressure cylinder, \$945.25.—L. Fawssett & Co.
1238. Morwell, Technical School, concrete paving, asphalt paving, \$4,796.00.—G. Frankland.
1239. Belmont, State School No. 26, gas heating, \$2,975.00.—The Geelong Gas Co.
1240. Bacchus Marsh, State School No. 28, site works, \$1,593.00.—J. H. Gould.
1241. Ballarat, High School, site works, \$5,897.00.—J. H. Gould.
1242. Ballarat East, State School No. 1998, asphalt and concrete paving, drainage and associated works, \$2,289.00.—J. H. Gould.
1243. Karingal, High School, Mechanical services to new Assembly Hall, \$5,890.00.—Frederick W. Nielsen Pty. Ltd.

1244. Ballarat, School of Mines, new roof to Administration Building, \$1,816.00.—A. & B. Oswald Pty. Ltd.

1245. Fairfield, Fairlea Female Prison, renewal of flooring in dining room, \$1,200.00.—Owen & Churchill.

1246. Kerang, High School Residence, 50 Albert-street, renovations, \$1,290.00.—W. M. Lowe & Sons Pty. Ltd.

1247. Lake Bolac, State School No. 854, internal and external repairs and painting, \$2,654.00.—Peter C. Nicholson.

1248. Kingston, State School No. 759, new floors and cupboards, \$1,340.00.—A. & B. Oswald Pty. Ltd.

1249. Studfield, State School No. 4920, surface and underground drainage, asphalt, concrete and gravel pavements, \$14,278.00.—Pelmon Construction Co. Pty. Ltd.

1250. Maryborough, Technical School, construction of concrete cover over drain approximately 320 feet long and 5 feet wide and associated works, \$2,722.30.—W. Phelan & Sons Pty. Ltd.

1251. Pascoe Vale, Melbourne School of Textiles, re-modelling existing buildings for wool classing, \$25,187.00.—P.R.P. Trio Builders.

1252. Moe, High School, additions to male toilet, \$2,728.00.—S. & W. Plumbing & Hardware Pty. Ltd.

1253. Myrtleford, Tobacco Research Station, repairs, renovations and painting to various buildings, \$4,777.00.—N. G. & N. M. Stephens.

1254. Inverleigh, State School No. 1147, renovations, residence, \$2,495.00.—P. Tesic.

1255. Bundoora, Mental Hospital, erection of new implement shed, \$2,650.00.—Trevor Steel Constructions.

1256. Clayton, Monash Secondary Teachers' College, drainage, retaining walls, landscaping and associated work, \$31,936.00.—J. Warner (Civil Engineering).

1257. Poowong North, State School No. 4102, Residence, internal and external repairs and painting, \$1,165.00.—F. G. Withall.

1258. Molyullah, State School No. 2130 and Residence, internal and external repairs and painting, \$1,812.32.—Wolffs Painting Service.

1259. Port Melbourne, P.W.D. Storeyard, supply; mats rubber, \$1,314.00.—Clark Rubber Stores Pty. Ltd.

1260. Port Melbourne, P.W.D. Storeyard, supply, suspension frames and folders, \$1,635.00.—P.S.R. Products Pty. Ltd.

1261. Port Melbourne, P.W.D. Storeyard, supply divan beds, \$1,303.40.—Weeks & Hansen.

1262. Kew, Children's Cottages, supply meal trolleys, \$4,780.00.—Ahearn, Main & Scott Pty. Ltd.

1263. Doveton, Technical School, supply lathes and equipment, \$3,729.08.—McPherson's Ltd.

1264. Doveton, Technical School, supply lathes and equipment, \$6,336.10.—Demco Machinery Co. (Vic.) Pty. Ltd.

1265. Doveton, Technical School, supply shaping machine, \$1,554.00.—Marweight Equipment Pty. Ltd.

1266. Doveton, Technical School, supply drilling machine, \$1,008.00.—Brown & Dureau Ltd.

1267. Nunawading, Mitcham, Technical School, supply drilling machines, \$1,471.90.—Waldown Pty. Ltd.

1268. Nunawading, Mitcham, Technical School, supply lathes and equipment, \$5,194.24.—McPherson's Ltd.

1269. Williamstown, P.W.D. Dredging Depot, supply steel pipes, \$1,920.00.—Toorong Steel Construction Pty. Ltd.

1270. Port Melbourne, P.W.D. Storeyard, supply stools, chemistry, \$15,840.00.—Aristoc Industries Pty. Ltd.

1271. Port Melbourne, P.W.D. Storeyard, supply blankets, \$1,225.00.—Laycock Son & Co. Pty. Ltd.

1272. Prahran, Technical School, supply tables and drilling machines, \$1,134.00.—Waldown Pty. Ltd.

1273. Prahran, Technical School, supply lathes and equipment, \$3,021.52.—McPherson's Ltd.

1274. Prahran, Technical School, supply shaping machine, \$1,554.00.—Marweight Equipment Pty. Ltd.

1275. West Melbourne, Government Cool Stores, supply timber, \$2,273.08.—Alex Sturrock & Sons Pty. Ltd.

1276. Port Melbourne, P.W.D. Depot, supply International tractors, \$9,185.60.—International Harvester Co. of Aust. Pty. Ltd.

1277. Beechworth, Mental Hospital, supply and erect curtains, \$2,102.60.—Fischer Furnishings Pty. Ltd.

1278. Hamilton, Technical School, supply and erect cubicles, \$1,604.00.—G.K.N. Building & Engineering.

1279. Sunshine, Sunshine North Technical School, supply benches, cupboards, \$1,321.00.—D. F. Cowan Sales Pty. Ltd.

1280. Ballarat, Mental Hospital, supply and fix curtains, \$1,416.90.—Fischer Furnishings Pty. Ltd.

1281. Bundoora, Repatriation Hospital, supply and install wardrobe units, \$3,935.00.—Johnstone & Morrison Pty. Ltd.

1282. Carlton, Motor Registration Branch, supply, office furniture, steel, \$28,325.70.—Namco Products Pty. Ltd.

1283. Heidelberg, Technical School, supply workshop equipment, \$1,737.00.—D. F. Cowan Sales Pty. Ltd.

1284. Port Melbourne, P.W.D. Storeyard, supply balancing forms, \$1,813.20.—Otto Industries Pty. Ltd.

1285. Ararat, Mental Hospital, supply bedside lockers, \$1,386.00.—Namco Furniture, Contract Division.

1286. Ararat, Mental Hospital, supply mattress covers, \$1,800.00.—Seafoam Pty. Ltd.

MURRAY PORTER, Commissioner of Public Works, 6.10.66.

GENERAL STORES.

Gazette No. 28, 15th April, 1966, Schedule No. 52, Tools (General).—For rates shown opposite the following items, substitute the rates as set out hereunder, as from 4th October, 1966:—Item No. 87, \$1.03 each; Item No. 250, Unhandled, 5-in., \$0.39; 6-in., \$0.43; 7-in., \$0.46 each; Handled, 5-in., \$0.85; 6-in., \$0.88; 7-in., \$0.93 each; Item No. 253, 6-in., \$1.75; 7-in., \$1.81; 8-in., \$1.97 each; Item No. 267, Unhandled, \$1.94, Handled, \$2.55 each.

Gazette No. 53, 19th July, 1966, Schedule No. 29, Cordage, Lines, &c.—For rates shown opposite the following items, substitute the rates as set out hereunder:—Item No. 1, \$0.224 per lb.; Item No. 2, \$0.254 per lb.; Item No. 16, 1½-in. and up, \$0.254; 1½-in. and 1½-in., \$0.264; 1½-in. \$0.264; 1-in., \$0.264; ¾-in. \$0.274; ¾-in., \$0.284; ¾-in., \$0.314; ¾-in., \$0.344 per lb.; Item No. 17, 1½-in. and up, \$0.294; 1½-in. and 1½-in., \$0.304; 1½-in., \$0.304; 1-in., \$0.304; ¾-in., \$0.314; ¾-in., \$0.324; ¾-in., \$0.354; ¾-in., \$0.384 per lb.; Item No. 26, \$12.24 per packet; Item No. 27, \$12.00 per packet, as from 5th October, 1966; Item No. 9, \$0.795 per lb.; Item No. 10, \$1.065 per lb.; Item No. 11, \$4.21 per gross yards; Item No. 18, \$4.08 per packet; Item No. 19, \$3.66 per packet; Item No. 20, \$3.30 per packet; Item No. 21, \$5.88 per packet; Item No. 22, \$5.70 per packet; Item No. 23, \$5.70 per packet; Item No. 28, \$4.29 per packet, as from 3rd October, 1966. (Six reels per packet.)

Gazette No. 53, 19th July, 1966, Schedule No. 39, Furniture.—Rates for Item Nos. 5, 15, 26, 30 and 40 have been increased by 5 per cent. as from 1st August, 1966.

Gazette No. 53, 19th July, 1966, Schedule No. 57, Nails, Rivets, Screws, &c.—Rates in respect of the following items have been amended as under:—Item Nos. 1, 5, 6, 10 and 33, list price amended as from 1st September, 1966. Discounts remain unaltered. Item Nos. 7, 25, 26, 27 and 28, Standard Packs, list price less 38 per cent; Broken Packs, list price less 23 per cent. as from 1st September, 1966; Item Nos. 3 and 4, list price less 12½ per cent., as from 1st September, 1966; Item No. 14, list price plus 7½ per cent., less 19 per cent., as from 5th September, 1966; Item No. 18, list price, less 20 per cent., as from 5th September, 1966; Item No. 9, \$0.25 per lb.; Item Nos. 11, 12 and 13, list price less 30 per cent., as from 1st September, 1966; Item No. 30, list price plus 7½ per cent., less 27½ per cent., as from 5th September, 1966.

Gazette No. 53, 19th July, 1966, Schedule No. 64, Polishers, Dusters, &c.—For Item No. 20, substitute 60 cents per gross, as from 27th September, 1966.

Gazette No. 53, 19th July, 1966, Schedule No. 77, Red Lead, White Lead, &c.—For rates shown opposite the following items, substitute the rates as set out hereunder, as from 4th October, 1966; Item No. 4, \$18.65 per cwt.; Item No. 5, \$18.85 per cwt.; Item No. 6, \$19.15 per cwt.; 14-lb. tins, \$20.65 per cwt.; 7-lb. tins, \$21.25 per cwt.

Gazette No. 55, 27th July, 1966, Schedule No. 1, Printing Papers.—For rates shown opposite the following items, substitute the rates as set out hereunder:—Item No. 221, \$385.00 per ton; Item No. 263, \$333.00 per ton; Item No. 264, \$333.00 per ton; Item No. 279, \$271.00 per ton; Item No. 281, \$277.00 per ton; Item No. 282, \$232.00 per ton; Item No. 402, \$154.00 per ton; Item No. 416, \$160.00 per ton; Item No. 431, \$160.00 per ton; Item No. S.81, \$336.00 per ton.

H. COUTTS, Secretary to the Tender Board. 11.10.66.

PRISONERS' MEALS IN LOCK-UPS.

CONTRACT CANCELLED.

Gazette No. 55, 27th July, 1966, Prisoners' Meals, Bourke-street West.—Contract No. 264 is hereby cancelled.

CONTRACT ACCEPTED.

1319. For the supply of Prisoners' Meals at Bourke-street West, as from 18th September, 1966, Breakfast and Tea, 45 cents; Hot Dinner, 50 cents.—Salvation Army People's Palace.

H. COUTTS, Secretary to the Tender Board. 11.10.66.

ORDERS IN COUNCIL.—(Series 1966-67.)

EDUCATION DEPARTMENT.

1287. One only wide range oscillator for Caulfield Technical College, \$590.—Sample Electronics Pty. Ltd.

1288. One only digital logic laboratory for Caulfield Technical College, \$1,289.23.—Digital Equipment Aust.

1289. One only ice making machine for Yallourn Technical College, \$490.00.—Ray Johnson Commercial Refrigeration Pty. Ltd.

1290. One only vacuum pump for Yallourn Technical College, \$310.00.—Dynavac High Vacuum Pty. Ltd.

1291. One only desk type laboratory recorder for Yallourn Technical College, \$712.00.—National Instrument Co. Pty. Ltd.

1292. Two only cathode ray oscilloscopes single beam for Yallourn Technical College, \$640.00.—B.W.D. Electronics Pty. Ltd.

1293. One only electro polisher for Yallourn Technical College, \$1,070.00.—Watson Victor Ltd.

1294. One only impact testing machine for plastics for Yallourn Technical College, \$520.00.—W. & T. Avery (Aust.) Pty. Ltd.

1295. One only audio signal generator (\$169.10) and one only fluxmeter and search coils (\$182.00) for Yallourn Technical College, \$351.10.—Astronic Imports.

1296. One only double beam cathode ray oscilloscope for Yallourn Technical College, \$630.00.—B.W.D. Electronics Pty. Ltd.

1297. One only A.C. ammeter probe for Caulfield Technical College, \$225.00.—Sample Electronics (Vic.) Pty. Ltd.

1298. One only synchronising and power flow panel for Caulfield Technical College, \$710.00.—A. J. William.

1299. One only bench folder for Frankston Technical School, \$315.00.—McPherson's Ltd.

1300. One only overhead projector and accessories for Swinburne Technical College, \$217.05.—Nairn Audio Visual Activities.

Approved by the Governor in Council, 4th October, 1966.—J. COLQUHOUN, Clerk of the Executive Council.

PUBLIC WORKS.

1301. Croydon, State School No. 2900, demolition of dangerous fire-damaged buildings, &c., \$1,899.57.—A. V. Jennings Industries (Australia) Ltd.—(N.E.100387.)

1302. Croydon, State School No. 2900, erection of three class-rooms and staff room, \$16,545.20.—A. V. Jennings Industries (Australia) Ltd.—(N.E.100546.)

1303. Geelong, High School, Residence, external and internal renovations, &c., \$4,865.00.—I. Bulat.—(S.W.309888.)

1304. Melbourne, Therapy School, "Lincoln House", supply of furniture and furnishings, \$4,027.00.—Ultra Steel and Chair Pty. Ltd., and \$4,208.70.—Hoad Manufacturing Pty. Ltd.—(E.M.82780.)

1305. Melbourne, Titles Office, supply and installation of special mobile steel shelving units, \$4,325.00.—Brownbuilt Ltd.—(C.102613.)

1306. Mont Park, Mental Hospital, supply of geriatric chairs, \$1,970.00.—Aristoc Industries Pty. Ltd.—(N.E.101505.)

Approved by the Governor in Council, 4th October, 1966.—J. COLQUHOUN, Clerk of the Executive Council.

STATE ELECTRICITY COMMISSION.

1307. For the supply of 220-kV switchgear insulators for the transmission system, to Specification No. 65-66/320, \$16,685.—Doultons Insulators Aust. Pty. Ltd.

1308. For the supply of 220-kV switchgear insulators for the transmission system, for a period of two years to Specification No. 65-66/320, at Schedule rates.—R. M. Hall Pty. Ltd.

Approved by the Governor in Council, 23rd August, 1966.—J. COLQUHOUN, Clerk of the Executive Council.

1309. For the supply of four 22-kV. electronic reclosers and accessories for the Ouyen Substation, to Quotation No. 4397, \$12,078.—A.E. Supplies Pty. Ltd.

1310. For the supply of paper insulated supervisory control cable for a period of two years, to Specification No. 66-67/39, at Schedule rates.—G.E.C. (Australia) Pty. Ltd.

1311. For the laying of extensions of steel pipes and supply and installation of miscellaneous fittings for fire and water service mains at Morwell Open Cut, to Specification No. 66-67/58, at Schedule rates.—Aventino Construction Co. Pty. Ltd.

Approved by the Governor in Council, 30th August, 1966.—J. COLQUHOUN, Clerk of the Executive Council.

1312. For the supply and installation of fire service, water mains and two steel tanks and construction of brick pump house at South Morang Terminal Station, to Specification No. 66-67/84, \$46,316.95, plus items at Schedule rates.—John F. Hearn.

Approved by the Governor in Council, 13th September, 1966.—J. COLQUHOUN, Clerk of the Executive Council.

1313. For the supply and installation of heat insulation of flues and I.D. fans on Nos. 1 and 2 boilers, Hazelwood Power Station, Stage 1, to Specification No. 66-67/52, \$73,550.—Olympic General Products Pty. Ltd.

1314. For the supply of bare and double cotton covered annealed copper strip for transformer windings, for a period of two years, to Specification No. 65-66/423, at Schedule rates.—Cablemakers (A.C.T.) Pty. Ltd.

1315. For the supply of bare and double cotton covered annealed copper strip for transformer windings, for a period of two years, to Specification No. 65-66/423, at Schedule rates.—Copper and Aluminium Co. of Aust. Pty. Ltd.

1316. For the supply of 130 typistes' desks for the new Head Office building to Quotation 982, \$15,210.—Feature Furniture Pty. Ltd.

Approved by the Governor in Council, 20th September, 1966.—J. COLQUHOUN, Clerk of the Executive Council.

1317. For the supply of 500-kV transmission line hardware, comprising strain and suspension assemblies for use on Hazelwood-Keilor transmission line, to Specification No. 65-66/56, \$50,100.—Australian Line Materials Pty. Ltd.

1318. For the supply of 500-kV transmission line hardware, comprising strain and suspension assemblies for use on Hazelwood/Keilor transmission line, to Specification No. 65-66/56, \$32,250.—Dulmison (Aust.) Pty. Ltd.

Approved by the Governor in Council, 27th September, 1966.—J. COLQUHOUN, Clerk of the Executive Council.

APPOINTMENTS

APPOINTMENTS.

HIS Excellency the Governor of the State of Victoria, by and with the advice of the Executive Council thereof, has, by Orders made on the 4th day of October, 1966, been pleased to make the under-mentioned appointments, viz.:

DEPARTMENT OF AGRICULTURE.

Inspectors Authorized to Take Proceedings.

ROBERT REGINALD GAMBELL,
FREDERICK JAMES JENNINGS,
COLIN KEITH MCEWAN, and
ERIC JAMES PRITCHARD,

in accordance with the provisions of section 48 of the *Fruit and Vegetables Act 1958* (No. 6256), be authorized to take proceedings in respect of offences against Part II. of the said Act or the Regulations thereunder.

CHIEF SECRETARY'S DEPARTMENT.

Assistant to the Inspector of Fisheries.

CAMPBELL GELSTON COX,
pursuant to the provisions of section 6 of the *Fisheries Act 1958*, to be an Assistant to the Inspector of Fisheries.

Auditors of Friendly Societies.

JACK ALFRED HARRISON, and
EDWARD COULSON,
pursuant to the provisions of section 41 of the *Friendly Societies Act 1958*, to be Auditors for the purposes of the said Act.

Electoral Registrar (Acting).

MAXWELL BARNET PERKINS
to be Electoral Registrar (Acting) for the Bendigo, Eaglehawk, Elmore, Raywood and Sandhurst East Subdivisions of the Electoral District of Bendigo; the Kyneton

Subdivision of the Electoral District of Gisborne; and for the Castlemaine, Golden Square, Heathcote, Maldon, Marong, Seymour and Strathfieldsaye Subdivisions of the Electoral District of Midlands, to take effect on and from the 3rd October, 1966, during the absence on leave of William Frederick Bridger.

Licensing Inspector.

GORDON ALBERT NORTH, Inspector of Police, Grade I, to be a Licensing Inspector for the purposes of the Licensing Act 1958.

Member, Zoological Board.

MAURICE RESS, pursuant to the provisions of section 5 of the Zoological Gardens Act 1936, to be a member of the Zoological Board of Victoria, for the period ending the 16th May, 1969, vice Councillor Sir Harold Gengoult Smith.

DEPARTMENT OF CROWN LANDS AND SURVEY.

Bailiff of Crown Lands.

PETER MITCHELL, Ranger, of Point Leo, as a Bailiff of Crown lands without salary, in pursuance of section 30 of the Land Act 1958.

MINISTRY OF FUEL AND POWER.

Deputy Commissioner of State Electricity Commission of Victoria.

CHARLES ROGER DARVALL, C.B.E., F.A.S.A., to act as a Deputy Commissioner during the absence of Mr. W. H. Connolly, C.B.E., Chairman of the State Electricity Commission of Victoria, for the period commencing on the 10th day of October, 1966, and ending on the 13th day of November, 1966.

MINISTRY OF HEALTH.

Members of Committees of Management of Hospitals.

DAVID GEORGE ALLSOP, to be a Member of the Committee of Management of Numurkah and District War Memorial Hospital, pursuant to proviso (a) to section 48 (1) of the Hospitals and Charities Act 1958, for a period of three years, vice A. C. Corbett, resigned; and

WILTON CAMERON MCKEAN, to be a Member of the Committee of Management of Bendigo Home and Hospital for the Aged, pursuant to proviso (a) to section 48 (1) of the Hospitals and Charities Act 1958, for a further period of three years ending the 28th October, 1969.

LAW DEPARTMENT.

Commissioners for Taking Declarations, &c.

THOMAS NORMAN SCOTT, McAlister-street, Stratford, and

ALOYSIUS PERCY DONOVAN, Picola, to be Commissioners for taking Declarations and Affidavits, pursuant to the provisions of the Evidence Act 1958, to resign upon removing from the neighbourhood of the addresses stated; and

JOSEPH ALOYSIUS WALLACE, care of the State Savings Bank of Victoria, Blackburn North, and
IAN CASSILI ATWOOD, care of the State Savings Bank of Victoria, Ouyen,

to be Commissioners for taking Declarations and Affidavits, pursuant to the provisions of the Evidence Act 1958, to resign upon ceasing to occupy their present positions.

Justices of the Peace.

RICHARD AINSLIE CROTHERS, Wangoom, to Keep the Peace in the Western Bailiwick of the State of Victoria; and

WILLIAM ARTHUR WILTON, Oke-street, Ouyen, to Keep the Peace in the Midland Bailiwick of the State of Victoria.

LOCAL GOVERNMENT DEPARTMENT.

Member of Advisory Board.

ARTHUR JOHN SAUNDERS, pursuant to the provisions of section 17 of the Local Government Act 1958 as a member of the Advisory Board constituted under the said Act for a period of three years as from 12th October, 1966, vice Clive Lester Tingate, retired.

DEPARTMENT OF MINES.

Chairman Coal Miners' Accidents Relief Board.

PAUL EDWARD CLARKE, in pursuance of the provisions of the Coal Mines Act, as Chairman of the Victorian Coal Miners' Accidents Relief Board, as from 1st October, 1966, vice Gilbert Hadden, resigned.

DEPARTMENT OF THE TREASURER.

Receiver of Revenue (Acting).

GEOFFREY STEPHEN HOARE, to act temporarily as Receiver of Revenue, Kerang, vice P. W. Westmore, on leave.

J. COLQUHOUN,
Clerk of the Executive Council.

At the Executive Council Chamber,
Melbourne, 4th October, 1966.

APPOINTMENT.

HIS Excellency the Governor of the State of Victoria, by and with the advice of the Executive Council thereof, has, by Orders made on the 11th day of October, 1966, been pleased to make the under-mentioned appointment, viz:—

CHIEF SECRETARY'S DEPARTMENT.

Totalizator Inspector.

KEVIN JOHN CRADDOCK, pursuant to the provisions of the Racing Act 1958, to be a Totalizator Inspector for the purposes of the said Act.

J. COLQUHOUN,
Clerk of the Executive Council.

At the Executive Council Chamber,
Melbourne, 11th October, 1966.

Railways Act 1958.

BOARD OF DISCIPLINE.

APPOINTMENT OF RETURNING OFFICER AND

DEPUTY RETURNING OFFICERS.

PURSUANT to the provisions of sub-paragraph (ii) of paragraph (c) sub-section 13 of section 170 of the Railways Act 1958, His Excellency the Governor of the State of Victoria, by and with the advice of the Executive Council thereof, has, by an Order made on the 11th day of October, 1966, been pleased to make the following appointments, viz:—

KEITH LIONEL NEWTON to be the Returning Officer to conduct the election for the nomination by the officers and employees in the railway service of a Deputy to the Officers' and Employees' representative on the Board of Discipline, constituted as provided in the aforesaid Act; and

DOUGLAS FREDERICK O'MARA and ALAN JOHN BRENCHLEY to be Deputy Returning Officers to act in the place of the said Keith Lionel Newton, if required, and to assist him with the conduct of the said election.

J. COLQUHOUN,
Clerk of the Executive Council.

At the Executive Council Chamber,
Melbourne, 11th October, 1966.

APPOINTMENT OF SECRETARY TO THE TOBACCO QUOTA COMMITTEE.

IN pursuance of the powers conferred upon me by section 12 (A) of the Tobacco Leaf Industry Stabilization Act 1966 (No. 7427), I, Gilbert Lawrence Chandler, Minister of Agriculture for the time being of the State of Victoria, hereby appoint:—

PATRICK CHARLES CONDON, an officer of the Department of Agriculture, as Secretary to the Tobacco Quota Committee.
4th October, 1966.

G. L. CHANDLER,
Minister of Agriculture.

RESIGNATIONS.

HIS Excellency the Governor of the State of Victoria, by and with the advice of the Executive Council thereof, has, by Orders made on the 4th day of October, 1966, accepted the resignations of the persons named hereunder of the office mentioned, viz:—

LAW DEPARTMENT.

The persons named in the first column of the Schedule hereto, from the Commission of the Peace for the respective Bailiwicks of the State of Victoria set opposite their names in the second column of the said Schedule.

SCHEDULE.
Name. **Bailiwick.**
 HERBERT HORRIE KNIGHTS .. Western and Midland.
 LENNERT MAX WEGENER .. Central.
 JACK JONES .. Central.

LAW DEPARTMENT.
REMOVAL OF JUSTICE OF THE PEACE.

HIS Excellency the Governor of the State of Victoria, by and with the advice of the Executive Council thereof, doth by Order made on the 4th day of October, 1966, remove Lindsay Gordon Harris from the Commission of the Peace for the Central Bailiwick of the State of Victoria.

J. COLQUHOUN,
 Clerk of the Executive Council.

At the Executive Council Chamber,
 Melbourne, 4th October, 1966.

J. COLQUHOUN,
 Clerk of the Executive Council.

ORDERS IN COUNCIL

Forests Act 1958.

EXCHANGE OF FOREST AREAS FOR CROWN LANDS.

At the Executive Council Chamber, Melbourne, the twentieth day of September, 1966.

PRESENT :

His Excellency the Governor of the State of Victoria.

Mr. Porter | Mr. Meagher
 Mr. Hamer | Mr. Balfour.

IN pursuance of the provisions of Section 49 of the *Forests Act 1958* No. 6254 His Excellency, the Governor of the State of Victoria, by and with the advice of the Executive Council, doth hereby order that the areas of Reserved Forest situated in the Parishes of Ararat, Argyle, Balrook, Baranduda, Berringama, Bruarong, Bullarto, Bungil, Castlemaine, Chiltern, Clarkesdale, Creswick, Drik Drik, Dueran, Eglinton, Glenmaggie, Gorae, Gunbower, Heywood, Irrewillipe, Jan Juc, Jindivick, Killawarra, Kimbolton, Korweinguboora, Maryborough, Merbein, Monbulk, Mouzie, Moyhu, Myrtleford, Narrawong, Narrung, Noojee East, Palpara, Pompapeli, Sandhurst, Tambo, Tarnagulla, Tarrawarra North, Tong Bong, Tonghi, Toombullup North, Wangaratta North, Warburton, Warrandyte, Wataepoolan, and Wombat described in the accompanying Excision Schedule No. 152 and comprising 7,508 acres more or less be excised from the Forest Reserves and that the areas of unoccupied Crown lands in the Parishes of Argyle, Bamba, Barongarook, Barramunga, Barwongemoong, Bellaura, Beremboke, Boho, Boorooopki, Bullarto, Callignee, Colvinsby, Craigie, Glenaulin, Illawarra, Jindivick, Korweinguboora, Manango, Maryborough, Merrijig, Murroon, Myamyn, Pernim, Redesdale, Tambo, Toolongrook, Warburton, Warrak and Wombat and described in the accompanying Dedication Schedule No. 189 and comprising 8,083 acres more or less be dedicated as Reserved Forest in exchange in lieu thereof.

Such excisions and dedications to take effect on the fourteenth day after the publication of this order in the *Government Gazette*.

EXCISION SCHEDULE No. 152.

Seven thousand five hundred and eight acres more or less of Reserved Forest comprising the areas tabulated hereunder and shown by cross hatched lines in diagrams 1092 to 1139 inclusive on the accompanying plans A, B, C, D, E and F.

Diagram.	Correspondence Number.		Parish.	Plan Number.	County.	Area in Acres. (More or less).
	Forests.	Lands.				
1092	64/72	J31543	Ararat	10B	Ripon	A. R. P.
1135	{ 62/1980 } { 63/1329 }	C99004 J31412	Argyle	12	Grenville	0 0 18
1132	61/1532	J30793	Argyle	12	Grenville	2
1093	53/4089	H027336	Balrook & Drik Drik	19 & 166	Normanby	3,000
1138	65/65	C99798	Baranduda	24	Bogong	13
1094	{ 58/873 } { 62/921 }	H023868 895/44	Berringama	43B	Benambra	3 2 0
1095	64/1746	W87226	Bruarong	76	Bogong	30
1096	58/1507	H026783	Bruarong	76	Bogong	30
1133	61/821	W81798	Bullarto	81	Talbot	1
1097	{ 62/785 } { 62/1201 }	A028634 H028888	Bungil	92B	Benambra	108
1098	53/2480	J31088	Castlemaine	118	Talbot	30
1099	60/1558	J31408	Chiltern	119	Bogong	70
1100	62/919	H028459	Chiltern	119	Bogong	10
1101	62/822	J31129	Clarkesdale	121	Grenville	4
1102	{ 64/966 } { 64/1386 }	H030035 H030163	Creswick	149B	Talbot	10
			Dueran	168	Delatite	200
			Eglinton	176	Talbot	167
			Glenmaggie	205c	Tanjil	67
			Glenmaggie	205c	Tanjil	84

EXCHANGE OF FOREST AREAS FOR CROWN LANDS—continued.

Diagram.	Correspondence Number.		Parish.	Plan Number.	County.	Area in Acres. (More or less).		
	Forests.	Lands.				A.	R.	P.
1103	{64/456}	J31773	Gorae	212	Normanby	40		
	{64/1719}	Rs5145	Gorae	212	Normanby	0	0	13
1104	{63/136}	266/155	Gunbower	217A	Gunbower	4		
	{63/136}	W87755	Gunbower	217B	Gunbower	10		
1105	63/199	J31284	Heywood	223 A & B	Normanby	48		
1106	64/34	G63847	Irrewillipe	230	Polwarth	3		
1107	59/2497	G62202	Jan Juc	232	Grant	274		
1108	63/2096	Rs7286	Jindivick	236	Buln Buln	14		
1109	{62/1552}	H029214	Killawarra	254	Moira	320		
	{65/3478}	H025948	Killawarra	254	Moira	0	0	28
1134	62/363	H028937	Killawarra	254	Moira	2		
1136	64/1844	C99637	Kimbolton	255	Bendigo	1,440		
1112	53/2967	J31974	Korweinguboora	265	Grant	5		
1110	63/1394	C99267	Maryborough	298B	Talbot	2		
1111	62/1971	M33657	Merbein	Cty. 22N	Karkaroc	27		
1113	65/2778	M3022	Monbulk	312A	Mornington	0	2	0
1114	62/1678	J30929	Mouzie	327A	Normanby	38		
1115	61/960	H028713	Moyhu	329B	Delatite	7		
1116	63/1058	H029152	Myrtleford	343	Bogong	44		
1118	64/229	J31544	Narrawong	349	Normanby	13		
1117	62/274	M60042	Narrung	349A	Tatchera	4		
1119	65/3642	G66271	Noojee East	364A	Buln Buln	4		
1121	66/674	334/44	Palpara	202	Follett	27		
1120	62/1355	O1923/138	Pompapiel	388	Bendigo	1	2	0
1137	{64/84}	W87107	Sandhurst	402C	Bendigo	4	2	0
	{64/928}	W87087	Sandhurst	402C	Bendigo	2		
1122	61/822	H028044	Tambo	424B	Dargo	720		
1124	59/2384	W83590	Tarnagulla	428A	Gladstone	2		
1123	63/1190	G64116	Tarrawarra North	429	Evelyn	220		
1125	59/2315	H027271	Tong Bong	446A	Buln Buln	12		
1126	64/1523	H027997	Tonghi	447	Croajingolong	174		
1127	62/1568	H028826	Toombullup North	450	Delatite	60		
1128	62/1162	H029008	Wangaratta North	470B	Bogong	30		
1129	59/601	O1638/121	Warburton	474A	Evelyn	0	1	0
1130	62/2005	G61967	Warrandyte	479	Evelyn	120		
1131	64/1487	J31803	Wataépoolan	483B	Normanby	1		
1139	59/2727	W82111	Wombat	502F	Talbot	2		

DEDICATION SCHEDULE No. 189.

Eight thousand and eighty-three acres more or less of unoccupied Crown lands, comprising the areas tabulated hereunder and shown by diagonal hatched lines in diagrams 895 to 921 inclusive shown on the accompanying plans G, H and J.

Diagram.	Correspondence Number.		Parish.	Plan Number.	County.	Area in Acres. (More or less).		
	Forests.	Lands.				A.	R.	P.
895	{62/1980}	C99004	Argyle	12	Grenville	2		
	{63/1329}	J31412	Argyle	12	Grenville	2		
896	59/1549	J27353	Bambra	20	Polwarth	78		
897	64/1098	G64132	Barongarook	30	Polwarth	588		
898	{62/55}	G62195	Barramunga	32	Polwarth	7		
	{62/636}	398/44	Barramunga	32	Polwarth	155		
899	63/428	C76011	Barwongemoong	34A	Polwarth	1,045		
900	61/352	Misc. 3633	Beremboke	43	Grant	8		
901	47/2285	H019456	Boho	52B	Delatite	150		
902	60/861	O437/130	Booroopki	Cty. 23s	Lowan	580		
903	{63/1972}	W86656	Bullarto	81	Talbot	2		
	{65/2236}	W82399	Bullarto	81	Talbot	36		
904	65/130	H030427	Callignee	103	Buln Buln	10		
905	63/566	W82676	Craigie	148	Talbot	3		
906	59/2620	O726/130	Glenaulin	198	Normanby	67		
907	60/129	M48605	Illawarra and Bellaura	228 & Cty. 5s	Borong	110		
908	63/2096	Rs7286	Jindivick	236	Buln Buln	4		
909	59/353	Rs1104	Korweinguboora	265	Grant	562		
911	61/1398	Misc. 3646	Manango	293B	Evelyn	64		
910	64/1350	W83518	Maryborough	298B	Talbot	100		
912	59/2622	38/121	Merrijig	302	Delatite	200		
913	59/1550	J28062	Murroon	340	Polwarth	63		
914	60/737	Z31708	Myamyn	340A	Normanby	375		
915	63/284	G63564	Purnim	Cty. 35	Villiers	2,700		
916	60/735	W70736	Redesdale	396	Dalhousie	3		
917	61/882	H028044	Tambo	424B	Dargo	170		
918	60/44	M53557	Toolongrook	Cty. 23s	Lowan	340		
920	60/449	G62158	Warburton	474B	Evelyn	450		
921	63/1698	C99359	Warrak & Colvinby	478 & 136	Borong and Ripon	149		
919	64/1270	W86931	Wombat	502A	Talbot	60		

EXCISION SCHEDULE Nº152 PLAN A

66/349 29 . 8 . 66 C9918

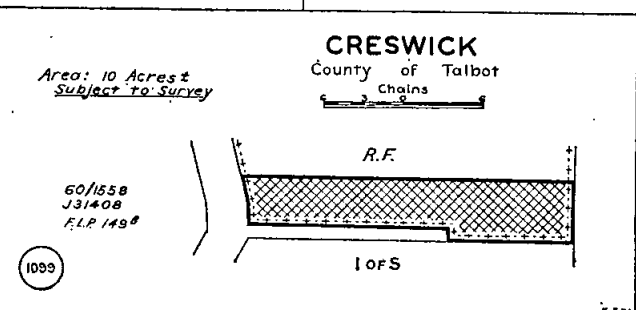
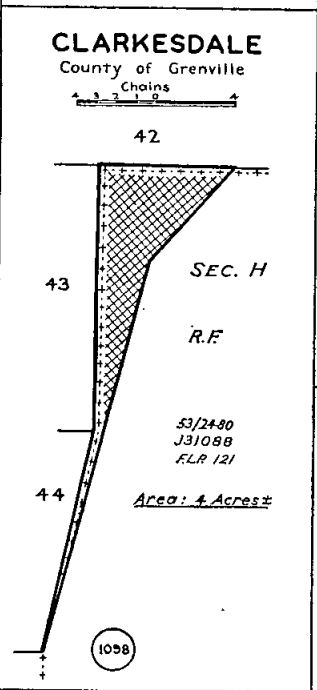
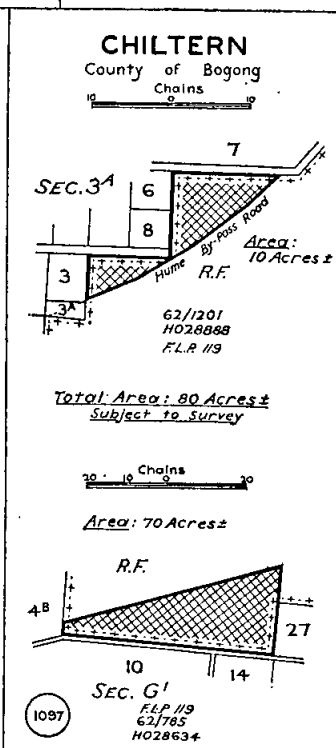
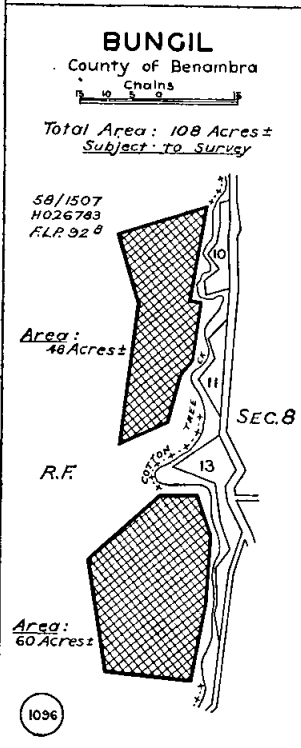
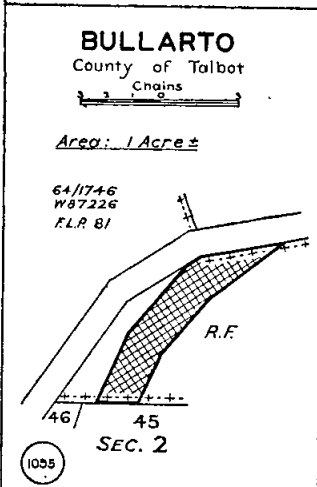
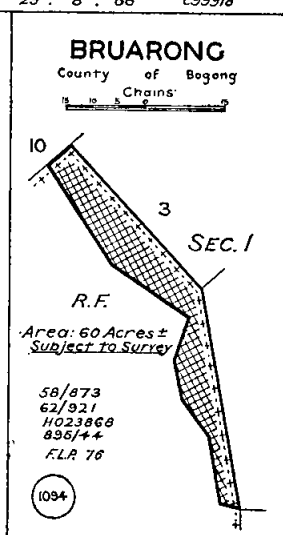
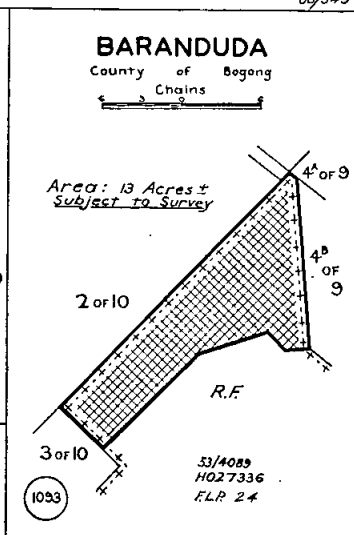
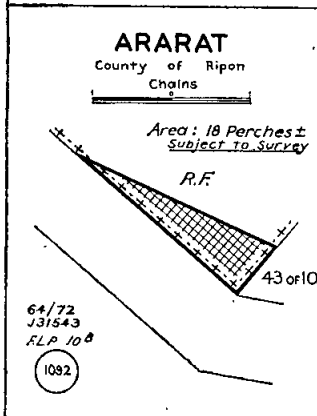

K.J.M.

EXCISION SCHEDULE N°152 PLAN B

66/349 29.8.66 C939/8

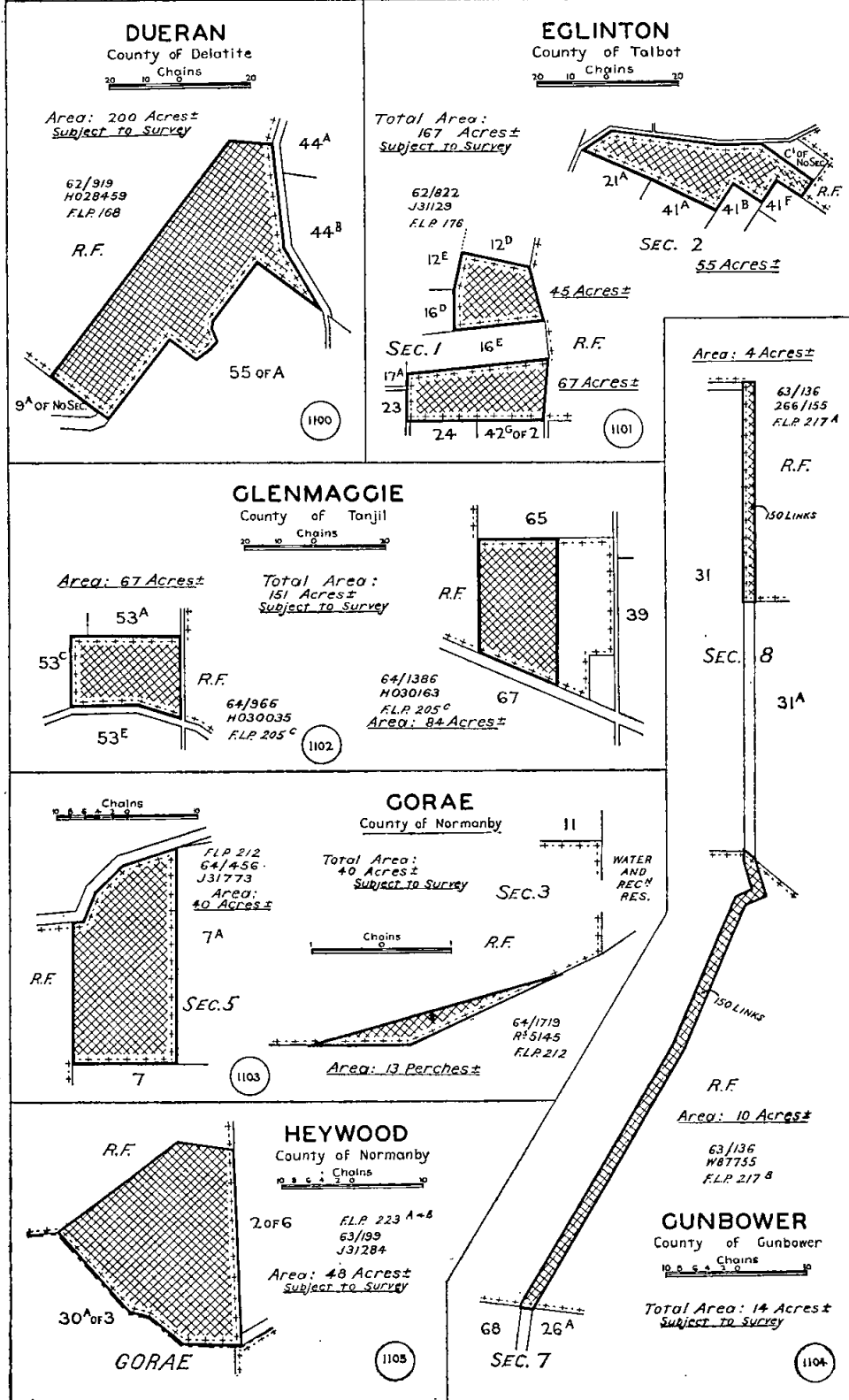

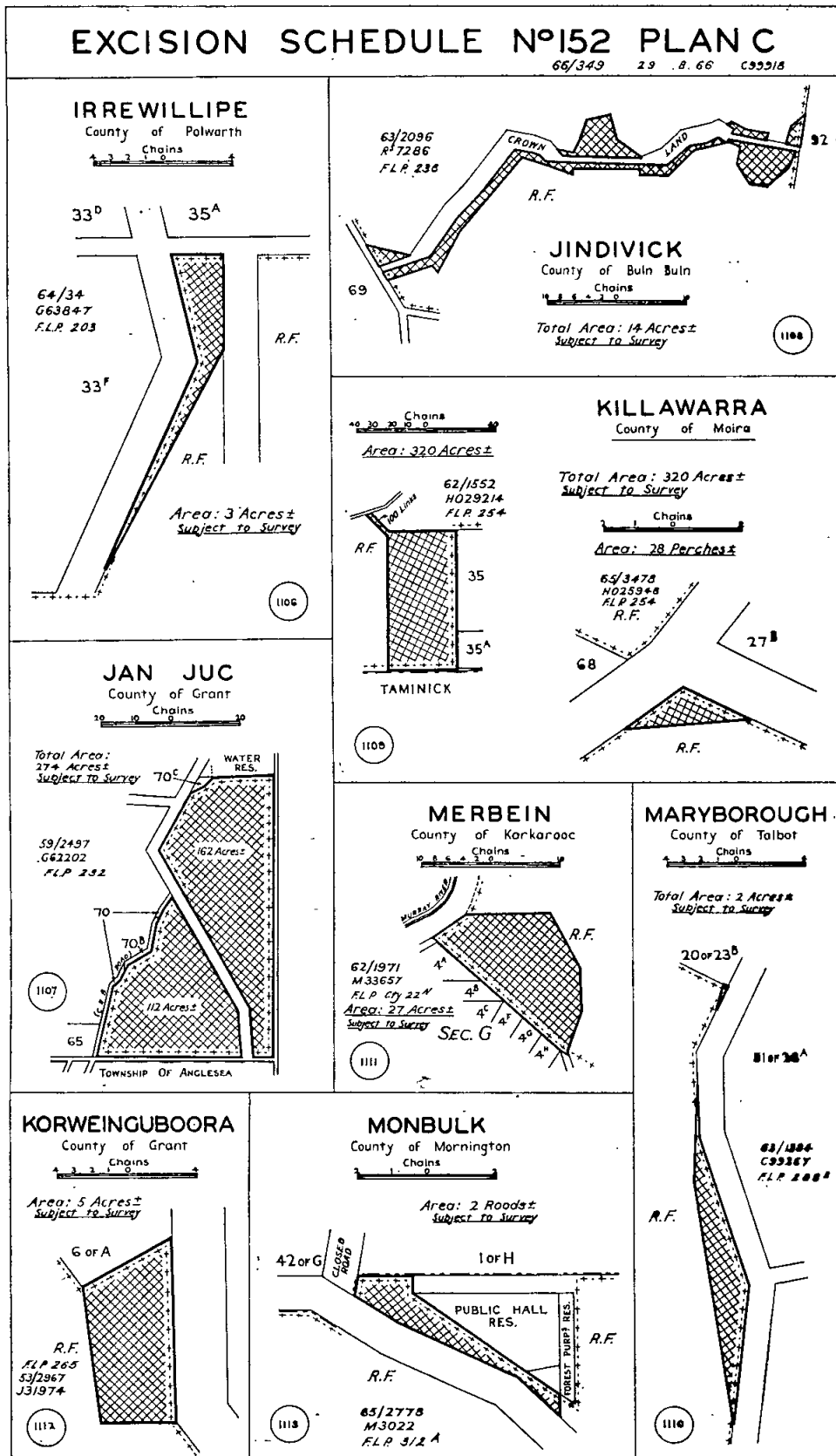

EXCISION SCHEDULE N^o152 PLAN D

69/349 29 . 8 . 66 C.99918

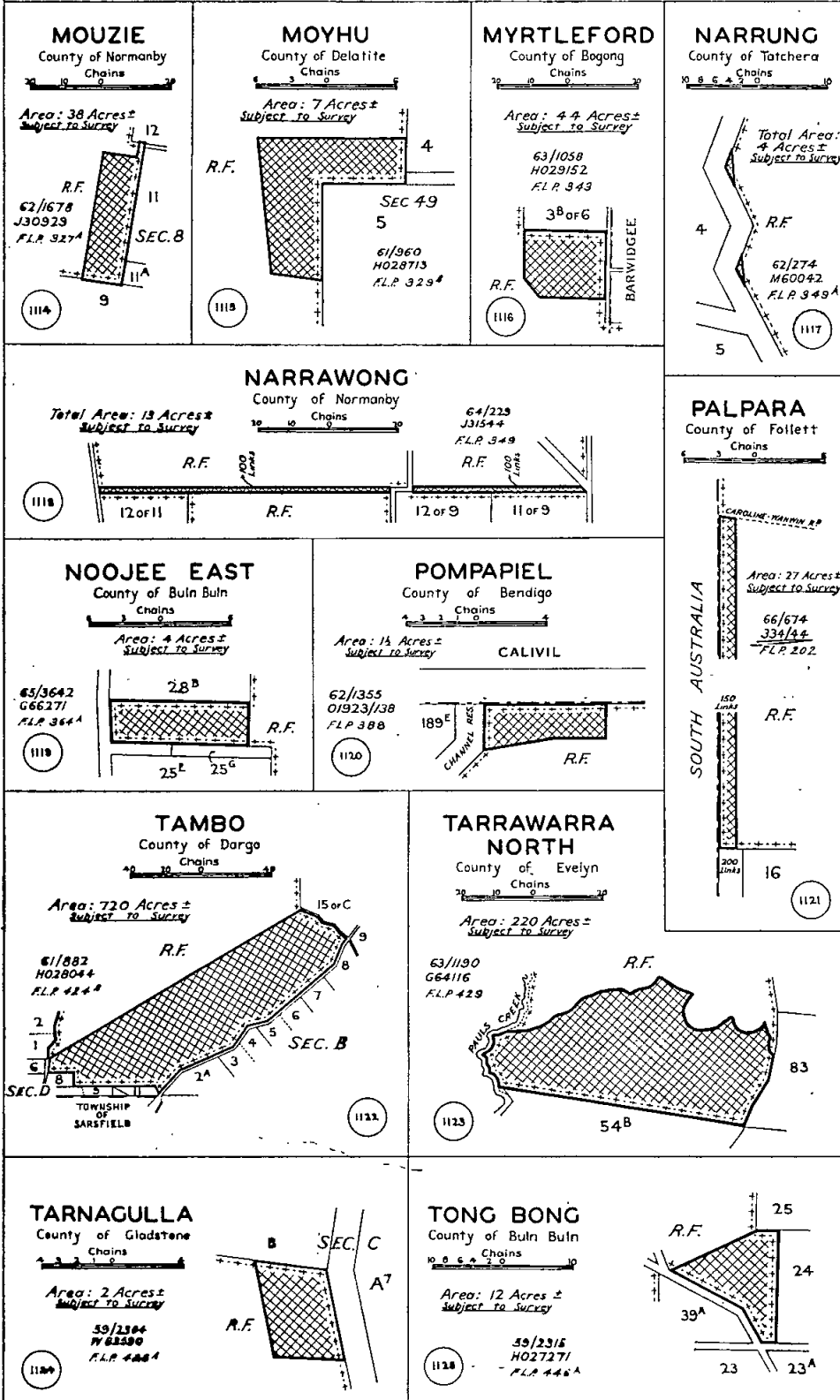

EXCISION SCHEDULE Nº152 PLAN E

66/349 29. 8. 66 C.99/18

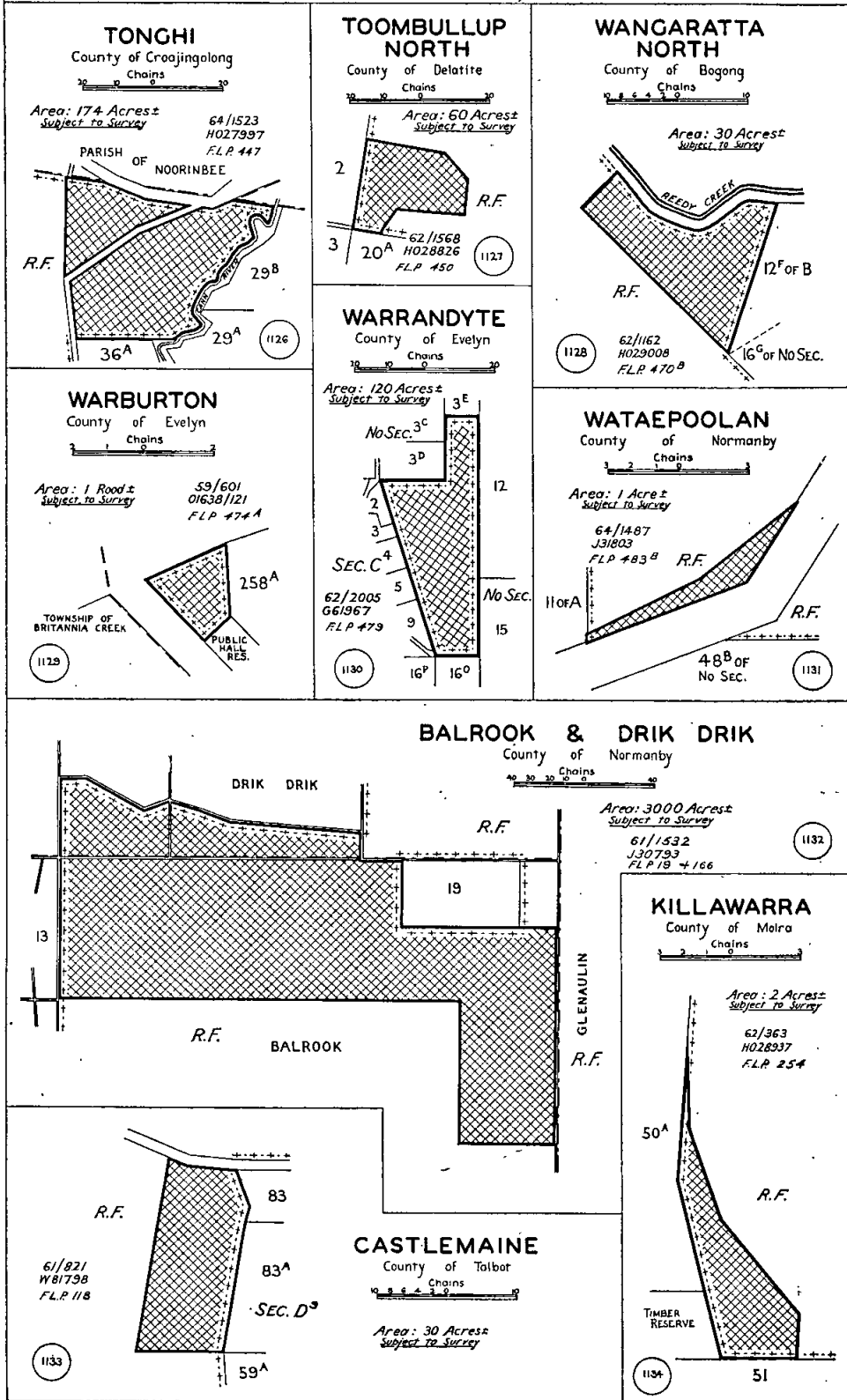

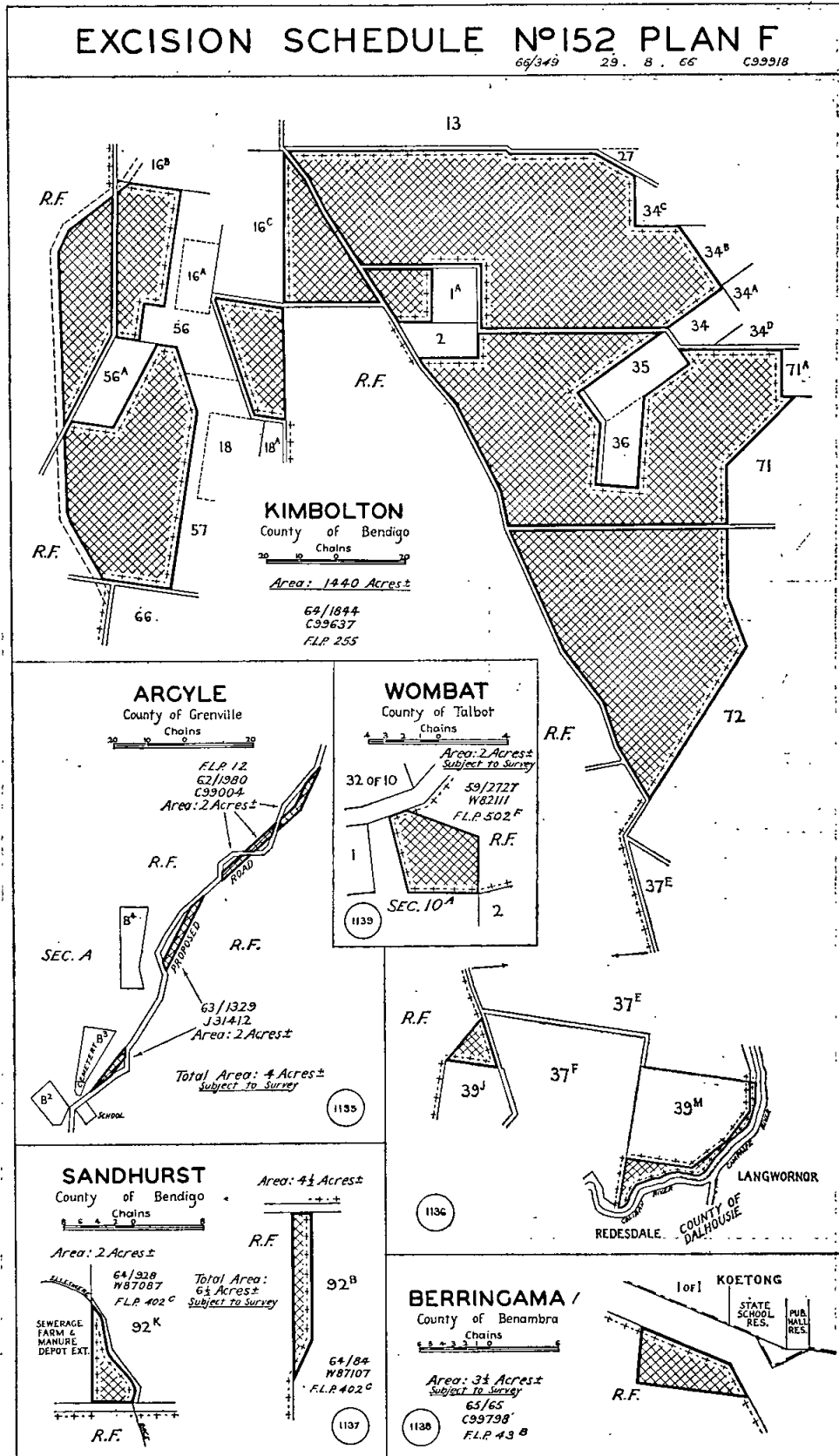

DEDICATION SCHEDULE Nº189 PLAN G

66/349 29.8.66 C93918

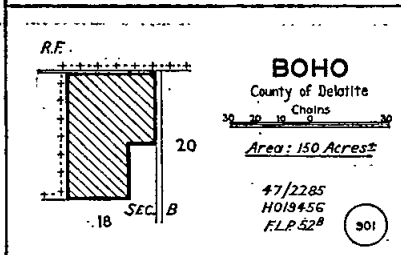
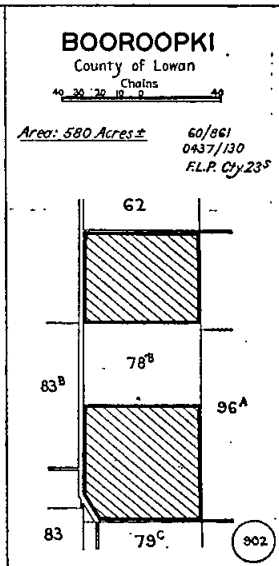
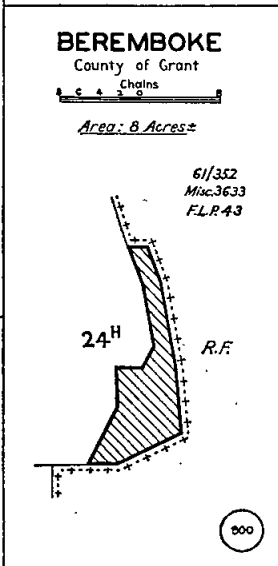
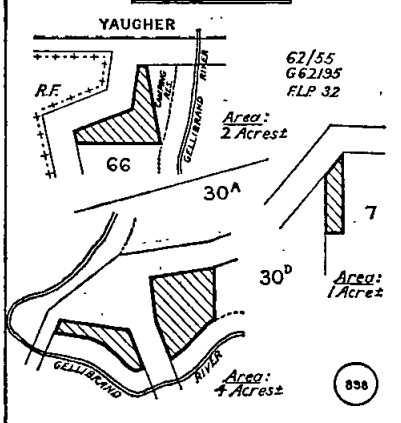
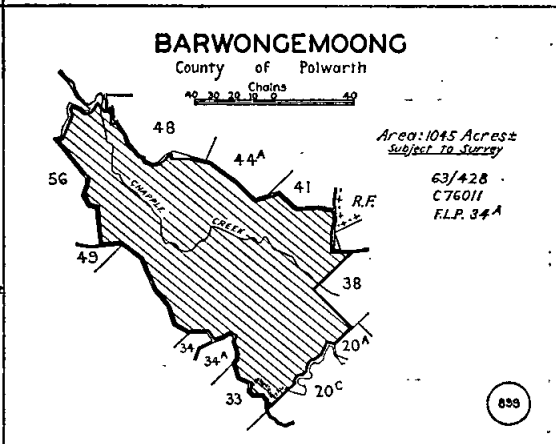
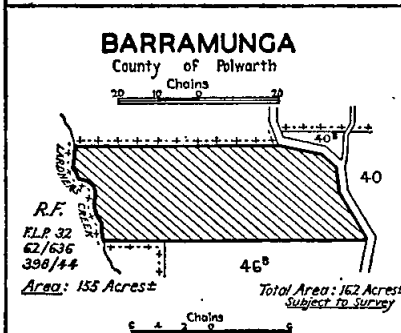
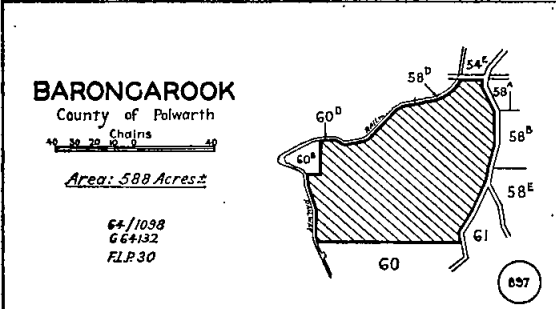
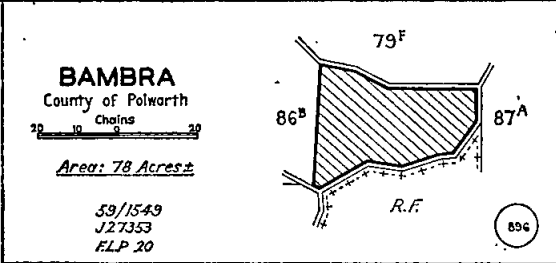
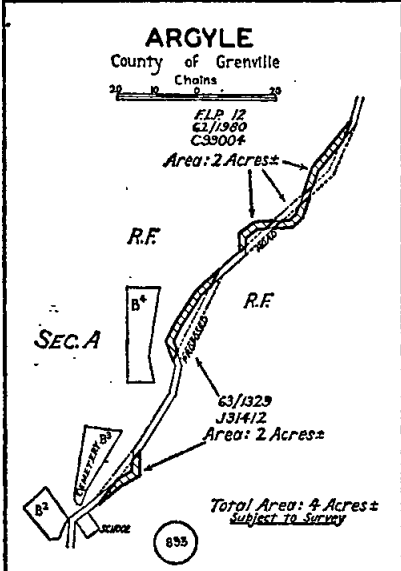

DEDICATION SCHEDULE N°189 PLAN H

66/349 29.8.66 C939/B

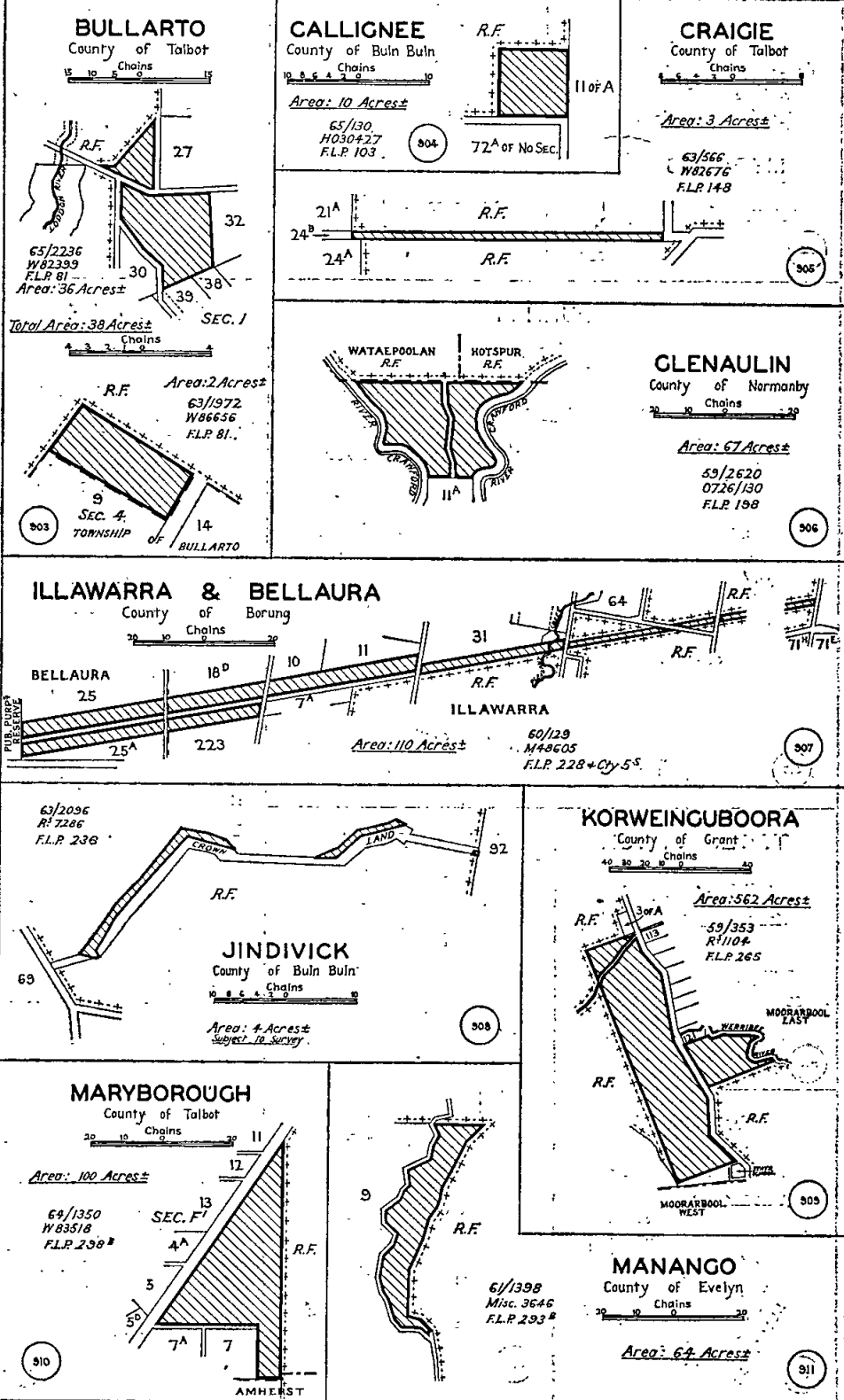

DEDICATION SCHEDULE N^o189 PLAN J

66/349 23. 8. 66 C99918

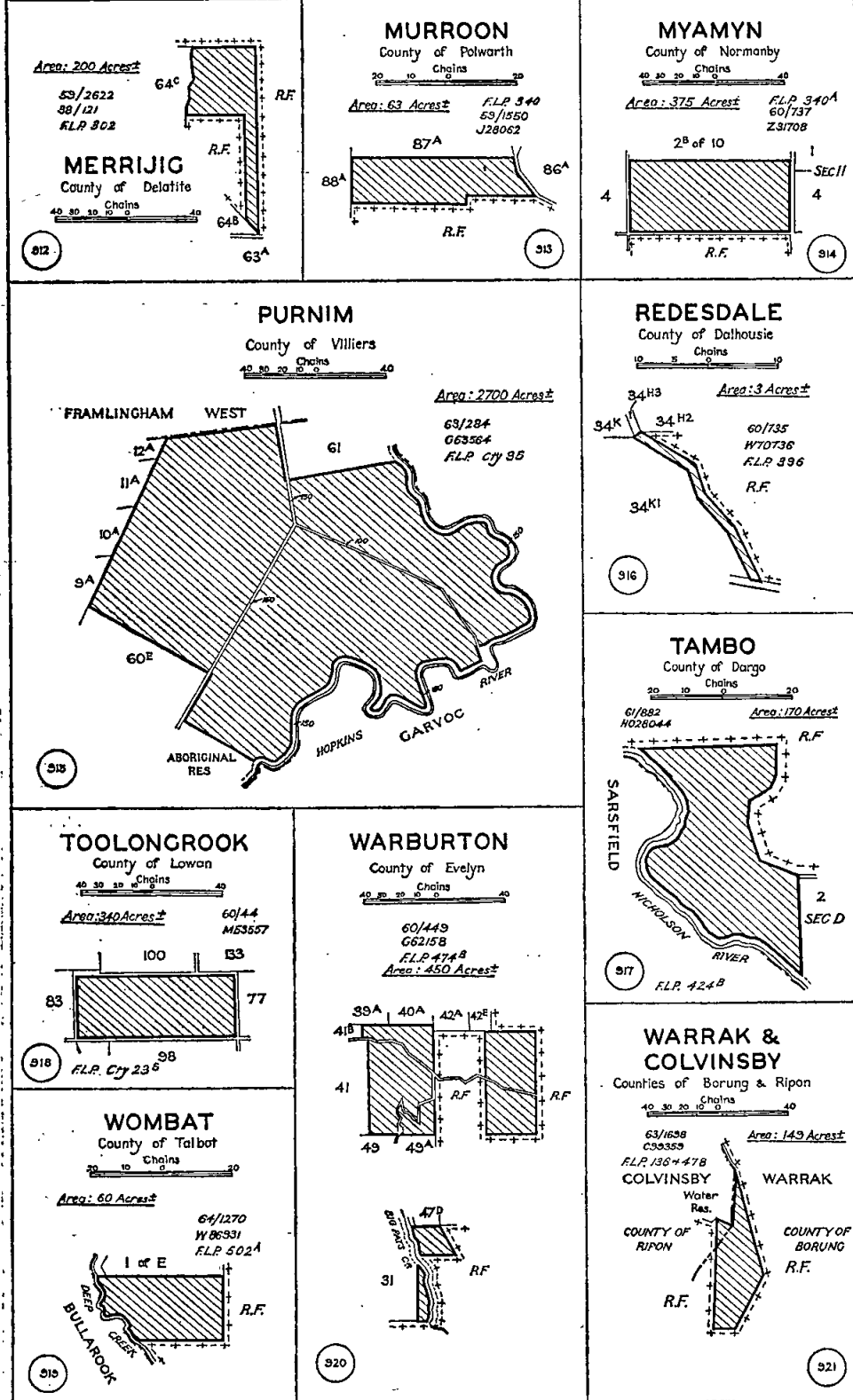

And the Honorable Lindsay Hamilton Simpson Thompson, Her Majesty's Minister of Forests for the State of Victoria, shall give the necessary directions herein accordingly.

J. COLQUHOUN,
Clerk of the Executive Council.

This Order is published in lieu of that published in the *Government Gazette* of the 28th September on page 3458.

COUNTRY ROADS BOARD.

At the Executive Council Chamber, Melbourne, the
fourth day of October, 1966.

PRESENT:

His Excellency the Governor of Victoria.

Mr. Thompson
Mr. Wilcox

Mr. Bloomfield.

ORDER CONFIRMING RESOLUTIONS OF THE COUNTRY ROADS BOARD.

HIS Excellency the Governor of the State of Victoria, by and with the advice of the Executive Council thereof, doth hereby, in pursuance of the provisions of the *Country Roads Act 1958*, confirm the Resolutions of the Country Roads Board, the dates whereof and the terms of which are scheduled hereunder:—

SCHEDULE.

Main Roads.

Resolution dated 26th September, 1966, made pursuant to section 21 of the *Country Roads Act 1958*, declaring the widening of the Barwon Heads-road in the Shire of South Barwon, as shown hatched on the plans numbered G.P.8856 and G.P.8857 hereunder, to be part of a main road within the meaning and for the purposes of the *Country Roads Act 1958*.

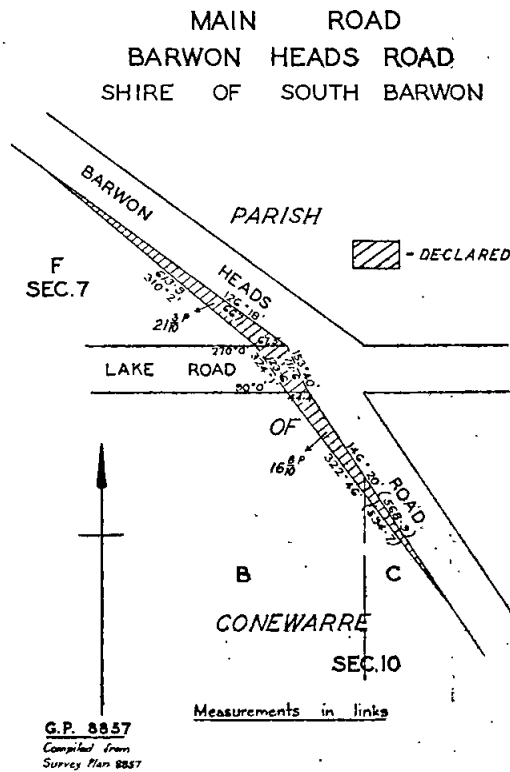
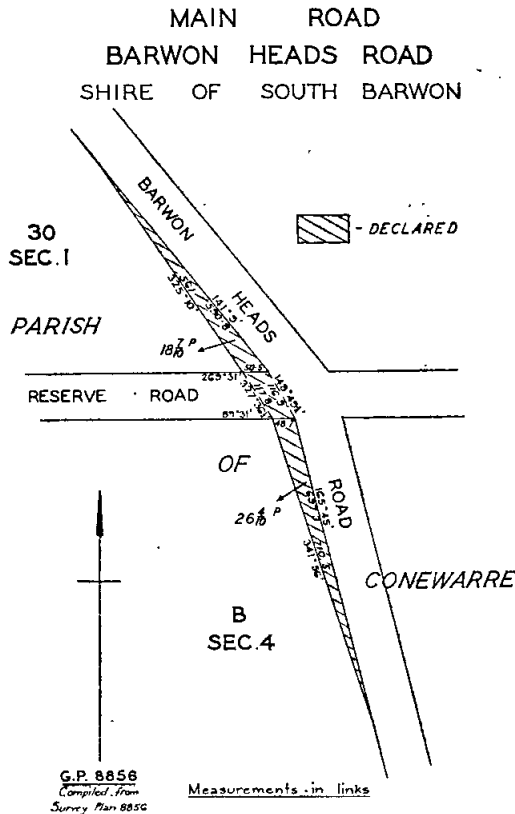

Resolution dated 26th September, 1966, made pursuant to sections 21 and 58 of the *Country Roads Act 1958*, declaring the deviation from the Nerrena-road in the Shire of Woorayl, as indicated by diagonal hatching on the plan numbered G.P.9877 hereunder, to be part of a main road within the meaning and for the purposes

of the Country Roads Act 1958, and also declaring that such deviation shall be in lieu of the existing road or part thereof indicated by cross hatching on the said plan and that such part of the said existing road shall be discontinued.

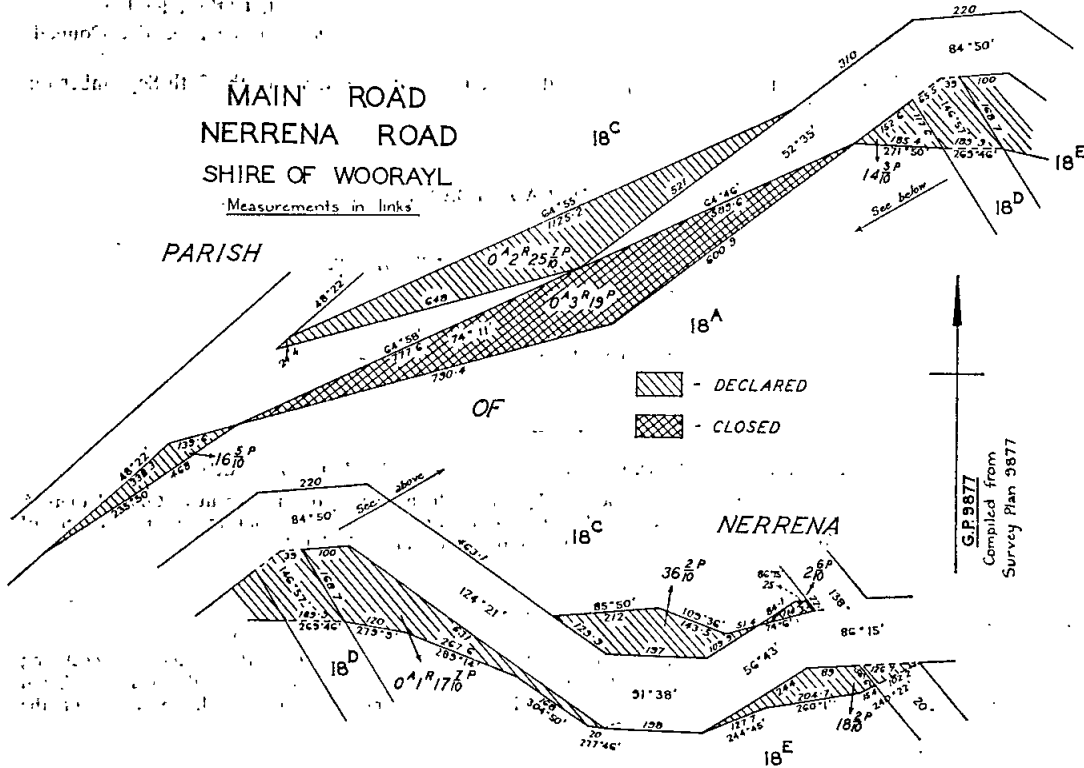

And the Honorable Murray, Victor Porter, Her Majesty's Minister of Public Works for the State of Victoria, shall give the necessary directions herein accordingly.

J. COLQUHOUN,
Clerk of the Executive Council.

COUNTRY ROADS BOARD.

At the Executive Council Chamber, Melbourne, the fourth day of October, 1966.

PRESENT:

His Excellency the Governor of Victoria.
Mr. Thompson Mr. Bloomfield.
Mr. Wilcox

ORDER APPROVING OF A DEVIATION FROM A MAIN ROAD IN THE SHIRE OF KORUMBURRA.

WHEREAS the Country Roads Board constituted under the Country Roads Act 1958 (No. 6229) has represented to His Excellency the Governor in Council that it appears to it desirable that the deviation hereinafter referred to from the existing Loch-Poowong road in the Shire of Korumburra (declared to be a main road, under the said Act which declaration was confirmed by the Order in Council published in the Government Gazette of the 12th March, 1941, on page 1247) should be made by the said Board; And whereas the said Board in accordance with the requirements of section 19 of the said cited Act has caused to be prepared a map plan and estimate showing the points between, which and on and through what land the said deviation is proposed to be made and the cost of acquiring the land; And whereas on an inspection of the said map and plan and a consideration of the said estimate His Excellency the Governor in Council is satisfied that there are funds legally available for acquiring the land: Now therefore be it known by this present Order that His Excellency the Governor of the State of Victoria with the advice of the Executive Council thereof doth hereby approve of the said road being made, that is to say:—

All those pieces of land in the Parish of Jeetho West the boundaries of which are as follow:—

- (a) Commencing at the north-eastern angle of allotment 22b of the said parish; thence by lines bearing respectively 213 deg. 54 min. 97 links,

257 deg. 36½ min. 1,240 links, 252 deg. 52½ min. 294.2 links, 241 deg. 4½ min. 312.8 links, 48 min. 33½ min. 536 links, 78 deg. 6 min. 1,310.7 links and 106 deg. 35 min. 142 links to the point of commencement.

- (b) Commencing at a point on the southern boundary of allotment 22c of the said parish, distant 255 deg. 8½ min. 436.4 links from the south-eastern angle of the said allotment; thence by lines bearing respectively 255 deg. 8½ min. 323.6 links, 286 deg. 34½ min. 72.9 links; 78 deg. 18 min. 161.9 links and 82 deg. 32½ min. 226 links to the point of commencement.
- (c) Commencing at an angle in the southern boundary of allotment 25 of the said parish formed by the intersection of lines bearing 103 deg. 57½ min. and 49 deg. 19½ min.; thence by lines bearing respectively 283 deg. 57½ min. 221.4 links, 65 deg. 49½ min. 635.7 links and 229 deg. 19½ min. 481.3 links to the point of commencement.
- (d) Commencing at the south-eastern angle of allotment 25 of the said parish; thence by lines bearing respectively 262 deg. 13½ min. 411.8 links; 59 deg. 2½ min. 479.9 links, 70 deg. 1 min. 606.2 links, 232 deg. 46½ min. 645.1 links and 262 deg. 9½ min. 60 links to the point of commencement.
- (e) Commencing at an angle in the northern boundary of allotment 26 of the said parish, formed by the intersection of lines bearing 128 deg. 29 min. and 74 deg. 36 min.; thence by lines bearing respectively 254 deg. 36 min. 26.7 links, 283 deg. 48½ min. 1,397.8 links, 262 deg. 19½ min. 730.3 links, 52 deg. 46½ min. 373.7 links, 31 deg. 26½ min. 65.6 links, 70 deg. 1 min. 115.8 links, 103 deg. 48½ min. 1,450.9 links and 128 deg. 29 min. 328.4 links to the point of commencement.
- (f) Commencing at a point on the northern boundary of allotment 25A of the said parish, distant 49 deg. 13½ min. 339.7 links from the north-western angle of the said allotment;

thence by lines bearing respectively 49 deg. 13½ min. 302.3 links, 82 deg. 13½ min. 318.8 links and 246 deg. 10½ min. 595.5 links to the point of commencement—

which said pieces of land are particularly delineated and shown coloured red, yellow and green on survey plans numbered 10566, 10567 and 10568, lodged in the office of the Country Roads Board.

And the Honorable Murray Victor Porter, Her Majesty's Minister of Public Works for the State of Victoria, shall give the necessary directions herein accordingly.

J. COLQUHOUN,
Clerk of the Executive Council.

COUNTRY ROADS BOARD.

At the Executive Council Chamber, Melbourne, the fourth day of October, 1966.

PRESENT:

His Excellency the Governor of Victoria.
Mr. Thompson | Mr. Bloomfield.
Mr. Wilcox

ORDER APPROVING OF LAND BEING ACQUIRED AND ROADS, DEVIATIONS OR WIDENINGS BEING MADE.

HIS Excellency the Governor of the State of Victoria, by and with the advice of the Executive Council thereof, being satisfied that there are funds legally available for acquiring the land, doth hereby approve the acquiring of the land described in the schedule hereunder and the making of new roads and deviations from and widenings of existing roads referred to in the said schedule.

SCHEDULE.

Main Roads.

The land shown hatched on plan numbered G.P.10622 hereunder, required for the widening of the Creswick-road in the Shire of Newstead and making of the widening thereon.

MAIN ROAD
CRESWICK ROAD
SHIRE OF NEWSTEAD

Measurements in links

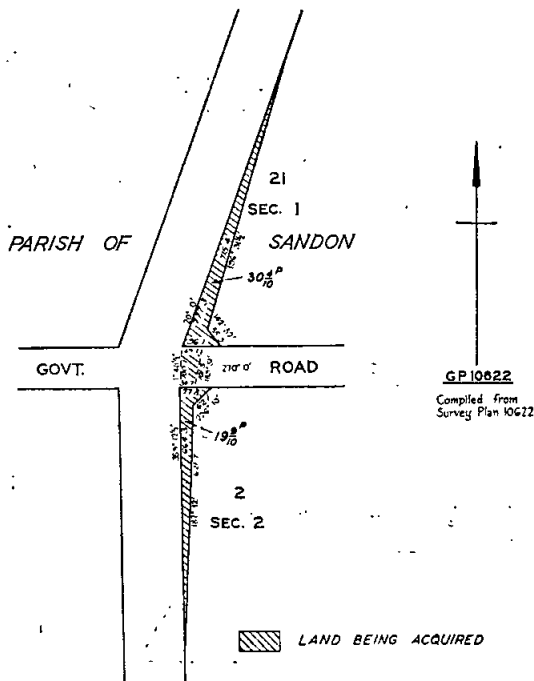

The land shown hatched on plan numbered G.P.10480 hereunder, required for the deviation of the Warragul-Korumburra-road in the Shire of Warragul and making of the deviation thereon.

MAIN ROAD
WARRAGUL-KORUMBURRA ROAD
SHIRE OF WARRAGUL
MEASUREMENTS IN LINKS

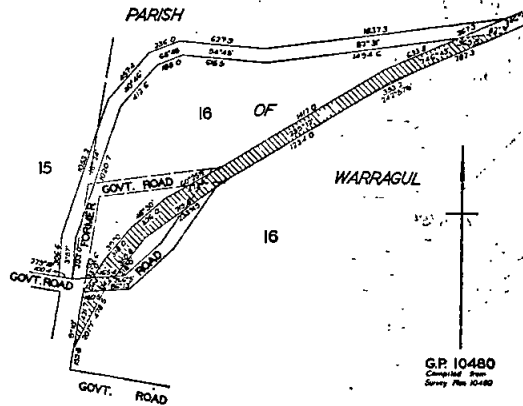

State Highways.

The land shown hatched on plan numbered G.P.10673 hereunder, required for the widening of the Kiewa Valley Highway in the Shire of Yackandandah and making of the widening thereon.

STATE HIGHWAY
KIEWA VALLEY HIGHWAY
SHIRE OF YACKANDANDAH
Measurements in links

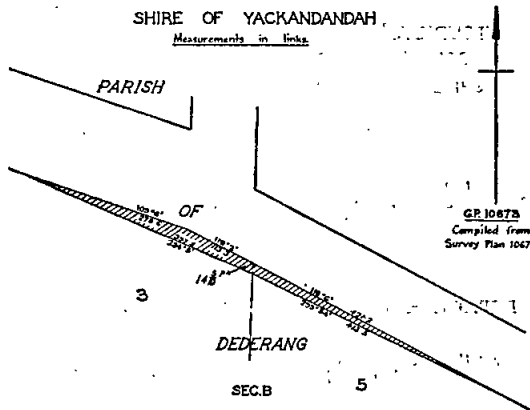

And the Honorable Murray Victor Porter, Her Majesty's Minister of Public Works for the State of Victoria, shall give the necessary directions herein accordingly.

J. COLQUHOUN,
Clerk of the Executive Council.

The above-mentioned plans are lodged in the offices of the Country Roads Board and may be inspected by any person without fee at any time at which such offices are open for business.

COUNTRY ROADS BOARD.

At the Executive Council Chamber, Melbourne, the fourth day of October, 1966.

PRESENT:

His Excellency the Governor of Victoria.
Mr. Thompson | Mr. Bloomfield.
Mr. Wilcox

ORDER CONFIRMING RESOLUTION OF THE COUNTRY ROADS BOARD.

HIS Excellency the Governor of the State of Victoria, by and with the advice of the Executive Council thereof, doth hereby, in pursuance of the provisions of

the *Country Roads Act 1958*, confirm the Resolution of the *Country Roads Board*, the date whereof and the terms of which are scheduled hereunder:—

SCHEDULE.

Tourists' Roads.

Resolution dated 26th September, 1966, made pursuant to sections 21, 58 and 88 of the *Country Roads Act 1958*, proclaiming the deviation from the Ocean-road in the Shire of Otway, as indicated by diagonal hatching on the plan numbered G.P.10024 hereunder, to be part of a tourists' road within the meaning and for the purposes of the *Country Roads Act 1958*, and also, proclaiming that such deviation shall be in lieu of the existing road or part thereof indicated by cross-hatching on the said plan and that such part of the said existing road shall be discontinued.

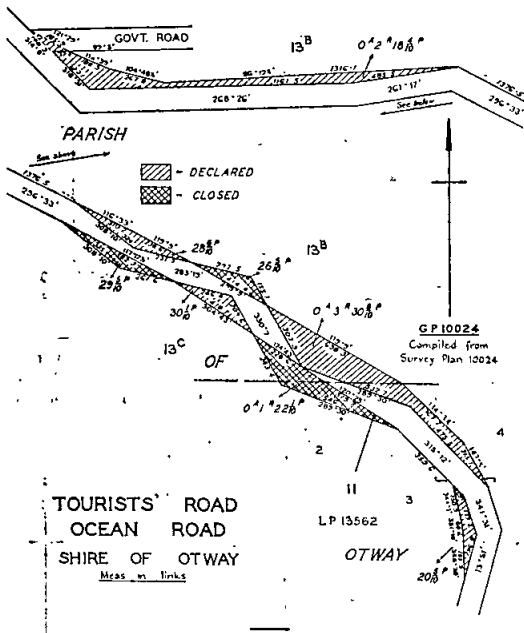

And the Honorable Murray Victor Porter, Her Majesty's Minister of Public Works for the State of Victoria, shall give the necessary directions herein accordingly.

J. COLQUHOUN,
Clerk of the Executive Council.

DEPARTMENT OF CROWN LANDS AND SURVEY.

At the Executive Council Chamber, Melbourne, the fourth day of October, 1966.

PRESENT:

His Excellency the Governor of Victoria.
Mr. Thompson | Mr. Bloomfield.
Mr. Wilcox

LAND PERMANENTLY RESERVED AS A SITE.

HIS Excellency the Governor of the State of Victoria, by and with the advice of the Executive Council, thereof, doth hereby, in pursuance of section 14 of the *Land Act 1958*, reserve permanently from sale and from being leased and from having a licence granted in respect thereof and also except from occupation for mining purposes under any miner's right, the land hereinafter described:—

YARPTURK.—7 acres 1 rood, 13 perches, more or less, in the Parish of Yarturk, County of Villiers, as defined by the description published in the *Government Gazette* of 31st August, 1966, which is required for Public Recreation. (Rs.4671.)

And the Honorable James Charles Murray Balfour, Her Majesty's Minister of Lands for the State of Victoria, shall give the necessary directions herein accordingly.

J. COLQUHOUN,
Clerk of the Executive Council.

DEPARTMENT OF CROWN LANDS AND SURVEY.

At the Executive Council Chamber, Melbourne, the fourth day of October, 1966.

PRESENT:

His Excellency the Governor of Victoria.
Mr. Thompson | Mr. Bloomfield.
Mr. Wilcox

LANDS TEMPORARILY RESERVED AS SITES.

HIS Excellency the Governor of the State of Victoria, by and with the advice of the Executive Council thereof, doth hereby, in pursuance of section 14 of the *Land Act 1958*, reserve temporarily from sale, from being leased and from having a licence granted in respect thereof, and also except from occupation for mining purposes under any miner's right, the lands hereinafter described:—

ELLIMINYT (COLAC).—Site for Public purposes (use of Mental Health Authority), 170 acres 3 roods 26 perches, Parish of Elliminyt, County of Polwarth, as indicated by hachure on plan hereunder.—(E.35(?) (Rs.8723).

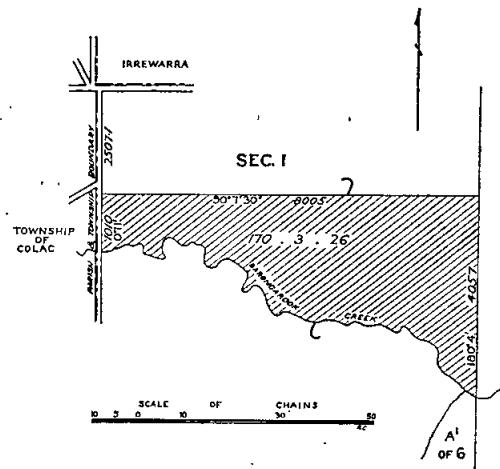

PIMPINIO.—Site for Water Supply purposes, 3 acres 26 perches, more or less, Township of Pimpinio, Parish of Wail, County of Borung, as indicated by hachure on plan hereunder.—(P.141(?) (Rs.7518).

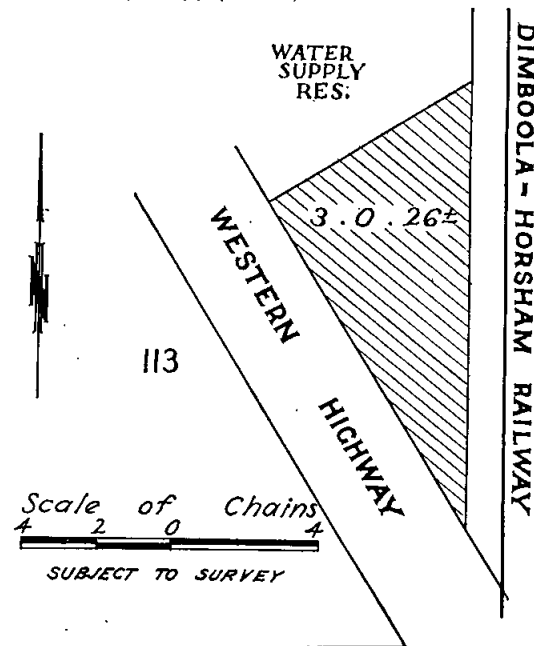

TIMBEROO.—Site for Water Supply, the Growth and Preservation of Timber, and Public purposes, 4 acres 3 roods 12 perches, Parish of Timberoo, County of Kararoc, as indicated by hachure on plan hereunder.—(T.225⁽²⁾) (Rs.4339).

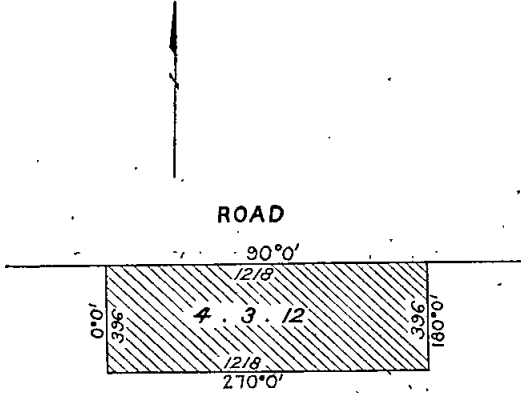

RESERVED FOR WATER SUPPLY, THE GROWTH AND PRESERVATION OF TIMBER AND PUBLIC PURP

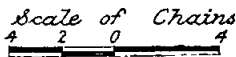

SANDHURST (Strathfieldsaye).—Site for Public purposes (Police purposes), 1 rood 1 perch, Parish of Sandhurst, County of Bendigo, as indicated by hachure on plan hereunder.—(S.371⁽¹⁰⁾) (Rs.8719).

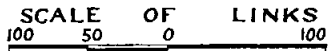
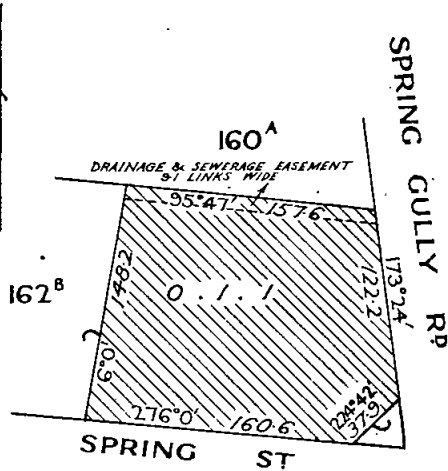

BEAUFORT.—Site for Public purposes (Forests Department purposes), 1 rood, Township of Beaufort, Parish of Beaufort, County of Ripon, as indicated by hachure on plan hereunder.—(B.304⁽⁶⁾) (Rs.8560).

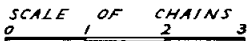
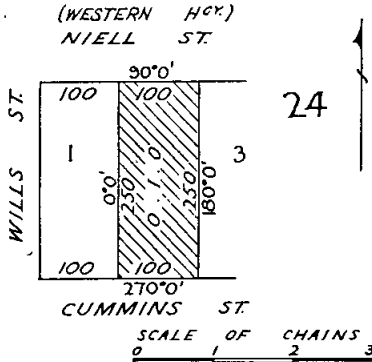

SEBASTOPOL.—Site for State School purposes, 17 acres 21 perches, Township of Sebastopol, Parish of Ballarat, County of Grenville, as indicated by hachure on plan hereunder.—(S.353⁽⁵⁾) (Rs.8710).

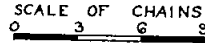
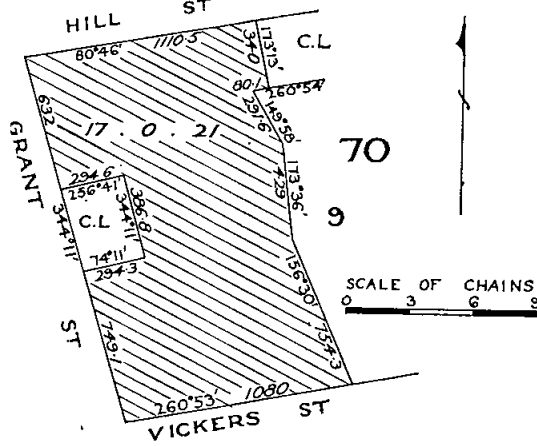

TONGIO-MUNJIE WEST.—Site for Public purposes (Forests Department purposes), 2 roods, Parish of Tongio-Munjie West, County of Dargo, as indicated by hachure on plan hereunder.—(T.159⁽¹²⁾) (Rs.8721).

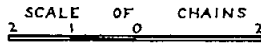
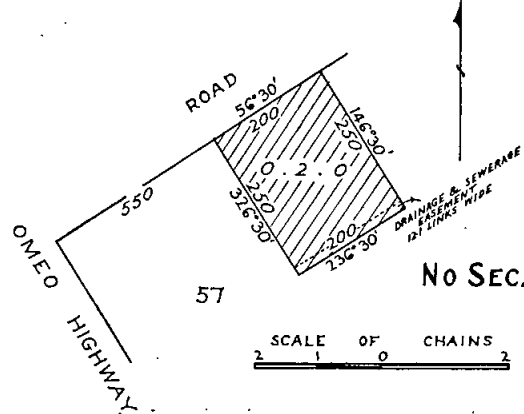

SOUTH MELBOURNE.—Site for State school purposes, 5/10 perch, City of South Melbourne, Parish of Melbourne South, County of Bourke, as indicated by hachure on plan hereunder.—(M.333⁽²⁸⁾) (Rs.5320).

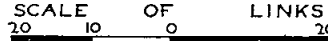
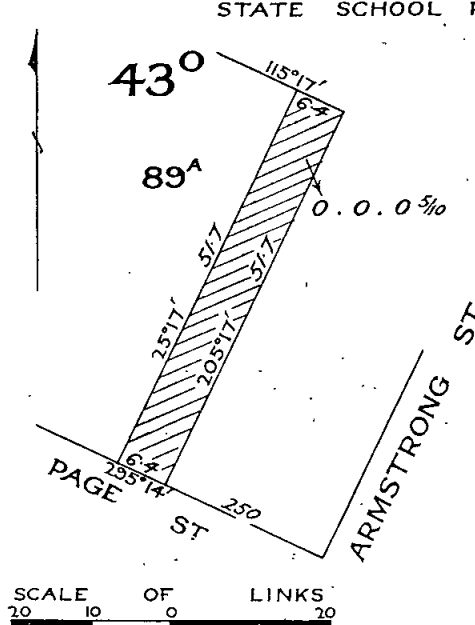

STATE SCHOOL RES.

SCARSDALE.—Site for Public purposes (Forests Department purposes), 1 rood 34 perches, Parish of Scarsdale, County of Grenville, as indicated by hachure on plan hereunder.—(S.249(12) (Rs.8483).

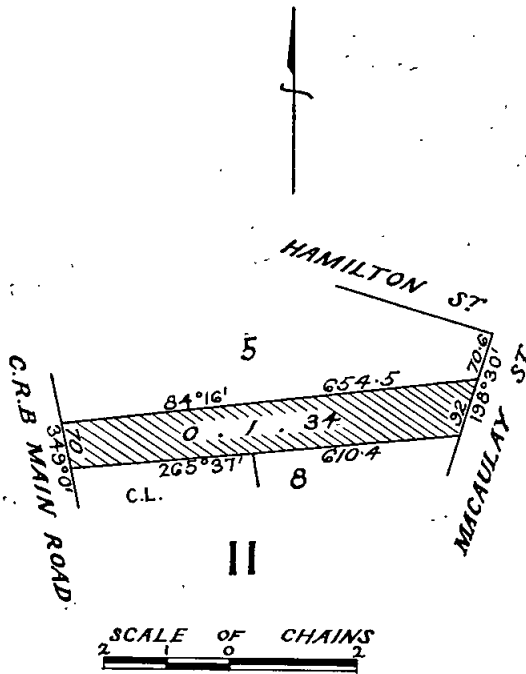

And the Honorable James Charles Murray Balfour, Her Majesty's Minister of Lands for the State of Victoria, shall give the necessary directions herein accordingly.

J. COLQUHOUN,
Clerk of the Executive Council.

DEPARTMENT OF CROWN LANDS AND SURVEY.

At the Executive Council Chamber, Melbourne, the fourth day of October, 1966.

PRESENT:

His Excellency the Governor of Victoria.
Mr. Thompson | Mr. Bloomfield.
Mr. Wilcox

REVOCATIONS OF TEMPORARY RESERVATIONS OF LAND BY ORDERS IN COUNCIL.

HIS Excellency the Governor of the State of Victoria, by and with the advice of the Executive Council thereof, doth hereby, in pursuance of the provisions of the Land Act 1958, revoke the temporary reservations of land by Orders in Council hereinafter referred to, viz.:—

BROADFORD.—Order in Council of 30th September, 1911, of 3 acres of land in the Parish of Broadford, as a site for supply of gravel, so far only as regards the portion thereof comprised within the boundaries published in the Government Gazette of 7th September, 1966, and containing 1 rood 32 perches. (Rs.8610.)

GRANTON.—Order in Council of 22nd July, 1958, of 1 acre of land in the Parish of Granton, as a site for Public Hall, so far only as regards the portion thereof comprised within the boundaries published in the Government Gazette of 7th September, 1966, and containing 31 perches.

And the Honorable James Charles Murray Balfour, Her Majesty's Minister of Lands for the State of Victoria, shall give the necessary directions herein accordingly.

J. COLQUHOUN,
Clerk of the Executive Council.

DEPARTMENT OF CROWN LANDS AND SURVEY.

At the Executive Council Chamber, Melbourne, the fourth day of October, 1966.

PRESENT:

His Excellency the Governor of Victoria.
Mr. Thompson | Mr. Bloomfield.
Mr. Wilcox

UNUSED ROADS CLOSED.

HIS Excellency the Governor of the State of Victoria, by and with the advice of the Executive Council thereof, doth hereby direct that, in pursuance of the provisions of section 349 of the Land Act 1958, the unused roads referred to hereunder be closed, viz.:—

Township of Alexandra, Parish of Alexandra, County of Anglesey, being the road between allotments 2A, 2, section 6, and allotments 4A, 4, section 6.—(A.160(8) (C.99784).

Township of Berriwillock, Parish of Boigbeat, County of Karkaroc, being the road between the land reserved as a site for Plantation purposes by Order in Council of the 29th August, 1950, and the Water Reserve (Departmental).—(B.748(7) (22/134).

Parish of Bitchigal, County of Karkaroc, being the road between allotments 26, 26A, 25A, and allotments 30, 28.—(B.759(4) (M.40985).

Parish of Everton, County of Bogong, being the road between allotments 12 and 12A, section 8.—(E.87(8) (H.O.29324).

Township of Hamilton, Parish of North Hamilton, County of Dundas, being the portion of the width of road indicated by hachure on plan hereunder.—(H.45(8) (J.31797).

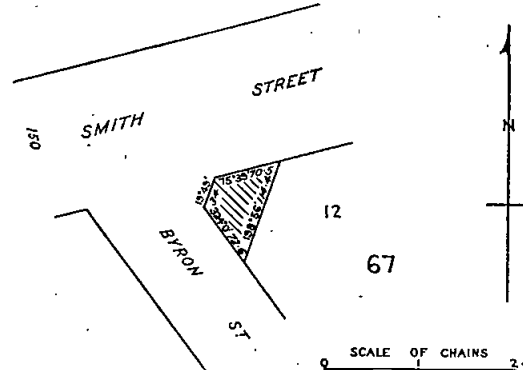

Parish of Waranga, County of Rodney, being the road indicated by hachure on plan hereunder.—(W.37(4) (H.030536).

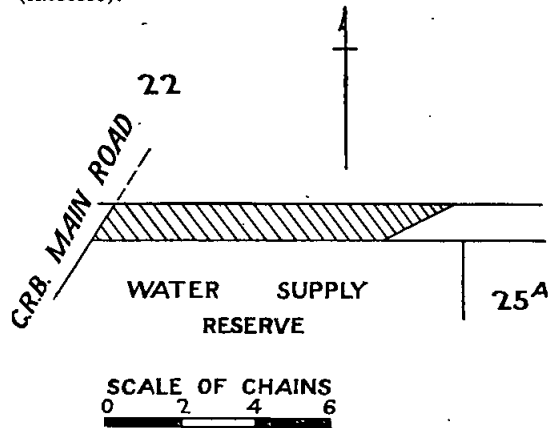

And the Honorable James Charles Murray Balfour, Her Majesty's Minister of Lands for the State of Victoria, shall give the necessary directions herein accordingly.

J. COLQUHOUN,
Clerk of the Executive Council.

DEPARTMENT OF CROWN LANDS AND SURVEY.

At the Executive Council Chamber, Melbourne, the fourth day of October, 1966.

PRESENT:

His Excellency the Governor of Victoria.
Mr. Thompson | Mr. Bloomfield.
Mr. Wilcox

REVOCATIONS OF TEMPORARY RESERVATIONS OF LAND BY ORDERS IN COUNCIL.

HIS Excellency the Governor of the State of Victoria, by and with the advice of the Executive Council thereof, doth hereby, in pursuance of the provisions of the Land Act 1958, revoke the temporary reservations of land by Orders in Council hereinafter referred to, viz.:

BOORT.—Order in Council of 1st March, 1880, of 2 acres of land in the Parish of Boort, as a site for Public Purposes (State School).—(C.97235.)

BOORT.—Order in Council of 8th November, 1887, of 4 acres 2 roods 5 perches of land in the Parish of Boort, as a site for Public Recreation.—(Rs.6941.)

BRIAGOLONG.—Order in Council of 4th September, 1893, of 20 acres 3 roods 16 4/10 perches of land in the Parish of Briagolong, as a site for Supply of Gravel.—(Rs.2530.)

COBDEN.—Order in Council of the 13th September, 1886, of 60 acres 31 perches of land in the Township of Cobden, as a site for Public Recreation.—(Rs.1015.)

CRESWICK.—Order in Council of 7th July, 1941, of 4 acres of land in the Township of Creswick, as a site for Public Recreation.—(Rs.5231.)

CURYO.—Order in Council of 30th May, 1893, of 40 acres 2 roods 10 perches of land in the Parish of Curyo, as a site for Water Supply purposes.—(C.81202.)

DAYLESFORD.—Order in Council of 14th January, 1964, of 3 acres 3 roods 26 perches of land in the Township of Daylesford, as a site for Water Supply Purposes.—(Rs.8295.)

DOWLING FOREST.—Order in Council of the 19th November, 1866, of 46 acres more or less, of land in the Parish of Dowling Forest, as a site for Watering and other public purposes.—(Rs.6805.)

ELDORADO.—Order in Council of 14th August, 1939, of 7 acres more or less, of land in the Township of Eldorado, as a site for Public Park.—(Rs.4972.)

GERAHMIN.—Order in Council of 29th April, 1913, of 1 acre of land in the Parish of Gerahmin, as a site for Public Hall.—(Rs.975.)

GOWAR.—Order in Council of the 25th August, 1879, of 53 acres 9 perches of land in the Parish of Gowar, as a site for a Quarry.—(O.888/130.)

MARYBOROUGH.—Order in Council of 27th November, 1923, of 11 acres 1 rood 38 perches of land in the Parish of Maryborough, as a site for Supply of Gravel.—(Rs.2858.)

MARYSVILLE.—Order in Council of 31st October, 1950, of 27 perches of land in the Township of Marysville, as a site for an Infant Welfare Centre.—(Rs.6590.)

MARYSVILLE.—Order in Council of 3rd March, 1959, of 27 perches of land in the Township of Marysville, as a site for a Pre-School Centre.—(Rs.7803.)

NARBETHONG.—Order in Council of 10th July, 1917, of 3 acres 12 perches of land in the Township of Narbethong, as a site for Camping and Recreation purposes.—(Rs.1635.)

NUMURKAH.—Order in Council of 17th August, 1885, of 5 acres of land in the Township of Numurkah, as a site whence sand may be removed under licence.—(Rs.480.)

SKIPTON.—Order in Council of 11th September, 1916, of 23 perches of land in the Township of Skipton, as a site for Railway purposes.—(Rs.1185.)

TARRANGINIE.—Order in Council of 28th June, 1880, of 2 acres of land in the Parish of Tarranginnie, as a site for Public Purposes (State School).—(Rs.8638.)

TOOLONGROOK.—Order in Council of 31st July, 1882, of 40 acres more or less, of land in the Parish of Toolongrook, as a site for Supply of Limestone.—(Rs.7079.)

TRAGOWEL.—Order in Council of the 25th April, 1881, of 5 acres of land in the Parish of Tragowel, as a site for Public Purposes (State School).—(C.97591.)

WANGARATTA.—Order in Council of 18th December, 1871, of 65 acres more or less, of land in the Township of Wangaratta, as a site for Public Park.—(Rs.2441.)

And the Honorable James Charles Murray Balfour, Her Majesty's Minister of Lands for the State of Victoria, shall give the necessary directions herein accordingly.

J. COLQUHOUN,
Clerk of the Executive Council.

LOCAL GOVERNMENT DEPARTMENT.

At the Executive Council Chamber, Melbourne, the fourth day of October, 1966.

PRESENT:

His Excellency the Governor of Victoria.
Mr. Thompson | Mr. Bloomfield.
Mr. Wilcox

VESTING OF RESERVES IN THE DONCASTER AND TEMPLESTOWE SHIRE COUNCIL.

WHEREAS it is provided by section 569BA of the Local Government Act 1958, as amended, that where any map or plan has been lodged or deposited with the Registrar of Titles pursuant to section 97 of the Transfer of Land Act or any corresponding previous enactment (whether before or after the commencement of the Local Government Act 1963) and any allotment on that map or plan has been transferred the Governor in Council on the request of the council of the municipality may by Order published in the Government Gazette direct that the whole or any part of the land comprised in any reserve shown on that map or plan shall vest in the council whereupon such land shall so vest freed and discharged from any mortgage charge lease or sub-lease:

And whereas the Council of the Shire of Doncaster and Templestowe has requested that reserves shown on a plan of subdivision be vested in the Council and an allotment on that plan has been transferred:

Now therefore the Governor of the State of Victoria, by and with the advice of the Executive Council thereof, doth by this Order vest in the Council of the Shire of Doncaster and Templestowe certain lands being the Drainage Sewerage and Recreation Reserves coloured green on plan of subdivision No. 40186, lodged in the Office of Titles.

And the Honorable Rupert James Hamer, Her Majesty's Minister for Local Government for the State of Victoria, shall give the necessary directions herein accordingly.

J. COLQUHOUN,
Clerk of the Executive Council.

LOCAL GOVERNMENT DEPARTMENT.

At the Executive Council Chamber, Melbourne, the fourth day of October, 1966.

PRESENT:

His Excellency the Governor of Victoria.
Mr. Thompson | Mr. Bloomfield.
Mr. Wilcox

VESTING OF A RESERVE IN THE DONCASTER AND TEMPLESTOWE SHIRE COUNCIL.

WHEREAS it is provided by section 569BA of the Local Government Act 1958, as amended, that where any map or plan has been lodged or deposited with the Registrar of Titles pursuant to section 97 of the Transfer of Land Act 1958 or any corresponding previous enactment (whether before or after the commencement of the Local Government Act 1963) and any allotment on that map or plan has been transferred the Governor in Council on the request of the council of the municipality may by Order published in the Government Gazette direct that the whole or any part of the land comprised in any reserve shown on that map or plan shall vest in the council whereupon such land shall so vest freed and discharged from any mortgage charge lease or sub-lease:

And whereas the Council of the Shire of Doncaster and Templestowe has requested that a reserve shown on a plan of subdivision be vested in the Council and an allotment on that plan has been transferred:

Now therefore, the Governor of the State of Victoria, by and with the advice of the Executive Council thereof, doth by this Order vest in the Council of the Shire of

Doncaster and Templestowe certain land being the Recreation Reserve coloured green on plan of subdivision No. 34856, lodged in the office of Titles.

And the Honorable Rupert James Hamer, Her Majesty's Minister for Local Government for the State of Victoria, shall give the necessary directions herein accordingly.

J. COLQUHOUN,
Clerk of the Executive Council.

LOCAL GOVERNMENT DEPARTMENT.

At the Executive Council Chamber, Melbourne, the fourth day of October, 1966.

PRESENT:

His Excellency the Governor of Victoria.
Mr. Thompson | Mr. Bloomfield.
Mr. Wilcox

APPROVAL TO CONSTRUCT A NEW METROPOLITAN MAIN HIGHWAY.—CITIES OF MELBOURNE, ESSENDON, BRUNSWICK, COBURG AND BROADMEADOWS.

WHEREAS by section 206 of the Melbourne and Metropolitan Board of Works Act 1958, as amended, it is enacted that the Melbourne and Metropolitan Board of Works may, from time to time, recommend to the Governor in Council that a new metropolitan main highway within the metropolitan area be made (whether in whole or in part) on or through any land, and that the recommendation shall be accompanied by maps, plans and estimates showing the points between which and the land on or through which it is proposed to make the highway, and what land it is proposed to take or purchase; and the estimated cost of taking or purchasing the land and of making the highway, and that the Governor in Council may by Order approve the recommendation with or without modification or may refuse to approve it:

And whereas the Melbourne and Metropolitan Board of Works has recommended that a new metropolitan main highway be made between Flemington-road and Mount Alexander-road in the City of Melbourne (line A on Plan R14-00-20G) and approximately three hundred (300) feet north of Greenbank-crescent in the City of Coburg (line B on Plan R14-042-6G), on or through land reserved for the purpose and shown coloured pink and yellow respectively on the accompanying plans RES 14/1A, 2A, 3A and 4A, at an estimated cost for the taking or purchasing of the land between line A and the eastern boundary of Pascoe Vale-road and the making of the highway between lines A and B of \$17,000,000:

Now therefore, His Excellency the Governor of the State of Victoria, by and with the advice of the Executive Council thereof, doth hereby approve the said recommendation without modification.

And the Honorable Rupert James Hamer, Her Majesty's Minister for Local Government for the State of Victoria, shall give the necessary directions herein accordingly.

J. COLQUHOUN,
Clerk of the Executive Council.

LOCAL GOVERNMENT DEPARTMENT.

At the Executive Council Chamber, Melbourne, the fourth day of October, 1966.

PRESENT:

His Excellency the Governor of Victoria.
Mr. Thompson | Mr. Bloomfield.
Mr. Wilcox

ROAD DISCONTINUED.—CITY OF RINGWOOD.

WHEREAS it is provided in section 528 (2) of the Local Government Act 1958, as amended, that where a road (whether or not a public highway, but not being a road set out on land of the Crown) or any part thereof is not required for public use, the Governor in Council, on the request of the Council of the municipality in which such road is situated made not less than one month after publishing in a newspaper generally circulating in the

district and posting to the registered proprietor (if any) of the land and any person known to have an interest in the land notice of intention to make such a request may by Order published in the Government Gazette direct that such road or part shall be discontinued and thereupon such road or part shall be discontinued accordingly.

And whereas the Council of the City of Ringwood has requested that the Governor in Council direct that portion of Adelaide-street, Ringwood, be discontinued and not less than one month previously, has published in a newspaper generally circulating in the district and posted to the registered proprietor of the land in the said road notice of intention to make such request.

And whereas the said Council is the owner of all adjoining land.

Now therefore His Excellency the Governor of the State of Victoria, by and with the advice of the Executive Council thereof, hereby directs that the portion of the said road, which is shown hatched on the plan hereunder, shall be discontinued and that the land shall be retained by Council of the City of Ringwood for municipal purposes.

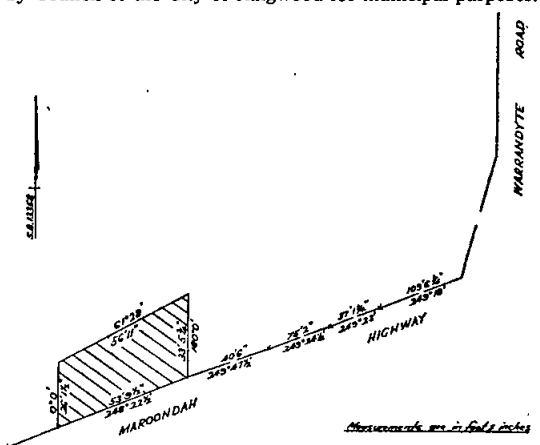

And the Honorable Rupert James Hamer, Her Majesty's Minister for Local Government for the State of Victoria, shall give the necessary directions herein accordingly.

J. COLQUHOUN,
Clerk of the Executive Council.

LOCAL GOVERNMENT DEPARTMENT.

At the Executive Council Chamber, Melbourne, the fourth day of October, 1966.

PRESENT:

His Excellency the Governor of Victoria.
Mr. Thompson | Mr. Bloomfield.
Mr. Wilcox

ROAD DISCONTINUED.—CITY OF DANDENONG.

WHEREAS it is provided in section 528 (2) of the Local Government Act 1958, that where a road (whether or not a public highway but not being a road set out on land of the Crown) or any part thereof is not required for public use the Governor in Council on the request of the Council of the municipality in which such road is situated made not less than one month after publishing in a newspaper generally circulating in the district and posting to the registered proprietor (if any) of the land and any person known to have an interest in the land notice of intention to make such a request may by Order published in the Government Gazette direct that such road or part shall be discontinued and thereupon such road or part shall be discontinued accordingly.

And whereas the Council of the City of Dandenong has requested that the Governor in Council direct that a right-of-way between Hutton-street and Pickett-street, Dandenong, be discontinued and not less than one month previously has published in a newspaper generally circulating in the district and posted to the registered proprietor of the land in the road and to all persons known to have an interest in the said land notice of intention to make such request.

Now therefore His Excellency the Governor of the State of Victoria, by and with the advice of the Executive Council thereof, hereby directs—

- (a) That the said road, which is shown by hachure and cross-hachure on the plan hereunder, shall be discontinued.
- (b) That notwithstanding such discontinuance the Dandenong Sewerage Authority shall continue to have and possess the same right, title, power, authority or interest in or in relation to the land shown by cross-hachure on the said plan as it had or possessed prior to such discontinuance with respect to or in connexion with any pipes laid or erected in, on or over such land for the purposes of drainage or sewerage.
- (c) That, subject to any such right, title, power, authority or interest, the land in the said road may be sold by the Council of the City of Dandenong by agreement.

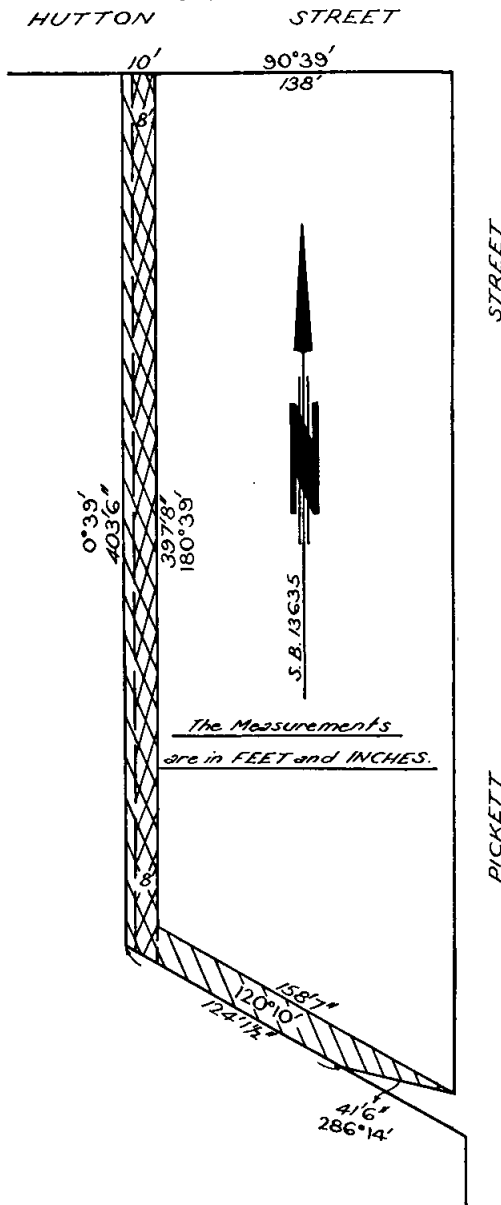

And the Honorable Rupert James Hamer, Her Majesty's Minister for Local Government for the State of Victoria, shall give the necessary directions herein accordingly.

J. COLQUHOUN,
Clerk of the Executive Council.

LOCAL GOVERNMENT DEPARTMENT.

At the Executive Council Chamber, Melbourne, the fourth day of October, 1966.

PRESENT:

His Excellency the Governor of Victoria.
Mr. Thompson | Mr. Bloomfield.
Mr. Wilcox

VESTING OF A RESERVE IN THE CROYDON SHIRE COUNCIL.

WHEREAS it is provided by section 569BA of the Local Government Act 1958, as amended, that where any map or plan has been lodged or deposited with the Registrar of Titles pursuant to section 97 of the Transfer of Land Act 1958 or any corresponding previous enactment (whether before or after the commencement of the Local Government Act 1963) and any allotment on that map or plan has been transferred the Governor in Council on the request of the Council of the municipality may by Order published in the Government Gazette direct that the whole or any part of the land comprised in any reserve shown on that map or plan shall vest in the council whereupon such land shall so vest freed and discharged from any mortgage charge lease or sub-lease:

And whereas the Council of the Shire of Croydon has requested that a reserve shown on a plan of subdivision be vested in the Council and an allotment on that plan has been transferred:

Now therefore I, the Governor of the State of Victoria, by and with the advice of the Executive Council thereof, doth by this Order vest in the Council of the Shire of Croydon certain land being the Reserve for Drainage Purposes and Proposed Park coloured green on plan of subdivision No. 50744, lodged in the Office of Titles.

And the Honorable Rupert James Hamer, Her Majesty's Minister for Local Government for the State of Victoria, shall give the necessary directions herein accordingly.

J. COLQUHOUN,
Clerk of the Executive Council.

(This Order is published in lieu of that published in the Government Gazette of the 21st September, 1966, at page 3403.)

LOCAL GOVERNMENT DEPARTMENT.

At the Executive Council Chamber, Melbourne, the fourth day of October, 1966.

PRESENT:

His Excellency the Governor of Victoria.
Mr. Thompson | Mr. Bloomfield.
Mr. Wilcox

VESTING OF RESERVES IN THE BOX HILL CITY COUNCIL.

WHEREAS it is provided by section 569BA of the Local Government Act 1958, as amended, that where any map or plan has been lodged or deposited with the Registrar of Titles pursuant to section 97 of the Transfer of Land Act or any corresponding previous enactment (whether before or after the commencement of the Local Government Act 1963) and any allotment on that map or plan has been transferred the Governor in Council on the request of the council of the municipality may by Order published in the Government Gazette direct that the whole or any part of the land comprised in any reserve shown on that map or plan shall vest in the council whereupon such land shall so vest freed and discharged from any mortgage charge lease or sub-lease:

And whereas the Council of the City of Box Hill has requested that certain reserves shown on plans of subdivision be vested in the Council and an allotment on each of such plans has been transferred:

Now therefore, the Governor of the State of Victoria, by and with the advice of the Executive Council thereof, doth by this Order vest in the Council of the City of Box Hill the lands being the recreational, drainage and sewerage reserve coloured purple on plan of subdivision No. 43187, lodged in the Office of Titles and the drainage, sewerage and recreation reserves coloured green on plans of subdivision Nos. 25052, 31986 and 52619, lodged as aforesaid.

And the Honorable Rupert James Hamer, Her Majesty's Minister for Local Government for the State of Victoria, shall give the necessary directions herein accordingly.

J. COLQUHOUN,
Clerk of the Executive Council.

CEMETERIES ACT 1958 (No. 6217).

At the Executive Council Chamber, Melbourne, the fourth day of October, 1966.

PRESENT:

His Excellency the Governor of Victoria.
Mr. Thompson | Mr. Bloomfield.
Mr. Wilcox

BURIALS IN THE YARROCK PUBLIC CEMETERY TO BE DISCONTINUED.

WHEREAS by section 44 of the Cemeteries Act 1958 (No. 6217) it is amongst other things enacted that the Governor in Council may by Order direct that burials in any cemetery or burial ground shall be wholly discontinued.

Now therefore His Excellency the Governor of the State of Victoria, by and with the advice of the Executive Council of the said State, doth by this Order direct that burials in the Yarrock Public Cemetery situated on land described in the Schedule attached hereto shall be wholly discontinued after the expiry date of a period of three months from the date of this Order.

SCHEDULE.

All that piece of land comprising five acres in the County of Lowan, Parish of Yarrock:—Commencing at a point bearing south 0 deg. 19 min. east one chain from the north-east angle of the Yanyip Homestead section; bounded thence by lines bearing respectively north 89 deg. 41 min. east five chains, south 0 deg. 19 min. east ten chains, and south 89 deg. 41 min. west five chains; and thence by road bearing north 0 deg. 19 min. west ten chains to the point of commencement.

And the Honorable Vance Oakley Dickie, Her Majesty's Minister of Health for the State of Victoria, shall give the necessary directions herein accordingly.

J. COLQUHOUN,
Clerk of the Executive Council.

LABOUR AND INDUSTRY ACT 1958.

At the Executive Council Chamber, Melbourne, the fourth day of October, 1966.

PRESENT:

His Excellency the Governor of Victoria.
Mr. Thompson | Mr. Bloomfield.
Mr. Wilcox

APPOINTMENT OF A DOCKMENS BOARD.

UNDER the powers in that behalf conferred by the *Labour and Industry Act 1958*, His Excellency the Governor of the State of Victoria, by and with the advice of the Executive Council thereof, doth hereby:—

1. Declare that it is expedient to appoint, and doth hereby appoint a Wages Board for the occupation of a Dockman employed by the Melbourne Harbor Trust Commissioners.

2. Order that such Wages Board shall consist of four members and a chairman.

3. Direct that such Wages Board may be described for all purposes as the Dockmens Board.

4. Define the area within which the Determination of such Wages Board shall be operative as being the whole of the State of Victoria.

And the Honorable Vernon Francis Wilcox, Her Majesty's Minister of Labour and Industry for the State of Victoria, shall give the necessary directions herein accordingly.

J. COLQUHOUN,
Clerk of the Executive Council.

DRAINAGE AREAS ACT 1958.

At the Executive Council Chamber, Melbourne, the fourth day of October, 1966.

PRESENT:

His Excellency the Governor of Victoria.
Mr. Thompson | Mr. Bloomfield.
Mr. Wilcox

ABOLITION OF THE GRETA-LACEBY DRAINAGE AREA AND CONSTITUTION OF THE OXLEY SHIRE DRAINAGE AREA.—SHIRE OF OXLEY.

PURSUANT to the provisions of the *Drainage Areas Act 1958*, as amended, and in compliance with the prayer of a petition presented by the Council of the Shire of Oxley, notice of which petition was duly published in the *Government Gazette* of the 4th May, 1966, His Excellency the Governor of the State of Victoria, by and with the advice of the Executive Council thereof, doth by this Order direct:

- (i) that the Greta-Lacey Drainage Area, constituted by Order published in the *Government Gazette* of the 19th January, 1949, and extended by Order published in the *Government Gazette* of the 15th November, 1961, shall be abolished; and
- (ii) that the whole of the municipal district of the Shire of Oxley shall be constituted a drainage area within the meaning of the said Act under the name of the Oxley Shire Drainage Area.

And the Honorable Rupert James Hamer, Her Majesty's Minister for Local Government for the State of Victoria, shall give the necessary directions herein accordingly.

J. COLQUHOUN,
Clerk of the Executive Council.

STAMPS ACT 1958, No. 6375.

At the Executive Council Chamber, Melbourne, the eleventh day of October, 1966.

PRESENT:

His Excellency the Governor of Victoria.
Mr. Chandler | Mr. Reid.
Mr. Darcy

HIS Excellency the Governor of the State of Victoria, by and with the advice of the Executive Council thereof, doth by this Order made pursuant to section 131c of the *Stamps Act 1958* (No. 6375) revoke the declaration made on 8th August, 1961, and published in the *Government Gazette* on 9th August, 1961, declaring certain persons to be "approved vendors" for the purposes of subdivision (14) of Division three of Part II of the *Stamps Act 1958* in so far as the said declaration refers to the undermentioned person—

184. Freighters Acceptance Company Limited.

And the Honorable Sir Henry Edward Bolte, Her Majesty's Treasurer for the State of Victoria, shall give the necessary directions herein accordingly.

J. COLQUHOUN,
Clerk of the Executive Council.

STAMPS ACT 1958 (No. 6375).

At the Executive Council Chamber, Melbourne, the eleventh day of October, 1966.

PRESENT:

His Excellency the Governor of Victoria.
Mr. Chandler | Mr. Reid.
Mr. Darcy

DECLARATION OF APPROVED VENDOR.

HIS Excellency the Governor of the State of Victoria, by and with the advice of the Executive Council thereof, doth by this Order made pursuant to section 131c (1) of the *Stamps Act 1958*, declare the undermentioned person carrying on business as a vendor of

goods under instalment purchase agreements to be an "approved vendor" for the purposes of subdivision (14) of Division three of Part II. of the *Stamps Act 1958*.

227. INTERNATIONAL HARVESTER CREDIT CORPORATION OF AUSTRALIA LIMITED.

And the Honorable Sir Henry Edward Bolte, Her Majesty's Treasurer for the State of Victoria, shall give the necessary directions herein accordingly.

J. COLQUHOUN,
Clerk of the Executive Council.

STAMPS ACT 1958 (No. 6375).

At the Executive Council Chamber, Melbourne, the eleventh day of October, 1966.

PRESENT:

His Excellency the Governor of Victoria.	
Mr. Chandler	Mr. Reid.
Mr. Darcy	

HIS Excellency the Governor of the State of Victoria, by and with the advice of the Executive Council thereof, doth by this Order made pursuant to section 131C of the *Stamps Act 1958* (No. 6375) revoke the declaration made on 12th January, 1960, and published in the *Government Gazette* on the 13th January, 1960, declaring certain persons to be "approved vendors" for the purposes of subdivision (14) of Division three of Part II. of the *Stamps Act 1958* in so far as the said declaration refers to the under-mentioned person:—

121. FRED ARMFIELD MOTORS AND SCOOTERS.

And the Honorable Sir Henry Edward Bolte, Her Majesty's Treasurer for the State of Victoria, shall give the necessary directions herein accordingly.

J. COLQUHOUN,
Clerk of the Executive Council.

STAMPS ACT 1958 (No. 6375).

At the Executive Council Chamber, Melbourne, the eleventh day of October, 1966.

PRESENT:

His Excellency the Governor of Victoria.	
Mr. Chandler	Mr. Reid.
Mr. Darcy	

HIS Excellency the Governor of the State of Victoria, by and with the advice of the Executive Council thereof, doth by this Order made pursuant to section 131C of the *Stamps Act 1958* (No. 6375) revoke the declaration made on 11th June, 1959, and published in the *Government Gazette* on the 17th June, 1959, declaring certain persons to be "approved vendors" for the purposes of subdivision (14) of Division three of Part II. of the *Stamps Act 1958* in so far as the said declaration refers to the under-mentioned person:—

89. CONTRACT INVESTMENTS PROPRIETARY LIMITED.

And the Honorable Sir Henry Edward Bolte, Her Majesty's Treasurer for the State of Victoria, shall give the necessary directions herein accordingly.

J. COLQUHOUN,
Clerk of the Executive Council.

Water Act 1958.

STATE RIVERS AND WATER SUPPLY COMMISSION.

At the Executive Council Chamber, Melbourne, the eleventh day of October, 1966.

PRESENT:

His Excellency the Governor of Victoria.	
Mr. Chandler	Mr. Reid.
Mr. Darcy	

ROBINVALE URBAN DISTRICT.—AREA OF DISTRICT INCREASED.

UNDER the powers conferred by the *Water Act 1958* and all other powers enabling him in that behalf, His Excellency the Governor of the State of Victoria, with

the advice of the Executive Council of the said State, on the recommendation of the State Rivers and Water Supply Commission, doth hereby declare, order, and direct as follows:—

That the area of the Robinvale Urban District be increased by adding thereto the lands set out and described in the Schedule hereto and as on and from the 1st day of November, 1966, the area of such District shall be deemed to be so increased.

SCHEDULE.

Commencing at the most western angle of lot 11 on lodged plan of subdivision No. 12824, Parish of Bumbang, County of Karkarook; thence north-easterly by the south-eastern boundary of Ronald-street and easterly by the southern boundary of Alexander-street and a line in continuation thereof to the eastern boundary of Latje-road; thence southerly by that road boundary to a point opposite the intersection of the western boundary of Latje-road and the south-western boundary of George-street; thence westerly by a line across Latje-road to the said intersection; thence north-westerly by the south-western boundary of George-street to a point in line with the south-eastern boundary of lot 38 on lodged plan of subdivision No. 56452; thence north-easterly by a line in production of the last mentioned lot boundary to the north-eastern boundary of George-street; thence north-westerly by that street boundary to the point of commencement.

The lands set out and described in the foregoing Schedule are shown on a plan approved by the Governor in Council and deposited in the office of the State Rivers and Water Supply Commission, Melbourne.—(Corr. 60/2870).

And the Honorable Thomas Anthony Darcy, Her Majesty's Minister of Water Supply for the State of Victoria, shall give the necessary directions herein accordingly.

J. COLQUHOUN,
Clerk of the Executive Council.

LILYDALE SEWERAGE AUTHORITY.

At the Executive Council Chamber, Melbourne, the eleventh day of October, 1966.

PRESENT:

His Excellency the Governor of Victoria.	
Mr. Chandler	Mr. Reid.
Mr. Darcy	

APPROVAL OF SITE FOR TREATMENT WORKS AND DISPOSAL AREA AND TO ITS COMPULSORY ACQUISITION.

HIS Excellency the Governor of the State of Victoria, by and with the advice of the Executive Council thereof, doth hereby approve in accordance with the provisions of the Sewerage Districts Acts the site for treatment works and disposal area of the Lilydale Sewerage Authority on the lands as described in the Schedule hereto and to the compulsory acquisition of the said land.

SCHEDULE.

All that land within the boundaries described as follows with the exception of that land vested in the Victorian Railways Commissioners:—

Commencing at a point being the intersection of the right bank of Olinda Creek and the northern boundary of Nelson-road, Parish of Yering, County of Evelyn; thence generally northerly along the right bank of Olinda Creek to a point on the southern boundary of Crown section 18; thence westerly along the southern boundary of the said Crown section 18 to its south-western angle; thence northerly along the western boundary of the said Crown section 18 a distance 3,200 links; thence through the said Crown section 18 by a line bearing 98 deg. 38 min. to a point on the western boundary of the Lilydale-Healesville railway reserve; thence generally south-westerly along the western boundary of the said railway reserve to its intersection with a line bearing 98 deg. 55 min., passing through a point on the western boundary of Crown section 24, being distant 3,021 3-10ths links northerly from the south-western angle of the said Crown section 24; thence through the said Crown section 24 by lines bearing 98 deg. 55 min. a distance of 1,124 1/2 links and 188 deg. 46 min. a distance of 3,043 3-10th links to a point on the northern boundary of Nelson-road; thence westerly along

the northern boundary of Nelson-road to a point on the right bank of Olinda Creek being the point of commencement.

All of which lands are shown on a plan approved by the Governor in Council and deposited in the office of the State Rivers and Water Supply Commission, Melbourne.—(Corr. 61/1276/24.)

And the Honorable Thomas Anthony Darcy, Her Majesty's Minister of Water Supply for the State of Victoria, shall give the necessary directions herein accordingly.

J. COLQUHOUN,
Clerk of the Executive Council.

KYABRAM SEWERAGE AUTHORITY.

At the Executive Council Chamber, Melbourne, the eleventh day of October, 1966.

PRESENT:
His Excellency the Governor of Victoria.
Mr. Chandler | Mr. Reid.
Mr. Darcy

EXTENT OF DISTRICT INCREASED.

UNDER the powers conferred by the Sewerage Districts Act and all other powers enabling him in that behalf, His Excellency the Governor of the State of Victoria, by and with the advice of the Executive Council of the said State, doth hereby declare, order and direct that the extent of the Sewerage District of the Kyabram Sewerage Authority be increased by adding thereto the lands within the boundaries described in the Schedule hereto and as on and from the date hereof the extent of the said Sewerage District shall be deemed to be increased accordingly.

SCHEDULE.
PORTION I.

Commencing at the south-eastern angle of lot 44 on lodged plan of subdivision No. 4466, Parish of Kyabram East, County of Rodney, being a point on the boundary of the existing Sewerage District; thence northerly along the eastern boundary of the said lot 44 to its north-eastern angle; thence westerly along the northern boundary of the said lot 44 to a point in line with the western boundary of lot 1 on lodged plan of subdivision No. 66149; thence northerly by a line across McCormick-street and along the said western boundary of lot 1 to its north-western angle; thence easterly along the northern boundary of the said lot 1 to a point on the western boundary of lot 1 on lodged plan No. 64534; thence northerly and easterly along the western and northern boundaries of the said lot 1 on lodged plan No. 64543 to its north-eastern angle; thence southerly along the eastern boundary of the said lot 1 to a point in line with the northern boundary of Barton-road; thence easterly by a line through lot 45 on lodged plan No. 4466 and along the said northern boundary of Barton-road to a point on the eastern boundary of lot 46; thence southerly along the said eastern boundary of lot 46 to a point on the northern boundary of McCormick-street being a point on the boundary of the existing Sewerage District; thence westerly, southerly and westerly along the said boundary of the Sewerage District to the point of commencement.

PORTION II.

Commencing at the north-western angle of a recreation ground, Gazette 98, 3977, Parish of Kyabram East, County of Rodney, being a point on the boundary of the existing Sewerage District; thence easterly along the northern boundary of the said recreation ground a distance of 660 ft. 5 1/4 in. to a point in line with the eastern boundary of a road; thence northerly by a line across a road and along the said eastern boundary of a road a distance of 358 ft. 10 in. to a point on the boundary of the existing Sewerage District; thence westerly and southerly along the said boundary of the Sewerage District to the point of commencement.

PORTION III.

Commencing at a point on the western boundary of Julia-street south, Parish of Kyabram East, County of Rodney, being distant 900 links southerly from the southern boundary of Allan-street being a point on the boundary of the existing Sewerage District; thence southerly along the said eastern boundary of Julia-street south to a point in line with the northern boundary of lot 21 on lodged plan

No. 5261; thence easterly by a line across a road and along the said northern boundary of lot 21 to its north-eastern angle; thence southerly along the eastern boundary of the said lot 21 and of lot 22 to the north-western angle of lot 18; thence easterly along the northern boundary of the said lot 18 to a point on the boundary of the existing Sewerage District; thence northerly and westerly along the said boundary of the Sewerage District to the point of commencement.

All of which land is shown on a plan approved by the Governor in Council and deposited in the office of the State Rivers and Water Supply Commission, Melbourne.—(Corr. 59/1582/166.)

And the Honorable Thomas Anthony Darcy, Her Majesty's Minister of Water Supply for the State of Victoria, shall give the necessary directions herein accordingly.

J. COLQUHOUN,
Clerk of the Executive Council.

LANDLORD AND TENANT ACT 1958:

At the Executive Council Chamber, Melbourne, the eleventh day of October, 1966.

PRESENT:
His Excellency the Governor of Victoria.
Mr. Chandler | Mr. Reid.
Mr. Darcy

ORDER EXTENDING APPLICATION OF PART V. OF THE LANDLORD AND TENANT ACT 1958 TO CERTAIN PREMISES.

IN pursuance of the powers conferred by section 44 of the *Landlord and Tenant Act 1958*, His Excellency the Governor of Victoria, by and with the advice of the Executive Council, doth hereby declare that the application of Part V. of the *Landlord and Tenant Act 1958* shall extend to the following premises:—

1. The whole of the premises known as Number 49 Rowan-street, Bendigo, and to all premises forming part of such premises.

And the Honorable Arthur Gordon Rylah, Her Majesty's Attorney-General for the State of Victoria, shall give the necessary directions herein accordingly.

J. COLQUHOUN,
Clerk of the Executive Council.

MELBOURNE AND METROPOLITAN TRAMWAYS ACT 1958, No. 6311.

At the Executive Council Chamber, Melbourne, the eleventh day of October, 1966.

PRESENT:
His Excellency the Governor of Victoria.
Mr. Chandler | Mr. Reid.
Mr. Darcy

WHEREAS His Excellency the Governor of the State of Victoria, by and with the advice of the Executive Council thereof has this day consented, pursuant to the provisions of section 28 of the *Melbourne and Metropolitan Tramways Act 1958*, to the Melbourne and Metropolitan Tramways Board raising by way of loan an amount not exceeding Four hundred thousand dollars (\$400,000); And whereas His Excellency the Governor is satisfied that a sufficient proportion of the loan to be so raised will fall due and be repaid in each year during the currency of the proposed loan: Now therefore it is directed, pursuant to the provisions of section 28 (6) of the said Act, that it shall not be necessary to provide a sinking fund in connexion with such loan.

And the Honorable Sir Henry Edward Bolte, Her Majesty's Treasurer for the State of Victoria, shall give the necessary directions herein accordingly.

J. COLQUHOUN,
Clerk of the Executive Council.

TOBACCO LEAF INDUSTRY STABILIZATION ACT
1966 (No. 7427).

At the Executive Council Chamber, Melbourne, the
eleventh day of October, 1966.

PRESENT:

His Excellency the Governor of Victoria.
Mr. Chandler | Mr. Reid.
Mr. Darcy |

APPOINTMENT OF SECRETARY TO THE TOBACCO
QUOTA APPEALS TRIBUNAL.

IN pursuance of the powers conferred by section 19 of
the Tobacco Leaf Industry Stabilization Act 1966
(No. 7427), His Excellency the Governor of the State
of Victoria, by and with the advice of the Executive
Council thereof, doth by this Order hereby appoint
JAMES MCKANE, an officer of the Department of Agri-
culture as Secretary to the Tobacco Quota Appeals
Tribunal from and inclusive of the 11th October, 1966.

And the Honorable Gilbert Lawrence Chandler, Her
Majesty's Minister of Agriculture for the State of Victoria,
shall give the necessary directions herein accordingly.

J. COLQUHOUN,
Clerk of the Executive Council.

LANDS DEPARTMENT NOTICES

APPROACHING LAND SALES.

SALES of Crown lands, in fee-simple, will be held at the
under-mentioned places and dates, viz.:—

	No. of Gazette.
Bairnsdale.—Monday, 7th November, 1966 ..	74
Bendigo.—Thursday, 10th November, 1966 ..	76
Bright.—Thursday, 17th November, 1966 ..	76
Castlemaine.—Tuesday, 8th November, 1966 ..	76
Orbost.—Tuesday, 25th October, 1966 ..	72
Wangaratta.—Thursday, 17th November, 1966 ..	77
Warracknabeal.—Wednesday, 19th October, 1966 ..	66
Warragul.—Thursday, 20th October, 1966 ..	64
Wodonga.—Tuesday, 15th November, 1966 ..	76

SALE OF FREEHOLD LAND BY AUCTION.

Chiltern.—Tuesday, 15th November, 1966 .. 76

SALE OF CROWN LAND BY AUCTION.

The land will be offered for sale in fee-simple, and
subject to the provisions of the Land Act and Regulations
thereunder.

The **upset price** is the sum at which bidding will start,
and no bid below that sum can be accepted. The highest
bidder at or above that sum shall be the purchaser, subject
to signature of contract and any necessary payment.

TERMS:—

A **deposit** of at least 12½% of the purchase price must
be paid at the sale, either in cash or by cheque.

The **residue** is payable in half-yearly instalments, in
accordance with the following scale, or may be paid off
at any earlier time.

\$40 and under, 6 instalments.
Over \$40, and not exceeding \$100, 8 instalments.
Over \$100, and not exceeding \$200, 10 instalments.
Over \$200, and not exceeding \$400, 12 instalments.
Over \$400, and not exceeding \$600, 14 instalments.
Over \$600, and not exceeding \$800, 16 instalments.
Over \$800, and not exceeding \$1,000, 18 instalments.
Over \$1,000, 20 instalments.

Interest at the rate of 5% per annum is payable with
all payments of residue, and is computed for each instal-
ment from the date of sale to the date of such payment.
Additional interest is charged if any instalment is not paid
on or before the due date.

If paid off within 30 days of sale, no interest is payable.

No. 77.—9351/66.—4

FEES, ETC.:

Also payable at the sale, in addition to the deposit, are
the survey fee and, if applicable, the valuation of improve-
ments (if purchaser be not the owner thereof).

Payable with balance of purchase money—

Crown Grant fee—	
50 acres and under	\$3
Over 50 acres	\$4
Purchase money \$10 or under ..	\$2

Assurance Fund contribution.—One cent in every Five
dollars or part thereof of purchase price. (This is a fund
established to guarantee the validity of freehold titles.)

Transfer of interest prior to completion of payment
may be allowed on payment of \$2 fee and subject to
stamp duty.

If unable to attend personally, a prospective purchaser
may arrange for another person to bid as his agent.

Attention is drawn to section 95, Land Act 1958, which
provides that the purchaser shall be deemed to be the
owner for the purposes of other Acts; also to an amend-
ment to the Local Government Act providing for Govern-
ment roads, in certain circumstances, to be declared
"private streets", thus making the purchaser liable to
contribute to the cost of street construction.

J. C. M. BALFOUR,
Minister of Lands.

Office of Crown Lands and Survey,
Melbourne, 12th October, 1966.

WANGARATTA.—Sale (No. 11841) of Crown land in
fee-simple, by auction, will be held at the LAND
OFFICE, MURPHY-STREET, WANGARATTA, on THURS-
DAY, the 17th NOVEMBER, 1966, at half-past NINE
o'clock a.m. To be conducted by D. M. O'CONNOR,
Land Officer, Wangaratta.

TOWNSHIP OF GLENROWEN, PARISH OF GLENROWEN,
COUNTY OF MOIRA.

Fronting at the eastern end the northern side of the
Government road north of the railway station.

Upset price \$100 per lot. Survey fee \$13 per lot.

- Lot 1. Area 1r. 24p., allotment 7, section 35.
Lot 2. Area 1r. 24p., allotment 8, section 35.
Lot 3. Area 1r. 24p., allotment 9, section 35.
Lot 4. Area 1r. 24p., allotment 10, section 35.—
(H.O.29221.)

TOWNSHIP OF ELDORADO, PARISH OF BYAWATHA, COUNTY OF
BOGONG.

Lot 5.

Fronting the north side of Main-street opposite Public Park
Reserve.

Upset price \$135 the lot. Survey fee \$17. 75.

Area 3a. 0r. 10p., allotment 16, section 15.—(H.O.30927.)

Lot 6.

TOWNSHIP OF ELDORADO, PARISH OF TARRAWINGEE,
COUNTY OF BOGONG.

On the south side of the main road, about 25 chains west
of Bowman-street.

Upset price \$60 the lot. Survey fee \$13. 25.

Area 3r. 4p., allotment 10, section 16. One month
allowed for removal of improvements.—(H.O.24974.)

ALSO THE FOLLOWING FREEHOLD LAND WILL BE
OFFERED:—

Note.—This lot is not subject to the provisions of the
Land Act as set out above, but comprises freehold land
offered on behalf of the Education Department on the
following conditions:—

- (a) Deposit of at least 12½ per cent. payable at the
sale and balance within 60 days.
(b) Purchaser to arrange for, and bear costs of, regis-
tration of transfer of title.

Lot 7.

TOWNSHIP OF WANGARATTA, PARISH OF WANGARATTA,
COUNTY OF MOIRA.

Fronting the eastern side of Swan-street about 4½ chains
north of Templeton-street.

Upset price \$3,925 the lot.

Area 1r. 29p., part allotment 3, section 63A, being the
whole of the land described in freehold certificate of title,
volume 5234, folio 620, and the improvements erected
thereon, comprising old brick and weatherboard house,
outbuildings, fencing, &c.—(H.O.31101.)

PROPOSED REVOCATIONS OF TEMPORARY RESERVATIONS OF LANDS BY ORDERS IN COUNCIL.

IN pursuance of the provisions of the Land Act 1958, notice is hereby given that it is the intention of the Governor in Council to revoke the temporary reservations of lands by Orders in Council hereunder referred to, viz.:

The following Notices were published 1° on the 12th October, 1966, pursuant to Orders of the 4th October, 1966.

BERRIWILLOCK.—The temporary reservation by Order in Council of the 29th August, 1950, of 43 acres 2 roods of land in the Township of Berriwillock as a site for Plantation purposes so far only as the portion containing 18 acres 2 roods 5 perches, indicated by hachure on plan hereunder, is concerned.—(B.748⁽¹⁾) (Rs.6472).

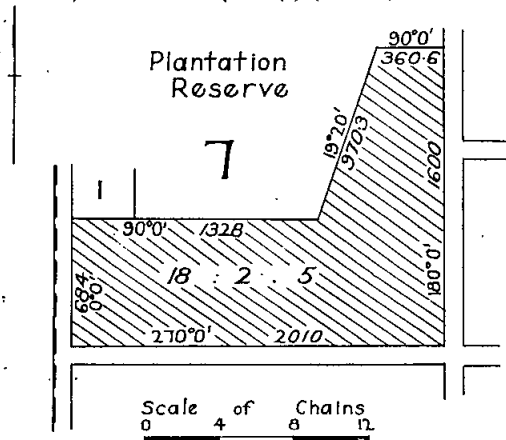

CANNIE.—The temporary reservation, by Order in Council of the 27th October, 1890 (see Government Gazette 31st October, 1890, page 4273) of 50 acres 14 perches of land in the Parish of Cannie, as a site for Water Supply purposes, so far only as the portion containing 4 acres 1 rood 18 perches, indicated by hachure on plan hereunder, is concerned.—(C.463⁽¹⁾) (C.99457).

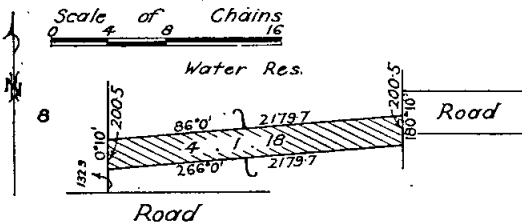

DURDIDWARRAH (formerly the municipal district of Steiglitz).—The temporary reservation as a site for Public purposes (State School purposes) and the withholding from sale, leasing and licensing by Order in Council of the 5th January, 1880, of 2 acres of land in the Parish of Durdidwarrah.—(D.135⁽⁴⁾) (G.61957).

LALKALDARNO.—The temporary reservation, by Order in Council of the 28th October, 1872 (see Government Gazette, 1st November, 1872, page 2007), of 612 acres of land in the Parish of Lalkaldarno as a site for Public purposes, revoked as to part by various Orders, so far only as the portion containing 160 acres 1 rood, more or less, indicated by hachure on plan hereunder, is concerned.—(L.116⁽²⁾).

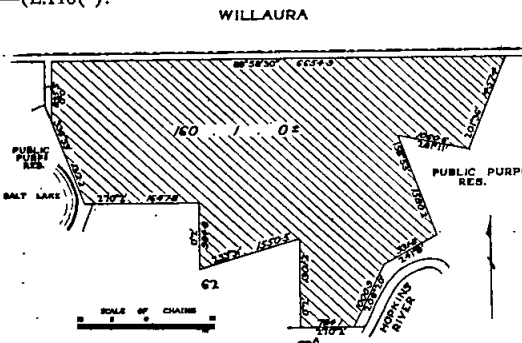

MANSFIELD.—The temporary reservation, by Order in Council of the 10th February, 1862, of 2 acres of land in the Parish of Mansfield as a site for a Public Pound, so far only as the portion containing 1 rood 8 perches, indicated by hachure on plan hereunder, is concerned.—(M.35⁽⁸⁾) (Rs.5430).

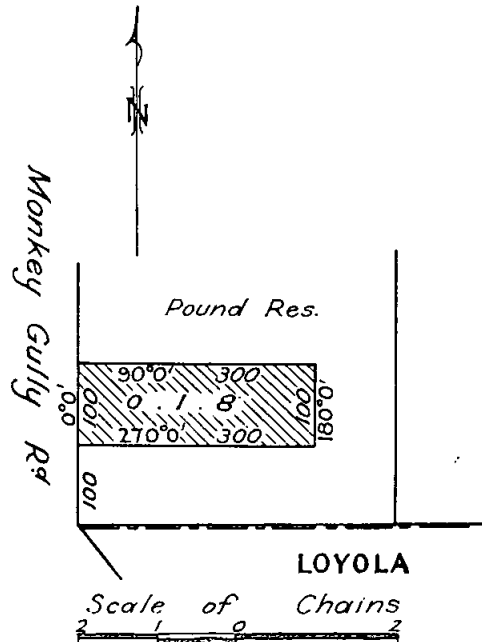

MELBOURNE SOUTH (St. Kilda).—The temporary reservation, by Order in Council of the 18th May, 1965, of 1 rood 7 perches of land at St. Kilda, Parish of Melbourne South, as a site for Public purposes (Police purposes), so far only as the portion containing 19 perches, more or less, indicated by hachure on plan hereunder, is concerned.—(M.333⁽²⁰⁾) (Rs.8441).

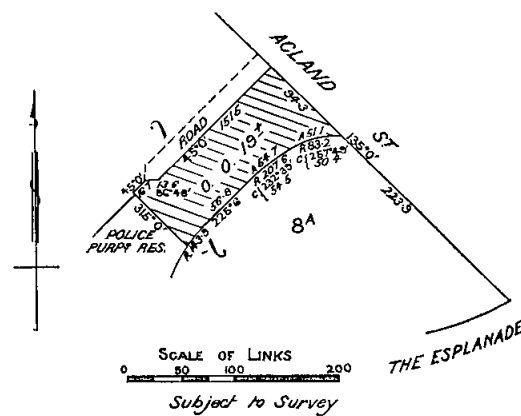

MIEPOLL.—The temporary reservation as a site for Public purposes (State School) and the withholding from sale, leasing and licensing by Order in Council of the 12th April, 1882 (see Government Gazette, 14th April, 1882, page 869), of 2 acres of land in the Parish of Miepoll.—(M.495⁽³⁾) (C.99793).

MURTOA.—The temporary reservation as a site for Shire Hall and Offices and the withholding from sale, leasing and licensing by Order in Council of the 12th December, 1881, of 1 rood 33 7/10 perches of land in the Township of Murtoa, revoked as to part by Order in Council of the 7th October, 1952, so far as the balance thereof containing 1 rood 11 7/10 perches, more or less, is concerned.—(M.483⁽²⁾) (Rs.7783).

WARRA WARRA.—The temporary reservation as a site for Camping and Watering purposes and the withholding from sale, leasing and licensing by Order in Council of the 5th July, 1875, of 180 acres of land in the Parish of Warra Warra, revoked as to part by Order in Council of the

14th June, 1904, so far only as the portion containing 19 acres 7 perches, indicated by hachure on plan hereunder, is concerned.—(W.261^(*)) (Rs.7219).

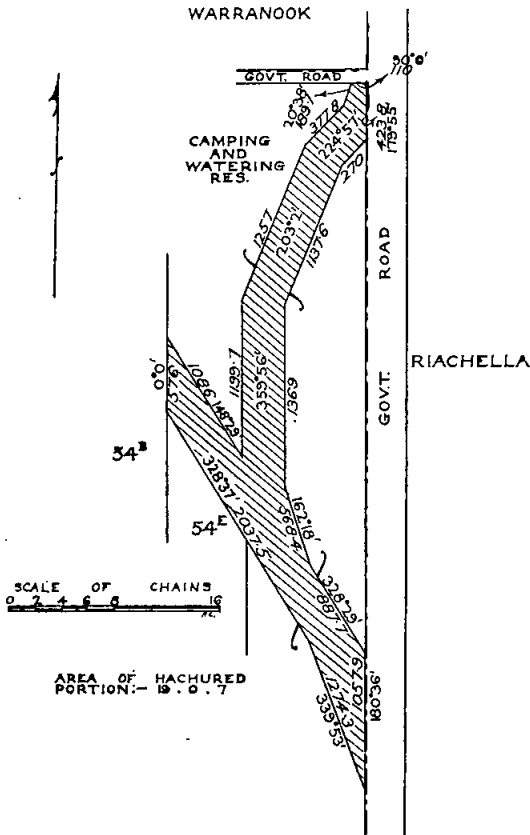

SEA LAKE.—The temporary reservation, by Order in Council of the 27th August, 1907, of 32 acres of land in the Township of Sea Lake as a site for Water Supply purposes.—(S.452^(*)) (Rs.2378).

J. C. M. BALFOUR,
Minister of Lands.

PROPOSED REVOCATION OF TEMPORARY RESERVATION OF LAND BY ORDER IN COUNCIL.

IN pursuance of the provisions of the Land Act 1958, notice is hereby given that it is the intention of the Governor in Council to revoke the temporary reservation of land by Order in Council hereunder referred to, viz.:

The following Notice was published 1° on the 5th October, 1966, pursuant to Order of the 27th September, 1966.

MURCHISON NORTH.—The temporary reservation, by Order in Council of the 14th May, 1913, of 5 acres of land in the Parish of Murchison North, as a site for Water Supply purposes.—M.273^(*) (C.57258).

J. C. M. BALFOUR,
Commissioner of Crown Lands and Survey.

PROPOSED REVOCATIONS OF TEMPORARY RESERVATIONS OF LANDS BY ORDERS IN COUNCIL.

IN pursuance of the provisions of the Land Act 1958, notice is hereby given that it is the intention of the Governor in Council to revoke the temporary reservations of lands by Orders in Council hereunder referred to, viz.:

The following Notices were published 1° on the 21st September, 1966, pursuant to Orders of the 13th September, 1966.

BAGHALLAH.—The temporary reservation, by Order in Council of the 6th February, 1903, of 40 acres of land in the Parish of Baghallah, as a site for a quarry and Manure Depot.—(B.86^(*)) (Rs.7346).

BONNIE DOON (formerly DOON).—The temporary reservation, by Order in Council of the 25th November, 1889, of 1 rood 2 perches of land in the Township of Bonnie Doon, as a site for a Mechanics Institute.—(D.164^(*)) (Rs.6686).

WORROUGH.—The temporary reservation by Order in Council of the 25th October, 1886, of 20 acres 3 roods 9 perches of land in the Parish of Worrough, as a site for Watering purposes.—(W.286^(*)) (81/121).

J. C. M. BALFOUR,
Minister of Lands.

PROPOSED PERMANENT RESERVATIONS OF LANDS AS SITES.

IN pursuance of the provisions of the Land Act 1958, notice is hereby given that it is the intention of the Governor in Council to permanently reserve as sites, and also except from occupation for mining purposes under any miner's right, the lands hereunder referred to:—

The following Notices were published 1° on the 12th October, 1966, pursuant to Orders of the 4th October, 1966.

NEPEAN.—Land proposed to be permanently reserved as a site for Public purposes, 30 perches, Parish of Nepean, County of Mornington, as indicated by hachure on plan hereunder.—(N.57^(*)) (Rs.2362).

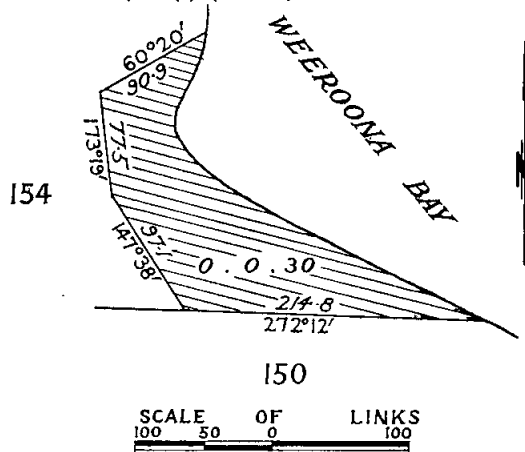

WALPEUP.—Land proposed to be permanently reserved as a site for Public Recreation, 35 acres 17 perches, Parish of Walpeup, County of Karkaroc, indicated by hachure on plan hereunder, being the site and the addition thereto temporarily reserved therefor by Orders in Council of 15th July, 1913, and 24th December, 1935, respectively.—(W.406^(*)) (Rs.1948).

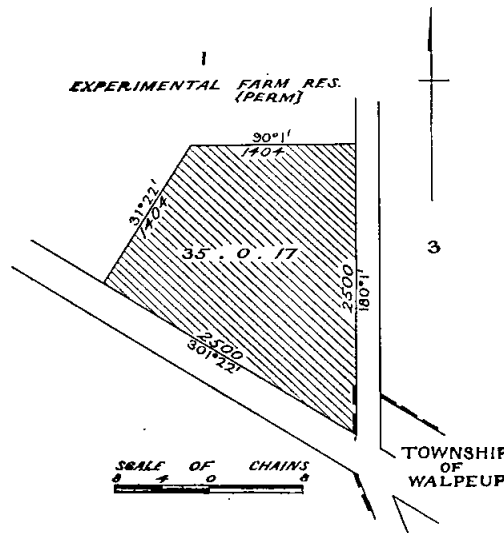

J. C. M. BALFOUR,
Minister of Lands.

LOCAL LAND BOARDS.

IN pursuance of the provisions of section 34 of the Land Act 1958, notice is hereby given that public hearings at the following places and times, will be conducted by the persons respectively mentioned, being duly appointed in that behalf.

J. C. M. BALFOUR,
Minister of Lands.

Department of Crown Lands and Survey,
Melbourne.

SCHEDULE.

LAND INSPECTOR'S OFFICE, ORBOST, 10 a.m., Tuesday, 25th October, 1966.—W. Harry.

BOARD ROOM, SECOND FLOOR, NEW TREASURY BUILDINGS, MELBOURNE, 2 p.m., 27th October, 1966.—E. Kennedy and J. R. Wilding.

LANDS DEPARTMENT, RED CLIFFS, 9 a.m., 29th November, 1966.—N. J. FITZGERALD.

Land Act 1958.

LICENCE UNDER THE LAND ACTS DECLARED VOID.

NOTICE is hereby given that the Licence in the Schedule hereunder has been Declared Void for the reason specified.

District.	Corr. No.	Name of Licensee.	Section of Land Act 1958, under which Licensed.	Parish.	Allotment.	Section.	Area.	Annual Rental.	Reason for Voiding.
Northern.	0460/138	J. R. Adamson	138	Castlemaine	67E	D9	A. R. P. 0 0 29	\$ 9.00	Surrendered

Department of Crown Lands and Survey,
Melbourne, 10th October, 1966.

J. C. M. BALFOUR,
Minister of Lands.

Land Act 1958.

LEASE SURRENDERED.

NOTICE is hereby given that the Governor in Council has accepted the surrender of the Lease mentioned in the schedule hereunder for the reason specified.

District.	Corr. No.	Name.	Section of Land Act 1958 under which Leased.	Parish.	Allotment.	Section.	Area.	Reason.
Melbourne	0650/134	Gunnersen Limited Nosworthy	134	City of Port Melbourne, Parish of Melbourne South	6D	59	A. R. P. 3 2 21	Surrendered — New lease to issue

Department of Crown Lands and Survey,
Melbourne, 11th October, 1966.

J. C. M. BALFOUR,
Minister of Lands.

TENDERS

PUBLIC WORKS DEPARTMENT

TENDERS will be received at Public Works Department, Treasury-place, Melbourne, until TEN a.m. on dates shown and for purposes mentioned hereunder.

Particulars and tender forms available at Contracts Office, Room 7, Building Division, Parliament-place and at places indicated in brackets hereunder.

Abbreviations in brackets mean:—W.O.—Inspector of Works Office; P.S.—Police Station; C.S.—Consolidated School; H.E.S.—Higher Elementary School; H.S.—High School; S.S.—State School; T.S.—Technical School.

Tenders to be submitted on the Department's printed Tender Form and will not be received by telephone. All tenders must be on a "Firm Tender" basis. The lowest or any tender will not necessarily be accepted.

Address tenders to the Minister of Public Works, and endorse the envelope containing the tender "Tender for , closing Tuesday, ".

No preliminary deposit is required with any tender, but a successful tenderer will be required to pay a deposit for any accepted tender of \$5,000 or over.

Tuesday, 18th October, 1966.

Building, Electrical and Mechanical Works.

Beechworth.—External renovations to Main Block (Stage One), Mental Hospital. (Specified Bill of Quantities). (W.O., Wangaratta; P.S., Wodonga; Mental Hospital, Beechworth.)

Belmont.—Renovations and new front fence, Police Station and Residence. (W.O., Geelong.) (Re-advertised.)
Casterton.—Water supply, storm water drains and pump house, High School. (W.O., Hamilton; H.S., Casterton.) (Amended Specification.) (Re-advertised.)
Charlton.—Sewerage main, High School. (H.S., Charlton.)
Clayton.—Electrical installation in First and Second Sections, Monash High School.
Dandenong.—Central heating service, Police Station.
Dandenong.—Hot water service in General Purpose Hall, Technical School.
Echuca.—Modifications to Chemistry Laboratory, Technical School. (W.O., Shepparton; T.S., Echuca.)
Hamilton.—Roof repairs, &c., S.S. 295. (W.O., Hamilton.) (Amended Specification.)
Nagambie.—New porch, repairs and painting, S.S. 1104 and Residence. (W.O., Alexandra.) (Amended Specification.)
South Melbourne.—Renewal of cisterns, &c. and part water supply, Technical School.
Thomastown East.—Erection of four additional class-rooms, S.S. 4827.
Thomastown East.—Electrical installation in additional four (4) class-rooms, &c., S.S. 4827.
Thomastown East.—Plenum heating, S.S. 4827.
Wodonga West.—Erection of two additional class-rooms, S.S. 4814. (W.O., Wangaratta; S.S. Wodonga West.)

Furniture and Furnishings.

Carlton.—Supply and install curtains, Motor Registration Branch, Lygon-street.
Carlton.—Supply and installation of steel shelving, Motor Registration Branch, Lygon-street.

Site Works.

Koo-Wee-Rup.—Site works, High School. (Re-advertised.)

Watsonia.—Earthworks, light and heavy duty asphalt, concrete, drainage and associated works, High School.

Miscellaneous.

Box Hill.—Supply and delivery of machine tools, Technical School.

Preston.—Supply of one glass blowing lathe and accessories, Technical College.

Tuesday, 25th October, 1966.**Building, Electrical and Mechanical Works.**

Albert Park.—New toilet block, S.S. 1181.

Carlton.—External louvre awnings to Edward Wilson Block, St. Nicholas Hospital.

Corryong.—Erection of four residences, Consolidated School. (Re-advertised.) (W.O., Wangaratta; C.S., Corryong.)

Dandenong.—New Science Wing and alterations, High School. (Bill of Quantities available.)

Dandenong.—Electrical installation in existing Main Building and New Wing, High School.

Dandenong.—Mechanical services, High School.

Dimboola.—Installation of ceiling type air circulators, High School. (W.O., Horsham; H.S., Dimboola.)

Geelong.—Mechanical services in Heat Engines Laboratory, Gordon Institute of Technology. (W.O., Geelong.)

Geelong.—Supply and installation of a Package Steam Boiler, Gordon Institute of Technology.

Mt. Dandenong.—Electrical services associated with site development, Observatory, Tourist Development Authority.

Mont Park.—Erection of five (5) proprietary type brick veneer residences, Mental Hospital, Larundel and Plenty Mental Hospitals.

Werribee.—Air conditioning unit in laboratory of Hay Shed, Research Farm.

Furniture and Furnishings.

North Melbourne.—Supply of steel framed dining tables, Melbourne School of Printing and Graphic Arts.

Royal Park.—Supply and fix curtains, Psychiatric Hospital.

Site Works.

Box Hill North.—Construction of asphalt paving, concrete paving, asphalt repairs, drainage works, grassing and associated works, S.S. 4717.

Heathmont.—Construction of site works, fencing, batters and drainage works, S.S. 4688.

Watsonia Heights.—Earthworks, asphalt, concrete, drainage, rock wall, gravel, grassing, water reticulation and associated works, S.S. 4935.

Miscellaneous.

Middle Brighton.—Supply of red gum piles, Ports and Harbours Branch.

Port Melbourne.—Supply of Science Autotrays, 1966/67, Public Works Department, Storeyard, Salmon-street.

Port Melbourne.—Supply of dual Art and Typewriter Tables, 1966/67, Public Works Department, Storeyard, Salmon-street.

Port Melbourne.—Supply of garbage bins, Public Works Department, Storeyard, Salmon-street.

Port Melbourne.—Supply and delivery of seven (7) tons chassis and cabin with 30,000 lb. capacity mechanical winch, Public Works Department, Depot, Salmon-street. (Amended Specification.)

Port Melbourne.—Supply and delivery of two (2) four wheeled pneumatic tired dumpers three-quarter cubic yard capacity, Public Works Department, Depot.

White Hills.—Supply of "London" fluorescent fittings, Technical School.

Wednesday, 2nd November, 1966.**Building, Electrical and Mechanical Works.**

Balmoral.—Septic tank installation, Consolidated School. (W.O., Hamilton; C.S., Balmoral.)

Clayton.—Installation of packaged sewerage treatment plant, Monash High School.

Coburg.—Alterations to gate post No. 1, Pentridge Prison.

Dandenong.—Electrical installation, Police Station.

Jeparit.—Erection of shelter pavilion, S.S. 2988. (W.O., Warracknabeal; S.S., Jeparit.)

Maribyrnong.—Fencing, Government Printing Office—Bulk Paper Store.

Royal Park.—Pipe and chain mesh security fence, Classification Centre, "Turana". (Re-advertised.)

Rushworth.—Electrical installation and rewiring of existing building, &c., High School. (W.O., Shepparton and Bendigo; H.S., Rushworth.)

Rushworth.—Mechanical services, High School. (W.O., Shepparton and Wangaratta.)

Traralgon.—Erection of refuse can wash and can store, Hobson Park Hospital. (W.O., Traralgon; Hobson Park Hospital, Traralgon.) (Re-advertised.)

Various.—Erection of 74 timber class-rooms, staff-rooms and stores, &c., in 32 sub-district contracts, schools. (W.O., Alexandra, Ballarat, Bairnsdale, Camperdown, Geelong, Korumburra, Kyneton, Maryborough, Shepparton, Traralgon, Wangaratta, Warracknabeal and Warragul.)

Furniture and Furnishings.

Horsham.—Supply of timber furniture, Technical School.

Royal Park.—Supply and fix curtains, Psychiatric Hospital.

Site Works.

Heidelberg.—New light and heavy duty asphalt, concrete paving, drainage works, &c., Technical School.

North Park.—Asphalting, concreting, drainage and associated works, S.S. 4787.

M. V. PORTER,
Minister of Public Works.

Public Works Department,
Melbourne, C.2, 10th October, 1966.

LIBRARY OF THE PARLIAMENT OF VICTORIA.**Library Assistant—Female.**

APPLICATIONS are invited for the position of Temporary Assistant (Female—single or married).

Salary.—Depending on age, qualifications and experience. Maximum \$2,612 per annum.

Duties.—Routine library duties including cataloguing, classifying and reference work.

Qualifications.—To be eligible to matriculate, some progress towards professional qualifications and previous library experience.

Prospective applicants may obtain further particulars concerning conditions of employment, hours of duty, &c., from the Librarian, Parliament House, Melbourne. (Telephone 65 1348.)

Written applications, giving details of age, marital status, qualifications and experience will be received by the Chairman of the Library Committee, Parliament House, Melbourne, C.1.

Applications close 4 p.m., 20th October, 1966.

PUBLIC SERVICE NOTICES

No. 1677.

Public Service Act 1958, Section 50.

REGULATIONS.—PART IV.—SALARIES AND INCREMENTS

THE Public Service Board, in pursuance of the powers conferred by the *Public Service Act 1958* hereby amends its Regulations as shown below:—

SIXTH SCHEDULE.**TEMPORARY EMPLOYEES.***Designations of Positions and Rates of Salaries.*

Department and Designation of Position.	Yearly Rate of Salary.		Increments (Annual).
	Minimum.	Maximum.	
DEPARTMENT OF AGRICULTURE. <i>Dookie Agricultural College.</i>	\$	\$	
Add— Dairy Assistant	2,078	2,186	£
£ See Regulation 83 (2).			

F. E. CAHILL, Chairman.
N. J. SIMMANCE, Acting Secretary.

Office of the Public Service Board,
Melbourne, 26th September, 1966.

No. 1676.

Public Service Act 1958, Section 39.

REGULATIONS.—PART IV.—SALARIES AND INCREMENTS.

THE Public Service Board, in pursuance of the powers conferred by the Public Service Act 1958, hereby amends its Regulations as shown below :—

FIRST SCHEDULE.
PROFESSIONAL DIVISION.

Amount of Salary Assigned to Offices in Class "A1"

Office.	Yearly Rate of Salary.
TREASURY.	
\$	
Add—	
Senior Architect (Design), Housing Commission	6,926
Senior Architect (Design), Housing Commission	6,550
Senior Architect (Design), Housing Commission	6,266
Senior Architect (Design), Housing Commission	5,982

This Regulation shall have effect as on and from the 3rd June, 1966.

F. E. CAHILL, Chairman.
N. J. SIMMANCE, Acting Secretary;

Office of the Public Service Board,
Melbourne, 4th October, 1966.

No. 1675.

Public Service Act 1958, Section 50.

REGULATIONS.—PART IV.—SALARIES AND INCREMENTS.

THE Public Service Board, in pursuance of the powers conferred by the Public Service Act 1958 hereby amends its Regulations as shown below :—

SIXTH SCHEDULE.
TEMPORARY EMPLOYEES.

Designations of Positions and Rates of Salaries.

Department and Designation of Position.	Yearly Rate of Salary.		Increments (Annual).
	Minimum.	Maximum.	
DEPARTMENT OF HEALTH.			
MENTAL HYGIENE.			
Delete—			
Pharmaceutical Chemist (Male)	3,492	3,978	*
Pharmaceutical Chemist (Female)	3,092	3,578	1 of \$242 and 2 of \$122
*Increments in accordance with the scale of rates of salaries as set out in Part A of the Third Schedule to these Regulations.			
Add—			
Pharmaceutical Chemist (Male)	3,856	4,100	1 of \$244
Pharmaceutical Chemist (Female)	3,456	3,700	1 of \$244

This Regulation shall have effect as on and from the 25th September, 1966.

F. E. CAHILL, Chairman.
N. J. SIMMANCE, Acting Secretary.

Office of the Public Service Board,
Melbourne, 20th September, 1966.

PRIVATE ADVERTISEMENTS

NOTICE is hereby given that Frigrite Limited has applied for a lease under section 134, Land Act 1958, for a term of 45 years from the 27th November, 1966, of allotment 12, section 67D, City of Port Melbourne, containing 3 acres 2 roods 1 perch, as a site for a factory. 3624

WODONGA SEWERAGE AUTHORITY.

GENERAL NOTICE.

THE above-named Sewerage Authority, having made provision for carrying off the sewage from each and every property which or any part of which is within the Sewerage Area hereinafter described doth hereby declare that on and after the 1st day of October, 1966, each and every property which or any part of which is within the said Sewerage Area, shall be deemed to be a sewerage property within the meaning of the Sewerage Districts Act 1958.

The boundaries of the Sewerage Area hereinbefore referred to are starting at a point on the north-west corner of the Hume Highway and Melrose-drive 20 chains northerly along Melrose-drive; thence 29 chains easterly along Government road to the easterly side of Kelly-street; thence easterly to a point 10 chains; thence in a southerly direction a distance of 20 chains to Sangster-street; thence easterly along Sangster-street to House Creek; thence in a southerly direction by House Creek to the northern side of Elgin-street; thence 17 chains westerly to Kelly-street; thence 1 chain across Kelly-street; thence in a north-westerly direction a distance of 32 chains to the point of commencement.

By Order of the Wodonga Sewerage Authority.

J. A. TERRILL, Chairman.
3959 G. J. MORTON, Secretary.

NOTICE OF INTENTION TO APPLY FOR A LICENCE TO DIVERT WATER AND CUT RACE FROM THE RIVER MURRAY EFFLUENT, AT CARLYLE.

I HEREBY give notice that I intend to apply for a licence empowering me to divert water for a term of four years to the extent of 30 acre-feet per annum at a maximum rate of 3 acre-feet per day of 24 hours for the irrigation of 15 acres of summer crop and pasture, being part of allotments 1, 5, 6, 7, 8A, 8B and part of 9, section 35, Parish of Carlyle, and to occupy certain Crown lands for works of diversion, and to cut a race thereon.

Any objection to such application must be forwarded, in writing, to reach the State Rivers and Water Supply Commission, Melbourne, before 17th October, 1966, being 30 days from the first publication of this notice.

WILLIAM KEITH HEDRICK.
"Budgerie," Wahgunyah. 3955

CITY OF BROADMEADOWS.

LOAN No. 43.

Notice of Intention to Borrow the Sum of \$130,000.

NOTICE is hereby given that the Council of the City of Broadmeadows proposes to borrow the sum of \$130,000 on the credit of the Mayor, Councillors and Citizens of the said City of Broadmeadows such sum to be raised by the grant of a mortgage in accordance with the provisions of the Local Government Act.

1. The maximum rate of interest that may be paid is 5½ per cent. per annum payable on the 1st day of June and the 1st day of December in each year during the currency of the loan.

2. The period of the loan shall be forty (40) years.

3. The moneys borrowed shall be repayable on the 1st day of December, 2006, at the Commonwealth Trading Bank, at Glenroy, or the Council's Bankers for the time being in Melbourne.

4. The purposes for which the loan is to be applied are:—

Development of the A. T. C. Cook Reserve,
C. D. Seabrook Reserve and Reserve
Development in general \$130,000

The loan is to be liquidated by the creation of a sinking fund and an amount of \$1,214.61 will be set aside annually out of Municipal Funds for such purpose.

The plans and specifications and an estimate of the cost of the proposed works and a statement showing the proposed expenditure of the moneys to be borrowed are open for inspection at the offices of the Council, Municipal Offices, Broadmeadows.

Dated this 6th day of October, 1966.

E. F. SMILEY, Town Clerk.
Municipal Offices, Broadmeadows. 3886

CITY OF COBURG.

LOAN No. 102.

Notice of Intention to Borrow the Sum of \$50,000 for Permanent Works and Undertakings.

NOTICE is hereby given that the Council of the City of Coburg proposes to borrow the principal sum of Fifty thousand dollars, secured by a charge over the general rates of the municipality, such sum to be raised by the grant of a mortgage, in accordance with the provisions of the Local Government Act 1958.

1. The maximum rate of interest that may be paid is 5.75 per centum per annum.
2. The purpose for which the loan is to be applied is road, bridge and drainage works.
3. The period of the loan shall be 30 years.
4. The moneys borrowed shall be repayable by providing out of the municipal fund 60 equal half-yearly instalments of \$1,758.54 including principal and interest.
5. Such moneys shall be repayable to the Australian Mutual Provident Society, 425 Collins-street, Melbourne.

The plans and specifications and the estimate of the cost of the proposed works and a statement showing the proposed expenditure of the moneys to be borrowed are open for inspection at the office of the Council of the City of Coburg, at Town Hall, Coburg.

Date 11th October, 1966.

3970

G. A. BRIDGES, Town Clerk.

CITY OF ECHUCA.

DECLARATION OF PRIVATE STREETS AS PUBLIC HIGHWAYS.

IN pursuance of the powers conferred by section 587 (3) of the Local Government Act 1958, the Council of the City of Echuca on the application of the owners of so many of the premises as in rateable value are the greater part of all the premises fronting on the street hereinafter mentioned, being a private street within the municipal district of the City of Echuca more than 15 feet in width, constructed to the satisfaction of the Council, but not constructed pursuant to Division 10 of Part XIX. or Part XLII. of the Local Government Act 1958, or any constructed pursuant to Division 10 of Part XIX. or street to be dedicated to the public as a public highway.

The street in respect of which this declaration is made is:—

The whole of the roadway set out on plan of subdivision No. 69255 and forming part of Henry-street.

In witness whereof the common seal of the Mayor, Councillors and Citizens of the City of Echuca was hereto affixed this 26th day of September, 1966, in the presence of—

(SEAL) W. G. ELMS, Mayor.
W. L. ATLEY, Councillor.
K. F. McCARTNEY, Town Clerk.
3891

CITY OF ECHUCA.

DECLARATION OF PRIVATE STREETS AS PUBLIC HIGHWAYS.

IN pursuance of the powers conferred by section 587 (3) of the Local Government Act 1958, the Council of the City of Echuca on the application of the owners of so many of the premises as in rateable value are the greater part of all the premises fronting on the street hereinafter mentioned, being a private street within the municipal district of the City of Echuca more than 15 feet in width, constructed to the satisfaction of the Council, but not constructed pursuant to Division 10 of Part XIX. or Part XLII. of the Local Government Act 1958, or any corresponding previous enactment, hereby declares such street to be dedicated to the public as a public highway.

The street in respect of which this declaration is made is:—

The whole of Kennedy-court.

In witness whereof the common seal of the Mayor, Councillors and Citizens of the City of Echuca was hereto affixed this 26th day of September, 1966, in the presence of—

(SEAL) W. G. ELMS, Mayor.
W. L. ATLEY, Councillor.
K. F. McCARTNEY, Town Clerk.
3892

CITY OF MOORABBIN.

BY-LAW No. 271.

A By-law of the City of Moorabbin made under the provisions of the Local Government Acts and the Dog Acts and numbered 271 for fixing registration and other fees payable under the Dog Acts.

IN pursuance of the powers conferred by the Local Government Acts and the Dog Acts and of any and every other power it thereunto enabling the Council of the City of Moorabbin orders as follows:—

1. By-law No. 265 of the City of Moorabbin is hereby repealed.

2. The following fees and sums are hereby fixed under the provisions of the Dog Acts—

- (a) For registration of a dog, pursuant to Section 6 of the Dog Act, 1958 as amended by any Act .. \$1.00
- (b) For particulars of any registered dog or for the name of the registered owner thereof or for a certified copy of the receipt mentioned in Section 11 of the Dog Act, 1958 as amended by any Act \$0.25
- (c) The sum payable to the registration officer pursuant to Section 15 of the Dog Act, 1958, as amended by any Act .. \$6.00
- (d) The sum payable to the registration officer pursuant to Section 16 of the Dog Act, 1958 as amended by any Act .. \$6.00

This By-law shall apply to and have operation throughout the whole of the municipal district of the City of Moorabbin.

Resolution for passing this By-law agreed to by the Council on the 5th day of September, 1966, and confirmed on the 3rd day of October, 1966.

The Common seal of the Mayor, Councillors and Citizens of the City of Moorabbin was hereto affixed this 3rd day of October, 1966, in pursuance of a Resolution of the Council and in the presence of—

(SEAL) R. C. BUTLER, Mayor.
L. R. COATES, Councillor.
V. A. SMITH, Town Clerk.
3883

CITY OF MOORABBIN.

NOTICE OF INTENTION TO TAKE LAND COMPULSORILY.

NOTICE is hereby given that it is the intention of the Council of the City of Moorabbin, in exercise of the powers conferred on it by the Local Government Act 1958 to take compulsorily:—

All that piece of land containing 33 5/10 perches or thereabouts being lot 10 on plan of subdivision No. 954 lodged in the Office of Titles and being part of Dendy's Crown Special Survey, Parish of Moorabbin, County of Bourke and being the land described in certificate of title, volume 2279, folio 761.

The said land is required and being taken for the purpose of executing the following work or undertaking by the said Council—the providing of car parking areas in the vicinity of the Centre-road, Bentleigh, shopping centre.

The Council has caused to be prepared maps and other papers to show the general description of the work or undertaking, the description of the lands proposed to be taken and stating that the names of the owners of the said land are Edward George Howes and Margaret Louisa Wandin, both of 1 Mavho-street, Bentleigh.

The said maps and other papers have been approved by the Council and are now deposited for inspection by all persons interested at the offices of the City of Moorabbin, situate Nepean Highway, Moorabbin, and may be inspected there during office hours.

All persons affected by the proposed taking of the land are hereby required to set forth, in writing, addressed to the Council or the Municipal Clerk, within forty (40) clear days of the publication of this notice in the Government Gazette, all objections which they may have to the taking of the land.

Dated the 7th day of October, 1966.

(SEAL) By order of the Council,
V. A. SMITH, Town Clerk and Municipal Clerk.
3884

CITY OF RICHMOND.

LOAN NO. 45.

Notice of Intention to Borrow the Sum of \$40,000 for Permanent Works and Undertakings.

NOTICE is hereby given that the Council of the City of Richmond proposes to borrow the sum of \$40,000 (Forty Thousand Dollars) secured by a charge over the general rates of the Municipality such sum to be raised by the grant of a mortgage in accordance with the provisions of the *Local Government Act 1958*.

1. The amount of the principal moneys which it is proposed to borrow is \$40,000 (Forty Thousand Dollars).
2. The maximum rate of interest that may be paid is \$5.75 per cent. per annum.
3. The period of the loan shall be Fifteen years.
4. The times which the moneys borrowed are repayable are on the 1st July and 1st January during the years 1967-1982 inclusive and that the place such moneys shall be repayable is at the State Savings Bank of Victoria, corner Elizabeth-street and Bourke-street, Melbourne.
5. The purpose for which the Loan is to be applied is for:—

Reconstruction and extension of the Richmond Municipal Abattoirs . . . \$40,000

6. The manner in which the Loan is to be liquidated is by provision out of the Municipal Fund in each half year during the currency of the Loan of the sum of approximately \$2,008.00 (Two Thousand and Eight Dollars), which includes principal and interest. The first instalment shall be payable on the 1st day of July, 1967.

7. The plans and specifications and estimate of the cost of the proposed works and a statement showing the proposed expenditure of the moneys to be borrowed are open for inspection at the Municipal Offices.

Dated the 3rd day of October, 1966.

3870 C. C. EYRES, Town Clerk.

CITY OF TRARALGON.

LOAN NO. 20.

Notice of Intention to Borrow the Sum of \$60,000 for Permanent Works and Undertakings.

NOTICE is hereby given that the Council of the City of Traralgon proposes to borrow the principal sum of \$60,000 on the credit of the municipal revenues of the Mayor, Councillors and Citizens of the said City, such sum to be raised by the grant of a mortgage in accordance with the provisions of the *Local Government Act 1958*.

1. The maximum rate of interest that may be paid is 5½ per centum per annum.
2. The interest is to be payable half-yearly during the currency of the loan.
3. The purpose for which the loan is to be applied is permanent works (concrete, drainage and road works).
4. The period of the loan shall be forty (40) years.
5. The loan is to be liquidated by the creation of a sinking fund pursuant to section 428A of the *Local Government Act 1958*.

6. Such moneys shall be repayable to the State Superannuation Board at its Office in Treasury-place, Melbourne, C.2.

The plans and specifications and the estimate of the cost of the proposed works and a statement showing the proposed expenditure of the moneys to be borrowed are open for inspection at the office of the Council of the City of Traralgon at the Municipal Offices, Kay-street, Traralgon.

3890 D. A. COOPER, Acting Town Clerk.

BOROUGH OF KERANG.

NOTICE OF CHANGE OF STREET NAME.

NOTICE is hereby given that in pursuance of the powers conferred by the *Local Government Act*, the Council of the Borough of Kerang at a meeting held on Wednesday, 28th September, 1966, did resolve to make the following alteration in a street name:—

Old Name.—Dillys-street.

New Name.—Mitchell-street.

Location.—From Boundary-street, Kerang, eastwards to Mitchell-street, Kerang.

3885 G. H. TATE, Town Clerk.

SHIRE OF AVON.

BY-LAW NO. 30.

A By-law of the Shire of Avon made under the provisions of section 197 (XL iia) of the *Local Government Act 1958* and numbered 30 prescribing areas within the municipal district within which the erection including the adoption for use of any building is prohibited unless the building is provided with a septic tank system.

IN pursuance of the powers contained in the *Local Government Act 1958* and every other power enabling them in that behalf, the President, Councillors and Ratepayers of the Shire of Avon do hereby order as follows:—

1. This By-law shall come into force and operation immediately after its publication in the *Government Gazette*.

2. This By-law shall apply and have operation throughout the township of Stratford.

3. No person shall erect, adapt or occupy any building or tenement for domestic or other purposes unless such building or tenement is provided with a septic sewerage system installed in accordance with the *Septic Tank Regulations 1932* as amended.

4. If any person or persons commit a breach of this By-law he or they shall for every such breach be liable to a penalty of not more than \$40, and in the case of a continuing offence to a further daily penalty of not more than \$10.

Resolution for passing this By-law agreed to by the Council on the fourth day of July, 1966, and confirmed on the first day of August, 1966.

In witness whereof the common seal of the President, Councillors and Ratepayers of the Shire of Avon was hereunto affixed in the presence of—

O. MATTHEWS, President.
ERIC LEE, Councillor.
ERIC C. BOCK, Shire Secretary.

Approved by the Governor in Council on the 27th September, 1966.—J. COLQUHOUN, Clerk of the Executive Council. 3963

Dog Act 1958.

SHIRE OF CHILTERN.

IN accordance with the provisions of section 17 of the *Dog Act 1958*, as amended, the Council of the Shire of Chiltern did at its meeting on the 3rd day of October, 1966, order by Resolution that the railway stations and streets or portions of streets within the municipal district hereinafter set out shall be and are hereby specified as "Railway Stations" and "Shopping Areas" respectively in or on which no dog is permitted unless under the effective control of some person by means of a chain or chord or leash.

RAILWAY STATIONS.

The railway stations known as "Chiltern" and "Barnawartha."

SHOPPING AREAS.

Chiltern Township.—Conness-street, between Oxford-street and a line being the continuation of the eastern boundary of allotment 13, section P, Parish of Chiltern.

Main-street, between a point 200 feet north and a point 200 feet south of the centre point of the intersection with Conness-street.

Barnawartha Township.—High-street, between a line being the continuation of the south western boundary of allotment 6, section 7, Parish of Barnawartha South and Canning-street.

Havlock-street, between a point 200 feet south-west and a point 200 feet north-east of the centre point of the intersection with High-street.

By order of the Council,

3882 P. C. ROWAN, Shire Secretary

SHIRE OF CORIO.

LOAN NO. 70.

Notice of Intention to Borrow the Sum of \$60,000 for Permanent Works and Undertakings.

NOTICE is hereby given that the Council of the Shire of Corio proposes to borrow the principal sum of \$60,000, secured by a charge over the general rate of the municipality, such sum to be raised by the grant of a mortgage in accordance with the provision of the *Local Government Act 1958*.

1. The maximum rate of interest that may be paid is 5.75 per cent. per annum.

2. The purposes for which the loan is to be applied is:—

Lara kindergarten	\$15,000
Lara Hall supper room	5,500
St. Helens Foreshore pool completion .. .	10,000
Hamlyn Park Youth Club kitchen & toilets ..	10,000
Caretakers residence	9,500
Lara Golf Club pavilion	2,000
Footpaths	8,000
	\$60,000

3. The period of the loan shall be fifteen years.
 4. The moneys borrowed shall be repayable by providing out of the municipal fund half-yearly instalments of approximately \$3,011.91 each, including principal and interest on the 1st day of January, and the 1st day of July, in each year, during the currency of the loan. The first instalment shall be payable on the 1st day of July, 1967.

5. Such moneys shall be repayable at The Commonwealth Savings Bank of Australia.

The plans and specifications and the estimates of the cost of the proposed works and a statement showing the proposed expenditure of the moneys to be borrowed are open for inspection at the office of the Council of the Shire of Corio, Osborne House, North Geelong.

W. H. MYERS, Shire Secretary.

12th October, 1966. Osborne House, North Geelong. 3902

SHIRE OF CORIO.

LOAN NO. 71.

Notice of Intention to Borrow the Sum of \$50,000 for Permanent Works and Undertakings.

NOTICE is hereby given that the Council of the Shire of Corio proposes to borrow the principal sum of \$50,000, secured by a charge over the general rate of the municipality, such sum to be raised by the grant of a mortgage in accordance with the provision of the Local Government Act 1958.

1. The maximum rate of interest that may be paid is 5½ per cent. per annum.
2. The purpose for which the loan is to be applied is for extensions to Municipal Offices (Osborne House).
3. The period of the loan shall be fifteen years.
4. The moneys borrowed shall be repayable by providing out of the municipal fund half-yearly instalments of approximately \$2,510 each, including principal and interest on the 1st day of January, and the 1st day of July, in each year, during the currency of the loan. The first instalment shall be payable on the 1st day of July, 1967.
5. Such money shall be repayable to The Commissioners of The State Savings Bank of Victoria at the office of the said Commissioners, corner Elizabeth and Bourke streets, Melbourne.

The plans and specifications and the estimates of the cost of the proposed works and a statement showing the proposed expenditure of the moneys to be borrowed are open for inspection at the office of the Council of the Shire of Corio, Osborne House, North Geelong.

W. H. MYERS, Shire Secretary.

12th October, 1966. Osborne House, North Geelong. 3903

SHIRE OF DAYLESFORD AND GLENLYON.

NOTICE OF INTENTION TO TAKE LAND COMPULSORILY.

NOTICE is hereby given:—

1. That the Council of the Shire of Daylesford and Glenlyon has deemed it expedient to exercise its power of taking compulsorily the land described hereunder for the work or undertaking of realigning the Stony Creek-road, Daylesford.
2. The said Council has caused to be prepared and has approved maps and other papers showing the general description of the work or undertaking for which the land proposed to be taken is to be used, the description of the land proposed to be so taken, and the names of the owners or reputed owners, lessees, or reputed lessees, mortgagees and occupiers of the said land so far as those names are known to or can be ascertained by the Council.
3. Such maps and other papers have been deposited at the office of the Council, Town Hall, Daylesford, and are open for inspection by all persons interested at all reasonable hours for 40 clear days after the publication of this notice in the Government Gazette.

4. The land proposed to be taken is part of Crown allotment M, section A, Borough of Daylesford, Parish of Wombat, County of Talbot, being part of the land comprised in Crown grant volume 6665, folio 933, and is coloured red on the said map.

5. All persons affected by the proposed taking of the said land are required to set forth, in writing, addressed to the Council or the Shire Secretary of the Shire of Daylesford and Glenlyon within 40 clear days from the publication of this notice in the Government Gazette, all objections which they may have to the taking of the said land.

Dated this 4th day of October, 1966.
 3871 S. HAUSER, Shire Secretary.

Local Government Act 1958.

SHIRE OF GORDON.

ORDER DECLARING PUBLIC HIGHWAY.

IN pursuance of the powers conferred by section 522 of the Local Government Act 1958, the Council of the Shire of Gordon by this order directs that the land in the Parish of Boort, shown hatched on the diagram hereunder, being part of Crown allotment 5, section B, comprised in certificate of title, volume 7136, folio 1427078, which has been purchased by it, shall be a public highway.

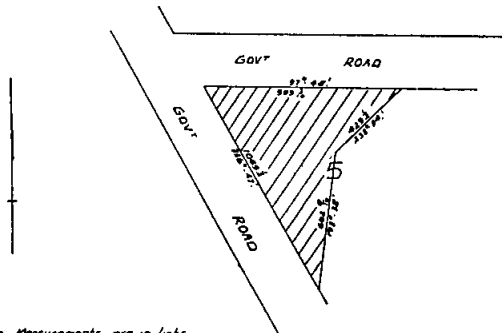

The common seal of the President, Councillors and Ratepayers of the Shire of Gordon was hereunto affixed this 5th day of October, 1966, in the presence of—

3904 (SEAL) K. H. HARRISON, President.
 R. M. SUTTON, Councillor.
 S. A. STEVENS, Shire Secretary.

SHIRE OF GOULBURN.

LOAN NO. 11.

Notice of Intention to borrow the Sum of \$12,000 for Permanent Works and Undertakings.

NOTICE is hereby given that the Council of the Shire of Goulburn proposes to borrow the principal sum of \$12,000 secured by a charge over the general rates of the municipality, such sum to be raised by the grant of a mortgage in accordance with the provisions of the Local Government Act 1958.

1. The maximum rate of interest that may be paid is 5½ per cent. per annum.
2. The purpose for which the loan is to be applied is the purchase of land for municipal offices.
3. The period of the loan shall be 15 years.
4. The moneys borrowed shall be repayable by providing out of the municipal fund half-yearly instalments of approximately \$602 each, including principal and interest on the first day of July, and the first day of January, during the currency of the loan. The first instalment shall be payable on the first day of July, 1967.
5. Such moneys shall be repayable to the Commissioners of the State Savings Bank of Victoria at the office of the said Commissioners, corner Elizabeth and Bourke streets, Melbourne.

The plans and specifications and the estimate of the cost of the proposed works and a statement showing the proposed expenditure of the moneys to be borrowed are open for inspection at the office of the Council of the Shire of Goulburn, at Nagambie.

Dated the 5th day of October, 1966.
 3877 C. D. RYAN, Shire Secretary.

SHIRE OF HAMPDEN.

LOAN No. 13.

Notice of Intention to borrow the Sum of \$22,000 for Permanent Works and Undertakings.

NOTICE is hereby given that the Council of the Shire of Hampden proposes to borrow the sum of Twenty-two thousand dollars (\$22,000) on the credit of the municipal revenues of the President Councillors and Ratepayers of the said Shire, such sum to be raised by the grant of a mortgage in accordance with the provisions of the *Local Government Act 1958*.

1. The maximum rate of interest that may be paid is 5½ per cent. per annum.

2. The purposes for which the loan is to be applied are:—

(a) Completion of Shire Hall Alterations	\$2,500
(b) Furnishings and Floor Coverings for Shire Hall	19,500
	\$22,000

3. The period of the loan shall be fifteen (15) years.

4. The moneys shall be repayable by providing out of the municipal fund 30 half-yearly instalments of approximately \$1,104.36 each, including principal and interest, on the 19th day of June, and the 19th day of December, during the currency of the loan.

5. Such moneys shall be payable at the National Bank of Australasia Limited, Melbourne, or at the Council's bankers for the time being in Melbourne.

The plans and specifications and estimates of the costs of the proposed works and a statement showing the proposed expenditure of the moneys to be borrowed, are open for inspection at the Shire Office, Camperdown.

Dated 6th October, 1966.

3887

S. J. GRIMMER, Shire Secretary.

SHIRE OF KNOX.

LOAN No. 16.

Notice of Intention to Borrow the Sum of \$39,500 for Permanent Works and Undertakings.

NOTICE is hereby given that the Council of the Shire of Knox, in pursuance of powers conferred by the Local Government Acts, intends to borrow the sum of \$39,500 on the credit of the municipal revenues of the President, Councillors and Ratepayers of the said Shire, such sum to be raised by the grant of mortgage, in accordance with the said Acts and states:

The amount of principal moneys it is proposed to borrow is \$39,500.

The maximum rate of interest that may be paid is 5½ per cent. per annum.

The period of the loan will be fifteen years and the time or times at which the moneys borrowed are to be repayable on the 1st day of January and the 1st day of July in each year during the currency of the loan commencing on the 1st day of July, 1967.

The place of repayment will be E. S. and A. Bank Ltd., Boronia.

The purpose for which the loan is to be applied is for permanent works and undertakings, viz:

Roadworks: High-street, Bayswater. Olive-grove, Boronia.

The loan is to be liquidated by half-yearly payments of approximately \$1,983 including principal and interest payable out of the Municipal Fund.

Plans and specifications and an estimate of the cost of such works and undertakings, and a statement showing the proposed expenditure of the money to be borrowed, are open for inspection by ratepayers during office hours at the Shire Offices, Fern Tree Gully, for one month after the publication of this notice.

Dated at Fern Tree Gully, this 7th day of October, 1966.

3905

N. G. HAYNES, Shire Secretary.

SHIRE OF KNOX.

LOAN No. 19.

Notice of Intention to Borrow the Sum of \$18,000 for Permanent Works and Undertakings.

NOTICE is hereby given that the Council of the Shire of Knox, in pursuance of powers conferred by the Local Government Acts, intends to borrow the sum of \$18,000 on the credit of the Municipal revenues of the President,

Councillors and ratepayers of the said Shire, such sum to be raised by the grant of mortgage, in accordance with the said Acts and states:

The amount of principal moneys it is proposed to borrow is \$18,000.

The maximum rate of interest that may be paid is 5½ per cent. per annum.

The period of the loan will be sixteen years and the time or times at which the moneys borrowed are to be repayable on the 1st day of February and the 1st day of August in each year during the currency of the loan commencing on the 1st day of August, 1967.

The place of repayment will be E. S. and A. Bank Ltd., Boronia.

The purpose for which the loan is to be applied is for permanent works and undertakings, viz:

Scoresby drainage.

The loan is to be liquidated by half-yearly payments of approximately \$868 including principal and interest, payable out of the Municipal Fund.

Plans and specifications and an estimate of the cost of such works and undertakings, and a statement showing the proposed expenditure of the money to be borrowed, are open for inspection by ratepayers during office hours at the Shire Offices, Fern Tree Gully, for one month after the publication of this notice.

Dated at Fern Tree Gully, this 7th day of October, 1966.

3907

N. G. HAYNES, Shire Secretary.

SHIRE OF KNOX.

LOAN No. 20.

Notice of Intention to Borrow the Sum of \$30,000 for Permanent Works and Undertakings.

NOTICE is hereby given that the Council of the Shire of Knox, in pursuance of powers conferred by the Local Government Acts, intends to borrow the sum of \$30,000 on the credit of the Municipal revenues of the President, Councillors and Ratepayers of the said Shire, such sum to be raised by the grant of mortgage, in accordance with the said Acts and states:

The amount of principal moneys it is proposed to borrow is \$30,000.

The maximum rate of interest that may be paid is 5½ per cent. per annum.

The period of the loan will be fifteen years and the time or times at which the moneys borrowed are to be repayable on the 1st day of April and the 1st day of October, 1967.

The place of repayment will be E. S. and A. Bank Ltd., Boronia.

The purpose for which the loan is to be applied is for permanent works and undertakings, viz:

Drainage Works: Floriston-road to Turner-road, Johnson-park, Council proportion. Barton-avenue, Council proportion.

The loan is to be liquidated by half-yearly payments of approximately \$1,506 including principal and interest, payable out of the Municipal Fund.

Plans and specifications and an estimate of the cost of such works and undertakings, and a statement showing the proposed expenditure of the money to be borrowed, are open for inspection by ratepayers during office hours at the Shire Offices, Fern Tree Gully, for one month after the publication of this notice.

Dated at Fern Tree Gully, this 7th day of October, 1966.

3908

N. G. HAYNES, Shire Secretary.

SHIRE OF KNOX.

LOAN No. 18.

Notice in Intention to Borrow the Sum of \$12,500 for Permanent Works and Undertakings.

NOTICE is hereby given that the Council of the Shire of Knox, in pursuance of the powers conferred by the Local Government Acts, intends to borrow the sum of \$12,500 on the credit of the Municipal revenues of the President, Councillors and Ratepayers of the said Shire, such sum to be raised by the grant of mortgage, in accordance with the said Acts and states:

The amount of principal moneys it is proposed to borrow is \$12,500.

The maximum rate of interest that may be paid is 5½ per cent. per annum.

The period of the loan will be ten years and the time or times at which the moneys borrowed are to be repayable on the 1st day of January and the 1st day of July in each year during the currency of the loan commencing on the 1st day of July, 1967.

The place of repayment will be E. S. and A. Bank Ltd., Boronia.

The purpose for which the loan is to be applied is for permanent works and undertakings, viz:

Council contribution to private street construction.

The loan is to be liquidated by half-yearly payments of approximately \$826 including principal and interest, payable out of the Municipal Fund.

Plans and specifications and an estimate of the cost of such works and undertakings, and a statement showing the proposed expenditure of the money to be borrowed, are open for inspection by ratepayers during office hours at the Shire Offices, Fern Tree Gully, for one month after the publication of this notice.

Dated at Fern Tree Gully, this 7th day of October, 1966.

3906

N. G. HAYNES, Shire Secretary.

Town and Country Planning Act 1961 (Twelfth Schedule).
SHIRE OF KNOX PLANNING SCHEME AMENDMENTS
NOS. 6 AND 7.

NOTICE THAT A PLANNING SCHEME HAS BEEN PREPARED AND IS AVAILABLE FOR INSPECTION.

NOTICE is hereby given that the Council of the Shire of Knox, in pursuance of its powers under the *Town and Country Planning Act 1961*, has prepared Planning Schemes for portions of the Shire of Knox for the purpose of amending the Principal Scheme.

A copy of each scheme has been deposited at the Shire Offices, Shire of Knox, Spring-street, Fern Tree Gully, and at the office of the Town and Country Planning Board, 179 Queen-street, Melbourne, and may be inspected during office hours by any person free of charge.

Any persons affected by the Planning Schemes are required to set forth, in writing, all objections they may have, addressed to the Secretary, Shire of Knox, Spring-street, Fern Tree Gully, on or before the 12th day of November, 1966, in respect of Amendment No. 6 and the 12th day of January, 1967, in respect of Amendment No. 7, and to state whether they wish to be heard in respect of their objections.

Dated 12th October, 1966.

3961

N. G. HAYNES, Shire Secretary.

SHIRE OF MELTON.

LOAN NO. 26.

Notice of Intention to Borrow the Sum of \$13,800 for Permanent Works and Undertakings.

NOTICE is hereby given that the Council of the Shire of Melton proposes to borrow the principal sum of \$13,800 secured by a charge over the general rates of the municipality, such sum to be raised by the grant of a mortgage in accordance with the provisions of the *Local Government Act 1958*.

1. The maximum rate of interest that may be paid is 5-5/8 per centum per annum.

2. The purpose for which the loan is to be applied is:

Additions to Shire Buildings	\$1,500
Purchase of Office Equipment	\$6,000
Private Street Construction	\$6,300

3. The period of the loan shall be ten years.

4. The moneys borrowed shall be repayable by providing out of the municipal fund half-yearly instalments of approximately \$910 each including principal and interest on the 1st day of May and the 1st day of December during the currency of the loan. The first instalment shall be payable on the 1st day of May, 1967.

5. Such moneys shall be repayable at the National Bank Savings Bank Limited, 271 Collins-street, Melbourne.

The plans and specifications and the estimate of the cost of the proposed works and a statement showing the proposed expenditure of the moneys to be borrowed are open for inspection at the Office of the Council of the Shire of Melton at Melton.

12th October, 1966.

3960

D. J. R. DUNTON, Shire Secretary.

SHIRE OF MORNINGTON.

BY-LAW No. 114.

Health Act Registration Fees Amendment By-law.

NOTICE is hereby given that the Council of the Shire of Mornington has made a By-law under the *Local Government Act 1958*, as amended and all other powers it thereunto enabling Numbered 114 for the purposes of:

- Amending By-law No. 110 of the Shire of Mornington;
 - Prescribing the fees for registration and renewal of registration of Food Vending Machines;
 - Prescribing for an additional fee to be payable in all cases where an application for renewal of registration is received after 15th November in any year;
- and for other purposes.

Notice is also hereby given that a copy of the above-mentioned By-law is open for inspection, free of charge, during office hours, at the office of the said Council, Queen Street, Mornington.

Dated this 3rd day of October, 1966.

3872

D. G. COLLINS, Shire Secretary.

SHIRE OF WODONGA.

LOAN No. 42.

Notice of Intention to Borrow.

NOTICE is hereby given that the Council of the Shire of Wodonga intends to borrow Twelve thousand five hundred dollars (\$12,500) on the credit of the President, Councillors and Ratepayers of the said Shire of Wodonga by the grant of a mortgage, in accordance with provisions of the *Local Government Acts*.

In connexion therewith the following information is stated:—

- The amount of the principal moneys which it is proposed to borrow is Twelve thousand five hundred dollars.
- The maximum rate of interest that may be paid is 5.75 per centum per annum.
- The times which the moneys borrowed are to be repayable are the 21st day of June, 1967, and the 21st days of December and June, during the years 1967-1981 inclusive, and that the place such moneys shall be repayable is at the Bank of New South Wales.
- The purpose for which the loan is to be applied is:
 - Construction of underground draining from Kelly-street to House Creek.
 - Construction of Kelly-street extension.
- The manner in which the loan is to be liquidated is by provision out of the municipal fund in each half-year during the currency of the loan of the sum of \$627.48 which includes principal and interest.

The Plans and Specifications and estimate of the cost of the works and a statement showing the proposed expenditure of the moneys to be borrowed are open for inspection at the Shire Office.

Dated this 11th day of October, 1966.

3962

G. J. MORTON, Shire Secretary.

NOTICE is hereby given that the partnership heretofore subsisting between Roy Samuel Gill, Harry Stanley Gill and Lloyd Morris Gill, carrying on the business of printers, at 286 Main-street, Lilydale, under the firm name of "N. W. Gill & Sons", has been dissolved as from the 1st day of September, 1966, so far as concerns the said Lloyd Morris Gill, who retired from the said firm on the 31st day of August, 1966.

Dated this 14th day of September, 1966.

LLOYD M. GILL.
HARRY S. GILL.
R. S. GILL.

J. W. GLOVER, LL.B., solicitor, 422 Collins-street, Melbourne. 3954

NOTICE is hereby given that the partnership heretofore subsisting between Norman George Stewart, deceased, Doris Jane Stewart, Clive Norman Suckling and Betty Suckling, carrying on business as farmers and graziers, at Dean, under the name of "Stewart and Suckling", has been dissolved by the death of the said Norman George

Stewart, as from the 17th July 1966. All debts due to and owing by the said late firm will be received and paid by Clive Norman Suckling and Betty Suckling, who will continue to carry on the business at the same place under the name "C. N. & B. Suckling".

Dated at Ballarat, the 30th day of September, 1966.

D. J. STEWART.
C. N. SUCKLING.
BETTY SUCKLING.

Witness—G. K. SUTTON, solicitor, Ballarat.

Dooley, Sutton and A. W. Long, solicitors, 43 Lydiard-street south, Ballarat. 3899

NOTICE is hereby given that the partnership between Anthony Michael Peter Hillman, and Reginald Frederick Sweet, estate agents, at 62 Church-street, North Brighton, has been dissolved as from the 21st day of September, 1966.

We hereby confirm that the above partnership has been dissolved by mutual consent.

Dated the 21st day of September, 1966.

3956 ANTHONY MICHAEL PETER HILLMAN.
REGINALD FREDERICK SWEET.

R.M.H. CONSTRUCTIONS PTY. LTD. (IN LIQUIDATION).
APPROXIMATE STATEMENT OF AFFAIRS AS AT 5TH SEPTEMBER, 1966.

Unsecured Creditors.

J. Baxter	\$4,192.81	
Harston & Partridge	2.10	
				\$4,194.91

Shareholders Loans.

R. C. Milne	5,274.35	
C. C. Price	7,126.82	
				12,401.17
				\$16,596.08

Cash on Hand	\$86.48
Debtors, \$15,612	800.00
Deficiency	15,709.60
				\$16,596.08

This statement has been prepared according to information supplied by the debtors.

KENNEDY, SMAIL & MIDDLEMISS, chartered accountants, 296 Little Lonsdale-street, Melbourne, C.I. 3964

R.M.H. CONSTRUCTIONS PTY. LTD. (IN LIQUIDATION).
SUMMARY OF RECEIPTS AND DISBURSEMENTS FROM 5TH SEPTEMBER, 1965, TO 5TH SEPTEMBER, 1966.

Receipts.

Cash at Bank as at 5th September, 1965	..	\$143.62
--	----	----------

Disbursements.

Advertising meeting of creditors	..	\$15.14
Lodgment fee	..	2.00
Liquidator's fees	..	38.50
Bank charges	..	1.50
		57.14
Bank balance as at 5th September, 1966	..	86.48

3965 \$143.62

The Companies Act 1961.—In the matter of YOUNGER LODGE PROPRIETARY LIMITED.

AT a General Meeting of the members of Younger Lodge Proprietary Limited duly convened and held at the offices of Kennedy, Smail & Middlemiss, 296 Little Lonsdale-street, Melbourne, on Monday, the 3rd day of October, 1966, the following Special Resolution was duly passed:—

"That the company be and is hereby wound up voluntarily pursuant to the provisions of subdivision (2) of division 3 of Part X. of the Companies Act 1961, and that for the purpose of such winding up, Edward Ronald Smail, of 296 Little Lonsdale-street, Melbourne, be appointed liquidator."

Dated this 4th day of October, 1966.

E. R. SMAIL, Liquidator.

Kennedy, Smail & Middlemiss, 296 Little Lonsdale-street, Melbourne, C.I. 3939

The Companies Act 1961.

J. A. THEAR PROPRIETARY LIMITED.

NOTICE is hereby given, in pursuance of section 254 (2) of the Companies Act 1961, that J. A. Thear Proprietary Limited, whose registered office was situated at 88 Dare-street, Ocean Grove, by a Special Resolution passed at a meeting of shareholders held on 10th day of October, 1966, agreed that the company be wound up voluntarily.

Dated this 10th day of October, 1966.

NORMAN HARRIS, Liquidator.

Hughes, Fincher and Rodda, Chartered Accountants, 290 Latrobe-street, Melbourne. 3928

Companies Act 1961.

R. WERNER & CO. PTY. LIMITED.

NOTICE is hereby given, pursuant to section 254 (2) of the Companies Act 1961, that at an Extraordinary General Meeting of the shareholders of R. Werner and Co. Pty. Limited, held on the 16th September, 1966, the following Special Resolution was passed:—

That the Company be wound up voluntarily.

Dated this Third day of October, 1966.

3929 JACK KENNEDY, Liquidator.

Companies Act 1961.

VIC WALKER PTY. LIMITED.

NOTICE is hereby given, pursuant to section 254 (2) of the Companies Act 1961, that at an Extraordinary General Meeting of the shareholders of Vic Walker Pty. Limited held on the 16th September, 1966, the following Special Resolution was passed:—

That the Company be wound up voluntarily.

Dated this Third day of October, 1966.

3930 JACK KENNEDY, Liquidator.

Companies Act 1961.

CLUB RAZOR BLADES PTY. LIMITED.

NOTICE is hereby given, pursuant to section 254 (2) of the Companies Act 1961, that at an Extraordinary General Meeting of the shareholders of Club Razor Blades Pty. Limited held on the 16th September, 1966, the following Special Resolution was passed:—

That the Company be wound up voluntarily.

Dated the Third day of October, 1966.

3931 JACK KENNEDY, Liquidator.

Companies Act 1961.

B. R. PROPERTIES PTY. LIMITED.

NOTICE is hereby given, pursuant to section 254 (2) of the Companies Act 1961, that at an Extraordinary General Meeting of the shareholders of B. R. Properties Pty. Limited held on the 16th September, 1966, the following Special Resolution was passed:—

That the Company be wound up voluntarily.

Dated this Third day of October, 1966.

3932 JACK KENNEDY, Liquidator.

Companies Act 1961.

RIBRA PTY. LIMITED.

NOTICE is hereby given, pursuant to section 254 (2) of the Companies Act 1961, that at an Extraordinary General Meeting of the shareholders of Ribra Pty. Limited held on the 16th September, 1966, the following Special Resolution was passed:

That the Company be wound up voluntarily.

Dated this Third day of October, 1966.

3933 JACK KENNEDY, Liquidator.

Companies Act 1961.

EMMCO (VICTORIA) PTY. LIMITED.

NOTICE is hereby given, pursuant to section 254 (2) of the Companies Act 1961, that at an Extraordinary General Meeting of the shareholders of Emmco (Victoria) Pty. Limited held on the 16th September, 1966, the following Special Resolution was passed:

That the Company be wound up voluntarily.

Dated this Third day of October, 1966.

3934 JACK KENNEDY, Liquidator.

*Companies Act 1961.***CITY PROPERTIES PROPRIETARY LIMITED (IN VOLUNTARY LIQUIDATION).**

NOTICE OF GENERAL MEETING OF SHAREHOLDERS, PURSUANT TO SECTION 272.

NOTICE is hereby given that the Final General Meeting of shareholders of City Properties Limited (in Voluntary Liquidation), will be held at the offices of Blake & Riggall, solicitors, 120 William-street, Melbourne, Victoria, on Monday, 28th November, 1966, at 9.30 a.m.

The object of the meeting is to consider an account by the liquidator showing how the winding up has been conducted and the property of the company disposed of, and for the giving of any explanations thereof.

Dated this 4th day of October, 1966.

K. O. HARRIS, Liquidator.

Blake & Riggall, 120 William-street, Melbourne, solicitors for the liquidator. 3926

The *Companies Act 1961*.—In the matter of R.M.H. CONSTRUCTIONS PTY. LTD. (in liquidation).

NOTICE TO MEMBERS AND CREDITORS OF MEETING PURSUANT TO SECTION 271.

NOTICE is hereby given that a General Meeting of members and creditors of the above-named company will be held on Monday, the 17th day of October, 1966, at 4 p.m. in the afternoon in the meeting room, Kennedy, Smail and Middlemiss, 296 Little Lonsdale-street, Melbourne, pursuant to the provisions of section 271 of the *Companies Act*. It would be appreciated if you could be in attendance or represented.

Dated this 6th day of October, 1966.

3966 N. E. STRETTON, Liquidator.

In the matter of R.M.H. CONSTRUCTIONS PTY. LTD. (in liquidation).

REPORT OF LIQUIDATOR PURSUANT TO SECTION 271 OF THE COMPANIES ACT 1961.

DURING the twelve months since the date of liquidation, no funds have been received.

We are still awaiting the final dividend from Brickwood Homes Pty. Ltd., and we understand that this matter is expected to be concluded within the next few months.

This will enable a further distribution to be made to creditors of approximately 4 cents to 5 cents in the \$.

3967 N. E. STRETTON, liquidator.

The *Companies Act 1961*.—Pursuant to Section 272 GIANT KANDYLAND PTY. LTD. (in Voluntary Liquidation).

NOTICE is hereby given that a Final Meeting of Members will be held at the offices of the liquidator on Monday, 28th November, 1966, at 10 a.m. for the purpose of laying before the meeting the liquidator's account and to give any explanations thereof.

Dated this 10th day of October, 1966.

P. C. SIMMONS, liquidator, 8th Floor, 150 Queen-street, Melbourne. 3973

*Companies Act 1961.***J. R. MUNRO PROPRIETARY LIMITED.**

AT a General Meeting of the members of the above-named company, duly convened and held at Mount Waverley, on the 6th day of October, 1966, the Special Resolution set out below was duly passed:—

"That the company be wound up voluntarily and that Robert William Parry of 59 Elizabeth-street, Melbourne, be and is hereby appointed liquidator for the purposes of the winding-up."

Dated this 6th day of October, 1966.

3972 J. R. MUNRO, Director.

EAGLE METAL AND INDUSTRIAL PRODUCTS PTY. LIMITED (IN VOLUNTARY LIQUIDATION).

PURSUANT TO SECTION 254 (2) OF THE COMPANIES ACT 1961. AT an Extraordinary General Meeting of members of the said company duly convened and held at 17-19 Bridge-street, Sydney, New South Wales, on Thursday, the 6th day of October, 1966, at Four o'clock p.m., the following Resolution was passed:—

"That the company be wound up voluntarily and that Eric Ernest Fookes, of 339 Collins-street, Melbourne, be appointed liquidator for such winding-up."

Dated this 10th day of October, 1966.

3974 ERIC E. FOOKES, Secretary.

In the matter of FABTEX (HOLDINGS) PROPRIETARY LIMITED.—Notice of Winding-up Order.

WINDING-UP Order made the 5th day of October, 1966.

Name and address of official liquidator; Robert Foster Hughes, of 360 Collins-street, Melbourne.

JAMES CANNY, Deputy Commissioner of Taxation of the Commonwealth of Australia, petitioner. 3971

The *Companies Act 1961*.—In the matter of MARDELL FOUNDRY SUPPLIES PTY. LTD.—Notice to Creditors of Meeting, Pursuant to Section 260.

NOTICE is hereby given that a meeting of creditors of the above company will be held at 332 Burke-road, Camberwell, on Friday, the 21st October, 1966, at 3 p.m., pursuant to the provisions of section 260 of the *Companies Act 1961* (a meeting of members of the company having been convened on the same day) for the purpose of considering and if thought fit passing a Resolution that the company be wound up voluntarily.

Dated this 6th day of October, 1966.

For and on behalf of the Board,

F. P. MARDELL, Director.

H. McIntosh, Joss & Co., 6 Albany-road, Toorak. 3889

The *Companies Act 1961*.—In the matter of HEATHERLEIGH HOLDINGS PTY. LTD. (in Voluntary Liquidation).—Notice of Final Meeting.—Members Winding Up.

NOTICE is hereby given that, pursuant to section 272 of the *Companies Act 1961*, that the Final General Meeting of members of the above-named company will be held at 44 Queen-street, Melbourne (4th Floor), on 11th day of November, 1966, at 9 a.m., when I shall lay before the meeting an account of how the winding up has been conducted, and the property of the company disposed of.

Dated this 4th day of October, 1966.

3880 C. J. WAUGH, Liquidator.

The *Companies Act 1961*.—In the matter of AUTOMOTIVE PRODUCTS LIMITED (in Voluntary Liquidation).

NOTICE is hereby given that the Final Meeting of shareholders in the above-named company will be held at 9.30 in the forenoon on Monday, 14th November, 1966, at the office of Teele & Teele, 3rd Floor, A.N.A. Buildings, 28 Elizabeth-street, Melbourne, for the purpose of section 272 of the *Companies Act 1961*, and the submission of the accounts, which have now been finalized, and giving any explanation thereof.

Dated this 3rd day of October, 1966.

A. D. TEELE, Liquidator.

Teele & Teele, chartered accountants, 28 Elizabeth-street, Melbourne, C.I. 3873

The *Companies Act 1961*.—In the matter of RUKAL BUILDERS PTY. LTD. (In Liquidation).

NOTICE is hereby given that, pursuant to section 272 of the *Companies Act*, a Final Voting of the creditors of the above company will be held at Suite 18, 545 St. Kilda-road, Melbourne, on Thursday, 10th November, 1966, at 12 noon.

Business: To receive the liquidator's accounts.

Dated this 4th day of September, 1966.

E. T. BENT, Liquidator.

Bastian, Bent & Cogle, public accountants, Suite 18, 545 St. Kilda-road, Melbourne. 3875

*Companies Act 1961, Section 272.***ACME PIPE COMPANY PROPRIETARY LIMITED (IN VOLUNTARY LIQUIDATION).**

NOTICE CONVENING FINAL MEETING.

NOTICE is hereby given, pursuant to section 272 of the *Victorian Companies Act 1961*, that a General Meeting of members of the above-named company will be held on the 28th day of November, 1966, at 2 o'clock in the afternoon, for the purpose of having an account laid before them, showing the manner in which the winding up has been conducted and the property of the company disposed of and of hearing any explanations that may be given by the liquidators.

Dated this 10th day of October, 1966.

F. R. HAVERFIELD, Liquidator.
H. W. CREELMAN, Liquidator.

John MacKinnon & Co., chartered accountants, 562 St. Kilda-road, Melbourne. 3958

The Companies Act 1961.—In the matter of BLUE MOON (SHEPPARTON) PTY. LTD. (IN VOLUNTARY LIQUIDATION).

NOTICE is hereby given that at an Extraordinary General Meeting of shareholders of the above-named company, held on the 5th day of October, 1966, it was resolved that the company be wound up voluntarily, and that Douglas Orson Oldfield, chartered accountant, of 395 Collins-street, Melbourne, be and is hereby appointed liquidator for the purpose of such winding up.

Dated this 6th day of October, 1966.

D. O. OLDFIELD, liquidator, 395 Collins-street, Melbourne, C.I. 3922

The Companies Act 1961.—In the matter of ARUNDEL HOLDINGS PROPRIETARY LIMITED (in Liquidation).

NOTICE is hereby given that, pursuant to section 272 of the Companies Act, a Final Meeting of the members of the above company will be held at the office of Gandy & Skate, 59 Elizabeth-street, Melbourne, on Monday, the 14th November, 1966, at 9 o'clock a.m.

Business: To receive the liquidator's accounts.

Dated this 6th day of October, 1966.

B. I. GANDY, Liquidator.

Gandy & Skate, 59 Elizabeth-street, Melbourne, C.I. 3927

Companies Act 1961.—In the matter of D. C. MILLS & Co. PROPRIETARY LIMITED (in Voluntary Liquidation).

NOTICE is hereby given in accordance with section 254 (2) (a) of the Companies Act 1961 that at an Extraordinary General Meeting of shareholders held on Tuesday, the 4th October, 1966, the following Special Resolution was passed.

"That the company be wound up voluntarily and that Mr. Keith Lewis Paroissien, public accountant, of 280 Church-street, Richmond, be appointed liquidator for the purposes of winding up of the company."

Notice is also given that after 21 days from this date I shall proceed to distribute the assets of the company. All creditors having any claim against the company should furnish particulars of same by that date otherwise I shall proceed to distribute the assets, without regard to their claim.

Dated this 4th day of October, 1966.

K. L. PAROISSIEN, Liquidator.

K. L. Paroissien, public accountant, 280 Church-street, Richmond. 3941

Companies Act 1961.—Section 272 (2).

A. P. VINCENT (BUILDERS) PROPRIETARY LIMITED (IN LIQUIDATION).

THE Final Meeting of the company and its creditors will be held at the office of the liquidator, on 15th November, 1966, at 10 a.m., for the purpose of receiving the liquidator's account showing how the winding up has been conducted and the property of the company disposed of.

3rd October, 1966.

F. Y. RATRAY, liquidator, 24 Jeffcott-street, Melbourne. 3943

The Companies Act 1961.

INTERSTATE TAXATION & ACCOUNTANCY CO. LTD. (IN LIQUIDATION).

NOTICE is hereby given that a First and Final Dividend is intended to be declared in the above matter. Creditors who have not proved their debts by the 31st day of October, 1966, may be excluded from this Dividend.

Dated this 7th day of October, 1966.

J. R. MENZIES, Liquidator.

Hall & Rose, chartered accountants, 260 Queen-street, Melbourne, C.I. 3949

Companies Act 1961.—In the matter of F.K.P. INDUSTRIES PROPRIETARY LIMITED (in Liquidation).

NOTICE is hereby given the creditors having claims against the above-named company, should lodge proofs of debt with the official liquidator, R. C. D. Warne-Smith, 440 Collins-street, Melbourne.

Creditors who have not proved their debts by 31st October, 1966, will be excluded from dividends.

Dated this 4th day of October, 1966.

R. C. D. WARNE-SMITH, official liquidator, 440 Collins-street, Melbourne. 3938

In the matter of the Companies Act 1961; and in the matter of REED ENGINEERING PTY. LTD.

NOTICE is hereby given that at an Extraordinary General Meeting of the above-named company duly convened and held at 59-61 Irving-street, Footscray, at 1 o'clock in the afternoon on the 4th day of October, 1966, the following Special Resolution was duly passed:—

"That the company be wound up voluntarily."

For this purpose, Reginald Wilfrid Ellis, chartered accountant, of 360 Collins-street, Melbourne, was appointed liquidator.

Dated the 5th day of October, 1966.

J. McDONALD SMITH, Chairman.

J. McDonald Smith & Co., solicitors, 59-61 Irving-street, Footscray. 3935

In the matter of the Companies Act 1961, and in the matter of A. SAUNDERS AND Co. PROPRIETARY LIMITED.

NOTICE is hereby given that at an Extraordinary General Meeting of the above-named company, duly convened and held at 388 Bourke-street, Melbourne, at 11 o'clock in the forenoon, on the 6th day of October, 1966, the following Special Resolution was duly passed, viz.:—

"That A. Saunders and Co. Proprietary Limited be wound up voluntarily and that Eric Anthony Kellam, of 4th Floor, 431 Bourke-street, Melbourne, chartered accountant, be appointed liquidator for the purposes of such winding up."

Dated the 6th day of October, 1966.

3948

N. SPATT, chairman.

CREDITORS, next of kin and others having claims in respect of the estate of Edward Kennedy, late of 5 Louise-avenue, Mont Albert, retired public servant, deceased (who died on the 4th day of June, 1966), are to send particulars of their claims to the executrix, Lillian May Kennedy, care of the under-mentioned solicitors by the 14th day of December, 1966, after which date the executrix will distribute the assets, having regard only to the claims of which she then has notice.

GILBERT, FIELD & WARNE, solicitors, 406 Collins-street, Melbourne. 3919

CREDITORS, next of kin and others having claims in respect of the estate of Walter Creaton, late of 21 Prospect Hill-road, Camberwell, company manager, deceased (who died on the 29th day of June, 1966), are to send particulars of their claims to the executors, Frank Alfred Creaton and Florence Annie Creaton, care of the under-mentioned solicitors, by the 14th day of December, 1966, after which date the executors will distribute the assets, having regard only to the claims of which they then have notice.

GILBERT, FIELD & WARNE, solicitors, 406 Collins-street, Melbourne. 3920

CREDITORS, next of kin and others having claims in respect of the estate of Ann Elizabeth Gibson Hosking, late of 53 Victoria-street, Sandringham, widow, deceased (who died on the fourth day of August, 1966), are to send particulars of their claims to the executor, Maxwell Allan Price, care of the under-mentioned solicitors, by the 14th day of December, 1966, after which date the executor will distribute the assets, having regard only to the claims of which he then has notice.

GILBERT, FIELD & WARNE, solicitors, 406 Collins-street, Melbourne. 3921

CREDITORS, next of kin and others having claims against the estate of Frederick John Eberhard, late of Service-street, Clunes, retired manufacturer, deceased (who died on the 13th November, 1965), are to send particulars of their claims to The Union-Fidelity Trustee Company of Australia Limited, 101 Lydiard-street north, Ballarat, by the 16th day of December, 1966, after which date the company will distribute the assets, having regard only to the claims of which it then has notice.

3897

WILLIAM THOMAS STEVENS, late of Ellis-street, Bendigo, farmer (who died on the 1st day of March, 1966).

ALL persons having claims against the estate of the above-named, are required to forward written particulars thereof to the executrix Patricia Joan Hancock, of Leitchville, in care of the undersigned solicitors, not later than the 14th day of December, 1966.

SCHLEIGER & SMALLEY, solicitors, 290 Williamson-street, Bendigo. 3881

WLADYSLAW MOSZKOWSKI, late of 195 Clarke-street, Northcote, apartment house owner, DECEASED.

CREDITORS, next of kin and others having claims in respect of the estate of the deceased (who died on the 4th day of August, 1966), are required by The Perpetual Executors and Trustees Association of Australia Limited of 100-104 Queen-street, Melbourne, to send particulars of their claims to the said company by the 14th day of December, 1966, after which date it will convey or distribute the assets, having had regard only to the claims of which the company then has notice.

UPTON & ETTTELSON, solicitors, 100 Queen-street, Melbourne. 3923

AGNES YOUNG WILSON, formerly of 15 Clarence-street, Hamilton, but late of 399 Autumn-street, Herne Hill, Geelong, home duties, DECEASED.

CREDITORS, next of kin and others having claims in respect of the estate of the deceased (who died on the 20th day of July, 1966), are required by The Perpetual Executors and Trustees Association of Australia Limited, of 100-104 Queen-street, Melbourne, to send particulars of their claims to the said company by the 14th day of December, 1966, after which date it will convey or distribute the assets, having had regard only to the claims of which the company then has notice.

UPTON & ETTTELSON, solicitors, 100 Queen-street, Melbourne. 3924

CREDITORS, next of kin and others having claims in respect of the estate of Lottie Elizabeth Huckson, late of Beechworth, widow, deceased, intestate (who died on 28th June, 1966), are to send particulars of their claims to the administratrix, Elizabeth Muriel Borwick, of 2 Dendy-street, Brighton, married woman, care of the under-mentioned solicitors, by the 14th December, 1966, after which date she will distribute the assets, having regard only to the claims of which she then has notice.

UPTON & ETTTELSON, solicitors, 100 Queen-street, Melbourne. 3925

CREDITORS, next of kin and others having claims in respect of the estate of Margaret Rachel McLennan, late of Flat 17, 6 Chaucer-street, Canterbury, spinster (who died on 14th August, 1966), are to send particulars of their claims to the Union-Fidelity Trustee Company of Australia Limited, at its registered office, 100 Exhibition-street, Melbourne, by the 15th day of December, 1966, after which date it will distribute the assets, having regard only to the claims of which it then has notice.

COOK & McCALLUM, solicitors, 422 Collins-street, Melbourne. 3975

ERNEST JAMES GOSBELL, formerly of 2 Harris-avenue, South Hawthorn, but late of 51 Park-road, Camberwell, in the State of Victoria, gentleman, DECEASED.

CREDITORS, next of kin and others having claims in respect of the estate of the above-named deceased (who died on the 6th day of April, 1966), are required by the executor of the said deceased's estate, William Gordon Gosbell, of 14 Ruyton-street, Burwood, manager, to send particulars to him by the 13th December, 1966, after which date the executor may convey or distribute the assets of the estate, having regard only to the claims of which he then has notice.

KEITH A. NESS & SON, solicitors, 411 Collins-street, Melbourne. 3976

CREDITORS, next of kin and others having claims in respect of the estate of Charles Arthur Latimer, late of 152 Derby-street, Pascoe Vale, school teacher (who died on the 12th day of July, 1966), are to send particulars of their claims to The Trustees, Executors and Agency Company Limited, of 401 Collins-street, Melbourne, by the 19th day of December, 1966, after which date it will distribute the assets, having regard only to the claims of which it then has notice.

RUSSELL, KENNEDY & COOK, solicitors, 401 Collins-street, Melbourne. 3977

CREDITORS, next of kin and others having claims in respect of the estate of Angelo Biviano, late of 299 Hawthorn-road, Caulfield, retired fruiterer (who died on the 31st October, 1965), are to send particulars of their claims to the executrices Francesca Biviano and Gina Biviano, care of the under-mentioned solicitor, by the 15th December, 1966, after which date he will distribute the assets, having regard only to the claims of which he then has notice.

ROWLAND P. HASSALL, 360 South-road, Moorabbin. 3878

CREDITORS, next of kin and others having claims in respect of the estate of Robert Hugh Cornwell, late of 5 Northbrook-avenue, Malvern, retired clerk, deceased (who died on 13th March, 1966), are to send particulars of their claims to the executrix Lorna Elizabeth Cornwell of 5 Northbrook-avenue, Malvern, widow, care of the under-mentioned solicitors, by the 14th December, 1966, after which date they will distribute the assets, having regard only to the claims of which they then have notice.

UPTON & ETTTELSON, solicitors, 100 Queen-street, Melbourne. 3915

CREDITORS, next of kin and others having claims in respect of the estate of James Francis Johnson, late of 22 Tarneit-road, Werribee, gentleman, deceased (who died on the 7th day of August, 1966), are to send particulars of their claim to National Trustees Executors and Agency Company of Australasia Limited, of 95 Queen-street, Melbourne, by the 13th day of December, 1966, after which date it will distribute the assets, having regard only to the claims of which it then has notice.

MARTIN & MARTIN, solicitors, 37 Queen-street, Melbourne. 3937

OLIVE MAY HOLLOWAY, late of 29 Bay-road, Sandringham, widow, DECEASED.

CREDITORS, next of kin and others having claims in respect of the estate of the above-named deceased (who died 5th March, 1966), are required by the executor, National Trustees Executors and Agency Company of Australasia Limited, of 95 Queen-street, Melbourne, to send particulars to the said company at its address aforesaid by the 19th day of December, 1966, after which date the said company may convey or distribute the assets, having regard only to the claims of which it then has notice.

BERNARD NOLAN, solicitor, 595 Bourke-street, Melbourne. 3944

CREDITORS, next of kin and others having claims in respect of the estate of Eric Roy Smart, late of 113 Dalgetty-road, Beaumaris, retired butcher, deceased (who died on the 25th day of March, 1966), are to send particulars of claims to the executrix, Mary Louise Jones, care of the under-mentioned solicitors, by the 14th day of December, 1966, after which date the executrix will distribute the assets, having regard only to the claims of which she then has notice.

GILBERT FIELD & WARNE, solicitors, 406 Collins-street, Melbourne. 3918

CREDITORS, next of kin and others having claims in respect of the estate of William Albert Clover, late of 2 McLean-street, Morwell, pensioner, deceased (who died on the 13th day of May, 1966), are to send particulars of their claims to the executrix, Margaret Ann Sandiford, care of the undersigned, by the 16th day of December, 1966, after which date she will distribute the assets, having regard only to the claims of which they then have notice.

LEO BROWNE, solicitor, of 180 Elgin-street, Carlton. 3946

CREDITORS, next of kin and others having claims in respect of the estate of Charles John Nagel, late of 51 Grundy-street, Pascoe Vale South (who died on the 29th November 1965, at Melbourne, in the State of Victoria), are to send particulars of their claims to The Trustees Executors and Agency Company Limited, carrying on business at 401 Collins-street, Melbourne, in the State of Victoria, by the 15th day of December, 1966, after which date it will distribute the assets, having regard only to the claims of which it has notice.

COLE & O'HEARE, solicitors, 465 Collins-street, Melbourne. 3947

CREDITORS, next of kin and all others having claims against the estate of William James Marshall Webster, late of 68 Williamson-street, Bendigo, in the State of Victoria, sports store proprietor (who died on the 3rd day of December, 1965), are required to send particulars thereof to Sandhurst and Northern District Trustees, Executors and Agency Company Limited, of View-street, Bendigo, aforesaid, by the 22nd day of December, 1966, after which date the executors will distribute the assets of the said deceased, having regard only to the claims of which the said company then has notice.

WATSON, JAMES & ROGERS, solicitors, Bull-street, Bendigo. 3957

LEWIS LEONARD HIGGS, late of "Woodacres" Wandin North, in the State of Victoria, gentleman, DECEASED.

CREDITORS, next of kin and others having claims in respect of the estate of the deceased (who died on the 16th day of June, 1966), are required by the personal representative, The Trustees, Executors and Agency Company Limited, of 401 Collins-street, Melbourne, in the said State, to send particulars to it by the 14th day of December, 1966, after which date the personal representative may convey or distribute the assets, having regard only to the claims of which it then has notice.

ELLISON, HEWISON & WHITEHEAD, 421 Bourke-street, Melbourne. 3936

HUGH MORRISON BROWN, late of, care of Home and Hospital for Aged, Warrigal-road, Cheltenham, in the State of Victoria, gentleman, DECEASED.

CREDITORS, next of kin and others having claims in respect of the estate of the above-named deceased (who died on the 17th day of August, 1966), are required by The Trustees, Executors and Agency Company Limited, of 401 Collins-street, Melbourne, to send particulars to the company by the 20th day of December, 1966, after which date the company may convey or distribute the assets, having regard only to the claims of which it then has notice.

DAVID THOMAS & FRENKEL, of 104 Queen-street, Melbourne, solicitors for the said company. 3968

CREDITORS, next of kin and others having claims in respect of the estate of Maude Edith Margaret Murray, late of 18 Hoddle-street, Essendon, in the State of Victoria, widow, deceased (who died on the 1st December, 1965), are required by the executrices, Margaret Bridget Murray, spinster, and Mary Wells Dugan, married woman, both of 18 Hoddle-street, Essendon, aforesaid, and Mabel Amelia Langtry, married woman, of 5 Riverview-road, Essendon, aforesaid, to send particulars to them, care of the undermentioned solicitors, by the 13th day of December, 1966, after which date they will distribute the assets, having regard only to the claims of which they then have notice.

AITKEN, WALKER & STRACHAN, solicitors, 414 Collins-street, Melbourne, C.1. 3969

JACQUES LITTMAN, also known as Jack Littman, late of 6 Belmont-avenue, Glen Iris, retired, DECEASED, (who died on the 8th day of June, 1966).

CREDITORS, next of kin and all other persons having claims against the estate of the deceased are required by the executrix of his will, Sidonie Littman, of 6 Belmont-avenue, Glen Iris, widow, to send particulars thereof to her, care of the under-mentioned solicitors before the 19th day of December, 1966, after which date she may distribute the assets of the deceased, having regard only to the claims of which she then has notice.

COLTMAN, WYATT & ANDERSON, solicitors, of 578 Bourke-street, Melbourne. 3945

CREDITORS, next of kin and others having claims in respect of the estate of Olivia Emily Burston, late of Flat 18, 174 Toorak-road, South Yarra, deceased (who died on or about the 27th day of September, 1965), are required by the executors of the estate Keith Wood Burston, of Matupi Plantation, Madang, New Guinea, and Jack Cohen, of 224 Queen-street, Melbourne to send particulars to them, care of Jack Cohen, Marks & Co., solicitors, 224 Queen-street, Melbourne, on or before the 22nd day of December, 1966, after which date the executors may convey or distribute the assets, having regard only to claims of which they have notice.

JACK COHEN, MARKS & CO., solicitors, 224 Queen-street, Melbourne. 3914

PATRICK WALLACE LANDY, formerly of Swan Hill, in the State of Victoria, licensed victualler, but late of 351 Beveridge-street, Swan Hill, aforesaid, director, DECEASED.

CREDITORS, next of kin and other persons having claims against the estate of the said deceased (who died on the 28th day of January, 1966), are required to send particulars of same to the executors, Thomas Patrick Brophy and Dorothy June Landy, in care of the under-signed, on or before the 15th day of December, 1966, after which date they will distribute the assets, having regard only to the claims of which they then have notice.

DELANY & DELANY, barristers and solicitors, 270 Campbell-street, Swan Hill. 3950

LAURA ANN BALLANTINE, formerly of Glazebrook-street, Ballarat, but late of 102 Ascot-street, Ballarat, in the State of Victoria, widow, DECEASED (who died on the 19th September, 1964).

CREDITORS, next of kin and all other persons having claims against the estate of the said deceased, are required by the executor, Desmond Clive Gaunt, of 41 Lydiard-street south, Ballarat, solicitor, to send detailed particulars of their claims in respect of the said estate to the executor, at 41 Lydiard-street south, Ballarat, on or before the 12th day of December, 1966, after which date he will proceed to distribute the said estate, having regard only to the claims of which he then has notice.

Dated this 12th day of October, 1966.

R. H. RAMSAY AND GAUNT, 41 Lydiard-street south, Ballarat, solicitors for the executor. 3898

CREDITORS, next of kin and others having claims in respect of the estate of Alexander Carapiperis, late of 173 Sydney-road, Brunswick, motor mechanic, deceased (who died on 4th August, 1966), are to send particulars of their claims to the executor, Phillip Windmiller Ettelson, of 100 Queen-street, Melbourne, solicitor, care of the under-mentioned solicitors, by the 14th December, 1966, after which date they will distribute the assets, having regard only to the claims of which they then have notice.

UPTON & ETTELSON, solicitors, 100 Queen-street, Melbourne. 3916

HENRY CHARLES BEAMENT, late of Nyah, in the State of Victoria, retired farmer, DECEASED, intestate.

CREDITORS, next of kin and other persons having claims against the estate of the said deceased (who died on the 14th day of May, 1966), are required to send particulars of same to the administrator, Ronald Beament, in care of the under-signed on or before the 15th day of December, 1966, after which date they will distribute the assets, having regard only to the claims of which they then have notice.

DELANY & DELANY, barristers and solicitors, 270 Campbell-street, Swan Hill. 3951

CREDITORS, next of kin and others having claims in respect of the estate of Maxwell Henry Ewen Edwards, formerly of "Riversleigh", Heathmere, in the State of Victoria, gentleman, and Must-street, Portland, in the said State, clerk, but late of Flat 1, 287 Barkers-road, Kew, in the said State, accountant, deceased (who died on the 31st day of July, 1966), are to send particulars of their claims to Messrs. Nicol Silvester and Culhane, solicitors, Percy-street, Portland, Victoria, by the 15th day of December, 1966, after which date they will distribute the assets, having regard only to the claims of which they then have notice. 3953

CREDITORS, next of kin and others having claims in respect of the estate of Gertrude Muriel Stoll, late of 18 Denman-avenue, East St. Kilda, deceased (who died on the 27th day of May, 1965), are required by the executor of the estate, Jack Cohen, of 8 Lempriere-avenue, East St. Kilda, to send particulars to him, care of Jack Cohen, Marks & Co., solicitors, of 224 Queen-street, Melbourne, on or before the 22nd day of December, 1966, after which date the executor may convey or distribute the assets, having regard only to the claims of which he has notice.

JACK COHEN, MARKS & CO., solicitors, 224 Queen-street, Melbourne. 3912

EDWARD STANLEY WALKER, late of 118 Wendouree-parade, Ballarat, in the State of Victoria, retired grazier, DECEASED (who died on the 31st May, 1966).

CREDITORS, next of kin and all other persons having claims against the estate of the said deceased are required by the executors, The Union-Fidelity Trustee Company of Australia Limited, of 100 Exhibition-street, Melbourne, and Joan Margaret McKinley, of 1428 Sturt-street, Ballarat, married woman, to send detailed particulars of their claims in respect of the said property to the said executors, care of the said company, at 101 Lydiard-street north, Ballarat, on or before the 12th day of December, 1966, after which date it and she will proceed to distribute the said estate, having regard only to the claims of which it and she has notice.

Dated this 12th day of October, 1966.

R. H. RAMSAY AND GAUNT, 41 Lydiard-street south, Ballarat, solicitors for the executors. 3896

JOSEPH HENRY STUCKEY, late of Traralgon, Victoria, retired farmer, DECEASED.

CREDITORS, next of kin and others having claims in respect of the estate of the deceased (who died on 22nd July, 1966), are required by the executor Ian Thomas Stuckey of Drouin West, farmer, to send particulars to him, care of the under-mentioned solicitor, by 31st December, 1966, after which date the executor may convey or distribute the assets, having regard only to the claims of which he then has notice.

C. H. FORD, LL.M., solicitor, Princes-street, Traralgon.
3874

ARTHUR RUEBEN ROUTLEY, late of Swan Hill, in the State of Victoria, farmer, DECEASED (who died on the 4th day of June, 1966).

CREDITORS, next of kin and all other persons having claims against the estate of the deceased, are required by the executors of the will, Arthur Charles Routley, and Margaret Isabella Luhrs, to send particulars to them, care of the undersigned, on or before the 3rd day of January, 1967, after which date they will distribute the assets, having regard only to the claims of which they then have notice.

GARDEN & GREEN, solicitors, 4 McCallum-street, Swan Hill.
3876

BENJAMIN RUPERT BOON, formerly of Moe and Warragul, but late of 23 Carisbrook-crescent, Lower Plenty, in the State of Victoria, retired civil engineer DECEASED.

CREDITORS, next of kin and others having claims in respect of the estate of the deceased (who died on the 16th day of July, 1966), are required by the trustee, Lucy Elma Boon, of 23 Carisbrook-crescent, Lower Plenty, in the State of Victoria, widow, to send particulars to her, care of the undersigned solicitors, by the 23rd day of December, 1966, after which date the trustee may convey or distribute the assets, having regard only to the claims of which she then has notice.

GRAY, FRIEND & LONG, solicitors, Warragul. 3894

FRANCIS MICHAEL DAVEY MATTHEWS, late of Cohuna, in the State of Victoria, printer and publisher, DECEASED (who died on the 17th day of February, 1966).

CREDITORS, next of kin and all other persons having claims against the estate of the deceased are required by the executors of the will, Edna Constance Matthews and Thomas Bridson Green, to send particulars to them, care of the undersigned, on or before the 6th day of January, 1967, after which date they will distribute the assets, having regard only to the claims of which they then have notice.

GARDEN & GREEN, solicitors, 4 McCallum-street, Swan Hill.
3895

NEIL ARTHUR GUNN, late of 21 Grant-street, Newtown, Geelong, medical practitioner, DECEASED.

CREDITORS, next of kin and others having claims in respect of the estate of the deceased (who died on the 27th day of May, 1966), are required by the personal representatives Norma Joan Gunn, of 21 Grant-street, Newtown, Geelong, widow, and The Union-Fidelity Trustee Company of Australia Limited, of 100 Exhibition-street, Melbourne, to send particulars to the Geelong Branch, of the said company, 8 Malop-street, Geelong, by the 19th day of December, 1966, after which date the personal representatives may convey or distribute the assets, having regard only to the claims of which they then have notice.

WHYTE, JUST & MOORE, solicitors, 27 Malop-street, Geelong.
3888

MICHAEL PATRICK WILLIAM HURLEY, (also known as William Michael Patrick Hurley), late of Derrinal, labourer (who died on the 28th day of July, 1966).

ALL persons having claims against the estate of the above named are required to forward written particulars thereof to the administratrix, Eileen Veronica Comer, care of Cohen, Kirby and Company, solicitors, corner Pall Mall and Bull streets, Bendigo, not later than the 1st day of January, 1967, after which date the administratrix will proceed to distribute the assets, amongst the persons entitled thereto, having regard only to the claims of which she then has notice.

COHEN, KIRBY AND COMPANY, solicitors, corner Pall Mall and Bull streets, Bendigo. 3900

CREDITORS, next of kin and others having claims in respect of the estate of Henry Clifford Bate, late of 25 Guildford-road, Surrey Hills, deceased (who died on the 1st day of October, 1963), are required by the executor of the estate, Jack Cohen, of 224 Queen-street, Melbourne, to send particulars to him, care of Jack Cohen, Marks & Co., solicitors, 224 Queen-street, Melbourne, on or before the 22nd day of December, 1966, after which date the executor may convey or distribute the assets, having regard only to the claims of which he has notice.

JACK COHEN, MARKS & CO., solicitors, 224 Queen-street, Melbourne. 3913

CREDITORS, next of kin and others having claims in respect of the estate of Frederick William Carter, late of 665 South-road Moorabbin, pensioner (who died on the 9th August, 1966), are to send particulars of their claims to Margorie Walker, care of the under-mentioned solicitor, by the 15th December, 1966, after which date he will distribute the assets, having regard only to the claims of which he then has notice.

ROWLAND P. HASSALL, 360 South-road, Moorabbin.
3879

MAURICE JOSEPH MARSHALL, late of Orbost, hotel-keeper, DECEASED.

CREDITORS, next of kin and others having claims in respect of the estate of the above deceased (who died on the 18th day of March, 1966), are required to send particulars of their claims to the executrix, Patricia Mary Marshall, care of the under-mentioned solicitors, by the 16th day of December, 1966, after which date they shall distribute the assets, having regard only to the claims of which they have notice.

MOSLEY AND PALMER, solicitors, Orbost. 3901

THOMAS HARTLEY ORMANDY, late of Hamilton, farmer and grazier, DECEASED.

CREDITORS, next of kin and others having claims in respect of the estate of the above-named deceased (who died on the 6th day of July, 1966), are required to send particulars of their claims to the executor, The Union-Fidelity and Trustee Company of Australia Limited, care of the undermentioned solicitors, by the 12th day of December, 1966, after which date it shall distribute the estate, having regard only to the claims of which it has notice.

MELVILLE, ORTON AND LEWIS, solicitors, 66 Thompson-street, Hamilton. 3910

CREDITORS, next of kin and all other persons having claims against the estate of John Claude Luckie, late of 10 Marchington-avenue, Mornington, in the State of Victoria, retired postal employee, deceased (who died on the 4th day of November, 1965, probate of whose will was granted by the Supreme Court of Victoria in its probate jurisdiction to Desmond Cory of Tamleugh via Violet Town, in the said State, accountant, and James Amis, of 46 Renwick-street, Glen Iris, in the said State, sales manager), are requested to send in their claims in writing to the said executors, care of Donald E. Roberts, solicitor, Nepean Highway, Dromana, in the said State on or before the 12th day of December, 1966, after which date the executors will distribute the assets, having regard only to the claims of which they shall then have notice.

DONALD E. ROBERTS, LL.B., solicitor, Dromana. 3911

CREDITORS, next of kin and others having claims in respect of the estate of William Leslie Hicks, late of 7 Burnside-avenue, Canterbury, retired accountant, deceased (who died on the 13th day of August, 1966), are required by the executor, Ronald John Hicks, of 16 Ellerslie-place, Toorak, accountant, to send particulars of their claims to him, in care of the under-mentioned solicitors, by the 14th day of December, 1966, after which date he will distribute the assets, having regard only to the claims of which he then has notice.

MCCAY, & THWAITES, solicitors, 360 Collins-street, Melbourne. 3917

NOTICE TO CLAIMANTS.

Winifred Johanna Fagan, late of Kerang, accountant, deceased.—Claims to the executrix, Wilhelmina Margaret Fagan, in care of Willan and McKenzie, solicitors, Kerang, by the 14th December, 1966. 3909

In the Supreme Court of the State of Victoria.

SALE BY THE SHERIFF.

ON Monday, the 14th of November, 1966, at 12.30 p.m., at the Police station, Ringwood (unless process be stayed or satisfied):—

All the estate and interest (if any) of Nancy Russo, of 54 Whitehorse-road, Ringwood, married woman, as joint proprietor with Bartolo Russo, of an estate in fee-simple in the land described in certificate of title, volume 8033, folio 726, upon which is erected a weatherboard dwelling house with fibro-cement roof known as No. 75 Canterbury-road, Heathmont.

Registered Caveat No. B998410 affects the said estate and interest.

Terms: Cash only.

DAVID J. JOHNSTON, Sheriff's Officer.

7th October, 1966. 3952

INSOLVENCY NOTICES

COMMONWEALTH OF AUSTRALIA.

The Bankruptcy Act 1924-60.—Part XII.

In the matter of the Assigned Estate of ROBERT MAYNARD BLOOMFIELD, of 73 Parrott-street, Cobden and GEORGE SPENCER LEGG, of 48 Allendale-road, Croydon.

No. 20 of 1962.

NOTICE is hereby given that a First Dividend is intended to be declared in the above matter.

Creditors who have not proved their debts by the 7th day of November, 1966, will be excluded therefrom.

Dated this 8th day of October, 1966.

R. D. WIDDOWS, Trustee.
6 Marylin-court, East Bentleigh. 3942

COMMONWEALTH OF AUSTRALIA.

The Bankruptcy Act 1924-60.—Part XII.

In the matter of the Assigned Estate of ROBERT MAYNARD BLOOMFIELD, of 73 Parrott-street, Cobden.

No. 20 of 1962.

NOTICE is hereby given that a First Dividend is intended to be declared in the above matter.

Creditors who have not proved their debts by the 7th day of November, 1966, will be excluded therefrom.

Dated this 8th day of October, 1966.

R. D. WIDDOWS, Trustee.
6 Marylin-court, East Bentleigh. 3940

IMPOUNDING

MAFFRA.—Impounded in Maffra Pound, from Myrtle-bank:

1 Jersey bull; no visible brand

If not claimed and expenses paid, to be sold on 26th October, 1966.

F. GIESCHEN,
3978—\$1.75 Poundkeeper.

Subordinate Legislation Act 1962.

NOTICE OF MAKING OF STATUTORY RULES.

IN pursuance of the provisions of the Subordinate Legislation Act 1962 and the Regulations made thereunder, notice is given of the making of the following statutory rules:—

No.	Price.
Apprenticeship Act 1958.	
283/1966. Apprenticeship (Boilermaking Trades) (Amendment) Regulations 1966	10c
Apprenticeship Act 1958.	
284/1966. Apprenticeship (Moulding Trades) (Amendment No. 2) Regulations 1966	10c
Apprenticeship Act 1958.	
285/1966. Apprenticeship (Vehicle Trades) (Amendment No. 2) Regulations 1966	10c

No.	Price.
Apprenticeship Act 1958.	
286/1966. Apprenticeship (Motor Mechanics Trades) (Amendment No. 2) Regulations 1966	10c
Transport Regulation Act 1958— Commercial Goods Vehicles Act 1958.	
287/1966. Transport (Licence Windscreen Labels) Regulations 1966	10c

Copies of these statutory rules may be purchased at the Sale of Publications Section of the Government Printing Office, located at Macarthur-street, Melbourne, C.2. If ordered by mail, remittance should be addressed to "The Government Printer, Box 203, P.O., North Melbourne, N.1.", and should include 5c extra for postage. If a credit account is held at this office, no remittance is required with the mail order.

The annual subscription rate for Statutory Rules (including a Bound Volume) is \$15, payable in advance. The subscription year commences on 1st January.

A. C. BROOKS,
Government Printer,

ACTS REPRINTED IN ACCORDANCE WITH THE AMENDMENTS INCORPORATION ACT 1958 (No. 6422), AND FOR SALE AT THE SALE OF PUBLICATIONS BRANCH OF THE GOVERNMENT PRINTING OFFICE, MACARTHUR-STREET, MELBOURNE.

(These prices do not include postage.)

No.	Price.
6189. Acts Interpretation (Incorporating amendments up to No. 7146)	\$0.15
6191. Administration and Probate (Third Reprint—Incorporating amendments up to No. 7332)	\$0.38
6194. Agricultural Colleges (First Reprint—Incorporating amendments up to No. 7302)	\$0.12
6199. Apprenticeship (First Reprint—Incorporating amendments up to No. 7312)	\$0.25
6209. Boiler Inspection (Incorporating amendments up to No. 7072)	\$0.18
6210. Building Societies (Incorporating amendments up to No. 7125)	\$0.25
6218. Children's Court (Incorporating amendments up to No. 7084)	\$0.20
6219. Children's Welfare (Incorporating amendments up to No. 6812)	\$0.25
6220. Clean Air (Incorporating amendments up to No. 6886)	\$0.10
6222. Commercial Goods Vehicles (Second Reprint—Incorporating amendments up to No. 7358)	\$0.22
6839. Companies Act 1961 (Second Reprint—Incorporating amendments up to No. 7332)	\$2.32
6225. Co-operation (Second Reprint—Incorporating amendments up to No. 7083)	\$0.42
6226. Co-operative Housing Societies (Incorporating amendments up to No. 7097)	\$0.40
6228. Country Fire Authority (Incorporating amendments up to No. 7065)	\$0.40
6229. Country Roads (Incorporating amendments up to No. 6943)	\$0.40
6231. Crimes (Second Reprint—Incorporating amendments up to No. 7407)	\$1.33
6236. Dog (Second Reprint—Incorporating amendments up to No. 7065)	\$0.15
6242. Employers and Employés (Incorporating amendments up to No. 6740)	\$0.18
6245. Estate Agents (Second Reprint—Incorporating amendments up to No. 7134)	\$0.38
6246. Evidence (Second Reprint—Incorporating amendments up to No. 7366)	\$0.42
6249. Fences (Incorporating amendments up to No. 6550)	\$0.12
6250. Fertilizers (Incorporating amendments up to No. 7142)	\$0.18
6251. Firearms (Incorporating amendments up to No. 6716)	\$0.22
6916. Foreign Judgments Act 1962 (First Reprint—Including amendments made by No. 7332)	\$0.12
6585. Forests (Pulpwood Agreement) (Incorporating amendments up to No. 6886)	\$0.15
6259. Gaols (Incorporating amendments up to No. 6651)	\$0.15
6265. Goods (Third Reprint—Incorporating amendments up to No. 7131)	\$0.28
6270. Health (Incorporating amendments up to No. 6886)	\$1.45
6274. Hospitals and Charities (Incorporating amendments up to No. 6716)	\$0.35
6279. Instruments (Third Reprint—Incorporating amendments up to No. 7315)	\$0.38

ACTS REPRINTED IN ACCORDANCE WITH THE AMENDMENTS INCORPORATION ACT 1958 (No. 6422)—*continued*.

No.	Price.
6282. Justices (Second Reprint—Incorporating amendments up to No. 7369)	\$1.23
6283. Labour and Industry (Second Reprint—Incorporating amendments up to No. 7143)	\$0.75
6284. Land (Incorporating amendments up to No. 7360)	\$1.53
6285. Landlord and Tenant (Second Reprint—Incorporating amendments up to No. 6996)	\$0.50
6289. Land Tax (Incorporating amendments up to No. 7099)	\$0.32
6291. Legal Profession Practice (Incorporating amendments up to No. 7065)	\$0.45
6293. Licensing (Second Reprint—Incorporating amendments up to No. 7054)	\$0.95
6577. Lifts and Cranes (Incorporating amendments up to No. 6886)	\$0.12
6295. Limitation of Actions (Incorporating amendments up to No. 6845)	\$0.15
6298. Local Authorities Superannuation (Incorporating amendments up to No. 6894)	\$0.25
6299. Local Government (Incorporating amendments up to No. 7052)	\$3.50
6302. Marine (Incorporating amendments up to No. 7350)	\$0.72
6309. Medical (Second Reprint—Incorporating amendments up to No. 7408)	\$0.40
6310. Melbourne and Metropolitan Board of Works (Incorporating amendments up to No. 7054)	\$0.85
6312. Melbourne Harbor Trust (First Reprint—Incorporating amendments up to No. 7356)	\$0.48
6605. Mental Health (Incorporating amendments up to No. 7135)	\$0.45
6315. Metropolitan Fire Brigades (Incorporating amendments up to No. 6886)	\$0.28
6317. Milk and Dairy Supervision (Incorporating amendments up to No. 6964)	\$0.40
6318. Milk Board (Incorporating amendments up to No. 7093)	\$0.22
6324. Money Lenders (Incorporating amendments up to No. 6886)	\$0.25
6832. Motor Boating (Incorporating amendments up to No. 6961)	\$0.15
6325. Motor Car (Second Reprint—Incorporating amendments up to No. 7361)	\$0.82
6326. National Parks (Incorporating amendments up to No. 7275)	\$0.15
6328. Nurses (Incorporating amendments up to No. 6716)	\$0.20
6330. Partnership	\$0.15
6889. Poisons (Incorporating amendments up to No. 7065)	\$0.35
6337. Police Offences (Incorporating amendments up to No. 7145)	\$0.82
6338. Police Regulation (Incorporating amendments up to No. 7081)	\$0.45
6890. Probate Duty (Incorporating amendments up to No. 6970)	\$0.38
6343. Process Servers and Inquiry Agents (Incorporating amendments up to No. 7126)	\$0.12
6344. Property Law (Incorporating amendments up to No. 6867)	\$0.90
6349. Public Service (Second Reprint—Incorporating amendments up to No. 7356)	\$0.40
6350. Public Trustee (Incorporating amendments up to No. 6961)	\$0.35
6353. Racing (First Reprint—Incorporating amendments up to No. 7404)	\$0.70
6359. Road Traffic (Second Reprint—Incorporating amendments up to No. 7332)	\$0.18
6360. Rural Finance (First Reprint—Incorporating amendments up to No. 7328)	\$0.12
6846. Rural Finance and Settlement Commission Act 1961 (First Reprint—Incorporating amendments up to No. 7332)	\$0.20
6975. Sale of Land Act 1962 (First Reprint—Incorporating amendments up to No. 7332)	\$0.18
6363. Second-Hand Dealers	\$0.12
6367. Settled Land (Incorporating amendments up to No. 6505)	\$0.40
6368. Sewerage Districts (First Reprint—Incorporating amendments up to No. 7332)	\$0.62
6651. Social Welfare Act 1960 (Third Reprint—Incorporating amendments up to No. 7332)	\$0.20
6372. Soil Conservation and Land Utilization (Incorporating amendments up to No. 6961)	\$0.20
6373. Soldier Settlement (First Reprint—Incorporating amendments up to No. 7328)	\$0.42
6375. Stamps (Third Reprint—Incorporating amendments up to No. 7359)	\$0.82

ACTS REPRINTED IN ACCORDANCE WITH THE AMENDMENTS INCORPORATION ACT 1958 (No. 6422)—*continued*.

No.	Price.
6377. State Electricity Commission (Incorporating amendments up to No. 7054)	\$0.50
6379. State Savings Bank (Incorporating amendments up to No. 6886)	\$0.42
6886. Subordinate Legislation (Incorporating amendments up to No. 6961)	\$0.15
6849. Town and Country Planning (First Reprint—Incorporating amendments up to No. 7276)	\$0.35
6399. Transfer of Land (Second Reprint—Incorporating amendments up to No. 7130)	\$0.52
6400. Transport Regulation (First Reprint—Incorporating amendments up to No. 7358)	\$0.22
6401. Trustee (Second Reprint—Incorporating amendments up to No. 6963)	\$0.42
6879. Unclaimed Moneys (Incorporating amendments up to No. 6961)	\$0.12
6653. Valuation of Land Act 1960 (Second Reprint—Incorporating amendments up to No. 7333)	\$0.22
6413. Water (Incorporating amendments up to No. 7228)	\$1.42
6414. Weights and Measures (Second Reprint—Incorporating amendments up to No. 7332)	\$0.32
6419. Workers Compensation (Second Reprint—Incorporating amendments up to No. 7332)	\$0.52

FIRST NOTIFICATION OF REPRINT—

6331. Patriotic Funds (First Reprint—Incorporating amendments up to No. 7338)	\$0.25
6341. Pounds (First Reprint—Incorporating amendments up to No. 7315)	\$0.25

A. C. BROOKS,
Government Printer.

STATE ACTS, 1966

COPIES of the following Acts of Parliament of Victoria may be obtained at the Government Printing Office, or from any accredited agents, at the price set opposite to each (these prices do not include postage).

The annual subscription for State Acts 1967 et seq. is \$8, payable in advance.

Bound Volumes of State Acts are also available on a subscription basis at \$15 per annum.

No.	Price.
7372. Education (Council of Adult Education)	\$0.05
7373. Legal Profession Practice (Amendment)	\$0.05
7374. Co-operation (Amendment)	\$0.05
7375. Nurses (Amendment)	\$0.05
7376. Property Law (Loans to Minors)	\$0.05
7377. Audit (Amendment)	\$0.08
7378. Marketing of Primary Products (Tobacco Leaf Marketing Board)	\$0.05
7379. State Library, National Gallery, National Museum and Institute of Applied Science (Amendment)	\$0.05
7380. Reid Murray Acceptance Limited (Scheme of Arrangement)	\$0.12
7381. Lake Corangamite	\$0.10
7382. Tobacco Leaf Marketing Board (Appointment of Manager)	\$0.05
7383. Country Fire Authority (Borrowing Powers)	\$0.05
7384. Labour and Industry (Sheltered Workshops)	\$0.05
7385. Wombat Bonuses	\$0.05
7386. Country Fire Authority (Interstate Fire Brigades)	\$0.05
7387. Loch Public Hall Trust	\$0.12
7388. Co-operative Housing Societies (Amendment)	\$0.05
7389. Fisheries and Game (Amendment)	\$0.08
7390. Marine Stores and Old Metals (Collectors)	\$0.05
7391. Companies	\$0.22
7392. The Constitution Act Amendment	\$0.05
7393. Vagrancy	\$0.12
7394. Consolidated Revenue	\$0.05
7395. Land (Plantation Areas)	\$0.10
7396. Daylesford Springs Land	\$0.05
7397. Barley Marketing (Amendment)	\$0.05
7398. Sheep Dipping (Repeal)	\$0.05
7399. Grain Elevators (Amendment)	\$0.05
7400. Seymour Racecourse Land	\$0.05
7401. Shepparton Abattoirs	\$0.05
7402. Paisley-Galvin Railway Land Exchange	\$0.08
7403. Aerial Spraying Control	\$0.12
7404. Racing (Amendment)	\$0.08

STATE ACTS, 1966—continued.

No.	Price.
7405. Summary Offences	\$0.28
7406. Friendly Societies (Amendment)	\$0.05
7407. Crimes (Dangerous Driving)	\$0.05
7408. Medical (Foreign Practitioners Qualification Committee)	\$0.05
7409. Opticians Registration (Amendment)	\$0.05
7410. Labour and Industry (Petrol Shops)	\$0.08
7411. Melbourne and Metropolitan Board of Works (Amendment)	\$0.08
7412. Carlton (Recreation Ground) Land	\$0.08
7413. Boilers Inspection (Amendment)	\$0.05
7414. Warragul and Neerim Railway Lands	\$0.08
7415. Victoria Institute of Colleges (Council)	\$0.05
7416. Marketable Securities	\$0.18
7417. Pensions Supplementation	\$0.20
7418. Evidence (Medical Evidence)	\$0.05
7419. Water (Rating by Area)	\$0.05
7420. County Court (Common Law Jurisdiction)	\$0.05
7421. State Electricity Commission (Amendment)	\$0.05
7422. Gas and Fuel Corporation (Borrowing)	\$0.05
7423. Vegetation and Vine Diseases (Amendment)	\$0.05
7424. Motor Car	\$0.05
7425. Estate Agents (Amendment)	\$0.10
7426. Melbourne University (Chancellorship)	\$0.05
7427. Tobacco Leaf Industry Stabilization	\$0.15
7428. Consolidated Revenue	\$0.05
7429. Lotteries Gaming and Betting	\$0.35
7430. Stamps (Mortgages)	\$0.05
7431. Money Lenders (Exemption)	\$0.05
7432. Protection of Animals	\$0.12

A. C. BROOKS,
Government Printer.

THE "VICTORIA GOVERNMENT GAZETTE".

SUBSCRIPTIONS.—The subscription, including postage, is \$10 per annum, or \$5 per half year, payable in advance.

Subscriptions are required for whole months, and must cover at least a half year.

Single copies are 20 cents, posted 25 cents. Subscribers do not receive the Acts of Parliament with the GAZETTE.

GAZETTES are held in stock for five years only.

PRIVATE ADVERTISEMENTS.—The charge for insertion is 25 cents per line single column, and 50 cents per line double column. The title forms one or more lines as a heading. On an average ten words make a line of single column. Every signature must likewise be counted as a line. The final words of a paragraph, though only portion of a line, must be counted as one line. Signatures (in particular) and proper names must be written very plainly in the text; ONE SIDE ONLY of each sheet of paper should be WRITTEN UPON.

All documents illegibly written will be returned unpublished, and where brands occur unprovided for by the ordinary letters of the alphabet, a worded explanatory description must be furnished.

THE VICTORIA GOVERNMENT GAZETTE is published on WEDNESDAY EVENING in each week, and Notices for insertion will be received by the Government Printer at or before ONE p.m. at ordinary rates, and late advertisements between ONE p.m. and FOUR p.m. at double rates on the day preceding the day of publication.

PAYMENTS.—Unless the advertiser has a credit account, all payments are required in advance. Remittances should be made by cheque, postal note, or money order payable to "GOVERNMENT PRINTER".

ADDRESS.—All communications should be addressed to "The Government Printer, Box 203, P.O., North Melbourne".

PUBLICATION OF OFFICIAL MATTER.

ATTENTION is invited to the following procedure in relation to the publication of official matter in the Government Gazette:—

1. Matter submitted to the Executive Council.

Matters submitted to the Executive Council which requires gazettal will normally be published in the issue of the following week.

Where urgent gazettal is required, special arrangements should be made with the Gazette Officer, Room 9, first floor, Old Treasury Building.

Publication will be facilitated by the submission of carbon copies for the use of the Gazette Officer.

2. Other matter.

(a) All other matter duly certified by a responsible officer for publication should be lodged with the Gazette Officer not later than half-past Ten a.m. on Tuesday.

(b) Lengthy or involved notices should be forwarded several days before publication.

(c) Proofs, which will be supplied only when specifically requested or, at the direction of the Gazette Officer, should be returned promptly to avoid delay in publication.

(d) No additions or amendments to matter for publication will be accepted by telephone.

CONTENTS

	PAGE
Acts of Parliament	3557
Acts of Parliament on sale at the Government Printing Office	3620
Appointments	3578
Auction Sales Act	3572
Bank Half-Holiday	3557
Contracts	3575
Courts	3557
Estates of Deceased Persons	3573
Government Notices	3557
Impoundings	3620
Insolvency Notices	3620
Lands	3603
Mining	3574
Notice to attend for Radiological Examination	3562
Notice to Mariners	3574
Notice of Making of Statutory Rules	3620
Orders in Council—	
Acts—Forests; Country Roads; Land; Local Government; Cemeteries; Labour and Industry; Drainage Areas; Stamps; Water; Sewerage Districts; Landlord and Tenant; Melbourne and Metropolitan Tramways; Tobacco Leaf Industry Stabilization.	3580 et seq
Private Advertisements	3608
Proclamations	3555
Public Holidays	3556
Public Service Notices	3607
Resignations	3579
Tenders	3606
Transport Regulation Board—Public Hearings	3558
Waterworks Trusts	3563