

[1959]



# VICTORIA GOVERNMENT GAZETTE

Published by Authority

[Registered at the General Post Office, Melbourne, for transmission by post as a newspaper.]

No. 29]

FRIDAY, MARCH 31

[1967

## PROCLAMATIONS

### BANK HALF-HOLIDAY.

#### PROCLAMATION

By His Excellency the Governor of the State of Victoria and its Dependencies in the Commonwealth of Australia, &c., &c., &c.

IN pursuance of the provisions of the *Bank Holidays Act 1958*, I, the Governor of the State of Victoria, in the Commonwealth of Australia, do by this my Proclamation appoint the day and date named hereunder a special day to be observed as a Bank Half-Holiday at the place mentioned, that is to say:—

*Bank Half-Holiday from the Hour of Eleven o'clock a.m.:—*  
WEDNESDAY, THE 19TH APRIL, 1967, at Hamilton.

Given under my Hand and the Seal of the State of Victoria aforesaid, at Melbourne, this twenty-first day of March, in the year of our Lord One thousand nine hundred and sixty-seven, and in the sixteenth year of the reign of Her Majesty Queen Elizabeth II.

(L.S.) ROHAN DELACOMBE.

By His Excellency's Command,  
A. G. RYLAH,  
Chief Secretary.

GOD SAVE THE QUEEN!

### PUBLIC HIGHWAY.—CITY OF NUNAWADING.

#### PROCLAMATION

By His Excellency the Governor of the State of Victoria and its Dependencies in the Commonwealth of Australia, &c., &c., &c.

WHEREAS by the *Local Government Act 1958* as amended, Section 519 it is amongst other things enacted that it shall be lawful for the Governor-in-Council at any time and from time to time upon the request of

the Council of any municipality by notice in the *Government Gazette* to proclaim any land reserved used or by purchase or exchange acquired for a street, road, highway, thoroughfare, bridge, square, court, alley or right-of-way or any street, road, lane or passage made or laid out or proposed to be made or laid out on any land of which a plan of subdivision delineating that street, road, lane, or passage has been sealed with the seal of the municipality under subdivision (3) of Division 9 of Part XIX of the *Local Government Act 1958*, as amended, or a corresponding previous enactment to be a public highway and that such land shall thereupon and thenceforth from the date of such proclamation become and be absolutely dedicated to the public as a public highway within the meaning of any law then or thereafter in force.

AND WHEREAS the Council of the City of Nunawading has requested that the land hereinafter mentioned, being a street, road, lane or passage made or laid out or proposed to be made or laid out on land of which a plan of subdivision delineating that street, road, lane or passage has been sealed with the seal of the municipality under subdivision (3) of Division 9 of Part XIX of the *Local Government Act 1958*, as amended, or a corresponding previous enactment, be so declared to be a public highway.

NOW THEREFORE I, the Governor of the State of Victoria in the Commonwealth of Australia, by and with the advice of the Executive Council of the said State, do by this Proclamation declare that Boyd-street, coloured brown on Plan of Subdivision No. 25574 lodged in the Office of Titles, shall be a public highway within the meaning of the said Act.

Given under my Hand and the Seal of the State of Victoria aforesaid, at Melbourne, this twenty-first day of March, in the year of our Lord One thousand nine hundred and sixty-seven, and in the sixteenth year of the reign of Her Majesty Queen Elizabeth II.

(L.S.) ROHAN DELACOMBE.

By His Excellency's Command,  
R. J. HAMER,  
Minister for Local Government.

GOD SAVE THE QUEEN!

**GOVERNMENT NOTICES**

**ERRATUM.**

IN *Victoria Government Gazette*, No. 28, of 22nd March, 1967, page 905, the notice under the *Workers Compensation Act 1958*, section 72, is to be deleted and replaced by the following:—

*Workers Compensation Act 1958*, Section 72.

His Excellency the Governor of the State of Victoria, by and with the advice of the Executive Council thereof, has, by Order made on the 21st day of March, 1967, pursuant to the provisions of the *Workers Compensation Act 1958*, approved The Country Traders Mutual Insurance Ltd., as an "insurer" for the period ending the 30th June, 1967.

J. COLQUHOUN,  
Clerk of the Executive Council.

At the Executive Council Chamber,  
Melbourne, 21st March, 1967.

**ANZAC DAY HOLIDAY.**

IT is hereby notified that on—

TUESDAY, THE 25TH APRIL, 1967,

the Public Offices will be closed, such day having been appointed by the *Public Service Act 1958*, to be observed as a holiday in the Public Offices throughout the State of Victoria.

This notice relates only to the closing of the State Public Offices. All inquiries regarding the holiday in other offices and in shops and industry should be directed to the Department of Labour and Industry, 110 Exhibition-street, Melbourne, C.I. (Telephone 63 0321, Extension 6158 or 6721.)

A. G. RYLAH,  
Chief Secretary.

Chief Secretary's Office,  
Melbourne, C.I., 29th March, 1967.

**SHIRE OF HAMPDEN.  
ROAD DEVIATION ORDER.**

PURSUANT to the provisions of sections 522 and 526 of the *Local Government Act 1958*, the Council of the Shire of Hampden hereby directs that the land in the Parish of Vite Vite, indicated by hatching on the diagram hereunder, which has been purchased, taken or acquired by it, shall be a public highway on and from the date of publication of this Order in the *Government Gazette* and declares that such land shall be a public highway in lieu of the land indicated by cross-hatching on the said diagram.

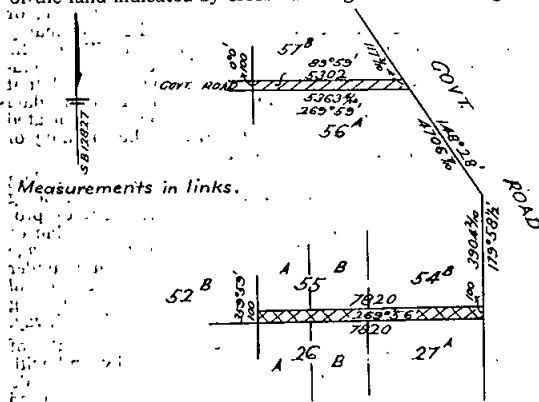

The common seal of the President, Councillors and Ratepayers of the Shire of Hampden was hereunto affixed this fifth day of August, 1966, in the presence of—

(SEAL) W. G. MANIFOLD, President.  
A. C. BORRIDGE, Councillor.  
S. J. GRIMMER, Secretary.

**State Savings Bank Act 1958, Section 30.  
THE STATE SAVINGS BANK OF VICTORIA.  
ESTABLISHMENT OF BRANCH.**

THE Commissioners of the State Savings Bank of Victoria hereby give notice of the establishment of a Sub-Branch of the bank at 62 Silverdale-road, Eaglemont, on 3rd April, 1967.

T. E. HALL,  
General Manager.

**LOCAL GOVERNMENT ACT 1958.**

IN pursuance of the powers conferred by sub-section 3A of section 575 of the *Local Government Act 1958*, I, James Charles Murray Balfour, Her Majesty's Minister of Lands in the State of Victoria hereby declare that the road set out on Crown land in the Parish of Bright, County of Delatite, as delineated and indicated by hachure on the plan hereunder be a private street within the meaning of and for the purposes of Division 10, Part XIX. of the said Act.

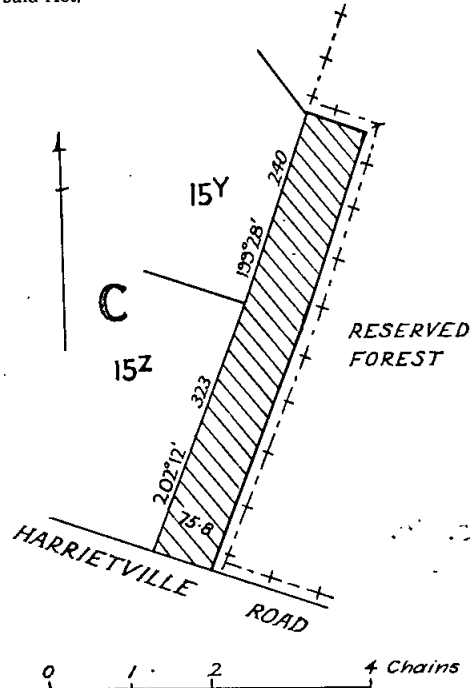

Corres. No. H.011756.

Dated at Melbourne this 23rd day of March, 1967.

JIM BALFOUR,  
Minister of Lands.

**LOCAL GOVERNMENT DEPARTMENT.**

**ORDER CONFIRMED.—CITY OF HORSHAM.**

THE Minister of the Crown administering the *Local Government Act 1958*, as amended, on the 23rd day of March, 1967, confirmed the Order hereinafter referred to, in pursuance of section 514 of the said Act, namely:

An Order of the Council of the City of Horsham made on the 6th March, 1967, directing the compulsory taking of the lands described in certificates of title, volume 3188, folio 587 and volume 5206, folio 190, as a site for a Library, Art Gallery, Meeting Room and for the purposes of a place of public resort or recreation.

R. J. HAMER,  
Minister for Local Government.

Local Government Department,  
Melbourne.

**LOCAL GOVERNMENT DEPARTMENT.**

**ORDER CONFIRMED.—CITY OF RINGWOOD.**

THE Minister of the Crown administering the *Local Government Act 1958*, as amended, on the 23rd day of March, 1967, confirmed the Order hereinafter referred to, in pursuance of section 514 of the said Act, namely:

An Order of the Council of the City of Ringwood made on the 13th February, 1967, directing the compulsory taking of an easement of drainage over the land described hereunder:

All that piece of land being part of lot 33 on plan of subdivision No. 11434 commencing at a point bearing 201 deg. 48 min. distant 8 ft. 3 1/2 in. from the north-east corner of the said lot; thence bearing 201 deg. 48 min. for 13 ft. 5 1/2 in. 333 deg. 31 1/2 min. for 28 ft. 10 1/2 in., 105 deg. 15 min. for 13 ft. 5 in. and 153 deg. 31 1/2 min. for 11 ft. 1/2 in. to the commencing point.

R. J. HAMER,  
Minister for Local Government.

Local Government Department,  
Melbourne.

Transport Regulation Act.  
TRANSPORT REGULATION BOARD.

## HEARING OF APPLICATIONS.

NOTICE is hereby given that the following applications will be considered by the Transport Regulation Board at its offices at corner Lygon and Princes streets, Carlton, at 10.15 a.m. on Wednesday, 19th April, 1967.

**BELL STREET BUS CO. PTY. LTD.**, 326 Bell-street, Preston. Application for authority to operate the following turning procedure at the corner of Bell-street and Sydney-road, Coburg, only when special feeder buses are operated to assist peak worker loadings between the Heidelberg, Preston areas and the corner of Bell-street and Sydney-road, Coburg, on Route 6A (West-breen-Pascoe Vale-Coburg-Heidelberg):—From Bell-street via Elm-grove, Urquhart-street, and Sydney-road to the bus stop on the north side of Bell-street, east of Sydney-road.

NOTE.—This application replaces application published in the *Government Gazette* on 22nd February, 1967.

**LACK, R. J.**, Killawarra Roadside via Wangaratta. One commercial passenger vehicle (S/C. 20) or more persons to operate as a country special service omnibus from Wangaratta.

**SITA, G.**, and **F. BONO** (on behalf of Avondale Heights-Footscray Bus Service), 81-83 Station-road, Deer Park. One commercial passenger vehicle with large seating capacity to be purchased to operate as a metropolitan stage omnibus on the following route:—Route 17 (North Melbourne-Carlton-Clifton Hill). Commencing at the corner of Ireland-street and Anderson-street, North Melbourne (opposite the North Melbourne Railway Station), via Ireland, Dryburgh, Victoria, Errol, Gatehouse, Story, Park and Gatehouse streets, Colledge-crescent, Cemetery-road East, Princes-street, Alexander-parade, Wellington-street, Queen's-parade, Kilgour-crescent, Hoddle-street to Clifton Hill Railway Station. Returning via Hoddle and Turnbull streets to Queen's-parade; thence to normal route (turning procedure at North Melbourne to be from the corner of Dryburgh and Victoria streets, via Victoria and Anderson streets to the corner of Ireland-street).

Sections and fares and time-tables to be observed.

Sections and Fares—	Adult.	Child.
1. North Melbourne Railway Station—Victoria-street ..	6c	4c
2. Victoria-street—Courtney-street ..	10c	6c
3. Courtney-street—Royal-parade ..	12c	7c
4. Royal-parade—Nicholson-street ..	14c	8c
5. Nicholson-street—corner Alexander-parade and Wellington-street ..	16c	9c
6. Corner Alexander-parade and Wellington-street—Clifton Hill Railway Station ..	18c	10c

Time-table to be observed.

Weekdays (Mondays—Fridays). Minimum service—60 minutes, 6.30 a.m. to 6 p.m.

**SUTTON, J. N. & N. M.**, 17 Macarther-street, Bairnsdale. One commercial passenger vehicle (S/C. 5) to operate for the carriage only of patients attending the "Noweyung" centre for retarded persons at Bairnsdale to and from the centre from and to their respective residences, under contract to the centre.

APPLICATION for renewal of licences as shown, by persons listed hereunder to operate under the same terms and conditions.

**ALLAN, T. V.**, corner High and Main streets, Maldon; C.H.116.

**OLSEN, K.**, Lot 80, Newton-street, Seaford; C.T.823.

**ROBERTS, E. G. & K. G.**, 51 George-street, Robinvale; C.T.610.

Notice of any objection should be forwarded to reach the Secretary of the Board not later than Wednesday, 12th April, 1967.

Applicants are advised that it will not be necessary to appear on the hearing date specified above, unless advised in writing by the Board.

B. P. KAY,  
Secretary.

Corner Lygon and Princes streets, Carlton, Wednesday, 29th March, 1967.

Commercial Goods Vehicles Act.  
TRANSPORT REGULATION BOARD.

## HEARING OF APPLICATIONS.

NOTICE is hereby given that the following applications will be considered by the Transport Regulation Board at its offices at corner Lygon and Princes streets, Carlton, at 10.15 a.m. on Wednesday, 19th April, 1967.

**AUSTRALASIAN JAM COY. PTY. LTD.**, 1 Garden-street, South Yarra. One commercial goods vehicle (L/C. 120 cwt.) to operate within a 50-mile radius from the post office situate at the corner of Bourke and Elizabeth streets in the City of Melbourne in the course of business as "Food Manufacturers"—own goods.

**BARTY, S. S.**, Sutton Grange. Application to vary the conditions of licence No. D.A.47380 (L/C. 79 cwt.) by deleting paragraph (b) and adding in lieu as paragraph (b) within a 50-mile radius from the post office at Sutton Grange in the course of business as "Stock Fodder Merchant"—stock foods.

**BRICK & PIPE INDUSTRIES LTD.**, 125 Springvale-road, Springvale. One commercial goods vehicle (L/C. 19 cwt.) to operate: (a) Within a 50-mile radius of own premises at East Burwood in the course of business as "Brick and Pipe Manufacturers"—own goods. (b) Throughout the State of Victoria for the purpose of servicing and repairing own equipment and vehicles—tools of trade, spare parts and materials incidental to servicing.

**BRUMNIACH, M. & C.**, 5-7 Neal-street, Bell Post Hill, Geelong. One commercial goods vehicle (L/C. 235 cwt.) to operate: (a) Within a 25-mile radius from the chief post office in the City of Geelong—general goods. (b) Within a 35-mile radius from the pits of You Yangs Granitic Sand Supply Pty. Ltd. at the You Yangs—crushed rock, gravel, sand and screenings.

**CATTANACH, J. E., M. R. & A. H.**, Goldie Park, Lancefield. One commercial goods vehicle (L/C. 112 cwt.) to operate within a 25-mile radius of the G.P.O., Melbourne and to and from own yard at Lancefield in the course of business as "Demolition Contractors"—own goods.

**CHAMPION, G. R.**, Lot 3, Wong-road, North Ringwood. One commercial goods vehicle (L/C. 110 cwt.) to operate within a 70-mile radius from the premises of Commonwealth Pottery Pty. Ltd., at Blackburn—earthenware pipes and fittings solely on behalf of the said company.

**COCKSHUTT, R.**, Powelltown. Application to vary the conditions of licence No. D.A.843 (L/C. 256 cwt.) by deleting the present conditions and adding in lieu, "from forest landings within a 50-mile radius of Maryvale to the Australian Paper Manufacturers Ltd.'s mill at Maryvale—pulpwood."

**THE COMMONWEALTH INDUSTRIAL GASES LTD.**, 90 Bell-street, Preston. Application to vary the conditions of licence No. D.A.838/23 (L/C. 10 cwt.) by deleting the present conditions and adding in lieu, "throughout the State of Victoria in the course of business as 'Medical and Industrial Gas Manufacturers'—medical gases and equipment for demonstration and servicing purposes only."

**DENNIS BROS. DELIVERIES PTY. LTD.**, 743 Burwood-road, Hawthorn. Two commercial goods vehicles (L/C. 10 and 19 cwt.) to operate throughout the State of Victoria in the course of business as "Caterers"—own catering equipment and victuals.

**ELLIOT, A. R.**, Bethanga. One commercial goods vehicle (L/C. 160 cwt.) to operate: (a) Within a 25-mile radius of the post office at Talgarno—general goods, provided that no goods shall be carried whether by one stage or by more than one stage between places within the above radius, which are more than 30 road miles apart by the nearest practicable route. (b) From and to places in paragraph (a) above and from places within a 50-mile radius of the post office at Talgarno—livestock.

**EMOLEUM (AUST.) PTY. LTD.**, Arden-street, North Melbourne. One commercial goods vehicle (L/C. 98 cwt.) to operate throughout the State of Victoria in the course of business as "Manufacturer and Supplier of Bitumen Emulsion" for the purpose of operating the vehicle as an "Emoleum Spray Unit" under contract to municipalities and shires.

**EXCAVATIONS PTY. LTD.**, 2 Kirkdale-street, East Brunswick. One commercial goods vehicle (L/C. 20 cwt.) to operate: (a) Within a 50-mile radius of own premises at East Brunswick in the course of business as "Earth-moving and Civil Engineering Contractors"—own goods. (b) Throughout the State of Victoria—tools of trade, equipment, plant, machinery to own contracts. (c) Within a 20-mile radius of any contract currently engaged upon or from the nearest railway station thereto—materials for use on such contract.

- EXCAVATIONS PTY. LTD., 2 Kirkdale-street, East Brunswick. One commercial goods vehicle (L/C. 13 cwt.) to operate throughout the State of Victoria in the course of business as "Earth-moving and Civil Engineering Contractors" for the purpose of supervising own contracts and servicing own equipment—tools of trade, spare parts and materials incidental to the completion of a contract and for servicing in the field only.
- FORREST, H. T., P.O. Box 361, Warmambool. One commercial goods vehicle (L/C. 30 cwt.) to operate for the carriage of spray painting equipment and small quantities of paint incidental to completion of own painting contracts as "Painting Contractors" throughout the State of Victoria and for the carriage of paint from a railway station within a 20-mile radius of such station.
- GALLAGHER, D. A., 52 Mackie-road, East Bentleigh. One commercial goods vehicle (L/C. 330 cwt.) to operate: (a) Throughout the State of Victoria in the course of business as "Earth-moving Contractor" with special low loader trailer—own earth-moving machinery, machinery parts for repair or having been repaired and a small quantity of fuel to operate machinery on site. (b) Within a 25-mile radius of the post office at the corner of Bourke and Elizabeth streets in the City of Melbourne—general goods.
- GALLI BROS. (EQUIPMENT) PTY. LTD., 2 Kirkdale-street, East Brunswick. Seven commercial goods vehicles (L/C. 8, 9, 7, 15, 7, 14, 7 cwt.) to operate throughout the State of Victoria in the course of business as "Earth-moving and Civil Engineering Contractors" for the purpose of supervising own contracts and servicing own equipment—tools of trade, spare parts and materials incidental to the completion of a contract and for servicing in the field only.
- GALLI BROS. (EQUIPMENT) PTY. LTD., 2 Kirkdale-street, East Brunswick. Eight commercial goods vehicles (L/C. 64, 138, 220, 128, 121, 124, 126 and 119 cwt.) to operate: (a) Within a 50-mile radius of own premises at East Brunswick in the course of business as "Earth-moving and Civil Engineering Contractors"—own goods. (b) Throughout the State of Victoria—tools of trade, equipment, plant and machinery incidental to own contracts. (c) Within a 20-mile radius of any contract currently engaged upon or from the nearest railway station thereto—materials for use on such contract.
- GRAYMORE, E. J. & A. J., 28 Geelong-road, Portarlington. One commercial goods vehicle (L/C. 180 cwt.) to operate: (a) Within a 25-mile radius of the chief post office in the City of Geelong—general goods. (b) From places situated within an 8-mile radius of the post office at Drysdale to the City of Melbourne—market garden and orchard produce but excluding the carriage of potatoes and brown onions in bags. (c) From and to the Townships of St. Leonards and Portarlington to and from fish markets in the City of Melbourne—fish and scallops and empty fish boxes and scallop bags for return.
- GUYETT, E. J., PTY. LTD., 224 Timor-street, Warmambool. One commercial goods vehicle (L/C. 10 cwt.) to operate throughout the State of Victoria as "Mortuary Vehicle" in the course of business as "Funeral Director."
- HANCOCK, C. F., PTY. LTD., Lakes Entrance. One commercial goods vehicle (L/C. 265 cwt.) to operate: (a) From the Township of Lakes Entrance to the City of Melbourne via Princes Highway—fish and fishermen's gear for repair. (b) From the City of Melbourne to the Township of Lakes Entrance—fishermen's gear and equipment solely on behalf of and for use by professional fishermen. (c) From and to the City of Melbourne to and from the Township of Lakes Entrance—those goods only as specified in paragraphs 1 and 2 of the Third Schedule of the *Commercial Goods Vehicles Act 1958*. (d) From and to the Township of Bairnsdale to and from the Township of Lakes Entrance—general goods.
- HIAM, R., 66 Westmere-crescent, Broadmeadows. One commercial goods vehicle (L/C. 127 cwt.) to operate within a 70-mile radius of Clifton Brick Holdings Ltd., at Brunswick, solely on behalf of the said company—bricks.
- HOBLEY, A. C., Ford-street, Wangaratta. One commercial goods vehicle (L/C. 11 cwt.) to operate within a 50-mile radius of own premises at Wangaratta in the course of business as "Electrical Retailer"—electrical goods for repair or having been repaired, tools of trade, spare parts and materials incidental to the repair or servicing of electrical goods.
- LEWIS, M. J., 1363 Nepean Highway, Cheltenham. One commercial goods vehicle (L/C. 18 cwt.) to operate within a 50-mile radius of the G.P.O., Melbourne as an "Installation Contractor" solely on behalf of Dural Leeds Pty. Ltd.—blinds, awnings, insect screens, cornice boxes, screens and doors manufactured by the said Company for installation only and small quantities of materials incidental to such installation.
- LUKE, K. G., AUSTRALIA PTY. LTD., 30 Queens-parade, North Fitzroy. One commercial goods vehicle (L/C. 6 cwt.) to operate throughout the State of Victoria in the course of business as "Metalware Manufacturers and Wholesalers" for the purpose of towing a specially constructed trailer for the display of own goods, viz.; cutlery, china, crystal and fancy goods.
- LYON, R. C., Box 40, Numurkah. One commercial goods vehicle (L/C. 28 cwt.) to operate: (a) Within a 50-mile radius of own premises at Numurkah in the course of business as "Sausage Casing Manufacturers"—own goods. (b) Throughout the State of Victoria for the collection of raw sausage casings and for the delivery of processed sausage casings in the course of business as "Sausage Casing Manufacturers".
- THE NESTLÉ COMPANY (AUST.) PTY. LTD., Midland Highway, Yinnar. One commercial goods vehicle (L/C. 15 cwt.) to operate within a 50-mile radius of own branch premises at Yinnar in the course of business as "Milk Processors"—own goods.
- PHILLIPS, G. W., 58 Railway-place, Newmarket. One commercial goods vehicle (L/C. 30 cwt.) to operate throughout the State of Victoria in the course of business as "Marine Collector"—special wares, marine stores or old metals as designated in the *Marine Stores and Old Metals Act 1958* (No. 6303), Part 1, Section (3) with the proviso that the combined load capacities of both prime mover and any trailer attached thereto shall not exceed 120 cwt.
- PIANTA, E. J. & M. V., Private Bag, Glenorchy. One commercial goods vehicle (L/C. 114 cwt.) to operate: (a) Within a 25-mile radius of the post office at Wal Wal—general goods, provided that no goods shall be carried whether by one stage or by more than one stage between places within the above radius, which are more than 30 road miles apart by the nearest practicable route. (b) Within a 50-mile radius from the post office at Wal Wal in the course of trade as "Primary Producers"—own goods.
- PORTER, G. E., 15-33 Queen's-parade, Clifton Hill. Application to vary the conditions of licence No. T.D.A. 54561/2 (L/C. 206 cwt.) by deleting paragraph (c).
- PRITCHARD, G. E., 6 Brophy-street, Ballarat. One commercial goods vehicle (L/C. 148 cwt.) to operate from the Trentham, Daylesford and Ballan forest areas to the C.S.R. factory at Bacchus Marsh—pulpwood.
- PYKE, C. J., 99 Patrick-street, Stawell. One commercial goods vehicle (L/C. 257 cwt.) to operate from forest landings within a 50-mile radius of Stawell to saw-mills at Stawell—logs.
- RAVELL, J. R., 242 Barker-street, Castlemaine. One commercial goods vehicle (L/C. 12 cwt.) to operate within a 50-mile radius of own premises at Castlemaine and from or to Castlemaine to or from the City of Melbourne in the course of business as "Second-hand Dealer"—loose second-hand goods ex auction sales and damaged second-hand goods.
- SILVESTER, D. P., 130 Grey-street, Traralgon. Application to vary the conditions of licence No. T.T.D.549 (L/C. 303 cwt.) by adding to paragraph (d) the additional words "pulpwood logs."
- SMYTH, D., & SON (SALES) PTY. LTD., 13-19 St. Andrews-avenue, Bendigo. Application to vary the conditions of licence No. T.D.16337 (L/C. 5 cwt.) by adding as an additional paragraph "(c) throughout the State of Victoria—spare parts and equipment required for servicing own contracts."
- SUCKLING, J. W., Korweinguboorra. One commercial goods vehicle (L/C. 149 cwt.) to operate from Dwyer's mills at Sailor Falls and Howard's mills at Korweinguboorra to Lee Bros. at Thornbury and Lyndon's of Sunshine—palings.

## TOW TRUCK.

- SHARPE, W., 220 Broadway, Reservoir. One commercial goods vehicle (L/C. 30 cwt.) to operate throughout the State of Victoria as a "Tow Truck" for the purpose of lifting and carrying or towing and/or repairing wrecked or disabled vehicles—tools of trade, spare parts and materials incidental thereto.

APPLICATIONS for renewal of licences as shown by persons listed hereunder to operate under the same terms and conditions from the expiry date shown in each case.

ARMSTRONG, V. H., 17 Sherrard-street, Ballarat; D.A.21733; 18th April, 1967; 18 cwt.  
 BROOKLANDS ACCESSORIES PTY. LTD., 68-78 Sturt-street, South Melbourne; D.A.34805/1; 25th May, 1967; 6 cwt.  
 DENT, G. E., Manderville-street, Hopetoun; D.A.48568; 22nd April, 1967; 11 cwt.  
 DOLE, J., Marong-road, Maiden Gully; D.A.48603; 8th April, 1967; 20 cwt.  
 DONELAN, A. L., Eskdale; D.A.988; 18th April, 1967; 139 cwt.  
 DOODI, NORM, & SONS PTY. LTD., Creswick-road, Ballarat; D.A.24214/9; 18th April, 1967; 226 cwt.  
 DUNLOP TYRE SERVICE (BENDIGO) PTY. LTD., 191 Lyttleton-terrace, Bendigo; D.A.60416/57; 18th April, 1967; 11 cwt.  
 DUNLOP TYRE SERVICE (BALLARAT) PTY. LTD., 21 Doveton-street North, Ballarat; D.A.60416/52; 29th April, 1967; 11 cwt.  
 DUNLOP TYRE SERVICE (BALLARAT) PTY. LTD., 21 Doveton-street North, Ballarat; D.A.60416/48; 20th April, 1967; 15 cwt.; D.A.60416/49; 20th April, 1967; 11 cwt.; D.A.60416/50; 20th April, 1967; 18 cwt.  
 FARMER, GEO. PTY. LTD., Eureka-street, Ballarat; T.D.A.44430/14; 21st April, 1967; 24 cwt.  
 FINGER, W. L., 121 Burwood-road, Burwood; D.A.49219; 27th May, 1967; 122 cwt.  
 FORDIGRAPH SUPPLIES PTY. LTD., 521 Latrobe-street, Melbourne; D.A.44199/2; 27th May, 1967; 7 cwt.  
 FROZO FOOD CO. PTY. LTD., corner Maria-street and Cherry-lane, Brooklyn; T.D.A.46652/3; 9th May, 1967; 79 cwt.  
 FROZO PROCESSORS, corner Maria-street and Cherry-lane, Brooklyn; T.D.A.46652; 16th May, 1967; 61 cwt.  
 GUYETT, E. J., PTY. LTD., 224 Timor-street, Warrnambool; D.A.36333/2; 16th April, 1967; 10 cwt.  
 HILLGROVES GRADING SERVICE, 29 Everingham-street, Swan Hill; D.A.42087/1; 22nd April, 1967; 10 cwt.  
 JAMES, H. K. & M. S. F., 12-18 Northumberland-street, South Melbourne; D.A.381020/1; 6th May, 1967; 80 cwt.  
 JONES, D. W., PTY. LTD., 126 Cecil-street, Williamstown; D.A.1392; 24th January, 1967; 146 cwt.  
 KING, R. J., Robinson-street, Murchison; D.A.35477; 23rd March, 1967; 68 cwt.  
 LAPPIN, R. G., High-street, Chiltern; D.A.25111/1; 20th April, 1967; 109 cwt.  
 LLOYD, H. C., Stanhope-road, Rushworth; D.A.20188; 18th April, 1967; 118 cwt.  
 LOCKETT, H., & SONS PTY. LTD., Box 554, Ballarat; D.A.48578; 25th March, 1967; 90 cwt.  
 MASKELL & GRIBBEN, 201 Corio-street, Shepparton; D.A.1566/9; 23rd March, 1967; 105 cwt.; D.A.1566/10; 23rd March, 1967; 243 cwt.  
 McCAIG, F. A., 22 Burns-street, Golden Square; D.A.47630; 29th October, 1966; 7 cwt.  
 McINTOSH, N. G., 40 Apex-avenue, Moorabbin; D.A.49046; 6th May, 1967; 7 cwt.  
 McNEILAGE, C. J., 12 Brisbane-street, Berwick; D.A.49006; 6th May, 1967; 232 cwt.  
 PHOENIX BISCUIT CO. PTY. LTD., Grosvenor-street, Abbotsford; D.A.39491/4; 18th March, 1967; 16 cwt.  
 PHOENIX BISCUIT CO. PTY. LTD., Grosvenor-street, Abbotsford; D.A.39491/5; 20th May, 1967; 62 cwt.  
 PIONEER REFRIGERATION (MELBOURNE) PTY. LTD., 178-196 Normanby-road, South Melbourne; D.A.29803/13; 13th May, 1967; 11 cwt.; D.A.29803/14; 13th May, 1967; 8 cwt.  
 REID, G. H. (CONSTRUCTIONS) LTD., 338 Sydney-road, Coburg; D.A.1901/11; 6th May, 1967; 16 cwt.  
 REID, G. H. (CONSTRUCTIONS) LTD., 338 Sydney-road, Coburg; D.A.1901/13; 27th May, 1967; 10 cwt.  
 RUSSO, G., 16 Edward-street, Upper Ferntree Gully; D.A.49102; 13th May, 1967; 11 cwt.  
 RYAN, J. B. & S. P., 7 Queens-street, Rochester; D.A.35619; 20th April, 1967; 256 cwt.  
 SIM, N. C., 15 Rotherham-street, Belmont, Geelong; D.A.48564; 25th March, 1967; 8 cwt.  
 SPENCER, A. B., 11 Charles-street, Koo-Wee-Rup; D.A.49251; 27th May, 1967; 138 cwt.  
 SUNKIST FOODS PTY. LTD., 50 Nott-street, Port Melbourne; T.D.A.47865/34; 16th May, 1967; 59 cwt.  
 TRAILL, A. J., Dargo P.O., via Shepparton; T.D.A.51055; 21st April, 1967; 81 cwt.  
 WILSON, C. D., & SONS, 33 Carmen-street, Dandenong; D.A.27928/4; 8th April, 1967; 6 cwt.  
 WREN, T. & I. R., Spry-street, Tungamah; D.A.30096/4; 12th March, 1967; 256 cwt.

## TOW TRUCKS.

CARMICHAEL, J. F. & B. L., Marine-parade, San Remo; D.A.46195; 13th May, 1967; 126 cwt.  
 COURTNEY'S, G. E., MOTORS PTY. LTD., 102 Grant-street, Alexandra; D.A.47710; 26th February, 1967; 58 cwt.

## RENEWAL WITH VARIATION.

APPLICATION by the person listed hereunder for renewal of the licence listed with variation of conditions in the manner set out opposite the name.

HILLIER, J. H. & N. E., Donaldson-street, Corryong; D.A.34473; 15th December, 1967; application to renew and vary the conditions of licence No. D.A.34473 (L/C. 140 cwt.) by adding as an additional paragraph (c) "To and from the sale-yards at Wodonga from and to the Township of Corryong—livestock."

Notice of any objections should be forwarded to reach the Secretary of the Board not later than Wednesday, 12th April, 1967.

Applicants are advised that it will not be necessary to appear on the hearing date specified above, unless advised in writing by the Board.

B. P. KAY,  
Secretary.

Corner of Lygon and Princes streets, Carlton, N.3, 29th March, 1967.

## Country Fire Authority Act 1958.

## VARIATION OF SUMMER PERIOD IN RESPECT OF SPECIFIED PARTS OF THE COUNTRY AREAS OF VICTORIA.

WHEREAS by section 4 of the Country Fire Authority Act 1958, it is enacted that the Chief Secretary of Victoria, after consultation with the Minister of Forests, may from time to time by declaration published in the Government Gazette declare any period to be the summer period in respect of the country area of Victoria, or any specified part or parts thereof and, without affecting the generality of the foregoing, may declare different periods to be the summer period in respect of different parts of the said country area:

And whereas by the said section it is further enacted that any declaration so published may be revoked, amended or varied by a subsequent declaration so published:

And whereas by declaration issued on the date stated in Schedule A annexed hereto, different summer periods expiring on the thirtieth day of April, 1967, were declared in respect of different parts of the country area of Victoria, including the parts of the said country area specified in Schedule B hereto:

And whereas the Chief Secretary and the Minister of Forests have consulted accordingly:

Now therefore I, the Chief Secretary of Victoria, do by this my declaration vary the aforesaid declaration by declaring that the summer period in respect of the parts of the country area of Victoria specified in Schedule B hereto shall end at midnight on the thirty-first day of March, 1967.

## SCHEDULE A.

Date of Declaration; Date of Publication in  
"Government Gazette".

15th December, 1966; 16th December, 1966.

## SCHEDULE B.

Those portions of the Nineteenth Fire Control Region comprised by the municipal districts of the Town of St. Arnaud and the Shires of Kara Kara and Korong; those portions of the Twenty-First Fire Control Region comprised by the municipal districts of the Shires of East Loddon and Huntly; and

those portions of the Twenty-Second Fire Control Region comprised by the municipal districts of the Cities of Echuca and Shepparton, the Borough of Kyabram and the Shires of Cobram, Deakin, Euroa, Numurkah, Rodney, Shepparton, Tungamah, Violet Town and Waranga.

A. G. RYLAH,  
Chief Secretary.

Chief Secretary's Office,  
Melbourne, 30th March, 1967.

FARM PRODUCE MERCHANTS AND COMMISSION AGENTS ACT, 1965 (No. 7274).

LIST of persons to whom Farm Produce Merchants, Commission Agents or Secondary Wholesalers licences have been issued up to 16th March, 1967. In accordance with the above Act, those issued with a Merchants' or Commission Agents' licence have lodged a fidelity bond. All licences, unless earlier cancelled, shall continue in force until the 30th June, 1967.

MERCHANTS.

Name; Principal Place of Business.

- A. B. Cambridge Poultry Distributors, 582-586 Chapel-street, South Yarra.  
 Adelaide and Local Tomato Supply, 51 Peel-street, West Melbourne.  
 Aidone, S., 122 Peel-street, North Melbourne.  
 Aloï, C. D. N. and P., 67 Bruce-street, Colac.  
 Andrews Fruit and Vegetable Market, Lyttleton-terrace, Bendigo.  
 Anguey, R., 51 Nungerner-street, Balwyn.  
 Ashworth, K. P., Hays-place, Geelong.  
 Austral Fruit Agency, 145 Therry-street, Melbourne.  
 Banson, George and Son, Store 20, Wholesale Fruit Market, Melbourne.  
 Barbaro, A., 4 Murray-street, West Brunswick.  
 Barker, Green and Parke Pty. Ltd., 294 Victoria-street, North Melbourne.  
 Barker, Growers and Packers Pty. Ltd., Gembrook-road, Nar Nar Goon.  
 Barker, Produce (Vic.) Pty. Ltd., 294 Victoria-street, North Melbourne.  
 Barker and Staff Pty. Ltd., 294 Victoria-street, North Melbourne.  
 Bennett, J. F., and Co. Pty. Ltd., 404 Dana-street, Ballarat.  
 Bertucci, G., 7 Gunnedah-street, Sunshine.  
 Black, H. R., Pty. Ltd., 395 Queen-street, Melbourne.  
 Blythe, F. D., 85 Kerford-street, North Essendon.  
 B. and M. Fruit Agency, 462 Queen-street, Melbourne.  
 Bonney, S., 11 Cobden-street, North Melbourne.  
 Booth, Frank, and Sons Pty. Ltd., 16 Wholesale Fruit Market, Melbourne.  
 Borgia, Bros., Lonsdale-street, South Geelong.  
 Borthwick, Thomas, and Sons (A'asia) Pty. Ltd., 543 Little Collins-street, Melbourne.  
 Borwick, P. B., and R. W., 47 Bromfield-street, Colac.  
 Bove, A., 50 Capel-street, West Melbourne.  
 Bradbury, J. C., and Sons Pty. Ltd., 1 Maryland-street, Caulfield South.  
 Brophy, Foley and Co., 204 Mair-street, Ballarat.  
 Bryant and Gourley, 22 Peel-street north, Ballarat.  
 Bunge (Aust.) Pty. Ltd., 447 Collins-street, Melbourne.  
 Cambridge, A. B. Pty. Ltd., 77 Whitehall-street, Footscray.  
 Captain Distributing Co. Pty. Ltd., 120-130 Western-street, East Brunswick.  
 Chen, W. D., Fruit Co. Pty. Ltd., 9 Wholesale Fruit Market, Melbourne.  
 Chin, S. H. Bros. Pty. Ltd., 33 Wholesale Fruit Market, Melbourne.  
 Chinn, F. A., and Co., 40 Wholesale Fruit Market, Melbourne.  
 Chitty Struan, H. Pty. Ltd., 175 Mollison-street, Kyneton.  
 Christie, W. J., 30 Madden-avenue, Mildura.  
 Cole, A. H., and D. M., 93 Leibig-street, Warrnambool.  
 Claudio, I., 157 West-street, Coburg.  
 Clements, C. E., and Co. Pty. Ltd., 34 Queen-street, Melbourne.  
 Cornish, R., and Sons Pty. Ltd., 5 Wholesale Fruit Market, Melbourne.  
 Cowin, W., 200 Brighton-street, Richmond.  
 Crema, R., and Co., 808-810 Sydney-road, Brunswick.  
 Cristofaro and Sons Pty. Ltd., 249 Franklin-street, Melbourne.  
 Croker, A. E., 3 Satre-court, Glen Waverley.  
 Davis, J., Pty. Ltd., 8 Wholesale Fruit Market, Melbourne.  
 Davis, Lancaster, and Co., 601-611 Little Lonsdale-street, Melbourne.  
 Di Labia, M., and F., 810 Sydney-road, Brunswick.  
 Dimattina, F., and Co. Pty. Ltd., 50 Wholesale Fruit Market, Melbourne.  
 Donoghue, J. E., Pty. Ltd., 527 Collins-street, Melbourne.  
 Douglas, Harold, Pty. Ltd., 47 Wholesale Fruit Market, Melbourne.  
 Dreyfus, Louis, and Co. Ltd., 505 St. Kilda-road, Melbourne.  
 Duster, Stefan, and Co., 63 Peel-street, West Melbourne.  
 Dykes, Mark, Pty. Ltd., 8 Oakhill-avenue, Regent.  
 Echuca Flour Mills, Pty. Ltd., 200-204 Darling-street, Echuca.  
 Faba, S., Lot 29d, off McBride-street, Fawkner.  
 Farquhar, Stan, Pty. Ltd., Learmonth-road, Wendouree.  
 Ferguson, A. T., Flat 7, 42 Burnett-street, St. Kilda.  
 Ferlazzo, G., and Co. Pty. Ltd., 49. Wholesale Fruit Market, Melbourne.  
 Festival Packers Pty. Ltd., 10 Hamlet-street, Cheitenham.  
 Forbes and Snell, Pty. Ltd., 530 Collins-street, Melbourne.  
 Frankel, H., and S., Store 44, Peel-street, West Melbourne.  
 Fratantaro, J., and M., Melbourne-road, Werribee.  
 Gavin, C. P., and L. M., Crossley.  
 The Geelong and Cressy Trading Co. Ltd., Corner Yarra and Malop-streets, Geelong.  
 Gem Fruit Supply, 260 Victoria-street, North Melbourne.  
 Gembrook Potato Growers Pty. Ltd., Main-road, Gembrook.  
 Geraldton Fruit Co., 401 Queen-street, Melbourne.  
 Giblin, T. J., and K., 13 Mile-road, Garfield.  
 Golden Valley Fruit Co. Pty. Ltd., 15 Wholesale Fruit Market, Melbourne.  
 Goodwin, N., 40 High-street, Coburg.  
 Goulburn Valley Wholesale Fruit Supplies Pty. Ltd., 314 Wyndham-street, Shepparton.  
 Green, N., and Son Pty. Ltd., 113A Therry-street, Melbourne.  
 Green, R. E. Wholesale, 11 Cobden-street, North Melbourne.  
 Green Star Fruit Palace, 121-123 Malop-street, Geelong.  
 Guger, N. A., and Z. A., Hyland-street, Fyansford via Geelong.  
 Hamilton Fruit Co., 122 Gray-street, Hamilton.  
 Hancock, A. W., and Co. Pty. Ltd., 104 Armstrong-street north, Ballarat.  
 Hanger, H., Pty. Ltd., 173 Como-parade, Parkdale.  
 Harwood and Ahern, Pty. Ltd., 1-3 Cobden-street, North Melbourne.  
 Hester Bros., Poultry Service, Powells-avenue, Bendigo East.  
 Hibbins, W. R., and Sons, 40 Talbot-avenue, East St. Kilda.  
 Huile Trading Co., 125 Therry-street, Melbourne.  
 Hyland, D., and Sons, Pty. Ltd., 157 Salmon-street, Port Melbourne.  
 Hyman, J., and Son, Pty. Ltd., 51 Wholesale Fruit Market, Melbourne.  
 Interlandi, G., 270 Victoria-street, North Melbourne.  
 International Fruit and Mercantile Co. Pty. Ltd., 6 Wholesale Fruit Market, Melbourne.  
 Italiano, L. L., 391 Victoria-street, Melbourne.  
 Jackson Shands, Pty. Ltd., 540 Little Collins-street, Melbourne.  
 Jonas Wholesale, Pty. Ltd., 146 Dudley-street, Melbourne.  
 Kelly and Whaley, Bungaree.  
 Kimpton, W. S., and Son Pty. Ltd., 143 Queen-street, Melbourne.  
 King, E. G., Pty. Ltd., 33 Peel-street, West Melbourne.  
 King, J. L., and Co., 9 Queen-street, Bendigo.  
 Kinglake Potato Washers, Kinglake West via Whittlesea.  
 Kleeman, P. E., 26 Head-street, Elwood.  
 Koroit and Tower Hill Farmers Co-operative Society Ltd., High-street, Koroit.  
 Lanera, P. G., and Sons, 15 Spicer-street, Beaumaris.  
 Lanteri, S., 249 Brighton-road, Elwood.  
 Launceston Market Supplies Pty. Ltd., 7 William-street, Launceston, Tasmania.  
 Lauritz, W. G., and Sons, Pty. Ltd., 21 Viaduct Buildings, Queens Bridge, Melbourne.  
 Layne, J. J., 69 Clausen-street, North Fitzroy.  
 Lee, G., 2 Violet-court, South Blackburn.  
 Leong Hoong Cheong Pty. Ltd., 16 Barnes-avenue, Burwood.  
 Louey Pang, H., and Co. Pty. Ltd., Store 4, 186 Franklin-street, Melbourne.  
 Lovett, H. L. E., and Co. Pty. Ltd., 27 Wholesale Fruit Market, Melbourne.  
 Lowen, H. W., 206 Edward-street, East Brunswick.  
 McBeth J., Produce Merchant, Moira-street, Darling.  
 McCraith, John A., and G., Pty. Ltd., 284 City-road, South Melbourne.  
 McKenzie, M. J., and Sons, Woorarra-avenue, East Doncaster.  
 McKinnon, C., 137 Napier-street, St. Arnaud.  
 McRae, John, and Son, Pty. Ltd., Jung.  
 Malcolm, James, and Co. Pty. Ltd., McMahan-street, St. Arnaud.  
 Marazita, G., and M., and Co., 36 Melville-road, Pascoe Vale South.  
 Marr, W. C., 78 Capel-street, West Melbourne.  
 Martakis and Sons Pty. Ltd., 390 Clarendon-street, South Melbourne.  
 Maryborough Flour Mills Pty. Ltd., 38 Albert-street, Maryborough.  
 Mason, Geoff F., and Son, 33 Peel-street, West Melbourne.  
 Mentiplay, D., and Co. Pty. Ltd., 27 Wholesale Fruit Market, Melbourne.  
 Mentiplay, D., and Co. (Vegetables) Pty. Ltd., 27 Wholesale Fruit Market, Melbourne.

- Midland Fruit Supply Wholesale Depot, 163 Hargreaves-street, Bendigo.
- Millis, Alfred, and Sons Pty. Ltd., 436 Queen-street, Melbourne.
- M. K. Fruit Merchants., 250 Victoria-street, North Melbourne.
- Moss, J., and Sons Pty. Ltd., 11 Wholesale Fruit Market, Melbourne.
- Mullholland, D. J., and Co. Pty. Ltd., 22 Arthurton-road, Northcote.
- Mumford, J. G., Pty. Ltd., 35 Wholesale Fruit Market, Melbourne.
- Muratore, F., 15 Avondale-street, Hampton.
- Murphy, W. T., Bros. Pty. Ltd., 592 Burwood-road, Hawthorn.
- Murray's Wholesale Fruit Supply, 187-189 Adderley-street, West Melbourne.
- Murray Valley By-Products Pty. Ltd., 18 Ryley-street, Wangaratta.
- Nash, S., and Sons, 114 Greaves-street, Werribee.
- Nichol, A., and Sons Pty. Ltd., 30-31 Wholesale Fruit Market, Melbourne.
- Noonan, J. F., Pty. Ltd., 623 Collins-street, Melbourne.
- North Eastern Co-operative Society Ltd. (The), Corner Reid and Murray streets, Wangaratta.
- Orlando, T., and Co. (Fruit) Pty. Ltd., 13 Wholesale Fruit Market, Melbourne.
- Orlando, T., and Co. (Vegetables) Pty. Ltd., 13 Wholesale Fruit Market, Melbourne.
- Pack Kee, 55 Wholesale Fruit Market, Melbourne.
- Patchett Produce Distributors Pty. Ltd., 103 Victoria-street, West Melbourne.
- Pays (Kerang) Pty. Ltd., 147-179 Alexandra-parade, Abbotsford.
- Peachy, R. A., and Sons Pty. Ltd., 623 Collins-street, Melbourne.
- Pearce, G. A., 9 Winston-drive, South Caulfield.
- Pellegrino, A., 43 Studley Park rd., Kew.
- Pellegrino, C., and Co. Pty. Ltd., 280 Victoria-street, North Melbourne.
- Permewans (Colac) Pty. Ltd., 147-179 Alexandra-parade, Abbotsford.
- Permewans (Horsham) Pty. Ltd., 147-179 Alexandra-parade, Abbotsford.
- Permewans (Traralgon) Pty. Ltd., 147-179 Alexandra-parade, Abbotsford.
- Permewans (Wangaratta) Pty. Ltd., 147-179 Alexandra-parade, Abbotsford.
- Permewans (Warragul) Pty. Ltd., 147-179 Alexandra-parade, Abbotsford.
- Permewan Wright Ltd., 147-179 Alexandra-parade, Abbotsford.
- Pette, V., 20 Brougham-street, North Melbourne.
- Pettolino, A., and Co., 2 Wholesale Fruit Market, Melbourne.
- Pirrie Bros., 136 Exhibition-street, Melbourne.
- Pitt, A. E., 14 Wholesale Fruit Market, Melbourne.
- Ponte, C., 96 Weston-street, Brunswick.
- Ponte, V., and S., 450 Queensberry-street, North Melbourne.
- Potter Bros. Pty. Ltd., 219 Williamson-street, Bendigo.
- Potter (Melb.) Pty. Ltd., 49 Wholesale Fruit Market, Melbourne.
- Poultrymen and Farmers Trading Co. Pty. Ltd., 710 Queensberry-street, North Melbourne.
- Poultrymen and Farmers Trading Co. (Frankston) Pty. Ltd., 696 Queensberry-street, North Melbourne.
- Poultrymen and Farmers Trading Co. (Somerville) Pty. Ltd., 696 Queensberry-street, North Melbourne.
- Pratt, David, and Sons, 215-221 Mair-street, Ballarat.
- Presti, L., 92 Paisley-street, Footscray.
- Pullar, P., and Nephew, 59 Wholesale Fruit Market, Melbourne.
- P. W. Pty. Ltd., 147-179 Alexandra-parade, Abbotsford.
- Quale and Hutton, 23 Mair-street east, Ballarat.
- Quick, P. R., and Sons (Vic.) Pty. Ltd., 456-458 Queen-street, Melbourne.
- Quong Hie Shing Pty. Ltd., 407 Queen-street, Melbourne.
- Quong Hoong Wah Pty. Ltd., 41 Peel-street, Melbourne.
- Radeff, S., 57 Peel-street, Melbourne.
- Raifs and Bravo, 24 Wholesale Fruit Market, Melbourne.
- Robertson, H. A., and H. D., 46 John-street, East Brunswick.
- Rosenfield, B., 52 Wholesale Fruit Market, Melbourne.
- Ross, J. W. Pty. Ltd., 13 Wholesale Fruit Market, Melbourne.
- Rural Distributing Co. Pty. Ltd., 20 Wholesale Fruit Market, Melbourne.
- Sabatino, R., and Co. Pty. Ltd., 201 Peel-street, North Melbourne.
- Sang Goon and Co., 56 Wholesale Fruit Market, Melbourne.
- Santalucia, A., and Sons Pty. Ltd., 47-53 Capel-street, West Melbourne.
- Santarosa, G., 118 Peel-street, North Melbourne.
- Schultz, A. J., 20 Edgevale-road, Kew.
- Schutt and Barrie Pty. Ltd., Geelong-road, West Footscray.
- Scollo, J., 1420 Heatherton-road, Dandenong.
- Shea, Hood, and Co. Pty. Ltd., 535 Flinders-lane, Melbourne.
- Shue, D. Louey Bros. Pty. Ltd., 186 Franklin-street, Melbourne.
- Silbert Sharp and Davies Pty. Ltd., 17 Wholesale Fruit Market, Melbourne.
- Silks Vegetables Pty. Ltd., 49 Peel-street, West Melbourne.
- Simos Bros., Tasmania Fruit Merchants, 33 Albert-street, Windsor.
- Smith, David Pty. Ltd., 188 Franklin-street, Melbourne.
- Sparks, J. W., 39 Peel-street, Melbourne.
- Stabb, A. E., 49 Neerim-road, Caulfield.
- Star Fruit Co. Pty. Ltd., 460 Queen-street, Melbourne.
- Stellato Louis Pty. Ltd., 741 Nepean Highway, East Brighton.
- Stott, T., and Sons Pty. Ltd., 26 Wholesale Fruit Market, Melbourne.
- Sun Sui Wah Pty. Ltd., 58 Wholesale Fruit Market, Melbourne.
- Tesoriero and Natoli Pty. Ltd., 11 Station-street, Frankston.
- The Committee of Direction of Fruit Marketing, 168 Franklin-street, Melbourne.
- Thierry, J. C., and H. J., Chapel-street, Whittington.
- Thomas, I. H., 942 Canterbury-road, Box Hill.
- Thompson Bros., Chaff and Produce, Cherry-street, Werribee.
- Thompson, Geoffrey, and Co., 42 Peel-street, Melbourne.
- Till, H., and Son Pty. Ltd., 33 Peel-street, West Melbourne.
- Tinker, W., and W., 183 Fairy-street, Warramboul.
- Torre, C., 440 Victoria-street, North Melbourne.
- Townley, R., Rossiter-road, Koo Wee Rup.
- Trethowan, B. J., and Co., Brooklyn-road, Melton South.
- Tulloch, A., and Co., 114 King-street, Melbourne.
- Tulloch Jenkin Pty. Ltd., 33 Desailly-street, Sale.
- Tyner, J., and R., 465 Collins-street, Melbourne.
- Valentino, M., and Mazzetto, B., 305 Cumberland-road, Pascoe Vale.
- Valos, S., 16 Finney-street, Moonee Ponds.
- Valpied, Bill, 13 Sturt-street, Ballarat.
- Vear, F. W., Pty. Ltd., 28 Wholesale Fruit Market, Melbourne.
- Vear, F. W., (Provedores) Pty. Ltd., 28 Wholesale Fruit Market, Melbourne.
- Vear, F. W., (Fruit) Pty. Ltd., 28 Wholesale Fruit Market, Melbourne.
- Vear, F. W., (Vegetables) Pty. Ltd., 28 Wholesale Fruit Market, Melbourne.
- Venuto, A., and Co., 256 Victoria-street, North Melbourne.
- Wake, H. J., 101 Pearson-street, West Brunswick.
- Walker, F., and Son, 1167 Dandenong-road, East Malvern.
- Ward, H. S. K., Pty. Ltd., 24-38 Spencer-street, Melbourne.
- Watkins Fruit Co. Pty. Ltd., 184 Franklin-street, Melbourne.
- Watson, J., and Co. Pty. Ltd., 3-7 Gordon-avenue, West Geelong.
- Webb, L. G., and M. M., Commercial-road, Yarram.
- Webber Bros. Pty. Ltd., 4 Courtney-street, North Melbourne.
- Western Murray Fruit Supply Pty. Ltd., 147 Nineth-street, Mildura.
- Whaley, Geo, and Sons, 9 Fitzgibbon-avenue, West Brunswick.
- Williams, G. R., 49 Welfare-parade, Burwood.
- Wills, I. R., 36 Hopetoun-street, Bendigo.
- Wilson, Herbert, Pty. Ltd., 10 Wholesale Fruit Market, Melbourne.
- Wilson and Sons Produce Merchants Pty. Ltd., 407 Royal-parade, Parkville.
- Wimmera and Mallee Fruit and Vegetables Distributors, 87 Firebrace-street, Horsham.
- Wing Hie, and Co. Pty. Ltd., 409 Queen-street, Melbourne.
- Wing, R. A., and Co. Pty. Ltd., 37 Wholesale Fruit Market, Melbourne.
- Wing Young, and Co. Pty. Ltd., 38 Wholesale Fruit Market, Melbourne.
- Woodward, K., and V. F., Koo Wee Rup-North.
- Wright Stevenson, and Co. Ltd., 330 St. Kilda-road, South Melbourne.
- Yee Hop Loong Pty. Ltd., 32 Wholesale Fruit Market, Melbourne.
- Yee Tong, and Co., 43 Wholesale Fruit Market, Melbourne.
- Yick, Sam, and Co., 39 Wholesale Fruit Market, Melbourne.
- Young Sang, 45 Peel-street, Melbourne.
- Youngs Wholesale Supply, 39 Railway-street, Seymour.
- Young, Tim, and Co. Pty. Ltd., 18 Wholesale Fruit Market, Melbourne.
- Zorro Produce, Rear 280, Victoria-street, North Melbourne.

## LICENSED COMMISSION AGENTS.

- Abidin, B., 48 Evans-street, Brunswick.  
 Albioli, V., 200 Pascoe Vale-road, Moonee Ponds.  
 Allen, C. J., Station-street, Somerville.  
 Amalfi, F., 201 Camberwell-road, Camberwell.  
 Amalfi, J., 28 Elizabeth-street, Fawkner.  
 Arena, L., 191 Errol-street, North Melbourne.  
 Augello, M., 71 The Grove, Coburg.  
 Aumann, E. G., 11 Yarra-road, Croydon.  
 Australian Mercantile Land and Finance Co. Ltd., 122 William-street, Melbourne.  
 Baker, L. F., Burwood-road, Wantirna.  
 Bandias, A., South Warrandyte.  
 Barratt, W. H., Monbulk-road, Seville.  
 Bellofiore, M., 173 Melville-road, West Brunswick.  
 Bickford, A. G., Old Yarra-road, Wonga Park.  
 Black, M. D., 36 Hammond-street, Dandenong.  
 Bourgazas, N., Pomona, via Wentworth, N.S.W.  
 Bourke, F. W. Pty. Ltd., 34-36 Doveton-street, Ballarat.  
 Briggs, N. J., 3 Allaware-avenue, Croydon.  
 Byrne, D., Lot 15, David-street, Monbulk.  
 Cammaroto, F., 33 Robertson-street, Kensington.  
 Careri, R., 14 Lind-street, Strathmore.  
 Carozza, D., 15 Birch-street, West Preston.  
 Chapman, L. E., Chateris rd, Wandin East.  
 Ciccone, V., 285 George-street, Fitzroy.  
 Cook, G. J., Hastings-road, Somerville.  
 Cooper, G. W., Main-road, Silvan.  
 Co-operated Dried Fruits Sales Pty. Ltd., 16-32 Jeffcott-street, Melbourne.  
 Corstorphan, J. F., Morack-road, Vermont.  
 Crossland, A. C., and A. E., Warburton-road, Wandin North.  
 Croydon Market Auction and Real Estate Pty. Ltd., 13 Kent-avenue, Croydon.  
 Curnow's (Bendigo), Queen-street, Bendigo.  
 Cutrale, T., 39 Mirams-street, Ascot Vale.  
 D'Agostino, F., 60 North-road, Reservoir.  
 Dalgety and New Zealand Loan Ltd., 538 Collins-street, Melbourne.  
 D'Aloisio, V. D. F., and A., 29 Slevin-street, Lilydale.  
 De Bernardi, E. L., Jones-road, Somerville.  
 De Cicco, C. P., 110 O'Shannassy-street, North Melbourne.  
 De Julio, A., and Son, 19 The Eyrie, Lilydale.  
 De Maria, D., 136 Reynard-road, Coburg.  
 De Maria, G., 9 Shuter-street, Moonee Ponds.  
 De Marte, D., 80 Chapman-street, North Melbourne.  
 Dennys Lascelles Ltd., 26-32 Moorabool-street, Geelong.  
 D'Esposito, G., Moxham-road, Monbulk.  
 De Vincentis, G., 35 Slevin-street, Lilydale.  
 Dickson, D. S., Wonga-road, Ringwood North.  
 Edwards, M. T., Red Hill South.  
 Evans, C. W., 4 Gordon-street, Korumburra.  
 Gallo, G., 41 Miller-street, West Melbourne.  
 Gangemi, R., 27 Byron-street, Moonee Ponds.  
 Gaudion, P. G., and L. B., Beenak-road, Wandin.  
 Gippsland and Northern Co-operative Co. Ltd., 492 Flinders-lane, Melbourne.  
 Godfrey, Dan, and Co. Pty. Ltd., 29 Clow-street, Dandenong.  
 Goodrich, F. G., Shoreham-road, Red Hill South.  
 Gould, R., Warrandyte-road, Baxter.  
 Groves McVitty and Co. Pty. Ltd., Blackburn-road, Clayton.  
 Haag, S. G., School-road, Seville.  
 Hardidge, H. J., King-street, East Doncaster.  
 Harrison, N. J., Williamsons-road, Doncaster.  
 Harvey, G. R., Seville.  
 How, K. C., 79 Holmes-road, Moonee Ponds.  
 Ierianni, A., 54 Fischer-street, Coburg.  
 Iles, C. L., Dromona-road, Balnarring.  
 Italia, S., 40 Linda-street, Coburg.  
 Johnston, H., Jenner-street, Birregurra.  
 Jones, J. R., Main-street, Bacchus Marsh.  
 Knee, A. T., Dudley-road, Wonga Park.  
 Knee, F. J., Dudley-road, Wonga Park.  
 Kolmanic, M., Swan Bay-road, Mennarim.  
 Lanteri, A., 113 Wellington-street, Flemington.  
 Legudi, F., 40 Borva-drive, East Keilor.  
 Lincinti, L., 1 Montgomery-street, Moonee Ponds.  
 McKirdy, I. J., Queens-road, Wandin.  
 Madafferi, F., and Co., 110 Peel-street, North Melbourne.  
 Maionchi, G., Bayview-road, Hastings.  
 Mandica, D., 1 Ailisa-street, Ascot Vale.  
 Massaro, G., 17 South-street, Ascot Vale.  
 Mastromauro, A., 89 Suffolk-road, Footscray.  
 Menta, M., 25 Oakland-street, Maribyrnong.  
 Midgley, L. B., Box 214, P.O. Robinvale.  
 Miller, A. F., and R. P., Church-road, Doncaster.  
 Mimmo, J., 265 Albion-street, Brunswick.  
 Mirabella, D., McKurdy's-road, Tyabb.  
 Montague, W. F., Pty. Ltd., Horswood-road, Narre Warren North.  
 Morriss, G. N., and Co., Central Mart, Colac.  
 Motta, G., 24 Princess-street, Flemington.  
 Natalizio, E., 201 Raleigh-street, Thornbury.  
 Neim, P., 4 McLean-street, West Brunswick.  
 Nicholas, P., 38 Lincoln-road, Essendon.  
 Pakenham Fruit Growers and Producers Co-op. Ltd., 38 James-street, Pakenham East.  
 Peck, C., Pakenham East.  
 Petracca, N., 107 Anderson-street, Lilydale.  
 Petty, J. W., and Co., Merricks North.  
 Piccolo, C., 41 Borva-drive, East Keilor.  
 Piccolo, F., 46 Moyangul-drive, East Keilor.  
 Piccone, J., 2 Beatty-street, Reservoir.  
 Pignataro, G., Monbulk-Seville-road, Silvan.  
 Pignataro, R., Monbulk-Seville-road, Silvan.  
 Pistrutto, F., 1 Chapman-street, North Melbourne.  
 Prestia, A., 16 James-street, Fawkner.  
 Quattrocchi, A., 5 Nolan-street, Niddrie.  
 Radatti, S., 125 Christmas-street, Fairfield.  
 Rando, S. A., 17 Virginia-grove, Chadstone.  
 Richardson, H. F., and Co., Lonsdale-street, South Geelong.  
 Rullo, P., 9 Byron-street, Moonee Ponds.  
 Rushin, S., 100 Union-street, Brunswick.  
 Sciarrone, G., 10 Menzies-court, West Brunswick.  
 Scott, Alex, and Co. Pty. Ltd., 147 Lonsdale-street, Dandenong.  
 Seamer, A. F., and M. F., Mt. Pleasant-road, Monbulk.  
 Sesto, G., 104 Capel-street, North Melbourne.  
 Sicura, G., 420 Brunswick-road, West Brunswick.  
 Smith, W. D., Main-road, Seville.  
 Soccio, M., 40 McColl-street, West Brunswick.  
 Soccio, S., and L., 450 Albion-street, West Brunswick.  
 Sortino, M., 45 Murray-street, West Brunswick.  
 Spence, J. G., and A. J., Red Hill South.  
 Strachan and Co. Ltd., 25-43 Moorabool-street, Geelong.  
 Tainton, K., Burwood-road, East Burwood.  
 Tainton, Ray, and Sons, 28 Luba-street, Forest Hill.  
 Tartaglia, G., 207 Reynard-street, Pascoe Vale.  
 Taverna, V., 27 St. James-street, Moonee Ponds.  
 Taverna, B., 7 Tuhans-road, Mt. Waverley.  
 Taylor, E. J., and Son, "Somerset", Moorooduc.  
 Testarotta, A., 22 Johnson-street, North Sunshine.  
 Trellis, J. G., 41 Peel-street, West Melbourne.  
 Triplett, L., 271 High-street, Lower Templestowe.  
 Tripodi, S., 12 Combermerc-street, Essendon.  
 Tully, L. J., Victoria-street, Doncaster.  
 Varapodio, A., 47 Falconer-street, North Fitzroy.  
 Villani, A., 39 Dundas-street, Preston.  
 Villani, L., 46-48 Erskine-street, North Melbourne.  
 Visalli, G., 261 Maribyrnong-road, Ascot Vale.  
 Westaway, W. O., Calder Highway, Harcourt.  
 Westmore, F. W., and Son, 271 Canterbury-road, Heathmont.  
 White, A. G., Queens-road, Silvan.  
 Willey, G. T., and J., 94 Stevens-street, Portarlington.  
 Williams, K. E., Haynes-street, Silvan.  
 Williamson, D. G., and Son, Olinda-road, Monbulk.  
 Wilson, J. V., Harcourt.  
 Yarrafarm Fruit and Produce, 43 Peel-street, Melbourne.  
 Younghusband Ltd., 94 King-street, Melbourne.  
 Zammicheli, U., 18 Moore-street, Coburg.  
 Zerbe, L. H., Andersons Creek-road, East Doncaster.  
 Zissis, N., Lot 30, Winnallee-drive, Glen Waverley.

## LICENSED SECONDARY WHOLESALERS.

- Alexander, J. M., and Son, 39 Liverpool-street, Coburg.  
 Argentino, A., 29 Shedden-street, Pascoe Vale.  
 Austral Grain and Ambler, 46-52 King-street, Melbourne.  
 Biviano, A., 56 Preston-street, Geelong West.  
 Box, A. D., 528 Collins-street, Melbourne.  
 Brown, G. M., 98 Myers-street, Bendigo.  
 Captain House Pty. Ltd., 120-130 Weston-street, East Brunswick.  
 Carrazza and Co., Buronga, N.S.W.  
 Central Export Packers Pty. Ltd., 294 Victoria-street, North Melbourne.  
 Central Fruit Palace, 130A Eighth-street, Mildura.  
 Cleary, M. J., 33 Dudley-street, North Essendon.  
 Copolov, M., 6 Shelley-street, Elwood.  
 Davies, N. D., and E. W., 1 Odin-street, Strathmore.  
 D.B.F. Rural Trading Pty. Ltd., Lardner-road, Drouin.  
 Dyer, W., and A., 601 Lt. Lonsdale-street, Melbourne.  
 Fallow Products, 483 Collins-street, Melbourne.  
 Foley Brothers (London) Pty. Ltd., 213-215 King-street, Melbourne.  
 Fox, E. J., 120 King-street, Melbourne.  
 Gammaldi, G., 116 Peel-street, North Melbourne.  
 Gazis, Z., 114 Nolan-street, Maryborough.  
 Greaves, A. G., 81 Capel-street, Melbourne.  
 Harris, H. R., Knights-place, Melbourne.



Hurst and Green, 11 Cobden-street, North Melbourne.  
Jackett, Herbert, Pty. Ltd., A.P.A. Building, 43 Elizabeth-street, Melbourne.

Jochinke, O. W., Pty. Ltd., Wimmera-street, Dimboola.  
Joosen, M. C., and A. M., 38 Gawler-street, Portland.  
Kilgour, Douglas D., 479 Collins-street, Melbourne.  
La Bozzetta, S., 8 Wayne-street, East Burwood.  
Mackanness Produce Pty. Ltd., 9-11 Cobden-street, North Melbourne.

Makin, J., 5 Lawrence-street, Ardeer.  
Marsh, E. C., Pty. Ltd., 522 Flinders-lane, Melbourne.  
Monarch Potatoes Pre-packed, 8 Beauford-street, Huntingdale.

Moore, Robert S. M., 90 William-street, Melbourne.  
Penna, A. W., Pty. Ltd., 1 Canning-street, Avondale Heights.

Priestly, F. R., and E. M., 18 Melville-street, Numurkah.  
Rohr, George, 261 Grant-street, South Melbourne.  
See, John, 1136 Malvern-road, Malvern.

Smith, E., and Son, 528 Collins-street, Melbourne.  
Thomas, E. W., 119 Victoria-street, West Melbourne.  
Vaccaro's Fruit Palace, Standish-street, Myrtleford.  
Victorian Butter Factories Co-operative Co. Ltd., 54-60 King-street, Melbourne.

Weddell, W., and Co. (Aust.) Pty. Ltd., 43 King-street, Melbourne.

Western District Co-operative Company Ltd., 14-20 King-street, Melbourne.

Weiss, Albert, 65 Peel-street, Melbourne.  
Wood, C. H., and Co., 4 Dawson-avenue, Elwood.

FRANK M. READ,  
Director of Agriculture.

#### Dairy Products Act.

#### QUOTAS FOR BUTTER AND CHEESE.

##### BUTTER QUOTA.

I, GILBERT LAWRENCE CHANDLER, Minister of Agriculture in the State of Victoria, after consultation with the Victorian Dairy Products Board, and after ascertaining that the supply and distribution of butter at reasonable prices to consumers thereof in Victoria will be ensured, hereby determine a quota for butter as follows:—

The proportion shall be Sixty-seven point zero six per cent.

The period for which this quota is to operate shall be the month of April, 1967.

##### CHEESE QUOTA.

I, GILBERT LAWRENCE CHANDLER, Minister of Agriculture in the State of Victoria, after consultation with the Victorian Dairy Products Board, and after ascertaining that the supply and distribution of cheese at reasonable prices to consumers thereof in Victoria will be ensured, hereby determine a quota for cheese as follows:—

The proportion shall be Eighty-nine point ninety-three per cent.

The period for which this quota is to operate shall be the month of April, 1967.

G. L. CHANDLER,  
Minister of Agriculture.

#### Labour and Industry Act 1958.

#### LABOUR AND INDUSTRY (EXPLOSIVE POWERED TOOLS) REGULATIONS 1965.

PURSUANT to the provisions of the *Labour and Industry (Explosive Powered Tools) Regulations 1965*, I give notice that, having determined because of the characteristics of samples and drawings numbered F1464/13C, F1211/13C and BD926 submitted by Scan Trading Company Proprietary Limited for approval as interchangeable components of a sample of an explosive powered tool known as OBO SGII, serial number 11798, submitted by Scan Trading Company Proprietary Limited and approved by me on 31st May, 1966, I do hereby this 16th day of March, 1967, grant my approval for these components to be interchangeable with the corresponding components of the said sample tool OBO SGII, serial number 11798.

P. F. PRIOR,  
Chief Inspector of Factories and Shops.

#### PENTAL ISLAND RIVER IMPROVEMENT TRUST.

##### BY-LAW NO. 10.

THE Pental Island River Improvement Trust, in pursuance and exercise of the powers conferred by the *River Improvement Act, 1958*, doth hereby make the By-law following:—

(1) The following rate to be called the Pental Island River Improvement District River Improvement Rate is hereby made and shall be levied upon the occupiers or owners of all properties within the Pental Island River Improvement District which are rateable in the municipality, the rate of two cents in the dollar on the net annual municipal value of such properties. Provided that the sum of ten cents shall be the minimum amount of rate in respect of any property liable to be rated in the said district.

(2) Such rate is made and shall be levied for the period beginning with the 1st day of January, 1967, and ending with the 31st day of December, 1967, and shall be payable on the 1st day of July, 1967, at the office of the Pental Island River Improvement Trust, at Swan Hill.

(3) Such person or persons as the Pental Island River Improvement Trust may from time to time appoint for that purpose is or are hereby authorized to demand, receive and collect and recover the said rate.

The foregoing By-law was made by the Pental Island River Improvement Trust on the 3rd day of February, 1967, and the common seal of the said Trust was hereunto affixed, on the 3rd day of February, 1967, in the presence of—

(SEAL) JAMES E. TEAGUE, Chairman.  
R. BURNS, Secretary.

Approved by the Governor in Council, 21st March, 1967.  
—J. COLQUHOUN, Clerk of the Executive Council.

#### LANG LANG SEWERAGE AUTHORITY.

##### RATING BY-LAW.

THE Lang Lang Sewerage Authority, in pursuance and exercise of the powers conferred by the *Sewerage Districts Act*, doth hereby make the following By-Law:—

The following sewerage rate is hereby made under the provisions of the *Sewerage Districts Act*, and shall be levied upon the net annual value of all rateable properties within the Lang Lang Sewerage District:—

1. Of any land or tenement within the declared Lang Lang Sewerage District, a sewerage rate of Twelve and one-half cents (12½c) in the Dollar of the net annual value of all rateable "sewered property" within the said District.

2. In no case shall the amount of sewerage rate payable be less than Fourteen Dollars (\$14) in respect of any rateable sewered property on which there is a building, and six dollars (\$6) in respect of any rateable property on which there is no buildings.

3. Of any land or tenement within the Lang Lang Sewerage District a special sewerage rate of Ten Cents (10c) in the Dollar of the net annual value of all rateable "unsewered property" within the said district.

4. Such rate is made and shall be levied for the year beginning with the 1st day of October, 1966, and ending with the 30th day of September, 1967, and shall be payable on the 28th day of March, 1967, at the office of the Authority.

5. If any rateable property which is unsewered at the time of the making of the aforesaid rate becomes during the year 1967 a "sewered property" there shall be levied upon such property proportionate part of the sewerage rate for the portion of the year after it has become a sewered property, and such property shall be deemed to have been lawfully rated accordingly.

6. For making and levying such rate the valuation for the time being of such lands and tenements for the municipal rate of the municipality in the municipal district of which such lands and tenements are situate, shall be deemed and taken to be the valuation of such lands and tenements respectively; but if any such lands are not included in a valuation in force for the municipality in whose district they are situate, or if there is no such valuation the net annual value thereof may for all purposes of such rate be determined in the manner provided in the *Sewerage Districts Acts*.

7. Such person or persons as the Lang Lang Sewerage Authority may from time to time appoint for that purpose shall be or is or are hereby authorized to demand, receive, collect and recover the said rate and charges.

The resolution for passing the foregoing By-Law was agreed to by the Lang Lang Sewerage Authority on the 6th day of October, 1966, and was confirmed by the said Authority on the 3rd day of November, 1966.

The seal of the Lang Lang Sewerage Authority was affixed hereto on the 3rd day of November, 1966.

(SEAL) M. SUPER, Chairman.  
K. M. LAWRENCE, Member.  
E. R. LLOYD, Secretary.

Approved by the Governor in Council, 21st March, 1967.  
—J. COLQUHOUN, Clerk of the Executive Council.

SWAN HILL WATERWORKS TRUST.  
AUTHORITY TO OBTAIN BANK OVERDRAFT.

**HIS** Excellency the Governor of the State of Victoria, by and with the advice of the Executive Council thereof, doth by Order made on the 30th day of March, 1967, authorize the Swan Hill Waterworks Trust to obtain, in pursuance of the provisions of section 286 of the *Water Act 1958* (No. 6413), an advance or advances during the year 1967, from the English, Scottish and Australian Bank Limited, Swan Hill, by overdraft of the Trust's current account thereat, such overdraft not to exceed at any one time the sum of Thirty-five thousand dollars (\$35,000).

J. COLQUHOUN,  
Clerk of the Executive Council.

At the Executive Council Chamber,  
Melbourne, 30th March, 1967.

AXEDALE WATERWORKS TRUST.  
RATING BY-LAW FOR THE YEAR 1967.

**THE** Axedale Waterworks Trust, in pursuance and exercise of the powers conferred by the *Water Act*, doth hereby make a rate for the supply of water for domestic purposes of Thirteen cents in the Dollar on the annual municipal valuation of lands and tenements liable to be rated within the Axedale Urban District.

Provided that in no case shall the amount of rate payable per annum in respect of any tenement (other than land on which there is not a building) be less than Fourteen dollars and in respect of land on which there is no building less than Six dollars.

Such rates are made and shall be levied upon the occupiers or owners of the said lands and tenements for the year commencing 1st January, and ending 31st December, 1967, and shall be payable in one amount on the 3rd April 1967 at the office of the said Trust.

The maximum quantity of water to be supplied for the year without further charge to any property rated by the Trust or in respect of which payments are made to the Trust *ex gratia* or by agreement is hereby fixed at the quantity which, at a charge of Thirty cents per 1,000 gallons on a quantity up to 40,000 gallons and Twenty cents per 1,000 gallons on any further quantity, would produce an amount equal to the amount of the rate levied on or payment received in respect of such property for the said year.

The charge for water supplied by measure to any such property in excess of such maximum quantity, computed as in the last preceding clause, is hereby fixed at Twenty cents per 1,000 gallons.

The charge for water supplied by measure shall be payable, on demand, at the office of the Trust.

The seal of the Axedale Waterworks Trust was hereto affixed this 27th day of February, 1967, in the presence of—

(SEAL) JOHN K. ELLISON, Chairman.  
JOHN A. COLVIN, Commissioner.  
THOMAS H. BOWLES, Secretary.

Approved, 22nd March, 1967.—T. A. DARCY, Minister of Water Supply.

LORNE WATERWORKS TRUST.  
RATING BY-LAW No. 77.

**THE** Lorne Waterworks Trust, in pursuance and exercise of the powers conferred by the *Water Act*, doth hereby make a rate for the supply of water for domestic purposes of Five Cents in the Dollar on the net annual municipal valuation of lands and tenements liable to be rated within the Lorne Waterworks Urban District.

Provided that in no case shall the amount of rate payable per annum in respect of any tenement (other than land on which there is no building), be less than Eight Dollars and in respect of any land on which there is no building less than Four dollars.

The maximum quantity of water to be supplied in any one year without further charge to any property rated by the Trust is hereby fixed at the quantity which, at a charge of Twenty cents per 1,000 gallons would produce an amount equal to the amount of the rate levied on such property for the said year.

The charge for water supplied by measure to any property rated by the Trust in excess of such maximum quantity, computed as in the last preceding clause, is hereby fixed at Twenty cents per 1,000 gallons.

The charge for water supplied by measure shall be payable on demand.

Such rates are made and shall be levied upon the occupiers or owners of the said lands and tenements for the year commencing on the 1st day of January, 1967 and ending on the 31st day of December, 1967 and shall be payable on the 1st day of May, 1967, at the office of the Trust, 59 Mountjoy Parade, Lorne.

Passed this 1st day of March, 1967.

(SEAL) J. V. HAYES, Chairman.  
L. A. ALLEN, Commissioner.  
W. K. MATHISON, Secretary.

Approved, 20th March, 1967.—T. A. DARCY, Minister of Water Supply.

Melbourne and Metropolitan  
BOARD OF WORKS.

NOTICE TO THE OWNERS OF TENEMENTS IN THE UNDERMENTIONED STREETS, AND THE PRIVATE STREETS, LANES, COURTS AND ALLEYS OPENING THERETO.

**THE** main pipe in the said streets being laid down, the owners of all tenements situated as under are hereby required on or before the 1st May, 1967, to cause a proper pipe and stop cocks to be laid so as to supply water within such tenements from the main pipe.

H. J. SNADDEN,  
Secretary.

21st March, 1967.

STREET AND POSITION.  
*Broadmeadows.*

Blair-street, from King William-street southwards 7½ chains.  
Raleigh-street, from Elizabeth-street eastwards 10¼ chains.

*Doncaster and Templestowe.*

Rathmullen-quadrant, from Reisling-street westwards, southwards and eastwards to Rathmullen-quadrant.  
Rathmullen-quadrant, from Reisling-street eastwards and southwards 22 chains.  
Bordeaux-street, from 6 chains east of Burgundy-drive eastwards 3½ chains.  
Benalong-court, from Rathmullen-quadrant northwards 5½ chains.  
Cranbrook-court, from Rathmullen-quadrant northwards 5½ chains.  
Nambour-road, from Williamson-road westwards 23½ chains.  
Reisling-street, from Bordeaux-street to Rathmullen-quadrant.

*Eltham.*

Old Eltham-road, from Prosperity-road westwards 5½ chains.

*Fitzroy.*

Right of Way 1½ chains south of Bell-street, from Fisher's-lane eastwards ¾ chain.

*Heidelberg.*

Jones-crescent, from 9 chains east of Rosanna-road eastwards 2½ chains.

*Moorabbin.*

Roper-street, from 9 chains east of Bulli-street, eastwards 1 chain.

Roberna-street, from Keys-road to Levanswell-road.  
Spring-road, from Locinda-street to Hightt-road.  
Hightt-road, from Spring-road westwards 2½ chains.

*Preston.*

Harrow-street, from Albert-street eastwards 4½ chains.

*Ringwood.*

Lockhart-road, from 5½ chains west of Balmoral-road westwards 8½ chains.  
Lansell-close, from Lockhart-road northwards and eastwards 7½ chains.  
Goldsmith-avenue, from ¾ chain west of Albany-close westwards 12 chains.  
Park Hill-drive, from Goldsmith-avenue southwards and eastwards 14½ chains.  
Elm-court, from Park Hill-drive south-westwards 3 chains.  
Hilldale-close, from Park Hill-drive northwards and eastwards 9 chains.

*Springvale.*

Latimer-street, from 3½ chains north of Maureen-crescent northwards and westwards 12½ chains.  
Maureen-crescent, from Latimer-street southwards 4 chains.

*Sunshine.*

Matthews-street, from 3½ chains east of Alfred-street eastwards 2½ chains.  
Walter-street, from Matthews-street northwards 5 chains.  
Duke-street, from 7¼ chains south of Parsons-road southwards 1½ chains.

*Waverley.*

Brighton-street, from Campbell-street southwards 20½ chains.  
Winston-street, from Brighton-street eastwards 4 chains.  
Chapel-street, from Brighton-street eastwards 4 chains.  
Olympic-avenue, from Brighton-street, eastwards 4 chains.  
Edinburgh-avenue, from Brighton-street westwards 4½ chains.  
Shirley-avenue, from 10½ chains south of Matthews-street eastwards 1 chain.

*Whittlesea.*

Mount View-road, from Kingsway-drive southwards 11½ chains.  
Nebel-street, from Mount View-road eastwards 2 chains.  
Duncan-road, from Mount View-road eastwards 2 chains.  
Settlement-road, from Yan Yean Pipe Track southwards and eastwards 70½ chains.

**CONTRACTS ACCEPTED.—(Series 1966-67.)****PUBLIC WORKS.**

2623. Laburnum, State School No. 4863, plenum heating, \$3,322.00.—Thermic Heating and Ventilation.  
2624. Melbourne, Public Offices, 179 Queen-street, maintenance cleaning for the period 1st January, 1967, to 31st May, 1969, \$26,250.00 per annum.—Palenti Dutch Cleaning Service.  
2625. Prahran, Chest Clinic, Chapel-street, maintenance cleaning for the period 1st January, 1967, to 31st May, 1969, \$900.00 per annum.—Emerald Cleaning Service.  
2626. Beechworth, Mental Hospital, external renovations to main block (Stage 1), \$181,247.00.—W. J. Cody & Quinn Pty. Ltd.  
2627. Box Hill, High School, erection of new building, \$424,998.00.—Johns & Reid.  
2628. Burnley Gardens, Plant Research Laboratories, fire escape stairs and extensions to fire service, \$2,322.07.—Idl-O Pty. Ltd.  
2629. Bendigo, State School No. 4728, provision of rest room and toilet, \$1,433.59.—L. J. Morey.  
2630. Clayton North, State School No. 734, new fire service and connexion to sewer, \$6,202.25.—G. T. Nicholds.  
2631. Croydon, State School No. 2900, improved water supply, \$1,180.00.—Lewis Bros. Plumbing Contractors.  
2632. Dandenong, Technical School, electrical services for General Purpose School Hall, \$6,560.00.—Field & Hall Pty. Ltd.  
2633. Dandenong, Police Station, electrical installation, \$2,073.00.—Field & Hall Pty. Ltd.  
2634. Dandenong, High School, electrical installation in existing main building and new wing, \$17,240.00.—Field & Hall Pty. Ltd.  
2635. Derrinalum, High School Residences, Lloyd-street and Chatsworth-road, pump houses, tanks and stands, \$1,116.77.—F. Ballinger & Son.  
2636. Dimboola, Court House, toilet facilities, \$2,627.00.—A. R. Wheatley.  
2637. Donvale, State School No. 4961, plenum heating, \$7,540.00.—Thermic Heating & Ventilation.  
2638. Doveton, Technical School, installation of sawdust extraction system in woodwork department, \$1,770.00.—Chadstone Air-conditioning Services Pty. Ltd.  
2639. Pembroke, State School No. 4937, surface and underground drainage, asphalt, concrete and gravel pavements, \$15,149.40.—Action Constructions Pty. Ltd.

2640. Malmsbury, Youth Training Centre, mechanical services, new education block, \$21,375.00.—A.F.D.A. Heating & Plumbing Service.

2641. Red Cliffs, High School, repair and resurfacing of access road, replacement of concrete and associated works, \$3,123.20.—Allen Bros. (Asphalting Contractors) Pty. Ltd.  
2642. Quarry Hill, State School No. 1165, fencing to boys' playground, \$1,126.60.—A.R.C. Engineering Pty. Ltd.  
2643. Belmont, State School No. 26, non-party fencing, \$1,191.57.—A.R.C. Engineering Pty. Ltd.  
2644. Flora Hill, State School No. 4667, supply and erect pipe post and weld mesh fencing, \$1,198.56.—A.R.C. Engineering Pty. Ltd.

2645. Sunbury, Mental Hospital, supply and installation of sixteen (16) slow combustion heaters to sixteen residences, \$1,528.00.—Bourke Appliances Pty. Ltd.

2646. Yarrowonga, High School, construction of concrete works, drainage, new asphalt, &c., \$7,304.00.—T. Bunn & Co.

2647. St. Albans, High School, electrical services, Assembly Hall, \$6,500.00.—P. Cave.

2648. Keilor Heights, State School No. 4877, plenum heating, \$3,820.00.—Chadstone Air-conditioning Services Pty. Ltd.

2649. Werribee, Research Farm, air-conditioning unit in laboratory of hay shed, \$1,730.00.—Chadstone Air-conditioning Services Pty. Ltd.

2650. Footscray, State School No. 253, supply and installation of gas space-heating equipment, \$4,502.00.—The Colonial Gas Association Ltd.

2651. Blackburn South, State School No. 4035, supply and installation of gas heating, \$4,363.47.—The Colonial Gas Association Ltd.

2652. Casterton, High School, erection of concrete water storage tank, \$2,790.00.—Concrete Tanks (Vic.) Pty. Ltd.

2653. Boort, High School, erection of concrete tank, \$1,932.00.—Concrete Tanks (Vic.) Pty. Ltd.

2654. Corryong, Consolidated School, erection of four timber residences, \$45,673.00.—Consolidated Home Industries Ltd.

2655. Deer Park, State School No. 1434, installation of stainless-steel urinal and alter cisterns, \$1,382.68.—Dundon & Roming.

2656. Moorabbin, Technical School, electrical installation, improved lighting, \$2,329.00.—Edwards Electrics Pty. Ltd.

2657. Swan Hill, High School, re-wiring of old school building and rectification of defects in electrical installation, \$2,240.80.—G. & J. M. Elliott Pty. Ltd.

2658. Geelong, Gordon Institute of Technology, electrical installation in heat engines laboratory, \$4,856.00.—Fenton & Douglas.

2659. Dandenong, High School, mechanical services, \$39,704.00.—Gray & Wood.

2660. Maribyrnong, High School, erection of brick veneer residence, \$11,825.00.—H. Hingst.

2661. Sunbury, High School, grading and sealing of existing gravelled road, \$4,496.40.—Wm. Loud Pty. Ltd.

2662. Preston East, High School, concreting, drainage and asphalt works, &c., \$32,007.82.—Wm. Loud Pty. Ltd.

2663. Port Melbourne, Public Works Department, Depot, supply and installation of one 15-ton capacity vehicle and equipment hoist, \$5,100.00.—Mechanical Handling Ltd.

2664. Neerim South, Police Station Residence, external repairs and painting, \$1,270.00.—F. C. Mephram.

2665. Caulfield, High School, erection of standard type hall, "800", \$88,960.00.—B. M. Morgan.

2666. St. Albans, High School, erection of Assembly Hall, \$88,431.00.—T. W. Morris & Son Pty. Ltd.

2667. Coburg North, State School No. 4543, renewal of cisterns and urinal, \$1,196.00.—D. W. & M. W. McAuslan Pty. Ltd.

2668. Carlton, Melbourne Teachers' College, security lighting, \$1,780.00.—J. Newall Pty. Ltd.

2669. Ballarat, Public Offices, provision of additional office space, renovations to third floor, \$1,065.00.—A. & B. Oswald Pty. Ltd.

2670. Carlton, Visual Education Centre, 92 Victoria-street, renewal of roof, \$1,130.00.—J. Penman.

2671. Royal Park, Mental Hospital, installation of equipment for closed circuit television, \$1,377.12.—Philips Electrical Pty. Ltd.

2672. Melbourne, Royal Melbourne Institute of Technology, supply and installation of gas heaters in machine shop, \$2,068.60.—Pyrox Ltd.

2673. Footscray, Technical School, retaining walls, paving, &c., \$8,591.00.—Rainbow Construction Company.

2674. Hampton, High School, electrical installation, new science block, \$2,340.00.—Sillery Electrics.

2675. Kyabram, Research Station, supply and erection of storage shed, \$1,112.60.—Somerfield & Kellow.

2676. Melbourne, 179 Queen-street, State Public Offices, waterproofing of eastern and southern sections of flat roof up to south-western corner of caretaker's quarters, \$1,937.00.—Specialized Building Services Pty. Ltd.

2677. Malmsbury, Youth Training Centre, electrical installation, education block, \$11,998.80.—A. E. Stone.

2678. Yackandandah, State School No. 1103, erection of out-offices, \$2,592.00.—R. O. Tobias.

2679. Carlton, Motor Registration Branch, maintenance cleaning to 31st May, 1969, \$33,840.00 per annum.—Utility Cleaning Company (Vic.) Pty. Ltd.

2680. Carlton, Secondary Teachers' College, alterations to building and installation of folding wall, \$1,400.00.—V.I.A. Limited.

2681. Brighton, Domestic Arts Teachers' College Hostel, 23 Moule-avenue, bathroom additions and alterations, \$2,234.00.—B. J. Virtue.

2682. Elwood, Central School No. 3942, repairs to old toilets and additional staff facilities, \$1,989.00.—F. Waddell & Son Pty. Ltd.

2683. Flemington, High School, earthworks, road construction, concrete paving, &c., \$49,996.00.—J. Warner (Civil Engineering).

2684. Ashwood, High School, asphaltting, concreting, drainage, &c., \$14,496.00.—J. Warner (Civil Engineering).

2685. Mont Park, Plenty Mental Hospital, heavy duty asphalt access roadways, light duty concrete paving, &c., \$25,936.00.—J. Warner (Civil Engineering).

2686. Yallourn, Technical School, electrical installation to Bristol prefabricated class-rooms, \$1,900.00.—W. T. Waterfall & Sons Pty. Ltd.

2687. Ballarat, State School No. 695, replacement of roof slates with concrete roofing tiles, \$3,564.28.—Whitelaw-Monier Pty. Ltd.

2688. Don Valley, State School No. 3956, erection of residence and garage, \$11,600.00.—W. Willis.

MURRAY PORTER, Minister of Public Works. 15.3.67.

#### EXTRAS ON CONTRACTS.

2689. Serial No. 64/65-4351.—\$1,255.90.  
 2690. Serial No. 65/66-4457.—\$246.88.  
 2691. Serial No. 65/66-4354.—\$780.00.  
 2692. Serial No. 64/65-2535.—\$9.00.  
 2693. Serial No. 66/67-1170.—\$3,784.00.  
 2694. Serial No. 66/67-1181.—\$791.65.  
 2695. Serial No. 64/65-3880.—\$5,885.69.  
 2696. Serial No. 65/66-1483.—\$140.00.  
 2697. Serial No. 65/66-3943.—\$458.50.  
 2698. Serial No. 65/66-4334.—\$110.20.  
 2699. Serial No. 65/66-4042.—\$214.80.  
 2700. Serial No. 64/65-992.—\$80.79.  
 2701. Serial No. 65/66-2240.—\$1,474.00.  
 2702. Serial No. 61/62-2601.—\$72.10.  
 2703. Serial No. 65/66-2233.—\$20.00.  
 2704. Serial No. 65/66-2585.—\$2,338.00.  
 2705. Serial No. 66/67-92.—\$2,681.00.  
 2706. Serial No. 63/64-5225.—\$18,660.91.  
 2707. Serial No. 65/66-4368.—\$38.44.  
 2708. Serial No. 65/66-1460.—\$1,053.97.  
 2709. Serial No. 64/65-4053.—\$137.83.  
 2710. Serial No. 66/67-867.—\$423.78.  
 2711. Serial No. 66/67-897.—\$164.79.  
 2712. Serial No. 66/67-1383.—\$346.00.  
 2713. Serial No. 65/66-4061.—\$444.90.  
 2714. Serial No. 64/65-1942.—\$2,739.69.  
 2715. Serial No. 64/65-4518.—\$1,068.64.  
 2716. Serial No. 65/66-4375.—\$530.00.  
 2717. Serial No. 66/67-2533.—\$794.10.  
 2718. Serial No. 66/67-4356.—\$121.00.  
 2719. Serial No. 65/66-1386.—\$1,884.08.  
 2720. Serial No. 64/65-4566.—\$341.50.  
 2721. Serial No. 65/66-4369.—\$1,224.80.  
 2722. Serial No. 66/67-576.—\$173.75.  
 2723. Serial No. 65/66-894.—\$2,527.00.  
 2724. Serial No. 65/66-1151.—\$263.95.  
 2725. Serial No. 66/67-1344.—\$1,176.26.  
 2726. Serial No. 65/66-3772.—\$1,480.90.  
 2727. Serial No. 63/64-4354.—\$89.00.  
 2728. Serial No. 66/67-1332.—\$2,510.33.  
 2729. Serial No. 66/67-1737.—\$915.00.  
 2730. Serial No. 65/66-4382.—\$184.04.

MURRAY PORTER, Minister of Public Works. 21.3.67.

#### SOIL CONSERVATION AUTHORITY.

CONTRACT No. 6706.

Earthworks.—Eildon Group Conservation Area.

2620. Hire of tractor and attachments for earthworks, Bonnie Doon, \$5.50 an hour.—G. T. S. & J. D. Smith, Buxton.

P. J. McCALLUM, Secretary.

#### VICTORIAN RAILWAYS.

84. Supply and delivery of tea at the rate of 41c per lb. (Contract 63087).—Robert Timms Pty. Ltd. 85. Supply and delivery of tea and coffee at rates (Contract 6314).—Griffiths Brothers Products. 86. Design, supply, delivery and installation of an Automatic High Pressure Carbon Dioxide Fire Protection and Combustion Product Detection System in the E.D.P. Rooms at Railways Administrative Offices, for the amount of \$14,032.00 (Contract 63085).—Wormald Bros. (Australia) Pty. Ltd. 87. Cleaning glass in windows, &c., at the Victorian Railways Administrative Offices, Outwards Parcels Office, Spencer-street, Melbourne, and Bookkeeper's Office, Melbourne Goods Yard for the amount of \$3,552.00 (Contract 63108).—Ace Window and General Cleaning Service Pty. Ltd.

By Order of the Victorian Railways Commissioners,  
 W. Walker, Secretary. 29.3.67.

#### PRISONERS' MEALS IN LOCK-UPS.

##### CONTRACTS CANCELLED.

Gazette No. 55, 7th July, 1966, Prisoners' Meals, Prahran.—Contract No. 331 is hereby cancelled.

Gazette No. 55, 7th July, 1966, Prisoners' Meals, Sandringham.—Contract No. 333 is hereby cancelled.

##### CONTRACT ACCEPTED.

2619. For the supply of Prisoners' Meals at Prahran as from 27th December, 1966, Breakfast and Tea, 35 cents; Hot Dinner, 45 cents.—K. Kovacic.

H. COUTTS, Secretary to the Tender Board. 23.3.67.

#### ORDERS IN COUNCIL.—(Series 1966-67.)

##### PUBLIC WORKS DEPARTMENT.

2731. Croydon South, State School No. 4890, urgent completion of a contract commenced by another contractor but not proceeded with, \$3,850.00.—J. & B. Ranking Pty. Ltd.—(N.E.245355 "A").

2732. Longerenong, Agricultural College, erection of a prefabricated residence, \$11,825.35.—W. Phelan & Sons Pty. Ltd.—(W.108376.)

2733. Melbourne, Law Courts, supply of stone to match existing, \$1,825.53.—Gosford Quarries Pty. Ltd.—(C.10575 "B").

2734. Monash, Secondary Teachers' College, Caretaker, erection of a residence, \$9,851.00.—Consolidated Home Industries Ltd.—(E.M.87566 "B").

Approved by the Governor in Council, 21st March, 1967.  
 —J. COLQUHOUN, Clerk of the Executive Council.

##### EDUCATION DEPARTMENT.

2735. Two (2) only 15-in. Remington International Typewriters for Warrnambool Technical College, \$264.00.—Rand-Chartres Pty. Ltd.

2736. One (1) only smoke tunnel for Castlemaine Technical College, \$856.83.—Jepson & Bolton.

2737. Two (2) only model 650 sewing machines and two (2) only model 328P sewing machines for Fawcner Technical School, \$292.00.—Singer (Australia) Pty. Ltd.

2738. Six (6) only model 328 P3 532 sewing machines for Kangaroo Flat Technical School, \$456.00.—Singer (Australia) Pty. Ltd.

2739. One (1) only photographic enlarger for Prahran Technical School, \$473.85.—Southern Cross Cameras.

2740. Various sheetmetal stakes for Warrnambool Technical College, \$205.80.—Precision Engineering Co.

Approved by the Governor in Council, 21st March, 1967.  
 —J. COLQUHOUN, Clerk of the Executive Council.

##### FORESTS COMMISSION.

Loan Fund Act No. 7453, Item 6—

2621. To the purchase of that portion of lots 38, 39 and 40 on plan of subdivision No. 6588, being parts of Crown allotments 61, 62 and 82, Parish of Mooroolbark, County of Mornington, comprising 13 acres 2 roods 27 perches for forest purposes, \$2,040.00.—Johannes Herbert Hezel.

Approved by the Governor in Council, 23rd August, 1966.  
 —J. COLQUHOUN, Clerk of the Executive Council.

2622. To the purchase of that part of allotment 84, Parish of Scoresby, County of Mornington, comprising 5 acres 2 roods 10 perches for forest purposes, \$1,668.75.—Francis Wyndhan Grevis-James.

Approved by the Governor in Council, 25th October, 1966.—J. COLQUHOUN, Clerk of the Executive Council.

*Process Servers and Inquiry Agents Act 1958.*

## APPLICATIONS FOR LICENCES LODGED WITH CLERKS OF COURTS.

BY direction of the Chief Secretary, the subjoined lists of "new" applications for process servers and inquiry agents licences are published for general information.

Applicant.	Address.	Court.	Tentative Date of Hearing of Application.
<i>Process Servers.</i>			
Cook, Bruce Waldron .. .. .	18 Wallace-avenue, Murrumbeena .. .. .	Oakleigh ..	21.4.67
Richter, Juergen .. .. .	c/o MI-4 Investigation Service Pty. Ltd., 65 Queens-road, Melbourne	South Melbourne ..	12.5.67
<i>Inquiry Agent.</i>			
Richter, Juergen .. .. .	c/o MI-4 Investigation Service Pty. Ltd., 65 Queens-road, Melbourne	South Melbourne ..	12.5.67

Attention is directed to the provisions of the above Act and regulations thereunder relating to the lodgement of objections to applications.

Chief Secretary's Office,  
Melbourne, 29th March, 1967.

E. L. RICHARDSON, Registrar,  
Process Servers and Inquiry Agents.

## APPOINTMENTS

## APPOINTMENTS.

HIS Excellency the Governor of the State of Victoria, by and with the advice of the Executive Council thereof, has, by Orders made on the 21st day of March, 1967, been pleased to make the under-mentioned appointments, viz.:—

## CHIEF SECRETARY'S DEPARTMENT.

*Member of Street Traders' Licences Board.*

JOHN CHRISTIE HOLLAND,  
to be a member of the Street Traders' Licences Board, pursuant to the provisions of the *Street Trading Act 1958*, for a period of two years from the 1st April, 1967.

## MINISTRY OF HEALTH.

*Superintendent of Mental Hospital.*

THOMAS JOSEPH LEONARD, M.B., B.S., D.P.M.,  
to be Superintendent of the Mental Hospital, Warrnambool, pursuant to section 26 (1) of the *Mental Health Act 1959*, vice Dr. E. L. Roberts.

## LAW DEPARTMENT.

*Clerk of Petty Sessions (Acting).*

DESMOND JOHN DEVLIN,  
to be Clerk of Petty Sessions and Clerk of the Children's Court at Ouyen, Woomelang and Murrayville, during the absence of A. R. Dunlop, on annual leave, to take effect from the date of commencement of duty, and

*Assistant Registrar of County Court.*

DESMOND JOHN DEVLIN,  
to be Assistant Registrar, pursuant to the provisions of sections 20 and 21 of the *County Court Act 1958*, for the County Court at Mildura, during the absence of A. R. Dunlop, on annual leave, to take effect from the date of commencement of duty.

## DEPARTMENT OF THE TREASURER.

*Collector of Imposts (Acting).*

KELVIN MAXWELL PERRY,  
to act temporarily as Collector of Imposts, Office of the Government Statist, Chief Secretary's Department, vice G. L. Watson, on leave.

J. COLQUHOUN,  
Clerk of the Executive Council.

At the Executive Council Chamber,  
Melbourne, 21st March, 1967.

## APPOINTMENTS.

HIS Excellency the Governor of the State of Victoria, by and with the advice of the Executive Council thereof, has, by Orders made on the 30th day of March, 1967, been pleased to make the under-mentioned appointments, viz.:—

## DEPARTMENT OF WATER SUPPLY.

*Improvement Trust Commissioner.*

THOMAS HENRY KING  
to be a Commissioner of the Latrobe River Improvement Trust, to hold office as such, subject to the provisions of the River Improvement Act, for a period of four years from the date hereof.

*Waterworks Trust Commissioner.*

KENNETH BOYCE TERRY  
to be a Commissioner of the Benalla Waterworks Trust, to hold such position for a period of four years from the date hereof, subject to the provisions of the Water Act.

J. COLQUHOUN,

Clerk of the Executive Council.

At the Executive Council Chamber,  
Melbourne, 30th March, 1967.

## APPOINTMENTS.

HIS Excellency the Governor of the State of Victoria, by and with the advice of the Executive Council thereof, has, by Orders made on the 21st day of March, 1967, been pleased to make the under-mentioned appointments, viz.:—

## DEPARTMENT OF CROWN LANDS AND SURVEY.

*Trustees of a Site.*

TIMOTHY JAMES CANTWELL,  
ALBERT WILLIAM HEIGHT,  
DOUGLAS ALEXANDER FERRIER, and  
HAROLD HUNTER WATSON,  
to be Trustees of the land permanently reserved on 14th April, 1885, as a site for a Racecourse at Echuca, vice Keith Lindsay Clark, Timothy Richard Cantwell, John Tehan, James Augustine Dowling and Hugh McKenzie, deceased.

J. COLQUHOUN,

Clerk of the Executive Council.

At the Executive Council Chamber,  
Melbourne, 21st March, 1967.

EDUCATION DEPARTMENT.  
SUMMONING OFFICERS.

UNDER section 5 of the Education Act 1958, I hereby appoint—

First Constable WILLIAM HUGH MILES,  
Senior Constable BRIAN RICHARD HEGARTY, and  
First Constable LESLIE ALEXANDER HOGG  
to summon parents within the State of Victoria.

J. S. BLOOMFIELD,  
Minister of Education.

14th March, 1967.

ORDERS IN COUNCIL

LOCAL GOVERNMENT DEPARTMENT.

At the Executive Council Chamber, Melbourne, the  
twenty-first day of March, 1967.

PRESENT:

His Excellency the Governor of Victoria.  
Mr. Porter | Mr. Meagher.  
Mr. Rossiter

ALTERATION, FIXATION AND DECLARATION OF  
BREADTHS OF A CARRIAGE-WAY AND FOOTWAYS.  
—CITY OF SOUTH MELBOURNE.

IN pursuance of the provisions of section 520 of the Local Government Act 1958, as amended, His Excellency the Governor of the State of Victoria, by and with the advice of the Executive Council thereof, and in compliance with a request of the Council of the City of South Melbourne, hereby alters the breadths of the carriage-way and footways of that portion of Cobden-street, South Melbourne, shown on the plan hereunder, which were fixed and declared by an Order published in the Government Gazette on the 19th July, 1895, and fixes and declares such breadths in the manner indicated on the said plan.

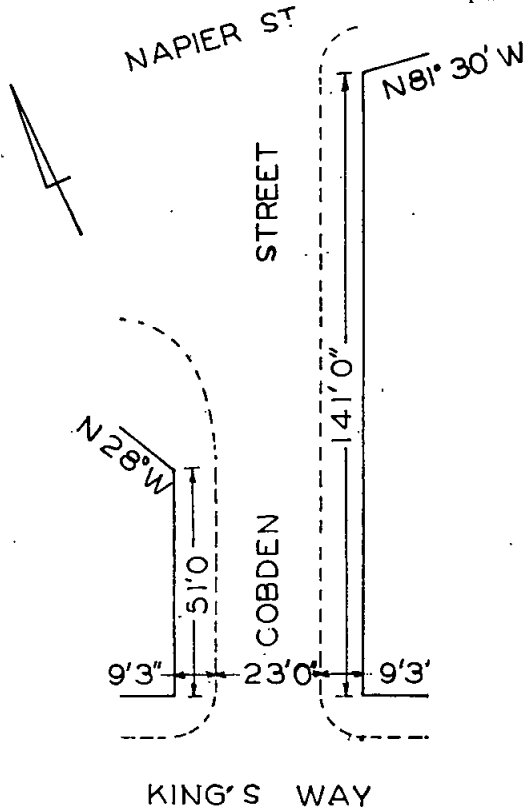

And the Honorable Rupert James Hamer, Her Majesty's Minister for Local Government for the State of Victoria, shall give the necessary directions herein accordingly.

J. COLQUHOUN,  
Clerk of the Executive Council.

LOCAL GOVERNMENT DEPARTMENT.

At the Executive Council Chamber, Melbourne, the  
twenty-first day of March, 1967.

PRESENT:

His Excellency the Governor of Victoria.  
Mr. Porter | Mr. Meagher.  
Mr. Rossiter

ROAD DISCONTINUED.—CITY OF MOE.

WHEREAS it is provided in section 528 (2) of the Local Government Act, as amended, that where a road (whether or not a public highway, but not being a road set out on land of the Crown) or any part thereof is not required for public use, the Governor in Council, on the request of the Council of the municipality in which such road is situated made not less than one month after publishing in a newspaper generally circulating in the district and posting to the registered proprietor (if any) of the land and any person known to have an interest in the land notice of intention to make such a request may by Order published in the Government Gazette direct that such road or part shall be discontinued and thereupon such road or part shall be discontinued accordingly.

And whereas the Council of the City of Moe has requested that the Governor in Council direct that portion of Scott-street, Moe, be discontinued and not less than one month previously has published in a newspaper generally circulating in the district and posted to all persons known to have an interest in the land in the said road notice of intention to make such request.

And whereas the Council of the City of Moe is the registered proprietor of the land in the said road.

Now therefore His Excellency the Governor of the State of Victoria, by and with the advice of the Executive Council thereof, hereby directs that the said road, which is shown hatched on the plan hereunder, shall be discontinued and that the land may be sold by the Council of the City of Moe by agreement.

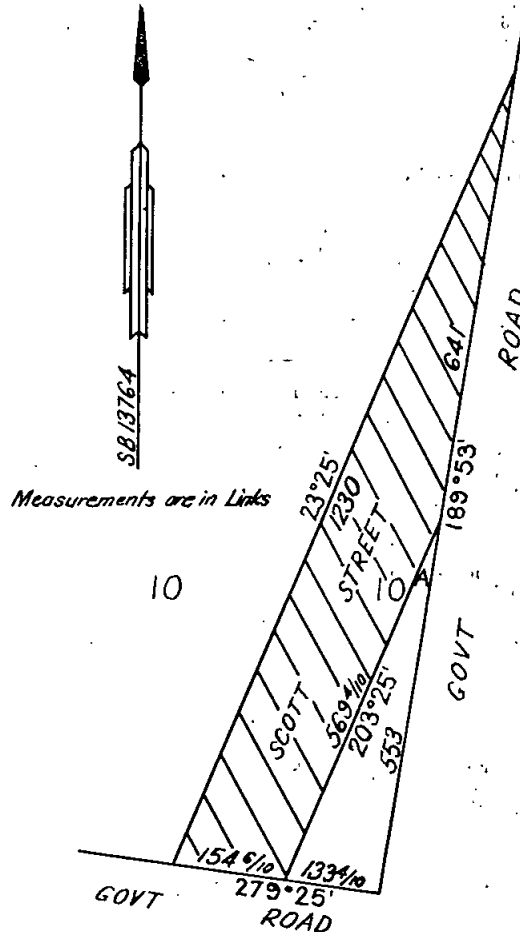

And the Honorable Rupert James Hamer, Her Majesty's Minister for Local Government for the State of Victoria, shall give the necessary directions herein accordingly.

J. COLQUHOUN, Clerk of the Executive Council.

LOCAL GOVERNMENT DEPARTMENT.

At the Executive Council Chamber, Melbourne, the twenty-first day of March, 1967.

PRESENT:

His Excellency the Governor of Victoria. Mr. Porter Mr. Rossiter Mr. Meagher.

ROAD DISCONTINUED.—CITY OF RINGWOOD.

WHEREAS it is provided in section 528 (2) of the Local Government Act 1958, as amended, that where a road (whether or not a public highway but not being a road set out on land of the Crown) or any part thereof is not required for public use, the Governor in Council, on the request of the Council of the municipality in which such road is situated made not less than one month after publishing in a newspaper generally circulating in the district and posting to the registered proprietor (if any) of the land and any person known to have an interest in the land notice of intention to make such a request may by Order published in the Government Gazette direct that such road or part shall be discontinued and thereupon such road or part shall be discontinued accordingly.

And whereas the Council of the City of Ringwood has requested that the Governor in Council direct that portion of Maggs-street Extension, Ringwood, be discontinued and not less than one month previously, has published in a newspaper generally circulating in the district and posted to the registered proprietor of the land in the said road and to all persons known to have an interest in the said road notice of intention to make such request.

Now therefore His Excellency the Governor of the State of Victoria, by and with the advice of the Executive Council thereof, hereby directs that the portion of the said road, which is shown hatched on the plan hereunder, shall be discontinued, and that the land shall be retained by the Council of the City of Ringwood for municipal purposes.

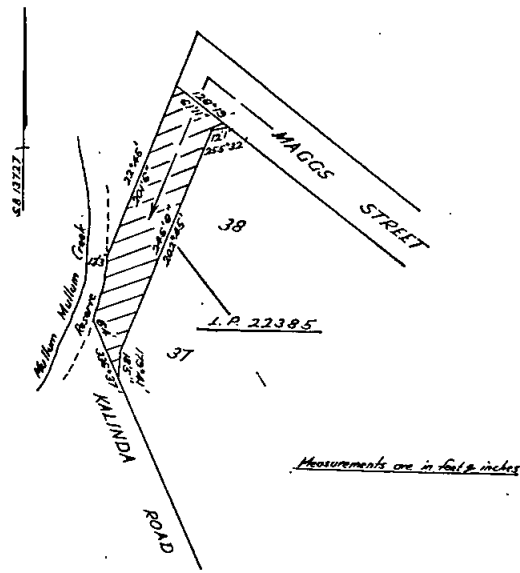

And the Honorable Rupert James Hamer, Her Majesty's Minister for Local Government for the State of Victoria, shall give the necessary directions herein accordingly.

J. COLQUHOUN, Clerk of the Executive Council.

LOCAL GOVERNMENT DEPARTMENT.

At the Executive Council Chamber, Melbourne, the twenty-first day of March, 1967.

PRESENT:

His Excellency the Governor of Victoria. Mr. Porter Mr. Rossiter Mr. Meagher.

ROAD DISCONTINUED.—CITY OF CAULFIELD.

WHEREAS it is provided in section 528 (2) of the Local Government Act 1958, that where a road (whether or not a public highway but not being a road set out on land of the Crown) or any part thereof is not required for public use, the Governor in Council, on the request of the Council of the municipality in which such road is situated made not less than one month after publishing in a newspaper generally circulating in the district and posting to the registered proprietor (if any) of the land and any person known to have an interest in the land notice of intention to make such a request may by Order published in the Government Gazette direct that such road or part shall be discontinued and thereupon such road or part shall be discontinued accordingly.

And whereas the Council of the City of Caulfield has requested that the Governor in Council direct that portion of a right-of-way between Newlyn-street and Bambra-road, Caulfield, be discontinued and not less than one month previously has published in a newspaper generally circulating in the district and posted to the registered proprietor of the land in the road and to all persons known to have an interest in the said land notice of intention to make such request.

Now therefore His Excellency the Governor of the State of Victoria, by and with the advice of the Executive Council thereof, hereby directs—

- (a) That the said road, which is shown by hachure and cross-hachure on the plan hereunder, shall be discontinued. (b) That notwithstanding such discontinuance the Melbourne and Metropolitan Board of Works shall continue to have and possess the same right, title, power, authority or interest in or in relation to the land shown by cross-hachure on the said plan as it had or possessed prior to such discontinuance with respect to or in connexion with any pipes laid or erected in on or over such land for the purposes of drainage or sewerage. (c) That, subject to any such right, title, power, authority or interest, the land in the said road may be sold by the Council of the City of Caulfield by agreement.

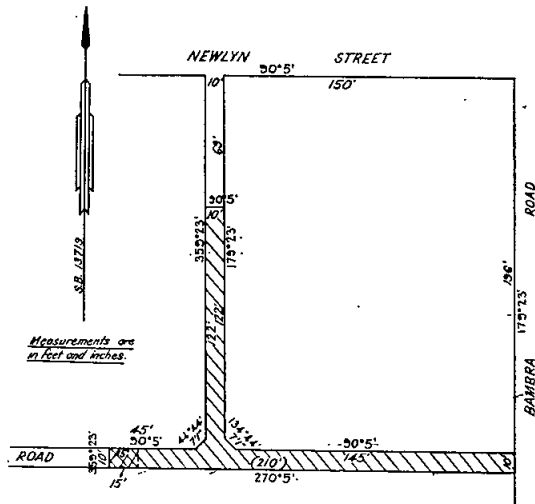

And the Honorable Rupert James Hamer, Her Majesty's Minister for Local Government for the State of Victoria, shall give the necessary directions herein accordingly.

J. COLQUHOUN, Clerk of the Executive Council.

DEPARTMENT OF CROWN LANDS AND SURVEY.

At the Executive Council Chamber, Melbourne, the twenty-first day of March, 1967.

PRESENT:

His Excellency the Governor of Victoria.  
Mr. Porter | Mr. Meagher.  
Mr. Rossiter

LAND TEMPORARILY RESERVED AS A SITE.

HIS Excellency the Governor of the State of Victoria, by and with the advice of the Executive Council thereof, doth hereby, in pursuance of section 14 of the Land Act 1958, reserve temporarily from sale, from being leased and from having a licence granted in respect thereof, and also except from occupation for mining purposes under any miner's right, the land hereinafter described:—

**BITTERN.**—Site for Water Supply purposes, 24 acres 1 rood 3 perches, Parish of Bittern, County of Mornington, as indicated by hatching on plan hereunder.—(B.397<sup>(9)</sup>) (Rs.8789).

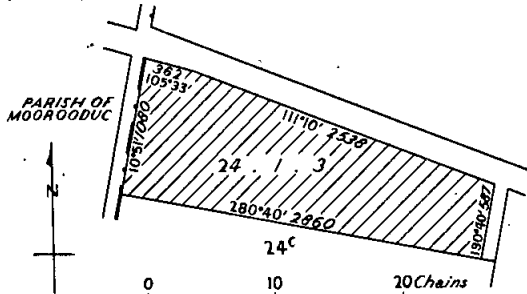

**TRARALGON.**—Site for Public purposes (Forests Department purposes), 26 perches, Township of Traralgon, Parish of Traralgon, County of Buln Buln, as indicated by hatching on plan hereunder.—(T.115<sup>(13)</sup>) (Rs.8706).

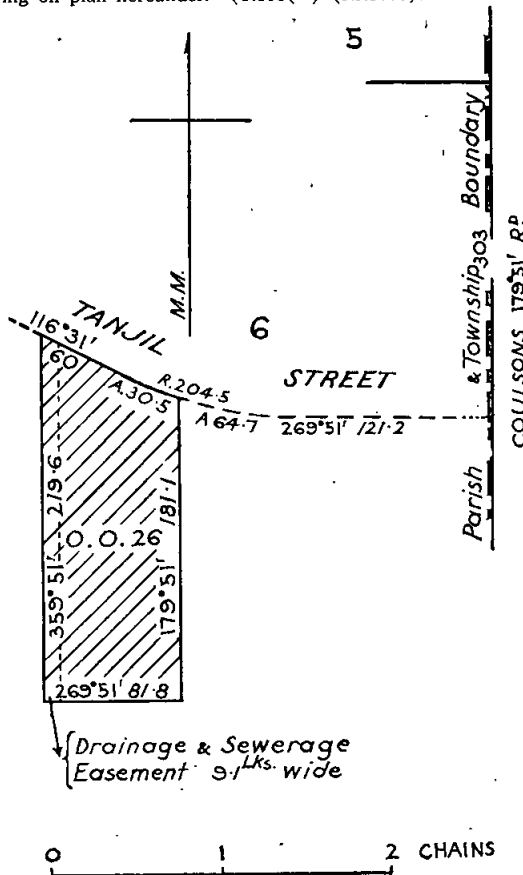

And the Honorable James Charles Murray Balfour, Her Majesty's Minister of Lands for the State of Victoria, shall give the necessary directions herein accordingly.

J. COLQUHOUN,  
Clerk of the Executive Council.

HEALTH ACT 1958 (No. 6270), SECTIONS 165 AND 166.

At the Executive Council Chamber, Melbourne, the twenty-first day of March, 1967.

PRESENT:

His Excellency the Governor of Victoria.  
Mr. Porter | Mr. Meagher.  
Mr. Rossiter

PURSUANT to the provisions of sections 165 and 166 of the Health Act 1958, His Excellency the Governor of the State of Victoria, by and with the advice of the Executive Council thereof, doth hereby appoint the under-mentioned persons as members of the Fairfield Hospital Board for a further period ending the twenty-second day of February, 1973:—

- MICHAEL FRANCIS LUCY, Esq.,
- PROFESSOR BARRIE PATRICK MARMION, M.D., B.S., F.C.Path., M.C.P.A., M.R.C.S., L.R.C.P.,
- DORIS LYNE OFFICER, M.B., B.S., M.R.C.S., L.R.C.P.,
- SIR ALBERT ERNEST COATES, Kt., O.B.E., M.D., M.S., F.R.C.S., F.R.A.C.S.,
- SAMUEL THEODORE EGEBERG, Esq.,
- WILLIAM ALFRED KEMP, Esq.,
- ALBERT RICHARD ROBERTS, Esq.,
- ERNEST IVAN FRANCIS HALLEY, Esq.,
- WILLIAM JOHN STEVENSON, L.R.C.P., L.R.C.S., L.R.F.P. and S., D.T.M., D.P.H., M.P.H.,
- FRANCIS WILLIAM CREMEAN, Esq.,
- MALCOLM WILLIAM PARKER, Esq.,
- EDGAR DUNCAN OATES, Esq.,
- PHILIP GILBERT, M.B., B.S., D.P.H.

And the Honorable Vance Oakley Dickie, Her Majesty's Minister of Health for the State of Victoria, shall give the necessary directions herein accordingly.

J. COLQUHOUN,  
Clerk of the Executive Council.

HOSPITALS AND CHARITIES ACT 1958, SECTION 52.

At the Executive Council Chamber, Melbourne, the twenty-first day of March, 1967.

PRESENT:

His Excellency the Governor of Victoria.  
Mr. Porter | Mr. Meagher.  
Mr. Rossiter

VARIATION OF THE OBJECTS OR PURPOSES OF THE CITIZENS WELFARE SERVICE OF VICTORIA.

WHEREAS The Citizens Welfare Service of Victoria is an incorporated benevolent society within the meaning of the Hospitals and Charities Act 1958:

And whereas the Committee of Management of the said benevolent society has agreed that the objects or purposes of the said benevolent society should be varied:

And whereas the Hospitals and Charities Commission after inquiry has recommended that the said objects or purposes should be varied:

Now therefore His Excellency the Governor of the State of Victoria by and with the advice of the Executive Council of the said State, and by virtue of the powers conferred on him by section 52 of the Hospitals and Charities Act 1958 and all other powers enabling him in that behalf, hereby varies the objects or purposes of The Citizens Welfare Service of Victoria so that such objects or purposes shall be as follows:—

To organize and maintain a family welfare agency in Victoria the standards of which are in accord with those recognized in professional social work, to provide for the relief of aged, helpless and poor persons, and to aid, advise and assist all persons regardless of race or creed who are in distress or difficulty and to furnish complementary and ancillary services, excluding housekeeper services and elderly citizens club activities.

And the Honorable Vance Oakley Dickie, Her Majesty's Minister of Health for the State of Victoria, shall give the necessary directions herein accordingly.

J. COLQUHOUN,  
Clerk of the Executive Council.



MARINE STORES AND OLD METALS ACT 1958.

At the Executive Council Chamber, Melbourne, the thirtieth day of March, 1967.

PRESENT:

His Excellency the Governor of Victoria.  
Mr. Bloomfield | Mr. Reid.  
Mr. Dickie

WHEREAS by section 4 of the *Marine Stores and Old Metals Act 1958*, it is enacted that the Governor in Council may from time to time upon the petition of any shire council within Victoria, make an Order directing that the provisions of Part II. of the said Act shall be extended to that Shire:

And whereas the Council of the Shire of Mildura has petitioned the Governor in Council to extend the provisions of Part II. of the said Act to the Shire of Mildura:

Now therefore, His Excellency the Governor of the State of Victoria, in the Commonwealth of Australia, by and with the advice of the Executive Council of the said State, doth hereby direct that the provisions of Part II. of the *Marine Stores and Old Metals Act 1958*, shall be extended to and shall be in force from the first day of April, 1967, within and throughout the boundaries of the Shire of Mildura.

And the Honorable Arthur Gordon Rylah, Her Majesty's Chief Secretary for the State of Victoria, shall give the necessary directions herein accordingly.

J. COLQUHOUN,  
Clerk of the Executive Council.

PORTLAND HARBOR TRUST ACT 1958.

At the Executive Council Chamber, Melbourne, the thirtieth day of March, 1967.

PRESENT:

His Excellency the Governor of Victoria.  
Mr. Bloomfield | Mr. Reid.  
Mr. Dickie

REAPPOINTMENT OF COMMISSIONERS AND CHAIRMAN AND DEPUTY CHAIRMAN AND APPOINTMENT OF COMMISSIONER OF THE PORTLAND HARBOR TRUST.

IN accordance with the provisions of the *Portland Harbor Trust Act 1958*, His Excellency the Governor of the State of Victoria, by and with the advice of the Executive Council thereof, doth by this order reappoint Theodore Cuyler Jarrett, as Commissioner and Chairman for a period of five years ending 31st March, 1972, and Ralph Bryant Anderson, as Commissioner and Deputy Chairman, for a period of four years ending 31st March, 1971, and appoints Norman Campbell Myers, as Commissioner for a period of one year ending 31st March, 1968, and doth hereby determine that the salary payable to the said Theodore Cuyler Jarrett shall be \$3,200.00 per annum, and the salary payable to each of Ralph Bryant Anderson, and Norman Campbell Myers shall be \$800.00 per annum.

And the Honorable Murray Victor Porter, Her Majesty's Minister of Public Works for the State of Victoria, shall give the necessary directions herein accordingly.

J. COLQUHOUN,  
Clerk of the Executive Council.

COUNTRY ROADS BOARD.

At the Executive Council Chamber, Melbourne, the thirtieth day of March, 1967.

PRESENT:

His Excellency the Governor of Victoria.  
Mr. Bloomfield | Mr. Reid.  
Mr. Dickie

ORDER APPROVING OF LAND BEING ACQUIRED AND ROADS, DEVIATIONS OR WIDENINGS BEING MADE.

HIS Excellency the Governor of the State of Victoria, by and with the advice of the Executive Council thereof, being satisfied that there are funds legally available for acquiring the land, doth hereby approve

the acquiring of the land described in the Schedule hereunder and the making of new roads and deviations from and widenings of existing roads referred to in the said Schedule.

SCHEDULE.

Main Roads.

The land shown hatched on plan No. G.P.10760A hereunder required for the widening of Stud-road in the Shire of Knox and making of the widening thereon.

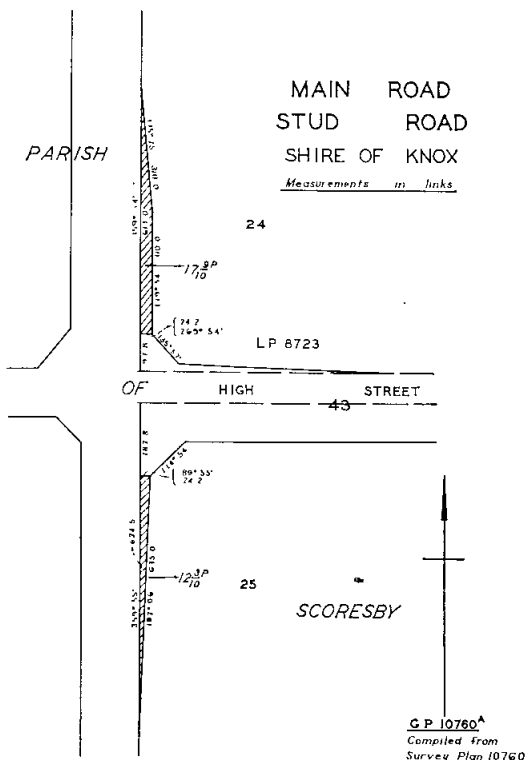

The land shown hatched on plans No. G.P.10816 and G.P.10817 hereunder required for the deviation of the Korumburra-Warragul road in the Shire of Korumburra and making of the deviation thereon.

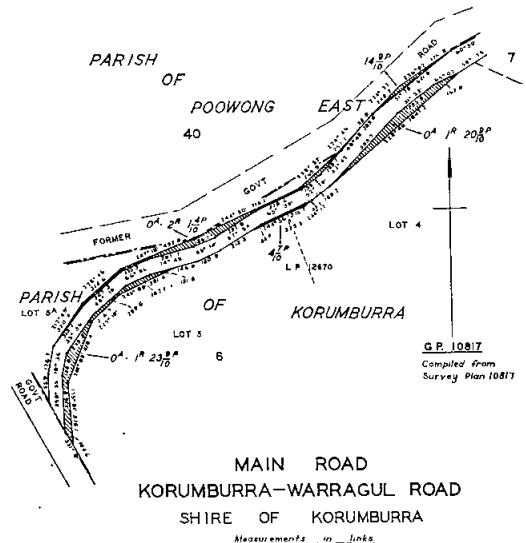

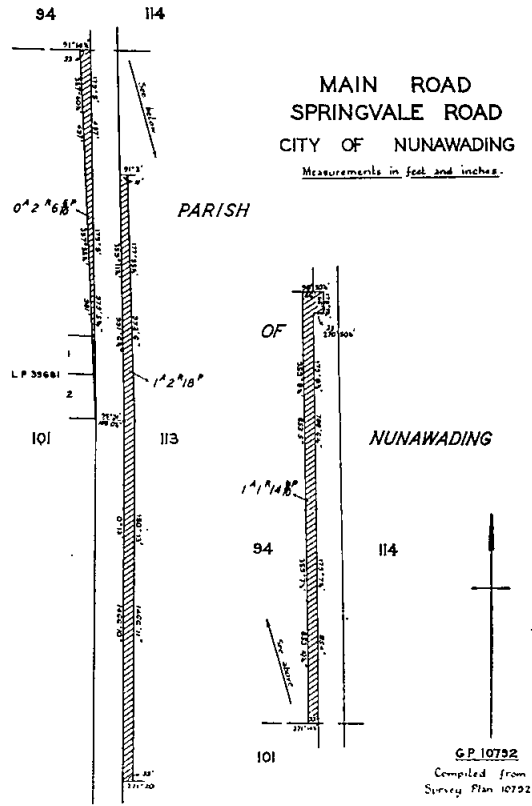
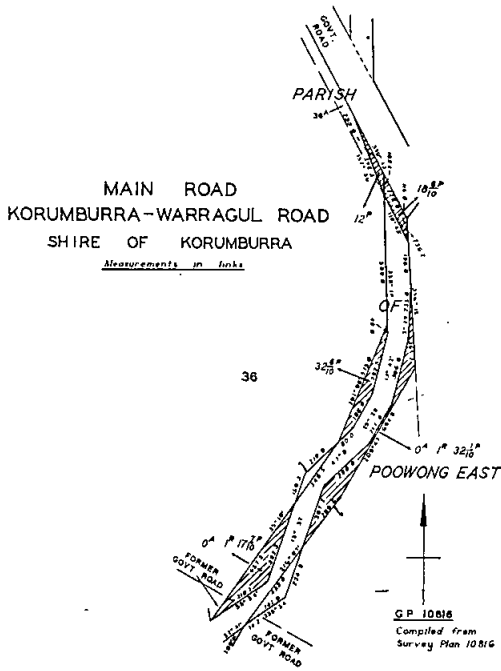

The land shown hatched on plans No. G.P.10791, G.P.10792 and G.P.10793 hereunder required for the widening of Springvale road in the City of Nunawading and making of the widening thereon.

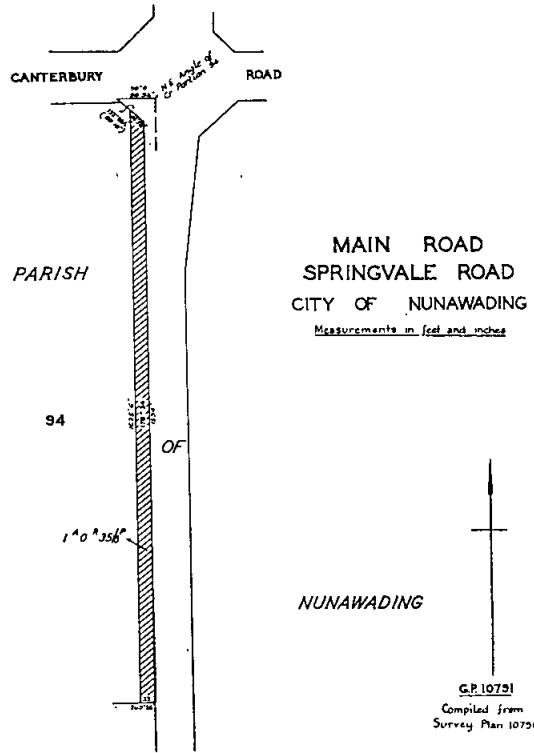
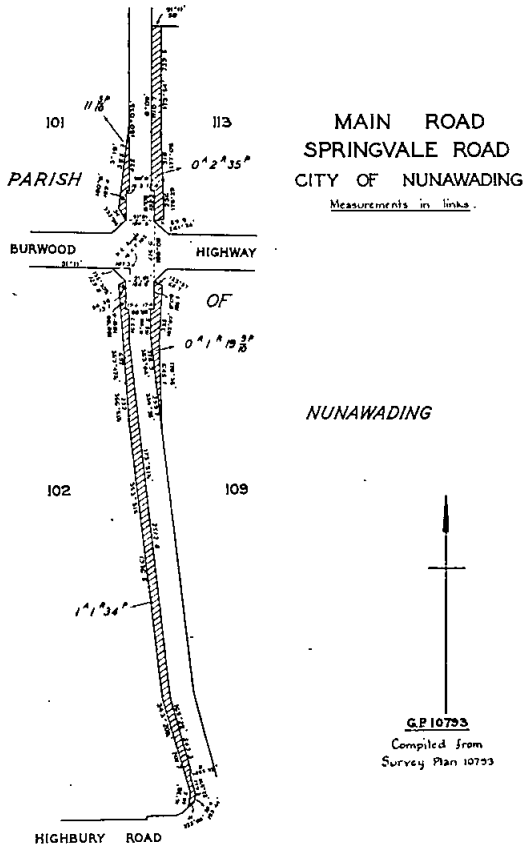

And the Honorable Murray Victor Porter, Her Majesty's Minister of Public Works for the State of Victoria, shall give the necessary directions herein accordingly.

J. COLQUHOUN,  
Clerk of the Executive Council.

## LANDS DEPARTMENT NOTICES

### APPROACHING LAND SALES.

**S**ALES of Crown lands, in fee-simple, will be held at the under-mentioned places and dates, viz.:-

	No. of Gazette.
Walhalla.—Saturday, 22nd April, 1967 ..	23
Warragul.—Wednesday, 26th April, 1967 ..	28

### SALE OF FREEHOLD LAND BY AUCTION.

Hamilton.—Friday, 28th April, 1967 ..	23
---------------------------------------	----

### AUCTION OF THE RIGHT TO LEASE CROWN LAND.

Meeniyah.—Wednesday, 26th April, 1967 ..	28
Melbourne.—Wednesday, 3rd May, 1967 ..	29

### AUCTION OF RIGHT TO LEASE CROWN LAND.

**M**ELBOURNE.—A sale by auction of the right to lease Crown land will be held at **KELVIN HALL, 55 EXHIBITION-STREET, MELBOURNE, on WEDNESDAY, the 3rd MAY, 1967, at half-past TEN o'clock a.m.** To be conducted by **J. R. WILDING, Land Officer, Melbourne.** Auctioneers: **CAROLAN & CO., 243 Collins-street, Melbourne.**

The right to lease will be offered, pursuant to section 134 of the *Land Act 1958*, for the purpose of manufacture of steel, steel products, machinery and for storage, subject to the provisions summarized hereunder:—

All mineral rights will be reserved under the provisions of the *Mines Act 1958* and all petroleum rights under the provisions of the *Petroleum Act 1958*.

The lease will commence on the 4th May, 1967, or such later date as may be determined in accordance with the special conditions shown below, the rent therefor will be the highest offer (not less than the upset rent) accepted at the sale, subject to re-appraisal at the end of each ten years' period if the lease be for a longer term than ten years. The rent will be payable quarterly in advance, and the first quarter's rent must be paid at the time of the sale.

The lessee shall pay all taxes, rates, duties, charges, assessments, &c., and discharge all obligations under any Act in respect of the leased premises.

The land shall not (unless with the consent of the Minister of Lands (hereinafter called "the Minister")) be used for any other purpose than that declared by the purchaser and approved.

Plans of all buildings proposed to be erected on the land shall be submitted to the Minister for his consideration, and work shall not be commenced until approval is given.

The buildings and other improvements shall be maintained throughout the term of the lease in good order and repair to the satisfaction of the Minister.

The lessee shall adopt such sanitary measures as the Minister requires and carry out all requirements of the Melbourne and Metropolitan Board of Works.

The lessee shall keep all buildings insured in the name of the Secretary for Lands for an amount fixed by him, and the policy and the renewal receipts in respect thereof shall be deposited with the Secretary for Lands, Melbourne.

The Minister or his servants shall have the right of entry for inspection purposes, and in case of default with regard to maintenance, to make good any defects at lessee's expense.

Arrangements must be made for the prevention of nuisance.

No advertising matter or medium will be permitted on the land or premises or fencing, provided, however, that the Minister may permit a sign or other advertisement which refers solely to the purpose for which the lease is granted.

The site shall not be used for the storage of any explosive, combustion or inflammable materials unless and until an application has been submitted and consented to by the Minister.

The lessee shall not assign, sublet, mortgage, or transfer the land, or any part thereof, without the consent of the Minister.

The lessee shall at the expiry, or sooner determination of the lease, yield and deliver the land and premises to Her Majesty, her heirs and successors in good order and condition.

The lessee shall observe any other conditions and provisions agreed upon before the issue of the lease.

The lease shall be voidable for failure to use the land bona fide for the purpose for which it has been demised, or for non-payment of rent or interest on rent in arrear, or for breach of any condition, or if the affairs of the lessee be wound up, or in the event of bankruptcy of the lessee. In the event of the lease being declared void, it shall be lawful for the Crown to enter into and take full possession of the land and premises.

At the expiration or sooner determination of the term of the lease, the land and all improvements (except machinery, and appliances which can be removed without material injury to the land or buildings) shall revert to the Crown.

The land is subject to resumption for mining purposes under section 205 of the *Land Act 1958*.

The Governor in Council has the right to resume the whole or any part of the land for public purposes on payment of compensation for the lessee's interest in the unexpired term of the lease in respect of the resumed area.

The lessee shall, within the time specified hereunder, have erected buildings (the walls of which shall be of brick, concrete, or other material agreed to by the Minister) and/or other permanent improvements on the land of not less than the value stated hereunder, in accordance with plans and specifications approved by the Minister. It will be the lessee's obligation to ensure compliance with the building covenant notwithstanding any restrictions on capital issues.

The lessee shall contribute to the cost incurred by the local municipality for the construction of any roadway, footpath, and channel on any road abutting on the leased land, or in the drainage of such land, in the same way as if liable under the *Local Government Act 1958*.

No buildings or other structures shall be erected at a level lower than that required for proper and effective drainage of the leased land.

If the purchaser covenants to erect further substantial improvements the term of the lease may be fixed by the Minister for a longer term, to be determined by him within the provisions of the *Land Acts*.

Printed forms of the general conditions of the lease, in full, may be inspected at Room 229, 2nd Floor, Crown Lands Department, State Public Offices, Melbourne.

A. J. HOLT,  
Secretary for Lands.

Melbourne, 31st March, 1967.

### PARISH OF DOUTTA GALLA, COUNTY OF BOURKE.

*About 265 feet east of Kensington-road fronting the southern side of Dynon-road east and west of the railway which crosses Dynon-road.*

This allotment at present is occupied under licence by Humes Ltd.

Upset rental \$7,324 per annum for the first ten years.

Term of lease 35 years.

Area 10a. 3r. 12p., subject to survey, water main easement, State Electricity Commission easement and Railways-State Electricity Commission underground cable easement.

Minimum expenditure for improvements \$200,000 within five years. This requirement is in addition to existing improvements. Valuation of improvements in favour of licensee \$314,200.

If the purchaser of the right to lease be other than the licensee or its wholly owned subsidiary, then—

(a) Such purchaser shall pay to the Secretary for Lands, within seven days from the date of the sale, the valuation of the improvements amounting to \$314,200.

(b) The licensee may elect to remain in possession for any period not exceeding three months from the date of sale, and in that event the lease shall commence on the day following the expiration of such period.

Special condition requiring the following shall apply:—

(a) The lessee to participate in a drainage scheme for the undergrounding of the tidal channel in suitable pipe drains for its full-length within the leasehold under such terms and conditions

as fixed by the Melbourne City Council and of the Melbourne and Metropolitan Board of Works.

- (b) No buildings to be erected on that portion of the leasehold west of the railway.
- (c) Access by the Victorian Railways Commissioners or their agents, servants, &c., to be allowed at all reasonable times over the area west of the railway for maintenance of the adjacent railway bridge.
- (d) The lessee to permit the resumption on three years' notice without compensation of any kind of certain areas at the northern and eastern boundaries of the leasehold if required for road purposes.—(O.1890/138.)

**EAGLEHAWK (MYERS FLAT).**—The temporary reservation, by Order in Council of the 1st August, 1859, of 2 roods of land at Eaglehawk, Parish of Nerring, as a site for Church of England School purposes is about to be revoked.—(N.116<sup>(11)</sup>) (C.96828).

**TARRANGINNIE.**—The temporary reservation as a site for a Cemetery and the withholding from sale, leasing and licensing by Order in Council of the 11th October, 1880, of 5 acres of land in the Parish of Tarranginnie, revoked as to part by Order in Council of the 8th October, 1888, are about to be revoked so far as the balance thereof, containing 8 perches, is concerned.—(T.199<sup>(3)</sup>) (Rs.8628).

**YANGERAHWILL (LAKE GOLDSMITH).**—The temporary reservation, by Order in Council of the 11th January, 1927, of 2 roods of land in the Parish of Yangerahwill, as a site for a State School, is about to be revoked.—(Y.47<sup>(4)</sup>) (Rs.3407).

JIM BALFOUR,  
Minister of Lands.

**PROPOSED REVOCATIONS OF TEMPORARY RESERVATIONS OF LANDS BY ORDERS IN COUNCIL.**

IN pursuance of the provisions of the Land Act 1958, notice is hereby given that it is the intention of the Governor in Council to revoke the temporary reservations of lands by Orders in Council hereunder referred to, viz.:—

The following Notices were published 1° on the 22nd March, 1967, pursuant to Orders of the 15th March, 1967.

**BUDGERUM WEST.**—The temporary reservation, by Order in Council of the 7th February, 1939, of 123 acres, more or less, of land in the Parish of Budgerum West, as a site for Public purposes, is about to be revoked so far only as the portions containing 4 acres, indicated by hatching on plan hereunder, is concerned.—(B.688<sup>(10)</sup>) (Rs.4915).

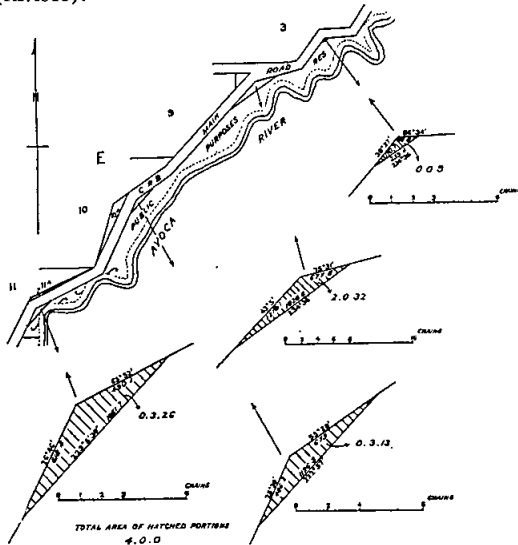

**DIMBOOLA.**—The temporary reservation as a site for the use of the Police Department and the withholding from sale, leasing and licensing, by Order in Council of the 18th September, 1882, of 6 acres 1 rood 1 perch of land in the Township of Dimboola, revoked as to part by various Orders are about to be revoked so far only as the portion containing 1 rood 22 perches, indicated by hatching on plan hereunder, is concerned.—(D.150<sup>(9)</sup>) (Rs.5081).

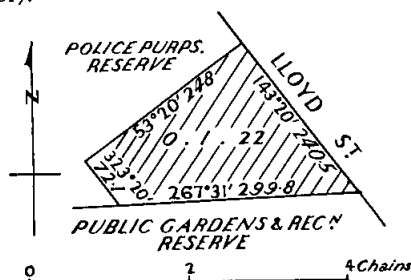

**PROPOSED REVOCATIONS OF TEMPORARY RESERVATIONS OF LANDS BY ORDERS IN COUNCIL.**

IN pursuance of the provisions of the Land Act 1958, notice is hereby given that it is the intention of the Governor in Council to revoke the temporary reservations of lands by Orders in Council hereunder referred to, viz.:—

The following Notices were published 1° on the 1st March, 1967, pursuant to Orders of the 21st February, 1967.

**ARCHDALE.**—The temporary reservation as a site for a Quarry and the withholding from sale, leasing and licensing by Order in Council of the 5th August, 1878, of 1 acre of land in the Township of Archdale.—(A.157<sup>(4)</sup>) (Rs.8764).

**BARWIDGEE.**—The temporary reservation, by Order in Council of the 26th July, 1960, of 20 acres 1 rood 20 perches, more or less, of land in the Parish of Barwidgee, as a site for Travelling Stock purposes.—(B.637<sup>(9)</sup>) (Rs.7960).

**GALAH.**—The temporary reservation, by Order in Council of the 20th November, 1939, of 2 roods 16 perches of land in the Township of Galah, as a site for a Public Hall.—(G.247<sup>(3)</sup>) (Rs.5135).

**LUDRIK-MUNJIE.**—The temporary reservation by Order in Council of the 1st March, 1949, of 1,300 acres, more or less, of land in the Parish of Ludrik-Munjie, as a site for the growth of timber, for the purpose of the manufacture or production of eucalyptus oil.—(L.172<sup>(1)</sup>) (73/141).

**WEDDERBURN.**—The temporary reservation, by Order in Council of the 30th October, 1944, of 8 acres, more or less, of land in the Township of Wedderburn, as a site for Public Garden and Recreation, is about to be revoked so far only as the portion containing 1 acre 1 rood 30 perches, more or less, indicated by hatching on plan hereunder, is concerned.—(W.116<sup>(6)</sup>) (Rs.5523).

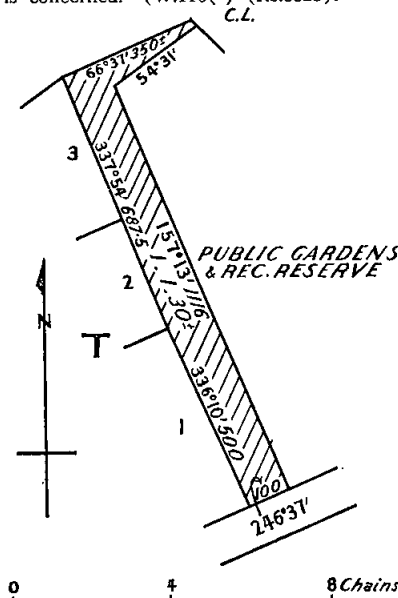

JIM BALFOUR,  
Minister of Lands.

**PROPOSED REVOCATIONS OF TEMPORARY RESERVATIONS OF LANDS BY ORDERS IN COUNCIL.**

IN pursuance of the provisions of the *Land Act 1958*, notice is hereby given that it is the intention of the Governor in Council to revoke the temporary reservations of lands by Orders in Council hereunder referred to, viz.:

The following Notices were published 1° on the 15th March, 1967, pursuant to Orders of the 7th March, 1967.

**BALLARAT.**—The temporary reservation, by Order in Council of the 31st October, 1938, of 9 acres 2 roods 25 5/10 perches of land in the Township of Ballarat as a site for Public Recreation, revoked as to part by various Orders is about to be revoked so far only as the portion containing 1 rood 22 perches, indicated by hatching on plan hereunder, is concerned.—(B.128<sup>(72)</sup>) (Rs.3420).

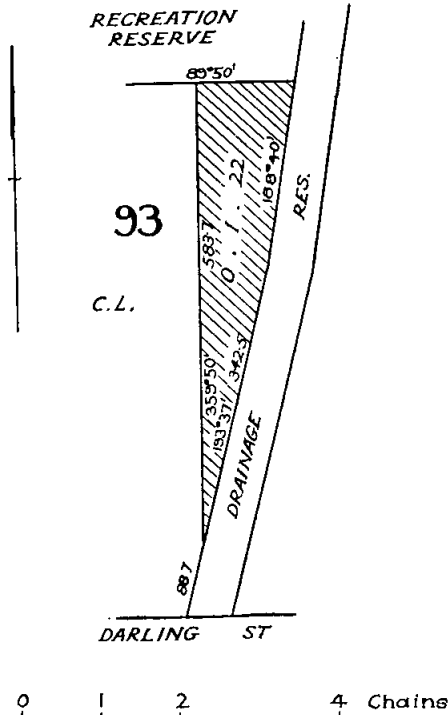

**SWANPOOL.**—The temporary reservation, by Order in Council of the 11th August, 1873, of 2 acres of land in the Parish of Lima (now Township of Swanpool), as a site for State School purposes is about to be revoked.—(L.153<sup>(5)</sup>) (Rs.3010).

**MOORpanyal (GEElong WEST).**—The temporary reservation, by Order in Council of the 21st June, 1949, of 2 roods 2 5/10 perches of land in the Parish of Moorpanyal, as a site for Hospital purposes, is about to be revoked.—(M.199<sup>(5)</sup>) (Rs.6378).

JIM BALFOUR,  
Minister of Lands.

**PROPOSED REVOCATIONS OF TEMPORARY RESERVATIONS OF LANDS BY ORDERS IN COUNCIL.**

IN pursuance of the provisions of the *Land Act 1958*, notice is hereby given that it is the intention of the Governor in Council to revoke the temporary reservations of lands by Orders in Council hereunder referred to, viz.:

The following Notices were published 1° on the 8th March, 1967, pursuant to Orders of the 28th February, 1967.

**BLACKWOOD.**—The temporary reservation by Order in Council of the 24th April, 1871, of 3 roods 38 3/10th perches of land in the Township of Blackwood as a site for Police purposes.—(B.405<sup>(12)</sup>) (Rs.2077).

**INGLEWOOD.**—The temporary reservation by Order in Council of the 10th April, 1865, of 5 acres 3 roods 26 perches of land in the Township of Inglewood as a site for a Pipeline in connexion with the public reservoir, revoked as to part by various Orders, is about to be revoked so far as the balance thereof, containing 5 acres 2 roods 6 perches, is concerned.—(L.4<sup>(5, 6)</sup>) (Rs.5354).

**LORQUON.**—The temporary reservation as a site for a Quarry and the withholding from sale leasing and licensing by Order in Council of the 8th October, 1883, of 7 acres 3 roods 39 perches of land in the Parish of Lorquon, revoked as to part by Order in Council of the 14th October, 1935, is about to be revoked so far only as the portion containing 4 acres 29 perches, indicated by hatching on plan hereunder, is concerned.—(L.154<sup>(2)</sup>) (Rs.6541).

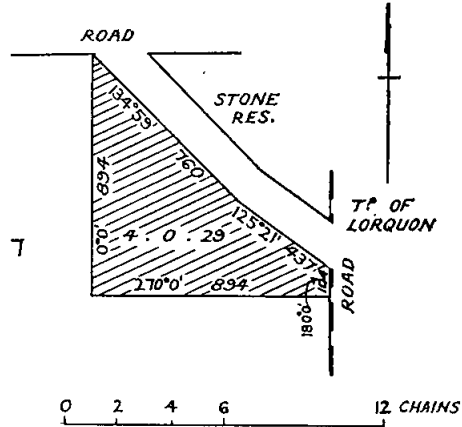

**SANDHURST.**—The temporary reservation, by Order in Council of the 14th October, 1867 (see *Government Gazette* October 22nd, 1867, page 2052) of 17 acres 2 roods 8 perches of land in the Parish of Sandhurst as a site for Public Purposes, revoked as to part by Order in Council of the 22nd May, 1928, is about to be revoked so far as the balance thereof, containing 6 acres 1 rood 27 perches, is concerned.—(S.371<sup>(16)</sup>) (Rs.8799).

JIM BALFOUR,  
Minister of Lands.

**PROPOSED REVOCATIONS OF TEMPORARY RESERVATIONS OF LANDS BY ORDERS IN COUNCIL.**

IN pursuance of the provisions of the *Land Act 1958*, notice is hereby given that it is the intention of the Governor in Council to revoke the temporary reservations of lands by Orders in Council hereunder referred to, viz.:

The following Notices were published 1° on the 15th March, 1967, pursuant to Orders of the 1st February, 1967.

**HOTHAM.**—The temporary reservation, by Order in Council of the 14th March, 1962, of 38,000 acres, more or less, of land in the Counties of Bogong, Dargo, Delatite and Wonnangatta, as a site for an Alpine Resort, revoked as to part by Order in Council of the 22nd September, 1964, is about to be revoked so far only as the portion in the Parish of Hotham, County of Bogong, containing 3 roods 30 perches, indicated by hatching on plan hereunder, is concerned.—(County Plan No. 4) (Rs.8115.)

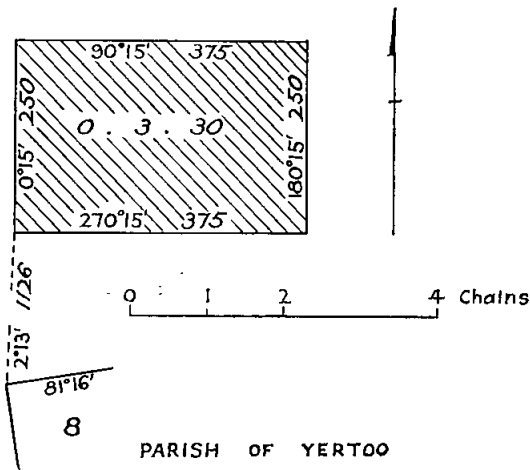

JIM BALFOUR,  
Minister of Lands.



## "CLEAR LAKE RECREATION RESERVE."

Alfred Frank Watson, Thomas Albert McClure, Reginald Keith Emmerson, Kenneth Norman Scott, Arthur William Hickmott, Clement Graham Eldridge, Peter Graeme Scott, John Munro Pollock and Alexander Francis Pekin, as a Committee of Management for a period of three (3) years of the land in the Parish of Carchap temporarily reserved by Order in Council dated the 10th September, 1963, as a site for Public Recreation.—(Corres. Rs.8257.)

## "ESKDALE CAMPING AND WATERING RESERVE."

Alexander R. Marks, Robert William Swasbrick, Cecil John Bock, Leonard John Moroney, Henry Francis Bock, James Ignatius Tobin, William John Forster, Geoffrey Neville Bock and Leslie Michael Kay as a Committee of Management for a period of three (3) years of the land temporarily reserved by Orders in Council dated the 14th April, 1932, and the 4th July, 1960, as sites for Camping and Watering purposes in the Township of Eskdale, Parish of Dorchap, and known as the "Eskdale Camping and Watering Reserve".—(Corres. Rs.4198.)

## "HAVEN PUBLIC HALL RESERVE."

William L. Taylor, Robert T. Voigt, John J. Cox, Donald Haylor, Keith V. Olson, Richard T. Hunter and John W. Morrison as a Committee of Management for a period of three (3) years of the land temporarily reserved by Order in Council of the 29th June, 1948, as a site for a Public Hall in the Parish of Bungalally, and known as the "Haven Public Hall Reserve".—(Corres. Rs.6195.)

## "HEATHCOTE RACECOURSE RESERVE."

John Thomas Farley, Francis Louis Hill, Edwin Alfred Kemp, James Lang, Garrett William Dowd, Allen Desmond Stephenson and Frederick James Granter as a Committee of Management for a period of three (3) years of the land temporarily reserved by Orders in Council dated 9th July, 1894, and 3rd August, 1954, as a site for a Racecourse Reserve in the Township of Heathcote, and known as the "Heathcote Racecourse Reserve".—(Corres. Rs.1165.)

## "HOGAN'S PARK RESERVE."

Arnold Major Moore, Leslie Reaburn and Maureen Hogan as a Committee of Management for a period of three (3) years of the land temporarily reserved by Order in Council of 8th May, 1923, as a site for Park and Recreation purposes in the Township of Emerald, and known as "Hogan's Park".—(Corres. Rs.2742.)

## "JEPARIT RECREATION RESERVE" AND THE "JEPARIT RECREATION AND SHOW GROUNDS RESERVES".

John Koenig Livingston, Roy Thomas Livingston, Leslie James B. Binns, Arnold Rae Keam, Frank Edward Strauss, Roy Natt, James Brian Morcom, Roy William Witney and Gordon Albert Livingston as a Committee of Management for a period of three (3) years of the reserved Crown land coloured green on plan marked J over 7.9.60 attached to Lands Department Correspondence Rs.1563, and known as the "Jeparit Recreation Reserve", together with the land temporarily reserved by Order in Council dated 18th October, 1927, as a site for Public Recreation in the Parish of Jeparit, and the land temporarily reserved by Order in Council dated 26th October, 1928, as a site for Public Recreation and Showgrounds in the Parish of Jeparit.—(Corres. Rs.1563, Rs.3774.)

## "LAKE OMEO RESERVE."

Colin White Scott, Henry Louis Pendergast, Owen Herbert Pendergast, Albert Edward Hollonds, Charles John Pendergast and John William Cook as a Committee of Management for a period of three (3) years of the land permanently reserved by Order in Council dated the 23rd October, 1953, as a site for Public purposes in the Parish of Hinomunje, and known as the "Lake Omeo Reserve".—(Corres. Rs.1069.)

## "MOLESWORTH MEMORIAL HALL."

William Robert Morris, Vincent Newman, Fay Margaret Morris, Kathleen Morris, Robert Morris, William M. Reid and John H. Sinclair, as a Committee of Management for a period of three (3) years of the land in the Parish of Whanregarwen, deemed permanently reserved for the recreation, convenience and amusement of the people.—(Corres. Rs.8711.)

## "MOOROODUC SCHOOL RECREATION RESERVE."

W. J. Jones, R. T. Jones, J. J. Richardson, A. A. Read, J. H. Wheeler, P. C. Parnell, J. A. Babington and R. D. Johnstone as a Committee of Management for a period of three (3) years of the land in the Parish of Bittern temporarily reserved by Order in Council dated the 26th July, 1960, as a site for Public Recreation and known as the "Moorooduc School Recreation Reserve".—(Corres. Rs.7958.)

## "NORADJUHA RECREATION RESERVE."

Melville Gustuy Nitschke, Daniel Mannix Carey, Donald James Leslie, Neil Sinclair McDonald, James Henry Northfield, George Ambrose Walter, John Donald Light, Alvin Charles Walker and Keith Brown, as a Committee of Management for a period of three (3) years of the lands temporarily reserved by Orders in Council dated 11th July, 1922, for Recreation Purposes, and 30th December, 1927 and 4th September, 1956, for Public Recreation, in the Parish of Darragan, Township of Noradjuha, and known as the "Noradjuha Recreation Reserve".—(Corres. Rs.2536.)

## "ROKEWOOD RECREATION RESERVE."

William John Carr, Edward Thomas Lynes, Neil Robert Turnbull, Percy Ernest Dunstan, Lloyd Thomas Dark, Stanley James Klein, David Maxwell Gribble, William Henry Stone, Gordon Daniel Carr and S. James Stanilaus O'Brien as a Committee of Management for a period of three (3) years of the land reserved for Cricket and Public Recreation purposes in the Parish of Corindhap, Township of Rokewood and known as the "Rokewood Recreation Reserve".—(Corres. Rs.2329.)

## "WILLATOOK PUBLIC HALL."

R. G. Brian, H. V. Glare, D. R. R. Malseed, J. J. Farley, G. L. Swarbrick, A. G. Gow, C. O. Habel and W. D. Malseed, as a Committee of Management for a period of three (3) years of the land in the Parish of Willatook, temporarily reserved by Order in Council, dated the 4th September, 1963, as a site for a Public Hall and known as the "Willatook Public Hall".—(Corres. Rs.8260.)

## "MARENGO" PUBLIC RECREATION PURPOSES RESERVE AT APOLLO BAY, PARISH OF KRAMBRUK.

Eric Victor Aylward, Albert Victor Taylor, Allan Thomas Armistead, Harry Wales, William Harrison, Richard John Patterson, Ian David MacDonald as a Committee of Management for a period ending the 26th January, 1970, and Neil McFarlane (for so long only as he remains a Councillor and the elect of the Council of the Shire of Otway, but nevertheless for no longer than a period ending the 26th January, 1970), as a Committee of Management of the land in the Parish of Krambruk, temporarily reserved by Order in Council dated the 25th October, 1966, as a site for Public Recreation purposes.—(Corres. Rs.8685.)

## "MOUNT HOTHAM ALPINE RESERVE."

J. W. Heid as the representative of Country Roads Board in the place of R. W. Angus, as a member of the Committee of Management of the reserved Crown land within the red outline on plan marked MH/9.4.62 attached to Lands Department correspondence Rs.8115, and known as the "Mount Hotham Alpine Reserve".—(Corres. Rs.8115.)

## "PUBLIC PURPOSES (RECREATION AND MUNICIPAL PURPOSES) RESERVE, TOWNSHIP OF MARYSVILLE."

The Council of the Shire of Healesville as the Committee of Management of the land in the Township of Marysville temporarily reserved by Order in Council, dated the 17th January, 1967, as a site for Public Purposes (Recreation and Municipal purposes) together with the portion of the permanent reserve to the Stevenson River as shown bordered red on M/10.2.1967, attached to Lands Department correspondence Rs.8757.—(Corres. Rs.8757.)

## "PUBLIC RECREATION RESERVE, CORNER LIGAR AND CORNISH STREETS, SUNBURY."

The Council of the Shire of Bulla as a Committee of Management of the land in the Township of Sunbury, temporarily reserved by Order in Council dated the 24th January, 1967, as a site for Public Recreation.—(Corres. Rs. 8758.)

## "ULLINA RECREATION RESERVE."

The Council of the Shire of Creswick as a Committee of Management of the land in the Township of Smeaton, at Ullina, temporarily reserved by Order in Council dated the 13th December, 1923, as a site for Public Recreation purposes known as the "Ullina Recreation Reserve."—(Corres. Rs.4536.)

This appointment is in lieu of all previous appointments in respect of the said lines which are hereby revoked.

JIM BALFOUR,  
Minister of Lands.

23rd March, 1967.

## TENDERS

## PUBLIC WORKS DEPARTMENT

TENDERS will be received at Public Works Department, Treasury-place, Melbourne, until TEN a.m. on dates shown and for purposes mentioned hereunder.

Particulars and tender forms available at Contracts Office, Room 7, Building Division, Parliament-place and at places indicated in brackets hereunder.

Abbreviations in brackets mean:—W.O.—Inspector of Works Office; P.S.—Police Station; C.S.—Consolidated School; H.E.S.—Higher Elementary School; H.S.—High School; S.S.—State School; T.S.—Technical School.

Tenders to be submitted on the Department's printed Tender Form and will not be received by telephone. All tenders must be on a "Firm Tender" basis. The lowest or any tender will not necessarily be accepted.

Address tenders to the Minister of Public Works, and endorse the envelope containing the tender "Tender for closing Tuesday,

No preliminary deposit is required with any tender, but a successful tenderer will be required to pay a deposit for any accepted tender of \$5,000 or over.

Tuesday, 4th April, 1967.

## Building, Electrical and Mechanical Works.

Beechworth.—Replacement of roofing, Wards M.1 to M.6, Mental Hospital. (W.O., Wangaratta; P.S., Beechworth.) (Amended Specification.)

Burwood.—New brick toilet block, S.S. 461.

Dalyston.—Renovations, &c., S.S. 3376 and Residence. (W.O., Korumburra; S.S., Dalyston.)

Geelong.—Electrical installation, S.S. 1094. (W.O., Geelong.)

Geelong.—Enlarging Principal's Office, &c., Technical School. (W.O., Geelong.)

Horsham North.—Electrical installation, S.S. 4926. (W.O., Horsham and Ballarat.)

Kew.—Steam condensate and hot water service reticulation, Children's Cottages. (Amended Specification.)

Lalor.—Erection of third section, High School.

Lalor.—Electrical installation, High School.

Lalor.—Mechanical services, High School.

Melbourne.—Electrical installation (supply and sub-main revisions), National Gallery and Museum.

Melbourne.—Extensions to heating, Public Library.

Mentone.—Roof repairs, Girls' High School.

Sunshine.—Erection of Assembly Hall, High School.

Sunshine.—Electrical installation, Assembly Hall, High School.

Sunshine.—Mechanical services, Assembly Hall, High School.

Wodonga.—Repairs and painting and new car port, Fisheries and Wildlife Branch, Residence. (W.O., Wangaratta; Fisheries and Wildlife Branch Residence, Wodonga.)

Furniture and Furnishings.

Royal Park.—Supply and fix curtains, Psychiatric Hospital. (Amended Specification.)

Site Works.

Scoresby.—Construction of earth dam (to contain approximately 30 acre-feet water), Research Station.

Shepparton South.—Supply, grading and consolidation of filling, Technical School. (W.O., Shepparton.)

Toolangi.—Clearing, grading, &c., Potato Research Station. (Potato Research Station, Toolangi.)

Various.—Asphalting, concreting, drainage, water reticulation, &c., Merrilands, S.S. 4826, Pender's Grove, S.S. 3806, Bundoora, S.S. 1915, Epping, S.S. 1477 and Macleod, Technical School.

Watsonia.—Earthworks, light and heavy duty asphalt, concrete, drainage works, &c., High School. (Re-advertised.)

## Miscellaneous.

Ocean Grove.—Supply and delivery of 2,000 tons of stone to river foreshore, Ports & Harbours Branch. (Buoy Depot, Ports & Harbours Branch, Queenscliff.)

Queenscliff.—Supply and delivery of 2,000 tons of stone to foreshore, Ports & Harbours Branch. (Buoy Depot, Ports & Harbours Branch, Queenscliff.)

Williamstown.—Supply and delivery of one (1) marine propulsion engine, Ports & Harbours Dredging Depot.

Tuesday, 11th April, 1967.

## Building, Electrical and Mechanical Works.

Ballarat.—Replacement of sewer mains, Mental Hospital. (W.O., Ballarat.)

Ballarat.—Internal and external renovations, Teachers' College. (W.O., Ballarat.) (Amended Specification.)

Beechworth.—Repairs and painting, S.S. 1560 Residence, 5 Sydney-road. (W.O., Wangaratta; S.S., Beechworth.)

Beechworth.—Supply of slow combustion heaters, S.S. 1560. (W.O., Wangaratta; S.S., Beechworth.)

Bell Park North.—Erection of new Primary School, S.S. 4962. (W.O., Geelong.)

Bell Park North.—Electrical installation, S.S. 4962. (W.O., Geelong.)

Bell Park North.—Plenum heating, S.S. 4962. (W.O., Geelong.)

Blackburn.—Overhaul slate roof, repairs and painting, S.S. 2923. (Amended Specification.)

Brunswick.—Renovations of toilets, S.S. 1213.

Bungador.—Renovations, new shelter shed, S.S. 4255. (W.O., Camperdown.)

Colac.—Erection of new Science Wing and class-room, &c., High School. (W.O., Geelong.)

Colac.—Electrical installation, High School. (W.O., Geelong; H.S., Colac.)

Colac.—Mechanical services, High School. (W.O., Warrnambool.)

Fairfield.—Central heating and hot water service extensions, Exotic Diseases Hospital.

Fairfield.—Electrical installation, Exotic Diseases Hospital.

Kew.—(a) Erection of brick veneer Staff Quarters. (b) Erection of brick Children's Play Room. "The Gables", Princess-street. (Amended Specification.)

Lara.—Construction of reinforced concrete waterfowl pen, &c. "Serenip" Wildlife Research Station. (W.O., Geelong.)

Macarthur.—Repairs, internal and external painting, Court House. (W.O., Warrnambool; P.S., Macarthur.) (Amended Specification.)

Melbourne.—Alterations to Green's Building and new Pathology Block, Cancer Institute Board, 278 William-street. (Specified Bills of Quantities Available.)

Melbourne.—Electrical installation, Green's Building and new Pathology Building, Cancer Institute Board, 278 William-street.

Melbourne.—Mechanical services, Green's Building and new Pathology Block, Cancer Institute Board, 278 William-street.

Melbourne.—Removal of existing lift and supply and installation of new electric lift, Green's Building, 278 William-street.

Mitta Junction.—Renovations, S.S. 4080. (W.O., Wangaratta.)

North Melbourne.—Repairs and painting, S.S. 1402 and Residence.

Queenscliff.—Renovations, High School. (W.O., Geelong; H.S., Queenscliff.) (Amended Specification.)

Richmond.—Floor renewals and repairs, S.S. 2084.

Rosanna.—New fencing and gates, S.S. 4568.

Roslyn.—Fire and domestic water service installation, S.S. 4663. (W.O., Geelong; S.S., Roslyn.)

Tooborac.—New toilet, repairs and painting, S.S. 1225 and Residence. (W.O., Bendigo.)

Toolamba.—New toilet block, septic tank systems, &c., S.S. 1455 and Residence. (W.O., Shepparton; S.S., Toolamba.)

Traralgon.—Repairs and painting, S.S., 3584. (W.O., Traralgon.)

Wangaratta.—Repairs and painting, part re-roofing, High School. (W.O., Wangaratta.)

Warragul.—Replacement of roof decking, Technical School. (W.O., Warragul.)

Winchelsea.—Renovations, new heaters, S.S. 2015. (W.O., Geelong; S.S., Winchelsea.)

Yarrowonga.—Repairs and painting to Residence, renewal of garage, S.S. 1819. (W.O., Benalla; S.S., Yarrowonga.)



**Furniture and Furnishings.**

Hamilton.—Tables and display cases, Technical School.  
 Melbourne.—Desks, Lands and Survey Department Head Office, Treasury-place.  
 Royal Park.—Supply and fix curtains, Psychiatric Hospital. (Amended Specification.)  
 Warrnambool.—Benches, tables and wall racks, Technical School.

**Site Works.**

Mount View.—Asphalting, concreting, drainage works, &c., S.S. 4923.

M. V. PORTER,  
 Minister of Public Works.

Public Works Department,  
 Melbourne, C.2, 29th March, 1967.

**PUBLIC SERVICE NOTICES****PUBLIC SERVICE OF PAPUA AND NEW GUINEA.****COMMUNICATIONS IN NEW GUINEA.**

THE Department of Posts and Telegraphs in Papua and New Guinea is seeking trained and experienced men for the important development work of the Territory's communications systems.

**Senior Communications Officers, Grade 1.**

\$3,665—\$3,865 per annum.

*Qualifications.*—Qualified by examination plus the ability to control and instruct staff.

*Duties.*—Either as second-in-charge at a Zone Centre (operating more important circuits) or controlling both telegraph office and telephone exchange at a smaller centre. Training of local staff.

**RADIO.****Senior Technical Instructor (Radio).**

\$4,767—\$4,887 per annum.

*Qualifications.*—Equivalent to Senior Technical (Radio P.M.G. standard or equivalent. Experienced in instructing trainees.

*Duties.*—Instruct trainees in telecommunication (radio) subjects and general academic subjects. Prepare syllabi and class lecture notes, conduct practical work and arrange field exercises.

*Length of Duty.*—Six months.

**Senior Technicians (Radio).**

\$3,827—\$4,027 per annum.

*Qualifications.*—Equivalent to Senior Technical (Radio Telecommunications) Postmaster-General's Department.

*Duties.*—Either responsible for maintenance of equipment at a Zone Centre or attached to the Installation Section based at Port Moresby from where it is necessary to travel to smaller centres on providing works. Could be called on to do V.H.F. survey work which may require some "camping out".

**Technicians (Radio).**

\$2,897—\$3,323 per annum.

*Qualifications.*—Completion of an approved course of training in telecommunications (Radio).

*Duties.*—If appointed to Maintenance Section Technician will maintain equipment at one of fourteen Zone Centres. If appointed to Installation Section at Port Moresby will travel to smaller centres on providing works. May be required to do V.H.F. survey work which could require some "camping out".

**TELEPHONE.****Senior Technicians (Telephones).**

\$3,827—\$4,027 per annum.

*Qualifications.*—Equivalent to Senior Technician (Telephones) in the Postmaster-General's Department.

*Duties.*—Installation of telephone exchange equipment (Magneto C.B. or automatic) including associated power plant or install and maintain subscriber equipment plus supervision of technical staff and operation of trunk and subscriber test desk.

**Technicians (Telephones).**

\$2,897—\$3,323 per annum.

*Qualifications.*—Completion of an approved training course in Telecommunications (Telephones).

*Duties.*—Responsible under direction for installation and/or maintenance of telephone equipment in exchanges and associated outstations or for the fabrication and installation of outstation consoles roughly equivalent in complexity to a floor-pattern switchboard.

**TELEGRAPH.****Technicians (Telegraphs).**

\$2,897—\$3,323 per annum.

*Qualifications.*—Qualified telegraph technician or equivalent.

*Duties.*—Install and maintain machine and manual telegraph equipment throughout the Territory.

**LINES.****Line Foreman, Grade 1.**

\$3,311—\$3,475 per annum.

*Qualifications.*—Completion of approved course of training with wide experience in lines work. Supervisory ability. Preferably also qualified cable joiner, commencing salary for whom will be \$3,475 per annum.

*Duties.*—Most work involves distribution within town areas using lead covered paper-insulated cables—there is only a small amount of aerial line construction. Oversighting the work of local line-man's assistants and labourers.

**POSTAL.****Postal Assistants.**

\$2,613—\$3,153 per annum.

*Qualifications.*—Qualified Postal Officer with a pass in written postal knowledge examinations covering Money Order duties and international mail work; or equivalent P.M.G. qualification.

*Duties.*—Generally in either mail room or Money Order Counter duties. However, at smaller offices they may be required to do money order and general counter duties, mail room duties and customs assessments. Supervision of a small team of local Postal Officers.

*Engagement* is by contract for a minimum of two years or longer if preferred (except for the Senior Technical Instructor (Radio). Applicants employed by a Government authority may be considered for secondment to the Territory Service for an initial period of two years with preservation of existing rights.

*Salaries* quoted are for single males. Married men receive an additional \$360 per annum. Income tax in the Territory is at present about half that paid in Australia.

*Conditions* include three months' leave after 21 months' service with assisted fares to Australia; educational allowance for children attending secondary school in Australia.

Details and application forms from the Secretary, Department of Territories, Canberra, A.C.T. Please quote position and advertisement No. 344. Applications close April 15th, 1967.

By order of the Secretary,

DEPARTMENT OF TERRITORIES, CANBERRA, A.C.T.

**PUBLIC SERVICE OF PAPUA AND NEW GUINEA.****Agricultural Chemist, Class II. or III.**

**A**N Agricultural Chemist with experience in Soil Chemistry is needed by the Public Service of Papua and New Guinea for its Division of Plant Industry.

**Salary.—**

Class II.—\$5,581—\$6,221 per annum (single male).

Class III.—\$6,431—\$7,051 per annum (single male).

Married men receive an additional \$360 per annum. Income tax in the Territory is at present about half that payable in Australia.

*Qualifications.*—Degree in Science or Agricultural Science with a major in Chemistry, and post-graduate experience in Soil Chemistry.

Applicants for Class III. must have wide experience, including considerable research experience, in Soil Chemistry.

**Duties.**—Physical and chemical analysis of soils.

Interpretation and correlation of results of soil surveys in relation to agricultural potential and land use. Research into specific soil problems. Co-operation with Agronomists in field experiments. Supervise chemical laboratory.

**Working Conditions.**—The Soils Laboratory is located at Kila, a suburb of Port Moresby, and is adequately equipped with modern equipment.

**Accommodation.**—Married or single accommodation available at nominal rate.

**Conditions.**—Include three months' leave after 21 months' service, with assisted leave fares to Australia and an education allowance for children attending secondary schools in Australia.

**Engagement.**—By contract for a minimum period of two years or longer if preferred. Applicants employed by a government authority may be considered for secondment to the Territory Service for an initial period of two years with preservation of existing rights.

**Applications.**—Should be made to the Secretary, Department of Territories, Canberra, A.C.T., from whom details and application forms are available. Please quote advertisement No. 345. Applications close 15th April, 1967.

**PUBLIC SERVICE OF PAPUA AND NEW GUINEA.**

By order of the Secretary, Department of Territories, Canberra, A.C.T.

**LAND ACT 1958 (No. 6284 AS AMENDED BY ACT No. 7075).****WHEREAS:**

I. Application has been made, pursuant to sub-section (1) of section 22c of the *Land Act 1958* by John James Watts, sole surviving trustee for the time being of the Kotta Public Hall site being the land described in the schedule hereto for permission to surrender the said land to Her Majesty Queen Elizabeth the Second.

II. By the said sub-section (1) it is provided that the Attorney-General may by notice published in the *Government Gazette* grant permission to the trustees to surrender the land to Her Majesty pursuant to the said section 22c and by sub-section (4) of the said section 22c. It is further provided that the Attorney-General shall specify the purpose mentioned in section 14 of the *Land Act 1958* for which the land was vested in the trustees or was used or to which the purpose for which it was vested in the trustees or was used is in his opinion substantially similar.

Now, I, Arthur Gordon Rylah, in my capacity as Her Majesty's Attorney-General for the State of Victoria—

- (a) grant permission to the said trustees to surrender the said land to Her Majesty pursuant to section 22c of the *Land Act 1958*; and
- (b) specify pursuant to sub-section (4) of section 22c aforesaid the following purpose mentioned in section 14 of the *Land Act* aforesaid, namely—

“the recreation convenience or amusement of the people.”

**SCHEDULE.**

All that piece of land being part of Crown allotment 4, Parish of Bamawm, County of Rodney, and being the land comprised in certificate of title, volume 5160, folio 909.

Given under my hand this 8th day of March, 1967.

6164

A. G. RYLAH,  
Attorney-General.

**WANGARATTA SEWERAGE AUTHORITY.****GENERAL NOTICE—SIXTH SCHEDULE.**

THE above-mentioned Sewerage Authority, having made provision for carrying off the sewage from each and every property which or any part of which is within the sewerage area hereinafter described, doth hereby declare that, on and after the first day of April, 1967, each and every property which or any part of which is within the said sewerage area shall be deemed to be seweraged property within the meaning of the *Sewerage Districts Act 1958*.

The boundaries of the Sewerage area, hereinbefore referred to are:—

1. *College-street-Park-lane area:* Commencing at the intersection of the southern alignment of College-street and the western alignment of Park-lane; thence southerly along the western alignment of Park-lane a distance of 300 feet; thence westerly a distance of 26 feet; thence northerly a distance of 300 feet to the southern alignment of College-street; thence easterly along the southern alignment of College-street to the point of commencement.

2. *Park-lane area:* Commencing at the intersection of the eastern alignment of Park-lane and the northern alignment of College-street; thence northerly along the eastern alignment of Park-lane, a distance of 827 ft. 2 in.; thence easterly a distance of 130 feet; thence southerly a distance of 252 ft. 1½ in.; thence easterly a distance of 76 ft. 9 in.; thence southerly a distance of 94 ft. 6 in.; thence easterly a distance of 96 ft. 11 in.; thence southerly a distance of 481 ft. 10½ in. to the northern alignment of College-street; thence westerly along the northern alignment of College-street to the point of commencement.

By order of the said Sewerage Authority.

H. P. BARR, Chairman.  
6128 W. R. FEATHERSTON, Secretary.

**CITY OF BALLAARAT.****NOTICE OF MAKING OF BY-LAW No. 165.**

NOTICE is hereby given that the Council of the City of Ballarat has made and passed a By-law under the Local Government Acts and numbered 165 for the purpose of:—

- (a) Regulating the use of streets, roads and public places by street hawkers and itinerant traders;

**PRIVATE ADVERTISEMENTS****ARARAT PISTOL CLUB.**

NOTICE is hereby given that the Ararat Pistol Club has applied for a lease under section 134 of the *Land Act 1958*, for a term of 21 years, in respect of an area of approximately 3 acres in the Township of Ararat as a site for amusement and recreation (pistol range).

F. ALLENDER,  
6092 Hon. Secretary, Ararat Pistol Club.

NOTICE is hereby given that the Violet Town Bowling Club has applied for a lease under section 134 of the *Land Act 1958* for a term of 21 years in respect of an approximate area of 1 acre in the Township of Violet Town as a site for Amusement and Recreation.

C. J. McDONNELL, Hon. Secretary, Violet Town Bowling Club. 5884

**NOTICE OF INTENTION TO APPLY FOR A LICENCE TO DIVERT WATER AND CUT RACE (RE-ISSUE) FROM THE BUFFALO RIVER AT MERRIANG.**

I HEREBY give notice that I intend to apply for a licence empowering me to divert water for a term of four years to the extent of 30 acre-feet per annum at a maximum rate of ½ acre-foot per day of 24 hours for the irrigation of pasture, being part of allotment 37B, section P, Parish of Myrtleford, and to occupy certain Crown lands for works of diversion, and to cut a race thereon.

Any objection to such application must be forwarded, in writing, to reach the State Rivers and Water Supply Commission, Melbourne before 28th April, 1967, being 30 days from the first publication of this notice.

NICHOLAS JAMES CROUCHER.  
Bird-avenue, Myrtleford. 6151

**NOTICE OF INTENTION TO APPLY FOR A LICENCE TO DIVERT WATER AND CUT RACE FROM THE COWANNA BILLABONG AT YELTA.**

WE hereby give notice that we intend to apply for a licence empowering us to divert water for a term of four years to the extent of 18 acre-feet per annum at a maximum rate of 1 acre-foot per day of 24 hours for irrigating an area of 5 acres being part of allotment 7A section G, Parish of Merbein, and to occupy certain Crown lands for works of diversion, and to cut a race thereon.

Any objection to such application must be forwarded in writing to reach the State Rivers and Water Supply Commission, Melbourne, before 29th March, 1967, being 30 days from the first publication of this notice.

FRANK ISKRA.  
ROSA LUCIA ISKRA.  
P.O. Box 187, Merbein. 6185

- (b) Prohibiting and regulating the sale of goods from stalls, motor cars, carts, trucks, barrows and other receptacles standing or placed on any street, road or public place or vacant land;
- (c) Prohibiting or regulating the erection or use on any land of tents or other temporary structures or buildings for the sale of goods therein or therefrom and the sale of goods in or from such tents, structures or buildings.

Such By-law has been approved by the Governor in Council.

A copy of the above-mentioned By-law has been deposited at the office of the City Council, Town Hall, Ballaarat, and is open for inspection free of charge during office hours.

Dated the 21st day of March, 1967.

H. R. MADDERN,

6182 Town clerk.

Local Government Act 1958, Section 605.

CITY OF BRIGHTON.

NOTICE OF SCHEME.

**PURSUANT** to section 605 of the *Local Government Act* 1958, the Mayor, Councillors and Citizens of the City of Brighton has passed a resolution that—

1. It is desirable to alter and increase the width of the street known as Francis-road or Snook's-lane on part of Dendy's Crown Special Survey Parish of Moorabbin and that in addition to purchasing or compulsorily taking the land required for the purpose of altering and increasing the width of Francis-road aforesaid it is also desirable that other lands forming part of the said Dendy's Crown Special Survey (hereinafter referred to as surplus land) situated in the neighbourhood thereof though not actually required for the aforesaid purposes should also be purchased or compulsorily taken and that after the aforesaid purchase and compulsory taking has been completed the street or road known as Francis-road be altered and increased in width as is delineated and coloured brown on the plans marked Nos. 2958/1.2 A and B prepared by the City Engineer and approved by the Council (which plans are deposited at the office of the Council and is there open for inspection during office hours by any person free of charge).

2. That part of the surplus land be retained by the Council for leasing purposes and the balance together with other lands owned by the Council be resubdivided into allotments at least complying with the requirements of clause 3 of Table 804 of the Uniform Building Regulations (Victoria) in order to improve the locality by providing allotments of a reasonable size as delineated and coloured red on the said plans and that such allotments be sold for cash or on terms.

3. That the roads or rights-of-way coloured blue, blue hatched and orange on plan No. 2958/1.2B be closed.

The Council has prepared for submission to the Minister for the approval of the Governor in Council a scheme the purport whereof is that the works and undertakings proposed to be carried out consist in substance of the alteration and widening of Francis-road or Snook's-lane the closing of the rights-of-way as shown on the said plan and the retention for leasing purposes of part of the surplus land and the resubdivision of the balance of the surplus land into lots of larger size to accord at least with Uniform Building Regulations, Victoria, that such new lots shall be sold for cash or on terms not exceeding two years with interest at \$7.50 per centum per annum that the estimated cost of the scheme is \$236,000.00 that it is not proposed to impose a betterment charge that it is anticipated that the proceeds of the sale of the surplus land will substantially recoup the cost of the scheme and that funds for carrying out the scheme are to be first provided from overdraft and subsequently by mortgage from the Commonwealth Bank to cover the nett deficit.

A copy of such scheme is deposited at the office of the Council, Boxshall-street, Brighton, and is there open for inspection during office hours by any person free of charge.

All persons affected by the scheme are requested to set forth, in writing, addressed to the Municipal Clerk, Municipal Offices, Boxshall-street, Brighton, within 40 clear days from the publication hereof in the *Government Gazette*, all objections which they may have to the scheme.

At the next ordinary meeting of the Council, after the expiration of the said 40 clear days the Council will consider any objection to the scheme, and will hear any person affected by the scheme who attends such meeting.

A. C. G. DEGARIS, Town Clerk.

Municipal Offices, Boxshall-street, Brighton, S.5, 23rd March, 1967. 6167

CITY OF SALE.

LOAN NO. 40.

*Notice of Intention to Borrow the Sum of \$30,300 for Permanent Works and Undertakings.*

**NOTICE** is hereby given that the Council of the City of Sale proposes to borrow the principal sum of Thirty thousand three hundred dollars (\$30,300), secured by a charge over the general rates of the municipality, such sum to be raised by the grant of a mortgage in accordance with the provisions of the *Local Government Act* 1958.

1. The maximum rate of interest that may be paid is 5½ per cent. per annum.

2. The purpose for which the loan is to be applied is—

(a) Council depot—land acquisition and first stage construction .. .. .	\$16,300
(b) Off-street car parking—land acquisition and first stage construction .. .. .	8,000
(c) Local contribution towards the cost of a new caravan camp park on the Princes Highway .. .. .	6,000
	\$30,300

3. The period of the loan shall be ten years.

4. The moneys borrowed shall be repayable by providing out of the municipal fund twenty equal half-yearly instalments of \$2,013.18 each, including principal and interest, on the 1st day of June and the 1st day of December, during the currency of the loan. The first instalment shall be payable on the 1st day of December, 1967.

5. Such moneys shall be repayable at the Commonwealth Savings Bank of Australia at Melbourne.

The plans and specifications and the estimate of the cost of the proposed works and a statement showing the proposed expenditure of the moneys to be borrowed, are open for inspection at the office of the Council of the City of Sale, at Macalister-street, Sale.

J. R. RAY, Town Clerk.

22nd March, 1967. 6125

CITY OF SPRINGVALE.

LOAN NO. 125.

*Special Order to Borrow the Sum of \$50,000.*

**NOTICE** is hereby given that the Council at an Ordinary Meeting held on Monday, 20th March, 1967, at 7 p.m. passed the following Resolution as a Special Order:—

“That—

1. (a) This Council borrow moneys by the grant of a mortgage upon the credit of the municipality pursuant to section 585 of the *Local Government Act* 1958.

(b) The amount of the principal moneys to be borrowed be \$50,000.

(c) The rate of interest to be paid be 5½ per cent. per annum.

(d) The moneys borrowed be repayable by twenty equal instalments payable respectively on the 21st day of April and the 21st day of October of each year, the first such instalment being repayable on the 21st day of October, 1967.

(e) The moneys borrowed be repayable at the Australia and New Zealand Bank Limited, Springvale.

(f) The loan be applied for the purposes of liquidating or of partly liquidating the amount due on overdraft of current account to the Council's bankers in respect of the execution of private street construction schemes pursuant to Division 10 of Part XIX. of the *Local Government Acts*.

(g) The loan be liquidated by providing out of the municipal fund on the 21st day of April and on the 21st day of October of each year the sum necessary to pay the half-yearly instalment and the interest then due in respect of the loan.

2. The Council directs that this Resolution be brought forward for confirmation as a Special Order at a meeting of the Council to be held on the 17th day of April, 1967, at seven o'clock in the afternoon.”

Notice is hereby given that the said Resolution will be submitted for confirmation at the Ordinary Meeting of the Council to be held on Monday, 17th April, 1967, at 7 p.m. in the Council Chambers, City Offices, Springvale.

H. L. WILLIAMS, Town Clerk.

Dog Act 1958.

CITY OF SPRINGVALE.

THE Council of the City of Springvale hereby, pursuant to section 17 of the Dog Act 1958, by this Order specifies the shopping areas in which the owner of any dog (other than a dog being used for the droving of stock) which is found in or on any such shopping area and which is not under the effective control of some person by means of a chain or cord or leash, shall be liable to the penalty prescribed by such section.

SHOPPING AREAS REFERRED TO—

- Alfred-street, west side, from Agnes-street northwards 98 ft. 9 in.
- Avondale-street, north side, from Lewis-street eastwards a distance of 120 feet.
- Police-road, south side, from a point 140 feet east of Hillside-street to Edinburgh-street.
- View-road, west side, from Vardon-street north a distance of 130 feet.
- Buckley-street, both sides, from Douglas-street southwards a distance of 300 feet.
- Leonard-avenue, both sides, from Douglas-street southwards a distance of 300 feet.
- The area bounded by Springvale-road, Windsor-avenue, Buckingham-avenue and the railway line.
- Springvale-road, west side, from Windsor-avenue to St. James-avenue.
- Springvale-road, east side, from the Gippsland Railway southward to Ash-grove.
- Springvale-road, east side, from the railway line northward to Rosalie-street.
- Springvale-road, east side, from Mary-street northward a distance of 150 feet.
- Heatherton-road, south side, from Ian-street eastward a distance of 150 feet.
- Heatherton-road, south side, from Chandler-road westward a distance of 150 feet.
- Douglas-street, from Heatherton-road to Stuart-street.
- Ian-street, from Heatherton-road to Mons-parade.
- Princes Highway, from Bowmore-road to Ardgower-road.
- Buckingham-avenue, west side, north of Balmoral-avenue to Osborne-avenue.
- Sandown-road, east of Springvale-road, north side of Sandown-road to Kelvin-avenue.
- Springvale-road, west side, northwards from railway line to Newcomen-road.
- Springvale-road, from Princes Highway east side to Kemp-avenue.
- Garnsworthy-street, south side, west from Gove-street to 150 feet.
- Buckley-street, east side, north of David-street for 100 feet.
- Wardale-road, north side, from Noble-street for 140 feet.
- Hosken-street, west side, north of Myrtle-street for 140 feet.
- Lightwood-road, south side, from Lawn-road to Somers-street.
- Springvale-road, east side, from Mary-street to Lucian-avenue northwards.
- Chelsea-road, Chelsea Heights, west side, north from Fourth-avenue for 100 feet.
- Centre Dandenong-road, Dingley, north side, from Marcus-road east a distance of 165 feet.
- Pauline-avenue, Dingley, west side, from the southern side Service-road of Centre Dandenong-road south to Anita-avenue.

PENALTY.—First offence not more than Eight Dollars and for a second or any subsequent offence, of not more than Twenty Dollars. Any dog so found may be seized by the Police or by the officers of the Municipality duly authorized on that behalf and dealt with as if it had been seized under section 15 or section 16 of the Dog Act 1958.

6127 H. L. WILLIAMS, Town Clerk.

CITY OF TRARALGON.

LOAN No. 23.

Notice of Intention to Borrow the Sum of \$50,000 for Permanent Works and Undertakings.

NOTICE is hereby given that the Council of the City of Traralgon proposes to borrow the sum of \$50,000, secured by a charge over the general rates of the municipality, such sum to be raised by the grant of a mortgage in accordance with the provisions of the Local Governments Acts, and notice is hereby further given—

- (a) That the maximum rate of interest that may be paid is \$5.875 per centum per annum.
- (b) That the purpose for which the loan is to be applied is—
 

Concrete and Drainage Works	..	..	\$20,000
Road/Street Construction	..	..	\$30,000
- (c) That the period of the loan shall be 40 years.

(d) That moneys borrowed shall be repayable in one sum on the 1st day of June, 2007, for which purpose a sinking fund will be provided to which payment of \$228.19 will be made each six months during the currency of the loan.

(e) Such moneys shall be repayable at the State Superannuation Board, Treasury Buildings, Melbourne, C.2.

The plans and specifications and estimate of the cost of the proposed works, and a statement showing the proposed expenditure of the money to be borrowed, are open for inspection at the offices of the Council, Municipal Offices, Kay-street, Traralgon, during office hours.

6168 K. J. SAUNDERS, Town Clerk.

Local Government Act 1958, as Amended.

SHIRE OF ALBERTON.

NOTICE OF INTENTION TO TAKE LAND COMPULSORILY.

WHEREAS the Council of the Shire of Alberton deems it expedient to take certain lands compulsorily for the widening of McLoughlin's Beach-road, and has caused to be prepared a plan showing the description of the land proposed to be taken together with the names of the owners or reputed owners, lessees or reputed lessees and occupiers of those lands so far as can be ascertained by the Council.

The said Council doth hereby publish and give notice—

- (a) The lands proposed to be taken for purpose of widening McLoughlin's Beach-road are parts of Crown allotments 25B, 25c, 25d, 31c and 30A, section 1, Parish of Balloong, County of Buln Buln.
- (b) The plan is deposited for inspection at the Shire Office, Commercial-road, Yarram.
- (c) To all persons affected by the proposed taking of the land to set forth, in writing, addressed to the Council or the Municipal Clerk within 40 clear days of the publication of the notice in the Government Gazette, all objections which they may have to the taking of the land.

6169 A. W. CURRY, Shire Secretary.

SHIRE OF ALEXANDRA.

LOAN No. 26.

Notice of Intention to Borrow the Sum of \$20,000 for Permanent Works and Undertakings.

NOTICE is hereby given that the Council of the Shire of Alexandra proposes to borrow the sum of Twenty thousand dollars secured by a charge over the general rates of the municipality, such sum to be raised by a grant of mortgage in accordance with the provisions of the Local Government Act 1958.

- 1. The maximum rate of interest that may be paid is 5.5625 per cent. per annum.
- 2. The purpose for which the loan is to be applied is:—
  - Purchase of four-wheel drive loader—\$20,000.
- 3. The period of the loan shall be seven years.
- 4. The moneys borrowed shall be repayable by providing out of the municipal fund fourteen half-yearly instalments of \$1,744.23 each, including principal and interest on the 3rd January and 3rd July in each year, during the currency of the loan, the first instalment being payable on the 3rd January, 1968.
- 5. Such moneys shall be repayable at the head office of the National Bank of Australasia Ltd., Melbourne, or at the Council's bankers, for the time being.

The plans and specifications and the estimate of the cost of the proposed works and a statement showing the proposed expenditure of the moneys to be borrowed, are open for inspection at the Municipal Offices, Shire of Alexandra.

6124 R. G. HATFIELD, Shire Secretary.

SHIRE OF ALTONA.

LOAN No. 63.

Private Streets Account.

NOTICE is hereby given that at the meeting of the Council of the Shire of Altona held at the Civic Offices, Altona, on Monday, 13th February, 1967, the said Council did agree to the following Resolution:—

That the Council of the Shire of Altona borrows the principal sum of \$50,000.00 secured by a charge over the general rates of the municipality, such sum to be raised by the grant of a mortgage in accordance with the provisions of the Local Government Act 1958:—

- 1. The maximum rate of interest that may be paid is \$5.625 per centum per annum.

2. The purpose for which the loan is to be applied is private street construction—\$50,000.

3. The period of the loan shall be ten years.

4. The loan shall be repaid by providing out of the municipal fund twenty half-yearly instalments of approximately \$3,303 each, including principal and interest on the 1st day of April and the 1st day of October, during the currency of the loan. The first instalment shall be payable on the 1st day of October, 1967.

5. Such money shall be repayable at the office of the State Savings Bank of Victoria, Melbourne.

And notice is hereby further given that at the meeting of the said Council held at the Civic Offices, Altona, on Monday, 20th March, 1967, the said Resolution was confirmed.

6123 JAMES W. WATERS, Shire Secretary.

SHIRE OF ALTONA.

LOAN No. 62.

*Notice of Intention to Borrow the Sum of \$100,000 for Permanent Works and Undertakings.*

NOTICE is hereby given that the Council of the Shire of Altona proposes to borrow the principal sum of One hundred thousand dollars secured by a charge over the general rates of the municipality, such sum to be raised by the grant of a mortgage in accordance with the provisions of the *Local Government Act 1958*.

1. The maximum rate of interest to be paid is \$5.75 per centum per annum.

2. The purpose for which the loan is to be applied is:—

(i) Road construction, Freemans-road ..	\$52,000
(ii) C.R.B. construction works, Council proportion (Millers-road, Mason-street) ..	\$48,000
	\$100,000

3. The period of the loan shall be ten years.

4. The moneys borrowed shall be repayable by providing out of the municipal fund half-yearly instalments of approximately \$6,644.00 each, including principal and interest on the 9th day of June and the 9th day of December in each year, during the currency of the loan. The first instalment shall be payable on the 9th day of December, 1967.

5. Such moneys shall be repayable to the trustees of the Australian Natives Association, at the office of the said trustees, 28-32 Elizabeth-street, Melbourne.

The plans and specifications and the estimate of cost of the proposed works and a statement showing the proposed expenditure of the moneys to be borrowed, are open for inspection at the Civic Offices, 115 Civic-parade, Altona.

6209 JAMES W. WATERS, Shire Secretary.

SHIRE OF ALTONA.

LOAN No. 64.

*Notice of Intention to Borrow the Sum of \$50,000 for Permanent Works and Undertakings.*

NOTICE is hereby given that the Council of the Shire of Altona proposes to borrow the principal sum of Fifty thousand dollars secured by a charge over the general rates of the municipality such sum to be raised by the grant of a mortgage in accordance with the provisions of the *Local Government Act 1958*.

1. The maximum rate of interest to be paid is \$5.875 per centum per annum.

2. The purpose for which the loan is to be applied is:—

Construction of underground drains at Altona North Recreation Reserve (part cost)—\$50,000.

3. The period of the loan shall be 40 years.

4. The loan shall be repaid by the establishment and accumulation of a sinking fund, pursuant to the provisions of section 428 (a) of the *Local Government Act 1958*, by provisions out of the municipal fund of an amount of \$467.16 in each year, during the period of the loan.

5. Interest shall be payable at the office of the State Superannuation Board on the 1st days of June and December in each year, during the period of the loan. The first interest payment shall be made on the 1st day of December, 1967.

6. Such moneys shall be repayable at the office of the State Superannuation Board, Treasury Gardens, Melbourne, or at such other place or places as the Board may, from time to time require.

The plans, specifications and estimates of the cost of the proposed works and a statement showing the proposed expenditure of the moneys to be borrowed, are open for inspection at the Civic Offices, 115 Civic-parade, Altona, during office hours.

6210 JAMES W. WATERS, Shire Secretary.

SHIRE OF COBRAM.

LOAN No. 24.

*Notice of Intention to Borrow the Sum of \$7,500 for Permanent Works and Undertakings.*

NOTICE is hereby given that the Council of the Shire of Cobram proposes to borrow the sum of \$7,500 on the credit of the Municipal Revenues of the President, Councilors and Ratepayers of the Shire of Cobram, such sum to be raised by the grant of a mortgage in accordance with the provisions of the *Local Government Act 1958*, as amended.

1. The maximum rate of interest that may be paid is \$11.50 per cent.

2. The purpose for which the loan is to be applied is—	
Drainage works ..	\$5,000
Saleyards improvements ..	\$2,500

3. The period of the loan shall be for a ten-year term.

4. The moneys borrowed shall be repayable by twenty half-yearly instalments of \$498.31, including principal and interest on the 1st day of January and the 1st day of July each year, to the A.N.Z. Savings Bank Limited, 394 Collins-street, Melbourne.

5. The plans and specifications and the estimate of the cost of the proposed expenditure of the money to be borrowed are open for inspection at the Shire Office, Cobram.

R. T. CUTTS, Shire Secretary.

23rd March, 1967.

6176

SHIRE OF CRESWICK.

NAMING OF STREETS.

NOTICE is hereby given that at a meeting held on 13th February, 1967, the Council of the Shire of Creswick did resolve and agree to alter the names of the following streets in the Township of Creswick, Parish of Creswick—

- (a) Old Name—Old Boundary-road.  
New Name—Semmens-avenue.
- (b) Old Name—Ascot-road.  
New Name—Bald Hills-road.

6091

B. C. REES, Shire Secretary.

SHIRE OF DIAMOND VALLEY.

CHANGES OF NAMES.

NOTICE is hereby given that pursuant to the provisions of the *Local Government Act 1958*, the Council of the Shire of Diamond Valley doth order that the names of streets within the municipality be changed as set out hereunder:—

Old Name.	New Name.	Location Referred to.
Glen Park-road } Murrays-road }	Wattle Tree-road	That portion of Glen Park-road fronting lots 17 to 26 on Part C of lodged plan 6091 and the whole of Murrays-road as deviated from Ryans-road to Glen Park-road fronting lots 38 and 39 on Part B of lodged plan 6091
Glen Park-road	Lower-road ..	That portion of Glen Park-road fronting lots 27 to 32 on Part C and lot 39 on Part D of lodged plan 6091
Glen Park-road	Banks-road ..	That portion of Glen Park-road fronting lots 87 and 1 to 16 on Part C of lodged plan 6091
Patani-place ..	Medbury-avenue	As shown on Plan of Subdivision 61600
Narbethong-drive	Warruga-place ..	As shown on Plan of Subdivision 64365
Attunga-road ..	Sainsbury-avenue	As shown on Plan of Subdivision 64364
Cornwall-street	Greenwood-drive	The whole of Cornwall-street as shown on Plans of Subdivision 60324, 4393, 10777, 41741

6119

B. J. MORGAN, Shire Secretary.

SHIRE OF EAST LODDON.

IN pursuance of the powers conferred by section 522 of the Local Government Act 1958, the Council of the Shire of East Loddon, doth hereby direct that the land shown hatched on the plan hereunder, being part of Crown allotment 85, Parish of Pompapeli, and being the land more particularly described in Certificate of Title, Volume 8594, Vol. 297, which has been taken purchased or acquired by it, shall be a public highway from and after the date of publication of this Order in the Government Gazette.

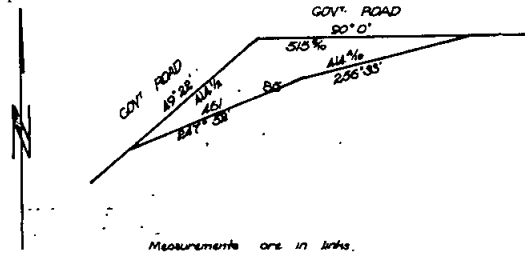

The common seal of the President, Councillors and Ratepayers of the Shire of East Loddon was hereunto affixed this 9th day of March, 1967, in the presence of—

(SEAL) D. A. PICKLES, President.  
W. DALZIEL, Councillor.  
T. J. RUDKINS, Secretary.

6177

SHIRE OF GRENVILLE.

NOTICE is hereby given that the President, Councillors and Ratepayers of the Shire of Grenville have applied for a lease of allotment 39A, Parish of Dereel, containing approximately 290 acres, pursuant to section 134, Land Act 1958, for the purpose of removing gravel for a term of 21 years.

5719

L. OLDHAM, Shire Secretary.

SHIRE OF HEYTESBURY.

LOAN No. 22.

Notice of Intention to Borrow the Sum of \$90,000 for Permanent Works and Undertakings.

NOTICE is hereby given that the Council of the Shire of Heytesbury proposes to borrow the sum of Ninety thousand dollars on the security of the general rates of the said shire, such sum to be raised by the grant of a mortgage in accordance with the provisions of the Local Government Act 1958.

1. Maximum rate of interest that may be paid is 5½ per centum per annum.

2. The purposes for which the loan is to be applied are:—

- Part cost of improvements to, and construction of pavilion and the installation of a water clarification and purification plant at the Cobden Swimming Pool . . . \$29,000
- Part cost of construction of a swimming pool and pavilion at Timboon . . . \$61,000

3. The period of the loan shall be fifteen years.

4. The loan is to be liquidated by providing out of the municipal fund 30 half-yearly instalments of approximately \$4,554.71 each, (including principal and interest), payable on the 23rd day of December and the 23rd day of June each year at the National Bank of Australasia Ltd., Melbourne.

Plans and specifications and the estimate of the cost of the proposed works and a statement showing the proposed expenditure of the moneys to be borrowed are open for inspection at the Shire Offices, Cobden.

6174

P. J. NORTHEAST, Shire Secretary.

SHIRE OF KILMORE.

LOAN No. 28.

Notice of Intention to Borrow the Sum of \$2,000 for Permanent Works and Undertakings.

NOTICE is hereby given that the Council of the Shire of Kilmore proposes to borrow the principal sum of \$2,000 secured by a charge over the general rates of the municipality, such sum to be raised by the grant of a mortgage in accordance with the provisions of the Local Government Act 1958.

1. The maximum rate of interest that may be paid is 5½ per cent. per annum.

2. The purpose for which the loan is to be applied is—  
The extension of a water main in the Wallan Water Supply Scheme.

3. The period of the loan shall be fifteen years.

4. The moneys borrowed shall be repayable by providing out of the municipal fund half-yearly instalments of approximately \$101 each, including principal and interest on the 1st day of July and the 1st day of January, during the currency of the loan. The first instalment shall be payable on the 1st day of January, 1968.

5. Such moneys shall be repayable to the Commissioners of the State Savings Bank of Victoria at the office of the said Commissioners, corner Elizabeth and Bourke streets, Melbourne.

The plans and specifications and the estimate of the cost of the proposed works and a statement showing the proposed expenditure of the moneys to be borrowed are open for inspection at the office of the Council of the Shire of Kilmore, at the Shire Offices, Kilmore.

Date: 21st March, 1967.

6090

BRIAN J. HOBAN, Shire Secretary.

SHIRE OF LILLYDALE.—SHIRE OF LILLYDALE PLANNING SCHEME 1958.

NOTICE THAT A PLANNING SCHEME HAS BEEN PREPARED AND IS AVAILABLE FOR INSPECTION.

Amendment No. 4, 1967.

NOTICE is hereby given that the Shire of Lillydale in pursuance of its powers under the Town and Country Planning Act 1961 has prepared a planning scheme for portion of the Shire of Lillydale for the purpose of amending the principal scheme (Shire of Lillydale Planning Scheme 1958).

A copy of the scheme has been deposited at the Shire Offices, Lillydale, and at the office of the Town and Country Planning Board, 179 Queen-street, Melbourne, and will be open for inspection during office hours by any person free of charge.

Any persons affected by the planning scheme are required to set forth in writing all objections they may have, addressed to the Shire Secretary, Shire of Lillydale, Shire Offices, Anderson-street, Lillydale, on or before the 29th day of June, 1967, and to state whether they wish to be heard in respect of their objections.

6120

T. H. COWLEY, Shire Secretary.

SHIRE OF LILLYDALE.

NOTICE OF INTENTION TO TAKE LAND COMPULSORILY.

WHEREAS the Council of the Shire of Lillydale deems it expedient to exercise its power of taking compulsorily the land delineated and hatched on the map at the foot hereof for public purposes. And whereas the Council has caused to be prepared a map and other papers setting out the general description of the work or undertaking for which the land proposed to be taken is to be used the description of the land proposed to be taken and the names of the owners or reputed owners lessees or reputed lessees mortgagees and occupiers of that land so far as those names are known to or can be ascertained by the Council. And whereas the said map and other papers are deposited at the office of the said Council at Lillydale and are and shall be open for inspection by all persons interested at all reasonable hours for the space of 40 clear days after the publication of this notice in the Government Gazette. Now notice is hereby given to all persons affected by the proposed taking of the said land to set forth in writing addressed to the Council or the Shire Secretary within 40 clear days of the publication of this notice in the Government Gazette all objections which they may have to the taking of the said land, being part of Crown allotment 10, section 29, Parish of Yering.

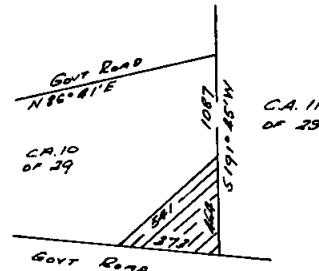

Dated the 20th day of March, 1967.

By order of the Council.

6121

T. H. COWLEY, Shire Secretary.

## SHIRE OF MORWELL.

## LOAN No. 38.

*Notice of Intention to Borrow the Sum of \$20,000 for Permanent Works and Undertakings.*

NOTICE is hereby given that the Council of the Shire of Morwell proposes to borrow the principal sum of \$20,000 secured by a charge over the general rates of the municipality, such sum to be raised by the grant of a mortgage in accordance with the provisions of the *Local Government Act 1958*.

1. The maximum rate of interest that may be paid is 5.75 per cent. per annum.
2. The purpose for which the loan is to be applied is—Alterations and additions to Municipal Offices and Council Chambers.
3. The period of the loan shall be ten years.
4. The moneys borrowed shall be repayable by providing out of the municipal fund equal half-yearly instalments of approximately \$1,328.83 each, including principal and interest on the 1st day of January and 1st day of July during the currency of the loan. The first instalment shall be due and payable on the 1st January, 1968.
5. Such moneys shall be repayable at the English Scottish & Australian Bank Limited, Melbourne.
6. The plans and specifications and the estimate of the cost of the proposed works and a statement showing the proposed expenditure of the moneys to be borrowed are open for inspection at the office of the Council of the Shire of Morwell, Commercial-road, Morwell.

6172

R. J. LORD, Shire Secretary.

## SHIRE OF MORWELL.

## LOAN No. 37.

*Notice of Intention to Borrow the Sum of \$15,000 for Permanent Works and Undertakings.*

NOTICE is hereby given that the Council of the Shire of Morwell proposes to borrow the principal sum of \$15,000 secured by a charge over the general rates of the municipality, such sum to be raised by the grant of a mortgage in accordance with the provisions of the *Local Government Act 1958*.

1. The maximum rate of interest that may be paid is 5.875 per cent. per annum.
2. The purposes for which the loan is to be applied are:—
 

Alterations to factory premises for an approved decentralized industry . . . . .	\$5,000
Improvements to the Morwell Caravan Park . . . . .	10,000
	\$15,000

3. The period of the loan shall be fifteen years.
4. The moneys borrowed shall be repayable by providing out of the municipal fund equal half-yearly instalments of approximately \$759.12 each, including principal and interest on the 1st day of January and the 1st day of July, during the currency of the loan. The first instalment shall be due and payable on the 1st January, 1968.
5. Such moneys shall be repayable at the Commercial Savings Bank of Australia Limited, Melbourne.
6. The plans and specifications and the estimate of the cost of the proposed works and a statement showing the proposed expenditure of the moneys to be borrowed are open for inspection at the office of the Council of the Shire of Morwell, Commercial-road, Morwell.

6171

R. J. LORD, Shire Secretary.

*Town and Country Planning Act 1961 (Twelfth Schedule).*  
SHIRE OF MORWELL.—MORWELL PLANNING SCHEME 1954.

## NOTICE THAT A PLANNING SCHEME HAS BEEN PREPARED AND IS AVAILABLE FOR INSPECTION.

*Amendment No. 22, 1967.*

NOTICE is hereby given that the Shire of Morwell in pursuance of its powers under the *Town and Country Planning Act 1961*, has prepared a planning scheme for—

That part of the municipal district of the Shire of Morwell within the Parish of Maryvale described as follows:—

All that land fronting the north side of Princes Highway between Hoyle-street and Hopetoun-avenue to a depth of 147 feet.

The purpose of the scheme is to re-zone land from residential zone to commercial C zone.

A copy of the scheme has been deposited at the Shire Office, Commercial-road, Morwell, and at the office of the Town and Country Planning Board, 179 Queen-street, Melbourne, and will be open for inspection during office hours by any person free of charge.

Any persons affected by the planning scheme are required to set forth in writing all objections they may have, addressed to the Shire Secretary, Shire Office, Commercial-road, Morwell, on or before the 1st day of May, 1967, and state whether they wish to be heard in respect of these objections.

28th March, 1967.

6173

R. J. LORD, Shire Secretary.

## SHIRE OF UPPER MURRAY.

## LOAN No. 21.

*Notice of Intention to Borrow the Sum of \$16,000 for Permanent Works and Undertakings.*

NOTICE is hereby given that the Council of the Shire of Upper Murray proposes to borrow the principal sum of Sixteen thousand dollars, secured by a charge over the general rates of the municipality, such sum to be raised by the grant of a mortgage, in accordance with the provisions of the *Local Government Act 1958*.

1. The maximum rate of interest that may be paid is 5.75 per centum per annum.
2. The purposes for which the loan is to be applied are as under:—
 

(a) Construction of kerb, channel and crossings—Township of Corryong . . . . .	\$6,700
(b) Construction of footpath—Township of Corryong . . . . .	900
(c) Additions to aerodrome terminal building . . . . .	500
(d) Part grader purchase . . . . .	1,900
(e) Compulsory land acquisition for aerodrome . . . . .	6,000
	\$16,000

3. The period of the loan shall be ten years.
  4. The moneys borrowed shall be repayable by providing out of the municipal fund twenty half-yearly instalments of approximately \$1,063 each, including principal and interest, on the 1st day of January and the 1st day of July during the currency of the loan. The first instalment shall be payable on the 1st day of January, 1968.
  5. Such moneys shall be repayable to the Australia and New Zealand Savings Bank Limited, Melbourne.
- The plans and specifications and the estimate of the cost of the proposed works, and a statement showing the proposed expenditure of the moneys to be borrowed, are open for inspection at the office of the Council of the Shire of Upper Murray, at the Shire Office, Corryong, Victoria.

Dated 23rd March, 1967.

6170

R. McDIARMID, Shire Secretary.

## SHIRE OF WARRACKNABEAL.

## CHANGE OF STREET NAME.

NOTICE is given that Council, by Resolution dated the 16th March, 1967, has directed that the street formally named "The Avenue", located between Lyle and Woolcock streets, Warracknabeal, shall in future be named "Warunda-avenue".

6175

S. FELL, Shire Secretary.

NOTICE is hereby given that the partnership heretofore subsisting between us the undersigned George Katchor and Colin Stuart Reid as medical practitioners at 144 Canterbury-road, Canterbury, has been dissolved as from the 1st day of March, 1967, so far as concerns the said Colin Stuart Reid who retires from the said partnership.

Dated the 1st day of March, 1967.

6152

COLIN STUART REID.  
GEORGE KATCHOR.

NOTICE is hereby given that the partnership heretofore subsisting between the undersigned, Bramwell Archibald Forster, and Irene Olive Forster, carrying on business as wig sellers at 45 Royal-arcade annexe, Melbourne, under the name of "Personality Wigs" has been dissolved by mutual consent as from the 11th March, 1967. All debts due to and owing by the said late firm will be received and paid by Irene Olive Forster who will continue to carry on the business at the same place.

Dated the 17th day of March, 1967.

I. O. FORSTER.  
BRAM. A. FORSTER.

Witness—E. GIOFCHES.

6222

Unclaimed Moneys Act 1962.

REGISTER of Unclaimed Moneys held by the—

Name of Owner on Books and Last Known Address.	Total Amount Due to Owner.	Description of Unclaimed Moneys.	Date when Amount first became Payable.
--	----------------------------	----------------------------------	--

JOSEPH LUCAS (AUSTRALIA) PTY. LTD.

		\$		
Matthews, H. R., 2 Church-street, Lidcombe, N.S.W.	.. ..	16.60	Wages .. ..	.. ..
Rogers, H. S., P.O. Box 22, Bayup Brook, W.A.	.. ..	56.78	Trade Deposit .. ..	.. ..
				—7.65
				—11.65

5995

THE MYER EMPORIUM LIMITED.

Melbourne Register.

Balloul, Esther, 222 Domain-road, South Yarra .. ..	10.25	Dividend .. ..	13.5.65
Davis, R. L., c/o C.P.O.S. Mess, Flinders Naval Depot .. ..	11.25	" .. ..	" .. ..
Dreverman, A. C., c/o Commonwealth Bank of Australia, Warrnam- bool .. ..	11.25	" .. ..	" .. ..
Howley, D. G., 66 Glydon-road, Camberwell .. ..	16.88	" .. ..	" .. ..
MacKinnon, J. K., Marida Yallock, Boorcan .. ..	11.25	" .. ..	" .. ..
Pollock, M. J. (Mrs.), Webster-street, Alexandra .. ..	11.25	" .. ..	" .. ..
Sargood, G., Flat 4, 42 Murphy-street, South Yarra .. ..	11.25	" .. ..	" .. ..
Swetenham, C. A., c/o The Manager, A.N.Z. Bank, Pitt and Hunter streets, Sydney, N.S.W.	38.25	" .. ..	" .. ..
Thompson, J. B., Flat 3, 16 Murphy-street, South Yarra .. ..	22.50	" .. ..	" .. ..
Thorpe, D. (Mrs.), 82 Collins-street, Melbourne .. ..	11.25	" .. ..	" .. ..
Trehella, B. F. and Mrs. M. E., 12 Clara-street, Preston .. ..	11.25	" .. ..	" .. ..
Prioleau, C. L. G., c/o Martins Bank Ltd., 23 St. James-street, London, U.K.	19.12	" .. ..	" .. ..
Williams, E. M. (Mrs.), 13 The Grove, Isleworth, Middlesex, U.K.	19.12	" .. ..	" .. ..
O'Grady, Peter J., 11 Jenkin-street, Collaroy, N.S.W. .. ..	21.00	Note Interest .. ..	31.7.65
Baker, R. J. and Mrs. M. J., 94A Devereux-road, Beaumont, S.A.	10.00	Dividend .. ..	4.11.65
Del Bartlam, J. W., Box 306, Gunnedah, N.S.W. .. ..	10.00	" .. ..	" .. ..
Buxton, A. I. (Mrs.), 264 Warrigal-road, Burwood, E.13, Vic. ..	58.40	" .. ..	" .. ..
Carstens, D. M. (Mrs.), 10 Brightside-road, Epsom, S.E.3, Auckland, N.Z.	17.00	" .. ..	" .. ..
Ellis, R. L. W., 29 Burns-street, Hamilton .. ..	45.00	" .. ..	" .. ..
Feather, N. T., c/o T. H. Feather, 30 Highlands-avenue, Wahroonga, N.S.W.	15.00	" .. ..	" .. ..
Garfield, E. (Mrs.), 617 North-road, Ormond .. ..	60.00	" .. ..	" .. ..
Le Guen, Marie J. A. F., Wellington-avenue, Quatre Bornes, Mauritius	13.12	" .. ..	" .. ..
Harvey, R. C., P.O. Box 551, Geelong .. ..	10.00	" .. ..	" .. ..
Healey, J. A. D., Clare House, London-road, Tonbridge, Kent, U.K.	10.62	" .. ..	" .. ..
Joseph, V. R. (Mrs.), 2 Leura-grove, Hawthorn East .. ..	15.00	" .. ..	" .. ..
MacKinnon, D., Marida Yallock, Boorcan .. ..	30.00	" .. ..	" .. ..
MacKinnon, J. K., Marida Yallock, Boorcan .. ..	15.00	" .. ..	" .. ..
Berence M. Murrie, Flat 3, Towradgi, 1 Murrarar, Woollongong, N.S.W.	15.00	" .. ..	" .. ..
McNeil, A. E. (Miss), 141 Westbury-street, St. Kilda, S.E.2. ..	24.60	" .. ..	" .. ..
Samuell, E. J., Flat 6, 7 Adair-parade, Mt. Lawley, W.A. .. ..	10.00	" .. ..	" .. ..
Skevington, A. J., c/o Yorkshire Bank Ltd., 56 Cheapside, London, E.C.2, U.K.	17.00	" .. ..	" .. ..
Swetenham, C. A., c/o The Manager, A.N.Z. Bank Ltd., Pitt and Hunter streets, Sydney, N.S.W.	51.00	" .. ..	" .. ..
Thorpe, D. (Mrs.), 82 Collins-street, Melbourne .. ..	15.00	" .. ..	" .. ..
Wansbrough, H. R. (Miss), 10 Grange-avenue, Canterbury .. ..	15.00	" .. ..	" .. ..
Debden Wilkins, C. M., P.O. Box 9140, Auckland, N.Z. .. ..	12.75	" .. ..	" .. ..
Williams, E. M. (Mrs.), 13 The Grove, Isleworth, Middlesex, U.K.	25.50	" .. ..	" .. ..
Burke, F. S., Bennetts Building, Taihape, N.Z. .. ..	12.75	" .. ..	" .. ..

Sydney Register.

Biddulph, M. C., Unit 16, Swept Rocks, 24A Musgrave-street, Mosman, N.S.W.	18.75	" .. ..	13.5.65
Schiess, A. G., 10 Hugh-Avenue, Dulwich Hill, N.S.W. .. ..	11.25	" .. ..	" .. ..
Schiess, D. J. (Mrs.), 10 Hugh-avenue, Dulwich Hill, N.S.W. ..	11.25	" .. ..	" .. ..
Buddle, C. B., 352 Alfred-street, North Sydney, N.S.W. .. ..	15.00	" .. ..	4.11.65
Coughlan, M. (Miss), 8 Mosman-street, Mosman, N.S.W. .. ..	20.00	" .. ..	" .. ..

Brisbane Register.

Daniel, Ethene M. J., c/o The Commonwealth Trading Bank, Queen- street, Brisbane, Q'ld.	12.50	" .. ..	" .. ..
--	-------	---------	---------

Canberra Register.

Downing, M. E. (Mrs.), 325 Marion-road, Plympton, S.A. .. ..	10.00	" .. ..	" .. ..
--	-------	---------	---------

Hobart Register.

Thomas, A. J. S., 2 Dowling-parade, Mount Stuart, Tasmania ..	10.10	" .. ..	" .. ..
---	-------	---------	---------

5996

NATIONAL AND GENERAL INSURANCE COMPANY LIMITED.

Rural Car Sales, 858 Whitehorse-road, Box Hill .. ..	17.04	Return Premium CV13174 .. ..	7.6.65
D. Brady, Blackhill-road, Kyneton .. ..	15.08	Workers Compensation Claim W4/3528 .. ..	25.5.65
Moretti, B., 12 Winona-grove, Pascoe Vale .. ..	26.85	Workers Compensation Claim W4/3726 .. ..	28.7.65
Medic, Roy, c/o W. J. McLuffie, Buffalo River .. ..	26.00	Return Premium .. ..	3.10.65
Knight, E. J. and Herran, A. F., 68 Marion-street, Altona North ..	13.00	Claim 34130 .. ..	12.11.65

5964



## Unclaimed Moneys Act 1962.

## REGISTER of Unclaimed Moneys held by the—

Name of Owner on Books and Last Known Address.	Total Amount Due to Owner.	Description of Unclaimed Moneys.	Date when Amount first became Payable.
<b>WINDSOR HOTEL LIMITED.</b>			
\$			
Newman, Maisie Anna and Leonard Reginald, Melbourne-road, Norlane	13.00	3½ per cent. interest on £200	30.6.65
Cheeseman, Edward Thomas, Bellevue Park, St. Marys, N.S.W.	16.25	6½ per cent. convertible notes	14.5.65
Zerfas, Alfred John, 67 Wellington-street, Kew	65.00	6½ per cent. dividend on 125 £1 ordinary shares	29.9.65
		6½ per cent. dividend on 500 £1 ordinary shares	"
5981			
<b>TOPPA HOLDINGS LIMITED.</b>			
Andrews, J. E., Willowbank, Kitchen-street, Mansfield	18.00	Dividend	19.11.65
Bourne, W., Poowong	11.25	"	"
Bowman, Elsie, Pier Point, Warringa-road, Frankston	10.00	"	14.4.65
Dobbie, J. W., 508 Highgate, Dunedin, N.W., N.Z.	12.75	"	19.11.65
Gilchrist, P. (estate of), c/o J. Fear, Swannanoa R.D. Rangiora, Canterbury, N.Z.	21.25	"	14.4.65
Lundsgaard, Eskild, c/o Whakatane Board Mills, Whakatane, N.Z.	34.00	"	19.11.65
Muhlebach, W. X. and S. G., Retreat Farm, Batesford	17.20	"	14.4.65
Nash, Colin J., c/o Post Office, Buderim, Qld.	25.00	"	"
Ogilvie, E. J., 166 Skene-street, Newtown, Geelong	18.00	"	19.11.65
Omana Properties Ltd., P.O., Box 9196, Auckland, N.Z.	25.50	"	14.4.65
Pell, M. H., Box 9, Unera	12.00	"	"
Shambrook, Thomas (estate of), c/o E. Shambrook, 17 Grandview-avenue, Pascoe Vale South	12.00	"	"
5982			
<b>DALGETY AND N.Z.L. LIMITED.</b>			
Unknown vendor	13.83	3 sacks wool branded BB/BRM	8.7.64
"	53.90	Proceeds 1 horse ex Dandenong	14.5.65
"	94.92	Proceeds 1 cow ex Dandenong	19.1.65
"	68.53	Proceeds 1 cow ex Dandenong	29.6.65
"	26.41	Proceeds 1 calf ex Dandenong	28.9.65
"	52.11	Proceeds 1 cow ex Dandenong	7.1.66
"	11.40	Proceeds table and chairs ex Maffra	24.9.65
"	38.78	Proceeds 1 cattle ex Heyfield	2.12.65
"	11.68	Proceeds 1 calf ex Sale	8.2.66
"	37.59	Proceeds 10 sheep ex Shepparton	19.3.65
"	18.58	Surplus ex cashier Shepparton Branch	5.7.65
"	21.45	Proceeds 3 sheep ex Shepparton	18.2.66
Bothers, E. N., 44 Spring-street, Thomastown	64.04	Proceeds 1 cow ex Dandenong	6.1.65
Brown, J., (address unknown)	12.72	Balance underpaid on 7 pigs sold at Shepparton 7.2.66	7.2.66
Corowa and District Transport Service Pty. Ltd., 10 Arnot-street, Corowa, N.S.W.	64.50	Cartage wool	28.2.66
Fella, W., (address unknown)	29.84	Proceeds 3 calves ex Dandenong	2.9.65
Fulton, J. L., Fernbank, Lockhart, N.S.W.	21.99	Proceeds skins paid to vendor who returned cheque claiming not his proceeds	22.2.65
Henderson, A. N. and W. J., Boort	41.86	Adj. bin sorting wool	7.2.66
Hickey, J. J., 7 Walmer-avenue, St. Albans	12.00	Cartage Bacchus Marsh to Sunbury	1.11.65
Kenneally, P., Dandenong	17.78	Cartage stock	25.11.65
McDonald, H., Nagambie	47.66	Proceeds 6 sheep ex Shepparton	3.7.64
McKenzie, J., Glenburn	24.68	Cartage stock	25.11.65
Shay Bros., 69 Brunel-street, East Malvern	176.73	Proceeds wool	24.12.65
Smith, O., Wangaratta	28.12	Proceeds pigs	12.10.65
Stray, N., Broadford	18.75	Cartage wool a/c J. C. and W. V. Kelly	4.2.66
Thomas, H., East Wangaratta	26.48	Balance Account	7.5.65
5983			
<b>MINERAL INDUSTRIES PTY. LTD.</b>			
Perry, George, c/o Mineral Industries Pty. Ltd., Arden-street, North Melbourne, N.I	24.30	Wages	18.2.66
5991			
<b>HOWARD SMITH LTD.</b>			
Farrell, Moira H. (Miss), 1a Olympia-road, Naremburn, N.S.W.	12.00	Interim dividend on 150 ordinary shares	29.10.65
Fawckner, Dorothy M. (Mrs.), "Bonnie Downs" Corfield, Queensland	240.00	Interim dividend on 3,000 ordinary shares	"
5992			
<b>BALLARAT AND WESTERN VICTORIA TELEVISION LIMITED.</b>			
Croydon, Elizabeth C. (Miss), c/o Flat 5, 12 Riversdale-road, Hawthorn	17.50	Dividend	29.11.65
Martyn, Florence E. (Mrs.), Jamieson-street, Daylesford	17.50	"	"
Thornley, John H. (estate of), 10 Hampden-road, Armadale	17.50	"	"
Troup, William M., Tourello Lodge, Tourello	35.00	"	"
5963			

## Unclaimed Moneys Act 1962.

## REGISTER of Unclaimed Moneys held by the—

Name of Owner on Books and Last Known Address.	Total Amount Due to Owner.	Description of Unclaimed Moneys.	Date when Amount first became Payable.
<b>AUSTRALIAN PAPER MANUFACTURERS LIMITED.</b>			
	\$		
Alford, Robert G., 34 Wolseley-road, Mosman, N.S.W. . . . .	35.00	Dividend on ordinary shares	30.4.65
Anderson, Helen J., 57A Fitzwilliam-road, Vaucluse, N.S.W. . . . .	13.33	" " " " " "	27.10.65
Andrews, Charles F., Godfrey-street, Boort . . . . .	25.00	" " " " " "	30.4.65
Baker, Rex R., 90 Warrimo-avenue, St. Ives, N.S.W. . . . .	32.73	" " " " " "	30.4.65
Brinsmead, Pamela M., 65 Stewart-avenue, Hamilton, Newcastle, N.S.W. . . . .	21.87	" " " " " "	29.10.65
Cusack, Colleen M., 185 Elizabeth-street, Sydney, N.S.W. . . . .	170.62	" " " " " "	"
Delbridge, Edward L., Flat 2, 14 Hennessey-avenue, Elwood . . . . .	10.07	" " " " " "	30.4.65
Erskine, Margaret E. B., 189 Grange-road, Flinders Park, S.A. . . . .	21.87	" " " " " "	30.4.65
			29.10.65
Flavas, Samuel, 19 Swanston-street, Melbourne . . . . .	21.87	" " " " " "	30.4.65
			29.10.65
Fletcher, Frederick B. C., 39 Wetherill-street, Narrabeen . . . . .	23.97	" " " " " "	"
Fulton, Hallam B., 6 Cotswold-road, Strathfield, N.S.W. . . . .	12.47	" " " " " "	"
Gidley, Madeline, 64 Raglan-street, Mosman, N.S.W. . . . .	11.02	" " " " " "	30.4.65
			29.10.65
Harwood, Nancy E., 1 Montreal-street, Bentleigh . . . . .	21.84	" " " " " "	"
Hogan, Arnold M., 9 Mindham-street, Mysterton Estate, Townsville, North Queensland . . . . .	32.73	" " " " " "	30.4.65
			29.10.65
Kellway, John Evelyn Esq., 261 Mitchell-street, Bendigo . . . . .	56.88	" " " " " "	"
Paximadas, Apostolos, 421 Cardigan-street, Carlton . . . . .	32.73	" " " " " "	"
Renard, Clement J., 65 Manning-road, East Malvern . . . . .	21.87	" " " " " "	"
Steinmetz, Wolfgang, 496 Punt-road, South Yarra . . . . .	16.28	" " " " " "	"
Watt, Robert D. and Lack, Robert H., c/o 74 Murray-street, Coburg West . . . . .	36.05	" " " " " "	"
White, Dr. Richard C., 196 Rowe-street, Eastwood, N.S.W. . . . .	163.98	" " " " " "	"
Graham, Malcolm D. B., c/o The Treasury, Brunei . . . . .	11.67	" " " " " "	30.4.65
Thompson, Barry R., Ulster Bank Ltd., Longford, Republic of Ireland . . . . .	14.00	" " " " " "	"
Balmford, Glenys A., 28 Brenbeal-street, Balwyn . . . . .	30.60	" " " " " "	2.7.65
			29.10.65
Bailey, Kathleen M. B., 5 Fitzroy-place, Hobart, Tas. . . . .	10.08	" " " " " "	29.10.65
Iles, Irene G., 248½ Kensington-road, Leabrook, Marrickville, S.A. . . . .	21.67	" " " " " "	"
Meek, Mary P., c/o Commonwealth Bank of Australia, Maitland, N.S.W. . . . .	50.70	" " " " " "	"
Moss, Richard D. I., Argyle-street, Mossvale, N.S.W. . . . .	14.84	" " " " " "	"
Pasfield, Marcella J. and Arnold, M. J., c/o The President, Sancta Sophia Assn., (Mrs.) F. J. Kavanagh, 18 David-street, Clifton Gardens, N.S.W. . . . .	20.26	" " " " " "	29.10.65
Prior, Margaret L. M., 3 Commercial-road, Strathalbyn, S.A. . . . .	21.87	" " " " " "	"
Turnbull, Adrian R. T., Flat 8, 162 Barkers-road, Hawthorn . . . . .	10.83	" " " " " "	"
Wilks, Janet A., 9 Wooden-street, Wagga Wagga, N.S.W. . . . .	15.82	" " " " " "	"
Tregaskis, M. M. and Collett, W. D., 14 Hopetoun-avenue, Canterbury Irby, Florence M. and Irby, Winifred E., Crysallen-street, Flynn's Beach Pt., Macquarie . . . . .	11.22	" " " " " "	3.11.65
	21.87	" " " " " "	30.4.65
			29.10.65
Hunt, Griffyth G., 81 Kent-avenue, Croydon . . . . .	10.83	" " " " " "	"
Watts, S. (estate of), Exors., c/o Nicol, Robinson, Fallu and Kidd, 400 Queen-street, Brisbane, Qld. . . . .	15.50	Debenture Interest	30.6.65
			31.12.65
Murray, Daisy M., 27 Hope-street, Pymble, N.S.W. . . . .	12.60	Unsecured Note Interest	30.6.65
Ennis, Rex W., c/o The Ministry of Education, Isadim, Nigeria . . . . .	35.00	" " " " " "	"

5965

## RADIO CORPORATION PTY. LTD.

Grzinch, H., 35 Michael-street, North Fitzroy . . . . .	11.50	Wages	18.5.65
Singh, E., 652 High-street, Armadale . . . . .	19.40	"	16.11.65

5974

## WINTERBOTTOM HOLDINGS LIMITED.

Allerhand, M. (Mrs.), 185 Orrong-road, East St. Kilda . . . . .	28.13	Dividends on ordinary shares	—4.65
			—10.65

5975

## NORTH BROKEN HILL LIMITED.

Adkins, George James, 250 Cummins-street, Broken Hill, N.S.W. . . . .	40.00	Dividend No. 168 . . . . .	4.6.65
Edgar, David Herbert Harriss, 6 St. Johns-avenue, Mont Albert . . . . .	32.50	" " 168 . . . . .	4.6.65
Hurn, Ruby Jane (estate of), c/o Ritchie and Arnold, 112 Castlereagh-street, Sydney, N.S.W. . . . .	37.50	" " 169 . . . . .	26.11.65
McDonald, Donald Wesley, 19 Nagle-avenue, Maroubra, N.S.W. . . . .	15.00	" " 168 . . . . .	4.6.65
Phillips, Kenneth Macdonald, c/o C.R.A. Exploration Pty. Ltd., P.O. Box 1096, Cairns, Qld. . . . .	10.00	" " 168 . . . . .	4.6.65
Rose, Jean Hilda, 17 Marns-street, Wagga, N.S.W. . . . .	37.50	" " 168 . . . . .	4.6.65
		" " 169 . . . . .	26.11.65
Watson, Richard Roger Darnton, 326 Macquarie-street, Hobart, Tas. . . . .	1.50	" " 168 . . . . .	4.6.65
Wright, Laurence and Elizabeth Rosemary, c/o 1 Werambie-street, Woolwich Point, N.S.W. . . . .	12.50	" " 168 . . . . .	4.6.65
		" " 169 . . . . .	26.11.65

5959

## Unclaimed Moneys Act 1962.

## REGISTER of Unclaimed Moneys held by the—

Name of Owner on Books and Last Known Address.	Total Amount Due to Owner.	Description of Unclaimed Moneys.	Date when Amount first became Payable.
<b>K. G. LUKE GROUP INDUSTRIES LIMITED.</b>			
\$			
Pell, Marjorie H., P.O. Box 9, Undera .. .. .	10.00	Dividend .. .. .	12.10.65
Redmond, Hester A., 17 Howse-street, Campbell, A.C.T. .. .. .	10.00	" .. .. .	"
Roberts, Rosemary, 22 Grandview-road, Brighton .. .. .	10.00	" .. .. .	"
5997			
<b>MERCANTILE CREDITS LTD.</b>			
Kelly, R. W., c/o National Bank of Australasia, 271 Collins-street, Melbourne .. .. .	39.37	Interest on debenture stock .. .. .	16.2.66
5998			
<b>GODFREY PHILLIPS INTERNATIONAL PTY. LTD.</b>			
McCall, Catherine, 21 Boyd-crescent, West Heidelberg .. .. .	17.78	Wages .. .. .	1.3.65
Lowe, Pamela, Flat 5, 533 Rathdowne-street, Carlton .. .. .	17.60	" .. .. .	3.8.65
Manning, Wendy, 49 Bindi-street, Glenroy .. .. .	14.75	" .. .. .	11.9.65
5999			
<b>GODFREY PHILLIPS HOLDINGS LTD.</b>			
Parker, Howard K. E., Burwood-road, Vermont .. .. .	30.00	Prof. dividend a/c No. 26 .. .. .	31.7.65
6000			
<b>VICTORIAN BROADCASTING NETWORK LTD.</b>			
Kareela Pty. Ltd., 21 Howard-street, Perth, W.A. .. .. .	158.85	Interim dividend on 4,236 shares .. .. .	26.3.65
Kornan, Bella, Flat 2, 115 Grange-road, Toorak .. .. .	15.00	Interim dividend on 400 shares .. .. .	"
Milner, George Frederik, 101 Bruce-street, Nedlands, W.A. .. .. .	18.75	Interim dividend on 500 shares .. .. .	"
6053			
<b>GEE LONG R.S. AND S. WOOLLEN AND WORSTED CO-OPERATIVE MANUFACTURING COY. LIMITED</b>			
Watson, F. T. H., 31 Queensberry-street, North Melbourne .. .. .	12.80	39th dividend on 4 shares .. .. .	19.11.65
Davies, P. E. (estate of), c/o P. T. Davies, Post Office, Talbot .. .. .	12.80	" " " 4 " .. .. .	"
Gordon, G. (estate of), c/o J. E. Gordon, "Ballangech," Ellerslie .. .. .	12.80	" " " 4 " .. .. .	"
Leckie, W. G. (estate of), c/o E. R. Hudson, P.O. Box 452, Broken Hill, N.S.W. .. .. .	32.00	" " " 10 " .. .. .	"
Minnett, S., 394 St. Kilda-road, Melbourne .. .. .	19.20	" " " 6 " .. .. .	"
Polkinghorne, J., 695 Mowbray-road West, Lane Cove, N.S.W. .. .. .	12.80	" " " 4 " .. .. .	"
Reed, R. A., 40 Prout-street, Iron Bark, Bendigo .. .. .	12.80	" " " 4 " .. .. .	"
Tinney, J. S. (estate of), c/o H. G. Tinney, 104 Pleasant-street north, Ballarat .. .. .	12.80	" " " 4 " .. .. .	"
6064			
<b>MARYBOROUGH KNITTING MILLS (CUTTLE) LTD.</b>			
Rouse, Pamela Joan (Mrs.), 60 Waverley-road, East Malvern .. .. .	28.24	Dividend Nos. 33 and 34 .. .. .	6.7.64
6065			
<b>THE SWAN BREWERY COMPANY LIMITED.</b>			
Bade, Maurice J., Victor Harbor, S.A. .. .. .	13.34	Dividends .. .. .	11.12.65
Berger, Peter A., Flat 7, 31 Lansell-road, Toorak .. .. .	62.50	" .. .. .	28.5.65
Evans, Phyllis E., 2A Eringa-avenue, Glenunga, S.A. .. .. .	19.40	" .. .. .	11.12.65
Evandale Pty. Limited Box 32, G.P.O., Glebe, N.S.W. .. .. .	39.06	" .. .. .	"
Foulsham, Ruth K., 58 Crows Nest-road, Wollstonecraft, N.S.W. .. .. .	23.43	" .. .. .	28.5.65
Grosser, Virginia, Esplanade, Mornington .. .. .	26.68	" .. .. .	"
Hegarty, Ernest H., 4 Delta-avenue, Merlynston .. .. .	11.55	" .. .. .	11.12.65
Kalingra Pty. Ltd., 20 Carters-avenue, Toorak .. .. .	19.52	" .. .. .	28.5.65
Knabe, Marjorie I., 120 Grant-avenue, Toorak .. .. .	176.75	" .. .. .	"
Lowe, Patricia M. L., 11 Leopold-street, South Yarra .. .. .	14.84	" .. .. .	"
MacKinnon, Mary H., Marida Yallock, Boorcan .. .. .	46.81	" .. .. .	11.12.65
Milne, Dorothy I., Unit 3, 20 Male-street, Brighton .. .. .	71.40	" .. .. .	"
O'Donoghue, Phyllis E., 293 Alma-road, North Caulfield .. .. .	13.34	" .. .. .	"
Rice, Edna E., 117 Doveton-street, Ballarat .. .. .	19.52	" .. .. .	"
Robertson, Margaret K., 101 Mathoura-road, Toorak .. .. .	58.59	" .. .. .	"
Roth, Henrietta H., 16 Tisbett-avenue, Burwood .. .. .	89.25	" .. .. .	28.5.65
Styles Investments Proprietary Limited, c/o Routley and Routley, A.G.C. House, 124 Phillip-street, Sydney, N.S.W. .. .. .	102.09	" .. .. .	11.12.65
Steele, Agnes C., 19 Navigation-street, McCrae .. .. .	31.25	" .. .. .	28.5.65
Swift, Agnes M. C., Hironelle, Flat 1, cnr. Hampden and McWilliam roads, Artarmon, N.S.W. .. .. .	44.59	" .. .. .	11.12.65
Wallace, Weymouth G., Box 15, P.O. Newstead .. .. .	23.97	" .. .. .	"
Fausser, Erwin F., Apartment 2, 6 Kent-court, Toorak .. .. .	186.90	" .. .. .	"
Hodgkinson, Robert E., c/o National Trustees Executors and Agency Co. of Aust. Ltd. and Treleaven, Margaret M., 95 Queen-street, Melbourne .. .. .	11.72	" .. .. .	"
Hocking, Horace J., c/o H. Winrow, 119 West-street, Mt. Isa, Qld. .. .. .	22.28	" .. .. .	"
Miehuus, Eva E., c/o Elders Trustee and Executors Co. Ltd., 172 North Terrace, Adelaide, S.A. .. .. .	11.88	" .. .. .	"
Hastie, Sydney J., R.D. 6, Te Puke, N.Z. .. .. .	10.63	" .. .. .	"
6066			

In the Supreme Court of Victoria.—1967 Co. 7331.—In the matter of the *Companies Act 1961*; and in the matter of TOMADA CONCRETE PAVING & CONSTRUCTION PTY. LIMITED.

NOTICE is hereby given that a petition for the winding up of the above-named company by the Supreme Court was on the 14th day of March, 1967, presented by James Canny, Deputy Commissioner of Taxation of the Commonwealth of Australia and that the said petition is directed to be heard before the court sitting at the Fourteenth Court, Law Courts, William-street, Melbourne, at the hour of 10.30 o'clock in the forenoon on the 19th day of April, 1967, and any creditor or contributory of the said company desiring to support or oppose the making of an order on the said petition may appear at the time of hearing by himself or his counsel for that purpose; and a copy of the said petition will be furnished to any creditor or contributory of the said company requiring the same by the undersigned on payment of the regulated charge for the same.

The petitioner's official address is 436 Lonsdale-street, Melbourne.

The petitioner's solicitor is Harold Edward Renfree, Crown Solicitor for the Commonwealth, of 440 Little Collins-street, Melbourne.

H. E. RENFREE.

NOTE.—Any person who intends to appear on the hearing of the said petition must serve on or send by post to the above-named H. E. Renfree, notice, in writing, of his intention so to do. The notice must state the name and address of the person, or, if a firm, the name and address of the firm, and must be signed by the person or firm, or his or their solicitor (if any), and must be served or, if posted, must be sent by post in sufficient time to reach the above named not later than Four o'clock in the afternoon of the 18th day of April, 1967.

In the Supreme Court of Victoria.—1967 Co. 7332.—In the matter of the *Companies Act 1961*; and in the matter of COLORCROME CONSOLIDATED INDUSTRIES PROPRIETARY LIMITED.

NOTICE is hereby given that a petition for the winding up of the above-named company by the Supreme Court was on the 14th day of March, 1967, presented by James Canny, Deputy Commissioner of Taxation of the Commonwealth of Australia and that the said petition is directed to be heard before the court sitting at the Fourteenth Court, Law Courts, William-street, Melbourne, at the hour of 10.30 o'clock in the forenoon on the 19th day of April, 1967, and any creditor or contributory of the said company desiring to support or oppose the making of an order on the said petition may appear at the time of hearing by himself or his counsel for that purpose; and a copy of the said petition will be furnished to any creditor or contributory of the said company requiring the same by the undersigned on payment of the regulated charge for the same.

The petitioner's official address is 436 Lonsdale-street, Melbourne.

The petitioner's solicitor is Harold Edward Renfree, Crown Solicitor for the Commonwealth, of 440 Little Collins-street, Melbourne.

H. E. RENFREE.

NOTE.—Any person who intends to appear on the hearing of the said petition must serve on or send by post to the above-named H. E. Renfree, notice, in writing, of his intention so to do. The notice must state the name and address of the person, or, if a firm, the name and address of the firm, and must be signed by the person or firm, or his or their solicitor (if any), and must be served or, if posted, must be sent by post in sufficient time to reach the above named not later than Four o'clock in the afternoon of the 18th day of April, 1967.

The *Companies Act 1961*.—In the matter of FISHERMAN'S WHARF RESTAURANT PTY. LTD.—Notice re Meeting of Creditors Pursuant to Section 260.

NOTICE is hereby given that a Meeting of Creditors of the above-named company will be held at Room 516, Fifth Floor, 342 Flinders-street, Melbourne, on Thursday, 13th April, 1967, at 11 a.m. the company having convened a meeting of its members for the same day for the purpose of considering a Resolution that the company be wound up voluntarily.

Dated this 22nd day of March, 1967.

N. NISSEN, Director.

Bent & Cogle, public accountants, Suite 18, 545 St. Kilda-road, Melbourne, S.C.3. 6180

The *Companies Act 1961*.—In the matter of K.S. INTERSTATE TRANSPORT PTY. LTD.

NOTICE is hereby given that at an Extraordinary General Meeting of the members of the above-named company, held on the 20th day of March, 1967, it was resolved that the company be wound up voluntarily, and at a meeting of creditors held on the same day, pursuant to section 260, it was resolved that for such purpose, Alan Murray Horsburgh, of 296 Little Lonsdale-street, Melbourne, accountant, be appointed liquidator.

Notice is also given that after 21 days from this date I shall proceed to distribute the assets. All creditors having any claims against the company should furnish particulars of same by that date, otherwise I shall proceed to distribute the assets, without regard to their claim.

Dated this 31st day of March, 1967.

A. M. HORSBURGH, Liquidator.

Kennedy, Smail & Middlemiss, 296 Little Lonsdale-street, Melbourne. 6224

A.M.J. PROPRIETARY LIMITED.

AT an Extraordinary Meeting of the above-named company duly convened and held at 100 Flinders-street, Melbourne, on the 16th day of March, 1967, the following Resolution was duly passed as a Special Resolution, viz.:—

"That the company be wound up voluntarily, and that John Horton Wyss, public accountant, be appointed liquidator for the purposes of such winding up."

Dated the 17th day of March, 1967.

6225 M. SHAW, Chairman.

The *Companies Act 1961*.

KLEER-VU PTY. LTD. (IN VOLUNTARY LIQUIDATION).

MEMBERS WINDING UP.

NOTICE is hereby given that it is intended to make a Final Return of Capital to the shareholders. Any person claiming to be a creditor is required to lodge proof of debt with the liquidator on or before the 30th April, 1967, otherwise he will be excluded from the distribution:

C. T. GOODE, Liquidator.

Goode, Morris & Toner, chartered accountants, 340 Little Collins-street, Melbourne, C.1. 6208

The *Companies Act 1961*.—In the matter of GRANT'S SALES PTY. LTD.—Notice re Meeting of Creditors, pursuant to Section 260.

NOTICE is hereby given that a meeting of creditors of the above-named company will be held at 342 Flinders-street, Melbourne, on Monday, 3rd April, 1967, at 10.30 a.m., the company having convened a meeting of its members for earlier the same day, for the purpose of considering a Resolution that the company be wound up voluntarily.

Dated this 22nd day of March, 1967.

BENT & COUGLE, public accountants, Suite 18, St. Kilda-road, Melbourne. 6129

The *Companies Act 1961*.—In the matter of JEDDA STYLES PTY. LTD. (in Liquidation).

NOTICE is hereby given that, pursuant to section 272 of the *Companies Act*, a Final Meeting of the creditors of the above company will be held at Suite 18, 545 St. Kilda-road, Melbourne, on Friday, 28th April, 1967, at 12 noon.

Business.—To receive the liquidator's accounts.

Dated this 20th day of March, 1967.

E. T. BENT, Liquidator.

Bent & Cogle, public accountants, Suite 18, 545 St. Kilda-road, Melbourne. 6093

No. of Company 48031.—In the matter of the *Companies Act 1961* and in the matter of HARRY F. WHINERAY PROPRIETARY LIMITED.

AT an Extraordinary General Meeting of the members of Harry F. Whineray Proprietary Limited, duly convened and held at the registered office, 16 James-street, Geelong, on the 21st day of March, 1967, the following Special Resolution was duly passed:—

"That the company be wound up voluntarily, and that Robert Graham Farrow, of 16 James-street, Geelong, be appointed liquidator for this purpose at this meeting."

Dated this 21st day of March, 1967.

6150 I. M. WHINERAY, Director.

Companies Act 1961. Form 92.

COMPANIES REGULATIONS 28 (2) (b).

Notice of Meeting of Creditors.

S. & H. WERNER BUILDING CO. PTY. LTD.

NOTICE is hereby given that a Meeting of Creditors of S. & H. Werner Building Co. Pty. Ltd., will be held in the Board Room, First Floor, Australian Primary Producers Building, 527 Collins-street, Melbourne, on the 10th day of April, 1967, at 11 o'clock in the morning.

For the purposes of considering:

- (1) A report by the Directors.
- (2) A Resolution by the Directors that the company be wound up in accordance with section 260 of the Act (Creditors Voluntary Winding Up).
- (3) The appointment of a liquidator.
- (4) The appointment of a Committee of Inspection.

By order of the Board,

WERNER SCHLEUTER, Director.  
HELGA SCHLEUTER, Director.

6160

In the matter of RAY'S SHOES PROPRIETARY LIMITED.—Notice of Winding-up Order.

WINDING-UP Order made 22nd March, 1967.

Name and address of official liquidator, John Kenneth Hall, of 250 Queen-street, Melbourne.

James Canny, Deputy Commissioner of Taxation of the Commonwealth of Australia, petitioner. 6161

In the matter of ALLANDOR TIMBER INDUSTRIES PTY. LIMITED.—Notice of Winding-up Order.

WINDING-UP Order made 22nd March, 1967.

Name and address of official liquidator, Guy Newton Moore, of 34 Queens-road, Melbourne.

James Canny, Deputy Commissioner of Taxation of the Commonwealth of Australia, petitioner. 6162

Companies Act 1961.

L.B.C. TIMBER PTY. LTD.

MEMBERS' VOLUNTARY WINDING UP.

TAKE notice that by a Special Resolution of L.B.C. Timber Pty. Ltd., passed on the 22nd day of March, 1967, it was resolved that the company be wound up voluntarily. 6163

ARNOLD G. LLOYD, Director.

BEATRICE COOK PROPRIETARY LIMITED.

AT an extraordinary meeting of the above-named company duly convened and held at 100 Flinders-street, Melbourne, on the 16th day of March, 1967, the following resolution was duly passed as a Special Resolution, viz.:

That the company be wound up voluntarily and that John Horton Wyss, public accountant, be appointed liquidator for the purposes of such winding up.

Dated the 17th day of March, 1967.

6223

M. SHAW, Chairman.

THE HAVANAH PTY. LTD.

SECTION 254 (2) (b) OF THE COMPANIES ACT 1961.

AT a General Meeting of the members of The Havanah Pty. Ltd., duly convened and held on 21st March, 1967, the following was duly passed as a Special Resolution:—

"Resolved that the company be wound up voluntarily, and that Mr. G. S. Stuart, of 418 Centre-road, Bentleigh, be appointed as liquidator."

6131

G. S. STUART, Liquidator.

CREDITORS, next of kin and others having claims in respect of the estate of William John McInnes, late of Dunedin, in the Dominion of New Zealand, public accountant, deceased (who died on the 27th day of August, 1966), are required to send particulars of their claims to the Trustees Executors and Agency Company Limited, of 401 Collins-street, Melbourne, the Attorney under power of the executor, The Trustees Executors and Agency Company of New Zealand Limited, on or before the 7th day of June, 1967, after which date the said executor will proceed to distribute the assets having regard only to the claims of which it then has notice.

T. A. RANK & ROBINSON, solicitors, 388 Bourke-street, Melbourne. 6178

CREDITORS, next of kin and others having claims in respect of the estate of Angelina May Murray, late of 18 Garnet-street, West Brunswick, widow, deceased intestate (who died 3rd October, 1966), are to send particulars of their claims to the administrator of the said estate, care of the under-mentioned firm by the 9th June, 1967, after which date the administrator will distribute the assets, having regard only to the claims of which he then has notice.

PATRICIA O'DONOGHUE & O'BRIEN, solicitors, 44 Pascoe Vale-road, Moonee Ponds. 6183

TREVOR JOHN VORWERK, late of Condah, in the State of Victoria, shearer, DECEASED, intestate.

CREDITORS, next of kin and others having claims in respect of the estate of the deceased (who died on the 20th day of April, 1966), are required by the administrator, Edwin Roy Vorwerk, of Condah aforesaid farmer, to send particulars to him, care of the under-mentioned solicitors by the 25th day of May, 1967, after which date the administrator may convey or distribute the assets, having regard only to the claims of which he then has notice.

MESSRS. CAMERON & LOWENSTERN, solicitors, Box 413, Hamilton. 6186

MATILDA EMMA FINLAY, late of Peshurst, in the State of Victoria, widow, DECEASED.

CREDITORS, next of kin and others having claims in respect of the estate of the deceased (who died on the 26th day of January, 1967), are required by the executor Kevin Edward Finlay, of Peshurst, aforesaid manager, to send particulars to him, care of the under-mentioned solicitors, by the 31st day of May, 1967, after which date the executor may convey or distribute the assets, having regard only to the claims of which he then has notice.

CAMERON & LOWENSTERN, solicitors, Box 413, Hamilton. 6187

CREDITORS, next of kin and others having claims in respect of Elsie Victoria Rust, late of 139 Atherton-road, Oakleigh, widow, deceased (who died on the 24th August, 1966), are to send particulars of their claims to the executors, care of the undersigned by the 7th June, 1967, after which date they will distribute the assets, having regard only to the claims of which they then have notice.

GEO. J. WISE, CAMPBELL & CO., solicitors, 118 Queen-street, Melbourne. 6216

MICHAEL FITZPATRICK, late of 69 Commercial-road, Footscray, retired labourer, DECEASED.

CREDITORS, next of kin and others having claims in respect of the estate of the above-named deceased (who died on the 4th of October, 1966), are required by the executor, William Fitzpatrick, of 57 Couch-street, Sunshine, retired labourer, to send particulars to him, care of the undernamed solicitor, on or before the 21st day of June, 1967, after which date the executor may convey or distribute the assets, having regard only to the claims of which he then has notice.

JOHN GINNANE, solicitor, 153A Barkly-street, Footscray. 6217

CREDITORS, next of kin and others having claims in respect of the estate of George Hodgson, late of The Cheltenham Home and Hospital for the Aged, Warrigal-road, Cheltenham, Victoria (who died on the 6th December, 1966), are requested to send particulars of their claims to the executor, The Union-Fidelity Trustee Company of Australia Limited, 100 Exhibition-street, Melbourne, on or before the 29th day of May, 1967, after which date the said company will distribute the assets, having regard only to the claims of which it then has notice. 6221

SARAH THERESA STANTON, late of Cranbourne, widow DECEASED.

CREDITORS, next of kin and others having claims in respect of the estate of the deceased (who died on 28th November, 1966), are required by the personal representative, Francis Damon Stanton, to send particulars to him, care of the undersigned by the 7th June, 1967, after which date he may convey or distribute the assets, having regard only to the claims of which he then has notice.

WILFRID J. OSBORNE AND OSBORNE, solicitors, Seymour. 6211

DONALD ALBERT McLAREN, late of 18 Retford-street, North Newborough, in the State of Victoria, electrical plant operator, DECEASED.

CREDITORS, next of kin and others having claims in respect of the estate of the deceased (who died on the 6th day of May, 1966), are required by the administratrix Patricia McLaren, of 18 Retford-street, North Newborough, in the said State, widow, to send particulars to her solicitors, Messrs. F. X. O'Halloran, Davis and Co., Kirk-street, Moe, by the 29th day of May, 1967, after which date the administratrix may convey or distribute the assets, having regard only to the claims of which she then has notice.

Dated the 27th day of March, 1967.

F. X. O'HALLORAN, DAVIS & CO., solicitors, Moe, 6184

CREDITORS, next of kin and others having claims in respect of the estate of Francis Xavier Mamo, late of 38 Canning-street, North Melbourne, in the State of Victoria, labourer, deceased, intestate (who died on the 7th February, 1966), and letters of administration of whose estate have been granted to Zaro Mamo, of 14 Buzzaq-lane, B'Kara, Malta, retired harbor trust employee, are to send particulars, in writing, of their claims to the said administrator, care of the under-mentioned solicitors, by the 5th day of June, 1967, after which date he will distribute the assets, having regard only to the claims of which he then has notice.

FREDERICK W. COX & SON, solicitors, 452 Lonsdale-street, Melbourne. 6157

CREDITORS, next of kin and others having claims in respect of the estate of Melvena Annie McClymont, late of 61 Wellington-street, Windsor, married woman, deceased (who died on the 21st day of May, 1966), are to send particulars of their claims to the executrix, Elizabeth Joyce Kerin, care of the under-mentioned solicitors, by the 31st day of May, 1967, after which date the executrix will distribute the assets, having regard only to the claims of which she then has notice.

GILBERT, FIELD & WARNE, solicitors, 406 Collins-street, Melbourne. 6153

FRANK EDMUND SANDERS, late of Boyeo, in the State of Victoria, retired farmer, DECEASED.

CREDITORS, next of kin and others having claims in respect of the estate of the deceased (who died on the 9th day of April, 1965), are required by the trustees, Maurice James Hall, of Boyeo, farmer, and Thomas Mitchell Hobday, of 10 Victoria-street, Nhill, solicitor, to send particulars to them, care of the undersigned, by the 1st day of June, 1967, after which date the trustees may convey or distribute the assets, having regard only to the claims of which they then have notice.

Dated the 21st day of March, 1967.

TURNER & HOBDDAY, 10 Victoria-street, solicitors for the said trustees. 6155

MARION COLMAN, late of 6 Gordon-grove, South Yarra, Victoria, widow, DECEASED.

CREDITORS, next of kin and others having claims in respect of the estate of the deceased (who died on 11th October, 1966), are required by the personal representatives, the Trustees, Executors and Agency Company Limited, of 401 Collins-street, Melbourne, Victoria, and George Hay Colman, of 31 Wallace-avenue, Toorak, Victoria, pastoral executive, to send particulars to them, in care of the said company, by 31st May, 1967, after which date they may convey or distribute the assets, having regard only to the claims of which they then have notice.

HEDDERWICK, FOOKES & ALSTON, 103 William-street, Melbourne. 6156

CREDITORS, next of kin and others having claims in respect of the estate of Nita Carmichael Cleeland, late of 6 Clifford-street, Ashburton, in the State of Victoria, gentlewoman, deceased (who died on the 3rd day of September, 1966), are required by the executors, Graeme Page Cleeland, of 89 Fitzroy-street, Kerang, in the said State, consultant surveyor, and Fraser Thompson Cleeland, of 6 Clifford-street, Ashburton, aforesaid, retired grazier, to send particulars of their claims to them, care of the under-mentioned solicitors, by the 30th day of May, 1967, after which date they may convey or distribute the assets, having regard only to the claims of which they then have notice.

AITKEN, WALKER & STRACHAN, solicitors, 414 Collins-street, Melbourne. 6145

ERIC ROBERT FREEMAN FRASER, late of 294 Koornang-road, Carnegie, in the State of Victoria, contractor, DECEASED.

CREDITORS, next of kin and others having claims in respect of the estate of the deceased (who died on the 27th day of March, 1964), are required by National Trustees Executors and Agency Company of Australasia Limited, of 95 Queen-street, Melbourne, to send particulars to the said National Trustees Executors and Agency Company of Australasia Limited, at its aforesaid address, by the 5th day of June, 1967, after which date it may convey or distribute the assets, having regard only to the claims of which it then has notice.

Dated this 31st day of March, 1967.

LOUGHREY & LOUGHREY, of 108 Queen-street, Melbourne, solicitors for the company. 6139

LEONARD ARTHUR BIRCH, late of 18 Aintree-road, East Malvern, retired, DECEASED.

CREDITORS, next of kin and others having claims against the estate of the deceased (who died on the 30th December, 1966), are required by the executors, Albert Edward Birch, and Charles Victor Birch, to send particulars to them, care of 120 William-street, Melbourne, by the 2nd June, 1967, after which date they may convey and distribute the assets, having regard only to the claims of which they then have notice.

6154

CREDITORS, next of kin and others having claims against the estate of Alice Mary Rowe, late of 22 Hall-street, Hawthorn, married woman, deceased (who died on 14th January, 1967), are required to send particulars thereof, to National Trustees, Executors and Agency Company of Australasia Limited, the executor of the will of the deceased, addressed to the care of the said company at its registered office, 95 Queen-street, Melbourne, by 31st May, 1967, after which date the said company will distribute the assets of the deceased, having regard only to the claims of which the said company shall then have notice.

GAVAN, DUFFY & KING, solicitors, 95 Queen-street, Melbourne. 6134

REGINALD ARTHUR THOMAS COLEMAN, formerly of 41 McDonald-street, Mordialloc, in the State of Victoria, but late of Swan Hill, in the said State, accountant, DECEASED.

CREDITORS, next of kin and others having claims in respect of the estate of the deceased (who died on the 5th day of September, 1966), are required by the executrix, Margaret Winifred Coleman, of Swan Hill, widow, to send particulars to her, care of the undersigned, by the 13th day of June, 1967, after which date the executrix may convey or distribute the assets, having regard only to the claims of which she then has notice.

Dated this 21st day of March, 1967.

ALEC M. HAYES, solicitor, 148 Campbell-street, Swan Hill. 6130

CREDITORS, next of kin and others having claims in respect of the estate of Emma Bertha Richter, late of 268 Bellair-street, Kensington, in the State of Victoria, spinster, deceased (who died on the 6th day of December, 1966), are required by the executor, The Trustees, Executors and Agency Company Limited, of 401 Collins-street, Melbourne, in the said State, to send particulars of their claims to it by the 7th day of June, 1967, after which date the executor will distribute the assets, having regard only to the claims of which it then has notice.

T. A. RANK & ROBINSON, solicitors, 388 Bourke-street, Melbourne. 6179

FREDERICK RICHARD BAXTER, late of Gisborne, in the State of Victoria, S.E.C. employee, DECEASED, intestate.

CREDITORS, next of kin and others having claims in respect of the estate of the said deceased (who died on the 5th day of October, 1965), are required by the administrator, Alexander Norman Baxter, of 15 Central-avenue, Newborough, S.E.C. employee, to send particulars in writing to him at the office of the undersigned at Kyneton, by the 31st day of May, 1967, after which date the administrator may convey or distribute the assets, having regard only to the claims of which he then has notice.

H. HURRY & SON, solicitors, Kyneton, and at Woodend. 6089

**CREDITORS**, next of kin and others having claims in respect of the estate of Renwick Mansfield Young, late of 2 Fairholm-grove, Camberwell, and formerly of 4 Scottsdale-street, Surrey Hills, retired (who died on the 8th day of November, 1966), are required by the executors, Ronald Fulton Young and Doris Helen Young, to send particulars of their claims to them, care of the under-signed, by the 31st day of May, 1967, after which date the said executors will distribute the assets, having regard only to the claims of which they then have notice.

JOHN R. L. SALISBURY, solicitor, 882, Whitehorse-road, Box Hill. 6148

**CREDITORS**, next of kin and others having claims against the estate of John Bell, junior, late of Newlyn North, in the State of Victoria, gentleman, deceased (who died on the 25th November, 1966), are requested by the executor of the will of the said deceased, the Union-Fidelity Trustee Company of Australia Limited, of 101 Lydiard-street north, Ballarat, in the said State, to send particulars of their claims to the said company on or before the 29th day of May, 1967, after which date the executor will distribute the assets, having regard only to the claims of which it shall then have notice.

CUTHBERT, MORROW, MUST & SHAW, solicitors, Ballarat. 6181

IRENE EDITH LEVY, late of 2 Sunburst-avenue, North Balwyn, widow, DECEASED.

**CREDITORS**, next of kin and others having claims in respect of the estate of the deceased (who died on the 4th January, 1967), are required by the executor, The Equity Trustees Executors and Agency Company Limited, of 472 Bourke-street, Melbourne, to send particulars to it by the 6th June, 1967, after which date it may distribute the estate, having regard only to the claims of which it then has notice.

W. B. & O. McCUTCHEON, solicitors, 150 Queen-street, Melbourne. 6132

**CREDITORS**, next of kin and others having claims in respect of the estate of Samuel James Sharples, late of 63 Burnett-street, Mitcham, retired cleaner, deceased (who died on 29th January, 1967), are to send particulars of their claims to Kenneth Samuel Sharples, of 7 McDowall-street, Mitcham, general blacksmith, the executor appointed by the will of the said deceased by the 31st May, 1967, after which date the executor will distribute the assets, having regard only to the claims of which it shall then have notice.

H. L. YUNCKEN & YUNCKEN, solicitors, 443 Little Collins-street, Melbourne. 6133

**CREDITORS**, next of kin and others having claims in respect of the estate of John Saville Eastwood, late of "Merrimu", Tamleugh, via Violet Town, in the State of Victoria, grazier, deceased (who died on the 1st day of November, 1966), are to send in writing the particulars of their claims to the executors, care of the Trustees, Executors and Agency Company Limited, of 401 Collins-street, Melbourne, in the said State, by the 15th day of June, 1967, after which date the executors will distribute the assets, having regard only to the claims of which they then have notice.

PEARCE & WEBSTER, solicitors, 430 Little Collins-street, Melbourne. 6136

**CREDITORS**, next of kin and others having claims in respect of the estate of Daniel Andrew Anderson, late of Omoto, in the Provincial District of Westland in the Dominion of New Zealand, sawmiller, deceased (who died on the 4th day of November, 1965), are to send the particulars of their claims to The Trustees, Executors and Agency Company Limited, at its registered office, 401 Collins-street, Melbourne, by the 1st day of June, 1967, after which date it will distribute the assets, having regard only to the claims of which it then has notice.

SEWELL & SEWELL, solicitors, 422 Collins-street, Melbourne. 6138

**CREDITORS**, next of kin or others having claims in respect of the estate of Harold Hamilton Kerr, late of 16 Woorigoleen-road, Toorak, engineer, deceased (who died on the 2nd September, 1966), are to send particulars of their claims to Ida Ellen Kerr, of 16 Woorigoleen-road, Toorak, widow, the executrix named in the said will, by the 31st May, 1967, after which date she will distribute the assets, having regard only to the claims of which she then has notice.

CORR & CORR, solicitors, 290 Latrobe-street, Melbourne. 6135

**CREDITORS**, next of kin and others having claims in respect of the estate of Mary Elizabeth Wallis, late of 22 Wills-street, Gardiner, widow, deceased (who died on the 8th day of February, 1967), are to send particulars of their claim to the executor, who has applied for probate of the will dated the 16th day of August, 1962, namely National Trustees, Executors and Agency Company of Australasia Limited, whose registered address is situate at 95 Queen-street, Melbourne, care of The National Trustees, Executors and Agency Company of Australasia Limited at its head office, by the 2nd day of June, 1967, after which date the said executor will distribute the estate, having regard only to the claims of which it then has notice.

VIRGIL B. GILL, KANE & CO., solicitors, 450 Little Collins-street, Melbourne. 6140

MILLICENT HONOR McCOLL, formerly of Port Fairy, in the State of Victoria, but late of 20 Flaxman-street, East Warrnambool, in the said State, widow, DECEASED.

**CREDITORS**, next of kin and others having claims in respect of the estate of the deceased (who died on the 19th day of July, 1964, at Warrnambool), are required by the trustees, Myrtle Jean Wall, of Wollaston, near Warrnambool, in the said State, married woman, and Norman John Wall, of the same place, farmer, to send particulars to them by the 14th day of June, 1967, after which date the trustees may convey or distribute the assets, having regard only to the claims of which they then have notice.

Dated the 22nd day of March, 1967.

J. S. TAIT & CO., solicitors, 125 Kepler-street, Warrnambool. 6141

**CREDITORS**, next of kin and others having claims in respect of the estate of Marjorie Martha Rowell, late of 17 Lansdowne-road, East St. Kilda, in the State of Victoria, married woman, deceased (who died on the 9th day of September, 1966), are required by the executors, Marjorie June Beasley, married woman, and Frank Trevenen Beasley, company director, both of 63 Seymour-road, Elsternwick, in the said State, to send particulars of their claims to them, care of the under-mentioned solicitors, by the 30th day of May, 1967, after which date they may convey or distribute the assets, having regard only to the claims of which they then have notice.

AITKEN, WALKER & STRACHAN, solicitors, 414 Collins-street, Melbourne. 6142

**CREDITORS**, next of kin and others having claims in respect of the estate of Colin Gibson Macfarlan, late of 98 South-road, Brighton, in the State of Victoria, journalist, deceased (who died on the 21st day of November, 1966), are required by the executors, Ross Gibson Macfarlan and Philip Edginton Aitken, both of 414 Collins-street, Melbourne, in the said State, solicitors, to send particulars of their claims to them, care of the under-mentioned solicitors, by the 30th day of May, 1967, after which date they may convey or distribute the assets, having regard only to the claims of which they then have notice.

AITKEN, WALKER & STRACHAN, solicitors, 414 Collins-street, Melbourne. 6143

**CREDITORS**, next of kin and others having claims in respect of the estate of Andree Marcelle Frame, late of 36 Marne-street, South Yarra, in the State of Victoria, physiotherapist, deceased (who died on the 8th day of February, 1967), are required by the executor, Malcolm George Croke, of 35 Aitchison-avenue, Ashburton, in the said State, school teacher, to send particulars of their claims to him, care of the under-mentioned solicitors, by the 30th day of May, 1967, after which date he may convey or distribute the assets, having regard only to the claims of which he then has notice.

AITKEN, WALKER & STRACHAN, solicitors, 414 Collins-street, Melbourne. 6144

GILBERT JOSIAH CHEGWIDDEN, late of 34 Hedderwick-street, North Balwyn, retired, DECEASED (who died on 2nd February, 1967).

**CREDITORS**, next of kin and all other persons having claims against the estate of the deceased are required by the executor of his will, Leslie Gilbert Chegwidden, of 3 Gildan-avenue, North Balwyn, engineer, to send particulars thereof to him, care of the under-mentioned solicitors, before 7th June, 1967, after which date he may distribute the assets of the deceased, having regard only to the claims of which he then has notice.

COLTMAN, WYATT & ANDERSON, solicitors, of 578 Bourke-street, Melbourne. 6137

**CREDITORS**, next of kin and others having claims in respect of the estate of Margaret Annie Tyrrell, late of 14 Cambridge-street, Armadale, widow, deceased (who died on the 31st day of December, 1966), are to send particulars of their claims to the executor, Angus Edward Wishart, care of the under-mentioned solicitors, by the 1st day of June, 1967, after which date the executor will distribute the assets, having regard only to the claims of which he then has notice.

F. E. O'BRIEN & CO., solicitors, of 470 Bourke-street, Melbourne. 6166

**ELIZABETH HARRIETT SMITH**, late of 57 St. Helen's-road, East Hawthorn, in the State of Victoria, widow, DECEASED.

**CREDITORS**, next of kin and others having claims in respect of the estate of the deceased (who died on the 13th October, 1966), are required by the executrix, Winifred Emily Smith, of 57 St. Helen's-road, East Hawthorn, widow, to send particulars to her, care of the undersigned solicitors, by the 31st May, 1967, after which date she may convey or distribute the assets, having regard only to the claims of which she then has notice.

Dated 17th March, 1967.

R. E. LEWIS, ORR & GIBSON, 825 Burke-road, Camberwell. 6146

**CREDITORS**, next of kin and others having claims in respect of the estate of Ellen Emma Fellowes, late of 45 Highfield-road, Canterbury, spinster (who died on the 22nd day of December, 1966), are required by the executors, Wilfred Hastings Moody and Frederick Alfred Sangster, to send particulars of their claims to them care of the undersigned, by the 31st day of May, 1967, after which date the said executors will distribute the assets, having regard only to the claims of which they then have notice.

JOHN R. L. SALISBURY, solicitor, 882 Whitehorse-road, Box Hill. 6149

**IMPOUNDINGS**

**HAMILTON**.—Impounded in Hamilton Pound from King-street, by City Ranger.

1 longtailed Corriedale ram, no visible brand.  
If not claimed and expenses paid, to be sold on 27th March, 1967.

6165—\$1.75 I. FYFE, Poundkeeper.

**TATURA**.—Impounded in Tatura Pound.

2 black Friesian cross-bred heifers, no visible brand.  
1 black and white Friesian heifer, brand V tip of right ear.

If not claimed and expenses paid, to be sold on 13th April, 1967.

6122—\$2.00 J. H. MACTIER, Poundkeeper.

*Subordinate Legislation Act 1962.*

**NOTICE OF MAKING OF STATUTORY RULES.**

IN pursuance of the provisions of the *Subordinate Legislation Act 1962* and the Regulations made thereunder notice is given of the making of the following statutory rules:—

No.	Labour and Industry Act 1958.	Price.
77/1967.	Labour and Industry (Spray Painting) Regulations 1967 .. .. .	15c

No.	Motor Car Act 1958.	Price.
78/1967.	Motor Car (Transfer and Roadworthiness Amendment) Regulations 1967 .. .. .	10c
	<i>Fisheries Act 1958.</i>	
79/1967.	Amendment to Minimum Legal Size for Southern Crayfish .. .. .	10c
	<i>Fisheries Act 1958.</i>	
80/1967.	Revocation of Proclamations Prescribing a Close Season for and Terms and Conditions for the Sale, Etc., of School or Snapper Shark and Gummy Shark .. .. .	10c
	<i>Local Government Act 1958.</i>	
81/1967.	Private Street Construction (Notices) Regulations Amending Regulations No. 2, 1967 .. .. .	10c

Copies of these statutory rules may be purchased at the Sale of Publications Section of the Government Printing Office, located at Macarthur-street, Melbourne, C.2. If ordered by mail, remittance should be addressed to "The Government Printer, Box 203, P.O., North Melbourne, N.I.", and should include 5c extra for postage. If a credit account is held at this office, no remittance is required with the mail order.

The annual subscription rate for Statutory Rules (including a Bound Volume) is \$15, payable in advance. The subscription year commences on 1st January.

A. C. BROOKS,  
Government Printer.

**CONTENTS**

	PAGE
Anzac Day Holiday .. .. .	960
Appointments .. .. .	971
Contracts .. .. .	969
Government Notices .. .. .	960
Impoundings .. .. .	942
Lands .. .. .	977
Melbourne and Metropolitan Board of Works— Notice .. .. .	968
Notice of Making of Statutory Rules .. .. .	942
Orders in Council— Acts—Local Government; Land; Health; Hos- pitals and Charities; Marine Stores et seq and Old Metals; Portland Harbor Trust; Country Roads.	972
Private Advertisements .. .. .	984
Proclamations .. .. .	959
Public Service Notices .. .. .	983
Tenders .. .. .	982
Transport Regulation Board—Public Hearings .. .. .	961
Waterworks Trusts .. .. .	968