

[1993]



VICTORIA  
GOVERNMENT GAZETTE

Published by Authority

[Registered at the General Post Office, Melbourne, for transmission by post as a newspaper.]

No. 501

WEDNESDAY, JUNE 14

[1967

Government House,  
Melbourne,  
10th June, 1967.

**THE QUEEN** has been graciously pleased to signify Her Majesty's intention of conferring the following Honours, Decoration and Award in the Birthday Honours, 1967:—

**TO BE KNIGHTS BACHELOR.**

The Honourable John Stoughton Bloomfield, Q.C.,  
M.L.A.

James Alexander Forrest, Esquire, LL.B.

The Honourable Ronald William Mack, M.L.C.

**THE MOST DISTINGUISHED ORDER OF SAINT  
MICHAEL AND SAINT GEORGE.**

To be a Companion of the said most Distinguished Order:  
Councillor Ian Francis Beaurepaire.

**THE MOST EXCELLENT ORDER OF THE BRITISH  
EMPIRE.**

To be a Commander of the Civil Division of the said Most Excellent Order:

Doctor Thomas Edward Lowe, D.Sc., M.D.

**To be Officers of the Civil Division of the said Most Excellent Order:**

Edgar James Bartrop, Esquire.  
Mrs. Annie Edith Galvin.  
Councillor Ebenezer William Giles.  
William Balcombe Griffiths, Esquire, M.C., E.D.,  
B.Arch.  
Raymond Edward Trickey, Esquire.  
The Reverend Canon Philip St. John Wilson, M.A.,  
Th.L.

**To be Members of the Civil Division of the said Most Excellent Order:**

Mrs. Sylvia Blogg.  
Francis James Eric Gyngell, Esquire.  
Councillor Alan Hall, J.P.  
Joseph Paul Larkings, Esquire.  
Miss Kathleen Ferrin.  
Councillor Martin Patrick Smith, J.P.  
Miss Isobel Strahan, Dip.Soc.Stud.  
Councillor Vincent Edmund Vibert, J.P.  
Councillor Arthur Ernest Walsh.

**THE IMPERIAL SERVICE ORDER.**

To be a Companion of the said Order:  
James Harold Aldred, Esquire.

**AWARD OF THE BRITISH EMPIRE MEDAL.**  
Miss Marjorie Ann Lineham.

J. ROSSITER,  
Acting Official Secretary to the Governor.

**PROCLAMATION**

*Land Act 1958.*

UNALIENATED CROWN LAND AVAILABLE FOR SETTLEMENT UNDER IMPROVEMENT PURCHASE LEASES.

**PROCLAMATION**

By His Excellency the Governor of the State of Victoria and its Dependencies in the Commonwealth of Australia, &c., &c., &c. IN pursuance of the provisions of Section 153 of the *Land Act 1958*, I, the Governor of the State of Victoria, in the Commonwealth of Australia, by and with the advice of the Executive Council of the said State, do by this Proclamation declare the unalienated Crown lands mentioned in the subjoined schedule, to be available for settlement under improvement purchase leases.

**SCHEDULE.**

County.	Parish.	Allotment.	Section.	Area.	Land Valuation.
				A. R. P.	
Tanjil .. .. .	Glenmaggie .. .. .	53F	..	66 3 6	\$3 per acre
Evelyn .. .. .	Nangana .. .. .	..	..	5 0 22	On south side of Woori-Yallock Gembrook road about 5 miles from Woori-Yallock
Weeah .. .. .	Nanowie .. .. .	20	..	65 0 0	\$16.00 per acre

Given under my Hand and the Seal of the State of Victoria aforesaid, at Melbourne, this sixth day of June, in the year of our Lord One thousand nine hundred and sixty-seven, and in the sixteenth year of the reign of Her Majesty Queen Elizabeth II.

ROHAN DELACOMBE.

(L.S.)

By His Excellency's Command.

W. J. F. McDONALD,  
Minister of Lands.

GOD SAVE THE QUEEN !

**GOVERNMENT NOTICES**

*Health Act 1958.*

VICTORIA—DEPARTMENT OF HEALTH.

**NOTICE TO ATTEND FOR RADIOLOGICAL EXAMINATION.**

To all persons aged twenty-one years and over enrolled or resident in the Subdivisions specified hereunder in the State Electoral District of Brunswick West.

TAKE notice that you are required to attend at a Department of Health X-ray unit sited in the public street at or as near as possible to the main entrance to the premises specified in this notice, at any time between the hours specified on one of the days specified and during the period specified in respect of those premises, and thereat to submit yourself to radiological examination of the chest for the purpose of ascertaining whether you may be suffering from pulmonary tuberculosis. If you have had a Chest X-ray within the last twelve months and for that reason do not wish to be examined now, you should attend the unit as directed and submit particulars of the previous examination.

**SPECIFIED SUBDIVISIONS, PREMISES, PERIODS, DAYS AND HOURS.**

Subdivision.	Premises:	Period.	Days.	Hours.
Coburg West	Gordon Service Station, cnr. Bell and Gordon streets, Coburg West	Thursday, 29th June, 1967, to Tuesday, 4th July, 1967 (inclusive)	Each day during the period except Saturday, Sunday and Public Holidays	From 10 a.m. to 8.30 p.m.
	Cnr. Portland and Reynard streets, Coburg West	Tuesday, 4th July, 1967, to Monday, 10th July, 1967 (inclusive)	Each day during the period except Saturday, Sunday and Public Holidays	From 10 a.m. to 8.30 p.m.
Pascoe Vale South	France's Pharmacy, 65 Coonans-road, Pascoe Vale South	Tuesday, 4th July, 1967, to Friday, 7th July, 1967 (inclusive)	Each day during the period except Public Holidays	From 10 a.m. to 8.30 p.m.
	Woolworth's Store, Bell-street, Pascoe Vale South	Wednesday, 5th July, 1967, to Wednesday, 12th July, 1967 (inclusive)	Each day during the period except Saturday, Sunday and Public Holidays	From 10 a.m. to 8.30 p.m.
	Hillcrest Service Station, cnr. Reynard-street and Melville-road, Pascoe Vale South	Monday, 10th July, 1967, to Wednesday, 12th July, 1967 (inclusive)	Each day during the period except Public Holidays	From 10 a.m. to 8.30 p.m.
	Golden Fleece Service Station, cnr. Bell and Cumberland streets, Pascoe Vale South	Tuesday, 11th July, 1967 to Thursday, 13th July, 1967 (inclusive)	Each day during the period except Public Holidays	From 10 a.m. to 8.30 p.m.

NOTE.—Any person to whom this notice applies and who without reasonable excuse fails to comply with the requirements of the notice shall be guilty of an offence, and shall be liable to a penalty of not more than Forty dollars.

Dated this 16th day of May, One thousand nine hundred and sixty-seven.

R. J. FARNBACH, Chief Health Officer.

Commercial Goods Vehicles Act.  
TRANSPORT REGULATION BOARD.

HEARING OF APPLICATIONS.

NOTICE is hereby given that the following applications will be considered by the Transport Regulation Board at its offices at the corner of Lygon and Princes streets, Carlton, at 10.15 a.m., on Wednesday, 5th July, 1967.

**AUTO TYRE & RUBBER CO.**, 154-160 Fairy-street, Warrnambool. One commercial goods vehicle (L/C. 10 cwt.) to operate within a 50-mile radius from own premises at Warrnambool, in the course of business as "New and Second-hand Tire and Car Accessory Distributors"—tires and tubes for sale and delivery, used tires for repair and retreading or having been repaired or retreaded, batteries, oil, motor car accessories and polythene piping.

**BLACKWOOD HODGE (AUSTRALIA) PTY. LTD.**, 2161-2181 Princes Highway, North Clayton. Six commercial goods vehicles (L/C. 11 cwt. each) to operate throughout the State of Victoria in the course of business as "Earth-moving Equipment Distributors" for the purpose of servicing heavy earth-moving equipment—tools of trade, spare parts and materials incidental to servicing.

**BURGESS, J. B.**, 30 Tucker-street, Horsham. One commercial goods vehicle (L/C. 227 cwt.) to operate: (a) Within a 50-mile radius from the post office at Horsham as a "Road Contractor"—road-making plant and materials. (b) Within a 25-mile radius of the post office at Horsham—general goods, provided that no goods shall be carried whether by one stage or by more than one stage between places within the above radius, which are more than 30 road miles apart by the nearest practicable route.

**CLEARY, R. G.**, care of 62 McDonald-street, Morwell. One commercial goods vehicle (L/C. 160 cwt.) to operate from landings within a 20-mile radius of Morwell to sawmills within the said radius and to Pearces sawmill at Bunyip—logs.

**CONNELLY, M. J.**, Box 162, Birchip. One commercial goods vehicle (L/C. 240 cwt.) to operate: (a) Within a 50-mile radius from the post office at Birchip as a "Road Contractor"—road-making plant and materials. (b) Within a 25-mile radius of the post office at Birchip—general goods, provided that no goods shall be carried whether by one stage or by more than one stage between places within the above radius, which are more than 30 road miles apart by the nearest practicable route.

**CROTHERS, A. J.**, 5 Pollard-street, Wodonga. One commercial goods vehicle (L/C. 200 cwt.) to operate within a 50-mile radius from the post office at Wodonga, solely on behalf of Ready-Mixed Concrete (Vic.) Pty. Ltd.—pre-mixed concrete in a specially constructed agitator vehicle.

**DELANEY, J. J.**, 20 Townsend-street, Mortlake. One commercial goods vehicle (L/C. 233 cwt.) to operate: (a) Within a 50-mile radius from the post office at Mortlake—road-making plant and materials. (b) Within a 25-mile radius from the post office at Mortlake—general goods, with the proviso that no one journey to exceed more than 30 road miles by the nearest practicable route. (c) From pits at Chatsworth to places situate within a 50-mile radius from the post office at Chatsworth—river washed sand.

**DE VRIES, L.**, 20 Charles-street, Moe. One commercial goods vehicle (L/C. 47 cwt.) to operate throughout the State of Victoria in the course of business as "Marine Collector"—special wares, marine stores or old metals as designated in the *Marine Stores and Old Metals Act 1958* (No. 6303), Part 1, section (3), but excluding the carriage of any such goods to wharves, docks or ships for shipment or export purposes. *Special Condition*.—That the combined load capacity of prime mover together with any trailer attached thereto shall not exceed 120 cwt.

**EDWARDS, G. E.**, 11 Grandview-avenue, Dandenong. One commercial goods vehicle (L/C. 168 cwt.) to operate within a 70-mile radius from the premises of Monier Besser Pty. Ltd. at Dandenong, solely on behalf of the said company—bricks.

**FOUNTAIN, R. J. & A.**, 3 Elizabeth-street, Warrnambool. One commercial goods vehicle (L/C. 8 cwt.) to operate within a 75-mile radius of the post office at Warrnambool in the course of business as a "Distributor"—jubbly in cartons, crumpets, pies and pasties, such goods having been initially consigned by rail to Warrnambool.

**GEELONG PLASTER MILLS PTY. LTD.**, Separation-street, North Geelong. One commercial goods vehicle (L/C. 136 cwt.) to operate between the City of Mildura and own mine at Hattah in the course of business as "Plaster Manufacturers"—own mining machinery and spare parts.

**HARRIS, S. T.**, 49 Menzies-avenue, Dandenong. One commercial goods vehicle (L/C. 11 cwt.) to operate throughout the State of Victoria in the course of business as "Marine Collector"—special wares, marine stores or old metals as designated in the *Marine Stores and Old Metals Act 1958* (No. 6303), Part 1, section (3) but excluding the carriage of any such special wares, marine stores or old metals to wharves, docks or ships for shipment or export purposes, with the proviso that the combined load capacities of both prime mover and any trailer together shall not exceed 120 cwt.

**INTERNATIONAL HARVESTER CO. OF AUST. PTY. LTD.**, "The Esplanade", North Shore, Geelong. One commercial goods vehicle (L/C. 151 cwt.) to operate: (a) Within a 25-mile radius of the chief post office in Geelong—own goods. (b) Throughout the State of Victoria in the course of business as "Truck, Tractor and Farm Implement Manufacturers"—farm implements and accessories for experimental and demonstration purposes only, also tools of trade incidental to the servicing and maintenance of own machinery and equipment, and also such spare parts only as are required for use on the site of the machinery being serviced. (c) Throughout the State of Victoria for the purpose of experimental testing only—ballast.

**LEAHY, R. B.**, 10 Latrobe-road, Morwell. One commercial goods vehicle (L/C. 122 cwt.) to operate: (a) Within a 20-mile radius of the post office at Morwell—sand. (b) Within a 50-mile radius of the post office at Morwell on behalf of Mobile Quarries and Rowlands Quarries—screenings.

**LIOLIOS, A.**, 9 Bungay-street, Fawkner. One commercial goods vehicle (L/C. 140 cwt.) to operate: (a) Within a 35-mile radius of the premises of Bayview Quarries Pty. Ltd., at Tullamarine—screenings, stone dust and premix on behalf of the said company. (b) From pits within a 35-mile radius of Tullamarine to the plant of Bayview Quarries Pty. Ltd.—sand.

**MANSERRA, L., & A. BODDI**, 78 Williams-road, Horsham. One commercial goods vehicle (L/C. 228 cwt.) to operate: (a) Within a 50-mile radius from the post office at Horsham as a "Road Contractor"—road-making plant and materials. (b) Within a 25-mile radius of the post office at Horsham—general goods, provided that no goods shall be carried whether by one stage or by more than one stage between places within the above radius, which are more than 30 road miles apart by the nearest practicable route.

**MATHEWS, R. A. & E. T.**, Government-road, Buchan. One commercial goods vehicle (L/C. not available) to operate: (a) Within that part of the State of Victoria east of the Mitchell and Dargo Rivers and west of the Snowy River—logs. (b) From any sawmill situated within the area specified in paragraph (a) above:—(i) The railway station nearest to the particular sawmill but excluding any operations north of a line drawn due east and west through the settlement of Glen Wills and also excluding any operations within a 20-mile radius of the post office at Omeo—sawn timber. (ii) Any customer or building contract site within a 20-mile radius of the post office at Buchan—sawn timber.

**MORGAN, P. L.**, lot 12, Benbow-crescent, Boronia. One commercial goods vehicle (L/C. 118 cwt.) to operate: (a) Within a 70-mile radius from the premises of Evans Brothers Pty. Ltd., Stud-road, Scoresby, solely on behalf of the said company—bricks. (b) Within a 70-mile radius from the premises of Evans Brothers Pty. Ltd., Park-road, Oakleigh, solely on behalf of the said company—roofing tiles.

**MOTOR TYRE SERVICE PTY. LTD.**, 309 Lyttleton-terrace, Bendigo. One commercial goods vehicle (L/C. 11 cwt.) to operate within a 50-mile radius of own premises at Bendigo in the course of business as "Tire Retreaders and Distributors"—new and second-hand tires and tubes, tires and tubes for repair or having been repaired, batteries, oil and motor car accessories.

**NEWCOMBE, G. P.**, 4 Carr-street, Colac. One commercial goods vehicle (L/C. 58 cwt.) to operate to the premises of Thos. Peacock & Sons Pty. Ltd., Waste Merchants at Abbotsford in the city of Melbourne from points within a 50-mile radius of the post office at Colac in the course of business as "Waste Collector"—waste paper and waste rags collected on behalf of the Colac District Hospital.

- NORMAN, E. J., E. I. & R. W., Colemans-road, Dandenong. One commercial goods vehicle (L/C. 133 cwt.) to operate within a 70-mile radius from the premises of Monier Besser Pty. Ltd. at Dandenong, solely on behalf of the said company—concrete masonry.
- O'BRIEN, G. O., & SONS PTY. LTD., 55 Parer-road, Airport West. One commercial goods vehicle (L/C. 10 cwt.) to operate throughout the State of Victoria in the course of business as "Caterers"—own caterer's equipment and victuals.
- PARKER, W. J., Fairway-drive, Mooroopna. One commercial goods vehicle (L/C. 122 cwt.) to operate within a 50-mile radius of the post office at Mooroopna in the course of business as "Wood Merchant"—own firewood.
- RADDAN, D. W., 287 Little Lonsdale-street, Melbourne. One commercial goods vehicle (L/C. 17 cwt.) to operate within a 50-mile radius from own branch premises at Shepparton in the course of business as "Wholesale Tobacconist"—own goods subject to the condition that any goods so carried shall only be those having been initially consigned to Shepparton by rail.
- REDMAN, K. C., (trading as C. E. Redman & Sons), Napier-street, Stawell. Two commercial goods vehicles (L/C. 15 and 19 cwt.) to operate within a 100-mile radius from own premises at Stawell in the course of business as "Bridge Builders"—tools of trade, equipment and materials incidental to the completion of own contracts.
- SPLATT, R. V., 7 Leigh-street, Huntingdale. One commercial goods vehicle (L/C. 151 cwt.) to operate within a 70-mile radius of Monier Besser Pty. Ltd. at Dandenong, solely on behalf of the said company—building bricks and blocks.
- VELLA, P. R., 1 East-street, Yallourn North. One commercial goods vehicle (L/C. 8 cwt.) to operate within a 30-mile radius of Yallourn North—cosmetics having been initially consigned on rail to Yallourn on behalf of Mystic Cosmetics Pty. Ltd.
- WANGARATTA STEAM LAUNDRY, 72 Norton-street, Wangaratta. Application to vary the conditions of licence No. D.A.2233/1 (L/C. 10 cwt.) by adding to the present conditions after the words "Post Office"—"and to Shepparton and towns en route".
- WANGARATTA STEAM LAUNDRY, 72 Norton-street, Wangaratta. Application to vary the conditions of licence No. T.D.16677 (L/C. 10 cwt.) by adding to the existing conditions an additional paragraph "(e) Between the Towns of Wangaratta and Shepparton and towns en route".
- WAREHOUSE SERVICES, 41 Archer-street, Shepparton. One commercial goods vehicle (L/C. 5 cwt. and 10 cwt. trailer) to operate: (a) Within a 50-mile radius of the post office at Shepparton in the course of business as "General Merchants"—own goods. (b) Within a 50-mile radius of the post office at Shepparton as an agent on behalf of H. Burns of Balaclava—paint.

## TOW TRUCKS.

- SQUIRES, L. A., 245 Princes Highway, Dandenong. One commercial goods vehicle (L/C. 60 cwt.) to operate within a 25-mile radius of own premises at Dandenong as a "Tow Truck", for the purpose of lifting and carrying or towing and/or repairing wrecked or disabled vehicles—tools of trade, spare parts and materials incidental thereto.
- JONES, S. V. (trading as Wedderburn Panels), High-street, Wedderburn. One commercial goods vehicle (L/C. 68 cwt.) to operate within a 25-mile radius of the post office at Wedderburn as a "Tow Truck", for the purpose of lifting and carrying or towing and/or repairing wrecked or disabled vehicles—tools of trade, spare parts and materials incidental thereto.
- DOAK, A. C. & Y. F., 137 Verner-street, East Geelong; D.A.49386; 1st July, 1967; 203 cwt.
- FORD-SWINTON INDUSTRIES PTY. LTD., 8-12 James-street, Clayton; D.A.34456/4; 5th August, 1967; 11 cwt.
- FOWLER, T., & SONS, Streatham-road, Skipton; D.A.1094; 30th June, 1967; 247 cwt.; D.A.1094/1; 30th June, 1967; 243 cwt.
- FOX, R., P.O. Box 48, Macarthur; D.A.1097; 30th July, 1967; 109 cwt.
- GILBERT & BARKER MFG. CO. (AUST.) PTY. LTD., 11 Anderson-road, Thornbury; D.A.1144/4; 1st August, 1967; 13 cwt.; D.A.1144/5; 1st August, 1967; 19 cwt.
- GODFREY, A. V., 2 Camp-street, Daylesford; D.A.36175; 29th June, 1967; 7 cwt.
- GREEN, W. W., 88 Quinn-street, Numurkah; D.A.1199; 30th June, 1967; 103 cwt.
- HAYNES, R. L., & CO. PTY. LTD., 4 Wells-road, Oakleigh; D.A.8467; 29th August, 1967; 63 cwt.
- HOLDENSON & NIELSON FRESH FOODS PTY. LTD., 95 Cecil-street, South Melbourne; D.A.47779/1; 29th July, 1967; 246 cwt.
- HOUGH, J. A., Box 132, Sea Lake; D.A.21776; 11th July, 1967; 34 cwt.
- HOVEY'S TRANSPORT SERVICE, Thompsons-road, North Geelong; D.A.1332/5; 1st July, 1967; 256 cwt.
- HOWES, C. D., 15 Kingsley-grove, Mt. Waverley; D.A.36950; 17th August, 1967; 118 cwt.
- HUTTON, J. C., PTY. LTD., 65 High-street, Preston; T.D.A.48355/14; 7th July, 1967; 54 cwt.
- LEMCHENS, A., & A. SKULTE (trading as Lemchens & Skulte), 22 Charles-street, Maffra; D.A.49434; 8th July, 1967; 119 cwt.
- LOCK, W. & J., 9 Nelson-avenue, Newcomb, Geelong; D.A.49415; 1st July, 1967; 123 cwt.
- LYNDON SMITH, N., & SON, "Coniston", Fernihurst; D.A.31600/1; 27th July, 1967; 88 cwt.
- MILES PAINT SERVICE PTY. LTD., 1032 Dandenong-road, Carnegie; D.A.41523/28; 5th August, 1967; 8 cwt.
- MORSMILK PTY. LTD., 185 Raglan-parade, Warrnambool; D.A.8368/1; 22nd July, 1967; 6 cwt.
- MURPHY, P. J. & J. L., Cobden-road, Timboon; D.A.60000; 29th July, 1967; 136 cwt.
- MCDONALD, J. & W., 127 Fyfe-street, Hamilton; D.A.48931; 1st July, 1967; 251 cwt.
- MCDOWELL, J. W., 93 Wawunna-road, Horsham; D.A.1676; 30th July, 1967; 10 cwt.
- NORTHERN TYRE SERVICE PTY. LTD., 298 High-street, Shepparton; D.A.47685/2; 8th July, 1967; 11 cwt.
- ORMOND SLATE SUPPLIES, 774 North-road, Ormond; D.A.49235; 17th August, 1967; 159 cwt.
- PERMEWANS (HORSHAM) PTY. LTD., 147-179 Alexandra-pde., Abbotsford; D.A.1809/11; 24th August, 1967; 130 cwt.
- RITCHIE, W. S., P.O. Brown Hill; D.A.33959; 13th October, 1966; 142 cwt.
- SINCLAIR, H. R., Ross-street, Heatherton; D.A.48290; 11th February, 1967; 135 cwt.
- SIPTHORPE, W. J. & B. L., Post Office, Neerin Neerin; D.A.52769; 20th July, 1967; 7 cwt.
- STEVENS, L. S., Post Office Box 17, Ararat; D.A.35775; 27th July, 1967; 261 cwt.
- STEVENSON, H. F., PTY. LTD., 10 Duffy-street, Burwood; T.D.A.2111/2; 7th August, 1967; 79 cwt.
- THOMPSONS (CASTLEMAINE) LTD., 5 Parker-street, Castlemaine; D.A.2156; 30th July, 1967; 12 cwt.
- WHITE WINGS LTD., 108 Newlands-road, Reservoir; T.D.A.60073; 15th August, 1967; 10 cwt.; T.D.A.60073/1; 15th August, 1967; 11 cwt.
- WILSON ELECTRIC TRANSFORMER CO. PTY. LTD., 310 Springvale-road, Glen Waverley; D.A.34340/2; 11th June, 1967; 19 cwt.
- WINZAR, N. S., Uley-street, Bendigo; D.A.21115; 11th July, 1967; 121 cwt.

## TOW TRUCK RENEWALS.

- APPLICATIONS for renewal of licences as shown, by persons listed hereunder to operate under the same terms and conditions from the expiry shown in each case.
- ALLEN, M. J., Everton; D.A.49385; 1st July, 1967; 88 cwt.
- BEGLEY, A. E., & SONS, 217 Koroit-street, Warrnambool; D.A.49714; 22nd July, 1967; 4 cwt.
- BELSAIR PTY. LTD., 319 Middleborough-road, Box Hill; D.A.35952/1; 16th June, 1967; 21 cwt.
- BOOTS PURE DRUG CO. (AUST.) PTY. LTD., 33 Stewart-street, Richmond; D.A.36645/1; 27th July, 1967; 8 cwt.
- BOOTS PURE DRUG CO. (AUST.) PTY. LTD., 33 Stewart-street, Richmond; D.A.36645/5; 28th August, 1967; 8 cwt.
- BOURKE, W. B., 12 Howard-avenue, Ormond; D.A.6298; 19th July, 1967; 6 cwt.
- CLARK, J. H., 19 Hindmarsh-street, Dimboola; D.A.17176/4; 8th July, 1967; 107 cwt.
- HEWSON, A. J. (trading as Andy's Autos), 1109 Sydney-road, North Coburg; D.A.46261/2; 5th August, 1967; 52 cwt.
- GRIFFITHS, B. W. (trading as Dennis Panel Beating Works), 87 South-crescent, Northcote; D.A.49465; 5th August, 1967; 25 cwt.
- WELLS, F. E. (trading as Griffith Panel Works), 258 Wickham-road, Moorabbin; D.A.60117/1; 29th August, 1967; 30 cwt.
- INNES, G. R., & SONS, 411 Hargreaves-street, Bendigo; D.A.1349/2; 22nd June, 1967; 66 cwt.
- LANE, M. J., 16 Berl-court, Blackburn South; D.A.49869; 5th August, 1967; 44 cwt.
- WILSON BOLTON & Co. PTY. LTD., 29 Scott-street, Warracknabeal; T.D.A.34878/3; 11th July, 1967; 10 cwt.

**A**PPPLICATION by the persons listed hereunder for renewal of the licences listed with variation of conditions in the manner set out opposite the names.

A.H. AGENCIES & SALES PTY. LTD., 1122 High-street, Armadale; T.D.A.45101/6; 16th May, 1967; application to renew and vary the conditions of licence No. T.D.A.45101/6 (L/C. 17 cwt.) by deleting the present conditions and by adding in lieu:—"To operate within a 50-mile radius from own depot at 215 Raymond-street, Sale, and to consignees within a western border of Pakenham to San Remo, and also to consignees at Lakes Entrance to Orbost in the course of business as 'Motor Parts and Accessories Distributors'—own motor parts and car accessories—such goods having been railed to Sale."

POLLARD, W. R., 30 Lucerne-avenue, Mornington; D.A.36953; 17th August, 1967; application to renew and vary the conditions of licence No. D.A.36953 (L/C. 52 cwt.) by deleting the existing paragraph (a) and by adding in lieu as a new paragraph (a) within a 25-mile radius from the post office at Mornington—general goods, with the proviso that no journey be more than 30 miles in length within the said radius.

Notice of any objections should be forwarded to reach the Secretary of the Board not later than Wednesday, 28th June, 1967.

Applicants are advised that it will not be necessary to appear on the hearing date specified above, unless advised in writing by the Board.

B. P. KAY,  
Secretary.

Corner Lygon and Princes streets, Carlton, N.3, 14th June, 1967.

Transport Regulation Act.  
TRANSPORT REGULATION BOARD.

HEARING OF APPLICATIONS.

**N**OTICE is hereby given that the following applications will be considered by the Transport Regulation Board at its offices at corner Lygon and Princes streets, Carlton, at 10.15 a.m., on Wednesday, 5th July, 1967.

CROYDON BUS SERVICE PTY. LTD., Maroondah Highway, Croydon. Application for variation of Route 242A to operate the following service for an initial experimental period of three months. Commencing at the Mooroolbark Railway Station via Brice-avenue, Hull-road, Cardigan-road, Dreyden Concourse, Cambridge-road, Pembroke-road to the corner of Pembroke and Cardigan roads then via Cardigan-road, Chaucer-street, Kipling-avenue, Pembroke and Taylor roads (Taylor-road depending on road condition) to corner of Taylor and Blackburn roads.

GRENDAS BUS SERVICES, 9 Foster-street, Dandenong. One commercial passenger vehicle (S/C. 41) to operate as an additional metropolitan special service omnibus within a 50-mile radius of the General Post Office, Melbourne.

HILL, J. G. & A. G., Hawkesdale. One commercial passenger vehicle (S/C. 35) to operate as follows:—(a) For the carriage of school children only between Macarthur and Hawkesdale, under contract to the Education Department. (b) As a country special service omnibus from Macarthur.

NEWTON, J. A. & O. L., Whitfield. One commercial passenger vehicle (S/C. 37) to operate in substitution for but not in addition to existing T.S. licences in the applicant's name.

ADAMS, R. W., corner York & Swansea roads, Lilydale. One commercial passenger vehicle (S/C. 44) to operate under the same terms and conditions as C.O. licences held in the name of the applicant.

**A**PPPLICATIONS for renewal of licences as shown, by persons listed hereunder to operate under the same terms and conditions.

ANSETT MOTORS PTY. LTD., 210 Gray-street, Hamilton; T.P.128.

ARTHUR, D. W. & E. R., 3 Florence-court, Dandenong; T.P.70.

BUCHAN TIMBER CO. PTY. LTD., Buchan; T.P.223.

CLARK, A. G., 63 Gordon-street, Ararat; T.S.693.

FAKHRI, T., 25 Prospect-grove, Northcote; M.T.1672.

GEBERT, G. L., Bow-street, Rainbow; T.S.365, T.S.645.

HARRISON, G. J. F. & M., COACHES, 31 Francis-street, Echuca; T.S.632.

ITALIANO, F., 234 Scotchmere-street, North Fitzroy; M.T.1520.

MARTIN, G. R., 2 Rainer-street, Pascoe Vale South; M.H.1964.

O'NEILL, E., & B. I. SPROULE, care of 10 Havelock-street, Wodonga; C.T.580.

PARLORCARS PTY. LTD., 377 Gore-street, Fitzroy; M.C.32, M.C.33, M.C.34, M.C.157, M.C.262, M.C.263, M.C.264, M.C.265, M.C.266, M.C.267, M.C.268, M.C.302, M.C.303, M.C.304, M.C.354, M.C.355.

PAYNE, H. W., 44 Wilfred-road, Ivanhoe; M.H.2203.

WHISTON, A. J., 39 Williams-road, North Coburg; M.T.4100.

WHITFIELD, T. B., 124 William-street, Fawkner; M.H.2204.

WOMBELL, D. N. P., Coleraine-road, Merino; C.O.160, T.S.486.

Notice of any objection should be forwarded to reach the Secretary of the Board not later than Wednesday, 28th June, 1967.

Applicants are advised that it will not be necessary to appear on the hearing date specified above, unless advised, in writing, by the Board.

B. P. KAY,  
Secretary.

Corner Lygon and Princes streets, Carlton, Wednesday, 14th June, 1967.

LOCAL GOVERNMENT DEPARTMENT.

ORDER CONFIRMED.—CITY OF NUNAWADING.

**T**HE Minister of the Crown administering the Local Government Act 1958, as amended, on the 7th day of June, 1967, confirmed the Order hereinafter referred to in pursuance of section 514 of the said Act namely:

An Order of the Council of the City of Nunawading made on the 24th June, 1966, directing the compulsory taking of the land described hereunder for the purpose of providing a footway to connect Bond-avenue and Hearty-street.

All that piece of land commencing at the north-west corner of the land described in certificate of title, volume 8531, folio 250; thence bearing 101 deg. 36 min. for 119 ft. 5 in., 180 deg. 43 min. for 6 ft. 1½ in., 281 deg. 36 min. for 119 ft. 3 in. and 359 deg. 10 min. for 6 ft. 2 in. to the commencing point.

R. J. HAMER,  
Minister for Local Government.

Local Government Department,  
Melbourne.

SHIRE OF DIAMOND VALLEY.

**P**URSUANT to the provisions of section 522 and 526 of the Local Government Act 1958, the Council of the Shire of Diamond Valley hereby directs that the land in the Parish of Keelbundora indicated by hatching on the diagram annexed hereto, which has been purchased, taken or acquired by it, shall be a public highway on and from the date of publication of this order in the Government Gazette, and declares that such land shall be a public highway in lieu of the land indicated by cross-hatching on the said diagram.

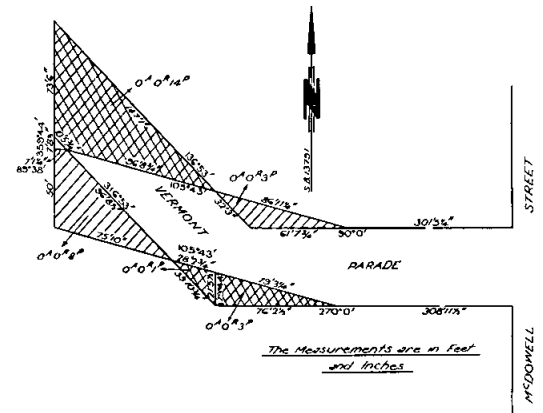

The common seal of the President, Councillors and Ratepayers of the Shire of Diamond Valley was hereunto affixed this 9th day of May, 1967, in the presence of—

G. T. UPTON, President.  
H. W. NASH, Councillor.  
B. J. MORGAN, Shire Secretary.

Approved by the Governor in Council, 6th June, 1967.—  
J. ROSSITER, Acting Clerk of the Executive Council.

**CONTRACTS ACCEPTED.—(Series 1966-67.)****PUBLIC WORKS.**

3638. Altona North, Technical School, asphaltting, concreting, drainage works, &c., \$9,349.50.—Roy Senior & Son Pty. Ltd.

3639. Appin South, State School No. 3495, repairs and painting, &c., \$3,000.00.—K. H. Helstrup.

3640. Ararat, Mental Hospital, asphalt paving, concrete and drainage works, garages and car park, \$5,953.50.—C. J. Stewart.

3641. Ararat, H.M. Prison, erection of three brick veneer proprietary type residences, \$40,427.00.—Contemporary Homes Pty. Ltd.

3642. Bacchus Marsh, Police Station, erection of brick veneer extension, renovations to office, \$9,511.00.—A. & B. Oswald Pty. Ltd.

3643. Bangholme, State School No. 3884, provision of additional toilets, \$1,340.00.—G. L. Mackie.

3644. Bannockburn, Police Station, erection of brick veneer residence, office and brick cell unit, \$19,578.26.—R. J. Doolan.

3645. Beechworth, State School No. 1560, Residence, 5 Sydney-road, external and internal repairs and painting, \$3,088.80.—Burrige & Jensen.

3646. Beechworth, State School No. 1560, new slow combustion heaters, \$2,158.00.—Burrige & Jensen.

3647. Bell Park, High School, Science Wing, electrical installation, \$2,450.00.—A. G. Walker.

3648. Bell Park North, State School No. 4962, plenum heating, \$3,940.00.—Gray & Wood.

3649. Belmont, Police Station and Residence, renovations and new front fence, \$1,850.00.—P. Tesic.

3650. Brunswick, State School No. 1213, renovations to toilets, \$3,116.00.—B. J. Virtue.

3651. Bungaree, Police Station and Residence, repairs and painting, \$1,978.50.—H. Tenthly.

3652. Burwood, "Allambie" Reception Centre, Elgar-road, electrical installation, Children's Cottage, \$1,900.00.—Namford Electrical Consultants & Contractors.

3653. Burwood, "Allambie" Reception Centre, Elgar-road, mechanical services, Children's Cottage, \$4,696.20.—N. G. Fleming.

3654. Burwood, "Allambie" Reception Centre, Elgar-road, erection of Children's Cottage, \$49,680.00.—McKenzie Constructions Pty. Ltd.

3655. Caulfield, Technical College, Junior Section, light duty paving and drainage works, \$5,805.37.—Wm. Loud Pty. Ltd.

3656. Coburg, H.M. Pentridge Prison, alterations to gate post No. 1, \$6,362.00.—G. & A. Power Pty. Ltd.

3657. Doncaster East, State School No. 2096, concreting, drainage, earthworks, &c., \$6,430.80.—Rainbow Construction Co. Pty. Ltd.

3658. Dookie, Agricultural College, construction of an earth dam, \$5,456.50.—E. B. Mawson & Sons Pty. Ltd.

3659. Donvale, High School, erection of first and second sections and science block, \$274,874.00.—P. M. Versteegen & Sons Pty. Ltd.

3660. Dunolly, Police Station and Residence, internal and external painting, repairs to fence, \$1,993.55.—A. L. Lawrence.

3661. East Loddon, Consolidated School, extension of Teachers' Flats, \$5,800.00.—K. D. Ryan.

3662. Eastwood, State School No. 4702, earthworks, asphalt paving, concrete paving, retaining walls, drainage works, &c., \$16,500.88.—Wm. Loud Pty. Ltd.

3663. Frankston, Keith Turnbull Research Station, erection of head house and store, \$109,400.00.—S. W. & J. Gardiner Pty. Ltd.

3664. Geelong, Technical School, enlarging Principal's Office, &c., \$4,920.00.—G. N. McGaskill.

3665. Kew, Mental Hospital, Maintenance Workshop, asphaltting, concreting, drainage works, &c., \$7,851.43.—Wm. Loud Pty. Ltd.

3666. Langi Kal Kal Youth Training Centre, Education Block, First Stage, mechanical services, \$8,374.00.—George Stone & Sons.

3667. Laverton North, State School No. 4964, electrical installation, \$5,730.00.—J. F. & E. E. Veall.

3668. Lyndale, High School, electrical installation, \$6,200.00.—W. T. Waterfall & Sons Pty. Ltd.

3669. Melbourne, National Gallery & Museum, electrical installation (supply and submain revisions), \$6,994.00.—R. A. Waldron Trading Co.

3670. Melbourne, Royal Melbourne Institute of Technology, 528-532 Little Lonsdale-street, remodelling, painting and decorating school (Henry Berry Building), \$103,444.00.—W. J. Cody & Quinn Pty. Ltd.

3671. Mont Park, Janefield Mental Hospital, construction of roads, drainage, water reticulation, concrete works, &c., \$44,970.70.—Regent Constructions Pty. Ltd.

3672. Mount View, State School No. 4923, asphaltting, concreting, drainage works, &c., \$22,809.30.—L. J. Towers.

3673. Nagambie, State School No. 1104 and Residence, new porch, repairs and painting, \$7,425.00.—Alf Richardson Constructions.

3674. Nathalia, Police Station, Manifold-street, repairs and painting to residence, \$2,087.00.—C. H. McDonald.

3675. Point Wilson, Explosives Reserve, supply of pumping equipment for fire service, \$2,714.00.—Tieman Bros. Pty. Ltd.

3676. Portland, State School No. 489, Residence, 15 Bancroft-street, repairs and painting, \$2,354.00.—T. F. Creasey.

3677. Port Melbourne, Salmon-street, Storeyard, structural steel framework, concrete floor and footings, \$13,890.00.—Lamers Constructions Pty. Ltd.

3678. Richmond, Technical School, renovations to toilet block, \$1,288.00.—N. Peshut.

3679. Rosanna, State School No. 4568, erection of new fencing and gates, \$1,307.00.—Melbourne Wire Works Pty. Ltd.

3680. Royal Park, "Turana" Reception and Classification Centre, electrical installation, \$17,940.00.—J. Newall Pty. Ltd.

3681. Scoresby, Research Station, construction of earth dam (to contain approximately 30 acre-feet of water), \$5,572.00.—Janus Constructions Pty. Ltd.

3682. Shepparton, "Ambermere" Hospital, Mental Health Authority, mechanical services, \$4,879.00.—A. I. Industries.

3683. Shepparton, Police Station Residence, new porch, repairs and painting, \$1,820.00.—W. J. Pryde.

3684. Southvale, State School No. 4859, asphaltting, concreting, drainage, &c., \$16,045.41.—Wm. Loud Pty. Ltd.

3685. South Yarra, Melbourne High School, internal repairs, renovations, &c., \$19,400.00.—G. J. Little.

3686. South Yarra, Lands and Survey Department, Royal Botanic Gardens, new lodge in Nursery Area, \$10,790.00.—Falcon Construction Co.

3687. Swan Hill, New Court House, erection of first stage, \$71,275.00.—A.R.P. Crow & Sons Pty. Ltd.

3688. Toolangi, Potato Research Station, construction of 6-in. diameter asbestos cement water main and concrete headwork, \$6,448.00.—J. Fowler.

3689. Wangaratta, High School, electrical installation, \$8,090.00.—A. E. Webster.

3690. West Melbourne, Government Cool Stores, electrical installation switchboard and submain revisions, \$6,089.00.—Roy Ivey & Sons Pty. Ltd.

3691. White Hills, Technical School, installation of ceiling type air circulators, \$1,270.65.—W. R. Parker.

3692. Yallourn, Police Station and Residence, internal and external renovations, \$1,413.00.—John Hare.

G. SERPELL, Secretary for Public Works. 5.6.67.

**VICTORIAN RAILWAYS.**

110. Manufacture, supply and delivery of electro-pneumatic point mechanisms for Goods Yard Service, at rates (Contract 63071).—McKenzie & Holland (Aust.) Pty. Ltd. 111. Construction of telephone pole line between Ballarat and Ararat (labour only), at rates (Contract 63096).—J. Robertson & Co. 112. Manufacture, supply and delivery of cast steel bogie parts at the rate of \$1,037.70 per wagon set (Contract 63110).—Bradford Kendall Ltd.

By order of the Victorian Railways Commissioners,

W. WALKER, Secretary. 9.6.67.

**CONTRACTS ACCEPTED.—(Series 1967-68.)****PUBLIC WORKS.**

99. Box Hill, Technical School, supply surface grinder, \$4,213.80.—Recco Power Pty. Ltd.

100. Box Hill, Technical School, supply machine tools, \$22,760.00.—Demco Machinery Co. (Vic.) Pty. Ltd.

101. Malvern, Toorak Teachers' College, supply kitchen equipment, \$1,248.85.—E.G.A. (S. Cunningham) Pty. Ltd.

102. Malvern, Toorak Teachers' College, supply gas range, \$1,515.50.—Waldorf Appliances Pty. Ltd.

103. Malvern, Toorak Teachers' College, supply kitchen equipment, \$4,192.50.—Ahearn, Main & Stott Pty. Ltd.

104. Malvern, Toorak Teachers' College, supply kitchen equipment, \$1,151.00.—Brice Equipment Pty. Ltd.

105. Ballarat, Mental Hospital, supply "Horscroft Falcon" Press, \$1,737.00.—Hardie Trading Ltd.

106. Sunbury, Mental Hospital, supply food containers, \$1,438.20.—Silverglo Stainless Steel Pty. Ltd.

107. Ararat, Mental Hospital, supply lockers, bedside, \$1,232.00.—Namco Furniture Contract Division.

108. Kew, Mental Hospital, supply and fix curtains, \$1,900.00.—Myer Teale Pty. Ltd.

109. Royal Park, Psychiatric Hospital, supply and fix curtains, \$1,548.92.—Fischer Furnishings Pty. Ltd.

110. Swan Hill, Technical School, supply lathe and equipment, \$2,530.90.—Demco Machinery Co. (Vic.) Pty. Ltd.

111. Wodonga, Technical School, supply fans, ceiling, \$1,537.25.—Noyes Bros. Pty. Ltd.
112. Preston, Technical College, supply welding equipment, \$1,403.99.—The Commonwealth Industrial Gases Ltd.
113. Stawell, Pleasant Creek Special School, supply beds, Hospital, \$1,150.80.—Namco Furniture, Contract Division.
114. Echuca, Technical School, supply fans, ceiling, \$1,397.50.—Noyes Bros. Pty. Ltd.
115. Corio, Technical School, supply drilling machines, \$1,386.00.—Waldown Pty. Ltd.
116. Corio, Technical School, supply lathes and equipment, \$14,976.96.—Demco Machinery Co. (Vic.) Pty. Ltd.
117. Royal Park, Turana Reception Centre, supply windows, \$4,362.00.—Crittall Manufacturing Co. (Aust.).
118. Melbourne, Public Works Department, supply steel sheet, piling, \$20,180.00.—Broken Hill Pty. Ltd.
119. Stawell, Technical School, supply tables, \$1,076.00.—Westbury Timber Co. Pty. Ltd.
120. Port Melbourne, Public Works Department Store-yard, supply tables, \$3,935.50.—Bera Cabinet Works Pty. Ltd.
121. Geelong, Technical School, supply lathes and equipment, \$4,320.80.—Demco Machinery Co. (Vic.) Pty. Ltd.
122. Geelong, Technical School, supply shaping machine, \$1,554.00.—Marweight Equipment Pty. Ltd.
123. Brighton, Hampton, St. Kilda, Breakwaters, supply and deliver spalls quarried stone, \$9,465.00.—Excavating Equipment Co.
124. Box Hill, Technical School, supply grinding machine, \$4,391.00.—Elgar Machinery (Aust.) Pty. Ltd.
125. Melbourne, Police Barracks, supply kitchen equipment, \$2,890.00.—Ahearn, Main & Stott Pty. Ltd.
126. Melbourne, Department of Lands and Survey, supply desks, \$1,148.00.—Lloyd Industries.
127. Williamstown, Ports and Harbours Dredging Depot, supply marine diesel engine, \$5,520.00.—Detroit Engine & Tool Co.
128. Hamilton, Technical School, supply tables, \$1,122.08.—Bera Cabinet Works Pty. Ltd.
129. Richmond, Technical School, supply welding tables, \$1,290.00.—W. E. Tuck.

#### ORDERS IN COUNCIL.—(Series 1966-67.)

##### EDUCATION DEPARTMENT.

3693. One (1) only power hacksaw, for Wonthaggi Technical School, \$408.50.—McPhersons Ltd.
3694. One (1) only A.C. electric welding machine, for Bairnsdale Technical School, \$235.98.—Replacement Parts Pty. Ltd.
3695. One (1) only hydraulic hand operated press, for Bairnsdale Technical School, \$520.20.—E. A. Machin & Co. Pty. Ltd.
3696. One (1) only electric resistance strain gauging equipment, for Footscray Technical College, \$533.90.—Jacoby Mitchell.

Approved by the Governor in Council, 6th June, 1967.—J. ROSSITER, Acting Clerk of the Executive Council.

##### PUBLIC WORKS.

3697. Castlemaine, High School, construction of an access road, additional, \$1,317.75.—City of Castlemaine.—(N.W.58349.)
3698. Geelong, Gordon Institute of Technology, provision of gas heating and hot water, \$1,127.00.—The Geelong Gas Company.—(S.W.114611.)
3699. Longerenong, Agricultural College, removal and re-siting of timber buildings to provide for erection of a new Glass House, \$1,560.00.—M. O'Callaghan (W.109233.)
3700. Melbourne, Public Works Department, supply of three life rafts to match standard equipment on small craft, \$1,896.00.—R.F.D. Co. Australia Pty. Ltd.—(P. & H. 43628.)
3701. Melbourne, Public Works Department, Architectural Branch, supply of drafting benches, \$1,215.00.—Westbury Timber Co. Pty. Ltd.—(C.111837 "B".)
3702. Sunshine, Technical School, urgent demolition and reinstatement of fire damaged building, \$7,419.00.—A. V. Jennings Industries (Australia) Ltd.—(W.116368.)
3703. Toorak, Marathon Spastic Centre, Physiotherapy Section, extension to section, \$1,400.00.—G. J. Little.—(E.M.70189.)
3704. Werribee, Research Farm, installation of a P.A.B.X. telephone installation, \$20,910.00.—L. M. Ericsson Pty. Ltd.—(S.W.87887.)
3705. Werribee, State School 649, provision of additional washing facilities, \$1,288.50.—Futuristic Plumbing & Contracting Service.—(S.W.46828.)
3706. Williamstown, Public Works Depot, Amenities Block, for electrical installation, \$1,450.00.—P. J. Lynch Pty. Ltd.—(P. & H. 99984 "A".)

Approved by the Governor in Council, 6th June, 1967.—J. ROSSITER, Acting Clerk of the Executive Council.

##### FORESTS COMMISSION.

Loan Fund Act No. 7453, Item 6—

3707. To the purchase of that lot 2, on plan of subdivision No. 26960, being part of Crown allotment 126, Parish of Scoresby, County of Mornington, for forest purposes, \$616.00.—Michael John and Marcia Judith Sawyer.

3708. To the purchase of that lots 106, 107 and 108, on plan of subdivision No. 26961, being parts of Crown allotment 126, Parish of Scoresby, County of Mornington, for forest purposes, \$858.00.—F. A. Ettwell and J. V. Riddle.

3709. To the purchase of that lot 76, on plan of subdivision No. 26961, being part of Crown allotment 126, Parish of Scoresby, County of Mornington, for forest purposes, \$500.00.—A. and B. S. Frey.

3710. To the purchase of that lot 111, on plan of subdivision No. 16961, being part of Crown allotment 126, Parish of Scoresby, County of Mornington, for forest purposes, \$484.00.—Jessie Margaret Pearl Stone.

3711. To the purchase of that lot 53, on plan of subdivision No. 26960, being part of Crown allotment 126, Parish of Scoresby, County of Mornington, for forest purposes, \$500.00.—Werner B. Grumach.

Approved by the Governor in Council, 17th May, 1967.—J. ROSSITER, Acting Clerk of the Executive Council.

Loan Fund Act No. 7453, Item 6—

3712. To the purchase of that lot 289, on plan of subdivision No. 12973, being part of Crown allotments 86 and 87, Parish of Scoresby, County of Mornington, for forest purposes, \$528.00.—Margaret Alice Molony.

Approved by Governor in Council, 30th May, 1967.—J. ROSSITER, Acting Clerk of the Executive Council.

##### STATE ELECTRICITY COMMISSION.

3713. For the construction of steel shell concrete core pile foundations for substation SO, South Melbourne, to Specification No. 66-67/303, at Schedule rates.—Frankipile Australia Pty. Ltd.

Approved by the Governor in Council, 2nd May, 1967.—J. COLQUHOUN, Clerk of the Executive Council.

3714. For the supply of 155 amp. active or neutral junction boxes for consumers' premises for a period of two years, with optional three months' extension, to Specification No. 66-67/306, at Schedule rates.—Mahlico Plastic Industries Pty. Ltd.

Approved by the Governor in Council, 10th May, 1967.—J. COLQUHOUN, Clerk of the Executive Council.

3715. For the supply and erection of coal conveyor from Morwell Open Cut to Hazelwood Power Station, to Specification No. 66-67/132, \$606,889.—Production Equipment Pty. Ltd.

3716. For the construction of brick oil store, hardstanding areas, fencing and drainage at Ringwood Area Centre, to Specification No. 66-67/326, \$30,644.—Williamsons Constructions.

Approved by the Governor in Council, 17th May, 1967.—J. ROSSITER, Acting Clerk of the Executive Council.

3717. For the supply of wooden guy warning devices for the distribution system for a period of two years with optional three months' extension, to Specification No. 66-67/239, at Schedule rates.—A. Arlavs.

3718. For the reroofing of storm damaged houses at Yallourn and East and North Newborough, to Quotation No. 2845A, at Schedule rates.—Ekon Industries Pty. Ltd.

3719. For the construction of ancillary store buildings and toilet blocks and alterations to pump house at Hazelwood Power Station, to Specification No. 66-67/301, \$47,926.72.—L. Sola Construction Co.

3720. For the supply of copper tie wire and toggles for the distribution system for a period of two years with optional three months' extension, to Specification No. 66-67/286, at Schedule rates.—Cablemakers (A.C.T.) Pty. Ltd.

3721. For the Supply of aluminium and copper tie wires for the distribution system for a period of two years with optional three months' extension, to Specification No. 66-67/286, at Schedule rates.—Copper and Aluminium Co. of Australia Pty. Ltd.

Approved by the Governor in Council, 23rd May, 1967.—J. ROSSITER, Acting Clerk of the Executive Council.

## State Electricity Commission Acts.

## ELECTRICAL APPROVALS BOARD.

PURSUANT to Regulation 16 of the Electrical Approvals Regulations—Approval of Equipment, 1953, the State Electricity Commission of Victoria hereby gives notice that it has withdrawn approval of the under-mentioned articles as from the dates shown hereunder :—

Name of Applicant.	Article and Reference No.	Date of Withdrawal.	Date of Certificate of Approval.	Approvals Marking.
Mrs. I. Newman, 25 Kooyong-road, Caulfield. Flo-Lite, Manufacturing Co.	Portable Lamp Cat. No. 27, 240 Volts, Ref. No. BN/A6L/01	21.4.67	18.10.62	V/A6L/27
	Portable Lamp Trade Name "Flo-Lite" Cat. No. F4S, 240 Volts, Ref. No. BN/A70/06	26.4.67	9.4.64	V/A70/F4S

Dated the 31st day of May, 1967.

F. P. CHIPPERFIELD, Secretary.

*Electric Light and Power Act 1958.*

## ORDER GRANTED BY THE GOVERNOR IN COUNCIL.

IT is hereby notified that an order pursuant to the provisions of the *Electric Light and Power Act 1958* (No. 6241) as hereunder mentioned has been granted by His Excellency the Governor in Council, viz.:—

Order No. 345. Order under section 10 of the above-mentioned Act granted to Mayor, Councillors and Citizens of City of Heidelberg in respect of land within the Shire of Diamond Valley.

J. C. M. BALFOUR,  
Minister for Fuel and Power.

## STAMPS ACT 1958.

NOTICE is hereby given that the certificate appearing in the *Government Gazette*, No. 389, dated 30th December, 1937, that Western Mining Corporation Limited was engaged solely or principally in the search or mining for gold is withdrawn as from the 14th day of June, 1967.

Dated the 14th day of June, 1967.

D. G. RICHARDS,  
Comptroller of Stamps.

*Housing Act 1958 (Section 99 of Act No. 6275).*

## GENERAL NOTICE TO PARTIES EMPOWERED BY THE "LANDS COMPENSATION ACT 1958" TO SELL AND CONVEY OR GRANT AND RELEASE PURSUANT TO SECTION 99 OF ACT 6275.

## GENERAL NOTICE TO TREAT FOR LAND IN A RECLAMATION AREA AT CARLTON.

IN pursuance of the provisions contained in the *Housing Act 1958* and of the *Lands Compensation Act 1958* Housing Commission (hereinafter referred to as the Commission) hereby doth give notice that the lands tenements and hereditaments described in the Schedule hereto are required for the purpose of the *Housing Act 1958* and that the Commission is authorized by the provisions of section 68 of the *Housing Act 1958* to purchase or take compulsorily the said lands.

And the Commission accordingly hereby gives notice to all the parties interested in such lands and to all persons empowered by the *Lands Compensation Act 1958* to sell and convey or grant and release the lands so required that it requires to take and purchase the lands referred to in the said Schedule hereto and that it is willing to treat with such parties or persons for the purchase thereof and as to the compensation to be made and for the damage that may be sustained by reason of the execution of the works.

And further the Commission hereby requires such parties or persons on or before the expiration of 21 days from the twenty-fourth day of June, 1967, to deliver to the offices of the Commission at 179 Queen-street, Melbourne, a statement in writing of the particulars of the estate and interest in the said lands tenements and hereditaments and of the claims made in respect thereof.

Dated the sixth day of June, 1967.

By order of the Commission,  
G. V. MONGAN,  
Acting Secretary.

## SCHEDULE.

All that land situate within the municipality of the City of Melbourne and being the whole of Crown allotments 1 to 10 (both inclusive), section 62, at Carlton, Parish of Jika Jika.

Plans are available for inspection at the Estates Branch of the Housing Commission situated on the Seventh Floor at 179 Queen-street, Melbourne, and forms for the making of claims will also be available on application to the Commission.

## DEPARTMENT OF LABOUR AND INDUSTRY.

## DETERMINATION OF THE CONDENSERIES BOARD.

ATTENTION is drawn to the fact that a notice of appeal to the Industrial Appeals Court has been lodged against the definition of "Ordinary Pay" appearing in Clause C of Clause 22—Annual Holiday of the Determination of the Condenseries Board made on the 17th May, 1967.

Section 45 (1) (b) of Act 6283 provides that when an appeal is made in accordance with that Act, the parts of the Determination appealed against shall not come into operation until the appeal has been dealt with by the Court.

M. WALSH, Secretary.

## DEPARTMENT OF LABOUR AND INDUSTRY.

## DETERMINATION OF THE BUTTER FACTORIES BOARD.

ATTENTION is drawn to the fact that a notice of appeal to the Industrial Appeals Court has been lodged against the definition of "Ordinary Pay" appearing in Clause C of Clause 22—Annual Holiday of the Determination of the Butter Factories Board made on the 17th May, 1967.

Section 45 (1) (b) of Act 6283 provides that when an appeal is made in accordance with that Act, the parts of the Determination appealed against shall not come into operation until the appeal has been dealt with by the Court.

M. WALSH, Secretary.

*Motor Car Act 1958.*

## APPROVAL OF PROTECTIVE HELMET FOR MOTOR CYCLISTS.

NOTICE is hereby given that the under-mentioned protective helmet has been approved by me as complying with Section 31 (1) of the *Motor Car Act 1958*.

Trade Name.	Submitted by.	Approval No.
A.G.V. Summit..	Protector Safety Products Pty. Ltd., 82-90 Gaffney-street, Coburg	H.6

R. H. ARNOLD,  
Chief Commissioner.



STATE RIVERS AND WATER SUPPLY COMMISSION.

LICENCE TO DIVERT WATER AND CUT RACE PURSUANT TO THE PROVISIONS OF SECTION 204 OF THE WATER ACT 1958 (AS AMENDED).

THE Licence as detailed hereunder to divert water and cut race has been revoked by the Governor in Council as from the date shown :—

Licence No.	Name of Licensee.	Source of Supply.	Term of Licence and Commencing Date.	Date of Revocation.
1141	Thomas Thornton, Tallygaroopna .. ..	Goulburn River ..	Fourteen and a half years from 1.1.58	1.1.67

Office of the State Rivers and Water Supply Commission, Melbourne, 6th June, 1967.

G. W. LEWIS, Secretary,  
State Rivers and Water Supply Commission.

MUNICIPAL ENGINEERS BOARD.

EXAMINATION—1967.

THE annual examination for the Certificate of Qualification as Municipal Engineer will be held during the month of August, 1967.

Applications for permission to sit must be lodged with the Secretary not later than 30th June, 1967.

G. T. MINSTER, Secretary,  
Municipal Engineers Board.

Local Government Department,  
61 Spring-street, Melbourne, C.1, Tel. 63 0321, Ext. 6741.

Cemeteries Act 1958.

SCALE OF FEES OF THE TARNAGULLA PUBLIC CEMETERY.

IN pursuance of the powers conferred upon them by the Cemeteries Act the trustees of the Tarnagulla Public Cemetery hereby make the following scale of fees, which shall come into operation upon publication in the *Government Gazette*, and from and after such publication every scale of fees heretofore made by the said trustees shall be and is hereby rescinded to the extent to which it conflicts with this scale.

Land, 8 ft. x 4 ft. . . . .	\$4.00
Sinking grave to a depth of 6 feet . . . . .	\$24.00
Sinking grave to a depth of 7 feet . . . . .	\$29.00
Reopening fee (no cover) . . . . .	\$18.00
Reopening fee (with cover) . . . . .	\$22.00
Number peg . . . . .	\$0.60
Interment on Saturdays, Sundays and Public Holidays (extra) . . . . .	\$6.00
Permission to erect a headstone or monument . . . . .	\$2.00

J. ALLEN, Trustee.  
J. HARWOOD, Trustee.  
A. HANCOCK, Trustee.

Approved by the Governor in Council, 6th June, 1967.—  
J. ROSSITER, Acting Clerk of the Executive Council.

Cemeteries Act 1958.

SCALE OF FEES OF THE YALLOURN PUBLIC CEMETERY.

IN pursuance of the powers conferred upon them by the Cemeteries Act the trustees of the Yallourn Public Cemetery hereby make the following scale of fees, which shall come into operation upon publication in the *Government Gazette*, and from and after such publication every scale of fees heretofore made by the said trustees shall be and is hereby rescinded to the extent to which it conflicts with this scale.

Lawn Section (Undenominational).

Land, 8 ft. x 4 ft. . . . .	\$60.00
For each interment therein . . . . .	\$30.00
Bronze plaque for each interment . . . . .	\$21.00
Flower container supplied by Trust . . . . .	\$8.00

Memorials.

Trees, from . . . . .	\$120.00
Shrubs . . . . .	\$60.00
Ashes buried in lawn . . . . .	\$10.00
Memorial plaques for any of the above . . . . .	\$12.00

Other Charges.

Land, 8 ft. x 4 ft. . . . .	\$20.00
Sinking grave 7 feet deep . . . . .	\$20.00
Sinking each additional foot . . . . .	\$4.00
Sinking oversize grave (6 feet) (extra) . . . . .	\$4.00
Sinking oversize grave for American casket (7 feet) (extra) . . . . .	\$10.00
Sinking grave for stillborn child . . . . .	\$3.00
Reopening grave (no cover) . . . . .	\$20.00
Reopening grave (with cover or kerb) . . . . .	\$24.00
Interment fee . . . . .	\$4.00
Interment fee on Saturdays . . . . .	\$8.00
Interment fee outside prescribed hours, Sundays or Public Holidays . . . . .	\$10.00
Permission to erect a headstone or monument 5 per cent. of cost, with a minimum of . . . . .	\$2.00
Permission to construct a brick grave or to erect any stone kerb, brick tilework or concrete . . . . .	\$2.00
Exhuming the remains of a body (when authorized) . . . . .	\$20.00
Interment of ashes in a private grave . . . . .	\$4.00
Removal of slab . . . . .	\$4.00

W. WALLACE, Trustee.  
J. LAWSON, Trustee.  
M. PHILLIPS, Trustee.  
P. OWEN, Trustee.

Approved by the Governor in Council, 6th June, 1967.—  
J. ROSSITER, Acting Clerk of the Executive Council.

Cemeteries Act 1958.

SCALE OF FEES OF THE CASTLEMAINE PUBLIC CEMETERY.

IN pursuance of the powers conferred upon them by the Cemeteries Act the trustees of the Castlemaine Public Cemetery hereby make the following scale of fees, which shall come into operation upon publication in the *Government Gazette*, and from and after such publication every scale of fees heretofore made by the said trustees shall be and is hereby rescinded to the extent to which it conflicts with this scale.

Lawn Section.

Land, 8 ft. x 4 ft. . . . .	\$48.00
-----------------------------	---------

L. CHAPMAN, Chairman and Trustee.  
R. SEDDON, Trustee.  
A. HEATHER, Trustee.  
J. HARRIS, Trustee.  
E. COOPER, Trustee.  
L. W. SWIFT, Secretary.

Approved by the Governor in Council, 6th June, 1967.—  
J. ROSSITER, Acting Clerk of the Executive Council.

Cemeteries Act 1958.

SCALE OF FEES OF THE DAYLESFORD PUBLIC CEMETERY.

IN pursuance of the powers conferred upon them by the Cemeteries Act the trustees of the Daylesford Public Cemetery hereby make the following scale of fees, which shall come into operation upon publication in the *Government Gazette*, and from and after such publication every

scale of fees heretofore made by the said trustees shall be and is hereby rescinded to the extent to which it conflicts with this scale.

Depositing of ashes in a private grave or vault . . \$10.00

D. MCKINNON, Trustee.  
N. WALKER, Trustee.  
H. WILLIAMS, Trustee.  
W. HART, Trustee.  
H. BATH, Trustee.  
V. NEWTON, Trustee.

Approved by the Governor in Council, 6th June, 1967.—  
J. ROSSITER, Acting Clerk of the Executive Council.

*Cemeteries Act 1958.*

SCALE OF FEES OF THE HARKAWAY PUBLIC CEMETERY.

IN pursuance of the powers conferred upon them by the Cemeteries Act the trustees of the Harkaway Public Cemetery hereby make the following scale of fees, which shall come into operation upon publication in the *Government Gazette*, and from and after such publication every scale of fees heretofore made by the said trustees shall be and is hereby rescinded to the extent to which it conflicts with this scale.

Interment fee . . . . . \$4.00

H. WANKE, Trustee and Secretary.  
A. WANKE, Trustee.  
S. EXELL, Trustee.  
A. ROBINSON, Trustee.

Approved by the Governor in Council, 6th June, 1967.—  
J. ROSSITER, Acting Clerk of the Executive Council.

*Cemeteries Act 1958.*

SCALE OF FEES OF THE PORTLAND PUBLIC CEMETERY.

IN pursuance of the powers conferred upon them by the Cemeteries Act the trustees of the Portland Public Cemetery hereby make the following scale of fees, which shall come into operation upon publication in the *Government Gazette*, and from and after such publication every scale of fees heretofore made by the said trustees shall be and is hereby rescinded to the extent to which it conflicts with this scale.

*Private Graves.*

Land, 8 ft. x 4 ft. . . . .	\$25.00
Sinking grave to a depth of 6 feet . . . . .	\$16.00
Sinking grave to a depth of 7 feet . . . . .	\$20.00
Reopening grave . . . . .	\$16.00
Burials on Saturdays, Holidays (extra) . . . . .	\$12.00
Insufficient notice . . . . .	\$5.00
Interment of a child under twelve years . . . . .	\$8.00
Interment of a stillborn child . . . . .	\$6.00

E. KEMPTON, Trustee.  
J. PITTS, Trustee.  
D. BREWSTER, Trustee.

Approved by the Governor in Council, 6th June, 1967.—  
J. ROSSITER, Acting Clerk of the Executive Council.

*Cemeteries Act 1958.*

SCALE OF FEES OF THE SORRENTO PUBLIC CEMETERY.

IN pursuance of the powers conferred upon them by the Cemeteries Act the trustees of the Sorrento Public Cemetery hereby make the following scale of fees, which shall come into operation upon publication in the *Government Gazette*, and from and after such publication every scale of fees heretofore made by the said trustees shall be and is hereby rescinded to the extent to which it conflicts with this scale.

*Private Graves.*

Land, 8 ft. x 4 ft. . . . .	\$9.00
Land, 8 ft. x 8 ft. . . . .	\$18.00
Reopening grave (no cover) . . . . .	\$8.00
Reopening grave (with cover) . . . . .	\$12.00
Burials on Saturdays, Sundays and Holidays (extra) . . . . .	\$6.00
Sinking grave . . . . .	\$12.00

H. WATTS, Trustee.  
A. CROAD, Trustee.  
H. STRINGER, Trustee.

Approved by the Governor in Council, 6th June, 1967.—  
J. ROSSITER, Acting Clerk of the Executive Council.

Melbourne and Metropolitan

BOARD OF WORKS

GENERAL NOTICE.

THE Melbourne and Metropolitan Board of Works having made provision for carrying off the sewage of each and every property which or any part of which is situate in the Sewerage Areas hereinafter described doth hereby declare that on and after the 14th day of July, 1967, each and every property so situate shall be deemed to be a sewerer property within the meaning of the *Melbourne and Metropolitan Board of Works Act 1958*.

The Sewerage Areas hereinbefore referred to are:—

*Sewerage Area No. 2112.*

*City of Sunshine.*—Commencing at the junction of Ballarat-road and Perth-avenue; thence southerly along Perth-avenue, westerly along Westwood Way, southerly along the eastern boundary of lot 54 Westward Way to the boundary of Sewerage Area No. 1,778, westerly generally southerly and easterly following the said area boundary to the junction of Delmont-street and Selwyn-street, southerly and south-easterly along Selwyn-street, westerly along the southern boundaries of lots 109 Selwyn-street and 107 to 104 Dalworth-street, northerly along portion of the western boundary of the said lot 104, westerly along the southern boundaries of lots 103 and 110 Norwood-street, northerly along the western boundaries of lots 110 to 136, 16 to 20 and 41 to 33 Norwood-street to Ballarat-road, easterly along Ballarat-road to the commencing point.

*Sewerage Area No. 2113.*

*City of Broadmeadows.*—Commencing at the junction of North-street and David-street; thence southerly along David-street, westerly along Middle-street, generally northerly along Volga-street, easterly along North-street, southerly along the eastern boundaries of lots 3 North-street and 4 to 16 Volga-street, easterly along portion of the northern boundary of a reserve, further easterly along the northern boundaries of lots 32 to 19 Angus-street, northerly by a line 409 feet west of and parallel to the western boundary of David-street to North-street, easterly along North-street to the commencing point.

*Sewerage Area No. 2114.*

*Cities of Box Hill and Camberwell.*—Commencing at the junction of Winfield-road and Clifton-street; thence north-easterly along Clifton-street to Koonung Creek, generally easterly and southerly following the said creek to the boundary of Sewerage Area No. 1,764, further southerly, westerly, southerly and westerly following the said area boundary to Winfield-road, northerly and westerly along Winfield-road to the commencing point.

*Sewerage Area No. 2115.*

*City of Nunawading.*—Commencing at the junction of Berl-court and Orchard-grove; thence southerly along Orchard-grove, westerly along the southern boundary of lot 5 Orchard-grove, northerly along the western boundaries of lots 5 to 3 Orchard-grove, westerly along the southern boundaries of lots 10 to 1 Canora-street, northerly along the western boundary of the said lot 1, westerly along Canora-street, northerly along the western boundary of lot 34 Canora-street, easterly along the northern boundaries of the said lot 34 and lot 35 Canora-street, northerly along the western boundary of lot 26 Baratta-street, westerly along Baratta-street, southerly along the eastern boundary of lot 9 Baratta-street, westerly and northerly along the southern and western boundaries of the said lot 9, westerly along Baratta-street, northerly along the western boundaries of lots 58 Baratta-street and 57 Edinburgh-road, easterly along Edinburgh-road, northerly along the western boundaries of lots 68 Edinburgh-road, 60 and 59 Baird-court and 51 St. James-court to the boundary of Sewerage Area No. 2,099, generally easterly following the said area boundary to Orchard-grove, southerly along Orchard-grove to the commencing point.

By order of the Board,

H. J. SNADDEN,

Secretary.

110 Spencer-street, Melbourne, C.1.  
13th June, 1967.

## APPOINTMENTS AND RESIGNATIONS

### APPOINTMENTS.

**H**IS Excellency the Governor of the State of Victoria, by and with the advice of the Executive Council thereof, has, by Orders made on the 6th day of June, 1967, been pleased to make the under-mentioned appointments, viz.:—

#### CHIEF SECRETARY'S DEPARTMENT.

##### *Assistants to the Inspector of Fisheries.*

SAMUEL WILLIAM BARRETT,  
DAVID BATCHER,  
JACK CLIFFORD WOODS, and  
ALAN KENNETH WAY,  
pursuant to section 6 of the Fisheries Act 1958, to be Assistants to the Inspector of Fisheries.

##### *Stipendiary Probation Officer, &c.*

MICHAEL HAMEL-GREEN,  
pursuant to the provisions of section 9 (2) of the Children's Court Act 1958, section 507 (1) and section 533 (3) of the Crimes Act 1958 and section 36 (1) of the Social Welfare Act 1960, to be a Stipendiary Probation Officer for every Children's Court, a Stipendiary Probation Officer and a Stipendiary Parole Officer and a Stipendiary Youth Parole Officer, respectively.

#### HEALTH DEPARTMENT.

##### *Members of the Committees of Management of Hospitals.*

CLARENCE HEDLEY COLLINS, J.P.,  
to be a Member of the Committee of Management of Kerang and District Hospitals, and

STANLEY ARTHUR HOOD STEVENS  
to be a Member of the Committee of Management of Boort District Hospital, pursuant to proviso (a) to section 48 (1) of the Hospitals and Charities Act 1958, for a further period of three years ending 16th June, 1970; and

HUBERT JOHN PRISTON ELMS  
to be a Member of the Committee of Management of Waranga Memorial Hospital, pursuant to proviso (a) to section 48 (1) of the Hospitals and Charities Act 1958, for a further period of three years ending the 29th May, 1970.

##### *Member of Victorian Nursing Council.*

MURIEL MARCIA YARRINGTON  
to be a Member of the Victorian Nursing Council, on the nomination of the Mental Health Authority, pursuant to section 4 (2) (c) of the Nurses Act 1958, for the period ending 28th September, 1968, vice Miss B. M. Holmes, resigned.

##### *Trustees of Public Cemeteries.*

ALFRED ANDREW DAVIS  
to be a Trustee of the Buninyong Public Cemetery, additional Trustee;

DOUGLASS IAN WESTLAND  
to be a Trustee of the Kerang Public Cemetery, additional Trustee;

ALEXANDER MOORE,  
RAYMOND STOCKDALE and  
WILLIAM TOM  
to be Trustees of the Darraweit Guim Public Cemetery, additional Trustees;

LEO FLYNN  
to be a Trustee of the Toolamba Public Cemetery, vice W. Daunt, deceased;

JOHN GREIG,  
STANLEY LEE and  
LESLIE VAGG  
to be Trustees of the Camperdown Public Cemetery, additional Trustees;

DONALD PERCIVAL GRAHAM,  
to be a Trustee of the Wunghnu Public Cemetery, additional Trustee;

WALLACE PERCIVAL BROWN,  
to be a Trustee of the Drik Drik Public Cemetery, vice N. Lightbody, resigned;

WILLIAM THOMAS BYRNE and  
PATRICK BRODY  
to be Trustees of the Balmoral Public Cemetery, vice T. Byrne and H. Brody, both deceased;

RALPH CAINER  
to be a Trustee of the Brighton General Cemetery, vice A. Groenewoud, resigned;

GORDON HAROLD SMITH,  
PETER MELKSHAM HANNAFORD and  
GEORGE BRICE CRAIG  
to be Trustees of the Apsley Public Cemetery, vice D. Cooper, T. Ruth and E. McDonald, all resigned;

ALBERT CULVENOR  
to be a Trustee of the Glen Gower Public Cemetery, vice W. O'Callaghan, resigned; and

ROBERT SCHOFIELD JENKINS  
to be a Trustee of the Templestowe Public Cemetery, vice J. Aumann, deceased.

##### *Public Vaccinator.*

NICHOLAS CHARLES DIAMOND, M.B., B.S.,  
to be Public Vaccinator for the Municipality of South Gippsland.

#### LAW DEPARTMENT.

##### *Commissioners for Taking Declarations, &c.*

CEDRIC WILFRED FAIRHALL, care of the Anderson Co-operative Credit Society Limited, 11 Anderson-road, Thornbury,  
to be a Commissioner for taking Declarations and Affidavits, pursuant to the provisions of the Evidence Act 1958, to resign upon ceasing to occupy his present position; and

LEWIS SCHEMBRI, 14 Maryvale-street, Sunshine,  
to be a Commissioner for taking Declarations and Affidavits, pursuant to the provisions of the Evidence Act 1958, to resign upon removing from the neighbourhood of the address stated.

##### *Deputy Prothonotary.*

JOHN JOSEPH CAVEN, Clerk of Courts, Class "CC-3", Professional Division, Department of Law,  
to be Deputy Prothonotary at Mildura, during the absence of J. Kearney on annual leave, to take effect from the date of commencement of duty.

##### *Justices of the Peace.*

ROBERT VALENTINE DICKSON, Grandview-crescent, Healesville,  
ALFRED SHIFF, 365 Alma-road, Caulfield, and  
RUPERT WILLIAM GILMORE, Main-street, Garfield,  
to Keep the Peace in the Central Bailiwick of the State of Victoria.

#### DEPARTMENT OF PUBLIC WORKS.

##### *Wharf Manager.*

Senior Constable WILLIAM JAMES HOPKINS, No. 11985,  
to be Wharf Manager, at Altona, to carry out that portion of Part II. of the Marine Act 1958 which relates to the management of Public Wharfs, and to be an officer under section 19 of such Act, to levy and collect wharfage rates thereat, vice Senior Constable Sydney Phillip Emerson, No. 8740, superannuated.

#### DEPARTMENT OF WATER SUPPLY.

##### *Waterworks Trusts Commissioners.*

DAVID RATRAY MCFARLANE  
to be a Commissioner of the Avoca River Improvement Trust for a period of four years from the date hereof, subject to the provisions of the River Improvement Act 1958;

PHILIP CARDIGAN KING  
to be a Commissioner of the Bairnsdale Waterworks Trust, to hold office as such for a period of one year from the date hereof, subject to the provisions of the Water Act;

ALBERT NEVILL SARGENT  
to be a Commissioner of the Bruthen Waterworks Trust, to hold office as such for a period of four years from the date hereof, subject to the provisions of the Water Act;

DAVID BLOODWORTH  
to be a Commissioner of the Nagambie Waterworks Trust, to hold office as such for a period of four years from the date hereof, subject to the provisions of the Water Act;

JAMES HENRY TREVASKIS  
to be a Commissioner of the Tatura Waterworks Trust, to hold office as such for a period of four years from the date hereof, subject to the provisions of the Water Act; and

PHILLIP BRADSHAW WEST  
to be a Commissioner of the Westernport Waterworks Trust, to hold office as such for a period of four years from the date hereof, subject to the provisions of the Water Act.

*Sewerage Authority Member.*

LINDSAY COUPE WHITWELL  
to be a member of the Springvale and Noble Park Sewerage Authority, to hold office as such for a period of four years from the date hereof, subject to the provisions of the Sewerage Districts Act.

J. ROSSITER,  
Acting Clerk of the Executive Council.

At the Executive Council Chamber,  
Melbourne, 6th June, 1967.

## FORESTS COMMISSION.

## APPOINTMENT OF COMMITTEE OF MANAGEMENT OF THE MCKENZIE RIVER RESERVE.

WHEREAS by section 50 of the *Forests Act 1958* (No. 6254), it is provided that the Minister of Forests may, on the recommendation of the Forests Commission, appoint any number of persons, not less than three, to be a Committee of Management of any land forming part of any reserved forest, such land being set aside as a Special Purpose Reserve, and may remove any of those persons: Now therefore, I, Edward Raymond Meagher, Her Majesty's Minister of Forests for the State of Victoria, on the recommendation of the Forests Commission, do hereby appoint—

R. H. CARINE,  
Cr. E. F. P. GERLACH,  
J. A. MCCORMACK,  
S. R. CARR,  
E. M. FLOYD,  
Cr. J. P. MCDOWELL,  
Cr. G. L. MCTAVISH,  
A. J. PRYOR, and  
C. H. G. PAVEY,

as members of the Committee of Management until the twelfth day of December, 1969, of the land forming part of the reserved forest in the Parishes of Burrong North and Burrong South, County of Borung, described in the accompanying Schedule and known as "McKenzie River Reserve".

## SCHEDULE ABOVE REFERRED TO.

Parishes of Burrong North and Burrong South, County of Borung, 847 acres, more or less, being the area shown by pink colour on plan marked A.52/1382 over 13.12.54, on file of correspondence No. 58/1308 of the Forests Department.

Dated at Melbourne, the ninth day of June, 1967.

E. R. MEAGHER,  
Minister of Forests.

*National Parks Act 1958.*

## APPOINTMENTS.

NOTICE is hereby given that the National Parks Authority has made the following appointments:—

*Fern Tree Gully National Park.—Committee of Management.*

D. P. MAGUIRE,

as a member of the Committee of Management of the Fern Tree Gully National Park, for the period ending 30th September, 1969, vice A. Blair, resigned.

*Fraser National Park.—Committee of Management.*

K. JEROME,

as a member of the Committee of Management of the Fraser National Park, for the period ending 30th September, 1969, vice J. Channon, resigned.

*Authorized Officers.*

KEITH HATELEY, of Kiata,  
WILLIAM CORRIE, of Mallcoota, and  
OWEN PETER McDONALD, of Warmambool.

as Authorized Officers for the purposes of the National Park Regulations 1959, to hold office for so long as they remain officers of the Authority.

L. H. SMITH, Director.

Office of the National Parks Authority,  
1st June, 1967.

## RESIGNATIONS.

HIS Excellency the Governor of the State of Victoria, by and with the advice of the Executive Council thereof, has, by Orders made on the 6th day of June, 1967, accepted the resignations of the persons named hereunder of the offices mentioned, viz.:—

## LAW DEPARTMENT.

*Commissioner for Taking Declarations, &c.*

PAUL COURT, as a Commissioner for taking Declarations and Affidavits, pursuant to the provisions of the *Evidence Act 1958*.

*Justices of the Peace.*

The resignations of the persons named in the first column of the Schedule hereto, from the Commission of the Peace for the respective Bailiwicks of the State of Victoria set opposite their names in the second column of the said Schedule.

## SCHEDULE.

Name.	Bailiwick.
JOHN WILLIAM STORR .. .. .	Central
FRANCIS SAMUEL WATERS .. .. .	Central
DESMOND JULES HEALEY .. .. .	Central
GEORGE FLEETWOOD ROWE .. .. .	Midland

J. ROSSITER,

Acting Clerk of the Executive Council.

At the Executive Council Chamber,  
Melbourne, 6th June, 1967.

## ORDERS IN COUNCIL

*Hospitals and Charities Act 1958, Section 52.*

## VARIATION OF THE OBJECTS OR PURPOSES OF THE NHILL HOSPITAL.

At the Executive Council Chamber, Melbourne, the sixth day of June, 1967.

## PRESENT:

His Excellency the Governor of Victoria.

Mr. Chandler | Mr. Thompson.

WHEREAS The Nhill Hospital is an incorporated institution within the meaning of the *Hospitals and Charities Act 1958*;

AND WHEREAS the Committee of Management of the said institution has agreed that the objects or purposes of the said institution should be varied;

AND WHEREAS the Hospitals and Charities Commission after enquiry has recommended that the objects or purposes should be varied;

NOW THEREFORE His Excellency the Governor of the State of Victoria, by and with the advice of the Executive Council of the said State, and by virtue of the powers conferred on him by Section 52 of the *Hospitals and Charities Act 1958* and all other powers enabling him in that behalf, hereby varies the objects or purposes of The Nhill Hospital so that such objects or purposes shall be as follows:—

- To afford relief, including maintenance and the treatment or cure of, or attention to, any disease or ailment, or any injury consequent on any accident, medical and/or surgical attendance, medicine, nursing assistance, support or aid of any kind or in any form to such persons as are entitled thereto under the Act;
- to provide facilities for the treatment of intermediate and private patients or either of them;
- to provide facilities for the training of nursing aides.

And the Honorable Vance Oakley Dickie, Her Majesty's Minister of Health for the State of Victoria, shall give the necessary directions herein accordingly.

J. ROSSITER,

Acting Clerk of the Executive Council.

DEPARTMENT OF CROWN LANDS AND SURVEY.

At the Executive Council Chamber, Melbourne, the sixth day of June, 1967.

PRESENT:

His Excellency the Governor of Victoria.  
Mr. Chandler | Mr. Thompson.

LANDS TEMPORARILY RESERVED AS SITES.

HIS Excellency the Governor of the State of Victoria, by and with the advice of the Executive Council thereof, doth hereby, in pursuance of section 14 of the Land Act 1958, reserve temporarily from sale, from being leased and from having a licence granted in respect thereof, and also except from occupation for mining purposes under any miner's right, the lands hereinafter described:—

BOORT.—Site for State School purposes, 2 acres 2 roods 16 perches, Township of Boort, Parish of Boort, County of Gladstone, as indicated by hatching on plan hereunder.—(B.654<sup>(10)</sup>) (Rs.8775).

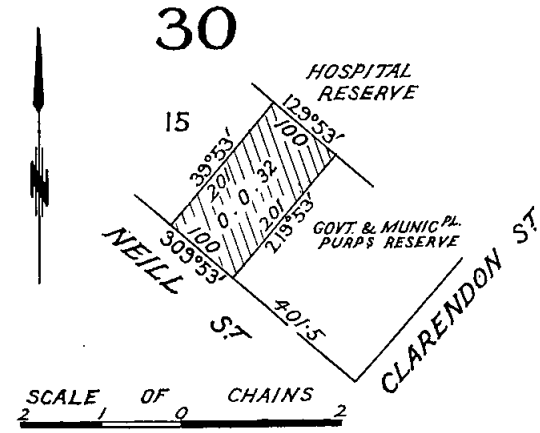
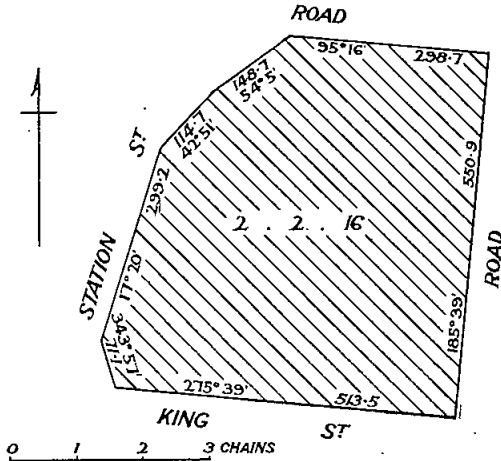

SCALE OF CHAINS

NELSON.—Site for Public Recreation, 1 acre 30 perches, more or less, Township of Nelson, Parish of Glenelg, County of Normanby, as indicated by hatching on plan hereunder.—(N.51<sup>(8)</sup>) (Rs.4725).

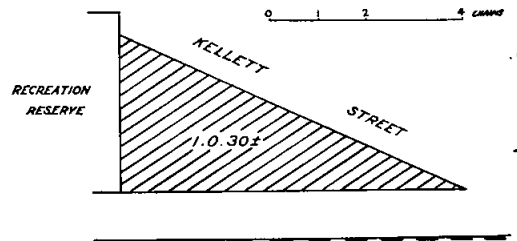

GEELONG.—Site for Agricultural Showgrounds and Public Recreation, 1 acre 1 rood 10 perches, more or less, City of Geelong, Parish of Corio, County of Grant, as indicated by hatching on plan hereunder.—(C.272<sup>(6)</sup>) (Rs.8262).

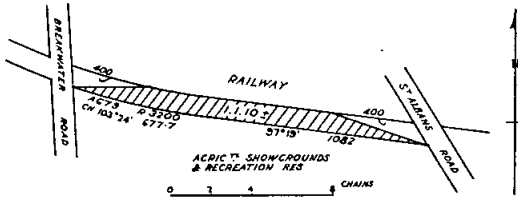

GEELONG.—Site for Railway purposes, 1 rood 25 perches, more or less, City of Geelong, Parish of Corio, County of Grant, as indicated by hatching on plan hereunder.—(C.272<sup>(6)</sup>) (Rs.8832).

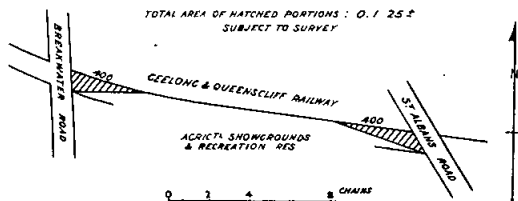

NEWRY.—Site for Public Recreation, 1 rood 10 perches, more or less, Township of Newry, Parish of Maffra, County of Tanjil, as indicated by hatching on plan hereunder.—(N.101<sup>(2)</sup>) (Rs.6069).

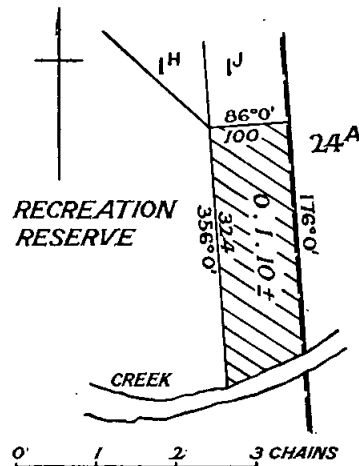

MILDURA (at Red Cliffs).—Site for Public purposes, Park and Recreation and convenience of the people, 20 perches, at Red Cliffs, Parish of Mildura, County of Karkaroc, as indicated by hatching on plan hereunder.—(R.87<sup>(3)</sup>) (Rs.3631).

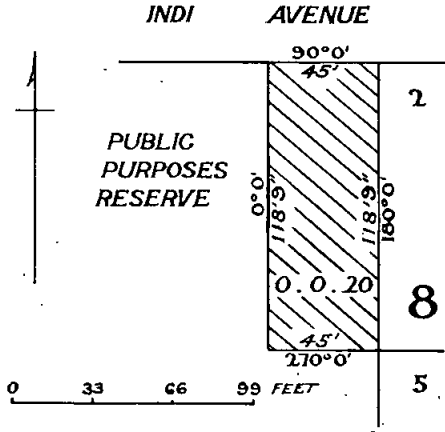

provisions of section 349 of the Land Act 1958, the unused roads referred to hereunder be closed, viz.:

Parish of Axedale, County of Rodney, being the road indicated by hatching on plan hereunder.—(A.98<sup>(4)</sup>) (W.83753).

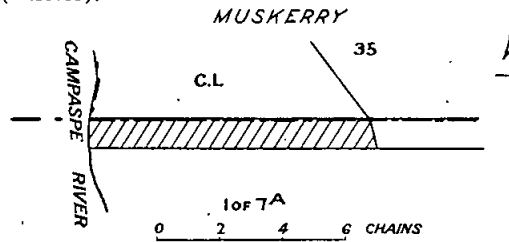

Parish of Acheron, County of Anglesey, being the road indicated by hatching on plan hereunder.—(A.159<sup>(5)</sup>) (H.029754).

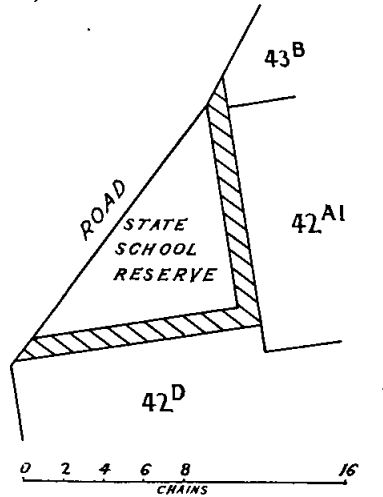

STAWELL.—Site for Hospital purposes, 1 rood, Township of Stawell, Parish of Stawell, County of Borung, as indicated by hatching on plan hereunder.—(S.329<sup>(13)</sup>) (Rs.6104).

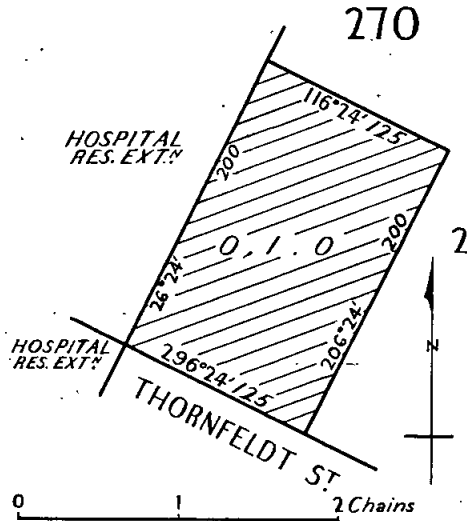

Parish of Arcadia, County of Moira, being the road forming the western boundary of allotment 28B.—(A.171<sup>(6)</sup>) (H.013456).

Township of Ballarat, Parish of Ballarat, County of Grenville, being the roads indicated by hatching on plan hereunder.—(B.128<sup>(67)</sup>) (Rs.3712).

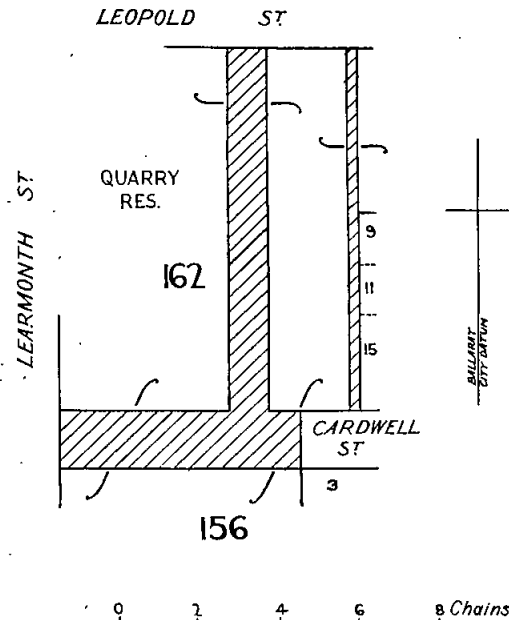

And the Honorable William John Farquhar McDonald, Her Majesty's Minister of Lands for the State of Victoria, shall give the necessary directions herein accordingly.

J. ROSSITER,  
Acting Clerk of the Executive Council.

DEPARTMENT OF CROWN LANDS AND SURVEY.

At the Executive Council Chamber, Melbourne, the sixth day of June, 1967.

PRESENT:  
His Excellency the Governor of Victoria.  
Mr. Chandler                      Mr. Thompson.

UNUSED ROADS CLOSED.

HIS Excellency the Governor of the State of Victoria, by and with the advice of the Executive Council thereof, doth hereby direct that, in pursuance of the

Parish of Buninyong, County of Grant, being the portion of the width of the road indicated by hatching on plan hereunder.—(B.489<sup>(10)</sup>) (C.99893).

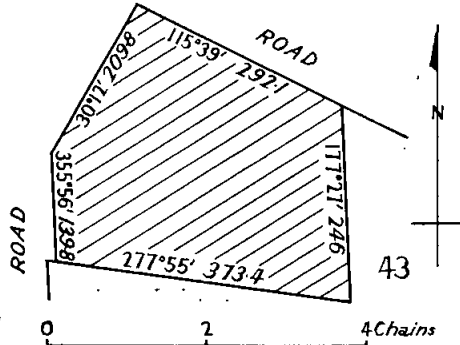

Township of Nowa Nowa, Parish of Ninnie, County of Tambo, being the road indicated by hatching on plan hereunder.—(N.144 (C<sup>1</sup>)) (H.03641).

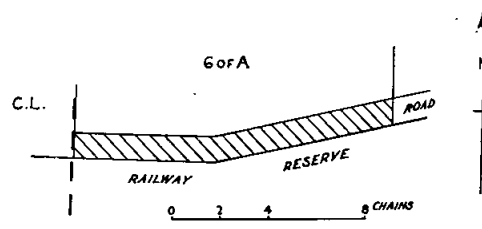

And the Honorable William John Farquhar McDonald, Her Majesty's Minister of Lands for the State of Victoria, shall give the necessary directions herein accordingly.

J. ROSSITER,  
Acting Clerk of the Executive Council.

City of Hawthorn, Parish of Boroondara, County of Bourke, being the portion of the width of the road indicated by hatching on plan hereunder.—(B.415<sup>(9)</sup>) (Misc. 3757).

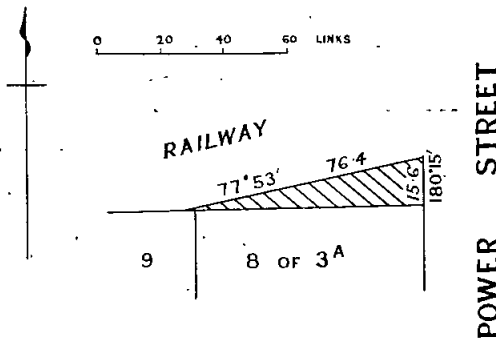

LABOUR AND INDUSTRY ACT 1958.

At the Executive Council Chamber, Melbourne, the sixth day of June, 1967.

PRESENT:

His Excellency the Governor of Victoria.  
Mr. Chandler | Mr. Thompson.

INDUSTRIAL APPEALS COURT.—APPOINTMENT OF PRESIDENT.

IN pursuance of the powers conferred by the *Labour and Industry Act 1958*, His Excellency the Governor of the State of Victoria, by and with the advice of the Executive Council thereof, doth by this Order appoint—

GEORGE LEO DETHRIDGE

a Judge of County Courts having experience in industrial matters, to be President of the Industrial Appeals Court for a term of five years as on and from the twelfth day of June, 1967.

And the Honorable John Frederick Rossiter, Her Majesty's Minister of Labour and Industry for the State of Victoria, shall give the necessary directions herein accordingly.

J. ROSSITER,  
Acting Clerk of the Executive Council.

Parish of Koyuga, County of Rodney, being the road indicated by hatching on plan hereunder.—(K.98<sup>(8)</sup>) (W.87723).

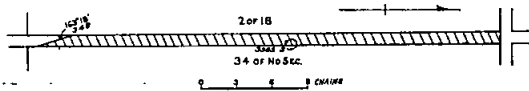

Parish of Nurrabiel, County of Lowan, being the portion of the width of the road indicated by hatching on plan hereunder.—(N.103<sup>(9)</sup>) (M.53537).

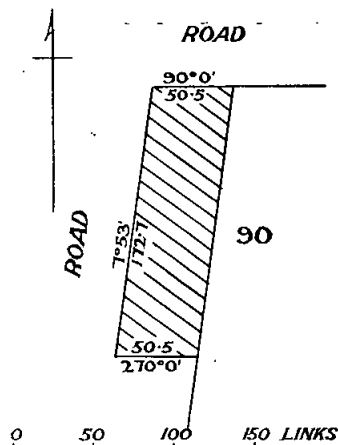

LANDS DEPARTMENT NOTICES

APPROACHING LAND SALES.

SALES of Crown lands, in fee-simple, will be held at the under-mentioned places and dates, viz.:—

	No. of Gazettes.
Ararat.—Thursday, 15th June, 1967	40
Ballarat.—Tuesday, 4th July, 1967	38
Geelong.—Wednesday, 26th July, 1967	49
Ouyen.—Tuesday, 18th July, 1967	49
Rushworth.—Thursday, 15th June, 1967	40
Stawell.—Friday, 16th June, 1967	40
Tongala.—Thursday, 15th June, 1967	40
Wangaratta.—Thursday, 13th July, 1967	49

LOCAL LAND BOARDS.

IN pursuance of the provisions of section 34 of the *Land Act 1958*, notice is hereby given that public hearings at the following places and times, will be conducted by the persons respectively mentioned, being duly appointed in that behalf.

W. J. F. McDONALD,  
Minister of Lands.

Department of Crown Lands and Survey,  
Melbourne.

SCHEDULE.

BRIGHT, LAND INSPECTOR'S OFFICE, on Wednesday, 28th June, 1967, at 10.30 a.m.—F. F. Holt.

ECHUCA, COURT HOUSE, on Thursday, 29th June, 1967, at 3 p.m., and Friday, 30th June, 1967, at 9 a.m.—T. A. Comte.

*Land Act 1958.*

## LICENCES UNDER THE LAND ACTS DECLARED VOID.

NOTICE is hereby given that the Licence in the Schedule hereunder has been Declared Void for the reason specified.

District.	Corr. No.	Name of Licensee.	Section of Land Act under which Licensed.	Township.	Allotment.	Section.	Area.	Annual Rental.	Reason for Voiding.
Ballarat ..	0278/129	Estate of James Braidie, Dec'd.	Sec. 129 <i>Land Act 1915</i>	Sebastopol	3	12B	A. R. P. 3 0 0	\$ 0.10	Non-compliance with Conditions of Licence

Department of Crown Lands and Survey,  
Melbourne, 2nd June, 1967.

W. J. F. McDONALD,  
Minister of Lands.

*Land Act 1958.*

## PERMIT CANCELLED.

NOTICE is hereby given that the Permit in the Schedule hereunder has been cancelled.

District.	Corr. No.	Name of Permit Holder.	Parish.	Allotment.	Section.	Area.
Mallee .. ..	79/8	Ernest Adams .. ..	Koleya .. ..	51, 52	..	A. R. P. 3,629 0 0

Department of Crown Lands and Survey,  
Melbourne 2nd June, 1967.

W. J. F. McDONALD,  
Minister of Lands.

*Land Act 1958.*

## LEASE DECLARED VOID.

NOTICE is hereby given that the Governor in Council has declared void the Lease mentioned in the Schedule hereunder for the reason specified.

District.	Corr. No.	Name.	Section of Land Act under which Leased.	Parish.	Allotment.	Section.	Area.	Class.	Reason.
Mallee ..	7/4	Kenneth John Crozier	Sec. 4 <i>L.A 1934</i>	Mullroo ..	..	..	12,784 acres	..	Lease Expired

Department of Crown Lands and Survey,  
Melbourne, 6th June, 1967.

W. J. F. McDONALD,  
Minister of Lands.

## PROPOSED REVOCATIONS OF TEMPORARY RESERVATIONS OF LANDS BY ORDERS IN COUNCIL.

IN pursuance of the provisions of the *Land Act 1958*, notice is hereby given that it is the intention of the Governor in Council to revoke the temporary reservation of land by Order in Council hereunder referred to, viz.:

The following Notice was published 1° on the 14th June, 1967, pursuant to Orders of the 6th June, 1967.

CRANBOURNE.—The temporary reservation, by Order in Council of the 14th October, 1867, of 45 acres 1 rood, more or less, of land in the Parish of Cranbourne, as a site for Camping and Watering purposes, revoked as to part by various Orders, is about to be revoked so far as the balance thereof, containing 8 acres 2 roods 8 perches, more or less, is concerned.—(C.329(+)) (Rs.7649).

W. J. F. McDONALD,  
Minister of Lands.

## PROPOSED PERMANENT RESERVATION OF LAND AS A SITE.

IN pursuance of sections 14 and 21 of the *Land Act 1958*, notice is hereby given that it is the intention of the Governor in Council to reserve permanently from sale, from being leased and from having a licence granted in respect thereof the land hereinafter described:—

The following notice was published 1° on the 24th May, 1967, pursuant to Order of the 28th February, 1967.

TATURA.—Land proposed to be permanently reserved as a Site for Racecourse and other purposes of Public Recreation, 94 acres 3 roods 27 perches, Township of Tatura, Parish of Toolamba West, County of Rodney, being the remaining portion of the site temporarily reserved therefor by Order in Council of the 21st February, 1881.—(T.252(°)) (Rs.478).

JIM BALFOUR,  
Minister of Lands.



PROPOSED REVOCATIONS OF TEMPORARY RESERVATIONS OF LANDS BY ORDERS IN COUNCIL.

IN pursuance of the provisions of the *Land Act 1958*, notice is hereby given that it is the intention of the Governor in Council to revoke the temporary reservations of lands by Orders in Council hereunder referred to, viz.:

The following Notices were published 1° on the 31st May, 1967, pursuant to Orders of the 23rd May, 1967.

**BALMORAL.**—The temporary reservation, by Order in Council of the 18th June, 1894, of 3 acres 2 roods of land in the Township of Balmoral, as a site for a Manure Depot, is about to be revoked so far only as the portion containing 18 perches, more or less, indicated by hatching on plan hereunder, is concerned.—(B.43<sup>(5)</sup>) (Rs.3047).

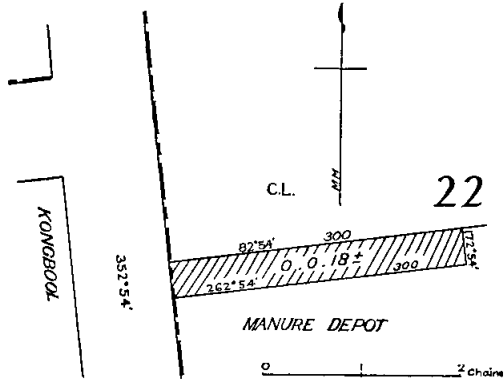

**COLONGULAC.**—The temporary reservation, by Order in Council of the 28th October, 1872, of 9 acres, more or less, of land in the Parish of Colongulac, as a site for Public purposes, revoked as to part by various orders, is about to be revoked so far only as the portion containing 6 perches, indicated by hatching on plan hereunder, is concerned.—(C.294<sup>(2)</sup>) (Rs.187).

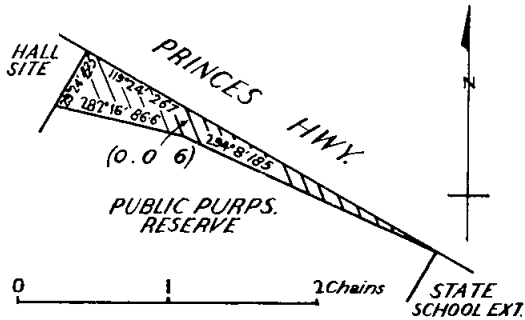

**COLONGULAC.**—The temporary reservation, by Order in Council of the 31st March, 1925, of 2 roods of land in the Parish of Colongulac, as a site for a Public Hall, is about to be revoked so far only as the portion containing 36 perches, indicated by hatching on plan hereunder, is concerned.—(C.294<sup>(2)</sup>) (Rs.3093).

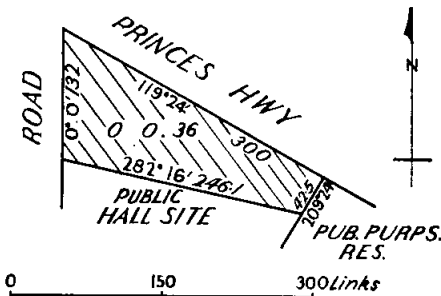

W. J. F. McDONALD,  
Minister of Lands.

PROPOSED REVOCATION OF TEMPORARY RESERVATION OF LAND BY ORDER IN COUNCIL.

IN pursuance of the provisions of the *Land Act 1958*, notice is hereby given that it is the intention of the Governor in Council to revoke the temporary reservation of land by Order in Council hereunder referred to, viz.:

The following Notice was published 1° on the 7th June, 1967, pursuant to Order of the 30th May, 1967.

**SCORESBY.**—The temporary reservation, by Order in Council of the 11th July, 1923, of 1 acre 2 roods 37 perches of land in the Parish of Scoresby as a site for obtaining road-making material is about to be revoked so far only as the portion containing 2 roods 15 perches, indicated by hatching on plan hereunder, is concerned.—(S.250(A<sup>6</sup>)) (Rs.2739).

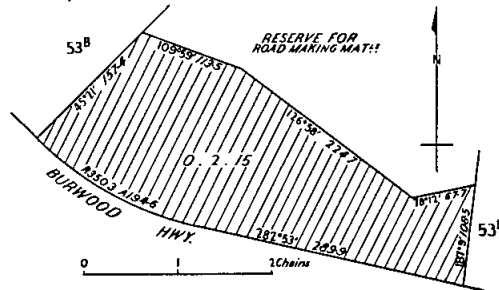

W. J. F. McDONALD,  
Minister of Lands.

COMMITTEES OF MANAGEMENT OF RESERVES.

APPOINTMENTS.

NOTICE is hereby given that, in pursuance of section 221 of the *Land Act 1958*, the following appointments of Committees of Management of reserved Crown lands have been made by the Minister of Lands:—

ALEXANDRA SHOW GROUNDS AND RECREATION RESERVE.

Reginald Norman Stillman, Edward Maurice Stillman, John Patrick O'Brien, Robert George Webster for a period of three (3) years and John Hextor Sutherland, Alexander William Seaton, William James Free, James Pearce Swanton, Roy Mervyn Fox and Douglas Graham Weeding as the representatives and the elect of the Alexandra Pastoral and Agricultural Association as a Committee of Management of the land in the Township of Alexandra temporarily reserved by Order in Council dated the 26th February, 1957, as a site for Show Grounds and Public Recreation.—(Corres. Rs.2593.)

"CHATSWORTH PUBLIC HALL RESERVE."

J. A. Mackirdy, J. Hearne, A. W. Edmonds and L. A. Osmond as a Committee of Management for a period of three (3) years of the land temporarily reserved by Order in Council dated the 27th July, 1915, as a site for a Public Hall in the Township of Chatsworth, and known as the "Chatsworth Public Hall Reserve".—(Corres. Rs.941.)

"GRANTVILLE FORESHORE RESERVE."

Alan Murray, Don Sutherland, Shirley Roberts, William Martin, Margaret Sutherland, Don Wheatley, Ted Wheatley, Ray Stack and George Weir as a Committee of Management for a period of three (3) years of the reserved Crown land in the Parish of Corinella indicated by red colour on plan marked C/19.3.63, and known as the "Grantville Foreshore Reserve".—(Corres. C.98025.)

"HAMILTON SHOW GROUNDS RESERVE."

Hugh David Moodie, John Stanley Hutton and Michael John Stewart as a Committee of Management for a period of three (3) years of the lands in municipal district of Hamilton temporarily reserved by Orders in Council dated 24th April, 1883, and 16th April, 1889, as a site for the Hamilton Pastoral and Agricultural Society's Show Yards and known as "Hamilton Show Grounds Reserve".—(Corres. Rs.3575.)

## NEWTOWN PUBLIC LIBRARY AND READING ROOM.

Thomas Gwynn, John W. Head, Frederick Weybury, Herbert Palmer Hatfield, Thomas James Carey, Joseph Denis Sharp, and George Gilbert Risk as a Committee of Management for a period of three (3) years of the land temporarily reserved by Order in Council dated 27th July, 1885, as a site for a Public Library and Reading Room at Newtown, in the Parish of Scarsdale, and known as the "Newtown (Scarsdale) Public Library and Reading Room Reserve".—(Corres. Rs.5348.)

## "NANGILOC RECREATION RESERVE."

Kevin Laurence Wiffen, Laurence George McEwan, Geoffrey Selway Beacham, James Hugh Bowring, Alma Lynette Lampard, Margaret Mary Watts, Kenneth David McDonald, Ivan Laurence Thomas Wiffen, George William Le Brun, and Kenneth Heyward Baker as a Committee of Management for a period of three (3) years of the land in the Parish of Carwarp, temporarily reserved by Order in Council of the 7th August, 1957, as a site for Public Recreation, and known as the "Nangiloc Recreation Reserve".—(Corres. Rs.7655.)

## "PORTARLINGTON PUBLIC RESERVE."

James Henderson, Stanley Samuel Nash, Donald Robert Cuttriss, John Oliver Sutherland, William Lindsay Good, James Henry Black and Gordon Ralph Stevens as a Committee of Management for a period of three (3) years of the under-mentioned land:—

1. "Portarlington Foreshore Reserve" being such portions of the land reserved for Public purposes in the Township of Portarlington and the Parish of Paywit, as are indicated by red colour on plan marked P/26.4.1950, attached to Lands Department correspondence Rs.6395.

2. "Eastern Park" being the remaining land temporarily reserved by Order in Council dated 19th October, 1936, as a site for Public Park in the Township of Portarlington, Parish of Bellarine.—(Rs.1931.)

3. "Western Park", temporarily reserved by Orders in Council of the 7th July, 1887, and 17th January, 1888, as a site for Public purposes in the Township of Portarlington.—(Rs.2383.)

4. The land in the Township of Portarlington temporarily reserved as a site for a Public Park.—(Rs.6314.)

5. The land in the Township of Portarlington temporarily reserved by Order in Council dated the 28th April, 1964, as a site for Public Recreation.—(Rs.8322.)

This appointment is in lieu of all previous appointments, in respect of the said land which are hereby revoked.—(Corres. Rs. 6395, Rs.1931, Rs.2383, Rs.6314, and Rs.8322.)

## "VICTORIA PARK", INVERLEIGH.

William Thomas Stokie, William Clifford Bath, Leigh Craig Earl, Graham McLean Smyth, Terrell Gordon Peel, Harold James Crowe, Gladstone William Bolte Lake, Charles Keith McIntosh, Eric Thomas Peel and Robert Stanley McMillan as a Committee of Management for a period of three (3) years of the land temporarily reserved by Order in Council, dated 27th February, 1900, as a site for a Public Park in the Town of Inverleigh, and known as "Victoria Park".—(Corres. Rs.2141.)

## "WELSHMAN'S REEF RECREATION RESERVE."

Sydney Riddler, Donald John Gordon, Colin William Edgar, William George Seers, William Archibald Wilson, Elva Elizabeth Edgar and Kevin James Lethbridge as a Committee of Management for a period of three (3) years of the lands temporarily reserved by Orders in Council dated 5th December, 1898, and 11th February, 1936, as sites for Cricket and other purposes of Public Recreation in the Parish of Tarrngower, and known as the "Welshman's Reef Recreation Reserve".—(Corres. Rs.4522.)

## "BENDIGO RACECOURSE RESERVE."

Cyril John Watson and Allen Rupert Guy in the places of John H. Leinhop and Robert Matchett (both deceased) as members of the Committee of Management of the land in the City of Bendigo, Parish of Sandhurst, permanently reserved by Order in Council dated the 11th August, 1873, as a site for a Racecourse and known as the "Bendigo Racecourse Reserve".—(Corres. Rs.5552.)

## "GOLDEN SQUARE PUBLIC PARK", BENDIGO.

The Council of the City of Bendigo as the Committee of Management of the land at Bendigo in the Parish of Sandhurst temporarily reserved by Order in Council dated the 11th April, 1967, as a site for a Public Park and known as the "Golden Square Public Park".—(Corres. Rs.8729.)

W. J. F. McDONALD,  
Minister of Lands.

Department of Crown Lands and Survey,  
Melbourne, 2nd June, 1967.

## PUBLIC WORKS DEPARTMENT

## TENDERS

TENDERS will be received at Public Works Department, Treasury-place, Melbourne, until TEN a.m. on dates shown and for purposes mentioned hereunder.

Particulars and tender forms available at Contracts Office, Room 7, Building Division, Parliament-place and at places indicated in brackets hereunder.

Abbreviations in brackets mean:—W.O.—Inspector of Works Office; P.S.—Police Station; C.S.—Consolidated School; H.E.S.—Higher Elementary School; H.S.—High School; S.S.—State School; T.S.—Technical School.

Tenders to be submitted on the Department's printed Tender Form and will not be received by telephone. All tenders must be on a "Firm Tender" basis. The lowest or any tender will not necessarily be accepted.

Address tenders to the Minister of Public Works, and endorse the envelope containing the tender "Tender for , closing Tuesday,

No preliminary deposit is required with any tender, but a successful tenderer will be required to pay a deposit for any accepted tender of \$5,000 or over.

Tuesday, 20th June, 1967.

## Building, Electrical and Mechanical Works.

- Altona North.—Renovations, Technical School.
- Balmoral.—Renovations, Consolidated School. (Re-advertised.) (W.O., Hamilton; C.S., Balmoral.)
- Berrybank.—Renovations, S.S. 3639. (W.O., Camperdown; S.S., Berrybank.)
- Beverley Hills.—Renovations, S.S. 4813.
- Binginwarri.—Renovations, S.S. 2863 and Residence. (W.O., Traralgon; S.S., Binginwarri.)
- Bobinawarra East.—Renovations, S.S. 3325. (W.O., Benalla; S.S., Bobinawarra East.)
- Brooklyn West.—Enclosing entrance, &c., S.S. 4825.
- Brunswick.—Repairs to floors, Technical School.
- Brunswick North-West.—Renovations, S.S. 4399.
- Buffalo.—Renovations, Residence, S.S. 3240. (W.O., Korumburra; S.S., Buffalo.)
- Cobram.—New laundry and renovations, Residence, Consolidated School. (W.O., Benalla; C.S., Cobram.)
- Cobram.—Renovations, Residence, 43 Wirbill-street, High School. (W.O., Benalla; H.S., Cobram.)
- Corio South.—Extension of six additional class-rooms, S.S. 4927. (W.O., Geelong.)
- Corio South.—Electrical installation, S.S. 4927. (W.O., Geelong.)
- Corio South.—Plenum heating, S.S. 4927. (W.O., Geelong.)
- Deepdene.—Renovations, S.S. 3680.
- Doncaster.—Erection of toilet block, &c., S.S. 197.
- Frankston Heights.—Renovations, S.S. 4815.
- Glenaladale.—Conversion to septic tank systems, S.S. 2373. (W.O., Bairnsdale.)
- Glengarry.—Renovations, S.S. 2888. (W.O., Traralgon; S.S., Glengarry.)
- Huntingdale.—Renovations, S.S. 4716.
- Invergordon.—Renovations, Residence, S.S. 4896. (W.O., Benalla.)
- Kancoona.—New shelter pavilion, &c., S.S. 3576. (W.O., Wangaratta; S.S., Kancoona.)
- Kialla.—Renovations, S.S. 1366 and Residence. (Re-advertised.) (W.O., Shepparton; S.S., Kialla.)
- Leongatha.—Renovations, Residence, High School. (W.O., Korumburra; H.S., Leongatha.)

Lorne.—Renovations, Higher Elementary School 2162. (Re-advertised.) (W.O., Geelong; H.E.S., Lorne.)

Lyndale.—Renovations, S.S. 4771.

Macclesfield.—Renovations, S.S. 3620.

Mailor's Flat.—Re-siting of partition, &c., S.S. 1210. (W.O., Warrnambool; S.S., Mailor's Flat.)

Melbourne.—Mechanical services, Greens Building and Pathology Block, Cancer Institute Board, 278 William-street. (Re-advertised.) (Amended Specification.)

Mitcham.—Renovations, S.S. 2904.

Moe.—Renovations, S.S. 4740. (W.O., Traralgon; S.S., Moe.)

Mt. Eliza.—Connexion to sewerage, fire service, &c., S.S. 1368 and Residence. (W.O., Mornington.)

Narre Warren East.—Renovations, S.S. 3719. (S.S., Narre Warren East.)

Nerrena.—Renovations, S.S. 3395. (W.O., Korumburra; S.S., Nerrena.)

Olympic Village.—Renovations, S.S. 4713.

Parkdale.—Erection of extended third section, &c., High School.

Parkdale.—Electrical installation, High School.

Parkdale.—Mechanical services, High School.

Pearcedale.—Renovations, Residence, S.S. 2961.

Portland.—Renovations, Residence, High School. (Re-advertised.) (W.O., Warrnambool; H.S., Portland.)

Richmond.—Renewal of bicycle shed, Technical School. (Re-advertised.)

Rushworth.—Renovations to four residences, S.S. 1057. (W.O., Shepparton; S.S., Rushworth.)

Sale.—Renovations, Residence, Technical School. (W.O., Traralgon; T.S., Sale.)

Sebastopol.—Renovations, S.S. 1167. (W.O., Ballarat.)

Shepparton South.—Electrical installation, Technical School. (W.O., Shepparton, Benalla and Bendigo.)

Somers.—Conversion to wet septic tanks, &c., S.S. 4458. (W.O., Mornington.)

Upper Yarra.—Renovations, provision of new laundry, Residence, High School. (Re-advertised.)

Various.—Erection of 72 timber class-rooms, 3 Libraries, Staffrooms and Stores, &c., in 29 Sub-District Contracts, Schools. (W.O., Ballarat, Bairnsdale, Benalla, Bendigo, Geelong, Horsham, Korumburra, Kyneton, Mildura, Orbost, Shepparton, Traralgon, Warracknabeal, Warragul and Warrnambool.)

Warrnambool.—Water cooling system for Chassis Dynamometer, Technical School. (W.O., Warrnambool.)

Whittlesea.—Erection of toilet block, S.S. 2090.

Wonthaggi.—Renovations, Residence, Technical School. (W.O., Korumburra; T.S., Wonthaggi.)

Yarrowonga.—Renovations, Residence, High School. (W.O., Wangaratta and Benalla; H.S., Yarrowonga.)

#### Furniture and Furnishings.

Warrnambool.—Supply and fix draw curtains, Mental Hospital.

#### Miscellaneous.

Brighton.—Initial cleaning and maintenance cleaning for the period 1st July, 1967 to 31st May, 1970, Court House.

Various.—Cleaning chimney flues, for the period 1st July, 1967, to 30th June, 1968, Government Buildings, Melbourne and Suburbs. (Re-advertised.)

West Melbourne.—Supply of timber, Government Cool Stores.

### Tuesday, 27th June, 1967.

#### Building, Electrical and Mechanical Works.

Broadford.—Renovations, S.S. 1125. (Re-advertised.) (W.O., Kyneton; S.S., Broadford.)

Charlton.—Erection of one proprietary type brick veneer residence, Soil Conservation Authority. (Amended Specification.) (W.O., Bendigo.)

Dandenong.—Erection of type "572" Assembly Hall, High School.

Dandenong.—Electrical installation, High School.

Dandenong.—Mechanical services, High School.

Echuca.—Supply and fitting of laboratory sinks, &c., Technical School. (W.O., Shepparton; T.S., Echuca.)

Echuca East.—Renovations, Residence, 67 Hovell-street, S.S. 2667. (Re-advertised.) (W.O., Shepparton; S.S., Echuca East.)

Greenwald.—Erection of toilets, &c., S.S. 2653. (W.O., Warrnambool; S.S., Greenwald.)

Heidelberg.—Renovations, Caretaker's Residence, S.S. 294.

Keon Park East.—Erection of Primary School building of eight class-rooms, S.S. 4889.

Keon Park East.—Electrical installation, S.S. 4889.

Keon Park East.—Plenum heating, S.S. 4889.

Maryvale.—Erection of first stage of type C. 800 school building, High School. (Specified Bills of Quantities Available.) (W.O., Traralgon.)

Maryvale.—Electrical installation, High School. (W.O., Warragul and Traralgon.)

Maryvale.—Mechanical services, High School. (W.O., Warragul and Traralgon.)

Newport.—Renovations, S.S. 113. (Re-advertised.)

Niddrie.—Connexion to town sewerage, S.S. 4849.

Noble Park.—Construction of a steel fabrication school, Technical School.

Noble Park.—Mechanical services, Technical School.

Noble Park.—Erection of crane, Technical School.

Timboon.—Renovations, &c., High School. (Re-advertised.) (W.O., Camperdown.)

Tower Hill.—Extension of garage, &c., Fisheries and Wildlife Branch Residence. (W.O., Warrnambool.)

Tullamarine.—Construction of sewerage treatment plant, S.S. 4852.

Wangaratta.—Electrical installation, High School. (W.O., Wangaratta.)

Wangaratta.—Electrical installation, Technical School. (W.O., Wangaratta.)

#### Site Works.

Laburnum.—Concreting and retaining wall construction, S.S. 4863.

Swan Hill North.—Drainage and gravelling works, S.S. 4743. (W.O., Swan Hill.)

Syndal.—Concreting and drainage works, Technical School.

Watsonia.—Retaining wall, asphaltting and concreting works, S.S. 4838.

Whiteside.—New asphalt, asphalt repairs, concreting and gravelling, S.S. 4785. (Re-advertised.)

Yarrunga.—Asphaltting and drainage works, S.S. 4761. (W.O., Wangaratta and Benalla.)

### Tuesday, 4th July, 1967.

#### Building, Electrical and Mechanical Works.

Cheltenham.—Renovations, Police Station and Residence.

Eastwood.—Renovations, S.S. 4702.

Footscray.—Renewal of domestic water supply, Girl's High School.

Konongwootong North.—Erection of shelter pavilion and minor repairs to residence, S.S. 4362. (W.O., Hamilton; S.S., Konongwootong North.) (Amended Specification.)

Oberon.—Erection of third section with Physical Education wing and Canteen, High School. (W.O., Geelong.)

Oberon.—Electrical installation, High School. (W.O., Geelong.)

Oberon.—Mechanical services, High School. (W.O., Geelong.)

Ruthven.—Erection of new Primary School of ten class-rooms and library, S.S. 4956.

Ruthven.—Electrical installation, S.S. 4956.

Ruthven.—Plenum heating, S.S. 4956.

Wangaratta.—Renovations and extensions, Fisheries and Wildlife Branch, Office and Residence. (W.O., Wangaratta.)

Woods Point.—Renovations, S.S. 789 and Residence. (Re-advertised.) (W.O., Alexandra.)

#### Site Works.

Box Hill South.—Asphaltting, concreting and drainage works, &c., S.S. 4138.

Cheltenham.—Asphalt, concreting and drainage works, &c., S.S. 84.

#### Miscellaneous.

Upper Yarra Dam.—Purchase and removal of school buildings, S.S. 4660.

M. V. PORTER,  
Minister of Public Works.

Public Works Department,  
Melbourne, 9th June, 1967.

**PUBLIC SERVICE NOTICES**

No. 1737.

*Public Service Act 1958.*

THE Public Service Board, in pursuance of the powers conferred by the *Public Service Act 1958*, hereby amends the Public Service (Public Service Board) Regulations as follows:—

**PART V.—ALLOWANCES.**

**DIVISION II.—OVERTIME AND STAND-BY ALLOWANCES.**

WATER SUPPLY DEPARTMENT.

Regulation 107.

At the end of sub-regulation (1) insert the following:—

Office or Position.	Stand-by per Annum.	Commuted Overtime Percentage.
"Water Bailiffs (Diversion)	\$	%
Bridgewater (Boort)	Nil	18 "

F. E. CAHILL, Chairman.  
V. P. SCULLY, Secretary.

Office of the Public Service Board,  
Melbourne, 8th May, 1967.

No. 1738.

*Public Service Act 1958.*

**REGULATIONS.—PART IV.—SALARIES AND INCREMENTS.**

THE Public Service Board, in pursuance of the powers conferred by the *Public Service Act 1958*, hereby amends its Regulations as shown below:—

**THIRD SCHEDULE.**

**PART B.**

PROFESSIONAL DIVISION.

Scale of Rates of Annual Salaries.

STIPENDIARY MAGISTRATES.

Class.	Annual Salary of Each Class.
	\$
Delete—	
SM-1	8,298
SM-2	8,799
Add—	
SM-1	8,750
SM-2	9,250

This Regulation shall have effect as on and from the 28th May 1967.

F. E. CAHILL, Chairman.  
V. P. SCULLY, Secretary.

Office of the Public Service Board,  
Melbourne, 26th May, 1967.

No. 1739.

*Public Service Act 1958, Section 39.*

**REGULATIONS.—PART IV.—SALARIES AND INCREMENTS.**

THE Public Service Board, in pursuance of the powers conferred by the *Public Service Act 1958*, hereby amends its Regulations as shown below:—

**FIRST SCHEDULE.**

PROFESSIONAL DIVISION.

Amount of Salary Assigned to Offices in "Special" Class.

Office.	Yearly Rate of Salary.
<b>LAW DEPARTMENT.</b>	\$
Delete—	
Chief Stipendiary Magistrate	9,844
Deputy Chief Stipendiary Magistrate	9,332
Add—	
Chief Stipendiary Magistrate	10,350
Deputy Chief Stipendiary Magistrate	9,800

This Regulation shall have effect as on and from the 28th May, 1967.

F. E. CAHILL, Chairman.  
V. P. SCULLY, Secretary.

Office of the Public Service Board,  
Melbourne, 26th May, 1967.

No. 1740.

**PUBLIC SERVICE ACT 1958.**

THE Public Service Board, in pursuance of the powers conferred by the *Public Service Act 1958*, hereby amends the Public Service (Public Service Board) Regulations as follows:—

**PART III.—PROMOTIONS AND TRANSFERS.**

**DIVISION III.—SPECIAL REQUIREMENTS.**

ADMINISTRATIVE DIVISION.

Chief Secretary's Department.—Actuarial Positions.

Regulation 54 (1).

EXAMINATIONS IN ACTUARIAL SCIENCE.

In Part 1 the expression "(3 hours)" is substituted for the expression "(2 hours)" wherever appearing.

F. E. CAHILL, Chairman.  
V. P. SCULLY, Secretary.

Office of the Public Service Board,  
Melbourne, 1st June, 1967.

*Teaching Service Act 1958.*

**TEACHING SERVICE (TEACHERS TRIBUNAL) REGULATIONS.**

AMENDMENT No. 119.

THE Teachers Tribunal, in pursuance of the powers conferred by the *Teaching Service Act 1958*, hereby amends Regulation 1 of the Teaching Service (Teachers Tribunal) Regulations in the manner following, that is to say:—

**REGULATION 1.**

In clause 10, under the sub-heading "(a) District Inspectors", insert the following new Inspectorates and commuted reimbursements:—

"Inspectorate"	Own Car \$'s a year.	Government-owned Car \$'s a year.
Altona	280	Nil
Doncaster	280	Nil
Monash	280	Nil "

To take effect from and including the 1st June, 1967.

LOUIS F. C. GARLICK, Chairman.  
G. FENNELL, Secretary.

Office of the Teachers Tribunal,  
Melbourne, 6th June, 1967.

## PRIVATE ADVERTISEMENTS

I, MARGARET ALMA PHILLIPS, of 2 Shirley-avenue, Sorrento, in the State of Victoria, packer, heretofore called and known by the name of Margaret Alma Dickie hereby give public notice that by a deed poll dated the 10th day of March, 1967, duly executed and attested and deposited with the Registrar General of the said State, on the 24th day of May, 1967, I formally and absolutely renounced and abandoned the said surname of Dickie and declared that I had assumed and adopted and intended thenceforth upon all occasions whatsoever to use and subscribe the surname of Phillips instead of the said surname of Dickie, and so as to be at all times thereafter called known and described by the said surname of Phillips.

Dated this 26th day of May, 1967.

M. A. PHILLIPS.

Witness.—John Chadwell Wright-Smith, solicitor,  
Rosebud. 7460

## Water Act.

## PROPOSED BACCHUS MARSH SHIRE COUNCIL WATER AUTHORITY.

NOTICE is hereby given that the Bacchus Marsh Shire Council has made application to the Honorable the Minister of Water Supply for the constitution of a Local Governing Body, and for the Proclamation of a Water Supply District at the Township of Myrmiong, for the construction of new works to supply the said township, and for the maintenance and continuance of water supply works within the said district under the provisions of the Water Act.

A general plan and description of the proposal has been submitted with the application, and copies of same may be seen at the Council Chambers, Bacchus Marsh.

Dated at Bacchus Marsh, the 8th day of May, 1967.

7188

A. W. BOND, Secretary.

## NOTICE OF INTENTION TO APPLY FOR A LICENCE TO DIVERT WATER AND CUT RACE (RE-ISSUE) FROM THE RIVER MURRAY, AT MILDURA.

WE hereby give notice that we intend to apply for a licence empowering us to divert water for a term of four years to the extent of 78 acre-feet per annum at a maximum rate of 4 acre-feet per day of 24 hours, being part of allotment Mildura P.R., Parish of Mildura, and to occupy certain Crown lands for works of diversion, and to cut a race thereon.

Any objection to such application must be forwarded, in writing, to reach the State Rivers and Water Supply Commission, Melbourne, before 8th July, 1967, being 30 days from the first publication of this notice.

ALFRED ASHLEY LEES.  
IRIS MARY LEES.

Mildura West.

7443

## NOTICE OF INTENTION TO APPLY FOR A LICENCE TO DIVERT WATER AND CUT RACE (RE-ISSUE), FROM THE RIVER MURRAY AT MILDURA.

I HEREBY give notice that I intend to apply for a licence empowering me to divert water for a term of four years to the extent of 60 acre-feet per annum at a maximum rate of 5 acre-feet per day of 24 hours for the irrigation of 20 acres of vines, being part of allotment 1, section 10, Parish of Mildura, and to occupy certain Crown lands for works of diversion, and to cut a race thereon.

Any objection to such application must be forwarded, in writing, to reach the State Rivers and Water Supply Commission, Melbourne, before 10th July, 1967, being 30 days from the first publication of this notice.

MARIA C. BIAGUS.

P.O. Box 701, Mildura, Victoria.

7435

## THE BALLARAT SEWERAGE AUTHORITY.

## GENERAL NOTICE.

THE above-mentioned Sewerage Authority having made provision for carrying off the sewage from each and every property which or any part of which is within the Sewerage Area hereinafter described, doth hereby declare that on and after the 1st day of July, 1967, each and every property which or any part of which is within the said Sewerage Area shall be deemed to be a sewered property within the meaning of the *Sewerage Districts Act 1958*.

The boundaries of the Sewerage Area hereinbefore referred to are:—

## SEWERAGE AREA No. 274.

## Shire of Ballarat.

Commencing at the north-east corner of Grevillea-road and Forest-street, being a point on the boundary of Sewerage Area No. 266; thence westerly along the north building line of Grevillea-road to the north-west corner of Grevillea-road and Harold-street, southerly along the west building line of Harold-street to the north-east corner of No. 7 Harold-street, westerly to the north-west corner of the said No. 7, southerly to the south-west corner of No. 5 Harold-street, westerly along the north building line of Adela-street and prolongation thereof to the east building line of Margaret-street, southerly along the east building line of Margaret-street to the north-east corner of Margaret and Norman streets, easterly along the north building line of Norman-street to the north-east corner of Norman and Forest streets; thence northerly along the boundaries of Sewerage Areas Nos. 264 and 266 to the point of commencement.

Further particulars regarding the streets or parts of streets in which sewers have been laid may be ascertained on inquiry at the Authority's Office.

By Order of the said Sewerage Authority—

A. W. NICHOLSON, Chairman.

T. V. JOHNSTON, Acting Secretary.

7434

## Victoria.

## ACT No. 391.—FIRST SCHEDULE.

I, JOHN GRAEME BUCKNALL, authorized representative of the denomination known as the Presbyterian Church of Victoria with the consent of The Presbyterian Church of Victoria Trusts Corporation trustees of the land described in the subjoined statement of trusts, and of Victor Jackson Murrell being the person entitled to minister in or occupy a building or buildings upon the said land, hereby apply to the Governor of the State of Victoria for leave to dispose of the said land by the means and for the purposes mentioned in the said statement of trusts, and I hereby certify: That the said land was permanently reserved by Order in Council on the 21st day of February, 1870, for the purpose of site for Presbyterian Church purposes, that the only trustees of the said land resident in the State of Victoria are: The Presbyterian Church of Victoria Trusts Corporation: That the only buildings upon the said land are Brick Church with slate roof, timber and cement sheet hall with iron roof and weatherboard residence with tile roof, and that the only person entitled to minister in or occupy the same is the above-named Victor Jackson Murrell.

Signature of authorized representative—J. GRAEME BUCKNALL.

We consent to this application.

The common seal of The Presbyterian Church of Victoria Trusts Corporation was hereto affixed, in the presence of—

W. M. HODGES, Trustee.

H. L. RICHARDSON, Trustee.

(SEAL) S. K. WILLIAMS, Treasurer of the  
Presbyterian Church of Victoria  
and Financial Secretary.

Attested by:—J. P. ADAM, Law Agent.

Signature of person entitled to minister in or occupy building or buildings.—VICTOR J. MURRELL.

## STATEMENT OF TRUSTS.

*Description of Land.*—1 acre 2 roods, Township of Berwick, Parish of Berwick, County of Mornington, being allotments 7, 8 and 9, section 14: Commencing at the western angle of allotment 10, being a point on the north-eastern side of the Prince's Highway; bounded thence by that highway being 300 deg. 15 min. 300 links, by allotment 6, bearing 30 deg. 15 min. 500 links, by Wilson-street bearing 120 deg. 15 min. 300 links and thence by allotment 10, bearing 210 degrees 15 min. 500 links to the point of commencement.

*Names of Trustees.*—The Presbyterian Church of Victoria Trusts Corporation.

*Powers of Disposition.*—With the consent of the General Assembly of "The Presbyterian Church of Victoria", to mortgage, sell, lease, exchange and transfer, and grant easements over the said land or any part or parts thereof, and subject to such powers and the exercise thereof, to hold the said land, or so much thereof as may from time to time remain vested in the said trustees upon such trusts for the said Presbyterian Church of Victoria and for such

purposes and with and subject to such powers and provisions as are contained in the document enrolled by the Registrar-General of the State of Victoria, pursuant to the provisions of the *Presbyterian Trusts Act 1890*, and styled "The Presbyterian Church of Victoria Model Trust Deed for Church and Manse Site".

*Purposes to which Proceeds of Disposition are to be Applied.*—To pay the money coming to the hands of such trustees by virtue of any such power of disposition to the Treasurer for the time being of the Presbyterian Church of Victoria, to be by him applied first in payment of all incidental costs, next in payment to the said Presbyterian Church of Victoria of all deductions heretofore or hereafter to be authorized by the General Assembly of the said Church and as to the residue, for such purposes as the said Assembly has heretofore authorized or may hereafter authorize. 7465

## CITY OF BROADMEADOWS.

## LOAN No. 44.

*Notice of Intention to Borrow the Sum of \$100,000 for Permanent Works and Undertakings.*

NOTICE is hereby given that the Council of the City of Broadmeadows proposes to borrow the principal sum of \$100,000, secured by a charge over the general rates of the municipality, such sum to be raised by the grant of a mortgage, in accordance with the provisions of the *Local Government Act 1958*.

1. The maximum rate of interest that may be paid is 5.75 per cent. per annum.

2. The purpose for which the loan is to be applied is—

(a) Oak Park Swimming Pool ..	\$42,600
(b) Tullamarine Reserve Pavilion ..	10,500
(c) Strathmore North Pre-school Centre ..	7,600
(d) Parking Bays, Olsen-place ..	5,000
(e) Jacana Foot-bridge ..	16,300
(f) Improvements, J. P. Fawcner Reserve	18,000
	<hr/> \$100,000

3. The period of the loan shall be fifteen years.

4. The moneys borrowed shall be repayable by providing out of the municipal fund 30 half-yearly instalments of approximately \$5,020 each, including principal and interest, on the 1st day of April and the 1st day of October during the currency of the loan. The first instalment shall be payable on the 1st day of October, 1967.

5. Such moneys shall be repayable to the Local Authorities Superannuation Board at the offices of the said Board, "Rigby House", 15 Queens-road, Melbourne.

The plans and specifications and the estimate of the cost of the proposed works, and a statement showing the proposed expenditure of the moneys to be borrowed, are open for inspection at the offices of the Council of the City of Broadmeadows, Municipal Offices, Broadmeadows.

7437

E. F. SMILEY, Town Clerk.

## CITY OF BROADMEADOWS.

WHEREAS the Council of the Municipality of Broadmeadows has received an application from the owners of so many premises fronting on the under-mentioned streets in Broadmeadows as in rateable value are the greater part of all premises so fronting, the Council hereby declares the same to be dedicated to the public as a public highway:—

Dallas-drive, from Riggall-street to Lismore-street.

Kiewa-crescent, from Blair-street to Riggall-street.

Benalla-street, from Dallas-drive to west of lot 763.

The whole of the following streets:—Murtoa-street,

Towong-court, Lismore-street, Apollo-crescent, Antwerp-street, Leigh-court, McIvor-street, Boort-street,

Calivil-street, Yea-street, Romsey-crescent, Pyalong-crescent.

The common seal of the Mayor, Councillors and

Citizens of the City of Broadmeadows was here-

unto affixed this 14th day of June, 1967—

(SEAL)

JOHN P. MUTTON, Mayor.

L. K. JOHNSON, Councillor.

E. F. SMILEY, Town Clerk.

7438

*Town and Country Planning Act 1961 (Twelfth Schedule).*

NOTICE THAT A PLANNING SCHEME HAS BEEN PREPARED AND IS AVAILABLE FOR INSPECTION.

## CITY OF CAMBERWELL PLANNING SCHEME 1954.

*Amendment No. 35, 1967.*

NOTICE is hereby given that the City of Camberwell in pursuance of its powers under the *Town and Country Planning Act 1961* has prepared a Planning Scheme for the Whole of the Municipality of the City of Camberwell

for the purpose of Amending the Ordinance of the Principal Scheme as it applies to reduction of frontages or depths of irregular shape blocks for flats.

A copy of the Scheme has been deposited at the Municipal Offices, Civic Centre, Camberwell, and at the offices of the Town and Country Planning Board, 179 Queen-street, Melbourne, and will be open for inspection during office hours by any person, free of charge.

Any persons affected by the Planning Scheme are required to set forth, in writing, all objections they may have, addressed to the Chief Administrator, Civic Centre, Camberwell, on or before the 14th July, 1967, and to state whether they wish to be heard in respect of their objections.

7424

L. F. CHEFFERS, Chief Administrator.

*Town and Country Planning Act 1961 (Twelfth Schedule).*

NOTICE THAT A PLANNING SCHEME HAS BEEN PREPARED AND IS AVAILABLE FOR INSPECTION.

## CITY OF CAMBERWELL PLANNING SCHEME 1954.

*Amendment No. 36, 1967.*

NOTICE is hereby given that the City of Camberwell in pursuance of its powers under the *Town and Country Planning Act 1961* has prepared a Planning Scheme for the Whole of the Municipality of the City of Camberwell for the purpose of Amending the Ordinance of the Principal Scheme as it applies to the 20 feet set back area within the Light Industrial Zone.

A copy of the Scheme has been deposited at the Municipal Offices, Civic Centre, Camberwell, and at the offices of the Town and Country Planning Board, 179 Queen-street, Melbourne, and will be open for inspection during office hours by any person, free of charge.

Any persons affected by the Planning Scheme are required to set forth, in writing, all objections they may have, addressed to the Chief Administrator, Civic Centre, Camberwell, on or before the 14th July, 1967, and to state whether they wish to be heard in respect of their objections.

7425

L. F. CHEFFERS, Chief Administrator.

*Pounds Act 1958.*

## CITY OF MARYBOROUGH.

## ABOLITION OF POUND.

NOTICE is hereby given that the Maryborough Pound, situated in Christian-street, Maryborough, will be abolished, effective the 30th June, 1967.

7423

E. S. MOORE, Town Clerk.

## CITY OF SOUTH MELBOURNE.

## LOAN No. 62.

*Notice of Intention to Borrow the Sum of \$40,000 for Permanent Works and Undertakings.*

NOTICE is hereby given that the Council of the City of South Melbourne proposes to borrow the principal sum of Forty thousand dollars (\$40,000) secured by a charge over the general rates of the municipality, such sum to be raised by the grant of a mortgage, in accordance with the provisions of the *Local Government Act 1958*.

1. The maximum rate of interest that may be paid is 5.875 per centum per annum.

2. The purpose for which the loan is to be applied is—

The erection of new building in Bank-street for Maternal and Child Welfare Centre and Social Work Department .. .. \$40,000

3. The period of the loan shall be fifteen years.

4. The moneys borrowed shall be repayable by providing out of the municipal fund 30 equal half-yearly instalments of \$2,024.00 each, including principal and interest, on the 1st day of March and the 1st day of September, during the currency of the loan. The first instalment shall be payable on the 1st day of March, 1968.

5. Such moneys shall be repayable to the English, Scottish and Australian Bank Limited, South Melbourne, or such other place or places as the bank from time to time may require.

The plans and specifications and the estimate of cost of the proposed works, and a statement showing the proposed expenditure of the moneys to be borrowed, are open for inspection at the office of the Council of the City of South Melbourne, at the Town Hall, Bank-street, South Melbourne, during office hours.

Dated 31st May, 1967.

7439

R. E. DARLING, Town Clerk.

## BOROUGH OF PORT FAIRY.

## BY-LAW No. 21.

A By-law of the Borough of Port Fairy made under the Dog Acts and Numbered Twenty One for fixing registration and other fees thereunder.

IN pursuance of the powers conferred by the Dog Acts and of any and every other power it thereunto enabling the Council of the Borough of Port Fairy in the name and on behalf of the Mayor, Councillors and Burgesses of the said Borough order as follows:

1. By-law No. 15 of this Borough shall be and is hereby repealed.

2. The following fees and sums are hereby fixed pursuant to the Dog Acts.

- |                                                                                                                                                                                                   |        |
|---------------------------------------------------------------------------------------------------------------------------------------------------------------------------------------------------|--------|
| (a) For registration pursuant to Sections 5 and 6 of the Dog Act 1958 as amended by any Act . . . . .                                                                                             | \$1.00 |
| (b) For particulars of any dog or for the name of the registered owner thereof or for a certified copy of the receipt mentioned in Section 12 of the Dog Act 1958 as amended by any Act . . . . . | \$0.25 |
| (c) Sum payable to the Registration Officer pursuant to Section 15 of the Dog Act 1958 as amended by any Act . . . . .                                                                            | \$2.00 |
| (d) Sum payable to the Registration Officer pursuant to Section 16 of the Dog Act 1958 as amended by any Act . . . . .                                                                            | \$4.00 |

3. This By-law shall apply to and have operation throughout the whole of the Municipal District.

Resolution for passing this By-law agreed to by the Council of the Borough of Port Fairy on the 1st day of March, 1967 and confirmed on the 10th day of May, 1967.

The common seal of the Borough of Port Fairy was hereunto affixed on the 7th day of June, 1967, in the presence of:

7475 (SEAL) ERNEST P. GUYETT, Mayor.  
I. ROY HUMPHRYS, Councillor.  
JOHN W. PHILLIPS, Town Clerk.

## SHIRE OF BELLARINE.

## LOAN No. 38.

*Notice of Intention to Borrow the Sum of \$10,000.00 for Permanent Works and Undertakings.*

NOTICE is hereby given that the Council of the Shire of Bellarine proposes to borrow the principal sum of Ten thousand dollars secured by a charge over the general rates of the municipality, such sum to be raised by the grant of a mortgage in accordance with the provisions of the *Local Government Act 1958*.

1. The maximum rate of interest that may be paid is 5.75 per cent. per annum.
2. The purpose for which the loan is to be applied is for improvements to the Ocean Grove Recreation Reserve.
3. The period of the loan shall be ten years.
4. The moneys borrowed shall be repayable by providing out of the municipal fund half-yearly instalments of \$664.41 each, including principal and interest on the 15th day of March and the 15th day of September, during the currency of the loan. The first instalment shall be payable on the 15th day of March, 1968.
5. Such moneys shall be repayable to the Australian and New Zealand Savings Bank Ltd., 394-396 Collins-street, Melbourne.

The plans and specifications and the estimate of the cost of the proposed works and a statement showing the proposed expenditure of the moneys to be borrowed are open for inspection at the office of the Council of the Shire of Bellarine, at Drysdale.

Dated 8th June, 1967.

7478 H. A. WILLIAMS, Shire Secretary.

## Sewerage Districts Acts.

## SHIRE OF FLINDERS.

## PROPOSED SEWERAGE AUTHORITY.

NOTICE is hereby given that the Council of the Shire of Flinders has made application to the Honorable the Minister of Water Supply for the constitution of a Sewerage Authority and for the proclamation of a Sewerage District at Dromana and Rosebud, and for the construction, maintenance and continuance of sewerage works within those districts, under the provision of the Sewerage Districts Acts.

A general plan and description of the proposed works have been submitted with the application, and copies may be seen at the Shire Office, Dromana.

Dated at Dromana, the 7th day of June, 1967.

7440 S. WILLIAMS, Shire Secretary.

## Town and Country Planning Act 1961.

## SHIRE OF HASTINGS.—THE SHIRE OF HASTINGS PLANNING SCHEME 1962.

NOTICE THAT A PLANNING SCHEME HAS BEEN PREPARED AND IS AVAILABLE FOR INSPECTION.

NOTICE is hereby given that the Council of the Shire of Hastings in pursuance of its powers under the *Town and Country Planning Act 1961* has prepared a Planning Scheme for the whole of the Shire of Hastings for the purpose of regulating, restricting, restraining or prohibiting the use or the development of any land or the erection, construction, or carrying out of any buildings or works on any land within the area described.

A copy of the Scheme has been deposited at the Shire Office, Hastings, and the Office of the Town and Country Planning Board, 179 Queen-street, Melbourne, and is open for inspection during office hours by any person free of charge. Any persons affected by the Planning Scheme are required to set forth, in writing, any objections they may have, on or before, the 14th September, 1967, and to state whether they wish to be heard in respect of their objections.

Dated the 9th day of June, 1967.

7480 L. A. WALKER,  
Shire Secretary and Municipal Clerk.

## SHIRE OF MARONG.

## LOAN No. 17.

*Notice of Intention to Borrow the Sum of \$10,000 for Permanent Works and Undertakings.*

NOTICE is hereby given that the Council of the Shire of Marong proposes to borrow the principal sum of ten thousand dollars secured by a charge over the general rates of the municipality, such sum to be raised by the grant of a mortgage in accordance with the provisions of the *Local Government Act 1958*.

1. The maximum rate of interest that may be paid is 5½ per cent. per annum.
2. The purpose for which the loan is to be applied is the purchase of two trucks.
3. The period of the loan shall be five years.
4. The moneys borrowed shall be repayable by providing out of the municipal fund half-yearly instalments of approximately \$1,157 each including principal and interest on the 1st day of October and the 1st day of April, during the currency of the loan. The first instalment shall be payable on the 1st day of April, 1968.
5. Such moneys shall be repayable to the Commissioners of the State Savings Bank of Victoria, at the office of the said Commissioners, corner Elizabeth and Bourke streets, Melbourne.

The plans and specifications and the estimate of the cost of the proposed works and a statement showing the proposed expenditure of the moneys to be borrowed are open for inspection at the office of the Council of the Shire of Marong, Shire Office, at Marong.

Dated 1st June, 1967.

7477 ROSS M. GRAHAM, Shire Secretary.

## SHIRE OF SHERBROOKE.

## CHANGE OF STREET NAME.

NOTICE is hereby given that pursuant to the provisions of the *Local Government Act 1958*, the Council of the Shire of Sherbrooke doth order that the name of a street within the Municipality be changed as set out herewith.

*Old Name; New Name; Location.*

Roberts-road; McIntosh-road; commencing at the Kallista-Emerald road at the south-western corner of Crown allotment 1, section H, Parish of Monbulk; thence generally easterly along the southern boundaries of Crown allotments 1, 7, 8, 11 and 12, section H, of the said parish to the junction of Kallista-Emerald road and Grantulla-road.

7463 A. JONES, Shire Secretary.

SHIRE OF WHITTLESEA.

BY-LAW No. 60.

A By-law of the Shire of Whittlesea, made under the Health Act, 1958, as amended, and numbered 60 for the purpose of prescribing the fees to be charged for the registration of premises and for the renewal and transfer of registration thereof, pursuant to the said Act.

IN pursuance of the powers conferred by the Health Act, 1958, as amended, the President, Councillors, and Ratepayers of the Shire of Whittlesea (hereinafter called the Council) order as follows:—

1. All former By-laws so far as they relate to the matters and things in this By-law are hereby repealed provided that such repeal shall not prejudice or affect any right accrued or liability incurred prior to the commencement of this By-law.

2. This By-law shall apply to and have effect throughout the whole of municipal district of the Shire of Whittlesea.

3. The fees payable to the Council for the granting or annual renewal of registration of premises or for any transfer of registration shall be those specified in the Schedule hereto.

THE SCHEDULE.

Fees Payable.

(a) For the granting or annual renewal of registration of premises.

Nature of Premises.	Fees Payable for Registration or Renewal Thereof.
	\$
Offensive trades premises (being fat extracting or melting or rendering works which are conducted at premises occupied principally as a butcher's shop and at which fat is extracted melted or rendered only from materials derived from such shop)	5.00
Offensive trades premises (being abattoirs in meat areas or piggeries)	20.00
Offensive trades premises (other than those referred to above)—	
(i) where not more than ten persons (including the proprietor and his family) are employed	10.00
(ii) where more than ten such persons but not more than twenty such persons are employed	15.00
(iii) where more than twenty such persons but not more than thirty such persons are employed	20.00
(iv) where more than thirty such persons are employed	30.00
Cattle saleyards	10.00
Boarding-houses	10.00
Common lodging-houses	10.00
Eating-houses	10.00
Apartment-houses—	
Containing not more than one apartment	5.00
Containing more than one apartment	10.00
Camping areas	10.00
Food premises—	
(i) where not more than five persons (including the proprietor and his family) are employed	5.00
(ii) where more than five such persons are employed additional for each person in excess of five	0.50
Provided that the maximum fee payable shall be	100.00
Premises at or in any part of which eggs for sale are received or stored for the purpose of being chilled	5.00
Food vending machines operated by—	
(i) one or two cents a sale	0.50
(ii) a coin or coins in excess of two cents in value but not exceeding five cents in value a sale	2.00
(iii) a coin or coins in excess of five cents in value a sale	4.00

(b) For any transfer of Registration—\$1 or fifty per cent. of the registration fee (whichever is the lesser amount).

(c) Where application for renewal of registration is not lodged with the Council until after the last day fixed for the lodging thereof, an additional fee of one-half the above registration fees shall be paid.

The Resolution adopting this By-Law No. 60 was agreed to at the meeting of the Council held on 3rd day of April, 1967, and confirmed on the 1st day of May, 1967.

As Witness the Common Seal of the President, Councillors and Ratepayers of the Shire of Whittlesea was hereunto affixed this day, the 1st day of May, 1967, in the presence of—

(SEAL) GEORGE E. DRAPER, President.  
K. N. BALHARRIE, Councillor.  
R. G. C. COOK, Shire Secretary.

Submitted to the Commission of Public Health on 9th May, 1967.—A. T. GARDNER, Secretary, Commission of Public Health.

Approved by the Governor in Council, 6th June, 1967.—J. ROSSITER, Acting Clerk of the Executive Council. 7479

NOTICE OF DISSOLUTION OF PARTNERSHIP.

NOTICE is hereby given that the partnership heretofore subsisting between the undersigned Harold Francis Vessey, John Blake Young, and John Moore Chanter, of 841 Nepean Highway, Moorabbin, in the State of Victoria, under the firm name of Young, Vessey & Chanter, was dissolved by mutual consent on the 31st day of January, 1967.

Dated the 2nd day of June, 1967.

JOHN BLAKE YOUNG.

Witness—JOHN W. KENNY.

JOHN MOORE CHANTER.

Witness—JOHN W. KENNY.

HAROLD FRANCIS VESSEY.

Witness—J. LIDDY. 7488

NOTICE OF DISSOLUTION OF PARTNERSHIP.

NOTICE is hereby given that the partnership heretofore subsisting between Jeffrey Smith and Ruth Smith, both of 17 Maple-crescent, Camberwell, and Charles George Robertson, of 7 Kaneira-avenue, Croydon, carrying on business at 17 Maple-crescent, Camberwell, as builders under the firm name of "Camberwell Constructions" has been dissolved by mutual consent as from the 20th day of May, 1967. All debts due to and owing by the said late firm will be received and paid by the said Jeffrey Smith and Ruth Smith who will continue to carry on the said business in partnership under the same firm name at 17 Maple-crescent, Camberwell.

Dated this 3rd day of June, 1967.

G. ROBERTSON.  
J. SMITH.  
R. SMITH.

Gregory, Gray & Co., solicitors, 23 Burwood-road, Burwood. 7442

Companies Act 1961.

MARJEL PROPRIETARY LIMITED (IN VOLUNTARY LIQUIDATION).

PURSUANT TO SECTION 254 (2).

NOTICE is hereby given that at an Extraordinary General Meeting of the above-named company duly convened and held at 15 Maud-street, Clapham, South Australia, on the 8th day of June, 1967, the following Special Resolution was duly passed:—

"That the company be wound up voluntarily."

Mr. Alan Douglas, of 229 Exhibition-street, Melbourne, was duly appointed liquidator of the company.

7436 ALAN DOUGLAS, Secretary.

Victoria—Companies Act 1961.

MULGOA DISTRIBUTORS PROPRIETARY LIMITED (IN VOLUNTARY LIQUIDATION).

PURSUANT TO SECTION 254 (2).

NOTICE is hereby given that at an Extraordinary General Meeting of the above-named company duly convened and held at 229 Exhibition-street, Melbourne, on the 5th day of June, 1967, the following Special Resolution was duly passed:—

"That the company be wound up voluntarily."

Mr. Ronald Stanley Schnellbeck, of 229 Exhibition-street, Melbourne, was duly appointed liquidator of the company.

7427 ALAN DOUGLAS, Secretary.



Unclaimed Moneys Act 1962.

REGISTER of Unclaimed Moneys held by the—

Name of Owner on Books and Last Known Address.	Total Amount Due to Owner.	Description of Unclaimed Moneys.	Date when Amount first became Payable.
<b>G. J. COLES &amp; COY. LIMITED.</b>			
\$			
Kennedy, Mary (Mrs.), 70 South-road, Braybrook .. ..	22.90	Holiday pay .. ..	15.2.66
Hojnik, Maria (Mrs.), 282 Mannigham-road, Lower Tempestowe ..	12.32	Balance of wages and holiday pay	6.10.65
Gillick, Mary (Mrs.), 8 Union-street, Collingwood .. ..	18.40	" " " " " " " "	14.5.65
Stevens, Elizabeth Anne (Mrs.), Flat 1, 32 Grosvenor-street, Moonee Ponds	21.45	Wages and holiday pay " ..	20.2.65
Upjohn, Dianne (Miss), 9 Latham-court, Dandenong North ..	22.95	Holiday pay .. ..	9.4.65
Dubbeld, Adrianus Teun Johan, 57 Thompson-road, Upwey ..	22.50	Wages and holiday pay ..	21.4.65
Johanning, Rae (Mrs.), 45 Box-street, Doveton .. ..	19.77	" " " " " " " "	3.7.65
Blake, K. F., 217 Moorefields-road, Lakemba, N.S.W. .. ..	12.50	Goods " .. " ..	—3.65

7513

G. J. COLES & CO. LTD.—E. A. DUNCAN, TRUST ACCOUNT.

Hodgson, Rodney B., Dept. of External Affairs, A.C.T. .. ..	16.67	Rights sold by Trustee ..	—9.64
Laughton, Diana M., c/o James Watson & Co., Cophall House, 13 Cophal-avenue, London, England	16.67	" " " " " "	" "
Harding, Margaret S., 123 Harbord-road, Harbord, Manly, N.S.W.	41.67	" " " " " "	" "
Flynn, Patrick, 337 Waterworks-road, Ashgrove, Qld. .. ..	25.00	" " " " " "	" "
Shannon, Charles H. C., c/o Y.M.C.A. Hostel, Edward-street, Brisbane	25.00	" " " " " "	" "
Ellis, Mary, A., Lees-road, Tardale, Napier, N.Z. .. ..	50.00	" " " " " "	" "
Gibson, Gladys C., 44 Murphy-street, Wellington, N.Z. ..	100.00	" " " " " "	" "
Harris, Amy G. (estate of), c/o Knapp, Connery & Pearman, P.O. Box 203, Nelson, N.Z.	16.67	" " " " " "	" "
Hennessy, James, M. "Misty Hills," Duvauchelle-road, Banks Peninsular, N.Z.	41.67	" " " " " "	" "
Johnson, Walter (estate of), c/o Hill, Lee & Scott, P.O. Box 288, Christchurch, N.Z.	50.00	" " " " " "	" "
Brown, Peter H., "Ballynanhinch", Berrima, N.S.W. .. ..	16.67	" " " " " "	" "
Campbell, Jacqueline H., 33 Hay-street, Collaroy N.S.W. ..	16.67	" " " " " "	" "
Cato, Roy C., 31 Trevetts-road, North Ryde, N.S.W. .. ..	41.67	" " " " " "	" "
Hynd, Millicent, c/o M. P. Carool, 40 Miller-street, North Sydney	16.67	" " " " " "	" "
Lumsden, Harold P., 19 Henson-street, Summer Hill, N.S.W.	16.67	" " " " " "	" "
Stanton, Mary C. (Mrs.), 95 Broadway, Camberwell, Vic. ..	133.33	" " " " " "	" "
Tanner, Robert B. C., "Piney Creek", Uriwin-road, Canberra	29.58	" " " " " "	" "
Armstrong, John W., 3 Macolm-street, Perth, W.A. .. ..	37.92	" " " " " "	" "
Alexander, Lionel E. (estate of), c/o Salek, Turner & Brown, Wellington, N.Z.	71.25	" " " " " "	" "
Simcox, Heata R., Weber, near Dannevirke, N.Z. .. ..	29.58	" " " " " "	" "
Higgins, Mona B. (estate of), c/o Box 1342, Sydney, N.S.W. ..	46.25	" " " " " "	" "
Orr, Maeline G. (estate of), 12 Jubilee-avenue, Pymble, N.S.W. ..	21.25	" " " " " "	" "
Webb, Bernice F., c/o G. J. Coles & Coy. Limited, 236 Bourke-street, Melbourne	12.92	" " " " " "	" "
Levay, Joan A., & William C. Levay, c/o G. J. Coles & Coy. Limited, 236 Bourke-street, Melbourne	50.00	" " " " " "	" "
Harman, William D., 29 Gurney-street, Vermont .. ..	16.67	" " " " " "	" "

7514

Victoria—Companies Act 1961.

MULGOA HOLDINGS PROPRIETARY LIMITED (IN VOLUNTARY LIQUIDATION).

PURSUANT TO SECTION 254 (2).

NOTICE is hereby given that at an Extraordinary General Meeting of the above-named company duly convened and held at 229 Exhibition-street, Melbourne, on the 5th day of June, 1967, the following Special Resolution was duly passed:—

"That the company be wound up voluntarily."

Mr. Ronald Stanley Schnellbeck, of 229 Exhibition-street, Melbourne, was duly appointed liquidator of the company.

7428

ALAN DOUGLAS, Secretary.

In the matter of the Companies Act 1961 and in the matter of BRADFORD COTTON SPINNING MILLS (VIC.) PTY. LIMITED (in Liquidation).

TAKE notice that the affairs of the above-named company are now fully wound up and that in pursuance of section 272 (1) of the Companies Act 1961, a General Meeting of the company will be held at Bradmill House, Missenden-road, Camperdown, on the 24th day of July, 1967, at 10 o'clock in the forenoon for the purpose of laying before it an account showing how the winding up has been conducted and the property of the company disposed of and giving any explanation thereof.

Dated this 8th day of June, 1967.

7482

B. W. RUFFELS, Liquidator.

In the matter of the Companies Act 1961 and in the matter of BRADFORD COTTON WEAVING MILLS (VIC.) PTY. LIMITED (in Liquidation).

TAKE notice that the affairs of the above-named company are now fully wound up and that in pursuance of section 272 (1) of the Companies Act 1961, a General Meeting of the company will be held at Bradmill House, Missenden-road, Camperdown on the 24th day of July, 1967, at 10 o'clock in the forenoon for the purpose of laying before it an account showing how the winding up has been conducted and the property of the company disposed of and giving any explanation thereof.

Dated this 8th day of June, 1967.

7481

B. W. RUFFELS, Liquidator.

In the matter of the Companies Act 1961 and in the matter of BRADFORD COTTON MILLS (BENDIGO) PTY. LIMITED (in Liquidation).

TAKE notice that the affairs of the above-named company are now fully wound up and that in pursuance of section 272 (1) of the Companies Act 1961, a General Meeting of the company will be held at Bradmill House, Missenden-road, Camperdown, on the 24th day of July, 1967, at 10 o'clock in the forenoon for the purpose of laying before it an account showing how the winding up has been conducted and the property of the company disposed of and giving any explanation thereof.

Dated this 8th day of June, 1967.

7483

B. W. RUFFELS, Liquidator.

In the matter of the *Companies Act 1961* and in the matter of **BRADFORD COTTON WEAVING MILLS (VIC.) PTY. LIMITED** (in Liquidation).

**NOTICE** is hereby given that at a General Meeting of the above-named company duly convened and held at Bradmill House, Missenden-road, Camperdown, on the 6th day of June 1967, the following Special Resolution was duly passed:—

"That the company be wound up voluntarily and that Brendon Walter Burton Ruffels of 395 Collins-street, Melbourne be appointed Liquidator for the purpose of such winding up."

Dated this 6th day of June, 1967.

7484

L. A. LOCHRIN, Chairman.

In the matter of the *Companies Act 1961* and in the matter of **BRADFORD COTTON SPINNING MILLS (VIC.) PTY. LIMITED** (in Liquidation).

**NOTICE** is hereby given that at a General Meeting of the above-named company duly convened and held at Bradmill House, Missenden-road, Camperdown, on the 6th day of June 1967, the following Special Resolution was duly passed:—

"That the company be wound up voluntarily and that Brendon Walter Burton Ruffels of 395 Collins-street, Melbourne be appointed Liquidator for the purpose of such winding up."

Dated this 6th day of June, 1967.

7485

L. A. LOCHRIN, Chairman.

In the matter of the *Companies Act 1961* and in the matter of **BRADFORD COTTON MILLS (BENDIGO) PTY. LIMITED** (in Liquidation).

**NOTICE** is hereby given that at a General Meeting of the above-named company duly convened and held at Bradmill House, Missenden-road, Camperdown, on the 6th day of June 1967, the following Special Resolution was duly passed:—

"That the company be wound up voluntarily and that Brendon Walter Burton Ruffels of 395 Collins-street, Melbourne be appointed Liquidator for the purpose of such winding up."

Dated this 6th day of June, 1967.

7486

L. A. LOCHRIN, Chairman.

*Companies Act 1961.*

**PHILLIPS WILKINSON PROPRIETARY LIMITED.**

PURSUANT TO SECTION 260 OF THE COMPANIES ACT 1961.

**NOTICE** is hereby given that a Meeting of Creditors of Phillips Wilkinson Proprietary Limited will be held at the office of the Institute of Chartered Accountants, 23 McKillop-street, Melbourne, on Friday, the 23rd June, 1967, at 10.30 a.m. for the purpose of considering the company's affairs, the company having convened an Extraordinary General Meeting of its Members to be held on the same day and for the purpose of considering and if thought fit passing the following Special Resolution:—

"That it has been proved to the satisfaction of this meeting that the company cannot, by reason of its liabilities, continue its business, and that it is advisable to wind up the company and accordingly that the same be wound up voluntarily."

Upon the aforesaid Resolution being passed, a liquidator need then be appointed and notice is hereby given to creditors that the following Resolution will be then considered and passed if approved:—

"That Mr. T. J. McCarthy, a public accountant and registered liquidator be appointed official liquidator of the company, although a previous officer of the company and presently in partnership with Mr. T. M. Kennedy, the secretary of the company."

Upon appointment of a liquidator it will then be necessary to fix the remuneration of the proposed liquidator.

An individual or a member of a partnership may attend and vote personally whilst a company may be represented personally by a Director, the Manager or Secretary, but in all other cases the proxy must be completed and lodged with the company prior to the Meeting.

A form of proxy is attached.

Dated this 7th day of June, 1967.

7444

By order of the Board,

L. E. PHILLIPS, Director.

*Companies Act 1961.*—In the matter of **LEFOE CONSTRUCTIONS PROPRIETARY LIMITED.**—Notice to Creditors of Meeting, pursuant to Section 260.

**NOTICE** is hereby given that a Meeting of Creditors of the above company will be held at the Board Room, Institute of Chartered Accountants, 23 McKillop-street, Melbourne, on Monday, 19th June, 1967, at 3.30 p.m., pursuant to the provisions of section 260 of the *Companies Act 1961*, a meeting of members of the company having been convened on the same day for the purpose of considering and if thought fit passing a Resolution that the company be wound up voluntarily. 7448

*The Companies Act 1961.*—Form 92.

**NOTICE OF MEETING OF CREDITORS OF INGRID FURNISHINGS PROPRIETARY LIMITED (UNDER OFFICIAL MANAGEMENT).**

**NOTICE** is hereby given that a Meeting of Creditors of Ingrid Furnishings Proprietary Limited, will be held at the Institute of Chartered Accountants in Australia, on the 20th day of June, 1967, at 11.30 o'clock in the forenoon, the company having convened a meeting of its members for the same day for the purpose of considering, and if thought fit, passing as a Special Resolution that the company be wound up voluntarily.

Dated this 30th day of May, 1967.

H. W. C. BLYTH, Official Manager.

Cox Johnston & Co., chartered accountants, 446 Collins-street, Melbourne, C.I. 7498

*The Companies Act 1961.*—Pursuant to Section 272.

**TOBINS FURNISHINGS PTY. LTD. (IN LIQ.).**

*Notice Convening Final Meeting of Members and Creditors.*

**NOTICE** is hereby given in pursuance of section 272 of the *Companies Act 1961* that a meeting of the members and creditors of the above-named company will be held on the 7th day of July, 1967, at the offices of Hall and Rose, 260 Queen-street, Melbourne, at 9.30 a.m. in the forenoon, for the purpose of having an account laid before them showing the manner in which the winding up has been conducted and the property of the company disposed of and of hearing any explanations that may be given by the liquidator.

Dated this 9th day of June, 1967.

J. K. HALL, Liquidator.

Hall & Rose, chartered accountants, 260 Queen-street, Melbourne, C.I. 7453

**NOTICE OF MEETING OF CREDITORS TO CONSIDER WINDING UP RESOLUTION.**

**NOTICE** is hereby given that in accordance with section 260 of the *Companies Act*, a meeting of creditors of W. & E. King Pty. Ltd., will be held at "Bankers Institute Meeting Room", 51 Queen-street, Melbourne, on Friday, 23rd June, 1967, at 11.30 a.m.

The meeting is convened for the purpose of considering the position of the company's affairs and, if thought expedient, resolve that the company be voluntarily wound up, the company having convened an Extraordinary General Meeting of its members to be held on the same day for the purpose of considering and if deemed expedient, passing a Special Resolution that the company be voluntarily wound up, and that Messrs. Leslie P. Smart and Vernan K. Reynolds, of 51 Queen-street, Melbourne, 3000, be and are hereby appointed as liquidators, to act jointly or severally for the purpose of the winding up of the company.

7489

W. KING, Director.

E. KING, Director.

*The Companies Act 1961.*

**LOVE'S PROPERTIES PTY. LTD.**

**NOTICE Re MEETING OF CREDITORS PURSUANT TO SECTION 260.**

**NOTICE** is hereby given that a meeting of creditors of the above-named company will be held at the Bankers Institute Auditorium on Tuesday, the 20th June, 1967, at 10.30 a.m., the company having convened a meeting of its members for Monday, the 19th June, 1967, for the purpose of considering a Resolution that the company be wound up voluntarily.

Dated this 9th day of June, 1967.

7490

The Companies Act 1961.

EDWARD LOVE & CO. PTY. LTD.

NOTICE Re MEETING OF CREDITORS PURSUANT TO SECTION 260.

NOTICE is hereby given that a meeting of creditors of the above-named company will be held at the Bankers Institute Auditorium on Tuesday, the 20th June, 1967, at 11.30 a.m., the company having convened a meeting of its members for Monday, the 19th June, 1967, for the purpose of considering a Resolution that the company be wound up voluntarily.

Dated this 9th day of June, 1967.

7491

The Companies Act 1961.

JUBILEE INVESTMENTS PTY. LTD.

NOTICE Re MEETING OF CREDITORS PURSUANT TO SECTION 260.

NOTICE is hereby given that a meeting of creditors of the above-named company will be held at the Bankers Institute Auditorium on Tuesday, the 20th June, 1967, at 11 a.m., the company having convened a meeting of its members for Monday, the 19th June, 1967, for the purpose of considering a Resolution that the company be wound up voluntarily.

Dated this 9th day of June, 1967.

7492

Companies Act 1961.

SECTION 260.—NOTICE OF MEETING OF CREDITORS.

SUPERIOR SERVICES PTY. LIMITED.

NOTICE is hereby given that a meeting of creditors of the above-named company will be held at the Meeting Room of the Institute of Chartered Accountants in Australia, 23 McKillop-street, Melbourne, on Friday, 16th June, 1967, at 10.15 a.m., the company having convened a meeting of its members for the same day for the purpose of considering a Resolution that the company be wound up voluntarily.

Agenda:

To consider and if thought fit, resolve:

1. The company be wound up voluntarily and that Mr. Peter William Harvey, chartered accountant, of 440 Collins-street, Melbourne, be appointed liquidator.

2. The liquidator be paid remuneration in accordance with the scale of fees from time to time paid by the Institute of Chartered Accountants in Australia.

Dated this 5th day of June, 1967.

E. WHITEFORD, Director.

A. L. Royce and Warne-Smith, chartered accountants, 440 Collins-street, Melbourne.

Creditors not able to attend meeting should complete the enclosed form of proxy and return it to this office.

7495

In the matter of NOEL FERRIER PRODUCTIONS PTY. LIMITED.

WINDING-UP Order made 31st May, 1967.

Name and address of official liquidator: Jack Bastian, of 545 St. Kilda-road, Melbourne.

JAMES CANNY, Deputy Commissioner of Taxation of the Commonwealth of Australia, petitioner.

7493

In the matter of the Companies Act, and in the matter of AFCO MANUFACTURING PROPRIETARY LIMITED.

NOTICE is hereby given that at an Extraordinary General Meeting of members of the above-named company duly convened and held at the office of W. A. Prendergast and Robinson, 406 Lonsdale-street, Melbourne, at 2.15 o'clock in the afternoon on the 7th day of June, 1967, the following Special Resolution was duly passed, viz.:

"That the company be wound up voluntarily and that Francis Seddon Millard, of 63 Wimbledon-avenue, Mount Eliza, company director, be appointed liquidator for the purposes of such winding up."

Dated the 7th day of June, 1967.

7450

I. M. VASS, Chairman.

The Companies Act 1961.

APPLIANCE ACCEPTANCE PTY. LTD. (IN VOLUNTARY LIQUIDATION).

NOTICE is hereby given that at an Extraordinary General Meeting of members of the above-named company duly convened and held on the 9th day of June, 1967, the following resolution was proposed and passed as a Special Resolution.

That the company be wound up voluntarily and that James Hamilton Davis of the firm of Sloman and Mogg, of 401 Collins-street, Melbourne, be appointed liquidator for the purpose of such winding up, and that he be authorized to draw as remuneration for his services as liquidator his normal hourly charges in respect thereto.

Dated this 9th day of June, 1967.

7496

E. H. GRAY, Director.

The Companies Act 1961.—In the matter of APPLIANCE ACCEPTANCE PTY. LTD. (in Voluntary Liquidation)

Members winding up.

CREDITORS and others having claims against the above company should send details to me before the 29th June, 1967, after which date I will distribute the assets of the company having regard only to claims of which I have had notice.

Dated this 9th day of June, 1967.

JAMES H. DAVIS, Liquidator.

Sloman & Mogg, 401 Collins-street, Melbourne. 7515

The Companies Act 1961.—In the matter of EDGELEIGH FURNISHING AND DISPLAY PTY. LTD. (in Liquidation)

NOTICE is hereby given that pursuant to section 272 of the Companies Act a final meeting of the creditors of the above company will be held at the offices of Kennedy, Smail and Middlemiss, 296-300 Little Lonsdale-street, Melbourne, on Wednesday the 12th day of July, 1967, at 11.00 a.m.

Business to receive the liquidator's accounts.

Dated this 7th day of June, 1967.

NORMAN ERIC STRETTON, liquidator.

Kennedy, Smail & Middlemiss, 296-300 Little Lonsdale-street, Melbourne. 7497

The Companies Act 1961.—In the matter of B. & L. WAKEHAM (AUSTRALIA) PTY. LTD. (in Liquidation).

NOTICE is hereby given that pursuant to section 272 of the Companies Act a final meeting of the creditors of the above company will be held at the offices of Kennedy, Smail and Middlemiss, 296 Little Lonsdale-street, Melbourne, on Wednesday, the 12th day of July, 1967, at 11.30 a.m.

Business to receive the liquidator's accounts.

Dated this 8th day of June, 1967.

NORMAN ERIC STRETTON, liquidator.

Kennedy, Smail & Middlemiss, 296-300 Little Lonsdale-street, Melbourne. 7499

Companies Act 1961.—In the matter of N. E. HOME FOOD SERVICES PROPRIETARY LIMITED.

Notice Re Meeting of Creditors, Pursuant to Section 260.

NOTICE is hereby given that a meeting of creditors of the above-named company will be held at Room 511, Federation House, 342 Flinders-street, Melbourne, at 3.30 p.m., on Thursday the 22nd day of June, 1967, the company having convened a meeting of its members for the same day for the purpose of considering a Resolution that the company be wound up voluntarily.

Dated this 7th day of June, 1967.

T. C. WISE, Director.

A. NEVILLE BIRD & CO., chartered accountants, 289 Flinders-lane, Melbourne. Telephone 63 8833. 7501

In the matter of the Companies Act 1961 and H. ANGUEY & SONS PROPRIETARY LIMITED.

NOTICE is hereby given that at a general meeting of shareholders held on the 8th day of June, 1967, the following Resolution was passed as a Special Resolution:

"That the company be wound up voluntarily as a members voluntary winding up in accordance with the provisions of the "Companies Act 1961".

7474

*Companies Act 1961.*—In the matter of **FOODWISE PTY. LTD.**  
Notice Re Meeting of Creditors, Pursuant to  
Section 260.

NOTICE is hereby given that a meeting of creditors of the above-named company will be held at Room 511, Federation House, 342 Flinders-street, Melbourne, at 2.30 p.m., on Thursday, 22nd June, 1967, the company having convened a meeting of its members for the same day for the purpose of considering a Resolution that the company be wound up voluntarily.

Dated this 7th day of June, 1967.

T. C. WISE, Director.

A. NEVILLE BIRD & CO., chartered accountants, 289  
Flinders-lane, Melbourne. Telephone 63 8833. 7502

*Companies Act 1961.*—In the matter of **CLARINDA TRADING  
CO. PTY. LTD.** (in Liquidation).

NOTICE is hereby given that pursuant to section 272 (1) of the Companies Act, a final meeting of members of the above company will be held at 36 Holloway-street, Ormond on Wednesday, the 19th of July, 1967, at 7.00 p.m.

Business to receive the liquidator's accounts.

Dated this 8th day of June, 1967.

MARTIN HYNES, liquidator, 36 Holloway-street,  
Ormond, 58 1120. 7506

In the matter of **HANBURY LODGE PTY. LIMITED** (in  
Voluntary Liquidation) and the *Companies Act 1961.*

PURSUANT TO SECTION 254 (a) (b).

NOTICE is hereby given that a meeting of the members of Hanbury Lodge Pty. Limited held at the office of L. Lasky & Co., public accountants, 2nd Floor, 394 Latrobe-street, Melbourne, on the 22nd May, 1967, the following Resolution was passed as a Special Resolution.

"That the company be wound up voluntarily."

Dated at Melbourne the 22nd day of May, 1967.

7511 LEON LASKY, liquidator.

*Companies Act 1961.*

**DYMAC-COMMERCIAL PROPRIETARY LIMITED.**

AT an Extraordinary General Meeting of the above-named company, duly convened and held at 440 Collins-street, Melbourne, on the 9th June, 1967, the following Resolution was duly passed as a Special Resolution:—

"Resolved that the company be wound up voluntarily".

And at this meeting Mr. Andrew David Warne-Smith of 440 Collins-street, Melbourne, was appointed liquidator for the purposes of the winding up.

Dated this 9th day of June, 1967.

7507 A. D. WARNE-SMITH, Secretary.

CREDITORS, next of kin and others having claims in respect of the estate of Ann Cecilia O'Halloran, late of 4 Huntley-street, Elsternwick, widow, deceased (who died on the 5th day of February, 1967), are requested to send particulars of their claims to Kenneth John Clements, of 255 Glenhuntly-road, Elsternwick, solicitor, and Patricia Ann O'Halloran, of 4 Huntley-street, Elsternwick, spinster, the executors of the will of the said deceased, in care of the under-mentioned firm of solicitors by the 31st day of August, 1967, after which date the executors will distribute the assets, having regard only to the claims of which they have notice.

KENNETH J. CLEMENTS & SON, solicitors, 255 Glen-huntly-road Elsternwick. 7429

CREDITORS, next of kin and others having claims in respect of the estate of Johanna Sophie Krause (also known as Bray), formerly of 43 Eighth-street, Parkdale, but late of Eventide Homes, Hamilton, widow, deceased (who died on the 16th day of March, 1967), are requested to send particulars of their claims to Norman Oswald Krause, of 7 Moore-street, Hamilton, and Laurence Herbert Krause, of 67 Ballarat-road, Hamilton, contractors, the executors of the will of the said deceased, in care of the under-mentioned firm of solicitors by the 31st day of August, 1967, after which date the executors will distribute the assets, having regard only to the claims of which they have notice.

KENNETH J. CLEMENTS & SON, solicitors, 255 Glen-huntly-road, Elsternwick. 7430

FLORENCE ELLEN HOLT, late of 50 Williamson-street,  
Bendigo, widow, DECEASED.

CREDITORS, next of kin and others having claims against the estate of the above-named deceased are required by the executors therein, Harold Verdun Holt, of 5 Growler-street, Eaglehawk, poultry farmer and William Arthur Ernest Holt, of 30 Melvor-road, Bendigo, transport operator, to forward particulars thereof to them care of the under-mentioned solicitors on or before the 15th day of August, 1967, after which date they will distribute the assets of the said estate, having regard only to the claims of which they then have notice.

Dated the 6th day of June, 1967.

Messrs. HYETT & HYETT, solicitors, 51 Bull-street,  
Bendigo. 7431

CARL MILRAY, DECEASED, intestate.

CREDITORS, next of kin and others having claims in respect of the estate of Carl Milray, late of Gisborne, in the State of Victoria, builder, deceased, intestate (who died on the 20th day of August, 1966), are to send particulars of their claims to The Equity Trustees, Executors and Agency Company Limited, of No. 472 Bourke-street, Melbourne, by the 20th day of August, 1967, after which date it will distribute the assets, having regard only to the claims of which it then has notice.

H. HURRY & SON, solicitors, Kyneton and Woodend.  
7432

CREDITORS, next of kin and others having claims against the estate of Henry James Angee, late of Elaine, in the State of Victoria, farmer, deceased (who died on the 7th day of February, 1967), are required to send particulars of their claims to the Union-Fidelity Trustee Company of Australia Limited, of 101 Lydiard-street north, Ballarat, in the said State, the executor of the will of the said deceased, by the 12th day of August, 1967, after which date the said executor will distribute the assets, having regard only to the claims of which it then has notice.

BYRNES, JONES & TORNEY, solicitors, Ballarat. 7433

CREDITORS, next of kin and others having claims against the estate of Harold Jones, late of 72 Napier-street, South Melbourne, in the State of Victoria, municipal employee, deceased (who died on the 24th day of April, 1967), are required to send particulars of their claims to the administratrix, Mavis Millicent Jones, care of the under-signed solicitor, before the 31st day of August, 1967, after which date she will distribute the assets, having regard only to the claims of which she then has notice.

JOHN F. CARROLL, solicitor, 118 Queen-street,  
Melbourne. 7445

CREDITORS, next of kin and others having claims in respect of the estate of Eileen Mary Brain, late of 23 Kitchener-grove, East Preston, in the State of Victoria, married woman, deceased (who died on the 23rd day of August, 1966), are to send particulars of their claims to Royston T. Cahir & Martin, solicitors, of 475 Collins-street, Melbourne, by the 16th day of August, 1967, after which date the executrix will distribute the assets of the said estate, having regard only to claims of which she then has notice.

ROYSTON T. CAHIR & MARTIN, solicitors, of 475  
Collins-street, Melbourne. 7457

CREDITORS, next of kin and others having claims in respect of the estate of Arthur Edward Hartt, late of 34 Grey-street, St. Kilda, retired, deceased (who died on the 2nd day of April, 1967), are to send particulars of their claims to Royston T. Cahir & Martin, solicitors, of 475 Collins-street, Melbourne, by the 16th day of August, 1967, after which date the executor will distribute the assets, of the said estate having regard only to claims of which he then has notice.

ROYSTON T. CAHIR & MARTIN, solicitors, 475 Collins-street, Melbourne. 7458

ALLAN BAXTER, late of 76 Downshire-road, Elsternwick,  
gentleman, DECEASED.

CREDITORS, next of kin and others having claims in respect of the estate of the deceased (who died on 16th December, 1915), are required by the trustees Valentine Allan Baxter and Louis Norman Baxter, of 31 Tintern-avenue, Toorak, to send particulars to them by the 31st day of August, 1967, after which date the trustees may convey or distribute the assets, having regard only to the claims of which they then have notice.

7461

CHRISTINA NOONAN, formerly of 1230 Dandenong-road, Murrumbidgee, but late of Mont Park Mental Hospital, Mont Park, widow, DECEASED (who died on the 22nd December, 1966).

CREDITORS, next of kin and all others having claims in respect of the estate of the said deceased are requested by the executor, National Trustees, Executors and Agency Company of Australasia Limited, of 95 Queen-street, Melbourne, to send particulars of such claims to the said company by the 7th August, 1967, after which date the said company will distribute the assets, having regard only to the claims of which it then has notice.

K. G. CRANAGE, solicitor, 273A Glenferrie-road, Malvern, Victoria. 7462

PATRICIA LORRAINE GREENOUGH, late of 19 Violet-crescent, East Brighton, widow, DECEASED.

CREDITORS, next of kin and others having claims in respect of the estate of the deceased (who died on the 8th November, 1966), are required by the executrices, Lorraine Rosslyn Greenough, of 19 Violet-crescent, East Brighton, spinster, and Valerie Millicent Lees, of 67 Ash-street, Doveton, married woman, to send particulars to them care of the undersigned solicitors, by the 21st August, 1967, after which date they may convey or distribute the assets, having regard only to the claims of which they then have notice.

Dated 6th June, 1967.

R. E. LEWIS, ORR & GIBSON, 825 Burke-road, Camberwell. 7459

HAROLD ALLAN SEPTIMUS WALKER, late of Swan Hill, in the State of Victoria, grazier, DECEASED (who died on 6th March, 1967).

CREDITORS, next of kin and all other persons having claims against the estate of the deceased are required by the executor of the will, Thomas Maxwell Walker, to send particulars to him, care of the undersigned, on or before the 8th day of September, 1967, after which date he will distribute the assets, having regard only to the claims of which he then has notice.

GARDEN & GREEN, solicitors, 4 McCallum-street, Swan Hill. 7467

CLIVE CAMPBELL WAKEMAN, late of Swan Hill, in the State of Victoria, motor body builder, DECEASED (who died on 20th November, 1966).

CREDITORS, next of kin and all other persons having claims against the estate of the deceased are required by the executors of the will, Neil Wakeman and Ernest Slater, to send particulars to them, care of the undersigned, on or before the 8th day of September, 1967, after which date they will distribute the assets, having regard only to the claims of which they then have notice.

GARDEN & GREEN, solicitors, 4 McCallum-street, Swan Hill. 7468

MARGARET ELLEN WHITE, late of Mount Clear, married woman, DECEASED.

CREDITORS, next of kin and others having claims in respect of the estate of the deceased (who died on the 28th November, 1966), are required by the applicants for a grant of probate of the deceased's will, Thomas Alfred Pratt, of 108 Nelson-street, Ballarat, butcher, and Neil William Titheridge, of 47 Waller-avenue, Ballarat, estate agent, to send particulars to them, care of the under-mentioned solicitors, by the 22nd August, 1967, after which date they may convey or distribute the assets, having regard only to the claims of which they then have notice.

Dated the 14th day of June, 1967.

DOOLEY, SUTTON & A. W. LONG, solicitors, 43 Lydiard-street south, Ballarat. 7469

The estate of the late SARAH FLOYD LEE, DECEASED, late of Glenrowan West, in the State of Victoria.

CREDITORS, next of kin and others having claims in respect of the estate of the above deceased (who died on the 27th day of May, 1966), are to send the particulars of their claims to The Union-Fidelity Trustee Company of Australia Limited, of 100 Exhibition-street, Melbourne, by the 13th day of September, 1967, after which date it will distribute the assets, having regard only to the claims of which it then has notice.

F. TRENERRY BROWN & SON, solicitors, Benalla. 7470

CREDITORS, next of kin and others having claims in respect of the estate of Leslie John Williams, late of 53 Halifax-street, Middle Brighton, in the State of Victoria, public servant, deceased (who died on the 20th October, 1966), are required to send particulars of their claims to the executrix, Margaret Clark Williams, care of the under-mentioned solicitor, by the 18th September, 1967, after which date he will distribute the assets, having regard only to the claims of which he then has notice.

ROWLAND P. HASSALL, solicitor, 360 South-road, Mor-rabbin. 7471

KIERAN WILLIAM GERARD RYAN, late of 34 Candover-street, Geelong West, shearers' cook, DECEASED.

CREDITORS, next of kin and others having claims in respect of the estate of the said deceased (who died on 12th February, 1967), are required by the applicant for grant of probate of the will, Keith Ethelbert Busbridge, of 33 Scott-street, Belmont, Geelong, wool buyer, to send particulars to him care of the undersigned solicitors, by 16th August, 1967, after which date the said applicant may convey or distribute the assets, having regard only to the claims of which he then has notice.

WIGHTON & McDONALD, solicitors, 189-191 Moorabool-street, Geelong. 7472

CREDITORS, next of kin and others having claims in respect of the estate of Isla Hyde, late of Flat 4, 220 Orrong-road, Toorak, in the State of Victoria, widow, deceased (who died on the 7th day of March, 1967), are required by the executors, Richard Stanley Allen, of 54 Albany-road, Toorak, aforesaid merchant and James Ford Strachan, of 414 Collins-street, Melbourne, in the said State, solicitor to send particulars of their claims to them care of the under-mentioned solicitors by the 15th day of August, 1967, after which date they may convey or distribute the assets, having regard only to the claims of which they then have notice.

AITKEN, WALKER & STRACHAN, solicitors, 414 Collins-street, Melbourne, C.I. 7456

CREDITORS, next of kin and others having claims against the estate of Mary Lizetta Martin, late of 21 Eva-street, Clayton, in the State of Victoria, widow, deceased (who died on the 15th day of March, 1967), are required to send particulars of their claims to the executors, William Peter Martin, and Kathleen Mary LeBrocq, care of the under-signed solicitor, before the 31st day of August, 1967, after which date they will distribute the assets, having regard only to the claims of which they then have notice.

JOHN F. CARROLL, solicitor, 118 Queen-street, Melbourne. 7446

CREDITORS, next of kin and others having claims in respect of the estate of Margaret Ellen Mullany, late of 79 Heidelberg-road, Clifton Hill, widow, deceased (who died on the 16th day of March, 1967), are to send particulars of their claims to Brian Joseph Mullany, care of R. P. Barrett & Son, solicitors, 473 Bourke-street, Melbourne, on or before, the 14th day of August, 1967, after which date he will distribute the assets, having regard only to the claims of which he then has notice.

R. P. BARRETT & SON, solicitors, 473 Bourke-street, Melbourne. 7447

CREDITORS, next of kin and others having claims in respect of the estate of Claude Wilfred Corby, late of 5 Jinghi-road, Reservoir, plumber, deceased (who died on the 19th June, 1965), are to send particulars to Lawrence William McMahon, of 18 Wilfred-road, Ivanhoe, plumber, the executor of the will of the said deceased, care of the under-mentioned solicitors by the 24th August, 1967, after which date he will distribute the assets, having regard only to the claims of which he then has notice.

COLE & O'HEARE, solicitors, 465 Collins-street, Melbourne. 7451

CREDITORS, next of kin and others having claims in respect of the estate of Mary Storer, late of 96 Smith-street, Collingwood, produce dealer, deceased (who died on the 10th day of December, 1923), are to send particulars of their claims to the executor, John Savill Storer, care of the under-mentioned solicitors by the 1st day of October, 1967, after which date he will distribute the assets, having regard only to the claims of which he then has notice.

W. A. PRENDERGAST & ROBINSON, solicitors, 406 Lonsdale-street, Melbourne. 7452

**CREDITORS**, next of kin and others having claims against the estate of Arthur George Edwards, late of 9 Rogers-street, Richmond, in the State of Victoria, plastic operator, deceased (who died on the 21st day of April, 1967), are required to send particulars of their claims to the executor, Charles Arthur Mainwarring Edwards, care of the undersigned solicitor, before the 31st day of August, 1967, after which date he will distribute the assets, having regard only to the claims of which he then has notice.

JOHN F. CARROLL, solicitor, 118 Queen-street, Melbourne. 7454

**CREDITORS**, next of kin and others having claims in respect of the estate of Archibald Wallace Napier, formerly of 136 and 140 Mont Albert-road, Canterbury, but late of 34 Walbundry-avenue, North Balwyn, gentleman, deceased (who died on the 16th March, 1967), are to send particulars of their claims to the Trustees, Executors and Agency Company Limited, of 401 Collins-street, Melbourne, by the 16th day of August, 1967, after which date it will distribute the assets, having regard only to the claims of which it then has notice.

J. M. SMITH & EMMERTON, solicitors, 170 Queen-street, Melbourne. 7455

**CREDITORS**, next of kin and others having claims in respect of the estate of Jane Jones, late of Inverleigh, in the State of Victoria, spinster, deceased (who died on the 2nd day of March, 1966), are to send the particulars of their claims to The Union-Fidelity Trustee Company of Australia Limited, at its office at 8 Malop-street, Geelong, in the said State, by the 25th day of August, 1967, after which date it will distribute the assets, having regard only to the claims of which it then has notice.

FREEMAN & FALLAW, solicitors, 41 Yarra-street, Geelong. 7473

**CREDITORS**, next of kin and others having claims in respect of the estate of Amy Whetton, late of 13 Power-street, Hawthorn, in the State of Victoria, housemaid (who died on the 26th day of September, 1965), are to send particulars of their claims to Charles Ernest Copley, the administrator of the deceased's estate, care of the under-mentioned solicitors, by the 16th day of August, 1967, after which date he will distribute the assets, having regard only to the claims of which he then has notice.

TREVAKS, HAVYATT & STEWARD, solicitors, 472 Bourke-street, Melbourne. 7466

**CREDITORS**, next of kin and others having claims in respect of the estate of Reginald Hugh Cecil Langley, late of 416 Auburn-road, Auburn, retired, deceased (who died on 17th December, 1966), are requested to send particulars of their claims to the executrices, Ella Langley and Norma Loris Yvonne Chinnery, care of the under-mentioned solicitors, on or before the 16th day of August, 1967, after which date they will distribute the assets, having regard only to the claims of which they then have notice.

McKEAN & PARK, solicitors, 84 William-street, Melbourne. 7487

**CREDITORS**, next of kin and others having claims in respect of the estate of Margaret Lloyd, late of 48A Black-street, Brighton, married woman (who died on 1st May, 1967), are to send the particulars of their claims to The Union-Fidelity Trustee Company of Australia Limited, of 100 Exhibition-street, Melbourne, by the 15th day of August, 1967, after which date it will distribute the assets, having regard only to the claims of which it then has notice.

RYLAH & RYLAH, solicitors, 349 Collins-street, Melbourne. 7494

**CREDITORS**, next of kin and others having claims in respect of the estate of William Joseph Hannan, formerly of 6 Bedford-road, Ringwood, but late of Flat 1, 7 Woonsocket-court, St. Kilda, gentleman, deceased (who died on the 11th of March, 1967), are to send particulars of their claims to the executor, The Trustees, Executors and Agency Company Limited, of 401 Collins-street, Melbourne, by the 14th day of August, 1967, after which date it shall commence to distribute the assets, having regard only to the claims of which it then has notice.

RENNICK & GAYNOR, solicitors, 473 Bourke-street, Melbourne. 7500

**CREDITORS**, next of kin and others having claims in respect of the estate of Annie Ellinor Nightingale, late of 15 Hyton-crescent, Croydon, widow, deceased (who died on the 29th December, 1966), are requested by the executors, Norman Nightingale, of "Leyton Park", Myers-road, Bittern, retired, bank officer, and Jean May Stanton, of 15 Hyton-crescent, Croydon, widow, to send particulars of their claims to the executors care of the undersigned solicitors, by 20th August, 1967, after which date they will distribute the assets, having regard only to the claims of which they then have notice.

FREDERICK OWEN & ASSOCIATES, solicitors, 84 William-street, Melbourne. 7503

ELSIE MAY LOUISE RICHARDS, late of 1 Macorna-street, Frankston, widow, DECEASED.

**CREDITORS**, next of kin and others having claims in respect of the estate of the deceased (who died on the 12th day of March, 1967), are required by the trustee, William Boyd, of 19 Scotts-street, Bentleigh, to send particulars to him care of Messrs. Best, Hooper, Rentoul & Shallard, solicitors, 100 Queen-street, Melbourne, by the 22nd day of August, 1967, after which date the trustee may convey or distribute the assets, having regard only to the claims of which he then has notice.

Dated this 14th day of June, 1967.

BEST, HOOPER, RINTOUL & SHALLARD, solicitors, 100 Queen-street, Melbourne. 7504

**CREDITORS**, next of kin and others having claims in respect of the estate of Rose Esther Bredmeyer, late of 10 Chadwell-grove, Chelsea, married woman, deceased (who died on the 1st day of March, 1967), and probate of whose will has been granted to William Joseph Bredmeyer, of 10 Chadwell-grove, Chelsea, pensioner are required to send particulars of their claims to the said executor, care of the under-mentioned solicitors by the 18th day of August, 1967, after which date he will distribute the assets, having regard only to the claims of which he then has notice.

PEARCE & WEBSTER, solicitors, of 430 Little Collins-street, Melbourne. 7449

**CREDITORS**, next of kin and others having claims in respect of the estate of Hephzibah Elsie Thompson, late of 3 Smith-street, Hampton, in the State of Victoria, widow, deceased (who died on the 30th day of April, 1967), are to send particulars of their claims to the executor of the will of deceased, Thomas Keith Burgin, of 23 Wavell-street, Bentleigh, care of the under-mentioned solicitors of 388 Bourke-street, Melbourne, by the 1st day of September, 1967, after which date he will distribute the assets, having regard only to the claims of which he then has notice.

LLOYD P. GOODE & CO., solicitors, 388 Bourke-street, Melbourne. 7505

**CREDITORS**, next of kin and others having claims in respect of the estate of Louis Henry Sudholz, late of Natimuk, farmer, deceased (who died on 26th day of March, 1967), are required by the executors, Edward Albert Sudholz and Louis Herman Lange, both of Natimuk, farmers, to send particulars to them at the address of their solicitors, R. C. Bieske and Edgar, 52 Wilson-street, Horsham, by the 22nd August, 1967, after which date they may convey or distribute the assets, having regard only to the claims of which they then have notice.

R. C. BIESKE & EDGAR, solicitors, 52 Wilson-street, Horsham. 7508

**CREDITORS**, next of kin and others having claims in respect of the estate of Ernest Dudley Partington, late of 16 Wanda-street, Springvale North, stationery and property officer, deceased (who died on or about the 26th day of December, 1965), are required by the executor, William Keith Bond, of 43 Jeffery-street, Lower Templestowe, clerk, to send particulars of their claims to him, care of Messrs. Rogers and Gaylard, solicitors, of 281 Collins-street, Melbourne, by the 16th day of August, 1967, after which date the said executor will distribute the assets of the deceased, having regard only to the claims of which he then shall have had notice.

ROGERS & GAYLARD, solicitors, of 281 Collins-street, Melbourne. 7509

**CREDITORS**, next of kin and all others having claims in respect of the estate of Bessie Wood, late of 2-4 Gascoyne-street, Canterbury, spinster (who died on the 19th March, 1967), are required by the executor, The Trustees, Executors and Agency Company Limited, of 401 Collins-street, Melbourne, to send particulars of such claims to the said company on or before the 16th August, 1967, after which date the said company will distribute the assets, having regard only to the claims of which it then has notice.

DAVIES, CAMPBELL & PIESSE, solicitors, 401 Collins-street, Melbourne. 7510

MAXWELL ERNEST BUCHANAN, late of 55 Carmichael-street, Hamilton, in the State of Victoria, accountant, DECEASED.

**CREDITORS**, next of kin and others having claims in respect of the estate of the deceased (who died on the 27th day of July, 1965), are required by the executrix, Grace Aglena Buchanan, of 55 Carmichael-street, Hamilton, aforesaid, widow, to send particulars to her care of the under-mentioned solicitors, by the 8th day of August, 1967, after which date the executrix may convey or distribute the assets, having regard only to the claims of which she then has notice.

CAMERON & LOWENSTERN, solicitors, 62 Thompson-street, Hamilton. 7512

**IMPOUNDINGS**

**ROSEDALE**.—Impounded in Rosedale Pound, on 23rd May, 1967.

1 black and white Friesian bull calf, 6 months, no visible brand  
Impounded on 29th May, 1967.

1 crossbred ram (shorn) long tail with red A on right shoulder

If not claimed and expenses paid, to be sold on 27th June, 1967.

7441—\$2.75 E. W. HAMMOND, Poundkeeper.

**SUNSHINE**.—Impounded in Ardeer Pound.

1 skewbald gelding, 13 hands, shod, no visible brands or marks

If not claimed and expenses paid, to be sold on 1st July, 1967.

7464—\$1.75 D. THOMPSON, Poundkeeper.

**UPWEY**.—Impounded in Upwey Pound, from Main-road, Upwey.

1 lamb, no visible brand

If not claimed and expenses paid, to be sold on 27th June, 1967.

7476—\$1.75 K. McMAHON, Poundkeeper.

*Subordinate Legislation Act 1962.*

**NOTICE OF MAKING OF STATUTORY RULES.**

IN pursuance of the provisions of the *Subordinate Legislation Act 1962* and the Regulations made thereunder, notice is given of the making of the following statutory rules:—

No.	Stamps Act 1958.	Price.
	<i>Marketable Securities Act 1966.</i>	
141/1967.	Stamps (Marketable Securities) Regulations 1967	10c
	<i>Grain Elevators Act 1958 (No. 6266).</i>	
142/1967.	Grain Elevators Board By-law (Relating to the Conditions of Employment of Staff) No. 47b	10c
	<i>State Electricity Commission Act 1958.</i>	
143/1967.	State Electricity Commission (Briquette Appliance Testing Stamp) Regulations 1967	10c

No.	Motor Car Act 1958.	Price.
144/1967.	Motor Car (Transfer and Roadworthiness Amendment No. 3) Regulations 1967	10c

Copies of these statutory rules may be purchased at the Sale of Publications Section of the Government Printing Office, located at Macarthur-street, Melbourne, C.2. If ordered by mail, remittance should be addressed to "The Government Printer, Box 203, P.O., North Melbourne, N.I.", and should include 5c extra for postage. If a credit account is held at this office, no remittance is required with the mail order.

The annual subscription rate for Statutory Rules (including a Bound Volume) is \$15, payable in advance. The subscription year commences on 1st January.

A. C. BROOKS,  
Government Printer.

**STATE ACTS, 1967**

COPIES of the following Acts of Parliament of Victoria may be obtained at the Government Printing Office, or from any accredited agents, at the price set opposite to each (these prices do not include postage).

The annual subscription for State Acts 1967 et seq. is \$8 payable in advance.

Bound Volumes of State Acts are also available on a subscription basis at \$15 per annum.

No.		Price.
7515.	New Melbourne Cemetery Lands	\$0.10
7516.	Country Fire Authority (Prosecutions)	\$0.10
7517.	Social Welfare (Detention)	\$0.10
7518.	Zoological Gardens	\$0.15
7519.	Richmond (South-Eastern Freeway) Lands	\$0.10
7520.	The Geelong Gas Company's	\$0.10
7521.	Co-operative Housing Societies (Indemnities)	\$0.10
7522.	Supreme and County Courts (Sittings)	\$0.10
7523.	Dandenong Valley Authority (Amendment)	\$0.15
7524.	State Savings Bank (Amendment)	\$0.10
7525.	Land (Surf Life Saving Association)	\$0.10
7526.	Warragul (Public Park) Lands	\$0.10
7527.	Tobacco Leaf Marketing Board (Appointment of Manager) (Amendment)	\$0.10
7528.	Stock Artificial Breeding (Amendment)	\$0.10
7529.	Second-hand Dealers (Amendment)	\$0.10
7530.	Legal Aid (Amendment)	\$0.10
7531.	Weights and Measures (Amendment)	\$0.25
7532.	The Constitution Act Amendment (Electoral)	\$0.10
7533.	Education and Teaching Service (Amendment)	\$0.15
7534.	Public Officers Salaries and Allowances	\$0.10
7535.	Railways (State Coal Mine Officers)	\$0.10
7536.	Public Officers (Long Service Leave)	\$0.15
7537.	Pipelines (Submerged Lands)	\$0.30
7538.	Police Regulation (Pensions)	\$0.10
7539.	Legal Profession Practice (Victoria Law Foundation)	\$0.10
7540.	Petroleum (Barracouta and Marlin Fields Agreement)	\$0.25
7541.	Pipelines	\$0.25
7542.	Local Government (Amendment)	\$0.15
7543.	Stamps (Amendment)	\$0.10
7544.	Police Offences (Obscene Publications)	\$0.10
7545.	Melbourne University (Amendment)	\$0.10
7546.	Crimes	\$0.15
7547.	Instruments (Corporate Bodies Contracts)	\$0.10
7548.	Land (Amendment)	\$0.25
7549.	Water (Amendment)	\$0.10
7550.	Dowling Forest Racecourse Lands	\$0.15
7551.	Strata Titles	\$0.40
7552.	Revocation and Excision of Crown Reservations	\$0.15
7553.	Tullamarine Freeway Lands	\$0.15
7554.	Friendly Societies Investment	\$0.10
7555.	Victoria Institute of Colleges (Board of Studies)	\$0.10

A. C. BROOKS,  
Government Printer.

## PUBLICATION OF OFFICIAL MATTER.

ATTENTION is invited to the following procedure in relation to the publication of official matter in the *Government Gazette*:—

## 1. Matter submitted to the Executive Council.

Matters submitted to the Executive Council which requires gazettal will normally be published in the issue of the following week.

Where urgent gazettal is required, special arrangements should be made with the Gazette Officer, Room 9, first floor, Old Treasury Building.

Publication will be facilitated by the submission of carbon copies for the use of the Gazette Officer.

## 2. Other matter.

(a) All other matter duly certified by a responsible officer for publication should be lodged with the Gazette Officer not later than half-past Ten a.m. on Tuesday.

(b) Lengthy or involved notices should be forwarded several days before publication.

(c) Proofs, which will be supplied only when specifically requested or, at the direction of the Gazette Officer, should be returned promptly to avoid delay in publication.

(d) No additions or amendments to matter for publication will be accepted by telephone.

## AGENTS FOR THE "VICTORIA GOVERNMENT GAZETTE".

THE following have been appointed agents to receive Advertisements and Subscriptions for the *Victoria Government Gazette*:—

ARMSTRONG'S AGENCY, 205 Queen-street, Melbourne.

ARNALL & JACKSON, 390 Barkly-street, Brunswick, N.10.

BAIRNSDALE AUTHORIZED NEWSAGENCY, 132 Main-street, Bairnsdale.

DAVIES, G. & M. V., 112 Gray-street, Hamilton.

DAVIS, WM. (MILDURA) PTY. LTD., 126 Eighth-street, Mildura.

DIXON'S NEWSAGENCY, 89 Firebrace-street, Horsham.

EDGAR'S NEWSAGENCY PTY. LTD., 293 Hargreaves-street, Bendigo.

EDGAR'S AUTHORIZED NEWSAGENCY, 45 Bridge-street, Benalla.

FRANKS, H. & CO., 184 Ryrie-street, Geelong.

GORDON & GOTCH AUSTRALASIA LTD., 511 Little Collins-street, Melbourne.

GULLAN'S NEWSAGENCY, 88 Bridge-street, Ballarat.

HAMPTON, A. C., 243 Mitchell-street, Bendigo.

HARSTON, PARTRIDGE & CO. PTY. LTD., 455 Little Collins-street, Melbourne.

KYNETON GUARDIAN PTY. LTD., P.O. Box 18, Kyneton.

LATIMER'S, Newsagents, 45 Station-street, Malvern.

LIVINGSTON'S SHEPPARTON NEWSAGENCY, 246 Wyndham-street, Shepparton.

THE MERCANTILE EXCHANGE, 90 Queen-street, Melbourne.

McGILL'S AUTHORIZED NEWSAGENCY, 183-5 Elizabeth-street, Melbourne.

PETTY, R. H. & W. M., 83 Murphy-street, Wangaratta.

PURDIE, J., & CO., 138 Moorabool-street, Geelong.

R. G. CARTER ADVERTISING SERVICE PTY. LTD., 26-32 King-street, Melbourne.

SALE AUTHORIZED NEWSAGENCY, 142 Raymond-street, Sale.

SKINNER'S AUTHORIZED NEWSAGENCY, 49-51 Franklin-street, Traralgon.

STEVENSON, A. C. & M., NEWSAGENTS, 132 Henty-street, Casterton.

VERNON, C. F. & H. J., 162 Bridge-road, Richmond.

VIEW POINT AUTHORIZED NEWSAGENCY, 4 View-Point, Bendigo.

A copy of the *Gazette* filed at each place for public reference.

## THE "VICTORIA GOVERNMENT GAZETTE".

SUBSCRIPTIONS.—The subscription, including postage, is \$10 per annum, or \$5 per half year, payable in advance.

Subscriptions are required for whole months, and must cover at least a half year.

Single copies are 20 cents, posted 25 cents. Subscribers do not receive the Acts of Parliament with the GAZETTE.

GAZETTES are held in stock for five years only.

PRIVATE ADVERTISEMENTS.—The charge for insertion is 25 cents per line single column, and 50 cents per line double column. The title forms one or more lines as a heading. On an average ten words make a line of single column. Every signature must likewise be counted as a line. The final words of a paragraph, though only portion of a line, must be counted as one line. Signatures (in particular) and proper names must be written very plainly in the text; ONE SIDE ONLY of each sheet of paper should be WRITTEN UPON.

All documents illegibly written will be returned unpublished, and where brands occur unprovided for by the ordinary letters of the alphabet, a worded explanatory description must be furnished.

THE VICTORIA GOVERNMENT GAZETTE is published on WEDNESDAY EVENING in each week, and Notices for insertion will be received by the Government Printer at or before ONE p.m. at ordinary rates, and late advertisements between ONE p.m. and FOUR p.m. at double rates on the day preceding the day of publication.

PAYMENTS.—Unless the advertiser has a credit account, all payments are required in advance. Remittances should be made by cheque, postal order, or money order payable to "GOVERNMENT PRINTER".

ADDRESS.—All communications should be addressed to "The Government Printer, Box 203, P.O., North Melbourne".

## CONTENTS

	PAGE
Acts of Parliament on sale at the Government Printing Office .. .. .	2003
Appointments .. .. .	2003
Cemetery—Scale of Fees .. .. .	2001
Contracts .. .. .	1998
Government Notices .. .. .	1994
Honours, Decoration and Award .. .. .	1993
Impoundings .. .. .	2023
Lands .. .. .	2007
Melbourne and Metropolitan Board of Works— Notice .. .. .	2002
Notice of Making of Statutory Rules .. .. .	2023
Orders in Council— Acts—Hospitals and Charities; Labour and Industry.	2004 et seq
Private Advertisements .. .. .	2013
Proclamation .. .. .	1994
Public Service Notices .. .. .	2012
Resignations .. .. .	2004
State Rivers and Water Supply Commission .. .. .	2001
Tenders .. .. .	2010
Transport Regulation Board—Public Hearings .. .. .	1995