



# VICTORIA GOVERNMENT GAZETTE

Published by Authority

[Registered at the General Post Office, Melbourne, for transmission by post as a newspaper.]

No. 72]

WEDNESDAY, SEPTEMBER 20

[1967

## PROCLAMATIONS

*Land Act 1958.*

AREA OF LAND COMPRISED IN CERTAIN CLASSES DIMINISHED OR INCREASED.

### PROCLAMATION

By His Excellency the Governor of the State of Victoria and its Dependencies in the Commonwealth of Australia, &c., &c., &c.

WHEREAS by the *Land Act 1958* it is amongst other things enacted that the Governor in Council may, by Proclamation to be published in the *Government Gazette*, at any time diminish or increase the area of land comprised in any of the classes mentioned in Part I., Division 1, Section 5, of the said *Land Act 1958*, but that the area of lands which may be sold by auction (Class 6), shall not be increased except as in certain cases in the said Act provided; Now therefore I, the Governor of the State of Victoria, in the Commonwealth of Australia, by and with the advice of the Executive Council of the said State, and in accordance with the provisions of Sections 94 and 117 of the *Land Act 1958* aforesaid, do hereby diminish or increase (as the case may be) the areas of Crown lands comprised in Classes 6 and 7 of the classes mentioned in Section 5 of the *Land Act 1958* aforesaid, to the extent set forth in the subjoined Schedule (that is to say):—

Schedule referred to  
CLASSES DIMINISHED OR INCREASED.

County.	Parish.	Allotment.	Section.	Area.	Diminished. Class.	Increased. Class.	Description.
				A. R. P.			
Evelyn .. ..	Warburton ..	77c	..	3 0 0	..	6	¼ mile south-east of Millgrove Railway Station
Dalhousie ..	Tooborac ..	1D	7	7 0 0±	..	6	In the middle of the Parish
Bogong .. ..	Beechworth ..	4 and 4A	K3	5 1 7	7	6	South of the Township of Beechworth

Given under my Hand and the Seal of the State of Victoria, aforesaid, at Melbourne, this twelfth day of September, in the year of our Lord One thousand nine hundred and sixty-seven, and in the sixteenth year of the reign of Her Majesty Queen Elizabeth II.

ROHAN DELACOMBE.

(L.S.)

By His Excellency's Command,

W. J. F. McDONALD,  
Minister of Lands.

GOD SAVE THE QUEEN!

Survey Co-ordination Act 1958.  
PROCLAIMED SURVEY AREA.

PROCLAMATION

By His Excellency the Governor of the State of Victoria and its Dependencies in the Commonwealth of Australia, &c., &c., &c.

WHEREAS it is provided by section 12, sub-section 2 (b) of the Survey Co-ordination Act 1958 that upon a report of the Surveyor-General in writing to the effect that there are in existence in any area within Victoria sufficient permanent works for the establishment of a local traverse for such area, the Governor in Council may proclaim such area to be a "proclaimed survey area" for the purposes of the said Act: Now therefore, I, the Governor of the State of Victoria, in the Commonwealth of Australia, by and with the advice of the Executive Council thereof, do by this my Proclamation proclaim approximately 1,540 acres, being the Township of Lilydale and parts of the Parishes of Yering and Mooroolbark, County of Evelyn, as indicated by hatching on plan hereunder, a "proclaimed survey area" for the purposes of the Survey Co-ordination Act 1958.—(Proclaimed Survey Area No. 13—L.66<sup>(\*)</sup>; Y.65<sup>(\*)</sup>, M.152<sup>(\*)</sup>; C.O.S.3214; X.107.)

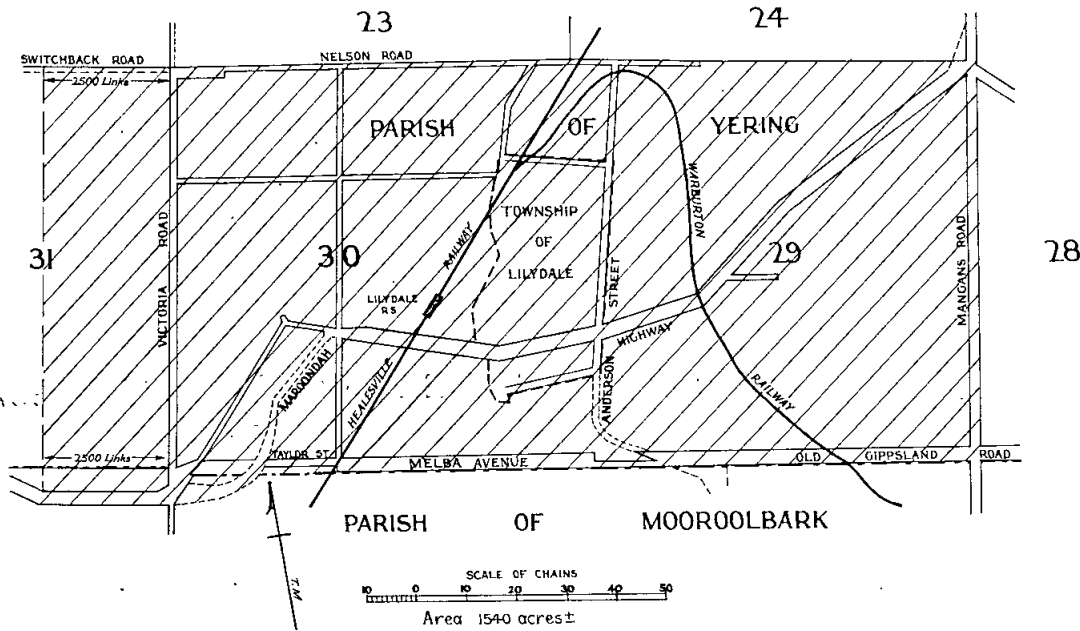

Given under my Hand and the Seal of the State of Victoria aforesaid, at Melbourne, this Twelfth day of September, in the year of our Lord One thousand nine hundred and sixty-seven, and in the sixteenth year of the reign of Her Majesty Queen Elizabeth II.

(L.S.)

ROHAN DELACOMBE.

By His Excellency's Command,

W. J. F. McDONALD,  
Minister of Lands.

GOD SAVE THE QUEEN!

MELBOURNE CUP DAY.—BANK HOLIDAY.

PROCLAMATION

By His Excellency the Governor of the State of Victoria and its Dependencies in the Commonwealth of Australia, &c., &c., &c.

IN pursuance of the provisions of the Bank Holidays Act 1958, I, the Governor of the State of Victoria, in the Commonwealth of Australia, do by this my Proclamation appoint the day and date named hereunder as a special day to be observed as a Bank Holiday at the places mentioned, that is to say:—

Bank Holiday:—

TUESDAY, THE 7TH NOVEMBER, 1967, throughout the Cities of Box Hill, Brighton, Broadmeadows, Brunswick, Camberwell, Caulfield, Chelsea, Coburg, Collingwood, Dandenong, Doncaster and Templestowe, Essendon, Fitzroy, Footscray, Frankston, Hawthorn, Heidelberg;

Keilor, Kew, Malvern, Melbourne, Moorabbin, Mordialloc, Northcote, Nunawading, Oakleigh, Port Melbourne, Prahran, Preston, Richmond, Ringwood, St. Kilda, Sandringham, South Melbourne, Springvale, Sunshine, Waverley and Williamstown; the Shires of Altona, Bacchus Marsh, Berwick, Bulla, Cranbourne, Croydon, Diamond Valley, Eltham, Gisborne, Hastings, Knox, Lillydale, Melton, Mornington, Romsey, Sherbrooke, Werribee and Whittlesea.

Given under my Hand and the Seal of the State of Victoria aforesaid, at Melbourne, this twelfth day of September, in the year of our Lord One thousand nine hundred and sixty-seven, and in the sixteenth year of the reign of Her Majesty Queen Elizabeth II.

(L.S.)

ROHAN DELACOMBE.

By His Excellency's Command,

A. G. RYLAH,  
Chief Secretary.

GOD SAVE THE QUEEN!

## BANK HOLIDAYS.

## PROCLAMATION

By His Excellency the Governor of the State of Victoria and its Dependencies in the Commonwealth of Australia, &c., &c., &c.

IN pursuance of the provisions of the *Bank Holidays Act 1958, I*, the Governor of the State of Victoria, in the Commonwealth of Australia, do by this my Proclamation appoint the days and dates named hereunder special days to be observed as Bank Holidays or Bank Half-Holidays (as the case may be) at the places respectively mentioned, that is to say:—

*Bank Holidays:—*

MONDAY, THE 25TH SEPTEMBER, 1967, at Romsey and Lancefield.

WEDNESDAY, THE 27TH SEPTEMBER, 1967, at Trérantham.

TUESDAY, THE 7TH NOVEMBER, 1967, at Ouyen.

TUESDAY, THE 7TH NOVEMBER, 1967, at Yarra Glen.

*Bank Half-Holidays from the Hour of Eleven o'clock a.m.:—*

WEDNESDAY, THE 27TH SEPTEMBER, 1967, at Alexandra.

WEDNESDAY, THE 11TH OCTOBER, 1967, at Kerang.

FRIDAY, THE 13TH OCTOBER, 1967, at Woomelang.

WEDNESDAY, THE 25TH OCTOBER, 1967, at Wycheproof.

TUESDAY, THE 7TH NOVEMBER, 1967, at Mildura, Red Cliffs and Merbein.

Given under my Hand and the Seal of the State of Victoria aforesaid, at Melbourne, this twelfth day of September, in the year of our Lord One thousand nine hundred and sixty-seven, and in the sixteenth year of the reign of Her Majesty Queen Elizabeth II.

(L.S.) ROHAN DELACOMBE.

By His Excellency's Command,

A. G. RYLAH,  
Chief Secretary.

GOD SAVE THE QUEEN!

## PUBLIC HOLIDAYS

## PROCLAMATION

By His Excellency the Governor of the State of Victoria and its Dependencies in the Commonwealth of Australia, &c., &c., &c.

IN pursuance of the provisions contained in Part III. of the *Public Service Act 1958, I*, the Governor of the State of Victoria, in the Commonwealth of Australia, by and with the advice of the Executive Council of the said State, do by this my Proclamation appoint the days and dates hereunder mentioned to be observed as Public Holidays or Public Half-Holidays (as the case may be) at the places respectively specified, viz.:—

*Public Holidays:—*

TUESDAY, THE 24TH OCTOBER, 1967, throughout the United Shire of Beechworth.

MONDAY, THE 25TH SEPTEMBER, 1967, throughout the Shire of Kilmore.

WEDNESDAY, THE 4TH OCTOBER, 1967, throughout the Townships of Donald, Corack East and Litchfield of the Shire of Donald.

*Public Half-Holidays from the Hour of Twelve o'clock noon:—*

TUESDAY, THE 10TH OCTOBER, 1967, throughout the Shire of Cobram.

WEDNESDAY, THE 29TH NOVEMBER, 1967, throughout the Borough of Kyabram.

Given under my Hand and the Seal of the State of Victoria aforesaid, at Melbourne, this twelfth day of September, in the year of our Lord One thousand nine hundred and sixty-seven, and in the sixteenth year of the reign of Her Majesty Queen Elizabeth II.

(L.S.) ROHAN DELACOMBE.

By His Excellency's Command,

A. G. RYLAH,  
Chief Secretary.

GOD SAVE THE QUEEN!

## PUBLIC HOLIDAYS.

## PROCLAMATION

By His Excellency the Governor of the State of Victoria, and its Dependencies in the Commonwealth of Australia, &c., &c., &c.

IN pursuance of the provisions contained in Part III. of the *Public Service Act 1958, I*, the Governor of the State of Victoria, in the Commonwealth of Australia, by and with the advice of the Executive Council of the said State, do by this my Proclamation appoint the days and dates hereunder mentioned to be observed as Public Holidays or Public Half-Holidays (as the case may be) at the places respectively specified, viz.:—

*Public Holidays:—*

SATURDAY, THE 10TH FEBRUARY, 1968, throughout the Central Riding of the Shire of Kowree.

*Public Holiday from 11 a.m.*

WEDNESDAY, THE 18TH OCTOBER, 1967, throughout the Shire of Rochester.

*Public Half-Holidays from the Hour of Twelve o'clock noon:—*

TUESDAY, THE 3RD OCTOBER, 1967, throughout the Shire of Kilmore.

THURSDAY, THE 12TH OCTOBER, 1967, throughout the North Riding of the Shire of Wimmera.

WEDNESDAY, THE 8TH NOVEMBER, 1967, throughout the Kyneton Riding of the Shire of Kyneton.

WEDNESDAY, THE 15TH NOVEMBER, 1967, throughout the City of Bendigo.

THURSDAY, THE 16TH NOVEMBER, 1967, throughout the Shire of Dundas.

Given under my Hand and the Seal of the State of Victoria aforesaid, at Melbourne, this 19th day of September, in the year of our Lord One thousand nine hundred and sixty-seven, and in the sixteenth year of the reign of Her Majesty Queen Elizabeth II.

(L.S.) ROHAN DELACOMBE.

By His Excellency's Command,

A. G. RYLAH,  
Chief Secretary.

GOD SAVE THE QUEEN!

*Apprenticeship Act 1958.*

BUTCHERING TRADES PROCLAIMED APPRENTICESHIP TRADES OUTSIDE THE METROPOLITAN DISTRICT.

## PROCLAMATION

By His Excellency the Governor of the State of Victoria and its Dependencies in the Commonwealth of Australia, &c., &c., &c.

WHEREAS Section 13 of the *Apprenticeship Act 1958* provides, *inter alia*, that after the Minister has taken into consideration any recommendation made by the Apprenticeship Commission the Governor in Council, for the purposes of the said Act, may from time to time by Proclamation proclaim any trades to be apprenticeship trades:

AND WHEREAS the Governor in Council did on the 9th October, 1939 proclaim the trades of Butchering, Smallgoods Making, and Butchering and Smallgoods Making to be apprenticeship trades in so far as they are carried on within the Metropolitan District:

AND WHEREAS the Apprenticeship Commission having notified in the manner prescribed by the said Act its intention to recommend that the trades set out hereunder, in so far as they are carried on in the whole of the State of Victoria outside and excepting the Metropolitan District, be proclaimed apprenticeship trades under the said Act, and having considered the representations made on behalf of the employers and employees in the said trades, has recommended to the Minister that the said trades be so proclaimed:

AND WHEREAS the Minister has taken the said recommendation into consideration:

NOW THEREFORE I, the Governor of the State of Victoria, in the Commonwealth of Australia, by and with the advice of the Executive Council of the said State, do by this my Proclamation proclaim the trades set out

hereunder, in so far as they are carried on in the whole of the State of Victoria outside and excepting the Metropolitan District, to be apprenticeship trades, viz.:—

Butchering  
Smallgoods Making  
Butchering and Smallgoods Making

Given under my Hand and the Seal of the State of Victoria aforesaid, at Melbourne, this twelfth day of September, in the year of our Lord One thousand nine hundred and sixty-seven, and in the sixteenth year of the reign of Her Majesty Queen Elizabeth II.

(L.S.) ROHAN DELACOMBE.

By His Excellency's Command,  
J. F. ROSSITER,  
Minister of Labour and Industry.  
GOD SAVE THE QUEEN!

*Health Act 1958 (No. 6270).*

CONSTITUTION OF THE BALLAN MEAT AREA.

PROCLAMATION

By His Excellency the Governor of the State of Victoria and its Dependencies in the Commonwealth of Australia, &c., &c., &c.

BY virtue of the powers conferred by the *Health Act 1958 (No. 6270)*, I, the Governor of the State of Victoria in the Commonwealth of Australia, on the recommendation of the Commission of Public Health and by and with the advice of the Executive Council of the said State, do by this my Proclamation constitute as a meat area, to be known as the Ballan Meat Area, the whole of the municipal district of the Shire of Ballan.

Given under my Hand and the Seal of the State of Victoria aforesaid, at Melbourne, this twelfth day of September, in the year of our Lord One thousand nine hundred and sixty-seven, and in the sixteenth year of the reign of Her Majesty Queen Elizabeth II.

(L.S.) ROHAN DELACOMBE.

By His Excellency's Command,  
VANCE DICKIE,  
Minister of Health.  
GOD SAVE THE QUEEN!

*Milk Pasteurization Act 1958*

DECLARING AREAS TO BE PASTEURIZED MILK DISTRICTS

PROCLAMATION

By His Excellency the Governor of the State of Victoria and its Dependencies in the Commonwealth of Australia, &c., &c., &c.

WHEREAS by section 4 of the *Milk Pasteurization Act 1958* it is amongst other things enacted that the Governor in Council may by proclamation published in the *Government Gazette* declare any area specified in such proclamation to be a pasteurized milk district on and after a date specified in the proclamation, and any such proclamation may in like manner be revoked, amended or varied by the Governor in Council: NOW THEREFORE I, the Governor of the State of Victoria by and with the advice of the Executive Council thereof do by this my Proclamation hereby—

1. AMEND the proclamation made on the twentieth day of December, One thousand nine hundred and sixty-six declaring areas specified to be pasteurized milk districts, as follows:—

Paragraph (o) of clause (2) of the Schedule to the said proclamation shall be deleted on and after the first day of October, One thousand nine hundred and sixtyseven.

2. DECLARE the areas specified in the Schedule hereto to be pasteurized milk districts on and after the first day of October, One thousand nine hundred and sixtyseven.

SCHEDULE.

- (1) The municipal districts of the—  
(a) City of Sale  
(b) Shire of Healesville  
(c) Shire of Korumburra  
(d) Shire of South Barwon

(2) All that portion of the municipal district of the Shire of Alexandra within the Ridings of Alexandra and Eildon.

Given under my Hand and the Seal of the State of Victoria aforesaid, at Melbourne, this nineteenth day of September in the year of our Lord One thousand nine hundred and sixty-seven, and in the sixteenth year of the reign of Her Majesty Queen Elizabeth II.

(L.S.) ROHAN DELACOMBE.

By His Excellency's Command,  
G. L. CHANDLER,  
Minister of Agriculture.  
GOD SAVE THE QUEEN!

GOVERNMENT NOTICES

HOLIDAY—ROYAL AGRICULTURAL SHOW.

NOTICE is hereby given that on

THURSDAY, THE 28TH SEPTEMBER, 1967,

the Public Offices in the municipalities mentioned hereunder will be closed, that day being appointed by the *Public Service Act 1958* to be observed as a holiday in the Public Offices:—

The Cities of Box Hill, Brighton, Broadmeadows, Brunswick, Camberwell, Caulfield, Chelsea, Coburg, Collingwood, Dandenong, Doncaster and Templestowe, Essendon, Fitzroy, Footscray, Frankston, Hawthorn, Heidelberg, Keilor, Kew, Malvern, Melbourne, Moorabbin, Mordialloc, Northcote, Nunawading, Oakleigh, Port Melbourne, Prahran, Preston, Richmond, Ringwood, St. Kilda, Sandringham, South Melbourne, Springvale, Sunshine, Waverley and Williamstown; the Shires of Altona, Berwick, Bulla, Cranbourne, Croydon, Diamond Valley, Eltham, Frankston, Gisborne, Hastings, Knox, Lillydale, Melton, Mornington, Sherbrooke, Werribee and Whittlesea.

This notice relates only to the closing of the State Public Offices. All inquiries regarding holidays in other offices and in shops and industry should be directed to the Department of Labour and Industry, 110 Exhibition-street, Melbourne, 3000. (Telephone 63-0321, Extension 6158 or 6721.)

W. BORTHWICK,  
for Chief Secretary.

Chief Secretary's Office,  
Melbourne, 1st September, 1967.

*Motor Car Act 1958, Section 41.*

EFFECTIVE DATE OF WITHDRAWAL BY AUTHORIZED INSURER.

WHEREAS by notice in writing dated the thirty-first day of August, 1967, the following authorized insurer under Part V. of the *Motor Car Act 1958*, namely—

GENERAL ACCIDENT FIRE AND LIFE ASSURANCE CORPORATION LIMITED

has withdrawn from business in terms of the aforesaid part:

Now therefore I, Her Majesty's Chief Secretary for the State of Victoria, in pursuance of Section 41 of the said Act do hereby fix the first day of December, 1967, as the date upon which such withdrawal shall have effect.

A. G. RYLAH,  
Chief Secretary.

Chief Secretary's Office,  
Melbourne, 15th September, 1967.

AUCTION SALES ACT 1958.

SALE.—Notice is hereby given that the Annual Meeting of Justices for the Licensing of Auctioneers will be held at the Court House, Sale, on Tuesday, the 28th day of November, 1967, at the hour of Ten o'clock in the forenoon. Dated at Sale this 29th day of September, 1967.—D. R. WALKER, Clerk of Petty Sessions.

## Health Act 1958.

VICTORIA—DEPARTMENT OF HEALTH.

**NOTICE TO ATTEND FOR RADIOLOGICAL EXAMINATION.**

To all persons aged twenty-one years and over enrolled or resident in the Subdivisions specified hereunder in the State Electoral District of Bendigo.

**T**AKE notice that you are required to attend at a Department of Health X-ray unit sited in the public street at or as near as possible to the main entrance to the premises specified in this notice, at any time between the hours specified on one of the days specified and during the period specified in respect of those premises, and thereat to submit yourself to radiological examination of the chest for the purpose of ascertaining whether you may be suffering from pulmonary tuberculosis. If you have had a Chest X-ray within the last twelve months and for that reason do not wish to be examined now, you should attend the unit as directed and submit particulars of the previous examination.

## SPECIFIED SUBDIVISION, PREMISES, PERIODS, DAYS AND HOURS.

Subdivision.	Premises.	Period.	Days.	Hours.
Elmore ..	Memorial Hall, Elmore	Thursday, 5th October, 1967, and Friday, 6th October, 1967	Thursday, 5th October, 1967 Friday, 6th October, 1967	From 11 a.m. to 5.30 p.m. and 7 p.m. to 9 p.m. From 10 a.m. to 5.30 p.m. and 7 p.m. to 9 p.m.
	Memorial Hall, Goornong	Monday, 9th October, 1967, and Tuesday, 10th October, 1967	Monday, 9th October, 1967 Tuesday, 10th October, 1967	From 7 p.m. to 9 p.m. From 10 a.m. to 5.30 p.m. and 7 p.m. to 9 p.m.
	Post Office, Huntly ..	Wednesday, 11th October, 1967	Wednesday, 11th October, 1967	From 11 a.m. to 5.30 p.m. and 7 p.m. to 9 p.m.
	Public Hall, Epsom ..	Thursday, 12th October, 1967	Thursday, 12th October, 1967	From 11 a.m. to 5.30 p.m. and 7 p.m. to 9 p.m.
Raywood ..	Post Office, Raywood	Monday, 9th October, 1967, and Tuesday, 10th October, 1967	Monday, 9th October, 1967 Tuesday, 10th October, 1967	From 7 p.m. to 9 p.m. From 10 a.m. to 5.30 p.m. and 7 p.m. to 9 p.m.
	Bowling Club, Bridge-water	Wednesday, 11th October, 1967	Wednesday, 11th October, 1967	From 11 a.m. to 5.30 p.m. and 7 p.m. to 9 p.m.
Eaglehawk ..	Town Hall, Eaglehawk	Monday, 9th October, 1967, to Thursday, 19th October, 1967 (inclusive)	Monday, 9th October, 1967 All other days during the period except Saturday, Sunday and Public Holidays	From 7 p.m. to 9 p.m. From 10 a.m. to 5.30 p.m. and 7 p.m. to 9 p.m.
Sandhurst East	Reading Rooms, Napier-street, White Hills	Thursday, 12th October, 1967, and Friday, 13th October, 1967	Thursday, 12th October, 1967 Friday, 13th October, 1967	From 11 a.m. to 5.30 p.m. and 7 p.m. to 9 p.m. From 10 a.m. to 5.30 p.m. and 7 p.m. to 9 p.m.
	Methodist Church, cnr. Arnold and Atkins streets, North Bendigo	Friday, 13th October, 1967, to Wednesday, 18th October, 1967 (inclusive)	Friday, 13th October, 1967 All other days during the period except Saturday, Sunday and Public Holidays	From 11 a.m. to 5.30 p.m. and 7 p.m. to 9 p.m. From 10 a.m. to 5.30 p.m. and 7 p.m. to 9 p.m.
	Golden Fleece Road-house, cnr. McCrae and Nolan streets, Lake Weeroona	Monday, 16th October, 1967, to Friday, 20th October, 1967 (inclusive)	Monday, 16th October, 1967 All other days during the period except Public Holidays	From 11 a.m. to 5.30 p.m. and 7 p.m. to 9 p.m. From 10 a.m. to 5.30 p.m. and 7 p.m. to 9 p.m.
	Richards Store, cnr. Langston and View streets, North Bendigo	Thursday, 19th October, 1967 and Friday, 20th October, 1967	Thursday, 19th October, 1967 Friday, 20th October, 1967	From 11 a.m. to 5.30 p.m. and 7 p.m. to 9 p.m. From 10 a.m. to 5.30 p.m. and 7 p.m. to 9 p.m.
	Methodist Church, cnr. Daly and Wilson streets, Long Gully	Monday, 23rd October, 1967, to Thursday, 26th October, 1967 (inclusive)	Monday, 23rd October, 1967 All other days during the period except Public Holidays	From 7 p.m. to 9 p.m. From 10 a.m. to 5.30 p.m. and 7 p.m. to 9 p.m.
	Bendigo ..	Pre School Centre, Neale-street, Kennington	Monday, 23rd October, 1967, to Thursday, 26th October, 1967 (inclusive)	Monday, 23rd October, 1967 All other days during the period except Public Holidays
Vanstan's Pharmacy, cnr. Hammer and Neale streets, Flora Hill		Monday, 23rd October, 1967, to Friday, 27th October, 1967 (inclusive)	Monday, 23rd October, 1967 All other days during the period except Public Holidays	From 7 p.m. to 9 p.m. From 10 a.m. to 5.30 p.m. and 7 p.m. to 9 p.m.
(1) Town Hall, Hargreaves street, Bendigo (2) Woolworths Store, Hargreaves-street, Bendigo		Friday, 27th October, 1967, to Friday, 3rd November, 1967 (inclusive)	Each day during the period except Saturday, Sunday and Public Holidays	From 10 a.m. to 5.30 p.m. and 7 p.m. to 9 p.m.
Miller's Store, cnr. Olinda and Russell streets, Quarry Hill		Monday, 30th October, 1967, to Thursday, 2nd November, 1967 (inclusive)	Each day during the period except Public Holidays	From 10 a.m. to 5.30 p.m. and 7 p.m. to 9 p.m.

NOTE.—Any person to whom this notice applies and who without reasonable excuse fails to comply with the requirements of the notice shall be guilty of an offence, and shall be liable to a penalty of not more than forty dollars.

Dated this 12th day of September One thousand nine hundred and sixty-seven.

R. J. FARNBACH,  
Chief Health Officer.

Transport Regulation Act.  
TRANSPORT REGULATION BOARD.

## HEARING OF APPLICATIONS.

NOTICE is hereby given that the following applications will be considered by the Transport Regulation Board at its offices at corner Lygon and Princes streets, Carlton, at 10.15 a.m. on Wednesday, 11th October, 1967.

**BINAISSE, E. E.**, Sladen-street, Cranbourne. One commercial passenger vehicle (S/C. 5) to operate as a country hire car from Cranbourne.

**MILDURA BUS LINES PTY. LTD.**, 78 Seventh-street, Mildura. Application to vary C.O. licences to include the ability to operate a tour along the following route:—Departing Mildura; thence via Calder Highway to Red Cliffs; thence via Nangiloc and Colignan citrus and vegetable growing irrigation areas, Kulkyn National Forest Reserve to Hattah, returning via Calder Highway. Fare, including picnic lunch, \$5.00.

**PINCINI, E. J. & L., PTY. LTD.**, Bath-road, Mirboo North. One commercial passenger vehicle (S/C. 41) to operate under the same terms and conditions as existing T.O. licensed vehicles in the name of the applicant company.

**WILLIAMSON, E. N.** (trading as Whitehorse Bus Service), 688 Whitehorse-road, Mont Albert. One commercial passenger vehicle (S/C. 39) to operate as an additional metropolitan stage omnibus on Route 108A (Box Hill—North Balwyn Tram Terminus) under the same terms and conditions as licences already held by the applicant.

APPLICATIONS for renewal of licences as shown, by persons listed hereunder, to operate under the same terms and conditions.

**BENDERS BUSWAYS PTY. LTD.**, Edol-street, North Geelong; U.O.415, U.O.476, U.O.457.

**BRUK-BRUK BUS SERVICE PTY. LTD.**, care of J. E. Morton, Post Office Box 172, Casterton; T.S.173.

**"COOINDA" RETARDED CHILDREN'S CENTRE**, Don-street, Terang; T.P.147.

**COOK, I. J., A. A. & R. H. J.**, 321 Autumn-street, Herne Hill; T.P.184.

**CRAMP, K. H.**, Main-street, Speed; T.S.677.

**LEBIDKA, P.**, Caveat; T.S.521.

**MOONEY, J. E.**, 25 Keith-street, Parkdale; C.T.183.

**MCCALLUM, J. C.**, Box 59, Coleraine-road, Casterton; T.S.534, T.S.569, T.S.543.

**MCCONVILLE, T. R.**, Litchfield; T.S.783.

**SMITH, J. H.**, 101 Wyndham-street, Shepparton; T.P.67.

**STANLEY, R. J.**, 1317 Centre-road, Clayton; C.T.741, C.T.79.

**STUCHBERY, R. L.**, Nyah; T.S.664.

Notice of any objection should be forwarded to reach the Secretary of the Board not later than Wednesday, 4th October, 1967.

Applicants are advised that it will not be necessary to appear on the hearing date specified above, unless advised in writing by the Board.

B. P. KAY,  
Secretary.

Corner Lygon and Princes streets, Carlton, Wednesday, 20th September, 1967.

Commercial Goods Vehicles Act.  
TRANSPORT REGULATION BOARD.

## HEARING OF APPLICATIONS.

NOTICE is hereby given that the following applications will be considered by the Transport Regulation Board at its offices at the corner of Lygon and Princes streets, Carlton, at 10.15 a.m., on Wednesday, 11th October, 1967.

**BAYVIEW QUARRIES PTY. LTD.**, 83 Riversdale-road, Hawthorn, 3122. Application to vary the conditions of licence No. D.A.44014/135 (L/C. 137 cwt.) by deleting the present conditions and adding in lieu: "Within a 35-mile radius of the plants of Bayview Quarries Pty. Ltd., at Tullamarine, Fowler, Sunshine, Montrose, Dandenong, Lysterfield, Coldstream, Bacchus Marsh, Narre Warren, Regal, Fowler, Wellington, Albion Northern on behalf of the said company—screenings, stone dust and premix."

**BLATCHFORD, W. E. L.**, 37A North Western-road, St. Arnaud, 3478. One commercial goods vehicle (L/C. 242 cwt.) to operate within a 100-mile radius of own premises at St. Arnaud in course of business as "Agricultural Contractors"—own tools of trade and earth-moving equipment and up to two drums of fuel.

**BOOTH, J. H. & B.**, 7 Shannon-avenue, North Geelong, 3215. Two commercial goods vehicles (L/C. 75 and 10 cwt.) to operate throughout the State of Victoria in the course of business as "Drainage Contractors"—own tools of trade, plant and equipment and fuel sufficient only for the operation of such plant and equipment on site.

**BRUHN, F. & N.**, Murray Valley Highway, Cohuna, 3568. Application to vary the conditions of licence No. D.A.37161/8 (L/C. 211 cwt.) by adding to the existing conditions an additional paragraph "(d) Within a 25-mile radius of the post office at Cohuna—premixed concrete in a specially constructed agitator vehicle."

**CANT, F. W.**, 88 Waterloo-road, Trafalgar, 3824. One commercial goods vehicle (L/C. 145 cwt.) to operate within a 50-mile radius of the G.P.O., Melbourne, on behalf of Marchants Aerated Waters and Cordials Pty. Ltd., excluding operations to the City of Geelong— aerated waters and cordials.

**COUANI, J. L.**, 27A Ross-street, Westgarth, 3070. One commercial goods vehicle (L/C. 40 cwt.) to operate throughout the State of Victoria in course of business as "Bag Dealer" for the purpose of collecting second-hand uncleaned bags.

**CURSARO, P. & A.**, Lot 25, Dorset-road, Fern Tree Gully, 3156. One commercial goods vehicle (L/C. 22 cwt.) to operate: (a) Within a 50-mile radius from own premises at Fern Tree Gully in the course of business as "Grocer"—own goods. (b) Throughout the State of Victoria in the course of business as "Hawker"—own groceries and continental smallgoods subject to the condition that such goods so carried shall not be supplied to retail stores for resale.

**FERGUSON, J. D. & B. M.**, 6 High Street-road, Ashburton, 3147. One commercial goods vehicle (L/C. 138 cwt.) to operate within a 70-mile radius of the premises of the The City Bricks Co., at Malvern, solely on behalf of the said company—bricks.

**FISHER'S (KORUMBURRA) PTY. LTD.**, Bridge-street, Korumburra, 3950. Application to vary the conditions of licence No. D.A.8754 (L/C. 258 cwt.) by adding to the existing details an additional paragraph "(g) From landings within a 10-mile radius of Woodside to own yard at Korumburra—fencing posts."

**FLETCHER, W. L.**, 320 Main-street, Bairnsdale, 3875. One commercial goods vehicle (L/C. 10 cwt.) to operate throughout that part of the State of Victoria east of a north/south line drawn through the City of Sale, in course of business as "Electrical Mechanic"—tools of trade, spare parts and electrical appliances to be repaired or having been repaired.

**GALTIERI, V. & G. PULITANO**, 28 Bayview-road, Seddon, 3011. One commercial goods vehicle (L/C. 156 cwt.) to operate within a 70-mile radius from the premises of Atlas Industries Australia Limited, at Springvale—roofing tiles, roof battens and tile fixing materials solely on behalf of the said company.

**GERARDS, J.**, 9 Soudan-street, Malvern, 3144. One commercial goods vehicle (L/C. 8 cwt.) to operate throughout the State of Victoria in the course of business as "Painting Contractor" on behalf of Cleveland Coatings Pty. Ltd.—tools of trade, ladders, equipment and advertising materials.

**GROUND SPRAY PTY. LTD.**, 23 Murray-street, Colac, 3250. One commercial goods vehicle (L/C. 12 cwt.) to operate within that part of the State of Victoria west of a line drawn due north and south through the City of Melbourne in the course of business as "Agricultural Spray Contractors"—small quantities of agricultural chemicals, pesticides, insecticides and weedicides not exceeding a total weight of four hundredweight (4 cwt.) at any one time together with tools of trade and spraying equipment incidental to completion of own contracts subject to the condition that all supplies of concentrated chemicals, pesticides, insecticides and weedicides carried on the vehicle shall have been initially consigned by rail to the Colac Railway Station.

**GOVAN INDUSTRIES PTY. LTD.**, 156 Bamfield-road, West Heidelberg, 3081. One commercial goods vehicle (L/C. 9 cwt.) to operate throughout the State of Victoria in the course of business as "Agricultural Pumping and Spraying Manufacturers and Distributors"—tools of trade, spare parts and equipment for repair or having been repaired.

**HAMILTON & MILBOURNE**, 17 Alber-road, Lilydale, 3140. One commercial goods vehicle (L/C. 140 cwt.) to operate: (a) Within a 25-mile radius of the railway station at Lilydale in the course of business as "Super Spreaders"—own bulk superphosphate for spreading purposes. (b) Within a 40-mile radius of the railway station at Lilydale in the course of business as "Bulk Lime Distributors"—own bulk lime for spreading purposes.

- HARDY ROAD-MAKING & CONSTRUCTION PTY. LTD.**, 17 Axleton-street, Cheltenham, 3192. One commercial goods vehicle (L/C. 142 cwt.) to operate: (a) Within a 50-mile radius of the G.P.O., Melbourne, in the course of business as "Road-making and Construction Contractors"—tools of trade and own earth-moving plant and equipment. (b) Within a 20-mile radius from site of construction or maintenance work performed pursuant to paragraph (a) above, or from the railway station nearest thereto—any other materials required for such work.
- HOVEY, R. C.**, Thompson-road, North Geelong, 3220. One commercial goods vehicle (L/C. 497 cwt.) to operate: (a) Within a 25-mile radius of the chief post office in the City of Geelong—general goods. (b) From and to places within the radius specified in part (a) to and from places outside that radius but wholly within a 50-mile radius of the chief post office in the City of Geelong—livestock.
- HUTTON, J. C., PTY. LTD.**, 65 High-street, Preston, 3072. One commercial goods vehicle (L/C. 35 cwt.) to operate throughout the State of Victoria in the course of business as "Bacon and Smallgoods Manufacturers" in a specially constructed insulated refrigerated vehicle—fresh meat, cooked meats, sausages and smallgoods with the ability to carry up to three hundredweight (3 cwt.) of lard, dripping, cheese, canned hams and margarine.
- IERACI, O.**, 348 Rathdowne-street, Carlton, 3053. One commercial goods vehicle (L/C. 15 cwt.) to operate: (a) Within a 50-mile radius of own premises at Carlton, in the course of business as "Grocer"—own goods. (b) Throughout the State of Victoria in the course of business as "Hawker"—own groceries and continental smallgoods.
- SPECIAL CONDITION.**—It is also a condition that any of the goods carried for resale shall not be supplied to retail stores.
- LOYD, F.**, Howard-street, Sea Lake, 3533. One commercial goods vehicle (L/C. 160 cwt.) to operate: (a) Within a 25-mile radius of the post office at Sea Lake—general goods, provided that no goods shall be carried whether by one stage or by more than one stage between places within the above radius which are more than 30 road miles apart in distance by the nearest practicable route. (b) From the Township of Charlton to the Township of Sea Lake—petroleum products in prescribed types of containers and empty return containers on behalf of Esso Standard Oil Aust. Pty. Ltd.
- MAJOR BUILDING SERVICE PTY. LTD.**, 171 Blackshaws-road, Spotswood, 3015. Application to vary the conditions of licence Nos. D.A.56523/1, D.A.56523/2, D.A.56523/3, D.A.56523/4, D.A.56523/5 and D.A.56523/6 (L/C. 9, 18, 8, 18, 10 and 18 cwt.) by adding to the existing conditions an additional paragraph "(b) Throughout the State of Victoria on behalf of Caltex Oil (Aust.) Pty. Ltd., for the purpose of repairing and erecting advertising signs—tools of trade and small quantities of materials incidental to the completion of the contract."
- MILLER, D. J.**, 17 Moreton-crescent, Bundoora, 3083. One commercial goods vehicle (L/C. 15 cwt.) to operate within a 50-mile radius of the G.P.O., Melbourne solely on behalf of the Totalizator Agency Board of Victoria—office furniture and stationery from the Totalizator Agency Board's bulk store, Queen's-road, Melbourne or from agency to agency as required.
- MILNER, R. K. P., & P. R. OSLER**, Buln Buln, 3821. One commercial goods vehicle (L/C. 192 cwt.) to operate within a 50-mile radius of Warragul—premixed concrete on behalf of Sure-Mix Pty. Ltd., in a specially constructed agitator vehicle.
- MCMAHON, J., & SONS**, 491 Ryrie-street, Geelong, 3220. One commercial goods vehicle (L/C. 120 cwt.) approximately (vehicle to be purchased) to operate from the premises of Robert Hutchinson Ltd. at Glenroy and own premises at Geelong to places within a 25-mile radius of Geelong and to the City of Colac in the course of business as "Produce Merchants"—bulk poultry and stock foods.
- NORKEN TRANSPORT PTY. LTD.**, 31 Norweena-street, Doncaster, 3108. One commercial goods vehicle (L/C. 189 cwt.) to operate within a 50-mile radius of Ready Mixed Concrete Pty. Ltd., premises at Laurens-street, North Melbourne in the course of business as "Contractor" for Ready Mixed Concrete Pty. Ltd.—premixed concrete in a specially constructed agitator vehicle.
- PASA, R.**, 616 Drummond-street, North Carlton, 3054. Application to vary the conditions of licence No. D.A.53766 (L/C. 147 cwt.) by deleting from the present conditions "Woodstock Quarries at Woodstock" (A subsidiary of Rowlands Quarries Ltd.) and by adding in lieu "of Consolidated Quarries Ltd. at Brooklyn."
- PICTON LTD.**, Forster-road, Notting Hill, 3168. One commercial goods vehicle (L/C. 125 cwt.) to operate throughout the State of Victoria in the course of business as "Frozen Food Distributors" in a specially constructed refrigerated vehicle—frozen processed vegetables, frozen fish and frozen poultry at a temperature not exceeding 10 deg. Fahrenheit.
- PRICE, J. A.**, Elvins-street, Mansfield, 3722. Application to vary the conditions of licence No. D.T.320 (L/C. 271 cwt.) by adding to the existing conditions an additional paragraph "(b) From Timber Top sawmills at Mansfield to consignees within a 50-mile radius of Mansfield—sawn timber."
- PRIMMER, T. L.**, 2 Princess-street, Warrnambool, 3280. One commercial goods vehicle (L/C. 77 cwt.) to operate throughout the State of Victoria in the course of business as "Marine Dealer"—special wares, marine stores or old metals within the meaning of the *Marine Stores and Old Metals Act 1958* (No. 6303) Part 1, (3), but excluding the right to carry any such special wares, marine stores or old metals to wharves, docks or ships for shipment or export purposes, with the proviso that the combined load capacities of both prime mover and any trailer attached thereto shall not exceed 120 cwt.
- RAND, D. A.**, 44 Skye-road, Frankston, 3199. One commercial goods vehicle (L/C. 285 cwt.) to operate within a 100-mile radius from the premises of V.I.A. Ltd. at Airport West in the course of business as "Installation Contractor"—prefabricated house roof trusses for installation tools of trade, materials and special lifting equipment incidental thereto.
- READY MIXED CONCRETE (VIC.) PTY. LTD.**, 501 Swanston-street, Melbourne, 3000. One commercial goods vehicle (L/C. 310 cwt. approximately) to operate in the course of business as "Ready Mixed Concrete Manufacturers" as follows: (a) Within a 25-mile radius of the post office situated at the corner of Bourke and Elizabeth streets in the City of Melbourne and to the township of Bittern—raw materials for use in manufacture of concrete. (b) From suppliers situated within a 20-mile radius of the post office at Bittern, own plant at Bittern—sand and screenings. (c) From quarries situated within a 10-mile radius of the chief post office in the City of Geelong and/or from pits in the You Yangs area to own plant at Geelong—sand and screenings.
- RIGBY MOTORS PTY. LTD.**, 40-44 Lime-avenue, Mildura, 3500. One commercial goods vehicle (L/C. 10 cwt.) to operate within a 100-mile radius of the chief post office at Mildura in course of business as "Farm Machinery and Motor Vehicle Distributor" for the purpose of towing tractors and motor cars for display and demonstration and repossessed motor cars.
- SCHRIEBER, S. E.**, 11 Canberra-street, Moe, 3825. One commercial goods vehicle (L/C. 7 cwt.) to operate throughout the State of Victoria in course of business as "Painting Contractor" on behalf of Stone-Tex Surface Coatings (Aust.) Pty. Ltd.—tools of trade, ladders, equipment and advertising materials.
- SCHWEPPE (AUST.) PTY. LTD.**, Chesterville-road, Moorabbin, 3189. One commercial goods vehicle (L/C. 76 cwt.) to operate within a 50-mile radius of own branch premises at Ballarat in course of business as "Aerated Water Manufacturers"—own aerated waters and empty returns.
- SENIOR, D. W.**, Nobility-street, Moolap. One commercial goods vehicle (L/C. 99 cwt.) to operate within a 50-mile radius of the chief post office in the City of Geelong in the course of business as "Waste Collector"—waste paper collected on behalf of the Geelong Mentally Handicapped Children's Welfare Association and for delivery to General Paper Industries Pty. Ltd., Brooklyn.
- SHEPPARTON DEALERS & FARM SUPPLIERS**, Benalla-road, Shepparton, 3630. One commercial goods vehicle (L/C. 18 cwt. and 30 cwt. trailer) to operate: (a) Within a 50-mile radius of own premises at Shepparton in course of business as "Farm Machinery and Motor Part Distributor and Machinery Hirer"—farm machinery, motor parts, machinery for hire and tools of trade. (b) Within a 25-mile radius of Melbourne for the purpose of operating from own depots at Essendon and Preston—own goods.
- VERSTRATEN, K.**, 5 Tamar-street, Ringwood, 3134. One commercial goods vehicle (L/C. 261 cwt.) to operate within a 25-mile radius of Melbourne and from the You Yangs to places within the Melbourne Metropolitan Area—sand and screenings on behalf of Pronto Mixed Concrete Co. Pty. Ltd.

WILSON, W. C., 60 Grey-street, Traralgon, 3844. Application to vary the conditions of licence No. D.T.822/1 (L/C. 238 cwt.) by adding to the existing conditions an additional paragraph: "From private landings within a 10-mile radius of Carrajung to the premises of the Australian Paper Manufacturers Pty. Ltd. at Maryvale—pulpwood".

WILKINSON, C. G., Post Office, Rokeby, 3821. One commercial goods vehicle (L/C. 150 cwt.) to operate from forest landings situated within a 5-mile radius of Rokeby to the premises of the State Coal Mine at Wonthaggi—mining timbers.

## TOW TRUCKS.

COLLINS AUTO PANELS, 100 Renver-road, Clayton, 3168. Application to vary the conditions of licence No. D.A.48545/2 (L/C. 38 cwt.) by adding to the existing conditions paragraph "(b) Within a 25-mile radius of Clayton for the purpose of towing trailers, compressors and vehicles other than those wrecked or disabled".

PEDDLE, M. H., 9 Surrey-road, Mount Waverley, 3149. One commercial goods vehicle (L/C. 160 cwt.) to operate throughout the State of Victoria as a "Heavy Duty Tow Truck and Salvage Unit" for the purpose of lifting and carrying or towing and/or repairing wrecked or disabled vehicles—tools of trade, spare parts and materials incidental thereto.

APPLICATIONS for renewal of licences as shown by persons listed hereunder to operate under the same terms and conditions from the expiry shown in each case.

BEAUREPAIRE TYRE SERVICE PTY. LTD., 102 Victoria-street, Carlton, 3053; D.A.629/38; 16th November, 1967; 16 cwt.; D.A.629/39; 16th November, 1967; 11 cwt.

BEAUREPAIRE TYRE SERVICE PTY. LTD., 102 Victoria-street, Carlton, 3053; D.A.629/40; 16th November, 1967; 17 cwt.

BEAUREPAIRE TYRE SERVICE PTY. LTD., 102 Victoria-street, Carlton, 3053; D.A.629/41; 16th November, 1967; 11 cwt.

BEAUREPAIRE TYRE SERVICE PTY. LTD., 102 Victoria-street, Carlton, 3053; D.A.629/42; 16th November, 1967; 12 cwt.

BROWN, H. S., 12 Station-street, Ringwood, 3134; D.A.739; 26th November, 1967; 133 cwt.

DENHAM CONSTRUCTIONS PTY. LTD., 10 Mitchell-street, Mornington, 3931; D.A.37214; 16th November, 1967; 139 cwt.

E.I.L. SERVICE PTY. LTD., 161 Sturt-street, South Melbourne, 3205; D.A.30374/16; 9th November, 1967; 11 cwt.

FERRIS BROS. PTY. LTD., 44 Egan-street, Richmond, 3121; D.A.36851; 27th July, 1967; 10 cwt.

FERRIS BROS. PTY. LTD., 44 Egan-street, Richmond, 3121; D.A.36851/1; 27th July, 1967; 10 cwt.

FERRIS, D. T., 17 Tatra-avenue, Mildura, 3500; D.A.49977; 3rd September, 1967; 109 cwt.

FIBRO WALLS & CEILINGS CO. PTY. LTD., 867 Nepean Highway, Moorabbin, 3189; D.A.36128/3; 5th November, 1967; 11 cwt.

GENERAL PROVIDORS (AUST.) PTY. LTD., 51 Playne-street, Frankston, 3199; T.D.A.53767; 9th November, 1967; 43 cwt.; T.D.A.53767/1; 9th November, 1967; 44 cwt.

JAQUES BROS. LTD., cnr. Griffiths and Palmer streets, Richmond, 3121; D.A.20624/2; 11th November, 1967; 24 cwt.

JEFFREY, J., & SONS PTY. LTD., P.O. Box 125, Morwell, 3840; D.A.32735/18; 30th September, 1967; 18 cwt.

JORDAN, R. A., PTY. LTD., 16 Levenswell-road, Moorabbin, 3189; D.A.44035/6; 18th November, 1967; 61 cwt.

KEOGH, P., PTY. LTD., 371 Francis-street, Yarraville, 3013; D.A.6989/7; 3rd September, 1967; 10 cwt.

LEWIS, F. H., 5 Bayview-road, Beaumaris, 3193; T.D.19773; 7th December, 1967; 148 cwt.

MONSON, E. J., 219 Fletcher-street, Albury, N.S.W., 2640; D.A.7362; 24th October, 1967; 7 cwt.

NESTLE CO. AUST. LTD., THE, 159 Racecourse-road, Flemington, 3031; D.A.31378/36; 18th November, 1967; 8 cwt.

NU-BRENT FORD PTY. LTD., 137 Kepler-street, Warrambool, 3280; D.A.36424/5; 30th September, 1967; 11 cwt.; D.A.36424/7; 30th September, 1967; 11 cwt.

OLIVER-DAVEY GLASS CO. PTY. LTD., 35-53 Crockford-street, Port Melbourne, 3207; D.A.39088/6; 18th November, 1967; 30 cwt.

PATERSONS PTY. LTD., 152 Bourke-street, Melbourne, 3000; D.A.1782/9; 21st November, 1967; 48 cwt.

PETERSVILLE AUSTRALIA LTD., Wellington-road, Clayton, 3168; T.D.A.1813/18; 20th November, 1967; 74 cwt.; T.D.A.1813/47; 11th November, 1967; 68 cwt.; T.D.A.1813/49; 11th November, 1967; 68 cwt.; T.D.A.1813/51; 11th November, 1967; 72 cwt.;

T.D.A.1813/52; 11th November, 1967; 78 cwt.;

T.D.A.1813/53; 11th November, 1967; 69 cwt.;

T.D.A.1813/54; 11th November, 1967; 73 cwt.;

T.D.A.1813/55; 11th November, 1967; 78 cwt.;

T.D.A.1813/56; 11th November, 1967; 77 cwt.;

T.D.A.1813/57; 11th November, 1967; 74 cwt.;

T.D.A.1813/58; 11th November, 1967; 67 cwt.;

T.D.A.1813/59; 11th November, 1967; 70 cwt.;

T.D.A.1813/60; 11th November, 1967; 73 cwt.;

T.D.A.1813/61; 11th November, 1967; 74 cwt.;

T.D.A.1813/62; 11th November, 1967; 74 cwt.;

T.D.A.1813/63; 11th November, 1967; 76 cwt.;

T.D.A.1813/64; 11th November, 1967; 74 cwt.;

T.D.A.1813/65; 11th November, 1967; 72 cwt.;

T.D.A.1813/66; 11th November, 1967; 73 cwt.;

T.D.A.1813/67; 11th November, 1967; 74 cwt.;

T.D.A.1813/68; 11th November, 1967; 73 cwt.;

T.D.A.1813/69; 11th November, 1967; 74 cwt.;

T.D.A.1813/70; 11th November, 1967; 73 cwt.;

T.D.A.1813/71; 11th November, 1967; 73 cwt.;

T.D.A.1813/72; 11th November, 1967; 74 cwt.;

T.D.A.1813/73; 11th November, 1967; 72 cwt.;

T.D.A.1813/74; 11th November, 1967; 62 cwt.;

T.D.A.1813/75; 11th November, 1967; 73 cwt.;

T.D.A.1813/76; 11th November, 1967; 75 cwt.;

T.D.A.1813/77; 11th November, 1967; 69 cwt.;

T.D.A.1813/78; 11th November, 1967; 63 cwt.;

T.D.A.1813/130; 8th November, 1967; 69 cwt.;

T.D.A.1813/131; 20th November, 1967; 69 cwt.

PROCTOR, A. W., c/o Post Office, Box 84, Lakes Entrance, 3909; D.A.22770/1; 7th October, 1967; 58 cwt.

ROBERTSON, C. J., & Co. (Horsham), 21 Stawell-road, Horsham, 3400; D.A.23358/3; 30th September, 1967; 34 cwt.

ROCHE BROS. PTY. LTD., 22 Dynion-road, South Kensington, 3031; D.A.1941/27; 3rd November, 1967; 30 cwt.

SEAL, T. W., 31 Dover-road, Williamstown, 3016; D.A.2005; 19th November, 1967; 240 cwt.

SHUSTER, D., 343 Glenhuntly-road, Elsternwick, 3185; D.A.23855; 21st November, 1967; 10 cwt.

STAFFORD, C., 29 McCrae-street, Bacchus Marsh, 3340; D.A.36875/1; 12th October, 1967; 249 cwt.

STAMPTON BROS., 9 Boonah-street, Springvale, 3171; D.A.50591; 18th November, 1967; 144 cwt.

WALSH, R. D., 16 Naretha-street, Swan Hill, 3585; D.A.37371; 12th October, 1967; 319 cwt.

WISEMAN, J. H., & SONS PTY. LTD., 69 Gipps-street, Collingwood, 3066; D.A.37454; 3rd November, 1967; 6 cwt.; D.A.37454/1; 3rd November, 1967; 10 cwt.; D.A.37454/2; 3rd November, 1967; 10 cwt.

## TOW TRUCK RENEWALS.

ASHWOOD SERVICE STATION, 34 High Street-road, Ashwood, 3147; D.A.47025; 18th November, 1967; 36 cwt.

GRANT MOTORS, 66 Grant-street, Bacchus Marsh, 3340; T.D.A.31078; 5th November, 1967; 28 cwt.

MURCHISON EAST GARAGE, Murchison East, 3611; D.A.46600; 3rd September, 1967; 79 cwt.

ZUKANOVIC, R. (trading as Opslan Motors), Duncans-road, Werribee South, 3030; D.A.50195; 5th November, 1967; 25 cwt.

## RENEWALS WITH VARIATION.

APPLICATION by the persons listed hereunder for renewal of the licences listed with variation of conditions in the manner set out opposite the names.

POXON, R. E. & M. D., 12 New-street, Dandenong, 3175; D.A.50692; 18th November, 1967; Application to renew and vary the conditions of licence No. D.A.50692 (L/C. 143 cwt.) by deleting the existing conditions and by adding in lieu "(a) Within a 35-mile radius from the premises of Albion Reid Pty. Ltd., at Lysterfield—quarry materials solely on behalf of the said company. (b) From pits situated within the radius as defined in paragraph (a) above to the premises of Albion Reid Pty. Ltd., at Lysterfield—sand."

SILVER, S., 12 Neil-court, East Bentleigh, 3165; D.A.23135; 21st November, 1967; Application to renew and vary the conditions of licence No. D.A.23135 (L/C. 8 cwt.) by adding to the existing conditions "Kitchen Ware and Crockery."

Notice of any objections should be forwarded to reach the Secretary of the Board not later than Wednesday, 4th October, 1967.

Applicants are advised that it will not be necessary to appear on the hearing date specified above, unless advised in writing by the Board.

B. P. KAY,  
Secretary.

Corner Lygon and Princes streets, Carlton, 3053, 20th September, 1967.



**CONTRACTS ACCEPTED.—(Series 1967-68.)****PUBLIC WORKS.**

1063. Mont Park, Janefield Mental Hospital, supply and installation of milking machine, \$2,360.82.—Alfa-Laval (V.) Pty. Ltd.
1064. Glengarry, State School No. 2888, renovations, \$1,847.00.—H. Amos.
1065. Moe, State School No. 4740, renovations, \$3,107.00.—H. Amos.
1066. Castlemaine, State School No. 119, erection of one 32 ft. x 16 ft. new timber shelter pavilion, \$1,320.00.—D. Boyer and C. Brown.
1067. Highton, State School No. 304, residence, repairs and painting, \$1,930.00.—I. Bulat.
1068. Karingal, State School No. 4922, plenum heating, \$3,980.00.—Chadstone Airconditioning Services Pty. Ltd.
1069. Vermont, State School No. 1022, supply and installation of gas heating, \$5,296.00.—The Colonial Gas Association Ltd.
1070. Nunawading, State School No. 4190, supply and installation of gas heating, \$4,158.28.—The Colonial Gas Association Ltd.
1071. Heathmont, State School No. 4688, gas heating to two (2) additional class-rooms, \$1,547.04.—The Colonial Gas Association Ltd.
1072. Footscray West, State School No. 3890, supply and installation of gas heating, \$4,266.00.—The Colonial Gas Association Ltd.
1073. Box Hill, High School, installation of temporary heating, \$1,479.98.—The Colonial Gas Association Ltd.
1074. Kaniva, Consolidated School Residence, Warwick-street, repairs and painting, &c., \$1,940.00.—Cosmopolitan Painters & Decorators.
1075. Murrumbidgee, High School, electrical installation, assembly hall, \$7,250.90.—D. J. Electrical.
1076. Glenaladale, State School No. 2373, conversion to septic tank system, \$1,573.00.—Glen F. Dungey.
1077. Hamilton, Technical School, erection of wool classing room, \$28,020.00.—W. G. Feary & Sons.
1078. Mt. Eliza, State School No. 1368, and Residence, connexion to sewerage, fire service, &c., \$12,351.00.—John F. Ferrero.
1079. Somers, State School No. 4458, conversion to wet septic tanks, &c., \$1,165.00.—John F. Ferrero.
1080. Cressy, State School No. 731, replacement of pipe post and weld mesh and concrete post and wire fencing (non-party), \$1,091.30.—Geelong Fencing Suppliers Pty. Ltd.
1081. Belmont, High School, non-party and party fencing, \$2,662.80.—Geelong Fencing Suppliers Pty. Ltd.
1082. Geelong, Teachers' College Hostel, "Ariston", fencing, \$1,122.00.—Geelong Fencing Suppliers Pty. Ltd.
1083. Hastings, Police Station and Residence, internal and external renovations, \$1,336.00.—J. Hare.
1084. Ouyen, High School, mechanical services, \$16,879.39.—J. G. Hibberd Pty. Ltd.
1085. Ascot Vale, State School No. 2608, erection of one (1) additional class-room C.R. 24 ft. x 24 ft., complete with entry porch, 24 ft. x 8 ft., concrete steps and landing, storeroom, &c., \$5,704.88.—A. V. Jennings Industries (Aust.) Ltd.
1086. Corryong, High School, erection of science wing, \$108,951.00.—A. V. Jennings Industries (Aust.) Ltd.
1087. Ruthven, State School No. 4956, erection of new primary school of ten class-rooms and library, \$102,736.00.—A. V. Jennings Industries (Aust.) Ltd.
1088. Karingal, State School No. 4922, erection of four class-rooms and library, \$31,839.00.—A. V. Jennings Industries (Aust.) Ltd.
1089. Belmont, High School, site works, \$8,012.55.—J. H. Lewis & Son.
1090. Traralgon, Hobson Park Hospital, attention to floor surfacing to stairs and landing internally and external to four wards, \$2,230.00.—List Bros. (Metal Protection) Pty. Ltd.
1091. Thomastown East, State School No. 4827, gravel and concrete paving, \$3,905.00.—Wm. Loud Pty. Ltd.
1092. Oberon, High School, construction of third section with physical education wing and canteen, \$123,921.00.—E. J. Lyons & Son Pty. Ltd.
1093. Myall, State School No. 3271, external and internal repairs and painting and erection of new shelter pavilion, \$2,220.00.—V. Maher.
1094. Hamilton, Technical School, electrical installation, \$2,198.00.—Moon Electrics.
1095. Templestowe, State School No. 1395, reblocking, &c., residence, \$2,140.00.—C. McCarthy.
1096. Doncaster, State School No. 197, erection of toilet block, &c., \$17,374.00.—C. McCarthy.
1097. Clayton South, State School No. 4348, renovations, \$2,904.00.—J. P. McElligott & Co. Pty. Ltd.
1098. Werribee, State School No. 649, residence, 25 Jellicoe-street, renovations, \$1,738.00.—J. P. McElligott & Co. Pty. Ltd.
1099. Kyneton, High School, electrical installation, \$2,485.00.—R. T. Ogden.
1100. Geelong, State School No. 3123, internal and external renovations to school and outbuildings, \$1,670.00.—J. Paulus.
1101. Westgarth, State School No. 4177, repairs to wooden floors, \$2,300.00.—Pavlidis & Staff Development & Renovations Pty. Ltd.
1102. Pascoe Vale South, State School No. 4704, asphalt and drainage works, &c., \$14,016.60.—Rainbow Construction Co. Pty. Ltd.
1103. Swan Hill, High School, asphalt and concrete works, grading, &c., \$8,420.30.—H. & L. E. Richards.
1104. Mt. Beauty, State School No. 4644, Residence, 18 Tawonga-crescent, internal and external renovations, \$2,712.00.—Rinius Bros. Painting Service.
1105. Mitta Mitta, State School No. 887 and Residence, repairs and painting, \$5,346.00.—Rinius Bros. Painting Service.
1106. Kerang, State School No. 1410, renewal of water service, \$1,232.10.—R. J. Smith.
1107. Dandenong, High School, mechanical services, \$10,985.00.—J. C. Thomson.
1108. Kialla, State School No. 1366 and Residence, renovations, \$1,180.00.—M. R. & J. E. Trewin.
1109. Hawthorn, Social Welfare Department, Training Centre, 12 Lisson-grove, maintenance cleaning for the period 1st July, 1967, to 31st May, 1970, \$2,496.00 (per annum).—Utility Cleaning Co. (Vic.) Pty. Ltd.
1110. Bendigo, Teachers' College, enclosing cycle shelters and bird proofing, \$1,551.00.—C. G. Watson.
1111. Yarrunga, State School No. 4761, asphaltting and drainage works, \$2,664.80.—Wilkinson & Brock Pty. Ltd.
1112. Beechworth, Mental Hospital, Female Hospital, hot-water service, \$4,012.00.—Wiltshire & Rattray Pty. Ltd.
1113. Broadford, High School Residence, McKenzie-street, repairs and painting, \$1,786.00.—C. J. Bates.
1114. Horsham West, State School No. 4697, re-glaze windows with special glass to combat heat conditions, \$1,085.00.—Lansdell Glass (Vic.) Pty. Ltd.
1115. Melbourne, Public Works Department, Public Offices, Parliament-place, alterations to partitioning, 1st floor, \$3,270.00.—V.I.A. Limited.
1116. Sandringham, Technical School, external repairs and painting, \$6,691.00.—McDougall-Ireland Pty. Ltd.
1117. Cobains, State School No. 4387, external repairs and painting, \$1,115.00.—East Gippsland Painting Co.
1118. Various, Government Buildings, removal of rubbish for period 1st February, 1967, to 31st January, 1968, \$9,383.16.—Industrial Waste Collections Pty. Ltd.
1119. Alamein, State School No. 4649, new brick toilet block, \$12,293.00.—W. Rutherford Pty. Ltd.
1120. Middlefield, State School No. 4878, erection of two additional class-rooms, \$8,732.00.—J. P. & J. W. Wolbers Pty. Ltd.
1121. Langi Kal Kal, Youth Training Centre, supply of general purpose laundry press, \$1,678.00.—Hardie Trading Ltd.
1122. Beechworth, Training Prison, supply and installation of hydro extractor, \$1,288.00.—Hardie Trading Ltd.
1123. South Yarra, Melbourne High School, supply and fixing of aluminium sashes for swimming pool, \$2,622.00.—Fasham Building Products Pty. Ltd.

G. SERPELL, Secretary for Public Works. 12.9.67.

**GENERAL STORES.**

Gazette No. 70, 13th September, 1967, Schedule No. 27, Cocks & Fittings, &c.—Rate for Item No. 26 should read \$6.90 per dozen.

H. COUTTS, Secretary to the Tender Board. 19.9.67.

**ORDERS IN COUNCIL.—(Series 1966-67.)****STATE ELECTRICITY COMMISSION.**

4284. For construction of asbestos cement and mild steel water mains for Hazelwood Power Station, to Specification No. 67/50, \$72,299.—J. R. Pillars Pty. Ltd.

Approved by the Governor in Council, 15th August, 1967.—J. ROSSITER, Acting Clerk of the Executive Council.

4285. For construction of brick maintenance building, South Morang Terminal Station, to Specification No. 67/38, \$31,544.—A. V. Jennings Industries (Aust.) Ltd.

4286. For supply of automatic boiler water analysers for Hazelwood Power Station, stages 3 and 4, to Specification No. 66-67/378, \$34,963.—Technicon Equipment Pty. Ltd.

4287. For supply of fifteen 22 kV capacitor banks with series reactors for the distribution system, to Specification No. 66-67/231, \$199,788.—Ducon Condenser Pty. Ltd.

4288. For supply of five 22 kV capacitor banks with series reactors for the distribution system, to Specification No. 66-67/231, \$26,140.—Tyree Electrical Co. Pty. Ltd.

Approved by the Governor in Council, 22nd August, 1967.—J. ROSSITER, Acting Clerk of the Executive Council.

4289. For construction of turbine lifting gear store, general services personnel building, boilermakers workshop and sootblower maintenance building at Hazelwood Power Station, to Specification No. 67/3A, \$59,800.—A. Gathercole and Co. Pty. Ltd.

4290. For supply of electrical appliances and spare parts for merchandising for a period of three years, to Quotation No. 697, at Schedule rates.—Sunbeam Corporation Ltd.

Approved by the Governor in Council, 29th August, 1967.—J. ROSSITER, Acting Clerk of the Executive Council.

**ORDERS IN COUNCIL.—(Series 1967-68.)**

**FORESTS COMMISSION.**

Loan Fund Act No. 7453, Item 6—

1053. To the purchase of that lots 56, 58 and 60 on plan of subdivision No. 26960, being parts of Crown allotment 126, Parish of Scoresby, County of Mornington, for forest purposes, \$1,500.00.—Archie L. Browne.

Approved by the Governor in Council, 25th July, 1967.—J. ROSSITER, Acting Clerk of the Executive Council.

**EDUCATION DEPARTMENT.**

1054. One only Heine 57 H. bench folder for Kangaroo Flat Technical School, \$319.00.—McPherson's Limited.

Approved by the Governor in Council, 12th September, 1967.—J. ROSSITER, Acting Clerk of the Executive Council.

**PUBLIC WORKS.**

1055. Bayswater, State School No. 2163, electrical installation in class-rooms and library, \$1,540.00.—Arthur Raymond.—(N.E.95317 "A".)

1056. Broadmeadows, various schools, repairs to damaged ceiling, \$1,442.87.—City of Broadmeadows.—(N.W.31352.)

1057. Carlton, Mental Health Authority's Clinic, mechanical services, \$1,869.65.—Wm. Kean Industries.—(E.M.77763 "B".)

1058. Carlton, Exhibition Police Huts, maintenance cleaning for the period 1st July, 1967, to 31st May, 1968, \$1,100.00.—Utility Cleaning Co. (Vic.) Pty. Ltd.—(E.M.36856.)

1059. Langi Kal Kal, Youth Training Centre, replacement of power poles, \$1,682.00.—Widgery & Wilson.—(N.W.105780.)

1060. Merbein, High School, installation of air circulators, \$1,204.98.—K. J. Dupuy.—(N.W.107605.)

1061. Mont Park, Mental Hospital, electrical installation in vegetable store, \$1,720.46.—Geo. Anderson.—(N.E.92066.)

1062. West Melbourne, Government Cool Stores, overhaul of ammonia compressor, \$6,306.00.—Gordon Bros. Pty. Ltd.—(S.W.118998.)

Approved by the Governor in Council, 12th September, 1967.—J. ROSSITER, Acting Clerk of the Executive Council.

**State Electricity Commission Acts.**

**ELECTRICAL APPROVALS BOARD.**

**P**URSUANT to Regulation 16 of the Electrical Approvals Regulations—Approval of Equipment, 1953, the State Electricity Commission of Victoria hereby gives notice that it has withdrawn approval of the undermentioned article as from the date shown hereunder:—

Name of Applicant.	Article and Reference No.	Date of Withdrawal.	Date of Certificate of Approval.	Approvals Marking.
P.Q.R. Services Pty. Ltd.	Sewing Machine, Trade Name "Sew-Maid", Cat. No. SM4, Ref. No. BT/B6G/02	21.8.67	13.12.66	V/B6G/SM4

Dated the 18th day of September, 1967.

F. P. CHIPPERFIELD, Secretary.

*Process Servers and Inquiry Agents Act 1958.*

**APPLICATIONS FOR LICENCES LODGED WITH CLERKS OF COURTS.**

**B**y direction of the Chief Secretary, the subjoined lists of "new" applications for process servers' and inquiry agents' licences are published for general information.

Applicant.	Address.	Court.	Tentative Date of Hearing of Application.
<i>Inquiry Agents' Licences.</i>			
Capstick, Edmund	22 Cuthbert-avenue, Highton	Geelong	26.9.67
Manning, William Thomas	Foy and Gibson Ltd., 130 Smith-street, Collingwood	Collingwood	12.10.67
<i>Process Servers' Licences.</i>			
Brown, Roy Meikle	50 Belgrave-road, East Malvern	Malvern	4.10.67
Capstick, Edmund	22 Cuthbert-avenue, Highton	Geelong	26.9.67
Capstick, Joan Margaret	252 Mt. Pleasant-road, Highton	Geelong	26.9.67
Foley, John Patrick	414 Lonsdale-street, Melbourne	Melbourne	10.10.67
Manning, William Thomas	Foy and Gibson Ltd., 130 Smith-street, Collingwood	Collingwood	12.10.67

Attention is directed to the provisions of the above Act and regulations thereunder relating to the lodgement of objections to applications.

Chief Secretary's Office,  
Melbourne, 19th September, 1967.

E. L. RICHARDSON, Registrar,  
Process Servers and Inquiry Agents.

STATE RIVERS AND WATER SUPPLY COMMISSION.

LICENCE TO DIVERT WATER AND CUT RACE PURSUANT TO THE PROVISIONS OF SECTION 204 OF THE WATER ACT. (AS AMENDED).

THE Schedule of one Licence as detailed hereunder to divert water and cut race has been revoked by the Governor in Council:—

SCHEDULE.

Licence No.	Term of Licence and Commencing Date.	Name and Address of Person to whom Licence Granted.	Source of Supply.
200	Fifteen years from 1.7.58	C. and W. B. Ibbs, Kerang	Gunbower Creek

Office of the State Rivers and Water Supply Commission,  
Melbourne, 19th September, 1967.

G. W. LEWIS, Secretary,  
State Rivers and Water Supply Commission.

Victoria.

ACT 391.—SECOND SCHEDULE.

A STATEMENT of trusts having been submitted by the head or authorized representative of the denomination of the Presbyterian Church of Victoria (Trusts Corporation) under the provisions of the "Act to provide for the Abolition of State Aid to Religion", for allowance by the Governor, the same was allowed by him on the twelfth day of September, 1967, and the following is the form in which such statement of trusts has been allowed:—

STATEMENT OF TRUSTS.

*Description of Land.*—1 acre, 2 roods, Parish of Rochford, County of Bourke, being allotment 22F:—Commencing at the south-eastern angle of portion 16 of allotment 22, bounded thence by that portion bearing 0 deg. 0 min. 435 links, by allotment 22c bearing 89 deg. 5 min. 343 links and thence by roads bearing 180 deg. 0 min. 440 links and 270 deg. 0 min. 343 links to the point of commencement.

*Names of Trustees.*—The Presbyterian Church of Victoria Trusts Corporation.

*Powers of Disposition.*—With the consent of the General Assembly of "The Presbyterian Church of Victoria," to mortgage, sell, lease, exchange and transfer, and grant easements over the said land, or any part or parts thereof, and, subject to such powers and the exercise thereof, to hold the said land, or so much thereof as may from time to time remain vested in the said trustees, upon such trusts for the said Presbyterian Church of Victoria, and for such purposes, and with subject to such powers, and provisions as are contained in the document enrolled by the Registrar-General of the State of Victoria, pursuant to the provisions of the *Presbyterian Trusts Act 1890*, and styled "The Presbyterian Church of Victoria Model Trust Deed for Church Site".

*Purposes to which Proceeds of Disposition are to be Applied.*—To pay the money coming to the hands of such trustees by virtue of any such power of disposition to the Treasurer for the time being of the Presbyterian Church of Victoria, to be by him applied first in payment of all incidental costs, next in payment to the said Presbyterian Church of Victoria, of all deductions heretofore or hereafter to be authorized, by the General Assembly of the said Church and as to the residue, for such purposes as the said Assembly has heretofore authorized or may hereafter authorize. 1438

Victoria.

ACT 391.—SECOND SCHEDULE.

A STATEMENT of trusts having been submitted by the head or authorized representative of the denomination of the Presbyterian Church of Victoria (Trusts Corporation) under the provisions of the "Act to provide for the Abolition of State Aid to Religion", for allowance by the Governor, the same was allowed by him on the twelfth day of September, 1967, and the following is the form in which such statement of trusts has been allowed:—

STATEMENT OF TRUSTS.

*Description of Land.*—1 acre 30 perches, Parish of Creswick, County of Talbot, being Crown allotment 3c, section 2: Commencing at the northern angle of allotment 3, section 2; bounded thence by that allotment bearing 197 deg. 47 min. 357 links; by allotment 3A, bearing 287

deg. 57 min. 300 links and 17 deg. 57 min. 400 links and thence by the Daylesford-Ballararat road bearing 107 deg. 57 min. 252 links and 148 deg. 38 min. 65 links to the point of commencement.

*Names of Trustees.*—The Presbyterian Church of Victoria Trusts Corporation.

*Powers of Disposition.*—With the consent of the General Assembly of "The Presbyterian Church of Victoria," to mortgage, sell, lease, exchange and transfer, and grant easements over the said land, or any part or parts thereof and, subject to such powers and the exercise thereof, to hold the said land, or so much thereof as may from time to time remain vested in the said trustees, upon such trusts for the said Presbyterian Church of Victoria, and for such purposes, and with and subject to such powers, and provisions as are contained in the document enrolled by the Registrar-General of the State of Victoria, pursuant to the provisions of the *Presbyterian Trusts Act 1890*, and styled "The Presbyterian Church of Victoria Model Trust Deed for Church Site".

*Purposes to which Proceeds of Disposition are to be Applied.*—To pay the money coming to the hands of such trustees by virtue of any such power of disposition to the Treasurer for the time being of the Presbyterian Church of Victoria, to be by him applied first in payment of all incidental costs, next in payment to the said Presbyterian Church of Victoria, of all deductions heretofore or hereafter to be authorized, by the General Assembly of the said Church and as to the residue, for such purposes as the said Assembly has heretofore authorized or may hereafter authorize. 7669

Victoria.

ACT 391.—SECOND SCHEDULE.

A STATEMENT of trusts having been submitted by the head or authorized representative of the denomination of the Presbyterian Church of Victoria (Trusts Corporation) under the provisions of the "Act to provide for the Abolition of State Aid to Religion", for allowance by the Governor, the same was allowed by him on the twelfth day of September, 1967, and the following is the form in which such statement of trusts has been allowed:—

STATEMENT OF TRUSTS.

*Description of Land.*—0 acres 1 rood 2 perches, allotment 14, section 16, Township of Creswick, Parish of Creswick, County of Talbot, commencing at the north-east angle of the allotment, being a point on the western side of Ford-street; bounded thence by Ford-street bearing 199 deg. 47 min., 100 links; by allotment 15 bearing 289 deg. 47 min., 262 links; by allotment 9 bearing 19 deg. 47 min. 100 links; and thence by allotment 13 bearing 109 deg. 47 min., 262 links to the point of commencement.

*Names of Trustees.*—The Presbyterian Church of Victoria Trusts Corporation.

*Powers of Disposition.*—With the consent of the General Assembly of "The Presbyterian Church of Victoria," to mortgage, sell, lease, exchange and transfer, and grant easements over the said land, or any part or parts thereof and, subject to such powers and the exercise thereof, to hold the said land, or so much thereof as may from time to time remain vested in the said trustees, upon such trusts for the said Presbyterian Church of Victoria, and for such purposes, and with and subject to such powers, and provisions as are contained in the document enrolled

by the Registrar-General of the State of Victoria, pursuant to the provisions of the *Presbyterian Trusts Act 1890*, and styled "The Presbyterian Church of Victoria Model Trust Deed for Manse Site".

*Purposes to which Proceeds of Disposition are to be Applied.*—To pay the money coming to the hands of such trustees by virtue of any such power of disposition to the Treasurer for the time being of the Presbyterian Church of Victoria, to be by him applied first in payment of all incidental costs, next in payment to the said Presbyterian Church of Victoria, of all deductions heretofore or hereafter to be authorized, by the General Assembly of the said Church and as to the residue, for such purposes as the said Assembly has heretofore authorized or may hereafter authorize. 3189

*Town and Country Planning Act 1961.*

SHIRE OF MORNINGTON PLANNING SCHEME 1959.

AMENDMENT No. 17, 1966.

*Notice of Approval.*

IN pursuance of the powers conferred by the *Town and Country Planning Act 1961*, the Governor in Council on the 19th September, 1967, approved a planning scheme entitled the Shire of Mornington Planning Scheme 1959, Amendment No. 17, 1966, in respect of part of the municipal district of the Shire of Mornington, and such planning scheme comes into operation on the date this notice of approval is published in the *Government Gazette*.

A copy of the planning scheme as approved may be inspected free of charge during office hours at the office of the Town and Country Planning Board, 179 Queen-street, Melbourne; at the office of the Mornington Shire Council at Mornington; and when available, at the Office of Titles, Melbourne, and at the Central Plan Office of the Department of Crown Lands and Survey, Melbourne.

W. H. CRAIG, Secretary.  
Town and Country Planning Board.

*Town and Country Planning Act 1961.*

SHIRE OF KNOX PLANNING SCHEME.

AMENDMENT No. 9, 1966.

*Notice of Approval.*

IN pursuance of the powers conferred by the *Town and Country Planning Act 1961*, the Governor in Council on the 19th September, 1967, approved a planning scheme entitled the Shire of Knox Planning Scheme, Amendment No. 9, 1966, in respect of the municipal district of the Shire of Knox and such planning scheme comes into operation on the date this notice of approval is published in the *Government Gazette*.

A copy of the planning scheme as approved may be inspected free of charge during office hours at the office of the Town and Country Planning Board, 179 Queen-street, Melbourne; at the office of the Knox Shire Council at Fern Tree Gully, and when available, at the Office of Titles, Melbourne, and at the Central Plan Office of the Department of Crown Lands and Survey, Melbourne.

W. H. CRAIG, Secretary.  
Town and Country Planning Board.

*Town and Country Planning Act 1961.*

SHIRE OF KNOX PLANNING SCHEME.

AMENDMENT No. 13, 1967.

*Notice of Approval.*

IN pursuance of the powers conferred by the *Town and Country Planning Act 1961*, the Governor in Council on the 19th September, 1967, approved a planning scheme entitled the Shire of Knox Planning Scheme, Amendment No. 13, 1967, in respect of part of the municipal district of the Shire of Knox and such planning scheme comes into operation on the date this notice of approval is published in the *Government Gazette*.

A copy of the planning scheme as approved may be inspected free of charge during office hours at the office of the Town and Country Planning Board, 179 Queen-street, Melbourne; at the office of the Knox Shire Council at Fern Tree Gully, and when available, at the Office of Titles, Melbourne, and at the Central Plan Office of the Department of Crown Lands and Survey, Melbourne.

W. H. CRAIG, Secretary.  
Town and Country Planning Board.

THE COMPANIES ACT 1961.

WHEREAS Mortgage Management Limited (hereinafter called "the Company") is the Management Company within the meaning of section 76 of the *Companies Act 1961*, in relation to a Deed constituting Commonwealth Securities and Mortgage Trust No. 1 (hereinafter called "the Deed"); And whereas Permanent Trustee Nominees (Canberra) Limited (hereinafter called "the Trustee") is the Trustee for the purpose of the Deed: And whereas application has been made on behalf of the company for exemption from compliance with certain provisions of Division 5 of Part IV. of the said Act in respect of the Deed: Now therefore I, the undersigned, the Minister for the time being administering the said Act by virtue of the powers contained in sub-section (1) of section 88 of the said Act, do hereby exempt the company:—

1. from complying with the provisions of sub-section (1) (b) (iii) of section 80 of the said Act on the condition that covenants in terms of clauses 23 (h) and 23 (i) of the Deed will be included and retained in the Deed;
2. from complying with the provisions of paragraph (g) of sub-section (1) of section 80 of the said Act in respect of the Deed; and
3. subject to the following conditions from compliance with the provisions of section 84 of the said Act:
  - (a) that the company keep in the State of New South Wales a complete register of holders of interests under the Deed in accordance with section 84 of the said Act;
  - (b) that the company keep at a proper place in the State of Victoria a register of the holders of interests under the Deed who are resident in Victoria which register complies with section 84 except to the extent that it need not register holders other than those resident in Victoria;
  - (c) that the company makes available for inspection at the place where the register is kept in the State of Victoria a copy of the register of all holders of interests under the Deed wherever resident within fourteen (14) days after a request has been made to the company in that behalf by any person entitled to inspect the register by virtue of the provisions of sub-section (2) of section 153 of the said Act.

Dated at Melbourne, this 15th day of September, 1967.

G. O. REID,  
Attorney-General.

PUBLIC TRUSTEE ACT 1958 (No. 6350), SECTION 17.

I HEREBY give notice that on the 31st August, 1967, the Public Trustee filed elections to administer the following deceased persons' estates, in accordance with section 17 of the *Public Trustee Act 1958*:—

BEDFORD, IVY, late of 2 Hayes-road, Strathmore, married woman, died 15th July, 1967.

DAVIE, ARTHUR, late of 24 Little Bourke-street, Melbourne, pensioner, died 20th July, 1967.

ENNOR, SAMUEL JAMES, late of 5 Harold-street, Preston, retired ink manufacturer, died 9th March, 1967.

SHIPTON, ELSIE OLIVE MAY, late of 5 Nocton-street, Reservoir, married woman, died 1st July, 1967.

SMITH, HERBERT LESLIE, late of 27 Hall-street, Coburg, retired tram driver, died 25th June, 1967.

THORNE, WALTER REGINALD, late of 19 Chandos-street, Coburg, baker, died 7th February, 1954.

I HEREBY give notice that on the 7th September, 1967, the Public Trustee filed elections to administer the following deceased persons' estates, in accordance with section 17 of the *Public Trustee Act 1958*:—

McKENNA, IRENE ELIZABETH MARY, also known as McKenna, Irene Elizabeth, late of Wesley College, St. Kilda-road, Prahran, domestic, died 20th July, 1967.

RANTALL, JONAS, Sunnyside House, Camperdown, pensioner, died 16th July, 1966.

A. D. DUNCAN,  
Public Trustee.

256 Flinders-street, Melbourne, 13th September, 1967.

## NOTICE.

**CREDITORS**, next of kin and others having claims against the estate of any of the under-mentioned deceased persons are required to send particulars of their claims to the Public Trustee, 256 Flinders-street, Melbourne, the personal representative, on or before the 28th November, 1967, after which date the Public Trustee may convey or distribute the assets, having regard only to the claims of which the Public Trustee then has notice:—

**BARRIE, MARTHA LAYBANK**, late of 32 Russell-street, Camberwell, widow, died on the 21st July, 1967.

**BEDFORD, IVY**, late of 2 Hayes-road, Strathmore, married woman, died 15th July, 1967.

**BORG, HERTHA LAURA**, formerly of 345 North-road, Ormond, but late of 37 Webster-street, Chadstone, widow, died 2nd June, 1967.

**CLIFF, AGNES MARIE**, late of 13 Carrum-street, Oakleigh, spinster, died 22nd July, 1967.

**DAVE, ARTHUR**, late of 24 Little Bourke-street, Melbourne, pensioner, died 20th July, 1967.

**DAVIES, ODO YESTIN**, late of 2 Gray-street, Ballarat East, pensioner, died 18th April, 1967.

**ENNOR, HUBERT STANLEY**, formerly of Ward 4 West, Prince Henry's Hospital, Melbourne, but late of 24 Pakington-street, Kew, retired actor and singer, died 10th July, 1967.

**ENNOR, SAMUEL JAMES**, late of 5 Harold-street, Preston, retired ink manufacturer, died 9th March, 1967.

**GAY, WALTER SELWYN**, formerly of 54 Barkers-road, Hawthorn, but late of 8 Belmore-road, Balwyn, gentleman, died 30th May, 1967.

**JAMIESON, ANDREW BLAIR**, late of 18 Narrawong-road, Caulfield, retired civil servant, died 5th July, 1967.

**JENKINS, FRANCIS**, late of 4 Charlotte-street, Richmond, invalid pensioner, died 12th June, 1967.

**KNELL, CLIVE THOMAS BURROWS**, late of 62 Argyle-road, Kew, retired barrister & solicitor, died 17th March, 1967.

**KRUG, ALBERT WILLIAM**, late of 94 Biggs-street, St. Albans, fitter & turner, died 31st March, 1967.

**LANE, HARRY**, late of 10 Queen-street, Ballarat, labourer, died 6th June, 1966.

**McFARLANE, ISABEL JOY BROWN**, formerly of 15 Park-street, Parkville, but late of Flat 3, 453 Glenferrie-road, Kooyong, retired teacher, died 19th June, 1967.

**MCKENNA, IRENE ELIZABETH MARY**, also known as McKenna, Irene Elizabeth, late of Wesley College, St. Kilda-road, Prahran, domestic, died 20th July, 1967.

**McLELLAN, JAMES ALFRED**, late of Flat 5, 150 St. Georges-road, Shepparton, motor mechanic, died 10th July, 1967.

**MERKULSKI, JOSEPHINE**, late of 9 High-street, Coburg, widow, died 24th July, 1967.

**RANTALL, JONAS**, Sunnyside House, Camperdown, pensioner, died 16th July, 1966.

**SHIPTON, ELSIE OLIVE MAY**, late of 5 Nocton-street, Reservoir, married woman, died 1st July, 1967.

**SMITH, HERBERT LESLIE**, late of 27 Hall-street, Coburg, retired tram driver, died 25th June, 1967.

**TAYLOR, KENNETH WILLIAM**, late of 24 Draper-street, South Melbourne, truck driver, died 16th April, 1967.

**THORNE, WALTER REGINALD**, late of 19 Chandos-street, Coburg, baker, died 7th February, 1954.

**WILLS, JOHN HENRY JOSEPH**, late of 118 Hutton-street, Thornbury, pensioner, died 15th July, 1967.

A. D. DUNCAN,  
Public Trustee.

Melbourne, 13th September, 1967.

## DEPARTMENT OF MINES.

**SUBJECT** to any necessary excisions, &c., it is proposed to grant the following mining leases:—

8482, Mineral; Joan Pauling Welby, Bruce Combe Calman, John Cyril Moon, Brian James Hatfield, Lewis Henry Gardiner; 370a. 2r. 10p., Parish of Costerfield.

8568, Mineral; Martin Stoneware Pipe Limited; 29a. 1r. 36p., Parish of Ballarat.

## APPLICATIONS FOR LEASES DECLARED ABANDONED.

8419, Beechworth; Mervyn Raymore Cocks; 7 acres, Parish of Bungil.

8418, Mineral; David Hamilton Hume; 640 acres, Parishes of Wombete and Jan Juc.

8603, Mineral; Albert Alexander Bergmark; 22 acres, Parish of Buchan.

## APPLICATION FOR LEASE REFUSED.

8628, Mineral; Martin Francis Sexton, Geoffrey Patrick Ryan; 40 acres, Parish of Moorarbool West.

## TERMS OF EXPLORATION LICENCES EXPENDED.

25, Exploration Licence; Planet Mining Company Pty. Ltd.

26, Exploration Licence; Planet Mining Company Pty. Ltd.

27, Exploration Licence; Planet Mining Company Pty. Ltd.

28, Exploration Licence; Planet Mining Company Pty. Ltd.

J. C. M. BALFOUR,  
Minister of Mines.

## MINING LEASE DECLARED VOID.

8492, Mineral; Kenneth Vincent Harris, Clarice Elizabeth Harris; 24a. Or. 16p., Parishes of Cudgewa, Walwa.

E. CONDON,  
Secretary for Mines.

## Melbourne and Metropolitan

## BOARD OF WORKS.

## GENERAL NOTICE.

**THE** Melbourne and Metropolitan Board of Works, having made provision for carrying off the sewage of each and every property which or any part of which is situate in the Sewerage Areas hereinafter described doth hereby declare that on and after the 20th day of October, 1967 each and every property so situate shall be deemed to be a seweraged property within the meaning of the *Melbourne and Metropolitan Board of Works Act 1958*.

The Sewerage Areas hereinbefore referred to are:—

## Sewerage Area No. 2124.

*City of Waverley*.—Commencing at the junction of Jubilee-street and Bengal-crescent; thence easterly along Bengal-crescent and the northern boundary of lot 47 Bengal-crescent, southerly along the eastern boundaries of the said lot 47 and lot 46 Bengal-crescent, easterly by a line to the southern angle of lot 19 Monomeith-crescent, northerly and easterly along the western and northern boundaries of the said lot 19, easterly along Monomeith-crescent, southerly along Stephenson's-road to the southern boundary of the Waverley North State School property, westerly along the said property boundary to the north-eastern angle of lot 20 Birch-street, southerly and south-easterly along the eastern and north-eastern boundaries of the said lot 20, westerly along Birch-street, southerly along the eastern boundaries of lots 57 Birch-street and 63 Fir-court, south-westerly along the south-eastern boundary of the said lot 63, westerly along Fir-court, southerly along Sunhill-road, westerly along the southern boundary of lot 12 Sunhill-road, southerly along the eastern boundaries of lots 12 and 11 Alice-street, westerly along the southern boundary of the said lot 11, northerly along Alice-street, westerly along Gillian-road to the eastern boundary of Melbourne and Metropolitan Board of Works property, southerly and generally westerly following the boundaries of the said property to the north-eastern extremity of the south-western section of Gillian-road, south-westerly along Gillian-road, northerly along Park-road and Jubilee-street to the commencing point.

## Sewerage Area No. 2125.

*City of Moorabbin*.—Commencing at the junction of Walsh-avenue and Isabella-street; thence easterly along Isabella-street to the boundary of Sewerage Area No. 1974, generally southerly following the said area boundary to the south-eastern angle of lot 108 Wickham-road, westerly along Wickham-road, northerly along the western boundaries of lots 1 Wickham-road and 9 Harlow-court, easterly along the northern boundary of the said lot 9, further easterly along Harlow-court, northerly along Walsh-avenue to the commencing point.

## Sewerage Area No. 2126.

*Cities of Heidelberg and Preston*.—Commencing at a point in Crissane-road 100 feet west of the western boundary of Korong-road; thence westerly along Crissane-road to the western boundary of the Rosanna High School property, northerly, easterly and southerly following the boundaries of the said property to Crissane-road, easterly along Crissane-road, southerly along the eastern boundaries of lots 32 Crissane-road and 38 Northern-road, westerly along Northern-road, southerly along the eastern boundaries of lots 248 to 259 Korong-road, westerly along the southern boundaries of lots 259 and 236 Korong-road, northerly along the western boundaries of lots 236 to 247 Korong-road and 50 Northern-road, easterly along the northern boundary of the said lot 50, northerly along the western boundary of lot 21 Crissane-road to the commencing point.

*Sewerage Area No. 2127.*

*City of Ringwood.*—Commencing at the junction of Wilson-street and Braeside-avenue on the boundary of Sewerage Area No. 1971; thence south-westerly, westerly, southerly and westerly following the said area boundary to the junction of Mount Dandenong-road and Maroondah Highway, north-easterly along Maroondah Highway, north-westerly along Wingrove-place and continuing north-westerly along the boundary of Sewerage Area No. 2051 to Mullum Creek, generally easterly along Mullum Creek, south-easterly along Dublin-road Drain to Maroondah Highway, north-easterly along Maroondah Highway, south-easterly along Everard-road, south-westerly along Lilydale-road, further south-westerly and westerly along Mount Dandenong-road, northerly along Mines-road, westerly along Wilson-street to the commencing point.

*Sewerage Area No. 2128.*

*City of Broadmeadows.*—Commencing at the junction of Bushfield-crescent and Westmere-crescent; thence southerly along Westmere-crescent, further southerly along the eastern boundary of a reserve to Barry-road, westerly along Barry-road, northerly along the western boundary of lot 408 Exford-street, easterly along Exford-street, southerly along the eastern boundary of lot 416 Exford-street, easterly along the northern boundary of lot 417 Longford-crescent, south-easterly by a line to the north-western angle of lot 482 Longford-crescent, easterly along the northern boundary of the said lot 482, north-westerly along portion of the south-western boundary of lot 483 Wimba-court, easterly along Wimba-court, north-easterly along the north-western boundary of lot 489 Wimba-court, north-westerly along the south-western boundary of lot 502 Digby-court, north-easterly by a line to and along the north-western boundary of lot 505 Digby-court, easterly along portion of the northern boundary of the said lot 505, northerly along the western boundary of lot 525 Bushfield-crescent, westerly along Bushfield-crescent to the western boundary of lot 1 Bushfield-crescent, northerly, easterly and southerly following the boundaries of the said lot 1 to the commencing point.

*Sewerage Area No. 2129.*

*City of Oakleigh.*—Commencing at the junction of Valley-street and Huntingdale-road; thence northerly along Huntingdale-road to the boundary of Sewerage Area No. 1640, generally easterly, southerly and easterly following the said area boundary to the junction of Natalia-avenue and Foran-grove, southerly along Foran-grove, westerly along Valley-street, southerly along the eastern boundary of lot 1 Valley-street, easterly along portion of the northern boundary of lot 3 Olinda-grove, southerly along Olinda-grove to its southern extremity, further southerly along the eastern boundaries of properties on the eastern side of Legon-road to Coombs-avenue, easterly along Coombs-avenue, southerly along Scotsburn-avenue to a point 616 feet south of the southern boundary of Coombs-avenue, westerly along the southern boundary of lot 4 Scotsburn-avenue, northerly along the western boundaries of lots 4 to 1 Scotsburn-avenue, westerly by a line to the south-western angle of lot 7 Alvina-street, northerly along Alvina-street, westerly along Coombs-avenue to its western extremity, further westerly along the southern boundaries of lots 12 Peter-street, 11 and 12 Wallace-avenue, 25 and 26 Myrtle-court and 1 Huntingdale-road, northerly along Huntingdale-road to the commencing point.

By order of the Board,

H. J. SNADDEN,  
Secretary.

110 Spencer-street, Melbourne, 3001, 19th September, 1967.

**BARNAWARTHA WATERWORKS TRUST.****AUTHORITY TO OBTAIN BANK OVERDRAFT.**

**HIS** Excellency the Governor of the State of Victoria, by and with the advice of the Executive Council thereof doth by Order made on the 19th day of September, 1967, authorize the Barnawartha Waterworks Trust to obtain in pursuance of the provisions of Section 286 of the *Water Act 1958* (No. 6413) an advance or advances during the year ending 30th September, 1968, from the Bank of New South Wales, Chiltern, by overdraft of the Trust's current account thereat, such overdraft not to exceed at any one time the sum of Three thousand five hundred dollars (\$3,500).

J. ROSSITER,  
Clerk of the Executive Council.

At the Executive Council Chamber,  
Melbourne, 19th September, 1967.

**LITTLE RIVER WATERWORKS TRUST.****FIXING LIMIT OF BANK OVERDRAFT.**

**HIS** Excellency the Governor of the State of Victoria, by and with the advice of the Executive Council thereof doth by Order made on the 19th day of September, 1967, fix the limit of the overdraft to be obtained by the Little River Waterworks Trust pursuant to the provisions of Section 288 of the *Water Act* at Forty thousand dollars (\$40,000).

J. ROSSITER,  
Clerk of the Executive Council.

At the Executive Council Chamber,  
Melbourne, 19th September, 1967.

**COBRAM SEWERAGE AUTHORITY.****ANNUAL BALANCE.**

**HIS** Excellency the Governor of the State of Victoria, by and with the advice of the Executive Council thereof doth by Order made on the 19th day of September, 1967, and in pursuance of the provisions of the *Sewerage Districts Act*, fix the thirtieth day of September in each year as the day to which the accounts of the Cobram Sewerage Authority shall be balanced.

J. ROSSITER,  
Clerk of the Executive Council.

At the Executive Council Chamber,  
Melbourne, 19th September, 1967.

**COLERAINE SEWERAGE AUTHORITY.****ANNUAL BALANCE.**

**HIS** Excellency the Governor of the State of Victoria, by and with the advice of the Executive Council thereof, doth by Order made on the 19th day of September, 1967, and in pursuance of the provisions of the *Sewerage Districts Act*, fix the thirtieth day of September in each year, as the day to which the accounts of the Coleraine Sewerage Authority shall be balanced.

J. ROSSITER,  
Clerk of the Executive Council.

At the Executive Council Chamber,  
Melbourne, 19th September, 1967.

**YALLOURN NORTH SEWERAGE AUTHORITY.****ANNUAL BALANCE.**

**HIS** Excellency the Governor of the State of Victoria, by and with the advice of the Executive Council thereof, doth by Order made on the 19th day of September, 1967, and in pursuance of the provisions of the *Sewerage Districts Act*, fix the thirty-first day of December in each year, as the day to which the accounts of the Yallourn North Sewerage Authority shall be balanced.

J. ROSSITER,  
Clerk of the Executive Council.

At the Executive Council Chamber,  
Melbourne, 19th September, 1967.

**APPOINTMENTS AND RESIGNATION****APPOINTMENTS.**

**HIS** Excellency the Governor of the State of Victoria, by and with the advice of the Executive Council thereof, has by Orders made on the 12th day of September, 1967, been pleased to make the under-mentioned appointments, viz.:—

**DEPARTMENT OF AGRICULTURE.***Inspector of Stock.*

KEVIN ALEXANDER KENNEDY  
to be an Inspector of Stock, pursuant to the provisions of the *Stock Diseases Act 1958*.

**CHIEF SECRETARY'S DEPARTMENT.***Electoral Registrar (Acting).*

KEVIN ROBERT FORBES  
to be Electoral Registrar (Acting) for the South Barwon Subdivision of the Electoral District of Bellarine; the Belmont North Subdivision of the Electoral District of Geelong; the Ararat, Beaufort, Camperdown, Linton, Rokewood, Smythesdale and Willaura Subdivisions of the Electoral District of Hampden; the Beeac, Beech Forest, Birregurra, Colac, Jancourt, Krambruk and Port Campbell Subdivisions of the Electoral District of Polwarth; and the

Cobden and Terang Subdivisions of the Electoral District of Warmambool; to take effect on and from the 18th September, 1967, during the absence on leave of Clous Steffen.

*Governor of Reforestation Prison.*

GEORGE ALLAN PETRIE, pursuant to the provisions of the *Gaols Act 1958*, to be Governor of Morwell River Reforestation Prison, vice G. J. Armstrong, transferred.

*Honorary Probation Officers.*

FREDERICK GEORGE DEARING, 33 Castlemaine-street, Yarraville,  
JOHN FRANCIS MEEHAN, 802 Talbot-street, Ballarat,  
THOMAS IAN PAXTON, 36 Chapman-street, North Melbourne, and

EDWARD ERNEST SAUNDERS, 18 Kelvin-avenue, Seaford, pursuant to the provisions of section 10 (1) of the *Children's Court Act 1958*, to be Honorary Probation Officers for all Children's Courts in Victoria; and

WILLIAM CHARLES CRAIG, 20 Cole-court, Toorak,  
PATRICK LEO COGGIN, 29 Lake-street, Wendouree,  
JOHN ALISTAIR KENNETH MCLEAN (the Reverend), St. Andrews Manse, Bacchus Marsh,  
Captain ALLAN WILLIAM PARKINSON, 56 Timor-street, Warmambool,  
EDWARD ERNEST SAUNDERS, 18 Kelvin-avenue, Seaford,  
ALFRED GRAY TAYLOR, Post Office, Bealiba,  
JAMES THOMAS WATSON, 21 Essex-street, Wendouree,  
LAURA LILLIAN CAMERON (Mrs.), 50 York-street, Eltham, and  
LALLA-ANN GIBSON (Miss), 19 Tambo-avenue, Reservoir,

pursuant to the provisions of section 507 (2) of the *Crimes Act 1958*, to be Honorary Probation Officers for all Adult Courts in Victoria.

LAW DEPARTMENT.

*Commissioners for Taking Declarations, &c.*

IAN WILLIAM DUNCAN, care of Department of Crown Lands and Survey, Public Offices, Melbourne, and  
ROBERT JAMES VASSETT,  
WALTER ADRIAN CONNOLLY,  
ALEXANDER MCLEAN COLLARD,  
JOHN GRAEME FRANCIS,  
BRIAN JOHN CURTIS,  
HAROLD PHILLIP SCANLON,  
DESMOND ROSS WATERS, and  
KEITH NICHOLLS GORDON,  
care of Department of Labour and Industry, 110 Exhibition-street, Melbourne,  
to be Commissioners for taking Declarations and Affidavits, pursuant to the provisions of the *Evidence Act 1958*, to refrain from charging fees and to resign upon ceasing to occupy their present positions; and

BARRY JOHN RYAN, care of Echuca District Hospital, Echuca,  
to be a Commissioner for taking Declarations and Affidavits, pursuant to the provisions of the *Evidence Act 1958*, to resign upon ceasing to occupy his present position.

*Justices of the Peace.*

WALTER FUERST, 1 Greenview-court, East Bentleigh, and  
FRANCIS CLARENCE GOLDBERG, 603 Sydney-road, Brunswick,  
to Keep the Peace in the Central Bailiwick of the State of Victoria;

WILLIAM KARL NIEWAND, "Knapdale", Minyip,  
BRUCE INGLIS MURRIE, Caramut, and  
THEODORE CLIVE RIORDAN, 9 Myall-street, Woomelang,  
to Keep the Peace in the Western Bailiwick of the State of Victoria; and

FRANCIS JOSEPH HAYDEN, Barwon Downs,  
to Keep the Peace in the Southern Bailiwick of the State of Victoria.

DEPARTMENT OF THE TREASURER.

*Collector of Imposts (Acting).*

HENRY VICTOR BOARDER  
to act temporarily as Collector of Imposts, County Court, Melbourne, vice M. A. Tuohy, on sick leave; and

ISTVAN LOVASS  
to act temporarily as Collector of Imposts, Social Welfare Branch, Office of the Chief Secretary, vice N. R. Semmens, on leave.

*Collector of Imposts.*

ROBERT RUSSELL COUGHLAN  
to be Collector of Imposts, Department of Health, vice D. Smith, transferred.

J. ROSSITER,  
Acting Clerk of the Executive Council.  
At the Executive Council Chamber,  
Melbourne, 12th September, 1967.

RESIGNATION.

HIS Excellency the Governor of the State of Victoria, by and with the advice of the Executive Council thereof, has, by Order made on the 12th day of September, 1967, accepted the resignation of the person named hereunder of the office mentioned, viz.:—

LAW DEPARTMENT.

*Commissioner for Taking Declarations, &c.*

JOHN HUGH WILSON, as a Commissioner for taking Declarations and Affidavits, pursuant to the provisions of the *Evidence Act 1958*.

J. ROSSITER,  
Acting Clerk of the Executive Council.  
At the Executive Council Chamber,  
Melbourne, 12th September, 1967.

ORDERS IN COUNCIL

ERRATUM.

IN *Government Gazette* No. 70, of 13th September, 1967, page 2842, Department of Crown Lands and Survey Order in Council "Unalienated Crown Land";

In the body of the Order " . . . in pursuance of the provisions of Section 11 (L) (C) of the *Gippsland Railway (Duplication and Regrading) Act 1948* "

should read

" in pursuance of the provisions of Section 11 (1) (C) ".

LABOUR AND INDUSTRY ACT 1958.

At the Executive Council Chamber, Melbourne, the twelfth day of September, 1967.

PRESENT:

His Excellency the Governor of Victoria.  
Mr. Chandler | Sir William McDonald.  
Mr. Borthwick

INDUSTRIAL APPEALS COURT.—APPOINTMENT OF DEPUTY MEMBER TO REPRESENT EMPLOYERS.

IN pursuance of the powers conferred by the *Labour and Industry Act 1958*, His Excellency the Governor of the State of Victoria, by and with the advice of the Executive Council thereof, doth by this Order appoint for a term of five years, as on and from the 28th September, 1967—

IAN OSWALD SPICER  
to be a Deputy Member of the Industrial Appeals Court, to represent employers.

And the Honorable John Frederick Rossiter, Her Majesty's Minister of Labour and Industry for the State of Victoria, shall give the necessary directions herein accordingly.

J. ROSSITER,  
Acting Clerk of the Executive Council.

LOCAL GOVERNMENT DEPARTMENT.

At the Executive Council Chamber, Melbourne, the twelfth day of September, 1967.

PRESENT:

His Excellency the Governor of Victoria.  
Mr. Chandler | Sir William McDonald.  
Mr. Borthwick

ROAD DISCONTINUED.—CITY OF MELBOURNE.

WHEREAS it is provided in Section 528 (2) of the *Local Government Act 1958*, that where a road (whether or not a public highway but not being a road set out on land of the Crown) or any part thereof is not required for public use the Governor-in-Council on the request of

the Council of the municipality in which such road is situated made not less than one month after publishing in a newspaper generally circulating in the district and posting to the registered proprietor (if any) of the land and any person known to have an interest in the land notice of intention to make such a request may by Order published in the *Government Gazette* direct that such road or part shall be discontinued and thereupon such road or part shall be discontinued accordingly:

AND WHEREAS the Council of the City of Melbourne has requested that the Governor-in-Council direct that a right-of-way, off Hotham Street, East Melbourne, be discontinued and not less than one month previously has published in a newspaper generally circulating in the district and posted to the registered proprietor of the land in the road and to all persons known to have an interest in the said land notice of intention to make such request.

NOW THEREFORE His Excellency the Governor of the State of Victoria, by and with the advice of the Executive Council thereof, hereby directs:

- (a) that the said road, which is shown by hachure on the diagram hereunder, shall be discontinued;
- (b) that notwithstanding such discontinuance the Melbourne and Metropolitan Board of Works shall continue to have and possess the same right title power authority or interest in or in relation to the whole of the land shown hatched on the said diagram as it had or possessed prior to such discontinuance with respect to or in connection with any drains or pipes laid or erected in on or over such land for the purposes of drainage or sewerage;
- (c) that notwithstanding such discontinuance the Postmaster-General's Department shall continue to have and possess the same right title power authority or interest in or in relation to the whole of the land shown hatched on the said diagram as it had or possessed prior to such discontinuance with respect to any wires or cables laid or erected in on or over such land for the purposes of telegraph or telephone;
- (d) that, subject to any such right title power authority or interest, the land in the said road may be sold by the Council of the City of Melbourne by agreement.

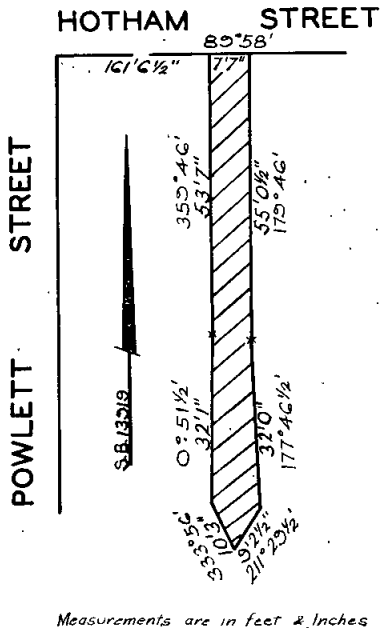

And the Honorable Rupert James Hamer, Her Majesty's Minister for Local Government for the State of Victoria, shall give the necessary directions herein accordingly.

J. ROSSITER,  
Acting Clerk of the Executive Council.

COUNTRY ROADS BOARD.

At the Executive Council Chamber, Melbourne, the twelfth day of September, 1967.

PRESENT:

His Excellency the Governor of Victoria.  
Mr. Chandler | Sir William McDonald.  
Mr. Borthwick

ORDER CONFIRMING RESOLUTIONS OF THE COUNTRY ROADS BOARD.

HIS Excellency the Governor of the State of Victoria, by and with the advice of the Executive Council thereof, doth hereby, in pursuance of the provisions of the *Country Roads Act 1958*, confirm the resolutions of the Country Roads Board, the dates whereof and the terms of which are scheduled hereunder:—

SCHEDULE.

Main road

Resolution dated the Fourth day of September, One Thousand Nine Hundred and Sixty-seven, made pursuant to Sections 21 and 58 of the *Country Roads Act 1958*, declaring the deviation from the Cobden-Port Campbell Road in the Shire of Heytesbury as indicated by diagonal hatching on the Plan numbered G.P. 10592 hereunder to be part of a main road within the meaning and for the purposes of the *Country Roads Act 1958*, and also declaring that such deviation shall be in lieu of the existing road or part thereof indicated by cross hatching on the said plan and that such part of the said existing road shall be discontinued.

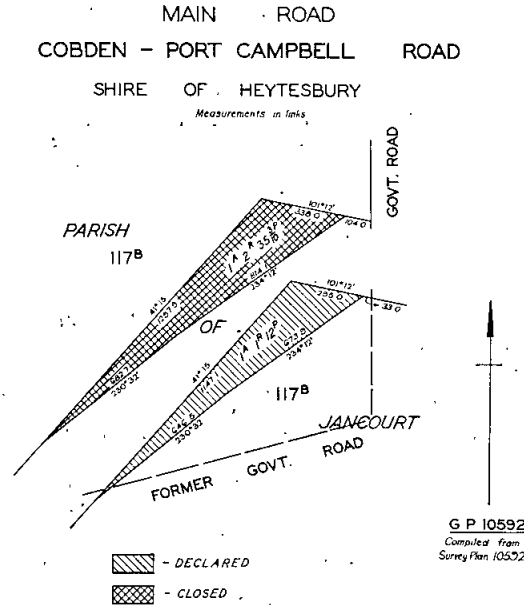

And the Honorable Murray Victor Porter, Her Majesty's Minister of Public Works for the State of Victoria, shall give the necessary directions herein accordingly.

J. ROSSITER,  
Acting Clerk of the Executive Council.

COUNTRY ROADS BOARD.

At the Executive Council Chamber, Melbourne, the twelfth day of September, 1967.

PRESENT:

His Excellency the Governor of Victoria.  
Mr. Chandler | Sir William McDonald.  
Mr. Borthwick

ORDER APPROVING OF LAND BEING ACQUIRED AND ROADS, DEVIATIONS OR WIDENINGS BEING MADE.

HIS Excellency the Governor of the State of Victoria, by and with the advice of the Executive Council thereof, being satisfied that there are funds legally



available for acquiring the land, doth hereby approve the acquiring of the land described in the schedule hereunder and the making of new roads and deviations from and widenings of existing roads referred to in the said schedule.

SCHEDULE.

State highways

The land shown hatched on Plan numbered G.P.11034 hereunder required for the widening of the Princes Highway in the Shire of Orbost and making of the widening thereon.

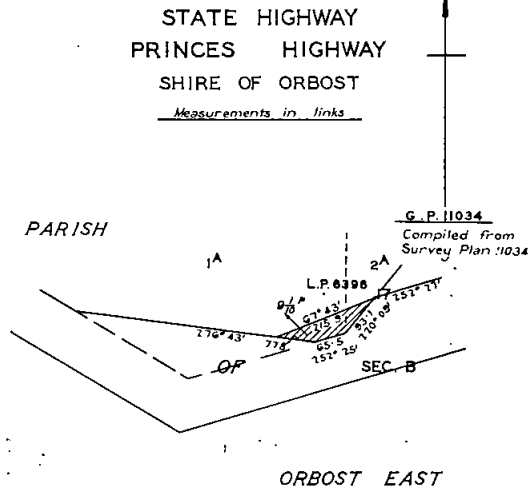

The land shown hatched on Plan numbered G.P.11008 hereunder required for the widening of the Princes Highway in the Shire of Rosedale and making of the widening thereon.

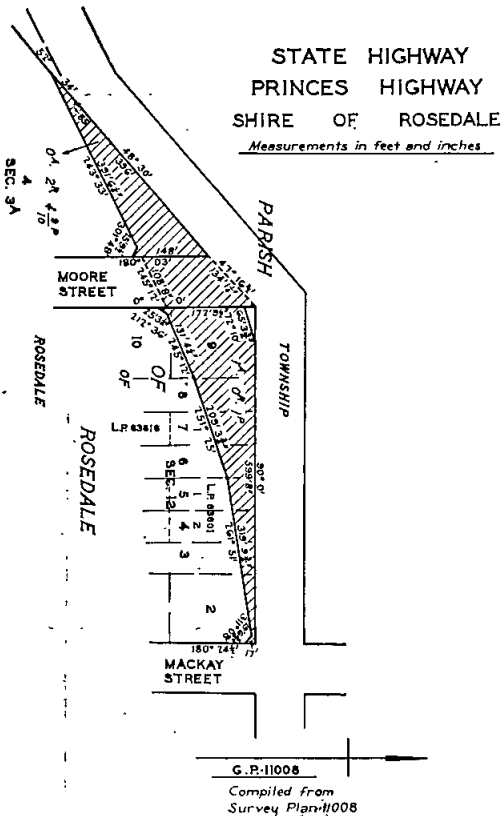

Main roads

The land shown hatched on Plan numbered G.P.11018 hereunder required for the widening of the Corangamite Lake Road in the Shire of Colac and making of the widening thereon.

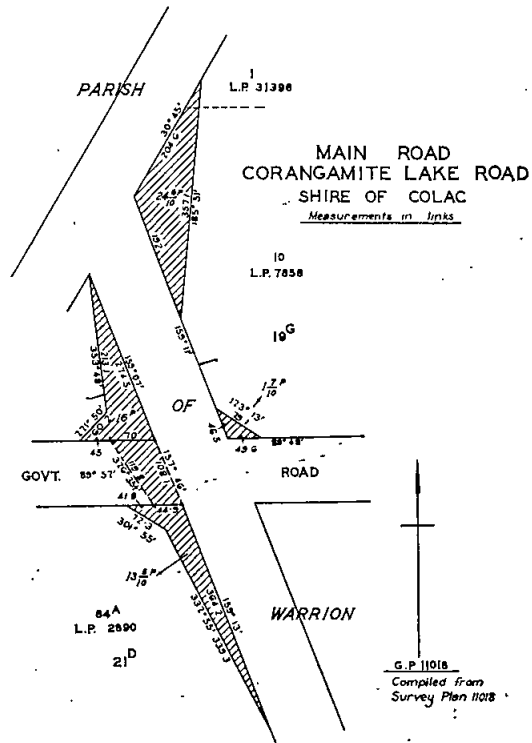

The land shown hatched on Plans numbered G.P.10973 and G.P.10974 hereunder required for the deviation of the Trafalgar-Thorpdale Road in the Shire of Narracan and making of the deviation thereon.

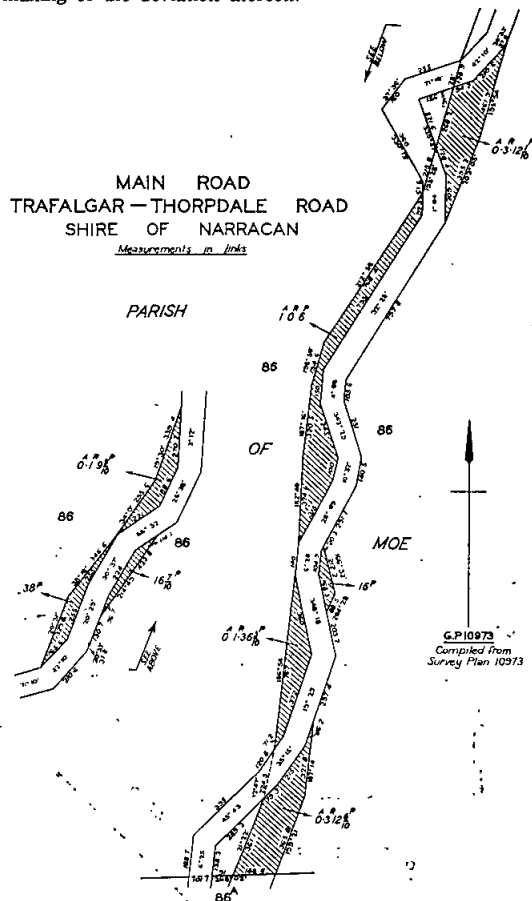

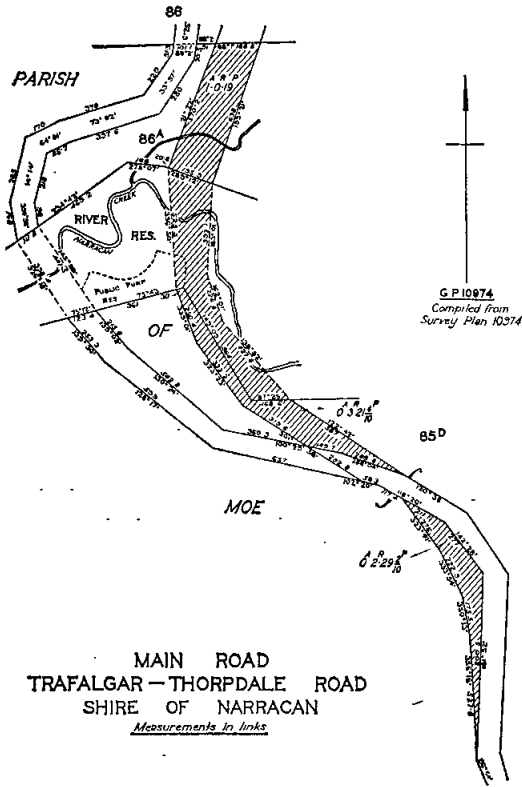

Township of Girgarre, Parish of Kyabram, County of Rodney, being the roads indicated by hachure on plan hereunder.—(G.175A<sup>4</sup>) (W.87076).

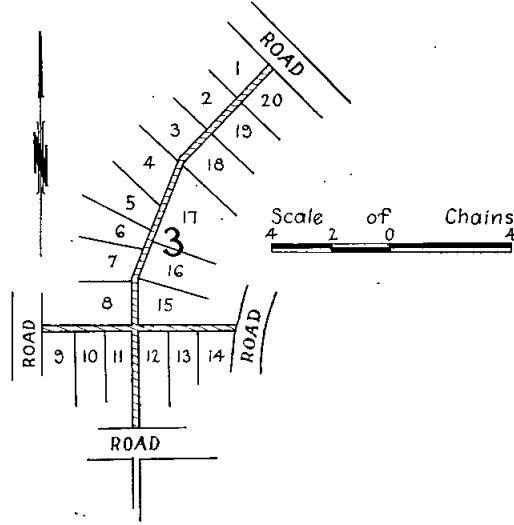

Township of Dartmoor, Parish of Dartmoor, County of Normanby, being the road indicated by hatching on plan hereunder.—(D.32<sup>(9)</sup>) (J.32180).

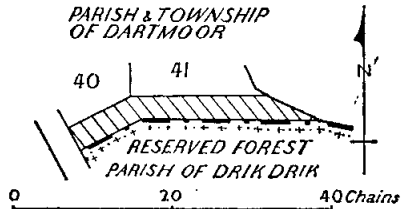

And the Honorable Murray Victor Porter, Her Majesty's Minister of Public Works for the State of Victoria, shall give the necessary directions herein accordingly.

J. ROSSITER,  
Acting Clerk of the Executive Council.

DEPARTMENT OF CROWN LANDS AND SURVEY.

At the Executive Council Chamber, Melbourne, the twelfth day of September, 1967.

PRESENT:

His Excellency the Governor of Victoria.  
Mr. Chandler | Sir William McDonald.  
Mr. Borthwick |

UNUSED ROADS CLOSED.

HIS Excellency the Governor of the State of Victoria, by and with the advice of the Executive Council thereof, doth hereby direct that, in pursuance of the provisions of section 349 of the Land Act 1958, the unused roads referred to hereunder be closed, viz:—

Township of Wonwondah North, Parish of Wonwondah, County of Borung, being the roads indicated by hatching on plan hereunder.—(W.327<sup>(9)</sup>) (Rs.6059).

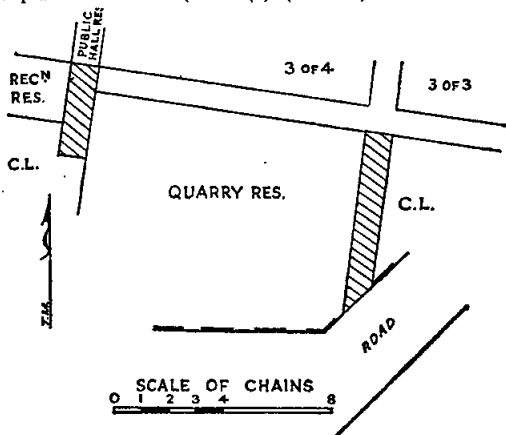

At Bendigo, Parish of Sandhurst, County of Bendigo, being the road indicated by hatching on plan hereunder.—(S.372<sup>(118)</sup>) (W.88573).

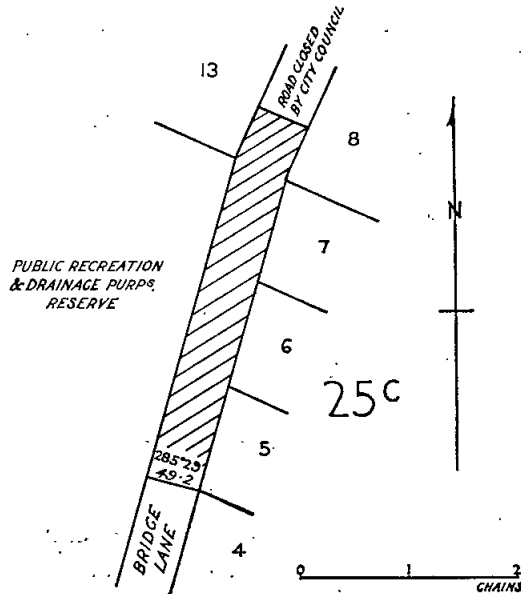

Parish of Haddon, County of Grenville, being the roads indicated by hatching on plan hereunder.—(H.2<sup>(3)</sup>) (J.31594).

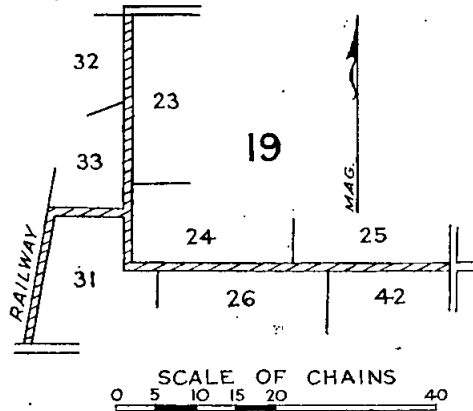

Parish of Warrenheip, County of Grant, being the road indicated by hatching on plan hereunder.—(W.8<sup>(4)</sup>) (J.22061).

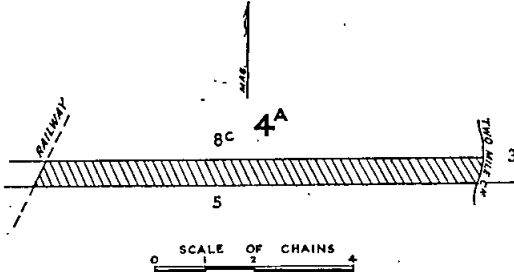

Parish of Glencoe South, County of Buln Buln, being the road between allotments 4, 6B, 6A, 7A and 10, 9, 7, section A.—(G.176<sup>(6)</sup>) (H.O.30963).

Parish of Boho, County of Delatite, being the road indicated by hatching on plan hereunder.—(B.431<sup>(8)</sup>) (H.O.23227).

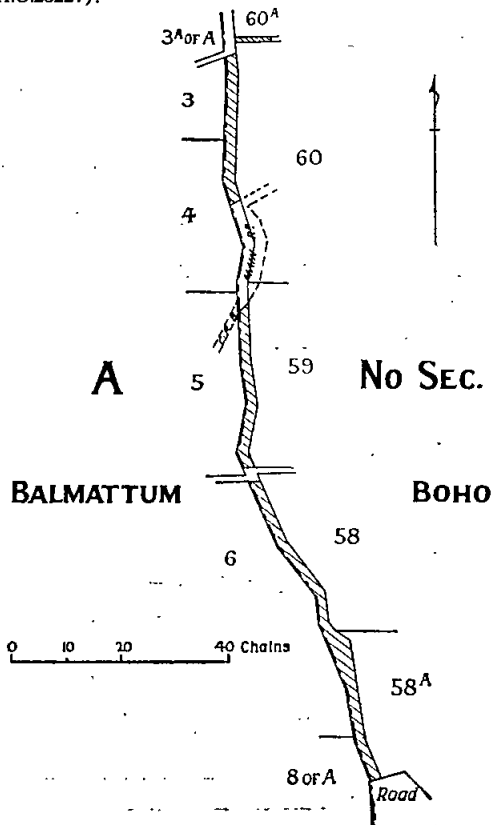

Parish of Bullarook, County of Talbot, being the road between allotments 31 and 32, section A.—(B.541<sup>(5)</sup>) (J.31973).

Parish of Raglan, County of Ripon, being the road between allotments 10F and 11B, section A.—(R.3<sup>(14)</sup>) (J.31948).

Parish of Dimboola, County of Borung, being the road indicated by hatching on plan hereunder.—(D.150<sup>(10)</sup>) (M.45531).

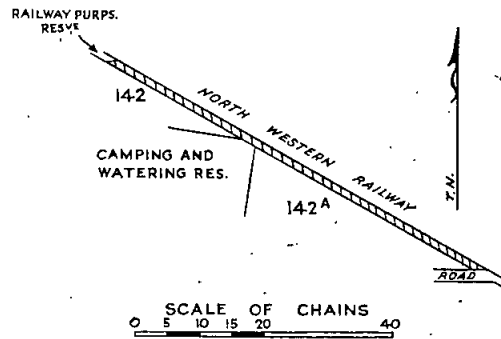

Parish of Gelantipy West, County of Tambo, being the road indicated by hatching on plan hereunder.—(G.223<sup>(2)</sup>) (H.O.30484).

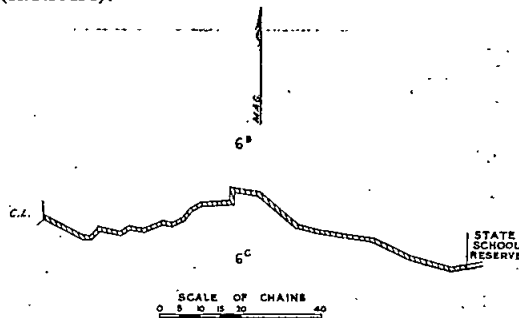

Township of Lexton, Parish of Lexton, County of Talbot, being the road indicated by hatching on plan hereunder.—(L.49<sup>(3)</sup>) (J.32126).

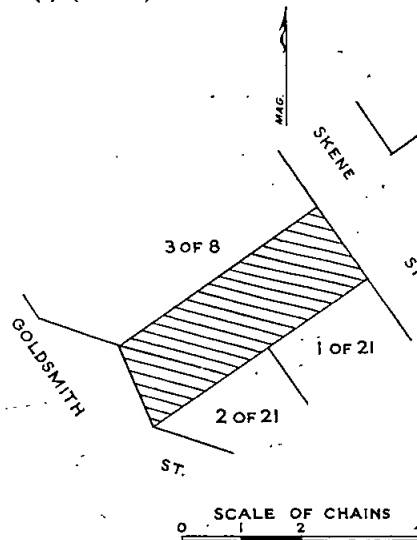

Township of Carlruhe, Parish of Carlruhe, County of Dalhousie, being the road between sections 4 and 5.—(C.139<sup>(4)</sup>) (W.87916).

Township of Newmerella, Parish of Newmerella, County of Tambo, being the road between allotment 17, section B, Township of Newmerella and allotment 1, section D, Parish of Newmerella.—(N.136<sup>(5)</sup>) (H.O.31157).

Township of Marysville, Parish of Steavenson, County of Anglesey, being the road indicated by hatching on plan hereunder.—(M.431(3) (C.99772).

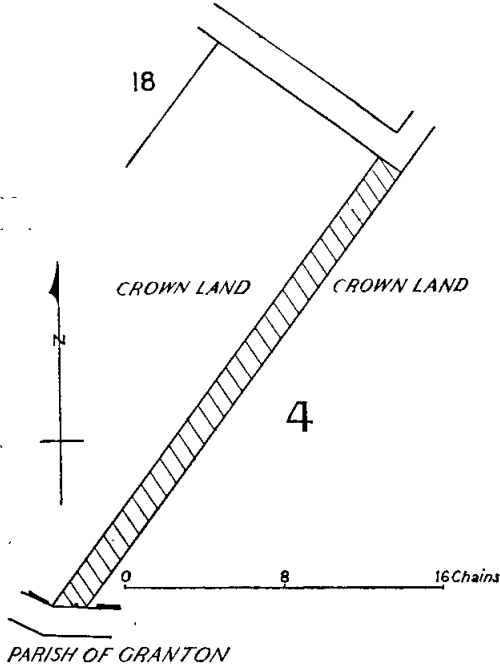

And the Honorable Sir William John Farquhar McDonald, Her Majesty's Minister of Lands for the State of Victoria, shall give the necessary directions herein accordingly.

J. ROSSITER,  
Acting Clerk of the Executive Council.

DEPARTMENT OF CROWN LANDS AND SURVEY.

At the Executive Council Chamber, Melbourne, the twelfth day of September, 1967.

PRESENT:

His Excellency the Governor of Victoria.  
Mr. Chandler | Sir William McDonald.  
Mr. Borthwick

LAND TEMPORARILY RESERVED AS A SITE.

HIS Excellency the Governor of the State of Victoria, by and with the advice of the Executive Council thereof, doth hereby, in pursuance of section 14 of the Land Act 1958, reserve temporarily from sale, from being leased and from having a licence granted in respect thereof, and also except from occupation for mining purposes under any miner's right, the land hereinafter described:—

BUNINYONG (MOUNT HELEN).—Site for Public Recreation, 1 acre 3 perches, Parish of Buninyong, County of Grant, as indicated by hatching on plan hereunder.—(B.489(10) (Rs.8847).

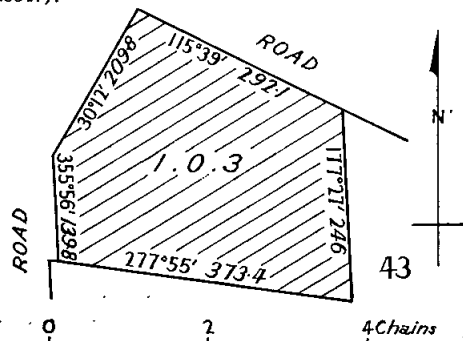

MANNIBADAR.—Site for Public Recreation, 10 acres 3 rods 39 perches, Parish of Mannibadar, County of Grenville, as indicated by hatching on plan hereunder.—(M.90(2) (Rs.8609).

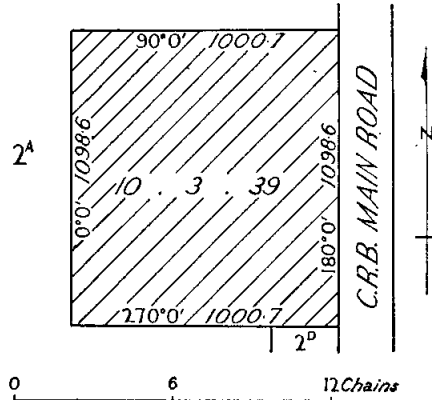

COLAC.—Site for Public purposes (Municipal purposes), 27 perches, Township of Colac, Parish of Colac, County of Polwarth, as indicated by hatching on plan hereunder.—(C.279(3) (Rs.8872).

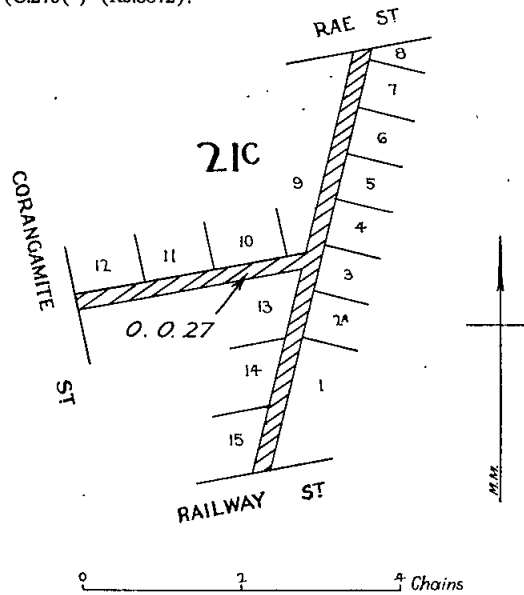

NHILL.—Site for Public purposes (Municipal purposes), 2 rods 8 perches, Township of Nhill, Parish of Balrootan, County of Lowan, as indicated by hatching on plan hereunder.—(N.102(4) (Rs.8838).

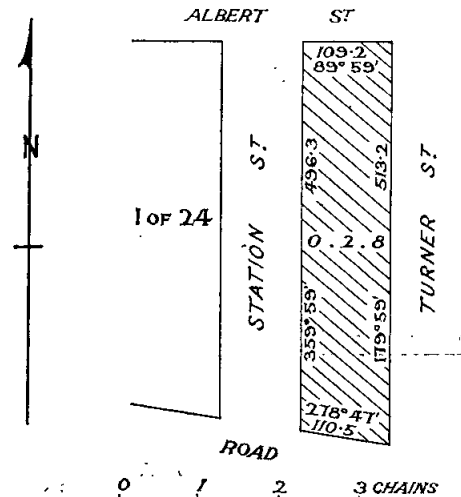

WILLENABRINA.—Site for State School purposes, 2 acres 1 rood 9 perches, Township of Willenabrina, Parish of Willenabrina, County of Borung, as indicated by hatching on plan hereunder.—(W.352<sup>(5)</sup>) (Rs.8823).

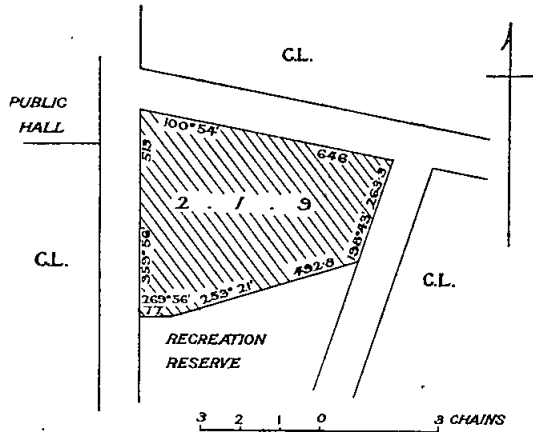

WARANGA.—Site for Water Supply purposes, 3 roods 14 perches, Parish of Waranga, County of Rodney, as indicated by hatching on plan hereunder.—(W.37<sup>(4)</sup>) (C.78574).

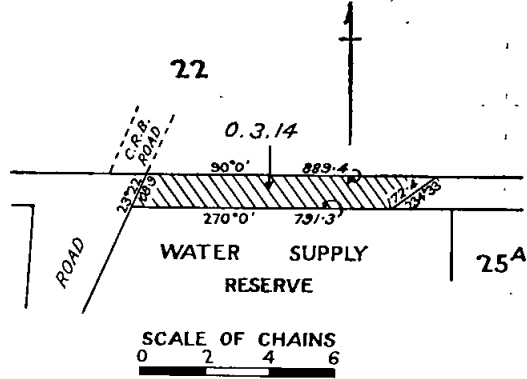

STAWELL.—Site for Public Recreation, 2 roods 12 perches, Parish of Stawell, County of Borung, as indicated by hatching on plan hereunder.—(S.329<sup>(17)</sup>) (Rs.2088).

WILLENABRINA.—Site for Public Recreation, 1 acre 1 rood 14 perches, Township of Willenabrina, Parish of Willenabrina, County of Borung, as indicated by hatching on plan hereunder.—(W.352<sup>(5)</sup>) (Rs.8824).

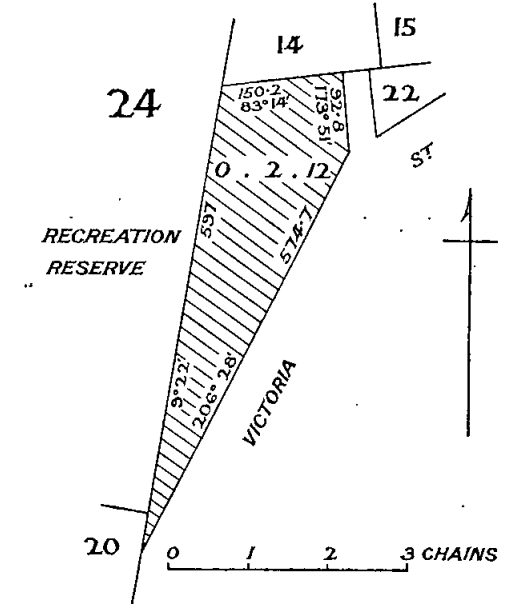
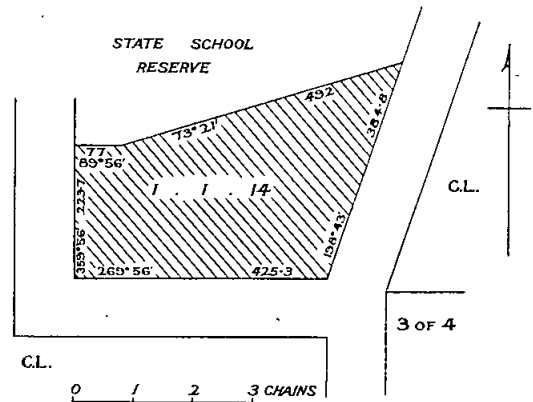

MARYBOROUGH.—Site for Public Purposes (Municipal purposes), 1 rood 6 perches, Township of Maryborough, Parish of Maryborough, County of Talbot, as indicated by hatching on plan hereunder.—(M.66<sup>(15)</sup>) (Rs.8870).

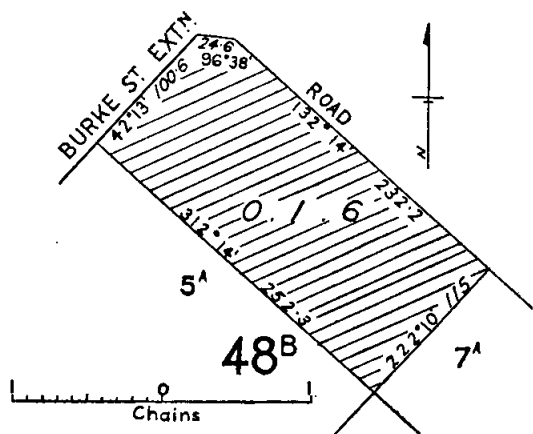

YANGERY.—Site for the purposes of the Fisheries and Wildlife Department, 3 acres 2 roods 15 perches, Parish of Yangery, County of Villiers, as indicated by hatching on plan hereunder.—(Y.53<sup>(4)</sup>) (Rs.2687).

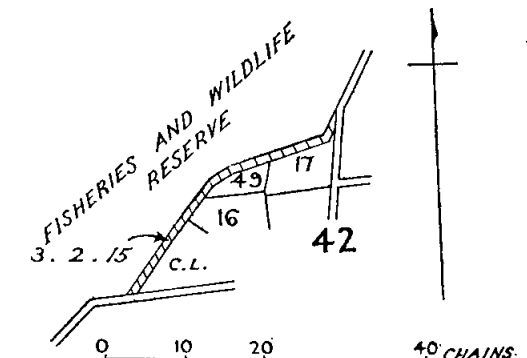

MYRTLEFORD.—Site for Aboriginal Inhabitants, 22 perches, Parish of Myrtleford, County of Bogong, as indicated by hatching on plan hereunder.—(M.295<sup>(10)</sup>) (Rs.8878).

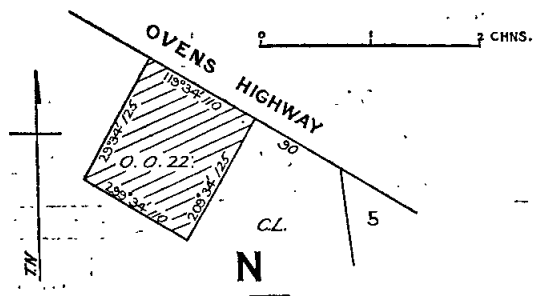

And the Honorable Sir William John Farquhar McDonald, Her Majesty's Minister of Lands for the State of Victoria, shall give the necessary directions herein accordingly.

J. ROSSITER,  
Acting Clerk of the Executive Council.

DEPARTMENT OF CROWN LANDS AND SURVEY.

At the Executive Council Chamber, Melbourne, the twelfth day of September, 1967.

PRESENT:  
His Excellency the Governor of Victoria.  
Mr. Chandler | Sir William McDonald.  
Mr. Borthwick |

REVOCATION OF TEMPORARY RESERVATION OF LAND BY ORDER IN COUNCIL.

HIS Excellency the Governor of the State of Victoria, by and with the advice of the Executive Council thereof, doth hereby, in pursuance of the provisions of the Land Act 1958, revoke the temporary reservation of land by Order in Council hereinafter referred to, viz.:

BALMORAL.—Order in Council of 28th October, 1872 of 2 acres of land in the Township of Balmoral as a site for Police purposes so far only as regards the portion thereof comprised within the boundaries published in the Government Gazette of 9th August, 1967 and containing 27 perches, more or less.—(Rs.6649.)

BUNINYONG.—Order in Council of 10th May, 1869 of 2 roods of land in the Parish of Buninyong as a site for Common School.—(Rs.1471.)

BUNINYONG.—Order in Council of 30th June, 1959 of 2 acres 10 perches, more or less, of land in the Parish of Buninyong as a site for State School Purposes so far only as regards the portion thereof comprised within the boundaries published in the Government Gazette of 19th July, 1967 and containing 1 rood.—(Rs.1471.)

HEALESVILLE.—Order in Council of 31st July, 1945 of 9 acres 3 roods 12 perches of land in the Township of Healesville as a site for State School purposes and revoked as to part by Order in Council dated the 25th October, 1955.—(Rs.5683.)

KERRIE.—Order in Council of 8th November, 1886 of 1 acre 1 rood 15 4/10 perches of land in the Parish of Kerrie as a site for Police Purposes save and except the portion thereof comprised within the boundaries published in the Government Gazette of 5th July, 1967, and containing 1 acre 1 rood 1 perch.—(Rs.2342.)

KERRIE.—Order in Council of 31st August, 1863 of 5 acres 5 perches of land in the Parish of Kerrie as a site for Public Purposes and revoked as to part by Order in Council of the 17th October, 1923.—(Rs.2342.)

MANANGATANG.—Order in Council of 20th October, 1914 of 3 acres 3 roods 31 3/10 perches of land in the Township of Manangatang as a site for a State School and revoked as to part by Order in Council of 9th September, 1947, so far only as regards the portion thereof comprised within the boundaries published in the Government Gazette of 19th July, 1967, and containing 17 perches, more or less.—(Rs.211.)

MANANGATANG.—Order in Council of 14th October, 1947 of 1 acre 1 rood 17 5/10 perches of land in the Township of Manangatang as a site for Public Recreation.—(Rs.6008.)

MARAMINGO.—Order in Council of 17th February, 1914 of 10 acres of land in the Parish of Maramingo as a site for Camping purposes and revoked as to part by Order in Council of 16th December, 1941.—(Rs.1481.)

NARREE WORRAN.—Order in Council of 27th April, 1868 of 3 roods 13 perches of land in the Parish of Narree Worrان as a site for Church of England purposes so far only as regards the portion thereof comprised within the boundaries published in the Government Gazette of 9th August, 1967, and containing 3 perches.—(Rs.6603.)

NARREE WORRAN.—Order in Council of 4th December, 1865 of 1 acre of land in the Parish of Narree Worrان as a site for Wesleyan Church purposes so far only as regards the portion thereof comprised within the boundaries published in the Government Gazette of 9th August, 1967 and containing 3 perches.—(C.56579.)

SOUTH MELBOURNE.—Order in Council of 4th September, 1963 of 1 acre 16 perches of land in the City of South Melbourne as a site for Hospital purposes so far only as regards the portion thereof comprised within the boundaries published in the Government Gazette of 9th August, 1967 and containing 1 rood 12 perches.—(Rs.8236.)

SWAN HILL.—Order in Council of 14th February, 1939 of 3 acres 25 5/10 perches of land in the Township of Swan Hill as a site for Public purposes (Children's Playground) and revoked as to part by Act No. 5810.—(Rs.4914.)

WIRIDJIL.—Order in Council of 13th August, 1946 of 2 acres 20 perches of land in the Parish of Wiridjil as a site for State School purposes.—(Rs.5849.)

And the Honorable Sir William John Farquhar McDonald, Her Majesty's Minister of Lands for the State of Victoria, shall give the necessary directions herein accordingly.

J. ROSSITER,  
Acting Clerk of the Executive Council.

Water Act 1958.

STATE RIVERS AND WATER SUPPLY COMMISSION.

At the Executive Council Chamber, Melbourne, the nineteenth day of September, 1967.

PRESENT:  
His Excellency the Governor of Victoria.  
Mr. Porter | Mr. Meagher  
Mr. Hamer | Mr. Balfour.

GOULBURN-MURRAY IRRIGATION DISTRICT—PORTIONS EXCISED.—RODNEY IRRIGATION AREA—BOUNDARIES VARIED.

UNDER the powers conferred by the Water Act 1958 and all other powers enabling him in that behalf, His Excellency the Governor of the State of Victoria, with the advice of the Executive Council of the said State, on the recommendation of the State Rivers and Water Supply Commission, doth hereby declare, order, and direct as follows:—

That there shall be excised from the Goulburn-Murray Irrigation District those portions of the same set out and described in the Schedule hereto and that the boundaries of the Rodney Irrigation Area be varied to excise from the said Area the aforesaid portions, which portions shall be deemed to be excised from the said Irrigation District and Irrigation Area as from the 30th day of September, 1967.

SCHEDULE.

PORTION 1.—Commencing at the south-eastern angle of the land described in certificate of title volume 4848 folio 438 being part of allotment 32, parish of Kyabram East, county of Rodney; thence westerly by the southern boundaries of the land described in that title and of the land described in Certificate of Title volume 4913 folio 402 to the eastern boundary of Kyabram-Tongala-road; thence northerly by that road boundary to a point distant 9 chains southerly from the southern boundary of Allan-street; thence easterly by a line parallel to Allan-street to the eastern boundary of the land described in aforesaid certificate of title volume 4848 folio 438; thence southerly by the last-mentioned boundary to the point of commencement.

PORTION 2.—Commencing at the south-western angle of Lot 2 on lodged plan of subdivision No. 73735 being part of allotment 32, parish of Kyabram East, County of Rodney; thence northerly by the western boundary of that lot to a point 9 chains southerly from the southern boundary of Allan-street; thence easterly by a line parallel to Allan-street to a point in the eastern boundary of Julia-street; thence southerly by the last-mentioned street boundary to a point in line with the southern boundary of said lot 2; thence easterly by a line and the last-mentioned boundary to the point of commencement.

The lands set out and described in the foregoing Schedule are shown on a plan approved by the Governor in Council, and deposited in the Office of the State Rivers and Water Supply Commission, Melbourne.—(Corr. No. 66/1260.)

And the Honorable William Archibald Borthwick, Her Majesty's Minister of Water Supply for the State of Victoria, shall give the necessary directions herein accordingly.

J. ROSSITER,  
Clerk of the Executive Council.

Water Act 1958.

STATE RIVER AND WATER SUPPLY COMMISSION.

At the Executive Council Chamber, Melbourne, the nineteenth day of September, 1967.

PRESENT:

His Excellency the Governor of Victoria.  
Mr. Porter | Mr. Meagher  
Mr. Hamer | Mr. Balfour.

KYABRAM WATER SUPPLY DISTRICT—LOCAL GOVERNING BODY, KYABRAM BOROUGH COUNCIL.—AREA OF DISTRICT INCREASED.

UNDER the powers conferred by the Water Act 1958 and all other powers enabling him in that behalf, His Excellency the Governor of the State of Victoria, with the advice of the Executive Council of the said State, doth hereby declare, order, and direct as follows:—

That the area of the Kyabram Water Supply District, under the control of the Kyabram Borough Council, as a local governing body, be increased by adding thereto the lands set out and described in the Schedule hereto, and as on and from the 1st day of October, 1967 the area of such District shall be deemed to be so increased.

SCHEDULE.

1. Commencing at the south-eastern angle of the land described in Certificate of Title volume 4848 folio 438 being part of allotment 32, parish of Kyabram East, county of Rodney; thence westerly by the southern boundaries of the land described in that title and of the land described in certificate of title volume 4913 folio 402 and a line in continuation thereof to the western boundary of Kyabram-Tongala-road; thence northerly by that road boundary to a point in line with the southern boundary of lot 43 on lodged plan of subdivision No. 4466 being part of allotment 3 said parish and county; thence easterly by a line to the south-western angle of said lot 43; thence southerly by the eastern boundary of Kyabram-Tongala-road to a point in the western boundary of the land described in certificate of title volume 3895 folio 901 being part of said allotment 32 distant 9 chains southerly from the southern boundary of Allan-street; thence easterly by a line parallel to Allan-street to the eastern boundary of the land described in aforesaid certificate of title volume 4848, folio 438; thence southerly by the last-mentioned boundary to the point of commencement.

2. Commencing at the south-western angle of lot 2 on lodged plan of subdivision No. 73735 being part of allotment 32, parish of Kyabram East, County of Rodney; thence northerly by the western boundary of that lot to a point 9 chains southerly from the southern boundary of Allan-street; thence easterly by a line parallel to Allan-street to the eastern boundary of Julia-street; thence southerly by the last-mentioned street boundary to a point in line with the southern boundary of said lot 2; thence easterly by a line and the last-mentioned boundary to the point of commencement.

The lands set out and described in the foregoing Schedule are shown on a plan approved by the Governor in Council, and deposited in the Office of the State Rivers and Water Supply Commission, Melbourne.—(Corr. No. 66/1260.)

And the Honorable William Archibald Borthwick, Her Majesty's Minister of Water Supply for the State of Victoria, shall give the necessary directions herein accordingly.

J. ROSSITER,  
Clerk of the Executive Council.

Water Act 1958.

STATE RIVERS AND WATER SUPPLY COMMISSION.

At the Executive Council Chamber, Melbourne, the nineteenth day of September, 1967.

PRESENT:

His Excellency the Governor of Victoria.  
Mr. Porter | Mr. Meagher  
Mr. Hamer | Mr. Balfour.

MURRABIT URBAN DISTRICT—AREA OF DISTRICT DIMINISHED.

UNDER the powers conferred by the Water Act 1958 and all other powers enabling him in that behalf, His Excellency the Governor of the State of Victoria, with the advice of the Executive Council of the said State, on the recommendation of the State Rivers and Water Supply Commission, doth hereby declare, order, and direct as follows:—

That the area of the Murrabit Urban District be diminished by excising therefrom the portion of the same set out and described in the Schedule hereto, which portion, as from the 30th day of September, 1967, shall be deemed to be excised accordingly.

SCHEDULE.

The south-eastern part of allotment 86, parish of Murrabit West, county of Gunbower (being that portion of the said allotment within the Murrabit Urban District prior to the date of this Order).

The portion set out and described in the foregoing Schedule is shown on a plan approved by the Governor in Council, and deposited in the office of the State Rivers and Water Supply Commission, Melbourne.—(Corr. No. 67/1813.)

And the Honorable William Archibald Borthwick, Her Majesty's Minister of Water Supply for the State of Victoria, shall give the necessary directions herein accordingly.

J. ROSSITER,  
Clerk of the Executive Council.

FRANKSTON SEWERAGE AUTHORITY.

At the Executive Council Chamber, Melbourne, the nineteenth day of September, 1967.

PRESENT:

His Excellency the Governor of Victoria.  
Mr. Porter | Mr. Meagher  
Mr. Hamer | Mr. Balfour.

CONSENT TO BORROWING \$100,000.

UNDER the powers conferred by the Sewerage Districts Act and all other powers enabling him in that behalf, His Excellency the Governor of the State of Victoria, by and with the advice of the Executive Council of the said State, doth hereby consent to the Frankston Sewerage Authority borrowing by mortgage of the General Fund the sum of One hundred thousand dollars (\$100,000) to meet the cost of sewerage works as set forth in the detailed statement bearing date 14th September, 1967.

And the Honorable William Archibald Borthwick, Her Majesty's Minister of Water Supply for the State of Victoria, shall give the necessary directions herein accordingly.

J. ROSSITER,  
Clerk of the Executive Council.

## WODONGA SEWERAGE AUTHORITY.

At the Executive Council Chamber, Melbourne, the nineteenth day of September, 1967.

PRESENT:

His Excellency the Governor of Victoria.	
Mr. Porter	Mr. Meagher
Mr. Hamer	Mr. Balfour.

## CONSENT TO BORROWING \$200,000.

UNDER the powers conferred by the Sewerage Districts Act and all other powers enabling him in that behalf, His Excellency the Governor of the State of Victoria, by and with the advice of the Executive Council of the said State, doth hereby consent to the Wodonga Sewerage Authority borrowing by mortgage of the General Fund the sum of Two hundred thousand dollars (\$200,000) to meet the cost of sewerage works as set forth in the detailed statement bearing date 14th September, 1967.

And the Honorable William Archibald Borthwick, Her Majesty's Minister of Water Supply for the State of Victoria, shall give the necessary directions herein accordingly.

J. ROSSITER,  
Clerk of the Executive Council.

## SEYMOUR SEWERAGE AUTHORITY.

At the Executive Council Chamber, Melbourne, the nineteenth day of September, 1967.

PRESENT:

His Excellency the Governor of Victoria.	
Mr. Porter	Mr. Meagher
Mr. Hamer	Mr. Balfour.

## CONSENT TO BORROWING \$250,000.

UNDER the powers conferred by the Sewerage Districts Act and all other powers enabling him in that behalf, His Excellency the Governor of the State of Victoria, by and with the advice of the Executive Council of the said State, doth hereby consent to the Seymour Sewerage Authority borrowing by mortgage of the General Fund the sum of Two hundred and fifty thousand dollars (\$250,000) in one amount of Fifty thousand dollars (\$50,000) and two amounts each of One hundred thousand dollars (\$100,000) to meet the cost of sewerage works as set forth in the detailed statement bearing date the 14th September, 1967.

And the Honorable William Archibald Borthwick, Her Majesty's Minister of Water Supply for the State of Victoria, shall give the necessary directions herein accordingly.

J. ROSSITER,  
Clerk of the Executive Council.

## ORBOST SEWERAGE AUTHORITY.

At the Executive Council Chamber, Melbourne, the nineteenth day of September, 1967.

PRESENT:

His Excellency the Governor of Victoria.	
Mr. Porter	Mr. Meagher
Mr. Hamer	Mr. Balfour.

## AMENDMENT OF ORDER.

UNDER the powers conferred by the Sewerage Districts Act and all other powers enabling him in that behalf, His Excellency the Governor of the State of Victoria, by and with the advice of the Executive Council of the said State, doth hereby amend as follows the Order in Council proclaiming the Sewerage District and constituting the Orbost Sewerage Authority made on 29th March, 1951, as amended by Orders in Council made on 17th December, 1963, and 16th March, 1966, and published in the *Government Gazettes* dated 4th April, 1951, 18th December, 1963 and 23rd March, 1966, respectively.

In Clause (a) for the expression "Six hundred thousand dollars (\$600,000)" there shall be substituted the expression "Seven hundred thousand dollars (\$700,000)".

And the Honorable William Archibald Borthwick, Her Majesty's Minister of Water Supply for the State of Victoria, shall give the necessary directions herein accordingly.

J. ROSSITER,  
Clerk of the Executive Council.

## BENDIGO SEWERAGE AUTHORITY.

At the Executive Council Chamber, Melbourne, the nineteenth day of September, 1967.

PRESENT:

His Excellency the Governor of Victoria.	
Mr. Porter	Mr. Meagher
Mr. Hamer	Mr. Balfour.

## CONSENT TO BORROWING \$100,000.

UNDER the powers conferred by the Sewerage Districts Act and all other powers enabling him in that behalf, His Excellency the Governor of the State of Victoria, by and with the advice of the Executive Council of the said State, doth hereby consent to the Bendigo Sewerage Authority borrowing at interest, by mortgage of the General Fund, the sum of One hundred thousand dollars (\$100,000) to meet the cost of sewerage works as set forth in the detailed statement bearing date the 14th September, 1967.

And the Honorable William Archibald Borthwick, Her Majesty's Minister of Water Supply for the State of Victoria, shall give the necessary directions herein accordingly.

J. ROSSITER,  
Clerk of the Executive Council.

## CHELSEA SEWERAGE AUTHORITY.

At the Executive Council Chamber, Melbourne, the nineteenth day of September, 1967.

PRESENT:

His Excellency the Governor of Victoria.	
Mr. Porter	Mr. Meagher
Mr. Hamer	Mr. Balfour.

## CONSENT TO BORROWING \$100,000.

UNDER the powers conferred by the Sewerage District Act and all other powers enabling him in that behalf, His Excellency the Governor of the State of Victoria, by and with the advice of the Executive Council of the said State, doth hereby consent to the Chelsea Sewerage Authority borrowing at interest, by mortgage of the General Fund, the sum of One hundred thousand dollars (\$100,000) to meet the cost of sewerage works as set forth in the detailed statement bearing date the 14th September, 1967.

And the Honorable William Archibald Borthwick, Her Majesty's Minister of Water Supply for the State of Victoria, shall give the necessary directions herein accordingly.

J. ROSSITER,  
Clerk of the Executive Council.

## DANDENONG SEWERAGE AUTHORITY.

At the Executive Council Chamber, Melbourne, the nineteenth day of September, 1967.

PRESENT:

His Excellency the Governor of Victoria.	
Mr. Porter	Mr. Meagher
Mr. Hamer	Mr. Balfour.

## CONSENT TO BORROWING \$100,000.

UNDER the powers conferred by the Sewerage Districts Act and all other powers enabling him in that behalf, His Excellency the Governor of the State of Victoria, by and with the advice of the Executive Council of the said State, doth hereby consent to the Dandenong Sewerage Authority borrowing at interest, by mortgage of the General Fund, the sum of One hundred thousand dollars (\$100,000) to meet the cost of sewerage works as set forth in the detailed statement bearing date the 14th September, 1967.

And the Honorable William Archibald Borthwick, Her Majesty's Minister of Water Supply for the State of Victoria, shall give the necessary directions herein accordingly.

J. ROSSITER,  
Clerk of the Executive Council.



COUNTRY ROADS BOARD.

At the Executive Council Chamber, Melbourne, the nineteenth day of September, 1967.

PRESENT:

His Excellency the Governor of Victoria.  
 Mr. Porter | Mr. Meagher  
 Mr. Hamer | Mr. Balfour.

ORDER CONFIRMING RESOLUTIONS OF THE COUNTRY ROADS BOARD.

HIS Excellency the Governor of the State of Victoria, by and with the Advice of the Executive Council thereof, doth hereby, in pursuance of the provisions of the Country Roads Act 1958, confirm the resolutions of the Country Roads Board, the dates whereof and the terms of which are scheduled hereunder:—

SCHEDULE.

State Highway.

Resolution dated the Eleventh day of September, One Thousand Nine Hundred and Sixty-seven, made pursuant to Sections 21, 58 and 74 of the Country Roads Act 1958 declaring the deviation from the Murray Valley Highway in the Shire of Swan Hill as indicated by diagonal hatching on the Plans numbered G.P.10578 and G.P.10580 hereunder to be part of a State highway within the meaning and for the purposes of the Country Roads Act 1958, and also declaring that such deviation shall be in lieu of the existing road or part thereof indicated by cross hatching on the said plans and vertical hatching on Plan numbered G.P.10580, which part indicated by cross hatching on the said plans shall be discontinued.

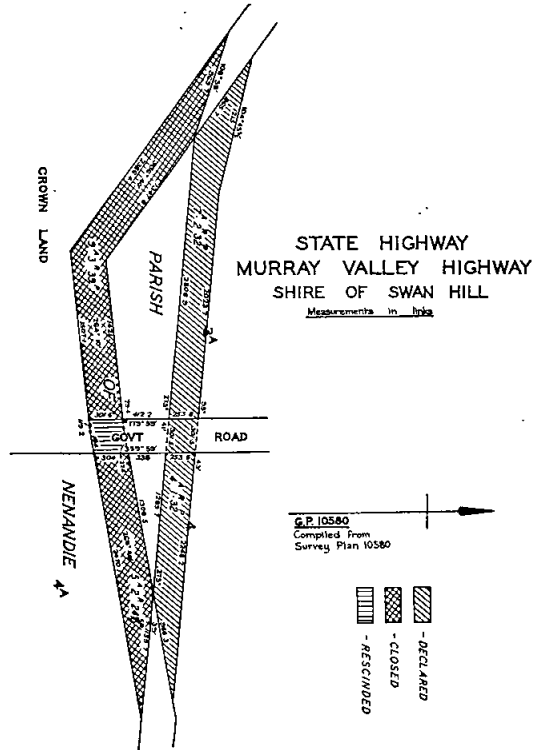
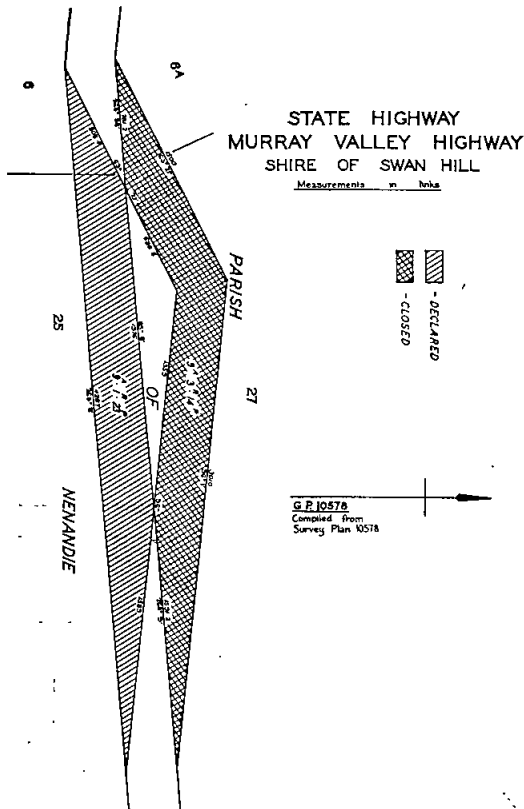

15'

State Highway.

Resolution dated the Eleventh day of September, One Thousand Nine Hundred and Sixty-seven, made pursuant to Sections 21, 58 and 74 of the Country Roads Act 1958 declaring the deviation from the Ouyen Highway in the Shire of Walpeup as indicated by diagonal hatching on the Plans numbered G.P.10126 and G.P.10127 hereunder to be part of a State highway within the meaning and for the purposes of the Country Roads Act 1958, and also declaring that such deviation shall be in lieu of the existing road or part thereof indicated by cross hatching on Plans numbered G.P.10126 and G.P.10127 and vertical hatching on Plan numbered G.P.10126 which roads indicated by cross hatching on the said plans shall be discontinued.

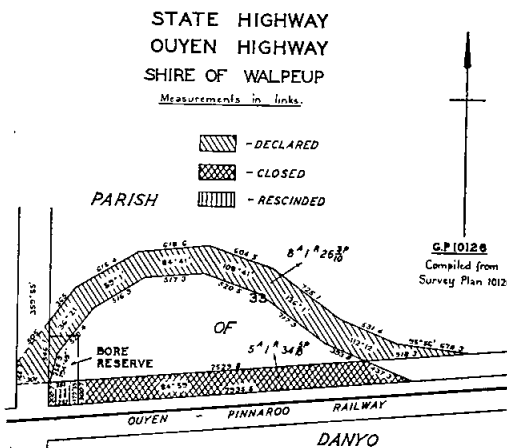

STATE HIGHWAY  
OUYEN HIGHWAY  
SHIRE OF WALPEUP

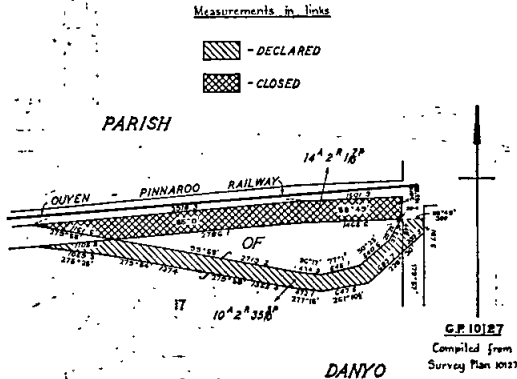

Main Roads.

Resolution dated the Eleventh day of September, One Thousand Nine Hundred and Sixty-seven, made pursuant to Sections 21 and 58 of the Country Roads Act 1958, declaring the deviation from the Albert River Road in the Shire of Alberton as indicated by diagonal hatching on the Plan numbered G.P.10586 hereunder to be part of a main road within the meaning and for the purposes of the Country Roads Act 1958, and also declaring that such deviation shall be in lieu of the existing road or part thereof indicated by cross hatching on the said plan and that such part of the said existing road shall be discontinued.

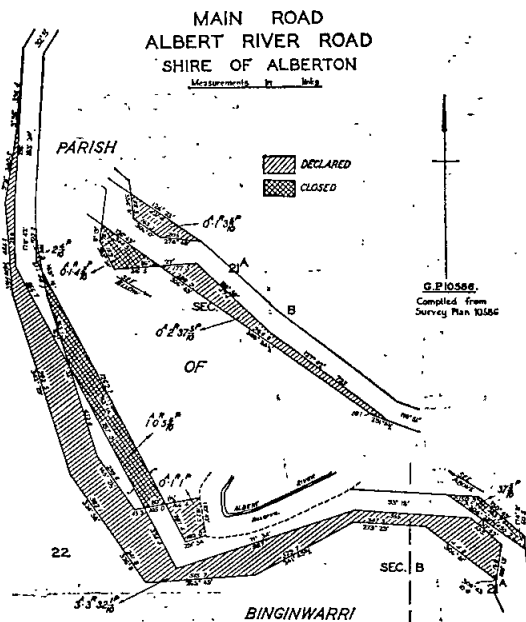

Resolution dated the Eleventh day of September, One Thousand Nine Hundred and Sixty-seven, made pursuant to Section 21 of the Country Roads Act 1958, declaring the widening of Lancefield Road in the City of Keilor as

shown hatched on the Plan numbered G.P.4659 hereunder, to be part of a main road within the meaning and for the purposes of the Country Roads Act 1958.

MAIN ROAD  
LANCEFIELD ROAD  
CITY OF KEILOR

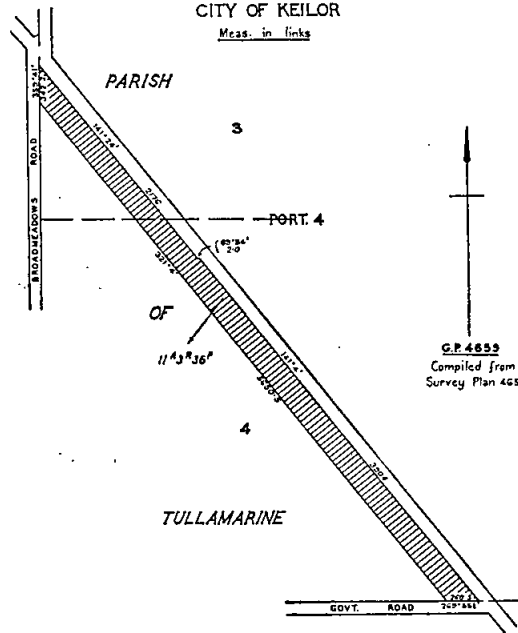

Main Road.

Resolution dated the Eleventh day of September, One Thousand Nine Hundred and Sixty-seven, made pursuant to Sections 21 and 58 of the Country Roads Act 1958, declaring the deviation from Koroop Road in the Shire of Kerang as indicated by diagonal hatching on the Plans numbered G.P.10795 and G.P.10796 hereunder to be part of a main road within the meaning and for the purposes of the Country Roads Act 1958, and also declaring that such deviation shall be in lieu of the existing road or part thereof indicated by vertical hatching on the Plan numbered G.P.10795 and cross hatching on the Plan numbered G.P.10796, which part indicated by cross hatching on the Plan numbered G.P.10796 shall be discontinued.

MAIN ROAD  
KOROOP ROAD  
SHIRE OF KERANG

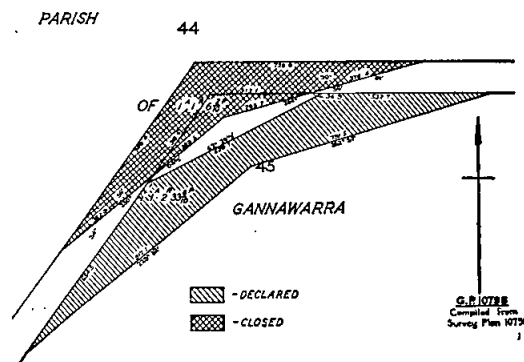

**MAIN ROAD  
KOROOP ROAD  
SHIRE OF KERANG**  
Measurements in links

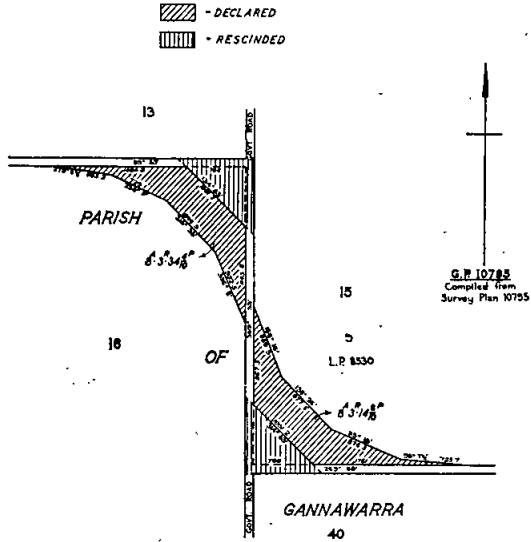

**BY-PASS ROAD  
MULGRAVE BY-PASS ROAD  
CITY OF WAVERLEY**  
Measurements in feet and inches

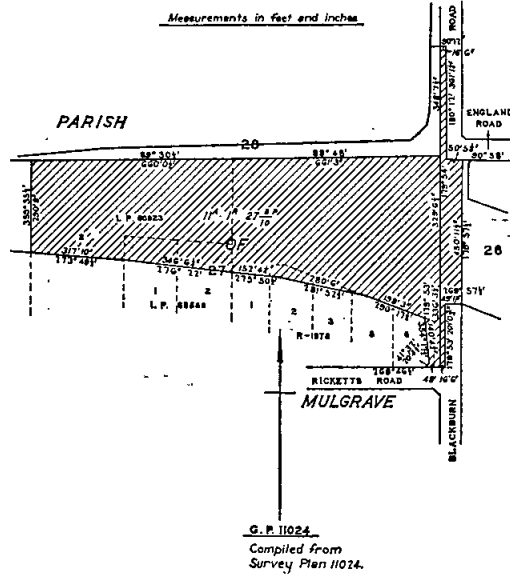

And the Honorable Murray Victor Porter, Her Majesty's Minister of Public Works for the State of Victoria, shall give the necessary directions herein accordingly.

J. ROSSITER,  
Clerk of the Executive Council.

The land shown hatched on Plans numbered G.P.11035 and G.P.11036 hereunder required for the Lower Yarra Freeway By-pass Road in the Shire of Altona and City of Footscray and the making of the road thereon.

**COUNTRY ROADS BOARD.**

At the Executive Council Chamber, Melbourne, the nineteenth day of September, 1967.

**PRESENT:**

His Excellency the Governor of Victoria.  
Mr. Porter | Mr. Meagher  
Mr. Hamer | Mr. Balfour.

**ORDER APPROVING OF LAND BEING ACQUIRED AND ROADS DEVIATIONS OR WIDENINGS BEING MADE.**

HIS Excellency the Governor of the State of Victoria, by and with the advice of the Executive Council thereof, being satisfied that there are funds legally available for acquiring the land, doth hereby approve the acquiring of the land described in the schedule hereunder and the making of new roads and deviations from and widenings of existing roads referred to in the said schedule.

**SCHEDULE.**

**By-pass roads**

The land shown hatched on plan numbered G.P.11024 hereunder required for the Mulgrave By-pass Road in the City of Waverley and the making of the road thereon.

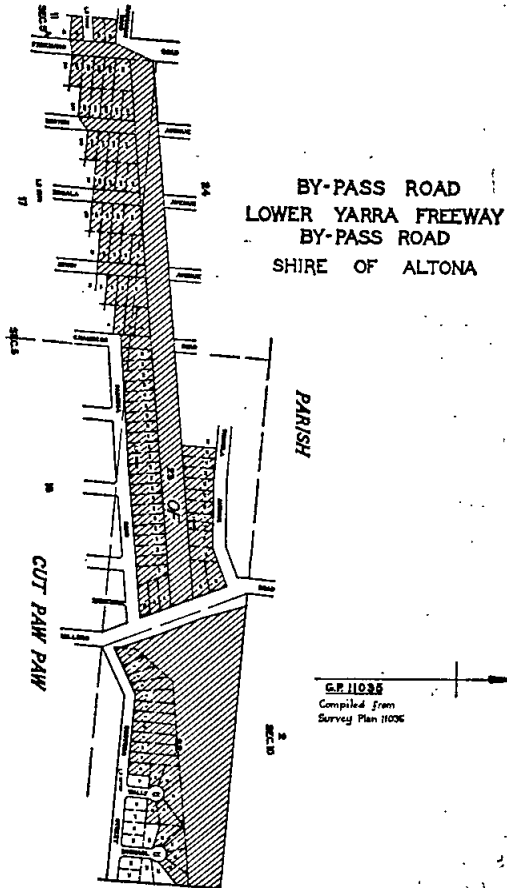

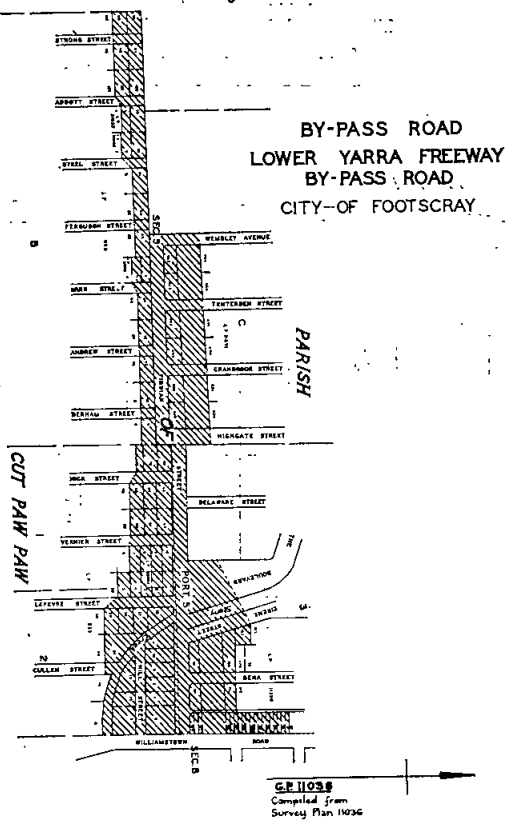

*Unclassified roads*

The land shown hatched on Plan numbered G.P.11019 hereunder required for the widening of Larpent Road in the Shire of Colac and making of the widening thereon.

**ROAD  
LARPENT ROAD  
SHIRE OF COLAC**  
*Measurements in links*

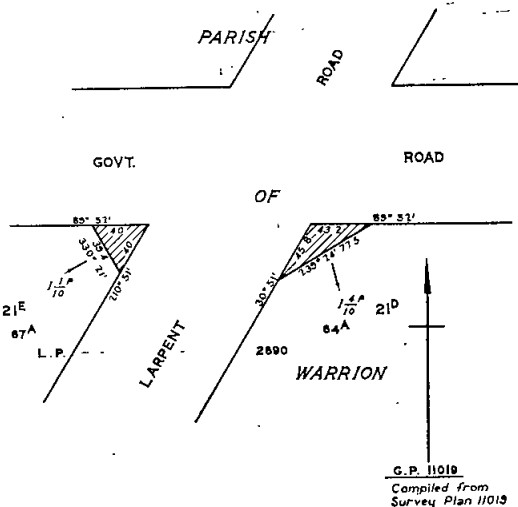

The land shown hatched on Plan numbered G.P.11052 hereunder required for the making of the Lewis Street Pedestrian Overpass in the City of Footscray.

**ROAD  
LEWIS STREET PEDESTRIAN  
OVERPASS**

CITY OF FOOTSCRAY

*Measurements in feet and inches*

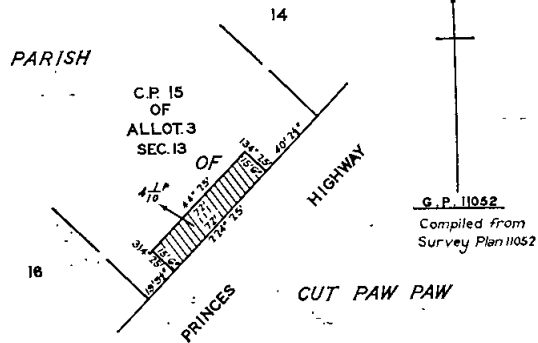

And the Honorable Murray Victor Porter, Her Majesty's Minister of Public Works for the State of Victoria, shall give the necessary directions herein accordingly.

J. ROSSITER,  
Clerk of the Executive Council.

**LANDS DEPARTMENT NOTICES**

**APPROACHING LAND SALES.**

**SALES** of Crown Lands, in fee-simple, will be held at the under-mentioned places and dates, viz.:-

	No. of Gazette.
Avoca.—Friday, 27th October, 1967	72
Ballarat.—Tuesday, 3rd October, 1967	58
Balmoral.—Friday, 22nd September, 1967	61
Edenhope.—Friday, 22nd September, 1967	61
Maryborough.—Friday, 27th October, 1967	72
Melbourne.—Wednesday, 1st October, 1967	72
Robinvale.—Thursday, 19th October, 1967	70
St. Arnaud.—Thursday, 26th October, 1967	72

**SALES OF CROWN LAND BY AUCTION.**

The land will be offered for sale in fee-simple, and subject to the provisions of the Land Act or the Closer Settlement Act as indicated.

The upset price is the sum at which bidding will start, and no bid below that sum can be accepted. The highest bidder at or above that sum shall be the purchaser, subject to signature of contract and any necessary payment.

**TERMS:—**

A deposit of at least 12½% of the purchase price must be paid at the sale, either in cash or by cheque.

The residue is payable in half-yearly instalments, in accordance with the following scale, or may be paid off at any earlier time.

\$40 and under,	6 instalments.
Over \$40, and not exceeding \$100,	8 instalments.
Over \$100, and not exceeding \$200,	10 instalments.
Over \$200, and not exceeding \$400,	12 instalments.
Over \$400, and not exceeding \$600,	14 instalments.
Over \$600, and not exceeding \$800,	16 instalments.
Over \$800, and not exceeding \$1,000,	18 instalments.
Over \$1,000,	20 instalments.

Interest at the rate of 5% per annum is payable with all payments of residue, and is computed for each instalment from the date of sale to the date of such payment. Additional interest is charged if any instalment is not paid on or before the due date.

If paid off within 30 days of sale, no interest is payable.

**FEEs, ETC.:**

Also payable at the sale, in addition to the deposit, are the survey fee and, if applicable, the valuation of improvements (if purchaser be not the owner thereof).

**Payable with balance of purchase money—**

Crown Grant fee—	
50 acres and under	\$3
Over 50 acres	\$4
Purchase money \$10 or under	\$2

Assurance Fund contribution.—One cent in every Five dollars or part thereof of purchase price. (This is a fund established to guarantee the validity of freehold titles.)

Transfer of interest prior to completion of payment may be allowed on payment of \$2 fee and subject to stamp duty.

If unable to attend personally, a prospective purchaser may arrange for another person to bid as his agent.

Attention is drawn to section 95, *Land Act 1958*, which provides that the purchaser shall be deemed to be the owner for the purposes of other Acts; also to an amendment to the Local Government Act providing for Government roads, in certain circumstances, to be declared "private streets", thus making the purchaser liable to contribute to the cost of street construction.

W. J. F. McDONALD,  
Minister of Lands.

Office of Crown Lands and Survey,  
Melbourne, 20th September, 1967.

**MELBOURNE.**—Sale (No. 11887) of Crown land in fee-simple, by auction, will be held at KELVIN HALL, 55 EXHIBITION-STREET, MELBOURNE, on WEDNESDAY, 1st OCTOBER, 1967, at half-past TEN o'clock a.m. To be conducted by J. R. WILDING, Land Officer, Melbourne. Auctioneers: CAROLAN & CO., 243 Collins-street, Melbourne.

Lot 1.

TOWNSHIP OF NARBETHONG, PARISH OF NAR-BE-THONG,  
COUNTY OF ANGLESEY.

In the north-east corner of the township between the reservation to the Fisher creek and Marysville-road.

Upset price \$400 the lot. Survey fee \$17.75.

Area 3a. 1r. 4p., allotment 4 of section 13.

NOTE.—This allotment is within the area of the Shire of Healesville Planning Scheme.—(G.64999.)

Lot 2.

PARISH OF NANGANA, COUNTY OF EVELYN.

Fronting the southern side of the Woori Yallock—Gembrook road, about 5 miles east of Woori Yallock.

Upset price \$150 the lot. Survey fee \$19.25.

Area 5a. 0r. 22p., subject to survey, allotment 71c.

NOTE.—This allotment is within the area of the Shire of Upper Yarra Planning Scheme.—(G.66299.)

Lot 3.

PARISH OF BEENAK, COUNTY OF EVELYN.

About  $\frac{1}{2}$  mile west of the Township of Powelltown.

Upset price \$100 the lot. Survey fee \$15.

Area 2r. 15p., allotment 58N. One month allowed for removal of improvements.—(G.61226.)

TERMS FOR LOTS 4 AND 5.

(Offered under *Closer Settlement Act 1938*.)

A deposit of at least 20% of the purchase price must be paid at the sale, either in cash or by cheque.

The residue is payable in twenty equal half-yearly instalments, or may be paid off at any earlier time.

Interest at the rate of 5% per annum is payable with all payments of residue, and is computed on the unpaid balance.

PARISH OF BERWICK, COUNTY OF MORNINGTON.

Lot 4.

Having frontages of about  $7\frac{1}{2}$  chains to the western side of the Clyde-Berwick road and about  $15\frac{1}{2}$  chains to the southern side of Golf Links-road.

Upset price \$8,900 the lot. Survey fee \$40.

Area 11a. 1r. 20p., allotment 1A of section 4. Subject to two drainage easements each 20 links wide and State Electricity Commission easement. Valuation of improvements \$161. (I. V. Jonas).

Subject to special conditions requiring that, until the purchase money has been paid in full, the purchaser shall at his own expense maintain the property in good order and keep all improvements thereon insured with the Closer Settlement Insurance Fund, and that he shall not remove or make any alterations to such improvements without the consent of the Secretary for Lands.

NOTES.—Purchase price includes Crown improvements, comprising five-roomed weatherboard dwelling, outbuildings, fencing, &c., but does not include improvements

effected by former lessee. The valuation of the former lessee's improvements (\$161) is payable in addition to the purchase price.

Lot 5.

Having a frontage of about  $7\frac{1}{2}$  chains to the western side of the Clyde-Berwick road about  $7\frac{1}{2}$  chains south of Golf Links-road.

Upset price \$5,740 the lot. Survey fee \$40.

Area 11a. 2r. 12p., allotment 1B of section 4. Subject to two drainage easements each 20 links wide.

NOTE.—1. It is understood that water which is available to Lots 4 and 5 from the State Rivers and Water Supply Commission system is not available for market gardening.

2. Both lots 4 and 5 are within the planning scheme area of the Shire of Berwick.—(G.61349.)

**MARYBOROUGH.**—Sale (No. 11888) of Crown land, in fee-simple, by auction, will be held at the LAND OFFICE, SHIRE OF TULLAROOP BUILDING, NEILL-STREET, MARYBOROUGH, on FRIDAY, the 27th OCTOBER, 1967, at ELEVEN o'clock a.m. To be conducted by D. J. YURCINA, Land Officer, Maryborough. Auctioneers: R. J. WHITMORE PTY. LTD., Nolan-street, Maryborough.

TOWNSHIP OF MARYBOROUGH, PARISH OF MARYBOROUGH,  
COUNTY OF TALBOT.

Lot 1.

Fronting the western corner of Christian-street and Bourke-street extension.

Upset price \$7,200 the lot. Survey fee \$250.

Area 1a. 1r. 29p., allotment 17 of section 48B. Valuation of improvements \$115,515. (W. J. Phelan & Sons Pty. Ltd.)

Subject to the condition that should the land be purchased by a person other than the ex-lessee, such ex-lessee may elect to remain in possession for a period to be named by him not exceeding three (3) months from the date of the sale and the contract to purchase shall commence on the day following the expiration of the period so named. Otherwise the contract shall be dated the day of the sale.

Lot 2.

Fronting the north-western side of Napier-street, about  $1\frac{1}{2}$  chains north-east of Clarke-street.

Upset price \$800 the lot. Survey fee \$13.

Area 1r. 1p., subject to survey, allotment 15 of section 56. Valuation of improvements \$3,600 (dwelling, outbuildings, fencing and paving) (Estate of S. Chadwick).—(W.59252.)

**AVOCA.**—Sale (No. 11885) of Crown land, in fee-simple, by auction, will be held at the LAND INSPECTOR'S OFFICE, AVOCA, on FRIDAY, the 27th OCTOBER, 1967, commencing at half-past NINE o'clock a.m. To be conducted by D. J. YURCINA, Land Officer, St. Arnaud.

Lot 1.

PARISH OF RATHSCAR, COUNTY OF GLADSTONE.

Fronting the western side of the Avoca-Natte Yallock road, about  $1\frac{1}{2}$  miles south of Natte Yallock.

Upset price \$240 the lot. Survey fee \$19.25.

Area 8a. 1r. 32p., allotment 6E, section 1.—(W.86077.)

Lot 2.

PARISH OF MOYRIESK, COUNTY OF KARA KARA.

Fronting the eastern side of a Government road in the south-west of the parish.

Upset price \$30. Survey fee \$15.

Area 1 acre, subject to survey, allotment 55E, section 1. One month allowed for removal of improvements.—(W.88087.)

**ST. ARNAUD.**—Sale (No. 11886) of Crown land, in fee-simple, by auction, will be held at the LAND OFFICE, ST. ARNAUD, on THURSDAY, 26th OCTOBER, 1967, commencing at TEN o'clock a.m. To be conducted by D. J. YURCINA, Land Officer, St. Arnaud.

Lot 1.

PARISH OF GOWAR, COUNTY OF GLADSTONE.

On the north side of the Gower East-Coonoer road, approximately 4 miles south-east of Coonoer.

Upset price \$672. Survey fee \$60.

Area 48 acres, subject to survey, allotment 29, section E. Valuation of improvements, \$66 (fencing) (M. A. Radford).—(W.88332.)

## Lot 2.

PARISH OF KOOROC, COUNTY OF GLADSTONE.

Fronting the north side of C.R.B. road, approximately  $\frac{1}{4}$  mile east of the Township of Lower Emu.

Upset price \$130 the lot. Survey fee \$15.25.

Area 3a. 2r. 19p., allotment 22c. One month allowed for removal of improvements.—(W.69916.)

## Lot 3.

TOWNSHIP OF WOOMELANG, PARISH OF CRONOMBY, COUNTY OF KARKAROO.

Fronting the north side of Brock-street, about 3 chains west of the Sealake-road.

Upset price \$400 the lot. Survey fee \$20.

Area 1r. 25p., subject to survey, allotment 19A, section 8.—(M.45541.)

## Lot 4.

PARISH OF DALYENONG, COUNTY OF KARA KARA.

About 5 miles south of the St. Arnaud-Dunolly road, between the former State School site and the reservation to Avoca River.

Upset price \$60. Survey fee \$16.

Area 5a. 2r. 37p., allotment 13f. One month allowed for removal of improvements. Subject to State Electricity Commission easement, 48 links wide.

NOTE.—This allotment is offered without legal access and on the understanding that no such access will be provided in the future by the Crown.—(W.87994.)

## Lot 5.

TOWNSHIP OF BEALIBA, PARISH OF BEALIBA, COUNTY OF GLADSTONE.

Fronting the south-west side of the Government road approximately 24 chains south-east of the Railway Station.

Upset price \$50 the lot. Survey fee \$15.

Area 2r. 35p., allotment 18b, section 16. One month allowed for removal of improvements.—(W.87207.)

## Lot 6.

PARISH OF JIL JIL, COUNTY OF KARKAROO.

Being the site and building erected thereon of the former State School Reserve at Jil Jil.

Upset price \$20. Survey fee \$15.

Area 1 acre, allotment 45b. Valuation of improvements, \$95 (school room, tanks and toilets) (Education Department).—M.61167.)

ALSO THE FOLLOWING FREEHOLD LAND WILL BE OFFERED:—

NOTE.—This lot is not subject to the provisions of the Land Act as set out above, but comprises freehold land offered on behalf of the Education Department on the following conditions:—

- (a) Deposit of at least 12½ per cent. payable at the sale and balance within 60 days.
- (b) Purchaser to arrange for, and bear costs of, registration of transfer of title.

## Lot 7.

PARISH OF DARKBONEE, COUNTY OF KARA KARA.

Being the site and improvements erected thereon of the former Waterloo Plains State School.

Upset price \$120.

Area 2 acres, allotment part 21, and being the land contained in Freehold Certificate of Title, Volume 5858, folio 509.

NOTE.—Improvements consist of old buildings and fencing.—(W.87458.)

## COMMITTEES OF MANAGEMENT OF RESERVES.

## APPOINTMENTS.

NOTICE is hereby given that, in pursuance of section 221 of the Land Act 1958, the following appointments of Committees of Management of reserved Crown Lands have been made by the Minister of Lands:—

## "ADELAIDE LEAD PUBLIC PURPOSE (PUBLIC HALL) RESERVE."

John Charles Harkin, Noréen Anne Martin, Keith Ronald Taggart, Carol Isabel Martin, Annie Elizabeth Martin, John Morice Ford, Rebecca Lillian Bartlett, Judith A. Bartlett, Arthur T. Bartlett, Arthur F. Martin, Gloria Jean Bartlett, Colin Henderson Bartlett, Keith H. A. Bartlett, and Francis G. Martin as a Committee of Management for a period of three (3) years of the land in the Parish of

Amherst, temporarily reserved by Order in Council dated the 30th May, 1967 as a site for Public Purposes (Public Hall).—(Corres. Rs.8829.)

## "ARDMONA RECREATION RESERVE."

Ronald Alfred Maude and Francis Rutherford Pullar as members of the Committee of Management for a period ending 2nd August, 1970 of the land in the Parish of Mooroopna reserved as a site for Public Recreation and known as the "Ardmona Recreation Reserve".—(Corres. Rs.6350.)

## "BALLARAT EAST PUBLIC PARK AND GARDENS."

The Council of the City of Ballarat as the Committee of Management of the Land in the Township of Ballarat temporarily reserved by Orders in Council dated the 28th November, 1892, the 18th December, 1930 and the 11th July, 1967 as a site for Public Park and Gardens.—(Corres. Rs.5414.)

## "COONOOER BRIDGE MECHANICS' INSTITUTE AND FREE LIBRARY RESERVE."

Frank Oswald Sanderson, Ian John Watts, Donald Ewen Pritchard, Lloyd Charles Watts, Trevor Grimmett Brian Watts, John Clyne Postlethwaite, Oswald Williams, Lewis Williams, John Raymond Williams and John William Hodgson as a Committee of Management for a period of three (3) years of the land in the Township of Coonooer temporarily reserved by Order in Council dated the 7th July, 1914 as a site for a Mechanics' Institute and Free Library and known as the "Coonooer Bridge Mechanics' Institute and Free Library Reserve".—(Corres. Rs.4326.)

## "CORINDHAP RECREATION RESERVE."

George Edward Buttler, Gordon James Boyle, Roy Donald Hall, Laurence Brendan Buttler, William Russell Hall, Lloyd Neil Laidler, Geoffrey Buttler, Maxwell Arthur Taylor, Kenneth Edward Caldwell and Walter Speed Terry as a Committee of Management for a period of three (3) years of the land temporarily reserved by Orders in Council dated the 22nd May, 1899 and 11th August, 1931 as sites for Public Recreation in the Township of Corindhap and known as the "Corindhap Recreation Reserve".—(Corres. Rs.3385.)

## "COWWARR PUBLIC HALL RESERVE."

Norman T. Farley, H. P. Baxter, B. J. Houston, R. J. Donaldson, E. P. McGillivray, F. J. Harkin, Edward Jones, L. J. Harkin, E. R. Kelley and N. J. Murphy as a Committee of Management for a period of three (3) years of the land temporarily reserved by Order in Council of the 15th October, 1957 as a site for a Public Hall in the Parish of Toongabbie North and known as the "Cowwarr Public Hall".—(Corres. Rs.7662.)

## "DEEPLAKE PUBLIC RECREATION RESERVE", PARISHES OF DUNNAWALLA AND GEELONGLA.

Oral Malcolm Rowe, Lowell Winston French, William Oswald Williams, Harold Jenkins, John Nugent Osborne, Andrew Charles Borbidge, Laweton Peter French, Reginald Morgan Snibson, Norman Leslie McClure and John Robert Lane as a Committee of Management for a period of three (3) years of the land in the Parishes of Dunnawalla and Geelongla temporarily reserved by Order in Council dated the 9th June, 1964 as a site for Public Recreation and known as the "Deep Lake Public Recreation Reserve".—(Corres. Rs.8336.)

## "ELLERSLIE AND BALLANGEICH SOLDIERS' MEMORIAL PARK."

D. E. Alford, A. Jennings, P. Y. Wynd, J. E. Gordon and S. F. Dohle as a Committee of Management for a period of three (3) years of the land permanently reserved by Order in Council dated 26th October, 1926, as a site for a Public Park in the Parish of Ballangeich and known as "Ellerslie and Ballangeich Soldiers' Memorial Park".—(Corres. Rs.3370.)

## "GEELONG PUBLIC RECREATION RESERVE."

Eric G. Hooper, Gilbert E. Belton, John Patrick Power, Walter Roy Pike and Dudley C. D'Helin as a Committee of Management for a period of three (3) years of the land temporarily reserved by Order in Council dated 24th March, 1938 as a site for Public Recreation in the City of Geelong, Parish of Corio, and known as the "Geelong Public Recreation Reserve".—(Corres. Rs.430.)

"GEMBROOK MEMORIAL HALL RESERVE."

N. W. Smith, John Thomas Munday, William Arthur Bishop, Irene Elizabeth Bishop, Dorothy Bates, Sydney Albert Bates, Laurence Charles DeLaRue, Norman William DeLaRue as a Committee of Management for a period of one (1) year of the land temporarily reserved by Order in Council dated the 17th February, 1942 as a site for a Public Hall in the Parish of Gembrook and known as the "Gembrook Memorial Hall Reserve".—(Corres. Rs.5339.)

"HALL'S GAP RECREATION RESERVE."

J. R. D'Alton, D. G. Dean, F. J. Conboy, J. E. Dalton, W. J. Kelly, I. E. Read, as a Committee of Management for a period of three (3) years of the land in the Parish of Boroka temporarily reserved by Order in Council dated 19th October, 1936 as a site for Public Recreation and known as the "Hall's Gap Recreation Reserve".—(Corres. Rs.4611.)

"HEYFIELD RECREATION RESERVE."

Bryan Leonard Rodaughan, Gregory James Higgins, Gordon Ernest Louis Smith, Vincent Edward Cummins, Leonard Robert Anderson, James Henry Anderson, Ralph Lay, John Joseph Mahoney, Victor Frederick Fawaz, Ronald James Kerr, David Thomas Ware, Carl Vernon Graham, Francis Merlin Zacher and Allan George Trew for a period of three (3) years and F. M. Zacher, V. F. Fawaz and A. G. Trew (for so long only as they continue to be Councillors and the elect of the Council of the Shire of Maffra) as a Committee of Management of the land in the Township of Heyfield, Parish of Tinambra temporarily reserved by Order in Council dated the 23rd November, 1885, as a site for Public Recreation, and known as the "Heyfield Recreation Reserve".—(Corres. Rs.3531.)

"MALDON ATHENAEUM RESERVE."

Alfred George Shaw, Alexander Meldrum, Ivan C. Park, Vera M. Somer as a Committee of Management for a period of three (3) years from 9th September, 1964, of the land in the Township of Maldon, permanently reserved by Order in Council of 12th March, 1889, as a site for an Athenaeum, Mining Museum and Free Library and adjoining land temporarily reserved by Order in Council of 10th December, 1946, as a site for Athenaeum and Free Library Purposes, together known as the "Maldon Athenaeum Reserve".—(Corres. Rs.3060.)

"MOYSTON PUBLIC PARK RESERVE" AND "MOYSTON CRICKET AND RECREATION RESERVE."

Alfred Horace Duffy, Leslie Charles Mason, Romney Hobill Cole, Geoffrey Ernest Millear, Thomas Wensley Hewitt, John Douglas Coad, Robert Marshall as a Committee of Management for a period ending 9th March, 1970, of the remaining portion of the land temporarily reserved by Order in Council dated 31st May, 1886 as a site for a Public Park in the Parish of Moyston and known as the "Moyston Public Park" and of the land temporarily reserved by Orders in Council dated the 9th May, 1933 and 5th October, 1948 and the remaining portion of the land temporarily reserved by Order in Council dated 27th February, 1865 as sites for Cricket and Recreation purposes in the Township of Moyston and known as the "Moyston Cricket and Recreation Reserve".—(Corres. Rs.2482, Rs.2671.)

"NULLAWIL RECREATION RESERVE."

Vincent Joseph Lowry, Jack Donald Cobham McLean, Keith Douglas Bartram, Bruce McLennan, Herbert Adrian Clarke, Martin Mervyn Ryan, Ian Ronald Poyner, James McDonald Cooper, James B. Hogan, John Ryan, William James Watts, George Edwin Abraham, Ronald Joseph Hogan, Leo Pierce Hogan, Robert Lawrence Kelly, George Percy Cobham McLean, Edwin Clive Townrow, Matthew Milton Bennett, James Michael Brennan, John Goddard Prentice and Stanley John Watson as a Committee of Management for a period of three (3) years of the land temporarily reserved by Order in Council of 1st November, 1948 as a site for Public Recreation in the Parish of Nullawil and known as the "Nullawil Recreation Reserve".—(Corres. Rs.6276.)

"NYAH PUBLIC PARK AND RECREATION RESERVE."

Frederick Lawrence Boulton in the place of John Doueal (resigned) as a member of the Committee of Management for a period ending the 28th August, 1968 of the land in

the Township of Nyah temporarily reserved by Order in Council dated the 9th December, 1919 as a site for Public Park and Recreation together with the adjoining permanent reservation for Public purposes along the Murray River both areas known as the "Nyah Recreation Reserve", and the land in the Township of Nyah temporarily reserved by Order in Council dated the 1st September, 1926, as a site for Public Park and known as "Nyah Public Park".—(Corres. Rs.2051.)

"PUBLIC PURPOSES (HISTORICAL PURPOSES) RESERVE,"  
PARISH OF NEERIM.

The Council of the Shire of Buln-Buln as the Committee of Management of the land in the Parish of Neerim temporarily reserved by Order in Council dated the 8th August, 1967, as a site for Public Purposes (Historical Purposes).—(Corres. Rs.8679.)

"STANLEY RECREATION RESERVE."

Gifford Neil Thompson, Graeme Sinclair, Harold Raymond Sinclair, Keith Stanley Sinclair, Raymond Alexander Lloyd Sinclair, Harold James Detlefsen, Mervyn John Sinclair, Ian Alfred Smith, Reginald Leopold Sinclair, Percival Wilfred Hill, Henry Robert Collins, Peter Myles Thompson, Rochford Henry Johnson, Eric Cyril Harding, Maurice Reginald Sinclair, Thomas Antoine Chambeyon as a Committee of Management for a period of three (3) years of the land temporarily reserved by Orders in Council dated the 6th April, 1914, and 22nd April, 1952, as a site for Public Recreation in the Town of Stanley, and known as the "Stanley Recreation Reserve".—(Corres. Rs.635.)

"YEA PUBLIC PURPOSES (SWIMMING POOL) RESERVE."

Leslie Noel Moore, Richard Edward Powell, Cathrine Bridget Sier, Jean Grace Apps, James Arthur Desmond, Kenneth William Aldous, Thomas Andrew Apps, Kevin George Cunningham, Leonard George Walsh, Manuel Desmond Mullane, Alan Ernest Long and Keith Lindsay Higgins as a Committee of Management for a period of three (3) years of the land in the Township of Yea temporarily by Order in Council dated the 2nd August, 1966, as a site for Public Purposes (Swimming Pool).—(Corres. Rs.8596.)

W. J. F. McDONALD,  
Minister of Lands.

Department of Crown Lands and Survey,  
Melbourne, 13th September, 1967.

REGULATIONS FOR THE CARE, PROTECTION AND MANAGEMENT OF THE COLAC PUBLIC PURPOSES (USE OF MENTAL HEALTH AUTHORITY) RESERVE.

WHEREAS by section 218 of the *Land Act 1958* the Minister of Lands is empowered to make regulations as to any land which under the provisions of that Act or of any other Act relating to Crown lands has been reserved for any public purposes whatsoever and which has not been conveyed to or vested in trustees: And whereas certain Crown lands in the Parish of Elliminyt and described in a notice published in the *Gazette* of the 12th day of October, 1966, were reserved as a site for Public Purposes (use of Mental Health Authority): And whereas such land (hereinafter called "the Reserve") have not been conveyed to or vested in trustees; And whereas it is expedient that regulations for the care, protection and management of the Reserve and for other purposes connected therewith should be made: Now therefore I, William John Farquhar McDonald, Her Majesty's Minister of Lands in and for the State of Victoria, in pursuance of the powers aforesaid, do hereby make the following Regulations for or with respect to the Reserve:—

The Reserve has been placed under the control of the Mental Health Authority as the Committee of Management.

REGULATIONS.

1. No unauthorized person shall interfere with, move, damage, or destroy any shrub, tree, plant, grass, flowers, or any property or enter on any flower beds or borders or light fires within the Reserve.
2. No person shall throw stones or missiles of any kind within the Reserve.
3. No person shall discharge firearms within the Reserve without the permission, in writing, of the Psychiatrist Superintendent or Secretary of that Hospital.

4. No unauthorized person shall climb on any portion or any building balustrade, fence, or property in the Reserve or jump over any fence or ledge thereon.

5. No person shall, without the permission of the Psychiatrist Superintendent or Secretary of the Hospital, affix any placard, bill, notice, or marking of any kind on any building, structure, tree, constructed surface, or anything within the Reserve nor shall any person without a like permission interfere with any such placard, bill, notice or marking.

6. No person shall enter or travel over the Reserve with or on any bicycle or vehicles or any kind of animal, except on such portions thereof provided for wheeled traffic, and the driver of any such vehicle or the driver or rider of any such bicycle or animal shall be guided and directed and shall abide by any notice, post, or sign marking, or barrier guide which has been marked or erected for the purpose of traffic guidance, control or direction.

7. No person shall ride or drive a bicycle, motor cycle, motor car, or other motor driven vehicle, or any other type of vehicle within the Reserve, recklessly, or at a speed or in a manner which is dangerous, to the public, or to the members of the staff or the Hospitals or to the inmates thereof, having regard to all the circumstances of the case, including the nature, condition, and use of the Reserve and to the amount of traffic, wheeled or vehicular, or pedestrian which actually is at the time or which might reasonably be expected to be in the Reserve.

8. No person shall park any bicycle, motor cycle or vehicle of any kind in such a manner as to interfere in any way with or obstruct the free passage of any other person or vehicles within the Reserve.

9. No person shall spit or expectorate on the paths or seats or any wall, structure or property within the Reserve.

10. No person in the state of intoxication or who is disorderly or is not decorously dressed shall enter or remain in the Reserve and no person shall commit therein any nuisance or any indecent or offensive act.

11. No person shall remain in the Reserve or any property therein when lawfully directed to leave the same by a bailiff of the Crown lands, or member of the Police Force, or any members of the staff of the Hospital authorized in that behalf by the Psychiatrist Superintendent or Secretary thereof.

12. No person shall camp in the Reserve or erect therein any building or booth for the purpose of offering for sale any article.

13. No person shall hawk or sell or offer for sale within the Reserve any goods, fruit, or merchandise, or anything, or solicit or gather money therein without the authority, in writing, of the Psychiatrist Superintendent or Secretary of such Hospital.

14. No person shall give out or distribute any handbills, placards, notices, advertisements, books, pamphlets, or papers in the Reserve or litter the same by scattering or throwing down handbills, placards, notices, advertisements, books, pamphlets or papers.

15. No person shall bring into the Reserve any dog unless securely held and controlled by a chain or cord or leash.

16. No person shall bring in or allow to remain in the Reserve any horse, cow, sheep, pig or goat. Any such animal found wandering therein shall be liable to be impounded or destroyed.

17. No person except on lawful occasions may enter any enclosed area or any building, garage, or shed, or other structure within the Reserve.—(Rs.8723.)

Given under my hand at Melbourne on the 13th day of September, 1967.

W. J. F. McDONALD,  
Minister of Lands.

Every person who contravenes or fails to comply with these Regulations shall, in accordance with the provisions of section 218 of the Land Act 1958, for each offence be liable to a penalty of not more than Fifty dollars, and every person who contravenes or fails to comply with any such Regulations, and who, after he has been warned by any bailiff of Crown lands or by any member of the Police Force, does not desist therefrom may be forthwith apprehended by such Bailiff or member of the Police Force and taken before some justice to be dealt with according to law and shall be liable to a penalty of not more than One Hundred Dollars.

PROPOSED REVOCATIONS OF TEMPORARY RESERVATIONS OF LANDS BY ORDERS IN COUNCIL.

IN pursuance of the provisions of the Land Act 1958, notice is hereby given that it is the intention of the Governor in Council to revoke the temporary reservations of lands by Orders in Council hereunder referred to, viz.:—

The following Notices were published 1° on the 20th September, 1967, pursuant to Orders of the 12th September, 1967.

WARANGA.—The temporary reservation, by Order in Council of the 8th January, 1902, of 247 acres 1 rood 25 perches of land in the Parish of Waranga, as a site for Water Supply purposes, revoked as to part by Order in Council of the 25th February, 1964, is about to be revoked so far only as the portion containing 1 acre 28 perches, indicated by hatching on plan hereunder, is concerned.—(W.37<sup>(4)</sup>) (C.78574).

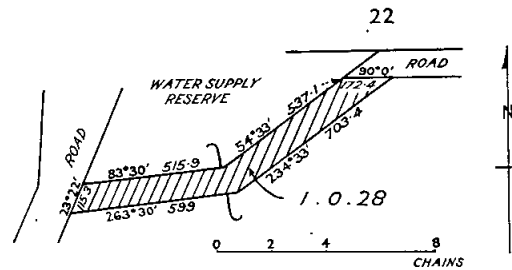

TANGAMBALANGA.—The temporary reservation by Order in Council of the 31st December, 1946, of 1 acre 1 rood 1 perch of land in the Parish of Tangambalanga, as a site for State School purposes, is about to be revoked.—(T.35<sup>(12)</sup>) (Rs.5912).

WANGARATTA.—The temporary reservation, by Order in Council of the 11th October, 1904, of 9 acres 3 roods of land in the Township of Wangaratta, as a site for a Public Park, is about to be revoked so far only as the portions containing 2 roods 25 perches, more or less, indicated by hatching on plan hereunder, are concerned.—(W.85<sup>(6)</sup>) (Rs.2715).

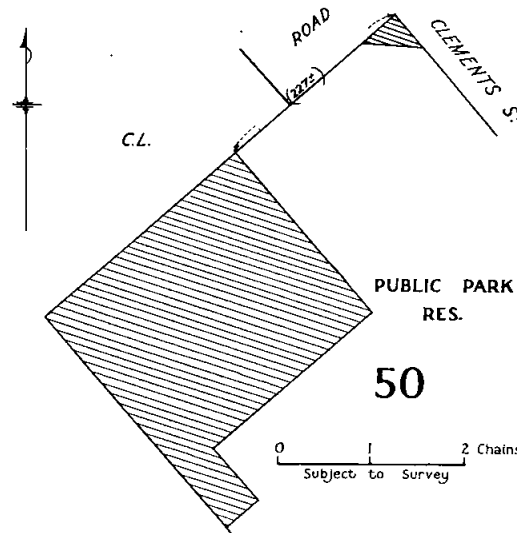

Total Area of Hatched Portions—0.2.25±

YARRAYNE AND POWLETT.—The temporary reservation, by Order in Council of the 21st February, 1870 (see Government Gazette, 25th February, 1870, page 382) of 75 acres, more or less, of land in the Parishes of Yarrayne and Powlett, as a site for Watering purposes, revoked as to part by Order in Council of the 13th September, 1875 (see Government Gazette, 24th September, 1875, page 1826) is about to be revoked, save and except the area of 18 acres, more or less, indicated by hatching on plan hereunder, is



concerned. Please note that this is a "save and except" case and that the area hatched is that which is to remain in the reserve.—(Y.9<sup>(2)</sup> & P.36<sup>(2)</sup> (Rs.8735).

taining 2 acres 1 rood 35 perches, more or less, indicated by hatching on plan hereunder is concerned.—(M.236<sup>(\*)</sup> (Rs.8858).

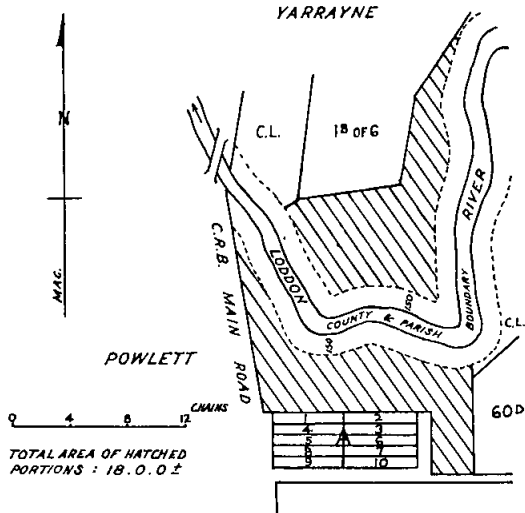

STUARTMILL.—The temporary reservation by Order in Council of the 21st February, 1870, of 1 acre 2 roods of land in the Township of Stuartmill, as a site for Common School purposes, is about to be revoked.—(S.355<sup>(2)</sup> (Rs.2126).

TABBERABBERA.—The temporary reservation, by Order in Council of the 19th April, 1887, of 27 acres 3 roods 39 perches of land in the Parish of Tabberabbera (formerly Parish of Angora), as a site for Watering purposes, is about to be revoked.—(T.285(3) (Rs.8856).

JIRNKEE.—The temporary reservation, by Order in Council, of the 19th April, 1887, of 10 acres of land in the Parish of Jirnkee (formerly Parish of Tongio—Munjie West), as a site for Watering purposes, is about to be revoked.—(J.51<sup>(3)</sup> (Rs.8855).

WY-YUNG.—The temporary reservation by Order in Council of the 24th March, 1904, of 1 acre of land in the Parish of Wy-Yung as a site for a State School is about to be revoked.—(W.236<sup>(14)</sup> (C.23008).

WOODEND.—The temporary reservation, by Order in Council of the 12th February, 1866, of 3 acres of land in the Parish of Woodend, County of Dalhousie, as a site from which stone may be procured, is about to be revoked.—(W.200(K<sup>6</sup>) (Rs.8859).

WOODEND.—The temporary reservation by Order in Council of the 15th April, 1872, of 1 acre 3 roods 20 perches of land in the Parish of Woodend, County of Dalhousie, as a site for a Pound, is about to be revoked.—(W.200(K<sup>6</sup>) (C.95380).

TOOAN.—The temporary reservation and the withholding from sale, leasing and licensing, by Order in Council of the 14th July, 1879 (see *Government Gazette* of the 18th July, 1879, page 1815) of 5 acres of land in the Parish of Tooan, as a site for Public purposes (State School), are about to be revoked.—(T.185<sup>(4)</sup> (Rs.8868).

BEAUFORT.—The temporary reservation, by Order in Council of the 15th November, 1937, of 3 acres 3 roods 20 perches of land in the Parish of Beaufort, as a site for a State School, is about to be revoked.—(B.305<sup>(7)</sup> (Rs.4466).

BEAUFORT.—The temporary reservation, by Order in Council of the 29th April, 1908, of 3 acres of land in the Township of Beaufort, as a site for Children's Playground, is about to be revoked.—(B.304<sup>(5)</sup> (Rs.5390).

WONWONDAH NORTH.—The temporary reservation, by Order in Council of the 18th of July, 1887, of 7 acres 3 roods 1 perch of land in the Township of Wonwondah North (Parish of Wondondah), as a site for the Supply of Stone, is about to be revoked.—(W.327<sup>(4)</sup> (Rs.6705).

LONGWOOD.—The temporary reservation, by Order in Council of the 17th November, 1885, of 1 acre 29 perches of land in the Parish of Longwood, as a site for a State School, is about to be revoked.—(L.96<sup>(4)</sup> (C.99881).

METCALFE (GREEN HILL).—The temporary reservation by Order in Council of the 1st March, 1869 (see *Government Gazette*, 5th March, 1869, page 410), of 5 acres of land in the Parish of Metcalfe, as a site for a Cemetery, is about to be revoked so far only as the portion con-

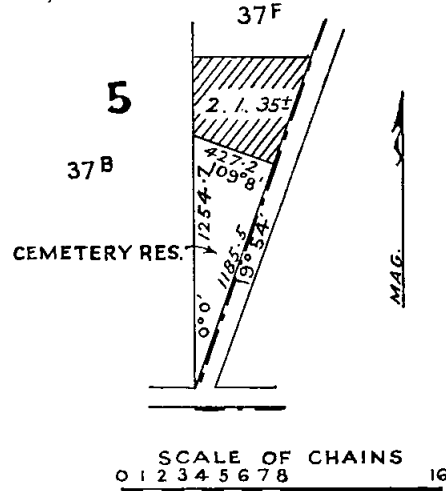

LA TROBE.—The temporary reservation, by Order in Council of the 6th July, 1891, of 2 acres of land in the Parish of La Trobe, as a site for a State School, is about to be revoked, so far only as the portion containing 13 perches, indicated by hatching on plan hereunder, is concerned.—(L.143<sup>(3)</sup> (Rs.2697).

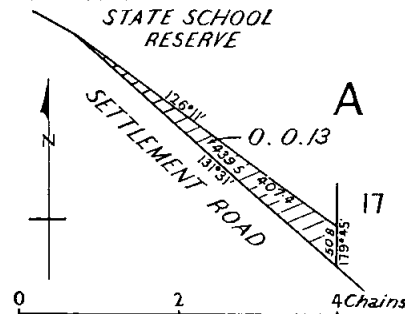

CASTLEMAINE.—The temporary reservation, by Order in Council of the 20th April, 1926, of 13 acres 2 roods 20 perches of land in the Parish of Castlemaine, as a site for the Supply of Gravel, revoked as to part by Order of the 6th December, 1966, is about to be revoked, so far only as the portion containing 4 acres 2 roods 1 perch, indicated by hatching on plan hereunder, is concerned.—(C.100<sup>(26)</sup> (Rs.3293).

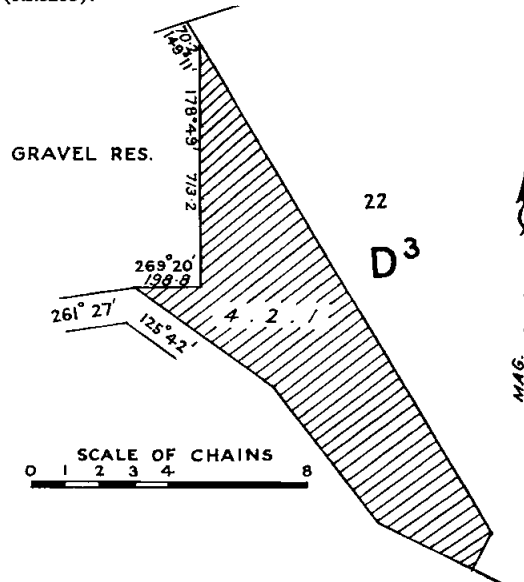

WOORAK.—The temporary reservation, by Order in Council of the 18th October, 1886 (see *Government Gazette*, 22nd October, 1886, page 2984) of 10 acres of land in the Parish of Woorak, as a site for Watering purposes, is about to be revoked, so far only as the portion containing 7 acres 3 perches, indicated by hatching on plan hereunder, is concerned.—(W.297(4) (Rs.8743).

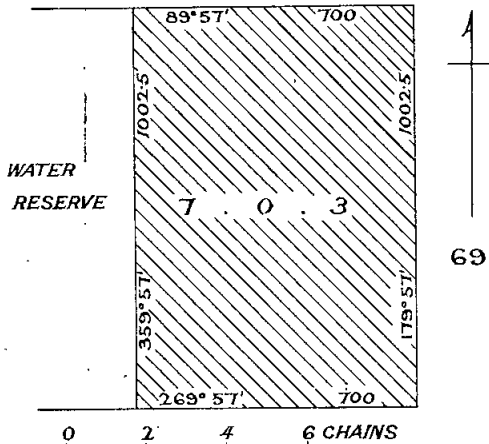

W. J. F. McDONALD,  
Minister of Lands.

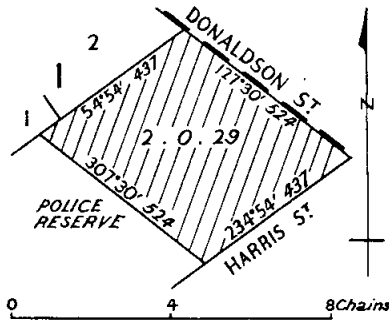

LONGWOOD.—The temporary reservation, by Order in Council of the 9th July, 1888 (see *Government Gazette*, 13th July, 1888, page 2303) of 5 acres of land in the Parish of Longwood as a site for a State School is about to be revoked.—(L.96(4) (C.99867).

OAKLEIGH.—The temporary reservation, by Order in Council of the 15th September, 1941, of 5 acres 2 roods 23 perches of land in the Township of Oakleigh (City of Oakleigh) as a site for Public park and recreation, revoked as to part by Order in Council of the 26th July, 1960, is about to be revoked so far only as the portions containing 19 perches, indicated by hatching on plan hereunder, are concerned.—(O.1(2) (Rs.1121).

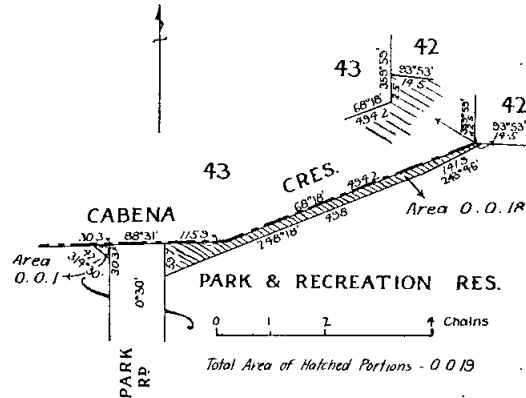

PROPOSED REVOCATIONS OF TEMPORARY RESERVATIONS OF LANDS BY ORDERS IN COUNCIL.

IN pursuance of the provisions of the *Land Act 1958*, notice is hereby given that it is the intention of the Governor in Council to revoke the temporary reservations of lands by Orders in Council hereunder referred to, viz.:—

The following Notices were published 1° on the 20th September, 1967, pursuant to Orders of the 5th September, 1967.

MONBULK.—The temporary reservation, by Order in Council of the 12th January, 1915, of 3 acres 2 roods 19 perches of land in the Parish of Monbulk as a site for a Quarry and the temporary reservation, by Order in Council of the 8th July, 1924, of 2 acres 3 roods 27 perches of land as an extension thereto are about to be revoked.—(M.555(12) (Rs.474).

WORAIKWORM.—The temporary reservation, by Order in Council of the 8th November, 1955, of 537 acres 2 roods 30 perches of land in the Parish of Woralgworm as a site for the Protection of Native Fauna and Flora is about to be revoked.—(W.325(2) (Rs.7401).

W. J. F. McDONALD,  
Minister of Lands.

YALLOCK.—The temporary reservation, by Order in Council of the 20th June, 1932, of 3 acres 3 roods 36 perches of land in the Parish of Yallock as a site for Public gardens and plantation, revoked as to part by Order in Council of the 8th July, 1947, is about to be revoked so far only as the portion containing 6 perches, indicated by hatching on plan hereunder, is concerned.—(Y.22(3) (Rs.4214).

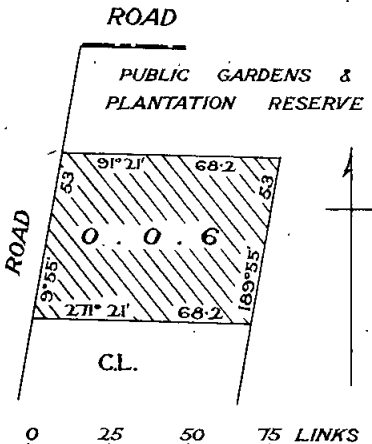

W. J. F. McDONALD,  
Minister of Lands.

PROPOSED REVOCATIONS OF TEMPORARY RESERVATIONS OF LANDS BY ORDERS IN COUNCIL.

IN pursuance of the provisions of the *Land Act 1958*, notice is hereby given that it is the intention of the Governor in Council to revoke the temporary reservations of lands by Orders in Council hereunder referred to, viz.:—

The following Notices were published 1° on the 6th September, 1967, pursuant to Orders of the 29th August, 1967.

CORRYONG.—The temporary reservation as a site for the use of the Police Department and the withholding from sale, leasing and licensing by Order in Council of the 4th January, 1883, of 4 acres 10 perches of land in the Township of Corryong are about to be revoked so far only as the portion containing 2 acres 29 perches, indicated by hatching on plan hereunder, is concerned.—(C.427(3) (Rs.8209).

## Land Act 1958.

## LICENCE UNDER THE LAND ACTS DECLARED VOID.

NOTICE is hereby given that the Licence in the Schedule hereunder has been Declared Void for the reason specified.

District.	Corr. No.	Name of Licensee.	Section of Land Act under which Licensed.	Parish.	Allotment.	Section.	Area.	Annual Rental.	Reason for Voiding.
Northern	0142/138	F. Taggart	138	Amherst	24b	9A	A. R. P. 1 0 0	\$ 1.00	Non-compliance with conditions of licence

Department of Crown Lands and Survey,  
Melbourne, 15th September, 1967.

W. J. F. McDONALD,  
Minister of Lands.

## LOCAL LAND BOARDS.

IN pursuance of the provisions of Section 34 of the Land Act 1958, notice is hereby given that public hearings at the following places and times, will be conducted by the persons respectively mentioned, being duly appointed in that behalf.

## SCHEDULE.

BENALLA LAND INSPECTOR'S OFFICE, Monday, 2nd October, 1967, at 1 p.m.—E. Kennedy and F. F. Holt.

WANGARATTA LAND OFFICE, Monday, 2nd October, 1967, at 3.30 p.m.; Thursday, 5th October, 1967 at 9 a.m.—E. Kennedy and F. F. Holt.

WODONGA LAND INSPECTOR'S OFFICE, Tuesday, 3rd October, 1967, at 10 a.m.—E. Kennedy and F. F. Holt.

CHILTERN LAND INSPECTOR'S OFFICE, Tuesday, 3rd October, 1967, at 2.30 p.m.; Wednesday, 4th October, 1967, at 10 a.m.—E. Kennedy and F. F. Holt.

RED CLIFFS LAND OFFICE, Monday, 23rd October, 1967, at 9 a.m.—N. J. Fitzgerald.

ROBINVALE LAND INSPECTOR'S OFFICE, Thursday and Friday, 19th and 20th October, 1967, at 10 a.m.—T. A. Comte.

W. J. F. McDONALD,  
Minister of Lands.

Department of Crown Lands and Survey,  
Melbourne.

## TENDERS

## PUBLIC WORKS DEPARTMENT

TENDERS will be received at Public Works Department, Treasury-place, Melbourne, until TEN a.m. on dates shown and for purposes mentioned hereunder.

Particulars and tender forms available at Contracts Office, Room 7, Building Division, Parliament-place and at places indicated in brackets hereunder.

Abbreviations in brackets mean:—W.O.—Inspector of Works Office; P.S.—Police Station; C.S.—Consolidated School; H.E.S.—Higher Elementary School; H.S.—High School; S.S.—State School; T.S.—Technical School.

Tenders to be submitted on the Department's printed Tender Form and will not be received by telephone. All tenders must be on a "Firm Tender" basis. The lowest or any tender will not necessarily be accepted.

Address tenders to the Minister of Public Works, and endorse the envelope containing the tender "Tender for , closing Tuesday, ".

No preliminary deposit is required with any tender, but a successful tenderer will be required to pay a deposit for any accepted tender of \$5,000 or over.

Tuesday, 26th September, 1967.

## Building, Electrical and Mechanical Works.

Auburn.—Steel fire escape stairs, S.S. 2948.

Bacchus Marsh.—Erection of brick veneer extension, renovations to office, Police Station. (Amended Specification.) (W.O., Ballarat; P.S., Bacchus Marsh.)

Ballarat.—Enclosure of water softener, Mental Hospital. (W.O., Ballarat.)

Casterton.—Renovations, Residence, 39 Jackson-street, S.S. 2058. (Amended Specification.) (W.O., Hamilton.)

Caulfield.—Renovations, Main Building, Technical College.

Coatesville.—Completion of internal toilets, S.S. 4712.

Echuca.—Renovations, Residence, S.S. 208. (W.O., Shepparton; S.S., Echuca.) (Re-advertised.)

Elliminyt.—Renovations and erection of shelter pavilion, S.S. 2028. (W.O., Camperdown; S.S., Elliminyt.) (Re-advertised.)

Ellinbank.—Renovations, Residence, S.S. 2189. (Re-advertised.) (W.O., Warragul; S.S., Ellinbank.)

Hamilton.—Electrical installation, High School. (W.O., Hamilton; Warmmambool.)

Heatherton.—Replacement of Bio-Cabin and provision of change rooms and toilet facilities, Sanatorium.

Horsham.—Renovations, Residence, 36 Stewart-street, Lands and Survey Department. (Re-advertised.) (W.O., Horsham.)

Knox.—Erection of 1st, 2nd and 3rd stages, Composite Technical School.

Knox.—Electrical installation, Composite Technical School.

Knox.—Mechanical services, Composite Technical School.

Lakeside.—Erection of one proprietary type residence and garage, High School.

Melbourne.—Repairs and renovations to existing passenger lift, Titles Office, 283 Queen-street. (Re-advertised.)

Minhamite.—Renovations, S.S. 3999 and Residence. (W.O., Warmmambool.)

Mont Park.—Boiling water sterilizers, Gresswell Sanatorium.

Moonee Ponds.—Electrical installation, Central School No. 3987.

Moreland.—Erection of two shelter pavilions, S.S. 2837.

Noble Park.—Erection of Type 572C Assembly Hall, Technical School.

Noble Park.—Electrical installation, Technical School.

Noble Park.—Mechanical services, Technical School.

Noorat.—Water and fire service installation, S.S. 1178 and Residence. (Re-advertised.) (W.O., Camperdown.)

Northcote.—Erection of toilet block, Technical School.

Prahran.—Renovations, Secondary Teachers' College Hostel, "Kuranda", 174 Punt-road.

Ringwood East.—Connexion to sewer, S.S. 4180.

Seymour.—Connexion to sewer, High School. (W.O., Alexandra; H.S., Seymour.)

Vermont.—Increased office, staff and storeroom accommodation, S.S. 1022.

Whealers Hill.—Erection of additional class-rooms, "Hillside" Boys' Home.

**Furniture and Furnishings.**

Caulfield.—Supply and fix stage curtains, High School.  
Rosebud.—Supply and fix stage curtains, High School.

**Site Works.**

Benalla.—Earth-works, drainage, asphalt and concrete works, &c., Technical School. (W.O., Benalla, Shepparton and Wangaratta.)

Bendigo.—Sweep clean and sand seal existing primed roads, Mental Hospital. (W.O., Bendigo.)

Essex Heights.—Asphalt and concrete works, &c., S.S. 4903.

Heatherhill.—Preliminary earth-works, &c., High School.

Knox.—Pre-building site development involving approximately 110,000 cubic yards earth-works and underground drainage, Composite Technical School.

Shepparton.—Gravel paving, drainage and concrete works, &c., Technical School. (W.O., Shepparton.)

Wangaratta.—Asphalt, concrete and drainage works, &c., High School. (W.O., Wangaratta.)

Westgarth.—Drainage and asphalt works, S.S. 4177.

**Tuesday, 3rd October, 1967.****Building, Electrical and Mechanical Works.**

Burnley Gardens.—Evaporative coolers to Agrostology Glasshouse, Agriculture Department.

Edenhope.—Modifications to heating system, High School. (W.O., Ballarat and Horsham.)

Heatherhill.—Renovations, S.S. 4802. (Amended Specification.)

Melbourne.—Repairs to roofs and water service, 2, 4 and 6 Parliament-place, Public Works Department.

Moreland.—Additional accommodation, High School. (Specified Bills of Quantities Available.)

Moreland.—Mechanical services, High School.

Moreland.—Electrical services, High School.

Queenscliff.—Erection of Administration, Manual Arts and Science Wings, High School. (W.O., Geelong.)

Queenscliff.—Electrical installation, High School. (W.O., Geelong.)

Queenscliff.—Mechanical services, High School.

Various.—Erection of three proprietary type residences and garages at Koondrook S.S. 2268, Swan Hill North S.S. 4743, and Merbein High School. (W.O., Maryborough, Mildura and Swan Hill.)

Various.—Disconnexion, transportations and re-erection of approximately 200 existing timber-framed portable class-rooms from and to various school sites in Victoria.

Yarram.—Renovations and re-blocking, Residence, High School. (Re-advertised.) (W.O., Traralgon.)

**Furniture and Furnishings.**

Clayton.—Supply of blackout blinds and screens, Monash High School.

Malvern.—Supply and install gymnasium equipment, Toorak Teachers' College, "Stonnington".

Syndal.—Supply of school furniture, Technical School.

Wodonga.—Supply of school furniture, Technical School.

**Miscellaneous.**

Various.—Supply and delivery of laundry clothing, Mental Hospitals.

**Site Works.**

Echuca.—Concrete and drainage works, gravel paving, &c., High School. (Amended Specification.) (W.O., Bendigo and Shepparton; H.S., Echuca.)

Laverton North.—Concrete and drainage works, &c., S.S. 4964.

Malvern.—Asphalt, concrete and drainage works, &c., "Stonnington", Toorak Teachers' College.

Preston East.—Asphalt, concrete and drainage works, S.S. 4316.

Stawell.—Design and construction of swimming pool, Pleasant Creek Special School.

Warrnambool.—Asphalt, concrete and gravel paving, &c., High School. (W.O., Geelong, Hamilton and Warrnambool.)

**Tuesday, 10th October, 1967.****Building, Electrical and Mechanical Works.**

Brighton.—Fire service installation, Technical School.  
Colac South West.—Renovations, S.S. 4775. (W.O., Geelong; S.S., Colac South West.)

Croydon.—Fire service installation, High School.  
Essendon.—Supply and installation of sawdust plant, Technical School.

Grenville.—New out-offices and septic tank installation, S.S. 1153. (W.O., Ballarat.)

Heatherhill.—Electrical services, High School.

Heatherhill.—Erection of first stage, High School. (Specified Bills of Quantities Available.)

Heatherhill.—Mechanical services, High School.

Heatherston.—Electrical installation, Recreation Hall, Sanatorium.

Kerang.—Erection of type "800" Assembly Hall, High School. (W.O., Swan Hill.)

Kerang.—Electrical services, High School. (W.O., Bendigo and Swan Hill; H.S., Kerang.)

Kerang.—Mechanical services, High School. (W.O., Swan Hill and Bendigo.)

Kingston.—New toilet block and septic tank installation, S.S. 759. (W.O., Ballarat.)

Kyneton.—Installation of alternate water service, &c., High School. (Re-advertised.) (Amended Specification.) (W.O., Kyneton.)

Nhill.—Erection of Wool Classing Room, High School. (W.O., Horsham and Warracknabeal; P.S., Nhill.)

Nhill.—Electrical installation, High School. (W.O., Horsham and Warracknabeal; H.S., Nhill.)

Nhill.—Mechanical services, High School. (W.O., Ballarat and Horsham.)

Yarrunga.—Electrical installation, S.S. 4761. (W.O., Benalla and Wangaratta.)

**Miscellaneous.**

Various.—Removal, lopping and pruning of trees, Schools, Western District. (W.O., Ballarat.)

Wodonga.—Supply of Motor Mechanics equipment, Technical School.

M. V. PORTER,

Minister of Public Works.

Public Works Department,  
Melbourne, 3002, 18th September, 1967.

**Teaching Service Act 1958.****TEACHING SERVICE (CLASSIFICATION, SALARIES AND ALLOWANCES) REGULATIONS.****AMENDMENT No. 126.**

THE Teachers Tribunal, in pursuance of the powers conferred by the *Teaching Service Act 1958*, hereby amends the *Teaching Service (Classification, Salaries and Allowances) Regulations* in the manner following, that is to say:—

**PART V.—PROFESSIONAL OFFICERS.**

In clause 12, under the sub-heading "(d) Other Positions", after the words "Assistant Superintendent of Teacher Education" insert the words "Survey and Statistics Officer".

LOUIS F. C. GARLICK, Chairman.

G. FENNELL, Secretary.

Office of the Teachers Tribunal,  
Melbourne, 15th September, 1967.

**PUBLIC SERVICE NOTICES**

**CORRIGENDUM.**

PUBLIC SERVICE BOARD OF VICTORIA.

*Public Service Act 1958.*

**REGULATIONS.—PART IV.—SALARIES AND INCREMENTS.**

In Serial No. 1772 published in *Government Gazette*, No. 70, dated 13th September, 1967 :—

For—  
Secretary, General Health Branch .. .. 7,987

Read—  
Secretary, General Health Branch .. .. 7,897

By Order,  
V. P. SCULLY, Secretary.

Office of the Public Service Board,  
Melbourne, 19th September, 1967.

No. 1775.

*Public Service Act 1958, Section 50.*

**REGULATIONS.—PART IV.—SALARIES AND INCREMENTS.**

THE Public Service Board, in pursuance of the powers conferred by the *Public Service Act 1958*, hereby amends its Regulations as shown below :—

**SIXTH SCHEDULE.**  
**TEMPORARY EMPLOYEES.**

*Designations of Positions and Rates of Salaries.*

Department and Designation of Position.	Yearly Rate of Salary.		Increments (Annual).
	Minimum.	Maximum.	
CHIEF SECRETARY'S DEPARTMENT. <i>Office of the Chief Commissioner of Police.</i>	\$	\$	
Delete— Tradesman (Mechanic) ..	..	†	..
Add— Tradesman (Mechanic), Junior .. ..	..	†	..

† Rates in accordance with the Metal Trades award.  
|| In addition, an allowance at the rate of an amount equal to the difference between the appropriate award rate expressed as an annual figure and the actual salary rate appropriate to the yearly rate of salary prescribed above for the adult tradesman designation.

F. E. CAHILL, Chairman.  
V. P. SCULLY, Secretary.

Office of the Public Service Board,  
Melbourne, 28th August, 1967.

No. 1776.

**PUBLIC SERVICE ACT 1958.**

THE Public Service Board, in pursuance of the powers conferred by the *Public Service Act 1958*, hereby amends the Public Service (Public Service Board) Regulations as shown below—

**PART V.—ALLOWANCES.**

**DIVISION II.—OVERTIME AND STAND-BY ALLOWANCES.**

*Water Supply Department.—Regulation 107 (1).*

Under the heading "Mechanical Supervisors, Mechanical Assistants, Grades I. and II." the words "Mallee Pumping Stations, Frankston Centre and Bendigo Centre" are substituted for the words "Mallee Pumping Stations and Frankston Centre".

F. E. CAHILL, Chairman.  
V. P. SCULLY, Secretary.

Office of the Public Service Board,  
Melbourne, 24th August, 1967.

No. 1773

*Public Service Act 1958.*

THE Public Service Board, in pursuance of the powers conferred by the *Public Service Act 1958*, hereby amends the Public Service (Public Service Board) Regulations as shown below—

**PART IV.—SALARIES AND INCREMENTS.**

**DIVISION I.—GENERAL.**

The scale of rates shown in the proviso to Regulation 69 is deleted and the following scale of rates is inserted in lieu thereof—

Age.	Amount.	
	Male.	Female.
	\$	\$
Under 18 years .. ..	683	427
At 18 years .. ..	512	384
At 19 years .. ..	341	256
At 20 years .. ..	171	128

F. E. CAHILL, Chairman.

V. P. SCULLY, Secretary.

Office of the Public Service Board,  
Melbourne, 24th August, 1967.

No. 1774.

*Public Service Act 1958, Section 50.*

**REGULATIONS.—PART IV.—SALARIES AND INCREMENTS.**

THE Public Service Board, in pursuance of the powers conferred by the *Public Service Act 1958*, hereby amends its Regulations as shown below :—

**SIXTH SCHEDULE.**

**TEMPORARY EMPLOYEES.**

*Designations of Positions and Rates of Salaries.*

Department and Designation of Position.	Yearly Rate of Salary.		Increments (Annual).
	Minimum.	Maximum.	
CHIEF SECRETARY'S DEPARTMENT. <i>State Library, National Gallery, National Museum and Institute of Applied Science.</i>	\$	\$	
Add— Assistant (Female), National Museum*— Junior—			
At 16 years of age ..	..	1,002	..
At 17 years of age ..	..	1,073	..
At 18 years of age ..	..	1,203	..
At 19 years of age ..	..	1,393	..
At 20 years of age ..	..	1,591	..
Adult .. ..	1,800	2,022	1 of \$148 and 1 of \$74

\* Appointees shall be eligible, within the limits of this range, to receive allowances for qualifications in terms of the scales prescribed in Regulation 94 (1).

F. E. CAHILL, Chairman.

V. P. SCULLY, Secretary.

Office of the Public Service Board,  
Melbourne, 22nd August, 1967.

**PUBLIC SERVICE OF PAPUA AND NEW GUINEA.**

**LEGAL OFFICERS FOR NEW GUINEA.**

BARRISTERS and Solicitors are needed by the Public Service of Papua and New Guinea for the Territory's Department of Law. The main branches of the Department are the Headquarters of the Secretary for Law, the Legislative Draftsman's Office and the Public Solicitor's Office. Legal Officers, particularly prosecuting or defending officers and those engaged in Land Titles Restorations, must be prepared to travel to various parts of the Territory.

Salary including allowances is \$4,723–\$6,535 per annum for a single man (a married man receives an additional allowance of \$360 per annum) and \$4,295–\$6,107 per annum for a single woman. Income tax is at present about half that paid in Australia.

*Engagement* is by contract for a minimum of two years, or longer if preferred. Applicants employed by a Government authority may be considered for secondment to the Territory Service for an initial period of two years with preservation of existing rights.

*Leave*.—Three months' leave after each period of 21 months' service with assisted leave fares to Australia.

Details and application forms from—

RECRUITMENT OFFICER, Department of Territories  
Hobart-place, Canberra, A.C.T., 26001 .. 4 0477  
46 Market-street, Sydney, N.S.W., 2001 .. 29 5151  
188 Queen-street, Melbourne, Vic., 3000 .. 67 3604

Applications close in Canberra on 30th September. Please quote advertisement No. 391.

### PRIVATE ADVERTISEMENTS

NOTICE is hereby given that Viaduct Property Proprietary Limited has applied for a lease, pursuant to section 134 of the *Land Act 1958*, for a term of fifteen years from 12th November, 1967, in respect of allotments 53 and 54c, City of South Melbourne, containing 1 rood 11 4/10 perches as a site for service and repair of motor vehicles. 8803

NOTICE is hereby given that the Mallacoota Golf and Country Club has applied for a lease under Section 134 of the *Land Act 1958*, for a term of 21 years, in respect of an area of 156 acres 2 roods 18 perches being allotment 1d, Parish of Mallacoota as a site for amusement and recreation (Golf Course).—(HO28199.) 9102

Victoria.

#### ACT No. 391.—FIRST SCHEDULE.

I. THE RIGHT REVEREND WILLIAM AUCHTERLONIE HARDIE, of Cathedral Buildings, Ballarat, Bishop of Ballarat, head or authorized representative of the denomination known as the Church of England in the diocese of Ballarat, in Victoria, with the consent of The Corporation styled The Ballarat Diocesan Trustees, of Cathedral Buildings, Dana-street, Ballarat, the trustees of the land described in the subjoined statement of trusts, and of the Reverend Gordon Danby Steele, being the person entitled to minister in or occupy a building or buildings upon the said land, hereby apply to the Governor of the State of Victoria for leave to dispose of the said land by the means and for the purposes mentioned in the said statement of trusts, and I hereby certify that the said land hereinafter mentioned was reserved from sale by the Governor in Council as a site for Church of England purposes by Order in Council dated the 13th day of December, 1869. That the only trustee of the said land is the said Corporation styled The Ballarat Diocesan Trustees.

That the only buildings upon the said land are a church and church hall and that the only person entitled to minister in or occupy the same (if any) is the above-named Gordon Danby Steele.

Dated the 2nd day of May, 1967.

Signature of head or authorized representative.—X  
WILLIAM BALLARAT.

The Corporation styled The Ballarat Diocesan Trustees hereby consents to this application.

The common Seal of The Corporation styled The Ballarat Diocesan Trustees was affixed hereto in the presence of us being three of the Trustees authorized to attest the affixing of such Seal.

(SEAL) X WILLIAM BALLARAT, Trustee.  
ROBERT G. PORTER, Trustee.  
P. ROWLANDS, Trustee.

Signature of person entitled to minister in or occupy building or buildings.—G. STEELE.

#### STATEMENT OF TRUST.

*Description of Land*.—Ballarat (Mount Clear) Church of England, 1 acre, permanently reserved as a site for Church of England purposes by Order in Council of the 13th December, 1869. *Government Gazette*, 17th December, 1869, page 2009; 1 acre, Parish of Ballarat, County of Grant, being allotment 3, section 12. Commencing at the north-east angle of allotment 2, section 12, being a point on the

western alignment of the Midland Highway; bounded thence by that highway bearing 344 deg. 54 min. 200 links, by the State School Reserve bearing 254 deg. 54 min., 500 links, by allotment 4a bearing 164 deg. 54 min. 200 links; and thence by allotment 2 bearing 74 deg. 54 min. 500 links to the point of commencement.

*Name of Trustees*.—The Ballarat Diocesan Trustees of Cathedral Buildings, Dana-street, Ballarat.

*Powers of Disposition*.—To permit and suffer so much of the land as shall not be disposed of under the powers hereinafter specified to be used for the purposes for which it was promised or permanently reserved from sale by the Crown. To let lease sell mortgage or exchange if concurred in by the said Head or Authorized Representative for the time being, the said land or any portion thereof or any buildings thereon on such terms and conditions as shall be specified by such Head or Representative.

*Purposes to which proceeds of disposition are to be Applied*.—Moneys obtained from sale leases mortgages or exchanges to be paid to the Bishop to be dealt with for Church of England purposes as shall be directed by the said Trustees but to be subject nevertheless to the payment or deduction therefrom of all costs charges and expenses incurred by the Trustee or for which it shall be liable in respect of the trust estate.

CUTHBERT MORROW MUST & SHAW, Lydiard-street, Ballarat, solicitors for the applicant. 9038

NOTICE OF INTENTION TO APPLY FOR A LICENCE TO DIVERT WATER AND CUT RACE FROM THE RIVER MURRAY, AT PIAMBIE.

WE hereby give notice that we intend to apply for a licence empowering us to divert water for a term of four years to the extent of 300 acre-feet per annum at a maximum rate of 10 acre-feet per day of 24 hours for the irrigation of 100 acres, being part of allotment 37, Parish of Piambie, and to occupy certain Crown lands for works of diversion, and to cut a race thereon.

Any objection to such application must be forwarded, in writing, to reach the State Rivers and Water Supply Commission, Melbourne, before 30th September, 1967, being 30 days from the first publication of this notice.

GILMORE JOSEPH.  
HEATHER PAUL.

Boundary Bend, Victoria.

8988

NOTICE OF INTENTION TO APPLY FOR A LICENCE TO DIVERT WATER AND CUT RACE FROM THE RIVER MURRAY, AT PIAMBIE.

WE hereby give notice that we intend to apply for a licence empowering us to divert water for a term of four years to the extent of 300 acre-feet per annum at a maximum rate of 12 acre-feet per day of 24 hours for the purpose of irrigating 100 acres of lucerne, being part of allotment 29, Parish of Piambie, and to occupy certain Crown lands for works of diversion, and to cut a race thereon.

Any objection to such application must be forwarded, in writing, to reach the State Rivers and Water Supply Commission, Melbourne, before 15th October, 1967, being 30 days from the first publication of this notice.

DOUGLAS NORMAN DOHNT.  
GWENDOLINE STELLA DOHNT.

61 Gummow-street, Swan Hill.

Delaney & Dwyer, barristers and solicitors, 270 Campbell-street, Swan Hill. 9044

NOTICE OF INTENTION TO APPLY FOR A LICENCE TO DIVERT WATER AND CUT RACE (RE-ISSUE) FROM THE RIVER MURRAY, AT YUNGERA VIA BOUNDARY BEND.

WE hereby give notice that we intend to apply for a licence empowering us to divert water for a term of four years to the extent of 500 acre-feet per annum at a maximum rate of 16 acre-feet per day of 24 hours for the irrigation of 170 acres for pastures and fodder crops, being part of allotment 2A, 2B, 2c, section 527, Parish of Yungera, and to occupy certain Crown lands for works of diversion, and to cut a race thereon.

Any objection to such application must be forwarded, in writing, to reach the State Rivers and Water Supply Commission, Melbourne before 19th of October, 1967, being 30 days from the first publication of this notice.

H.L.B. CONSTRUCTIONS.

P.O. Box 1008, Mildura, Vic. Reg. Office: 1 Raglan-street, St. Arnaud, Victoria. 9088

## THE BALLARAT SEWERAGE AUTHORITY.

PURSUANT to section 119 (2) of the *Sewerage Districts Act 1958* (No. 6368), notice is hereby given of the intention to construct sewers to provide for properties situated in portions of the areas bounded approximately by—

*Borough of Sebastopol:*

Rubicon, Alfred, Hertford and Cromwell streets;

*City of Ballarat:*

York, English and Clayton streets and Canadian Creek;

more particularly as shown on maps which are open for inspection at this office between the hours of 9 a.m. and 4 p.m., Monday to Friday inclusive.

12th September, 1967.

9034 T. V. JOHNSTON, Acting Secretary.

## FRANKSTON SEWERAGE AUTHORITY.

NOTICE is hereby given that construction works will be carried out in the Excelsior Drive area in the Housing Commission, Victoria Forest Estate.

A map showing the precise boundaries of the works is open for inspection at the office of the Authority, Civic Centre, Frankston, during office hours.

G. C. PENTLAND, Secretary.

Civic Centre, Frankston. 9027

## WODONGA SEWERAGE AUTHORITY.

## GENERAL NOTICE.

THE above-mentioned Sewerage Authority, having made provision for carrying off the sewage from each and every property which or any part of which is within the Sewerage Area hereinafter described, do hereby declare that, on and after the 1st day of October, 1967, each and every property which, or any part of which, is within the said Sewerage Area shall be deemed to be a Sewered Property within the meaning of the *Sewerage District Act 1958*. The boundaries of the Sewerage Area hereinbefore referred to are:—

Commencing at a point on the south side of Jack Hore-place with intersection of western side of Havelock-street; then easterly across Havelock-street and along the southern side of Railway Reserve to a point 420 feet from the eastern side of Havelock-street; thence south-westerly till intersection with the northern side of Ethel-street at a point 420 feet south-east from the north-eastern corner of Havelock and Ethel streets; thence south-westerly across Ethel-street to a point being the intersection of the southern side of Ethel-street and the western side of Ethel-lane; thence south-westerly along the western side of Ethel-lane till intersection with the northern side of Lawrence-street; thence southerly across Lawrence-street intersecting the southern side of Lawrence-street at a point 350 feet west of the south-western corner of Lawrence and Anne streets; then easterly along the southern side of Lawrence-street till intersection with the western side of Anne-street; thence southerly along the western side of Anne-street till intersection with the north-eastern side of Tallangatta-road; thence south-westerly across Tallangatta-road to a point being the intersection of the southern side of Tallangatta-road and the western side of Mitchell-street; thence southerly along the western side of Mitchell-street till intersection with Brockley-street; thence southerly across Brockley-street and continuing in the same direction along the western side of Mitchell-street till intersection with the northern side of Wilson-street; thence westerly along the northern side of Wilson-street for a distance of 390 feet; thence southerly across Wilson-street to a point being the intersection of the southern side of Wilson and the western side of Leonard-street; thence southerly along the western side of Leonard-street till intersection with the northern side of Richardson-street; thence southerly across Richardson-street to the south-east corner of Richardson-street and Schubert-crescent; thence in an easterly direction on the south side of Richardson-street to the intersection of the western side of Mitchell-street; thence easterly across Mitchell-street and continuing easterly a distance of 975 feet from the intersection of the south-east corner of Richardson-street and Mitchell-street; thence in a northerly direction 2,120 feet to the south side of Brockley-street at a point 770 feet east of Mitchell-street; thence westerly along the south side of Brockley-street a distance of 570 feet; thence northerly across Brockley-street and continuing northerly 595 feet to the south side of Tallangatta-road at a point 195 feet east of Mitchell-street; thence in a north-easterly direction 200 feet across Tallangatta-road to the intersection of Tallangatta-road and the east side of Anne-street; thence south-easterly along the northern side of Tallangatta-road to a western boundary of Railway Reserve

a distance of 1,430 feet; thence 1,545 feet along the south-west side of Railway Reserve to the south-west corner of Lawrence-street and Railway Reserve; thence 66 feet across Lawrence-street to the north side of Lawrence-street at a point 40 feet west of Queen-street; thence along the north side of Lawrence-street in an easterly direction across Queen-street; thence 1,035 feet to the north-west corner of Wigg and Lawrence streets; thence in a northerly direction on the west side of Wigg-street to Reid-street; thence across Reid-street and continuing in a northerly direction to Mint-street; thence across Mint-street and continuing in a northerly direction to the south-west corner of Wigg and Bradford streets; thence in a westerly direction on the south side of Bradford-street, across Queen-street and continuing in a westerly direction a distance of 770 feet to the south-east corner of Huon-street and Railway Reserve; thence in a northerly direction along the western side of Railway Reserve a distance of 1,090 feet; thence in a westerly direction a distance of 260 feet to the eastern side of Hovell-street; thence north a distance of 93 feet to a point on the north side of Wodonga-street 333 feet east of Day-street; thence in a westerly direction on the north side of Wodonga-street to Day-street; thence across Day-street and continuing in a westerly direction a distance of 345 feet to a point on the north-east corner of High and Wodonga streets; thence in a south-easterly direction along the eastern side of High-street, across Wodonga-street; thence on east side of High-street to a distance of 530 feet; thence in an easterly direction 500 feet; thence in a south-westerly direction till the intersection with the northern side of Huon-street; thence south-westerly across Huon-street intersection, the southern side of Huon-street, to a point 170 feet west from the south-west corner of Huon and Hovell streets; thence south-easterly along the southern side of Huon-street till intersection of the western side of Hovell-street; thence south-westerly along the western side of Hovell-street for a distance of 140 feet; thence north-westerly for a distance of 180 feet; thence a distance of 65 feet north-westerly for a distance of 150 feet; thence south-westerly for a distance of 325 feet; thence south-easterly for a distance of 170 feet; thence south-westerly till the intersection with the northern side of Osburn-street; thence across Osburn-street intersecting the southern side of Osburn-street to a point 165 feet west from south-west corner of Osburn and Hovell streets; thence in a north-easterly direction along the southern side of Osburn-street to a point 345 feet from the south-eastern corner of High and Osburn streets; thence in a south-westerly direction and parallel to High-street a distance of 535 feet; then south-easterly a distance of 60 feet; thence south-westerly intersecting the northern side of South-street at a distance of 390 feet east of the eastern side of High-street; thence across South-street at a distance of 330 feet east of the eastern side of High-street; thence south-westerly a distance of 150 feet; thence south-east a distance of 70 feet; thence south-westerly across Railway Reserve and across Jack Hore-place till the intersection with southern side of Jack Hore-place, intersecting the southern side of Jack Hore-place to a point 155 feet west from the south-west corner of Jack Hore-place and Hovell-street; thence in a south-easterly direction to Hovell-street, and continuing in a south-easterly direction in Jack Hore-place to the point of commencement.

By order of the Wodonga Sewerage Authority,

9028 H. W. DRAPER, Chairman.  
G. J. MORTON, Secretary.

## CITY OF CASTLEMAINE.

## LOAN No. 41.

*Notice of Intention to Borrow the Sum of \$3,750 for Permanent Works and Undertakings.*

NOTICE is hereby given that the Council of the City of Castlemaine proposes to borrow the principal sum of \$3,750 secured by a charge over the general rates of the municipality, by the grant of a mortgage in accordance with the provisions of the *Local Government Act 1958*.

1. The maximum interest that may be paid is 5.875 per cent. per annum.
2. The purpose for which the loan is to be applied is to meet the balance of cost for erecting a factory building at 65-67 Templeton-street, Castlemaine, pursuant to an agreement made under the provisions of Part XLA of the *Local Government Act 1958*.
3. The period of the loan shall be nineteen years.
4. The moneys borrowed shall be repayable by providing out of the municipal fund 38 equal half-yearly instalments of \$165.11 each, including principal and interest on the 1st day of June and the 1st day of December, during the currency of the loan. The first instalment shall be payable on the 1st day of June, 1968.

5. Such moneys shall be repayable to the National Bank Savings Bank Ltd., Melbourne.

Plans and specifications of the proposed works are open for inspection at the office of the Council of the City of Castlemaine, at the Town Hall, Castlemaine.

Dated 11th September, 1967.

9005

I. C. SMITH, Town Clerk.

CITY OF DONCASTER AND TEMPLESTOWE.

NOTICE is hereby given that pursuant to the provisions of the *Local Government Act 1958*, the Council of the City of Doncaster and Templestowe doth order that the names of the following streets within the Municipality be changed as set out hereunder:—

*Old Name; New Name; Present Location.*

- (a) That part of Warringal-street; between the eastern boundary of Swanston-street and the eastern boundary of Pleasant-road as shown on L.P.10285; Gisborne-street; west of Swanston-street to Pleasant-road.
- (b) That part of Lightwood-crescent shown on L.P.73565 from a line joining the western boundaries of Lots 27 and 33 to a line joining the intersection of the northern and eastern property lines of lot 23 and the common boundary of lots 1 and 28; Sinclair-avenue; west of Colonsay-street.

9020

H. M. F. MEARS, Acting Town Clerk.

CITY OF DONCASTER AND TEMPLESTOWE.

LOAN No. 104.

*Notice of Intention to Borrow the sum of \$50,000 for Permanent Works and Undertakings.*

NOTICE is hereby given that the Council of the City of Doncaster and Templestowe proposes to borrow the principal sum of \$50,000 secured by a charge over the general rates of the municipality, such sum to be raised by the grant of a mortgage in accordance with the provisions of the *Local Government Act 1958*.

1. The maximum rate of interest that may be paid is 5.75 per centum per annum.

2. The purpose for which the loan is to be applied is Capital Works in the Council's electric supply undertaking—\$50,000.

3. The period of the loan will be ten years.

4. The moneys borrowed shall be repayable by providing out of the municipal fund twenty equal half-yearly instalments of \$3,322.07 each including principal and interest on the 1st day of January and the 1st day of July during the currency of the loan. The first instalment shall be payable on the 1st day of July, 1968.

5. Such moneys shall be repayable to the Trustees for the time being of the Australian Natives' Association, 23-32 Elizabeth-street, Melbourne.

The plans and specifications and the estimate of the cost of the proposed works and a statement showing the proposed expenditure of the moneys to be borrowed are open for inspection at the office of the Council of the City of Doncaster and Templestowe, at the Municipal Offices, Doncaster-road, Doncaster.

9070

H. M. F. MEARS, Acting Town Clerk.

CITY OF FITZROY.

LOAN No. 27.—Re-advertised.

*Notice of Intention to Borrow the Sum of \$40,000 for Permanent Works and Undertakings.*

NOTICE is hereby given that the Council of the City of Fitzroy proposes to borrow the principal sum of \$40,000 secured by a charge over the general rates of the municipality, such sum to be raised by the grant of a mortgage in accordance with the provisions of the *Local Government Act 1958* and its amendments.

1. The amount of the principal moneys which it is proposed to borrow is \$40,000.

2. The maximum rate of interest that may be paid is 5½ per centum per annum.

3. The period of the loan shall be twenty years and the times at which the moneys borrowed are to be repayable will be the 1st day of March and September in each year during the currency of the loan, commencing on the 1st day of March, 1968. The place of repayment will be the Commonwealth Savings Bank of Australia, Melbourne.

4. The purpose for which the loan is to be applied is for the construction of an Infant Welfare, Pre-natal and Dental Clinic Centres and Hallkeepers Residence, Young-street, Fitzroy.

5. The manner in which the loan is to be liquidated is by provision out of the municipal fund in each year during the currency of the loan of the sum of \$1,713.06 which includes principal and interest.

6. The plans and specifications and the estimated cost of such works and the statement showing the proposed expenditure of the money to be borrowed are open for inspection at the office of the Council, Town Hall, Fitzroy during office hours.

9073

J. O'HALLORAN, Town Clerk.

CITY OF FITZROY.

LOAN No. 28.—Re-advertised.

*Notice of Intention to Borrow the Sum of \$46,000 for Permanent Works and Undertakings.*

NOTICE is hereby given that the Council of the City of Fitzroy proposes to borrow the principal sum of \$46,000 secured by a charge over the general rates of the municipality, such sum to be raised by the grant of a mortgage in accordance with the provisions of the *Local Government Act 1958* and its amendments.

1. The amount of the principal moneys which it is proposed to borrow is \$46,000.

2. The maximum rate of interest that may be paid is 5½ per centum per annum.

3. The period of the loan shall be ten years and the times at which the moneys borrowed are to be repayable will be the 1st day of March and September in each year during the currency of the loan, commencing on the 1st day of March, 1968.

4. The purposes for which the loan is to be applied is for Road Works, reconstruction of Rushall-crescent.

5. The manner in which the loan is to be liquidated is by provision out of the Municipal Fund in each year during the currency of the loan of the sum of \$3,056.31 which includes principal and interest.

6. The plans and specifications and the estimated cost of such works and the statement showing the proposed expenditure of the money borrowed are open for inspection at the office of the Council, Town Hall, Fitzroy, during office hours.

9074

J. O'HALLORAN, Town Clerk.

CITY OF FRANKSTON.

LOAN No. 120.

*Notice of Intention to Borrow the Sum of \$50,000 for Permanent Works and Undertakings.*

NOTICE is hereby given that the Council of the City of Frankston proposes to borrow the principal sum of \$50,000 secured by a charge over the general rates of the municipality, such sum to be raised by the grant of a mortgage in accordance with the provisions of the *Local Government Act 1958*.

1. The maximum rate of interest that may be paid is 5½ per centum per annum.

2. The purposes for which the loan is to be applied is—  
Outfall Drainage.

3. The period of the loan shall be twenty years.

4. The money borrowed shall be repayable by providing out of the municipal fund half-yearly instalments of approximately \$2,141.32 each including principal and interest on the 15th day of December and the 15th day of June during the currency of the loan. The first instalment shall be payable on the 15th day of June, 1968.

5. Such moneys shall be repayable at The Colonial Mutual Life Assurance Society, Melbourne.

The plans and specifications and the estimate of the cost of the proposed works and a statement showing the proposed expenditure of the moneys to be borrowed are open for inspection at the office of the Council of the City of Frankston at Davey-street, Frankston.

G. C. PENTLAND, Town Clerk.

Civic Centre, Frankston.

9017

CITY OF FRANKSTON.

LOAN No. 117.

*Notice of Intention to Borrow the Sum of \$100,000 for Permanent Works and Undertakings.*

NOTICE is hereby given that the Council of the City of Frankston proposes to borrow the principal sum of \$100,000 secured by a charge over the general rates of the municipality, such sum to be raised by the grant of a mortgage in accordance with the provisions of the *Local Government Act 1958*.

1. The maximum rate of interest that may be paid is 5½ per centum per annum.



2. The purposes for which the loan is to be applied are—

Town Planning—Land Purchase .. .	\$50,000
Construction of Pre-school and Infant Welfare Centres .. .	15,000
Erection of Public Hall, Bruce Park (part cost)	20,000
Erection of Comfort Station, Olivers Hill (part cost) .. .	3,000
Initial Recreation Reserve Development—	
Ballam Park .. .	6,000
Delacombe Park .. .	6,000
	<u>\$100,000</u>

3: The period of the loan shall be twenty years.

4. The money borrowed shall be repayable by providing out of the municipal fund half-yearly instalments of approximately \$4,282.64 each including principal and interest on the 10th day of December and the 10th day of June during the currency of the loan. The first instalment shall be payable on the 10th day of June, 1968.

5. Such moneys shall be repayable at The Commercial Savings Bank of Australia Limited, Melbourne.

The plans and specifications and the estimate of the cost of the proposed works and a statement showing the proposed expenditure of the moneys to be borrowed are open for inspection at the office of the Council of the City of Frankston at Davey-street, Frankston.

G. C. PENTLAND, Town Clerk.

Civic Centre, Frankston.

9018

CITY OF KEILOR.

LOAN No. 76.

Notice of Intention to Borrow the Sum of Thirty Thousand Dollars for Permanent Works and Undertakings.

NOTICE is hereby given that the Council of the City of Keilor proposes to borrow the sum of Thirty thousand dollars (\$30,000) secured by a charge over the general rates of the municipality, such sum to be raised by the grant of a mortgage in accordance with the provisions of the Local Government Act 1958.

1. The maximum interest that may be paid is 5.75 per centum per annum.

2. The purposes for which the loan is to be applied are as under:—

(a) Part Council contribution to the Elizabeth-street group private street construction scheme .. .	\$8,000
(b) Council contribution to the Arthur-street group private street construction scheme .. .	\$22,000
	<u>Total .. \$30,000</u>

3. The period of the loan shall be ten years.

4. The moneys borrowed shall be repayable by providing out of the municipal fund twenty approximately equal half-yearly instalments of approximately \$1,993.00 on the 1st day of July and the 1st day of January during the currency of the loan. The first instalment shall be payable on the 1st day of July, 1968.

5. Such money shall be repayable at the English, Scottish and Australian Savings Bank Limited, Niddrie.

Plans and specifications and the estimate of the cost of the proposed works and the statement showing the proposed expenditure of the money to be borrowed are open for inspection at the Municipal Offices, Calder Highway, Keilor, during office hours.

Dated this 18th day of September, 1967.

9086

R. F. B. KELLY, Acting Town Clerk.

CITY OF MILDURA.

LOAN No. 70.

Notice of Intention to Borrow the Sum of \$30,000 for Permanent Works and Undertakings.

NOTICE is hereby given that the Council of the City of Mildura intends to borrow the principal sum hereinafter mentioned secured by a charge over the general rates of the City of Mildura by the grant of a mortgage in accordance with the provisions of the Local Government Act and notice is hereby further given—

(a) that the amount of the principal sum which it is proposed to borrow is \$30,000;

(b) the maximum rate of interest that may be paid is 5½ per centum per annum;

(c) the moneys borrowed and interest thereon are to be repayable by 30 half-yearly instalments each of approximately \$1,518 on the 1st day of June and the 1st day of December in each year and the place at which such moneys are to be repayable is the State Savings Bank, corner Elizabeth and Bourke streets, Melbourne, the first instalment shall be payable on the 1st day of June, 1968;

(d) the purposes for which the loan is to be applied are Council's proportion in part C.A.R. Grant Works—

Sixth-street (Lockside-avenue to Cherry-avenue) .. .	\$7,280
San Mateo-avenue (Twelfth to Thirteenth streets) .. .	\$5,615
Thirteenth-street (Deakin-avenue to San Mateo-avenue) (including kerbing and channelling) .. .	\$17,105
	<u>\$30,000</u>

(e) the loan is to be liquidated by appropriation out of the Municipal Fund;

(f) the plans, specifications and estimate for the cost of such works and the statement showing the proposed expenditure of the money to be borrowed are open for inspection at the Office of the Council, Civic Buildings, Deakin-avenue, Mildura, during office hours.

20th September, 1967.

9025

W. J. DOWNIE, Town Clerk.

CITY OF MILDURA.

LOAN No. 71.

Notice of Intention to Borrow the Sum of \$20,000 for Permanent Works and Undertakings.

NOTICE is hereby given that the Council of the City of Mildura intends to borrow the principal sum hereinafter mentioned secured by a charge over the general rates of the City of Mildura by the grant of a mortgage in accordance with the provisions of the Local Government Act and notice is hereby further given—

(a) that the amount of the principal sum which it is proposed to borrow is \$20,000;

(b) the maximum rate of interest that may be paid is 5½ per centum per annum;

(c) the moneys borrowed and interest thereon are to be repayable by twenty half-yearly instalments each of approximately \$1,328.83 on the 1st day of June and the 1st day of December in each year and the place at which such moneys are to be repayable is the National Bank Savings Bank of Australasia Ltd., 271-279 Collins-street, Melbourne, the first instalment shall be payable on the 1st day of June, 1968;

(d) the purposes for which the loan is to be applied are Council's proportion in part C.A.R. Grant Works—

Thirteenth-street area .. .	\$20,000
-----------------------------	----------

(e) the loan is to be liquidated by appropriation out of the Municipal Fund;

(f) the plans, specifications and estimate for the cost of such works and the statement showing the proposed expenditure of the money to be borrowed are open for inspection at the Office of the Council, Civic Buildings, Deakin-avenue, Mildura, during office hours.

20th September, 1967.

9026

W. J. DOWNIE, Town Clerk.

CITY OF MOORABBIN.

LOAN No. 153.

Notice of Intention to Borrow the Sum of \$30,000 for Permanent Works and Undertakings.

NOTICE is hereby given that the Council of the City of Moorabbin proposes to borrow the principal sum of Thirty thousand dollars secured by a charge over the general rates of the municipality, such sum to be raised by the grant of a mortgage in accordance with the provisions of the Local Government Act 1958.

1. The maximum rate of interest that may be paid is 5½ per cent. per annum.

2. The purposes for which the loan is to be applied are—

Construction of main drain, Argus-street—Wilson-street, Cheltenham .. .	\$28,000
Erection of pedestrian traffic lights, South-road, Moorabbin, near Fletcher-street—part cost .. .	2,000
	<u>\$30,000</u>

3. The period of the loan shall be fifteen years.

4. The moneys borrowed shall be repayable by providing out of the municipal fund 30 half-yearly instalments of approximately \$1,518 each including principal and interest on the 1st day of June and the 1st day of December, during the currency of the loan. The first instalment shall be payable on the 1st day of June, 1968.

5. Such moneys shall be repayable to The Commissioners of The State Savings Bank of Victoria at the office of the said Commissioners, corner Elizabeth and Bourke streets, Melbourne.

The plans and specifications and the estimate of the cost of the proposed works and a statement showing the proposed expenditure of the moneys to be borrowed are open for inspection at the office of the Council of the City of Moorabbin, at Nepean Highway, Moorabbin.

Dated the 18th day of September, 1967.

9006

V. A. SMITH, Town Clerk.

#### CITY OF NORTHCOTE.

BYLAW No. 173.

A Bylaw of the City of Northcote, made under the provisions of the *Local Government Act 1958*, and numbered 173, for altering Bylaw No. 93, and for controlling and managing and preserving public reserves of which the management is vested in the Council, and for other purposes.

IN pursuance of the powers conferred by the *Local Government Act* and of all other powers in that behalf it thereunto enabling the Mayor, Councillors and Citizens of the City of Northcote order as follows:

1. The following shall be added after the words "Golf course land within the area bounded by the Merri Creek, Beavers-road, Leinster-grove and Normanby-avenue" in the First Schedule to Bylaw No. 93:—

"John Cain Memorial Park".

Resolution for passing this Bylaw agreed to by the Council of the City of Northcote on the 10th day of July, 1967, and confirmed on the 7th day of August, 1967.

The common seal of the Mayor, Councillors and Citizens of the City of Northcote was hereunto affixed in the presence of—

(SEAL) H. J. GRIFFITHS, Mayor.  
R. E. BRYAN, Councillor.  
A. J. HILL, Town Clerk.

Approved by the Governor in Council on the 5th day of September, 1967.—J. ROSSITER, Acting Clerk of the Executive Council. 8990

#### CITY OF OAKLEIGH.

LOAN No. 109.

*Notice of Intention to Borrow the Sum of \$50,000 for Permanent Works and Undertakings.*

NOTICE is hereby given that the Council of the City of Oakleigh proposes to borrow the principal sum of Fifty Thousand Dollars (\$50,000) secured by a charge over the general rates of the municipality, such sum to be raised by the grant of a mortgage in accordance with the provisions of the *Local Government Act 1958*.

1. The maximum rate of interest that may be paid is 5½ per cent. per annum.

2. The purpose for which the loan is to be applied is Road reconstruction—Barkly-street.

3. The period of the loan shall be 10 years.

4. The moneys borrowed shall be repayable by providing out of the municipal fund twenty half-yearly instalments of approximately \$3,322 each including principal and interest on the 1st day of June and the 1st day of December during the currency of the loan. The first instalment shall be payable on the 1st day of June, 1968.

5. Such moneys shall be repayable to The Commissioners of The State Savings Bank of Victoria at the office of the said Commissioners, corner Elizabeth and Bourke streets, Melbourne.

The plans and specifications and the estimate of the cost of the proposed works and a statement showing the proposed expenditure of the moneys to be borrowed are open for inspection at the office of the Council of the City of Oakleigh at Atherton-road, Oakleigh.

Dated 12th September, 1967.

9019

J. H. HOCKING, Town Clerk.

#### CITY OF RICHMOND.

LOAN No. 47.

*Notice of Intention to Borrow.*

NOTICE is hereby given that the Council of the City of Richmond intends to borrow \$30,000 (Thirty thousand dollars) secured by a charge over the general rates of the municipality by the grant of a mortgage in accordance with the provisions of the *Local Government Acts*.

In connexion therewith the following information is stated:—

(a) The amount of the principal moneys which it is proposed to borrow is \$30,000.

(b) The maximum rate of interest that may be paid is \$5.875 per centum per annum.

(c) The times which the moneys borrowed are to be repayable are the 1st day of June, 1968, and the 1st days of June and December, during the years 1968-1982 inclusive, and that the place such moneys shall be repayable is at the Bank of New South Wales, Richmond.

(d) The purpose for which the loan is to be applied is—

The erection of a new pork house at the Richmond Municipal Abattoirs.

(e) The manner in which the loan is to be liquidated is by provision out of the municipal fund in each half-year, during the currency of the loan of the sum of \$1,518.24, which includes principal and interest.

The plans and specifications and estimate of the cost of the works and a statement showing the proposed expenditure of the moneys to be borrowed, are open for inspection at the Town Hall.

Dated this 12th day of September, 1967.

8991

C. C. EYRES, Town Clerk.

#### CITY OF SPRINGVALE.

LOAN No. 128.

*Notice of Intention to Borrow the Sum of \$25,000 for Permanent Works and Undertakings.*

NOTICE is hereby given that the Council of the City of Springvale, in pursuance of powers conferred by the *Local Government Acts*, intends to borrow the sum of \$25,000 secured by a charge over the General Rates of the municipality, such sum to be raised by the grant of a mortgage in accordance with the said *Acts* and states:—

(a) The amount of principal moneys it is proposed to borrow is \$25,000.

(b) The maximum rate of interest that may be paid is 5.875 per cent. per annum.

(c) The period of the loan will be fifteen years and the time or times at which the moneys borrowed are to be repayable are the 30th day of May and the 30th day of November in each year during the currency of the loan commencing on the 30th day of May, 1968. The place of repayment will be the Commonwealth Savings Bank of Australia at Springvale.

(d) The purpose for which the loan is to be applied is for permanent works and undertakings, viz.:—

Part cost of construction of Edmond and Prince streets and Warwick-avenue, Springvale \$25,000

(e) The loan is to be liquidated by 30 half-yearly payments of approximately \$1,265.20 including principal and interest, payable out of the Municipal Fund.

Plans and specifications and an estimate of the cost of such works and undertakings, and a statement showing the proposed expenditure of the money to be borrowed, are open for inspection by ratepayers, during office hours, at the City Offices, Springvale, for one month after the publication of this notice.

Dated at Springvale this 18th day of September, 1967.

9021

H. L. WILLIAMS, Town Clerk.

#### SHIRE OF ALTONA

BY-LAW No. 35.

#### HEALTH ACT REGISTRATION FEES BY-LAW

NOTICE is hereby given that the Council of the Shire of Altona has made By-Law No. 35—Health Act Registration Fees By-Law—for the purposes of prescribing the fees to be paid to the Council for registration of premises and food vending machines required to be registered under the said *Act*, and for the renewal and transfer of such registrations. The resolution for passing the By-Law was agreed to on 24th April, 1967, and the resolution

confirmed on 22nd May, 1967. The By-Law was submitted to Commission of Public Health on 1st of August, 1967, and confirmed by Governor in Council on 22nd of August, 1967.

Copies of the By-Law are open for inspection free of charge during office hours at the office of the Council at the Civic Offices at 115 Civic Parade, Altona.

9007 JAMES W. WATERS, Shire Secretary.

SHIRE OF ALTONA.

LOAN No. 66.—\$100,000.

NOTICE is hereby given that the Council of the Shire of Altona proposes to borrow the principal sum of \$100,000 secured by a charge over the General Rates of the Municipality such sum to be raised by the grant of a mortgage in accordance with the provisions of the *Local Government Act 1958*—

1. The maximum rate of interest that may be paid is 5.75 per cent. per annum.
2. The purposes for which the loan is to be applied are—
 

(a) Drainage works—Altona North Recreation Reserve	\$38,000
(b) Hockey Pavilion—Grant Reserve, Altona	20,000
(c) Road works—Chambers-road, McArthurs-road to Barnes-road—Part cost	42,000
	\$100,000

3. The period of the loan shall be ten years.
4. The loan shall be repaid by providing out of the Municipal Fund twenty half-yearly instalments of approximately \$6,644.14 each including principal and interest on the 30th day of May and the 30th day of November during the currency of the loan. The first instalment shall be payable on the 30th day of May, 1968.
5. Such money shall be repayable at the office of the Commonwealth Savings Bank, Melbourne.

The plans and specification and the estimate of cost of the proposed works and a statement showing the proposed expenditure of the moneys to be borrowed are open for inspection at the Civic Offices, 115 Civic-parade, Altona.

9013 JAMES W. WATERS, Shire Secretary.

SHIRE OF ALTONA.

LOAN No. 67.—\$100,000.

NOTICE is hereby given that the Council of the Shire of Altona proposes to borrow the principal sum of \$100,000 secured by a charge over the general rates of the municipality, such sum to be raised by the grant of a mortgage in accordance with the provisions of the *Local Government Act 1958*—

1. The maximum rate of interest that may be paid is 5.75 per cent. per annum.
2. The purposes for which the loan is to be applied are:—
 

(a) Council contribution Millers-road duplication Noordenne-avenue to Australian Carbon Black	\$22,000
(b) Council contribution—Mason-street, construction—Millers-road to Mills-street	20,000
(c) Chambers-road construction—McArthurs-road to Barnes-road—part cost	13,000
(d) Main drains—Laverton Estate—Council contribution	10,000
(e) McArthurs-road construction—Chambers-road to Fleetways Pty. Ltd.	35,000
	\$100,000

3. The period of the loan shall be ten years.
4. The loan shall be repaid by providing out of the Municipal Fund twenty half-yearly instalments of approximately \$6,644.14 each including principal and interest on the 1st day of June and the 1st day of December during the currency of the loan. The first instalment shall be payable on the 1st day of June, 1968.

5. Such moneys shall be repayable to the Commissioners of the State Savings Bank of Victoria at the office of the said Commissioners, corner Elizabeth and Bourke streets, Melbourne.

The plans and specification and the estimate of cost of the proposed works and a statement showing the proposed expenditure of the moneys to be borrowed are open for inspection at the Civic Offices, 115 Civic-parade, Altona.

9075 JAMES W. WATERS, Shire Secretary.

SHIRE OF BERWICK.

WHEREAS the Council of the Shire of Berwick deems it expedient to exercise its power of taking compulsorily the land delineated and hatched on the map at the foot hereof for the work or undertaking of opening a road thereon: And whereas the Council has caused to be prepared a map and other papers setting out the general description of the work or undertaking for which the land proposed to be taken is to be used, the description of the land proposed to be taken and the names of the owners or reputed owners, lessees or reputed lessees, mortgagees and occupiers of that land so far as those names are known to or can be ascertained by the Council: And whereas the said map and other papers are deposited at the office of the said Council at Pakenham East and are and shall be open for inspection by all persons interested at all reasonable hours for the space of 40 clear days after the publication of this notice in the *Government Gazette*: Now notice is hereby given to all persons affected by the proposed taking of the said land to set forth, in writing, addressed to the Council or Shire Secretary, within 40 clear days of the publication of this notice in the *Government Gazette*, all objections which they may have to the taking of the said land.

Part of lot 193, lodged plan 5068, Parish of Gembrook, volume 1671, folio 095.

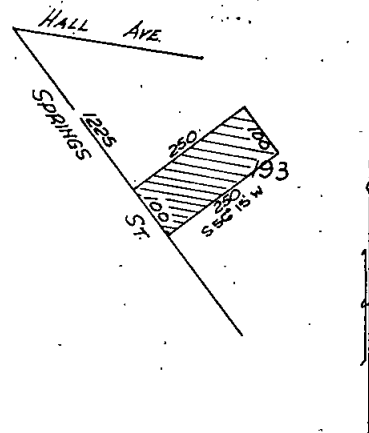

Dated the 21st day of August, 1967.

8995 By order of the Council,  
B. J. WALLIS, Shire Secretary.

SHIRE OF CROYDON.

NOTICE is hereby given that the Council of the Shire of Croydon did, at a meeting held on the 7th August and adjourned to 11th August, 1967, order that the names of the streets within the Shire of Croydon be changed as set out hereunder—

Old name; New name; Location.

Grandview-grove; Bemboka-road; off Plymouth-road.  
Rangeview-parade; Omeo-parade; off Brysons-road.

9023 K. A. MCKAY, Shire Secretary.

SHIRE OF MANSFIELD.

LOAN No. 58.

Notice of Intention to Borrow the Sum of \$11,790 for Permanent Works and Undertakings.

NOTICE is hereby given that the Council of the Shire of Mansfield proposes to borrow the principal sum of Eleven thousand seven hundred and ninety dollars, secured by a charge over the general rates of the municipality, such sum to be raised by the grant of a mortgage in accordance with the provisions of the *Local Government Act 1958*.

1. The maximum rate of interest that may be paid is 5½ per cent. per annum.
2. The purpose for which the loan is to be applied is purchase of plant (three motor trucks).
3. The period of the loan shall be five years.
4. The moneys borrowed shall be repayable by providing out of the municipal fund ten half-yearly instalments of approximately \$1,365 each, including principal and interest on the 1st day of June and the 1st day of December, during the currency of the loan. The first instalment shall be payable on the 1st day of June, 1968.

5. Such moneys shall be repayable to the Commissioners of the State Savings Bank of Victoria at the office of the said Commissioners, corner Elizabeth and Bourke streets, Melbourne.

The plans and specifications and the estimate of the cost of the proposed works and a statement showing the proposed expenditure of the moneys to be borrowed, are open for inspection at the office of the Council of the Shire of Mansfield, at Mansfield.

Dated 10th September, 1967.

8993 R. WOMERSLEY, Shire Secretary.

SHIRE OF MINHAMITE.

LOAN No. 8.

Notice of Intention to Borrow the Sum of \$10,000 for Permanent Works and Undertakings.

NOTICE is hereby given that the Council of the Shire of Minhamite proposes to borrow the sum of Ten thousand dollars on the credit of the municipal revenues of the President, Councillors and Ratepayers of the said Shire, such sum to be raised by the grant of a mortgage in accordance with the provisions of the *Local Government Act 1958*.

1. The maximum rate of interest that may be paid is \$5.75 per centum per annum.
2. The purpose for which the loan is to be applied is the provision of a staff residence at Macarthur.
3. The period of the loan shall be ten (10) years.
4. The moneys borrowed shall be repayable by providing out of the municipal fund twenty half-yearly instalments of \$664.41 each, including principal and interest on the 1st days of December and June, during the currency of the loan. The first instalment shall be repayable on the 1st day of June, 1968.
5. Such moneys shall be repayable at the National Bank of Australasia Limited Savings Bank, Melbourne.

The plans and specifications and the estimate of cost of the proposed works and a statement showing the proposed expenditure of the moneys to be borrowed, are open for inspection at the Shire Hall, Hawkesdale.

8994 R. J. TOWLER, Shire Secretary.

SHIRE OF OTWAY.

BY-LAW No. 44.

NOTICE is hereby given that the Council of the Shire of Otway has passed By-law No. 44 on the 19th day of July, 1967, and such has been approved by the Governor in Council on the 29th day of August, 1967.

Such By-law related to the following:—

Regulating the driving of cattle in or along certain specified streets within the Riding of Apollo Bay.

A full copy of the said By-law may be seen, free of charge, during office hours, at the Shire Office, Beech Forest.

8992 T. J. FRY, Shire Secretary.

SHIRE OF MOUNT ROUSE.

WHEREAS the Council of the Shire of Mount Rouse deems it expedient to exercise its power of taking compulsorily the land described in the Schedule at the foot hereof for the work or undertaking of providing road deviations: And whereas the Council has caused to be prepared a map and other papers setting out the general description of the work or undertaking for which the land proposed to be taken is to be used, the description of the land proposed to be taken, and the names of the owners or reputed owners, lessees or reputed lessees, mortgages and occupiers of that land so far as those names are known to or can be ascertained by the Council: And whereas the said map and other papers are deposited at the office of the said Council at Peshurst and are and shall be open for inspection by all persons interested at all reasonable hours for the space of 40 clear days after the publication of this notice in the *Government Gazette*, all objections which they may have to the taking of the said land.

SCHEDULE HEREINBEFORE REFERRED TO.

All that piece of land being part of Crown allotment 1A, Section 22, Parish of Nareeb Nareeb, County of Villiers, containing 23 perches, commencing at a point within the said allotment distant from the south-east corner of Crown allotment 1A by a line bearing 269 deg. 53 min. for a distance of 472 links; thence by a line bearing 294 deg. 38 min. for a distance of 809 links; thence by a line bearing 44 deg. 47 min. for a distance of 909.7 links; thence bounded by a line on a bearing of 44 deg. 47 min. for a distance of 197.3 links; thence on a bearing of 97 deg.

36 min. for a distance of 181.6 links; thence on a bearing of 250 deg. 1 min. for a distance of 339.5 links to the point of commencement.

Reference certificate of title, volume 8158, folio 147.

AND

All that piece of land being part of CA1, Section 22, Parish of Nareeb Nareeb, County of Villiers, containing 2 roods 5 perches and commencing at a point 3,859.2 links distant and bearing 179 deg. 58 min. from the north-east corner of CA1; thence bounded by a line on a bearing 179 deg. 58 min. for a distance of 311.8 links; thence on a bearing of 238 deg. 37 min. for distance of 398.4 links; thence on a bearing of 33 deg. 12 min. for a distance of 620.6 links to the point of commencement.

Reference certificate of title volume 1858, folio 147.

Dated the 13th day of September, 1967.

By order of the Council,

9076 G. M. COMMONS, Shire Secretary.

SHIRE OF WERRIBEE.

DEDICATION TO THE PUBLIC AS A PUBLIC HIGHWAY OR STREET CONSTRUCTED TO THE SATISFACTION OF THE COUNCIL.

NOTICE is hereby given in accordance with section 587 (3) of the *Local Government Act 1958*, that the Council of the Shire of Werribee, having received a request from the Housing Commission of Victoria, hereby declares—

Lohse-street (Maher-road to Woods-street) in the Shire of Werribee, to be dedicated to the public as a public highway, the said street having been constructed to the satisfaction of the Council.

The common seal of the Shire of Werribee was hereto affixed this 25th day of August, 1967, in the presence of:—

(SEAL) H. L. B. POWELL, President.  
B. F. JACKSON, Councillor.  
N. G. MINNS, Secretary.

9024

TAKE notice that on the 29th day of August, 1967, the partnership between Torrens Myles Bunn and Norino Sirocchini conducted under the business name "T. Bunn & Co." was dissolved and Norino Sirocchini retired from the firm at that date. The business will be conducted by Torrens Myles Bunn from that date under the name "T. Bunn & Co.".

9097

NOTICE is hereby given that the partnership heretofore subsisting between John Leslie Byron and Lindsay Gordon Byron, carrying on business as primary producers and spreaders of superphosphate, at Ararat, under the name of "Byron Bros.", has been dissolved by the death, on the 29th day of May, 1967, of Lindsay Gordon Byron.

All debts due to and owing by the said firm will be received and paid by The Union-Fidelity Trustee Company of Australasia Limited at its office, 101 Lydiard-street north, Ballarat.

Dated the 14th day of September, 1967.

9030 J. L. BYRON.  
S. T. BYRON.

TO WHOM IT MAY CONCERN.

WE, Clyde James Thorburn, Gwilma Jean Bell and Patrick Geoffrey Bell, all of Morwell, and registered as the proprietors of "Thorburn & Bell" which said business was carried on at Beatrice Court Morwell, hereby give notice that the partnership heretofore carried on by us was by mutual agreement by Instrument of Dissolution of Partnership dated the 31st day of August, 1967, dissolved the said Clyde James Thorburn, having retired therefrom and the said Gwilma Jean Bell and Patrick Geoffrey Bell taking over and assuming all interest therein.

The said business "Thorburn & Bell" will continue to be carried on from Beatrice Court, Morwell, by us, the said Gwilma Jean Bell and Patrick Geoffrey Bell.

CLYDE JAMES THORBURN.  
GWILMA JEAN BELL.  
PATRICK GEOFFREY BELL.

Dated 31st August, 1967.

9089

THIS is to confirm that Hervey John Acutt Newton and John Laurence Morton have retired from the firm of R. Hare & Associates, of 18 Little Collins-street, Melbourne, as from the 30th of June, 1967, and that the partnership is now comprised of Reginald Hare, Beryl Marguerite Hare, Darwin Campi and Kenneth Edward Fletcher.

OAKLEY THOMPSON & CO., solicitors, 626 Bourke-street, Melbourne.

9087

NOTICE is hereby given that the partnership heretofore subsisting between the undersigned, Domenico Biviano, Anna Sgambellone and Vincenzo Sgambellone, carrying on business of cabinet makers, at 228 Station-street, Thomastown, has been dissolved by mutual consent as from the 7th day of August, 1967. All debts due to and owing by the said late firm will be received and paid by Domenico Biviano, who will continue to carry on the business at the same place.

Dated at Ascot Vale this 12th day of September, 1967.

D. BIVIANO.  
A. SGAMBELLONE.  
V. SGAMBELLONE.

8996

*Companies Act 1961.*

GIPPSLAND HOTEL PROPRIETARY LIMITED (IN VOLUNTARY LIQUIDATION).

NOTICE OF GENERAL MEETING OF SHAREHOLDERS, PURSUANT TO SECTION 272.

NOTICE is hereby given, in pursuance of section 272 of the *Companies Act 1961*, that a General Meeting of shareholders of Gippsland Hotel Proprietary Limited (in Voluntary Liquidation) will be held at 5 Karbarook-avenue, Armadale, on Thursday, 19th October, at 2.15 p.m.

The object of the meeting is to consider an account by the liquidator showing how the winding up has been conducted and the property of the company disposed of, and for the giving of any explanations thereof.

Dated this 15th day of September, 1967.

JOHN H. DONEGAN, Liquidator, 390 Lonsdale-street, Melbourne. 9057

*Companies Act 1961.*

NEW GUINEA ESTATES PROPRIETARY LIMITED (IN VOLUNTARY LIQUIDATION).

NOTICE OF FINAL MEETING, IN PURSUANCE OF SECTION 272 OF THE "COMPANIES ACT 1961".

NOTICE is hereby given that, pursuant to section 272 of the *Companies Act 1961*, a Final General Meeting of the members of the above company will be held at the offices of Messrs. Hancock, Woodward & Neill, 7th Floor, 143 Queen-street, Melbourne, on Monday, the 23rd day of October, 1967, at 10 a.m., for the purposes of presenting the liquidator's account of the winding up and showing how the property of the company has been disposed of.

Dated at Melbourne, this 14th day of September, 1967.

J. ARNOLD HANCOCK, Liquidator.

Any member may appoint a proxy to vote on his behalf. A proxy need not be a member of the company. Proxies may be in the usual common form and must be lodged at the above address not less than 36 hours before the time of the meeting. 9062

The *Companies Act 1961*.—In the matter of PASTORAL BETTER FOODS COMPANY PROPRIETARY LIMITED (in Liquidation).

NOTICE is hereby given that, pursuant to section 272 of the *Companies Act*, a Final Meeting of the creditors of the above company will be held at the offices of Kennedy, Small and Middlemiss, 296-300 Little Lonsdale-street, Melbourne, on Wednesday, the 18th day of October, 1967, at 10.30 a.m.

Business: To Receive the Liquidator's accounts.

Dated this 13th day of September, 1967.

ALAN MURRAY HORSBURGH, Liquidator.

Kennedy, Small and Middlemiss, 296-300 Little Lonsdale-street, Melbourne, 3000. 9063

*Companies Act 1961.*

SWAN HILL FLOUR MILLS PTY. LTD.

PURSUANT TO SECTIONS 254 AND 258.

AT an Extraordinary General Meeting of the members of Swan Hill Flour Mills Pty. Ltd., convened and held at 10 Prospect Hill-road, Camberwell, on Friday, 8th September, 1967, at 9 a.m., the following Special Resolution was duly passed:—

"That the company be put into voluntary liquidation forthwith, and that Mervyn Stanley Hill, chartered accountant, of 105 King-street, Melbourne, be appointed liquidator at a fee calculated in accordance with the scale of fees recommended by the Institute of Chartered Accountants."

9065

T. H. JACKETT, Chairman.

*The Companies Act 1961.*

CORONA INVESTMENTS PTY. LTD. (IN VOLUNTARY LIQUIDATION).

NOTICE is hereby given that a Final Meeting of members of Corona Investments Pty. Ltd. (in Voluntary Liquidation) will be held at the office of Wilson, Danby & Giddy, 105 King-street, Melbourne, on Monday, the 16th day of October, 1967, at 9.30 a.m., for the purpose of receiving an account showing how the winding up has been conducted and the property of the company disposed of.

Dated this 11th day of September, 1967.

J. C. BENZIES, Liquidator.

Wilson, Danby & Giddy, 105 King-street, Melbourne. 9066

LINKMASTER PROPRIETARY LIMITED.

NOTICE is hereby given that the Extraordinary General Meeting of the above company, which was to have been held on Thursday, 28th September, 1967, at 2.30 p.m., has been postponed. The meeting shall now be held at the offices of John Rezak and Co., public accountants, 2nd Floor, 224 Queen-street, Melbourne, on Thursday, 5th October, 1967, at 2.30 p.m., at which the following Resolution will be considered as a Special Resolution:—

"That the company finding itself in a position in which it is unable to meet its commitments and pay its debts shall be voluntarily wound up".

9084

JOHN REZAK, Secretary.

ELEMAT LIMITED.

NOTICE OF FINAL MEETING IN VOLUNTARY WINDING UP.

TAKE notice that the affairs of the above-named company are now fully wound up and that, in pursuance of section 272 (1) of the *Companies Act 1961*, a General Meeting of the company will be held at 414 Collins-street, Melbourne, on the 20th day of October, 1967, at 12 o'clock in the forenoon for the purpose of laying before it an account showing how the winding up has been conducted and the property of the company disposed of and giving any explanation thereof.

Dated the 18th day of September, 1967.

9085

A. B. CURRIE, Liquidator.

In the Supreme Court of Victoria.—1967, No. Co. 7420.—

In the matter of the *Companies Act 1961*; and in the matter of BORSUMY WEHRY (AUST.) PTY. LTD.

NOTICE is hereby given that the Order of the Supreme Court of Victoria dated the 15th September, 1967, confirming the reduction of the capital of the above-named company from \$200,000 to \$80,012 was registered by the Registrar of Companies on the 18th September, 1967.

Dated the 18th day of September, 1967.

WHITING & BYRNE, solicitors for the company. 9093

*Companies Act 1961.*

MANNUM DOWNS PROPRIETARY LIMITED.

MEMBERS VOLUNTARY WINDING UP.

AT an Extraordinary General Meeting of the members of Mannum Downs Proprietary Limited duly convened and held at 440 Collins-street, Melbourne, on the 13th day of September, 1967, the following Resolution was passed as a Special Resolution:—

"That the company be wound up voluntarily under the provisions of the *Companies Act 1961*—applicable to a members' voluntary winding up and that Arthur Neville Davie, accountant of 440 Collins-street, Melbourne, be appointed liquidator."

Dated the 13th day of September, 1967. 9010

*Companies Act 1961.*

STANMAT PROPRIETARY LIMITED.

AT an Extraordinary General Meeting of the above-named company duly convened and held on Thursday, 8th September, 1967, at 17 Jassa-street, South Oakleigh, the following Special Resolution was passed:—

"That Stanmat Pty. Ltd. be placed in voluntary liquidation under section 254 (1) of the *Companies Act 1961*, and that Alan Leigh Middleton, of 11 Bank-place, Melbourne, be appointed liquidator."

Dated 11th September, 1967.

8989

A. L. MIDDLETON, Liquidator.

GEELONG CITIZENS CO-OPERATIVE HOUSING SOCIETY No. 1 LIMITED.

SPECIAL RESOLUTION PASSED 11TH SEPTEMBER, 1967.

AT a Special General Meeting of the above-named society, duly convened and held at Master Builders' Board Room, 62 Ryrie-street, Geelong, on Monday, 11th September, 1967, at 8 p.m., the subjoined Special Resolutions were duly passed:—

(i) That the society, having successfully completed its objectives twelve months ahead of its expected term, be wound up voluntarily, and that Mr. A. R. David, of 64 Little Malop-street, Geelong, be appointed liquidator for the purpose of the winding up.

(ii) That the remuneration of the liquidator be fixed at \$200 or such lesser amount, as may be fixed by the Registrar of Co-operative Housing Societies.

(iii) That the liquidator be empowered to compromise with debtors and/or creditors and/or contributors.

R. M. SWEETMAN, Chairman.

A. R. DAVID, Secretary.

9002

In the matter of the Co-operative Housing Societies Act 1958, and the Companies Act 1961; and in the matter of GEELONG CITIZENS CO-OPERATIVE HOUSING SOCIETY No. 1 LIMITED (in Liquidation).

NOTICE is hereby given that all persons having any claim against the above society are required on or before the 18th day of October, 1967, to send their names and addresses and particulars of their debts or claims to Alan Ray David, the liquidator of the said society, at his office, and if so required by notice, in writing, from the said liquidator are personally, or by their solicitors, to come in and prove their said debts or claims at such time and place as shall be specified in such notice; or, in default thereof, they shall be excluded from the benefit of any distribution made before such debts or claims are so lodged or proved.

Dated at Geelong this 12th day of September, 1967.

A. R. DAVID, Liquidator.

64 Little Malop-street, Geelong.

9003

G.F. PTY. LTD. (IN VOLUNTARY LIQUIDATION).

NOTICE is hereby given that, pursuant to section 272 (2) of the Companies Act 1961, a Final Meeting of the members of the above company will be held at Astor House, 161-173 Sturt-street, South Melbourne, at 11.30 a.m., on Friday, the 20th October, 1967, to receive the accounts of the liquidator.

Dated this 14th day of September, 1967.

9004 R. W. FOTHERINGHAM, Liquidator.

E.R.C. PTY. LTD. (IN VOLUNTARY LIQUIDATION).

NOTICE is hereby given that, pursuant to section 272 (2) of the Companies Act 1961, a Final Meeting of the Members of the above company will be held at Astor House, 161-173 Sturt-street, South Melbourne, at 11.30 a.m., on Friday, 20th October, 1967, to receive the accounts of the liquidator.

Dated this 14th day of September, 1967.

9016 R. W. FOTHERINGHAM, Liquidator.

THE WOOLGROWERS CO-OPERATIVE LIMITED (IN LIQUIDATION).

SPECIAL RESOLUTIONS.

(Passed 11th September, 1967.)

AT the Seventh Annual General Meeting of the above-named co-operative, duly convened and held at the Portland Wool Exchange, Learmonth-street, Portland, on the 11th day of September, 1967, at 2 p.m., the following Special Resolutions were passed:—

(a) That the Co-operative be wound up voluntarily; and

(b) That Ronald William Longney, of 58 Julia-street, Portland, was appointed liquidator for the purposes of the winding up.

9015

R. W. LONGNEY, Liquidator.

Companies Act 1961.—In the matter of SUPA GRADE FLOORS PROPRIETARY LIMITED.

NOTICE is hereby given that at an Extraordinary General Meeting of the members of the above-mentioned company, held on the 1st day of September, 1967, it was resolved that the company be wound up voluntarily and that Ronald Dennis Widdows, of 6 Marylin-court, East Bentleigh, be appointed liquidator for the purpose of such winding up.

Notice is also hereby given that after 21 days from this date the above-named liquidator shall proceed to distribute the assets. All creditors having any claim against the company should furnish particulars of the same by that date, otherwise the liquidator shall proceed to distribute the assets without regard to their claim.

Dated this 1st day of September, 1967.

R. D. WIDDOWS, 6 Marylin-court, East Bentleigh. 9047

The Companies Act 1961.—In the matter of JOHN RAMAGE MOTORS PROPRIETARY LIMITED (in Liquidation).

NOTICE is hereby given that a Second Dividend is intended to be declared in this matter. Creditors who have not proved their debts by the 9th day of October, 1967, will be excluded from the dividend.

Dated this 18th day of September, 1967.

N. E. STRETTON, Liquidator.

Kennedy, Small and Middlemiss, 296 Little Lonsdale-street, Melbourne, 3000. 9049

In the matter of the Companies Act 1961 and MURRA'S MEATS PTY. LTD. (in Liquidation).

NOTICE is hereby given that creditors having claims against the above-named company should lodge proofs of debt with the official liquidator, R. C. D. Warne-Smith, care of A. L. Royce and Warne-Smith, 440 Collins-street, Melbourne. Creditors who have not proved their debts by the 4th October, 1967, will be excluded from dividends.

Dated this 13th day of September, 1967.

R. C. D. WARNE-SMITH, Official Liquidator, 440 Collins-street, Melbourne. 9053

Companies Act 1961.

ELECTRICAL AND INDUSTRIAL EQUIPMENT COMPANY PROPRIETARY LIMITED.

NOTICE is hereby given that at a Meeting of Creditors of the above-named company, held on Tuesday, the 12th day of September, 1967, it was resolved that the company be wound up. It was also resolved that for such purposes, Peter William Harvey, chartered accountant, of 440 Collins-street, Melbourne, be appointed liquidator.

Notice is also given that creditors having claims against the company should lodge proofs of debt with the liquidator. Creditors who have not proved their debts by 4 p.m. on the 16th October, 1967, will be excluded from dividends.

Dated this 13th day of September, 1967.

P. W. HARVEY, Liquidator.

A. L. Royce & Warne-Smith, chartered accountants, 440 Collins-street, Melbourne. 9054

In the matter of FURY MOCCASINS PROPRIETARY LIMITED.—Notice of Winding-up Order.

WINDING-UP Order made 15th September, 1967.

Name and Address of Official Liquidator: Bruce Edward Fordham, 170 Toorak-road, South Yarra.

JAMES CANNY, Deputy Commissioner of Taxation of the Commonwealth of Australia, petitioner. 9104

VIDECO INDUSTRIES PTY. LTD.

NOTICE is hereby given that a Meeting of Creditors of the above company will be held in the Victorian Chamber of Manufactures Meeting Rooms, Nos. 3 and 4, 370 St. Kilda-road, Melbourne, on Friday, 29th September, 1967, at 4 p.m., for the purposes set out in Sections 260 and 261 of the Companies Act 1961.

Dated this 4th day of September, 1967.

By order of the Board,

9096

S. CERMAK, Secretary.

No. 25008.

Companies Act 1961.

SOUTHERN UNIT TRUSTS LIMITED

(IN VOLUNTARY LIQUIDATION).

IN PURSUANCE OF SECTION 272 OF THE COMPANIES ACT 1961.

Notice of Final Meeting.

NOTICE is hereby given that pursuant to Section 272 of the Companies Act 1961, a Final General Meeting of the members of the above company will be held at the offices of Messrs. Hancock Woodward & Neill, 7th Floor, 143 Queen-street, Melbourne, on Monday, the 23rd day of October, 1967, at 12 noon, for the purposes of presenting the liquidator's account of the winding-up and showing how the property of the company has been disposed of.

Dated at Melbourne, this 19th day of September, 1967.

A. S. McLAUGHLAN, Liquidator.

Any member may appoint a proxy to vote on his behalf. A proxy need not be a member of the company. Proxies may be in the usual common form and must be lodged at the above address before the time of the meeting.

9105

The Companies Act 1961, Pursuant to Section 254 (2).

ROBIAN PTY. LTD. (IN LIQUIDATION).

NOTICE is hereby given that at an Extraordinary General Meeting of members of the above-named company held on Thursday, 14th September, 1967, the following Special Resolution was duly passed, and that at a meeting of creditors held the same day the said resolution was confirmed:

"That owing to the Company being unable to meet its debts as and when they become due that the company be and is hereby wound up voluntarily and that Maxwell George Gee, a registered liquidator, be and is hereby appointed liquidator to wind the company up and attend to all matters relative thereto in accordance with the Companies Act 1961."

M. G. GEE, Registered Liquidator.

Gee &amp; O'Keefe, 325 Warrigal-road, Burwood, telephone 288-5911.

9077

D. K. KNIFE SERVICES PTY. LTD., of 10 Buchanan-street, St. Albans (previous name, Romeiso Proprietary Limited), commenced on 12th September, 1967.—Members' Voluntary Liquidation.

CREDITORS are invited to send particulars of their claims against the above company to the liquidator, Alfred G. Blondell, of 147 Bambra-road, Caulfield, by 10th October, this year, after which date the liquidator proposes making a final distribution of surplus assets of the company amongst shareholders.

The accounts are to be sent to my office.

9081

A. G. BLONDELL, Liquidator.

MURIEL ALBERTA BARKLA LUCAS, late of 7 Martin-avenue, Ballarat, married woman, DECEASED (who died on the 28th March, 1967).

CREDITORS, next of kin and all persons having claims against the estate of the deceased, are required to send particulars to the executor, The Union-Fidelity Trustee Company of Australia Limited, of 100 Exhibition-street, Melbourne, on or before the 21st November, 1967, after which date it will distribute the assets, having regard only to the claims of which it shall then have notice.

HEINZ &amp; GORDON, solicitors, 209 Dana-street, Ballarat.

9035

EDGAR ALBERT COOK, late of 106A Pleasant-street north, Ballarat, grocer, DECEASED (who died on the 30th March, 1967).

CREDITORS, next of kin and all persons having claims against the estate of the deceased, are required to send particulars to the executors, The Union-Fidelity Trustee Company of Australia Limited, of 100 Exhibition-street, Melbourne, Elliot Thomas Morris, formerly of 1359 Gregory-street, Ballarat, now of Creswick, company officer, and Ivy Phyllis Cook, of 106A Pleasant-street north, Ballarat, widow, care of the said company, at its address above given on or before the 21st November, 1967, after which date it will distribute the assets, having regard only to the claims of which it shall then have notice.

HEINZ &amp; GORDON, solicitors, 209 Dana-street; Ballarat.

9036

CREDITORS, next of kin and others having claims in respect of the Estate of Michele Domenico Santilli, late of 81 Bay-street, Port Melbourne, in the State of Victoria, driver, deceased (who died on the 1st day of April, 1967), are to send particulars of their claims to the executors, Remo Santilli and Claudia Santilli, care of the undersigned, by the 22nd day of November, 1967, after which date they will distribute the assets, having regard only to the claims of which they then have notice.

LEO BROWNE, solicitor of 180 Elgin-street, Carlton.

9039

CREDITORS, next of kin and others having claims in respect of the estate of John McGauchie, senior, late of Woodlands Estate, Bagshot, in the State of Victoria, grazier (who died on the 14th day of April, 1967), are to send the particulars of their claims to Norman McLaren Young, of 16 View-street, Bendigo, by the 22nd day of November, 1967, after which date he will distribute the assets, having regard only to the claims of which he then has notice.

H. E. EVERY, solicitor, V. P. C. Building, Bull-street, Bendigo.

9029

CREDITORS, next of kin and others having claims against the estate of Thomas Whateley, late of Happy Valley, in the State of Victoria, retired farmer, deceased (who died on the 18th day of February, 1967), are required by the executors, Desmond Clive Gaunt, of 41 Lydiard-street south, Ballarat, solicitor, and John Gordon Cairns, of 120 Howitt-street, Ballarat, farmer, to send particulars of their claims to the under-mentioned firm by the 20th day of November, 1967, after which date the said executors will distribute the assets, having regard only to the claims of which they then have notice.

R. H. RAMSAY &amp; GAUNT, solicitors, of 41 Lydiard-street south, Ballarat.

9032

CREDITORS, next of kin and others having claims against the estate of Alexander Francis Nicol, late of 56 Albert-street, Sebastopol, in the State of Victoria, accountant, deceased (who died on the 3rd day of February, 1967), are required by the executors, Ada May Schulz, of 2A Hertford-street, Sebastopol, married woman, and Desmond Clive Gaunt, of 41 Lydiard-street south, Ballarat, solicitor, to send particulars of their claims to the under-mentioned firm by the 20th day of November, 1967, after which date the said executors will distribute the assets, having regard only to the claims of which they then have notice.

R. H. RAMSAY &amp; GAUNT, solicitors, of 41 Lydiard-street south, Ballarat.

9033

EDWARD GOONAN, late of 36 Henry-street, Kensington, pensioner, DECEASED.

CREDITORS, next of kin and others having claims in respect of the estate of the deceased (who died on 10th March, 1967) are required by the executor, Franz Louis Caddell, of 15 Price-street, Essendon, sales representative, to send particulars to him, care of the under-mentioned solicitors, by the 30th day of November, 1967, after which date he may convey or distribute the assets, having regard only to the claims of which he then has notice.

KEITH HERCULES &amp; SON, solicitors, 443 Little Collins-street, Melbourne.

9082

CREDITORS, next of kin and others having claims in respect of the estate of Frank Crowther Jefferson, late of Rua Artur Araripe 18, Gavea, Rio de Janeiro Guanabara, Brazil South America, manager, deceased, are requested to send particulars of their claims to the administrator, Arthur Leslie Park, care of the under-mentioned solicitors, on or before the 21st November, 1967, after such date he will distribute the assets, having regard only to the claims of which he then has notice.

McKean &amp; Park, solicitors, 84 William-street, Melbourne.

9091

CREDITORS, next of kin and others having claims in respect of the estate of Myrtle Johanna England, late of 7 Greenham-street, Maidstone, in the State of Victoria, widow, deceased, intestate (who died on the 20th May, 1967), are required to send particulars of their claims to the administrator, care of the under-mentioned solicitor by the 25th day of November, 1967, after which date the administrator will distribute the assets, having regard only to the claims of which he then has notice.

K. P. REES, B.A., LL.B., solicitor, 89 Queen-street, Melbourne.

9100

**CREDITORS**, next of kin and others having claims in respect of the estate of Winifred Caroline Henty Hindson, late of "Seacombe", Sorrento (who died on the 13th day of July, 1967) and probate of whose codicils will and codicils thereto was granted by the Supreme Court of Victoria, on the 13th day of September, 1967, to The Trustees Executors and Agency Company Limited, of 401 Collins-street, Melbourne, one of the executors named in the said will, are to send particulars of their claims to the said executor at its address above-mentioned, by the 29th day of November, 1967, after which date it will distribute the assets, having regard only to the claims of which it then has notice.

Dated this 18th day of September, 1967.

SEWELL & SEWELL, 422 Collins-street, Melbourne,  
solicitors for the said executor. 9083

DAISY ATHERLIA PRINCE, formerly of 58 Hotham-street, St. Kilda, formerly Daisy Atherlia Hyslop, of 4 Beaconsfield-parade, St. Kilda, and 11 Sydney-street, Armadale, but late of 5 Chaddesley-avenue, East St. Kilda, in the State of Victoria, widow, DECEASED.

**CREDITORS**, next of kin and others having claims in respect of the estate of the deceased (who died on 22nd May, 1967), are required by the executor, John Kenneth Hyslop, of 23 Finsbury Way, Camberwell, company secretary, to send particulars to him, care of the undersigned solicitors, by the 3rd December, 1967, after which date he may convey or distribute the assets, having regard only to the claims of which he then has notice.

Dated 18th September, 1967.

R. E. LEWIS ORR & GIBSON, 825 Burke-road,  
Camberwell. 9090

**CREDITORS**, next of kin and others having claims in respect of the estate of Eric Pearson Learmonth, late of 165A Orrong-road, Toorak, in the State of Victoria, retired grazier, deceased (who died on the 22nd May, 1967), are required to serve particulars of their claims to the executors, The Union-Fidelity Trustee Company of Australia Limited, of 100 Exhibition-street, Melbourne, in the said State and Peter Learmonth, of 5 Coronal-avenue, Herne Hill, Geelong, in the said State, auctioneer, care of the said company, by the 21st day of November, 1967, after which date they may convey or distribute the assets, having regard only to the claims of which they then have notice.

AITKEN, WALKER & STRACHAN, solicitors, 414  
Collins-street, Melbourne. 9092

EDWARD THOMAS SMITH, late of 15 Salisbury-avenue,  
Blackburn, gentleman, DECEASED.

**CREDITORS**, next of kin and others having claims in respect of the estate of the deceased (who died on 21st January, 1967), are required by the executor, Sydney Edward Smith, of 6 Barrina-street, Blackburn, civil servant, to send particulars to him, care of the undersigned solicitors, by the 3rd December, 1967, after which date he may convey or distribute the assets, having regard only to the claims of which he then has notice.

Dated 18th September, 1967.

R. E. LEWIS ORR & GIBSON, 825 Burke-road Camber-  
well. 9094

**CREDITORS**, next of kin and others having claims in respect of the estate of Eric Hazel Jones, late of 135 Locksley-road, Ivanhoe, in the State of Victoria, draughtsman, deceased (who died on 13th April, 1967), are required by the administratrix, Joan Jones, of 135 Locksley-road, Ivanhoe, in the said State, widow, to send particulars to the under-mentioned firm by 17th November, 1967, after which date the said administratrix may convey or distribute the assets, having regard only to the claims of which she then has notice.

SETON WILLIAMS & HEATHFIELD, solicitors, 230  
Collins-street, Melbourne. 9031

**CREDITORS**, next of kin and others having claims in respect of the estate of Ida Bowley, late of Albert-street, Creswick, retired state school teacher (who died on the 23rd May, 1967), are to send the particulars of their claims to the Trustees Executors and Agency Company Limited, of 401 Collins-street, Melbourne, by the 30th November, 1967, after which date it will distribute the assets, having regard only to the claims of which it then has notice. 9014

**CREDITORS**, next of kin and others having claims in respect of the estate of Ethel Maud O'Brien (also known as Ethel Maude O'Brien), formerly of 45 St. Vincent's-street, Albert Park, but late of 48 Jasper-road, Moorabbin, in the State of Victoria, widow, deceased (who died on the 7th day of January, 1967), are to send particulars of their claims to Phyllis Bertha Jean Drew, care of the under-mentioned solicitors, by the 20th day of November, 1967, after which date she will distribute the assets, having regard only to the claims to which she then has notice.

Dated this 14th day of September, 1967.

REGINALD C. BUTLER & CO., solicitors, 312 Centre-  
road, Bentleigh. 9008

**CREDITORS**, next of kin and others having claims in respect of the estate of Edith Mary Harris, late of 39 Wheatley-road, Bentleigh, in the State of Victoria, formerly married woman, but then widow, deceased (who died on the 21st day of February, 1967) are to send particulars of their claims to Lawrence John Harris and Neville Thomas Griffiths, care of the under-mentioned solicitors, by the 20th day of November, 1967, after which date they will distribute the assets, having regard only to the claims to which they then have notice.

Dated this 14th day of September, 1967.

REGINALD C. BUTLER & CO., solicitors, 312 Centre-  
road, Bentleigh. 9009

**CREDITORS**, next of kin and others having claims in respect of the estate of Raymond Thomas Corrie, late of 85 Strathalbyn-street, East Kew, retired, advertising manager, deceased (who died on 4th September, 1967) are required by the executors Allan George Snibson, of 21 Longstaff-street, East Ivanhoe, and Ralph Girvan Corrie, of 16 Darian-road, Torquay, accountants, to send particulars to the under-mentioned firm, by 15th November, 1967, after which date the said executors may convey or distribute the assets, having regard only to the claims of which they then have notice.

SETON WILLIAMS & HEATHFIELD, solicitors, 230  
Collins-street, Melbourne. 9011

**CREDITORS**, next of kin and others having claims in respect of the estate of George William Snibson, late of 17 Irymple-avenue, East Kew, in the State of Victoria, retired, working foreman, deceased (who died on 18th July, 1967) are required by the executrix Emily Ada Snibson, of 17 Irymple-avenue, East Kew, widow, to send particulars to the under-mentioned firm, by 14th November, 1967, after which date the said executrix may convey or distribute the assets, having regard only to the claims of which she then has notice.

SETON WILLIAMS & HEATHFIELD, solicitors, 230  
Collins-street, Melbourne. 9012

**CREDITORS**, next of kin and others having claims in respect of the estate of John Malachy McGrath, late of 97 Stephenson-street, Mount Waverley, in the State of Victoria, telephone technician, deceased (who died on the 4th day of June, 1967), are to send particulars of their claims to the executor, Eugene Patrick Rodaughan, care of the undersigned, by the 22nd day of November, 1967, after which date he will distribute the assets, having regard only to the claims of which he then has notice.

LEO BROWNE, solicitor, of 180 Elgin-street, Carlton.  
9040

**PURSUANT** to the provisions of the Trustee Act 1958, creditors, next of kin and all other persons having claims in respect of the estate of Alfred Watson, late of 5 Elliott-avenue, Carnegie, retired printing industry employee, deceased (who died on the 15th June, 1967), are required to send particulars of their claims to the executor, Lyston Arthur Chisholm, of 339 Collins-street, Melbourne, solicitor, by the 29th November, 1967, after which date the executor will distribute the assets, having regard only to the claims of which he shall then have had notice.

MADDOCK, LONIE & CHISHOLM, solicitors, 339  
Collins-street, Melbourne. 9041

WILLIAM JAMES PALFRAMAN, late of 13 Kimberley-avenue, Swan Hill, in the State of Victoria, farmer, DECEASED.

**CREDITORS**, next of kin and other persons having claims against the estate of the said deceased (who died on the 3rd day of July, 1967), are required to send particulars of same to the executors, Aubrey William



Palframan and Ivy Joyce Palframan, in care of the undersigned, on or before the 27th day of November, 1967, after which date they will distribute the assets, having regard only to the claims of which they then have notice.

DELANEY & DWYER, barristers and solicitors, 270 Campbell-street, Swan Hill. 9042

LEONARD GEORGE McDONALD, formerly of Lake Boga, but late of 32 Palaroo-street, Swan Hill, in the State of Victoria, farmer, DECEASED.

CREDITORS, next of kin and other persons having claims against the estate of the said deceased (who died on the 4th day of July, 1967), are required to send particulars of same to the executrix, Mary Elizabeth McDonald, in care of the undersigned, on or before the 27th day of November, 1967, after which date they will distribute the assets, having regard only to the claims of which they then have notice.

DELANY & DWYER, barristers and solicitors, 270 Campbell-street, Swan Hill. 9043

CREDITORS, next of kin and others having claims in respect of the estate of John Maurice Leyden, late of Mount Dandenong-road, Kilsyth, in the State of Victoria, retired farmer, deceased (who died on the 19th day of November, 1966), are to send particulars of their claims to The Union-Fidelity Trustee Company of Australia Limited, of 100 Exhibition-street, Melbourne, by the 24th day of November, 1967, after which date it will distribute the assets, having regard only to the claims of which it then has notice.

GODFREY STEWART & CO., solicitors, 37 Queen-street, Melbourne, solicitors for the applicant company. 9045

CHARLES LUKER, late of 30 Bambra-road, Caulfield, in the State of Victoria, retired electrotyper, DECEASED.

CREDITORS, next of kin and others having claims in respect of the estate of the deceased (who died on the 7th July, 1967), are required by the executor, The Equity Trustees, Executors and Agency Company Limited, of 472 Bourke-street, Melbourne, to send particulars to it by the 28th November, 1967, after which date the executor may distribute the estate, having regard only to the claims of which it then has notice.

W. B. & O. McCUTCHEON, solicitors, 150 Queen-street, Melbourne. 9046

MARION CAROLINE SLADE, late of 70 Wornack-road, Murrumbidgee, in the State of Victoria, widow, DECEASED.

CREDITORS, next of kin and others having claims in respect of the estate of the deceased (who died on the 31st day of May, 1967), are required by the trustee The Equity Trustees, Executors and Agency Company Limited, of 472 Bourke-street, Melbourne, in the said State, to send particulars to it by the 30th day of November, 1967, after which date the trustee may convey or distribute the assets, having regard only to the claims of which it then has notice.

Dated the 18th day of September, 1967.

BRAHAM & PIRANI, solicitors, 53 Queen-street, Melbourne. 9095

MARGARET WILSON, late of 47 Riversdale-road, Hawthorn, spinster, DECEASED.

CREDITORS, next of kin and others having claims in respect of the estate of the deceased (who died on the 15th day of August, 1967), are hereby required by her personal representative Arthur Wilson Baird, of 586 Rathdowne-street, North Carlton, managing Law Clerk, to send particulars to him, care of the undersigned at the address mentioned hereunder by the 22nd day of November, 1967, after which date he may convey or distribute the assets, having regard only to the claims of which he then has notice.

RIGBY & FIELDING and HOLT NEWMAN & HOLT, solicitors, 331 Collins-street, Melbourne. 9098

CREDITORS, next of kin and others having claims in respect of the estate of Annie Katie Gurr, late of 17 Allen-street, Hawthorn, in the State of Victoria, widow, deceased (who died on the 9th day of June, 1967), are to send particulars of their claims to the executor Arthur James Downing, care of the undersigned solicitors, on or before the 24th day of November, 1967, after which date he will proceed to distribute the said estate, having regard only to the claims of which he then has notice.

F. J. ORAMES & DOWNING, solicitors, 84 William-street, Melbourne. 9099

LESLIE CHARLES THORNHILL, late of 23 Cromwell-street, Burwood, company officer, DECEASED (who died on the 19th July, 1967).

CREDITORS, next of kin and all others having claims in respect of the estate of the said deceased, are requested by the administrator, The Trustees, Executors and Agency Company Limited, of 401 Collins-street, Melbourne, to send particulars of such claims to the said company by the 1st December, 1967, after which date the said company will distribute the assets, having regard only to the claims of which it then has notice.

DAVIES, CAMPBELL & PIESSE, solicitors, 401 Collins-street, Melbourne. 9101

SIDNEY JOHN THORP, formerly of 49 Ranfurly-crescent, Glen Iris, but late of Maroo-street, Hughesdale, in the State of Victoria, storeman, DECEASED.

CREDITORS, next of kin and others having claims in respect of the estate of the deceased (who died on the 14th day of May, 1967), are required by The Perpetual Executors and Trustees Association of Australia Limited, of 100-104 Queen-street, Melbourne, to send particulars of their claims to the said company by the 15th day of November, 1967, after which date it will convey or distribute the assets, having had regard only to the claims of which the company then has notice.

WM. MURRAY & SON, solicitors, 422 Collins-street, Melbourne. 9103

CREDITORS, next of kin and all other persons having claims against the estate of Amy Stanberry Bear, late of 48 Prentice-street, Elsternwick, in the State of Victoria, widow, deceased (who died on the 5th day of August, 1967, probate of whose will was granted by the Supreme Court of the said State in its probate jurisdiction to Roy Leonard Yelland, of 37 Swanston-street, Melbourne, solicitor, and Charles Oliver Welsh, of 11A Vickery-street, Bentleigh, gentleman), are requested to send particulars of their claims, in writing, to the said Roy Leonard Yelland and Charles Oliver Welsh, care of their solicitors, Messrs. Yelland & Yelland, of 37 Swanston-street, Melbourne, on or before the 22nd day of November, 1967, after which date the said Roy Leonard Yelland and Charles Oliver Welsh will distribute the assets, having regard only to the claims of which they will then have had notice. And notice is hereby further given that the said Roy Leonard Yelland and Charles Oliver Welsh will not be liable for the assets so distributed or any part thereof to any person of whose claim they shall not have had notice aforesaid.

YELLAND & YELLAND, solicitors, 37 Swanston-street, Melbourne. 9106

CREDITORS, next of kin and all other persons having claims against the estate of Mabel Anne Butt, late of 436 New-street, Elsternwick, in the State of Victoria, widow, deceased (who died on the 4th day of August, 1967, probate of whose will was granted by the Supreme Court of the said State in its probate jurisdiction to Roy Leonard Yelland, of 37 Swanston-street, Melbourne, solicitor), are requested to send particulars of their claims, in writing, to the said Roy Leonard Yelland, care of Yelland & Yelland, of 37 Swanston-street, Melbourne, solicitors, on or before the 22nd day of November, 1967, after which date the said Roy Leonard Yelland will distribute the assets, having regard only to the claims of which he then will have had notice. And notice is hereby further given that the said Roy Leonard Yelland will not be liable for the assets so distributed or any part thereof to any person of whose claim he shall not have had notice aforesaid.

YELLAND & YELLAND, solicitors, 37 Swanston-street, Melbourne. 9107

CREDITORS, next of kin and others having claims in respect of the estate of Allan Glen Parker, formerly of 25 May-street, East Bentleigh, in the State of Victoria, but late of School of Military Engineering, Australian Regular Army, in the State of New South Wales, Sapper No. 342952, deceased, interstate (who died on the 12th day of February, 1967), are to send particulars of their claims to Henry William Parker, care of the under-mentioned solicitors, by the 27th day of November, 1967, after which date he will distribute the assets, having regard only to the claims to which he then has notice.

Dated this 18th day of September, 1967.

REGINALD C. BUTLER & CO., solicitors, 312 Centre-road, Bentleigh. 9080

BARON DAVID SNIDER, late of Flat 1, 243 Dandenong-road, Windsor, in the State of Victoria, management consultant, DECEASED, intestate.

CREDITORS, next of kin and others having claims against the estate of the above-named deceased (who died on the 29th day of December, 1966), are required to send particulars of their claims to Evelyn Snider, the administratrix of the said deceased's estate, care of the under-mentioned solicitors, by the 1st day of December, 1967, after which date the said administratrix will distribute the assets in the said estate, having regard only to the claims of which she then has notice.

PAVEY, WILSON, COHEN & CARTER, solicitors, 390 Lonsdale-street, Melbourne. 9048

JESSIE HAY SWYERE, late of 8 Rochester-road, Canterbury, spinster, DECEASED.

CREDITORS, next of kin and others having claims in respect of the estate of the deceased (who died on the 25th day of March, 1967), are required by The Perpetual Executors and Trustees Association of Australia Limited, of 100-104 Queen-street, Melbourne, the applicant for a grant of probate, to send particulars of their claims to the said company, by the 21st day of November, 1967, after which date it will convey or distribute the assets, having regard only to the claims of which the company then has notice.

W. H. FLOOD & PERMEZEL, solicitors, 388 Bourke-street, Melbourne. 9050

CREDITORS, next of kin and others having claims in respect of the estate of Anne Skeats, late of 8 Glenbervie-road, Toorak, widow, deceased (who died on the 18th day of June, 1967), are to send the particulars of their claims to The Trustees, Executors and Agency Company Limited, of 401 Collins-street, Melbourne, by the 30th day of November, 1967, after which date it will distribute the assets, having regard only to the claims of which it then has notice.

Dated the 14th day of September, 1967.

MADDEN, BUTLER, ELDER & GRAHAM, solicitors, 31 Queen-street, Melbourne. 9051

ROSE SOPHIA STARKEY (also known as Rose Sophia Johnstone), late of 33 Second-avenue, Black Rock, widow, DECEASED.

CREDITORS, next of kin and others having claims in respect of the said deceased (who died on 19th November, 1966), are required by the trustees, Ronald Francis Pinsent and Ernest Geoffrey Lockwood, to send particulars to them, care of their solicitors, Messrs. Best, Hooper, Rintoul and Shallard, 100 Queen-street, Melbourne, by the 21st day of November, 1967, after which date the trustees may convey or distribute the assets, having regard only to the claims of which they may then have notice.

BEST, HOOPER, RINTOUL & SHALLARD, solicitors, 100 Queen-street, Melbourne. 9052

CLAUDE HUBERT DEEM, late of Henry County, Indiana, United States of America, retired consultant, DECEASED.

CREDITORS, next of kin and others having claims in respect of the estate of the deceased (who died on 10th June, 1967), are required by the personal representative, The Trustees, Executors and Agency Company Limited, of 401 Collins-street, Melbourne, to send particulars to the said company, by 27th November, 1967, after which date it may convey or distribute the assets, having regard only to the claims of which it then has notice.

HEDDERWICK, FOOKES & ALSTON, 103 William-street, Melbourne. 9055

CHARLES GORDON SHAW, late of 57 Clendon-road, Toorak, surgeon, DECEASED.

CREDITORS, next of kin and others having claims in respect of the estate of the deceased (who died on the 2nd day of July, 1967), are required by The Perpetual Executors and Trustees Association of Australia Limited, of 100-104 Queen-street, Melbourne, and Hugh Michael Shaw, of 5 Devorgilla-road, Toorak, medical practitioner, the applicants for a grant of administration, to send particulars of their claims to the said applicants, in the care of the said company, by the 22nd November, 1967, after which date they will convey or distribute the assets, having regard only to the claims of which they then have notice.

DAVIES, CAMPBELL & PIESSE, solicitors, 401 Collins-street, Melbourne. 9056

MILDRED ELIZABETH LEGGO, late of 5 Rubicon-street, East Sebastopol, married woman, DECEASED (who died on the 18th June, 1967).

CREDITORS, next of kin and all persons having claims against the estate of the deceased, are required to send particulars to the executor, The Union-Fidelity Trustee Company of Australia Limited, of 100 Exhibition-street, Melbourne (formerly The Fidelity Trustee Company Limited, of 101 Lydiard-street north, Ballarat), on or before the 21st November, 1967, after which date it will distribute the assets, having regard only to the claims of which it shall then have notice.

HEINZ & GORDON, solicitors, 209 Dana-street, Ballarat. 9037

JONAS PRANAUSKAS, late of 159 Victoria-street, North Geelong, gentleman, DECEASED.

CREDITORS, next of kin and others having claims in respect of the estate of the said deceased (who died 10th July, 1967, are required by the applicants for grant of probate of the will, Stasys Skapinskas, of 6 Glenleith-avenue, Drumcondra, first aid officer and Romas Norvydas, of 26 Barnfather-street, East Geelong, teacher), to send particulars to them, care of the undersigned solicitors by 29th November, 1967, after which date the said applicants may convey or distribute the assets, having regard only to the claims of which they then have notice.

WIGHTON & McDONALD, solicitors, 89 Myers-street, Geelong. 9079

ELSIE MAUD WILSON, late of 7 Crispe-street, Regent, married woman, DECEASED.

CREDITORS, next of kin and others having claims in respect of the estate of the above-named deceased (who died on 8th June, 1967), are required to send the particulars of their claims to the executor, The Equity Trustees, Executors and Agency Company Limited, care of the undernamed solicitors, by the 21st day of November, 1967, after which date it will distribute the assets, having regard only to those claims of which it then has notice.

NORRIS, COATES & HEARLE, of 422 Collins-street, Melbourne, solicitors. 9058

ROBERT HENRY JOHNS, late of 11 Bennett-street, Alphington, labourer, DECEASED, intestate.

CREDITORS, next of kin and others having claims in respect of the estate of the deceased (who died on the 17th June, 1967), are required by Elizabeth Helen Spencer, of 11 Bennett-street aforesaid, married woman, the administratrix of the deceased, to send particulars of the said claims to her by the 21st of November, 1967, after which date she may convey or distribute the assets, having regard only to the claims of which she then has notice.

Dated the 15th day of September, 1967.

FORD, ASPINWALL & DeGRUCHY, of 100-104 Queen-street, Melbourne, solicitors for the administratrix. 9060

CREDITORS, next of kin and others having claims in respect of the estate of Eric John Bartlett, late of 16 Rose-street, Box Hill, in the State of Victoria, retired linotype operator, deceased (who died on the 1st of January, 1967), are required to send particulars of their claims to the executor, care of the under-mentioned solicitor, by 22nd of November, 1967, after which date the executor will distribute the assets, having regard only to the claims of which he then has notice.

K. P. REES, B.A., LL.B., solicitor, 89 Queen-street, Melbourne. 9061

CREDITORS, next of kin and others having claims against the estate of Eileen Kate Hill, late of 6 Riversdale-road, Hawthorn, in the State of Victoria, spinster, deceased (who died on the 14th day of March, 1967), are required by The Perpetual Executors and Trustees Association of Australia Limited, of 100-104 Queen-street, Melbourne, in the said State, and David Anderson Hill, of 6 Riversdale-road, Hawthorn aforesaid, gentleman, the executors of the will and two codicils thereto of the said deceased, to send particulars of their claims to the said executors, in the care of the said company, by the 22nd day of November, 1967, after which date the executors will convey or distribute the estate of the said deceased, having regard only to the claims of which they then have notice.

MELVILLE & MELVILLE, solicitors, of 224 Glenferrie-road, Malvern. 9064

**CREDITORS** and others having claims in respect to the estate of Ida Elizabeth James, late of "Stillmeadows", Warminster-road, Bathampton, Somerset, England, gentlewoman, deceased, intestate (who died on the 11th April, 1967), are required by the Union-Fidelity Trustee Company of Australia Limited, of 100 Exhibition-street, Melbourne, administrator of the estate of the said deceased, to send particulars of their claim to the said company at its above address, on or before 22nd day of November, 1967, after which date it will distribute the assets, having regard only to the claims of which it then has notice. 9059

Trustee Act 1958.

**NOTICE TO CLAIMANTS.**

**PURSUANT** to the Trustee Act 1958, creditors, next of kin and all other persons having claims in respect of the estate of any deceased person named below are required to send particulars to the legal personal representative or representatives at the addresses stated, after which date the representative or representatives will distribute the assets, having regard only to the claims of which notice has been received:—

Annie Elizabeth Jean Stephen, late of Grant-street, Port Fairy, widow, deceased, died on 15th July, 1967.—Claims to the executor, Jack Sproal, 62 Princes Highway, Port Fairy, butcher, care of Conlan & Leishman, solicitors, 38 Bank-street, Port Fairy, by 30th November, 1967. 8997

John Morton Garner (usually known as Morton John Garner), late of Cohuna, farmer, who died on 6th May, 1964.—Claims to Sandhurst and Northern District Trustees, Executors and Agency Company Limited, of View-street, Bendigo, by 22nd November, 1967. Willan and McKenzie, solicitors, Cohuna. 9078

**CREDITORS**, next of kin and others having claims in respect of the estate of Herbert Samuel Cations, late of High-street, Kyneton, gentleman, deceased (who died on 5th July, 1967, and probate of whose will was granted by the Supreme Court of Victoria on 4th September, 1967, to John Graham Bolton, of Kyneton, solicitor, the executor therein named), are required to send particulars of their claims to the said executor in care of the undersigned solicitors before the 20th November, 1967, after which date he will distribute the assets, having regard only to the claims of which he shall then have had notice.

PALMER, STEVENS & RENNICK, solicitors, Kyneton. 9001

DAVID DUNLOP LEA, late of 51 Palaroo-street, Swan Hill, in the State of Victoria, pensioner, DECEASED, intestate.

**CREDITORS**, next of kin and others having claims in respect of the estate of the deceased (who died on the 7th day of January, 1966), are required by the administrator, John Charles Kruger, of 10 Milloo-street, Swan Hill, aforesaid, P.M.G. linesman, to send particulars to him, care of the undersigned by the 20th day of November, 1967, after which date the administrator may convey or distribute the assets, having regard only to the claims of which he then has notice.

Dated this 13th day of September, 1967.

ALEC. M. HAYES, solicitor, 148 Campbell-street, Swan Hill. 8998

HAZEL LEDWIDGE, late of Swan Hill, in the State of Victoria, widow, DECEASED.

**CREDITORS**, next of kin and others having claims in respect of the estate of the deceased (who died on the 22nd day of June, 1967), are required by the executors, Lena Margaret Bent (in the will named Lena Margaret McDonald), of 23 Waiora-road, West Heidelberg, in the said State, married woman and Elva Jean Reynolds (in the will named Elva Jean Ledwidge), of 2 Willow-road, Upper Fern Tree Gully, in the said State, married woman, to send particulars to them care of the undersigned by the 20th day of November, 1967, after which date the executors may convey or distribute the assets, having regard only to the claims of which they then have notice.

Dated this 13th day of September, 1967.

ALEC. M. HAYES, solicitor, 148 Campbell-street, Swan Hill. 8999

**CREDITORS**, next of kin and others having claims in respect of the estate of Irvine Sydham Sales, late of 22 Campbell-street, Bentleigh, in the State of Victoria, formerly clerk, but then retired gentleman, deceased, intestate (who died on the 8th day of May, 1967), are to send particulars of their claims to Rebecca May Sales, care of the under-mentioned solicitors by the 20th day of

November, 1967, after which date she will distribute the assets, having regard only to the claims to which she then has notice.

Dated this 13th day of September, 1967.

REGINALD C. BUTLER & CO., solicitors, 312 Centre-road, Bentleigh. 9000

In the Supreme Court of the State of Victoria.

SALE BY THE SHERIFF.

**ON** Monday, the 30th day of October, 1967, at 12.30 p.m., at the Police Station, Glenroy (unless process be stayed or satisfied):—

All the estate and interest (if any) of Joseph Francis Murphy and Betty Margaret Murphy, salesman and married woman respectively, both of 48 Sutherland-street, Glenroy, as joint proprietors of an estate in fee simple in the land described in certificate of title, volume 8419, folio 249, upon which is erected a brick veneer dwelling-house known as No. 48 Sutherland-street, Glenroy.

Registered mortgage No. B.678354 and Caveat No. B.713679 affect the said estate and interest.

Terms: Cash only.

DAVID J. JOHNSTON, Sheriff's Officer.

14th September, 1967. 9067

In the Supreme Court of the State of Victoria.

SALE BY THE SHERIFF.

**ON** Monday, the 30th day of October, 1967, at 2.45 p.m., at the Police Station, Blackburn (unless process be stayed or satisfied):—

All the estate and interest (if any) of Jacobus Hubertus Saasen and Gertruda Maria Saasen, mechanic and married woman respectively, both of 8 Aldinga-street, South Blackburn, as joint proprietors of an estate in fee simple in the land described in certificate of title, volume 8581, folio 358, upon which is erected a brick veneer dwelling-house known as No. 8 Aldinga-street, South Blackburn.

Registered mortgage No. C.306249 affects the said estate and interest.

Terms: Cash only.

DAVID J. JOHNSTON, Sheriff's Officer.

14th September, 1967. 9068

In the Supreme Court of the State of Victoria.

SALE BY THE SHERIFF.

**ON** Monday, the 30th day of October, 1967, at 10.30 a.m., at the Police Station, Blackburn (unless process be stayed or satisfied):—

All the estate and interest (if any) of Mrs. H. Lew, of 35 Bridge-street, Gardenvale, married woman, as proprietor of an estate in fee simple in the land described in certificate of title, volume 7760, folio 123, upon which is erected a dwelling-house of brick and weatherboard construction known as No. 35 Bridge-street, Gardenvale.

Registered mortgages Nos. C.15716 and C.588806 affect the said estate and interest.

Terms: Cash only.

DAVID J. JOHNSTON, Sheriff's Officer.

14th September, 1967. 9069

**IMPOUNDINGS**

**KEILOR**.—Impounded in Keilor Pound.

1 pet lamb, no visible brand

If not claimed and expenses paid, to sold on 5th October, 1967.

9072—\$1.50 C. M. MISSEN, Poundkeeper.

**KERANG**.—Impounded in Kerang Pound, on 15th September, 1967.

1 red steer, no visible marks or brand

If not claimed and expenses paid, to sold on 5th October, 1967.

9071—\$1.75 F. HASTIE, Poundkeeper.

**TRARALGON**.—Impounded from road on 8th September, 1967, in the Henry-street area.

1 ram lamb (long tail)

If not claimed and expenses paid, it will be sold on 5th October, 1967.

9022—\$1.75 E. KRUTOP, Poundkeeper.

*Subordinate Legislation Act 1962.***NOTICE OF MAKING OF STATUTORY RULES.**

**I**N pursuance of the provisions of the *Subordinate Legislation Act 1962* and the Regulations made thereunder, notice is given of the making of the following statutory rules:—

No.	Country Roads Act 1958 (No. 6229).	Price
240/1967.	Princes By-Pass Road (Agricultural Machinery) By-law 1967 .. ..	10c
	<i>Companies Act 1961.</i>	
241/1967.	Companies Regulations Takeover Offer (Offers) 1967 .. ..	10c
	<i>State Electricity Commission Acts.</i>	
242/1967.	State Electricity Commission (Licensing of Electrical Mechanics) Regulations 1967 .. ..	30c

Copies of these statutory rules may be purchased at the Sale of Publications Section of the Government Printing Office, located at Macarthur-street, Melbourne, 3002. If ordered by mail, remittance should be addressed to "The Government Printer, Box 203, P.O., North Melbourne, 3051", and should include 5c extra for postage. If a credit account is held at this office, no remittance is required with the mail order.

The annual subscription rate for Statutory Rules (including a Bound Volume) is \$15, payable in advance. The subscription year commences on 1st January.

A. C. BROOKS,  
Government Printer.

**CONTENTS**

	PAGE
Appointments .. ..	2886
Auction Sales Act .. ..	2876
Bank Holidays .. ..	2875
Contracts .. ..	2881
Estates of Deceased Persons .. ..	2884
Government Notices .. ..	2876
Holiday—Royal Agricultural Show .. ..	2876
Impoundings .. ..	2623
Lands .. ..	2900
Melbourne and Metropolitan Board of Works— Notice .. ..	2885
Melbourne Cup Day—Bank Holiday .. ..	2874
Mining .. ..	2885
Notice to attend for Radiological Examination .. ..	2877
Notice of Making of Statutory Rules .. ..	2624
Orders in Council— Acts—Land; Labour and Industry; Local Gov- ernment; Country Roads; Land; Water; Sewerage Districts; Country Roads.	2887 et seq
Private Advertisements .. ..	2910
Proclamations .. ..	2873
Public Holidays .. ..	2875
Public Service Notices .. ..	2909
Regulations— Acts—Teaching Service .. ..	2908
Resignation .. ..	2887
State Rivers and Water Supply Commission .. ..	2883
Tenders .. ..	2907
Transport Regulation Board—Public Hearings .. ..	2878
Waterworks Trusts .. ..	2886