



VICTORIA  
GOVERNMENT GAZETTE

Published by Authority

[Registered at the General Post Office, Melbourne, for transmission by post as a newspaper.]

No. 29]

WEDNESDAY, APRIL 3

[1968

PROCLAMATIONS

*Marketing of Primary Products Act 1958.*

DECLARING THAT CHICORY SHALL BECOME THE PROPERTY OF THE CHICORY MARKETING BOARD FOR A FURTHER PERIOD OF TWO (2) YEARS.

PROCLAMATION

By His Excellency the Governor of the State of Victoria and its Dependencies in the Commonwealth of Australia, &c., &c., &c.

WHEREAS by sub-section (1) of section 17 of the *Marketing of Primary Products Act 1958*, it is enacted that where a product has been declared a commodity and a board has been appointed in relation thereto, the Governor in Council may by proclamation—

- (a) provide and declare that the commodity shall forthwith, upon the date of publication of the proclamation or on from and after a later date specified in the proclamation, be divested from the producers of the commodity and become vested in and be the absolute property of the board as the owner thereof, and that upon any of the commodity coming into existence within a time specified in the same or a subsequent proclamation it shall by virtue of this Act become vested in and be the absolute property of the board as the owner thereof; and
- (b) make such further provision as will enable the board effectively to obtain possession of the commodity as such owner and to deal with the same:

AND WHEREAS by a proclamation made on the twenty-fourth day of December 1935, under the provisions of section 7 of the said Act the Governor in Council declared chicory to be a commodity under and for the purposes of the said Act: AND WHEREAS by an Order made on the eighth April 1936, the Governor in Council appointed

a marketing board in relation to chicory and assigned to such board the name of "The Chicory Marketing Board": NOW THEREFORE I, the Governor of the State of Victoria in the Commonwealth of Australia, by and with the advice of the Executive Council of the said State, do by this my proclamation hereby PROVIDE AND DECLARE that on, from and after the ninth day of April, 1968, all chicory shall subject to and in accordance with the *Marketing of Primary Products Act 1958* be divested from the producers of chicory and become vested in and be the absolute property of The Chicory Marketing Board as the owner thereof and that upon any chicory coming into existence within two (2) years from the ninth day of April, 1968, it shall by virtue of and subject to and in accordance with the said Act become vested in and be the absolute property of The Chicory Marketing Board as the owner thereof: AND to enable The Chicory Marketing Board as owner of the abovementioned commodity effectively to obtain possession thereof and to deal with the same I DO FURTHER PROVIDE that all such chicory shall subject to and in accordance with the provisions of the said Act be delivered by the producers thereof to The Chicory Marketing Board or its authorized agent within such times at such places and in such manner as The Chicory Marketing Board by public notice or in a particular case in writing, directs or as are prescribed by Regulations made under the said Act.

Given under my Hand and the Seal of the State of Victoria aforesaid, at Melbourne, this second day of April, in the year of our Lord One thousand nine hundred and sixty-eight, and in the seventeenth year of the reign of Her Majesty Queen Elizabeth II.

(L.S.) ROHAN DELACOMBE.

By His Excellency's Command,

G. L. CHANDLER,

Minister of Agriculture.

GOD SAVE THE QUEEN!

*Marketing of Primary Products Act 1958.*

DECLARING THAT ONIONS SHALL BECOME THE PROPERTY OF THE ONION MARKETING BOARD FOR A FURTHER PERIOD OF TWO (2) YEARS.

## PROCLAMATION

By His Excellency the Governor of the State of Victoria and its Dependencies in the Commonwealth of Australia, &c., &c., &c.

WHEREAS by sub-section (1) of section 17 of the *Marketing of Primary Products Act 1958*, it is enacted that where a product has been declared a commodity and a board has been appointed in relation thereto, the Governor in Council may by proclamation—

- (a) provide and declare that the commodity shall forthwith upon the date of publication of the proclamation or on from and after a later date specified in the proclamation, be divested from the producers of the commodity and become vested in and be the absolute property of the board as the owner thereof, and that upon any of the commodity coming into existence within a time specified in the same or a subsequent proclamation it shall by virtue of this Act become vested in and be the absolute property of the board as the owner thereof; and
- (b) make such further provision as will enable the board effectively to obtain possession of the commodity as such owner and to deal with the same:

AND WHEREAS by a proclamation made on the ninth day of December 1935 under the provisions of section 7 of the said Act the Governor in Council declared onions to be a commodity under and for the purposes of the said Act: AND WHEREAS by an Order made on the twenty-sixth day of March 1936 the Governor in Council appointed a marketing board in relation to onions and assigned to such board the name of "The Onion Marketing Board": NOW THEREFORE, I, the Governor of the State of Victoria in the Commonwealth of Australia, by and with the advice of the Executive Council of the said State, do by this my proclamation hereby PROVIDE AND DECLARE that on, from and after the fifth day of April, 1968, all onions shall subject to and in accordance with the *Marketing of Primary Products Act 1958* be divested from the producers of onions and become vested in and be the absolute property of The Onion Marketing Board as the owner thereof and that upon any onions coming into-existence within two (2) years from the fifth day of April, 1968, they shall by virtue of and subject to and in accordance with the said Act become vested in and be the absolute property of The Onion Marketing Board as the owner thereof: AND to enable The Onion Marketing Board as owner of the abovementioned commodity effectively to obtain possession thereof and to deal with the same I DO FURTHER PROVIDE that all such onions shall subject to and in accordance with the provisions of the said Act be delivered by the producers thereof to The Onion Marketing Board or its authorized agent within such times at such places and in such manner as The Onion Marketing Board by public notice, or in a particular case in writing, directs or as are prescribed by Regulations made under the said Act.

Given under my Hand and the Seal of the State of Victoria aforesaid, at Melbourne, this second day of April, in the year of our Lord One thousand nine hundred and sixty-eight, and in the seventeenth year of the reign of Her Majesty Queen Elizabeth II.

(L.S.) ROHAN DELACOMBE.

By His Excellency's Command,

G. L. CHANDLER,  
Minister of Agriculture.

GOD SAVE THE QUEEN!

## ACTS OF PARLIAMENT.

## PROCLAMATION

By His Excellency the Governor of the State of Victoria and its Dependencies in the Commonwealth of Australia, &c., &c., &c.

I, THE Governor of the State of Victoria, in the Commonwealth of Australia, do hereby declare that I have this day assented, in Her Majesty's name, to the Bills

passed by the Parliament of the said State, the titles whereof are hereunder set forth, together with the short titles, that is to say:—

No. 7657. "An Act to provide for the Closing of a Patriotic Fund known as The Victorian Limbless Soldiers' Provident Fund and for the Making of a Final Distribution of the Moneys and Securities constituting the Fund, and for other purposes." (*Victorian Limbless Soldiers' Provident Fund (Closing) Act 1968.*)

No. 7658. "An Act to amend Section 31 of the *Country Roads Act 1958.*" (*Country Roads (Borrowing Powers) Act 1968.*)

No. 7659. "An Act to amend the *Hairdressers Registration Act 1958.*" (*Hairdressers Registration (Amendment) Act 1968.*)

No. 7660. "An Act to amend Part IV. of the *Evidence Act 1958.*" (*Evidence (Attestations) Act 1968.*)

Given under my Hand and the Seal of the State of Victoria aforesaid, at Melbourne, this twenty-sixth day of March, in the year of our Lord One thousand nine hundred and sixty-eight, and in the seventeenth year of the reign of Her Majesty Queen Elizabeth II.

(L.S.) ROHAN DELACOMBE.

By His Excellency's Command,

HENRY BOLTE,  
Premier.

GOD SAVE THE QUEEN!

*Motor Boating Act 1961.*

EXEMPTION OF CERTAIN BOATS FROM THE PROVISIONS OF PART II. OF THE "MOTOR BOATING ACT 1961".

## PROCLAMATION

By His Excellency the Governor of the State of Victoria and its Dependencies in the Commonwealth of Australia, &c., &c., &c.

WHEREAS by an Act of Parliament of the State of Victoria passed in the tenth year of the reign of Her Majesty Queen Elizabeth II, intitled the *Motor Boating Act 1961* (No. 6832), it is amongst other things enacted that Part II of the *Motor Boating Act 1961* (No. 6832) shall not apply to any class or type of boat specified in any Proclamation made by the Governor in Council and published in the *Government Gazette* as exempted for the time being from compliance with the provisions of that part which Proclamation the Governor in Council may at any time in the like manner revoke, amend or vary:

NOW THEREFORE I, the Governor of the State of Victoria, in the Commonwealth of Australia, by and with the advice of the Executive Council of the said State, do by this my Proclamation exempt from registration as provided by the said Part II of the *Motor Boating Act 1961*—

All rubber dinghies being the property of the Victorian Air Rescue Service used for and in connection with search and rescue operations.

Given under my Hand and the Seal of the State of Victoria aforesaid, at Melbourne, this second day of April, in the year of our Lord One thousand nine hundred and sixty-eight, and in the seventeenth year of the reign of Her Majesty Queen Elizabeth II.

(L.S.) ROHAN DELACOMBE.

By His Excellency's Command,

A. G. RYLAH,  
Chief Secretary.

GOD SAVE THE QUEEN!

## COMPANIES ACT 1961.

PROCLAMATION OF STATES AND TERRITORIES FOR THE PURPOSES OF DIVISION 5 OF PART IV. OF THE COMPANIES ACT 1961.

By His Excellency the Governor of the State of Victoria and its Dependencies in the Commonwealth of Australia, &c., &c., &c.

WHEREAS sub-section (1) of section 76 of the *Companies Act 1961* provides *inter alia* that the Governor in Council may, by Proclamation, declare a State or

Territory of the Commonwealth to be a proclaimed State or Territory for the purposes of Division 5 of Part IV. of the *Companies Act 1961*.

NOW THEREFORE I, the Governor of the State of Victoria, by and with the advice of the Executive Council thereof, by this my Proclamation, do hereby declare the Territory of Papua and New Guinea to be a proclaimed Territory for the purposes of the said Division 5 of Part IV. of the *Companies Act 1961*.

Given under my Hand and the Seal of the State of Victoria aforesaid, at Melbourne, this 2nd day of April, in the year of our Lord One thousand nine hundred and sixty-eight, and in the seventeenth year of the reign of Her Majesty Queen Elizabeth II.

(L.S.) ROHAN DELACOMBE.

By His Excellency's Command,

G. O. REID,  
Attorney-General.

GOD SAVE THE QUEEN!

PUBLIC HOLIDAY.

PROCLAMATION.

By His Excellency the Governor of the State of Victoria and its Dependencies in the Commonwealth of Australia, &c., &c., &c.

IN pursuance of the provisions contained in Part III. of the *Public Service Act 1958*, I, the Governor of the State of Victoria, in the Commonwealth of Australia, by and with the advice of the Executive Council of the said State, do by this my Proclamation appoint the day and date hereunder mentioned to be observed as a Public Half-Holiday at the place specified, viz.:

*Public Half-Holiday from the Hour of Twelve o'clock noon:—*

WEDNESDAY, THE 3RD APRIL, 1968, throughout the Shire of Dundas.

Given under my Hand and the Seal of the State of Victoria aforesaid, at Melbourne, this second day of April, in the year of our Lord One thousand nine hundred and sixty-eight, and in the seventeenth year of the reign of Her Majesty Queen Elizabeth II.

(L.S.) ROHAN DELACOMBE.

By His Excellency's Command,

A. G. RYLAH,  
Chief Secretary.

GOD SAVE THE QUEEN!

*Public Service Act 1958.*

QUEEN'S BIRTHDAY HOLIDAY 1969.

PROCLAMATION

By His Excellency the Governor of the State of Victoria and its Dependencies in the Commonwealth of Australia, &c., &c., &c.

IN PURSUANCE of the powers conferred by sub-section (1) of Section 67 of the *Public Service Act 1958*, I, the Governor of the State of Victoria, in the Commonwealth of Australia, by and with the advice of the Executive Council of the said State, do by this my Proclamation appoint—

Monday, the 16th June, 1969,

as the day upon which the Anniversary of the birthday of Her Majesty for the year 1969, shall be observed as a holiday in the public offices throughout the State of Victoria.

Given under my Hand and the Seal of the State of Victoria aforesaid, at Melbourne, this second day of April, in the year of our Lord One thousand nine hundred and sixty-eight, and in the seventeenth year of the reign of Her Majesty Queen Elizabeth II.

(L.S.) ROHAN DELACOMBE.

By His Excellency's Command,

A. G. RYLAH,  
Chief Secretary.

GOD SAVE THE QUEEN!

GOVERNMENT NOTICES

PUBLICATION OF THE "VICTORIA GOVERNMENT GAZETTE".

EASTER HOLIDAYS:

BECAUSE of the Easter Holidays, the *Victoria Government Gazette* will be published on—

FRIDAY, THE 19TH APRIL, 1968  
instead of Wednesday, the 17th April, 1968.

All official matter for publication therein should be lodged with the *Gazette Officer*, Chief Secretary's Department (Telephone Extension 6282), not later than 9.30 a.m. on Thursday, the 18th April, 1968.

A. C. BROOKS,  
Government Printer.

RECEIPT OF MATERIAL FOR "GAZETTE".

ALTERATION OF CLOSING TIME.

FROM and after 1st April, 1968, copy for publication in the *Government Gazette*—must reach the *Gazette Officer*, Room 9, 1st Floor, Old Treasury Buildings, Spring-street, Melbourne, not later than 9.30 a.m. on the day prior to publication of the *Gazette*.

If copy contains plans or diagrams, these must be with the *Gazette Officer* by 12 noon on the Friday, prior to date of publication.

Inquiries regarding the publication of the *Government Gazette* can be made by telephoning the *Gazette Office*—63 0321, extension 6282.

EASTER HOLIDAYS.

IT is hereby notified that on—

FRIDAY, THE 12TH,

SATURDAY, THE 13TH,

MONDAY, THE 15TH,

TUESDAY, THE 16TH APRIL, 1968,

the Public Offices will be closed, such days being appointed by the *Public Service Act 1958* to be observed as holidays in the Public Offices throughout Victoria.

This notice relates only to the closing of the State Public Offices: All inquiries regarding holidays in other offices and in shops and industry should be directed to the Department of Labour and Industry, 110 Exhibition-street, Melbourne, 3000. (Telephone 63 0321, Extension 6158, 6721 or 6859.)

A. G. RYLAH,  
Chief Secretary.

Chief Secretary's Office,  
Melbourne, 18th March, 1968.

ANZAC DAY, HOLIDAY.

IT is hereby notified that on—

THURSDAY, THE 25TH APRIL, 1968,

the Public Offices will be closed, such day having been appointed by the *Public Service Act 1958*, to be observed as a holiday in the Public Offices throughout the State of Victoria.

This notice relates only to the closing of the State Public Offices. All inquiries regarding the holiday in other offices and in shops and industry should be directed to the Department of Labour and Industry, 110 Exhibition-street, Melbourne, 3000. (Telephone 63 0321, Extension 6158, 6721 or 6859.)

A. G. RYLAH,  
Chief Secretary.

Chief Secretary's Office,  
Melbourne, 3000, 29th March, 1968.

Co-operation Act 1958.

DUNKELD MEMORIAL SWIMMING POOL CO-OPERATIVE LIMITED, PARK ORCHARDS TENNIS CLUB CO-OPERATIVE LIMITED.

NOTICE is hereby given, in pursuance of section 78 (7) of the *Co-operation Act 1958*, and section 308 (2) of the *Companies Act 1961*, that at the expiration of three months from the date hereof, the names of the aforementioned societies will, unless cause is shown to the contrary, be struck off the register and the societies will be dissolved.

Dated this twentieth day of March, 1968.

M. V. HAMMOND,  
Acting Deputy Registrar.

*Private Agents Act 1966.*

NOTICE OF RECEIPT OF APPLICATIONS FOR LICENCES UNDER THE PROVISIONS OF THE PRIVATE AGENTS ACT 1966.

THE Clerk(s) of the Court(s) of Petty Sessions as listed hereunder hereby give notice that applications, as under, have been lodged for hearing by the said Court(s) on the date(s) specified.

Any person desiring to object to any of such applications must—

- (a) lodge with the respective Clerk of Petty Sessions a notice in the prescribed form of his objection and of the grounds thereof;
- (b) cause a copy of such notice to be served personally or by post upon the applicant at least three days before the hearing of the application; and
- (c) send or deliver—
  - (i) where the objection is not made by the officer in charge of the police district in which the Court is situated—a copy of the notice to such officer; and
  - (ii) where the objection is not made by the Registrar or Deputy Registrar—a copy to the Registrar.

Full Name of Applicant or in the case of a Firm or Corporation, of the Nominee.	Place of Abode of Applicant or Nominee.	Name of Firm or Corporation.	Address for Registration.	Type of Licence.	Date of Hearing of Application.
---	---	------------------------------	---------------------------	------------------	---------------------------------

COURT OF PETTY SESSIONS, HEIDELBERG

Taylor, Roy	32 Glen Park-road, North Eltham		42 Lantana-street, Ivanhoe	Watchman	17.4.68
-------------	---------------------------------	--	----------------------------	----------	---------

Dated at Heidelberg this 25th day of March, 1968.

T. K. HASSARD,  
Clerk of Petty Sessions.

COURT OF PETTY SESSIONS, BALLARAT.

Lyons, Margaret Mary	Navigator, via Ballarat		17 Doveton-street north, Ballarat	Commercial Sub-agent	18.4.68
----------------------	-------------------------	--	-----------------------------------	----------------------	---------

Dated at Ballarat this 27th day of March, 1968.

W. GUY,  
Clerk of Petty Sessions.

COURT OF PETTY SESSIONS, COBURG.

Combridge, Peter David	86 Brougham-street, Eltham	Mayne Nickless Ltd.	88 Bakers-road, North Coburg	Watchman	18.4.68
------------------------	----------------------------	---------------------	------------------------------	----------	---------

Dated at Coburg this 27th day of March, 1968.

F. J. TENNI,  
Clerk of Petty Sessions.

RULES UNDER THE JUSTICES ACT.

SELECTION BY A LAW OFFICER OF THE PLACES AND DAYS AND HOURS FOR HOLDING COURTS (WITHIN THE MEANING OF THE SAID RULES).

I, THE undersigned, George Oswald Reid, a Law Officer of the State of Victoria, in pursuance of the powers conferred upon me by Rule 2 of Chapter III, of the Justices Act Rules 1963, do hereby amend the days and hours selected on the 27th day of November, 1967 and published in the *Government Gazette* on the 6th day of December, 1967 as indicated in the Schedule hereto.

SCHEDULE.

Court.	Days and Hours.
Moe	Alternate Mondays at 10 a.m. and every Thursday at 10 a.m. except Public Holidays and Thursday, the 25th July, 1968, in lieu of the days and hours heretofore appointed—to take effect from the 13th May, 1968.
Morwell	Every Tuesday at 10 a.m. and alternate Wednesdays at 10 a.m. except Public Holidays—to take effect from the 15th May, 1968

Dated at Melbourne, this 29th day of March, 1968.

G. O. REID,  
Law Officer.

LAW DEPARTMENT.

ADMINISTRATION AND PROBATE ACT 1958—SECTION 57 (4).

HIS Excellency the Governor of the State of Victoria by and with the advice of the Executive Council thereof doth by Order made on the 26th day of March, 1968, approve of "The Automobile Fire and General Insurance Company of Australia Ltd", under the provisions of Section 57 (4) of the *Administration and Probate Act 1958*.

J. ROSSITER,  
Clerk of the Executive Council.

At the Executive Chamber,  
Melbourne, 26th March, 1968.

Notice.

*Aerial Spraying Control Act 1966.*

NOTICE AMENDING NORTH-EASTERN HAZARDOUS AREA.

PURSUANT to the provisions of sub-section (2) of section 7 of the *Aerial Spraying Control Act 1966* I, the responsible Minister of the Crown for the time being administering the said Act, do by this notice hereby amend the notice dated the fifth day of July, 1967, declaring the North-Eastern Hazardous Area specified in the Schedule thereto to be a hazardous area for the purposes of the said Act during the period from the first day of August, 1967, to the thirtieth day of April, 1968, both dates inclusive, on and from the eighth day of April, 1968, as follows:—

In the Schedule thereto for the expression—

"thence southerly by a line to the most southerly angle of the Township of Tolmie; thence north-easterly by a line to the summit of Mount Pleasant;"

there shall be substituted the expression—

"thence south-easterly by a line to the summit of Mount Pleasant".

Dated the twenty-eighth day of March, 1968.

G. L. CHANDLER,  
Minister of Agriculture.

EDUCATION DEPARTMENT.

SUMMONING OFFICER.

UNDER section 5 of the *Education Act 1958*, I hereby appoint—

Senior Constable Edward Stanislaus Moloney, and Senior Constable Hayden Charles Whitmore, to summon parents within the State of Victoria.

L. H. S. THOMPSON,  
Minister of Education.

25th March, 1968.

Transport Regulation Act.  
TRANSPORT REGULATION BOARD.

## HEARING OF APPLICATIONS.

NOTICE is hereby given that the following applications will be considered by the Transport Regulation Board at its offices at the corner of Lygon and Princess streets, Carlton, at 10.15 a.m. on Wednesday, 24th April, 1968.

BLUE & SILVER BUS LINE PTY. LTD., 250 Balcombe-road, Mentone. One commercial passenger vehicle with large seating capacity to operate as a country stage omnibus on the following route (Mentone-Southland-Cheltenham): Commencing at the Mentone Railway Station, via Swanson-street, Nepean Highway, Cobham-street, Ward-street, Follett-road, Ivy-street, Devon-street, Tenham-grove, Centre Dandenong-road, Coolac-street, Silver-street, Cavanagh-street, Argus-street to Southland; thence via Chesterville-road to Cheltenham Railway Station returning via same route.

## TIME-TABLE—MINIMUM SERVICE.

30 minutes, 8.00 a.m.—6.00 p.m. weekdays.  
30 minutes, 8.00 a.m.—12.15 p.m. Saturdays.

Subject to the cancellation of existing C.O. licences held by the applicant.

BLUE & SILVER BUS LINE PTY. LTD., 250 Balcombe-road, Mentone. A required number of commercial passenger vehicles with a large seating capacity to operate as country stage omnibuses on the following route (Mordialloc-Mentone-Southland): Commencing at the Mordialloc Railway Station via Barkly-street, White-street, Warren-road, Lawborough-street, McSwain-street, Marriott-street, Chandler-street, Marriott-street, Nepean Highway, Fourth-street, Como-parade east, Warrigal-road, Como-parade west to Mentone Railway Station; thence via Swanson-street and Nepean Highway to Southland returning via same route.

## TIME-TABLE—MINIMUM SERVICE.

30 minutes, 8.00 a.m.—6.00 p.m. weekdays.  
30 minutes, 8.00 a.m.—12.15 p.m. Saturdays.

Subject to the cancellation of existing C.O. licences held by the applicant.

BLUE & SILVER BUS LINE PTY. LTD., 250 Balcombe-road, Mentone. One commercial passenger vehicle with a large seating capacity to operate as country stage omnibus on the following route (Mordialloc-Mentone-Southland): Commencing at the Mordialloc Railway Station via Nepean Highway, Fourth-street, Como-parade east, Warrigal-road, Como-parade west, Mentone Railway Station, Swanson-street and Nepean Highway to Southland returning via same route.

## TIME-TABLE—MINIMUM SERVICE.

30 minutes, 8.00 a.m.—6.00 p.m. weekdays.  
30 minutes, 8.00 a.m.—12.15 p.m. Saturdays.

Subject to the cancellation of existing C.O. licences held by the applicant.

CROYDON BUS SERVICE PTY. LTD., Maroondah Highway, Croydon. One commercial passenger vehicle (S/C. 35) to operate under the same terms and conditions as existing C.O. licences in the name of the applicant.

FLOODS MOTOR SERVICES PTY. LTD., Arnold-street, Bendigo. One commercial passenger vehicle (S/C. 11) to operate as follows: (a) For the carriage of school children only between Muskerry and Barnadown, under contract to the Education Department. (b) To operate as a stage omnibus between Bendigo and Shepparton on Saturdays and public holidays only when a large seating capacity vehicle is not justified. (c) As a country special service omnibus from Bendigo.

NASH, THOMAS NORMAN, 8 Bergins-road, Rowville. One commercial passenger vehicle (S/C. 5) to operate as a country taxi-cab from Scoresby.

PRESTON COBURG BUS SERVICE PTY. LTD., 572 Murray-road, West Preston. Application for permit authority to operate any one M.O. licensed vehicle for the carriage of school children between the North Coburg State school and the Baths situated at the corner of Moreland and Melville roads, for swimming tuition during the winter months only, via O'Heas-road, Sussex-street, Bell-street and Melville-road.

## TIME-TABLE (Mondays Only).

Depart North Coburg State School . . . 10.45 a.m.  
Depart Baths . . . . . 12 noon.

WESTERN CONSOLIDATED PTY. LTD., 16 Roberts-road, Airport West. One commercial passenger vehicle with large seating capacity to operate Route 145A (Niddrie-Essendon Airport) as presently operated under an M.O. licence held by the applicant company with the

ability to extend service from the corner of Marshall and Bulla roads, via Bulla, Sharps and various Government roads within the boundary of Tullamarine Jetport to the terminal. No pick up or set down of passengers to occur *en route*.

## TIME-TABLE—At least 12 return trips daily.

## Sections and Fares:

From Section 1 to Tullamarine Jetport . . . 20c  
From Section 2 to Tullamarine Jetport . . . 18c  
From Section 3 to Tullamarine Jetport . . . 16c

WHITE, M. (Mrs.), on behalf of Mary Poppins Child Minding Centre, 27 Joy-parade, Noble Park. One commercial passenger vehicle (S/C. 5) to operate for the carriage of pre-school children between their homes and the applicant's child minding centre situated at the above address. No direct fee will be charged for the service.

APPLICATION for renewal of licences as shown, by persons listed hereunder to operate under the same terms and conditions.

GRAY, R. W. and H. A., 19 Truganini-road, Carnegie; M.H.2412.

NIMMO, W. A., 41 Linden-avenue, West Heidelberg; M.H.2404.

Notice of any objection should be forwarded to reach the Secretary of the Board not later than Wednesday, 17th April, 1968.

Applicants are advised that it will not be necessary to appear on the hearing date specified above, unless advised in writing by the Board.

B. P. KAY,

Secretary.

Corner Lygon and Princess streets, Carlton, Wednesday, 3rd April, 1968.

Commercial Goods Vehicles Act.  
TRANSPORT REGULATION BOARD.

## HEARING OF APPLICATIONS.

NOTICE is hereby given that the following applications will be considered by the Transport Regulation Board at its offices at the corner of Lygon and Princess streets, Carlton, at 10.15 a.m. on Wednesday, 24th April, 1968.

A.H. AGENCIES & SALES PTY. LTD., 1122 High-street, Armadale, 3143. Applications to vary conditions of licence No. D.A.45101/8 (L/C. 17 cwt.) by deleting the word "Warrnambool" from the existing conditions and adding in lieu the word "Hamilton".

BASIACO, G., 7 Weigall-street, East Brunswick, 3057. One commercial goods vehicle (L/C. 197 cwt.) to operate within a 50-mile radius from the premises of Blue Metal Quarries Pty. Ltd. at Epping, solely on behalf of the said company—premixed concrete in a specially constructed agitator vehicle.

BUCKINGHAM, T. P., 51 Gordon-grove, East Preston, 3072. One commercial goods vehicle (L/C. 61 cwt.) to operate: (a) Within a 25-mile radius of own premises at East Preston—general goods, provided that no goods shall be carried whether by one stage or by more than one stage between places within the above radius, which are more than 30 road miles apart by the nearest practicable route. (b) From and to places situated within a 50-mile radius of own premises at East Preston to and from places defined in paragraph (a) above—livestock.

CERIO, D., 1 Crawley-street, Regent, 3073. One commercial goods vehicle (L/C. 197 cwt.) to operate within a 50-mile radius from the premises of Blue Metal Quarries Pty. Ltd. at Fairfield, solely on behalf of the said company—premixed concrete in a specially constructed agitator vehicle.

CHAMBERS, B. M., 79 Moroney-street, Bairnsdale, 3875. One commercial goods vehicle (L/C. 30 cwt.) to operate in the course of business as "Produce Merchant, General Hardware Dealer and Distributor of Petroleum Products": (a) Between the Townships of Bairnsdale and Swift's Creek—bran, pollard, wheat, maize, oats, general hardware, coke and briquettes, sheep dips, weedicides, veterinary supplies, petroleum products in prescribed types of containers and empty containers for return on behalf of B.P. Australia Ltd. (b) Within a 20-mile radius of own premises at Bairnsdale in the course of business as "Pump Specialist"—pumps and pumping equipment. (c) From own premises at Swift's Creek—(i) To points situated within a 20-mile radius of the post office at Swift's Creek—goods as described in paragraph (a). (ii) To points situated within a 50-mile

- radius of the post office at Swift's Creek but excluding any part of the said radius situated within a 10-mile radius of the post office at Glen Valley—petroleum products in prescribed types of containers and empty containers for return on behalf of B. P. Australia Ltd.
- CHASEMORE, K. R., 307 Whitehorse-road, Nunawading, 3131. One commercial goods vehicle (L/C. 388 cwt.) to operate throughout the State of Victoria in course of business as "Land Clearing and Excavation Contractors"—own plant and own equipment incidental to own contracts.
- CHESTERFIELD MACHINERY PTY. LTD., Western Highway, Horsham, 3400. One commercial goods vehicle (L/C. 11 cwt.) to operate within a 50-mile radius of the main post office at Horsham and to Kaniva and Edenhope in course of business as "Agricultural Machinery Distributor"—tools of trade, spare parts and items of equipment for repair, having been repaired or for servicing.
- DEVANNY BROS. PTY. LTD., 108 Panton-street, Golden Square, 3555. One commercial goods vehicle (L/C. 226 cwt.) to operate: (a) Within a 50-mile radius from the post office at Bendigo as a "Road Contractor"—road-making plant and materials. (b) Within a 25-mile radius from the post office at Bendigo—general goods.
- DOWELL SCHLUMBERGER WESTERN S.A., Box 251, P.O. Sale, 3850. One commercial goods vehicle (L/C. 16 cwt.) to operate throughout the State of Victoria in the course of business as "Oil and Gas Prospectors"—electronic equipment incidental to measuring oil and gas flows at exploratory wells.
- DURAL LEEDS PTY. LTD., corner Calder Highway and Roberts-road, Niddrie, 3042. Three commercial goods vehicles (L/C. 10 cwt. each) to operate throughout the State of Victoria in course of business as "Blind and Awning Manufacturers" for the purpose of sales promotion, repairing and measuring contracts, samples, display materials, tools of trade, blinds and awnings for repair, having been repaired and for specialized installation, and materials incidental thereto.
- EDWARD, G. R., AUTO ELECTRICAL SERVICE PTY. LTD., 3 Eton-street, Wendouree, 3355. Two commercial goods vehicles (L/C. 17 and 19 cwt.) to operate within the State of Victoria in the area bounded by a line drawn through, and joining the Cities and/or Towns of Ballarat, Geelong, Colac, Camperdown, Mortlake, Hamilton, Stawell, Warracknabeal, Hopetoun, Lascelles, St. Arnaud, Bendigo, Bacchus Marsh and returning to Ballarat in course of business as "Automotive Electrical Spare Parts and Accessories Distributors"—automotive electrical spare parts and automotive accessories.
- EDWARDS, J. H., PTY. LTD., AND ASSOCIATED COMPANIES, 27 Melbourne-road, Ballarat, 3350. Application to vary conditions of licence No. D.A.61450 (L/C. 7 cwt.) by deleting from the existing conditions the proviso of the Board and adding in lieu: "That not more than a total load of 7 cwt. be carried at any one time on the said vehicle and any trailer which may be attached thereto."
- FERRUM METAL EXPORTS PTY. LTD., 60-62 Clarendon-street, South Melbourne, 3205. Application to vary conditions of licence No. D.A.28181/1 (L/C. 107 cwt.) by deleting the existing conditions and by adding in lieu: "Within a 50-mile radius of the G.P.O., Melbourne, in course of business as 'Metal Dealers' for the purpose of collecting scrap metals—scrap metal."
- FIRE FIGHTING EQUIPMENT PTY. LTD., 203 Bouverie-street, Carlton, 3053. One commercial goods vehicle (L/C. 11 cwt.) to operate throughout the State of Victoria in course of business as "Fire Protection Engineers"—own tools of trade, own equipment and own spare parts necessary for the completion of own maintenance contracts.
- GENERAL CONSTRUCTIONS PTY. LTD., 62 Mandoon-road, Girraween, N.S.W., 2145. One commercial goods vehicle (L/C. 68 cwt.) to operate: (a) Throughout the State of Victoria in course of business as "Construction Engineers"—own tools of trade, own plant and own equipment incidental to the completion of own contracts. (b) Within a 20-mile radius of any contract site currently engaged upon or from the nearest railway station thereto—materials for use on such contract.
- HALLIWELL, M. A., 141 Gordon-street, Coburg, 3058. Two commercial goods vehicles (L/C. 11 and 20 cwt.) to operate throughout the State of Victoria in course of business as "Fish and Frozen Food Distributor" in a specially constructed insulated vehicle—frozen fish, fresh fish, frozen vegetables, and up to four dozen bottles of mussels and onions.
- HARRINGTON, F. M., 90 Henna-street, Warrambool, 3280. One commercial goods vehicle (L/C. 32 cwt.) to operate within a 50-mile radius of the post office at Warrambool in the course of business as "Aerated Water Distributor"—aerated waters in glass containers and empty return containers.
- HOLDENSON & NIELSON FRESH FOOD PTY. LTD., 95 Cecil-street, South Melbourne, 3205. Application to vary the conditions of licence No. D.A.47779/7 (L/C. 109 cwt.) by adding to the existing conditions after "Trafalgar Milk Co. Pty. Ltd., at Trafalgar" the words "and Echuca Butter Factory and Trading Co. Pty. Ltd. at Echuca".
- KERR, F. C., & SON PTY. LTD., 176 Kororoit Creek-road, Williamstown, 3016. One commercial goods vehicle (L/C. 16 cwt.) to operate throughout the State of Victoria in course of business as "Cartage Contractors" for the purpose of servicing own vehicles and equipment—tools of trade, spare parts and materials incidental to servicing only.
- KRIEWALDT, BILL PTY. LTD., 2 Piper-street, Kyneton, Vic., 3444. One commercial goods vehicle (L/C. 142 cwt.) to operate: (a) Within a 30-mile radius from the post office at Kyneton as a "Road Contractor"—road-making plant and materials. (b) Within a 25-mile radius of the post office at Kyneton—general goods, provided that no goods shall be carried whether by one stage or by more than one stage between places within the above radius, which are more than 30 road miles apart by the nearest practicable route.
- LEAHY, K. R., 45 Kareela-road, Frankston, 3199. Application to vary conditions of licence No. D.A.60560 (L/C. 8 cwt. and 38 cwt. trailer) by deleting from the existing conditions the following: "but excluding the carriage of spare parts from any place situated within a 25-mile radius of the post office at the corner of Bourke and Elizabeth streets, in the City of Melbourne."
- LEE, F. W., 13 Creswick-street, Glen Iris, 3146. Application to vary conditions of licence No. D.A.51964 (L/C. 116 cwt.) by adding to the existing conditions paragraph (b)—"(b) Within a 25-mile radius of the G.P.O., Melbourne—general goods."
- LUFF, N. C., 50A Darlot-street, Horsham, 3400. One commercial goods vehicle (L/C. 17 cwt.) to operate within a 100-mile radius of the post office at Horsham in course of business as "Septic Tank Cleaners"—own tools of trade and equipment for use on own contracts.
- MILLER, J. F. & E. C., A'Beckett-street, Inverloch, 3996. Application to vary conditions of licence No. D.A.49468 (L/C. 130 cwt.) by adding to the existing conditions as paragraph (c)—"(c) From pits situated at Leongatha North, The Gardies, Leongatha South and Cranbourne to consignees situated within a 20-mile radius of the post office at Inverloch—sand and screenings."
- MORSE, G. W. & B. I., 722 High-street, Bendigo, 3550. Application to vary the conditions of licence No. D.A.61108 (L/C. 204 cwt.) by deleting the word "Bendigo" from the existing conditions and adding in lieu the word "Echuca".
- NEBOZUK, A. J., 4 Adela-street, Wendouree, 3355. One commercial goods vehicle (L/C. 8 cwt.) to operate throughout the State of Victoria in the course of business as "Carpet and Linoleum Layer"—tools of trade and small quantities of carpet, linoleum and floor tiles for laying purposes only.
- NORTHEY, J. N., Dundonnell, 3265. One commercial goods vehicle (L/C. 137 cwt.) to operate: (a) Within a 25-mile radius of the post office at Derrinallum—general goods, provided that no goods shall be carried whether by one stage or by more than one stage between places within the above radius which are more than 30 road miles apart by the nearest practicable route. (b) From and to places situated within the radius as defined in paragraph (a) above to and from places within a 50-mile radius from the post office at Derrinallum—livestock.
- RAVIDA, F., 5 Vila-court, North Oakleigh. One commercial goods vehicle (L/C. 163 cwt.) to operate: (a) Within a 50-mile radius of the premises of Alan Cope Pty. Ltd. at North Clayton—concrete septic tanks for installation only solely on behalf of the said company, and own installation equipment. (b) Within a 25-mile radius of the premises of Alan Cope Pty. Ltd., at North Clayton—concrete products manufactured by the said company viz.: Concrete septic tanks, concrete wash troughs, concrete grease traps, concrete pipes, concrete box culverts, concrete shower recess slabs, concrete gully rings, concrete gutterings, concrete lawn edgings, concrete paving slabs, concrete steps and concrete stumps.

**ROBERTS, J. V. & SON, PTY. LTD.**, Murray-street, Piangil, 3597. One commercial goods vehicle (L/C. 142 cwt.) to operate within a 50-mile radius of the post office at Swan Hill in course of business as "General Merchants and Distributors" for the delivery and spreading of bulk fertilizer—provided such fertilizer is delivered to railway sidings within the specified radius.

**SMYTH, D., & SON PTY. LTD.**, 13-19 St. Andrews-avenue, Bendigo, 3550. One commercial goods vehicle (L/C. 10 cwt.) to operate throughout the State of Victoria in the course of business as "Air Conditioning and Hot Water Engineers"—tools of trade, equipment, spare parts and small quantities of materials incidental to the repair or completion of own contracts subject to the condition that no spare parts or materials whatsoever shall be carried from the City of Melbourne.

**STIRZAKER, J. H. R.**, Private Bag, Noojee, 3833. One commercial goods vehicle (L/C. 369 cwt.) to operate from landings within a 10-mile radius of the post office at Matlock to sawmills at Matlock, Noojee and Warburton—logs.

**STOKER, B.**, Millers-road, The Basin, 3154. One commercial goods vehicle (L/C. 16 cwt.) to operate within a 100-mile radius from the post office at The Basin in the course of business as a "Hawke:"—tools, drapery and gifts but excluding the carriage of any such goods to retail stores for resale.

**TAYLOR, E.**, 95 Kanooka-grove, Clayton, 3168. One commercial goods vehicle (L/C. 108 cwt.) to operate within a 70-mile radius from the premises of The City Brick Works Co. Pty. Ltd. at Tooronga, solely on behalf of the said company—bricks.

**THOMPSON EARTHMOVERS PTY. LTD.**, 10 Ashburn-place, Blackburn, 3130. One commercial goods vehicle (L/C. 202 cwt.) to operate: (a) Within a 25-mile radius of own premises at Blackburn in course of business as "Earth-moving Contractors and Plant Hirers"—own goods. (b) Throughout the State of Victoria as Earth-moving Contractors—own tools of trade, own plant and own equipment. (c) Within a 20-mile radius of any contract currently engaged upon or from the nearest railway station thereto—materials for use on such contract.

**WANGARATTA STEAM LAUNDRY**, 72 Norton-street, Wangaratta, 3677. Application to vary conditions of licences numbered D.A.2233/1 and D.A.2233/2 (L/C. 10 cwt. each) by adding to the existing conditions an additional paragraph: "Between the Township of Wangaratta and Timbertop School near Mansfield in the course of business as 'Laundry Proprietor'—garments for cleaning and laundering or garments having been cleaned or laundered".

**WARANGA & HUME DISTRIBUTING CO. PTY. LTD.**, 94 Reid-street, Wangaratta, 3677. One commercial goods vehicle (L/C. 7 cwt.) to operate from any depot of the applicant situated at Echuca, Shepparton, Wangaratta, Yea, Bendigo or Yarrowonga to points within a 50-mile radius of the particular depot in substitution for, but not in addition to, any other vehicle of the licence holder which holds a current "D.A." licence to operate from the said depots, and when so operated shall adhere and be subject to all of the terms and conditions of the licence held in respect of the vehicle for which it is substituted.

#### TOW TRUCKS.

**MCKENZIE, I.**, Greens-lane, Dandenong, 3175. One commercial goods vehicle (to be purchased) to operate within a 25-mile radius of the post office at Dandenong as a "Tow Truck" solely: (a) For the purpose of lifting and carrying or towing motor cars and the carriage of tools and equipment necessary for such purposes only. (b) The carriage of spare parts necessary for the repair of a disabled motor to and from the place at which such disablement has occurred.

**WHARTON, A. H.**, 141 High-street, Kyneton, 3444. Application to vary conditions of licence No. D.A.59889 (L/C. 68 cwt.) by deleting from the existing conditions: "Within a 25-mile radius of the post office at Kyneton" and adding in lieu "Throughout the State of Victoria".

**WHITE HILLS SERVICE STATION**, nominees Ettore Ghiringhelli and Francis A. Kane, 2 McCrae-street, Bendigo, 3550. One commercial goods vehicle (L/C. 74 cwt.) to operate within a 50-mile radius from the post office at Bendigo as a "Tow Truck" solely: (a) For the purpose of lifting and carrying or towing motor cars and the carriage of tools and equipment necessary for such purpose only. (b) The carriage of spare parts necessary for the repair of a disabled motor to and from the place at which such disablement has occurred.

#### RENEWALS.

**A** PPLICATIONS for renewal of licences as shown by persons listed hereunder to operate under the same terms and conditions from the expiry shown in each case.

**BALLARAT ASSOCIATED FIBROUS PLASTER MANUFACTURERS PTY. LTD.**, corner Gillies and Gregory streets, Wendouree, 3355; D.A.33017/5; 18th May, 1968; 255 cwt.

**BEAUREPAIRE TYRE SERVICE PTY. LTD.**, 102 Victoria-street, Carlton, 3053; D.A.629/90; 27th January, 1968; 16 cwt.

**BIDEY, K. W.**, 105 Cavanagh-street, Cheltenham, 3192; D.A.35093/1; 18th May, 1968; 105 cwt.

**BRADLEY, A. H.**, Jenkins-street, California Gully, Bendigo, 3550; D.A.25223; 30th April, 1968; 134 cwt.

**CARMAN, I. H.**, Ward-street, Horsham, 3400; D.A.52254; 18th May, 1968; 70 cwt.

**CORDY, S. K.**, 187 Tone-road, Wangaratta, 3677; D.A.5066; 16th June, 1968; 7 cwt.

**DRISCOLL, B. H.**, Princes Highway, Boorcan, 3261; D.A.42627/3; 27th April, 1968; 245 cwt.

**DRUG HOUSES OF AUSTRALIA LTD.**, 504 Bourke-street, Melbourne, 3000; D.A.2414/8; 9th May, 1968; 11 cwt.

**EMBREY, K. L.**, Camperdown, 3260; D.A.17933; 9th May, 1968; 78 cwt.

**FROZO FOOD CO. PTY. LTD.**, corner Maria-street and Cherry-lane, Brooklyn, 3025; T.D.A.46652; 16th May, 1968; 61 cwt.

**GEELONG LAUNDRY CO.**, 23 Austin-street, Newtown, Geelong, 3220; D.A.30311/2; 16th May, 1968; 17 cwt.

**GREEN BROS. EPSOM PTY. LTD.**, Main-road, Epsom, 3551; D.A.1195; 21st April, 1968; 116 cwt.

**HEATHER, R. W. and M. F.**, 51 Lawson-street, Orbost, 3888; D.T.747/2; 28th March, 1968; 334 cwt.

**HODGSON, J. A.**, 140 San Mateo-avenue, Mildura, 3500; D.A.39461; 24th May, 1968; 101 cwt.

**HOVEY'S TRANSPORT SERVICE**, Thompson-road, North Geelong, 3215; D.A.1332; 30th April, 1968; 249 cwt.; D.A.1332/1; 16th May, 1968; 200 cwt.

**JASPER BROS.**, Main-street, Rutherglen, 3685; T.D.A.39428; 24th May, 1968; 15 cwt.

**JONES, K. M. T.**, 21 Charles-street, Maffra, 3860; D.A.51868; 27th April, 1968; 11 cwt.

**KEATH, ROBIN (S.A.) PTY. LTD.**, P.O. Box 128, Horsham, 3400; D.A.22517/17; 18th May, 1968; 220 cwt.

**LANEWAYS PTY. LTD.**, 146 Koroit-street, Warrambool, 3280; D.A.37300/1; 25th May, 1968; 48 cwt.

**MAC'S TYRE SERVICE**, 31 Main-street, Stawell, 3380; D.A.1539/2; 11th May, 1968; 11 cwt.

**MARSH, K. W. and J. W. DOHERTY**, Vincent-road, Wangaratta, 3677; D.A.25358; 9th April, 1968; 76 cwt.

**MERBEIN PLASTER WORKS PTY. LTD.**, 44 Avocado-street, Mildura, 3500; D.A.10581/2; 18th May, 1968; 77 cwt.

**MIDLAND TYRE SERVICE (GEELONG) PTY. LTD.**, 472 Moorabool-street, Geelong, 3220; D.A.43114/4; 9th April, 1968; 8 cwt.

**MILSOM, A.**, Monsonts-road, Maiden Gully, Bendigo, 3550; D.A.51834; 21st April, 1968; 72 cwt.

**MCDARMID, W. D.**, 7 Royal-avenue, North Essendon, 3040; D.A.51380; 18th May, 1968; 130 cwt.

**MCDONALD, W. L. & W. E.**, Whitfield, 3733; D.A.1671/2; 21st April, 1968; 156 cwt.

**NEON ELECTRIC SIGNS LTD.**, corner Cecil and Whiteman-streets, South Melbourne, 3205; D.A.1713/1; 17th May, 1968; 35 cwt.

**NOSKE, E. A. & B. J.**, Private Bag 15, Hamilton, 3300; D.A.52172; 18th May, 1968, 111 cwt.

**READER, E. W.**, Lower Dandenong-road, Braeside, 3195; D.A.51723; 6th April, 1968; 48 cwt.

**RONALDSON BROS. & TIPPETT LTD.**, Creswick-road, Ballarat, 3350; D.A.1947/2; 21st May, 1968; 20 cwt.

**SCARBOROUGH, E. H.**, P.O. Box 103, Merino, 3310; D.A.39341; 16th May, 1968; 12 cwt.

**SCHWEPPE (AUST.) PTY. LTD.**, 137 Chesterville-road, Highbett, 3190; T.D.A.34505/10; 4th May, 1968; 116 cwt.; T.D.A.34505/12; 4th May, 1968; 223 cwt.

**SINCLAIR, N.**, Dawson-street, Stratford, 3862; D.A.38449; 16th May, 1968; 118 cwt.

**SVANOSIO, N. L. & J. A.**, 129 Creek-street, Bendigo, 3550; D.A.36437/6; 27th April, 1968; 127 cwt.

**TRANS OTWAY LTD.**, corner Ryrie and Fenwick streets, Geelong, 3220; D.A.2179/8; 16th May, 1968; 83 cwt.

**VELCRETE TRANSPORT PTY. LTD.**, Wodonga-street, Wodonga, 3690; D.A.52259/1; 18th May, 1968; 185 cwt.; D.A.52259/2; 18th May, 1968; 212 cwt.; D.A.52259/3; 18th May, 1968; 199 cwt.; D.A.52259/4; 18th May, 1968; 142 cwt.

**WATERSON, G. G.**, Sparrowhawk-road, Long Gully, Bendigo, 3550; D.A.39466; 24th May, 1968; 11 cwt.

**YOUNG, W. H., & SONS**, 182 High-street, Shepparton, 3630; D.A.35594/28; 18th May, 1968; 244 cwt.

RENEWALS WITH VARIATION.

APPLICATION by the persons listed hereunder for renewal of the licences listed with variation of conditions in the manner set out opposite the names.

HAMILTON, S. J., Helena-road, Lilydale, 3140; D.A.1224; 28th May, 1968; application to renew and vary conditions of licence No. D.A.1224 (L/C. 140 cwt. approximately) by deleting the present conditions and adding in lieu: "Within a 50-mile radius of the premises of Albion Reid Pty. Ltd., at North Melbourne—road-making plant, materials, premix and hot asphalt on behalf of the said company."

SLADE, H. & Z., 28 Ashe-street, North Wonthaggi, 3995; D.A.51847; 21st April, 1968; application to renew and vary condition of licence No. D.A.51847 (L/C. 119 cwt.) by deleting paragraph (c) of the existing conditions and adding in lieu: "(c) Within a 25-mile radius of the post office at Wonthaggi—general goods, provided that no goods shall be carried whether by one stage or by more than one stage between places within the above radius, which are more than 30 road miles apart by the nearest practicable route."

Notice of any objections should be forwarded to reach the Secretary of the Board not later than Wednesday, 17th April, 1968.

Applicants are advised that it will not be necessary to appear on the hearing date specified above, unless advised in writing by the Board.

B. P. KAY,  
Secretary.

Corner Lygon and Princes streets, Carlton, 3053, 3rd April, 1968.

DEPARTMENT OF MINES.

SUBJECT to any necessary excisions, &c., it is proposed to grant the following lease:—

8487, Mineral; Douglas John McConnell; 13a. 2r. 16p., Parish of Boort.

MINING LEASE GRANTED.

8660, Mineral; William Akers; 2a. 1r. 18p., Parish of Dunolly.

EXPLORATION LICENCE GRANTED.

91, Exploration Licence; Alliance Oil Development Australia N.L.; 14 square miles, County of Buln Buln.

TAILINGS LICENCES GRANTED.

3538, Tailings Licence; William Akers; "Sydenham Mine" dump; Burnt Gully, Dunolly.

3539, Tailings Licence; William Akers; "Caledonia Mine" dump, Gravel Reserve, Dunolly.

3580, Tailings Licence; Allan Chan; "Johnson's No. 3 Shaft"; California Gully, Eaglehawk.

3581, Tailings Licence; Thomas William Needs; "Russell's No. 1 and No. 2 Mine" dump; Lauriston (in lieu of 3521, Tailings Licence, expired).

3582, Tailings Licence; Percy Ernest Outen; "Open Quarry Donkey Hill Mine" dump; Parish of Yehrip.

MINERAL SEARCH LICENCE EXPIRED.

813, Mineral Search Licence; John Gordon Antliff; 5 square miles, Parish of Bogong North.

ERRATUM.

On page 865 of *Government Gazette* No. 27, 27th March, 1968, the following reference should be deleted:—

PETROLEUM EXPLORATION PERMIT GRANTED.

63, Petroleum Exploration Permit; Magellan Petroleum Southern Pty. Ltd., 660 square miles offshore.

J. C. M. BALFOUR,  
Minister of Mines.

MINING LEASES DECLARED VOID.

8350, Beechworth; Donald Lloyd Howarde; Mavis Eleanor Howarde; 105 acres, Parish of Everton.

7716, Maryborough; Frank Edgar John Blake; 70a. 0r. 35p., Parish of Moliagul.

E. CONDON,  
Secretary for Mines.

Housing Act 1958.

NOTICE OF RESOLUTION UNDER SECTION 99 (4) OF ACT No. 6275.

NOTICE is hereby given that Housing Commission on the twenty-fifth day of March, 1968, resolved as follows:—

"Whereas Housing Commission in respect of the lands described in the Schedule hereto has published a general notice under sub-section (3) of section 99 of the *Housing Act 1958* Housing Commission hereby resolves that the lands described in the Schedule hereto are finally appropriated for the purpose of the *Housing Act 1958*."

SCHEDULE.

All that land being the whole of Crown allotments One to Seven (both inclusive), section 84B at North Melbourne, Parish of Jika Jika excepting thereout the land at present comprised in certificate of title, volume 6876, folio 079.

A. L. BOHN, Secretary.

Housing Act 1958.

NOTICE OF RESOLUTION UNDER SECTION 99 (4) OF ACT No. 6275.

NOTICE is hereby given that Housing Commission on the twenty-fifth day of March, 1968, resolved as follows:—

"Whereas Housing Commission in respect of the lands described in the Schedule hereto has published a general notice under sub-section (3) of section 99 of the *Housing Act 1958* Housing Commission hereby resolves that the lands described in the Schedule hereto are finally appropriated for the purpose of the *Housing Act 1958*."

SCHEDULE.

All those pieces of land situated within the municipality of the City of Melbourne, being parts of Crown allotment 18, section 2, Parish of Doutta Galla and being—

*First*.—The land remaining untransferred in certificate of title, volume 1907, folio 395.

*Secondly*.—The land remaining untransferred in certificate of title, volume 4936, folio 086.

*Thirdly*.—The land remaining untransferred in certificate of title, volume 5836, folio 032.

A. L. BOHN, Secretary.

*Soil Conservation and Land Utilization Act, 1958. (No. 6372).*

DAY'S CREEK NO. 1 GROUP CONSERVATION AREA.

NOTICE is hereby given that I, William John Farquhar McDonald, Her Majesty's Minister for Conservation for the State of Victoria under powers conferred by Division 1A Section 24A of the *Soil Conservation and Land Utilization Act 1958* (No. 6372) hereby declare to be a Group Conservation Area the land embraced by the Crown Allotments listed below, together with the Road Reserves in the Parishes of Cobungra and Jirnkee as particularly designated in Drawing No. 2057A, marked "GA/35" and lodged at the office of the Soil Conservation Authority, 378 Cotham-road, Kew, and do further declare that it shall be known as the Day's Creek Group Conservation Area.

Parish.	Crown Allotment.	Parts of Crown Allotments.
Cobungra ..	Section 4 C.A. A	Section 4, C.A.'s 14, 125, 126, 128, 128A, 129, 130, 130A and 131
Jirnkee ..	.. .. .	55. and 73

and all those Road Reserves, Crown Lands and State Forests embraced in Drawing No. 2057A.

W. J. F. McDONALD,  
Minister for Conservation.

26th March, 1968.



## Melbourne and Metropolitan

## BOARD OF WORKS.

## GENERAL NOTICE.

THE Melbourne and Metropolitan Board of Works, having made provision for carrying off the sewage of each and every property which or any part of which is situate in the Sewerage Areas hereinafter described, doth hereby declare that on and after the 3rd day of May, 1968, each and every property so situate shall be deemed to be a sewerer property within the meaning of the *Melbourne and Metropolitan Board of Works Act 1958*.

The Sewerage Areas hereinbefore referred to are:—

*Sewerage Area No. 2159.*

*City of Moorabbin.*—Commencing at the junction of Cavanagh-street and Bernard-street; thence easterly along Bernard-street southerly along the eastern boundaries of lots 6 Bernard-street and 15 Warren-road, easterly along Warren-road, southerly along the eastern boundary of lot 25 Warren-road, westerly along the southern boundaries of lots 25 to 22 Warren-road and a line in continuation to Cavanagh-street, southerly along Cavanagh-street to a point 321 feet north of the northern boundary of Dewrang-street, easterly by a line parallel to Dewrang-street to a point 300 feet east of the eastern boundary of Cavanagh-street, southerly by a line parallel to Cavanagh-street a distance of 104 feet to the northern boundary of lot 2 Cavanagh-street, easterly along the said boundary to a point 400 feet east of the eastern boundary of Cavanagh-street, southerly by a line parallel to Cavanagh-street to the southern boundary of the said lot 2, easterly along the northern boundaries of lots 8 to 10 Dewrang-street, southerly along the eastern boundary of the said lot 10, easterly along Dewrang-street, southerly along the eastern boundary of lot 11 Dewrang-street, westerly along the southern boundaries of lots 11 to 13 Dewrang-street, southerly along the eastern boundaries of lots 16 and 31 Pembroke-crescent, westerly along the southern boundaries of lots 31 to 29 Pembroke-crescent, southerly, westerly and northerly along Friendship-square, westerly along Argus-street, northerly along the western boundaries of lots 8 Argus-street and 13 Hartwell-place, westerly along Hartwell-place and the southern boundary of lot 2 Wilson-street, northerly along Wilson-street, westerly along the southern boundaries of lots 29 Wilson-street, 24 and 23 Ikara-court, 14 and 13 Lauriston-court and 8 Chesterville-road, northerly along Chesterville-road, easterly along the northern boundaries of lots 44 Chesterville-road, 43 to 32 Keamy-avenue and 30 Wilson-street, northerly along Wilson-street, easterly along Bernard-street to the commencing point.

*Sewerage Area No. 2160.*

*City of Oakleigh.*—Commencing at the junction of Centre-road and Knight-street on the boundary of Sewerage Area No. 1914; thence generally southerly and easterly following the said area boundary to the eastern boundary of lot 109 Cleary-court, southerly along the said eastern boundary, westerly along the southern boundaries of the said lot 109 and lot 1 Cleary-court, northerly along Clayton-road, westerly along the southern boundary of lot 1 Clayton-road, southerly along portion of the eastern boundary of lot 90 Glencannon-crescent, south-westerly along the south-eastern boundary of the said lot 90, westerly along Glencannon-crescent, northerly along the western boundary of lot 75 Glencannon-crescent to its north-western angle, westerly by a line to the north-eastern angle of lot 80 Ester-crescent, southerly and south-westerly along the eastern and south-eastern boundaries of the said lot 80, westerly along Ester-crescent, northerly along Springs-road, westerly along Bunny-road, northerly along the western boundaries of lots 28 Bunny-road, 29 and 50 Botany-court and 1 Raleigh-street, easterly along Raleigh-street, northerly and easterly along the western and portion of the northern boundaries of lot 9 Raleigh-street, northerly along the western boundary of lot 32 Inverness-street, westerly along Inverness-street, northerly along Elder-street, westerly by a line to and along the southern boundaries of lots 5 to 1 The Parade, northerly along Eulinga-road, easterly along Centre-road to the commencing point.

*Sewerage Area No. 2161.*

*Shire of Whittlesea.*—Commencing at the junction of Mount View-road and Robert-street; thence easterly along Robert-street, southerly along High-street, westerly along Hurtle-street, southerly along the eastern boundaries of lots 152 Hurtle-street and 175 Arndell-street, westerly along Arndell-street, southerly along Mount View-road, westerly along Chappel-street and the southern boundary of a reserve, northerly by a line to and along the western boundaries of lots 6 to 18 Thomas-street, easterly along the northern boundary of the said lot 18, northerly along the

western boundary of lot 19 Travers-street, easterly along the northern boundaries of lots 19 to 21 Travers-street, northerly along the western boundaries of lots 58 to 67 Mount View-road, easterly along the northern boundary of the said lot 67, northerly and north-westerly along Mount View-road to the commencing point.

*Sewerage Area No. 2162.*

*Shire of Eltham.*—Commencing at the junction of Looker-road and Airlie-road; thence north-westerly along Airlie-road, northerly along the western boundary of lot 3 Airlie-road, easterly along the northern boundary of the said lot 3, northerly along the western boundary of lot 9 Alban-street, westerly along Alban-street, northerly along the western boundary of lot 3 Alban-street, easterly along the northern boundary of the said lot 3 Alban-street and a line in continuation to the south-western angle of lot 2 Alban-street, northerly by a line to the south-eastern angle of lot 29 Astley-street, north-westerly along the south-western boundary of the said lot 29, northerly and north-easterly along Astley-street, northerly along Alban-street, north-easterly and south-easterly along Rattray-road West, southerly along Looker-road, easterly by a line to and along the northern boundary of lot 27c Looker-road, southerly along the eastern boundaries of the said lot 27c and lots 4 and 27f Looker-road, easterly along the northern boundaries of lots 211 to 215 Buena Vista-drive, southerly along the eastern boundary of the said lot 215, easterly along Buena Vista-drive, southerly along Marshall-avenue, south-westerly along Grand Boulevard, northerly along portion of the western boundary of lot 7 Grand Boulevard, westerly along the southern boundary of lot 6 Looker-road to the commencing point.

By order of the Board,

H. J. SNADDEN,  
Secretary.

110 Spencer-street, Melbourne, 3001, 2nd April, 1968.

**CONTRACTS ACCEPTED.**—(Series 1967-68.)

## VICTORIAN RAILWAYS.

99. Erection and completion of a new multi-story "West Tower" building (excluding pile foundations), Melbourne Yard, Dudley-street, West Melbourne, for the amount of \$353,630.00 (Contract 63243).—Hansen & Yuncken Pty. Ltd. 100. Removing Departmental Residences Nos. 3963, 3780, 3920 and 3974, from Warragul and re-establishing at Braybrook, together with fencing, out-buildings and services for the amount of \$16,561.06 (Contract 63268).—W. Phelan & Sons Pty. Ltd. 101. Supply and delivery of meat pies (as may be ordered during the period from 9th March, 1968, to 8th March, 1969), at the rate of \$1.02 per dozen, less 27½ per cent., plus 5 cents only pricing factor on each delivery docket (Contract 63296).—Cooley's Products Pty. Ltd.

By order of the Victorian Railways Commissioners.

W. WALKER, Secretary. 29.3.68.

**ORDERS IN COUNCIL.**—(Series 1967-68.)

## PUBLIC WORKS.

2853. Beechworth, Mental Hospital, supply of two pianos, \$1,030.00.—C. E. Davies & Sons Pty. Ltd.—(N.E.102212.)

2854. Heidelberg, Girls' Secondary School, supply and installation of a new hot-water boiler, \$1,854.60.—Ford-Swinton Industries Pty. Ltd.—(N.E.128954.)

2855. Horsham, Technical School, supply of benches and cupboards, \$1,473.92.—Weeks and Hansen.—(W.128824.)

2856. Melbourne, 200 Little Collins-street, Apprenticeship Commission and Lifts and Cranes Inspectorate, supply of furniture—

(a) \$1,276.00.—Myer-Teale Pty. Ltd., and

(b) \$1,113.34.—Brownbuilt Ltd.—(C.125556.)

2857. Mount Clear, S.S. No. 427, supply and installation of gas heating in class-rooms and staffroom, \$1,005.25.—The Gas Supply Co. Ltd.—(W.65550 "B".)

2858. Melbourne, Government House, hire of equipment and estimate of cost of catering for garden parties, on 22nd and 23rd March, 1968—

(a) \$1,199.00, Hire of marquees, &c.—Miller Bros. Hirings Pty. Ltd.

(b) \$1,800.00, Catering and hiring (estimate).—Turner Catering Services Pty. Ltd.—(C.129154.)

2859. Terang, High School, restoration of steel windows, \$2,644.00.—L. J. Grinter & Co. Pty. Ltd.—(S.W.93602.)

2860. Werribee, Gilbert Chandler Institute of Dairy Technology, supply and installation of Compactus mobile shelving, \$1,662.00.—Brownbuilt Ltd.—(S.W.259698 "B".)

2861. Westernport Bay, supply of second-hand chain for mooring buoys, \$1,425.00.—W. L. Bassett & Son Pty. Ltd.—(P. & H. 115865.)

Approved by the Governor in Council, 26th March, 1968.—J. ROSSITER, Clerk of the Executive Council.

STATE ELECTRICITY COMMISSION.

2862. For supply of electrical appliances and spare parts for merchandising in Commission show-rooms for a period of three years, to Quotation No. 3055, at Schedule rates.—Radiation (Aust.) Pty. Ltd.

2863. For supply of electrical appliances and spare parts for merchandising in Commission show-rooms for a period of three years, to Quotation No. 3056, at Schedule rates.—St. George Ranges Pty. Ltd.

2864. For supply and erection of air conditioning system for Control Building, Dederang Terminal Station, to Specification No. 67/203, \$15,413.—Trend-Aire Air Conditioning.

Approved by the Governor in Council, 5th March, 1968.—J. ROSSITER, Clerk of the Executive Council.

2865. For supply of 55-amp. active or neutral junction boxes for consumers' services for a period of two years with an optional three months' extension, to Specification No. 68/56, at Schedule rates.—G.W. Engineering Pty. Ltd.

2866. For supply and erection of structural steelwork for St. Kilda sub-station, to Specification No. 68/59, \$20,240.—Welded Pipelines Pty. Ltd.

Approved by the Governor in Council, 13th March, 1968.—J. ROSSITER, Clerk of the Executive Council.

2867. For supply and erection of chain mesh fencing at Hazelwood Terminal Station, to Specification No. 68/83, \$16,891.—Cyclone-K.M. Products Pty. Ltd.

2868. For supply of five turbo-generator Governor valve spindles for Hazelwood Power Station, to Quotation No. 3277, \$12,500.—A.E.I. Engineering Pty. Ltd.

2869. For supply of parts to uprate one 220 kV bulk oil circuit breaker at Rowville Terminal Station from 1,200-amp., 10,000 MVA to 2,000-amp., 10,000 MVA, to Quotation No. 2404, \$18,900.—A.E.I. Engineering Pty. Ltd.

Approved by the Governor in Council, 19th March, 1968.—J. ROSSITER, Clerk of the Executive Council.

NOTICE TO MARINERS.  
[No. 6 of 1968.]

AUSTRALIA.—VICTORIA.

THE following Notice to Mariners, which has been received from the Harbor Master, Geelong, is published for general information.

A. J. WAGGLEN,  
Port Officer.

Public Works Department,  
Ports and Harbours Branch,  
Melbourne, 3002, 25th March, 1968.

GEELONG HARBOR TRUST COMMISSIONERS.

PORT OF GEELONG.

Point Richards Channel.

Light Beacon Permanently Removed.

Date.—On or about 8th April, 1968.

Position.—No. 5 Light Beacon Point Richards Channel. Lat. 38 deg. 5 min. 46 sec. S., Long. 144 deg. 36 min. 12 sec. E. (approx.).

Details.—On or about the above date the existing No. 5 light beacon of the Point Richards Channel will be demolished and completely removed.

Remarks.—Dredging operations will take place in this vicinity immediately after the removal of the beacon.

NOTICE TO MARINERS.  
[No. 7 of 1968.]

AUSTRALIA.—VICTORIA.

THE following Notice to Mariners, which has been received from the Harbor Master, Geelong, is published for general information.

A. J. WAGGLEN,  
Port Officer.

Public Works Department,  
Ports and Harbours Branch,  
Melbourne, 3002, 25th March, 1968.

GEELONG HARBOR TRUST COMMISSIONERS.

PORT OF GEELONG.

Point Richards Channel.

Light Buoy Established—Temporarily.

Date.—On or about 8th April, 1968.

Position.—No. 5 Light Beacon Point Richards Channel. Lat. 38 deg. 5 min. 46 sec. S., Long. 144 deg. 36 min. 12 sec. E. (approx.).

Details.—On or about the above date a light buoy will be established in a position 059 degrees distant 600 feet from the former position of No. 5 beacon Point Richards Channel.

Character.—Flash red every four seconds.

Flash 0.3 seconds Eclipse 3.7 seconds.

Visibility.—3 miles.

Elevation.—10 feet.

Colour.—Red.

Remarks.—The buoy will remain in the above position for a period of approximately one month and will be removed on the opening for traffic of the new entrance to the Point Richards Channel.

NOTICE OF FIXING ALIGNMENTS OF MORNINGTON PENINSULA BY-PASS ROAD IN THE SHIRE OF FLINDERS.

NOTICE is hereby given that the Country Roads Board under the powers conferred upon it by the Country Roads Act 1958 (Act No. 6229) has fixed an alignment for each side of Mornington Peninsula By-pass Road in the Shire of Flinders as shown on plans numbered G.P.10970 and 10971 hereunder.

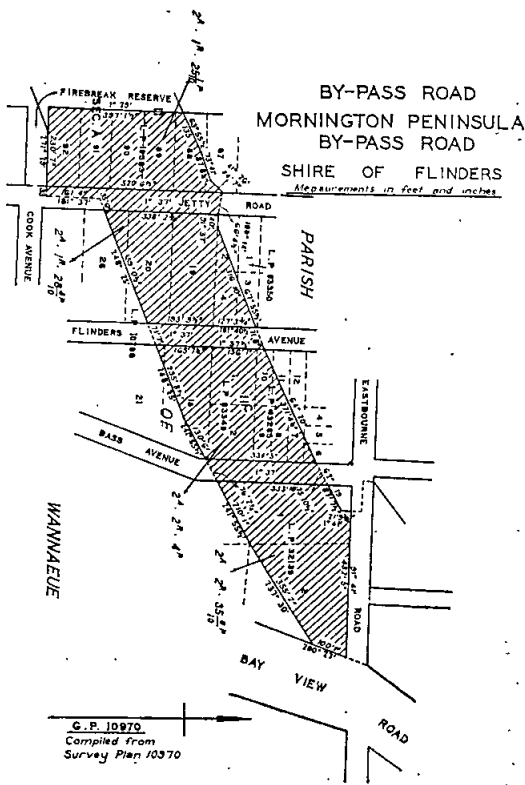

BY-PASS ROAD  
MORNINGTON PENINSULA BY-PASS ROAD  
SHIRE OF FLINDERS

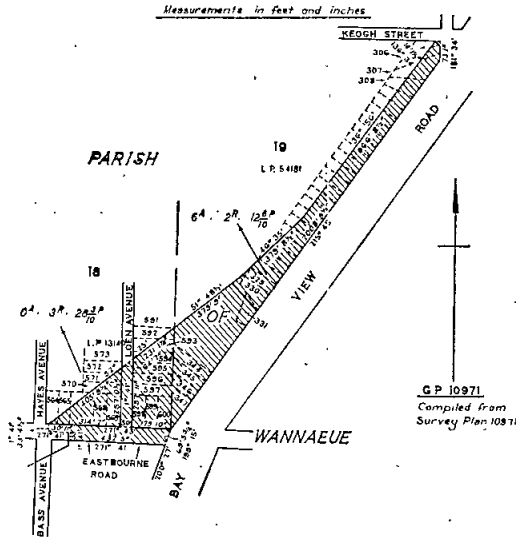

Copies of survey plans numbered 10970 and 10971 are lodged in the Office of the Country Roads Board, the municipality of the Shire of Flinders, The Registrar of Titles and the Registrar-General respectively and may be inspected by any person without a fee at any time at which such offices are open for business.

Dated the 22nd day of March, 1958.

N. L. ALLANSON, Secretary.  
Country Roads Board, 60 Denmark-street, Kew, 3101.

Victoria.

LOCAL GOVERNMENT DEPARTMENT.

ORDER CONFIRMED.—SHIRE OF CROYDON.

**THE** Minister of the Crown administering the *Local Government Act 1958*, as amended, on the 26th day of March, 1968, confirmed the Order hereinafter referred to in pursuance of section 514 of the said Act namely:

An Order made by the Council of the Shire of Croydon on the 15th January, 1968, directing the compulsory taking of the land described hereunder for the provision of public open space.

All that piece of land being part of lot 1, on plan of subdivision No. 8854, lodged in the Office of Titles, commencing at a point being the north-western angle of the said lot; thence by lines bearing 69 deg. 02 min. for 579 ft. 2 in.; 180 deg. 0 min. for 83 ft. 3½ in.; 255 deg. 30 min. for 447 ft. 10 in.; 234 deg. 26 min. for 133 ft. 10 in. and 1 deg. 24 min. for 66 ft. ½ in. to the point of commencement.

R. J. HAMER,  
Minister for Local Government.

Local Government Department,  
Melbourne.

Victoria.

LOCAL GOVERNMENT DEPARTMENT.

ORDER CONFIRMED.—CITY OF TRARALGON.

**THE** Minister of the Crown administering the *Local Government Act 1958*, as amended on the 26th day of March, 1968, confirmed the Order hereinafter referred to in pursuance of section 514 of the said Act namely:

An Order of the Council of the City of Traralgon made on the 26th February, 1968, directing the compulsory taking of the land described hereunder for the purposes of drainage, playgrounds and places of public resort or recreation:

All that piece of land being Crown allotments 13, 16, 17, 18 and 19 and parts of Crown allotments 14 and 15, section 8, Township and Parish of Traralgon, commencing at the south-west corner of the said Crown allotment 14; thence bearing 339 deg. 0 min. for 23 feet; 114 deg. 0 min. for 21 ft. 2½ in.; 69 deg. 0 min. for 99 ft. 11½ in.; 339 deg. 46 min. for 64 ft. 8 in.; 339 deg. 10 min. for 54 ft. 10 in.; 339 deg. 0 min. for 65 ft. 6 in.; 249 deg. 0 min. for 116 feet; 339 deg. 0 min. for 266 feet; 69 deg. for 334 feet; 159 deg.

29 min. for 131 ft. 2½ in.; 159 deg. 14½ min. for 330 ft. 9½ in. and 249 deg. 0 min. for 331 ft. 6 in. to the commencing point.

R. J. HAMER,  
Minister for Local Government.

Local Government Department,  
Melbourne.

Victoria.

LOCAL GOVERNMENT DEPARTMENT.

ORDER CONFIRMED.—SHIRE OF UPPER MURRAY.

**THE** Minister of the Crown administering the *Local Government Act 1958*, as amended, on the 26th day of March, 1968, confirmed the Order hereinafter referred to in pursuance of section 514 of the said Act namely:

An Order of the Council of the Shire of Upper Murray made on the 12th February, 1968, directing the compulsory taking of the land described hereunder for the purpose of constructing and establishing municipal saleyards:

All that piece of land being part of Crown allotment 2A, section O, Parish of Towong, commencing at a point on the north-eastern side of a Government road bearing 307 deg. 30 min. and distant 2,646 links from the most westerly corner of Crown allotment 2A<sup>2</sup> and bounded by lines bearing 37 deg. 27 min. for 1,000 links; 127 deg. 30 min. for 600 links; 217 deg. 37 min. for 1,000 links and 307 deg. 30 min. for 600 links to the commencing point.

R. J. HAMER,  
Minister for Local Government.

Local Government Department,  
Melbourne.

LOCAL GOVERNMENT DEPARTMENT.

ORDER CONFIRMED.—CITY OF NUNAWADING.

**THE** Minister of the Crown administering the *Local Government Act 1958*, as amended, on the 29th day of March, 1968, confirmed the Order hereinafter referred to, in pursuance of section 514 of the said Act namely:

An Order made by the Council of the City of Nunawading, on the 30th January, 1968, directing the compulsory taking of the land described hereunder for the purpose of providing a footway between Bond-avenue and Hearty-street, South Blackburn.

All that piece of land being part of Crown portion 96, Parish of Nunawading, County of Bourke, and being part of the land described as allotment 17 on a general law plan of subdivision numbered H.294, lodged in the office of the Registrar-General, Melbourne, and being part of the land more particularly described in a memorial of conveyance registered in book 621, number 649, in the office of the Registrar-General, Melbourne, and being the land contained within a boundary line commencing at a point being the north-east corner of the land described in the said conveyance; thence on a bearing of 179 deg. 58 min. for a distance of 4 ft. 9½ in.; thence on a bearing of 282 deg. 24 min. for a distance of 4 ft. 11½ in.; thence on a bearing of 359 deg. 58 min. for a distance of 3 ft. 10 in.; thence on a bearing of 91 deg. 16 min. for a distance of 4 ft. 10 in., to the point of commencement.

R. J. HAMER,  
Minister for Local Government.

Local Government Department,  
Melbourne.

COMPANIES ACT 1961.

**NOTICE** is hereby given, in pursuance of section 308 (4) of the *Companies Act 1961*, that the name of the Company referred to below has been struck off the Register.

Dated this 27th day of March, 1968.

E. B. MITCHAM,  
Assistant Registrar of Companies.

Companies Office,  
Melbourne.

COMPANY ABOVE REFERRED TO.

Name of Company.	Number of Registration.
Gold Coast Scenic Clippers Pty. Ltd.	F5115

## COMPANIES ACT 1961.

NOTICE is hereby given that in pursuance of section 308 (4) of the Companies Act 1961 the names of the Companies referred to below have been struck off the Register, and on publication of this notice in the Government Gazette the said Companies will be dissolved.

Dated this 27th day of March, 1968.

E. B. MITCHAM,  
Assistant Registrar of Companies.

Companies Office,  
Melbourne.

## COMPANIES ABOVE REFERRED TO.

Name of Company.	Number of Registration.
Mervel Manufacturing Co. Pty. Ltd.	11065
Colchin's Tea Stores Pty. Ltd.	18915
The Medical Practice Finance Company	23885
Entertainments Pty. Ltd.	29670
Glickman's Bakeries Pty. Ltd.	32155
C. F. Medlycott & Coy. Pty. Ltd.	34164
Marplex Acceptance Pty. Ltd.	35263
C. & F. Knitting Co. Pty. Ltd.	37984
C. & B. Holdings Pty. Ltd.	39253
Punch Distributors Pty. Ltd.	39810
A. L. Murrell & Son Pty. Ltd.	41743
A. U. Investments Pty. Ltd.	42080
The Buffeteria Pty. Ltd.	42133
Thomas Groome & Sons Pty. Ltd.	43422
Noel J. Danahay Hairstyles Pty. Ltd.	45263
Hiroyoshi (Melbourne) Pty. Ltd.	46359
Watson & Ewen Pty. Ltd.	47333
Heavy Repairs Pty. Ltd.	49343
Orion Imports Pty. Ltd.	49995
John Kennedy Motor Industries Pty. Ltd.	52341
Golden City Food Distributors Pty. Ltd.	52557
Constructive Credit Corporation Pty. Ltd.	54404
Boomerang Oil Co. (Aust.) Pty. Ltd.	54429
Domestic Food Supplies Pty. Ltd.	55029
H. R. Edwards & Sons Pty. Ltd.	55683
I. T. G. Mollison Pty. Ltd.	55896
Budex Constructions Pty. Ltd.	56563
Castplastic Pty. Ltd.	56718
Windhager & Robel Pty. Ltd.	58057
Stanmace Constructions Pty. Ltd.	58478
Boulevard Acceptance Pty. Ltd.	58648
Elkado Constructions Pty. Ltd.	59060
Plenty Homes Pty. Ltd.	59775
Rite-Lite (Holdings) Pty. Ltd.	59941
Golden Potato Crisps Products Pty. Ltd.	60024
Cymex Pty. Ltd.	60226
Carlson Investments Pty. Ltd.	60770
Zeffer Drainage & Plant Hire Coy. Pty. Ltd.	61095
Soraya Products Pty. Ltd.	61113
Building Conservations (Aust.) Pty. Ltd.	61652
A. La Rovere Joinery Pty. Ltd.	62720
A. La Rovere Constructions Pty. Ltd.	62721
Belmore Court Pty. Ltd.	62836
E. G. Poulter Pty. Ltd.	62864
Desea Auto Spares Pty. Ltd.	63759
Crest Real Estate Pty. Ltd.	67279
Wilton Rolfe Pty. Ltd.	22006
Whiteacres Estates Pty. Ltd.	23401
Buttabics Pty. Ltd.	25429
Heatex Manufacturing Coy. Pty. Ltd.	27847
Keith Sutherland & Co. Pty. Ltd.	31903
L. M. Glynn Pty. Ltd.	32571
Inter-Record Co. Pty. Ltd.	32756
Individual Home Builders Pty. Ltd.	33276
J. A. Belfrage Pty. Ltd.	35033
Rad-Air Pty. Ltd.	38406
Coburg Cement Products Pty. Ltd.	39334
Homepride Pty. Ltd.	39963
Calder Estates Pty. Ltd.	40306
John Foietta Pty. Ltd.	40879
Jeem Engineering Pty. Ltd.	41095
Mary Mill Pty. Ltd.	41236
Mornington Refrigeration Pty. Ltd.	41428
Manber Investments Pty. Ltd.	42024
Ron Matthew & Co. Pty. Ltd.	44320
River Crest Pty. Ltd.	45061
Naylor & Sons (Victoria) Pty. Ltd.	45086
McNamara's Kyabram Hotel Pty. Ltd.	45111
Hume Softwoods Pty. Ltd.	45510
Gilmore Quarries Pty. Ltd.	45909
Multiplex (Victoria) Pty. Ltd.	45949
Glen Iris Realty Pty. Ltd.	48318
Tomada Constructions Pty. Ltd.	49853
Steelmade Pty. Ltd.	50238
Latrobe Valley Steam Laundry Pty. Ltd.	50569

## Name of Company.

## Number of Registration.

Consolidated News Pty. Ltd.	51011
Labour Car Sales Pty. Ltd.	51144
Automotive Public Relations Pty. Ltd.	51412
J. D. Clarke Pty. Ltd.	51938
Raffles Court Pty. Ltd.	52118
J. A. Stewart Constructions Pty. Ltd.	54341
Monash Constructions Pty. Ltd.	54342
Greyhound Park (Training Track) Pty. Ltd.	54505
F. R. Swan (Sales) Pty. Ltd.	54620
Universal Fairings Pty. Ltd.	56972
Dripin Distributing Coy. Pty. Ltd.	57275
Australian Chesapeake Corporation Pty. Ltd.	57993
S. D. & J. Investments Pty. Ltd.	58040
Marin Structural Engineering Pty. Ltd.	59230
Liquefreeze (Vic.) Pty. Ltd.	59418
Anderson Clines Industries Pty. Ltd.	59569
Kosmos Travel Agency Pty. Ltd.	59754
Shane Printing Services Pty. Ltd.	60315
Canton Trading Coy. Pty. Ltd.	60574
Facile Creations (Aust.) Pty. Ltd.	60741
633 Inkerman Road, Pty. Ltd.	61591
F. D. J. Ukena & Sons Pty. Ltd.	62351
Anmore Industries Pty. Ltd.	62674
Sturt Constructions Pty. Ltd.	65441
Sturt Plant Hire Pty. Ltd.	65518
297 Bell Street Pty. Ltd.	69304
557 Balcombe Road Pty. Ltd.	70020

## COMPANIES ACT 1961.

NOTICE is hereby given, in pursuance of section 308 (2) and 308 (3) of the Companies Act 1961, that at the expiration of three months from the date hereof the names of the following companies will, unless cause is shown to the contrary, be struck off the Register and the said companies will be dissolved.

Dated this 29th day of March, 1968.

E. B. MITCHAM,  
Assistant Registrar of Companies.

Companies Office,  
Melbourne.

## COMPANIES ABOVE REFERRED TO.

Name of Company.	Number of Registration.
Bradley's Pty. Ltd.	7211
Lovely Banks Pty. Ltd.	14633
Frank Hale Pty. Ltd.	15348
H. E. Dowsett Pty. Ltd.	16673
O. C. A. Industries Pty. Ltd.	17179
J. F. Noonan Pty. Ltd.	17531
Stuckey and Moffat Pty. Ltd.	19775
Atkin's Tonic Pty. Ltd.	21448
M.S.K. Pty. Ltd.	22139
Tara Properties Pty. Ltd.	22642
Dandy Woodware Pty. Ltd.	24066
The T.G. Service Station Pty. Ltd.	29005
Lisa Proprietary Limited	29635
The Australian Institute of Public Health	29763
Modern Foods Pty. Ltd.	30122
B. A. Ferns Pty. Ltd.	31217
Installations and Demolitions Pty. Ltd.	31821
Goldbro of London Pty. Ltd.	32162
Austral Chambers Pty. Ltd.	32366
Julyan & Kiddle Pty. Ltd.	34639
Henry Richards Family Investments Pty. Ltd.	34875
Jennings Home Finance Ltd.	35242
Gainsborough Park Pty. Ltd.	36672
National Repair-Welding Services Pty. Ltd.	38014
Landsborough Pty. Ltd.	38208
Cameron Estates (Aust.) Pty. Ltd.	38212
Cameron Estates (Queensland) Pty. Ltd.	39051
Maffra Holdings Pty. Ltd.	39577
European-Continental Film Distributors Pty. Ltd.	39734
Pream Holdings Pty. Ltd.	41478
Austro Continental Self Service Pty. Ltd.	42104
Amalgamated Motors (Body Division) Pty. Ltd.	42298
Allandor Timber Industries Pty. Ltd.	43005
Willaura Motors Pty. Ltd.	43017
Bennett Transport Pty. Ltd.	43975
D. J. Arthur & Co. Pty. Ltd.	44396
Orana Finance & Investment Corporation Pty. Ltd.	44996
Belleville Estates Pty. Ltd.	45496
Green Winton Pty. Ltd.	45591
J. & S. Mercantile Agents Pty. Ltd.	45678
Denbigh Trading Company Pty. Ltd.	46420
Shelford Investments Pty. Ltd.	47090
Victorian Neon Co. Pty. Ltd.	47554
D. L. Mullaney & Co. Pty. Ltd.	48659

Name of Company.	Number of Registration.
Frank & Zappala Pty. Ltd. . . . .	50517
Yarrawonga Engineering Co. Pty. Ltd. . . . .	50560
Robert Richardson & Sons Pty. Ltd. . . . .	52098
Kellett & Griffiths Pty. Ltd. . . . .	53231
McCauliffe & Co. Pty. Ltd. . . . .	53766
Jay Cobb Storage Pty. Ltd. . . . .	54414
de Molnar's Associates Pty. Ltd. . . . .	54993
Eildon Weir Industries Pty. Ltd. . . . .	55149
Kathleen Estates Pty. Ltd. . . . .	57594
K. Kiley & Sons Pty. Ltd. . . . .	59080
I. M. Turner Real Estate Pty. Ltd. . . . .	59222

Notice.

Pipelines Act 1967, No. 7541.

MINISTRY OF FUEL AND POWER.

APPLICATION FOR A PERMIT TO OWN AND USE A PIPE-LINE.

1. In accordance with the provisions of section 11 (1) of the Pipelines Act 1967, notice is hereby given that applications have been received by me from The Colonial Gas Association Limited for a permit to own and use pipe-lines for the purpose of conveying gaseous hydrocarbons within areas covered by The Colonial Gas Association's western district reticulation system.

2. The proposed routes of the pipe-lines are as follows:—

Route No. 1.

A steel pipe-line approximately 7.7 miles in length, comprising sections with nominal diameters of 16-in., 12-in. and 8-in., commencing at the Colonial Gas Association's gate station in Mephan-street, Footscray, and dividing into two branches, one extending east along Mephan-street to Gordon-street, and turning south for one quarter of a mile and ending at a regulating station; and the other extending west along Mephan-street to Summerhill-road; thence proceeding south to Barkly-street, and extending west to Warleigh-road; thence turning south across Victorian Railways property to Sunshine-road, and proceeding west to Cala-street; thence turning south to Indwest-street and continuing west to Paramount-road; thence turning south to Somerville-road and continuing generally in a north-westerly direction along Somerville-road, Market-street, Fourth-avenue, Central-avenue, Wright-street, Stanford-street, Derby-road, Anderson-road and Forrest-street to the Association's depot at Sunshine.

Route No. 2.

A steel pipe-line approximately 5.5 miles in length comprising sections with nominal diameters 16-in., 12-in. and 8-in., commencing at the junction of Somerville and Paramount roads, West Footscray; thence continuing east along Somerville-road and turning south along Cromwell-parade and Richards-street to Francis-street; thence turning east to Wembley-avenue before dividing into two branches, one continuing east and ending at a regulating station in Williamstown-road, the other continuing in a southerly direction along Wembley-avenue, Ferguson-street, Moresby-street, Stephenson-street, Blackshaws-road, Johnston-street, Mason-street and Challis-street to Champion-road; thence in a south-easterly direction along Champion-road, Freyer-street, Melbourne-road and Stevedore-street to the Association's Williams-town depot at Macquarie-street.

3. Plans of the proposed routes of the foregoing pipe-lines may be inspected commencing Monday, 1st April, 1968, between the hours of 10 a.m. and 4 p.m., on Mondays to Fridays (excluding public holidays) at the following places:—

- (a) Ministry of Fuel and Power, 4th Floor, 100 Exhibition-street, Melbourne, 3000.
  - (b) The Colonial Gas Association Limited, Cowper-street, Footscray, 3011; and 480 St. Kilda-road, Melbourne, 3004.
- Additional sets or separate copies of plans are not available.

4. Any objections to the proposed routes of the pipe-lines must be addressed to me and reach the office of the Ministry no later than Friday, 19th April, 1968.

J. C. M. BALFOUR,  
Minister for Fuel and Power.

28th March, 1968.

Town and Country Planning Act 1961.

FRENCH ISLAND PLANNING SCHEME.

NOTICE THAT A PLANNING SCHEME HAS BEEN PREPARED AND IS AVAILABLE FOR INSPECTION.

Amendment No. 1, 1968.

NOTICE is hereby given that the Town and Country Planning Board, in pursuance of its powers under the Town and Country Planning Act 1961, has prepared a planning scheme to include in a Proposed Reserve for Public Purposes—State Electricity Commission, the following areas:—

- (1) Crown allotments 14A, 14B and part of Crown allotment 13, Parish of French Island; and
- (2) Crown allotment 24, section H, and Crown allotment 10, section O, Parish of French Island.

A copy of the scheme has been deposited at the Post Office, French Island, and at the office of the Town and Country Planning Board, 179 Queen-street, Melbourne, and will be open for inspection during office hours by any person free of charge.

Any persons affected by the planning scheme are required to set forth in writing all objections they may have, addressed to the Secretary, Town and Country Planning Board, 179 Queen-street, Melbourne, on or before the 3rd July, 1968, and to state whether they wish to be heard in respect of their objections.

W. H. CRAIG, Secretary,  
Town and Country Planning Board.

PUBLIC TRUSTEE ACT 1958 (No. 6350), SECTION 17.

I HEREBY give notice that on the 14th March, 1968, the Public Trustee filed elections to administer the following deceased persons' estates, in accordance with section 17 of the Public Trustee Act 1958:—

- DOBSON, NORMAN, late of 19 Thames Promenade, Chelsea, pensioner, died 18th January, 1968.
- FARRELL, ELAINE CAMBRIDGE, formerly of 78 Devon-road, Pascoe Vale, but late of 51 Nicholson-street, Fitzroy, widow, died 5th December, 1967.
- FOSTER, FREDERICK, late of 102 Moore-street, East Coburg, old-age pensioner, died 11th January, 1968.
- JONES, ALBERT CHARLES, late of 46 Kooyong-road, Armadale, pensioner, died 9th October, 1967.
- KELLOCK, ALBERT VICTOR MIDDLEMISS, formerly of 87 St. Vincent's-place, Albert Park, but late of 96 Canterbury-road, Middle Park, retired Commonwealth public servant, died 20th October, 1967.
- POLLOVINEO, PETER, late of Queen Elizabeth Home, 102 Ascot-street south, Ballarat, labourer, died 19th January, 1966.

I HEREBY give notice that on the 20th March, 1968, the Public Trustee filed elections to administer the following deceased persons' estates, in accordance with section 17 of the Public Trustee Act 1958:—

- CALVERT, AUGUSTINE AMELIA, late of 7 Douglas-street, Upwey, married woman, died 22nd December, 1967.
- GRUNDAHL, HANS, late of Gippsland Home and Hospital, Bairnsdale, pensioner, died 22nd May, 1967.
- HAMMOND, GEORGE JOHN, late of 27 Erin-street, West Preston, retired council employee, died 2nd December, 1967.
- HICKS, ARTHUR, late of Mount Royal, Parkville, war pensioner, died 29th January, 1968.
- RICE, JAMES ARTHUR, late of 92 Barkly-street, Carlton, labourer, died 27th November, 1967.
- RUBES, LADISLAV, late of 88 St. Andrew-street, North Brighton, tobacco worker, died 15th January, 1968.
- SMALL, EDWARD ROPER, late of Gill Memorial Home, Wills-street, Melbourne, pensioner, died 21st November, 1967.

A. D. DUNCAN,  
Public Trustee.

256 Flinders-street, Melbourne, 27th March, 1968.

NOTICE.

CREDITORS, next of kin and others having claims against the estate of any of the under-mentioned deceased persons are required to send particulars of their claims to the Public Trustee, 256 Flinders-street, Melbourne, 3000, the personal representative, on or before the 10th June, 1968, after which date the Public Trustee may convey or distribute the assets, having regard only to the claims of which the Public Trustee then has notice:—

- BOOTH, GRAHAM CYRIL, late of 5 Hillcroft-street, Reservoir, P.M.G. draughtsman, died 27th December, 1967.
- CALVERT, AUGUSTINE AMELIA, late of 7 Douglas-street, Upwey, married woman, died 22nd December, 1967.

DOBSON, NORMAN, late of 19 Thames Promenade, Chelsea, pensioner, died 18th January, 1968.

EVANS, GEORGE ALEXANDER, late of 13 Thanet-street, Malvern, retired public servant, died 8th January, 1968.

FARRELL, ELAINE CAMBRIDGE, formerly of 78 Devon-road, Pascoe Vale, but late of 51 Nicholson-street, Fitzroy, widow, died 5th December, 1967.

FINLAY, MARIE ALEXANDRA, late of 29 Sherwood-road, Ivanhoe, retired telephonist, died 10th December, 1967.

FOSTER, FREDERICK, late of 102 Moore-street, East Coburg, old-age pensioner, died 11th January, 1968.

GRUNDAHL, HANS, late of Gippsland Home and Hospital, Bairnsdale, pensioner, died 22nd May, 1967.

HAMMOND, GEORGE JOHN, late of 27 Erin-street, West Preston, retired council employee, died 2nd December, 1967.

HICKS, ARTHUR, late of Mount Royal, Parkville, war pensioner, died 29th January, 1968.

JONES, ALBERT CHARLES, late of 46 Kooyong-road, Armadale, pensioner, died 9th October, 1967.

KEENAN, ROBERT JAMES, also known as Robert James Keenan, formerly of 54 Powlett-street, East Melbourne, but late of 26 Langston-street, Northcote, watchman, died 15th August, 1967.

KELLOCK, ALBERT VICTOR MIDDLEMISS, formerly of 87 St. Vincent's-place, Albert Park, but late of 96 Canterbury-road, Middle Park, retired Commonwealth public servant, died 20th October, 1967.

KLINGER, ARCHIBALD, late of 36 Newcastle-street, Newport, retired labourer, died 25th October, 1967.

LALOR, LLOYD PATRICK, late of St. Leonard's-road, Healesville, pensioner, died 8th October, 1967.

LOVETT, BERTHA PEADEY, in the will called Bertha Peaddy Lovett, late of 82 William-street, Newport, widow, died 16th October, 1967.

MANIE, MAURICE JAMES, formerly of 7 Gordon-street, Hampton, but late of 11 Velden-avenue, Fern Tree Gully, secretary, died 25th September, 1967.

MEADOWS, HILDA MARY, late of 40 New-street, Armadale, married woman, died 2nd December, 1967.

POLLOVINEO, PETER, late of Queen Elizabeth Home, 102 Ascot-street south, Ballarat, labourer, died 19th January, 1966.

POULSEN, LORNA MAY, late of 5 Airlie-grove, Seaford, widow, died 2nd January, 1968.

RANDALL, IRENE MARGUERITE, late of Flat 3, 10 Rose-street, Armadale, spinster, died 31st October, 1967.

REID, MARGARET HELEN, late of 1 Fisher-street, East Bentleigh, widow, died 20th November, 1967.

RICE, JAMES ARTHUR, late of 92 Barkly-street, Carlton, labourer, died 27th November, 1967.

RICHTER, MAY GLEN, late of 3 Inverness-drive, Kew, home duties, died 1st January, 1968.

ROSE, ALLAN WILLIAM, late of Lansdowne-street, Macedon, truck driver, died 24th November, 1967.

RUBES, LADISLAV, late of 88 St. Andrew-street, North Brighton, tobacco worker, died 15th January, 1968.

SMALL, EDWARD ROPER, late of Gill Memorial Home, Wills-street, Melbourne, pensioner, died 21st November, 1967.

WADDINGTON, ALICE MABEL, late of Flat 2, 112 Victory Boulevard, Ashburton, spinster, died 28th August, 1967.

WATTERS, JOHN, late of 152 Buckhurst-street, South Melbourne, retired stoker, died between 23rd October, 1967, and 24th October, 1967.

WHITCHURCH, KATHERINE AGNES, also known as Katherine Whitchurch, late of 13 Fontein-street, Tottenham, machinist, died on or about the 29th August, 1967.

WILLS, ELSIE DORA MAUDE, formerly known as Elsie Dora Maude Jones, late of 131 Wood-street, Preston, widow, died 21st January, 1968.

A. D. DUNCAN,  
Public Trustee.

Melbourne, 27th March, 1968.

#### Country Fire Authority Act 1958.

#### VARIATION OF SUMMER PERIOD IN RESPECT OF SPECIFIED PARTS OF THE COUNTRY AREAS OF VICTORIA.

WHEREAS by Section 4 of the *Country Fire Authority Act 1958*, it is enacted that the Chief Secretary of Victoria, after consultation with the Minister of Forests, may from time to time by declaration published in the *Government Gazette* declare any period to be the summer period in respect of the country area of Victoria, or any specified part or parts thereof and, without affecting the generality of the foregoing, may declare different periods to be the summer period in respect of different parts of the said country area:

And whereas by the said section it is further enacted that any declaration so published may be revoked, amended or varied by a subsequent declaration so published:

And whereas by declaration issued on the date stated in Schedule A annexed hereto, different summer periods expiring on the thirtieth day of April, 1968, were declared in respect of different parts of the country area of Victoria, including the parts of the said country area specified in Schedule B hereto:

And whereas the Chief Secretary and the Minister of Forests have consulted accordingly:

Now therefore I, the Chief Secretary of Victoria, do by this my declaration vary the aforesaid declaration by declaring that the summer period in respect of the parts of the country area of Victoria specified in Schedule B hereto shall end at midnight on the 5th April, 1968.

#### SCHEDULE A.

*Date of Declaration; Date of Publication in "Government Gazette".*

17th November, 1967; 16th November, 1967.

24th November, 1967; 22nd November, 1967.

#### SCHEDULE B.

The First Fire Control Region comprised by the municipal districts of the City of Ballarat, the Borough of Sebastopol and those portions of the municipal districts of the Shires of Ballarat, Bungaree, Buninyong and Grenville not included in the Fifteenth Fire Control region;

the Second Fire Control Region comprised by the municipal districts of the City of Bendigo and the Borough of Eaglehawk and those portions of the municipal districts of the Shires of Marong and Strathfieldsaye not included in the Twenty-First Fire Control Region;

the Ninth Fire Control Region comprised by the municipal districts of the City of Moe and the Shires of Buln Buln, Korumburra, Mirboo, Narracan, South Gippsland, Warragul and Woorayl and the Yallourn Works Area;

the Fifteenth Fire Control Region comprised by the municipal districts of the City of Maryborough and the Shires of Ballan, Creswick, Daylesford and Glenlyon, Kyneton, Newstead, Talbot and Clunes and Tullaroop and those portions of the municipal districts of the Shires of Ballarat, Bungaree, Buninyong and Grenville not included in the First Fire Control Region;

the Sixteenth Fire Control Region comprised by the municipal districts of the City of Ararat, the Town of Stawell and the Shires of Ararat, Avoca, Lexton, Ripon and Stawell;

the Nineteenth Fire Control Region comprised by the municipal districts of the Town of St. Arnaud and the Shires of Bet Bet, Kara Kara and Korong;

the Twenty-First Fire Control Region comprised by the municipal districts of the City of Castlemaine and the Shires of East Loddon, Huntly, Maldon, Metcalfe and those portions of the municipal districts of the Shires of Marong and Strathfieldsaye not included in the Second Fire Control Region;

those portions of the Seventeenth Fire Control Region comprised by the municipal district of the Shire of Kowree and those portions of the municipal districts of the Shires of Arapiles and Wimmera respectively which be in a southerly direction from the under-mentioned boundaries, that is to say—

(a) Shire of Arapiles: Commencing at the intersection of Rifle Butts-road with the McKenzie River; thence generally westerly and north-westerly along the afore-mentioned road and the Clear Lake-Tooan-Duffholme road to its intersection with the western boundary of the municipal district.

(b) Shire of Wimmera: Commencing at the intersection of the Wimmera River with Rocklands-Lubeck channel on the eastern boundary of the municipal district; thence generally in a westerly and south-westerly direction along the afore-mentioned channel to its intersection with the McKenzie River on the western boundary of the municipal district;

those portions of the Twenty-Second Fire Control Region comprised by the municipal districts of the Cities of Echuca and Shepparton, the Borough of Kyabram and the Shires of Cobram, Deakin, Euroa, Goulburn, Numurkah, Rodney, Shepparton, Tungamah, Violet Town and Waranga;

those portions of the Twenty-Third Fire Control Region comprised by the municipal districts of the Cities of Benalla and Wangaratta and the Shires of Rutherglen and Yarrowonga and those portions of the municipal

district of the Shire of Benalla which lie in a northerly direction from the North-Eastern railway line and those portions of the municipal district of the Shire of Wangaratta which lie within the following boundaries:—

Commencing at the junctior of the Ovens River and the Murray Valley Highway; thence by the northern boundary of the municipality to the North-Eastern railway line; thence generally south-westerly by the North-Eastern railway line to the Reedy Creek, Parish of Wangaratta North; thence generally westerly by the Reedy Creek and northerly by the Ovens River to the point of commencement.

A. G. RYLAH,  
Chief Secretary.

Chief Secretary's Office,  
Melbourne, 2nd April, 1968.

*Country Fire Authority Act 1958.*

**VARIATION OF SUMMER PERIOD IN RESPECT OF SPECIFIED PARTS OF THE COUNTRY AREAS OF VICTORIA.**

WHEREAS by Section 4 of the *Country Fire Authority Act 1958*, it is enacted that the Chief Secretary of Victoria, after consultation with the Minister of Forests, may from time to time by declaration published in the *Government Gazette* declare any period to be the summer period in respect of the country area of Victoria, or any specified part or parts thereof and, without affecting the generality of the foregoing, may declare different periods to be the summer period in respect of different parts of the said country area:

And whereas by the said section it is further enacted that any declaration so published may be revoked, amended or varied by a subsequent declaration so published:

And whereas by declaration issued on the date stated in Schedule A annexed hereto, different summer periods expiring on the thirtieth day of April, 1968, were declared in respect of different parts of the country area of Victoria, including the parts of the said country area specified in Schedule B hereto:

And whereas the Chief Secretary and the Minister of Forests have consulted accordingly:

Now therefore I, the Chief Secretary of Victoria, do by this my declaration vary the aforesaid declaration by declaring that the summer period in respect of the parts of the country area of Victoria specified in Schedule B hereto shall end at midnight on the 8th April, 1968.

**SCHEDULE A.**

*Date of Declaration; Date of Publication in "Government Gazette".*

10th November, 1967; 8th November, 1967.  
8th November, 1967; 8th November, 1967.

**SCHEDULE B.**

The Fifth Fire Control Region comprised by the municipal districts of the Cities of Hamilton and Warrnambool and the Boroughs of Kororoit and Port Fairy and the Shires of Belfast, Dundas, Minhamite, Mortlake, Mount Rouse and Warrnambool;

the Tenth Fire Control Region comprised by the municipal districts of the Cities of Sale and Traralgon and the Shires of Alberton, Avon, Maffra, Morwell, Rosedale and Traralgon.

A. G. RYLAH,  
Chief Secretary.

Chief Secretary's Office,  
Melbourne, 2nd April, 1968.

**SHIRE OF NUMURKAH WATERWORKS TRUST.**

**BY-LAW No. 3.**

*Water Restrictions.*

THE Shire of Numurkah Waterworks Trust (hereinafter referred to as the Trust) in pursuance and exercise of the powers conferred by the *Water Act 1958* doth hereby make the By-Law following, restricting the use for other than domestic purposes of water supplied by the said Trust within the Wunghnu, Numurkah, Katunga and Strathmerton Urban Districts.

1. This By-Law shall come into operation at such time and in such Districts or parts of Districts (hereinafter referred to as "the specified area") as the Trust from time to time directs by notice published in a newspaper circulating generally within the Districts and cease to have operation at such time as the Trust from time to time directs by a notice so published.

2. Subject to the provisions of Clauses 3 and 4 of this By-law, no person shall, with water supplied by the Trust—

(a) Water any garden, lawn or other land (other than commercial market gardens, commercial nurseries or land used for the growing of green feed for commercial poultry farms) within the specified area except by means of a hose held in the hand or by means of a can or other vessel held in the hand, between the hours of 5.30 p.m. and 8 p.m. on each day.

(b) Fill, add to or cleanse any private swimming pool within the specified area.

3. No person shall, with water supplied by the Trust water any commercial market gardens, commercial nurseries or land used for the growing of green feed for commercial poultry farms within the specified area by means of fixed sprinklers between the hours of 5.30 p.m. and 8 p.m. of each day.

4. No person shall with water supplied by the Trust water and land comprising sports grounds, golf courses, racecourses, public and club bowling and croquet greens and public and club tennis courts within the specified area by means of fixed sprinklers except between the hours of 8 p.m. and 10 p.m. of each day.

5. Every person who uses or permits or suffers water supplied by the Trust to be used contrary to the provisions of this By-law shall be guilty of an offence, and shall be liable to a penalty not exceeding One Hundred Dollars.

6. If any person supplied with water by the Trust wrongfully does or causes or permits to be done anything in contravention of this By-Law, the Trust may (without prejudice to any remedy in respect thereof) close or cut off any of the pipes by or through which water is supplied to him or for his use and may cease to supply him with water as provided by the *Water Act 1958*.

The foregoing By-law was made by the Shire of Numurkah Waterworks Trust on the 19th day of March, 1968, and the common seal of the said Trust was hereunto affixed, the 19th day of March, 1968, in the presence of—

(SEAL) RAY W. HODGE, Chairman.  
A. M. FREESTONE, Commissioner.  
L. G. MITCHELL, Secretary.

Approved by the Governor in Council, 2nd April, 1968.  
—J. ROSSITER, Clerk of the Executive Council.

**SHIRE OF NUMURKAH WATERWORKS TRUST.**

**BY-LAW No. 4.**

*Water Restrictions.*

THE SHIRE OF NUMURKAH WATERWORKS TRUST (hereinafter referred to as "the Trust") in pursuance and exercise of the powers conferred by the *Water Act 1958* doth hereby make the By-law following, restricting the use for other than domestic purposes of water supplied by the said Trust within the Wunghnu, Numurkah, Katunga, and Strathmerton Urban Districts.

1. This By-law shall come into operation at such time and in such Districts or parts of Districts (hereinafter referred to as "the specified area") as the Trust from time to time directs by notice published in a newspaper circulating generally within the Districts and cease to have operation at such time as the Trust from time to time directs by a notice so published.

2. Subject to the provisions of Clause 3 of this By-law no person shall, with water supplied by the Trust—

(a) Water any garden, lawn or other land (other than commercial market gardens, commercial nurseries or land used for the growing of green feed for commercial poultry farms) within the specified area.

(b) Fill, add to or cleanse any private swimming pool within the specified area.

3. No person shall with water supplied by the Trust water any commercial market gardens, commercial nurseries or land used for the growing of green feed for commercial poultry farms within the specified area except by means of a can or other vessel held in the hand or between the hours of 6 a.m. and 8 a.m. of each day by means of a hose held in the hand.

4. Every person who uses or permits or suffers water supplied by the Trust to be used contrary to the provisions of this By-law shall be guilty of an offence, and shall be liable to a penalty not exceeding One Hundred Dollars.

5. If any person supplied with water by the Trust wrongfully does or causes or permits to be done anything in contravention of this By-law, the Trust may (without prejudice to any remedy in respect thereof) close or cut off any of the pipes by or through which water is supplied to him or for his use, and may cease to supply him with water as provided by the *Water Act 1958*.

The foregoing By-law was made by the Shire of Numurkah Waterworks Trust on the 19th day of March, 1968, and the common seal of the said Trust was hereunto affixed, the 19th day of March, 1968, in the presence of—

(SEAL) RAY W. HODGE, Chairman.  
A. M. FREESTONE, Commissioner.  
L. G. MITCHELL, Secretary.

Approved by the Governor in Council, 2nd April, 1968.  
—J. ROSSITER, Clerk of the Executive Council.

## SHIRE OF NUMURKAH WATERWORKS TRUST.

BY-LAW No. 5.

*Water Restrictions.*

**THE SHIRE OF NUMURKAH WATERWORKS TRUST** (hereinafter referred to as "the Trust") in pursuance and exercise of the powers conferred by the *Water Act 1958* doth hereby make the By-law following, restricting the use for other than domestic purposes of water supplied by the said Trust within the Wunghnu, Numurkah, Katunga and Strathmerton Urban Districts.

1. This By-law shall come into operation at such time and in such Districts or parts of Districts (hereinafter referred to as "the specified area") as the Trust from time to time directs by notice published in a newspaper circulating generally within the Districts and cease to have operation at such time as the Trust from time to time directs by a notice so published.

2. Subject to the provisions of Clauses 3 and 4 of this By-law no person shall, with water supplied by the Trust—

(a) Water any garden, lawn or other land (other than commercial market gardens, commercial nurseries or land used for the growing of green feed for commercial poultry farms) within the specified area except by means of a can or other vessel held in the hand.

(b) Fill, add to or cleanse any private swimming pool within the specified area.

3. No person shall with water supplied by the Trust water any commercial market gardens, commercial nurseries or land used for the growing of green feed for commercial poultry farms within the specified area by means of fixed sprinklers except between the hours of 6 a.m. and 10 a.m. of each day or by means of a hose held in the hand or by means of a can or other vessel held in the hand.

4. No person shall with water supplied by the Trust, water any land comprising sports grounds, golf courses, racecourses, public and club bowling and croquet greens and public and club tennis courts within the specified area except by means of a hose held in the hand or by means of a can or other vessel held in the hand, and then only for a maximum period of 14 hours a week at times and under conditions to be determined by the Trust Engineer.

5. No person shall wash a car within the specified area by means of a hose in the hand.

6. Every person who uses or permits or suffers water supplied by the Trust to be used contrary to the provisions of this By-law shall be guilty of an offence, and shall be liable to a penalty not exceeding One Hundred Dollars.

7. If any person supplied with water by the Trust wrongfully does or causes or permits to be done anything in contravention of this By-law, the Trust may (without prejudice to any remedy in respect thereof) close or cut off any of the pipes by or through which water is supplied to him or for his use, and may cease to supply him with water as provided by the *Water Act 1958*.

The foregoing By-law was made by the Shire of Numurkah Waterworks Trust on the 19th day of March, 1968, and the common seal of the said Trust was hereunto affixed, the 19th day of March, 1968, in the presence of—

(SEAL) RAY W. HODGE, Chairman.  
A. M. FREESTONE, Commissioner.  
L. G. MITCHELL, Secretary.

Approved by the Governor in Council, 2nd April, 1968.  
—J. ROSSITER, Clerk of the Executive Council.

## SHIRE OF TUNGAMAH WATERWORKS TRUST.

By-Law No. 278.

*Water Restrictions.*

TUNGAMAH AND ST. JAMES URBAN DISTRICTS.

**THE** Shire of Tungamah Waterworks Trust (hereinafter referred to as "the Trust") in pursuance and exercise of the powers conferred by the *Water Act 1958* doth hereby make the By-Law following, restricting the use for other than domestic purposes of water supplied by the said Trust within the Tungamah and St. James Urban Districts.

1. This By-Law shall come into operation at such time and in such District or Districts (hereinafter referred to as the "specified area") as the Trust from time to time directs by notice published in a newspaper circulating generally within the Districts and cease to have operation at such time as the Trust from time to time directs by a notice so published.

2. Subject to the provisions of Clauses 3 and 4 of this By-Law no person shall, with water supplied by the Trust:—

(a) Water any garden, lawn or other land (other than commercial market gardens, commercial nurseries or land used for the growing of green feed for commercial poultry farms) within the specified area except by means of a can or other vessel held in the hand, between the hours of 5.30 p.m. and 8 p.m. of each day.

(b) Fill, add to or cleanse any private swimming pool within the specified area.

3. No person shall, with water supplied by the Trust, water any commercial market gardens, commercial nurseries or land used for the growing of green feed for commercial poultry farms within the specified area by means of fixed sprinklers except between the hours of 6 a.m. and 10 a.m. of each day or by means of a hose held in the hand or by means of a can or other vessel held in the hand.

4. No person shall, with water supplied by the Trust, water any land comprising sports grounds, golf courses, racecourses, public and club bowling and croquet greens and public and club tennis courts within the specified area except by means of a hose held in the hand or by means of a can or other vessel held in the hand, between the hours of 8 p.m. and 10 p.m. of each day.

5. Every person who uses or permits or suffers water supplied by the Trust to be used contrary to the provisions of this By-Law shall be guilty of an offence, and shall be liable to a penalty not exceeding One Hundred Dollars.

6. If any person supplied with water by the Trust wrongfully does or causes or permits to be done anything in contravention of this By-Law, the Trust may (without prejudice to any remedy in respect thereof) close or cut off any of the pipes by or through which water is supplied to him or for his use and may cease to supply him with water as provided by the *Water Act 1958*.

The foregoing by-law was made by the Shire of Tungamah Waterworks Trust on 12th day of March, 1968, and the common seal of the said Trust was hereunto affixed, the 12th day of March, 1968, in the presence of—

(SEAL) D. F. LANE, Commissioner.  
L. J. BATEY, Commissioner.  
M. CLEARY, Secretary.

Approved by the Governor in Council, 2nd April, 1968.—  
J. ROSSITER, Clerk of the Executive Council.

## MORTLAKE WATERWORKS TRUST.

RATING BY-LAW FOR THE YEAR 1968.

**THE** Mortlake Waterworks Trust, in pursuance and exercise of the powers conferred by the *Water Act*, doth hereby make a rate for the supply of water for domestic purposes of Five Cents in the Dollar on the annual valuation of lands and tenements liable to be rated within the Mortlake Urban District.

Provided that in no case shall the amount of rate payable per annum in respect of any tenement (other than land on which there is no building) be less than Two Dollars, and in respect of any land on which there is no buildings be less than Fifty Cents.

Such rates are made and shall be levied upon the occupiers or owners of the said lands and tenements for the year commencing on the 1st day of January, 1968, and shall be payable on the 1st day of April, 1968, at the office of the said Trust.



The maximum quantity of water to be supplied in any one year without further charge to the property rated by the Trust is hereby fixed at the quantity which at a charge of Twenty-five Cents per 1,000 gallons would produce an amount equal to the amount of rate levied on such property for the said year.

The charge for water supplied by measure to any property rated by the Trust in excess of such maximum quantity computed as in the last preceding clause is hereby fixed at Twenty-five Cents per 1,000 gallons.

Passed this 12th day of March, 1968.

(SEAL) WM. L. HOLDSWORTH, Chairman.  
THOS. F. CLARKE, Commissioner.  
W. J. GRAY, Secretary.

Approved 22nd March, 1968.—W. BORTHWICK, Minister of Water Supply.

#### SHIRE OF TUNGAMAH WATERWORKS TRUST.

BY-LAW No. 279.

*Water Restrictions.*

TUNGAMAH AND ST. JAMES URBAN DISTRICTS.

THE Shire of Tungamah Waterworks Trust (hereinafter referred to as "the Trust") in pursuance and exercise of the powers conferred by the *Water Act 1958* doth hereby make the By-Law following, restricting the use for other than domestic purposes of water supplied by the said Trust within the Tungamah and St. James Urban Districts.

1. This By-Law shall come into operation at such time and in such District or Districts (hereinafter referred to as the "specified area") as the Trust from time to time directs by notice published in a newspaper circulating generally within the Districts and cease to have operation at such time as the Trust from time to time directs by a notice so published.

2. Subject to the provisions of Clause 3 of this By-Law, no person shall, with water supplied by the Trust:—

(a) Water any garden, lawn or other land (other than commercial market gardens, commercial nurseries or land used for the growing of green feed for commercial poultry farms) within the specified area.

(b) Fill, add to or cleanse any private swimming pool within the specified area.

3. No person shall, with water supplied by the Trust, water any commercial market gardens, commercial nurseries or land used for the growing of green feed for commercial poultry farms within the specified area except by means of a can or other vessel held in the hand or between the hours of 6 a.m. and 8 a.m. of each day by means of a hose held in the hand.

4. Every person who uses or permits or suffers water supplied by the Trust to be used contrary to the provisions of this By-Law shall be guilty of an offence, and shall be liable to a penalty not exceeding One Hundred Dollars.

5. If any person supplied with water by the Trust wrongfully does or causes or permits to be done anything in contravention of this By-Law, the Trust may (without prejudice to any remedy in respect thereof) close or cut off any of the pipes by or through which water is supplied to him or for his use and may cease to supply him with water as provided by the *Water Act 1958*.

The foregoing by-law was made by the Shire of Tungamah Waterworks Trust on 12th day of March, 1968, and the common seal of the said Trust was hereunto affixed, the 12th day of March, 1968, in the presence of—

(SEAL) D. F. LANE, Commissioner.  
L. J. BATEY, Commissioner.  
M. CLEARY, Secretary.

Approved by the Governor in Council, 2nd April, 1968.—  
J. ROSSITER, Clerk of the Executive Council.

#### SHIRE OF TUNGAMAH WATERWORKS TRUST.

BY-LAW No. 276.

*Water Restrictions.*

TUNGAMAH AND ST. JAMES URBAN DISTRICTS.

THE Shire of Tungamah Waterworks Trust (hereinafter referred to as "the Trust") in pursuance and exercise of the powers conferred by the *Water Act 1958* doth hereby make the By-Law following, restricting the use for other than domestic purposes of water supplied by the said Trust within the Tungamah and St. James Urban Districts.

No. 29.—2877/68.—2

1. This By-Law shall come into operation at such time and in such District or Districts (hereinafter referred to as the "specified area") as the Trust from time to time directs by notice published in a newspaper circulating generally within the Districts and cease to have operation at such time as the Trust from time to time directs by a notice so published.

2. Subject to the provisions of Clause 3 of this By-Law, no person shall, with water supplied by the Trust:—

(a) Water any garden, lawn or other land (other than commercial market gardens, commercial nurseries or land used for the growing of green feed for commercial poultry farms) within the specified area except by means of a hose held in the hand or by means of a can or other vessel held in the hand.

(b) Fill, add to or cleanse any private swimming pool within the specified area.

3. No person shall, with water supplied by the Trust, water any land comprising sports grounds, golf courses, racecourses, public and club bowling and croquet greens and public and club tennis courts within the specified area by means of fixed sprinklers except between the hours of 7 p.m. and 12 midnight of each day.

4. Every person who uses or permits or suffers water supplied by the Trust to be used contrary to the provisions of this By-Law shall be guilty of an offence and shall be liable to a penalty not exceeding One Hundred Dollars.

5. If any person supplied with water by the Trust wrongfully does or causes or permits to be done anything in contravention of this By-Law, the Trust may (without prejudice to any remedy in respect thereof) close or cut off any of the pipes by or through which water is supplied to him or for his use and may cease to supply him with water as provided by the *Water Act 1958*.

The foregoing by-law was made by the Shire of Tungamah Waterworks Trust on 12th day of March, 1968, and the common seal of the said Trust was hereunto affixed, the 12th day of March, 1968, in the presence of—

(SEAL) D. F. LANE, Commissioner.  
L. J. BATEY, Commissioner.  
M. CLEARY, Secretary.

Approved by the Governor in Council, 2nd April, 1968.—  
J. ROSSITER, Clerk of the Executive Council.

#### SHIRE OF TUNGAMAH WATERWORKS TRUST.

BY-LAW No. 277.

*Water Restrictions.*

TUNGAMAH AND ST. JAMES URBAN DISTRICTS.

THE Shire of Tungamah Waterworks Trust (hereinafter referred to as "the Trust") in pursuance and exercise of the powers conferred by the *Water Act 1958* doth hereby make the By-Law following, restricting the use for other than domestic purposes of water supplied by the said Trust within the Tungamah and St. James Urban Districts.

1. This By-Law shall come into operation at such time and in such District or Districts (hereinafter referred to as the "specified area") as the Trust from time to time directs by notice published in a newspaper circulating generally within the Districts and cease to have operation at such time as the Trust from time to time directs by a notice so published.

2. Subject to the provisions of Clauses 3 and 4 of this By-Law no person shall, with water supplied by the Trust:—

(a) Water any garden, lawn or other land (other than commercial market gardens, commercial nurseries or land used for the growing of green feed for commercial poultry farms) within the specified area except by means of a hose held in the hand or by means of a can or other vessel held in the hand, between the hours of 5.30 p.m. and 8 p.m. on each day.

(b) Fill, add to or cleanse any private swimming pool within the specified area.

3. No person shall, with water supplied by the Trust, water any commercial market gardens, commercial nurseries or land used for the growing of green feed for commercial poultry farms within the specified area by means of fixed sprinklers between the hours of 5.30 p.m. and 8 p.m. of each day.

4. No person shall, with water supplied by the Trust, water any land comprising sports grounds, golf courses, racecourses, public and club bowling and croquet greens and public and club tennis courts within the specified area by means of fixed sprinklers except between the hours of 8 p.m. and 10 p.m. of each day.

5. Every person who uses or permits or suffers water supplied by the Trust to be used contrary to the provisions of this By-Law shall be guilty of an offence, and shall be liable to a penalty not exceeding One Hundred Dollars.

6. If any person supplied with water by the Trust wrongfully does or causes or permits to be done anything in contravention of this By-Law, the Trust may (without prejudice to any remedy in respect thereof) close or cut off any of the pipes by or through which water is supplied to him or for his use and may cease to supply him with water as provided by the *Water Act 1958*.

The foregoing by-law was made by the Shire of Tungamah Waterworks Trust on 12th day of March, 1968, and the common seal of the said Trust was hereunto affixed, the 12th day of March, 1968, in the presence of—

(SEAL) D. F. LANE, Commissioner.  
L. J. BATEY, Commissioner.  
M. CLEARY, Secretary.

Approved by the Governor in Council, 2nd April, 1968.—  
J. ROSSITER, Clerk of the Executive Council.

## APPOINTMENTS

### APPOINTMENTS.

**H**IS Excellency the Governor of the State of Victoria, by and with the advice of the Executive Council thereof, has, by Orders made on the 26th day of March, 1968, been pleased to make the under-mentioned appointments, viz.:—

#### CHIEF SECRETARY'S DEPARTMENT.

##### Honorary Probation Officers.

RONALD EDWIN ALLENGAME (the Reverend), The Manse, Mount-street, Wycheproof,  
COLIN GORDON BURGESS (the Reverend), St. John's Rectory, Nagambie,  
WANDA VIOLET CHAPMAN (Mrs.), 607A Howitt-street, Ballarat,  
BERNARD JOHN CUMMINS, "Shron-El", Hepburn Springs,  
STUART CHARLES DAVIES (the Reverend), 56 Victoria-street, Daylesford,  
JOHN SYDNEY DEVEREAUX, 8 Goble-street, Laverton,  
ROBERT LINDSAY FERGUSON, 18 Anderson-street, Euroa,  
JOHN RICHARDSON FISHER, "Wahroonga", East Wangaratta,  
BARRY REGINALD FLETCHER (the Reverend Father), Catholic Presbytery, Euroa,  
ALLISTER LYNDON GRAY (Captain, Salvation Army), 148 Nicholson-street, Bairnsdale,  
GEOFFREY WILLIAM RAWSON, 66 Whittens-lane, Doncaster,  
RAYMOND LEITH SPRIGG (the Reverend), 14 Surrey-road, South Yarra, and  
ROBERT GEORGE TERRILL, 6 Clematis-avenue, Wendouree West,

pursuant to the provisions of section 10 (1) of the *Children's Court Act 1958*, to be Honorary Probation Officers for all Children's Courts in Victoria.

#### LAW DEPARTMENT.

##### Commissioners for Taking Declarations, &c.

FRANK HENRI TREYVAUD,  
RONALD JEFFERY GROSE,  
PATRICK JOSEPH McCORMACK, and  
JACK RAWADY,  
care of Forests Commission, Victoria, Melbourne,  
ALAN ROBERT EDDY, care of Forests Commission, Victoria, Creswick,  
HUBERT ROLAND PARKE, care of Forests Commission, Victoria, Bairnsdale,  
HUGH JOHN ADAMS, care of Forests Commission, Victoria, Heyfield,  
HUGH GUTHRIE BROWN, care of Forests Commission, Victoria, Casterton,  
JOHN KEMSHALL DONOVAN, care of Forests Commission, Victoria, Lal Lal,  
PHILLIP RALPH GARTH, care of Forests Commission, Broadford,

JOHN GRAEME HALLETT, care of Forests Commission, Victoria, Lara,  
RODNEY WILLIAM HANDMER, care of Forests Commission, Victoria, Forrest,  
JOHN BARRY JOHNSTON, care of Forests Commission, Victoria, Orbost,  
LEONARD JAMES LAING, care of Forests Commission, Victoria, Omeo,  
JOHN REGINALD MACDONALD, care of Forests Commission, Victoria, Tallangatta,  
JOHN ROSS MAY, care of Forests Commission, Victoria, Rennick,  
PHILIP TOM CROSBIE MORRISON, care of Forests Commission, Victoria, Corryong,  
KENNETH EDGAR NICHOLLS, care of Forests Commission, Victoria, Dunolly,  
ROBERT GEOFFREY NIGGL, care of Forests Commission, Victoria, Benalla,  
DAVID WILLIAM PATERSON, care of Forests Commission, Victoria, Nowa Nowa,  
JOHN PROUDFOOT SLATER, care of Forests Commission, Victoria, Bruthen,  
ALAN ROBERT TOLSHER, care of Forests Commission, Victoria, Heathcote,  
GEOFFREY REES WILLIAMS, care of Forests Commission, Victoria, Trentham, and  
THOMAS CUMMING JONES, care of Motor Registration Branch, Melbourne,

to be Commissioners for taking Declarations and Affidavits, pursuant to the provisions of the *Evidence Act 1958*, to refrain from charging fees and to resign upon ceasing to occupy their present positions; and

LEO JOSEPH DIGNAN, Wulgulmerang,  
FRANCIS WALTER HANDLEY, 106 Hayes-street, Shepparton,  
JOHN HOWARD KINNEAR, 51 Riversdale-road Camberwell,  
KEVIN THOMAS COOGAN, Werrimull, and

ALEXANDER EDWARD O'DEA, Disney-street, Crib Point, to be Commissioners for taking Declarations and Affidavits, pursuant to the provisions of the *Evidence Act 1958*, to resign upon removing from the neighbourhood of the addresses stated.

#### DEPARTMENT OF THE TREASURER.

##### Receiver of Revenue.

GEORGE KNIGHT OLDHAM  
to be Receiver of Revenue, Taxation Office, Commonwealth of Australia, vice A. J. Rooks, relieved.

##### Receivers of Revenue (Acting).

WILLIAM EDWARD GUY  
to act temporarily as Receiver of Revenue, Ballarat, vice E. W. Kinchington, on leave; and

IAN JOHN COLLARD  
to act temporarily as Receiver of Revenue, Stawell, vice B. J. Guinane, on leave.

##### Collector of Imposts (Acting).

RAYMOND JOHN WILSON  
to act temporarily as Collector of Imposts, State Rivers and Water Supply Commission, vice H. E. Pullar, on leave.

#### DEPARTMENT OF WATER SUPPLY.

##### Waterworks Trust Commissioners.

ARTHUR WILLIAM NICHOLSON  
to be a Commissioner of The Ballarat Water Commissioners and also Chairman thereof, for a period of four years from 10th April, 1968, his present term of office expiring on 9th April, 1968, in pursuance of the provisions of the *Water Acts*;

TALISKER ROBERT PURDUE  
to be a Commissioner of the Murrayville Waterworks Trust, for a period of four years from the date hereof, subject to the provisions of the *Water Act 1958*; and

HUBERT STANER REILLY  
to be a Commissioner of the Tatura Waterworks Trust, to hold such position for a period of four years from the date hereof, subject to the provisions of the *Water Act*.

J. ROSSITER,  
Clerk of the Executive Council.

At the Executive Council Chamber,  
Melbourne, 26th March, 1968.

## ORDERS IN COUNCIL

## CRIMES ACT 1958, SECTION 318 (7).

At the Executive Council Chamber, Melbourne, the  
twentieth day of February, 1968.

## PRESENT:

His Excellency the Governor of Victoria.  
Mr. Chandler | Mr. Meagher.  
Mr. Balfour

IN PURSUANCE of the powers conferred by section 318 of the Crimes Act 1958 His Excellency the Governor of the State of Victoria by and with the advice of the Executive Council thereof by Order hereby declares to be drugs for the purpose of the said Section 318 any active principle, any natural or synthetic derivative or any salt or compound of any of the following substances and any preparation or admixture of any such substances active principles salts or compounds, namely:—

Acetyldihydrocodeine  
Acetylmethadol  
Alphacetylmethadol  
Alphameprodine  
Alphamethadol  
Alphaprodine  
Amphetamine  
Anileridine  
Anti-diabetic (Hypoglycaemic) Substances which are sulphonamide or diguanide derivatives of urea.  
Anti-histamine Substances  
Ataractic Substances including—  
(i) phenothiazine derivatives;  
(ii) benzoic acid derivatives;  
(iii) 1 : 3 propanediol derivatives;  
(iv) benzhydrol derivatives;  
(v) piperazine derivatives;  
(vi) methylpentynol;  
Barbituric Acid  
Benzylmorphine  
Betacetylmethadol  
Betamethadol  
Betaprodine  
Bromides, metallic (including ammonium bromide)  
Bromvaletone  
Cannabis (Indian Hemp)  
Carbromal  
Chloral hydrate  
Clonitazene  
Coca Leaf  
Cocaine  
Concentrate of Poppy Straw  
Diacetylmorphine (Heroin)  
Diampromide  
Diethyl ether (commonly termed Ether)  
Diethylthiambutene  
Dihydrocodeine (Paracodine)  
Dihydrocodeinone (Hydrocodone)  
Dihydrodesoxymorphine (Desomorphine)  
Dihydrohydroxymorphine (Hydromorphinol)  
Dihydrohydroxymorphinone (Oxymorphone)  
Dihydromorphine  
Dihydromorphinone (Hydromorphone)  
Dimenoxadol  
Dimethylthiambutene  
Dioxyaphetyl Butyrate  
Diphenoxylate  
Dipipanone  
Ecgonine  
Ethylmethylthiambutene  
Etonitazene  
Fentanyl  
Glutethimide  
Hallucinogenic Substances including—  
(i) Dimethyl tryptamine;  
(ii) Lysergic Acid Diethylamide;  
(iii) Mescaline;  
(iv) Psilocybin;  
(v) Psilocyin  
Heptaine derivatives having addiction properties  
Hydroxypethidine  
Imipramine  
Insulin  
Isomethadone  
Ketobemidone  
Levomethorphan  
Levophenacymorphan  
Levorphan (Levorphanol)  
Metazocine  
Methadol (Dimepheptanol)  
Methadone (Amidone)

Methadone-Intermediate  
Methyl-desorphine  
Methyldihydromorphine  
Methyldihydromorphinone (Metopon)  
Methyl Phenidate  
1-Methyl-4-Phenylpiperidine-4-Carboxylic Acid  
Moramide-Intermediate  
Morphinan  
Morphine, except Codeine, Ethylmorphine and Pholcodine  
Morphine Methobromide  
Morphine-N-Oxide  
Morphinone  
Myrophine  
Nicocodine  
Nicomorphine  
Noracymethadol  
Norlevorphanol  
Normethadone  
Normorphine  
Norpipanone  
Opium in any form—except the alkaloid Papaverine  
Oxycodone  
Paraldehyde  
Pethidine  
Pethidine-Intermediate A.  
Pethidine-Intermediate B.  
Pethidine-Intermediate C.  
Phenadoxone  
Phenazocine  
Phenomorphin  
Piperidine derivatives with hypnotic properties  
Piritramide  
Pressor substances  
Proheptazine  
Propertidine  
Pyrrolidine derivatives with hypnotic properties  
Racemethorphan  
Racemorphan  
Thebacon  
Thebaine

And the Honorable George Oswald Reid, Her Majesty's Attorney-General for the State of Victoria, shall give the necessary directions herein accordingly.

J. ROSSITER,  
Clerk of the Executive Council.

## GRAIN ELEVATORS ACT 1958.

At the Executive Council Chamber, Melbourne, the  
twenty-sixth day of March, 1968.

## PRESENT:

His Excellency the Governor of Victoria.  
Mr. Rossiter | Mr. Dickie.  
Mr. Manson

## APPOINTMENT OF MEMBERS AND CHAIRMAN OF THE GRAIN ELEVATORS BOARD.

IN pursuance of the powers conferred by section 5 of the Grain Elevators Act 1958, and all other powers him thereunto enabling, His Excellency the Governor of the State of Victoria, by and with the advice of the Executive Council thereof, DOETH by this ORDER hereby APPOINT:—

1. The Honorable KEITH HECTOR TURNBULL to be a member and chairman of the Grain Elevators Board for the period from the 31st March, 1968, to the 31st March, 1971, both dates inclusive;

2. THOMAS ALFRED JAMES, an officer of the Victorian Railways Commissioners selected in accordance with the provisions of paragraph (b) of sub-section (2) of the said section of the said Act to be a member of the said Board for the period from the 1st April, 1968, to the 29th December, 1970, both dates inclusive; and

3. MILES BOURKE nominated in accordance with the provisions of paragraph (c) of sub-section (2) of the said section of the said Act to be a member of the said Board for the period from the 1st April, 1968, to the 31st March, 1971, both dates inclusive.

And the Honorable Gilbert Lawrence Chandler, Her Majesty's Minister of Agriculture for the State of Victoria, shall give the necessary directions herein accordingly.

J. ROSSITER,  
Clerk of the Executive Council.

COUNTRY ROADS BOARD.

At the Executive Council Chamber, Melbourne, the twenty-sixth day of March, 1968.

PRESENT:

His Excellency the Governor of Victoria.  
Mr. Rossiter | Mr. Dickie.  
Mr. Manson

ORDER APPROVING OF LAND BEING ACQUIRED AND ROADS, DEVIATIONS OR WIDENINGS BEING MADE.

HIS Excellency the Governor of the State of Victoria, by and with the advice of the Executive Council thereof, being satisfied that there are funds legally available for acquiring the land, doth hereby approve the acquiring of the land described in the schedule hereunder and the making of new roads and deviations from and widenings of existing roads referred to in the said schedule.

SCHEDULE.

State highway.

The land shown hatched on Plan numbered G.P.11276 hereunder required for the widening of the Maroondah Highway in the Shire of Healesville and making of the widening thereon.

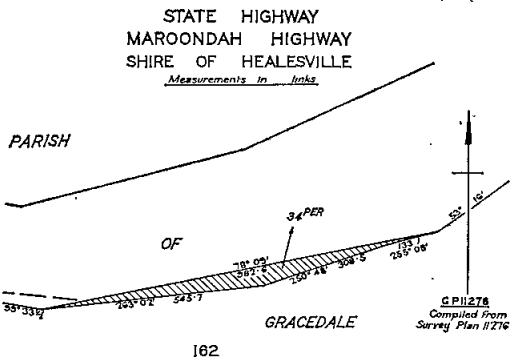

Unclassified road.

The land shown hatched on Plan numbered G.P.11289 hereunder required for the widening of Cadman Terrace in the Shire of Corio and making of the widening thereon.

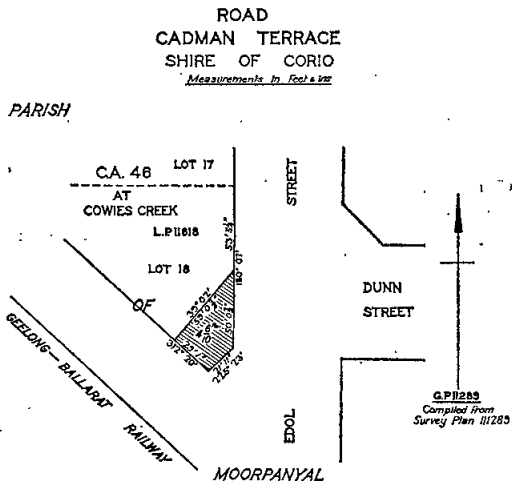

And the Honorable Murray Victor Porter, Her Majesty's Minister of Public Works for the State of Victoria, shall give the necessary directions herein accordingly.

J. ROSSITER,  
Clerk of the Executive Council.

COUNTRY ROADS BOARD.

At the Executive Council Chamber, Melbourne, the twenty-sixth day of March, 1968.

PRESENT:

His Excellency the Governor of Victoria.  
Mr. Rossiter | Mr. Dickie.  
Mr. Manson

ORDER CONFIRMING RESOLUTIONS OF THE COUNTRY ROADS BOARD.

HIS Excellency the Governor of the State of Victoria, by and with the advice of the Executive Council thereof, doth hereby, in pursuance of the provisions of the Country Roads Act 1958, confirm the resolutions of the Country Roads Board, the dates whereof and the terms of which are scheduled hereunder:—

SCHEDULE.

State highway.

Resolution dated the Eighteenth day of March, One Thousand Nine Hundred and Sixty-eight, made pursuant to Sections 21 and 74 of the Country Roads Act 1958, declaring the widening of the Cann Valley Highway in the Shire of Orbost as shown hatched on Plans numbered G.P.9531, G.P.9532 and G.P.9533 hereunder to be part of a State highway within the meaning and for the purposes of the said Act.

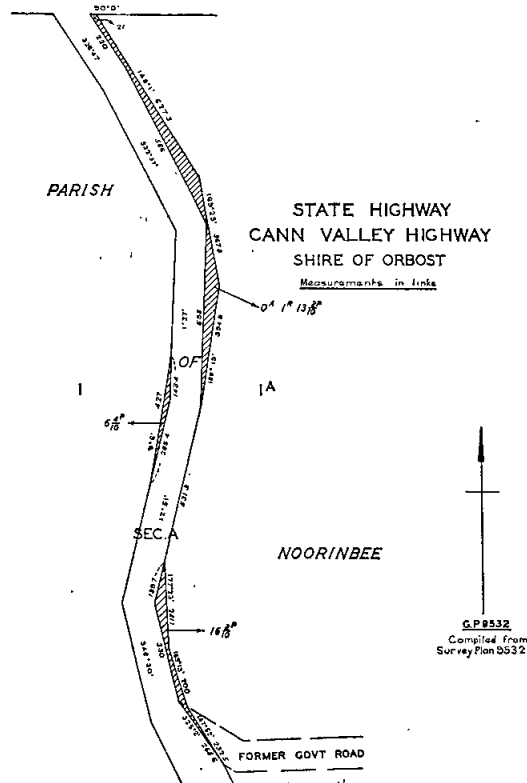

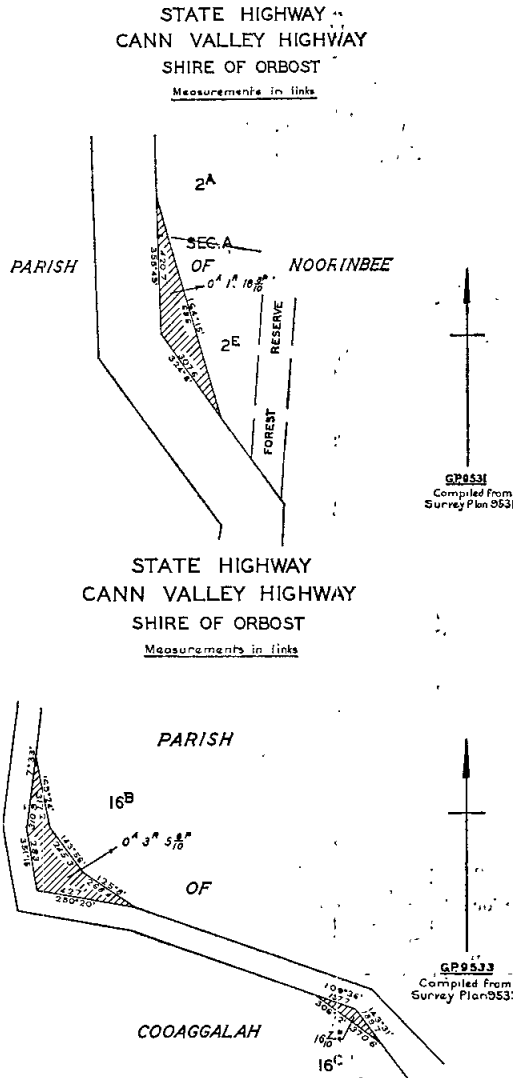

Resolution dated the Eighteenth day of March, One Thousand Nine Hundred and Sixty-eight, made pursuant to Section 21 of the *Country Roads Act 1958*, declaring the widening of the Sebastopol-Smythesdale Road in the Shire of Grenville as shown hatched on Plan numbered G.P. 9373 hereunder to be part of a main road within the meaning and for the purposes of the said Act.

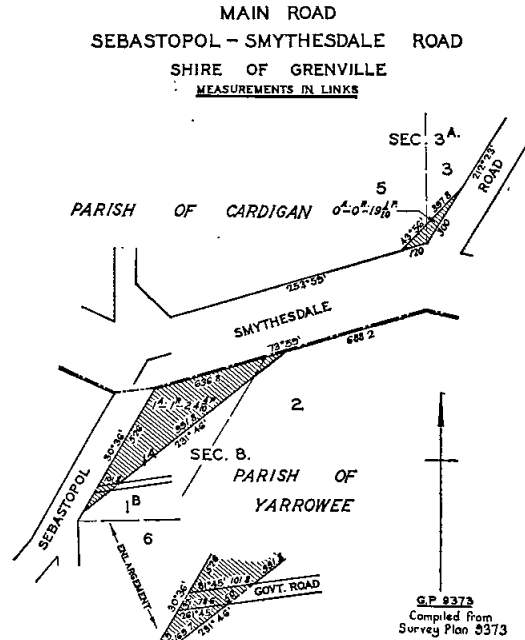

Main roads.

Resolution dated the Eighteenth day of March, One Thousand Nine Hundred and Sixty-eight, made pursuant to Sections 21 and 58 of the *Country Roads Act 1958* declaring the deviation from the Prairie-Borong Road in the Shire of East Loddon as indicated by diagonal hatching on Plan numbered G.P.10895 hereunder to be part of a main road within the meaning and for the purposes of the said Act, and also declaring that such deviation shall be in lieu of the existing road or part thereof indicated by cross hatching on the said plan and that such part of the said existing road shall be discontinued.

Resolution dated the Eighteenth day of March, One Thousand Nine Hundred and Sixty-eight, made pursuant to Section 21 of the *Country Roads Act 1958*, declaring the widening of the Poowong-Ranceby Road in the Shire of Korumburra as shown hatched on Plan numbered G.P.10999 hereunder to be part of a main road within the meaning and for the purposes of the said Act.

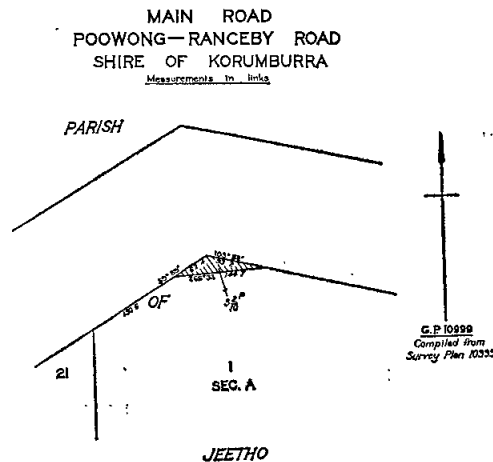
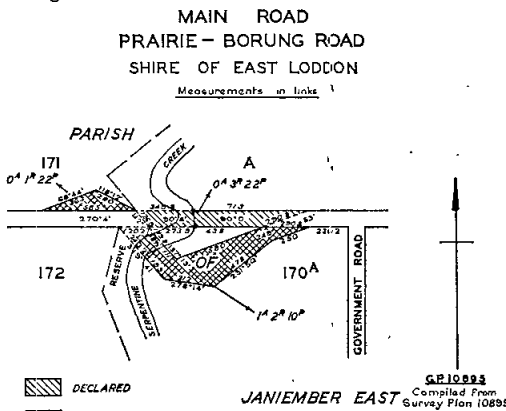

Resolution dated the Eighteenth day of March, One Thousand Nine Hundred and Sixty-eight, made pursuant to Section 21 of the *Country Roads Act 1958*, declaring the widening of the Leongatha-Mirboo Road in the Shire of Woorayl as shown hatched on Plan numbered G.P.7358 hereunder to be part of a main road within the meaning and for the purposes of the said Act.

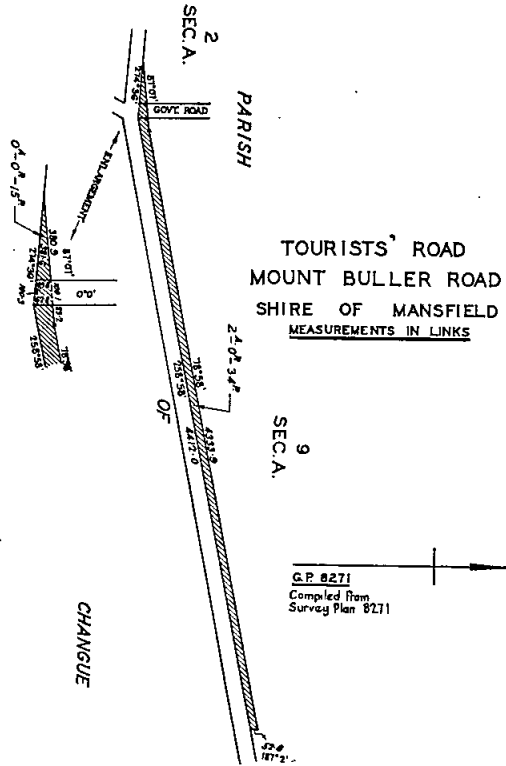
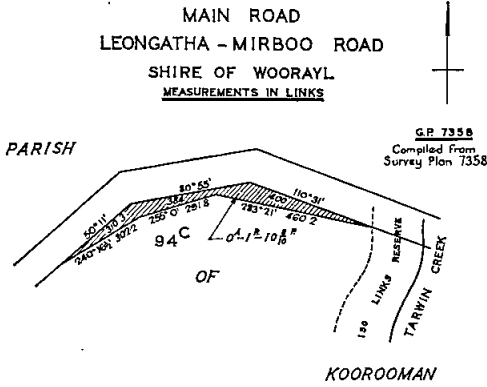

*Tourists' road.*

Resolution dated the Eighteenth day of March, One Thousand Nine Hundred and Sixty-eight, made pursuant to Sections 21 and 88 of the *Country Roads Act 1958*, declaring the widening of the Mount Buller Road in the Shire of Mansfield as shown hatched on Plans numbered G.P. 7267 and G.P.8271 hereunder to be part of a tourists' road within the meaning and for the purposes of the said Act.

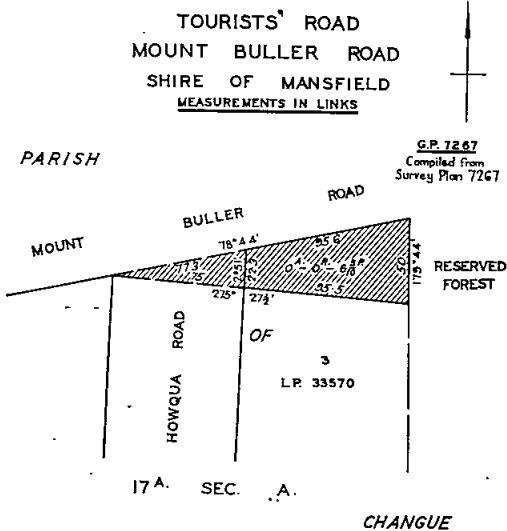

*Unclassified road.*

Resolution dated the Eighteenth day of March, One Thousand Nine Hundred and Sixty-eight, made pursuant to Sections 21 and 110 of the *Country Roads Act 1958*, declaring the road in the Shire of Knox as shown hatched on Plan numbered G.P. 9598 hereunder to be a road (Bergin Army Road) within the meaning and for the purposes of the said Act.

**ROAD BERGIN ARMY ROAD SHIRE OF KNOX MEASUREMENTS IN LINKS**

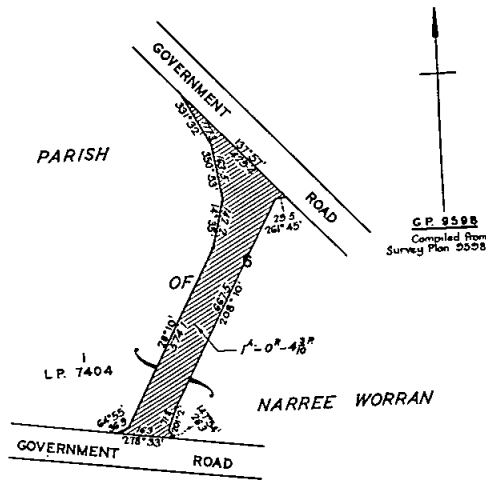

And the Honorable Murray Victor Porter, Her Majesty's Minister of Public Works for the State of Victoria, shall give the necessary directions herein accordingly.

J. ROSSITER,  
Clerk of the Executive Council.

HOUSING ACT 1958.

At the Executive Council Chamber, Melbourne, the twenty-sixth day of March, 1968.

PRESENT:

His Excellency the Governor of Victoria.
Mr. Rossiter Mr. Dickie.
Mr. Manson

CLOSING OF ROAD—SHIRE OF ORBOST.

WHEREAS by virtue and in exercise of the powers contained in the Housing Act 1958 (No. 6275) Housing Commission has recommended to the Governor-in-Council that the road described in the Schedule hereto be closed.

NOW THEREFORE His Excellency the Governor of the State of Victoria in the Commonwealth of Australia by and with the advice of the Executive Council of the said State, doth in pursuance of the powers conferred by the said Act and upon such recommendation, consent and by this Order hereby close such road.

SCHEDULE.

So much of the roads coloured brown on Plan of Subdivision Number 7027 lodged in the Office of Titles as is delineated and hachured on the plan hereunder.

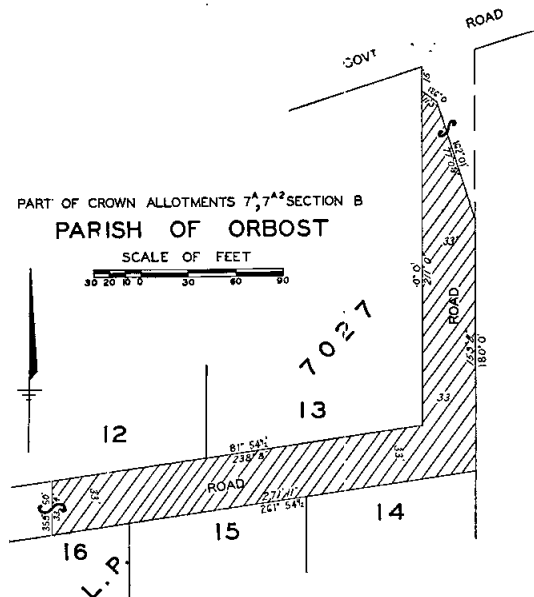

And the Honorable Edward Raymond Meagher, Her Majesty's Minister of Housing for the State of Victoria, shall give the necessary directions herein accordingly.

J. FOSSITER, Clerk of the Executive Council.

HOUSING ACT 1958.

At the Executive Council Chamber, Melbourne, the twenty-sixth day of March, 1968.

PRESENT:

His Excellency the Governor of Victoria.
Mr. Rossiter Mr. Dickie.
Mr. Manson

EXTINGUISHMENT OF EASEMENT—CITY OF SHEPPARTON.

WHEREAS by virtue and in exercise of the powers contained in the Housing Act 1958 (No. 6275) Housing Commission has recommended to the Governor-in-Council that the easement described in the Schedule hereto be extinguished.

NOW THEREFORE His Excellency the Governor of the State of Victoria in the Commonwealth of Australia by and with the advice of the Executive Council of the said

State, doth in pursuance of the powers conferred by the said Act and upon such recommendation, consent and by this Order hereby extinguish such easement.

SCHEDULE.

Any easements affecting that portion of land appropriated for drainage and sewerage purposes on Plan of Subdivision Number 71251 lodged in the Office of Titles as is shown delineated and hachured on the plan hereunder.

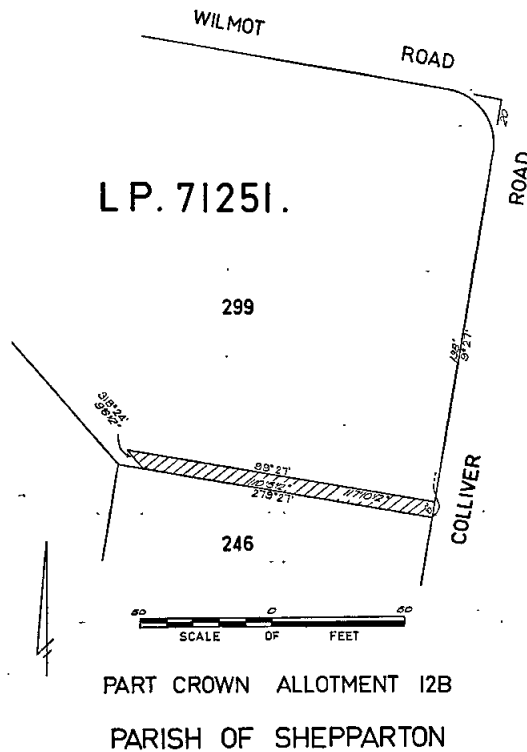

And the Honorable Edward Raymond Meagher, Her Majesty's Minister of Housing for the State of Victoria, shall give the necessary directions herein accordingly.

J. ROSSITER, Clerk of the Executive Council.

STOCK DISEASES ACT 1958.

At the Executive Council Chamber, Melbourne, the twenty-sixth day of March, 1968.

PRESENT:

His Excellency the Governor of Victoria.
Mr. Rossiter Mr. Dickie.
Mr. Manson

IN pursuance of the powers conferred by the Stock Diseases Act 1958 and all other powers him thereunto enabling, His Excellency the Governor of the State of Victoria, by and with the advice of the Executive Council thereof, doth hereby appoint THOMAS SAMUEL BAKER as an Inspector of Stock for the purposes of the said Act, vice THOMAS JOSEPH MCGUIRE, transferred.

And the Honorable Gilbert Lawrence Chandler, Her Majesty's Minister of Agriculture for the State of Victoria, shall give the necessary directions herein accordingly.

J. ROSSITER, Clerk of the Executive Council.

DEPARTMENT OF CROWN LANDS AND SURVEY.

At the Executive Council Chamber, Melbourne, the twenty-sixth day of March, 1968.

PRESENT:

His Excellency the Governor of Victoria.  
 Mr. Rossiter                      Mr. Dickie.  
 Mr. Manson

UNUSED ROAD CLOSED.

HIS Excellency the Governor of the State of Victoria, by and with the advice of the Executive Council thereof, doth hereby direct that, in pursuance of the provisions of section 349 of the Land Act 1958, the unused road referred to hereunder be closed, viz.:

Township of Inglewood, Parish of Inglewood, County of Gladstone, being the portion of the width of the road indicated by hatching on plan hereunder.—(L4<sup>(b)</sup>) (W.59238).

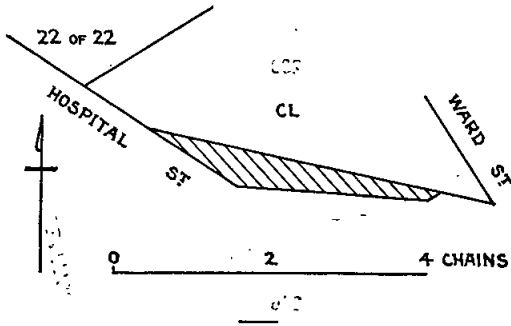

And the Honorable Sir William John Farquhar McDonald, Her Majesty's Minister of Lands for the State of Victoria, shall give the necessary directions herein accordingly.

J. ROSSITER,  
 Clerk of the Executive Council.

Lower Yarra Crossing Authority Act 1965, No. 7365.  
 ORDER SANCTIONING THE LOWER YARRA CROSSING AUTHORITY ENTERING INTO CONTRACTS.

At the Executive Council Chamber, Melbourne, the second day of April, 1968.

PRESENT:

His Excellency the Governor of Victoria.  
 Mr. Thompson                      Mr. Reid.  
 Mr. Wilcox

HIS Excellency the Governor of the State of Victoria, by and with the advice of the Executive Council thereof, in accordance with section 5 (3) of the Lower Yarra Crossing Authority Act 1965, No. 7365, doth hereby sanction the Lower Yarra Crossing Authority entering into the contracts described in the Schedule hereunder.

SCHEDULE.

1. John Holland & Co. Pty. Ltd., for the bridge foundations, at an estimated cost of \$4,750,000.
2. John Holland & Co. Pty. Ltd., for the concrete bridge works, at an estimated cost of \$10,692,000.
3. World Services & Construction Pty. Ltd., for the steel bridge works, at an estimated cost of \$6,930,000.

And the Honorable Rupert James Hamer, Her Majesty's Minister for Local Government for the State of Victoria, shall give the necessary directions herein accordingly.

J. ROSSITER,  
 Clerk of the Executive Council.

COUNTRY ROADS BOARD.

At the Executive Council Chamber, Melbourne, the second day of April, 1968.

PRESENT:

His Excellency the Governor of Victoria.  
 Mr. Thompson                      Mr. Reid.  
 Mr. Wilcox

ORDER APPROVING OF LAND BEING ACQUIRED AND ROADS, DEVIATIONS OR WIDENINGS BEING MADE.

HIS Excellency the Governor of the State of Victoria, by and with the advice of the Executive Council thereof, being satisfied that there are funds legally available for acquiring the land, doth hereby approve the acquiring of the land described in the schedule hereunder and the making of new roads and deviations from and widenings of existing roads referred to in the said schedule.

SCHEDULE.

State Highway.

The land shown hatched on Plans numbered G.P. 11160, G.P. 11161A and G.P. 11162 hereunder required for the deviation from the Murray Valley Highway in the Shire of Swan Hill and making of the deviation thereon.

STATE HIGHWAY  
 MURRAY VALLEY HIGHWAY  
 SHIRE OF SWAN HILL

Measurements in links

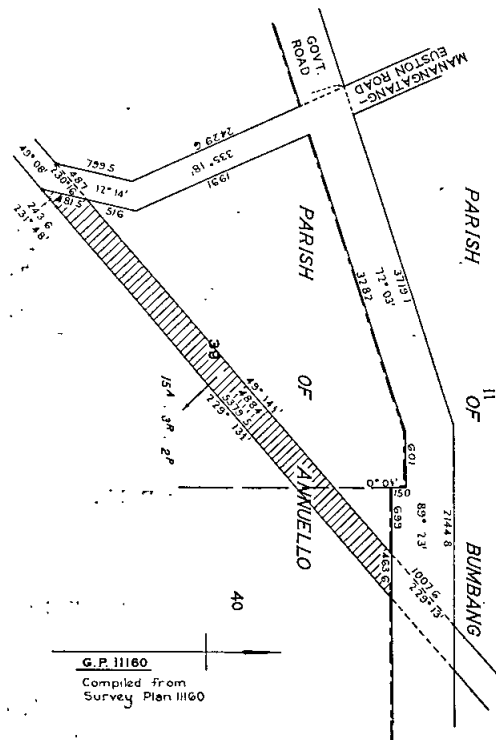



STATE HIGHWAY  
MURRAY VALLEY HIGHWAY  
SHIRE OF SWAN HILL

Measurements in links

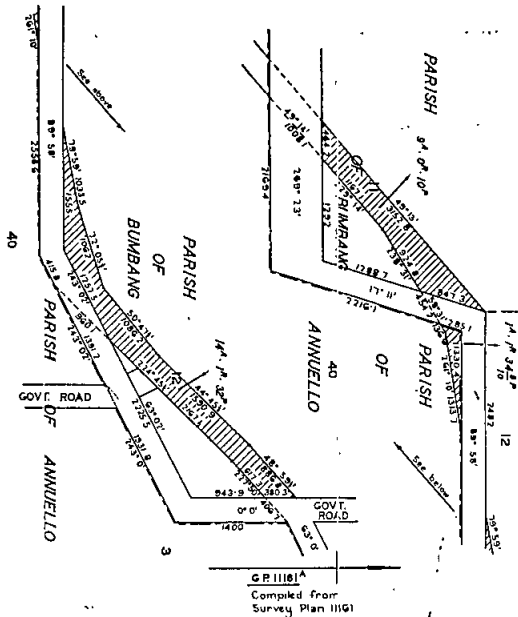

Main Roads.

The land shown hatched on Plans numbered G.P. 11069A and G.P. 11069B hereunder required for the widening of the Wangaratta-Kilfeera Road in the Shire of Oxley and making of the widening thereon.

MAIN ROAD  
WANGARATTA-KILFEERA ROAD  
SHIRE OF OXLEY

Measurements in links

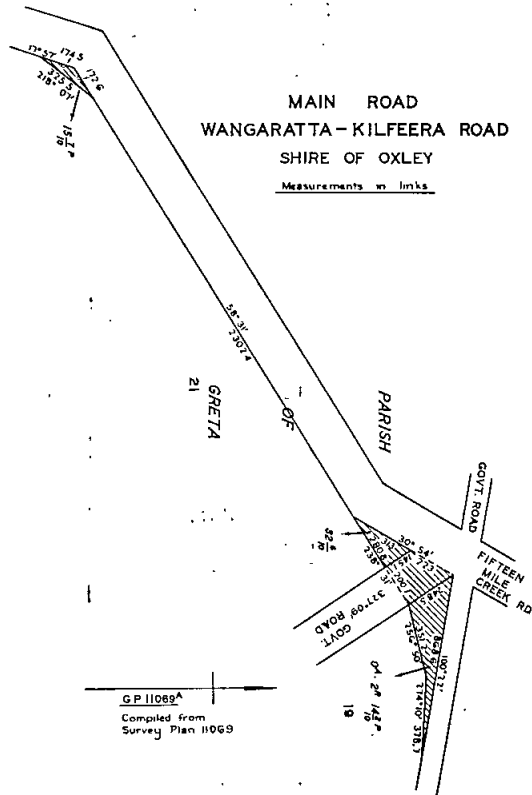

STATE HIGHWAY  
MURRAY VALLEY HIGHWAY  
SHIRE OF SWAN HILL

Measurements in links

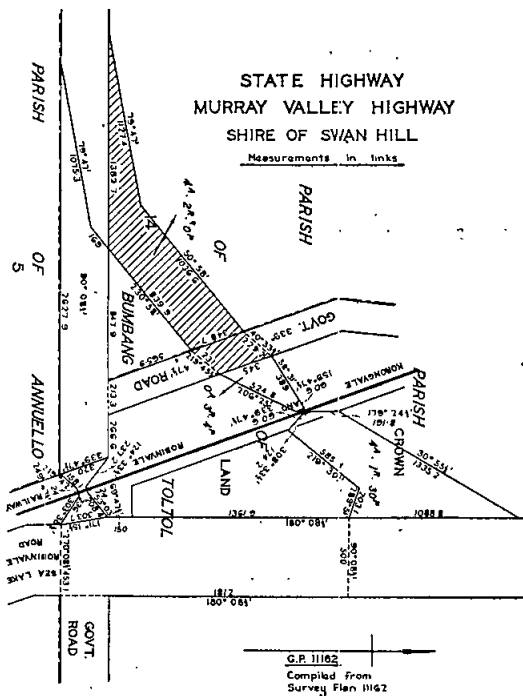

MAIN ROAD  
WANGARATTA-KILFEERA ROAD  
SHIRE OF OXLEY

Measurements in links

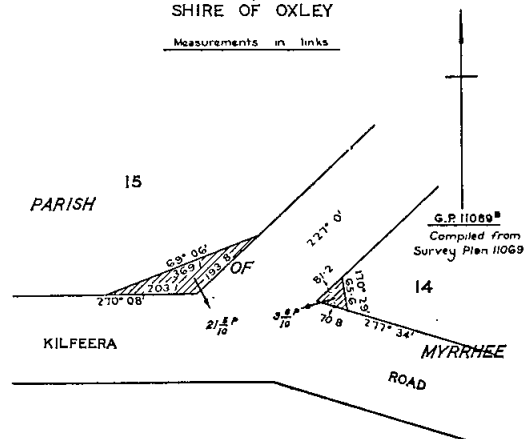

The land shown hatched on Plan numbered G.P. 10950A hereunder required for the deviation from the Birchip-Wycheproof Road in the Shire of Wycheproof and making of the deviation thereon.

MAIN ROAD  
BIRCHIP-WYCHEPROOF ROAD  
SHIRE OF WYCHEPROOF  
*Measurements in Links*

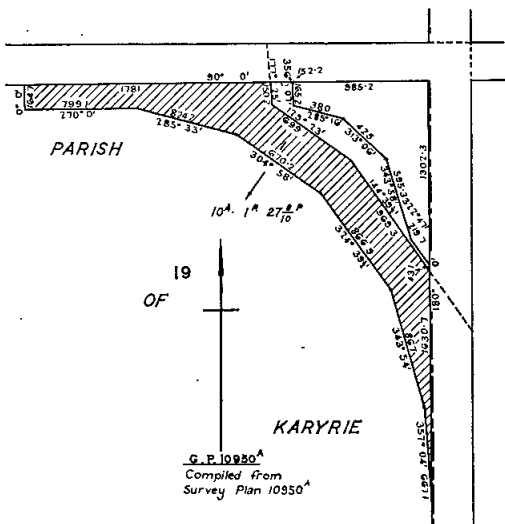

Unclassified Roads.  
The land shown hatched on Plan numbered G.P. 11303B hereunder required for the making of a new road (Lower Yarra Freeway By-pass Access Road) in the Shire of Altona.

ROAD  
LOWER YARRA FREEWAY BY-PASS ACCESS ROAD  
SHIRE OF ALTONA  
*Measurements in Feet*

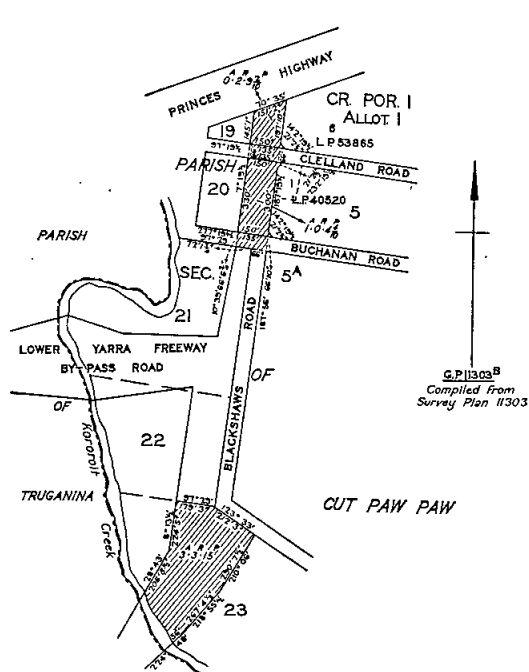

By-pass Road.  
The land shown hatched on Plan numbered G.P. 11303A hereunder required for the making of the Lower Yarra Freeway By-pass Road in the Shire of Altona.

BY-PASS ROAD  
LOWER YARRA FREEWAY BY-PASS ROAD  
SHIRE OF ALTONA  
*Measurements in Feet*

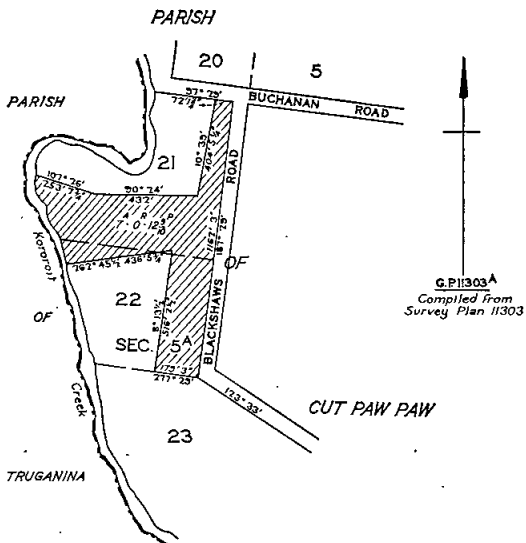

The land shown hatched on Plan numbered G.P. 11161B hereunder required for the making of a new road (Murray Valley Highway Access Road) in the Shire of Swan Hill.

ROAD  
MURRAY VALLEY HIGHWAY ACCESS ROAD  
SHIRE OF SWAN HILL  
*Measurements in links*

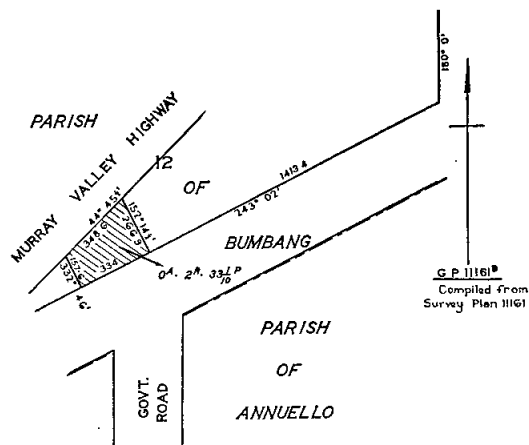

And the Honorable Murray Victor Porter, Her Majesty's Minister of Public Works for the State of Victoria, shall give the necessary directions herein accordingly.

J. ROSSITER,  
Clerk of the Executive Council.

## STAMPS ACT 1958, No. 6375.

At the Executive Council Chamber, Melbourne, the second day of April, 1968.

PRESENT:

His Excellency the Governor of Victoria.  
Mr. Thompson | Mr. Reid.  
Mr. Wilcox

## DECLARATION OF APPROVED VENDOR.

HIS Excellency the Governor of the State of Victoria, by and with the advice of the Executive Council thereof, doth by this Order made pursuant to Section 131c (1) of the *Stamps Act 1958*, declare the undermentioned person carrying on business as a vendor of goods under instalment purchase agreements to be an "approved vendor" for the purposes of subdivision (14) of Division three of Part II of the *Stamps Act 1958*.

241. Warburton Franki Industries (Melbourne) Pty. Ltd.

And the Honorable Sir Henry Edward Bolte, Her Majesty's Treasurer for the State of Victoria, shall give the necessary directions herein accordingly.

J. ROSSITER,  
Clerk of the Executive Council.

## STAMPS ACT 1958, No. 6375.

At the Executive Council Chamber, Melbourne, the second day of April, 1968.

PRESENT:

His Excellency the Governor of Victoria.  
Mr. Thompson | Mr. Reid.  
Mr. Wilcox

HIS Excellency the Governor of the State of Victoria, by and with the advice of the Executive Council thereof, doth by this Order made pursuant to Section 131c of the *Stamps Act 1958* (No. 6375) revoke the declaration made on 9th December, 1958, and published in the *Government Gazette* on the 10th December, 1958, declaring certain persons to be "approved vendors" for the purposes of subdivision (14) of Division three of Part II of the *Stamps Act 1958* insofar as the said declaration refers to the undermentioned person—

33. Pentagon Acceptance Pty. Ltd.

And the Honorable Sir Henry Edward Bolte, Her Majesty's Treasurer for the State of Victoria, shall give the necessary directions herein accordingly.

J. ROSSITER,  
Clerk of the Executive Council.

## PORTLAND HARBOR TRUST ACT 1958, No. 6340.

At the Executive Council Chamber, Melbourne, the second day of April, 1968.

PRESENT:

His Excellency the Governor of Victoria.  
Mr. Thompson | Mr. Reid.  
Mr. Wilcox

WHEREAS His Excellency the Governor in Council on the second day of April, 1968, consented pursuant to the provisions of the *Portland Harbor Trust Act 1958* to the Portland Harbor Trust Commissioners raising by way of loan the sum of one hundred thousand dollars (\$100,000); AND WHEREAS His Excellency the Governor in Council is satisfied that a sufficient proportion of the loan to be raised will fall due and be repaid in each year during the currency of the proposed loan; NOW THEREFORE it is directed pursuant to the provisions of Section 33 (3) of the said Act, that it shall not be necessary to provide a sinking fund in connection with such loan.

And the Honorable Sir Henry Edward Bolte, Her Majesty's Treasurer for the State of Victoria, shall give the necessary directions herein accordingly.

J. ROSSITER,  
Clerk of the Executive Council.

## THE BALLARAT SEWERAGE AUTHORITY.

At the Executive Council Chamber, Melbourne, the second day of April, 1968.

PRESENT:

His Excellency the Governor of Victoria.  
Mr. Thompson | Mr. Reid.  
Mr. Wilcox

## CONSENT TO BORROWING \$120,000.

UNDER the powers conferred by the Sewerage Districts Act and all other powers enabling him in that behalf, His Excellency the Governor of the State of Victoria, by and with the advice of the Executive Council of the said State, doth hereby consent to The Ballarat Sewerage Authority borrowing by mortgage of the General Fund the sum of One hundred and twenty thousand dollars (\$120,000) to meet the cost of sewerage works as set forth in the detailed statement bearing date the 28th March, 1968.

And the Honorable William Archibald Borthwick, Her Majesty's Minister of Water Supply for the State of Victoria, shall give the necessary directions herein accordingly.

J. ROSSITER,  
Clerk of the Executive Council.

## WANGARATTA SEWERAGE AUTHORITY.

At the Executive Council Chamber, Melbourne, the second day of April, 1968.

PRESENT:

His Excellency the Governor of Victoria.  
Mr. Thompson | Mr. Reid.  
Mr. Wilcox

## CONSENT TO BORROWING \$45,000.

UNDER the powers conferred by the Sewerage Districts Act and all other powers enabling him in that behalf, His Excellency the Governor of the State of Victoria, by and with the advice of the Executive Council of the said State, doth hereby consent to the Wangaratta Sewerage Authority borrowing by mortgage of the General Fund the sum of Forty-five thousand dollars (\$45,000) in two amounts of Thirty thousand dollars (\$30,000) and Fifteen thousand dollars (\$15,000) respectively to meet the cost of sewerage works as set forth in the detailed statement bearing date 27th March, 1968.

And the Honorable William Archibald Borthwick, Her Majesty's Minister of Water Supply for the State of Victoria, shall give the necessary directions herein accordingly.

J. ROSSITER,  
Clerk of the Executive Council.

## THE BALLARAT WATER COMMISSIONERS.

At the Executive Council Chamber, Melbourne, the second day of April, 1968.

PRESENT:

His Excellency the Governor of Victoria.  
Mr. Thompson | Mr. Reid.  
Mr. Wilcox

## CONSENT TO BORROWING \$30,000.

UNDER the powers conferred by the Water Act and all other powers enabling him in that behalf, His Excellency the Governor of the State of Victoria, by and with the advice of the Executive Council of the said State, doth hereby consent to The Ballarat Water Commissioners borrowing at interest the sum of Thirty thousand dollars (\$30,000) to meet the cost of water supply works.

And the Honorable William Archibald Borthwick, Her Majesty's Minister of Water Supply for the State of Victoria, shall give the necessary directions herein accordingly.

J. ROSSITER,  
Clerk of the Executive Council.

## MOE WATERWORKS TRUST.

At the Executive Council Chamber, Melbourne, the  
second day of April, 1968.

PRESENT:

His Excellency the Governor of Victoria.  
Mr. Thompson | Mr. Reid.  
Mr. Wilcox

## CONSENT TO BORROWING \$10,000.

UNDER the powers conferred by the Water Act and all other powers enabling him in that behalf, His Excellency the Governor of the State of Victoria, by and with the advice of the Executive Council of the said State, doth hereby consent to the Moe Waterworks Trust borrowing at interest the sum of Ten thousand dollars (\$10,000) to meet the cost of water supply works.

And the Honorable William Archibald Borthwick, Her Majesty's Minister of Water Supply for the State of Victoria, shall give the necessary directions herein accordingly.

J. ROSSITER,  
Clerk of the Executive Council.

## TRARALGON WATERWORKS TRUST.

At the Executive Council Chamber, Melbourne, the  
second day of April, 1968.

PRESENT:

His Excellency the Governor of Victoria.  
Mr. Thompson | Mr. Reid.  
Mr. Wilcox

## CONSENT TO BORROWING \$6,300.

UNDER the powers conferred by the Water Act and all other powers enabling him in that behalf, His Excellency the Governor of the State of Victoria, by and with the advice of the Executive Council of the said State, doth hereby consent to the Traralgon Waterworks Trust borrowing at interest the sum of Six thousand three hundred dollars (\$6,300) for the conversion of Loan No. 2.

And the Honorable William Archibald Borthwick, Her Majesty's Minister of Water Supply for the State of Victoria, shall give the necessary directions herein accordingly.

J. ROSSITER,  
Clerk of the Executive Council.

## GEELONG WATERWORKS AND SEWERAGE TRUST.

At the Executive Council Chamber, Melbourne, the  
second day of April, 1968.

PRESENT:

His Excellency the Governor of Victoria.  
Mr. Thompson | Mr. Reid.  
Mr. Wilcox

## CONSENT TO BORROWING \$400,000.

UNDER the powers conferred by the Geelong Waterworks and Sewerage Act and all other powers enabling him in that behalf, His Excellency the Governor of the State of Victoria, by and with the advice of the Executive Council of the said State, doth hereby consent to the Geelong Waterworks and Sewerage Trust borrowing at interest, subject to the Geelong Waterworks and Sewerage Act, the sum of Four hundred thousand dollars (\$400,000) in one amount of Two hundred thousand dollars (\$200,000) and two amounts each of One hundred thousand dollars (\$100,000) respectively to meet the cost of sewerage works.

And the Honorable William Archibald Borthwick, Her Majesty's Minister of Water Supply for the State of Victoria, shall give the necessary directions herein accordingly.

J. ROSSITER,  
Clerk of the Executive Council.

## COMPANIES ACT 1961.

At the Executive Council Chamber, Melbourne, the  
second day of April, 1968.

PRESENT:

His Excellency the Governor of Victoria.  
Mr. Thompson | Mr. Reid.  
Mr. Wilcox

## ORDER UNDER SECTION 348 (5) OF THE COMPANIES ACT 1961.

WHEREAS pursuant to the provisions of sub-section (5) of Section 348 of the Companies Act 1961, the Governor in Council may, by order published in the Government Gazette, declare a class of companies incorporated under the law of another State, Territory or country, to be a class of companies of a kind the same or substantially the same as exempt proprietary companies under the Companies Act 1961.

NOW THEREFORE the Governor of the State of Victoria, by and with the advice of the Executive Council thereof, doth hereby declare that exempt proprietary companies under the laws in force in the Territory of Papua and New Guinea are companies of a kind the same as exempt proprietary companies under the Companies Act 1961.

And the Honorable George Oswald Reid, Her Majesty's Attorney-General for the State of Victoria, shall give the necessary directions herein accordingly.

J. ROSSITER,  
Clerk of the Executive Council.

## COMPANIES ACT 1961.

At the Executive Council Chamber, Melbourne, the  
second day of April, 1968.

PRESENT:

His Excellency the Governor of Victoria.  
Mr. Thompson | Mr. Reid.  
Mr. Wilcox

## ORDER UNDER SECTION 318 (3) OF THE COMPANIES ACT 1961.

WHEREAS pursuant to the provisions of sub-section (3) of section 318 of the Companies Act 1961 the Governor in Council may, where it appears to him that an enactment in force in any State or Territory of the Commonwealth contains provisions similar to the said section 318, by Order published in the Government Gazette declare the State or Territory to be a proclaimed State for the purposes of the said section 318.

AND WHEREAS it appears to him that an enactment in force in the Territory of Papua and New Guinea contains provisions similar to the said section 318.

NOW THEREFORE the Governor of the State of Victoria, by and with the advice of the Executive Council thereof, doth hereby order that the Territory of Papua and New Guinea be a proclaimed State for the purposes of section 318 of the Companies Act 1961.

And the Honorable George Oswald Reid, Her Majesty's Attorney-General for the State of Victoria, shall give the necessary directions herein accordingly.

J. ROSSITER,  
Clerk of the Executive Council.

## LANDS DEPARTMENT NOTICES

### APPROACHING LAND SALES.

SALES of Crown Lands, in fee-simple, will be held at the under-mentioned places and dates, viz.:-

	No. of Gazette.
Apollo Bay.—Saturday, 18th May, 1968	25
Cann River.—Wednesday, 17th April, 1968	14
Euroa.—Friday, 17th May, 1968	29
Heathcote.—Friday, 17th May, 1968	29
Mallacoota.—Wednesday, 17th April, 1968	14
Melbourne.—Wednesday, 22nd May, 1968	25
Orbost.—Thursday, 18th April, 1968	14
Robinvale.—Tuesday, 30th April, 1968	25
Rushworth.—Friday, 17th May, 1968	29
Tallangatta.—Tuesday, 7th May, 1968	29
Yackandandah.—Tuesday, 7th May, 1968	29
Yarra Junction.—Friday, 24th May, 1968	29

### SALE OF FREEHOLD LAND BY AUCTION.

Apollo Bay.—Saturday 18th May, 1968 . . . . . 25

### AUCTION OF RIGHT TO LEASE CROWN LAND.

Melbourne.—Wednesday, 22nd May, 1968 . . . . . 25

### SALES OF CROWN LAND BY AUCTION.

The land will be offered for sale in fee-simple, and subject to the provisions of the Land Act and Regulations thereunder.

The upset price is the sum at which bidding will start, and no bid below that sum can be accepted. The highest bidder at or above that sum shall be the purchaser, subject to signature of contract and any necessary payment.

#### TERMS:—

A deposit of at least 12½% of the purchase price must be paid at the sale, either in cash or by cheque.

The residue is payable in half-yearly instalments, in accordance with the following scale, or may be paid off at any earlier time.

\$40 and under, 6 instalments.
Over \$40, and not exceeding \$100, 8 instalments.
Over \$100, and not exceeding \$200, 10 instalments.
Over \$200, and not exceeding \$400, 12 instalments.
Over \$400, and not exceeding \$600, 14 instalments.
Over \$600, and not exceeding \$800, 16 instalments.
Over \$800, and not exceeding \$1,000, 18 instalments.
Over \$1,000, 20 instalments.

Interest at the rate of 5% per annum is payable with all payments of residue, and is computed for each instalment from the date of sale to the date of such payment. Additional interest is charged if any instalment is not paid on or before the due date.

If paid off within 30 days of sale, no interest is payable.

#### FEES, ETC.:

Also payable at the sale, in addition to the deposit, are the survey fee and, if applicable, the valuation of improvements (if purchaser be not the owner thereof).

#### Payable with balance of purchase money—

Crown Grant fee—	
50 acres and under . . . . .	\$3
Over 50 acres . . . . .	\$4
Purchase money \$10 or under . . . . .	\$2

Assurance Fund contribution.—One cent in every Five dollars or part thereof of purchase price. (This is a fund established to guarantee the validity of freehold titles.)

Transfer of interest prior to completion of payment may be allowed on payment of \$2 fee and subject to stamp duty.

If unable to attend personally, a prospective purchaser may arrange for another person to bid as his agent.

Attention is drawn to section 95, Land Act 1958, which provides that the purchaser shall be deemed to be the owner for the purposes of other Acts; also to an amendment to the Local Government Act providing for Government roads, in certain circumstances, to be declared "private streets", thus making the purchaser liable to contribute to the cost of street construction.

W. J. F. McDONALD,  
Minister of Lands.

Office of Crown Lands and Survey,  
Melbourne, 4th April, 1968.

**YACKANDANDAH.**—Sale (No. 11925) of Crown land in fee-simple, by auction, will be held at the LAND INSPECTOR'S OFFICE, YACKANDANDAH, on TUESDAY, the 7th MAY, 1968, at half-past NINE o'clock a.m. To be conducted by F. F. HOLT, Land Officer, Beechworth.

#### Lot 1.

TOWNSHIP OF ALLAN'S FLAT, PARISH OF YACKANDANDAH,  
COUNTY OF BOGONG.

*Being the site and improvements thereon of the former Education Department residence at Allan's Flat.*

Upset price \$1,620 the lot. Survey fee \$17.75.

Area 3a. Or. 21 7/10p., subject to survey and any necessary easements disclosed thereby, allotment 11b.

NOTE.—Improvements comprise 13½ square timber dwelling of 5 rooms with iron roof, outbuildings, tanks and fencing the valuation of which is included in the upset price.

Until the purchase money has been paid in full, the following special conditions shall apply:—

- (i) The purchaser shall at his own expense maintain the property in good order and repair and keep all improvements thereon insured against fire in the name of the Secretary for Lands.
- (ii) A cover note for not less than \$1,420 for such insurance shall be lodged in the Lands Department, by the purchaser, within one week of the date of sale, and the policy shall be lodged immediately on issue.
- (iii) The purchaser shall not remove or make any alterations to the improvements on the site without the prior consent of the Secretary for Lands. —(H.031608.)

#### Lot 2.

PARISH OF YACKANDANDAH, COUNTY OF BOGONG.

*Fronting the reservation to the western side of the Yackandandah creek about 1¼ miles south-west of Yackandandah.*

Upset price \$30 the lot. Survey fee \$19.25.

Area 6a. Or. 36p., allotment 22E, of section B<sup>10</sup>.

One month allowed for removal of improvements. —(H.023697.)

#### Lot 3.

PARISH OF MURRAMURRANGBONG, COUNTY OF BOGONG.

*Fronting the eastern side of the Kiewa Valley-road about 2½ chains north-west of the junction of Woodong and Kiewa roads.*

Upset price \$400 the lot. Survey fee \$16.

Area 1a. 1r. 23p., allotment 6A of section 1. Valuation of improvements \$48.25 (tank, piping, gates and fencing), Education Department.—(H.028706.)

**TALLANGATTA.**—Sale (No. 11924) of Crown land in fee-simple, by auction, will be held at the LAND INSPECTOR'S OFFICE, TALLANGATTA, on TUESDAY, the 7th MAY, 1968, at half-past ELEVEN o'clock a.m. To be conducted by F. F. HOLT, Land Officer, Beechworth.

#### Lot 1.

TOWNSHIP OF MITTA MITTA, PARISH OF MAGORRA,  
COUNTY OF BOGONG.

*Fronting the southern side of the Omeo Highway in the west of the Township.*

Upset price \$80 the lot. Survey fee \$12.

Area 28 perches, allotment A<sup>31</sup>.—(H.022119.)

#### Lot 2.

PARISH OF WAGRA, COUNTY OF BENAMBRA.

*In the south of the Parish.*

Upset price \$300 the lot. Survey fee \$32.25.

Area 47a. 2r. 34p., allotments 6C, 6D and 6E of section 19. Subject to S.E.C. easement 455 links wide.—(H.032335.)

#### Lot 3.

PARISH OF NOORONGONG, COUNTY OF BOGONG.

*Fronting the western side of the Omeo Highway about 8 miles south of Murray Valley Highway.*

Upset price \$200 the lot. Survey fee \$24.50.

Area 19a. 3r. 15p., allotment 24.—(H.025568.)

**RUSHWORTH.**—Sale (No. 11926) of Crown land in fee-simple, by auction, will be held in the LAND INSPECTOR'S OFFICE, RUSHWORTH, on FRIDAY, 17th MAY, 1968, at half-past ELEVEN o'clock a.m. To be conducted by Land Officer, Seymour.

## Lot 1.

PARISH OF MOORA, COUNTY OF RODNEY.

About 12 chains east of Stanhope-road and about 23 chains north of the junction of Hill-street and Stanhope-road.

Upset price \$140 the lot. Survey fee \$17.75.

Area 5a. 0r. 26p., allotment 100B. Subject to S.E.C. easement 48 links wide.—(H.029249.)

## Lot 2.

Fronting the eastern side of Stanhope-road and about 24 chains north-west of Hill-street.

Upset price \$80 the lot. Survey fee \$16.

Area 1a. 2r. 19p., allotment 100b.—(H.022724.)

ALSO THE FOLLOWING FREEHOLD LAND WILL BE OFFERED:—

Note.—This lot is not subject to the provisions of the Land Act as set out above, but comprises freehold land offered on behalf of the Education Department on the following conditions:—

- (a) Deposit of at least 12½ per cent. payable at the sale and balance within 60 days.
- (b) Purchaser to arrange for, and bear cost of, registration of transfer of title.

## Lot 3.

PARISH OF BAILLESTON, COUNTY OF RODNEY.

Being the former State school site at Wirrate.

Upset price \$38.80 the lot.

Area 2 acres, being Crown allotment 100A and the whole of the land described in F.C.T., Vol. 3452, Fol. 273.—(H.032023.)

**HEATHCOTE.**—Sale (No. 11928) of Crown land in fee-simple, by auction, will be held at the LAND INSPECTOR'S OFFICE, HEATHCOTE, on FRIDAY, 17th MAY, 1968, at TEN a.m. To be conducted by the Land Officer, Seymour.

## Lot 1.

TOWNSHIP OF COSTERFIELD, PARISH OF COSTERFIELD, COUNTY OF DALHOUSIE.

Fronting the southern side of gravel road south of the Water Supply Reserve.

Upset price \$400 the lot. Survey fee \$27.25.

Area 24a. 0r. 26p., allotment 3 of section 9. Valuation of improvements \$460 (dwelling, sheep yards, loading ramp and fencing) (N. J. Mears).—(H.031814.)

PARISH OF TOOBORAC, COUNTY OF DALHOUSIE.

## Lot 2.

Fronting the western side of the Northern Highway, about 2 miles north-west of Tooborac.

Upset price \$160.00 the lot. Survey fee \$26.25.

Area 22a. 3r. 32p., allotment 77A.—(H.028766.)

## Lot 3.

Three-quarters of a mile west of the junction of the McIvor Highway and the Tooborac-Lancefield road.

Upset price \$150 the lot. Survey fee \$19.25.

Area 7 acres, allotment 1D of section 7.—(H.031991.)

**EUROA.**—Sale (No. 11929) of Crown land in fee-simple, by auction, will be held at the LAND INSPECTOR'S OFFICE, EUROA, on FRIDAY, the 17th MAY, 1968, at ONE p.m. To be conducted by the Land Officer, Seymour.

## Lot 1.

PARISH OF LONGWOOD, COUNTY OF DELATITE.

Former State school reserve, abutting the northern side of the Hume Highway, about 3¼ miles north-east of Longwood.

Upset price \$90 the lot. Survey fee \$16.

Area 1a. 0r. 29p., allotment 12F of section G.—(H.031757.)

**YARRA JUNCTION.**—Sale (No. 11929) of Crown land in fee-simple, by auction, will be held at the LAND INSPECTOR'S OFFICE, YARRA JUNCTION, on FRIDAY, 24th MAY, at TEN o'clock a.m. To be conducted by J. R. WILDING, Land Officer, Melbourne.

TOWNSHIP OF POWELLTOWN, PARISH OF BEENAK, COUNTY OF EVELYN.

## Lot 1.

In Surrey-road with a frontage to the reservation to Blake creek.

Upset price \$300 the lot. Survey fee \$30.

Area 3r. 12p., allotment 2 of section G. Valuation of improvements \$3,610 (dwelling, outbuildings, fencing, &c.) (A. V. Manning).—(G.71386.)

## Lot 2.

Fronting the northern side of the main road.

Upset price \$220 the lot. Survey fee \$30.

Area 34 perches, allotment 56A. Valuation of improvements \$500 (dwelling &c.). (E. H. Richards).—(G.65270.)

## Lot 3.

Fronting the southern side of the Powelltown-Noojee road.

Upset price \$120 the lot. Survey fee \$30.

Area 1r. 34p., allotment 3 of section H. Valuation of improvements \$800 (dwelling, &c.) (W. E. Loft).—(G.63876.)

## Lot 4.

Abutting the eastern side of the recreation reserve about 8 chains south of the main road.

Upset price \$100 the lot. Survey fee \$30.

Area 24 perches, subject to survey, allotment 4 of section E. Valuation of improvements \$92 (sheds) (H. McDonald). Subject to pipe-line easement.—(G.64647.)

## Lot 5.

PARISH OF WARBURTON, COUNTY OF EVELYN.

About ¼-mile south-east of the former Milgrove railway station.

Upset price \$200 the lot. Survey fee \$17.

Area 3 acres, allotment 77c.—(G.65229.)

PROPOSED REVOCATION OF TEMPORARY RESERVATION OF LAND BY ORDER IN COUNCIL.

IN pursuance of the provisions of the Land Act 1958, notice is hereby given that it is the intention of the Governor in Council to revoke the temporary reservation of land by Order in Council hereunder referred to, viz.:—

The following Notice was published 1° on the 3rd April, 1968, pursuant to Orders of the 26th March, 1968.

SWAN HILL.—The temporary reservation by Order in Council of the 5th March, 1895, of 1 acre 1 rood 33 perches of land in the Township of Swan Hill (formerly Township of Castle Donnington) as a site for a Public Park and Garden is about to be revoked.—(S.464(\*) (Rs.2601).

W. J. F. McDONALD,  
Minister of Lands.

PROPOSED PERMANENT RESERVATION OF LANDS AS SITES.

IN pursuance of sections 14 and 21 of the Land Act 1958, notice is hereby given that it is the intention of the Governor in Council to reserve permanently from sale, from being leased and from having a licence granted in respect thereof the land hereinafter described:—

The following Notice was published 1° on the 27th March, 1968, pursuant to Orders of the 19th March, 1968.

OAKLEIGH.—Land proposed to be permanently reserved as a site for Public Recreation, 2 roods 1 perch, more or less, Township of Oakleigh, Parish of Mulgrave, County of Bourke, being the site temporarily reserved therefor by Order in Council of the 5th February, 1952.—(O.1(2) (Rs.470).

OAKLEIGH.—Land proposed to be permanently reserved as a site for Public Recreation, 1 acre 10 perches, Township of Oakleigh, Parish of Mulgrave, County of Bourke, being the remaining portion of the site temporarily reserved therefor by Order in Council of the 12th May, 1925.—(O.1(2) (Rs.470).

W. J. F. McDONALD,  
Minister of Lands.

**PROPOSED REVOCATIONS OF TEMPORARY RESERVATIONS OF LANDS BY ORDERS IN COUNCIL.**

**I**N pursuance of the provisions of the *Land Act 1958*, notice is hereby given that it is the intention of the Governor in Council to revoke the temporary reservations of lands by Orders in Council hereunder referred to, viz.:—

The following Notices were published 1° on the 27th March, 1968, pursuant to Orders of the 19th March, 1968.

**BARWO.**—The temporary reservation, by Order in Council of the 26th September, 1887, of 89 acres 2 roods 35 perches of land in the Parish of Barwo as a site for a Racecourse is about to be revoked.—(B.690A<sup>(2)</sup>) (Rs.4890).

**TALLANGATTA VALLEY.**—The temporary reservation by Order in Council of the 16th December, 1941, of 3 acres 3 roods of land in the Township of Tallangatta Valley (formerly Township of Wyeeboo) as a site for Camping Purposes is about to be revoked.—(W.340C<sup>(2)</sup>) (Rs.5305).

W. J. F. McDONALD,  
Minister of Lands.

**PROPOSED PERMANENT RESERVATION OF LAND AS A SITE.**

**I**N pursuance of sections 14 and 21 of the *Land Act 1958*, notice is hereby given that it is the intention of the Governor in Council to reserve permanently from sale, from being leased and from having a licence granted in respect thereof the land hereinafter described:—

The following Notice was published 1° on the 13th March, 1968, pursuant to Order of the 5th March, 1968.

**JIKA JIKA (ROYAL PARK).**—Land proposed to be permanently reserved as a site for a Public Park, 2 roods 4 perches, Parish of Jika Jika, County of Bourke, as indicated by hatching on plan hereunder.—(M.314<sup>(15)</sup>) (Rs.5242).

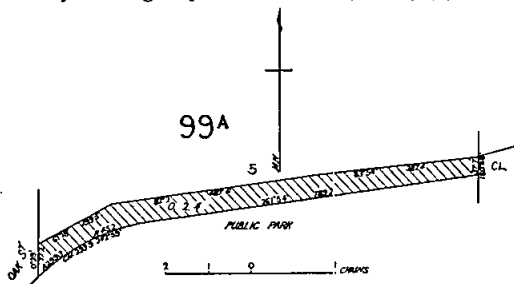

W. J. F. McDONALD,  
Minister of Lands.

**PROPOSED REVOCATION OF TEMPORARY RESERVATION OF LAND BY ORDER IN COUNCIL.**

**I**N pursuance of the provisions of the *Land Act 1958*, notice is hereby given that it is the intention of the Governor in Council to revoke the temporary reservation of land by Order in Council hereunder referred to, viz.:—

The following Notice was published 1° on the 13th March, 1968, pursuant to Order of the 5th March, 1968.

**MYAMYN.**—The temporary reservation, by Order in Council of the 29th June, 1885, of 23 acres 2 roods 6 perches of land in the Parish of Myamyn, as a site for the Supply of Gravel, revoked as to part by Order of the 3rd May, 1943, is about to be revoked so far as the balance thereof containing 22 acres 2 roods 6 perches is concerned.—(M.417<sup>(3)</sup>) (C.36458).

W. J. F. McDONALD,  
Minister of Lands.

**PROPOSED REVOCATIONS OF TEMPORARY RESERVATIONS OF LANDS BY ORDERS IN COUNCIL.**

**I**N pursuance of the provisions of the *Land Act 1958*, notice is hereby given that it is the intention of the Governor in Council to revoke the temporary reservations of lands by Orders in Council hereunder referred to, viz.:—

The following Notices were published 1° on the 20th March, 1968, pursuant to Orders of the 13th March, 1968.

**TONIMBUK.**—The temporary reservation, by Order in Council of the 20th November, 1934, of 6 acres 2 roods 3 perches of land in the Parish of Tonimbuk as a site for the Supply of Gravel is about to be revoked.—(T.280<sup>(9)</sup>) (Rs.4417.)

**BANNOCKBURN.**—The temporary reservation as a site for the use of the Police Department and the withholding from sale, leasing and licensing by Order in Council of the 9th August, 1881, of land in the Parish of Wabdallah (now in the Township of Bannockburn) are about to be revoked.—(B.35<sup>(1)</sup>) (Rs.8869.)

**KERANG.**—The temporary reservation, by Order in Council of the 24th June, 1902, of 41 acres 25 perches of land in the Township of Kerang as a site for a Sewage Farm, revoked as to part by various Orders, is about to be revoked so far as the balance thereof containing 16 acres 2 roods 5 perches, more or less, is concerned.—(K.19<sup>(11)</sup>) (Rs.5955.)

**ECHUCA.**—The temporary reservation, by Order in Council of the 30th November, 1874, of 2 acres 24 perches, more or less, of land in the Township of Echuca as a site for Drainage purposes, revoked as to part by Order of the 2nd July, 1963, is about to be revoked so far only as the portion containing 1 rood 10 perches, more or less, indicated by hatching on plan hereunder, is concerned.—(E.<sup>(4)</sup>) (C.76302.)

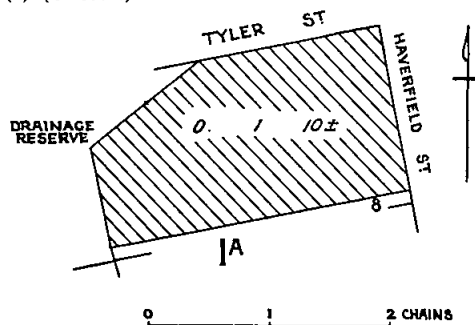

**STAWELL.**—The temporary reservation, by Order in Council of the 13th November, 1944, of 1 acre 1 rood 22 perches of land in the Township of Stawell (formerly Borough of Stawell) as a site for Racecourse and Public Recreation is about to be revoked.—(S.329<sup>(18)</sup>) (Rs.3938.)

**POREPUNKAH.**—The temporary reservation, by Order in Council of the 27th March, 1917, of 3 roods 16 perches of land in the Parish of Porepukah as a site for a Rubbish Depot is about to be revoked.—(P.70A<sup>(8)</sup>) (Rs. 1441.)

**PORT WELSHPOOL.**—The temporary reservation, by Order in Council of the 8th February, 1916, of 2 acres of land in the Township of Port Welshpool (formerly Township of Welshpool) as a site for a Rubbish Depot is about to be revoked.—(P.189<sup>(2)</sup>) (Rs.888.)

W. J. F. McDONALD,  
Minister of Lands.

**COMMITTEES OF MANAGEMENT OF RESERVES.**

**APPOINTMENTS.**

**N**OTICE is hereby given that, in pursuance of section 221 of the *Land Act 1958*, the following appointments of Committees of Management of reserved Crown lands have been made by the Minister of Lands:—

**"ANNUELLO PUBLIC RECREATION RESERVE."**

James Francis Taggart, John Bernard Gallagher and Albert John Edelsten as a Committee of Management for a period of three (3) years of the land in the Township of Annuello temporarily reserved by Order in Council dated the 28th February, 1967, as a site for Public Recreation and known as the "Annuello Public Recreation Reserve".—(Corres. No. Rs.8777.)

**"BATMAN PARK" RESERVE, INDENTED HEAD.**

Douglas Stephen Betts, Stephen Hughes, Thomas Arthur Hector, Percival Roy Pinder, Stanley Douglas McNeil, Harold Allan Albert Hocking and Ezra George Hannaford as a Committee of Management for a period ending the 25th June, 1970, of the portion of the Foreshore Reserve in the Township of Portarlington and Parish of Paywit indicated by red colour on plan marked P/26.2.68 and known as "Batman Park", Reserve, Indented Head.—(Corres. No. Rs.5154.)

This appointment is made in lieu of all previous appointments which are hereby revoked.

"BEAZLEY'S BRIDGE RECREATION AND PUBLIC HALL RESERVES."

Thomas James Jackson, George William Greenaway and Donald F. M. McIvor as a Committee of Management for a period of three (3) years of the land in the Parish of Tottington reserved by Order in Council dated the 17th November, 1884, as a site for a Public Hall and Recreation purposes, and also that land in the same Parish reserved by Order in Council dated the 29th July, 1895, as a site for Public Recreation, and known as the "Beazley's Bridge Recreation and Public Hall Reserves".—(Corres. Nos. Rs.1625, Rs.1626.)

"GREAT WESTERN PUBLIC HALL RESERVE."

Albert George Illig, Isobel Maie Champion, Ernest Robert Champion, Reginald Charles Bullock and Frederick Hamill Thomson as a Committee of Management for a period of three (3) years of the land in the Township of Great Western temporarily reserved by Order in Council dated the 13th October, 1964, as a site for a Public Hall, and known as the "Great Western Public Hall Reserve".—(Corres. No. Rs.8368.)

"HEPBURN RECREATION RESERVE."

Albert William Baker, Hepburn Colin McKinnon, Sylvester Menz, Robert Michael Rodoni, Alick William Glass, Bryan Johns and William Colin Stewart as a Committee of Management of the remaining portion of land in the Township of Hepburn, Parish of Wombat, temporarily reserved by Orders in Council dated the 8th May, 1871, and 5th February, 1952, as sites for Public Recreation, and known as the "Hepburn Recreation Reserve".—(Corres. No. Rs.5240.)

"JUNG RECREATION RESERVE."

Matthew William McRae, Robert Francis Thistlethwaite, Leslie Brian McRae, Robert Jack Whiteside, Noel Rawlinson Smith, Wesley Keith Bell and Keith Aver Bell as a Committee of Management for a period of three (3) years of the land in the Parish of Jung temporarily reserved as sites for Public Recreation by Orders in Council dated the 14th September, 1910, and 11th September, 1951, together with that portion of the permanent reservation along the Yarriambiack Creek as is indicated by blue colour on plan "J/11.12.51" attached to Lands Department correspondence Rs.5351, all of which areas are together known as the "Jung Recreation Reserve".—(Corres. No. Rs.5351.)

"LEONGATHA SOUTH PUBLIC HALL RESERVE."

David Anthony Kane, Harold Gordon Vagg, Peter James Glare, Claude Whyatt Williams and John Bartlett Moscript as a Committee of Management for a period of three (3) years of the land in the Parish of Leongatha permanently reserved by Order in Council dated the 8th July, 1902, as a site for a Mechanics Institute, and known as the "Leongatha South Public Hall Reserve".—(Corres. No. Rs.5728.)

"PEECHELBA RECREATION RESERVE."

Herbert John Nish, Ronald George Hayward, Arthur James Lavis, Fredrick Haintz and Charles Eric Davey as a Committee of Management for a period of three (3) years of the land in the Parish of Peechelba temporarily reserved by Orders in Council dated the 9th May, 1939, and 22nd December, 1959, as sites for Public Recreation, and known as the "Peechelba Recreation Reserve".—(Corres. No. Rs.4939.)

"STRATHMERTON RECREATION RESERVE."

John McDonald Farrall, Thomas Ignatius Kerrins, Roy Joseph Willis, Francis Murray Murrell, Lancelot William Oswald, Thomas Leonard Christie, Alfonsus Edward Thorpe, Claude Maurice Sutton and Clarence Bertram Haynes as a Committee of Management for a period of three (3) years of the land in the Parish of Strathmerton temporarily reserved by Order in Council dated the 16th May, 1949, as a site for Public Recreation, and known as the "Strathmerton Recreation Reserve".—(Corres. No. Rs.6351.)

"TEESDALE MECHANICS INSTITUTE RESERVE."

Ronald Charles Anderson, John Gordon Morrison, Alan Fredrick Symons, Murdoch Leish Martin, Albert Johannes Tischler, Leonard William Martin, William Hugh Grigsby, Laurence William Readhead, Allen Alfred Jolly, Lionel

Jeffrey Harrison and Donald Frank Wallace as a Committee of Management for a period of three (3) years of the land in the Township of Teesdale temporarily reserved by Order in Council dated the 15th October, 1875, as a site for a Mechanics Institute, and known as the "Teesdale Mechanics Institute Reserve".—(Corres. No. Rs.636.)

"UNIVERSITY WOMEN'S COLLEGE RESERVE."

Charles Chessell, Leslie Falloon, Helen Ferber, Meredith McComas, Noel Piper, Margaret Russell-Smith and Katherine Syme as a Committee of Management for a period of three (3) years of the land permanently reserved by Order in Council dated the 20th November, 1934, as a site for a Residential College for Women at the University of Melbourne, in the City of Melbourne, and known as the "University Women's College Reserve".—(Corres. No. Rs.2398.)

"VENUS BAY AND ANDERSON'S INLET FORESHORE RESERVES,"  
TARWIN.

John Meikle, Charles William Canterbury, Lawrence Walker, Charles Henry Arnup, Geoffrey James Clarke, James Cameron Zenner, Margaret Danby, William John Hinds, Gordon Smith and Antoon Gray as a Committee of Management for a period ending the 31st December, 1970, of the land in the Parish of Tarwin reserved as sites for Public Purposes and shown coloured blue on plans marked T/2-4-63, T/15-6-66 and T/29-6-66 attached to Lands Department correspondence, Rs.8095, and known as the "Venus Bay and Anderson's Inlet Foreshore Reserves".—(Corres. No. Rs.8095.)

"WONWONDAH NORTH PUBLIC HALL RESERVE"

Alan Thomas Heard, James Bromell Heard, George William Rosevear, John William Mott, Alan John McGennissen, Edgar Leslie Hallam, John Pearson Ireland, Dudley John Cowell and Hector Douglas Hallam as a Committee of Management for a period of three (3) years of the land in the Township and Parish of Wonwondah temporarily reserved by Order in Council dated the 11th June, 1940, as a site for a Public Hall, and known as the "Wonwondah North Public Hall Reserve".—(Corres. No. Rs.5048.)

"YAAPEET MEMORIAL HALL RESERVE."

Robert Alfred Boehm, Colin Keith Mathews, Ian Francis Fisher, Murdock Kenneth McKenzie, Jack Allan Fisher, Andrew George Newton, Lance C. Fisher, Alex Campbell, Leslie Campbell and William Francis Welch as a Committee of Management for a period of three (3) years of the land in the Township of Yaapeet temporarily reserved by Order in Council dated the 6th September, 1915, as a site for a Public Hall, and known as the "Yaapeet Memorial Hall Reserve".—(Corres. No. Rs.971.)

WATER SUPPLY PURPOSES RESERVE, TOWNSHIP OF  
YARRAWONGA.

The Corporation of the Council of the Shire of Yarrawonga as the Committee of Management of the remaining portion of the land in the Township of Yarrawonga temporarily reserved by Order in Council dated the 14th September, 1938, as a site for Water Supply Purposes.—(Corres. No. Rs.4852.)

W. J. F. McDONALD,

Minister of Lands.

Department of Crown Lands and Survey,  
Melbourne, 27th March, 1968.

TENDERS

PUBLIC WORKS DEPARTMENT

TENDERS will be received at Public Works Department, Treasury-place, Melbourne, until TWO p.m. on dates shown and for purposes mentioned hereunder.

Particulars and tender forms available at Contracts Office, Room 7, Building Division, Parliament-place and at places indicated in brackets hereunder.

Abbreviations in brackets mean:—W.O.—Inspector of Works Office; P.S.—Police Station; C.S.—Consolidated School; H.E.S.—Higher Elementary School; H.S.—High School; S.S.—State School; T.S.—Technical School.

Tenders to be submitted on the Department's printed Tender Form and will not be received by telephone. All tenders must be on a "Firm Tender" basis. The lowest or any tender will not necessarily be accepted.



Address tenders to the Minister of Public Works, and endorse the envelope containing the tender "Tender for closing Tuesday,

Hand delivered tenders to be placed in the Tender Box of the Public Works Department, located on the wall of the centre entrance foyer, Ground Floor, New Treasury Building, Treasury-place, Melbourne.

No preliminary deposit is required with any tender, but a successful tenderer will be required to pay a deposit for any accepted tender of \$5,000 or over.

### Tuesday, 9th April, 1968.

#### Building, Electrical and Mechanical Works.

Ballarat.—Modification to Plumbing and Sheetmetal Workshops, School of Mines. (W.O., Ballarat.)  
 Ballarat.—New electrical sub-station, Mental Hospital. (W.O., Ballarat.) (Re-advertised.)  
 Ballarat.—Steam heating installation, Wards F.14 and F.16, Mental Hospital. (W.O., Ballarat.)  
 Eildon.—Renovations, &c., S.S. 3931. (W.O., Alexandra; S.S. Eildon.)  
 Eltham.—Renovations, &c., High School. (Amended Specification.)  
 Fairfield.—Mechanical services, "Fairlea" Prison.  
 Fawkner.—Renovations, Technical School.  
 Kew.—Supply and installation of steam heaters, Ward 25, Children's Cottages.  
 Merlynston.—Renovations, Residence, S.S. 4328.  
 Metung.—Renovations, Residence, S.S. 3050. (W.O., Orbost; S.S. Metung.)  
 Mont Park.—Erection of new plant nursery, Larundel Mental Hospital. (W.O., Mont Park.)  
 Newborough East.—Renovations, &c. S.S. 4670. (W.O., Traralgon.) (Re-advertised.)  
 Northcote.—Renovations, Residence, S.S. 1401.  
 Portland.—Erection of Science and Woolclassing Wing, High School. (W.O., Warrnambool.)  
 Portland.—Electrical installation, High School. (W.O., Warrnambool; H.S. Portland.)  
 Portland.—Mechanical services, High School. (W.O., Warrnambool.)  
 Springvale.—Extensions to existing building, &c., Police Station.  
 Stawell.—Erection of fencing, Pleasant Creek Special School. (W.O., Ararat; P.S., Stawell.)  
 Traralgon.—Renovations, &c., S.S. 4652. (W.O., Traralgon.)  
 Wantirna.—Renovations, &c., S.S. 3709.  
 Westbreen.—Renovations, S.S. 4153.

#### Furniture and Furnishings.

Dandenong.—Supply and fix stage curtains, High School.  
 Mont Park.—Supply of metal bedside lockers, Mental Hospital. (Amended Specification.)  
 Mont Park.—Supply and lay rubber tiles, Nurses Hostel No. 1, Mental Hospital.  
 Noble Park.—Supply and fix stage and auditorium curtains, Technical School.

#### Site Works.

Altona East.—Asphalt paving, &c., S.S. 4805.  
 Doncaster Heights.—Asphalt concrete and gravel works, &c., S.S. 4888.  
 Morwell.—Construction of heavy duty roadway, Technical School. (W.O., Traralgon and Warragul.)

### Wednesday, 17th April, 1968.

#### Building, Electrical and Mechanical Works.

Alberton West.—Renovations, &c., S.S. 2140 and Residence. (W.O., Traralgon.) (Re-advertised.)  
 Boronia.—Erection of two new Science Rooms, High School.  
 Boronia.—Electrical installation, High School.  
 Boronia.—Mechanical services, High School.  
 Coorimungie.—Additional exterior lighting, H.M. Prison Farm. (W.O., Geelong and Camperdown.)  
 Elliminyt.—Connexion to sewer, S.S. 2028. (W.O., Geelong.)  
 Fitzroy North.—Alterations and additions to toilets, S.S. 1490.  
 Melbourne.—Supply and installation of an Air Conditioning System, South Australian Government Tourist Bureau, Royal Arcade. (Re-advertised.)  
 Morwell.—Erection of Assembly Hall, Technical School. (W.O., Traralgon; T.S., Morwell.)  
 Morwell.—Electrical services, Technical School. (W.O., Traralgon; T.S., Morwell.)

No. 29.—2877/68.—3

Morwell.—Mechanical services, Technical School. (W.O., Traralgon; T.S., Morwell.)  
 Murtoa.—Renovations, S.S. 1549. (W.O., Warracknabeal.)

Nambrook West.—Internal and external renovations, S.S. 3648 and Residence. (W.O., Traralgon; S.S., 3648, Nambrook West.)

Various.—Erection of three brick-veneer proprietary residences, Travancore Developmental Centre, Flemington, and Children's Cottages, Kew.

Wodonga.—Additional class-rooms, High School. (W.O., Wangaratta.)

Wodonga.—Electrical installation, High School. (W.O., Wangaratta.)

Wodonga.—Mechanical services, High School. (W.O., Wangaratta.)

#### Site Works.

Mount Macedon.—Construction of a concrete water storage tank, Memorial Cross Reserve. (Forests Commission, Macedon.)

Mount Macedon.—Kerbing, channelling and drainage works, Memorial Cross Reserve. (Forests Commission, Macedon.)

#### Miscellaneous.

Ararat.—Supply of timber and hardboard, Mental Hospital.

Beechworth.—Supply of Plumbing Fittings, Mental Hospital.

St. Albans.—Supply of universal milling machine, Technical School.

Various.—Supply of woodworking machines for the period 1st July, 1968, to 30th June, 1969, schools and other Government Departments.

Various.—Supply of engineers machine tools for the period 1st July, 1968, to 30th June, 1969, schools and other Government Departments.

Various.—Supply of engineers lathes for the period 1st July, 1968, to 30th June, 1969, schools and other Government Departments.

### Tuesday, 23rd April, 1968.

#### Building, Electrical and Mechanical Works.

Bendigo.—Mechanical services, Technical College. (W.O., Bendigo.)  
 Coburg.—Supply and installation of replacement furnace, H.M. Prison.  
 Dromana.—Erection of new court house. (W.O., Mornington.) (Re-advertised.)  
 Echuca.—Erection of a brick office block and cell block, Police Station. (W.O., Shepparton; P.S., Echuca.)  
 Echuca.—Electrical installation, Police Station. (W.O., Shepparton; P.S., Echuca.)  
 Echuca.—Mechanical services, Police Station. (W.O., Shepparton; P.S., Echuca.)  
 Hawthorn.—Erection of new building, Technical Teachers' College. (Bills of Quantities Available.)  
 Hawthorn.—Electrical installation, Technical Teachers' College.  
 Hawthorn.—Mechanical services, Technical Teachers' College.  
 Hawthorn.—Electric passenger lift, Technical Teachers' College.  
 Hawthorn West.—Additional toilet facilities, S.S. 293.  
 Rutherglen.—Erection of new staff Hostel, Agricultural Research Station. (W.O., Wangaratta.)  
 Rutherglen.—Mechanical services, Agricultural Research Station. (W.O., Wangaratta.)  
 Templestowe.—Connexion to sewer, High School.  
 Toora.—Erection of tile-roofed brick veneer office, Police Station. (W.O., Korumburra.) (Re-advertised.)  
 Warrnambool.—Erection of new cell, Police Station. (W.O., Warrnambool.)  
 Werribee.—Erection of boiler test shed, State Research Farm. (W.O., Geelong.) (Re-advertised.)

#### Furniture and Furnishings.

Ballarat.—Supply and fix curtains, Mental Hospital. (W.O., Ballarat, Horsham.)

#### Site Works.

Balwyn.—Asphalt and concrete paving, drainage, &c., "Iloura" Reception Centre, Social Welfare Department.  
 Brunswick North.—Asphalt, concrete and gravel paving, &c., S.S. 3585.

Mont Park.—Paving, drainage and roadway, Mental Hospital.

Wellington.—Asphalting, concreting, drainage, &c., S.S. 4947.

Tuesday, 30th April, 1968.

**Building, Electrical and Mechanical Works.**

- Balmoral.—Erection of combined kitchen and dining room, High School. (W.O., Hamilton.)
- Balmoral.—Electrical installation, High School. (W.O., Hamilton; H.S., Balmoral.)
- Balmoral.—Mechanical services, High School. (W.O., Warrnambool, Hamilton.)
- Benalla.—Erection of new wing, High School. (Bills of Quantities Available.) (W.O., Benalla.)
- Benalla.—Electrical installation, High School. (W.O., Wangaratta; H.S., Benalla.)
- Benalla.—Mechanical services, High School. (W.O., Benalla, Bendigo and Wangaratta.)
- Cranbourne.—Erection of brick veneer wing, S.S. 2068.
- Cranbourne.—Electrical installation, S.S. 2068.
- Cranbourne.—Plenum heating, S.S. 2068.

M. V. PORTER,  
Minister of Public Works.

Public Works Department,  
Melbourne, 3002, 1st April, 1968.

**PUBLIC SERVICE NOTICES**

No. 1824.

*Public Service Act 1958, Section 39.*

**REGULATIONS.—PART IV.—SALARIES AND INCREMENTS.**

THE Public Service Board, in pursuance of the powers conferred by the *Public Service Act 1958*, hereby amends its Regulations as shown below :—

**FIRST SCHEDULE.**

**PROFESSIONAL DIVISION.**

*Amount of Salary Assigned to Offices in "Special" Class.*

Office.	Yearly Rate of Salary.
<b>PUBLIC WORKS DEPARTMENT.</b>	
<i>Delete—</i>	
Chief Architect .. .. .	10,972
<i>Add—</i>	
Chief Architect .. .. .	10,357

F. E. CAHILL, Chairman.  
V. P. SCULLY, Secretary.

Office of the Public Service Board,  
Melbourne, 15th March, 1968.

**PUBLIC SERVICE OF PAPUA AND NEW GUINEA.**  
**DEPARTMENT OF INFORMATION AND EXTENSION SERVICES.**

**Senior Extension Officer.**

\$6,985—\$7,190 per annum single male. Married men receive an additional \$360 per annum.

**Duties.**—Oversight the training of local officers. In association with other Departments, plan and supervise surveys and evaluation studies in connexion with extension programmes.

**Qualifications.**—Full pass in Victorian Leaving Certificate, or equivalent, including English. Degree or diploma in the social sciences field desirable. Experience in adult education or community development is essential.

**Public Relations Officer.**

\$5,425—\$5,717 per annum single male. Married men receive an additional allowance of \$360 per annum.

**Duties.**—Prepare publicity material and arrange itineraries for visiting journalists and other officials.

**Qualifications.**—Victorian Leaving Certificate, or equivalent, and experience in journalism or public relations work.

**Principal Librarian.**

\$5,016—\$5,270 per annum single male.  
\$4,588—\$4,842 per annum female.  
Married men receive an additional \$360 per annum.

**Duties.**—Develop and manage the public library system in Papua and New Guinea, covering some twenty libraries.

**Qualifications.**—Appropriate degree or diploma, successful completion of the examination for Registration with the Library Association of Australia or equivalent, extensive experience as a librarian, and ability to train and direct staff.

**Extension Officer.**

\$5,755—\$6,165 per annum single male. Married men receive an additional \$360 per annum.

**Duties.**—Train field officers of other departments in extension methods and co-operate in the planning and execution of community education programmes, including the writing and designing of materials to be used.

**Qualifications.**—Leaving Certificate and some training in teaching methods essential. University degree or diploma desirable.

**Broadcasts Officer.**

\$4,985—\$5,601 per annum single male.  
\$4,557—\$5,173 per annum single female.  
Married men receive an additional \$360 per annum.

**Duties.**—Collect and prepare news. Prepare and produce feature programmes.

**Qualifications.**—Victorian Leaving Certificate or equivalent. Experience in broadcasting and script writing or journalism.

**Conditions of Service.**—All positions are with the Department of Information and Extension Services. Salaries quoted include allowances.

**Accommodation.**—Requirements will be discussed at interview.

**Leave.**—Three months' leave after 21 months' service with assisted leave fares to Australia. An additional three months' leave after each six years.

**Taxation.**—Income tax in the Territory is at present less than half that payable in Australia for the same net taxable income.

**Education Subsidy Scheme.**—Education in the Territory is based on the New South Wales curriculum, and high schools at Port Moresby, Lae and Rabaul teach to matriculation level. An Education Allowance and an annual return air fare as far as Sydney or the nearest suitable airport to Port Moresby are paid for all children attending secondary school in Australia.

An Education Allowance and an annual return air fare is also paid for children who have to live away from home within the Territory to receive secondary education.

**Engagement.**—By contract for a minimum period of two years, longer if preferred.

Applicants employed by a Government authority may be considered for secondment to the Territory Service for an initial period of two years, with preservation of existing rights.

Further details and application forms are available from the Department of External Territories,

- Hobart-place, Canberra, A.C.T., 2601. Phone 4 0477
- 46 Market-street, Sydney, N.S.W., 2000. Phone 29 5151
- 188 Queen-street, Melbourne, Vic., 3000. Phone 67 6159
- 145 Eagle-street, Brisbane, Qld., 4000. Phone 33 7575

Applications, quoting advertisement number 421A, should reach Canberra by 10th April.

By order of the Secretary,

DEPARTMENT OF EXTERNAL TERRITORIES,  
CANBERRA, A.C.T.

**PUBLIC SERVICE OF PAPUA AND NEW GUINEA.**  
**DEPARTMENT OF PUBLIC HEALTH.**

**Specialist Ophthalmologist.**

**Duties.**—Responsible for a Regional Eye Clinic. Consultant Regional Ophthalmologist to the Administration.

**Qualifications.**—Graduate in Medicine and Surgery with a Diploma in Ophthalmology, or equivalent qualifications, and wide post-graduate experience.

**Salary.**—\$9,067—\$11,257 per annum, plus an additional \$360 per annum for married men. \$8,639—\$10,829 per annum for a female.

**Medical Officer, Class 1.**

**Duties.**—A variety of challenging and interesting work which would be of exceptional value to the young practitioner.

**Qualifications.**—Registered medical practitioner with a genuine interest in the Papuan and New Guinean people. Graduate in Medicine and Surgery or equivalent acceptable qualifications.

**Salary.**—\$6,900–\$7,500 per annum including allowances for a male, \$6,498–\$7,098 per annum for a female. Married men receive an additional \$360 per annum.

Attractive conditions include—

Furnished housing at nominal rental for a married appointee—single accommodation also available.

Less than half current Australian income tax.

Three months' leave after 21 months' service—six months after six years.

Opportunity to gain tropical experience.

Contract engagement—minimum period twelve months.

Applicants employed by a Government authority may be considered for secondment to the Territory Service for an initial period of two years, with preservation of existing rights.

Further information and application forms are available from the Department of External Territories,

Hobart-place, Canberra, A.C.T., 2601. Phone 4 0477

46 Market-street, Sydney, N.S.W., 2000. Phone 29 5151

188 Queen-street, Melbourne, Vic., 3000. Phone 67 6159

145 Eagle-street, Brisbane, Qld., 4000. Phone 33 7575

Applications should refer to advertisement number 426A and should reach Canberra by 11th April.

By order of the Secretary,

DEPARTMENT OF EXTERNAL TERRITORIES,  
CANBERRA, A.C.T.

**PUBLIC SERVICE OF PAPUA AND NEW GUINEA.**  
**CADET PATROL OFFICER.**

DEPARTMENT OF DISTRICT ADMINISTRATION.

**FIT**, resourceful young men are needed to train as patrol officers in Papua and New Guinea. Applicants must be single male British subjects aged between 18 and 35 years and must hold a Leaving Certificate or equivalent. On appointment they will embark on a two-year probationary period commencing with a four months' training course at the Australian School of Pacific Administration in Sydney, starting on 24th June, 1968.

**Salary.**—Salary, including allowances, ranges from \$2,300 per annum at age 18 to \$3,490 per annum at age 23 or more, while a cadet, increasing to an eventual maximum of \$5,601 per annum as a Patrol Officer.

**Term of Engagement.**—Engagement is by contract for a period of six years, initially.

**Leave.**—Three months' leave after each 21 months' service and an additional three months' after each six years. Assistance with leave fares to Australia is provided and this assistance may be used for travel overseas.

**Taxation.**—Income tax in the Territory is at present less than half that payable in Australia for the same net taxable income.

Further information and application forms are available from the Department of External Territories,

Hobart-place, Canberra, A.C.T., 2601. Phone 4 0477

46 Market-street, Sydney, N.S.W., 2000. Phone 29 5151

188 Queen-street, Melbourne, Vic., 3000. Phone 67 6159

145 Eagle-street, Brisbane, Qld., 4000. Phone 33 7575

Applications should reach Canberra by 13th April and should refer to advertisement number 429A.

By order of the Secretary,

DEPARTMENT OF EXTERNAL TERRITORIES,  
CANBERRA, A.C.T.

**PRIVATE ADVERTISEMENTS**

**NOTICE** is hereby given that the Goroke Youth Club has applied for a lease under section 134 of the *Land Act* 1958, for a term of 21 years over an area of approximately 1 acre 2 rods, being part of an area of Crown land reserved as an extension for recreation purposes, Parish of Goroke, as a site for a Youth Club hall. 1805

**NOTICE OF INTENTION TO APPLY FOR A LICENCE TO DIVERT WATER AND CUT RACE FROM THE RIVER MURRAY, AT WHARPARILLA.**

**WE** hereby give notice that we intend to apply for a licence empowering us to divert water for a term of two years to the extent of 200 acre-feet per annum at a maximum rate of 24 acre-feet per day of 24 hours for the irrigation of 200 acres, being part of allotments 148 and 150, Parish of Wharparilla, and to occupy certain Crown lands for works of diversion, and to cut a race thereon.

Any objection to such application must be forwarded, in writing, to reach the State Rivers and Water Supply Commission, Melbourne, before 26th April, 1968, being 30 days from the first publication of this notice.

ROYCE FORBES TREDGETT.  
VERA FLORENCE TREDGETT.

275 High-street, Echuca, Vic. 3625.

2020

**NOTICE OF INTENTION TO APPLY FOR A LICENCE TO DIVERT WATER AND CUT RACE FROM THE RIVER MURRAY, AT BARMAH.**

**WE** hereby give notice that we intend to apply for a licence empowering us to divert water for a term of four years to the extent of 40 acre-feet per annum at a maximum rate of 2 acre-feet per day of 24 hours for the irrigation of 20 acres, being allotments 32 and 33, section A, Parish of Barmah, and to occupy certain Crown lands for works of diversion, and to cut a race thereon.

Any objection to such application must be forwarded, in writing, to reach the State Rivers and Water Supply Commission, Melbourne, before 3rd May, 1968, being 30 days from the first publication of this notice.

E. C. BURNESS.  
J. M. TREBILCOCK.  
per J. Trebilcock.

1 Norris-court, Shepparton, Vic. 3630.

2097

**NOTICE OF INTENTION TO APPLY FOR A LICENCE TO DIVERT WATER AND CUT RACE FROM THE RIVER MURRAY, AT WHARPARILLA.**

**I** HEREBY give notice that I intend to apply for a licence empowering me to divert water for a term of two years to the extent of 200 acre-feet per annum at a maximum rate of 24 acre-feet per day of 24 hours for the irrigation of 200 acres, being part of allotment 147, Parish of Wharparilla, and to occupy certain Crown lands for works of diversion, and to cut a race thereon.

Any objection to such application must be forwarded, in writing, to reach the State Rivers and Water Supply Commission, Melbourne, before 26th April, 1968, being 30 days from the first publication of this notice.

DAVID JOHN TREDGETT.

275 High-street, Echuca, Vic. 3625.

2021

**GEELONG WATERWORKS AND SEWERAGE TRUST.**

**THE** above-mentioned Trust, having made provision for carrying off the sewage from each and every property which or any part of which is within the sewerage area hereinafter described, doth hereby declare that on and after the 1st day of April, 1968, each and every property which or any part of which is within the said sewerage area shall be deemed and taken to be deemed property within the meaning of the *Geelong Waterworks and Sewerage Act* 1958.

SEWERAGE AREA No. 385.

Shire of Corio, Parish of Moorpanyal,  
County of Grant.

Commencing at a point being the south-west corner of lot No. 181 Fairy-street, Bell Post Hill, the said point being also on the boundary of Sewerage Area No. 352; thence northerly along the western boundary of the said lot No. 181 to the south side of Fairy-street; thence easterly along the south side of Fairy-street and crossing Ward-street to the north-east corner of lot No. 1 Fairy-street, which is 100 feet west from the south-west corner of the intersection of Fairy-street and Beauford-avenue; thence southerly along the eastern boundary of the said lot No. 1 for a distance of 135 feet to a point which is on the boundary of Sewerage Area No. 352; thence westerly along the boundary of Sewerage Area No. 352 and crossing Ward-street to the point of commencement.

## SEWERAGE AREA No. 386.

*Shire of Corio, Parish of Moorpanyal,  
County of Grant.*

Commencing at a point being the north-east corner of lot No. 50 Korumburra-avenue, Norlane, the said point being also on the west side of Korumburra-avenue and on the boundary of Sewerage Area No. 205; thence southerly along the west side of Korumburra-avenue to the north-west corner of the intersection of Korumburra-avenue and Elmore-street; thence westerly along the north side of Elmore-street and crossing Barcelona-street and Bates-street to the west side of Bates-street; thence northerly along the west side of Bates-street for a distance of approximately 480 feet to a point on the prolongation of the northern boundary of lot No. 4 Barcelona-street, which is also on the boundary of Sewerage Area No. 205; thence easterly following the boundary of Sewerage Area No. 205 and crossing Bates and Barcelona streets to the point of commencement.

## SEWERAGE AREA No. 387.

*Shire of Corio, Parish of Moorpanyal,  
County of Grant.*

Commencing at a point being the south-west corner of lot No. 2 Thompson-road, North Geelong, which is 350 feet south from the south-east corner of the intersection of Thompson-road and Doyle-avenue, the said point being also on the east side of Thompson-road and on the boundary of Sewerage Area No. 218; thence northerly along the east side of Thompson-road for a distance of 150 feet to the north-west corner of lot No. 4 Thompson-road; thence easterly along the northern boundary of the said lot No. 4 to the north-east corner of lot No. 4; thence southerly along the eastern boundaries of lots No. 4 to 2 inclusive Thompson-road to the south-east corner of the said lot No. 2, which is on the boundary of Sewerage Area No. 218; thence westerly following the boundary of Sewerage Area No. 218 to the point of commencement.

## SEWERAGE AREA No. 388.

*Shire of Corio, Parish of Moorpanyal,  
County of Grant.*

Commencing at a point being the south-west corner of the intersection of Hennessey-parade and Beckley-street, Heme Hill, the said point being also on the boundaries of Sewerage Areas Nos. 272 and 321; thence northerly across Beckley-street and continuing northerly along the west side of Hennessey-parade to the south-west corner of the intersection of Hennessey-parade and Bon View-avenue; thence easterly across Hennessey-parade and continuing easterly along the south side of Bon View-avenue to the north-east corner of lot No. 47 Bon View-avenue; thence southerly along the eastern boundaries of lot No. 47 Bon View-avenue and lot No. 49 Hennessey-parade to the north-west corner of lot No. 69 McCurdy-road; thence easterly along the northern boundary of the said lot No. 69 and across McCurdy-road to the south-east corner of the intersection of McCurdy-road and Joyce-parade, which is also on the boundary of Sewerage Area No. 234; thence southerly along the east side of McCurdy-road to the prolongation of the southern boundary of lot No. 69 McCurdy-road, which is on the boundaries of Sewerage Area Nos. 234 and 272; thence westerly across McCurdy-road and continuing westerly along the southern boundary of the said lot No. 69 to the south-east corner of lot No. 50 Hennessey-parade, which is on the boundary of Sewerage Area No. 272; thence southerly, westerly, southerly, easterly, southerly and westerly following the boundary of Sewerage Area No. 272 and crossing Beckley-street and Hennessey-parade to the point of commencement.

Signed under the seal of the Geelong Waterworks and Sewerage Trust, this 28th day of March, 1968.

J. W. CARR, Chairman.  
B. C. HENSHAW, Secretary.

2045

## GLENROWAN WATERWORKS TRUST.

NOTICE to the owners of tenements in:—

Gladstone-street, eastward from Beaconsfield-parade 1,950 feet;  
Beaconsfield-parade, from High-street to Gladstone-street 1,650 feet;  
Beaconsfield-parade, from Gladstone-street to Hill-street 400 feet;  
Burns-street, southward from Gladstone-street 746 feet;  
Church-street, from Beaconsfield-parade to Boundary-road 1,470 feet;  
Seige-street, from Beaconsfield-parade to Boundary-road 1,470 feet;

Railway-street, westward from Beaconsfield-parade 950 feet;  
Hill-street, from Burns-street to Boundary-road 770 feet;  
Hill-street, westward from Kate-street 94 feet;  
Hill-street, from Kate-street to Beaconsfield-parade 496 feet;  
Hill-street, eastward from Beaconsfield-parade 140 feet;  
Kate-street, from Railway-street to Hill-street 640 feet;  
Boundary-road, southward from Gladstone-street 746 feet;

and the private streets lanes courts and alleys opening thereto.

The main pipe in the said streets being laid down the owners of all tenements situated as above are hereby required on or before the 1st day of May, 1968, to cause a proper pipe and stopcocks to be laid so as to supply water within such tenements from the main pipe.

E. C. BATES, Secretary of Glenrowan Waterworks Trust. 1984

## DANDENONG SEWERAGE AUTHORITY.

## GENERAL NOTICE.

THE above-mentioned Sewerage Authority, having made provision for carrying off the sewage from each and every property which, or any part of which is within the sewerage areas hereinafter described, doth hereby declare that on and after the first day of April, 1968, each and every property which, or any part of which is within the said sewerage areas shall be deemed to be a sewered property within the meaning of the *Sewerage Districts Act 1958*.

The boundaries of the sewerage areas hereinbefore referred to, are:—

*Sewerage Area No. 174.*

Commencing at a point on the western side of Ebden-street, such point being the south-eastern angle of lot 91 on lodged plan of subdivision No. 62181; thence westerly along the southern boundary of the said lot 91 to its south-western angle; thence southerly along the western boundary of lot 90 on the said lodged plan to the southern angle of lot 109 on the said lodged plan; thence north-westerly along the south-western boundary of the said lot 109 to the eastern side of Elonera-road; thence northerly along the eastern side of Elonera-road and the northerly prolongation thereof to the northern side of Halton-road; thence easterly along the northern side of Halton-road to the south-western angle of lot 6 on lodged plan of subdivision No. 60938; thence northerly along the western boundary of the said lot 6 to its north-western angle; thence easterly by a line parallel to Halton-road to the western side of Bakers-road; thence southerly along the western side of Bakers-road and the southerly prolongation thereof to the southern side of Halton-road; thence westerly along the southern side of Halton-road to the north-eastern angle of lot 9 on lodged plan of subdivision No. 62952; thence southerly along the eastern boundary of the said lot 9 and the southerly prolongation thereof to the southern side of Titcher-road; thence westerly along the southern side of Titcher-road to its intersection with the western side of Ebden-street; thence southerly along the western side of Ebden-street to the point of commencement.

*Sewerage Area No. 175.*

All those pieces of land comprising lots 27 to 42 inclusive and lots 44 to 105 inclusive on lodged plan of subdivision No. 62087 and lots 1, 2 and 3 on plan of subdivision No. 5490, lodged at the office of the City of Dandenong.

Streets or parts of streets included in this area are McCees-road, Simpson-drive, Warren-court, Fraser-street, Worrell-street and Stud-road.

*Sewerage Area No. 176.*

All that piece of land comprising lots 4 and 5 on lodged plan of subdivision No. 63343, such lots having frontages to the northern side of Tooronga-street.

*Sewerage Area No. 177.*

Commencing at a point on the western side of Frankston-road, such point being the north-eastern angle of lot 20 on lodged plan of subdivision No. 66294; thence westerly by a line parallel to Greens-lane a distance of 400 feet; thence northerly by a line parallel to Frankston-road a distance of 165 feet; thence easterly by a line parallel to Greens-lane to the western side of Frankston-road; thence southerly along the western side of Frankston-road to the point of commencement.

*Sewerage Area No. 178.*

All those pieces of land comprising lots 42 to 46 inclusive, lots 50 to 63 inclusive and lots 17 to 34 inclusive on lodged plan of subdivision No. 77054 and lots 64 to 74 inclusive and lot 114 on plan of subdivision No. 5728, lodged at the office of the City of Dandenong.

Streets or parts of streets included in this area are Orloff-street, Woomera-avenue, Eldo-street, Apollo-court, Mahaia-close, Maralinga-avenue and Gemini-court.

For the purposes of these descriptions, the lodged plans of subdivision shall, unless otherwise specified, be taken as those lodged at the Office of Titles, Melbourne.

By Order of the Dandenong Sewerage Authority.

I. A. FOTHERINGHAM, Chairman.  
1983 A. R. EDWARDS, Secretary.

**THE BALLARAT SEWERAGE AUTHORITY.**

## GENERAL NOTICE.

THE above-mentioned Sewerage Authority, having made provision for carrying off the sewage from each and every property which or any part of which is within the Sewerage Areas hereinafter described, doth hereby declare that on and after the first day of May, 1968, each and every property which or any part of which is within the said Sewerage Areas shall be deemed to be a sewered property within the meaning of the *Sewerage Districts Act 1958*.

The boundaries of the Sewerage Areas hereinbefore referred to are:—

*Sewerage Area No. 285.*

*City of Ballarat.*—Commencing at the north-east corner of Park and Sutton streets, being a point on the boundary of Sewerage Area No. 167; thence northerly 264 feet along the east building line of Sutton-street, easterly to a point on the south building line of Winter-street, about 210 feet west of Adair-street, being a point on the boundary of Sewerage Area No. 159; thence southerly and westerly along the boundaries of Sewerage Areas Nos. 159 and 167 to the point of commencement.

*Sewerage Area No. 286.*

*Borough of Sebastopol.*—Commencing at the south-east corner of Hertford and Alexandra streets, being a point on the boundary of Sewerage Area No. 273; thence northerly to the north-east corner of Hertford and Alexandra streets, south-westerly along the north building line of Hertford-street to the north-east corner of Hertford and Cromwell-streets, northerly along the east building line of Cromwell-street to a point 125 feet south of Rubicon-street, being a point on the boundary of Sewerage Area No. 251; thence easterly, north-easterly, easterly, southerly, south-easterly and south-westerly along the boundaries of Sewerage Areas Nos. 251, 208, 145, 205 and 273 to the point of commencement.

Further particulars regarding the streets or parts of streets in which sewers have been laid may be ascertained on inquiry at the Authority's office.

By order of the said Sewerage Authority,

A. W. NICHOLSON, Chairman.  
2039 CHAS. H. CLAMP, Secretary.

**THE BALLARAT SEWERAGE AUTHORITY.**

PURSUANT to section 119 (2) of the *Sewerage Districts Act 1958* (No. 6368), notice is hereby given of the intention to construct sewers to provide for the properties situated in portion of the area bounded approximately by—

Shire of Ballarat.—Sturt-street West, Ningana, Balyarta and Kallioota streets; also Ningana-street east side from No. 1 to No. 19;

more particularly as shown on maps which are open for inspection at this office between the hours of 9 a.m. and 4 p.m. Monday to Friday inclusive.

Dated 27th March, 1968.

2040 CHAS. H. CLAMP, Secretary.

**HURSTBRIDGE WATERWORKS TRUST.**

NOTICE to the owners of tenements in the under-mentioned streets, and the private streets, lanes, courts and alleys opening thereto.

*Kangaroo Ground Urban District.*  
Main road,  
Yarra Glen road.

The main pipes in the said streets being laid down the owners of all tenements situated as above are hereby required on or before the 3rd day of May next to cause a proper pipe and stop-cocks to be laid so as to supply water within such tenements from the main pipe.

2031 M. B. WATSON, Secretary.

**PORTLAND SEWERAGE AUTHORITY.**

NOTICE is hereby given that the Authority intends to construct sewers within its district to serve the Housing Commission Estate (Hunt's), South Portland and the Ballater, Balmoral, Aberdeen streets area, South Portland.

Plans of the proposals are available for inspection at the Authority Office, Town Hall, Charles-street, Portland, during office hours, by owners or occupiers of land within the sewerage district.  
2024

L. FELL, Secretary.

**SPRINGVALE AND NOBLE PARK SEWERAGE AUTHORITY.**

## GENERAL NOTICE.

THE above-mentioned Sewerage Authority, having made provision for carrying off the sewage from each and every property which or any part of which is within the Sewerage Areas hereinafter described, doth hereby declare that on and after the 1st day of April, 1968, each and every property which or any part of which is within the said Sewerage Areas shall be deemed to be a sewered property within the meaning of the *Sewerage Districts Act 1958*.

The boundaries of the Sewerage Areas hereinbefore referred to are:—

*Sewerage Area No. 209—Noble Park.*

Commencing at a point on the southern side of Athol-road, such point being the north-western angle of lot 2 on lodged plan of subdivision No. 24228; thence easterly along the southern side of Athol-road to its intersection with the eastern side of Rowlands-avenue; thence southerly along the eastern side of Rowlands-avenue and the eastern boundary of lot 61 on lodged plan of subdivision No. 50186 to the south-eastern angle of the said lot 61; thence westerly along the southern boundaries of the said lot 61 and lots 60 to 49 inclusive on the said lodged plan to the south-western angle of the said lot 49; thence northerly by a line parallel to Rowlands-avenue to the northern angle of lot 24 on the said lodged plan; thence westerly by a line to the south-eastern angle of lot 1 on lodged plan of subdivision No. 24228; thence westerly along the southern boundaries of the said lot 1 and lot 2 on the said lodged plan to the south-western angle of the said lot 2; thence northerly along the western boundary of the said lot 2 to the point of commencement.

*Sewerage Area No. 210—Springvale.*

Commencing at a point being the intersection of the north-eastern side of Princes Highway with the north-western side of Hillside-street; thence north-westerly along the north-eastern side of Princes Highway to the western angle of lot 8 on lodged plan of subdivision No. 10899; thence north-easterly along the north-western boundary of the said lot 8 to the south-western boundary of lot 65 on the said lodged plan; thence south-easterly along the south-western boundary of the said lot 65 to the western side of Hillside-street; thence northerly along the western side of Hillside-street to its intersection with the southern side of Police-road; thence easterly along the southern side of Police-road to the north-eastern angle of lot 2 on lodged plan of subdivision No. 37367; thence southerly along the eastern boundary of the said lot 2 to the north-western angle of lot 3 on lodged plan of subdivision No. 40702; thence easterly along the northern boundary of the said lot 3 to its north-eastern angle; thence southerly along the eastern boundary of the said lot 3 to its south-eastern angle; thence westerly along the southern boundary of the said lot 3 to the north-eastern angle of lot 23 on lodged plan of subdivision No. 43681; thence southerly along the eastern boundary of the said lot 23 to the northern side of Marie-avenue; thence easterly along the northern side of Marie-avenue to its intersection with the western side of Edinburgh-road; thence southerly along the western side of Edinburgh-road to its intersection with the northern side of McWilliam-street; thence easterly along the northern side of McWilliam-street to its intersection with the eastern side of Smith-road; thence northerly along the eastern side of Smith-road to its intersection with the northern side of Morris-court; thence easterly along the northern side of Morris-court to the southern angle of lot 281 on lodged plan of subdivision No. 42441; thence north-easterly along the south-eastern boundary of the said lot 281 to the northern angle of lot 280 on the said lodged plan; thence southerly along the eastern boundaries of the said lot 280 and lot 279 on the said lodged plan to the north-western angle of lot 261 on lodged plan of subdivision No. 43680; thence easterly along the northern boundary of the said lot 261 to the western side of Phillip-avenue; thence northerly along the western side of Phillip-avenue to its intersection with the southern side of Police-road; thence easterly along the southern side of Police-road to the north-eastern angle

of lot 318 on lodged plan of subdivision No. 40794; thence southerly along the eastern boundaries of the said lot 318 and lots 316 to 309 inclusive on lodged plan of subdivision No. 40702 and lots 308 to 289 inclusive on lodged plan of subdivision No. 43680 to the south-eastern angle of the said lot 289; thence westerly along the southern boundary of the said lot 289 to its south-western angle; thence westerly along the southern side of McWilliam-street to its intersection with the western side of Smith-road; thence southerly, westerly and south-westerly along the western, northern and north-western sides respectively of Smith-road to the north-eastern side of Princes Highway; thence north-westerly along the north-eastern side of Princes Highway to the point of commencement.

For the purposes of these descriptions the lodged plans of subdivision herein referred to shall be taken as those lodged at the Office of Titles, Melbourne.

By order of the Springvale and Noble Park Sewerage Authority.

A. A. ERICKSEN, Chairman.  
H. L. WILLIAMS, Secretary.

2048

#### GEMBROOK-COCKATOO-EMERALD WATERWORKS TRUST.

##### NOTICE TO THE OWNERS OF TENEMENTS IN THE STREETS LISTED HEREUNDER.

THE main pipe in the said streets being laid down the owners of all tenements situated in the streets listed are hereby required on or before the 4th day of April, 1969, to cause a proper pipe and stopcocks to be laid so as to supply water within such tenements from the main pipe.

##### List of Streets.

##### Fielder.—

List of streets supplied with water: As at the 20th March, 1968.

Brisbane-road: From Lisheen-road to the east end.  
Doonaha-road: Whole.  
Dorchester-road: Whole.  
Edmunds-road: Whole.  
Georges-road: Whole.  
Haylock-avenue: Whole.  
Lisheen-road: From Brisbane-road easterly 2,300 feet.  
Pakenham-road: Between Georges-road and Dorchester-road.  
Tymon-road: Between Cockatoo-creek and Doonaha-road.

##### Cockatoo.—

List of streets supplied with water: As at the 20th March, 1968.

Alexander-road: Between Maurice-street and Ferngully-road.  
Between Seaview-road and Marcelle-street.  
Ferngully-road: Between Jeanne-street and Alexander-road.  
First-avenue: From 400 feet south-east of Bailey-street to 700 feet south-east of Midnight-avenue.  
Garden-street: From 600 feet south-east of Bailey-street to Hall-avenue.  
Glen-road: From Hall-avenue 1,450 feet north-west.  
Hazel-street: From un-named street 200 feet west.  
Jeanne-street: Whole.  
Maillard-street: Whole.  
Maurice-street: From Alexander-street, 1,300 feet westerly.  
Mayer-street: Whole.  
Seaview-road: From Gum-street, 1,200 feet west. From Alexander-street, 420 feet west.  
Second-avenue: From Boundary-road, 1,450 feet south-east.  
Spring-road: Between Gum-street and Alexander-road.  
Spring-street: From 150 feet east to 250 feet west of Midnight-avenue.  
View Hill-road: From 1,150 feet south of Mayer-street to 650 feet northerly from Vincent-street.  
Vincent-street: Whole.

##### Emerald.—

List of streets supplied with water: As at the 20th March, 1968.

Anne-street: Whole.  
Bay View-road: Whole.  
Beaconsfield-road: Between Steele-road and Heroes-avenue.  
Belgrave-Gembrook-road: Between Memorial-avenue and Beaconsfield-road.  
Benson-street: Whole.  
Boundary-road: Between Bay View-road and Beaconsfield-road.  
Church-street: Between Memorial-avenue and Ogilvy-road.

Cloverleigh-road: Whole.  
Curtis-road: From Legg-road, 400 feet east.  
Heroes-avenue: Whole.  
Kings-road: Whole.  
Legg-road: Whole.  
Memorial-avenue: Between Westlands-road and Benson-street.  
Nolan-road: From Steele-road, 350 feet north.  
Ogilvy-road: Clematis Park-road to Church-street.  
Paternoster-road: Between Emerald Hill and Albert-road.  
Pinnock-road: Between Railway and 250 feet west of Walnut-avenue.  
Railway-road: From Heroes-avenue, 150 feet south.  
Royal-parade: Whole.  
Russell-street: Whole.  
Steele-road: From Beaconsfield-road, 1,100 feet west.  
Upton-road: Whole.  
Westlands-road: From Memorial-avenue to 300 feet south of Woodlands-avenue.

BEATRICE THOMAS, Secretary.

Gembrook-Cockatoo-Emerald Waterworks Trust. 2087

#### CITY OF ARARAT.

##### BY-LAW No. 117.

A By-Law of the City of Ararat, made under the Local Government Acts and the Uniform Building Regulations, Victoria, and numbering 117, for determining, applying, dispensing with or regulating such matters or things as are left to be determined, applied, dispensed with or regulated under the Uniform Building Regulations, Victoria.

IN pursuance of the powers conferred by the Local Government Acts and the Regulations, and of any and every other power it thereunto enabling, the Mayor, Councillors and Citizens of the City of Ararat order as follows:

1. By-Law No. 98, Clause 2, shall be amended by the addition of Clause (b) as follows:

(b) Excepting the area of land being Crown Allotments 11 and 12, section 15A, Township and Parish of Ararat, which shall be classified under Column 1 of Table 804 of the Uniform Building Regulations as the minimum area, depth, and width of frontage of land on which a building shall be constructed thereon.

Resolution for the passing of this By-Law was passed by the Council at a meeting held on the 22nd day of January, 1968, and confirmed at a meeting held on the 19th day of February, 1968.

The common seal of the Mayor, Councillors and Citizens of the City of Ararat was hereunto affixed in the presence of—

GEOFFREY E. MARX, Mayor.  
R. D. JOHNSTONE, Councillor.  
J. I. GRENFELL, Town Clerk.

Approved by the Governor-in-Council, on 26th March, 1968.—J. ROSSITER, Clerk of the Executive Council. 2086

#### CITY OF BENDIGO.

##### BY-LAW No. 111.

A BY-LAW of the City of Bendigo made under Section 197 of the Local Government Act 1958 and numbered 111 for prohibiting or regulating cattle being allowed to graze or wander upon any land not enclosed by a substantial fence.

IN PURSUANCE of the powers conferred by the Local Government Act 1958 and every other power it thereunto enabling the Mayor, Councillors and Citizens of the City of Bendigo order as follows:—

1. No person shall allow cattle to graze (whether tethered or not) or wander upon any land not enclosed with a substantial fence.

2. This By-Law shall apply to and have operation throughout the whole of the Municipal district of the City of Bendigo.

3. Any person who shall be guilty of an offence against the provisions of this By-Law shall be liable to a penalty not exceeding \$40 for each offence and in case of a continuing offence to a further penalty of not more than \$10 for each day on which such offence is continued after a conviction or order by any Court.

RESOLUTION for passing this By-Law agreed to by the Council on the Nineteenth day of February, 1968, and confirmed on the Eighteenth day of March, 1968.

The common seal of the Mayor, Councillors and Citizens of the City of Bendigo was hereunto affixed in the presence of—

R. W. CAMBRIDGE, Mayor.  
N. J. OLIVER, Councillor.  
A. J. WATTS, Town Clerk.

2030

CITY OF CAMBERWELL.

LOAN No. 75.

Notice of Intention to Borrow the Sum of \$100,000 for Permanent Works and Undertakings.

NOTICE is hereby given that the Council of the City of Camberwell intends to borrow the sum hereinafter mentioned on the credit of the municipal revenues of the Mayor, Councillors and Citizens of the City of Camberwell by the grant of a mortgage in accordance with the provisions of the Local Government Acts, and notice is hereby further given—

(a) That the amount of the principal moneys which it is proposed to borrow is \$100,000.

(b) The maximum rate of interest that may be paid is 5½ per centum per annum.

(c) The moneys borrowed and interest thereon are to be repayable by 30 half-yearly instalments, each of approximately \$5,060.79 on the 10th day of January and the 10th day of July in each year, and the place at which such moneys are to be repayable is the Commercial Bank of Australia Ltd., Camberwell. The first instalment shall be payable on the 10th day of January, 1969.

(d) The purposes for which the loan is to be applied are:—

Council's proportion of C.R.B. Works	..	\$67,600
Road Reconstructions	..	14,400
Installation of Traffic Lights	..	18,000
		\$100,000

(e) The loan is to be liquidated by appropriation out of the municipal fund.

(f) The plans, specifications, and estimate for the cost of such works, and the statement showing the proposed expenditure of the money to be borrowed, are open for inspection at the office of the Council, Municipal Chambers, Camberwell, during office hours.

Dated the 2nd April, 1968.

1996 L. F. CHEFFERS,  
Chief Administrator and Town Clerk.

CITY OF FRANKSTON.

LOAN No. 124.

Notice of Intention to Borrow the Sum of \$75,000 for Permanent Works and Undertakings.

NOTICE is hereby given that the Council of the City of Frankston proposes to borrow the principal sum of \$75,000 secured by a charge over the general rates of the municipality, such sum to be raised by the grant of a mortgage in accordance with the provisions of the Local Government Act 1958.

1. The maximum rate of interest that may be paid is 5½ per centum per annum.

2. The purpose for which the loan will be applied is—

(a) Towards the construction of a Library-Cultural Centre	..	\$60,000
(b) Instruments—Frankston City Band	..	4,000
(c) Extension of Dog Pound	..	4,000
(d) Towards the construction of new Infant Welfare Centres	..	7,000
		Total \$75,000

3. The moneys borrowed shall be repayable out of the municipal fund twenty half-yearly instalments of approximately \$4,983.10 each, including principal and interest, on the 1st day of June and the 1st day of December, during the currency of the loan. The first instalment shall be payable on the 1st day of December, 1968.

4. Such moneys shall be repayable to the Trustees for the time being of the Australian Natives Association, 28-32 Elizabeth-street, Melbourne.

The plans and specifications and estimates of the cost of the proposed works and a statement showing the proposed expenditure of the moneys to be borrowed are open for inspection at the Civic Centre, Frankston.

G. C. PENTLAND, Town Clerk.

Civic Centre, Frankston. 2028

CITY OF HORSHAM.

BY-LAW No. 57.

A By-law of the City of Horsham made under the Local Government Act for providing for the protection and control of trees, reserves and gardens, garden plots, lawns and ornamental plantations in or upon any street or road within the municipality of the City of Horsham.

IN pursuance of the powers conferred by the Local Government Acts and every other power it thereunto enabling the Mayor, Councillors and Citizens of the City of Horsham order as follows:—

1. If any person wilfully and without the authority of the Council cut, break, bark, root-up or otherwise destroy, damage or remove the whole or any part of any tree, plant, sapling, shrub, underwood or timber in or upon any street, road, municipal garden or gardens, or place, under the control of the Mayor, Councillors and Citizens of the City of Horsham although the injury done be not to the amount of ten cents, he shall be liable to a penalty of not less than Ten Dollars and not more than Forty Dollars.

The resolution for passing this By-law was agreed to by the Council of the City of Horsham, on the 20th day of November, 1967, and confirmed at a Meeting of the said Council held on the 5th day of February, 1968.

The common seal of the Mayor, Councillors and Citizens of the City of Horsham was affixed hereto, in the presence of—

2029 (SEAL) J. W. McDOWELL, Mayor.  
R. F. DIXON, Councillor.  
A. R. CONN, Town Clerk.

Re-advertised.

CITY OF MALVERN.

LOAN No. 43.

Notice of Intention to Borrow the Sum of \$25,000 for Permanent Works and Undertakings.

NOTICE is hereby given that the Council of the Municipality of the City of Malvern intends to borrow the principal sum of Twenty-five thousand dollars on the security of the general rates of the said Municipality, such principal sum to be raised by the grant of a mortgage, in accordance with the provisions of the Local Government Act 1958.

1. The maximum rate of interest that may be paid is 5.75 per centum per annum.

2. The moneys borrowed are to be repayable on 1st January and 1st July each year at the Commonwealth Savings Bank of Australia, Melbourne, or at the Council's bankers for the time being in Melbourne.

3. The purpose for which the loan is to be applied is—  
Reconstruction of the Malvern Municipal Baths (Part) .. \$25,000

4. The loan is to be liquidated by providing out of the municipal fund twenty equal half-yearly instalments of \$1,661.04 (which instalments shall comprise principal and interest) each on the dates hereinbefore mentioned.

The plans and specifications and the estimate of the cost of the proposed works, and a statement showing the proposed expenditure of the moneys to be borrowed, are open for inspection at the City Hall, Malvern, during office hours.

D. W. LUCAS, Town Clerk.

City Hall, Malvern. 3144. 2101

CITY OF OAKLEIGH.

NOTICE is hereby given that the City of Oakleigh has appointed—

Sergeant ANGUS MELVILLE BARTROP, No. 10050, as Prosecuting and Summoning officer to take legal proceedings on behalf of the Council for and in connexion with breaches and non-observances of the Local Government Act or any other Act which the Council from time to time is empowered to enforce and any by-laws, rules and regulations made under such Acts.

Dated at Oakleigh this 22nd day of March, 1968.

1985 J. H. HOCKING, Town Clerk.

## CITY OF OAKLEIGH.

## BYLAW No. 178.

A Bylaw of the City of Oakleigh made under the provisions of the *Local Government Act 1958* for the purpose of controlling the keeping of Bees.

NOTICE is hereby given that this Bylaw was agreed to by the Council of the City of Oakleigh on the 5th February, 1968, and confirmed on the 18th March, 1968.

A copy of such Bylaw is open for inspection, free of charge, during Office Hours at the Office of the Council, Atherton Road, Oakleigh.

1981 J. H. HOCKING, Town Clerk.

## CITY OF RINGWOOD.

## LOAN No. 82.

*Notice of Intention to Borrow the sum of \$40,000 for Permanent Works and Undertakings.*

NOTICE is hereby given that the Council of the City of Ringwood proposes to borrow the principal sum of Forty thousand dollars (\$40,000) secured by a charge over the general rates of the municipality, such sum to be raised by the grant of a mortgage in accordance with the provisions of the *Local Government Act 1958*.

1. The maximum rate of interest that may be paid is 5.75 per centum per annum.

2. The purpose for which the loan is to be applied is:—

(a) Roads—Council Contribution — Wonga-road Reconstruction .. .. .	\$2,000
(b) Traffic Lights—	
Heatherdale-road (half cost) ..	\$5,250
Bedford-road—school .. .. .	2,100
Wantima-road, near Daisy-street ..	2,100
	9,450
(c) Main Drain—The Outlook .. .. .	6,150
(d) Bus Terminal—covered ways .. ..	1,400
(e) Land Purchase .. .. .	21,000
	\$40,000

3. The period of the loan shall be ten years.

4. The moneys borrowed shall be repayable by providing out of the municipal fund half-yearly instalments of approximately \$2,657.65 each on the 1st day of June and December in each year during the currency of the loan, and the first instalment shall be payable on the 1st day of December, 1968.

5. That such moneys shall be repayable to the E.S. & A. Savings Bank Ltd., of 287 Collins-street, Melbourne, at the office of the said Bank.

The plans and specifications and the estimate of the cost of the proposed works and a statement showing the proposed expenditure of the moneys to be borrowed, are open for inspection at the office of the Council of the City of Ringwood, Maroondah Highway, Ringwood.

1982 F. P. DWERRYHOUSE, Town Clerk.

## TOWN OF BAIRNSDALE.

## LOAN No. 1.

*Notice of Intention to Borrow the Sum of \$85,000 for Permanent Works and Undertakings.*

NOTICE is hereby given that Council of the Town of Bairnsdale proposes to borrow the principal sum of Eighty-five thousand dollars (\$85,000) secured by a charge over the general rates of the municipality, such sum to be raised by the grant of a mortgage, in accordance with the provisions of the *Local Government Act 1958*.

1. The maximum rate of interest that may be paid is 5.875 per centum per annum.

2. The purpose for which the loan is to be applied is for part cost of an Olympic Swimming Pool.

3. The period of the loan shall be fifteen years.

4. The moneys borrowed shall be repayable by providing out of the municipal fund 29 half-yearly instalments of \$2,770.16 and one final instalment of \$74,899.46, each including principal and interest, on the 1st day of January and the 1st day of July during the currency of the loan. The first instalment shall be payable on the 1st day of January, 1968.

5. Such moneys shall be repayable at the Australia and New Zealand Savings Bank Limited, Melbourne.

The plans and specifications and the estimate of the cost of the proposed works, and a statement showing the proposed expenditure of the moneys to be borrowed, are open for inspection at the offices of the Council, at Main-street, Bairnsdale, during office hours.

2033 T. N. MUNTZ, Town Clerk.

Town and Country Planning Act 1961 (Twelfth Schedule).  
SHIRE OF BARRABOOL.—OCEAN-ROAD PLANNING SCHEME.

NOTICE THAT A PLANNING SCHEME HAS BEEN PREPARED AND IS AVAILABLE FOR INSPECTION.

Amendment No. 9, 1967.

NOTICE is hereby given that the Shire of Barrabool, in pursuance of its powers under the *Town and Country Planning Act 1961*, has prepared a Planning Scheme for the purpose of rezoning land as Rural Forest to Reserves for Special Purposes—Protection of Flora and Fauna.

A copy of the scheme has been deposited at the Shire Office, 441 Moorabool-street, South Geelong, and at the office of the Town and Country Planning Board, 179 Queen-street, Melbourne, and will be open for inspection during office hours by any person free of charge.

Any persons affected by the Planning Scheme are required to set forth in writing all objections they may have, addressed to the Shire Secretary, 441 Moorabool-street, South Geelong, on or before the 4th July, 1968, and to state whether they wish to be heard in respect of their objections.

2041 G. L. PEARCE, Shire Secretary.

## SHIRE OF BERWICK.

## LOAN No. 40.

*Notice of Intention to Borrow the Sum of \$30,000 for Permanent Works and Undertakings.*

NOTICE is hereby given that the Council of the Shire of Berwick proposes to borrow the principal sum of \$30,000 secured by a charge over the general rates of the municipality, such sum to be raised by grant of a mortgage in accordance with the provisions of the *Local Government Act 1958*.

1. The maximum rate of interest that may be paid is 5.875 per cent. per annum.

2. The purpose for which the loan is to be applied is construction of Doveton Swimming Pool (part).

3. The period of the loan shall be twenty years.

4. The moneys borrowed shall be repayable by providing out of the municipal fund forty (40) half-yearly instalments of approximately \$1,284.80 each, including principal and interest, on the 1st day of January and the 1st day of July in each year, during the currency of the loan. The first instalment shall be payable on the 1st day of January, 1969.

5. Such moneys shall be repayable at the Commonwealth Savings Bank of Australia, Melbourne, Victoria.

The plans and specifications and the estimate of the cost of the proposed works and a statement showing the proposed expenditure of the moneys to be borrowed are open for inspection at the office of the Council of the Shire of Berwick, at Main-street, Pakenham East, during office hours.

Dated 18th March, 1968.

1978 B. J. WALLIS, Secretary.

## SHIRE OF BROADFORD.

## BY-LAW No. 29.

NOTICE is hereby given that the Council of the Shire of Broadford has made a By-law under the provisions of the *Local Government Act* and the *Uniform Building Regulations, Victoria* and numbered 29 for determining, applying, dispensing with or regulating such matters or things as are left to be determined, applied, dispensed with or regulated by the Council of the Shire of Broadford under the *Uniform Building Regulations, Victoria*.

A copy of the By-law is open for inspection, free of charge, during office hours at the Shire Office, Broadford.

The By-law was approved by the Governor in Council on the 19th March, 1968.

2017 M. D. WADE, Shire Secretary.

*Local Government Act 1958 and Amendments.*

## SHIRE OF DIAMOND VALLEY.

NOTICE TO ALL WHOM IT MAY CONCERN.

WHEREAS the Council of the Municipality of the Shire of Diamond Valley deems it expedient to execute a certain work or undertaking for the purpose of developing car parking facilities in Greensborough, whereof it is in the opinion of the said Council necessary and desirable that the said Council exercise its power of taking land compulsorily within the municipal district of the said Council, as provided by the *Local Government Act 1958* and amendments, and the said Council has caused to be



prepared such maps and other papers as may be necessary to show the general description of the work or undertaking for which the land proposed to be taken is to be used, the description of the land proposed to be taken, and the names of the owners or reputed owners, lessees or reputed lessees, mortgagees and occupiers of the land so far as those names are known to or can be ascertained by the Council; and the said maps and other papers so prepared have been approved by the said Council.

In pursuance of the provisions of the *Local Government Act 1958* and amendments, the said Council doth hereby publish and give notice that the description shortly of the purport of the said work or undertaking is as follows:—

The development of car parking facilities in the Main-street - Grimshaw-street, Greensborough, shopping centre.

And the land which it is necessary and desirable to take compulsorily is—

All that piece of land being part of lot 11 on plan of subdivision No. 4759 and more particularly described in certificate of title volume 8490, folio 680, in the names of Bernard John and June Anne McKenna.

And the said Council doth hereby give further notice that the said maps and other papers are deposited at the office of the Council, Shire Office, Greensborough, and are there open for inspection on all the days and between the hours the said municipal office is appointed to be open for the space of 40 clear days from the date of the publication of this notice in the *Government Gazette*.

And the said Council doth hereby call upon all persons affected by the said proposed work or undertaking to set forth, in writing, addressed to the said Council or the Shire Secretary thereof, at the Shire Office, Greensborough, within 40 clear days from the date of the publication of this notice as aforesaid, all objections which they may have to the said work or undertaking.

Dated the 29th day of March, 1968.

2025

B. J. MORGAN, Shire Secretary.

#### SHIRE OF DIAMOND VALLEY.

##### LOAN NO. 12.

*Notice of Intention to Borrow the Sum of \$100,000 for Permanent Works and Undertakings.*

NOTICE is hereby given that the Council of the Shire of Diamond Valley proposes to borrow the principal sum of \$100,000, secured by a charge over the general rates of the municipality, such sum to be raised by the grant of a mortgage, in accordance with the provisions of the *Local Government Act 1958*.

The maximum rate of interest that may be paid is 5.875 per cent. per annum.

The purposes for which the loan is to be applied are—

Land purchases and municipal buildings	\$54,500
Depot site and development.	
Civic Centre development (part provisions).	
Roads	18,500
Right-of-way, Albion-crescent to St. Helena-road—land acquisition for and construction.	
Grimshaw-street, from State School to cutting—construction of kerb and channel.	
Flintoff-street—Council proportion P.S.C.	
Greensborough-road, between Hobson and Nell streets—drainage.	
Buildings	18,000
Lower Greensborough Park—pavilion and toilets (part provision).	
Greensborough swimming pool—club rooms (part provision).	
Sharpes-road—oval development (part provision)	9,000
	<hr/>
	\$100,000

The period of the loan shall be 40 years.

The loan shall be repaid by the establishment and accumulation of a sinking fund, pursuant to section 428A (1) of the *Local Government Act 1958*, by the provision out of the municipal fund of an amount of \$934.32 each year during the period of the loan.

Interest is to be payable half-yearly on the 1st days of June and December during the period of the loan. The first interest payment shall be made on 1st December, 1968.

Such moneys shall be repayable at the office of the State Superannuation Board, Treasury Gardens, Melbourne, or at such other place or places as the Board may from time to time require.

The plans, specifications and estimates of the cost of the proposed works, and a statement showing the proposed expenditure of the moneys to be borrowed, are open for inspection at the office of the Council, Main-street, Greensborough.

B. J. MORGAN, Shire Secretary.

#### SHIRE OF HEALESVILLE.

##### BY-LAW No. 51

A By-Law of the Shire of Healesville made under Section 198 (1) (a) (b) (c) (d) (f) (g) and (h) and Section 107 (1) (xiv) of the *Local Government Act* and all other powers it thereunto enabling passed by a special order by the Shire of Healesville, sealed with the common seal of the Shire of Healesville, advertised in accordance with the provisions of the *Local Government Act*, duly confirmed, approved by the Governor in Council and numbered 51 for the purposes of:—

- (a) Regulating, restraining or prohibiting the erection of hoardings.
- (b) Requiring the pulling down and removal of hoardings.
- (c) Authorizing the Council to pull down, demolish and remove hoardings.
- (d) Authorizing the Council to sell materials resulting from its exercise of its powers under this By-Law and to apply the proceeds in reimbursing the expenses of pulling down demolishing and removing hoardings and to pay into the municipal funds any fees or penalties due by the owner thereof.
- (e) Regulating restricting or preventing the exhibition of advertisements in such places and in such manner or by such means as to affect injuriously the amenities of a public park or pleasure promenade or to disfigure the natural beauty of a landscape.
- (f) Appointing fees which may be charged and reserved by the Council for any act done or to be done by any of its officers under such By-laws and for any permit approval or licence to be issued by the Council.
- (g) Regulating the transportation or removal by road of wooden buildings or structural parts thereof including provision for the giving of reasonable security for due compliance with the By-Law, the route to be followed and any deviation thereof as determined by the Council or its engineers and the supervision of the work of transportation and removal and payment for reasonable charges for such supervision.
- (h) Prohibiting on and from the date hereinafter specified the erection or placing against or in front of any house or building abutting upon any public footway in any street or part thereof hereinafter specified of any verandah over or across such footway unless such verandah is supported by cantilevers brackets or projecting supports and not otherwise.
- (i) Requiring the pulling down and removal before the date hereinafter specified (not being less than ten years after the coming into operation of this By-Law) of all verandahs before the date so specified erected or placed against or in front of any house or building abutting upon any such public footway which verandahs are upon over or across such footway and are supported otherwise than by cantilevers brackets or projecting supports.

IN pursuance of the powers conferred by the above mentioned parts of the *Local Government Act 1958* as amended and of any every other power it thereunto enabling, the President, Councillors and Ratepayers of the Shire of Healesville orders as follows:—

1. This By-Law shall apply to and have operation throughout the whole of the municipal district of the Shire of Healesville.

2. This By-Law shall come into operation on the publication thereof or of notice of the making thereof in the *Victorian Government Gazette*.

3. Wherever used in this By-Law:—

- (i) The word "Council" shall mean the Council of the Shire of Healesville.
- (ii) "Shire" shall mean the Shire of Healesville.
- (iii) The word "hoarding" shall have the meaning attributed to it in Section 198 (i) (c) of the *Local Government Act 1958*.
- (iv) The word "person" shall be deemed to include the words "firm, partnership, body, company and corporation whether incorporated or not".

4. No person shall erect or construct any hoarding except in pursuance of a permit in writing of the Council first had and obtained.

5. The Council may at any time and from time to time require the owner (which expression shall be deemed to include the person rated in the Rate Book of the Shire) of any premises upon which a hoarding has been erected without a permit issued in pursuance of clause 4 hereof or otherwise than in accordance with the terms and conditions of such a permit by not less than fourteen days' notice in writing to pull down, demolish and remove such hoarding from the said premises.

6. Any hoarding erected and not pulled down demolished and removed within fourteen days after the service of any such notice may be pulled down demolished and removed by the Council which shall have full power and liberty to sell or dispose of any materials so obtained and apply any proceeds in reimbursing the expenses of pulling down demolishing and removing such hoarding. The Council may sue for and recover from the owner of the premises the costs of such pulling down demolition and removal unrecouped by sale of materials in any Court of competent jurisdiction.

7. No person shall exhibit any advertisement in such place or in such manner or by such means as to affect injuriously the amenities of a public park or pleasure promenade or to disfigure the natural beauty of a landscape.

8. No person shall transport or remove by road any wooden building or part thereof except under conditions laid down in a permit in writing first had and obtained from the Council and designed to secure the safety of road users, the avoidance of traffic congestion, the protection of road surfaces, drains, pipes and boundaries and the property of public utilities.

9. On or after the date of commencement of this By-Law no person shall erect or place against or in front of any building abutting upon any public footway in any street or part thereof any verandah over or across such footway unless such verandah is supported by cantilevers brackets or projecting supports of a type and specifications approved by the Council by written permit and not otherwise.

10. The owners of any premises having a verandah erected or placed against or in front of any house or building abutting upon any public footway which verandah is upon or over or across such footway and is supported otherwise than by cantilevers brackets or projecting supports approved by the Council by written permit shall pull down and remove such verandah before the 31st day of December, 1978, and if any owner shall fail to comply with this By-Law the Council may remove such verandah and sell or dispose of materials so obtained and apply any proceeds in reimbursing the expenses of pulling down and removing such verandah.

11. Any person may lodge with the Shire Secretary of the said Shire an application signed by the applicant substantially in the appropriate form set out in the First Schedule hereto for any permit or approval required by this By-Law.

12. The Council may in its discretion grant or refuse the said application and any grant of a permit or approval may be made for such period and subject to such terms and conditions as the Council may require to be endorsed on the permit or approval. Any such permit or approval shall be substantially in the appropriate form in the Second Schedule hereto together with such additions or alterations as the Council may require and shall be given under the hand of the Shire Secretary or Shire Engineer.

13. No permit or approval shall be issued pursuant to the provisions of this By-Law until a permit or approval fee shall first be paid to the Council of the said Shire being the following:

For erection of a hoarding . . . . .	2 dollars
For transportation or removal of wooden buildings . . . . .	1 dollar per 100 square feet with a maximum of 10 dollars.

Any person guilty of any wilful act or default contrary to this By-Law shall be liable to a penalty of not more than forty dollars and any person guilty of a continuing offence against this By-Law shall be liable to a penalty of not more than ten dollars for each day on which an offence against this By-Law is continued after notice has been given to the offender by the Council of the commission of the offence or after a conviction or order of any Court in respect thereof.

FIRST SCHEDULE.

PART ONE.

APPLICATION FOR PERMIT FOR ERECTION OF HOARDING.

PART TWO.

APPLICATION FOR PERMIT FOR TRANSPORTATION OR REMOVAL OF A WOODEN BUILDING OR PART THEREOF.

SECOND SCHEDULE.

PART ONE.

PERMIT FOR ERECTION OF HOARDING.

SECOND SCHEDULE—PART 2.

PERMIT FOR TRANSPORTATION OR REMOVAL OF WOODEN BUILDING OR PART THEREOF.

Resolution for the passing of this By-Law agreed to by the Council on 30th day of January, 1968.

Copy of this By-Law deposited at the Council Office for inspection on Wednesday, the 31st day of January, 1968.

Special Order advertisement printed in the *Yarra Valley News* Newspaper on Tuesdays, the 6th and 13th days of February, 1968.

Resolution confirmed on Tuesday the 27th day of February, 1968.

The common seal of the President, Councillors and Ratepayers of the Shire of Healesville was hereto affixed on 27th day of February, 1968, in the presence of—

(SEAL) G. G. CUZENS, President.  
E. R. FROGLEY, Councillor.  
W. M. OLIVER, Shire Secretary.

Approved by the Governor in Council on the 13th day of March, 1968.—J. ROSSITER, Clerk of the Executive Council. 2022

SHIRE OF LEIGH.

NOTICE OF INTENTION TO BORROW THE SUM OF \$32,000 FOR THE ERECTION OF NEW SHIRE OFFICES.

NOTICE is hereby given that the Council of the Shire of Leigh proposes to borrow the sum of Thirty-two thousand dollars on the credit of the municipal revenues of the President, Councillors and Ratepayers of the said Shire, such sum to be raised by the grant of a mortgage in accordance with the provisions of the *Local Government Act 1958*.

1. The maximum rate of interest that may be paid is 5.875 dollars per centum per annum.
2. The purpose for which the loan is to be applied is the erection of shire offices at Rokewood.
3. The period of the loan shall be fifteen years.
4. The moneys borrowed shall be repayable by providing out of the municipal fund thirty half-yearly instalments of approximately \$1,620 each including principal and interest, on the 10th day of February and the 10th day of August during the currency of the loan.

The first instalment shall be payable on the 10th day of February, 1969.

5. Such moneys shall be repayable at the Commercial Bank of Australia Limited, Rokewood.

The plans and specifications and the estimate of cost of the proposed works and a statement showing the proposed expenditure of the moneys to be borrowed are open for inspection at the Shire Office, Rokewood.

1988 C. G. HALLUM, Shire Secretary.

*Town and Country Planning Act 1961 (Twelfth Schedule).*  
SHIRE OF MORNINGTON.—SHIRE OF MORNINGTON PLANNING SCHEME 1959.

NOTICE THAT A PLANNING SCHEME HAS BEEN PREPARED AND IS AVAILABLE FOR INSPECTION.

Amendment No. 35, 1968.

NOTICE is hereby given that the Council of the Shire of Mornington, in pursuance of its powers under the *Town and Country Planning Act 1961*, has prepared a Planning Scheme for—

Ordinance amendment to permit licensed restaurants in the Commercial "A" Zone.

Ordinance amendment to permit reduced areas and frontages for subdivisions where land in the Agricultural Zone has been affected by compulsory acquisition by statutory authorities.

A copy of the scheme has been deposited at the Shire Office at Mornington and at the office of the Town and Country Planning Board, 179 Queen-street, Melbourne, and will be open for inspection during office hours by any person free of charge.

Any persons affected by the Planning Scheme are required to set forth in writing all objections they may have, addressed to the Shire Secretary, Shire of Mornington, Shire Office, Mornington, on or before the 3rd May, 1968, and to state whether they wish to be heard in respect of their objections.

D. G. COLLINGS, Shire Secretary.  
28th March, 1968. 2015

## SHIRE OF SOUTH BARWON.

## LOAN No. 70.

NOTICE is hereby given that the Council of the Shire of South Barwon did at its meeting held on Tuesday, 20th February, 1968, for which notice of the making of a Special Order for borrowing money had been given, agree to the following Resolution:—

"That this Council by Special Order, resolves to borrow Forty Thousand Dollars (\$40,000) to be secured by a charge over the General Rates of the Municipality by the grant of a Mortgage in accordance with the provisions of the Local Government Acts.

In connexion therewith the following information is stated—

- (a) The amount of the principal moneys which it is proposed to borrow is \$40,000.
- (b) The rate of interest to be paid is \$5.75 per centum per annum.
- (c) The times which the moneys borrowed are to be repayable are the 30th October, 1968, and the 30th days of April and October during 1969 to 1977 (inclusive) and a final payment on 30th April, 1978. The place the moneys shall be repayable is at the Bank of New South Wales, Belmont.
- (d) The purpose for which the said loan shall be applied is for the construction of Private Streets under the provisions of Division 10 of Part XIX. of the Local Government Act 1958 and amendments.
- (e) The loan shall be liquidated from the receipts of money payable under schemes under Division 10 of Part XIX. of the Local Government Act 1958 and amendments, by twenty half-yearly repayments of approximately \$2,657.65 which includes principal and interest."

Notice is further given hereby that the said Resolution was confirmed at a meeting of the said Council on Tuesday, 19th March, 1968.

1979 A. A. N. DEED, Shire Secretary.

## SHIRE OF SOUTH BARWON.

## LOAN No. 71.

NOTICE is hereby given that the Council of the Shire of South Barwon did at its meeting held on Tuesday, 20th February, 1968, for which notice of the making of a Special Order for borrowing money had been given, agree to the following Resolution:—

"That this Council by Special Order, resolves to borrow Thirty thousand dollars (\$30,000) to be secured by a charge over the General Rates of the Municipality by the grant of a Mortgage in accordance with the provisions of the Local Government Acts.

In connexion therewith the following information is stated—

- (a) The amount of the principal moneys which it is proposed to borrow is \$30,000.
- (b) The rate of interest to be paid is \$5.75 per centum per annum.
- (c) The times which the moneys borrowed are to be repayable are the 1st day of November, 1968, and the 1st days of May and November during 1969 to 1977 (inclusive) and a final payment on 1st May, 1978. The place the moneys shall be repayable is at the State Savings Bank, Belmont.
- (d) The purpose for which the said loan shall be applied is for the construction of Private Streets under the provisions of Division 10 of Part XIX. of the Local Government Act 1958 and amendments.

- (e) The loan shall be liquidated from the receipts of money payable under schemes under Division 10 of Part XIX. of the Local Government Act 1958 and amendments, by twenty half-yearly repayments of approximately \$1,993.24 which includes principal and interest."

Notice is further given hereby that the said Resolution was confirmed at a meeting of the said Council on Tuesday, 19th March, 1968.

1980 A. A. N. DEED, Shire Secretary.

## CITY OF SPRINGVALE.

## By-LAW No. 175

A by-law of the City of Springvale made under the provisions of Sections 197 and 198 of the Local Government Act 1958 and the Uniform Building Regulations (Victoria) for:—

- (a) regulating restricting restraining or prohibiting the erection construction use occupation conversion and alteration of and any addition to buildings or erections and regulating restraining or prohibiting the erection and construction of hoardings or of fences abutting on or within ten feet of any street or road;
- (b) authorising the Council to pull down demolish and remove buildings erections or hoardings or fences or any part thereof erected constructed converted altered or added to contrary to this by-law or not pulled down demolished or removed as required by or under this by-law, and to sell the materials and apply the proceeds in reimbursing the expenses of pulling down demolishing and removing such buildings erections hoardings or fences or such part thereof and in paying into the municipal fund any fees or penalties due by the owner thereof;
- (c) regulating restricting or preventing the exhibition of advertisements in such places and in such manner or by such means as to affect injuriously the amenities of a public park or pleasure promenade or to disfigure the natural beauty of a landscape;
- (d) regulating and controlling all advertisements attached or fixed to or painted on any hoardings or on any building or on any fence rock cliffs or tree and regulating and controlling the erection or use of coloured lights and signs in the vicinity of traffic lights or signs or of street intersections;
- (e) regulating or prohibiting the writing painting printing stencilling placing or fixing of any letter figure device poster sign or advertisement upon any footpath street or road or upon any building fence or other property vested in the municipality or under the control or management of the Council thereof;
- (f) prescribing determining applying adopting and dispensing with or regulating such matters as are left to be prescribed determined applied adopted dispensed with or regulated by the Council under the Uniform Building Regulations.

IN pursuance of the power conferred by sections 197 and 198 of the Local Government Act 1958 and the Uniform Building Regulations, Victoria, and every other power thereunto enabling the Mayor Councillors and Citizens of the City of Springvale order as follows:—

1. (1) In this by-law unless inconsistent with the context or subject matter—

"Area" applied to a building means that superficial area of a horizontal section thereof made at a point of greatest surface inclusive of the external walls and of such portions of any party wall as belong to the buildings.

"Consent of the Council" means the consent of the Council by a proper resolution duly passed at a properly constituted meeting.

"Dwelling" has the same meaning as "dwelling house" in Section 198(6) of the Local Government Act 1958 but does not include a building of Class III Occupancy or portion of such building.

"Flat" means a portion of a building used or intended adapted or designed for use as a dwelling but does not include a building of Class IV Occupancy.

"Frontage" means the boundary line between a site and the street upon which such site abuts and where the site abuts on more than one street then the boundary line between the site and the street to which any building that may be erected fronts.

"Ground Storey" means that storey closest to ground level in which the height of the ceiling above the level of the adjoining ground is greater than the distance from such level to the floor measured at the centre frontage.

"Height" as applied to hoardings means the distance from the natural surface of the ground to the top of the hoarding.

"Hoarding" has the same meaning as in Section 198(1)(c) of the *Local Government Act 1958* and includes placard, sign board, poster, sign or similar structure used for display or advertising purposes.

"Major Traffic Control Item" has the same meaning as in the *Road Traffic Regulations 1962*.

"Minor Traffic Control Item" has the same meaning as in the *Road Traffic Regulations 1962*.

"Municipal District" means the municipal district of the City of Springvale.

"Masonry" means stone brick terracotta block solid or hollow concrete block or other similar building unit or a combination of same laid up unit by unit and set in mortar.

"Occupancy" means the purpose for which a building is used or intended to be used.

"Proper Officer" means any officer of the Council authorised by the Council to carry out the provisions of this by-law.

"Regulations" means the *Uniform Building Regulations, Victoria*.

"Surveyor" means the building surveyor or any competent person appointed by the Council to carry out the duties of the building surveyor.

(2) The classification of buildings by occupancy set out in Clauses 601 and 602 of the Regulations shall apply "mutatis mutandis" for the purpose of this by-law wherever a building is referred to in this by-law as being of a specified class.

2. By-laws numbered 103, 112 and 118 of the City of Springvale (and where applicable formerly the Shire of Dandenong) are hereby repealed.

#### FEEs AND DEPOSITS.

3. (1) The fees specified in Chapter 4 of the Regulations are hereby appointed as the fees to be charged and received by the Council for any permit granted under the Regulations by it or for any inspection made or other service provided under the Regulations by an officer of the Council.

(2) The Council hereby determines that the following fees shall be payable to the Council for permits and services issued and provided by the Council for such matters as are left to be determined by the Council under the Regulations—

- (a) Openings in unmade streets and footpaths and in made streets where use of conduits is involved and where blowing is used—two dollars.
- (b) Openings not exceeding five feet in length in bitumen constructed streets—three dollars. Each additional five feet or part thereof—one dollar.
- (c) Openings in a constructed footpath where such footpath does not exceed five feet in width—four dollars.
- (d) Openings in a constructed footpath for each additional five feet or part thereof—one dollar.
- (e) Any other opening in roads, footpaths or channels not specified—three dollars for each five feet in length or part thereof.
- (f) Use of footpath or roadway during building operations—two dollars.
- (g) Inspection of temporary crossing—fifty cents.
- (h) Inspection of drains across pathway—one dollar.
- (i) Inspection of permanent crossing over footpath—two dollars.

(3) The Council hereby determines that the following deposits be lodged with it under the Regulations—

- (a) Construction of permanent crossing over footpath—deposit twenty dollars.
- (b) Construction of drains across pathway—deposit five dollars.
- (c) Construction of temporary crossing during building operations—
  - (i) buildings of Class I Occupancy—deposit fifty dollars.
  - (ii) buildings of Class II to IX Occupancy—deposit fifty dollars.

#### ASSISTANCE TO OFFICERS.

4. (1) Every person carrying on works for the erection, construction, conversion, alteration or addition to any building or other erection on any land or premises and the owner or occupier of any such land or premises shall give assistance to the Surveyor or any other officer of the Council in the carrying out of his duties under the Regulations and this by-law and shall allow him the use of any plant or scaffolding on or about any such land or premises or any works being carried out thereon to enable him to make any inspection he deems necessary.

(2) Any person who obstructs, impedes or in any other way hinders the Surveyor or any other officer of the Council from entering on any such land or premises or inspecting any works being carried out thereon shall be guilty of an offence against this by-law.

5. (1) Every person carrying out works for the erection, construction, conversion, alteration or the addition to any building or other erection shall give written notice to the Council of the completion of such works within seven days after the date of completion.

(2) Every person carrying out the work of constructing a crossing over a footpath shall notify the Council in writing of the date of completion of the work within seven days after the date of completion.

#### REQUIREMENTS FOR BUILDINGS.

6. The whole of the municipal district is hereby prescribed as an area in which buildings of Class II Occupancy shall contain not more than four flats per site.

7. The whole of the municipal district is hereby prescribed as an area within which no building of Class II Occupancy containing more than two storeys including the ground storey shall be constructed.

#### SITE REQUIREMENTS.

8. The minimum area, depth and width of frontage specified in Column 3 of Table 804 of the Regulations are hereby adopted as the minimum area, depth and width of frontage of land on which a building of Class I or II Occupancy shall be constructed throughout the whole of the municipal district.

9. (1) The minimum distance of the outer wall of any building of Class I or II Occupancy from the frontage of any land is hereby specified as twenty feet.

(2) No person shall erect or construct any building of Class I or II Occupancy or erect or construct any additions to any such building closer to the frontage of any land than twenty feet.

10. In the case of a building proposed to be constructed on land forming part of a subdivision approved by the Council and lodged in the Office of Titles prior to the date of the first coming into operation of the *Uniform Building Regulations, Victoria*, the Council may dispense with the requirements of Clause 813 of the Regulations.

11. (1) The areas described in the 1st Schedule hereto are hereby prescribed as brick areas—

#### FIRST SCHEDULE.

- Balmoral Avenue, Springvale, both sides from Buckingham Avenue to St. Johns Avenue.
- Buckley Street, Noble Park, both sides from Douglas Street to Noble Street.
- Douglas Street, Noble Park, both sides from Heatherton Road to Stuart Street.
- Douglas Street, Noble Park, south side, being Lots 35 and 36 on Lodged Plan 6156.
- Forster Street, Springvale, north side from Lawn Road to Somers Street.
- Heatherton Road, Springvale, north side from Springvale Road, easterly 198 feet.
- Heatherton Road, Noble Park, both sides from Railway Line to Mile Creek.
- Heatherton Road, Noble Park, south side from Chandler Road, westerly 198 feet.
- Heatherton Road, Noble Park, north side north-west corner with Kelvinside Road and being Lot 3 on lodged Plan 18903.
- Lawn Road, Springvale, east side from Lightwood Road to Forster Street.
- Lawn Road, Springvale, west side, being Lot 51 on Lodged Plan 4817.
- Leonard Avenue, Noble Park, both sides from Douglas Street to Noble Road.
- Leonard Avenue, Noble Park, west side, being Lot 32 on Lodged Plan 6156.

Lightwood Road, Springvale, southern side from Lawn Road to Somers Street.

Princes Highway East, both sides within the whole municipal district of the City of Springvale for a depth of 150 feet north and south of the respective side lines.

Sandown Road, Springvale, on the northern side from Springvale Road to Merton Street.

Somers Street, Springvale, west side Lightwood Road to Forster Street.

Springvale Road, Springvale, east side from Princes Highway East southerly 198 feet.

Springvale Road, Springvale, east side from Lucian Street to Mary Street.

Springvale Road, Springvale, both sides from Windsor Avenue to Mary Street.

Springvale Road, Springvale, east side from Ash Grove to State School.

Springvale Road, Springvale, west side from Windsor Avenue to 150 feet south of St. James Avenue.

Springvale Road, Springvale, east side from Ash Grove to Grace Park Avenue.

Stuart Street, Noble Park, west side from Douglas Street southerly 528 feet.

(2) No person shall in any of such areas construct, erect or cause to be constructed or erected any building or any addition or extension to any existing building the external walls of which are of material other than masonry or concrete with the exception that in cases of existing buildings of Class I Occupancy no addition to or any extension to such buildings shall be required to be constructed or erected in masonry or concrete materials.

(3) Notwithstanding anything contained in sub-clause (2) hereof the Council may permit the construction of a building or any additions or extension to any existing building the external walls of which are of material consisting of a composite of masonry, concrete, glass or aluminium.

#### ACCOMMODATION FOR VEHICLES LOADING AND UNLOADING VEHICLES.

12. The whole of the municipal district is hereby prescribed as an area within which off-street accommodation for stationary vehicles shall be provided for a building of Class II Occupancy within the boundaries of the site on which such building is erected but, except with the permission of the Council, no closer to the frontage than such building in accordance with the following prescribed schedule—

One garage or car-port for each flat contained in such building.

#### REMOVAL AND RE-ERECTION OF WOODEN BUILDINGS.

13. (1) Where any person is desirous of moving an existing brick-veneer building or erecting and re-erecting the same within the municipality such person shall give notice in writing to the Council of such intention to do so at least seven days before the date of intended removal.

(2) With such notice of intention, every such person shall supply the following information—

- (a) the present situation of such building or erection;
- (b) the situation of the land upon which it is proposed to re-erect the same;
- (c) the external dimensions and height of such building or erection;
- (d) plans and specifications of the proposed re-erected building;
- (e) the purpose for which the same is to be used when re-erected;
- (f) if the re-erected building or erection is intended to be used as a dwelling the number and sizes of the rooms contained therein; and
- (g) the purpose for which such building or erection was last used prior to the notice.

(3) The Surveyor shall cause every such building or erection to be inspected before removal and to ascertain whether same when re-erected or re-constructed will comply with the requirements of the Regulations.

(4) If in the Surveyor's opinion any such building or erection when re-erected will not comply with the Regulations or this by-law then he shall advise the applicant in writing accordingly and report his findings to the Council.

(5) No permit to re-erect any such building or erection will be issued by the Council unless all the provisions of the Regulations and of the *Health Act 1958* are complied with.

#### HOARDINGS AND ILLUMINATED SIGNS.

14. No person shall erect, alter, or add to any hoarding except in accordance with plans and specifications approved by the Council.

15. No person shall erect any hoarding (other than an illuminated or sky sign) within a distance from the boundary line of any street or road equal to the height of such hoarding or with the lowest part of any such hoarding other than the main supports thereof less than three feet from the level of the land.

16. (1) Every hoarding (other than a sky sign) shall be constructed of material and to a design approved by the Council.

(2) No person shall erect any hoarding (other than an illuminated sign)—

- (a) covering any window or architectural projection of any building;
- (b) over or in front of any dwelling house;
- (c) so that any part of the same is less than 9 feet over the level of any footpath over which it may be re-erected; or
- (d) (except with the approval of the Council) exceeding 5 feet in height or having a face area exceeding 30 square feet.

17. (1) No illuminated sign shall be erected, attached to the wall of any building unless—

- (a) it is so attached as not to cover any portion of any window or architectural projection in such wall;
- (b) it does not overhang or extend over any footpath at a lesser height than twelve feet unless it is also attached to a verandah;
- (c) it is attached to a metal frame or box secured firmly to such wall;
- (d) it or any part thereof does not project over any footpath if the face area exceeds ten square feet;
- (e) it is terminated at least 2 feet 6 inches from the edge of any kerb line in front of such building.

(2) No illuminated sign shall be attached to any verandah without the approval of the Council and unless—

- (a) any part of the same is not less than 9 feet above the level of any footpath over which it may be erected;
- (b) it has a face depth not exceeding 14 inches and a face length not exceeding 96 inches;
- (c) it is rigidly supported from the frame work of any such verandah by steel supports; and
- (d) it is terminated at least 2 feet 6 inches from the edge of the kerb line in front of the building to which such verandah is attached.

18. No person shall erect any illuminated sign erected on or supported by a pole, steel tower, or similar structure unless its location is approved by the Council.

19. No persons shall erect any sky sign unless its location, design and construction are approved by the Council and unless—

- (a) the maximum dimensions of any such sign does not exceed 30 feet;
- (b) the maximum area of any such sign does not exceed 200 square feet;
- (c) if attached to a building is erected not less than 6 feet from the frontage of the land on which the building is erected;
- (d) if erected on land or premises situated at an intersection of two streets and if illuminated it does not contain in such illumination the colours of red, green or amber if of a flashing or moving type or the colours of green or amber if a fixed type.

20. No person shall erect, establish, place, maintain or display on any public highway or in view of any person on any public highway any matter or thing which purports to be or is an imitation of or is similar to any major or minor traffic control item or interferes with the effectiveness of or prevents any person from clearly distinguishing any major or minor traffic control item.

21. (1) Every permit to erect a hoarding issued by or under the authority of the Council shall be issued on the express condition that any such hoarding shall be maintained at all times in good order and condition.

(2) If the Council is of the opinion that any hoarding erected pursuant to such a permit is in a ruinous dilapidated or dangerous condition it shall cause the proper officer to serve a notice in writing on the owner or occupier of the premises on which the hoarding is erected

requiring such owner or occupier to bring the same into conformity with the requirements of this by-law or demolish the same.

(3) Any persons failing to comply with the requirements of any such notice within the time specified therein shall be guilty of an offence against this by-law.

#### ROAD OPENING.

22. (1) No person shall carry out any work necessitating the disturbing of the surface of any road, street or lane without first obtaining the written permission of the Council.

(2) Every permit issued by the Council to excavate in any road, street or lane shall be issued on the following express conditions—

- (a) all water gas service pipes laid in any such excavation must be at least 1 foot 6 inches below the surface and must not be laid longitudinally without the written permission of the Council;
- (b) all refilling or any such excavation in any road pavement must be done with fine crushed rock or other approved crushed material thoroughly rammed with a heavy rammer every six inches.

#### TEMPORARY CROSSINGS.

23. (1) Where any channel or footpath in or on any street or road has been constructed or paved any person intending to carry out works for the erection, construction, conversion or alterations to buildings or erections on any premises fronting or abutting on any such street or road shall cause a proper temporary crossing to be constructed over such channel or footpath to give access to such premises before commencing such works.

(2) Every person who carries on any such works on any such premises and fails to so provide a proper temporary crossing shall be liable for the cost of repairing any damage caused to any such channel or footpath and in the event of the Council repairing the same shall be liable to reimburse the Council the cost thereof.

(3) Every person obtaining a permit to carry on any such works on any such premises shall lodge with the Council as security for the cost of repairing any channel or footpath damaged as a result of his building operations the following amounts—

- (a) in the case of a building of Class I Occupancy the sum of fifty dollars; and
- (b) in the case of a building of Class II to IX Occupancy the sum of fifty dollars.

#### FENCES.

24. (1) No person shall erect or construct or cause to be erected or constructed any fence abutting on or within ten feet of any street or road except in accordance with specifications approved by the Surveyor and subject to the following conditions—

- (a) *Timber*—All timber used in posts and struts shall be redgum.
- (b) *Gate and Corner Posts*—Gate posts and corner posts shall be not less than 5 inches x 5 inches in sectional area, plated and strutted on all four sides unless otherwise allowed by the Surveyor.
- (c) *Intermediate Posts*—Intermediate posts shall not be less than 5 inches x 3 inches in sectional area spaced not more than nine feet apart and every post shall be plated and strutted on two sides.
- (d) *Sole Plates and Struts*—Sole plates shall be not less than 3 inches x 2 inches housed one half an inch into post, and not less than three feet in length. Struts shall be not less than three inches x two inches and not less than two feet in length, cut to correct levels and securely nailed to posts and plates.
- (e) *Depth and Ground*—Posts shall be fixed vertically, and shall be sunk below the surface of the ground not less than two feet in the case of fences up to 5 feet 6 inches in height and 2 feet 6 inches in the case of fences over 5 feet 6 inches in height.
- (f) *Rails*—Rails for paling or similar fences shall be not less than 3 inches x 2 inches, spaced more than 2 feet 6 inches apart centre to centre, except in the case of fences 5 feet 6 inches or under in height, where the centre rail may be 3 inches x 1½ inches. Rails shall be in lengths sufficient to span two panels and shall break joints on alternate posts.
- (g) *Plinths*—Where a plinth is used at the bottom of a fence it shall be not less than 6 inches x 1 inch full and shall be in lengths to span two panels.

(h) *Palings*—Palings shall be hard wood, redgum or jarrah, not less than one half inch in thickness, and shall be fixed vertically. The tops of all paling or similar fences shall be cut off to a regular line.

(i) *Corrugated Iron*—Where corrugated iron is used as a covering it shall be fixed with corrugations vertically. It shall be new iron of not less than twenty-six gauge and finished to a regular line along the top.

(j) *Special Fences*—The method of construction or ornamental wire fences, picket fences, brick fences, concrete fences and other fences of special design must be approved by the Surveyor before being erected.

(k) *Short lengths*—The use of short lengths of timber in posts, rails, pickets and palings is not permitted.

(l) *Heights*—No fence or any addition thereto shall exceed seven feet in height.

(m) *Gates*—Every gate must be properly framed, braced, and constructed and hung on suitable hinges opening into the premises only.

(2) No person shall dig, break or remove or damage any paved or constructed footway for the purpose of erecting any strutted fence without first obtaining a permit under Clause 27 hereof.

#### ADVERTISEMENTS.

25. (1) No person shall write, paint, print, stencil, place or affix any letter, figure, device, poster, sign or advertisements upon any footpath, street or roadway or upon any building, fence or other property vested in the Council or under the management and control of the Council except with the written permission of the Council.

(2) Council may remove or obliterate or delete any letter, figure, device, poster, sign or advertisement written, painted, printed, stenciled, placed or affixed contrary to this clause and recover from the person responsible therefor the cost of so doing as a civil debt recoverable in any Court of competent jurisdiction.

26. No hoarding or sign for advertising purposes shall be exhibited in such places or in such manner or by such means as to effect injuriously the amenities of a public park or pleasure promenade or to disfigure the natural beauty of a landscape.

#### ENFORCEMENT OF BY-LAW.

27. (1) Where any building, erection, hoarding or fence is erected, constructed, converted, altered or added to contrary to Clause 9, 10, 17, 23 and 28 (all inclusive) of this by-law and the owner fails to comply with any written notice to make any such building, erection, hoarding or fence comply with the relevant provisions hereof then the Council is hereby authorised to—

- (a) enter upon the subject land or premises and pull down, demolish, and remove any such building, erection, hoarding or fence; and
- (b) sell the materials therefrom and apply the proceeds in reimbursing the expenses of such pulling down, demolishing and removing; and
- (c) pay into the municipal fund any fees or penalties due by the owner of any such building, erection, hoarding or fence.

(2) If the proceeds of any such sale are insufficient to meet the costs of the Council of such pulling down and removal then the amount of such costs still outstanding may be recovered by the Council from the owner as a civil debt recoverable in any Court of competent jurisdiction.

28. (1) In the event of any owner of premises being prevented by the occupier of such premises from complying with any notice served by him under the provisions of this by-law he shall notify the Proper Officer accordingly.

(2) The Proper Officer shall then serve a notice on the occupier of such premises requiring him to allow the owner to comply with the provisions of such notice within a time specified in such notice.

(3) If the occupier continues to prevent or obstruct the owner from complying with the requirements of the notice served on the owner after service of the notice referred to in sub-clause 2 hereof then he shall be guilty of an offence against this by-law.

29. (1) If at any time during the erection, construction, conversion, alteration of or addition to any building, erection, hoarding, or fence the Surveyor find on inspection that any defective or unsound material is being used in any such erection, construction, alteration or addition he shall immediately serve notice on the owner or the person

responsible for the use of such defective or unsound material to discontinue the use of the same and to remove it from the site.

(2) Any person who fails to comply with any such notice shall be guilty of an offence against this by-law.

30. Every person guilty of a wilful act or default contrary to the provisions of this by-law shall be liable to a penalty of not less than \$10.00 nor more than \$40.00 and to a further penalty of not more than \$10.00 for each day on which such offence is continued after a conviction or order by any Court.

31. This by-law (except Clauses 8, and 11 to 13 (inclusive) hereof which shall apply to and have operation throughout those parts of the municipal district to which each respective clause relates) shall apply to and have operation throughout the whole of the municipal district.

Resolution for passing this by-law agreed to by Council on the twenty-second day of January, 1968, and confirmed on the 19th day of February, 1968.

The common seal of the Mayor, Councillors and Citizens of the City of Springvale was hereunto affixed in the presence of—

(SEAL) K. C. MARRIOTT, Councillor.  
H. C. BOX, Councillor.  
K. D. MOODY, Acting Town Clerk.

Approved by the Governor in Council on the 26th day of March, 1968.—J. ROSSITER, Clerk of the Executive Council. 2027

SHIRE OF STAWELL.

BY-LAW No. 29.

A By-law of the Shire of Stawell, made under the provisions of the Health Act 1958, and numbered 29, for the purpose of prescribing fees for registration and renewal and transfer of registration of premises required to be registered under the said Act.

IN pursuance of the powers conferred by the said Act, the President, Councillors and Ratepayers of the Shire of Stawell order as follows:—

1. This By-law shall come into operation on the day after the day of publication thereof in the Government Gazette.

2. By-law No. 22 is hereby repealed.

3. The Fees for granting or annual renewal of registration of premises shall be as follows:—

Nature of Premises.	Fees.
	\$ c
Offensive trades premises (being fat extracting or melting or rendering works which are conducted at premises occupied principally as a butcher's shop and at which fat is extracted melted or rendered only from materials derived from such shop)	4.00
Offensive trades premises (being abattoirs in meat areas or piggeries)	12.00
Offensive trades premises (other than those referred to above)	8.00
Cattle Saleyards	10.00
Boarding Houses	8.00
Common Lodging Houses	8.00
Eating Houses	8.00
Apartment Houses—	
containing not more than one apartment	4.00
containing more than one apartment	8.00
Camping areas	2.00
Food premises—	
(i) where not more than five persons (including the proprietor and his family) are employed	5.00
(ii) where more than five such persons are employed additional for each person in excess of five	0.50
Provided that the maximum fee payable shall be	100.00
Food Vending Machines operated by—	
(i) one or two cents a sale	0.50
(ii) a coin or coins in excess of two cents in value a sale	2.00
Hairdressers' shops, beauty parlors or other like establishments and Chiropodists' establishments	5.00

4. The fee for any transfer of registration shall be One dollar or 50% of the registration fee (whichever is the lesser amount).

5. (a) Where application for the renewal of registration is not lodged with the Council until after the last day fixed for the lodging thereof, an additional fee equal to one-half of the relevant prescribed fee shall be paid.

(b) The last day for lodging applications for renewal of registration shall be the 1st day of November in the year preceding the year for which such registration is requested.

This By-law shall apply to and have operation throughout the whole of the municipal district of the Shire of Stawell.

Resolution for making and passing this By-law agreed to by the Council on the 6th day of June, 1967 and confirmed this 4th day of July, 1967.

The common seal of the President, Councillors and Ratepayers of the Shire of Stawell was hereunto affixed, in the presence of—

(SEAL) C. J. HUTCHINGS, President.  
E. W. GILES, Councillor.  
V. C. NIELSEN, Shire Secretary.

Submitted to the Commission of Public Health on the 12th September, 1967.—A. T. GARDNER, Secretary, Commission of Public Health.

Approved by the Governor in Council, 17th October, 1967.—J. ROSSITER, Clerk of the Executive Council. 1933

SHIRE OF TUNGAMAH WATERWORKS TRUST.

APPOINTMENT OF PROSECUTING OFFICER.

NOTICE is hereby given that First Constable Vernon Duncan Barnes was appointed Prosecuting Officer to the Shire of Tungamah Waterworks Trust at a meeting held on 13th November, 1967.

M. CLEARY, Trust Secretary.

29th March, 1968. 2049

SHIRE OF WERRIBEE.

BY-LAW No. 54.

NOTICE is given that in pursuance of the provisions of the Health Act 1958, the Council of the Shire of Werribee has made By-Law No. 54 for the purpose of:—

1. Repealing By-Law No. 52.
2. Fixing fees to be charged for the registration, annual renewal of registration and transfer of registration of premises and food vending machines.

The resolution for making the By-Law was made on the 26th October, 1967, and confirmed on the 14th December, 1967.

The By-Law was submitted to the Commission of Public Health on the 13th February, 1968, and approved by the Governor in Council on the 20th February, 1968.

A copy of the By-Law is open for inspection, free of charge, during Office hours at the Municipal Offices, Werribee.

N. G. MINNS, Shire Secretary.

AS from 29th March, 1968, the partnership of Drs. P. A. Crooke, A. W. Hopper and B. D. Amos, carried on at 197 Gilbert-road, Preston, shall be terminated.

The practice at the above address shall, from this date, be carried on by Drs. P. A. Crooke and A. W. Hopper.

BRUCE D. AMOS.  
P. A. CROOKE.  
A. W. HOPPER.

1991

NOTICE is hereby given that the partnership heretofore subsisting between Gilchrist Lundberg, of 37 Barkley-street, Box Hill and Leonard George Bright, of 1 Barrington-street, East Bentleigh, and Adrian Lindsay Bright, of Centre-road, Oakleigh, carrying on business as road and drainage construction contractors, under the name of "Lundberg Bright and Son", at 37 Barkley-street, Box Hill, has been dissolved as and from the 18th day of March, 1968.

G. LUNDBERG.  
L. G. BRIGHT.  
A. L. BRIGHT.

David Bullard, solicitor, 443 Law Courts-place, Melbourne. 1986

NOTICE is hereby given that the partnership heretofore subsisting between Vivian Basil Smith, of 18 Grant-street, Newtown, Geelong, in the State of Victoria, motor trimmer, and Clifford Henry Graham, of 5 Logan-street, West Geelong, in the said State, motor trimmer, carrying on business at 14 Gordon-avenue, Geelong West, under the firm name of "Geelong Car Upholstery Services", has been dissolved by mutual consent as from the 29th day of February, 1968. All debts due and owing by the said firm will be received and paid respectively by the said

Vivian Basil Smith, who will carry on the business of motor trimmer, at 14 Gordon-avenue, Geelong West, in the said State.

Dated the 23rd day of March, 1968.

V. B. SMITH.

Signed in Victoria by the said Vivian Henry Graham, presence of—H. T. HELWIG.

C. H. GRAHAM.

Signed in Victoria by the said Clifford Henry Graham, in the presence of H. T. HELWIG. 1990

**T**AKE notice that the partnership carried on by Moise Sauberman and Regina Sauberman, both of 20 Orrong-crescent, Caulfield, and Bernat Neumann and Marta Neumann, both formerly of 14 Milton-street, Elwood, but now of 311 Carlisle-street, St. Kilda, under the firm name of Sene Constructions, at 20 Orrong-crescent, Caulfield, was duly dissolved on the 22nd day of March, 1968.

Dated this 22nd day of March, 1968.

Signed by the said Moise Sauberman and Regina Sauberman—

M. SAUBERMAN.  
R. SAUBERMAN.

in the presence of: SERGE SAUBERN, solicitor, 17 Queen-street, Melbourne.

Signed by the said Bernat Neumann and Marta Neumann—

B. NEUMANN.  
M. NEUMANN.

in the presence of: SERGE SAUBERN, solicitor, 17 Queen-street, Melbourne.

Slonim Velik & Emanuel, incorporating Morgan Fyffe & Mulkearns, 17 Queen-street, Melbourne. 2023

**N**OTICE is hereby given that the partnership heretofore subsisting between Alexander William Stewart and Beatrice Sandra Stewart, of 6 Heyington-place, Toorak, with respect to racehorses and horse-racing, has been dissolved by mutual consent, as from the 10th day of March, 1968.

Dated the 1st day of April, 1968.

A. W. STEWART.

2078

BEATRICE SANDRA STEWART.

**N**OTICE is hereby given that the partnership herein-before subsisting between Eric Vincent Jones and Christophorus Antonious Kleiss, carrying on business as builders and agents, at 123 Ryrie-street, Geelong, in the State of Victoria, under the style or firm of "C.A.K. Homes", has been dissolved by mutual consent as from the 31st day of December, 1967, and from that date the said Christophorus Antonious Kleiss continued to carry on the said business under the style or firm of "C.A.K. Homes".

Dated the 28th day of March, 1968.

E. V. JONES.  
C. A. KLEISS.

Wighton & McDonald, 89 Myers-street, Geelong, solicitors for the said Eric Vincent Jones.

Wm. C. Ainsworth & Co., 71 Yarra-street, Geelong, solicitors for the said Christophorus Antonious Kleiss. 2047

**N**OTICE is hereby given that the partnership heretofore subsisting between John Marinopoulos and Paul Kenourgios and Anesti Yatras, carrying on the business of BU-T Distributors, on the premises at 309 Pigdon-street, North Carlton, in the State of Victoria, has been dissolved as from the 25th day of March, 1968, by the retirement of Anesti Yatras from the said business. All debts due and owing by the said business will be received and paid respectively by John Marinopoulos and Paul Kenourgios, who will continue to carry on the said business in the business name of BU-T Distributors.

HAINES, BLAKIE & POLITES, solicitors, 150 Queen-street, Melbourne. 2062

**N**OTICE is hereby given that on the 4th September, 1967, Elizabeth Mary Demaine, of 29 Ethel-avenue, Lalor, ceased to be a partner in the firm of J. A. & E. M. Demaine, trading as Roxana Autoport, at corner May-road and David-street, Lalor, and that since that date such business has been carried on solely by John Atkinson Demaine, of 29 Ethel-avenue, Lalor.

Dated this 1st day of April, 1968.

JOHN A. DEMAINE.  
E. M. DEMAINE.

Wm. Murray & Son, solicitors, 422 Collins-street, Melbourne. 2091

The Companies Act 1961.—In the matter of ELECTRIX (WHOLESALE) PTY. LTD. (in Liquidation).

**N**OTICE is hereby given that pursuant to section 272 of the Companies Act, a final meeting of the creditors of the above company will be held at the offices of Kennedy, Smail and Middlemiss, 296 Little Lonsdale-street, Melbourne, on Wednesday, 1st day of May, 1968, at 10 a.m.

Business.—To receive the liquidator's accounts.

Dated this 27th day of March, 1968.

A. M. HORSBURGH, Liquidator.

Kennedy, Smail & Middlemiss, 296 Little Lonsdale-street, Melbourne, 3000. 2063

The Companies Act 1961.—In the matter of ELECTRIX (VIC.) PROPRIETARY LIMITED (in Liquidation).

**N**OTICE is hereby given that pursuant to section 272 of the Companies Act a final meeting of the creditors of the above company will be held at the offices of Kennedy, Smail and Middlemiss, 296 Little Lonsdale-street, Melbourne, on Wednesday, the 1st day of May, 1968, at 10.30 a.m.

Business.—To receive the liquidator's accounts.

Dated this 27th day of March, 1968.

EDWARD RONALD SMAIL, Liquidator.

Kennedy, Smail and Middlemiss, 296 Little Lonsdale-street, Melbourne, 3000. 2064

The Companies Act 1961.—In the matter of C. & S. PROPRIETARY LIMITED (in Liquidation).

**N**OTICE is hereby given that pursuant to section 272 of the Companies Act a final meeting of the creditors of the above company will be held at the offices of Kennedy, Smail and Middlemiss, 296 Little Lonsdale-street, Melbourne, on Wednesday, the 1st day of May, 1968, at 11.30 a.m.

Business.—To receive the liquidator's accounts.

Dated this 27th day of March, 1968.

A. M. HORSBURGH, Liquidator.

Kennedy, Smail and Middlemiss, 296 Little Lonsdale-street, Melbourne, 3000. 2066

The Companies Act 1961.—In the matter of ELECTRIX (HOLDINGS) PROPRIETARY LIMITED (in Liquidation).

**N**OTICE is hereby given that pursuant to section 272 of the Companies Act a final meeting of the creditors of the above company will be held at the offices of Kennedy, Smail and Middlemiss, 296 Little Lonsdale-street, Melbourne, on Wednesday, the 1st day of May, 1968, at 11 a.m.

Business.—To receive the liquidator's accounts.

Dated this 27th day of March, 1968.

N. E. STRETTON, Liquidator.

Kennedy, Smail and Middlemiss, 296 Little Lonsdale-street, Melbourne, 3000. 2065

The Companies Act 1961.—In the matter of K. C. BATTY PTY. LTD. (in Liquidation).

**N**OTICE is hereby given that a First Dividend is intended to be declared in this matter. Creditors who have not proved their debts by the 17th day of April, 1968, will be excluded from the dividend.

Dated this 27th day of March, 1968.

N. E. STRETTON, Liquidator.

Kennedy, Smail & Middlemiss, 296-300 Little Lonsdale-street, Melbourne, 3000. 2067

Companies Act 1961.—In the matter of C. M. TIMMONS PTY. LTD.—Notice re Meeting of Creditors, Pursuant to Section 260.

**N**OTICE is hereby given that a meeting of creditors of the above-named company will be held at the Board Room, Honorary Justices Association, 34 Queen-street, Melbourne, at 10.30 a.m. on Tuesday, the 9th day of April, 1968, the company having convened a meeting of its members for the same day for the purpose of considering a Resolution that the company be wound up voluntarily.

Dated the 26th day of March, 1968.

CHARLES M. TIMMONS, Director.

A. Neville Bird & Co., chartered accountants, 289 Flinders-lane, Melbourne. Telephone No. 63 8833. 2069



## Unclaimed Moneys Act 1962.

## REGISTER of Unclaimed Moneys held by the—

Name of Owner on Books and Last Known Address.	Total Amount Due to Owner.	Description of Unclaimed Moneys.	Date when Amount first became Payable.
\$			
G. J. COLES AND COY. LIMITED.			
Baird, Maxwell F., Mountain Highway, Bayswater .. .. .	15.05	Dividend .. .. .	3.9.66
Brock, Kathleen M. (Mrs.), 101 Dendy-street, Brighton .. .. .	14.00	" .. .. .	" .. .. .
Cleland, Marion R. (Mrs.), Flat 10, 162 Power-street, Hawthorn .. .. .	22.05	" .. .. .	" .. .. .
Cribbes, Harold D., 24A High-street, Kyreton .. .. .	15.05	" .. .. .	" .. .. .
Dickenson, Audrey J. (Miss), 245 Kooyong-road, Toorak .. .. .	80.85	" .. .. .	" .. .. .
Mayne, Peter C., 16 James-street, Geelong .. .. .	11.55	" .. .. .	" .. .. .
Patullo, Gladys W. (Mrs.), 146 Gordon-street, West Coburg .. .. .	15.40	" .. .. .	" .. .. .
Renard, Clement J., 65 Manning-road, East Malvern .. .. .	28.35	" .. .. .	" .. .. .
Watkins, Mary (estate of), c/o H. P. R. Morganti, 191 McKean-street, North Fitzroy .. .. .	10.15	" .. .. .	" .. .. .
Cato, Roy C., 31 Trevitts-road, North Ryde, N.S.W. .. .. .	16.10	" .. .. .	" .. .. .
Dimarco, Joseph, 36 Cooper-avenue, Moorebank, N.S.W. .. .. .	15.40	" .. .. .	" .. .. .
Gre, Barbara (Mrs.), 11 Shirley-road, Wollstonecraft, N.S.W. .. .. .	14.35	" .. .. .	" .. .. .
Hendry, Lila (Miss), c/o Walter Dickson and Co., 75-77 Pitt-street, Sydney, N.S.W. .. .. .	19.25	" .. .. .	" .. .. .
Higgins, Florence M. (Mrs.), 67 Kincaid-street, Wagga Wagga, N.S.W. .. .. .	15.40	" .. .. .	" .. .. .
Johnston, Jack H., 139 Talbragar-street, Dubbo, N.S.W. .. .. .	12.60	" .. .. .	" .. .. .
Kingsford, Suzanne (Mrs.), 7 Edward-street, Wollongong, N.S.W. .. .. .	15.05	" .. .. .	" .. .. .
Mathews, Gertrude (estate of), Mathews, J. R., and Mathews, R. K., c/o Mark Murray, 26 O'Connell-street, Sydney, N.S.W. .. .. .	11.55	" .. .. .	" .. .. .
Morris, Hazel M. (estate of), c/o Fred W. Beehag, 37 Seven Ways, Rockdale, N.S.W. .. .. .	10.15	" .. .. .	" .. .. .
Saffler, Valerie G. (Mrs.), Flat 61, 355 Old South Head-road, North Bondi, N.S.W. .. .. .	30.10	" .. .. .	" .. .. .
Staniforth, Henry B., 11 Brisbane-street, Cowra, N.S.W. .. .. .	46.90	" .. .. .	" .. .. .
Collingridge, Hugh J., c/o Midland Bank Ltd., 38 North-street, Bishop's Stortford, Herts, England .. .. .	32.72	" .. .. .	" .. .. .
Collingridge, Philippa M., c/o Midland Bank Ltd., 38 North-street, Bishop's Stortford, Herts, England .. .. .	32.72	" .. .. .	" .. .. .
Levy, John A. and Levy, William C., 13 Clifford-road, New Barnet, Herts, England .. .. .	18.15	" .. .. .	" .. .. .
Lewis, Brian C., Doric House, 39 Shirley Hill-road, Addington, Surrey, England .. .. .	10.41	" .. .. .	" .. .. .
Spring, Joan K. (Miss), The Manor House, Chorley Wood Common, Herts, England .. .. .	49.09	" .. .. .	" .. .. .
Finlay, Jessie M. (Miss), 17 Giles-street, Kingston, Canberra, A.C.T. .. .. .	28.70	" .. .. .	" .. .. .
Alexander, Lionel E. (estate of), c/o Salek, Turner and Brown, P.O. Box 2696, Wellington, C.I., N.Z. .. .. .	28.26	" .. .. .	" .. .. .
Alexander, Sylvia E. (Mrs.), 10 Hillier-street, Christchurch, N.Z. .. .. .	23.20	" .. .. .	" .. .. .
Anderson, Marjory F. (Mrs.), c/o East Coast Permanent Trustees Ltd., McCulloch Butler and Spense, P.O. Box 524, Wellington, N.Z. .. .. .	39.27	" .. .. .	" .. .. .
Ashby, Frederick J. (estate of), c/o A. H. Cavell, Leitch and Pringle, cnr. Hereford and Manchester streets, Christchurch, N.Z. .. .. .	23.50	" .. .. .	" .. .. .
Coxon, William W. W., 34 Power-street, Levin, N.Z. .. .. .	48.49	" .. .. .	" .. .. .
Ellis, Mary A., Lees-road, Taradale, Napier, N.Z. .. .. .	18.44	" .. .. .	" .. .. .
Falkner, Harold W., 81 Ranui-terrace, Wellington, N.Z. .. .. .	21.42	" .. .. .	" .. .. .
Hayes, Denise M. (Mrs.), 11 Banks-avenue, Christchurch, N.Z. .. .. .	24.40	" .. .. .	" .. .. .
Livingstone, Robert R., 11 Holmwood-road, Christchurch, N.Z. .. .. .	30.05	" .. .. .	" .. .. .
McNeilly, Joan (Mrs.), P.O. Box 2178, Tauranga South Post Office, Tauranga, N.Z. .. .. .	16.96	" .. .. .	" .. .. .
Roydhouse, Garth S., P.O. Box 1367, Wellington, N.Z. .. .. .	12.79	" .. .. .	" .. .. .
Sclanders, Kathleen M. (estate of), Fell and Harley, P.O. Box 28, Nelson, N.Z. .. .. .	16.36	" .. .. .	" .. .. .
Silver, William C. A., R. D. 3, New Plymouth, N.Z. .. .. .	22.91	" .. .. .	" .. .. .
Whisker, Mary C. (Miss), c/o The Public Trust Officer of N.Z., 147 Albert-street, Auckland, N.Z. .. .. .	45.52	" .. .. .	" .. .. .
Wood, E. Norman, 27 Princess-street, Palmerston North, N.Z. .. .. .	22.61	" .. .. .	" .. .. .
Young, Laura L. R. (estate of), c/o Rowe and O'Sullivan, P.O. Box 479, Palmerston North, N.Z. .. .. .	16.96	" .. .. .	" .. .. .
Bayly, Hally M. B. (Miss), c/o Mary Ogilvie Home Society, 51 Pirie-street, New Town, Tas. .. .. .	17.50	" .. .. .	" .. .. .
Morgan, Jack W., 43 Burnett-street, North Hobart, Tas. .. .. .	28.00	" .. .. .	" .. .. .
Oldham, Desmond T., P.O. Box 551, Launceston, Tas. .. .. .	10.15	" .. .. .	" .. .. .
Flynn, Patrick, 29 Payne-street, Milton, Qld. .. .. .	10.50	" .. .. .	" .. .. .
Hogan, Geoffrey S., 56 Bellevue-terrace, Clayfield, Brisbane, Qld. .. .. .	10.15	" .. .. .	" .. .. .
Murray, John C., Crichton-street, Yerongpilly, Qld. .. .. .	22.05	" .. .. .	" .. .. .
Shannon, Charles H. C., 44 McCaul-street, Taringa, Qld. .. .. .	10.50	" .. .. .	" .. .. .
Williams, Herbert (estate of), c/o Heiser, Bayly and Behan, G.P.O. Box 234d, Brisbane, Qld. .. .. .	37.10	" .. .. .	" .. .. .
Winrow, Frederick J., 119 West-street, Mt. Isa, Qld. .. .. .	16.45	" .. .. .	" .. .. .
Armstrong, John W. (estate of), c/o J. W. Armstrong, G.P.O. Box N1012, Perth, W.A. .. .. .	20.30	" .. .. .	" .. .. .
Grierson, Reginald J., 15 Birchwood-avenue, Double View, W.A. .. .. .	15.40	" .. .. .	" .. .. .
Silbert, Suzanne R. (Mrs.), 28 Kylie-street, Wembley Downs, W.A. .. .. .	10.15	" .. .. .	" .. .. .
Crompton, Alfred O. (estate of), c/o Murray, Cudmore, Worth and Isaachsen, 35 Grenfell-street, Adelaide, S.A. .. .. .	30.80	" .. .. .	" .. .. .
Alexander, Noel W., 1353 Gregory-street, Wendouree .. .. .	12.60	" .. .. .	" .. .. .
Mogg, Marilyn A. (Miss), 30 Hawthorn Glen, Hawthorn .. .. .	17.60	" .. .. .	4.3.67
Renard, Clement J., 65 Manning-road, East Malvern .. .. .	16.20	" .. .. .	" .. .. .
Bingle, Isabel J. (Mrs.), c/o W. F. Allworth and Sons, G.P.O. Box 979, Sydney, N.S.W. .. .. .	23.60	" .. .. .	" .. .. .
Bradford, Ian H. and Bradford, Graeme F., "Carrigan Park", Deniliquin, N.S.W. .. .. .	14.40	" .. .. .	" .. .. .
Cooper, Sidney (estate of), c/o Lawrence F. Tanna and Co., 203 Castlereagh-street, Sydney, N.S.W. .. .. .	15.00	" .. .. .	" .. .. .

Unclaimed Moneys Act 1962.

REGISTER of Unclaimed Moneys held by the—

Name of Owner on Books and Last Known Address.	Total Amount Due to Owner.	Description of Unclaimed Moneys.	Date when Amount first became Payable.
§			
G. J. COLES AND COY. LIMITED.— <i>continued.</i>			
Fulton, Hallam B., 6 Cotswold-road, Strathfield, N.S.W. . . . .	13.20	" .. .. .	4.3.67
Hughes, Helen J. (Miss), 58 Epping-road, Double Bay, N.S.W. . .	14.20	" .. .. .	"
Julhan Pty. Limited, c/o Julius N. Hanson Pty. Ltd., 12 Boundary-street, Redfern, N.S.W.	20.00	" .. .. .	"
Lockhart, Margaret H. (Mrs.), c/o J. S. Lockhart, Selbourne Chambers, 174 Phillip-street, Sydney, N.S.W.	20.00	" .. .. .	"
Miller, Malcolm M. (estate of), and Miller, Florance M. (Mrs.), Akuna, Wentworth, N.S.W.	14.40	" .. .. .	"
Nettlefold, Ernest A. (estate of), c/o Permanent Trustee Co. of N.S.W. Ltd., 23-25 O'Connell-street, Sydney, N.S.W.	89.40	" .. .. .	"
Saffer, Valerie G. (Mrs.), Flat 61, 355 Old South Head-road, North Bondi, N.S.W.	17.20	" .. .. .	"
Hawkins, George A., and Hawkins, Thomas G. G., New Line-road, West Pennant Hills, N.S.W.	26.80	" .. .. .	"
Collingridge, Hugh J., c/o Midland Bank Ltd., 38 North-street, Bishop's Stortford, Herts, England	18.70	" .. .. .	"
CConnell, Susan M. (Miss), c/o Barclays Bank, Sandwich, Kent, England	10.88	" .. .. .	"
Levy, John A. and Levy, William C., 13 Clifford-road, New Barnet, Herts, England	10.37	" .. .. .	"
Alexander, Lionel E. (estate of), c/o Salek, Turner and Brown, P.O. Box 2696, Wellington, C.I., N.Z.	16.15	" .. .. .	"
Alexander, Sylvia E. (Mrs.), 10 Hillier-street, Christchurch, N.Z. . .	13.26	" .. .. .	"
Anderson, Marjory F. (estate of), East Coast Permanent Trustees Ltd., McCulloch Butler and Spense, P.O. Box 524, Wellington, C.I., N.Z.	22.44	" .. .. .	"
Bull, Peter M. M., "Brooklands", R.D. 1, Ngaruawahia, N.Z. . . .	11.39	" .. .. .	"
Coxon, William W. W., 34 Power-street, Levin, N.Z. . . . .	27.71	" .. .. .	"
Ellis, Mary A., Lees-road, Taradale, Napier, N.Z. . . . .	10.54	" .. .. .	"
Hussey, Gordon J., P.O. Box 292, Wanganui, N.Z. . . . .	21.59	" .. .. .	"
Hussey, James K., c/o Jack, Riddet, Rennie and Forbes, P.O. Box 5, Wanganui, N.Z.	82.11	" .. .. .	"
Livingstone, Robert R., 11 Holmwood-road, Christchurch, N.Z. . .	17.17	" .. .. .	"
Reichmann, Leontine (Mrs.), 16 Ruarangi-road, Mt. Albert, Auckland, N.Z.	20.91	" .. .. .	"
Ross, George (estate of), c/o Mondy, Stephens and Caudwell, P.O. Box 426, Dunedin, N.Z.	29.92	" .. .. .	"
Silver, William C. A., R.D. 3, New Plymouth, N.Z. . . . .	13.09	" .. .. .	"
Uren, Rupert W. (estate of), c/o McGarth and Blennerhasset, P.O. Box 757, Wellington, N.Z.	54.06	" .. .. .	"
Wood, E. Norman, 27 Princess-street, Palmerston North, N.Z. . . .	12.92	" .. .. .	"
Morgan, Jack W., 43 Burnett-street, North Hobart, Tas. . . . .	16.00	" .. .. .	"
Armstrong, John W. (estate of), c/o J. W. Armstrong, G.P.O. Box N1012, Perth, W.A.	11.60	" .. .. .	"
Stiles, Sarah (Mrs.), Flat 9, 14 Walsh-street, Ormond . . . . .	30.91	Balance of wages and holiday pay	15.11.66
Chivers, Pearl (Mrs.), 3 Rich-street, Noble Park . . . . .	23.92	Holiday Pay	20.1.67
Faull, Helen J. (Mrs.), 226 Station-street, Carlton . . . . .	14.77	Balance of wages and holiday pay	21.1.67
MacRobertsons Pty. Ltd., Melbourne . . . . .	181.32	Goods/Service	17.1.66
Mores Bakery, Brisbane, Qld. . . . .	25.76	" .. .. .	1.6.66
Moses, M. (estate of), Adelaide, S.A. . . . .	18.00	" .. .. .	4.10.66
	18.00	" .. .. .	"
	20.70	" .. .. .	14.2.67
Sheehan, A. W., Melbourne . . . . .	15.00	" .. .. .	21.2.67
Riverina Bottlers, Sydney, N.S.W. . . . .	33.20	" .. .. .	2.3.67
Laughton, Diana M. (Mrs.), c/o James Watson and Co., Copthall House, 13 Copthall-avenue, London, England	14.09	B. A. Langford, Trust A/c., London	31.1.67
Levy, John A. and Levy, William C., 13 Clifford-road, New Barnet, Herts, England	36.62	" .. .. .	"

1746

ALCOA OF AUSTRALIA PTY. LTD.

Jelenik, M., 193 Donnybrook-road, Norlane, Geelong . . . . .	56.85	Wages	16.1.66
BeEVERS, R., c/o A. W. Gray, 17 Heath-street, Southport, Queensland . .	20.23	" .. .. .	29.5.66
Tijuana, D., 2 Finch-street, Norlane, Geelong . . . . .	28.42	" .. .. .	18.6.66

1725

I. A. C. (HOLDINGS) LIMITED.

Cooper, G. (Mrs.), 18 Walsingham-road, Enfield, Middlesex, U.K. . . .	37.40	Ordinary dividend	{ —.4.66 —10.66 —4.66
Horne, E. M. (Mrs.), 434 Queens-parade, Clifton Hill . . . . .	15.36	" .. .. .	{ —.4.66 —10.66 —4.66
Philpott, R. E., 25 Weeroona-avenue, Bendigo . . . . .	12.00	" .. .. .	{ —.4.66 —10.66 —4.66
Reid, David J., 108 Howitt-street, Ballarat . . . . .	12.00	" .. .. .	{ —.4.66 —10.66 —4.66
Ward, Doreen P. (Mrs.), 46 Hardmans-road, Whitefield, Manchester, U.K.	15.52	" .. .. .	{ —.4.66 —10.66 —4.66
Watson, G. I. R., Elmore-avenue, Croydon . . . . .	12.00	" .. .. .	{ —.4.66 —10.66 —4.66

1780

## Unclaimed Moneys Act 1962.

## REGISTER of Unclaimed Moneys held by the—

Name of Owner on Books and Last Known Address.	Total Amount Due to Owner.	Description of Unclaimed Moneys.	Date when Amount first became Payable.
\$			
NATIONWIDE FINANCE LIMITED.			
Laneways Pty. Ltd., Raglan-parade, Warrnambool .. .. .	15.37	Dividend .. .. .	5.10.64
Grattan, Humphrey W., 882 Glenferrie-road, Kew .. .. .	35.00	" .. .. .	31.3.65
Grattan, Mable I. (Mrs.), 882 Glenferrie-road, Kew .. .. .	17.50	" .. .. .	" .. .. .
Hill, W. H. (estate of), c/o W. R. Richards, 9 Beech-street, East Malvern .. .. .	11.25	Interest .. .. .	31.5.65
Morton, John S., 36 Craigmores-street, Darling .. .. .	40.00	" .. .. .	" .. .. .
Parris, Keith G., Blayney-street, Nagambie .. .. .	14.00	" .. .. .	" .. .. .
Adams, Leslie B., 39 Hibiscus-road, Blackburn North .. .. .	10.50	Dividend .. .. .	4.10.65
Courtney, Kevin D., 505 Collins-street, Melbourne .. .. .	17.50	" .. .. .	" .. .. .
Mathews, Donald A., Lydiards-road, Traralgon .. .. .	10.50	" .. .. .	" .. .. .
Sussens, Antonie, 21 Rockbeare-grove, Ivanhoe .. .. .	17.50	" .. .. .	" .. .. .
Watts, M. (estate of), c/o G. F. Pitcher and Co., 406 Lonsdale-street, Melbourne .. .. .	52.50	" .. .. .	" .. .. .
Dennis, Catherine (Mrs.), 52 Galeka-street, Merlynston .. .. .	18.75	Interest .. .. .	30.11.65
Hope, C. D. S. (Mrs.), 51 Barkly-street, Mornington .. .. .	12.75	" .. .. .	" .. .. .
Murray, Sheila E. (Miss), 10 Calvert-avenue, Killara, N.S.W. .. .. .	16.00	" .. .. .	" .. .. .
Eldershaw, George M., 4 Arden-road, Pymble, N.S.W. .. .. .	12.00	" .. .. .	28.2.66
Hope, Christine D. S. (Mrs.), 51 Barkly-street, Mornington .. .. .	12.75	" .. .. .	" .. .. .
Lissiman, Effie M. (Mrs.), 6 Colin-street, Nedlands, W.A. .. .. .	16.00	" .. .. .	" .. .. .
Watts, M. (estate of), c/o G. F. Pitcher and Co., 406 Lonsdale-street, Melbourne .. .. .	52.50	Dividend .. .. .	31.3.66
Curry, Michael I., 6 Remy-court, 641 Malvern-road, Toorak .. .. .	37.50	Interest .. .. .	31.5.66
McCaul, Phyllis E. (Mrs.), 3A Wilson-terrace, Da Costa Park, East Glenelg, S.A. .. .. .	50.00	" .. .. .	" .. .. .
Mathews, Donald A., Lydiards-road, Traralgon .. .. .	10.50	Dividend .. .. .	4.10.66
Watts, M. (estate of), c/o G. F. Pitcher, 406 Lonsdale-street, Melbourne .. .. .	52.50	" .. .. .	" .. .. .
Curry, Michael I., 6 Remy-court, 641 Malvern-road, Toorak .. .. .	37.50	Interest .. .. .	31.8.66
McCaul, Phyllis E. (Mrs.), 3A Wilson-terrace, Da Costa Park, East Glenelg, S.A. .. .. .	37.50	" .. .. .	30.11.66
McCaul, Phyllis E. (Mrs.), 3A Wilson-terrace, Da Costa Park, East Glenelg, S.A. .. .. .	50.00	" .. .. .	31.8.66
Brown, Keith B., Sunningdale, 88 Kars-street, Frankston .. .. .	50.00	" .. .. .	30.11.66
McCaul, Phyllis E. (Mrs.), 3A Wilson-terrace, Da Costa Park, East Glenelg, S.A. .. .. .	40.00	" .. .. .	28.2.67
McCaul, Phyllis E. (Mrs.), 3A Wilson-terrace, Da Costa Park, East Glenelg, S.A. .. .. .	50.00	" .. .. .	" .. .. .
Weigall, Nancy G. (Mrs.), E.S. and A. Bank Limited, Box 89A, G.P.O., Melbourne .. .. .	21.25	" .. .. .	" .. .. .
Curry, Michael I., 6 Remy-court, 641 Malvern-road, Toorak .. .. .	2,037.50	Debenture Redemption and Interest .. .. .	" .. .. .
1930			
PETERSVILLE AUSTRALIA LIMITED.			
Baker, Gordon Charles, 61 Braeside-street, Wahroonga, N.S.W. .. .. .	12.00	Dividend .. .. .	7.4.66
Brereton, Charles Richard, Post Office, Gunbower .. .. .	14.00	" .. .. .	" .. .. .
Coghlan, Beatrice Maria (Miss), Flat 4, 4 Hayes-street, Neutral Bay, N.S.W. .. .. .	22.33	" .. .. .	14.11.66
Crowther, George (estate of), c/o L. Crowther and W. C. Schafer, c/o Aubrey Halloran, 28 Martin-place, Sydney, N.S.W. .. .. .	16.42	" .. .. .	" .. .. .
Elwell-Sutton, Rory Charles, 66 Swann-road, Taringa, Brisbane Queensland .. .. .	10.40	" .. .. .	" .. .. .
Hurst, Iris Vivienne (Mrs.), and John, 5 Gilpin-street, Camperdown, N.S.W. .. .. .	11.48	" .. .. .	7.4.66
Nicholas, Barbara Alice, (Mrs.) Culpha Estate, Mathoura, N.S.W. .. .. .	12.44	" .. .. .	14.11.66
Nicholas, Leonard Thomas, Culpha Estate, Mathoura, N.S.W. .. .. .	15.60	" .. .. .	" .. .. .
Oliver, Walter Scott (estate of), c/o Lancelot S. Hills and Co. 4 O'Connell-street, Sydney, N.S.W. .. .. .	15.60	" .. .. .	" .. .. .
Riddell, Florence Esme (Mrs.), Flat 10, 2 Collins-street, Melbourne .. .. .	337.74	" .. .. .	" .. .. .
Riddell, Florence Esme (Mrs.), Flat 10, 2 Collins-street, Melbourne .. .. .	24.00	" .. .. .	7.4.66
Riddell, Florence Esme (Mrs.), Flat 10, 2 Collins-street, Melbourne .. .. .	26.00	" .. .. .	14.11.66
Smith, Florence Emily (estate of), c/o E. C. Smith, 112 Marianne-way, Mt. Waverley .. .. .	43.20	" .. .. .	9.11.61
Stewart, Donald William Ross (estate of), c/o Lloyds Bank Ltd. Southborough, Tunbridge Wells, Kent, England .. .. .	11.05	" .. .. .	14.11.66
1938			
EMAIL LTD. (CONSUMER PRODUCTS DIVISION).			
Mutual Store Ltd., 256 Flinders-street, Melbourne .. .. .	153.50	Credit given for advertising allowance—Company now defunct .. .. .	—6.62
1939			
FORD MOTOR COMPANY OF AUSTRALIA LIMITED.			
Norman, B. C., 7 Banksia-road, Wendouree, Ballarat .. .. .	91.20	Wages .. .. .	—12.66
1966			
NOBEL (AUSTRALASIA) PTY. LTD.			
Reale, K., 181 Main-street, Bacchus Marsh .. .. .	34.64	Wages .. .. .	25.6.66
1967			
T. & G. NOMINEES PTY. LTD.			
Blake, Phyllis May (Mrs.), Horsham .. .. .	104.75	Principal and interest due on debenture stock .. .. .	30.11.66
1971			

## Unclaimed Moneys Act 1962.

## REGISTER of Unclaimed Moneys held by the—

Name of Owner on Books and Last Known Address.	Total Amount Due to Owner.	Description of Unclaimed Moneys.	Date when Amount first become Payable
\$			
IMPERIAL CHEMICAL INDUSTRIES OF AUSTRALIA AND NEW ZEALAND LIMITED.			
Clarke, B. L. W., E. E. Dunlop, C. Green, C. T. Newman, R. Piggott and H. B. Taylor, 12 Wood-street, Manly, N.S.W.	90.00	Preference Dividend No. 56 ..	31.7.66
Proverbs, Eleanor (Mrs.), c/o E. S. and A. Bank, Latrobe, S.A. . .	15.00	" " " " " " " "	" " " "
Clarke, B. L. W., E. E. Dunlop, C. Green, C. T. Newman, R. Piggott and H. B. Taylor, 12 Wood-street, Manly, N.S.W.	90.00	Preference Dividend No. 57 ..	31.1.67
Oliver, David J. (estate of), c/o Langley, Twigg, Doole, Cowley and Co., Box 606, Napier, N.Z.	12.75	" " " " " " " "	" " " "
Cook, Wayman M., 57 Patterson-street, Concord, N.S.W. . .	13.50	Interest 31 ..	31.5.66
Young, Janet I. N. (Mrs.), 38 Langside-road, Hamilton, Qld. . .	18.00	" " " " " " " "	" " " "
Burton, Lucas J. H. (Mrs.), I. Burton and A. Appelbe, 7 New Square, Lincoln's Inn, London, U.K.	42.00	Interest 05 ..	30.11.66
Hollis-Bee, R. J. (estate of), c/o Pearce and Webster, 430 Little Collins-street, Melbourne	31.25	" " " " " " " "	" " " "
Ingate, Iris D. (estate of), c/o M. G. Tuxford, 14 Kings-road, Brighton-le-Sands, N.S.W.	16.00	" " " " " " " "	" " " "
Statton, Florence A. (estate of), c/o Mr. J. W. Statton, 7 Abbotshill-road, Hawthorn, S.A.	21.00	" " " " " " " "	" " " "
Walker, Janet L. (Mrs.), 7 Berambil, 129 Bower-street, Manly, N.S.W.	92.50	" " " " " " " "	" " " "
Bull, Peter M. M., Brooklands, Ngaruawahia, N.Z. . .	15.75	Ordinary Dividend 30 ..	28.12.65
Carroll, Hazel E. (Miss), 32 Rusden-street, Elsternwick ..	14.00	" " " " " " " "	" " " "
Chase, Cicely M. (Mrs.), c/o A.N.Z. Bank, Piccadilly, London, U.K.	19.95	" " " " " " " "	" " " "
Darken, John H., 19 The Grange, East Malvern ..	24.02	" " " " " " " "	" " " "
Griffin, Norman C. and Frank A., 28 Waterloo-road, Wellington, Somerset, U.K.	10.72	" " " " " " " "	" " " "
Handbury, Alan J., c/o 224 Queen-street, Melbourne ..	21.00	" " " " " " " "	" " " "
Hancock, Dudley G. and Mrs. Evelyn B. Hancock, 3 Palfrey-avenue, Upper Hutt, N.Z.	15.13	" " " " " " " "	" " " "
Johnson, Irene (Mrs.), 58 Centre-street, Invercargill, N.Z. . .	16.42	Ordinary Dividend 30 ..	28.12.65
Kennard, Edwin A. c/o Straits Times Press, Kuala Lumpur, Malaya	14.70	" " " " " " " "	" " " "
Kerrison, Sybil M. (Mrs.), c/o Barclays Bank, Piccadilly, London U.K.	51.91	" " " " " " " "	" " " "
Livingstone, Robert R., 11 Holmwood-road, Christchurch, N.Z. . .	11.12	" " " " " " " "	" " " "
Lyons, Alison C. (Mrs.), 2060 Goggill-road, Kenmore, Qld. . .	14.00	" " " " " " " "	" " " "
McCulloch, Sarah (Mrs.), Oamaru, N.Z. . .	10.53	" " " " " " " "	" " " "
MacKinnon, Donald, Marida Yallock, Boorcan ..	21.00	" " " " " " " "	" " " "
Moore, Lyall J., 36 Roseberry-road, Killara, N.S.W. . .	10.69	" " " " " " " "	" " " "
O'Dea, Marjory E. (Mrs.), 857 New South Head-road, Walgett, N.S.W.	10.57	" " " " " " " "	" " " "
Steel, Karola (Mrs.), 42 Fairfax-road, Bellevue Hill, N.S.W. . .	14.00	" " " " " " " "	" " " "
Thurlow, Ronald A. S. and Mrs. Mary D. Pritchard, 129 York-street, Sydney, N.S.W.	17.50	" " " " " " " "	" " " "
Zador, Patricia (Miss), (address unknown) ..	10.50	" " " " " " " "	" " " "
McQuillen, Maude A. (Mrs.), c/o Burns Philp Trust Co. Ltd., 7 Bridge-street, Sydney, N.S.W.	21.81	Ordinary Dividend 31 ..	1.3.66
Turton, Charles E., Harold A. Wardle and George Clark, c/o Turton Ross and Co., 91 Talbot-street, Nottingham, U.K.	19.41	" " " " " " " "	" " " "
Wedderburn, Laurence D. M. (estate of), c/o Blake and Riggall, 120 William-street, Melbourne	13.88	" " " " " " " "	" " " "
Alford, Marion (Mrs.), 34 Wolsley-road, Mosman, N.S.W. . .	84.23	Ordinary Dividend 32 ..	1.9.66
Bull, Muriel E. (Mrs.), c/o P.O. Box 312, Auckland, N.Z. . .	28.63	" " " " " " " "	" " " "
Crow, Robert C., P.O. Box 29, Kaiapoi, N.Z. . .	31.62	" " " " " " " "	" " " "
Fletcher, Frederick B. C., 39 Wetherill-street, Narrabeen, N.S.W. . .	12.00	" " " " " " " "	" " " "
Handbury, Alan J., 224 Queen-street, Melbourne ..	18.00	" " " " " " " "	" " " "
Leake, Eleanor F., 97 MacLeay-street, Potts Point, N.S.W. . .	32.10	" " " " " " " "	" " " "
Lemann, Jane A. (Mrs.), Milton Park, Bowral, N.S.W. . .	13.46	" " " " " " " "	" " " "
Monckton, Elizabeth (Miss), Ingle-avenue, P.O. Taupo, N.Z. . .	40.82	" " " " " " " "	" " " "
Murray, Evelyn J. K. (Mrs.), P.O. Box 133, Balclutha, N.Z. . .	15.30	" " " " " " " "	" " " "
Robinson, Alexandra M. (Mrs.), 12 Head-street, Strathmore	11.91	" " " " " " " "	" " " "
Taylor, Cynthia V. (Mrs.), Hartham Farm, Corsham, Wilts., U.K.	25.53	" " " " " " " "	" " " "
Hope, Harriet (Mrs.), J. Hope and J. Armstrong, 61 Hailes Garden, Colinton, Edinburgh, Scotland	42.97	" " " " " " " "	" " " "
1937			
THE AUSTRALIAN MARITIME INDUSTRY LIMITED.			
Kidger, Alan N., Flat 16, 13 Kings Cross-road, Kings Cross, N.S.W.	14.70	Attendance Money ..	29.6.66
Steele, Arthur, 49 Park-street, St. Kilda ..	20.66	" " " " " " " "	26.10.66
Aspinall, John, 103 Victoria-street, Potts Point, N.S.W. . .	23.50	" " " " " " " "	" " " "
Smith, James, c/o Seamen's Union, Newcastle, N.S.W. . .	20.50	" " " " " " " "	28.4.66
Kirkpatrick, Norman, 105 Brooks-street, Bar Beach, N.S.W. . .	17.60	" " " " " " " "	9.5.66
Williams, Francis, 7 Charles-street, Abermaine, N.S.W. . .	17.60	" " " " " " " "	22.4.66
Green, Thomas, 30A Queens-street, Cooks Hill, N.S.W. . .	14.60	" " " " " " " "	16.9.66
Williams, George, R., c/o Seamen's Union, Fremantle, W.A. . .	20.50	" " " " " " " "	28.4.66
Hayman, Richard, 183 Bayswater-road, Rathmines, N.S.W. . .	11.70	" " " " " " " "	17.6.66
1968			
KUALA LUMPUR TIN NO LIABILITY.			
Brett, E. W. (Capt.), (address unknown) ..	244.00	Dividends ..	{ 30.6.61
Daly, A. J. (estate of) (address unknown) ..	47.40	" " " " " " " "	{ 31.3.62
Avery-Jones, H. T. (address unknown) ..	38.60	" " " " " " " "	" " " "
Meh Kim Hup (address unknown) ..	81.60	" " " " " " " "	" " " "
Morrison, K. (address unknown) ..	35.00	" " " " " " " "	" " " "
Penang Investments Ltd. (address unknown) ..	36.80	" " " " " " " "	30.6.61
1969			

## Unclaimed Moneys Act 1962.

## REGISTER of Unclaimed Moneys held by the—

Name of Owner on Books and Last Known Address.	Total Amount Due to Owner.	Description of Unclaimed Moneys.	Date when Amount first became Payable.
\$			
THE LONGWARRY AND DISTRICT DAIRYMEN'S CO-OPERATIVE ASSOCIATION LIMITED.			
Wootton, T. (Mrs.), 891 Rathdown-street, Carlton .. .. .	61.90	Dividend .. .. .	12.12.66
Watson, William James, Healesville .. .. .	61.90	" .. .. .	"
Speirs, James (estate of), Longwarry .. .. .	61.90	" .. .. .	"
Wright, Clifford (estate of), 6 Cecil-street, Kew .. .. .	61.90	" .. .. .	"
B. H. B. TIMBER PTY. LTD.			
Creeley, Arthur, c/o B. H. B. Timber, Heyfield .. .. .	15.35	Unclaimed wages .. .. .	21.2.67
THE EMU BAY RAILWAY COMPANY LIMITED.			
Aarons, John, 22 The Avenue, Windsor .. .. .	12.00	Ordinary dividends and/or preference dividends .. .. .	{ 3.5.66 18.10.66
Anderson, Edward L. (estate of), c/o E. H. Anderson, Moana-road, Days Bay, near Wellington, N.Z. .. .. .	34.92	" .. .. .	"
Bradshaw, Clarence E., 99 Queen-street, Melbourne .. .. .	15.00	" .. .. .	"
Brown, Elizabeth J. (Mrs.), c/o A. Brown, Godfrey-terrace, Seabrook, South Australia .. .. .	12.75	" .. .. .	"
Cameron, Andrew (estate of), c/o New Zealand Insurance Co. Ltd., P.O. Box 398, Invercargill, N.Z. .. .. .	19.13	" .. .. .	"
Cameron, Donald, P.O. Box 52, Rutherglen .. .. .	54.38	" .. .. .	"
Campbell, Allan, Young, New South Wales .. .. .	43.14	" .. .. .	"
Campbell, Captain Harper, "San Troprez", Avenue Elmers, Surbiton, England .. .. .	37.19	" .. .. .	"
Clota, Marcus (estate of), c/o Mrs. A. Cotter, 254 Beaconsfield-parade, Middle Park .. .. .	15.00	" .. .. .	"
Cohen, Neville D. (estate of), c/o E. L. Davis and Co., P.O. Box 2040, Sydney, N.S.W. .. .. .	32.63	" .. .. .	"
The Construction Co. of Aust. Ltd., 16 Barrack-street, Sydney, N.S.W. .. .. .	43.50	" .. .. .	"
Costlow, Charles, 19 York-street, Sydney, N.S.W. .. .. .	10.50	" .. .. .	"
Cox, Frank L. (estate of), c/o Mallesons, 105 King-street, Melbourne .. .. .	14.00	" .. .. .	"
Creighton, Frank A., Clarendon-street, Hamilton .. .. .	43.50	" .. .. .	"
Daly, Herbert J., c/o C. Templeton, 31 Queen-street, Melbourne .. .. .	59.45	" .. .. .	"
Elliget, Hugh J. (estate of), late of 91 Royal-parade, Parkville .. .. .	17.70	" .. .. .	"
Fairweather, F. J., Box 172, William-street, North Broken Hill, N.S.W. .. .. .	10.83	" .. .. .	"
Faviell, Harriet F. (estate of), c/o S. L. Parker, 1 Ord-street, West Perth, W.A. .. .. .	108.75	" .. .. .	"
Fraser, H. L. C., 34 Queen-street, Melbourne .. .. .	15.00	" .. .. .	"
Frecheville, William, 25 Phillimore Gardens, Lon'on, W.8 .. .. .	171.01	" .. .. .	"
Gale, Charles C., 26 Hunter-street, Sydney, N.S.W. .. .. .	37.46	" .. .. .	"
Gibbs, F. E. and Smith, J. W., 2 Great Winchester-street, London .. .. .	76.36	" .. .. .	"
Graham, Harold J. (estate of), c/o Mrs. A. I. H. Chatterton, 206 Kew-road, Richmond, Surrey, England .. .. .	13.60	" .. .. .	"
Gray, Alexander (estate of), c/o A. W. Gray and S. J. McGill, Little Malop-street, Geelong .. .. .	350.54	" .. .. .	"
Hallowes, Herbert C. (estate of), c/o Hardwicke Weedon, Launceston .. .. .	87.00	" .. .. .	"
Hawley, Annie (Mrs.), 10 Malvern-road, Malvern .. .. .	32.63	" .. .. .	"
Holden, Annette P. (Mrs.), Glen Prairie, Delungra, N.S.W. .. .. .	20.00	" .. .. .	"
Isaacs, John (estate of), c/o P. Isaacs and Co., 9 Hunter-street, Wellington, N.Z. .. .. .	12.75	" .. .. .	"
King, Thomas E., 69 Chancery-lane, Melbourne .. .. .	32.63	" .. .. .	"
Lilley, Alexander, 60 Queen-street, Melbourne .. .. .	15.00	" .. .. .	"
Miller, Everard S., "Glyn", Kooyong-road, Toorak .. .. .	18.00	" .. .. .	"
Miller, Mary (Mrs.), "Whernside", Albany-road, Toorak .. .. .	32.63	" .. .. .	"
Montgomery, Thomas, Mortlake .. .. .	108.75	" .. .. .	"
Moodie, John (estate of), 60 Queen-street, Melbourne .. .. .	43.50	" .. .. .	"
Moore, Ernest T., 360 Collins-street, Melbourne .. .. .	15.00	" .. .. .	"
McDonnell, Harvey J., 368 Collins-street, Melbourne .. .. .	15.00	" .. .. .	"
McPhee, Jane C. (Miss), 74 Auburn-road, Hawthorn .. .. .	32.63	" .. .. .	"
O'Connor, John, c/o Mr. Gosson, 19 Rathdown-road, Dublin, Ireland .. .. .	10.50	" .. .. .	"
Organ, Gordon P., Post Office, Stanhope .. .. .	15.00	" .. .. .	"
Phillips, Mary (Miss), c/o Bank of N.S.W., Fitzroy .. .. .	15.00	" .. .. .	"
Pye, David D. (estate of), c/o L. W. Pye, 9 Loftus-street, Sydney, N.S.W. .. .. .	65.25	" .. .. .	"
Rhodes, Sarah A. (estate of), c/o Moorhouse, Hadfield and Newman, Featherstone-street, Wellington, N.Z. .. .. .	13.60	" .. .. .	"
Rundle, Ernest S. (estate of), c/o Mr. V. Read, 133 King-street, Sydney, N.S.W. .. .. .	39.15	" .. .. .	"
Rushton, Frances I. (Mrs.), Zeehan, Tasmania .. .. .	15.00	" .. .. .	"
Shearn, Mary A. (Mrs.), 6 Patterson-street, Launceston, Tasmania .. .. .	15.00	" .. .. .	"
Speedie, Robert, c/o Australian Farms Ltd., 99 King-street Melb... .. .	152.25	" .. .. .	"
Stigant, Arthur E., Court House Hotel, Jamieson .. .. .	32.63	" .. .. .	"
Sutherland, John, 16 Borlase-street, Brooklyn, Wellington, N.Z. .. .. .	14.79	" .. .. .	"
Terry, Martha (Miss), 51 Hunter-street, Malvern .. .. .	10.83	" .. .. .	"
Thomson, George, Lathallan, Neutral Bay, N.S.W. .. .. .	65.25	" .. .. .	"
Tronson, Fairlie H. (estate of), c/o F. W. Parsons, Castlereagh-street, Sydney, N.S.W. .. .. .	47.37	" .. .. .	"
Waldie, James C. (estate of), c/o B. Allwood, 19 Ellen-street, Semaphore, S.A. .. .. .	11.25	" .. .. .	"
Walters, Edward E. (estate of), c/o Perpetual Executors and Trustees Association, 100 Queen-street, Melbourne .. .. .	130.50	" .. .. .	"
Watkin, Katherine J. (Mrs.), 273 George-street, Sydney, N.S.W. .. .. .	59.45	" .. .. .	"
Waxman, Samuel, 295 Swanston-street, Melbourne .. .. .	12.75	" .. .. .	"
Wilson, Francis (estate of), Boonah, Queensland .. .. .	21.67	" .. .. .	"
Woods, William F., (estate of), c/o D. Cameron, P.O. Box 52, Rutherglen .. .. .	15.00	" .. .. .	"

## Unclaimed Moneys Act 1962.

## REGISTER of Unclaimed Moneys held by the—

Name of Owner on Books and Last Known Address.	Total Amount Due to Owner.	Description of Unclaimed Moneys.	Date when Amount first became Payable.
§			
OVERSEAS CORPORATION (AUSTRALIA) LIMITED			
Wiles, Ralph J., c/o P.O. Box 209, Papapura, New Zealand ..	47.81	Dividend on Ordinary Shares	29.4.66
Knapman, Leslie G., c/o McIntyres Pharmacy, High-street, Wodonga ..	59.63	" " " "	" " "
	83.48	" " " "	31.10.66
Morgen, Kathleen H. (Mrs.), 1009 Malvern-road, Toorak ..	10.00	" " " "	29.4.66
	14.00	" " " "	31.10.66
Mowbray, John R., Whitemark, Flinders Island, Tasmania ..	12.50	" " " "	29.4.66
Blinkhorne, Shirley (Mrs.), Flat 1, 26 Belmore-street, Burwood, N.S.W.	14.28	" " " "	31.10.66
Leary, Donald (estate of), 127 Young-street, Annandale, N.S.W. ..	14.00	" " " "	" " "
Pallister, Alexander D., 1 Coveney-street, Bexley, N.S.W. ..	17.85	" " " "	" " "
Anderson, Keith D. (Dr.), 33 Chapel-street, St. Kilda ..	19.32	" " " "	" " "
Barber, Robert, 27 Florence-street, Carnegie, ..	19.68	" " " "	" " "
Perkins, Barbara (Mrs.), 10 Mitchell-street, West Darwin, N.T. ..	21.00	" " " "	" " "
Hughes, Vincent E., 9 Nautilus-crescent, Scarborough, W.A. ..	15.40	" " " "	" " "
1753			
I.A.C. LIMITED.			
Cropper, Nellie (Mrs.), Flat 1 162 Barkers-road, Hawthorn ..	225.00	Unsecured Notes Int. 6 months	28.2.66
	225.00	" " " "	31.8.66
	225.00	" " " "	28.2.67
1726			
BROKEN HILL SOUTH LIMITED			
<i>Victorian Register.</i>			
Ansell, Duncan L., 8 Burgandy-drive, Doncaster ..	24.00	Dividend No. 122 ..	2.12.66
Gilbert, Adeline M. (estate of), c/o C. T. Gilbert, Esq., 34 Queen-street, Melbourne	100.00	" " 121 ..	17.6.66
	120.00	" " 122 ..	2.12.66
Grimm, Martin J., c/o Grace National Bank of New York, Trust Dept., 7 Hanover-street, New York 5, New York, U.S.A.	51.00	" " 122 ..	2.12.66
Mould, Suzanne (Mrs.), Kondoolka Station, via Port Augusta, S.A. ..	25.00	" " 121 ..	17.6.66
Naughton, Martin P. (estate of), c/o J. C. Walsh & Sons, Montague-street, Goulburn, N.S.W.	75.00	" " 122 ..	" " "
	90.00	" " 122 ..	2.12.66
Nivison, Miss Sallyann P., c/o S. A. Kaaten, Esq., 62 Margaret-street, Sydney, N.S.W.	37.50	" " 121 ..	17.6.66
	45.00	" " 122 ..	2.12.66
Pooley, Gordon C., Pathungra Station, Winton, Qld. ..	18.75	" " 121 ..	17.6.66
	22.50	" " 122 ..	2.12.66
Shipham, William (Address unknown) ..	40.00	" " 121 ..	17.6.66
	48.00	" " 122 ..	2.12.66
Skinner, John K., P.O. Box 1205, Dunedin, New Zealand ..	8.50	" " 121 ..	17.6.66
	10.20	" " 122 ..	2.12.66
Swift, Malcolm, 82A Tinakori-road, Wellington, New Zealand ..	10.20	" " 122 ..	" " "
Watt, Prudence A. (Miss), 13 Asling-street, North Brighton, Vic. ..	18.00	" " 122 ..	" " "
<i>New South Wales Register.</i>			
Alford, Robert G., 34 Wolseley-road, Mosman, N.S.W. ..	15.00	" " 121 ..	17.6.66
	18.00	" " 122 ..	2.12.66
Griffin, Stephen, Flat 7, 20 Marlo-road, Cronulla, N.S.W. ..	10.00	" " 121 ..	17.6.66
McCrabb, Yvonne M. (Mrs.), "Avenel", Wanganella, via Deniliquin, N.S.W.	36.00	" " 122 ..	2.12.66
Trollope, Sir Anthony O. C., "Clavering", 77 Roseville-avenue, Roseville, N.S.W.	5.00	" " 121 ..	17.6.66
	6.00	" " 122 ..	2.12.66
Vessey, Jean (Miss), 80 Eyre-street, Townsville, Qld. ..	5.00	" " 121 ..	17.6.66
	6.00	" " 122 ..	2.12.66
<i>London Register.</i>			
Higgins, Fergus & Others, Treadwell House, Epsom, Surrey, U.K.	33.28	" " 122 ..	2.12.66
Linnett, Rae E. (Mrs.), 39 Davenant-road, Oxford, U.K. ..	11.07	" " 122 ..	" " "
Murphy, James B., c/o Munster & Leinster Bank Ltd., 2 Baggot-street, Dublin, 2. Eire.	10.50	" " 122 ..	" " "
1740			
V.I.A. LIMITED.			
Lemon, E. I. (Mrs.), c/o Mrs. Horton Lewis, Flat 7, 63 Wattle-road, Hawthorn	50.00	Preference dividend ..	31.3.66
Skews, W. T., 33 Guthrie-street, West Brunswick ..	10.00	Interim Ordinary dividend ..	29.7.66
Davey, L. M. (Mrs.), c/o Mr. John Davey, 53 Cascade-street, North Balwyn	15.00	Final " " ..	31.1.67
Jones, John C., 12 Virginia-street, Mt. Waverley ..	10.00	" " " " ..	" " "
Kirby, Sons & Daughters Pty. Ltd., 91A York-street, Sydney, N.S.W. ...	10.00	" " " " ..	" " "
Whiting, M. R., 14 Airlie-avenue, East Prahran ..	10.00	" " " " ..	" " "
Flenley, Sydney, High-street, Woodend ..	25.55	Unclaimed wages ..	26.4.66
Spittal, Bernard, 149 Athol-street, Moonee Ponds ..	15.90	" " " " ..	31.5.66
1741			
NEWLANDS LUMBER CO. PTY. LTD.			
Forrest, Raymond, Clarke-street, Heyfield ..	10.80	Unclaimed wages ..	28.8.66
1742			
B.H.B. TIMBER PTY. LTD.			
Lynch, William Francis, 51 McAdam-street, Maffra ..	13.95	Unclaimed wages ..	13.9.66
1743			

## Unclaimed Moneys Act 1962.

## REGISTER of Unclaimed Mobeys held by the—

Name of Owner on Books and Last Known Address.	Total Amount Due to Owner.	Description of Unclaimed Moneys.	Date when Amount first become Payable.
\$			
<b>TRARALGON JOINERY &amp; TRADING PTY. LTD.</b>			
Bennet, G., c/o Traralgon Joinery & Trading Pty. Ltd., Clift-street, Traralgon 1744	10.20	Unclaimed wages .. ..	2.6.65
<b>AUSTRALIAN NEWSPRINT MILLS HOLDINGS LIMITED.</b>			
Hedges, Keith E., 3 Station-street, Auburn, N.S.W. 1748	11.00	Dividend of 5 per cent. for half-year on 110 Ordinary Shares	29.10.64 (replaced in 1966)
<b>THE NESTLE COMPANY (AUST.) LIMITED.</b>			
Weiss, A., 2 Cooper-street, West Brunswick 1749	23.90	Unclaimed wages .. ..	17.1.67
<b>THE AUSTRALASIAN TEMPERANCE AND GENERAL MUTUAL LIFE ASSURANCE SOCIETY LIMITED.</b>			
Lazarou, Peter, 36 Moore-street, Footscray 1970	12.57	Refund of deposit on un-accepted proposal	27.9.66
<b>THE AUSTRALIAN ESTATES CO. LTD.</b>			
Whiting, H. A., 42 Edward-street, Essendon	235.00	Replacement Cheque .. ..	24.2.66
Jones, N. (address unknown) .. ..	13.38	Proceeds of produce .. ..	1.3.66
Heap, N. (address unknown) .. ..	12.72	" " " " .. ..	" " " "
Name and address unknown .. ..	49.30	" " " " .. ..	24.3.66
Name and address unknown .. ..	73.61	" " " " .. ..	26.5.66
Woodhead, P., 35 Thompson-street, Sale	16.03	" " " " .. ..	" " " "
Name and address unknown .. ..	435.53	Proceeds of Wool .. ..	27.5.66
Name and address unknown .. ..	154.22	" " " " .. ..	17.6.66
Name and address unknown .. ..	67.48	Proceeds of Produce .. ..	23.6.66
Name unknown, Morang .. ..	23.73	" " " " .. ..	" " " "
Name and address unknown .. ..	16.67	" " " " .. ..	" " " "
Name and address unknown .. ..	135.02	Proceeds of Wool .. ..	8.7.66
Webster, L. (address unknown) .. ..	16.15	Unclaimed Wages .. ..	9.7.66
Westmerland, (address unknown) .. ..	13.03	" " " " .. ..	19.7.66
Parsons, (address unknown) .. ..	25.02	Proceeds of Produce .. ..	1.9.66
Name and address unknown .. ..	25.55	" " " " .. ..	" " " "
Name unknown, Willaura .. ..	21.54	" " " " .. ..	" " " "
McRae, (address unknown) .. ..	13.00	" " " " .. ..	16.9.66
Brath, J. (address unknown) .. ..	35.86	" " " " .. ..	" " " "
Name and address unknown .. ..	35.86	" " " " .. ..	" " " "
Name and address unknown .. ..	24.56	" " " " .. ..	20.10.66
Andrews, G., Whittlesea .. ..	12.50	" " " " .. ..	" " " "
Tabin, G. (address unknown) .. ..	21.13	Unclaimed Wages .. ..	18.11.66
Gordon, W. (address unknown) .. ..	28.59	" " " " .. ..	" " " "
Name and address unknown .. ..	58.91	Proceeds of Wool .. ..	11.11.66
Name and address unknown .. ..	11.96	Proceeds of Produce .. ..	8.12.66
Malabur, H. (address unknown) .. ..	45.15	" " " " .. ..	" " " "
<b>THE AUSTRALIAN ESTATES CO. (AGENCIES) PTY. LTD.</b>			
Name and address unknown .. ..	13.22	Proceeds of two calves .. ..	15.9.66
<b>JOHN McNAMARA AND CO. PTY. LTD.</b>			
Dunn, F. (address unknown) .. ..	12.25	Proceeds .. ..	31.12.58
<b>ALLIED CREDITS PTY. LTD.</b>			
Fry, Margaret Jennene, Flat 28, 5 Fulton-street, Balacava 1934	12.95	Unpresented Cheque No. 5440	—12.66
<b>COMMERCIAL UNION ASSURANCE COMPANY OF AUSTRALIA LIMITED.</b>			
James, C. R. B., 19 Queen-street, Melbourne .. ..	10.00	WCA Claim .. ..	19.5.66
Ametco Aust. Pty. Ltd., 10 Whitehorse-road, Ringwood .. ..	49.80	" " " " .. ..	10.6.66
Chelmer Diagnostic Lab., 421 St Kilda-road, Melbourne .. ..	10.00	" " " " .. ..	20.6.66
Hobley, D., c/o Baillieus Ins., 360 Collins-street, Melbourne .. ..	57.50	M.P. Claim .. ..	21.7.66
Quirk, M., c/o Coco Cola Bottlers (Melb.), Levenswell-road, Moorabbin .. ..	12.02	WCA Claim .. ..	28.7.66
Stanson Products Pty. Ltd., 177 Buckley-street, Essendon .. ..	12.00	" " " " .. ..	24.8.66
Young, F., Flat 6, 3 Wimbledon-avenue, Elwood .. ..	16.50	Burglary Claim Payment .. ..	" " " "
McLaughlin and Elmore, 19 Queens-parade, Burwood .. ..	12.21	Refund of Premium .. ..	13.9.66
Carbone, P., c/o W. J. Drever Pty. Ltd., 8 Geelong-road, Footscray .. ..	16.00	WCA Claim Payment .. ..	6.9.66
Heal, M., P.O. Boort .. ..	16.13	Refund of Overpayment .. ..	7.10.66
Milnes, G. N., 22 Giles-street, Mirboo Ncrth .. ..	12.48	Credit Balance of Account .. ..	13.10.66
Carr, C. C., 1 Faircroft-avenue, Glen Iris .. ..	11.75	Motor Claim Payment .. ..	7.12.66
Coles, J. G., 41 Ryland-avenue, Croydon .. ..	27.74	Reduction on Policy .. ..	6.1.67
Gray, C. E. (estate of), 85 Hanley-street, Black Rock .. ..	19.10	Return Premium .. ..	19.1.67
Cody, P. (Dr.), c/o Richardson Kerr, 405 Collins-street, Melbourne .. ..	10.00	Allowance to damaged Refrigerator .. ..	8.2.67
McCoy, —, 3 Braeside-avenue, Burwood .. ..	15.20	Third Party Settlement .. ..	16.2.67
Muntello, L. and Co. Pty. Ltd., 81 Ellendale-road, Noble Park .. ..	11.00	Workers Comp. Payment .. ..	8.12.66

Unclaimed Moneys Act 1962.

REGISTER of Unclaimed Moneys held by the—

Name of Owner on Books and Last Known Address.	Total Amount Due to Owner.	Description of Unclaimed Moneys.	Date when Amount first become Payable.
\$			
<b>AUSTRALIAN MUTUAL PROVIDENT SOCIETY.</b>			
Croft, —, (address unknown) .. .. .	13.00	Unknown .. .. .	— 8.66
Eaton, R. N., 110 Celebration-street, East Cannington, W.A. .. .	19.00	Stale Cheque No. 142416 .. .	21.1.66
Flintham-Hale, E., 34 Samuel-road, Blackburn South .. .. .	27.58	Stale Cheque No. 203040 .. .	5.9.66
Lanca, J., 749 Brunswick-street, North Fitzroy .. .. .	10.00	Refund on incomplete proposal .. .	8.10.66
Simms, C. F., 24 Arthur-street, East Coburg .. .. .	16.00	Stale Cheque No. 159572 .. .	6.4.66
1861			
<b>A.R.C. INDUSTRIES LIMITED.</b>			
Caldwell, Tracy F., 177 West Coast Highway, Scarborough Beach, W.A. .. .	18.75	Dividend No. 26 on shares in A.R.C. Industries Limited .. .	30.9.64
.. .. .	22.92	Dividend No. 28 .. .. .	29.9.65
.. .. .	20.00	Dividend No. 31 .. .. .	28.2.67
Brebner, Jane G. (Miss), Willow Bank, Buangor .. .. .	15.00	Dividend No. 27 .. .. .	1.3.65
.. .. .	27.00	Dividend No. 28 .. .. .	29.9.65
Riddell, F. E. (estate of), c/o C. B. Ridings, Associated Pulp and Paper Mills Limited, 360 Collins-street, Melbourne .. .	12.50	Dividend No. 27 .. .. .	1.3.65
.. .. .	23.75	Dividend No. 30 .. .. .	30.9.66
.. .. .	20.00	Dividend No. 31 .. .. .	28.2.67
.. .. .	12.75	Dividend No. 27 .. .. .	1.3.65
Weatherby, James, Orchard Lodge, Avon Dassett, Leamington Spa, Warwickshire, U.K. .. .	15.58	Dividend No. 28 .. .. .	29.9.65
.. .. .	16.15	Dividend No. 30 .. .. .	30.9.66
.. .. .	13.60	Dividend No. 31 .. .. .	28.2.67
Manifold, Susan (Mrs.), Boortkoi, Hexham .. .. .	37.50	Dividend No. 27 .. .. .	1.3.65
Cook, Dorothy M. (Mrs.), 12 Kensington-road, South Yarra .. .	16.04	Dividend No. 28 .. .. .	29.9.65
Dakara Pty. Ltd., c/o Routley and Routley, 2 Bligh-street, Sydney, N.S.W. .. .	11.00	Dividend No. 28 .. .. .	"
Scott, Campbell R., c/o Campbell Scott Pty. Ltd., 253-255 Parramatta-road, Ashfield, N.S.W. 2131 .. .	45.83	Dividend No. 28 .. .. .	"
.. .. .	30.00	Dividend No. 31 .. .. .	28.2.67
.. .. .	11.46	Dividend No. 28 .. .. .	29.9.65
Thomson, John B., Flat 3, 16 Murphy-street, South Yarra .. .	10.00	Dividend No. 29 .. .. .	28.2.66
.. .. .	11.88	Dividend No. 30 .. .. .	30.9.66
.. .. .	60.00	Dividend No. 31 .. .. .	28.2.67
Hale-Kenny, James H., P.O. Box 1574, Wellington, N.Z. .. .	13.09	Dividend No. 28 .. .. .	29.9.65
Mason, Arthur D., 26 Pleasant-street, Ballarat, Vic. 3350 .. .	11.88	Dividend No. 30 .. .. .	30.9.66
Miegel, Herbert E., c/o Douglas Tomlinson, 1A Fortuna-avenue, North Balwyn, 3104 .. .	11.88	Dividend No. 30 .. .. .	30.9.66
.. .. .	10.00	Dividend No. 31 .. .. .	28.2.67
Nixon, Sidney R., Studley Park, Randwick, N.S.W. .. .	23.75	Dividend No. 30 .. .. .	30.9.66
Scarr, Elsie C. (estate of), c/o Joseph Thompson and Cattel, 25 O'Connell-street, Sydney, N.S.W. 2000 .. .	15.82	Dividend No. 30 .. .. .	28.2.67
.. .. .	13.32	Dividend No. 31 .. .. .	30.9.66
Sharpe, Kenneth C., 21 Hillview-avenue, Mount Waverley, 3149 .. .	47.50	Dividend No. 30 .. .. .	28.2.67
.. .. .	40.00	Dividend No. 31 .. .. .	30.9.66
Smith, Norman G., 16 William-street, South Yarra, 3141 .. .	11.88	Dividend No. 30 .. .. .	28.2.67
.. .. .	10.00	Dividend No. 31 .. .. .	30.9.66
Sharp, Wolfe, Flat 3, 5 Te Arai-avenue, East St. Kilda, 3182 .. .	26.13	Dividend No. 30 .. .. .	28.2.67
.. .. .	22.00	Dividend No. 31 .. .. .	30.9.66
.. .. .	17.64	Dividend No. 31 .. .. .	28.2.67
Millar, Anne R. (Mrs.), Flat 8, 30 Derbyshire-road, Leichardt, N.S.W., 2040 .. .	17.64	Dividend No. 31 .. .. .	"
Elwell-Sutton, Rory, 66 Swann-road, Taringa, Qld., 4066 .. .	10.00	Dividend No. 31 .. .. .	"
Webb, Brian E., c/o Bank of N.S.W., Southport, Qld., 4215 .. .	17.80	Dividend No. 31 .. .. .	"
1862			
<b>GRAZCOS CO-OPERATIVE LIMITED.</b>			
Allen, J., South Gippsland Highway, Lang Lang .. .. .	10.00	Shearing wages .. .. .	30.6.65
Campbell, J., 6 Langley-street, East Sydney, N.S.W. .. .	14.00	" " .. .. .	7.2.66
Cunningham, F., 83 Garden-street, Portland .. .. .	10.00	" " .. .. .	"
Hayes, L., 57 Wolseley-street, Bexley, N.S.W. .. .. .	15.44	" " .. .. .	30.6.66
McDonald, T. L., Griffith, N.S.W. .. .. .	10.05	" " .. .. .	"
O'Donnell, K., Adelong, N.S.W. .. .. .	20.00	" " .. .. .	7.2.66
Power, J., Mt. Morgan, Queensland .. .. .	15.50	" " .. .. .	30.6.65
Richmond, D., 11 Fraser-street, Te Amamutu, North Island, N.Z. .. .	89.21	" " .. .. .	"
1863			
<b>PATERSONS (AUSTRALIA) LIMITED.</b>			
Archer, G. R., Old Mornington-road, Mt. Eliza .. .. .	15.00	Ordinary dividend .. .. .	16.3.66
Brown, G. G., c/o B. Simpson, 10 Jutland-parade, Dalkeith, W.A. .. .	12.00	" " .. .. .	"
Bunny, C. L., Flat 3, 444 Dandenong-road, Caulfield .. .. .	15.00	" " .. .. .	"
Ogge, M. L., 3 Barnato-grove, Armadale .. .. .	11.22	" " .. .. .	"
Stocks, J., "Sunnyside", Warrigal-road, Burwood .. .. .	103.11	" " .. .. .	"
Wardlaw, R. N., 238 Flinders-lane, Melbourne .. .. .	58.50	" " .. .. .	"
Yule, M. B., 65 Yarrbat-avenue, Balwyn .. .. .	22.50	" " .. .. .	"
Archer, G. R., Old Mornington-road, Mt. Eliza .. .. .	12.50	" " .. .. .	5.10.66
Glantville, J. E., c/o P.O. Box 497H, Elizabeth-street, Melbourne .. .	12.50	" " .. .. .	"
Ritchie, I. M., 451 Wattle-tree-road, East Malvern .. .. .	18.75	" " .. .. .	"
Stocks, J., "Sunnyside", Warrigal-road, Burwood .. .. .	85.92	" " .. .. .	"
Thomas, W. J., (estate of), c/o W. C. Thomas, "Suite 103", 193 Domain-road, South Yarra .. .. .	39.35	" " .. .. .	"
Yule, M. B., 65 Yarrbat-avenue, Balwyn .. .. .	18.75	" " .. .. .	"
Gillam, A. A., 185 Maude-street, Shepparton .. .. .	12.50	" " .. .. .	"
Goodkind, H. (estate of), 619 St. Kilda-road, Melbourne .. .	24.19	Deposit interest .. .. .	31.8.66
Bottomly, A. L., 44 Albany-road, Toorak .. .. .	15.00	Preference dividend .. .. .	"
Ogge, M. L., 3 Barnato-grove, Armadale .. .. .	14.96	8 per cent. "S" Note interest .. .	30.6.66
Fleming, J. R., 55 Havelock-road, East Hawthorn .. .. .	16.00	" " .. .. .	31.12.66
Dawkins, P. C., Box 3, Gawler, S.A. .. .. .	10.00	8 per cent. "H" Note interest .. .	31.3.66
White, H. B., 12 Renwick-street, West Beach, S.A. .. .. .	16.00	" " .. .. .	"
1864			



## Unclaimed Moneys Act 1962.

## REGISTER of Unclaimed Moneys held by the—

Name of Owner on Books and Last Known Address.	Total Amount Due to Owner.	Description of Unclaimed Moneys.	Date when Amount first become Payable.
<b>§</b>			
<b>CLIFTON BRICK HOLDINGS LTD.</b>			
Oakes, Harry, 27 Belfort-street, Dandenong 1839	28.00	Unclaimed dividend	2.11.66
<b>MARYBOROUGH KNITTING MILLS (CUTTLE) LTD.</b>			
Rouse, Pamela Joan (Mrs.), 60 Waverley-road, East Malvern, 3145 1860	25.42	Dividend Nos. 34 and 35	5.7.65
<b>RADIO CORPORATION PTY. LTD.</b>			
Edwards, C., 12 Suffolk-road, Maidstone 1935	40.90	Wages	21.6.66
<b>H. J. HEINZ CO. AUSTRALIA LTD.</b>			
Cowan, R., 59 Boyd-street, North Dandenong	10.50	Wages	—8.66
Way, G., 5 Avenza-street, Mentone 1926	18.00	Workers Compensation	—4.66

Companies Act 1961, Section 254 (2).

L. A. NEALE (SALES) PROPRIETARY LIMITED  
(IN LIQUIDATION).

## NOTICE OF RESOLUTION.

AT an Extraordinary General Meeting of the members of L. A. Neale (Sales) Proprietary Limited, duly convened and held at 409 Lonsdale-street, Melbourne, on 1st day of April, 1968, the Special Resolution set out below was duly passed—

“That the company be wound up voluntarily as a members' voluntary winding up in accordance with the provisions of the Companies Act 1961. That Joseph Charles Hough, be and is hereby appointed liquidator.”

Notice is also given that after 21 days from this date I shall proceed to distribute the assets. All creditors having any claims against the company should furnish particulars of same by that date, otherwise I shall proceed to distribute the assets without regard to their claim.

Dated this 1st day of April, 1968.

JOSEPH C. HOUGH, Liquidator, 409 Lonsdale-street,  
Melbourne. 2076

Companies Act 1961, Section 254.

AT an Extraordinary General Meeting of the members of Alicante Restaurant Pty. Ltd., duly convened and held at 34 Queen-street, Melbourne, on the 29th day of March, 1968, the Special Resolution set out below was duly passed—

“Resolved that the company being unable to pay its debts be placed in voluntary liquidation.”

“Resolved that Alan James Gairns, chartered accountant, of 422 Little Collins-street, Melbourne, be appointed as liquidator of the company.”

Dated this 1st day of April, 1968.

2077 A. J. GAIRNS, Liquidator.

The Companies Act 1961.

HARWOOD MANUFACTURING COMPANY PTY. LTD.

PURSUANT TO SECTION 260 OF THE “COMPANIES ACT 1961”.

NOTICE is hereby given that a meeting of creditors of Harwood Manufacturing Company Proprietary Limited, will be held at the Institute of Chartered Accountants, 23 McKillop-street, Melbourne, on Friday, the 26th day of April, 1968, at 11 a.m., for the purpose of considering the company's affairs, the company having convened an Extraordinary General Meeting of its members to be held on the same day, and for the purpose of considering and if thought fit, passing a Special Resolution that the company be wound up voluntarily.

Dated this 2nd day of April, 1968.

H. HODGES, Director.

Hall & Rose, chartered accountants, 260 Queen-street,  
Melbourne, 3000. 2080HEIDELBERG DISTRICT CO-OPERATIVE HOUSING  
SOCIETY LIMITED (IN LIQUIDATION).

TAKE notice that the affairs of the above-named society are now fully wound up and that in pursuance of section 272 (1) of the Companies Act 1961 and of the Co-operative Housing Societies Act 1958, a General Meeting of the society will be held at 126 Wellington-parade, East Melbourne, on the 6th May, 1968, at 12.30 p.m., for the purposes of—

(i) laying before it an account showing how the winding up has been conducted and the property of the society disposed of and giving any explanations thereof; and

(ii) passing a Resolution that the books and papers of the said society and of the liquidator relevant to the affairs of the society be destroyed after a period of twelve months from the date of the meeting.

Dated the 26th day of March, 1968.

2016 J. P. CHAUNDY, Liquidator.

FORM B.

NEWNHAM PROPRIETARY LIMITED.

NOTICE is hereby given that an Extraordinary General Meeting of Newnham Proprietary Limited was held at 21-23 Macalister-street, Sale, on the 28th day of March, 1968, at 11 o'clock in the forenoon, for the purposes of passing the following Special Resolution:—

“That the company be wound up voluntarily, and that Edward Charles Peirce, of 21-23 Macalister-street, Sale, be appointed liquidator for the purposes of such winding up and that the remuneration of the said Edward Charles Peirce for his services in the winding up be fixed at the sum of \$40.00 in addition to his costs charges and expenses.”

2042

W. F. NEWNHAM, Secretary.

Notice of Winding-Up Order.—In the matter of BYLDAN  
TRADING PROPRIETARY LIMITED.

WINDING-UP Order made 29th March, 1968.

Name and address of official liquidator: Mr. Jack Bastian, of 545 St. Kilda-road, Melbourne.

James Canny, Deputy Commissioner of Taxation of the Commonwealth of Australia, petitioner. 2092

Notice of Winding Up Order.—In the matter of ARENCO  
(AUSTRALIA) PROPRIETARY LIMITED.

WINDING-UP Order made 29th March, 1968.

Name and address of official liquidator: Mr. Everett Thompson Bent, of 545 St. Kilda-road, Melbourne.

James Canny, Deputy Commissioner of Taxation of the Commonwealth of Australia, petitioner. 2093

*Companies Act 1961.*

GAMMA STERILIZATION PROPRIETARY LIMITED (IN VOLUNTARY LIQUIDATION).

NOTICE OF GENERAL MEETING OF SHAREHOLDERS, PURSUANT TO SECTION 272.

NOTICE is hereby given that the Final Meeting of Shareholders of the company will be held at the office of F. E. & K. W. Dixon, 23 McKillop-street, Melbourne, on Friday, 10th May, 1968, at 11 a.m., for the purpose of receiving the liquidator's account, showing how the winding up has been conducted, and the property of the company has been disposed of and giving any explanation thereof.

Dated this 26th day of March, 1968.

2070 K. W. DIXON, Liquidator.

*Companies Act 1961, Section 254 (2).*

GOLDSAND (SALES) PROPRIETARY LIMITED (IN LIQUIDATION).

## NOTICE OF RESOLUTION.

AT an Extraordinary General Meeting of the members of Goldsand (Sales) Proprietary Limited, duly convened and held at 409 Lonsdale-street, Melbourne, on 1st day of April, 1968, the Special Resolution set out below was duly passed—

"That the company be wound up voluntarily as a members' voluntary winding up in accordance with the provisions of the *Companies Act 1961*. That Joseph Charles Hough, be and is hereby appointed liquidator."

Notice is also given that after 21 days from this date I shall proceed to distribute the assets. All creditors having any claims against the company should furnish particulars of same by that date, otherwise I shall proceed to distribute the assets without regard to their claim.

Dated this 1st day of April, 1968.

JOSEPH C. HOUGH, Liquidator, 409 Lonsdale-street, Melbourne. 2073

*Companies Act 1961, Section 254 (2).*

HELBRO FASHIONS (SALES) PROPRIETARY LIMITED (IN LIQUIDATION).

## NOTICE OF RESOLUTION.

AT an Extraordinary General Meeting of the members of Helbro Fashions (Sales) Proprietary Limited, duly convened and held at 409 Lonsdale-street, Melbourne, on 1st day of April, 1968, the Special Resolution set out below was duly passed—

"That the company be wound up voluntarily as a members' voluntary winding up in accordance with the provisions of the *Companies Act 1961*. That Joseph Charles Hough, be and is hereby appointed liquidator."

Notice is also given that after 21 days from this date I shall proceed to distribute the assets. All creditors having any claims against the company should furnish particulars of same by that date, otherwise I shall proceed to distribute the assets without regard to their claim.

Dated this 1st day of April, 1968.

JOSEPH C. HOUGH, Liquidator, 409 Lonsdale-street, Melbourne. 2074

*Companies Act 1961, Section 254 (2).*

K.H.K. BODY WORKS (SALES) PROPRIETARY LIMITED (IN LIQUIDATION).

## NOTICE OF RESOLUTION.

AT an Extraordinary General Meeting of the members of K.H.K. Body Works (Sales) Proprietary Limited, duly convened and held at 409 Lonsdale-street, Melbourne, on 1st day of April, 1968, the Special Resolution set out below was duly passed—

"That the company be wound up voluntarily as a members' voluntary winding up in accordance with the provisions of the *Companies Act 1961*. That Joseph Charles Hough, be and is hereby appointed liquidator."

Notice is also given that after 21 days from this date I shall proceed to distribute the assets. All creditors having any claims against the company should furnish particulars of same by that date, otherwise I shall proceed to distribute the assets without regard to their claim.

Dated this 1st day of April, 1968.

JOSEPH C. HOUGH, Liquidator, 409 Lonsdale-street, Melbourne. 2075

The *Companies Act 1961*.—In the matter of WANNON TIMBERS PTY. LTD. (in Voluntary Liquidation).—Members Voluntary Winding Up.

NOTICE is hereby given that at an Extraordinary General Meeting of the above company, duly convened and held at the registered office of the company, on 29th March, 1968, the following Resolution was proposed and passed as a Special Resolution:—

"That the company be wound up voluntarily and that Ernest Harding Niemann, of 44 Queen-street, Melbourne, be appointed liquidator for the purpose of such winding up, and that he be authorized to draw as remuneration for his services as liquidator his normal hourly charges in respect thereto."

Dated the 1st April, 1968.

2085 P. E. FITZGERALD, Secretary.

OAKLEIGH CO-OPERATIVE HOUSING SOCIETY LIMITED (IN VOLUNTARY LIQUIDATION).

TAKE notice that the affairs of the above-named Society are now fully wound up and that, in pursuance of section 272 (1) of the *Companies Act 1961*, and of the *Co-operative Housing Societies Act 1958*, a General Meeting of the Society will be held at 63 Atherton-road, Oakleigh, on Wednesday, 8th May, 1968, at 7.30 p.m., for the purpose of—

- (i) laying before it an account showing how the winding up has been conducted and the property of the Society disposed of and giving any explanations thereof; and
- (ii) passing a Resolution that the books and papers of the said Society and of the liquidator relevant to the affairs of the Society be destroyed after a period of three months from the date of meeting.

Dated the 3rd April, 1968.

1994 E. A. B. GRAHAM, Liquidator.

The *Companies Act 1961*.—In the matter of GILMOURS MEATS PTY. LTD. (in Liquidation).

NOTICE is hereby given that pursuant to section 272 (1) of the *Companies Act 1961*, a final meeting of creditors of the above company will be held at the office of Bruce Fordham, chartered accountant, 170 Toorak-road, South Yarra, on Thursday, 9th May, 1968, at 9 a.m.

Business.—To receive the liquidator's accounts.

Dated this 25th day of March, 1968.

BRUCE FORDHAM, Liquidator.  
170 Toorak-road, South Yarra, 3141. Tel.: 24 7511. 2061

The *Companies Act 1961*.—In the matter of BLACK BOX NOVELTIES PTY. LTD.—Notice re Meeting of Creditors, Pursuant to Section 260.

NOTICE is hereby given that a Meeting of creditors of the above-named company will be held at Suite 18, 545 St. Kilda-road, Melbourne, on Tuesday, 9th April, 1968, at Eleven a.m., the company having convened a meeting of its members for the same day for the purpose of considering a Resolution that the company be wound up voluntarily.

Dated this 28th day of March, 1968.

R. HOWELL, Director.  
Bent & Cogle, public accountants, Suite 18, 545 St. Kilda-road, Melbourne, 3004. 2014

Notice of Winding-Up Order.—In the matter of R. & H. INDUSTRIAL CHEMICALS PROPRIETARY LIMITED.

WINDING-UP Order made 29th March, 1968.

Name and address of official liquidator: Mr. John Charles Couzens, of 527 Collins-street, Melbourne.  
Leo Thomas FitzGerald, Deputy Commissioner of Taxation of the Commonwealth of Australia, petitioner. 2094

In the Supreme Court of Victoria.—1968 No. CO 7497.—In the matter of the *Companies Act 1961*, and in the matter of SQUASHWAY PROPRIETARY LIMITED.

NOTICE is hereby given that a petition for the winding up of the above-named company by the Supreme Court was, on the 28th day of March, 1968, presented by Artprint Publicity Proprietary Limited: And that the said petition is directed to be heard before the court sitting at Melbourne at the hour of 10.30 a.m., on the 2nd day of May, 1968; and any creditor or contributory of the said company desiring to support or oppose the making of an order on the said petition may appear at the time of hearing by himself or his counsel for that

purpose; and a copy of the petition will be furnished to any creditor or contributory of the said company requiring the same by the undersigned on payment of the regulated charge for the same.

The petitioner's address is 3 Ferguson-street, Abbotsford.

The petitioner's solicitors are Messrs. Rogers and Gaylard, of 281 Collins-street, Melbourne.

ROGERS & GAYLARD, solicitors for the petitioner.

NOTE.—Any person who intends to appear on the hearing of the said petition must serve on or send by post to the above-named Messrs. Rogers and Gaylard notice, in writing, of his intention so to do. The notice must state the name and address of the person, or, if a firm, the name and address of the firm, and must be signed by the person or firm, or his or their solicitor (if any), and must be served, or, if posted, must be sent by post in sufficient time to reach the above named not later than Four o'clock in the afternoon of the 1st day of May, 1968, the day before the day appointed for the hearing of the petition or the Friday preceding the day appointed for the hearing of the petition if such day is a Monday or a Tuesday following a public holiday). 2096

CREDITORS, next of kin and others having claims in respect to the will of Mary Janet Brown, formerly of Middle Tarwin, but late of 20 Smith-street, Leongatha, widow, deceased (who died on the 15th day of December, 1967), are to send particulars of their claims to The Union-Fidelity Trustee Company of Australia Limited, of 100 Exhibition-street, Melbourne, by the 14th day of June, 1968, after which date it will distribute the assets, having regard only to the claims of which it then has notice.

BIRCH, ROSS & BARLOW, of Leongatha, solicitors for the said estate. 2026

SUSAN EVELINE SCOBLE (known usually as Susie Evelyn Scoble), late of 43 Whitehorse-road, Blackburn, in the State of Victoria, married woman, DECEASED.

CREDITORS, next of kin and others having claims against the estate of the above-named deceased (who died on the 5th day of November, 1967), are to send particulars of their claims to the Trustees, Executors and Agency Company Limited, of 401 Collins-street, Melbourne, by the 8th day of June, 1968, after which date the company will distribute the assets, having regard to the claims of which it then has notice.

JOHN H. FULTON, solicitor, 960 Whitehorse-road, Box Hill. 2037

JOHN PETER HASE, late of Amundsen-street, Belmont, Geelong, solicitor, DECEASED.

CREDITORS, next of kin and others having claims in respect of the estate of the deceased (who died on the 31st day of July, 1966) are required by Marjorie Hase, of Amundsen-street, Belmont, Geelong, widow, the executrix to whom probate was granted, to send particulars to her, care of Vivian Hill, LL.B., solicitor, 123 Ryrie-street, Geelong, by the 27th day of May, 1968, after which date the executrix may convey or distribute the assets, having regard only to the claims of which she then has notice.

Dated this 25th day of March, 1968.

VIVIAN HILL, LL.B., solicitor, 123 Ryrie-street, Geelong. 1987

WILLIAM JOSEPH HUTCHINSON, late of "Orange Grove", Bonnie Doon, grazier, DECEASED.

CREDITORS, next of kin and others having claims in respect of the deceased (who died on the 29th day of September, 1967), are required by his trustees, Beryl Ross Hutchinson, of 33 Paradise Sands, Old Burleigh-road, Surfers Paradise, in the State of Queensland, widow, William Ross Hutchinson, of "Woodlands", Mairdumple, in the State of Victoria, grazier, and Richard Douglas Hutchinson, of "Orange Grove", Bonnie Doon, grazier aforesaid, to send particulars to them, care of the under-mentioned firm of solicitors, by the 13th day of May, 1968, after which date the trustees may convey and distribute the assets, having regard only to the claims of which they then have notice.

MAL. RYAN & GLEN, High-street, Mansfield, solicitors for the trustees. 1992

CREDITORS, next of kin and others having claims in respect of the estate of Bronislaw Skibinski, late of 15 Mernda-parade, Belmont, Geelong, carpenter, deceased (who died on the 29th day of January, 1968), are to send particulars of their claims to the executor, to whom probate of the will of the said deceased has been granted, namely, Jack Athol Crawcour, of 39 Yarra-street, Geelong, solicitor, at his aforesaid address, by the 5th day of June, 1968, after which date the said executor will distribute the assets, having regard only to the claims of which he then has notice.

CRAWCOUR & HOLLYHOKE, solicitors, 39 Yarra-street, Geelong. 2046

FRANCOIS CHARLES DUBOIS, late of "Lake Wallace," Edenhope, pastoralist, DECEASED.

CREDITORS, next of kin and others having claims in respect of the estate of the deceased (who died on the 11th day of June, 1967), are required by the executors, Warwick Leon Dubois of "Lake Wallace", Edenhope, pastoralist, and Suzanne Paltridge, of "Papineu," Avenue Range, South Australia, gentlewoman, to send particulars of their claims to the executors, care of the under-mentioned solicitor, on or before the 15th day of June, 1968, after which date they may convey or distribute the assets, having regard only to the claims of which they then have notice.

Dated this 27th day of March, 1968.

S. E. CLUTTERBUCK, solicitor, Edenhope. 2019

CREDITORS, next of kin and others having claims in respect of the estate of Howard Spencer McCurdy, late of 39 Orr-street, Yarrowonga, in the State of Victoria, retired farmer (who died on the 17th day of May, 1967), are to send particulars of their claims to the executrix of the estate of Howard Spencer McCurdy, care of G. M. Castles and Middleton, solicitors, of 38 Belmore-street, Yarrowonga, by the 21st day of June, 1968, after which date the said executrix will distribute the estate of the said deceased, having regard only to the claims of which she then has notice.

G. M. CASTLES & MIDDLETON, solicitors, 38 Belmore-street, Yarrowonga, Vic. 2043

VICTORIA LAVINIA LYALL, late of 37 Hallam-road, Belgrave, spinster, DECEASED, intestate.

CREDITORS, next of kin and others having claims in respect of the estate of the deceased (who died on the 7th day of May, 1967), are required by The Trustees, Executors and Agency Company Limited, of 401 Collins-street, Melbourne, to send particulars of their claims to the said company by the 5th day of June, 1968, after which date it will convey or distribute the assets, having had regard only to the claims of which the company then has notice.

J. ERSKINE & ROSS, solicitors, Main-street, Belgrave. 1999

CREDITORS, next of kin and others having claims against the estate of Annabella Stewart, late of 106 Lyons-street north, Ballarat, widow, deceased (who died on the 19th day of January, 1968), are to send particulars of their claims to The Union-Fidelity Trustee Company of Australia Ltd., of 101 Lydiard-street north, Ballarat, by the 1st day of June, 1968, after which date the company will distribute the assets, having regard to the claims of which it then has notice. 1997

CREDITORS, next of kin and others having claims against the estate of Stanley Arthur Richards, late of 32 Otway-street, Ballarat, labourer, deceased (who died on the 7th day of December, 1967), are to send particulars of their claims to the Union-Fidelity Company of Australia Ltd., of 101 Lydiard-street north, Ballarat, by the 1st day of June, 1968, after which date the company will distribute the assets, having regard to the claims of which it then has notice. 1998

CREDITORS, next of kin and others having claims against the estate of Wilhelmina Matilda Florence Harris, late of Beaufort, in the State of Victoria, widow, deceased (who died on the 3rd day of December, 1967), are to send particulars of their claims to the executor, The Union-Fidelity Trustee Company of Australia Limited, of 100 Exhibition-street, Melbourne, by the 18th day of June, 1968, after which date the company will distribute the assets, having regard only to the claims of which it then has notice.

HALL & YOUNG, solicitors, Beaufort. 1995

**CREDITORS**, next of kin and others having claims in respect of the estate of Richard Alexander Hodge, late of Butchers Ridge, farmer, deceased (who died on the 12th day of August, 1967), are required to send the particulars of their claims to the The Union Fidelity Trustee Company of Australia Limited, of 100 Exhibition-street, Melbourne, by the first day of June, 1968, after which date it will distribute the assets, having regard only to the claims of which it then has notice.

J. I. LANFRANCHI, solicitor, Bairnsdale. 2032

ALICE LOUISA HANNAH LAMBURD, late of 551 Canterbury-road, Vermont, married woman, DECEASED.

**CREDITORS**, next of kin and others having claims in respect of the estate of the deceased (who died on the 9th day of January, 1968) are required by The Perpetual Executors and Trustees Association of Australia Limited, of 100-104 Queen-street, Melbourne, and Howard Sydney Lamburd, of 551 Canterbury-road, Vermont, gentleman, the applicants for a grant of administration, to send particulars of their claims to the said applicants, in the care of the said company, by the 3rd day of June, 1968, after which date they will convey or distribute the assets, having regard only to the claims of which they then have notice.

R. P. BARRETT & SON, solicitors, 473 Bourke-street, Melbourne. 2051

**CREDITORS**, next of kin and other persons having claims against the estate of Wallace Augustus Crane, late of 2 Northgate-street, Pascoe Vale, in the State of Victoria, manager, deceased (who died on the 14th day of September, 1967), are required to send particulars of their claims to the executors, John Radovick Cleary and Francis Patrick Mannix, both of 40 Queen-street, Melbourne, solicitors, by the 3rd June, 1968, after which date the executors will distribute the assets, having regard only for the claims of which they then have had notice.

CLEARY, ROSS & DOHERTY, solicitors, of 40 Queen-street, Melbourne. 2052

**CREDITORS**, next of kin and others having claims in respect of the estate of Francis George Palmer, late of 20 Calembena-road, Oakleigh, gentleman, deceased (who died 30th October, 1967), are required by the executor, National Trustees, Executors and Agency Company of Australasia Limited, of 95 Queen-street, Melbourne, to send particulars to it, at its address aforesaid, by the 4th day of June, 1968, after which date the said executor may convey or distribute the assets, having regard only to the claims of which it then has notice.

BERNARD NOLAN & CO., solicitors, 595 Bourke-street, Melbourne. 2053

**CREDITORS**, next of kin and others having claims in respect of the estate of Charles Llewellyn Jones, late of 2 Westgate-street, Oakleigh, builder's labourer, deceased (who died on the 24th day of December, 1967, and probate of whose will has been granted to Arthur Heyward, retired, and Arthur George Heyward, builder's labourer, both of 2 Westgate-street, Oakleigh), are required to send particulars of their claims to the said executors, care of the under-mentioned solicitors, by the 3rd day of June, 1968, after which date they will distribute the assets, having regard only to the claims of which they then have notice.

PEARCE & WEBSTER, solicitors, 430 Little Collins-street, Melbourne. 2054

**CREDITORS**, and others having claims in respect of the estate of James Renkin, late of Wileman-street, Willaura, gentleman, deceased (who died on the 24th October, 1967), are required by The Union-Fidelity Trustee Company of Australia Limited, of 101 Lydiard-street north, Ballarat, the executor of the will of the said deceased, to send particulars, in writing, of their claims to the said company, at its above address, on or before the 11th day of June, 1968, after which date it will distribute the assets, having regard only to claims of which it then has notice.

BRUCE R. TIVEY, solicitor, Ararat. 2071

**CREDITORS**, next of kin and others having claims against the estate of Lady Maria Ruby Jensen, formerly of 71 Illawarra-road, Hawthorn, late of 178 Doncaster-road, North Balwyn, married woman, deceased (who died on the 16th day of July, 1967), are required to send particulars of their claims to the National Trustees, Executors and Agency Company of Australasia Limited, of 95 Queen-street, Melbourne, by the 15th day of June, 1968, after which date it will distribute the assets, having regard only to the claims of which it shall then have had notice.

J. J. NUGENT, solicitor, 9 Missouri-avenue, Gardenvale. 2088

LILIAN MAUDE LAKELAND, late of 512 Glenferrie-road, Hawthorn, spinster, DECEASED.

**CREDITORS**, next of kin and others having claims in respect of the estate of the deceased (who died on the 11th day of November, 1967) are required by the personal representative, Edward Geoffrey Marriott, of "Eurambeen", Beaufort, manager, to send particulars to him, care of the undermentioned solicitors, by the 10th day of June, 1968, after which date the personal representative may convey or distribute the assets, having regard only to the claims of which he then has notice.

WHYTE, JUST & MOORE, solicitors, 27 Malop-street, Geelong. 2082

CLIFFORD HUGH TINDALE, late of 43 Grenville-street, Hampton, school teacher, DECEASED.

**CREDITORS**, next of kin and others having claims in respect of the estate of the deceased (who died on the 3rd day of October, 1967), are required by The Perpetual Executors and Trustees Association of Australia Limited, of 100-104 Queen-street, Melbourne, to send particulars of their claims to the said company, by the 5th June, 1968, after which date it will convey or distribute the assets, having had regard only to the claims of which the company then has notice.

POLKINGHORNE & WEBB, solicitors, Railway Walk, Hampton. 2089

**CREDITORS**, next of kin and others having claims in respect of the estate of John James Grant, late of 33 Stirling-street, Footscray (who died on the 26th April, 1967), are requested to send particulars of their claims to the executor, Alexander James Grant, of 78 Commercial-road, Footscray, on or before the 11th June, 1968, after which date the executor will distribute the assets, having regard only to the claims of which he then has notice.

2090

**CREDITORS**, next of kin and others having claims in respect of the estate of Senta Fischer, late of 38 Kingsley-street, Elwood, single woman, deceased (who died on the 20th day of September, 1967, and probate of whose will has been granted to Gordon Greatorex, of 168 Brighton-road, Elwood, accountant, and Jack Peter Brent, of 17 Queen-street, Melbourne, solicitor), are required to send particulars of their claims to the said executors by the 3rd day of June, 1968, care of their solicitors, after which date they will distribute the assets, having regard only to the claims of which they then have notice.

J. P. BRENT & STEPHENS, solicitors, 17 Queen-street, Melbourne. 2095

**CREDITORS**, next of kin and others having claims in respect of the estate of Tadeusz Antos, late of Lot 57, Argyle-street, Donvale, hairdresser, deceased (who died on the 10th day of October, 1967), are to send particulars of their claims to Mieczysława Antos, of Lot 57, Argyle-street, Donvale, widow, the executrix appointed by the will of the said deceased, by the 11th June, 1968, after which date the executrix will distribute the assets, having regard only to the claims of which she shall then have notice.

J. & S. SHATIN, solicitors, of 224 Queen-street, Melbourne. 2072

**CREDITORS**, next of kin and others having claims in respect of the estate of Ida Eleanor Hutchinson, late of 292 Bell-street, East Preston, in the State of Victoria, widow, deceased (who died on the 18th June, 1967), are required to send particulars of their claims to Reginald Gordon Ahyee, of 101 Chadstone-road, Chadstone, linotype operator, the executor to whom probate of the will of the said deceased was granted by the Supreme Court of Victoria, care of the undersigned solicitors, by the 12th day of June, 1968, after which date the executor will distribute the assets, having regard only to the claims of which he then has notice.

SEWELL & SEWELL, 422 Collins-street, Melbourne, solicitors for the above-named executor. 2079

**CREDITORS**, next of kin and others having claims in respect of the estate of Catherine Reid, formerly of 10 Aintree-street, East Brunswick, but late of 32 Finch-street, Burwood, in the State of Victoria, married woman, deceased (who died on the 22nd day of November, 1967), are to send particulars of their claims to the executor, George Cook Reid, care of the undermentioned solicitors, on or before the 31st day of May, 1968, after which date the said executor will distribute the assets, having regard only to the claims of which notice has been received.

A. L. C. FLINT & MARRIE, of 171 William-street, Melbourne, the solicitors for the applicant. 2057

MARIE LOUISE WINCHESTER, late of 72 Park-street, South Yarra, in the State of Victoria, married woman, DECEASED, intestate.

CREDITORS, next of kin and others having claims in respect of the estate of the deceased (who died on the 4th day of July, 1966), are required by The Perpetual Executors and Trustees Association of Australia Limited, of 100-104 Queen-street, Melbourne, to send particulars of their claims to the said company, by the 21st day of June, 1968, after which date it will convey or distribute the assets, having had regard only to the claims of which the company then has notice.

Dated the 29th day of March, 1968.

BOOTHBY & BOOTHBY, solicitors, 883 Dandenong-road, Caulfield East. 2056

CLIFFORD BENJAMIN NEWNHAM, late of 14 St. Andries-street, Camberwell, boiler attendant, DECEASED.

CREDITORS, next of kin and others having claims in respect of the estate of the deceased (who died on 26th October, 1967), are required by the applicants for grant of probate of the will of the deceased, Keith William Newnham, of Flat 12, 13&1 Nepean Highway, Cheltenham, milk bar proprietor, and Geoffrey William Newnham, of 36 Alma-road, Camberwell, mechanical engineer, to send particulars to them, care of the under-signed solicitors, by the 10th June, 1968, after which date they may convey or distribute the assets, having regard only to the claims of which they then have notice.

Dated 27th March, 1968.

R. E. LEWIS ORR & GIBSON, 825 Burke-road, Camberwell. 2059

RICHARD FREDERICK MARTIN, late of 39 Athelstan-road, Camberwell, retired sales executive, DECEASED.

CREDITORS, next of kin and others having claims in respect of the estate of the deceased (who died on the 4th January, 1968), are required by the applicants for grant of probate of the will of the deceased Harold Frederick Martin, of 22 Booth-street, Mordialloc, time and motion study engineer, and John Herbert Martin, of 39 Athelstan-road, Camberwell, commercial traveller, to send particulars to them, care of the under-signed solicitors, by the 10th June, 1968, after which date they may convey or distribute the assets, having regard only to the claims of which they then have notice.

Dated 27th March, 1968.

R. E. LEWIS ORR & GIBSON, 825 Burke-road, Camberwell. 2060

CREDITORS, next of kin and others having claims against the Estate of Ella Woods Danks, late of 418 Riversdale-road, Surrey Hills, widow, deceased, (who died on the 19th day of February, 1968), are required to send particulars of their claims to The Union-Fidelity Trustee Company of Australia Limited, of 100 Exhibition-street, Melbourne, by the 6th day of June, 1968, after which date the said company will distribute the assets, having regard only to the claims of which it then has notice.

PROUDFOOT, HORTON & COOKE, solicitors, 452 Lonsdale-street, Melbourne. 2050

ALEXANDER JAMES MUIR FABIAN, formerly of 18 Aitchison-avenue, Ashburton, but late of Coonara-road, Olinda, retired, DECEASED.

CREDITORS, next of kin and others having claims in respect of the estate of the deceased (who died on the 25th day of October, 1967) are required by the trustee, The Union-Fidelity Trustee Company of Australia Limited, of 100 Exhibition-street, Melbourne, to send particulars to it, at 100 Exhibition-street, Melbourne, by the 10th day of June, 1968, after which date the trustee may convey or distribute the assets, having regard only to the claims of which it then has notice.

Dated the 1st day of April, 1968.

JOHN P. RHODEN, solicitor, 376 Collins-street, Melbourne. 2068

In the Supreme Court of the State of Victoria.

SALE BY THE SHERIFF.

ON Friday, the 10th day of May, 1968, at 10 a.m., at the Police Station, Brighton (unless process be stayed or satisfied):—

All the estate and interest (if any) of Frederick William McKernan, of 27 Seymour-grove, Brighton Beach, public accountant, as proprietor of an estate in fee-simple in

the land described in certificate of title, volume 8070, folio 695, upon which is erected a large dwelling-house known as No. 27 Seymour-grove, Brighton Beach.

Registered mortgage No. B.956747 affects the said estate and interest.

Terms: Cash only.

N. FROGLEY, Sheriff's Officer.

28th March, 1968. 2058

In the Supreme Court of the State of Victoria.

SALE BY THE SHERIFF.

ON Thursday, the 9th day of May, 1968, at 2 p.m., at the Police Station, Shepparton (unless process be stayed or satisfied):—

All the estate and interest (if any) of Keith Knight, of 11 Quinane-parade, Shepparton, builder, as proprietor of an estate in fee-simple in the land described in certificate of title, volume 6991, folio 157, upon which is erected a brick veneer dwelling and outbuildings, known as No. 11 Quinane-parade, Shepparton.

Registered mortgage No. C.785351 affects the said estate and interest.

Terms: Cash only.

R. L. HARRINGTON, Sheriff's Officer.

25th March, 1968. 2081

### INSOLVENCY NOTICE

COMMONWEALTH OF AUSTRALIA.

The Bankruptcy Act 1924-1965.

THE ASSIGNED ESTATE OF D. D. VON SCHOENBERG.  
No. 60 OF 1963.

NOTICE is hereby given that a Third and Final Dividend is intended to be declared in the above matter. Creditors who have not proved their debts by the 21st day of April, 1968, may be excluded from this dividend.

J. K. HALL, Trustee.

Dated this 27th day of March, 1968.

Hall & Rose, chartered accountants, 260 Queen-street, Melbourne, 3000, Victoria. 2055

### IMPOUNDINGS

DIAMOND VALLEY.—Impounded in Diamond Creek Pound on 25th March, 1968.

1 Jersey cow, with black bull calf, no visible brands

If not claimed and expenses paid, to be sold on 18th April, 1968.

B. J. MORGAN,

Shire Secretary.

2035—\$1.75

HAMILTON.—Impounded in Hamilton Pound from Sale-yards by Superintendent.

21 Merino wethers, T on back

If not claimed and expenses paid, to be sold on 6th April, 1968.

Impounded from Tarrington—Chatsworth road, by Shire Ranger.

1 black gelding, branded RH near side, star on forehead.

Impounded from Mt. Bainbridge-road by City Ranger.

1 Corriedale ram, no visible brand

If not claimed and expenses paid, to be sold on 9th April, 1968.

I. FYFE,

Poundkeeper.

2038—\$3.50

HASTINGS.—Impounded in Hastings Pound from Coolart-road, Somerville, on 20th March.

1 black and white Friesian cow, approximately twelve months, no visible brand

If not claimed and expenses paid, to be sold on 3rd of April, 1968.

M. DICKINSON,

Poundkeeper.

2034—\$2

HEALESVILLE.—Impounded in Healesville Pound.

1 Hereford heifer, no visible brand

If not claimed and expenses paid, to be sold on 18th April, 1968.

E. PULLEN,

Poundkeeper.

2013—\$1.50

**KEILOR.**—Impounded in Keilor Pound.  
 1 pet lamb, wether, marked off side ear, blue crayon on back  
 If not claimed and expenses paid, to be sold on 18th April, 1968.  
 2100—\$1.75 C. M. MISSEN,  
 Poundkeeper.

**KYNETON.**—Impounded in Kyneton Pound.  
 40 Merino and crossbred ewes, various ages, mainly indistinct red brand on back  
 If not claimed and expenses paid, to be sold on Thursday, 18th April, 1968.  
 2083—\$1.75 H. COOK,  
 Poundkeeper.

**MORNINGTON.**—Impounded in Mornington Pound, on 21st March, 1968.  
 1 only Dorset ram, no visible brand  
 If not claimed and expenses paid, will be sold 18th April, 1968.  
 2044—\$1.75 M. CALVERLEY,  
 Poundkeeper.

**STRATFORD.**—Impounded in Stratford Pound by C.R.B. Ranger, from Princes Highway, Munro.  
 7 wethers, aluminium tag in ear 63-WGG, notch tip of left ear, some notch back and front left ear, no visible brand  
 If not claimed and expenses paid, to be sold on 18th April, 1968.  
 2098—\$2.25 Mrs. J. S. HARDY,  
 Poundkeeper.

**UPWEY.**—Impounded in Upwey Pound, on 28th March, 1968, from Clematis.  
 1 bay gelding, no visible brand  
 1 white gelding, no visible brand  
 1 grey mare, no visible brand  
 If not claimed and expenses paid, to be sold on 16th April, 1968.  
 2084—\$2.25 K. McMAHON,  
 Poundkeeper.

**VIOLET TOWN.**—Impounded in Violet Town Pound, from Kings-road.  
 1 Merino wether, notch off ear, no visible brand  
 If not claimed and expenses paid, to be sold on 18th April, 1968.  
 2099—\$1.75 H. G. HARRIS,  
 Poundkeeper.

*Subordinate Legislation Act 1962.*

**NOTICE OF MAKING OF STATUTORY RULES.**

IN pursuance of the provisions of the *Subordinate Legislation Act 1962* and the Regulations made thereunder, notice is given of the making of the following statutory rules:—

No.	Public Authorities Marks Act 1958.	Price.
67/1968.	Melbourne and Metropolitan Board of Works By-law No. 92—Testing Materials	10c
	<i>Supreme Court Act 1958.</i>	
68/1968.	Supreme Court (Service of Process) Rules 1968	10c
	<i>Town and Country Planning Act 1961.</i>	
69/1968.	Town and Country Planning Board (Staff) Regulations 1964, Amendment No. 24	10c
	<i>Gas and Fuel Corporation Act 1958.</i>	
70/1968.	Gas-Fitting (Amendment) Regulations of the Gas and Fuel Corporation of Victoria	10c
	<i>Marketing of Primary Products Act 1958.</i>	
71/1968.	Marketing of Primary Products (Producer of Eggs) Regulations 1968	10c
	<i>Fisheries Act 1958.</i>	
72/1968.	Prohibition of Fishing in Lake Purrumbete	10c

No.	Opticians Registration Act 1958.	Price.
73/1968.	Opticians Registration (Qualification) Regulations 1968	10c

Copies of these statutory rules may be purchased at the Sale of Publications Section of the Government Printing Office, located at Macarthur-street, Melbourne, 3002. If ordered by mail, remittance should be addressed to "The Government Printer, Box 203, P.O., North Melbourne, 3051", and should include 5c extra for postage. If a credit account is held at this office, no remittance is required with the mail order.

The annual subscription rate for Statutory Rules (including a Bound Volume) is \$15, payable in advance. The subscription year commences on 1st January.  
 A. C. BROOKS,  
 Government Printer.

**ACTS REPRINTED IN ACCORDANCE WITH THE AMENDMENTS INCORPORATION ACT 1958 (No. 6422), AND FOR SALE AT THE SALE OF PUBLICATIONS BRANCH OF THE GOVERNMENT PRINTING OFFICE, MACARTHUR-STREET, MELBOURNE, 3002.**

*(These prices do not include postage.)*

No.		Price.
6189.	Acts Interpretation (Incorporating amendments up to No. 7146)	\$0.15
6191.	Administration and Probate ( <i>Third Reprint</i> —Incorporating amendments up to No. 7332)	\$0.38
6194.	Agricultural Colleges ( <i>First Reprint</i> —Incorporating amendments up to No. 7302)	\$0.15
7117.	Appeal Costs Fund Act 1964 ( <i>First Reprint</i> —Incorporating amendments up to No. 7488)	\$0.25
6199.	Apprenticeship ( <i>First Reprint</i> —Incorporating amendments up to No. 7312)	\$0.25
6203.	Audit ( <i>First Reprint</i> —incorporating amendments up to No. 7377)	\$0.35
6209.	Boiler Inspection (Incorporating amendments up to No. 7072)	\$0.18
6210.	Building Societies (Incorporating amendments up to No. 7125)	\$0.25
6218.	Children's Court (Incorporating amendments up to No. 7084)	\$0.20
6219.	Children's Welfare ( <i>Second Reprint</i> —Incorporating amendments up to No. 7084)	\$0.35
6220.	Clean Air (Incorporating amendments up to No. 6886)	\$0.10
6222.	Commercial Goods Vehicles ( <i>Second Reprint</i> —Incorporating amendments up to No. 7358)	\$0.22
6839.	Companies Act 1961 ( <i>Second Reprint</i> —Incorporating amendments up to No. 7332)	\$2.32
6225.	Co-operation ( <i>Second Reprint</i> —Incorporating amendments up to No. 7083)	\$0.42
6226.	Co-operative Housing Societies (Incorporating amendments up to No. 7097)	\$0.40
6228.	Country Fire Authority ( <i>Second Reprint</i> —Incorporating Amendments up to No. 7476)	\$0.50
6229.	Country Roads ( <i>Second Reprint</i> —Incorporating Amendments up to No. 7506)	\$0.60
6230.	County Court Act ( <i>First Reprint</i> —Incorporating amendments up to No. 7420)	\$0.35
6231.	Crimes ( <i>Second Reprint</i> —Incorporating amendments up to, No. 7407)	\$1.33
6236.	Dog ( <i>Second Reprint</i> —Incorporating amendments up to No. 7065)	\$0.15
6240.	Education ( <i>First Reprint</i> —Incorporating amendments up to No. 7533)	\$0.45
6241.	Electric Light and Power ( <i>First Reprint</i> —Incorporating amendments up to No. 7315)	\$0.30
6242.	Employers and Employés (Incorporating amendments up to No. 6740)	\$0.18
6243.	Entertainments Tax ( <i>First Reprint</i> —Incorporating amendments up to No. 7315)	\$0.25
6245.	Estate Agents Act ( <i>Third Reprint</i> —Incorporating amendments up to No. 7425)	\$0.50
6246.	Evidence ( <i>Second Reprint</i> —Incorporating amendments up to No. 7366)	\$0.42
6249.	Fences (Incorporating amendments up to No. 6550)	\$0.12
6250.	Fertilizers (Incorporating amendments up to No. 7142)	\$0.25
6251.	Firearms ( <i>Second Reprint</i> —Incorporating amendments up to No. 7484)	\$0.40
6252.	Fisheries Act ( <i>First Reprint</i> —Incorporating amendments up to No. 7389)	\$0.35
6916.	Foreign Judgments Act 1962 ( <i>First Reprint</i> —including amendments made by No. 7332)	\$0.15
6585.	Forests (Pulpwood Agreement) (Incorporating amendments up to No. 6886)	\$0.15

ACTS REPRINTED IN ACCORDANCE WITH THE AMENDMENTS  
INCORPORATION ACT 1958 (No. 6422)—*continued.*

No.	Price.
6254. Forests ( <i>First Reprint</i> —Incorporating amendments up to No. 7356)	\$0.60
6256. Fruit and Vegetables ( <i>First Reprint</i> —incorporating amendments up to No. 6944)	\$0.30
6258. Game—( <i>First Reprint</i> —Incorporating amendments up to No. 7389)	\$0.30
6259. Gaols (Incorporating amendments up to No. 6651)	\$0.15
6262. Geelong Harbor Trust ( <i>First Reprint</i> —Incorporating amendments up to No. 7547)	\$0.45
6263. Geelong Waterworks and Sewerage ( <i>First Reprint</i> —Incorporating amendments up to No. 7547)	\$0.75
6265. Goods ( <i>Third Reprint</i> —Incorporating amendments up to No. 7131)	\$0.35
6266. Grain Elevators ( <i>First Reprint</i> —Incorporating amendments up to No. 7486)	\$0.35
6270. Health ( <i>Second Reprint</i> —Incorporating amendments up to No. 7490)	\$1.65
6933. Home Finance Act 1962 ( <i>First Reprint</i> —Incorporating amendments up to No. 7363)	\$0.25
6274. Hospitals and Charities ( <i>Second Reprint</i> —Incorporating amendments up to No. 7455)	\$0.50
6275. Housing ( <i>First Reprint</i> —Incorporating amendments up to No. 7507)	\$0.85
6279. Instruments ( <i>Third Reprint</i> —Incorporating amendments up to No. 7315)	\$0.38
6282. Justices ( <i>Second Reprint</i> —Incorporating amendments up to No. 7363)	\$1.23
6283. Labour and Industry ( <i>Third Reprint</i> —Incorporating amendments up to No. 7410)	\$1.00
6284. Land (Incorporating amendments up to No. 7360)	\$1.53
6534. Land Settlement Act 1959 ( <i>First Reprint</i> —Incorporating amendments up to No. 7328)	\$0.30
6289. Land Tax ( <i>Second Reprint</i> —Incorporating amendments up to No. 7465)	\$0.40
6285. Landlord and Tenant ( <i>Second Reprint</i> —Incorporating amendments up to No. 6996)	\$0.50
6286. Lands Compensation—( <i>First Reprint</i> —incorporating amendments up to No. 7332)	\$0.25
6290. Latrobe Valley ( <i>First Reprint</i> —Incorporating amendments up to No. 7332)	\$0.35
6291. Legal Profession Practice (Incorporating amendments up to No. 7065)	\$0.45
6293. Licensing ( <i>Second Reprint</i> —Incorporating amendments up to No. 7054)	\$0.95
6577. Lifts and Cranes (Incorporating amendments up to No. 6886)	\$0.12
6295. Limitation of Actions (Incorporating amendments up to No. 6845)	\$0.15
6298. Local Authorities Superannuation (Incorporating amendments up to No. 6894)	\$0.25
6299. Local Government (Incorporating amendments up to No. 7052)	\$3.50
6302. Marine (Incorporating amendments up to No. 7350)	\$0.72
6304. Marketing of Primary Products ( <i>First Reprint</i> —Incorporating amendments up to No. 7491)	\$0.45
6306. Marriage ( <i>First Reprint</i> —Incorporating amendments up to No. 6959)	\$0.25
6309. Medical ( <i>Second Reprint</i> —Incorporating amendments up to No. 7408)	\$0.40
6310. Melbourne and Metropolitan Board of Works ( <i>Second Reprint</i> —Incorporating amendments up to No. 7547)	\$1.10
6312. Melbourne Harbor Trust ( <i>First Reprint</i> —Incorporating amendments up to No. 7356)	\$0.48
6305. Mental Health (Incorporating amendments up to No. 7135)	\$0.45
6315. Metropolitan Fire Brigades (Incorporating amendments up to No. 6886)	\$0.28
6316. Mildura Irrigation and Water Trusts ( <i>First Reprint</i> —Incorporating amendments up to No. 7448)	\$0.75
6317. Milk and Dairy Supervision (Incorporating amendments up to No. 6964)	\$0.40
6318. Milk Board (Incorporating amendments up to No. 7093)	\$0.22
6184. Monash University ( <i>First Reprint</i> —Incorporating amendments up to No. 7533)	\$0.30
6324. Money Lenders (Incorporating amendments up to No. 6886)	\$0.25
6832. Motor Boating (Incorporating amendments up to No. 6961)	\$0.15
6325. Motor Car ( <i>Second Reprint</i> —Incorporating amendments up to No. 7361)	\$0.82
6326. National Parks (Incorporating amendments up to No. 7275)	\$0.25

ACTS REPRINTED IN ACCORDANCE WITH THE AMENDMENTS  
INCORPORATION ACT 1958 (No. 6422)—*continued.*

No.	Price.
6328. Nurses (Incorporating amendments up to No. 6716)	\$0.20
6330. Partnership ( <i>Second Reprint</i> —Incorporating amendments up to No. 7315)	\$0.25
6331. Patriotic Funds ( <i>First Reprint</i> —Incorporating amendments up to No. 7338)	\$0.25
6889. Poisons (Incorporating amendments up to No. 7065)	\$0.35
6337. Police Offences (Incorporating amendments up to No. 7145)	\$0.82
6338. Police Regulation (Incorporating amendments up to No. 7081)	\$0.45
6340. Portland Harbor Trust ( <i>First Reprint</i> —Incorporating amendments up to No. 7475)	\$0.35
6341. Pounds ( <i>First Reprint</i> —Incorporating amendments up to No. 7315)	\$0.25
6890. Probate Duty (Incorporating amendments up to No. 6970)	\$0.38
6343. Process Servers and Inquiry Agents (Incorporating amendments up to No. 7126)	\$0.12
6344. Property Law (Incorporating amendments up to No. 6867)	\$0.90
6349. Public Service ( <i>Second Reprint</i> —Incorporating amendments up to No. 7356)	\$0.40
6350. Public Trustee (Incorporating amendments up to No. 6961)	\$0.35
6353. Racing ( <i>First Reprint</i> —Incorporating amendments up to No. 7404)	\$0.70
6355. Railways ( <i>First Reprint</i> —Incorporating amendments up to No. 7475)	\$0.75
6564. Registration of Births Deaths and Marriages Act 1959 ( <i>First Reprint</i> —Incorporating amendments up to No. 7332)	\$0.25
6359. Road Traffic ( <i>Second Reprint</i> —Incorporating amendments up to No. 7332)	\$0.18
6360. Rural Finance ( <i>First Reprint</i> —Incorporating amendments up to No. 7328)	\$0.12
6846. Rural Finance and Settlement Commission Act 1961 ( <i>First Reprint</i> —Incorporating amendments up to No. 7332)	\$0.20
6975. Sale of Land Act 1962 ( <i>First Reprint</i> —Incorporating amendments up to No. 7332)	\$0.18
6363. Second-Hand Dealers	\$0.12
6367. Settled Land ( <i>Second Reprint</i> —Incorporating amendments up to No. 7065)	\$0.50
6368. Sewerage Districts ( <i>First Reprint</i> —Incorporating amendments up to No. 7332)	\$0.62
6651. Social Welfare Act 1960 ( <i>Third Reprint</i> —Incorporating amendments up to No. 7332)	\$0.20
6372. Soil Conservation and Land Utilization (Incorporating amendments up to No. 6961)	\$0.20
6373. Soldier Settlement ( <i>First Reprint</i> —Incorporating amendments up to No. 7328)	\$0.42
6375. Stamps ( <i>Third Reprint</i> —Incorporating amendments up to No. 7359)	\$0.82
6377. State Electricity Commission ( <i>Second Reprint</i> —Incorporating Amendments up to No. 7421)	\$0.65
6379. State Savings Bank (Incorporating amendments up to No. 6886)	\$0.42
6381. Stock and Share Brokers ( <i>First Reprint</i> —Incorporating amendments up to No. 7444)	\$0.15
6886. Subordinate Legislation (Incorporating amendments up to No. 6961)	\$0.15
6386. Superannuation ( <i>First Reprint</i> —Incorporating amendments up to No. 7417)	\$0.60
6387. Supreme Court ( <i>First Reprint</i> —Incorporating amendments up to No. 7522)	\$0.75
6391. Teaching Service ( <i>First Reprint</i> —Incorporating amendments up to No. 7536)	\$0.35
7223. Tomato Processing Industry (Uniform Agreement) Act 1964 ( <i>First Reprint</i> —Incorporating amendments up to No. 7342)	\$0.15
6395. Tourist ( <i>First Reprint</i> —Incorporating amendments up to No. 7335)	\$0.15
6849. Town and Country Planning ( <i>First Reprint</i> —Incorporating amendments up to No. 7276)	\$0.45
6399. Transfer of Land ( <i>Second Reprint</i> —Incorporating amendments up to No. 7130)	\$0.52
6400. Transport Regulation ( <i>First Reprint</i> —Incorporating amendments up to No. 7358)	\$0.22
6401. Trustee ( <i>Second Reprint</i> —Incorporating amendments up to No. 6963)	\$0.42
6879. Unclaimed Moneys (Incorporating amendments up to No. 6961)	\$0.12
6653. Valuation of Land Act 1960 ( <i>Second Reprint</i> —Incorporating amendments up to No. 7333)	\$0.22

ACTS REPRINTED IN ACCORDANCE WITH THE AMENDMENTS INCORPORATION ACT 1958 (No. 6422)—*continued.*

No.	Price.
6407. Vegetation and Vine Diseases ( <i>First Reprint</i> —Incorporating amendments up to No. 7423) ..	\$0.30
6409. Vermin and Noxious Weeds ( <i>First Reprint</i> —Incorporating amendments up to No. 7463) ..	\$0.35
6410. Veterinary Surgeons ( <i>First Reprint</i> —Incorporating amendments up to No. 7343) ..	\$0.15
6413. Water (Incorporating amendments up to No. 7228) ..	\$1.42
6414. Weights and Measures ( <i>Second Reprint</i> —Incorporating amendments up to No. 7332) ..	\$0.32
6419. Workers Compensation ( <i>Second Reprint</i> —Incorporating amendments up to No. 7332) ..	\$0.52

A. C. BROOKS,  
Government Printer.

Where urgent gazettal is required, special arrangements should be made with the *Gazette* Officer, Room 9, first floor, Old Treasury Building.

Publication will be facilitated by the submission of carbon copies for the use of the *Gazette* Officer.

2. *Other matter.*

(a) All other matter duly certified by a responsible officer for publication should be lodged with the *Gazette* Officer not later than half-past Nine a.m. on Tuesday.

(b) Lengthy or involved notices should be forwarded several days before publication.

(c) Proofs, which will be supplied only when specifically requested or, at the direction of the *Gazette* Officer, should be returned promptly to avoid delay in publication.

(d) No additions or amendments to matter for publication will be accepted by telephone.

**CONTENTS**

THE "VICTORIA GOVERNMENT GAZETTE".

SUBSCRIPTIONS.—*The subscription, including postage, is \$10 per annum, or \$5 per half year, payable in advance.*

*Subscriptions are required for whole months, and must cover at least a half year.*

*Single copies are 20 cents, posted 25 cents. Subscribers do not receive the Acts of Parliament with the GAZETTE.*

*GAZETTES are held in stock for five years only.*

PRIVATE ADVERTISEMENTS.—*The charge for insertion is 25 cents per line single column, and 50 cents per line double column. The title forms one or more lines as a heading. On an average ten words make a line of single column. Every signature must likewise be counted as a line. The final words of a paragraph, though only portion of a line, must be counted as one line. Signatures (in particular) and proper names must be written very plainly in the text; ONE SIDE ONLY of each sheet of paper should be WRITTEN UPON.*

*All documents illegibly written will be returned unpublished, and where brands occur unprovided for by the ordinary letters of the alphabet, a worded explanatory description must be furnished.*

THE VICTORIA GOVERNMENT GAZETTE is published on WEDNESDAY EVENING in each week, and Notices for insertion will be received by the Government Printer at or before ONE p.m. at ordinary rates, and late advertisements between ONE p.m. and FOUR p.m. at double rates on the day preceding the day of publication.

PAYMENTS.—*Unless the advertiser has a credit account, all payments are required in advance. Remittances should be made by cheque, postal order, or money order payable to "GOVERNMENT PRINTER".*

ADDRESS.—*All communications should be addressed to "The Government Printer, Box 203, P.O., North Melbourne", 3051.*

PUBLICATION OF OFFICIAL MATTER.

ATTENTION is invited to the following procedure in relation to the publication of official matter in the *Government Gazette*:—

1. *Matter submitted to the Executive Council.*

Matters submitted to the Executive Council which requires gazettal will normally be published in the issue of the following week.

	PAGE
Acts of Parliament on sale at the Government Printing Office .. .. .	974
Anzac Day Holiday .. .. .	915
Appointments .. .. .	930
Companies Act 1961—Notices .. .. .	923
Contracts .. .. .	921
Courts .. .. .	916
Easter Holidays .. .. .	915
Estates of Deceased Persons .. .. .	925
Government Notices .. .. .	915
Impoundings .. .. .	973
Insolvency Notices .. .. .	973
Lands .. .. .	941
Melbourne and Metropolitan Board of Works—Notice .. .. .	921
Mining .. .. .	920
Notice to Mariners .. .. .	922
Notice of Making of Statutory Rules .. .. .	974
Orders in Council—	
Acts—Crimes; Grain Elevators; Country Roads; Housing; Stock Diseases; Land; Country Roads; Lower Yarra Crossing Authority; Stamps; Portland Harbor Trust; Sewerage Districts; Water; Companies.	931 et seq
Private Advertisements .. .. .	947
Proclamations .. .. .	913
Public Holidays .. .. .	915
Public Service Notices .. .. .	946
Tenders .. .. .	944
Transport Regulation Board—Public Hearings .. .. .	917
Waterworks Trusts .. .. .	927