

[1901]



VICTORIA GOVERNMENT GAZETTE

Published by Authority

[Registered at the General Post Office, Melbourne, for transmission by post as a newspaper.]

No. 45]

WEDNESDAY, MAY 22

[1968

Government House,
Melbourne.

LEVEE AT PARLIAMENT HOUSE, MELBOURNE.

In honour of the Birthday of Her Majesty the Queen, His Excellency the Governor of Victoria, Major-General Sir Rohan Delacombe, K.C.M.G., K.B.E., C.B., D.S.O., K.St.J., will hold a Levee at Parliament House, Spring-street, Melbourne, at 9.45 a.m. on Friday, 7th June, 1968.

On the occasion of the celebration of The Queen's Birthday, His Excellency is anxious to receive as many citizens as possible.

In accordance with previous custom, there will be no precedence in the order of presentation, but it is requested that members of services and all public bodies group themselves together for presentation, as far as possible.

It is requested that those entitled to wear uniform or official dress will do so on this occasion, but His Excellency will be pleased to receive those not entitled to wear uniform or official dress in their ordinary morning or business dress.

For the guidance of those attending the Levee, it will be appropriate, for those who wish to do so, to wear Honours, Decorations and Awards.

Private Entree Cards will admit recipients to the South Door of the Spring-street Entrance at Parliament House at 9.30 a.m. All other citizens are requested to enter by the North Door of the Spring-street Entrance at 10.15 a.m.

It is particularly desired that gentlemen attending the Levee should provide themselves with a card on which should be printed or typed in capitals, or written in block letters, their styles of address for presentation in order to facilitate announcement to His Excellency.

By His Excellency's Command,

M. V. FLETCHER, Brigadier,
Private Secretary and Comptroller.

PROCLAMATIONS

Land Act 1958.

AREA OF LAND COMPRISED IN CERTAIN CLASSES DIMINISHED OR INCREASED.

PROCLAMATION

By His Excellency the Governor of the State of Victoria and its Dependencies in the Commonwealth of Australia, &c., &c., &c.

WHEREAS by the *Land Act 1958* it is amongst other things enacted that the Governor in Council may, by Proclamation to be published in the *Government Gazette*, at any time diminish or increase the area of land comprised in any of the classes mentioned in Part I., Division 1, Section 5, of the said *Land Act 1958*, but that the area of lands which may be sold by auction (Class 6), shall not be increased except as in certain cases in the said Act provided: Now therefore I, the Governor of the State of Victoria, in the Commonwealth of Australia, by and with the advice of the Executive Council of the said State, and in accordance with the provisions of Sections 94 and 117 of the *Land Act 1958* aforesaid, do hereby diminish or increase (as the case may be) the areas of Crown lands comprised in Class 7 of the classes mentioned in Section 5 of the *Land Act 1958* aforesaid, to the extent set forth in the subjoined Schedule (that is to say):—

Schedule referred to

CLASSES DIMINISHED OR INCREASED.

County.	Parish.	Allotment.	Section.	Area.	Diminished.	Increased.	Description.
					Class.	Class.	
				A. R. P.			
Grant	Buninyong ..	40B	..	0 2 18	7	..	In the north of the Parish

Given under my Hand and the Seal of the State of Victoria aforesaid, at Melbourne, this fourteenth day of May, in the year of our Lord One thousand nine hundred and sixty-eight, and in the seventeenth year of the reign of Her Majesty Queen Elizabeth II.

ROHAN DELACOMBE.

(L.S.)

By His Excellency's Command,

W. J. F. McDONALD,
Minister of Lands.

GOD SAVE THE QUEEN !

Land Act 1958.

UNALIENATED CROWN LAND AVAILABLE FOR SETTLEMENT UNDER IMPROVEMENT PURCHASE LEASES.

PROCLAMATION

By His Excellency the Governor of the State of Victoria and its Dependencies in the Commonwealth of Australia, &c., &c., &c.

IN pursuance of the provisions of Section 153 of the *Land Act 1958*, I, the Governor of the State of Victoria, in the Commonwealth of Australia, by and with the advice of the Executive Council of the said State, do by this Proclamation declare the unalienated Crown lands mentioned in the subjoined schedule, to be available for settlement under improvement purchase leases.

SCHEDULE.

County.	Parish.	Allotment.	Section.	Area.	Land Valuation.
				A. R. P.	
Buln Buln	Neerim East	33A	A ¹	249 2 20	\$12.00 per acre
Delatite	Tatong	33A	A	33 0 0	\$8.00 per acre
Benambra	Burrowye	15	13	35 0 0±	\$8.00 per acre
Bogong	Dorchap	5A, 5B, 2A, 2B	6	60 0 0±	\$12.50 per acre
Croajingolong	Tonghi	35	..	120 0 0±	\$5.00 per acre
Croajingolong	Winyar	19	..	60 0 0±	\$6.00 per acre
Tanjil	Nindoo	38A	B	100 0 0±	\$5.00 per acre
				(Subject to survey)	

Given under my Hand and the Seal of the State of Victoria aforesaid, at Melbourne, this fourteenth day of May, in the year of our Lord One thousand nine hundred and sixty-eight, and in the seventeenth year of the reign of Her Majesty Queen Elizabeth II.

ROHAN DELACOMBE.

(L.S.)

By His Excellency's Command,

W. J. F. McDONALD,
Minister of Lands.

GOD SAVE THE QUEEN !

Milk Pasteurization Act 1958.

PROCLAMATION

DECLARING AREAS TO BE PASTEURIZED MILK DISTRICTS.

By the Lieutenant-Governor as Deputy for His Excellency the Governor of the State of Victoria and its Dependencies in the Commonwealth of Australia, &c., &c., &c.

WHEREAS by section 4 of the Milk Pasteurization Act 1958 it is amongst other things enacted that the Governor in Council may by proclamation declare any area specified in such proclamation to be a pasteurized milk district on and after a date specified in the proclamation: NOW THEREFORE I, the Lieutenant-Governor as Deputy for the Governor of the State of Victoria by and with the advice of the Executive Council thereof do by this my Proclamation hereby—

DECLARE the areas specified in the Schedule hereto to be pasteurized milk districts on and after the first day of June, One thousand nine hundred and sixty-eight.

SCHEDULE.

- (1) The municipal district of the Shire of Yarrawonga.
- (2) The municipal district of the City of Wangaratta excluding all that portion of the said municipal district within the boundary formed by commencing at a point being the junction of Murdoch-road and Cribbes-road; thence north-easterly and northerly along the eastern alignment of Murdoch-road to Vernon-road; thence easterly along the southern alignment of Vernon-road to a point in line with the easterly alignment of Chomley-avenue; thence northerly along a line in continuation of the easterly alignment of Chomley-avenue and along the easterly alignment of Chomley-avenue to Gayer-avenue; thence easterly by Gayer-avenue to Riverview-crescent; thence northerly along the eastern alignment of Riverview-crescent to the King River; thence generally easterly, southerly and westerly along the city boundary to the point of commencement.

Given under my Hand and the Seal of the State of Victoria aforesaid, at Melbourne, this twenty-first day of May, in the year of our Lord One thousand nine hundred and sixty-eight, and in the seventeenth year of the reign of Her Majesty Queen Elizabeth II.

(L.S.) E. F. HERRING.

By His Excellency's Command,
G. L. CHANDLER,
Minister of Agriculture.

GOD SAVE THE QUEEN!

PUBLIC HIGHWAYS.—CITY OF HEIDELBERG.

PROCLAMATION

By His Excellency the Governor of the State of Victoria and its Dependencies in the Commonwealth of Australia, &c., &c., &c.

WHEREAS by the Local Government Act 1958, Section 519 it is amongst other things enacted that it shall be lawful for the Governor-in-Council at any time and from time to time upon the request of the Council of any municipality by notice in the Government Gazette to proclaim any land reserved used or by purchase or exchange acquired for a street road highway thoroughfare bridge square court alley or right-of-way or any street road lane or passage made or laid out or proposed to be made or laid out on any land of which a plan of subdivision delineating that street road lane or passage has been sealed with the seal of the municipality under subdivision (3) of Division 9 of Part XIX of the Local Government Act 1958, or a corresponding previous enactment to be a public highway and that such land shall thereupon and thenceforth from the date of such proclamation become and be absolutely dedicated to the public as a public highway within the meaning of any law then or thereafter in force:

AND WHEREAS the Council of the City of Heidelberg has requested that the lands hereinafter mentioned, used for streets, roads lanes or passages, be so declared to be public highways.

NOW THEREFORE I, the Governor of the State of Victoria in the Commonwealth of Australia, by and with the advice of the Executive Council of the said State, do by this Proclamation declare that Graham Court, Tyrone Avenue, Milton Street and an un-named right-of-way shown hatched on Plan "A" hereunder and the un-named road shown hatched on Plan "B" hereunder shall be public highways within the meaning of the said Act.

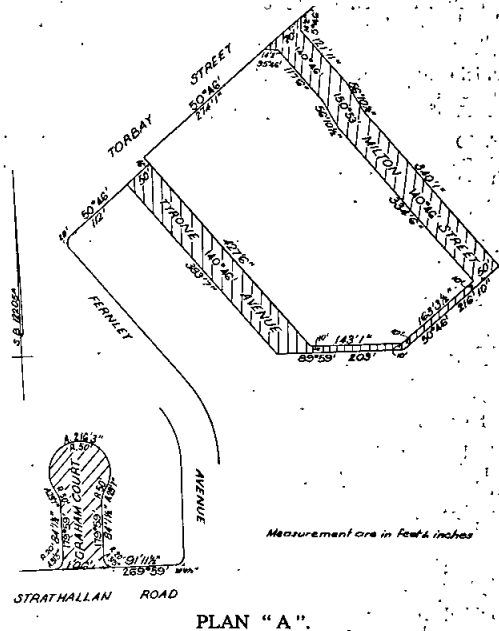

PLAN "A".

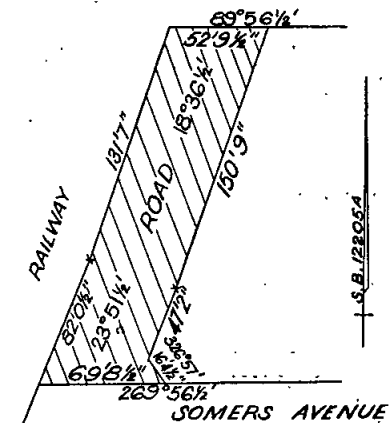

Measurements are in feet & inches.

PLAN "B".

Given under my Hand and the Seal of the State of Victoria aforesaid, at Melbourne, this fourteenth day of May, in the year of our Lord One thousand nine hundred and sixty-eight, and in the seventeenth year of the reign of Her Majesty Queen Elizabeth II.

(L.S.) ROHAN DELACOMBE.

By His Excellency's Command,
MURRAY PORTER,
Acting Minister for Local Government.
GOD SAVE THE QUEEN!

LOCAL GOVERNMENT DEPARTMENT.

PROCLAMATION EXTENDING THE OPERATION OF
THE UNIFORM BUILDING REGULATIONS.

By His Excellency the Governor of the State of Victoria and its Dependencies in the Commonwealth of Australia, &c., &c., &c.

WHEREAS Section 916 of the *Local Government Act 1958*, provides—*inter alia*—that the Governor-in-Council may, by proclamation published in the *Government Gazette*, at the request of the Council of any municipality (not being a city or town) extend the operation of Part XLIX of the said Act to the municipal district of such municipality or any part thereof:

AND WHEREAS by Proclamations published in the *Government Gazette* on the 4th September 1946 and the 5th September 1951, the operation of the said Part was extended to parts of the municipal district of the Shire of Tungamah.

AND WHEREAS the Council of the Shire of Tungamah has requested that the operation of the said Part be extended to the remainder of the municipal district of the Shire of Tungamah.

NOW THEREFORE I, the Governor of the State of Victoria by and with the advice of the Executive Council thereof, by this, my proclamation, do hereby extend the operation of the Regulations made under Part XLIX of the *Local Government Act 1958*, as amended to the remainder of the municipal district of the Shire of Tungamah.

And order that the said Regulation shall come into operation in the above described part of the municipal district of the Shire of Tungamah on publication of this Proclamation in the *Government Gazette* provided that parts I and II of Chapter 8 thereof shall not be deemed to come into operation till the 15th August 1968, except in so far as may be necessary to enable the Council of the said municipality to make by-laws pursuant to the powers conferred by Part III of the said Chapter and provided further that no such by-law shall come into operation before the 15th August 1968.

Given under my Hand and the Seal of the State of Victoria aforesaid, at Melbourne, this fourteenth day of May, in the year of our Lord One thousand nine hundred and sixty-eight, and in the seventeenth year of the reign of Her Majesty Queen Elizabeth II.

(L.S.) ROHAN DELACOMBE.

By His Excellency's Command,

MURRAY PORTER,
Acting Minister for Local Government.

GOD SAVE THE QUEEN !

FISHERIES (AMENDMENT) ACT 1967, No. 7641.

DATE OF COMING INTO OPERATION.

PROCLAMATION

By the Lieutenant-Governor as Deputy for His Excellency the Governor of the State of Victoria and its Dependencies in the Commonwealth of Australia, &c., &c., &c.

WHEREAS by an Act of Parliament of the State of Victoria passed in the sixteenth year of the reign of Her Majesty Queen Elizabeth II, entitled the *Fisheries (Amendment) Act 1967*, No. 7641, it is amongst other things enacted that the several provisions of the said Act shall come into operation on a day or the respective days to be fixed by Proclamation or successive proclamations of the Governor in Council published in the *Government Gazette*:

AND WHEREAS by a Proclamation issued on the twenty-seventh day of February, One thousand nine hundred and sixty-eight, Friday, the first day of March, One thousand nine hundred and sixty-eight was fixed as the day on which Section 3 of the *Fisheries (Amendment) Act 1967*, shall come into operation:

NOW THEREFORE I, the Lieutenant-Governor as Deputy for the Governor of the State of Victoria, in the Commonwealth of Australia, by and with the advice of the Executive Council of the said State, do by this my Proclamation fix Wednesday the twenty-second day of

May, One thousand nine hundred and sixty-eight, as the day on which Sections 1, 2 and 4 of the *Fisheries (Amendment) Act 1967*, No. 7641 shall come into operation.

Given under my Hand and the Seal of the State of Victoria, aforesaid, at Melbourne, this twenty-first day of May, in the year of our Lord One thousand nine hundred and sixty-eight, and in the seventeenth year of the reign of Her Majesty Queen Elizabeth II.

(L.S.) E. F. HERRING.

By His Excellency's Command,

A. G. RYLAH,
Chief Secretary.

GOD SAVE THE QUEEN !

GOVERNMENT NOTICES

MEENIYAN WATERWORKS TRUST.

AUTHORITY TO OBTAIN BANK OVERDRAFT.

THE Lieutenant-Governor as Deputy for His Excellency the Governor of the State of Victoria, by and with the advice of the Executive Council thereof, doth by Order made on the 21st day of May, 1968, authorize the Meeniyana Waterworks Trust to obtain in pursuance of the provisions of section 286 of the *Water Act 1958* (No. 6413) an advance or advances during the year 1968 by overdraft of the Trust's current account, such overdraft not to exceed at any one time the sum of Two thousand five hundred dollars (\$2,500).

J. ROSSITER,
Clerk of the Executive Council.

At the Executive Council Chamber,
Melbourne, 21st May, 1968.

THOMSON RIVER IMPROVEMENT TRUST.

RATING BY-LAW 1968.

THE Thomson River Improvement Trust, in pursuance and exercise of the powers conferred by the *River Improvement Act 1958*, doth hereby make the following By-Law:

1. The following rate, to be called "Thomson River Improvement Rate," is hereby made and shall be levied upon the occupiers or owners of all properties within the Thomson River Improvement District which are rateable to any Municipality:—

A rate of One Cent in the Dollar on the Net Annual Municipal Value of such properties. Provided that the sum of Ten Cents shall be the minimum amount of rate in respect of any property liable to be rated in the said District.

2. Such rate is made and shall be levied for the year beginning with the 1st January, 1968, and ending with the 31st December, 1968 and shall be payable on the 1st day of July, 1968 at the Office of the Thomson River Improvement Trust, at Rosedale.

3. Such person or persons as the Thomson River Improvement Trust may, from time to time, appoint for that purpose, shall be and is, or are hereby authorized to demand, receive, collect and recover the said rate.

The foregoing By-Law was made by the Thomson River Improvement Trust on the 2nd day of May, 1968 and the Common Seal of the Trust was hereunto affixed this 2nd day of May, 1968, in the presence of—

(SEAL) N. R. GOOCH, Chairman.
G. W. THOMSON, Secretary.

Approved by the Governor in Council, 14th May, 1968.—
J. ROSSITER, Clerk of the Executive Council.

Health Act 1958 (No. 6270).

MEAT SUPERVISION REGULATIONS 1956.

ALLOCATION OF MEAT BRANDS.

NOTICE is hereby given that the Commission of Public Health has allotted the letters "CSM" as the letters to be used as meat brands as indicating the City of South Melbourne.

A. T. GARDNER, Secretary,
Commission of Public Health.

Department of Health,
Melbourne, 14th May, 1968.

Health Act 1958.
VICTORIA—DEPARTMENT OF HEALTH.

NOTICE TO ATTEND FOR RADIOLOGICAL EXAMINATION.

To all persons aged twenty-one years and over enrolled or resident in the Subdivisions specified hereunder in the State Electoral District of Richmond.

TAKE notice that you are required to attend at a Department of Health X-ray unit sited in the public street at or as near as possible to the main entrance to the premises specified in this notice, at any time between the hours specified on one of the days specified and during the period specified in respect of those premises, and thereat to submit yourself to radiological examination of the chest for the purposes of ascertaining whether you may be suffering from pulmonary tuberculosis. If you have had a Chest X-ray within the last twelve months and for this reason do not wish to be examined now, you should attend the unit as directed and submit particulars of the previous examination.

SPECIFIED SUBDIVISIONS, PREMISES, PERIODS, DAYS AND HOURS.

Subdivision.	Premises.	Period.	Days.	Hours.
Fitzroy	Town Hall, Moor-street, Fitzroy	Tuesday, 4th June, 1968, to Thursday, 6th June, 1968 (inclusive)	Each day during the period except Public Holidays	From 10 a.m. to 8.30 p.m.
	Lawson's Pharmacy, 102-104 Gertrude-street, Fitzroy	Tuesday, 4th June, 1968, to Friday, 7th June, 1968 (inclusive)	Each day during the period except Public Holidays	From 10 a.m. to 8.30 p.m.
	Cnr. Victoria and Brunswick streets, Fitzroy	Thursday, 6th June, 1968, to Wednesday, 12th June, 1968 (inclusive)	Each day during the period except Saturday, Sunday and Public Holidays	From 10 a.m. to 8.30 p.m.
	Adriatic Service Station, cnr. Alexandra-parade and Rae-street, Fitzroy North	Friday, 7th June, 1968, to Friday, 14th June, 1968 (inclusive)	Each day during the period except Saturday, Sunday and Public Holidays	From 10 a.m. to 8.30 p.m.
Collingwood	Symes Milk Bar, 72-74 Vere-street, Collingwood	Tuesday, 11th June, 1968, to Thursday, 13th June, 1968 (inclusive)	Each day during the period except Public Holidays	From 10 a.m. to 8.30 p.m.
	Wellington Motors, 109 Peel-street, Collingwood	Monday, 17th June, 1968, and Tuesday, 18th June, 1968	Monday, 17th June, 1968 Tuesday, 18th June, 1968	From 10 a.m. to 8.30 p.m. From 10 a.m. to 8.30 p.m.
Collingwood North	Salvation Army Hall, cnr. Mater and Wellington-streets, Collingwood	Thursday, 13th June, 1968, to Tuesday, 18th June, 1968 (inclusive)	Each day during the period except Saturday, Sunday and Public Holidays	From 10 a.m. to 8.30 p.m.
	Luke's Mixed Business, cnr. Forest-street and Alexandra-parade, Collingwood	Friday, 14th June, 1968, and Monday, 17th June, 1968	Friday, 14th June, 1968 Monday, 17th June, 1968	From 10 a.m. to 8.30 p.m. From 10 a.m. to 8.30 p.m.
Abbotsford	St. Joseph's Technical School, Nicholson-street, Abbotsford	Tuesday, 18th June, 1968, and Wednesday, 19th June, 1968	Tuesday, 18th June, 1968 Wednesday, 19th June, 1968	From 10 a.m. to 8.30 p.m. From 10 a.m. to 8.30 p.m.
	Collingwood Town Hall, Hoddle-street, Abbotsford	Wednesday, 19th June, 1968, to Friday, 21st June, 1968 (inclusive)	Each day during the period except Public Holidays	From 10 a.m. to 8.30 p.m.
	Angelidis Caltex Service Station, cnr. Johnston and Hunter streets, Abbotsford	Wednesday, 19th June, 1968, and Thursday, 20th June, 1968	Wednesday, 19th June, 1968 Thursday, 20th June, 1968	From 10 a.m. to 8.30 p.m. From 10 a.m. to 8.30 p.m.
	Cnr. Nelson and Church streets, Abbotsford	Thursday, 20th June, 1968, and Friday, 21st June, 1968	Thursday, 20th June, 1968 Friday, 21st June, 1968	From 10 a.m. to 8.30 p.m. From 10 a.m. to 8.30 p.m.
Richmond	Prepousis Mixed Business, 27 Shelley-street, Richmond	Friday, 21st June, 1968, to Tuesday, 25th June, 1968 (inclusive)	Each day during the period except Saturday, Sunday and Public Holidays	From 10 a.m. to 8.30 p.m.
	Tsoukatos Mixed Business, cnr. Kent and Gardner streets, Richmond	Monday, 24th June, 1968, to Wednesday, 26th June, 1968 (inclusive)	Each day during the period except Public Holidays	From 10 a.m. to 8.30 p.m.
	Cnr. Kent and Church streets, Richmond	Monday, 24th June, 1968, and Tuesday, 25th June, 1968	Monday, 24th June, 1968 Tuesday, 25th June, 1968	From 10 a.m. to 8.30 p.m. From 10 a.m. to 8.30 p.m.
	Town Hall, cnr. Gleadell-street, and Bridge-road, Richmond	Wednesday, 26th June, 1968, to Monday, 1st July, 1968 (inclusive)	Each day during the period except Saturday, Sunday and Public Holidays	From 10 a.m. to 8.30 p.m.
	Albion Metal Ware, cnr. Lennox-street, and Bridge-road, Richmond	Wednesday, 26th June, 1968, to Tuesday, 2nd July, 1968 (inclusive)	Each day during the period except Saturday, Sunday and Public Holidays	From 10 a.m. to 8.30 p.m.
	Gideline Shoe Co. Pty. Ltd., 285 Lennox-street, Richmond	Thursday, 27th June, 1968, to Monday, 1st July, 1968 (inclusive)	Each day during the period except Saturday, Sunday and Public Holidays	From 10 a.m. to 8.30 p.m.
	Allison's Milk Bar, 142 Coppin-street, Richmond	Tuesday, 2nd July, 1968, to Thursday, 4th July, 1968 (inclusive)	Each day during the period except Public Holidays	From 10 a.m. to 8.30 p.m.
Cnr. Docker and Swan streets, Richmond	Tuesday, 2nd July, 1968, and Wednesday, 3rd July, 1968	Tuesday, 2nd July, 1968 Wednesday, 3rd July, 1968	From 10 a.m. to 8.30 p.m. From 10 a.m. to 8.30 p.m.	
Richmond South	Barkly Gardens, cnr. Mary and James streets, Richmond	Wednesday, 3rd July, 1968, to Friday, 5th July, 1968 (inclusive)	Each day during the period except Public Holidays	From 10 a.m. to 8.30 p.m.
	Cnr. Kelso and Cremorne streets, Richmond	Thursday, 4th July, 1968, and Friday, 5th July, 1968	Thursday, 4th July, 1968 Friday, 5th July, 1968	From 10 a.m. to 8.30 p.m. From 10 a.m. to 8.30 p.m.

NOTE.—Any person to whom this notice applies and who without reasonable excuse fails to comply with the requirements of the notice shall be guilty of an offence, and shall be liable to a penalty of not more than Forty dollars.

Dated this 30th day of April, One thousand nine hundred and sixty-eight.

R. J. FARNBACH, Chief Health Officer.

Transport Regulation Act.
TRANSPORT REGULATION BOARD.

HEARING OF APPLICATIONS.

NOTICE is hereby given that the following applications will be considered by the Transport Regulation Board at its offices at the corner of Lygon and Princes streets, Carlton, at 10.15 a.m. on Wednesday, 12th June, 1968.

HURST, R. R., & SONS, 6 Queen-street, Korumburra. One commercial passenger vehicle (S/C. 44) to operate as follows: (a) For the carriage of school children only between Strezlecki and Korumburra, under contract to the Education Department. (b) As a country special service omnibus with a pick-up radius of 10 miles from the Strezlecki Post Office.

HURST, R. R., & SONS, 6 Queen-street, Korumburra. One commercial passenger vehicle (S/C. 33) to operate as follows: (a) For the carriage of school children only between Loch and Korumburra under contract to the Education Department. (b) As a country special service omnibus with a pick-up radius of 10 miles from the Loch Post Office.

POINT COOK-WERRIBEE BUS SERVICE PTY. LTD., Railway-avenue, Laverton. Application for permit authority to operate any one C.O. licensed vehicle for the carriage of employees of Containers Ltd., 204 Geelong-road, West Footscray, free of charge between the West Footscray Railway Station and the company's new factory premises, Cherry-lane, Laverton, via Geelong-road, Doherty's-road and Cherry-lane.

Time-table.

Dep. West Footscray.	Dep. Containers Ltd.
Monday—Friday.	
6.30 a.m.	3.15 p.m.
2.30 p.m.	11.15 p.m.
Saturday.	
7.00 a.m.	3.55 p.m.
Sunday.	
6.30 a.m.	3.15 p.m.

VICTORIAN RAILWAYS, Spencer-street, Melbourne. Application for authority pursuant to section 33 (i) of the Transport Regulation Act (No. 6400) to deviate two trips of the Sandringham—Beaumaris bus service from the corner of Royal-avenue and Bluff-road via Bluff-road, Holloway-road, Green-parade, Spring-street, Wentworth-avenue and Tulip-street; thence to normal route, for the carriage of school children attending the Sandringham East State School and Sandringham Technical School.

Time-table.

Depart Beaumaris 8.19 a.m.
Depart Sandringham 3.39 p.m.

APPLICATION for renewal of licences as shown, by persons listed hereunder to operate under the same terms and conditions.

BELL, R. G. (trading as Bell's Nursery), 7 Stella-avenue, Noble Park; T.P.185.

BENNETT, J. F., 31 Gairlock-grove, Newtown, Geelong; U.T.616.

BLACHFORD, A. L., 4 Montgomery-street, Mordialloc; M.H.2268.

BLACK, S., 14 Everett-street, Brunswick West; M.H.2270.

BOEHM, R. A., 10 Anita-street, Beaumaris; M.H.2264.

BOURNE, F. B., Lot 14, Chandler-grove, Burwood; M.H.2269.

CARVER, L. F., 4 Beddoe-street, Bentleigh East; M.H.2267.

COAD, C. E. & R. I., Commercial-street, Yarram; T.P.123.

COCHRANE, W. J., 6 Patterson-street, Carrum; M.H.2258.

DARWALL, K. A., 13 Edinburgh-street, Bentleigh East; M.H.2265.

DEPARTMENT OF AGRICULTURE, Dookie; C.O.822.

DOYLE, W. J., 15 Gordon-grove, Montmorency; M.H.2247.

EAST GIPPSLAND TIMBER CO. PTY. LTD., Cabbage Tree Creek, via Orbost; T.P.109.

IMPERIAL CHEMICAL INDUSTRIES OF AUSTRALIA & NEW ZEALAND LTD., 1 Nicholson-street, Melbourne; T.P.28.

MASON, L. R., 9 Wattlebrae-street, Reservoir; M.H.2251.

MIDDLETON, S. E., Lot 16, Ithaca-court, Chadstone; M.H.2253.

MILLS, E. A. K., 8 Kimbarra-street, Clayton; M.H.2249.

MORROW, L. J., 499 Waterdale-road, West Heidelberg; M.H.2252.

MURNANE, D. A., 54 Williamson-avenue, Strathmore; M.H.2271.

MCDONALD, A. D., 73 Essex-road, Surrey Hills; M.H.2248.

OLIVER, J. E., 25 Sydney-street, Avondale Heights; M.H.2261.

PARSONS, R. E., 34 Oxford-street, Newport; M.H.2262.

QUINCES SCENICRUISERS PTY. LTD., 207 New-street, Brighton; M.C.604, M.C.616.

RILEY, A. G., Mount Pleasant-road, Eltham; C.T.109.

RYAN, D. N., Lang Lang Golf Course, Lang Lang; M.H.2260.

SEARCHFIELD, A., Flat 3, 191 Grange-road, Glenhuntly; M.H.4011.

SHANNON, E. M., 63 Denver-street, Bentleigh East; M.H.2254.

TAYLFORTH BROS. PTY. LTD., 16 Old Dookie-road, Shepparton; T.S.889.

WATERS, W. R., 9 Margot-street, Kingsville; M.H.2274.

WATSON, C. J., 28 Bayles-street, Mt. Waverley; M.H.2257.

WATSON CAMERON & CO., Whyte-street, Box 101, Coleraine; T.S.224, T.S.590.

WHYTCROSS, A., Lot 27, Thompson-crescent, Research; C.T.24.

YENDALL, W. O. (estate of the late), 14 Donald-street, Mount Waverley; M.H.2263.

Notice of any objection should be forwarded to reach the Secretary of the Board not later than Wednesday, 5th June, 1968.

Applicants are advised that it will not be necessary to appear on the hearing date specified above, unless advised in writing by the Board.

B. P. KAY,

Secretary.

Corner Lygon and Princes streets, Carlton, Wednesday, 22nd May, 1968.

Commercial Goods Vehicles Act.
TRANSPORT REGULATION BOARD.

HEARING OF APPLICATIONS.

NOTICE is hereby given that the following applications will be considered by the Transport Regulation Board at its offices at the corner of Lygon and Princes streets, Carlton, at 10.15 a.m. on 12th June, 1968.

ARNOTT-BROCKHOFF-GUEST PTY. LTD., 53 Huntingdale-road, Burwood, 3125. Nineteen commercial goods vehicles (L/C. 6, 10, 10, 10, 10, 10, 10, 10, 6, 6, 6, 6, 7, 7, 10, 10, 10, 10 cwt.) to operate throughout the State of Victoria in the course of business as "Biscuit Manufacturers" for the purpose of completing display and merchandising contracts—tools of trade, merchandising and display equipment, display and merchandising materials and samples of own products.

ASPLAND, S., 69 Walker-street, Sebastopol, 3356. One commercial goods vehicle (L/C. 123 cwt.) to operate within a 5-mile radius of the post office at Beaufort, in the course of business as "Sanitary Contractor".

BLACKSHAW, D., 7 Kallioota-street, Alfredton, Ballarat, 3350. One commercial goods vehicle (L/C. 7 cwt.) to operate within a 50-mile radius from the post office at Ballarat in course of business as "Merchandising Salesman" on behalf of Sunshine Biscuits Ltd. —biscuit products having been manufactured by the said company at Ballarat.

BOYLE, V. E., 51 Eram-road, Box Hill North, 3129. One commercial goods vehicle (L/C. 199 cwt.) to operate within a 50-mile radius of the premises of Pioneer Concrete Pty. Ltd., at Notting Hill, solely on behalf of the said company—premixed concrete in a specially constructed agitator vehicle.

CARMICHAEL, J., Stony Creek, 3957. One commercial goods vehicle (L/C. 135 cwt.) to operate: (a) Within a 70-mile radius of the post office at Yarram (Traralgon Division of the Country Roads Board)—road-making plant. (b) Within a 20-mile radius from current construction site or from the nearest railway station thereto—materials.

CASE, J. I., (AUSTRALIA) PTY. LTD., 1523 Sydney-road, Campbellfield, 3061. Four commercial goods vehicles (L/C. 11 cwt. each) to operate throughout the State of Victoria as a service vehicle in course of business as "Machinery Distributors"—tools of trade and spare parts incidental to the repair of construction equipment and agricultural tractors.

DELANEY, J. J. (trading as Delaney's Truck Co.), 20 Townsend-street, Mortlake, 3272. Two commercial goods vehicles (L/C. 213 cwt. each) to operate: (a) Within a 50-mile radius from the post office at Mortlake—plant the property of a contractor and required by him for use in connexion with the construction or maintenance of some specific, existing or proposed road, street, footpath, bridge, pier, wharf, weir or channel and also the following materials, viz.:—metal, stones, screenings, ashes, gravel, sand and earth. (b) Within a 20-mile radius from the site of any construction or maintenance work performed pursuant to paragraph (a) above, or from the railway station nearest thereto—any other materials required for such work. (c) Within a 25-mile radius of the post office at Mortlake—general goods, provided that no

- goods shall be carried whether by one stage or by more than one stage between places within the above radius, which are more than 30 road miles apart by the nearest practicable route. (d) From pits at Chatsworth to places situated within a 50-mile radius of the post office at Chatsworth—river washed sand.
- EASTERN PLANT HIRE PTY. LTD.**, 22 South-street, Wodonga, 3690. Two commercial goods vehicles (L/C. 100 and 124 cwt.) to operate: (a) Within a 50-mile radius from the post office at Wodonga in the course of business as "Earth-moving Contractors"—own plant and equipment for use in connexion with own contracts and also the following materials incidental to own contracts, viz.—metal, stones, screenings, gravel, sand and earth. (b) Within a 20-mile radius from the site of any current contract within that part of the State of Victoria bounded on the west by a north/south line drawn through Swan Hill, and on the south by an east/west line drawn through Seymour—metal, stones, screenings, gravel, sand and earth.
- FIAT OF AUSTRALIA PTY. LTD.** (trading as Fiat Tractors (Victoria)), 5 Warrigal-road, Moorabbin, 3189. One commercial goods vehicle (L/C. 30 cwt.) to operate throughout the State of Victoria in the course of business as "Tractor Manufacturers"—tools of trade and spare parts used for the service and repair of tractors and tractor equipment.
- GENERAL CONSTRUCTIONS PTY. LTD.**, 62 Mandoon-road, Girraween, 2145. One commercial goods vehicle (L/C. 55 cwt.) to operate: (a) Throughout the State of Victoria in the course of business as "Contractors"—tools of trade and equipment incidental to the completion of own contracts. (b) Within a 20-mile radius from current contract site or from the nearest railway station thereto—contract materials. (c) From current contract sites to site of disposal—overburden.
- THOMPSON, C. H., & L. A. DAVENPORT** (trading as Glenfield Contractors), 28 Becket-street, Glenroy, 3046. Two commercial goods vehicles (L/C. 16 and 15 cwt.) to operate: (a) Within a 25-mile radius of G.P.O., Melbourne as "Engineering and Building Contractors"—own goods. (b) Throughout the State of Victoria solely on behalf of Caltex Oil (Australia) Pty. Limited as "Installation and Servicing Contractors" for the purpose of installing and servicing petroleum dispensing equipment—tools of trade, pumps and a small quantity of materials incidental thereto.
- GOODLAND SALES & SERVICE PTY. LTD.**, 21 Mercer-street, Geelong, 3220. Two commercial goods vehicles (L/C. 16 and 23 cwt.) to operate: (a) Within a 50-mile radius of own premises in the City of Geelong in the course of business as "Farm Implement, Industrial Equipment and Automotive Distributors"—own goods. (b) Throughout the State of Victoria—tools of trade incidental to the servicing and maintenance of industrial equipment, and also such spare parts only as are required for the servicing of such machinery at the site where serviced.
- GUNTON, B. H.**, 98 Webster-street, Alexandra, 3714. One commercial goods vehicle (L/C. 234 cwt.) to operate from sawmills at Mansfield to the premises of General Paper Mills Pty. Ltd., at Brooklyn—pulpwood chips.
- HARBOUR, R.**, Yendon, 3332. One commercial goods vehicle (L/C. 86 cwt.) to operate to spreading sites within a 50-mile radius from the post office at Yendon from the railway siding nearest to such spreading site—bulk superphosphate for spreading purposes only.
- HUTTON, J. C., PTY. LTD.**, 65 High-street, Preston, 3072. One commercial goods vehicle (L/C. 36 cwt.) to operate throughout the State of Victoria in course of business as "Bacon and Smallgoods Manufacturers" in a specially constructed insulated and refrigerated vehicle—fresh meat, cooked meat, sausages and smallgoods with the ability to carry up to 3 cwt. of lard, dripping, cheese, canned ham and margarine.
- KILFOY, R. J.**, 174 Oriel-road, Heidelberg West, 3081. One commercial goods vehicle (L/C. 250 cwt.) to operate within a 50-mile radius from the premises of Albion Reid Pty. Ltd., at North Melbourne—road-making plant, materials, premix and hot asphalt on behalf of the said company, excluding the carriage of cement or lime from the Geelong Urban District.
- LAZENBY, J. G.**, 23 Havlin-street, Bendigo, 3550. One commercial goods vehicle (L/C. 10 cwt.) to operate within a 75-mile radius of the chief post office in the City of Bendigo but excluding any operation to the Metropolitan Area (as defined in the *Transport Regulation Act 1958*)—new washing machines for installation, used washing machines, motor mowers, motors for re-wind and vacuum cleaners and other electrical equipment for repair or having been repaired, tools of trade, spare parts and materials incidental to servicing and maintaining such equipment in the course of business as "Service Mechanic".
- LEITH, H. G.**, Lincoln-road, Warburton, 3799. Application to vary conditions of licence No. D.T.1195 (L/C. 123 cwt.) by deleting the existing conditions and adding in lieu:—(a) Within a 70-mile radius of the post office at Healesville (Dandenong Division of the Country Roads Board)—road-making plant. (b) Within a 20-mile radius from current construction site or from the nearest railway station thereto—materials. (c) Within a 25-mile radius of the post office at Warburton—general goods, provided that no goods shall be carried whether by one stage or by more than one stage between places within the above radius which are more than 30 road miles apart by the nearest practicable route.
- LIND, R. B.**, 1 Cameron-street, Hamilton, 3300. One commercial goods vehicle (L/C. 10 cwt. and 15 cwt. trailer) to operate within a 50-mile radius of own premises at Hamilton and to and from the City of Horsham in the course of business as "Tank Manufacturer"—own tanks, tools of trade and materials incidental to the installation of tanks.
- MAUDE, J. H.**, 109 Haldane-road, Niddrie, 3042. Application to vary conditions of licence No. D.A.49973 (L/C. 220 cwt.) by deleting "Berwick" from the existing conditions and adding in lieu "Tullamarine".
- NORTON, D. C.**, 11 Churchill-street, Warrnambool, 3280. One commercial goods vehicle (L/C. 7 cwt.) to operate within a 50-mile radius from the post office at Warrnambool in the course of business as "Electrician" on behalf of W. Hocking, Warrnambool—tools of trade, equipment and materials incidental to contracts currently engaged upon.
- PHILLIPS, G. F.**, 10 Ganton-court, Oakleigh, 3166. Application to vary conditions of licence No. D.A.57130 (L/C. 92 cwt.) by deleting paragraph (a) of the existing conditions and adding in lieu—"Within a 70-mile radius of the premises of Evans Bros. Pty. Ltd., at Scoresby—bricks and roofing tiles solely on behalf of the said company."
- SMITH, A. B. & D. E.**, Bowman-street, Warracknabeal, 3393. Two commercial goods vehicles (L/C. 32 and 109 cwt.) to operate: (a) Within a 50-mile radius of the Mobil Oil Australia Pty. Ltd. depot at Warracknabeal, petroleum products in prescribed types of containers and empty return containers. (b) Within a 50-mile radius of the Mobil Oil Australia Pty. Ltd. depot at Warracknabeal, bulk petroleum tanks for installation on properties within the said radius.
- SMITH, B. E.**, 11 Taronga-crescent, Croydon, 3136. One commercial goods vehicle (L/C. 220 cwt.) to operate within a 50-mile radius of the premises of Albion Reid Pty. Ltd., at North Melbourne—road-making plant, materials, premix and hot asphalt on behalf of the said company, excluding the carriage of cement or lime from the Geelong Urban District.
- SOMERVILLE, J.**, 24 Peachey-street, Casterton, 3311. One commercial goods vehicle (L/C. 11 cwt.) to operate: (a) Within a 50-mile radius from the post office at Casterton in the course of business as "Television Technician"—tools of trade, spare parts and television sets for repair or having been repaired. (b) From the Cities or Towns of Ballarat, Bacchus Marsh, Geelong, Colac, Warrnambool, Camperdown, Terang, Timboon, Heywood, Hamilton and Coleraine to own premises at Casterton—unserviceable television sets and television set chassis for rebuilding and for spare parts.
- SPITERI, E.**, 26A Donne-street, West Coburg, 3058. One commercial goods vehicle (L/C. 145 cwt.) to operate within a 70-mile radius from the premises of Atlas Industries Australia Ltd., at Springvale on behalf of the said company—roof tiles and battens.
- STUBBS, R. C.**, 174 Miller-street, West Preston, 3072. One commercial goods vehicle (L/C. 128 cwt.) to operate within a 70-mile radius of the premises of Brick and Pipe Industries Ltd., at Northcote, solely on behalf of the said company—bricks.
- TANK, J. M.**, 11 Polwarth-road, Lorne, 3232. One commercial goods vehicle (L/C. 18 cwt.) to operate: (a) From and to the City of Colac to and from the Township of Lorne via Dean's Marsh and Birregurra—general goods provided that the goods carried shall not exceed 5 cwt. in weight at any one time. (b) In the course of business as "Dairyman" within a 50-mile radius of the post office at Lorne—own goods.
- TANK, J. M.**, 11 Polwarth-road, Lorne, 3232. Two commercial goods vehicles (L/C. 54 and 56 cwt.) to operate: (a) From and to the City of Colac to and from the Township of Lorne via Dean's Marsh and Birregurra—general goods, provided that the goods

carried shall not exceed 20 cwt. in weight at any one time. (b) In the course of business as "Dairyman" within a 50-mile radius of the post office at Lorne—own goods.

TOWONEN, C. G., 23 Carawa-street, Mooroolbark, 3138. Application to vary conditions of licence No. D.A.61670 (L/C. 120 cwt.) by deleting the existing conditions and adding in lieu—"Within a 70-mile radius of the premises of Evans Bros. (Bricks) Pty. Ltd. at Scoresby solely on behalf of the said company—roofing tiles and face bricks."

TRANS OTWAY LTD., Corner Ryrrie and Fenwick streets, Geelong, 3220. One commercial goods vehicle (L/C. 221 cwt.) to operate for the carriage of general goods: (a) From and to the Metropolitan Area of the City of Melbourne as defined in the *Transport Regulation Act 1958*, or from and to the Geelong District as defined in the Second Schedule of the *Commercial Goods Vehicles Act 1958*, to and from places situated beyond an 8-mile radius from the chief post office in the City of Geelong along or accessible from the Geelong-Torquay road or the Waurm Ponds—Anglesea road and to and from places situated on or accessible only from the Great Ocean-road between Torquay and Apollo Bay and places within a 5-mile radius of the post office at Lorne and within a 10-mile radius from the post office at Apollo Bay. (b) From and to the Township of Apollo Bay and to and from the City of Colac. (c) Within a 20-mile radius from the post office at Apollo Bay. (d) Within a 25-mile radius from the chief post office in the City of Geelong. (e) From and to the Township of Lorne to and from the City of Colac. (f) Within a 20-mile radius from the post office at Lorne.

TRANS OTWAY (MELBOURNE) PTY. LTD., Corner Ryrrie and Fenwick streets, Geelong, 3220. One commercial goods vehicle (L/C. 140 cwt.) to operate for the carriage of general goods: (a) From and to the Metropolitan Area of the City of Melbourne as defined in the *Transport Regulation Act 1958*, or from and to the Geelong District as defined in the Second Schedule of the *Commercial Goods Vehicles Act 1958*, to and from places situated beyond an 8-mile radius from the chief post office in the City of Geelong along or accessible from the Geelong-Torquay road or the Waurm Ponds—Anglesea road and to and from places situated on or accessible only from the Great Ocean-road between Torquay and Apollo Bay and places within a 5-mile radius of the post office at Lorne and within a 10-mile radius from the post office at Apollo Bay. (b) From and to the Township of Apollo Bay and to and from the City of Colac. (c) Within a 20-mile radius from the post office at Apollo Bay. (d) Within a 25-mile radius from the chief post office in the City of Geelong. (e) From and to the Township of Lorne to and from the City of Colac. (f) Within a 20-mile radius from the post office at Lorne.

TOW TRUCKS.

EATON, A. J., & SONS, South Gippsland Highway, Tooradin, 3980. Application to vary conditions of licence No. D.A.51004 (L/C. 35 cwt.) by deleting the existing conditions and adding in lieu: "Throughout the State of Victoria as a Tow Truck solely—(a) For the purpose of lifting and carrying or towing motor cars and the carriage of tools and equipment necessary for such purpose only. (b) The carriage of spare parts necessary for the repair of a disabled motor to and from the place at which such disablement has occurred."

GAY, W. K., P.O. Leitchville, 3567. One commercial goods vehicle (L/C. 70 cwt.) to operate within a 50-mile radius of the chief post office at Cohuna as a "Tow Truck" solely—(a) For the purpose of lifting and carrying or towing motor cars and the carriage of tools and equipment necessary for such purpose only. (b) The carriage of spare parts necessary for the repair of a disabled motor to and from the place at which such disablement has occurred.

MALONEY, C., Box 110, Corryong, 3707. One commercial goods vehicle (to be purchased) to operate: (a) Within a 20-mile radius of the post office at Corryong—general goods. (b) Throughout the State of Victoria as a "Tow Truck" solely—(i) For the purpose of lifting and carrying or towing motor cars and the carriage of tools and equipment necessary for such purpose only (ii) The carriage of spare parts necessary for the repair of a disabled motor to and from the place at which such disablement has occurred.

RENEWALS.

APPPLICATIONS for renewal of licences as shown, by persons listed hereunder, to operate under the same terms and conditions from the expiry shown in each case.

ALLANS MUSIC (AUSTRALIA) PTY. LTD., 276 Collins-street, Melbourne, 3000; D.A.12692/3; 25th July, 1968; 19 cwt.

ALLEN, A. W., SALES PTY. LTD., 51-63 Riverside-avenue, South Melbourne, 3205; D.A.2218/3; 16th July, 1968; 73 cwt.

ALLEN, A. W., SALES PTY. LTD., 51-63 Riverside-avenue, South Melbourne, 3205; D.A.2218/4; 25th July, 1968; 73 cwt.

ALLEN, A. W., SALES PTY. LTD., 51-63 Riverside-avenue, South Melbourne, 3205; D.A.2218/5; 25th July, 1968; 65 cwt.

ALLEN, A. W., SALES PTY. LTD., 51-63 Riverside-avenue, South Melbourne, 3205; D.A.2218/6; 25th July, 1968; 74 cwt.

ALLEN, A. W., SALES PTY. LTD., 51-63 Riverside-avenue, South Melbourne, 3205; D.A.2218/7; 14th July, 1968; 60 cwt.

BEAUREPAIRE TYRE SERVICE PTY. LTD., 102 Victoria-street, Carlton, 3053; D.A.629/50; 25th July, 1968; 11 cwt.

BEAUREPAIRE TYRE SERVICE PTY. LTD., 102 Victoria-street, Carlton, 3053; D.A.629/51; 25th July, 1968; 11 cwt.

BOON, C., 262-266 Bay-road, Cheltenham, 3192; D.A.52315; 7th July, 1968; 32 cwt.

C.R.A. ENGINEERING PTY. LTD., Private Bag 5, Campbellfield, 3061; D.A.49644/10; 7th July, 1968; 176 cwt.; D.A.49644/11; 7th July, 1968; 176 cwt.

CHEETHAM SALT LTD., 71 Little Malop-street, Geelong, 3220; D.A.832/1; 24th June, 1968; 226 cwt.

COLDSTREAM REFRIGERATORS MELBOURNE PTY. LTD., 79 Lygon-street, East Brunswick, 3057; D.A.39871/1; 11th July, 1968; 11 cwt.; D.A.39871/4; 11th July, 1968; 11 cwt.

COLES, G. J., & COY. LTD., 236 Bourke-street, Melbourne, 3000; D.A.847; 13th July, 1968; 11 cwt.; D.A.847/1; 13th July, 1968; 18 cwt.

COMMONWEALTH INDUSTRIAL GASES LTD., THE, 90 Bell-street, Preston, 3072; D.A.838/8; 9th July, 1968; 18 cwt.

COMMONWEALTH INDUSTRIAL GASES LTD., THE, 90 Bell-street, Preston, 3072; D.A.838/12; 25th July, 1968; 9 cwt.

CROCKFORD & ROBERTSON PTY. LTD., 15 Abbott-street, Fairfield, 3078; D.A.914/9; 7th July, 1968; 16 cwt.; D.A.914/10; 7th July, 1968; 11 cwt.

DAVEY, F. W., & CO. PTY. LTD., 2 Hargreaves-street, Huntingdale, 3166; D.A.949/1; 9th July, 1968; 30 cwt.

DEPENAU, H. E., PTY. LTD., 73 Victoria-street, Brunswick East, 3057; D.A.17846/18; 20th July, 1968; 197 cwt.

EDWARDS, G. N., 1066 Bardia-street, Albury, 2640; T.D.A.16239/1; 3rd July, 1968; 67 cwt.

ELLARD, L. A., 4 Daleglen-street, Keon Park, 3073; D.A.51601; 9th May, 1968; 172 cwt.

GERRARD WIRE TYING MACHINES CO. PTY. LTD., cnr. Geelong and Little Boundary roads, Brooklyn, 3025; D.A.32176/2, D.A.32176/3; 7th July, 1968; 34 cwt.

HEMINGWAY, LEO, & PICKETT PTY. LTD., 330 Sydney-road, Brunswick, 3056; D.A.39955; 25th July, 1968; 48 cwt.; D.A.39955/1; 25th July, 1968; 22 cwt.; D.A.39955/4; 25th July, 1968; 36 cwt.; D.A.39955/5; 25th July, 1968; 65 cwt.; D.A.39955/6; 25th July, 1968; 64 cwt.

HOFFMAN BRICK POTTERIES PTY. LTD., 68 Dawson-street, Brunswick, 3056; D.A.35003/12; 25th July, 1968; 228 cwt.

HUTTON, J. C., PTY. LTD., 65 High-street, Preston, 3072; T.D.A.48355/14; 7th July, 1968; 54 cwt.

KELVINATOR AUSTRALIA LTD., 487 Williamstown-road, Port Melbourne, 3207; D.A.1420/20; 7th July, 1968; 14 cwt.

KORUMBURRA TYRE SERVICE PTY. LTD., Commercial-street, Korumburra, 3950; D.A.31537/3; 31st May, 1968; 11 cwt.

LANCASTER, A., 11 Dwyer-street, Clifton Hill, 3068; D.A.1467; 9th July, 1968; 114 cwt.

MOBILE INDUSTRIAL EQUIPMENT LTD., 410 Whitehorse-road, Mitcham, 3132; D.A.48327/10; 7th July, 1968; 7 cwt.

NELSON BROS. PTY. LTD., 7 Droop-street, Footscray, 3011; D.A.3611/4; 7th July, 1968; 10 cwt.

NORTHERN TYRE SERVICE PTY. LTD., 298 High-street, Shepparton, 3630; D.A.47685/3; 16th June, 1968; 10 cwt.

PETERSVILLE AUSTRALIA LTD., Wellington-road, Clayton, 3168; T.D.A.1813/96; 7th July, 1968; 38 cwt.; T.D.A.1813/97; 7th July, 1968; 72 cwt.; T.D.A.1813/98; 7th July, 1968; 76 cwt.; T.D.A.1813/99; 20th July, 1968; 37 cwt.; T.D.A.1813/124; 19th July, 1968; 79 cwt.

RUSSELL, E. A. C., PTY. LTD., Main-street, Gembrook, 3783; D.A.4901/5; 9th July, 1968; 116 cwt.

SOUTHERN PENINSULA TRANSPORT SERVICE PTY. LTD., P.O. Box 4, Rosebud, 3939; D.A.2075; 16th July, 1968; 140 cwt.; D.A.2075/1; 23rd June, 1968; 300 cwt.; D.A.2075/2; 23rd June, 1968; 241 cwt.; D.A.2075/3; 23rd July, 1968; 217 cwt.; D.A.2075/7; 2nd June, 1968; 59 cwt.

STOCKFEEDS, C. C., P.O. Box 100, Dandenong, 3175; T.D.A.60931; 17th July, 1968; 180 cwt.

V. S. SUPPLIES LTD., 11-21 Villiers-street, North Melbourne, 3051; D.A.26921; 9th July, 1968; 8 cwt.

TOPPA ICE-CREAM PTY. LTD., 99 Bell-street, Preston, 3072; D.A.40330; 25th July, 1968; 7 cwt.

TOPPA ICE-CREAM PTY. LTD., 99 Bell-street, Preston, 3072; D.A.40330/3; 25th July, 1968; 7 cwt.

TOPPA ICE-CREAM PTY. LTD., 99 Bell-street, Preston, 3072; D.A.40330/4; 25th July, 1968; 14 cwt.

TOW TRUCKS.

HUSSEY, J. H., JNR. (trading as A.T.S. Towing Service), 7 McCutchen-street, Northcote, 3070; T.D.A.59295/2; 11th July, 1968; 22 cwt.

COWELL, C. R., Melbourne-road, Foster, 3960; T.D.A.41554/1; 21st April, 1968; 4 cwt.

GARDINER TOWING SERVICE PTY. LTD., 286 Burke-road, Gardiner, 3146; D.A.52279; 7th July, 1968; 30 cwt.

RENEWALS WITH VARIATION.

APPLICATION by the persons listed hereunder for renewal of the licence listed with variation of conditions in the manner set out opposite the names.

DRAFFIN BROS. PTY. LTD., 45 City-road, South Melbourne, 3205; D.A.27827/6; 11th July, 1968; Application to renew and vary conditions of licence No. D.A.27827/6 (L/C. 11 cwt.) by adding to the existing conditions "And electric ranges".

WOOD, L. H., 53 Echuca-road, Mooroopna, 3629; D.A.2321; 12th July, 1968; Application to renew and vary conditions of licence No. D.A.2321 (L/C. 129 cwt.) by adding to paragraph (b) of the existing conditions after "Yarrowonga" the word "Avenel".

Notice of any objection should be forwarded to reach the Secretary of the Board not later than Wednesday, 5th June, 1968.

Applicants are advised that it will not be necessary to appear on the hearing date specified above, unless advised in writing by the Board.

B. P. KAY,
Secretary.

Corner Lygon and Princes streets, Carlton, 3053, 17th May, 1968.

LOCAL GOVERNMENT DEPARTMENT.

ORDER CONFIRMED.—SHIRE OF BET BET.

THE Minister of the Crown administering the Local Government Act 1958, on the 16th day of May, 1968, confirmed the Order hereinafter referred to, in pursuance of section 514 of the said Act, namely:

An Order of the Council of the Shire of Bet Bet, made on the 22nd December, 1965, directing the compulsory taking of the land described hereunder for the purposes of road construction.

All those pieces of land in the Township of Moliagul, Parish of Moliagul, the boundaries of which are as follow:—Commencing at a point on the north-east corner of allotment 4, section 1, of the Township of Moliagul, Parish of Moliagul, bearing 158 deg. 33 min. distant 83 links along High-street; thence by a line bearing 197 deg. 51 min. distant 711.9 links to Bealiba-street; thence bearing 338 deg. 33 min. distant 157.9 links along Bealiba-street; thence by a line bearing 17 deg. 51 min. distant 534.4 links; thence 8 deg. distant 71.9 links to Cochrane-street; thence 68 deg. 33 min. distant 77.2 links to point of commencement.

MURRAY PORTER,

Acting Minister for Local Government.

Local Government Department,
Melbourne.

DEPARTMENT OF MINES.

APPLICATION FOR LEASE DECLARED ABANDONED.
8552, Mineral; Roland Walton, 600 acres, Parishes of Wollonaby, Ludrik—Munjie.

MINERAL SEARCH LICENCES GRANTED.

787, Mineral Search Licence; The Broken Hill Proprietary Co. Ltd.; 112 square miles, County of Tambo.
802, Mineral Search Licence; Lindsay Gordon McRae, Keith McRae; 38 acres, Parish of Heathcote.
810, Mineral Search Licence; Gerald Howarth Gannan; 50 acres, Parish of Warrambat.

MINING LEASE TRANSFERRED.

8342, Mineral; from Charles James Dean to John Charles Dean.

TAILINGS LICENCE GRANTED.

3584, Tailings Licence; the President, Councillors and Rate-payers of the Shire of Beechworth; Crown land situated south of allotment 5, section K, Parish of Stanley.

J. C. M. BALFOUR,
Minister of Mines.

NOTICE TO MARINERS.

[No. 11 of 1968.]

THE following Notice to Mariners, which has been received from the Harbor Master, Geelong, is published for general information.

A. J. WAGGLEN,
Port Officer in Victoria.

Public Works Department,
Ports and Harbors Branch,
Treasury-place, Melbourne, 3002.
17th May, 1968.

GEELONG HARBOR TRUST COMMISSIONERS.

PORT OF GEELONG.

TEMPORARY BUOY WITHDRAWN.

Former Notice No. 2 of 1967.

Position.—291 deg. distant 3.3 miles from No. 1 Lt. Beacon Pt. Richards Channel (Lat. 38 deg. 04 min. 50 sec. S., Long. 144 deg. 38 min. 08 sec. E. Approx.)

Details.—The temporary Spoil Ground light buoy in the above position has been permanently removed.

Charts Affected.—Aus. 157, 2731.

Housing Act.

NOTICE OF RESOLUTION UNDER SECTION 99 (4) OF ACT No. 6275.

NOTICE is hereby given that Housing Commission on the Thirteenth day of May, 1968 resolved as follows:—

"Whereas Housing Commission in respect of the lands described in the Schedule hereto has published a general notice under sub-section 3 of section 99 of the Housing Act 1958 Housing Commission hereby resolves that the lands described in the Schedule hereto are finally appropriated for the purposes of the Housing Act 1958".

SCHEDULE.

All that land being Crown allotments 1 to 6 (both inclusive) section 58 and Crown allotments 1 to 5 (both inclusive) section 70 at Carlton Parish of Jika Jika.

A. L. BOHN,
Secretary.

Dried Fruits Act 1958.

STATE OF VICTORIA.

NOTICE.

I, GILBERT LAWRENCE CHANDLER, Minister of Agriculture, acting upon the recommendation of the Victorian Dried Fruits Board, hereby give notice that I have determined the maximum proportions of Dried Vine Fruits produced in Victoria in the year One thousand nine hundred and sixty-eight, that may be marketed within Victoria are as follows:—

Dried Currants	20 per cent.
Dried Sultanas	10 per cent.
Raisins	15 per cent.

G. L. CHANDLER,
Minister of Agriculture.

Department of Agriculture,
Melbourne, 10th May, 1968.

MOTOR CAR ACT 1958, SECTION 19.

NOTICE is hereby given that, for the purpose of section 19 of the Motor Car Act 1958, the Antique Car Club of Albury and Wodonga is approved as an association to organize and conduct official rallies of veteran and vintage motor cars.

R. H. ARNOLD,
Chief Commissioner of Police.

Private Agents Act 1966.

NOTICE OF RECEIPT OF APPLICATIONS FOR LICENCES UNDER THE PROVISIONS OF THE PRIVATE AGENTS ACT 1966.

THE Clerk(s) of the Court(s) of Petty Sessions as listed hereunder hereby give notice that applications, as under, have been lodged for hearing by the said Court(s) on the date(s) specified.

Any person desiring to object to any of such applications must—

- (a) lodge with the respective Clerk of Petty Sessions a notice in the prescribed form of his objection and of the grounds thereof;
- (b) cause a copy of such notice to be served personally or by post upon the applicant at least three days before the hearing of the application; and
- (c) send or deliver—
 - (i) where the objection is not made by the officer in charge of the police district in which the Court is situated—a copy of the notice to such officer; and
 - (ii) where the objection is not made by the Registrar or Deputy Registrar—a copy to the Registrar.

Full Name of Applicant or in the case of a Firm or Corporation, of the Nominee.	Place of Abode of Applicant or Nominee.	Name of Firm or Corporation.	Address for Registration.	Type of Licence.	Date of Hearing of Application.
---	---	------------------------------	---------------------------	------------------	---------------------------------

COURT OF PETTY SESSIONS, WODONGA.

Morris, Peter	515 Small-street, Albury	27 Ely-street, Wangaratta	Process Server ..	28.5.68
Patterson, Clifford Norman ..	45 Auburn-street, Wodonga	45 Auburn-street, Wodonga	" " ..	"
Watz, Hans Ivan	742 " Kiewa-street, Albury	125 " High-street, Wodonga	Inquiry Agent ..	29.5.68

Dated at Wodonga this 7th day of May, 1968.

J. T. KNIGHT,
Clerk of Petty Sessions.

COURT OF PETTY SESSIONS, GEELONG.

Roberts, Douglas Frank	16 Pinder-street, Whittington, Geelong	2A James-street, Geelong	Commercial Agent	31.5.68
" " "	" " "	" " "	Process Server ..	"
" " "	" " "	" " "	Inquiry Agent ..	"
" " "	" " "	" " "	Guard Agent ..	"

Dated at Geelong this 9th day of May, 1968.

J. R. AITKEN,
Clerk of Petty Sessions.

COURT OF PETTY SESSIONS, MALVERN.

Davis, Victor Alfred James ..	116 Kanooka-grove, Clayton	116 Glenferrie-road, Malvern	Process Server ..	31.5.67
-------------------------------	----------------------------	---------	------------------------------	-------------------	---------

Dated at Malvern this 9th day of May, 1968.

P. J. RODDA,
Clerk of Petty Sessions.

COURT OF PETTY SESSIONS, SALE.

Hanley, Brian Ross	Boundary-road, Sale	Australian Watching Co.	130 Abbotsford-street, North Melbourne	Watchman ..	25.6.68
----------------------------	---------------------	-------------------------	--	-------------	---------

Dated at Sale this 10th day of April, 1968.

D. R. WALKER,
Clerk of Petty Sessions.

COURT OF PETTY SESSIONS, ST. KILDA.

Eadie, George	Flat 18, 4 Wandogrove, East St. Kilda	Flat 18, 4 Wandogrove, East St. Kilda	Inquiry Agent ..	4.6.68
-----------------------	---------------------------------------	---------	---------------------------------------	------------------	--------

Dated at St. Kilda this 10th day of May, 1968.

J. E. REILLY,
Clerk of Petty Sessions.

COURT OF PETTY SESSIONS, PRAHRAN.

Walton, James Charles	2 Walker-avenue, Hampton	614 St. Kilda-road, St. Kilda	Watchman	7.6.68
Griffin, Kevin Roy	17 Henkley-avenue, West Croydon	181 Chapel-street, Prahran	Process Server ..	"

Dated at Prahran this 13th day of May, 1968.

G. T. WHEELHOUSE,
Clerk of Petty Sessions.

COURT OF PETTY SESSIONS, COBURG.

Leighton, Sidney George ..	4 Veronica-street, Northcote	151 Sussex-street, Coburg	Process Server ..	30.5.68
----------------------------	------------------------------	---------	---------------------------	-------------------	---------

Dated at Coburg this 13th day of May, 1968.

F. J. TENNI,
Clerk of Petty Sessions.

COURT OF PETTY SESSIONS, NUMURKAH.

Dickens, Douglas Alan	191 Melville-street, Numurkah	191 Melville-street, Numurkah	Guard Agent (Individual)	28.5.68
-------------------------------	-------------------------------	---------	-------------------------------	--------------------------	---------

Dated at Numurkah this 10th day of May, 1968.

J. L. COLLINS,
Clerk of Petty Sessions.

PRIVATE AGENTS—continued.

Full Name of Applicant or in the case of a Firm or Corporation, of the Nominee.	Place of Abode of Applicant or Nominee.	Name of Firm or Corporation.	Address for Registration.	Type of Licence.	Date of Hearing of Application.
---	---	------------------------------	---------------------------	------------------	---------------------------------

COURT OF PETTY SESSIONS, FERNTREE GULLY.

Beckett, Lillie Elizabeth	Lot 13; Hilton-road, Ferny Creek	Yarra Valley Process Agency	Lot 13, Hilton-road, Ferny Creek	Process Server	3.6.68
---------------------------	----------------------------------	-----------------------------	----------------------------------	----------------	--------

Dated at Ferntree Gully this 13th day of May, 1968.

F. J. DUTHIE,
Clerk of Petty Sessions.

COURT OF PETTY SESSIONS, MELBOURNE.

Young, David	982 Burke-road, Deepdene, 3103	George Laurens Pty. Ltd.	414 Lonsdale-street, Melbourne	Commercial Sub-agent Watchman	5.6.68
Burrows, James	90 Riggall-street, Broadmeadows, 3047	Australian Watching Co. Pty. Ltd.	130 Abbotsford-street, North Melbourne	"	"
Cameron, Ronald Henry	2 Shedden-street, Pascoe Vale, 3044	" " "	" " "	"	"
Cocks, Patrick Bradley	75 Parsons-street, Sunshine, 3020	" " "	" " "	"	"
Dare, Rodney	Lot 292, Craigieburn-road, West Craigieburn, 3064	" " "	" " "	"	"
Donnellan, John Francis	7 Goode-street, Chadstone, 3148	Mayne Nickless Ltd.	94 York-street, South Melbourne	"	"
Hamilton, Neil Graeme	3 Davidson-street, Springvale, 3171	Australian Watching Co. Pty. Ltd.	130 Abbotsford-street, North Melbourne	"	"
Jackson, Bernard Ward	29 Sussex-street, Seaholme, 3018	" " "	" " "	"	"
Kinna, Desmond	17 Edmondson-street, Lalor, 3075	" " "	" " "	"	"
Miechel, Phillip Henry	5 The Fairway, Kingsbury, 3083	" " "	" " "	"	"
McNair, Wesley Robert	20 Earlsfield-court, Deer Park, 3023	" " "	" " "	"	"
Oldfield, Ronald John	24 Greendale-road, East Doncaster, 3108	" " "	" " "	"	"
Osborne, Paul Francis	63 Rainer-street, Pascoe Vale South, 3044	" " "	" " "	"	"
Richards, Keith Edwin	99 Palmerston-street, Melton, 3337	" " "	" " "	"	"
Rood, William	Flat 1, 22 Churchill-avenue, Ascot Vale, 3032	" " "	" " "	"	"
Sheehy, Francis John	30 Farquharson-street, Mount Waverley, 3149	" " "	" " "	"	"
Welsh, John Gordon	Flat 5, 25 Mark-street, North Melbourne, 3051	" " "	" " "	"	"

Dated at Melbourne this 15th day of May, 1968.

G. L. WEBSTER,
Clerk of Petty Sessions.

COURT OF PETTY SESSIONS, SALE.

Callow, Barry Clyde	8 Raglan-street, Sale	Australian Watching Co.	130 Abbotsford-street, North Melbourne	Watchman	4.6.68
---------------------	-----------------------	-------------------------	--	----------	--------

Dated at Sale this 13th day of May, 1968.

D. R. WALKER,
Clerk of Petty Sessions.

COURT OF PETTY SESSIONS, FOOTSCRAY.

Fuller, Kevin John	7 Parker-street, Footscray	" " "	" " "	Watchman	5.6.68
--------------------	----------------------------	-------	-------	----------	--------

Dated at Footscray this 14th day of May, 1968.

G. S. HOARE,
Clerk of Petty Sessions.

COURT OF PETTY SESSIONS, SOUTH MELBOURNE.

Black, Constantine Nicklos	36 Yerrawa-drive, Watsonia	" " "	101-105 Clarke-street, South Melbourne	Watchman	12.6.68
Hartley-Smith, Terrence	Preston Hostel, Water-street, Preston	" " "	" " "	"	"
Newman, William Leslie	Princes Highway, Beaconsfield	" " "	" " "	"	"
Raper, Francis Ronald Henry	Flat 8, 174. Victoria-avenue, Albert Park	" " "	" " "	"	"

Dated at South Melbourne this 15th day of May, 1968.

G. MILLER,
Clerk of Petty Sessions.

PRIVATE AGENTS—continued.

Full Name of Applicant or in the case of a Firm or Corporation, of the Nominee.	Place of Abode of Applicant or Nominee.	Name of Firm or Corporation.	Address for Registration.	Type of Licence.	Date of Hearing of Application.
COURT OF PETTY SESSIONS, MELBOURNE.					
Arkie, Albert Melville ..	3 Payne-street, Gladstone Park, Tullamarine, 3043	Australian Watching Co. Pty. Ltd.	130 Abbotsford-street, North Melbourne	Watchman ..	29.5.68
Bradley, Francis Stanley ..	6 Fraser-street, Diamond Creek, 3089	" "	" "	" ..	"
Chalkiadakis, Peter ..	20 Primula-street, Blackburn, 3130	" "	" "	" ..	"
Clark, Robert Albert Graham ..	10 George-street, Preston, 3072	Max Hocking Security Service	288 Little Collins-street, Melbourne	" ..	"
Curran, William Callinan ..	19 Spruzen-avenue, North Kew	Australian Watching Co. Pty. Ltd.	130 Abbotsford-street, North Melbourne	" ..	"
Gadd, Barry John ..	20 Fletcher-street, Essendon, 3040	" "	" "	" ..	"
Hinton, Arthur James ..	72 Springhall-parade, Pascoe Vale South, 3044	" "	" "	" ..	"
Hobeika, Peter ..	4 Celeste-street, Doncaster, 3108	" "	" "	" ..	"
Long, Donald Richard ..	8 Newbury-street, Mitcham, 3132	" "	" "	" ..	"
Mafferzoni, Jeffrey James ..	1423 Centre-road, Clayton, 3168	" "	" "	" ..	"
Miller, Ronald Andrew ..	4 O'Hara-street, Blackburn, 3130	" "	" "	" ..	"
Roach, Henry Richard ..	3 Payne-street, Gladstone Park, Tullamarine, 3043	" "	" "	" ..	"
Skeggs, Harry Ernest ..	2 Laming-road, Deer Park, 3023	" "	" "	" ..	"

Dated at Melbourne, this 9th day of May, 1968.

G. L. WEBSTER,
Clerk of Petty Sessions.

COURT OF PETTY SESSIONS, TERANG.

Murnane, Ronald ..	26 Bolivar-street, Terang	Ron Murnane ..	87 High-street, Terang	Process Server ..	5.6.68
--------------------	---------------------------	----------------	------------------------	-------------------	--------

Dated at Terang this 13th day of May, 1968.

M. W. GERKENS,
Clerk of Petty Sessions.

COURT OF PETTY SESSIONS, OAKLEIGH.

Seidel, Ralph Donald ..	Lot 30, Sunhill-road, Mt. Waverley	Mulgrave Security Service Pty. Ltd.	310 Stephenson's-road, Mt. Waverley	Watchman ..	7.6.68
-------------------------	------------------------------------	-------------------------------------	-------------------------------------	-------------	--------

Dated at Oakleigh this 16th day of May, 1968.

F. McSWEENEY,
Clerk of Petty Sessions.

COURT OF PETTY SESSIONS, ST. KILDA.

Doyle, James ..	7 Cobden-street, Caulfield	" ..	7 Cobden-street, Caulfield	Inquiry Agent ..	7.6.68
-----------------	----------------------------	------	----------------------------	------------------	--------

Dated at St. Kilda this 17th Day of May, 1968.

J. E. REILLY,
Clerk of Petty Sessions.

COURT OF PETTY SESSIONS, SOUTH MELBOURNE.

Fry, Allan Percy ..	168 Noble-street, Noble Park	MSS Guard Service	101-105 Clarke-street, South Melbourne	Watchman ..	12.6.68
Hartley, Roy ..	23 Eade-street, Laver-ton	" " "	" "	" ..	"
Hayes, Stanislaud ..	6 Warrick-street, Ascot Vale	" " "	" "	" ..	"
Hearnden, Arthur Henry ..	1 Through-road, Burwood	" " "	" "	" ..	"
House, Michael Ronald ..	1A Lynch-street, Foots-cray	" " "	" "	" ..	"
Lander, Royston ..	20 Stanhope-street, Broadmeadows	" " "	" "	" ..	"
Van Ham, Theo ..	37 Lorne-road, East Prahran	" " "	" "	" ..	"

Dated at South Melbourne this 17th day of May, 1968.

J. M. DUGAN,
Clerk of Petty Sessions.

STAMPS ACT 1958.—ANNUAL LICENCES.

I HEREBY notify that the necessary stamp duty has been paid by the under-mentioned companies, persons and firms for Licences to carry on assurance and insurance business in Victoria during the year ending 31st December, 1968 and that the relevant Annual Licences have been issued accordingly:—

- A.C.I. Insurances Proprietary Limited.
 Affiliated Reinsurances Proprietary Limited.
 Ajax Insurance Company Limited.
 Albion Insurance Company Limited.
 Alliance Assurance Company Limited (with which is united the Imperial Insurance Company Limited).
 American Home Assurance Company.
 American International Assurance Company Limited.
 American Life Insurance Company.
 A.M.P. Fire and General Insurance Company Limited.
 Ansvar Insurance Company Limited.
 Anthony Gibbs—Insurance—Pty. Ltd.
 Anthony Gibbs Reinsurance Pty. Ltd.
 A.P.A. Fire & General Insurance Company Limited.
 Arthur Weller and Company Proprietary Limited.
 Associated General Contractors Insurance Company Limited.
 Associated National Insurance Company Limited.
 Atlas Assurance Company Limited (with which is incorporated the Manchester Assurance Company).
 Australasian Capital Assurances Limited.
 Australasian Temperance and General Mutual Life Assurance Society Limited.
 Australia and New Zealand Bank Limited.
 Australian Alliance Assurance Company.
 Australian and Eastern Insurance Company Limited.
 Australian Equitable Insurance Company Limited.
 Australian General Insurance Company Limited.
 Australian and International Insurances Limited.
 Australian Metropolitan Life Assurance Company Limited.
 Australian Mutual Fire Insurance Society Limited.
 Australian Mutual Provident Society.
 Australian National Assurance Company Limited.
 Australian Natives' Association Insurance Company Limited.
 Australian Provincial Assurance Association Limited.
 Australian Reinsurance Company Limited.
 Automobile Fire and General Insurance Company of Australia Limited.
 Baillieu Insurances (Vic.) Proprietary Limited.
 Baltica Insurance Company Limited.
 Bankers' and Traders' Insurance Company Limited.
 Bishopsgate Insurance Company Limited.
 C. T. Bowring and Swain (Vic.) Pty. Ltd.
 C. T. Bowring & Swain (Reinsurance) Pty. Ltd.
 British Crown Assurance Corporation Limited.
 British Equitable Assurance Company Limited.
 British and Foreign Marine Insurance Company Limited.
 British General Insurance Company of Australia Limited.
 British Medical Insurance Company of Victoria Limited.
 British Traders' Insurance Company Limited.
 Broken Hill Proprietary Company Limited.
 R. S. Bucknell and Company Proprietary Limited.
 Caledonian Insurance Company.
 Car Owners Mutual Insurance Company Limited.
 Catholic Church Property Insurance Company of Australasia Limited.
 Central Insurance Company Limited.
 Century Insurance Company Limited.
 C.G.A. Fire and Accident Insurance Company Limited.
 Chamber of Manufacturers Insurance Limited.
 City Mutual Fire Insurance Co. Ltd.
 City Mutual General Insurance Limited.
 T. P. Clark and Chapman Proprietary Limited.
 Club Motor Insurance Agency Proprietary Limited.
 C.M.L. Fire and General Insurance Company Limited.
 Colin McDonald Proprietary Limited.
 Colonial Mutual Fire Insurance Company Limited.
 Colonial Mutual Life Assurance Society Limited.
 Combined Insurance Company of America.
 Commercial and General Insurance Limited.
 Commercial of Australia Insurance Company Limited.
 Commercial Union Assurance Company of Australia Limited.
 Consolidated Insurances of Australia Limited.
 Co-operative Insurance Company of Australia Limited.
 Copenhagen Reinsurance Company (Aust.) Limited.
 Cornhill Insurance Company Limited.
 Country Traders' Mutual Insurance Limited.
 Derwent and Tamar Assurance Company Limited.
 The Dominion Insurance Company Limited.
 Eagle Star Insurance Company Limited.
 Eastern Insurance Brokers Proprietary Limited.
 Ecclesiastical Property Insurance Company Proprietary Limited.
 Economic Insurance Company Limited.
 Edward Lumley and Sons (Victoria) Proprietary Limited.
 Employers' Liability Assurance Corporation Limited.
 Farmers' and Graziers' Co-operative Company Limited.
 Farmers' and Settlers' Co-operative Insurance Company of Australia Limited.
 Federal Mutual Insurance Company of Australia Limited.
 Federation Insurance Limited.
 Fire and All Risks Insurance Company Limited.
 General Accident Fire and Life Assurance Corporation Limited.
 Glanvill Holland Proprietary Limited.
 Gray Dawes Australia Proprietary Limited.
 Gresham Fire and Accident Insurance Society Limited.
 Grieve and Irwin (Aust.) Pty. Ltd.
 Guardian Assurance Company Limited.
 Guild Insurance Company Limited.
 Guildhall Insurance Company Limited.
 Hanover Insurance Company.
 Hartford Fire Insurance Company.
 Harvey Trinder (Victoria) Proprietary Limited.
 H. J. Heinz Company Australia Limited.
 Home Insurance Company.
 Indemnity Marine Assurance Company Limited.
 India Reinsurance Corporation Limited.
 Insurance Commissioner (State Accident Insurance Office and State Motor Car Insurance Office).
 Insurance Company of North America.
 Insurance Corporation of Ireland Limited.
 Insurance Office of Australia Limited.
 Interstate Steamship Insurance Company Proprietary Limited.
 Invincible Fire and General Insurance Company Limited.
 Ipec Insurance Limited.
 Law Union and Rock Insurance Company Limited.
 Legal and General Assurance Society Limited.
 Legal Insurance Company Limited.
 Lep Insurance Brokers Proprietary Limited.
 Leslie N. Allen Proprietary Limited.
 Licenses and General Insurance Company Limited.
 Liverpool and London and Globe Insurance Company Limited.
 Lombard Insurance Company Limited.
 London Assurance.
 London Guarantee and Accident Company Limited.
 London and Lancashire Insurance Company Limited.
 London and Overseas Insurance Company Limited.
 London and Provincial Marine and General Insurance Company Limited.
 London and Scottish Assurance Corporation Limited.
 Maintenance Insurance Proprietary Limited.
 Manchester Unity Fire Insurance Company of Victoria Limited.
 Manufacturers' Mutual Insurance Limited.
 Maritime Insurance Company Limited.
 Marsh and McLennan Proprietary Limited.
 Master Builders' Insurance Company Limited.
 Matthews Wrightson (Australia) Proprietary Limited.
 Melbourne Fire Office Limited.
 Mercantile and General Reinsurance Company Limited.
 Mercantile and General Reinsurance Company of Australia Limited.
 Mercantile Mutual Insurance Company Limited.
 Merchants' Marine Insurance Company Limited.
 Milford Insurance Company Limited.
 J. H. Minet and Company (A.N.Z.) Proprietary Limited.
 M.L.C. Fire and General Insurance Company Limited.
 Monarch Insurance Company Limited.
 Mortgage Guaranty Insurance Corporation of Australia Limited.
 Mutual Life and Citizens' Assurance Company Limited.
 National Co-operative Insurance Society Limited.
 National Employers' Mutual General Insurance Association Limited.
 National and General Insurance Company.
 National Insurance Company of New Zealand Limited.
 National Mutual Casualty Insurance Limited.
 National Mutual Fire Insurance Company Limited.
 National Union Insurance Society.
 New India Assurance Company Limited.
 New Zealand Insurance Company Limited.
 Nippon Fire and Marine Insurance Company Limited.
 North British and Mercantile Insurance Company of Australia Limited.
 Northern Assurance Company Limited.
 Northumberland Insurance Company Limited.
 Norwich Union Fire Insurance Society Limited.
 Ocean Accident and Guarantee Corporation of Australia Limited.
 Ocean Marine Insurance Company Limited.
 Omnibus and General Insurance Brokers Proprietary Limited.
 Orion Insurance Company Limited.
 Overseas Shipping Insurance Company Proprietary Limited.
 Pacific Insurance Company Limited.
 Palatine Insurance Company of Australia Limited.
 Pan Australian Insurance Proprietary Limited.
 Patriotic Assurance Company Limited.
 P. & C. Fire & General Insurance Company Limited.
 Pearl Assurance Company Limited.
 Phoenix Assurance Company Limited.

H. G. Poland (Australia) Proprietary Limited.
 Price, Forbes, Leslie (Victoria) Proprietary Limited.
 Price, Forbes, Leslie (Reinsurance) Pty. Ltd.
 Producers' and Citizens' Co-operative Assurance Company Limited.
 Provident Fire Insurance Company Limited.
 Provident Life Assurance Company Limited.
 Provincial Insurance Company Limited.
 Prudential Assurance Company Limited.
 Queensland Insurance Company Limited.
 R. A. Forsyth Proprietary Limited.
 Real Australia Insurance Company Limited.
 Regent Insurance Limited.
 Reinsurance Company of Australasia Limited.
 Reliance Marine Insurance Company Limited.
 Royal Exchange Assurance.
 Royal Insurance Company Limited.
 Scottish Insurance Corporation Limited.
 Scottish Union and National Insurance Company.
 Sea Insurance Company Limited.
 Security and General Insurance Company Limited.
 Security Life Assurances Limited.
 Sedgwick Collins (Victoria) Proprietary Limited.
 Sedgwick Collins (Reinsurances) Proprietary Limited.
 Silver Self Aid Insurance Company Limited.
 Skandia Insurance Company Limited.
 South Australian Insurance Company Limited.
 South British Insurance Company Limited.
 Southern Cross Assurance Company Limited.
 Southern Star General Insurance Company Proprietary Limited.
 Southern Union Insurance Company of Australia Limited.
 Stanley Taylor and Company.
 State Assurance Company Limited.
 Steadfast Insurance Company Limited.
 Steeves, Agnew and Company (Victoria) Proprietary Limited.
 Stenhouse, Scott, North Australia Limited.
 Stenhouse Reinsurance Proprietary Limited.
 Stewart Smith & Co. (Vic.) Proprietary Limited.
 Stratford Insurance Company Limited.
 Sun Insurance Office Limited.
 Surrey Insurance Company Limited.
 Swann Insurance Limited.
 Swiss Reinsurance Company.
 Switzerland General Insurance Company Limited.
 Taisho Marine and Fire Insurance Company Limited.
 T. & G. Fire and General Insurance Company Limited.
 Thames and Mersey Marine Insurance Company Limited.
 Tokio Marine and Fire Insurance Company Limited.
 R. H. Tolley & Gardner Proprietary Limited.
 Tolley Reinsurance Proprietary Limited.
 Trade Indemnity Company Limited.
 Traders Prudent Insurance Company Limited.
 Transport and General Insurance Company Limited.
 Triton Insurance Company Limited (with which is incorporated the Eastern Insurance Company).
 Underwriting and Insurance Limited.
 Union Assurance Society of Australia Limited.
 Union Insurance Society of Canton Limited.
 Union Marine and General Insurance Company Limited.
 United Insurance Company Limited.
 Vanguard Insurance Company Limited.
 Vehicle and General Insurance Company (Australia) Limited.
 Victoria Insurance Company Limited.
 Victorian Automobile Chamber of Commerce Insurance Company Limited.
 Victorian Wheatgrowers Corporation Limited, trading as Wheatgrowers and General Insurance Company.
 Victory Reinsurance Company of Australia Limited.
 J. H. Wackerbarth (Australasia) Proprietary Limited.
 Western Assurance Company.
 Western Australian Insurance Company (Canberra) Limited.
 Westminster Insurance Company Limited.
 World Auxiliary Insurance Corporation Limited.
 World Marine and General Insurance Company Limited.
 Y.C.W. Co-operative Society Limited (Insurance Division).
 Yorkshire Insurance Company Limited.

R. M. PHIBBS,
 Comptroller of Stamps.

Chief Office for Stamp Duties,
 Melbourne, 15th May, 1968.

Stamps Act 1958, Section 97.

ANNUAL LICENCE.

I HEREBY notify that the necessary stamp duty has been paid by the under-mentioned company for a licence to carry on assurance and insurance business in Victoria from 29th April, 1968 to 31st December, 1968, and that the relevant Annual Licence has been issued accordingly:

CHARLICK LAMBERT BROTHERS PROPRIETARY LIMITED.

R. M. PHIBBS,
 Comptroller of Stamps.

CONTRACTS ACCEPTED.—(Series 1967-68.)

SOIL CONSERVATION AUTHORITY.

CONTRACT No. 6811.

3295. Construction of four (4) reinforced concrete structures in Wilby Almonds Project Area, \$3,691.00.—R. V. Spriggs, Wangaratta.

CONTRACT No. C.682.

3296. Construction of three (3) earth fill dams in the Nine Mile Project, Cat. D4D, 65-h.p. dozer, at \$10.00 per hour, and Cat. DC, 93-h.p. dozer, at \$12.00 per hour.—Blatchford Motors Pty. Ltd., St. Arnaud.

P. J. McCALLUM,
 Secretary.

GENERAL STORES.

Gazette No. 56, 17th July, 1967, Schedule No. 25, Chemicals.—The rates for Item No. 16 have been increased by \$76.91 per ton, as from 1st April, 1968.

Gazette No. 56, 17th July, 1967, Schedule No. 43, Haberdashery.—For rates shown opposite Item No. 18, substitute the rates as set out hereunder:— $\frac{1}{4}$ -in., 20 cents; $\frac{3}{8}$ -in., 55 cents; $\frac{1}{2}$ -in., 52 cents; $\frac{3}{4}$ -in., 75 cents; 1-in., 96 cents per dozen yards, as from 8th May, 1968.

Gazette No. 56, 17th July, 1967, Schedule No. 64, Polishes, Dusters, Cleaners, &c.—For Groves, McVitty & Co. Pty. Ltd., substitute Tongala Milk Products Pty. Ltd., as from 1st May, 1968.

CONTRACTS ACCEPTED.—(Series 1968-69.)

GENERAL STORES.

Gazette No. 30, 5th April, 1968, Schedule No. 52, Tools (General).—For rates shown opposite Item No. 52, substitute the rates as set out hereunder:—2 feet, \$5.78; 2 ft. 6 in., \$5.95; 3 feet, \$6.12; 3 ft. 6 in., \$6.29; 4 feet, \$6.46; 4 ft. 6 in., \$6.62; 5 feet, \$6.75; 5 ft. 6 in., \$6.92; 6 feet, \$7.04 each, as from 1st April, 1968.

H. COUTTS, Secretary to the Tender Board. 20.5.68.

ORDERS IN COUNCIL.—(Series 1967-68.)

PUBLIC WORKS.

3297. Ararat, Mental Hospital, road works, \$1,333.00.—City of Ararat.—(W.129762.)

3298. Dandenong, Technical School, supply and installation of manifold system, \$2,176.40.—W. S. Atherton & Co. Pty. Ltd.—(S.E.125348.)

3299. Fitzroy, S.S. 450, urgent demolition of three brick buildings in dangerous condition, \$1,145.00.—R. N. Collins.—(E.M.109180.)

3300. Footscray, S.S. 253, urgent attention to toilets, \$1,565.00.—Peter J. Mols.—(S.W.125929.)

3301. Horsham, High School, supply of gas cookers for Domestic Arts Section, \$1,132.72.—The Colonial Gas Association Ltd.—(W.105510 "C".)

3302. Melbourne, State Library, installation of hot-water heating, \$2,960.00.—W. S. Atherton & Co. Pty. Ltd.—(C.81806.)

3303. Mont Park, Mental Hospital, overhaul of an air-conditioning unit and replacement of compressor, \$1,795.00.—Carrier Air Conditioning Pty. Ltd.—(N.E.87967.)

3304. Mornington, slipway, supply an electrically driven winch, \$1,800.00.—F. A. Maker Pty. Ltd.—(P. & H. 85911.)

3305. Nunawading, High School, supply and fitting of venetian blinds, \$1,089.00.—G. P. Blind Repairs and Sales.—(E.M.79925 "C".)

3306. Royal Park, Psychiatric Hospital, supply of specially selected furniture, \$1,731.00.—Myer-Teale Pty. Ltd.—(E.M.246777 "G".)

3307. Syndal, Technical School, electrical installation of machines, \$1,383.00.—W. T. Waterfall & Sons Pty. Ltd.—(E.M.130373.)

Approved by the Governor in Council, 14th May, 1968.
 —J. ROSSITER, Clerk of the Executive Council.

STATE ELECTRICITY COMMISSION.

3308. For supply of guy type insulators for the distribution system for a period of two years with an optional three months' extension, to Specification No. 68/8, at Schedule rates.—Doulton Insulators Australia Pty. Ltd.

3309. For supply of guy type insulators for the distribution system for a period of two years with an optional three months' extension, to Specification No. 68/8, at Schedule rates.—Dulmison (Australia) Pty. Ltd.

3310. For supply of guy type insulators for the distribution system for a period of two years with an optional three months' extension, to Specification No. 68/8, at Schedule rates.—Nilsen Porcelains (Aust.) Pty. Ltd.

Approved by the Governor in Council, 2nd April, 1968.—
J. ROSSITER, Clerk of the Executive Council.

3311. For supply of steel and brass washers for construction and maintenance works for a period of two years with an optional three months' extension, to Specification No. 68/9, at Schedule rates.—M.F. Steel Washers Pty. Ltd.

Approved by the Governor in Council, 9th April, 1968.—
J. ROSSITER, Clerk of the Executive Council.

3312. For the supply of 25 sets of capacitor oil switches for use on the 22 kV distribution system, to Specification No. 68/7, \$13,684.—Email Ltd.

3313. For supply of 220 kV isolators and earthing devices for metropolitan and country terminal stations, to Specification No. 68/2, \$54,777.—Stanger & Co. Ltd.

3314. For supply of low voltage and 6.6/11 kV underground cable terminal box components for a period of two years with an optional three months' extension, to Specification No. 67/125, at Schedule rates.—Switchgear Pty. Ltd.

3315. For supply and erection of 220 kV isolators and earthing devices in metropolitan and country terminal stations, to Specification No. 68/2, \$258,523.—Switchgear Pty. Ltd.

Approved by the Governor in Council, 30th April, 1968.—
JOHN A. HORLOCK, Acting Clerk of the Executive Council.

3316. For the supply and delivery of five front end loaders and attachments for Latrobe Valley, to Specification No. 68/105, \$25,780.—Moore Road Machinery (Vic.) Pty. Ltd.

3317. For the supply and delivery of six agricultural tractors for Latrobe Valley, to Specification No. 68/104, \$23,272.—Moore Road Machinery (Vic.) Pty. Ltd.

3318. For the supply of steel columns for public lighting for a period of two years with optional extension of three months, to Specification No. 67/171, at Schedule rates.—Rheem (Aust.) Pty. Ltd.

3319. For the supply of steel columns and brackets for public lighting for a period of two years with optional extension of three months, to Specification No. 67/171, at Schedule rates.—Twin Engineering Pty. Ltd.

Approved by the Governor in Council, 7th May, 1968.—
J. ROSSITER, Clerk of the Executive Council.

PUBLIC TRUSTEE ACT 1958 (No. 6350), SECTION 17.

I HEREBY give notice that on the 26th April, 1968, the Public Trustee filed elections to administer the following deceased persons' estates, in accordance with section 17 of the Public Trustee Act 1958:—

HEINEKE, FREDERIK, also known as Frederik Hines, late of 25 Sir Garnet-road, Surrey Hills, mail officer, died 16th January, 1968.

MASON, GEORGE RUTTER, late of 323 Flemington-road, North Melbourne, retired fireman, died 10th February, 1968.

MEYERS, ALLAN THEODORE, late of 17 Palmerston-street, West Footscray, public servant, died 28th October, 1967.

I HEREBY give notice that on the 3rd May, 1968, the Public Trustee filed elections to administer the following deceased persons' estates, in accordance with section 17 of the Public Trustee Act 1958:—

BREMNER, ADOLPHINE, late of Queen Elizabeth Home, 102 Ascot-street, Ballarat, pensioner, died 2nd February, 1968.

DODD, HUGH GRIFFITH, late of care of Clare Castle Hotel, 168 Exhibition-street, Melbourne, died 18th February, 1968.

NEWMAN, CLEMENT DOUGLAS, also known as Clyde Douglas Newman, formerly of 63 Dunstan-parade, Garden City, but late of 107 Graham-street, Port Melbourne, storeman, died 13th October, 1967.

PODKOWIAK, WLADYSLAW, also known as Walter Podkowiak, late of 48 Railway-parade, Pascoe Vale, State Electricity Commission employee, died 21st January, 1968.

SIMKIN, ELLA, late of Hare-street, Merino, married woman, died 10th January, 1968.

VEITCH, HELEN HIND, also known as Ellen Veitch, late of 93 Harding-street, Coburg, widow, died 17th March, 1968.

A. D. DUNCAN,
Public Trustee.

256 Flinders-street, Melbourne, 15th May, 1968.

NOTICE.

CREDITORS, next of kin and others having claims against the estate of any of the under-mentioned deceased persons are required to send particulars of their claims to the Public Trustee, 256 Flinders-street, Melbourne, 3000, the personal representative, on or before the 29th July, 1968, after which date the Public Trustee may convey or distribute the assets, having regard only to the claims of which the Public Trustee then has notice:—

BELL, DOROTHY ANN, also known as Dorothy Annie Bell, late of Mont Park, spinster, died 13th January, 1968.

BREMNER, ADOLPHINE, late of Queen Elizabeth Home, 102 Ascot-street, Ballarat, pensioner, died 2nd February, 1968.

BROWN, ELSIE, late of 243 Nepean Highway, Seaford, widow, died 19th March, 1968.

BULL, KEITH THOMAS, late of Lake Tyers, Victorian railways employee, died 4th June, 1967.

CARTER, DAVID ARCHIBALD, late of The Centreway, East Keilor, retired fireman, died 25th February, 1968.

DODD, HUGH GRIFFITH, late of care of Clare Castle Hotel, 168 Exhibition-street, Melbourne, died 18th February, 1968.

FURUSAWA, MINNIE, late of 33 Kooyong-road, North Caulfield, old age pensioner, died 24th February, 1968.

GADSBURY, TYSON, late of Gaffney's Creek, retired public servant, died 6th October, 1967.

HEINEKE, FREDERIK, also known as Frederik Hines, late of 25 Sir Garnet-road, Surrey Hills, mail officer, died 16th January, 1968.

HENZEN, WILLIAM DERK, also known as Henzen Willem Derk, Henzen William Dark, late of 2 Muskgrove, Upper Ferntree Gully, baker, died 21st December, 1967.

JOWETT, ISABELLA FRANCES, late of 438 Brunswick-road, Brunswick, widow, died 2nd January, 1967.

LINDSEAY, VALMAY BEATRICE, late of 202 Lower Heidelberg-road, Ivanhoe, married woman, died 22nd January, 1968.

MASON, GEORGE RUTTER, late of 323 Flemington-road, North Melbourne, retired fireman, died 10th February, 1968.

MEYERS, ALLAN THEODORE, late of 17 Palmerston-street, West Footscray, public servant, died 28th October, 1967.

MUNN, JOHN MACFARLANE, late of 19 Newry-street, Windsor, retired metal moulder, died 25th February, 1968.

MCKENNON, GEORGE ANTHONY, late of 19 Ormond-street, Pascoe Vale, retired publishing hand, died 15th February, 1968.

MCLACHLAN, ROY VIVIAN, late of 338 Stephenson-road, Mt. Waverley, senior constable of police, died 12th February, 1968.

NEWMAN, CLEMENT DOUGLAS, also known as Clyde Douglas Newman, formerly of 63 Dunstan-parade, Garden City, but late of 107 Graham-street, Port Melbourne, storeman, died 13th October, 1967.

PHILLIPS, OLIVE, formerly of 16 Carlisle-avenue, East St. Kilda, but late of Corowa-court, Esplanade, Mornington, spinster, died 15th December, 1967.

PODKOWIAK, WLADYSLAW, also known as Walter Podkowiak, late of 48 Railway-parade, Pascoe Vale, State Electricity Commission employee, died 21st January, 1968.

PRICE, ARCHIBALD FREDERICK, late of 15 Hopetoun-street, Kensington, retired foreman, died 15th March, 1968.

PUTT, HILDA WINNIFRED, late of 7 Harker-street, Alphington, spinster, died 18th March, 1968.

ROBINSON, ARTHUR CYRIL, late of 240 Domain-road, South Yarra, retired postal employee, died 27th January, 1968.

SIMKIN, ELLA, late of Hare-street, Merino, married woman, died 10th January, 1968.

STOW, NEWMAN HUGH, formerly of 24 Station-street, Ascendale, but late of 29 Witt-street, Benalla, retired oar maker, died 15th February, 1968.

VEITCH, HELEN HIND, also known as Ellen Veitch, late of 93 Harding-street, Coburg, widow, died 17th March, 1968.

WEBB, CHARLES AUBONE, late of 6 Crawford-street, Cheltenham, storeman, died 27th December, 1967.

WHITE, JOSIAH, late of 17 Hex-street, West Footscray, gentleman, died 29th January, 1968.

WHITE, WILLIAM CULMER, late of 24 Eden-street, Cheltenham, proof reader, died 19th December, 1967.

A. D. DUNCAN,
Public Trustee.

Melbourne, 15th May, 1968.

LAW DEPARTMENT.

COURT OF PETTY SESSIONS—DAYS AND HOURS ALTERED.

HIS Excellency the Governor of the State of Victoria by and with the advice of the Executive Council thereof doth by Order made on the 14th day of May, 1968, and pursuant to the provisions of Section 64 of the *Justices Act 1958*, appoint the days and hours contained in the Schedule below for the holding of Courts of Petty Sessions at the place named in such Schedule in lieu of the days and hours heretofore appointed—to take effect as from the 27th May, 1968.

SCHEDULE.

Place.	Days and Hours.
Benalla ..	Every Monday at 11 a.m., and every Tuesday, Wednesday, Thursday and Friday at 10 a.m., except Public Holidays.

J. ROSSITER,
Clerk of the Executive Council.

At the Executive Council Chamber,
Melbourne, 14th May, 1968.

RULES UNDER THE JUSTICES ACT.

SELECTION BY A LAW OFFICER OF THE PLACES AND DAYS AND HOURS FOR HOLDING COURTS (WITHIN THE MEANING OF THE SAID RULES).

I, THE undersigned, George Oswald Reid, a Law Officer of the State of Victoria, in pursuance of the powers conferred upon me by Rule 2 of Chapter III. of the *Justices Act Rules 1963*, do hereby amend the days and hours selected on the 27th day of November, 1967, and published in the *Government Gazette* on the 6th day of December, 1967, as indicated in the Schedule hereto.

SCHEDULE.

Court.	Days and Hours.
St. Kilda ..	Every Monday at 10 a.m. (except Public Holidays) as from the 20th May, 1968, in addition to the days and hours heretofore appointed.
Chelsea ..	Every Tuesday at 10 a.m. (except Public Holidays) as from the 21st May, 1968, in lieu of the days and hours heretofore appointed.
Footscray ..	Every Monday and Thursday at 10 a.m. (except Public Holidays) as from the 3rd June, 1968, in addition to the days and hours heretofore appointed.

Dated at Melbourne this 14th day of May, 1968.

G. O. REID, Law Officer.

WORKERS COMPENSATION ACT 1958, SECTION 72.

THE Lieutenant-Governor as Deputy for His Excellency the Governor of the State of Victoria, by and with the advice of the Executive Council thereof, doth by Order made on the 21st day of May, 1968, and pursuant to the provisions of section 72 of the *Workers Compensation Act 1958*, approve of M. W. Payne Liability Agencies Pty. Limited as an insurer for the period ending 30th June, 1968.

J. ROSSITER,
Clerk of the Executive Council.

At the Executive Council Chamber,
Melbourne, 21st May, 1968.

WORKERS COMPENSATION ACT 1968, SECTION 72.

HIS Excellency the Governor of the State of Victoria, by and with the advice of the Executive Council thereof doth by Order made on the 14th day of May, 1968, and pursuant to the provisions of section 72 of the *Workers Compensation Act 1958*, approve of the English and American Insurance Company Limited as an Insurer for the period ending 30th June, 1968.

J. ROSSITER,
Clerk of the Executive Council.

At the Executive Council Chamber,
Melbourne, 14th May, 1968.

Melbourne and Metropolitan
BOARD OF WORKS.

NOTICE TO THE OWNERS OF TENEMENTS IN THE UNDER-MENTIONED STREETS AND THE PRIVATE STREETS, LANES, COURTS AND ALLEYS OPENING THERETO.

THE main pipe in the said streets being laid down, the owners of all tenements situated as under are hereby required on or before the 24th June, 1968, to cause a proper pipe and stop cocks to be laid so as to supply water within such tenements from the main pipe.

H. J. SNADDEN,
Secretary.

14th May, 1968.

STREET AND POSITION.

Altona.

Grieve Highway, from Nellie-street to Charles-road.
Belmar-avenue, from Medford-street to Grieve Highway.
Brook-drive, from Belmar-avenue to Charles-road.
Ford-road, from Grieve Highway to Brook-drive.
Charles-road, from Grieve Highway westwards 860 feet.
Keesham-court, from Brook-drive westwards 660 feet.
Spear-court, from Brook-drive westwards 630 feet.
Finley-road, from Brook-drive westwards 560 feet.
Deavey-court, from Brook-drive westwards 693 feet.
Galvin-street, from 510 feet south-east of Park-road south-eastwards 320 feet.

Box Hill.

Belmore-road, from Elgar-road to Box Hill-crescent.

Brighton.

Milleara-grove, from 462 feet north to Howell-street northwards 198 feet.
Valda-grove, from Male-street north-westwards 370 feet.

Broadmeadows.

Fran-street, from Valley-crescent to Centre-way.
Hutchinson-street, from Albert-street southwards 130 feet.

Brunswick.

Hopetoun-avenue diversion, from Hopetoun-avenue to Moreland-road.
Talbot-street, from Boase-street eastwards 110 feet.

Camberwell.

Millicent-avenue, from 50 feet west of Balwyn-road westwards 280 feet.
Minerva-avenue, from 295 feet north of Echo-street northwards 215 feet.

Caulfield.

Judith-street, from 345 feet south of Leila-road southwards 132 feet.

Dandenong.

Blamey-street, from 280 feet south-east of Leige-avenue south-eastwards 446 feet.
Frankston-road, from Greens-road southwards 974 feet.

Doncaster.

Eucalypt-avenue, from Williamson's-road westwards 1,100 feet.
Sophoro-court, from Eucalypt-avenue southwards 100 feet.
Alburnum-crescent, from Eucalypt-avenue south-westwards 260 feet.
Lignum-court, from Alburnum-crescent south-eastwards 440 feet.

Eltham.

Cheverton-road, from Eltham-road southwards 240 feet.

Heidelberg.

Grandview-grove, from 1,460 feet north of Darvall-street, to Davies-street.
Davies-street, from Grandview-grove westwards 430 feet.
Mountain View-parade, from 1,550 feet north of Darvall-street to Davies-street.
Victoria-avenue, from Grandview-grove southwards and eastwards 690 feet.
St. James-road, from Lower Plenty-road eastwards 110 feet.
Grantham-road, from Martins-lane northwards 630 feet.

Moorabbin.

Argus-street, from Herald-street to Brett-court.
Brett-court, from Argus-street southwards 410 feet.
Maude-street, from Charman-road westwards 266 feet.

Mordialloc.

Fleming-court, from Columbia-street north-westwards 510 feet.
Columbia-street, from Old Dandenong-road southwards 580 feet.
Ellesmere-street, from Old Dandenong-road southwards 440 feet.

Nunawading.

Springfield-road, from Ambrose-street north-eastwards 380 feet.
Venice-avenue, from Springfield-road southwards 170 feet.
Springvale-road, from Silver-street northwards 140 feet.

Oakleigh.

Dooga-street, from Moriah-street to Kionga-street.
Stamford-road, from Estelle-street northwards 250 feet.

Prahran.

Cheel-street, from High-street southwards 210 feet.
R.O.W. (165 feet south of Green-street), from Thomas-street westwards and southwards 198 feet.
Potter-street, from Aubrey-street eastwards 173 feet.

Richmond.

Clifton-street, from 100 feet north of Swan-street northwards 30 feet.

Sunshine.

Warrs-road, from Bloomfield-avenue to Hillside-crescent.
Sanders-avenue, from Fairbairn-road north-eastwards 1,270 feet.

Waverley.

Richard-road, from Alice-street westwards 280 feet.
Eula-court, from Huntingdale-road westwards 360 feet.
Brolga-street, from Bowman-street eastwards 560 feet.
Arthur-street, from Huntingdale-road westwards 875 feet.
Hume-court, from Arthur-street southwards 350 feet.
Kiewa-street, from Arthur-street to Eildon-road.
Eildon-road, from Huntingdale-road westwards 860 feet.
Moore-street, from Eildon-road to Rocklands-road.
Parkhill-drive, from Raymond-street to Moore-street.
Ainslie-drive, from 150 feet south of Darnley-grove southwards 910 feet.
Heritage-court, from Ainslie-drive eastwards 470 feet.
Vauluse-court, from Ainslie-drive south-westwards 390 feet.
Lum-road, from Gallaghers-road eastwards 350 feet.
Caithness-crescent, from Lum-road to Waverley-road.
Whiton-street, from Kevin-street eastwards 295 feet.

Water Act 1958.

STATE RIVERS AND WATER SUPPLY COMMISSION.

DANDENONG—SPRINGVALE, DROMANA, PORTSEA, FRANKSTON—MORNINGTON AND SEA LAKE URBAN DISTRICTS.

NOTICE to owners of tenements in the under-mentioned streets in the above-mentioned Urban Districts and the private streets, lanes, courts and alleys opening thereto:—

DANDENONG—SPRINGVALE URBAN DISTRICT.

Keysborough.

Apollo-court.
Avoca-avenue.
Birrong-avenue, from Buckley-street to a point opposite lot 127, about 13 chains generally north-easterly.
Brett-street, from Springside-road to a point opposite lot 79, about ½ chain easterly.
Buckley-street, from Narrabeen-court to a point opposite lot 61, about 12 chains generally northerly.
Bunnerong-crescent.
Cronulla-court.
Gemini-court.
Goodman-drive, from Pope-road to a point opposite lot 18, about 6 chains northerly; thence 2½ chains easterly.
Kingsclere-avenue, from Corrigans-road to Wahroonga-avenue.
Kurringgai-crescent, from Kingsclere-avenue to Avoca-avenue.
Malhala-court.
Maralinga-avenue, from Orloff-street to a point opposite lot 29, about 4½ chains southerly.
Maroubra-avenue.
Miranda-court.
Orloff-street, from Chandler-road to a point opposite lot 34, about 1½ chains easterly from Maralinga-avenue.
Parramatta-crescent.
Patonga-court.
Shearman-court.

No. 45.—4542/68.—2

Springside-road, from end of existing main (opposite lot 174), to a point opposite lot 96, about 1 chain northerly from Thurbro-drive.
Thurbro-drive, from end of existing main (opposite lot 31), to Springside-road.
Wahroonga-avenue, from Kingsclere-avenue to a point opposite lot 411, about 1½ chains easterly from Bunnerong-crescent.
Warrawee-court.
Woollahra-avenue, from Kingsclere-avenue to a point about 1 chain south-westerly.
Yagoona-avenue.

DROMANA—PORTSEA URBAN DISTRICT.

Blairgowrie.

Blairgowrie-avenue, from Stringer-road to a point opposite lot 76 about 3½ chains south-easterly.
Canterbury Jetty-road, from Nepean Highway to a point opposite lot 28, about 1½ chains southerly from Watts-street.
Caxton-street, from Geoffrey-street to a point opposite lot 714, about 3 chains south-westerly.
Lansdowne-street, from end of existing main (opposite lot 599), to a point opposite lot 637, about 8 chains south-easterly from Reeves-street.
Murray-street, from end of existing main (opposite lot 80), to Fern-grove.
Olive-street, from Nepean Highway to Blairgowrie-avenue.
Watts-street.

Dromana.

Brian-street, from Coutts-street to a point opposite lot 37, about 5 chains south-westerly.
Fig-street, from end of existing main (opposite lot 30), to a point opposite lot 9, about 3 chains north-easterly.

Rosebud.

Allambi-avenue, from end of existing main (opposite lot 89), to Barragowa-drive.
Barragowa-drive, from end of existing main (opposite lot 362), to Allambi-avenue.
Manooka-street, from Allambi-avenue to a point about 1 chain southerly.

Rye.

Anelida-street, from Rosemunde-street to a point opposite lot 1254, about 1½ chains southerly.
Golf-parade, from end of existing main (opposite lot 15), to a point opposite lot 16, about 1½ chains southerly.
Kanimbla-street, from Napier-street to a point opposite lot 209, about 3 chains westerly.
Mackie-court.
Rosemunde-street, from end of existing main (opposite lot 1274), to Anelida-street.
Woomera-street, from Old Melbourne-road to a point opposite lot 768, about 3 chains southerly.

Tootgarook.

Swans-way, from end of existing main (opposite lot 181), to a point opposite lot 174, about 6 chains south-westerly.

FRANKSTON—MORNINGTON URBAN DISTRICT.

Carrum.

Sunrae-court.

Frankston.

Acathea-court, from Wirilda-crescent to a point opposite lot 434, about 1 chain south-easterly.
Belar-avenue, from end of existing main (opposite lot 36) to a point opposite lot 159, about 2 chains northerly from Teri-street.
Bursaria-crescent, from Excelsior-drive to a point opposite lot 571, about ½ chain north-easterly.
Cliveden-avenue.
Darvell-lane.
Eumeralla-court.
Excelsior-drive, from end of existing main (opposite lot 94) to Frankston—Dandenong-road.
Fay-street, from Frankston—Dandenong road to a point opposite lot 268, about 4 chains north-westerly.
Frank-street, from Ilton-avenue to a point opposite lot 103, about 3 chains north-easterly from Jacana-avenue.
Gaven-court.
Hadley-street, from end of existing main (opposite lot 12) to a point opposite lot 13, about 1 chain south-westerly.
Jacana-avenue, from Frank-street to a point opposite lot 96, about 3½ chains easterly.
Laurina-crescent, from end of existing main (opposite lot 121) to Excelsior-drive.
Maslen-close.
Meerlu-avenue, from end of existing main (opposite lot 67), to Lindrum-road.

Minton-drive, from Oaklands-crescent to a point opposite lot 113, about 2 chains north-easterly.
 Oaklands-crescent, from Cliveden-avenue to a point opposite lot 33, about 7 chains generally northerly.
 Roberts-street, from end of existing main (opposite lot 3), to a point opposite lot 4, about 5 chains north-easterly from St. Johns-avenue.
 Spruce-court.
 Stricta-court.
 Tee-court.
 Teloepa-court.
 Teri-street.
 The Glen.
 Walbundry-avenue, from Phillip-avenue to a point opposite lot 104, about 3½ chains easterly.
 Wallowa-crescent.
 Wirilda-crescent, from end of existing main (opposite lot 458), to a point opposite lot 452 about 2 chains north-easterly from Acathea-court.
 Wooten-close.
 Zara-court.

Langwarrin.

Beech-street, from end of existing main (opposite lot 50), to a point opposite lot 58, about 7 chains generally westerly.

Mornington.

Caraar Creek-lane, from Kalinna-drive to a point opposite lot 14, about 2 chains southerly.
 Kalinna-drive, from Caraar Creek-lane to a point opposite lot 29, about 2 chains westerly.
 Karina-street—(i) from Wandella-road to a point opposite lot 121, about 1 chain north-easterly; and (ii) from end of existing main (opposite lot 69), to Wandella-road.
 Kiandra-street, from end of existing main (opposite lot 43), to Wandella-road.
 Nepean Highway (Service road), from a point opposite lot 1, to a point opposite lot 5, about 4 chains south-westerly from Tanti-road.
 Orchid-avenue, from Venice-street to a point opposite lot 6, about 4 chains north-easterly.
 Virginia-street, from Frank-street to—(i) a point opposite lot 10, about 1½ chains north-westerly; and (ii) a point opposite lot 2, about 2 chains south-easterly.
 Wandella-road, from Karina-street to—(i) a point opposite lot 84, about 9 chains easterly; and (ii) Maxwell-street.

Mount Eliza.

Bethanga-street, from end of existing main (opposite lot 410), to a point opposite lot 411, about 13½ chains north-westerly from Burnell-street.
 Kiata-street, from Kunyung-road to a point opposite lot 669, about 3 chains south-easterly.
 Winona-road, from Allison-road to a point opposite lot 16, about 6½ chains westerly.

Mount Martha.

Bridgford-avenue, from Lempriere-avenue to Two Bays-crescent.
 Kilburn-grove, from Somers-avenue to a point opposite lot 65, about 9 chains north-easterly.
 Pleasant View-court.
 Somers-avenue, from Kilburn-grove to a point opposite lot 75, about 7 chains easterly, thence 6 chains south-easterly.
 Two Bays-crescent.

Seaford.

James-street, from end of existing main (opposite lot 72), to a point opposite lot 70, about 1½ chains easterly.
 Lorna-street, from Hadley-street to a point opposite lot 122, about 3 chains north-westerly.
 Marion-street, from Seaford-road to a point opposite lot 27, about 5 chains south-easterly.
 Wicklow-street, from Seaford-road to a point opposite lot 88, about 5 chains northerly.

SEA LAKE URBAN DISTRICT.

Sea Lake.

Education-lane, from Sutcliffe-street to a point opposite lot 21, about 4½ chains westerly.
 Gallagher-street, from McClelland-avenue to Hannon-street.
 The main pipe in the said streets being laid down, the owners of all tenements situated as above are hereby required, on or before the 1st day of July next, to cause proper pipes and stop cocks to be laid, so as to supply water within such tenements from the main pipe.

G. W. LEWIS, Secretary,
 State Rivers and Water Supply Commission.
 Melbourne, 17th May, 1968.

SHIRE OF YACKANDANDAH.

PURSUANT to the provisions of sections 522 and 526 of the Local Government Act 1958 the Council of the Shire of Yackandandah hereby directs that the land in the Parish of Yackandandah indicated by hatching on the diagram hereunder, which has been purchased taken or acquired by it, shall be a public highway on and from the publication of this order in the Government Gazette and declares that such land shall be a public highway in lieu of the land indicated by cross hatching on the said diagram.

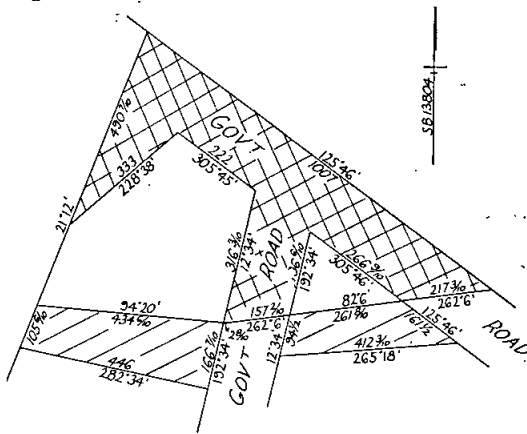

The measurements are in links.

The common seal of the Shire of Yackandandah was hereunto affixed, this 10th day of August, 1967, in the presence of—

(SEAL) RODERICK C. BARTON, President.
 W. E. TOMKINS, Councillor.
 L. KRUTLI, Secretary.

Confirmed by the Governor in Council, 14th May, 1968.
 —J. ROSSITER, Clerk of the Executive Council.

OCEAN-ROAD PLANNING SCHEME 1955.

AMENDMENT No. 9.

(SHIRE OF BARRABOOL.)

Interim Development Order.

THAT by virtue of the powers conferred by the Town and Country Planning Act 1961, as amended, and of every other power enabling it in that behalf, the Council of the Shire of Barrabool (hereinafter referred to as the responsible authority), having commenced the preparation of a planning scheme to amend the Ocean-road Planning Scheme, on the 16th March, 1967, in accordance with the Town and Country Planning Act 1961, hereby makes the following Interim Development Order for the purpose of regulating, restricting, restraining or prohibiting the use or development of any land or the erection, construction or carrying out of any buildings or works on any land within the area described in the Schedule hereto.

1. After the coming into operation of this Interim Development Order no person shall use or develop any land or erect, construct or carry out any buildings or works on any land within the area included in the Schedule, except in accordance with the provision of a permit issued by the responsible authority.

2. Every application for a permit under the provisions of this Order shall be made on the prescribed form, copies of which may be obtained from the office of the responsible authority, 441 Moorabool-street, South Geelong, 3220.

3. This Interim Development Order shall not prevent—

- (a) the continuance of the use of any land or buildings or works for the purposes for which such land or buildings or works were lawfully used immediately before the coming into operation of this Order;
- (b) any dealing or the registration of any dealing with any land in a subdivision of which a plan has been sealed by the Council of the Shire of Barrabool and lodged with the Registrar of Titles, pursuant to section 569 of the Local Government Act 1958, before the coming into operation of this Order.

4. *Schedule*.—The whole of the land within the following boundaries:—Commencing at the north-west corner of Crown allotment 28A¹; thence due south for a distance of 3,016.5 links; thence bearing 146 deg. 58½ min. for a distance of 966.5 links; thence bearing 134 deg. 43 min. for a distance of 547.2 links; thence bearing 154 deg. 33 min. for a distance of 1,528.2 links; thence bearing 173 deg. 20 min. for a distance of 706.2 links; thence bearing 162 deg. 20 min. for a distance of 513.4 links; thence bearing 146 deg. 03 min. for a distance of 492.1 links; thence bearing 128 deg. 28 min. for a distance of 1,036.3 links; thence bearing 146 deg. 50 min. for a distance of 363.8 links; thence bearing 169 deg. 42 min. for a distance of 355.8 links; thence bearing 182 deg. 35 min. for a distance of 865.5 links; thence bearing 160 deg. 01 min. for a distance of 276.5 links; thence bearing 95 deg. 21 min. for a distance of 48.0 links; thence bearing 20 deg. 00 min. for a distance of 1,933.0 links; thence due north to a point due west of the south-west corner of Crown allotment 20; thence due east to the south-west corner of Crown allotment 20; thence bearing 49 deg. 13 min. for a distance of 4,833 links; thence bearing 59 deg. 40 min. for a distance of 3,270 links; thence bearing 348 deg. 55 min. for a distance of 1,070 links; thence bearing 50 deg. 00 min. for a distance of 2,046 links; thence bearing 270 deg. 08 min. to the point of commencement, in the Parish of Jan Juc.

The common seal of the Councillors, President and Ratepayers of the Shire of Barrabool was hereto affixed this 24th day of April, 1968, in the presence of—

(SEAL) G. M. COCHRANE, President.
W. J. HUNT, Councillor.
G. L. PEARCE, Secretary.

Approved by the Governor in Council on the 21st day of May, 1968.—J. ROSSITER, Clerk of the Executive Council.

CHELSEA SEWERAGE AUTHORITY.

AUDIT OF ACCOUNTS.

Fee Payable to Auditor.

THE Lieutenant-Governor as Deputy for His Excellency the Governor of the State of Victoria, by and with the advice of the Executive Council thereof, doth by Order made on the 21st day of May, 1968, and in pursuance of the provisions of the *Sewerage Districts Act 1958* (No. 6368) approve of the payment to S. B. Wills Cooke of the sum of Two hundred and twenty dollars (\$220) as remuneration for making an audit of the accounts of the Chelsea Sewerage Authority for the year ended 30th September, 1967, he having been duly appointed by Order in Council made on 30th August, 1966, to make such audit.

J. ROSSITER,

Clerk of the Executive Council.

At the Executive Council Chamber,
Melbourne, 21st May, 1968.

FRANKSTON SEWERAGE AUTHORITY.

AUDIT OF ACCOUNTS.

Fee Payable to Auditor.

THE Lieutenant-Governor as Deputy for His Excellency the Governor of the State of Victoria, by and with the advice of the Executive Council thereof, doth by Order made on the 21st day of May, 1968, and in pursuance of the provisions of the *Sewerage Districts Act 1958* (No. 6368) approve of the payment to A. D. Foreshew of the sum of Two hundred and Twenty dollars (\$220) as remuneration for making an audit of the accounts of the Frankston Sewerage Authority for the year ended 30th September, 1967, he having been duly appointed to make such audit by Order in Council made 30th August, 1966.

J. ROSSITER,

Clerk of the Executive Council.

At the Executive Council Chamber,
Melbourne, 21st May, 1968.

SHIRE OF SHEPPARTON WATERWORKS TRUST.

RATING BY-LAW 1968.

THE Commissioners of the Shire of Shepparton Waterworks Trust in pursuance of the powers conferred by the *Water Act 1958* do hereby make the following By-Law:—

By-Law No. 76.

1. That a rate of one cent in the dollar on the net annual valuation of all rateable property within the Shire of Shepparton Waterworks Trust District, according to the valuation for the time being of all lands and tenements for the municipal rates of the Shire of Shepparton is hereby made for the year commencing on the first day of January, 1968, and ending on the 31st day of December, 1968.

2. Such rate is hereby made payable in one instalment and shall be due and payable on 31st May, 1968.

3. Such person or persons as the Trust may from time to time appoint for that purpose shall be authorised to demand and collect the said rate.

The foregoing By-Law was made by the Commissioners of the Shire of Shepparton Waterworks Trust on the 28th day of March, 1968.

The common seal of the Shire of Shepparton Waterworks Trust was affixed by the authority of the said Trust, and in the presence of—

(SEAL) R. D. HARMER, Chairman.
J. W. REED, Secretary.

Approved 17th May, 1968.—W. BORTHWICK, Minister of Water Supply.

LANG LANG SEWERAGE AUTHORITY.

RATING BY-LAW.

THE Lang Lang Sewerage Authority, in pursuance and exercise of the powers conferred by the *Sewerage Districts Act*, doth hereby make the following By-law:—

The following sewerage rate is hereby made under the provisions of the *Sewerage Districts Act*, and shall be levied upon the net annual value of all rateable properties within the Lang Lang Sewerage District:—

1. Of any land or tenement within the declared Lang Lang Sewerage District, a sewerage rate of Twelve and one-half cents (12½c) in the Dollar of the net annual value of all rateable "sewered property" within the said District.

2. In no case shall the amount of sewerage rate payable be less than Fourteen Dollars (\$14) in respect of any rateable sewered property on which there is a building, and six dollars (\$6) in respect of any rateable property on which there is no buildings.

3. Of any land or tenement within the Lang Lang Sewerage District a special sewerage rate of Ten Cents (10c) in the Dollar of the net annual value of all rateable "unsewered property" within the said District.

4. Such rate is made and shall be levied for the year beginning with the 1st day of October, 1967, and ending with the 30th day of September, 1968 and shall be payable on the 24th day of May, 1968, at the office of the Authority.

5. If any rateable property which is unsewered at the time of making of the aforesaid rate becomes during the year 1968 a "sewered property," there shall be levied upon such property proportionate part of the sewerage rate for the portion of the year after it has become a sewered property, and such property shall be deemed to have been lawfully rated accordingly.

6. For making and levying such rate the valuation for the time being of such lands and tenements for the municipal rate of the municipality in the municipal district

of which such lands and tenements are situate, shall be deemed and taken to be the valuation of such lands and tenements respectively; but if any such lands are not included in a valuation in force for the municipality in whose district they are situate, or if there is no such valuation the net annual value thereof may for all purposes of such rate be determined in the manner provided in the Sewerage Districts Acts.

7. Such person or persons as the Lang Lang Sewerage Authority may from time to time appoint for that purpose shall be or is or are hereby authorized to demand, receive, collect and recover the said rate and charges.

The Resolution for passing the foregoing By-law was agreed to by the Lang Lang Sewerage Authority on the 2nd day of November, 1967, and was confirmed by the said Authority on the 7th day of December, 1967.

The seal of the Lang Lang Sewerage Authority was affixed hereto on the 7th day of December, 1967, in the presence of—

(SEAL) WALTER A. R. SPARROW, Chairman.
E. R. LLOYD, Secretary.

Approved by the Governor in Council, 21st May, 1968.—
J. ROSSITER, Clerk of the Executive Council.

Town and Country Planning Act 1961.
BOX HILL PLANNING SCHEME 1965.

AMENDMENT NO. 1, 1968.

Notice of Amendment.

IN pursuance of the powers conferred by sub-section 6 of section 32 of the *Town and Country Planning Act 1961*, the Governor in Council, by and with the advice of the Executive Council thereof, on the 21st May, 1968, amended the Box Hill Planning Scheme in respect of the definition of "Planning Scheme Map".

A copy of the amendment may be inspected during office hours at the office of the Town and Country Planning Board, 179 Queen-street, Melbourne; at the office of the Council of the City of Box Hill, at Box Hill; and when available, at the Office of Titles, Melbourne; and at the Central Plan Office of the Department of Crown Lands and Survey, Melbourne.

W. H. CRAIG, Secretary,
Town and Country Planning Board.

Town and Country Planning Act 1961, as amended.
CITY OF CAMBERWELL PLANNING SCHEME 1954.

AMENDMENT NO. 28, 1965.

Notice of Approval.

IN pursuance of the powers conferred by the *Town and Country Planning Act 1961*, as amended, the Governor in Council, on the 21st May, 1968, approved a planning scheme entitled the City of Camberwell Planning Scheme 1954, Amendment No. 28, 1965, in respect of part of the municipal district of the City of Camberwell, and such planning scheme comes into operation on the date this notice of approval is published in the *Government Gazette*.

A copy of the planning scheme as approved may be inspected free of charge during office hours at the office of the Town and Country Planning Board, 179 Queen-street, Melbourne; at the office of the Camberwell City Council, at Camberwell; and when available, at the Office of Titles, Melbourne, and at the Central Plan Office of the Department of Crown Lands and Survey, Melbourne.

W. H. CRAIG, Secretary,
Town and Country Planning Board.

Town and Country Planning Act 1961, as amended.

SHIRE OF LILLYDALE PLANNING SCHEME 1958.

AMENDMENT NO. 2, 1966.

Notice of Approval.

IN pursuance of the powers conferred by the *Town and Country Planning Act 1961*, as amended, the Governor in Council, on the 14th May, 1968, approved a planning scheme entitled the Shire of Lillydale Planning Scheme 1958, Amendment No. 2, 1966, in respect of part of the municipal district of the Shire of Lillydale, and such planning scheme comes into operation on the date this notice of approval is published in the *Government Gazette*.

A copy of the planning scheme as approved may be inspected free of charge during office hours at the office of the Town and Country Planning Board, 179 Queen-street, Melbourne; at the office of the Shire of Lillydale; and when available, at the Office of Titles, Melbourne, and at the Central Plan Office of the Department of Crown Lands and Survey, Melbourne.

W. H. CRAIG, Secretary,
Town and Country Planning Board.

This notice of approval is published in lieu of the notice published on page 1768 of *Government Gazette* No. 40, dated the 8th May, 1968.

Town and Country Planning Act 1961, as Amended.

MELBOURNE METROPOLITAN PLANNING SCHEME.

NOTICE OF APPROVAL.

IN pursuance of the powers conferred by the *Town and Country Planning Act 1961*, as amended, the Governor in Council on the 30th April, 1968, approved a planning scheme entitled the Melbourne Metropolitan Planning Scheme, in respect of part of the metropolitan area as defined in the Second Schedule to the said Act and such planning scheme comes into operation on the date this notice of approval is published in the *Government Gazette*.

A copy of the planning scheme as approved may be inspected, free of charge, during office hours at the office of the Town and Country Planning Board, 179 Queen-street, Melbourne; at the office of the Melbourne and Metropolitan Board of Works, 110 Spencer-street, Melbourne; at the office of each municipality within the area of the scheme; and when available, at the Office of Titles, Melbourne, and at the Central Plan Office of the Department of Crown Lands and Survey, Melbourne.

W. H. CRAIG, Secretary,
Town and Country Planning Board.

APPOINTMENTS AND RESIGNATIONS

APPOINTMENTS.

HIS Excellency the Governor of the State of Victoria, by and with the advice of the Executive Council thereof, has, by Orders made on the 14th day of May, 1968, been pleased to make the under-mentioned appointments, viz.:—

MINISTRY OF HEALTH.

Chairman, Mental Health Authority (Acting).

DAVID JOHN HARDING BARLOW, M.B., B.Ch., D.P.M., to be Chairman, Mental Health Authority, to act as from and inclusive of 8th May, 1968, until the return of Dr. E. C. Dax from his current absence overseas.

LAW DEPARTMENT.

Commissioners for Taking Declarations, &c.

JOHN LANGFORD WORRALL, care of Housing Commission, Victoria, 179 Queen-street, Melbourne,

RONALD PATRICK HANNON, care of Mechanical Maintenance Section, State Electricity Commission of Victoria, Morwell, and

RONALD JAMES WILSON, care of Hazelwood Power Station, State Electricity Commission of Victoria, Hazelwood,

to be Commissioners for taking Declarations and Affidavits, pursuant to the provisions of the *Evidence Act 1958*, to refrain from charging fees and to resign upon ceasing to occupy their present positions;

ORDERS IN COUNCIL

ERRATUM.

IN *Government Gazette* No. 41 of 15th May, 1968, page 1831, Order in Council—"Appointment of Members of Council of Adult Education".

GORDON ANDREW THOMPSON, B.A., nominated by the Trustees of the National Gallery of Victoria, should read—
GORDON ANDREW THOMSON.

LOCAL GOVERNMENT DEPARTMENT.

At the Executive Council Chamber, Melbourne, the fourteenth day of May, 1968.

PRESENT:

His Excellency the Governor of Victoria.
Mr. Chandler | Sir William McDonald.
Mr. Borthwick |

ROAD DISCONTINUED.—CITY OF SUNSHINE.

WHEREAS it is provided in Section 528 (2) of the *Local Government Act 1958*, as amended, that where a road (whether or not a public highway but not being a road set out on land of the Crown) or any part thereof is not required for public use, the Governor-in-Council, on the request of the Council of the municipality in which such road is situated made not less than one month after publishing in a newspaper generally circulating in the district and posting to the registered proprietor (if any) of the land and any person known to have an interest in the land notice of intention to make such a request may by Order published in the *Government Gazette* direct that such road or part shall be discontinued and thereupon such road or part shall be discontinued accordingly.

AND WHEREAS the Council of the City of Sunshine has requested that the Governor-in-Council direct that Barry Street, Sunshine, be discontinued and not less than one month previously has published in a newspaper generally circulating in the district and posted to the registered proprietor of the land in the road and to all persons known to have an interest in the said road notice of intention to make such request.

NOW THEREFORE, His Excellency the Governor of the State of Victoria, by and with the advice of the Executive Council thereof, hereby directs that the said road, which is shown hatched on the plan hereunder, shall be discontinued and that the land may be sold by the Council of the City of Sunshine by agreement.

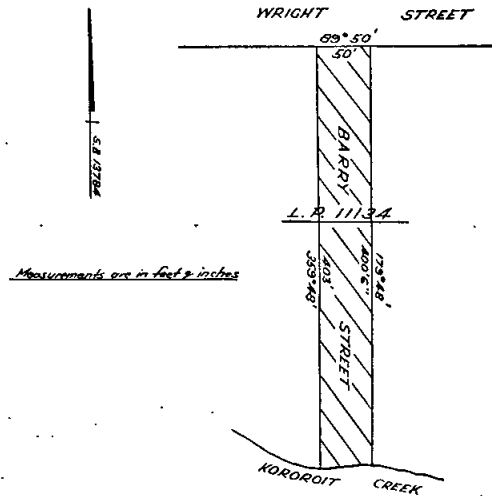

Measurements are in feet & inches

And the Honorable Murray Victor Porter, Her Majesty's Acting Minister for Local Government for the State of Victoria, shall give the necessary directions herein accordingly.

J. ROSSITER,
Clerk of the Executive Council.

GEORGE WOODFULL STEVENS, care of I.B.M. Australia Limited, 173 Fitzroy-street, St. Kilda, and

FRANCIS JOSEPH URQUHART, care of A. J. Brooks Pty. Ltd., 546 Flinders-street, Melbourne,

to be Commissioners for taking Declarations and Affidavits, pursuant to the provisions of the *Evidence Act 1958*, to resign upon ceasing to occupy their present positions; and

WILLIAM ARTHUR HENDERSON, 150 St. Vidgeon's-road, Reservoir,

THOMAS HENRY ROBERTSON, 18 Yarra-avenue, Reservoir East, and

GERARDUS MARINUS VAN ROSMALEN, 108 Carr-crescent, Mooroopna,

to be Commissioners for taking Declarations and Affidavits, pursuant to the provisions of the *Evidence Act 1958*, to resign upon removing from the neighbourhood of the addresses stated.

Justice of the Peace.

JOHN NEVILLE FAULTLEY, 59-61 Colebrook-street, Brunswick,

to Keep the Peace in the Central Bailiwick of the State of Victoria.

DEPARTMENT OF THE TREASURER.

Receiver of Revenue (Acting).

GEOFFREY JOHN WATERS

to act temporarily as Receiver of Revenue, Benalla, vice R. F. Freeman, on leave.

DEPARTMENT OF WATER SUPPLY.

Improvement Trust Commissioner.

THOMAS CLIFFORD SPINK

to be a Commissioner of the Whorouly Creek Improvement Trust, for a period of four years from the date hereof, subject to the provisions of the *River Improvement Act 1958*.

J. ROSSITER,

Clerk of the Executive Council.

At the Executive Council Chamber,
Melbourne, 14th May, 1968.

EDUCATION DEPARTMENT.

SUMMONING OFFICER.

UNDER section 5 of the *Education Act 1958*, I hereby appoint—

Sergeant Alan Coysh,

to summon parents within the State of Victoria.

L. H. S. THOMPSON,

Minister of Education.

13th May, 1968.

RESIGNATIONS.

HIS Excellency the Governor of the State of Victoria, by and with the advice of the Executive Council thereof, has, by Orders made on the 14th day of May, 1968, accepted the resignations of the persons named hereunder of the offices mentioned, viz.:—

CHIEF SECRETARY'S DEPARTMENT.

Licensing Inspector.

LEONARD MASON, as a Licensing Inspector for the purposes of the *Licensing Act 1958*, as from the 29th April, 1968.

LAW DEPARTMENT.

Judges Associate.

THOMAS MAURICE TYRER MOORE, as Associate to His Honour Judge Gray, to take effect from midnight on the 12th May, 1968.

J. ROSSITER,

Clerk of the Executive Council.

At the Executive Council Chamber,
Melbourne, 14th May, 1968.

LOCAL GOVERNMENT DEPARTMENT.

At the Executive Council Chamber, Melbourne, the fourteenth day of May, 1968.

PRESENT:

His Excellency the Governor of Victoria.
Mr. Chandler | Sir William McDonald.
Mr. Borthwick

ROAD DISCONTINUED.—CITY OF RICHMOND.

WHEREAS it is provided in Section 528 (2) of the Local Government Act 1958, as amended, that where a road (whether or not a public highway but not being a road set out on land of the Crown) or any part thereof is not required for public use, the Governor-in-Council, on the request of the Council of the municipality in which such road is situated made not less than one month after publishing in a newspaper generally circulating in the district and posting to the registered proprietor (if any) of the land and any person known to have an interest in the land notice of intention to make such a request may by Order published in the Government Gazette direct that such road or part shall be discontinued and thereupon such road or part shall be discontinued accordingly.

AND WHEREAS the Council of the City of Richmond has requested that the Governor-in-Council direct that a right-of-way off William Street, Richmond, be discontinued and not less than one month previously has published in a newspaper generally circulating in the district and posted to the proprietor of the land in the said road and to all persons known to have an interest in the said land notice of intention to make such request.

NOW THEREFORE His Excellency the Governor of the State of Victoria, by and with the advice of the Executive Council thereof, hereby directs that the said road which is shown hatched on the plan hereunder, shall be discontinued and that the land may be sold by the Council of the City of Richmond by agreement.

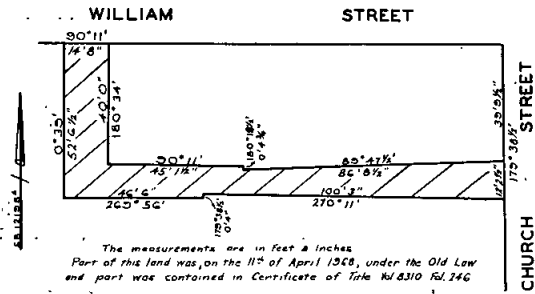

And the Honorable Murray Victor Porter, Her Majesty's Acting Minister for Local Government for the State of Victoria, shall give the necessary directions herein accordingly.

J. ROSSITER,
Clerk of the Executive Council.

TEACHING SERVICE ACT 1958.

At the Executive Council Chamber, Melbourne, the fourteenth day of May, 1968.

PRESENT:

His Excellency the Governor of Victoria.
Mr. Chandler | Sir William McDonald.
Mr. Borthwick

IN pursuance of the powers conferred by the Teaching Service Act 1958 (No. 6391), His Excellency the Governor of the State of Victoria by and with the advice of the Executive Council thereof doth hereby appoint Reginald Henry Jennings, a member of the Teachers Tribunal, who shall represent the Government of Victoria, as from and including the fifteenth day of May 1968.

And the Honorable Lindsay Hamilton Simpson Thompson, Her Majesty's Minister of Education for the State of Victoria, shall give the necessary directions herein accordingly.

J. ROSSITER,
Clerk of the Executive Council.

TEACHING SERVICE ACT 1958.

At the Executive Council Chamber, Melbourne, the fourteenth day of May, 1968.

PRESENT:

His Excellency the Governor of Victoria.
Mr. Chandler | Sir William McDonald.
Mr. Borthwick

TERM OF OFFICE FOR THE MEMBER OF THE TEACHERS TRIBUNAL REPRESENTING THE GOVERNMENT OF VICTORIA.

IN pursuance of the powers conferred by the Teaching Service Act 1958 (No. 6391), His Excellency the Governor of the State of Victoria by and with the advice of the Executive Council thereof doth by this Order—

Fix, before his appointment, the period from the fifteenth day of May 1968 to the eighteenth day of August 1970 (both dates inclusive) as the term which the member of the Teachers Tribunal representing the Government of Victoria shall hold office.

And the Honorable Lindsay Hamilton Simpson Thompson, Her Majesty's Minister of Education for the State of Victoria, shall give the necessary directions herein accordingly.

J. ROSSITER,
Clerk of the Executive Council.

TEACHING SERVICE ACT 1958.

At the Executive Council Chamber, Melbourne, the fourteenth day of May, 1968.

PRESENT:

His Excellency the Governor of Victoria.
Mr. Chandler | Sir William McDonald.
Mr. Borthwick

APPOINTMENT OF MEMBER AND CHAIRMAN OF TEACHERS TRIBUNAL.

IN pursuance of the powers conferred by the Teaching Service Act 1958 (No. 6391) and all other powers him thereunto enabling, His Excellency the Governor of the State of Victoria, by and with the advice of the Executive Council thereof doth by this order appoint William Edward Sampson to be a member and the Chairman of the Teachers Tribunal as from and including the 15th day of May, 1968.

And the Honorable Lindsay Hamilton Simpson Thompson, Her Majesty's Minister of Education for the State of Victoria, shall give the necessary directions herein accordingly.

J. ROSSITER,
Clerk of the Executive Council.

COUNTRY ROADS BOARD.

At the Executive Council Chamber, Melbourne, the fourteenth day of May, 1968.

PRESENT:

His Excellency the Governor of Victoria.
Mr. Chandler | Sir William McDonald.
Mr. Borthwick

ORDER APPROVING OF LAND BEING ACQUIRED AND ROADS, DEVIATIONS OR WIDENINGS BEING MADE.

HIS Excellency the Governor of the State of Victoria, by and with the advice of the Executive Council thereof, being satisfied that there are funds legally available for acquiring the land, doth hereby approve the acquiring of the land described in the schedule hereunder and the making of new roads and deviations from and widenings of existing roads referred to in the said schedule.

SCHEDULE.

State highway.

The land shown hatched on Plans numbered G.P.11280 and G.P.11281 hereunder required for the deviation from the Murray Valley Highway in the Shire of Upper Murray and making of the deviation thereon.

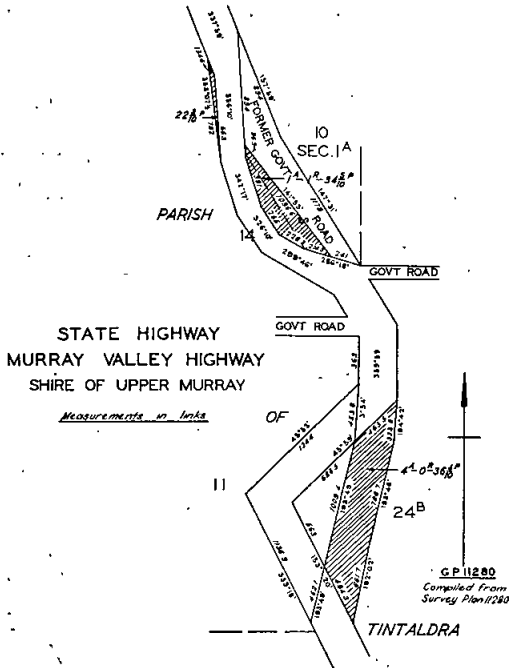

STATE HIGHWAY
MURRAY VALLEY HIGHWAY
SHIRE OF UPPER MURRAY
Measurements in links

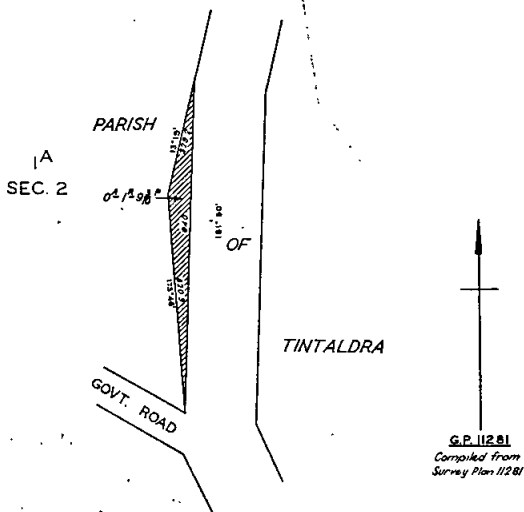

Main roads.

The land shown hatched on Plan numbered G.P.11288 hereunder required for the deviation from the Traralgon Creek Road in the Shire of Traralgon and making of the deviation thereon.

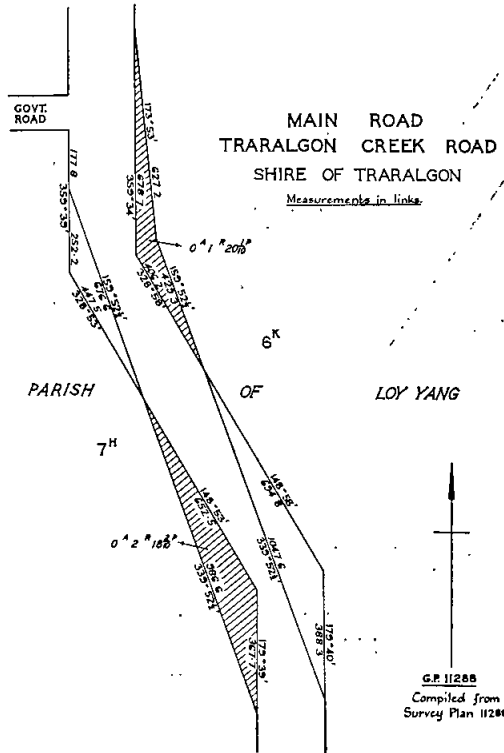

The land shown hatched on Plan numbered G.P.11170 hereunder required for the deviation from the Beauford-Carngham Road in the Shire of Ripon and making of the deviation thereon.

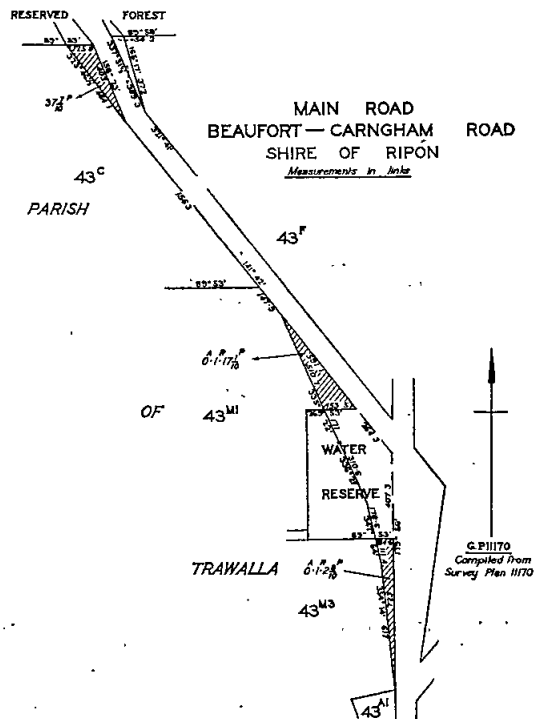

The land shown hatched on Plan numbered G.P.11270 hereunder required for the widening of the Euroa-Strathbogie Road in the Shire of Euroa and making of the widening thereon.

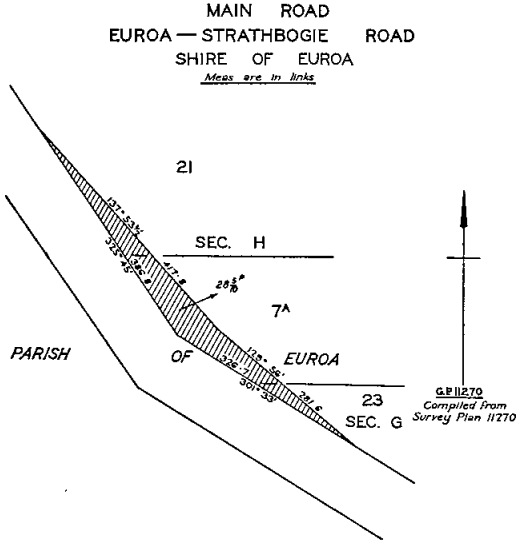

By-pass road.

The land shown hatched on Plan numbered G.P.11227 hereunder required for the making of the Hume By-pass Road in the Shire of Seymour.

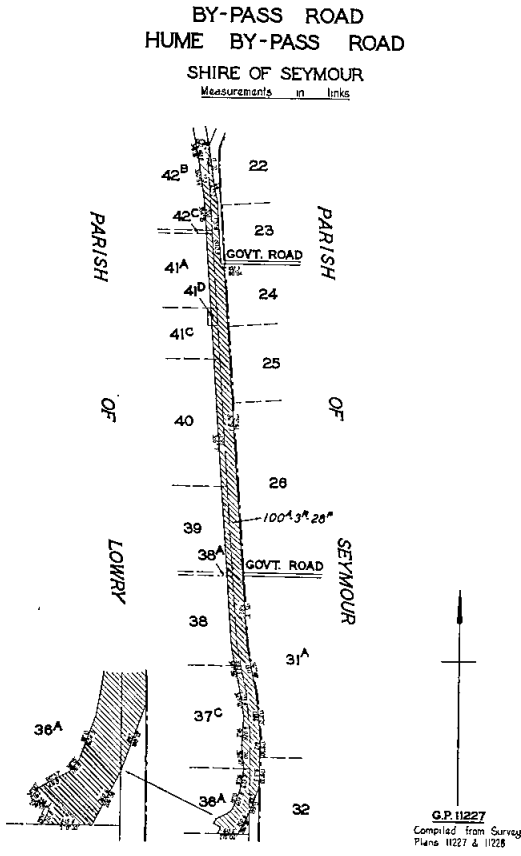

And the Honorable Murray Victor Porter, Her Majesty's Minister of Public Works for the State of Victoria, shall give the necessary directions herein accordingly.

J. ROSSITER,
Clerk of the Executive Council.

COUNTRY ROADS BOARD.

At the Executive Council Chamber, Melbourne, the fourteenth day of May, 1968.

PRESENT:

His Excellency the Governor of Victoria.
Mr. Chandler | Sir William McDonald.
Mr. Borthwick

ORDER CONFIRMING RESOLUTIONS OF THE COUNTRY ROADS BOARD.

HIS Excellency the Governor of the State of Victoria, by and with the advice of the Executive Council thereof, doth hereby, in pursuance of the provisions of the Country Roads Act 1958, confirm the resolutions of the Country Roads Board, the dates whereof and the terms of which are scheduled hereunder:—

SCHEDULE.

State highways.

Resolution dated the Sixth day of May, One Thousand Nine Hundred and Sixty-eight, made pursuant to Sections 21 and 74 of the Country Roads Act 1958, declaring the widening of the Princes Highway in the Shire of Heytesbury as shown hatched on Plan numbered G.P.10216 hereunder to be part of a State highway within the meaning and for the purposes of the said Act.

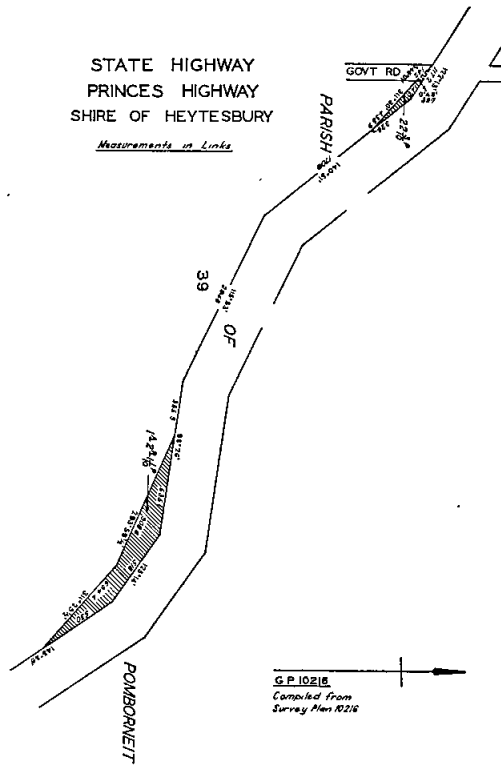

Resolution dated the Sixth day of May, One Thousand Nine Hundred and Sixty-eight, made pursuant to Sections 21 and 74 of the Country Roads Act 1958, declaring the widening of the Calder Highway in the Shire of Marong

as shown hatched on Plans numbered G.P.9317 and G.P.9318 hereunder to be part of a State highway within the meaning and for the purposes of the said Act.

**STATE HIGHWAY
CALDER HIGHWAY**
SHIRE OF MARONG
Measurements in links

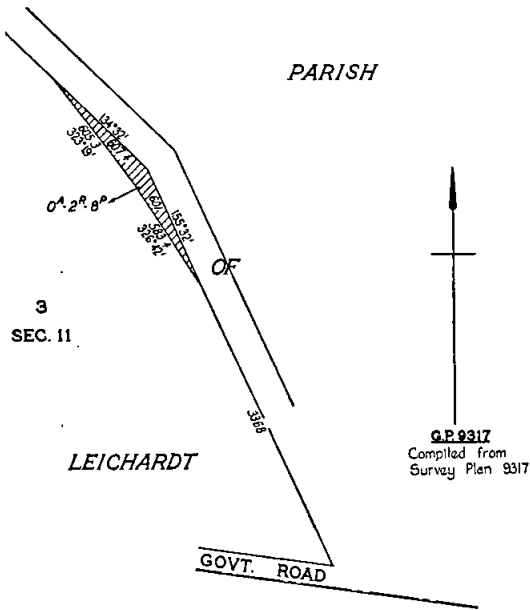

**STATE HIGHWAY
CALDER HIGHWAY**
SHIRE OF MARONG
Measurements in links

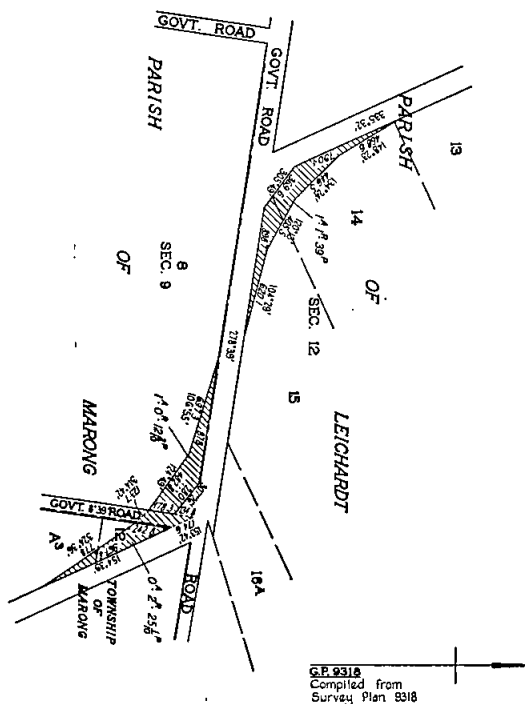

G.P. 9318
Compiled from
Survey Plan 9318

Main roads.

Resolution dated the Sixth day of May, One Thousand Nine Hundred and Sixty-eight, made pursuant to Section 21 of the Country Roads Act 1958, declaring the widening of Hamilton Road in the Shire of Belfast as shown hatched on Plan numbered G.P.10723 hereunder to be part of a main road within the meaning and for the purposes of the said Act.

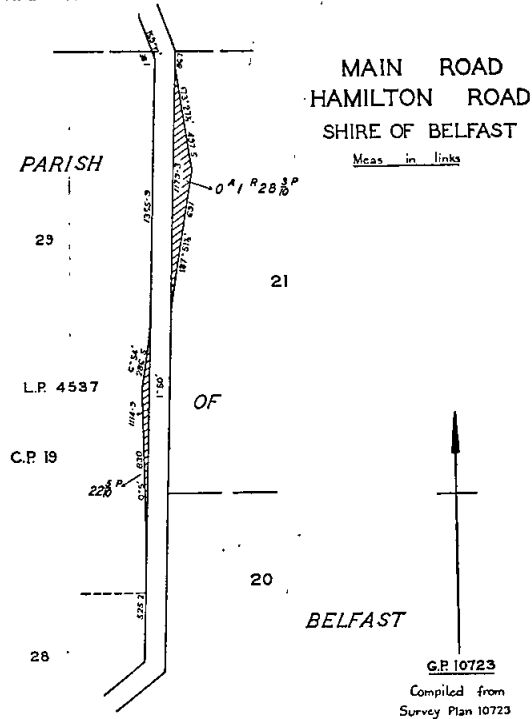

Resolution dated the Sixth day of May, One Thousand Nine Hundred and Sixty-eight, made pursuant to Section 21 of the Country Roads Act 1958, declaring the widening of Harrietteville Road in the Shire of Bright as shown hatched on Plans numbered G.P.8718, G.P.8719 and G.P.8720 hereunder to be part of a main road within the meaning and for the purposes of the said Act.

**MAIN ROAD
HARRIETVILLE ROAD**
SHIRE OF BRIGHT
Measurements in links

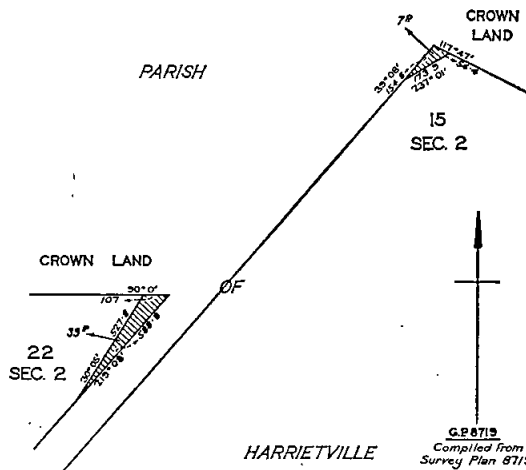

G.P. 8719
Compiled from
Survey Plan 8719

MAIN ROAD
HARRIETVILLE ROAD
SHIRE OF BRIGHT.
Measurements in links

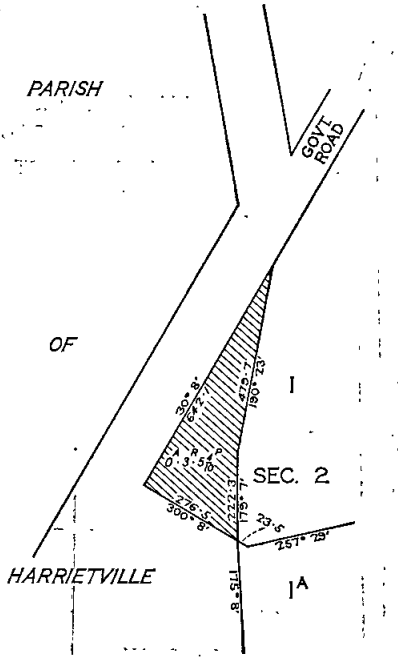

G.P.8718
Compiled from
Survey Plan 8718

Resolution dated the Sixth day of May, One Thousand Nine Hundred and Sixty-eight, made pursuant to Section 21 of the *Country Roads Act 1958*, declaring the widening of the Drouin-Poowong Road in the Shire of Buln Buln as shown hatched on Plans numbered G.P.9767 and G.P.9768 hereunder to be part of a main road within the meaning and for the purposes of the said Act.

MAIN ROAD
DROUIN-POOWONG ROAD
SHIRE OF BULN BULN
Measurements in links

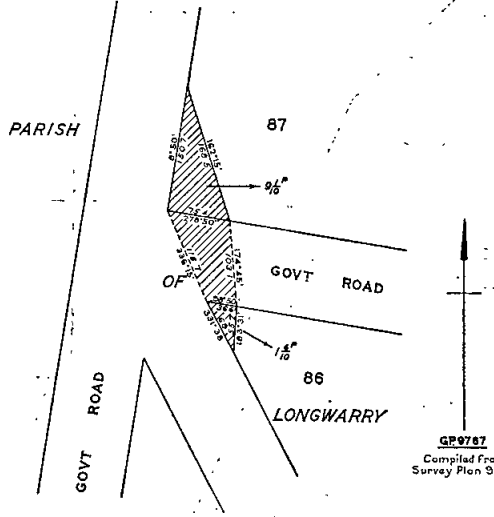

G.P.9767
Compiled from
Survey Plan 9767

MAIN ROAD
DROUIN-POOWONG ROAD
SHIRE OF BULN BULN
Measurements in links

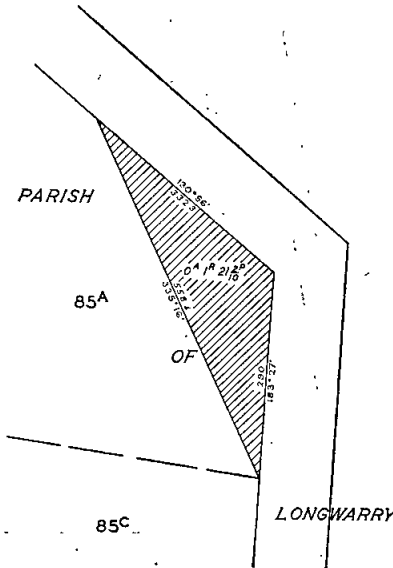

G.P.9768
Compiled from
Survey Plan 9768

MAIN ROAD
HARRIETVILLE ROAD
SHIRE OF BRIGHT.
Measurements in links

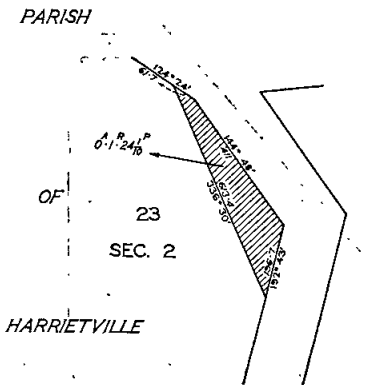

G.P.8720
Compiled from
Survey Plan 8720

Resolution dated the Sixth day of May, One Thousand Nine Hundred and Sixty-eight, made pursuant to Section 21 of the Country Roads Act 1958, declaring the widening of the Doncaster-Mordialloc Road in the City of Oakleigh as shown hatched on Plan numbered G.P.10618 hereunder to be part of a main road within the meaning and for the purposes of the said Act.

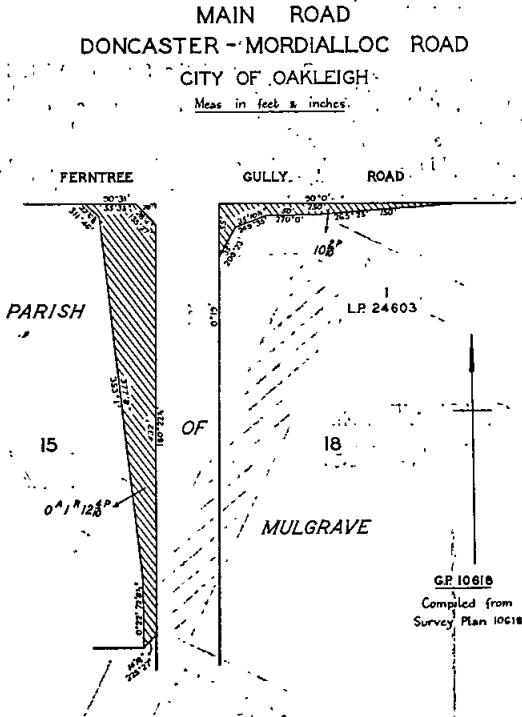

Unclassified road.

Resolution dated the Sixth day of May, One Thousand Nine Hundred and Sixty-eight, made pursuant to Sections 21, 58 and 110 of the Country Roads Act 1958, declaring the road in the Shire of Alexandra as shown hatched on Plans numbered G.P.11061, G.P.11062 and G.P.11063 hereunder to be a road (Taylor Bay Road) within the meaning and for the purposes of the said Act; and declaring the deviation from the Taylor Bay Road in the said Shire as indicated by diagonal hatching on Plan numbered G.P.11060 hereunder to be part of a road within the meaning and for the purposes of the said Act, and also declaring that such deviation shall be in lieu of the existing road or part thereof indicated by cross hatching on the said plan and that such part of the said existing road shall be discontinued, save and except such part as is included in the area diagonally hatched.

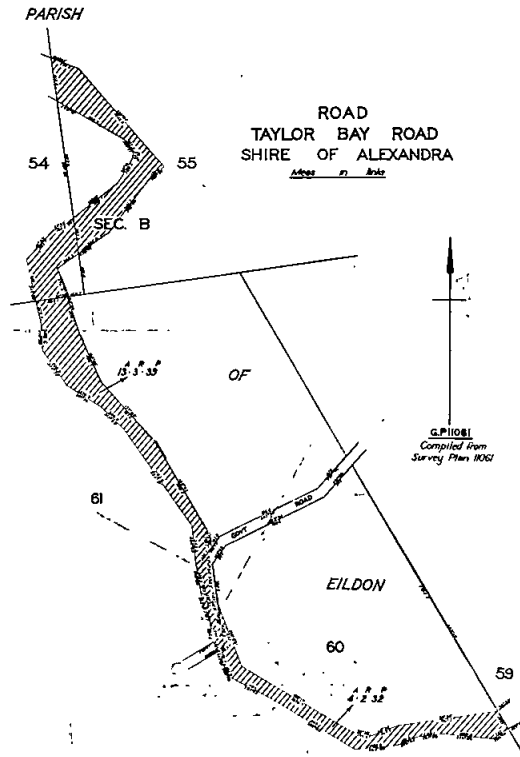

Resolution dated the Sixth day of May, One Thousand Nine Hundred and Sixty-eight, made pursuant to Section 21 of the Country Roads Act 1958, declaring the widening of the Belgrave-Gembrook Road in the Shire of Sherbrooke as shown hatched on Plan numbered G.P.10689 hereunder to be part of a main road within the meaning and for the purposes of the said Act.

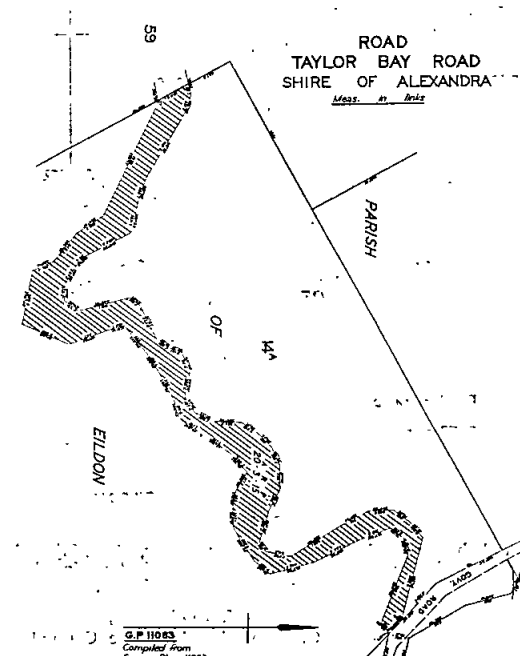
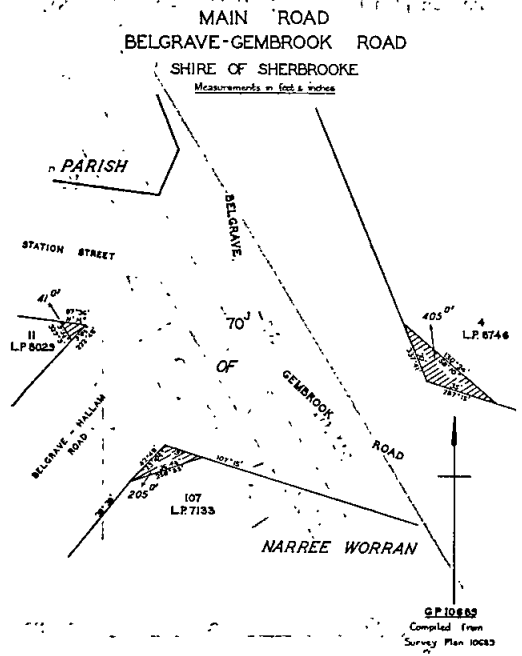

DEPARTMENT OF CROWN LANDS AND SURVEY.

At the Executive Council Chamber, Melbourne, the
fourteenth day of May, 1968.

PRESENT:

His Excellency the Governor of Victoria.
Mr. Chandler | Sir William McDonald.
Mr. Borthwick

UNUSED ROADS CLOSED.

HIS Excellency the Governor of the State of Victoria,
by and with the advice of the Executive Council
thereof, doth hereby direct that, in pursuance of the
provisions of section 349 of the Land Act 1958, the unused
roads referred to hereunder be closed, viz.:—

Township of Avenel, Parish of Avenel, County of Dela-
tite, being the road indicated by hatching on plan here-
under.—(A.74⁽⁸⁾) (Rs.1920).

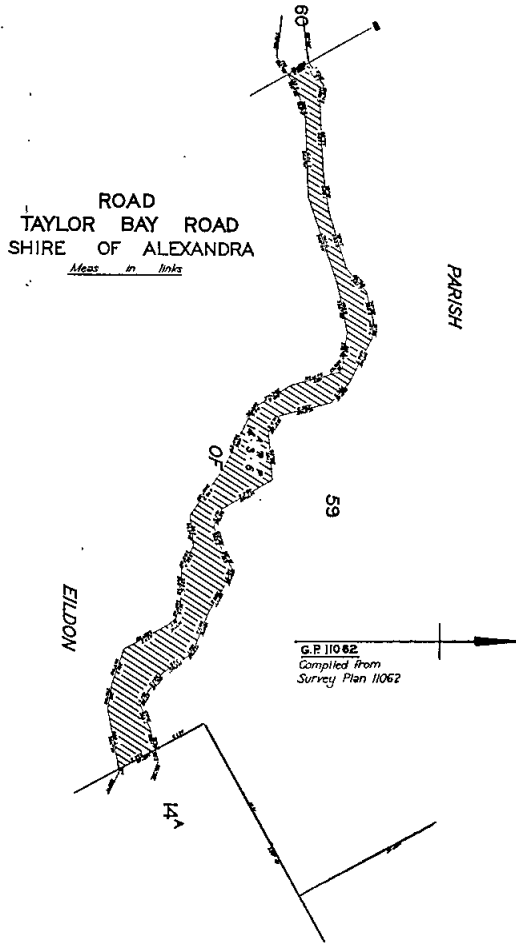

ROAD
TAYLOR BAY ROAD
SHIRE OF ALEXANDRA
Meas. in links

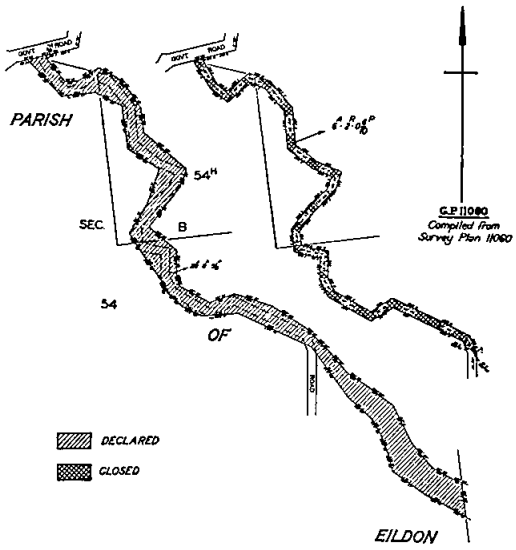

▨ DECLARED
▨ CLOSED

And the Honorable Murray Victor Porter, Her Majesty's
Minister of Public Works for the State of Victoria, shall
give the necessary directions herein accordingly.

J. ROSSITER,
Clerk of the Executive Council.

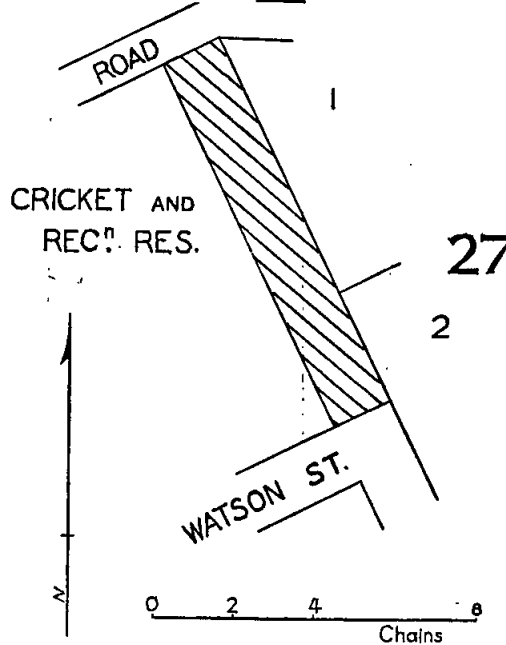

At Bendigo, Parish of Sandhurst, County of Bendigo,
being the portion of the width of Elliott-street indicated by
hatching on plan hereunder.—(S.372⁽¹²⁰⁾) (W.68868).

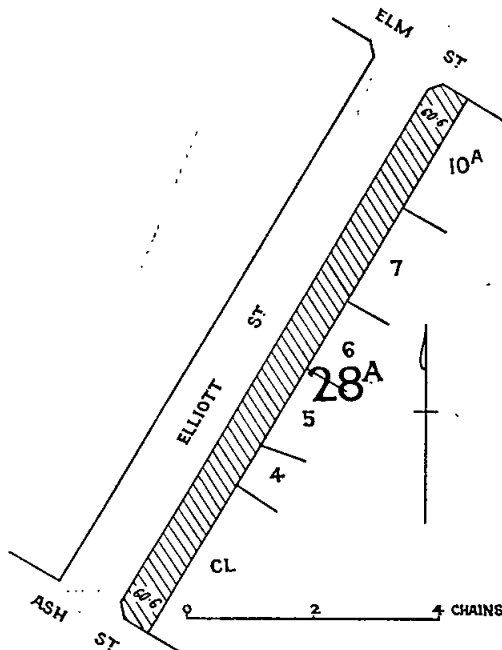

Parish of Bumberrah, County of Tambo, being the roads indicated by hatching on plan hereunder.—(B.99⁽⁴⁾) (H.026307).

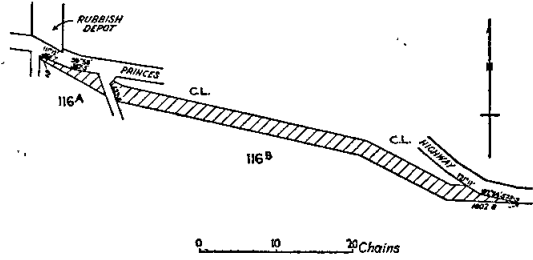

Parish of Prooinga, County of Tatchera, being the portion of the width of the road indicated by hatching on plan hereunder.—(P.179⁽⁸⁾) (M.61514).

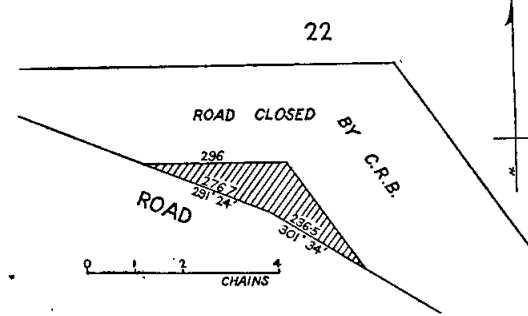

Parish of Clarksdale, County of Grenville, being the road indicated by hatching on plan hereunder.—(C.374⁽⁶⁾) (J.32421).

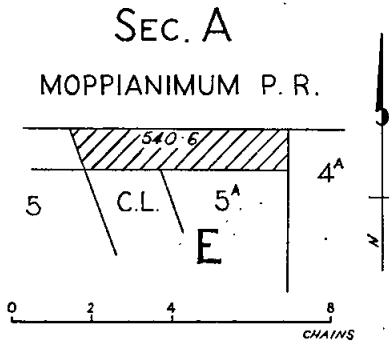

And the Honorable Sir William John Farquhar McDonald, Her Majesty's Minister of Lands for the State of Victoria, shall give the necessary directions herein accordingly.

J. ROSSITER,
Clerk of the Executive Council.

DEPARTMENT OF CROWN LANDS AND SURVEY.

At the Executive Council Chamber, Melbourne, the
fourteenth day of May, 1968.

PRESENT:

His Excellency the Governor of Victoria.
Mr. Chandler | Sir William McDonald.
Mr. Borthwick |

LANDS TEMPORARILY RESERVED AS SITES.

HIS Excellency the Governor of the State of Victoria, by and with the advice of the Executive Council thereof, doth hereby, in pursuance of section 14 of the Land Act 1958, reserve temporarily from sale, from being leased, and from having a licence granted in respect thereof, and also except from occupation for mining purposes under any miner's right, the land hereinafter described:—

AXEDALE.—Site for Public purposes (Police purposes), 1 road 4 perches, Township of Axedale, Parish of Axedale, County of Bendigo, as indicated by hatching on plan hereunder.—(A.98⁽⁵⁾) (Rs.8979).

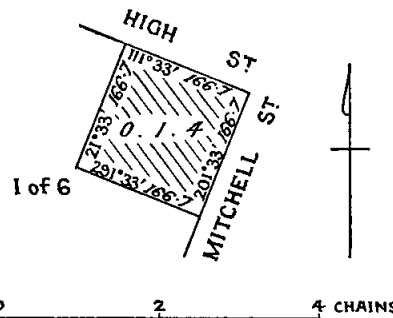

CORINDHAP.—Site for Water Supply purposes, 26 acres 31 perches, Township of Corindhap, Parish of Axedale, County of Grenville, as indicated by hatching on plan hereunder.—(C.269⁽⁵⁾) (Rs.8990).

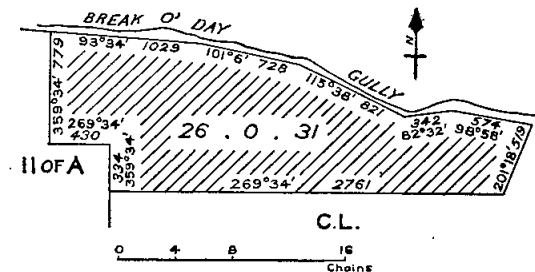

Parish of Drik Drik, County of Normanby, being the roads indicated by hatching on plan hereunder.—(D.152⁽⁴⁾) (J.31902).

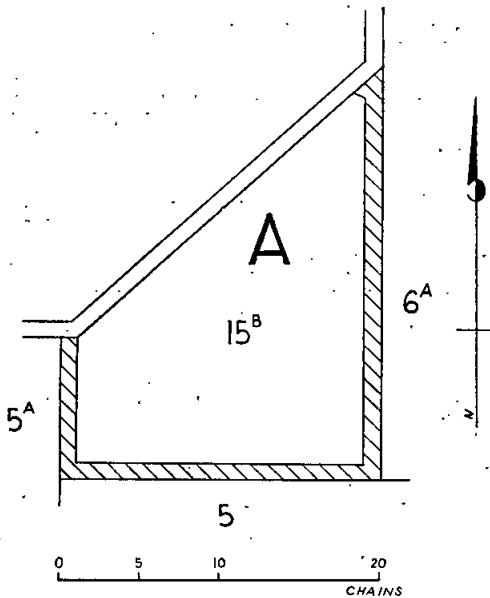

Parish of Kout Narin, County of Lowan, being the road between allotments 13, 14A, Parish of Kout Narin, and allotment 11, Parish of Toolongrook.—(K.123⁽²⁾) (M.60603).

HEATHCOTE.—Site for Public purposes (Police purposes), 1 acre 1 rood 33 perches, Township of Heathcote, Parish of Heathcote, County of Dalhousie, as indicated by hatching on plan hereunder.—(H.74⁽³⁾) (Rs.8944).

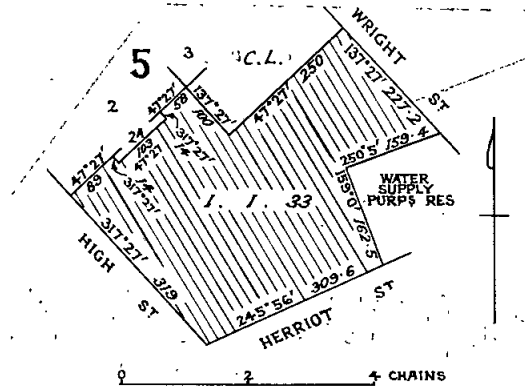

HEYWOOD.—Site for Public purposes (Municipal purposes), 3 roods, Township of Heywood, Parish of Heywood, County of Normanby, as indicated by hatching on plan hereunder.—(H.86⁽³⁾) (Rs.8966).

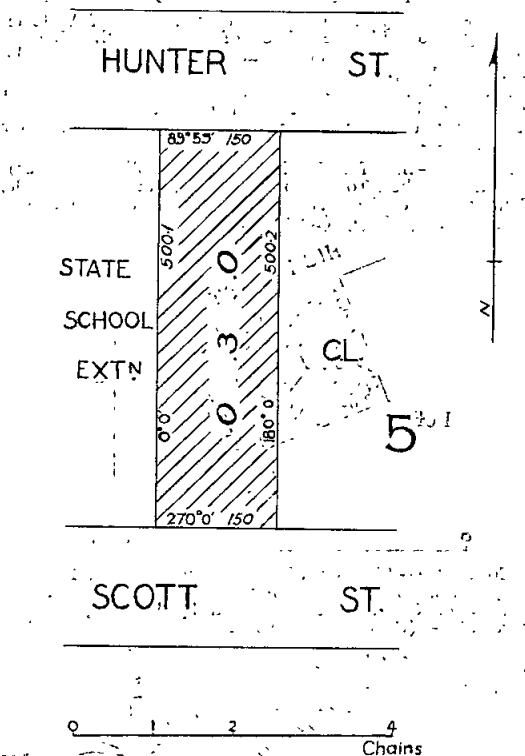

And the Honorable Sir William John Farquhar McDonald, Her Majesty's Minister of Lands for the State of Victoria, shall give the necessary directions herein accordingly.

J. ROSSITER,
Clerk of the Executive Council.

DEPARTMENT OF CROWN LANDS AND SURVEY.

At the Executive Council Chamber, Melbourne, the fourteenth day of May, 1968.

PRESENT:

His Excellency the Governor of Victoria.

Mr. Chandler
Mr. Borthwick

Sir William McDonald.

REVOCATION OF TEMPORARY RESERVATION OF LAND BY ORDER IN COUNCIL.

HIS Excellency the Governor of the State of Victoria, by and with the advice of the Executive Council thereof, doth hereby, in pursuance of the provisions of the Land Act 1958, revoke the temporary reservation of land by Order in Council hereinafter referred to, viz.:

BENDIGO.—Order in Council of 17th January, 1950, of 1 acre 1 rood 15 perches more or less of land in the City of Bendigo (now at Bendigo) as a site for Water Supply purposes so far only as regards the portion thereof comprised within the boundaries published in the Government Gazette of 19th April, 1968, and containing 2 roods 14 perches.—(Rs.5975.)

BENDIGO.—Order in Council of 1st July, 1947, of 16 acres 14 8/10 perches of land in the City of Bendigo (now at Bendigo) as a site for Water Supply purposes so far only as regards the portion thereof comprised within the boundaries published in the Government Gazette of 19th April, 1968, and containing 1 acre 6 perches.—(Rs.5975.)

CASTERTON.—Order in Council of 21st November, 1893, of 4 acres 3 roods 36 perches of land in the Township of Casterton as a site for Hospital so far only as regards the portion thereof comprised within the boundaries published in the Government Gazette of 19th April, 1968, and containing 39 perches.—(Rs.1577.)

ECHUCA.—Order in Council of 30th November, 1874, of 2 acres 0 roods 24 perches, more or less, of land in the Township of Echuca as a site for Drainage purposes (revoked as to part by Order of the 2nd July, 1963) so far only as regards the portion thereof comprised within the boundaries published in the Government Gazette of 20th March, 1968, and containing 1 rood 10 perches, more or less.—(C.76302.)

FRYERSTOWN.—Order in Council of 25th October, 1869, of 3 acres 0 roods 32 perches of land in the Township of Fryerstown as a site for Market and Public Buildings, revoked as to part by Order of the 12th May, 1930.—(Rs.8712.)

FRYERSTOWN.—Order in Council of 6th May, 1890, of 1 acre 0 roods 17 3/10 perches of land in the Township of Fryerstown as a site for Police purposes.—(Rs.8975.)

JEFFCOTT.—Order in Council of 1st November, 1880, of 159 acres 3 roods 30 perches of land in the Parish of Jeffcott as a site for Public purposes and the temporary reservation by Order in Council of the 23rd September, 1889, of the same land as a site for a Public Park.—(Rs.4896.)

MORTLAKE.—Order in Council of 23rd December, 1861, of 2 acres 0 roods 8 perches of land in the Township of Mortlake as a site for Police Station, and revoked as to part by various Orders.—(C.85832.)

VIOLET TOWN.—Order in Council of 7th May, 1884, of 33 acres of land in the Township of Violet Town as a site for Public Recreation so far only as regards the portion thereof comprised within the boundaries published in the Government Gazette of 19th April, 1968, and containing 1 acre 0 roods 1 perch.—(Rs.2179.)

And the Honorable Sir William John Farquhar McDonald, Her Majesty's Minister of Lands for the State of Victoria, shall give the necessary directions herein accordingly.

J. ROSSITER,
Clerk of the Executive Council.

WESTERNPORT WATERWORKS TRUST.

At the Executive Council Chamber, Melbourne, the twenty-first day of May, 1968.

PRESENT:

The Lieutenant-Governor as Deputy for His Excellency the Governor of Victoria.

Mr. Balfour | Mr. Wilcox.

AMENDMENT OF ORDER.

UNDER the powers conferred by the Water Act and all other powers enabling him in that behalf, the Lieutenant-Governor as Deputy for His Excellency the Governor of the State of Victoria, by and with the advice of the Executive Council of the said State, doth hereby order that, as from 1st June, 1968, the Order constituting the Westernport Waterworks Trust made on the 6th May, 1947, and published in the *Victoria Government Gazette* dated 14th May, 1947, shall be amended as follows:—

In Clause 2 for the expression "and one other person" there shall be substituted the expression "and two other persons".

And the Honorable William Archibald Borthwick, Her Majesty's Minister of Water Supply for the State of Victoria, shall give the necessary directions herein accordingly.

J. ROSSITER,
Clerk of the Executive Council.

GEELONG WATERWORKS AND SEWERAGE TRUST.

At the Executive Council Chamber, Melbourne, the twenty-first day of May, 1968.

PRESENT:

The Lieutenant-Governor as Deputy for His Excellency the Governor of Victoria.

Mr. Balfour | Mr. Wilcox.

POWER TO BORROW \$385,000.

UNDER the powers conferred by the Geelong Waterworks and Sewerage Act and all other powers enabling him in that behalf, the Lieutenant-Governor as Deputy for His Excellency the Governor of the State of Victoria by and with the advice of the Executive Council of the said State, doth hereby consent to the Geelong Waterworks and Sewerage Trust borrowing at interest subject to the provisions of the Geelong Waterworks and Sewerage Act the sum of Three hundred and eighty-five thousand dollars (\$385,000) in one amount of One hundred and eighty-five thousand dollars (\$185,000) and two amounts each of One hundred thousand dollars (\$100,000) respectively for the conversion of Loans YYY, P6 and T6.

And the Honorable William Archibald Borthwick, Her Majesty's Minister of Water Supply for the State of Victoria, shall give the necessary directions herein accordingly.

J. ROSSITER,
Clerk of the Executive Council.

GEELONG WATERWORKS AND SEWERAGE TRUST.

At the Executive Council Chamber, Melbourne, the twenty-first day of May, 1968.

PRESENT:

The Lieutenant-Governor as Deputy for His Excellency the Governor of Victoria.

Mr. Balfour | Mr. Wilcox.

CONSENT TO BORROWING \$485,000.

UNDER the powers conferred by the Geelong Waterworks and Sewerage Act and all other powers enabling him in that behalf, the Lieutenant-Governor as Deputy for His Excellency the Governor of the State of Victoria by and with the advice of the Executive Council of the said State, doth hereby consent to the Geelong Waterworks and Sewerage Trust borrowing

at interest, subject to the Geelong Waterworks and Sewerage Act, the sum of Four hundred and eighty-five thousand dollars (\$485,000) in one amount of One hundred and eighty-five thousand dollars (\$185,000) and two amounts each of One hundred and fifty thousand dollars (\$150,000) respectively for the conversion of Loan Nos. 70, 107 and 110.

And the Honorable William Archibald Borthwick, Her Majesty's Minister of Water Supply for the State of Victoria, shall give the necessary directions herein accordingly.

J. ROSSITER,
Clerk of the Executive Council.

DANDENONG VALLEY AUTHORITY ACT 1963.

At the Executive Council Chamber, Melbourne, the twenty-first day of May, 1968.

PRESENT:

The Lieutenant-Governor as Deputy for His Excellency the Governor of Victoria.

Mr. Balfour | Mr. Wilcox.

AGREEMENT BETWEEN DANDENONG VALLEY AUTHORITY AND THE SHIRE OF KNOX REGARDING THE REMODELLING OF OLD JOES CREEK AT THE MOUNTAIN HIGHWAY CROSSING.

WHEREAS the Dandenong Valley Authority and the Shire of Knox have agreed that the remodelling of Old Joes Creek at the Mountain Highway crossing comprising a fully piped crossing should be carried out:

And, whereas, in pursuance of the provisions of Section 20 (2) of the *Dandenong Valley Authority Act 1963* the Authority may, with the consent of the Governor in Council, contract upon such terms and conditions as it sees fit with any public authority for or with respect to the construction of any works which the Authority is by law empowered to construct:

And whereas the Shire of Knox has agreed to pay the Authority half the cost of this remodelling up to maximum of \$21,000, such payment to be made not later than the 1st day of December, 1968:

Now therefore the Lieutenant-Governor as Deputy for His Excellency the Governor of Victoria, acting by and with the advice of the Executive Council thereof and in pursuance of the said Act and all other powers thereunto him enabling, hereby consents to the Dandenong Valley Authority entering into an agreement with the Shire of Knox to carry out the said remodelling of Old Joes Creek under the above-mentioned terms and conditions.

And the Honorable William Archibald Borthwick, Her Majesty's Minister of Water Supply for the State of Victoria, shall give the necessary directions herein accordingly.

J. ROSSITER,
Clerk of the Executive Council.

HURSTBRIDGE WATERWORKS TRUST.

At the Executive Council Chamber, Melbourne, the twenty-first day of May, 1968.

PRESENT:

The Lieutenant-Governor as Deputy for His Excellency the Governor of Victoria.

Mr. Balfour | Mr. Wilcox.

EXTENT OF WATERWORKS DISTRICT INCREASED.

UNDER the powers conferred by the Water Act and all other powers enabling him in that behalf, the Lieutenant-Governor as Deputy for His Excellency the Governor of the State of Victoria, by and with the advice of the Executive Council of the said State, doth hereby declare, order and direct that the extent of the Waterworks District of the Hurstbridge Waterworks Trust be increased by adding to the same the lands comprised within the boundaries shown on a plan approved by the Governor in Council and deposited in the office of the State Rivers and Water Supply Commission, Mel-

bourne (Corr. No. 59/7459/176) and as on and from the date hereof, the extent of such District shall be and be deemed to be increased accordingly.

And the Honorable William Archibald Borthwick, Her Majesty's Minister of Water Supply for the State of Victoria, shall give the necessary directions herein accordingly.

J. ROSSITER,
Clerk of the Executive Council.

MORWELL WATERWORKS TRUST.

*At the Executive Council Chamber, Melbourne, the
twenty-first day of May, 1968.*

PRESENT:

The Lieutenant-Governor as Deputy for His Excellency
the Governor of Victoria.

Mr. Balfour | Mr. Wilcox.

EXTENT OF WATERWORKS DISTRICT INCREASED.

UNDER the powers conferred by the Water Acts and all other powers enabling him in that behalf, the Lieutenant-Governor as Deputy for His Excellency the Governor of the State of Victoria, by and with the advice of the Executive Council of the said State, doth hereby declare, order and direct that the extent of the Yinnar Waterworks District of the Morwell Waterworks Trust be increased by adding to the same the lands comprised within the boundaries shown on a plan approved by the Governor in Council and deposited in the office of the State Rivers and Water Supply Commission, Melbourne (Corr. No. 59/1177/143) and as on and from the date hereof, the extent of such District shall be deemed to be increased accordingly.

And the Honorable William Archibald Borthwick, Her Majesty's Minister of Water Supply for the State of Victoria, shall give the necessary directions herein accordingly.

J. ROSSITER,
Clerk of the Executive Council.

Water Act 1958.

STATE RIVERS AND WATER SUPPLY COMMISSION.

*At the Executive Council Chamber, Melbourne, the
twenty-first day of May, 1968.*

PRESENT:

The Lieutenant-Governor as Deputy for His Excellency
the Governor of Victoria.

Mr. Balfour | Mr. Wilcox.

BELLARINE URBAN DISTRICT—AREA OF DISTRICT INCREASED.

UNDER the powers conferred by the *Water Act 1958* and all other powers enabling him in that behalf, the Lieutenant-Governor as Deputy for His Excellency the Governor of the State of Victoria, with the advice of the Executive Council of the said State on the recommendation of the State Rivers and Water Supply Commission, doth hereby declare, order, and direct as follows:—

That the area of the Bellarine Urban District be increased by adding thereto the lands set out and described in the Schedule hereto and as on and from the first day of June, 1968 the area of such District shall be deemed to be so increased.

SCHEDULE.

1. Commencing at the most westerly angle of lot 30 on lodged plan of subdivision No. 58881, being part of allotment 10, section 3A, parish of Paywit, county of Grant; thence north-easterly by the north-western boundary of the land in the said plan of subdivision and by a line in continuation thereof to the north-eastern boundary of Lawrence-road; thence south-easterly by that road boundary to its intersection with the north-western boundary of the Bellarine Urban District prior to the date of this Order; thence south-westerly by the last-mentioned boundary to the south-western boundary of Laker-drive; thence north-westerly by that road boundary to a point in line with the north-western boundary of aforesaid lot 30 on plan of subdivision No. 58881; thence north-easterly by a line to the point of commencement.

2. Commencing at the north-western angle of lot 1 on lodged plan of subdivision No. 76014 being part of Crown portion 6, block 1, parish of Moolap, county of Grant; thence easterly by the northern boundaries of lots 1 to 5 (both inclusive) on said lodged plan of subdivision No. 76014 and lots 1 to 5 (both inclusive) on lodged plan of subdivision No. 76032 and lines connecting those boundaries to the north-eastern angle of lot 5 on said lodged plan of subdivision No. 76032; thence southerly by the eastern boundary of the last-mentioned lot to its south-eastern angle; thence westerly by the northern boundary of Dorothy-street to the south-western angle of lot 1 on said lodged plan of subdivision No. 76014; thence northerly by the western boundary of the last-mentioned lot to the point of commencement.

3. Commencing at the north-western angle of lot 62 on lodged plan of subdivision No. 77911 being part of Crown portion 17, block 1, parish of Moolap, county of Grant; thence easterly and southerly by the northern and eastern boundaries of lot 62 and southerly by the eastern boundary of lot 59 and a line connecting those boundaries to the south-eastern angle of the last-mentioned lot; thence easterly by the northern boundary of lot 58 and southerly by the eastern boundaries of that lot and of lots 57 and 56 and a line in continuation thereof to the southern boundary of Carroll-street; thence westerly by that street boundary to the most northerly angle of lot 55; thence generally southerly by the eastern boundaries of lots 55 and 54 to the most southerly angle of the last-mentioned lot; thence northerly by the western boundary of Crown portion 1, block 17, to the eastern boundary of Claremont-drive; thence generally northerly by that drive to the point of commencement.

The lands set out and described in the foregoing Schedule are shown on plans numbered 1 and 2 approved by the Governor in Council, and deposited in the office of the State Rivers and Water Supply Commission, Melbourne.—(Corr. No. 66/2311.)

And the Honorable William Archibald Borthwick, Her Majesty's Minister of Water Supply for the State of Victoria, shall give the necessary directions herein accordingly.

J. ROSSITER,
Clerk of the Executive Council.

WATER ACT 1958.

*At the Executive Council Chamber, Melbourne, the
twenty-first day of May, 1968.*

PRESENT:

The Lieutenant-Governor as Deputy for His Excellency the
Governor of Victoria.

Mr. Balfour | Mr. Wilcox.

SHIRE OF TUNGAMAH WATERWORKS TRUST— EXTENT OF WATERWORKS DISTRICT DIMINISHED.

UNDER the powers conferred by the *Water Act 1958* and all other powers enabling him in that behalf, the Lieutenant-Governor as Deputy for His Excellency the Governor of the State of Victoria, with the advice of the Executive Council of the said State, doth hereby declare, order and direct as follows:—

That the extent of the Waterworks District of the Shire of Tungamah Waterworks Trust be diminished by excising therefrom the portion of the same set out and described in the Schedule hereto, and as from the 31st day of May, 1968, the extent of the said Waterworks District shall be deemed to be diminished accordingly.

SCHEDULE.

Commencing at the south-eastern angle of allotment 43, township and parish of Katamatite, county of Moira; thence westerly by the southern boundaries of allotments 43 and 42 and a line in continuation thereof to the western boundary of Buddee-street; thence northerly by that street boundary to the left bank of Boosey-creek; thence generally easterly by that creek bank to a point in line with the eastern boundary of allotment 44; thence southerly by a line, the eastern boundaries of allotments 44 and 43 and a line connecting those boundaries to the point of commencement.

The lands set out and described in the foregoing schedule are shown on a plan approved by the Governor in Council, and deposited in the office of the State Rivers and Water Supply Commission, Melbourne.—(Corr. No. 63/1001.)

And the Honorable William Archibald Borthwick, Her Majesty's Minister of Water Supply for the State of Victoria, shall give the necessary directions herein accordingly.

J. ROSSITER,
Clerk of the Executive Council.

Water Act 1958.

STATE RIVERS AND WATER SUPPLY COMMISSION.

*At the Executive Council Chamber, Melbourne, the
twenty-first day of May, 1968.*

PRESENT:

The Lieutenant-Governor as Deputy for His Excellency the Governor of Victoria.

Mr. Balfour | Mr. Wilcox.

GOULBURN-MURRAY IRRIGATION DISTRICT—DISTRICT EXTENDED.—MURRAY-VALLEY IRRIGATION AREA—BOUNDARIES VARIED.

UNDER the powers conferred by the *Water Act 1958* and all other powers enabling him in that behalf, the Lieutenant-Governor as Deputy for His Excellency the Governor of the State of Victoria, with the advice of the Executive Council of the said State, on the recommendation of the State Rivers and Water Supply Commission, doth hereby declare, order, and direct as follows:—

That the Goulburn-Murray Irrigation District be extended and the boundaries of the Murray-Valley Irrigation Area be varied by adding to the said District and Area the lands set out and described in the Schedule hereto, and as on and from the 1st June, 1968, such District shall be deemed to be so extended and the boundaries of such Area shall be so varied.

SCHEDULE.

Commencing at the south-eastern angle of allotment 43, township and parish of Katamatite, county of Moira; thence westerly by the southern boundaries of allotments 43 and 42 and a line in continuation thereof to the western boundary of Buddee-street; thence northerly by that street boundary to the left bank of Boosey-creek; thence generally easterly by that creek bank to a point in line with the eastern boundary of allotment 44; thence southerly by a line, the eastern boundaries of allotments 44 and 43 and a line connecting those boundaries to the point of commencement.

The lands set out and described in the foregoing Schedule are shown on a plan approved by the Governor in Council, and deposited in the office of the State Rivers and Water Supply Commission, Melbourne.—(Corr. No. 63/1001.)

And the Honorable William Archibald Borthwick, Her Majesty's Minister of Water Supply for the State of Victoria, shall give the necessary directions herein accordingly.

J. ROSSITER,
Clerk of the Executive Council.

Water Act 1958.

STATE RIVERS AND WATER SUPPLY COMMISSION.

*At the Executive Council Chamber, Melbourne, the
twenty-first day of May, 1968.*

PRESENT:

The Lieutenant-Governor as Deputy for His Excellency the Governor of Victoria.

Mr. Balfour | Mr. Wilcox.

FRANKSTON-MORNINGTON URBAN DISTRICT—AREA OF DISTRICT INCREASED.

UNDER the powers conferred by the *Water Act 1958* and all other powers enabling him in that behalf, the Lieutenant-Governor as Deputy for His Excellency the Governor of the State of Victoria, with the advice of the

Executive Council of the said State, on the recommendation of the State Rivers and Water Supply Commission, doth hereby declare, order and direct as follows:—

That the area of the Frankston-Mornington Urban District be increased by adding to the same the lands set out and described in the Schedule hereto, and as on and from the 1st day of June, 1968, the area of such District shall be deemed to be so increased.

SCHEDULE.

The whole of lot 2 on lodged plan of subdivision No. 24582 being part of allotments 3 and 3A, parish of Moorooduc, county of Mornington.

The lands set out and described in the foregoing Schedule are shown on a plan approved by the Governor in Council, and deposited in the office of the State Rivers and Water Supply Commission, Melbourne.—(Corr. No. 61/2643.)

And the Honorable William Archibald Borthwick, Her Majesty's Minister of Water Supply for the State of Victoria, shall give the necessary directions herein accordingly.

J. ROSSITER,
Clerk of the Executive Council.

Water Act 1958.

STATE RIVERS AND WATER SUPPLY COMMISSION.

*At the Executive Council Chamber, Melbourne, the
twenty-first day of May, 1968.*

PRESENT:

The Lieutenant-Governor as Deputy for His Excellency the Governor of Victoria.

Mr. Balfour | Mr. Wilcox.

MALLEE WATERWORKS DISTRICT—PORTION EXCISED.

UNDER the powers conferred by the *Water Act 1958* and all other powers enabling him in that behalf, the Lieutenant-Governor as Deputy for His Excellency the Governor of the State of Victoria, with the advice of the Executive Council of the said State, on the recommendation of the State Rivers and Water Supply Commission, doth hereby declare, order and direct as follows:—

That there shall be excised from the Mallee Waterworks District that portion of the same set out and described in the Schedule hereto which portion, as from the 30th June, 1968, shall be deemed to be excised accordingly.

SCHEDULE.

The whole of allotment 15, section 2, parish of Kunat Kunat, county of Tatchera.

The portion set out and described in the foregoing Schedule is shown on a plan approved by the Governor in Council, and deposited in the office of the State Rivers and Water Supply Commission, Melbourne.—(Corr. No. 67/4951.)

And the Honorable William Archibald Borthwick, Her Majesty's Minister of Water Supply for the State of Victoria, shall give the necessary directions herein accordingly.

J. ROSSITER,
Clerk of the Executive Council.

Water Act 1958.

STATE RIVERS AND WATER SUPPLY COMMISSION.

*At the Executive Council Chamber, Melbourne, the
twenty-first day of May, 1968.*

PRESENT:

The Lieutenant-Governor as Deputy for His Excellency the Governor of Victoria.

Mr. Balfour | Mr. Wilcox.

GOULBURN-MURRAY IRRIGATION DISTRICT—DISTRICT EXTENDED. SWAN HILL IRRIGATION AREA—BOUNDARIES VARIED.

UNDER the powers conferred by the *Water Act 1958* and all other powers enabling him in that behalf, the Lieutenant-Governor as Deputy for His Excellency the Governor of the State of Victoria, with the advice of the

Executive Council of the said State, on the recommendation of the State Rivers and Water Supply Commission, doth hereby declare, order and direct as follows:—

That the Goulburn-Murray Irrigation District be extended and the boundaries of the Swan Hill Irrigation Area be varied by adding to the said District and Area the lands set out and described in the Schedule hereto, and as on and from the 1st July, 1968, such District shall be deemed to be so extended and the boundaries of such Area shall be so varied.

SCHEDULE.

Commencing at the south-western angle of allotment 15, section 2, Parish of Kunat Kunat, county of Tatchera; thence northerly by the western boundary of said allotment 15 and easterly by the northern boundaries of that allotment and allotment 3A, section 2, and a line connecting those boundaries and a line in continuation of the last-mentioned boundary to the north-western angle of allotment 3, section 2; thence generally northerly by the eastern boundary of a road and a line in continuation thereof to a point in the south-western boundary of allotment 1A, section 1, in line with the western boundary of allotment 1B, section 1; thence south-easterly by the north-eastern boundary of a road to the most westerly angle of allotment 1B, section B; thence generally easterly by the northern boundaries of the last-mentioned allotment and allotments 11 and 11A, section 1, and by a line in continuation thereof to the north-western angle of lot 1 on lodged plan of subdivision No. 58209; thence generally north-easterly by the western boundary of allotment 10, section 1, to the north-western angle of that allotment; thence generally easterly by the northern boundaries of said allotment 10, section 1, and generally south-westerly by the eastern and south-eastern boundaries of allotments 10 and 9 to the most southerly angle of the last-mentioned allotment; thence north-westerly by the north-eastern boundary of a road to the most westerly angle of lot 4 on the said lodged plan of subdivision No. 58209; thence northerly by the western boundary of said lot 4 to the south-western angle of lot 3; thence westerly by a line to the left bank of the Long Lake Channel; thence generally southerly by that channel bank to the north-eastern angle of allotment 2n, section 2; thence easterly by a line in production of the northern boundary of the last-mentioned allotment to the western shore of Long Lake; thence generally southerly by that shore to the most westerly angle of Crown section A, Lake Boga P.R.; thence south-easterly by the north-eastern boundary of a road and the eastern shore of Round Lake to the most westerly angle of lot 21 on lodged plan of subdivision No. 3507; thence north-easterly by the north-western boundaries of lots 21 and 22 and south-easterly by the north-eastern boundary of lot 22 to the most easterly angle of that lot; thence generally westerly by the northern boundary of a road to the most westerly angle of allotment 5, section 2; thence generally north-easterly by the north-western boundaries of the last-mentioned allotment and north-westerly by the south-western boundary of allotment 3A and by a line connecting those boundaries to the south-western angle of allotment 3A; thence generally westerly southerly and westerly by a line and the southern boundaries of allotment 15, section, 2 to the point of commencement.

The lands set out and described in the foregoing Schedule are shown on a plan approved by the Governor in Council, and deposited in the office of the State Rivers and Water Supply Commission, Melbourne.—(Corr. No. 67/4951.)

And the Honorable William Archibald Borthwick, Her Majesty's Minister of Water Supply for the State of Victoria, shall give the necessary directions herein accordingly.

J. ROSSITER,
Clerk of the Executive Council.

STATE SAVINGS BANK ACT 1958, No. 6379.

At the Executive Council Chamber, Melbourne, the twenty-first day of May, 1968.

PRESENT:

The Lieutenant-Governor as Deputy for His Excellency the Governor of Victoria.

Mr. Balfour | Mr. Wilcox.

IN accordance with the provisions of subsection (6) of Section 8 of the *State Savings Bank Act 1958*, the Lieutenant-Governor as Deputy for His Excellency the

Governor of the State of Victoria by and with the advice of the Executive Council thereof doth by this Order appoint

WILLIAM KIRKHOPE, O.B.E., F.C.A., F.A.S.A.,
a Commissioner of the State Savings Bank of Victoria for a period of seven years.

And the Honorable Sir Henry Edward Bolte, Her Majesty's Treasurer for the State of Victoria, shall give the necessary directions herein accordingly.

J. ROSSITER,
Clerk of the Executive Council.

LANDLORD AND TENANT ACT 1958.

At the Executive Council Chamber, Melbourne, the twenty-first day of May, 1968.

PRESENT:

The Lieutenant-Governor as Deputy for His Excellency the Governor of Victoria.

Mr. Balfour | Mr. Wilcox.

ORDER EXTENDING APPLICATION OF PART V. OF THE LANDLORD AND TENANT ACT 1958 TO CERTAIN PREMISES.

IN pursuance of the powers conferred by section 44 of the *Landlord and Tenant Act 1958*, the Lieutenant-Governor as Deputy for His Excellency the Governor of Victoria, by and with the advice of the Executive Council, doth hereby declare that the application of Part V. of the *Landlord and Tenant Act 1958* shall extend to the following premises—

1. The premises known as Number 32 Castlemaine Street, Yarraville.

2. The premises known as Number 6 Coleman Street, North Fitzroy.

And the Honorable George Oswald Reid, Her Majesty's Attorney-General in and for the State of Victoria, shall give the necessary directions herein accordingly.

J. ROSSITER,
Clerk of the Executive Council.

MILK AND DAIRY SUPERVISION ACT 1958.

At the Executive Council Chamber, Melbourne, the fourteenth day of May, 1968.

PRESENT:

His Excellency the Governor of Victoria.

Mr. Chandler | Sir William McDonald.
Mr. Borthwick

APPOINTMENT OF MEMBERS OF THE DAIRY PRODUCE BOARD.

IN pursuance of the powers conferred by section 6 of the *Milk and Dairy Supervision Act 1958* and all other powers him thereunto enabling His Excellency the Governor of the State of Victoria, by and with the advice of the Executive Council thereof, doth by this Order hereby appoint the undermentioned persons as members of the Dairy Produce Board for a period of one (1) year from and inclusive of the 14th May, 1968:—

THOMAS MATTHEW JENSEN,
DAVID ANDREW LANCASTER, and
RUSSELL IAN HOWEY,
Officers of the Department of Agriculture;

GEORGE JOSEPH SADLER, and
JAMES CAMPBELL GLEESON,
Representatives of Factory Owners;

JOSEPH ARTHUR FORD, Representative of Factory Managers; and

COSMO BOND GARDINER, Dairyman supplying milk or cream to a factory;

and doth appoint the said Thomas Matthew Jensen to be the Chairman of the said Dairy Produce Board.

And the Honorable Gilbert Lawrence Chandler, Her Majesty's Minister of Agriculture for the State of Victoria, shall give the necessary directions herein accordingly.

J. ROSSITER,
Clerk of the Executive Council.

LANDS DEPARTMENT NOTICES*Land Act 1958.***LEASES DECLARED VOID.**

NOTICE is hereby given that the Governor in Council has declared void the Leases mentioned in the schedule hereunder for the reason specified in each case.

District.	Corr. No.	Name.	Section of Land Act under which Leased.	Parish.	Allotment.	Section.	Area.	Reason.
Melbourne	0707/134	Geoffrey Scobie Gair..	134	Waratah ..	28	..	A. R. P. 3 1 23	Lease surrendered
Beechworth	107/155	Giovanni Vozzoler ..	155	Mullagong ..	14 and 15	11	30 0 0	Non-payment of rent

Department of Crown Lands and Survey,
Melbourne, 7th May, 1968.

W. J. F. McDONALD,
Minister of Lands.

*Land Act 1958.***LEASE DECLARED VOID.**

NOTICE is hereby given that the Governor in Council has declared void the Lease mentioned in the schedule hereunder for the reason specified.

District.	Corr. No.	Name.	Act under which Leased.	Parish.	Allotment.	Section.	Area.	Reason.
Mallee ..	195/8	Horace Clarence Simmons	North-West Mallee Settlement Acts, Section 8	Ginquam	64, 65 and 67	..	A. R. P. 4,210 0 0	Purchase lease to issue

Department of Crown Lands and Survey,
Melbourne, 7th May, 1968.

W. J. F. McDONALD,
Minister of Lands.

*Land Act 1958.***LICENCES UNDER THE LAND ACTS DECLARED VOID.**

NOTICE is hereby given that the Licences in the Schedule hereunder have been Declared Void for the reason specified in each case.

District.	Corr. No.	Name of Licensee.	Section of Land Act under which Licensed.	Parish.	Allotments.	Section.	Area.	Annual Rental.	Reason for Voiding.
Northern	02155/138	G.F.DeArango	138	At Bendigo, Sandhurst	21E	57B	A. R. P. 0 0 29	\$ 18.50	Surrendered
Melbourne	1966/138	Griffiths Towels Proprietary Limited	138	City of South Melbourne, Parish of Melbourne South	9	..	0 1 3 $\frac{10}{100}$	1,648.00	Surrendered

Department of Crown Lands and Survey,
Melbourne, 20th May, 1968.

W. J. F. McDONALD,
Minister of Lands.

APPROACHING LAND SALES.

SALES of Crown Lands, in fee-simple, will be held at the under-mentioned places and dates, viz.:

	No. of Gazette.
Bendigo.—Thursday, 13th June, 1968 ..	40
Foster.—Friday, 28th June, 1968 ..	45
Yarra Junction.—Friday, 24th May, 1968 ..	29

SALE OF CROWN LAND BY AUCTION.

The land will be offered for sale in fee-simple, and subject to the provisions of the Land Act and Regulations thereunder.

The upset price is the sum at which bidding will start, and no bid below that sum can be accepted. The highest bidder at or above that sum shall be the purchaser, subject to signature of contract and any necessary payment.

TERMS:—

A deposit of at least 12½% of the purchase price must be paid at the sale, either in cash or by cheque.

The residue is payable in half-yearly instalments, in accordance with the following scale, or may be paid off at any earlier time.

- \$40 and under, 6 instalments.
- Over \$40, and not exceeding \$100, 8 instalments.
- Over \$100, and not exceeding \$200, 10 instalments.
- Over \$200, and not exceeding \$400, 12 instalments.
- Over \$400, and not exceeding \$600, 14 instalments.
- Over \$600, and not exceeding \$800, 16 instalments.
- Over \$800, and not exceeding \$1,000, 18 instalments.
- Over \$1,000, 20 instalments.

Interest at the rate of 5% per annum is payable with all payments of residue, and is computed for each instalment from the date of sale to the date of such payment. Additional interest is charged if any instalment is not paid on or before the due date.

If paid off within 30 days of sale, no interest is payable.

FEES, ETC.:

Also payable at the sale, in addition to the deposit, are the survey fee and, if applicable, the valuation of improvements (if purchaser be not the owner thereof).

Payable with balance of purchase money—

Crown Grant fee—	
50 acres and under	\$3
Over 50 acres	\$4
Purchase money \$10 or under	\$2

Assurance Fund contribution.—One cent in every Five dollars or part thereof of purchase price. (This is a fund established to guarantee the validity of freehold titles.)

Transfer of interest prior to completion of payment may be allowed on payment of \$2 fee and subject to stamp duty.

If unable to attend personally, a prospective purchaser may arrange for another person to bid as his agent.

Attention is drawn to section 95, Land Act 1958, which provides that the purchaser shall be deemed to be the owner for the purposes of other Acts; also to an amendment to the Local Government Act providing for Government roads, in certain circumstances, to be declared "private streets", thus making the purchaser liable to contribute to the cost of street construction.

W. J. F. McDONALD,
Minister of Lands.

Office of Crown Lands and Survey,
Melbourne, 22nd May, 1968.

FOSTER.—Sale (No. 11931) of Crown land in fee-simple, by auction, will be held at the LAND INSPECTOR'S OFFICE, at FOSTER, on FRIDAY, 28th JUNE, 1968, at half-past TEN o'clock a.m. To be conducted by J. R. WILDING, Land Officer, Melbourne.

Lot 1.

TOWNSHIP OF FOSTER, PARISH OF WONGA WONGA SOUTH, COUNTY OF BULN BULN.

Having a frontage of about 9 chains to the western side of the Foster By-Pass about 7 chains north of the South Gippsland Highway.

Upset price \$4,000 the lot. Survey fee \$200.

Area 3a. 1r. 10p., allotment 26 of section 2. Sale of this lot is subject to a condition requiring that the purchaser shall erect a building thereon to the value of \$20,000 within 12 months from the date of sale or such further period as may be determined by the Minister of Lands; a Crown Grant will not be issued until this condition has been complied with. Building construction shall comply with all requirements of the responsible authorities.—(G.67177.)

Lot 2.

PARISH OF BINGINWARRI, COUNTY OF BULN BULN.

Fronting the western side of the Morwell-Yarram road about 17 miles north-west of Yarram being the former Madalya School site.

Upset price \$30 the lot. Survey fee \$16.

Area 1a. 3r. 0p., allotment 54M.—(G.64084.)

PROPOSED REVOCATIONS OF TEMPORARY RESERVATIONS OF LANDS BY ORDERS IN COUNCIL.

IN pursuance of the provisions of the Land Act 1958, notice is hereby given that it is the intention of the Governor in Council to revoke the temporary reservations of lands by Orders in Council hereunder referred to, viz.:

The following Notices were published 1° on the 1st May, 1968, pursuant to Orders of the 23rd April, 1968.

DUNKELD.—The temporary reservation, by Order in Council of the 17th December, 1860, of 12 acres 0 roods 30 perches of land in the Township of Dunkeld as sites for Public Buildings (revoked as to part by Order of the 27th June, 1898, is about to be revoked save and except the area of 4 acres, indicated by hatching on plan hereunder, is concerned.—(D.143(*) (Rs.8063.)

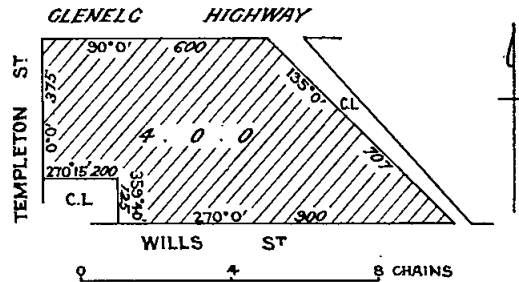

ANGLESEA.—The temporary reservation, by Order in Council of the 26th February, 1917, of 74 acres, more or less, of land in the Township of Anglesea as a site for Public Recreation, revoked as to part by Order of the 30th January, 1963, is about to be revoked so far only as the portion containing 2 acres 0 roods 27 perches, indicated by hatching on plan hereunder is concerned.—(A.183(*) (Rs.1527).

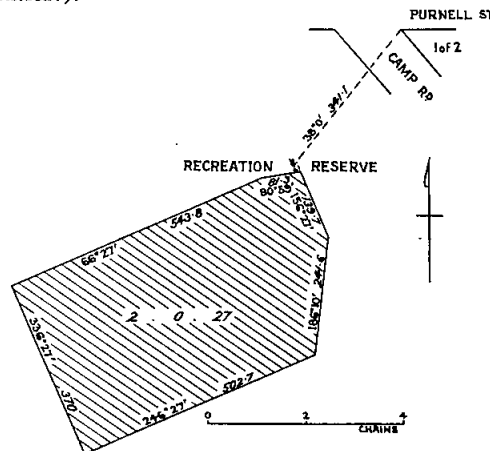

HEATHCOTE.—The temporary reservation, by Order in Council of the 20th January, 1891 (see Government Gazette, 23rd January, 1891, page 417) of 1 acre 2 roods 4 perches of land in the Township of Heathcote as a site for Municipal Cattle Sale Yards is about to be revoked.—(H.74(*) (Rs.8983).

HOWQUA.—The temporary reservation as a site for the use of the Police Department and the withholding from sale, leasing and licensing by Order in Council of the 29th October, 1883, of 3 roods 7 perches of land in the Township of Howqua are about to be revoked.—(H.111⁽¹³⁾) (Rs.8985).

LALBERT.—The temporary reservation by Order in Council of the 26th August, 1940, of 3 roods 6 8/10 perches of land in the Parish of Lalbert as a site for Police Station purposes is about to be revoked.—(L.159⁽⁴⁾) (Rs.5086).

MATLOCK.—The temporary reservation, by Order in Council of the 18th July, 1864, of 39 perches of land in the Township of Matlock as a site for Police purposes is about to be revoked.—(M.429⁽²⁾) (Rs.8984).

NARRACAN.—The temporary reservation, by Order in Council of the 14th December, 1954, of 9 acres 2 roods 35 perches of land in the Parish of Narracan as a site for Hospital purposes, revoked as to part by Order of the 9th April, 1963, is about to be revoked so far only as the portion containing 1 acre 0 roods 9 perches, indicated by hatching on plan hereunder, is concerned.—(N.129⁽¹²⁾) (Rs.6912).

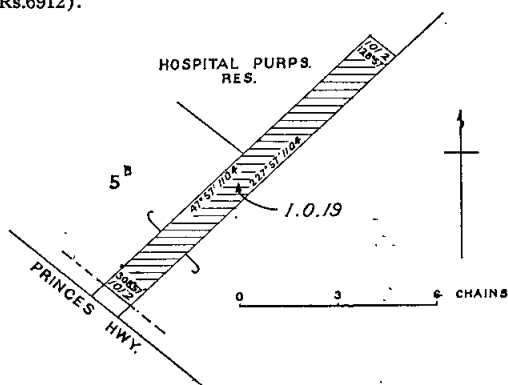

TYABB.—The temporary reservation, by Order in Council of the 12th July, 1937, of 390 acres, more or less, of land in the Townships of Tyabb and Hastings and the Parish of Tyabb as a site for Public purposes, revoked as to part by Order of the 31st May, 1955, and by Act 1967, No. 7652, is about to be revoked so far only as the portion in the Parish of Tyabb containing 9 acres, 0 roods, 20 perches, more or less, indicated by hatching on plan hereunder, is concerned.—(T.125⁽⁸⁾) (Rs.3699).

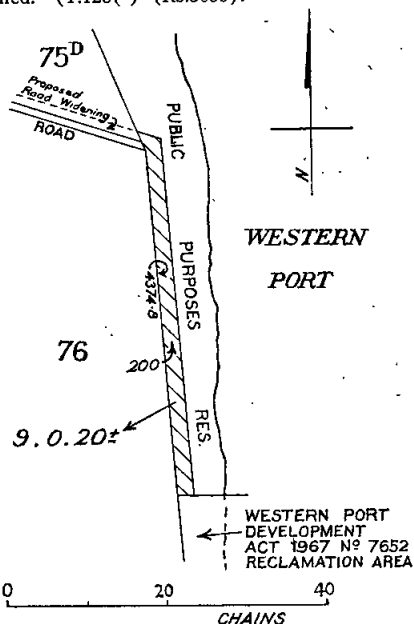

YACKANDANDAH.—The temporary reservation, by Order in Council of the 9th April, 1923, of 2 acres 3 roods of land in the Parish of Yackandandah, as a site for Public purposes (Swimming Pool) is about to be revoked.—(Y.45⁽¹⁶⁾) (Rs.2721).

W. J. F. McDONALD,
Minister of Lands.

PROPOSED REVOCATIONS OF TEMPORARY RESERVATIONS OF LANDS BY ORDERS IN COUNCIL.

IN pursuance of the provisions of the Land Act 1958, notice is hereby given that it is the intention of the Governor in Council to revoke the temporary reservations of lands by Orders in Council hereunder referred to, viz.:

The following Notices were published 1° on the 8th May, 1968, pursuant to Orders of the 30th April, 1968.

BEVERIDGE.—The temporary reservation as a site for Pound and the withholding from sale, leasing and licensing by Order in Council of the 17th January, 1884, of 1 acre 3 roods 36 perches of land in the Township of Beveridge are about to be revoked so far only as the portion containing 12 perches, indicated by hatching on plan hereunder is concerned.—(B.309⁽³⁾) (Rs.2685).

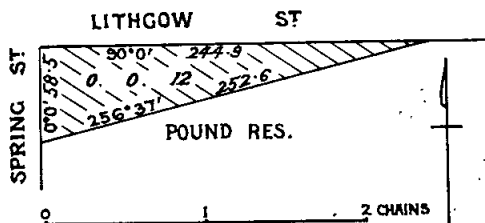

TARNAGULLA.—The temporary reservation as a site for Public Purposes (State School) and the withholding from sale, leasing and licensing by Order in Council of the 3rd September, 1877, of 1 acre of land in the Parish of Tarnagulla are about to be revoked.—(T.173⁽¹²⁾) (77E1461).

W. J. F. McDONALD,
Minister of Lands.

PROPOSED PERMANENT RESERVATION OF LAND AS A SITE.

IN pursuance of sections 14 and 21 of the Land Act 1958, notice is hereby given that it is the intention of the Governor in Council to reserve permanently from sale, from being leased and from having a licence granted in respect thereof the land hereinafter described:

The following Notice was published 1° on the 1st May, 1968, pursuant to Order of the 23rd April, 1968.

MINERS REST.—Land proposed to be permanently reserved as a site for Public Recreation, 4 acres 2 roods, Township of Miners Rest, Parish of Dowling Forest, County of Ripon, as indicated by hatching on plan hereunder.

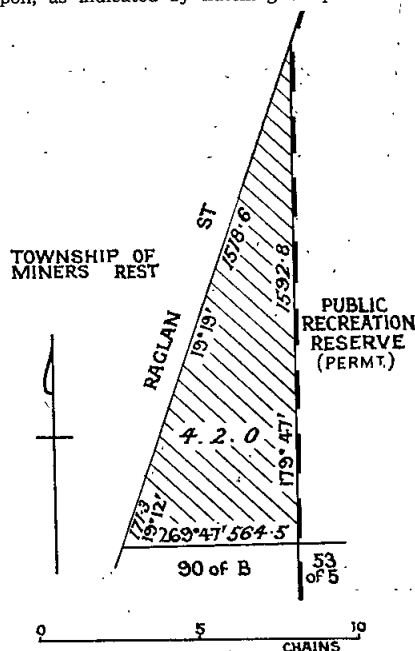

W. J. F. McDONALD,
Minister of Lands.

PROPOSED REVOCATIONS OF TEMPORARY RESERVATIONS OF LANDS BY ORDERS IN COUNCIL.

IN pursuance of the provisions of the Land Act 1958, notice is hereby given that it is the intention of the Governor in Council to revoke the temporary reservations of lands by Orders in Council hereunder referred to, viz.:—

The following Notices were published 1° on the 22nd May, 1968, pursuant to Orders of the 14th May, 1968.

ALLAMBEE EAST.—The temporary reservation by Order in Council of the 13th September, 1950, of 12 acres 3 roods 20 perches of land in the Parish of Allambee East as a site for Timber Reserve is about to be revoked.—(A.177⁽¹⁴⁾) (Rs.6584).

GRACEDALE.—The temporary reservation by Order in Council of the 19th April, 1955, of 340 acres, more or less, of land in the Parish of Gracedale as a site for Public purposes is about to be revoked so far only as the portion containing 1 rood 36 perches, indicated by hatching on plan hereunder, is concerned.—(G.166⁽⁶⁾) (Rs.3939).

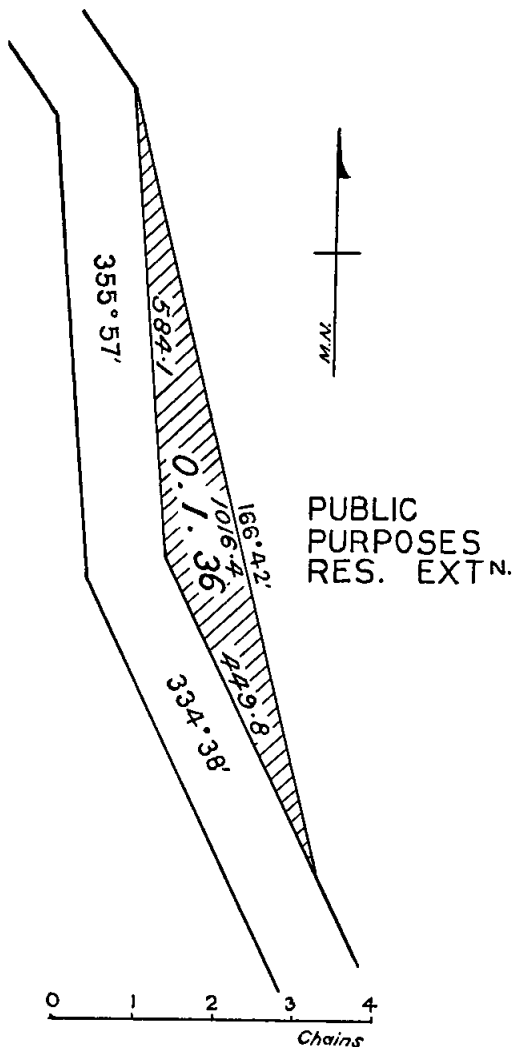

W. J. F. McDONALD,
Minister of Lands.

PROPOSED REVOCATIONS OF TEMPORARY RESERVATIONS OF LANDS BY ORDERS IN COUNCIL.

IN pursuance of the provisions of the Land Act 1958, notice is hereby given that it is the intention of the Governor in Council to revoke the temporary reservations of lands by Orders in Council hereunder referred to, viz.:—

The following Notices were published 1° on the 15th May, 1968, pursuant to Orders of the 7th May, 1968.

FRANKSTON.—The temporary reservation, by Order in Council of the 16th April, 1962, of 189 acres 2 roods 38 perches of land in the Parish of Frankston, as a site for the purposes of the Vermin and Noxious Weeds Destruction Board is about to be revoked so far only as the portion containing 32 acres 2 roods 11 perches, indicated by hatching on plan hereunder, is concerned.—(F.87⁽⁵⁾) (Rs.8127.)

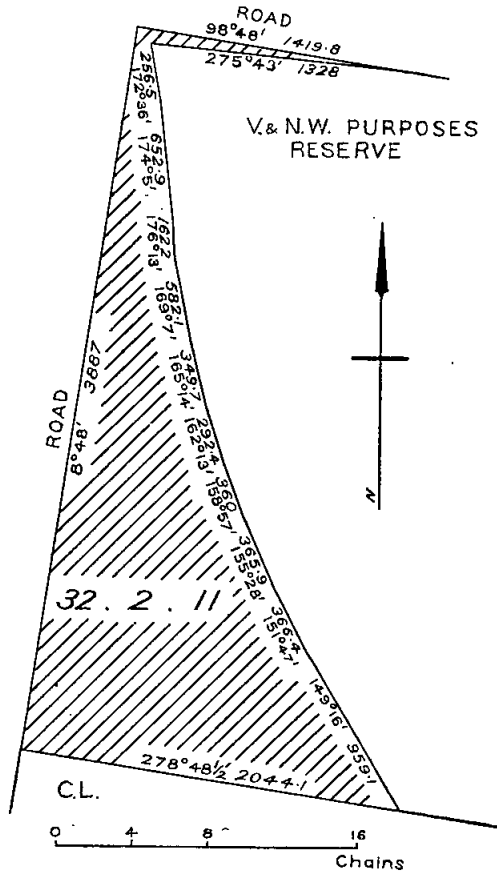

LEONGATHA.—The temporary reservation, by Order in Council of the 21st August, 1917, of 2 acres 1 6/10 perches of land in the Township of Leongatha, as a site for a

Public Garden is about to be revoked so far only as the portion containing 1 perch, indicated by hatching on plan hereunder, is concerned.—(L.167(6) (Rs.1677.)

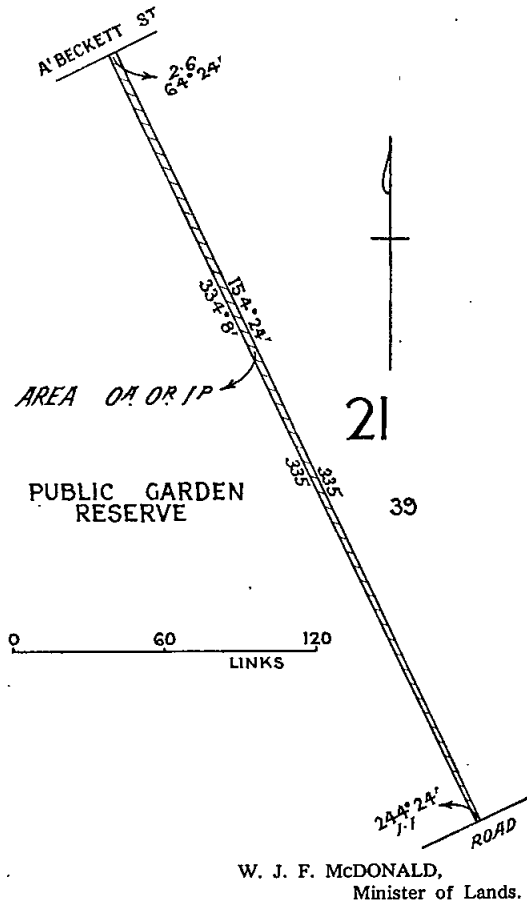

W. J. F. McDONALD,
Minister of Lands.

COMMON ABOUT TO BE DIMINISHED.

IN pursuance of the provisions contained in the *Land Act 1958*, notice is hereby given that it is the intention of the Governor in Council to diminish the common herein-after mentioned, viz.:—

The following Notice was published 1^o on the 22nd May, 1968, pursuant to Order of the 14th May, 1968.

The Ballarat West Town Common, proclaimed as such by the Governor in Council on the 28th January, 1861 (see *Government Gazette*, 6th February, 1861, page 256) is about to be diminished by the excision therefrom of the portion in the Parish of Dowling Forest containing 6 acres 2 roods 12 perches, indicated by hatching on plan hereunder.—(C.91998.)

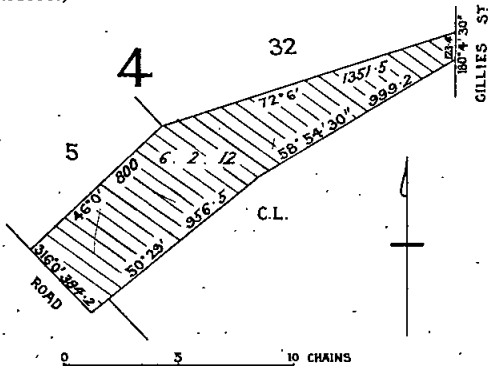

W. J. F. McDONALD,
Minister of Lands.

REGULATIONS FOR THE CARE, PROTECTION AND MANAGEMENT OF THE "MOUNT ECKERSLEY RECREATION RESERVE".

WHEREAS by section 218 of the *Land Act 1958* the Minister of Lands is empowered to make Regulations with respect to certain land and for extending or applying all or any of those Regulations to certain other land: Now therefore I, William John Farquhar McDonald, Her Majesty's Minister of Lands in and for the State of Victoria do hereby make the following Regulation.

All the Regulations made on the 16th May, 1955 with respect to the land in the Parish of Myamyn temporarily reserved by Order in Council dated the 10th August, 1954 as a site for Public Recreation are hereby applied to the land in the Parish of Myamyn temporarily reserved by Order in Council dated the 27th February, 1968 as a site for Public Recreation.—(Rs.7287.)

Given under my hand, at Melbourne, on the 6th day of May, 1968.

W. J. F. McDONALD,
Minister of Lands.

Every person who contravenes or fails to comply with these Regulations shall, in accordance with the provisions of section 218 of the *Land Act 1958*, for each offence be liable to a penalty of not more than Fifty dollars, and every person who contravenes or fails to comply with any such Regulations, and who, after he has been warned by any bailiff of Crown lands or by any member of the Police Force, does not desist therefrom may be forthwith apprehended by such Bailiff or member of the Police Force and taken before some justice to be dealt with according to law and shall be liable to a penalty of not more than One hundred dollars.

REGULATIONS FOR THE CARE, PROTECTION AND MANAGEMENT OF THE "NATIMUK SWIMMING POOL RESERVE".

WHEREAS by section 218 of the *Land Act 1958*, the Minister of Lands is empowered to make Regulations with respect to certain land and for extending or applying all or any of those Regulations to certain other land: Now therefore I, William John Farquhar McDonald, Her Majesty's Minister of Lands in and for the State of Victoria, do hereby make the following Regulation:—

REGULATION.

All the Regulations made on the 9th August, 1961, with respect to the land in the Parish of Natimuk, reserved by Order in Council dated the 29th January, 1935, as a site for Public Recreation, are hereby applied to the land in the Parish of Natimuk, reserved by Order in Council dated the 27th February, 1968, as a site for Public Recreation.—(Rs.4433.)

Given under my hand at Melbourne on the 17th day of May, 1968.

W. J. F. McDONALD,
Minister of Lands.

Every person who contravenes or fails to comply with these Regulations shall, in accordance with the provisions of section 218 of the *Land Act 1958*, for each offence be liable to a penalty of not more than Fifty dollars, and every person who contravenes or fails to comply with any such Regulations, and who, after he has been warned by any bailiff of Crown lands or by any member of the Police Force, does not desist therefrom, may be forthwith apprehended by such bailiff or member of the Police Force and taken before some justice to be dealt with according to law, and shall be liable to a penalty of not more than One hundred dollars.

COMMITTEES OF MANAGEMENT OF RESERVES.

APPOINTMENTS.

NOTICE is hereby given that, in pursuance of section 221 of the *Land Act 1958*, the following appointments of Committees of Management of reserved Crown lands have been made by the Minister of Lands:—

"BEEAC RECREATION RESERVE."

Thomas Ford Daffy, Douglas George Grant, Donald Fraser Lang, Joseph Michael Lynch, Malcolm Noel Quick, Graham Thomas Shinnars, Francis Clifton Simpkin, Ronald Francis Simpkin and Bruce Watson as a Committee of Management for a period of three (3) years of the land in the Parish of Ondit deemed permanently reserved for the recreation, convenience or amusement of the people and known as the "Beeac Recreation Reserve".—(Corres. No. Rs.8865.)

"BRIDGEWATER RECREATION RESERVE" AND "BRIDGEWATER PUBLIC PARK RESERVE."

Leslie Reid, Kevin James Poyser, Hugh Thomas Collins, Charles Wray Higgs, John Francis Jenkins, Thomas George Sargent, Edwin Thomas Brooker, Geoffrey John Turpie, Ronald Desmond Rothacker, Arthur Kenneth Collins, Malcolm Thompson and John Hildebrandt Smith as a Committee of Management for a period of three (3) years of the lands in the Township and Parish of Bridgewater permanently reserved by Orders in Council dated the 27th July, 1965 and 28th September, 1965 as sites for Public Recreation and Public Park, and known as the "Bridgewater Recreation Reserve" and the "Bridgewater Public Park Reserve".—(Corres. Nos. Rs.1932, Rs.2337.)

"COBRAM RECREATION RESERVE AND RACECOURSE."

Thomas Henry Stillard, James Cox, John Gerald O'Dwyer, William Horace McPherson, John Haughton Smithers, John Henry Feltham, Norman Alexander Gilmour, John Edward Clarence Radcliffe, George Rowan Bell and Sidney M. Scott as a Committee of Management for a period of three (3) years of the land in the Parish of Cobram temporarily reserved by Orders in Council dated the 6th March, 1896 and 12th December, 1961, as sites for a Racecourse and Public Recreation and known as the "Cobram Recreation Reserve and Racecourse".—(Corres. No. Rs.2162.)

"CRANBOURNE PUBLIC HALL AND GARDENS RESERVE."

Ethel Butcher, Valda Menzies, Ernest James Marriott, John Clarence Finning, Joseph Arthur Cam, Raymond D. Wentworth and William Donald McNab as a Committee of Management for a period of three (3) years of the remaining land in the Township and Parish of Cranbourne temporarily reserved by Order in Council dated the 2nd July, 1958, as a site for a Public Hall and Gardens and known as the "Cranbourne Public Hall and Gardens Reserve".—(Corres. No. Rs.3386.)

"PUBLIC PARK, GARDENS AND RECREATION RESERVE", TOWNSHIP AND PARISH OF EDENHOPE.

Leon Blake Harris, David Gordon McDonald, Noel John Pettit, Ian Ellis Burns, James Leslie Caldwell, Clement Mervyn Hausler, Percy John Neil Wilson, Kevin Roy Walter, Kenneth Edward Forster, Earle Pahl, John Duncan McFarlane, Francis Oswald Sagasser, Alexander Pahl and William Alan Wales as a Committee of Management for a period of three (3) years of the land in the Township and Parish of Edenhope, temporarily reserved by Order in Council dated the 20th February, 1968, as a site for Public Park, Gardens and Recreation purposes.—(Corres. No. Rs.2468.)

"FOSTER RACECOURSE AND RECREATION RESERVE."

Anthony Wilson, Robert James Mitchell, James Lewis Wilson, Stuart William Griffiths, Frank Kenneth Fythe, Thomas Joseph Morgan, Robert James Carruthers, Lawrence Arthur Robertson, Owen Taylor, William Keith Newton, Alfred Edwin Linton and Alfred John Freeman as a Committee of Management for a period of three (3) years of the reserved land in the Township of Foster, Parish of Wonga Wonga South, as indicated by red outline on plan marked F/5.4.65 attached to Lands Department correspondence Rs.880, together with the land temporarily reserved by Order in Council dated the 24th January, 1967, as a site for Racecourse and other purposes of Public Recreation, the whole known as the "Foster Racecourse and Recreation Reserve".—(Corres. No. Rs.880.)

"SEAFORD FORESHORE RESERVE."

Bruce Aitken, Michael Semmens, Reginald Albert Marriott (for a period ending 9th May, 1971), Henry George James Woodley and Fay Nottage (for so long only as they shall continue to be Councillors and the elect of the City of Frankston) and Alfred Watson Read (as representative of the Department of Crown Lands and Survey) as a Committee of Management of such portions of the Crown land in the Parishes of Frankston and Lyndhurst reserved for Public purposes, as are indicated by red colour on plan marked "S/29.4.1937" attached to Lands Department correspondence Rs.4674, together with the area between the high and low water mark bordering such portions, all of which is known as the "Seaford Foreshore Reserve".—(Corres. No. Rs.4674.)

"FRENCH ISLAND RECREATION AND MECHANICS INSTITUTE RESERVES."

John William A. King, Cecil Bernard Duscher, Arthur Edward Tulk, David Michael Thompson, Ernest Harold Thompson, Arthur Griffin and Robert Thompson as a Committee of Management for a period of three (3) years of the land in the Parish of French Island permanently reserved by Order in Council dated the 31st July, 1933, as a site for Public Recreation, together with the land in the same parish temporarily reserved by Order in Council dated the 10th November, 1931, as a site for a Mechanics Institute and Free Library, both areas known together as the "French Island Recreation and Mechanics Institute Reserves".—(Corres. Nos. Rs.4162, Rs.4315.)

"HOPETOUN WEST PUBLIC HALL RESERVE."

Stanley Raymond Donnan, Leslie William Brown, Robert Geoffrey Burdett, Keith Stanley Burdett, James Terence Sheehy, Edwin Albert Solly, Kenneth Graeme Kealey, Lloyd Clarence Poulton, Alfred Lloyd Moyle and Alan Keith Afford as a Committee of Management for a period of three (3) years of the land in the Parish of Cambacanya temporarily reserved by Order in Council dated the 18th August, 1964, as a site for a Public Hall and known as the "Hopetoun West Public Hall Reserve".—(Corres. No. Rs.3475.)

"KERANG EAST PUBLIC HALL AND RECREATION RESERVE."

Geoffrey Herbert Boyd, Laurence Troy, Leo James Hosking, Reginald Keith Salter, L. W. Brown, R. J. Mitchell and N. G. Sewell as a Committee of Management for a period of three (3) years of the land in the Parish of Gannawarra temporarily reserved as a site for Public Hall and Public Recreation by Order in Council dated the 19th June, 1957, and known as the "Kerang East Public Hall and Recreation Reserve".—(Corres. No. Rs.7580.)

"LOY YANG PUBLIC RECREATION RESERVE."

Wilfred Bascombe, Reginald Gaudion, Arthur Silvester, Ralph Spencer, Ralph Greenough, Walter Bates, Kenneth Crawford, Ronald Miles and Basil Mackerell as a Committee of Management for a period of three (3) years of the land in the Parish of Loy Yang temporarily reserved as a site for Public Recreation by Order in Council dated the 6th February, 1968, and known as the "Loy Yang Recreation Reserve".—(Corres. No. Rs.8936.)

"NEERIM SOUTH MECHANICS INSTITUTE."

Hugh Finlay McCay and John Edward Delzoppo (for so long only as they shall continue to be councillors and the elect of the Shire of Buln Buln) and Charles Bell, Ellen Mary Kelliher, Alfred Gustav Sommer, Edmond Joseph Kelliher, Thomas Alan Rhodes, Rita Fanny Wilson, Effie Agnus Rhodes, Molly Kelliher, Nellie Gleeson and Stanislaus Michael Gleeson as a Committee of Management for a period of three (3) years of the land in the Parish of Neerim temporarily reserved by Order in Council dated the 25th October, 1961, as a site for a Public Hall and Library and known as the "Neerim South Mechanics Institute Reserve".—(Corres. No. Rs.8079.)

"NOWA NOWA PUBLIC HALL RESERVE."

Rhonda Taylor, Mary Ann Sinclair, Joan Laura Nelson, Laraine Pearl Jennings, Beryl Mary Bruce, Lloyd Richard Jennings, Jeffrey Alan Jennings, Gladys Rose Kingston, Thomas Arthur Munn and Merle Ashlakoff as a Committee of Management for a period of three (3) years of the land in the Township of Nowa Nowa temporarily reserved by Order in Council dated the 23rd October, 1962, as a site for a Public Hall and known as the "Nowa Nowa Public Hall Reserve".—(Corres. No. Rs.8172.)

"PURNIM MECHANICS INSTITUTE RESERVE."

William McKinnon, James Williams, Keith White, Ken Robinson, Thomas Carter, Thomas Woolley and James Riordan as a Committee of Management for a period of three (3) years of the land in the Parish of Purnim, temporarily reserved by Order in Council dated the 14th October, 1958, as a site for a Public Hall, and known as the "Purnim Mechanics Institute Reserve".—(Corres. No. Rs.7766.)

"RUSHWORTH WILDFLOWER SANCTUARY RESERVE."

Ronald Stewart Rustron, Alfred William Raglus, Arthur Bayes Boulton, Margurite Mary Crute, Angelina Vera Donovan, Heather Jean Wall, Annie Marie Richie Stewart, Doris Gwendoline Boulton, Leo Francis Elliott, Greville Edward Crute, Thomas McKenzie King, Hubert John

Priston Elms, Leonard Charles Coyle and Charles Fleming as a Committee of Management for a period of three (3) years of the land in the Parish of Moora temporarily reserved by Order in Council dated the 1st July, 1952, as a site for a Public Park and the Preservation of Native Flora and known as the "Rushworth Wildflower Sanctuary Reserve".—(Corres. No. Rs.6955.)

"VIEW STREET PUBLIC HALL RESERVE", CASTLEMAINE.

Joseph Maxwell Bouch, Francis Matthew Farnsworth and William James Hodgson (for a period of three (3) years) together with John Stanley Verlin and Keith Elston Lewis (for so long only as they shall continue to be Councillors and the elect of the Council of the Town of Castlemaine) as a Committee of Management of the land in the Parish of Castlemaine temporarily reserved by Order in Council dated the 11th February, 1958, as a site for a Public Hall, and known as the "View Street Public Hall Reserve".—(Corres. No. Rs.7694.)

"YARRARA PUBLIC HALL RESERVE."

Stewart Edward Hards, Stanley Keith Johnson, Barry Howard Fox, Alexander Frederick Boord, Kerwin Morris Matschoss and Neil Frederick Boord as a Committee of Management for a period of three (3) years of the land in the Parish of Yarrara temporarily reserved by Order in Council dated the 17th March, 1936, as a site for a Public Hall, and known as the "Yarrara Public Hall Reserve".—(Corres. No. Rs.4545.)

"CAMPING AND WATER SUPPLY PURPOSES RESERVE",
PARISH OF RATHSCAR.

Theodor James Hanley, Keith Jardine, John Paul Walker, Frank Jardine, John James McArdle, James Richardson, Leslie Cecil Jardine, Duncan Donald McArdle and John Stewart Ross as a Committee of Management for a period ending the 8th November, 1970, of the remaining portions of land in the Parish of Rathscar temporarily reserved by Order in Council dated the 28th October, 1935, as a site for Camping and Water Supply purposes, and as is shown by orange colour on plan marked "R/10.4.1968" attached to Lands Department correspondence Rs.4492.—Corres. No. Rs.4492.)

"KILLARNEY RECREATION GROUND."

Lawrence Shanley (for so long only as he shall continue to be a Councillor and the elect of the Shire of Belfast) and John Lane, Percival Hoy, George Gallagher, William Ryan, Joseph Harrington, Brian Moloney, William G. Gleeson, Leo Mugavin, Kevin Gleeson, Cyril Mahoney, John Gallagher and Thomas Mugavin (for a period of three years) as a Committee of Management of the reserved Crown land in the Parishes of Koroit and Yangery as shown by red cross-hachure, green colour and brown colour on plan marked "K/30.8.1966" attached to Lands Department correspondence C.99926, known as the "Killarney Recreation Ground", and being part of the area reserved as a site for a Public Park.—(Corres. No. C.99926.)

"WESTERN RESERVE", CASTLEMAINE.

The under-mentioned persons in the representative capacity set out hereunder as members of the Committee of Management of the land in the Township of Castlemaine reserved by Order in Council dated the 5th May, 1936, as a site for Public Recreation and Educational purposes and of the land in the Parish of Castlemaine reserved by Order in Council dated the 5th April, 1921, as a site for a District High School, together known as the "Western Reserve"—

Name; Representative Capacity.

Anthony John Nesbit and
J. M. Dalton;
for so long only as each continues to be a
Councillor of the Town of Castlemaine.
Thomas Augustine Kavanagh;
as Headmaster of the Castlemaine High School.
Alexander Cornwell Sinclair;
as Principal of the Castlemaine Technical School.
Ian Grant McDonald,
Henry Alfred Slingo, and
Joseph Maxwell Bouch;
as representatives of the Council of the Castle-
maine Technical School.
Harold Ewing,
Robert Swift, and
Trevor W. Douglas;
as representatives of the Council of the Castle-
maine High School.

This appointment is made in lieu of all previous appointments, in respect of the said land, which are hereby revoked.—(Corres. No. Rs.3445.)

"PUBLIC RECREATION RESERVE", TOWNSHIP OF MARYSVILLE.

Robert Skinner, Charles Gavin Delaney, Sabatino Gianforte and James Frederick Darmody (for so long only as they shall be members of the Marysville Golf Club) and Lewis Henry Potter (for so long only as he shall be a member of the Marysville Angling Club) as a Committee of Management of the land in the Parishes of Granton and Steavenson, Township of Marysville, temporarily reserved by Order in Council dated the 20th February, 1968, as a site for Public Recreation.—(Corres. No. Rs.8943.)

"FERNY CREEK ORNAMENTAL GARDENS."

Arthur Victor Burgess, Harold James Manley, George Barrand Tindale, Keith Henry James, Horace George Bleakley, Ralph Joseph Farnbach and James Clement Faden (for so long only as they shall continue to be members of the Ferny Creek Horticultural Society) as a Committee of Management of the land in the Parish of Monbulk (Ferny Creek) temporarily reserved by Orders in Council dated the 24th September, 1957, and 28th November, 1967, as sites for Ornamental Gardens, and known as the "Ferny Creek Ornamental Gardens".—(Corres. No. Rs.474, Rs.7650.)

"M. K. JOHANSEN MEMORIAL RESERVE."

(Lake Cullulleraine Public Recreation and Camping Reserve.)

The Corporation of the Council of the Shire of Mildura as the Committee of Management of the Crown land in the Parish of Mullroo permanently reserved by Order in Council dated the 8th August, 1967, for Public Recreation and Camping purposes and as is shown by blue border on plan marked "L.C./68/5124" attached to Lands Department correspondence Rs.5124, and known as the "M. K. Johansen Memorial Reserve".—(Corres. No. Rs.5124.)

"PUBLIC PURPOSES (MUNICIPAL DEPOT) RESERVE",
TOWNSHIP OF KANIVA.

The Corporation of the Council of the Shire of Kaniva as the Committee of Management of the land in the Township and Parish of Kaniva temporarily reserved by Order in Council dated the 9th April, 1968, as a site for Public purposes (Municipal Depot).—(Corres. No. Rs.8981.)

"LAKE CULLULLERAINE PUBLIC RECREATION RESERVE",
PARISH OF MULLROO.

The Corporation of the Council of the Shire of Mildura and Rex John Howard (as representative of the State Rivers and Water Supply Commission) as the Committee of Management of the Crown land in the Parish of Mullroo permanently reserved by Order in Council dated the 8th August, 1967, for Public Recreation purposes and as is shown by red colour border on plan marked "L.C./68/5124" attached to Lands Department correspondence Rs.5124, and known as the "Lake Cullulleraine Public Recreation Reserve".—(Corres. No. Rs.5124.)

"PUBLIC RECREATION RESERVE" IN VAUGHAN-STREET, KERANG.

The Corporation of the Council of the Borough of Kerang as the Committee of Management of the land in the Township of Kerang, temporarily reserved by Order in Council dated the 19th March, 1968, as a site for Public Recreation.—(Corres. No. Rs.8967.)

SITE FOR KINDERGARTEN PURPOSES, CORNER OF WINDHAM
AND MURRAY STREETS, KERANG.

The Corporation of the Council of the Borough of Kerang as the Committee of Management of the land in the Township of Kerang temporarily reserved by Order in Council dated the 19th March, 1968, as a site for Public purposes (Kindergarten).—(Corres. No. Rs.8968.)

"CIVIC CENTRE AND HISTORICAL MUSEUM RESERVE",
TOWNSHIP OF KERANG.

The Corporation of the Council of the Borough of Kerang as the Committee of Management of the land in the Township of Kerang temporarily reserved by Order in Council dated the 18th April, 1968, as a site for Public purposes (Civic Centre and Historical Museum).—(Corres. No. Rs.8982.)

W. J. F. McDONALD,
Minister of Lands.

Department of Crown Lands and Survey,
Melbourne, 13th May, 1968.

COMMITTEES OF MANAGEMENT OF RESERVES.

APPOINTMENTS.

NOTICE is hereby given that, in pursuance of section 221 of the *Land Act* 1958, the following appointments of Committees of Management of reserved Crown lands have been made by the Minister of Lands:—

"AVOCA RACECOURSE RESERVE."

Horace Bingham Worthington, Claude Bertram Harrison, Keith Joseph McDonald, William Rigol Schmidt, Noel Vincent Jess and Frederick John Gleisner as a Committee of Management for a period of three (3) years of the land at Avoca, reserved by Order in Council dated the 8th March, 1958, as a site for a Racecourse and other purposes of Public Recreation, and known as the "Avoca Racecourse Reserve".—(Corres. No. Rs.2699.)

"CRESSY AND DISTRICT COMMUNITY CENTRE."

Thomas Wright, Douglas Thomas Nelson, Albert Otto Giddings, Robert Bruce Nelson, John Timothy Keating, Eric Lorraine Nelson, Stewart Reynolds, Joseph Fraser Walker and Colin McLean as a Committee of Management for a period of three (3) years of the land in the Township of Cressy, temporarily reserved by Order in Council dated the 29th November, 1960, as a site for Public Recreation and known as the "Cressy and District Community Centre".—(Corres. No. Rs.7955.)

"DARGO CRICKET GROUND AND RECREATION RESERVE."

Daniel Joseph Phelan, Keith William Scott, William Traill, Vincent Thomas Phelan, Sydney John Treasure, James Stanley Treasure, Neal John Butright and James William Kinley as a Committee of Management for a period of three (3) years of the land in the Parish of Dargo, temporarily reserved by Orders in Council dated the 13th September, 1869, and 22nd January, 1957, as sites for a Cricket Ground and Public Recreation respectively, and together known as the "Dargo Cricket Ground and Recreation Reserve".—(Corres. Nos. Rs.5775, Rs.7448.)

"DARGO MECHANICS' INSTITUTE RESERVE."

Neal John Butright, Daniel Joseph Phelan, Graeme Bernard Spaul, Keith W. Scott, James William Kinley, Sydney John Treasure and Vincent Thomas Phelan as a Committee of Management for a period of three (3) years of the land in the Parish of Dargo, temporarily reserved by Order in Council dated the 3rd November, 1879, as a site for Mechanics' Institute, and known as the "Dargo Mechanics' Institute Reserve".—(Corres. No. Rs.7742.)

"GELLIBRAND RECREATION RESERVE."

John Thomas Denning, Ernest Oliver Denning, William Henry Wilson, Michael John Waffy, Ian Denning, Patrick Noel Waffy, Harry William Arthur Kitt, George Samuel Armistead, Ernest Charles Armistead, Alfred Goldman, John William Clancy and Rex Norman as a Committee of Management for a period of three (3) years of the remaining portion of land in the Parish of Yaughner, Township of Gellibrand, temporarily reserved by Orders in Council dated the 26th October, 1928, and 26th August, 1958, as sites for Public Recreation and known as the "Gellibrand Recreation Reserve".—(Corres. No. Rs.3772.)

"GNOTUK PUBLIC HALL AND LAKE GNOTUK PUBLIC PURPOSES RESERVES."

Rupert Frederick George Jeffs, Ronald Ian McLean, Geoffrey Laurence Cook, Peter Robert Harvey, Cyril Ford Hill, Joseph Denis Ryan, Gordon Donald McLeod, Albert Edward Michael Burkett and Ronald Lindsay Cook as a Committee of Management for a period of three (3) years of the remaining portion of land in the Parish of Colongulac, temporarily reserved by Order in Council dated the 31st March, 1925, as a site for a Public Hall and known as the "Gnotuk Public Hall Reserve" (Rs.3093), together with the remaining portion of land in the Parish of Colongulac, at Lake Gnotuk, temporarily reserved by Order in Council dated the 28th October, 1872, as a site for Public Purposes, as is indicated by red colour on plan marked "C/13.1.53" attached to Lands Department correspondence, Rs.187, and known as the "Lake Gnotuk Public Purposes Reserve".—(Corres. Nos. Rs.187, Rs.3093.)

"LAKE DANAHAR RESERVE", PARISH OF KINNABULLA.

Barry James Rickard, Noel Phillip Lawlor, Edward Glen Lehmann, Brian David Phelan, Reginald Gordon Lehmann, Alan Robert Neville, Donald Lewis Crosbie, John Rickard, Reginald James Taylor and Kenneth W. Rickard as a Committee of Management for a period of three (3)

years of the land in the Parish of Kinnabulla, temporarily reserved by Order in Council dated the 23rd May, 1961, as a site for Public Purposes, and known as the "Lake Danahar Reserve".—(Corres. No. Rs.8037.)

"MIRBOO NORTH RECREATION RESERVE."

William Albert Kerr, Laurence William Pincini, Robert William Burdekin, Albert Greenwood Bright, Maurice James Sellings, May N. Martyn and Robert Henry Bruhn as a Committee of Management for a period of three (3) years of the land in the Township of Mirboo North, permanently reserved by Order in Council dated the 27th July, 1965, as a site for Racecourse, Showground and General Recreation purposes, and known as the "Mirboo North Recreation Reserve".—(Corres. No. Rs.3667.)

"MORGIANA RECREATION RESERVE."

Ralph Slade, Francis Charles Cross, Mervyn Stewart Holmes, Bernard John Kosch, Clifford Kenneth Crozier, Harold Wayne Gould and Edwin Francis Herbert Annett as a Committee of Management for a period of three (3) years of the land in the Parish of Yulecart, temporarily reserved by Order in Council dated the 2nd August, 1960, as a site for Public Recreation and known as the "Morgiana Recreation Reserve".—(Corres. Rs.7959.)

"MT. WALLACE PUBLIC PURPOSES RESERVE."

Donald Keith Marshall, Ivor John Marshall, Arthur Francis Cameron, John Ernest Lloyd, Frederick W. Robertson, Kenneth A. Robertson, Lillas Amelia Robertson, Gladys Jean Cameron and Eva Joyce Connor as a Committee of Management for a period of three (3) years of the land in the Parish of Ballark, temporarily reserved by Order in Council dated the 27th February, 1934, as a site for Public Purposes, and reserved for the additional purpose of Public Recreation by Order in Council of the 22nd June, 1965, and known as the "Mt. Wallace Public Purposes Reserve".—(Corres. No. Rs.4358.)

"MURRAYVILLE RECREATION AND SHOWGROUNDS RESERVE."

Kingsley Charles Lackmann, Harry H. Sporn, Talisker Robert Purdue, Alfred James Tavener, Ronald Sidney Niejalke, Friedrich Wilhelm Kalms, John Joseph Rice, Nelson Archibald Peers, Hedley Albert Parker and Clarence Clement Thurlow as a Committee of Management for a period of three (3) years of the land in the Township of Murrayville, Parish of Danyo, permanently reserved by Order in Council dated the 24th January, 1967, for Public Recreation and Show Grounds, and known as the "Murrayville Recreation and Showgrounds Reserve".—(Corres. No. Rs.2072.)

"NICHOLS ROAD RECREATION RESERVE," PARISH OF MIRBOO.

Maurice Alan Fowkes, George William Mayo, Leonard Mansfield, Jam Kistemalen, Vivian Wallace Bateman, James Walker and William Wareham as a Committee of Management for a period of three (3) years of the land in the Parish of Mirboo, temporarily reserved by Order in Council dated the 10th October, 1967, as a site for Public Recreation, and known as the "Nichols Road Recreation Reserve".—(Corres. No. Rs.8866.)

"PIANGIL RECREATION RESERVE."

Alan J. Branson, Samuel E. Gibson, Daryl H. Rodgers, Leslie James Granger, Reginald Becker Hungerford, Donald William Hayden, Murray Good and James Valentine Roberts as a Committee of Management for a period of three (3) years of the land in the Parish of Piangil, temporarily reserved by Order in Council dated the 15th February, 1955, as a site for Public Recreation, and known as the "Piangil Recreation Reserve".—(Corres. No. Rs.7329.)

"TOOTGAROOK FORESHORE RESERVE."

Mervyn Joseph Drew, Herbert Thomas Cann, Herbert Oliver Clements, Henry Charles Doig and Charles Edward Williams as a Committee of Management for a period of three (3) years of such portion of the Foreshore Reserve in the Parish of Wannanaeue as is shown by green colour on plan marked "W/1.5.1968" attached to Lands Department correspondence Rs.8334 and known as the "Tootgarook Foreshore Reserve".—(Corres. No. Rs.8334.)

"TRAWALLA AND DISTRICT RECREATION RESERVE."

Neil Douglas, John Albert Wallish, Colin McKenzie, Hilton George Dunn, William Robert Broadbent, Kenneth William Mackenzie and David Ernest Vowles as a Committee of Management for a period of three (3) years of the land in the Parish of Livingstone, temporarily reserved by Order in Council dated the 15th July, 1952, as a site for Public Recreation, and known as the "Trawalla and District Recreation Reserve".—(Corres. No. Rs.6965.)

"YALLA-Y-POORA RECREATION RESERVE."

Brian Edmund Joyce, Thomas Brunton Barr, Geoffrey Alec Sim, Kenneth William Waring and Phillip Archibald Atkin as a Committee of Management for a period of three (3) years of the land in the Parish of Yalla-Y-Poora temporarily reserved by Order in Council dated the 13th May, 1952, as a site for Public Recreation, and known as the "Yalla-Y-Poora Recreation Reserve".—(Corres. No. Rs.6911.)

"YARRAWALLA RECREATION RESERVE."

Hedley Arthur Miles, David Leslie Rule, Kenneth William Pickles, Ronald McCallum Hercus, Lyndon John Miles, Harold Oliver Fawcett, Frederick Russell Smith, Stewart Roy Gronow, John Munro Ferguson, Graeme David Hercus, Hugh Victor Aitken and Ronald Frederick Pickles as a Committee of Management for a period of three (3) years of the land in the Parish of Mologa, temporarily reserved by Order in Council dated the 28th November, 1967, as a site for Public Recreation, and known as the "Yarrawalla Recreation Reserve".—(Corres. No. Rs.8900.)

"KENNETT RIVER CAMPING RESERVE."

Joseph Gerard Cassidy, Joseph Philip Cassidy, James Harvey Lyle, William Bennet Boyd, Albert Roy Brobers, Clarence Alfred Gebert, Albert Leslie Russell Cocking, George Edward Morris Cocking, George William Allison, John Dion Maddox and Ronald Albert Larsen as a Committee of Management for a period ending the 25th July, 1968 of the reserved Crown lands in the Parish of Wongarra, as is shown hatched black on plan marked "K.R.4936" attached to Lands Department correspondence Rs.4936, including the land temporarily reserved by Order in Council dated the 16th January, 1968 as a site for Public Purposes (Tourist Camping), together with the frontage on both sides of the Kennett River, permanently reserved for Public Purposes, the whole known as the "Kennett River Camping Reserve".—(Corres. No. Rs.4936.)

"KYABRAM RACECOURSE AND RECREATION RESERVE."

Arthur Alexander Arnel (as representative of the Kyabram Golf Club) in the place of Gordon Alexander Fraser (resigned) as a member of the Committee of Management, for a period ending the 3rd April, 1971, of the land in the Parish of Kyabram East, temporarily reserved by Order in Council dated the 5th December, 1967, as a site for Racecourse and Recreation purposes, and known as the "Kyabram Racecourse and Recreation Reserve".—(Corres. No. Rs.1446.)

"LAKES ENTRANCE FORESHORE RESERVE."

Ronald Sidney Hickman, Rex Owen Fish, George Symons, William Menzies, Ian Rutherford Bulmer, Jon Van den Born, Raymond Gordon Standerwick, John Maxwell Anderson, Naughton Stephen McDonald (for a period ending the 31st October, 1970) and John Kilby, Clem Jones and Clyde James Sykes (for so long only as they continue to be Councillors and the elect of the Council of the Shire of Tambo) as a Committee of Management of the land in the Parish of Colquhoun, as is shown hatched black on plan marked "C/10.4.1968" attached to Lands Department correspondence Rs.3353, and known as the "Lakes Entrance Foreshore Reserve".—(Corres. No. Rs. 3353.)

SITE FOR PUBLIC PURPOSES (SUPPLY OF GRAVEL), PARISH OF BELLAURA.

The Corporation of the Council of the Shire of Stawell as the Committee of Management of the land in the Parish of Bellaura, temporarily reserved by Order in Council dated the 18th April, 1968, as a site for Public Purposes (Supply of Gravel).—(Corres. No. Rs.8977.)

W. J. F. McDONALD,
Minister of Lands.

Department of Crown Lands and Survey,
Melbourne, 17th May, 1968.

LOCAL LAND BOARDS.

IN pursuance of the provisions of section 34 of the *Land Act 1958*, notice is hereby given that public hearings at the following places and times, will be conducted by the persons respectively mentioned, being duly appointed in that behalf.

W. J. F. McDONALD,
Minister of Lands.

Department of Crown Lands and Survey,
Melbourne.

SCHEDULE.

BENDIGO, KENNINGTON PUBLIC HALL, on Wednesday, 5th June, 1968, at 9 a.m.—A. C. Brown and T. A. Comte.

ECHUCA, ECHUCA COURT HOUSE, on Friday, 7th June, 1968, at 10 a.m.—A. C. Brown and T. A. Comte.

AVOCA, LAND INSPECTOR'S OFFICE, Friday, 31st May, 1968, at 9.30 a.m.—D. J. Yurcina.

LOCAL LAND BOARDS.

IN pursuance of the provisions of section 34 of the *Land Act 1958*, notice is hereby given that public hearings at the following places and times, will be conducted by the persons respectively mentioned, being duly appointed in that behalf.

W. J. F. McDONALD,
Minister of Lands.

Department of Crown Lands and Survey,
Melbourne.

SCHEDULE.

ST. ARNAUD, LAND OFFICE, Monday, 27th May, 1968, at 1 p.m.—D. J. Yurcina and E. Kennedy.

TENDERS**PUBLIC WORKS DEPARTMENT**

TENDERS will be received at Public Works Department, Treasury-place, Melbourne, until **TWO** p.m. on dates shown and for purposes mentioned hereunder.

Particulars and tender forms available at Contracts Office, Room 7, Building Division, Parliament-place and at places indicated in brackets hereunder.

Abbreviations in brackets mean:—W.O.—Inspector of Works Office; P.S.—Police Station; C.S.—Consolidated School; H.E.S.—Higher Elementary School; H.S.—High School; S.S.—State School; T.S.—Technical School.

Tenders to be submitted on the Department's printed Tender Form and will not be received by telephone. All tenders must be on a "Firm Tender" basis. The lowest or any tender will not necessarily be accepted.

Address tenders to the Minister of Public Works, and endorse the envelope containing the tender "Tender for closing Tuesday,"

Hand delivered tenders to be placed in the Tender Box of the Public Works Department, located on the wall of the centre entrance foyer, Ground Floor, New Treasury Building, Treasury-place, Melbourne.

No preliminary deposit is required with any tender, but a successful tenderer will be required to pay a deposit for any accepted tender of \$5,000 or over.

Tuesday, 28th May, 1968.

Building, Electrical and Mechanical Works.

Ballarat.—Supply and fix aluminium screens and doors, "Novar" Hospital and "Norwood" Clinic. (W.O., Ballarat.)

Bayswater North.—Renovations, S.S. 4143.

Box Hill.—Extensions and remodelling, Girls' Technical School. (Bills of Quantities Available.)

Box Hill.—Electrical installation, Girls' Technical School.

Box Hill.—Mechanical services, Girls' Technical School.

Box Hill.—Passenger lift installation, Girls' Technical School.

Camperdown.—Renovations, Residence, Court House. (W.O., Camperdown.)
 Footscray.—Renovations, High School.
 Kingsbury.—Erection of six (6) additional class-rooms, S.S. 4845.
 Kingsbury.—Plenum heating, S.S. 4845.
 Melbourne.—Erection of partitions, Head Office, Lands and Survey Department.
 Morwell.—Mechanical services, Technical School. (W.O., Traralgon; T.S., Morwell.) (Re-advertised.)
 Richmond.—New display boards, chalkboards and renovations, S.S. 1567 and Residence.
 Shepparton.—Renovations, Girls' Secondary School. (W.O., Shepparton.)
 Swan Marsh.—New toilets, septic tank, &c., S.S. 3488. (W.O., Camperdown.)

Site Works.

Croydon.—Asphalt, concrete and drainage works, S.S. 2900.
 Doncaster Park.—Asphalt paving, drainage works, &c., S.S. 4861.
 Murrumbeena.—Asphalt, concrete and drainage works, &c., High School.
 Noble Park.—Asphalt, concrete and drainage works, &c., Technical School.

Miscellaneous.

Dookie.—Supply of timber, Agricultural College.
 Kew.—Supply and delivery of one clothes press, Mental Hospital. (Amended Specification.)
 Sunbury.—Supply and delivery of timber, Mental Hospital.
 Various.—Supply of domestic equipment for the period 1st July, 1968, to 30th June, 1969, Schools and other Government Departments.
 Various.—Supply of kitchen equipment for the period 1st July, 1968, to 30th June, 1969, Schools and other Government Departments.

From 1st June, 1968, a deposit will be required for any accepted tender of \$4,000 or over.

Tuesday, 4th June, 1968.**Building, Electrical and Mechanical Works.**

Balmoral.—Erection of combined kitchen and dining room, High School. (Re-advertised.) (W.O., Hamilton.)
 Barfold.—Conversion of septic closets to wet septic tank, S.S. 3424. (W.O., Kyneton.)
 Braybrook.—Modifications to heating system, S.S. 1102.
 Brighton.—Construction of Assembly Hall, Technical School.
 Brighton.—Electrical installation, Technical School.
 Brighton.—Mechanical services, Technical School.
 Brunswick.—Renewal of roof and sanitary fittings, Technical School.
 Burnley Gardens.—Construction of an Incubator Building, Agriculture Department.
 Camberwell.—Renovations, Court House and Police Station and Residence.
 Carlton.—Mechanical services, St. Nicholas Hospital.
 Coburg East.—Renewal of water service and sanitary fittings, S.S. 4260.
 Cocoroc.—New toilet block, S.S. 3230.
 Coolaroo South.—Erection of chain wire fencing, S.S. 4952.
 Eskdale.—Renovations, S.S. 2318. (W.O., Wangaratta.)
 Keon Park.—Renovations, S.S. 4739.
 Keon Park.—Renovations, Technical School.
 Mentone.—Additional class-rooms and toilet block, &c., Girls' High School.
 Mentone.—Electrical installation, Girls' High School.
 Mentone.—Mechanical services, Girls' High School.
 Purrumbete South.—Renovations, Residence, S.S. 1822. (W.O., Camperdown.)
 Shepparton.—Additions and alterations, Residence, 6 St. Andrews-road, Ambermere Hospital. (Re-advertised.) (W.O., Shepparton.)
 Southmoor.—Erection of additional class-rooms, &c., S.S. 4910.
 Southmoor.—Electrical installation, S.S. 4910.
 Southmoor.—Plenum heating, S.S. 4910.
 Strathmerton.—Renovations, &c., Residence, S.S. 2790. (W.O., Shepparton.)
 Sunbury.—Re-bricking of two steam boilers, Mental Hospital. (Amended Specification.)
 St. Albans East.—Connexion to sewerage, S.S. 4741.
 St. Arnaud.—Renovations, S.S. 1646. (W.O., Maryborough.)
 Toolamba.—Renovations, &c., Residence, S.S. 1455. (W.O., Shepparton.) (Amended Specification.)

Furniture and Furnishings.

Parkville.—Supply and fix curtains, "Turana".
 Parkville.—Supply and lay sheet flooring, "Turana".
 Traralgon.—Supply and fix curtains and bedspreads, Hobson Park Hospital. (W.O., Traralgon.)

Site Works.

Alamein.—Asphalt repairs, S.S. 4649.
 Caulfield North.—Asphalt repairs, Central School, 3820.
 Malvern.—Asphalt repairs, S.S. 1604.
 North Melbourne.—Asphalt, concrete and drainage works, &c., Melbourne School of Printing and Graphic Arts.
 Nunawading.—Concrete and drainage works, "Winlaton", Girls' Youth Training Centre.
 Shelley.—Earthworks, drainage and concrete and gravel pavements, S.S. 4538. (W.O., Wangaratta; P.S., Tallangatta.)

Miscellaneous.

Mont Park.—Supply and installation of P.A.X. Unit, Janefield Training Centre.
 Yallourn.—Supply and delivery of a variable compression engine test rig, Technical College.

Tuesday, 11th June, 1968.**Building, Electrical and Mechanical Works.**

Ballarat.—Extension of heating system, Mental Hospital. (W.O., Ballarat.)
 Benalla.—Mechanical services, High School. (W.O., Benalla, Bendigo and Wangaratta.) (Re-advertised.)
 Castlemaine.—Installation of sound system, Technical College. (W.O., Bendigo, Kyneton and Maryborough; T.C., Castlemaine.)
 Keilor.—Renovations, S.S. 1578. (Amended Specification.)
 Mont Park.—Modifications to C and R Wards, Plenty Mental Hospital.
 Mont Park.—Electrical installation, Plenty Mental Hospital.
 Mont Park.—Mechanical services, Plenty Mental Hospital.
 Nhill.—Erection of brick veneer Police Station and Residence. (W.O., Horsham; P.S., Nhill.)
 Nhill.—Electrical installation, Police Station and Residence. (W.O., Horsham; P.S., Nhill.)
 Parkville.—New Science Centre, Secondary Teachers' College. (Specified Bills of Quantities Available.)
 Sydenham.—Renovations, S.S. 3559.
 St. Albans.—Renovations, S.S. 2969.
 Walpeup.—Supply and erection of glasshouse, Research Station. (W.O., Mildura.)
 Walpeup.—Mechanical services, Research Station. (W.O., Mildura.)

Site Works.

Armata.—Asphalt, concrete and drainage works, &c., S.S. 4965.
 Greenwood.—Paving and drainage works, S.S. 4944.

Miscellaneous.

Buxton.—Supply of timber, &c., Youth Camp.
 Coburg.—Maintenance cleaning for the period 1st July, 1968, to 31st May, 1971, Chest Clinic, 93 Bell-street.
 Collingwood.—Maintenance cleaning for the period 1st July, 1968, to 31st May, 1971, Court House and Police Station.
 Melbourne.—Maintenance cleaning for the period 1st July, 1968, to 31st May, 1971, Publications Branch, 19-25 Windsor-place.

Tuesday, 18th June, 1968.**Building, Electrical and Mechanical Works.**

Heidelberg.—Completion of Arthur Rylah Research Institute, Fisheries & Wildlife Branch. (Specified Bills of Quantities Available.)
 Heidelberg.—Electrical installation, Arthur Rylah Research Institute, Fisheries & Wildlife Branch. (Amended Specification.)
 Heidelberg.—Supply and installation of fire alarm system, Arthur Rylah Research Institute, Fisheries & Wildlife Branch.
 Heidelberg.—Supply and installation of 90 line P.A.B.X. telephone system, Arthur Rylah Research Institute, Fisheries & Wildlife Branch.

M. V. PORTER,
 Minister of Public Works.

Public Works Department,
 Melbourne, 3002, 20th May, 1968.

PUBLIC SERVICE NOTICES

No. 3.

Public Service Act 1958, Section 50.
REGULATIONS.—PART IV. SALARIES AND INCREMENTS.

THE Public Service Board, in pursuance of the powers conferred by the *Public Service Act 1958*, hereby amends its Regulations as shown below:—

SIXTH SCHEDULE.
TEMPORARY EMPLOYEES.

Designations of Positions and Rates of Salaries.

Department and Designation of Position.	Yearly Rate of Salary.		Increments (Annual).
	Minimum.	Maximum.	
TREASURY.	\$	\$	

For the expression "116" in the footnote to that part of the Schedule relating to the Government Printing Office insert the expression "159".

This Regulation shall have effect as on and from the 1st May, 1968.

F. E. CAHILL, Chairman.
 V. P. SCULLY, Secretary.

Office of the Public Service Board,
 Melbourne, 10th May, 1968.

EXAMINATION OF APPLICANTS FOR LICENCE AS SHORTHAND WRITER.

IT is hereby notified that an examination of applicants for licence as Shorthand Writer will be held at the Royal Melbourne Institute of Technology, Building No. 1, 124-126 Latrobe-street, Melbourne, on Saturday, the 29th June, 1968, at ten o'clock a.m.

Applications for permission to attend the examination together with an entry fee of two dollars ten cents (\$2.10) must be forwarded to reach the Secretary, Public Service Board, Treasury-place, Melbourne 3002 (where a copy of the Regulations may be obtained), not later than Saturday, the 15th June, 1968.

Satisfactory evidence of—

- (1) Name in full,
- (2) Having attained the age of twenty-one (21) years, and
- (3) Good moral character

should be submitted with application.

By order,
 V. P. SCULLY,
 Secretary.

Office of the Public Service Board,
 Melbourne, 20th May, 1968.

PRIVATE ADVERTISEMENTS

NOTICE is hereby given that Autobody Repairs Pty. Limited has applied for a lease pursuant to Section 134 of the *Land Act 1958* for a term of nine years and six months in respect of allotment 59 J3, City of South Melbourne, Parish of Melbourne South, containing 27 perches as a site for stores, dwellings, warehouses, factories and general engineering works. 2427

I, JOSEPH BACOS GARAN, of "Cherrywoods", Eiseman-road, Yarrambat, in the State of Victoria, school teacher, heretofore called and known by the name of Jozsef Garan, hereby give notice that on the 28th day of April, 1968, I renounced and abandoned the use of my said name of Jozsef Garan, and assumed in lieu thereof the name of Joseph Bacos Garan, so that the names, Bacos Garan shall be treated as a single surname, and further that such change of name is evidenced by a deed dated 28th April, 1968, duly executed by me and attested and filed in the office of the Registrar-General.

Dated the 28th day of April, 1968.

JOSEPH BACOS GARAN.
 (late) Jozsef Garan.

2771

Water Acts.

PROPOSED WOORI YALLOCK-LAUNCHING PLACE WATERWORKS TRUST.

NOTICE is hereby given that the Upper Yarra Shire Council has made application to the Honorable the Minister of Water Supply for the constitution of a Waterworks Trust, and for the proclamation of a Waterworks District at Woori Yallock-Launching Place and the construction, maintenance and continuance of Water Supply Works within that District under the provisions of the Water Acts.

A general plan and description of the proposed works have been submitted with the application, and copies of same may be seen at the Shire Office, at Yarra Junction.

Dated at Yarra Junction the 8th day of May, 1968.
 2691 J. N. EDDY, Shire Secretary.

MOE SEWERAGE AUTHORITY.

PLANS have been prepared for the laying of sewers to serve the following areas.

- Area 1. Saviges-road, Moe C/A 33 and 34 of 1 Moe.
- Area 2. Thompsons-road, Moe, to serve Ritzers poultry farm. This sewer will run through property west of said poultry farm.

These plans are available for inspection during normal office hours at the office of the Authority.

Dated the 16th day of May, 1968.
 2803 A. DEWAR, Secretary.

DANDENONG VALLEY AUTHORITY.

NOTICE OF INTENTION TO DECLARE FLOOD-PRONE AREAS.

UNDER section 27 of the Dandenong Valley Authority Act No. 7060, the Dandenong Valley Authority proposes on or after the 28th June, 1968, to have proclaimed specified areas along the Kilsyth Main Drain from Dorset-road to Colchester-road, being within the District of the Dandenong Valley Authority to be within the flood plain of the Dandenong Creek and its tributaries.

Plans specifying the areas to be proclaimed may be inspected at—

- The Offices of the Authority, 208 Princes Highway, Dandenong.
- The State Rivers and Water Supply Commission, 90 Orrong-road, Armadale.
- The Municipal Offices of the Shire of Croydon.

Any objections to the making of such proclamation made within six weeks of this notice are to be considered by the Dandenong Valley Authority before any such proclamation is made.

Dated the 15th May, 1968.
 By direction of the Authority,
 K. G. ABBERTON, Secretary,
 Dandenong Valley Authority.

2775

FRANKSTON SEWERAGE AUTHORITY.

DECLARATION OF SEWERED AREAS NOS. 4, 5, AND 6.

THE Frankston Sewerage Authority having made provision for carrying off sewage from each and every property which or any part of which is within the sewerage areas hereinafter described doth hereby declare that on and after the first day of June, 1968, each and every property which or any part of which is within the said sewerage areas shall be deemed to be a seweraged property within the meaning of the *Sewerage Districts Act 1958*.

The boundaries of the sewerage areas hereinbefore referred to are:—

AREA No. 4.

Commencing at the corner of Cricklewood-avenue and Dandenong-road East, east along Cricklewood-avenue and Lorraine-street to Swift-street, north along Swift-street to the northern boundary of No. 1 Swift-street, the northern boundary of No. 1 Swift-street, south-east along Wells By-pass road to Francis-street, west along Francis-street to McAlister-street, south along McAlister-street to the southern boundary of No. 30 McAlister-street, the southern boundary of No. 30 McAlister-street, the northern boundary of No. 32 Queen-street, south along Queen-street to Burrow-street, west along Burrow-street to Stanley-street, south along Stanley-street to the northern boundary of No. 5 Stanley-street, the northern boundary of No. 5 Stanley-street, the northern boundary of No. 5 Queen-street, south along Queen-street and Joy-street to the southern boundary of No. 25 Joy-street, southern boundary of 25 Joy-street, southern boundary of No. 4 Rex-street to the north-west corner of Joy-street Kindergarten, along the rear boundaries

of the properties on the west side of Joy-street, the western boundary of 34 Cranbourne-road, west along Cranbourne-road to Melvin-street, south along Melvin-street to the rear boundary of No. 29 Cranbourne-road, the rear boundaries of Nos. 29 to No. 3 Cranbourne-road, from the south-west corner of No. 3 Cranbourne-road west to the Melbourne-Mornington railway line; thence north along the boundary of Area No. 1 to Cricklewood-avenue.

AREA No. 5.

Commencing at the south-west corner of lot 2 Frankston-Dandenong road being approximately 600 feet south-west of Excelsior-drive, along the south-west boundary of lot 2, along the south-eastern boundary of lot 2 to the north-west corner of lot 22 fronting Laurina-crescent, the south-west boundary of lot 22, across Laurina-crescent, along the south-west boundary of lot 120 Laurina-crescent, along the rear of lots 122 to 127 Laurina-crescent, along the rear of lots 88 to 93 Darley-court, along the north-east boundary of lot 95 Excelsior-drive, south-east along Excelsior-drive to Monterey-boulevard, along Monterey-boulevard to lot 1093, western boundary of lot 1093. The northern boundary of lot 1092, north-western boundary of lot 1069 to Juniper-court, along the frontages of lots 1069 to 1066 western boundary of lot 1066, the southern and western boundaries of lot 1051 to Aleppo-crescent, along Aleppo-crescent to western boundary of lot 855 western and northern boundary of lot 855, along the western boundaries of lot 165 to 161 inclusive and 139 Moreton-street, along Moreton-street to the south-west corner of lot 822, western boundary of lot 822, southern boundary of lot 821, western boundary of lot 800, along the frontages of lot 800 to 797 inclusive, western boundary of lot 797, along the southern and western boundaries of lot 784 to Radiata-street, along Radiata-street to Corsican-street, along Corsican-street to the south-west corner of lot 480, along the southern and eastern boundaries of lot 480 to the Frankston-Dandenong road, along the Frankston-Dandenong road to the point of commencement.

AREA No. 6.

Commencing at the south-west corner of lot 2 Frankston-Dandenong road (approximately 600 feet south-west of intersection of Frankston-Dandenong road and Excelsior-drive) along the boundary of Sewerage Area No. 5 to the intersection of Excelsior-drive and Wirilda-crescent, along Wirilda-crescent to the south-east corner of lot 452, along eastern boundary of lots 452, 467, 468, 483, 484 and 501 to Wallowa-crescent, along the eastern boundary of lots 521 and 540 to Mulberry-crescent, along the northern boundary of lots 561 and 576, along the eastern boundary of lot 604, along the rear boundary of lots 604 to 614 inclusive, along the eastern boundary of lot 615 to the Frankston-Dandenong road, along the Frankston-Dandenong road to the point of commencement.

By order of the said Sewerage Authority,

V. S. McCOMB, Chairman.
G. C. PENTLAND, Secretary.

Civic Centre, Frankston. 2788

NOTICE OF INTENTION TO APPLY FOR A LICENCE TO DIVERT WATER AND CUT RACE FROM THE RIVER MURRAY AND BURRA CREEK AT A POINT DOWNSTREAM FROM NYAH.

WE hereby give notice that we intend to apply for a licence empowering us to divert water for a term of 15 years to the extent of 225 acre-feet per annum at a maximum rate of 15 acre-feet per day of 24 hours for the purpose of irrigation of 128 acres 11 perches of all that piece of land being lot 6 on plan of subdivision No. 50817 lodged in the office of titles and being part of allotment 22, Parish of Burra, and to occupy certain Crown lands for works of diversion, and to cut a race thereon.

Any objection to such application must be forwarded in writing to reach the State Rivers and Water Supply Commission, Melbourne, before 21st June, 1968, being 30 days from the first publication of this notice.

Dated the 22nd day of April, 1968.

ROBERT WILLIAM COBURN, of Nyah.
ROBERT NORMAN COBURN, of Nyah.

BRUCE HOLLAND COBURN, of Thurla-street, Swan Hill. 2849

NOTICE OF INTENTION TO APPLY FOR A LICENCE TO DIVERT WATER AND CUT RACE (RE-ISSUE) FROM THE RIVER MURRAY, AT BOUNDARY BEND.

I HEREBY give notice that I intend to apply for a licence empowering me to divert water for a term of four years to the extent of 15 acre-feet per annum at a maximum rate of $\frac{1}{2}$ acre-foot per day of 24 hours for

the irrigation of 5 acres of citrus, being part of allotment 2a, lot 10, Parish of Narrung, and to occupy certain Crown lands for works of diversion, and to cut a race thereon.

Any objection to such application must be forwarded, in writing, to reach the State Rivers and Water Supply Commission, Melbourne, before 21st June, 1968, being 30 days from the first publication of this notice.

GEORGE GREGORY MYERS.

Boundary Bend. 2855

NOTICE OF INTENTION TO APPLY FOR A LICENCE TO DIVERT WATER AND CUT RACE FROM THE NEWLYN RESERVOIR, AT NEWLYN.

I HEREBY give notice that I intend to apply for a licence empowering me to divert water for a term of two years to the extent of 25 acre-feet per annum at a maximum rate of 1 acre-feet per day of 24 hours for the irrigation of an area of 25 acres of land being allotments 1-5, section 2, Township of Bullarook, and to occupy certain Crown lands for works of diversion, and to cut a race thereon.

Any objection to such application must be forwarded, in writing, to reach the State Rivers and Water Supply Commission, Melbourne, before 21st June, 1968, being 30 days from the first publication of this notice.

WILLIAM NEIL SOBEY.

Newlyn North. 2858

NOTICE OF INTENTION TO APPLY FOR A LICENCE TO DIVERT WATER AND CUT RACE (RE-ISSUE) FROM THE RIVER MURRAY, AT TOL TOL, ROBINVALE.

I HEREBY give notice that I intend to apply for a licence empowering me to divert water for a term of four years to the extent of 105 acre-feet per annum at a maximum rate of 4 acre-feet per day of 24 hours for the irrigation of 35 acres of vines and vegetables and citrus, being part of allotment Part 7 (lot 5, L.P.24785), Parish of Tol Tol, and to occupy certain Crown lands for works of diversion, and to cut a race thereon.

Any objection to such application must be forwarded, in writing, to reach the State Rivers and Water Supply Commission, Melbourne, before 22nd June, 1968, being 30 days from the first publication of this notice.

ANTONIOS PSAROLOGOS.

Box 178, Robinvale. 2856

NOTICE OF INTENTION TO APPLY FOR A LICENCE TO DIVERT WATER AND CUT RACE (RE-ISSUE) FROM THE RIVER MURRAY, AT ROBINVALE.

I HEREBY give notice that I intend to apply for a licence empowering me to divert water for a term of four years to the extent of 18 acre-feet per annum at a maximum rate of 1 acre-feet per day of 24 hours for the irrigation of 3 acres of vines and market garden, being part of allotment 33, Parish of Bumbang, and to occupy certain Crown lands for works of diversion, and to cut a race thereon.

Any objection to such application must be forwarded, in writing, to reach the State Rivers and Water Supply Commission, Melbourne, before 15th June, 1968, being 30 days from the first publication of this notice.

ERNEST JOSEPH SMITH.

Goldings Bend, care of P.O. Robinvale, 3549. 2857

NOTICE OF INTENTION TO APPLY FOR A LICENCE TO DIVERT WATER AND CUT RACE (RE-ISSUE) FROM THE RIVER MURRAY, AT KARADOC.

I HEREBY give notice that I intend to apply for a licence empowering me to divert water for a term of four years to the extent of 90 acre-feet per annum at a maximum rate of 3 acre-feet per day of 24 hours for the irrigation of 30 acres, being part of allotment A, Parish of Karadoc, and to occupy certain Crown lands for works of diversion, and to cut a race thereon.

Any objection to such application must be forwarded, in writing, to reach the State Rivers and Water Supply Commission, Melbourne, before 15th June, 1968, being 30 days from the first publication of this notice.

ANDREA FENU.

Box 424, Red Cliffs. 2859

NOTICE OF INTENTION TO APPLY FOR A LICENCE TO DIVERT WATER AND CUT RACE (RE-ISSUE) FROM THE RIVER MURRAY (NARCOOYIA CREEK), AT LAKE POWELL JUNCTION.

I HEREBY give notice that I intend to apply for a licence empowering me to divert water for a term of four years to the extent of 120 acre-feet per annum at

a maximum rate of 3 acre-feet per day of 24 hours for the irrigation of 40 acres of trees, vines, pasture and vegetables, being part of allotment 7A, Parish of Nenandie, and to occupy certain Crown lands for works of diversion, and to cut a race thereon.

Any objection to such application must be forwarded, in writing, to reach the State Rivers and Water Supply Commission, Melbourne, before 15th June, 1968, being 30 days from the first publication of this notice.

DULCIE MAY ENGSTROM.

Per OLAF ENGSTROM.

Private Bag, Piangil.

2790

NOTICE OF INTENTION TO APPLY FOR A LICENCE TO DIVERT WATER AND CUT RACE FROM THE RIVER MURRAY, AT LAKE POWELL JUNCTION.

WE hereby give notice that we intend to apply for a licence empowering us to divert water for a term of three years to the extent of 252 acre-feet per annum at a maximum rate of 3 acre-feet per day of 24 hours for the irrigation of 84 acres of vegetables, pasture, cereal crops, trees and vines, being part of allotment 3, Lake Powell, Parish of Nenandie, and to occupy certain Crown lands for works of diversion, and to cut a race thereon.

Any objection to such application must be forwarded, in writing, to reach the State Rivers and Water Supply Commission, Melbourne, before 14th June, 1968, being 30 days from the first publication of this notice.

JOHN FRANCIS.

MELVA JOAN O'CONNOR.

Robinvale.

2791

NOTICE OF INTENTION TO APPLY FOR A LICENCE TO DIVERT WATER AND CUT RACE FROM THE RIVER MURRAY, AT YUNGERA (BOUNDARY BEND).

WE hereby give notice that we intend to apply for a licence empowering us to divert water for a term of four years to the extent of 900 acre-feet per annum at a maximum rate of 20 acre-feet per day of 24 hours for the irrigation of 300 acres of pasture and lucerne, being allotments 4, 4A, 4B, Parish of Yungera, and to occupy certain Crown lands for works of diversion, and to cut a race thereon.

Any objection to such application must be forwarded, in writing, to reach the State Rivers and Water Supply Commission, Melbourne, before 21st June, 1968, being 30 days from the first publication of this notice.

ARTHUR REGINALD EDWARDS.

NEIL JAMES WILTON.

ARTHUR EDWARDS.

WILLIAM JAMES WILTON.

58 Corrigan-avenue, Brooklyn.

2798

CITY OF CAMBERWELL.

LOAN No. 77.

Notice of Intention to Borrow the Sum of \$150,000 for Permanent Works and Undertakings.

NOTICE is hereby given that the Council of the City of Camberwell proposes to borrow the principal sum of One hundred and fifty thousand dollars (\$150,000) secured by a charge over the general rates of the municipality, such sum to be raised by the grant of a mortgage, in accordance with the provisions of the *Local Government Act 1958*.

1. The maximum rate of interest that may be paid is $5\frac{1}{2}$ per cent. per annum.

2. The purpose for which the loan is to be applied is—Construction of new Civic Centre (part cost)—\$150,000.

3. The period of the loan shall be fifteen years.

4. The moneys borrowed shall be repayable by providing out of the municipal fund half-yearly instalments of approximately \$7,591.19 each, including principal and interest, on the 1st day of February and the 1st day of August during the currency of the loan. The first instalment shall be payable on the 1st day of February, 1969.

5. Such moneys shall be repayable at the Commercial Bank of Australia Ltd., Burke-road, Camberwell.

The plans and specifications and the estimate of the cost of the proposed works, and a statement showing the proposed expenditure of the moneys to be borrowed, are open for inspection at the office of the Council of the City of Camberwell, at the Civic Centre, Camberwell.

Dated 21st May, 1968.

L. F. CHEFFERS, Town Clerk and Chief Administrator.

2776

CITY OF CAMBERWELL.

LOAN No. 76.

Notice of Intention to Borrow the Sum of \$100,000 for Permanent Works and Undertakings.

NOTICE is hereby given that the Council of the City of Camberwell proposes to borrow the principal sum of One hundred thousand dollars (\$100,000) secured by a charge over the general rates, such sum to be raised by a grant of a mortgage, in accordance with the provisions of the *Local Government Act 1958*.

1. The maximum rate of interest that may be paid is 5.875 per cent. per annum.

2. The purpose for which the loan is to be applied is—Construction of new Civic Centre (part cost)—\$100,000.

3. The period of the loan shall be fifteen years.

4. The moneys borrowed shall be repayable by providing out of the municipal fund half-yearly instalments of approximately \$5,061.00 each, including principal and interest, on the 1st day of February and the 1st day of August during the currency of the loan. The first instalment shall be payable on the 1st day of February, 1969.

5. Such moneys shall be repayable to the Commissioners of the State Savings Bank of Victoria at the office of the said Commissioners, corner of Elizabeth and Bourke streets, Melbourne.

The plans and specifications and the estimate of the cost of the proposed works, and a statement showing the proposed expenditure of the moneys to be borrowed, are open for inspection at the office of the Council of the City of Camberwell, at the Civic Centre, Camberwell.

L. F. CHEFFERS, Town Clerk and Chief Administrator.

2777

CITY OF CAMBERWELL.

By-Law No. 167.

Building.

A By-Law of the City of Camberwell made under Section 926 of the *Local Government Act 1958* and the Uniform Building Regulations, Victoria, and numbered 167 for determining dispensing with or regulating certain matters left to be determined applied dispensed with or regulated by the Council of the said City or in respect of which powers are conferred or duties are imposed on the Council under the Uniform Building Regulations, Victoria.

IN pursuance of the powers conferred by the *Local Government Act 1958*, the Uniform Building Regulations, Victoria and any and every other power it thereunto enabling the Mayor, Councillors and Citizens of the City of Camberwell order as follows:—

1. This By-Law shall come into operation and have effect immediately upon its publication in the "*Victoria Government Gazette*".

2. This By-Law shall from the time of its coming into operation be read and construed as one with By-Law No. 115.

3. Clause 2 of By-Law No. 115 is hereby amended by including therein after the words "Schedule A" and "Schedule B" the words "and Schedule A" of By-Law No. 167.

4. Each of the areas of land in the said Municipal District set out and described in "Schedule A" hereto is hereby prescribed as an area of land on which a building or buildings of Class II. Occupancy shall contain in the aggregate not more than the number of flats as set out against the particular area.

5. In this By-Law unless inconsistent with the context or subject matter:—

(a) "Building of Class II Occupancy" has the meaning assigned to that expression in Chapter 6 of the Uniform Building Regulations, Victoria.

(b) "Flat" has the meaning assigned thereto in Chapter 1 of the said Regulations.

(c) "Site" shall have the same meaning as in Clause 815 of the said Regulations.

SCHEDULE "A".

Land—3 High-road, Camberwell—east side, commencing 266 feet north from Toorak-road, being Lot No. 38, having a frontage of 66 feet by varying depths of 309 feet and 309 feet and 9 inches, and being the land more particularly described in Certificate of Title, Volume 8200, Folio 284.—7 flats.

Resolution for passing this By-Law agreed to by the Council the 26th day of February, 1968.

Confirmed the 1st day of April, 1968.

The common seal of the Mayor, Councillors and Citizens of the City of Camberwell was hereto affixed by order of the Council the 1st day of April, 1968, in the presence of—

(SEAL) W. G. BOUNDY, Mayor.
R. EDWIN GILLIES, Councillor.
L. F. CHEFFERS, Town Clerk.

Approved by the Governor in Council, the 7th day of May, 1968.—J. ROSSITER, Clerk of the Executive Council.

2782

CITY OF KEILOR.

LOAN NO. 84.

Notice of Intention to Borrow.

NOTICE is hereby given that the Council of the City of Keilor intends to borrow One thousand dollars (\$1,000) secured by a charge over the general rates of the municipality by the grant of a mortgage in accordance with the provisions of the Local Government Acts.

In connexion therewith the following information is stated.—

- (a) The amount of the principal moneys which it is proposed to borrow is \$1,000.
- (b) The maximum rate of interest that may be paid is \$5.875 per centum per annum.
- (c) The times which the moneys borrowed are to be repayable are the 1st days of February and August, during the years 1969-1983 inclusive, and that the place such moneys shall be repayable is the Commonwealth Savings Bank of Australia, Niddrie.
- (d) The purpose for which the loan is to be applied is:—

Part of Council's proportion of private street schemes	..	\$1,000
--	----	---------

Total ..	\$1,000
----------	---------

- (e) The manner in which the loan is to be liquidated is by provision out of the municipal fund in each half-year, during the currency of the loan the sum of \$50.61, which includes principal and interest.

The plans and specifications and the estimate of the cost of the works and a statement showing the proposed expenditure of the moneys to be borrowed, are open for inspection at the Town Hall.

Dated this 9th day of May, 1968.

2781

R. F. B. KELLY, Town Clerk.

CITY OF NEWTOWN.

LOAN NO. 37.

Notice of Intention to Borrow the Sum of \$52,500 for Permanent Works and Undertakings.

NOTICE is hereby given that the Council of the City of Newtown proposes to borrow the principal sum of Fifty-two thousand five hundred dollars, secured by a charge over the general rates of the municipality, such sum to be raised by the grant of a mortgage, in accordance with the provisions of the Local Government Act 1958.

1. The maximum rate of interest that may be paid is 5.75 per centum per annum.
2. The purposes for which the loan is to be applied are:—

Road and Drainage Works	..	\$30,000
Additional Contribution—Geelong Memorial Swimming Centre	..	5,000
Water Reticulation System—Queen's Park	..	10,000
Extensions to Clubrooms—Elderslie Reserve	..	7,500
		\$52,500

3. The period of the loan shall be ten years.

4. The moneys borrowed shall be repayable by providing out of the municipal fund twenty half-yearly instalments of \$3,488.17 each, including principal and interest, on the 1st day of February and the 1st day of August, during the currency of the loan. The first instalment shall be repayable on the 1st day of February, 1969.

5. Such moneys shall be repayable at the C.B.C. Savings Bank Limited, Melbourne.

The plans and specifications and the estimate of the cost of the proposed works, and a statement showing the proposed expenditure of the moneys to be borrowed, are open for inspection at the office of the Council of the City of Newtown, at the City Hall, Newtown, Geelong.

2812

J. D. BACKWELL, Town Clerk.

CITY OF NUNAWADING.

No. 1308

WHEREAS the Council of the City of Nunawading deems it expedient to exercise its power of taking compulsorily an easement of carriageway over the land described in the Schedule at the foot hereof for the work of undertaking of constructing Cochrane-street for the full width of 50 feet: And whereas the council has caused to be prepared a map and other papers setting out the general description of the work or undertaking for which the land proposed to be taken is to be used the description of the land proposed to be taken and the names of the owners or reputed owners lessees or reputed lessees mortgagees and occupiers of that land so far as those names are known to or can be ascertained by the council: And whereas the said map and other papers are deposited at the office of the said council at Nunawading and are and shall be open for inspection by all persons interested at all reasonable hours for the space of forty clear days after the publication of this notice in the *Government Gazette*: Now notice is hereby given to all persons affected by the proposed taking of the said land to set forth in writing addressed to the Council or the Town Clerk within forty clear days of the publication of this notice in the *Government Gazette* all objections which they may have to the taking of the said land.

SCHEDULE HEREINBEFORE REFERRED TO.

All that piece of land being part of Crown Portion 126, Parish of Nunawading, County of Bourke, and commencing at a point on the southern boundary of Crown Portion 126 a distance of 283 ft. 5 in. east of Glenburnie-road; thence on a bearing of 357 deg. 36 min. for a distance of 71 ft. 3½ in.; thence on a bearing of 350 deg. 51 min. for a distance of 80 feet; thence on a bearing of 81 deg. 2 min. for a distance of 17 feet; thence on a bearing of 170 deg. 51 min. for a distance of 150 ft. 10½ in.; thence on a bearing of 261 deg. 7 min. for a distance of 25 ft. 4¼ in. to the point of commencement.

Dated the 17th day of May, 1968.

By order of the Council.

2865

J. H. BROWN, Town Clerk.

TOWN OF STAWELL.

LOAN NO. 34.

Notice of Intention to Borrow the Sum of \$20,000 for Permanent Works and Undertakings.

NOTICE is hereby given that the Council of the Town of Stawell proposes to borrow the principal sum of \$20,000 secured by a charge over the general rates of the municipality, such sum to be raised by the grant of a mortgage in accordance with the provisions of the Local Government Act 1958.

1. The maximum rate of interest that may be paid is 5.75 per cent. per annum.
2. The purpose for which the loan is to be applied is—

1. Purchase of Road-making Plant	..	\$19,000
2. Heating for Town Hall Supper Room	..	\$1,000

3. The period of the loan shall be ten years.
4. The moneys borrowed shall be repayable by providing out of the municipal fund half-yearly instalments of approximately \$1,329 each, including principal and interest on the 1st day of August and the 1st day of February, during the currency of the loan. The first instalment shall be repayable on the first day of February, 1969.

5. Such moneys shall be repayable to the Commissioners of the State Savings Bank of Victoria at the office of the said Commissioners, corner Elizabeth and Bourke streets, Melbourne.

The plans and specifications and the estimate of the cost of the proposed works and a statement showing the proposed expenditure of the moneys to be borrowed are open for inspection at the office of the Council of the Town of Stawell, at Municipal Offices, Town Hall, Stawell.

L. L. SMITH, Town Clerk.

Dated 8th May, 1968.

2795

TOWN OF STAWELL.

LOAN No. 35.

Notice of Intention to Borrow the Sum of \$6,000 for Permanent Works and Undertakings.

NOTICE is hereby given that the Council of the Town of Stawell proposes to borrow the principal sum of \$6,000 secured by a charge over the general rates of the municipality, such sum to be raised by the grant of a mortgage in accordance with the provisions of the *Local Government Act 1958*.

1. The maximum rate of interest that may be paid is 5.875 per cent. per annum.

2. The purpose for which the loan is to be applied is—

Construction of kerbing and channels in Stawell at Upper Main-street, Fisher-street, Jennings-street, Wimmera-street, Stone-street.

3. The period of the loan shall be fifteen years.

4. The moneys borrowed shall be repayable by providing out of the municipal fund half-yearly instalments of approximately \$304 each, including principal and interest on the 1st day of August and the 1st day of February, during the currency of the loan. The first instalment shall be payable on the first day of February, 1969.

5. Such moneys shall be repayable to the Commissioners of the State Savings Bank of Victoria at the office of the said Commissioners, corner Elizabeth and Bourke streets, Melbourne.

The plans and specifications and the estimate of the cost of the proposed works and a statement showing the proposed expenditure of the moneys to be borrowed are open for inspection at the office of the Council of the Town of Stawell, at Municipal Offices, Town Hall, Stawell.

L. L. SMITH, Town Clerk.

Dated 8th May, 1968.

2796

Town and Country Planning Act 1961 (Twelfth Schedule).

SHIRE OF BARRABOOL—GEELONG PLANNING SCHEME (AMENDMENT No. 3).

NOTICE THAT A PLANNING SCHEME HAS BEEN PREPARED AND IS AVAILABLE FOR INSPECTION.

NOTICE is hereby given that the Shire of Barrabool, in pursuance of its powers under the *Town and Country Planning Act 1961*, has prepared a planning scheme for the purpose of permitting the erection of radio or telecommunications mast subject to the grant of a permit by the responsible authority after taking into consideration the likely adverse effect on the landscape in the Agricultural "A" Zone.

A copy of the scheme has been deposited at the shire office, 441 Moorabool-street, South Geelong, and at the office of the Town and Country Planning Board, 179 Queen-street, Melbourne, and will be open for inspection during office hours by any person, free of charge.

Any persons affected by the planning scheme are required to set forth, in writing, all objections they may have, addressed to the Shire Secretary, 441 Moorabool-street, South Geelong, on or before the 18th June, 1968, and to state whether they wish to be heard in respect of their objections.

2813

G. L. PEARCE, Shire Secretary.

SHIRE OF BELLARINE.

WHEREAS the Council of the Shire of Bellarine deems it expedient to exercise its power of taking compulsorily the land described in the Schedule hereto for a recreation reserve at Newcomb, pursuant to section 511 of the *Local Government Act 1958*, and acquiring the said land for that purpose: And whereas the Council has caused to be prepared a map and other papers setting out the general description of the work or undertaking for which the land proposed to be taken is to be used, the description of the lands proposed to be taken and the names of the owners or reputed owners, lessees or reputed lessees, mortgagees and occupiers of that land so far as those names are known to or can be ascertained by the Council: And whereas the said map and other papers are deposited at the office of the said Council at Drysdale, and are and shall be open for inspection by all persons interested at all reasonable hours for the space of 40 clear days after the publication of this notice in the *Government Gazette*: Now notice is hereby given to all persons affected by the proposed taking of the said land to set forth, in writing, addressed to the Council or the Shire Secretary within 40 clear days of the publication of this notice in the *Government Gazette*, all objections which they may have to the taking of the said land.

No. 45.—4542/68.—4

THE SCHEDULE HEREINBEFORE REFERRED TO.

All that piece of land being lot 40 on plan of subdivision No. 31381, Parish of Moolap, being the balance of the land comprised in certificate of title, volume 8129, folio 934. 2773

SHIRE OF BELLARINE.

WHEREAS the Council of the Shire of Bellarine deems it expedient to exercise its power of taking compulsorily the land described in the Schedule hereto for a recreation reserve at Newcomb, pursuant to section 511 of the *Local Government Act 1958*, and acquiring the said land for that purpose: And whereas the Council has caused to be prepared a map and other papers setting out the general description of the work or undertaking for which the land proposed to be taken is to be used, the description of the lands proposed to be taken and the names of the owners or reputed owners, lessees or reputed lessees, mortgagees and occupiers of that land so far as those names are known to or can be ascertained by the Council: And whereas the said map and other papers are deposited at the office of the said Council at Drysdale, and are and shall be open for inspection by all persons interested at all reasonable hours for the space of 40 clear days after the publication of this notice in the *Government Gazette*: Now notice is hereby given to all persons affected by the proposed taking of the said land to set forth, in writing, addressed to the Council or the Shire Secretary within 40 clear days of the publication of this notice in the *Government Gazette*, all objections which they may have to the taking of the said land.

THE SCHEDULE HEREINBEFORE REFERRED TO.

All that piece of land being lot 20 on plan of subdivision No. 11151, Parish of Moolap, being the balance of the land comprised in certificate of title, volume 6269, folio 334.

Dated the 13th May, 1968.

H. A. WILLIAMS, Shire Secretary.

Shire Office, Drysdale.

2772

SHIRE OF BIRCHIP.

BY-LAW No. 30.

NOTICE is hereby given that the Council of the Shire of Birchip has made a By-Law No. 30, pursuant to the provisions of the *Health Act 1958*, as amended and all other powers it thereunto enabling for the purpose of:

1. Repealing By-Law No. 27.

2. Prescribing fees to be charged for registration, annual renewal of registration, and transfer of registration of premises and food vending machines.

A copy of the By-Law is open for inspection, free of charge, during office hours, at the Shire Office, Cumming Avenue, Birchip.

2780

WALTER J. McQUILLEN, Shire Secretary.

SHIRE OF CROYDON.

LOAN No. 74.

Notice of Intention to Borrow.

NOTICE is hereby given that the Council of the Shire of Croydon intends to borrow Fifty Thousand Dollars (\$50,000) secured by a charge over the general rates of the Municipality by the grant of mortgage in accordance with the provisions of the *Local Government Acts*.

In connexion therewith the following information is stated:—

(a) The amount of the principal moneys which it is proposed to borrow is Fifty Thousand Dollars (\$50,000).

(b) The maximum rate of interest that may be paid is \$5.75 per centum per annum.

(c) The times which the moneys borrowed are to be repayable are the 1st day of March, 1969, and the 1st days of March and September during the years 1969–1978 inclusive and that the place such moneys shall be repayable is at the Bank of New South Wales, Croydon.

(d) The purpose for which the loan is to be applied is:—

Purchase and development of Reserves and Public Open Spaces \$50,000

(e) The manner in which the loan is to be liquidated is by provision out of the municipal fund in each half-year during the currency of the loan of the sum of \$3,322.06 which includes principal and interest.

The plans and specifications and estimate of the cost of the works and a statement showing the proposed expenditure of the moneys to be borrowed are open for inspection at the Shire Offices.

Dated this 21st day of May, 1968.

2808 K. A. McKAY, Shire Secretary.

SHIRE OF CROYDON.

NOTICE OF INTENTION TO TAKE LAND COMPULSORILY.

NOTICE is given that it is the intention of the Council of the Shire of Croydon in exercise of the powers conferred on it by the *Local Government Act 1958* to take compulsorily all that piece of land being Part Crown allotment 25b, Parish of Ringwood (Benson-road).

1. The said land is required for, and it is proposed to take it compulsorily for the purpose of executing the work or undertaking by the said Council of providing Public Open Space.

2. The said council has caused to be prepared maps and other papers showing a general description of the said work or undertaking, a description of the land to be taken and that the owners of the said land are:—

Est. Reginald John Monichon and Madeline Alice Monichon.

3. The said maps and other papers have been approved by the said council and are now deposited for inspection by all persons affected by the proposed taking of the said land at the office of the Shire of Croydon situate in Railway-crescent, Croydon, during office hours.

4. All persons affected by the proposed taking of the said land are hereby required to set forth in writing addressed to the said council or the municipal clerk thereof within forty clear days of the publication of this notice in the *Government Gazette* all objections which they may have to the taking of the said land.

Dated this 21st day of May, 1968.

2809 K. A. McKAY, Shire Secretary.

SHIRE OF DUNDAS.

WATER ACT.

Proposed Shire of Dundas Waterworks Trust.

NOTICE is hereby given that the Council of the Shire of Dundas has made application to the Honorable the Minister of Water Supply for the constitution of a Waterworks Trust, and for the proclamation of a Waterworks District at Cavendish and for the construction, maintenance, and continuance of Water Supply Works within that District under the provisions of the Water Act.

A general plan and description of the proposed works have been submitted with the application, and copies of same may be seen at the office of the council, Market-place, Hamilton.

Dated at Hamilton the 2nd day of May, 1968.

2679 J. R. MITCHELL, Shire Secretary.

SHIRE OF HAMPDEN.

NOTICE is hereby given that Mr. William Robert Sheedy has been appointed by the council of the Shire of Hampden to carry out the duties of ranger, impounding officer and officer to administer the provisions of the Dog Act, with authority to collect dog registration fees throughout the Shire of Hampden, and impound any stock trespassing on any road or land under the control of the council within the boundaries of the Shire of Hampden.

Shire Office, Camperdown, Victoria, 17th May, 1968.

2802 S. J. GRIMMER, Shire Secretary.

SHIRE OF SHERBROOKE.

APPOINTMENT OF PROSECUTING OFFICER.

NOTICE is hereby given that the Council of the Shire of Sherbrooke has appointed Senior Constable Neil Evans, 10571, of Emerald Police Station, as a Prosecuting Officer for the Shire of Sherbrooke, in lieu of Senior Constable John Dean Booker, 10807.

2784 A. JONES, Shire Secretary.

SHIRE OF SHERBROOKE.

NOTICE OF INTENTION TO ACQUIRE LAND COMPULSORILY.

WHEREAS the Council of the Shire of Sherbrooke deems it expedient to exercise its powers of taking land compulsorily for the purpose of creating a drainage easement, and whereas in the opinion of Council such compulsory taking of land is necessary and desirable.

Notice is hereby given as follows:—

1. The Council intends to acquire a drainage easement 6 feet wide along the whole of the northern boundary of lot 10, L.P. 7133, Railway-place, Belgrave, being part of Crown allotment 70J, Parish of Narree Worrان, for the purpose of construction of an outfall drain.

2. The Council has caused to be prepared maps and other papers describing the proposed work or undertaking and the land proposed to be taken, together with the name of the owner, or reputed owner in so far as this can be ascertained by Council.

3. Such maps and other papers are deposited at the Shire Offices, Glenfern-road, Upwey, and shall be kept open for inspection by all persons interested at all reasonable hours for the space of 40 clear days after publication of this notice in the *Government Gazette*.

4. All persons affected by the proposed taking of the land are hereby called to set forth, in writing, addressed to the Council or the Shire Secretary of the Shire of Sherbrooke within 40 clear days from the publication of this notice in the *Government Gazette*, all objections which they may have to the taking of the said land.

Dated the 16th day of May, 1968.

By order of the Council.

2783 A. JONES, Shire Secretary.

SHIRE OF SOUTH BARWON.

NOTICE is hereby given that in pursuance of the powers conferred by the *Local Government Act 1958* the Council of the Shire of South Barwon at a meeting held on 7th May, 1968, ordered that the name of the following road within the municipal district be changed—

Old Name; New Name; Location.

Byambee-crescent, Grovedale; Byambee-court, Grovedale. Part of Crown allotments 13 and 14, Parish of Duneed, County of Grant.

A. A. N. DEED, Shire Secretary.

Shire Hall, Belmont. 2787

SHIRE OF WANGARATTA.

APPOINTMENT OF PROSECUTING OFFICER.

NOTICE is hereby given that Senior Constable Lewis William Wilson, No. 12195, was appointed Prosecuting Officer to the Shire of Wangaratta at a meeting of Council held on 20th March, 1968.

2863 B. J. HALLINAN, Shire Secretary.

SHIRE OF WIMMERA.

BY-LAW No. 15.

A By-law of the Shire of Wimmera made under the Local Government Acts and the Uniform Building Regulations of Victoria and numbered 15, for determining, applying, dispensing with or regulating such matters or things as are left to be determined, applied, dispensed with or regulated by the Council of the said Shire under the Uniform Building Regulations of Victoria.

IN pursuance of the powers conferred by the Local Government Acts and the Uniform Building Regulations of Victoria and of any and every power it thereunto enabling, the President, Councillors and Ratepayers of the Shire of Wimmera order as follows:—

1. OPERATION.

This By-law shall apply to and have operation to that part of the Municipal District of the Shire of Wimmera defined hereunder:—

Horsham and Dooen area.

All of that area enclosed by a line commencing at the north west corner of allotment 170 Parish of Vectis East thence easterly to the south east corner of allotment 24 Parish of Dooen thence north east to the north east corner of allotment 20 of Parish of Dooen thence westerly to the south west corner of allotment 60 of that Parish thence northerly to the north west corner of the above allotment thence easterly to the north west corner of allotment 62 Parish of Dooen, southerly to the south west corner of that allotment, south easterly to the north east corner of allotment 114A Parish of Dooen, southerly to the Wimmera river thence generally westerly along the Wimmera River to the north east corner of allotment 30 of the Parish of Horsham thence southerly to the south east corner of allotment 55 Parish of Bungalally thence westerly to the boundary of the Shire of Wimmera with the Shire of Arapiles thence north easterly along this boundary to the boundary of the Shire of Wimmera with the City of Horsham thence easterly along the southern boundary,

northerly along the eastern boundary and westerly along the northern boundary between the City of Horsham and Shire of Wimmera to the southern corner of allotment 170 Parish of Vectis East, thence north westerly to the starting point at the north west corner of this allotment.

Jung area.

The area contained within Crown Allotments 117, 151, 116 and 8B Parish of Jung Jung.

Pimpinio area.

The area contained within the Township of Pimpinio, Parish of Wail.

2. MINIMUM AREA, DEPTH AND WIDTH OF FRONTAGE.

The minimum area, depth and width of frontage specified in column 3 of Table 804 of the Uniform Building Regulations of Victoria, are hereby adopted as the minimum area, depth and width of frontage of land on which a building of Class 1 or Class 2 occupancy as defined by the said Uniform Building Regulations of Victoria, shall be constructed.

3. MINIMUM DISTANCE OF OUTER WALLS FROM BOUNDARY.

(a) The minimum distance from the frontage of any land of the outer walls of any building of Class 1 or Class 2 occupancy as defined by the Uniform Building Regulations of Victoria, shall be 25 feet.

(b) The minimum distance from boundaries other than frontage of outer walls of any building of Class 1 or Class 2 occupancy as defined by the Uniform Building Regulations of Victoria shall be as specified in Column 3 of Table 804 of the said Uniform Building Regulations of Victoria.

The Resolution for passing this by-law was agreed to by the Council of the Shire of Wimmera on the 9th day of February, 1968, and confirmed on the 8th day of March, 1968.

The common seal of the President, Councillors and Ratepayers of the Shire of Wimmera was affixed hereto, this 8th day of March, 1968, in the presence of—

W. L. HUF, Shire President.
J. D. MCINTYRE, Councillor.
K. H. LOVETT, Shire Secretary.

Approved by the Governor in Council, the 18th day of April, 1968.—J. ROSSITER, Clerk of the Executive Council. 2770

SHIRE OF WINCHELSEA.

By-Law No. 61.

A By-Law of the Shire of Winchelsea made under Section 197 of the Local Government Act 1958 and numbered 61 for the purpose of regulating the keeping of animals and limiting the number of animals kept on any property.

IN pursuance of the powers conferred by the Local Government Act 1958 the President, Councillors and Ratepayers of the Shire of Winchelsea order as follows:—

1. No person shall keep, or permit to be kept, on any property more than two dogs without the consent in writing of the council.

2. Every person who shall by any wilful act or default be guilty of any breach of the provisions of this By-Law shall be liable to a penalty of not more than Forty Dollars and in the case of a continuing offence to a penalty of not more than Ten dollars for each day on which such offence is continued after a conviction by any court.

3. This By-Law shall apply to and have operation throughout the following parts of the municipal district, that is to say, the townships of Winchelsea, Birregurra and Lorne.

The resolution for passing this By-Law was agreed to by the Council of the Shire of Winchelsea on the Thirteenth day of December, 1967, and confirmed on the Fourteenth day of February 1968.

The common seal of the President, Councillors and Ratepayers of the Shire of Winchelsea was affixed hereto in the presence of—

GEO. BENNETT, President.
COLIN F. WORLAND, Councillor.
W. K. MATHISON, Shire Secretary.

Approved by the Governor in Council on the 7th day of May, 1968.—J. ROSSITER, Clerk of the Executive Council. 2800

NOTICE is hereby given that the partnership heretofore subsisting between the undersigned Rodger. Walter Bullock and Peter Hyam Williams, carrying on in business as footwear manufacturers, at lot 4, Dorset-road, Bayswater, under the firm name of "Peter Rodgers Footwear" has been dissolved as from 7th May, 1968, so far as concerns the said Rodger Walter Bullock, who retires from the said firm.

Dated this 7th day of May, 1968.

R. W. BULLOCK.
P. H. WILLIAMS.

2876

NOTICE is hereby given that the partnership between Rachel Birati, of 4 Seattle-street, Balwyn, in the State of Victoria, and Ruby Levin, of 37 Coleman-avenue, North Kew, in the said State, carrying on business at 14 (12) Woolacott-street, Coburg, under the firm name of "Austral Synthetic Fabrics", has been dissolved by mutual consent as from the 6th day of May, 1968, and from that date the said Ruby Levin continued to carry on the said business under the firm name of "Austral Synthetic Fabrics". All debts due and owing by the said firm will be received and paid respectively by the said Ruby Levin, who will carry on the said business in the firm name of "Austral Synthetic Fabrics".

Signed, sealed and delivered by the said Rachel Birati, in the presence of—

T. LEVIN.

Signed, sealed and delivered by the said Ruby Levin, in the presence of—

M. BIRATI.

2793

NOTICE is hereby given that the partnership heretofore subsisting between Bert Osborne Stagg, of Taylor's-lane, Rowville, and Frank Leslie Stagg, of 15 Hakeville-avenue, Nunawading, carrying on business at 926 North-road, East Bentleigh, as gold and silver leaf beaters under the name of "Australian Leaf & Foils" has been dissolved by mutual consent as from the 20th day of September, 1967, by the retirement of the said Frank Leslie Stagg from the said firm on that date. All debts due to and owing by the said firm shall be received and paid by the said Bert Osborne Stagg, who will continue to carry on the business under the same firm name at 926 North-road, East Bentleigh, Victoria. 2837

NOTICE OF DISSOLUTION OF PARTNERSHIP.

NOTICE is hereby given that the partnership heretofore subsisting between the undersigned, Kensington (Aust.) Proprietary Limited, of 55 Princes-street, Preston, in the State of Victoria, and Permar Pigments Proprietary Limited, of 28 Parkers-road, Parkdale, in the said State, carrying on trading activities at 55 Princes-street, Preston, in the said State, and 28 Parkers-road, Parkdale, in the said State, under the name of Kensington (Aust.) Proprietary Limited No. 2 has been dissolved by mutual consent as from the 14th day of October, 1967. All debts due and owing by the said late firm will be received and paid by the said Kensington (Aust.) Proprietary Limited and Permar Pigments Proprietary Limited equally. 2844

Dated the 15th day of May, 1968.

NOTICE is hereby given that the partnership of Douglas Alan Wright and Lorna Madeline Wright, both of 11 Wongella-court, Aspendale, and Ronald William MacCormack, and Beverley Ellen MacCormack, both of 45 Saniky-street, North Clayton, trading as Doug Wright Motors, at 211-213 Hoddle-street, Collingwood, is dissolved with effect from the 30th day of April, 1968.

D. A. WRIGHT.
L. M. WRIGHT.
R. W. MACCORMACK.
B. E. MACCORMACK.

Wm. Murray & Son., solicitors, 422 Collins-street, Melbourne. 2850

P. STUBLEY AND SON PROPRIETARY LIMITED.
(IN LIQUIDATION).

NOTICE is hereby given that at an Extraordinary General Meeting of the members of the above-named company, held on the 16th day of May, 1968, it was resolved that the company be wound up voluntarily; and at a meeting of creditors held on the same day pursuant to section 260, it was resolved that for such purpose, John Rezak, of 224 Queen-street, Melbourne, public accountant, be appointed liquidator.

Dated this 20th day of May, 1968.

2867 JOHN REZAK, Liquidator.

Unclaimed Moneys Act 1962.

REGISTER of Unclaimed Moneys held by the—

Name of Owner on Books and Last Known Address.	Total Amount Due to Owner.	Description of Unclaimed Moneys.	Date when Amount first became Payable.
§			
ANSETT TRANSPORT INDUSTRIES LIMITED.			
Adam, William Leslie, (address unknown)	21.00	Ordinary Dividend No. 46 ..	2.12.66
Baumanis, Roberts Voldemars, 726 Mt. Alexander-road, Moonce Ponds	15.40	" " " " ..	" "
Bofinger, Rosena E. (Mrs.), 58 Empire-street, Haberfield, N.S.W. ..	26.67	" " " " ..	" "
Brown, William E., 15 Westbourne-street, East Prahran	10.00	" " " " ..	" "
Cooke, Amy M. (Mrs.), 21 Chellcove-road, Neutral Bay, N.S.W. ..	32.00	" " " " ..	" "
Curtis, Mary J. C. (Mrs.), (address unknown)	19.82	" " " " ..	" "
Desmat Investments Pty. Ltd., 605 ^B Latrobe-street, Ballarat	27.50	" " " " ..	" "
Flanagan, Patrick, (address unknown)	12.50	" " " " ..	" "
Glenwood Ltd., c/o C. J. Helman, 42 Le Fevre-terrace, North Adelaide, S.A.	17.82	" " " " ..	" "
Hickey, Gerald J., 86 Lyndhurst-street, Richmond	165.10	" " " " ..	" "
Ingram, William R., "Moonbiana", Wagga Wagga, N.S.W.	19.20	" " " " ..	" "
Knossew, Isador Sigmund, (estate of) c/o T. G. D. Marshall, Lands and Co., 251-153 George-street, Sydney, N.S.W.	12.50	" " " " ..	" "
Krug, Heidi E. Gross, (Mrs.), Victoria Gardens, 206 Victoria-road, Bellevue Hill, N.S.W.	27.50	" " " " ..	" "
Lander, Christopher J., 126 Flinders-lane, Melbourne	11.00	" " " " ..	" "
Levison, Millicent (Mrs.), (address unknown)	13.87	" " " " ..	" "
MacKinnin, Jessie (Miss), 8 Augusta-street, Concord, N.S.W.	10.00	" " " " ..	" "
Mallen, Robert H., 41 Eight-avenue, Campsie, N.S.W.	20.62	" " " " ..	" "
Meadows, Thomas Joseph, (address unknown)	10.00	" " " " ..	" "
Mitchell, Emma M. F. (estate of), c/o H. Wiltshire, Webb, Son and Doyle, 4 Castlereagh-street, Sydney, N.S.W.	12.80	" " " " ..	" "
Moore, Grace L. (Mrs.), 8 Mimosa-drive, Vale Park, S.A.	13.75	" " " " ..	" "
Mufson, William E., c/o Harris Park Post Office, Harris Park, N.S.W. ..	128.30	" " " " ..	" "
Muhleisen, Lewis F., 39 Temple-street, Victoria Park, W.A.	11.00	" " " " ..	" "
Murray, Bessie (Mrs.), 42 French-street, Maroubra, N.S.W.	136.80	" " " " ..	" "
Nolan, Marjorie J. (Mrs.), (address unknown)	18.40	" " " " ..	" "
O'Sullivan, Cora Daisy (Mrs.), (address unknown)	20.40	" " " " ..	" "
Paine, Noelene Moyra (Mrs.), 8 Coronet-street, Flemington	10.00	" " " " ..	" "
Robinson, Alexandra M., 12 Head-street, Strathmore	10.30	" " " " ..	" "
Satchell, John L., 420 North-road, Ormond	20.00	" " " " ..	" "
Sexton, Patrick John, (address unknown)	10.00	" " " " ..	" "
Tangible Securities Ltd., G.P.O. Box 4276, Sydney, N.S.W.	522.50	" " " " ..	" "
McDonald, Lennan R., P.O. Box 1024, Auckland, N.Z.	21.25	" " " " ..	" "
Paterson, Andrew M., c/o Spence and Patterson, P.O. Box 11, Blenheim, N.Z.	42.50	" " " " ..	" "
Skinner, John, P.O. Box 1205, Dunedin, N.Z.	41.44	" " " " ..	" "
Torrance, Arthur S., 1215 Dominion-road, Auckland, N.Z.	23.38	" " " " ..	" "
Wiener, Ascher, P.O. Box 1912, Wellington, N.Z.	18.27	" " " " ..	" "
Wills, Morris W., c/o Dept. of Industries and Commerce, Private Bag, Wellington, N.Z.	34.00	" " " " ..	" "
McCallum, A. (Miss), (address unknown)	14.05	" " " " ..	" "
Jacques, Ernest P. (estate of), Marys Hope-road, Rosetta, Tas. ..	10.00	Preference Dividend No. 40 ..	30.4.66
Barry, Albert Thomas H., Unit 2, 52 Maude-street, North Balwyn ..	15.00	Preference Dividend No. 41 ..	31.10.66
Barry, Albert Thomas H., Unit 2, 52 Maude-street, North Balwyn ..	50.00	" " " " ..	" "
Barfield, John G., c/o Mrs. Lois J. Barfield, Walkerston via Mackay, Qld.	17.50	Note Interest No. 12	31.12.65
King, Winifred M. (Mrs.), Vermont, Bell, Qld.	17.50	" " " " ..	" "
McGregor, Alan S., 56 Albert-street, Ashburton, Canterbury, N.Z. ..	33.25	" " " " ..	" "
Slinner, John K., P.O. Box 1205, Dunedin, N.Z.	10.52	" " " " ..	" "
Darling, Margaret F. (Mrs.), 193 Domain-road, South Yarra	70.00	Note Interest No. 13	30.6.66
Williams, Gordon A., 1 Leslie-road, Essendon	19.08	" " " " ..	" "
Mallard, Flora C. (Mrs.), 53 Bombay-street, Wellington, N.Z.	16.64	" " " " ..	" "
Skinner, John K., P.O. Box 1205, Dunedin, N.Z.	10.52	" " " " ..	" "
Brown, Ernest E., 15 Leader-avenue, Toorak Gardens, S.A.	20.00	Deposit Interest No. 28 ..	31.3.66
Chivell, Mary A. L. (Mrs.), P.O. Box 2, Rosebery	82.50	" " " " ..	" "
Keene, Leonard J. (estate of), c/o McDonnell and Moffit, G.P.O. Box 512, Sydney, N.S.W.	40.00	" " " " ..	" "
Kennedy, William, 53 Mair-street, Ballarat,	21.25	" " " " ..	" "
Matthews, Joseph C., (address unknown)	42.50	" " " " ..	" "
Powys, Mabel V. (Mrs.), c/o Mrs. P. M. Cawsey, 10 Virginia-street, Mt. Waverley	78.75	" " " " ..	" "
Rzepka, Kazimir, 95 Frederick-street, Welland, S.A.	41.25	" " " " ..	" "
Skerman, Thora M. (Mrs.), 717 Ruthven-street, Toowoomba, Qld. ..	37.50	" " " " ..	" "
Trewin, Norman R., 50 Briggs-street, Caulfield	21.25	" " " " ..	" "
Warren, Evelyn A. (Miss), c/o Giles Magarey and Lloyd, 97 King William-street, Adelaide, S.A.	18.75	" " " " ..	" "
Scott, Alexander, 204 King Georges-road, Lakemba, N.S.W.	37.50	" " " " ..	" "
Ellacott, Emily E. (estate of), c/o F. C. Petrie and Son, 375-377 George-street, Sydney, N.S.W.	16.25	Deposit Interest No. 29 ..	30.6.66
Hunt, Ivan., c/o W. C. and L. C., Darlington Point, N.S.W.	41.25	" " " " ..	" "
Matthews, Joseph C., (address unknown)	42.50	" " " " ..	" "
Ellacott, Emily E. (estate of), c/o F. C. Petrie and Son, 375 George-street, Sydney, N.S.W.	16.25	Deposit Interest No. 30 ..	30.9.66
Hunt, Ivan, (address unknown)	41.25	" " " " ..	" "
Matthews, Joseph C., (address unknown)	42.50	" " " " ..	" "
Mitton, Ruth W. L. (Mrs.), c/o J. S. Shepherd and Son, 16 Rechabite Chambers, Victoria Square, Adelaide, S.A.	21.25	" " " " ..	" "
Reid, Thelma J. (Mrs.), 31 Gallipoli-road, Coffs Harbour, N.S.W. ..	17.00	" " " " ..	" "
Smith, Thomas Joseph, 35 Princes-street, Brighton Le Sands, N.S.W. ..	16.00	" " " " ..	" "
Stainforth, Douglas K., No. 1 B.E.T.S., R.A.A.F., Point Cook	32.00	" " " " ..	" "

Unclaimed Moneys Act 1962.

REGISTER of Unclaimed Moneys held by the—

Name of Owner on Books and Last Known Address.	Total Amount Due to Owner.	Description of Unclaimed Moneys.	Date when Amount first became Payable.
\$			
ANSETT TRANSPORT INDUSTRIES LIMITED—continued.			
Bray, Alfred, Channel Highway, Kingston, Tas.	28.00	Deposit Interest No. 31	31.12.66
Burns, Harold J., 21 Sutherland-crescent, Darling Point, Sydney, N.S.W.	40.00	" " " "	" "
Cooper, Charlotte E. (Miss), 76 Marion-street, Bankstown, N.S.W.	12.75	" " " "	" "
Hunt, Ivan, (address unknown)	41.25	" " " "	" "
Matthews, Joseph C., (address unknown)	42.50	" " " "	" "
Morton, Roy E., c/o Mrs. R. H. Morton, Three Picnic Bay, Magnetic Island, Townsville, Qld.	26.00	" " " "	" "
Preece, Robert W. A., 22 Reddie-street, Henley Beach, S.A.	26.00	" " " "	" "
R.S.S. and ALLA, Lae Sub Branch, Lae, T.P.N.G.	10.00	" " " "	" "
Storey, Doris, (Mrs.), Toolern Vale	21.25	" " " "	" "
Townsend Olive, (Mrs.), 12 Glen-street, Bondi, N.S.W.	70.00	" " " "	" "
Walsh, Selinda (Mrs.), 23 Clarendon-street, Frankston	24.50	" " " "	" "
Wilson, Neil D., c/o Mrs. Arrowsmith, Otway-street, Holland Park, Brisbane, Qld.	17.50	" " " "	" "
Woodman, Alberta (Miss), 528 Fitzgerald-street, North Perth, W.A.	22.50	Debenture Issue No. 4	31.8.66
Matthews, Joseph C., 17 Derowie-avenue, Homebush, N.S.W.	75.00	" " " "	" "
Siojo Paz V. (Miss), c/o The Good Shepherd Convent, Leederville, W.A.	67.86	" " " "	" "
Adam, William Leslie, (address unknown)	21.00	Ordinary Dividend No. 44	3.12.65
Causley, Earl Raymond, Police Station, Goulburn, N.S.W.	12.50	" " " "	" "
Chick, Halbart J. M., 6/320 Beaconsfield-parade, St. Kilda	25.00	" " " "	" "
Chisholm, Bettie M. (Miss), c/o 91 Gipps-street, East Melbourne	18.55	" " " "	" "
Cooper, Nellie I. (Mrs.), 9 Norfolk-street, Killara, N.S.W.	15.00	" " " "	" "
Corbett, James, "Strathmore", Dulacca, Qld.	37.50	" " " "	" "
Cowan, Effie H. (Lady), c/o Exec. Trustee and Agency Co. of S.A., 22 Grenfell-street, Adelaide, S.A.	31.25	" " " "	" "
Cunnington, Alfred Ernest, 133 Hume-street, Toowoomba, Qld.	75.00	" " " "	" "
Curtis, Mary J. C. (Mrs.), 76 Elizabeth Bay-road, Elizabeth Bay, N.S.W.	19.82	" " " "	" "
Danougaras, Demetrios, 32 Blyth-street, Brunswick	11.65	" " " "	" "
Flanagan, Geoffrey Charles, 304 MacKinnon-road, Bentleigh	12.90	" " " "	" "
Flanagan, Patrick J., (address unknown)	12.50	" " " "	" "
Fleming, Stanley Cyril, Powell-road, Blackman's Bay, Tas.	28.00	" " " "	" "
Ford, Stanley N. Esq., Takalvin-street, Bundaberg, Qld.	10.00	" " " "	" "
Hayden, Patricia Constance (Mrs.), "Positano", Kunyung-road, Mount Eliza	25.00	" " " "	" "
Irving, Cecil C., 76 Yanco-road, West Pymble, N.S.W.	12.50	" " " "	" "
Levinson, Millicent (Mrs.), (address unknown)	13.88	" " " "	" "
Meadows, Thomas J., (address unknown)	10.00	" " " "	" "
Morrison, Peter Sides, Ceduna, S.A.	15.00	" " " "	" "
Muhleisen, Lewis Frederick, 8 Nisbet-road, Applecross, W.A.	10.00	" " " "	" "
Murray, Bessie (Mrs.), 67 Gordon-street, C/A Roseberry, N.S.W.	136.80	" " " "	" "
Murray, John C., "Oban" Maxwellton, North Qld.	37.05	" " " "	" "
McCulloch, William Neil, c/o Cherry Mount, Glenthompson	10.00	" " " "	" "
McMillan, Peter (estate of), and Mrs. Judith McMillan, c/o Skinner and Hart, Commercial-road, Yarram	15.00	" " " "	" "
Paine, Noeline Moya (Mrs.), 8 Coronet-street, Flemington	10.00	" " " "	" "
Robinson, Hazel (Mrs.), 10 Dunoon-street, Murrumbena	10.00	" " " "	" "
Simpson, Eric W., Unit 9 York Lodge, 19 Ralson-street, Lane Cove, N.S.W.	12.50	" " " "	" "
Smith, Francis H., P.O. Box 20, Proserpine, Qld.	11.20	" " " "	" "
Vernon, Violet L. (Miss), 24 Davies-street, Kew	10.00	" " " "	" "
Wood, Edric M., 22 Herbert-street, Toowong, Brisbane	10.00	" " " "	" "
Skinner, John K., P.O. Box 1205, Dunedin, N.Z.	37.19	" " " "	" "
Waiwetu Developments Ltd., P.O. Box 996, Wellington, N.Z.	25.50	" " " "	" "
Baalman, John, c/o Grey and Perkins, G.P.O. Box 1342, Sydney, N.S.W.	48.88	" " " "	" "
Imlach, John, 274 Esplanade, Island Bay, Wellington, N.Z.	16.36	Ordinary Dividend No: 45	30:4.66
Narang, Rambhai, 579 Mantukau-road, Auckland, N.Z.	10.62	" " " "	" "
Skinner, John, P.O. Box 1205, Dunedin, N.Z.	41.44	" " " "	" "
Adam, Leslie, (address unknown)	21.00	" " " "	" "
Armstrong, Alexander, 69 Latimer-road, Bellevue Hill, N.S.W.	55.00	" " " "	" "
Busby, Alexander I., c/o Allen, Allen and Hensley, G.P.O. Box 50, Sydney, N.S.W.	16.50	" " " "	" "
Curtis, Mary J. (Mrs.), (address unknown)	19.82	" " " "	" "
Flanagan, Geoffrey C., 304 McKinnon-road, Bentleigh	12.90	" " " "	" "
Flanagan, Patrick, (address unknown)	12.50	" " " "	" "
Krug, Heidie Gross (Mrs.), (address unknown)	27.50	" " " "	" "
O'Sullivan, Cora D. (Mrs.), (address unknown)	20.40	" " " "	" "
Paine, Noelene M. (Mrs.), 8 Coronet-street, Flemington	10.00	" " " "	" "
Levenson, Millicent (Mrs.), (address unknown)	13.87	" " " "	" "
Mackinnin, Jessie (Miss), 8 Augusta-street, Concord, N.S.W.	10.00	" " " "	" "
Meadows, Thomas Joseph, (address unknown)	10.00	" " " "	" "
Nolan, Majorie J. (Mrs.), (address unknown)	18.40	" " " "	" "
Savage, Patricia (Miss), 81 Bay-road, Sandringham	18.40	" " " "	" "
Sexton, Patrick J., (address unknown)	10.00	" " " "	" "
Tschumy, Charles R., c/o A Rail, M.S. 102 Private Mail Bag, Ingham, North Qld.	12.50	" " " "	" "

Unclaimed Moneys Act 1962.

REGISTER of Unclaimed Moneys held by the—

Name of Owner on Books and Last Known Address.	Total Amount Due to Owner.	Description of Unclaimed Moneys.	Date when Amount first became Payable.
§			
CAMPBELL'S SOUPS (AUST.) PTY. LIMITED.			
Ruff, K., Bendigo	64.30	Wages	— 2.62
Industrial Security Service, South Melbourne	10.50	Security Service	— 3.63
Ceratti, G., 52 Wondah-street, Cobram	193.42	Goods	— 3.65
Anstee Bros. Pty. Ltd., Elsternwick	14.50	Advertising	— 8.62
Neil, N (address unknown)	10.90	Wages	— 4.65
Emmett, D. (address unknown)	32.79	"	— 8.65
Hawkins, H. E. (address unknown)	10.80	"	— 12.66
McAuliffe, P. (address unknown)	24.00	Workers Compensation	— 12.66
2741			
LINCOLN STUART AND COMPANY PROPRIETARY LIMITED.			
Willder, Derebin, Collins-street, Melbourne	12 00	Dividend	{ 10.3 66
2799			{ 13.10 66

65 WILLIAM STREET PTY. LTD. (IN VOLUNTARY LIQUIDATION).
 NOTICE OF FINAL MEETING.
 NOTICE is hereby given, in pursuance of section 272 of the Companies Act 1961, that a Final Meeting of members of 65 William-street Pty. Ltd. (in Voluntary Liquidation) will be held at the offices of Price Waterhouse & Co., 14th Floor, 447 Collins-street, Melbourne, on the 28th day of June, 1968, at 2 o'clock in the afternoon, for the purpose of having an account laid before it, showing the manner in which the winding up has been conducted and the property of the company disposed of, and hearing any explanation that may be given by the liquidator.
 Dated this 17th day of May, 1968.
 R. E. CHANCELLOR, Liquidator.
 Price Waterhouse & Co., chartered accountants, 447 Collins-street, Melbourne, 3000. 2866

The Companies Act 1961.—In the matter of CONSOLIDATED TRANSPORT CO. PTY. LTD.—Notice re Meeting of Creditors Pursuant to Section 260.
 NOTICE is hereby given that a meeting of creditors of the above-named company will be held at the offices of Kennedy, Small & Middlemiss, 296 Little Lonsdale-street, Melbourne, at 11 a.m. on the 29th day of May, 1968, the company having convened a meeting of its members for the same day for the purpose of considering a Resolution that the company be wound up voluntarily.
 Dated this 21st day of May, 1968.
 H. W. SUTHERLAND, Secretary.
 Kennedy, Small & Middlemiss, 296 Little Lonsdale-street, Melbourne. 2869

Companies Act 1961.—Regulation 56.—In the matter of CROSS CONSTRUCTIONS PTY. LTD. (in Liquidation).
 NOTICE is hereby given that a First and Final Dividend is intended to be declared in this matter. Creditors who have not proved their debt by the 5th day of June, 1968, will be excluded from the dividend.
 Dated this 20th day of May, 1968.
 JOHN C. COUZENS, Liquidator.
 John C. Couzens & Associates, 527 Collins-street, Melbourne, 3000. 2872

The Companies Act 1961.
 THE HARCOURT FRUIT SUPPLY SOCIETY LIMITED (IN LIQUIDATION).
 NOTICE TO CREDITORS OF INTENTION TO DECLARE DIVIDEND.
 A FIRST Dividend is intended to be declared in the above matter.
 Creditors who have not proved their debt by 14th June, 1968, will be excluded from this dividend.
 Dated this 20th day of May, 1968.
 WARWICK N. JOHANSON, Liquidator.
 National Bank Chambers, Pall Mall, Bendigo. 2861

IN the matter of the Companies Act 1961 as amended and in the matter of Linkmaster Pty. Ltd. (in Liquidation) notice is hereby given that an Extraordinary General Meeting of the company and its creditors will be held at the office of N. C. Rundle & Co., 443 Lt. Collins-street, Melbourne, on Friday, 28th June, 1968, at 12 o'clock noon for the purpose of having an account laid before it showing how the winding up has been conducted and the property of the company disposed of and of hearing any explanations which may be given by the liquidator.
 Dated at Melbourne this 14th day of May, 1968.
 N. C. RUNDLE, liquidator, 443 Lt. Collins-street, Melbourne. 2873

Companies Act 1961.
 ROY C. WRIGHT & CO. PROPRIETARY LIMITED (IN VOLUNTARY LIQUIDATION).
 NOTICE CONVENING FINAL MEETING OF MEMBERS PURSUANT TO SECTION 272.
 NOTICE is hereby given pursuant to section 272 of the Companies Act 1961 that a General Meeting of the members of the above-named company will be held at the offices of John C. Couzens & Associates, ground floor, 527 Collins-street, Melbourne, on Wednesday, the 19th day of June, 1968, at 2.30 in the afternoon, for the purpose of having an account laid before them showing the manner in which the winding up has been conducted and the property of the company disposed of, and of hearing any explanations that may be given by the liquidator.
 Dated this 20th day of May, 1968.
 2874 DAVID A. CRAWFORD, Liquidator.

NOTICE is hereby given that in pursuance of section 254 (2) (b) of the Companies Act 1961, Bendigo Amusements Proprietary Limited, whose registered office is situated at 254 Little Lonsdale-street, Melbourne, Victoria, by a Special Resolution passed at a meeting of the shareholders held on the 20th May, 1968, agreed that the company be wound up voluntarily.
 Dated this 21st day of May, 1968.
 2862 R. S. CONNOLLY, Liquidator.

The Companies Act 1961.
 PETER HENRY PROPRIETARY LIMITED.
 PURSUANT TO SECTION 254 (2).
 AT an Extraordinary General Meeting of the above-named company, duly convened and held at 1 Southway, Yallourn, on the 13th day of May, 1968, the following Special Resolution was duly passed:
 "That the company be wound up voluntarily."
 and at such meeting Harry Leslie Richardson of 6th Floor, 37 Queen-street, Melbourne, was appointed liquidator for the purpose of the winding up.
 Dated this 16th day of May, 1968.
 2834 G. J. WILKINSON, Secretary.

Companies Act 1961.—Section 272 (2).

JACKNIT COMPANY PROPRIETARY LIMITED.

NOTICE OF FINAL MEETING IN VOLUNTARY WINDING UP.

TAKE notice that the date of the Final Meeting appearing in this Gazette on May the 8th last should have read 10th day of June, 1968, and not the 10th day of May, 1968.

Dated the 16th day of May, 1968.

2814 R. LOFTUS, Liquidator.

In the Supreme Court of Victoria.—1968 No. 7507.—In the matter of the *Companies Act 1961* and in the matter of Autotrak (Australia) Proprietary Limited.

NOTICE is hereby given that a petition for the winding up of the above-named company by the Supreme Court was on the 3rd day of May, 1968, presented by the said company.

And that the said petition is directed to be heard before the court sitting at Law Courts, William-street, Melbourne, at the hour of 10.30 a.m. on the 7th day of June, 1968; and any creditor or contributory of the said company desiring to support or oppose the making of an order on the said petition may appear at the time of hearing by himself or his counsel for that purpose; and a copy of the petition will be furnished to any creditor or contributory of the said company requiring the same by the undersigned on payment of the regulated charge for same.

The petitioner's address is 39 Victoria-street, Dimboola.

The petitioner's solicitor is Messrs. Bieske & Edgar, of 52 Wilson-street, Horsham, whose Melbourne agent is Messrs. Virgil B. Gill, Kane & Co., of 450 Little Collins-street, Melbourne.

VIRGIL B. GILL, KANE & CO.

NOTE.—Any person who intends to appear on the hearing of the said petition must serve on or send by post to the above-named Virgil B. Gill, Kane & Co., notice in writing of his intention so to do. The notice must state the name and address of the person, or, if a firm, the name and address of the firm, and must be signed by the person or firm, or his or their solicitor (if any), and must be served, or, if posted, must be sent by post in sufficient time to reach the above named not later than four o'clock in the afternoon of 6th day of June, 1968.

The Companies Act 1961.

GAMLIN & METES PROPRIETARY LIMITED.

PURSUANT TO SECTION 260 OF THE COMPANIES ACT 1961.

NOTICE is hereby given that a Meeting of Creditors of Gamlin & Metes Proprietary Limited will be held at the Institute of Chartered Accountants, 23 McKillop-street, Melbourne, on Friday, the 24th day of May, 1968, at 11.00 o'clock in the forenoon for the purpose of considering the company's affairs, the company having convened an extraordinary general meeting of its members to be held on the same day and for the purpose of considering and if thought fit passing a Special Resolution that the company be wound up voluntarily.

Dated this 15th day of May, 1968.

J. A. THORNE, Director.

Hall & Rose, chartered accountants, 260 Queen-street, Melbourne, Vic., 3000. 2829

The Companies Act 1961.

HIGHWAY CARAVANS PROPRIETARY LIMITED.

NOTICE is hereby given that a First Dividend is intended to be declared in the above matter. Creditors who have not proved their debts by the 2nd day of June, 1968, may be excluded from this dividend.

Dated this 17th day of May, 1968.

G. O. HARRISON, Liquidator.

Hall & Rose, chartered accountants, 260 Queen-street, Melbourne, Vic., 3000. 2827

M.I.P. Holdings Proprietary Limited.

NOTICE is hereby given that at an Extraordinary General Meeting of shareholders of M.I.P. Holdings Proprietary Limited held on the 15th day of May, 1968, at Flat 8-1, 193 Domain-road, South Yarra, the following Resolution was passed as a Special Resolution:—

That M.I.P. Holdings Proprietary Limited be wound up voluntarily.

Dated this 17th day of May, 1968.

2838 W. E. WEBB, Liquidator.

RIALTO DISTRIBUTORS PROPRIETARY LIMITED.

NOTICE is hereby given that at an Extraordinary General Meeting of shareholders of Rialto Distributors Proprietary Limited held on the 15th day of May, 1968, at Flat 8-1, 193 Domain-road, South Yarra, the following Resolution was passed as a Special Resolution:—

That Rialto Distributors Proprietary Limited be wound up voluntarily.

Dated this 17th day of May, 1968.

2836 W. E. WEBB, Liquidator.

The Companies Act 1961.—In the matter of ROBERTS TRANSPORT PROPRIETARY LIMITED (in Liquidation).

NOTICE is hereby given that a First Dividend is intended to be declared in this matter. Creditors who have not proved their debts by the 7th day of June, 1968, will be excluded from the dividend.

Dated this 17th day of May, 1968.

N. E. STRETTON, Liquidator.

Kennedy, Smail & Middlemiss, 296-304 Little Lonsdale-street, Melbourne, 3000. 2841

AT a General Meeting of the members of Doveton Proprietary Limited duly convened and held at 379 Collins-street, Melbourne, on the 9th day of May, 1968, the Special Resolution set out below was duly passed.

"That the company be wound up voluntarily and that Douglas Stanley Anderson, of 39 Little Collins-street, Melbourne, chartered accountant, be appointed liquidator for the purpose of such winding up and that the remuneration of Douglas Stanley Anderson be fixed in accordance with the scale of fees of the Institute of Chartered Accountants."

2792 D. S. ANDERSON, Liquidator.

FREDERICK FRANCIS PROPRIETARY LIMITED.

TAKE notice that the affairs of the above-named company are now fully wound up and that in pursuance of section 272 (1) of the *Companies Act 1961* a General Meeting of the company will be held at the registered office, at 89 Queen-street, Melbourne, on the 21st day of June, 1968, at 10 a.m. for the purpose of laying before it an account showing how the winding up has been conducted and the property of the company disposed of and giving any explanation thereof.

Dated this 17th day of May, 1968.

2835 A. A. GIBBS, Liquidator.

The Companies Act 1961.

CUMMING MANUFACTURING CO. PTY. LTD. (IN VOLUNTARY LIQUIDATION).

NOTICE CONVENING FINAL MEETING OF MEMBERS.

NOTICE is hereby given that, pursuant to section 272 of the *Companies Act 1961*, a meeting of members of the above company will be held at the office of Hosking, Quinn & Partners, 422 Collins-street, Melbourne, on the 20th day of June, 1968, at 12.30 p.m., for the purpose of having an account laid before them showing how the winding up of the company has been conducted and the property of the company disposed of and of hearing any explanations that may be given by the liquidator.

Dated this 15th day of May, 1968.

2843 A. W. NORTHEY, Liquidator.

Companies Act 1961, Victoria.

BOURKE STREET PROPERTY PTY. LTD. (IN VOLUNTARY LIQUIDATION).

NOTICE CONVENING FINAL MEETING OF MEMBERS, PURSUANT TO SECTION 272.

PURSUANT to section 272 of the *Companies Act 1961*, notice is hereby given that a General Meeting of the members of the above-named company will be held at 95 Collins-street, Melbourne, on Monday, the 24th day of June, 1968, at 9.30 a.m., for the purpose of having an account laid before them, showing the manner in which the winding up has been conducted, and the property of the company disposed of, and the hearing of any explanations that may be given by the liquidator.

Dated this 16th day of May, 1968.

2799 K. J. FLANNERY, Liquidator.

*Companies Act 1961.***MURRA'S MEATS PTY. LTD. (IN LIQUIDATION).**

NOTICE CONVENING A FINAL MEETING PURSUANT TO SECTION 272 (1) OF THE COMPANIES ACT 1961.

NOTICE is hereby given that a meeting of creditors of the above-named company will be held at my office, 440 Collins-street, Melbourne, on Friday, 28th June, 1968, at 9.15 a.m. for the purpose of having an account laid before them showing the manner in which the winding up has been conducted and the property of the company disposed of and of hearing any explanation that may be given by the liquidator.

Dated this 15th day of May, 1968.

R. C. D. WARNE-SMITH, Liquidator.

A. L. Royce and Warne-Smith, chartered accountants,
440 Collins-street, Melbourne. 2847

Companies Act 1961.—Section 254 (2).

NOTICE OF RESOLUTION.

TOULEMONDE (AUSTRALIA) PROPRIETARY LIMITED (IN VOLUNTARY LIQUIDATION).

AT an Extraordinary General Meeting of the members of Toulemonde (Australia) Proprietary Limited, duly convened and held at 409 Lonsdale-street, Melbourne, on 20th day of May, 1968, the Special Resolution set out below was duly passed.

"That the company be wound up voluntarily as a members' voluntary winding up in accordance with the provisions of the *Companies Act 1961*. That Joseph Charles Hough be and is hereby appointed liquidator."

Notice is also given that after 21 days from this date I shall proceed to distribute the assets. All creditors having any claims against the company should furnish particulars of same by that date, otherwise I shall proceed to distribute the assets without regard to their claim.

Dated this 20th day of May, 1968.

JOSEPH C. HOUGH, Liquidator.

409 Lonsdale-street, Melbourne. 2810

The *Companies Act 1961*.—In the matter of TAUNUS MOTORS PTY. LTD.—Notice re Meeting of Creditors, Pursuant to Section 260.

NOTICE is hereby given that a meeting of creditors of the above-named company will be held at the offices of Kennedy, Smail and Middlemiss, 296 Little Lonsdale-street, Melbourne, at 11 a.m., on the 24th day of May, 1968, the company having convened a meeting of its members for the same day for the purpose of considering a Resolution that the company be wound up voluntarily.

Dated this 15th day of May, 1968.

K. LOTT, Director.

Kennedy, Smail and Middlemiss, 296 Little Lonsdale-street, Melbourne. 2845

*Companies Act 1961.—Section 254 (2) (b).***NIELSEN & ROBINSON PROPRIETARY LIMITED.**

NOTICE is hereby given that at an Extraordinary General Meeting of the above-named company duly convened and held at 229-231 Boundary-road, Mordialloc, on 9th May, 1968, the following Special Resolution was passed:—

"That the company be wound up voluntarily and that R. A. Waters, chartered accountant, 170 Queen-street, Melbourne, be appointed liquidator of such winding up."

Dated this 10th day of May, 1968.

2768 R. A. WATERS, Liquidator.

*The Companies Act 1961.***MERVYN DUNNING PTY. LTD.**

AT an Extraordinary Meeting of the above-named company duly convened and held at Room 112, 237 Lonsdale-street, Dandenong, on 14th May, 1968, the following Resolution was duly passed as a Special Resolution:—

Resolution:

That the company be wound up voluntarily and that Mr. Mervyn Dunning, of 211 Foster-street, Dandenong, be appointed liquidator for the purpose of such winding up.

Dated this 14th day of May, 1968.

2779 M. DUNNING, Secretary.

The Companies Act 1961.—In the matter of ALCORN FURNITURE CO. PTY. LTD.

NOTICE is hereby given that at a meeting of the members of the above-named company held on 10th day of May, 1968, it was resolved that the company be wound up voluntarily and at a meeting of the creditors held on the same day, pursuant to section 260, it was resolved that for such purpose, Dennis John Cogle, of 545 St. Kilda-road, Melbourne, public accountant, be appointed liquidator.

Notice is also given that a First and Final Dividend is intended to be declared. Creditors who do not lodge proof of debt by 20th June, 1968, will be excluded.

BENT & GOUGLE, public accountants, Suite 18, 545 St. Kilda-road, Melbourne, 3004. 2786

Companies Act 1961.—In the matter of QUALITY CARS PTY. LTD.—Notice re Meeting of Creditors Pursuant to Section 260.

NOTICE is hereby given that a meeting of creditors of the above-named company will be held at Room 311, 3rd Floor, Princes Gate, East Par., 151 Flinders-lane, Melbourne, at 10.30 a.m., on Monday, the 27th day of May, 1968, the company having convened a meeting of its members for the same day for the purpose of considering a Resolution that the company be wound up voluntarily.

Dated the 15th day of May, 1968.

JOHN HUSTWAITE, Director.

A. Neville Bird & Co., chartered accountants, 289 Flinders-lane, Melbourne. Telephone No. 63 8833. 2846

AT an Extraordinary General Meeting of the members of M. & S. Batagol Pty. Limited, duly convened and held at 54 Princess-street, Kew, on the 16th day of May, 1968, it was resolved that the company be wound up voluntarily and that Mr. Ronald J. Sicree, of 38 Walsh-street, Melbourne, 3003, be and is hereby appointed liquidator. 2811

EDWARD RICHARD JAMES (sometimes called James Richard Edwards), late of 5 Leslie-street, Eaglehawk, gentleman, DECEASED.

CREDITORS, next of kin and others having claims in respect of the estate of the deceased (who died on the 17th day of April, 1966), are required by the personal representative, John Henry James, care of Louis S. Lazarus, solicitor, 76 Spencer-street, Melbourne, to send particulars to him by the 24th day of July, 1968, after which date the personal representative may convey or distribute the assets, having regard only to the claims of which he then has notice.

Dated the 22nd day of May, 1968.

LOUIS S. LAZARUS, 76 Spencer-street, Melbourne, solicitor. Proctor for the personal representative 2831

FRANCES FLORENCE MAY TRENEAR, late of 32 Gordon-grove, East Preston, in the State of Victoria, widow, DECEASED.

CREDITORS, next of kin and others having claims in respect of the estate of the deceased (who died on the 3rd day of October, 1967), are to send particulars of their claims to the executors, Alan Keith Garnham and Frank Thomas, care of the undersigned solicitor, by the 23rd day of July, 1968, after which date they will proceed to distribute the estate, having regard only to the claims of which they then have notice.

MARJORY C. COATES, solicitor, of 422 Collins-street, Melbourne. 2832

VERA GRACE MATHEW, late of 28 Cavendish-street Geelong, in the State of Victoria, widow, DECEASED.

CREDITORS, next of kin and others having claims in respect of the estate of the deceased (who died on the 11th day of November, 1967), are required by the personal representatives, Frank Stanley Dunt, of 25 Lily-street, Geelong West, in the said State, painter, and John Pearce Mockridge, of Flat E, 26 Hotham Gardens, O'Shannassy-street, North Melbourne, in the said State, architect, to send particulars to them, care of the under-mentioned solicitors, by the 24th day of July, 1968, after which date the personal representatives may convey or distribute the assets, having regard only to the claims of which they then have notice.

Dated this 18th day of May, 1968.

FREEMAN & FALLAW, solicitors, 64 Little Malop-street, Geelong. 2805

CREDITORS, next of kin and others having claims in respect of the estate of Adrian Percy John Buchanan, late of 7 Evelyn-road, North Ringwood, insurance executive, deceased (who died on the 14th of August, 1967), are to send particulars of their claims to Patricia Anne Buchanan, the administratrix, in care of the undersigned, on or before the 30th day of July, 1968, after which date she will distribute the assets, having regard only to the claims of which she then has notice.

EVANS, GUSS & HOLT, solicitors, of 421 Bourke-street, Melbourne. 2840

CREDITORS, next of kin and others having claims in respect of the estate of Malcolm Donald Thomson, late of 8 Van Ness-avenue, Glen Iris, retired mercer, deceased (who died on the 17th day of December, 1967), are required by the executors, Alan Bryce Currie, of 6 Brunel-court, Essendon, chartered accountant, and Donald Lindsay Johnson, of 1 Crown-avenue, Camberwell, butcher, to send particulars of their claims to them, care of Rogers and Gaylard, solicitors, of 281 Collins-street, Melbourne, by the 24th day of July, 1968, after which date the said executors will distribute the assets of the deceased, having regard only to the claims of which they then shall have had notice.

ROGERS & GAYLARD, solicitors, 281 Collins-street, Melbourne. 2842

CREDITORS, next of kin and others having claims in respect of the estate of Mussa Chaparov, late of Flat 2, 15 Wrexham-road, Windsor, retired labourer, deceased (who died on the 19th day of August, 1967), are to send particulars of their claims to Anna Chaparov, of 61 Kionga-street, Clayton, the administratrix of the estate of the said deceased, by the 22nd July, 1968, after which date the administratrix will distribute the assets, having regard only to the claims of which she shall then have notice.

J. & S. SHATIN, solicitors, of 224 Queen-street, Melbourne. 2785

CREDITORS, next of kin and others having claims in respect of the estate of Theresa Agnes Jarrett, late of 33 Imperial-avenue, South Caulfield, in the State of Victoria, married woman, deceased (who died on the 2nd day of August, 1967), are required by the executors, National Trustees, Executors and Agency Company of Australasia Limited, to send particulars to them at 95 Queen-street, Melbourne, by the 22nd day of July, 1968, after which date they will distribute the assets, having regard only to the claims of which they then have notice.

KENNETH J. CLEMENTS & SON, solicitors, 255 Glen-huntly-road, Elsternwick. 2778

CREDITORS, next of kin and others having claims in respect of the estate of Alice Lindsay, late of 62 Collett-street, Kensington, in the State of Victoria, widow, deceased (who died on the 16th day of October, 1967), are required to send particulars of their claims to the executor, Alan Anderson, care of the under-named solicitors, on or before the 23rd day of July, 1968, after which date the said executor will distribute the estate of the said deceased, having regard only to the claims of which he then has notice.

R. J. O'HARA & CO., solicitors, 357 Burwood-road, Hawthorn. 2794

CREDITORS, next of kin and others having claims in respect of the estate of Charles Cowling, late of 51 Carpenter-street, Bendigo, retired monumental mason, deceased (who died on the 13th day of November, 1967), are to send particulars of their claims to National Trustees, Executors and Agency Company of Australasia Limited, of 46-48 Queen-street, Bendigo, by the 31st day of August, 1968, after which date they will distribute the assets, having regard only to the claims of which they then have notice.

HOGAN, HOGAN AND PETERSEN, solicitors for the applicant. 2801

CREDITORS, next of kin and others having claims in respect of the estate of Mary Ellen Nicholls, late of 7 Centre-road, Brighton, widow, deceased (who died on 2nd January, 1968), are to send particulars of their claims to Lloyd William Cowdell and Laura Isabel Rogers, care of the undersigned, by 30th July, 1968, after which date they will distribute the assets, having regard only to claims of which they have notice.

JOHN DON & EDNEY, solicitors, 24-26 Riddell-parade, Elsternwick. 2804

THOMAS GEORGE LLOYD, late of 21 Diamond-street, East Preston, in the State of Victoria, retired, DECEASED.

CREDITORS, next of kin and others having claims in respect of the estate of the deceased (who died on the 23rd day of October, 1967), are to send particulars of their claims to the executors, Neil Edwin George Lloyd and Gwenda Madeline McComb, care of the undersigned solicitor, by the 23rd day of July, 1968, after which date they will proceed to distribute the estate, having regard only to the claims of which they then have notice.

MARJORY C. COATES, solicitor, of 422 Collins-street, Melbourne, 3000. 2833

WILLIAM JAMES KEAST, late of Cobden, foreman, DECEASED, intestate.

CREDITORS, next of kin and others having claims in respect of the estate of the deceased (who died on the 19th day of November, 1967), are required by the administratrix, Kathleen Monica Keast, to send particulars of their claims to her, care of the under-mentioned solicitors, by the 1st day of August, 1968, after which date the administratrix may convey or distribute the assets, having regard only to the claims of which she then has notice.

BUCKLAND & NEVETT, solicitors, Camperdown. 2769

CREDITORS, next of kin and others having claims in respect of the estate of Gertrude Loudon, late of 10 Dreadnought-street, Sandringham, widow (who died on the 1st October, 1967), are to send particulars of their claim to the administrator of the said estate, care of the undersigned, by the 26th July, 1968, after which date the administrator will distribute the assets, having regard only to the claims of which he then has notice.

JOHN H. WARREN, B.A., LL.B., solicitor, 24 Abbott-street, Sandringham. 2774

ARTHUR JOHN JAMIESON, late of 37 Westbourne-street, Prahran, retired brass moulder, DECEASED.

CREDITORS, next of kin and others having claims against the estate of the deceased (who died on the 24th day of March, 1968), are required to send particulars thereof to Alfred John Wilden, of 745 Malvern-road, Toorak, plumber, care of the undersigned solicitor, by the 24th day of July, 1968, after which date he will distribute the assets of the deceased, having regard only to the claims of which he then has notice.

E. K. O'DONNELL, solicitor, 173 Greville-street, Prahran. 2816

CREDITORS, next of kin and others having claims against the estate of Robert Thomson MacDonald, late of Kirkbrae 39B, Kilsyth, in the State of Victoria, gentleman, deceased (who died on the 12th day of February, 1968), are to send particulars of their claims to The Equity Trustees, Executors and Agency Company Limited, of 472 Bourke-street, Melbourne, by the 27th day of July, 1968, after which date it will distribute the assets, having regard only to the claims of which it then has notice.

G. A. BURCHILL, solicitor, 34 Queen-street, Melbourne. 2822

CREDITORS, next of kin and others having claims in respect of the estate of Winifred Grace Brown, late of 7 Centre-road, Carnegie, married woman, deceased (who died on the 1st December, 1967), are requested to send particulars of their claims to the executor, Peter John Brown, care of the under-mentioned solicitors, on or before the 27th July, 1968, after which date they will distribute the assets, having regard only to the claims of which they then have notice.

McKEAN & PARK, solicitors, 84 William-street, Melbourne. 2853

CREDITORS, next of kin and others having claims in respect of the estate of Dorothy Rice, late of 9 Stanley-grove, Canterbury, widow, deceased (who died on the 25th October, 1967), are requested to send particulars of their claims to the executors, Vernon Irvine Rice, and Clive Hillard Rice, care of the under-mentioned solicitors, on or before the 27th July, 1968, after which date they will distribute the assets, having regard only to the claims of which they then have notice.

McKEAN & PARK, solicitors, 84 William-street, Melbourne. 2854

THE TRUSTEES, EXECUTORS AND AGENCY COMPANY LIMITED, of 401 Collins-street, Melbourne, the executor of the will of Christina Wilson Binnie Hammond, late of Colaba Convalescent Nursing Home, 88 Orrong-road, Elsternwick, spinster, deceased (who died on the 23rd day of February, 1968), requires all creditors, next of kin and others having claims against the property or estate of the said deceased, to send to it the said executor, at the address afore-mentioned, on or before the 23rd day of July, 1968, particulars, in writing, of such claims, after which date the said executor, intends to convey or distribute such property or estate to or among the persons entitled thereto, having regard only to the claims of which it shall have had notice.

DARVALL & HAMBLETON, solicitors, 7th Floor, T. & G. Building, 147 Collins-street, Melbourne. 2848

STEVENETTE FLORENCE ELIZABETH RIVERS, formerly of River-street, Swan Hill, in the State of Victoria, but late of 8 Job's Gully-road, Eaglehawk, in the said State, spinster, DECEASED (who died on the 22nd June, 1967).

CREDITORS, next of kin and all other persons having claims against the estate of the deceased are required by the administratrix, Ruby Florence Edmonston, to send particulars to her, care of the undersigned, on or before the 17th day of August, 1968, after which date she will distribute the assets, having regard only to the claims of which she then has notice.

GARDEN & GREEN, solicitors, 4 McCallum-street, Swan Hill. 2807

CREDITORS, next of kin and others having claim on the estate of Mary Jones, late of 25 The Grove, Coburg, in the State of Victoria, social welfare worker (who died on the 16th day of November, 1966, at Werribee), are to send particulars of their claims to Edward Jones, of 105 Tambat-street, East Bentleigh, in the State of Victoria, the executor, who has proved the will of the late Mary Jones, at care of his solicitors, Cole and O'Heare, 465 Collins-street, Melbourne, by the 1st day of August, 1968, after which date the executor will distribute the assets, having regard to the claims of which he then has notice.

COLE & O'HEARE, solicitors, 465 Collins-street, Melbourne. 2830

WILLIAM HENRY IRELAND, late of 77 Beverley-street, East Doncaster, retired hotelkeeper, DECEASED (who died on the 16th May, 1967).

CREDITORS, next of kin and all others having claims in respect of the estate of the said deceased are requested by the executor, The Equity Trustees, Executors and Agency Company Limited, of 472 Bourke-street, Melbourne, to send particulars of such claims to the said company by the 29th July, 1968, after which date the said company will distribute the assets, having regard only to the claims of which it then has notice.

A. J. McNAMARA & BRENTON, solicitors, 89 Queen-street, Melbourne. 2820

FRANK WILLIAM BARTLEY, late of 2 Judith-court, North Croydon, salesman, DECEASED, intestate (who died on the 3rd November, 1967).

CREDITORS, next of kin and all others having claims in respect of the estate of the said deceased are requested by the administrator, The Trustees, Executors and Agency Company Limited, of 401 Collins-street, Melbourne, to send particulars of such claims to the said company by the 25th July, 1968, after which date the said company will distribute the assets, having regard only to the claims of which it then has notice.

DAVIES, CAMPBELL & PIESSE, solicitors, 401 Collins-street, Melbourne. 2839

CREDITORS, next of kin and others having claims in respect of the estate of Jeanne Marie Bain, late of 30 Thomas-street, Mitcham, widow, deceased (who died on the 12th day of March, 1968), and probate of whose will has been granted to Alexander Maurice Bain, of Ronald-street, Bruthen, shire engineer, and George Aimee Bain, of 10 Saxton-street, Box Hill North, construction estimator, and Percival Joseph Bain, of 8 Jackson-street, Forest Hill, service control officer, are required to send particulars of their claims to the said executors, care of the under-mentioned solicitors, by the 25th day of July, 1968, after which date they will distribute the assets, having regard only to the claims of which they then have notice.

PEARCE & WEBSTER, solicitors, of 430 Little Collins-street, Melbourne. 2819

CREDITORS, next of kin and others having claims in respect of the estate of Eadith Elizabeth Sherard Clark, late of 29A Sussex-street, Middle Brighton, widow, deceased (who died on the 15th January, 1968), are requested to send particulars of their claims to the executors, Margaret Millicent McDonald (formerly Margaret Millicent Clark), and Vincent King Clark, care of the under-mentioned solicitors, on or before the 27th July, 1968, after which date they will distribute the assets, having regard only to the claims of which they then have notice.

McKEAN & PARK, solicitors, 84 William-street, Melbourne. 2852

CREDITORS, next of kin and others having claims in respect of the estate of Florence Hosking, late of St. Michael's Hospital, corner Omana and Hobart streets, Murrumbena, widow, deceased (who died on the 8th day of March, 1968), are to send the particulars of their claims to the Union-Fidelity Trustee Company of Australia Limited, of 100 Exhibition-street, Melbourne, by the 30th day of June, 1968, after which date it will distribute the assets, having regard only to the claims of which it then has notice.

McNAB & McNAB, solicitors, 17 Queen-street, Melbourne. 2817

FRANK WILLIAM MORGAN, late of 10 Mowbray-street, Hawthorn East, retired builder, DECEASED.

CREDITORS, next of kin and others having claims in respect of the estate of the deceased (who died on the 10th March, 1968), are required by the applicants for grant of probate of the will of the deceased, Frank William Morgan, of Flat 15, 37 George-street, East Melbourne, architectural draftsman, Arthur Robert Morgan, of 9 Nyorie-court, Ivanhoe, managing director, and Mary Catherine Morgan, of 10 Mowbray-street, Hawthorn East, deaconess, to send particulars to them, care of the under-signed solicitors, by the 29th July, 1968, after which date they may convey or distribute the assets, having regard only to the claims of which they then have notice.

Dated 15th May, 1968.

LEWIS ORR & GIBSON, solicitors, 825 Burke-road, Camberwell. 2818

CREDITORS, next of kin and others having claims in respect of the estate of Gertrude Claudine Fromhold, late of Victoria-street, Doncaster, widow, deceased (who died on 5th February, 1968), are to send particulars of their claims to Lindsay Keith Fromhold, of Victoria-street, Doncaster, orchardist, and Brian Laurence Fromhold, of Main Creek-road, Main Ridge, orchardist, the executors appointed by the will of the said deceased, by the 26th July, 1968, after which date the executor will distribute the assets, having regard only to the claims of which it shall then have notice.

H. L. YUNCKEN & YUNCKEN, solicitors, 443 Little Collins-street, Melbourne. 2825

ELSIE JESSIE EBBOTT, late of 37 Kinkora-road, Hawthorn, widow, DECEASED.

CREDITORS, next of kin and others having claims in respect of the estate of the said deceased (who died on the 23rd November, 1967), are required by the executors, Clarence Albert Cook, of 87 Buchanan-avenue, North Balwyn, and Andrew Kenneth Duncan, of 11 Bank-place, Melbourne, solicitor, to send particulars to them, care of the under-signed, on or before the 23rd July, 1968, after which date they will distribute the assets, having regard only to the claims of which they then have notice.

WISEWOULD DUNCAN & HANGER, solicitors, 11 Bank-place, Melbourne. 2823

LINDA VICTORIA WOODHEAD, late of 8 Cooke-street, Abbotsford, widow, DECEASED.

CREDITORS, next of kin and others having claims in respect of the estate of the said deceased (who died on the 31st day of January, 1968), are required by the executors, Andrew Kenneth Duncan, and John George Rennie McArthur, both of 11 Bank-place, Melbourne, solicitors, to send particulars to them, care of the under-signed, on or before the 23rd July, 1968, after which date they will distribute the assets, having regard only to the claims of which they then have notice.

WISEWOULD DUNCAN & HANGER, solicitors, 11 Bank-place, Melbourne. 2824

LUCY OLIVIA WHITESIDE, formerly of Netherlee-street, East Malvern, but late of The Cheltenham Home and Hospital for the Aged, spinster, DECEASED.

CREDITORS, next of kin and others having claims in respect of the estate of the deceased (who died on the 10th day of January, 1968), are required by the applicants for a grant of probate, Arthur William Edwin Bennett, of The Vicarage, Terang, clerk in holy orders, and The Equity Trustees Executors and Agency Company Limited, of 472 Bourke-street, Melbourne, to send particulars to them by the 1st day of August, 1968, after which date the applicants for a grant of probate may convey or distribute the assets, having regard only to the claims of which they then have notice.

T. D. ARMSTRONG, solicitor, 422 Collins-street, Melbourne. 2821

ELSIE VIVIENNE GORDON, late of "Warrawee", 8 Redcourt-avenue, Armadale, married woman, DECEASED.

CREDITORS, next of kin and others having claims in respect of the estate of the deceased (who died on the 7th day of April, 1968), are required by The Perpetual Executors and Trustees Association of Australia Limited, of 100-104 Queen-street, Melbourne, Kenneth Heather Graham Gordon, of 46 Gold-street, Blakehurst, and Douglas Frederick Gordon, of 90 William-street, Melbourne, the applicants for a grant of administration to send particulars of their claims to the said applicants in the care of the said company by the 22nd day of July, 1968, after which date they will convey or distribute the assets, having regard only to the claims of which they then have notice.

2815

CREDITORS, next of kin and others having claims in respect of the estate of Michael Joseph Fogarty, formerly of Rankins Springs, in the State of New South Wales, farmer, but late of St. Georges-road, Northcote, in the State of Victoria, gentleman, deceased (who died on the 26th February, 1968), are required to send particulars of their claims to the executor of the estate, The Trustees, Executors and Agency Company Limited, of 401 Collins-street, Melbourne, addressed to the manager of the said company, by the 1st August, 1968, after which date the said company will distribute the assets of the said deceased, having regard only to those claims of which it shall then have notice.

ROWLAND P. HASSALL, solicitor, 360 South-road, Moorabbin. 2864

CREDITORS, next of kin and others having claims in respect of the estate of Alice May Pryn, late of 35 Mitchell-street, Brunswick, spinster, deceased (who died on the 23rd day of December, 1967), are to send particulars of their claims to the executor, William Albert Coghlan, care of the under-mentioned solicitors, by the 31st day of July, 1968, after which date he will convey or distribute the assets, having regard only to the claims of which he then has notice.

UPTON & ETTIELSON, solicitors, 100 Queen-street, Melbourne. 2870

ISABELLA JANE COTTAM, late of 4 Hartwood-street, East Kew, in the State of Victoria, widow, DECEASED.

CREDITORS, next of kin and others having claims in respect of the estate of the deceased (who died on the 24th day of February, 1968), are required by her executor, The Trustees, Executors and Agency Company Limited, of 401 Collins-street, Melbourne, to send particulars to it by the 25th day of July, 1968, after which date the said executor may convey or distribute the assets, having regard only to the claims of which it then has notice.

HADEN SMITH & FITCHETT, solicitors, 405 Collins-street, Melbourne. 2871

BRIDGET PETERSEN, late an inmate of Wodonga District Hospital, formerly of Ann-street, Wodonga, widow, DECEASED.

CREDITORS, next of kin and others having claims in respect of the estate of the said deceased (who died on the 18th October, 1966), are required by the executor, John Maher, to send to him, care of McKenzie-McHarg, Gunson & Co., solicitors, Wodonga, particulars by the 25th day of July, 1968, after which date the said executor may convey or distribute the assets, having regard only to claims of which he then has notice.

Dated the 21st day of May, 1968.

MCKENZIE-MCHARG, GUNSON & CO., solicitors, Wodonga. 2875

In the Supreme Court of the State of Victoria.

SALE BY THE SHERIFF.

ON Monday, the 1st of July, 1968, at 10 a.m., at the Police Station, Malvern (unless process be stayed or satisfied):—

All the estate and interest (if any) of Francis Ambrose Davis, road haulier, of 3 Hornsby-street, Malvern, as joint proprietor with Verna Davis, married woman, of an estate in fee-simple in the land described in certificate of title volume 3802, folio 218, upon which is erected a brick dwelling-house, known as No. 3 Hornsby-street, Malvern.

Registered mortgage No. C.66039 affects the said estate and interest.

Terms: Cash only.

N. FROGLEY, Sheriff's Officer.

21st May, 1968.

2851

INSOLVENCY NOTICES

Commonwealth of Australia.

The *Bankruptcy Act* 1966.

B. A. & P. A. JOHNSON.

NOTICE OF MEETING OF CREDITORS.

TAKE notice Barrie Alfred and Patricia Annette Johnson, of 37 Meakin-street, Watsonia, have on the 13th day of May, 1968, signed an Authority under sub-section (1) of section 188 of the *Bankruptcy Act* 1966 authorizing Scott Maurice Nunan, of 260 Queen-street, Melbourne, to call a meeting of their creditors (and to take control over their property) and that in pursuance of section 194 of the *Bankruptcy Act* 1966 a meeting of the creditors of the above-mentioned debtors will be held at the Institute of Chartered Accountants, 23 McKillop-street, Melbourne, on Wednesday, the 29th day of May, 1968, at 10.30 a.m.

S. M. NUNAN, Controlling Trustee.

Dated this 15th day of May, 1968.

Hall and Rose, chartered accountants, 260 Queen-street, Melbourne, 3000. 2828

Commonwealth of Australia.

The *Bankruptcy Act* 1966.

O. B. HOLBROOK & W. C. MARTIN.

"HOLBROOK ROAD & CONCRETE CONSTRUCTIONS".

NOTICE OF MEETING OF CREDITORS.

TAKE notice that Owen Brice Holbrook, of 104 The Parade, Ocean Grove and William Cobden Martin, of 120 The Parade, Ocean Grove, have on the 20th day of May, 1968, signed an Authority under sub-section (1) of section 188 of the *Bankruptcy Act* 1966, authorizing Scott Maurice Nunan, of 260 Queen-street, Melbourne, to call a meeting of their creditors (and to take over control of their property) and that, in pursuance of section 194 of the *Bankruptcy Act* 1966, a meeting of the creditors of the above-named debtors will be held at the Institute of Chartered Accountants, 23 McKillop-street, Melbourne, on Tuesday, the 11th day of June, 1968, at 11 o'clock in the forenoon.

Dated this 21st day of May, 1968.

S. M. NUNAN, Controlling Trustee.

Hall & Rose, chartered accountants, 260 Queen-street, Melbourne, Vic., 3000. 2868

IMPOUNDINGS

BEARS LAGOON.—Impounded in Bears Lagoon Pound by C.R.B. Ranger.

2 Border-Merino cross lambs, no visible brand

If not claimed and expenses paid, to be sold on 5th June, 1968.

2797—\$1.75

G. TURNER,
Poundkeeper.

BUNINYONG.—Impounded in Buninyong Pound.

1 Corriedale ram, no visible brand, nick off both ears

If not claimed and expenses paid, to be sold on 4th June, 1968.

2806—\$1.50

E. T. SUTHERLAND,
Poundkeeper.

KEILOR.—Impounded in Keilor Pound.

1 grey pony gelding, unshod, no visible brand

If not claimed and expenses paid, to be sold on 6th June, 1968.

C. M. MISSEN,

2860—\$1.50

Poundkeeper.

PAKENHAM.—Impounded in Pakenham Pound, from Upper Beaconsfield.

2 heifers, 1 Black Poll, 1 Friesian crossbred about 9 months old, both with rope around neck, no visible brands

If not claimed and expenses paid, to be sold on 5th June, 1968.

H. SMITH,

2877—\$2.25

Poundkeeper.

*Subordinate Legislation Act 1962.***NOTICE OF MAKING OF STATUTORY RULES.**

IN pursuance of the provisions of the *Subordinate Legislation Act 1962* and the Regulations made thereunder, notice is given of the making of the following statutory rules:—

No.	Melbourne Harbor Trust Act 1958.	Price.
106/1968.	Melbourne Harbor Trust Superannuation Regulations 1957 (Amendment No. 2/68)	10c
	<i>Collusive Practices Act 1965.</i>	
113/1968.	Collusive Practices (Exemption) Regulations 1968	10c
	<i>Water Act 1958.</i>	
114/1968.	Water (Lake Hume (Shire of Wodonga) Recreational Area) Regulations 1968	15c
	<i>Library Council of Victoria Act 1965.</i>	
115/1968.	Library Council of Victoria (Travelling Expenses Amendment No. 1) Regulations 1968	10c
	<i>Country Fire Authority Act 1958.</i>	
116/1968.	Country Fire Authority (Expenses of Officers and Employees Amendment No. 1) Regulations 1968	10c
	<i>Labour and Industry Act 1958.</i>	
117/1968.	Labour and Industry (Evidence of Convictions) Regulations 1968	10c
	<i>Fisheries Act 1958.</i>	
118/1968.	Commercial Fisheries Council (Travelling Allowances) Regulations 1968	10c
	<i>Racing Act 1958.</i>	
119/1968.	Dog Racing Control Board (Travelling Expenses Amendment No. 1) Regulations 1968	10c
	<i>Motor Car Act 1958.</i>	
120/1968.	Premiums Committee (Travelling Allowances) Regulations 1968	10c
	<i>Country Fire Authority Act 1958.</i>	
121/1968.	Country Fire Authority (Meetings and Expenses of Members Amendment No. 1) Regulations 1968	10c

Copies of these statutory rules may be purchased at the Sale of Publications Section of the Government Printing Office, located at Macarthur-street, Melbourne, 3002. If ordered by mail, remittance should be addressed to "The Government Printer, Box 203, P.O., North Melbourne, 3051", and should include 5c extra for postage. If a credit account is held at this office, no remittance is required with the mail order.

The annual subscription rate for Statutory Rules (including a Bound Volume) is \$15, payable in advance. The subscription year commences on 1st January.

A. C. BROOKS,
Government Printer.

STATE ACTS, 1965

COPIES of the following Acts of Parliament of Victoria may be obtained at the Government Printing Office, or from any accredited agents, at the price set opposite to each (these prices do not include postage).

No.		Price
7238.	Wills (Minors')	\$0.05
7239.	Cattle Compensation (Amendment)	\$0.05
7240.	Swine (Amendment)	\$0.05
7241.	Social Welfare (Cadetships)	\$0.05
7242.	Appeal Costs Fund (Amendment)	\$0.05
7243.	Altona Railway Extension	\$0.08
7244.	Transfer of Land (Removal of Caveats)	\$0.05
7245.	Water Authorities Accident Insurance	\$0.08
7246.	Portland Harbor Trusts (Amendment)	\$0.10
7247.	Melbourne and Metropolitan Board of Works (Borrowing Powers)	\$0.05
7248.	Justices (Registration)	\$0.10
7249.	Mildura Irrigation and Water Trusts (Amendment)	\$0.08
7250.	Health (Tuberculosis Arrangement)	\$0.08
7251.	Children's Court (Admission to Hearings)	\$0.05
7252.	Bendigo Land (Special Grant)	\$0.05
7253.	Werribee Waterworks District (Abolition)	\$0.05
7254.	Dandenong Valley Authority (Amendment)	\$0.05
7255.	Legal Aid (Costs)	\$0.05
7256.	Agricultural Education (Continuation)	\$0.05
7257.	Geelong (Kardinia Park) Land	\$0.05
7258.	Water (Amendment)	\$0.08
7259.	Victorian Inland Meat Authority (Amendment)	\$0.05
7260.	The Constitution Act Amendment (Subordinate Legislation Committee)	\$0.05
7261.	Country Fire Authority	\$0.08
7262.	Subordinate Legislation (Amendment)	\$0.05
7263.	Crimes (Illegal Use of Motor Cars)	\$0.08
7264.	Property Law (Loans to Minors)	\$0.08
7265.	Soil Conservation (Water Resources)	\$0.08
7266.	Grain Elevators (Borrowing Powers)	\$0.05
7267.	Aborigines (Amendment)	\$0.05
7268.	Stamps	\$0.10
7269.	Crimes (Parole)	\$0.05
7270.	Electoral Provinces and Districts	\$0.12
7271.	Mordialloc Public Hall and Court House	\$0.08
7272.	Sale of Land	\$0.15
7273.	Labour and Industry (Amendment)	\$0.10
7274.	Farm Produce Merchants and Commission Agents	\$0.30
7275.	National Parks (Amendment)	\$0.10
7276.	Valuation of Land (Appeals)	\$0.20
7277.	Medical (Foreign Practitioners)	\$0.05
7278.	Rural Finance and Settlement Commission	\$0.05
7279.	Home Finance (Amendment)	\$0.05
7280.	Road Traffic (Infringements)	\$0.10
7281.	Companies (Amendment)	\$0.10
7282.	Health (Household Insecticides)	\$0.08
7283.	Roads (Special Projects)	\$0.10
7284.	Consolidated Revenue	\$0.05
7285.	Consolidated Revenue	\$0.05
7286.	Local Government (Amendment)	\$0.15
7287.	Teaching Service (Amendment)	\$0.05
7288.	Marketing of Primary Products (Egg Marketing)	\$0.10
7289.	Maintenance	\$0.52
7290.	Veterinary Surgeons (Amendment)	\$0.10
7291.	Victoria Institute of Colleges	\$0.18
7292.	Workers Compensation (Amendment)	\$0.18
7293.	Petroleum Products Subsidy	\$0.10
7294.	Consolidated Revenue	\$0.05
7295.	Acts Interpretation	\$0.08
7296.	Administration and Probate (Surviving Actions)	\$0.05
7297.	Mines (Regulations)	\$0.05
7298.	Electric Light and Power (Interstate Supplies)	\$0.05
7299.	Supreme Court (Judges)	\$0.05
7300.	Local Government (Brighton Land Reclamation)	\$0.08
7301.	Racing (Totalizer Percentages)	\$0.05
7302.	Agricultural Colleges (Cadetships)	\$0.05
7303.	State Electricity Commission (Chairman)	\$0.08
7304.	Geelong Harbor Trust Lands	\$0.08
7305.	San Remo—Newhaven Land	\$0.08
7306.	Echuca Stockyards Railway Construction	\$0.08
7307.	Metropolitan Transportation Committee (Amendment)	\$0.05
7308.	Fuel and Power	\$0.08
7309.	Albert Park Lands	\$0.05
7310.	Presbyterian Trusts (Common Fund)	\$0.08
7311.	Melbourne Harbor Trust (Amendment)	\$0.10
7312.	Apprenticeship (Amendment)	\$0.10
7313.	Country Roads (Collection Costs)	\$0.05

STATE ACTS, 1965—continued.

No.	Price.
7314. Motor Car	\$0.10
7315. Decimal Currency	\$0.20
7316. Joint Select Committee (Drainage)	\$0.10
7317. Stamps (Amendment)	\$0.08
7318. Country Fire Authority (Service of Notices)	\$0.05
7319. Licensing	\$0.15
7320. Railway Loan Application	\$0.10
7321. Water Licences and Permits	\$0.10
7322. Railways (Amendment)	\$0.05
7323. Local Government (Constitution of Municipalities)	\$0.20
7324. Evidence (Reproductions)	\$0.12
7325. Milk and Dairy Supervision (Cheese Factory Licences)	\$0.05
7326. Water Supply Loan Application	\$0.15
7327. Motor Car (Driving Offence)	\$0.08
7328. Land Settlement and Rural Finance	\$0.08
7329. Committees (Amendment)	\$0.05
7330. Public Works Loan Application	\$0.10
7331. Weights and Measures (Amendment)	\$0.12
7332. Statute Law Revision	\$0.15
7333. Valuation of Land (General Amendment)	\$0.10
7334. Cul-de-sac Applications	\$0.05
7335. Tourist Resorts	\$0.05
7336. Gas Regulation (Amendment)	\$0.08
7337. Dried Fruits (Amendment)	\$0.05
7338. Patriotic Funds (Amendment)	\$0.10
7339. Flinders-lane Alignments	\$0.08
7340. Forests (Amendment)	\$0.08
7341. Poultry Levy (Collection Arrangement)	\$0.08
7342. Tomato Processing Industry (Amendment)	\$0.08
7343. Veterinary Surgeons (Further Amendment)	\$0.05
7344. Motor Car (Portable Speed-measuring Devices)	\$0.05
7345. Justices (Amendment)	\$0.05
7346. Judges' Salaries and Allowances	\$0.05
7347. Country Roads (Cadetships)	\$0.05
7348. St. Kilda Land	\$0.10
7349. Public Officers	\$0.08
7350. Marine (Amendment)	\$0.08
7351. Racing (Dog Racing)	\$0.08
7352. Land Tax (Rates)	\$0.08
7353. Collusive Practices	\$0.12
7354. Hospitals Superannuation	\$0.20
7355. Psychological Practices	\$0.15
7356. Public Officers Salaries and Allowances	\$0.10
7357. Superannuation	\$0.10
7358. Road Transport	\$0.15
7359. Stamps (Bills of Exchange)	\$0.05
7360. Survey Co-ordination (Place Names)	\$0.10
7361. Motor Car (Further Amendment)	\$0.05
7362. Universities (Amendment)	\$0.10
7363. Home Finance (Second Mortgages)	\$0.05
7364. Library Council of Victoria	\$0.10
7365. Lower Yarra Crossing Authority	\$0.10
7366. Evidence (Amendments)	\$0.08
7367. State Forests Loan Application	\$0.05
7368. Labour and Industry	\$0.10
7369. Justices (Sentencing)	\$0.05
7370. Consolidated Revenue	\$0.05
7371. Appropriation of Revenue	\$0.85

A. C. BROOKS,
Government Printer.

STATE ACTS 1966—continued.

No.	Price.
7380. Reid Murray Acceptance Limited (Scheme of Arrangement)	\$0.12
7381. Lake Corangamite	\$0.10
7382. Tobacco Leaf Marketing Board (Appointment of Manager)	\$0.05
7383. Country Fire Authority (Borrowing Powers)	\$0.05
7384. Labour and Industry (Sheltered Workshops)	\$0.05
7385. Wombat Bonuses	\$0.05
7386. Country Fire Authority (Interstate Fire Brigades)	\$0.05
7387. Loch Public Hall Trust	\$0.12
7388. Co-operative Housing Societies (Amendment)	\$0.05
7389. Fisheries and Game (Amendment)	\$0.08
7390. Marine Stores and Old Metals (Collectors)	\$0.05
7391. Companies	\$0.22
7392. The Constitution Act Amendment	\$0.05
7393. Vagrancy	\$0.12
7394. Consolidated Revenue	\$0.05
7395. Land (Plantation Areas)	\$0.10
7396. Daylesford Springs Land	\$0.05
7397. Barley Marketing (Amendment)	\$0.05
7398. Sheep Dipping (Repeal)	\$0.05
7399. Grain Elevators (Amendment)	\$0.05
7400. Seymour Racecourse Land	\$0.05
7401. Shepparton Abattoirs	\$0.05
7402. Paisley-Galvin Railway Land Exchange	\$0.08
7403. Aerial Spraying Control	\$0.12
7404. Racing (Amendment)	\$0.08
7405. Summary Offences	\$0.28
7406. Friendly Societies (Amendment)	\$0.05
7407. Crimes (Dangerous Driving)	\$0.05
7408. Medical (Foreign Practitioners Qualification Committee)	\$0.05
7409. Opticians Registration (Amendment)	\$0.05
7410. Labour and Industry (Petrol Shops)	\$0.08
7411. Melbourne and Metropolitan Board of Works (Amendment)	\$0.08
7412. Carlton (Recreation Ground) Land	\$0.08
7413. Boilers Inspection (Amendment)	\$0.05
7414. Warragul and Neerim Railway Lands	\$0.08
7415. Victoria Institute of Colleges (Council)	\$0.05
7416. Marketable Securities	\$0.18
7417. Pensions Supplementation	\$0.20
7418. Evidence (Medical Evidence)	\$0.05
7419. Water (Rating by Area)	\$0.05
7420. County Court (Common Law Jurisdiction)	\$0.05
7421. State Electricity Commission (Amendment)	\$0.05
7422. Gas and Fuel Corporation (Borrowing)	\$0.05
7423. Vegetation and Vine Diseases (Amendment)	\$0.05
7424. Motor Car	\$0.05
7425. Estate Agents (Amendment)	\$0.10
7426. Melbourne University (Chancellorship)	\$0.05
7427. Tobacco Leaf Industry Stabilization	\$0.15
7428. Consolidated Revenue	\$0.05
7429. Lotteries Gaming and Betting	\$0.35
7430. Stamps (Mortgages)	\$0.05
7431. Money Lenders (Exemption)	\$0.05
7432. Protection of Animals	\$0.12
7433. Marketing of Primary Products (Maize Marketing Board)	\$0.10
7434. Consolidated Revenue	\$0.10
7435. Firearms (Competition Weapons)	\$0.10
7436. Provincial Sewerage Authorities Association of Victoria	\$0.10
7437. Waterworks Trusts Association of Victoria	\$0.10
7438. Maffra Lands Exchange	\$0.10
7439. Trewalla Lands Exchange	\$0.10
7440. Tattersall Consultations	\$0.10
7441. Public Authorities (Contributions)	\$0.10
7442. Racing (Totalizator Percentages)	\$0.10
7443. Lower Yarra Crossing Authority (Guarantee)	\$0.10
7444. Stock and Share Brokers (Amendment)	\$0.15
7445. Moorpanyal Lands Exchange	\$0.10
7446. North Melbourne Lands	\$0.15
7447. Marine (Amendment)	\$0.10
7448. Mildura Irrigation and Water Trusts (Amendment)	\$0.10
7449. State Accident Insurance Office Land	\$0.10
7450. Public Account (Bona Vacantia)	\$0.10
7451. Motor Car (Hospital and Charities Contributions)	\$0.10
7452. Commonwealth and States Financial Agreement	\$0.15
7453. State Forests Loan Application	\$0.10
7454. Water (Amendment)	\$0.15
7455. Hospitals and Charities (Liability of Patients)	\$0.15
7456. Sewerage District's (Amendment)	\$0.10
7457. Limitation of Actions (Notice of Action)	\$0.10
7458. Long Island Country Club	\$0.10
7459. Country Roads (Level Crossings) (Amendment)	\$0.10

STATE ACTS, 1966

COPIES of the following Acts of Parliament of Victoria may be obtained at the Government Printing Office, or from any accredited agents, at the price set opposite to each (these prices do not include postage).

The annual subscription for State Acts 1967 et seq. is \$8 payable in advance.

Bound Volumes of State Acts are also available on a subscription basis at \$15 per annum.

No.	Price.
7372. Education (Council of Adult Education)	\$0.05
7373. Legal Profession Practice (Amendment)	\$0.05
7374. Co-operation (Amendment)	\$0.05
7375. Nurses (Amendment)	\$0.05
7376. Property Law (Loans to Minors)	\$0.05
7377. Audit (Amendment)	\$0.08
7378. Marketing of Primary Products (Tobacco Leaf Marketing Board)	\$0.05
7379. State Library National Gallery National Museum and Institute of Applied Science (Amendment)	\$0.05

STATE ACTS 1966—continued.

No.		Price.
7460.	Evidence (Foreign Tribunals)	\$0.10
7461.	San Remo Lands	\$0.10
7462.	The Constitution Act Amendment (Con-joint Elections)	\$0.10
7463.	Vermin and Noxious Weeds (Financial) ..	\$0.10
7464.	Co-operative Housing Societies (Financial)	\$0.10
7465.	Morwell National Park	\$0.10
7466.	Land Tax (Rates)	\$0.10
7467.	Teaching Service (Married Women) ..	\$0.10
7468.	Melbourne Cricket Ground (Guarantees) ..	\$0.10
7469.	Gaols (Commencement of Sentences) ..	\$0.10
7470.	Revocation and Excision of Crown Reservations	\$0.15
7471.	Soil Conservation and Land Utilization (Advisory Council)	\$0.10
7472.	Legal Profession Practice (Further Amend-ment)	\$0.10
7473.	Forests (Wood Pulp Agreement)	\$0.15
7474.	Companies (Amendment)	\$0.10
7475.	Portland Harbor Trust (Railways)	\$0.10
7476.	Country Fire Authority (Fire Prevention) ..	\$0.10
7477.	Victorian Pipelines Commission	\$0.15
7478.	Bees	\$0.15
7479.	Milk Board (Amendment)	\$0.10
7480.	Milk Pasteurization (Amendment)	\$0.10
7481.	State Insurance (Payments into Court) ..	\$0.10
7482.	National Gallery of Victoria	\$0.15
7483.	Building Societies (Amendment)	\$0.10
7484.	Firearms (Amendment)	\$0.15
7485.	Geelong Waterworks and Sewerage (Amend-ment)	\$0.10
7486.	Grain Elevators (Further Amendment) ..	\$0.10
7487.	Settlement Purchase Leases	\$0.10
7488.	Appeal Costs Fund (Amendment)	\$0.15
7489.	Geelong Harbor Trust (Amendment)	\$0.30
7490.	Health (Amendment)	\$0.15
7491.	Marketing of Primary Products (Onion Marketing Board)	\$0.10
7492.	State Coal Mine	\$0.10
7493.	Horse Breeding (Amendment)	\$0.10
7494.	Private Agents	\$0.30
7495.	Local Government	\$0.40
7496.	Wrongs (Assessment of Damages)	\$0.10
7497.	Melbourne and Metropolitan Board of Works (Reconstitution)	\$0.15
7498.	Port Phillip Authority	\$0.15
7499.	Extractive Industries	\$0.35
7500.	Stamps	\$0.25
7501.	Companies (Defaulting Officers)	\$0.15
7502.	Labour and Industry (Amendment)	\$0.15
7503.	Juries	\$0.10
7504.	Public Works Loan Application	\$0.15
7505.	Commercial Goods Vehicles (Tow Trucks) ..	\$0.10
7506.	Motor Car (Trailers)	\$0.15
7507.	Housing (Commonwealth and State Agree-ment)	\$0.10
7508.	Consolidated Revenue	\$0.10
7509.	Revenue Deficits Funding	\$0.10
7510.	The Constitution Act Amendment (Postal Voting)	\$0.25
7511.	Railway Loan Application	\$0.15
7512.	Inflammable Liquids	\$0.25
7513.	Water Supply Loan Application	\$0.25
7514.	Appropriation of Revenue	\$1.15

A. C. BROOKS,
Government Printer.

STATE ACTS, 1967

COPIES of the following Acts of Parliament of Victoria may be obtained at the Government Printing Office, or from any accredited agents, at the price set opposite to each (these prices do not include postage).

The annual subscription for State Acts 1967 et seq. is \$8 payable in advance.

Bound Volumes of State Acts are also available on a subscription basis at \$15 per annum.

No.		Price.
7515.	New Melbourne Cemetery Lands	\$0.10
7516.	Country Fire Authority (Prosecutions) ..	\$0.10
7517.	Social Welfare (Detention)	\$0.10
7518.	Zoological Gardens	\$0.15
7519.	Richmond (South-Eastern Freeway) Lands	\$0.10
7520.	The Geelong Gas Company's	\$0.10
7521.	Co-operative Housing Societies (Indemnities)	\$0.10
7522.	Supreme and County Courts (Sittings) ..	\$0.10
7523.	Dandenong Valley Authority (Amendment)	\$0.15

STATE ACTS, 1967—continued.

No.		Price.
7524.	State Savings Bank (Amendment)	\$0.10
7525.	Land (Surf Life Saving Association)	\$0.10
7526.	Warragul (Public Park) Lands	\$0.10
7527.	Tobacco Leaf Marketing Board (Appointment of Manager) (Amendment)	\$0.10
7528.	Stock Artificial Breeding (Amendment) ..	\$0.10
7529.	Second-hand Dealers (Amendment)	\$0.10
7530.	Legal Aid (Amendment)	\$0.10
7531.	Weights and Measures (Amendment)	\$0.25
7532.	The Constitution Act Amendment (Electoral)	\$0.10
7533.	Education and Teaching Service (Amend-ment)	\$0.15
7534.	Public Officers Salaries and Allowances ..	\$0.10
7535.	Railways (State Coal Mine Officers)	\$0.10
7536.	Public Officers (Long Service Leave)	\$0.15
7537.	Pipelines (Submerged Lands)	\$0.30
7538.	Police Regulation (Pensions)	\$0.10
7539.	Legal Profession Practice (Victoria Law Foundation)	\$0.10
7540.	Petroleum (Barracouta and Marlin Fields Agreement)	\$0.25
7541.	Pipelines	\$0.25
7542.	Local Government (Amendment)	\$0.15
7543.	Stamps (Amendment)	\$0.10
7544.	Police Offences (Obscene Publications) ..	\$0.10
7545.	Melbourne University (Amendment)	\$0.10
7546.	Crimes	\$0.15
7547.	Instruments (Corporate Bodies Contracts)	\$0.10
7548.	Land (Amendment)	\$0.25
7549.	Water (Amendment)	\$0.10
7550.	Dowling Forest Racecourse Lands	\$0.15
7551.	Strata Titles	\$0.40
7552.	Revocation and Excision of Crown Reser-vations	\$0.15
7553.	Tullamarine Freeway Lands	\$0.15
7554.	Friendly Societies Investment	\$0.10
7555.	Victorian Institute of Colleges (Board of Studies)	\$0.10
7556.	Consolidated Revenue	\$0.10
7557.	Consolidated Revenue	\$0.10
7558.	Joint Select Committee (Drainage)	\$0.15
7559.	Consolidated Revenue	\$0.10
7560.	Consolidated Revenue	\$0.10
7561.	Grain Elevators (Borrowing Powers)	\$0.10
7562.	Building Societies (Unsecured Loans) ..	\$0.10
7563.	Money Lenders (Corporation Licences) ..	\$0.10
7564.	Barley Marketing (Amendment)	\$0.10
7565.	Medical (Foreign Practitioners)	\$0.10
7566.	Masseurs (Amendment)	\$0.10
7567.	Firearms (Prohibited Persons)	\$0.10
7568.	Joint Select Committee (Meat Industry) ..	\$0.10
7569.	Council of Law Reporting in Victoria ..	\$0.15
7570.	Marketable Securities	\$0.15
7571.	Railway Lands	\$0.10
7572.	Labour and Industry (Fees)	\$0.10
7573.	Geelong Waterworks and Sewerage	\$0.10
7574.	Aboriginal Affairs	\$0.25
7575.	Co-operative Housing Societies (Amendment)	\$0.10
7576.	Rural Finance (Amendment)	\$0.10
7577.	Crimes (Amendment)	\$0.10
7578.	Revocation and Excision of Crown Reser-vations (No. 2)	\$0.15
7579.	Gaols (Amendment)	\$0.10
7580.	Gas Regulation (Amendment)	\$0.10
7581.	Judges and Public Officers Salaries	\$0.15
7582.	Portland Harbor (Exchange of Land)	\$0.15
7583.	Carlton (Recreation Ground) (Amendment) Land	\$0.10
7584.	Superannuation (Amendment)	\$0.15
7585.	Stamps	\$0.30
7586.	Educational Grants	\$0.10
7587.	Motor Car (Hours of Driving)	\$0.10
7588.	Poisons (Amendment)	\$0.10
7589.	Housing (Amendment)	\$0.10
7590.	Water (Further Amendment)	\$0.15
7591.	Petroleum (Submerged Lands)	\$0.90
7592.	Supreme Court (Judges)	\$0.10
7593.	Motor Car	\$0.15
7594.	Labour and Industry (Bread)	\$0.15
7595.	Pesticides (Amendment)	\$0.10
7596.	Judicial Proceedings Report (Amendment)	\$0.10
7597.	Administration and Probate (Amendment)	\$0.10
7598.	Mental Health (Pathological Examinations)	\$0.10
7599.	Veterinary Surgeons (Amendment)	\$0.10
7600.	Licensing (Rutherglen Wine Festival) ..	\$0.10
7601.	Estate Agents (Objections)	\$0.10
7602.	Joint Select Committee (Road Safety) ..	\$0.10
7603.	Richmond High School Land	\$0.10
7604.	Fertilizers (Amendment)	\$0.15
7605.	Milk and Dairy Supervision (Amendment) ..	\$0.10
7606.	Country Fire Authority (Notices)	\$0.10
7607.	Stock Foods (Amendment)	\$0.15

STATE ACTS, 1967—continued.		Price.
No.		
7608.	Litter ..	\$0.10
7609.	Municipal Association (Amendment) ..	\$0.10
7610.	Maintenance (Amendment) ..	\$0.10
7611.	Yea Civic Centre and Court House ..	\$0.15
7612.	Shepparton Abattoirs ..	\$0.15
7613.	Yarraville (Recreation Ground) Lands ..	\$0.15
7614.	Swine Compensation ..	\$0.25
7615.	Cattle Compensation ..	\$0.25
7616.	Ringwood and Warrandyte Lands ..	\$0.10
7617.	Harbor Charges ..	\$0.15
7618.	Melbourne Harbor Trust Land ..	\$0.10
7619.	Justices (Amendment) ..	\$0.10
7620.	Portland Harbor Trust (Amendment) ..	\$0.10
7621.	Racing ..	\$0.15
7622.	Melbourne and Metropolitan Tramways (Detours) ..	\$0.10
7623.	Land (Committees of Management) ..	\$0.15
7624.	Mildura Irrigation and Water Trusts (Amendment) ..	\$0.10
7625.	Apprenticeship (Amendment) ..	\$0.10
7626.	Local Government (Municipalities Assistance Fund) ..	\$0.10
7627.	Fitzroy (Edinburgh Gardens) Lands ..	\$0.15
7628.	Coal Mines (Pensions) ..	\$0.10
7629.	Lifts and Cranes ..	\$0.15
7630.	Licensing (Amendment) ..	\$0.10
7631.	The Geelong Gas Company's (Amendment) ..	\$0.15
7632.	Extractive Industries (Amendment) ..	\$0.10
7633.	Land Tax (Rates) ..	\$0.10
7634.	Sunday Entertainment ..	\$0.15
7635.	Summary Offences ..	\$0.10
7636.	Stamps (Exemptions) ..	\$0.10
7637.	Rain-making Control ..	\$0.15
7638.	Cemeteries (St. Kilda Public Cemetery) ..	\$0.10
7639.	Weights and Measures (Pre-packed Articles) ..	\$0.30
7640.	State Forests Loan Application ..	\$0.10
7641.	Fisheries (Amendment) ..	\$0.15
7642.	Barry Beach Railway Construction ..	\$0.10
7643.	Marketing of Primary Products (Amendment) ..	\$0.10
7644.	Victoria Institute of Colleges ..	\$0.15
7645.	Crimes (Driving Offences) ..	\$0.15
7646.	Private Agents ..	\$0.10
7647.	Teaching Service (Teachers Tribunal) ..	\$0.15
7648.	Motor Car (Compulsory Third Party Insurance) ..	\$0.10
7649.	Public Works Loan Application ..	\$0.15
7650.	Railway Loan Application ..	\$0.15
7651.	Juries ..	\$0.35
7652.	Westport Development ..	\$0.15
7653.	North Melbourne Lands (Amendment) ..	\$0.10
7654.	Water Supply Loan Application ..	\$0.25
7655.	Appropriation of Revenue ..	\$1.15

A. C. BROOKS,
Government Printer.

STATE ACTS, 1968

COPIES of the following Acts of Parliament of Victoria may be obtained at the Government Printing Office, or from any accredited agents, at the price set opposite to each (these prices do not include postage).

The annual subscription for State Acts 1968 et seq. is \$8 payable in advance.

Bound Volumes of State Acts are also available on a subscription basis of \$15 per annum.

No.		Price.
7656.	The Constitution Act Amendment (Governor's Salary) ..	\$0.10
7657.	Victorian Limbless Soldiers' Provident Fund (Closing) ..	\$0.15
7658.	Country Roads (Borrowing Powers) ..	\$0.10
7659.	Hairdressers Registration (Amendment) ..	\$0.10
7660.	Evidence (Attestations) ..	\$0.10
7661.	Melbourne Harbor Trust (Borrowing Powers) ..	\$0.10
7662.	Cheltenham Cemetery Lands Exchange ..	\$0.10
7663.	Administration and Probate (Amendment) ..	\$0.10
7664.	Road Traffic (Infringements) ..	\$0.10
7665.	Transport Regulation (Amendment) ..	\$0.10
7666.	Commercial Goods Vehicles (Amendment) ..	\$0.10
7667.	Tyabb to Long Island Railway Construction ..	\$0.10
7668.	Marriage (Liability in Tort) ..	\$0.10
7669.	La Trobe University (Amendment) ..	\$0.10
7670.	Children's Court (Procedure) ..	\$0.10

A. C. BROOKS,
Government Printer.

AGENTS FOR THE "VICTORIA GOVERNMENT GAZETTE".

THE following have been appointed agents to receive Advertisements and Subscriptions for the Victoria Government Gazette:—

ARMSTRONG'S AGENCY, 205 Queen-street, Melbourne, Victoria 3000.
 ARNALL & JACKSON, 390 Barkly-street, Brunswick, Victoria 3056.
 BAIRNSDALE AUTHORIZED NEWSAGENCY, 132 Main-street, Bairnsdale, Victoria 3875.
 BICKNELL, M. J., Authorized Newsagent, 196 Timor-street, Warrnambool, Victoria 3280.
 BLANE'S AUTHORIZED NEWSAGENTS, 162 Murray-street, Colac, Victoria 3250.
 CARTER, R. G., ADVERTISING SERVICE PTY. LTD., 26-32 King-street, Melbourne, Victoria 3000.
 DAVIES, G. & M. V., 112 Gray-street, Hamilton, Victoria 3300.
 DAVIS, WM. (MILDURA) PTY. LTD., 126 Eighth-street, Mildura, Victoria 3500.
 DIXON'S NEWSAGENCY, 89 Firebrace-street, Horsham, Victoria 3400.
 EDGAR'S NEWSAGENCY PTY. LTD., 293 Hargreaves-street, Bendigo, Victoria 3550.
 EDGARS' AUTHORIZED NEWSAGENCY, 45 Bridge-street, Benalla, Victoria 3672.
 FRANKS, H., & CO., 184 Ryrie-street, Geelong, Victoria 3220.
 GORDON & GOTCH AUSTRALASIA LTD., 511 Little Collins-street, Melbourne, Victoria 3000.
 GULLAN'S NEWSAGENCY, 88 Bridge-street, Ballarat, Victoria 3350.
 HAMPTON, A. C., 243 Mitchell-street, Bendigo, Victoria 3550.
 HARSTON, PARTRIDGE & CO. PTY. LTD., 455 Little Collins-street, Melbourne, Victoria 3000.
 KYNETON GUARDIAN PTY. LTD., P.O. Box 18, Kyneton, Victoria 3444.
 LATIMERS, Newsagents, 45 Station-street, Malvern, Victoria 3144.
 LIVINGSTON'S SHEPPARTON NEWSAGENCY, 246 Wyndham-street, Shepparton, Victoria 3630.
 THE MERCANTILE EXCHANGE, 67 Queen-street, Melbourne, Victoria, 3000.
 MCGILL'S AUTHORIZED NEWSAGENCY, 183-5 Elizabeth-street, Melbourne, Victoria 3000.
 PHILLIPS AUTHORIZED AGENCY, 83 Murphy-street, Wangaratta, Victoria 3677.
 PURDIE, J., & CO., 138 Moorabool-street, Geelong, Victoria 3220.
 SALE AUTHORIZED NEWSAGENCY, 142 Raymond-street, Sale, Victoria 3850.
 SKINNER'S AUTHORIZED NEWSAGENCY, 49-51 Franklin-street, Traralgon, Victoria 3844.
 STEVENSON, A. C. & M., NEWSAGENTS, 132 Henty-street, Casterton, Victoria 3311.
 VERNON, C. F. & H. J., 162 Bridge-road, Richmond, Victoria 3121.
 VIEW POINT AUTHORIZED NEWSAGENCY, 4 View-Point, Bendigo, Victoria 3550.

A copy of the Gazette filed at each place for public reference.

PUBLICATION OF OFFICIAL MATTER.

ATTENTION is invited to the following procedure in relation to the publication of official matter in the *Government Gazette*:—

1. Matter submitted to the Executive Council.

Matters submitted to the Executive Council which requires gazettal will normally be published in the issue of the following week.

Where urgent gazettal is required, special arrangements should be made with the Gazette Officer, Room 9, first floor, Old Treasury Building.

Publication will be facilitated by the submission of carbon copies for the use of the Gazette Officer.

2. Other matter.

(a) All other matter duly certified by a responsible officer for publication should be lodged with the Gazette Officer not later than half-past Nine a.m. on Tuesday.

(b) Lengthy or involved notices should be forwarded several days before publication.

(c) Proofs, which will be supplied only when specifically requested or, at the direction of the Gazette Officer, should be returned promptly to avoid delay in publication.

(d) No additions or amendments to matter for publication will be accepted by telephone.

THE "VICTORIA GOVERNMENT GAZETTE".

CONTENTS

SUBSCRIPTIONS.—The subscription, including postage, is \$10 per annum, or \$5 per half year, payable in advance.

Subscriptions are required for whole months, and must cover at least a half year.

Single copies are 20 cents, posted 25 cents. Subscribers do not receive the Acts of Parliament with the GAZETTE.

GAZETTES are held in stock for five years only.

PRIVATE ADVERTISEMENTS.—The charge for insertion is 25 cents per line single column, and 50 cents per line double column. The title forms one or more lines as a heading. On an average ten words make a line of single column. Every signature must likewise be counted as a line. The final words of a paragraph, though only portion of a line, must be counted as one line. Signatures (in particular) and proper names must be written very plainly in the text; ONE SIDE ONLY of each sheet of paper should be WRITTEN UPON.

All documents illegibly written will be returned unpublished, and where brands occur unprovided for by the ordinary letters of the alphabet, a worded explanatory description must be furnished.

THE VICTORIA GOVERNMENT GAZETTE is published on WEDNESDAY EVENING in each week, and Notices for insertion will be received by the Government Printer at or before ONE p.m. at ordinary rates, and late advertisements between ONE p.m. and FOUR p.m. at double rates on the day preceding the day of publication.

PAYMENTS.—Unless the advertiser has a credit account, all payments are required in advance. Remittances should be made by cheque, postal order, or money order payable to "GOVERNMENT PRINTER".

ADDRESS.—All communications should be addressed to "The Government Printer, Box 203, P.O., North Melbourne", 3051.

	PAGE
Acts of Parliament on sale at the Government Printing Office	1960
Appointments	1920
Contracts	1914
Courts	1916
Estates of Deceased Persons	1915
Government Notices	1904
Impoundings	1959
Insolvency Notices	1959
Lands	1935
Levee at Parliament House, Melbourne	1901
Melbourne and Metropolitan Board of Works— Notice	1916
Mining	1909
Notice to attend for Radiological Examination	1905
Notice to Mariners	1909
Notice of Making of Statutory Rules	1960
Orders in Council— Acts—Erratum; Local Government; Teaching Service; Country Roads; Land; Water; Geelong Waterworks and Sewerage; Dandenong Valley Authority; State Savings Bank; Landlord and Tenant; Milk and Dairy Supervision. et seq	1921
Private Advertisements	1945
Proclamations	1902
Public Service Notices	1945
Resignations	1921
State Rivers and Water Supply Commission	1917
Tenders	1943
Transport Regulation Board—Public Hearings	1906
Waterworks Trusts	1904, 1919