



# VICTORIA GOVERNMENT GAZETTE

Published by Authority

[Registered at the General Post Office, Melbourne, for transmission by post as a newspaper.]

No. 771

WEDNESDAY, SEPTEMBER 11

[1968

## PROCLAMATIONS

### PUBLIC HOLIDAYS.

#### PROCLAMATION

By His Excellency the Lieutenant-Governor of the State of Victoria and its Dependencies in the Commonwealth of Australia, &c., &c., &c.

IN pursuance of the provisions contained in Part III. of the *Public Service Act 1958*, I, the Lieutenant-Governor of the State of Victoria, in the Commonwealth of Australia, by and with the advice of the Executive Council of the said State, do by this my Proclamation appoint the days and dates hereunder mentioned to be observed as Public Holidays or Public Half-Holidays (as the case may be) at the places respectively specified, viz.:—

#### Public Holidays:—

SATURDAY, THE 5TH OCTOBER, 1968, throughout the Shire of Nathalia.

TUESDAY, THE 5TH NOVEMBER, 1968, throughout the Shire of McIvor.

Public Half-Holidays from the Hour of Twelve o'clock noon:—

WEDNESDAY, THE 6TH NOVEMBER, 1968, in the Kyneton Riding of the Shire of Kyneton.

WEDNESDAY, THE 30TH OCTOBER, 1968, throughout the City of Swan Hill.

FRIDAY, THE 11TH OCTOBER, 1968, throughout the Shire of Karkarook.

TUESDAY, THE 15TH OCTOBER, 1968, throughout the Shire of Birchip.

TUESDAY, THE 8TH OCTOBER, 1968, throughout the Shire of Cobram.

Given under my Hand and the Seal of the State of Victoria aforesaid, at Melbourne, this tenth day of September, in the year of our Lord One thousand nine hundred and sixty-eight, and in the seventeenth year of the reign of Her Majesty Queen Elizabeth II.

(L.S.)

E. F. HERRING.

By His Excellency's Command,

JAMES W. MANSON,  
Acting Chief Secretary.

GOD SAVE THE QUEEN!

### BANK HOLIDAYS.

#### PROCLAMATION

By His Excellency the Lieutenant-Governor of the State of Victoria and its Dependencies in the Commonwealth of Australia, &c., &c., &c.

IN pursuance of the provisions of the *Bank Holidays Act 1958*, I, the Lieutenant-Governor of the State of Victoria, in the Commonwealth of Australia, do by this my Proclamation appoint the days and dates named hereunder special days to be observed as Bank Holidays or Bank Half-Holidays (as the case may be) at the places respectively mentioned, that is to say:—

#### Bank Holidays:—

WEDNESDAY, THE 2ND OCTOBER, 1968, at Donald.

TUESDAY, THE 5TH NOVEMBER, 1968, at Maryborough.

WEDNESDAY, THE 25TH SEPTEMBER, 1968, at Trentham.

MONDAY, THE 23RD SEPTEMBER, 1968, at Romsey and Lancefield.

TUESDAY, THE 5TH NOVEMBER, 1968, at Yarra Glen.

TUESDAY, THE 5TH NOVEMBER, 1968, at Bendigo, Eaglehawk and Kangaroo Flat.

#### Bank Half-Holidays from Eleven a.m.:—

WEDNESDAY, THE 16TH OCTOBER, 1968, at Sea Lake and Culgoa.

WEDNESDAY, THE 9TH OCTOBER, 1968, at Rupanyup.

TUESDAY, THE 8TH OCTOBER, 1968, at Minyip.

WEDNESDAY, THE 23RD OCTOBER, 1968, at Geelong, Geelong West, North Geelong, East Geelong, Norlane and the Shire of South Barwon.

WEDNESDAY, THE 13TH NOVEMBER, 1968, at Bendigo, Eaglehawk and Kangaroo Flat.

Given under my Hand and the Seal of the State of Victoria aforesaid, at Melbourne, this tenth day of September, in the year of our Lord One thousand nine hundred and sixty-eight, and in the seventeenth year of the reign of Her Majesty Queen Elizabeth II.

(L.S.)

E. F. HERRING.

By His Excellency's Command,

JAMES W. MANSON,  
Acting Chief Secretary.

GOD SAVE THE QUEEN!

**PUBLIC HIGHWAYS.—CITY OF FRANKSTON.**

**PROCLAMATION**

By His Excellency the Lieutenant-Governor of the State of Victoria and its Dependencies in the Commonwealth of Australia, &c., &c., &c.

WHEREAS by the *Local Government Act 1958*, as amended, Section 519 it is amongst other things enacted that it shall be lawful for the Governor-in-Council at any time and from time to time upon the request of the Council of any municipality by notice in the *Government Gazette* to proclaim any land reserved used or by purchase or exchange acquired for a street road highway thoroughfare bridge square court alley or right-of-way or any street road lane or passage made or laid out or proposed to be made or laid out on any land of which a plan of subdivision delineating that street road lane or passage has been sealed with the seal of the municipality under subdivision (3) of Division 9 of Part XIX. of the *Local Government Act 1958*, as amended, or a corresponding previous enactment to be a public highway and that such land shall thereupon and thenceforth from the date of such proclamation become and be absolutely dedicated to the public as a public highway within the meaning of any law then or thereafter in force.

AND WHEREAS the Council of the City of Frankston has requested that the lands hereinafter mentioned, being streets roads lanes or passages made or laid out or proposed to be made or laid out on lands of which a plan of subdivision delineating those streets roads lanes or passages has been sealed with the seal of the municipality under subdivision (3) of Division 9 of Part XIX. of the *Local Government Act 1958*, as amended, or a corresponding previous enactment, be so declared to be public highways.

NOW THEREFORE, I, the Lieutenant-Governor of the State of Victoria in the Commonwealth of Australia, by and with the advice of the Executive Council of the said State, do by this Proclamation declare that Derinya Drive and Wandana Court coloured brown on Plan of Subdivision No. 76282 lodged in the Office of Titles, shall be public highways within the meaning of the said Act.

Given under my Hand and the Seal of the State of Victoria aforesaid, at Melbourne, this third day of September, in the year of our Lord One thousand nine hundred and sixty-eight, and in the seventeenth year of the reign of Her Majesty Queen Elizabeth II.

(L.S.)

E. F. HERRING.

By His Excellency's Command,

R. J. HAMER,  
Minister for Local Government.

GOD SAVE THE QUEEN!

**PUBLIC HIGHWAY.—SHIRE OF COHUNA.**

**PROCLAMATION**

By His Excellency the Lieutenant-Governor of the State of Victoria and its Dependencies in the Commonwealth of Australia, &c., &c., &c.

WHEREAS by the *Local Government Act 1958*, as amended, Section 519 it is amongst other things enacted that it shall be lawful for the Governor-in-Council at any time and from time to time upon the request of the Council of any municipality by notice in the *Government Gazette* to proclaim any land reserved used or by purchase or exchange acquired for a street road highway thoroughfare bridge square court alley or right-of-way or any street road lane or passage made or laid out or proposed to be made or laid out on any land of which a plan of subdivision delineating that street road lane or passage has been sealed with the seal of the municipality under subdivision (3) of Division 9 of Part XIX. of the *Local Government Act 1958*, as amended, or a corresponding previous enactment to be a public highway and that such land shall thereupon and thenceforth from the date of such proclamation become and be absolutely dedicated to the public as a public highway within the meaning of any law then or thereafter in force.

AND WHEREAS the Council of the Shire of Cohuna has requested that the land hereinafter mentioned, being a street road lane or passage made or laid out or proposed to be made or laid out on land of which a plan of subdivision delineating that street road lane or passage has been sealed with the seal of the municipality under

subdivision (3) of Division 9 of Part XIX. of the *Local Government Act 1958*, as amended, or a corresponding previous enactment, be so declared to be a public highway.

NOW THEREFORE, I, the Lieutenant-Governor of the State of Victoria in the Commonwealth of Australia, by and with the advice of the Executive Council of the said State, do by this Proclamation declare that an unnamed right-of-way, off Hay Street, Cohuna, shown hatched on the plan hereunder, shall be a public highway within the meaning of the said Act.

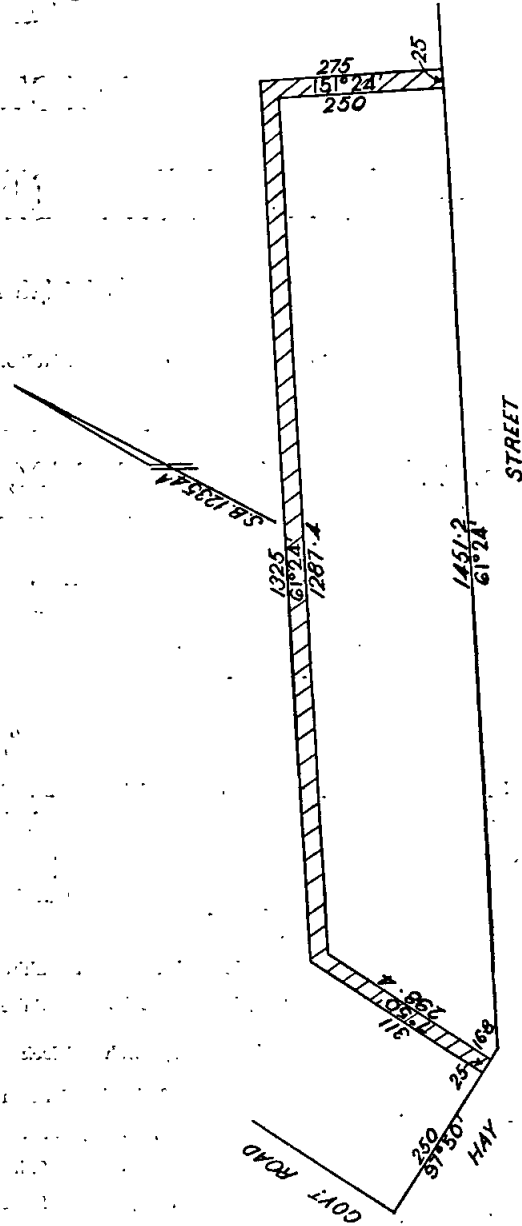

*The measurements are in links.*

Given under my Hand and the Seal of the State of Victoria aforesaid, at Melbourne, this third day of September, in the year of our Lord One thousand nine hundred and sixty-eight, and in the seventeenth year of the reign of Her Majesty Queen Elizabeth II.

(L.S.)

E. F. HERRING.

By His Excellency's Command,

R. J. HAMER,  
Minister for Local Government.

GOD SAVE THE QUEEN!

PUBLIC HIGHWAY.—CITY OF FRANKSTON.

PROCLAMATION

By His Excellency the Lieutenant-Governor of the State of Victoria and its Dependencies in the Commonwealth of Australia, &c., &c., &c.

WHEREAS by the Local Government Act 1958, Section 519 it is amongst other things enacted that it shall be lawful for the Governor-in-Council at any time and from time to time upon the request of the Council of any municipality by notice in the Government Gazette to proclaim any land reserved used or by purchase or exchange acquired for a street road highway thoroughfare bridge square court alley or right-of-way or any street road lane or passage made or laid out or proposed to be made or laid out on land of which a plan of subdivision delineating that street road lane or passage has been sealed with the seal of the municipality under subdivision (3) of Division 9 of Part XIX. of the Local Government Act 1958, or a corresponding previous enactment, to be a public highway and that such land shall thereupon and thenceforth from the date of such proclamation become and be absolutely dedicated to the public as a public highway within the meaning of any law then or thereafter in force;

AND WHEREAS the Council of the City of Frankston has requested that the land hereinafter mentioned, being a street road lane or passage made or laid out or proposed to be made or laid out on land of which a plan of subdivision delineating that street road lane or passage has been sealed with the seal of the municipality under subdivision (3) of Division 9 of Part XIX. of the Local Government Act 1958, or a corresponding previous enactment, be so declared to be a public highway.

NOW THEREFORE I, the Lieutenant-Governor of the State of Victoria in the Commonwealth of Australia, by and with the advice of the Executive Council of the said State, do by this Proclamation declare that the unnamed road, off Playne Street, Frankston, shown hatched on the plan hereunder, shall be a public highway within the meaning of the said Act.

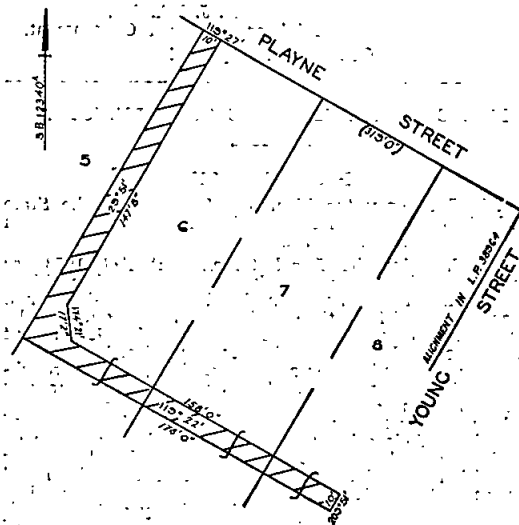

THE MEASUREMENTS ARE IN FEET & INCHES

Given under my Hand and the Seal of the State of Victoria aforesaid, at Melbourne, this third day of September, in the year of our Lord One thousand nine hundred and sixty-eight, and in the seventeenth year of the reign of Her Majesty Queen Elizabeth II.

(L.S.) E. F. HERRING.

By His Excellency's Command,

R. J. HAMER,  
Minister for Local Government.

GOD SAVE THE QUEEN!

PUBLIC HIGHWAY.—CITY OF FRANKSTON.

PROCLAMATION

By His Excellency the Lieutenant-Governor of the State of Victoria and its Dependencies in the Commonwealth of Australia, &c., &c., &c.

WHEREAS by the Local Government Act 1958, Section 519 it is amongst other things enacted that it shall be lawful for the Governor-in-Council at any time and from time to time upon the request of the Council of any municipality by notice in the Government Gazette to proclaim any land reserved used or by purchase or exchange acquired for a street road highway thoroughfare bridge square court alley or right-of-way or any street road lane or passage made or laid out or proposed to be made or laid out on land of which a plan of subdivision delineating that street road lane or passage has been sealed with the seal of the municipality under subdivision (3) of Division 9 of Part XIX. of the Local Government Act 1958, or a corresponding previous enactment, to be a public highway and that such land shall thereupon and thenceforth from the date of such proclamation become and be absolutely dedicated to the public as a public highway within the meaning of any law then or thereafter in force.

AND WHEREAS the Council of the City of Frankston has requested that the land hereinafter mentioned, being a street road lane or passage made or laid out or proposed to be made or laid out on land of which a plan of subdivision delineating that street road lane or passage has been sealed with the seal of the municipality under subdivision (3) of Division 9 of Part XIX. of the Local Government Act 1958, or a corresponding previous enactment, be so declared to be a public highway.

NOW THEREFORE I, the Lieutenant-Governor of the State of Victoria in the Commonwealth of Australia, by and with the advice of the Executive Council of the said State, do by this Proclamation declare that Valley Road, shown hatched on the plan hereunder, shall be a public highway within the meaning of the said Act.

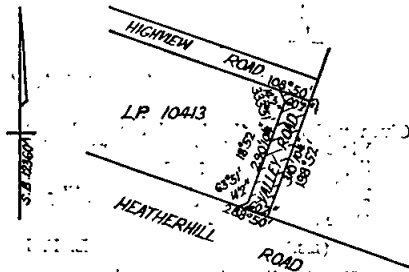

The measurements are in feet & inches

Given under my Hand and the Seal of the State of Victoria aforesaid, at Melbourne, this third day of September, in the year of our Lord One thousand nine hundred and sixty-eight, and in the seventeenth year of the reign of Her Majesty Queen Elizabeth II.

(L.S.) E. F. HERRING.

By His Excellency's Command,

R. J. HAMER,  
Minister for Local Government.

GOD SAVE THE QUEEN!

PUBLIC HIGHWAY.—CITY OF FRANKSTON.

PROCLAMATION

By His Excellency the Lieutenant-Governor of the State of Victoria and its Dependencies in the Commonwealth of Australia, &c., &c., &c.

WHEREAS by the Local Government Act 1958, Section 519 it is amongst other things enacted that it shall be lawful for the Governor-in-Council at any time and from time to time upon the request of the Council of any municipality by notice in the Government Gazette to proclaim any land reserved used or by purchase or exchange acquired for a street road highway thoroughfare bridge square court alley or right-of-way or any street road lane or passage made or laid out or proposed to be made or laid out on land of which a plan of

subdivision delineating that street, road, lane or passage has been sealed with the seal of the municipality under subdivision (3) of Division 9 of Part XIX. of the *Local Government Act 1958*, or a corresponding previous enactment to be a public highway and that such land shall thereupon and thenceforth from the date of such proclamation become and be absolutely dedicated to the public as a public highway within the meaning of any law then or thereafter in force.

AND WHEREAS the Council of the City of Frankston has requested that the land hereinafter mentioned, being a street, road, lane or passage made or laid out or proposed to be made or laid out on land of which a plan of subdivision delineating the street, road, lane or passage has been sealed with the seal of the municipality under subdivision (3) of Division 9 of Part XIX. of the *Local Government Act 1958*, or a corresponding previous enactment, be so declared to be a public highway.

NOW THEREFORE I, the Lieutenant-Governor of the State of Victoria in the Commonwealth of Australia, by and with the advice of the Executive Council of the said State, do by this Proclamation declare that Highview Road, shown hatched on the plan hereunder, shall be a public highway within the meaning of the said Act.

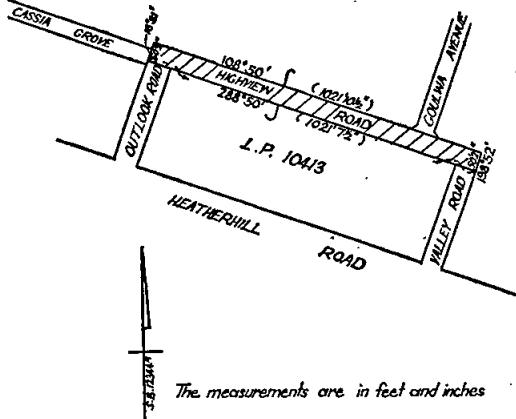

The measurements are in feet and inches

Given under my Hand and the Seal of the State of Victoria aforesaid, at Melbourne, this third day of September, in the year of our Lord One thousand nine hundred and sixty-eight, and in the seventeenth year of the reign of Her Majesty Queen Elizabeth II.

(L.S.) E. F. HERRING.

By His Excellency's Command,  
R. J. HAMER,  
Minister for Local Government.  
GOD SAVE THE QUEEN!

PUBLIC HIGHWAY.—SHIRE OF WODONGA.

PROCLAMATION

By His Excellency the Lieutenant-Governor of the State of Victoria and its Dependencies in the Commonwealth of Australia, &c., &c., &c.

WHEREAS by the *Local Government Act 1958*, as amended, Section 519 it is amongst other things enacted that it shall be lawful for the Governor-in-Council at any time and from time to time upon the request of the Council of any municipality by notice in the *Government Gazette* to proclaim any land reserved used or by purchase or exchange acquired for a street road highway thoroughfare bridge square court alley or right-of-way or any street road lane or passage made or laid out or proposed to be made or laid out on any land of which a plan of subdivision delineating that street road lane or passage has been sealed with the seal of the municipality under subdivision (3) of Division 9 of Part XIX. of the *Local Government Act 1958*, as amended, or a corresponding previous enactment to be a public highway and that such land shall thereupon and thenceforth from the date of such proclamation become and be absolutely dedicated to the public as a public highway within the meaning of any law then or thereafter in force.

AND WHEREAS the Council of the Shire of Wodonga has requested that the land hereinafter mentioned, used for a street, be so declared to be a public highway.

NOW THEREFORE I, the Lieutenant-Governor of the State of Victoria in the Commonwealth of Australia, by and with the advice of the Executive Council of the State, do by this Proclamation declare that Manns Lane Extension, Wodonga, shown hatched on the plan hereunder shall be a public highway within the meaning of the said Act.

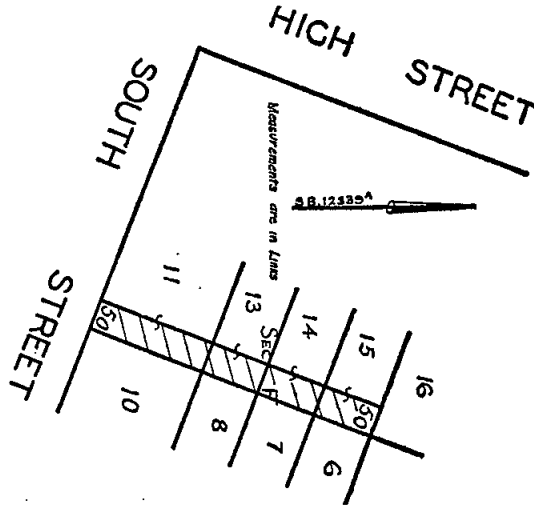

Given under my Hand and the Seal of the State of Victoria aforesaid, at Melbourne, this third day of September, in the year of our Lord One thousand nine hundred and sixty-eight, and in the seventeenth year of the reign of Her Majesty Queen Elizabeth II.

(L.S.) E. F. HERRING.

By His Excellency's Command,  
R. J. HAMER,  
Minister for Local Government.  
GOD SAVE THE QUEEN!

PUBLIC HIGHWAYS.—SHIRE OF MORNINGTON.

PROCLAMATION

By His Excellency the Lieutenant-Governor of the State of Victoria and its Dependencies in the Commonwealth of Australia, &c., &c., &c.

WHEREAS by the *Local Government Act 1958*, as amended, Section 519 it is amongst other things enacted that it shall be lawful for the Governor-in-Council at any time and from time to time upon the request of the Council of any municipality by notice in the *Government Gazette* to proclaim any land reserved used or by purchase or exchange acquired for a street road highway thoroughfare bridge square court alley or right-of-way or any street road lane or passage made or laid out or proposed to be made or laid out on any land of which a plan of subdivision delineating that street road lane or passage has been sealed with the seal of the municipality under subdivision (3) of Division 9 of Part XIX. of the *Local Government Act 1958*, as amended, or a corresponding previous enactment to be a public highway and that such land shall thereupon and thenceforth from the date of such proclamation become and be absolutely dedicated to the public as a public highway within the meaning of any law then or thereafter in force.

AND WHEREAS the Council of the Shire of Mornington has requested that the lands hereinafter mentioned, being streets roads lanes or passages made or laid out or proposed to be made or laid out on lands of which a plan of subdivision delineating those streets roads lanes or passages has been sealed with the seal of the municipality under subdivision (3) of Division 9 of Part XIX. of the *Local Government Act 1958*, as amended, or a corresponding previous enactment, be so declared to be public highways.

NOW THEREFORE I, the Lieutenant-Governor of the State of Victoria in the Commonwealth of Australia, by and with the advice of the Executive Council of the said State, do by this Proclamation declare that Manatee Avenue, Osprey Avenue and Sturio Parade coloured brown

on Plan of Subdivision No. 10897 lodged in the Office of Titles, shall be public highways within the meaning of the said Act.

Given under my Hand and the Seal of the State of Victoria aforesaid, at Melbourne, this third day of September, in the year of our Lord One thousand nine hundred and sixty-eight, and in the seventeenth year of the reign of Her Majesty Queen Elizabeth II.

(L.S.) E. F. HERRING.

By His Excellency's Command,  
R. J. HAMER,  
Minister for Local Government.  
GOD SAVE THE QUEEN!

**PUBLIC HIGHWAY.—CITY OF NORTHCOTE.**

**PROCLAMATION**

By His Excellency the Lieutenant-Governor of the State of Victoria and its Dependencies in the Commonwealth of Australia, &c., &c., &c.

WHEREAS by the *Local Government Act 1958*, as amended, Section 519 it is amongst other things enacted that it shall be lawful for the Governor-in-Council at any time and from time to time upon the request of the Council of any municipality by notice in the *Government Gazette* to proclaim any land reserved used or by purchase or exchange acquired for a street road highway thoroughfare bridge square court alley or right-of-way or any street road lane or passage made or laid out or proposed to be made or laid out on any land of which a plan of subdivision delineating that street road lane or passage has been sealed with the seal of the municipality under subdivision (3) of Division 9 of Part XIX. of the *Local Government Act 1958*, as amended, or a corresponding previous enactment to be a public highway and that such land shall thereupon and thenceforth from the date of such proclamation become and be absolutely dedicated to the public as a public highway within the meaning of any law then or thereafter in force.

AND WHEREAS the Council of the City of Northcote has requested that the land hereinafter mentioned, used for a street be so declared to be a public highway.

NOW THEREFORE, I, the Lieutenant-Governor of the State of Victoria in the Commonwealth of Australia, by and with the advice of the Executive Council of the State, do by this Proclamation declare that portion of Beavers Road, shown hatched on the plan hereunder, shall be a public highway within the meaning of the said Act.

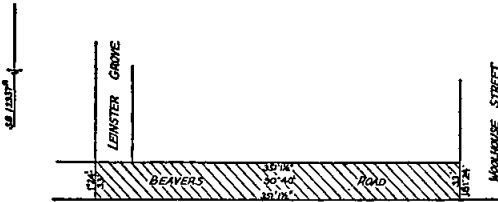

The measurements are in feet and inches

Given under my Hand and the Seal of the State of Victoria aforesaid, at Melbourne, this third day of September, in the year of our Lord One thousand nine hundred and sixty-eight, and in the seventeenth year of the reign of Her Majesty Queen Elizabeth II.

(L.S.) E. F. HERRING.

By His Excellency's Command,  
R. J. HAMER,  
Minister for Local Government.  
GOD SAVE THE QUEEN!

**PUBLIC HIGHWAYS.—SHIRE OF MANSFIELD.**

**PROCLAMATION**

By His Excellency the Lieutenant-Governor of the State of Victoria and its Dependencies in the Commonwealth of Australia, &c., &c., &c.

WHEREAS by the *Local Government Act 1958*, Section 519 it is amongst other things enacted that it shall be lawful for the Governor-in-Council at any time

and from time to time upon the request of the Council of any municipality by notice in the *Government Gazette* to proclaim any land reserved used or by purchase or exchange acquired for a street road highway thoroughfare bridge square court alley or right-of-way or any street road lane or passage made or laid out or proposed to be made or laid out on land of which a plan of subdivision delineating that street road lane or passage has been sealed with the seal of the municipality under subdivision (3) of Division 9 of Part XIX. of the *Local Government Act 1958*, or a corresponding previous enactment to be a public highway and that such land shall thereupon and thenceforth from the date of such proclamation become and be absolutely dedicated to the public as a public highway within the meaning of any law then or thereafter in force.

AND WHEREAS the Council of the Shire of Mansfield has requested that the lands hereinafter mentioned, being streets roads lanes or passages made or laid out or proposed to be made or laid out on lands of which a plan of subdivision delineating those streets roads lanes or passages has been sealed with the seal of the municipality under subdivision (3) of Division 9 of Part XIX. of the *Local Government Act 1958* or a corresponding previous enactment, be so declared to be public highways.

NOW THEREFORE I, the Lieutenant-Governor of the State of Victoria in the Commonwealth of Australia, by and with the advice of the Executive Council of the said State, do by this Proclamation declare that Moonah Road, Warringa Road and Nanda Court coloured brown on Plan of Subdivision No. 75839 lodged in the Office of Titles, shall be public highways within the meaning of the said Act.

Given under my Hand and the Seal of the State of Victoria aforesaid, at Melbourne, this third day of September, in the year of our Lord One thousand nine hundred and sixty-eight, and in the seventeenth year of the reign of Her Majesty Queen Elizabeth II.

(L.S.) E. F. HERRING.

By His Excellency's Command,  
R. J. HAMER,  
Minister for Local Government.  
GOD SAVE THE QUEEN!

**ROAD PROCLAIMED.**

**PROCLAMATION**

By His Excellency the Lieutenant-Governor of the State of Victoria and its Dependencies in the Commonwealth of Australia, &c., &c., &c.

IN pursuance of the provisions of Section 25 of the *Land Act 1958*, the Lieutenant-Governor of the State of Victoria, by and with the advice of the Executive Council of the said State, do hereby proclaim as a road the land in the Parish of Yinnar, County of Buln Buln as indicated by hatching on plan hereunder.—(Y.113(4) (H.031312).

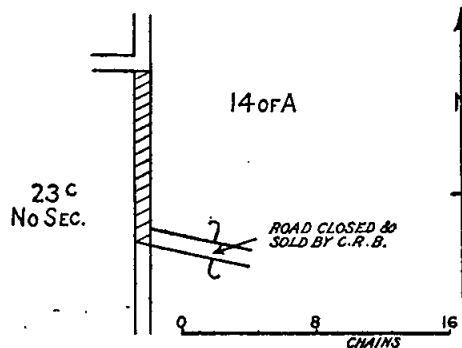

Given under my Hand and the Seal of the State of Victoria aforesaid, at Melbourne, this third day of September, in the year of our Lord One thousand nine hundred and sixty-eight, and in the seventeenth year of the reign of Her Majesty Queen Elizabeth II.

(L.S.) E. F. HERRING.

By His Excellency's Command,  
W. J. F. McDONALD,  
Minister of Lands.  
GOD SAVE THE QUEEN!

**GOVERNMENT NOTICES**

**HOLIDAY—ROYAL AGRICULTURAL SHOW.**

NOTICE is hereby given that on

THURSDAY, THE 26TH SEPTEMBER, 1968,

the Public Offices in the municipalities mentioned hereunder will be closed, that day being appointed by the Public Service Act 1958 to be observed as a holiday in the Public Offices:—

The Cities of Box Hill, Brighton, Broadmeadows, Brunswick, Camberwell, Caulfield, Chelsea, Coburg, Collingwood, Dandenong, Doncaster and Templestowe, Essendon, Fitzroy, Footscray, Frankston, Hawthorn, Heidelberg, Keilor, Kew, Malvern, Melbourne, Moorabbin, Mordialloc, Northcote, Nunawading, Oakleigh, Port Melbourne, Prahran, Preston, Richmond, Ringwood, St. Kilda, Sandringham, South Melbourne, Springvale, Sunshine, Waverley and Williamstown; the Shires of Altona, Berwick, Bulla, Cranbourne, Croydon, Diamond Valley, Eltham, Gisborne, Hastings, Knox, Lillydale, Melton, Mornington, Sherbrooke, Werribee and Whittlesea.

This notice relates only to the closing of the State Public Offices. All inquiries regarding holidays in other offices and in shops and industry should be directed to the Department of Labour and Industry, 110 Exhibition-street, Melbourne, 3000. (Telephone 63-0321, Extension 6158, 6721 or 6859.)

JAMES W. MANSON,  
for Chief Secretary.

Chief Secretary's Office,  
Melbourne, 2nd September, 1968.

*Pounds Act 1958.*

**CITY OF TRARALGON.**

TABLE of Rates to be charged for the trespass of cattle and their sustenance while impounded in the City of Traralgon Pound fixed by the Council of the City of Traralgon.

| Description of Cattle Trespassing.                            | Trespass Rates.  |  | Sustenance Fees. |
|---|--|--|------------------|
|   | Upon land other than Tillage land Enclosed by a Substantial Fence. | Upon Tillage land Enclosed by a Substantial Fence. |                  |
|   | \$   | \$   | \$               |
| For every sheep   | 0.03   | 0.10   | 0.20             |
| For every goat  | 0.50   | 1.00   | 0.50             |
| For every pig   | 0.50   | 1.00   | 0.50             |
| For every head of other cattle                                | 1.00   | 2.00   | 1.00             |
| <i>Additional rates payable in respect of entire animals.</i> |  |  |                  |
| For every entire horse, bull or ram                           | 20.00  | 20.00  |                  |

By Order of the Council,  
K. J. SAUNDERS,  
Town Clerk.

Approved by the Governor in Council, 3rd September, 1968.—  
J. ROSSITER, Clerk of the Executive Council.

*Town and Country Planning Act 1961.*

**SHIRE OF SHERBROOKE PLANNING SCHEME 1965.**

AMENDMENT No. 15, 1968.

*Notice of Amendment.*

IN pursuance of the powers conferred by sub-section 6 of section 32 of the Town and Country Planning Act 1961, the Governor in Council on the 3rd September, 1968, amended the Shire of Sherbrooke Planning Scheme 1965, in respect of the zoning of lots 5 and 6, lodged plan 6470, in Monbulk-road, Belgrave.

A copy of the amendment may be inspected during office hours at the office of the Town and Country Planning Board, 179 Queen-street, Melbourne; at the office of the Council of the Shire of Sherbrooke, at Upwey; and when available at the Office of Titles, Melbourne; and at the Central Plan Office of the Department of Crown Lands and Survey, Melbourne.

W. H. CRAIG, Secretary,  
Town and Country Planning Board.

*Town and Country Planning Act 1961.*  
**BOROUGH OF KYABRAM PLANNING SCHEME 1963.**

AMENDMENT No 1, 1968.

*Notice of Approval.*

IN pursuance of the powers conferred by the Town and Country Planning Act 1961, the Governor in Council on the 3rd September, 1968, approved a Planning Scheme entitled the Borough of Kyabram Planning Scheme 1963, Amendment No. 1, 1968, in respect of part of the municipal district of the Borough of Kyabram and such Planning Scheme comes into operation on the date this notice of approval is published in the Government Gazette.

A copy of the Planning Scheme, as approved, may be inspected free of charge during office hours at the office of the Town and Country Planning Board, 179 Queen-street, Melbourne, at the office of the Kyabram Borough Council, at Kyabram, and when available, at the Office of Titles, Melbourne, and at the Central Plan Office of the Department of Crown Lands and Survey, Melbourne.

W. H. CRAIG, Secretary,  
Town and Country Planning Board.

**ADOPTION OF CHILDREN ACT 1964.**

PURSUANT to the provisions of section 21 of the Adoption of Children Act 1964, notice is hereby given that, as from and inclusive of 15th September, 1968,

ALFRED SPENCER COLLIVER

has been approved as Principal Officer of the Presbyterian Social Services Department Private Adoption Agency, vice the Reverend L. F. F. Gunn.

JAMES W. MANSON,  
Acting Chief Secretary.

Chief Secretary's Office,  
Melbourne, 3rd September, 1968.

*Co-operation Act 1958.*

**CHANGE OF NAME OF SOCIETY.**

NOTICE is hereby given that Icianz (Ascot Vale) Employees' Credit Co-operative Limited which was incorporated as a Credit Society under the above-named Act on the twenty-second day of July, 1965, has registered a change of its name and is now incorporated under the name of Ascot Vale Area Employees' Credit Co-operative Limited under the said Act.

Dated at Melbourne this 29th day of August, 1968.

J. W. JUNGWIRTH,  
Registrar of Co-operative Societies.

**POLICE OFFENCES ACT 1958.**

IN pursuance of the powers conferred upon the Chief Secretary by sub-section (3) of section 184 of the Police Offences Act 1958, I, do by this Notice grant exemption from compliance with sub-sections (1) and (2) of section 184 of the said Act with respect to the publication "An Expensive Place to Die" distributed by Color-gravure Publications, 61 Flinders-lane, Melbourne.

JAMES W. MANSON,  
Acting Chief Secretary.

Chief Secretary's Office,  
Melbourne, 2nd September, 1968.

*Police Regulation Act 1958, Section 122.*

**SALE OF UNCLAIMED MOTOR VEHICLE.**

AN owner is required for a 1953 model, grey Austin A40 Panel Van, ex-Registered No. GBC-380, engine No. IG.783424.

The vehicle came into the possession of Police on the 18th April, 1968, and if not claimed, will be sold by public auction at the Reservoir Police Station, Edwardes-street, Reservoir, at 2 p.m., on the 27th September, 1968.

R. H. ARNOLD,  
Chief Commissioner of Police.

## Police Regulation Act 1958.

## POLICE FORCE OF VICTORIA.

## DETERMINATION NO. 144 OF THE POLICE SERVICE BOARD.

THE Police Service Board, in pursuance of the powers in that behalf conferred by the *Police Regulation Act 1958*, hereby makes the following Determination, that is to say:—

1. The Determination No. 107 of the Police Service Board of the 15th November, 1963, and published in the *Government Gazette* of the 4th February, 1964, as amended, is hereby further amended as follows:—

By deleting paragraph 72 and substituting therefor the following:—

"72. Members who use their own motor cars, motor cycles with side-cars, motor cycles or bicycles on police duty, shall be paid for such use in accordance with the following scale:—

(a) For members who are issued with the "B" Pass by the Victorian Government Motor Transport Committee authorizing the holder to obtain supplies of petrol and oil at Government rates—

|                             | For the first                       | Mileage over                        |
|-----------------------------|-------------------------------------|-------------------------------------|
|                             | 5,000 miles in a<br>financial year. | 5,000 miles in a<br>financial year. |
|                             | A mile.                             | A mile.                             |
|                             | c.                                  | c.                                  |
| Motor cars—                 |                                     |                                     |
| 17 h.p. and over            | 10·2                                | 5·7                                 |
| Under 17 h.p. . .           | 8·4                                 | 4·4                                 |
| Motor cycles with side-cars | 4·2                                 | 2·2                                 |
| Motor cycles                | 3·6                                 | 1·9                                 |

(b) For members who are not issued with the "B" Pass referred to in sub-paragraph (a):—

|                             | For the first                       | Mileage over                        |
|-----------------------------|-------------------------------------|-------------------------------------|
|                             | 5,000 miles in a<br>financial year. | 5,000 miles in a<br>financial year. |
|                             | A mile.                             | A mile.                             |
|                             | c.                                  | c.                                  |
| Motor cars—                 |                                     |                                     |
| 17 h.p. and over            | 10·7                                | 7·2                                 |
| Under 17 h.p. . .           | 8·7                                 | 5·6                                 |
| Motor cycles with side-cars | 4·5                                 | 2·9                                 |
| Motor cycles                | 3·9                                 | 2·4                                 |

(c) In addition to the allowances prescribed in sub-paragraph (b) hereof, members—

(i) who are not issued with the "B" Pass referred to in sub-paragraph (a); and

(ii) who do not exceed in any one financial year the maximum number of miles set out hereunder, shall be paid at the end of that financial year an additional amount calculated at the appropriate following rate:—

|                   | For the first                     | Exceeding 500 miles<br>but not exceeding |
|-------------------|-----------------------------------|--|
|                   | 500 miles in a<br>financial year. | 1,500 miles in a<br>financial year.      |
|                   | A mile.                           | A mile.                                  |
|                   | c.                                | c.                                       |
| Motor cars—       |                                   |  |
| 17 h.p. and over  | 3·5                               | 0·75                                     |
| Under 17 h.p. . . | 2·7                               | 0·75                                     |

(d) For bicycles—at the rate of 1·3c per mile, irrespective of mileage."

2. This Determination shall come into operation on the 15th day of September, 1968.

Dated at Melbourne, this 2nd day of September, 1968.

(Signed) BEN. J. DUNN,  
A Judge of the County Court of Victoria,  
Chairman and Member of the  
Police Service Board.

(Signed) C. H. PETTY,  
Member of the Police Service Board.

(Signed) P. H. BENNETT,  
Member of the Police Service Board.

## Transport Regulation Act.

## TRANSPORT REGULATION BOARD.

## HEARING OF APPLICATIONS.

NOTICE is hereby given that the following applications will be considered by the Transport Regulation Board at its offices at the corner of Lygon and Princes streets, Carlton, at 10.15 a.m. on Wednesday, 2nd October, 1968.

DEVILLE, E. L. & H., PTY. LTD., 120 King-street, Melbourne. One commercial passenger vehicle (S/C. 8) to operate for the carriage of company's employees free of charge, from Oulton-crescent, Preston via Oulton-crescent, Chaley-street, Plenty-road, High-street, Hutton-street, St. Georges-road, Holden-street, Brunswick-road, Sydney-road, Royal-parade, Elizabeth-street, Queensberry-street, Abbotsford-street, Millers-street, Dynon-road, Sims-street, Footscray-road, Napier-street, Moreland-street, Whitehall-street, Somerville-road, Geelong-road, Little Boundary-road, Pipe-road and Stanley-street to the company's premises at Derrimut. Vehicle to operate between the hours 7.00 a.m. and 8.00 a.m. and 4.30 p.m. and 6.00 p.m.

EAST PRESTON & EPPING BUS SERVICES HOLDINGS PTY. LTD., 922 High-street, Reservoir. Application for variation of M.O. licence conditions, Route 1A Part A (Edwards Park-Reservoir-Northland Shopping Centre) and Route 122A (Epping-Reservoir-East Preston-Northland Shopping Centre) to delete the restriction applied to the picking up and setting down of passengers between the corner of Plenty-road and Wood-street and Northland Shopping Centre.

McHARRY, A. M. & N. J., 23 Catherine-street, Geelong. One commercial passenger vehicle (S/C. 40) to operate under the same terms and conditions as licence U.O. 418 in the name of the applicants.

SOUTHLAND BUS SERVICE PTY. LTD., corner Keys and Kilpa roads, Moorabbin. One commercial passenger vehicle (S/C. 30) to be purchased to operate as an additional country stage omnibus on Route 218A (Moorabbin-Cheltenham-Clayton).

APPLICATIONS for renewal of licences as shown, by persons listed hereunder to operate under the same terms and conditions.

BENDERS BUSWAYS PTY. LTD., Edol-street, Geelong; T.P.196.  
 BINAISSE, E. E., Sladen-street, Cranbourne; C.H.72.  
 BRUK BRUK BUS SERVICE PTY. LTD., care of J. E. Morton, P.O. Box 172, Casterton; T.S.173.  
 CLOHESY, L. J., 54 Sturt-street, Echuca East; T.S.337.  
 CRAMP, K. H., Main-street, Speed; T.S.677.  
 DORF TAPS PTY. LTD., 42-46 Buckland-street, Clayton; T.P.92.  
 GILBERTSON, R. J., PTY. LTD., Kyle-road, Altona North; T.P.101, T.P.102, T.P.13.  
 JERMYN, J. E., Slips-road, Paynesville; T.S.551.  
 KRAFT FOODS LTD., Salmon-street, Port Melbourne; T.P.142.  
 LITTLES GIPPSLAND COACHES PTY. LTD., 9 McAlister-street, Sale; C.O.740.  
 LUCIEER, W. S., 26 Ellen-street, Springvale; C.T.311.  
 McCONVILLE, T. R., Litchfield; T.S.783.  
 NUGENT, E. M. & J. H., (trading as Kiddievale Day Nursery), 25 Fallon-street, Caulfield; T.P.217.  
 RICCIARDI, P., 34 Bruce-street, North Geelong; T.P.52.  
 ROSS, C. C., 150 Scott-street, Warracknabeal; T.P.173.  
 ROSS, H. E. (Miss), 8 Willow-grove, West Coburg; T.P.108.  
 SHANAHAN, J. T., Chinkapook; T.S.695.  
 SMITH, J. H., 101 Wyndham-street, Shepparton; T.P.67.  
 TRASK, J. T., 291 Main-street, Bacchus Marsh; T.P.68  
 VICTORIAN SEWERAGE CONTRACTORS PTY. LTD., 557 Nicholson-street, Carlton; T.P.61.  
 WALLACE, J. (Mrs.), Fairyland Child Minding Centre, 214 Dorset-road, Croydon; T.P.1.

Notice of any objection should be forwarded to reach the Secretary of the Board not later than Wednesday, 25th September, 1968.

Applicants are advised that it will not be necessary to appear on the hearing date specified above, unless advised in writing by the Board.

B. P. KAY,  
Secretary.

Corner Lygon and Princes streets, Carlton, Wednesday, 11th September, 1968.

## Commercial Goods Vehicles Act.

## TRANSPORT REGULATION BOARD.

## HEARING OF APPLICATIONS.

NOTICE is hereby given that the following applications will be considered by the Transport Regulation Board at its offices at the corner of Lygon and Princes streets, Carlton, at 10.15 a.m. on Wednesday, 2nd October, 1968.

A. H. AGENCIES & SALES PTY. LTD., 1122 High-street, Armadale, 3143. Application to vary conditions of licence No. T.D.A.45101/6 (L/C. 17 cwt.) by deleting "215 Raymond-street, Sale" and the word "Sale" from the existing conditions and adding in lieu "Morwell".

ASCOM EQUIPMENT PTY. LTD., 63 Queen's Bridge-street, South Melbourne, 3205. One commercial goods vehicle (L/C. 22 cwt.) to operate in the course of business as "Civil Engineers and Contractors" as follows: (a) Within a 50-mile radius of the post office situated at the corner of Bourke and Elizabeth streets in the City of Melbourne—own goods incidental to own contracts confined wholly within the said radius. (b) Throughout the State of Victoria—tools of trade, equipment and small quantities of materials incidental to the repair or completion of own contracts but excluding the carriage of any materials whatsoever within the Metropolitan Area (as defined in the *Transport Regulation Act 1958*) except as authorized in part (a) of this document and excluding also the carriage of cement from the Geelong urban district (as also defined in the *Transport Regulation Act 1958*).

ASCOM EQUIPMENT PTY. LTD., 63 Queen's Bridge-street, South Melbourne, 3205. One commercial goods vehicle (L/C. 13 cwt.) to operate throughout the State of Victoria in the course of business as "Civil Engineers and Contractors" for the purposes of supervising own contracts—tools of trade, spare parts and a small quantity of materials incidental to the completion of own contracts.

BAGLIN, I. W., 2 Sussex-street, Blackburn, 3130. One commercial goods vehicle (L/C. 7 cwt.) to operate throughout the State of Victoria as a "Wholesale Philatelist" for the purpose of carrying stamps, stamp accessories, albums and up to four dozen packs of playing cards for display and sale to prospective purchasers.

BALLARAT PINE INDUSTRIES PTY. LTD., Vickers-street, Sebastopol, 3356. Two commercial goods vehicles (L/C. 218 and 144 cwt.) to operate: (a) Within a 25-mile radius of the chief post office in the City of Ballarat in the course of business as "Sawmillers"—own goods. (b) From landings within a 30-mile radius of Ballarat to own sawmills at Sebastopol—logs.

BELL, G. J., Wangoom, 3279. One commercial goods vehicle (L/C. 120 cwt.) to operate: (a) Within a 25-mile radius of the post office at Wangoom—general goods provided that no goods shall be carried whether by one stage or by more than one stage between places within the above radius which are more than 30 miles apart by the nearest practicable route. (b) Within a 50-mile radius of the post office at Wangoom—livestock. (c) Within a 50-mile radius of the post office at Wangoom in the course of business as "Primary Producer"—own goods.

BIGGS, D., 101 White-road, North Wonthaggi, 3995. One commercial goods vehicle (L/C. 320 cwt.) to operate within a 70-mile radius of the post office at Wonthaggi in course of business as an "Earth-moving Contractor"—own earth-moving equipment, tools of trade and spare parts incidental to the servicing of own equipment in the field only but excluding the carriage of spare parts from Melbourne.

CAMERON, D. A., Colbinabbin, 3559. One commercial goods vehicle (L/C. 6 cwt.) to operate within a 60-mile radius of the post office at Colbinabbin in the course of business as "Hawker"—goods on behalf of W. T. Rawleigh & Co. Ltd., subject to the condition that any goods so carried shall not be supplied to retail stores for resale.

CAMPBELL, R. E., 8 Rubicon-street, Reservoir, 3073. One commercial goods vehicle (L/C. 53 cwt.) to operate: (a) Within a 25-mile radius of the G.P.O., Melbourne—general goods. (b) Within a 70-mile radius of the premises of the Barkly Brick Co. Pty. Ltd., at Brunswick—solely on behalf of the said company—bricks.

CARLTON & UNITED BREWERIES LTD., 16 Bouverie-street, Carlton, 3053. One commercial goods vehicle (L/C. 11 cwt.) to operate throughout the State of Victoria in the course of business as "Brewers"—tools of trade, spare parts and materials incidental to the servicing and maintenance of beer drawing equipment.



- COCA-COLA BOTTLERS (MELBOURNE) PTY. LTD.**, Levanswell-road, Moorabbin, 3189. One commercial goods vehicle (L/C. 144 cwt.) to operate within a 50-mile radius of the G.P.O., Melbourne, in course of business as "Aerated Water Manufacturers"—aerated waters and empty return containers.
- CREA, P.**, 767 High-street, Preston, 3072. One commercial goods vehicle (L/C. 8 cwt.) to operate: (a) Within a 50-mile radius of own premises at Preston in course of business as "Motor Wrecker"—own goods. (b) Throughout the State of Victoria for the purpose of collecting second-hand and disabled vehicles for wrecking purposes—second-hand and disabled motor cars on a specially constructed car carrying trailer.
- CULHANE, J. M.**, Norong, via Rutherglen, 3685. One commercial goods vehicle (L/C. 140 cwt. approximately) to operate: (a) Within a 50-mile radius of the post office at Rutherglen as a "Road Contractor"—road-making plant and materials. (b) Within a 25-mile radius of the post office at Rutherglen—general goods provided that no goods shall be carried whether by one stage or by more than one stage between places within the above radius which are more than 30 road miles apart by the nearest practicable route.
- DAWSON, V. J.**, 509 Pascoe Vale-road, Pascoe Vale, 3044. One commercial goods vehicle (L/C. 123 cwt.) to operate within a 70-mile radius of the premises of The Barkly Brick Co. Pty. Ltd., at Brunswick, solely on behalf of the said company—bricks.
- DOWELL SCHLUMBERGER WESTERN S.A.**, Darling-street, Sale, 3850. Application to vary conditions of licence No. D.A.61776 (L/C. 16 cwt.) by deleting the existing conditions and adding in lieu: "In the course of own business as 'Evaluators of Oil and Gas Flows' in Gippsland off-shore wells—tools of trade, chemicals and other materials and equipment incidental to such business. (a) Within a 50-mile radius of the post office at Sale. (b) Between Sale and Lakes Entrance. (c) Between Sale and Barry Beach".
- DUNLOP TYRE SERVICE (VIC.) PTY. LTD.**, Benalla Branch, 108 Flinders-street, Melbourne, 3000. Two commercial goods vehicles (L/C. 11 cwt. each) to operate within a 50-mile radius of own branch premises at Benalla in the course of business as "Tire Retreaders and Distributors"—new tires and tubes for sale and delivery, also used tires for repair or retreading or having been repaired or retreaded, also batteries, oil and motor car accessories.
- EWING, R.**, 18 MacLise-street, Castlemaine, 3450. One commercial goods vehicle (L/C. 300 cwt. approximately) to operate within a 50-mile radius of the chief post office at Castlemaine in the course of business as "Excavating Contractor"—own bulldozer, tools of trade and excavating equipment.
- FARMAIR PTY. LTD.**, 7 Raymond-street, Sale, 3850. One commercial goods vehicle (L/C. 14 cwt.) to operate in the course of business as "Aerial Spraying Contractor". (a) Throughout the State of Victoria—own tools of trade, equipment and spare parts incidental to servicing. (b) Within a 20-mile radius from the site of any contract currently engaged upon or from the railway station or fuel depot nearest thereto—superphosphate and chemicals for aerial spreading, aviation fuel and lubricants.
- FYFE, K. F.**, 9 Turnbull-street, Sale, 3850. One commercial goods vehicle (L/C. 185 cwt.) to operate within a 50-mile radius of the post office at Sale and within a 50-mile radius of the post office at Bairnsdale, solely on behalf of Pioneer Concrete Pty. Ltd.—premixed concrete in specially constructed agitator vehicle.
- MCKEON, E. J.** (trading as Geelong Laundry Co.), 25-27 Austin-street, Newtown, 3220. One commercial goods vehicle (L/C. 6 cwt.) to operate within a 50-mile radius from own premises at Newtown in the course of business as "Launderers". (a) Articles for laundering or having been laundered. (b) Goods in connexion with own business.
- GENERAL CONSTRUCTIONS PTY. LTD.**, 62 Mandoon-road, Girraween, N.S.W., 2145. One commercial goods vehicle (L/C. 33 cwt.) to operate in the course of business as "General Construction Engineers". (a) Throughout the State of Victoria—own tools of trade and own equipment incidental to own contracts. (b) Within a 20-mile radius of the site of any contract currently engaged upon or from the railway station nearest thereto—materials for use on such contract. (c) From the site of own contracts to sites of disposal—overburden.
- GILL, F. W.**, 16 Desmond-street, Maidstone, 3012. One commercial goods vehicle (L/C. 8 cwt.) to operate throughout the State of Victoria in course of business as "Refrigeration Servicemen"—tools of trade, spare parts and equipment incidental to the servicing and maintenance of refrigeration equipment.
- GLACIER FOODS PTY. LTD.**, 421 Swan-street, Richmond, 3121. Two commercial goods vehicles (L/C. 18 and 22 cwt.) to operate throughout the State of Victoria in the course of business as "Frozen Food Distributors" in a specially constructed refrigerated van—frozen meat, frozen fish, frozen poultry, frozen vegetables, frozen dim sims, frozen chicken rolls, frozen chop suey, and up to 20 lb. of puff pastry and 10 lb. of canned fruit juice at a temperature not exceeding 10° F.
- GOODALL, H., & SON PTY. LTD.**, Dunlop-street, Mortlake, 3272. One commercial goods vehicle (L/C. 7 cwt.) to operate within a 70-mile radius from own premises at Mortlake in the course of business as "Farm Machinery Distributor and Servicing Specialist"—tools of trade, spare parts incidental to servicing, farm machinery for repair or having been repaired, second-hand trade-in machinery and new machinery for delivery or installation.
- GRANDY, K. A.**, Box 159, Lakes Entrance, 3909. Application to vary conditions of licence No. D.T.624/1 (L/C. 301 cwt.) by adding as an additional paragraph (d)—"(d) From forest landings within a 50-mile radius of the post office at Corryong to the sawmill of N. Smith Pty. Ltd., at Corryong—logs".
- GREEVES, K. J.**, Flat 7, 21 Mark-street, North Melbourne, 3051. One commercial goods vehicle (L/C. 100 cwt.) to operate within a 70-mile radius of the premises of The Barkly Brick Co. Pty. Ltd., at Brunswick, solely on behalf of the said company—bricks.
- HARCON TRADING CO. PTY. LTD.**, 2 South Wharf, South Melbourne, 3205. One commercial goods vehicle (L/C. 75 cwt.) to operate: (a) Within a 50-mile radius of own premises at South Melbourne in the course of business as "Frozen Foods and Fish Distributors"—own goods. (b) Throughout the State of Victoria in a specially constructed insulated vehicle—frozen and fresh fish, frozen poultry, frozen meat, frozen vegetables, onions and a small quantity of mussels, not exceeding four dozen bottles at any one time.
- HARTLEY, ERN (WARRNAMBOOL), PTY. LTD.**, 223 Koroi-street, Warrnambool, 3280. One commercial goods vehicle (L/C. 11 cwt.) to operate: (a) For the carriage of aerated waters, groceries, medical supplies, cordials, confectionery and cakes in the course of business as "Distributor" from own premises in the City of Warrnambool to resellers whose premises are situated only within the area of Victoria bounded as follows:—On the west by the border of South Australia and Victoria, on the north and east by the main road from Naracoorte (South Australia) via the Townships of Edenhope and Natimuk to the City of Horsham; thence via the Western Highway to the City of Ballarat; thence via the main road through the Township of Cressy, the City of Colac and the Townships of Forrest and Apollo Bay and including all places situated within a 5-mile radius of such roads. (b) Within a 50-mile radius of the post office at Warrnambool and from and to the City of Warrnambool to and from the Township of Willaura but excluding any place situated on the Henty Highway between the Township of Portland and the City of Hamilton—biscuit products on behalf of Nabisco Pty. Ltd., subject to the condition that all goods so carried shall have been initially consigned by rail to Warrnambool.
- HEALY, K. M.**, Jellico-avenue, Tallangatta, 3700. One commercial goods vehicle (L/C. 150 cwt. approximately) to operate: (a) Within a 25-mile radius of the post office at Tallangatta—general goods provided that no goods shall be carried whether by one stage or by more than one stage between places within the above radius which are more than 30 road miles apart by the nearest practicable route. (b) To and from places within the radius as defined in paragraph (a) above from and to places within a 50-mile radius of the post office at Tallangatta—livestock.
- HOBBS, E. R., PTY. LTD.**, 24 Alex-avenue, Moorabbin, 3189. One commercial goods vehicle (L/C. 142 cwt.) to operate: (a) Within a 25-mile radius of G.P.O., Melbourne in course of business as "Paving and Road-making Contractors"—own goods. (b) Throughout the State of Victoria—tools of trade and own road-making and paving plant. (c) Throughout the State of Victoria—hot asphalt at a temperature of 300°-400°F. in an insulated vehicle.
- INTERNATIONAL HARVESTER CO. OF AUSTRALIA PTY. LTD.**, The Esplanade, North Shore, 3214. One commercial goods vehicle (L/C. 62 cwt.) to operate throughout the State of Victoria in the course of business as "Truck, Tractor and Farm Implement Manufacturer"—farm implements and accessories for experimental and/or for demonstration purposes, also tools of trade incidental to the servicing and maintenance of own machinery and equipment, also spare parts for use solely at site of the machinery being serviced.

- JOHNSON, P. F. & R. B., Forest-street, Whittlesea, 3757. Application to vary conditions of licence No. D.T.1109 (L/C. 249 cwt.) by deleting "Kingleke West" from the existing conditions and adding in lieu "Broadford".
- KEE, R. E., 63 Scotch-parade, Bonbeach, 3196. One commercial goods vehicle (L/C. 140 cwt. approximately) to operate: (a) Within a 25-mile radius of own premises at Carrum in the course of business as "Sand, Screening, Soil and Stone Supplier"—own goods. (b) From pits at Healesville to places within the area defined in paragraph (a) above—own soil. (c) From pits at Bacchus Marsh to places within the area defined in paragraph (a) above—own river pebbles and own river gravel. (d) From the Werribee, Laverton, Bacchus Marsh and Rockbank areas to own premises at Carrum—own garden stone. (e) From Beveridge to own premises at Carrum—own scoria.
- KEAYS, R. G. (trading as R. & M. Keays), Strath Creek via Broadford, 3658. Two commercial goods vehicles (L/C. 247 and 131 cwt.) to operate from and to points within the Shire of Broadford to and from the Melbourne Metropolitan Area for the carriage of general goods.
- NOTE.—This application replaces previous application in the name of R. & M. Keays which appeared in the *Government Gazette*, dated 3rd July, 1968.
- KLEINITZ, I. A., Forest-road, Orbost, 3888. One commercial goods vehicle (L/C. 86 cwt.) to operate: (a) Within a 25-mile radius of the post office at Orbost—general goods provided that no goods shall be carried whether by one stage or by more than one stage between places within the above radius which are more than thirty road miles apart by the nearest practicable route. (b) From and to places within the radius as defined in paragraph (a) above to and from places within a 50-mile radius of the post office at Orbost—livestock.
- LEWIS, T. K., 11 Nottingham-street, Sunshine, 3020. One commercial goods vehicle (L/C. 138 cwt) to operate within a 50-mile radius from the premises of Albion Reid Pty. Ltd. at North Melbourne—road-making plant, materials, premix and hot asphalt on behalf of the said company excluding the carriage of cement or lime from the Geelong Urban District.
- LOCKYER, W. R., 3 Nelson-street, Sebastopol, 3356. One commercial goods vehicle (L/C. 139 cwt.) to operate: (a) Within a 50-mile radius of the post office at Ballarat—as a "Road Contractor"—road-making plant and materials. (b) Within a 25-mile radius of the post office at Ballarat—general goods.
- LOUDER, S., 32 Johnston-street, Collingwood, 3066. One commercial goods vehicle (L/C. 11 cwt.) to operate throughout the State of Victoria in the course of business as "Engineer" solely on behalf of Supa-Flame Pty. Ltd., at Collingwood, for the purpose of installing and maintaining stoves and oil burner units—tools of trade, spare parts and materials incidental to the installation and maintenance of such appliances.
- MAHAN, P. L., P.O. Box 57, Daylesford, 3460. One commercial goods vehicle (L/C. 10 cwt.) to operate within a 50-mile radius from the post office at Daylesford in the course of trade as "Radio, Washing Machines and Television Serviceman"—tools of trade, spare parts, materials and clients' own electrical equipment for repair or having been repaired.
- MILLER, J. (trading as Milleradio), 550-562 Malvern-road, Prahran, 3181. One commercial goods vehicle (L/C. 8 cwt.) to operate throughout the State of Victoria for the purposes of servicing and installing radio equipment in the course of business as "Manufacturer of Radio Communication Equipment"—tools of trade, spare parts and materials incidental thereto, also radio equipment for installation, for repair or having been repaired.
- MULLINS, J. B., Dunnstown, 3343. One commercial goods vehicle (L/C. 140 cwt.) to operate: (a) Within a 55-mile radius of the post office at Beaufort (Ballarat Division of the Country Roads Board)—road-making plant. (b) Within a 20-mile radius from any current construction site or from the nearest railway station thereto—materials. (c) Within a 25-mile radius of the post office at Dunnstown—general goods provided that no goods shall be carried whether by one stage or by more than one stage between places within the above radius which are more than thirty road miles apart by the nearest practicable route.
- NEWCOMBE, G. P., Main-street, Elliminyt, 3249. One commercial goods vehicle (L/C. 18 cwt.) to operate to the premises of Thomas Peacock & Sons Pty. Ltd., waste merchants at Abbotsford from points within a 50-mile radius of the post office at Colac in the course of business as "Waste Collector"—waste paper and waste rags collected on behalf of the Colac District Hospital.
- NEWMAN, G. W., 78 Clarke-street, Lilydale, 3140. One commercial goods vehicle (L/C. 276 cwt.) to operate within a 50-mile radius of the post office at Lilydale in the course of business as an "Earth-moving Contractor"—own earth-moving equipment, tools of trade and spare parts incidental to the servicing of own equipment in the field only.
- PERMEWAN WRIGHT LTD., 147-179 Alexandra-parade, Abbotsford, 3067. One commercial goods vehicle (L/C. 16 cwt.) to operate within a 50-mile radius of own branch premises at Colac in the course of business as "General and Produce Merchants"—own goods.
- PETERSVILLE AUSTRALIA LTD., Wellington-road, Clayton, 3168. One commercial goods vehicle (L/C. 23 cwt.) to operate throughout the State of Victoria for the purposes of installing, servicing and maintaining commercial refrigerators—own refrigerators for installation and replacement and spare parts, tools of trade and materials incidental to such installation, servicing and maintenance.
- PHILIP MORRIS LTD., Chesterville-road, Moorabbin, 3189. Four commercial goods vehicles (L/C. 7 cwt. each) to operate throughout the State of Victoria as a Traveller's Vehicle for the display and sales promotion of own products and agency lines in the course of business as "Manufacturers and Distributors"—samples of own products and agency lines together with display materials relating to goods for sale and a small quantity of stocks of the various lines for sale to enable a sample to be left with a customer when required or an interim supply of any product to be left with a retailer pending despatch of normal supplies.
- PROCESSED FOOD DISTRIBUTORS PTY. LTD., 8-10 Fishmarket, New Footscray-road, Footscray, 3011. One commercial goods vehicle (L/C. 20 cwt.) to operate: (a) Within a 50-mile radius of own premises at Footscray in the course of business as "Frozen Food Distributors"—own goods. (b) Within that part of the State of Victoria east of a line drawn due north and south through the City of Melbourne in a specially constructed refrigerated vehicle—frozen fish, frozen poultry, frozen processed vegetables, frozen chicken rolls, frozen dim sims, frozen hamburgers, ice-cream, frozen fruit, juices, frozen egg whites, and frozen pastries at a temperature of 0 deg. F.
- READY MIXED CONCRETE (VIC.) PTY. LTD., 68 Burwood-road, Burwood, 3125. Two commercial goods vehicles (L/C. 225 cwt. each) to operate: (a) Within a 25-mile radius of G.P.O., Melbourne in course of business as "Premixed Concrete Manufacturers"—own goods. (b) From Bacchus Marsh to places within a radius defined in paragraph (a) above—sand. (c) Within a 50-mile radius of G.P.O., Melbourne, as an Agitator Vehicle—premixed concrete.
- REEVE, B. R., 3 Whiteman-street, South Melbourne, 3205. One commercial goods vehicle (L/C. 11 cwt.) to operate: (a) Within a 50-mile radius of own premises at South Melbourne in course of business as "Engineers"—own goods. (b) Throughout the State of Victoria for the purpose of displaying and servicing pumps and pumping equipment—tools of trade, spare parts, pumps and equipment for display, for repair or having been repaired.
- REPLACEMENT PARTS PTY. LTD., 618 Elizabeth-street, Melbourne, 3000. One commercial goods vehicle (L/C. 13 cwt.) to operate within a 50-mile radius of own branch premises at Sale in the course of business as "Spare Parts Distributors and Reconditioners"—spare parts, automobile accessories, engines and parts for reconditioning or having been reconditioned.
- RIDD CO. (AUST.) PTY. LTD., 167 King-street, Melbourne, 3000. One commercial goods vehicle (L/C. 7 cwt.) to operate throughout the State of Victoria for the purpose of servicing milk machinery in the course of business as "Milk Machinery Manufacturers"—tools of trade, spare parts and materials incidental thereto.
- ROONEY, J. A. W., Box 81, Kergunyah, 3691. One commercial goods vehicle (L/C. 81 cwt.) to operate: (a) To or from properties within a 25-mile radius of the post office at Kimbank from and to the railway station at either Wodonga or Huon—general goods. (b) From and to places within a 25-mile radius of the post office at Kergunyah to and from places within a 50-mile radius of such post office—livestock.
- SALTER, R. A., Rupanyup, 3388. One commercial goods vehicle (L/C. 65 cwt.) to operate: (a) Within a 25-mile radius of the post office at Rupanyup—general goods provided that no goods shall be carried whether by one stage or by more than one stage between places within the above radius which are more than 30 road miles apart by the nearest practicable route. (b) Within a 50-mile radius of the

- depot of B.P. (Aust.) Ltd., at Horsham—petroleum products in prescribed types of containers and empty return containers.
- SAVILLE, R., 15 Regent-street, Shepparton, 3630. One commercial goods vehicle (L/C. 7 cwt.) to operate: (a) Within a 50-mile radius of own premises at Shepparton in the course of business as "Builder"—own goods. (b) Throughout the State of Victoria for the carriage of own tools of trade and equipment. (c) From Shepparton to own contract sites at Bright—own goods incidental to the completion of such contracts. (d) Within that part of the State of Victoria east of a north/south line drawn through Kerang, north of an east/west line drawn through Seymour and west of a north/south line drawn through Wodonga—goods incidental to the completion of a contract held with the Housing Commission of Victoria provided that all such goods be initially consigned by rail to Shepparton or to the nearest railway station to such contract.
- BUTLER, J. J. (trading as A. R. Scoones & Co.), Somers-avenue, Shepparton, 3630. One commercial goods vehicle (L/C. 20 cwt.) to operate within a 50-mile radius of own branch premises at Shepparton in the course of business as "Petroleum Agent and Distributor"—own goods.
- SIGMA COMPANY LTD., 589 Collins-street, Melbourne, 3000. One commercial goods vehicle (L/C. 8 cwt.) to operate within a 50-mile radius of own branch premises at Shepparton as "Wholesale Manufacturing Chemists"—own goods with the proviso that all goods are initially forwarded to Shepparton by rail.
- SPILLER, H. H., Yana-street, Swan Hill, 3585. Application to vary conditions of licence No. D.A.61953 (L/C. 11 cwt.) by adding to the existing conditions after "air conditioning units for", the word "installation".
- STONES, G., Hamilton-street, Rutherglen, 3685. One commercial goods vehicle (L/C. 120 cwt.) to operate: (a) Within a 25-mile radius of the post office at Rutherglen—general goods provided that no goods shall be carried whether by one stage or by more than one stage between places within the above radius which are more than 30 road miles apart by the nearest practicable route. (b) Within a 50-mile radius of the depot of BP Australia Ltd., at Wodonga—petroleum products in prescribed types of containers solely on behalf of the said company and empty containers for return.
- TINDALL, H. R., 491 Brunswick-road, West Brunswick, 3055. One commercial goods vehicle (L/C. 10 cwt.) to operate throughout the State of Victoria in the course of business as "Serviceman Fitter" on behalf of Gilbarco Aust. Ltd., for the purpose of installing and maintaining petroleum dispensing equipment—tools of trade and parts incidental thereto.
- TSOTRAS, E., 10 Ewart-street, Malvern, 3144. One commercial goods vehicle (L/C. 34 cwt.) to operate throughout the State of Victoria in the course of business as "Hawker"—drapery, manchester and footwear subject to the condition that no goods so carried shall be supplied to retail stores for resale.
- UNILEVER AUSTRALIA PTY. LTD., Ingles-street, Port Melbourne, 3207. One commercial goods vehicle (L/C. 140 cwt.) to operate within a 25-mile radius of the G.P.O., Melbourne, and to and from places on the Mornington Peninsula in course of business as "Soap and Food Stuff Manufacturers"—own margarine, own fats and own edible oils in an insulated van.
- BIELBY, D. E. & G. A. (trading as Wendouree Confectionery—Wholesalers); 28 Lake-street, Wendouree, 3355. One commercial goods vehicle (L/C. 26 cwt.) to operate: (a) Within a 50-mile radius of the post office at Ballarat in the course of business as "Wholesale Confectioner"—own goods. (b) From Ballarat to the City of Ararat and the Town of Lake Bolac serving places en route—own goods.
- WESTON, S. C., 119 Princes-street, Flemington, 3031. One commercial goods vehicle (L/C. 109 cwt.) to operate within a 50-mile radius of own premises at Flemington in course of business as "Drum Merchant" for the purpose of collecting empty used drums—empty used drums.
- WILSON, W. G., 322 Windermere-street, Ballarat, 3350. One commercial goods vehicle (L/C. 10 cwt.) to operate within a 100-mile radius of the post office at Ballarat in the course of business as "Piano Tuner"—tools of trade, spare parts and materials incidental to the completion of own contracts.
- solely: (a) For the purpose of lifting and carrying or towing motor cars and the carriage of tools and equipment necessary for such purposes only. (b) The carriage of spare parts necessary for the repair of a disabled motor to and from the place at which such disablement has occurred.
- GRUNDMAN, P. M., 609 Keilor-road, Niddrie, 3042. One commercial goods vehicle (L/C. 40 cwt.) to operate within a 50-mile radius from the G.P.O., Melbourne, as a "Tow Truck" solely: (a) For the purpose of lifting and carrying or towing motor cars and the carriage of tools and equipment necessary for such purpose only. (b) The carriage of spare parts necessary for the repair of a disabled motor to and from the place at which such disablement has occurred.
- POWELL, D. (trading as Volksway), 90 Governor-road, Mordialloc, 3195. One commercial goods vehicle (to be purchased) to operate within a 50-mile radius of the post office at Mordialloc as a "Tow Truck" solely: (a) For the purpose of lifting and carrying or towing motor cars and the carriage of tools and equipment necessary for such purpose only. (b) The carriage of spare parts necessary for the repair of a disabled motor to and from the place at which such disablement has occurred.

## RENEWALS.

- APPLICATIONS for renewal of licences as shown by persons listed hereunder to operate under the same terms and conditions from the expiry shown in each case.
- BAKER, G. W., & F. I., Scott-street, Glenthompson, 3292; D.A.53536; 5th October, 1968; 104 cwt.
- BAR'S LEAKS (AUSTRALIA) PTY. LTD., 75A Bonanza-road, Beaumaris, 3193; D.A.27657; 19th November, 1968; 6 cwt.
- BROWN, H. M., 120 Harris-street, Corryong, 3707; T.D.A.34160; 20th October, 1968; 32 cwt.
- BROWN'S OFFICE CLEANING SERVICES PTY. LTD., 367 High-street, Kew, 3101; D.A.750/27; 9th November, 1968; 17 cwt.
- BUURMAN, B. T. (trading as Buurman Bros.), 1 Laburnam-street, Morwell, 3840; D.A.53613; 19th October, 1968; 73 cwt.
- CAIRNS, P., 30 Coster-street, Alexandra, 3714; T.T.D.534/1; 15th August, 1968; 255 cwt.
- CARLTON & UNITED BREWERIES LTD., 16 Bouverie-street, Carlton, 3053; D.A.808/8; 15th November, 1968; 11 cwt.; D.A.808/9; 15th November, 1968; 11 cwt.
- COLONIAL GAS ASSOCIATION LTD., THE, 480 St. Kilda-road, Melbourne, 3004; D.A.25112/20; 7th November, 1968; 45 cwt.
- COOPER BROS. & MALLOWS PTY. LTD., Goorambat, 3725; D.A.52539; 5th October, 1968; 120 cwt.
- COTTEE'S GENERAL FOODS LTD., 160 Mitcham-road, Blackburn, 3130; D.A.30358/9; 19th October, 1968; 11 cwt.
- CROCKFORD & ROBERTSON PTY. LTD., 15 Abbott-street, Fairfield, 3078; D.A.914/11; 9th November, 1968; 18 cwt.
- DEIPENAU, H. E., PTY. LTD., 73 Victoria-street, East Brunswick, 3057; T.D.A.17846/17; 5th October, 1968; 215 cwt.
- GEORGE FARMER PTY. LTD., Eureka-street, Ballarat, 3350; T.D.A.44430/9; 14th October, 1968; 81 cwt.
- MALE, H. E. (trading as H.P.M. Water Carriers), Fisheries-road, Devon Meadows; D.A.53410; 5th October, 1968; 68 cwt.
- REPCO TRANSMISSION CO. PTY. LTD. (trading as Hardy Spicer (Australia) Co.), McNaughton-road, Clayton, 3168; D.A.53653; 19th October, 1968; 21 cwt.
- HATTY, W. J., 165 Raglan-street, Preston, 3072; D.A.38788/2; 27th April, 1968; 69 cwt.
- HINGSTON, C. E., 43 Dennis-street, Northcote, 3070; D.A.1304/1; 14th November, 1968; 67 cwt.
- KILNER, F., & SONS PTY. LTD., 799 Burke-road, Camberwell, 3124; D.A.28569; 1st October, 1968; 11 cwt.
- KRUGER, P. E., 56 Princes Highway, East Warramboul, 3280; D.A.1458/1; 29th October, 1968; 140 cwt.
- LOWNDES, J. W., 15 Alexandra-avenue, East Geelong, 3219; D.A.1526/1; 1st October, 1968; 11 cwt.
- MAHONEY, D. D. & P. M., Coragulac, 3249; D.A.38190; 1st October, 1968; 124 cwt.
- MÁNDEL, N., 54 Spray-street, Elwood, 3184; D.A.53586; 19th October, 1968; 199 cwt.
- MATTHEWS, A. A. & SONS PTY. LTD., 186 Raglan-parade, Warramboul, 3280; D.A.1575/2; 24th October, 1968; 212 cwt.
- MAWSON, E. B. & SONS PTY. LTD., 141 King George-street, Cohuna, 3568; D.A.30119/38; 26th October, 1968; 240 cwt.
- MOBILE INDUSTRIAL EQUIPMENT LTD., 410 Whitehorse-road, Mitcham, 3132; D.A.48327/11; 5th October, 1968; 19 cwt.
- MURPHY, J. F., 1 Wondah-avenue, Tallangatta, 3700; D.A.40348/1; 24th October, 1968; 131 cwt.

## TOW TRUCKS.

- GROGAN, N. J. (trading as Glenfield Towing), 1470 Sydney-road, Campbellfield, 3061. Two commercial goods vehicles (to be purchased) to operate within a 50-mile radius of the G.P.O., Melbourne, as a "Tow Truck"

- MYER SOUTHERN STORES LTD., 91 Pall Mall, Bendigo, 3550; D.A.61148/2; 24th October, 1968; 40 cwt.  
 PACE, L., 155 Clarke-street, Northcote, 3070; D.A.53322; 5th October, 1968; 139 cwt.  
 PATERSONS PTY. LTD., 152 Bourke-street, Melbourne, 3000; D.A.1782/13; 18th November, 1968; 73 cwt.  
 PATERSONS PTY. LTD., 152 Bourke-street, Melbourne, 3000; D.A.1782/15; 18th November, 1968; 14 cwt.  
 PATERSONS PTY. LTD., 152 Bourke-street, Melbourne, 3000; D.A.1782/16; 18th November, 1968; 54 cwt.  
 PAULLS COMPLETE HOME FURNISHERS PTY. LTD., 21 Lloyd-street, Moe, 3825; D.A.53606; 19th October, 1968; 8 cwt.  
 PETERS, I. B., Jumbunna-road, Korumburra, 3950; D.A.53390; 5th October, 1968; 116 cwt.  
 PETERSVILLE AUSTRALIA LTD., Wellington-road, Clayton, 3168; D.A.1813/3; 29th October, 1968; 11 cwt.; D.A.1813/5; 29th October, 1968; 10 cwt.  
 PETERSVILLE AUSTRALIA LTD., Wellington-road, Clayton, 3168; D.A.1813/105; 5th October, 1968; 209 cwt.; D.A.1813/127; 18th October, 1968; 70 cwt.; D.A.1813/128 18th October, 1968; 70 cwt.; D.A.1813/129; 18th October, 1968; 70 cwt.  
 PHELAN, W. & SONS PTY. LTD., 157 High-street, Maryborough, 3465; D.A.3633/24; 19th October, 1968; 215 cwt.; D.A.3633/26; 19th October, 1968; 217 cwt.  
 PRESTON, J. T., 32 Primula-avenue, Altona, 3025; D.A.53175; 5th October, 1968; 140 cwt.  
 QUINLAN, E. W., 323 Buckley-street, Essendon, 3040; D.A.53720; 5th October, 1968; 144 cwt.; D.A.53720/1; 5th October, 1968; 143 cwt.  
 SEMMENS, A. V. & W. J., 74 Thea-grove, East Doncaster, 3109; D.A.53659; 19th October, 1968; 192 cwt.  
 SHORT, D. & E., 7 Newlyn-parade, Deer Park, 3023; D.A.53351; 5th October, 1968; 143 cwt.  
 SIDES, W. L. & SON PTY. LTD., P.O. Box 228, Clayton, 3168; D.A.28601; 1st October, 1968; 11 cwt.; D.A.28601/4; 1st October, 1968; 13 cwt.  
 SIMPSON POPE LTD., 128-144 Wellington-street, Collingwood, 3066; D.A.34725/30, D.A.34725/31; 26th October, 1968; 11 cwt.  
 SOUTHERN PENINSULA TRANSPORT SERVICE PTY. LTD., 1403 Nepean Highway, Rosebud, 3939; D.A.2075/11; 28th November, 1968; 60 cwt.  
 STREETS ICE CREAM PTY. LTD., 615 Warrigal-road, Holmesglen, 3148; D.A.2011/27; 9th November, 1968; 8 cwt.  
 THE TERANG & DISTRICT CO-OPERATIVE SOCIETY LTD., High-street, Terang, 3264; D.A.28610; 8th October, 1968; 90 cwt.  
 VENUTO, A., 16 Lebanon-street, Strathmore, 3041; D.A.53772; 9th November, 1968; 140 cwt.  
 WILLIS, R. R., Strathmerton, 3641; D.A.40646; 10th October, 1968; 79 cwt.  
 WRIGHT, WALTER H., PTY. LTD., Sudholz-street, West Melbourne, 3003; D.A.19947/6; 9th November, 1968; 308 cwt.

TOW TRUCK RENEWALS.

- LITTLE, E. J. (trading as Little's Black Rock Motors), 298 Beach-road, Black Rock, 3193; D.A.1506; 4th November, 1968; 78 cwt.  
 SOUTH GIPPSLAND MOTORS PTY. LTD., 59 Graham-street, Wonthaggi, 3995; T.D.A.46490; 22nd October, 1968; 85 cwt.

RENEWALS WITH VARIATION.

APPLICATIONS by the persons listed hereunder for renewal of the licences listed with variation of conditions in the manner set out opposite the names:—

- BRAUND, W. P., 13 Russell-street, Camperdown, 3260; D.A.28525; 1st October, 1968; application to renew and vary conditions of licence No. D.A.28525 (L/C. 140 cwt.) by deleting "Ellerslie" from the existing conditions and adding in lieu "Irrewarra".  
 SELBY, H. B., & Co. PTY. LTD., 352-368 Ferntree Gully-road, Notting Hill, 3168; D.A.40849; 7th November, 1968; application to renew and vary conditions of licence No. D.A.40849 (L/C. 11 cwt.) by deleting "in the City of Melbourne" from the existing conditions and adding in lieu "Situated at 352-368 Ferntree Gully-road, Notting Hill".

Notice of any objection should be forwarded to reach the Secretary of the Board not later than 25th September, 1968.

Applicants are advised that it will not be necessary to appear on the hearing date specified above, unless advised in writing by the Board.

B. P. KAY,  
Secretary.

Corner of Lygon and Princes streets, Carlton, 3053, 6th September, 1968.

SHIRE OF SOUTH BARWON.

ROAD EXCHANGE.

PURSUANT to the provisions of sections 522 and 526 of the Local Government Act 1958, the Council of the Shire of South Barwon hereby directs that the land in the Parish of Barrabool indicated by hatching on the diagram hereunder, which has been purchased, taken or acquired by it, shall be a public highway on and from the date of publication of this order in the Government Gazette and declares that such land shall be a public highway in lieu of the land indicated by cross-hatching on the said diagram.

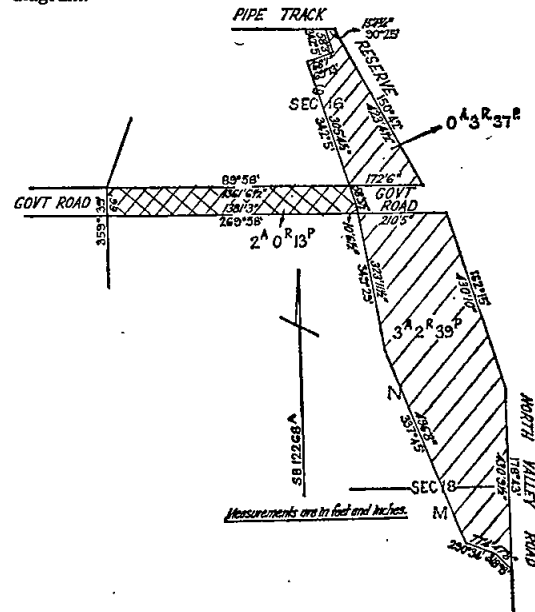

The common seal of the President, Councillors and Ratepayers of the Shire of South Barwon was hereunto affixed this 3rd day of September, 1968, in the presence of—

(SEAL) R. J. REYNOLDS, President.  
 H. BLYTH, Councillor.  
 A. A. N. DEED, Secretary.

Approved by the Governor in Council, 10th September, 1968.—J. ROSSITER, Clerk of the Executive Council.

LEXTON WATERWORKS TRUST.

AUTHORITY TO OBTAIN BANK OVERDRAFT.

HIS Excellency the Lieutenant-Governor of the State of Victoria, by and with the advice of the Executive Council thereof, doth by Order made on the tenth day of September, 1968, authorize the Lexton Waterworks Trust to obtain in pursuance of the provisions of Section 286 of the Water Act 1958 (No. 6413) an advance or advances during the year ending 30th September, 1969, by overdraft of the Trust's current account, such overdraft not to exceed at any one time the sum of One thousand six hundred dollars (\$1,600).

J. ROSSITER,  
Clerk of the Executive Council.

At Government House,  
Melbourne, 10th September, 1968.

CITY OF WARRNAMBOOL.

WATER SUPPLY DISTRICT.

Authority to Obtain Bank Overdraft.

HIS Excellency the Lieutenant-Governor of the State of Victoria, by and with the advice of the Executive Council thereof, doth by Order made on the tenth day of September, 1968, authorize the Council of the City of Warrnambool to obtain in pursuance of the provisions of Section 286 of the Water Act 1958 (No. 6413) an advance or advances during the year ending 30th September, 1969, by overdraft of the Council's current account, such overdraft not to exceed at any one time the sum of Seventy thousand dollars (\$70,000).

J. ROSSITER,  
Clerk of the Executive Council.

At Government House,  
Melbourne, 10th September, 1968.

## MARYBOROUGH WATERWORKS TRUST.

## BY-LAW NO. 48.

**T**HE Maryborough Waterworks Trust (hereinafter referred to as "the Trust") in pursuance and exercise of the powers conferred by the *Water Act 1958* doth hereby make the By-law following, restricting the use for other than domestic purposes of water supplied by the said Trust within the Maryborough Urban Districts.

1. This By-law shall come into operation at such time and in such part or parts of the Maryborough Urban District (hereinafter referred to as "the specified area") as the Trust from time to time directs by notice published in a newspaper circulating generally within the District and cease to have operation at such time as the Trust from time to time directs by a notice so published.

2. Subject to the provision of clause 3 of this By-law no person shall, except with the permission in writing of the Trust, with water supplied by the Trust.

- (a) water any garden lawn or other land (other than commercial market gardens, commercial nurseries or land used for growing of green feed for commercial poultry farms) within the specified area except by means of a hose held in the hand or by means of a can or other vessel held in the hand excepting between the hours of 5 p.m. and 8 p.m. of each day during which period fixed sprinklers may be used.

- (b) Fill or cleanse any private swimming pool of a depth greater than one foot, within the specified area.

3. No person shall, with water supplied by the Trust water any land comprising sports grounds golf courses, racecourses, public and club bowling and croquet greens and public and club tennis courts within the specified area by means of fixed sprinklers except between the hours of 12 noon and 9.00 p.m. each day.

4. Every person who uses or permits or suffers water supplied by the Trust to be used contrary to the provisions of this By-law shall be guilty of an offence and shall be liable to a penalty not exceeding One Hundred Dollars.

5. If any person supplied with water by the Trust wrongfully does or causes or permits to be done anything in contravention of this By-law, the Trust may (without prejudice to any remedy in respect thereof) close or cut off any of the pipes by or through which water is supplied to him or for his use and may cease to supply him with water as provided by the *Water Act 1958*.

The foregoing By-law was made by the Maryborough Waterworks Trust on the 18th day of July, 1968, and the common seal of the said Trust was hereunto affixed the 18th day of July, 1968, in the presence of :

(SEAL) A. G. LEECH, Commissioner.  
F. R. DRAKE, Commissioner.  
E. S. MOORE, Secretary.

Approved by the Governor in Council, 10th September, 1968.—J. ROSSITER, Clerk of the Executive Council.

## DONALD WATERWORKS TRUST.

## BY-LAW NO. 74.

*Restrictions on the use of water.*

**T**HE Donald Waterworks Trust (hereinafter referred to as "the Trust") in pursuance and exercise of the powers conferred by the *Water Act 1958* doth hereby make the By-law following, restricting the use for other than domestic purposes of water supplied by the Trust within the Donald Waterworks Trust District.

1. This By-law shall come into operation at such time as the Trust from time to time directs by a notice published in a newspaper circulating generally within the District, and cease to have operation at such time as the Trust from time to time directs by a notice so published.

2. Subject to the provisions of Clauses 3 and 4 of this By-law no person shall, with water supplied by the Trust—

- (a) Water any garden, lawn or other land (other than commercial market gardens, commercial nurseries or land used for the growing of green feed for commercial poultry farms) within the specified area except by means of a hose held in the hand or by means of a can or other vessel held in the hand, between the hours of 5.30 p.m. and 6.30 p.m. on each day.

- (b) Fill, add to or cleanse any private swimming pool within the specified area.

- (c) Water any land, grass, lawn or ornamental garden comprising a nature strip on road reserve within the specified area.

- (d) Wash or cleanse any motor vehicle except by means of a hose held in the hand or by means of a can or other vessel.

3. No person shall, with water supplied by the Trust, water any commercial market gardens, commercial nurseries or land used for the growing of green feed for commercial poultry farms within the specified area by means of fixed sprinklers between the hours of 6.00 p.m. and 10.00 p.m. of each day.

4. No person shall with water supplied by the Trust, water any land comprising sports grounds, golf courses, racecourses, public and club bowling and croquet greens and public and club tennis courts within the specified area by means of fixed sprinklers except between the hours of 8.00 p.m. and 10.00 p.m. each day.

5. Every person who uses or permits or suffers water supplied by the Trust to be used contrary to the provisions of this By-law shall be guilty of an offence, and shall be liable to a penalty not exceeding One Hundred Dollars.

6. If any person supplied with water by the Trust wrongfully does or causes or permits to be done anything in contravention of this By-law, the Trust may (without prejudice to any remedy in respect thereof) close or cut off any of the pipes by or through which water is supplied to him or for his use and may cease to supply him with water as provided by the *Water Act 1958*.

The foregoing By-law was made by the Donald Waterworks Trust on the 23rd day of August, 1968, and the common seal of the said Trust was hereunto affixed on the 23rd day of August, 1968, in the presence of :

(SEAL) B. HUNTER, Chairman.  
K. J. RYE, Commissioner.  
H. C. SMALE, Secretary.

Approved by the Governor in Council, 10th September, 1968.—J. ROSSITER, Clerk of the Executive Council.

## DEPARTMENT OF MINES.

## MINING LEASES GRANTED.

- 9254, Castlemaine; Beryl Lillian West; 30a. Or. 0p., Parish of Wombat.  
7123, Maryborough; Alan McKinlay; 100a. Or. 4p., Parish of Moliagul.  
8231, Mineral; Shaw River Alluvials No Liability; 31a. 1r. 25p., Parish of Walwa.  
8598, Mineral; Robert Henry Webb, Lloyd Owen Lehmann, Frank Leslie Doyle, James Robert Slatter; 89a. 1r. 36p., Parish of Boort.  
8742, Mineral; Albert Ernest Doherty, William Rex Doherty; 28a. Or. 26p., Parish of Queenstown.

## APPLICATION FOR LEASE DECLARED ABANDONED.

- 8689, Mineral; Francis F. Sargeant; 344 acres, Parish of Everton.

## APPLICATION FOR LEASE REFUSED.

- 8813, Mineral; Terence Michael O'Kane, John Patrick Tidd; 640 acres, Parishes of Devenish, Dookie.

## MINING LEASE EXPIRED.

- 7353, Mineral; Bendigo Pottery Proprietary Limited; 18a. 1r. 1p., Parish of Huntly.

## MINING LEASES TRANSFERRED.

- 8321, Mineral; from Harry Sydney Nottle and Alice Agnes Nottle to Alice Agnes Nottle and Graham Stanley Nottle.  
8416, Beechworth; from Eric Dahlstrom to Nicholas James Ramsay, Ellen Muriel Ramsay, Kenneth Stanley Ramsay and David Charles Ramsay.

J. C. M. BALFOUR,  
Minister of Mines.

## MINING LEASE DECLARED VOID.

- 7385, Mineral; R. R. Mining Company Proprietary Limited; 22a. 1r. 37p., Parishes of Cudgewa and Walwa.

E. CONDON,  
Secretary of Mines.

AUCTION SALES ACT.

LIST of persons to whom Auctioneer's Licences have been issued during the month of September, 1968 and prior months.

| Name.                         | Address.                         | Date of Issue. |
|-------------------------------|----------------------------------|----------------|
| Adams, Ronald William         | Tallarook                        | 5.8.68         |
| Aspel, Reginald William       | 94 Cubitt-street, Richmond       | 24.6.68        |
| Birner, John                  | 5 Charles Street, Brighton East  | 24.7.68        |
| Calder, Bruce William         | Meadows-avenue, Benalla          | 26.6.68        |
| Chester, James Norman         | 2 Manor-street, Middle Brighton  | 22.7.68        |
| Cleary, Roger John            | 9 Marshall-street, Ivanhoe       | 24.7.68        |
| Dal Santo, Giovanni Batista   | 97 Cumberland-road, Pascoe Vale  | 24.6.68        |
| De Gruchy, John Robert        | 2 Jensen-street, Glenroy         | 4.6.68         |
| Edmonds, Roger John           | 56 Edwards-street, Sandringham   | 3.6.68         |
| Ferguson, Noel Francis        | 40 Griffin-street, Hamilton      | 27.6.68        |
| Fletcher, Peter J.            | 19 Hassett-street, Leongatha     | 17.7.68        |
| Geer, Ian Whitney             | Boundary-road, Orbost            | 23.8.68        |
| Gibbon, Peter Robert          | Manks-road, Koo-wee-rup          | 27.6.68        |
| Hicks, Laurence Edwin         | Lot 435, Crown Point, Lilydale   | 21.6.68        |
| Hogan, Timothy John           | 2c Wilks-avenue, Malvern         | 31.7.68        |
| Jan, William John             | 29 Wrixon-street, Kew            | 13.6.68        |
| Joiner, William Henry         | 10 Peel-street, North Ballarat   | 30.7.68        |
| Jones, Tyrone Morris          | 60 Carnarvon-road, Strathmore    | 25.6.68        |
| McLaughlin, Malcolm Fraser    | 15 Sunset-avenue, Beaumaris      | 12.6.68        |
| Mackenzie, Geoffrey Thomas    | Archibald-street, Lockington     | 2.7.68         |
| Newton, Peter Thomas Liddiard | 56 Clarence-street, East Malvern | 27.6.68        |
| Neylan, Keith George          | 6 Love-street, Black Rock        | 24.6.68        |
| O'Keefe, Patrick Brendan      | 59 Grosvenor-street, Balaclava   | 20.6.68        |
| O'Meara, Terrance Francis     | 8 Benambra-street, West Preston  | 16.7.68        |
| Peters, Peter Phillip         | 17 Beaumont-street, Watsonia     | 5.6.68         |
| Robson, Leonard Philip        | 65 Dudley-street, Rochester      | 2.7.68         |
| Rourke, Adrian                | Frances-street, Moama, N.S.W.    | 6.8.68         |
| Stagg, Charles Alexander      | 44 King-street, Maffra           | 8.8.68         |
| Waite, Bruce Edwin            | 30 Aberfeldie-street, Essendon   | 11.6.68        |

The Treasury,  
Melbourne, 3002.

E. W. COATES,  
Director of Finance.

STATE RIVERS AND WATER SUPPLY COMMISSION.

LICENCES TO DIVERT WATER AND CUT RACES PURSUANT TO THE PROVISIONS OF SECTION 204 OF THE WATER ACT 1958 (AS AMENDED).

THE Governor in Council has approved of the granting by the State Rivers and Water Supply Commission of licences as detailed hereunder for the term of years from the date specified in each case to the persons named in the following Schedule:—

SCHEDULE.

| Licence No. | Term of Licence and Commencing Date. | Name and Address of Person to Whom Licence is to be Granted.     | Source of Supply.         | Area Authorized to be Irrigated Per Annum. | Volume of Water Authorized to be Diverted Per Annum. |
|-------------|--------------------------------------|--|---------------------------|--|--|
|             |                                      |  |                           | acres.                                     | ac. ft.  |
| 702         | Four years from 1.7.68               | Dante Alojz Kocjancic and Ludivina Kockancic, Mildura            | River Murray              | 18   | 54   |
| 724/691     | Four years from 1.7.68               | Gesualdo Lazzara, Robinvale                                      | River Murray              | 6  | 18   |
| 1955        | Four years from 1.7.68               | Amedeo Silverii, Filippo Silverii and Alfredo Silverii, Piangili | River Murray              | 60   | 180  |
| 2407        | Four years from 1.7.68               | Ronald James Conibear, Wodonga                                   | River Murray              | 50   | 100  |
| 2408        | Four years from 1.7.67               | William Thomas Norman, Gooramadda                                | River Murray (Ana-Branch) | 30   | 60   |
| 2409        | Five years from 1.7.68               | Colin MacDonald, and Sylvia Lillian MacDonald, Myrtleford        | Buffalo River             | 70   | 105  |

In each case, the annual fee payable in respect of each acre-foot of water authorized to be diverted is the equivalent of one-half of the irrigation charge per acre-foot fixed in the Goulburn-Murray Irrigation District for the preceding financial year.

Office of the State Rivers and Water Supply Commission,  
Melbourne, 10th September, 1968.

G. W. LEWIS, Secretary,  
State Rivers and Water Supply Commission.

## CONTRACTS ACCEPTED.—(Series 1968-69.)

## PUBLIC WORKS.

693. Aberfeldie, State School No. 4220, asphalt, concrete and drainage works, \$9,063.78.—L. J. Towers.
694. Altona North, State School No. 4931, erection of eight class-rooms, \$40,285.00.—Hosie Constructions Pty. Ltd.
695. Altona North, State School No. 4931, plenum heating, \$4,630.00.—Bruce Sheet Metal Service.
696. Altona West, State School No. 4862, plenum heating, \$4,480.00.—Chadstone Airconditioning Services Pty. Ltd.
697. Armadale, "Redcourt" Domestic Arts Teachers' College Hostel, asphalt, concrete and drainage works, &c., \$6,720.10.—Ajax Constructions.
698. Balwyn, "Illoura" Girls' Home, asphalt and concrete paving, drainage, &c., \$7,646.95.—Sheffield Paving & Construction Co. Pty. Ltd.
699. Banyule, High School, renovations, \$2,300.00.—Martin & Cooper Pty. Ltd.
700. Box Hill, High School, completion of class-room additions, \$27,425.00.—G. T. Constructions.
701. Camberwell, Court House and Police Station Residence, internal and external renovations, \$1,792.00.—McKenzie Constructions Pty. Ltd.
702. Buckley Park, High School, mechanical services, \$7,621.70.—R. & H. Rivett Pty. Ltd.
703. Coburg East, State School No. 4260, renewal of water service and sanitary fittings, \$5,305.00.—Barry J. Virtue.
704. Coburg, Pentridge Prison, replacement of steam line, \$2,062.00.—Mech. Engineering Pty. Ltd.
705. Dookie, Agricultural College, erection of new kitchen and dining hall, \$203,105.00.—Hansen & Yuncken Pty. Ltd.
706. Greenhills, State School No. 4893, renovations, \$2,752.00.—L. J. Jessop.
707. Greenwood, State School No. 4944, paving, and drainage works, \$22,911.60.—G. R. Williams.
708. Kananook, State School No. 4783, connexion to sewer, \$3,230.00.—Rotterdam Constructors (Aust.) Pty. Ltd.
709. Keilor, State School No. 1578, renovations, \$2,199.00.—L. J. Jessop.
710. Kew, Children's Cottages, steam and condensate reticulation, \$14,400.00.—Mech. Engineering Pty. Ltd.
711. Kew, Children's Cottages, re-routing of underground fire alarm cables, \$2,780.00.—May-Oatway Fire Alarms Pty. Ltd.
712. Maidstone, Police Station and Residence, renovations, \$1,320.00.—P. Heppleston.
713. Melbourne, Royal Arcade, South Australian Government Tourist Bureau, supply and installation of an air conditioning system, \$3,546.00.—Chadstone Airconditioning Services Pty. Ltd.
714. Mont Park, Janefield Training Centre, residences, supply and installation of slow combustion heaters, \$1,699.00.—L. J. Jessop.
715. Mont Park, Plenty Mental Hospital, mechanical services, \$34,987.00.—R. J. Weekes Pty. Ltd.
716. Morwell, Technical School, erection of assembly hall, \$93,153.00.—W. J. Cody & Quinn Pty. Ltd.
717. Robinvale, High School, external repairs and painting, \$5,877.00.—Pascoe Vale Painters Construction Co.
718. Robinvale, 228 Bromley-road, Consolidated School Hostel, repairs and painting, \$3,156.00.—Pascoe Vale Painters Construction Co.
719. Robinvale, Consolidated School, external repairs and painting, \$5,598.00.—Pascoe Vale Painters Construction Co.
720. Royal Park, Mental Hospital, supply and installation of insulated flues for two steam boilers, \$1,920.00.—G. T. Laird & Co. Pty. Ltd.
721. Valkstone, State School No. 4778, asphalt, concrete and drainage works, \$1,283.00.—L. J. Towers.
722. Vinifera, State School No. 4150, residence, internal and external repairs and painting, \$2,793.00.—Pascoe Vale Painters Construction Co.
723. Williamstown, High School and Residence, renovations, \$10,000.00.—Bendinelli & Carlini.
724. Williamstown, High School, completion of mechanical services, \$21,109.00.—Gray & Wood.
725. Baranduda, State School No. 2222 and Residence, internal and external repairs and painting, \$3,132.00.—Roy O. Tobias.
726. Benalla, High School, erection of new wing, \$349,561.71.—L. H. Brown Constructions Pty. Ltd.
727. Benalla East, State School No. 2256, Residence, 4 Hope-street, repairs and renovations, \$1,384.00.—Wolff's Painting Service.
728. Blackwood, State School No. 1074 and Residence, external repairs and painting, \$1,222.00.—Duro Radeka.
729. Brown Hill, State School No. 35, repairs to toilet block, &c., \$1,210.00.—H. R. Dobbin.
730. Cobden, State School No. 864, extra water service and new drinking troughs, \$1,050.00.—M. & L. Driscoll.
731. Macarthur, State School No. 1571, site works, \$1,809.40.—John Keen.
732. Maryborough, State School No. 404, additions to staff and store rooms, \$1,765.88.—W. G. Hart & Sons (Maryborough).
733. Merbein West, State School No. 3996 and Residence, erection of non party fencing, \$1,898.00.—K. P. Collins.
734. Orbost, High School Residence, 7 Tarra-street, internal and external painting and repairs, \$1,465.55.—"Star-Brite" Painting Decorating Service.
735. Ouyen, Police Station, erection of new residential station, \$31,300.00.—G. H. Bayles.
736. Rosedale, State School No. 770 and Residence, external repairs and painting, \$2,650.00.—W. H. & A. H. Becker inc. Chris Humphrey & Co.
737. Shepparton, Girls' Secondary School, renovations, \$17,827.00.—R. J. Carnie.
738. Talbot, State School No. 954, internal repairs and painting to class-room, &c., and painting of fence, \$1,502.00.—W. Phelan & Sons Pty. Ltd.
739. Tatyoon, State School No. 1812, external and internal renovations, \$1,196.00.—R. D. Johnstone.
740. Toolangi, Agriculture Department, Potato Research Station, clearing, grading, &c., \$1,728.00.—Frank Wood Plant Hire.
741. Toora, Police Station, erection of tile-roofed brick veneer office, \$5,698.00.—P. E. Darvill.
742. White Hills, State School No. 1916, fencing (non party), \$1,636.00.—Richard George Lowe.
743. Wood Wood, State School No. 3353 and Residence, replacement of fencing (non party), \$1,088.00.—K. C. & B. M. Harris.
744. Cheltenham, High School, concrete and drainage works, \$1,246.00.—Ajax Constructions.
745. Mossiface, State School No. 3176, connexion to water main, \$1,592.00.—Graham G. Betts.
746. Moe, State School No. 2142, Teacher's Flat, general renovations, \$1,093.00.—I. Beasley.
747. Ascot Vale West, State School No. 4025, provision of fire escape stairs, \$3,457.52.—Peter Cash.
748. Murrayville, Consolidated School, external painting and repairs, \$6,845.00.—K. L. & E. M. Cooke.
749. Kyabram, High School, Residence, 20 Richards-street, internal and external renovations, \$1,400.00.—C. J. Cody.
750. Bendigo, Girls' High School, installation of ceiling type air circulators, \$1,261.50.—R. L. Campbell Pty. Ltd.
751. Rainbow, State School No. 3313, concrete and drainage works, \$1,000.00.—T. J. Dickson.
752. Irrewarra, State School No. 4099 and Residence, external painting and repairs, \$1,950.00.—H. De Vries.
753. Heidelberg, Fisheries and Wildlife Branch, Arthur Rylah Research Institute, electrical installation, \$60,064.00.—K. J. Dupuy.
754. Melbourne, Royal Melbourne Institute of Technology, Gold and Silver-smithing Shop, provision of fume exhaust system and lighting, \$6,086.00.—S. W. G. Forde.
755. Balmoral, High School, erection of combined kitchen and dining room, \$21,926.80.—Fort & Jacobson.
756. Geelong, State School No. 1094, fencing—street frontages—non party, \$1,159.00.—Geelong Fencing Suppliers Pty. Ltd.
757. Yandoit, State School No. 691 and Residence, repairs and painting to residence and new heater to school, \$2,120.00.—A. T. & P. Green.
758. Sorrento, Police Station, erection of new office block, &c., \$31,200.00.—M. Gallagher.
759. Ecklin South, State School No. 2647 and Residence, external repairs and painting, \$1,156.50.—Hammond & Sons (Contracting) Pty. Ltd.
760. Warrambool South, State School No. 1902, external painting, \$1,449.10.—Hammond & Sons (Contracting) Pty. Ltd.
761. Warrambool, High School, painting and repairs, &c., \$4,418.00.—Hammond & Sons (Contracting) Pty. Ltd.
762. Rutherglen, High School, external renovations, \$3,830.00.—B. Holland.
763. Golden Square, State School No. 1189, internal and external renovations, &c., \$10,580.00.—G. W. Hardy.
764. Speed, State School No. 3861, Residence, internal and external repairs and painting, \$1,466.50.—Wallace J. Harding.
765. Carlton, Collins Motors Building, alterations and additions, \$1,667,430.00.—F. T. Jeffrey Pty. Ltd.
766. Camperdown, State Public Offices, asphalt pavement repair, works, \$1,086.00.—J. Keen.
767. Wallacedale North, State School No. 3332 and Residence, erection of non party fencing, \$1,229.00.—A. H. Langley & Sons.
768. Callignee, State School No. 2649, internal and external repairs and painting, \$1,076.00.—Friedrich Leitner.

769. Maryborough, State School No. 404, external repairs and painting and internal renovations, \$12,606.80.—A. L. Lawrence.

770. Neerim East, State School No. 3158 and Residence, external repairs and painting, \$2,398.50.—F. C. Mephram.

771. Tyers, State School No. 2182, Residence, renovations, \$1,075.00.—Gaetano Manfre.

772. Various, Schools, asphalt, concrete and drainage works, S.S. 2948, Auburn; S.S. 4715, Blackburn North; Glendonald School for Deaf Children No. 4683, Kew; S.S. 4816, Kerrimuir and S.S. 1075, Kew, \$12,497.00.—S. J. Moran.

773. Noble Park, Technical School, asphalt, concrete and drainage works, &c., \$10,313.20.—G. Mueller.

774. Chelsea, State School No. 3729, asphalt, concrete and drainage works, \$5,316.50.—G. Mueller.

775. Balmoral, High School, electrical installation, \$1,040.00.—Moon Electrics.

776. Armata, State School No. 4965, asphalt, concrete and drainage works, &c., \$16,910.75.—H. Mueller.

777. Eskdale, State School No. 2318, renovations, \$2,989.00.—K. D. & M. F. MacKay.

778. Gisborne, State School No. 262, external repairs and painting, \$2,880.00.—J. P. McElligott & Co. Pty. Ltd.

779. Gorae West, State School No. 4556 and Residence, external and internal painting, \$1,300.00.—Richard J. McLean.

780. Rutherglen, Research Station, water pumping installation, \$5,948.00.—A. J. Norton Pty. Ltd.

781. Newport West, State School No. 4665, roof repairs, \$5,598.00.—N. Peshut.

782. Guildford, State School No. 264 Residence, erection of new laundry, toilet, septic tank and metal framed garage, \$1,790.00.—W. Phelan & Sons Pty. Ltd.

783. Campbelltown, State School No. 1129, Residence, reblocking, internal and external renovations, \$3,295.00.—Duro Radeka.

784. Mount Macedon, Memorial Cross Reserve, kerbing, channelling and drainage works, \$3,250.85.—C. W. A. Scott.

785. Ringwood East, State School No. 4180, new internal toilet, \$1,250.00.—A. V. Steele.

786. Elmhurst, State School No. 959, internal and external repairs and painting, \$2,276.50.—R. C. Smith.

787. Warragul, Ellinbank Dairy Research Station, Staff Residence No. 10, internal and external repairs and painting, \$1,135.20.—L. Smit & Son.

788. Yulungah, State School No. 3413, Residence, internal and external renovations, \$1,406.00.—L. Smit & Son.

789. Ellinbank, Workers Residences, Nos. 1, 2, 3, 4, and 5, internal and external repairs and painting, Dairy Research Station, \$3,648.80.—L. Smit & Son.

790. Balwyn, State School No. 1026, asphalt and drainage works, \$4,195.20.—L. J. Towers.

791. Fairfield, "Fairlea" Prison, installation of a steam generator, \$3,300.00.—T.B.S. Heating.

792. Strathbogie, State School No. 2181, new out-offices, septic tank and water supply, \$3,050.76.—R. O. Tobias.

793. Drouin, High School, Cleaner's Residence, repairs and painting, \$1,090.00.—F. C. Woodhouse.

794. Mirboo North, State School No. 2383, erection of shelter shed, \$1,578.50.—J. H. Wickes.

795. Royal Park, Mental Hospital, supply and lay vinyl flooring, \$1,940.00.—William Bros. Vinyl Floor & Wall Tile Laying Service.

796. Port Melbourne, Public Works Department, supply compressors, \$14,136.00.—Holman Bros. (Aust.) Pty. Ltd.

797. Port Melbourne, Public Works Department, supply fire extinguishers, \$1,116.00.—Wormald Bros. (Aust.) Pty. Ltd.

798. Noble Park, Technical School, supply stacking chairs, \$4,653.60.—Aristoc Industries Pty. Ltd.

799. Bendigo, Technical College, supply student's tables, \$1,920.35.—Precise Tubular Products.

800. Parkville, "Turana", supply and lay Armourflor flooring, \$6,068.40.—Reliable Floor Pty. Ltd.

801. Parkville, "Turana", supply chairs, \$1,851.60.—Myer Teale Pty. Ltd.

802. Parkville, "Turana", supply and fix curtains, \$2,697.54.—Fischer Furnishings Pty. Ltd.

803. Frankston, Monterey Technical School, supply furniture, \$9,397.00.—Lloyd Industries.

804. Burwood, "Allambie" Reception Centre, supply stainless steel cots, \$5,940.00.—Bendix Consolidated Industries Ltd.,

805. Plenty, Mental Hospital, supply refrigerators, \$1,048.60.—Ahearn Main & Stott Pty. Ltd.

806. Doon, Longerenong Agricultural College, supply divan beds, \$1,305.00.—Westbury Timber Co. Pty. Ltd.

807. Ballarat, Mental Hospital, supply bedside lockers, \$2,310.00.—Bendix Consolidated Industries Ltd.

808. Mooroolbark, Technical School, supply furniture, \$3,615.20.—Kennett Bros. & Rayner Pty. Ltd.

809. Coburg, H.M. Pentridge Prison, supply concrete, \$4,028.66.—Blue Metal Quarries Pty. Ltd.

810. Kew, Children's Cottage, supply and fit curtains, \$1,216.33.—Fischer Furnishings Pty. Ltd.

811. Noble Park, Technical School, supply workshop machinery, \$5,328.00.—East Australian Electric Co.

812. Mont Park, Mental Hospital, supply refrigerator, \$1,064.60.—Ahearn Main & Stott Pty. Ltd.

813. Morwell, High School, supply tables and trolleys, \$4,922.59.—D. F. Cowan Pty. Ltd.

814. Morwell, High School, supply and install library shelves, \$6,477.30.—Brownbuilt Ltd.

815. Noble Park, Technical School, supply tables, \$1,432.00.—D. F. Cowan Pty. Ltd.

816. Mont Park, Mental Hospital, supply deep freeze units, \$2,862.00.—Pioneer Refrigeration (Melb.) Pty. Ltd.

817. Melbourne, Emily McPherson College, supply and lay vinyl tiles, \$1,151.50.—Laminex Industries.

G. SERPELL, Secretary for Public Works. 4.9.68.

#### GENERAL STORES.

Gazette No. 58, 1st July, 1968, Schedule No. 49, Steel (Mild).—For rates shown opposite the following items, substitute the rates as set out hereunder, as from 15th August, 1968:—Item No. 4, 1½ in. to 2½ in., Billet, \$117.50 per ton; 3-in., \$117.50 per ton. Item No. 16, 1 in. x 1 in. x ¼ in. to 1½ in. x 1½ in. x ¼ in., \$128.00 per ton; 1 in. x 1 in. x ½ in. to 1½ in. x 1½ in. x ½ in., \$133.00 per ton; 1 in. x 1 in. x 3/16 in. to 1½ in. x 1½ in. x 3/16 in., \$130.50 per ton; 1½ in. x 1½ in. x ½ in. to 1½ in. x 1½ in. x ¼ in., \$125.50 per ton; 1½ in. x 1½ in. x ½ in. to 1½ in. x 1½ in. x ⅜ in., \$130.50 per ton; 1½ in. x 1½ in. x 3/16 in. to 1½ in. x 1½ in. x 3/16 in., \$128.00 per ton. Item No. 17, 2 in. x 2 in. x ¼ in. to 3 in. x 3 in. x ¼ in., \$123.50 per ton; 2 in. x 2 in. x ½ in., \$130.50 per ton; 2 in. x 2 in. x 3/16 in., \$125.50 per ton; 3 in. x 3 in. x 3/16 in., \$125.50 per ton.

Gazette No. 58, 1st July, 1968, Schedule No. 64, Polishes, Dusters, &c.—For Item No. 31 substitute \$4.59 each, as from 1st August, 1968.

J. M. PAWSON, Acting Secretary to the Tender Board. 10.9.68.

#### VICTORIAN RAILWAYS.

25. Fabrication, supply and delivery of 2 No. bridge spans, comprising 4 No. steel plate girders complete with all cross girders, stringers, bracing angles, ballast plates and field bolts, &c., for the amount of \$51,092.00, loaded on road vehicles at contractor's works, Sandringham (Contract 63312).—Johns & Waygood Ltd. 26. Manufacture, supply and delivery of tarpaulin canvas, \$1.57 per lin. yard, f.i.s., Newport, less 2½ per cent. 30 days (Contract 63301).—Davies, Coop & Co. Ltd. 27. Manufacture, supply and delivery of tarpaulin canvas, at rate of 95d. (sterling) per lineal yard, f.o.b., Glasgow (Contract 63333).—The Boase Spinning Co. Ltd. 28. Manufacture, supply and delivery of tarpaulin canvas, at rate of 96½d. (sterling) per lineal yard, f.o.b., Glasgow (Contract 63334).—Gilbert Lode & Co. Ltd.

NOTE.—Gazette No. 75, of 28th August, 1968:—Serial No. 20, Colex Cranes Ltd., should read Coles Cranes Ltd. Serial No. 23, W. J. & J. P. McKenzie, should read W. J. & V. P. McKenzie.

By order of the Victorian Railways Commissioners,

W. WALKER, Secretary. 6.9.68.

#### ORDERS IN COUNCIL.—(Series 1967-68.)

##### FORESTS COMMISSION.

Loan Fund Act No. 7640, Item 6—

4155. To the purchase of that lot 127 on plan of subdivision No. 12973, being part of Crown allotment 86, Parish of Scoresby, County of Mornington, for forest purposes, \$475.00.—Elsa Margaret Bartlau.

Approved by the Governor in Council, 18th June, 1968.—J. ROSSITER, Clerk of the Executive Council.

#### ORDERS IN COUNCIL.—(Series 1968-69.)

##### PUBLIC WORKS.

681. Ballarat, Mental Hospital, replacement of defective fire alarm cables, \$1,707.00.—May-Oatway Fire Alarms Pty. Ltd.—(W.49802.)

682. Benalla East, S.S. 2256, renovations to residence, \$1,450.00.—Ben Holland.—(N.E.111186.)

683. Coburg North, S.S. 4543, site works, \$1,349.90.—Roy Senior & Son Pty. Ltd.—(N.W.87253.)

684. Elwood, High School, roofing works, \$3,365.10.—Steel Decks and Ceilings Pty. Ltd.—(E.M.17221.)



685. Kew, Mental Hospital, supply of hospital furniture, \$8,389.00.—Aristoc Industries Pty. Ltd.—(E.M.123764.)

686. Kew, Soil Conservation Authority, supply of furniture, \$1,067.89.—Brownbilt Ltd.; \$1,495.70.—Aristoc Industries Pty. Ltd.; \$2,792.48.—Stylecraft Desks & Chairs Pty. Ltd.; and \$1,295.70.—Betterbuilt Office Equipment Pty. Ltd.—(E.M.54860 "D".)

687. Kiewa Valley Consolidated School, renovations to residence, \$1,484.00.—H. A. Morley.—(N.E.268515.)

688. Monterey, Technical School, various items required by Education Department:—\$1,232.00.—Ahearn Main & Stott Pty. Ltd.; and \$1,488.00.—Singer Australia Ltd.—(S.E.107801 "E".)

689. Mont Park, Mental Hospital, Wards F.7 & F.8, supply of geriatric chairs, trolleys, &c.:—\$2,850.80.—Aristoc Industries Pty. Ltd.; and \$2,619.60.—Namco Furniture, Contract Division.—(N.E.130980.)

690. Port Melbourne, P.W.D. Storeyard, supply of scaffolding, \$1,046.02.—Auto-Inverta (Distributors) Pty. Ltd.—(S.W.165598.)

691. Royal Park, Medical Officers' Residences, supply of furniture as selected by the Mental Health Authority, \$1,547.70.—Myer Teale Pty. Ltd.—(E.M.136059.)

692. Westport, special anti-corrosive treatment of gas buoys, \$1,085.00.—Dimet (Vic.) Pty. Ltd.—(P. & H. 73706 "A".)

Approved by the Governor in Council, 3rd September, 1968.—J. ROSSITER, Clerk of the Executive Council.

#### STATE ELECTRICITY COMMISSION.

818. For the supply of eight 10 MVA and two 20 MVA transformers for main substations, to Specification No. 68/64, \$350,870.—The English Electric Co. of Aust. Pty. Ltd.

819. For the supply of 66 kV outdoor oil immersed condenser bushings for main transformers, to Specification No. 68/30A.—\$47,618.—O. H. O'Brien Pty. Ltd.

Approved by the Governor in Council, 13th August, 1968.—J. ROSSITER, Clerk of the Executive Council.

820. For the supply of pole type junction boxes for a period of one year with optional extension of three months, to Specification 68/264, at Schedule rates.—G. W. Engineering Pty. Ltd.

821. For the supply of firebricks for power station maintenance for a period of two years with optional extension of three months, to Specification 68/125, at Schedule rates.—Newbold General Refractories Ltd.

Approved by the Governor in Council, 27th August, 1968.—J. ROSSITER, Clerk of the Executive Council.

822. For the supply of fully preserved wooden poles for transmission and distribution lines for a period of one year, to Specification 68/149, at Schedule rates.—Alstergren Pty. Ltd.

823. For the supply of fully preserved wooden poles for transmission and distribution lines for a period of one year, to Specification 68/149, at Schedule rates.—Duncan-Innes Pty. Ltd.

824. For the supply of fully preserved wooden poles for transmission and distribution lines for a period of one year, to Specification 68/149, at Schedule rates.—Hickson's Timber Impregnation Co. (Aust.) Pty. Ltd.

Approved by the Governor in Council, 20th August, 1968.—J. ROSSITER, Clerk of the Executive Council.

Victoria.

#### ACT 391.—SECOND SCHEDULE.

A STATEMENT of trusts having been submitted by the head or authorized representative of the denomination of Methodist Church of Australasia, under the provisions of the "Act to provide for the Abolition of State Aid to Religion", for allowance by the Lieutenant-Governor, the same was allowed by him on the 3rd day of September, 1968, and the following is the form in which such statement of trusts has been allowed:—

##### EXISTING STATEMENT OF TRUSTS.

*Description of Land.*—1 acre, Township of Newhaven, Parish of Phillip Island, County of Mornington, being allotment 1, section 5, commencing at a point being the intersection of the southern alignment of Cleeland-street and the western alignment of Forrest-avenue; bounded thence by Forrest-avenue bearing 180 deg. 0 min. 500 links; by Anderson-street bearing 270 deg. 0 min. 200 links; by allotment 2 bearing 0 deg. 0 min. 500 links; and thence by Cleeland-street bearing 90 deg. 0 min. 200 links to the point of commencement.

No. 77.—8211/68.—2

*Names of Trustees.*—Arnold Harry Atkinson, Harry George Mackay, Norman Allen McCasker and John Daniel Wade.

*Powers of Disposition.*—Such powers of disposition, including powers of sale, lease or mortgage, as are contained in the Model Deed as defined by the *Methodist Union Act 1902*, under the trusts, powers and provisions of which deed the said property shall until disposed of be held.

*Purposes to which Proceeds of Disposition are to be Applied.*—To such Methodist Church purposes as shall be approved by the Trustees, or a majority thereof, with the consent of the Annual Conference of the Methodist Church of Australasia in Victoria.

As witness the hand of the Lieutenant-Governor of the State of Victoria, this third day of September, 1968.

E. F. HERRING,  
Lieutenant-Governor of the State of Victoria.

Victoria.

#### ACT 391.—SECOND SCHEDULE.

A STATEMENT of trusts having been submitted by the head or authorized representative of the denomination of Methodist Church of Australasia, under the provisions of the "Act to provide for the Abolition of State Aid to Religion", for allowance by the Lieutenant-Governor, the same was allowed by him on the 3rd day of September, 1968, and the following is the form in which such statement of trusts has been allowed:—

##### EXISTING STATEMENT OF TRUSTS.

*Description of Land.*—Site for a place of Public Worship in connexion with the Wesleyan Church temporarily reserved by Order in Council of the 22nd November, 1869, 1 acre, Township of Cowes, Parish of Phillip Island, County of Mornington, being Crown allotment 13, section 2, commencing at the south-western angle of allotment 12, section 2; bounded thence by that allotment bearing 90 deg. 0 min. 250 links; by allotments 14, 15, 19 bearing 180 deg. 0 min. 400 links; by Chapel-street bearing 270 deg. 0 min. 250 links; and thence by Bass-avenue bearing 0 deg. 0 min. 400 links to the point of commencement.

*Names of Trustees.*—John Daniel Wade, Norman Allen McCasker and Harry George Mackay.

*Powers of Disposition.*—Such powers of disposition, including powers of sale, lease or mortgage, as are contained in the Model Deed as defined by the *Methodist Union Act 1902*, under the trusts, powers and provisions of which deed the said property shall until disposed of be held.

*Purposes to which Proceeds of Disposition are to be Applied.*—To such Methodist Church purposes as shall be approved by the Trustees, or a majority thereof, with the consent of the Annual Conference of the Methodist Church of Australasia in Victoria.

As witness the hand of the Lieutenant-Governor of the State of Victoria, this third day of September, 1968.

E. F. HERRING,  
Lieutenant-Governor of the State of Victoria.

Victoria.

#### ACT 391.—SECOND SCHEDULE.

A STATEMENT of trusts having been submitted by the head or authorized representative of the denomination of Methodist Church of Australasia, under the provisions of the "Act to provide for the Abolition of State Aid to Religion", for allowance by the Lieutenant-Governor, the same was allowed by him on the 3rd day of September, 1968, and the following is the form in which such statement of trusts has been allowed:—

##### EXISTING STATEMENT OF TRUSTS.

*Description of Land.*—1 acre 1 rood, Township of Rhyll, Parish of Phillip Island, County of Mornington, being allotment 4, section 2, commencing at a point being the intersection of the southern alignment of Reid-road and the western alignment of Jansson-road; bounded thence by Jansson-road bearing 180 deg. 0 min. 500 links; by allotments 5 and 3 bearing 270 deg. 0 min. 250 links and 0 deg. 0 min. 500 links; and thence by Reid-road bearing 90 deg. 0 min. 250 links to the point of commencement.

*Names of Trustees.*—Arnold Harry Atkinson, Harry George Mackay, Norman Allen McCasker and John Daniel Wade.

*Powers of Disposition.*—Such powers of disposition, including powers of sale, lease or mortgage, as are contained in the Model Deed as defined by the *Methodist Union Act 1902*, under the trusts, powers and provisions of which deed the said property shall until disposed of be held.

Purposes to which Proceeds of Disposition are to be Applied.—To such Methodist Church purposes as shall be approved by the Trustees, or a majority thereof, with the consent of the Annual Conference of the Methodist Church of Australasia in Victoria.

As witness the hand of the Lieutenant-Governor of the State of Victoria, this third day of September, 1968.

E. F. HERRING,  
Lieutenant-Governor of the State of Victoria.

COMPANIES ACT 1961.

NOTICE is hereby given that in pursuance of section 308 (4) of the Companies Act 1961 the names of the Companies referred to below have been struck off the Register, and on publication of this notice in the Government Gazette the said Companies will be dissolved.

Dated this 4th day of September, 1968.

E. B. MITCHAM,  
Assistant Registrar of Companies.

Companies Office,  
Melbourne.

COMPANIES ABOVE REFERRED TO.

| Name of Company.   | Number of Registration. |
|--|-------------------------|
| Australian & Eastern Co. Pty. Ltd. . . . .                                   | 8000                    |
| Universal Automatic Sprinklers Co. Pty. Ltd. . . . .                         | 15035                   |
| H. & J. P. Byrne Pty. Ltd. . . . .   | 17813                   |
| John Scarff Pty. Limited . . . . .   | 20648                   |
| Castles Hardware Pty. Ltd. . . . .   | 22210                   |
| Bond's Modern Tailoring Pty. Ltd. . . . .                                    | 23703                   |
| Avonlyn Investments Pty. Ltd. . . . .  | 24251                   |
| Heyfield Lumber Co. Pty. Ltd. . . . .  | 27383                   |
| J. & V. Pty. Ltd. . . . .  | 27421                   |
| Licola Motors Pty. Ltd. . . . .  | 27821                   |
| H. & C. Investments Pty. Ltd. . . . .  | 29028                   |
| R.P.M. Holdings Pty. Ltd. . . . .  | 29418                   |
| Ayers & Clark Pottery Co. Pty. Ltd. . . . .                                  | 31212                   |
| North Suburban Auctions Pty. Limited . . . . .                               | 34101                   |
| H. W. Hall Pty. Ltd. . . . .   | 35392                   |
| Keltons Drapery Pty. Ltd. . . . .  | 35748                   |
| Burwood Service Grocery Pty. Limited . . . . .                               | 38017                   |
| Residential Estates Pty. Ltd. . . . .  | 38637                   |
| Residential Investment & Mortgage Co. Ltd. . . . .                           | 38648                   |
| Auburn Press Pty. Ltd. . . . .   | 38807                   |
| Cameron Estates (Vic.) Pty. Ltd. . . . .                                     | 38973                   |
| Cameron Listings Pty. Ltd. . . . .   | 41335                   |
| Cameron Investments Pty. Ltd. . . . .  | 41362                   |
| Cameron Pastoral Pty. Ltd. . . . .   | 41530                   |
| Cameron Advertising Pty. Ltd. . . . .  | 41531                   |
| Security Superannuation Trusts Ltd. . . . .                                  | 41763                   |
| Intercontinental Mercantile Brokers Pty. Ltd. . . . .                        | 43388                   |
| C. E. Tobias Pty. Ltd. . . . .   | 43776                   |
| Development Consolidated Pty. Ltd. . . . .                                   | 44136                   |
| Geelong Septic Tanks Pty. Ltd. . . . .                                       | 45100                   |
| Clay Bros. Pty. Ltd. . . . .   | 45729                   |
| M. & W. Hardware Pty. Limited . . . . .                                      | 45904                   |
| Style Rite Homes Pty. Ltd. . . . .   | 45989                   |
| Infantswear Pty. Ltd. . . . .  | 47491                   |
| Parkmore Consolidated Pty. Limited . . . . .                                 | 48415                   |
| Public Fidelity & Audit Ltd. . . . .   | 49215                   |
| Cobram Hotel Pty. Ltd. . . . .   | 50146                   |
| Hindley Investments Pty. Ltd. . . . .  | 50751                   |
| Yelt Constructions Pty. Ltd. . . . .   | 50810                   |
| R. M. Moody Pty. Ltd. . . . .  | 52744                   |
| Jasoncraft Boats Pty. Ltd. . . . .   | 52866                   |
| Kenneth Kirk Motors Pty. Ltd. . . . .  | 52924                   |
| Electrical Distributors Pty. Ltd. . . . .                                    | 54552                   |
| Aboyne Transport Company Pty. Ltd. . . . .                                   | 55279                   |
| Holland-Australia Post Pty. Ltd. . . . .                                     | 55397                   |
| Shirley Creations Pty. Ltd. . . . .  | 56185                   |
| Riethof and Company Pty. Ltd. . . . .  | 57089                   |
| Rewind Services Pty. Ltd. . . . .  | 57094                   |
| Beizer Developments Pty. Ltd. . . . .  | 58326                   |
| M. & K. Pty. Ltd. . . . .  | 58508                   |
| Sharp Mt. Beauty Pty. Ltd. . . . .   | 58554                   |
| Mt. Beauty Tobacco Pty. Ltd. . . . .   | 58555                   |
| Louis Williams and Associates Architects Pty. Ltd. . . . .                   | 58586                   |
| D. & N. Porritt Pty. Ltd. . . . .  | 58869                   |
| G. H. Mooney (Victoria) Pty. Ltd. . . . .                                    | 59105                   |
| Bendle's Motors (Wholesale) Pty. Ltd. . . . .                                | 60717                   |
| D.N. Investments Pty. Ltd. . . . .   | 60919                   |
| Palace Newmarket Hotel Pty. Ltd. . . . .                                     | 61180                   |
| Polychem Industries Pty. Ltd. . . . .  | 61200                   |
| United Clothing Pty. Ltd. . . . .  | 61241                   |
| Shelleys Restaurant Pty. Ltd. . . . .  | 61581                   |
| Meat Broking & Trading Coy. Pty. Ltd. . . . .                                | 61598                   |
| G. & I. Lierkamp Pty. Ltd. . . . .   | 61695                   |
| Frogman School of Underwater Diving and Marine Contractors Pty. Ltd. . . . . | 62223                   |

| Name of Company.   | Number of Registration. |
|--|-------------------------|
| Talshep Restaurants Pty. Ltd. . . . .                          | 62261                   |
| Emmlee Transport Pty. Ltd. . . . .                             | 62657                   |
| S. Jablo & Co. Pty. Ltd. . . . .                               | 62691                   |
| J.P. (Share Group) Pty. Ltd. . . . .                           | 63818                   |
| British American Australian (BAA) Management Pty. Ltd. . . . . | 64092                   |
| Reliable Plastics Pty. Ltd. . . . .                            | 64455                   |
| Malthorne Joinery Pty. Ltd. . . . .                            | 64870                   |
| Malthorne Constructions Pty. Ltd. . . . .                      | 65037                   |
| Kerriden Pty. Ltd. . . . .                                     | 65378                   |
| Sydney-Shepparton Haulage Pty. Ltd. . . . .                    | 65604                   |
| Australian Thoroughbred Syndicate Ltd. . . . .                 | 66038                   |
| Renshaw Wire Products (Aust.) Pty. Ltd. . . . .                | 66138                   |
| Jules Millinery Pty. Ltd. . . . .                              | 68256                   |
| Julie's Coin Laundry Pty. Ltd. . . . .                         | 68269                   |
| Keilor Insurance Service Pty. Ltd. . . . .                     | 69899                   |
| Athenian Market Pty. Ltd. . . . .                              | 70035                   |
| F.S.R. (Vic.) Pty. Ltd. . . . .                                | 70489                   |

PUBLIC TRUSTEE ACT 1958 (No. 6350), SECTION 17.

I HEREBY give notice that on the 21st August, 1968, the Public Trustee filed elections to administer the following deceased persons' estates, in accordance with section 17 of the Public Trustee Act 1958:—

- HOWARD, DAVID LEON, late of Kew, of no occupation, died 30th November, 1967.
- KUPER, SAMUEL, late of Flat 3, 16 Cardigan-street, East St. Kilda, estate agent, died 19th April, 1964.
- MCDALD, PATRICK NOEL, late of 49 Buckley-street, Morwell, labourer, died 9th April, 1968.
- SALON, ALFRED, late of 293 Latrobe-street, Melbourne, packer, died 13th April, 1968.
- SHANNON, HILDA MAY, late of 9 Bailey-avenue, Armadale, married woman, died 7th June, 1968.
- SMITH, CYRIL ROY, late of 2 Mountain-street, South Melbourne, railway employee, died 23rd May, 1968.

I HEREBY give notice that on the 28th August, 1968, the Public Trustee filed elections to administer the following deceased persons' estates, in accordance with section 17 of the Public Trustee Act 1958:—

- ABDAT, AZZAM, late of 335 Beaconsfield-parade, St. Kilda, mail sorter, died 10th May, 1968.
- BROWN, FRITZ STANLEY, also known as Stanley Brown, late of 47 Tivoli-road, South Yarra, pensioner, died 29th June, 1968.
- GREGORY, LAURA NAOMI, late of 10 Rupert-street, Ringwood, spinster, died 20th June, 1968.
- JONES, HARRY BAYLEY, late of 19 William-street, North Brighton, gasfitter, died 13th March, 1958.

D. HOOKEY,  
Acting Public Trustee.

256 Flinders-street, Melbourne, 4th September, 1968.

NOTICE.

CREDITORS, nex of kin and others having claims against the estate of any of the under-mentioned deceased persons are required to send particulars of their claims to the Public Trustee, 256 Flinders-street, Melbourne, 3000, the personal representative, on or before the 19th November, 1968, after which date the Public Trustee may convey or distribute the assets, having regard only to the claims of which the Public Trustee then has notice:—

- ABDAT, AZZAM, late of 335 Beaconsfield-parade, St. Kilda, mail sorter, died 10th May, 1968.
- ATHERTON, LESLIE WILLIAM, late of 11 Montrose-street, Auburn, retired bootmaker, died 13th July, 1968.
- BARTON, ERNEST JAMES, formerly of 36 Doynton-parade, Mount Waverley, but late of 6 Drummond-street, Chadstone, military pensioner, died 3rd July, 1968.
- BROWN, FRITZ STANLEY, also known as Stanley Brown, late of 47 Tivoli-road, South Yarra, pensioner, died 29th June, 1968.
- BRYAN, AGNES LOUISA, formerly of 14 Temple-street, West Brunswick, but late of 37 Nirvana-avenue, East Malvern, widow, died 21st July, 1968.
- CAIRNS, ALBERT, late of 142 Civic-parade, Altona, retired council employee, died 3rd July, 1968.
- CAMMIADE, MARGARET ANNE, late of 56 Mayston-street, Hawthorn, widow, died 7th June, 1968.
- CHAPLIN, WILLIAM JAMES, late of 62 Lillimur-road, Ormond, military pensioner, died 3rd July, 1968.
- DAVIES, HILDA, late of 17 Mary-street, Coburg, spinster, died 7th June, 1968.
- GREGORY, LAURA NAOMI, late of 10 Rupert-street, Ringwood, spinster, died 20th June, 1968.
- HOPPER, WILLIAM JOHN, formerly of 5 Malabar-road, Blackburn, but late of 21 Halls-parade, Mitcham, clerk, died 25th April, 1968.

HOWARD, DAVID LEON, late of Kew, of no occupation, died 30th November, 1967.

JONES, HARRY BAYLEY, late of 19 William-street, North Brighton, gasfitter, died 13th March, 1958.

KINSELLA, ANNIE, late of 64 Shaftesbury-parade, Thornbury, widow, died 9th September, 1956.

KÖRS, FRIEDA, late of 8 Sander-street, Hamburg-Bergedorf, Germany, widow, died 3rd March, 1963.

KUPER, SAMUEL, late of Flat 3, 16 Cardigan-street, East St. Kilda, estate agent, died 19th April, 1964.

MACKIE, ROBERT CAMPBELL, late of Flat 2, 6 Wallace-avenue, Bayswater, clerk, died 30th April, 1968.

MAGALAA, NABIL SAMUEL, late of 16 Vincent-street, Coburg, bank teller, died 30th October, 1967.

MASON, HERMAN, late of 10 Kelso-street, Frankston, retired municipal employee, died 22nd June, 1968.

MATTHEWS, CLARA HARRIET FLORELLA, late of 8 Daly-road, Sandringham, widow, died 9th April, 1968.

MISH, JOHN NORMAN, late of 34 Croydon-road, Croydon, chartered engineer, died 10th May, 1968.

MOLONEY, HELEN VERONICA, also known as Helen Moloney, late of 33 Elphin-grove, Hawthorn, spinster, died 23rd May, 1968.

MORRISSEY, LEONORA VERONICA, formerly of 138 Peel-street, Windsor, but late of 17 Kernan-street, Strathmore, widow, died 18th January, 1968.

MCDAID, PATRICK NOEL, late of 49 Buckley-street, Morwell, labourer, died 9th April, 1968.

MCGUIRE, MARY PHYLLIS, late of 121 Kent-street, Richmond, drink dispenser, died 28th June, 1967.

PORTER, ALBERT JOHN LEONARD, late of Inglewood, New Zealand, driver, died 9th November, 1967.

RUSSELL, LESLIE GEORGE, late of Unit 4, 56 Webster-street, Chadstone, crockery despatcher, died 21st June, 1968.

SALON, ALFRED, late of 293 Latrobe-street, Melbourne, packer, died 13th April, 1968.

SAVORY, EDITH, late of 274 Canterbury-road, Surrey Hills, widow, died 6th June, 1968.

SHANNON, HILDA MAY, late of 9 Bailey-avenue, Armadale, married woman, died 7th June, 1968.

SMITH, ARCHIBALD BRASH, late of 20 Grandview-avenue, Burwood, retired commercial traveller, died 23rd April, 1968.

SMITH, CYRIL ROY, late of 2 Mountain-street, South Melbourne, railway employee, died 23rd May, 1968.

SMITH, GEORGE FREDERIC, also known as George Frederick Smith, late of 259 Rae-street, North Fitzroy, retired labourer, died 9th June, 1967.

WILLS, JOHN ADOLPHUS, formerly of 19 Harold-street, Thornbury, but late of Flat 4, 28 Milton-crescent, Preston, pitman, died 5th July, 1968.

D. HOOKEY,  
Acting Public Trustee.

Melbourne, 4th September, 1968.

*Private Agents Act 1966.*

**NOTICE OF RECEIPT OF APPLICATIONS FOR LICENCES UNDER THE PROVISIONS OF THE PRIVATE AGENTS ACT 1966.**

THE Clerk(s) of the Court(s) of Petty Sessions as listed hereunder hereby give notice that applications, as under, have been lodged for hearing by the said Court(s) on the date(s) specified.

Any person desiring to object to any of such applications must—

- (a) lodge with the respective Clerk of Petty Sessions a notice in the prescribed form of his objection and of the grounds thereof;
- (b) cause a copy of such notice to be served personally or by post upon the applicant at least three days before the hearing of the application; and
- (c) send or deliver—
  - (i) where the objection is not made by the officer in charge of the police district in which the Court is situated—a copy of the notice to such officer; and
  - (ii) where the objection is not made by the Registrar or Deputy Registrar—a copy to the Registrar.

| Full Name of Applicant or in the case of a Firm or Corporation, of the Nominee. | Place of Abode of Applicant or Nominee. | Name of Firm or Corporation. | Address for Registration. | Type of Licence. | Date of Hearing of Application. |
|---|---|------------------------------|---------------------------|------------------|---------------------------------|
|---|---|------------------------------|---------------------------|------------------|---------------------------------|

COURT OF PETTY SESSIONS, SPRINGVALE.

|                              |                                  |         |                            |             |         |
|------------------------------|----------------------------------|---------|----------------------------|-------------|---------|
| Kelly, Ian Patrick Aubrey .. | Lot 10, Brisbane-street, Berwick | .. .. . | 9 Bowmore-road, Noble Park | Watchman .. | 20.9.68 |
|------------------------------|----------------------------------|---------|----------------------------|-------------|---------|

Dated at Springvale this 30th day of August, 1968.

F. J. DUTHIE, Clerk of Petty Sessions.

COURT OF PETTY SESSIONS, PRAHRAN.

|                   |                                 |         |                              |                      |         |
|-------------------|---------------------------------|---------|------------------------------|----------------------|---------|
| Goodwin, James .. | 30 Reichelt-avenue, Montmorency | .. .. . | 614 St Kilda-road, Melbourne | Commercial Sub-agent | 30.9.68 |
|-------------------|---------------------------------|---------|------------------------------|----------------------|---------|

Dated at Prahran this 2nd day of September, 1968.

G. T. WHEELHOUSE, Clerk of Petty Sessions.

COURT OF PETTY SESSIONS, SOUTH MELBOURNE.

|                            |                                  |         |  |             |         |
|----------------------------|----------------------------------|---------|--|-------------|---------|
| Curtis, Frederick James .. | 86 William-street, Greensborough | .. .. . | 101-105 Clarke-street, South Melbourne | Watchman .. | 27.9.68 |
|----------------------------|----------------------------------|---------|--|-------------|---------|

Dated at South Melbourne this 30th day of August, 1968.

G. MILLER, Clerk of Petty Sessions.

COURT OF PETTY SESSIONS, SPRINGVALE.

|                           |                            |         |                            |                  |         |
|---------------------------|----------------------------|---------|----------------------------|------------------|---------|
| Thomas, Raymond George .. | 20 Wall-street, Noble Park | .. .. . | 20 Wall-street, Noble Park | Inquiry Agent .. | 20.9.68 |
|---------------------------|----------------------------|---------|----------------------------|------------------|---------|

Dated at Springvale this 30th day of August, 1968.

F. J. DUTHIE, Clerk of Petty Sessions.

COURT OF PETTY SESSIONS, PRAHRAN.

|                             |                                     |                       |   |             |         |
|-----------------------------|-------------------------------------|-----------------------|---|-------------|---------|
| Armstrong, David Maxwell .. | Flat 6, 544 New-street, Elsternwick | Factory Guard Service | Suite 17, 562 St. Kilda-road, Melbourne | Watchman .. | 1.10.68 |
| Martin, Donald Alexander .. | 43 Louis-street, Doveton            | .. .. .               | .. .. .                                 | .. .. .     | 7.10.68 |

Dated at Prahran this 3rd day of September, 1968.

G. T. WHEELHOUSE, Clerk of Petty Sessions.

PRIVATE AGENTS—continued.

| Full Name of Applicant or in the case of a Firm or Corporation, of the Nominee. | Place of Abode of Applicant or Nominee. | Name of Firm or Corporation. | Address for Registration. | Type of Licence. | Date of Hearing of Application. |
|---|---|------------------------------|---------------------------|------------------|---------------------------------|
|---|---|------------------------------|---------------------------|------------------|---------------------------------|

COURT OF PETTY SESSIONS, DANDENONG.

|                     |                           |  |                           |          |         |
|---------------------|---------------------------|--|---------------------------|----------|---------|
| Kearns, Kevin James | 29 Chestnut-road, Doveton |  | 29 Chestnut-road, Doveton | Watchman | 23.9.68 |
|---------------------|---------------------------|--|---------------------------|----------|---------|

Dated at Dandenong this 2nd day of September, 1968.

C. F. LEWIS, Clerk of Petty Sessions.

COURT OF PETTY SESSIONS, SOUTH MELBOURNE.

|                      |                                   |  |                                  |          |         |
|----------------------|-----------------------------------|--|----------------------------------|----------|---------|
| Simcox, Raymond John | Lot 96, Thompson-road, Upwey      |  | 101-105 Clarke-street, Melbourne | Watchman | 27.9.68 |
| Harry, Allan         | 2 Primrose-street, East Brunswick |  | " "                              | "        | "       |

Dated at South Melbourne this 4th day of September, 1968.

G. MILLER, Clerk of Petty Sessions.

COURT OF PETTY SESSIONS, SOUTH MELBOURNE.

|                        |                               |  |                                  |          |         |
|------------------------|-------------------------------|--|----------------------------------|----------|---------|
| Hearnden, Arthur Henry | Flat 8, 12 May-street, Elwood |  | 101-105 Clarke-street, Melbourne | Watchman | 27.9.68 |
|------------------------|-------------------------------|--|----------------------------------|----------|---------|

Dated at South Melbourne this 5th day of September, 1968.

G. MILLER, Clerk of Petty Sessions.

COURT OF PETTY SESSIONS, MELBOURNE.

|  |                                     |   |  |                                |         |
|--|-------------------------------------|---|--|--------------------------------|---------|
| Cusack, Bernard Anthony as nominee for The Secretariat Limited | 219 Napier-street, Essendon         | The Federal Secretariat Proprietary Limited | Sixth Floor, 340 Collins-street, Melbourne | Commercial Agent (Corporation) | 25.9.68 |
| Walsh, Gerald John   | 4 Hayes-road, Strathmore            | " "   | " "  | Commercial Sub-Agent           | "       |
| Edwards, Gordon Ashton   | Flat 1, 123 Tennyson-street, Elwood | Australian Watching Co. Pty. Ltd.           | 340 Abbotsford-street, North Melbourne     | Watchman                       | "       |
| Fincher, Hugh William Robert                                   | Marine - parade, Hastings           | " "   | " "  | "                              | "       |
| Gormley, John Anthony  | 149 Edward-street, Brunswick        | " "   | " "  | "                              | "       |
| Hutchings, David George  | 223 Highett-street, Richmond        | " "   | " "  | "                              | "       |
| Le Busque, Alfred Joseph                                       | 162 Wantirna-road, Ringwood         | " "   | " "  | "                              | "       |
| Noble, Roy Douglas   | 2 May-street, Essendon              | " "   | " "  | "                              | "       |
| Olney, Frederick William                                       | 134 Paperbark-street, Doveton       | " "   | " "  | "                              | "       |
| Pabst, Rainer  | 34 Park-place, South Yarra          | " "   | " "  | "                              | "       |
| Williams, Alan   | 57 Athol-street, Moonee Ponds       | Mayne Nickless Ltd.                         | 94 York-street, South Melbourne            | "                              | "       |

Dated at Melbourne this 4th day of September, 1968.

G. L. WEBSTER, Clerk of Petty Sessions.

COURT OF PETTY SESSIONS, PRAHRAN.

|                     |                               |                                 |                               |          |         |
|---------------------|-------------------------------|---------------------------------|-------------------------------|----------|---------|
| Cook, Allan William | 29 Heffernan-street, Laverton | Factory Guard Service Pty. Ltd. | 562 St. Kilda-road, Melbourne | Watchman | 4.10.68 |
|---------------------|-------------------------------|---------------------------------|-------------------------------|----------|---------|

Dated at Prahran this 6th day of September, 1968.

G. T. WHEELHOUSE, Clerk of Petty Sessions.

APPOINTMENTS AND RESIGNATIONS

APPOINTMENTS.

HIS Excellency the Lieutenant-Governor of the State of Victoria, by and with the advice of the Executive Council thereof, has, by Orders made on the 3rd day of September, 1968, been pleased to make the under-mentioned appointments, viz.:-

CHIEF SECRETARY'S DEPARTMENT.

Governor of Training Prison (Acting).

WILLIAM GEORGE SMITHERAM, pursuant to the provisions of the Gaols Act 1958, to be Governor (Acting) of Her Majesty's Training Prison, Beechworth, from the 23rd August, 1968, to 9th September, 1968, inclusive, during the absence on leave of James Henry Fellows.

Honorary Probation Officers.

ROBERT THOMAS BAXTER (The Reverend), 22 Urquhart-street, Horsham,  
 MARIE AGNES CONROY (Sister Matthew), 116 Nicholson-street, Fitzroy,  
 ELIZABETH ANNE COOGAN, 15 Iribarra-road, Canterbury,

ALISON MACKINNON COWELL, 8 Wedgwood-avenue, Belgrave,  
 OENONE MARY DEASEY, St. Matthew's Vicarage, 30 Widford-street, Glenroy,  
 LEO JOHN GORMAN, 33 Batten-street, Seymour,  
 KENNETH MAURICE GRANT, Flat 2, 33 Clyde-street, East Kew,  
 JUDITH ANN LANG, Flat 1, 55 Stewart-street, Colac,  
 ARTHUR ROBERT MAWSON (Captain, Salvation Army), 36 Henty-street, Portland,  
 WALTER JAMES EDWARD MOORE, 4 High-street, Eildon,  
 MOIRA MORGAN, 11 O'Brien-street, Bairnsdale,  
 DOROTHY JOAN RAMAGE, 14 Photinia-street, Doveton,  
 AGNES ANNE JOSEPHINE TERRY, Harold-road, Springvale South,  
 MICHAEL JAMES WATERS, 22 McLaren-street, Bendigo,  
 TERENCE ALAN WHITE, 3 Cunninghame-street, Sale, and  
 PATRICIA JEAN WILLIAMS, 13 Mill-street, St. Arnaud, pursuant to the provisions of section 10 (1) of the Children's Court Act 1958, to be Honorary Probation Officers for all Children's Courts in Victoria; and  
 MARIE AGNES CONROY (Sister Matthew), 116 Nicholson-street, Fitzroy,  
 ELIZABETH ANNE COOGAN, 15 Iribarra-road, Canterbury,

ALISON MACKINNON COWELL, 8 Wedgwood-avenue, Belgrave,  
 OENONE MARY DEASEY, St. Matthew's Vicarage, 30 Widford-street, Glenroy,  
 MOIRA MORGAN, 11 O'Brien-street, Bairnsdale,  
 AGNES ANNE JOSEPHINE TERRY, Harold-road, Springvale South,  
 PATRICIA JEAN WILLIAMS, 13 Mill-street, St. Arnaud,  
 HAZEL NANCY YOUNG, 6 The Boulevard, Glen Waverley,  
 RONALD JAMES CLARKE, 24 Lower Heidelberg-road, Ivanhoe,  
 JACK AMOS GOODRIDGE, 19 Gisborne-road, Bacchus Marsh, and  
 HENRY WILLIAM STEVENS, 10 Lampards-road, Drouin,  
 pursuant to the provisions of section 507 (2) of the Crimes Act 1958, to be Honorary Probation Officers for all Adult Courts in Victoria.

Member and Chairman of the Totalizator Agency Board.

THOMAS CHESTER MANIFOLD (Sir),  
 pursuant to the provisions of the Racing Act 1958, to be a Member and Chairman of the Totalizator Agency Board, from the 1st August, 1968, to the 12th September, 1968, both dates inclusive.

#### MINISTRY OF HEALTH.

Member of Committee of Management of Hospital.

WILLIAM THOMAS CHRISTIAN  
 to be a Member of the Committee of Management of The Mortlake District Hospital, pursuant to proviso (a) to section 48 (1) of the Hospitals and Charities Act 1958, for a further period of three years ending 17th September, 1971.

#### LAW DEPARTMENT.

Commissioners for Taking Declarations, &c.

JOHN EDWARD HOWARD, care of Fell and Starkey, chartered accountants, 360 Collins-street, Melbourne,  
 RUSSELL CHARLES WALTER RAYSON, care of The Association of Professional Engineers, Australia, 114 King-street, Melbourne,  
 PETER ERNEST SIMPSON, Statax Co-operative Credit Society Ltd., care of Taxation Department, 436 Lonsdale-street, Melbourne,  
 EDWARD MCCORMICK, care of Waterside Workers' Federation of Australia, Melbourne Branch, 480 Flinders-street, Melbourne,  
 DAVID ALAN MORGAN, care of The British Phosphate Commissioners, Phosphate House, 515 Collins-street, Melbourne, and  
 STUART GARDINER PATTERSON, care of The Bank of Adelaide, 267 Collins-street, Melbourne,  
 to be Commissioners for taking Declarations and Affidavits, pursuant to the provisions of the Evidence Act 1958, to resign upon ceasing to occupy their present positions; and

EDWARD JOHN FAIRBRIDGE, Post Office, Avenel,  
 JOHN GREGORY BEUS, 33 Balmoral-avenue, Springvale,  
 PETER BLAIR, 18 Plunkett-street, West Heidelberg, and  
 JOHN VAN DE LOO, 362 Waterloo-road, Glenroy,  
 to be Commissioners for taking Declarations and Affidavits, pursuant to the provisions of the Evidence Act 1958, to resign upon removing from the neighbourhood of the addresses stated.

#### Justices of the Peace.

CLAUD EDGAR MCKNIGHT, 1 Bennett-street, Balwyn,  
 JOHN ALBERT EDEN, 274 Camberwell-road, Camberwell,  
 JOHN MARION PETER BASSETT-SMITH, Menzies-road, Kangaroo Ground, and  
 LEONARD GEORGE ENDACOTT, 35 Finmere-crescent, Upper Ferntree Gully,  
 to Keep the Peace in the Central Bailiwick of the State of Victoria;  
 NORMAN DOUGLASS SMITH, "Welbanite", Pura Pura,  
 to Keep the Peace in the Southern Bailiwick of the State of Victoria; and  
 IVAN JEFFREY KING, 37 Contingent-street, Trafalgar,  
 NORMAN MONTAGUE FOWLER, Contingent-street, Trafalgar,  
 ALBERT ALEXANDER MORRISON, 4 Summerlea-street, Trafalgar, and  
 ALBERT GEORGE FARRINGTON, South-road, Warragul,  
 to Keep the Peace in the Eastern Bailiwick of the State of Victoria.

#### DEPARTMENT OF THE TREASURER.

Collectors of Imposts (Acting).

JAMES RONALD NOLAN  
 to act temporarily as Collector of Imposts, Education Department, vice R. J. Senior, on leave; and

ISTVAN LOUASS  
 to act temporarily as Collector of Imposts, Social Welfare Department, vice N. R. Semmens, on leave.

J. ROSSITER,  
 Clerk of the Executive Council.

At the Executive Council Chamber,  
 Melbourne, 3rd September, 1968.

#### FORESTS DEPARTMENT.

APPOINTMENT OF MEMBERS OF COMMITTEE OF MANAGEMENT OF "THE OLINDA GOLF COURSE AREA".

WHEREAS by section 50 of the Forests Act 1958 (No. 6254), it is provided that the Minister of Forests may, on the recommendation of the Forests Commission, appoint any number of persons, not less than three, to be a Committee of Management of any land forming part of any reserved forest, such land being set aside as a Golf Course Area, and may remove any of those persons: Now therefore, I, Edward Raymond Meagher, Her Majesty's Minister of Forests for the State of Victoria, on the recommendation of the Forests Commission, do hereby appoint—

VERA STEWART DODD (Mrs.),  
 ALLAN PERCY DODD,  
 Brigadier HUGH RONALD OFFICER,  
 FRANCIS STEWART BANKIN,  
 JAMES ANTOINE MARTY,  
 JACK LLOYD BASKETT,  
 JAMES CAMPBELL WESTCOTT,  
 ROY VICTOR BUTLER,  
 HENRY EDWIN RICH,

as members of the Committee of Management until the 19th day of June, 1971, of the land forming part of the reserved forest in the Parish of Monbulk, County of Evelyn, described in the accompanying Schedule, and known as "The Olinda Golf Course Area".

#### SCHEDULE ABOVE REFERRED TO.

Parish of Monbulk, County of Evelyn, 127 acres, more or less, being the area shown by pink colour on the plan marked A.58/1462 over 28.9.62 in file of correspondence No. 67/720 of the Forests Department.

Dated at Melbourne the second day of September, 1968.

E. R. MEAGHER,  
 Minister of Forests.

#### National Parks Act 1958.

##### APPOINTMENTS.

NOTICE is hereby given that the National Parks Authority has made the following appointments:

##### AUTHORIZED OFFICERS.

Donald Yorke and Jeffrey Alan Davies of Wilson's Promontory, as Authorized Officers for the purpose of the National Park Regulations 1959.

J. T. McDONALD,  
 Secretary.  
 Office of the National Parks Authority,  
 Melbourne, 3rd September, 1968.

##### RESIGNATIONS.

HIS Excellency the Lieutenant-Governor of the State of Victoria, by and with the advice of the Executive Council thereof, has, by Orders made on the 3rd day of September, 1968, accepted the resignations of the persons named hereunder of the offices mentioned, viz.:—

##### LAW DEPARTMENT.

Commissioner for Taking Declarations, &c.

HARRY ABBOTT DOWNES, as a Commissioner for taking Declarations and Affidavits, pursuant to the provisions of the Evidence Act 1958.

##### Justices of the Peace.

The persons named in the first column of the Schedule hereto, from the Commission of the Peace for the respective Bailiwicks of the State of Victoria set opposite their names in the second column of the said Schedule.

| Name.                 | SCHEDULE. | Bailiwick.           |
|-----------------------|-----------|----------------------|
| JOHN JOSEPH NOLAN     | ..        | Northern.            |
| MAURICE VINCENT KENNY | ..        | Midland and Western. |

J. ROSSITER,  
Clerk of the Executive Council.

At the Executive Council Chamber,  
Melbourne, 3rd September, 1968.

**ORDERS IN COUNCIL**

DEPARTMENT OF CROWN LANDS AND SURVEY.

At the Executive Council Chamber, Melbourne, the  
third day of September, 1968.

PRESENT:

His Excellency the Lieutenant-Governor of Victoria.  
Mr. Reid | Mr. Wilcox.

LAND WITHHELD FROM SALE, ETC.—ORDER  
REVOKED.

HIS Excellency the Lieutenant-Governor of the State of Victoria by and with the advice of the Executive Council thereof, doth hereby revoke the Order in Council of the 28th February, 1881, withholding from sale, leasing, and licensing 400 acres more or less of land in the Parish of Colquhoun (now in the Parish of Colquhoun East) so far only as regards 48 acres more or less as indicated by hatching of the plan hereunder.—(C.383<sup>(12)</sup>) (H.030863).

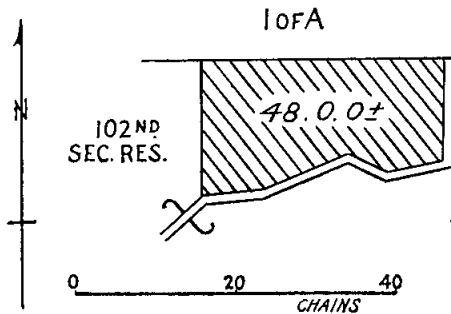

And the Honorable Sir William John Farquhar McDonald, Her Majesty's Minister of Lands for the State of Victoria, shall give the necessary directions herein accordingly.

J. ROSSITER,  
Clerk of the Executive Council.

DEPARTMENT OF CROWN LANDS AND SURVEY.

At the Executive Council Chamber, Melbourne, the  
third day of September, 1968.

PRESENT:

His Excellency the Lieutenant-Governor of Victoria.  
Mr. Reid | Mr. Wilcox.

LAND TEMPORARILY RESERVED AS A SITE.

HIS Excellency the Lieutenant-Governor of the State of Victoria, by and with the advice of the Executive Council thereof, doth hereby, in pursuance of section 14 of the Land Act 1958, reserve temporarily from sale, from being leased and from having a licence granted in respect thereof, and also except from occupation for mining purposes under any miner's right, the land hereinafter described:—

KORUMBURRA.—Site for Public Recreation, 4 acres 35 perches, more or less, Township of Korumburra, Parish of Korumburra, County of Buln Buln, as indicated by hatching on plan hereunder.—(K.172<sup>(12)</sup>) (Rs.8639).

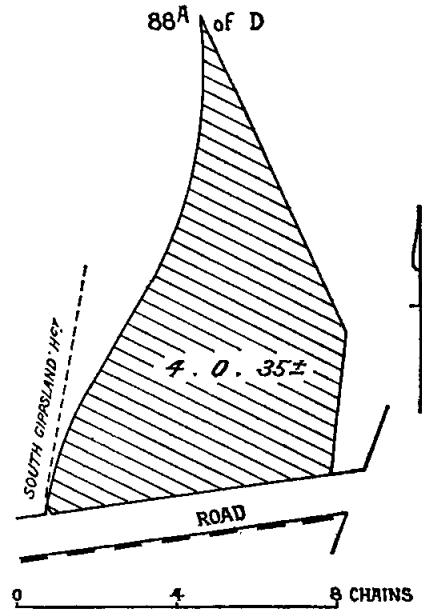

And the Honorable Sir William John Farquhar McDonald, Her Majesty's Minister of Lands for the State of Victoria, shall give the necessary directions herein accordingly.

J. ROSSITER,  
Clerk of the Executive Council.

DEPARTMENT OF CROWN LANDS AND SURVEY.

At the Executive Council Chamber, Melbourne, the  
third day of September, 1968.

PRESENT:

His Excellency the Lieutenant-Governor of Victoria.  
Mr. Reid | Mr. Wilcox.

UNUSED ROADS CLOSED.

HIS Excellency the Lieutenant-Governor of the State of Victoria, by and with the advice of the Executive Council thereof, doth hereby direct that, in pursuance of the provisions of section 349 of the Land Act 1958, the unused roads referred to hereunder be closed, viz:—

Parish of Glenhope, County of Dalhousie, being the road indicated by hatching on plan hereunder.—(G.64<sup>(6)</sup>) (W.84744).

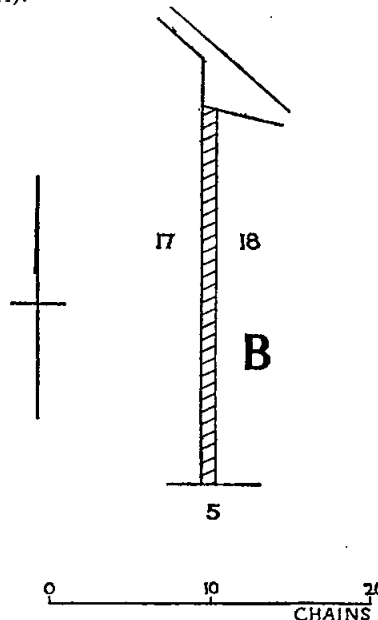



The land shown hatched on Plan numbered G.P.11251 hereunder required for the widening of the Goulburn Valley Highway in the Shire of Numurkah and making of the widening thereon.

STATE HIGHWAY  
GOULBURN VALLEY HIGHWAY  
SHIRE OF NUMURKAH  
*Measurements in links.*

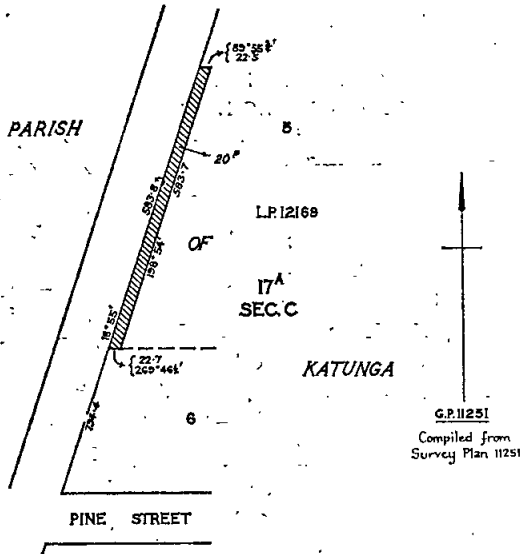

G.P.11251  
Compiled from  
Survey Plan 11251

Main roads.

The land shown hatched on Plan numbered G.P.11385 hereunder required for the widening of the Penshurst Road in the Shire of Belfast and making of the widening thereon.

MAIN ROAD  
PENSURST ROAD  
SHIRE OF BELFAST  
*Measurements in links.*

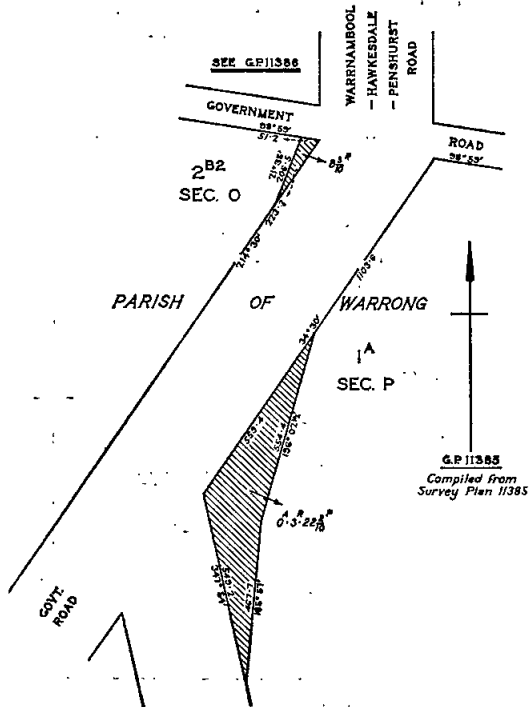

G.P.11385  
Compiled from  
Survey Plan 11385

The land shown hatched on Plan numbered G.P.11323 hereunder required for the widening of the Rainbow Rises Road in the Shire of Dimboola and making of the widening thereon.

MAIN ROAD  
RAINBOW RISES ROAD  
SHIRE OF DIMBOOLA  
*Measurements in links.*

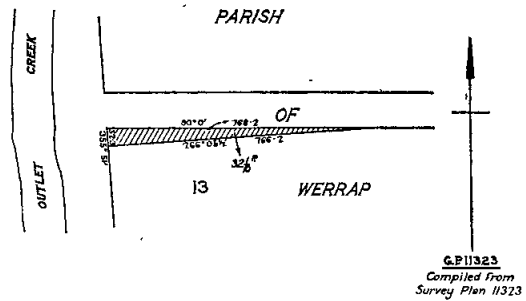

G.P.11323  
Compiled from  
Survey Plan 11323

The land shown hatched on Plans numbered G.P.11427 and G.P.11428 hereunder required for the widening of the Timboon-Nullawarre Road in the Shire of Heytesbury and making of the widening thereon.

MAIN ROAD  
TIMBOON - NULLAWARRE ROAD  
SHIRE OF HEYTESBURY  
*Measurements in links.*

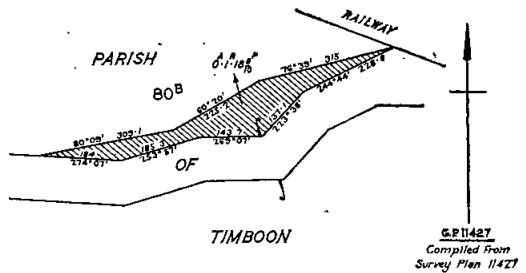

G.P.11427  
Compiled from  
Survey Plan 11427

MAIN ROAD  
TIMBOON - NULLAWARRE ROAD  
SHIRE OF HEYTESBURY  
*Measurements in links.*

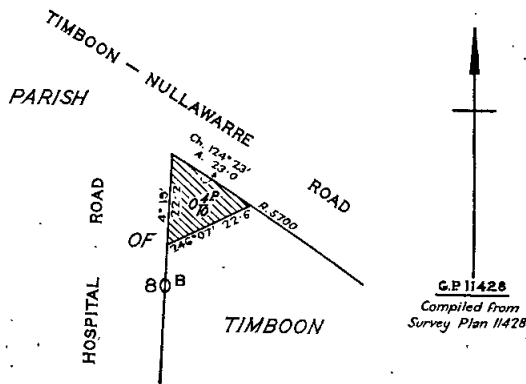

G.P.11428  
Compiled from  
Survey Plan 11428



The land shown hatched on Plan numbered G.P.11386 hereunder required for the widening of the Warrnambool-Hawkesdale-Penshurst Road in the Shire of Minhamite and the making of the widening thereon.

MAIN ROAD  
WARRNAMBOOL-HAWKESDALE-PENSHURST ROAD  
SHIRE OF MINHAMITE  
*Measurements in links*

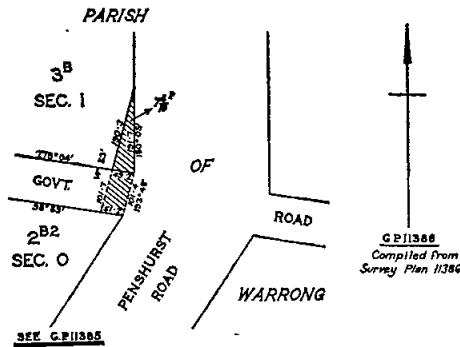

The land shown hatched on Plan numbered G.P.11429 hereunder required for the widening of the Navarre Road in the Shire of Stawell and making of the widening thereon.

MAIN ROAD  
NAVARRE ROAD  
SHIRE OF STAWELL  
*Measurements in links*

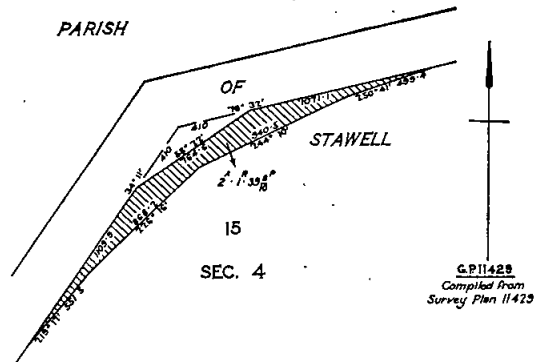

By-pass road.

The land shown hatched on Plan numbered G.P.11457 hereunder required for the making of part of the Calder By-pass Road in the City of Keilor.

BY-PASS ROAD  
CALDER BY-PASS ROAD  
CITY OF KEILOR  
*Measurements in feet & inches*

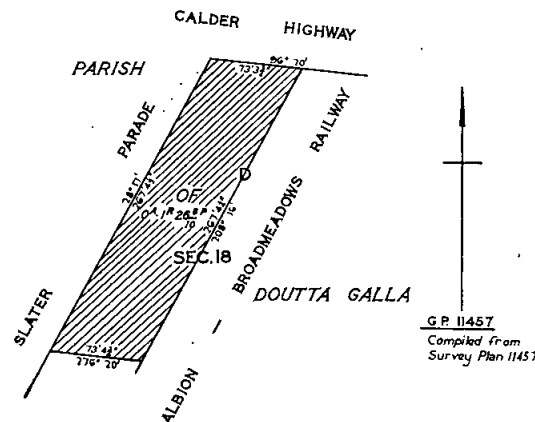

NOTE.—This Order is in lieu of that published for S.P.9451 in the Government Gazette of the Twelfth day of August One Thousand Nine Hundred and Sixty-four on Page 2637.

Tourists' road.

The land shown hatched on Plans numbered G.P.10777A and G.P.10778A hereunder required for the deviation from the Ocean Road in the Shire of Otway and making of the deviation thereon.

The land shown hatched on Plan numbered G.P.11277 hereunder required for the widening of the Torquay Road in the Shire of South Barwon and making of the widening thereon.

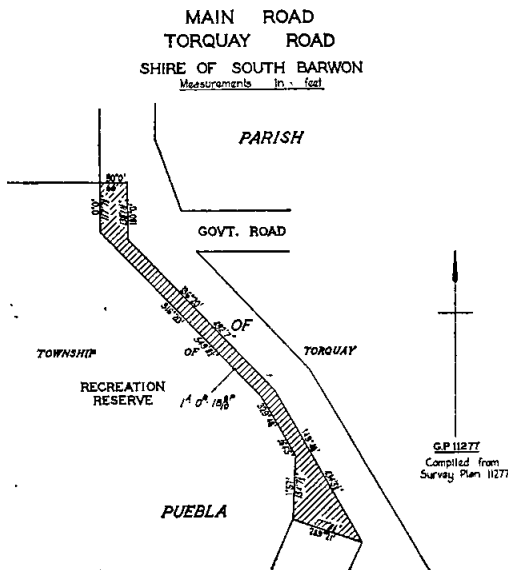

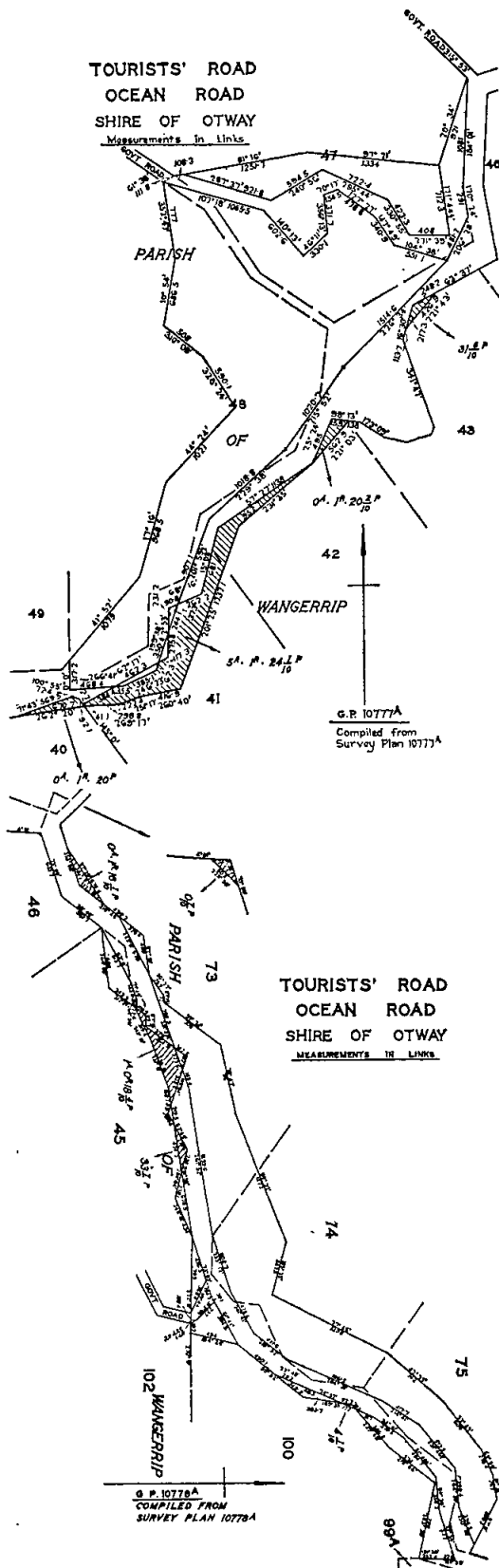

Forest road.  
The land shown hatched on Plans numbered G.P.11474 and G.P.11475 hereunder required for the widening of the Meredith-Steiglitz-Maude Road in the Shire of Bannockburn and making of the widening thereon.

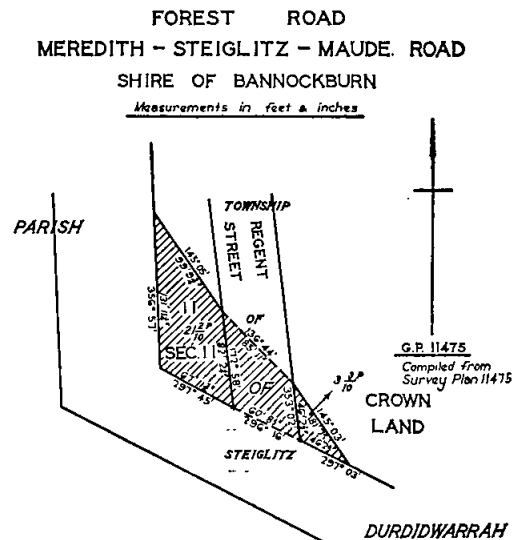
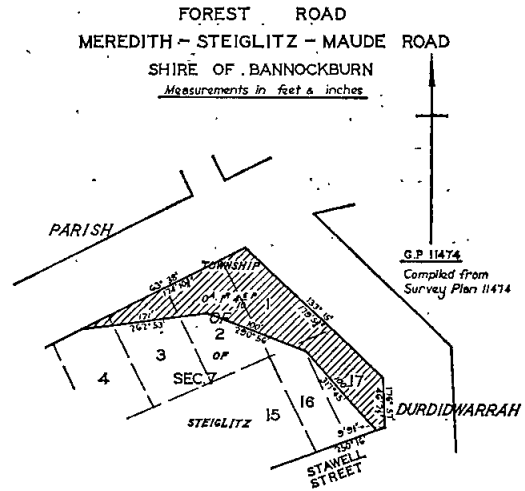

And the Honorable Murray Victor Porter, Her Majesty's Minister of Public Works for the State of Victoria, shall give the necessary directions herein accordingly.

J. ROSSITER,  
Clerk of the Executive Council.

NOTE.—This Order is in lieu of part of the Order published in the Government Gazette of the Nineteenth day of April One Thousand Nine Hundred and Sixty-seven on page 1142.

LOCAL GOVERNMENT DEPARTMENT.

At the Executive Council Chamber, Melbourne, the third day of September, 1968.

PRESENT:

His Excellency the Lieutenant-Governor of Victoria.  
Mr. Reid | Mr. Wilcox.

VESTING OF A RESERVE IN THE BROADMEADOWS CITY COUNCIL.

WHEREAS it is provided by Section 569BA of the *Local Government Act 1958* that where any map or plan has been lodged or deposited with the Registrar of Titles pursuant to Section 97 of the *Transfer of Land Act* or any corresponding previous enactment (whether before or after the commencement of the *Local Government Act 1963*) and any allotment on that map or plan has been transferred the Governor-in-Council on the request of the Council of the municipality may by Order published in the *Government Gazette* direct that the whole or any part of the land comprised in any reserve shown on that map or plan shall vest in the council whereupon such land shall so vest freed and discharged from any mortgage charge lease or sub-lease.

AND WHEREAS the Council of the City of Broadmeadows has requested that a reserve shown on a plan of subdivision be vested in the council and an allotment on that plan has been transferred:

NOW THEREFORE, His Excellency the Lieutenant-Governor of the State of Victoria, by and with the advice of the Executive Council thereof, doth by this Order vest in the Council of the City of Broadmeadows the land shown hatched on the plan hereunder, such land being a Reserve for Drainage on Plan of Subdivision No. 12048 lodged in the Office of Titles.

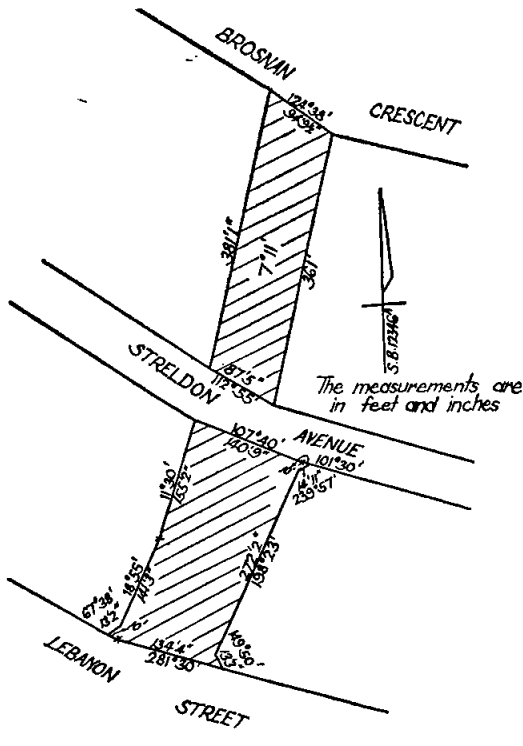

And the Honorable Rupert James Hamer, Her Majesty's Minister for Local Government for the State of Victoria, shall give the necessary directions herein accordingly.

J. ROSSITER,  
Clerk of the Executive Council.

LOCAL GOVERNMENT DEPARTMENT.

At the Executive Council Chamber, Melbourne, the third day of September, 1968.

PRESENT:

His Excellency the Lieutenant-Governor of Victoria.  
Mr. Reid | Mr. Wilcox.

CONFIRMATION OF SEPARATE RATE.—CITY OF SPRINGVALE.

IN pursuance of the provisions of Section 287 of the *Local Government Act 1958*, as amended, His Excellency the Lieutenant-Governor of the State of Victoria, by and with the advice of the Executive Council thereof, hereby confirms a separate rate of 2.03 cents in the dollar on the unimproved capital value of certain properties described hereunder, which rate was made by the Council of the City of Springvale on the 5th August, 1968, for the purpose of providing off-street parking facilities for use in connection with the Springvale Road, East Side, Springvale Shopping Centre.

Properties to be Rated:

Rateable properties fronting the east side of Springvale Road, Springvale, and numbered 279/281, 285, 287, 289, 291/297, 301, 303/305, 307/313, 315, 323/325, 333/335, 337, 339, 341, 343/345, 351, 353 and 355.

And the Honorable Rupert James Hamer, Her Majesty's Minister for Local Government for the State of Victoria, shall give the necessary directions herein accordingly.

J. ROSSITER,  
Clerk of the Executive Council.

LOCAL GOVERNMENT ACT 1958.—PUBLIC SERVICE ACT 1958.

At the Executive Council Chamber, Melbourne, the third day of September, 1968.

PRESENT:

His Excellency the Lieutenant-Governor of Victoria.  
Mr. Reid | Mr. Wilcox.

APPOINTMENT OF SECRETARY FOR LOCAL GOVERNMENT.

WHEREAS by Section Twenty-four of the *Public Service Act 1946* and the Second Schedule thereto, and Section Five of the *Local Government Act 1958*, it is amongst other things enacted that the officer for the time being holding office of Secretary for Local Government shall be the permanent head of the Local Government Department;

AND whereas it is provided by Section Thirty-two of the *Public Service Act 1946* that appointment to an office of permanent head shall be made by the Governor in Council after reference of the matter to the Public Service Board:

AND whereas the matter has been referred to the Public Service Board accordingly:

NOW, therefore, His Excellency the Lieutenant-Governor of the State of Victoria in the Commonwealth of Australia, by and with the advice of the Executive Council of the said State and in pursuance of the powers conferred by Section Thirty-two of the *Public Service Act 1946*, doth by this Order appoint—

EDWARD RUSSELL INGLIS  
an officer of the Public Service, to the office of Secretary for Local Government, Local Government Department, from and inclusive of the Third day of September, 1968, vice P. P. Mithen, deceased.

And the Honorable Rupert James Hamer, Her Majesty's Minister for Local Government for the State of Victoria, shall give the necessary directions herein accordingly.

J. ROSSITER,  
Clerk of the Executive Council.

LOCAL GOVERNMENT DEPARTMENT.

At the Executive Council Chamber, Melbourne, the third day of September, 1968.

PRESENT:

His Excellency the Lieutenant-Governor of Victoria.  
Mr. Reid | Mr. Wilcox.

ROAD DISCONTINUED.—SHIRE OF WHITTLESEA.

WHEREAS it is provided in Section 528 (2) of the Local Government Act 1958, as amended, that where a road (whether or not a public highway but not being a road set out on land of the Crown) or any part thereof is not required for public use, the Governor-in-Council, on the request of the Council of the municipality in which such road is situated made not less than one month after publishing in a newspaper generally circulating in the district and posting to the registered proprietor (if any) of the land and any person known to have an interest in the land notice of intention to make such a request may by Order published in the Government Gazette direct that such road or part shall be discontinued and thereupon such road or part shall be discontinued accordingly.

AND WHEREAS the Council of the Shire of Whittlesea has requested that the Governor-in-Council direct that portion of Mount View Road, Thomastown, be discontinued and not less than one month previously has published in a newspaper generally circulating in the district and posted to the registered proprietor of the land in the said road and to all persons known to have an interest in the said land notice of intention to make such request.

NOW THEREFORE His Excellency the Lieutenant-Governor of the State of Victoria, by and with the advice of the Executive Council thereof, hereby directs that the said road, which is shown hatched on the plan hereunder, shall be discontinued and that the land shall be retained by the municipality for municipal purposes.

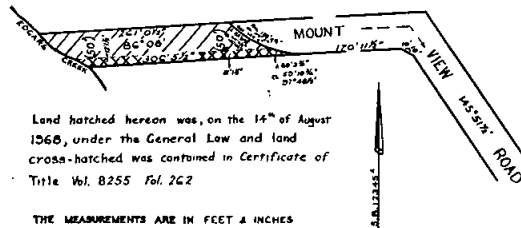

Land hatched hereon was, on the 14<sup>th</sup> of August 1968, under the General Law and land cross-hatched was contained in Certificate of Title Vol. B255 Fol. 262

THE MEASUREMENTS ARE IN FEET & INCHES

And the Honorable Rupert James Hamer, Her Majesty's Minister for Local Government for the State of Victoria, shall give the necessary directions herein accordingly.

J. ROSSITER,  
Clerk of the Executive Council.

LOCAL GOVERNMENT DEPARTMENT.

At the Executive Council Chamber, Melbourne, the third day of September, 1968.

PRESENT:

His Excellency the Lieutenant-Governor of Victoria.  
Mr. Reid | Mr. Wilcox.

ROAD DISCONTINUED.—CITY OF MOORABBIN.

WHEREAS it is provided in Section 528 (2) of the Local Government Act 1958, that where a road (whether or not a public highway but not being a road set out on land of the Crown) or any part thereof is not required for public use the Governor-in-Council on the request of the Council of the municipality in which such road is situated made not less than one month after publishing in a newspaper generally circulating in the district and posting to the registered proprietor (if any) of the land and any person known to have an interest in the land notice of intention to make such request may by Order published in the Government Gazette direct that such road or part shall be discontinued and thereupon such road or part shall be discontinued accordingly.

AND WHEREAS the Council of the City of Moorabbin has requested that portion of Victor Road, Bentleigh be discontinued and not less than one month previously has published in a newspaper generally circulating in the district and posted to the registered proprietor of the land in the road and to all persons known to have an interest in the said land notice of intention to make such request.

NOW THEREFORE, His Excellency the Lieutenant-Governor of the State of Victoria, by and with the advice of the Executive Council thereof, hereby directs:

- (a) that the portion of the said road which is shown by hachure and cross-hachure on the plan hereunder shall be discontinued;
- (b) that notwithstanding such discontinuance the Moorabbin City Council shall continue to have and possess the same right title power authority or interest in or in relation to the land shown by cross-hachure on the said plan as it had or possessed prior to such discontinuance with respect to or in connection with any drains or pipes laid or erected in on or over such land for the purpose of drainage; and
- (c) that, subject to any right title power authority or interest, the land in the said road may be sold by the Council of the City of Moorabbin by agreement.

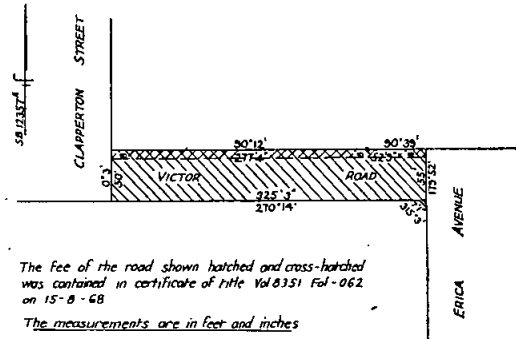

The fee of the road shown hatched and cross-hatched was contained in certificate of title Vol B351 Fol-062 on 15-8-68

The measurements are in feet and inches

And the Honorable Rupert James Hamer, Her Majesty's Minister for Local Government for the State of Victoria, shall give the necessary directions herein accordingly.

J. ROSSITER,  
Clerk of the Executive Council.

LOCAL GOVERNMENT DEPARTMENT.

At the Executive Council Chamber, Melbourne, the third day of September, 1968.

PRESENT:

His Excellency the Lieutenant-Governor of Victoria.  
Mr. Reid | Mr. Wilcox.

ROAD DISCONTINUED.—CITY OF CAULFIELD.

WHEREAS it is provided in Section 528 (2) of the Local Government Act 1958, that where a road (whether or not a public highway but not being a road set out on land of the Crown) or any part thereof is not required for public use, the Governor-in-Council on the request of the municipality in which such road is situated made not less than one month after publishing in a newspaper generally circulating in the district and posting to the registered proprietor (if any) of the land and any person known to have an interest in the land notice of intention to make such a request may by Order published in the Government Gazette direct that such road or part shall be discontinued and thereupon such road or part shall be discontinued accordingly.

AND WHEREAS the Council of the City of Caulfield has requested that portion of Mars Street, Caulfield, be discontinued and not less than one month previously has published in a newspaper generally circulating in the district and posted to the registered proprietor of the land in the road and to all persons known to have an interest in the said road notice of intention to make such request.

NOW THEREFORE His Excellency the Lieutenant-Governor of the State of Victoria, by and with the advice of the Executive Council thereof, hereby directs:

- (a) that the portion of the road, which is shown by hachure on the plan hereunder, shall be discontinued;
- (b) that notwithstanding such discontinuance the Melbourne and Metropolitan Board of Works shall continue to have and possess the same right title power authority or interest in or in relation to the whole of the land shown by hachure on the said plan as it had or possessed prior to such discontinuance with respect to or in connection with any pipes or drains laid or erected in on or over such land for the purposes of drainage or sewerage; and
- (c) that, subject to any such right title power authority or interest, the land in the said road may be sold by the Council of the City of Caulfield by agreement.

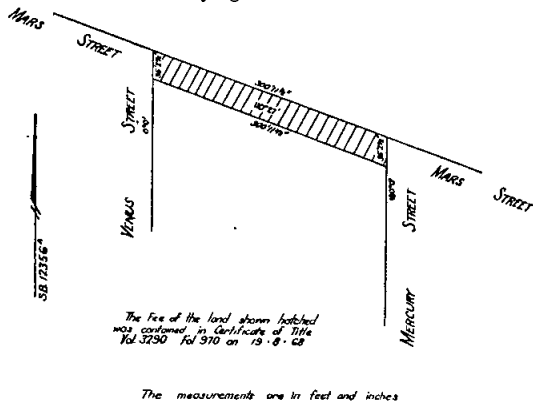

And the Honorable Rupert James Hamer, Her Majesty's Minister for Local Government for the State of Victoria, shall give the necessary directions herein accordingly.

J. ROSSITER,  
Clerk of the Executive Council.

LOCAL GOVERNMENT DEPARTMENT.

At the Executive Council Chamber, Melbourne, the third day of September, 1968.

PRESENT:

His Excellency the Lieutenant-Governor of Victoria.  
Mr. Reid | Mr. Wilcox.

ROAD DISCONTINUED.—SHIRE OF SEYMOUR.

WHEREAS it is provided in Section 528 (2) of the Local Government Act, as amended, that where a road (whether or not a public highway but not being a road set out on land of the Crown) or any part thereof is not required for public use the Governor-in-Council on the request of the Council of the Municipality in which such road is situated made not less than one month after publishing in a newspaper generally circulating in the district and posting to the registered proprietor (if any) of the land and any person known to have an interest in the land notice of intention to make such a request may by Order published in the *Government Gazette* direct that such road or part shall be discontinued and thereupon such road or part shall be discontinued accordingly.

AND WHEREAS the Council of the Shire of Seymour has requested that the Governor-in-Council direct that Hall Street, Seymour be discontinued and not less than one month previously has published in a newspaper generally circulating in the district and posted to the registered proprietor of the land in the road and to all persons known to have an interest in the said road notice of intention to make such request.

NOW THEREFORE His Excellency the Lieutenant-Governor of the State of Victoria, by and with the advice of the Executive Council thereof, hereby directs that the said road, which is shown hatched on the plan hereunder, shall be discontinued and that the land may be sold by the Council of the Shire of Seymour by agreement.

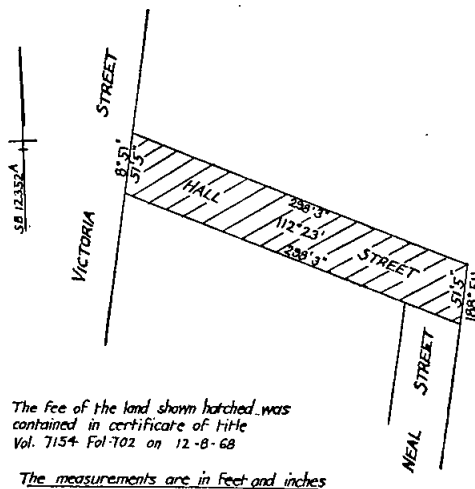

And the Honorable Rupert James Hamer, Her Majesty's Minister for Local Government for the State of Victoria, shall give the necessary directions herein accordingly.

J. ROSSITER,  
Clerk of the Executive Council.

DEPARTMENT OF CROWN LANDS AND SURVEY.

At Government House, Melbourne, the tenth day of September, 1968.

PRESENT:

His Excellency the Lieutenant-Governor of Victoria.  
Sir William McDonald | Mr. Borthwick.

REVOCATION OF TEMPORARY RESERVATIONS OF LANDS BY ORDERS IN COUNCIL.

HIS Excellency the Lieutenant-Governor of the State of Victoria, by and with the advice of the Executive Council thereof, doth hereby in pursuance of the provisions of the *Land Act 1958*, revoke the temporary reservations of lands by Orders in Council hereinafter referred to, viz.:

BOORONGIE.—Order in Council of 17th February, 1916, of 42 acres of land in the Parish of Boorongie, as a site for Water Supply purposes.—(Rs.903.)

CARINA.—Order in Council of 21st December, 1910, of 4 acres of land in the Parish of Carina, as a site for a State School.—(Rs.7022.)

CASTLEMAINE.—Order in Council of 23rd March, 1954, of 79 acres 0 roods 11 perches of land in the Township of Castlemaine, as a site for Public Recreation, Tourist Camping and Public Park purposes, so far only as regards the portion thereof comprised within the boundaries published in the *Government Gazette* of 7th August, 1968, and containing 6 acres 3 roods 13 perches.—(Rs.177.)

CUNNINGHAME AND LAKES ENTRANCE.—Order in Council of 15th November, 1966, of 26 acres 2 roods of land in the Townships of Cunninghame and Lakes Entrance, as a site for Public purposes, so far only as regards the portion thereof comprised within the boundaries published in the *Government Gazette* of 7th August, 1968, and containing 7 acres 1 rood 34 perches.—(Rs.3353.)

FLINDERS.—Order in Council of 23rd March, 1874, of 2 acres of land in the Township of Flinders, as a site for State School purposes.—(Rs.6971.)

FLINDERS.—Order in Council of 2nd July, 1958, of 1 acre 1 rood 24 perches more or less of land in the Township of Flinders, as a site for a Public Park.—(Rs.7696.)

HAMILTON.—Order in Council of 31st May, 1938, of 4 acres 1 rood more or less of land in the Township of Hamilton, as a site for Public purposes (Swimming Pool), so far only as regards the portion thereof comprised within the boundaries published in the *Government Gazette* of 7th August, 1968, and containing 1 rood 2 perches.—(Rs.4822.)

**INVERLOCH** (formerly **ANDERSON'S INLET**).—Order in Council of 12th May, 1891, of 2 acres 1 rood 12 perches of land in the Township of Inverloch (formerly Anderson's Inlet), as a site for Police purposes, so far only as regards the portion thereof comprised within the boundaries published in the *Government Gazette* of 7th August, 1968, and containing 1 rood 38 perches.—(Rs.1686.)

**KURTING, SALISBURY WEST, GLENALBYN, INGLEWOOD AND TARNAGULLA**.—Order in Council of 26th March, 1901, of 10,700 acres of unappropriated Crown land in the Parishes of Kurting, Salisbury West, Glenalbyn, Inglewood and Tarnagulla, as a site for the Growth of Timber for the purpose of the manufacture or production of Eucalyptus Oil and revoked as to part by various Orders so far only as regards the portion thereof comprised within the boundaries published in the *Government Gazette* of 14th August, 1968, and containing 43 acres 2 roods 20 perches.—(Rs.1614.)

**OMEQ**.—Order in Council of 29th April, 1958, of 4 acres 1 rood 36 perches more or less, of land in the Township of Omeo, as a site for Court House and Police purposes, so far only as regards the portion thereof comprised within the boundaries published in the *Government Gazette* of 14th August, 1968, and containing 1 rood 25 perches more or less.—(Rs.7367.)

**SALE**.—Order in Council of 14th December, 1874, of 1 acre of land in the Parish of Sale, as a site for State School purposes.—(H.028894.)

**SANDHURST**.—Order in Council of the 2nd March, 1892, of 127 acres 3 roods 20 perches of land in the Parish of Sandhurst, as a site for Sewage Farm and Manure Depot, revoked as to part by Order in Council of the 12th May, 1959, and to revoke the temporary reservation by Order in Council of the 19th March, 1894, of 221 acres 1 rood 12 perches of land as an extension thereto.—(Rs.1741.)

**SCORESBY**.—Order in Council of 27th March, 1956, of 25 acres 3 roods 37 perches of land in the Parish of Scoresby, as a site for Horticultural Research Station.—(Rs.5885.)

**STRATFORD**.—Order in Council of 31st July, 1899, of 40 acres of land in the Parish of Stratford, as a site for Watering purposes.—(Rs.9030.)

And the Honorable Sir William John Farquhar McDonald, Her Majesty's Minister of Lands for the State of Victoria, shall give the necessary directions herein accordingly.

J. ROSSITER,  
Clerk of the Executive Council.

#### MILDURA URBAN WATER TRUST.

*At Government House, Melbourne, the tenth day of September, 1968.*

PRESENT:

His Excellency the Lieutenant-Governor of Victoria.  
Sir William McDonald | Mr. Borthwick.

#### EXTENT OF URBAN DISTRICT INCREASED.

**UNDER** the powers conferred by the Mildura Irrigation and Water Trusts Act and all other powers enabling him in that behalf, His Excellency the Lieutenant-Governor of the State of Victoria, by and with the advice of the Executive Council of the said State, doth hereby declare, order and direct that the extent of the Urban District of the Mildura Urban Water Trust be increased by adding to the same the lands comprised within the Boundaries shown on a plan approved by the Governor in Council and deposited in the office of the State Rivers and Water Supply Commission, Melbourne (Corr. No. 68/1930/21) and as on and from the date hereof, the extent of such District shall be deemed to be increased accordingly.

And the Honorable William Archibald Borthwick, Her Majesty's Minister of Water Supply for the State of Victoria, shall give the necessary directions herein accordingly.

J. ROSSITER,  
Clerk of the Executive Council.

#### THE BALLARAT WATER COMMISSIONERS.

*At Government House, Melbourne, the tenth day of September, 1968.*

PRESENT:

His Excellency the Lieutenant-Governor of Victoria.  
Sir William McDonald | Mr. Borthwick.

#### CONSENT TO BORROWING \$100,000.

**UNDER** the powers conferred by the Water Act and all other powers enabling him in that behalf, His Excellency the Lieutenant-Governor of the State of Victoria, by and with the advice of the Executive Council of the said State, doth hereby consent to The Ballarat Water Commissioners borrowing at interest by mortgage of the General Fund the sum of One hundred thousand dollars (\$100,000) to meet the cost of water supply works.

And the Honorable William Archibald Borthwick, Her Majesty's Minister of Water Supply for the State of Victoria, shall give the necessary directions herein accordingly.

J. ROSSITER,  
Clerk of the Executive Council.

#### BENDIGO SEWERAGE AUTHORITY.

*At Government House, Melbourne, the tenth day of September, 1968.*

PRESENT:

His Excellency the Lieutenant-Governor of Victoria.  
Sir William McDonald | Mr. Borthwick.

#### CONSENT TO BORROWING \$20,000.

**UNDER** the powers conferred by the Sewerage Districts Act and all other powers enabling him in that behalf, His Excellency the Lieutenant-Governor of the State of Victoria, by and with the advice of the Executive Council of the said State, doth hereby consent to the Bendigo Sewerage Authority borrowing at interest, by mortgage of the General Fund, the sum of Twenty thousand dollars (\$20,000) for the conversion of Loan Z.

And the Honorable William Archibald Borthwick, Her Majesty's Minister of Water Supply for the State of Victoria, shall give the necessary directions herein accordingly.

J. ROSSITER,  
Clerk of the Executive Council.

#### COLAC SEWERAGE AUTHORITY.

*At Government House, Melbourne, the tenth day of September, 1968.*

PRESENT:

His Excellency the Lieutenant-Governor of Victoria.  
Sir William McDonald | Mr. Borthwick.

#### CONSENT TO BORROWING \$30,000.

**UNDER** the powers conferred by the Sewerage Districts Act and all other powers enabling him in that behalf, His Excellency the Lieutenant-Governor of the State of Victoria, by and with the advice of the Executive Council of the said State, doth hereby consent to the Colac Sewerage Authority borrowing at interest by mortgage of the General Fund, the sum of Thirty thousand dollars (\$30,000) in two amounts of Eleven thousand dollars (\$11,000) and Nineteen thousand dollars (\$19,000) for the conversion of Loans Nos. 6 and 11 respectively.

And the Honorable William Archibald Borthwick, Her Majesty's Minister of Water Supply for the State of Victoria, shall give the necessary directions herein accordingly.

J. ROSSITER,  
Clerk of the Executive Council.

*Water Act 1958.*

## STATE RIVERS AND WATER SUPPLY COMMISSION.

*At Government House, Melbourne, the tenth day of September, 1968.*

## PRESENT:

His Excellency the Lieutenant-Governor of Victoria.  
Sir William McDonald | Mr. Borthwick.

## MERBEIN IRRIGATION DISTRICT—PORTION EXCISED.

UNDER the powers conferred by the *Water Act 1958* and all other powers enabling him in that behalf, His Excellency the Lieutenant-Governor of the State of Victoria, with the advice of the Executive Council of the said State, on the recommendation of the State Rivers and Water Supply Commission, doth hereby declare, order, and direct as follows:—

That there shall be excised from the Merbein Irrigation District that portion of the same set out and described in the Schedule hereto, which portion, as from the 30th day of September, 1968 shall be deemed to be excised accordingly.

## SCHEDULE.

The whole of lot 1 on lodged plan of subdivision No. 82140, being part of allotment 32b, parish of Merbein, county of Karkaroc.

The portion set out and described in the foregoing Schedule is shown on a plan approved by the Governor in Council, and deposited in the office of the State Rivers and Water Supply Commission, Melbourne.—(Corres. No. 68/1395.)

And the Honorable William Archibald Borthwick, Her Majesty's Minister of Water Supply for the State of Victoria, shall give the necessary directions herein accordingly.

J. ROSSITER,  
Clerk of the Executive Council.

*Water Act 1958.*

## STATE RIVERS AND WATER SUPPLY COMMISSION.

*At Government House, Melbourne, the tenth day of September, 1968.*

## PRESENT:

His Excellency the Lieutenant-Governor of Victoria.  
Sir William McDonald | Mr. Borthwick.

## WOORINEN URBAN DISTRICT.—AREA OF DISTRICT INCREASED.

UNDER the powers conferred by the *Water Act 1958* and all other powers enabling him in that behalf, His Excellency the Lieutenant-Governor of the State of Victoria, with the advice of the Executive Council of the said State, on the recommendation of the State Rivers and Water Supply Commission, doth hereby declare, order and direct as follows:—

That the area of the Woorinen Urban District be increased by adding to the same the lands set out and described in the Schedule hereto, and as on and from the 1st day of October 1968, the area of such District shall be deemed to be so increased.

## SCHEDULE.

Commencing at the north-western angle of allotment 20, section A, parish of Tyntynder, county of Tatchera; thence easterly by the northern boundary of that allotment a distance of 3 chains; thence southerly by a line parallel to the western boundary of said allotment 20 to the northern boundary of Monday-street; thence westerly by that street boundary to the western boundary of said allotment 20; thence northerly by the last-mentioned boundary to the point of commencement.

The lands set out and described in the foregoing Schedule are shown on a plan approved by the Governor in Council and deposited in the office of the State Rivers and Water Supply Commission, Melbourne.—(Corr. No. 66/885.)

And the Honorable William Archibald Borthwick, Her Majesty's Minister of Water Supply for the State of Victoria, shall give the necessary directions herein accordingly.

J. ROSSITER,  
Clerk of the Executive Council.

*Water Act 1958.*

## STATE RIVERS AND WATER SUPPLY COMMISSION.

*At Government House, Melbourne, the tenth day of September, 1968.*

## PRESENT:

His Excellency the Lieutenant-Governor of Victoria.  
Sir William McDonald | Mr. Borthwick.

## MERBEIN WATERWORKS DISTRICT.—DISTRICT EXTENDED—MERBEIN URBAN DISTRICT.—AREA OF DISTRICT INCREASED.

UNDER the powers conferred by the *Water Act 1958* and all other powers enabling him in that behalf, His Excellency the Lieutenant-Governor of the State of Victoria, with the advice of the Executive Council of the said State, on the recommendation of the State Rivers and Water Supply Commission, doth hereby declare, order, and direct as follows:—

That the Merbein Waterworks District be extended and the area of the Merbein Urban District be increased by adding to such Districts the lands set out and described in the Schedule hereto, and as on and from the first day of October, 1968, the said Waterworks District shall be deemed to be so extended and the area of the said Urban District shall be deemed to be so increased.

## SCHEDULE.

The whole of lot 1 on lodged plan of subdivision No. 82140, being part of allotment 32b, parish of Merbein, county of Karkaroc, together with that portion of a channel reserve adjoining the southern boundary of that lot.

The lands set out and described in the foregoing Schedule are shown on a plan approved by the Governor in Council, and deposited in the office of the State Rivers and Water Supply Commission, Melbourne.—(Corr. No. 68/1395.)

And the Honorable William Archibald Borthwick, Her Majesty's Minister of Water Supply for the State of Victoria, shall give the necessary directions herein accordingly.

J. ROSSITER,  
Clerk of the Executive Council.

## MELBOURNE AND METROPOLITAN TRAMWAYS ACT 1958, No. 6311.

*At Government House, Melbourne, the tenth day of September, 1968.*

## PRESENT:

His Excellency the Lieutenant-Governor of Victoria.  
Sir William McDonald | Mr. Borthwick.

WHEREAS His Excellency the Lieutenant-Governor of the State of Victoria by and with the advice of the Executive Council thereof has this day consented pursuant to the provisions of Section 28 of the *Melbourne and Metropolitan Tramways Act 1958*, to the Melbourne and

Metropolitan Tramways Board raising by way of a loan an amount not exceeding One hundred thousand dollars (\$100,000); AND WHEREAS His Excellency the Lieutenant-Governor is satisfied that a sufficient proportion of the loan to be so raised will fall due and be repaid in each year during the currency of the proposed loan; NOW THEREFORE it is directed, pursuant to the provisions of Section 28 (6) of the said Act, that it shall not be necessary to provide a sinking fund in connection with such loan.

And the Honorable Sir Henry Edward Bolte, Her Majesty's Treasurer for the State of Victoria, shall give the necessary directions herein accordingly.

J. ROSSITER,  
Clerk of the Executive Council.

STATE ELECTRICITY COMMISSION ACT 1958, No. 6377.

At Government House, Melbourne, the tenth day of September, 1968.

PRESENT:

His Excellency the Lieutenant-Governor of Victoria.

Sir William McDonald | Mr. Borthwick.

WHEREAS His Excellency the Lieutenant-Governor of the State of Victoria by and with the advice of the Executive Council thereof has this day consented pursuant to the provisions of the *State Electricity Commission Act 1958* to the State Electricity Commission of Victoria raising by way of loan the sum of Five hundred and forty-one thousand dollars (\$541,000); AND WHEREAS His Excellency the Lieutenant-Governor is satisfied that a sufficient proportion of the loan to be raised will fall due and be repaid in each year during the currency of the proposed loan; NOW THEREFORE it is directed pursuant to the provisions of Section 91 (3) of the said Act, that it shall not be necessary to provide a sinking fund in connection with such loan.

And the Honorable Sir Henry Edward Bolte, Her Majesty's Treasurer for the State of Victoria, shall give the necessary directions herein accordingly.

J. ROSSITER,  
Clerk of the Executive Council.

LANDLORD AND TENANT ACT 1958.

At Government House, Melbourne, the tenth day of September, 1968.

PRESENT:

His Excellency the Lieutenant-Governor of Victoria.

Sir William McDonald | Mr. Borthwick.

ORDER EXTENDING APPLICATION OF PART V. OF THE LANDLORD AND TENANT ACT 1958 TO CERTAIN PREMISES.

IN pursuance of the powers conferred by section 44 of the *Landlord and Tenant Act 1958*, His Excellency the Lieutenant-Governor of the State of Victoria, by and with the advice of the Executive Council thereof, doth hereby declare that the application of Part V. of the *Landlord and Tenant Act 1958* shall extend to the following premises:—

1. The premises known as Number 33 Haines Street, Hawthorn;
2. The premises known as Number 27 Johnston Street, East St. Kilda; and
3. The premises known as Number 19 Hawthorn Road, Northcote, and to all premises forming part of such premises.

And the Honorable George Oswald Reid, Her Majesty's Attorney-General in and for the State of Victoria, shall give the necessary directions herein accordingly.

J. ROSSITER,  
Clerk of the Executive Council.

LANDS DEPARTMENT NOTICES

APPROACHING LAND SALES.

SALES of Crown Lands, in fee-simple, will be held at the under-mentioned places and dates, viz.:—

|  | No. of Gazette. |
|--|-----------------|
| Alexandra.—Friday, 27th September, 1968    | 71              |
| Avoca.—Friday, 13th September, 1968        | 67              |
| Boort.—Thursday, 10th October, 1968        | 76              |
| Chiltern.—Monday, 30th September, 1968     | 75              |
| Dunolly.—Friday, 13th September, 1968      | 67              |
| Heathcote.—Friday, 4th October, 1968       | 71              |
| Inglewood.—Thursday, 10th October, 1968    | 76              |
| Kilmore.—Friday, 4th October, 1968         | 71              |
| Maryborough.—Friday, 13th September, 1968  | 67              |
| Mitta Mitta.—Monday, 30th September, 1968  | 75              |
| Mortlake.—Thursday, 17th October, 1968     | 77              |
| Rushworth.—Friday, 4th October, 1968       | 71              |
| St. Arnaud.—Thursday, 12th September, 1968 | 67              |
| Sea Lake.—Thursday, 10th October, 1968     | 76              |
| Stawell.—Friday, 11th October, 1968        | 75              |

SALE OF FREEHOLD LAND BY AUCTION.

|   |    |
|---|----|
| Tallangatta.—Monday, 30th September, 1968 | 75 |
| Timboon.—Thursday, 17th October, 1968     | 77 |

SALES OF CROWN LAND BY AUCTION.

The land will be offered for sale in fee-simple, and subject to the provisions of the Land Act and Regulations thereunder.

The upset price is the sum at which bidding will start, and no bid below that sum can be accepted. The highest bidder at or above that sum shall be the purchaser, subject to signature of contract and any necessary payment.

TERMS:—

A deposit of at least 12½% of the purchase price must be paid at the sale, either in cash or by cheque.

The residue is payable in half-yearly instalments, in accordance with the following scale, or may be paid off at any earlier time.

|  |
|--|
| \$40 and under, 6 instalments.                         |
| Over \$40, and not exceeding \$100, 8 instalments.     |
| Over \$100, and not exceeding \$200, 10 instalments.   |
| Over \$200, and not exceeding \$400, 12 instalments.   |
| Over \$400, and not exceeding \$600, 14 instalments.   |
| Over \$600, and not exceeding \$800, 16 instalments.   |
| Over \$800, and not exceeding \$1,000, 18 instalments. |
| Over \$1,000, 20 instalments.                          |

Interest at the rate of 5% per annum is payable with all payments of residue, and is computed for each instalment from the date of sale to the date of such payment. Additional interest is charged if any instalment is not paid on or before the due date.

If paid off within 30 days of sale, no interest is payable.

FEES, ETC.:

Also payable at the sale, in addition to the deposit, are the survey fee and, if applicable, the valuation of improvements (if purchaser be not the owner thereof).

Payable with balance of purchase money—

|                              |     |
|------------------------------|-----|
| Crown Grant fee—             |     |
| 50 acres and under           | \$3 |
| Over 50 acres                | \$4 |
| Purchase money \$10 or under | \$2 |

Assurance Fund contribution.—One cent in every Five dollars or part thereof of purchase price. (This is a fund established to guarantee the validity of freehold titles.)

Transfer of interest prior to completion of payment may be allowed on payment of \$2 fee and subject to stamp duty.

If unable to attend personally, a prospective purchaser may arrange for another person to bid as his agent.

Attention is drawn to section 95, *Land Act 1958*, which provides that the purchaser shall be deemed to be the owner for the purposes of other Acts; also to an amendment to the Local Government Act providing for Government roads, in certain circumstances, to be declared "private streets", thus making the purchaser liable to contribute to the cost of street construction.

W. J. F. McDONALD,  
Minister of Lands.

Office of Crown Lands and Survey,  
Melbourne, 11th September, 1968.



**MORTLAKE.**—Sale (No. 11965) of Crown land in fee-simple, by auction, will be held at the LAND INSPECTOR'S OFFICE, MORTLAKE, on THURSDAY, 17TH OCTOBER, 1968, at TWO o'clock p.m. To be conducted by D. M. O'CONNOR, Land Officer, Geelong.

Lot 1.

TOWNSHIP OF CARAMUT, PARISH OF CARAMUT, COUNTY OF VILLIERS.

Being the site and improvements thereon of the former Education Department residence at Caramut, having frontages to both Brown and Palmer streets, about 5 chains north of Ritchie-street.

Upset-price \$1,400 the lot. Survey fee \$13.

Area 2 roods, allotment 6 of section 4.

NOTE.—Improvements comprise old timber residence and outbuildings the valuation of which is included in the upset price.

Until the purchase money has been paid in full, the following special conditions shall apply:—

- (i) The purchaser shall at his own expense maintain the property in good order and repair and keep all improvements thereon insured against fire in the name of the Secretary for Lands.
- (ii) A cover note for not less than \$1,100 for such insurance shall be lodged in the Lands Department, by the purchaser, within one week of the date of sale, and the policy shall be lodged immediately on issue.
- (iii) The purchaser shall not remove or make any alterations to the improvements on the site without prior consent of the Secretary for Lands.—(G.68539.)

**SALE OF FREEHOLD LAND BY AUCTION.**

**TIMBOON.**—A sale of freehold land by auction for and on behalf of the Minister of Education will be held at the LAND INSPECTOR'S OFFICE, TIMBOON, on THURSDAY, 17TH OCTOBER, 1968, at ELEVEN o'clock a.m. To be conducted by D. M. O'CONNOR, Land Officer, Geelong.

CONDITIONS.—Deposit of at least 12½ per cent. of purchase price to be paid at sale and balance within 60 days. Purchaser to arrange for and bear costs of registration of transfer of title.

Lot 1.

PARISH OF PAARATTE, COUNTY OF HEYTESBURY.

In the north-east corner of the Parish, about 2 miles south-east of the Township of Timboon on the main Curdie Vale Road being the former Paaratte North West School Site.

Upset price \$240 the lot.

Area 3 acres, allotment 9A of Section 1. Being the land more particularly described in freehold certificate of title, volume 5809, folio 758.—(G.69187.)

**WITHDRAWAL FROM SALE.**

NOTICE is hereby given that lot 3 of Alexandra sale for 27th September, 1968, advertised in the Victoria Government Gazette, No. 72, of 21st August, 1968, has been withdrawn from sale.

**LOCAL LAND BOARDS.**

IN pursuance of the provisions of section 34 of the Land Act 1958, notice is hereby given that public hearings at the following places and times, will be conducted by the persons respectively mentioned, being duly appointed in that behalf.

W. J. F. McDONALD,  
Minister of Lands.

Department of Crown Lands and Survey,  
Melbourne.

**SCHEDULE.**

ARARAT LAND OFFICE, Thursday, 26th September, 1968, 10 a.m.—N. J. Fitzgerald.

BAIRNSDALE, STATE PUBLIC OFFICES, Tuesday and Wednesday, 24th and 25th September, 1968, 9 a.m.—E. Kennedy and J. Buck.

No. 77.—8211/68.—3

**PROPOSED REVOCATIONS OF TEMPORARY RESERVATIONS OF LANDS BY ORDERS IN COUNCIL.**

IN pursuance of the provisions of the Land Act 1958, notice is hereby given that it is the intention of the Governor in Council to revoke the temporary reservations of lands by Orders in Council hereunder referred to, viz.:—

The following Notices were published 1° on the 11th September, 1968, pursuant to Orders of the 3rd September, 1968.

**BAYNTON.**—The temporary reservation as a site for Public Purposes (State School) and the withholding from sale, leasing and licensing by Order in Council of the 26th March, 1877, of 1 acre 16 perches of land in the Parish of Baynton, are about to be revoked.—(B.24(?) (76E608).

**BOROKA (HALL'S GAP).**—The temporary reservation, by Order in Council of the 29th June, 1953, of 3 acres 1 rood 20 perches, more or less, of land in the Parish of Boroka as a site for State School purposes, is about to be revoked so far only as the portion containing 1 rood, indicated by hatching on plan hereunder, is concerned.—(B.678(?) (Rs.3550).

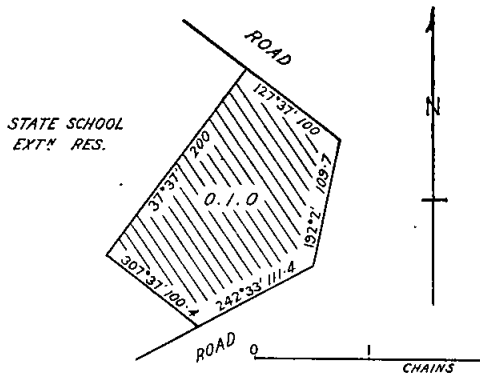

**GREENSBOROUGH (QUEENSTOWN).**—The temporary reservation, by Order in Council of the 14th May, 1866, of 5 acres of land in the Parish of Greensborough as a site for a Cricket Ground, revoked as to part by Order of the 19th December, 1961, is about to be revoked so far as the balance thereof, containing 4 acres 2 roods 13 perches, is concerned.—(G.179(?) (Rs.1460).

**LORNE.**—The temporary reservation as a site for Cricket and other purposes of Public Recreation and the withholding from sale, leasing and licensing by Order in Council of the 31st May, 1880, of 6 acres 1 rood 12 perches of land in the Township of Lorne, revoked as to part by various Orders, is about to be revoked, so far only as the portion containing 8 perches, more or less, indicated by hatching on plan hereunder, is concerned.—(L.147(?) (Rs.90).

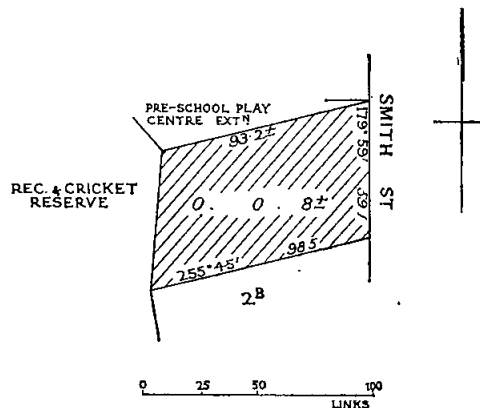

W. J. F. McDONALD,  
Minister of Lands.

**PROPOSED REVOCATIONS OF TEMPORARY RESERVATIONS OF LANDS BY ORDERS IN COUNCIL.**

**I**N pursuance of the provisions of the *Land Act 1958*, notice is hereby given that it is the intention of the Governor in Council to revoke the temporary reservations of lands by Orders in Council hereunder referred to, viz.:-

The following Notices were published 1° on the 21st August, 1968, pursuant to Orders of the 13th August, 1968.

**BUDGEREE.**—The temporary reservation as a site for a Quarry and the withholding from sale, leasing and licensing by Order in Council of the 21st July, 1884 (see *Government Gazette* of the 25th July, 1884, page 2151) of 11 acres 0 roods 3 perches of land in the Parish of Budgerree are about to be revoked.—(B.713<sup>(s)</sup>) (C.52758).

**GAVAN DUFFY.**—The temporary reservation, by Order in Council of the 1st December, 1873, of 3 acres 2 roods 39 perches of land in the Township of Gavan Duffy as a site for State School purposes is about to be revoked.—(G.195<sup>(s)</sup>) (Rs.5239).

W. J. F. McDONALD,  
Minister of Lands.

**PROPOSED REVOCATIONS OF TEMPORARY RESERVATIONS OF LANDS BY ORDERS IN COUNCIL.**

**I**N pursuance of the provisions of the *Land Act 1958*, notice is hereby given that it is the intention of the Governor in Council to revoke the temporary reservations of lands by Orders in Council hereunder referred to, viz.:-

The following Notices were published 1° on the 28th August, 1968, pursuant to Orders of the 20th August, 1968.

**ASHENS.**—The temporary reservation as a site for Public purposes (State School) and the withholding from sale, leasing and licensing by Order in Council of the 2nd July, 1883 (see *Government Gazette*, 6th July, 1883, page 1585) of 1 acre of land in the Parish of Ashens are about to be revoked.—(A.168<sup>(s)</sup>) (Rs.9039).

**CASTLEMAINE.**—The temporary reservation, by Order in Council of the 20th September, 1955, of 1 acre 12 perches, more or less, of land in the Township of Castlemaine as a site for a Market and Comfort Station is about to be revoked.—(C.99<sup>(s)</sup>) (Rs.2341).

**DOOLAM.**—The temporary reservation, by Order in Council of the 19th August, 1902 (see *Government Gazette* 27th August, 1902, page 3595), of 16 acres 2 roods 9 perches of land in the Parish of Doolam as a site for Camping and Watering purposes is about to be revoked so far only as the portion containing 1 acre 3 roods 17 perches, indicated by hatching on plan hereunder, is concerned.—(D.154<sup>(s)</sup>) (C.100140).

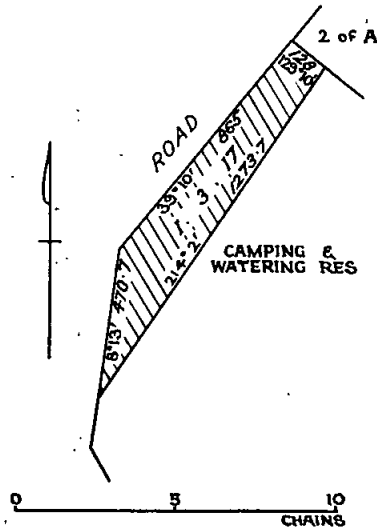

**HINNO-MUNJIE.**—The temporary reservation, by Order in Council of the 2nd July, 1919, of 4 acres 3 roods 39 perches of land in the Parish of Hinno-Munjie as a site for a State School is about to be revoked so far only as the portion containing 3 roods 10 perches, indicated by hatching on plan hereunder, is concerned.—(H.108<sup>(s)</sup>) (Rs.1937).

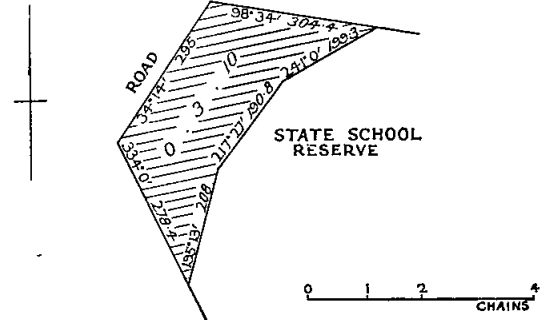

**POREPUNKAH.**—The Temporary reservation, by Order in Council of the 14th August, 1928, of 40 acres 2 roods 23 perches of land in the Parish of Porepunkah as a site for Public purposes (State School Forest Plantation) is about to be revoked so far only as the portion containing 9 acres 3 roods 38 perches, more or less, indicated by hatching on plan hereunder, is concerned.—(P.70<sup>(A<sup>s</sup>)</sup>) (Rs.3728).

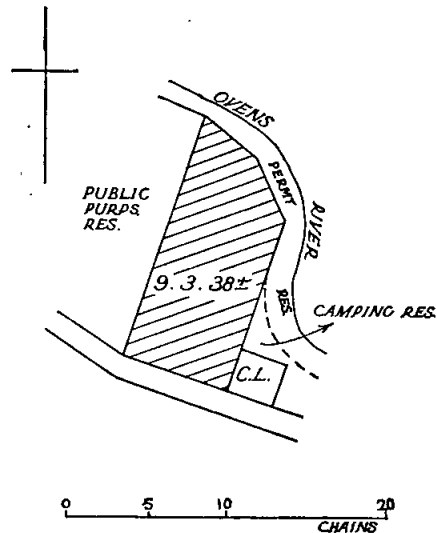

**SOUTH MELBOURNE.**—The temporary reservation, by Order in Council of the 23rd July, 1934, of 3 roods 34 8/10 perches of land in the City of South Melbourne as a site for Public Gardens and Plantation Purposes is about to be revoked so far only as the portion containing 25 perches, indicated by hatching on plan hereunder, is concerned.—(M.333<sup>(s)</sup>) (Rs.4394).

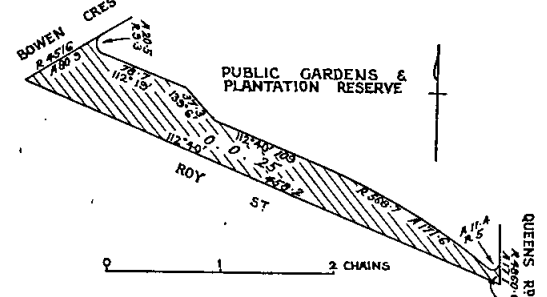

**LA TROBE.**—The temporary reservation, by Order in Council of the 6th July, 1891, of 2 acres of land in the Parish of La Trobe as a site for a State School, revoked as to part by Order of the 31st October, 1967, is about to be revoked so far as the balance thereof containing 1 acre 3 roods 27 perches, is concerned.—(L.143<sup>(s)</sup>) (Rs.2697).

**SANDHURST.**—The temporary reservation, by Order in Council of the 13th August, 1946, of 272 acres, more or less, of land in the Parish of Sandhurst as a site for the growth of Timber for the purpose of the manufacture or production of eucalyptus oil and revoked as to part by various Orders, is about to be revoked so far only as the portion containing 1 acre 2 roods 30 perches, more or less, indicated by hatching on plan hereunder, is concerned.—(S.371<sup>(17)</sup>) (Rs.5844).

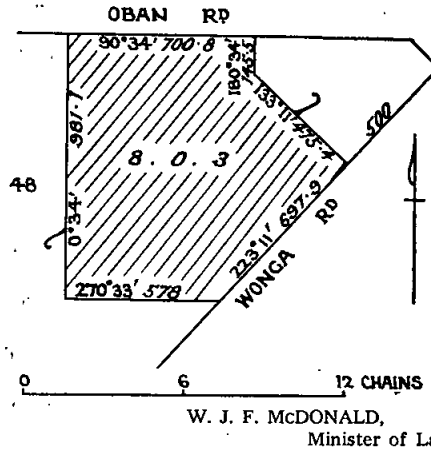
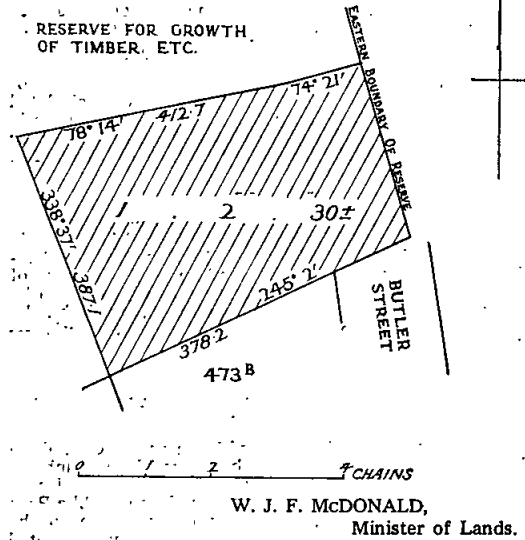

**COMMON ABOUT TO BE DIMINISHED.**  
**IN** pursuance of the provisions contained in the Land Act 1958, notice is hereby given that it is the intention of the Governor in Council to diminish the common hereinafter mentioned, viz.:—

The following Notice was published 1° on the 4th September, 1968, pursuant to Order of the 27th August, 1968.  
 The Ballarat West Town Common, proclaimed as such by the Governor in Council on the 28th January, 1861 (see Government Gazette, 6th February, 1861, page 256) is about to be diminished by the excision therefrom of the portion in the Parish of Dowling Forest containing 1 acre, indicated by hatching on plan hereunder.—(C.91998.)

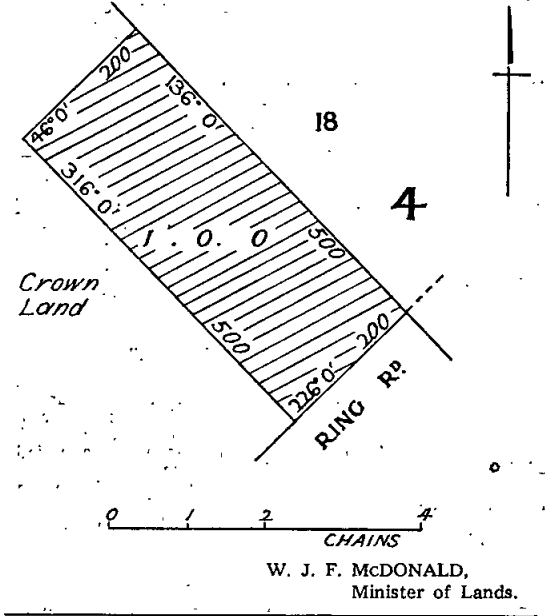

**PROPOSED REVOCATIONS OF TEMPORARY RESERVATIONS OF LANDS BY ORDERS IN COUNCIL.**

**IN** pursuance of the provisions of the Land Act 1958, notice is hereby given that it is the intention of the Governor in Council to revoke the temporary reservations of lands by Orders in Council hereunder referred to, viz.:—

The following Notices were published 1° on the 4th September, 1968, pursuant to Orders of the 27th August, 1968.

**BUMBERRAH, (SWAN REACH).**—The temporary reservation, by Order in Council of the 10th February, 1914, of 3 acres of land in the Parish of Bumberrah, as a site for a Rubbish Depot is about to be revoked.—(B.99<sup>(6)</sup>) (Rs.1576).

**TALLAROOK.**—The temporary reservation, by Order in Council of the 18th December, 1934, of 29 acres 3 roods 3 perches of land in the Township of Dabyminga (now Tallarook), as a site for Public Recreation is about to be revoked.—(D.149<sup>(3)</sup>) (Rs.4426).

**DIMBOOLA.**—The temporary reservation, by Order in Council of the 30th August, 1886 (see Government Gazette, 24th September, 1886, page 2735), of 8 perches of land in the Township of Dimboola, as a site for Railway purposes is about to be revoked.—(D.150<sup>(9)</sup>) (Rs.8552).

**TALLAROOK.**—The temporary reservation, by Order in Council of the 14th May, 1963, of 2 acres 2 roods 20 perches, more or less, of land in the Township of Tallarook, as a site for a Rubbish Depot is about to be revoked.—(D.149<sup>(3)</sup>) (Rs.8221).

W. J. F. McDONALD,  
 Minister of Lands.

**PROPOSED PERMANENT RESERVATION OF LAND AS A SITE.**

**IN** pursuance of sections 14 and 21 of the Land Act 1958, notice is hereby given that it is the intention of the Governor in Council to reserve permanently from sale, from being leased and from having a licence granted in respect thereof the land hereinafter described:—

The following Notice was published 1° on the 28th August, 1968, pursuant to Order of the 20th August, 1968.

**WARRANDYTE (RINGWOOD).**—Land proposed to be permanently reserved as a site for Public Recreation, 8 acres 0 roods 3 perches, Parish of Warrandyte, County of Evelyn, as indicated by hatching on plan hereunder.—(W.26<sup>(6)</sup>) (Rs.9037).

**COMMITTEES OF MANAGEMENT OF RESERVES. APPOINTMENTS.**

**NOTICE** is hereby given that in pursuance of section 221 of the Land Act 1958, the following appointments of Committees of Management of reserved Crown lands have been made by the Minister of Lands:—

“BYADUK RECREATION RESERVE” (OLD FOOTBALL GROUND).  
 Archibald Ralph de Garis, Francis James Holmes, James George McKinnon Richards and John Christie Holcombe as a Committee of Management for a period of three (3) years of the land in the Parish of Byaduk, temporarily reserved by Order in Council dated the 3rd March, 1897 as a site for cricket and other purposes of Public Recreation, and known as the “Byaduk Recreation Reserve” (Old Football Ground).—(Corres. No. Rs.3287.)

**"CALLIGNEE MECHANICS INSTITUTE RESERVE."**

Charles Richardson, Garry V. Pratt, Raymond Arthur Symons, Marjorie V. Curtis, Charles Victor Tovell, and Margaret Dorothy Symons as a Committee of Management for a period of three (3) years of the land in the Township of Toomung, temporarily reserved by Order in Council dated the 27th May, 1909, as a site for a Mechanics Institute and known as the "Callignee Mechanics Institute Reserve".—(Corres. No. Rs.1399.)

**"CHARLTON COURSING RESERVE."**

Ronald Desmond Giles, Martin John Sait, Alan Thomas Carlson, William John Hilson Turner, Vincent Joseph Sait, Leo F. Noonan, Kevin William O'Connor, Mathew Maloughney Donaldson and Trevor John Turner as a Committee of Management for a period of three (3) years of the remaining portion of the land, in the Parish of Wooroonook temporarily reserved by Order in Council dated the 16th September, 1895, as a site for a Racecourse and other purposes of Public Recreation, and known as the "Charlton Coursing Reserve".—(Corres. No. Rs.2363.)

**"CRESSY RECREATION RESERVE."**

Charles Henry Smart, Brian F. Armytage, Ronald Fraser Walker, Noel William Nelson, John Stewart McMullin, Ernest Stammers and Thomas Joseph Day as a Committee of Management for a period of three (3) years of the land in the Township of Cressy, temporarily reserved by Order in Council dated the 22nd May, 1917, as a site for Recreation purposes and known as the "Cressy Recreation Reserve".—(Corres. No. Rs.1539.)

**"FRAMLINGHAM RECREATION RESERVE."**

Frank Creed, Ivan Bergen, Alan Edward Sawyer, Kevin Daniel Lynch, Thomas Inverarity, Donald Elliott Vaughan, Alexander Neil Campbell, Philip George Creed, William Donald Munro, and Leslie Ernest Nash as a Committee of Management for a period of three (3) years of the land in the Township of Framlingham temporarily reserved by Order in Council dated the 18th January, 1909, as a site for Public Recreation, and known as the "Framlingham Recreation Reserve".—(Corres. No. Rs.2138.)

**"MERTON MEMORIAL HALL RESERVE."**

Robert William Catherwood, John William Redfern, Albert Ernest Shaw, Max Dudley Purcell, Keith William Kipping, John Charles Walter, Francis James Redfern, Arthur Danks Fraser and John Leonard Purcell as a Committee of Management for a period of three (3) years of the land in the Township of Merton, temporarily reserved by Order in Council dated the 29th May, 1911, as a site for a Mechanics' Institute and known as the "Merton Memorial Hall Reserve".—(Corres. No. Rs.869.)

**"MURRABIT RECREATION RESERVE."**

Vincent Maher, Ronald David McDonald, Charles A. Humphry, Thomas J. Laursen, William P. Laursen, Frederick John Walters, Frank David Hughes, Maxwell John Major, David John Danson and Maurice Neil Willoughby as a Committee of Management for a period of three (3) years of the land in the Township of Murrabit temporarily reserved by Order in Council dated the 7th December, 1942, as a site for Public Recreation, and known as the "Murrabit Recreation Reserve".—(Corres. No. Rs.5379.)

**"NUNGURNER FORESHORE RESERVE."**

Peter John C. Bury, Jack Palmer, Jean Halley, Arthur Francis Fulford, Frank Pollard Stephenson, Edith Fanny Ferguson, Mary Palmer, Raymond Duke Kleinitz, Elizabeth Hyland Fulford and Earl Bearham as a Committee of Management for a period of three (3) years of the reserved Crown land in the Parishes of Colquhoun and Bumberrah and the Township of Nungurner, as indicated by red colour on plan "B/21.10.54" attached to Lands Department correspondence C.95531, and known as the "Nungurner Foreshore Reserve".—(Corres. No. C.95531.)

**"AVENEL CRICKET AND RECREATION RESERVE."**

J. Shelton, J. Alexanderson, M. Green, E. Sidebottom, R. Walker, W. Moran, D. Patton, L. Tingay, C. Vearing and A. Willis as a Committee of Management for a period ending the 13th June, 1969, of the land in the Township/Parish of Avenel, temporarily reserved by Order in

Council dated the 6th August, 1968, as a site for a Cricket Ground and other purposes of Public Recreation, being an area reserved in addition to the existing reservation known as the "Avenel Cricket and Recreation Reserve".—(Corres. No. Rs.1920.)

**"HOWITT PARK", TOWNSHIP OF LUCKNOW.**

Thomas David Smyth and Joan Elizabeth Phillips in the places of Mavis Una McKimmie, Theodore James Webster and Bruce Malcolm Nicholson (who have resigned) as members of the Committee of Management, for a period ending the 3rd June, 1971, of the remaining portion of the land in the Township of Lucknow, Parish of Wy-Yung temporarily reserved by Orders in Council dated the 26th November, 1928, 4th March, 1958 and 18th April, 1961, as sites for Public Park, Recreation and Public Purposes, and known as "Howitt Park".—(Corres. No. Rs.3789.)

**"CRICKET AND PUBLIC RECREATION RESERVE", NEWSTEAD.**

The Corporation of the Shire of Newstead as the Committee of Management of the land in the Township of Newstead (Parish of Strangways) temporarily reserved by Orders in Council dated the 18th June, 1888, and 30th July, 1968, for cricket and other purposes of Public Recreation.—(Corres. No. Rs.3412.)

**"RESERVE FOR PUBLIC PARK AND RECREATION IN THE TOWNSHIP OF SUNBURY."**

The Corporation of the Shire of Bulla as the Committee of Management of the land in the Township of Sunbury, Parish of Buttletjork, temporarily reserved by Order in Council dated the 30th July, 1968, as a site for Public Park and General Recreation, and being an extension to the areas temporarily reserved by Orders in Council dated the 16th March, 1897, and 15th January, 1963, for Public Park and General Recreation.—(Corres. No. Rs.1758.)

W. J. F. McDONALD,  
Minister of Lands.

Department of Crown Lands and Survey,  
Melbourne, 3rd September, 1968.

**PUBLIC SERVICE NOTICES**

No. 67.

*Public Service Act 1958, Section 50.*

**REGULATIONS.—PART IV.—SALARIES AND INCREMENTS.**

THE Public Service Board, in pursuance of the powers conferred by the *Public Service Act 1958*, hereby amends its Regulations as shown below :—

**SIXTH SCHEDULE.**

**TEMPORARY EMPLOYEES.**

*Designations of Positions and Rates of Salaries.*

| Department and Designation of Position.             | Yearly Rate of Salary. |          | Increments (Annual). |
|---|------------------------|----------|----------------------|
|   | Minimum.               | Maximum. |                      |
| CHIEF SECRETARY'S DEPARTMENT.                       | \$                     | \$       |                      |
| SOCIAL WELFARE.                                     |                        |          |                      |
| <i>Family Welfare Division.</i>                     |                        |          |                      |
| Delete—<br>Matron, "Sutton Grange"                  | ..                     | 3,353    | ..                   |
| Add—<br>Superintendent (Female),<br>"Sutton Grange" | 2,920                  | 3,135    | £                    |
| Σ See Regulation 97 (2).                            |                        |          |                      |

F. E. CAHILL, Chairman.  
V. P. SCULLY, Secretary.

Office of the Public Service Board,  
Melbourne, 29th August, 1968.

No. 71.

Public Service Act 1958, Section 50.

REGULATIONS.—PART IV.—SALARIES AND INCREMENTS.

THE Public Service Board, in pursuance of the powers conferred by the Public Service Act 1958, hereby amends its Regulations as shown below—

SIXTH SCHEDULE.

TEMPORARY EMPLOYEES.

Designations of Positions and Rates of Salaries.

| Department and Designation of Position.   | Yearly Rate of Salary. |          | Increments (Annual). |
|---|------------------------|----------|----------------------|
|   | Minimum.               | Maximum. |                      |
|   | \$                     | \$       |                      |
| <i>Delete the existing yearly rates of salary for the following positions and substitute the rates shown hereunder in lieu thereof—</i> |                        |          |                      |
| <b>GENERAL.</b>   |                        |          |                      |
| Electrician .. .. .   | 2,819                  | 3,111    | Σ                    |
| Motor Mechanic .. .. .  | 2,819                  | 3,111    | Σ                    |
| <b>DEPARTMENT OF AGRICULTURE.</b>   |                        |          |                      |
| Fitter .. .. .  | 2,819                  | 3,111    | Σ                    |
| Maintenance Officer, Cool Stores .. .. .  |                        | 3,306    |                      |
| <b>DOOKIE AGRICULTURAL COLLEGE.</b>   |                        |          |                      |
| Blacksmith .. .. .  | 2,819                  | 3,130    | Σ                    |
| Farm Mechanic .. .. .   | 2,819                  | 3,111    | Σ                    |
| <b>DEPARTMENT OF CROWN LANDS AND SURVEY.</b>  |                        |          |                      |
| Engineer Mechanic, Buchan Caves .. .. .   | 3,041                  | 3,306    | Σ                    |
| <b>DEPARTMENT OF HEALTH.</b>  |                        |          |                      |
| <b>TUBERCULOSIS<sup>φ</sup></b>   |                        |          |                      |
| <i>State Sanatoria<sup>φ</sup></i>  |                        |          |                      |
| Engineer Mechanic .. .. .   | 3,041                  | 3,306    | Σ                    |
| <sup>φ</sup> See Regulation 121.  |                        |          |                      |
| <b>MINES DEPARTMENT.</b>  |                        |          |                      |
| Fitter and Turner .. .. .   | 2,819                  | 3,111    | Σ                    |
| Mechanic, Senior .. .. .  | 3,041                  | 3,306    | Σ                    |
| Section Cutter .. .. .  | 2,496                  | 2,762    | Σ                    |
| Welder .. .. .  | 2,819                  | 3,111    | Σ                    |
| <b>PUBLIC WORKS DEPARTMENT.</b>   |                        |          |                      |
| Electrical Fitter .. .. .   | 2,819                  | 3,111    | Σ                    |
| Electrical Mechanic .. .. .   | 2,819                  | 3,111    | Σ                    |
| Mechanic .. .. .  | 2,819                  | 3,111    | Σ                    |
| <b>PORTS AND HARBOURS.<sup>††φ  </sup></b>  |                        |          |                      |
| Fitter and Turner= .. .. .  | 2,819                  | 3,111    | Σ                    |
| <sup>††</sup> See Regulation 156.   |                        |          |                      |
| <sup>φ</sup> See Regulation 155.  |                        |          |                      |
| <sup>  </sup> See Regulation 153.   |                        |          |                      |
| = See Regulation 154.   |                        |          |                      |
| <b>STATE FORESTS DEPARTMENT.</b>  |                        |          |                      |
| Mechanic, Leading Hand, Fire Protection .. .. .   | 3,041                  | 3,306    | Σ                    |
| Mechanic, Fire Protection .. .. .   | 2,819                  | 3,111    | Σ                    |

SIXTH SCHEDULE—continued.

| Department and Designation of Position.                  | Yearly Rate of Salary. |          | Increments (Annual). |
|--|------------------------|----------|----------------------|
|  | Minimum.               | Maximum. |                      |
|  | \$                     | \$       |                      |
| <b>STATE FORESTS DEPARTMENT—continued.</b>               |                        |          |                      |
| <b>CENTRAL WORKSHOP.</b>                                 |                        |          |                      |
| Electrical Fitter, Leading Hand <sup>¶</sup> .. .. .     | 3,041                  | 3,306    | Σ                    |
| Fitter, Leading Hand <sup>¶</sup> .. .. .                | 3,041                  | 3,306    | Σ                    |
| Fitter and Turner, Leading Hand <sup>¶</sup> .. .. .     | 3,041                  | 3,306    | Σ                    |
| Welder, Special Class, Leading Hand <sup>¶</sup> .. .. . | 3,130                  | 3,468    | Σ                    |
| Welder, Special Class <sup>¶</sup> .. .. .               | 2,911                  | 3,216    | Σ                    |
| Welder, Leading Hand <sup>¶</sup> .. .. .                | 3,041                  | 3,306    | Σ                    |
| Welder <sup>¶</sup> .. .. .                              | 2,819                  | 3,111    | Σ                    |
| Fitter <sup>¶</sup> .. .. .                              | 2,819                  | 3,111    | Σ                    |
| <sup>¶</sup> See Regulation 160.                         |                        |          |                      |
| <b>WATER SUPPLY DEPARTMENT.</b>                          |                        |          |                      |
| Mechanic, Senior .. .. .                                 | 3,041                  | 3,306    | Σ                    |
| <sup>Σ</sup> See Regulation 97 (2).                      |                        |          |                      |

This Regulation shall have effect as on and from the 25th August, 1968.

F. E. CAHILL, Chairman.  
V. P. SCULLY, Secretary.

Office of the Public Service Board,  
Melbourne, 23rd August, 1968.

No. 68.

Public Service Act 1958, Section 50.

REGULATIONS.—PART IV.—SALARIES AND INCREMENTS.

THE Public Service Board, in pursuance of the powers conferred by the Public Service Act 1958, hereby amends its Regulations as shown below :—

SIXTH SCHEDULE.

TEMPORARY EMPLOYEES.

Designations of Positions and Rates of Salaries.

| Department and Designation of Position.  | Yearly Rate of Salary. |          | Increments (Annual). |
|--|------------------------|----------|----------------------|
|  | Minimum.               | Maximum. |                      |
|  | \$                     | \$       |                      |
| <b>CHIEF SECRETARY'S DEPARTMENT.</b>   |                        |          |                      |
| <b>STATE LIBRARY, NATIONAL GALLERY, NATIONAL MUSEUM AND INSTITUTE OF APPLIED SCIENCE</b> |                        |          |                      |
| <i>Delete—</i>   |                        |          |                      |
| <i>Attendant—</i>  |                        |          |                      |
| <i>Junior—</i>   |                        |          |                      |
| At 16 years of age .. .. .   |                        | 947      |                      |
| At 17 years of age .. .. .   |                        | 1,109    |                      |
| At 18 years of age .. .. .   |                        | 1,292    |                      |
| At 19 years of age .. .. .   |                        | 1,486    |                      |
| At 20 years of age .. .. .   |                        | 1,743    |                      |
| Adult .. .. .  | 2,458                  | 2,534    | Σ                    |
| <i>Add—</i>  |                        |          |                      |
| <i>Attendant, Grade I.—</i>  |                        |          |                      |
| <i>Junior—</i>   |                        |          |                      |
| At 16 years of age .. .. .   |                        | 947      |                      |
| At 17 years of age .. .. .   |                        | 1,109    |                      |
| At 18 years of age .. .. .   |                        | 1,292    |                      |
| At 19 years of age .. .. .   |                        | 1,486    |                      |
| At 20 years of age .. .. .   |                        | 1,743    |                      |
| Adult .. .. .  | 2,458                  | 2,572    | Σ                    |
| Attendant, Grade II. .. .. .   | 2,610                  | 2,648    | Σ                    |
| <sup>Σ</sup> See Regulation 97 (2).  |                        |          |                      |

F. E. CAHILL, Chairman.  
V. P. SCULLY, Secretary.

Office of the Public Service Board,  
Melbourne, 27th August, 1968.

No. 69.

Public Service Act 1958, Section 50.

REGULATIONS.—PART IV.—SALARIES AND INCREMENTS.

THE Public Service Board, in pursuance of the powers conferred by the Public Service Act 1958, hereby amends its Regulations as shown below :—

FIFTH SCHEDULE.

TEMPORARY EMPLOYEES.

DEPARTMENT OF HEALTH.

MENTAL HYGIENE.

Designations of Positions and Rates of Salaries.

| Designation of Position.                   | Yearly Rate of Salary. Σ |          |
|--|--------------------------|----------|
|  | Minimum.                 | Maximum. |
|  | \$                       | \$       |
| Delete—<br>Inquiry Officer .. .. .         | 2,458                    | 2,648    |
| Add—<br>Inquiry Officer—<br>Junior .. .. . |                          |          |
| At 19 years of age .. .. .                 |                          | 1,702    |
| At 20 years of age .. .. .                 |                          | 1,971    |
| Adult .. .. .                              | 2,458                    | 2,648    |

Σ Annual increments shall be in accordance with those prescribed by Sub-Regulations 97 (2) and 97 (3), provided that in the case of the position of Assistant (Male), Administrative, the annual increments shall be in accordance with those prescribed by Part A of the Third Schedule.

F. E. CAHILL, Chairman.

V. P. SCULLY, Secretary.

Office of the Public Service Board,  
Melbourne, 26th August, 1968.

No. 70

Public Service Act 1958, Section 50.

REGULATIONS.—PART IV.—SALARIES AND INCREMENTS.

THE Public Service Board, in pursuance of the powers conferred by the Public Service Act 1958, hereby amends its Regulations as shown below :—

FIFTH SCHEDULE.

TEMPORARY EMPLOYEES.

DEPARTMENT OF HEALTH.

MENTAL HYGIENE.

Designations of Positions and Rates of Salaries.

| Designation of Position.   | Yearly Rate of Salary. Σ |          |
|--|--------------------------|----------|
|  | Minimum.                 | Maximum. |
|  | \$                       | \$       |
| Delete the existing yearly rates of salary for the following positions and substitute the rates shown hereunder in lieu thereof— |                          |          |
| Electrical Mechanic .. .. .  | 2,819                    | 3,111    |
| Engineer Mechanic .. .. .  | 2,819                    | 3,111    |
| Motor Mechanic .. .. .   | 2,819                    | 3,111    |

Σ Annual increments shall be in accordance with those prescribed by Sub-Regulations 97 (2) and 97 (3), provided that in the case of the position of Assistant (Male), Administrative, the annual increments shall be in accordance with those prescribed by Part A of the Third Schedule.

This Regulation shall have effect as on and from the 25th August, 1968.

F. E. CAHILL, Chairman.

V. P. SCULLY, Secretary.

Office of the Public Service Board,  
Melbourne, 23rd August, 1968.

TENDERS

PUBLIC WORKS DEPARTMENT

TENDERS will be received at Public Works Department, Treasury-place, Melbourne, until TWO p.m. on dates shown and for purposes mentioned hereunder.

Particulars and tender forms available at Contracts Office, Room 7, Building Division, Parliament-place and at places indicated in brackets hereunder.

Abbreviations in brackets mean:—W.O.—Inspector of Works Office; P.S.—Police Station; C.S.—Consolidated School; H.E.S.—Higher Elementary School; H.S.—High School; S.S.—State School; T.S.—Technical School.

Tenders to be submitted on the Department's printed Tender Form and will not be received by telephone. All tenders must be on a "Firm Tender" basis. The lowest or any tender will not necessarily be accepted.

Address tenders to the Minister of Public Works, and endorse the envelope containing the tender "Tender for .. .. . closing Tuesday,

Hand delivered tenders to be placed in the Tender Box of the Public Works Department, located on the wall of the centre entrance foyer, Ground Floor, New Treasury Building, Treasury-place, Melbourne.

No preliminary deposit is required with any tender, but a successful tenderer will be required to pay a deposit for any accepted tender of \$4,000 or over.

Tuesday, 17th September, 1968.

Building, Electrical and Mechanical Works.

Buchan.—Electrical distribution and switchboards, Caves Reserve. (W.O., Bairnsdale.)

Bullioh.—Completion of renovations, &c., S.S. 2495 and residence. (W.O., Wangaratta; S.S., Bullioh.)

Buxton.—Hot and cold water services, Youth Camp. (W.O., Alexandra.)

Laverton.—Renovations, S.S. 4765. (W.O., Geelong.)

Toolondo.—Supply and installation of an elevated tank system on water supply, S.S. 3051 and residence. (W.O., Horsham.)

Various.—Erection of 80 timber class-rooms, &c., Schools. (W.O., Alexandra, Ballarat, Bairnsdale, Bendigo, Benalla, Camperdown, Geelong, Hamilton, Horsham, Mornington, Shepparton, Traralgon and Warrnambool.)

Furniture and Furnishings.

Ballarat.—Supply and fix curtains, Nurses' Home, Mental Hospital. (W.O., Ballarat.)

Caulfield.—Supply and fix auditorium curtains, High School.

Kew.—Supply and fix curtains, Wards 13, 28 and 29, Children's Cottages.

Site Works.

Doncaster.—Concrete and drainage works, &c., S.S. 197.

Footscray.—Paving and drainage works, &c., Technical School.

Miscellaneous.

Castlemaine.—Supply and fix kitchen equipment, Gaol.

Tuesday, 24th September, 1968.

Building, Electrical and Mechanical Works.

Armada.—Ventilation of kitchen, "Frank Tate House", Secondary Teachers' College Hostel, 373 Dandenong-road.

Berwick.—Renovations, S.S. 40. (S.S., Berwick.)

Collingwood.—Sawdust extraction and compressed air systems, Technical School.

Footscray.—Replacement of Parquet flooring, College of Technology. (Re-advertised.)

Hawksburn.—Demolition of shelter shed and erection of shelter pavilion, S.S. 1467.

Lakeside.—Erection of type "800" Assembly Hall, High School.

Lakeside.—Electrical installation, High School.

Lakeside.—Mechanical services, High School.

Murrumbena.—Additional class-rooms and alterations, High School.

Murrumbena.—Electrical installation, High School.  
 Murrumbena.—Mechanical services, High School.  
 Pascoe Vale.—Provision of partition, Melbourne School of Textiles.  
 Port Melbourne.—Renewal of roof, &c., S.S. 2932.  
 Warrnambool.—Renovations, S.S. 1743. (W.O., Warrnambool.)  
 Werribee.—Electrical installation, Research Farm.  
 Westgarth.—Electrical installation, S.S. 4177.

**Site Works.**

Canterbury.—Asphalt, concrete and drainage works, &c., Girls' High School.  
 Moorleigh.—Asphalt, concrete and drainage works, &c., High School.  
 Springview.—Asphalt, concrete and drainage works, &c., S.S. 4912.

**Miscellaneous.**

Ballarat.—Supply and delivery of 16-in. hand planing and jointing machine, Mental Hospital.  
 Langi Kal Kal.—Supply of timber, Youth Training Centre.  
 Williamstown.—Construction of two all-welded mild steel work barges, Dredging Depot, Ports and Harbours Branch.

**Tuesday, 1st October, 1968.**

**Building, Electrical and Mechanical Works.**

Ellinbank.—Erection of two Proprietary type brick veneer Residences, Research Station. (W.O., Warragul.)  
 Euroa.—Erection of brick cell, Police Station. (W.O., Alexandra.)  
 Kaniva.—Modifications to heating system, Consolidated School. (W.O., Horsham.)  
 Kerang.—Electrical installation, S.S. 1410. (W.O., Bendigo and Swan Hill; S.S., Kerang.) (Re-advertised.)  
 Maidstone.—Renovations, S.S. 4658.  
 Melbourne.—Supply and installation of cooling unit, Royal Melbourne Institute of Technology.  
 Melbourne.—Construction of a restaurant, Royal Botanic Gardens. (Specification and bills of quantities available.)  
 Melbourne.—Electrical installation, Restaurant, Royal Botanic Gardens.  
 Melbourne.—Mechanical services, Restaurant, Royal Botanic Gardens.  
 Melbourne.—Precast or *in situ* reinforced concrete, or alternatively steel tubular concrete-filled piles, designed, constructed and installed to sustain the loads given in the contract documents. Tenderers shall submit full details of piles offered, Restaurant, Royal Botanic Gardens.  
 Mildura.—Erection of brick workshop, Plant Research Station. (W.O., Mildura.)  
 Newborough East.—Renovations, &c., S.S. 4670. (W.O., Traralgon.) (Re-advertised.)  
 Williamstown.—Electrical installation, High School.  
 Yallourn North.—Electrical installation, S.S. 3967. (W.O., Traralgon and Warragul; S.S., Yallourn North.)

**Furniture and Furnishings.**

Stawell.—Supply of furniture, Technical School.

**Site Works.**

Mitcham.—Asphalt, concrete and drainage works, &c., S.S. 2904.  
 Shepparton South.—Concrete and drainage works and gravel roads, &c., Technical School. (W.O., Shepparton.)  
 Syndal North.—Concrete, asphalt and drainage works, &c., S.S. 4946.

M. V. PORTER,  
 Minister of Public Works.

Public Works Department,

Melbourne, 3002, 9th September, 1968.

**PRIVATE ADVERTISEMENTS**

**NOTICE** is hereby given that The Boy Scouts Association (Wannon Scout District) has applied for a lease of approximately 10 acres situated in the south-east corner of allotment 1, Parish of Panyyabyr, pursuant to section 134, Land Act 1958, for the purpose of amusement and recreation, for a term of 21 years. 4263

**NOTICE** is hereby given that the St. Leonards Bowling Club has applied for a lease under section 134 Land Act 1958, of allotment 3, section A, Township of St. Leonards, containing 2 acres 24 perches, for a term of twenty years, as a site for amusement and recreation (Bowling Club). 4550

Sewerage Districts Act.

**PROPOSED SEWERAGE AUTHORITY.**

**NOTICE** is hereby given that the Shire of Numurkah has made application to the Honorable the Minister of Water Supply for the constitution of a Sewerage Authority and for the proclamation of a Sewerage District at Numurkah and for the construction, maintenance and continuance of sewerage works within that District under the provisions of the Sewerage Districts Act.

A general plan and description of the proposed works have been submitted with the application and copies of same may be seen at the Shire Office, Numurkah.

Dated at Numurkah the 26th day of August, 1968.

L. G. MITCHELL, Secretary.

The Act requires that this notice be published weekly for three weeks in a newspaper circulating locally and the *Government Gazette* and provides that within one month of the third notice in the *Government Gazette*, any person having an interest therein, who is likely to be injuriously affected by the proposed sewerage works, may forward to the Minister of Water Supply a petition, seeking refusal or amendment to the application.

In this case the period for objections will expire on 11th October, 1968. 4353

**NOTICE OF INTENTION TO APPLY FOR A LICENCE TO DIVERT WATER AND CUT RACE FROM THE BROKEN RIVER, AT BENALLA.**

**I** HEREBY give notice that I intend to apply for a licence empowering me to divert water for a term of four years to the extent of 40 acre-feet per annum at a maximum rate of 4 acre-feet per day of 24 hours for the irrigation of an area to be determined, being part of allotments 2, 3, 13, 14, 15, 18, 19 and 20, Parish of Goorambat, and to occupy certain Crown lands for works of diversion, and to cut a race thereon.

Any objections to such application must be forwarded, in writing, to reach the State Rivers and Water Supply Commission, Melbourne, before 16th October, 1968, being 30 days from the first publication of this notice.

THE UNION-FIDELITY TRUSTEE COMPANY OF AUSTRALIA LIMITED, 100 Exhibition-street, Melbourne, 3000. 4622

**NOTICE OF INTENTION TO APPLY FOR A LICENCE TO DIVERT WATER AND CUT RACE FROM THE BROKEN RIVER, AT BENALLA.**

**I** HEREBY give notice that I intend to apply for a licence empowering me to divert water for a term of four years to the extent of 40 acre-feet per annum at a maximum rate of 4 acre-feet per day of 24 hours for the irrigation of an area to be determined, being part of allotments 29A, 29B, 32, 33A<sup>1</sup>, 33A<sup>2</sup>, 33B and part 31, Parish of Goorambat, and to occupy certain Crown lands for works of diversion, and to cut a race thereon.

Any objections to such application must be forwarded, in writing, to reach the State Rivers and Water Supply Commission, Melbourne, before 16th October, 1968, being 30 days from the first publication of this notice.

THE UNION-FIDELITY TRUSTEE COMPANY OF AUSTRALIA LIMITED, 100 Exhibition-street, Melbourne, 3000. 4623

**NOTICE OF INTENTION TO APPLY FOR A LICENCE TO DIVERT WATER AND CUT RACE (RE-ISSUE) FROM THE BROKEN RIVER, AT SWANPOOL.**

**I** HEREBY give notice that I intend to apply for a licence empowering me to divert water for a term of four years to the extent of 22 acre-feet per annum at a maximum rate of 2 acre-feet per day of 24 hours for the irrigation of lucerne, being part of allotment 53

and the whole of allotments 54, 55 and 56, Parish of Moornag, and to occupy certain Crown lands for works of diversion, and to cut a race thereon.

Any objection to such application must be forwarded, in writing, to reach the State Rivers and Water Supply Commission, Melbourne, before 10th October, 1968, being 30 days from the first publication of this notice.

ANDREW JAMES BOWDEN CARTER.

Mallum Creek, Benalla, Victoria, 3672. 4624

#### AUSTRALIAN MUTUAL PROVIDENT SOCIETY.

PURSUANT to the provisions of an Act of the Parliament of Victoria, No. 214 intitled "An Act for conferring certain powers on Australian Mutual Provident Society": Notice is hereby given that Byrne Hart, of 14 Gerald-street, Ascot, Queensland, director, retired on the 1st day of July, 1968, and on the 1st day of July, 1968, Rodney Wickham McDonald, of 162 Yabba-street, Ascot, Queensland, was appointed a Director of the Society in the place of the said Byrne Hart.

Dated this 28th day of August, 1968.

N. H. TAYLER, Manager for Victoria and Agent in Victoria for the said Society.

PURVES & PURVES, solicitors, 90 William-street, Melbourne. 4583

#### FERN TREE GULLY CLINIC.

DR. L. L. O. BEVAN has retired from practice with the Fern Tree Gully Clinic, 28 Station-street, Fern Tree Gully, as from Monday, 2nd September, 1968. 4530

#### Town and Country Planning Act 1961.

#### CITY OF BENDIGO PLANNING SCHEME.

NOTICE THAT A PLANNING SCHEME HAS BEEN PREPARED AND IS AVAILABLE FOR INSPECTION.

#### Amendment No. 3.

NOTICE is hereby given that the City of Bendigo in pursuance of its powers under the Town and Country Planning Act 1961 has prepared a Planning Scheme for the following purposes:—

- (1) Rezone from Residential to Commercial A—
  - (i) Land on northern side of Forest Street between High and McKenzie streets.
  - (ii) Land on north-western side of Calvin-street between Mitchell and Mundy streets.
- (2) Rezone from Rural to Residential—
  - (i) Land bounded by Murphy, Heinz, Andrew and Ross streets.
  - (ii) Land bounded by John, Jacob streets and the rear of the residential zone facing Holdsworth-road.
- (3) Rezone from Industrial to Residential land bounded by Maple, Pallett, Wade and Rowan streets.
- (4) Rezone from Residential to Public Open Space (Showgrounds) land between Long Gully Creek, Prouses-road and Bendigo-Swan Hill railway line.
- (5) Rezone from Industrial to Public Open Space (Showgrounds) portion of land on south-west side of Holmes-road between Havilah-road and Long Gully Creek.
- (6) Rezone from Public Open Space to Residential portions of land in Nolan, Lobb, Castle and Bannister streets.
- (7) To amend the ordinance to provide for:—
  - (i) The number of vehicle parking spaces required for new buildings, new usages of land and buildings in respect of which there are alterations and additions or changes of use. (This requirement will apply to the whole of the municipal district of the City of Bendigo.)
  - (ii) The erection of petrol service stations in the Industrial Zone subject to the approval of the responsible authority.

A copy of the scheme has been deposited at the City Hall, Bendigo, and at the office of the Town and Country Planning Board, 179 Queen-street, Melbourne, and will be open for inspection during office hours by any person free of charge.

Any persons affected by the Planning Scheme are required to set forth, in writing, all objections they may have, addressed to the Town Clerk, City Hall, Bendigo, on or before the 15th day of December, 1968, and to state whether they wish to be heard in respect of their objections.

4566

A. J. WATTS, Town Clerk.

#### CITY OF ECHUCA.

#### LOAN No. 55.

#### Notice of Intention to Borrow the Sum of \$17,000 for Permanent Works and Undertakings.

NOTICE is hereby given that the Council of the City of Echuca proposes to borrow the principal sum of Seventeen thousand dollars secured by a charge over the general rates of the municipality, such sum to be raised by the grant of a mortgage in accordance with the provisions of the Local Government Act 1958.

1. The maximum rate of interest that may be paid is 5.5625 per cent. per annum.
2. The purpose for which the loan is to be applied is:—  
Part cost of one only heavy duty diesel powered road grader.
3. The period of the loan shall be seven years.
4. The moneys borrowed shall be repayable by providing out of the municipal fund fourteen half-yearly instalments of approximately \$1,482 each, including principal and interest on the first day of October and the first day of April during the currency of the loan. The first instalment shall be payable on the first day of April, 1969.
5. Such moneys shall be repayable to The Commissioners of The State Savings Bank of Victoria at the office of the said Commissioners, corner Elizabeth and Bourke streets, Melbourne.

The plans and specifications and the estimate of the cost of the proposed works and a statement showing the proposed expenditure of the moneys to be borrowed are open for inspection at the office of the Council of the City of Echuca at the corner of Hare and Heygarth streets, Echuca.

K. F. McCARTNEY, Town Clerk.

City Offices,  
Echuca, 6th September, 1968. 4559

#### Local Government Act 1958 and Amendments.

#### CITY OF HEIDELBERG.

#### NOTICE TO ALL WHOM IT MAY CONCERN.

WHEREAS the Council of the Municipality of the City of Heidelberg, in the State of Victoria, deems it expedient to execute a certain work or undertaking for the purpose of provision of car parking areas for Rosanna Shopping Centre, whereof it is in the opinion of the said Council necessary and desirable that the said Council exercise its power of taking land compulsorily within the municipal district of the said Council, as provided by the Local Government Act 1958 and amendments, and the said Council has caused its surveyor to prepare plans of the said work or undertaking as are necessary and in which are expressed the nature and extent of such work or undertaking and the exact site and admeasurements thereof and on and through what land the said work or undertaking is proposed to be placed and the names of the owners or reputed owners, lessees or reputed lessees and the occupiers of such land so proposed to be taken so far as known and the said plans so prepared have been approved by the said Council.

In pursuance of the provisions of the Local Government Act 1958 and amendments, the said Council doth hereby publish and give notice that the description shortly of the purport of the said work or undertaking is as follows:—

#### Provision of car parking areas for Rosanna Shopping Centre.

And the land which it is necessary and desirable to take compulsorily is—

- (i) All that piece of land being lot 4 on plan of subdivision No. 34096, and being part of Crown portion 5, Parish of Keelbundora, County of Bourke, and more particularly described in certificate of title, volume 8119, folio 391, in the name of THOMAS DAVIS, as proprietor, and INA ANNIE DRAIN, as the rated owner.
- (ii) All that piece of land being part of lots 1, 2 and 3 on plan of subdivision No. 34096, and being part of Crown portion 5, Parish of Keelbundora, County of Bourke, and more particularly described in certificate of title, volume 8119, folio 392, in the name of PINKAS SCHEUER, as proprietor, and COMMERCIAL BANK OF AUSTRALIA LTD., as mortgagee.
- (iii) All that piece of land being part of lot 17 on plan of subdivision No. 4725, and being part of Crown portion 5, Parish of Keelbundora, County of Bourke, and more particularly described in certificate of title, volume 7849, folio 125, in the name of FREDERICK EDWARD DAVID BRIDGER and NOEL LA CROISSETTE SHRIMPSON, as proprietors.



- (iv) All that piece of land being lot 6 on plan of subdivision No. 14310, and being part of Crown portion 5, Parish of Keelbundora, County of Bourke, and more particularly described in certificate of title, volume 6228, folio 417, in the name of JEAN McDONALD MCLELLAN, as proprietor.

And the said Council doth hereby give further notice that the said plans are deposited at the office of the said Council, Town Hall, Ivanhoe, and are there open for inspection and perusal on all days and between the hours the Municipal Office is appointed to be open, for the space of 40 clear days from the date of the publication of this notice in the *Government Gazette*.

And the said Council doth hereby call upon all persons interested in or affected by the said proposed work or undertaking, to set forth, in writing, addressed to the said Council or the Town Clerk thereof, at the Town Hall, Ivanhoe, within 40 clear days from the date of the publication of this notice, as aforesaid, all objections which they may have to the said working or undertaking.

Dated the 10th day of September, 1968.

The common seal of the Mayor, Councillors and Citizens of the City of Heidelberg was hereto affixed by me—

E. C. W. JACK, Town Clerk.

in the presence of—

(SEAL)

P. H. CLELAND, Mayor.

4594

V. C. HENDERSON, Councillor.

#### CITY OF KEW.

NOTICE OF INTENTION TO RESOLVE TO BORROW PRINCIPAL MONEYS AMOUNTING TO \$200,000 FOR PERMANENT WORKS AND UNDERTAKINGS.

NOTICE is hereby given that the Council of the City of Kew proposes to resolve to borrow principal moneys amounting to \$200,000 secured by charges over the general rates of the municipality such moneys to be raised by the grant of mortgages in accordance with the provisions of the Local Government Acts.

1. The maximum rate of interest that may be paid is 5½ per centum per annum.

2. The period of the loans shall be 40 years.

3. The moneys borrowed shall be repayable in full at maturity and by half-yearly instalments of interest on the 1st day of April and 1st day of October, during the currency of the loans. The first payments to be made on the 1st day of October, 1969, and the final payments and repayments of principal in full on the 1st day of April, 2009.

4. Such payments shall be made at the National Bank of Australasia Limited, Melbourne, or at the Council's bankers for the time being in Melbourne.

5. The purpose for which the loans are to be applied is the erection of new municipal offices (part cost).

6. The loans are to be liquidated by sinking funds created in accordance with the provisions of the Local Government Acts by the half-yearly investment of such amounts as the Auditor-General certifies will be sufficient to repay the principal moneys secured by the mortgages within the currency of the loans.

The plans and specifications and the estimate of the cost of the proposed works, and a statement showing the proposed expenditure of the moneys to be borrowed, are open for inspection at the Town Hall, Walpole-street, Kew.

Dated this 4th day of September, 1968.

4544

J. L. JOHNSON, Town Clerk.

#### CITY OF NUNAWADING.

No. 1353

##### BY-LAW No. 72.

##### Street Plantation Protection By-Law.

A By-Law of the City of Nunawading made under Section 197 of the *Local Government Act 1958* and Numbered 72 for providing for the protection and control of—

(a) tree reserves and gardens, garden plots, lawns and ornamental plantations in or upon any street or road;

(b) trees, shrubs and plants planted and tree guards, statues, monuments, fountains and seats erected in or upon any street or road.

IN pursuance of the powers conferred by the *Local Government Act 1958* and of any and every other power it thereunto enabling the Mayor Councillors and Citizens of the City of Nunawading orders as follows:

1. This By-Law may be known as the Street Plantation Protection By-Law.

2. No person other than an officer or servant of the Council in the due execution of his duties shall cut maim injure mutilate or destroy any tree shrub or plant planted or any tree guard statue monument fountain or seat erected in or upon any street or road.

3. No person shall drive or ride any vehicle or animal or permit any hooped animal of which he is the owner or in charge to be on or upon any garden, garden plot lawn or ornamental plantation in or upon any street or road.

4. No person shall throw stones or other missiles in any garden, garden plot lawn or ornamental plantation in or upon any street or road or place or leave thereon any refuse or rubbish whatsoever save in a receptacle placed therein by the Council for the purpose.

5. This By-Law shall apply to and have operation throughout the whole of the municipal district.

Resolution for passing this By-Law agreed to by the Council of the City of Nunawading on the 15th day of July 1968 and confirmed on the 12th day of August 1968.

The corporate seal of the Mayor Councillors and Citizens of the City of Nunawading was hereunto affixed in the presence of—

C. R. T. MCCALL, Mayor.

G. H. COX, Councillor.

J. H. BROWN, Town Clerk.

(SEAL)

4529

#### CITY OF OAKLEIGH.

##### LOAN No. 113.

Notice of Intention to Borrow the Sum of \$50,000 for Permanent Works and Undertakings.

NOTICE is hereby given that the Council of the City of Oakleigh proposes to borrow the sum of Fifty Thousand Dollars secured by a charge over the general rates of the municipality, such sum to be raised by the grant of a mortgage in accordance with the provisions of the *Local Government Act 1958*.

1. The maximum rate of interest that may be paid is 5½ per centum per annum.

2. The purpose for which the loan is to be applied is purchase and development of lands for parking facilities in the Oakleigh Shopping Centre.

3. The currency of the loan shall be four years.

4. The moneys borrowed shall be liquidated by the payment of eight half-yearly instalments of approximately \$7,047.90, each including principal and interest on the 1st day of November and the 1st day of May during the currency of the loan. The first instalment shall be payable on the 1st day of May, 1969.

5. The place that the moneys shall be repayable is at the C.B.C. Savings Bank Limited, Melbourne.

The plans and specifications and the estimate of the cost of the proposed works and statement showing the expenditure of the moneys to be borrowed are open for inspection at the Municipal Offices, Atherton-road, Oakleigh.

4538

J. H. HOCKING, Town Clerk.

#### CITY OF OAKLEIGH.

##### LOAN No. 114.

Notice of Intention to Borrow the Sum of \$50,000 for Permanent Works and Undertakings.

NOTICE is hereby given that the Council of the City of Oakleigh proposes to borrow the principal sum of \$50,000 secured by a charge over the general rates of the municipality, such sum to be raised by the grant of a mortgage in accordance with the provisions of the *Local Government Act 1958*.

1. The maximum rate of interest that may be paid is 5.75 per cent. per annum.

2. The purpose for which the loan is to be applied is:—

(1) Erection of Pavilions at Main-road Reserve, Carlson-avenue Reserve, Davies Reserve (Wallace-avenue).

(2) Elderly Citizens Clubrooms, Clayton-road Clayton.

(3) Clayton Branch Library (part cost).

\$50,000

3. The period of the loan shall be ten years.

4. The moneys borrowed shall be repayable by providing out of the municipal fund twenty half-yearly instalments of approximately \$3,322 each, including principal and

interest on the first day of June and the first day of December, during the currency of the loan. The first instalment shall be payable on the first day of June, 1969.

5. Such moneys shall be repayable to The Commissioners of The State Savings Bank of Victoria at the office of the said Commissioners, corner Elizabeth and Bourke-streets, Melbourne.

The plans and specifications and the estimate of the proposed works and a statement showing the proposed expenditure of the moneys to be borrowed are open for inspection at the office of the Council of the City of Oakleigh, Atherton-road, Oakleigh.

4561 J. H. HOCKING, Town Clerk.

CITY OF SPRINGVALE.

ORDER CHANGING NAME OF STREET.

NOTICE is hereby given that at a Meeting of the Council of the City of Springvale, held on the 5th day of August, 1968, the said Council, in pursuance of the powers conferred by the *Local Government Act 1958*, made an Order changing the name of the following street.—

Location.—Lower Dandenong-road south to Wells-road.

Old Name.—Edithvale-road.

New Name.—Springvale-road.

4546 H. L. WILLIAMS, Town Clerk.

CITY OF WAVERLEY.

NOTICE is hereby given that in pursuance of the powers conferred by the *Local Government Act*, the Council of the City of Waverley did at a meeting, held on 3rd September, 1968, order that the following alteration be made in the name of the under-mentioned street and that such order take effect from the date of this publication.

Old Name.—The "road" shown on lodged plan of Sub-division No. 50047 abutting the eastern boundaries of lots 17 to 22 inclusive on lodged plan of subdivision No. 50047.

New Name.—Hamilton Walk.

4532 F. S. BALES, Town Clerk.

SHIRE OF BUNINYONG.

ORDER.

PURSUANT to the provisions of Section 522 of the *Local Government Act 1958*, the Council of the Shire of Buninyong, hereby directs that the land in the undermentioned Parishes, and more particularly described in the undermentioned certificates of title, and which has been purchased, taken, or acquired by it shall be a public highway on and from the date of publication of this Order in the *Government Gazette*.

Land referred to in the above Order.

| Crown Allotment.                              | Section. | Parish.          | Volume. | Folium. |
|---|----------|------------------|---------|---------|
| Part 48 .. ..                                 | ..       | Borhoneyghurk    | 8634    | 061     |
| Part 76 .. ..                                 | ..       | Borhoneyghurk    | 8634    | 063     |
| Part 77 .. ..                                 | ..       | Borhoneyghurk    | 8634    | 064     |
| Part 78 .. ..                                 | ..       | Borhoneyghurk    | 8634    | 060     |
| Part 81 .. ..                                 | ..       | Borhoneyghurk    | 8634    | 062     |
| Part 13 .. ..                                 | B        | Bungal ..        | 8630    | 453     |
| Part 16, Part 17,<br>and Part 29 ..           | ..       | Buninyong ..     | 8638    | 088     |
| Part 17b .. ..                                | 27       | Buninyong ..     | 8638    | 089     |
| Part 45D .. ..                                | ..       | Kerrit Bareet    | 8630    | 454     |
| Part 90E .. ..                                | ..       | Kerrit Bareet .. | 8630    | 452     |
| Part 53i .. ..                                | ..       | Yarrowee ..      | 8664    | 530     |
| Part 53L, Part<br>53M, and Part<br>53N, .. .. | ..       | Yarrowee ..      | 8638    | 086     |
| Part 53o .. ..                                | ..       | Yarrowee ..      | 8638    | 090     |
| Part 53q .. ..                                | ..       | Yarrowee ..      | 8638    | 091     |
| Part 148 .. ..                                | ..       | Yarrowee ..      | 8638    | 087     |

The common seal of the President, Councillors and Ratepayers of the Shire of Buninyong was hereunto affixed this fifth day of September, 1968, in the presence of:—

(SEAL) H. R. HUGGINS, President.  
ROY G. BIGGS, J.P., Councillor.  
A. C. LORD, Shire Secretary.

4568

SHIRE OF CROYDON.

NOTICE is hereby given that the Council of the Shire of Croydon did, at a meeting held on the 2nd September, 1968, order that the name of the street within the Shire of Croydon be changed as set out hereunder:—

Old Name.—Eros-street.

New Name.—Jesmond-road.

Location.—Off Eastfield-road (on lodged plan 51414).

4565 K. A. MCKAY, Shire Secretary.

SHIRE OF AVOCA.

PROPOSED REDBANK WATERWORKS TRUST.

NOTICE is hereby given that the Avoca Shire Council has made application to the Honorable the Minister of Water Supply for the constitution of a Waterworks Trust, and for the proclamation of a Waterworks District at Redbank and the construction, maintenance, and continuance of Water Supply Works within that District under the provisions of the *Water Acts*.

A general plan and description of the proposed works have been submitted with the application, and copies of same may be seen at the Shire Office, Rutherford-street, Avoca.

Dated at Avoca, the 23rd day of August, 1968.

4380 F. C. S. EDWARDS, Shire Secretary.

Local Government Act 1958 and Amendments.

SHIRE OF DIAMOND VALLEY.

NOTICE TO ALL WHOM IT MAY CONCERN.

WHEREAS the Council of the Municipality of the Shire of Diamond Valley deems it expedient to execute a certain work or undertaking for the purpose of developing car parking facilities in Greensborough, whereof it is in the opinion of the said Council necessary and desirable that the said Council exercise its power of taking land compulsorily within the municipal district of the said Council, as provided by the *Local Government Act 1958* and Amendments, and the said Council has caused to be prepared such maps and other papers as may be necessary to show the general description of the work or undertaking for which the land proposed to be taken is to be used, the description of the land proposed to be taken and the names of the owners or reputed owners, lessees or reputed lessees, mortgagees and occupiers of the land so far as those names are known to or can be ascertained by the Council and the said maps and other papers so prepared have been approved by the said Council.

In pursuance of the provisions of the *Local Government Act 1958* and Amendments, the said Council doth hereby publish and give notice that the description shortly of the purport of the said work or undertaking is as follows:—

The development of car parking facilities in the main street—Grimshaw-street, Greensborough, Shopping Centre.

And the land which it is necessary and desirable to take compulsorily is—

All that piece of land being Lot 1 on plan of subdivision No. 47541 and more particularly described in certificate of title, volume 8317, folio 207 in the name of Lewis Harold Lanyon.

And the said Council doth hereby give further notice that the said maps and other papers are deposited at the office of the said Council, Shire Office, Greensborough, and are there open for inspection on all the days and between the hours the said municipal office is appointed to be open for the space of 40 clear days from the date of the publication of this notice in the *Government Gazette*.

And the said Council doth hereby call upon all persons affected by the said proposed work or undertaking to set forth, in writing, addressed to the said Council or the Shire Secretary thereof, at the Shire Office, Greensborough, within 40 clear days from the date of the publication of this notice as aforesaid all objections which they may have to the said work or undertaking.

Dated the 5th day of September, 1968.

4570 B. J. MORGAN, Shire Secretary.

SHIRE OF KNOX.

LOAN No. 39.

Notice of Intention to Borrow the Sum of \$45,500 for Permanent Works and Undertakings.

NOTICE is hereby given that the Council of the Shire of Knox in pursuance of powers conferred by the *Local Government Acts*, intends to borrow the sum of \$45,500 secured by a charge over the general rates of the

municipality, such sum to be raised by the grant of a mortgage, in accordance with the said Acts and states:

(a) The amount of principal moneys it is proposed to borrow is \$45,500.

(b) The maximum rate of interest that may be paid is 5.75 per cent. per annum.

(c) The period of the loan will be ten years and the time or times at which the moneys borrowed are to be repayable is on the 1st day of May and the 1st day of November in each year during the currency of the loan commencing on the 1st day of May, 1969, until the final payment on 1st November, 1978.

(d) The purpose for which the loan is to be applied is for permanent works and undertakings, viz.:

Council contribution to private street construction in the following schemes:—

Marie-street, Alma-avenue, Church-street, The Avenue, Allandale-road, Power-road, Barton-avenue, Sydney-road.

(e) The loan is to be liquidated by half-yearly payments of approximately \$3,023, including principal and interest, payable out of the municipal fund.

(f) The place of repayment will be the State Savings Bank of Victoria, Box 267d, Post Office, Melbourne, 3001.

Plans and specifications and an estimate of the cost of such works and undertakings, and a statement showing the proposed expenditure of the money to be borrowed, are open for inspection by ratepayers, during office hours, at the Shire Offices, Fern Tree Gully, for one month after the publication of this notice.

Dated at Fern Tree Gully, this 5th day of September, 1968.

4556

N. G. HAYNES, Shire Secretary.

#### SHIRE OF KNOX.

##### LOAN No. 40.

#### Notice of Intention to Borrow the Sum of \$22,000 for Permanent Works and Undertakings.

NOTICE is hereby given that the Council of the Shire of Knox in pursuance of powers conferred by the Local Governments Acts, intends to borrow the sum of \$22,000 secured by a charge over the general rates of the municipality, such sum to be raised by the grant of a mortgage, in accordance with the said Acts and states:

(a) The amount of principal moneys it is proposed to borrow is \$22,000.

(b) The maximum rate of interest that may be paid is 5.875 per cent. per annum.

(c) The period of the loan will be fifteen years and the time or times at which the moneys borrowed are to be repayable is on the 1st day of May and the 1st day of November in each year during the currency of the loan commencing on the 1st day of May, 1969, until the final payment on 1st November, 1983.

(d) The purpose for which the loan is to be applied is for permanent works and undertakings, viz.:

Boronia Off Street Parking Area (part cost), Turner-road, Boronia.

(e) The loan is to be liquidated by half-yearly payments of approximately \$1,113, including principal and interest, payable out of the municipal fund.

(f) The place of repayment will be the State Savings Bank of Victoria, Box 267d, Post Office, Melbourne, 3001.

Plans and specifications and an estimate of the cost of such works and undertakings, and a statement showing the proposed expenditure of the money to be borrowed, are open for inspection by ratepayers, during office hours, at the Shire Offices, Fern Tree Gully, for one month after the publication of this notice.

Dated at Fern Tree Gully, this 5th day of September, 1968.

4557

N. G. HAYNES, Shire Secretary.

#### SHIRE OF KNOX.

##### LOAN No. 41.

#### Notice of Intention to Borrow the Sum of \$32,500 for Permanent Works and Undertakings.

NOTICE is hereby given that the Council of the Shire of Knox in pursuance of powers conferred by the Local Government Acts, intends to borrow the sum of \$32,500 secured by a charge over the general rates of the municipality, such sum to be raised by the grant of a mortgage, in accordance with the said Acts and states:

(a) The amount of principal moneys it is proposed to borrow is \$32,500.

(b) The maximum rate of interest that may be paid is 5.875 per cent. per annum.

(c) The period of the loan will be fifteen years and the time or times at which the moneys borrowed are to be repayable is on the 1st day of May and the 1st day of November in each year during the currency of the loan commencing on the 1st day of May, 1969, until the final payment on 1st November, 1983.

(d) The purpose for which the loan is to be applied is for permanent works and undertakings, viz.:

Road Construction.—

(a) Albert-avenue (to complete section from Miller-road to Boronia-road).

(b) Scoresby-road (i) K/C east side, Burton-court to opposite Orange-grove.

(ii) Pipe drain on east side, north of West Wattle Tree-road to Boronia-road.

(e) The loan is to be liquidated by half-yearly payments of approximately \$1,644, including principal and interest, payable out of the municipal fund.

(f) The place of repayment will be the State Savings Bank of Victoria, Box 267d, Post Office, Melbourne, 3001.

Plans and specifications and an estimate of the cost of such works and undertakings, and a statement showing the proposed expenditure of the money to be borrowed, are open for inspection by ratepayers, during office hours, at the Shire Offices, Fern Tree Gully, for one month after the publication of this notice.

Dated at Fern Tree Gully, this 5th day of September, 1968.

4558

N. G. HAYNES, Shire Secretary.

#### Town and Country Planning Act 1961 (Twelfth Schedule).

##### SHIRE OF KNOX PLANNING SCHEME 1965.

NOTICE THAT A PLANNING SCHEME HAS BEEN PREPARED AND IS AVAILABLE FOR INSPECTION.

##### Amendment No. 43, 1968.

NOTICE is hereby given that the Council of the Shire of Knox, in pursuance of its powers under the *Town and Country Planning Act 1961*, has prepared a Planning Scheme for the purpose of amending the Shire of Knox Planning Scheme Ordinance to allow for the establishment of small offices in Zone No. 4 Commercial (Local) in respect of clause 7 (Table of Zones) of the Ordinance.

A copy of the scheme has been deposited at the office of the Shire of Knox, Spring-street, Fern Tree Gully, and at the office of the Town and Country Planning Board, 179 Queen-street, Melbourne, and will be open for inspection during office hours by any person free of charge.

Any persons affected by the Planning Scheme are required to set forth, in writing, all objections they may have, addressed to the Shire Secretary, Shire of Knox, Spring-street, Fern Tree Gully, on or before the 11th day of October, 1968, and to state whether they wish to be heard in respect of their objections.

4569

N. G. HAYNES, Shire Secretary.

#### SHIRE OF KORUMBURRA.

##### By-Law No. 64.

A By-Law of the Shire of Korumburra made under and in pursuance of the Powers in that behalf conferred by the *Local Government Act 1958* as amended and numbered 64.

(a) For regulating the market places yards and premises and the buildings, stalls, pens, and standings therein and for preventing nuisances or obstructions therein and in the immediate approaches thereto.

(b) For fixing the days and hours during each day on which the markets shall be held.

IN pursuance of the powers conferred by the *Local Government Act 1958*, the President, Councillors and Ratepayers of the Shire of Korumburra, order as follows:—

(i) By-Law No. 8 of the Shire of Poowong and Jeetho is hereby repealed.

(ii) The word "cattle" in this By-Law shall include any horse, mare, gelding, colt, filly, foal, and any bull, cow, ox, steer, heifer or calf, and any ram, ewe, sheep, lamb, and any ass, mule, goat or pig unless inconsistent with the context or subject matter.

(iii) The municipal market at Korumburra being part Lot 2 on Plan of Subdivision 4717 being part Crown Allotment 89, Parish of Korumburra, County of Mornington and being the land more particularly described in Certificate

of Title Volume 7935 Folio 002, and part Lot 1 on Plan of Subdivision 6688 being the land more particularly described in Certificate of Title Volume 8415 Folio 786 and part Lot 10 Plan of Subdivision 4717 being the land more particularly described in Certificate of Title Volume 8648 Folio 281 and the municipal market at Poowong being part Crown Allotment 20, Parish of Jeetho, County of Mornington shown on Plan of Subdivision 28799 being the land more particularly described in Certificate of Title Volume 8077 Folio 910 shall be open for the reception, delivery and sale of cattle and other livestock, marketable commodities, garden, farm and dairy produce on such days during the year and for such hours during each day as hereinafter mentioned.

(iv) The municipal market at Poowong shall be open for the reception and sale of stock and produce of every description as the Council from time to time determines and the municipal market at Korumburra shall be open on every alternate Monday from 7 o'clock in the forenoon to 7 o'clock in the afternoon of the same day for the reception and sale of pigs, calves and sheep, and shall be open on every alternate Friday for the said hours for the reception and sale of all kinds of cattle excluding pigs and bobby calves.

(v) No business whatsoever shall be transacted in the municipal markets on any Sunday or on Good Friday or Christmas day. Should any of the days hereby fixed for the sale of stock or produce fall on any of the aforementioned days or in the event of any special cause rendering it necessary or desirable, the markets shall be open on the day preceding or on such other day as the Council may substitute and appoint in lieu thereof for the holding of such market. All days fixed pursuant to Clause (iv) hereof shall be called regular sale days.

(vi) Special sale days may be allotted on any day other than regular sale days and the holidays set out in Clause (v) hereof and any application for a special sale must be lodged in writing with the Council not less than fourteen days nor more than six months prior to the date of the sale.

(vii) All cattle yarded other than pigs and calves in the Poowong, the Korumburra or any other market licensed with the Council within the municipal district for sale by public auction shall be divided into classes as follows—

- (a) Bulls.
- (b) Fat and chopper cattle.
- (c) Store Cattle and yearling dairy heifers.
- (d) Dairy cows and heifers—that is to say cows in milk, cows with calf at foot and springers.

(viii) In all municipal markets, all cattle shall be sold in classes and in the order as below set out.

All cattle shall be sold in the selling rotunda or within the pens at the discretion of the auctioneer having the sale of them.

(ix) In the municipal markets auctioneers having a sale of cattle shall draw lots for priority of sale in each class and they shall sell or offer for sale the whole of the cattle in each separate class in the order of such drawing before another is commenced and any person interfering with or in any way preventing such auctioneer from conducting such sale shall be guilty of an offence against this By-Law.

(x) Only one auctioneer shall sell or offer any cattle of the one class for sale by public auction in either of the municipal markets at any one time.

(xi) There shall be appointed by the Council, if and when it deems necessary, an inspector who shall be empowered to enforce the provisions of all Acts, By-Laws and Regulations governing the operation of the said markets.

(xii) Every auctioneer which term includes a firm or incorporated company exercising his, her or its vocation or business within the said markets shall, at the end of each month forward to the Council a statement setting out the number of ordinary and special sales conducted during that month together with the numbers and types of cattle and chattels sold and such statement shall be accompanied by the total amount of the fees appertaining to such sales.

(xiii) Any auctioneer not present and proceeding with his sale when his time arrives to commence selling shall besides being guilty of a breach of this By-Law forfeit his priority of right to sell and shall be placed at the foot of the list of auctioneers entitled to sell.

(xiv) No pig shall be placed in any yards within the markets other than the yards provided for the sale of pigs.

(xv) All stock brought to the markets and/or placed in the yards or pens thereof by the owner of such stock or his agent, shall be at the sole risk of such owner and neither the Council nor any employee of the Council shall in any circumstances incur any liability or responsibility therewith.

(xvi) No stock which have been placed in any auctioneers hands for sale shall be permitted to leave the markets without the authority of the auctioneer concerned.

(xvii) No person shall bring, cause or allow any dog to enter or remain in the said market areas without the express permission of an authorised Council officer.

(xviii) No person shall in any thoroughfare or avenue within the said markets or in the immediate approaches thereto, give out or distribute hand bills, placards, notices, advertisements, books, pamphlets or papers or take up collections of money without the consent of Council.

(xix) No person shall place any produce, article or thing whatsoever so as to obstruct any thoroughfare or avenue in or of the said markets or neglect or refuse to remove the same on being required to do so by any duly authorised officer of the Council.

(xx) No person shall enter or appear in the markets in a drunken or disorderly state.

(xxi) No person shall place or drive any hook, nail or peg or other instrument into any part of the wood, stone, brickwork or iron of any shed, stall or building or shall in any way fit up or enclose any stall without the consent, in writing, of the Council.

(xxii) Any person resisting or obstructing an authorized officer of the Council in the performance of his duties shall independently of any penalty incurred for assault, improper behaviour or otherwise, be deemed to have committed a breach of this By-Law.

(xxiii) No person shall offer for sale in any part of the markets any commodity produce, goods, horses, cattle, etc., before or after the hours fixed for holding the said markets nor upon any day not fixed by the Council as a day upon which the market will be open without the sanction of the Council in writing.

(xxiv) No holder of any stall or right of selling in the said markets shall neglect or refuse to remove therefrom and from the precincts of the market when required to do so by any duly authorized Council officer any fat, offal or refuse liable to or in a state of putrescence.

(xxv) All horses or cattle must be removed from the market before noon of the day following the day of the sale.

(xxvi) No person shall use the truck washing bay installed at the Korumburra market or any hose, fitting or attachment connected thereto, without express permission of the Council in writing.

(xxvii) No person other than the auctioneer having charge of a particular sale or his clerks or the owner of the cattle or his authorized agent shall be permitted to use the selling rail during such time as such sale is in progress.

(xxviii) Any person, firm or Company guilty of a breach of this By-Law shall be liable for every such offence to a penalty not exceeding Forty Dollars.

(xxix) This By-Law shall apply to and have operation throughout the whole of the Shire of Korumburra and shall come into operation immediately after its publication in the *Victoria Government Gazette*.

The Resolution for passing this By-Law was agreed to by the Council of the Shire of Korumburra on the 17th day of July, 1968, and confirmed by the said Council on the 21st day of August, 1968.

The common seal of the President, Councillors and Ratepayers of the Shire of Korumburra was hereto affixed, this 21st day of August, 1968.

(SEAL)  
4543 R. ATTENBOROUGH, President.  
S. A. GREAVES, Councillor.  
W. O. CLARK, Secretary.

#### SHIRE OF MARONG.

##### LOAN No. 20.

*Notice of Intention to Borrow the Sum of \$29,000 for Permanent Works and Undertakings.*

NOTICE is hereby given that the Council of the Shire of Marong proposes to borrow the principal sum of \$29,000 secured by a charge over the general rates of the municipality, such sum to be raised by the grant of a mortgage in accordance with the provisions of the *Local Government Act 1958*.

1. The maximum rate of interest that may be paid is 5.5 per cent. per annum.

2. The purpose for which the loan is to be applied is purchase of road making machinery as follows:—

|                                 |    |          |
|---------------------------------|----|----------|
| (a) one heavy duty power grader | .. | \$18,200 |
| (b) one front end loader        | .. | \$7,400  |
| (c) one tractor                 | .. | \$3,400  |

3. The period of the loan shall be six years.

4. The moneys borrowed shall be repayable by providing out of the municipal fund half-yearly instalments of approximately \$2,870 each, including principal and interest on the first day of June and the first day of December during the currency of the loan. The first instalment shall be payable on the first day of June, 1969.

5. Such moneys shall be repayable to the Commissioners of the State Savings Bank of Victoria at the office of the said Commissioners, corner Elizabeth and Bourke streets, Melbourne.

The plans and specifications and the estimate of the cost of the proposed works and a statement showing the proposed expenditure of the moneys to be borrowed are open for inspection at the office of the Council of the Shire of Marong, at Marong.

Dated 4th September, 1968.

4600 ROSS M. GRAHAM, Shire Secretary.

#### SHIRE OF OTWAY.

LOAN No. 18.

*Notice of Intention to Borrow.*

NOTICE is hereby given that the Council of the Shire of Otway intends to borrow the sum of \$40,000 (Forty Thousand Dollars) on the credit of the municipal revenues of the President, Councillors and Ratepayers of the said Shire, such sum to be raised by grant of mortgage, in accordance with the said Acts and states:—

1. The amount of principal moneys it is proposed to borrow is \$40,000.

2. The maximum rate of interest that may be paid is 5.75 per centum per annum.

3. The period of the loan shall be for ten years and the time or times at which the moneys borrowed are to be repayable on the 1st day of December and the 1st day of June in each year during the currency of the loan, commencing on the 1st day of June, 1969. The place of repayment will be the Commercial Bank of Australia Limited, Melbourne.

4. The purpose for which the loan is to be applied is for permanent works and undertakings, viz.:

Construction of roads and streets in the Townships of Wye River and Separation Creek.

5. The loan is to be liquidated by half-yearly payments of approximately \$2,656 including principal and interest, payable out of the Municipal Fund.

Plans and specifications and an estimate of the cost of such works and undertakings, and a statement showing the proposed expenditure of the moneys to be borrowed, are open for inspection by ratepayers during office hours, at the Shire Office, Beech Forest, for one month after publication of this notice.

Dated at Beech Forest, this 21st day of August, 1968.

4562 T. J. FRY, Shire Secretary.

*Town and Country Planning Act 1961.*

#### SHIRE OF SEYMOUR.—SHIRE OF SEYMOUR PLANNING SCHEME 1965.

NOTICE THAT A PLANNING SCHEME HAS BEEN PREPARED AND IS AVAILABLE FOR INSPECTION.

*Amendment No. 2, 1968.*

NOTICE is hereby given that the Shire of Seymour, in pursuance of its powers under the *Town and Country Planning Act 1961*, has prepared a Planning Scheme for the Shire of Seymour for the following purpose:—

1. To rezone lot No.'s 35 and 36 of lodged plan No. 25278, commencing 268 ft. 11 in. north-west of Keith-street in Anzac-avenue, Seymour, from Public Purposes Proposed (Local Government) to Commercial Local; in accordance with the *Town and Country Planning Act 1961*, and determines that the date of commencement of the preparation of such planning scheme shall be the 9th day of September, 1968.

A copy of the scheme has been deposited at the Shire Office, Seymour, and at the office of the Town and Country Planning Board, 179 Queen-street, Melbourne, and will be open for inspection during office hours by any person free of charge.

Any persons affected by the planning scheme are required to set forth, in writing, all objections they may have, addressed to the Shire Secretary, Shire Office, Seymour, on or before 11th December, 1968, and state whether they wish to be heard in respect of their objections.

4545 A. W. HALL, Shire Secretary.

#### SHIRE OF STAWELL.

ORDER DECLARING PUBLIC HIGHWAY.

IN pursuance of the powers conferred by section 522 of the *Local Government Act 1958*, the Council of the Shire of Stawell doth hereby order:—

That the lands hereinafter described, which have been acquired by it shall be public highways, viz.:

All that piece of land being parts of Crown allotment 4A, Parish of Bellemen, as described in certificates of title, volume 8692, folio 067, and volume 8692, folio 068.

All that piece of land being part of Crown allotment 80, Parish of Riachella, as described in certificate of title, volume 8692, folio 069.

The common seal of the President, Councillors and Ratepayers of the Shire of Stawell was hereto affixed this 4th day of June, 1968, in the presence of—

(SEAL) E. J. WEAN, President.  
F. H. THOMSON, Councillor.  
V. C. NIELSEN, Secretary.

4560

#### SHIRE OF VIOLET TOWN.

LOAN No. 23.

(Re-Advertized)

*Notice of Intention to Borrow the Sum of \$23,000 for Permanent Works and Undertakings.*

NOTICE is hereby given that the Council of the Shire of Violet Town proposes to borrow the principal sum of Twenty-three thousand dollars, secured by a charge over the general rates of the municipality, such sum to be raised by the grant of a mortgage in accordance with the provisions of the *Local Government Act 1958*.

1. The maximum rate of interest that may be paid is 5.5 per centum per annum.

2. The purpose for which the loan is to be applied is the purchase of a Grader—\$23,000.

3. The period of the loan shall be five years.

4. The moneys borrowed shall be repayable by providing out of the municipal fund half-yearly instalments of \$2,662.01 each, including principal and interest, on the 1st day of May and the 1st day of November, during the currency of the loan. The first instalment shall be payable on the 1st day of May, 1969.

5. Such moneys shall be repayable at the National Bank Savings Bank Limited, Melbourne.

The plans and specifications and the estimate of the cost of the proposed works and a statement showing the proposed expenditure of the moneys to be borrowed, are open for inspection at the office of the Council of the Shire of Violet Town at the Shire Office, Lily-street, Violet Town.

4549 T. R. RICHARDSON, Shire Secretary.

NOTICE is hereby given that the partnership heretofore subsisting between Clifford Norman Reed, Ronald Arthur Reed and Robert Maxwell Reed carrying on business as farmers and graziers at Delegate River, under the style or firm name of C. N. Reed & Sons has been dissolved as from the 30th day of June, 1968.

Dated the 30th day of June, 1968.

C. N. REED.  
R. A. REED.  
R. M. REED.

4531

NOTICE is hereby given that the partnership heretofore subsisting between Medija Velija and the undersigned Barica Velija both formerly of 7 Francis-street, Glenroy, but now of 11 Francis-street, Glenroy, carrying on a brick-laying business and activities incidental thereto has been dissolved by notice dated the 28th day of August, 1968, whereby the undersigned retired from the said partnership. All debts due to and owing by the said partnership are required to be received and paid by the said Medija Velija who will continue to carry on the said business.

Dated the 30th day of August, 1968.

4539

BARICA VELLIJA.

NOTICE is hereby given that the partnership subsisting between Gerald George Brown, known also as Jerry George Brown, and Robert Ian Maclean, carrying on business as automotive retailers at Centre Dandenong-road, Braeside (and formerly at 150 White-street, Mordialloc), under the style or firm of New Form Auto Laundry has been dissolved, as from or about the 4th day of October, 1967, by notice given by the said Gerald George Brown to the said Robert Ian Maclean. All debts due to and

owing by the said firm will be received and paid respectively by the said Robert Ian Maclean who will continue to carry on the said business under the style or firm of New Form Auto Laundry.

MADDOCK, LONIE & CHISHOLM, solicitors, 339 Collins-street, Melbourne. 4591

The Companies Act 1961.—In the matter of ANTHONY L. LIDDY PTY. LTD. (in Liquidation).

NOTICE is hereby given that pursuant to section 272 of the Companies Act a Final Meeting of the Members and Creditors of the above company will be held at the offices of K. D. Courtney and Son, 505 Bourke-street, Melbourne, on Monday, 28th October, 1968, at 10.30 a.m.

Business.—To receive the liquidator's final accounts.

Dated this 9th day of September, 1968.

KEVIN FRANCIS COURTNEY, Liquidator.  
K. D. Courtney & Son, 505 Bourke-street, Melbourne. 4606

The Companies Act 1961.

AI CONSOLIDATED GOLD NO LIABILITY.

PURSUANT TO SECTION 260 OF THE COMPANIES ACT 1961.

NOTICE is hereby given that a Meeting of Creditors of AI Consolidated Gold No Liability will be held at Room 311, Third Floor, East Tower, Princes Gate, 151 Flinders-street, Melbourne, on Wednesday, the 2nd day of October, 1968, at 2 o'clock in the afternoon for the purpose of considering the company's affairs, the company having convened an Extraordinary General Meeting of its Members to be held on the same day and for the purpose of considering and if thought fit passing a Special Resolution that the company be wound up voluntarily.

Dated this 9th day of September, 1968.

K. H. GRANT, Secretary.  
Grant & Falk, 18 Queen-street, Melbourne, Victoria. 4615

In the matter of R.S.S.W. PTY. LTD.—Notice of Winding-up Order.

WINDING-UP Order made the 28th day of August, 1968.

Name and address of Official Liquidator, John Kenneth Hall, of 260 Queen-street, Melbourne.

JAMES CANNY, Deputy Commissioner of Taxation of the Commonwealth of Australia, petitioner. 4616

In the matter of AUSTRALITE TRAVEL GOODS CO. PROPRIETARY LIMITED.—Notice of Winding-up Order.

WINDING-UP Order made the 26th day of August, 1968.

Name and address of Official Liquidator, John Charles Couzens, of 527 Collins-street, Melbourne.

JAMES CANNY, Deputy Commissioner of Taxation of the Commonwealth of Australia, petitioner. 4617

In the matter of ROBERT MALTUS PROPRIETARY LIMITED.—Notice of Winding-up Order.

WINDING-UP Order made the 30th day of August, 1968.

Name and address of Official Liquidator, Bruce Edward Fordham, 170 Toorak-road, South Yarra.

JAMES CANNY, Deputy Commissioner of Taxation of the Commonwealth of Australia, petitioner. 4618

In the matter of the Co-operative Housing Societies Act 1958, and the Companies Act 1961; and in the matter of FRANKSTON CO-OPERATIVE HOUSING SOCIETY LIMITED (in liquidation).—Notice to Creditors.

NOTICE is hereby given that all persons having any claim against the above society are required, on or before, the 2nd day of October, 1968, to send their names and addresses and particulars of their debts or claims to Edward Ernest Shepard and Arthur Alexis Blaikie Webster, the liquidators of the said society, at their office and if so required by notice, in writing, from the said liquidators are personally, or by their solicitors, to come in and prove their said debts or claims at such time and place as shall be specified in such notice; or, in default thereof, they shall be excluded from the benefit of any distribution made before such debts or claims are so lodged or proved.

Dated at Frankston this 7th day of September, 1968.

E. E. SHEPARD, Liquidator.  
A. A. B. WEBSTER, Liquidator. 4553

In the Supreme Court of Victoria.—1968 No. Coy. 7577.—In the matter of the Companies Act 1961; and in the matter of CONTINENT OF AUSTRALIA INSURANCE COMPANY LIMITED.

NOTICE is hereby given that a petition for the winding up of the above-named company by the Supreme Court was, on the 3rd day of September, 1968, presented by C.I.L. Brokerage (N.S.W.) Pty. Limited and that the said petition is directed to be heard before the Court, sitting at Melbourne, at the hour of 10.30 a.m., on the 30th day of September, 1968; and any creditor or contributory of the said company desiring to support or oppose the making of an order on the said petition may appear at the time of hearing by himself or his counsel for that purpose; and a copy of the petition will be furnished to any creditor or contributory of the said company requiring the same by the undersigned on payment of the regulated charge for the same.

The petitioner's address is 572 Princes Highway, Rockdale, New South Wales.

The petitioner's solicitors are Messrs. Hedderwick Fookes & Alston, of 103 William-street, Melbourne.

HEDDERWICK FOOKES & ALSTON.

NOTE.—Any person who intends to appear on the hearing of the said petition must serve on or send by post to the above named Messrs. Hedderwick Fookes & Alston, notice, in writing, of his intention so to do. The notice must state the name and address of the person, or, if a firm, the name and address of the firm, and must be signed by the person or firm, or his or their solicitor (if any), and must be served, or, if posted, must be sent by post in sufficient time to reach the above named not later than Four o'clock in the afternoon of the 27th day of September, 1968. 4625

Companies Act 1961. Section 272 (2).

HATCRAFT PROPRIETARY LIMITED (IN VOLUNTARY LIQUIDATION).

NOTICE OF FINAL MEETING OF MEMBERS.

NOTICE is hereby given that the above meeting will be held at 95 Queen-street, Melbourne, on the 15th October, 1968, at 11 a.m.

The object of this meeting is to submit the liquidator's final accounts, showing how the winding up has been conducted and the property of the company has been disposed and to give any explanation thereof.

Dated this 5th day of September, 1968.

4621 P. C. SIMMONS, Liquidator.

In the Supreme Court of Victoria.—1968 Co. No. 7580.—In the matter of Part X. of the Companies Act 1961; In the matter of a Petition for the Winding Up of ZEROTEX INVESTMENTS PTY. LTD.

NOTICE is hereby given that a petition for the winding up of the above-named company by the Supreme Court was on the 6th day of September, 1968, presented by Freighter-Hino Pty. Ltd.: And that the said petition is directed to be heard before the Court sitting at Melbourne at the hour of 10.30 o'clock in the forenoon on the 27th day of September, 1968, and any creditor or contributory of the said company desiring to support or oppose the making of an order on the said petition may appear at the time of hearing by himself or his counsel for that purpose; and a copy of the petition will be furnished to any creditor or contributory of the said company requiring the same by the undersigned on payment of the regulated charge for the same.

The petitioner's address is Warrigal-road, Moorabbin.

The petitioner's solicitors are Arthur Robinson & Co., of 447 Collins-street, Melbourne.

ARTHUR ROBINSON & CO.

NOTE.—Any person who intends to appear on the hearing of the said petition must serve on or send by post to the above-named Arthur Robinson & Co., notice, in writing, of his intention so to do. The notice must state the name and address of the person, or, if a firm, the name and address of the firm, and must be signed by the person or firm, or his or their solicitor (if any), and must be served or if posted, must be sent by post in sufficient time to reach the above named not later than Four o'clock in the afternoon of the 26th day of September, 1968.

ARTHUR ROBINSON & CO., solicitors, 447 Collins-street, Melbourne. 4619

## Unclaimed Moneys Act 1962.

**R**EGISTER of Unclaimed Moneys held by the—

| Name of Owner on Books and Last Known Address.                         | Total Amount Due to Owner. | Description of Unclaimed Money. | Date when Amount first became Payable. |
|--|----------------------------|---------------------------------|--|
| <b>S</b>   |                            |                                 |  |
| <b>H. B. DICKIE LTD.</b>   |                            |                                 |  |
| West, Edna (Mrs.), 10 Cook-crescent, Newnham, Launceston, Tas.<br>4537 | 21.47                      | Wages .. .. .                   | 9.4.64                                 |

In the Supreme Court of Victoria.—1968 Co. No. 7579.—  
In the matter of Part X. of the Companies Act 1961;  
In the matter of a Petition for the Winding Up of  
SPECIALISED INTERSTATE FREIGHTERS PTY. LTD.

NOTICE is hereby given that a petition for the winding up of the above-named company by the Supreme Court was on the 6th day of September, 1968, presented by Freighter-Hino Pty. Ltd.: And that the said petition is directed to be heard before the Court sitting at Melbourne at the hour of 10.30 o'clock in the forenoon on the 27th day of September, 1968, and any creditor or contributory of the said company desiring to support or oppose the making of an order on the said petition may appear at the time of hearing by himself or his counsel for that purpose; and a copy of the petition will be furnished to any creditor or contributory of the said company requiring the same by the undersigned on payment of the regulated charge for the same.

The petitioner's address is Warrigal-road, Moorabbin.

The petitioner's solicitors are Arthur Robinson & Co., of 447 Collins-street, Melbourne.

ARTHUR ROBINSON & CO.

NOTE.—Any person who intends to appear on the hearing of the said petition must serve on or send by post to the above-named Arthur Robinson & Co., notice, in writing, of his intention so to do. The notice must state the name and address of the person, or, if a firm, the name and address of the firm, and must be signed by the person or firm, or his or their solicitor (if any), and must be served or if posted, must be sent by post in sufficient time to reach the above named not later than Four o'clock in the afternoon of the 26th day of September, 1968.

ARTHUR ROBINSON & CO., solicitors, 447 Collins-street, Melbourne. 4520

The Companies Act 1961.—In the matter of HAMPTON INVESTMENTS PROPRIETARY LIMITED (in Voluntary Liquidation).—Notice of Final Meeting.

NOTICE is hereby given that, pursuant to section 272 of the Companies Act, a General Meeting of Members of the above company will be held at the Fifth Floor, 395 Collins-street, Melbourne, on Tuesday, 15th October, 1968, at 11 a.m. for the purpose of laying before the meeting an account showing how the winding up has been conducted and the property of the company disposed of and hearing any explanation required to be given.

Dated this 3rd day of September, 1968.

4599 B. W. B. RUFFELS, Liquidator.

The Companies Act 1961.—In the matter of J. T. RING PTY. LIMITED.

NOTICE is hereby given that a First and Final Dividend is intended to be declared in this matter. Creditors who have not proved their debts by the 26th day of September, 1968, will be excluded from the Dividend.

Dated this 3rd day of September, 1968.

E. R. SMAIL, Liquidator.

Kennedy, Smail & Middlemiss, 296-300 Little Lonsdale-street, Melbourne, 3000. 4581

The Companies Act 1961.—In the matter of SPACE CONFECTIONERY PROPRIETARY LIMITED.

NOTICE is hereby given that a Second and Final Dividend is intended to be declared in this matter. Creditors who have not proved their debts by the 26th day of September, 1968, will be excluded from the Dividend.

Dated this 3rd day of September, 1968.

A. M. HORSBURGH, Liquidator.

Kennedy, Smail & Middlemiss, 296-300 Little Lonsdale-street, Melbourne, 3000. 4582

EDMESTON INVESTMENTS PTY. LIMITED.

(IN VOLUNTARY LIQUIDATION).

NOTICE CONVENING FINAL MEETING.

NOTICE is hereby given pursuant to section 272 (2) of the Victorian Companies Act 1961 that a General Meeting of members of the above company will be held at the offices of Alexander and Spencer, 94 Elizabeth-street, Melbourne, on Wednesday, 16th October, 1968, commencing 10 a.m., for the purpose of having an account laid before them showing the manner in which the winding up has been conducted and the property of the company disposed of, and of hearing any explanation that may be given by the liquidator.

Dated this 6th day of September, 1968.

4595 L. E. ALEXANDER, Liquidator.

The Companies Act 1961.

ALMA INVESTMENTS PTY. LTD.

(IN VOLUNTARY LIQUIDATION).

NOTICE OF GENERAL MEETING OF SHAREHOLDERS PURSUANT TO SECTION 272.

NOTICE is hereby given that the Final General Meeting of Shareholders of Alma Investments Pty. Ltd. (in Voluntary Liquidation) will be held at the office of Miller, Hannaker and Middleton, 11 Bank-place, Melbourne, on Thursday, 17th October, 1968, at 2.15 p.m.

The object of the meeting is to consider an account by the liquidator showing how the winding up has been conducted and the assets of the company disposed of, and for the giving of any explanations thereof.

Dated this 11th day of September, 1968.

A. K. Miller, liquidator, 11 Bank-place, Melbourne. 4541

The Companies Act 1961.

MARJEL PTY. LTD. (IN VOLUNTARY LIQUIDATION).

NOTICE is hereby given that a General Meeting, being the Final Meeting of the members of the above-named company will be held at 229 Exhibition-street, Melbourne, on the 15th day of October, 1968, at 3 o'clock in the afternoon.

The object of the meeting is the presentation by the liquidator of an account of the winding up of the company and the disposal of the assets of the company.

4533 A. DOUGLAS, Liquidator.

BERITA PTY. LIMITED.

NOTICE OF MEETING.

NOTICE is hereby given that an Extraordinary General Meeting of Members of Berita Pty. Limited will be held at 4 Wannon-court, Toorak, on the 13th day of September, 1968, at 8 p.m., when the following Resolution will be proposed as a Special Resolution of the company:—

RESOLUTION.

That the company be wound up voluntarily and that James Manson Poulton, of 447 Collins-street, Melbourne, be appointed liquidator for the purpose of winding up, and that he be authorized at the expense of the company to do all things he may consider necessary in connexion with the winding up including the employment and remuneration of servants and agents and the distribution in specie amongst the contributors of the company of the whole or any part of its assets remaining after the liabilities of the company have been paid or secured. If thought expedient, any such distribution may be otherwise than in accordance with the legal rights of the contributors and in particular any class may be given preferential or special rights or may be excluded altogether or in part.

4603 J. M. HILLIARD, Secretary.

GWENLEAN (also known as Gwenyloan) THOMAS, late of 4 Beryl-street, Burwood, spinster, DECEASED.

CREDITORS, next of kin and others having claims in respect of the estate of the deceased (who died on the 16th day of July, 1968), are required by the applicant for grant of probate of the will of the deceased, John Winnell Thomas, of 4 Beryl-street, Burwood, retired, to send particulars to him, care of the undersigned solicitors, by the 20th November, 1968, after which date he may convey or distribute the assets, having regard only to the claims of which he then has notice.

Dated 6th September, 1968.

LEWIS, ORR & GIBSON, 825 Burke-road, Camberwell.  
4571

ETHEL ELIZABETH HART, late of Glengollan Village, 91 Underwood-road, Ferntree Gully, widow, DECEASED.

CREDITORS, next of kin and others having claims in respect of the estate of the deceased (who died on 26th June, 1968), are required by the applicant for grant of probate of the will of the deceased, Leslie John Hiscock, of 28 Walpole-street, Kew, retired bank manager, to send particulars to him, care of the undersigned solicitors, by the 6th November, 1968, after which date he may convey or distribute the assets, having regard only to the claims of which he then has notice.

Dated 6th September, 1968.

LEWIS, ORR & GIBSON, 825 Burke-road, Camberwell.  
4572

ALICE MAUD PEDDER, late of Greenhills Private Hospital, Loch, home duties, DECEASED.

CREDITORS, next of kin and others having claims in respect of the estate of the deceased (who died on 6th day of July, 1968), are required by The Perpetual Executors and Trustees Association of Australia Limited, of 100-104 Queen-street, Melbourne, to send particulars of their claims to the said company, by 13th day of November, 1968, after which date it will convey or distribute the assets, having had regard only to the claims of which the company then has notice.

4575

CREDITORS, next of kin and others having claims in respect of the estate of Gertrude Elizabeth Cole, late of 34 Abbott-street, Sandringham, married woman, deceased (who died on the 3rd day of May, 1968), are required to send particulars of their claims to National Trustees, Executors and Agency Company of Australasia Limited, of 46-48 Queen-street, Bendigo, and George Percival Cole, of 34 Abbott-street, Sandringham, shoe repairer, the executors of the will of the said deceased, by the 19th day of November, 1968, care of the above-mentioned company, after which date they will distribute the assets, having regard only to the claims of which they then have notice.

HERBERT, GEER & RUNDLE, solicitors, 612-614 Balcombe-road, Black Rock.  
4576

CREDITORS, next of kin and others having claims against the estate of William Joseph Wilton, late of 51 Wyona-avenue, West Rosebud, gentleman, deceased (who died on the 10th day of January, 1968), are required to send particulars of their claims to the executor, Gordon William Wilton, care of J. A. Redmond and Co., solicitors, 358 Collins-street, Melbourne, by the 11th day of November, 1968, after which date the executor will distribute the assets of the deceased, having regard only to the claims which he then has notice.

J. A. REDMOND & CO., solicitors, 358 Collins-street, Melbourne.  
4577

JOHN PATRICK HOARE, formerly of 259 Barker-street, Castlemaine, but late of 31 Candy-street, Westgarth, public servant, DECEASED.

CREDITORS, next of kin and others having claims in respect of the estate of the deceased (who died on the 17th day of July, 1968), are required by the legal personal representative of the estate of the deceased, namely Marie Patricia Hoare, of 5 Freeman-street, Castlemaine, to send particulars of such claims to her care of the under-mentioned solicitors, by the 14th day of November, 1968, after which date the said legal personal representative may convey or distribute such assets, having regard only to the claims of which she then has notice.

Dated the 5th day of September, 1968.

H. S. W. LAWSON & CO., solicitors, 38 Lyttleton-street, Castlemaine.  
4552

ANNIE JORDAN DOUGLAS, late of "Ellerslie", 16 Harcourt-street, Hawthorn East, in the State of Victoria, widow, DECEASED (who died on the 25th February, 1968).

CREDITORS, next of kin and others having claims against the estate of the deceased are required by the executors The Union-Fidelity Trustee Company of Australia Limited, of 100 Exhibition-street, Melbourne, in the said State, Percy Chamberlain Thompson, of 140 Punch Bowl-road, Launceston, in the State of Tasmania, retired, and Geoffrey William Thompson of 138 Punch Bowl-road, Launceston, in the State of Tasmania, manager, to send particulars of their claims to the executors, care of the undersigned solicitors on or before the 15th November, 1968, after which date they will distribute the assets, having regard only to the claims of which they then have notice.

HOME, WILKINSON & LOWRY, solicitors, of 401 Collins-street, Melbourne.  
4614

CREDITORS, next of kin and others having claims against the estate of Heather May Shearing, late of 21 Goodwood-drive, Springvale, home duties, deceased (who died on the 24th day of March, 1968), are required to send particulars of their claims to the executrix, Yvonne Grant, care of J. A. Redmond and Co., solicitors, 358 Collins-street, Melbourne, by the 11th day of November, 1968, after which date the executrix will distribute the assets of the deceased, having regard only to the claims which she then has notice.

J. A. REDMOND & CO., solicitors, 358 Collins-street, Melbourne.  
4578

LILY MARTIN KELLET, late of 3 Rockbeare-grove, Ivanhoe, spinster, DECEASED.

CREDITORS, next of kin and others having claims in respect of the estate of the deceased (who died on the 7th day of June, 1967), are required by the trustee, Pauline Lazarus, of 76 Spencer-street, Melbourne, solicitor, to send particulars to her, by the 14th day of November, 1968, after which date the trustee may convey or distribute the assets, having regard only to the claims of which she then has notice.

Dated the 11th day of September, 1968.

LOUIS S. LAZARUS, of 76 Spencer-street, Melbourne, proctor for the applicant.  
4579

GEORGE SINCLAIR ANDERSON CLYNE, late of Maffra, in the State of Victoria, grazier, DECEASED.

CREDITORS, next of kin and others having claims in respect of the estate of the above-named deceased (who died on the 10th August, 1936), are required by the trustees, Robert Hatch, of 69 Johnson-street, Maffra, solicitor, and Arthur Lawrence Smith, of Flat 5, 12 Errard-street south, Ballarat, retired bank officer, to send particulars to them, care of the under-mentioned solicitors, by the 19th November, 1968, after which date they may convey or distribute the assets, having regard only to the claims of which they then have notice.

SEMMENS, HATCH & ANDERSON, solicitors, Maffra.  
4592

CREDITORS, next of kin and others having claims in respect of the estate of John Phillips, late of Watgania, via Willaura, retired grazier, deceased (who died on 8th March, 1968), are required by The Union-Fidelity Trustee Company of Australia Limited, of 101 Lydiard-street north, Ballarat, the executor of the will of the said deceased, to send particulars, in writing, of their claims to the said company, at its above address, on or before the 11th day of November, 1968, after which date it will distribute the assets, having regard only to the claims of which it then has notice.

BRUCE R. TIVEY, solicitor, Ararat.  
4593

ELSIE MCCLELLAND, late of Flat 2, 15 Mangan-street, Balwyn, widow, DECEASED.

CREDITORS, next of kin and others having claims in respect of the estate of the deceased (who died on the 12th March, 1968), are required to send particulars of their claims to NATIONAL TRUSTEES, EXECUTORS AND AGENCY COMPANY OF AUSTRALASIA LIMITED, of 95 Queen-street, Melbourne, by the 15th day of November, 1968, after which date the said National Trustees, Executors and Agency Company of Australasia Limited will distribute the assets, having regard only to the claims of which it then has notice.

F. J. CORDER & CO., solicitors, 358 Lonsdale-street, Melbourne.  
4589



CECIL JOSEPH McFEELY, late of Damum, Victoria, welder, DECEASED.

CREDITORS, next of kin and others having claims in respect of the estate of the deceased (who died on the 5th May, 1968), are required by the executor, Albert James Surplice, of 16 William-street, Fawkner, maintenance engineer, to send particulars of such claims to the executor care of the under-mentioned solicitor, by the 18th day of November, 1968, after which date the executor may distribute the assets, having regard only to the claims of which he then has notice.

B. T. E. FLYNN, [LL.B.], solicitor, 125 Bell-street, Coburg. 4554

FREDERICK CHARLES O'BRIEN, late of 508 Talbot-street south, Ballarat, postal officer, DECEASED (who died on the 28th January, 1968).

CREDITORS, next of kin and all persons having claims against the estate of the deceased are required to send particulars to the executor, The Union-Fidelity Trustee Company of Australia Limited, of 101 Lydiard-street north, Ballarat, on or before the 12th November, 1968, after which date it will distribute the assets, having regard only to the claims of which it shall then have notice. 4555

AFTER fourteen clear days application will be made to the Supreme Court of Victoria that Probate of the Will dated the 6th day of December, 1965, of Alma Frederica Gertrude Cloonan, late of Montgomery-crescent, White Hills, in the State of Victoria, married woman, deceased, be granted to Kevin Daniel Cloonan, of Mead-street, Cohuna, in the said State, engineer, and Brian William Cloonan, of Tinamba-road, Maffra, in the said State, farmer, the executors appointed by the said will.

WATSON, JAMES & ROGERS, solicitors, 61 Bull-street, Bendigo. 4563

CREDITORS, next of kin and other persons having claims against the estate of Gerald Joseph Kennedy, late of Lisfarron, Broadway-street, Cobram, medical practitioner, deceased (who died on the 26th day of December, 1967), are requested to send particulars of their claims to the executor, National Trustees, Executors and Agency Company of Australasia Limited, whose registered office is situate at 95 Queen-street, Melbourne, by the 30th November, 1968, after which date the executor will distribute the assets, having regard only for the claims of which it then has notice.

JOHN W. CASSIDY, solicitor, Station-street, Cobram. 4564

HERBERT JOHN BRERETON, late of Swan Hill, in the State of Victoria, salesman, DECEASED (who died on the 1st June, 1968).

CREDITORS, next of kin and all other persons having claims against the estate of the deceased are required by the executors of the will, Violet Susan Brereton and John David Brereton, to send particulars of their care of the undersigned, on or before, the 4th day of December, 1968, after which date they will distribute the assets, having regard only to the claims of which they then have notice.

GARDEN & GREEN, solicitors, 4 McCallum-street, Swan Hill. 4567

CREDITORS, next of kin and others having claims in respect of the estate of Florence Fricke, late of 85 Belford-road, North Kew, widow, deceased (who died on 29th June, 1968), are to send particulars of their claims to the executor, The Trustees, Executors and Agency Company Limited, at 401 Collins-street, Melbourne, by 20th November, 1968, after which date it will distribute the assets, having regard only to the claims of which it then has notice.

PEARCE & WEBSTER, solicitors, 430 Little Collins-street, Melbourne. 4590

WILLIAM REGINALD CAVE, late of 49 Price-street, Essendon, in the State of Victoria, retired company manager, DECEASED.

CREDITORS, next of kin and others having claims in respect of the estate of the deceased (who died on the 5th day of July, 1968), are required by The Trustees, Executors and Agency Company Limited, of 401 Collins-street, Melbourne, to send particulars of their claims to the said company, by the 11th day of November, 1968, after which date they will convey or distribute the assets, having regard only to claims of which the company then has notice.

WEIGALL & CROWTHER, solicitors, 83 William-street, Melbourne. 4574

CREDITORS, next of kin and others having claims in respect of the estate of Wallace Edwin Mitchell, late of 75 Shady-grove, Forest Hill, linesman, deceased (who died on the 19th day of September, 1967), are required by the executrix, Olive Martha Mitchell, of 75 Shady-grove, Forest Hill, widow, to send particulars of their claims to her, care of Messrs. Rogers & Gaylard, of 281 Collins-street, Melbourne, by the 3rd day of October, 1968, after which date the said executrix will distribute the assets of the deceased, having regard only to claims of which she then shall have had notice.

ROGERS & GAYLARD, solicitors, of 281 Collins-street, Melbourne. 4580

CREDITORS, next of kin and others having claims in respect of the estate of Anna Helena Elizabeth Christina Williams, late of 6 Thomas-street, Yarraville, widow, deceased (who died on the 8th day of June, 1968), are required by the executor, National Trustees, Executors and Agency Company of Australasia Limited, of 95 Queen-street, Melbourne, to send particulars to it, at 95 Queen-street, Melbourne, by the 18th day of November, 1968, after which date it will distribute the assets of the deceased, having regard only to the claims of which it then shall have notice.

JOHN GINNANE, solicitor, 153A Barkly-street, Footscray. 4584

CREDITORS, next of kin and others having claims in respect of the estate of Louisa Bishop, late of 34 Bambra-road, Caulfield, in the State of Victoria, music teacher, deceased (who died on the 19th day of June, 1968), are required by the executors, Frank Hansford Bishop, of 17 Killarney-street, Mosman, in the State of New South Wales, manufacturer, and Maxwell Harry Joseph, of 118 Queen-street, Melbourne, solicitor, to send particulars of their claims to them, care of Strongman & Crouch, solicitors, of 118 Queen-street, Melbourne, by the 15th day of November, 1968, after which date the said executors will distribute the assets of the deceased, having regard only to the claims of which they then shall have had notice.

STRONGMAN & CROUCH, solicitors, of 118 Queen-street, Melbourne. 4585

CREDITORS, next of kin and others having claims in respect of the estate of Fanny Pearl Fletcher, late of "Sunnyside", Mount Dandenong-road, Montrose, widow, deceased (who died on the 30th May, 1968), are to send particulars of their claims to Ronald Noel Fletcher, care of the under-mentioned solicitors, by the 20th November, 1968, after which date he will distribute the assets, having regard only to the claims of which he then has notice.

CORR & CORR, solicitors, 290 Latrobe-street, Melbourne. 4586

CREDITORS, next of kin and others having claims in respect of the estate of Richard Alfred Fletcher, late of "Sunnyside", Mount Dandenong-road, Montrose, retired, deceased (who died on the 3rd March, 1968), are to send particulars of their claims to Ronald Noel Fletcher, care of the under-mentioned solicitors, by the 20th November, 1968, after which date he will distribute the assets, having regard only to the claims of which he then has notice.

CORR & CORR solicitors, 290 Latrobe-street, Melbourne. 4587

EDITH ELSIE LOWE, late of 49 Waldemar-road, Heidelberg, in the State of Victoria, widow, DECEASED.

CREDITORS, next of kin and others having claims in respect of the estate of the said deceased (who died on the 1st day of December, 1967), are to send particulars of their claims to the executor of her will, namely John Charles Wright, at 49 Waldemar-road aforesaid, by the 1st day of December, 1968, after which date the said executor will distribute the assets in the said estate, having regard only to the claims of which he then has notice.

PAVEY, WILSON, COHEN & CARTER, solicitors, 390 Lonsdale-street, Melbourne. 4588

EULALIE MYRTLE CRIPPS, of 171 Royal-parade, Parkville, widow, DECEASED.

CREDITORS, next of kin and others having claims in respect of the estate of the deceased (who died on the 25th day of December, 1967), are required by National Trustees, Executors and Agency Co. of Australasia Ltd., of 95 Queen-street, Melbourne, to send particulars of their claims to the said company by the 18th day of November, 1968, after which date it will convey or distribute the assets, having regard only to the claims of which the company then has notice. 4612

**CREDITORS**, next of kin and others having claims in respect of the estate of Margaret Macleod, late of 104 Powlett-street, East Melbourne, in the State of Victoria, superfluous hair specialist, deceased (who died on the 6th day of June, 1968), are required by The Perpetual Executors and Trustees Association of Australia Limited, of 100-104 Queen-street, Melbourne, in the said State to send particulars of their claims to the said company by the 12th day of November, 1968, after which date it will convey or distribute the assets, having regard only to the claims of which the company then has notice.

K. P. REES, B.A., LL.B., barrister and solicitor, 89 Queen-street, Melbourne, 3000. 4613

**CREDITORS**, next of kin and others having claims in respect of the estate of Harry Morris, late of 6 Primrose-crescent, East Brighton, in the State of Victoria, retired builder, deceased (who died on the 17th day of June, 1968), are to send particulars of their claims to Winifred May Kidd, care of the under-mentioned solicitors, by the 11th day of November, 1968, after which date she will distribute the assets, having regard only to the claims to which she then has notice.

Dated this 3rd day of September, 1968.

REGINALD C. BUTLER & CO., solicitors, 312 Centre-road, Bentleigh. 4601

**CREDITORS**, next of kin and others having claims in respect of the estate of Frederick James Atkins, formerly of Trafalgar and 5 Clonmult-avenue, Highett, but late of 22 Rose-street, Highett, in the State of Victoria, formerly farmer, but then gentleman, deceased (who died on the 2nd day of February, 1968), are to send particulars of their claims to Reginald Charles Butler, care of the under-mentioned solicitors, by the 11th day of November, 1968, after which date he will distribute the assets, having regard only to the claims to which he then has notice.

Dated this 3rd day of September, 1968.

REGINALD C. BUTLER & CO., solicitors, 312 Centre-road, Bentleigh. 4602

AMY MARGARET BROWN, late of "Peniel", Sandells-road, Tecoma, widow, DECEASED.

**CREDITORS**, next of kin and others having claims in respect of the estate of the deceased (who died on the 9th day of June, 1968), are required by the executor, Donald Stuart Munro, of Bannockburn, farmer, to send particulars to him by the 12th day of November, 1968, after which date the executor may convey or distribute the assets, having regard only to the claims of which he then has notice.

Dated the 10th day of September, 1968.

OSWALD, BURT & CO., solicitors, 178 William-street, Melbourne. 4609

WILLIAM JAMES BURNELL NEWMAN, late of 2 Warra-street, Tallangatta, in the State of Victoria, motion picture exhibitor, DECEASED, intestate.

**CREDITORS**, next of kin and others having claims in respect of the estate of the deceased (who died on the 8th day of May, 1966), are required by the applicant for grant of administration, Marguerite Eulie Newman, then of 2 Warra-street, Tallangatta, aforesaid, widow, to send particulars to her at the under-mentioned address, by the 21st day of November, 1968, after which date the applicant for grant of administration may convey or distribute the assets, having regard only to the claims of which she then has notice.

Dated the 30th day of August, 1968.

TIETYENS, ANGEL & JACKLING, proctors for the administratrix, 541 Kiewa-street, Albury, N.S.W., 2640. 4536

PETER JOHN DAVID, late of Flat 7, 613 Inkerman-road, North Caulfield, in the State of Victoria, computer systems analyst, DECEASED.

**CREDITORS**, next of kin and others having claims in respect of the estate of the said deceased (who died on the 5th day of September, 1967), are required by the personal representative, Lance Francis David, of 1A St. Aubins-avenue, Caulfield, to send particulars to him by 15th November, 1968, after which date he may convey or distribute the assets, having regard only to the claims of which he then has notice.

HEDDERWICK, FOOKES & ALSTON, 103 William-street, Melbourne. 4611

ELIZABETH McDONALD, late of 23 Swanston-street, Geelong, spinster, DECEASED.

**CREDITORS**, next of kin and others having claims in respect of the estate of the said deceased (who died on 6th July, 1968), are required by the applicant for a grant of probate of the will, Ivan James Lewis, of 89 Myers-street, Geelong, solicitor, to send particulars to him care of the undersigned solicitors, by 13th November, 1968, after which date the said applicant may convey or distribute the assets, having regard only to the claims of which he then has notice.

WIGHTON & McDONALD, solicitors, 89 Myers-street, Geelong. 4547

WILLIAM MASON, late of Gillies-street, Ballarat, in the State of Victoria, storeman, DECEASED (who died on the 23rd June, 1968).

**CREDITORS**, next of kin and all other persons having claims against the estate of the said deceased are required by the executor, The Union-Fidelity Trustee Company of Australia Limited, of 100 Exhibition-street, Melbourne, to send detailed particulars of their claims to the said executor, care of the said company, at 101 Lydiard-street north, Ballarat, on or before the 11th day of November, 1968, after which date it will proceed to distribute the said estate, having regard only to the claims of which it then has notice.

Dated this 11th day of September, 1968.

RAMSAY, GAUNT & FRASER, solicitors, 41 Lydiard-street south, Ballarat, solicitors for the executor. 4542

VERA WATSON, late of 132 Yarra-street, Geelong, in the State of Victoria, spinster, DECEASED.

**CREDITORS**, next of kin and others having claims in respect of the estate of the deceased (who died on the 1st June, 1968), are required by the personal representative, Olive Ruth Holdaway, of 135 Myers-street, Geelong aforesaid, married woman, to send particulars to her, in care of the under-mentioned solicitors, by the 15th day of November, 1968, after which date the personal representative may convey or distribute the assets, having regard only to the claims of which she then has notice.

FREEMAN & FALLAW, solicitors, 64 Little Malop-street, Geelong. 4548

**CREDITORS**, next of kin and others having claims against the estate of Graeme William Walker, late of 23 Walker-street, Murrumbena, in the State of Victoria, brick layer, deceased (who died on the 13th day of December, 1967), are required to send particulars of their claims to the administratrix of the estate, Pauline Walker, care of the under-mentioned solicitors, before the 20th of November, 1968, after which date the said administratrix will distribute the estate of the said deceased having regard only to the claims of which she then has notice.

LESTER, PEARN & FIELDEN, solicitors, 14 Haughton-road, Oakleigh. 4540

**CREDITORS**, next of kin and all other persons having claims against the estate of Alexander Boldiston, late of 83 Archer-street, Shepparton, retired joiner, deceased (who died on 14th June, 1967), are required by the executors of the will, Thomas Charles Boldiston, of 10 Sheriff-street, Shepparton, carpenter, and Mary Boldiston, of 8 Robert-street, Willoughby, New South Wales, widow, to send particulars of such claims to them, care of the undersigned, on or before, the 7th November, 1968, after which date the executors will distribute the assets, having regard only to the claims of which they then have notice.

Dated the 23rd day of August, 1968.

RIORDAN & RIORDAN, solicitors, 26 Fryers-street, Shepparton. 4535

KAYE MARY DAVID, late of Flat 7, 613 Inkerman-road, North Caulfield, in the State of Victoria, widow, DECEASED.

**CREDITORS**, next of kin and others having claims in respect of the estate of the said deceased (who died on the 5th day of September, 1967), are required by the personal representative, Douglas Whiteford, of 24 Acland-street, St. Kilda, to send particulars to him by 15th November, 1968, after which date he may convey or distribute the assets, having regard only to the claims of which he then has notice.

HEDDERWICK, FOOKES & ALSTON, 103 William-street, Melbourne. 4610

**CREDITORS**, next of kin and others having claims against the estate of Chana Faiga Kotlarz, late of Flat 2, 60 Denbigh-road, Armadale, in the State of Victoria, finisher, deceased (who died on the 9th day of June, 1968), are required to send particulars of their claims to the executor of her will, Joseph Torbiner, care of the under-mentioned solicitors before the 10th day of November, 1968, after which date the said executor will distribute the estate of the said deceased, having regard only to the claims of which he then has notice.

J. OKNO & CO., solicitors, of 390 Lonsdale-street, Melbourne. 4607

EDITH LINKLATER, late of Flat 4, 76 Riversdale-road, Camberwell, widow, DECEASED.

**CREDITORS**, next of kin and others having claims in respect of the estate of the deceased (who died on the 18th day of July, 1968), are required by The Perpetual, Executors and Trustees Association of Australia Limited, of 100-104 Queen-street, Melbourne, to send particulars of their claims to the said company by the 16th day of November, 1968, after which date it will convey or distribute the assets, having had regard only to the claims of which the company then has notice.

HENDERSON & BALL, solicitors, 430 Little Collins-street, Melbourne. 4608

In the Supreme Court of the State of Victoria.  
SALE BY THE SHERIFF.

**ON** Tuesday, the 29th day of October, 1968, at 2 p.m., at the Police Station, Newstead (unless process be stayed or satisfied):—

*Firstly*.—All the estate and interest (if any) of Riva Pia Ellis, widow, of 223 Glenlyon-road, Brunswick, as a tenant-in-common in equal shares with Maria Mason, married woman, and Gina Parravicini, spinster, both of above address, in and to the land described in Crown grants, volume 2781, folio 009 and volume 2845, folio 921. These Crown allotments adjoin one another in Church-street, Newstead, about 50 yards south-east from the Newstead-Ballarat road, and are bounded on the north-east by Church-street and on the south-east by Racecourse-road, upon which is erected a single-story brick residential building divided into two self-contained apartments of four rooms each.

*Secondly*.—All the estate and interest (if any) of John Parravicini (known as John William Parry), tool maker, of 15 Gainsborough-road, Mentone, as proprietor of an estate in fee-simple in the land described in certificate of title, volume 6125, folio 920, comprising approximately 82 acres of hilly semi-cleared land. The property is situated immediately north of the Township of Newstead. The south-east corner of the property is about 12 chains north-west along a private road from its intersection with the Newstead-Maldon road, which intersection is close to the point where the Newstead-Maldon road crosses Mia Creek at McLaren's Bridge.

Terms: Cash only.  
K. R. VALE, Sheriff's Officer.  
Castlemaine, 10th September, 1968. 4604

In the Supreme Court of the State of Victoria.  
SALE BY THE SHERIFF.

**ON** Monday, the 21st of October, 1968, at 10.30 a.m., at the Police Station, Sunshine (unless process be stayed or satisfied):—

All the estate and interest (if any) of Marjam Djikic, of 44 Chelsey-street, Deer Park, labourer, as joint proprietor with Francesca Djikic, married woman, of an estate in fee-simple in the land described in certificate of title, volume 8099, folio 040, upon which is erected a bungalow and a shed known as No. 44, Chelsey-street, Deer Park.

Terms: Cash only.  
DAVID J. JOHNSTON, Sheriff's Officer.  
10th September, 1968. 4605

In the Supreme Court of the State of Victoria.  
SALE BY THE SHERIFF.

**ON** Friday, the 18th day of October, 1968, at Ten a.m., at the Police Station, Altona (unless process be stayed or satisfied):—

All the estate and interest (if any) of Frances Jean Ford, married woman, of 62 Romawi-street, Altona, as joint proprietor with James Ford, of an estate in fee-simple in the land described in certificate of title, volume 4666, folio 091, upon which is erected a dwelling-house known as No. 62 Romawi-street.

○

Registered mortgage No. 1021930 affects the said estate and interest.

Terms: Cash only.  
N. FROGLEY, Sheriff's Officer.  
6th September, 1968. 4573

**IMPOUNDINGS**

**BRANXHOLME**.—Impounded in Branhholme Pound.

1 woolly weather, back notch near ear, no visible brand  
2 woolly ewes, no visible brand  
1 woolly weaner, no visible brand

If not claimed and expenses paid, to be sold on 14th September, 1968.

V. LATHER,  
4534—\$2 Poundkeeper.

**BROADMEADOWS**.—Impounded in Campbellfield Pound.

1 bay mare, 13 hands, black points, no visible brand  
1 white nanny goat, no visible brand  
1 pet lamb, with dog chain attached, yellow paint mark on back

If not claimed and expenses paid, to be sold on 26th September, 1968.

G. SCHNEIDER,  
4598—\$2.25 Poundkeeper.

**CRESWICK**.—Impounded in Creswick Pound, by Ranger T. Flynn, on 5th September, 1968.

1 Jersey steer, no visible brand

If not claimed and expenses paid, to be sold on 3rd October, 1968.

JEAN McNICOL,  
4626—\$1.75 Poundkeeper.

**ORBOST**.—Impounded in Orbost Pound.

1 black heifer, about 18 months old, notch bottom of right ear, no visible brand

If not claimed and expenses paid, to be sold on 25th September, 1968.

H. DOMINEY,  
4551—\$1.75 Poundkeeper.

**UPWEY**.—Impounded in Upwey Pound, by Shire Ranger.

3 yearling bulls, no visible brands

If not claimed and expenses paid, to be sold on 17th September, 1968.

K. McMAHON,  
4596—\$1.50 Poundkeeper.

**YEA**.—Impounded in Yea Pound.

1 Hereford cow, half near ear missing, silver tag off ear, no visible brand

If not claimed and expenses paid, to be sold on 27th September, 1968.

V. F. STANLEY,  
4597—\$1.75 Poundkeeper.

*Subordinate Legislation Act 1962.*

**NOTICE OF MAKING OF STATUTORY RULES.**

**IN** pursuance of the provisions of the *Subordinate Legislation Act 1962* and the Regulations made thereunder, notice is given of the making of the following statutory rules:—

| No.       | Motor Car Act 1958.  | Price. |
|-----------|--|--------|
| 216/1968. | Motor Car (Transfer and Roadworthiness Amendment No. 1) Regulations 1968 ..            | 10c    |
|           | <i>Explosives Act 1960.</i>  |        |
| 217/1968. | Classification of Explosives ..  | 15c    |
|           | <i>West Moorabool Water Board Act 1968.</i>  |        |
| 218/1968. | West Moorabool Water Board (Members' Fees and Travelling Expenses) Regulations 1968 .. | 10c    |

|           |  |        |
|-----------|--|--------|
| No.       | Health Act 1958.   | Price. |
| 219/1968. | Indoor Heating Appliances Regulations-1968   | 10c    |
|           | <i>Mental Health Act 1959</i><br>(No. 6605).   |        |
| 220/1968. | Mental Health (Medical Positions) Regulations 1968 (No. 3)                                   | 10c    |
|           | <i>Public Service Act 1958.</i>  |        |
| 221/1968. | Public Service (Governor in Council) Regulations 1968, No. 30                                | 10c    |
|           | <i>Local Government Act 1958.</i>  |        |
| 222/1968. | Storage of Petrol and Other Volatile Fluids (Amendment) Regulations 1968                     | 10c    |
|           | <i>Transport Regulation Act 1958.</i><br><i>Commercial Goods Vehicles Act 1958 (Part 1).</i> |        |
| 223/1968. | Transport Consolidated (Amendment) Regulations 1968  | 10c    |

Copies of these statutory rules may be purchased at the Sale of Publications Section of the Government Printing Office, located at Macarthur-street, Melbourne, 3002. If ordered by mail, remittance should be addressed to "The Government Printer, Box 203, P.O., North Melbourne, 3051", and should include 5c extra for postage. If a credit account is held at this office, no remittance is required with the mail order.

The annual subscription rate for Statutory Rules (including a Bound Volume) is \$15, payable in advance. The subscription year commences on 1st January.

A. C. BROOKS,  
Government Printer.

AGENTS FOR THE "VICTORIA GOVERNMENT GAZETTE".

THE following have been appointed agents to receive Advertisements and Subscriptions for the *Victoria Government Gazette*:-

- ARMSTRONG'S AGENCY, 205 Queen-street, Melbourne, Victoria 3000.
- ARNALL & JACKSON, 390 Barkly-street, Brunswick, Victoria 3056.
- BAIRNSDALE AUTHORIZED NEWSAGENCY, 132 Main-street, Bairnsdale, Victoria 3875.
- BICKNELL, M. J., Authorized Newsagent, 196 Timor-street, Warrambool, Victoria 3280.
- BLANE'S AUTHORIZED NEWSAGENTS, 162 Murray-street, Colac, Victoria 3250.
- R. G. CARTER ADVERTISING SERVICE PTY. LTD., Suite 24, 65 Queens-road, Melbourne, Victoria 3004.
- DAVIES, G. & M. V., 112 Gray-street, Hamilton, Victoria 3300
- DAVIS, WM. (MILDURA) PTY. LTD., 126 Eighth-street, Mildura, Victoria 3500.
- DIXON'S NEWSAGENCY, 89 Firebrace-street, Horsham, Victoria 3400.
- EDGAR'S NEWSAGENCY PTY. LTD., 293 Hargreaves-street, Bendigo, Victoria 3550.
- EDGARS' AUTHORIZED NEWSAGENCY, 45 Bridge-street, Benalla, Victoria 3672.
- FRANKS, H., & CO., 184 Ryrie-street, Geelong, Victoria 3220.
- GORDON & GOTCH AUSTRALASIA LTD., 511 Little Collins-street, Melbourne, Victoria 3000.
- GULLAN'S NEWSAGENCY, 88 Bridge-street, Ballarat, Victoria 3350.

- HAMPTON, A. C., 243 Mitchell-street, Bendigo, Victoria 3550.
  - HARSTON, PARTRIDGE & CO. PTY. LTD., 455 Little Collins-street, Melbourne, Victoria 3000.
  - KYNETON GUARDIAN PTY. LTD., P.O. Box 18, Kyneton, Victoria 3444.
  - LATIMER'S, Newsagents, 45 Station-street, Malvern, Victoria 3144.
  - LIVINGSTON'S SHEPPARTON NEWSAGENCY, 246 Wyndham-street, Shepparton, Victoria 3630.
  - THE MERCANTILE EXCHANGE, 67 Queen-street, Melbourne, Victoria, 3000.
  - MCGILL'S AUTHORIZED NEWSAGENCY, 183-5 Elizabeth-street, Melbourne, Victoria 3000.
  - PHILLIPS AUTHORIZED AGENCY, 83 Murphy-street, Wangaratta, Victoria 3677.
  - PURDIE, J., & CO., 138 Moorabool-street, Geelong, Victoria 3220.
  - SALE AUTHORIZED NEWSAGENCY, 142 Raymond-street, Sale, Victoria 3850.
  - SKINNER'S AUTHORIZED NEWSAGENCY, 49-51 Franklin-street, Traralgon, Victoria 3844.
  - STEVENSON, A. C. & M., NEWSAGENTS, 132 Henty-street, Casterton, Victoria 3311.
  - VERNON, C. F. & H. J., 162 Bridge-road, Richmond, Victoria 3121.
  - VIEW POINT AUTHORIZED NEWSAGENCY, 4 View-Point, Bendigo, Victoria 3550.
- A copy of the *Gazette* filed at each place for public reference.

CONTENTS

|  | PAGE           |
|--|----------------|
| Appointments .. .. .   | 3186           |
| Auction Sales Act .. .. .  | 3180           |
| Bank Holidays .. .. .  | 3167           |
| Companies Act 1961—Notice .. .. .  | 3184           |
| Contracts .. .. .  | 3181           |
| Estates of Deceased Persons .. .. .  | 3184           |
| Government Notices .. .. .   | 3172           |
| Holiday—Royal Agricultural Show .. .. .  | 3172           |
| Impoundings .. .. .  | 3217           |
| Lands .. .. .  | 3198           |
| Mining .. .. .   | 3179           |
| Notice of Making of Statutory Rules .. .. .  | 3217           |
| Orders in Council—   |                |
| Acts—Land; Country Roads; Local Govern-<br>ment; Land; Mildura Irrigation and<br>Water Trusts; Water; Sewerage Dis-<br>tricts; Melbourne and Metropolitan<br>Tramways; State Electricity Commis-<br>sion; Landlord and Tenant. | 3188<br>et seq |
| Police Sale .. .. .  | 3172           |
| Private Advertisements .. .. .   | 3205           |
| Proclamations .. .. .  | 3167           |
| Public Holidays .. .. .  | 3167           |
| Public Service Notices .. .. .   | 3202           |
| Regulations—   |                |
| Acts—Police Regulation .. .. .   | 3173           |
| Resignations .. .. .   | 3187           |
| State Rivers and Water Supply Commission .. .. .   | 3180           |
| Tenders .. .. .  | 3204           |
| Transport Regulation Board—Public Hearings .. .. .   | 3174           |
| Waterworks Trusts .. .. .  | 3178           |