

[3621]



VICTORIA
GOVERNMENT GAZETTE

Published by Authority

No. 104]

WEDNESDAY, NOVEMBER 18

[1970

**PUBLICATION OF THE "VICTORIA
GOVERNMENT GAZETTE".**

Christmas and New Year Holidays.

Because of the Christmas and New Year Holidays, the last issue of the Victoria Government Gazette for 1970 will be published on **Wednesday, the 23rd December, 1970.**

All official matter for publication therein should be lodged with the Gazette Officer, Chief Secretary's Department (Telephone Extension 6282), not later than 9.30 a.m. on Tuesday, the 22nd December, 1970.

The next Gazette, the first for 1971, will be published on Friday, the 8th January, 1971, and thereafter on each Wednesday, as usual.

**C. H. RIXON,
Government Printer.**

PROCLAMATIONS**BANK HOLIDAY.****PROCLAMATION**

By His Excellency the Governor of the State of Victoria and its Dependencies in the Commonwealth of Australia, &c., &c., &c.

IN pursuance of the provisions of the *Bank Holidays Act 1958*, I, the Governor of the State of Victoria, in the Commonwealth of Australia, do by this my Proclamation appoint the day and date named hereunder a special day to be observed as a Bank Holiday at the places mentioned, that is to say:—

Bank Holiday:—

MONDAY, THE 28TH DECEMBER, 1970, throughout the State of Victoria.

Given under my Hand and the Seal of the State of Victoria aforesaid, at Melbourne, this seventeenth day of November, in the year of our Lord One thousand nine hundred and seventy, and in the nineteenth year of the reign of Her Majesty Queen Elizabeth II.

(L.S.) ROHAN DELACOMBE.

By His Excellency's Command,

A. G. RYLAH,
Chief Secretary.

GOD SAVE THE QUEEN!

This Proclamation is in lieu of the Proclamation made under the *Bank Holidays Act 1958*, and published in the *Victoria Government Gazette* No. 99, of 28th October, 1970.

PUBLIC HALF-HOLIDAY.**PROCLAMATION**

By His Excellency the Governor of the State of Victoria and its Dependencies in the Commonwealth of Australia, &c., &c., &c.

IN pursuance of the provisions contained in Part III. of the *Public Service Act 1958*, I, the Governor of the State of Victoria, in the Commonwealth of Australia, by and with the advice of the Executive Council of the said State, do by this my Proclamation appoint the day and date hereunder mentioned to be observed as a Public Half-Holiday at the place specified, viz.:—

Public Half-Holiday from the Hour of Twelve o'clock noon:—

THURSDAY, THE 25TH FEBRUARY, 1971; throughout the City of Sale.

Given under my Hand and the Seal of the State of Victoria aforesaid, at Melbourne, this seventeenth day of November, in the year of our Lord One thousand nine hundred and seventy, and in the nineteenth year of the reign of Her Majesty Queen Elizabeth II.

(L.S.) ROHAN DELACOMBE.

By His Excellency's Command,

A. G. RYLAH,
Chief Secretary.

GOD SAVE THE QUEEN!

JUSTICES ACT 1958.**PROCLAMATION**

By His Excellency the Governor of the State of Victoria and its Dependencies in the Commonwealth of Australia, &c., &c., &c.

WHEREAS:

1. by an Act of the State of Victoria intituled the *Justices Act 1958* it is provided in sub-section (2) of Section 24 thereof that the Governor in Council may by proclamation published in the *Government Gazette* specify municipal districts for the purpose of Section 24 of the said Act; and

2. it is considered desirable that the municipal district named in the Schedule hereto be so specified.

Now therefore I, the Governor of the said State of Victoria, by and with the advice of the Executive Council thereof, do by this my proclamation hereby specify for the purpose of the said Section 24 of the said Act the municipal district whose name appears in the said Schedule—to take effect as on and from the fourteenth day of December 1970.

SCHEDULE.

Shire of Cranbourne.

Given under my Hand and the Seal of the State of Victoria aforesaid, at Melbourne, this seventeenth day of November, in the year of our Lord One thousand nine hundred and seventy, and in the nineteenth year of the reign of Her Majesty Queen Elizabeth II.

(L.S.) ROHAN DELACOMBE.

By His Excellency's Command,

G. O. REID,
Attorney-General.

GOD SAVE THE QUEEN!

**BANNOCKBURN DISTRICT WATERWORKS TRUST.—
PORTION OF DISTRICT PROCLAIMED AN URBAN DISTRICT.****PROCLAMATION**

By His Excellency the Governor of the State of Victoria and its Dependencies in the Commonwealth of Australia, &c., &c., &c.

UNDER the powers conferred by the Water Act and all other powers enabling him in that behalf, I, the Governor of the State of Victoria, in the Commonwealth of Australia, by and with the advice of the Executive Council of the said State, do hereby proclaim that on and from the date hereof that portion of the Waterworks District of the Bannockburn District Waterworks Trust comprised within the areas shaded red on the plan (Corr. No. 70/2566/11) shall be and become an Urban District for the purposes of and within the meaning of the said Act and shall be known as the Meredith Urban District.

Given under my Hand and the Seal of the State of Victoria aforesaid, at Melbourne, this seventeenth day of November, in the year of our Lord One thousand nine hundred and seventy, and in the nineteenth year of the reign of Her Majesty Queen Elizabeth II.

(L.S.) ROHAN DELACOMBE.

By His Excellency's Command,

IAN SMITH,
Minister of Water Supply.

GOD SAVE THE QUEEN!

GOVERNMENT NOTICES**CHRISTMAS AND NEW YEAR HOLIDAYS.**

IT is hereby notified that on—

FRIDAY, THE 25TH DECEMBER, 1970,
SATURDAY, THE 26TH DECEMBER, 1970,
MONDAY, THE 28TH DECEMBER, 1970, and
FRIDAY, THE 1ST JANUARY, 1971,

the Public Offices will be closed, such days having been appointed by the *Public Service Act 1958* to be observed as holidays in the Public Offices throughout the State of Victoria.

This notice relates only to the closing of the State Public Offices. All inquiries regarding holidays in other offices and in shops and industry should be directed to the Department of Labour and Industry, 110 Exhibition-street, Melbourne (Telephone 63 0321, Extension 6158 or 6721 or 6859).

A. G. RYLAH,
Chief Secretary.

Chief Secretary's Office,
Melbourne, 3000, 17th November, 1970.

Transport Regulation Act.
TRANSPORT REGULATION BOARD.

HEARING OF APPLICATIONS.

NOTICE is hereby given that the following applications will be considered by the Transport Regulation Board at its offices at the corner of Lygon and Princes streets, Carlton, at 10.15 a.m. on Wednesday, 9th December, 1970.

ALL WEATHER SCENIC COACHES PTY. LTD., 105 Acland-street, St. Kilda. Application for variations of M.O. licence conditions on Route 37 (St. Kilda—Port Melbourne) to delete service along Pickles, Bridge, Bay and Graham streets and instead operate via Liardet, Bay and Bridge streets and Williamstown-road; thence via normal route.

PHILLIPS, F. A., BUS SERVICE, PTY. LTD., 8 Mereweather-avenue, Frankston. Application for one commercial passenger vehicle with large seating capacity to operate as an additional country stage omnibus.

MCKENZIES TOURIST SERVICES PTY. LTD., 53 Barkers-road, Kew. Application for variation of C.O. licence conditions to operate an additional service on the Melbourne to Healesville stage service, only on days that Healesville Trotting meetings are conducted as follows:—

Depart Melbourne 11 a.m.
Depart Healesville 5 p.m.

NEWTON, J. & I. W., Fuller-avenue, Rochester. Application for variation of conditions of licence T.P. 120 to include the ability to operate the vehicle for charter purposes at Echuca.

POINT COOK—WERRIBEE PASSENGER SERVICE PTY. LTD., Railway-avenue, Laverton. Application for variation of all C.O. licence conditions to operate a route as follows:— Commencing at Hoppers Crossing Railway Station; then via Morris and Branton roads, Mossfield-drive, Heaths-road to the corner of Heaths and Derrimut roads. With extensions to Werribee via Derrimut and Tarnait roads, Meek-street, Market-road, Watton-street to Werribee Post Office. No service will operate Saturday, Sunday or Public Holidays.

Time-table (Weekdays only)			
To Railway Station		From Railway Station	
A.M.	6.55	A.M.	7.15
	7.30		* 9.30
	9.15	P.M.	1.15
+10.15	10.30		* 1.40
P.M.	12.25		3.00
	1.25		4.25
+ 2.10	2.25		5.15
	4.40		6.05
	5.00		

+ Departs Werribee P. O. * Extends to Werribee.
Sections and fares to be determined.

APPLICATION for renewal of licences as shown, by persons listed hereunder to operate under the same terms and conditions.

COOKE, M. P., 60 Melbourne-avenue, Glenroy; M.H.4106.
HARGREAVES, E. A., 196 Wattle-street, Bendigo; U.T.206.
HILL, J. T., 11 Lyell-road, Boronia; M.H.2505.
LAVERTON TAXI SERVICE, Railway-avenue, Laverton; C.H.134, C.H.135, C.H.136.

SALTER, H., 22 Rosehill-road, Niddre; M.H.4096.
SHEPPARD, B. F., 6 Well-street, Middle Brighton; M.T.1914.
HUTTON, F. R. & P. M., 24 Hilltop-road, Upper Ferntree Gully; C.T.265.

MANKS, G. E. & M. T., 28 James-street, Dandenong; C.T.135.

REID, D. F., S., & P. A., and Mrs. VAN DER KORPUT (trading as Reids Bus Service), 252 St. Georges-road, Northcote; M.C.269, M.C.270, M.C.271, M.C.272, M.C.419, M.C.420, M.C.421.

STEFANOVIC, M., 119 Ballarat-road, North Geelong; T.P.157.

Notice of any objection should be forwarded to reach the Secretary of the Board not later than Wednesday, 2nd December, 1970.

Applicants are advised that it will not be necessary to appear on the hearing date specified above, unless advised in writing by the Board.

B. P. KAY,
Secretary.

Corner Lygon and Princes streets, Carlton, Wednesday, 18th November, 1970.

Commercial Goods Vehicles Act.
TRANSPORT REGULATION BOARD.

HEARING OF APPLICATIONS.

NOTICE is hereby given that the following applications will be considered by the Transport Regulation Board at its offices at the corner Lygon and Princes streets, Carlton, at 10.15 a.m. on Wednesday, 9th December, 1970.

ALBION REID PTY. LTD., 83 Riversdale-road, Hawthorn, 3122. One commercial goods vehicle (L/C. 94 cwt.) to operate throughout the State of Victoria for the purpose of operating the vehicle as a specially constructed road-spraying unit—tar and bitumen in bulk incidental to own contracts.

WILLIAMSON, R. T., & W. BIRCHALL (trading as Alexandra Freighters), 124 Grant-street, Alexandra, 3714. One commercial goods vehicle (L/C. 299 cwt.) to operate: (a) From and to the City of Melbourne to and from places situated on or most conveniently reached from the road between the Townships of Fernshaw and Alexandra via St. Fillans and Buxton—general goods other than wool provided that no goods whatsoever shall be carried to or from the City of Melbourne from or to any place within a 3-mile radius from the Township of Alexandra. (b) From and to the Township of Healesville to and from places situated on or most conveniently reached from the road between the aforesaid Townships of Fernshaw and Alexandra via St. Fillans and Buxton—general goods provided that no goods whatsoever are carried to or from any place within a 3-mile radius from the Township of Alexandra.

NOTE.—(i) Goods shall not be carried on the vehicle to any place or to any area as mentioned above for the purpose of being transferred to any licensed vehicle for the carriage to a further destination outside or beyond the places or areas as mentioned above. (ii) The off-loading or transfer of goods from or to this vehicle to or from any other licensed vehicle for the carriage of goods to or from any place or area other than that area as mentioned above is absolutely prohibited and any such off-loading or transfer of goods as aforesaid to or from any other vehicle will be deemed to be an infringement of the above conditions.

AMALGAMATED CHEMICALS LTD., 24 Prahran-grove, Elsternwick, 3185. One commercial goods vehicle (L/C. 10 cwt.) to operate within a 50-mile radius of own branch premises at Wangaratta in the course of business as "Agricultural Chemical Manufacturers and Marketers"—own goods with the proviso that all such goods are initially consigned to Wangaratta by rail.

SMITH, W. G. (trading as Bendigo Motor Wreckers), 172 Mundy-street, Bendigo, 3550. One commercial goods vehicle (L/C. 11 cwt. and 20 cwt. trailer) to operate within a 100-mile radius of the chief post office in the City of Bendigo and to and from the City of Swan Hill but excluding operations to or from places within a 25-mile radius of the G.P.O., Melbourne in the course of business as "Motor Wreckers"—vehicles for wrecking and second-hand parts from wrecked vehicles.

BROWN, K., 21 Edward-avenue, Dandenong, 3175. One commercial goods vehicle (L/C. 112 cwt.) to operate within a 50-mile radius of the premises of Albion Reid Pty. Ltd. at North Melbourne on behalf of the said company—road-making plant, hot asphalt, premix and road-making materials but excluding the carriage of cement and lime from the Geelong Urban District (as defined in the Transport Regulation Act 1958).

BRUMBY, M. G., 29 Royalden-avenue, Boronia, 3155. One commercial goods vehicle (L/C. 141 cwt.) to operate throughout the State of Victoria in course of business as "Earth-moving Contractor"—own earth-moving plant and equipment and up to a maximum of 3 x 44 gallon drums of fuel for operation of own equipment on site.

BULLER, G. S., P.O. Box 82, Warburton, 3799. One commercial goods vehicle (L/C. 10 cwt. approximately) to operate from and to municipal district of the City of Melbourne and the vicinity within the distance of eight (8) miles of the corporate limits of such city to and from the Township of Warburton East via the Township of Lilydale and also serving places situated within 5 miles of any point along that part of the main highway situated between and including the Townships of Lilydale and Warburton East but excluding any operations whatsoever to or from any places or properties on or adjacent to the Yarra Junction—Powelltown road—general goods.

CARTER, G., 12 Royal-crescent, Hamlyn Heights, Geelong, 3215. Three commercial goods vehicles (L/C. 200, 230, 216 cwt.) to operate: (a) Within a 75-mile radius of the post office at Waubra (Ballarat Division

of the Country Roads Board)—road-contracting plant used in the construction or maintenance of a road, street, footpath, bridge, wharf, pier, weir or channel. (b) Within a 20-mile radius from site of construction or maintenance work performed pursuant to paragraph (a) above or from a railway station nearest thereto—materials required for such work.

CHARTER, C. J., 450 Bellevue-street, Albury, N.S.W., 2640. One commercial goods vehicle (L/C. 15 cwt.) to operate from Shepparton to Yarrawonga via Numurkah and Katamatite Monday to Friday inclusive for the carriage of motor parts, cakes, small goods, parcels, fruit and vegetables and one (1) passenger.

NOTE.—No passenger or goods are to be carried between Katamatite and Yarrawonga on Tuesday and Thursday of each week.

Time-table.

Depart Shepparton 2.00 p.m.
Depart Numurkah 2.30 p.m.
Depart Katamatite 3.00 p.m.
Arrive Yarrawonga 3.45 p.m.

CLARK KING & CO. PTY. LTD., 324 William-street, Melbourne, 3000. One commercial goods vehicle (L/C. 164 cwt.) to operate within a 50-mile radius of G.P.O., Melbourne in course of business as "Stock-feed Manufacturers"—own stockfeed.

CLEMENTS, E. A. (trading as Ern Clements Mobile T.V. Service), 92 Nolan-street, Bendigo, 3550. One commercial goods vehicle (L/C. 24 cwt.) to operate within a 50-mile radius of the chief post office in the City of Bendigo in course of business as "Radio and Television Serviceman"—electrical equipment for repair or having been repaired, tools of trade, spare parts and materials incidental to the servicing and maintaining of such equipment.

CURTHOYS, J. S., P.O. Box 22, Lalbert, 3542. One commercial goods vehicle (L/C. 234 cwt.) to operate: (a) Within a 50-mile radius from the post office at Lalbert as a "Road Contractor"—road-making plant and materials. (b) Within a 20-mile radius from the site of any construction or maintenance work performed pursuant to paragraph (a) above, or from the railway station nearest thereto any other materials required for such work. (c) Within a 20-mile radius from the post office at Lalbert—general goods excluding any plant or materials carried or to be carried pursuant to paragraphs (a) and (b) above.

DOODT, NORM, & SONS PTY. LTD., Creswick-road, Ballarat, 3350. One commercial goods vehicle (L/C. 306 cwt.) to operate: (a) Within a 25-mile radius of the chief post office in the City of Ballarat—general goods. (b) Within a 70-mile radius of the chief post office in the City of Ballarat as follows:—(i) Tiles, roof battens and tile fixing materials and bricks on behalf of Eureka Terra Cotta and Tile Co. of Aust. Ltd. (ii) Bricks, glazed bricks and glazed earthenware pipes and fittings on behalf of Martins Stoneware Pty. Ltd.

DOWDELL, D., 48 Annerley-avenue, Shepparton, 3630. One commercial goods vehicle (L/C. 263 cwt.) to operate: (a) Within a 100-mile radius from own premises at Shepparton in the course of business as "House Remover"—houses, sheds and outbuildings for removal and re-erection also tools of trade and equipment incidental thereto. (b) Within a 25-mile radius from the post office at Shepparton—general goods, provided that no goods shall be carried whether by one stage or by more than one stage between places within the above radius which are more than thirty (30) road miles apart by the nearest practicable route. This application replaces licence No. D.A.60200.

DUNLOP, R. A., 509 Abercorn-street, Albury, N.S.W., 2640. One commercial goods vehicle (L/C. 116 cwt.) to operate: (a) Within a 95-mile radius of the post office at Wangaratta (Benalla Division of the Country Roads Board)—road-contracting plant used in the construction or maintenance of a road, street, footpath, bridge, wharf, pier, weir or channel. (b) Within a 20-mile radius from site of construction or maintenance work performed pursuant to paragraph (a) above or from the railway station nearest thereto—materials required for such work. (c) Within a 25-mile radius of the post office at Wodonga—general goods, provided that no goods shall be carried whether by one stage or by more than one stage between places within the above radius, which are more than thirty (30) road miles apart by the nearest practicable route.

DURAL LEEDS PTY. LTD., corner Calder Highway and Roberts-road, Niddrie, 3042. One commercial goods vehicle (L/C. 14 cwt.) to operate throughout the State of Victoria in course of business as "Blind and Awning Manufacturers" for the purpose of sales promotion, repairing and measuring contracts—samples, display materials, tools of trade, blinds and

awnings for repair having been repaired or for specialized installation and materials incidental thereto.

EAGLAND, K., 151 Greensborough-road, Macleod, 3085. One commercial goods vehicle (L/C. 197 cwt.) to operate within a 50-mile radius of the premises of Albion Reid Pty. Ltd. at North Melbourne as a Specially Constructed Agitator Vehicle—premixed concrete.

EASTERN PLANT HIRE PTY. LTD., 22 South-street, Wodonga, 3690. Application to vary the conditions of licence No. D.A.61924/1 (L/C. 124 cwt.) by deleting from paragraph (a) of the existing conditions "Within a 50-mile radius" and adding in lieu: "Within a 100-mile radius".

EGAN, G. F. (trading as G. F. & D. M. Egan), Anderson-street, Heyfield, 3858. One commercial goods vehicle (L/C. 300 cwt.) to operate from sawmills situated at Heyfield to the premises of Smorgon Consolidated Industries Pty. Ltd. at Brooklyn—pulpwood chips.

EVE, E., 950 Heatherton-road, Springvale, 3171. Two commercial goods vehicles (L/C. 191 and 172 cwt.) to operate within a 50-mile radius of the plant of Albion Reid Pty. Ltd. at Montrose as a specially constructed agitator vehicle—premixed concrete.

NOTE.—These applications replace licences numbered D.A.60268, D.A.60269 which expired on 17th October, 1970.

FOX, ALBERT H., PTY. LTD., 6 Regent-court, Warragul, 3820. One commercial goods vehicle (L/C. 14 cwt.) to operate: (a) Within a 50-mile radius of the post office situated at Warragul in the course of business as "Musical Instrument Retailer"—new musical instruments. (b) Throughout the State of Victoria—tools of trade, pianos and organs for repair or having been repaired also pianos and organs for demonstration purposes.

GLEESON, G. M., Curdie Vale, 3268. One commercial goods vehicle (L/C. 253 cwt.) to operate: (a) Within a 50-mile radius of the post office at Curdie Vale as a "Road Contractor"—road-making plant and materials. (b) Within a 25-mile radius of the post office at Curdie Vale—general goods, provided that no goods shall be carried whether by one stage or by more than one stage between places within the above radius, which are more than thirty (30) road miles apart by the nearest practicable route.

GONDOPOULOS, T. & E., 4 Susan-court, Cheltenham, 3192. One commercial goods vehicle (L/C. 132 cwt.) to operate within a 50-mile radius of the plant of Albion Reid Pty. Ltd. at North Melbourne solely on behalf of the said company—road-making plant, hot asphalt, premix and road-making materials excluding the carriage of cement and lime from the Geelong Urban District (as defined in the Transport Regulation Act 1958).

JACKSON, WM. C. (SEWING MACHINES) PTY. LTD., 169 Victoria-parade, Collingwood, 3066. Four commercial goods vehicles (L/C. 14, 11, 12, 14 cwt.) to operate: (a) Within a 50-mile radius of own premises at Collingwood in the course of business as "Textile Machinery Manufacturers"—own goods. (b) Throughout the State of Victoria—new industrial sewing machines for specialized installation, industrial sewing machines for repair or having been repaired, together with tools of trade and equipment incidental to the servicing or installation of industrial sewing machines.

JAMES, E. V., 16 Royalden-avenue, Boronia, 3155. One commercial goods vehicle (L/C. 153 cwt.) to operate: (a) Within a 25-mile radius of own premises at Ferntree Gully in the course of business as "Garden Supplier"—own goods. (b) From Toolangi to places within paragraph (a) above—own mountain soil. (c) From Bacchus Marsh to places within paragraph (a) above—own river pebbles. (d) From Diggers Rest to places within paragraph (a) above—own rock. (e) From Beveridge to places within paragraph (a) above—own scoria.

JAMIESON, B. H., Lower Bendoc, via Delegate, 3888. One commercial goods vehicle (L/C. 124 cwt.) to operate: (a) Within a 95-mile radius of the post office at Nowa Nowa (Bairnsdale Division of the Country Roads Board)—road-contracting plant used in the construction or maintenance of a road, street, footpath, bridge, wharf, pier, weir or channel. (b) Within a 20-mile radius from site of construction or maintenance work performed pursuant to paragraph (a) above or from a railway station nearest thereto—materials required for such work. (c) Within a 25-mile radius of the post office at Bendoc—general goods, provided that no goods shall be carried whether by one stage or by more than one stage between places within the above radius, which are more than thirty (30) road miles apart by the nearest practicable route.

JUCIELAND, PTY. LTD., 217 Wade-avenue, Mildura, 3500. One commercial goods vehicle (L/C. 49 cwt.) to operate as a distributor of products of Heleys Pty. Ltd., an approved decentralized secondary industry from the factory of Heleys Pty. Ltd. at Mildura West of an area bounded by a line drawn north and south through Kerang and north of an area bounded by a line drawn east and west through Hopetoun—soft drinks, cordials, two-on-beer, vinegar and empty return containers.

KELLY, J. A., P.O. Box 269, Portland, 3305. One commercial goods vehicle (L/C. 136 cwt.) to operate: (a) From Portland via Geelong to Melbourne and return—fish and empty return fish boxes. (b) Throughout the western portion of the State of Victoria west of a line drawn north and south from Lorne to Kerang, in the course of business as a "Marine Collector"—special wares, marine stores, old metals as designated in the Marine Stores and Old Metals Act.

KENNEDY, PATRICK, EXCAVATIONS, P.O. Box 11, Wendouree, 3355. One commercial goods vehicle (L/C. 327 cwt.) to operate in the course of business as "Excavation Contractors" as follows: (a) Throughout the State of Victoria—own excavation machinery and a quantity not exceeding three drums 44-gallons capacity each at any one time of fuel for the operation of such machinery on site. (b) Within a 20-mile radius of the site of any contract currently engaged upon—materials for use in such contract.

KENT, J. M., 59 Shiels-terrace, Casterton, 3311. One commercial goods vehicle (L/C. 233 cwt.) to operate: (a) Within a 25-mile radius of the post office at Casterton—general goods, provided that no goods shall be carried whether by one stage or by more than one stage between places within the above radius which are more than thirty (30) road miles apart by the nearest practicable route. (b) Within a 100-mile radius of the post office at Casterton in the course of business as "Superphosphate Spreading Contractor"—bulk superphosphate, provided that all such superphosphate is initially consigned by rail to the station nearest to the site of spreading.

KERSTING, M. J., 82 Purrumbete-avenue, Manifold Heights, 3218. One commercial goods vehicle (L/C. 207 cwt.) to operate: (a) Within a 75-mile radius of the post office at Waubra (Ballarat Division of the Country Roads Board)—road contracting plant used in the construction or maintenance of a road, street, foot-path, bridge, wharf, pier, weir or channel. (b) Within a 20-mile radius from site of construction or maintenance work performed pursuant to paragraph (a) above, or from the railway station nearest thereto—metal, stones, screenings, ashes, gravel, sand, earth and any other materials required for such work.

KOLEV, J., 49 Wilmoth-street, Thornbury, 3071. One commercial goods vehicle (L/C. 200 cwt.) to operate within a 50-mile radius of the G.P.O. in the City of Melbourne solely on behalf of Pioneer Concrete (Vic.) Pty. Ltd.—premixed concrete in a specially constructed agitator vehicle.

KOLIOPANOS, P., 73 St. Georges-road, North Fitzroy, 3068. One commercial goods vehicle (L/C. 238 cwt.) to operate within a 35-mile radius of the G.P.O., Melbourne, on behalf of Consolidated Quarries Ltd.—sand, soil, screenings, premix and quarry products.

LEMPRIERE METALS PTY. LTD., P.O. Box 226, Footscray, 3011. One commercial goods vehicle (L/C. 52 cwt.) to operate throughout the State of Victoria in the course of business as "Marine Collector"—special wares, marine stores and old metals as designated in the *Marine Stores and Old Metals Act 1958* (No. 6303), Part 1, section 3.

NOTE.—The total combined load capacity of the vehicle as prime mover and of any trailer hauled in conjunction with the vehicle for the carriage of goods shall not exceed 120 cwt.

LIFE SAVERS (AUST.) PTY. LTD., 2 Bromham-place, Richmond, 3121. One commercial goods vehicle (L/C. 11 cwt.) to operate: (a) Within a 50-mile radius of own branch premises at Bendigo in the course of business as "Confectionery Manufacturers"—own goods. (b) Within that part of the State of Victoria west of a north/south line drawn from Echuca to Kilmore, north of a south/westerly line drawn from Kilmore to Gisborne, north of a line drawn from Gisborne through Maryborough, St. Arnaud and Donald to Warracknabeal, and east of a north/south line drawn from Warracknabeal through Hopetoun to Robinvale for the purposes of booking orders and sales promotion—samples, display and advertising materials.

NOTE.—All goods are to be initially consigned by rail to Bendigo.

LIFE SAVERS (AUST.) PTY. LTD., 2 Bromham-place, Richmond, 3121. One commercial goods vehicle (L/C. 11 cwt.) to operate: (a) Within a 50-mile radius of own branch premises at Wangaratta in the course of business as "Confectionery Manufacturers"—own goods. (b) Within that part of the State of Victoria west of a south/westerly line drawn from the River Murray through Corryong, Mount Beauty and Mansfield to Eildon, north of an east/west line drawn from Eildon to Kilmore and east of a north/south line drawn from Kilmore to Echuca for the purposes of booking orders and sale promotion—samples, display and advertising materials.

NOTE.—All goods are to be initially consigned by rail to Wangaratta.

LIFE SAVERS (AUST.) PTY. LTD., 2 Bromham-place, Richmond, 3121. One commercial goods vehicle (L/C. 11 cwt.) to operate: (a) Within a 50-mile radius of own branch premises at Ballarat in the course of business as "Confectionery Manufacturers"—own goods. (b) Within that part of the State of Victoria east of a line drawn from Portland, through Casterton and Edenhope to Nhill, south of a line drawn from Nhill through Warracknabeal, Donald, St. Arnaud and Maryborough to Gisborne, west of a line drawn from Gisborne through Bacchus Marsh, Meredith and Inverleigh to Anglesea for the purposes of booking orders and sales promotion—samples, display and advertising materials.

NOTE.—All goods are to be initially consigned by rail to Ballarat.

LIFE SAVERS (AUST.) PTY. LTD., 2 Bromham-place, Richmond, 3121. One commercial goods vehicle (L/C. 11 cwt.) to operate: (a) Within a 50-mile radius of own branch premises at Traralgon in the course of business as "Confectionery Manufacturers"—own goods. (b) Within that part of the State of Victoria south of a south/westerly line drawn from the River Murray through Corryong, Mount Beauty and Mansfield to Eildon, and east of a north/south line drawn from Eildon to Wonthaggi for the purposes of booking orders and sales promotion—samples, display and advertising materials.

NOTE.—All goods are to be initially consigned by rail to Traralgon.

LONGYEAR (AUSTRALIA) PTY. LTD., 34 Tibrockney-street, Hightett, 3190. One commercial goods vehicle (L/C. 12 cwt.) to operate throughout the State of Victoria in the course of business as "Drilling Contractors"—tools of trade, spare parts and equipment for the purpose of servicing own equipment and vehicles and equipment for repair or having been repaired.

MANTON, W. J., Pearce-street, Crib Point, 3919. Application to vary the conditions of licence No. D.A.62977 (L/C. 127 cwt.) by adding to the existing conditions—"manufactured fruit cases and sawn pine timber" and add as an additional paragraph: "From private properties within a 25-mile radius of Hastings to the sawmill of Woods Case Supply at Hastings"—pine logs.

MAY, S. F., 46 Secull-drive, Chelsea Heights, 3196. One commercial goods vehicle (L/C. 6 cwt.) to operate throughout the State of Victoria as a "Contract Carpet Layer"—tools of trade, floor coverings for laying purposes only and materials incidental to carpet laying contracts.

MORTIMER, L. G., & T. COULSHED, Narre Warren North, 3084. Application to vary the conditions of licence No. D.A.45048 (L/C. 145 cwt.) by deleting from the existing conditions "Monier-Reid Asphalt Pty. Ltd." and adding in lieu: "Ready Mixed Concrete (Vic.) Pty. Ltd."

MCCCLUSKEY, M. J., 195 Westblade-avenue, Kerang, 3579. Application to vary the conditions of licences numbered D.A.60782/1 and D.A.60782/2 (L/C. 246 and 250 cwt.) by deleting from paragraph (a) of the existing conditions "Within a 50-mile radius from the post office at Kerang" and adding in lieu: "Within a 75-mile radius of the post office at Elmore and within a 65-mile radius of the post office at Nyah".

MCKEE, R. J., Glenberry Timber Mill, Porepunkah, 3740. One commercial goods vehicle (L/C. 228 cwt.) to operate: (a) From forest landings within a 50-mile radius of Porepunkah to timber mills at Porepunkah—logs. (b) From Selwyn Timbers Mill at Porepunkah to consignees within a 50-mile radius thereof—sawn timber.

PETERS ICE CREAM PTY. LTD., Wellington-road, Clayton, 3168. Two commercial goods vehicles (L/C. 76 cwt. each) to operate throughout the State of Victoria as a specially constructed insulated and refrigerated van for the purpose of supplying own distributors with ice-cream, frozen vegetables, frozen fish and frozen poultry at a temperature not exceeding 10 degrees F.

PIGDON, N. F., Private Bag, Delatite Station via Mansfield, 3722. One commercial goods vehicle (L/C. 146 cwt.) to operate within a 50-mile radius of the post office at Mansfield solely on behalf of Mansfield Quarries Pty. Ltd.—screenings, stones, gravel and sand.

PULLEN, P., P.O. Box 157, Casterton, 3311. One commercial goods vehicle (L/C. 230 cwt.) to operate: (a) Within a 50-mile radius of the post office at Casterton, as a "Road Contractor"—road-making plant and materials. (b) Within a 20-mile radius from the site of any construction or maintenance work performed pursuant to paragraph (a) above, or from the railway station nearest thereto—any other materials required for such work. (c) Within a 20-mile radius of the post office at Casterton—general goods.

READY MIXED CONCRETE (VICTORIA) PTY. LTD., 68 Burwood-road, Burwood, 3125. One commercial goods vehicle (L/C. 334 cwt.) to operate in the course of business as "Ready Mixed Concrete Manufacturers" as follows: (a) Within a 25-mile radius of the post office situated at the corner of Bourke and Elizabeth streets, in the City of Melbourne, and to Township of Bittern—raw materials for use in the manufacture of concrete. (b) From suppliers situated within a 20-mile radius of the post office at Bittern to own premises at Bittern—sand and screenings. (c) To own plant at Geelong from quarries situated within a 10-mile radius of the said plant and from pits in the You Yangs area—sand and screenings. (d) From pits at Bacchus Marsh to own plants within a 25-mile radius of the post office situated at the corner of Bourke and Elizabeth streets, Melbourne, or to own plant at Geelong—own sand. (e) From pits at Bunyip, Tynong and Nar-Nar-Goon to own plant at Vermont—own sand. (f) From quarries at Anakie to own plants within a 25-mile radius of the post office at the corner of Bourke and Elizabeth streets, Melbourne—own rock.

ROBERTS, S. L., 71 Somerville-street, Bendigo, 3550. One commercial goods vehicle (10 cwt.) to operate within a 100-mile radius of the chief post office in the City of Bendigo in the course of business as "Refrigeration Serviceman" but excluding any operations to or from any point within a 25-mile radius of the post office situated at the corner of Bourke and Elizabeth streets, Melbourne—uncrated refrigeration and electrical appliances for specialized installation, for repair or having been repaired, tools of trade, spare parts and materials incidental to the installation, servicing and maintenance of such appliances.

SEYMOUR, W. S. C., 462 Queensberry-street, North Melbourne, 3051. One commercial goods vehicle (L/C. 50 cwt.) to operate throughout the State of Victoria in the course of business as "Travelling Showman"—own equipment and novelty prizes.

NOTE.—This application replaces licence No. D.A.48065 held in the same name.

SINGER AUSTRALIA LTD., 45 Pall Mall, Bendigo, 3550. Application to vary the conditions of licence No. D.A.28753/1 (L/C. 7 cwt.) by deleting the present conditions and adding in lieu: "Within a 70-mile radius of the chief post office in the City of Bendigo for the purpose of delivering and servicing sewing machines and knitting machines—sewing machines, knitting machines, tools of trade and materials incidental thereto.

SMITH, B. E., 11 Taronga-crescent, Croydon, 3136. One commercial goods vehicle (L/C. 227 cwt.) to operate within a 50-mile radius of the premises of Albion Reid Pty. Ltd. at North Melbourne on behalf of the said company—road-making plant, hot asphalt, premix and road-making materials but excluding the carriage of cement and lime from the Geelong Urban District (as defined in the *Transport Regulation Act 1958*).

THOMAS, J. W., "Yandilaby", Mortlake, 3272. One commercial goods vehicle (L/C. 109 cwt.) to operate: (a) Within a 25-mile radius of the post office at Mortlake—general goods subject to the condition that no goods shall be carried whether in one or more stages from any one point within the said radius to any other point within the said radius situated more than thirty (30) miles apart by the nearest and most practicable route. (b) Within a 50-mile radius of the post office at Mortlake—livestock. (c) Within a 50-mile radius of the post office at Mortlake in the course of business as "Primary Producer"—own goods.

TWINNESS DISTRIBUTORS PTY. LTD., 99 Thistlewaite-street, South Melbourne, 3205. Two commercial goods vehicles (L/C. 24 and 28 cwt.) to operate throughout the State of Victoria in course of business as "Frozen Food Distributors" as a specially constructed refrigerated vehicle—frozen processed vegetables, ice cream, frozen chicken rolls, frozen dim sims, frozen fish, frozen hamburgers, frozen dinners and frozen meat.

VAN LOCHEM, J. H., 33 Lincoln-street, Moe, 3825. One commercial goods vehicle (L/C. 10 cwt.) to operate throughout that part of the State of Victoria situated east of a north/south line drawn through the township of Warragul in the course of business as "Electrical Maintenance Contractor"—own tools of trade, equipment and materials with the proviso that no materials carried shall exceed 5 cwt. any one time.

WAGEN, L., 57 Briggs-street, South Caulfield, 3162. One commercial goods vehicle (L/C. 7 cwt.) to operate within a 50-mile radius of own premises at Caulfield and to Warragul market in course of business as "Stallholder"—own clothing.

WARD, I. L., 58 Old High-street, Golden Square, 3555. One commercial goods vehicle (L/C. 109 cwt.) to operate within a 50-mile radius of the premises of Pioneer Concrete Victoria Pty. Ltd. at Bendigo solely on behalf of the said company—premixed concrete in a specially constructed agitator vehicle.

WATTS, K. I., Princes Highway, Port Fairy, 3284. One commercial goods vehicle (L/C. 246 cwt.) to operate: (a) Within a 50-mile radius from the post office at Port Fairy—as a "Road Contractor"—road-making plant and materials. (b) Within a 20-mile radius from the site of any construction or maintenance work performed pursuant to paragraph (a) above, or from the railway station nearest thereto—any other materials required for such work. (c) Within a 20-mile radius from the post office at Port Fairy—general goods. (d) From and to the depot of B.P. Aust. Ltd. at Portland to and from places situated within the radius defined in paragraph (c) above—petroleum products in prescribed types of containers and empty return containers.

NOTE.—This application replaces licence No. D.A.37192/3 in the same name expired 7th March 1970.

WEIR, C. J. (trading as C. J. & I. Weir), care of Downie Thomson & Robb, P.O. Box 19, Warragul, 3820. One commercial goods vehicle (L/C. 225 cwt.) to operate: (a) From forest and private landings situated within a 25-mile radius of the post office situated at Darnum to:—(i) Sawmills within the above area—mill logs. (ii) Own premises at Darnum—poles and posts. (b) From own premises at Darnum to consignees situated within a 25-mile radius of the post office at Darnum—treated poles and posts.

YOUNGER, R. N., Greta, 3675. One commercial goods vehicle (L/C. 94 cwt.) to operate: (a) Within a 50-mile radius of the post office at Wangaratta as a "Road Contractor"—road-making plant and materials. (b) Within a 25-mile radius of Greta—general goods, provided that no goods shall be carried whether by one stage or by more than one stage between places within the above radius which are more than thirty (30) road miles apart by the nearest practicable route.

TOW TRUCKS.

GRIBBIN, J. M. & J. B. WEBSTER, High-street, Nagambie, 3608. One commercial goods vehicle (L/C. 40 cwt.) to operate throughout the State of Victoria as a "Tow Truck" solely—(a) For the purpose of lifting and carrying or towing motor vehicles and the carriage of tools and equipment necessary for such purposes only and; (b) The carriage of spare parts necessary for the repair of a disabled motor vehicle to and from the place at which such disablement has occurred.

H. & S. PANELS, 31 Booloora-road, Springvale, 3171. One commercial goods vehicle (to be purchased) to operate within a 20-mile radius of the post office at Springvale as a "Tow Truck" solely—(a) For the purpose of lifting and carrying or towing motor cars and the carriage of tools and equipment necessary for such purpose only and; (b) The carriage of spare parts necessary for the repair of a disabled motor to and from the place at which such disablement has occurred.

RENEWALS.

APPLICATIONS made for renewal of licences as shown by persons listed hereunder to operate under the same terms and conditions from the expiry shown in each case.

ABERFELDIE QUARRIES SAND SUPPLY PTY. LTD., Knighton-avenue, East Keilor, 3042; D.A.37391/25; 26th April, 1971; 238 cwt.

ARMOURD ESCORTS PTY. LTD., corner Arden & Lothian streets, North Melbourne, 3051; D.A.37566/3; 29th April, 1971; 10 cwt.

CLARK, NORMAN G. (AUST.) PTY. LTD., 278 Barkly-street, Brunswick, 3056; D.A.60685; 17th April, 1971; 14 cwt.

CLARKE MOBILE CRANES PTY. LTD., 167 Normanby-road, South Melbourne, 3205; D.A.49787/6; 6th February, 1971; 251 cwt.

DAVIES, EDGAR PTY. LTD., 45 Alex-avenue, Moorabbin, 3189; D.A.60682; 17th April, 1971; 6 cwt.

DEVILEE, J. J. & H. D., P.O. Box 947, Mildura, 3500; D.A.60651; 3rd April, 1971; 17 cwt.

DOWNES, R. E., PTY. LTD., Gembrook-road, Nar Nar Goon, 3812; D.A.27544/12; 6th March, 1971; 308 cwt.

DOWSETT, S. J., 38 Pier-street, Dromana, 3936; D.A.60719; 26th April, 1971; 99 cwt.

DUNLOP TYRE SERVICE (VIC.) PTY. LTD., Colac Branch, 108 Flinders-street, Melbourne, 3000; D.A.60416/40; 8th April, 1971; 11 cwt.

FLEETWAYS TRANSPORT SERVICES PTY. LTD., 61 Bertie-street, Port Melbourne, 3207; T.D.A.48587/1; 22nd April, 1971; 69 cwt.

FLEETWAYS TRANSPORT SERVICES PTY. LTD., 61 Bertie-street, Port Melbourne, 3207; D.A.48587/4; 29th April, 1971; 55 cwt.

HALL, G. W. & T. J., 15 Callen-street, Seymour, 3660; D.A.24141/3; 17th April, 1971; 147 cwt.

HICKS, W. G., PTY. LTD., 562 City-road, South Melbourne, 3205; T.D.A.62469/2; 27th April, 1971; 65 cwt.

JAMES, E. O., 80 Eleventh-street, Mildura, 3500; D.A.27031/2; 8th April, 1971; 8 cwt.

LLOYD, H. C., Stanhope-road, Rushworth, 3612; D.A.20188; 18th April, 1971; 118 cwt.

MARTIN, J., 54 Gillies-crescent, Bridle Estate, Morwell, 3840; D.A.48876; 29th April, 1971; 135 cwt.

MAY'S VIBRATED CONCRETE PTY. LTD., 277-281 Wickham-road, Moorabbin, 3189; D.A.34611/5; 26th April, 1971; 235 cwt.

MORRISH, N. K., 30 Emmett-street, Ouyen, 3490; D.A.1633; 18th April, 1971; 141 cwt.; D.A.1633/1; 18th April, 1971; 145 cwt.

NELSON NOMINEES PTY. LTD., Lot 25, Stewart-street, Mt. Waverley, 3149; D.A.41484/1; 17th April, 1971; 22 cwt.

NESTLE CO., THE (AUSTRALIA) LTD., 159 Racecourse-road, Flemington, 3031; D.A.31378/6; 29th April, 1971; 8 cwt.; D.A.31378/7; 29th April, 1971; 10 cwt.; D.A.31378/9; 29th April, 1971; 8 cwt.; D.A.31378/10; 27th April, 1971; 8 cwt.; D.A.31378/11; 27th April, 1971; 8 cwt.; D.A.31378/12; 27th April, 1971; 8 cwt.; D.A.31378/13; 27th April, 1971; 8 cwt.; D.A.31378/14; 27th April, 1971; 10 cwt.; D.A.31378/15; 27th April, 1971; 10 cwt.; D.A.31378/17; 27th April, 1971; 8 cwt.; D.A.31378/18; 27th April, 1971; 8 cwt.; D.A.31378/19; 27th April, 1971; 10 cwt.; D.A.31378/20; 27th April, 1971; 10 cwt.; D.A.31378/21; 27th April, 1971; 10 cwt.; D.A.31378/22; 29th April, 1971; 8 cwt.; D.A.31378/24; 29th April, 1971; 10 cwt.; D.A.31378/25; 29th April, 1971; 10 cwt.; D.A.31378/26; 29th April, 1971; 10 cwt.; D.A.31378/27; 29th April, 1971; 8 cwt.; D.A.31378/28; 29th April, 1971; 10 cwt.; D.A.31378/30; 29th April, 1971; 8 cwt.; D.A.31378/34; 29th April, 1971; 8 cwt.; D.A.31378/32; 29th April, 1971; 8 cwt.; D.A.31378/23; 29th April, 1971; 10 cwt.; D.A.31378/8; 29th April, 1971; 10 cwt.

NICHOLAS PTY. LTD., 699 Warragul-road, Chadstone, 3148; D.A.56963/32; 17th April, 1971; 8 cwt.; D.A.56963/31; 17th April, 1971; 12 cwt.; D.A.56963/30; 17th April, 1971; 10 cwt.; D.A.56963/29; 17th April, 1971; 8 cwt.; D.A.56963/28; 17th April, 1971; 8 cwt.

O'BRIEN, G., & SONS PTY. LTD., 55 Parer-road, Airport West, 3042; D.A.49833/1; 26th April, 1971; 149 cwt.

PALLOT, H. S. & S., 25 Palk-street, Horsham, 3400; D.A.35692; 27th April, 1971; 16 cwt.

PATINSON, G. H., 115 Argyle-street, Traralgon, 3844; D.A.35506; 6th April, 1971; 126 cwt.

PORTER, G. E., PTY. LTD., 15 Queen's-parade, Clifton Hill, 3068; D.A.54561/4; 26th April, 1971; 19 cwt.

RICHARDSON, JAMES PTY. LTD., 35-45 Lithgow-street, Abbotsford, 3067; D.A.45596/6; 21st April, 1971; 36 cwt.

RUNDELL, D. N., 6 Adams-street, Portland, 3305; D.A.60718/1; 26th April, 1971; 174 cwt.

SEA LAKE TRANSPORT CO. PTY. LTD., Sutcliffe-street, Sea Lake, 3533; D.A.37362/4; 17th April, 1971; 250 cwt.

SOU-WEST FROZEN FOOD PACKERS LTD., 99 Bell-street, Preston, 3072; D.A.50046/7; 6th February, 1971; 11 cwt.; D.A.50046/8; 6th February, 1971; 11 cwt.; D.A.50046/9; 6th February, 1971; 11 cwt.; D.A.50046/10; 6th February, 1971; 11 cwt.; D.A.50046/11; 6th February, 1971; 11 cwt.; D.A.50046/12; 6th February, 1971; 11 cwt.; D.A.50046/13; 6th February, 1971; 11 cwt.; D.A.50046/14; 6th February, 1971; 11 cwt.; D.A.50046/15; 6th February, 1971; 11 cwt.; D.A.50046/16; 6th February, 1971; 11 cwt.; D.A.50046/17; 6th February, 1971; 11 cwt.; D.A.50046/18; 6th February, 1971; 11 cwt.; D.A.50046/20; 13th February, 1971; 11 cwt.; D.A.50046/21; 13th February, 1971; 11 cwt.

STUART & HARRISON (SALES) PTY. LTD., Herbert and George streets, Robinvale, 3549; D.A.46285/1; 17th April, 1971; 6 cwt.

WATSON, G. E., & SON, P.O. Box 30, Rochester, 3561; D.A.57600/1; 26th April, 1971; 148 cwt.

WATSON, G. J., Darlington, 3271; D.A.9846; 29th April, 1971; 69 cwt.

WRIGHT STEPHENSON & CO. LTD., P.O. Box 159, Heywood, 3304; D.A.38919/7; 26th April, 1971; 140 cwt.

WRIGHT STEPHENSON & CO. LTD., P.O. Box 159, Heywood, 3304; D.A.38919/8; 26th April, 1971; 106 cwt.

TOW TRUCK RENEWALS.

BATSON, C. G., 52 Moore-street, Colac, 3250; D.A.29351/3; 25th March, 1971; 97 cwt.

FECHNER, A. (trading as Clayton Motors), corner Clayton and Centre roads, Clayton, 3168; D.A.60544; 17th April, 1971; 40 cwt.

ESTATE OF THE LATE F. C. HILL, 276 High-street, Belmont, 3216; D.A.30446/2; 26th February, 1971; 30 cwt.

CRADDOCK, H. J. (trading as Lane Way Panel Beating and Spray Painting Works), 370 Murray-street, Colac, 3250; D.A.48356; 22nd April, 1971; 70 cwt.

C. R. TURNER MOTORS PTY. LTD., 347 Main-street, Mornington, 3931; D.A.35515; 6th April, 1971; 32 cwt.

RENEWALS WITH VARIATION.

APPLICATIONS made by the persons listed hereunder for renewal of the licences listed with variation of conditions in the manner set out opposite the names.

BARKER, H. (trading as Barker Bros.), Main-road, Yarra Junction, 3797; D.T.117/4; 6th March, 1971; Application to renew and vary the conditions of licence No. D.T.117/4 (L/C. 210 cwt.) by deleting paragraph (a) and (c) of the existing conditions also add as an additional paragraph—"From forest landings in the Upper Yarra Forestry District to the sawmill of the Victorian Hardwood Co. at Powelltown—logs.

CRYSTAL CORDIAL CO., 34 Macalister-street, Sale, 3850; D.A.48303/1; 10th April, 1971; D.A.48303/2; 10th April, 1971; D.A.48303/3; 10th April, 1971; D.A.48303/4; 10th April, 1971; Application to renew and vary the conditions of licences numbered D.A.48303/1 and D.A.48303/2 and D.A.48303/3 and D.A.48303/4 (L/C. 82, 32, 10, 171 cwt.) by deleting paragraph (a) (ii) of the existing conditions and adding in lieu:—From own premises at Sale for delivery to places within 65 miles radius of Sale, cordials, soft drinks and aerated waters being products of such approved decentralized industry; also delete from the existing conditions paragraph (b) and add in lieu "In the course of business as "Distributing Agents" from own premises at Sale to customers within 65 miles radius of Sale, bottles, soft drinks, canned soft drinks, wrapping paper, vinegar and potato chips".

FELMINGHAM, F. J., 58 Stawell-street, Sale, 3850; D.A.50527; 14th March, 1971; D.A.50078/4; 6th March, 1971; Application to renew and vary the conditions of licences D.A.50078/4 and D.A.60527 (L/C. 143 cwt. and 210 cwt.) by deleting the existing conditions and adding in lieu: (a) Within a 95-mile radius of the post office at Nowa Nowa (Bairnsdale Division of the Country Roads Board) road contracting plant used in the construction or maintenance of a road, street, footpath, bridge, wharf, pier, weir or channel. (b) Within a 20-mile radius from site of construction or maintenance work performed pursuant to paragraph (a) above or from a railway station nearest thereto—materials required for such work. (c) Within a 25-mile radius of the post office at Sale—general goods, with the proviso that no journey shall exceed 30 miles in length.

PHILLIPS & STONE, 288 Main-street, Bairnsdale, 3875; D.A.14248/1; 6th March, 1971; D.A.14248/2; 6th March, 1971; D.A.14248/3; 6th March, 1971; D.A.14248/4; 6th March, 1971; Application to renew and vary the conditions of licences numbered D.A.14248/1, D.A.14248/2, D.A.14248/3 and D.A.14248/4 (L/C. 10, 110, 73, 91 cwt.) by deleting from paragraph (b) of the existing conditions "Marchants".

SINCLAIR, H. R., Ross-street, Heatherton, 3202; D.A.48290; 11th February, 1971; Application to renew and vary the conditions of licence No. D.A.48290 (L/C. 135 cwt.) by adding to paragraph (b) of the existing conditions after "Scoresby bricks and tiles".

SOUTH EASTERN MILK PRODUCTS LTD., Commercial-road, Yarram, 3971; D.A.34669/2; 8th April, 1971; Application to renew and vary the conditions of licence No. D.A.34669/2 (L/C. 11 cwt.) by deleting from the existing conditions "Heyfield" and adding in lieu: "Yarram".

TURK, A. K. & M. J., A'Beckett-road, Narre Warren North, 3804; D.A.6756/2; 17th April, 1971; Application to renew and vary the conditions of licence No. D.A.6756/2 (L/C. 208 cwt.) by deleting "Rowlands Quarries Pty. Ltd." and adding in lieu: "Pioneer Quarries Pty. Ltd."

Notice of any objection should be forwarded to reach the Secretary of the Board not later than Wednesday, 2nd December, 1970.

Applicants are advised that it will not be necessary to appear on the hearing date specified above, unless advised in writing by the Board.

B. P. KAY,
Secretary.

Corner Lygon and Princes streets, Carlton, Wednesday, 18th November, 1970.

Justices Act 1958.

MAGISTRATES' COURTS.—DAYS APPOINTED IN ADDITION OR IN LIEU.

HIS Excellency the Governor of the State of Victoria by and with the advice of the Executive Council thereof doth by Order made on the 10th day of November, 1970, and pursuant to the provisions of section 64 of the Justices Act 1958, appoint the days and hours contained in the Schedule below for the holding of Magistrates' Courts at the places named in such Schedule, in lieu of or in addition to the days and hours heretofore appointed—to take effect as from the dates shown.

SCHEDULE.

Place.	Days and Hours.
HAWTHORN	Every Friday at 10 a.m. except public holidays in addition to the days and hours heretofore appointed as from the 8th January, 1971.
MOONEE PONDS	Every Wednesday, Thursday and Friday at 10 a.m. except public holidays in lieu of the days and hours heretofore appointed as from the 1st April, 1971.
MORDIALLOC	Every Monday at 10 a.m. except public holidays in addition to the days and hours heretofore appointed as from the 4th January, 1971.
NORTHCOTE	Every Wednesday at 10 a.m. except public holidays in addition to the days and hours heretofore appointed as from the 6th January, 1971.
WILLIAMSTOWN	Every Tuesday and Thursday at 10 a.m. except public holidays in addition to the days and hours heretofore appointed as from the 5th January, 1971.
WILLIAMSTOWN	Every Tuesday and Thursday at 10 a.m. except public holidays in lieu of the days and hours heretofore appointed as from the 1st April, 1971.
YALLOURN	Every Monday at 10 a.m. except public holidays in lieu of the day and hour heretofore appointed as from the 4th January, 1971.
RINGWOOD	Every Monday, Tuesday, Thursday and Friday at 10 a.m. except public holidays in lieu of the days and hours heretofore appointed as from the 4th January, 1971.

J. ROSSITER,
Clerk of the Executive Council.

At the Executive Council Chamber,
Melbourne, 10th November, 1970.

POLICE-OFFENCES ACT 1958.

IN pursuance of the powers conferred upon the Chief Secretary by sub-section (3) of Section 184 of the Police Offences Act 1958, I do by this notice grant exemption from compliance with sub-sections (1) and (2) of Section 184 of the said Act with respect to the publication "Know Your Pet" distributed by The Herald and Weekly Times Limited, 44-74 Flinders-street, Melbourne.

A. G. RYLAH,
Chief Secretary.

Chief Secretary's Office,
Melbourne, 12th November, 1970.

DEPARTMENT OF MINES.

APPLICATION FOR MINING LEASE DECLARED ABANDONED.

8980, Mineral; Leslie Driscoll, John N. Gartside; 630 acres, Parish of Barkly.

MINING LEASES GRANTED.

9265, Castlemaine; Lillian Wilson, Peter John Wilson; 75a. 3r. 20p., Parish of Queenstown.

8608, Mineral; Abraham David Hargreaves; 43a. 3r. 12p., Parish of Kerrit Bareet.

9025, Mineral; Edward Arthur Knox; 53a. 0r. 6p., Parish of Enoch's Point.

APPLICATION FOR MINERAL SEARCH LICENCE REFUSED.

1049, Mineral Search Licence; Roland Walton; 38.5 square miles, Parishes of Bemboka, Wongungarra, Cowa.

MINERAL SEARCH LICENCE GRANTED.

971, Mineral Search Licence; Michael Mackey; 50 acres, more or less, Parish of Toorong.

EXPLORATION LICENCE GRANTED.

169, Exploration Licence; C.R.A. Exploration Pty. Ltd.; 303 square miles, Counties of Anglesey, Delatite.

TAILINGS LICENCE GRANTED.

3678, Tailings Licence; Robert John Pyle, Hayden Maxwell Mustey; 129a. 2r. 32p., Parish of Byawatha.

TAILINGS LICENCES EXPIRED.

3494, Tailings Licence; The President, Councillors and Ratepayers of the Shire of Buninyong; "Imperial Mullock" dump situated at Buninyong.

3608, Tailings Licence; Kelvin D. Donaldson; "South New Moon" shaft site situated at Growlers-street, Eaglehawk.

EXTRACTIVE INDUSTRY SEARCH PERMIT GRANTED.

15, Extractive Industry Search Permit; The Victoria Portland Cement Company Proprietary Limited; 5.32 square miles, Parishes of Holey Plains, Coolungoolun.

J. C. M. BALFOUR,
Minister of Mines.

WORKERS COMPENSATION ACT 1958, SECTION 72.

HIS Excellency the Governor of the State of Victoria by and with the advice of the Executive Council thereof doth by Order made on the 17th day of November, 1970, and pursuant to the provisions of section 72 of the Workers Compensation Act, approve of the BRITISH PROTECTION INSURANCE COMPANY PTY. LTD., as an insurer, for the period ending 30th June, 1971.

J. ROSSITER,
Clerk of the Executive Council.

At the Executive Council Chamber,
Melbourne, 17th November, 1970.

TEACHING SERVICE ACT 1958.—SECTION 73.

MICHAEL STANLEY COUNIHAN, Teacher, Assistant Class, Secondary Schools Division, Horsham High School, Education Department, having been charged under the provisions of section 55 of the Public Service Act 1958, as extended and made applicable to members of the teaching service by section 73 of the Teaching Service Act 1958, with being absent without leave from the 2nd June, 1969 to the 17th June, 1970, and such charge having been referred, by direction of the Honorable the Minister of Education, to the Teachers Tribunal, the Tribunal after enquiry finds such charge proved and under the provisions of the section of the Act above cited, hereby dismisses the said Michael Stanley Counihan from the Teaching Service as from and including the 10th November, 1970.

W. E. SAMPSON, Chairman.
A. F. LE CLERCQ, Secretary.

Office of the Teachers Tribunal,
Melbourne, 9th November, 1970.

Private Agents Act 1966.

NOTICE OF RECEIPT OF APPLICATIONS FOR LICENCES UNDER THE PROVISIONS OF THE PRIVATE AGENTS ACT 1966.

THE Clerk(s) of the Magistrates' Court(s) as listed hereunder hereby give notice that applications, as under, have been lodged for hearing by the said Court(s) on the date(s) specified.

Any person desiring to object to any of such applications must—

- (a) lodge with the respective Clerk of the Magistrates' Court a notice in the prescribed form of his objection and of the grounds thereof;
- (b) cause a copy of such notice to be served personally or by post upon the applicant at least three days before the hearing of the application; and
- (c) send or deliver—
 - (i) where the objection is not made by the officer in charge of the police district in which the Court is situated—a copy of the notice to such officer; and
 - (ii) where the objection is not made by the Registrar or Deputy Registrar—a copy to the Registrar.

Full Name of Applicant or in the Case of a Firm or Corporation, of the Nominee.	Place of Abode of Applicant or Nominee.	Name of Firm or Corporation.	Address for Registration.	Type of Licence.	Date of Hearing of Application.
---	---	------------------------------	---------------------------	------------------	---------------------------------

MAGISTRATES' COURT, PRAHRAN.

Boxall, Christopher Robert ..	Flat 31, 12 Sutton-street, North Melbourne	Suite 17, 562 St. Kilda-road, Melbourne	Watchman ..	3.12.70
Guymmer, William Robert ..	28 Charlesworth-street, Laverton	" "	" ..	"
Horvath, Tibor ..	14 Munro-street, Ringwood	" "	" ..	"

Dated at Prahran this 6th day of November, 1970.

J. PRESNELL, Clerk of the Magistrates' Court.

MAGISTRATES' COURT, RINGWOOD.

Halliwell, Brian Raymond ..	56 Menin-road, Forest Hill	56 Menin-road, Forest Hill	Inquiry Agent ..	23.11.70
-----------------------------	----------------------------	---------	----------------------------	------------------	----------

Dated at Ringwood this 2nd day of November, 1970.

L. T. GOULD, Clerk of the Magistrates' Court.

MAGISTRATES' COURT, SOUTH MELBOURNE.

Birmingham, William Richard	9 Malva-road, Fern-tree Gully	101-105 Clarke-street, South Melbourne	Watchman ..	23.11.70
Heffernan, William Bernard ..	17 Armata-crescent, Frankston	" "	" ..	"
Long, David Audubon ..	21 Victor-avenue, Cheltenham	" "	" ..	"
Porter, Sidney Robert ..	18 Nicholson-street, Brunswick West	" "	" ..	"
Smith, Alexander James ..	41 Hiller-street, Brunswick West	" "	" ..	"
Taylor, Wilfred ..	4/27 Wilma-avenue, Dandenong	" "	" ..	"

Dated at South Melbourne this 4th day of November, 1970.

J. M. DUGAN, Clerk of the Magistrates' Court.

MAGISTRATES' COURT, MELBOURNE.

Darlow, Denis Roy ..	15 Withers-road, Bayswater	15 Withers-road, Bayswater	Process Server ..	2.12.70
----------------------	----------------------------	---------	----------------------------	-------------------	---------

Dated at Melbourne this 4th day of November, 1970.

G. L. WEBSTER, Clerk of the Magistrates' Court.

MAGISTRATES' COURT, PORT FAIRY.

Hull, Evelyn Joan ..	34 William-street, Port Fairy	34 William-street, Port Fairy	Process Server ..	25.11.70
----------------------	-------------------------------	---------	-------------------------------	-------------------	----------

Dated at Port Fairy this 3rd day of November, 1970.

G. MEEHAN, Clerk of the Magistrates' Court.

MAGISTRATES' COURT, GEELONG.

Sheerin, James ..	9 Elizabeth-street, Whittington	Geelong Armed Escort and Security Service Co. Pty. Ltd.	94 Seabright-street, North Shore	Watchman ..	20.11.70
-------------------	---------------------------------	---	----------------------------------	-------------	----------

Dated at Geelong this 29th day of October, 1970.

D. W. HAMMOND, Clerk of the Magistrates' Court.

MAGISTRATES' COURT, SALE.

Montgomery, Harry Corrigan Stanley	Irwin-crescent, Wurruk via Sale	Sale Security Services Limited	26 Overend-crescent, Sale	Watchman ..	1.12.70
------------------------------------	---------------------------------	--------------------------------	---------------------------	-------------	---------

Dated at Sale this 6th day of November, 1970.

D. R. WALKER, Clerk of the Magistrates' Court.

MAGISTRATES' COURT, MALVERN.

Cox, Ronald Ross ..	27 Morton-road, Burwood	M and I Services Pty. Limited	19 Bella Vista-road, Glen Iris	Inquiry Agent ..	9.12.70
---------------------	-------------------------	-------------------------------	--------------------------------	------------------	---------

Dated at Malvern this 10th day of November, 1970.

P. J. RODDA, Clerk of the Magistrates' Court.

PRIVATE AGENTS—continued.

Full Name of Applicant or in the Case of a Firm or Corporation, of the Nominee.	Place of Abode of Applicant or Nominee.	Name of Firm or Corporation.	Address for Registration.	Type of Licence.	Date of Hearing of Application.
---	---	------------------------------	---------------------------	------------------	---------------------------------

MAGISTRATES' COURT, COBURG.

Rowley, Maxwell Alfred	3 Heath-street, Pascoe Vale		88 Bakers-road, North Coburg	Watchman	1.12.70
------------------------	-----------------------------	--	------------------------------	----------	---------

Dated at Coburg this 10th day of November, 1970.

F. J. TENNI, Clerk of the Magistrates' Court.

MAGISTRATES' COURT, SHEPPARTON.

Vanderleest, Adrian Francis	New Dookie-road, Shepparton		New Dookie-road, Shepparton	Watchman	10.12.70
Banner, William John	9 Rimes-court, Shepparton	M.S.S.	9 Rimes-court, Shepparton	"	"
Kidd, James Reginald	43 Annerly-avenue, Shepparton	M.S.S.	9 Hariem-street, Shepparton	"	"
Thomas, Louis Hamilton	27 Numurkah-road, Shepparton		27 Numurkah-road, Shepparton	Process Server	"
Banner, William John	9 Rimes-court, Shepparton		9 Rimes-court, Shepparton	"	"

Dated at Shepparton this 10th day of November, 1970.

R. N. HOLLIS, Clerk of the Magistrates' Court.

MAGISTRATES' COURT, HASTINGS.

Nowlan, Michael Arthur	101 Rosebud-parade, Rosebud		340 Abbotsford-street, North Melbourne	atchWman	9.12.70
Lowery, Edward Ernest	11 Hayman-avenue, Seaford		" "	"	"
Rooke, Arthur George	Mornington-road Tyabb		" "	"	"

Dated at Hastings this 5th day of November, 1970.

T. O'KEEFE, Clerk of the Magistrates' Court.

Police Regulation Act 1958.

POLICE FORCE OF VICTORIA.

DETERMINATION NO. 171 OF THE POLICE SERVICE BOARD.

THE Police Service Board, in pursuance of the powers in that behalf conferred by the *Police Regulation Act 1958*, hereby makes the following Determination (that is to say):—

The Determination No. 169 of the Police Service Board of the 30th October, 1970, is hereby amended as follows:—

In paragraph 12—

By renumbering sub-paragraph (a) as (a) (i) and adding the following sub-paragraph:—

“(ii) There shall be paid to a member appointed by the Chief Commissioner to the Research and Planning Division to perform the duties of a Systems Analyst/Programmer in the field of electronic data processing, and whilst occupying that position, an allowance (inclusive of any other Special Duties Allowance) equivalent to the amount by which the sums of \$5,926 for the first year, \$6,090 for the second year and \$6,255 for the third and subsequent years of service in the performance of such duties exceed the salary and allowances, except the allowance for uniform, prescribed or hereafter to be prescribed for the rank of such member by any Determination of the Police Service Board.”

Dated this 9th day of November, 1970.

BEN. J. DUNN,
A Judge of the County Court of Victoria,
Chairman and Member of the Police
Service Board.

J. G. BROWN,
Member of the Police Service Board.

G. DAVIDSON,
Member of the Police Service Board.

STATE RIVERS AND WATER SUPPLY COMMISSION.

LICENCES TO DIVERT WATER AND CUT RACES PURSUANT TO THE PROVISIONS OF SECTION 204 OF THE WATER ACT 1958 (AS AMENDED).

THE Governor in Council has approved of the granting by the State Rivers and Water Supply Commission of licences as detailed hereunder for the term of years from the date specified in each case to the persons named in the following Schedule :—

SCHEDULE.

Licence No.	Term of Licence and Commencing Date.	Name and Address of Person to whom Licence is to be Granted.	Source of Supply.	Area Authorized to be Irrigated Per Annum.	Volume of Water Authorized to be Diverted Per Annum.	Annual Fee.
				acres.	ac. ft.	\$
3055	Four years from 1.7.69	Dr. John Bell McMiken, Shepparton	Goulburn River ..	4½	9	15.00
3056	Four years from 1.7.69	William Edward Taylor, Echuca	Goulburn River ..	3	6	15.00
3057/1180	Four years from 1.7.69	Andrew Norman McLeish, Eddington	Loddon River ..	10	20	10.00
3058	Four years from 1.7.69	Audrey Helen Young, Wemen	River Murray ..	57	171	213.75

Licence No.	Term of Licence and Commencing Date.	Name and Address of Person to Whom Licence is to be Granted.	Source of Supply.	Area Authorized to be Irrigated Per Annum.	Volume of Water Authorized to be Diverted Per Annum.
2540	Four years from 1.7.69 ..	Pulvirenti, G. & M., Markwood ..	Ovens River ..	acres 34	ac. ft. 51

The annual fee payable in respect of each acre-foot of water authorized to be diverted is the equivalent of one-half of the irrigation charge per acre-foot fixed in the Goulburn-Murray Irrigation District for the preceding financial year.

764	Six years from 1.7.69 ..	The Executrix of the Estate of Murray Adams, Swan Hill.	Little Murray River	100	200
-----	--------------------------	---	---------------------	-----	-----

The annual fee payable in respect of each acre-foot of water authorized to be diverted is the equivalent of the irrigation charge per acre-foot fixed in the Goulburn-Murray Irrigation District for the preceding financial year.

Office of the State Rivers and Water Supply Commission,
Melbourne, 10th November, 1970.

G. W. LEWIS, Secretary,
State Rivers and Water Supply Commission.

STATE RIVERS AND WATER SUPPLY COMMISSION.

LICENCES TO DIVERT WATER PURSUANT TO THE PROVISIONS OF SECTION 204 OF THE WATER ACT 1958 (AS AMENDED).

THE Governor in Council has approved of the granting by the State Rivers and Water Supply Commission of licences as detailed hereunder for the term of years from the date specified in each case to the persons named in the following Schedule :—

SCHEDULE.

Licence No.	Term of Licence and Commencing Date.	Name and Address of Person to whom Licence is to be Granted.	Source of Supply.	Area Authorized to be Irrigated Per Annum.	Volume of Water Authorized to be Diverted Per Annum.	Annual Fee.
				acres	ac. ft.	\$
2612	Fifteen years from 1.7.69	Maurice Edmond Byrne, Wangarratta	Ovens River ..	100	150	187.50
3059	Four years from 1.7.69	Wattle Park Pastoral Co. Pty. Ltd., Seymour	Goulburn River ..	50	100	125.00

Office of the State Rivers and Water Supply Commission,
Melbourne, 10th November, 1970.

G. W. LEWIS, Secretary,
State Rivers and Water Supply Commission.

CONTRACTS ACCEPTED.—(Series 1970-71.)

GENERAL STORES.

Gazette No. 63, 26th June, 1970, supply of General Stores, Schedule No. 18, Bolts, Nuts, Washers and Spikes, Iron.—For rates shown opposite Item Nos. 1 to 10 inclusive, 12 and 14 to 17, substitute Ajax List Price No. 69 less 42½ per cent. net for standard packs and less 27½ per cent. for broken packs, as from 9th November, 1970. Schedule No. 64, Polishes, Dusters, Cleansers, &c. For contractors name shown opposite Item No. 2, substitute Hunters Industrials Pty. Ltd. as from 7th September, 1970.

TOOLS (GENERAL).

Gazette No. 23, 19th March, 1970, Schedule No. 52, Tools (General).—For rates and contractor shown opposite the following items, substitute details as set out hereunder as from 10th November, 1970:—Item No. 344, \$8.36 per dozen, McPhersons Limited; Item No. 366, 5 ft. and 5 ft. 6 in., \$4.18 per dozen, 6 ft. x 1 in., \$4.67 per dozen, 6 ft. 6 in. x 1½ in., \$6.36 per dozen, McPhersons Limited.

J. M. PAWSON, Acting Secretary to the Tender Board.
16.11.70.

VICTORIAN RAILWAYS.

54. Rewinding of G.E.237 motor armatures to specification E.E.B.248b for "Y" class locomotives and suburban stock at rates.—(Contract 63602).—Cheltenham Electric Pty. Ltd.

By Order of the Victorian Railways Commissioners,
W. WALKER, Secretary. 13.11.70.

PUBLIC WORKS.

661. Kingsbury, Technical School, supply workshop equipment, \$6,004.36.—Demco Machinery Co. (Sales);
662. Glenormiston, Agricultural College, supply and install oven, \$4,534.—Allied Ironfounders Pty. Ltd.
663. Glenormiston, Agricultural College, supply kitchen equipment, \$7,561.—Ahearn Main & Stott Pty. Ltd.
664. Port Melbourne, P.W.D. Storeyard, supply extinguishers, \$4,950.—Wormald Bros. Aust. Pty. Ltd.
665. Leongatha Technical School, supply workshop equipment, \$4,609.87.—McPhersons Limited.
666. Leongatha, Technical School, supply workshop equipment, \$13,633.—Demco Machinery Co. (Vic.) Pty. Ltd.
667. Girgarre, Primary School 3971 and Residence, internal and external repairs and renovations, \$6,400.—N. Peshut.
668. Balwyn, "Yooralla" Primary School 4675, alterations to three class-rooms and stage in Assembly Hall, \$8,475.—Alf Richardson Constructions.
669. Wodonga, High School, mechanical services—hall, \$5,509.30.—Ross's Pty. Ltd.
670. Reservoir West, Primary School 4711, external and internal repairs and painting, \$5,600.—Show Painters.
671. Bairnsdale, High School, renovations, \$14,340.—Reihold Strecker.
672.—Pakenham, High School, site works, \$65,327.20.—L. J. Towers.
673. Bonbeach, High School, electrical services—hall, \$9,200.—W. T. Waterfall & Sons Pty. Ltd.
674. Burwood, "Allambie" Reception Centre, site works, \$8,839.10.—Mulsite Company.
675. Bendigo, Institute of Technology, installation of road lighting, \$6,654.49.—T. E. Turner Pty. Ltd.
676. Watsonia, Technical School, connexion to sewer, \$4,563.—C. J. Brittain & R. Sutherland.
677. Various, mechanical services for standard primary class-rooms, &c., within 30-mile radius of Melbourne, Zone 2 Northern (70/71), at Rates.—Chadstone Airconditioning Services Pty. Ltd.
678. Traralgon, Primary School 4700, plenum heating—six additional class-rooms, \$4,805.—Chadstone Airconditioning Services Pty. Ltd.
679. Cobram, Consolidated School and outbuildings, renovations, \$4,052.20.—K. M. Coates.
680. Heidelberg, Technical School, external renovations, \$6,650.—Don Renovations.
681. Koondrook, Primary School 2265, internal and external repairs and painting, \$5,312.—Mick Hood & Co. Pty. Ltd.
682. Meeniyah, Primary School 3165, external and internal renovations and re-blocking, \$5,370.—N. B. & H. H. Schack.
683. Lalor Park, Primary School 5003, paving and drainage, \$19,480.88.—Sheffield Paving & Construction Co. Pty. Ltd.
684. Preston South, Primary School 824, paving and drainage, \$19,933.68.—Sheffield Paving & Construction Co. Pty. Ltd.
685. Newport, Primary School 113, renovations old section of school, \$6,200.—N. Peshut.
686. Charlton, Primary School 1480, erection of L.T.C. toilet block and connexion to town sewerage, \$16,444.—H. J. & K. B. Onley.
687. Northcote, High School, completion of external repairs and painting, \$13,995.—C. B. Bramich.
688. Kyabram, Primary School 4866, mechanical services—4 additional class-rooms, \$4,795.—Bruce Sheet Metal Service.
689. Hawksburn, Primary School 1467, internal repairs and painting, \$5,300.00.—Colouramics & Co.
690. Dimboola, Memorial High School, internal renovations, \$10,506.00.—Don Renovations.
691. Echuca South, Primary School 4994, erection of a seven class-room brick veneer primary school, \$74,927.00.—Hosie Constructions Pty. Ltd.
692. Various, Erection of standard primary class-rooms, &c., within 30-mile radius of Melbourne—Region 1, at Rates.—A. V. Jennings Industries (Aust.) Ltd.
693. Various, Erection of standard primary class-rooms, &c., within 30-mile radius of Melbourne—Region 2, at Rates.—P. M. Versteegen & Sons Pty. Ltd.

694. Various, Erection of standard primary class-rooms, &c., within 30-mile radius of Melbourne—Region 3, at Rates.—A. V. Jennings Industries (Aust.) Ltd.

695. Maribyrnong, Primary School 3736, internal and external repairs and paintings, \$4,400.00.—Alan Martin Pty. Ltd.

696. Melbourne, New State Offices, Stage II, 1 MacArthur-street, maintenance cleaning for the period 14.9.70 to 30.9.73, \$42,611.17 per annum.—Samuel-Kay Services Pty. Ltd.

697. Benalla, Electrical services—general purpose hall type '572C', technical school, \$9,465.00.—Sillery Electrics Pty. Ltd.

698. Kew, John Cannon House, 32 Belmont-avenue, supply and erection of a Terrapin hostel building, \$69,692.00.—Willcroft-Terrapin Pty. Ltd.

699. Beaumaris, Primary School 3899, external painting and repairs, \$4,980.00.—Show Painters.

700. Nhill, High School, erection of new science wing in brick veneer, \$46,625.00.—P. & A. Coutts Pty. Ltd.

701. Traralgon, Hobson Park Hospital, external repairs and painting, \$8,975.00.—R. Bendinelli Renovations and Painting.

702. Balwyn, High School, provision of fire service, \$5,986.00.—C. B. Bramich.

703. Sunshine, Technical School, erection of new brick library, \$64,040.00.—W. J. Cody & Quinn Pty. Ltd.

704. St. Kilda, Initial clean and maintenance cleaning for the period from 3.8.70 to 2.8.73, Court House, \$975.00 per annum (maintenance) \$48.00 (initial clean).—A. L. Dee & Sons Cleaning Service.

705. Maidstone, Primary School 4658, erection of new toilet block, \$16,790.00.—Don Renovations.

706. Corio West, Primary School 5031, electrical installation—new school, \$8,715.95.—Fenton & Douglas.

707. Echuca South, Primary School 4994, mechanical services—seven class-room primary school, \$6,200.00.—Gray & Wood

708. South Melbourne, Primary School 1253, external plaster and painting repairs, \$4,540.00.—J. Grigg.

709. Frankston, Teachers Training College, internal repairs and painting, \$8,475.00.—Industrial Alterations and Building Decorat. Co.

710. Brunswick, Girls' High School, external renovations, \$4,276.00.—Industrial Alterations and Building Decorat. Co.

711. Healesville, High School, asphalt repairs and resurfacing, \$8,794.00.—Wm. Loud Pty. Ltd.

712. Moe, Lands Depot, renovations, toilet block, sewer and storm water drains, &c., \$4,200.00.—W. J. Maslen Pty. Ltd.

713. Hartwell, Primary School 4055, external renovations, \$5,160.00.—Joseph Mazzetti.

714. Preston, Girls' Technical School, mechanical services, \$5,887.00.—L. F. Murray Pty. Ltd.

715. Wendouree, Primary School 1813, erection of two class-rooms and library in brick veneer, \$36,504.00.—John Nolan & Sons Pty. Ltd.

G. SERPELL, Director-General of Public Works. 5.11.70.

ORDERS IN COUNCIL.—(Series 1970-71.)

PUBLIC WORKS.

660. Westport, supply of navigational lighting equipment for the port, \$12,441.60.—AGA Products Australia Pty. Ltd.—(P. & H. 32801.)

Approved by the Governor in Council, 10th November, 1970.—J. ROSSITER, Clerk of the Executive Council.

STATE ELECTRICITY COMMISSION.

716. For the supply of galvanised eyebolts and insulator pins for distribution lines for a period of one year, eight months with optional extension of three months, to Specification No. 70/203, at Schedule rates.—S. G. Sewell Pty. Ltd.

717. For the supply of galvanised eyebolts and insulator pins for distribution lines for a period of one year, eight months with optional extension of three months, to Specification No. 70/203, at Schedule rates. West Footscray Engineering Works Pty. Ltd.

Approved by the Governor in Council, 8th September, 1970.—J. ROSSITER, Clerk of the Executive Council.

718. For the supply of polythene insulated and sheathed supervisory control cable for a period of two years with optional extension of three months, to Specification No. 70/197, at Schedule rates.—Cablemakers (A.C.T.) Pty. Ltd.

Approved by the Governor in Council, 6th October, 1970.—J. ROSSITER, Clerk of the Executive Council.

719. For the supply and installation of 66 kV underground cables between substations "VM" and "LQ" Melbourne, to Specification No. 70/104, at Schedule rates.—British Insulated Callender's Cables (Aust.) Pty. Ltd.

720. For the compilation and supply of instruction manuals for Yallourn "W" Power Station, to Specification No. 70/196, at Schedule rates.—I.S.I. Australasia Pty. Ltd.

721. For the provision and operation of a helicopter for patrol and inspection of high voltage transmission lines for a period of two years with optional extension of three months, to Specification No. 70/220, at Schedule rates.—Jayrow Helicopters.

722. For the supply of switch fuses and end fittings for use in the distribution system for a period of two years with optional extension of three months, to Specification No. 70/209, at Schedule rates.—Stanger & Co. Ltd.

Approved by the Governor in Council, 13th October, 1970.—J. ROSSITER, Clerk of the Executive Council.

723. For the supply of safety footwear for a period of two years with optional extension of three months, to Specification No. 70/232, at Schedule rates.—Heidelberg Footwear Distributors.

724. For the supply of twelve 22 kV pad mounted substations and spare parts for use in distribution system, to Specification No. 70/225, \$94,304.—Tyree Industries (Qld.) Pty. Ltd.

Approved by the Governor in Council, 20th October, 1970.—J. ROSSITER, Clerk of the Executive Council.

725. For the supply of firebricks for power station maintenance for a period of two years with optional extension of three months, to Specification No. 70/216, at Schedule rates.—Newbold General Refractories Ltd.

726. For the supply of steel pipe and fittings for general construction and maintenance works for a period of two years with optional extension of three months, to Specification No. 70/224, at Schedule rates.—Tubemakers of Australia Ltd.

Approved by the Governor in Council, 27th October, 1970.—J. ROSSITER, Clerk of the Executive Council.

COMPANIES ACT 1961.

NOTICE is hereby given in pursuance of Section 308 (2) and 308 (3) of the Companies Act 1961 that at the expiration of three months from the date hereof the names of the following Companies will, unless cause is shown to the contrary, be struck off the Register and the said Companies will be dissolved.

Dated this 10th day of November, 1970.

E. B. MITCHAM,
Assistant Registrar of Companies.

Companies Registration Office,
Melbourne.

COMPANIES ABOVE REFERRED TO.

Name of Company.	Number of Registration.
Hicks Atkinson Pty. Ltd.	7734
Curt Investments Pty. Ltd.	13864
Australian Cricketer Pty. Ltd. (The)	16909
A. Garrick & Sons Pty. Ltd.	17549
Radioprogram Pty. Ltd.	18698
Radio City Pty. Ltd.	22295
R.T. Co. Pty. Ltd.	22846
Au Charne De Paris Pty. Ltd.	24156
Nunawading Timber Co. Pty. Ltd.	24404
Regan & Kenny Pty. Ltd.	25270
Hambrook Plating Pty. Ltd.	26762
R.S.L. (Victoria) Trading Co. Pty. Ltd.	27534
Airport Plaster Co. Pty. Ltd.	30312
Bunn's Service Station Pty. Ltd.	30336
Benalla West Motors Pty. Ltd.	31694
Universal Wire Products Pty. Ltd.	32051
Universal Wire Mattress Co. Pty. Ltd.	33365
Champion Used Cars Pty. Ltd.	34561
Alexander Constructions Pty. Ltd.	37250
L. & J. Dunn Pty. Ltd.	37276
Northey Bros. & Co. Pty. Ltd.	37326
Darlene Pty. Ltd.	40079
New York Junk Co. Pty. Ltd.	40757
Rodd Australia Employees Securities Pty. Ltd.	41686
Typographical Designers Pty. Ltd.	42909
Mount Buller Lodge Pty. Ltd.	43277
Gipps Trading Co. Pty. Ltd.	43476
Birchwood Sports Cars Pty. Ltd.	44456
Webbinsur Pty. Ltd.	44655

COMPANIES ABOVE REFERRED TO.

Name of Company.	Number of Registration.
Cosmopolitan Building Construction Pty. Ltd.	46912
Australian Financial Times Pty. Ltd.	49344
Interlock Knitting Enterprises Pty. Ltd.	49398
Australian Trade File Services Pty. Ltd.	49543
G.G. Knit Pty. Ltd.	50192
Merri Bridge Motors Pty. Ltd.	50284
178 Faraday Street, Carlton Pty. Ltd.	52657
Streamline Fashions Pty. Ltd.	52771
Candy Cash Vans Associated Pty. Ltd.	52904
Counsel (Public Relations) Pty. Ltd.	53030
Stan Jones Motors Pty. Ltd.	53690
Tweed Operations Pty. Ltd.	54295
Universal Baby Carriages Pty. Ltd.	54674
Harpers' Eggs Pty. Ltd.	55879
Wentworth U.K. Motors Pty. Ltd.	56023
Used Car Wholesalers Pty. Ltd.	56857
Kidstone Homes Pty. Ltd.	56914
Syrena Products Pty. Ltd.	57001
Ivor Jones Pty. Ltd.	57109
Byldan Trading Pty. Ltd.	57559
Berwin Engineering Pty. Ltd.	58137
Bennettswood Plumbing Services Pty. Ltd.	58279
Phoenix Ventilation Co. (Vic.) Pty. Ltd.	58427
Astragal Pty. Ltd.	58674
Brighton's Dendy Movie Bowl Ltd.	59422
George Johns Pty. Ltd.	60301
Mitcham Plant Hire Pty. Ltd.	60733
Newcomb Plaster Pty. Ltd.	61036
C.C.G. Transport Pty. Ltd.	61571
Atlantis Travel Service Pty. Ltd.	61738
Charles Jack Pty. Ltd.	61980
Cassar Transport Pty. Ltd.	62236
Wamma Pty. Ltd.	62649
Visichange Battery Distributors (Vic.) Pty. Ltd.	62977
Bourke Hill Pty. Ltd.	62994
Steelformed Pty. Ltd.	63724
Unitrade Pty. Ltd.	64136
Global Traders & Distributors Pty. Ltd.	64139
L. & T. Pty. Ltd.	65088
Halsall Motors Pty. Ltd.	65465
Sandilands Investments Pty. Ltd.	65848
Tollis Young Pty. Ltd.	66087
Stanley & Jones Pty. Ltd.	67278
Sub-Sea Roughnecks Pty. Ltd.	67434
Survey Mapping (Victoria) Pty. Ltd.	67866
Taylor Agricultural Contractors Pty. Ltd.	68040
Style Patterns (Aust.) Pty. Ltd.	68626
All-States Publishing Co. Pty. Ltd.	68947
Scoble Staff Services Pty. Ltd.	69266
Magnettype Pty. Ltd.	70469
Quality X Ray Welding Co. Pty. Ltd.	70870
Cawdor Investments Pty. Ltd.	71139
Cents Investments Pty. Ltd.	71895
Garrett Electronics Pty. Ltd.	74138
Thelpat Trading Co. Pty. Ltd.	74413
Selwood Insurance Underwriters (Australia) Pty. Ltd.	76955
Japrom Nominees Pty. Ltd.	78386
Lawnhill Securities Ltd.	78860
Arcade Health Studios Pty. Ltd.	79000
Chris Chris International Ltd.	79029
Silver Spoon Mine Ltd.	81268
Conquest Finance Ltd.	82137
Guttridge Financial Planning Pty. Ltd.	82176

COMPANIES ACT 1961.

NOTICE is hereby given in pursuance of Section 308 (2) of the Companies Act 1961 that at the expiration of three months from the date hereof the names of the following companies will, unless cause is shown to the contrary, be struck off the Register.

Dated this 10th day of November, 1970.

E. B. MITCHAM,
Assistant Registrar of Companies.

Companies Registration Office,
Melbourne.

COMPANIES ABOVE REFERRED TO.

Name of Company.	Number of Registration.
Associated Dominions Assurance Society Pty. Ltd.	F1450
Tilli Craft (Vic.) Pty. Ltd.	F3706
Redline Coaches Pty. Ltd.	F4674
Trade Plywood Distributors Pty. Ltd.	F4727

*Farm Produce Merchants and Commission Agents
Act 1965 (7274).*

LIST OF NAMES AND ADDRESSES OF PERSONS TO
WHOM LICENCES HAVE BEEN GRANTED DURING
OCTOBER, 1970.

IN accordance with the above Act, those issued with a Merchant's or Commission Agent's licence have paid the prescribed fee to the Farm Produce Merchants and Commission Agents Guarantee Fund. All licences, unless earlier cancelled, shall continue in force until 30th June, 1971.

D. S. WISHART,
Director of Agriculture.

MERCHANTS.

Name; Principal Place of Business.

Accurso, Giuseppe; 70 Short-road, Coburg. 3058.
Bertucci, Giuseppe; 7 Gunnedah-street, Sunshine. 3020.
Bryant and Gourley; 22 Peel-street north, Ballarat. 3350.
Christie, W. J.; 30 Madden-avenue, Mildura. 3500.
Costapack Produce; 20 Callister-street, Shepparton. 3630.
Cox, L. G., Pty. Ltd., trading as Wangaratta Wholesale Fruit and Vegetables; "Florida", South Wangaratta. 3678.
De Luca and Son; 50 Reid-street, Wangaratta. 3677.
Diggerson, J. and L.; Rear of 35 Thames Promenade, Chelsea. 3196.
Dyer, P. J.; Williamson's-road, Gembrook. 3783.
Finch, A. W. and D. E., and Sons; Blake-street, Nathalia. 3638.
Fiorelli Packing Co.; 205-207 Darling-road, East Malvern. 3145.
Gaffney, K. B. and I. T.; 91 Main-street, Drouin. 3818.
Golden Poultry Farm Pty. Ltd.; Grants-road, Somerville. 3912.
Hoyle, P., and Son; Yelta.
Huncha, A. R. and J. G.; Sands-avenue, Jeparit. 3423.
Jackel, I. K.; 123 Swan-street, Wangaratta. 3677.
Jacksons Corio Meat Packing Division of Canada Packers Ltd.; Corio Quay, North-Geelong. 3215.
Koroit and Tower Hill Farmers Co-op. Soc. Ltd.; High-street, Koroit. 3282.
Lopes, J. and C.; 121 Nicholson-street, Footscray. 3011.
Lyndon and Jones Pty. Ltd.; 40 Princes-street, Traralgon. 3844.
Micheli, J.; Lea-road, Koo-Wee-Rup. 3981.
Mills Bros.; 135 Burnley-street, Richmond. 3121.
Moss, J., and Sons Pty. Ltd.; Stores 359-361 Melbourne Wholesale Fruit and Vegetable Market, Footscray-road, Footscray. 3011.
Motta, John; 34 Macey-avenue, Avondale Heights. 3034.
Murray Citrus Marketing Co. Pty. Ltd.; Stores 73-78 Melbourne Wholesale Fruit and Vegetable Market, Footscray-road, Footscray. 3011.
McLaine, G. H., and Sons; Main-road, Toolangi. 3777.
Perilli, Benito; Melbourne Wholesale Fruit and Vegetable Market, Footscray-road, Footscray. 3011.
Pirrie Bros.; 31 New Footscray-road, West Melbourne. 3003.
Potato Products (Aust.) Pty. Ltd.; East-street, Daylesford. 3460.
Quayle, J. A.; 41-43 Mair-street, Ballarat. 3350.
Quick, P. R., and Sons (Vic.) Pty. Ltd.; Melbourne Wholesale Fruit and Vegetable Market, Footscray-road, Footscray. 3011.
Silk Bros. (Melb.) Pty. Ltd.; Stores 194-197 Melbourne Wholesale Fruit and Vegetable Market, Footscray-road, Footscray. 3011.
Till, H., and Son Pty. Ltd.; Stores 356-358 Melbourne Wholesale Fruit and Vegetable Market, Footscray-road, Footscray. 3011.
Valley Producers Pty. Ltd.; Bridge-street, Benalla. 3672.
Wallaces, Arthur, Potato Market; 140 Koroit-street, Warrnambool. 3280.
Warrnambool Cool Stores; 179 Drummond-street, Dennington. 3279.
Webber and Lane; Stores 199-200 Melbourne Wholesale Fruit and Vegetable Market, Footscray-road, Footscray. 3011.
Western District Fruit Supply; 281 Timor-street, Warrnambool. 3280.
Williams, George Robert; 49 Welfare Parade, Burwood. 3125.
Zagami, B., and Sons; 170 Main-street, Bairnsdale. 3875.
Zagami, G., and Sons; Esplanade, Lakes Entrance. 3909.

COMMISSION AGENTS.

Arharidis, K.; Virginia, South Australia. 5120.
Aurora Packing Co. Pty. Ltd.; Irymple. 3498.
*Brown, D. A. and R. C.; Wyelangta. 3237.
Craig, Mostyn and Growers Packing Co. Pty. Ltd.; 144 Jolimont-road, East Melbourne. 3002.

Name; Principal Place of Business.

Geelong Banana Co-op. Ltd.; 512-60 Latrobe-terrace, Geelong. 3220.
Godfrey, Dan, and Co. Pty. Ltd.; 29 Clow-street, Dandenong. 3175.
Harcourt Co-operative Fruitgrowers Ltd.; Coldstore-road, Harcourt, 3453.
Lankester, M. G.; Stand 265 Melbourne Wholesale Fruit and Vegetable Market, Footscray-road, Footscray. 3011.
Miano, Carmelo; 11 Rupert-street, East Brunswick. 3057.
Montague, W. F., Pty. Ltd.; Horswood-road, Narre Warren North. 3804.
Morriss, G. N. and Co.; Bromfield-street, Colac. 3250.
Nolan, T. J.; 64 Bimney-street, Euroa. 3666.
Ripepi, Rocco; Banfield-road, Mount Evelyn. 3796.
*Exempt from fee to the Farm Produce Merchant's and Commission Agent's Guarantee Fund under Regulation 9 (1).

SECONDARY WHOLESALERS.

Dickson, L. M.; Second-street, Hepburn Springs. 3461.
Fair Save Pty. Ltd.; Benalla-road, Shepparton. 3630.
Fiorelli Distributing Co. Pty. Ltd.; 11 Ricketts-road, Notting Hill. 3168.
Fiorelli Produce Co. Pty. Ltd.; 11 Ricketts-road, Notting Hill. 3168.
Glen Park Cream Co. Pty. Ltd.; Koornang-place, Carnegie. 3163.
Kilgour, Douglas D.; 479 Collins-street, Melbourne. 3000.
Masciarelli, F. and A.; Myrtle-street, Myrtleford. 3737.
Wood, C. H., and Co.; 4 Dawson-avenue, Elwood. 3184.

NOTICE TO MARINERS.

[No. 27 (T) of 1970.]

AUSTRALIA.—VICTORIA.

PORT PHILLIP—SOUTH CHANNEL.

LIGHT BUOY TO BE ESTABLISHED.

Date.—On or about 16th November, 1970.

Position.—South Channel Pile Light (Lat. 38 deg. 20 min. S., Long. 144 deg. 51 min. E. (approx.))

Light Buoy Station.—097 deg. 02 min. distant 2.09 miles from above position.

Abridged Description.—Fl. 3 Sec.

Description.—Light buoy with framework superstructure painted black and white vertical stripes and unnumbered showing a white flashing light every three seconds.

Characteristics.—Flash one second, eclipse two seconds.

Elevation.—Fourteen feet (4m2).

Visibility.—Seven miles.

Remarks.—The buoy will be established for a trial period to define the southern limit of the 41-foot contour. Over a distance of two cables southward of the buoy the depths vary from 41 feet to 36 feet. Deep draught vessels should pass to the north of buoy.

Charts Affected.—B.A. 2747, 1171.

Publication.—Sailing Directions, Victoria, 1970, pages 199, 206.

D. P. BARKLEY,
Port Officer in Victoria.

Public Works Department,
Ports and Harbors Division,
2 Treasury-place,
Melbourne, Vic. 3002.
29th October, 1970.

NOTICE TO MARINERS.

[No. 28. of 1970.]

AUSTRALIA.—VICTORIA.

PORT PHILLIP.

NAVAL EXERCISE.

MINING and sweeping exercises will be carried out by Royal Australian Navy vessels in Port Phillip Bay in vicinity of Frankston and Mordialloc on 11th to 13th and 16th to 18th November, 1970, (dates inclusive).

Vessels engaged will be towing sweeps and operating divers on occasions and vessels are warned to keep 1,000 yards clear of the ships exercising in the area.

A. J. WAGGLEN,
Port Officer in Victoria.

Public Works Department,
Ports and Harbors Division,
2 Treasury-place,
Melbourne, Vic. 3002.
6th November, 1970.

NOTICE TO MARINERS.
[No. 29 (T) of 1970.]

AUSTRALIA.—VICTORIA.
PORT PHILLIP.

DISPLAY OF FESTOON LIGHTING.

MARINERS are advised that coloured lights will be visible during the hours of darkness for approximately two months from 15th December, 1970, from a tall tree between Queenscliff and Point Lonsdale and located 012 deg. distant 1.14 miles from Point Lonsdale lighthouse (Lat. 38 deg. 17 min. S., Long 144 deg. 37 min. E. approx. A cluster of white lights may also be visible. The lights will discontinue before the end of February, 1971.

A. J. WAGGLEN,
Port Officer in Victoria.

Public Works Department,
Ports and Harbors Division,
2 Treasury-place,
Melbourne, Vic. 3002.
9th November, 1970.

SURVEY CO-ORDINATION (PLACE NAMES) ACT
No. 7360.

NOTICE OF AN ALTERATION.

PURSUANT to the powers conferred under section 29 of the above Act, the Place Names Committee hereby gives notice of an alteration to the name of the under-mentioned Mountain:—

Municipality.—Shire of Omeo.

Location.—Situating on the Great Dividing Range approximately 1½ miles north of Mount Tambo, Parish of Thorkidaan, Counties of Benambra and Tambo.

Old Name.—Mt. Little Tambo.

New Name.—Little Mount Tambo.

By order of the Committee,
C. E. E. BARLOW,
Secretary.

11th November, 1970.

SURVEY CO-ORDINATION (PLACE NAMES) ACT
No. 7360.

NOTICE OF APPROVAL OF ALTERATIONS TO NAMES OF POST OFFICES.

PURSUANT to the powers conferred under section 32 of the above Act, the Place Names Committee hereby gives notice of its approval of the following alterations to the names of the under-mentioned Post Offices:—

Municipality.—Shire of Berwick.

Present Name.—Pakenham East.

New Name.—Pakenham.

Present Name.—Pakenham.

New Name.—Pakenham West.

By order of the Committee,
C. E. E. BARLOW,
Secretary.

11th November, 1970.

SURVEY CO-ORDINATION (PLACE NAMES) ACT
No. 7360.

NOTICE OF AN ALTERATION.

PURSUANT to the powers conferred under section 29 of the above Act, the Place Names Committee hereby gives notice of an alteration to the name of the under-mentioned Mountain:—

Municipality.—Shire of Bright.

Location.—Approximately 3 miles west of Mt. Bogong, Parish of Wermatong, County of Bogong.

Old Name.—Mt. Little Bogong.

New Name.—Little Mount Bogong.

By order of the Committee,
C. E. E. BARLOW,
Secretary.

11th November, 1970.

Aboriginal Affairs Act 1967.

ABORIGINAL AFFAIRS ADVISORY COUNCIL
ELECTIONS REGULATIONS 1968.

PURSUANT to the Aboriginal Affairs Advisory Council Elections Regulations 1968, I, Edward Raymond Meagher, Her Majesty's Minister for Aboriginal Affairs for the State of Victoria, do hereby declare that the Aborigine named hereunder was elected as a member of the Aboriginal Affairs Advisory Council for the remainder of the term of office of three years ending on the first day of July, 1972, as representative for the Mallee Electoral Region:—

DAVID R. ANDERSON.

Dated this 11th day of November, 1970.

E. R. MEAGHER,
Minister for Aboriginal Affairs.

Ministry of Aboriginal Affairs,
Melbourne.

Children's Welfare Act 1958.

DECLARATION OF AN INSTITUTION AS AN APPROVED
CHILDREN'S HOME.

IN accordance with the provisions of Regulation 42 of Division I. of the Social Welfare Regulations 1962, notice is hereby given that on the twenty-third day of October, 1970, acting in pursuance of the powers conferred by sub-section (1) of section 14 of the Children's Welfare Act 1958, I declare the premises situated at the corner of Sunset-drive and Cuthbert-street, Heathmont, as an Approved Children's Home for the purposes of the said Act.

A. G. RYLAH,
Chief Secretary.

Chief Secretary's Office,
Melbourne, 23rd October, 1970.

ESTATE AGENTS ACT 1958.

WHEREAS by sub-section (2) of section 11A of the Estate Agents Act 1958 it is provided that if the Estate Agents Committee is satisfied that estate agency work is a minor part of the work of any Corporation it may recommend to the Minister that a declaration be made to that effect and the Minister may by notice published in the Government Gazette make a declaration accordingly; and whereas the Estate Agents Committee is satisfied that the estate agency work of the under-mentioned Corporation is a minor part of the work of the said Corporation and has recommended that a declaration be made to that effect: Now therefore I, Henry Edward Bolte, the Treasurer for the State of Victoria, do hereby declare the following Corporation:

ESTATES HILL & CO. PTY. LTD.,
114-116 William-street,
Melbourne.

Dated at Melbourne, this 16th day of November, 1970.

HENRY BOLTE,
Treasurer.

Cattle Compensation Act 1967 (No. 7615).

NOTICE UNDER SECTION 14.

APPROVED AGENT.

No. C.S.—11.

I HEREBY revoke the declaration made and published in the Government Gazette No. 102, of 4th December, 1968, of John McGregor, trading as Ralph H. McGregor & Co., as an "approved agent" for the purposes of Part II of the Cattle Compensation Act 1967, with effect from 18th July, 1969, and, in lieu thereof, I hereby declare—

Number in the Register.	Name.
-------------------------	-------

C.S. 11.—Kevin Thomas Rea and Elaine Florence Rea, trading as "Ralph H. McGregor & Co.", being a person carrying on business as a stock and station agent, to be an "approved agent" for the said purposes with effect from 19th July, 1969.	
--	--

Pursuant to the provisions of Regulation 81 of the Stamps Regulations 1960, I hereby state that the aforesaid revocation is being made at the request of the said John H. McGregor & Co.

R. M. PHIBBS,
Comptroller of Stamps.

Chief Office for Stamp Duties,
Melbourne, 18th November, 1970.

Swine Compensation Act 1967 (No. 7614).

NOTICE UNDER SECTION 14.

APPROVED AGENT.

No. C.S.—11.

I HEREBY revoke the declaration made and published in the *Government Gazette* No. 102, of 4th December, 1968, of John McGregor, trading as Ralph H. McGregor & Co., as an "approved agent" for the purposes of Part II. of the *Swine Compensation Act 1967*, with effect from 18th July, 1969, and, in lieu thereof, I hereby declare—

Number in the Register.

Name.

C.S. 11.—Kevin Thomas Rea and Elaine Florence Rea, trading as "Ralph H. McGregor & Co.", being a person carrying on business as a stock and station agent, to be an "approved agent" for the said purposes with effect from 19th July, 1969.

Pursuant to the provisions of Regulation 81 of the *Stamps Regulations 1960*, I hereby state that the aforesaid revocation is being made at the request of the said John H. McGregor & Co.

R. M. PHIBBS,
Comptroller of Stamps.

Chief Office for Stamp Duties,
Melbourne, 18th November, 1970.

METUNG WATERWORKS TRUST.

AUTHORITY TO OBTAIN BANK OVERDRAFT.

HIS Excellency the Governor of the State of Victoria by and with the advice of the Executive Council thereof doth by Order made on the 17th day of November, 1970, authorize the Metung Waterworks Trust to obtain, during the year 1971, in pursuance of the provisions of Section 286 of the *Water Act 1958* (No. 6413), an advance or advances by overdraft of the Trust's current account, such overdraft not to exceed at any one time the sum of Three thousand dollars (\$3,000).

J. ROSSITER,
Clerk of the Executive Council.

At the Executive Chamber,
Melbourne, 17th November, 1970.

Country Fire Authority Act 1958.

FIRE DANGER PERIOD IN RESPECT OF SPECIFIED PARTS OF THE COUNTRY AREA OF VICTORIA.

WHEREAS by section 4 of the *Country Fire Authority Act 1958* it is enacted that the Chief Secretary of Victoria, after consultation with the Minister of Forests, may from time to time by declaration published in the *Government Gazette* declare any period to be the fire danger period in respect of the country area of Victoria, or any specified part or parts thereof and, without affecting the generality of the foregoing, may declare different periods to be the fire danger period in respect of different parts of the said country area:

And whereas the Chief Secretary and the Minister of Forests have consulted accordingly:

Now therefore I, the Chief Secretary of Victoria, do hereby declare the period commencing at midnight on the 21st November, 1970, and ending at midnight on the 30th April, 1971, to be the fire danger period in respect of the parts of the country area of Victoria situated within the municipal districts or parts of municipal districts, and being portions of the Eighteenth Fire Control Region, specified in the Schedule hereunder:—

SCHEDULE (No. 2).

Shire of Karkaroc.
Shire of Walpeup.
Shire of Wycheproof (that portion lying north of the Woomelang-Banyan-Berriwillock road, the western, southern and eastern boundaries of the Township of Berriwillock and the Berriwillock-Springfield-Ultima road).

A. G. RYLAH,
Chief Secretary.

Chief Secretary's Office,
Melbourne, 17th November, 1970.

PLOTTING OF CADASTRAL INFORMATION.

QUOTATIONS will be received until noon, December 9th, 1970, for the up-dating of cadastral information on existing 400 feet to 1 inch Base Maps. The lowest or any tender will not necessarily be accepted.

Full particulars may be obtained from the Surveyor-General, Department of Crown Lands and Survey, Treasury-place, Melbourne, 3002.

Melbourne and Metropolitan

BOARD OF WORKS.

NOTICE TO THE OWNERS OF TENEMENTS IN THE UNDERMENTIONED STREETS AND THE PRIVATE STREETS, LANES, COURTS AND ALLEYS OPENING THERETO.

The main pipe in the said streets being laid down, the owners of all tenements situated as under are hereby required on or before the 21st December, 1970, to cause a proper pipe and stopcocks to be laid so as to supply water within such tenements from the main pipe.

W. C. S. ELLIS,

10th November, 1970.

Secretary.

LIST OF WATER MAINS TO BE PROCLAIMED IN CONTINUATION OF LIST OF 13TH OCTOBER, 1970.

STREET AND POSITION.

Box Hill.
Excelsior-street, from 300 feet south of Ailsa-street southwards 30 feet.

Broadmeadows.

Hare-street, from McBryde-street eastwards 940 feet.
Hood-street, from Hare-street southwards and westwards 530 feet.

Brunswick.

Moreland-road, from Johnson-street westwards 480 feet.

Coburg.

Moreland-road, from Johnson-street westwards 480 feet.

Chelsea.

Mulkarra-drive, from 850 feet southwards and eastwards of Embankment-grove eastwards 130 feet.

Diamond Valley.

Aminya-place, from Britnells-road eastwards 460 feet.
Avandina-crescent, from Diamond Creek-road westwards 530 feet.

Bunyana-court, from Avandina-crescent north-westwards 350 feet.

Yalta Mews, from Bunyana-court northwards 40 feet.
Civic-drive, from Plenty River-drive eastwards 1,420 feet.
Plenty River-drive, from Civic-drive northwards 420 feet.
Morewell-avenue, from Greenwood-drive northwards 120 feet.

Doncaster and Templestowe.

Lawanna-drive, from Church-road westwards 1,660 feet.
Clays-court, from Lawanna-drive northwards 610 feet.
Solson-place, from Springvale-road eastwards 440 feet.
Solson-place, from 170 feet east of Springvale-road northwards 140 feet.
Braeside-drive, from High-street to Studley-street.
Studley-street, from Greenwood-street to Braeside-drive.
Studley-street, from Braeside-drive southwards 160 feet.

Essendon.

Hoffmans-road, from Market-street northwards 590 feet.

Knox.

Fonteyn-drive, from 180 feet south of Giselle-avenue to Helpmann-street.
Sylphide-way, from 130 feet south of Giselle-avenue to Helpmann-street.
Coppelia-street, from Fonteyn-drive to Sylphide-way.
Tatiana-street, from Fonteyn-drive to Sylphide-way.
Helpmann-street, from Fonteyn-drive westwards 130 feet.
Helpmann-street, from Fonteyn-drive eastwards 520 feet.

Lillydale.

Manchester-road, from 480 feet north of Sweetland-road to McDermott-avenue.

McDermott-avenue, from Manchester-road to Anaba-court.
Anaba-court, from McDermott-avenue eastwards 370 feet.
Larnook-crescent, from McDermott-avenue to Woodville-road.

Aintree-street, from Larnook-crescent southwards 180 feet.

Wongala-way, from Larnook-crescent to Myoora-drive.

Myoora-drive, from Wongala-way to Erang-court.

Dakara-court, from Wongala-way north-eastwards 410 feet.

Woodville-road, from Marlowe-street to Avalon-street.

Myoora-drive, from Wongala-way westwards 40 feet.

Erang-court, from Myoora-drive southwards 210 feet.

Garden-street, from 300 feet of Mersey-road westwards 690 feet.

Edgar-avenue, from Yarra-road eastwards 810 feet.

Birch-road, from Brushy Park-road to Kerryanne-crescent.

Kerryanne-crescent, from Birch-road northwards and westwards 490 feet.

Kerryanne-crescent, from Birch-road southwards and westwards 540 feet.

Moorabbin.

Bourke-road, from Enngonia-crescent westwards 550 feet.
Nellbern-road, from South-road southwards and eastwards
1,030 feet.

Delacombe-court, from Herald-street westwards 820 feet.
Springvale.

Loris-street, from 240 feet north of Dianne-court north-
wards 240 feet.

Montana-street, from 220 feet south of Devon-drive south-
wards 220 feet.

Treeby-court, from Parker-street westwards 1,090 feet.
Coniston-drive, from Treeby-court southwards 90 feet.

Waverley.

Buller-road, from Rowitta-drive north-eastwards 780 feet.
Whittlesea.

Rufus-street, from Peppercorn-drive south-westwards 127
feet.

Savannah-crescent, from 120 feet south-east of Rufus-
street southwards 570 feet.

Bastings-court, from Savannah-crescent south-westwards
360 feet.

Farrelly-court, from Savannah-crescent eastwards 520 feet.
Bawker-place, from Savannah-crescent eastwards 430 feet.

Railway-road, from 450 feet east of Epping-road eastwards
240 feet.

Co-operation Act 1958.

NOTICE OF DISSOLUTION OF SOCIETY.

PORTLAND FERTILISER CO-OPERATIVE LIMITED.

NOTICE is hereby given that I have this day registered
the dissolution of the above-named society and
cancelled its registration under the above-named Act.

Dated at Melbourne, this 13th day of November, 1970.

M. V. HAMMOND,
Deputy Registrar of Co-operative Societies.

NOTICE.

CREDITORS, next of kin, and others having claims against
the estate of any of the under-mentioned deceased
persons are required to send particulars of their claims
to the Public Trustee, 256 Flinders-street, Melbourne,
Vic. 3000, the personal representative, on or before the
25th January, 1971, after which date the Public Trustee
may convey or distribute the assets, having regard only
to the claims of which the Public Trustee then has
notice:—

ADAMS, DERRICK GEORGE, also known as ADAMS, DEREK
GEORGE, late of 30 Silver-street, Malvern, storeman, died
6th August, 1970.

BENNETT, MARTIN ANDREW, late of 58 Beavers-road,
Northcote, retired wood machinist, died 25th August, 1970.
APPLEYARD, CLEMENT HARRY COURTNEY, formerly of
43 McAllister-street, Frankston, but late of 7 Salisbury-
street, Moonsee Ponds, retired auditor, died 22nd August,
1970.

CLOUGH, OLIVE ADELAIDE LYDIA JANE, late of 7 Hatton-
grove, Coburg, widow, died 12th September, 1970.

COSTLEY, EVA, late of Flat 1, 86 Park-street, St. Kilda,
widow, died 24th August, 1970.

DALEY, THOMAS BERNARD, late of 150 Alma-road, St.
Kilda, pensioner, died 7th August, 1970.

ELRINGTON, MONTGOMERY GOODALL, formerly of Flat 4,
4 Williams-road, Balwyn, but late of 1 Salisbury-street,
Balwyn, retired clerk, died 8th August, 1970.

GREEN, SUSAN JANE, late of 17 Young-street, Preston,
widow, died 19th July, 1970.

HENDERSON, JOSEPH RUDOLPH, late of 27 Monash-street,
West Heidelberg, retired clerk, died 31st August, 1970.

KELLY, COLIN EDWIN, formerly of 28 Chamberlain-street,
Ballarat East, but late of 89 Albert-street, Preston, air
force officer, died 8th March, 1970.

KENNEDY, JAMES JOHN, formerly of 6 Leslie-street, North
Richmond, but late of 124 Canterbury-road, Middle Park,
retired engineer, died 9th February, 1970.

KNIGHT, ANDREW NORTHCOTE, late of Wilsons Pocket,
Gympie, Queensland, pensioner, died 30th June, 1969.

KOVATCHEV, YVAN, late of 18 Hotham-street, East Mel-
bourne, retired tie manufacturer, died 25th February, 1970.

MADDOCKS, HILDA MABEL, late of 7 Pretoria-street, South
Caulfield, widow, died 19th June, 1970.

MALLIA, JOSEPH, late of 10 O'Shannassy-street, North
Melbourne, toy maker, died 17th July, 1970.

MELDRUM, KEITH HARRIDANCE, late of R.S.L. Club, 4 St.
Georges-road, Elsternwick, retired survey foreman, died
5th September, 1970.

MULLER, RONALD CHARLES, formerly of 472 Hargreaves-
street, Bendigo, but late of Bundoora, retired film pro-
jectionist, died 2nd April, 1970.

O'CALLAGHAN, MARGARET MARY, late of 79 Bastings-
street, Northcote, widow, died 16th August, 1970.

PHILLIPS, JANE, formerly of 27 Sussex-street, Yarraville,
but late of Kew, widow, died 22nd July, 1970.

SMITH, COLIN BURNSIDE, formerly of care of Zinc Cor-
poration, Broken Hill, N.S.W., but late of 4 Leonard-street,
Frankston, retired foreman, died 8th July, 1970.

SMITH, WILLIAM ERNEST, late of 4 Hinkler-street, Mount
Martha, retired, died 29th June, 1970.

SUCHOTEPHLYJ, TEODOR, also known as Todor SUCHO-
TEPLYJ, and TUDOR SWCHOTEPLY, late of 99 Lahinch-street,
Broadmeadows, storeman, died 3rd December, 1969.

WEEKS, MYRTLE EMILY, also known as WEEKS, EMILY
MYRTLE, late of 3 (formerly 1) Samanda-street, Frankston,
widow, died 29th August, 1970.

N. P. BRODY,
Public Trustee.

Melbourne, 11th November, 1970.

APPOINTMENTS AND RESIGNATIONS

APPOINTMENTS.

HIS Excellency the Governor of the State of Victoria,
by and with the advice of the Executive Council
thereof, has, by Orders made on the 10th day of November,
1970, been pleased to make the under-mentioned appoint-
ments, viz.:—

CHIEF SECRETARY'S DEPARTMENT.

Electoral Returning Officer.

NORBERT FELIX KNUPPEL
to be Returning Officer for the Electoral District of
Mentone, vice Joseph Peake, resigned.

CROWN LANDS AND SURVEY DEPARTMENT.

Bailiff of Crown Lands.

RONALD JOHN BROWN
to be a Bailiff of Crown lands, without additional salary,
pursuant to section 30 of the *Land Act 1958*; and

WILLIAM ANDREW JOHN HEMMING
to be a Bailiff of Crown lands, with respect to the "Tyron-
e Foreshore Reserve", without salary, pursuant to section 30
of the *Land Act 1958*.

MINISTRY OF HEALTH.

Member of the Fairfield Hospital Board.

JOHN GIVAN McMAHON, M.B., B.S.,
to be a Member of the Fairfield Hospital Board, pursuant to
section 166 (4) of the *Health Act 1958*, for the period
ending 22nd February, 1973, vice W. A. Kemp, deceased.

LAW DEPARTMENT.

Commissioners for Taking Declarations, &c.

GRAHAM NOEL POWNEY, 50 Manuka-drive, Boronia,
GEORGE HUTCHINSON WRIGHT, 58 Old Sale-road, North
Newborough,

JOSEPH JAMES RATCLIFFE, 11 Layton-crescent, Newtown,
and

WILLIAM NOEL HARKINS, 33 Donald-street, Morwell,
to be Commissioners for taking Declarations and Affidavits,
pursuant to the provisions of the *Evidence Act 1958*, to
resign upon removing from the neighbourhood of the
addresses stated; and

ARTHUR JAMES KENNEDY, care of Shire Office,
Dunolly,

PATRICK MICHAEL QUINN, and
LEONARD McEWAN BERRY, care of Camberwell Civic
Centre, Camberwell; and

LINDSAY CORBY, care of Donga Meats Ltd., Kelly-street,
Wodonga,
to be Commissioners for taking Declarations and Affidavits,
pursuant to the provisions of the *Evidence Act 1958*, to
resign upon ceasing to occupy their present positions.

Registrar of County Court.

KEVIN THOMAS RYAN
to be Registrar of the County Court, at Kerang, in the place
of P. Westmore, transferred, to take effect from the date
of commencement of duty.

Clerk of the Magistrates' Court, &c.

TERENCE JOHN SMALLEY
to be Clerk of the Magistrates' Court and Clerk of the
Children's Court, at Nhili, Dimboola, Jeparit, Kaniva and
Rainbow and Assistant Registrar at Nhili, for the County
Court, at Ararat, to take effect from the date of com-
mencement of duty.

PUBLIC WORKS DEPARTMENT.

Wharf Manager.

Sergeant J. MAXWELL, No. 10516, to be Wharf Manager at St. Kilda for a period of six (6) months, to carry out that portion of Part II. of the *Marine Act 1958*, which relates to the Management of Public Wharves, and to be an officer under section 19 of such Act to levy and collect wharfage rates thereat, *vice* Sergeant Richard Harvey, No. 10482, on long service leave.

DEPARTMENT OF THE TREASURER.

Receiver of Revenue.

JOHN ANTHONY BARNES to be Receiver of Revenue, Horsham, *vice* J. M. Duffy, transferred.

J. ROSSITER,
Clerk of the Executive Council.

At the Executive Council Chamber,
Melbourne, 10th November, 1970.

VERMIN AND NOXIOUS WEEDS ACT 1958.

APPOINTMENT OF INSPECTOR.

IT is hereby notified that the Public Service Board, in exercise of its powers, has appointed the under-mentioned person as an Inspector under the provisions of section 4 of the *Vermine and Noxious Weeds Act 1958* without additional salary:—

GRAHAM FREDERICK CANN.

A. J. HOLT,
Secretary for Lands.

Melbourne, 16th November, 1970.

APPOINTMENT OF COMMITTEE OF MANAGEMENT OF "MT. BULLER ALPINE RESERVE".

WHEREAS by section 50 of the *Forests Act 1958* (No. 6254), it is provided that the Minister of Forests may, on the recommendation of the Forests Commission, appoint any number of persons, not less than three, to be a Committee of Management of any land forming part of any reserved forest, such land being set aside as an alpine reserve, and may remove any of those persons: Now therefore, I, Edward Raymond Meagher, Her Majesty's Minister of Forests for the State of Victoria, on the recommendation of the Forests Commission, do hereby appoint—

RONALD JEFFREY GROSE,
ROY WILLAN BOSTOCK,
ROBERT PETER MCINTYRE,
IAN MALCOLM SUTHERLAND,
ERNEST FORRAS,
GWILYM KENNETH WILLIAMS,
REGINALD RAYNER PATTERSON, and
JOHN RAYMOND CHANNON,

as members of the Committee of Management until the 30th day of September, 1973, of the land forming part of the reserved forest in the Parish of Changue, County of Wonnangatta, described in the accompanying Schedule, and known as "Mt. Buller Alpine Reserve".

SCHEDULE ABOVE REFERRED TO.

Parish of Changue, County of Wonnangatta, 2,357 acres, more or less, being the area shown within pink border on plan marked 18.11.60 over 58/2260, in file of correspondence No. 65/2273 of the Forests Department.

Dated at Melbourne, the 9th day of November, 1970.

E. R. MEAGHER,
Minister of Forests.

RESIGNATIONS.

HIS Excellency the Governor of the State of Victoria, by and with the advice of the Executive Council thereof, has, by Orders made on the 10th day of November, 1970, accepted the resignations of the persons named hereunder of the office mentioned, *viz.*:—

LAW DEPARTMENT.

Commissioners for taking Declarations, &c.

DAISY ISOBEL BATTANTA, and
ROGER EDWARD LAMB, as Commissioners for taking Declarations and Affidavits, pursuant to the provisions of the *Evidence Act 1958*.

J. ROSSITER,
Clerk of the Executive Council.

At the Executive Council Chamber,
Melbourne, 10th November, 1970.

ORDERS IN COUNCIL

BOARD OF INQUIRY.

At the Executive Council Chamber, Melbourne, the fourth day of November, 1970.

PRESENT:

His Excellency the Governor of Victoria.

Mr. Reid
Mr. Dickie

Mr. Wilcox.

WHEREAS it is deemed expedient that a Board of Inquiry be appointed to inquire into, report upon and make recommendations concerning the existing system of land transport in Victoria:

Now therefore, His Excellency the Governor of the State of Victoria, by and with the advice of the Executive Council thereof, doth by this Order constitute and appoint—

Sir HENRY ARMAND BLAND, Kt., C.B.E.,

to be a Board to inquire into, report upon and make recommendations concerning the existing system of land transport in Victoria (with the exception of passenger transport within the areas of metropolitan Melbourne and the urban areas of Ballarat, Bendigo and Geelong for which transportation plans have been or are being prepared) and in particular—

(1) Whether the existing land transport system is satisfactory to meet the needs of agriculture, commerce and industry, and the public.

(2) Whether the present division of freight traffic as to area and type of goods between road and rail is desirable.

(3) Whether there is duplication of existing transport services which is wasteful and, if so, how such duplication could be avoided.

(4) Whether the existing system of transport regulation allows a flexible transport system which can adapt reasonably to changing conditions.

(5) What changes, if any, should be brought about in the system of transport regulation and the provision of rail services to give the most efficient transport service practicable in the public interest.

(6) What effects any changes proposed would be likely to have on the transport industry and Government finances generally.

And it is hereby directed that the said Sir Henry Armand Bland shall, with as little delay as possible, report under his hand on this inquiry.

Whereof the said Sir Henry Armand Bland and all other persons whom it may concern are to take notice and govern themselves accordingly.

And the Honorable Sir Arthur Gordon Rylah, Her Majesty's Chief Secretary for the State of Victoria, shall give the necessary directions herein accordingly.

J. ROSSITER,
Clerk of the Executive Council.

ROYAL COMMISSION INTO WEST GATE BRIDGE.

At the Executive Council Chamber, Melbourne, the fourth day of November, 1970.

PRESENT:

His Excellency the Governor of Victoria.

Mr. Reid
Mr. Dickie

Mr. Wilcox.

HIS Excellency the Governor of the State of Victoria, in the Commonwealth of Australia, by and with the advice of the Executive Council of the said State, and in pursuance of the powers conferred by the Public Accounts and Stores Regulations made under the provisions of the *Audit Act 1958* and all other powers him thereunto enabling, doth by this Order sanction a maximum expenditure of the sum of Sixty Thousand Dollars (\$60,000) by the Royal Commission appointed to inquire into the failure of the bridge known as "West Gate Bridge".

And the Honorable Sir Arthur Gordon Rylah, Her Majesty's Chief Secretary for the State of Victoria, shall give the necessary directions herein accordingly.

J. ROSSITER,
Clerk of the Executive Council.

ROAD TRAFFIC ACT 1958.

At the Executive Council Chamber, Melbourne, the tenth day of November, 1970.

PRESENT:

His Excellency the Governor of Victoria.

Mr. Balfour
Mr. Byrne

Mr. Rafferty.

IN pursuance of the powers conferred by the Road Traffic Act 1958, His Excellency the Governor of the State of Victoria, in the Commonwealth of Australia, by and with the advice of the Executive Council of the said State, and at the request in writing of the Council of the City of Ringwood, doth by this Order extend the provisions of the said Act to the following land under the control of the City of Ringwood.

All that land shown shaded on the plan hereunder and known as the "Jubilee Park" Access road.

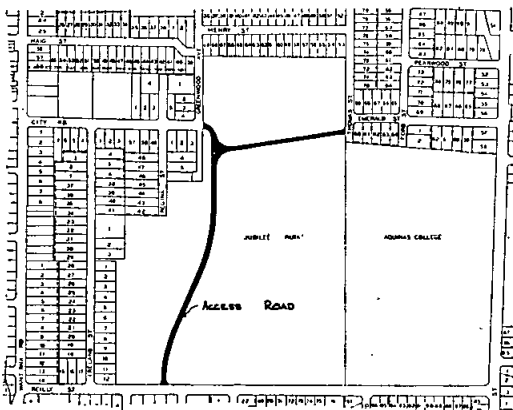

And the Honorable Sir Arthur Gordon Rylah, Her Majesty's Chief Secretary for the State of Victoria, shall give the necessary directions herein accordingly.

J. ROSSITER,
Clerk of the Executive Council.

PUBLIC SERVICE ACT 1958.

At the Executive Council Chamber, Melbourne, the tenth day of November, 1970.

PRESENT:

His Excellency the Governor of Victoria.

Mr. Balfour
Mr. Byrne

Mr. Rafferty.

IN pursuance of the powers conferred by the Public Service Act 1958 (No. 6349) His Excellency the Governor of the State of Victoria, by and with the advice of the Executive Council thereof doth by this Order hereby appoint—

ARTHUR JOHN ALLIANCE GARDNER, B.Com., Dip.Pub. Admin., F.A.S.A., to be a Member and Chairman of the Public Service Board as from and including the Sixteenth day of November, 1970.

And the Honorable Sir Henry Edward Bolte, Her Majesty's Premier for the State of Victoria, shall give the necessary directions herein accordingly.

J. ROSSITER,
Clerk of the Executive Council.

AUDIT ACT 1958.

At the Executive Council Chamber, Melbourne, the tenth day of November, 1970.

PRESENT:

His Excellency the Governor of Victoria.

Mr. Balfour
Mr. Byrne

Mr. Rafferty.

IN pursuance of the powers conferred by section 4 of the Audit Act 1958 (No. 6203) His Excellency the Governor of the State of Victoria by and with the advice of the Executive Council thereof doth by this Order appoint—

BRUCE HAMILTON, A.A.S.A., A.C.I.S., to be Auditor-General as from and including the Sixteenth day of November, 1970.

And the Honorable Sir Henry Edward Bolte, Her Majesty's Premier for the State of Victoria, shall give the necessary directions herein accordingly.

J. ROSSITER,
Clerk of the Executive Council.

STAMPS ACT 1958, No. 6375.

At the Executive Council Chamber, Melbourne, the tenth day of November, 1970.

PRESENT:

His Excellency the Governor of Victoria.

Mr. Balfour
Mr. Byrne

Mr. Rafferty.

HIS Excellency the Governor of the State of Victoria, by and with the advice of the Executive Council thereof, doth by this Order made pursuant to section 131c of the Stamps Act 1958 (No. 6375) revoke the declaration made on 9th July, 1963, and published in the Government Gazette on 17th July, 1963, declaring certain persons to be "approved vendors" for the purposes of subdivision (14) of Division three of Part II. of the Stamps Act 1958 in so far as the said declaration refers to the under-mentioned person—

211. SECURITY INVESTMENTS PTY. LTD.

And the Honorable Sir Henry Edward Bolte, Her Majesty's Treasurer for the State of Victoria, shall give the necessary directions herein accordingly.

J. ROSSITER,
Clerk of the Executive Council.

HOSPITALS AND CHARITIES ACT 1958—SECTION 66.

At the Executive Council Chamber, Melbourne, the tenth day of November, 1970.

PRESENT:

His Excellency the Governor of Victoria.

Mr. Balfour
Mr. Byrne

Mr. Rafferty.

PURSUANT to the provisions of section 66 of the Hospitals and Charities Act 1958 (No. 6274), His Excellency the Governor of the State of Victoria by and with the advice of the Executive Council of the said State, doth hereby approve of the granting of a lease of the whole of the Medical Consulting Rooms Block at the Coleraine and District Hospital as Lessor to Doctors Charles Russell Wain and Sheila Wilson Hyland, as Lessees, at a rental of Seven hundred and eighty dollars. (\$780) a year to be paid half-yearly in advance for a period of three (3) years from the 18th September, 1970, with the option of rental for a further period of two years after the 18th September, 1973.

And the Honorable John Frederick Rossiter, Her Majesty's Minister of Health for the State of Victoria, shall give the necessary directions herein accordingly.

J. ROSSITER,
Clerk of the Executive Council.

LAND ACT 1958.

At the Executive Council Chamber, Melbourne, the tenth day of November, 1970.

PRESENT:

His Excellency the Governor of Victoria.
Mr. Balfour | Mr. Rafferty.
Mr. Byrne

UNUSED ROAD(S) CLOSED.

IN pursuance of the provisions of section 349 of the Land Act 1958, His Excellency the Governor of Victoria, by and with the advice of the Executive Council thereof and the concurrence in writing of the Council of the Municipality concerned doth hereby close the unused road(s) referred to hereunder, viz.:—

Township of Murrayville, Parish of Danyo, County of Weeah, being the roads indicated by hatching on plan hereunder.—M.575(5) (C.100383).

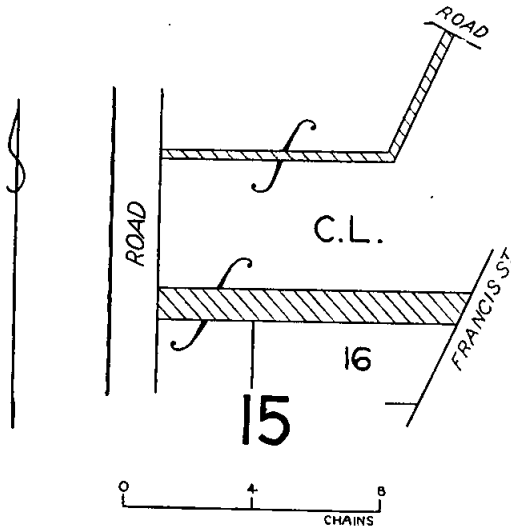

And the Honorable William Archibald Borthwick, Her Majesty's Minister of Lands for the State of Victoria, shall give the necessary directions herein accordingly.

J. ROSSITER,
Clerk of the Executive Council.

COUNTRY ROADS BOARD.

At the Executive Council Chamber, Melbourne, the tenth day of November, 1970.

PRESENT:

His Excellency the Governor of Victoria.
Mr. Balfour | Mr. Rafferty.
Mr. Byrne

ORDER APPROVING OF LAND BEING ACQUIRED AND ROADS, DEVIATIONS OR WIDENINGS BEING MADE.

HIS Excellency the Governor of the State of Victoria, by and with the advice of the Executive Council thereof, being satisfied that there are funds legally available for acquiring the land, doth hereby approve the acquiring of the land described in the Schedule hereunder and the making of new roads and deviations from and widenings of existing roads referred to in the said Schedule.

SCHEDULE.

State Highway.

The land shown hatched on Plan numbered G.P.12077 hereunder required for the deviation from the Goulburn Valley Highway in the Shire of Yea and making of the deviation thereon.

STATE HIGHWAY
GOULBURN VALLEY HIGHWAY
SHIRE OF YEA
Measurements in links

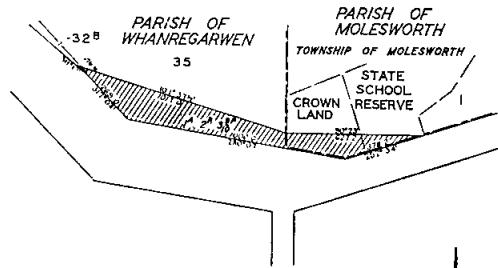

G.P.12077
Compiled from
S.P.12077

Main Road.

The land shown hatched on Plan numbered G.P.12312 hereunder required for the widening of the Wangaratta-Kilfeera-road in the Shire of Oxley and making of the widening thereon.

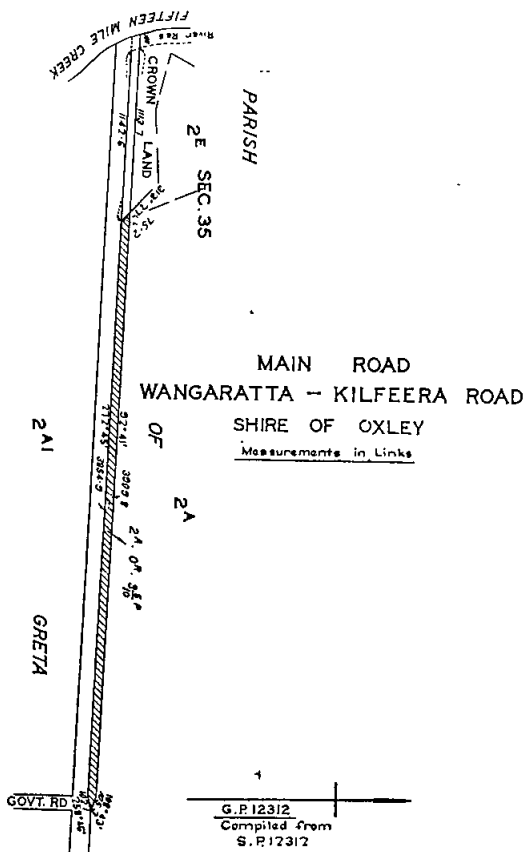

G.P.12312
Compiled from
S.P.12312

Tourists' Road.

The land shown hatched on Plan numbered G.P.12357 hereunder required for the deviation from Ocean-road in the Shire of Heytesbury and making of the deviation thereon.

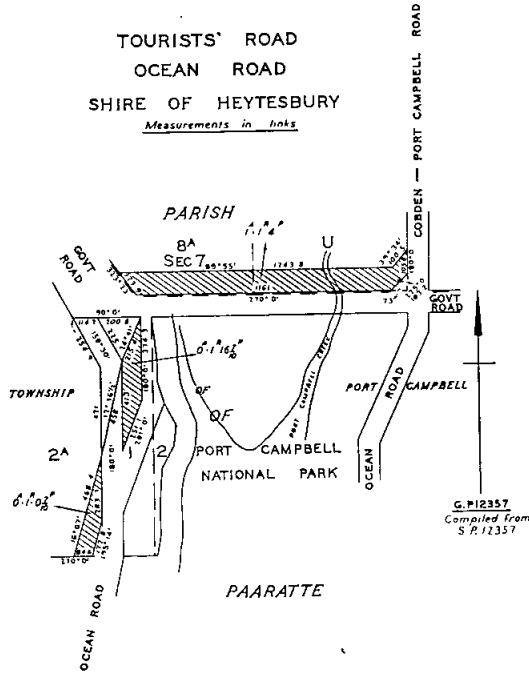

Now, therefore His Excellency the Governor of the State of Victoria by and with the advice of the Executive Council of the said State and in pursuance of the powers conferred by section 107 of the Housing Act and upon recommendation of the Housing Commission, doth by this Order declare the streets more particularly delineated and shown hatched on the plan hereunder to be absolutely dedicated to the public as Public Highways within the meaning of any law now or hereafter in force and that the Council of the Municipality in which the streets are situate shall hereafter be liable for all cost of any maintenance, repair, alteration or reconstruction thereof.

PART OF CROWN ALLOTMENTS 42^B 42^C & 42^E

PARISH OF FRANKSTON

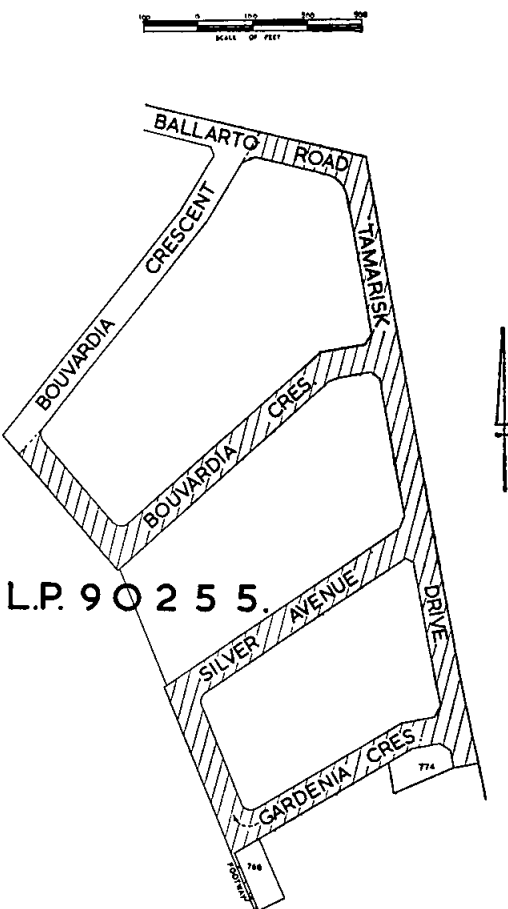

And the Honorable Rupert James Hamer, Her Majesty's Minister for Local Government for the State of Victoria, shall give the necessary directions herein accordingly.

J. ROSSITER,
Clerk of the Executive Council.

HOUSING ACT 1958.

At the Executive Council Chamber, Melbourne, the seventeenth day of November, 1970.

PRESENT:
His Excellency the Governor of Victoria.
Mr. Hamer | Mr. Smith.

DECLARATION OF PRIVATE STREETS AS PUBLIC HIGHWAYS WITHIN THE CITY OF FRANKSTON.

WHEREAS pursuant to section 107 of the Housing Act 1958 it is among other things enacted that where works have been carried out in accordance with an Agreement for the full construction of any roads, pavements, culverts or drains made pursuant to the provisions of the said section 107 such roads, pavements, culverts or drains shall be under the care and management of the Municipality which shall be liable for the cost of any maintenance, repair, alteration or reconstruction thereof and the Governor in Council may by Order published in the *Government Gazette* declare any road so constructed to be a public highway.

And whereas by Order dated the seventeenth day of September, 1968, the Governor in Council consented to an Agreement between the Housing Commission and the City of Frankston regarding street and drainage construction in part Bouvardia-crescent, part Silver-avenue, Gardenia-crescent, part Tamarisk-drive and part Ballarto-road-Service-road in the Frankston-Forest No. 2 Estate situate in the Municipality of the City of Frankston and the carrying out of the works enumerated in the said Agreement.

And whereas the works of road pavements, culvert and drainage construction have now been carried out in accordance with the said Agreement between the Housing Commission and the City of Frankston.

And the Honorable Edward Raymond Meagher, Her Majesty's Minister of Housing for the State of Victoria, shall give the necessary directions herein accordingly.

J. ROSSITER,
Clerk of the Executive Council.

POLICE REGULATION ACT 1958.

At the Executive Council Chamber, Melbourne, the seventeenth day of November, 1970.

PRESENT:
His Excellency the Governor of Victoria.
Mr. Hamer | Mr. Smith.

NOMINATION AND APPOINTMENT AS A MEMBER OF THE POLICE DISCIPLINE BOARD.

HIS Excellency the Governor of the State of Victoria, in the Commonwealth of Australia, by and with the advice of the Executive Council of the said State, and in

pursuance of the powers conferred by the *Police Regulation Act 1958* and the Regulations made thereunder and all other powers him thereunto enabling, doth by this Order nominate and appoint—

WILLIAM NORMAN THOMPSON, Stipendiary Magistrate, to be a member of the Police Discipline Board for the period from 23rd November, 1970 to 27th May, 1973.

And the Honorable Sir Arthur Gordon Rylah, Her Majesty's Chief Secretary for the State of Victoria, shall give the necessary directions herein accordingly.

J. ROSSITER,
Clerk of the Executive Council.

LANDLORD AND TENANT ACT 1958.

At the Executive Council Chamber, Melbourne, the seventeenth day of November, 1970.

PRESENT:

His Excellency the Governor of Victoria.
Mr. Hamer | Mr. Smith.

ORDER EXTENDING APPLICATION OF PART V. OF THE LANDLORD AND TENANT ACT 1958 TO CERTAIN PREMISES.

IN pursuance of the powers conferred by section 44 of the *Landlord and Tenant Act 1958*, His Excellency the Governor of Victoria, by and with the advice of the Executive Council thereof, doth hereby declare that the application of Part V. of the *Landlord and Tenant Act 1958* shall extend to the following premises—

The premises known as Number 22 Campbell-street, Richmond.

And the Honorable George Oswald Reid, Her Majesty's Attorney-General in and for the State of Victoria, shall give the necessary directions herein accordingly.

J. ROSSITER,
Clerk of the Executive Council.

SHIRE OF SHEPPARTON WATERWORKS TRUST.

At the Executive Council Chamber, Melbourne, the seventeenth day of November, 1970.

PRESENT:

His Excellency the Governor of Victoria.
Mr. Hamer | Mr. Smith.

EXTENT OF WATERWORKS DISTRICT INCREASED AND APPROVAL OF PLANS SHOWING THE WORKS FOR THE SUPPLY OF WATER TO DOOKIE.

UNDER the powers conferred by the *Water Act* and all other powers enabling him in that behalf, His Excellency the Governor of the State of Victoria, by and with the advice of the Executive Council of the said State, doth hereby:

- (a) declare, order and direct that the extent of the Waterworks District of the Shire of Shepparton Waterworks Trust be increased by adding to the same the lands comprised within the boundaries shaded pink on the plan marked B, and on and from the date hereof the extent of such District shall be and be deemed to be increased accordingly; and
- (b) approve the works to be constructed by the Shire of Shepparton Waterworks Trust for the supply of water to Dookie, comprising a storage reservoir, a pumping station, a rising main from the pumping station to a service basin, a chlorinator, a supply main from the service basin to the reticulation at Dookie, such works being shown on the plan marked A.

The said plans marked A. and B are approved by the Governor in Council by and with this Order and deposited in the office of the State Rivers and Water Supply Commission, Melbourne.—(Corr. No. 60/418/54.)

And the Honorable Ian Winton Smith, Her Majesty's Minister of Water Supply for the State of Victoria, shall give the necessary directions herein accordingly.

J. ROSSITER,
Clerk of the Executive Council.

GEELONG WATERWORKS AND SEWERAGE TRUST.

At the Executive Council Chamber, Melbourne, the seventeenth day of November, 1970.

PRESENT:

His Excellency the Governor of Victoria.
Mr. Hamer | Mr. Smith.

CONSENT TO BORROWING \$576,000.

UNDER the powers conferred by the *Geelong Waterworks and Sewerage Act* and all other powers enabling him in that behalf, His Excellency the Governor of the State of Victoria, by and with the advice of the Executive Council of the said State, doth hereby consent to the *Geelong Waterworks and Sewerage Trust* borrowing at interest, subject to the *Geelong Waterworks and Sewerage Act*, the sum of Five hundred and seventy-six thousand dollars (\$576,000), in two amounts of Four hundred thousand dollars (\$400,000) and One hundred and seventy-six thousand dollars (\$176,000), for the conversion of Loans W4, E7 and G7.

And the Honorable Ian Winton Smith, Her Majesty's Minister of Water Supply for the State of Victoria, shall give the necessary directions herein accordingly.

J. ROSSITER,
Clerk of the Executive Council.

WEST MOORABOOL WATER BOARD.

At the Executive Council Chamber, Melbourne, the seventeenth day of November, 1970.

PRESENT:

His Excellency the Governor of Victoria.
Mr. Hamer | Mr. Smith.

CONSENT TO BORROWING \$150,000.

UNDER the powers conferred by the *West Moorabool Water Board Act* and all other powers enabling him in that behalf, His Excellency the Governor of the State of Victoria, by and with the advice of the Executive Council of the said State, doth hereby consent to the *West Moorabool Water Board* borrowing at interest the sum of One hundred and fifty thousand dollars (\$150,000) to meet the cost of water storage works as set forth in the detailed statement bearing date 11th November, 1970.

And the Honorable Ian Winton Smith, Her Majesty's Minister of Water Supply for the State of Victoria, shall give the necessary directions herein accordingly.

J. ROSSITER,
Clerk of the Executive Council.

MALLACOOTA WATERWORKS TRUST.

At the Executive Council Chamber, Melbourne, the seventeenth day of November, 1970.

PRESENT:

His Excellency the Governor of Victoria.
Mr. Hamer | Mr. Smith.

APPROVAL TO INSTALL SERVICE PIPES.

WHEREAS by section 212 (1) of the *Water Act* it is amongst other things provided that any Authority may with the sanction of the Governor in Council do all or any of the things which the owner of any tenement is required or empowered to do for conveying a supply of water within such tenement.

And, whereas, the *Mallacoota Waterworks Trust* has laid main pipes for the service of water to certain tenements within the *Mallacoota Urban District*.

And, whereas, the said Trust deems it desirable for all service pipes from the Trust's mains to the boundary of the respective tenements to be laid by the Trust on behalf of the owners of the said tenements.

Now, therefore, His Excellency the Governor of the State of Victoria, by and with the advice of the Executive Council of the said State, doth hereby sanction that the

Mallacoota Waterworks Trust may lay service pipes from its mains to the boundaries of tenements to be served the cost and expense of such service pipes being a debt by the respective owners of the tenements to the said Trust which debt may be recovered in any Court of competent jurisdiction.

And the Honorable Ian Winton Smith, Her Majesty's Minister of Water Supply for the State of Victoria, shall give the necessary directions herein accordingly.

J. ROSSITER,
Clerk of the Executive Council.

THE BALLARAT WATER COMMISSIONERS.

At the Executive Council Chamber, Melbourne, the seventeenth day of November, 1970.

PRESENT:

His Excellency the Governor of Victoria.
Mr. Hamer | Mr. Smith.

PURCHASE OF LAND.

UNDER the powers conferred by the Water Act and all other powers enabling him in that behalf, His Excellency the Governor of the State of Victoria, by and with the advice of the Executive Council of the said State, doth hereby approve the purchase of land by The Ballarat Water Commissioners being 1 acre 2 roods 25 2/10 perches in area, comprising part of Crown allotment 7, section 2 Parish of Ballarat, such land being shown on a plan approved by the Governor in Council by and with this Order and deposited in the office of the State Rivers and Water Supply Commission, Melbourne.—(Corr. No. 70/551/44.)

And the Honorable Ian Winton Smith, Her Majesty's Minister of Water Supply for the State of Victoria, shall give the necessary directions herein accordingly.

J. ROSSITER,
Clerk of the Executive Council.

MACEDON WATERWORKS TRUST.

At the Executive Council Chamber, Melbourne, the seventeenth day of November, 1970.

PRESENT:

His Excellency the Governor of Victoria.
Mr. Hamer | Mr. Smith.

EXTENT OF WATERWORKS DISTRICT DECREASED.

UNDER the powers conferred by the Water Act and all other powers enabling him in that behalf, His Excellency the Governor of the State of Victoria, by and with the advice of the Executive Council of the said State, doth hereby declare, and direct that the extent of the Waterworks District of the Macedon Waterworks Trust be decreased by excising the lands as shown on a plan approved by the Governor in Council, by and with this Order and deposited in the office of the State Rivers and Water Supply Commission, Melbourne, (Corr. No. 59/1529/151), and as on and from the date hereof the extent of such District shall be and be deemed to be decreased accordingly.

And the Honorable Ian Winton Smith, Her Majesty's Minister of Water Supply for the State of Victoria, shall give the necessary directions herein accordingly.

J. ROSSITER,
Clerk of the Executive Council.

MOUNT MACEDON WATERWORKS TRUST.

At the Executive Council Chamber, Melbourne, the seventeenth day of November, 1970.

PRESENT:

His Excellency the Governor of Victoria.
Mr. Hamer | Mr. Smith.

EXTENT OF WATERWORKS DISTRICT INCREASED.

UNDER the powers conferred by the Water Act and all other powers enabling him in that behalf, His Excellency the Governor of the State of Victoria, by and with the advice of the Executive Council of the said State,

doth hereby declare and direct that the extent of the Waterworks District of the Mount Macedon Waterworks Trust be increased by adding thereto the lands as shown on a plan approved by the Governor in Council, by and with the Order and deposited in the office of the State Rivers and Water Supply Commission, Melbourne (Corr. No. 59/837/71,75), and as on and from the date hereof the extent of such District shall be and be deemed to be increased accordingly.

And the Honorable Ian Winton Smith, Her Majesty's Minister of Water Supply for the State of Victoria, shall give the necessary directions herein accordingly.

J. ROSSITER,
Clerk of the Executive Council.

WESTERNPORT WATERWORKS TRUST.

At the Executive Council Chamber, Melbourne, the seventeenth day of November, 1970.

PRESENT:

His Excellency the Governor of Victoria.
Mr. Hamer | Mr. Smith.

EXTENT OF URBAN DISTRICT INCREASED.

UNDER the powers conferred by the Water Act and all other powers enabling him in that behalf, His Excellency the Governor of the State of Victoria, by and with the advice of the Executive Council of the said State, doth hereby declare, order and direct that the extent of Newhaven Urban District of the Westernport Waterworks Trust be increased by adding to the same the lands comprised within the boundaries shown on the accompanying plan approved by the Governor in Council by and with this Order and deposited in the office of the State Rivers and Water Supply Commission, Melbourne (Corr. No. 70/2515/27) and as on and from the date hereof, the extent of such District shall be and be deemed to be increased accordingly.

And the Honorable Ian Winton Smith, Her Majesty's Minister of Water Supply for the State of Victoria, shall give the necessary directions herein accordingly.

J. ROSSITER,
Clerk of the Executive Council.

NATHALIA SEWERAGE AUTHORITY.

At the Executive Council Chamber, Melbourne, the seventeenth day of November, 1970.

PRESENT:

His Excellency the Governor of Victoria.
Mr. Hamer | Mr. Smith.

EXTENT OF SEWERAGE DISTRICT INCREASED AND DIMINISHED.

UNDER the powers conferred by the Sewerage Districts Act and all other powers enabling him in that behalf, His Excellency the Governor of the State of Victoria, by and with the advice of the Executive Council of the said State, doth hereby declare, order and direct that the extent of the Sewerage District of the Nathalia Sewerage Authority be increased and diminished as shown on a plan approved by the Governor in Council by and with this Order and deposited in the office of the State Rivers and Water Supply Commission, Melbourne (Corr. No. 61/5704/87), and as on and from the date hereof the extent of such District shall be and be deemed to be increased and diminished accordingly.

And the Honorable Ian Winton Smith, Her Majesty's Minister of Water Supply for the State of Victoria, shall give the necessary directions herein accordingly.

J. ROSSITER,
Clerk of the Executive Council.

GEELONG WATERWORKS AND SEWERAGE TRUST.

At the Executive Council Chamber, Melbourne, the seventeenth day of November, 1970.

PRESENT:

His Excellency the Governor of Victoria.
Mr. Hamer | Mr. Smith.

CONSENT TO BORROWING \$282,000.

UNDER the powers conferred by the Geelong Waterworks and Sewerage Act and all other powers enabling him in that behalf, His Excellency the Governor of the State of Victoria, by and with the advice of the Executive Council of the said State, doth hereby consent to the Geelong Waterworks and Sewerage Trust borrowing at interest, subject to the Geelong Waterworks and Sewerage Act, the sum of Two hundred and eighty-two thousand dollars (\$282,000), in two amounts of One hundred and eighty-two thousand dollars (\$182,000) and One hundred thousand dollars (\$100,000) for the conversion of Loans Nos. 85 and 126.

And the Honorable Ian Winton Smith, Her Majesty's Minister of Water Supply for the State of Victoria, shall give the necessary directions herein accordingly.

J. ROSSITER,
Clerk of the Executive Council.

LANDS DEPARTMENT NOTICES

APPROACHING LAND SALES.

SALES of Crown lands, in fee-simple, will be held at the under-mentioned places and dates, viz.:-

	No. of Gazette
Wonthaggi.—Friday, 18th December, 1970 . .	100

PROPOSED REVOCATIONS OF TEMPORARY RESERVATIONS OF LANDS BY ORDERS IN COUNCIL.

IN pursuance of the provisions of the Land Act 1958, notice is hereby given that it is the intention of the Governor in Council to revoke the temporary reservations of lands by Orders in Council hereunder referred to, viz.:-

The following Notices were published 1° on the 28th October, 1970, pursuant to Orders of the 20th October, 1970.

MELBOURNE.—The temporary reservation by Order in Council of the 10th April, 1951, of 1 acre 3 roods 30 perches, more or less, of land in the City of Melbourne, as a site for a Court House and Police purposes is about to be revoked so far only as the portion containing 31 perches, more or less, indicated by hatching on plan hereunder is concerned.—(M.314⁽⁹⁾) (Rs.1835).

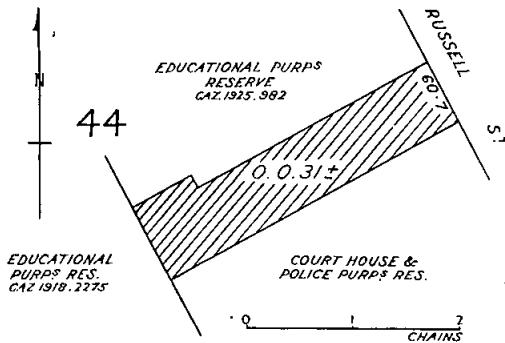

TERANG.—The temporary reservation by Order in Council of the 10th January, 1888, of 3 acres 1 rood 35 perches of land in the Township of Terang as a site for Public purposes is about to be revoked, so far only as the portion containing 3 roods 32 perches, indicated by hatching on plan hereunder is concerned.—(T.85⁽⁸⁾) (Rs.266).

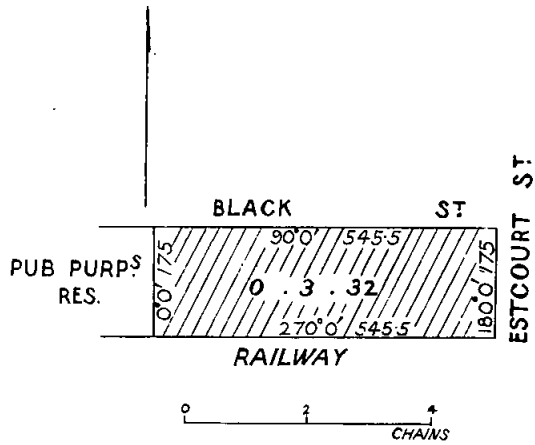

WHARPARILLA.—The temporary reservation, by Order in Council of the 10th October, 1887 (see Government Gazette 14th October, 1887, page 2978) of 10 acres 5 perches of land in the Parish of Wharparilla (named municipal district of Echuca in Order) as a site for a Manure Depot, is about to be revoked so far only as the portion containing 1 acre 2 roods 31 perches, indicated by hatching on plan hereunder is concerned.—(W.132⁽⁸⁾) (Rs.5515).

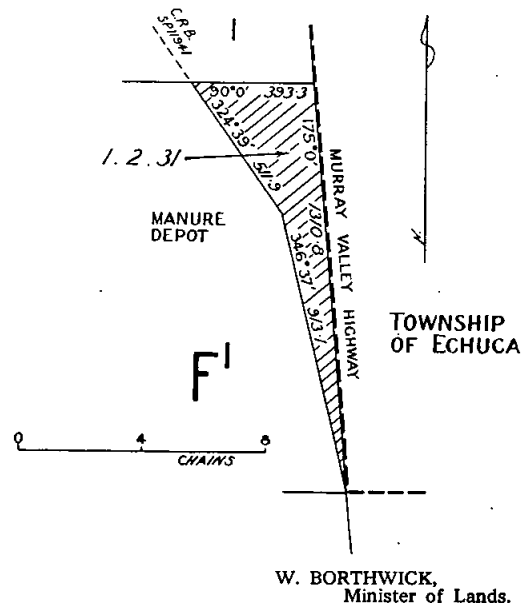

PROPOSED PERMANENT RESERVATION OF LAND AS A SITE.

IN pursuance of sections 14 and 21 of the Land Act 1958, notice is hereby given that it is the intention of the Governor in Council to reserve permanently from sale, from being leased and from having a licence granted in respect thereof the land hereinafter described:—

The following Notice was published 1° on the 28th October, 1970, pursuant to Orders of the 20th October, 1970.

SHERWOOD AND CRANBOURNE.—Land proposed to be permanently reserved as a site for the purposes of a Botanic Gardens and Research Institute devoted to the growing, display and study of Australian native plants, and for the enjoyment of the people of Victoria, 395 acres 2 roods 38 perches, Parishes of Sherwood and Cranbourne, County of Mornington, as indicated by hatching on plan hereunder.—(S.271⁽⁶⁾) (C.329⁽⁷⁾) (Rs.9375).

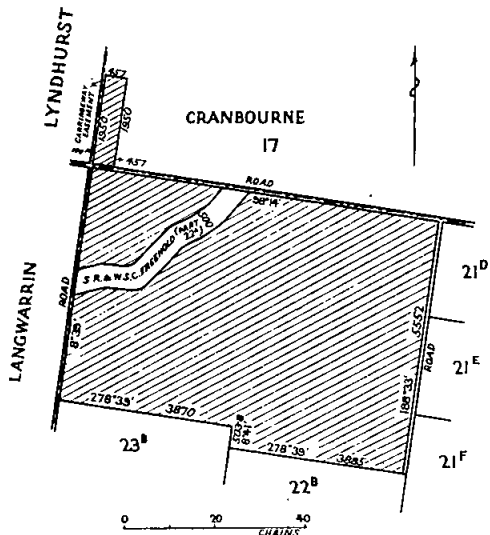

Total Area of Hatched Portions—
395 . 2 . 38

W. BORTHWICK,
Minister of Lands.

PROPOSED REVOCATIONS OF TEMPORARY RESERVATIONS OF LANDS BY ORDERS IN COUNCIL.

IN pursuance of the provisions of the Land Act 1958, notice is hereby given that it is the intention of the Governor in Council to revoke the temporary reservations of lands by Orders in Council hereunder referred to, viz.:

The following Notices were published 1° on the 11th November, 1970, pursuant to Orders of the 4th November, 1970.

BABATCHIO.—The temporary reservation by Order in Council of the 28th January, 1890, of 3 acres of land in the Parish of Babatchio, as a site for a State School, is about to be revoked.—(B.682⁽³⁾) (89E13647).

BEECHWORTH.—The temporary reservation by Order in Council of the 1st June, 1965, of 1 acre, more or less, of land in the Township of Beechworth, as a site for State School purposes is about to be revoked.—(B.348⁽⁷⁾) (Rs.6182).

CASTLE DONNINGTON.—The temporary reservation, by Order in Council of the 22nd April, 1952, of 29 3/10 perches of land in the Parish of Castle Donnington, as a site for Police purposes, is about to be revoked.—(C.114⁽⁶⁾) (Rs.6904).

RUNNYMEDE.—The temporary reservation by Order in Council of the 5th October, 1874 (see Government Gazette, 9th October, 1874, page 1806), of 2 acres of land in the Parish of Colbinabbin (now in the Parish of Runnymede), as a site for State School purposes, is about to be revoked.—(R.41⁽²⁾) (W.89926).

DARTAGOOK.—The temporary reservation as a site for Public purposes (State School) and the withholding from sale, leasing and licensing by Order in Council of the 27th October, 1879, of 4 acres 3 roods 37 perches of land in the Parish of Dartagook, is about to be revoked.—(D.188⁽⁷⁾) (Rs.8950).

GORYA.—The temporary reservation by Order in Council of the 25th August, 1911, of 3 acres of land in the Parish of Gorya, as a site for a State School, is about to be revoked.—(G.241⁽³⁾) (Rs.1836).

WHITFIELD.—The temporary reservation by Order in Council of the 27th February, 1900, of 7 perches of land in the Parish of Whitfield, as a site for Railway purposes, is about to be revoked.—(W.317⁽⁹⁾) (C.100544). (99C.10129).

BALLARAT EAST.—The temporary reservation, by Orders in Council of the 24th November, 1925 and the 20th January, 1926, of 110 acres 1 rood 16 perches of land in the Township of Ballarat East, as a site for the Growth and Preservation of Timber, and for Public Recreation, revoked as to part by various Orders, is about to be revoked so far only as the portion containing 3 acres 2 roods 38 perches, indicated by hatching on plan hereunder, is concerned.—(B.128⁽⁴⁴⁾) (Rs.1530).

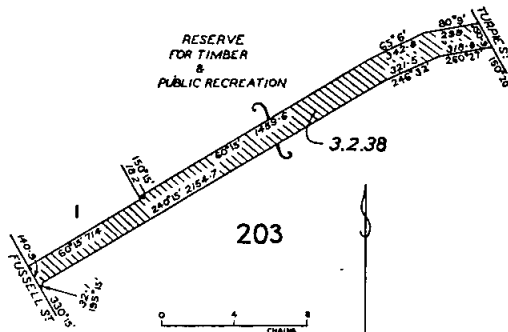

BALLARAT EAST.—The temporary reservation by Orders in Council of the 24th November, 1925, and the 20th January, 1926, of 110 acres 1 rood 16 perches of land in the Township of Ballarat East, as a site for the Growth and Preservation of Timber and for Public Recreation, revoked as to part by various Orders, is about to be revoked, so far only as the portion containing 2 acres 1 rood 20 perches, indicated by hatching on plan hereunder, is concerned.—(B.128⁽⁴⁴⁾) (Rs.1530).

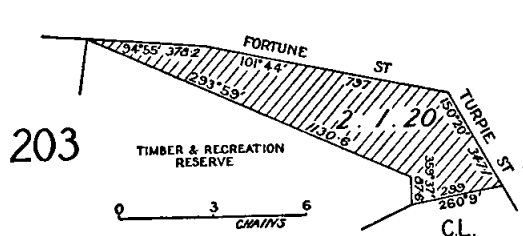

HEATHCOTE.—The temporary reservation by Order in Council of the 8th December, 1890 (see Government Gazette, 12th December, 1890, page 5027), of 40 acres, more or less, of land in the Parish of Heathcote, as a site for the Supply of Gravel, is about to be revoked, so far only as the portion containing 3 acres 0 roods 12 perches, indicated by hatching on plan hereunder, is concerned.—(H.75⁽¹²⁾) (C.98590).

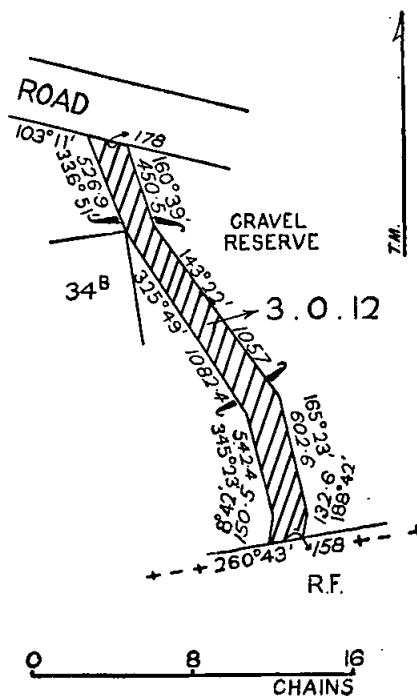

OUYEN.—The temporary reservation by Order in Council of the 27th April, 1920, of 32 acres 0 roods 3 perches of land in the Parish of Ouyen, as a site for Public Park and Gardens, revoked as to part by Order of the 19th March, 1957, is about to be revoked, so far only as the portion containing 2 acres 1 rood 31 perches, indicated by hatching on plan hereunder, is concerned.—(O.22^(e)) (Rs.2562).

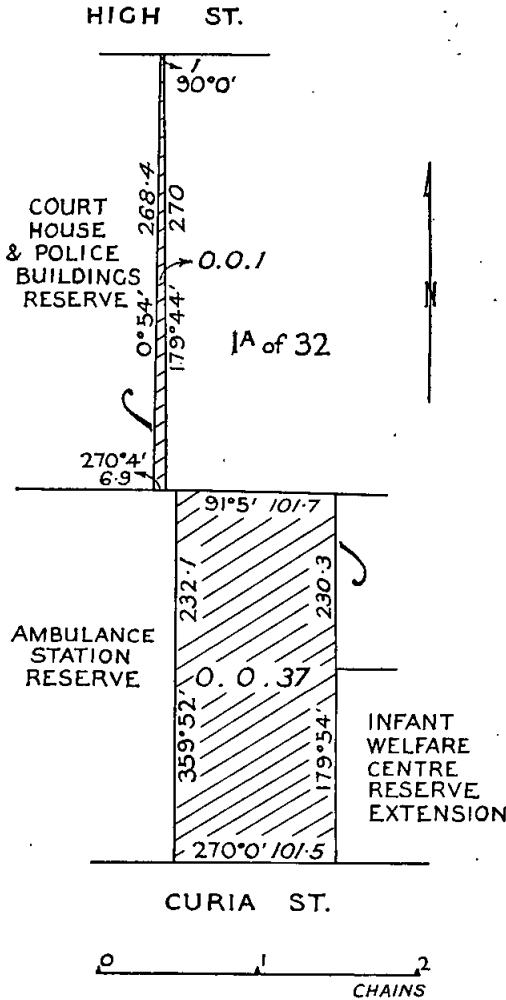
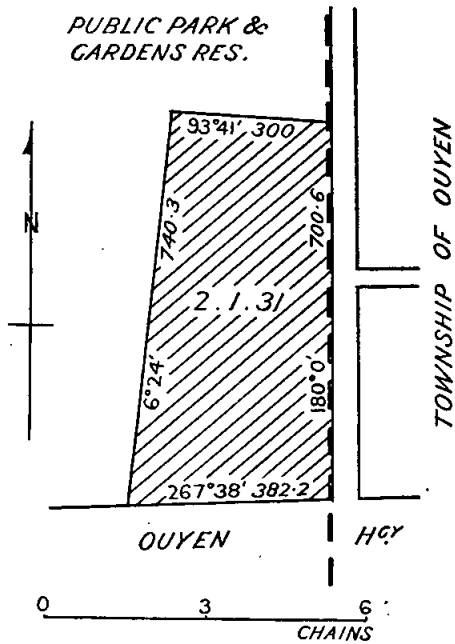

Total Area of hatched portions 0. 0. 38

MOLOGA.—The temporary reservation by Order in Council of the 28th November, 1967, of 7 acres 3 roods 16 perches of land in the Parish of Mologa, as a site for Public Recreation, is about to be revoked, so far only as the portion containing 5 perches, indicated by hatching on plan hereunder, is concerned.—(M.506⁽³⁾) (Rs.8900).

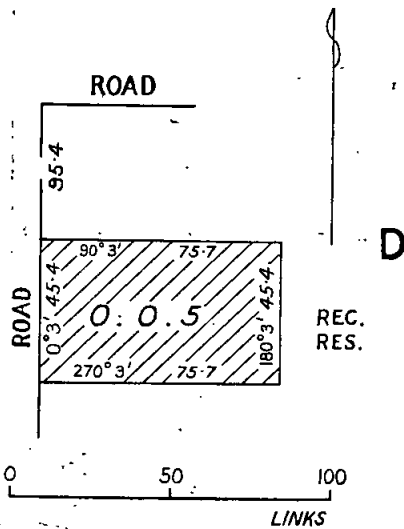

WY-YUNG.—The temporary reservation by Order in Council of the 27th May, 1921, of 5 acres 1 rood 25 perches of land in the Parish of Wy-Yung, as a site for a State School, is about to be revoked, so far only as the portion containing 8 perches, indicated by hatching on plan hereunder, is concerned.—(W.236⁽¹⁰⁾) (Rs.2297).

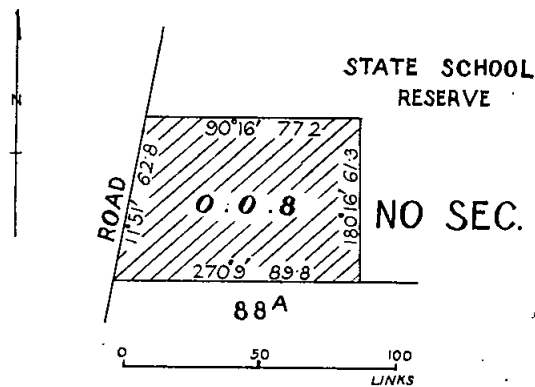

MANSFIELD.—The temporary reservation, by Order in Council of the 6th February, 1865, of 2 acres of land in the Township of Mansfield, as a site for Court House and Police Buildings, revoked as to part by various Orders, is about to be revoked, so far only as the portions containing 38 perches, indicated by hatching on plan hereunder, are concerned.—(M.35⁽⁵⁾) (Rs.8549).

BANYENA.—The temporary reservation as a site for Public purposes (State School) and the withholding from sale, leasing and licensing by Order in Council of the 21st February, 1876 (see Government Gazette, 25th

February, 1876, page 398), of 5 acres of land in the Parish of Banyena, are about to be revoked.—(B.656⁽⁷⁾) (Rs.9230).

BET BET.—The temporary reservation by Order in Council of the 5th January, 1869, of 2 roods 8 perches of land in the Parish of Bet Bet, as a site for Common School purposes, is about to be revoked.—(B.325⁽⁶⁾) (Rs.6750).

GALLA (BRADVALE).—The temporary reservation by Order in Council of the 3rd May, 1949, of 24 perches of land in the Parish of Galla, as a site for a Public Hall, is about to be revoked.—(G3⁽⁶⁾) (Rs.6342).

LAKES ENTRANCE.—The temporary reservation by Order in Council of the 29th June, 1953, of 1 acre 1 rood 30 perches, more or less, of land in the Township of Lakes Entrance, as a site for Tourist Camping and Picnic Ground is about to be revoked.—(C.383^(F3)) (Rs.7123).

MAFEKING.—The temporary reservation by Order in Council of the 1st July, 1901 (see *Government Gazette*, 19th July, 1901, page 2772), of 1 rood of land in the Township of Mafeking (formerly the Township of Naram Naram), as a site for a Mechanics' Institute, is about to be revoked.—(N.163⁽¹⁾) (C.100044).

MINCHA.—The temporary reservation as a site for Public purposes (State School) and the withholding from sale, leasing and licensing by Order in Council of the 6th November, 1876 (see *Government Gazette*, 10th November, 1876, page 2059), of 4 acres 3 roods 39 perches of land in the Parish of Mincha, is about to be revoked.—(M.488⁽¹¹⁾) (76W.972).

NARINGANINGALOOK.—The temporary reservation as a site for Public purposes (State School) and the withholding from sale, leasing and licensing by Order in Council of the 25th May, 1880, of 2 acres of land in the Parish of Naringaningalook, is about to be revoked.—(N.137⁽²⁾) (H.031907).

WALHALLA.—The temporary reservation by Order in Council of the 30th September, 1872 (see *Government Gazette*, 4th October, 1872, page 1837), of certain land in the Township of Walhalla, as a site for Telegraph purposes, is about to be revoked.—(W.277⁽¹²⁾) (H.034006).

WONGARRA.—The temporary reservation by Order in Council of the 22nd April, 1904, of 3 acres 1 rood 32 perches of land in the Parish of Wongarra, as a site for Camping and Watering purposes, is about to be revoked.—(W.374⁽⁸⁾) (Rs.999).

CANN RIVER.—The temporary reservation by Order in Council of the 13th July, 1948, of 20 acres, more or less, of land in the Township of Cann River, as a site for Public purposes, revoked as to part by Order of the 5th November, 1952, is about to be revoked, so far only as the portion containing 1 rood 24 perches, indicated by hatching on plan hereunder, is concerned.—(N.156⁽⁶⁾) (Rs.6202).

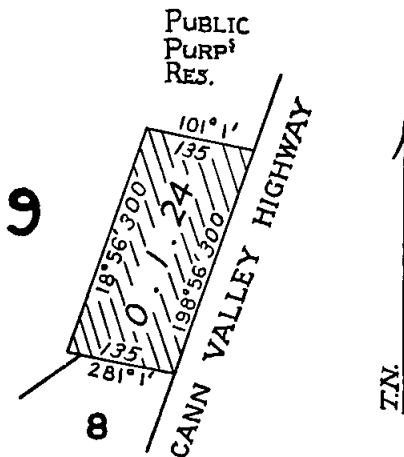

WATCHUPGA.—The temporary reservation by Order in Council of the 24th March, 1903 (see *Government Gazette*, 1st April, 1903, page 1049), of 55 acres 3 roods 15 perches of land in the Parish of Watchupga, as a site for Water Supply purposes, revoked as to part by various Orders, is about to be revoked, so far as the balance containing 19 acres 0 roods 11 perches, is concerned.—(W.392⁽⁴⁾) (Rs.8860).

W. BORTHWICK,
Minister of Lands.

COMMON ABOUT TO BE ABOLISHED.

IN pursuance of the provisions contained in section 184 of the *Land Act 1958*, notice is hereby given that it is the intention of the Governor in Council to abolish the common hereinafter mentioned, viz:—

The following Notice was published 1° on the 28th October, 1970, pursuant to Order of the 20th October, 1970.

The Inverleigh and Teesdale United Town and Farmers' Common proclaimed as such by the Governor in Council on the 14th May, 1884.—(Rs.313.)

W. BORTHWICK,
Minister of Lands.

TENDERS

PUBLIC WORKS DEPARTMENT

TENDERS will be received at Public Works Department, 2 Treasury-place, Melbourne, until TWO p.m. on dates shown and for purposes mentioned hereunder.

Particulars and tender forms available at Contracts Office, Room 8, Building Division, Parliament-place and at places indicated in brackets hereunder.

Abbreviations in brackets mean:—W.O.—Inspector of Works Office; P.S.—Police Station; C.S.—Consolidated School; H.E.S.—Higher Elementary School; H.S.—High School; Pr.S.—Primary School; T.S.—Technical School.

Tenders to be submitted on the Department's printed Tender Form and will not be received by telephone. All tenders must be on a "Firm Tender" basis. The lowest or any tender will not necessarily be accepted.

Address tenders to the Minister of Public Works, and endorse the envelope containing the tender "Tender for , closing Tuesday,

Hand delivered tenders to be placed in the Tender Box of the Public Works Department, located on the wall of the centre entrance foyer, Ground Floor, 2 Treasury-place, Melbourne.

No preliminary deposit is required with any tender, but a successful tenderer will be required to pay a deposit for any accepted tender of \$4,000 or over.

Tuesday, 24th November, 1970.

Building, Electrical and Mechanical Works.

- Banyule.—Erection of new science wing, &c., High School.
- Banyule.—Mechanical services, new science wing, High School.
- Colac.—Resiting of residence, Technical School. (W.O., Camperdown and Geelong.)
- Footscray.—Supply and installation of 180 line extensible P.A.B.X. telephone system, Institute of Technology.
- Heidelberg Heights.—Internal repairs and painting; Pr.S.4774.
- Keilor.—Erection of new toilet block and sewerage treatment plant, Pr.S.1578.
- Melbourne.—Supply and installation of P.A.B.X. telephone system, Agriculture Department, 131 Queen-street.
- Oak Park.—Electrical installation, new library, High School.
- Oak Park.—Erection of new brick library, High School.
- Oak Park.—Plenum heating and hot water service, Library High School.
- South Melbourne.—Internal repairs and painting, Pr.S.1253.
- Various.—Erection of four (4) brick veneer proprietary type residences, Royal Park and Flemington, M.H.A.

Site Works.

- Overport Heights.—Siteworks, Pr.S.4996. (W.O., Mornington.)

Miscellaneous.

- Melbourne.—Maintenance cleaning for the period, 7th December, 1970, to 30th November, 1973, Public Offices, 179 Queen-street.
- Sunshine.—Supply of workshop machine tools, Technical School.

Tuesday, 1st December, 1970.

Building, Electrical and Mechanical Works.

- Ascot Vale West.—External renovations, Pr.S.4025.
- Balwyn.—External repairs and painting, High School.
- Boneo.—Extension of Pr.S.1184 with one class-room removed from Langwarrin Pr.S. (W.O., Mornington.)
- Burwood.—Supply and installation of 120 extension, extensible P.A.B.X. system, Teachers College.

Coburg.—Erection of new chapel, Pentridge Prison.
 Kyabram.—Internal and external repairs and renovations, Pr.S.2902. (W.O., Shepparton.)
 Montmorency.—New toilet block and female staff toilet, Pr.S.4112.
 Red Hill.—Internal and external renovations, Consolidated School. (W.O., Mornington.)
 Richmond.—Demolition of buildings, Pr.S.2084.

Site Works.

Bendigo.—Construction of residential road and footpath, Psychiatric Centre. (W.O., Bendigo.)

Miscellaneous.

Stony Point.—Recharging, acetoning and inspection of acetylene navigation light cylinders, from 1st January, 1971 to 31st December, 1971, Buoy Depot.
 Williamstown.—Recharging, acetoning and inspection of acetylene navigation light cylinders, from 1st January, 1971 to 31st December, 1971, Dredging Depot.

Tuesday, 8th December, 1970.

Building, Electrical and Mechanical Works.

Braybrook.—External and internal painting, Pr.S.1102.
 Glenroy.—Erection of brick library and alterations to C/V, Trades Wing, T.S.
 Glenroy.—Electrical installation, Library, &c., T.S.
 Glenroy.—Plenum heating and hot water service, Library, &c., T.S.
 Greythorn.—Erection of science wing, H.S.
 Greythorn.—Mechanical services, science wing, H.S.
 Templestowe.—Erection of science wing in C/V., H.S.
 Templestowe.—Mechanical services, science wing, H.S.

Site Works.

Elsternwick.—New asphalt and asphalt repairs, &c., Pr.S.2870.

Miscellaneous.

Parkville.—Supply and delivery of laundry equipment, "Turana" Youth Training Centre.

MURRAY BYRNE,
 Minister of Public Works.

Public Works Department,
 Melbourne, 3002, 16th November, 1970.

TENDERS FOR THE SERVICE, 1970-71.
PROVISIONS—MEAT.

TENDERS will be received until Eleven o'clock a.m. on Friday, 4th December, 1970, from persons willing to furnish the under-mentioned supplies, in such quantities as may be ordered by the Victorian Government—delivery to be made at the under-mentioned places—during the three months commencing on 1st February, 1970.

In all cases the total cost of each item must be extended in the columns provided.

The places for which tenders will be received and the amount of the security required for the due fulfilment of each contract, are as follows:—

	Security.
Schedule No. 1.—Melbourne District—	\$
Meat—Kew Mental Hospital	40
" Children's Cottages, Kew	30
Meat—Pentridge Penal Establishment ..	60
" "Fairlea" Female Prison, Fairfield ..	10
" "Turana" Youth Training Centre ..	10
" "Travancore" Developmental Centre, Flemington	10
" "Winlaton" Girls' Training Centre, Nunawading, and "Allambie" Reception Centre, 70 Elgar-road, Burwood	10
" Psychiatric Hospital, Royal Park ..	20
Schedule No. 2.—Mont Park, Bundoora, Larundel, Janefield, and Gresswell—	
Meat—Mont Park, &c.	100
Schedule No. 3.—S.S. Rip and Dredges—	
Meat	10
Schedule No. 4.—Teachers' College and Hostels at Grattan-street, 93 Drummond-street, Carlton; 470, 481 and 572 St. Kilda-road, Melbourne; 19 Queen's-road, Melbourne; 152 Toorak-road west, South Yarra; Frank Tate House, 373 Dandenong-road, Armadale; "Redcourt", 6, "Larnook", 13 and No. 10A Orrong-road, Armadale; 11 Patterson-street, Hawthorn; 174 Punt-road, Prahran; 221 Burwood-road, Burwood; John Cannon House, 32 Belmont-avenue,	

	Security.
Kew; 23 Moule-avenue, Brighton; and Hastings-road, Frankston; and Police Hospital, St. Kilda-road, Melbourne; Mental Hygiene Clinic, 321 Glenferrie-road, Malvern, St. Nicholas Hospital—	
Meat	30
Schedule No. 5.—Heatherston Sanatorium, Cheltenham—	
Meat	10
Schedule No. 6.—Ararat District—	
Meat—Mental Hospital	60
" Gaol	10
Schedule No. 7.—Ballarat District—	
Meat—Mental Hospital	70
" Teachers' Hostels	10
Schedule No. 8.—Beechworth District—	
Meat—Mental Hospital	60
" Gaol	10
Schedule No. 9.—Bendigo District—	
Meat—Gaol	10
" Teachers' Hostels	10
" Sandhurst Boys' Centre, Mental Hygiene	10
Schedule No. 10.—Castlemaine District—	
Meat—Gaol	10
Schedule No. 11.—School of Forestry, Creswick—	
Meat	6
Schedule No. 13.—McLeod Settlement, French Island—	
Meat	10
Schedule No. 14.—Geelong District—	
Meat—Gaol	10
" Teachers' Hostels	10
Schedule No. 15.—Cooriemungle Prison Camp, Heytesbury Forest—	
Meat	8
Schedule No. 17.—Langi Kal Kal Training Centre—	
Meat	10
Schedule No. 20.—Sale Gaol—	
Meat	6
Schedule No. 21.—Pleasant Creek Special School, Stawell—	
Meat	6
Schedule No. 22.—Sunbury District—	
Meat	80
Schedule No. 23.—Warrnambool District—	
Meat	30
Schedule No. 24.—Hobson Park Hospital, Traralgon—	
Meat	10
Schedule No. 25.—Morwell River Reforestation Prison—	
Meat	10
Schedule No. 26.—State Research Farm, Werribee—	
Meat	10
Schedule No. 27.—"Hillside" Boys' Home, Wheelers Hill—	
Meat	6
Schedule No. 28.—Malmsbury Youth Training Centre—	
Meat	6
Schedule No. 29.—Won Wron Reforestation Prison—	
Meat	10
Schedule No. 30.—Dhurringile Rehabilitation Centre—	
Meat	10
Schedule No. 31.—Ambermere Hospital, Shepparton—	
Meat	10

Printed forms of tender and the conditions of contract may, in all cases, be obtained from the Secretary to the Tender Board, 2nd Floor, South Building, New State Public Offices, Treasury-place, Melbourne 3002, by whom also any information or explanation will be afforded to persons tendering.

Security will be acquired either in Commonwealth Treasury Bonds, or approved bank guarantee, fixed deposit receipt, Savings Bank deposit book, or non-negotiable cheque in favour of the Secretary to the Tender Board. as the tenderer may elect.

The security must be completed and the contract signed within five days of acceptance of the tender, failing which the service may be again advertised, or another tender accepted.

The lowest or any tender will not necessarily be accepted.

In the event of tenderers withdrawing or attempting to withdraw their tenders before notification of acceptance of same, or failing to take up their accepted tenders within the prescribed period after notification of acceptance they may be disqualified from tendering or holding any future contracts for Government supplies for a period of twelve months, such disqualification to date from the notification of acceptance of tender. It is also stipulated that, if a tenderer be a member of a firm and such firm be interested in the contract, the tender shall be in the name of the firm and not in that of the individual and that, for a breach of this condition, the tender will be declared informal.

Tenders enclosed in a separate envelope, and having the words "Tender for at" (as the case may be) written thereon, must be deposited in the Tender Box at the Tender Board Offices, 2nd Floor, South Building, New State Public Offices, Treasury-place, Melbourne, 3002, or, if sent by post, postage must be prepaid, and the tenders addressed to the Chairman of the Tender Board, Tender Board Offices, 2nd Floor, South Building, New State Public Offices, Treasury-place, Melbourne, 3002, which office they must reach not later than by first post on the date of closing of tenders.

CONDITIONS OF CONTRACT.

The conditions of contract are those published in the Victoria Government Gazette, No. 20, dated 18th March, 1970.

HENRY BOLTE,
Treasurer.

The Treasury,
Melbourne, 16th November, 1970.

PUBLIC SERVICE NOTICES

No. 582.

Public Service Act 1958, Section 50.

REGULATIONS.—PART IV.—SALARIES AND INCREMENTS.

THE Public Service Board, in pursuance of the powers conferred by the *Public Service Act 1958*, hereby amends its Regulations as shown below :—

FIFTH SCHEDULE.

TEMPORARY EMPLOYEES.

DEPARTMENT OF HEALTH.

MENTAL HYGIENE.

Designations of Positions and Rates of Salaries.

Designation of Position.	Yearly Rate of Salary. £	
	Minimum.	Maximum.
	\$	\$
<i>Add—</i> Machinist (Data Processing) (Female), Supervising, Grade I.	3,133
Machinist (Data Processing) (Female), Grade I. †— Junior— Under 17 years of age	1,569
At 17 years of age	1,701
At 18 years of age	1,836
At 19 years of age	2,105
At 20 years of age	2,374
Adult	2,762	2,876

† See Regulation 113.

£ Annual increments shall be in accordance with those prescribed by Sub-Regulations 97 (2) and 97 (3), provided that in the case of the position of Assistant (Male), Administrative, the annual increments shall be in accordance with those prescribed by Part A of the Third Schedule.

A. H. RIGG, Acting Chairman.
V. P. SCULLY, Secretary.

Office of the Public Service Board,
Melbourne, 26th October, 1970.

No. 583.

Public Service Act 1958, Section 50.

REGULATIONS.—PART IV.—SALARIES AND INCREMENTS.

THE Public Service Board, in pursuance of the powers conferred by the *Public Service Act 1958*, hereby amends its Regulations as shown below :—

SIXTH SCHEDULE.

TEMPORARY EMPLOYEES.

Designations of Positions and Rates of Salaries.

Department and Designation of Position.	Yearly Rate of Salary.		Increments (Annual).
	Minimum.	Maximum.	
	\$	\$	
WATER SUPPLY DEPARTMENT. <i>Add—</i> Assistant (Male), Grade III.	3,458	3,531	£
£ See Regulation 97 (2).			

This Regulation shall have effect as on and from the 1st November, 1970.

A. H. RIGG, Acting Chairman.
V. P. SCULLY, Secretary.

Office of the Public Service Board,
Melbourne, 30th October, 1970.

PRIVATE ADVERTISEMENTS

Town and Country Planning Act, 1961.

CITY OF ARARAT.

NOTICE THAT A PLANNING SCHEME HAS BEEN PREPARED AND IS AVAILABLE FOR INSPECTION.

Amendment No. 11.

NOTICE is hereby given that the Council of the City of Ararat in pursuance of its powers under the *Town and Country Planning Act 1961* has prepared a Planning Scheme amending the definition of the word "Shop" as defined in Clause 3 of the Planning Scheme Ordinance.

A copy of the Scheme has been deposited at the Municipal Offices, Ararat, and at the office of the Town and Country Planning Board, 61 Spring-street, Melbourne, and will be open for inspection during office hours by any person, free of charge.

Any persons affected by the Planning Scheme are required to set forth, in writing, all objections they may have, addressed to the Town Clerk, City of Ararat, Municipal Offices, Ararat, on or before the 16th December, 1970, and to state whether they wish to be heard in respect of their objections.

7182 E. F. O'NEILL, Deputy Town Clerk.

CITY OF BOX HILL.

LOAN No. 222.

Notice of Intention to Borrow the Sum of \$100,000 for Permanent Works and Undertakings.

NOTICE is hereby given that the Council of the City of Box Hill proposes to borrow the principal sum of \$100,000 secured by a charge over the general rates of the municipality, such sum to be raised by the grant of a mortgage in accordance with the provisions of the *Local Government Act 1958*.

1. The maximum rate of interest that may be paid is 7.4 per cent. per annum.

2. The purpose for which the loan is to be applied is part cost of erection of new Central Library building on land purchased for the purpose in Whitehorse-road, Box Hill, for the Regional Library Service conducted by the Cities of Box Hill and Doncaster and Templestowe.

3. The period of the loan shall be fifteen years.

4. The moneys borrowed shall be repayable by providing out of the municipal fund half-yearly instalments of approximately \$5,574 each including principal and interest on the 1st day of February and the 1st day of August, during the currency of the loan. The first instalment shall be payable on the 1st day of August, 1971.

5. Such moneys shall be repayable to The Commissioners of The State Savings Bank of Victoria, at the office of the said Commissioners, corner Elizabeth and Bourke streets, Melbourne.

The plans and specifications and the estimate of the cost of the proposed works and a statement showing the proposed expenditure of the moneys to be borrowed are open for inspection at the office of the Council of the City of Box Hill, at Town Hall, Box Hill.

Dated the 2nd November, 1970.

7226

A. N. WALLS, Town Clerk.

CITY OF BENDIGO.

LOAN No. 57.

Notice of Intention to Borrow the Sum of \$50,000 for Permanent Works and Undertakings.

NOTICE is hereby given that the Council of the City of Bendigo proposes to borrow the principal sum of Fifty thousand dollars secured by a charge over the general rates of the municipality, such sum to be raised by the grant of a mortgage in accordance with the provisions of the Local Government Act 1958.

1. The maximum rate of interest that may be paid is 7.4 per cent. per annum.
2. The loan is to be applied for the purpose of providing Off Street Parking and Administration building (part cost).
3. The period of the loan shall be 15 years.
4. The moneys borrowed shall be repayable by providing out of the municipal fund thirty (30) half-yearly instalments of \$2,787.11 each including principal and interest.
5. Such moneys shall be payable to the Mutual Life and Citizens Assurance Co. Ltd., 454-456 Collins-street, Melbourne.

The plans and specifications and estimate of the cost of the proposed works, and a statement showing the proposed expenditure of the moneys to be borrowed are open for inspection at the office of the Council of the City of Bendigo at the City Hall, Bendigo.

7177

A. J. WATTS, Town Clerk.

Local Government Act 1958 and Amendments.

CITY OF HEIDELBERG.

NOTICE TO ALL WHOM IT MAY CONCERN.

WHEREAS the Council of the Municipality of the City of Heidelberg, in the State of Victoria, deems it expedient to execute a certain work or undertaking for the purpose of reconstruction of Hawdon-street-Brown-street to St. James'-road, whereof it is in the opinion of the said Council necessary and desirable that the said Council exercise its power of taking land compulsorily within the municipal district of the said Council, as provided by the Local Government Act 1958, and amendments and the said Council has caused its surveyor to prepare plans of the said work or undertaking as are necessary and in which are expressed the nature and extent of such work or undertaking and the exact site and admeasurements thereof and on and through what land the said work or undertaking is proposed to be placed and the names of the owners or reputed owners, lessees or reputed lessees, and the occupiers of such land so proposed to be taken, so far as known, and the said plans so prepared have been approved by the said Council.

In pursuance of the provisions of the Local Government Act 1958 and amendments, the said Council doth hereby publish and give notice that the description shortly of the purport of the said work or undertaking is as follows:—

Reconstruction of Hawdon-street-Brown-street to St. James'-road.

And the land which it is necessary and desirable to take compulsorily is:—

All that portion of land as hatched on the attached plan being part of 100 Brown-street and being part of Crown portion 5, Parish of Keelbundora, County of Bourke and more particularly described in certificate of title, volume 3453, folio 690488, in the name of James Lloyd Smith as proprietor.

CITY OF HEIDELBERG

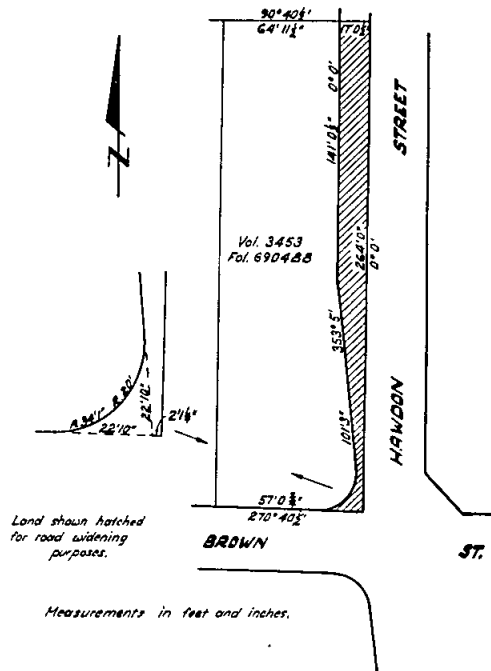

And the said Council doth hereby give further notice that the said plans are deposited at the office of the said Council, Town Hall, Ivanhoe, and are there open for inspection and perusal on all days and between the hours the Municipal Office is appointed to be open, for the space of 40 clear days from the date of the publication of this notice in the Government Gazette.

And the said Council doth hereby call upon all persons interested in or affected by the said proposed work or undertaking to set forth, in writing, addressed to the said Council or the Town Clerk thereof, at the Town Hall, Ivanhoe, within 40 clear days from the date of the publication of this notice, as aforesaid, all objections which they may have to the said working or undertaking.

Dated the 10th day of November, 1970.

The common seal of the Mayor, Councillors and Citizens of the City of Heidelberg was hereto affixed by me—

7143

(SEAL)
E. C. W. JACK, Town Clerk.
V. C. HENDERSON, Mayor.
D. J. BAKER, Councillor.

CITY OF MOORABBIN.

BY-LAW No. 284.

A By-law of the City of Moorabbin made under the provisions of the Local Government Acts and the Dog Acts and numbered 284 for fixing registration and other fees payable under the Dog Acts.

IN pursuance of the powers conferred by the Local Government Acts and the Dog Acts and of any and every other power it thereunto enabling the Council of the City of Moorabbin orders as follows:—

1. By-law No. 271 of the City of Moorabbin is hereby repealed.
2. The following fees and sums are hereby fixed under the provisions of the Dog Acts—
 - (a) For registration of a dog, pursuant to Section 6 of the Dog Act 1958, as amended by any Act . . . \$2.00
 - (b) For particulars of any registered dog or for the name of the registered owner thereof or for a certified copy of the receipt mentioned in Section 11 of the Dog Act 1958, as amended by any Act . . . \$0.25
 - (c) The sum payable to the registration officer pursuant to Section 15 of the Dog Act 1958, as amended by any Act . . . \$6.00

- (d) The sum payable to the registration officer pursuant to Section 16 of the Dog Act 1958, as amended by any Act . . . \$6.00

This By-law shall apply to and have operation throughout the whole of the municipal district of the City of Moorabbin.

Resolution for passing this By-law agreed to by the Council on the 19th day of October, 1970, and confirmed on the 9th day of November, 1970.

The common seal of the Mayor, Councillors and citizens of the City of Moorabbin was hereunto affixed this 9th day of November, 1970, in pursuance of a resolution of the Council and in the presence of—

(SEAL) KEITH M. DUCKMANTON, Councillor.
A. T. ALEXANDER, Councillor.
7151 V. A. SMITH, Town Clerk.

CITY OF OAKLEIGH.

LOAN No. 123.

Notice of Intention to Borrow.

NOTICE is hereby given that the Council of the City of Oakleigh intends to borrow Thirteen thousand dollars (\$13,000) secured by a charge over the general rates of the municipality, such sum to be raised by the grant of a mortgage in accordance with the provisions of the *Local Government Act 1958* (as amended).

In connexion therewith the following information is stated:—

- (a) The amount of the principal moneys which it is proposed to borrow is \$13,000 (Thirteen thousand dollars).
- (b) The maximum rate of interest that may be paid is 7.3 per cent per annum.
- (c) The times the moneys borrowed are to be repayable are the first days of August and February during the years 1971/81 inclusive and that the place such moneys shall be repayable is at the C.B.C. Savings Bank Limited, Melbourne.
- (d) The purpose for which the loan is to be applied is:—
Erection of clubrooms . . . \$13,000
- (e) The manner in which the loan is to be liquidated is by the provision out of the municipal fund in each half year during the currency of the loan of the sum of \$927.16 (Nine hundred and twenty-seven dollars and sixteen cents), which includes principal and interest.

The plans and specifications and estimate of the cost of works, and a statement showing the proposed expenditure of the moneys to be borrowed, are open for inspection at the Town Hall.

Dated this 11th day of November, 1970.

7146 J. H. HOCKING, Town Clerk.

CITY OF PRESTON.

LOAN No. 88.

Notice of Intention to Borrow.

NOTICE is hereby given that the Council of the City of Preston intends to borrow the sum of \$175,000 (One hundred and seventy-five thousand dollars), by the grant of a mortgage secured by a charge over the general rates of the municipality in accordance with the provisions of the *Local Government Acts*.

In connexion therewith, the following information is stated:—

- (a) The amount of the principal moneys which it is proposed to borrow is \$175,000 (One hundred and seventy-five thousand dollars).
- (b) The maximum rate of interest that may be paid is 7.4 per centum per annum.
- (c) The times which the moneys borrowed are to be repayable are the 30th day of June and the 31st day of December respectively in each of the years 1971 to 1985 inclusive, and that the place such moneys shall be repayable is at the Bank of New South Wales, Preston.
- (d) The purposes for which the loan is to be applied are—

Erection of East Preston Elderly Citizens' Club (part)	\$8,950
Private street construction charge on council property—Callander-street group	2,500
Land acquisition—Blake-street	36,000
Council contribution—Country Roads Board Works	60,000

Installation of Traffic Control Signals—	
Cr. Bell-street and St. Georges-road	\$8,666
Cr. High-street and Broadway	7,334
Cr. Albert-street and Plenty-road	8,000
Installation of pedestrian-operated signals—	
High-street, north of Church-street	2,650
Edwardes Park basketball courts	10,000
Traffic signal equipment	4,000
Reconstruction of Burbank Estate roads	6,500
Town Hall—Stove and refrigerator	2,000
“J. E. Moore” Park—Extension of No. 1 Pavilion	3,900
Water Reticulation—“C. H. Sullivan” Reserve	3,200
Oval Construction—“C. H. Sullivan” Reserve	11,300
	<hr/> \$175,000

(e) The manner in which the loan is to be liquidated is by provision out of the municipal fund in each half-year during the currency of the loan of the sum of \$9,754.90, which includes principal and interest.

The plans and specifications and estimate of the cost of the works and a statement showing the proposed expenditure of the moneys to be borrowed are open for inspection at the Town Hall, Preston, during office hours.

Dated this 16th day of November, 1970.

7223 J. C. DONATH, F.I.M.A., Town Clerk.

TOWN OF CAMPERDOWN.

By-Law No. 30.

A By-Law of the Town of Camperdown made under Section 197 (1) XXXVII of the *Local Government Act 1958* and numbered 30 for prohibiting or regulating the use of private property situated at the junction of streets or roads for the growing of trees, shrubs, hedges or other vegetation abutting on any such street or road, or within 10 feet therefrom or within a distance of 30 feet from the junction of such streets or roads and for requiring the removal or lopping of such trees, shrubs, hedges or other vegetation and for the reduction in height of any portion of a fence within 30 feet of the junction of a street or road and for authorizing the Council, at the expense of the owner of the property to remove or lop such trees, shrubs, hedges or vegetation and to reduce in height any such portion of a fence.

IN pursuance of the powers conferred by the *Local Government Act 1958* and all other powers enabling them in that behalf, the Mayor, Councillors and Burgesses of the Town of Camperdown order as follows:—

1. In this By-Law, “Council” means the Council of the Town of Camperdown.
2. By-Law No. 3 of the Borough of Camperdown is hereby repealed.
3. This By-Law shall come into force and operation immediately after its publication in the *Government Gazette*.
4. Where in the opinion of the Council, any property situated at the junction of any streets or roads is used for the growing of any trees, shrubs, hedges or other vegetation abutting on any such streets or roads or within 10 feet therefrom or within a distance of 30 feet from the junction of any streets or roads so as to constitute a danger to traffic or prevent drivers of vehicles from obtaining a clear view of other vehicles or be otherwise prejudicial to the safe and convenient use of the road by traffic, the Council may cause a written notice to be served on the owner or occupier of such property, requiring him to remove the trees, shrubs, hedges or other vegetation or to lop them or reduce them to such height as may be specified in the notice.
 - 4b. In default of compliance with such order within 21 days after a copy thereof has been served on the owner, such owner shall be liable to a penalty of not more than \$10.
 - 4a. Any portion of a fence exceeding 3 feet 6 inches in height within 30 feet of the junction of any streets or roads, shall be reduced by the owner or occupier, to a height not exceeding three feet six inches, within 21 days after the date of the coming into force of this By-Law.
 - 4b. The Council may reduce in height any portion of a fence which is not reduced in height as required by or under the last preceding paragraph at the expense of the owner or occupier and may recover the cost thereof as a civil debt recoverable summarily from such owner or occupier.
6. This By-Law shall apply to and have operation throughout the whole of the Municipal District of the Town of Camperdown.

Resolution for this By-Law was agreed to by the Council on the 23rd September, 1970, and confirmed at a meeting of the said Council on the 28th October, 1970.

The common seal of the Mayor, Councillors and Burgesses of the Town of Camperdown was hereunto affixed on the 28th October, 1970, in the presence of—

(SEAL) J. V. GUTHRIE, Mayor.
7140 R. C. BEAVIS, Councillor.
H. D. H. LEARMONTH, Town Clerk.

Town and Country Planning Act 1961.

SHIRE OF BACCHUS MARSH.

NOTICE THAT A PLANNING SCHEME HAS BEEN PREPARED AND IS AVAILABLE FOR INSPECTION.

SHIRE OF BACCHUS MARSH.—PLANNING SCHEME.

NOTICE is hereby given that the Shire of Bacchus Marsh in pursuance of its powers under the *Town and Country Planning Act 1961*, has prepared a Planning Scheme for the whole of the municipal district of the Shire of Bacchus Marsh for the purpose of regulating, restricting, restraining or prohibiting the use or development of any land except in accordance with the provisions of the Planning Scheme.

A copy of the Scheme has been deposited at the Shire Offices, Main-street, Bacchus Marsh and at the office of the Town and Country Planning Board, 235 Queen-street, Melbourne, and will be open for inspection during office hours by any person free of charge.

Any persons affected by the Planning Scheme are required to set forth in writing all objections they may have, addressed to the Shire Secretary, Shire of Bacchus Marsh, Shire Offices, Main-street, Bacchus Marsh, on or before the 18th February, 1971, and to state whether they wish to be heard in respect of their objections.

16th November, 1970.

7224 B. E. LEACH, Shire Secretary.

SHIRE OF BULLA.

LOAN No. 26.

Notice of Intention to Borrow the Sum of \$30,000.

NOTICE is hereby given that the Council of the Shire of Bulla proposes to borrow the sum of \$30,000 on the credit of the municipal revenues of the President, Councillors and Ratepayers of the Shire, such sum to be raised by the grant of a mortgage in accordance with the provisions of the *Local Government Act 1958*.

1. The maximum rate of interest that may be paid is 7.4 per cent. per annum.

2. The purpose for which the loan is to be applied is towards the construction of a Pavilion at the Sunbury Recreation Reserve.

3. The period of the loan shall be fifteen years.

4. The moneys borrowed shall be repayable by providing out of the municipal fund thirty half-yearly instalments of approximately \$1,672 including interest on the 12th day of August and the 12th day of February, during the currency of the loan. The first instalment shall be payable on the 12th August, 1971.

5. Such moneys shall be repayable at the Head Office of the State Savings Bank of Victoria.

7148 JOHN M. KELLY, Shire Secretary.

Town and Country Planning Act 1961.

SHIRE OF CROYDON PLANNING SCHEME 1961.

NOTICE THAT A PLANNING SCHEME HAS BEEN PREPARED AND IS AVAILABLE FOR INSPECTION.

Amendment No. 15, 1970.

NOTICE is hereby given that the Croydon Shire Council in pursuance of its powers under the *Town and Country Planning Act 1961*, has prepared a planning scheme for parts of C.A. 20, 21B, 21A, 14A and 13, Parish of Warrandyte, and part of C.A. 8, Parish of Mooroolbark, part of lot 2, P/S. 8854 and lots 7-9, 10-12 and 25-27, P/S. 10145, part of lot 52, P/S. 8854 and lot 1, P/S. 67779, part of lot 179, P/S. 74001, and part of lot 45, P/S. 5504, for the purpose of rezoning to Existing and Proposed Public Purposes Reserve.

A copy of the scheme has been deposited at the Croydon Shire Offices, Foch-avenue, Croydon, and at the offices of the Town and Country Planning Board, 235 Queen-street, Melbourne, and will be open for inspection during office hours by any person free of charge.

Any persons affected by the planning scheme are required to set forth in writing all objections they may have, addressed to the Shire Secretary, Croydon Shire Council, P.O. Box 206, Croydon, on or before the 19th day of February, 1971, and to state whether they wish to be heard in respect of their objections.

7217 K. A. MCKAY, Shire Secretary.

SHIRE OF FLINDERS.

NOTICE OF CHANGE OF STREET NAME.

NOTICE is hereby given that in pursuance of the powers conferred by the *Local Government Act*, the Council of the Shire of Flinders, at a meeting held on 21st October, 1970, did resolve to make the following alteration in a street name.

Old Name.—Summit-drive.

New Name.—Nestle-court.

Situation.—Street on lodged plans 58601, 19123, 79564, Parish of Kangerong at Arthurs Seat.

7144 S. WILLIAMS, Shire Secretary.

Town and Country Planning Act 1961.

SHIRE OF FLINDERS PLANNING SCHEME 1962.

AMENDMENT No. 29, 1970.

Extension of Period for Lodging Objections.

NOTICE is hereby given by the Council of the Shire of Flinders that the period during which objections to the Shire of Flinders Planning Scheme 1962, Amendment No. 29, may be lodged is extended to the 11th day of December, 1970.

13th November, 1970.

7173 S. WILLIAMS, Shire Secretary.

SHIRE OF HASTINGS.

LOAN No. 37.

Notice of Intention to Borrow the Sum of \$50,000 for Permanent Works and Undertakings.

NOTICE is hereby given that the Council of the Shire of Hastings proposes to borrow the principal sum of fifty thousand dollars (\$50,000) secured by a charge over the general rates of the municipality, such sum to be raised by the issue of debentures in accordance with the provisions of the *Local Government Act 1958*.

1. The maximum rate of interest that may be paid is 7.4 per cent. per annum.

2. The purposes for which the loan is to be applied are:—

- | | |
|--|---------|
| (1) Part reconstruction, Lower Somerville-road, Somerville | \$7,000 |
| (2) Part reconstruction, sealing and kerbing—Coolstores-road, Hastings | 17,000 |
| (3) Part reconstruction and sealing (.75 miles) Governors-road, Crib Point | 6,600 |
| (4) Part reconstruction and sealing (.5 miles) Merricks-road, south from Kentucky-road, Merricks | 15,400 |
| (5) Part Hastings Main Drainage | 4,000 |

3. The period of the loan shall be fifteen (15) years.

4. The moneys borrowed shall be repayable by providing out of the municipal fund half-yearly instalments of \$2,787.11 each, including principal and interest on the 30th day of June and the 30th day of December during the currency of the loan. The first instalment shall be payable on the 30th day of June, 1971.

5. Such moneys shall be repayable at the office of The Mutual Life and Citizens Assurance Company Limited, 454-456 Collins-street, Melbourne.

The plans and specifications and the estimate of the costs of the proposed works and a statement showing the proposed expenditure of the moneys to be borrowed are open for inspection at the office of the Council of the Shire of Hastings, at Marine-parade, Hastings.

L. A. WALKER, Shire Secretary.

Municipal Offices, Hastings, 13th November, 1970.

7225

SHIRE OF MORNINGTON.

BY-LAW No. 124.

Dog By-Law.

NOTICE is hereby given that the Council of the Shire of Mornington has made a By-Law Numbered 124 under the *Local Government Act 1958*, as amended, and all other

powers it thereunto enabling, for the purpose of fixing fees payable under the *Dog Act 1958*, and for other purposes.

Notice is also hereby given that a copy of the above-mentioned By-Law is available for inspection, free of charge, during office hours, at the Office of the Council, Queen-street, Mornington.

7175 D. G. COLLINGS, Shire Secretary.

SHIRE OF ORBOST.

By-Law No. 62.

A By-Law of the Shire of Orbost made under section 65 of the *Health Act 1958*, as amended by the *Health Act 1960*, and numbered 62, for fixing the fee for the examination of plans, specifications, particulars and descriptions of proposed septic tank systems or alterations to existing systems, and any inspection of sites and installations.

IN pursuance of the powers contained in the *Health Act 1958* and amendments thereto and every power enabling it in this behalf, the Council of the Shire of Orbost, in the name and on behalf of the President, Councillors and Ratepayers of the said Shire, for the purpose of carrying the said Act into execution within its jurisdiction, doth hereby make the following By-Law, that is to say:—

(1) This By-Law shall come into effect and have operation within the Municipal boundaries of the Shire of Orbost immediately after publication in the *Victorian Government Gazette*.

(2) The following fee is hereby fixed:—

For the examination of plans, specifications, particulars and description of proposed septic tank installations or alterations to existing systems and any inspection of sites and installations of septic tank systems—\$8.

Resolution for passing this By-Law was agreed to by the Council of the Shire of Orbost on the 11th day of September, 1970, and confirmed on the 9th day of October, 1970.

The common seal of the President, Councillors and Ratepayers of the Shire of Orbost was affixed hereunto, this 9th day of October, 1970, in the presence of—

7150 (SEAL) J. D. TORLEY, President.
J. A. TANNER, Councillor.
R. K. SOULSBY, Secretary.

SHIRE OF SEYMOUR.

DECLARATION OF A PUBLIC HIGHWAY.

PURSUANT to the provisions of section 522 of the *Local Government Act 1958*, the Council of the Shire of Seymour hereby directs that the land in the Township of Seymour, contained in certificate of title, volume 2488, folio 497591, indicated by hatching on the diagram hereunder which has been purchased, taken or acquired by it, shall be a public highway on and from the date of publication of this Order in the *Government Gazette*.

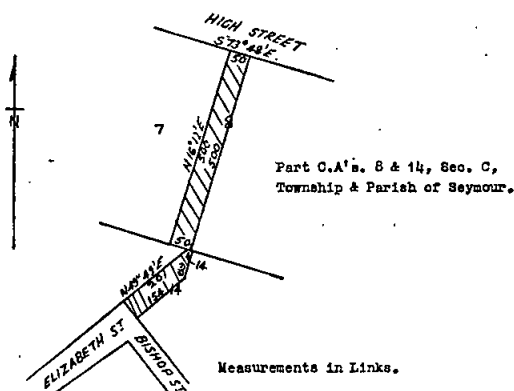

The common seal of the President, Councillors and ratepayers of the Shire of Seymour was hereunto affixed this 9th day of November, 1970, in the presence of—

7171 (SEAL) D. L. COUGHLIN, President.
L. SHILTON, Councillor.
G. G. McWHINNEY, Secretary.

SHIRE OF WHITTLESEA.

LOAN No. G.19.

Notice of Intention to Borrow the Sum of \$50,000 for Permanent Works and Undertakings.

NOTICE is hereby given that the Council of the Shire of Whittlesea proposes to borrow the principal sum of \$50,000 secured by a charge over the general rates of the municipality, such sum to be raised by the grant of a mortgage in accordance with the provisions of the *Local Government Act 1958*.

1. The maximum rate of interest that may be paid is 7.4 per cent. per annum.

2. The purposes for which the loan is to be applied are:—

(a) Construction of Streets, Whittlesea ..	\$4,750
(b) Construction of Streets, Epping ..	9,875
(c) Purchase of Infant Welfare Centre, 12 Rochdale-square, Lalor ..	11,000
(d) Council's proportion of part cost of reconstruction works Main Whittlesea-road, Bundoora ..	10,640
(e) Council's proportion of part cost of reconstruction works High-street-Mahoneys-road intersection including boom barriers Keon-parade Level Crossing ..	13,735
	<u>\$50,000</u>

3. The period of the loan shall be fifteen years.

4. The moneys borrowed shall be repayable by providing out of the municipal fund half-yearly instalments of \$2,787.11 each, including principal and interest, on the 30th day of June and the 31st day of December, during the currency of the loan. The first instalment shall be payable on the 30th day of June, 1971.

5. Such moneys shall be repayable to The Mutual Life and Citizens' Assurance Co. Ltd., at 454-456 Collins-street, Melbourne.

The plans and specifications and the estimate of the cost of the proposed works and a statement showing the proposed expenditure of the moneys to be borrowed are open for inspection at the Office of the Council of the Shire of Whittlesea, at High-street, Epping.

7169 R. G. C. COOK, Shire Secretary.

NOTICE is hereby given that Alpine Motels Proprietary Limited has applied for a lease under section 134, *Land Act 1958*, for a term of 50 years in respect of an area of 2 roods 0 perches, more or less, section B, Parish of Hotham, as a site for a motel.—(H.033818).

6934 ALPINE MOTELS PROPRIETARY LIMITED.

WARRNAMBOOL SEWERAGE AUTHORITY.

GENERAL NOTICE.

THE above-mentioned Sewerage Authority, having made Sewers for carrying off the sewage from each and every property which, or any part of which abuts on the streets or parts of streets, in which such sewers are laid, and which are included within the Sewerage Area hereinafter described, doth hereby declare that, on and after the 1st day of December, 1970, each and every property which, or any part of which abuts on the said streets or part of streets shall be deemed to be seweraged property within the meaning of the *Sewerage Districts Act 1958*.

Sewerage Area No. 77.

The boundaries of the Sewerage Area hereinbefore referred to are:

That part of the Warrnambool Sewerage District situated to the south of the Princes Highway and west of Morriss-road and extending in one section to the east side of Walsh-road, and being part of Crown allotments 83 and 84, Parish of Wangoom, County of Villiers, and which consists of lots 66 to 73, Princes Highway, lots 76 to 81, Morriss-road, the Warrnambool Sewerage Authority pumping station site in Morriss-road and lot 83, Morriss-road, lots 1 to 3 Walsh-road, lots 4 to 23, Bradley-street, lots 24 to 35 Osbourne-court, lots 36 to 50, and lot 52, Bradley-street, lot 51 Mack-street and the portion of lot 106 which fronts Bradley-street and is to the north of the sewer easement together with those sections of all road reserves which are adjacent to all of the aforementioned lots.

7145 R. A. MITCHELL, Chairman.
K. L. ARNEL, Secretary.

DANDENONG VALLEY AUTHORITY.

DECLARATION OF ARTERIAL DRAINS.

THE Dandenong Valley Authority, in pursuance and exercise of the powers conferred by the *Dandenong Valley Authority Act 1963*, doth hereby declare that the rivers, creeks, watercourses and drains, and new arterial drains proposed within the district of the Authority as set out and described in the Schedule hereto shall be arterial drains under and for the purposes of the Act.

SCHEDULE.

1. *Amalfi-drive Drain No. 5147*.—Commencing at a point on the eastern boundary of lot 2, plan of subdivision 89664, approximately 80 feet north of the southern boundary of said lot being part of Crown portion 5, Parish of Eumemmerring, generally north-westerly along the proposed road to be named Amalfi-drive and westerly to its junction with the Power-road—Heather-ton-road Drain No. 5146.

2. *Boggy Creek No. 5740*.—Commencing at the northern boundary of the Frankston—Cranbourne road reserve near the eastern end of Lloyd Park, Langwarrin, generally northerly and north-westerly to the existing declaration of this Creek at Boundary-road.

3. *Lloyd Park Drain No. 5741*.—Commencing on the eastern boundary of C.A. 41 in the Parish of Langwarrin, approximately 1,190 feet north of the Frankston—Cranbourne road, generally easterly to its junction with Boggy Creek No. 5740.

4. *Exell's Drain No. 5160*.—Commencing near the intersection of the southern boundary of the Mulgrave By-Pass road with the western boundary of the Gladstone-road reserve in the Parish of Dandenong, generally northerly along Gladstone-road; thence easterly to a junction with Dandenong Creek No. 5100.

5. *Un-named Drain No. 5162*.—Commencing at a point on the southern boundary of C.A. 84, Parish of Dandenong, approximately 1,690 feet east of Gladstone-road, generally northerly to its junction with Exell's Drain No. 5160.

6. *Waverley-road Drain No. 5224*.—Commencing at a point on the northern boundary of land Certificate of Title, volume 6508, folio 507, part C.A. 87, Parish of Mulgrave, County of Bourke; thence generally north-easterly and easterly to its junction with Dandenong Creek No. 5200.

7. *Vermont South Drain No. 5240*.—Commencing at a point near the northern boundary of Terrara-road approximately 100 feet west of George-road in the municipality of Nunawading, generally easterly and south-easterly to its junction with Dandenong Creek No. 5200.

8. *Burwood Highway Drain No. 5241*.—Commencing at a point near the south-eastern corner of the intersection of Terrara-road and Burwood Highway in the municipality of Nunawading, generally easterly along Burwood Highway and northerly to its junction with Vermont South Drain No. 5240.

9. *Vermont Drain No. 5244*.—Commencing at a point near the north-western corner of lot 5, plan of subdivision 25179, fronting Sunnyside-crescent in the municipality of Nunawading, generally southerly to its junction with Vermont South Drain No. 5240.

10. *Un-named Drain No. 5393*.—Commencing at the south-western corner of lot 3, plan of subdivision 52040, in the Parish of Mooroolbark, generally northerly to the present declaration of this drain at the north-western corner of lot 19, plan of subdivision 17979, in the Parish of Mooroolbark. 7216

BEECHWORTH SEWERAGE AUTHORITY.

GENERAL NOTICE.

THE above-mentioned Sewerage Authority having made provision for carrying off sewage from each and every property which or any part of which is within the sewerage area hereinafter described, doth hereby declare that on and after the 18th day of November, 1970, each and every property which is within the said sewerage area shall be deemed to be a seweraged property within the meaning of the *Sewerage Districts Act 1958*.

The said sewerage area shall be known as "Sewerage Area Number 4".

Sewerage Area No. 4.

Commencing at the most easterly angle of C.A. 11, section 9, Township and Parish of Beechworth, County of Bogong, a point on the boundary of Sewerage Area No. 1; thence south-easterly across Ford-street along the south-western boundary of William-street and across High-street to the south-eastern boundary thereof; thence south-westerly along the said boundary across Tanswell-street

to the south-western boundary thereof; thence south-easterly along the said boundary to the most easterly angle of C.A. 4A, section 24; thence south-westerly along the south-eastern boundaries of C.A.'s 4A and 6 to the north-eastern boundary of Albert-road; thence south-easterly along the said boundary across Stanley-road to the south-eastern boundary thereof; thence north-easterly along the said boundary to the northernmost angle of C.A. 2, section F2; thence south-easterly along the north-eastern boundary of C.A. 2, across Hodge-street to the south-eastern boundary thereof; thence north-easterly along the said boundary across a road to the boundary of Mental Hospital Reserve being a point on the Sewerage District Boundary; thence generally easterly, southerly and north-westerly along the Sewerage District Boundary to the eastern boundary of Buckland-road being a point on the boundary of Sewerage Area No. 3; thence generally northerly and westerly along the boundary of Sewerage Area No. 3 to the western boundary of Bridge-street; thence northerly along the western boundary of Bridge-street to the most southerly angle of C.A. 23, section 6, being a point on the boundary of Sewerage Area No. 2; thence generally easterly, northerly and westerly along the boundary of Sewerage Area No. 2 to the north-western boundary of Ford-street being a point on the boundary of Sewerage Area No. 1; thence north-easterly along the boundary of Sewerage Area No. 1 to the point of commencement.

By order of the said Sewerage Authority,

7179 D. A. MCKENZIE MCHARG, Chairman.
G. T. GRAY, Secretary.

NOTICE OF INTENTION TO APPLY FOR A LICENCE TO DIVERT WATER AND CUT RACE (RE-ISSUE) FROM THE RIVER MURRAY, AT BEVERFORD.

I HEREBY give notice that I intend to apply for a licence empowering me to divert water for a term of six years to the extent of 100 acre-feet per annum at a maximum rate of 2 acre-feet per day of 24 hours for the purpose of irrigating 50 acres of citrus, pomes and vegetables, being lot 4 and part of lot 5 L.P.10404, section A and lot 2, L.P.16325, section B, Parish of Tyntynder, and to occupy certain Crown lands for works of diversion, and to cut a race thereon.

Any objection to such application must be forwarded in writing to reach the State Rivers and Water Supply Commission, Melbourne, before 18th December, 1970, being 30 days from the first publication of this notice.

RICHARD WILLIAM HOLLOWAY.

Tyntynder Homestead, Beverford, Victoria. 7174

NOTICE OF INTENTION TO APPLY FOR A LICENCE TO DIVERT WATER AND CUT RACE (RE-ISSUE) FROM THE LITTLE RIVER, AT LITTLE RIVER.

I HEREBY give notice that I intend to apply for a licence empowering me to divert water for a term of fifteen years to the extent of 14 acre-feet per annum at a maximum rate of 2 acre-feet per day of 24 hours for the irrigation, being part of lot 8 of 12 and 13c, section 11c, Parish of Bulban, and to occupy certain Crown lands for works of diversion, and to cut a race thereon.

Any objection to such application must be forwarded in writing to reach the State Rivers and Water Supply Commission, Melbourne, before 18th December, 1970, being 30 days from the first publication of this notice.

R. D. RAWOLLE.

12 Pyke-street, Werribee. 7158

NOTICE OF INTENTION TO APPLY FOR A LICENCE TO DIVERT WATER AND CUT RACE FROM THE WERRIBEE RIVER, AT BACCHUS MARSH.

WE hereby give notice that we intend to apply for a licence empowering us to divert water for a term of four years to the extent of 12 acre-feet per annum at a maximum rate of 4 acre-feet per day of 24 hours for the irrigation of 12 acres of market garden, being part of allotment 6, section 3, Parish of Korkuperimul, and to occupy certain Crown lands for works of diversion, and to cut a race thereon.

Any objection to such application must be forwarded in writing to reach the State Rivers and Water Supply Commission, Melbourne, before 18th December, 1970, being 30 days from the first publication of this notice.

KATRANSKI PTY. LTD.

449 Swanston-street, Melbourne, Vic. 3000. 7141

NOTICE OF INTENTION TO APPLY FOR A LICENCE TO DIVERT WATER AND CUT RACE FROM THE RIVER MURRAY, AT MERBEIN.

WE hereby give notice that we intend to apply for a licence empowering us to divert water for a term of fifteen years to the extent of 1 acre-foot per annum at a maximum rate of — acre-feet per day of 24 hours for domestic and garden, being part of allotment 4, section 57526, Parish of Mildura, and to occupy certain Crown lands for works of diversion, and to cut a race thereon.

Any objection to such application must be forwarded in writing to reach the State Rivers and Water Supply Commission, Melbourne, before 18th December, 1970, being 30 days from the first publication of this notice.

ROBERT VICTOR and HILDA MURIEL HAYHOE.

33 Windsor-street, Mildura, 3500.

7159

NOTICE OF INTENTION TO APPLY FOR A LICENCE TO DIVERT WATER AND CUT RACE FROM THE RIVER MURRAY AT MERBEIN.

I HEREBY give notice that I intend to apply for a licence empowering me to divert water for a term of fifteen years to the extent of 90 acre-feet per annum at a maximum rate of 3 acre-feet per day of 24 hours for the irrigation of 30 acres of vines, being part of allotment 12E, section H, Parish of Merbein, and to occupy certain Crown lands for works of diversion, and to cut a race thereon.

Any objection to such application must be forwarded in writing to reach the State Rivers and Water Supply Commission, Melbourne, before 18th December, 1970, being 30 days from the first publication of this notice.

STANLEY JOHN SMYTHE.

West Merbein P.O., Vic.

7220

NOTICE OF INTENTION TO APPLY FOR A LICENCE TO DIVERT WATER AND CUT RACE FROM THE RIVER MURRAY AT MERBEIN.

I HEREBY give notice that I intend to apply for a licence empowering me to divert water for a term of fifteen years to the extent of 60 acre-feet per annum at a maximum rate of 3 acre-feet per day of 24 hours for the irrigation of 20 acres of vines, being part of allotments 197 and 195, Parish of Merbein, and to occupy certain Crown lands for works of diversion, and to cut a race thereon.

Any objection to such application must be forwarded in writing to reach the State Rivers and Water Supply Commission, Melbourne, before 18th December, 1970, being 30 days from the first publication of this notice.

FRANK W. SYLVIA.

West Merbein P.O., Vic.

7222

The Companies Act 1961.—In the matter of GOTHIC FIBROUS PLASTER PROPRIETARY LIMITED (in Voluntary Liquidation).

NOTICE is hereby given that at an Extraordinary Meeting of the members of the above-named company held on Monday, the 9th day of November, 1970, it was resolved that the company be wound up voluntarily and at a meeting of creditors, held on Monday, the 9th day of November, 1970, it was resolved that for such purpose Scott Maurice Nunan, of Hall & Rose, 254 Queen-street, Melbourne, chartered accountant, be appointed liquidator.

Notice is also given that after 21 days from this date I shall proceed to distribute the assets. All creditors having any claim against the company should furnish particulars of same by that date, otherwise I shall proceed to distribute the assets, without regard to their claim.

Dated this 11th day of November, 1970.

S. M. NUNAN, Liquidator.

Hall & Rose, chartered accountants, 254 Queen-street, Melbourne.

7202

The Companies Act 1958.—In the matter of BAS PLUMBING SERVICES PTY. LTD., (in Voluntary Liquidation).—Creditors winding-up, and in the matter of the Companies Act.

NOTICE is hereby given that a Third and Final Dividend is intended to be declared in the above matter.

Creditors who have not proved their debts by the 12th day of December, 1970, will be excluded therefrom.

Dated this 13th day of November, 1970.

R. D. WIDDOWS, Liquidator.

6, Marylin-court, East Bentleigh, 3165.

7204

The Companies Act 1961.—In the matter of W. E. WHITE & SONS PTY. LTD.—Notice Re Meeting of Creditors, Pursuant to Section 260.

NOTICE is hereby given that a Meeting of Creditors of the above-named company will be held at the offices of Kennedy, Smail & Middlemiss, 296 Little Lonsdale-street, Melbourne, at 3 p.m., on the 19th day of November, 1970, the company having convened a meeting of its members for the same day for the purpose of considering a Resolution that the company be wound up voluntarily.

Dated this 12th day of November, 1970.

I. W. G. WHITE, Director.

Kennedy, Smail & Middlemiss, 296 Little Lonsdale-street, Melbourne, 3000.

7213

The Companies Act 1961.—Pursuant to Section 272. J. P. McMEEKIN PTY. LTD. (IN VOLUNTARY LIQUIDATION). NOTICE TO MEMBERS.

NOTICE is hereby given that a Final Meeting of members of the above-named company will be held at the office of Norman A. Moore & Co., 75 Bridge-road, Richmond, at 12 noon, on the 21st day of December, 1970, for the purpose of laying before the meeting the liquidator's account showing the manner in which the winding up has been conducted and the property of the company disposed of, and hearing any explanations that may be given by the liquidator.

Dated this 17th day of November, 1970.

7207

J. A. McDONALD, Liquidator.

The Companies Act 1961. MERRIMAX HOLDINGS PTY. LTD. (IN VOLUNTARY LIQUIDATION). NOTICE OF FINAL MEETING.

NOTICE is hereby given that the Final General Meeting of the company will be held at the offices of Wilson, Bishop, Bowes & Craig, 4th Floor, 191 Queen-street, Melbourne, on 18th December, 1970, at 10 a.m., when the liquidator's account of the winding up will be presented and any explanations given.

11th November, 1970.

7214

R. B. VANCE, Liquidator.

M. O. VERNON PTY. LTD. (IN VOLUNTARY LIQUIDATION). NOTICE CONVENING FINAL MEETING OF MEMBERS, PURSUANT TO SECTION 272.

NOTICE is hereby given in pursuance of section 272 of the Companies Act 1961, that a General Meeting of the members of the above-named company will be held on the 18th day of December, 1970, at 11.30 a.m., at the office of A. A. Armitage & Partners, chartered accountants, 238 Elizabeth-street, Melbourne, for the purpose of having before them accounts showing the manner in which the winding up has been conducted and the assets of the company disposed of and hearing any explanation which may be given by the liquidator.

Dated this 10th day of November, 1970.

7166

B. K. SIMMONS, Liquidator.

ROLLS WRIGHT (AUST.) PTY. LIMITED.

NOTICE is hereby given that a General Meeting of members of Rolls Wright (Aust.) Pty. Limited (in liquidation) will be held at the offices of Messrs. R. W. Nelson, Wheeler & Barton, 27 O'Connell-street, Sydney, on the 21st day of December, 1970, at 9.15 a.m., for the purpose of receiving the liquidator's account showing how the winding up has been conducted and the property of the company has been disposed of and of hearing any explanation which may be given by the liquidator.

Dated this 13th day of November, 1970.

7240

J. G. WHEELER, Liquidator.

WADDING PRODUCTS PTY. LTD. (IN LIQUIDATION). NOTICE OF FINAL DIVIDEND.

NOTICE is hereby given that a Final Dividend is intended to be declared at the above meeting. Creditors who have not proved their debt by the 14th day of December, 1970, may be excluded from this dividend.

Dated the 16th November, 1970.

7239

W. B. McMAHON, Liquidator.

Unclaimed Moneys Act 1962.

REGISTER of Unclaimed Moneys held by the—

Name of Owner on Books and Last Known Address.	Total Amount Due to Owner.	Description of Unclaimed Moneys.	Date when Amount first became Payable.
ARCHIE'S CREEK DAIRY PRODUCE CO. LTD.			
Atkinson, Kingsley G., Queensland	17.28	Dividend Shares	—10.68
Excell, John R. & Phillip A., Lang Lang	22.08	" "	" "
Parry, Herbert William, Cowes	15.80	" "	" "
Pearson, James, Melbourne	12.16	" "	" "
Perrin, Herbert E. J., Grantville	16.32	" "	" "
Trewin, T. Jnr., Ainslie A.C.T.	13.76	" "	" "
7160			
VICTORIAN WHEATGROWERS CORPORATION LTD.			
Allen, George Hamilton, 182 Nepean Highway, Aspendale, 3195	15.00	Interest Cheque	—9.68
Altman, Wilhelm, Angip via Warracknabeal, 3393	15.00	" "	" "
Cheatley, Henry Osborne, Colbinabbin West, 3559	10.00	" "	" "
Lanyon, Thomas Westcott, "Fairview" Barraport, 3535	30.00	" "	" "
Lehmann Bros., Concordia P.B. Horsham, 3400	26.60	" "	" "
Smith Bros., Bundalong, via Yarrowonga, 3730	13.40	" "	" "
Speer, John, Corop, 3559	15.00	" "	" "
William, Walter Alexander, c/o Cuthbert, Morrow, Must and Shaw, Box 122, Ballarat, 3350	33.00	" "	" "
7086			

The Companies Act 1961.

SIREMA ELECTRIC CO. PTY. LTD.

PURSUANT TO SECTION 260 OF THE COMPANIES ACT 1961.

NOTICE is hereby given that a meeting of creditors of Sirema Electric Co. Pty. Ltd. will be held at The Institute of Chartered Accountants, 23 McKillop-street, Melbourne, on Friday, the 4th day of December, 1970 at 11.00 a.m. for the purpose of considering the company's affairs, the company having convened an Extraordinary General Meeting of its members to be held on the same day and for the purpose of considering and if thought fit, passing a Special Resolution that the company be wound up voluntarily.

Dated this 12th day of November, 1970.

B. SILVASIC, Director.

Hall & Rose, chartered accountants, 254 Queen-street, Melbourne. 7203

Companies Act 1961.

JAMISON HOLDINGS PTY. LTD.

NOTICE OF SPECIAL RESOLUTION.

NOTICE is hereby given that at an Extraordinary General Meeting of Jamison Holdings Pty. Ltd. duly convened and held on 13th November, 1970 at the Registered Office, 545 Little Collins-street, Melbourne, the Special Resolution set out below was duly passed.

SPECIAL RESOLUTION

"Resolved as a Special Resolution that the Company be wound up voluntarily."

It was also resolved that John David Spence, of 440 Little Collins-street, Melbourne, be appointed Liquidator of the company.

Dated 13th day of November, 1970.

7215

K. F. HESSE, Secretary.

The Companies Act 1961.

JENSEN INDUSTRIAL ELECTRICAL SERVICES PTY. LTD. (IN LIQUIDATION).

PURSUANT TO SECTION 254 (2).

NOTICE is hereby given that at an Extraordinary General Meeting of members of the above-named company held on Thursday, 5th November, 1970, the following Special Resolution was duly passed, and that at a meeting of creditors held the same day, Mr. Gee's appointment was confirmed:

"That owing to the company being unable to meet its debts as and when they become due that the company be and is hereby wound up voluntarily and that Maxwell George Gee, a registered liquidator, be and is hereby appointed liquidator to wind the company up and attend to all matters relative thereto in accordance with the Companies Act 1961."

M. G. GEE, registered liquidator, care of Max Gee and Co., 325 Warrigal-road, Burwood, Vic., 3125, 288-5911.

7163

Co-operation Act 1958.

YARRA VALLEY A. B. CO-OPERATIVE LIMITED (IN LIQUIDATION).

NOTICE is hereby given that, after 21 days from this date, I shall proceed to distribute the assets of the Co-operative. All creditors having any claim against the Co-operative should furnish particulars of same by that date, otherwise I shall proceed to distribute the assets without regard to their claim.

Dated this 17th day of November, 1970.

PETER STEWART RANDALL, Liquidator.

F. Oswald Barnett & Co., chartered accountants, 422 Collins-street, Melbourne, 3000 (67-8855). 7241

The Companies Act 1961, as amended.

NOTICE OF MEETING OF CREDITORS OF CAMMAC'S REFRIGERATED TRANSPORT PTY. LTD. (UNDER OFFICIAL MANAGEMENT).

PURSUANT TO SECTION 206 (4), FORM 92.

Companies Regulations—Regulation 28 (2) (b).

NOTICE is hereby given that a meeting of creditors of Cammac's Refrigerated Transport Pty. Ltd. (under Official Management) will be held at the Board Room of the Institute of Chartered Accountants in Australia, 4th Floor, McKillop House, 23 McKillop-street, Melbourne, on Thursday, 26th November, 1970, at 10 a.m.

AGENDA.

1. To consider a Special Resolution passed by the above-named company for winding up and the appointment of Maxwell George Gee, a registered liquidator, as the liquidator of the company.

2. To consider the report of the official manager explaining why official management failed and to consider a statement of the position of the company's affairs together with a list of creditors and the estimated amount of their claims.

3. To confirm the appointment of the liquidator for the purpose of winding up the affairs and distributing the assets of the company.

4. If thought fit, to appoint a committee of inspection.

5. To consider the persons and number thereof to be appointed as a committee of inspection.

6. To fix the remuneration of the liquidator.

NOTE.—No person will be entitled to vote as a creditor at the meeting unless he has lodged with the chairman of the meeting a proof of debt which he claims to be due to him from the company.

Dated 18th November, 1970.

M. G. GEE, Official Manager.

Max Gee & Co., public accountants, 325 Warrigal-road, Burwood, Vic., 3125, telephones: Accounts 288-5911, Bankruptcy and Liquidation 288-5109. 7180

The Companies Act 1961.
WINDERS ELECTRICS PTY. LTD. (IN MEMBERS'
VOLUNTARY LIQUIDATION).

NOTICE CONVENING FINAL MEETING OF MEMBERS
PURSUANT TO SECTION 272.

NOTICE is hereby given in pursuance of section 272 of the Companies Act 1961, that a meeting of the members of the above-named company will be held on the 29th day of November, 1970, at the offices of L. W. Collins & Associates, 127 Paisley-street, Footscray, at 9 a.m., for the purpose of having an account laid before them showing the manner in which the winding up has been conducted and the property of the company disposed of and of hearing any explanations that may be given by the liquidator.

Dated this 12th day of November, 1970.

7219 NORMAN LARS FRAMSTAD, Liquidator.

The Companies Act 1961.—In the matter of LONDONDERRY HOUSE (AUSTRALIA) PTY. LIMITED (in Voluntary Liquidation).—Members winding-up.

NOTICE is hereby given that at the Extraordinary General Meeting of Londonderry House (Australia) Pty. Limited, duly convened and held at 461 Bourke-street, Melbourne, in the State of Victoria, on the 10th day of November, 1970, the following Resolution was proposed and passed as a Special Resolution:—

“That the company be wound up voluntarily.”

Dated this 10th day of November, 1970.

R. W. BETTS, Liquidator.

Cooper Brothers & Co., chartered accountants, 461 Bourke-street, Melbourne, 3001. 7152

The Companies Act 1961.—In the matter of PAGE AGRICULTURAL MACHINERY PTY. LTD., Registered Office, 37 Cambro-road, Clayton.—Notice Re Meeting of Creditors, Pursuant to Section 260.

NOTICE is hereby given that a meeting of creditors of the above-named company will be held at room 328, Princes Gate, 3rd Floor, East Tower, 151 Flinders-street, Melbourne, on Thursday, 26th November, 1970, at 10.30 a.m., the company having convened a meeting of its members for earlier the same day for the purpose of considering a Special Resolution that the company be wound up voluntarily.

Dated this 17th day of November, 1970.

ALEX L. BAKER, Director.

Nicholas O'Donohue & Co., solicitors, 493 Law Courts-place, Melbourne, 3000. 7221

Companies Act 1961.—Section 260.
FREMEX CONSTRUCTIONS PTY. LTD.

NOTICE is hereby given that a meeting of creditors of the above-named company will be held at Croydon Hall, Supper Room, Croydon, at 2 p.m., on the 25th day of November, 1970, the company having convened a meeting of its members for the same day for the purpose of considering a resolution that the company be wound up voluntarily.

Dated the 18th November, 1970.

7244 A. F. GUISE, Director.

In the Supreme Court of Victoria.—No. Co. 7983 of 1970.—In the matter of the Companies Act 1961; and in the matter of ALPINE MOTORS (CORYONG) PROPRIETARY LIMITED.—Notice of Winding-up Order.

WINDING-UP order made the 16th day of October, 1970.

Name and address of liquidator: Ronald Dennis Widdows, of 6 Marilyn-court, East Bentleigh.

WEIGALL & CROWTHER, solicitors for the petitioner. 7187

In the Supreme Court of Victoria.—1970 No. Co. 8029.—In the matter of the Companies Act 1961; and in the matter of BEL-KNIT PTY. LIMITED.

NOTICE is hereby given that a petition for the winding up of the above-named company by the Supreme Court was on the 16th day of November, 1970, presented by Bernard R. Oddy & Co., solicitors, whose address for service is 568 Lonsdale-street, Melbourne, solicitors for the petitioner B.L.B. Corporation of Australia Establishment. And that the said petition is directed to be heard before the Court sitting at Melbourne at the hour of 10.30 o'clock in the forenoon on the 16th day of December, 1970; and any creditor or contributory of the said company desiring

to support or oppose the making of an order on the said petition may appear at the time of hearing by himself or his counsel for that purpose; and a copy of the petition will be furnished to any creditor or contributory of the said company requiring the same by the undersigned on payment of the regulated charge for the same.

The petitioner's address is 552 Lonsdale-street, Melbourne.

The petitioner's solicitors are Messrs. Bernard R. Oddy & Co., of 568 Lonsdale-street, Melbourne.

B. R. ODDY.

Bernard Raymond Oddy of the firm of Bernard R. Oddy & Co., solicitors for the petitioner.

NOTE.—Any person who intends to appear on the hearing of the said petition must serve or send by post to the above-named Bernard R. Oddy & Co. notice in writing of his intention so to do. The notice must state the name and address of the person, or if a firm, the name and address of the firm, and must be signed by the person or firm, or his or their solicitor (if any), and must be served, or, if posted, must be sent by post in sufficient time to reach the abovenamed not later than four o'clock in the afternoon of the 15th day of December, 1970.

7242

WESLEY NEEDHAM, late of 3 Wheildon-street, Mirboo North, in the State of Victoria, retired farmer, DECEASED.

CREDITORS, next of kin and others having claims in respect of the estate of the deceased (who died on the 12th day of March, 1970), are required by the executors, Alan Francis Gunn (in the said will called “Alan Gunn”), of Thorpdale, carrier, and Isabel Gladys Guy, of 3 Wheildon-street, Mirboo North, widow, to send particulars to their solicitors, Messrs F. X. O'Halloran, Davis & Co., Kirk-street, Moe, by the 2nd day of February, 1971, after which date the executors may convey or distribute the assets, having regard only to the claims of which they then have notice.

Dated the 16th day of November, 1970.

F. X. O'HALLORAN, DAVIS & CO., solicitors, Moe.

7227

EMILY ELIZABETH ILLINGWORTH, late of 157 Gladstone-avenue, Northcote, spinster, DECEASED.

CREDITORS, next of kin and others having claims in respect of the estate of the deceased (who died on the 7th day of October, 1970), are requested to send particulars of their claims to the executors, Harold Andrew Stevens, and Andrew William George Stevens, care of the undersigned solicitor, by the 20th day of January, 1971, after which date the said executors will proceed to distribute the estate, having regard only to the claims of which they then have notice.

MARJORY C. COATES, solicitor, of 422 Collins-street, Melbourne, 3000. 7228

JESSIE MARGORY BARRENGER, late of 85 Grange-road, Toorak, in the State of Victoria, widow, DECEASED.

CREDITORS, next of kin and others having claims in respect of the estate of the above-named deceased (who died on 24th June, 1970), are required by The Trustees Executors and Agency Company Limited, of 401 Collins-street, Melbourne, and Douglas Alistair Craven, of 20 Harold-avenue, Glen Iris, chartered accountant, the executors of the will and codicil of the said deceased, to send particulars of claims to the said The Trustees, Executors and Agency Company Limited by the 19th January, 1971, after which date the executors will convey or distribute the assets, having regard only to the claims of which notice has been received.

WEIGALL AND CROWTHER, solicitors, 459 Little Collins-street, Melbourne, solicitors for the executors.

7230

CREDITORS, next of kin and others having claims in respect of the estate of Grace Isabell Dean, late of Abalene Private Hospital, 569 Glenhuntly-road, Elsternwick, widow (who died on the 15th August, 1970), are requested to send particulars of their claims to the executor, The Union-Fidelity Trustee Company of Australia Limited, care of the under-mentioned solicitors, on or before 20th January, 1971, after which date it will distribute the assets, having regard only to the claims of which it then has notice.

McKEAN & PARK, solicitors, 84 William-street, Melbourne. 7231

GEORGE ROBERTSON KELLY, late of Swan Hill, in the State of Victoria, farmer, DECEASED.

CREDITORS, next of kin and others having claims in respect of the estate of the deceased (who died on the 26th day of July, 1970), are required by the executors, May Mansfield Kelly, of Swan Hill, aforesaid, widow, and Ronald George Kelly, of Lake Boga, in the said State, farmer to send particulars to them care of the undersigned by the 26th day of January, 1971, after which date the executors may convey or distribute the assets, having regard only to the claims of which they then have notice.

Dated this 13th day of November, 1970.

ALEC M. HAYES, solicitor, 148 Campbell-street, Swan Hill. 7172

CREDITORS, next of kin and others having claims in respect of the estate of Florence Annie Bois, late of 12 Montclair-avenue, North Brighton, widow, deceased (who died on the 18th September, 1970), are requested to send particulars of their claims to the executors, William George Chadwick, and Arthur Leslie Park, care of the under-mentioned solicitors, on or before 20th January, 1971, after which date they will distribute the assets, having regard only to the claims of which they then have notice.

MCKEAN & PARK, solicitors, 84 William-street, Melbourne. 7186

WILLIAM HANAGHAN (also known as William Patrick Hanaghan), formerly of 462 Little Lonsdale-street, Melbourne, storeman, late of lot 87, Beatty-parade, Cockatoo, in the State of Victoria, pensioner, DECEASED.

CREDITORS, next of kin and others having claims in respect of the estate of the deceased (who died on the 7th day of July, 1970), are required to send particulars of their claims to The Equity Trustees Executors and Agency Company Limited, of 472 Bourke-street, Melbourne, the executor of the will of the said deceased, by the 19th January, 1971, after which date the said executor will distribute the assets, having regard only to the claims of which it then shall have had notice.

T. A. KENNEDY, LL.B., solicitor, 509 Collins-street, Melbourne. 7189

MARY ROSE O'CALLAGHAN, late of 175 The Avenue, Coburg, in the State of Victoria, widow, DECEASED.

CREDITORS, next of kin and others having claims in respect of the estate of the deceased (who died on the 21st September, 1970), are required by the executor, Michael Joseph O'Callaghan, to send particulars to him care of the undersigned solicitors by the 30th day of January, 1971, after which date he will distribute the assets, having regard only to the claims of which he then has notice.

HEFFEY & BUTLER, solicitors, 358 Lonsdale-street, Melbourne. 7190

CREDITORS, next of kin and others having claims in respect of the estate of Alice Kennealy, late of 19 Townsend-street, Ivanhoe, spinster, deceased (who died on the 26th day of April, 1970), are to send particulars of their claims to Harriet Terese Kennealy, care of R. P. Barrett & Son, solicitors, of 472 Bourke-street, Melbourne, by the 23rd January, 1971, after which date they will distribute the assets, having regard only to the claims of which they then have notice.

R. P. BARRETT & SON, solicitors, 472 Bourke-street, Melbourne. 7191

RICHARD LESLIE GAIR, late of 1 Belmont-avenue, Balwyn, gentleman, DECEASED.

CREDITORS, next of kin and others having claims in respect of the estate of the deceased (who died on 23rd September, 1970), and probate of whose will was granted by the Supreme Court of Victoria, to Graeme Leslie Gair of 22 Somers-street, Burwood, company director, and Lloyd George Anderson, of 7 Smythe-avenue, Mont Albert, company director, as the executors thereof, are required by the executors to send particulars of their claims to them at the address of their solicitors appearing hereunder on or before the 25th day of January, 1971, after which date the executors will convey or distribute the assets in the estate, having regard only to the claims of which they shall then have notice.

KIDDLE, BRIGGS & WILLOX, 400 Collins-street, Melbourne, solicitors for the executors. 7211

JOHN JOSEPH PEOPLES, formerly of 23 Johnson-street, Hawthorn, but late of Cecil-avenue, Tecoma, in Victoria, retired railway employee, DECEASED.

CREDITORS, next of kin, and others having claims in respect of the estate of the deceased (who died on the 19th May, 1970), are required by the executor, Francis Harold Warren, of 19 Yarralea-street, Alphington law clerk, to send particulars to the under-mentioned firm by 14th February, 1971, after which date the said executor may convey or distribute the assets, having regard only to the claims of which he then has notice.

SETON, WILLIAMS & SMYTH, solicitors, 954 Main-road, Eltham. 7137

LENA COOPER SKIPPER, formerly of Main-road, Eltham, but late of "Montsalvat" Hillcrest-avenue, Eltham, in Victoria, widow, DECEASED.

CREDITORS, next of kin, and others having claims in respect of the estate of the deceased (who died on 29th April, 1970), are required by the executor, Brian Redmond Smyth, of 230 Collins-street, Melbourne, solicitor, to send particulars to the under-mentioned firm by the 14th February, 1971, after which date the said executor may convey or distribute the assets, having regard only to the claims of which he then has notice.

SETON, WILLIAMS & SMYTH, solicitors, 230 Collins-street, Melbourne. 7138

GEOFFREY BERNARD LITTLE, late of Wyuna-avenue, Ascendale, in Victoria, spray painter, DECEASED.

CREDITORS, next of kin, and others having claims in respect of the estate of the deceased (who died on the 3rd May, 1970), are required by the administrator, Brian Redmond Smyth, of 230 Collins-street, Melbourne, solicitor, to send particulars to the under-mentioned firm by the 14th February, 1971, after which date the said administrator may convey or distribute the assets, having regard only to the claims of which he then has notice.

SETON, WILLIAMS & SMYTH, solicitors, 954 Main-road, Eltham. 7139

HENRY NEVILL LITHGOW, formerly of 64, but late of 72 McCrae-street, Swan Hill, in the State of Victoria, radio station manager, DECEASED, (who died on the 30th June, 1970).

CREDITORS, next of kin, and all other persons having claims against the estate of the deceased, are required by the executors of the will, Sandhurst and Northern District Trustees Executors and Agency Company Limited and Gwendolene Jean Lithgow to send particulars to them, care of the undersigned on or before the 9th February, 1971, after which date they will distribute the assets, having regard only to the claims of which they then have notice.

GARDEN & GREEN, solicitors, 4 McCallum-street, Swan Hill. 7142

JEFFREY WILLIAM MANNING SPRINGFIELD, late of 2 Amys-grove, Mitcham, in the State of Victoria, porter-clerk, DECEASED.

CREDITORS, next of kin, and others having claims in respect of the estate of the deceased (who died on the 9th day of April, 1970), are required by the trustee, Frederick Allen Courtney Springfield, to send particulars to him, care of the under-mentioned solicitors, by the 23rd day of January, 1971, after which date the trustee may convey or distribute the assets, having regard only to the claims of which he then has notice.

B. J. T. STONE & LEIGHTON, solicitors, 221 High-street, Kew. 7147

CREDITORS, next of kin, and others having claims in respect of the estate of Ronald James King, late of 78 Breed-street, Traralgon, in the State of Victoria, formerly soldier, lately tiler, deceased, who died on the 15th June, 1970, and probate of whose will was granted by the Supreme Court of Victoria, on the 23rd October, 1970, to James King, of 4 Maguire-court, Traralgon, aforesaid council employee, are to send particulars of their claims to the executor, care of the below mentioned solicitors, by the 31st day of January, 1971, after which date he will distribute the assets of the deceased, having regard only to the claims of which he then has notice.

Dated the 12th day of November, 1970.

BRUCE, LITTLETON & HACKFORD, solicitors, Traralgon. 7149

CREDITORS, next of kin, and others having claims in respect of the estate of Ethel Bower, late of 22 Stanhope-grove, Camberwell, widow, deceased, (who died on the 7th day of August, 1970), are to send particulars of their claims to The Equity Trustees Executors and Agency Company Limited, of 472 Bourke-street, Melbourne, by the 22nd day of January, 1971, after which date it will distribute the assets, having regard only to the claims of which it then has notice.

WILLIAM M. SERONG, solicitor, 167 Queens-parade, Clifton Hill. 7153

CREDITORS, next of kin and others having claims in respect of the estate of Albert George Henry Heywood, late of 7 Glencairn-avenue, East Brighton, in the State of Victoria, gentleman, deceased, (who died on the 29th day of May, 1970), are to send particulars of their claims to Garnet Florence Ernestine Heywood, care of the under-mentioned solicitors, by the 18th day of January, 1971, after which date she will distribute the assets, having regard only to the claims to which she then has notice.

Dated this 11th day of November, 1970.

REGINALD C. BUTLER & CO. solicitors, 312 Centre-road, Bentleigh. 7154

MAURICE INGLIS HUTTON, late of 423 Glenferrie-road, Malvern, in the State of Victoria, knight, DECEASED.

CREDITORS, next of kin and others having claims in respect of the estate of the deceased (who died on 2nd May, 1970), are required by the personal representatives, The Trustees Executors and Agency Company Limited, of 401 Collins-street, Melbourne, and Vera Luise Hutton, of 423 Glenferrie-road aforesaid, widow, to send particulars to them in the care of the said company by 29th January, 1971, after which date they may convey or distribute the assets, having regard only to the claims of which they then have notice.

HEDDERWICK, FOOKES & ALSTON,¹ 121 William-street, Melbourne. 7212

WALLIS GEORGE RING, formerly of 6A Merrion-place, Kew, in the State of Victoria, grazier, but late of 102 Ascot-street south, Ballarat, in the said State, retired, DECEASED.

AFTER fourteen clear days George Frederick Ring, of 307a Dana-street, Ballarat, in the said State, accountant, one of the executors named in the deceased's will, dated 20th May, 1965, will apply to the Supreme Court for a grant of probate of the said will reserving leave to Robert Thomas Ring and Wallis Anthony Ring, the other executors named therein, to come in and prove the same at any time.

RAMSAY, GAUNT & FRASER, solicitors, 41 Lydiard-street south, Ballarat, 3350. 7162

CREDITORS, next to kin and others having claims in respect of the estate of Zoe Rosalind McHenry, late of 38 St. Helen's-road, Hawthorn East, in the State of Victoria, spinster, deceased (who died on the 26th day of July, 1970), are to send particulars of their claims to the Trustees, Executors and Agency Company Limited, care of the under-mentioned solicitors, by the 14th day of January, 1971, after which date the said Trustees, Executors and Agency Company Limited will distribute the assets, having regard only to the claims of which they then have notice.

MACKENZIE & ROSS, solicitors, 365 Burwood-road, Hawthorn. 7165

MARGARET MARY WILLIAMSON, late of Caulfield Convalescent Hospital, 294 Kooyong-road, Caulfield, spinster, DECEASED.

CREDITORS, next of kin and others having claims in respect of the estate of the above-named Margaret Mary Williamson, deceased (who died on the 12th of June, 1970), are to send particulars of their claims to Rene Percival Yuncken, of 443 Little Collins-street, Melbourne, solicitor, the executor appointed by the will of the said deceased, by the 22nd of January, 1971, after which date the executor will distribute the assets, having regard only to the claims of which he shall then have notice.

H. L. YUNCKEN & YUNCKEN, solicitors, 443 Little Collins-street, Melbourne, 3000. 7197

ANNIE QUARREL, late of 14 Peace-avenue, Warragul, married woman, DECEASED.

CREDITORS, next of kin, and others having claims in respect of the estate of the deceased (who died on the 19th August, 1969) are requested by the trustees, Phyllis Ikin, of Forest-road, The Basin, and Elaine Grubb, of Loch Park-road, Traralgon, to send particulars to them, care of the undersigned solicitors by the 24th day of January, 1971, after which date the trustees may convey or distribute the assets, having regard only to the claims of which they have notice.

GRAY, FRIEND & LONG, solicitors, Warragul. 7156

MARJORY EVELYN MACKIE, late of 131 Lloyd-street, Moe, in the State of Victoria, married woman, DECEASED.

CREDITORS, next of kin, and others having claims in respect of the estate of the above deceased (who died on the 16th day of February, 1970) are required by the personal representatives, Donald Allan Jones and Marion Grace Jones, both of 7 Watsons-road, Moe, in the said State, to send particulars to them, by the 8th day of January, 1971, after which date the personal representatives may convey or distribute the assets, having regard only to the claims of which they then have notice.

KEVIN DAVINE & SONS, solicitors, Contingent-street, Trafalgar. 7164

CREDITORS, next of kin and others having claims in respect of the estate of Alice Ellen Ellis, late of 257 Nicholson-street, East Brunswick, in the State of Victoria, home duties, deceased (who died on the 30th day of July, 1970), are to send particulars of their claims to the executor, The Union-Fidelity Trustee company of Australia Limited, of 100 Exhibition-street, Melbourne, by 25th February, 1971, after which date it will distribute the assets, having regard only to the claims of which it then has notice.

LE GRAND, RANGLES, GAFFNEY & CO., solicitors, of 644 Sydney-road, Brunswick. 7218

ANNA ROSA SCHLEIGER, late of 224 King-street, Bendigo, married woman, DECEASED.

CREDITORS, next of kin and others having claims in respect of the estate of the deceased (who died on 2nd day of July, 1970), are required by Sandhurst and Northern District Trustees, Executors and Agency Company Limited, of View-street, Bendigo, Arthur Hamilton Schleiger, of 224 King-street, Bendigo, insurance inspector, and Gwendoline Menga Beecham, of 84 Eaglehawk-road, Bendigo, married woman, to send particulars to them care of the said company by the 16th day of January, 1971, after which date they may convey or distribute the assets, having regard only to the claims of which they then have notice.

ERNEST S. CAHILL & SON, solicitors, 16 View-street, Bendigo. 7155

THE TRUSTEES, EXECUTORS AND AGENCY COMPANY LIMITED, of 401 Collins-street, Melbourne, the executor of the will of John Cluny McPherson Harkness, late of 6 Kent-court, Toorak, gentleman, deceased (who died on the 10th day of May, 1970), require all creditors next of kin and others having claims against the property or the estate of the said deceased to send to it the said executor at its forementioned address on or before the 19th day of January, 1971, particulars in writing of such claims after which date the said executor intends to convey or distribute such property or estate to or among the persons entitled thereto, having regard only to the claims of which it shall have had notice.

DARVALL & HAMBLETON, solicitors, 7th Floor, T. & G. Building, 147 Collins-street, Melbourne. 7235

GEORGE WALDEMAR SAENGER, late of 25 Linlithgow-road, Toorak, in the State of Victoria, retired consulting engineer, DECEASED.

CREDITORS, next of kin and others having claims in respect of the estate of the deceased (who died on 25th April, 1970), are required by the personal representative, The Trustees, Executors and Agency Company Limited, of 401 Collins-street, Melbourne, to send particulars to the said company by 30th January, 1971, after which date it may convey or distribute the assets, having regard only to the claims of which it then has notice.

HEDDERWICK, FOOKES & ALSTON, 121 William-street, Melbourne. 7206

CREDITORS, next of kin and others having claims in respect of the estate of Frank Henry Bolton, late of 78 Roberts-street, Essendon, aircraft engineer, deceased (who died on the 8th day of July, 1970), are requested to send particulars of their claims to the executors, The Trustees, Executors and Agency Company Limited, of 401 Collins-street, Melbourne, by the 18th day of January, 1971, after which date the executors will distribute the assets, having regard only to the claims of which it then has notice.

SLATER & GORDON, solicitors, 395 Collins-street, Melbourne. 7205

EMILY MARIAN KIRKPATRICK, late of Dreeite-road, Alvie via Colac, in the State of Victoria, married woman, DECEASED.

CREDITORS, next of kin and others having claims in respect of the estate of the deceased (who died on the 8th day of May, 1970), are required by The Perpetual Executors and Trustees Association of Australia Limited, of 100-104 Queen-street, Melbourne, to send particulars of their claims to the said company by the 25th day of February, 1971, after which date it will convey or distribute the assets, having had regard only to the claims of which the company then has notice.

DOOLAN, KEMP & TOWNSEND, solicitors, of 340 Collins-street, Melbourne. 7161

STELLA NANCE, late of Flat 12, 205 Church-street, Middle Brighton, married woman, DECEASED.

CREDITORS, next of kin and all other persons having claims against the estate of the deceased are required by the executor, Alexander Ernest Nance, of Flat 12, 205 Church-street, Middle Brighton, public servant, to send particulars to him, care of the under-mentioned solicitors, on or before the 27th day of January, 1971, after which date he will distribute the assets, having regard only to the claims of which he then has notice.

J. ALLAN ANDERSON & SON, solicitors, 472 Bourke-street, Melbourne, 3000. 7192

CREDITORS, next of kin and others having claims in respect of the estate of Mary Constance Coats, late of Mitchell-street, Brunswick, widow, deceased (who died on the 2nd September, 1970), are requested to send particulars of their claims to the executor, Michael Joseph Mornane, of 118 Queen-street, Melbourne, solicitor, by the 21st January, 1971, after which date he will distribute the assets, having regard only to the claims of which he then has notice.

M. MORNANE, solicitor, 118 Queen-street, Melbourne. 7210

CREDITORS, next of kin and others having claims in respect of the estate of Sydney James Parson, late of 1 Leoni-avenue, Heathmont, retired, deceased (who died on the 10th day of August, 1970), are to send particulars of their claims to The Union-Fidelity Trustee Company of Australia Limited, of 100 Exhibition-street, Melbourne, the executor of the will of the said deceased by the 19th day of January, 1971, after which date it will distribute the assets, having regard only to the claims of which it then has notice.

RYLAH & RYLAH, solicitors, 349 Collins-street, Melbourne. 7209

ETHEL MAY ROSE PAYNE, late of 90 May-street, North Fitzroy, in the State of Victoria, widow, DECEASED.

CREDITORS, next of kin and others having claims in respect of the estate of the deceased (who died on the 13th May, 1970), are required by The Equity Trustees Executors and Agency Company Limited, of 472 Bourke-street, Melbourne, to send particulars to the said company by the 20th day of January, 1971, after which date the said company may convey or distribute the assets, having regard only to the claims of which it then has notice.

C. E. TIBB, solicitor, 17 Queen-street, Melbourne. 7208

CREDITORS, next of kin and other persons having claims against the estate of Mary Doxford Ford, late of 3 Moffatt-street, South Yarra, in the State of Victoria, widow, deceased (who died on the 9th July, 1970), are required to send particulars of their claims to the executor, Charles Willis Ford, care of the under-mentioned solicitors by the 25th January, 1971, after which date the executor will distribute the assets, having regard only for the claims of which he then has had notice.

JAMES P. OGGE & CO., solicitors, of 165 Greville-street, Prahran. 7184

CREDITORS, next of kin and others having claims in respect of the estate of Florence Harriett Cossstick, late of 7 Aisbett-avenue, Burwood, in the State of Victoria, widow, deceased (who died on 4th August, 1970), are to send particulars of their claims to the executor, Colin Keon-Cohen, 472 Bourke-street, Melbourne, by the 20th January, 1971, after which date he will distribute the assets, having regard only to the claims of which he then has notice.

Dated 12th November, 1970.

COLIN KEON-COHEN, solicitors, 472 Bourke-street, Melbourne. 7200

CREDITORS, next of kin and other persons having claims against the estate of Wilfred James Warne-Hunter, late of Athol Lodge, 9 Wrexham-road, Windsor, in the State of Victoria, gentleman, deceased (who died on the 13th day of September, 1970), are required to send particulars of their claims to the executor, National Trustees Executors and Agency Company of Australasia Limited, of 95 Queen-street, Melbourne, by the 20th January, 1971, after which date the executor will distribute the assets, having regard only for the claims of which it then has had notice.

JAMES P. OGGE & CO., solicitors, of 165 Greville-street, Prahran. 7185

CREDITORS, next of kin and all other persons having claims against the estate of William Lewis Martin, late of Tamleugh, farmer, deceased (who died on 15th October, 1970), are required by the executors of the will, Kathleen Martin, widow, William Adrian Martin, farmer, both of Tamleugh, and Mary Kathleen Rebbeck, married woman, of 15 Orwell-street, Wangaratta, to send particulars of such claims to them, care of the undersigned on or before the 31st January, 1971, after which date the executors will distribute the assets, having regard only to the claims of which they then have notice.

Dated the 13th day of November, 1970.

RIORDAN & RIORDAN, solicitors, 26 Fryers-street, Shepparton. 7178

MICHAEL CHORINSKY, late of Hazelwood-road, San Remo, underwater engineer, DECEASED intestate (who died on the 2nd day of May, 1970).

CREDITORS, next of kin and all other persons having claims against the estate of the deceased, are required by the administratrix of his estate, Ursula Elfriede Chorinsky, to send particulars thereof, to her care of the under-mentioned solicitors before the 25th day of January, 1971, after which date she may distribute the assets of the deceased, having regard only to the claims of which she then has notice.

COLTMAN, WYATT & ANDERSON, solicitors, 379 Collins-street, Melbourne. 7193

CREDITORS, next of kin and all other persons having claims against the estate of Antonio Fiscaro, late of 173 Centre Dandenong-road, Cheltenham, gentleman, deceased (who died on the 15th day of June 1970), are to send particulars of such claims to John Cooke, of 472 Bourke-street, Melbourne, solicitor, the executor appointed by deceased's will by the 30th day of January, 1971, after which date the executor will distribute the assets, having regard only to the claims of which he shall then have had notice.

COOKE & CUSSEN, solicitors; 472 Bourke-street, Melbourne. 7201

JESSIE MAY HARVEY, late of 78 Verdon-street, Williamstown, widow, DECEASED.

CREDITORS, next of kin and others having claims against the estate of the said deceased (who died on 11th March, 1970), are to send particulars of their claims to Alexander Allen Stewart, and William Neil McNicol, care of 120 William-street, Melbourne, by the 22nd day of January, 1971, after which date they will distribute the assets, having regard only to the claims of which they then have notice.

BLAKE & RIGGALL, solicitors, 120 William-street, Melbourne. 7237

EVALINE GORDON LYON (also known as Evaline Lyon), formerly of 18 Montvue-street, Lilydale, but late of Croydon Park Private Hospital, widow, DECEASED.

CREDITORS, next of kin and others having claims against the estate of the said deceased (who died on 2nd June, 1970), are to send particulars of their claims to John Gordon Lyon, and The Union-Fidelity Trustee Company of Australia Limited, the registered office of which is

situate at 100 Exhibition-street, Melbourne, by the 22nd day of January, 1971, after which date they will distribute the assets, having regard only to the claims of which they then have notice.

BLAKE & RIGGALL, solicitors, 120 William-street, Melbourne. 7238

JACK ALLEN MURRAY HUTTON McCALLUM, late of 11 Coronation-street, West Footscray, retired, DECEASED.

CREDITORS, next of kin and others having claims in respect of the estate of the said deceased (who died on 16th July, 1970), are required by The Trustees Executors and Agency Company Limited, of 401 Collins-street, Melbourne, to send particulars of their claims to the company by the 27th day of January, 1971, after which date it will distribute the assets, having regard only to the claims of which it then has notice.

DAVID THOMAS & FRENKEL, solicitors, of 104 Queen-street, Melbourne. 7199

GLADSTONE GREY ROBB, late of 38 Bossington-street, Oakleigh South, gentleman, DECEASED.

CREDITORS, next of kin and others having claims in respect of the estate of the said deceased (who died on 31st day of August, 1970), are required by The Trustees Executors and Agency Company Limited, of 401 Collins-street, Melbourne, to send particulars of their claims to the company by the 27th day of January, 1971, after which date it will distribute the assets, having regard only to the claims of which it then has notice.

DAVID THOMAS & FRENKEL, solicitors, of 104 Queen-street, Melbourne. 7198

EILEEN MAUDIE ASKEW, late of 62 Park-street, South Yarra, widow, DECEASED.

CREDITORS, next of kin and others having claims in respect of the estate of the above-named Eileen Maudie Askew, deceased (who died on the 26th of July, 1970), are to send particulars of their claims to The Trustees, Executors and Agency Company Limited, of 401 Collins-street, Melbourne, the executor appointed by the will of the said deceased, by the 22nd day of January, 1971, after which date the executor will distribute the assets, having regard only to the claims of which it shall then have notice.

H. L. YUNCKEN & YUNCKEN, solicitors, 443 Little Collins-street, Melbourne, 3000. 7196

CREDITORS, next of kin and others having claims in respect of the estate of Annie O'Connor, late of 84 Cowper-street, Footscray, widow, deceased (who died on the 16th March, 1970), are required by the executrix, Eileen Butterworth, of 84 Cowper-street, Footscray, married woman, to send particulars of their claim to her, care of the under-named solicitor on or before the 31st day of January, 1971, after which date she will distribute the assets of the deceased, having regard only to the claims of which she then has notice.

JOHN GINNANE, solicitor, 6 Paisley-street, Footscray. 7195

CREDITORS, next of kin and others having claims in respect of the estate of Frank Vincent Bladen, late of 2 Verdun-street, Maidstone, retired, deceased (who died on 29th September, 1970), are required by the executrix Mary Andrews, of 2 Verdun-street, Maidstone, widow, to send particulars of their claims to her, care of the under-named solicitor on or before the 31st day of January, 1971, after which date she will distribute the assets of the deceased, having regard only to the claims of which she then has notice.

JOHN GINNANE, solicitor, 6 Paisley-street, Footscray. 7194

THOMAS WILLIAM HUNT, late of Wallington, gentleman, DECEASED.

CREDITORS, next of kin and others having claims in respect of the estate of the said deceased (who died 2nd June, 1970), are required by the applicants for a grant of probate of the will, Alan Wynne Hunt, of 10 Roberts-road, Belmont, Geelong, groundsmen, and Iris Anne Crabbe, of Larpent Wayside, Colac, home duties, to send particulars to them, care of the undersigned solicitors, by 27th January, 1971, after which date the said applicants may convey or distribute the assets, having regard only to the claims of which they then have notice.

WIGHTON & McDONALD, solicitors, 89 Myers-street, Geelong. 7176

CREDITORS, next of kin and others having claims in respect of the estate of Vida Patricia Bowie, late of Flat 8, 150 Jolimont-road, East Melbourne, in the State of Victoria, widow, (who died on the 18th day of May, 1970), are requested to send the particulars of their claims to F. Miller Robinson & Co., of 440 Collins-street, Melbourne, in the said State by the 18th day of January, 1971, after which date they will distribute the assets, having regard only to the claims of which they then have notice.

F. MILLER ROBINSON & CO., solicitors, 440 Collins-street, Melbourne, 3000. 7181

CREDITORS, next of kin and others having claims in respect of the estate of Esmá Linton Wilson, late of Flat 14, No. 48 Scott-grove, Glen Iris, gentlewoman, deceased (who died on the 28th September, 1969), are requested to send particulars of their claims to the executor, Erik Wilson, care of the under-mentioned solicitors, on or before 20th January, 1970, after which date he will distribute the assets, having regard only to the claims of which he then has notice.

McKEAN & PARK, solicitors, 84 William-street, Melbourne. 7232

PHYLLIS OLGA SAMPSON, late of Unit 4, 5 Myrtle-grove, Blackburn, in the State of Victoria, widow, DECEASED.

CREDITORS, next of kin and others having claims in respect of the estate of the deceased (who died on the 1st day of November, 1970), are required by the trustees, Reginald John Sampson and Raymond Anthony Sampson, both of Unit 4, 5 Myrtle-grove, Blackburn, in the said State, to send particulars to them by the 13th day of January, 1971, after which date the trustees may convey or distribute the assets, having regard only to the claims of which they then have notice.

Dated this 10th day of November, 1970. 7236

CREDITORS, next of kin and others having claims in respect of the estate of Mary Elizabeth Morgan, formerly of 505 Royal-parade, Parkville, Victoria, but late of Wolston Park Hospital, Wacol, Queensland, spinster, deceased (who died on the 13th day of July, 1970), are to send particulars of their claims to The Equity Trustees Executors and Agency Company Limited, of 472 Bourke-street, Melbourne, by the 31st day of January, 1971, after which date it will distribute the assets, having regard only to the claims of which it then has notice.

LEACH & THOMSON, solicitors, 472 Bourke-street, Melbourne. 7243

In the Supreme Court of the State of Victoria.

SALE BY THE SHERIFF.

ON Tuesday, the 22nd day of December, 1970, at 2 p.m., at the Police Station, Bunyip (unless process be stayed or satisfied):—

All the estate and interest (if any) of Stanley Stephen Richard Kemp, of Chambers-road, Modella, farmer, as proprietor of an estate in fee-simple in the land described in certificate of title, volume 3705, folio 825, upon which is erected a dwelling-house and outbuildings. The property measures approximately 3,565.5 links by 7,054 links, and is known as Chambers-road, Modella.

Registered mortgages Nos. C.908409, C.961471 and caveats D.161136 and D.492816 affect the said estate and interest.

Terms: Cash only.

Sgt. K. KIDD, Sheriff's Officer.

16th November, 1970.

7233

In the Supreme Court of the State of Victoria.

SALE BY THE SHERIFF.

ON Friday, the 18th of December, 1970, at 3.30 p.m., at the Police Station, Reservoir (unless process be stayed or satisfied):—

All the estate and interest (if any) of Charles Thomas Wolfe, of 41 Banbury-street, Reservoir, cordage worker, as proprietor of an estate in fee-simple in the land described in certificate of title, volume 4580, folio 899, upon which is erected a dwelling-house known as No. 41 Banbury-street, Reservoir.

Caveat No. D.605452 affects the said estate and interest.

Terms: Cash only.

DAVID J. JOHNSTON, Sheriff's Officer.

17th November, 1970.

7234

In the Supreme Court of the State of Victoria.

SALE BY THE SHERIFF.

ON Friday, the 18th of December, 1970, at 2.30 p.m., at the Police Station, Doncaster (unless process be stayed or satisfied).

All the estate and interest (if any) of Peter John Weston, of lot 2, Pound Bend-road, Warrandyte, as proprietor of an estate in fee-simple the land described in certificate of title, volume 7408, folio 541, upon which is erected a dwelling house known as lot 2, Pound Bend-road, Warrandyte.

The property is situated on the north-west side of Pound Bend-road, commencing 686 ft. 2 in. south of the intersection of Pound Bend-road and Gallatlys-lane.

Registered mortgage No. D.182887 and Caveat D.474748 affects the said estate and interest.

Terms: Cash only.

DAVID J. JOHNSTON, Sheriff's Officer.

13th November, 1970. 7188

IMPOUNDINGS

ARDEER.—Impounded in Ardeer Pound.

1 Shorthorn steer, no visible brand

If not claimed and expenses paid to be sold on 5th December, 1970.

7229—\$1.50

D. L. THOMPSON,
Poundkeeper.

DANDENONG.—Impounded in Dandenong Pound by George Langden from the P.M.G. Depot, Centre-road, Clayton.

1 Friesian cow, branded off rump, dehorned

If not claimed and expenses paid, to be sold on 8th December, 1970.

7168—\$2

D. D. NAPIER,
Poundkeeper.

KYNETON.—Impounded in Kyneton Pound, on Friday, 13th November, 1970, by Mr. C. Prictor.

2 six-tooth crossbred ewes, full wool, no visible brand
1 F & F crossbred ewe, full wool, no visible brand
1 FM crossbred ewe, full wool, no visible brand
1 six-tooth crossbred ewe, shorn, no visible brand
5 woolly lambs at foot

If not claimed and expenses paid, to be sold on 4th December, 1970.

7170—\$2.75

L. GRADY,
Poundkeeper.

SWAN HILL.—Impounded in Swan Hill Pound, on 9th November, 1970.

1 Jersey heifer, blue ear tag, No. 13, right ear, no visible brand

If not claimed and expenses paid, to be sold on 30th November, 1970.

7157—\$2

F. G. BLAIR,
Poundkeeper.

TEMPLESTOWE.—Impounded in Templestowe Pound, corner Parker-street and Ruffey-street, Templestowe Lower.

1 black gelding, no visible brand

If not claimed and expenses paid, to be sold on 7th December, 1970.

7183—\$2

T. M. PARKER,
Poundkeeper.

YEA.—Impounded in Yea Pound.

4 comeback ewes and 8 Dorset Horn lambs, notches on both ears of ewes, no visible marks on lambs

If not claimed and expenses paid to be sold on 3rd December, 1970.

7167—\$1.75

H. RIDD,
Poundkeeper.

Subordinate Legislation Act 1962.

NOTICE OF MAKING OF STATUTORY RULES.

IN pursuance of the provisions of the *Subordinate Legislation Act 1962* and the Regulations made thereunder, notice is given of the making of the following statutory rules:—

No.		Price.
	<i>Mental Health Act 1959</i> (No. 6605).	
263/1970.	<i>Mental Health (Medical Positions and Salaries) Regulations 1970</i> (No. 4) ..	10c
	<i>Education Act 1958.</i>	
264/1970.	<i>Adult Education (Salaries) Regulations 1970</i> , No. 9 ..	10c
	<i>Sale of Land Act 1962</i> (No. 6975).	
265/1970.	<i>Sale of Land Regulations 1970</i> (Arbitrator's Salary and Travelling Expenses) ..	10c
	<i>Discharged Servicemen's Preference Act 1943.</i>	
266/1970.	<i>Discharged Servicemen's Preference Act 1943—Salaries Regulations</i> ..	10c
	<i>Teaching Service Act 1958.</i>	
267/1970.	<i>Teaching Service (Governor in Council) Regulations</i> ..	10c
	<i>State Savings Bank Act 1958.</i>	
268/1970.	<i>State Savings Bank (Provident Fund) General Order 1970</i> ..	10c

Copies of these statutory rules may be purchased at the Sale of Publications Section of the Government Printing Office, located at Macarthur-street, Melbourne, 3002. If ordered by mail, remittance should be addressed to "The Government Printer, Box 203, P.O., North Melbourne, 3051", and should include 6c extra for postage. If a credit account is held at this office, no remittance is required with the mail order.

The annual subscription rate for Statutory Rules (including a Bound Volume) is \$15, payable in advance. The subscription year commences on 1st January.

C. H. RIXON,
Government Printer.

STATE ACTS, 1969

COPIES of the following Acts of Parliament of Victoria may be obtained at the Government Printing Office, Sale of Publications Branch, off Parliament-place, Melbourne, phone 63 0321, extension 6181, or from any accredited agent, at the price set opposite to each (these prices do not include postage).

The annual subscription for State Acts 1969 et seq. is \$8 payable in advance.

Bound Volumes of State Acts are also available on a subscription basis of \$15 per annum.

No.		Price.
7786.	Summary Offences (Sunday Newspapers) ..	\$0.10
7787.	Town and Country Planning (Transitional Appeals) ..	\$0.10
7788.	Discharged Servicemen's Preference (Amendment) ..	\$0.10
7789.	Water (Amendment) ..	\$0.10
7790.	Agricultural Education Cadetships ..	\$0.10
7791.	Trustee (Amendment) ..	\$0.10
7792.	Appeal Costs Fund (Amendment) ..	\$0.10
7793.	Footscray (Lower Yarra Crossing Access Road) Land ..	\$0.10
7794.	River Improvement (Amendment) ..	\$0.15
7795.	Geelong Waterworks and Sewerage (Amendment) ..	\$0.15
7796.	West Moorabool Water Board (Amendment) ..	\$0.10
7797.	Sewerage Districts (Amendment) ..	\$0.15
7798.	Drought Relief (Amendment) ..	\$0.10
7799.	Legal Profession Practice (Amendment) ..	\$0.10
7800.	Parliamentary Salaries and Superannuation (Administration) ..	\$0.10
7801.	Protection of Animals (Penalties) ..	\$0.10
7802.	Lotteries Gaming and Betting (Calcutta Sweepstakes) ..	\$0.10
7803.	Belmont Common Recreation Ground Lands ..	\$0.10
7804.	Listening Devices ..	\$0.10
7805.	Coal Mines (Pensions) ..	\$0.10
7806.	Marine (Amendment) ..	\$0.10
7807.	Theatres (Amendment) ..	\$0.15

STATE ACTS 1969—continued.		Price.
No.		
7808	Victorian Inland Meat Authority (Amendment)	\$0.10
7809	The Constitution Act Amendment (Electoral)	\$0.15
7810	Consolidated Revenue	\$0.10
7811	Gas and Fuel Corporation (Borrowing)	\$0.10
7812	Weights and Measures (Amendment)	\$0.10
7813	Health (Municipal Charges)	\$0.10
7814	Transfer of Land (Subdivision of Allotments)	\$0.15
7815	St. Vincent's Private Hospital (Guarantees)	\$0.10
7816	Strata Titles (Amendment)	\$0.15
7817	Sunday Entertainment (Evidence)	\$0.10
7818	Dried Fruits (Packing Houses)	\$0.10
7819	Town and Country Planning (Further Amendment)	\$0.10
7820	Milk Board (Amendment)	\$0.10
7821	Medical (Pharmaceutical Chemists)	\$0.10
7822	Melbourne Wholesale Fruit and Vegetable Market (Amendment)	\$0.10
7823	Education (Director-General)	\$0.10
7824	Wombat Bonuses	\$0.10
7825	Revocation and Excision of Crown Reservations	\$0.15
7826	Mildura Irrigation and Water Trusts	\$0.25
7827	South Melbourne (Roman Catholic Orphanage) Lands	\$0.15
7828	Racing (Amendment)	\$0.10
7829	Commercial Goods Vehicles (Tow Trucks)	\$0.10
7830	Stamps (Amendment)	\$0.15
7831	Gas and Fuel Corporation (Sale Undertaking)	\$0.15
7832	Melbourne (St. Kilda-road Underpass)	\$0.15
7833	Trustee (Authorized Investments)	\$0.10
7834	Consolidated Revenue	\$0.10
7835	Local Government	\$0.60
7836	Melbourne Wholesale Fruit and Vegetable Market (Advisory Committee)	\$0.10
7837	Teaching Service (Amendment)	\$0.10
7838	State Electricity Commission (Borrowing and Investing Powers)	\$0.10
7839	Motor Car (Amendment)	\$0.10
7840	Mines (Abolition of Courts)	\$0.30
7841	Manango (O'Shanessy River Watershed) Lands	\$0.10
7842	State Savings Bank (Amendment)	\$0.10
7843	Apprenticeship (Commission)	\$0.10
7844	Swan Hill Race-course and Golf-course Lands	\$0.15
7845	Imitation Milk	\$0.15
7846	Finance Brokers	\$0.25
7847	Local Government (Rating Exemptions)	\$0.15
7848	Labour and Industry (Amendment)	\$0.10
7849	Groundwater	\$0.30
7850	Consolidated Revenue	\$0.10
7851	Mental Health (Chairmanship)	\$0.10
7852	Instruments (Bills of Exchange Amendment)	\$0.10
7853	Supreme Court (Correction of Sentences)	\$0.10
7854	Summary Offences	\$0.10
7855	Church of England in Australia (Mount Shadwell Land)	\$0.10
7856	State Rivers and Water Supply Commission (Special Projects)	\$0.10
7857	Coal Mines (Pensions Increase)	\$0.10
7858	Trustee Companies (Burns Philp Trustee Company Limited)	\$0.10
7859	Latrobe Valley (Amendment)	\$0.10
7860	Maintenance (Amendment)	\$0.10
7861	Aboriginal Affairs (Amendment)	\$0.10
7862	Goods (Trade Descriptions)	\$0.10
7863	Marine Stores and Old Metals (Amendment)	\$0.15
7864	Fire Authorities (Borrowing Powers)	\$0.10
7865	Acts Interpretation (Time)	\$0.10
7866	Narre Worrnan Lands	\$0.10
7867	Moorpanyal Lands	\$0.10
7868	Juries (Amendment)	\$0.10
7869	Apprenticeship (Regulations)	\$0.10
7870	Portland Lands Exchange	\$0.10
7871	Melbourne University (Property)	\$0.10
7872	Latrobe Valley (Lands for Ambulance Services)	\$0.10
7873	Ministry of Transport (Director of Transport)	\$0.10
7874	Administration and Probate (Foreign Grants)	\$0.10
7875	Road Traffic (Amendment)	\$0.10
7876	Justices (Amendment)	\$0.35
7877	Country Fire Authority (Amendment)	\$0.15
7878	Coal Mines (Accidents Relief)	\$0.10
7879	Preston School of Design and Free Library Land	\$0.10
7880	Lands Compensation (Costs and Expenses)	\$0.10
7881	Evidence (Bankers' Books)	\$0.10
7882	Transport Regulation (Financial)	\$0.10
7883	Railways (Surplus Lands)	\$0.10
7884	Abolition of Obsolete Offences	\$0.10
7885	Fire Brigades (Contributions)	\$0.15
7886	Gas	\$0.30

STATE ACTS 1969—continued.		Price.
No.		
7887	Tobacco Leaf Industry Stabilization (Tobacco Quotas)	\$0.10
7888	The Constitution Act Amendment (Standing Appropriations)	\$0.10
7889	Legal Profession Practice	\$0.10
7890	Navigable Waters (Oil Pollution) (Amendment)	\$0.15
7891	Stamps (Mortgages)	\$0.10
7892	State Forests Loan Application	\$0.10
7893	Melbourne and Metropolitan Board of Works (Amendment)	\$0.15
7894	Wheat Marketing	\$0.25
7895	Revenue Deficits Funding	\$0.15
7896	Land Tax (Rates)	\$0.10
7897	Probate Duty	\$0.10
7898	Sale of Land (Amendment)	\$0.10
7899	Racing (Trotting Racing)	\$0.10
7900	Crown Proceedings (Forfeited Recognisances)	\$0.15
7901	Weights and Measures (Fees)	\$0.10
7902	Town and Country Planning (Compensation)	\$0.10
7903	Wheat Industry Stabilization (Amendment)	\$0.10
7904	Railway Loan Application	\$0.15
7905	North Melbourne Lands (Loans to Lessees)	\$0.10
7906	Theatres (Performance of Sacred Works)	\$0.10
7907	Marketing of Primary Products (Amendment)	\$0.15
7908	Water Supply Loan Application	\$0.25
7909	Health (Amendment)	\$0.15
7910	Superannuation (Amendment)	\$0.25
7911	Friendly Societies (Amendment)	\$0.15
7912	The Constitution Act Amendment (Conjoint Elections)	\$0.10
7913	Labour and Industry (Long Service Leave)	\$0.10
7914	Public Service (Amendment)	\$0.15
7915	Motor Car (Traffic Offenders)	\$0.10
7916	Motor Car	\$0.15
7917	Farm Produce Merchants and Commission Agents (Amendment)	\$0.25
7918	Education (Army Apprentices School)	\$0.10
7919	Legal Aid	\$0.15
7921	Crown Reservations (Revocation and Excision)	\$0.15
7922	Firearms (Amendment)	\$0.10
7923	Labour and Industry (Further Amendment)	\$0.10
7924	Forests (Softwood Timber Agreement)	\$0.15
7925	Public Works Loan Application	\$0.15
7926	Metropolitan Fire Brigades (Amendment)	\$0.15
7927	Consolidated Revenue	\$0.10
7928	National Parks (Amendment)	\$0.25
7929	Railways (Offences)	\$0.10
7930	Tourist	\$0.15
7931	Country Roads (Amendment)	\$0.15
7932	Appropriation of Revenue	\$1.15

C. H. RIXON,
Government Printer.

STATE ACTS, 1970

COPIES of the following Acts of Parliament of Victoria may be obtained at the Government Printing Office, Sale of Publications Branch, off Parliament-place, Melbourne, phone 63 0321, extension 6181, or from any accredited agent, at the price set opposite to each (these prices do not include postage).

The annual subscription for State Acts 1969 et seq. is \$8 payable in advance.

Bound Volumes of State Acts are also available on a subscription basis of \$15 per annum.

No.		Price.
7920	Educational Grants (Amendment)	\$0.10
7933	Evidence (Boards and Commissions)	\$0.10
7934	The Constitution Act Amendment	\$0.10
7935	Coroners (Amendment)	\$0.10
7936	Town and Country Planning (Appeals Tribunal)	\$0.10
7937	Melbourne (Veterinary Schools) Lands	\$0.10
7938	Board of Inquiry (Corrupt Practices)	\$0.10
7939	Cabrini Private Hospital (Guarantees)	\$0.10
7940	Judges' Salaries and Allowances	\$0.10
7941	Instruments (Amendment)	\$0.10
7942	La Trobe University (Amendment)	\$0.10
7943	Business Names (Amendment)	\$0.10
7944	Acts Interpretation (Nationality)	\$0.10
7945	Dairy Products (Board Membership)	\$0.10
7946	Melbourne Harbor Trust (Amendment)	\$0.10
7947	Aboriginal Affairs (Amendment)	\$0.10
7948	River Murray Waters	\$0.15
7949	River Murray Waters (Dartmouth Reservoir)	\$0.10

STATE ACTS 1970—continued.

No.	Price.
7950. Western Port (Steel Works)	\$0.25
7951. Extractive Industries (Licences)	\$0.10
7952. Stamps (Salary or Wages)	\$0.10
7953. Melbourne Lands Exchange	\$0.10
7954. Public Officers Salaries and Allowances	\$0.15
7955. Ballarat (Sovereign Hill) Land	\$0.15
7956. Wombat Bonuses	\$0.10
7957. Richmond and Hawthorn Lands	\$0.15
7958. Solicitor-General (Pensions)	\$0.10
7959. Australia and New Zealand Banking Group	\$0.25
7960. Mildura Irrigation and Water Trusts	\$0.10
(Amendment)	\$0.10
7961. Land Settlement (Financial)	\$0.10
7962. Securities Industry	\$0.35
7963. Mildura College Lands (Amendment)	\$0.10
7964. Door to Door (Sales) (Amendment)	\$0.15
7965. Consumer Protection	\$0.10
7966. Justices (Alternative Procedure)	\$0.15
7967. Summary Offences	\$0.10
7968. Local Government (Amendment)	\$0.30
7969. Motor Car (Falsification of Mileage)	\$0.10
7970. Marketable Securities	\$0.25
7971. Carriers and Innkeepers (Amendment)	\$0.10
7972. Cemeteries (Coburg Public Cemetery)	\$0.10
7973. Judges Pensions	\$0.10
7974. Victoria Institute of Colleges (Affiliated	\$0.10
Colleges)	\$0.10
7975. Town and Country Planning (Responsible	\$0.10
Authority)	\$0.10
7976. Wheat Marketing (Special Quotas)	\$0.10
7977. Joint Select Committee (Meat Industry)	\$0.10
7978. Joint Select Committee (Road Safety)	\$0.10
7979. Consolidated Revenue (Supply—July to Sep-	\$0.10
tember 1969-70)	\$0.10
7980. Consolidated Revenue (Supplementary	\$0.10
Estimates 1969-70)	\$0.10

C. H. RIXON,
Government Printer.

AGENTS FOR THE "VICTORIA GOVERNMENT GAZETTE".

THE following have been appointed agents to receive Advertisements and Subscriptions for the *Victoria Government Gazette*:—

- ARMSTRONG'S AGENCY, 205 Queen-street, Melbourne, Victoria 3000.
- ARNALL & JACKSON, 390 Barkly-street, Brunswick, Victoria 3056.
- BAIRNSDALE AUTHORIZED NEWSAGENCY, 132 Main-street, Bairnsdale, Victoria 3875.
- BICKNELL, M. J., Authorized Newsagent, 196 Timor-street, Warrnambool, Victoria 3280.
- BLANE'S AUTHORIZED NEWSAGENTS, 162 Murray-street, Colac, Victoria 3250.
- CARTER, R. G., ADVERTISING SERVICE PTY. LTD., Suite 24, 65 Queens-road, Melbourne, Victoria 3004.
- DAVIES, G. & M. V., 112 Gray-street, Hamilton, Victoria 3300
- DAVIS, WM. (MILDURA) PTY. LTD., 126 Eighth-street, Mildura, Victoria 3500.
- DIXON'S NEWSAGENCY, 89 Firebrace-street, Horsham, Victoria 3400.
- EDGARS' AUTHORIZED NEWSAGENCY, 45 Bridge-street, Benalla, Victoria 3672.
- FRANKS, H., & CO., 184 Ryrie-street, Geelong, Victoria 3220.
- GATLEY, A. & J., 250 Lonsdale-street, Dandenong, Victoria 3175.
- GORDON & GOTCH AUSTRALASIA LTD., 467 Collins-street, Melbourne, Victoria 3000.
- GULLAN'S NEWSAGENCY, 88 Bridge-street, Ballarat, Victoria 3350.
- HAMPTON, A. C., 243 Mitchell-street, Bendigo, Victoria 3550.
- HARSTON, PARTRIDGE & CO. PTY. LTD., 455 Little Collins-street, Melbourne, Victoria 3000.
- KYNETON GUARDIAN PTY. LTD., P.O. Box 18, Kyneton, Victoria 3444.
- LATIMER'S, Newsagents, 45 Station-street, Malvern, Victoria 3144.
- LIVINGSTON'S SHEPPARTON NEWSAGENCY, 246 Wyndham-street, Shepparton, Victoria 3630.
- THE MERCANTILE EXCHANGE, 34 Queen-street, Melbourne, Victoria, 3000.
- MCGILL'S AUTHORIZED NEWSAGENCY, 183-5 Elizabeth-street, Melbourne, Victoria 3000.
- PHILLIPS AUTHORIZED AGENCY, 83 Murphy-street, Wangaratta, Victoria 3677.

- POWNEYS AUTHORIZED NEWSAGENCY, 293 Hargreaves-street, Bendigo, Victoria 3550.
- PURDIE, J., & CO., 138 Moorabool-street, Geelong, Victoria 3220.
- SALE AUTHORIZED NEWSAGENCY, 142 Raymond-street, Sale, Victoria 3850.
- SKINNER'S AUTHORIZED NEWSAGENCY, 49-51 Franklin-street, Traralgon, Victoria 3844.
- STEVENSON, A. C. & M., NEWSAGENTS, 132 Henty-street, Casterton, Victoria 3311.
- VERNONS OF RICHMOND, 162 Bridge-road, Richmond, Victoria 3121.
- VIEW POINT AUTHORIZED NEWSAGENCY, 4 View-Point, Bendigo, Victoria 3550.

A copy of the Gazette filed at each place for public reference.

PUBLICATION OF OFFICIAL MATTER

ATTENTION is invited to the following procedure in relation to the publication of official matter in the *Government Gazette*:—

Publication will be facilitated by the submission of carbon copies for the use of the *Gazette* Officer.

1. Matter submitted to the Executive Council.

Matter submitted to the Executive Council which requires gazettal will normally be published in the issue of the following week.

Where urgent gazettal is required, special arrangements should be made with the *Gazette* Officer, Room 9, first floor, Old Treasury Building.

2. Other matter.

(a) All other matter duly certified by a responsible officer for publication should be lodged with the *Gazette* Officer not later than half-past Nine a.m. on Tuesday.

(b) Lengthy or involved notices should be forwarded several days before publication.

(c) Proofs, which will be supplied only when specifically requested or at the direction of the *Gazette* Officer, should be returned promptly to avoid delay in publication.

(d) No additions or amendments to matter for publication will be accepted by telephone.

CONTENTS

	PAGE
Acts of Parliament on Sale at the Government Printing Office	3662
Appointments	3637
Bank Holiday	3622
Christmas and New Year Holidays	3622
Companies Act 1961—Notice	3633
Contracts	3631
Courts	3628
Estates of Deceased Persons	3637
Government Notices	3622
Impoundings	3662
Lands	3644
Melbourne and Metropolitan Board of Works—	
Notice	3636
Mining	3628
Notices to Mariners	3634
Notice of Making of Statutory Rules	3662
Orders in Council—	
Acts—Board of Inquiry; Audit; Road Traffic; Public Service; Stamps; Hospitals and Charities; Land; Country Roads; Housing; Police Regulation; Landlord and Tenant; Water; West Moorabool Water Board; Sewerage Districts; Geelong Waterworks and Sewerage.	et seq
Private Advertisements	3649
Proclamations	3622
Public Half-Holiday	3622
Public Service Notices	3649
Regulations—	
Acts—Police Regulation	3630
Resignations	3638
State Rivers and Water Supply Commission	3631
Tenders	3647
Transport Regulation Board—Public Hearings	3623
Waterworks Trust	3636