



VICTORIA
GOVERNMENT GAZETTE

Published by Authority

No. 831

WEDNESDAY, SEPTEMBER 9

11970

PROCLAMATIONS

Public Service Act 1958.

ALTERATION OF DAY APPOINTED A PUBLIC HOLIDAY
IN THE SHIRE OF BACCHUS MARSH.

PROCLAMATION

By His Excellency the Governor of the State of Victoria and its Dependencies in the Commonwealth of Australia, &c., &c., &c.

WHEREAS by sub-section (1) of Section 67 of the *Public Service Act 1958*, Thursday, the twenty-fourth day of September, 1970, shall be observed as a public holiday throughout the municipalities mentioned in the Fourth Schedule to the said Act, including the Shire of Bacchus Marsh:

And whereas it is made to appear to me expedient that the said day should not be a public holiday throughout the Shire of Bacchus Marsh:

Now therefore, I, the Governor of the State of Victoria, in the Commonwealth of Australia, by and with the advice of the Executive Council of the said State, and in pursuance of the provisions of sub-section (3) of Section 67 of the *Public Service Act 1958*, do by this my Proclamation declare that the said day shall not be a public holiday throughout the Shire of Bacchus Marsh and appoint Monday, the twenty-first day of September, 1970, to be a public holiday throughout the Shire of Bacchus Marsh.

Given under my hand and the Seal of the State of Victoria aforesaid, at Melbourne, this first day of September, in the year of our Lord, One thousand nine hundred and seventy, and in the nineteenth year of the reign of Her Majesty Queen Elizabeth II.

(L.S.)

ROHAN DELACOMBE.

By His Excellency's Command,

IAN SMITH,
Acting Chief Secretary.

GOD SAVE THE QUEEN !

Dandenong Valley Authority Act 1963.

FLOOD-PRONE AREA NUMBER 13.

PROCLAMATION

By His Excellency the Governor of the State of Victoria and its Dependencies in the Commonwealth of Australia, &c., &c., &c.

WHEREAS Section 27 of the *Dandenong Valley Authority Act 1963*, provides that the Governor in Council may, at the request of the Dandenong Valley Authority, declare by proclamation any specified area or areas of land within the district of the Authority to be within the flood plain of any river or group of rivers within that district:

And whereas the said Authority has complied with the provisions of Section 27 of the aforementioned Act relative to the publication and service of notices in relation thereto:

Now therefore I, the Governor of the State of Victoria by and with the advice of the Executive Council thereof, do by this Proclamation declare that the areas shown coloured pink on the plans numbered F24 and F25, approved by the Governor in Council and deposited in the office of the State Rivers and Water Supply Commission, Melbourne, are within the flood plain of the Hallam Valley Contour Drain for the purposes of the said Act and shall be known as Flood-Prone Area Number 13.

Given under my hand and the Seal of the State of Victoria aforesaid, at Melbourne, this first day of September, in the year of our Lord, One thousand nine hundred and seventy, and in the nineteenth year of the reign of Her Majesty Queen Elizabeth II.

(L.S.)

ROHAN DELACOMBE.

By His Excellency's Command,

IAN SMITH,
Minister of Water Supply.

GOD SAVE THE QUEEN !

LOCAL GOVERNMENT DEPARTMENT.
PUBLIC HIGHWAY.—TOWN OF PORTLAND.

PROCLAMATION

By His Excellency the Governor of the State of Victoria and its Dependencies in the Commonwealth of Australia, &c., &c., &c.

WHEREAS by the Local Government Act 1958, Section 519, it is amongst other things enacted that it shall be lawful for the Governor in Council at any time and from time to time upon the request of the Council of any municipality by notice in the Government Gazette to proclaim any land reserved used or by purchase or exchange acquired for a street, road, highway, thoroughfare, bridge, square, court, alley or right-of-way or any street, road, lane or passage made or laid out or proposed to be made or laid out on any land of which a plan of subdivision delineating that street, road, lane or passage has been sealed with the seal of the municipality under subdivision (3) of Division 9 of Part XIX. of the Local Government Act 1958, or a corresponding previous enactment to be a public highway and that such land shall thereupon and thenceforth from the date of such proclamation become and be absolutely dedicated to the public as a public highway within the meaning of any law then or thereafter in force:

And whereas the Council of the Town of Portland has requested that the land hereinafter mentioned, being a street, road, lane or passage made or laid out or proposed to be made or laid out on land of which a plan of subdivision delineating the street, road, lane or passage has been sealed with the seal of the municipality under subdivision (3) of Division 9 of Part XIX. of the Local Government Act 1958, or a corresponding previous enactment, be so declared to be a public highway:

Now therefore, I, the Governor of the State of Victoria, in the Commonwealth of Australia, by and with the advice of the Executive Council of the said State, do by this Proclamation declare that Aberdeen Street coloured brown on Plan of Subdivision No. 79670 lodged in the Office of Titles shall be a public highway within the meaning of the said Act.

Given under my hand and the Seal of the State of Victoria aforesaid, at Melbourne, this first day of September, in the year of our Lord, One thousand nine hundred and seventy, and in the nineteenth year of the reign of Her Majesty Queen Elizabeth II.

(L.S.) ROHAN DELACOMBE.

By His Excellency's Command,
JIM BALFOUR,
Acting Minister for Local Government.
GOD SAVE THE QUEEN!

PUBLIC HOLIDAYS.

PROCLAMATION

By His Excellency the Governor of the State of Victoria and its Dependencies in the Commonwealth of Australia, &c., &c., &c.

IN pursuance of the provisions contained in Part III. of the Public Service Act 1958, I, the Governor of the State of Victoria, in the Commonwealth of Australia, by and with the advice of the Executive Council of the said State, do by this my Proclamation appoint the days and dates hereunder mentioned to be observed as Public Holidays or Public Half-Holidays (as the case may be) at the places respectively specified, viz.:

Public Holidays:—

MONDAY, THE 21ST SEPTEMBER, 1970, throughout the Shire of Newham and Woodend.
TUESDAY, THE 6TH OCTOBER, 1970, throughout the Western Riding of the Shire of Waranga.
WEDNESDAY, THE 7TH OCTOBER, 1970, throughout the Townships of Donald, Litchfield and Corack.
THURSDAY, THE 8TH OCTOBER, 1970, throughout the Shire of Warracknabeal.

Public Half-Holidays. from the Hour of Twelve o'clock noon:—

THURSDAY, THE 1ST OCTOBER, 1970, throughout the Shire of Wimmera.
TUESDAY, THE 6TH OCTOBER, 1970, throughout the Shire of Cobram.
THURSDAY, THE 8TH OCTOBER, 1970, throughout the North Riding of the Shire of Wimmera.
TUESDAY, 13TH OCTOBER, 1970, throughout the Shire of Birchip.

WEDNESDAY, THE 14TH OCTOBER, 1970, throughout the Murrayville Riding of the Shire of Walpeup.
THURSDAY, THE 22ND OCTOBER, 1970, throughout the Coleraine Riding of the Shire of Wannon.

Given under my Hand and the Seal of the State of Victoria aforesaid, at Melbourne, this first day of September, in the year of our Lord One thousand nine hundred and seventy, and in the nineteenth year of the reign of Her Majesty Queen Elizabeth II.

(L.S.) ROHAN DELACOMBE.

By His Excellency's Command,
IAN SMITH,
Acting Chief Secretary.

GOD SAVE THE QUEEN!

ROAD PROCLAIMED.

PROCLAMATION

By His Excellency the Governor of the State of Victoria and its Dependencies in the Commonwealth of Australia, &c., &c., &c.

IN pursuance of the provisions of section 25 (3) (c) of the Land Act 1958, I, the Governor of the State of Victoria by and with the advice of the Executive Council of the said State, do hereby, proclaim as a road the land in the Township of Portland, Parish of Portland, County of Normanby as indicated by hatching on plan hereunder.—(P.69(?) (Rs.9364.)

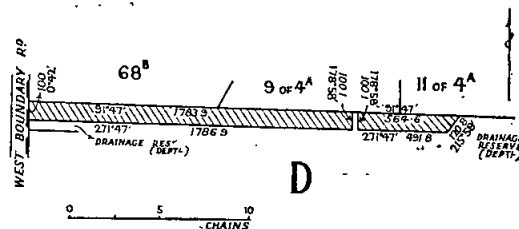

Given under my Hand and the Seal of the State of Victoria aforesaid, at Melbourne, this first day of September, in the year of our Lord One thousand nine hundred and seventy, and in the nineteenth year of the reign of Her Majesty Queen Elizabeth II.

(L.S.) ROHAN DELACOMBE.

By His Excellency's Command,
W. BORTHWICK,
Minister of Lands.

GOD SAVE THE QUEEN!

GOVERNMENT NOTICES

HOLIDAY—ROYAL AGRICULTURAL SHOW.

NOTICE is hereby given that on

THURSDAY, THE 24TH SEPTEMBER, 1970.

the Public Offices in the municipalities mentioned hereunder will be closed, that day being appointed by the Public Service Act 1958 to be observed as a holiday in the Public Offices:—

The Cities of Altona, Box Hill, Brighton, Broadmeadows, Brunswick, Camberwell, Caulfield, Chelsea, Coburg, Collingwood, Dandenong, Doncaster and Templestowe, Essendon, Fitzroy, Footscray, Frankston, Hawthorn, Heidelberg, Keilor, Kew, Knox, Malvern, Melbourne, Moorabbin, Mordialloc, Northcote, Nunawading, Oakleigh, Port Melbourne, Prahran, Preston, Richmond, Ringwood, St. Kilda, Sandringham, South Melbourne, Springvale, Sunshine, Waverley and Williamstown; the Shires of Berwick, Bulla, Cranbourne, Croydon, Diamond Valley, Eltham, Hastings, Lillydale, Melton, Mornington, Sherbrooke, Werribee and Whittlesea.

This notice relates only to the closing of the State Public Offices. All inquiries regarding holidays in other offices and in shops and industry should be directed to the Department of Labour and Industry, 110 Exhibition-street, Melbourne, 3000. (Telephone 63-0321, Extension 6158, 6924 or 6859.)

IAN SMITH,
Acting Chief Secretary.

Chief Secretary's Office,
Melbourne, 1st September, 1970.

Transport Regulation Act.
TRANSPORT REGULATION BOARD.

HEARING OF APPLICATIONS.

NOTICE is hereby given that the following applications will be considered by the Transport Regulation Board at its offices at the corner of Princes and Lygon streets, Carlton, at 10.15 a.m., on Wednesday, 30th September, 1970.

DUNNE, E., 578 Canterbury-road, Vermont. Application for one commercial passenger vehicle to be purchased to operate for the carriage of passengers between the 1st Car Park on Lake Mountain and the summit of Lake Mountain.

TIME-TABLE (Snow Season Only).

Saturday and Public Holidays as and when required.

FARES:

Adult: \$1.

Child (up to 15 years old): 50c.

GRANT, H. F., 13 Birch-street, Shepparton. Application for one commercial passenger vehicle to be purchased to operate as an additional country stage omnibus on the route between Melbourne and Shepparton under existing terms and conditions.

MOAIT, M. E., Margaret-street, Macedon. One commercial passenger vehicle (S/C. 5) to operate as a country hire car from Macedon subject to the cancellation of licence No. C.T.41 in the name of the applicant.

MCCALLUM, W. R., N. E. & P. W., Beech Forest. Application for variation of licence No. T.S.707 to delete operations as a country special service omnibus within a one-mile radius of Beech Forest and instead operate within a one-mile radius of Birregurra.

SCALE, E., 578 Canterbury-road, Vermont. Application for one commercial passenger vehicle to be purchased to operate for the carriage of passengers between the 1st Car Park on Lake Mountain and the summit of Lake Mountain.

TIME-TABLE (Snow Season Only).

Saturday and Public Holidays as and when required.

FARES:

Adult: \$1.

Child (up to 15 years old): 50c.

PHILLIP ISLAND MOTELS PTY. LTD., The Esplanade, Cowes, Phillip Island. Application for one commercial passenger vehicle (S/C. 5) to operate for the carriage of guests of the applicant's motel as and when required on the following routes:—(a) From Melbourne Airport, Tullamarine and or the City of Melbourne to Cowes, Phillip Island and to the Penguin Parade and return. (b) From Melbourne Airport, Tullamarine and or the City of Melbourne to Sir Colin McKenzie Sanctuary, Healesville; thence to Cowes, Phillip Island and Penguin Parade and direct return to Melbourne.

Fares: Inclusive in accommodation cost at the Erehwon Point Motel, Cowes.

TREWEEK, W. J., 105 Evans-street, Sunbury. Application for variation of licence No. T.S.1271 to include the ability to operate as a country special service omnibus within a one-mile radius of the Gisborne Post Office.

WOODHALL PIPELINES PROPERTIES PTY. LTD., 12 Olive-grove, Dandenong. Application for one commercial passenger vehicle (S/C. 38) to operate for the carriage of employees free of charge between the applicant company's construction site office at Werribee and work sites between Brooklyn and Geelong.

TIME-TABLE.

Depart Werribee—7.00 a.m.
Depart Work site—5.30 p.m.

APPLICATION for renewal of licences as shown, by persons listed hereunder to operate under the same terms and conditions.

MARKS BUS SERVICES PTY. LTD., 12 Lydiard-street north, Ballarat; T.S.864, T.S.865, T.S.866, T.S.867, T.S.868, T.S.869, U.O.543, U.O.544.

WILKINS, B. A. & R. A., 12 Lydiard-street north, Ballarat; T.S.37, T.S.623, T.S.650, T.S.1102, U.O.201, U.O.245, U.O.247.

Notice of any objection should be forwarded to reach the Secretary of the Board not later than Wednesday, 23rd September, 1970.

Applicants are advised that it will not be necessary to appear on the hearing date specified above, unless advised in writing by the Board.

B. P. KAY,
Secretary.

Corner Lygon and Princes streets, Carlton, Wednesday, 9th September, 1970.

Commercial Goods Vehicles Act.
TRANSPORT REGULATION BOARD.

HEARING OF APPLICATIONS.

NOTICE is hereby given that the following applications will be considered by the Transport Regulation Board at its offices at the corner Lygon and Princes streets, Carlton at 10.15 a.m. on Wednesday, 30th September, 1970.

ANDERWALD, E., Grant-street, Alexandra, 3714. One commercial goods vehicle (L/C. 84 cwt.) to operate in course of business as an "Earth-moving, Land-clearing and General Contractor"—(a) Within that part of a 100-mile radius of the post office at Alexandra which is situated south of an east/west line drawn through the Township of Yarck—own earth-moving machines, own front-end loader and tools of trade. (b) Within a 20-mile radius of the site of any contract performed pursuant to paragraph (a) above—earth, rubbish and/or any materials required in the completion of such contract.

BEISSOUNDAS, J., 118 Mills-street, Albert Park, 3206. One commercial goods vehicle (L/C. 149 cwt.) to operate within a 35-mile radius of the G.P.O., Melbourne, on behalf of Consolidated Quarries Ltd.—sand, soil, screenings, premix and quarry products.

BOOTS PURE DRUG CO. PTY. LTD. (AUST.), 24 Woorayl-street, Carnegie, 3163. One commercial goods vehicle (L/C. 8 cwt.) to operate: (a) Within a 50-mile radius of own premises at Carnegie in the course of business as "Wholesale Chemists and Druggists"—own goods. (b) Throughout the State of Victoria as a traveller's vehicle for the purpose of booking orders—samples and display materials with the ability to leave a small medicinal order in an emergency.

BROERSEN, T. A., P.O. Box 391, Orbost, 3888. One commercial goods vehicle (L/C. 260, cwt.) to operate: (a) Throughout that part of the State of Victoria east of the Snowy River—logs and poles. (b) From and to the area specified in part (a) of this document to and from the settlements of Waygara and Newmerella—logs. (c) From sawmills situated in the area specified in part (a) of this document and at Newmerella to the Orbost Railway Station—sawn timber. (d) From sawmills in the area specified in part (a) of this document and at Newmerella to consignees within a 20-mile radius of the Orbost Post Office—sawn timber.

CLOSTER, J. E., Fitzroy-street, Darley via Bacchus Marsh, 3340. One commercial goods vehicle (L/C. 240 cwt.) to operate within a 50-mile radius of the premises of Albion Reid Pty. Ltd. at North Melbourne on behalf of the said company—road-making plant, hot asphalt, premix and road-making materials but excluding the carriage of cement and lime from the Geelong Urban District (as defined in the Transport Regulation Act 1958).

CONTI, R., 12 Morris-street, Keon Park, 3073. One commercial goods vehicle (L/C. 240 cwt.) to operate within a 35-mile radius of the G.P.O., Melbourne, on behalf of Consolidated Quarries Ltd.—sand, soil, screenings, premix and quarry products.

CRIVERA, T., 200 Dorset-road, Boronia, 3155. One commercial goods vehicle (L/C. 198 cwt.) to operate within a 50-mile radius of the plant of Pronto Mixed Concrete Co. Pty. Ltd. at Ringwood on behalf of the said company—premixed concrete in a specially constructed agitator vehicle.

CUMMINS, I. J., 2 Callow-street, Ballarat, 3350. Application to vary the conditions of licence No. D.A.36945 (L/C. 161 cwt.) by deleting from the existing conditions paragraph (a) (i) and adding in lieu—"Within a 75-mile radius of the post office at Waubra (Ballarat Division of the C.R.B.)."

DAHLESEN, J. C., PTY. LTD., 90-120 Nicholson-street, Bairnsdale, 3875. One commercial goods vehicle (L/C. 22 cwt.) to operate within a 50-mile radius of the post office at Bairnsdale and/or within that part of the State of Victoria east of a line drawn due north and south through the Township of Fernbank in the course of business as "General Merchants"—own goods.

DON, H. J., East-street, Woodend 3442. One commercial goods vehicle (L/C. 204 cwt.) to operate: (a) Within a 25-mile radius of the post office at Woodend—general goods provided that no goods shall be carried by one stage or by more than one stage between

- places within the above radius which are more than thirty (30) road miles apart by the nearest practicable route. (b) From places within paragraph (a) above to saleyards at Newmarket—livestock. (c) From the works at Yarraville to places within paragraph (a) above in the course of business as "Superphosphate Spreading Contractor"—superphosphate for spreading purposes only.
- ELEFANTIS, H.**, 16 Leighton-crescent, Fawkner, 3060. One commercial goods vehicle (L/C. 197 cwt.) to operate within a 50-mile radius of the G.P.O. Melbourne on behalf of Blue Metal Concrete—premixed concrete in a specially constructed agitator vehicle.
- ESPOSITO, P. A.** 110 North-road, Yallourn North, 3837. Application to vary the conditions of licence No. D.A.60571 (L/C. 160 cwt.) by adding to the existing conditions as an additional paragraph (c)—"From the premises of Albion Reid Pty. Ltd. at Morwell to consignees situated at places within a 40-mile radius of the post office at Morwell and to places within the Shires of Bairnsdale and Tambo—hot asphalt and premix."
- ESPOSITO, P. A.**, 110 North-road, Yallourn North, 3837. Application to vary the conditions of licence No. D.A.60571/1 (L/C. 138 cwt.) by deleting from paragraph (c) of the existing conditions and adding in lieu—"From the premises of Albion Reid Pty. Ltd., at Morwell to consignees situated at places within a 40-mile radius of the post office at Morwell and to places within the Shires of Bairnsdale and Tambo—hot asphalt and premix."
- FINLAYSON, K. J.**, 261 High-street Wodonga, 3690. One commercial goods vehicle (L/C. 20 cwt.) to operate in the course of business as "Caravan and Trailer Dealers"—(a) Within a 50-mile radius of own premises at Wodonga—own caravans and trailers. (b) From Ballarat to own premises at Wodonga for the purpose of towing own caravans. (c) From manufacturers in Ballarat and Melbourne to own premises at Wodonga—own trailers.
- FISCHER & PORTER PTY. LTD.**, 14-24 Whiteside-road, Clayton, 3168. One commercial goods vehicle (L/C. 14 cwt.) to operate throughout the State of Victoria in the course of business as "Instrument and Chlorination Engineers" for the servicing and installing of instruments and chlorination equipment—chlorination equipment and plant for installation and/or for repair or having been repaired and own tools of trade and materials incidental thereto.
- FREEMAN, F. G.**, 24 Whitby-road, Brunswick West, 3055. One commercial goods vehicle (L/C. 59 cwt.) to operate throughout the State of Victoria in the course of business as "Travelling Showman"—own side-show equipment and novelty prizes.
- G.M.D. REFRIGERATION PTY. LTD.**, 14-16 Kolora-road, West Heidelberg, 3081. One commercial goods vehicle (L/C. 13 cwt.) to operate throughout the State of Victoria in the course of business as "Refrigeration Manufacturers and Engineers" for the purpose of servicing and/or supervising the installation of refrigeration equipment—tools of trade and spare parts incidental thereto also refrigeration units for repair or having been repaired or for installation together with materials incidental thereto.
- GELBE, L.**, 12 Franklyn-street, Huntingdale, 3166. Application to vary the conditions of licence No. D.A.50167 (L/C. 237 cwt.) by deleting the existing conditions and adding in lieu—" (a) Within a 50-mile radius of the asphalt plants of the Ready Mix Group (Vic.) at Narre Warren North, Thomastown and Vermont—hot asphalt. (b) From sand pits at Nar Nar Goon to asphalt plants of the Ready Mix Group (Vic.) at Narre Warren North and Vermont—sand. (c) Within a 25-mile radius of Melbourne on behalf of the Ready Mix Group (Vic.) for the purpose of supplying asphalt plants with raw materials—screenings, sand and raw materials."
- GULLIVER, F. W.**, care of Hampton Park P.O., 3976. One commercial goods vehicle (L/C. 208 cwt.) to operate within a 50-mile radius of the premises of Albion Reid Pty. Ltd. at North Melbourne on behalf of the said company—road-making plant, hot asphalt, premix and road-making materials but excluding the carriage of cement and lime from the Geelong Urban District (as defined in the *Transport Regulation Act 1958*).
- HALL, G. W.**, 15 Callen-street, Seymour, 3660. One commercial goods vehicle (L/C. 261 cwt.) to operate: (a) Within a 25-mile radius of the post office at Seymour—general goods, provided that no goods shall be carried whether by one stage or by more than one stage between places within the above radius which are more than thirty (30) road miles apart by the nearest practicable route. (b) From the rail siding at Murchison East to the premises of Aggregate Contracting Co. Pty. Ltd. at Seymour—bulk cement in a specially constructed bulk tanker unit.
- HEDT, G. J.**, 126 Moola-street north, Ballarat, 3350. One commercial goods vehicle (L/C. 14 cwt.) to operate throughout the State of Victoria in the course of business as "Floor Sander"—tools of trade, equipment and sufficient materials only for the completion of own floor sanding contracts but excluding the carriage of any materials from places within a 25-mile radius of the G.P.O. Melbourne.
- HESZ, S.**, Mary-street, Heyfield, 3858. One commercial goods vehicle (L/C. 272 cwt.) to operate from forest landings in the Connors Plains, Mount Tamboritha and Mount McDonald Areas to sawmills at Heyfield—logs.
- NOTE.—This application replaces licence No. D.T.235 held by the applicant and which expired on 26th July, 1970.
- INNESS, D. & E. M.**, 24 West-street, Pascoe Vale, 3044. One commercial goods vehicle (L/C. 136 cwt.) to operate: (a) Within a 25-mile radius of own premises at Pascoe Vale in course of business as "Garden Supplier"—own goods. (b) From Toolangi to places in paragraph (a)—own mountain soil. (c) From Cranbourne to places in paragraph (a)—own sand. (d) From Bacchus Marsh to places in paragraph (a)—own sand and own river pebbles.
- JACKSON, L. E. & J. E.**, 10 Cooinda-court, Frankston, 3199. One commercial goods vehicle (L/C. 178 cwt.) to operate within a 50-mile radius of the G.P.O. Melbourne solely on behalf of Consolidated Quarries Ltd. —premix concrete in a specially constructed agitator vehicle.
- KEBL, G. W.**, lot 29, Nathalia-road, Belgrave South, 3160. One commercial goods vehicle (L/C. 133 cwt.) to operate: (a) Within a 50-mile radius of the asphalt plants of the Ready Mix Group (Vic.) at Narre Warren North, Thomastown and Vermont—hot asphalt. (b) From sand pits at Nar Nar Goon to asphalt plants of the Ready Mix Group (Vic.) at Narre Warren North and Vermont—sand. (c) Within a 25-mile radius of Melbourne on behalf of the Ready Mix Group (Vic.) for the purpose of supplying asphalt plants with raw materials—screenings, sand and raw materials.
- LANGENSCHWARZ, H.**, 109 Greta-road, Wangaratta, 3677. One commercial goods vehicle (L/C. 10 cwt.) to operate: (a) Within a 50-mile radius of the post office at Wangaratta—chemicals, spray equipment and drill equipment in course of business as "Pest Exterminator". (b) Within an area bounded by the Murray River to the north and a straight line running from Wangaratta to Echuca to the south and towns en route from Echuca to Swan Hill, along the Murray Valley Highway, in course of business as "Pest Exterminator"—chemicals and spray equipment. (c) All materials used in course of business to be railed to Wangaratta Railway Station from the manufacturers.
- MEMBREY, B. R. & L. I.**, 1 Garden-grove, Traralgon, 3844. Application to vary the conditions of licence No. D.T.895 (L/C. 241 cwt.) by adding to the existing conditions as an additional paragraph (b)—" (b) Within the area specified in paragraph (a) above—own bulldozer when being moved from contract site to contract site."
- MILDURA BRICK & PIPE WORKS PTY. LTD.**, P.O. Box 208, Mildura, 3500. One commercial goods vehicle (L/C. 147 cwt.) to operate within a 100-mile radius of the post office at Mildura—bricks and pipes exclusively on behalf of Mildura Brick and Pipe Works Pty. Ltd.
- MORRISON, C. F.**, 164 Queenscliff-road, Leopold, 3221. Application to vary the conditions of licence No. D.A.61940 (L/C. 57 cwt.) by deleting from paragraph (a) of the existing conditions "Within a 55-mile radius of the post office at Beaufort (Ballarat Division of the C.R.B.)" and adding in lieu—"Within a 75-mile radius of the post office at Waubra (Ballarat Division of the Country Roads Board)."
- NOSKE FLOUR MILLS PTY. LTD.**, 359 Plummer-street, Port Melbourne, 3207. Two commercial goods vehicles (L/C. 142 cwt. each) to operate: (a) Within a 25-mile radius of the G.P.O., Melbourne in the course of business as "Flour Millers and Stockfeed Manufacturers"—own goods. (b) Within a 50-mile radius of the G.P.O., Melbourne—own flour, such flour having been milled at own approved decentralized secondary industry at Charlton and Horsham and initially railed to Melbourne. (c) Within a 50-mile radius of G.P.O., Melbourne—own stockfeed—such stockfeed having been manufactured at own approved decentralized secondary industry at Horsham and Nhill and initially railed to Melbourne.

NOWAK, T., Blackwarry, via Traralgon, 3844. Application to vary the conditions of licence No. D.A.61441 (L/C. 154 cwt.) by adding to the existing conditions as additional paragraphs (d) and (e)—“(d) From own sawmill at Blackwarry to consignees situated within a 50-mile radius of Blackwarry—sawn timber. (e) From private landings situated within a 20-mile radius of Blackwarry to consignees situated within a 40-mile radius of Blackwarry—split fence posts.”

NOWAK, T. & E., Blackwarry, via Traralgon, 3844. One commercial goods vehicle (L/C. 260 cwt.) to operate: (a) From private landings situated within a 20-mile radius of Blackwarry to the premises of Hicksons Timber Impregnation Co. (Aust.) Pty. Ltd. at Officer—poles. (b) From private landings situated within a 20-mile radius of Blackwarry to—(i) Own sawmill at Blackwarry—mill logs. (ii) The premises of Port Albert sawmill at Port Albert—mill logs. (iii) W. J. Duff's sawmill at Morwell—mill logs. (iv) McMillan and Pyle Pty. Ltd.'s sawmill at Morwell. (v) The premises of Drouin West sawmill located at Boolarra and Drouin West respectively—mill logs.

PAIN, R. J., 12 Orr Brien-crescent, Traralgon, 3844. One commercial goods vehicle (L/C. 144 cwt.) to operate: (a) Within a 95-mile radius of the post office at Nowa Nowa (Orbost Division of the Country Roads Board)—road contracting plant used in the construction or maintenance of a road, street, footpath, bridge, wharf, pier, weir or channel. (b) Within a 20-mile radius from site of construction or maintenance work performed pursuant to paragraph (a) above or from a railway station nearest thereto—materials required for such work. (c) Within a 25-mile radius of the post office at Traralgon—general goods, provided that no goods shall be carried whether by one stage or by more than one stage between places within the above radius, which are more than thirty (30) road miles apart by the nearest practicable route.

PALAJA, G., 79 Clausen-street, North Fitzroy, 3068. One commercial goods vehicle (L/C. 35 cwt.) to operate throughout the State of Victoria in course of business as “Grocery Hawker” for the purpose of calling on private householders only—own groceries, subject to the proviso that no goods are sold to retail stores for resale.

PANNOWITZ, F., 7 Gardenia-street, Horsham, 3400. Application to vary the conditions of licence No. D.A.48614 (L/C. 133 cwt.) by deleting from paragraph (a) of the existing conditions “Within an 80-mile radius of the post office at Dimboola” and adding in lieu: “Within an 80-mile radius of the post office at Linga and/or 85-mile radius of the post office at Dimboola”.

PEATY, A. H., PTY. LTD., 429 Albert-street, Brunswick, 3056. One commercial goods vehicle (L/C. 21 cwt.) to operate throughout the State of Victoria in course of business as “Marine Collector”—special wares, marine stores and old metals as designated in the *Marine Stores and Old Metals Act 1958* (No. 6303), Part I, Section 3.

NOTE.—The combined load capacity of the prime mover and any trailer attached thereto shall not exceed 120 cwt.

PFEIFFER, W. M., 7 York-street, Ballarat, 3350. Application to vary the conditions of licence No. D.A.34788 (L/C. 218 cwt.) by deleting from paragraph (a) of the existing conditions “Within a 55-mile radius of the post office at Beaufort” and adding in lieu: “Within a 75-mile radius of the post office at Waubra”.

READY MIXED CONCRETE (VIC.) PTY. LTD., 68 Burwood-road, Burwood, 3125. One commercial goods vehicle (L/C. 97 cwt.) to operate within a 50-mile radius of own premises at Swan Hill in the course of business as “Premixed Concrete Manufacturers”—own premixed concrete in a specially constructed agitator vehicle.

READY MIXED CONCRETE (VIC.) PTY. LTD., 68 Burwood-road, Burwood, 3125. One commercial goods vehicle (L/C. 257 cwt.) to operate in the course of business as “Ready-Mixed Concrete Manufacturers” as follows:—(a) Within a 25-mile radius of the post office situated at the corner of Bourke and Elizabeth streets, in the City of Melbourne and to Township of Bittern—raw materials for use in the manufacture of concrete. (b) From suppliers situated within a 20-mile radius of the post office at Bittern to own premises at Bittern—sand and screenings. (c) To own plant at Geelong from quarries situated within a 10-mile radius of the said plant and from pits in the You Yangs area—sand and screenings. (d) From pits at Bacchus Marsh to own plants within a 25-mile radius of the post office situated at the corner of Bourke and Elizabeth streets, Melbourne, or to own plant at Geelong—own sand. (e) From pits at Bunyip, Tynong and Nar-Nar-Goon to own plant at

Vermont—own sand. (f) From quarries at Anakie to own plants within a 25-mile radius of post office at the corner of Bourke and Elizabeth streets, Melbourne—own rock.

SCHWEPPE (AUST.) LTD., P.O. Box 12, Sebastopol, 3356. Two commercial goods vehicles (L/C. 110 and 141 cwt.) to operate from own premises at Sebastopol to places within that part of the State of Victoria bounded on the east by a line drawn from Lower Gellibrand to Bannockburn, Ballan, Daylesford and St. Arnaud, on the north by a line drawn from St. Arnaud to Murtoa and Natimuk; on the west by a line drawn from Natimuk to Moyston, Dunkeld and Port Fairy; on the south by the Victorian Coastline between the Towns Port Fairy to Lower Gellibrand—aerated waters, milk bar syrups, canned drinks and cordials.

SERRANO, D., 18 Buckley-avenue, North Sunshine, 3020. One commercial goods vehicle (L/C. 319 cwt.) to operate within a 35-mile radius of the G.P.O., Melbourne on behalf of Consolidated Quarries Ltd.—sand, soil, screenings, premix and quarry products.

SIMSMETAL TRANSPORT PTY. LTD., McDonald-road, Brooklyn, 3025. Two commercial goods vehicles (L/C. 59 and 73 cwt.) to operate within a 50-mile radius of own premises at Brooklyn solely on behalf of Simsmetal Ltd., Parent Company, in course of business as “Scrap Metal Merchants”—scrap metal.

SORDELLO, G. & E., 66 Stawell-road, Horsham, 3400. Application to vary the conditions of licence No. D.A.51434 (L/C. 145 cwt.) by deleting from paragraph (a) of the existing conditions “Within an 80-mile radius of the post office at Dimboola” and adding in lieu—“Within an 85-mile radius of the post office at Dimboola and/or 80-mile radius of the post office at Linga”.

TAYLOR, B. J., 8 Victoria-street, Warragul, 3820. One commercial goods vehicle (L/C. 147 cwt.) to operate: (a) Within a 50-mile radius from the post office at Warragul as a “Road Contractor”—road-making plant and materials. (b) Within a 20-mile radius from the site of any construction or maintenance work performed pursuant to paragraph (a) above, or from the railway station nearest thereto—any other materials required for such work.

THOMAS, R. W., Macarthur, 3286. Application to vary the conditions of licence No. D.A.63841 (L/C. 123 cwt.) by adding to the existing conditions as an additional paragraph—“Within a 25-mile radius of Mount Eccles in course of business as Scoria and Sand Supply—own scoria and sand.”

TURNBULL, L., 20 Paschal-street, Moorabbin, 3189. One commercial goods vehicle (L/C. 22 cwt.) to operate: (a) Within a 50-mile radius of own premises at Moorabbin in the course of business as “Painters and Decorators”—own goods. (b) Throughout the State of Victoria—tools of trade, scaffolding and painting equipment, with the ability to return to Moorabbin with surplus materials from contract sites. (c) Within a 50-mile radius of any current contract site or from the railway station nearest thereto—any materials required for completion of such contracts.

TYNER, J. & R., PTY. LTD., 446 Collins-street, Melbourne, 3000. One commercial goods vehicle (L/C. 113 cwt.) to operate within a 50-mile radius of own premises at North Melbourne in the course of business as “Stock-feed Manufacturers and Merchants”—own chaff, own grain and own stockfeed.

VEAL, R. C., 209 Howitt-street, Ballarat, 3350. Application to vary the conditions of licence No. D.A.31891 (L/C. 133 cwt.) by deleting the existing area of operation and adding in lieu: “Within a 75-mile radius of the post office at Waubra”.

VELJKOVIC, K. H., 44 Buckley-street, Morwell, 3840. One commercial goods vehicle (L/C. 30 cwt. approximately) to operate between points situated within a 20-mile radius of the post office situated at the corner of Bourke and Elizabeth streets in the City of Melbourne and points situated on the Princes Highway east between Dandenong and Genoa—second-hand motor vehicles in the course of own business as “Used Car Dealer”.

WOOLLARD, J. L., 6 Karrin-court, Chadstone, 3148. One commercial goods vehicle (L/C. 156 cwt.) to operate within a 70-mile radius of the premises of The City Brick Works Co. Pty. Ltd. at Scoresby on behalf of the said company—bricks and returning with empty pallets.

ZAVERDINOS, A., 11 Banks-street, Traralgon, 3844. One commercial goods vehicle (L/C. 160 cwt.) to operate from forest and private landings situated within a 25-mile radius of the premises of Australian Paper Manufacturers Ltd. at Maryvale to the said premises at Maryvale—pulpwood.

TOW TRUCKS.

MIRBOO SERVICE STATION PTY. LTD., 28 Ridgway, Mirboo North, 3871. One commercial goods vehicle (L/C. 74 cwt.) to operate within a 50-mile radius of the post office at Mirboo North as a "Tow Truck" solely—(a) For the purpose of lifting and carrying or towing motor cars and the carriage of tools and equipment necessary for such purpose only. (b) The carriage of spare parts necessary for the repair of a disabled motor to and from the place at which such disablement has occurred.

NOTE.—This application replaces licence No. D.A.37665 which expired 18.7.70 in the same name.

HARRIS, G. T. & I. I., King-street, Yarra Glen, 3775. One commercial goods vehicle (to be purchased) to operate within a 50-mile radius of the post office at Yarra Glen as a "Tow Truck" solely—(a) For the purpose of lifting and carrying or towing motor cars and the carriage of tools and equipment necessary for such purpose only. (b) The carriage of spare parts necessary for the repair of a disabled motor to and from the place at which such disablement has occurred.

RENEWALS.

APPLICATIONS for renewals of licences as shown by persons listed hereunder to operate under the same terms and conditions from the expiry shown in each case.

ADAMS, B. W., Ballarat-street, Talbot, 3371; D.A.60582; 27th February, 1971; 124 cwt.

ALLEN, A. W., SALES PTY. LTD., 2-14 Byrne-street, South Melbourne, 3205; D.A.2218/11; 28th January, 1971; 73 cwt.

AUSTRALIAN CEMENT LTD., P.O. Box 120, Geelong, 3220; D.A.36141/1; 14th January, 1971; 96 cwt.

BRAY, W. D. & O. E., 36 Dudley-street, Rochester, 3561; D.A.34918; 28th January, 1971; 243 cwt.

CANAVAN, P. J. & E., Myamyn, 3292; D.A.32732/2; 10th December, 1970; 163 cwt.

REX CASTLES PTY. LTD., 63 Raymond-street, Sale, 3850; D.A.26939/2; 15th December, 1970; 100 cwt.

CONNOR, SHEA & CO. PTY. LTD., Fourth-avenue, Sunshine, 3020; D.A.40050/3; 4th February, 1971; 6 cwt.

COOPER, R. R., 72 Vincent-street, Daylesford, 3460; D.A.50734; 26th January, 1971; 14 cwt.

CREDLIN, G. E., K. J. & L. J. (trading as A. Credlin & Co.), P.O. Box 100, Wycheproof, 3527; D.A.911; 1st November, 1970; 233 cwt.

CROCKFORD & ROBERTSON PTY. LTD., 15 Abbott-street, Fairfield, 3078; D.A.914/15; 6th February, 1971; 25 cwt.

DOOD, NORM & SONS PTY. LTD., Creswick-road, Ballarat, 3350; D.A.24214/8; 11th February, 1971; 301 cwt.

DUNLOP TYRE SERVICE (Vic.) PTY. LTD., 158 Melbourne-road, North Geelong, 3215; D.A.60416; 27th February, 1971; 14 cwt.; D.A.60416/1; 27th February, 1971; 10 cwt.

FOLEY, D. J., 9 off Stanley-street, Warrnambool South, 3280; D.A.16125; 14th January, 1971; 109 cwt.

GEE, R. F., 1 Rutledge-street, Warrnambool, 3280; D.A.41050/2; 14th January, 1971; 31 cwt.

GRIFFIN, M. J., 42 Cambridge-street, Wendouree, 3355; D.A.48210; 4th February, 1971; 136 cwt.

HARRISON, E. W. (trading as E. W. & M. A. Harrison), 149 Swallow-street, Shepparton, 3630; D.A.60518; 6th February, 1971; 68 cwt.

HARRISON, E. W. (trading as E. W. & M. A. Harrison), 149 Swallow-street, Shepparton, 3630; D.A.60518/1; 6th February, 1971; 8 cwt.

HEATH'S MOTORS PTY. LTD., 160 Little Malop-street, Geelong, 3220; D.A.35210/6; 18th February, 1971; 10 cwt.; D.A.35210/7; 18th February, 1971; 10 cwt.

HENRY, I. B., 43 Hopetoun-street, Bendigo, 3550; D.A.47878; 10th December, 1970; 10 cwt.

HURLEY, A. & J., Dargo, 3862; D.A.33138; 28th January, 1971; 61 cwt.

KENNEDY, P., PTY. LTD., P.O. Box 11, Wendouree, 3355; D.A.60559; 13th February, 1971; 8 cwt.; D.A.60559/3; 13th February, 1971; 8 cwt.; D.A.60559/4; 13th February, 1971; 10 cwt.; D.A.60559/5; 13th February, 1971; 11 cwt.

KENNEDY, P., PTY. LTD., P.O. Box 11, Wendouree, 3355; D.A.60559/2; 13th February, 1971; 221 cwt.

KNIGHT, A. A. & A. J., (trading as A. A. Knight & Son), Bakewell-street, Tooradin, 3980; D.A.42608/4; 15th September, 1970; 115 cwt.

KOHLER, A. S., 701 Whitehorse-road, Mont Albert, 3127; D.A.22678/2; 4th February, 1971; 11 cwt.; D.A.22678/3; 4th February, 1971; 11 cwt.

LAIRD, R. J., De Motts-road, Anakie, 3221; D.A.60534; 27th February, 1971; 141 cwt.

LIND, V. S., 78 Bredt-street, Bairnsdale, 3875; D.T.538/1; 21st January, 1971; 260 cwt.

MALONE, W. J., 15 Albert-street, Port Fairy, 3284; D.A.60491; 6th February, 1970; 151 cwt.; D.A.60491/1; 6th February, 1970; 66 cwt.; D.A.60491/2; 6th February, 1970; 111 cwt.

MINTERN, T. H. (trading as M. Mintern & Sons), 67 McPherson-street, Horsham, 3400; D.A.48394; 26th February, 1971; 186 cwt.

MITCHELL, S. G., Piavella, via Prairie, 3572; D.A.47902; 4th February, 1971; 79 cwt.

MCCABE, J. J., P.O. Box 101, Yarrowonga, 3730; D.A.38303; 11th January, 1971; 17 cwt.

MCKEILL, N. A. & D. A., 27 Northcote-street, Rochester, 3561; D.A.34836; 14th January, 1971; 246 cwt.

NAISH, L., 46 Park-lane, Wangaratta, 3677; D.A.13159; 12th December, 1970; 70 cwt.

NORTH EASTERN READY MIXED CONCRETE PTY. LTD., P.O. Box 37, Wangaratta, 3677; D.A.46615/1; 4th February, 1971; 184 cwt.

PERMEWAN WRIGHT LTD., 147 Alexandra-parade, Abbotsford, 3067; D.A.1809/66; 6th February, 1971; 10 cwt.

PETERSVILLE AUSTRALIA LTD., Wellington-road, Clayton, 3168; D.A.1813/160; 6th February, 1971; 240 cwt.; D.A.1813/161; 6th February, 1971; 78 cwt.; D.A.1813/164; 13th February, 1971; 78 cwt.; D.A.1813/165; 6th February, 1971; 78 cwt.; D.A.1813/162; 6th February, 1971; 24 cwt.

PFEIFFER, W. M., 7 York-street, Ballarat East, 3350; D.A.34788; 15th December, 1970; 218 cwt.

REYNOLDS, J. B., P.O. Box 58, Horsham, 3400; D.A.60521; 6th February, 1971; 238 cwt.

SMITH, G. J. (trading as G. J. & A. W. M. Smith), 3 Agnes-street, Stawell, 3380; D.T.1156; 14th November, 1970; 137 cwt.

STONE BROS. PTY. LTD., 49 Rowan-street, Wangaratta, 3677; D.A.56703/3; 6th February, 1971; 10 cwt.; D.A.56703/4; 6th February, 1971; 11 cwt.

T. R. SERVICES PTY. LTD., 497 Queensberry-street, North Melbourne, 3051; D.A.23673/4; 6th February, 1971; 10 cwt.

TRICKEY, L., 9 Speke-street, Beaufort, 3373; D.T.373/2; 27th February, 1971; 258 cwt.

TRIMBLE, W. T., Shelbourne 3463; D.A.60414; 16th January, 1971; 77 cwt.

TUTT BRYANT (Vic.) PTY. LTD., Gwelo-street, Tottenham, 3012; D.A.2187/19; 14th January, 1971; 14 cwt.

TUTT BRYANT (Vic.) PTY. LTD., Gwelo-street, Tottenham, 3012; D.A.2187/20; 14th January, 1971; 14 cwt.; D.A.2187/21; 14th January, 1971; 14 cwt.

UNILEVER AUSTRALIA PTY. LTD., 164-220 Ingles-street, Port Melbourne, 3207; D.A.24437/4; 4th February, 1971; 8 cwt.; D.A.24437/5; 4th February, 1971; 10 cwt.; D.A.24437/6; 4th February, 1971; 10 cwt.; D.A.24437/7; 4th February, 1971; 10 cwt.; D.A.24437/8; 4th February, 1971; 10 cwt.; D.A.24437/10; 4th February, 1971; 10 cwt.; D.A.24437/11; 4th February, 1971; 8 cwt.; D.A.24437/12; 4th February, 1971; 10 cwt.; D.A.24437/14; 4th February, 1971; 8 cwt.; D.A.24437/16; 4th February, 1971; 8 cwt.; D.A.24437/17; 4th February, 1971; 10 cwt.; D.A.24437/18; 4th February, 1971; 10 cwt.; D.A.24437/19; 4th February, 1971; 8 cwt.; D.A.24437/21; 4th February, 1971; 10 cwt.; D.A.24437/22; 4th February, 1971; 10 cwt.; D.A.24437/23; 4th February, 1971; 8 cwt.; D.A.24437/24; 4th February, 1971; 10 cwt.; D.A.24437/25; 4th February, 1971; 8 cwt.; D.A.24437/26; 4th February, 1971; 8 cwt.; D.A.24437/27; 4th February, 1971; 8 cwt.; D.A.24437/28; 4th February, 1971; 8 cwt.; D.A.24437/29; 4th February, 1971; 10 cwt.; D.A.24437/30; 4th February, 1971; 8 cwt.

WINDERLICH, W. H., 22 Viviani-crescent, Heathmont, 3135; D.A.17638; 24th January, 1971; 99 cwt.

YOUNG, W. H., & SONS (PLANT HIRE) PTY. LTD., 182 High-street, Shepparton, 3630; D.A.35594/43; 6th February, 1971; 159 cwt.

TOW TRUCK RENEWALS.

BOYD, I. D., 30 McGibbony-street, Ararat, 3377; D.A.35094; 28th January, 1971; 40 cwt.

THOMSON, A. J. (trading as Ferris & Thomson), P.O. Box 1, Walwa, 3709; T.D.A.47642; 18th February, 1971; 25 cwt.

HAMS, A. D., 29 Bourke-street, Korumburra, 3950; D.A.60271; 17th October, 1970; 60 cwt.

MARTYNS SERVICE PTY. LTD., 45 Vincent-street, Daylesford, 3460; D.A.47565; 14th January, 1971; 70 cwt.

TEDGE, H. R., 82 Links-street, Sunshine, 3020; D.A.63718; 6th November, 1970; 79 cwt.

THOMPSON, K. R. (trading as Stratford Motors), Tyers-street, Stratford, 3862; T.D.A.47271; 14th January, 1971; 30 cwt.

RENEWALS WITH VARIATION.

APPLICATIONS made by the persons listed hereunder for renewal of the licences listed with variation of conditions in the manner set out opposite the names.

MIDDLEBROOK, C. L., 4 Gerald-street, Ferntree Gully, 3156; D.A.60494; 16th January, 1971; Application to renew and vary the conditions of licence No. D.A.60494 (L/C. 193 cwt.) by deleting from the existing conditions "Bayview Quarries Pty. Ltd." and adding in lieu: "Albion Reid Pty. Ltd."

MORRISSEY, M. G., 21 Fisher-street, Wendouree, 3355; D.A.60413; 6th February, 1971; Application to renew and vary the conditions of licence No. D.A.60413 (L/C. 284 cwt.) by deleting paragraph (b) of the existing conditions and adding in lieu: "Throughout the State of Victoria—tools of trade and equipment".

Notice of any objection should be forwarded to reach the Secretary of the Board not later than 23rd September, 1970.

Applicants are advised that it will not be necessary to appear on the hearing date specified above, unless advised in writing by the Board.

B. P. KAY,
Secretary.

Corner Lygon and Princes streets, Carlton, 3053, Wednesday, 9th September, 1970.

Commercial Goods Vehicles Act.
TRANSPORT REGULATION BOARD.

HEARING OF APPLICATION.

NOTICE is hereby given that the following application will be considered by the Transport Regulation Board at "Playmore", Betka-road, Mallacoota, at 9.30 a.m. on Thursday, 17th September, 1970.

McLEOD, C., Betka-road, Mallacoota, 3889. One commercial goods vehicle (L/C. 294 cwt.) to operate from and to the City of Melbourne to and from the Townships of Genoa, Gipsy Point and Mallacoota—general goods.

Notice of any objection should be forwarded to reach the Secretary of the Board not later than the 16th September, 1970.

SPECIAL NOTICE.
MALLACOOTA HEARING.

Notice is hereby given that the application by Reo Transport Co. of Orbost for a discretionary licence, details of which appeared in the *Government Gazette* of the 22nd July, 1970, should have read the applicant as being Massey Herbert Pty. Ltd. (trading as Reo Transport Co. of Orbost) and the application will now be proceeded with in this name.

Notice is hereby given that the application by F. G. Buckland of Mallacoota for a discretionary licence, the details of which appeared in the *Government Gazette* of the 19th August, 1970, should have read the applicant as being F. G. and J. T. Buckland and J. P. Rudge (trading as J. T. Buckland of Mallacoota) and the application will now be proceeded with in this name.

B. P. KAY,
Secretary.

Corner Lygon and Princes streets, Carlton, 3053.

TEACHING SERVICE (TEACHERS TRIBUNAL)
REGULATIONS.

ELECTION OF A MEMBER AND DEPUTY MEMBER OF THE COMMITTEE OF CLASSIFIERS FOR THE PRIMARY SCHOOLS DIVISION.

I HEREBY give notice, pursuant to clause 12 of Regulation 2 of the Teaching Service (Teachers Tribunal) Regulations, at the election of a member of the Classifiers for the Primary Schools Division, Phillip Thurlby Dwyer was the only candidate duly nominated, and I hereby declare the said—

PHILLIP THURLBY DWYER to be duly elected to the office of Member of the Committee of Classifiers for the Primary Schools Division for the period commencing on 17th November, 1970.

I further advise that at the election for a Deputy to such Member, Denis Forrer was the only candidate duly nominated, and I therefore declare the said—

DENIS FORRER to be duly elected to the office of Deputy Member of the Committee of Classifiers for the Primary Schools Division for the period commencing on 17th November, 1970.

J. T. MINTER,
Returning Officer.

CANCER ACT 1958 (No. 6213).

WHEREAS by Part II. of the *Cancer Act 1958* (No. 6213) the Cancer Institute Board is empowered (*inter alia*) to make By-Laws in connexion with the charges and expenses payable by patients for their maintenance attendance or relief in the Institute:

Now therefore in pursuance of the said powers conferred by such Act the Cancer Institute Board doth hereby make the following By-Law (that is to say):—

In pursuance of the provisions contained in sub-section (1) of section 48 of the said Act No. 6213 the Board by this By-Law determines that charges and expenses as set out in the following Schedule shall be the maximum amounts payable in connexion with attendance and treatment of patients in the Institute or at any special clinic established in accordance with paragraph (c) of sub-section (2) of section 33 of the said Act.

SCHEDULE.

Charges for cost of treatment—

- (a) Deep Therapy .. \$6.50 per attendance.
- (b) Superficial Therapy .. \$4.50 per attendance.

Provided that the Executive Committee of the Cancer Institute Board at its discretion may remit the whole or any part of any charge for which any patient may be liable under the provisions of sub-section (1) of section 48 of the said Act No. 6213 and of this By-Law.

The common seal of the Cancer Institute Board was hereunto affixed by order of the Board, in the presence of—

H. F. STOKES, Chairman.
R. K. CHURCHES, Manager and Secretary.

Confirmed by the Governor in Council on the 1st day of September, 1970.—J. ROSSITER, Clerk of the Executive Council.

Housing Act 1958.

NOTICE OF RESOLUTION UNDER SECTION 99 (4) OF ACT No. 6275.

NOTICE is hereby given that Housing Commission on the 24th day of August, 1970, resolved as follows:—

"Whereas Housing Commission in respect of the lands described in the Schedule hereto has given notice to the parties interested under section 9 of the *Lands Compensation Act 1958* as incorporated with the *Housing Act 1958* Housing Commission hereby resolves that the lands described in the Schedule hereto are finally appropriated for the purposes of the *Housing Act 1958*."

SCHEDULE.

Firstly.—Lots 284, 316, 415, 416, 481, 483 and 528 all on Plan of Subdivision Number 9619 lodged in the Office of Titles.

Secondly.—So much of the land remaining untransferred in Certificate of Title, volume 3321, folio 092 as is delineated and hachured on the plan hereunder.

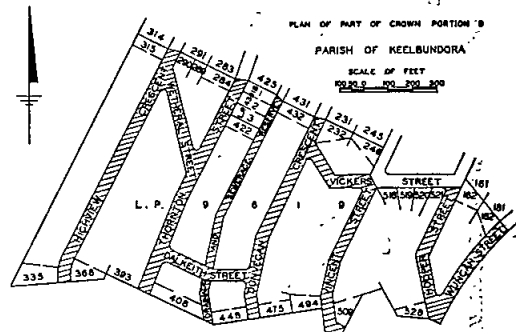

Thirdly.—Lots 21, 22, 23, 51, 106 and 107 all on Plan of Subdivision Number 12597 lodged in the Office of Titles.

Fourthly.—The land remaining untransferred in Certificate of Title, volume 5423, folio 587.

A. L. BOHN,
Secretary.

LOTTERIES GAMING AND BETTING ACT 1966.

NOTICE is hereby given that at the Supreme Court, Melbourne, on the 27th day of August, 1970, a declaration pursuant to the provisions of section 51 (1) (a) of the Lotteries Gaming and Betting Act 1966, was made by His Honour Mr. Justice Lush, that the house or place being the premises situate at 19 Glass-street, North Melbourne, is a house or place which is a common gaming house.

SECTION 54 of the Lotteries Gaming and Betting Act 1966 provides that any person found in or on or entering or leaving the said house may be arrested by any member of the Police Force without a warrant and taken before a Justice.

Dated at Melbourne the 27th day of August, 1970.

GEORGE FREDERICK EARL,
Inspector of Police.

John Downey, Crown Solicitor and solicitor for the applicant.

COUNTRY ROADS BOARD.

RESOLUTIONS OF THE COUNTRY ROADS BOARD.

THE Country Roads Board, in pursuance of the provisions of the Country Roads Act 1958, has passed Resolutions the dates whereof and the terms of which are scheduled hereunder:—

SCHEDULE.
State Highway.

Resolution dated the Twenty-fourth day of August, One thousand nine hundred and seventy, made pursuant to sections 21, 58 and 74 of the Country Roads Act 1958, declaring the deviation from the Princes Highway in the Shire of Rosedale as indicated by diagonal hatching on Plan numbered G.P.10195 and diagonal hatching and vertical hatching on Plan numbered G.P.10195A hereunder to be part of a State highway within the meaning and for the purposes of the said Act, and also declaring that such deviation shall be in lieu of the existing road or part thereof indicated by cross-hatching on Plan numbered G.P.10195A and that such part of the said existing road shall be discontinued.

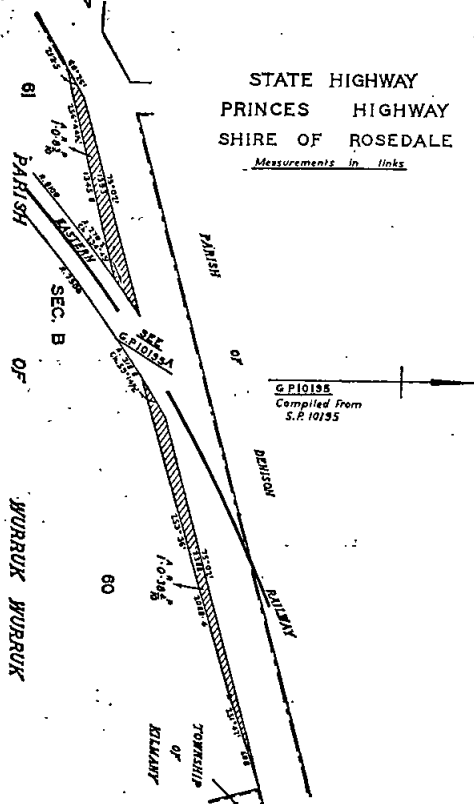
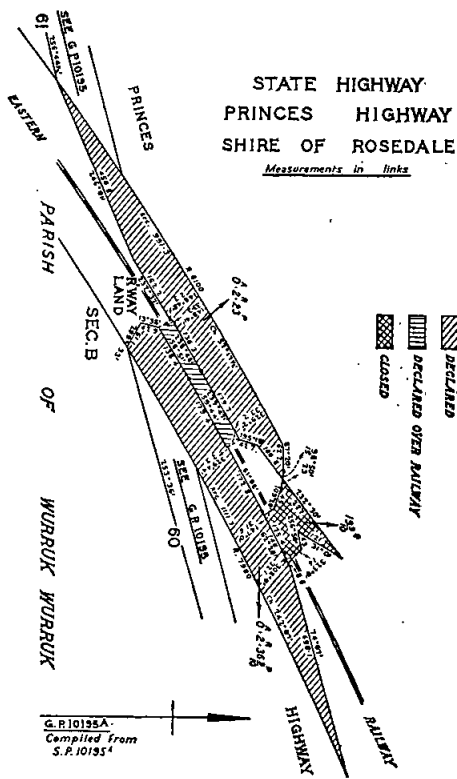

Main Roads.

Resolution dated the Twenty-fourth day of August, One thousand nine hundred and seventy, made pursuant to section 21 of the Country Roads Act 1958, declaring the widening of Gembrook-road in the Shire of Berwick, as shown hatched on Plans numbered G.P.9630, G.P.9631A, G.P.9631B and G.P.11223 hereunder to be part of a main road within the meaning and for the purposes of the said Act.

MAIN ROAD
GEMBROOK ROAD
SHIRE OF BERWICK.
Measurements in links.

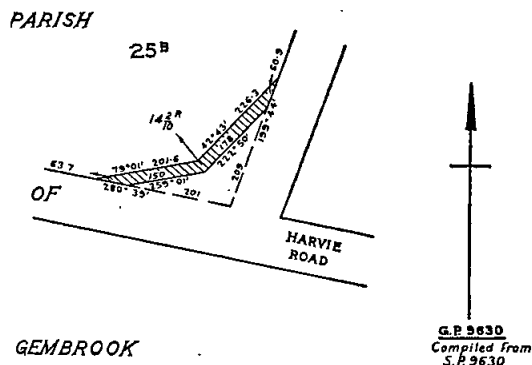

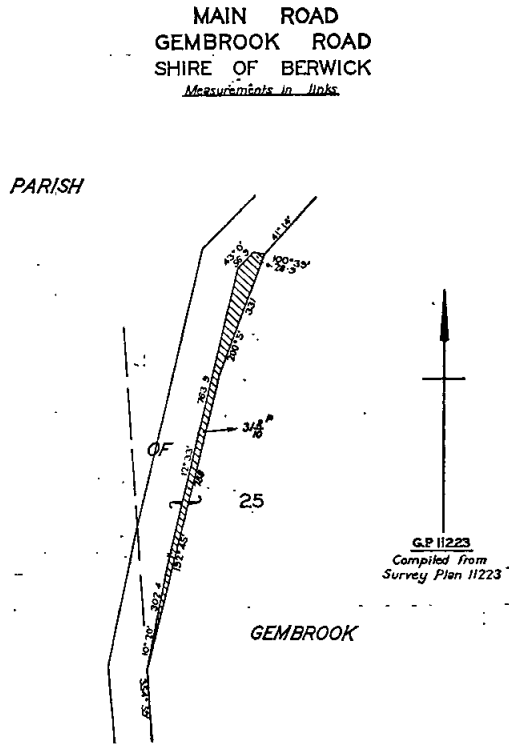
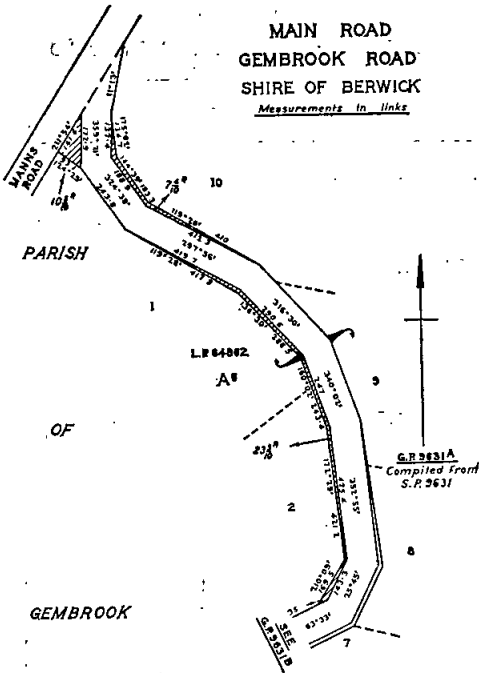

Resolution dated the Twenty-fourth day of August, One thousand nine hundred and seventy, made pursuant to sections 21 and 58 of the *Country Roads Act 1958*, declaring the deviation from the Rochester-Bamawm-Prairie road in the Shire of Rochester as indicated by diagonal hatching on Plans numbered G.P.10361, G.P.10362, G.P.10363 and G.P.10364 hereunder to be part of a main road within the meaning and for the purposes of the said Act, and also declaring that such deviation shall be in lieu of the existing road or part thereof indicated by cross-hatching on Plan numbered G.P.10361.

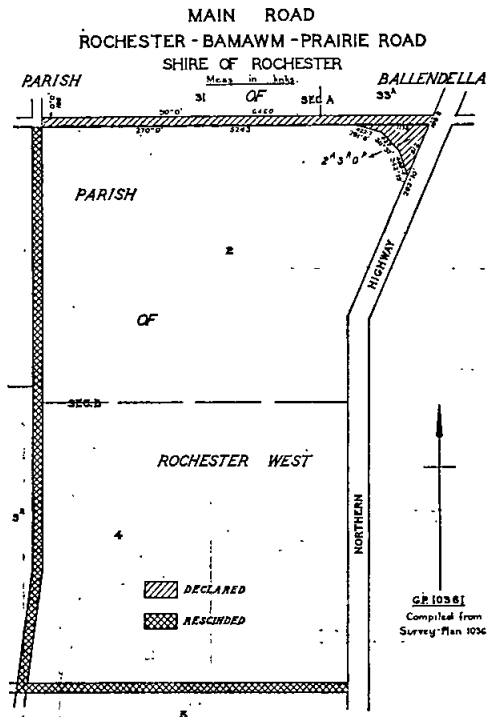
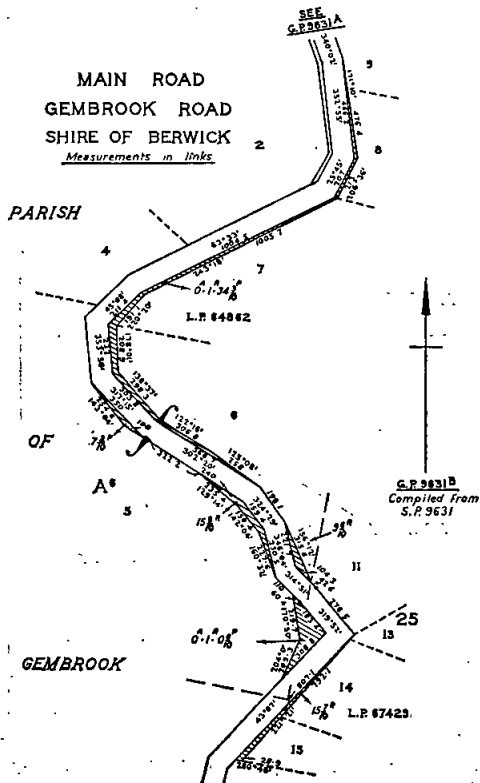

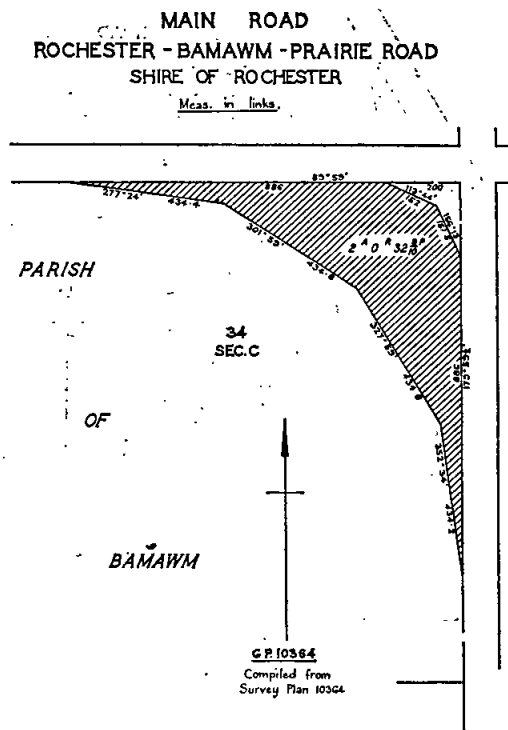
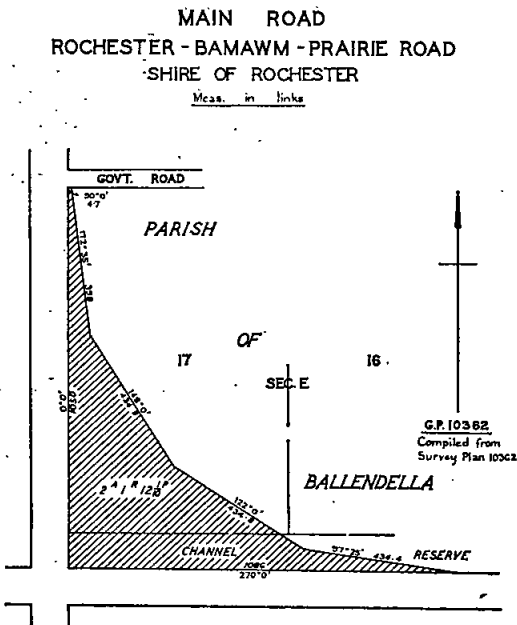

Unclassified Roads.

Resolution dated the Twenty-fourth day of August, One thousand nine hundred and seventy, made pursuant to sections 21 and 110 of the *Country Roads Act 1958*, declaring the road in the Shire of Rosedale as shown hatched on Plan numbered G.P.10195b hereunder to be a road (Toongabbie-road) within the meaning and for the purposes of the said Act.

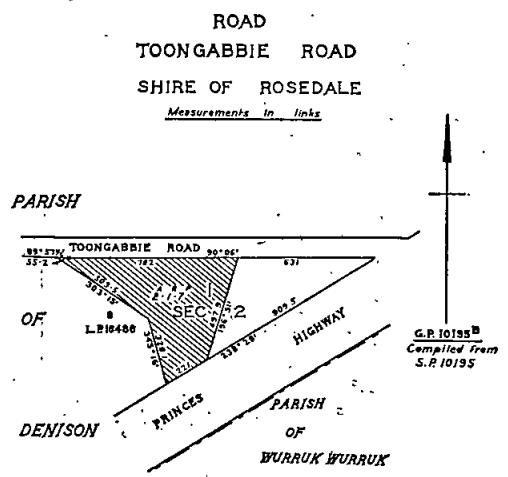
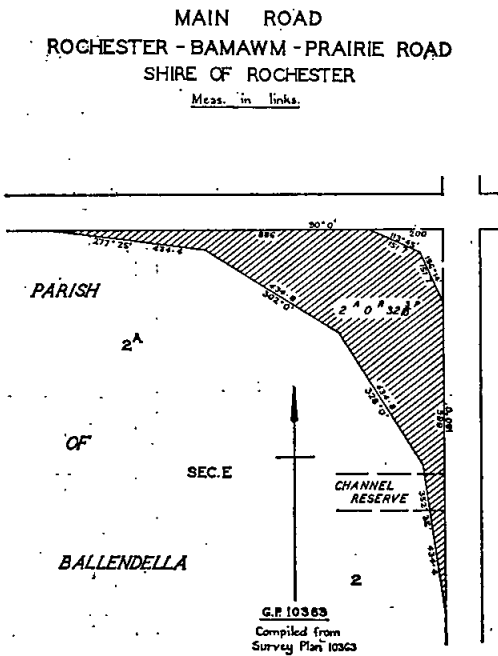

Resolution dated the Twenty-fourth day of August, One thousand nine hundred and seventy, made pursuant to sections 21 and 110 of the *Country Roads Act 1958*, declaring the widening of Leakes-road in the Shire of Werribee as shown hatched on Plan numbered G.P.10902A hereunder to be part of a road within the meaning and for the purposes of the said Act.

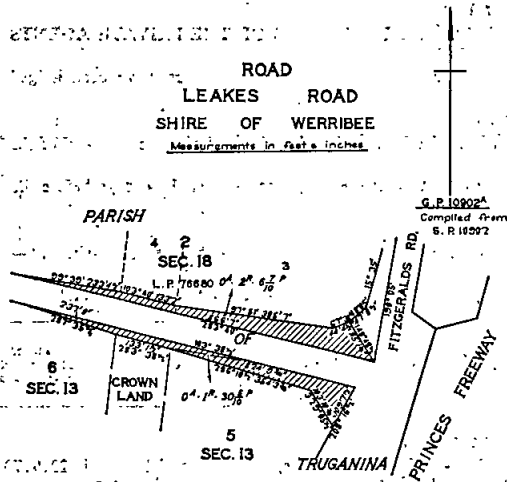

Resolution dated the Twenty-fourth day of August, One thousand, nine hundred and seventy, made pursuant to sections 21 and 110 of the *Country Roads Act 1958*, declaring the widening of Fitzgeralds-road in the Shire of Werribee as shown hatched on Plan numbered G.P.10902B hereunder to be part of a road within the meaning and for the purposes of the said Act.

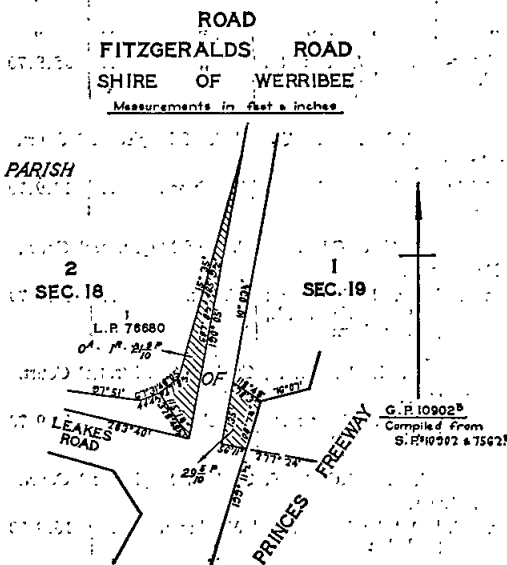

N. L. ALLANSON,
Secretary.
26th August, 1970.

Crimes Act 1958.

CURATOR OF CONVICT'S PROPERTY.

HIS Excellency the Governor of the State of Victoria by and with the advice of the Executive Council thereof doth by Order made on the 1st day of September, 1970, and pursuant to the provisions of section 550 of the *Crimes Act 1958*, commit the custody and management of the property of the convict JANKO STEFAN MIAKA to FRANCIS KEITH O'DONNELL, of 15 Hobson-street, Greensborough, as a curator hereby appointed in that behalf.

J. ROSSITER,
Clerk of the Executive Council.

At the Executive Council Chamber,
Melbourne, 1st September, 1970.

Crimes Act 1958.

CURATOR OF CONVICT'S PROPERTY.

HIS Excellency the Governor of the State of Victoria by and with the advice of the Executive Council thereof doth by Order made on the 1st day of September, 1970, and pursuant to the provisions of section 550 of the *Crimes Act 1958*, commit the custody and management of the property of the convict RAYMOND JOHN WILLIAMSON to THOMAS WILLIAMSON, of 6 Ross-street, Bentleigh, as a curator hereby appointed in that behalf.

J. ROSSITER,
Clerk of the Executive Council.

At the Executive Council Chamber,
Melbourne, 1st September, 1970.

DEPARTMENT OF LABOUR AND INDUSTRY.

DETERMINATION OF THE HOSPITAL DENTAL OFFICERS BOARD.

ATTENTION is drawn to the fact that notice of appeal to the Industrial Appeals Court has been lodged against the whole of the Determination of the Hospital Dental Officers Board made on the 20th August, 1970.

Section 45 (1) (b) of Act 6283 provides that when an appeal is made in accordance with that Act, the parts of the Determination appealed against shall not come into operation until the appeal has been dealt with by the Court.

M. WALSH,
Secretary.

Police Regulation Act 1958, Section 122.

SALE OF UNCLAIMED MOTOR VEHICLE.

AN owner is required for a blue Ford Thames panel van, ex-registered No. GVB-929, engine No. 400E 8038.

The vehicle came into the possession of Police on 23rd October, 1969, and if not claimed, will be sold by public auction, at the Ballarat Police Station, Camp-street, Ballarat, at 2 p.m. on 30th September, 1970.

R. JACKSON,
Acting Chief Commissioner of Police.

Police Regulation Act 1958, Section 122.

SALE OF UNCLAIMED MOTOR VEHICLE.

AN owner is required for a grey 1957 model Holden sedan, N.S.W. ex-registered No. CUH-566, engine No. 611045P.

The vehicle came into the possession of Police on the 28th March, 1970, and if not claimed, will be sold by public auction, at the Richmond Police Station, 317 Bridge-road, Richmond, at 2 p.m. on 7th October, 1970.

R. JACKSON,
Acting Chief Commissioner of Police.

Police Regulation Act 1958, Section 122.

SALE OF UNCLAIMED MOTOR VEHICLE.

AN owner is required for a 1961 model Vauxhall sedan, N.S.W. ex-registered No. EWU-79, engine No. PA6/61187.

The vehicle came into the possession of Police on 30th September, 1969, and if not claimed, will be sold by public auction, at the Dandenong Police Station, Langhorne-street, Dandenong, at 2.00 p.m. on 30th September, 1970.

N. WILBY,
Chief Commissioner of Police.

Private Agents Act 1966.

NOTICE OF RECEIPT OF APPLICATIONS FOR LICENCES UNDER THE PROVISIONS OF THE PRIVATE AGENTS ACT 1966.

THE Clerk(s) of the Magistrates' Court(s) as listed hereunder hereby give notice that applications, as under, have been lodged for hearing by the said Court(s) on the date(s) specified.

Any person desiring to object to any of such applications must—

- (a) lodge with the respective Clerk of the Magistrates' Court a notice in the prescribed form of his objection and of the grounds thereof;
- (b) cause a copy of such notice to be served personally or by post upon the applicant at least three days before the hearing of the application; and
- (c) send or deliver—
 - (i) where the objection is not made by the officer in charge of the police district in which the Court is situated—a copy of the notice to such officer; and
 - (ii) where the objection is not made by the Registrar or Deputy Registrar—a copy to the Registrar.

Full Name of Applicant or in the Case of a Firm or Corporation, of the Nominee.	Place of Abode of Applicant or Nominee.	Name of Firm or Corporation.	Address for Registration.	Type of Licence.	Date of Hearing of Application
---	---	------------------------------	---------------------------	------------------	--------------------------------

MAGISTRATES' COURT, PORTLAND.

Willoughby, Wayne Grant	19 North-terrace East, Mt. Gambier, South Australia	Dunn and Bradstreet (Australia) Pty. Ltd.	McIntyre's-arcade, Portland	Commercial Sub-Agent	23.9.70
-------------------------	---	---	-----------------------------	----------------------	---------

Dated at Portland this 26th day of August, 1970.

G. MURPHY, Clerk of Magistrates' Court.

MAGISTRATES' COURT, GEELONG.

Walters, Bruce Paul	121 Fyans-street, Newtown		James-street, Geelong	Process Server	16.9.70
---------------------	---------------------------	--	-----------------------	----------------	---------

Dated at Geelong this 26th day of August, 1970.

W. W. HAMMOND, Clerk of Magistrates' Court.

MAGISTRATES' COURT, BENDIGO.

Sutton, Hector Alfred	66 Mt. Korong-road, Eaglehawk		27 Queen-street, Bendigo	Process Server	16.9.70
" " "	" " "		" " "	Commercial Sub-Agent	"

Dated at Bendigo this 25th day of August, 1970.

A. T. RYALL, Clerk of Magistrates' Court.

MAGISTRATES' COURT, PRAHRAN.

Joiner, John Royston	58 Market-road, Werribee	Melbourne Night Patrol Pty. Ltd.	Flat 18, 614 St. Kilda-road, Melbourne	Watchman	17.9.70
Hensby, J. A.	3 Wackett-street, Laverton	" "	" "	"	"
Slater, Derek	24 Williams-road, Laverton	" "	" "	"	"
McIntyre, Peter	14 Wright-street, Laverton	" "	" "	"	"
Bubb, Raymond Charles	5 Charlesworth-street, Laverton	" "	" "	"	"
McLeay, Hector John	62 Old Geelong-road, Laverton	Factory Guard Service Pty. Ltd.	Flat 17, 562 St. Kilda-road, Melbourne	"	25.9.70

Dated at Prahran this 27th day of August, 1970.

H. V. BOARDER, Clerk of Magistrates' Court.

MAGISTRATES' COURT, PRESTON.

Goode, William Joseph	33 Wellington-street, Coburg	Victorian Night Patrol Services	High-street, Preston	Watchman	17.9.70
-----------------------	------------------------------	---------------------------------	----------------------	----------	---------

Dated at Preston this 27th day of August, 1970.

P. C. CLOTHIER, Clerk of Magistrates' Court.

MAGISTRATES' COURT, HAWTHORN.

Dutton, Hedley Chester	59 Nungerner-street, Balwyn	Mayne Nickless	Cnr. Kinkora and Glenferrie roads, Hawthorn	Watchman	16.9.70
------------------------	-----------------------------	----------------	---	----------	---------

Dated at Hawthorn this 26th day of August, 1970.

T. K. HASSARD, Clerk of Magistrates' Court.

MAGISTRATES' COURT, MORDIALLOC.

Beauliv, Drecy Ridi	13 Dangerfield-drive, Springvale		123 Station-street, Ascendale	Watchman	17.9.70
---------------------	----------------------------------	--	-------------------------------	----------	---------

Dated at Mordialloc this 27th day of August, 1970.

J. T. FERGUSON, Clerk of Magistrates' Court.

MAGISTRATES' COURT, ST. KILDA.

Wiederhold, Sieglinde Luise	38 Wave-street, Elwood	Checkmate Pty. Ltd.	82 Acland-street, St. Kilda	Watchman	16.9.70
-----------------------------	------------------------	---------------------	-----------------------------	----------	---------

Dated at St. Kilda this 25th day of August, 1970.

R. F. FREEMAN, Clerk of Magistrates' Court.

MAGISTRATES' COURT, COBURG.

Robertson, Bryan Douglas	55 Strathallan-road, Macleod		88 Bakers-road, Coburg	Watchman	22.9.70
--------------------------	------------------------------	--	------------------------	----------	---------

Dated at Coburg this 24th day of August, 1970.

F. TENNI, Clerk of Magistrates' Court.

PRIVATE AGENTS—continued.

Full Name of Applicant or in the Case of a Firm or Corporation, of the Nominee.	Place of Abode of Applicant or Nominee.	Name of Firm or Corporation.	Address for Registration.	Type of Licence.	Date of Hearing of Application.
---	---	------------------------------	---------------------------	------------------	---------------------------------

MAGISTRATES' COURT, FITZROY.

Morris, Ronald William	27 Bennett-street, North Fitzroy		27 Bennett-street, North Fitzroy	Process Server	22.9.70
------------------------	----------------------------------	--	----------------------------------	----------------	---------

Dated at Fitzroy this 31st day of August, 1970.

G. N. HOARE, Clerk of the Magistrates' Court.

MAGISTRATES' COURT, BALLARAT.

Winter, Richard Alan	48 Kline-street, Ballarat		48 Kline-street, Ballarat	Process Server	22.9.70
----------------------	---------------------------	--	---------------------------	----------------	---------

Dated at Ballarat this 31st day of August, 1970.

E. KINCHINGTON, Clerk of the Magistrates' Court.

MAGISTRATES' COURT, PRAHRAN.

Hrissinis, Peter	29 Snell-grove, Pascoe Vale	Carol Furzer	Suite 12, 614 St. Kilda-road, Melbourne	Commercial Sub-Agent	25.9.70
------------------	-----------------------------	--------------	---	----------------------	---------

Dated at Prahran this 2nd day of September, 1970.

H. V. BOARDER, Clerk of the Magistrates' Court.

MAGISTRATES' COURT, PRESTON.

Goode, William Joseph	33 Wellington-street, Coburg	Victorian Night Patrol Services	High-street, Preston	Watchman	17.9.70
-----------------------	------------------------------	---------------------------------	----------------------	----------	---------

Dated at Preston this 27th day of August, 1970.

P. C. CLOTHIER, Clerk of the Magistrates' Court.

MAGISTRATES' COURT, MELBOURNE.

Smith, Ernest Roy	39 Angliss-street, Yarraville	Australian Watching Co. Pty. Ltd.	340 Abbotsford-street, North Melbourne	Watchman	30.9.70
Wingard, Wilfred Arthur	22 McLennan-street, Braybrook	" "	" "	" "	" "
Elliott, John Anthony	594 Balcombe-road, Black Rock	" "	" "	" "	" "
Heath, Trevor Alec	Flat 12, 24 Acland-street, St. Kilda	" "	" "	" "	" "
Hennigan, William Timothy	17 Canterbury-street, Flemington	" "	" "	" "	" "
Hutzelman, Harold	162 Mooltan-street, Ascot Vale	" "	" "	" "	" "
Nyari, Julius William	86 Outer-crescent, Brighton	" "	" "	" "	" "
O'Connell, Anthony John	630 Riversdale-road, Box Hill	" "	" "	" "	" "
Pankhurst, William George	515 Victoria-street, North Melbourne	" "	" "	" "	" "
Papp, Joseph	3 Rosine-court, Doncaster	" "	" "	" "	" "
Pettit, Lyle Leroy	1 South-street, Hawthorn	" "	" "	" "	" "
Scott, Clifford	61 McBain-street, Altona	" "	" "	" "	" "

Dated at Melbourne this 3rd day of September, 1970.

G. L. WEBSTER, Clerk of the Magistrates' Court.

MAGISTRATES' COURT, RINGWOOD.

Montgomery, Geoffrey Allen	76 Wantirna-road, Ringwood	Eastern Escorts	76 Wantirna-road, Ringwood	Guard Agent	28.9.70
----------------------------	----------------------------	-----------------	----------------------------	-------------	---------

Dated at Ringwood this 4th day of September, 1970.

L. T. GOULD, Clerk of the Magistrates' Court.

MAGISTRATES' COURT, PRAHRAN.

Pinder, Terry	Flat 19, 49 Brougham-street, North Melbourne	Carol Furzer	Flat 12, 614 St. Kilda-road, Melbourne	Commercial Sub-Agent	25.9.70
---------------	--	--------------	--	----------------------	---------

Dated at Prahran this 3rd day of September, 1970.

H. V. BOARDER, Clerk of the Magistrates' Court.

MAGISTRATES' COURT, COBURG.

Andrevla, Saverio	205 Widford-street, Broadmeadows		7 Pipe-street, Fawkner	Watchman	1.10.70
-------------------	----------------------------------	--	------------------------	----------	---------

Dated at Coburg this 4th day of September, 1970.

M. ROUND, Clerk of the Magistrates' Court.

MAGISTRATES' COURT, GEELONG.

Murrell, Bruce Douglas	89 Dattiwel-street, Bell Post Hill, Geelong		94 Seabright-street, North Shore	Watchman	25.9.70
------------------------	---	--	----------------------------------	----------	---------

Dated at Geelong this 4th day of September, 1970.

D. W. HAMMOND, Clerk of the Magistrates' Court.

PRIVATE AGENTS—continued.

Full Name of Applicant or in the Case of a Firm or Corporation, of the Nominee.	Place of Abode of Applicant or Nominee.	Name of Firm or Corporation.	Address for Registration.	Type of Licence.	Date of Hearing of Application.
---	---	------------------------------	---------------------------	------------------	---------------------------------

MAGISTRATES' COURT, HAWTHORN.

Taaffe, Harry William	Flat 2, 83 Comoparade, Parkdale East		Cnr. Glenferrie and Kinkora roads, Hawthorn	Watchman	23.9.70
-----------------------	--------------------------------------	--	---	----------	---------

Dated at Hawthorn this 28th day of August, 1970.

T. K. HASSARD, Clerk of the Magistrates' Court.

MAGISTRATES' COURT, SOUTH MELBOURNE.

Crooks, Brian	42 Raynor-street, Altona		101-105 Clarke-street, South Melbourne	Watchman	18.9.70
Davies, Edward Henry	13 Laverton Cole-street, Laverton		" " "	"	23.9.70
Lester, Morris William	R.A.A.F. Base, Laverton		" " "	"	"
Reese, Lyle Clifford	76 Essendon Price-street, Essendon		" " "	"	21.9.70
Todd, John Percival	97/332 South Melbourne Park-street, South Melbourne		" " "	"	"

Dated at South Melbourne this 31st day of August, 1970.

J. M. DUGAN, Clerk of the Magistrates' Court.

Cemeteries Act 1958.

SCALE OF FEES OF THE KATAMATITE PUBLIC CEMETERY.

IN pursuance of the powers conferred upon them by the Cemeteries Act, the trustees of the Katamatite Public Cemetery hereby make the following scale of fees, which shall come into operation upon publication in the Government Gazette, and from and after such publication every scale of fees heretofore made by the said trustees shall be and is hereby rescinded to the extent to which it conflicts with this scale.

Public Graves.

Interment in grave without exclusive right—stillborn child	\$6.00
Interment in grave without exclusive right—others	\$12.00
Number peg or label	\$1.00

Private Graves.

Land, 8 ft. x 4 ft.	\$20.00
Own selection of land (extra)	\$5.00

Sinking Charges for Private Graves.

Sinking grave 6 feet deep	\$30.00
Each additional foot	\$3.00
Sinking oversize grave (extra)	\$10.00
Cancellation of order to sink (if commenced)	\$5.00

Reopening Charges.

Reopening grave (no cover)	\$25.00
Reopening grave (with cover)	\$30.00

Extra Charges.

Interment outside prescribed hours, or on Saturdays, Sundays or Public Holidays	\$10.00
Interment in a private grave without due notice	\$10.00

Miscellaneous Charges.

Interment fee	\$10.00
Certificate of right of burial	\$1.00
Number plate or brick	\$1.00
Permission to erect a headstone or monument—5 per cent. of cost with a minimum of \$6.00.	
Permission to construct a brick grave or to erect any stone kerb, brick tilework or concrete	\$4.00
Exhuming the remains of a body (when authorized)	\$25.00
Interment of ashes in a private grave	\$10.00

K. W. LUKIES, Trustee.

JOHN J. PARNELL, Trustee.

R. CHURCH, Trustee.

Approved by the Governor in Council, 1st September, 1970.—J. ROSSITER, Clerk of the Executive Council.

Cemeteries Act 1958.

SCALE OF FEES OF THE BRIMPAEN PUBLIC CEMETERY.

IN pursuance of the powers conferred upon them by the Cemeteries Act, the trustees of the Brimpaen Public Cemetery hereby make the following scale of fees, which shall come into operation upon publication in the Government Gazette, and from and after such publication every scale of fees heretofore made by the said trustees shall be and is hereby rescinded to the extent to which it conflicts with this scale.

Public Graves.

Interment in grave without exclusive right—stillborn child	\$6.00
Interment in grave without exclusive right—others	\$12.00
Number peg or label	\$1.00

Private Graves.

Land, 8 ft. x 4 ft.	\$12.00
Own selection of land (extra)	\$5.00

Sinking Charges for Private Graves.

Sinking grave 6 feet deep	\$30.00
Each additional foot	\$3.00
Sinking oversize grave (extra)	\$10.00
Cancellation of order to sink (if commenced)	\$5.00

Reopening Charges.

Reopening grave (no cover)	\$25.00
Reopening grave (with cover)	\$30.00

Extra Charges.

Interment outside prescribed hours, or on Saturdays, Sundays or Public Holidays	\$10.00
Interment in a private grave without due notice	\$10.00

Miscellaneous Charges.

Interment fee	\$10.00
Certificate of right of burial	\$1.00
Number plate or brick	\$1.00
Permission to erect a headstone or monument—5 per cent. of cost with a minimum of \$6.00.	
Permission to construct a brick grave or to erect any stone kerb, brick tilework or concrete	\$4.00
Exhuming the remains of a body (when authorized)	\$25.00
Interment of ashes in a private grave	\$10.00

H. H. SMITH, Trustee.

I. J. HILL, Trustee.

GARTH E. O. REES, Trustee.

Approved by the Governor in Council, 1st September, 1970.—J. ROSSITER, Clerk of the Executive Council.

GEELONG WATERWORKS AND SEWERAGE TRUST.

BY-LAW NUMBER 98.

A By-Law to amend By-Law Number 97.

THE Geelong Waterworks and Sewerage Trust (herein after called the Trust) pursuant to and in exercise and execution of the powers and authorities conferred upon or vested in the Trust by the Geelong Waterworks and Sewerage Acts or by any other Acts incorporated therewith and in exercise and execution of any other powers and authorities in any wise enabling the Trust in that behalf hereby makes the following By-Law in respect of the Geelong Drainage Area and any extension thereof.

1. Clause 4 of By-Law number 97 is deleted and the following clause substituted.

DIVISION 2.

PREPARATION OF HOUSE DRAINAGE PLANS AND AMENDMENTS.

4. Copies of the Trust's plans and/or designs of individual house drainage will be furnished by the Trust upon application, on the form appended hereto, and payment for the same and subject to such conditions as follows:—

- (a) (i) Where the Trust designs the work and prepares a plan and has same carried out for the owner, a charge shall be made equal to ten per centum (10 per cent.) on the capital cost of the work, for designing, specifying, letting contract and supervising all details in connexion with such work.
- (ii) Consent for additions to and/or amendments of approved plans or to works previously approved will be made only on the application of the owner or his authorized agent, and on payment of a fee of Two dollars and fifty cents (\$2.50) for each fitting or drain altered or added.
- (b) When the Trust designs the works for the owner and the owner then carries out his own work:—
- (i) For plan of design, a fee of Ten dollars (\$10.00) plus One dollar twenty five cents (\$1.25) for each fitting.
- (ii) For making and/or examining any alterations or additions to a plan previously issued or approved by the Engineer-in-Chief, a fee of Two dollars fifty cents (\$2.50) shall be made by the Trust for each fitting or drain altered or added.
- (iii) The Engineer-in-Chief may during construction of work order the owner to carry out such additions and/or amendments as may be necessary for the satisfactory completion of the work. The house connexion will not be passed until the installation, together with the amendments ordered, have been completed to the satisfaction of the Engineer-in-Chief.
- (c) Where an owner designs and carries out his own work:—
- (i) For the supply of a block plan, a fee of Two dollars fifty cents (\$2.50).
For tenements exceeding 4,000 square feet in ground floor area and/or properties exceeding 2 acres in extent, an additional fee of One dollar twenty five cents (\$1.25) shall be charged for each additional 4,000 square feet, or part thereof, and/or for each additional 2 acres, or part thereof.
- (ii) The owner shall submit for examination a properly drawn design on tracing cloth and a typewritten specification. The tracing cloth shall be of a standard size of 12 inches by 8½ inches and the drawing shall be to a scale of 40 feet to 1 inch, unless such standard tracing cloth and such standard scale are too small to show clearly the nature and position of all fittings. In cases where it is necessary to use a larger tracing cloth and a larger scale, in order to show clearly the nature and position of all fittings, such larger tracing cloth and such larger scale shall be approved by the Trust.

The design and specification shall be supplied to the Trust in triplicate. The work shall not proceed until the owner's design and specification have been approved by the Engineer-in-Chief and the third copy returned to the owner with official endorsement.

- (iii) For the examination of the owner's plan of design and specification, a fee of Five dollars (\$5.00) for each plan and from one to six fittings, plus One dollar twenty five cents (\$1.25) for every fitting over six.
- (iv) For examining any alterations or additions to a plan previously issued or approved by the Engineer-in-Chief, a fee of One dollar twenty five cents (\$1.25) shall be made by the Trust for each fitting or drain altered or added.
- (v) The Engineer-in-Chief may during construction of the work order the owner to carry out such additions and/or amendments as may be necessary for the satisfactory completion of the work. The house connexion will not be passed until the installation, together with the amendments ordered have been completed to the satisfaction of the Engineer-in-Chief.

The foregoing By-Law was made and passed by the Geelong Waterworks and Sewerage Trust on the 17th day of June, 1970, and the common seal of the said Trust was hereunto affixed on the date aforesaid in the presence of:—

(SEAL) A. S. THOMSON, Chairman.
R. W. WHITESIDE, Commissioner.
B. C. HENSHAW, Secretary.

Approved by the Governor in Council, 1st September, 1970.—J. ROSSITER, Clerk of the Executive Council.

LEXTON WATERWORKS TRUST.

AUTHORITY TO OBTAIN BANK OVERDRAFT.

HIS Excellency the Governor of the State of Victoria by and with the advice of the Executive Council thereof, doth by Order made on the 8th day of September, 1970, authorize the Lexton Waterworks Trust to obtain in pursuance of the provisions of section 286 of the Water Act 1958 (No. 6413) an advance or advances during the year ending 30th September, 1971, by overdraft of the Trust's current account, such overdraft not to exceed at any one time the sum of One thousand six hundred dollars (\$1,600).

J. ROSSITER,
Clerk of the Executive Council.

At the Executive Council Chamber,
Melbourne, 8th September, 1970.

DROUIN SEWERAGE AUTHORITY.

FIXING THE LIMIT OF BANK OVERDRAFT.

HIS Excellency the Governor of the State of Victoria by and with the advice of the Executive Council thereof, doth by Order made on the 8th day of September, 1970, fix the total amount of the sums which the Drouin Sewerage Authority may owe at any one time in respect of moneys borrowed by overdraft of current account pursuant to the provisions of section 79A of the Sewerage Districts Act 1958 at One hundred thousand dollars (\$100,000).

J. ROSSITER,
Clerk of the Executive Council.

At the Executive Council Chamber,
Melbourne, 8th September, 1970.

State Savings Bank Act 1958, Section 30.
THE STATE SAVINGS BANK OF VICTORIA.

ESTABLISHMENT OF BRANCH.

THE Commissioners of The State Savings Bank of Victoria hereby give notice of the establishment of Collingwood Branch of the Bank, at 150-152 Smith-street, Collingwood, on Monday, 21st September, 1970.

T. E. HALL,
General Manager.

PUBLIC TRUSTEE ACT 1958 (No. 6350).—SECTION 17.

I HEREBY give notice that on the 25th June, 1970, the Public Trustee filed an election to administer the following deceased person's estate in accordance with section 17 of the *Public Trustee Act 1958*.

SMITH, JOHN EDWARD, late of 8 Tooronga-road, East Malvern, trainee cook, died 5th April, 1970.

I HEREBY give notice that on the 13th August, 1970, the Public Trustee filed elections to administer the following deceased persons' estates in accordance with section 17 of the *Public Trustee Act 1958*.

BURNS, ELIZABETH, late of 2 Downs-street, Pascoe Vale, widow, died 15th June, 1970.

BUSSELL, IRENE MASSIE, late of Unit 24, 8 Rochester-road, Canterbury, retired trained nurse, died 16th June, 1970.

JOHNSON, MARY VIOLET, late of Brotherhood of Saint Laurence, 121 Weigall-avenue, Carrum Downs, widow, died 23rd May, 1970.

NOVAK, FRANK, late of Homes for the Aged, Princes-street, Mildura, retired labourer, died 11th February, 1970.

RIMMEL, KAROLINE BARBARA, late of Flat 3, 8 High-street, Frankston, pensioner, died 23rd November, 1969.

SEXTON, DORA ETHEL, late of 8 Rochester-road, Canterbury, retired nurse, died 2nd May, 1970.

SMITH, ALFRED CHARLES, formerly of 2 Yarrinup-avenue, Chadstone, but late of Cheltenham Home and Hospital for the Aged, Cheltenham, retired wharf labourer, died 9th May, 1970.

STONE, JOHN ARTHUR GEORGE, late of 18 Mowbray-street, Hawthorn East, retired motor painter, died 6th June, 1970.

WAKELY, MAUD ALICE, late of 102 Stephenson-street, Richmond, widow, died 22nd May, 1970.

I HEREBY give notice that on the 26th August, 1970, the Public Trustee filed elections to administer the following deceased persons' estates in accordance with section 17 of the *Public Trustee Act 1958*.

BERINGER, NANCE MARJORIE, late of 124 Ivanhoe-parade, Ivanhoe, married woman, died 2nd May, 1970.

CHEETHAM, CLARICE LOUISE, late of 60 Lygon-street, Carlton South, spinster, died 15th June, 1970.

COOK, ALICE MAUD, formerly of 29 Dover-street, Richmond South, but late of 31 Garibaldi-street, Traralgon, widow, died 30th August, 1967.

GEGGIE, WALTER, late of 261 Station-street, Fairfield, retired, died 3rd October, 1970.

GREEN, HARRY JOSEPH, late of Kingspark State Hospital, New York, U.S.A., chauffeur, died 14th October, 1965.

HANLON, VICTORIA THERESA, late of 13 Francis-street, Ascot Vale, pensioner, died 27th September, 1949.

HAYES, EILEEN GRACE, formerly of 227 Gower-street, Preston, late of 67 Avoca-street, South Yarra, retired machinist, died 16th July, 1970.

N. P. BRODY,
Public Trustee.

256 Flinders-street, Melbourne, 2nd September, 1970.

NOTICE.

CREDITORS, next of kin and others having claims against the estate of any of the under-mentioned deceased persons are required to send particulars of their claims to the Public Trustee, 256 Flinders-street, Melbourne, Vic. 3000, the personal representative, on or before the 16th November, 1970, after which date the Public Trustee may convey or distribute the assets having regard only to the claims of which the Public Trustee then has notice:—

BERINGER, NANCE MARJORIE, late of 124 Ivanhoe-parade, Ivanhoe, married woman, died 2nd May, 1970.

BURNS, ELIZABETH, late of 2 Downs-street, Pascoe Vale, widow, died 15th June, 1970.

BUSSELL, IRENE MASSIE, late of Unit 24, 8 Rochester-road, Canterbury, retired trained nurse, died 16th June, 1970.

CARLSON, VIOLET MAY, late of 61 Argyle-avenue, Chelsea, married woman, died 14th November, 1968.

CHALMERS, ELLA MARION, late of 244 Nepean Highway, Seaford, widow, died 19th April, 1970.

8070/70.—2

CHEETHAM, CLARICE LOUISE, late of 60 Lygon-street, Carlton South, spinster, died 15th June, 1970.

CLAXTON, CECIL CHARLES, late of 14 Prospect-street, Box Hill, retired dental assistant, died 25th June, 1970.

CLEMENTS, HILDA MAY, formerly of 48 Merrin-crescent, Wonthaggi, but late of Caulfield Convalescent Hospital, Caulfield, widow, died 8th November, 1967.

COOK, ALICE MAUD, formerly of 29 Dover-street, Richmond South, but late of 31 Garibaldi-street, Traralgon, widow, died 30th August, 1967.

COULTER, JOHN EDWARD, late of 11 Durrant-street, North Brighton, cleaner, died 26th May, 1970.

DEWAR, KEITH IVAN, late of 26 Clifton-street, Collie, Western Australia, Member No. 5715633 of the Australian Military Forces, died 24th June, 1969.

GEGGIE, WALTER, late of 261 Station-street, Fairfield, retired, died 3rd October, 1970.

GREEN, HARRY JOSEPH, late of Kingspark State Hospital, New York, U.S.A., chauffeur, died 14th October, 1965.

HANLON, VICTORIA THERESA, late of 13 Francis-street, Ascot Vale, pensioner, died 27th September, 1949.

HAYES, EILEEN GRACE, formerly of 227 Gower-street, Preston, late of 67 Avoca-street, South Yarra, retired machinist, died 16th July, 1970.

JOHNSON, MARY VIOLET, late of Brotherhood of Saint Laurence, 121 Weigall-avenue, Carrum Downs, widow, died 23rd May, 1970.

MITTON, ARTHUR CHARLES, late of Kinglake-road, St. Andrews, Vic., retired farmer, died 28th March, 1970.

NOVAK, FRANK, late of Homes for the Aged, Princes-street, Mildura, retired labourer, died 11th February, 1970.

O'NEILL, ALBERT ERNEST, formerly of Coburg, but late of 22 Duffy-street, North Essendon, retired deputy town clerk, died 18th December, 1969.

RIMMEL, KAROLINE BARBARA, late of Flat 3, 8 High-street, Frankston, pensioner, died 23rd November, 1969.

SEXTON, DORA ETHEL, late of 8 Rochester-road, Canterbury, retired nurse, died 2nd May, 1970.

SMITH, ALFRED CHARLES, formerly of 2 Yarrinup-avenue, Chadstone, but late of Cheltenham Home and Hospital for the Aged, Cheltenham, retired wharf labourer, died 9th May, 1970.

STONE, JOHN ARTHUR GEORGE, late of 18 Mowbray-street, Hawthorn East, retired motor painter, died 6th June, 1970.

TURNER, FLORENCE ANN, formerly of 36 Milverton-street, Burwood, but late of 9 Springfield-avenue, Camberwell, home duties, died 8th May, 1970.

WAGSTAFF, VICTOR NEIL, formerly of 5 Charworth-street, Laverton, and formerly No. 312756 Australian Regular Army Reinforcement Wing of Ingleburn, N.S.W., but late of Vietnam, soldier, died 29th January, 1970.

WAKELY, MAUD ALICE, late of 102 Stephenson-street, Richmond, widow, died 22nd May, 1970.

WATYCHOWICZ, FRANCISZEK, late of 79 Creswick-street, West Footscray, machinist, died 16th June, 1970.

N. P. BRODY,
Public Trustee.

Melbourne, 2nd September, 1970.

Town and Country Planning Act 1961.

CITY OF CAMBERWELL PLANNING SCHEME 1954.

AMENDMENT No. 38, 1970.

Notice of Amendment.

IN pursuance of the powers conferred by sub-section 6 of section 32 of the *Town and Country Planning Act 1961*, the Governor in Council, by and with the advice of the Executive Council on the 8th September, 1970, amended the City of Camberwell Planning Scheme in so far as it relates to the driveway requirements for two houses on one allotment in the Residential Zones.

A copy of the amendment may be inspected during office hours at the office of the Town and Country Planning Board, 235 Queen-street, Melbourne; at the office of the Council of the City of Camberwell, at Camberwell and when available at the Office of Titles, Melbourne; and at the Central Plan Office of the Department of Crown Lands and Survey, Melbourne.

W. H. CRAIG, Secretary.
Town and Country Planning Board.

CONTRACTS ACCEPTED.—(Series 1970-71.)**PUBLIC WORKS.**

387. Ballarat, High School, renovations to Bristol Building, \$4,482.00.—Aluminium Roofing Pty. Ltd.
 388. Sale, Primary School 5021, mechanical services, \$9,948.00.—Chadstone Airconditioning Services Pty. Ltd.
 389. Benalla, Technical School, mechanical services, \$6,222.00.—Ross's Pty. Ltd.
 390. Warragul, Technical School, mechanical services, \$88,740.00.—Thos. J. Tait Pty. Ltd.
 391. Irymple, Mildura Horticultural Research Station, electrical installation—glasshouse, \$4,975.00.—G. W. Tyler Pty. Ltd.

G. SERPELL, Director-General of Public Works. 2.9.70.

VICTORIAN RAILWAYS.

9. Erection and completion of a new station building on the existing platform at Gardiner for the amount of \$18,222.00 (Contract 63544).—Fiedler Builders Pty. Ltd. 10. Removing Departmental Residence No. 3969 from Creswick and re-assembling at North Ballarat together with out-building for the amount of \$1,300.00 (Contract 63546).—Ballarat Heavy Haulage Co. 11. Supply and lay bituminous concrete on roadway and car park at Broadmeadows for the amount of \$2,660.00 (Contract 63547).—Albion Reid Pty. Ltd.

W. WALKER, Secretary. 4.9.70.

Co-operation Act 1958.

**KERANG OLYMPIC POOL CO-OPERATIVE LIMITED.
 PORTLAND FERTILIZER CO-OPERATIVE LIMITED.
 3RD STRATHMORE SCOUT GROUP CO-OPERATIVE LIMITED.**

NOTICE is hereby given in pursuance of section 78 (7) of the *Co-operation Act 1958* and section 308 (2) of the *Companies Act 1961* that, at the expiration of three months from the date hereof, the names of the afore-mentioned societies will, unless cause is shown to the contrary, be struck off the register and the societies will be dissolved.

Dated at Melbourne, this 3rd day of September, 1970.

M. V. HAMMOND,
 Deputy Registrar of Co-operative Societies.

Co-operation Act 1958.

**FREEWAY CO-OPERATIVE CREDIT SOCIETY LIMITED.
 NOTICE OF DISSOLUTION OF SOCIETY.**

NOTICE is hereby given that I have this day registered the dissolution of the above-named society and cancelled its registration under the above-named Act.

Dated at Melbourne, this 3rd day of September, 1970.

M. V. HAMMOND,
 Deputy Registrar of Co-operative Societies.

Co-operation Act 1958.**NOTICE OF AMALGAMATION OF SOCIETIES.**

NOTICE is hereby given that, pursuant to the provisions of the *Co-operation Act 1958*, Numurkah and District "A.B." Co-operative Limited and East Goulburn Artificial Breeders Co-operative Limited were amalgamated into one Society under the name of Numurkah, East Goulburn A.B. Co-operative Limited, on the 12th day of August, 1970.

Dated at Melbourne this 12th day of August, 1970.

M. V. HAMMOND,
 Deputy Registrar of Co-operative Societies.

APPOINTMENTS AND RESIGNATIONS**APPOINTMENTS.**

HIS Excellency the Governor of the State of Victoria, by and with the advice of the Executive Council thereof, has, by Orders made on the 1st day of September, 1970, been pleased to make the under-mentioned appointments, viz.:—

CHIEF SECRETARY'S DEPARTMENT.**Honorary Probation Officers.**

- ROBERT MCALPINE BARRIE (the Reverend), 10 Grace-street, Watsonia,
 RICHARD BERNARD LEWIS BRETTEL, 14 Barnett-street, Swan Hill,
 JOHN THOMAS DONNE, 2 Elmore-street, Hamilton,
 ALEXANDER FRASER, 153 Queen-street, Bendigo,
 KERIN JOHN HEMPENSTALL, 10 El Alamein-avenue, Swan Hill,

- ROBERT GEORGE JERRAM, 3 Bernard-court, East Keilor,
 ABEL ALEXANDER KAY, Waroona-court, Pakenham East,
 KEITH ALFRED STEPHENS (the Reverend), 314 Beveridge-street, Swan Hill,
 GRAEME DUNCAN STOREY, 204 Brougham-street, Ballarat,
 WILLIAM JOHN SULLIVAN, Flat 2, 79 Park-street, St. Kilda, and
 ARTHUR THOMAS TRENEREY, Flat 2, 196 Lennox-street, Richmond,

pursuant to the provisions of section 10 (1) of the *Children's Court Act 1958*, to be Honorary Probation Officers for all Children's Courts in Victoria.

Honorary Inspector of Fisheries.

RONALD DREW COOK,
 pursuant to the provisions of section 6 (1) of the *Fisheries Act*, for so long as he is employed as Ranger of the Lakes National Park Committee of Management, to be an Honorary Inspector of Fisheries.

CROWN LANDS AND SURVEY DEPARTMENT.**Authorized Person Under Land Act 1958.**

ROBERT LAWRENCE MCMAHON, an officer of the Department of Crown Lands and Survey, to be as provided in section 165 of the *Land Act 1958*, a duly authorized person to grant to an applicant a right to occupy, as a residence area under the said Act, any Crown lands.

Land Officer.

ROBERT LAWRENCE MCMAHON, an officer of the Department of Crown Lands and Survey, to be a Land Officer in and for the State of Victoria.

Manager of Common.

DAVID ALEXANDER BAIRD
 to be Manager of the Ballarat West Town Common for a period ending the 31st December, 1970, vice William MacGregor Troup, resigned.

MINISTRY OF HEALTH.**Member of Committee of Management of Hospital.**

THOMAS JAMES MCKENZIE
 to be Government Appointee on the Committee of Management of Apollo Bay and District Memorial Hospital, for a term of three years, vice Ian David MacDonald, resigned, pursuant to section 48 (1) (a) (ii) of the *Hospitals and Charities Act 1958*.

Trustees of Cemeteries.

NOEL ARTHUR BOATMAN,
 MAXWELL JOHN WILLIAMS, and
 BERNARD ALEXANDER BOATMAN,
 to be Trustees of the Crowlands Public Cemetery, vice J. Boatman, resigned, E. Boatman, deceased, and R. Williams, deceased, pursuant to section 3 (1) of the *Cemeteries Act 1958*;

EDWARD HENRY PARSONS
 to be a Trustee of the Warracknabeal Public Cemetery, vice G. Felton, resigned, pursuant to section 3 (1) of the *Cemeteries Act 1958*;

ROY KENT,
 JOHN KILBY, and
 REX OWEN FISH,
 to be Trustees of the Lakes Entrance Public Cemetery, additional trustees, pursuant to section 3 (1) of the *Cemeteries Act 1958*; and

AUSTIN WALTER KAY
 to be a Trustee of the Kialla West Public Cemetery, vice H. Moore, deceased, pursuant to section 3 (1) of the *Cemeteries Act 1958*.

Public Vaccinators.

NEIL FURPHY PESCOTT, M.B., B.S.,
 to be a Public Vaccinator for the Municipality of the Shire of Ballarat;

ERINA JANE MARGARET BATT, M.B., B.S.,
 to be a Public Vaccinator for the Municipality of the Shire of South Barwon; and

NEIL FURPHY PESCOTT, M.B., B.S.,
 to be a Public Vaccinator for the Municipality of the Shire of Grenville, pursuant to section 151 of the *Health Act 1958*.

LAW DEPARTMENT:

Commissioners for Taking Declarations, &c.

GRAEME DAVID MCPHEE, care of Commonwealth Department of Social Services, Commonwealth Offices, corner Maud and Fraser streets, Shepparton,
 ANTHONY JAMES MITHEN, care of Commonwealth Department of Social Services, District Office, 215 Princes Highway, Morwell, and
 ALLAN EDWARD PURDEY, care of Commonwealth Department of Social Services, District Office, 59th Playne-street, Frankston,

to be Commissioners for taking Declarations and Affidavits, pursuant to the provisions of the Evidence Act 1958, to refrain from charging fees and to resign upon ceasing to occupy their present positions; and

WAYNE AUBIN DEAL, care of International Insurance Brokers Pty. Limited, 48 High-street, St. Kilda,
 NORMAN McMILLAN, care of Vickers Ruwolt Proprietary Limited, 524-582 Victoria-street, Richmond,
 WINSTON EDWARD FERRIS, care of Seymour District Memorial Hospital, Brettoneaux-street, Seymour, and
 RONALD LESLIE GREENAWAY, care of Melbourne Harbor Trust Commissioners, 29 Market-street, Melbourne,

to be Commissioners for taking Declarations and Affidavits, pursuant to the provisions of the Evidence Act 1958, to resign upon ceasing to occupy their present positions.

Clerk of Children's Courts.

STEPHEN ARTHUR CORLETT,
 to be Clerk of the Children's Court at Box Hill, Brunswick, Camberwell, Carlton, Chelsea, Collingwood, Hawthorn, Heidelberg, Moonee Ponds, Northcote, North Melbourne, Port Melbourne, Preston, Richmond, Ringwood, South Melbourne, Springvale, Sunshine and Williamstown, in the place of D. B. Dennis, transferred, to take effect from the date of commencement of duty.

MINES DEPARTMENT.

Mining Registrar (Acting).

Senior Constable JOSEPH DRAPER
 to act as Mining Registrar for the Corryong Division of the Beechworth Mining District, vice Senior Constable Derek Raymond Dobert, resigned, fees received to be the only remuneration.

PUBLIC WORKS DEPARTMENT.

Wharf Manager.

Senior Constable JAMES WINN, No. 11089,
 to be Deputy Wharf Manager, Lakes Entrance, to act as Wharf Manager, at Lakes Entrance, in accordance with section 7, Part II. of the Marine Act 1958, in any absence of the Wharf Manager, without remuneration.

DEPARTMENT OF THE TREASURER.

Receivers of Revenue (Acting).

PHILIP ALBERT ROCKE
 to act temporarily as Receiver of Revenue, Liquor Control Commission, Chief Secretary's Department, vice P. J. Smolka, resigned; and

THOMAS CHARLES WARD
 to act temporarily as Receiver of Revenue, State Land Tax and Probate Duties Office, Treasury Department, vice I. M. Green, on leave.

Collectors of Imposts (Acting).

VINCENT PATRICK O'DONOHUE
 to act temporarily as Collector of Imposts, Office of the Government Statist, Chief Secretary's Department, vice T. A. Millis, transferred;

NORMAN COLBERT
 to act temporarily as Collector of Imposts, Education Department, vice R. J. C. Senior, on leave; and

BARRY ARTHUR SHALLARD
 to act temporarily as Collector of Imposts, Library Council of Victoria, Chief Secretary's Department, vice P. A. Rocke, transferred.

DEPARTMENT OF WATER SUPPLY.

Waterworks Trust Commissioners.

GOLLAN MACDONALD, and
 JOHN PAUL MCCARTY,
 to be Commissioners of the Buninyong Waterworks Trust, to hold such position for a period of four years from the date hereof, subject to the provisions of the Water Act; and

GRAHAM TOMLINSON

to be a Commissioner of the Shire of Deakin Waterworks Trust, to hold such position for a period of four years from the date hereof, subject to the provisions of the Water Act.

Sewerage Authority Members.

PERCIAN FRANK HARRISON BATTEN
 to be a Member of the Croydon Sewerage Authority, to hold such a position for a period of four years from the date hereof, subject to the provisions of the Sewerage Districts Act; and

JAMES BLANE PATON,
 GORDON GRAY, and
 CHRISTOPHER BRUCE BAILEY,
 to be Members of the Hastings Sewerage Authority, to hold such positions for a period of four years from the date hereof, subject to the provisions of the Sewerage Districts Act.

J. ROSSITER,
 Clerk of the Executive Council.

At the Executive Council Chamber,
 Melbourne, 1st September, 1970.

APPOINTMENTS.

HIS Excellency the Governor of the State of Victoria, by and with the advice of the Executive Council thereof, has, by Orders made on the 8th day of September, 1970, been pleased to make the under-mentioned appointments, viz.:—

DEPARTMENT OF WATER SUPPLY.

Sewerage Authority Members.

DOUGLAS HARRY PULLYBLANK,
 ALEXANDER JAMES LILLIE, and
 ROBIN MCCOLL HAWTHORNE,
 to be Members of the Lilydale Sewerage Authority, to hold such positions for a period of four years from the date hereof, subject to the provisions of the Sewerage Districts Act.

J. ROSSITER,
 Clerk of the Executive Council.

At the Executive Council Chamber,
 Melbourne, 8th September, 1970.

Liquor Control Act 1968.

APPOINTMENT OF LICENSING INSPECTOR.

IN accordance with the authority conferred upon me by Section 6 of the Police Regulation Act 1968, I, Reginald Jackson, Deputy Commissioner of Police, do hereby appoint under sub-section (1) of Section 22 of the Liquor Control Act 1968, the following Officer of Police as a Licensing Inspector for the Division of the Police District as shown :—

Division Number.	Police District.	Rank and Name.
1	Flinders	Inspector Fredrick Gordon Jones (from 24.8.1970 to 12.9.1970)

24.8.70.

R. JACKSON,
 Deputy Commissioner.

RESIGNATIONS.

HIS Excellency the Governor of the State of Victoria, by and with the advice of the Executive Council thereof, has, by Orders made on the 1st day of September, 1970, accepted the resignations of the persons named hereunder of the offices mentioned, viz.:—

CHIEF SECRETARY'S DEPARTMENT.

Honorary Probation Officers.

ROBERT GEORGE BENTLEY (the Reverend), and
 PERCY ALFRED EMPEY,
 as Honorary Probation Officers, pursuant to the provisions of section 10 (1) of the Children's Court Act 1958, for all Children's Courts in Victoria; and

JOHN ROBERT WRATTEN, as an Honorary Probation Officer, pursuant to section 507 (1) of the Crimes Act 1958.

Stipendiary Probation and Parole Officer.

JAMES MCCAMISH PEARCE, as a Stipendiary Probation and Parole Officer, pursuant to the provisions of sections 507 (1) and 533 (3) of the Crimes Act 1958, section 9 (2) of the Children's Court Act 1958 and section 36 (1) of the Social Welfare Act 1960.

LAW DEPARTMENT.
Justices of the Peace.

LESLIE JOHN TAYLOR,
WALTER GEORGE CRESSER, and
LESLIE PATEMAN BRIANT,
from the Commission of the Peace for the State
of Victoria.

Commissioners for Taking Declarations, &c.

WILLIAM RATCLIFFE WHITNEY,
PETER JOHANN SMOLKA, and
STUART COLQUHOUN MURRAY,
as Commissioners for taking Declarations and
Affidavits, pursuant to the provisions of the
Evidence Act 1958.

J. ROSSITER,
Clerk of the Executive Council.

At the Executive Council Chamber,
Melbourne, 1st September, 1970.

ORDERS IN COUNCIL

Groundwater Act 1969.

STATE RIVERS AND WATER SUPPLY COMMISSION

At the Executive Council Chamber, Melbourne, the
first day of September, 1970.

PRESENT:

His Excellency the Governor of Victoria.
Mr. Reid | Mr. Dickie.

UNDER the powers conferred by section 2 (2) (e) of
the Groundwater Act 1969 and all other powers
enabling him in that behalf, His Excellency the Governor
of the State of Victoria, by and with the advice of the
Executive Council of the said State, on the recommenda-
tion of the State Rivers and Water Supply Commission,
doth hereby declare any bore well gallery drive or excava-
tion or any artificially constructed or improved under-
ground cavity which is supplied in whole or in part by
water coming by a natural sub-surface path from a river
creek stream or watercourse or lake lagoon swamp or
marsh to be a bore to which the Groundwater Act does
not apply.

And the Honorable Ian Winton Smith, Her Majesty's
Minister of Water Supply for the State of Victoria, shall
give the necessary directions herein accordingly.

J. ROSSITER,
Clerk of the Executive Council.

PORT PHILLIP AUTHORITY ACT 1966.

At the Executive Council Chamber, Melbourne, the
first day of September, 1970.

PRESENT:

His Excellency the Governor of Victoria.
Mr. Reid | Mr. Dickie.

TRAVELLING EXPENSES FOR CHAIRMAN OF THE
PORT PHILLIP AUTHORITY.

IN pursuance of the provisions of section 4 of the Port
Phillip Authority Act 1966, and all other powers him
thereunto enabling, His Excellency the Governor of the
State of Victoria, by and with the advice of the Executive
Council thereof, doth hereby amend the travelling expenses
of the Chairman of the Port Phillip Authority made
pursuant to the provisions of the Port Phillip Authority
Act 1966 in Order of the 5th August, 1969:—

In paragraph (a) the amount "\$1" is substituted
for the amount "75c."

In paragraph (b) the amount "\$1.10" is substituted
for the amount "90c."

In paragraph (c) the amount "\$1.45" is substituted
for the amount "\$1.25."

And the Honorable William Archibald Borthwick, Her
Majesty's Minister of Lands for the State of Victoria,
shall give the necessary directions herein accordingly.

J. ROSSITER,
Clerk of the Executive Council.

DEPARTMENT OF CROWN LANDS AND SURVEY.

At the Executive Council Chamber, Melbourne, the
first day of September, 1970.

PRESENT:

His Excellency the Governor of Victoria.
Mr. Reid | Mr. Dickie.

LANDS TEMPORARILY RESERVED AS SITES.

HIS Excellency the Governor of the State of Victoria,
by and with the advice of the Executive Council
thereof, doth hereby, in pursuance of section 14 of the
Land Act 1958, reserve temporarily from sale, from being
leased and from having a licence granted in respect
thereof, and also except from occupation for mining pur-
poses under any miner's right, the land hereinafter
described:—

GEELONG (THOMSON).—Site for Public purposes (Public
Hall), 4 perches, City of Geelong, Parish of Corio, County
of Grant, as indicated by hatching on plan hereunder.—
(G.25(W¹) (Rs.7291).

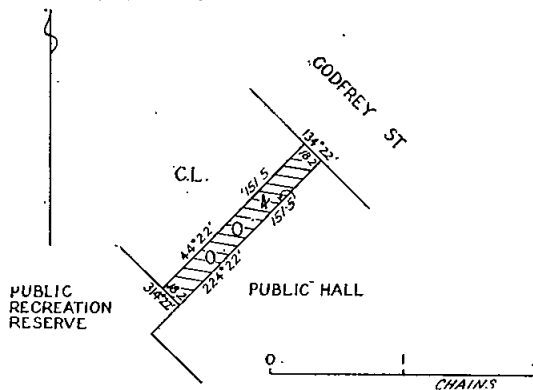

GEELONG (THOMSON).—Site for Public purposes (Elderly
Citizens' Club Rooms), 34 perches, City of Geelong, Parish
of Corio, County of Grant, as indicated by hatching on
plan hereunder.—(G.25(W¹) (Rs.9371).

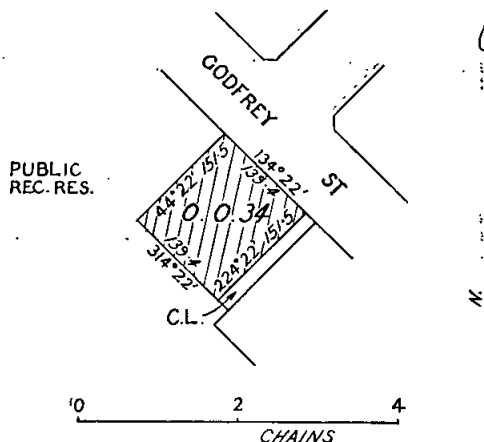

PORTLAND.—Site for Public purposes (Drainage purposes),
7 acres 1 rood 20 perches, Township of Portland, Parish
of Portland, County of Normanby, as indicated by hatching
on plan hereunder.—(P.69(?) (Rs.9364).

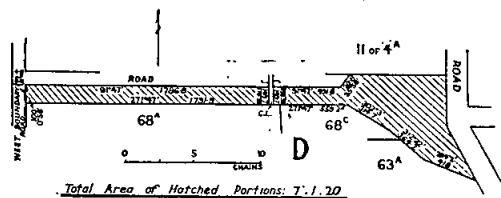

MAINDAMPLE.—Site for Public Recreation, 3 acres 3 roods 19 perches, Township of Maindample, Parish of Doolam, County of Delatite, being the land indicated by hatching on plan hereunder.—(M.36⁽⁸⁾) (Rs.9370).

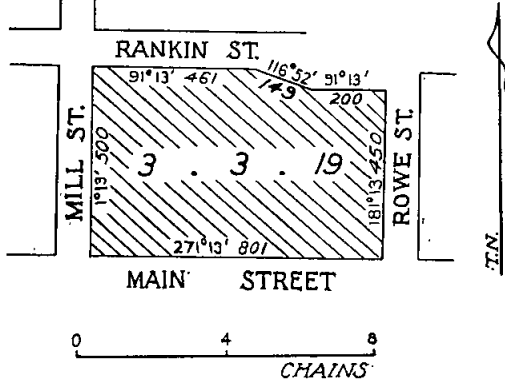

PORTLAND.—Site for Public purposes (Police purposes), 31 perches, Township of Portland, Parish of Portland, County of Normanby, as indicated by hatching on plan hereunder.—(P.69⁽⁷⁾) (Rs.9366).

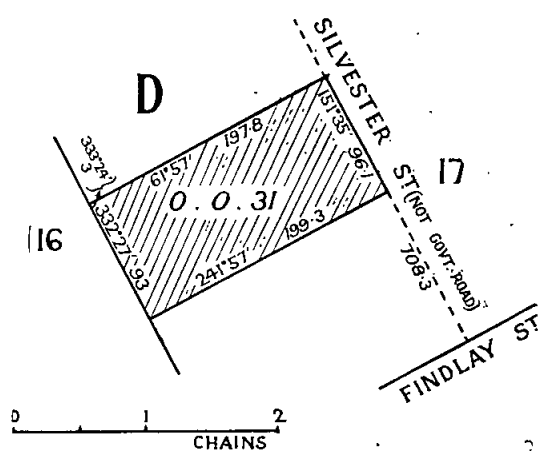

PORTARLINGTON.—Site for Public Recreation and Public purposes, 30 acres 3 roods 30 perches, Township of Portarlington, Parish of Bellarine, County of Grant, being the land indicated by hatching on plan hereunder.—(P.37⁽⁸⁾) (Rs.6395).

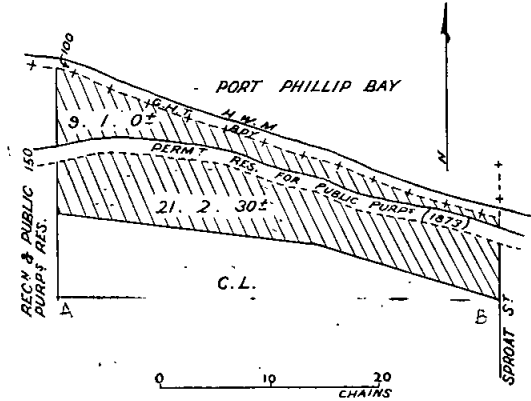

PORTLAND.—Site for Public purposes (Police purposes), 29 perches, Township of Portland, Parish of Portland, County of Normanby, as indicated by hatching on plan hereunder.—(P.69⁽⁷⁾) (Rs.9366).

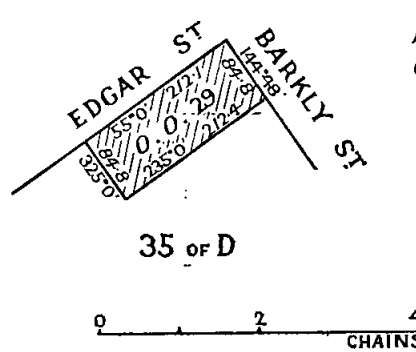

Total area of hatched portions 30.3.30±
 PORTLAND.—Site for Public purposes (Police purposes), 36 perches, Township of Portland, Parish of Portland, County of Normanby, as indicated by hatching on plan hereunder.—(P.69⁽⁷⁾) (Rs.9366).

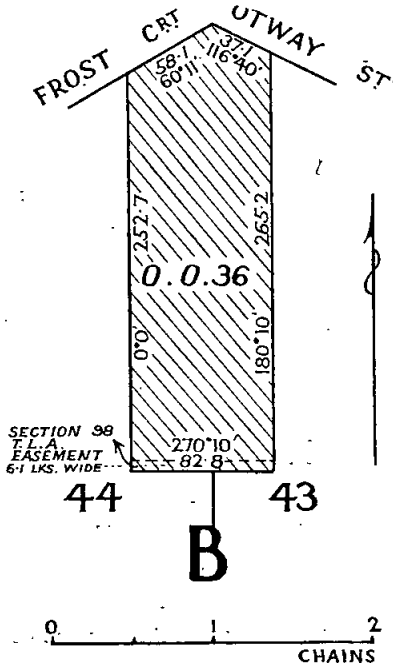

SHEPPARTON.—Site for Public purposes (Departmental Residence), 25 perches, Parish of Shepparton, County of Moira, as indicated by hatching on plan hereunder.—(S.283⁽¹⁰⁾) (Rs.9362).

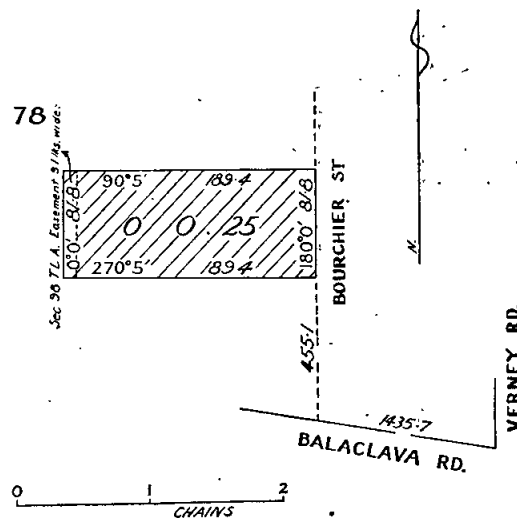

STAWELL.—Site for Public Recreation, 2 acres 15 perches, Township of Stawell, Parish of Stawell, County of Borung, as indicated by hatching on plan hereunder.—(S.329⁽¹⁸⁾) (Rs.9369).

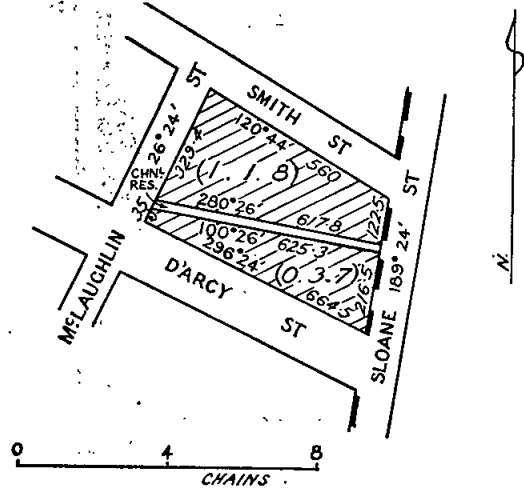

Total area of hatched portions: 2.0.15

And the Honorable William Archibald Borthwick, Her Majesty's Minister of Lands for the State of Victoria, shall give the necessary directions herein accordingly.

J. ROSSITER,
Clerk of the Executive Council.

DEPARTMENT OF CROWN LANDS AND SURVEY.

At the Executive Council Chamber, Melbourne, the first day of September, 1970.

PRESENT:
His Excellency the Governor of Victoria.
Mr. Reid | Mr. Dickie.

LAND TEMPORARILY RESERVED "FROM SALE".
His Excellency the Governor of the State of Victoria, by and with the advice of the Executive Council thereof, doth hereby, in pursuance of section 14 of the Land Act 1958, reserve temporarily "from sale" and also except from occupation for mining purposes under any miner's right, the land hereinafter described:—

GATUM GATUM.—Site for Public purposes (Trigonometrical Survey Station) 1 acre 2 roods, Parish of Gatum Gatum, County of Dundas, as indicated by hatching on plan hereunder.—(G.148⁽⁸⁾) (Rs.9308).

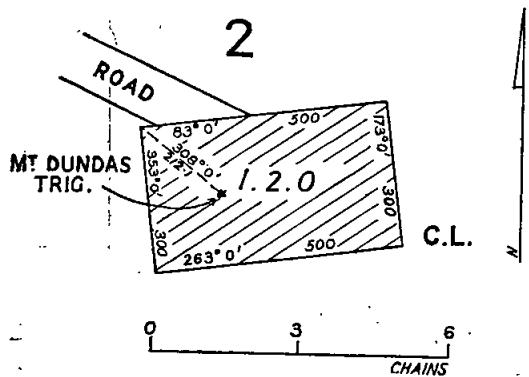

And the Honorable William Archibald Borthwick, Her Majesty's Minister of Lands, for the State of Victoria shall give the necessary directions herein accordingly.

J. ROSSITER,
Clerk of the Executive Council.

DEPARTMENT OF CROWN LANDS AND SURVEY.

At the Executive Council Chamber, Melbourne, the first day of September, 1970.

PRESENT:
His Excellency the Governor of Victoria.
Mr. Reid | Mr. Dickie.

UNUSED ROADS CLOSED.

His Excellency the Governor of the State of Victoria, by and with the advice of the Executive Council thereof, doth hereby direct that, in pursuance of the provisions of section 349 of the Land Act 1958, the unused roads referred to hereunder be closed, viz:—

At Bendigo, Parish of Sandhurst, County of Bendigo, being the road indicated by hatching on plan hereunder.—(S.372^(124, 129)) (Rs.3458).

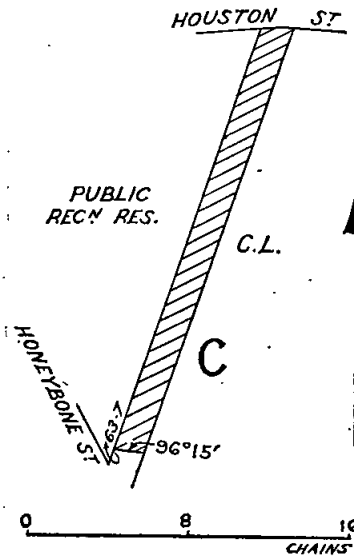

Parish of Gatum Gatum, County of Dundas, being the road indicated by hatching on plan hereunder.—(G.148⁽⁸⁾) (Rs.9308).

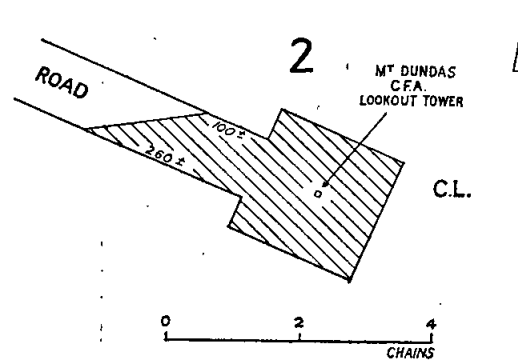

And the Honorable William Archibald Borthwick, Her Majesty's Minister of Lands for the State of Victoria, shall give the necessary directions herein accordingly.

J. ROSSITER,
Clerk of the Executive Council.

COUNTRY ROADS BOARD.

At the Executive Council Chamber, Melbourne, the first day of September, 1970.

PRESENT:

His Excellency the Governor of Victoria.
Mr. Reid | Mr. Dickie.

ORDER APPROVING OF LAND BEING ACQUIRED AND ROADS, DEVIATIONS OR WIDENINGS BEING MADE.

HIS Excellency the Governor of the State of Victoria, by and with the advice of the Executive Council thereof, being satisfied that there are funds legally available for acquiring the land, doth hereby approve the acquiring of the land described in the schedule hereunder and the making of new roads and deviations from and widenings of existing roads referred to in the said schedule.

SCHEDULE.

State Highway.

The land shown hatched on Plan numbered G.P.12271 hereunder required for the widening of the Midland Highway in the Shire of Creswick and making of the widening thereon.

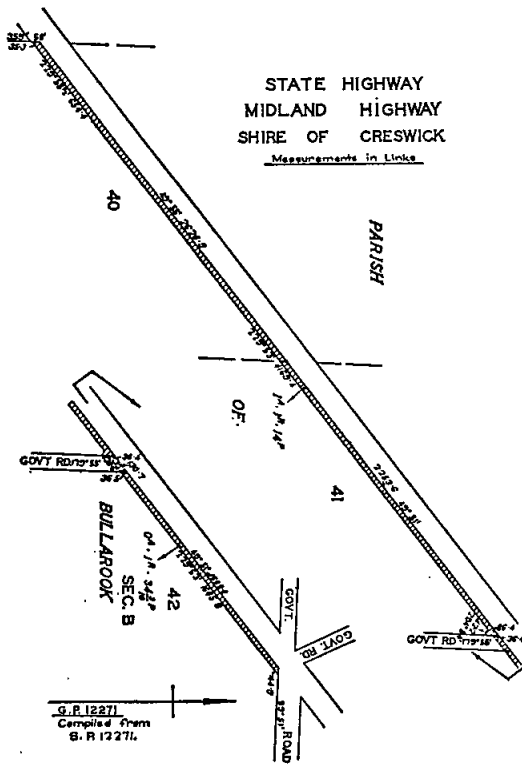

Main Roads.

The land shown hatched on Plans numbered G.P.12245A and G.P.12245B hereunder required for the deviation from Irrewillipe-road in the Shire of Colac and making of the deviation thereon.

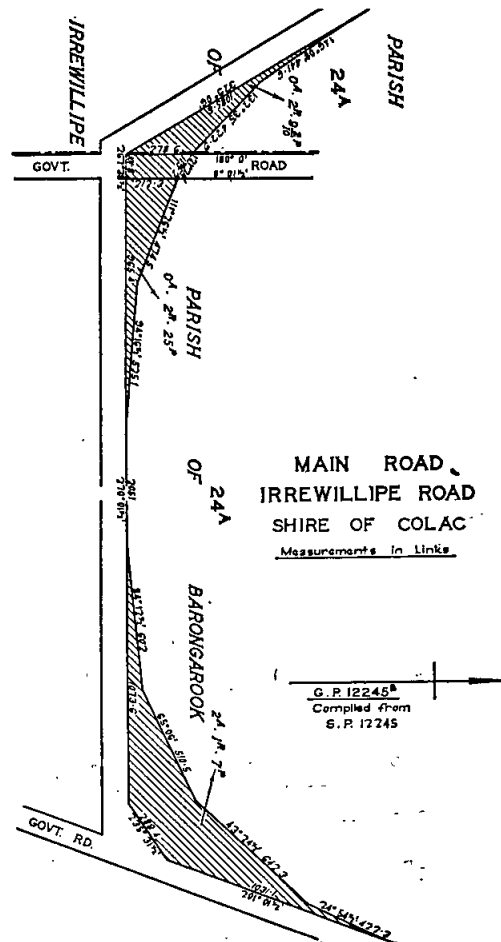
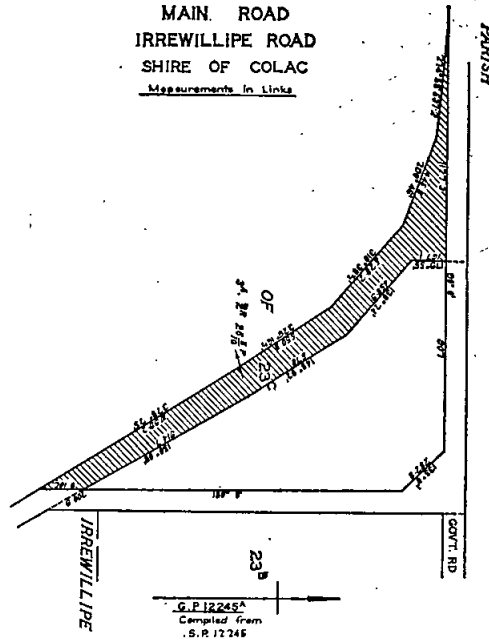

The land shown hatched on Plan numbered G.P.12120 hereunder required for the widening of the Heidelberg-Kinglake road in the Shire of Diamond Valley and making of the widening thereon.

The land shown hatched on Plan numbered G.P.12229 hereunder required for the deviation from the Lancefield-Tooborac road in the Shire of Pyalong and making of the deviation thereon.

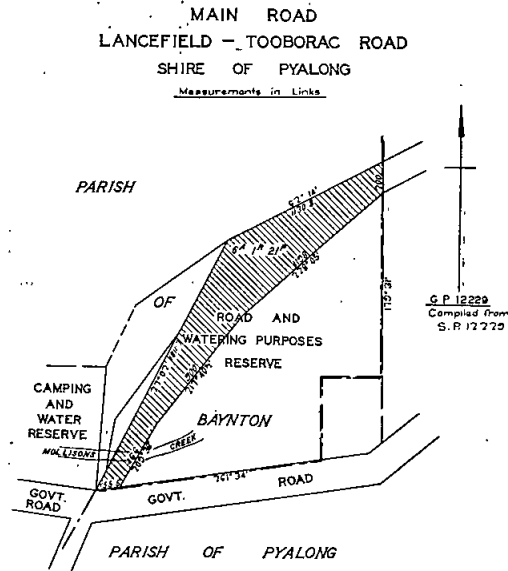
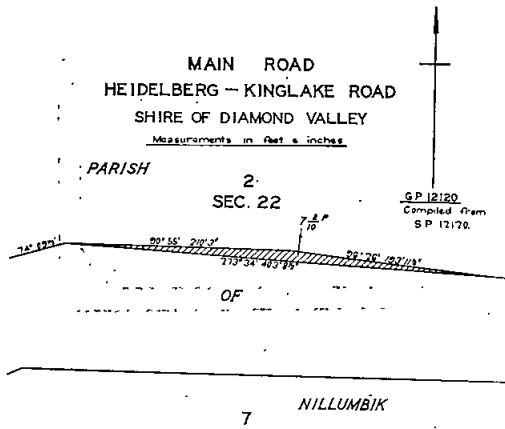

The land shown hatched on Plan numbered G.P.12301 hereunder required for the widening of the Traralgon-Creek road in the Shire of Traralgon and making of the widening thereon.

Unclassified Road.
The land shown hatched on Plan numbered G.P.12320 hereunder required for the making of a new road in the City of Sunshine.

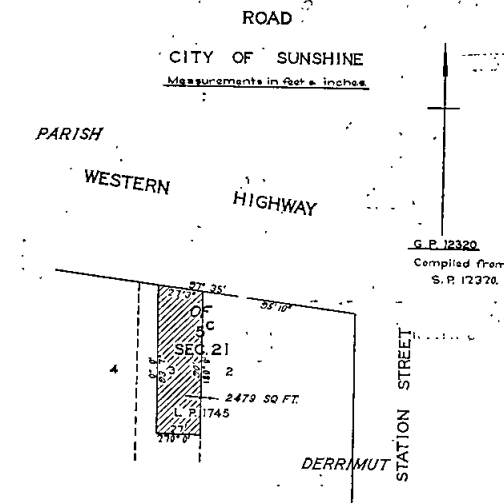
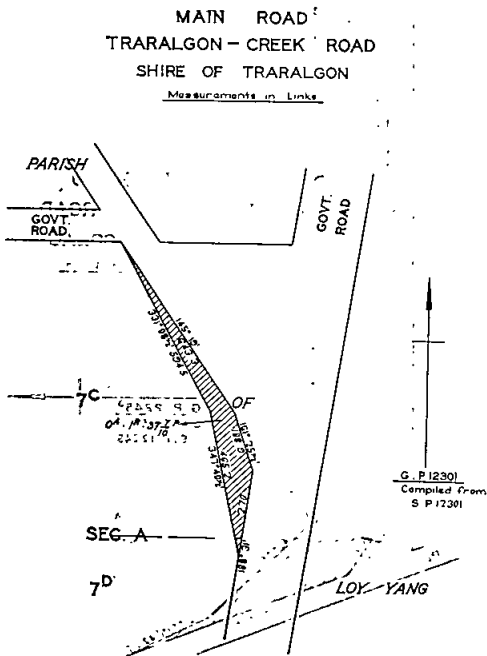

Tourists' Road.

The land shown hatched on Plan numbered G.P.12331 hereunder required for the widening of Grampians-road in the Shire of Stawell and making of the widening thereon.

**TOURISTS' ROAD
GRAMPIANS ROAD
SHIRE OF STAWELL**
Measurements in links

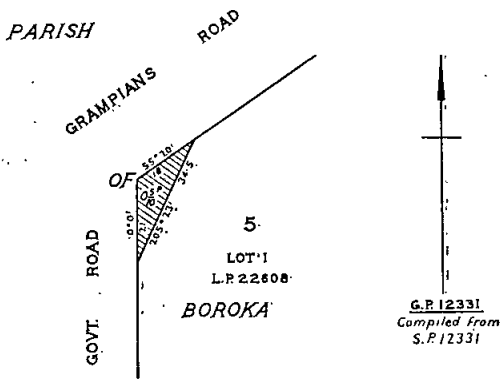

And the Honorable Rupert James Hamer, Her Majesty's Minister for Local Government for the State of Victoria, shall give the necessary directions herein accordingly.

J. ROSSITER,
Clerk of the Executive Council.

COUNTRY ROADS BOARD.

At the Executive Council Chamber, Melbourne, the first day of September, 1970.

PRESENT:

His Excellency the Governor of Victoria.
Mr. Reid | Mr. Dickie.

ORDER CONFIRMING RESOLUTIONS OF THE COUNTRY ROADS BOARD.

HIS Excellency the Governor of the State of Victoria, by and with the advice of the Executive Council thereof, doth hereby, in pursuance of the provisions of the Country Roads Act 1958, confirm the resolutions of the Country Roads Board, the dates whereof and the terms of which are scheduled hereunder:—

SCHEDULE.

State Highway.

Resolution dated the Twenty-fourth day of August, One thousand nine hundred and seventy, made pursuant to section 70 of the Country Roads Act 1958, rescinding the Resolution passed by the Country Roads Board on the Ninth day of October, One thousand nine hundred and forty-seven, and confirmed by an Order in Council published in the Government Gazette of the Twenty-ninth day of October, One thousand nine hundred and forty-seven, on pages 5573-5575, declaring a highway to be a State highway (Glenelg Highway) in the Shire of Grenville, so far as it relates to the part of the said State highway as indicated by cross-hatching on Plan numbered G.P.11555A hereunder.

**STATE HIGHWAY
GLENELG. HIGHWAY
SHIRE OF GRENVILLE**

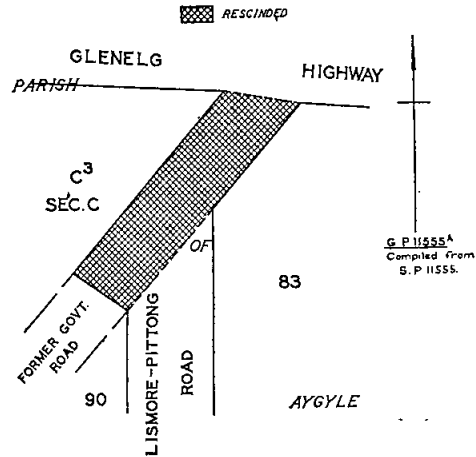

Main Road.

Resolution dated the Twenty-fourth day of August, One thousand nine hundred and seventy, made pursuant to section 18 of the Country Roads Act 1958, declaring the highway in the Shire of Grenville as shown hatched on Plan numbered G.P.11555 hereunder to be a main road (Lismore-Pittong road) within the meaning and for the purposes of the said Act.

**MAIN ROAD
LISMORE - PITTONG ROAD
SHIRE OF GRENVILLE**
Measurements in Links

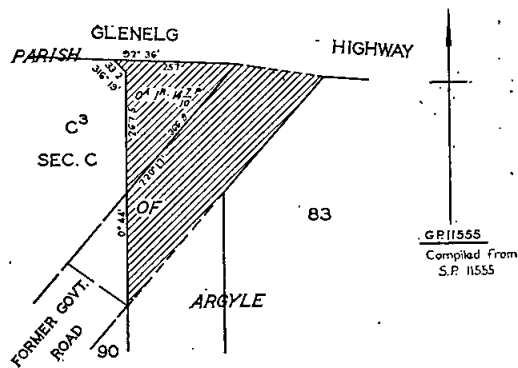

And the Honorable Rupert James Hamer, Her Majesty's Minister for Local Government for the State of Victoria, shall give the necessary directions herein accordingly.

J. ROSSITER,
Clerk of the Executive Council.

LOCAL GOVERNMENT DEPARTMENT.

At the Executive Council Chamber, Melbourne, the first day of September, 1970.

PRESENT:

His Excellency the Governor of Victoria.
Mr. Reid | Mr. Dickie.

ROAD DISCONTINUED—CITY OF SUNSHINE.

WHEREAS it is provided in section 528 (2) of the Local Government Act 1958, that where a road (whether or not a public highway but not being a road set out on land of the Crown) or any part thereof is not required for public use, the Governor in Council on the request

the municipality in which such road is situated made less than one month after publishing in a newspaper circulating in the district and posting to the registered proprietor (if any) of the land and the owners or occupiers (if any) of lands abutting or immediately adjacent to the road notice of intention to make such a request may by Order published in the *Government Gazette* that such road or part shall be discontinued and such road or part shall be discontinued.

And whereas the Council of the City of Sunshine has resolved that portion of Osbert-street, Sunshine be discontinued and not less than one month previously has in a newspaper generally circulating in the district and posted to the registered proprietor of the land abutting to the road and to the owners and occupiers of lands immediately adjacent to the road notice of intention to make such request.

Now therefore, His Excellency the Governor of the State of Victoria, by and with the advice of the Executive Council thereof, hereby directs.

- (a) that the said road, which is shown by hachure marked "A" and cross-hachure on the plan hereunder, shall be discontinued;

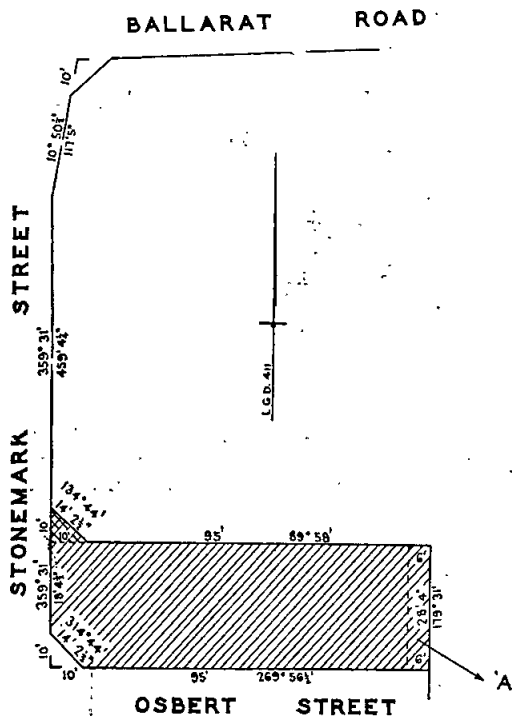

- (b) that notwithstanding such discontinuance the Melbourne and Metropolitan Board of Works shall continue to have and possess the same right title power authority or interest in or in relation to the whole of the land shown by hachure marked "A" on the said plan as it had or possessed prior to such discontinuance with respect to or in connexion with any drains or pipes laid or erected in on or over such lands for the purposes of drainage or sewerage;
- (c) that the land in the portion of the road shown by cross-hachure on the said plan may be sold by the Council of the City of Sunshine by agreement; and
- (d) that the land in the portion of the road shown hatched and hatched marked "A" on the said plan shall be retained by the municipality for municipal purposes.

And the Honorable James Murray Balfour, for and on behalf of Her Majesty's Minister for Local Government the State of Victoria, shall give the necessary directions herein accordingly.

J. ROSSITER,
Clerk of the Executive Council.

PUBLIC SERVICE ACT 1958.

At the Executive Council Chamber, Melbourne, the first day of September, 1970.

PRESENT:

His Excellency the Governor of Victoria.

Mr. Reid | Mr. Dickie.

APPOINTMENT OF A DEPUTY OF THE CHAIRMAN AND A DEPUTY OF THE GOVERNMENT REPRESENTATIVE MEMBER OF THE PUBLIC SERVICE BOARD.

IN pursuance of the provisions of section 15 of the *Public Service Act 1958*, His Excellency the Governor of the State of Victoria, by and with the advice of the Executive Council thereof, doth by this Order appoint ALWYN HARPER RIGG, the Government Representative Member of the Public Service Board, to be Deputy of FRANK ERNEST CAHILL, the Chairman of the Public Service Board, during the absence of the said FRANK ERNEST CAHILL from and inclusive of the 7th September, 1970, to the 9th November, 1970, or such earlier date as the said FRANK ERNEST CAHILL may return, and further doth appoint FRANK HENRI TREYVAUD Deputy of the said ALWYN HARPER RIGG during the period that he is acting as Deputy of the Chairman.

And the Honorable Sir Henry Bolte, Her Majesty's Premier for the State of Victoria, shall give the necessary directions herein accordingly.

J. ROSSITER,
Clerk of the Executive Council.

STATE ELECTRICITY COMMISSION ACT 1958, No. 6377.

At the Executive Council Chamber, Melbourne, the eighth day of September, 1970.

PRESENT:

His Excellency the Governor of Victoria.

Mr. Chandler | Mr. Balfour
Mr. Borthwick | Mr. Rafferty.

WHEREAS His Excellency the Governor of the State of Victoria by and with the advice of the Executive Council thereof has this day consented pursuant to the provisions of the *State Electricity Commission Act 1958* to the State Electricity Commission of Victoria raising by way of a loan the sum of Five hundred and thirty-one thousand dollars (\$531,000); And whereas His Excellency the Governor is satisfied that a sufficient proportion of the loan to be raised will fall due and be repaid in each year during the currency of the proposed loan; Now therefore it is directed pursuant to the provisions of section 91 (3) of the said Act, that it shall not be necessary to provide a sinking fund in connexion with such loan.

And the Honorable Sir Henry Edward Bolte, Her Majesty's Treasurer for the State of Victoria, shall give the necessary directions herein accordingly.

J. ROSSITER,
Clerk of the Executive Council.

COUNTRY ROADS BOARD.

At the Executive Council Chamber, Melbourne, the eighth day of September, 1970.

PRESENT:

His Excellency the Governor of Victoria.
Mr. Chandler | Mr. Balfour
Mr. Borthwick | Mr. Rafferty.

ORDER APPROVING OF LAND BEING ACQUIRED AND ROADS, DEVIATIONS OR WIDENINGS BEING MADE.

HIS Excellency the Governor of the State of Victoria, by and with the advice of the Executive Council thereof, being satisfied that there are funds legally available for acquiring the land, doth hereby approve the acquiring of the land described in the Schedule hereunder and the making of new roads and deviations from and widenings of existing roads referred to in the said Schedule.

SCHEDULE.

State Highways.

The land shown hatched on Plans numbered G.P.12366 and G.P.12367 hereunder required for the deviation from the Goulburn Valley Highway in the Shire of Yea and making of the deviation thereon.

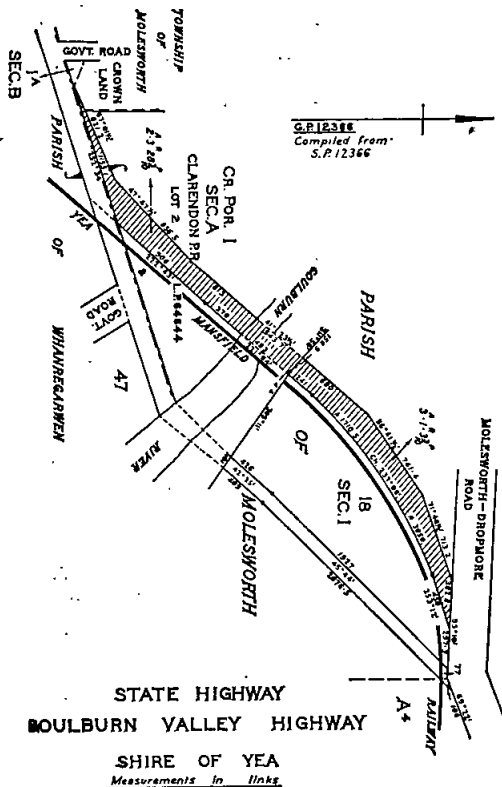
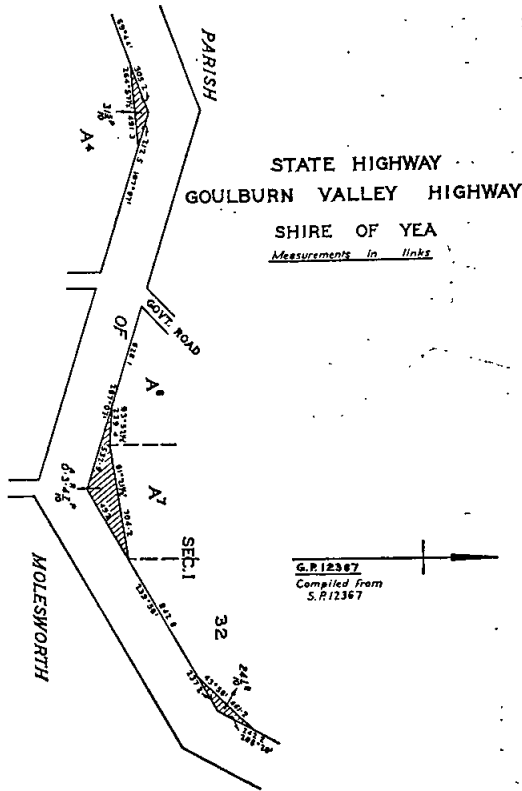

The land shown hatched on Plan numbered G.P.12317 hereunder required for the widening of the Warburton Highway in the Shire of Lillydale and making of the widening thereon.

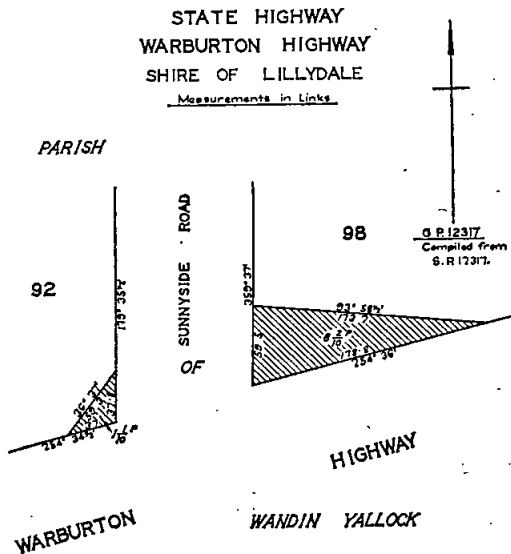

The land shown hatched on Plan numbered G.P.12383 hereunder required for the deviation from the Warburton Highway in the Shire of Lillydale and making of the deviation thereon.

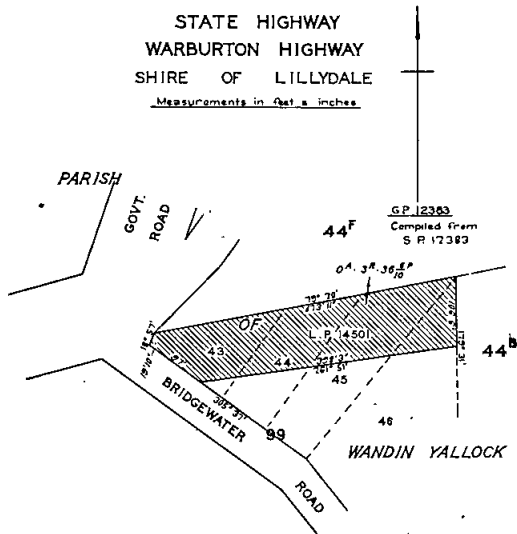

Unclassified Roads.

The land shown hatched on Plan numbered G.P.12308 hereunder required for the making of a new road in the Shire of Bacchus Marsh.

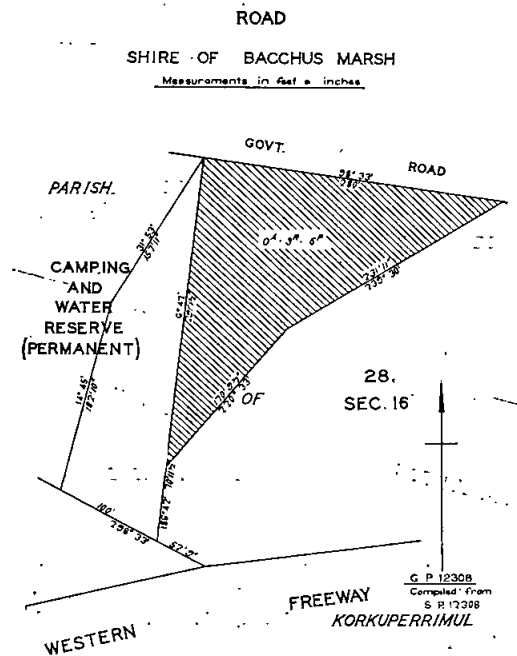

The land shown hatched on Plan numbered G.P.11975 hereunder required for the widening of Station-street in the City of Chelsea and making of the widening thereon.

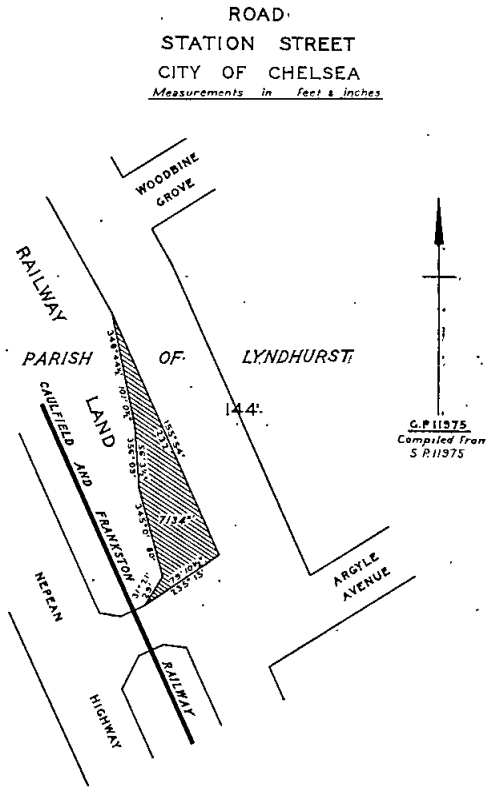

And the Honorable Rupert James Hamer, Her Majesty's Minister for Local Government for the State of Victoria, shall give the necessary directions herein accordingly.

J. ROSSITER,
Clerk of the Executive Council.

Water Act 1958.
STATE RIVERS AND WATER SUPPLY COMMISSION.

At the Executive Council Chamber, Melbourne, the eighth day of September, 1970.

PRESENT:

His Excellency the Governor of Victoria.
Mr. Chandler | Mr. Balfour
Mr. Borthwick | Mr. Rafferty.

WERRIBEE WATER SUPPLY DISTRICT — LOCAL GOVERNING BODY, WERRIBEE SHIRE COUNCIL— AREA OF DISTRICT INCREASED.

UNDER the powers conferred by the Water Act 1958 and all other powers enabling him in that behalf, His Excellency the Governor of the State of Victoria, with the advice of the Executive Council of the said State, doth hereby declare, order and direct that the area of the Werribee Water Supply District, under the control of the Werribee Shire Council, as a Local Governing Body, be increased by adding thereto the lands shown by blue colour on a plan approved by the Governor in Council and deposited in the office of the State Rivers and Water Supply Commission, Melbourne (Corr. Nos. 46/22659, 64/3065, 65/4852) and as on and from the 1st day of October, 1970, the area of such District shall be deemed to be so increased.

And the Honorable Ian Winton Smith, Her Majesty's Minister of Water Supply for the State of Victoria, shall give the necessary directions herein accordingly.

J. ROSSITER,
Clerk of the Executive Council.

Water Act 1958.

STATE RIVERS AND WATER SUPPLY COMMISSION.

At the Executive Council Chamber, Melbourne, the eighth day of September, 1970.

PRESENT:

His Excellency the Governor of Victoria.
Mr. Chandler | Mr. Balfour
Mr. Borthwick | Mr. Rafferty.

WERRIBEE IRRIGATION DISTRICT—PORTIONS EXCISED.

UNDER the powers conferred by the Water Act 1958 and all other powers enabling him in that behalf, His Excellency the Governor of the State of Victoria, with the advice of the Executive Council of the said State, on the recommendation of the State Rivers and Water Supply Commission, doth hereby declare, order and direct that there shall be excised from the Werribee Irrigation District those portions of the same shown by green colour on a plan approved by the Governor in Council and deposited in the office of the State Rivers and Water Supply Commission, Melbourne (Corres. Nos. 46/22659, 64/3065, 65/4852) which portions as from the 30th day of September, 1970, shall be deemed to be excised accordingly.

And the Honorable Ian Winton Smith, Her Majesty's Minister of Water Supply for the State of Victoria, shall give the necessary directions herein accordingly.

J. ROSSITER,
Clerk of the Executive Council.

WARRAGUL SEWERAGE AUTHORITY.

At the Executive Council Chamber, Melbourne, the eighth day of September, 1970.

PRESENT:

His Excellency the Governor of Victoria.
Mr. Chandler | Mr. Balfour
Mr. Borthwick | Mr. Rafferty.

CONSENT TO BORROWING \$50,000.

UNDER the powers conferred by the Sewerage Districts Act and all other powers enabling him in that behalf, His Excellency the Governor of the State of Victoria, by and with the advice of the Executive Council of the said State, doth hereby consent to the Warragul Sewerage Authority borrowing at interest, by mortgage of the General Fund the sum of Fifty thousand dollars (\$50,000) to meet the cost of sewerage works as set forth in the detailed statement bearing date 2nd September, 1970.

And the Honorable Ian Winton Smith, Her Majesty's Minister of Water Supply for the State of Victoria, shall give the necessary directions herein accordingly.

J. ROSSITER,
Clerk of the Executive Council.

KYABRAM SEWERAGE AUTHORITY.

At the Executive Council Chamber, Melbourne, the eighth day of September, 1970.

PRESENT:

His Excellency the Governor of Victoria.
Mr. Chandler | Mr. Balfour
Mr. Borthwick | Mr. Rafferty.

CONSENT TO BORROWING \$3,400.

UNDER the powers conferred by the Sewerage Districts Act and all other powers enabling him in that behalf, His Excellency the Governor of the State of Victoria, by and with the advice of the Executive Council of the said State, doth hereby consent to the Kyabram Sewerage Authority borrowing at interest by mortgage of the General Fund the sum of Three thousand four hundred dollars (\$3,400) for the conversion of Loan No. 11.

And the Honorable Ian Winton Smith, Her Majesty's Minister of Water Supply for the State of Victoria, shall give the necessary directions herein accordingly.

J. ROSSITER,
Clerk of the Executive Council.

BARNAWARTHA WATERWORKS TRUST.

At the Executive Council Chamber, Melbourne, the eighth day of September, 1970.

PRESENT:

His Excellency the Governor of Victoria.
Mr. Chandler | Mr. Balfour
Mr. Borthwick | Mr. Rafferty.

CONSENT TO BORROWING \$8,000.

UNDER the powers conferred by the Water Act and all other powers enabling him in that behalf, His Excellency the Governor of the State of Victoria, by and with the advice of the Executive Council of the said State, doth hereby consent to the Barnawartha Waterworks Trust borrowing at interest by mortgage of its revenue the sum of Eight thousand dollars (\$8,000) for the conversion of Loan No. 1.

And the Honorable Ian Winton Smith, Her Majesty's Minister of Water Supply for the State of Victoria, shall give the necessary directions herein accordingly.

J. ROSSITER,
Clerk of the Executive Council.

BEECHWORTH SEWERAGE AUTHORITY.

At the Executive Council Chamber, Melbourne, the eighth day of September, 1970.

PRESENT:

His Excellency the Governor of Victoria.
Mr. Chandler | Mr. Balfour
Mr. Borthwick | Mr. Rafferty.

CONSENT TO BORROWING \$20,000.

UNDER the powers conferred by the Sewerage Districts Act and all other powers enabling him in that behalf, His Excellency the Governor of the State of Victoria, by and with the advice of the Executive Council of the said State, doth hereby consent to the Beechworth Sewerage Authority borrowing at interest by mortgage of the General Fund the sum of Twenty thousand dollars (\$20,000) for the carrying out of works in accordance with the provisions of sections 95, 130 and 137 of the Sewerage Districts Act 1958. All moneys received by the said Authority in payment of costs and expenses of the said works, or any of them, shall be set aside for the purpose of and applied in repayment of the said sum so borrowed.

And the Honorable Ian Winton Smith, Her Majesty's Minister of Water Supply for the State of Victoria, shall give the necessary directions herein accordingly.

J. ROSSITER,
Clerk of the Executive Council.

LANDS DEPARTMENT NOTICES

APPROACHING LAND SALES.

SALES of Crown lands, in fee-simple, will be held at the under-mentioned places and dates, viz.:-

	No. of Gazette.
Bendigo.—Thursday, 8th October, 1970	82
East Melbourne.—Wednesday, 14th October, 1970	81
Heathcote.—Thursday, 10th September, 1970	74
Wangaratta.—Thursday, 24th September, 1970	77

CORRIGENDUM.

IN the Victorian Government Gazette, No. 81, of 26th August, 1970, page 2942, under the heading Lot 1, for the Parish of Melbourne substitute Parish of Melbourne North.

9th September, 1970.

ALAN J. HOLT,
Secretary of Lands.

PROPOSED REVOCATIONS OF TEMPORARY RESERVATIONS OF LANDS BY ORDERS IN COUNCIL.

IN pursuance of the provisions of the Land Act 1958, notice is hereby given that it is the intention of the Governor in Council to revoke the temporary reservations of lands by Orders in Council hereunder referred to, viz:—
The following Notices were published 1° on the 26th August, 1970, pursuant to Orders of the 18th August, 1970.

HORSHAM.—The temporary reservation, by Order in Council of the 2nd March, 1965, of 8 acres 1 rood 28 perches of land in the Township of Horsham as a site for Public Recreation, is about to be revoked so far only as the portion containing 3 roods 12 perches, indicated by hatching on plan hereunder, is concerned.—(H.91^(A)) (Rs.4656A).

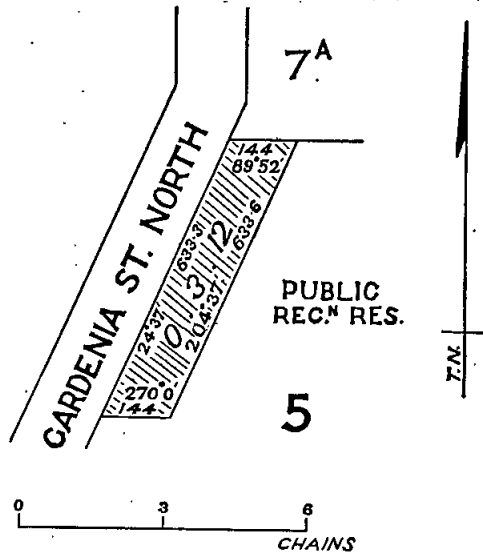

HOTHAM.—The temporary reservation, by Order in Council of the 14th March, 1962, of 38,000 acres, more or less, of land in the Counties of Bogong, Dargo, Delatite and Wonnangatta as a site for an Alpine Resort, revoked as to part by various Orders, is about to be revoked so far only as the portion in the Parish of Hotham containing 1 rood 6 perches, indicated by hatching on plan hereunder, is concerned.—(H.134^(B)) (Rs.8115).

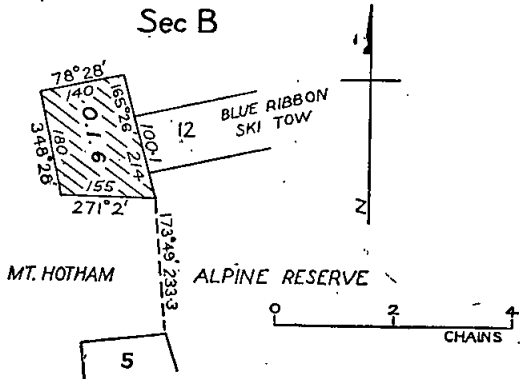

HOTHAM.—The temporary reservation, by Order in Council of the 14th March, 1962, of 38,000-acres, more or less, of land in the Counties of Bogong, Dargo, Delatite and Wonnangatta, as a site for an Alpine Resort, revoked as to part by various Orders, is about to be revoked so far only as the portion in the Parish of Hotham containing 7 perches, indicated by hatching on plan hereunder, is concerned.—(H.134^(C)) (Rs.8115).

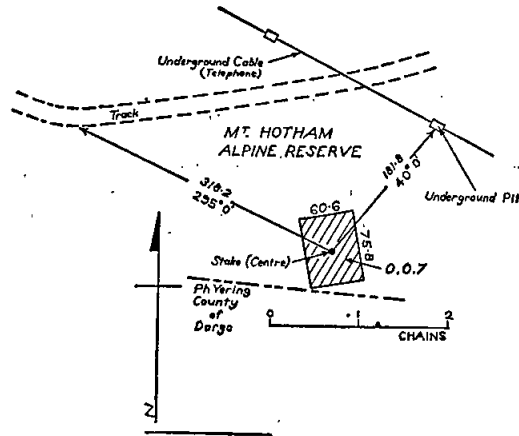

*Parish of Hotham
County of Bogong*

Corr. No R^s 8115
Prepared from OPH134° & VE1338 with corr.
R.F. 2-6-70

NILLUMBIK (DIAMOND CREEK).—The temporary reservation as a site for the Supply of Material for Road Making and the withholding from sale, leasing and licensing by Order in Council of the 6th September, 1881, of 1 acre 3 roods 7 perches of land in the Parish of Nillumbik, is about to be revoked.—(N.69^(?)) (81.H.20750, G.72578).

SANDFORD.—The temporary reservation, by Order in Council of the 25th August, 1903, of 4 acres 2 roods 30 perches of land in the Township of Sandford as a site for Public Recreation, is about to be revoked so far only as the portion containing 24 perches, indicated by hatching on plan hereunder, is concerned.—(S.233^(*)) (C.70586).

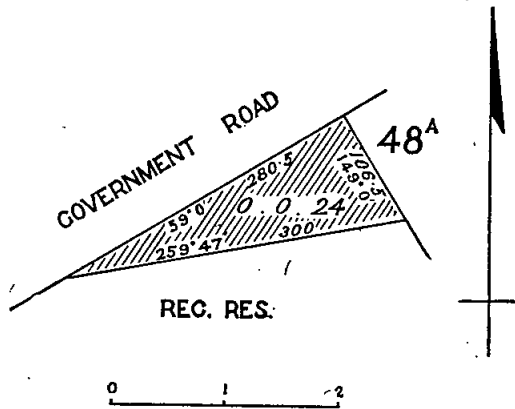

SANDHURST (BENDIGO).—The temporary reservation by Order in Council of the 29th October, 1963, of 7 acres 1 rood 19 perches of land, at Bendigo, Parish of Sandhurst, as a site for a Municipal Depot, is about to be revoked.—(S.372⁽¹²³⁾) (Rs.8270).

SMYTHESDALE.—The temporary reservation, by Order in Council of the 26th May, 1874 (see *Government Gazette* 29th May, 1874, page 1018), of 2 acres of land in the Parish of Smythesdale (now in the Township of Smythesdale), as a site for Watering purposes, is about to be revoked.—(S.297⁽⁵⁾) (74.N.1299, J.32382).

ST. ARNAUD.—The temporary reservation, by Order in Council of the 11th November, 1913, of 41 acres 1 rood of land in the Parish of St. Arnaud as a site for the Supply of Gravel, revoked as to part by Order of the 18th August, 1953, is about to be revoked so far only as the portion containing 30 perches indicated by hatching on plan hereunder, is concerned.—(S.366^(*)) (C.56463).

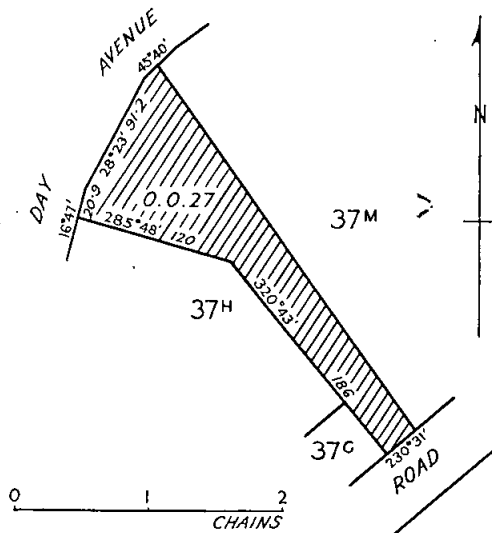

W. BORTHWICK,
Minister of Lands.

PROPOSED PERMANENT RESERVATION OF LAND AND REVOCATION AS TO PART OF ORDER IN COUNCIL.

IN pursuance of section 15 of the *Land Act 1958*, notice is hereby given that it is the intention of the Governor in Council to reserve permanently and to revoke as to part, certain land hereunder referred to, viz.:-

The following notice was published 1^o on the 9th September, 1970, pursuant to Order of the 1st September, 1970.

MAFFRA:—Land to be permanently reserved for Public purposes, Parish of Maffra, County of Tanjil; Crown land forming the new bed of the Macalister River, where the course of the said river has become altered since the 23rd May, 1881, as indicated by hatching on plan hereunder, and the Order in Council of the 23rd May, 1881 (see *Government Gazette* of the 27th May, 1881, page 1389) by which the beds of certain lakes, rivers and creeks specified therein, and Crown lands on the margins and banks thereof respectively were permanently reserved for Public purposes, is about to be revoked so far only as it relates to that portion of the bed of the Macalister River in the Parish of Maffra, County of Tanjil, as indicated by cross-hatching on plan hereunder, to which it is no longer applicable in consequence of the course of the said river having become altered after the date of the said Order.—(M89^(b)) (H.031117).

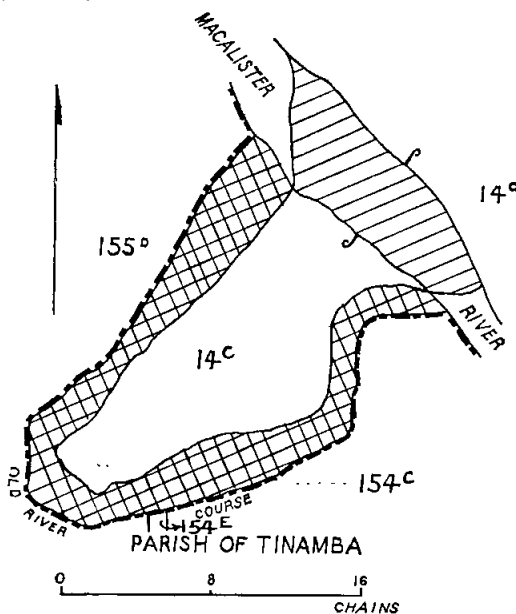

W. BORTHWICK,
Minister of Lands.

LOCAL LAND BOARDS.

IN pursuance of the provisions of section 34 of the *Land Act 1958*, notice is hereby given that a public hearing at the following place and time, will be conducted by the person mentioned, being duly appointed in that behalf.

W. BORTHWICK,
Minister of Lands.

Department of Crown Lands and Survey,
Melbourne.

SCHEDULE.

ROBINVALE, LAND INSPECTOR'S OFFICE, on Tuesday, the 29th September, 1970, at 10 a.m.—T. A. Comte (Corres. No. M.41663.)

COMMITTEES OF MANAGEMENT OF RESERVES.

APPOINTMENTS.

NOTICE is hereby given that, in pursuance of section 221 of the *Land Act 1958*, the following appointments of Committees of Management of reserved Crown lands have been made by the Minister of Lands:—

THE PUBLIC PURPOSES (DRAINAGE AND SEWERAGE) RESERVE, AT ALTONA, PARISH OF TRUGANINA.

The Melbourne and Metropolitan Board of Works as the Committee of Management of the lands in the Parish of Truganina, at Altona, temporarily reserved by Orders in Council dated the 30th November, 1965, and 26th May, 1970, as sites for Public purposes, and of so much of the permanent reservation for Public purposes along the Shore of Port Phillip Bay as abuts the land reserved by the last-mentioned Order, all of such lands being together indicated by pink colour on plan marked "B/1.6.65" attached to Lands Department Correspondence.—(Corres. No. Rs.8586.)

This appointment is made in lieu of all previous appointments with respect to the said land, which are hereby revoked.

"ANTWERP RECREATION RESERVE."

Jack M. Bond, Leslie W. Harders, Gordon S. Elliott, Roy T. Mallett, Ronald K. Bothe, Norman F. Kruger, Howard W. Greig, Dennis M. Hoffmann and Stanley D. Bell as a Committee of Management for a period of three (3) years of the land in the Parish of Banu Boniyit temporarily reserved by Order in Council dated the 31st October, 1928, as a site for Public Recreation and known as the "Antwerp Recreation Reserve".—(Corres. No. Rs.3780.)

"BARMAH PUBLIC HALL RESERVE."

Terrence O'Brien Tinkler, Hector Darcy Maloney, Maxwell Robert Moor, Clifford William Maloney, Bernard Joseph Maloney, Frances May Corry as a Committee of Management for a period of three (3) years of the land in the Township of Barmah temporarily reserved by Order in Council dated the 29th November, 1960, as a site for a Public Hall and known as the "Barmah Public Hall Reserve".—(Corres. No. Rs.7994.)

"CALIFORNIAN GULLY RECREATION RESERVE", MARYBOROUGH.

The Corporation of the City of Maryborough as the Committee of Management of the lands in the Township of Maryborough temporarily reserved by Orders in Council dated the 13th November, 1947, and 7th June, 1960, as sites for Public Recreation and Drainage purposes and of the remaining portion of the land in the same township temporarily reserved for the said purposes by Order in Council dated the 2nd October, 1951, and known as "Californian Gully Recreation Reserve".—(Corres. No. Rs.6079.)

"CHATSWORTH PUBLIC HALL RESERVE."

James Hearne, Ian Arthur MacNaughton, Frederick Charles Williamson, Peter Frederick Turner, Friedel Bast, Allan Edmonds, Alexander Neil Calvert, Alan James Shalders as a Committee of Management for a period of three (3) years of the land in the Township of Chatsworth temporarily reserved by Order in Council dated the 27th July, 1915, as a site for a Public Hall and known as the "Chatsworth Public Hall Reserve".—(Corres. No. Rs.941.)

"CLUNES RECREATION, CONVENIENCE OR AMUSEMENT OF THE PEOPLE RESERVE."

Alan Stanley Featherston, Mavis Lena Rieniets, D. A. Hill, Ugo Vito Vittoria, Terence Joseph Rieniets, A. D. Ross, Robert Edward Jones, Colin James Henderson-Drife

and Thelma Jona Annear as a Committee of Management for a period of three (3) years of the land in the Township of Clunes permanently reserved as a site for Recreation, Convenience or Amusement of the People.—(Corres. No. Rs.8830.)

“DRUMBORG PUBLIC HALL AND RECREATION RESERVE.”

William Bowles Hodzman, Stanley Roy Barr, Leslie Herbert Smith, James Francis Stuchbery, Ross Arthur Heinze, Thomas William Pola, and James Vincent Cunningham as a Committee of Management for a period of three (3) years of the land in the Parish of Drumborg temporarily reserved by Order in Council dated the 15th January, 1952, as a site for a Public Hall and Public Recreation and known as the “Drumborg Public Hall and Recreation Reserve”.—(Corres. No. Rs.1702.)

“GEELONG AND DISTRICT MEMORIAL SWIMMING POOL.”

John Emanuel Lakis, for so long only as he continues to be a Councillor and the elect of the Council of the City of Geelong, in the place of Victor Frederick Lambert, resigned, as a member of the Committee of Management of the land in the City of Geelong, Parish of Corio as is indicated by red colour on plan C/28.8.70 attached to Lands Department correspondence C99773 and known as the “Geelong and District Memorial Swimming Pool Reserve”.—(Corres. No. C99773.)

“GISBORNE PUBLIC PURPOSES (PLANTATION) RESERVE.”

The Corporation of the Shire of Gisborne as the Committee of Management of the land in the Township of Gisborne temporarily reserved as a site for Public purposes (Plantation) by Order in Council dated the 4th August, 1970, and known as the “Gisborne Public Purposes (Plantation) Reserve”.—(Corres. No. Rs.9346.)

“KATANDRA RECREATION RESERVE.”

Denis F. Lane, Kenneth P. Briggs, Robert Desmond Della-Vedova, Ronald E. Ford, Ernest Robert Kleinitz, John Ernest Jones, and Richard Charles Le Lievre as a Committee of Management for a period of three (3) years of the land in the Township of Katandra temporarily reserved by Order in Council dated the 12th July, 1960, as a site for Public Recreation and known as the “Katandra Recreation Reserve”.—(Corres. No. Rs.7943.)

THE LAKES ENTRANCE FORESHORE RESERVE.

The Corporation of the Shire of Tambo as the Committee of Management of that portion of the Lakes Entrance Foreshore Reserve as is shown coloured red on plan LE/24.8.70 attached to Lands Department Correspondence No. Rs.9350.—(Corres. No. Rs.9350.)

“LORQUON RECREATION RESERVE.”

Victor Herman Deckert, Roy Vincent Morrison, Leo John Purtle, Colin Graham Pipkorn, Stanley Robert Morrison, Edgar Roy Borgelt, Roy James Duthie, Clifford Thomas Dodds, and Norman Wilfred Schneider as a Committee of Management for a period of three (3) years of the land in the Township of Lorquon temporarily reserved by Orders in Council dated the 9th April, 1923, and 19th February, 1957, as a site for Recreation purposes and known as the “Lorquon Recreation Reserve”.—(Corres. No. Rs.2183.)

“MUCKATAH RECREATION RESERVE.”

Daniel Kennedy, Desmond Nunan, Trevor Ennals, Kenneth McKenzie, Lindsay Carter, Vincent Kennedy, Thomas Joseph Kennedy, John Joseph Parnell and James Patrick Parnell as a Committee of Management for a period of three (3) years of the land in the Township of Muckatah temporarily reserved by Order in Council dated the 30th June, 1884, as a site for a Racecourse and other purposes of Public Recreation and known as the “Muckatah Recreation Reserve”.—(Corres. No. Rs.2367.)

“PRINCETOWN RESERVES.”

The Committee of Management of the Crown lands in the Township of Princetown as are indicated by yellow, blue and red colours on plan P/11.8.60 as the Committee of Management (for the period ending 3rd April, 1971) of the land coloured green on said plan attached to Lands Department Correspondence No. C76060. All the aforesaid lands are together known as the “Princetown Reserves”.—(Corres. No. C76060.)

8070/70.—3

“QUEENSCLIFF RECREATION RESERVE.”

John Andrew Monahan, Keith Edward Wayth, William Robert Thomson (for a period of three (3) years) and Francis Charles Heweston (for so long only as he continues to be the Commanding Officer of the Military Forces at Queenscliff) and John Richard Golightly, John Paul Hume and James Lindsey Jordan (for so long only as they shall continue to be Councillors and the elect of the Council of the Borough of Queenscliff) as a Committee of Management of the land in the Township of Queenscliff permanently reserved by Order in Council dated the 30th March, 1931, as a site for the Recreation of the People and known as the “Queenscliff Recreation Reserve”.—(Corres. No. Rs.4111.)

THE PUBLIC RECREATION (TENNIS) RESERVE, SMYTHESDALE.

Gordon Evan Lee, Michael James Walsh, Norma May Lee, Ross Muller, Robert Sydney McCallum, Basil Daniel Murphy, Dianne Edith Madden as a Committee of Management for a period of three (3) years of the land in the Township of Smythesdale temporarily reserved by Order in Council dated the 17th December, 1963, as a site for Public Recreation.—(Corres. No. Rs.8291.)

“TIEGA RECREATION RESERVE.”

Thomas Giles, William Murray Arbuckle, George Herbert Nunn, John Joseph Gibbins, John Maybell Gillespie, John Alexander Arbuckle, Alexander Lindsay Morrish as a Committee of Management for a period of three (3) years of the land in the Parish of Tiega temporarily reserved by Order in Council dated the 10th December, 1929, as a site for Public Recreation and known as the “Tiega Recreation Reserve”.—(Corres. No. Rs.3941.)

“TURRIFF WEST PUBLIC HALL AND RECREATION RESERVE.”

Cecil Edward Mitchell, Eric Arthur Finch, Maxwell Charles Jolly, Thomas Alick Ronney, John McCarthy Grace, Archibald Raymond Mitchell and Harold Thomas Finch as a Committee of Management for a period of three (3) years of the land in the Parish of Denning temporarily reserved by Orders in Council dated the 9th August, 1927, and the 25th September, 1928, as sites for a Public Hall and Public Recreation and known as the “Turri West Public Hall and Recreation Reserve”.—(Corres. Nos. Rs.963 & Rs.3761.)

“WARRACKNABEAL SHOW YARDS RESERVE.”

Rex John Schulz, Wilfred Arthur Hewitt, John Quinton King, Frederick George Hewitt, Sydney Orville Chivell, Norman Wilfred Schultz, Archibald Lachlan McLean, John Colin McKenzie and William George Powell as a Committee of Management for a period of three (3) years of the remaining portion of the lands in the Township of Warracknabeal reserved by Orders in Council dated the 26th February, 1889, 2nd April, 1889, 8th September, 1892, and 2nd May, 1922, as sites for Show Yards and known as the “Warracknabeal Show Yards Reserve”.—(Corres. No. Rs.11.)

“WHITTLESEA SWIMMING POOL RESERVE.”

William Edward Lees, Robert E. Witte, Max Beattie, Harvey Murray, Peter Cain and Edward Christopher Collis Hocking as a Committee of Management for a period of three (3) years of that portion of the land, in the Township of Whittlesea as is indicated by red colour on plan marked W/18.12.56, attached to Lands Department Correspondence C.86542, reserved as a site for a Public Park and known as the “Whittlesea Swimming Pool Reserve”.—(Corres. No. C.86542.)

“WILLOW GROVE PUBLIC HALL RESERVE.”

William Mervyn Erbs, James Harold Wisewould, Francis Richard Needham, Harold David Whittaker, Raymond James Arnott, William Henry Hunt, Arthur Charles Mether, Cyril Harcourt Williams and Allan William Browning as a Committee of Management for a period of three (3) years of the land in the Township of Willow Grove permanently reserved by Order in Council dated the 8th November, 1904, as a site for a Public Hall and known as the “Willow Grove Public Hall Reserve”.—(Corres. No. Rs.5365.)

“YENDON RECREATION RESERVE.”

Alan Thomas Harbour, Graeme Edward Carbury, Henry Gordon Bowers, Ralph Stevens, Leslie Herbert Trigg, and Douglas R. Gent as a Committee of Management for a period of three (3) years of the land in the Township of Yendon temporarily reserved by Order in Council dated

the 21st October, 1872, as a site for Recreation Purposes and Cricket Ground and known as the "Yendon Recreation Reserve".—(Corres. No. Rs.5326.)

W. BORTHWICK,
Minister of Lands.

Department of Crown Lands and Survey,
Melbourne, 3rd September, 1970.

PUBLIC SERVICE NOTICES

CORRIGENDA.

Victoria Government Gazette No. 82, 2nd September, 1970, page 3005.

Public Service Notice No. 547. Regulations.—Part IV.—Salaries and Increments.

THIRD SCHEDULE, PART B.

Class DR-3, Column 3, figures \$6,153 should read \$6,159.
Class DR-4, Column 3, figures \$6,759 should read \$6,753.

No. 551. *Public Service Act 1958, Section 50.*

REGULATIONS.—PART IV.—SALARIES AND INCREMENTS.

THE Public Service Board, in pursuance of the powers conferred by the *Public Service Act 1958*, hereby amends its Regulations as shown below :—

THIRD SCHEDULE.

PART B.

PROFESSIONAL DIVISION.

Scale of Rates of Annual Salaries.

QUANTITY SURVEYORS.

The salary scale shown is deleted and the following salary scale is inserted in lieu thereof—

Class.	Annual Salary of Each Subdivision of Each Class.						
	1.	2.	3.	4.	5.	6.	7.
	\$	\$	\$	\$	\$	\$	\$
Q-1 ..	4,008	4,264	4,478	4,822	4,951	5,382	5,857
Q-2 ..	6,055	6,269	6,601	6,801
Q-3 ..	7,050
Q-4 ..	7,693

SIXTH SCHEDULE.

TEMPORARY EMPLOYEES.

Designations of Positions and Rates of Salaries.

Department and Designation of Position.	Yearly Rate of Salary.		Increments (Annual).
	Minimum.	Maximum.	
	\$	\$	
<i>Delete the existing yearly rates of salary for the following positions and insert the rates shown hereunder in lieu thereof—</i>			
PUBLIC WORKS DEPARTMENT.			
Quantity Surveyor ..	4,008	5,857	p
TREASURY.			
<i>Housing Commission.</i>			
Quantity Surveyor ..	4,008	5,857	p

p Increments in accordance with the scale of rates of salaries as set out for Quantity Surveyor, Class "Q-1" in Part B of the Third Schedule.

This Regulation shall have effect as on and from the 6th September, 1970.

A. H. RIGG, Acting Chairman.
V. P. SCULLY, Secretary.

Office of the Public Service Board,
Melbourne, 4th September, 1970.

No. 553.

Public Service Act 1958, Section 50.

REGULATIONS.—PART IV.—SALARIES AND INCREMENTS.

THE Public Service Board, in pursuance of the powers conferred by the *Public Service Act 1958*, hereby amends its Regulations as shown below :—

SIXTH SCHEDULE.

TEMPORARY EMPLOYEES.

Designations of Positions and Rates of Salaries.

Department and Designation of Position.	Yearly Rate of Salary.		Increments (Annual).
	Minimum.	Maximum.	
	\$	\$	
GENERAL.			
<i>Delete—</i> Plumber	3,568	3,868	Σ
<i>Add—</i> Plumber	3,660	3,977	Σ
Σ See Regulation 97 (2)			

This Regulation shall have effect as on and from the 23rd August, 1970.

A. H. RIGG, Acting Chairman.

V. P. SCULLY, Secretary.

Office of the Public Service Board,
Melbourne, 21st August, 1970.

No. 554.

Public Service Act 1958, Section 50.

REGULATIONS.—PART IV.—SALARIES AND INCREMENTS.

THE Public Service Board, in pursuance of the powers conferred by the *Public Service Act 1958*, hereby amends its Regulations as shown below :—

FIFTH SCHEDULE.

TEMPORARY EMPLOYEES.

DEPARTMENT OF HEALTH

MENTAL HYGIENE.

Designations of Positions and Rates of Salaries.

Designation of Position.	Yearly Rate of Salary.Σ	
	Minimum.	Maximum.
	\$	\$
<i>Delete—</i> Painter	3,476	3,792
<i>Add—</i> Painter	3,531	3,849

Σ Annual increments shall be in accordance with those prescribed by Sub-Regulations 97 (2) and 97 (3), provided that in the case of the position of Assistant (Male), Administrative, the annual increments shall be in accordance with those prescribed by Part A of the Third Schedule.

This Regulation shall have effect as on and from the 23rd August, 1970.

A. H. RIGG, Acting Chairman

V. P. SCULLY, Secretary.

Office of the Public Service Board,
Melbourne, 21st August, 1970.

No. 552.

Public Service Act 1958, Section 50.

REGULATIONS.—PART IV.—SALARIES AND INCREMENTS.

THE Public Service Board, in pursuance of the powers conferred by the Public Service Act 1958, hereby amends its Regulations as shown below :—

FIFTH SCHEDULE.
TEMPORARY EMPLOYEES.
DEPARTMENT OF HEALTH.
MENTAL HYGIENE.

Designations of Positions and Rates of Salaries.

Designation of Position.	Yearly Rate of Salary. £	
	Minimum.	Maximum.
<i>Delete—</i> Plumber	\$ 3,568	\$ 3,868
<i>Add—</i> Plumber	3,660	3,977

£ Annual increments shall be in accordance with those prescribed by Sub-Regulations 97 (2) and 97 (3), provided that in the case of the position of Assistant (Male), Administrative, the annual increments shall be in accordance with those prescribed by Part A of the Third Schedule.

This Regulation shall have effect as on and from the 23rd August, 1970.

A. H. RIGG, Acting Chairman.
V. P. SCULLY, Secretary.

Office of the Public Service Board,
Melbourne, 21st August, 1970.

No. 555.

Public Service Act 1958, Section 50.

REGULATIONS.—PART IV.—SALARIES AND INCREMENTS.

THE Public Service Board, in pursuance of the powers conferred by the Public Service Act 1958, hereby amends its Regulations as shown below :—

SIXTH SCHEDULE.
TEMPORARY EMPLOYEES.

Designations of Positions and Rates of Salaries.

Department and Designation of Position.	Yearly Rate of Salary.		Increments (Annual).
	Minimum.	Maximum.	
GENERAL.	\$	\$	
<i>Delete—</i> Painter	3,476	3,792	£
<i>Add—</i> Painter	3,531	3,849	£
DEPARTMENT OF CROWN LANDS AND SURVEY.			
<i>Royal Botanic Gardens.</i>			
<i>Delete—</i> Signwriter	3,476	3,792	£
<i>Add—</i> Signwriter	3,531	3,849	£
£ See Regulation 97 (2)			

This Regulation shall have effect as on and from the 23rd August, 1970.

A. H. RIGG, Acting Chairman.
V. P. SCULLY, Secretary.

Office of the Public Service Board,
Melbourne, 21st August, 1970.

No. 550.

Public Service Act 1958, Section 39.

REGULATIONS.—PART IV.—SALARIES AND INCREMENTS.

THE Public Service Board, in pursuance of the powers conferred by the Public Service Act 1958, hereby amends its Regulations as shown below :—

FIRST SCHEDULE.

PROFESSIONAL DIVISION.

Amount of Salary Assigned to Offices in "Special" Class.

Office.	Yearly Rate of Salary.
	\$
DEPARTMENT OF AGRICULTURE.	
<i>Delete—</i> Chief of Division of Agricultural Chemistry ..	12,060
<i>Add—</i> Chief of Division of Agricultural Chemistry and Chief Chemist	12,060

A. H. RIGG, Acting Chairman.
V. P. SCULLY, Secretary.

Office of the Public Service Board,
Melbourne, 21st August, 1970.

TENDERS

PUBLIC WORKS DEPARTMENT

TENDERS will be received at Public Works Department, 2 Treasury-place, Melbourne, until TWO p.m. on dates shown and for purposes mentioned hereunder.

Particulars and tender forms available at Contracts Office, Room 8, Building Division, Parliament-place and at places indicated in brackets hereunder.

Abbreviations in brackets mean:—W.O.—Inspector of Works Office; P.S.—Police Station; C.S.—Consolidated School; H.E.S.—Higher Elementary School; H.S.—High School; Pr.S.—Primary School; T.S.—Technical School.

Tenders to be submitted on the Department's printed Tender Form and will not be received by telephone. All tenders must be on a "Firm Tender" basis. The lowest or any tender will not necessarily be accepted.

Address tenders to the Minister of Public Works, and endorse the envelope containing the tender "Tender for , closing Tuesday,

Hand delivered tenders to be placed in the Tender Box of the Public Works Department, located on the wall of the centre entrance foyer, Ground Floor, 2 Treasury-place, Melbourne.

No preliminary deposit is required with any tender, but a successful tenderer will be required to pay a deposit for any accepted tender of \$4,000 or over.

Tuesday, 15th September, 1970.

Building, Electrical and Mechanical Works.

Bennetswood.—Erection of a new toilet block, Primary School 4693.

Girgarre.—Internal and external repairs and renovations, Primary School 3971 and residence. (W.O., Shepparton.)

Hartwell.—External renovations, Primary School 4055.

Various.—Erection of additional classrooms at Lalor, Sunshine West and Werribee High Schools.

Watsonia.—Connexion to sewer, Technical School.

Miscellaneous.

Port Melbourne.—Supply and delivery of ten (10) only 30 cwt. capacity vans, Plant Depot, P.W.D.

Various.—Supply and delivery of London Type lighting fittings for the year ending 30th June, 1971, Schools and other Government Departments.

Tuesday, 22nd September, 1970.

Building, Electrical and Mechanical Works.

Auburn South.—Internal and external renovations, Pr.S.4183.

Framlingham Settlement.—Transfer and re-instatement of Primary School 4532 Residence to Colac Technical School. (W.O., Colac, Geelong, Hamilton, Warrnambool.)

Various.—Rates Contract 1970/71, Electrical services, Primary Schools.

Various.—Rates Contract 1970/71, Mechanical services, Primary Schools.

Furniture and Furnishings.

Various.—Supply of approximately 8,000 chairs, classroom, stacking, 13-in. for period ending 30th June, 1971, Education Department.

Site Works.

Ferntree Gully North.—Pavement, drainage and associated works, Primary School 4718.

Miscellaneous.

Burwood.—Supply, delivery and placing in position of kitchen equipment, Teachers' College.

Tuesday, 29th September, 1970.

Building, Electrical and Mechanical Works.

Ardeer.—Internal and external painting, Pr.S.4848.
Mont Park.—Treatment of concrete floors, tiling, &c., Wards M1, M2 and M3, Mental Hospital. (W.O., Mont Park Mental Hospital.)

Northcote.—Completion of external repairs and painting, High School.

Traralgon.—Erection of six (6) additional class-rooms in concrete veneer, Pr.S.4700. (W.O., Traralgon and Warragul.)

Traralgon.—Plenum heating for six additional class-rooms, Pr.S.4700. (W.O., Bairnsdale and Traralgon.)

Various.—Erection of science wings at High Schools, Altona North, Buckley Park, Merrilands, Newlands and Sunshine.

Furniture and Furnishings.

Sunbury.—Supply and laying of sheet vinyl to Wards F1 and M1, Mental Hospital.

Various.—Supply of various items of furniture and bedding for the period, 1st November, 1970, to 30th October, 1971, Schools and other Government Departments.

MURRAY BYRNE,
Minister of Public Works.

Public Works Department,
Melbourne, 3002, 7th September, 1970.

PRIVATE ADVERTISEMENTS

Town and Country Planning Act 1961 (Twelfth Schedule).

CITY OF KNOX PLANNING SCHEME 1965.

NOTICE THAT A PLANNING SCHEME HAS BEEN PREPARED AND IS AVAILABLE FOR INSPECTION.

Amendment No. 79, 1970.

NOTICE is hereby given that the Council of the City of Knox in pursuance of its powers under the *Town and Country Planning Act 1961*, has prepared a Planning Scheme for the purpose of amending the City of Knox Principal Scheme in respect of uses permitted in the Rural A, B and Rural Forest Zones.

A copy of the scheme has been deposited at the office of the City of Knox, Spring-street, Fern Tree Gully, and at the office of the Town and Country Planning Board, 5th Floor, 235 Queen-street, Melbourne, and will be open for inspection during office hours by any person free of charge.

Any persons affected by the Planning Scheme are required to set forth in writing all objections they may have, addressed to the Town Clerk, City of Knox, Spring-street, Fern Tree Gully, on or before the 9th day of October, 1970, and to state whether they wish to be heard in respect of their objections.

Dated 9th September, 1970.

6148 N. G. HAYNES, Town Clerk.

CITY OF CAMBERWELL.
RATING POLL.

A proposal to determine that the basis of levying of rates in the municipal district be changed from the use of unimproved capital value of rateable property alone to the use of unimproved capital value of rateable property

with respect to fifty per centum of the estimated revenue from such rates and of net annual value of rateable property with respect to the remainder of such Revenue.

I HEREBY give notice that at a Poll held before me on the 29th day of August, 1970, on the above proposal, the following valid votes were recorded:—

For the proposal	13,787
Against the proposal	21,890

Majority against the proposal 8,103

I therefore declare the said proposal to be duly lost.

I further certify that the number of valid votes recorded (35,677—Thirty-five thousand, six hundred and seventy-seven) formed at least one-third of the number of persons whose names are inscribed on the Municipal Roll (49,944—Forty-nine thousand nine hundred and forty-four).

31st August, 1970.

6128 L. F. CHEFFERS, Returning Officer.

CITY OF MALVERN.

BY-LAW No. 150.

The Brick Area and Site Requirement By-law.

NOTICE is hereby given that the Council of the City of Malvern has made a By-law pursuant to Clause 815 (a), (d) and (e) of the Uniform Building Regulations 1969 and section 926 (1) (o) and 198 (1) (a) of the *Local Government Act 1958*, numbered 150 and entitled "The Brick Area and Site Requirements By-law", for the purposes of—

(a) Prescribing areas in which no person shall construct or cause to be constructed any building the external walls of which are of material other than masonry or concrete;

(b) Adopting—

(i) the minimum area, depth and width of frontage specified in Column 5 of Table 804 of the Uniform Building Regulations 1969 as the minimum area, depth and width of frontage of land on which a building of Class I or Class II Occupancy shall be constructed throughout portions of the municipal district;

(ii) the minimum area, depth and width of frontage specified in Column 3 of Table 804 of the Uniform Building Regulations 1969, as the minimum area, depth and width of frontage of land on which a building of Class I or Class II Occupancy shall be constructed throughout portions of the municipal district;

(c) Specifying a minimum distance of the outer walls of any building of Class I or Class II Occupancy from frontage in excess of that provided respectively in Columns 3 and 5 of Table 804 of the Uniform Building Regulations 1969;

(d) Repealing City of Malvern By-law No. 139.

A true copy of the said By-law is open for inspection free of charge during office hours at the office of the Council, City Hall, Glenferrie-road, Malvern.

D. W. LUCAS, Town Clerk.

City Hall, Malvern, 3144. 6139

CITY OF PORT MELBOURNE.

LOAN No. 33.

Notice of Intention to Borrow the Sum of \$55,000 for Permanent Works and Undertakings.

NOTICE is hereby given that the Council of the City of Port Melbourne proposes to borrow the sum of Fifty-five thousand dollars on the credit of the municipal revenues of the Mayor, Councillors and Citizens of the said City, such sum to be raised by mortgage deed in accordance with the provisions of the *Local Government Acts*.

1. The maximum rate of interest that may be paid is 7.4 per cent. per annum.

2. The purpose for which the loan is to be applied is as follows:—

Capital Extensions—

Electric Supply Undertaking .. \$55,000.00

3. The period of loan shall be fifteen years.

4. The moneys borrowed shall be repayable by providing out of the municipal fund, 30 half-yearly instalments

of approximately \$3,065.82 including principal and interest on the 1st day of May and the 1st day of November in each year during the currency of the loan. The first instalment shall be payable on the 1st day of May, 1971.

5. Such moneys shall be repayable at the Australia and New Zealand Bank Limited, Melbourne, or at the Council's bankers, for the time being in Melbourne.

The plans and specifications and the estimate of the cost of the proposed works and a statement showing the proposed expenditure of the moneys to be borrowed are open for inspection at the Town Hall, Port Melbourne, during office hours.

6141

J. G. FARROW, Town Clerk.

CITY OF WARRNAMBOOL.

LOAN No. 89.

Notice of Intention to Borrow the Sum of \$30,000 for Permanent Works and Undertakings.

NOTICE is hereby given that the Council of the City of Warrnambool proposes to borrow the principal sum of Thirty thousand dollars (\$30,000), secured by a charge over the general rates of the municipality, such sum to be raised by the grant of a mortgage in accordance with the provisions of the *Local Government Act 1958*.

1. The maximum rate of interest that may be paid is 7.4 per cent. per annum.

2. The purposes for which the loan is to be applied are:—

(a) Princess-street kerb, channel and drainage	\$2,470
(b) Banyan-place kerb, channel and drainage	3,250
(c) Merri-street kerb, channel and drainage	3,960
(d) King-street kerb, channel and drainage	4,100
(e) Tylden-street kerb, channel and drainage	2,220
(f) Council proportion C.A.R. grant	14,000
	<u>\$30,000</u>

3. The period of the loan shall be fifteen years.

4. The moneys borrowed shall be repayable by providing out of the municipal fund 30 half-yearly instalments of approximately \$1,672.27 each, including principal and interest, on the 1st day of May and the 1st day of November during the currency of the loan. The first instalment shall be payable on the 1st day of May, 1971.

5. Such moneys shall be repayable to the Commissioners of The State Savings Bank of Victoria, at the office of the said Commissioners, corner Elizabeth and Bourke streets, Melbourne.

The plans and specifications and the estimate of the cost of the proposed works and a statement showing the proposed expenditure of the moneys to be borrowed are open for inspection at the office of the Council of the City of Warrnambool, Timor-street, Warrnambool.

Dated 8th September, 1970.

6127

K. L. ARNEL, Town Clerk.

Town and Country Planning Act 1961 (Twelfth Schedule).

SHIRE OF BENALLA PLANNING SCHEME 1953,
AMENDMENT No. 2, 1970 (SHIRE OF BENALLA).

NOTICE THAT A PLANNING SCHEME HAS BEEN PREPARED AND IS AVAILABLE FOR INSPECTION.

NOTICE is hereby given that the Shire of Benalla, in pursuance of its powers under the *Town and Country Planning Act 1961*, has prepared a Planning Scheme for the area referred to hereunder—

the whole of the Parish of Benalla, situate within the Shire of Benalla,
for the purpose of re-defining some of the uses permitted in the Agricultural Zone.

A copy of the scheme has been deposited at the Shire Office, Mair-street, Benalla, and at the office of the Town and Country Planning Board, Melbourne, and will be open for inspection during office hours by any person, free of charge.

Any persons affected by the Planning Scheme are required to set forth, in writing, all objections they may have, addressed to the Shire Secretary, Shire of Benalla, Shire Office, Mair-street, Benalla, on or before the 10th day of October, 1970, and to state whether they wish to be heard in respect of their objections.

Dated 7th September, 1970.

6120

E. C. BATES, Shire Secretary.

SHIRE OF BULN BULN.

CHANGE OF ROAD NAME.

IN accordance with the provisions of the *Local Government Act 1958*, the Council of the Shire of Buln Buln did at a meeting held on 17th August, 1970, order that the name of the road set out hereunder be changed:—

Old Name.—Station-street.

New Name.—Kelliher-road.

Location.—Shown on plans of subdivision Nos. 3192 and 4114, lodged in the Office of Titles.

6119

K. A. PRETTY, Shire Secretary.

Local Government Act, Section 326.

SHIRE OF KILMORE.

DECLARATION OF POLL.

I HEREBY give notice that a Poll held before me on the 27th day of August, 1970, on the proposal that, in future, rates be made and levied throughout the municipal district on the unimproved capital value basis, the following valid votes were recorded:—

For the Proposal	338
Against the Proposal	311

Informal votes numbered 10 and the number of persons whose names are inscribed on the municipal roll total 1,295. As a majority of the valid votes recorded are in favour of the proposal, I declare the proposal to be carried.

27th August, 1970.

6173

B. J. HOBAN, Returning Officer.

SHIRE OF KORUMBURRA.

LOAN No. 54—\$100,000.

Notice of Intention to Borrow the Sum of \$100,000 for Permanent Works and Undertakings.

NOTICE is hereby given that the Council of the Shire of Korumburra proposes to borrow the principal sum of \$100,000 secured by a charge over the general rates of the municipality, such sum to be raised by the grant of a mortgage in accordance with the provisions of the *Local Government Act 1958*.

1. The maximum rate of interest that may be paid is 7.40 per cent. per annum.

2. The purposes for which the loan is to be applied are:—

Purchase of Land for E'derly Citizens' Homes	\$12 0/0
Library Construction	25,000
Completion Stage 1 Little Commercial-street off Street Parking Scheme	38,000
Purchase of Mechanics Hall	25,000
	<u>\$100,000</u>

3. The period of the loan shall be 40 years.

4. The moneys borrowed shall be repayable by providing out of the municipal fund half-yearly instalments of principal and interest on the 11th day of June and the 11th day of December during the currency of the loan. The first instalment shall be payable on 11th June, 1971.

5. Such moneys shall be repayable to the Australian Mutual Provident Society, Bourke-street, Melbourne.

The plans, specifications and estimates of the proposed works and a statement showing the proposed expenditure of the moneys to be borrowed are open for inspection at the office of the Council, Commercial-street, Korumburra, during office hours.

6137

W. O. CLARK, Shire Secretary.

SHIRE OF LILLYDALE.

LOAN No. 100.

Notice of Intention to Borrow the Sum of \$15,000 for Permanent Works and Undertakings.

NOTICE is hereby given that the Council of the Shire of Lillydale proposes to borrow the sum of \$15,000 (Fifteen thousand dollars) secured by a charge over the general rates of the municipality, such sum to be raised by the grant of a mortgage in accordance with the provisions of the *Local Government Act*, for permanent works and undertakings within the municipality.

1. The maximum rate of interest that may be paid is 7.3 per centum per annum.

2. The purpose for which the loan is to be applied is for purchase of plant.

3. The period of the loan shall be ten years.

4. The moneys borrowed shall be repayable by providing out of the municipal fund nineteen (19) half-yearly instalments, including principal and interest of approximately

\$1,069.79 each on the 15th days of April and October, during the years 1971 to 1980, and a final instalment including principal and interest of approximately \$1,069.87 on the 15th day of October, 1980. The first instalment shall be payable on the 15th day of April, 1971.

5. Such moneys shall be repayable at the Australia and New Zealand Bank Limited, 148 Main-street, Lilydale.

The plans, specifications and an estimate of the cost of the proposed works are open for inspection at the Shire Office, Anderson-street, Lilydale, during office hours.
6142 F. O. KENT, Shire Secretary.

SHIRE OF MORNINGTON.
By-Law No. 123.

Meetings Procedure By-Law.

NOTICE is hereby given that the Council of the Shire of Mornington has made a by-law, numbered 123, under the Local Government Act 1958, as amended, and all other powers it thereunto enabling, for the purpose of regulating the proceedings of Council meetings, Committee meetings and other meetings conducted by the Shire of Mornington and for other purposes.

Notice is also hereby given that a copy of the above-mentioned by-law is available for inspection, free of charge, during office hours, at the office of the Council, Queen-street, Mornington.

6145 D. G. COLLINGS, Shire Secretary.

Town and Country Planning Act 1961 (Twelfth Schedule).

SHIRE OF MORNINGTON PLANNING SCHEME 1959.

NOTICE THAT A PLANNING SCHEME HAS BEEN PREPARED AND IS AVAILABLE FOR INSPECTION.

Amendment No. 55, 1970.

NOTICE is hereby given that the Council of the Shire of Mornington in pursuance of its powers under the Town and Country Planning Act 1961, has prepared a Planning Scheme for the following areas and purposes:—

Land fronting the following roads—Balnarring-road, Bay-road, Bentons-road, Bungower-road, Craigie-road, Derril-road, Dunns-road, Moorooduc-road, Oakbank-road, Racecourse-road, Range-road, Rickards-road, Tuerong-road and Tyabb-road—requiring that buildings be set back distances varying from 30 feet to 199 feet from the existing alignments.

Land in the Agricultural Zone—Ordinance Amendment requiring that buildings be set back 100 feet from any street alignment, where not otherwise specifically referred to in the Ordinance.

A copy of the scheme has been deposited at the office of the Council, Queen-street, Mornington, and at the office of the Town and Country Planning Board, 235 Queen-street, Melbourne, and will be open for inspection during office hours by any person free of charge.

Any persons affected by the Planning Scheme are required to set forth, in writing, all objections they may have addressed to the Shire Secretary, Mornington Shire Council, P.O. Box 78, Mornington, 3931, on or before the 9th day of October, 1970, and to state whether they wish to be heard in respect of their objections.

4th September, 1970.

6125 D. G. COLLINGS, Shire Secretary.

Town and Country Planning Act 1961 (Twelfth Schedule).

SHIRE OF MORNINGTON PLANNING SCHEME 1959.

NOTICE THAT A PLANNING SCHEME HAS BEEN PREPARED AND IS AVAILABLE FOR INSPECTION.

Amendment No. 56, 1970.

NOTICE is hereby given that the Council of the Shire of Mornington in pursuance of its powers under the Town and Country Planning Act 1961, has prepared a Planning Scheme for the following areas and purposes:—

Land being Crown allotments 18, 19, 20, 21, 22, 23 and 24, Section B, Township of Osborne, Parish of Moorooduc, County of Mornington fronting Latrobe-drive, Milloo-drive and Seppelt-avenue, Mount Martha—rezoning from Agricultural Zone to Special Uses "B" Zone.

A copy of the scheme has been deposited at the office of the Council, Queen-street, Mornington, and at the office of the Town and Country Planning Board, 235 Queen-street, Melbourne, and will be open for inspection during office hours by any person free of charge.

Any persons affected by the Planning Scheme are required to set forth, in writing, all objections they may have, addressed to the Shire Secretary, Mornington Shire Council,

P.O. Box 78, Mornington, 3931, on or before the 9th day of December, 1970, and to state whether they wish to be heard in respect of their objections.

4th September, 1970.

6126 D. G. COLLINGS, Shire Secretary.

SHIRE OF ORBOST.
ROAD DEVIATION ORDER.

IN pursuance of the powers conferred by sections 522 and 526 of the Local Government Act 1958, the Council of the Shire of Orbost doth hereby direct that the land in the Parish of Orbost, shown hatched in the plan hereunder, which was taken, purchased or acquired by it, shall be a public highway from and after the date of publication of this Order in the Government Gazette, and doth declare this such land shall be a public highway in lieu of the land shown cross hatched on the said plan.

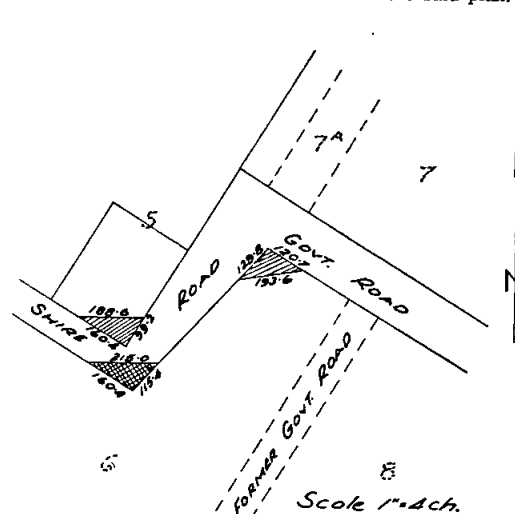

The common seal of the President, Councillors, and Ratepayers of the Shire of Orbost, was hereto affixed this 10th day of April, 1970, in the presence of—

S. J. W. LYNN, President.
J. A. TANNER, Councillor.
R. G. HEWSON, Shire Secretary.

6118

SHIRE OF RODNEY.
PROSECUTING OFFICER.

NOTICE is hereby given that Senior Constable F. C. Dempsey, No. 11678, has been appointed Prosecuting Officer for the Shire of Rodney, vice Sergeant P. Razga, No. 10532, resigned.

6123 R. PERRY, Shire Secretary.

SHIRE OF STRATHFIELDSAYE.

LOAN No. 12.

Notice of Intention to Borrow the Sum of \$25,000 for Permanent Works and Undertakings.

NOTICE is hereby given that the Council of the Shire of Strathfieldsaye proposes to borrow the principal sum of Twenty-five thousand dollars, secured by a charge over the general rates of the municipality, such sum to be raised by the grant of a mortgage in accordance with the provisions of the Local Government Act 1958.

1. The maximum rate of interest that may be paid is 7.4 per centum per annum.

2. The purposes for which the loan is to be applied is:—
Part cost of construction of Swimming Pool Complex in Brennan Park, Houlahan-street.

3. The loan is to be repayable over 30 years by 60 half-yearly instalments of \$1,042.90 on 27th May and 27th November in each year during the currency of the loan. The first instalment shall be repayable on the 27th May, 1971.

4. Such moneys shall be repayable to the Australian Mutual Provident Society, Melbourne.

The plans and specifications and the estimate of the cost of the proposed works and a statement, showing the proposed expenditure of the moneys to be borrowed, are open for inspection at the Office of the Council of the Shire of Strathfieldsaye, at the Shire Hall, Strathfieldsaye.

6146 M. BRENNAN, Shire Secretary.

**ORDER DECLARING CERTAIN LANDS TO BE
PUBLIC HIGHWAYS.**

UNDER the provisions of section 522 of the *Local Government Act 1958*, the Council of the Shire of Warracknabeal hereby orders that the following lands purchased by the Council shall be public highways:—

All the land contained in the following certificates of title:—Volume 6031, folio 1206042; volume 6706, folio 1341021; volume 4932, folio 986352; volume 8079, folio 927; volume 3884, folio 776619; volume 3391, folio 678083; volume 2026, folio 405184; volume 2444, folio 488706; volume 4161, folio 832116; volume 6089, folio 1217730; volume 3203, folio 640408; volume 5465, folio 1092982; volume 6435, folio 1286983; volume 5647, folio 1129242; volume 6413, folio 1282507; volume 6412, folio 1282387; volume 7534, folio 026; volume 8216, folio 441; volume 8240, folio 095; volume 8338, folio 927; volume 8338, folio 928; volume 8324, folio 879; volume 8260, folio 516; volume 8262, folio 166; volume 8262, folio 165; volume 8413, folio 613; volume 8453, folio 267; volume 8240, folio 096; volume 8240, folio 093; volume 8240, folio 094; volume 8671, folio 731; volume 8671, folio 963; volume 8673, folio 745; volume 8362, folio 967; volume 8760, folio 856; volume 8577, folio 284; volume 8606, folio 714; volume 8806, folio 667.

By the Order of the Council,

S. FELL, Shire Secretary.

21st August, 1970.

6121

**NOTICE OF PROPOSED SEWERAGE WASTEWATER
PURIFICATION AND DISPOSAL PROPOSALS.**

THE Mornington Sewerage Authority gives notice that general plans and a description of proposed sewerage works have been forwarded to the Minister of Water Supply for his approval and submission to the Governor in Council.

The proposals include the establishment of a new Wastewater Purification Plant upon a site approximating 190 acres which is located adjacent to the route proposed by the M. & M.B.W. for the South Eastern Outfall Sewer located between Craigie-road and Range-road, Mount Martha.

Copies of the general plans and description of the proposed works may be seen during office hours at:

1. The Mornington Civic Centre, Queen-street, Mornington.
2. The offices of the State Rivers and Water Supply Commission, 90 Orrong-road, Armadale.
3. The offices of the Commission of Public Health, 295 Queen-street, Melbourne.

Any person or corporation may make representations to the Minister of Water Supply concerning the proposed works during the period ending 23rd October, 1970.

Dated at Mornington the 9th day of September, 1970.

6117

D. G. COLLINGS, Secretary.

**NOTICE OF INTENTION TO APPLY FOR A LICENCE
TO DIVERT WATER AND CUT RACE (RE-ISSUE)
FROM THE RIVER MURRAY AT LAKE POWELL.**

WE hereby give notice that we intend to apply for a licence empowering us to divert water for a term of four years to the extent of 90 acre-feet per annum at a maximum rate of 8 acre-feet per day of 24 hours for the irrigation of vines, vegetables, pastures and cereal crops, being part of allotment 4A, Parish of Nenandie, and to occupy certain Crown lands for works of diversion, and to cut a race thereon.

Any objection to such application must be forwarded in writing to reach the State Rivers and Water Supply Commission, Melbourne, before 9th October, 1970, being 30 days from the first publication of this notice.

L. & F. ALEXIOU.

Robinvale.

6135

**NOTICE OF INTENTION TO APPLY FOR A LICENCE
TO DIVERT WATER AND CUT RACE FROM THE
LINDSAY CREEK AT LINDSAY POINT VIA REN-
MARK, VICTORIA.**

I HEREBY give notice that I intend to apply for a licence empowering me to divert water for a term of one year to the extent of 300 acre-feet per annum at a maximum rate of 2.5 acre-feet per day of 24 hours for the irrigation of an area of 100 acres, being part of Crown allotment 3A, Parish of Olney, and to occupy certain Crown lands for works of diversion, and to cut a race thereon.

Any objection to such application must be forwarded in writing to reach the State Rivers and Water Supply Commission, Melbourne, before 9th October, 1970, being 30 days from the first publication of this notice.

LINDSAY VINEYARDS.

RODNEY REVELT CANT.

Box 410, Renmark 5341.

6136

**NOTICE OF INTENTION TO APPLY FOR A LICENCE
TO DIVERT WATER AND CUT RACE FROM THE
HUME WEIR, AT TALLANGATTA.**

WE hereby give notice that we intend to apply for a licence empowering us to divert water for a term of four years to the extent of 30 acre-feet per annum at a maximum rate of 2 acre-feet per day of 24 hours, being part of allotment 3, section 1, Parish of Bolga, and to occupy certain Crown lands for works of diversion, and to cut a race thereon.

Any objection to such application must be forwarded, in writing, to reach the State Rivers and Water Supply Commission, Melbourne, before the 9th October, 1970, being 30 days from the first publication of this notice.

A. SMITH & SON.

Akuna-avenue, Tallangatta.

6178

NOTICE is hereby given that the Victorian Pipelines Commission has applied for a lease under section 134 of the *Land Act 1958*, for a term of 21 years, in respect of allotment 6A of section 6B in the Township of Lara and containing approximately 1 rood 17 perches as a site for a Gas Regulating and Metering Station.

5980

S. C. ARCHER, Secretary.

NOTICE is hereby given that the Trustees of the R.S.L. War Veterans Homes Trust of Victoria, have applied for a lease under section 134 of the *Land Act 1958*, for a term of twenty-one (21) years over allotment 226D, section B, Parish of Mildura, containing 2 roods and 39 perches, more or less for Public purposes (Homes for the Aged).

5922

NOTICE is hereby given that Hotham Heights Investments Pty. Ltd., has applied for a lease pursuant to section 134, *Land Act 1958*, for a term of 21 years in respect of an area in section B, Parish of Hotham as a site for the provision of accommodation and facilities for tourists (Flats). H.033940.

5879

NOTICE is hereby given that the partnership heretofore subsisting between John Lawrence Quinlivan and Thomas Charles Galvin, carrying on business as Dairy-farmers, at corner of Brown's-road and Princes Highway, Werribee, under the style or firm name of "J. L. Quinlivan & T. C. Galvin" has been dissolved.

Dated the 28th day of August, 1970.

6158

T. C. GALVIN.

**FIRST MILDURA CO-OPERATIVE HOUSING SOCIETY
LIMITED (IN LIQUIDATION).**

SPECIAL RESOLUTION PASSED 28TH AUGUST, 1970.

AT a Special General Meeting of the above-named society, duly convened and held at 148 Langtree-avenue, Mildura, on the 28th day of August, 1970, at 7.45 p.m., the sub-joined Special Resolution was duly passed:—

1. That the society having successfully completed its objectives twelve months ahead of its expected term, be wound up voluntarily, and that G. T. Stephenson, of 148 Langtree-avenue, Mildura, be appointed liquidator for the purposes of the winding up.
2. That the remuneration of the liquidator be fixed at \$172 or such lesser amount as is fixed by the Registrar of the Co-operative Housing Societies.
3. That the liquidator be empowered to compromise with debtors and/or creditors and/or contributories.

S. V. NICE, Chairman of Meeting.

6129

G. T. STEPHENSON, F.C.A., Secretary.

In the matter of the *Co-operative Housing Societies Act 1958*; and the *Companies Act 1961*; and in the matter of **FIRST MILDURA CO-OPERATIVE HOUSING SOCIETY LIMITED (in Liquidation)**.—Notice to Creditors.

NOTICE is hereby given that all persons having any claim against the above society are required, on or before the 30th day of September, 1970, to send their names and addresses and particulars of their debts or claims to G. T. Stephenson, 148 Langtree-avenue, Mildura, the liquidator of the said society, at his office, and if so required by notice, in writing, from the said liquidator are personally, or by their solicitors, to come in and prove their said debts or claims at such time and place as shall

be specified in such notice; or, in default thereof, they shall be excluded from the benefit of any distribution made before such debts or claims are so lodged or proved.

Dated at Mildura, this 1st day of September, 1970.

6130 G. T. STEPHENSON, F.C.A., Liquidator.

The Companies Act 1961.—In the matter of DON THOMSON MOTORS PTY. LTD.

NOTICE is hereby given that, at a meeting of the members of the above-named company held on the 3rd day of September, 1970, it was resolved that the company be wound up voluntarily, and at a meeting of the creditors held later the same day, pursuant to section 260, it was resolved that, for such purpose, Dennis John Cogle, of 545 St. Kilda-road, Melbourne, public accountant, be appointed liquidator.

Notice is also given that a first and final dividend is intended to be declared. Creditors who do not lodge proof of debt by 30th October, 1970, will be excluded.

Bent & Cogle, public accountants, Suite 18, 545 St. Kilda-road, Melbourne, 3004. 6138

The Companies Act 1961.—In the matter of SPRINGMONT SAND PTY. LTD. (in Liquidation).

NOTICE is hereby given that, pursuant to section 272 of the Companies Act, a Final General Meeting of the above company will be held at the offices of Bent & Cogle on Friday, 9th October, 1970, at 10 a.m.

Business:—To receive the liquidator's accounts.

Dated this 3rd day of September, 1970.

D. J. COUGLE, Liquidator.

Bent & Cogle, public accountants, Suite 18, 545 St. Kilda-road, Melbourne. 6140

In the Supreme Court of Victoria—1970 CO 7977.—In the matter of the Companies Act 1961; and in the matter of P.C.B. PASTORAL CO. PTY. LTD.

NOTICE is hereby given that a petition for the winding up of the above-named company by the Supreme Court was, on the 26th August, 1970, presented by the said company: And that the said petition is directed to be heard before the Court sitting at Melbourne in the Fourteenth Court at the hour of 10.30 o'clock in the forenoon on the 21st day of October, 1970; and any creditor or contributory of the said company desiring to support or oppose the making of an order on the said petition may appear at the time of hearing by himself or his counsel for that purpose; and a copy of the petition will be furnished to any creditor or contributory of the said company requiring the same by the undersigned on payment of the regulated charge for the same.

The petitioner's address is 14 St. Aubin's-avenue, North Caulfield.

The petitioner's solicitor is Mr. T. Irlight, of 447 Collins-street, Melbourne.

T. IRLICHT, solicitor for the petitioner.

NOTE.—Any person who intends to appear on the hearing of the said petition must serve on or send by post to the above-named solicitor for the petitioner notice, in writing, of his intention to do so. The notice must state the name and address of the person, or, if a firm, the name and address of the firm, and must be signed by the person or firm, or his or their solicitor (if any), and must be served, or if posted, must be sent by post in sufficient time to reach the above named not later than 4 o'clock in the afternoon of the 20th day of October, 1970. 6143

In the Supreme Court of the State of Victoria—1970 CO 7958.—In the matter of the Companies Act 1961; and in the matter of DONNEGAL DRAINAGE CO. PTY. LTD.

WINDING-UP order made:—The 28th day of August, 1970.

Name and address of liquidator:—Bruce Edward Fordham, of 170 Toorak-road, South Yarra.

Roy Schilling & Co., 330 Little Collins-street, Melbourne, solicitors for the petitioner. 6187

LUTWYCHE PTY. LTD. (IN VOLUNTARY LIQUIDATION).

NOTICE is hereby given that by a Resolution of the company, Richard Talbot Mims, of 545 Little Collins-street, Melbourne, was appointed liquidator of Lutwyche Pty. Ltd. on the 30th June, 1970, and that situation of the liquidator's office is care of Wm. Haughton & Co. Ltd., 545 Little Collins-street, Melbourne.

6166

R. T. MIMS, Liquidator.

The Companies Act 1961.

F. J. THOMAS PROPRIETARY LIMITED
(IN VOLUNTARY LIQUIDATION.)

NOTICE CONVENING FINAL MEETING OF MEMBERS,
PURSUANT TO SECTION 272.

NOTICE is hereby given in pursuance of section 272 of the Companies Act 1961, that a General Meeting of the members of the above-named company will be held on the 16th day of October, 1970, at 11 a.m., at the office of Hughes, Fincher & Rodda, 343 Little Collins-street, Melbourne, for the purpose of having an account laid before them showing the manner in which the winding up has been conducted and the property of the company disposed of and hearing any explanation that may be given by the liquidator.

Dated this 7th day of September, 1970.

6190 NORMAN HARRIS, Liquidator.

Companies Act 1961, Section 254 (1).

STILL EARTH PUBLICATIONS PTY. LTD.

NOTICE OF RESOLUTION.

At an Extraordinary General Meeting of the members of Still Earth Publications Pty. Ltd., duly convened and held at the offices of Duesbury & Johnston, 446 Collins-street, Melbourne, on the 2nd day of September, 1970, the Special Resolution set out below was duly passed:—

It was resolved that the company be wound up voluntarily and that Mr. Andrew Ian Sinclair, chartered accountant, of 446 Collins-street, Melbourne, be appointed liquidator of the company.

Dated this 3rd day of September, 1970.

6191 S. REED, Director.

Companies Act 1961.—In the matter of JUDY ALLISON CREATIONS PTY. LTD., Notice Re Meeting of Creditors, Pursuant to Section 260.

NOTICE is hereby given that a meeting of creditors of the above-named company will be held at the Institute of Chartered Accountants, 23 McKillop-street, Melbourne, at 10.30 a.m., on the 25th day of September, 1970, the company having convened a meeting of its members for the same day for the purpose of considering a resolution that the company be wound up voluntarily.

Dated the 5th day of September, 1970.

V. JAMES, Director.

A. Neville Bird & Co., chartered accountants, 289 Flinders-lane, Melbourne. Telephone No. 63 2874. 6152

The Companies Act 1961.—In the matter of CASCADE SWIMMING POOLS PROPRIETARY LIMITED (in Voluntary Liquidation).

NOTICE is hereby given that at an Extraordinary Meeting of the members of the above-named company held on Friday, the 28th day of August, 1970, it was resolved that the company be wound up voluntarily and at a meeting of creditors held on Friday, the 28th day of August, 1970, it was resolved that for such purpose Scott Maurice Nunan, of Hall & Rose, chartered accountants, 254 Queen-street, Melbourne, be appointed liquidator.

Notice is also given that after 21 days from this date I shall proceed to distribute the assets. All creditors having any claim against the company should furnish particulars of same by that date, otherwise I shall proceed to distribute the assets without regard to their claim.

Dated this 1st day of September, 1970.

S. M. NUNAN, Liquidator.

Hall & Rose, chartered accountants, 254 Queen-street, Melbourne. 6159

Companies Act 1961.

PAULINE M. MITCHELL PROPRIETARY LIMITED.

NOTICE PURSUANT TO SECTION 254 (2) (b).

NOTICE is hereby given that at a General Meeting of members of this company, duly convened and held at 12 Merriwoola-street, East St. Kilda, on 27th August, 1970, the following Resolution was passed as a Special Resolution:—

“That the company be wound up voluntarily.”

And at the same meeting, Stanley William Yates, of 406 Lonsdale-street, Melbourne, was appointed liquidator for the purposes of the winding up.

6160

S. W. YATES, Liquidator.

Notice of Winding-up Order.—In the matter of BRUCTON HOTELS PTY. LIMITED.

WINDING-UP Order made on the 1st day of September, 1970.

Michael Joseph O'Keeffe, of 162A High-street, Ashburton, in the State of Victoria, liquidator.

G. A. HILFORD & CO., solicitor for the petitioner.

6162

P. C. GROSSER & CO., LIMITED (IN LIQUIDATION).

NOTICE is hereby given that a meeting of the members of P. C. Grosser & Co. Limited (in Liquidation) will be held at 71-79 Macquarie-street, Sydney, on Wednesday, 21st October, 1970 at 9.30 a.m., for the purposes of laying before the meeting an account showing how the winding up has been conducted and the property of the company disposed of.

Dated this 3rd day of September, 1970.

6167

E. G. F. HORNE, Liquidator.

McFARLANE AND BURNS PROPRIETARY LIMITED (IN LIQUIDATION).

NOTICE is hereby given that a meeting of the members of McFarlane and Burns Proprietary Limited (in Liquidation) will be held at 71-79 Macquarie-street, Sydney, on Wednesday, 21st October, 1970 at 9.35 a.m., for the purposes of laying before the meeting an account showing how the winding up has been conducted and the property of the company disposed of.

Dated this 3rd day of September, 1970.

6168

E. G. F. HORNE, Liquidator.

KOOL-SPA PRODUCTS PROPRIETARY LIMITED (IN LIQUIDATION).

NOTICE is hereby given that a meeting of the members of Kool-Spa Products Proprietary Limited (in Liquidation) will be held at 71-79 Macquarie-street, Sydney, on Wednesday, 21st October, 1970 at 9.40 a.m., for the purposes of laying before the meeting an account showing how the winding up has been conducted and the property of the company disposed of.

Dated this 3rd day of September, 1970.

6169

E. G. F. HORNE, Liquidator.

GEELONG CREAMERIES PROPRIETARY LIMITED (IN LIQUIDATION).

NOTICE is hereby given that a meeting of the members of Geelong Creameries Proprietary Limited (in Liquidation) will be held at 71-79 Macquarie-street, Sydney, on Wednesday 21st October, 1970 at 9.45 a.m., for the purposes of laying before the meeting an account showing how the winding up has been conducted and the property of the company disposed of.

Dated this 3rd day of September, 1970.

6170

E. G. F. HORNE, Liquidator.

Regulation 56.

Companies Act 1961.—In the matter of OAK MOTOR PANEL PTY. LTD. (IN VOLUNTARY LIQUIDATION).

NOTICE is hereby given that a First Dividend is intended to be declared in this matter. Creditors who have not proved their debt by the 24th day of September, 1970, will be excluded from the dividend.

Dated this 3rd day of September, 1970.

THOMAS DUNN MACLEAN, Liquidator.

T. D. Maclean & Company, consulting accountants, Suite 3, 545 St. Kilda-road, Melbourne, 3004. Telephone 51 1207.

6171

The Companies Act 1961.

BARKLY CAR SALES PTY. LTD.

AT a General Meeting of the members of the above-named company, duly convened and held at 209 Nicholson-street, Footscray, the following Special Resolution was duly passed:—

"That this company will be wound up voluntarily and that Frederick W. Rohl, of Bridge Inn-lane, Mernda, be appointed liquidator for the purpose of the winding up."

Dated this 30th day of June, 1970.

6144

FREDERICK W. ROHL, Director.

CREDITORS, next of kin and others having claims against the estate of Desmond Thomas McKinnar, late of 28 Clarke-street, Wangaratta, in the State of Victoria, public servant, deceased intestate (who died on the 1st day of February, 1970), are required to send details of their claims to the administrator of the deceased's estate, care of the under-mentioned solicitor, by the 30th day of November, 1970, after which date the administrator will convey or distribute the assets of the said deceased, having regard only to the claims of which he then has notice.

DENIS JOHNSTON, solicitor, corner Bridge and Nunn streets, Benalla. 6164

CREDITORS, next of kin and others having claims against the estate of Eileen Mary Madden (sometimes known as Eily Madden), late of 70 Leopold-street, South Yarra, spinster, deceased (who died on the 7th day of May, 1970), are required to send particulars to the executors, National Trustees, Executors and Agency Company of Australasia Limited, of 95 Queen-street, Melbourne, Geoffrey Madden of "Boiardo", Camperdown, gentleman, and Henry Phillip Madden of "Wyseworth", Howlong-road, Albury, in the State of New South Wales, gentleman, care of the said company at its address aforesaid, by the 16th day of November, 1970, after which date the said executors will distribute the assets, having regard only to the claims of which they then have notice.

BERNARD NOLAN & CO., solicitors, 595 Bourke-street, Melbourne. 6161

CREDITORS, next of kin and others having claims in respect of the estate of Daisy Miller Mander-Jones, late of 22 Normanby-street, Brighton, married woman, deceased (who died on the 13th day of March, 1970), and probate of whose will was granted to Robert Geoffrey Mander-Jones, of 22 Normanby-street, Brighton, student, are required to send particulars of their claims to the said executor, care of the under-mentioned solicitors, by the 12th day of November, 1970, after which date he will distribute the assets, having regard only to the claims of which he then has notice.

PEARCE & WEBSTER, solicitors, 430 Little Collins-street, Melbourne. 6155

CHARLES EDWARD HUBBARD, late of 26 Hatfield-street, North Balwyn, fireman, DECEASED.

CREDITORS, next of kin and others having claims in respect of the estate of the deceased (who died on the 20th day of May, 1969), are required by the executor, Kevin Anthony Hubbard, of 83 Vicki-street, Forest Hill, company secretary, to send particulars to him, care of the under-mentioned solicitors, by the 16th day of November, 1970, after which date the executor may convey or distribute the assets, having regard only to the claims of which he then has notice.

HEFFEY & BUTLER, solicitors, 358 Lonsdale-street, Melbourne. 6156

DONALD ALEXANDER STRONACH, late of 23 Meredith-street, Elwood, director, DECEASED.

CREDITORS, next of kin and others having claims in respect of the estate of the deceased (who died on the 6th February, 1970), are required by the administratrix, Rebecca Maldon Stronach, of 23 Meredith-street, Elwood, aforesaid, to send particulars to her, care of the undersigned by the 19th November, 1970, after which date the administratrix may convey or distribute the assets, having regard only to the claims of which she then has notice.

W. B. & O. McCUTCHEON, 150 Queen-street, Melbourne. 6157

DAISY HAYWOOD, formerly of 23 Percy-street, Brunswick, in the State of Victoria but late of 43 Shaftesbury-street, Coburg, in the said State, widow, DECEASED.

CREDITORS, next of kin and others having claims in respect of the estate of the deceased (who died on the 13th day of August, 1970), are required to send particulars of their claims to the executrices, Alethea Daisy Ellen Officer and Lois Elizabeth Craig, care of the under-mentioned solicitors, by the 10th day of November, 1970, after which date they will distribute the assets, having regard only to the claims of which they then have notice.

GERALD E. DELANY & CO., solicitors, 452 Lonsdale-street, Melbourne. 6163

CREDITORS, next of kin and others having claims in respect of the estate of John Green, late of Bethlehem Home for the Aged, Taylor-street, Specimen Hill, Bendigo, pensioner, deceased (who died on the 12th day of May, 1970), are to send particulars of their claims to National Trustees, Executors & Agency Co. of Australasia Ltd., of 46 Queen-street, Bendigo, by the 20th day of November, 1970, after which date it will distribute the assets, having regard only to the claims of which it then has notice.

HOGAN, HOGAN AND PETERSEN, 68 Bull-street, Bendigo, solicitors for the applicant. 6174

CREDITORS, next of kin and others having claims in respect of the will of Duncan Russell (also known as Duncan MacIntyre Russell), late of 262 Racecourse-road, Newmarket, in the State of Victoria, formerly grocer but late retired, deceased (who died on the 9th July, 1970), are requested to send particulars of their claims to the administratrix, Annie Marshalina Louisa Russell, care of the under-mentioned solicitor, by the 20th November, 1970, after which date she will distribute the assets, having regard only as to the claims of which she then has notice.

JOHN STEWART, solicitor, of 290 Racecourse-road, Newmarket. 6176

CREDITORS, next of kin and others having claims in respect of the estate of John Michael William Rowe, late of 30 Finsbury-street, Flemington, in the State of Victoria, retired, deceased intestate (who died on the 3rd day of June 1970), are requested to send particulars of their claims to the administratrix, Jean Caldwell Rowe, care of the under-mentioned solicitor, by the 20th day of November, 1970, after which date she will distribute the assets, having regard only as to the claims of which she then has notice.

JOHN STEWART, solicitor, of 290 Racecourse-road, Newmarket. 6177

LAURA MARY DUNKIN, late of 28 Rose-street, Doncaster, in the State of Victoria, widow, DECEASED.

CREDITORS, next of kin and others having claims in respect of the estate of the deceased, (who died on the 24th day of July, 1970), are required by the executrix, Evelyn Mary Pollard, of 28 Rose-street, Doncaster, in the said State to send particulars to her by the 10th day of November, 1970, after which date the executrix may convey or distribute the assets, having regard only to the claims of which she then has notice.

HALL & WILCOX, solicitors, 20 Queen-street, Melbourne. 6179

GRACE ANNIE MANBY, late of Flat 6, 402 Whitehorse-road, Surrey Hills, in the State of Victoria, gentlewoman, DECEASED.

CREDITORS, next of kin and others having claims in respect of the estate of the deceased, (who died on the 23rd of May, 1970), are required by the executrix, Kathleen May Kefford, of Flat 6, 402 Whitehorse-road, Surrey Hills, in the said State to send particulars to her by the 10th day of November, 1970, after which date the executrix may convey or distribute the assets, having regard only to the claims of which she then has notice.

HALL & WILCOX, solicitors, 20 Queen-street, Melbourne. 6180

ALFRED JAMES DOW, late of 8 Arundel-crescent, Surrey Hills, clerk.

CREDITORS, next of kin and others having claims in respect of the estate of the deceased, (who died on the 18th day of February, 1970), are required by The Perpetual Executors and Trustees Association of Australia Limited, of 100-104 Queen-street, Melbourne, to send particulars of their claims to the said company, by the 16th day of November, 1970, after which date it will convey or distribute the assets, having had regard only to the claims of which the company then has notice.

6186

CREDITORS, next of kin and others having claims in respect of the estate of Jean Frances Firth, late of 16 Pakenham-street, Blackburn, married woman (who died on the 7th October, 1969), are to send particulars of their claims to the Equity Trustees, Executors and Agency Company Limited, of 472 Bourke-street, Melbourne, by the 10th November, 1970, after which date it will distribute the assets, having regard only to the claims of which it then has notice.

MCCRACKEN & MCCRACKEN, solicitors, 414 Collins-street, Melbourne. 6182

CREDITORS, next of kin and others having claims in respect of the estate of Kevin Frederick Candy, late of 6 Pamela-grove, Lower Templestowe, insurance surveyor, deceased intestate (who died on the 24th May, 1970), are required by the administrator, The Trustees, Executors and Agency Company Limited, of 401 Collins-street, Melbourne, to send particulars of their claims in writing in the care of the said company prior to the 18th November, 1970, after which date the said administrator will distribute the assets, having regard only to the claims of which it then shall have had notice.

ROGERS & GAYLARD, solicitors, 51 Queen-street, Melbourne. 6183

CREDITORS, next of kin and others having claims in respect of the estate of William Arthur Poolman Flewelen, late of Flat 2, 36 Paxton-street, East Malvern, in the State of Victoria, gentleman, deceased (who died on the 8th day of May, 1970), are required to send particulars of their claims to The Trustees, Executors and Agency Company Limited, of 401 Collins-street, Melbourne, which company is one of the executors appointed by the will of the said deceased, by the 13th day of November, 1970, after which date it will distribute the assets of the said deceased, having regard only to the claims of which it shall then have had notice.

J. A. WILMOTH & SON, 4 Bank-place, Melbourne, solicitors for the estate. 6181

GILBERT VERE POTTER (the Elder), late of 70 Kars-street, Frankston, in the State of Victoria, retired labourer, DECEASED.

CREDITORS, next of kin, and others having claims in respect of the estate of the deceased (who died on the 4th day of July, 1969), are required by the executors, Gilbert Vere Potter (the Younger), of Hallam-road, Belgrave South, in the said State, carrier, and Raymond Slattery, of 12 Camphor-court, Doveton, in the said State, wire winder, to send particulars to them, care of the under-signed by the 30th day of November, 1970, after which date the executors may convey or distribute the assets, having regard only to the claims of which they then have notice.

F. R. MONOTTI & CO., solicitors, 13 Scott-street, Dan-denong. 6147

CREDITORS, next of kin, and others having claims in respect of the estate of Henry Havelock Rice, late of 21 Webster-street, Ballarat, railway employee, deceased (who died on the 28th day of October, 1969), are required to send particulars of their claims to the administratrix, Edna Alice Morva Stewart, c/o Oakley Thompson & Co., solicitors, of 626 Bourke-street, Melbourne, on or before the 11th day of November, 1970, after which date the said executrix will proceed to distribute the assets, having regard only to the claims of which she then has notice.

OAKLEY THOMPSON & CO., solicitors, 626 Bourke-street, Melbourne. 6150

ROY LAEL CORDNER, late of Beechworth Mental Hospital, Beechworth, retired accountant, DECEASED.

CREDITORS, next of kin, and others having claims in respect of the estate of the deceased (who died on the 9th day of May, 1970), are required by The Perpetual Executors and Trustees Association of Australia Limited, of 100-104 Queen-street, Melbourne, to send particulars of their claims to the said company by the 15th day of December, 1970, after which date it will convey or distribute the assets, having had regard only to the claims of which the company then had notice.

ALAN WAINWRIGHT & CO., solicitors, 397 Little Collins-street, Melbourne. 6151

ELEANOR JAMESINA FINLAY, formerly of "Killamont", Kyabram, late of 320 Wattletree-road, East Malvern, widow, DECEASED.

CREDITORS, next of kin and others having claims in respect of the estate of the deceased, (who died on the 4th February, 1969), are required by the personal representatives, The Union-Fidelity Trustee Company of Australia Limited, of 100 Exhibition-street, Melbourne, and James Graham Finlay, of "Killamont", Kyabram, to send particulars to them, care of the said company, by the 13th November, 1970, after which date the personal representatives may convey or distribute the assets, having regard only to the claims of which they then have notice.

HEDDERWICK, FOKES & ALSTON, 121 William-street, Melbourne. 6189

LILIAN MAY HOWELL, formerly of 13 Stinton-avenue, Newtown, Geelong, but late of Grace McKellar House, Ballarat-road, North Geelong, widow, DECEASED.

CREDITORS, next of kin, and others having claims in respect of the above-named deceased (who died on the 29th day of July, 1970), are required by Jack Athol Crawcour, of 87 Yarra-street, Geelong, solicitor, the applicant for probate of the will of the said deceased, to send particulars to him, care of the undersigned solicitors, by the 11th day of November, 1970, after which date the said applicant intends to convey or distribute the assets, having regard only to the claims of which he then has notice.

CRAWCOUR & FIKKERS, solicitors, 87 Yarra-street, Geelong. 6131

RUBY RASMUSSEN, late of 648 Lygon-street, Carlton, in the State of Victoria, widow, DECEASED.

CREDITORS, next of kin, and others having claims in respect of the estate of the deceased (who died on the 8th day of July, 1970), are required by the personal representative James Patrick Hennessy, of 186 Elgin-street, Carlton, aforesaid, solicitor, to send particulars to him by the 10th day of November, 1970, after which date the personal representative may convey or distribute the assets, having regard only to the claims of which he then has notice.

Dated the 2nd day of September, 1970.

J. P. HENNESSY, barrister and solicitor, 186 Elgin-street, Carlton. 6133

REGINA MAUD DOWIE, late of 12 Seven Mile-road, Trafalgar, in the State of Victoria, widow, DECEASED, intestate.

CREDITORS, next of kin, and others having claims in respect of the estate of the deceased (who died on the 12th day of June, 1970), are required by the applicant for grant of administration Hector Fellowes Miller, of 92 Great Valley-road, Glen Iris, to send particulars to him by the 16th day of November, 1970, after which date the applicant for grant of administration may convey or distribute the assets, having regard only to the claims of which he then has notice.

KEVIN DAVINE & SONS, solicitors, Contingent-street, Trafalgar. 6134

BERNARD ANDREW HAMILL, late of 19 Doncaster-road, North Balwyn, in the State of Victoria, gentleman.

CREDITORS, next of kin, and others having claims in respect of the estate of the deceased (who died on the 13th day of May, 1970), are required by the National Trustees, Executors and Agency Company of Australasia Limited, of 95 Queen-street, Melbourne, the applicant for a grant of administration to send particulars of their claims to the said applicant at the above-mentioned address, by the 9th day of November, 1970, after which date it will convey or distribute the assets, having regard only to the claims of which it then has notice.

MESSRS. GRANT & CO., solicitors, 108 Queen-street, Melbourne. 6154

CREDITORS, next of kin, and others having claims in respect of the estate of William Clements Jack Saunders (also known as William Clements John Saunders), late of 81 Leopold-street, South Yarra, retired merchandising director, deceased (who died on the 20th day of April, 1970), are to send particulars of their claims to his trustee, Francis Ronald Hector Macdonald at the office of the solicitors mentioned below, by the 13th day of November, 1970, after which date the trustee may convey or distribute the deceased's assets, having regard only to the claims of which he then has notice.

LYNCH & MACDONALD, solicitors, 118 Queen-street, Melbourne. 6153

LILLIAN EMERALD WICKS, formerly of 1973 Malvern-road, East Malvern, in the State of Victoria, but late of Kiverton Park Private Hospital, 16 Willis-street, Gardiner, in the said State, widow, DECEASED.

CREDITORS, next of kin and others having claims in respect of the estate of the deceased, (who died on the 2nd day of March, 1970), are required by the trustees, Stanley Wallace Wicks, of 12 Kyora-parade, North Balwyn, in the said State, retired army officer, and Mavis Lillian Ivy Hall, of 131 Maud-street, North Balwyn, in the said State, married woman, to send particulars to them by the 12th day of November, 1970, after which date the trustees may convey or distribute the assets, having regard only to the claims of which they then have notice.

HALL & WILCOX, solicitors, 20 Queen-street, Melbourne. 6184

Trustee Act 1958.

NOTICE TO CLAIMANTS.

PURSUANT to the Trustee Act 1958, creditors, next of kin and all other persons having claims in respect of the estate of any deceased person named below are required to send particulars to the legal personal representative or representatives at the addresses stated, after which date the representative or representatives will distribute the assets, having regard only to the claims of which notice has been received:—

Elizabeth Blake Lyon Penny, late of 27 Milford-street, Newport, widow, deceased, died on the 20th day of June, 1970.—Claims to the executor, Stewart Penny, of 27 Milford-street, Newport, patrolman, care of John F. Carroll, of 4 Paisley-street, Footscray, solicitor, by the 12th day of November, 1970. John F. Carroll, LL.B., solicitor, 4 Paisley-street, Footscray. 6165

ENA HEGGIE of 291 Latrobe-terrace, Geelong, spinster, and The Union-Fidelity Trustee Company of Australia Limited, of 100 Exhibition-street, Melbourne, the executors named in, and applicants for a grant of probate of, the will of Hazel Tully Heggie, late of 291 Latrobe-terrace, Geelong, spinster, deceased, (who died on the 5th day of July, 1970), require all creditors, next of kin and others having claims against the property or estate of the said deceased to send to the said executors and applicants in the care of The Union-Fidelity Trustee Company of Australia Limited at its branch office situate at 8 Malop-street, Geelong, particulars, in writing, of such claims on or before the 11th day of November, 1970, after which date the said executors and applicants intend to convey or distribute such property or estate to or among the persons entitled thereto, having regard only to the claims of which they shall then have notice.

CRAWCOUR & FIKKERS, solicitors, 87 Yarra-street, Geelong. 6132.

ETHEL BEATRICE MAY WOOLLER, late of 12 Pilmer-street, Bacchus Marsh, in the State of Victoria, widow, DECEASED.

CREDITORS, next of kin and others having claims in respect of the estate of the deceased, (who died on the 16th day of March, 1970), are required by the trustee, Harold Samuel Hannah, of 5 Boyd-street, Bacchus Marsh, in the said State, to send particulars to him by the 10th day of November, 1970, after which date the trustee may convey or distribute the assets, having regard only to the claims of which he then has notice.

HALL & WILCOX, solicitors, 20 Queen-street, Melbourne. 6185

CREDITORS, next of kin and others having claims in respect of the estate of Garnet Hatherley Dowling, late of "Carinya", Glenburnie-road, Mitcham, in the State of Victoria, gentleman, deceased, (who died on the 14th day of April, 1970), are required by the executor, The Union-Fidelity Trustee Company of Australia Limited, of 100 Exhibition-street, Melbourne, to send particulars of their claims to the executor, care of the undersigned solicitors, by the 12th day of November, 1970, after which date it will distribute the assets, having regard only to the claims of which it then has notice.

FREDERICK OWEN & ASSOCIATES, solicitors, 84 William-street, Melbourne. 6188

In the Supreme Court of the State of Victoria.
SALE BY THE SHERIFF.

ON Friday, the 16th of October, 1970, at 10 a.m., at the Police Station, Footscray (unless process be stayed or satisfied):—

All the estate and interest (if any) of Paraskewia Skoryn, of 571 Barkly-street, West Footscray, as proprietor of an estate in fee-simple in the land described in certificate of title, volume 8634, folio 238, upon which is erected a dwelling-house known as No. 571 Barkly-street, West Footscray.

Registered mortgage No. C.694876 affects the said estate and interest.

Terms: Cash only.

N. FROGLEY, Sheriff's Officer.

8th September, 1970.

6172

In the Supreme Court of the State of Victoria.

SALE BY THE SHERIFF.

ON Wednesday, the 21st day of October, 1970, at 2 p.m., at the Police Station, Shepparton (unless process be stayed or satisfied):—

All the estate and interest (if any) of James Albert Jackson, of Wyndham-street, Shepparton, plumber, as proprietor of an estate in fee-simple in the land described in certificates of title, volume 5751, folio 175, and volume 7093, folio 431, upon which is erected a 6-roomed weather-board dwelling and double garage. The property has a frontage of 701 feet to Wyndham-street, and a depth of 600 feet.

Registered mortgages Nos. B.270430 and D.163957 affects the said estate and interest.

Terms: Cash only.

Sergeant K. BROWN, Sheriff's Officer.

4th September, 1970. 6149

IMPOUNDINGS

ALEXANDRA.—Impounded in Alexandra Pound, at approximately 11.20 a.m., on 28th August, 1970, by Mr. R. Hunter, from Goulburn Valley Highway, near Thomson.

1 ewe with horns, no earmarks, no visible brand

If not claimed and expenses paid, to be sold on 18th September, 1970.

G. MAUDOUIT,
Poundkeeper.

6122—\$2.25

KEILOR.—Impounded in Keilor Pound.

1 dark-brown colt, hogged mane, white star on forehead, no visible brand

If not claimed and expenses paid, to be sold on 25th September, 1970.

C. M. MISSEN,
Poundkeeper.

6175—\$1.75

YINNAR.—Impounded in Yinnar Pound.

1 crossbred wether, full wool, no visible brand

1 crossbred ewe, full wool, blue brand on back

If not claimed and expenses paid, to be sold on 17th September, 1970.

J. HEESOM,
Poundkeeper.

6124—\$1.75

Subordinate Legislation Act 1962.

NOTICE OF MAKING OF STATUTORY RULES.

IN pursuance of the provisions of the Subordinate Legislation Act 1962 and the Regulations made thereunder, notice is given of the making of the following statutory rules:—

No.	Water Act 1958.	Price.
174/1970.	Local Water Authorities (Long Service Leave) (Amendment) Regulations 1970	10c
	Stock Diseases Act 1968.	
175/1970.	Stock Diseases Regulations 1970	50c
	Seeds Act 1958.	
176/1970.	Seeds (Pasture Seed Certification) Regulations 1970	25c
	Wheat Marketing Act 1969.	
177/1970.	Wheat Marketing (Further Amendment) Regulations 1970	10c
	Labour and Industry Act 1958.	
178/1970.	Labour and Industry (Board of Examiners—Fees and Allowances) (Amendment) Regulations 1970	10c
	Country Fire Authority Act 1958.	
179/1970.	Country Fire Authority (Loan No. 82) Regulations 1970	10c
	Marine Act 1958.	
180/1970.	The Marine (Radio Telephony) Regulations 1970	15c

Copies of these statutory rules may be purchased at the Sale of Publications Section of the Government Printing Office, located at Macarthur-street, Melbourne, 3002. If ordered by mail, remittance should be addressed to "The Government Printer, Box 203, P.O., North Melbourne, 3051", and should include 5c extra for postage. If a credit account is held at this office, no remittance is required with the mail order.

The annual subscription rate for Statutory Rules (including a Bound Volume) is \$15, payable in advance. The subscription year commences on 1st January.

C. H. RIXON,
Government Printer.

ACTS REPRINTED IN ACCORDANCE WITH THE AMENDMENTS INCORPORATION ACT 1958 (No. 6422), AND FOR SALE AT THE SALE OF PUBLICATIONS BRANCH OF THE GOVERNMENT PRINTING OFFICE, MACARTHUR-STREET, MELBOURNE, 3002

No.	(These prices do not include postage.)	Price.
6189.	Acts Interpretation (Second Reprint—Incorporating amendments up to No. 7681)	\$0 28
6191.	Administration and Probate Act (Fourth Reprint—Incorporating amendments up to No. 7874)	\$0 50
6194.	Agricultural Colleges (First Reprint—Incorporating amendments up to No. 7302)	\$0 15
7117.	Appeal Costs Fund Act 1964 (First Reprint—Incorporating amendments up to No. 7488)	\$0 25
6199.	Apprenticeship Act (Second Reprint—Incorporating amendments up to No. 7869)	\$0 40
6203.	Audit (First Reprint—incorporating amendments up to No. 7377)	\$0 35
6209.	Boiler Inspection (Incorporating amendments up to No. 7072)	\$0 18
6529.	Bread Industry Act 1959 (First Reprint—Incorporating amendments up to No. 7728)	\$0 30
6210.	Building Societies (Second Reprint—Incorporating amendments up to No. 7911)	\$0 40
6213.	Cancer Act 1958 (First Reprint—Incorporating amendments up to Act No. 7455)	\$0 35
6217.	Cemeteries (First Reprint—Incorporating amendments up to No. 7672)	\$0 30
6218.	Children's Court (Incorporating amendments up to No. 7084)	\$0 20
6219.	Children's Welfare (Second Reprint—Incorporating amendments up to No. 7084)	\$0 35
6220.	Clean Air (Incorporating amendments up to No. 6886)	\$0 10
6221.	Coal Mines (First Reprint—Incorporating amendments up to No. 7628)	\$1 05
6222.	Commercial Goods Vehicles (Second Reprint—Incorporating amendments up to No. 7358)	\$0 22
6839.	Companies Act 1961 (Second Reprint—Incorporating amendments up to No. 7332)	\$2 32
6225.	Co-operation (Second Reprint—Incorporating amendments up to No. 7083)	\$0 42
6226.	Co-operative Housing Societies (Second Reprint—Incorporating amendments up to No. 7575)	\$0 53
6228.	Country Fire Authority (Second Reprint—Incorporating Amendments up to No. 7476)	\$0 50
6229.	Country Roads (Second Reprint—Incorporating Amendments up to No. 7506)	\$0 60
6230.	County Court Act (First Reprint—Incorporating amendments up to No. 7420)	\$0 35
6231.	Crimes Act (Third Reprint—Incorporating amendments up to No. 7884, but not including No. 7876)	\$1 60
7060.	Dandenong Valley Authority Act 1963 (First Reprint—Incorporating amendments up to No. 7523)	\$0 35
6815.	Disposal of Uncollected Goods Act 1961 (First Reprint—Incorporating amendments up to No. 7181)	\$0 15
6236.	Dog (Second Reprint—Incorporating amendments up to No. 7065)	\$0 15
6238.	Drainage of Land (First Reprint—Incorporating amendments up to No. 7876)	\$0 15
6239.	Dried Fruits Act 1968 (First Reprint—Incorporating amendments up to No. 7337)	\$0 25
6240.	Education (First Reprint—Incorporating amendments up to No. 7533)	\$0 45
6241.	Electric Light and Power (First Reprint—Incorporating amendments up to No. 7315)	\$0 30
6242.	Employers and Employés (Incorporating amendments up to No. 6740)	\$0 18

ACTS REPRINTED IN ACCORDANCE WITH THE AMENDMENTS
INCORPORATION ACT 1958 (No. 6422)—*continued*.

No.	Price.
6243. Entertainments Tax (<i>First Reprint</i> —Incorporating amendments up to No. 7315) ..	\$0.25
6245. Estate Agents Act (<i>Third Reprint</i> —Incorporating amendments up to No. 7425) ..	\$0.50
6246. Evidence Act (<i>Third Reprint</i> —Incorporating amendments up to No. 7933) ..	\$0.65
7499. Extractive Industries Act 1966 (<i>First Reprint</i> —Incorporating amendments up to No. 7632) ..	\$0.35
6250. Fertilizers (Incorporating amendments up to No. 7142) ..	\$0.25
6251. Firearms (<i>Second Reprint</i> —Incorporating amendments up to No. 7484) ..	\$0.40
6252. Fisheries Act (<i>First Reprint</i> —Incorporating amendments up to No. 7389) ..	\$0.35
6916. Foreign Judgments Act 1962 (<i>First Reprint</i> —including amendments made by No. 7332) ..	\$0.15
6585. Forests (Pulpwood Agreement) (Incorporating amendments up to No. 6886) ..	\$0.15
6254. Forests (<i>First Reprint</i> —Incorporating amendments up to No. 7356) ..	\$0.60
6255. Friendly Societies (<i>First Reprint</i> —Incorporating amendments up to No. 7554) ..	\$0.60
6256. Fruit and Vegetables (<i>First Reprint</i> —incorporating amendments up to No. 6944) ..	\$0.30
6258. Game—(<i>First Reprint</i> —Incorporating amendments up to No. 7389) ..	\$0.30
6259. Gaols (Incorporating amendments up to No. 6651) ..	\$0.15
6260. Gas and Fuel Corporation (<i>First Reprint</i> —Incorporating amendments up to No. 7422) ..	\$0.70
6261. Gas Regulation (<i>First Reprint</i> —Incorporating amendments up to No. 7580) ..	\$0.30
6262. Geelong Harbor Trust (<i>First Reprint</i> —Incorporating amendments up to No. 7547) ..	\$0.45
6263. Geelong Waterworks and Sewerage (<i>First Reprint</i> —Incorporating amendments up to No. 7547) ..	\$0.75
6265. Goods (<i>Third Reprint</i> —Incorporating amendments up to No. 7131) ..	\$0.35
6266. Grain Elevators (<i>First Reprint</i> —Incorporating amendments up to No. 7486) ..	\$0.35
6270. Health (<i>Second Reprint</i> —Incorporating amendments up to No. 7490) ..	\$1.65
6933. Home Finance Act 1962 (<i>First Reprint</i> —Incorporating amendments up to No. 7363) ..	\$0.25
6274. Hospitals and Charities (<i>Second Reprint</i> —Incorporating amendments up to No. 7455) ..	\$0.50
6275. Housing (<i>First Reprint</i> —Incorporating amendments up to No. 7507) ..	\$0.85
6279. Instruments (<i>Third Reprint</i> —Incorporating amendments up to No. 7315) ..	\$0.38
6282. Justices Act 1958 (<i>Third Reprint</i> —Incorporating amendments up to No. 7966) ..	\$1.40
6283. Labour and Industry (<i>Third Reprint</i> —Incorporating amendments up to No. 7410) ..	\$1.00
6284. Land (Incorporating amendments up to No. 7360) ..	\$1.53
6534. Land Settlement Act 1959 (<i>First Reprint</i> —Incorporating amendments up to No. 7328) ..	\$0.30
6289. Land Tax (<i>Second Reprint</i> —Incorporating amendments up to No. 7466) ..	\$0.40
6285. Landlord and Tenant (<i>Third Reprint</i> —Incorporating amendments up to No. 7332) ..	\$0.68
6286. Lands Compensation—(<i>First Reprint</i> —incorporating amendments up to No. 7332) ..	\$0.25
6290. Latrobe Valley (<i>First Reprint</i> —Incorporating amendments up to No. 7332) ..	\$0.35
6291. Legal Profession Practice (<i>Second Reprint</i> —Incorporating amendments up to No. 7539) ..	\$0.70
6295. Limitation of Actions (<i>Second Reprint</i> —Incorporating amendments up to No. 7457) ..	\$0.25
7145. Litter Act 1964 (<i>First Reprint</i> —Incorporating amendments up to No. 7608) ..	\$0.15
7695. Liquor Control Act 1968 (<i>First Reprint</i> —Incorporating Amendments up to No. 7753) ..	\$0.80
6298. Local Authorities Superannuation (<i>Second Reprint</i> —Incorporating amendments up to No. 7161) ..	\$0.40
6299. Local Government (<i>Second Reprint</i> —Incorporating amendments up to No. 7689) ..	\$4.00
6299. Local Government. New Parts X. and XI. (being a reprint of portion of No. 7835, as amended by No. 7847) ..	\$0.50
6302. Marine (Incorporating amendments up to No. 7350) ..	\$0.72
6301. Margarine Act (<i>First Reprint</i> —Incorporating amendments up to No. 7714) ..	\$0.18
6304. Marketing of Primary Products (<i>First Reprint</i> —Incorporating amendments up to No. 7491) ..	\$0.45

ACTS REPRINTED IN ACCORDANCE WITH THE AMENDMENTS
INCORPORATION ACT 1958 (No. 6422)—*continued*.

No.	Price.
6306. Marriage (<i>First Reprint</i> —Incorporating amendments up to No. 6959) ..	\$0.25
6309. Medical (<i>Second Reprint</i> —Incorporating amendments up to No. 7408) ..	\$0.40
6310. Melbourne and Metropolitan Board of Works (<i>Second Reprint</i> —Incorporating amendments up to No. 7547) ..	\$1.10
6311. Melbourne and Metropolitan Tramways (<i>First Reprint</i> —Incorporating amendments up to No. 7622) ..	\$0.70
6312. Melbourne Harbor Trust (<i>First Reprint</i> —Incorporating amendments up to No. 7356) ..	\$0.48
6605. Mental Health (Incorporating amendments up to No. 7135) ..	\$0.45
6315. Metropolitan Fire Brigades (Incorporating amendments up to No. 6886) ..	\$0.28
6316. Mildura Irrigation and Water Trusts (<i>First Reprint</i> —Incorporating amendments up to No. 7448) ..	\$0.75
6317. Milk and Dairy Supervision (Incorporating amendments up to No. 6964) ..	\$0.40
6318. Milk Board (Incorporating amendments up to No. 7093) ..	\$0.22
6319. Milk Pasteurization (<i>First Reprint</i> —Incorporating amendments up to No. 7480) ..	\$0.15
6320. Mines (<i>First Reprint</i> —Incorporating amendments up to No. 7499) ..	\$1.90
6184. Monash University (<i>First Reprint</i> —Incorporating amendments up to No. 7533) ..	\$0.30
6324. Money Lenders (Incorporating amendments up to No. 6886) ..	\$0.25
6832. Motor Boating (Incorporating amendments up to No. 6961) ..	\$0.15
6325. Motor Car (<i>Third Reprint</i> —Incorporating amendments up to No. 7777) ..	\$1.03
6326. National Parks (Incorporating amendments up to No. 7275) ..	\$0.25
6328. Nurses (Incorporating amendments up to No. 6716) ..	\$0.20
6330. Partnership (<i>Second Reprint</i> —Incorporating amendments up to No. 7315) ..	\$0.25
6331. Patriotic Funds (<i>First Reprint</i> —Incorporating amendments up to No. 7338) ..	\$0.25
6257. Pesticides Act 1968 (<i>First Reprint</i> —Incorporating amendments up to No. 7595) ..	\$0.15
6889. Poisons Act 1962 (<i>Second Reprint</i> —Incorporating amendments up to No. 7588) ..	\$0.50
6337. Police Offences (<i>Second Reprint</i> —Incorporating amendments up to No. 7678) ..	\$0.28
6338. Police Regulation (Incorporating amendments up to No. 7081) ..	\$0.45
6340. Portland Harbor Trust (<i>First Reprint</i> —Incorporating amendments up to No. 7475) ..	\$0.35
6341. Pounds (<i>First Reprint</i> —Incorporating amendments up to No. 7315) ..	\$0.25
6342. Printers and Newspapers (<i>First Reprint</i> —Incorporating amendments up to No. 7876) ..	\$0.15
7494. Private Agents Act 1966 (<i>First Reprint</i> —Incorporating amendments up to No. 7646) ..	\$0.35
6890. Probate Duty Act 1962 (<i>Second Reprint</i> —Incorporating amendments up to No. 7762) ..	\$0.48
6344. Property Law (<i>Second Reprint</i> —Incorporating amendments up to No. 7750) ..	\$1.15
6349. Public Service (<i>Second Reprint</i> —Incorporating amendments up to No. 7356) ..	\$0.40
6350. Public Trustee (Incorporating amendments up to No. 6961) ..	\$0.35
6353. Racing (<i>Second Reprint</i> —Incorporating amendments up to No. 7691) ..	\$0.85
6355. Railways (<i>First Reprint</i> —Incorporating amendments up to No. 7475) ..	\$0.75
6564. Registration of Births Deaths and Marriages Act 1959 (<i>First Reprint</i> —Incorporating amendments up to No. 7332) ..	\$0.25
6359. Road Traffic (<i>Second Reprint</i> —Incorporating amendments up to No. 7332) ..	\$0.18
6360. Rural Finance (<i>First Reprint</i> —Incorporating amendments up to No. 7328) ..	\$0.15
6846. Rural Finance and Settlement Commission Act 1961 (<i>First Reprint</i> —Incorporating amendments up to No. 7332) ..	\$0.30
2596. River Murray Waters Act 1915 (<i>First Reprint</i> —Incorporating amendments up to No. 7061) ..	\$0.35
6917. Sale of Human Blood Act 1962 (<i>First Reprint</i> —Incorporating amendments from No. 7332) ..	\$0.10
6975. Sale of Land Act 1962 (<i>First Reprint</i> —Incorporating amendments up to No. 7332) ..	\$0.18
6363. Second-hand Dealers (<i>First Reprint</i> —Incorporating amendments up to No. 7529) ..	\$0.25

ACTS REPRINTED IN ACCORDANCE WITH THE AMENDMENTS
INCORPORATION ACT 1958 (No. 6422)—*continued.*

No.	Price.
6367. Settled Land (<i>Second Reprint</i> —Incorporating amendments up to No. 7065) ..	\$0.50
6368. Sewerage Districts (<i>Second Reprint</i> —Incorporating amendments up to No. 7547) ..	\$0.75
6809. Sheep Owners Protection Act 1961 (<i>First Reprint</i> —Incorporating amendments up to Act No. 7756) ..	\$0.15
6651. Social Welfare Act 1960 (<i>Third Reprint</i> —Incorporating amendments up to No. 7332) ..	\$0.20
6372. Soil Conservation and Land Utilization (Incorporating amendments up to No. 6961) ..	\$0.20
6373. Soldier Settlement (<i>First Reprint</i> —Incorporating amendments up to No. 7328) ..	\$0.42
6375. Stamps (<i>Fourth Reprint</i> —Incorporating amendments up to No. 7698) ..	\$1.18
6377. State Electricity Commission (<i>Second Reprint</i> —Incorporating Amendments up to No. 7421) ..	\$0.65
6378. State Relief Committee (<i>First Reprint</i> —Incorporating amendments from No. 6886) ..	\$0.10
6379. State Savings Bank (Incorporating amendments up to No. 6886) ..	\$0.42
6381. Stock and Share Brokers (<i>First Reprint</i> —Incorporating amendments up to No. 7444) ..	\$0.15
6383. Stock Foods (<i>First Reprint</i> —Incorporating amendments up to No. 7607) ..	\$0.28
6385. Street Trading (<i>First Reprint</i> —Incorporating amendments up to No. 7084) ..	\$0.15
6886. Subordinate Legislation (Incorporating amendments up to No. 6961) ..	\$0.15
6386. Superannuation (<i>First Reprint</i> —Incorporating amendments up to No. 7417) ..	\$0.60
6387. Supreme Court (<i>First Reprint</i> —Incorporating amendments up to No. 7522) ..	\$0.75
6391. Teaching Service (<i>First Reprint</i> —Incorporating amendments up to No. 7536) ..	\$0.35
4989. The Discharged Servicemen's Preference Act 1943 (<i>First Reprint</i> —Incorporating amendments up to No. 7788) ..	\$0.20
6277. The Industrial and Provident Societies Act 1958 (<i>First Reprint</i> —Incorporating amendments up to No. 7547) ..	\$0.35
6237. The Drainage Areas (<i>First Reprint</i> —Incorporating amendment up to No. 7276) ..	\$0.35
6303. The Marine Stores and Old Metals Act (<i>First Reprint</i> —Incorporating amendments up to No. 7876) ..	\$0.35
6832. The Motor Boating Act 1961 (<i>Second Reprint</i> —Incorporating amendments up to No. 6961) ..	\$0.30
7551. The Strata Titles Act 1967 (<i>First Reprint</i> —Incorporating amendments up to No. 7816) ..	\$0.45
6384. The Stock Medicines (<i>First Reprint</i> —Incorporating amendments up to No. 7726) ..	\$0.20
6401. The Trustee (<i>Third Reprint</i> —Incorporating amendments up to No. 7833) ..	\$0.55
6402. The Trustee Companies Act 1958 (<i>First Reprint</i> —Incorporating amendments up to No. 7858) ..	\$0.35
7223. Tomato Processing Industry (Uniform Agreement) Act 1964 (<i>First Reprint</i> —Incorporating amendments up to No. 7342) ..	\$0.15
6849. Town and Country Planning (<i>Second Reprint</i> —incorporating amendments up to No. 7819) ..	\$0.55
6397. Trade Unions (<i>First Reprint</i> —Incorporating amendments up to No. 6839) ..	\$0.20
6399. Transfer of Land Act (<i>Third Reprint</i> —Incorporating amendments up to No. 7551) ..	\$0.65
6400. Transport Regulation (<i>First Reprint</i> —Incorporating amendments up to No. 7358) ..	\$0.22
6879. Unclaimed Moneys (Incorporating amendments up to No. 6961) ..	\$0.12
6653. Valuation of Land Act 1960 (<i>Second Reprint</i> —Incorporating amendments up to No. 7333) ..	\$0.22
6407. Vegetation and Vine Diseases (<i>First Reprint</i> —Incorporating amendments up to No. 7423) ..	\$0.30
6409. Vermin and Noxious Weeds (<i>First Reprint</i> —Incorporating amendments up to No. 7463) ..	\$0.35
6410. Veterinary Surgeons (<i>First Reprint</i> —Incorporating amendments up to No. 7343) ..	\$0.15
7291. Victoria Institute of Colleges Act 1965 (<i>First Reprint</i> —Incorporating amendments up to No. 7644) ..	\$0.25
6413. Water (<i>Second Reprint</i> —Incorporating amendments up to No. 7590) ..	\$1.95
6414. Weights and Measures (<i>Second Reprint</i> —Incorporating amendments up to No. 7332) ..	\$0.32

ACTS REPRINTED IN ACCORDANCE WITH THE AMENDMENTS
INCORPORATION ACT 1958 (No. 6422)—*continued.*

No.	Price.
6416. Wills (<i>First Reprint</i> —Incorporating amendments up to No. 7238) ..	\$0.25
6419. Workers Compensation (<i>Third Reprint</i> —Incorporating amendments up to No. 7455) ..	\$0.65
6421. Youth Organizations Assistance (<i>First Reprint</i> —Incorporating amendments from No. 6651) ..	\$0.10

FIRST NOTIFICATION OF REPRINT.

6214. Carriers and Innkeepers (<i>First Reprint</i> —Incorporating amendments up to No. 7971) ..	\$0.15
---	--------

C. H. RIXON,
Government Printer.

STATE ACTS, 1969

COPIES of the following Acts of Parliament of Victoria may be obtained at the Government Printing Office, Sale of Publications Branch, off Parliament-place, Melbourne, phone 63 0321, extension 6181, or from any accredited agent, at the price set opposite to each (these prices do not include postage).

The annual subscription for State Acts 1969 et seq. is \$8 payable in advance.

Bound Volumes of State Acts are also available on a subscription basis of \$15 per annum.

No.	Price.
7786. Summary Offences (Sunday Newspapers) ..	\$0.10
7787. Town and Country Planning (Transitional Appeals) ..	\$0.10
7788. Discharged Servicemen's Preference (Amendment) ..	\$0.10
7789. Water (Amendment) ..	\$0.10
7790. Agricultural Education Cadetships ..	\$0.10
7791. Trustee (Amendment) ..	\$0.10
7792. Appeal Costs Fund (Amendment) ..	\$0.10
7793. Footscray (Lower Yarra Crossing Access Road) Land ..	\$0.10
7794. River Improvement (Amendment) ..	\$0.15
7795. Geelong Waterworks and Sewerage (Amendment) ..	\$0.15
7796. West Moorabool Water Board (Amendment) ..	\$0.10
7797. Sewerage Districts (Amendment) ..	\$0.15
7798. Drought Relief (Amendment) ..	\$0.10
7799. Legal Profession Practice (Amendment) ..	\$0.10
7800. Parliamentary Salaries and Superannuation (Administration) ..	\$0.10
7801. Protection of Animals (Penalties) ..	\$0.10
7802. Lotteries Gaming and Betting (Calcutta Sweepstakes) ..	\$0.10
7803. Belmont Common Recreation Ground Lands ..	\$0.10
7804. Listening Devices ..	\$0.10
7805. Coal Mines (Pensions) ..	\$0.10
7806. Marine (Amendment) ..	\$0.10
7807. Theatres (Amendment) ..	\$0.15
7808. Victorian Inland Meat Authority (Amendment) ..	\$0.10
7809. The Constitution Act Amendment (Electoral) ..	\$0.15
7810. Consolidated Revenue ..	\$0.10
7811. Gas and Fuel Corporation (Borrowing) ..	\$0.10
7812. Weights and Measures (Amendment) ..	\$0.10
7813. Health (Municipal Charges) ..	\$0.10
7814. Transfer of Land (Subdivision of Allotments) ..	\$0.15
7815. St. Vincent's Private Hospital (Guarantees) ..	\$0.10
7816. Strata Titles (Amendment) ..	\$0.15
7817. Sunday Entertainment (Evidence) ..	\$0.10
7818. Dried Fruits (Packing Houses) ..	\$0.10
7819. Town and Country Planning (Further Amendment) ..	\$0.10
7820. Milk Board (Amendment) ..	\$0.10
7821. Medical (Pharmaceutical Chemists) ..	\$0.10
7822. Melbourne Wholesale Fruit and Vegetable Market (Amendment) ..	\$0.10
7823. Education (Director-General) ..	\$0.10
7824. Wombat Bonuses ..	\$0.10
7825. Revocation and Excision of Crown Reservations ..	\$0.15
7826. Mildura Irrigation and Water Trusts ..	\$0.25
7827. South Melbourne (Roman Catholic Orphanage) Lands ..	\$0.15
7828. Racing (Amendment) ..	\$0.10
7829. Commercial Goods Vehicles (Tow Trucks) ..	\$0.10
7830. Stamps (Amendment) ..	\$0.15

STATE ACTS 1969—continued.

No.	Price.
7831. Gas and Fuel Corporation (Sale Undertaking)	\$0.15
7832. Melbourne (St. Kilda-road Underpass)	\$0.15
7833. Trustee (Authorized Investments)	\$0.10
7834. Consolidated Revenue	\$0.10
7835. Local Government	\$0.60
7836. Melbourne Wholesale Fruit and Vegetable Market (Advisory Committee)	\$0.10
7837. Teaching Service (Amendment)	\$0.10
7838. State Electricity Commission (Borrowing and Investing Powers)	\$0.10
7839. Motor Car (Amendment)	\$0.10
7840. Mines (Abolition of Courts)	\$0.30
7841. Manango (O'Shanessy River Watershed) Lands	\$0.10
7842. State Savings Bank (Amendment)	\$0.10
7843. Apprenticeship (Commission)	\$0.10
7844. Swan Hill Race-course and Golf-course Lands	\$0.15
7845. Imitation Milk	\$0.15
7846. Finance Brokers	\$0.25
7847. Local Government (Rating Exemptions)	\$0.15
7848. Labour and Industry (Amendment)	\$0.10
7849. Groundwater	\$0.30
7850. Consolidated Revenue	\$0.10
7851. Mental Health (Chairmanship)	\$0.10
7852. Instruments (Bills of Exchange Amendment)	\$0.10
7853. Supreme Court (Correction of Sentences)	\$0.10
7854. Summary Offences	\$0.10
7855. Church of England in Australia (Mount Shadwell Land)	\$0.10
7856. State Rivers and Water Supply Commission (Special Projects)	\$0.10
7857. Coal Mines (Pensions Increase)	\$0.10
7858. Trustee Companies (Burns Philp Trustee Company Limited)	\$0.10
7859. Latrobe Valley (Amendment)	\$0.10
7860. Maintenance (Amendment)	\$0.10
7861. Aboriginal Affairs (Amendment)	\$0.10
7862. Goods (Trade Descriptions)	\$0.10
7863. Marine Stores and Old Metals (Amendment)	\$0.15
7864. Fire Authorities (Borrowing Powers)	\$0.10
7865. Acts Interpretation (Time)	\$0.10
7866. Narre Worrان Lands	\$0.10
7867. Moorpanyal Lands	\$0.10
7868. Juries (Amendment)	\$0.10
7869. Apprenticeship (Regulations)	\$0.10
7870. Portland Lands Exchange	\$0.10
7871. Melbourne University (Property)	\$0.10
7872. Latrobe Valley (Lands for Ambulance Services)	\$0.10
7873. Ministry of Transport (Director of Transport)	\$0.10
7874. Administration and Probate (Foreign Grants)	\$0.10
7875. Road Traffic (Amendment)	\$0.10
7876. Justices (Amendment)	\$0.35
7877. Country Fire Authority (Amendment)	\$0.15
7878. Coal Mines (Accidents Relief)	\$0.10
7879. Preston School of Design and Free Library Land	\$0.10
7880. Lands Compensation (Costs and Expenses)	\$0.10
7881. Evidence (Bankers' Books)	\$0.10
7882. Transport Regulation (Financial)	\$0.10
7883. Railways (Surplus Lands)	\$0.10
7884. Abolition of Obsolete Offences	\$0.10
7885. Fire Brigades (Contributions)	\$0.15
7886. Gas	\$0.30
7887. Tobacco Leaf Industry Stabilization (Tobacco Quotas)	\$0.10
7888. The Constitution Act Amendment (Standing Appropriations)	\$0.10
7889. Legal Profession Practice	\$0.10
7890. Navigable Waters (Oil Pollution) (Amendment)	\$0.15
7891. Stamps (Mortgages)	\$0.10
7892. State Forests Loan Application	\$0.10
7893. Melbourne and Metropolitan Board of Works (Amendment)	\$0.15
7894. Wheat Marketing	\$0.25
7895. Revenue Deficits Funding	\$0.15
7896. Land Tax (Rates)	\$0.10
7897. Probate Duty	\$0.10
7898. Sale of Land (Amendment)	\$0.10
7899. Racing (Trotting Racing)	\$0.10
7900. Crown Proceedings (Forfeited Recognisances)	\$0.15
7901. Weights and Measures (Fees)	\$0.10
7902. Town and Country Planning (Compensation)	\$0.10
7903. Wheat Industry Stabilization (Amendment)	\$0.10
7904. Railway Loan Application	\$0.15
7905. North Melbourne Lands (Loans to Lessees)	\$0.10
7906. Theatres (Performance of Sacred Works)	\$0.10
7907. Marketing of Primary Products (Amendment)	\$0.15
7908. Water Supply Loan Application	\$0.25
7909. Health (Amendment)	\$0.15

STATE ACTS 1969—continued.

No.	Price.
7910. Superannuation (Amendment)	\$0.25
7911. Friendly Societies (Amendment)	\$0.15
7912. The Constitution Act Amendment (Conjoint Elections)	\$0.10
7913. Labour and Industry (Long Service Leave)	\$0.10
7914. Public Service (Amendment)	\$0.15
7915. Motor Car (Traffic Offenders)	\$0.10
7916. Motor Car	\$0.15
7917. Farm Produce Merchants and Commission Agents (Amendment)	\$0.25
7918. Education (Army Apprentices School)	\$0.10
7919. Legal Aid	\$0.15
7920. Educational Grants (Amendment)	\$0.10
7921. Crown Reservations (Revocation and Ex-cision)	\$0.15
7922. Firearms (Amendment)	\$0.10
7923. Labour and Industry (Further Amendment)	\$0.10
7924. Forests (Softwood Timber Agreement)	\$0.15
7925. Public Works Loan Application	\$0.15
7926. Metropolitan Fire Brigades (Amendment)	\$0.15
7927. Consolidated Revenue	\$0.10
7928. National Parks (Amendment)	\$0.25
7929. Railways (Offences)	\$0.10
7930. Tourist	\$0.15
7931. Country Roads (Amendment)	\$0.15
7932. Appropriation of Revenue	\$1.15

C. H. RIXON,
Government Printer.

STATE ACTS, 1970

COPIES of the following Acts of Parliament of Victoria may be obtained at the Government Printing Office, Sale of Publications Branch, off Parliament-place, Melbourne, phone 63 0321, extension 6181, or from any accredited agent, at the price set opposite to each (these prices do not include postage).

The annual subscription for State Acts 1969 et seq. is \$8 payable in advance.

Bound Volumes of State Acts are also available on a subscription basis of \$15 per annum.

No.	Price.
7933. Evidence (Boards and Commissions)	\$0.10
7934. The Constitution Act Amendment	\$0.10
7935. Coroners (Amendment)	\$0.10
7936. Town and Country Planning (Appeals Tribunal)	\$0.10
7937. Melbourne (Veterinary Schools) Lands	\$0.10
7938. Board of Inquiry (Corrupt Practices)	\$0.10
7939. Cabrini Private Hospital (Guarantees)	\$0.10
7940. Judges' Salaries and Allowances	\$0.10
7941. Instruments (Amendment)	\$0.10
7942. La Trobe University (Amendment)	\$0.10
7943. Business Names (Amendment)	\$0.10
7944. Acts Interpretation (Nationality)	\$0.10
7945. Dairy Products (Board Membership)	\$0.10
7946. Melbourne Harbor Trust (Amendment)	\$0.10
7947. Aboriginal Affairs (Amendment)	\$0.10
7948. River Murray Waters	\$0.15
7949. River Murray Waters (Dartmouth Reservoir)	\$0.10
7950. Western Port (Steel Works)	\$0.25
7951. Extractive Industries (Licences)	\$0.10
7952. Stamps (Salary or Wages)	\$0.10
7953. Melbourne Lands Exchange	\$0.10
7954. Public Officers Salaries and Allowances	\$0.15
7955. Ballarat (Sovereign Hill) Land	\$0.15
7956. Wombat Bonuses	\$0.10
7957. Richmond and Hawthorn Lands	\$0.15
7958. Solicitor-General (Pensions)	\$0.10
7959. Australia and New Zealand Banking Group	\$0.25
7960. Mildura Irrigation and Water Trusts (Amendment)	\$0.10
7961. Land Settlement (Financial)	\$0.10
7962. Securities Industry	\$0.35
7963. Mildura College Lands (Amendment)	\$0.10
7964. Door to Door (Sales) (Amendment)	\$0.15
7965. Consumer Protection	\$0.10
7966. Justices (Alternative Procedure)	\$0.15
7967. Summary Offences	\$0.10
7968. Local Government (Amendment)	\$0.30
7969. Motor Car (Falsification of Mileage)	\$0.10
7970. Marketable Securities	\$0.25
7971. Carriers and Innkeepers (Amendment)	\$0.10
7972. Cemeteries (Coburg Public Cemetery)	\$0.10
7973. Judges Pensions	\$0.10
7974. Victoria Institute of Colleges (Affiliated Colleges)	\$0.10
7975. Town and Country Planning (Responsible Authority)	\$0.10

STATE ACTS 1970—continued.

No.		Price.
7976.	Wheat Marketing (Special Quotas) ..	\$0.10
7977.	Joint Select Committee (Meat Industry) ..	\$0.10
7978.	Joint Select Committee (Road Safety) ..	\$0.10
7979.	Consolidated Revenue (Supply—July to September 1969-70) ..	\$0.10
7980.	Consolidated Revenue (Supplementary Estimates 1969-70) ..	\$0.10

C. H. RIXON,
Government Printer.

THE "VICTORIA GOVERNMENT GAZETTE".

SUBSCRIPTIONS.—The subscription, including postage, is \$10 per annum, or \$5 per half year, payable in advance.

Subscriptions are required for whole months, and must cover at least a half year.

Single copies are 20 cents, posted 25 cents. Subscribers do not receive the Acts of Parliament with the GAZETTE.

GAZETTES are held in stock for five years only.

PRIVATE ADVERTISEMENTS.—The charge for insertion is 25 cents per line single column, and 50 cents per line double column. The title forms one or more lines as a heading. On an average ten words make a line of single column. Every signature must likewise be counted as a line. The final words of a paragraph, though only portion of a line, must be counted as one line. Signatures (in particular) and proper names must be written very plainly in the text; ONE SIDE ONLY of each sheet of paper should be WRITTEN UPON.

All documents illegibly written will be returned unpublished, and where brands occur unprovided for by the ordinary letters of the alphabet, a worded explanatory description must be furnished.

THE VICTORIA GOVERNMENT GAZETTE is published on WEDNESDAY EVENING in each week, and Notices for insertion will be received by the Government Printer at or before ONE p.m. at ordinary rates, and late advertisements between ONE p.m. and FOUR p.m. at double rates on the day preceding the day of publication.

PAYMENTS.—Unless the advertiser has a credit account, all payments are required in advance. Remittances should be made by cheque, postal order, or money order payable to "GOVERNMENT PRINTER".

ADDRESS.—All communications should be addressed to "The Government Printer, Box 203, P.O., North Melbourne". 3051.

AGENTS FOR THE "VICTORIA GOVERNMENT GAZETTE".

THE following have been appointed agents to receive Advertisements and Subscriptions for the Victoria Government Gazette:—

- ARMSTRONG'S AGENCY, 205 Queen-street, Melbourne, Victoria 3000.
- ARNALL & JACKSON, 390 Barkly-street, Brunswick, Victoria 3056.
- BAIRNSDALE AUTHORIZED NEWSAGENCY, 132 Main-street, Bairnsdale, Victoria 3875.
- BICKNELL, M. J., Authorized Newsagent, 196 Timor-street, Warrnambool, Victoria 3280.
- BLANE'S AUTHORIZED NEWSAGENTS, 162 Murray-street, Colac, Victoria 3250.
- CARTER, R. G., ADVERTISING SERVICE PTY. LTD., Suite 24, 65 Queens-road, Melbourne, Victoria 3004.
- DAVIES, G. & M. V., 112 Gray-street, Hamilton, Victoria 3300.
- DAVIS, WM. (MILDURA) PTY. LTD., 126 Eighth-street, Mildura, Victoria 3500.
- DIXON'S NEWSAGENCY, 89 Firebrace-street, Horsham, Victoria 3400.
- EDGARS' AUTHORIZED NEWSAGENCY, 45 Bridge-street, Benalla, Victoria 3672.

- FRANKS, H., & CO., 184 Ryrie-street, Geelong, Victoria 3220.
- GATLEY, A. & J., 250 Lonsdale-street, Dandenong, Victoria 3175.
- GORDON & GOTCH AUSTRALASIA LTD., 467 Collins-street, Melbourne, Victoria 3000.
- GULLAN'S NEWSAGENCY, 88 Bridge-street, Ballarat, Victoria 3350.
- HAMPTON, A. C., 243 Mitchell-street, Bendigo, Victoria 3550.
- HARSTON, PARTRIDGE & CO. PTY. LTD., 455 Little Collins-street, Melbourne, Victoria 3000.
- KYNETON GUARDIAN PTY. LTD., P.O. Box 18, Kyneton, Victoria 3444.
- LATIMER'S, Newsagents, 45 Station-street, Malvern, Victoria 3144.
- LIVINGSTON'S SHEPPARTON NEWSAGENCY, 246 Wyndham-street, Shepparton, Victoria 3630.
- THE MERCANTILE EXCHANGE, 34 Queen-street, Melbourne, Victoria, 3000.
- MCGILL'S AUTHORIZED NEWSAGENCY, 183-5 Elizabeth-street, Melbourne, Victoria 3000.
- PHILLIPS AUTHORIZED AGENCY, 83 Murphy-street, Wangaratta, Victoria 3677.
- POWNEYS AUTHORIZED NEWSAGENCY, 293 Hargreaves-street, Bendigo, Victoria 3550.
- PURDIE, J., & CO., 138 Moorabool-street, Geelong, Victoria 3220.
- SALE AUTHORIZED NEWSAGENCY, 142 Raymond-street, Sale, Victoria 3850.
- SKINNER'S AUTHORIZED NEWSAGENCY, 49-51 Franklin-street, Traralgon, Victoria 3844.
- STEVENSON, A. C. & M., NEWSAGENTS, 132 Henty-street, Casterton, Victoria 3311.
- VERNONS OF RICHMOND, 162 Bridge-road, Richmond, Victoria 3121.
- VIEW POINT AUTHORIZED NEWSAGENCY, 4 View-Point, Bendigo, Victoria 3550.

A copy of the Gazette filed at each place for public reference.

CONTENTS

	PAGE
Acts of Parliament on Sale at the Government Printing Office	3064
Appointments	3038
Cemeteries—Scale of Fees	3034
Contracts	3038
Country Roads Board	3028
Estates of Deceased Persons	3037
Government Notices	3022
Holiday—Royal Agricultural Show	3022
Impoundings	3064
Lands	3049
Mining	3036
Notice to Mariners	3036
Notice of Making of Statutory Rules	3064
Orders in Council—	
Acts—Groundwater; Port Phillip Authority; Land; Country Roads; Local Government; Public Service; State Electricity Commission; Country Roads; Water; Sewerage Districts.	3040 et seq
Police Sales	3031
Private Advertisements	3056
Proclamations	3021
Public Holidays	3022
Public Service Notices	3054
Resignations	3039
Tenders	3055
Transport Regulation Board—Public Hearings	3023
Waterworks Trusts	3035