

[1971]



VICTORIA GOVERNMENT GAZETTE

Published by Authority

No. 56]

WEDNESDAY, JUNE 9

[1971

Government House,
Melbourne.

LEVEE AT PARLIAMENT HOUSE, MELBOURNE.

In honour of the Birthday of Her Majesty the Queen, His Excellency the Governor of Victoria, Major-General Sir Rohan Delacombe, K.C.M.G., K.C.V.O., K.B.E., C.B., D.S.O., K.St.J., will hold a Levee at Parliament House, Spring-street, Melbourne, at 9.45 a.m. on Saturday, 12th June, 1971.

On the occasion of the celebration of The Queen's Birthday, His Excellency is anxious to receive as many citizens as possible.

In accordance with previous custom, there will be no precedence in the order of presentation, but it is requested that members of services and all public bodies group themselves together for presentation, as far as possible.

It is requested that those entitled to wear uniform or official dress will do so on this occasion, but His Excellency will be pleased to receive those not entitled to wear uniform or official dress in their ordinary morning or business dress.

For the guidance of those attending the Levee, it will be appropriate, for those who wish to do so, to wear Honours, Decorations and Awards.

Private Entree Cards will admit recipients to the South Door of the Spring-street Entrance at Parliament House at 9.30 a.m. All other citizens are requested to enter by the North Door of the Spring-street Entrance at 10.15 a.m.

It is particularly desired that gentlemen attending the Levee should provide themselves with a card on which should be printed or typed in capitals, or written in block letters, their styles of address for presentation in order to facilitate announcement to His Excellency.

By His Excellency's Command,

W. H. A. BECKE, Lieutenant Colonel,
Private Secretary and Comptroller.

PROCLAMATIONS

Land Act 1958, Section 25.

TOWNSHIP OF WONTHAGGI EXTENDED.

PROCLAMATION

By His Excellency the Governor of the State of Victoria and its Dependencies in the Commonwealth of Australia, &c., &c., &c.

IN pursuance of the provisions of Section 25 (3) (d) of the Land Act 1958, I, the Governor of the State of Victoria, by and with the advice of the Executive Council of the said State, do hereby extend the Township of Wonthaggi, proclaimed as such on the 14th September, 1910, by the addition thereto of the portion indicated by hatching on plan hereunder.—(W.345⁽¹⁶⁾) (C.50025).

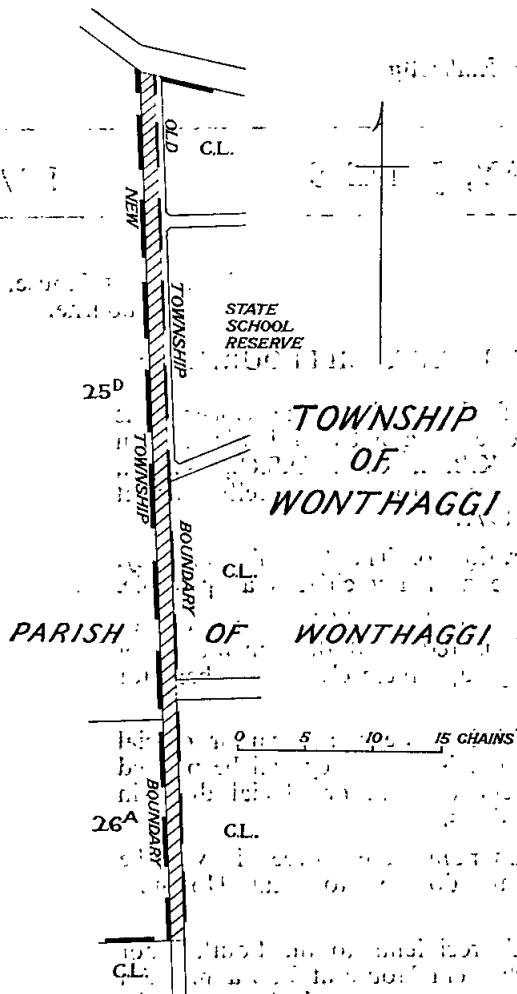

Given under my Hand and the Seal of the State of Victoria aforesaid, at Melbourne, this first day of June, in the year of our Lord One thousand nine hundred and seventy-one, and in the twentieth year of the reign of Her Majesty Queen Elizabeth II.
(L.S.) ROHAN DELACOMBE.

By His Excellency's Command,

W. BORTHWICK,
Minister of Lands.

GOD SAVE THE QUEEN!

Land Act 1958, Section 25.
ROADS PROCLAIMED.

PROCLAMATION

By His Excellency the Governor of the State of Victoria and its Dependencies in the Commonwealth of Australia, &c., &c., &c.

IN pursuance of the provisions of Section 25 (3) (c) of the Land Act 1958, I, the Governor of the State of Victoria, by and with the advice of the Executive Council of the said State, do hereby proclaim as roads the lands mentioned hereunder:—

Parish of Bellaura, County of Borung, being the land indicated by hatching on plan hereunder.—(B.572⁽⁴⁾) (C.98665).

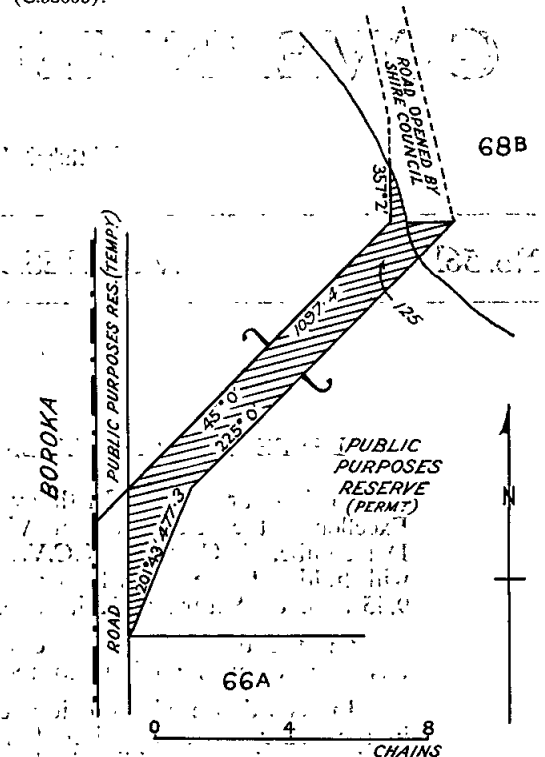

Parish of Mirampiram, County of Lowan, being the land indicated by hatching on plan hereunder.—(M.504⁽⁴⁾) (Z.23926).

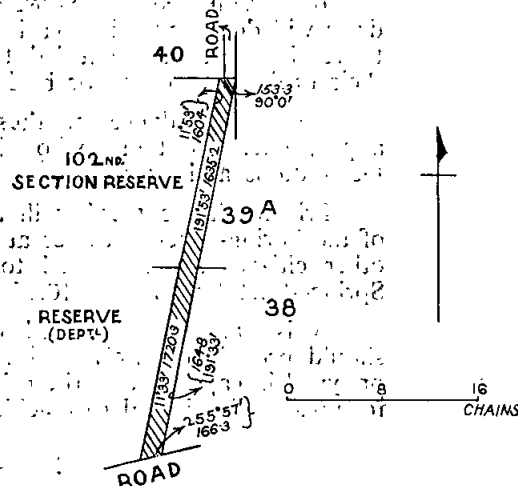

Township of Inverloch, Parish of Kirrak, County of Buln Buln, being the land indicated by hatching on plan hereunder.—(I.17⁽²⁾) (C.100246).

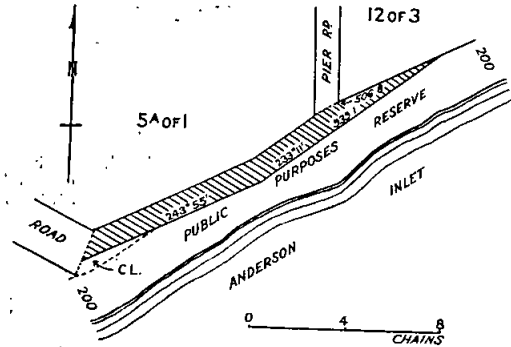

Given under my Hand and the Seal of the State of Victoria aforesaid, at Melbourne, this first day of June, in the year of our Lord One thousand nine hundred and seventy-one, and in the twentieth year of the reign of Her Majesty Queen Elizabeth II.

(L.S.) ROHAN DELACOMBE.

By His Excellency's Command,
 W. BORTHWICK,
 Minister of Lands.
 GOD SAVE THE QUEEN!

Water Act 1958.

STATE RIVERS AND WATER SUPPLY COMMISSION.
 BELLARINE PENINSULA WATERWORKS DISTRICT—PORTION OF
 DISTRICT PROCLAIMED A "RURAL DISTRICT".

PROCLAMATION

By His Excellency the Governor of the State of Victoria and its Dependencies in the Commonwealth of Australia, &c., &c., &c.

UNDER the powers conferred by the Water Act 1958 and all other powers enabling me in that behalf, I, the Governor of the State of Victoria, with the advice of the Executive Council thereof do hereby proclaim that as on and from the first day of July, 1971 that portion of the Bellarine Peninsula Waterworks District included within the boundaries set out and described in the Schedule hereto, shall be and become a "Rural District" for the purpose of the said Act and shall be known as Mount Duneed Rural District and the State Rivers and Water Supply Commission shall have jurisdiction and control over such Rural District.

SCHEDULE.

Boundaries of Mount Duneed Rural District.

Commencing at the north-western angle of allotment F, section 35, parish of Duneed; thence generally easterly by the right bank of Duneed Creek to the north-eastern angle of allotment E, section 35; thence northerly by the western boundary of a road to the south-eastern angle of allotment E, section 24; thence easterly by the northern boundary of Mount Duneed road to the south-western angle of allotment H, section 22; thence southerly by the eastern boundary of Anglesea road to the south-western angle of allotment A, section 37; thence easterly by the northern boundaries of allotments H, G and F, section 37 to the north-eastern angle of the last-mentioned allotment; thence northerly by the western boundary and easterly by the northern boundary of the land comprised in certificate of title volume 8404 folio 727 to the north-eastern angle of the land in that certificate of title; thence northerly by the western boundary of Ghazepore road to the south-eastern angle of allotment Z, section 9; thence easterly by the northern boundary of Whites road to the south-eastern angle of allotment C, section 11; thence northerly by the western boundary of a road to the north-eastern angle of the last-mentioned allotment; thence generally easterly by the right bank of Armstrong's Creek to the south-eastern angle of allotment E, section 12; thence northerly by the eastern boundary of the Torquay-Geelong road to a point in line with the southern boundary of allotment I, section 5, parish of Conewarre; thence easterly by a line and the southern boundary of allotment I, section 5, to the south-eastern angle of that allotment; thence northerly by the eastern boundaries of allotments I and H, section 5, to the north-eastern angle of the last-mentioned allotment; thence easterly by the northern boundary of allotment G, section 5 and by a line in continuation thereof to the north-western angle of

allotment F, section 5; thence southerly by the western boundaries of allotments F and K, section 5, to the south-western angle of the last-mentioned allotment; thence easterly by the southern boundaries of allotments K and L, section 5, to the south-eastern angle of the last-mentioned allotment; thence southerly by the western boundary of Horse-Shoe Bend road to a point in line with the southern boundary of allotment P, section 6; thence easterly by a line and the northern boundary of Lake road to the south-eastern angle of allotment O, section 6; thence northerly by the eastern boundary of the last-mentioned allotment to its north-eastern angle; thence westerly by the northern boundaries of allotments O and P, section 6, and by a line in continuation thereof to the north-eastern angle of allotment M, section 5; thence northerly by the western boundary of Horse-Shoe Bend road to a point in line with the northern boundary of allotment I, section 6; thence easterly by a line, the northern boundaries of allotments I, J and K, section 6 and by a line connecting those boundaries to the north-eastern angle of the last-mentioned allotment; thence southerly by the eastern boundary of allotment K, section 6, to its south-eastern angle; thence easterly by the northern boundary of allotment M, section 6, to its north-eastern angle; thence northerly by the western boundary of Charlemont road to the north-eastern angle of allotment L, section 6; thence easterly by a line and the northern boundary of allotment E, section 7, to its north-eastern angle; thence southerly by the eastern boundary of the last-mentioned allotment to the north-western angle of allotment H, section 7; thence generally easterly by the northern boundaries of allotments H, I, J, K, L, M and N, section 7 and allotments A2 and A3, section 13 and by a line in continuation thereof and by a line connecting those boundaries to the southern angle of allotment D1, section 13; thence generally northerly by the western boundary of that allotment to its north-western angle; thence generally easterly by the northern boundaries of allotments D1, D and E, section 13 and by a line connecting those boundaries to the north-eastern angle of the last-mentioned allotment; thence generally southerly by the eastern boundary of allotment E, section 13, to the north-western angle of allotment F, section 13; thence generally easterly by the northern boundaries of allotments F and G, section 13, to the north-eastern angle of the last-mentioned allotment; thence southerly by the eastern boundary of allotment G, section 13, to its south-eastern angle; thence westerly by the southern boundaries of allotments G and F, section 13 and by a line in continuation thereof to the north-eastern angle of allotment E, section 12; thence southerly by the eastern boundaries of allotments E, F and G, section 12, to the south-eastern angle of the last-mentioned allotment; thence generally south-easterly by the northern boundary of Mount Duneed road to the south-western angle of allotment A, section 14; thence northerly by the western boundary of the last-mentioned allotment to its north-western angle; thence generally easterly by the northern boundaries of allotments A, B, C and D, section 14, to a point in line with the western boundary of allotment H, section 14; thence northerly by a line and the western boundary of the last-mentioned allotment to its north-western angle; thence easterly by the northern boundaries of allotments H, J and K, section 14, to the most easterly angle of the last-mentioned allotment; thence generally south-westerly by the south-eastern boundary of allotment K, section 14, to its south-western angle; thence generally southerly by the eastern boundaries of allotments G, E and F, section 14, and allotments A, B and D, section 23 and by lines connecting those boundaries to the south-eastern angle of the last-mentioned allotment; thence westerly by the southern boundaries of allotments D and C, section 23, and the northern boundary of a Public Purposes Reserve and by a line connecting those boundaries to the north-western angle of that Reserve; thence southerly by the western boundary and south-easterly by the south-western boundary of the Public Purposes Reserve to a point in the western boundary of allotment N, section 23; thence northerly by the western boundary, easterly by the northern boundary, southerly by the eastern boundary and westerly by the southern boundary of the last-mentioned allotment to its south-western angle; thence generally westerly by the southern boundaries of Beach P.R., section 22, allotments D, E, F, K and L, section 21 and allotments F1 and G1, section 28 and by lines connecting those boundaries to the south-western angle of the last-mentioned allotment; thence northerly by the western boundary of allotment G1, section 28 to the south-eastern angle of allotment H, section 28; thence westerly by the southern boundary of allotment H, section 28 to its south-western angle; thence southerly by the eastern boundary of allotment I1, section 28 to the south-eastern angle of that allotment; thence westerly by the southern boundary of the last-mentioned allotment to its most westerly angle; thence generally southerly by the eastern boundary of Breamlea road to the north-eastern angle of a Reserve

for Municipal Purposes adjoining allotment 10, section D, township of Breamlea; thence northerly by a line in production of the eastern boundary of the Reserve for Municipal Purposes to the left bank of Thomson's (or Bream) Creek; thence generally north-westerly by that Creek bank to the south-eastern angle of allotment E, section 25; thence southerly by a line and the eastern boundary of a road to a point in line with the northern boundary of allotment 49, parish of Puebla; thence westerly by a line and the northern boundaries of allotments 49, 50, 51 and 52 and by a line connecting those boundaries to the north-western angle of the last-mentioned allotment; thence northerly by the western boundary of allotment 41 parish of Puebla, to the south-western angle of allotment C, section 24, parish of Conwarre; thence generally westerly by the left bank of Thomson's (or Bream) Creek and the southern boundary of allotment A, section 44, parish of Duneed and by a line in continuation thereof to a point in the eastern boundary of allotment C, section 45; thence northerly by the western boundary of Petavel road to the north-eastern angle of allotment D, section 34; thence easterly by a line and the northern boundaries of allotments K and G, section 35 to the north-eastern angle of the last-mentioned allotment; thence northerly by the western boundary of allotment F, section 35, to the point of commencement.

The lands set out and described in the foregoing Schedule are shown on a plan approved by the Governor in Council and deposited in the office of the State Rivers and Water Supply Commission, Melbourne (Corr. No. 71/1500).

Given under my Hand and the Seal of the State of Victoria aforesaid, at Melbourne this eighth day of June, in the year of our Lord One thousand nine hundred and seventy-one and in the twentieth year of the reign of Her Majesty Queen Elizabeth II.

(L.S.) ROHAN DELACOMBE.

By His Excellency's Command,
ROBERTS DUNSTAN,
Minister of Water Supply.

GOD SAVE THE QUEEN!

Vermin and Noxious Weeds Act 1958.

REVOCATION OF PROCLAMATION RESPECTING THE DECLARING OF THE WEDGE TAILED EAGLE "UROAETUS AUDAX" TO BE VERMIN WITHIN THE SHIRES OF WALPEUP AND AVOCA.

PROCLAMATION

By His Excellency the Governor of the State of Victoria and its Dependencies in the Commonwealth of Australia, &c., &c., &c.

IN pursuance of the provisions of Section 3, sub-section 2 of the *Vermin and Noxious Weeds Act 1958*, I, the Governor of the State of Victoria in the Commonwealth of Australia, by and with the advice of the Executive Council of the said State do, by this my Proclamation revoke the Proclamation made on the twenty-second day of July, 1929, published in the *Government Gazette* on the twenty-fourth day of July, 1929, respecting the declaring of the Wedge Tailed Eagle "Uroaetus Audax" to be vermin within the Shire of Walpeup, and do revoke the Proclamation made on the twenty-first day of August, 1939, published in the *Government Gazette* on the twenty-third day of August, 1939, respecting the declaring of the said Wedge Tailed Eagle "Uroaetus Audax" to be vermin within the Shire of Avoca.

Given under my Hand and the Seal of the State of Victoria aforesaid, at Melbourne, this first day of June, in the year of our Lord One thousand nine hundred and seventy-one, and in the twentieth year of the reign of Her Majesty Queen Elizabeth II.

(L.S.) ROHAN DELACOMBE.

By His Excellency's Command,
W. BORTHWICK,
Minister of Lands.

GOD SAVE THE QUEEN!

GOVERNMENT NOTICES

PUBLIC HOLIDAY.—QUEEN'S BIRTHDAY.

It is hereby notified that on—

MONDAY, THE 14TH JUNE, 1971,

the Public Offices will be closed, such day having been appointed by the *Public Service Act 1958*, to be observed as a holiday in the Public Offices throughout the State of Victoria.

This notice relates only to the closing of the State Public Offices. All inquiries regarding the holiday in other offices and in shops and industry should be directed to the Department of Labour and Industry, 110 Exhibition-street, Melbourne, 3000. (Telephone 63 0321, Extension 6158, 6859 or 6924.)

R. J. HAMER,
Chief Secretary.

Chief Secretary's Office,
Melbourne, 18th May, 1971.

Milk Board Acts.

SCHEDULE XXI.—REGULATIONS.

CONSIDERATION OF APPLICATIONS FOR MILK CARRIERS' LICENCES.

NOTICE is hereby given that the applications made by the persons named hereunder for Milk Carriers' Licences to operate upon the routes and in the areas set out opposite the names of the applicants will be considered by the Milk Board at its Office, Domville-avenue, Hawthorn, on Tuesday, 22nd June, 1971, commencing at 10.30 a.m.

Name and Address of Applicant.	Route and Area.
H. Hildenhagen, Amey's Track, Foster, 3960	Toora to Melbourne
M. T. Gallagher, 13 Mill-street, Toora, 3962	Toora to Melbourne

P. G. NUGENT,
Acting Secretary.

3rd June, 1971.

SOIL CONSERVATION AUTHORITY.

Soil Conservation and Land Utilization Act 1962 (No. 6911).
PARWAN VALLEY No. 4 GROUP CONSERVATION AREA.

NOTICE is hereby given that I, William Archibald Borthwick, Her Majesty's Minister for Conservation for the State of Victoria, under powers conferred by Division 1A Section 24A of the *Soil Conservation and Land Utilization Act 1962* (No. 6911) hereby declare to be a Group Conservation Area the land embraced by the Crown Allotments listed below together with the Road Reserves, Crown Land and River Frontages in the Parishes of Gorrockburkghap, Yaloak and Gorong as particularly designated in Drawings Nos. 1346, 1347, 1348 and 1349 marked GA/3D and lodged at the office of the Soil Conservation Authority, 378 Cotham-road, Kew 3101 and do further declare that it shall be known as the Parwan Valley No. 4 Group Conservation Area.

Parish.	Crown Allotment.	Part of Crown Allotment.
Gorrockburkghap	9 A. Glenmore P.R., C, G. 2, 3, and F
Yaloak 3, 4, 5, 6 1, 2, 5, 6	3 2, 7 Crown portion A 3, 4 3 1, 2 2, 4, 5
Gorong 3 4, 5 6 10	2 1, 2, 4 3 5 3, 8 3, 4

W. A. BORTHWICK,
Minister for Conservation.

Soil Conservation and Land Utilization Act 1958.
TARRA RIVER WATER SUPPLY CATCHMENT.

NOTICE OF DETERMINATION OF LAND-USE.

Proclaimed 26th January, 1971, Victoria Government Gazette, No. 13, dated 17th February, 1971, pursuant to section 22 of the Soil Conservation and Land Utilization Act 1958.

IN pursuance of the provisions of section 23, sub-section (1), of the Soil Conservation and Land Utilization Act 1958 (No. 6372), the Soil Conservation Authority after consultation with the Land Utilization Advisory Council has determined the land-use for all that area of land in the Parishes of Bulga, Devon and Jumbuk within the boundaries of the Tarra River Water Supply Catchment delineated and marked on Plan No. 2461, the original of which is lodged at the Head Office of the Soil Conservation Authority. All land within this area shall be used in accordance with the provisions of the particular category of land-use to which each area has been assigned. The boundaries of land-use areas shown on Plan No. 2508 are intended as a guide to landholders, who should consult with the Soil Conservation Authority before making any changes in land-use.

The provisions of each of the land-use categories are set out hereunder—

Category No. 1.

Land which shall be used for the protection of streams and watercourses where—

- (a) No building shall be erected, tree removed or soil disturbed in any way without the specific approval of the Soil Conservation Authority.
- (b) The crossing of streams and watercourses within this category if so required by the Authority shall be permitted only by means of crossings specifically approved for the particular site by the Soil Conservation Authority.

This category covers areas within a 10 chain radius of the offtake weir and within 1 chain, or such greater distance as the Authority may require, from the banks of all permanent and specified streams, springs or watercourses.

Category No. 2.

Land which shall be used for permanent forest or plantation purposes where forestry operations or any other changes affecting catchment interests shall be carried out only in accordance with management conditions made or approved by the Soil Conservation Authority. The construction of roads, tracks, dams or earthworks of any description are subject to the approval of the Authority.

Category No. 3.

Land suitable primarily for forestry or plantation purposes which may also be used for grazing, for limited cultivation or some kinds of approved recreational purposes subject to the observance of conditions specified by the Soil Conservation Authority for the particular circumstances, such conditions to include—

- (a) the specifications of areas which may be cleared and those which shall remain under forest;
- (b) the specification of the acreage which may be cleared in any one year;
- (c) the specification of areas suitable for plantation and for particular recreational purposes, for grazing and for cultivation;
- (d) the specification of management and conservation practices where necessary.

Category No. 4.

4A. Land used for roads on which any changes in land-use shall be made only after consultation with the Soil Conservation Authority.

4B. Land reserved for roads or other public purposes on which any changes in land-use shall be made only with the approval of the Soil Conservation Authority.

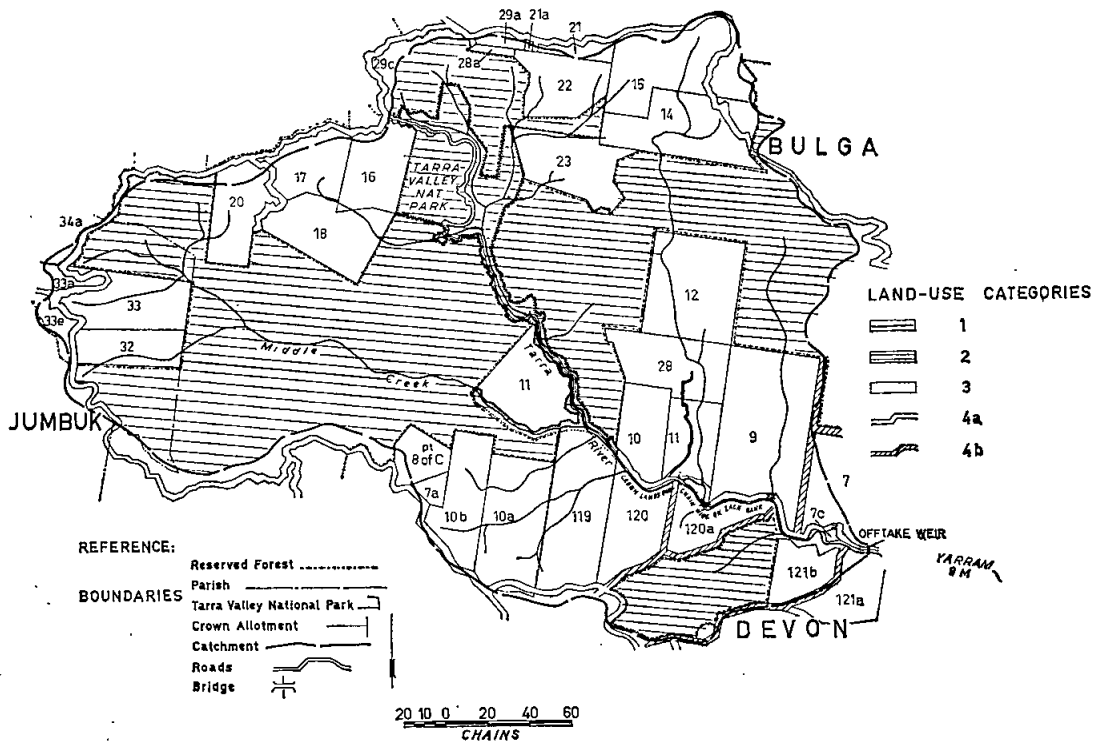

24th May, 1971.

P. J. McCALLUM, Secretary,
Soil Conservation Authority.

Transport Regulation Act.
TRANSPORT REGULATION BOARD.

HEARING OF APPLICATIONS.

NOTICE is hereby given that the following applications will be considered by the Transport Regulation Board at its offices at the corner of Lygon and Princes streets, Carlton, at 10.15 a.m. on Wednesday, 30th June, 1971.

- HOWELL, B. W., 192 Valley-drive, Rye. One commercial passenger vehicle (S/C. 5) to operate as a country taxi-cab at Rye.
- ZONNEVELT, A., 839-841 Mt. Dandenong-road, Montrose. One commercial passenger vehicle (S/C. 5) to operate as a country taxi-cab at Yarra Glen.
- STEPHENS, G. J. & J. W., 2 Delaney-avenue, Burwood. One commercial passenger vehicle (S/C. 5) to operate as a country taxi-cab at Cranbourne.
- SHAVE BUS SERVICE PTY. LTD., 12-14 Ricketts-road, Notting Hill. Application for permit authority to operate any one M.O. licensed vehicle held by the applicant company, for the carriage of school children at separate and distinct fares between Glen Waverley and Kilvington Girls' School on the following route:—Commencing from Glen Waverley Railway Station via Coleman-parade, Kingsway, Springvale, Waverley and Stephensons roads to Mount Waverley Railway Station; thence via Stephensons-road, The Highway, Mount Pleasant-drive, Waverley and Warrigal roads, Midlothian and Capon streets and Virginia-grove to Chadstone Shopping Centre; thence via Dandenong, Koornang, Neerim, Maroona and Glenhuntly roads, Royal-avenue and Katandra-road to Kilvington Girls' School.

TIME-TABLE (School days only).

- One-morning and one afternoon trip.
- CROYDON BUS SERVICE PTY. LTD., Black Spring-road, Croydon. Application for two commercial passenger vehicles with large seating capacity to operate under the same terms and conditions as existing C.O. licences held in the name of the applicant company.
- CURTIS, M., Marma-street, Murtoa. One commercial passenger vehicle (S/C. 16) to operate for the carriage of railway employees between Murtoa and places within a 50-mile radius under contract with the Victorian Railways.
- MARTYR, H. J., PTY. LTD., Main-street, Warburton. Application for one commercial passenger vehicle (S/C. 41) to operate as an additional stage omnibus under the same terms and conditions as existing C.O. licences held by the applicant company.
- PIANTA, A. R., High-street, Heathcote. One commercial passenger vehicle (S/C. 11) to operate for the carriage of students between Flower Hill and Mia Mia under contract to the Education Department.
- RALSTON, M. J., 299 High-street, Nagambie. One commercial passenger vehicle (S/C. 16) to operate for the carriage of school children to and from Nagambie along the Nagambie-Avenue road to Tabilk; thence via Goulburn Valley Highway, Mylo-crescent, Barwon-street, Goulburn Valley Highway, Prentice, Filson and Goulburn streets to and from the Nagambie State Primary School and Nagambie Convent School.

FARES.

- 5-mile section—\$3.50 per week return journey.
Town section—10 cents return.

TIME-TABLE (School days only).

- Depart Nagambie—8.30 a.m.
Depart Nagambie—3.30 p.m.
- DEPELER, V. (MRS.), 58 Stocks-road, Mt. Waverley. Application for one commercial passenger vehicle (S/C. 5), to operate as a touring omnibus for the carriage of passengers at separate and distinct fares on the following tours:—1. City through Ferntree Gully, Kalorama to lookout; then Montrose, Lilydale to Healesville, returning to City via Maroondah Highway. 2. City to Captain Cook's Cottage, Botanic Gardens, Governor Latrobe's Cottage, Como House and Montsalvaat. 3. Bayside trip around the beaches to Sorrento. 4. Freedom of choice for passengers who would like to follow other points of interest, i.e., the work of Australian artists which can be viewed at such areas as Eltham, the Dandenongs and Warrandyte or pottery in the making, visits to historic properties and tour of churches.
- VICARY, J. H., 273 Pakenham-street, Echuca. One commercial passenger vehicle (S/C. 37) to operate for the carriage of students between Hooker-road and Echuca under contract to the Education Department.

APPLICATION for renewal of licences as shown, by persons listed hereunder to operate under the same terms and conditions.

- ANDRIANOPOULOS, G., 765 Rathdowne-street, Carlton; M.T.4117.
- ASZTALOS, J., 4 Cameo-court, Bulleen; M.T.1810.
- BANKS, I. G. W., G.P.O. Box 5272ab, Melbourne; M.T.2765.
- BARKER, D. E., 34 Avocet-street, East Doncaster; S.T.7874.
- BLACKER, E. C., Flat 11, 60 Carlisle-street, St. Kilda; M.T.2740.
- BOYD, K., 39 Clarence-street, Elsternwick; M.T.4045.
- BURROWS, F. E., cnr. Dare and Harvey streets, Golden Square, Bendigo; U.T.337.
- CHRISTOFI, A., 126 Milleara-road, East Keilor; S.T.7884.
- CONWAY, H. J., 10 Toorong-road, East Malvern; M.T.2756.
- DE SANCTIS, F., 42 Collins-street, Bulleen; M.T.4042.
- EL-FAHKRI, J. M., 200 Bastings-street, Northcote; M.T.4035.
- GEORGE, M., 57 Fellows-street Kew; M.T.1591.
- GERMANOS, A., 24 Queens-avenue, Oakleigh; M.T.4292.
- GORMAN, E. E. (MRS.), 105 Middle-street, Glenroy; M.T.2753t.
- HARRIS, F. G., 133 York-street, Prahran; M.T.2755.
- KENNEDY, B. B., Flat 12, 313 Beaconsfield-parade, St. Kilda; M.T.4371.
- KENNEDY, K. J. & J. P., 50 Roberts-street, Frankston; C.T.129.
- KRYCER, S., 33 Tramere-avenue, Carnegie; M.T.1659.
- KWASNY, H. E., 29 Fricker-avenue, Greensborough; S.T.7888.
- LEURY, N. J., 12 Burnell-street, West Brunswick; M.T.2764.
- LEWIS, G., 61 Graham-street, Albert Park; M.T.2734.
- LIARAKOS, G., 1950 Malvern-road, East Malvern; M.T.4282.
- MARSHALL, R. G., 60 Sherbourne-road, Montmorency; C.H.384.
- MAY, E. P., 49 Cecil-street, Kew; M.T.4031.
- MOYNIHAN, N. V., 96 Maidstone-street, Altona West; S.T.7894.
- NTENTIS, G., 16 Coote-street, South Melbourne; M.T.1912.
- PAPANOTAS, C., 209 Belmore-road, Balwyn; M.T.1837.
- THOMSON, G. E., 1423 Dandenong-road, Oakleigh; M.T.4108.
- TUCKERMAN, A. G. (ESTATE OF THE LATE), 151 Bell-street, Coburg; M.T.2758.
- WELSH, R. T., 436 George-street, Fitzroy; M.T.2747.
- WISE, A. R., 1289 Nepean Highway, Rosebud; C.T.750.

Notice of any objection should be forwarded to reach the Secretary of the Board not later than Wednesday, 23rd June, 1971.

Applicants are advised that it will not be necessary to appear on the hearing date specified above, unless advised in writing by the Board.

B. P. KAY,
Secretary.

Corner Lygon and Princes streets, Carlton, Wednesday, 9th June, 1971.

Commercial Goods Vehicles Act.

TRANSPORT REGULATION BOARD.

HEARING OF APPLICATIONS.

NOTICE is hereby given that the following applications will be considered by the Transport Regulation Board at its offices at the Cnr. Lygon and Princes streets, Carlton, at 10.15 a.m. on Wednesday, 30th June, 1971.

- A.C.I. OPERATIONS PTY. LTD., 38 Lexton-road, Box Hill, 3128. One commercial goods vehicle (L/C. 13 cwt.) to operate throughout the State of Victoria in the course of business as "Food Machinery Manufacturers and Distributors" for the purpose of servicing food machinery—tools of trade, spare parts and materials incidental to on-site servicing.
- ALBION REID PTY. LTD., 83 Riversdale-road, Hawthorn, 3122. Application to vary the conditions of licence No. D.A.520/112 (L/C. 43 cwt.) by deleting from the existing conditions "Small Quantities of Materials".
- ALLEN, R. P., Rifle Range-road, Leongatha, 3953. One commercial goods vehicle (L/C. 194 cwt.) to operate from the plants of Readymix Concrete Pty. Ltd. at Leongatha, Morwell, Sale and Yallourn to consignees situated within a 50-mile radius of the particular plant—premixed concrete in a specially constructed agitator type vehicle solely on behalf of the said company.
- BOON SPA PTY. LTD., 264 Geelong-road, West Footscray, 3012. One commercial goods vehicle (L/C. 121 cwt.) to operate within a 50-mile radius from own premises at West Footscray, but excluding any operations to or from the City of Geelong or the Geelong Urban Area—own aerated waters and cordials in the course of business as "Aerated Water and Cordial Manufacturers". This application replaces licence No. D.A.28768/3 in the same name.

- BRUMNIACH, M., 5 Neil-street, Bell Post Hill, 3215. One commercial goods vehicle (L/C. 195 cwt.) to operate: (a) Within a 25-mile radius of the chief post office in the City of Geelong—general goods. (b) From the pits of You Yangs Granitic Sand Supply Pty. Ltd. in the You Yangs to the plant of Pronto Mixed Concrete Co. Pty. Ltd. at Footscray—gravel, and sand. (c) From the premises of Mountain View Quarries Pty. Ltd. at Point Wilson and Sunshine to the plant of Pronto Mixed Concrete Co. Pty. Ltd. at Footscray—screenings.
- BURNSIDE, R. J. & V. M., 29 Scott-street, Euroa, 3666. Application to vary the conditions of licence No. D.T.674/1 (L/C. 166 cwt.) by deleting paragraph (b) from the existing conditions and adding in lieu: "(b) Between the City of Shepparton and the Township of Euroa—general goods."
- C. & J. FARM SUPPLIES PTY. LTD., Cnr. John and Hutchinson streets, Lilydale, 3140. One commercial goods vehicle (L/C. 126 cwt.) to operate: (a) Within a 20-mile radius of own premises at Lilydale and to Glenburn and Nambethong in the course of business as "Produce Merchant"—own goods. (b) From places within an 8-mile radius of the G.P.O., Melbourne to places within paragraph (a) above—own goods.
- ESSO STANDARD OIL (AUST.) LTD., 386 Lonsdale-street, Melbourne, 3000. One commercial goods vehicle (L/C. 14 cwt.) to operate throughout the State of Victoria in the course of business as "Petroleum Products Distributors" for the purpose of installing, servicing and repairing liquefied petroleum gas installation—own bulk petroleum gas tanks for specialized installation, tools of trade, equipment and materials incidental to such installation or for the repair or servicing of such equipment on site.
- FENNELL, P. J., 38 Miranda-road, Reservoir, 3073. Application to vary the conditions of licence No. D.A.60588/1 (L/C. 131 cwt.) by deleting the existing conditions and adding in lieu: "Within a 70-mile radius from the premises of Brick and Pipe Industries Ltd. at Northcote solely on behalf of the said company—bricks"
- FIRESTONE AUST. PTY. LTD., Benalla-road, Shepparton, 3630. One commercial goods vehicle (L/C. 25 cwt.) to operate within a 50-mile radius of branch premises at Shepparton in the course of business as "New and Second-hand Tyre and Car Accessories Distributors"—tyres and tubes for sale and delivery, used tyres for repair or retreading or having been repaired or retreaded, also batteries, oil and motor car accessories and polythene piping.
- GUY, J., 4 Green-street, Yallourn, 3838. One commercial goods vehicle (L/C. 71 cwt.) to operate within a 30-mile radius of the post office at Yallourn in the course of business as "Waste Collector"—waste cardboard and paper.
- HAM, R. D., Box 69, Terang, 3246. One commercial goods vehicle (L/C. 210 cwt.) to operate within a 50-mile radius of the premises of Pioneer Concrete (Vic.) Pty. Ltd. at Terang, as a specially constructed agitator vehicle—premixed concrete.
- JOHNS, G. E. H., & CO. PTY. LTD., 395 Collins-street, Melbourne, 3000. One commercial goods vehicle (L/C. 16 cwt.) to operate throughout the State of Victoria in the course of business as "Painting Contractor"—tools of trade, scaffolding and up to a maximum of 1 cwt. at any one time of materials sufficient only to complete own contracts.
- KARCIUSKAS, E., 42 Moonya-road, Carnegie, 3163. One commercial goods vehicle (L/C. 11 cwt.) to operate throughout the State of Victoria in the course of business as "Scrap Tyre Dealer" for the purpose of collecting second-hand scrap tyres—scrap tyres for return to Melbourne.
- LATROBE VALLEY CORDIAL & CONFECTIONERY CO. PTY. LTD., 16-18 Abinger-street, Richmond, 3121. One commercial goods vehicle (L/C. 22 cwt.) to operate within a 50-mile radius of own premises at Traralgon and from and to Traralgon to and from Bairnsdale and Lakes Entrance and Orbost and places en route in course of business as "Confectionery and Cordial Distributors"—confectionery, milk bar sundries, cordials in plastic and glass containers and empty containers with the proviso that all goods are to be initially consigned by rail to Traralgon.
- LLOYD, S. A. & B., BROS., Merriang-road, Beveridge, 3653. One commercial goods vehicle (L/C. 132 cwt.) to operate: (a) Within a 25-mile radius of the post office at Beveridge—general goods provided that no goods shall be carried whether by one stage or by more than one stage between places within the above radius which are more than thirty (30) road miles apart by the nearest practicable route. (b) To and from places as defined in paragraph (a) above from and to places outside that radius but wholly within a 50-mile radius of the post office at Beveridge—livestock.
- MICHAEL, G., 40 Lanigan-street, Fawkner, 3060. Application to vary the conditions of licence No. D.A.55514 (L/C. 228 cwt.) by adding to existing conditions—"(a) From pits at Healesville and Toolangi to own yard at Fawkner—own mountain soil."
- MCCULLAGH, G. J. (trading as McCullagh Bros), 30 Kuck-street, Warrnambool, 3280. One commercial goods vehicle (L/C. 300 cwt.) to operate: (a) From forest landings within a 50-mile radius of the post office at Warrnambool to sawmills at Merrivale—logs. (b) From sawmills at Merrivale to places within a 50-mile radius of the Warrnambool Post Office—sawn timber. (c) Within a 20-mile radius of the post office at Warrnambool—general goods.
- NIELSEN, FREDERICK W., PTY. LTD., Bernard-street, Cheltenham, 3192. One commercial goods vehicle (L/C. 246 cwt.) to operate throughout the State of Victoria in the course of business as "Heating, Steam, Ventilation and Plumbing Engineers"—tools of trade, plant and equipment and assembled ductwork required for the installation of air conditioning and warm air plants.
- OAKLEIGH METALS PTY. LTD., 175 Kangaroo-road, Oakleigh, 3166. One commercial goods vehicle (L/C. 113 cwt.) to operate throughout the State of Victoria in the course of business as "Scrap Metal Dealer" for the purpose of collecting scrap metal—scrap metal, subject to the condition that the total load capacity of the vehicle as prime mover together with any trailer hauled in conjunction with such vehicle shall not exceed 120 cwt.
- NOTE.—Subject to the cancellation of licence No. D.A.63535 held in the name of M. E. O'Connor trading as Continental Metal Co.
- PADLOCK TRADING CO. PTY. LTD., Box 104, Mildura, 3500. One commercial goods vehicle (L/C. 20 cwt.) to operate within a 75-mile radius of own premises at Mildura in course of business as "Tractor and Farm Machinery Dealers" for the purpose of servicing tractors and farm machinery—tools of trade and spare parts for servicing only.
- MAYNE NICKLESS LTD., 94 York-street, South Melbourne, 3205. Two commercial goods vehicles (L/C. 160 cwt. each) to operate solely on behalf of A. V. Wehl Industries Ltd. (an approved decentralized secondary industry at Ballarat) as follows:—(a) From such decentralized industry at Ballarat to the Melbourne Metropolitan area—Particle Board Manufactured by the said company. (b) From the Melbourne Metropolitan area to the decentralized industry at Ballarat—bearers, strapping, vinyl, wehl board shelving, wax shavings and sawdust.
- PADLOCK TRADING CO. PTY. LTD., 8th-street, Mildura, 3500. One commercial goods vehicle (L/C. 74 cwt. and 70 cwt. trailer) to operate: (a) Within a 25-mile radius of the post office at Mildura in the course of business as "Tractor and Farm Machinery Dealer and Transport Operators"—general goods. (b) Within a 60-mile radius of own premises at Mildura in course of business as "Tractor and Farm Machinery Dealers"—tools of trade, tractors, farm machinery for delivery and having been traded-in, also tractors and farm machinery for repair or having been repaired.
- PEGORARO, F., PTY. LTD., 83 Palmerston-street, Carlton, 3053. One commercial goods vehicle (L/C. 10 cwt.) to operate throughout the State of Victoria in the course of business as "Earth-moving Contractors" for the purpose of supervising own contracts—tools of trade, spare parts and materials incidental to the completion of own contracts.
- PERONI, G., 31 Dickens-street, Lalor, 3075. One commercial goods vehicle (L/C. 229 cwt.) to operate: (a) Within a 25-mile radius of own premises at Keon Park in the course of business as "Sand, Screening and Garden Suppliers"—own goods. (b) From pits at Cranbourne to own yard at Lalor—own sand. (c) From Healesville to own yard at Lalor—own mountain soil.
- PETERS ICE CREAM PTY. LTD., Wellington-road, Clayton, 3168. One commercial goods vehicle (L/C. 7 cwt.) to operate throughout the State of Victoria as a specially constructed Insulated Van for the purpose of supplying own distributors with ice-cream, frozen vegetables, frozen fish and frozen poultry and frozen pies at a temperature not exceeding 10 degrees F.
- PETERSON, R. W., 44 John-street, Moe, 3825. One commercial goods vehicle (L/C. 140 cwt.) to operate from forest landings situated within a 5-mile radius from the post office situated at Jeeralang Junction to Pearces sawmill situated at Bunyip—mill logs.
- PIASTRI, G., 190 St. Georges-road, Shepparton, 3630. One commercial goods vehicle (L/C. 234 cwt.) to operate: (a) Within a 50-mile radius from the post office at

- Shepparton as a "Road Contractor"—road-making plant and materials. (b) Within a 25-mile radius of the post office at Shepparton—general goods provided that no goods shall be carried whether by one stage or by more than one stage between places within the above radius, which are more than thirty (30) road miles apart by the nearest practicable route.
- REED, A. & M., PTY. LTD.**, Princes Highway, Drouin, 3818. Application to vary the conditions of licence No. D.A.64197/5 (L/C. 88 cwt.) by deleting the existing conditions and adding in lieu—"Throughout the State of Victoria in the course of business as "Wholesale Stationer and Educational Equipment Supplier" as a mobile showroom—samples and display and advertising materials with the ability to leave an urgently required order".
- SGARGETTA, J.**, 1 Kelley-road, West Preston, 3072. One commercial goods vehicle (L/C. 221 cwt.) to operate within a 35-mile radius of the G.P.O., Melbourne on behalf of Consolidated Quarries Ltd.—sand, soil, screenings, premix and quarry products.
- SHRUBSOLE, I. J.**, 28 Glenelg-avenue, Frankston, 3199. Application to vary the conditions of licence No. D.A.65098 (L/C. 15 cwt.) by deleting the existing conditions and adding in lieu—"Within a 50-mile radius of the G.P.O. in the City of Melbourne on a specially constructed car carrying trailer—second-hand motor vehicles for delivery to auction sales within the said area".
- STOCKDALE EXPLORATION LTD.**, 60 Market-street, Melbourne, 3000. One commercial goods vehicle (L/C. 24 cwt.) to operate throughout the State of Victoria in the course of business as "Mineral Explorers"—tools of trade, equipment and allied exploration materials and samples of minerals or earth excavated.
- SURE TRANSPORT PTY. LTD.**, 48 Victoria-street, Warragul, 3820. One commercial goods vehicle (L/C. 215 cwt.) to operate: (a) From the premises (quarries and sand pits) operated by Sure Quarries Pty. Ltd. at Athlone, Ellinbank, Jindivick and Yallourn North to consignees within a 50-mile radius of the post office at Warragul excluding operations west of a north/south line drawn through Cranbourne—crushed rock, sand and screenings. (b) From the premises of Albion Reid Pty. Ltd. at Cranbourne to the premises of Sure Mix Pty. Ltd. at Warragul—sand. (c) Within a 50-mile radius of the post office at Warragul but excluding any place situated west of a north/south line drawn through Cranbourne—plant the property of a contractor and required by that Company for use in connexion with the construction or maintenance of some specific, existing or proposed road, street, footpath, bridge, pier, wharf, weir or channel and also the following materials on behalf of the said company viz.: metal, stones, screenings, ashes, gravel, sand and earth. (d) Within a 25-mile radius from the site of any construction work performed pursuant to paragraph (c) above, or from the railway station nearest thereto—any other materials required for such work.
- TREZISE, H. F. A.**, Lawrence-street, Myrtleford, 3737. One commercial goods vehicle (L/C. 65 cwt.) to operate: (a) Within a 20-mile radius of the post office at Myrtleford—general goods. (b) Within a 50-mile radius of the depot of Ampol Petroleum (Vic.) Pty. Ltd. at Myrtleford as an agent on behalf of the said company—petroleum products in prescribed types of containers and empty containers for return.
- WALLACE, S. O.**, Private Bag 9, Allansford, 3277. One commercial goods vehicle (L/C. 186 cwt.) to operate: (a) Within a 25-mile radius of the post office at Naringal—general goods, provided that no goods shall be carried whether by one stage or by more than one stage between places within the above radius which are more than thirty (30) road miles apart by the nearest practicable route. (b) Within a 50-mile radius of the post office at Naringal in the course of business as "Primary Producer"—own goods. (c) Within a 50-mile radius of the post office at Naringal—livestock.
- WARRAGUL TYRE SERVICE PTY. LTD.**, 26A Palmerston-street, Warragul, 3820. One commercial goods vehicle (L/C. 30 cwt.) to operate: (a) Within a 25-mile radius of the post office at Warragul in course of business as "Tyre and Battery Retailers and Repairers"—new tyres and tubes for delivery, used tyres and tubes for repair or retreading or having been repaired or retreaded together with batteries provided all such goods are initially consigned by rail to Warragul. (b) Within a 50-mile radius of the post office at Warragul—new tyres, tubes and batteries for fitting purposes, together with tools of trade incidental thereto provided all such goods are initially consigned by rail to Warragul.
- MARTELLONI, W.** (trading as Warrnambool Concrete & Paving Co.), 103 Davis-street, Warrnambool, 3280. One commercial goods vehicle (L/C. 144 cwt.) to operate within a 50-mile radius of own premises at Warrnambool in the course of business as "Pre-Mixed Concrete Manufacturer and Contractor"—own premixed concrete in specially constructed agitator vehicle.
- WILLATON, B. W.**, Jeeralang Junction, 3840. One commercial goods vehicle (L/C. 246 cwt.) to operate: (a) Within a 25-mile radius of the post office at Jeeralang Junction—general goods, provided that no goods shall be carried whether by one stage or more than one stage between places within the above radius which are more than thirty (30) miles apart by the nearest practicable route. (b) Within a 50-mile radius of the depot of Ampol Petroleum (Vic.) Pty. Ltd. at Morwell—petroleum products in prescribed types of containers and empty return containers.
- ZOVKO, S.**, 35 Fulton-crescent, Burwood, 3125. One commercial goods vehicle (L/C. 240 cwt.) to operate within a 35-mile radius of the G.P.O. in the City of Melbourne solely on behalf of Consolidated Quarries Ltd.—sand, soil, screenings, premix and quarry products.

TOW TRUCK.

- WANTIRNA BODY WORKS PTY. LTD.**, Boronia-road, Wantirna, 3152. One commercial goods vehicle (to be purchased) to operate throughout the State of Victoria as a "Heavy Duty Salvage Tow Truck" solely—(a) For the purpose of lifting and carrying or towing motor vehicles and the carriage of tools and equipment necessary for such purposes only. (b) The carriage of spare parts necessary for the repair of a disabled motor to and from the place at which such disablement has occurred.

RENEWALS.

APPLICATIONS for renewal of licences as shown by persons listed hereunder to operate under the same terms and conditions from the expiry shown in each case.

- ADAMS, WILLIAM, TRACTORS PTY. LTD.**, Nantilla-road, North Clayton, 3168; D.A.512/6; 21st November, 1971; 14 cwt.
- ARMoured ESCORTS PTY. LTD.**, corner Arden and Lothian streets, North Melbourne, 3051; D.A.37566; 16th November, 1971; 8 cwt.
- ASCOM PTY. LTD.**, 63 Queensbridge-street, South Melbourne, 3205; D.A.34589/1; 27th November, 1971; 11 cwt.
- AUSTRALIAN MODEL AERODROME, THE**, 367 St. Georges-road, North Fitzroy, 3068; D.A.61195; 13th November, 1971; 10 cwt.
- BREUER, B. R.** (trading as L. J. Breuer & Co.), 29 Wilson-street, Horsham, 3400; D.A.5195; 16th November, 1971; 14 cwt.
- BRITAIN, C. J.**, 8 Baird-street, Maidstone, 3012; D.A.37392; 3rd November, 1971; 11 cwt.
- BROWN, H. S.**, 12 Station-street, Ringwood, 3134; D.A.739; 26th November, 1971; 133 cwt.
- CARLTON & UNITED BREWERIES LTD.**, 16 Bouverie-street, Carlton, 3053; D.A.808/35; 23rd October, 1971; 11 cwt.; D.A.808/37; 23rd October, 1971; 11 cwt.; D.A.808/36; 23rd October, 1971; 11 cwt.
- COMMONWEALTH INDUSTRIAL GASES LTD., THE**, 90 Bell-street, Preston, 3072; D.A.838/23; 21st September, 1971; 10 cwt.
- COOMBS SHOWER SCREENS PTY. LTD.**, 141 Brighton-street, Richmond, 3121; D.A.61300/1; 27th November, 1971; 14 cwt.
- COOMBS, A. G. PTY. LTD.**, 26 Cochranes-road, Moorabbin, 3189; D.A.891/15; 13th November, 1971; 14 cwt.
- COUANI, J. L.**, 27A Ross-street, Northcote, 3070; D.A.61262; 20th November, 1971; 32 cwt.
- CROSBY, W.** (MERCHANDISE) PTY. LTD., 31-49 Queens Bridge-street, South Melbourne, 3205; D.A.916/2; 21st November, 1971; 56 cwt.
- CURSAO, P. & A.**, 133 Burwood Highway, Ferntree Gully, 3156; D.A.61264; 20th November, 1971; 22 cwt.
- D'ABACO, G.**, 12 Chandler-road, Noble Park, 3174; T.D.A.46772/3; 17th November, 1971; 55 cwt.
- DEVERALL, A. M. & W. T.**, Box 17, Gisborne, 3437; D.A.44947; 20th November, 1971; 143 cwt.
- DORÉ, J. R. & S. J.**, 22 McLeod-road, Carrum, 3197; D.A.63565; 13th November, 1971; 53 cwt.
- DOWNES, R. E. PTY. LTD.**, Nar-Nar-Goon, 3812; D.A.27544/11; 11th November, 1971; 207 cwt.
- DUNGEY, G. F.**, 4 Warde-street, Bairnsdale, 3875; D.A.37210; 9th November, 1971; 79 cwt.
- DUNN, G. E. & L. M.**, 2 Glencannon-crescent, South Clayton, 3169; T.D.A.64200; 16th November, 1971; 138 cwt.

- DURBRIDGE, W. T., 29 Shiels-terrace, Casterton, 3311; D.A.61288; 20th November, 1971; 190 cwt.
- E. I. L. SERVICE PTY. LTD., 161-173 Sturt-street, South Melbourne, 3205; D.A.30374/16; 9th November, 1971; 11 cwt.
- ELECTRONIC INDUSTRIES LTD., 161 Sturt-street, South Melbourne, 3205; D.A.54222/2; 27th November, 1971; 11 cwt.
- FIBRO WALLS & CEILING CO. PTY. LTD., 867 Nepean Highway, Moorabbin, 3189; D.A.36128/3; 5th November, 1971; 14 cwt.
- FLEETWAYS HAULWAY PTY. LTD., 61 Bertie-street, Port Melbourne, 3207; D.A.48588/1; 21st November, 1971; 134 cwt.
- GAINAY, T. W., 47 Kidman-avenue, Belmont, 3216; D.A.37569; 23rd November, 1971; 143 cwt.
- GIPPSLAND AGRICULTURAL CONTRACTORS PTY. LTD., 7-9 Janette-street, Traralgon, 3844; D.A.61260; 20th November, 1971; 294 cwt.
- GLEESON, S. M., Main-road, Neerim South, 3831; D.T.1236; 27th November, 1971; 235 cwt.
- GREEN, J. E., Club Terrace, P.O., via Orbost, 3888; D.A.50475; 5th November, 1971; 99 cwt.
- GRIFFITH, VES PTY. LTD., 4 Seaview-parade, Dromana, 3936; D.A.24878/2; 20th November, 1971; 254 cwt.
- GROUND SPRAY PTY. LTD., 23 Murray-street, Colac, 3250; D.A.60015/1; 20th November, 1971; 17 cwt.
- HARDY ROADMAKING & CONSTRUCTION PTY. LTD., 17 Axelton-street, Cheltenham, 3192; D.A.37547/2; 20th November, 1971; 62 cwt.
- HANSFORD, A. H., Box 43, Port Fairy, 3284; D.A.61240; 13th November, 1971; 150 cwt.
- HAWKING, C. R., 11 Hawkins-street, Kyabram, 3620; D.A.37555; 16th November, 1971; 119 cwt.
- HILL, G. L., 210-212 Manifold-street, Camperdown, 3260; D.A.50632; 18th November, 1971; 10 cwt.
- HUTTON, J. C. PTY. LTD., 65 High-street, Preston, 3072; D.A.48355/23; 20th November, 1971; 35 cwt.; D.A.48355/24; 27th November, 1971; 35 cwt.
- I'ANSON, M. PTY. LTD., 14 Osborne-avenue, McKinnon, 3204; D.A.50640; 18th November, 1971; 132 cwt.
- IERACI, O., 348 Rathdowne-street, North Carlton, 3054; D.A.31275/2; 20th November, 1971; 14 cwt.
- IMPALA CARTAGE CONTRACTING PTY. LTD., 25 Kiewa-street, Doncaster, 3108; D.A.61037; 28th August, 1971; 194 cwt.; D.A.61037/1; 28th August, 1971; 196 cwt.
- INTER HARVESTER CO. OF AUST. PTY. LTD., North Shore-road, North Shore, Geelong, 3215; D.A.1351/54; 5th November, 1971; 16 cwt.
- JORDAN, R. A., PTY. LTD., 16 Levanswell-road, Moorabbin, 3189; D.A.44035/6; 18th November, 1971; 61 cwt.
- KENNAN, R. B., 13 Southern-road, Mentone, 3194; D.A.61142; 20th November, 1971; 53 cwt.
- KING'S MARINE STORES, 203-205 Skipton-street, Ballarat, 3350; D.A.1439; 21st November, 1971; 134 cwt.
- KINGSTON MACHINERY PTY. LTD., 59 Cochranes-road, Moorabbin, 3189; D.A.41053/4; 20th November, 1971; 225 cwt.
- KNIGHT, D. G., 517 Armstrong-street north, Ballarat, 3350; D.A.60929; 20th November, 1971; 9 cwt.
- KORTUM, A. & A., 156 Waverley-road, East Malvern, 3145; D.A.61187; 16th October, 1971; 10 cwt.
- LARSON, A. A., Carlisle River, 3239; D.A.1472; 28th November, 1971; 14 cwt.; D.A.1472/1; 28th November, 1971; 131 cwt.
- MAHONY, E. P., 8 Cypress-avenue, Glen Waverley, 3150; D.A.61149; 27th November, 1971; 234 cwt.
- MALINOWSKI, R., 22 First-avenue, North Altona, 3025; D.A.52461/1; 23rd October, 1971; 215 cwt.
- MARSDEN, G. E., 19 Ercil-street, Wendouree, 3355; D.A.61393; 20th November, 1971; 14 cwt.
- MAYNE NICKLESS LTD., 94 York-street, South Melbourne, 3205; D.A.19753/29; 18th November, 1971; 147 cwt.
- MILES, T. C., 819 Princes Highway, Springvale, 3171; D.A.50691; 14th October, 1971; 24 cwt.
- NEILSON, A. S., P.O. Box 169, Orbost, 3888; D.A.61185; 20th November, 1971; 233 cwt.
- NESTLE CO. AUST. LTD., THE, 159 Racecourse-road, Flemington, 3031; D.A.31378/36; 18th November, 1971; 8 cwt.
- NICOL, G. R., 37 Errard-street, Dennington, 3279; D.A.37661; 23rd November, 1971; 140 cwt.
- OLIVER-DAVEY GLASS CO. PTY. LTD., 35-53 Crockford-street, Port Melbourne, 3207; D.A.39088/6; 18th November, 1971; 30 cwt.
- PARK AVENUE LAUNDRY & DRY CLEANING PTY. LTD., 8 Peace-avenue, Warragul, 3820; D.A.1775/3; 16th November, 1971; 34 cwt.
- PERMEWAN WRIGHT LTD., 147 Alexandra-parade, Abbotsford, 3067; D.A.1809/27; 18th November, 1971; 79 cwt.
- PICTON HOPKINS & SONS PTY. LTD., 130 Church-street, Richmond, 3121; D.A.1323/16; 18th November, 1971; 79 cwt.
- PRIDHAM, W. (AUST.) PTY. LTD., 11 Evans-street, Braybrook, 3019; D.A.1864/3; 20th November, 1971; 118 cwt.
- REPLACEMENT PARTS PTY. LTD., 618 Elizabeth-street, Melbourne, 3000; D.A.1907/3; 26th November, 1971; 14 cwt.
- REPLACEMENT PARTS PTY. LTD., 618 Elizabeth-street, Melbourne, 3000; D.A.1907/2; 26th November, 1971; 13 cwt.
- RHODES BROTHERS, 27 Bowden-street, Castlemaine, 3450; D.A.4246/4; 13th November, 1971; 11 cwt.
- SANITARIUM HEALTH FOOD CO., P.O. Box 40, Prahran, 3181; D.A.1984/10; 18th November, 1971; 10 cwt.
- 7X BEVERAGES (CENTRAL) PTY. LTD., 16 First-avenue, Sunshine, 3020; T.D.A.61307/10; 4th November, 1971; 64 cwt.; T.D.A.61307/11; 4th November, 1971; 65 cwt.
- STAGG, W. E., Midland Highway, Mooroopna, 3629; D.A.61392; 20th November, 1971; 16 cwt.
- SUCKLING, R. C., 26 Victoria-street, Daylesford, 3460; D.T.1237; 27th November, 1971; 212 cwt.
- TOBIN BROS. PTY. LTD., 189 Boundary-road, North Melbourne, 3051; D.A.3656/5; 20th November, 1971; 17 cwt.
- UNIGATE AUST. PTY. LTD., P.O. Box 13, Dandenong, 3175; D.A.27168/25; 20th November, 1971; 77 cwt.
- WARREN, D. E., Box 28, Halls Gap, 3381; D.A.37502; 16th November, 1971; 126 cwt.
- WILLIAMS, B. J., 6 Hunter-street, Keilor, 3036; D.A.61182; 16th October, 1971; 207 cwt.

TOW TRUCK RENEWALS.

- AMOR, E. B., 33 Woolcock-street, Warracknabeal, 3393; D.A.47450/1; 13th November, 1971; 52 cwt.
- ASHWOOD MOTORS PTY. LTD., Corner Warrigal & High Street roads, Ashwood, 3147; D.A.64218; 18th November, 1971; 38 cwt.
- BARTON, J., 208 Main-street, Bacchus Marsh, 3340; D.A.53716/1; 20th November, 1971; 45 cwt.
- LITTLE'S BLACK ROCK MOTORS, 298 Beach-road, Black Rock, 3193; D.A.1506/4; 5th November, 1971; 56 cwt.
- PATERSON, R., 118 Haines-street, North Melbourne, 3051; D.A.59055; 3rd November, 1971; 25 cwt.
- RHOOK, R. T., PTY. LTD., 14-16 High-street, Lismore, 3324; D.A.61298; 27th November, 1971; 43 cwt.

RENEWALS WITH VARIATION.

- APPLICATIONS made by the persons listed hereunder for renewal of the licences listed with variation of conditions in the manner set out opposite the names.
- ANDERTON, J., 314 Mont Albert-road, Surrey Hills, 3127; D.A.50467; 5th November, 1971; application to renew and vary the conditions of licence No. D.A.50467 (L/C. 80 cwt.) by deleting from the existing conditions "Atlas Products (Vic.) Pty. Ltd., at Oakleigh" and adding in lieu: "Atlas Industries Aust. Ltd. at Springvale."
- MOOLTAN ENTERPRISES PTY. LTD., Suite 5, 56 Nepean Highway, Aspendale, 3195; D.A.48936/2; 20th November, 1971; application to renew and vary the conditions of licence No. D.A.48936/2 by deleting from the existing conditions "Bayview Quarries Pty. Ltd. at Springvale" and adding in lieu: "Albion Reid Pty. Ltd. at Clayton."
- PHOENIX BISCUIT CO. PTY. LTD., Grosvenor-street, Abbotsford, 3067; D.A.39491/14; 23rd October, 1971; application to renew and vary the conditions of licence No. D.A.39491/14 (L/C. 70 cwt.) by deleting paragraph (b) from the existing conditions.
- REED, G. H., 31 Gordon-street, Orbost, 3888; D.T.1355; 20th November, 1971; application to renew and vary the conditions of licence No. D.T.1355 (L/C. 408 cwt.) by deleting the existing conditions and adding in lieu—"Within that part of the State of Victoria east of the Snowy River and/or from sawmills at Newmerella to—(i) The railway station at Orbost—sawn timber. (ii) Customers and/or building sites within a 20-mile radius of the post office at Orbost—sawn timber."
- RUSSELL, E. A. C., PTY. LTD., Main-street, Gembrook, 3783; D.A.4901/14; 18th November, 1971; application to renew and vary the conditions of licence No. D.A.4901/14 (L/C. 79 cwt.) by deleting paragraph (c) from the existing conditions.

Notice of any objection should be forwarded to reach the Secretary of the Board not later than 23rd June, 1971.

Applicants are advised that it will not be necessary to appear on the hearing date specified above, unless advised in writing by the Board.

B. P. KAY,
Secretary.

Corner Lygon and Princes streets, Carlton, 3053, Wednesday, 9th June, 1971.

Private Agents' Act 1966.

NOTICE OF RECEIPT OF APPLICATIONS FOR LICENCES UNDER THE PROVISIONS OF THE PRIVATE AGENTS' ACT 1966.

THE Clerk(s) of the Magistrates' Court(s) as listed hereunder hereby give notice that applications, as under, have been lodged for hearing by the said Court(s) on the date(s) specified.

Any person desiring to object to any of such applications must—

(a) lodge with the respective Clerk of the Magistrates' Court a notice in the prescribed form of his objection and of the grounds thereof;

(b) cause a copy of such notice to be served personally or by post upon the applicant at least three days before the hearing of the application; and

(c) send or deliver—

(i) where the objection is not made by the officer in charge of the police district in which the Court is situated—a copy of the notice to such officer; and

(ii) where the objection is not made by the Registrar or Deputy Registrar—a copy to the Registrar.

Full Name of Applicant or in the Case of a Firm or Corporation, of the Nominee.	Place of Abode of Applicant or Nominee.	Name of Firm or Corporation.	Address for Registration.	Type of Licence.	Date of Hearing of Application.
---	---	------------------------------	---------------------------	------------------	---------------------------------

MAGISTRATES' COURT, BALLARAT.

Richardson, John Samuel	Creswick-road, Mt. Rowan		Creswick-road, Mt. Rowan	Inquiry Agent Process Server	1.7.71
-------------------------	--------------------------	--	--------------------------	---------------------------------	--------

Dated at Ballarat this 28th day of May, 1971.

E. N. KINCHINGTON, Clerk of the Magistrates' Court.

MAGISTRATES' COURT, GEELONG.

Philp, David Watson	"Leyard", Modewarre		94 Seabright-street, North Shore	Watchman	18.6.71
---------------------	---------------------	--	----------------------------------	----------	---------

Dated at Geelong this 28th day of May, 1971.

J. E. REILLY, Clerk of the Magistrates' Court.

MAGISTRATES' COURT, GEELONG.

Cross, Brian	1 Glenmire-street, Highton	Mayne Nickless	1 Glenmire-street, Highton	Watchman	18.6.71
--------------	----------------------------	----------------	----------------------------	----------	---------

Dated at Geelong this 28th day of May, 1971.

J. E. REILLY, Clerk of the Magistrates' Court.

MAGISTRATES' COURT, PRAHRAN.

Murray, Ivan	8 Mulga-street, Altona	Factory Guard Service Pty. Ltd.	17/562 St. Kilda-road, Melbourne	Watchman	11.6.71
Loveridge, Jeffrey Peter	1/112 Ballantyne-street, Thornbury	Carol Furzer	12/614 St. Kilda-road, Melbourne	Commercial Sub-Agent	18.6.71
Welford, Thomas Arthur	35 Jasper-street, Noble Park	Factory Guard Service Pty. Ltd.	17/562 St. Kilda-road, Melbourne	Watchman	18.6.71
Percy, Robert Hamilton	14 Sturt-street, Sunshine				
Bombinski, Waldemar Z.	41 Finlayson-street, Doncaster	S. Colangelo (trading as C and C Investigations and Security Services)	126 Greville-street, Prahran	Commercial Sub-Agent	25.6.71

Dated at Prahran this 28th day of May, 1971.

J. F. PRESNELL, Clerk of the Magistrates' Court.

MAGISTRATES' COURT, OAKLEIGH.

Steele, Rodney Beresford	1 Boongarry-avenue, Blackburn	Waverley Watching Company	310 Stephenson-road, Mt. Waverley	Watchman	25.6.71
--------------------------	-------------------------------	---------------------------	-----------------------------------	----------	---------

Dated at Oakleigh this 31st day of May, 1971.

G. MEEHAN, Clerk of the Magistrates' Court.

MAGISTRATES' COURT, CAMBERWELL.

Dale, Ernest Talbot	12 Howie-street, Glen Iris		27 Morton-road, Burwood	Commercial Sub-Agent	21.6.71
---------------------	----------------------------	--	-------------------------	----------------------	---------

Dated at Camberwell this 31st day of May, 1971.

J. C. TOBIN, Clerk of the Magistrates' Court.

MAGISTRATES' COURT, NORTHCOTE.

Cass, William	78 Normanby-avenue, Thornbury		78 Normanby-avenue, Thornbury	Guard Agent	23.6.71
---------------	-------------------------------	--	-------------------------------	-------------	---------

Dated at Northcote this 1st day of June, 1971.

J. TUOHY, Clerk of the Magistrates' Court.

MAGISTRATES' COURT, LAKES ENTRANCE.

Love, Athol Byron	Marine-parade, Lakes Entrance	Lakes Entrance Security Service	Ocean View-parade, Lakes Entrance	Watchman	14.7.71
-------------------	-------------------------------	---------------------------------	-----------------------------------	----------	---------

Dated at Lakes Entrance this 28th day of May, 1971.

S. G. MACKIE, Clerk of the Magistrates' Court.

PRIVATE AGENTS—*continued.*

Full Name of Applicant or in the Case of a Firm or Corporation of the Nominee.	Place of Abode of Applicant or Nominee.	Name of Firm or Corporation.	Address for Registration.	Type of Licence.	Date of Hearing of Application.
--	---	------------------------------	---------------------------	------------------	---------------------------------

MAGISTRATES' COURT, FOOTSCRAY.

Farmer, Charles James Robert	Rockbank-road, Sydenham	Advance Service	Patrol 17 Richards-street, Yarraville	Watchman	22.6.71
------------------------------	-------------------------	-----------------	---------------------------------------	----------	---------

Dated at Footscray this 31st day of May, 1971.

D. A. THOMPSON, Clerk of the Magistrates' Court.

MAGISTRATES' COURT, BOX HILL.

Munzone, Claude	7 Ellison-street, Blackburn		7 Ellison-street, Blackburn	Process Server	25.6.71
Munzone, Claude	7 Ellison-street, Blackburn		7 Ellison-street, Blackburn	Inquiry Agent	25.6.71

Dated at Box Hill this 31st day of May, 1971.

A. J. JOHNSON, Clerk of the Magistrates' Court.

COMMONWEALTH OF AUSTRALIA.

Petroleum (Submerged Lands) Act 1967-1968.

STATE OF VICTORIA.

Petroleum (Submerged Lands) Act 1967.

DECLARATION OF LOCATION.

I, JAMES CHARLES MURRAY BALFOUR, Minister of Mines for the State of Victoria, the Designated Authority in respect of the area specified as being adjacent to the State of Victoria, hereby declare the blocks described hereunder, being blocks that are the subject of a permit of which Hematite Petroleum Proprietary Limited, of 500 Bourke-street, Melbourne, is the registered holder, to be a location for the purposes of Part III. of the Act under which this instrument is made.

Description of Blocks.

The blocks constituted by graticular sections numbered 1781, 1782, 1783, 1853, 1854, 1855, 1926 and 1927 shown on the plan hereunder.

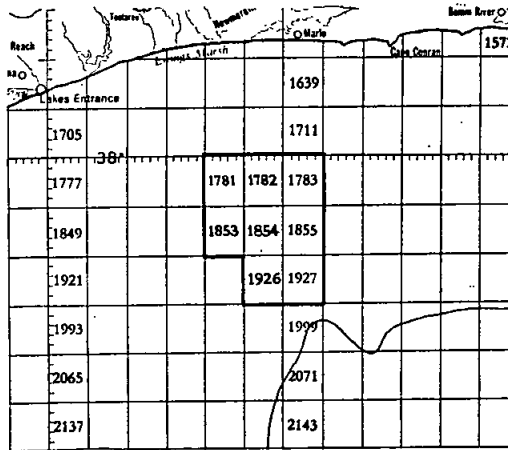

Dated this 31st day of May, 1971.

Made under the *Petroleum (Submerged Lands) Act 1967-1968* of the Commonwealth of Australia.

Made under the *Petroleum (Submerged Lands) Act 1967* of the State of Victoria.

JIM BALFOUR,
Designated Authority.

STATE RIVERS AND WATER SUPPLY COMMISSION.

LICENCE TO DIVERT WATER AND CUT RACE PURSUANT TO THE PROVISIONS OF SECTION 204 OF THE WATER ACT (AS AMENDED):

THE Schedule of Licence as detailed hereunder to divert water and cut race has been refused by the Governor in Council:—

SCHEDULE.

Licence Application No.	Term of Licence Sought.	Name and Address of Applicant.	Source of Supply.	Area Sought to be Authorized to be Irrigated.	Volume of Water Sought to be Authorized to be Diverted per annum.
3498	Four years from 1.7.70	Estate of E. J. Price, Shepparton	Goulburn River	55 acres.	110 ac. ft.

Office of the State Rivers and Water Supply Commission,
Melbourne, 8th June, 1971.

G. W. LEWIS, Secretary,
State Rivers and Water Supply Commission.

Stamps Act 1958.
ANNUAL LICENCES.

NOTIFICATIONS PURSUANT TO SECTION 97.

I HEREBY notify that stamp duty has been paid for licences under section 96 of the Stamps Act to carry on assurance and insurance business in Victoria during the year ending 31st December, 1971, by the following:—

A.C.I. Insurances Proprietary Limited.
A.M.P. Fire and General Insurance Company Limited.
A.P.A. Fire and General Insurance Company Limited.
Accident Insurance Mutual Limited.
Riunione Adriatica Di Sicurita—trading as Adriatic Insurance Coy.
Affiliated Reinsurances Proprietary Limited.
Ajax Insurance Company Limited.
Albion Insurance Company Limited.
Alliance Assurance Company Limited (with which is united The Imperial Insurance Company Limited).
American Home Assurance Company.
American International Assurance Co. Ltd.
American Life Insurance Company.
Ansvar Insurance Company Limited.
Antony Gibbs (Insurance) Pty. Ltd.
Antony Gibbs Reinsurance Pty. Ltd.
Arthur Weller and Company Proprietary Limited.
Associated General Contractors Insurance Company Limited.
Associated National Insurance Company Limited.
Associated Securities Insurance Corporation Ltd.
Atlas Assurance Company Limited (with which is incorporated The Manchester Assurance Company).
Australasian Temperance and General Mutual Life Assurance Society Limited.
Australian Alliance Assurance Company.
Australian and Eastern Insurance Company Limited.
Australian and International Insurances Limited.
Australian Associated Motor Insurers Ltd.
Australian Equitable Insurance Company Limited.
Australian General Insurance Company Limited.
Australian Marine Underwriting Agency Proprietary Limited.
Australian Motor Traders Insurance Limited.
Australian Mutual Fire Insurance Society Limited.
Australian Mutual Provident Society.
Australian National Assurance Company Limited.
Australian Natives' Association Insurance Company Limited.
Australian Provincial Assurance Association Limited.
Australian Reinsurance Company Limited.
Automobile Fire and General Insurance Company of Australia Limited.
B.T. Insurance Proprietary Limited.
Baillieu Reinsurances Proprietary Limited.
Baillieu Insurances Vic. Proprietary Limited.
Baltica Insurance Company Limited.
Bankers and Traders' Insurance Company Limited.
Bishopgate Insurance Company Limited.
Boral Insurance and Fund Management Ltd.
Bray Gibb and Company Pty. Ltd.
British and Foreign Marine Insurance Company Limited.
British Crown Assurance Corporation Limited.
British Equitable Assurance Company Limited.
British General Insurance Company of Australia Limited.
British Medical Insurance Company of Victoria Limited.
British Protection Insurance Company Proprietary Limited.
British Traders' Insurance Company Limited.
C.G.A. Fire and Accident Insurance Company Limited.
C.I.C. Insurance Pty. Ltd.
C.M.L. Fire and General Insurance Company Limited
C. T. Bowring and Swain (Professional Indemnity) Pty. Ltd.
C. T. Bowring and Swain Reinsurance Pty. Ltd.
C. T. Bowring and Swain (Vic.) Proprietary Limited.
Caledonian Insurance Company.
Car Owners Mutual Insurance Company Limited.
Casualty Insurance and Guarantee Corporation Pty. Ltd.
Catholic Church Insurances Limited.
Cayzer, Steel Brothers and Harlock Pty. Ltd.
Central Insurance Company Limited.
Century Insurance Company Limited.
Chamber of Manufactures Insurance Limited.
City Mutual General Insurance Limited.
The Closer Settlement Fire Insurance Fund of The Department of Crown Lands and Survey.
Colin McDonald Proprietary Limited.
Colonial Mutual Fire Insurance Company Limited.
Colonial Mutual Life Assurance Society Limited.
Combined Insurance Company of America.
Commercial and Industrial Insurance Limited.
Commercial of Australia Insurance Company Limited.
Commercial Loan Insurance Corp.
Commercial Union Assurance Company of Australia Limited.
Commissioners of The State Savings Bank of Victoria.

Consolidated Insurances of Australia Limited.
Continent of Australia Insurance Company Limited.
Co-operative Insurance Company of Australia Limited.
Copenhagen Reinsurance Company (Aust.) Limited.
Cornhill Insurance Company Limited.
Cumis Insurance Society Inc.
Derwent and Tamar Assurance Company Limited.
Dominion Insurance Company Limited.
Eagle Star Insurance Company Limited.
Eastern Insurance Brokers Proprietary Limited.
Ecclesiastical Property Insurance Company Proprietary Limited.
Economic Insurance Company Limited.
Edward Lumley and Sons (N.S.W.) Pty. Ltd.
Edward Lumley and Sons (Vic.) Proprietary Limited.
Employers Liability Assurance Corporation of Australia Ltd.
Equitable Life and General Insurance Company Limited.
Farmers and Graziers Co-operative Company Limited.
Farmers' and Settlers' Co-operative Insurance Company of Australia Limited.
Federal Mutual Insurance Company of Australia Limited.
Federation Insurance Limited.
Fire and All Risks Insurance Company Limited.
First Mortgage Insurance Company of Australia Proprietary Limited.
Forsikringsaktieselskapet Vesta—Vesta Insurance Company.
General Accident Fire and Life Assurance Corporation Limited.
General Mutual Insurance Co. Ltd.
Glanvill Holland Proprietary Limited.
Godfrey Orton Insurances Pty. Ltd.
Greater Pacific General Insurance Company Limited.
Gresham Fire and Accident Insurance Society Limited.
Grieve and Irwin Aust. Pty. Ltd.
Guardian Assurance Company Limited.
Guild Insurance Company Limited.
Guildhall Insurance Company Limited.
H. G. Poland (Australia) Proprietary Limited.
H. J. Heinz Company Australia Limited.
Hanover Insurance Company.
Hartford Fire Insurance Company.
Harvey Trinder (Southern) Pty. Ltd.
Henry G. Nicholson Aust. Pty. Ltd.
Hogg Robinson and Gardner Mountain (Aust.) Pty. Ltd.
Home Insurance Company.
Indemnity Marine Assurance Company of Australia Ltd.
Insurance Commissioner (State Accident Insurance Office and State Motor Car Insurance Office).
Insurance Company of North America.
Insurance Corporation of Ireland Limited.
Insurance Office of Australia Limited.
Interstate Steamship Insurance Company Proprietary Limited.
Invincible Life and General Insurance Company Limited.
Ipec Insurance Limited.
J. H. Minet and Company (ANZ) Proprietary Limited.
J. H. Wackerbarth (Australasia) Proprietary Limited.
John Forsaith Vic. Pty. Ltd.
Law Union and Rock Insurance Company Limited.
Legal and General Assurance Society Limited.
Legal Insurance Company Limited.
LEP Insurance Brokers Proprietary Limited.
Leslie N. Allen Proprietary Limited.
Leslie N. Allen Reinsurance P/L.
Licenses and General Insurance Company Limited.
Liverpool and London and Globe Insurance Company Limited.
Lombard Insurance Company Limited.
London and Lancashire Insurance Company Limited.
London and Overseas Insurance Company Limited.
London and Scottish Assurance Corporation of Australia Ltd.
London Assurance.
London Guarantee and Accident Company of Australia Ltd.
L Union Des Assurances De Paris.
M.L.C. Fire and General Insurance Company Proprietary Limited.
M. W. Payne Liability Agencies Pty. Ltd.
Manchester Unity Fire Insurance Company of Victoria Limited.
Manufacturers Mutual Insurance Limited.
Marine Hull and Liability Insurance Company Proprietary Limited.
Maritime Insurance Company Limited.
Marsh and McLennan Proprietary Limited.
Marshall, Golding, Adam Re-Insurance Proprietary Limited.
Master Builders' Insurance Company Limited.
Matthews Wrightson and Strapp Proprietary Limited.
Mercantile and General Re-Insurance Company of Australia Limited.
Mercantile Mutual Life Insurance Co. Ltd.
Mercantile Mutual Insurance Company Limited.
Milford Insurance Company Limited.
Monarch Insurance Company Limited.

Mortgage Guaranty Insurance Corporation of Australia Limited.
 Motorists Mutual Insurance Company Limited.
 Munich Reinsurance Company of Australia Limited.
 Mutual Life & Citizens' Assurance Company Limited.
 National and General Insurance Company Limited.
 National Co-operative Insurance Society Limited.
 National Employers' Mutual General Insurance Association Limited.
 National Insurance Company of New Zealand Limited.
 National Mutual Casualty Insurances Limited.
 National Mutual Fire Insurance Company Limited.
 New Reinsurance Geneva Proprietary Limited.
 New Zealand Insurance Company Limited.
 New Zealand Victoria Life Limited.
 Nippon Fire and Marine Insurance Company Limited.
 North British and Mercantile Insurance Company of Australia Limited.
 Northern Assurance Company of Australia Ltd.
 Northumberland Insurance Company Limited.
 Northumberland Insurance Co. (U.S.A.) Limited.
 Norwich Union Fire Insurance Society Limited.
 Ocean Accident and Guarantee Corporation of Australia Limited.
 Omnibus and General Insurance Brokers Proprietary Limited.
 Orion Insurance Company Limited.
 Overseas Shipping Insurance Company Proprietary Limited.
 Pacific Insurance Company Limited.
 Palatine Insurance Company of Australia Limited.
 Pan Australian Insurance Proprietary Limited.
 Patriotic Assurance Company Limited.
 Pearl Assurance Company Limited.
 Phoenix Assurance Company of Australia Limited—formerly Southern Union Insurance Company of Australia Limited.
 Phoenix Life Assurance Company of Australia Ltd.
 Price Forbes Leslie Proprietary Limited.
 Price, Forbes, Leslie (Reinsurance) Pty. Ltd.
 Producers' and Citizens' Life Insurance Company Limited.
 The Provident Fire Insurance Company of Australia Ltd.
 Provincial Insurance Company Limited.
 Prudential Assurance Company Limited.
 Queensland Insurance Company Limited.
 RACV Insurance Pty. Ltd.
 R. H. Tolley and Gardner Proprietary Limited.
 Real Australia Insurance Company Limited.
 Reinsurance Company of Australasia Limited.
 Reliance Marine Insurance Company Limited.
 Royal Exchange Assurance.
 Royal Insurance Company Limited.
 Rural Finance and Settlement Commission.
 Scottish Insurance Corporation Limited.
 Scottish Union and National Insurance Company.
 Sea Insurance Company Limited.
 Security and General Insurance Company Limited.
 Security Life Assurances Limited.
 Sedgwick Collins Reinsurances Pty. Ltd.
 Sedgwick Collins (Victoria) Proprietary Limited.
 Silver Self Aid Insurance Company Limited.
 Sirius Insurance Company Limited.
 Skandia Insurance Company Limited.
 South Australian Insurance Company Limited.
 South British Insurance Company Limited.
 Southern Star General Insurance Company Proprietary Limited.
 The Southern Union Commercial Insurance Company of Australia Ltd.
 Stanley Taylor and Company.
 State Assurance Company Limited.
 State Government Insurance Office—Queensland.
 Steadfast Insurance Company Limited.
 Steeves, Agnew and Company (Victoria) Proprietary Limited.
 Stenhouse Reinsurance Proprietary Limited.
 Stenhouse, Scott, North Australia Limited.
 Stenhouse Victoria Limited.
 Stewart, Smith and Co. (A'asia) Pty. Ltd.
 Sun Insurance Office Limited.
 Surrey Insurance Company Limited.
 Swann Insurance Limited.
 Swiss Reinsurance Company.
 Switzerland General Insurance Company Limited.
 T. & G. Fire and General Insurance Company Limited.
 T. P. Clark and Chapman Proprietary Limited.
 T. P. Clark and Chapman (Reinsurances) P/L.
 Taisho Marine and Fire Insurance Company Limited.
 Thames and Mersey Marine Insurance Company Limited.
 Tokio Marine and Fire Insurance Company Limited.
 Trade Indemnity Company Limited.
 Traders Prudent Insurance Company Limited.
 Transport Industries Insurance Company Proprietary Limited.
 Transport and General Insurance Company Limited.

Triton Insurance Company Limited (with which is incorporated the Eastern Insurance Company).
 Triumph Insurance Company (Australia) Ltd.
 U.G. Insurances Pty. Ltd.
 Underwriting and Insurance Limited.
 Union Assurance Society of Australia Limited.
 Union Insurance Society of Canton Limited.
 United Insurance Company Limited.
 VACC Insurance Coy. Ltd.
 Vanguard Insurance Company Limited.
 Victor Aghion and Sons Pty. Ltd.
 Victoria Insurance Company Limited.
 Victorian Wheatgrowers Corporation Limited—trading as Wheatgrowers and General Insurance Company.
 Victory Reinsurance Company of Australia Limited.
 Waltons Insurance Company Limited.
 Wells Coppin Pty. Ltd.
 Westchester Fire Insurance Company.
 Western Assurance Company.
 Western Australian Insurance Company (Canberra) Limited.
 Westminster Insurance Company Limited.
 World Marine and General Insurance Company Limited.
 Y.C.W. Co-operative Society Limited (Insurance Division).
 Yasuda Fire and Marine Insurance Company Limited.
 Yorkshire Insurance Company Limited.

R. M. PHIBBS,
 Comptroller of Stamps.

Chief Office for Stamp Duties,
 Melbourne, 9th June, 1971.

Stamps Act 1958.
 ANNUAL LICENCE.

NOTIFICATION PURSUANT TO SECTION 97.

I HEREBY notify that stamp duty has been paid for a licence under section 110 of the *Stamps Act 1958*, in respect of the year ending 31st December, 1971, by the following:—

THE BROKEN HILL PROPRIETARY COMPANY LIMITED.

R. M. PHIBBS,
 Comptroller of Stamps.

Chief Office for Stamp Duties,
 Melbourne, 10th June, 1971.

TERM OF PETROLEUM EXPLORATION PERMITS
 EXTENDED.

68, Petroleum Exploration Permit; Leon James Charles Say and Pursuit Oil No Liability; 149 square miles, County of Grant.
 70, W.Y.P. Development Pty. Limited; 770 square miles, County of Croajingolong.

J. C. M. BALFOUR,
 Minister of Mines.

Aboriginal Lands Act 1970.

REGISTER OF ABORIGINAL PERSONS ENTITLED TO FORM THE FRAMLINGHAM ABORIGINAL TRUST.

IN accordance with section 3 of the *Aboriginal Lands Act 1970*, I, Edward Raymond Meagher, Her Majesty's Minister for Aboriginal Affairs for the State of Victoria do hereby register the names of those Aboriginal persons who are entitled to form the Framlingham Aboriginal Trust, as follows:—

1. Austin, Arthur Herbert.
2. Berg, Henrietta.
3. Clarke, Albert.
4. Clarke, Alice Maude.
5. Clarke, David Herbert.
6. Clarke, Fay.
7. Clarke, Geoffrey Wayne.
8. Clarke, Henry.
9. Clarke, Herbert Edgar.
10. Clarke, Ian Norman.
11. Clarke, Leonard John Gary.
12. Clarke, Mary Maude.
13. Clarke, Norris Connolly.
14. Clarke, Percy.
15. Clarke, Violet Jennifer.
16. McKinnon, Alexander.
17. Rose, James Wallace Leslie.

Dated this 2nd day of June, 1971.

E. R. MEAGHER,
 Minister for Aboriginal Affairs.

Ministry of Aboriginal Affairs,
 Melbourne.

Aboriginal Lands Act 1970.

REGISTER OF ABORIGINAL PERSONS ENTITLED TO FORM THE LAKE TYERS ABORIGINAL TRUST.

IN accordance with section 3 of the *Aboriginal Lands Act 1970*; I, Edward Raymond Meagher, Her Majesty's Minister for Aboriginal Affairs for the State of Victoria do hereby register the names of those Aboriginal persons who are entitled to form the Lake Tyers Aboriginal Trust, as follows:—

1. Bryant, Leonard John.
2. Bryant, Leonard Joseph.
3. Bryant, Lucille Frances.
4. Bryant, William.
5. Bull, Agnes Julia.
6. Bull, Connelly Richard.
7. Bull, David Worrick.
8. Bull, Denise.
9. Bull, Elvie Constance.
10. Bull, Frances.
11. Bull, Owen Cedric.
12. Bull, Rita Maureen.
13. Bull, Rodney Clint.
14. Bull, Wallace Murray.
15. Carter, Alfred Charles Ronald (Senior).
16. Carter, Alfred Charles Ronald (Junior).
17. Carter, Alfred James.
18. Carter, Campbell Edward Lionel.
19. Carter, Gwen Rowena.
20. Carter, Iris Anne.
21. Carter, Karen Thelma.
22. Carter, Marion Elizabeth.
23. Carter, Maxine Phyllis.
24. Carter, Pamela.
25. Carter, Phyllis Frances.
26. Carter, Phyllis Frances.
27. Carter, Rowena Ann.
28. Carter, Thelma.
29. Carter, Wilfred James.
30. Carmichael, Edward Cornelius.
31. Edwards, Alfred James.
32. Edwards, Cornelius William.
33. Edwards, Julia Constance.
34. Edwards, Leon Warren Cedric.
35. Edwards, Madge Elizabeth.
36. Edwards, Maureen Theresa.
37. Edwards, Michael Charles.
38. Edwards, Noelene Sharon.
39. Edwards, Ronald William James.
40. Fenton, Clement Frederick.
41. Fenton, Conway.
42. Fenton, Gary Patrick.
43. Fenton, Geoffrey Terrence.
44. Fenton, Hilda Julia.
45. Fenton, Lloyd Martin.
46. Fenton, Melvyn.
47. Fenton, Phillip Edward.
48. Fenton, Sandra Marjorie.
49. Harrison, Ada May.
50. Harrison, Alice.
51. Harrison, Allan.
52. Harrison, Faye Agnes.
53. Harrison, Kathleen Amelia.
54. Harrison, Mirrell Laura.
55. Harrison, Olga Alma.
56. Harrison, Shirley Ann.
57. Johnson, Frederick William.
58. Johnson, Phyllis Joan.
59. Marks, Allan.
60. Marks, Brian Ronald.
61. Marks, Gordon.
62. Marks, Gwenneth Rowena.
63. Marks, Kevin.
64. Marks, Lillian.
65. Marks, Lola.
66. Marks, Rosemary.
67. Marks, Thomas.
68. Moubourne, Craig Anthony.
69. Moubourne, Claude Lindsay (Senior).
70. Moubourne, Claude Lindsay (Junior).
71. Moubourne, Daniel Lawson.
72. Moubourne, Darren Terrence.
73. Moubourne, Donna Marree.
74. Moubourne, Gail Iris.
75. Moubourne, Gladys Pauline.
76. Moubourne, Ivy May.
77. Moubourne, Janette Ann.
78. Moubourne, Lorna Dorothy.
79. Moubourne, Marjorie Dawn.
80. Moubourne, Russell Edward John.
81. Moffatt, Rupert Foster.
82. Mullett, Arthur Benjamin Alexander.
83. O'Rourke, Ella May.
84. O'Rourke, Ronald Alfred James.
85. Pepper, Alison Fay.

86. Pepper, Dulcie Daisy Kathleen.
87. Pepper, Elizabeth Ann.
88. Pepper, Hugh.
89. Pepper, Watson.
90. Tregonning, Hilda.
91. Wandin, Joseph Frederick James (Senior).
92. Wandin, Joseph Frederick James (Junior).

Dated this 2nd day of June, 1971.

E. R. MEAGHER,
Minister for Aboriginal Affairs.

Ministry of Aboriginal Affairs,
Melbourne.

SURVEY CO-ORDINATION ACT No. 6388.

NOTICE OF INTENTION TO ASSIGN A NAME.

PURSUANT to the powers conferred under section 28 of the above Act, the Place Names Committee hereby gives notice of its intention to assign the following name to the locality mentioned hereunder:—

Municipality.—City of Broadmeadows.

Location.—Situated on Moonee Ponds Creek in the north-western corner of the City.

Proposed Name.—Westmeadows.

Any person who objects to the above proposal may give notice of objection, in writing, stating the reasons therefor, to the Secretary of the Committee not more than two (2) months following the publication of this notice.

By order of the Committee,

C. E. E. BARLOW,
Secretary.

Victoria.

ACT No. 391.—SECOND SCHEDULE.

A STATEMENT of trusts having been submitted by the head or authorized representative of the denomination of The Presbyterian Church of Victoria, under the provisions of the "Act to provide for the Abolition of State Aid to Religion," for allowance by the Governor, the same was allowed by him on the twenty-fifth day of May, 1971; and the following is the form in which such statement of trusts has been allowed:—

STATEMENT OF TRUSTS.

Description of Land.—1 acre, Township of Drysdale, Parish of Bellarine, County of Grant, being allotment 2, section 15. Commencing at the intersection of the southern alignment of Eversley-street and the western alignment of Princess-street; bounded thence by Princess-street bearing 179 deg. 57 min. 439 links, by allotment 1 bearing 307 deg. 5 min. 419 links; by Elgin-street bearing 37 deg. 5 min. 350 links; and thence by Eversley-street bearing 127 deg. 5 min. 153 links to the point of commencement.

Names of Trustees.—The Presbyterian Church of Victoria Trusts Corporation.

Powers of Disposition.—With the consent of the General Assembly of "The Presbyterian Church of Victoria", to mortgage, sell, lease, exchange and transfer, and grant easements over the said land, or any part or parts thereof, and, subject to such powers and the exercise thereof, to hold the said land, or so much thereof as may from time to time remain vested in the said trustees, upon such trusts for the said Presbyterian Church of Victoria, and for such purposes, and with and subject to such powers, and provisions as are contained in the document enrolled by the Registrar-General of the State of Victoria, pursuant to the provisions of the *Presbyterian Trusts Act 1890*, and styled, "The Presbyterian Church of Victoria, Model Trust Deed for Church, Site".

Purposes to which Proceeds of Disposition are to be Applied.—To pay the money coming to the hands of such trustees by virtue of any such power of disposition to the Treasurer for the time being of the Presbyterian Church of Victoria, to be by him applied first in payment of all incidental costs, next in payment to the said Presbyterian Church of Victoria, of all deductions heretofore or hereafter to be authorized, by the General Assembly of the said Church and as to the residue, for such purposes as the said Assembly has heretofore authorized or may hereafter authorize.

As witness the hand of the Governor of the State of Victoria, this twenty-fifth day of May, 1971.

ROHAN DELACOMBE,
Governor of the State of Victoria.

CONTRACTS ACCEPTED.—(Series 1970-71.)**PUBLIC WORKS.**

1272. Thornbury, Northcote Technical School, supply furniture, \$10,158.00.—Bera Furniture Pty. Ltd.

1273. Port Melbourne, P.W.D. Depot, supply tractors, \$20,260.00.—Moore Road Machinery Vic. Ltd.

1274. Mooroolbark, Pembroke High School, supply chairs, \$6,572.16.—Furniture Makers of Aust. Pty. Ltd.

1275. North Fitzroy, Primary School 1490, erection of first stage, \$353,955.00.—McDougall-Ireland Pty. Ltd.

1276. Ballarat North, Technical School, erection of new girls' wing, \$283,981.00.—A. R. P. Crow Holdings Pty. Ltd.

1277. Footscray, Institute of Technology, supply and installation of 180-line extensible P.A.B.X. telephone system, \$30,938.00.—L. M. Ericsson Pty. Ltd.

1278. Melbourne, Agriculture Department, 131 Queen-street, supply and installation of P.A.B.X. telephone system, \$16,193.00.—L. M. Ericsson Pty. Ltd.

1279. Burwood, Teachers' College, supply and installation of 120-extension extensible P.A.B.X. system, \$24,600.00.—L. M. Ericsson Pty. Ltd.

1280. Melbourne, New State Offices, heavy duty asphalt pavement construction, \$14,812.00.—Wm. Loud Pty. Ltd.

1281. Upfield, High School, electrical installation, new wing and additions to existing buildings, \$12,576.00.—Oliver J. Nilsen & Co. Pty. Ltd.

1282. Donvale, High School, electrical installation new wing and additions to existing buildings, \$12,132.00.—Oliver J. Nilsen & Co. Pty. Ltd.

1283. Manangatang, Consolidated and Higher Elementary Schools, provision of fire service, \$4,988.00.—F. A. Petzke & Co. Pty. Ltd.

1284. Kangaroo Flat, Primary School 981, central heating system, \$13,425.00.—D. Smyth & Son Pty. Ltd.

1285. Werribee, High School, internal and external repairs and painting, \$14,182.00.—Industrial Alterations & Building Decorating Co.

1286. Sebastopol, Technical School, erection of L.T.C. science extensions, \$34,369.00.—S. J. Weir Pty. Ltd.

1287. Studfield, Primary School 4920, asphalt, concreting, grassing, drainage and associated works, \$13,471.10.—A. Infantino Constructions Pty. Ltd.

1288. Upwey, Primary School 4530, installation of gas heating, \$4,297.90.—Thermal Traders (Vic.) Pty. Ltd.

1289. Kyneton, High School, re-tiling roof of main building, \$13,654.00.—H. & A. Tinsley Pty. Ltd.

1290. Highton, Primary School 304; Point Lonsdale, Primary School 3322; Leopold, Primary School 1146; Grovedale, Primary School 283; Ocean Grove, Primary School 3100; Portarlington, Primary School 2455; Geelong East, Primary School 541, erection of class-rooms, staff-rooms, stores, &c. Bulk Contract 70/71, Part 1 Western. Sub-regional 1, \$88,649.00.—A. P. Van Dort & Sons.

1291. Various, electrical installation for standard primary class-rooms, &c., within 30-mile radius of Melbourne. Zone 3, Eastern (70/71), at Rates.—W. T. Waterfall & Sons Pty. Ltd.

1292. Broadmeadows, Attwood Research Station, erection of incinerator building and two virology units, \$87,350.00.—H. Willis.

1293. Frankston, Keith Turnbull Research Station, electrical installation, \$4,280.00.—E. S. & H. J. Hudson Pty. Ltd.

1294. Westernport, dredging at Hastings, \$54,830.00.—Australian Dredging & General Works Pty. Ltd.

G. G. BOLWELL, Acting Director of Public Works. 1.6.71.

ORDERS IN COUNCIL.—(Series 1970-71.)**PUBLIC WORKS.**

1269. Melbourne, Parliament-place, Nos. 2, 4, 6, 8 and 10, for demolition and removal, marking and making good, &c., "Tasma" and "Bella-Vista" Guest Houses, \$31,750.00.—Whelan the Wrecker Pty. Ltd.—(I. & D. 83332.)

1270. Melbourne, Tourist Bureau, 276 Collins-street, supply and installation of a P.A.B.X. System with Queuing facilities, \$136,589.00.—Standard Telephones and Cables Pty. Ltd.—(C.207401.)

1271. Parkville, Melbourne Teachers' College Library, supply of additional furniture, \$5,687.00.—Brownbuilt Ltd., and \$6,563.00.—Furniture Makers of Australia Pty. Ltd.—(I. & D. 123378 "E".)

Approved by the Governor in Council, 1st June, 1971.—J. ROSSITER, Clerk of the Executive Council.

Dried Fruits Act 1958.**NOTICE.**

IN accordance with the provisions of the *Dried Fruits Act 1958*, it is hereby notified that, with respect to the year ended 31st December, 1971, the amount of contribution payable by every packer is 80 cents per ton, computed, in accordance with the Regulations under the *Dried Fruits Act*, from the quantity of 1971 Season's dried fruits sold from each packing house and from the quantity of dried fruits forwarded therefrom for the purpose of trade and sale.

By order of the Board,

K. F. NEANDER,
Secretary.

Melbourne, 28th May, 1971.

ENGINEERS OF WATER SUPPLY.**EXAMINATION OF CANDIDATES FOR CERTIFICATES OF QUALIFICATION.**

THE Board of Examiners of Engineers of Water Supply for the State of Victoria, appointed under the provisions of the *Water Act*, hereby gives notice that an examination of candidates for Certificates of Qualification will be held on Monday and Tuesday, the 4th and 5th October, 1971, at the office of the State Rivers and Water Supply Commission, 90 Orrong-road, Armadale, Victoria.

C. J. CALVERT, Secretary,
Board of Examiners.

State Rivers and Water Supply Commission,
Armadale, 4th June, 1971.

Co-operation Act 1958.**NOTICE OF AMALGAMATION OF SOCIETIES.**

NOTICE is hereby given that, pursuant to the provisions of the *Co-operation Act 1958*, White Hills Parish Co-operative Credit Society Limited and St. Killians Co-operative Credit Society Limited, were amalgamated into one society under the name of Bendigo Credit Co-operative Limited, on the thirty-first day of May, 1971.

Dated at Melbourne this thirty-first day of May, 1971.

M. V. HAMMOND,
Deputy Registrar.

Co-operative Housing Societies Act 1958.**CHANGE OF NAME OF A SOCIETY.**

NOTICE is hereby given that Western Co-operative Housing Society Limited, of Lake-road, Stawell, which was incorporated as a Co-operative Housing Society under the above-named Act on the 16th day of December, 1968, has registered a change of its name and is now incorporated under the name of Western No. 1 Co-operative Housing Society Limited, under the said Act.

J. W. JUNGWIRTH,
Registrar of Co-operative Housing Societies.

NOTICE TO MARINERS.

[No. 12 OF 1971.]

AUSTRALIA.—VICTORIA.**GIPPSLAND LAKES.****Jetty Light Established.**

Position of Light.—Lat. 38 deg. 03 min. S., Long. 145 deg. 35 min. E. (Approx.).

Remarks.—A navigation light has been established on the seaward end of Loch Sport Jetty, Lake Victoria.

Characteristic.—Flashing every 5 seconds; flash $\frac{1}{2}$ second, eclipse $\frac{4}{5}$ seconds.

Elevation.—36 feet (10 m 9).

Visibility.—2 miles.

Abridged Characteristic.—Fl. 5 sec. 2 M.

Publication.—*Sailing Directions*, Victoria 1970, page 536.

A. J. WAGGLEN,
Port Officer.

Public Works Department,
Ports and Harbors Division,
2 Treasury-place, Melbourne, 3002.
4th June, 1971.

Crimes Act 1958.

CURATOR OF CONVICT'S PROPERTY.

HIS Excellency the Governor of the State of Victoria by and with the advice of the Executive Council thereof doth by Order made on the 1st day of June, 1971, and pursuant to the provisions of section 550 of the *Crimes Act 1958*, commit the custody and management of the property of the convict Jeffrey John Halmshaw Ponton to The Perpetual Executors and Trustees Association of Australia Ltd., 100-104 Queen-street, Melbourne, as a Curator hereby appointed in that behalf.

J. ROSSITER,
Clerk of the Executive Council.

At the Executive Council Chamber,
Melbourne, 1st June, 1971.

Pipelines Act 1967.

VARIATION OF PIPELINE LICENCE No. 61.

WHEREAS sub-section (3) of section 30 of the *Pipelines Act 1967* provides that by notice published in the *Government Gazette*, the Minister may amend, vary, add to or revoke any condition stated or included in a licence, I, James Charles Murray Balfour, Minister of Mines, do now hereby amend the conditions of Pipeline Licence No. 61 in the manner indicated in the Schedule hereto.

SCHEDULE.

Replace section I (C) (ii) of the Schedule to the licence with the following:—

“(ii) Outlet Pressure.”

The pressure of the natural gas leaving the pipeline to supply industrial and other consumers shall, unless otherwise approved in writing by the Minister, be controlled to a maximum of 75 psig by means of pressure regulator stations constructed in general conformity with the layouts shown on Drawings Nos. B.11237 and B.11238 accompanying the application.

At least one week prior to commencement of construction of these regulator stations the licensee shall submit to the Director, Oil and Gas Branch final construction drawings covering these installations.”

J. C. M. BALFOUR,
Minister of Mines.

Department of Mines,
Melbourne, 1st June, 1971.

Cemeteries Act 1958.

SCALE OF FEES OF HAMILTON PUBLIC CEMETERY.

In pursuance of the powers conferred upon them by the *Cemeteries Act* the trustees of the Hamilton Public Cemetery hereby make the following scale of fees, which shall come into operation upon publication in the *Government Gazette*, and from and after such publication every scale of fees heretofore made by the said trustees shall be and is hereby rescinded to the extent to which it conflicts with this scale.

<i>Private Graves.</i>	
Land 8 ft. x 4 ft.	\$42.00
<i>Sinking Charges for Private Graves.</i>	
Sinking grave 6 feet deep	\$36.00
Sinking grave 7 feet deep	\$40.00
<i>Reopening Charges.</i>	
Reopening grave (no cover) up to 6 feet	\$30.00
Reopening grave (with cover or kerb) up to 6 feet	\$35.00
Reopening, each additional foot	\$6.00
<i>Extra Charges.</i>	
Interment on Public Holidays (extra)	\$15.00
Digging fee for burial of destitute persons	\$11.00

H. N. MALLINSON, Trustee.
D. PARTINGTON, Trustee.
L. M. BALKIN, Trustee.

Approved by the Governor in Council, 1st June, 1971.—
J. ROSSITER, Clerk of the Executive Council.

ELECTION OF MEMBER OF COMMITTEE OF CLASSIFIERS FOR THE TECHNICAL SCHOOLS DIVISION.

PURSUANT to the Teaching Service (Teachers Tribunal) Regulations, I hereby notify that I have conducted an election of a member of the Committee of Classifiers for the Technical Schools Division, and I hereby declare that Alan Gordon Marriage has been elected a member of such Committee for the period commencing on the 6th June, 1971, and I further declare that Peter John Crocker has been elected as deputy member of such Committee for the same period.

L. D. JONES,
Returning Officer.

ELECTION OF MEMBER OF COMMITTEE OF CLASSIFIERS FOR THE SECONDARY SCHOOLS DIVISION.

PURSUANT to the Teaching Service (Teachers Tribunal) Regulations, I hereby notify that I have conducted an election of a member of the Committee of Classifiers for the Secondary Schools Division, and I hereby declare that Bernard George Blood has been elected a member of such Committee for the period commencing on the 7th August, 1971, and I further declare that Graeme Shaw Stuart has been elected as deputy member of such Committee for the same period.

L. D. JONES,
Returning Officer.

CHURCHILL SEWERAGE AUTHORITY.

ANNUAL BALANCE.

HIS Excellency the Governor of the State of Victoria, by and with the advice of the Executive Council thereof, doth by Order made on the 8th day of June, 1971, and in pursuance of the provisions of the *Sewerage Districts Act*, fix the 31st day of December in each year as the day to which the accounts of the Churchill Sewerage Authority shall be balanced.

J. ROSSITER,
Clerk of the Executive Council.

At the Executive Council Chamber,
Melbourne, 8th June, 1971.

LOCAL GOVERNMENT DEPARTMENT.

ORDER CONFIRMED.—CITY OF KNOX.

THE Minister of the Crown administering the *Local Government Act 1958*, on the 2nd day of June, 1971, confirmed the Order hereinafter referred to in pursuance of section 514 of the said Act, namely:

An Order of the Council of the City of Knox made on the 4th May, 1971, directing the compulsory taking of the land described hereunder for road widening purposes:—

All that piece of land being part of lot 71, on plan of subdivision No. 6538, lodged in the Office of Titles, commencing at the south-east intersection of Barry-street and Power-road; thence bearing 98 deg. 06 min. along the south building line of Barry-street a distance of 524 feet; thence bearing 232 deg. 14 min. 30 sec. for a distance of 22 ft. 3½ in.; thence bearing 278 deg. 06 min. for a distance of 160 ft. 7 in.; thence bearing 280 deg. 47 min. for a distance of 290 ft. 7 in.; thence by a circular arc of radius 22 feet and length 53 ft. 2 in. the chord of which bears 213 deg. 13 min. 15 sec. to the east building line of Power-road; thence by a line bearing 322 deg. 15 min. along the east building line of Power-road a distance of 58 ft. 2 in. to the commencing point.

A. J. HUNT,
Minister for Local Government.

Local Government Department,
Melbourne (21813113).

LOCAL GOVERNMENT DEPARTMENT.

ORDER CONFIRMED.—CITY OF KNOX.

THE Minister of the Crown administering the *Local Government Act 1958*, on the 2nd day of June, 1971, confirmed the Order hereinafter referred to in pursuance of section 514 of the said Act, namely:

An Order of the Council of the City of Knox made on the 4th May, 1971, directing the compulsory taking of the land described in certificates of title, volume 4323, folio 460 and volume 5170 folio 967, for the purpose of road making for fire access purposes.

A. J. HUNT,
Minister for Local Government.

Local Government Department,
Melbourne (21813112).

LOCAL GOVERNMENT DEPARTMENT.

ORDER CONFIRMED.—SHIRE OF TAMBO.

THE Minister of the Crown administering the *Local Government Act 1958*, on the 2nd day of June, 1971, confirmed the Order hereinafter referred to in pursuance of section 514 of the said Act, namely:

An Order of the Council of the Shire of Tambo made on 20th April, 1971, directing the compulsory taking of the land described in certificate of title, volume 2399, folio 796 for the purpose of providing a place of public resort and recreation.

A. J. HUNT,
Minister for Local Government.

Local Government Department,
Melbourne (3421313).

LOCAL GOVERNMENT DEPARTMENT.

ORDER CONFIRMED.—SHIRE OF ELTHAM.

THE Minister of the Crown administering the *Local Government Act 1958*, on the 2nd day of June, 1971, confirmed the Order hereinafter referred to in pursuance of section 514 of the said Act, namely:

An Order of the Council of the Shire of Eltham made on the 3rd May, 1971, directing the compulsory taking of the land described hereunder for the purpose of reconstructing portion of the Kangaroo Ground—St. Andrews road:—

All that piece of land being part of Crown allotment 74, section C, Parish of Greensborough, bounded by a line commencing at the north-eastern corner of the said allotment; thence by lines bearing 237 deg. 45 min. for 220 links and 36 deg. 43 min. for 192.3 links; thence by the northern boundary of the said allotment to the point of commencement.

A. J. HUNT,
Minister for Local Government.

Local Government Department,
Melbourne (1741318).

LOCAL GOVERNMENT DEPARTMENT.

ORDER CONFIRMED.—CITY OF GEELONG WEST.

THE Minister of the Crown administering the *Local Government Act 1958*, on the 2nd day of June, 1971, confirmed the Order hereinafter referred to in pursuance of section 514 of the said Act, namely:

An Order of the Council of the City of Geelong West made on the 4th May, 1971, directing the compulsory taking of the land described hereunder for the purpose of giving the same to the Housing Commission as provided in section 22 of the *Housing Act 1958*:

All that piece of land being part of Crown allotment 9, section 8, Parish of Moorpanyal commencing at the south-western intersection of Isabella-street with Raven-street and bounded on the east by Raven-street bearing 180 deg. 10 min. 214 ft. 11 in. on the south by Trigg-street bearing 269 deg. 51 min. 63 ft. 7 in. on the west by lines bearing 0 deg. 28 min. 112 ft. 5½ in.; 88 deg. 24 min. 9½ in.; 358 deg. 24 min. 7 ft. 6½ in.; 269 deg. 54 min. 5½ inches; through the centre of a brick party wall 9 inches wide 359 deg. 54 min. 23 ft. 6 in.; 358 deg. 35 min. 5 feet and 1 deg. 28 min. 66 ft. 9 in. and on the north by Isabella-street bearing 90 deg. 11 min. 61 ft. 7½ in. back to the commencing point.

A. J. HUNT,
Minister for Local Government.

Local Government Department,
Melbourne (1921326).

LOCAL GOVERNMENT DEPARTMENT.

ORDER CONFIRMED.—CITY OF MELBOURNE.

THE Minister of the Crown administering the *Local Government Act 1958*, on the 2nd day of June, 1971, confirmed the Order hereinafter referred to in pursuance of the provisions of section 514 of the said Act, namely:

An order of the Council of the City of Melbourne made on the 10th May, 1971, directing the compulsory taking of certain land being the land described in certificate of title, volume 3862, folio 362, for the purpose of off-street parking facilities.

A. J. HUNT,
Minister for Local Government.

Local Government Department,
Melbourne (2471316).

No. 56.—4892/71—2

LOCAL GOVERNMENT DEPARTMENT.

ORDER CONFIRMED.—CITY OF GEELONG WEST.

THE Minister of the Crown administering the *Local Government Act 1958*, on the 2nd day of June, 1971, confirmed the Order hereinafter referred to in pursuance of section 514 of the said Act, namely:

An Order of the Council of the City of Geelong West made on the 4th May, 1971, directing the compulsory taking of the land described hereunder for widening part of Hope-street, Geelong West:—

All that piece of land being part of lot 7, on plan of subdivision No. 8174, lodged in the Office of Titles, commencing at the north-western angle of the said lot; thence easterly along the northern boundary thereof to the north-eastern angle; thence southerly along the eastern boundary for a distance of 22 feet; and thence by a line bearing 296 deg. 36 min. for 49 ft. 2 in. to the point of commencement.

A. J. HUNT,
Minister for Local Government.

Local Government Department,
Melbourne (1921315).

LOCAL GOVERNMENT DEPARTMENT.

ORDER CONFIRMED.—SHIRE OF HASTINGS.

THE Minister of the Crown administering the *Local Government Act 1958*, on the 2nd day of June, 1971, confirmed the Order hereinafter referred to in pursuance of section 514 of the said Act, namely:

An Order of the Council of the Shire of Hastings made on the 1st April, 1969, directing the compulsory taking of the land described hereunder for road widening purposes:—

All that piece of land being part of lot 169, on plan of subdivision No. 2991, lodged in the Office of Titles, commencing at the north-eastern corner of the said lot 169; thence westerly on a bearing of 269 deg. 57 min. for a distance of 40 feet; thence southerly on a bearing of 180 deg. 00 min. for a distance of 20 feet; thence easterly on a bearing of 89 deg. 57 min. for a distance of 40 feet; thence northerly on a bearing of 0 deg. 00 min. for a distance of 20 feet to the point of commencement.

A. J. HUNT,
Minister for Local Government.

Local Government Department,
Melbourne (2031311).

LOCAL GOVERNMENT DEPARTMENT.

ORDER CONFIRMED.—CITY OF DONCASTER AND TEMPLESTOWE.

THE Minister of the Crown administering the *Local Government Act 1958*, on the 2nd day of June, 1971, confirmed the Order hereinafter referred to in pursuance of section 514 of the said Act, namely:

An Order of the Council of the City of Doncaster and Templestowe made on 19th April, 1971, directing the compulsory taking of the land described in certificate of title, volume 8844, folio 661, for the purpose of providing a place of public resort and recreation.

A. J. HUNT,
Minister for Local Government.

Local Government Department,
Melbourne (16713128).

PUBLIC TRUSTEE ACT 1958 (No. 6350), SECTION 17.

I HEREBY give notice that on the 21st May, 1971, the Public Trustee filed elections to administer the following deceased persons' estates, in accordance with section 17 of the *Public Trustee Act 1958*:—

BREWER, BENONI JOHN, formerly of 139 Wellington-street, Windsor, but late of 35 McIlwrick-street, Windsor, part-time barman, died 5th July, 1970.

HANNAH, ALEXANDER JOHN, late of 11 Valerie-street, East Kew, retired theatre manager, died 31st May, 1970.

JONES, ALLAN JOSEPH, late of Greenvale, pensioner, died 20th November, 1970.

LAWSON, ROBERT LESLIE, late of 53 Osborne-street, Williamstown, soldier, died 20th August, 1915.

LEWIS, JAMES WALTER, formerly of 15 Charles-street, Prahran, late of 34 Highland-avenue, Highett, retired motor engineer, died 12th January, 1971.

SLOAN, ROBERTA JOSEPHINE, formerly of 125A Hambleton-street, Middle Park, care of After Care Hospital, 45 Victoria-parade, Collingwood, Victoria, widow, died 7th March, 1971.

VAN DER BURGH, JOHN PETER WILLIAM SIMON, formerly of lot 86, Upper Glen Park-road, Eltham North, but late of 3 Clarke-street, Footscray West, maintenance scheduler, died 14th June, 1970.

WILLIAMS, RUPERT, late of "Alexander", Castlemaine, pensioner, died 14th January, 1971.

N. P. BRODY,
Public Trustee.

256 Flinders-street, Melbourne, 3000, 2nd June, 1971.

NOTICE.

CREDITORS, next of kin and others having claims against the estate of any of the under-mentioned deceased persons, are required to send particulars of their claims to the Public Trustee, 256 Flinders-street, Melbourne, Vic. 3000, the personal representative, on or before the 16th August, 1971, after which date the Public Trustee may convey or distribute the assets, having regard only to the claims of which the Public Trustee then has notice:—

ANDERSON, FREDERICK REGINALD, late of Flat 5, 37 Brighton-road, St. Kilda, tram driver, died between 26th and 29th June, 1970.

BREWER, BENONI JOHN, formerly of 139 Wellington-street, Windsor, but late of 35 McIlwrick-street, Windsor, part-time barman, died 5th July, 1970.

CONNELL, RICHARD SINCLAIR, late of 7 Canterbury-street, Yarraville, cargo superintendent, died 22nd September, 1969.

HANNAH, ALEXANDER JOHN, late of 11 Valerie-street, East Kew, retired theatre manager, died 31st May, 1970.

HENDERSON, WILLIAM, late of Yarrara, retired farmer, died 21st January, 1971.

JONES, ALLAN JOSEPH, late of Greenvale, pensioner, died 20th November, 1970.

LAWSON, ROBERT LESLIE, late of 53 Osborne-street, Williamstown, soldier, died 20th August, 1915.

LEWIS, JAMES WALTER, formerly of 15 Charles-street, Prahran, late of 34 Highland-avenue, Highett, retired motor engineer, died 12th January, 1971.

LONG, EMMA JANE, late of 68 Helen-street, St. Albans, married woman, died 6th October, 1970.

MALLAGHAN, CATHERINE, late of 65 Western-avenue, East Newborough, widow, died 8th November, 1970.

MORRISSIE, JOHN MATHEW, late of 84 St. Andrews-street, Brighton, retired railwayman, died 30th September, 1970.

PLUMB, NORMAN ALFRED, late of 2 Fitzroy-street, Laverton, retired R.A.A.F. officer, died 13th February, 1971.

MCDONALD, DONALD, formerly of 106 Keon-street, Thornbury, but late of Arlington Private Hospital, 3 Collins-street, Thornbury, retired postmaster, died 28th November, 1969.

RIDDELL, ANNE ELIZABETH, also known as Annie Elizabeth Riddell, late of 5 Pitt-street, Ashburton, married woman, died 18th February, 1971.

SLOAN, ROBERTA JOSEPHINE, formerly of 125A Hambleton-street, Middle Park, care of After Care Hospital, 45 Victoria-parade, Collingwood, Victoria, widow, died 7th March, 1971.

VAN DER BURGH, JOHN PETER WILLIAM SIMON, formerly of lot 86, Upper Glen Park-road, Eltham North, but late of 3 Clarke-street, Footscray West, maintenance scheduler, died 14th June, 1970.

VON GIZYCKI, ROSE, late of 90 Mentone-parade, Mentone, widow, died 1st January, 1971.

WESTCOTT, GEORGE ISDELL, late of 59 Outer-crescent, North Brighton, retired police inspector, died 2nd February, 1971.

WILLIAMS, RUPERT, late of "Alexander", Castlemaine, pensioner, died 14th January, 1971.

WHESTON, FRANCIS GEORGE, also known as Weston, Francis George, late of 17 Iona-street, Black Rock, storeman, died 8th February, 1971.

N. P. BRODY,
Public Trustee.

Melbourne, 2nd June, 1971.

APPOINTMENTS AND RESIGNATIONS

APPOINTMENTS.

HIS Excellency the Governor of the State of Victoria, by and with the advice of the Executive Council thereof, has, by Orders made on the 1st day of June, 1971, been pleased to make the under-mentioned appointments, viz.:—

MINISTRY OF HEALTH.

Trustees of Cemeteries.

MAXWELL WILLIAM FORD
to be a Trustee of the Katandra Public Cemetery, vice R. E. Ford, resigned; and

HARRY UXBRIDGE BEST, and
NEVILLE BERNARD JACKSON,
to be Trustees of the Sale Public Cemetery, vice R. Hack, and D. Nelligan, resigned, pursuant to section 3 (1) of the *Cemeteries Act 1958*.

Public Vaccinators.

WILLIAM JOSEPH ROGERS, M.B., B.S.,
WILLIAM HENRY BETTS, M.B., B.S., and
IAN EDWARD VALDEMAR ROBERTSON, M.B., B.S.,
to be Public Vaccinators for the municipality of the City of Waverley, pursuant to section 151 of the *Health Act 1958*.

Members of Committees of Management of Hospitals.

ARTHUR EDWARD NELSON
to be the Government Appointee on Committee of Management of Woorayl District Memorial Hospital (Leongatha), for a period of three years commencing the 23rd June, 1971, pursuant to the provisions of section 48 (1) (a) (ii) of the *Hospitals and Charities Act 1958*;

WILLIAM WALLACE HARGRAVE
to be the Government Appointee on Committee of Management of Yarrowonga District Hospital, for a period of three years commencing the 23rd June, 1971, pursuant to the provisions of section 48 (1) (a) (ii) of the *Hospitals and Charities Act 1958*; and

JOHN ALBERT HEPWORTH
to be the Government Appointee on Committee of Management of Austin Hospital, Heidelberg, for a period of three years commencing the 25th June, 1971, pursuant to the provisions of section 48 (1) (a) (ii) of the *Hospitals and Charities Act 1958*.

LAW DEPARTMENT.

Commissioners for Taking Declarations, &c.

WILLIAM STANLEY DICKINS, "Leven Vale", Wayside Delivery, Kyneton,

JOHN ROBERT STRUGNELL, 11 Sutton-street, North Balwyn,

WILLIAM GRAFMAN, 1A Garden-avenue, East Brighton,

NORMAN WILLIAM NUGENT, 6 Adrian-court, Bundoora,
WILLIAM GEORGE BOUCHER, 2 Bell-street, Box Hill North, and

RONALD OSMOND WILLIAMS, 440 Collins-street, Melbourne,

to be Commissioners for taking Declarations and Affidavits, pursuant to the provisions of the *Evidence Act 1958*, to resign upon removing from the neighbourhood of the addresses stated;

REINI JOSEPH STRYBOSCH, care of Housing Commission, Victoria, 179 Queen-street, Melbourne,

to be a Commissioner for taking Declarations and Affidavits, pursuant to the provisions of the *Evidence Act 1958*, to refrain from charging fees and to resign upon ceasing to occupy his present position; and

ALASTAIR GEORGE REED, care of Seatainer Terminals Ltd., Dudley-street, West Melbourne, and

BARRY ALAN RYAN, care of Seatainer Terminals Ltd., 459 Little Collins-street, Melbourne,

to be Commissioners for taking Declarations and Affidavits, pursuant to the provisions of the *Evidence Act 1958*, to resign upon ceasing to occupy their present positions.

Justice of the Peace.

GORDON RALPH STEVENS, 62 Newcomb-street, Port-arlington,

to keep the Peace in the State of Victoria.

PUBLIC WORKS DEPARTMENT.

Wharf Manager.

Senior Constable RALPH EDWARD YOUNG, No. 12041, to be Wharf Manager at Port Welshpool-Port Franklin, to carry out that portion of Part II. of the *Marine Act 1958*, which relates to the management of Public Wharves and

to be an officer under section 19 of such Act, to levy and collect wharfage rates thereat, vice First Constable John Henry Stafford, No. 11442, transferred.

SOCIAL WELFARE DEPARTMENT.

Honorary Probation Officers.

NORMAN CLAPHAM LOWE (Rev.), pursuant to the provisions of section 507 (2) of the Crimes Act 1958, to be an Honorary Probation Officer for all Adult Courts in Victoria; and

MICHAEL JOSEPH CARMODY, 5 Foote-street, Lower Templestowe,

WALTER ALEXANDER EACOTT, 13 Vaina-street, Werribee, WALTER ALEXANDER EVANS, 30 Curtis-avenue, Watsonia,

MICHAEL THOMAS FITZGERALD, Flat 6, 1 Cooper-street, West Brunswick,

MELVYN FRISBY-SMITH (Captain), 27 Wellington-parade, Williamstown,

MARSHA MYNDELLE GLASSER (Mrs.), Flat 7, 61 Maltravers-road, Ivanhoe,

ROMA ADA MATHESON (Mrs.), 2 Paisley-court, Mulgrave, and

GEOFFREY HENRY STEPHENS (Rev.), 287 Bell-street, West Heidelberg,

pursuant to the provisions of section 507 (2) of the Crimes Act 1958, to be Honorary Probation Officers for all Adult Courts in Victoria, and pursuant to the provisions of section 10 (1) of the Children's Court Act 1958, for all Children's Courts in Victoria.

DEPARTMENT OF THE TREASURER.

Receiver of Revenue (Acting).

IAN JOHN COLLARD

to act temporarily as Receiver of Revenue, Camperdown, vice C. J. Ryan, on leave.

J. ROSSITER,

Clerk of the Executive Council.

At the Executive Council Chamber,
Melbourne, 1st June, 1971.

APPOINTMENTS.

HIS Excellency the Governor of the State of Victoria, by and with the advice of the Executive Council thereof, has, by Orders made on the 8th day of June, 1971, been pleased to make the under-mentioned appointments, viz.:

DEPARTMENT OF WATER SUPPLY.

Waterworks Trust Commissioners.

ALBERT CHARLES TRIGG

to be a Commissioner of the Bungaree and Wallace Waterworks Trust, to hold such position for a period of one year as from 9th June, 1971, subject to the provisions of the Water Act;

GERALD O'NEIL

to be a Commissioner of the Chiltern Waterworks Trust, to hold such position for a period of four years from 14th June, 1971, subject to the provisions of the Water Act; and

KEITH JAMES WARD

to be a Commissioner of the Maffra Waterworks Trust, to hold such position for a period of four years from 13th June, 1971, subject to the provisions of the Water Act.

J. ROSSITER,

Clerk of the Executive Council.

At the Executive Council Chamber,
Melbourne, 8th June, 1971.

APPOINTMENTS.

HIS Excellency the Governor of the State of Victoria, by and with the advice of the Executive Council thereof, has, by Orders made on the 8th day of June, 1971, been pleased to make the under-mentioned appointments, viz.:

CROWN LANDS AND SURVEY DEPARTMENT.

Bailiffs of Crown Lands.

JOHN DE COURCEY WILKINSON, and

JOHANN WEIKL

to be bailiffs of Crown Lands, without salary, with respect to the "Mount Hotham Alpine Reserve", pursuant to section 30 of the Lands Act 1958.

J. ROSSITER,

Clerk of the Executive Council.

At the Executive Council Chamber,
Melbourne, 8th June, 1971.

APPOINTMENTS.

HIS Excellency the Governor of the State of Victoria, by and with the advice of the Executive Council thereof, has, by Order made on the 8th day of June, 1971, been pleased to make the under-mentioned appointments, viz.:

CROWN LANDS AND SURVEY DEPARTMENT.

Committee of Management.

The under-mentioned gentlemen to be a Committee of Management of the land in the City of Melbourne permanently reserved as a site for the Recreation, Convenience and Amusement of the People and for a Children's Playground by Order in Council of the 17th March, 1970, and known as "Olympic Park"—

Sir MAURICE ARNOLD NATHAN, K.B.E.,

HILAIRE GERARD CANTWELL,

STANDISH MICHAEL KEON,

LEWIS LUXTON, C.B.E.,

WILLIAM TREVOR LONG,

His Honour Judge JOHN XAVIER O'DRISCOLL, Q.C.,

O.B.E.,

PERCY PEMBROKE PAGE, O.B.E.,

KEVIN FRANCIS COLEMAN, LL.B.,

LAWRENCE KITCHEN KERR, and

MERVYN GEORGE LINCOLN, M.B.E., B.Comm., Dip.Ed.,

A.A.S.A.

for the period ending the 31st May, 1974, and Councillor Edward Wallace Best for so long only as he shall continue to be a Councillor and the elect of the Council of the City of Melbourne, but nevertheless for no longer than the 31st May, 1974.

J. ROSSITER,

Clerk of the Executive Council.

At the Executive Council Chamber,
Melbourne, 8th June, 1971.

Bees Act 1958.

APPOINTMENT OF INSPECTOR.

THE Public Service Board, by certificate dated the 19th May, 1971, appointed the under-mentioned officer as an Inspector, under the provisions of section 16 of the Bees Act 1958, without additional salary.

RUSSELL DAVID GOODMAN.

D. S. WISHART,

Director of Agriculture.

Melbourne, May, 1971.

Liquor Control Act 1968.

APPOINTMENT OF LICENSING INSPECTOR.

IN accordance with the authority conferred upon me by Section 6 of the Police Regulation Act 1968, I, Reginald Jackson, Deputy Commissioner of Police, do hereby appoint under subsection (1) of Section 22 of the Liquor Control Act 1968, the following Officer of Police as a Licensing Inspector for the Division of the Police District as shown:—

Division Number.	Police District.	Rank and Name.
2	Henty	Inspector, Grade I., George Frederick Earl (from 31.5.71 to 19.6.71 inclusive)

28.5.71.

R. JACKSON,
Deputy Commissioner.

RESIGNATIONS.

HIS Excellency the Governor of the State of Victoria, by and with the advice of the Executive Council thereof, has, by Orders made on the 1st day of June, 1971, accepted the resignations of the persons named hereunder of the offices mentioned, viz.:

CHIEF SECRETARY'S DEPARTMENT.

Member of the Metropolitan Fire Brigades Board.

CLAUDE REGINALD AMIET, a member of the Metropolitan Fire Brigades Board, pursuant to the provisions of the Metropolitan Fire Brigades Act 1958.

SOCIAL WELFARE DEPARTMENT.

Honorary Probation Officers.

EBERHARD BREITZKE (Mr.), 30 Bamburgh-street, Broadmeadows,

L. A. CROCKET (Mr.), 15 Savige-street, Morwell,
 WILLIAM JOHN FOX (Rev. Father), St. Finbar's Presby-
 tery, 90 Centre-road, East Brighton,
 JOHN ALOYSIUS GARGAN (Mr.), 7 Strachan-avenue,
 Manifold Heights,
 COLIN ARTHUR HARRISON (Rev.), St. John's Church,
 23 Peel-street, South Ballarat,
 JAMES ANTHONY KNIFE (Rev.), 11 Templeton-street,
 Sale, and
 ERNEST CLIVE SMITH (Rev.), 161 Hull-road, Moorool-
 bark,
 Honorary Probation Officers, pursuant to the pro-
 visions of section 507 (2) of the Crimes Act 1958,
 for all Adult Courts in the State of Victoria, and
 pursuant to the provisions of section 10 (1) of
 the Children's Courts Act 1958, for all Children's
 Courts in Victoria.

J. ROSSITER,
 Clerk of the Executive Council.
 At the Executive Council Chamber,
 Melbourne, 1st June, 1971.

ORDERS IN COUNCIL

STATE ELECTRICITY COMMISSION ACT 1958, No. 6377.

At the Executive Council Chamber, Melbourne, the
 first day of June, 1971.

PRESENT:
 His Excellency the Governor of Victoria.
 Mr. Wilcox | Mr. Dickie.
 Mr. Borthwick

APPOINTMENT OF DEPUTY COMMISSIONER OF THE STATE ELECTRICITY COMMISSION OF VICTORIA.

PURSUANT to the provisions of the State Electricity
 Commission Act 1958 (No. 6377), His Excellency
 the Governor of the State of Victoria, acting by and with
 the advice of the Executive Council thereof, doth by this
 Order appoint—

KYNASTON WILLIAM LATHROP MURRAY, F.I.E. Aust.,
 to be a Deputy Commissioner of the State Electricity Com-
 mission of Victoria for a period commencing on the 5th
 day of June, 1971, and ending on the 2nd day of August,
 1971.

And the Honorable James Charles Murray Balfour, Her
 Majesty's Minister for Fuel and Power for the State of
 Victoria, shall give the necessary directions herein
 accordingly.

J. ROSSITER,
 Clerk of the Executive Council.

COUNTRY ROADS BOARD.

At the Executive Council Chamber, Melbourne, the
 first day of June, 1971.

PRESENT:
 His Excellency the Governor of Victoria.
 Mr. Wilcox | Mr. Dickie.
 Mr. Borthwick

ORDER APPROVING OF LAND BEING ACQUIRED AND ROADS, DEVIATIONS OR WIDENINGS BEING MADE.

HIS Excellency the Governor of the State of Victoria,
 by and with the advice of the Executive Council
 thereof, being satisfied that there are funds legally available
 for acquiring the land, doth hereby approve the acquiring
 of the land described in the schedule hereunder and the
 making of new roads and deviations from and widenings of
 existing roads referred to in the said schedule.

SCHEDULE.

State Highway.

The land shown hatched on Plan numbered G.P.12476
 hereunder required for the deviation from the North-
 Western Highway in the Shire of Karkaroc and making of
 the deviation thereon.

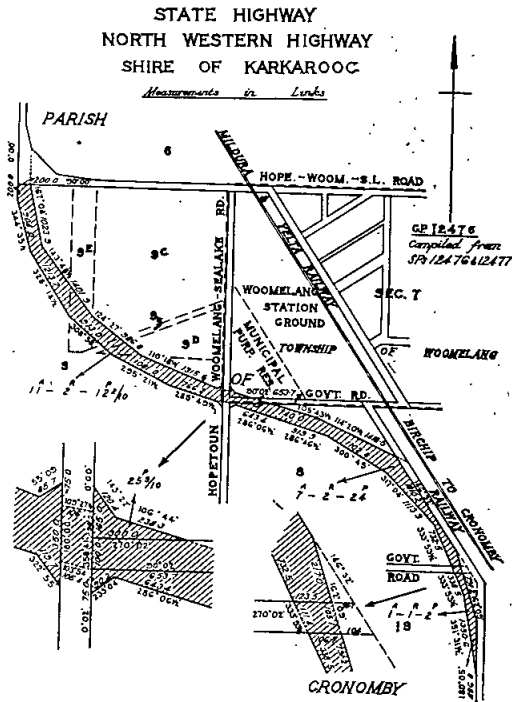

Main Road.

The land shown hatched on Plans numbered G.P.12569,
 G.P.12570, G.P.12571 and G.P.12572 hereunder required for
 the widening of Ridge-road in the Shire of Lillydale and
 making of the widening thereon.

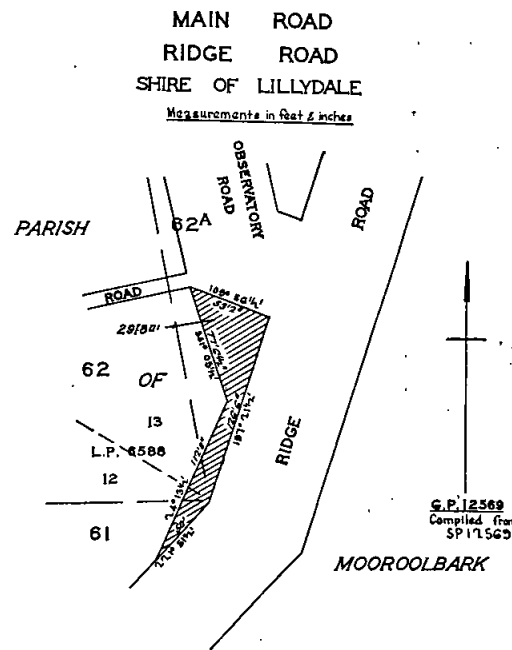

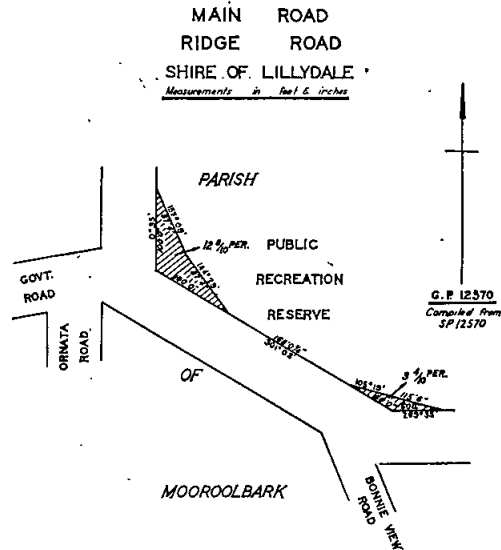
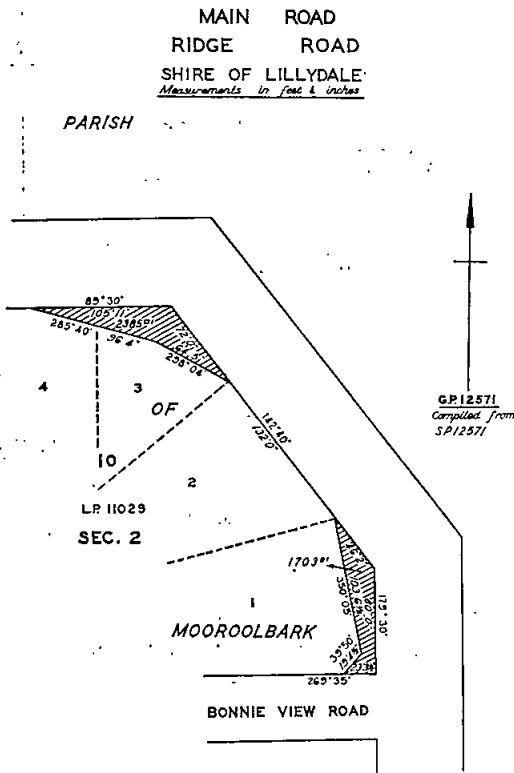

And the Honorable Alan John Hunt, Her Majesty's Minister for Local Government for the State of Victoria, shall give the necessary directions herein accordingly.

J. ROSSITER,
Clerk of the Executive Council.

DEPARTMENT OF CROWN LANDS AND SURVEY.

At the Executive Council Chamber, Melbourne, the first day of June, 1971.

PRESENT:

His Excellency the Governor of Victoria.
Mr. Wilcox
Mr. Borthwick

Mr. Dickie.

UNUSED ROADS CLOSED.

HIS Excellency the Governor of the State of Victoria, by and with the advice of the Executive Council thereof, doth hereby direct that, in pursuance of the provisions of section 349 of the Land Act 1958, the unused roads referred to hereunder be closed, viz.:—

Parish of Baynton, County of Dalhousie, being the road indicated by hatching on plan hereunder.—(B.24⁽²⁾) (W.83912).

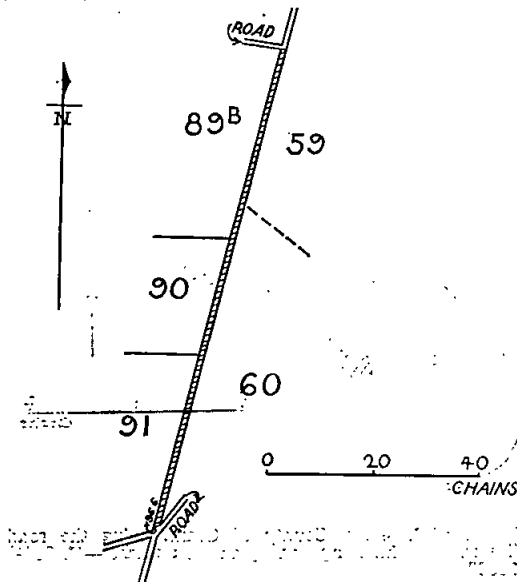
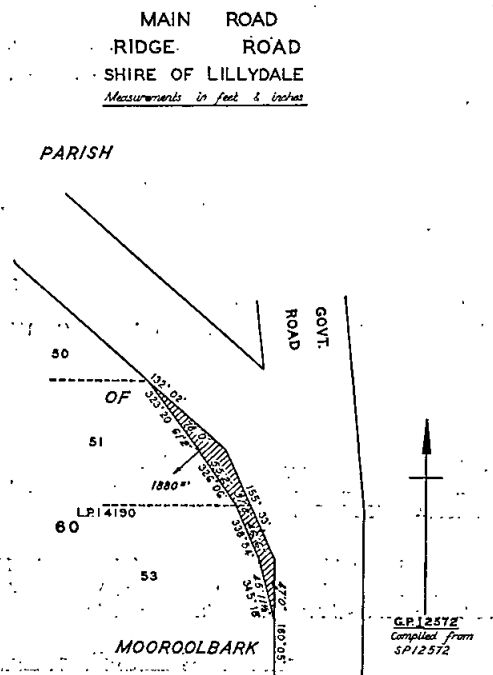

Parish of Glenaulin, County of Normanby, being the road indicated by hatching on plan hereunder.—(G.89⁽³⁾) (J.33035).

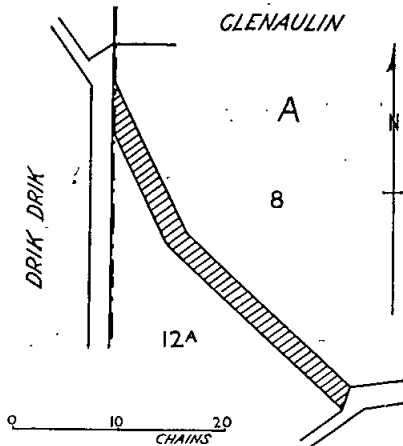

Parish of Kalkee, County of Borung, being the portion of the width of the road indicated by hatching on plan hereunder.—(K.143⁽³⁾) (M.62251).

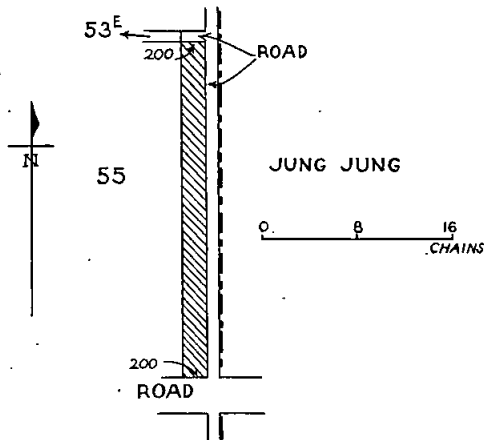

Parish of Tanjil, County of Buln Buln, being the road indicated by hatching on plan hereunder.—(T.189⁽¹⁶⁾) (C.99882).

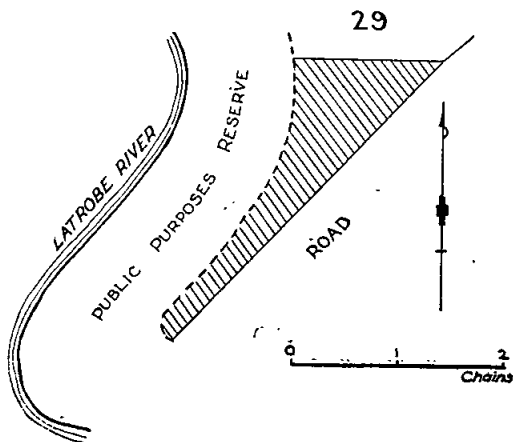

Parish of Yowang, County of Grant, being the road indicated by hatching on plan hereunder.—(Y.69⁽²⁾) (M.3900).

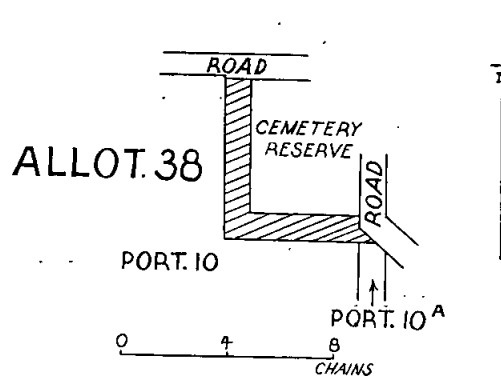

And the Honorable William Archibald Borthwick, Her Majesty's Minister of Lands for the State of Victoria, shall give the necessary directions herein accordingly.

J. ROSSITER,
Clerk of the Executive Council.

Land Act 1958.
DEPARTMENT OF CROWN LANDS AND SURVEY.

At the Executive Council Chamber, Melbourne, the first day of June, 1971.

PRESENT:
His Excellency the Governor of Victoria.
Mr. Wilcox | Mr. Dickie.
Mr. Borthwick

REVOCATION OF TEMPORARY RESERVATIONS OF LANDS BY ORDERS IN COUNCIL.

HIS Excellency the Governor of the State of Victoria, by and with the advice of the Executive Council thereof, doth hereby, in pursuance of the provisions of the Land Act 1958, revoke the temporary reservations of lands by Orders in Council hereinafter referred to, viz.:—

MOOROOPNA.—The temporary reservation by Order in Council of the 25th February, 1930, of 9 acres, more or less, of land in the Parish of Mooropna, as a site for Public purposes.—(M.458⁽¹⁵⁾) (Rs.3963).

CASTLE DONNINGTON.—The temporary reservation by Order in Council of the 18th February, 1941, of 3 acres 2 roods 6 perches of land in the Parish of Castle Donnington, as a site for a State School, so far only as regards the portion thereof comprised within the boundaries published in the Government Gazette of the 7th April, 1971, and containing 1 rood 16 perches.—(C.114⁽⁶⁾) (Rs.1120).

SCORESBY.—The temporary reservation by Order in Council of the 19th November, 1968, of 3 acres 9 perches of land in the Parish of Scoresby, as a site for Public Recreation, so far only as regards the portion thereof comprised within the boundaries published in the Government Gazette of the 7th April, 1971, and containing 34 perches.—(S.250^(A6)) (Rs.9077).

And the Honorable William Archibald Borthwick, Her Majesty's Minister of Lands for the State of Victoria, shall give the necessary directions herein accordingly.

J. ROSSITER,
Clerk of the Executive Council.

DEPARTMENT OF CROWN LANDS AND SURVEY.

At the Executive Council Chamber, Melbourne, the first day of June, 1971.

PRESENT:

His Excellency the Governor of Victoria.
 Mr. Wilcox | Mr. Dickie.
 Mr. Borthwick |

LANDS TEMPORARILY RESERVED AS SITES.

HIS Excellency the Governor of the State of Victoria, by and with the advice of the Executive Council thereof, doth hereby, in pursuance of section 14 of the Land Act 1958, reserve temporarily from sale, from being leased and from having a licence granted in respect thereof, and also except from occupation for mining purposes under any miner's right, the lands hereinafter described:—

BALLARAT.—Site for State School purposes, 36 perches, Township of Ballarat, Parish of Ballarat, County of Grenville, as indicated by hatching on plan hereunder.—(B.128⁽⁶⁹⁾) (Rs.8163).

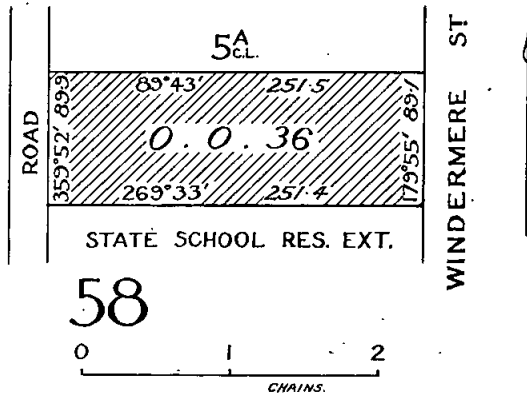

BALLARAT EAST.—Site for State School purposes, 35 perches, more or less, Township of Ballarat East, Parish of Ballarat, County of Grant, as indicated by hatching on plan hereunder.—(B.128⁽⁴⁶⁾) (Rs.9468).

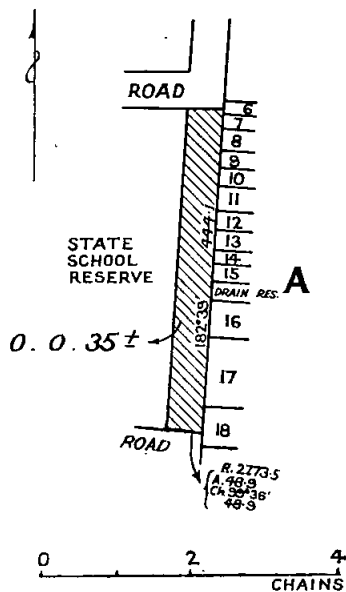

BARRABOOL.—Site for Water Supply purposes, 24 perches, more or less, Parish of Barrabool, County of Grant, as indicated by hatching on plan hereunder.—(B.34⁽³⁾) (Rs.7643).

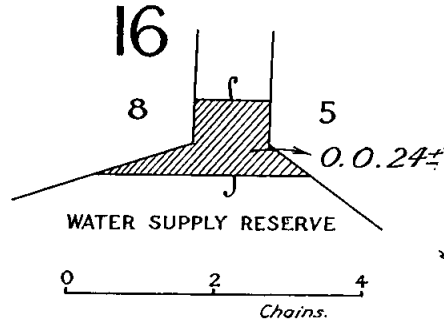

BEECHWORTH.—Site for Public purposes (Mental Health purposes), 11 acres 2 roods 16 perches, Township of Beechworth, Parish of Beechworth, County of Bogong, as indicated by hatching on plan hereunder.—(B.348⁽⁵⁾) (Rs.9471).

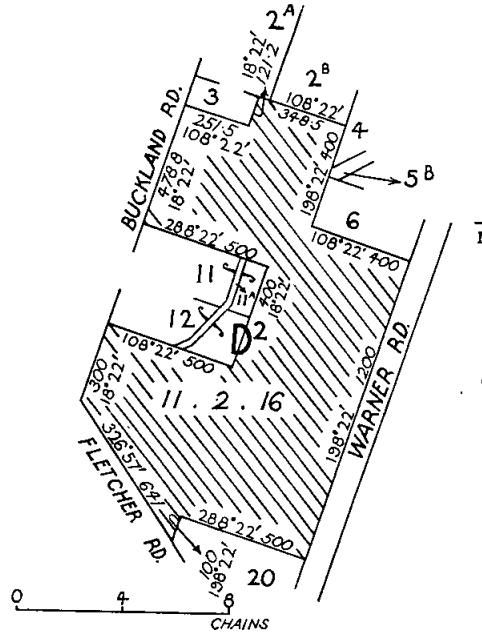

BENALLA.—Site for Public purposes (Departmental Residence), 29 perches, Township of Benalla, Parish of Benalla, County of Delatite, as indicated by hatching on plan hereunder.—(B.390⁽³⁾) (Rs.9453).

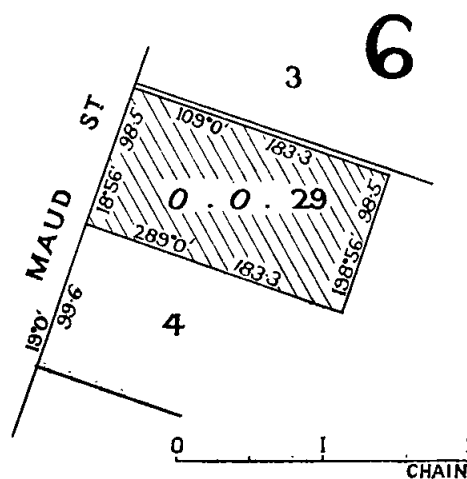

CASTLEMAINE (WESLEY HILL).—Site for Public purposes (Sewage Pumping Station), 2 roods, more or less, Parish of Castlemaine, County of Talbot, as indicated by hatching on plan hereunder.—(C.100(4A) (Rs.9459).

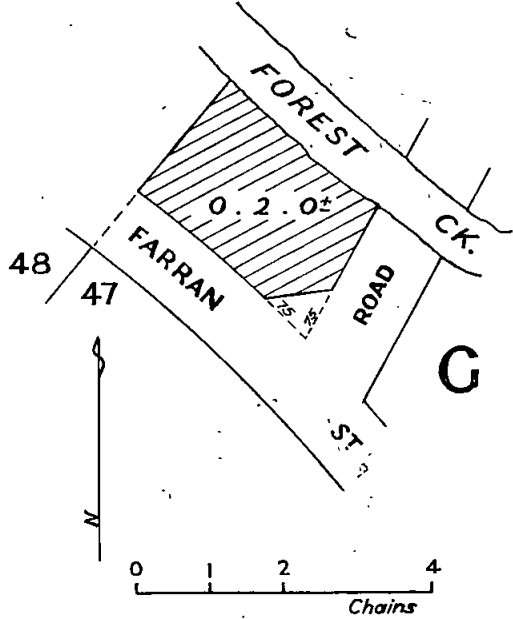

DAYLESFORD.—Site for a Museum, 1 rood 20 perches, Township of Daylesford, Parish of Wombat, County of Talbot, as indicated by hatching on plan hereunder.—(D.13(2) (Rs.9289).

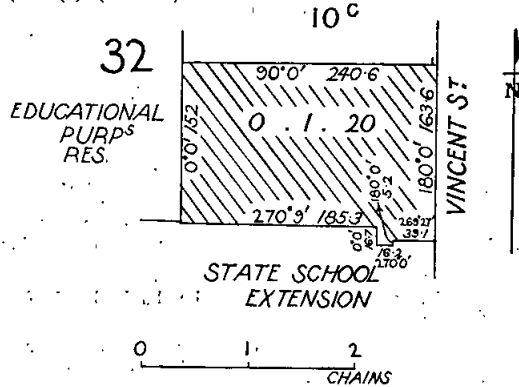

HEATHCOTE.—Site for Municipal purposes, 1 rood 22 perches, Township of Heathcote, Parish of Heathcote, County of Dalhousie, as indicated by hatching on plan hereunder.—(H.74(2) (Rs.1395).

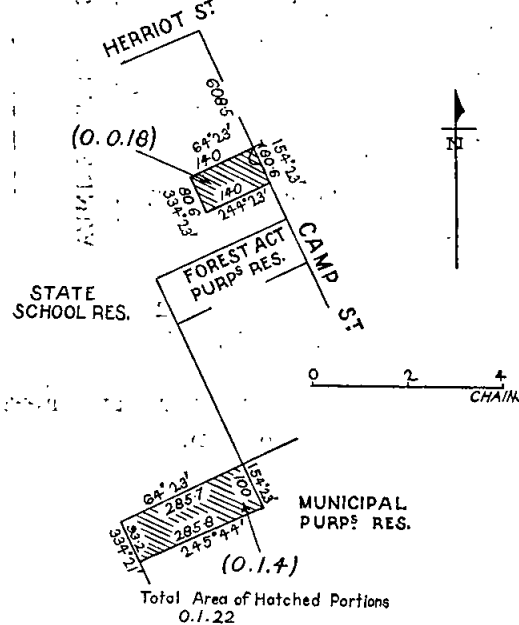

CASTLEMAINE.—Site for State School purposes, 1 acre 2 roods 20 perches, Township of Castlemaine, Parish of Castlemaine, County of Talbot, as indicated by hatching on plan hereunder.—(C.99(2) (Rs.9485).

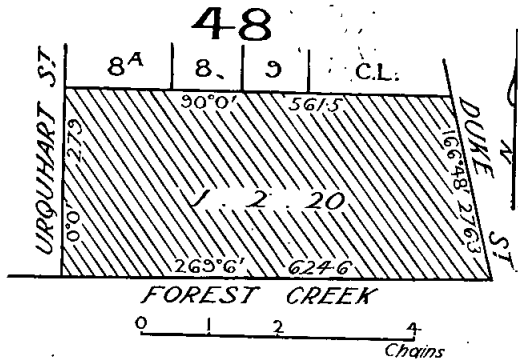

DANDENONG.—Site for Public Park, 20 perches, Township of Dandenong, Parish of Eumemmerring, County of Mornington, as indicated by hatching on plan hereunder.—(D.19(4) (Rs.314).

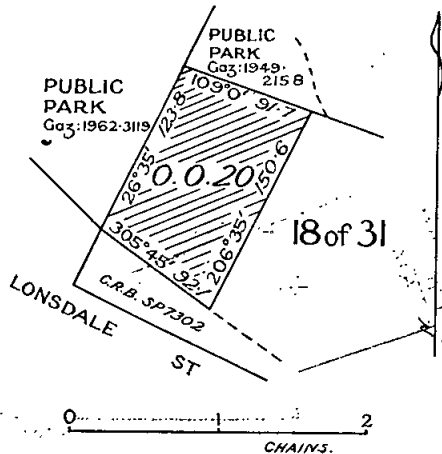

HEATHCOTE.—Site for Public purposes (Infant Welfare Centre), 1 rood 2 perches, Township of Heathcote, Parish of Heathcote, County of Dalhousie, as indicated by hatching on plan hereunder.—(H.74(2) (Rs.9492).

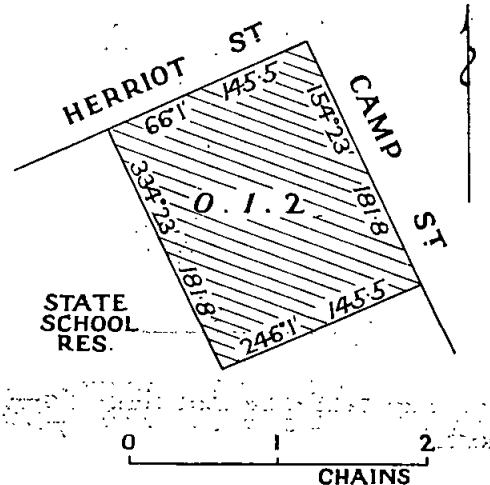

HEYWOOD.—Site for Water Supply purposes, 12 perches, Township of Heywood, Parish of Heywood, County of Normanby, as indicated by hatching on plan hereunder.—(H.86^(s)) (Rs.9455).

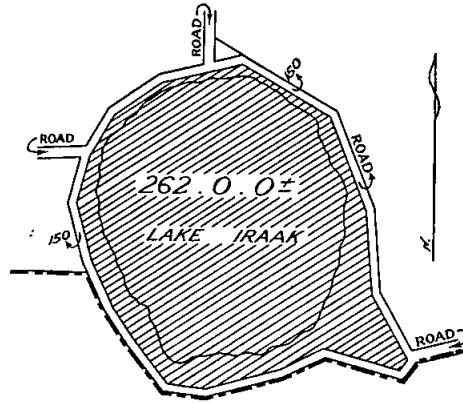
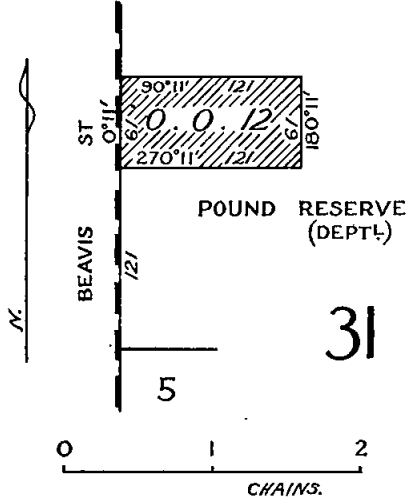

KORUMBURRA.—Site for Public Park and Recreation, 1 acre, more or less, Township of Korumburra, Parish of Korumburra, County of Buln Buln, as indicated by hatching on plan hereunder.—(K.172⁽¹⁸⁾) (Rs.9048).

HORSHAM.—Site for Public purposes (Departmental Residence), 1 rood 8 perches, Parish of Horsham, County of Borung, as indicated by hatching on plan hereunder.—(H.95⁽⁴⁾) (Rs.9488).

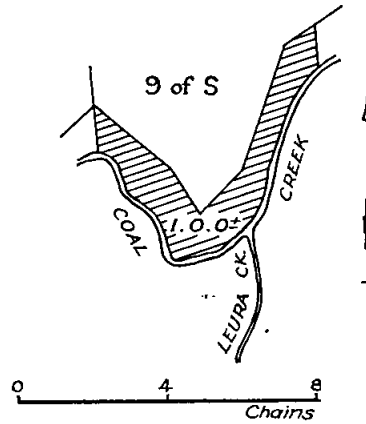
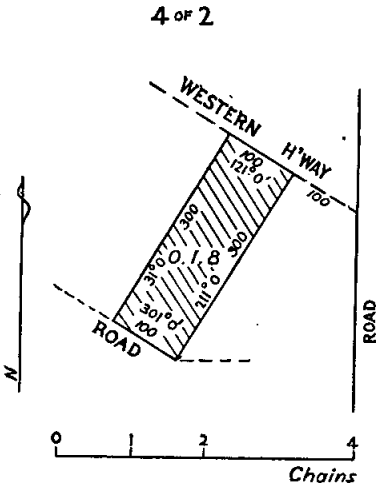

KYBEYAN.—Site for Public purposes (Trigonometrical Survey Station), 1 rood 24 perches, Parish of Kybeyan, Counties of Delatite and Wonnangatta, as indicated by hatching on plan hereunder.—(County Sheets 11A & 37) (Rs.9436).

HUNTLY.—Site for Water Supply purposes, 2 roods 11 perches, Township of Huntly, Parish of Huntly, County of Bendigo, as indicated by hatching on plan hereunder.—(H.107^(e)) (Rs.9482).

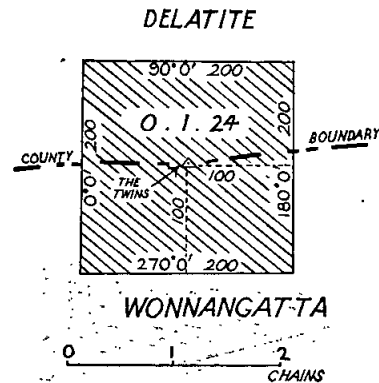
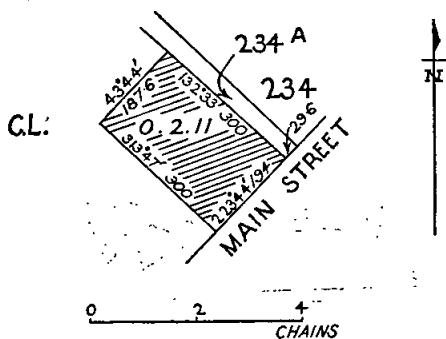

KARADOC.—Site for Public purposes (Drainage purposes), 262 acres, more or less, Parish of Karadoc, County of Karkaroc, as indicated by hatching on plan hereunder.—(K.212^(s)) (Rs.9461).

MOCAMBORO.—Site for Public purposes (Trigonometrical Survey Station), 15 acres, more or less, Parish of Mocamboro, County of Normanby, as indicated by hatching on plan hereunder.—(M.214⁽⁴⁾) (Rs.9438).

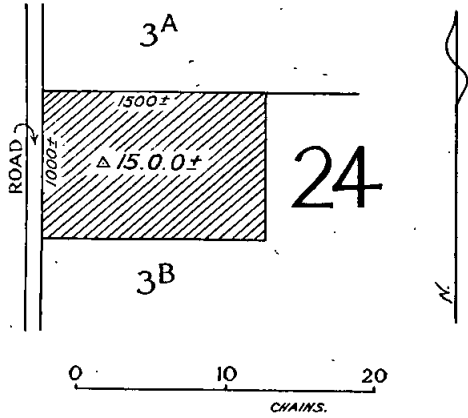

MURRAYVILLE.—Site for a State High School, 16 acres 1 rood 25 perches, Township of Murrayville, Parish of Danyo, County of Weeah, as indicated by hatching on plan hereunder.—(M.575⁽⁴⁾) (Rs.9439).

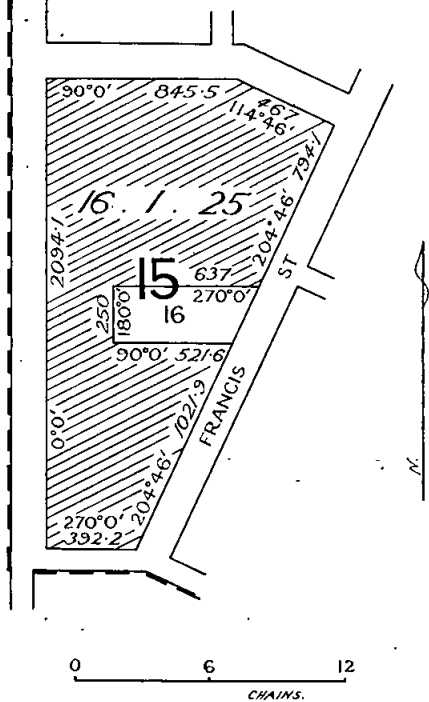

SANDHURST (BENDIGO).—Site for Public purposes (Preservation of Geological Feature), 1 rood 34 perches, more or less, at Bendigo, Parish of Sandhurst, County of Bendigo, as indicated by hatching on plan hereunder.—(S.372⁽¹⁰⁶⁾) (Rs.9454).

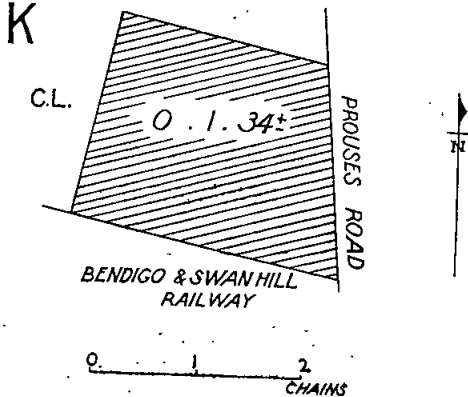

SANDHURST (BENDIGO).—Site for Public purposes (Mental Health Authority purposes), 13 acres 2 roods 4 perches, at Bendigo, Parish of Sandhurst, County of Bendigo, as indicated by hatching on plan hereunder.—S.372^(107 & 108) (Rs.9463).

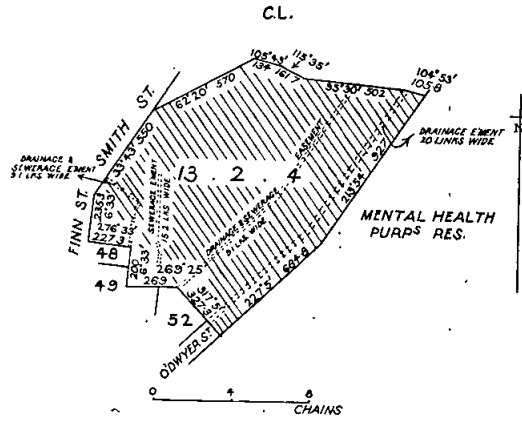

SANDHURST (KANGAROO FLAT).—Site for Public purposes (Departmental Residence), 24 perches, Parish of Sandhurst, County of Bendigo, as indicated by hatching on plan hereunder.—(S.371⁽⁴⁵⁾) (Rs.9478).

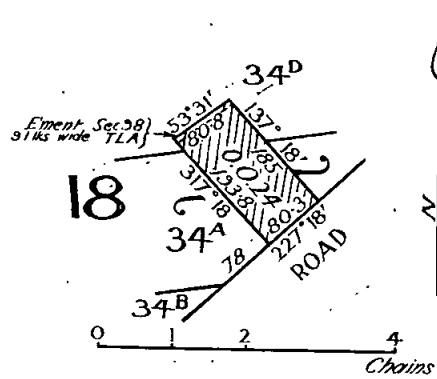

ARNOLD.—Site for Public purposes (Public Hall and Library), 1 rood 7 perches, Township of Arnold, Parish of Tamagulla, County of Gladstone, as indicated by hatching on plan hereunder.—(A.188⁽³⁾) (Rs.1536).

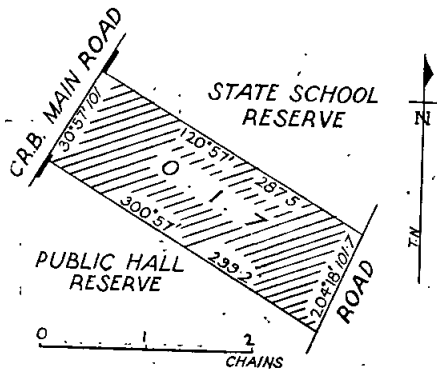

WANGARATTA NORTH.—Site for Public purposes (Departmental Residence), 22 perches, Parish of Wangaratta North, County of Moira, as indicated by hatching on plan hereunder.—(W.85⁽⁷⁾) (Rs.9475).

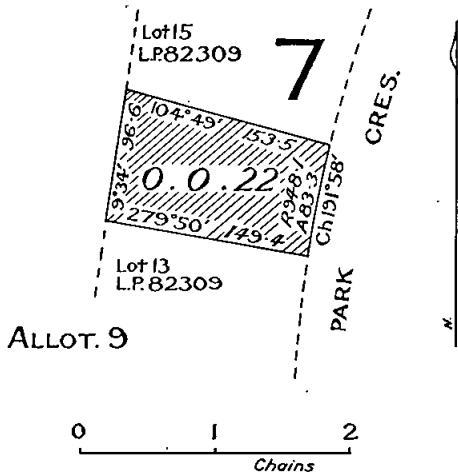

WANGARATTA SOUTH.—Site for Public purposes (Departmental Residence), 23 perches, Parish of Wangaratta South, County of Moira, as indicated by hatching on plan hereunder.—(W.85°) (Rs.9457).

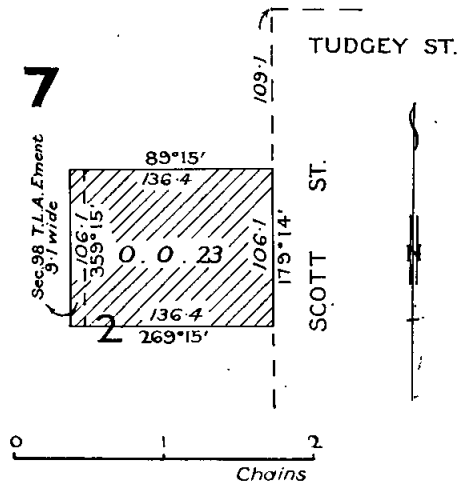

And the Honorable William Archibald Borthwick, Her Majesty's Minister of Lands for the State of Victoria, shall give the necessary directions herein accordingly.

J. ROSSITER,
Clerk of the Executive Council.

METROPOLITAN FIRE BRIGADES ACT 1958.

At the Executive Council Chamber, Melbourne, the first day of June, 1971.

PRESENT:
His Excellency the Governor of Victoria.
Mr. Wilcox | Mr. Dickie.
Mr. Borthwick

EXTRAORDINARY ELECTION OF A MEMBER OF THE METROPOLITAN FIRE BRIGADES BOARD.

WHEREAS amongst other things it is enacted by the Metropolitan Fire Brigades Act 1958 that all elections of members of the Metropolitan Fire Brigades Board shall be conducted in all respects whatsoever in such manner as is prescribed by the Regulations and every such election shall be held at such times and under the direction of such returning officers as the Governor in Council from time to time appoints:

And whereas the manner of conducting such elections is prescribed in the Metropolitan Fire Brigades General Regulations 1951:

And whereas pursuant to the said Act and the said Regulations it is necessary to conduct in the month of July, 1971, an extraordinary election of a member of the said Board:

Now therefore His Excellency the Governor of the State of Victoria, by and with the advice of the Executive Council thereof, and in pursuance of the Metropolitan Fire Brigades Act 1958 and all other powers him thereunto enabling, doth by this Order appoint—

Monday, the 12th July, 1971, to be the day for holding the election of a member by the insurance companies carrying on business and insuring property within Victoria; and

Raymond Phillip Schultz, the Secretary of the Fire and Accident Underwriters' Association of Victoria, to be the Returning Officer for such election.

And the Honorable Rupert James Hamer, Her Majesty's Chief Secretary for the State of Victoria, shall give the necessary directions herein accordingly.

J. ROSSITER,
Clerk of the Executive Council.

MARKETING OF PRIMARY PRODUCTS ACT 1958.

At the Executive Council Chamber, Melbourne, the first day of June, 1971.

PRESENT:
His Excellency the Governor of Victoria.
Mr. Wilcox | Mr. Dickie.
Mr. Borthwick

APPOINTMENT OF A DAY FOR A POLL TO BE TAKEN OF THE PRODUCERS OF TOBACCO LEAF FOR THE ELECTION OF FOUR REPRESENTATIVES OF SUCH PRODUCERS TO BE ELECTIVE MEMBERS OF THE TOBACCO LEAF MARKETING BOARD.

IN pursuance of the powers conferred by section 10 of the Marketing of Primary Products Act 1958, His Excellency the Governor of the State of Victoria, by and with the advice of the Executive Council thereof, doth by this Order hereby appoint Wednesday, the twentieth day of October, 1971, as the day for a poll to be taken of the producers of tobacco leaf for the election of four (4) representatives of such producers to be elective members of the Tobacco Leaf Marketing Board, and doth further appoint one electoral area covering the whole of the State of Victoria for such election.

And the Honorable William Archibald Borthwick, Her Majesty's Acting Minister of Agriculture for the State of Victoria, shall give the necessary directions herein accordingly.

J. ROSSITER,
Clerk of the Executive Council.

STAMPS ACT 1958, No. 6375.

At the Executive Council Chamber, Melbourne, the eighth day of June, 1971.

PRESENT:
His Excellency the Governor of Victoria.
Mr. Reid | Mr. Rafferty.
Mr. Smith

HIS Excellency the Governor of the State of Victoria, by and with the advice of the Executive Council thereof, doth by this Order made pursuant to section 131C of the Stamps Act 1958 No. 6375 revoke the declaration made on 12th January, 1960, and published in the Government Gazette on 13th January, 1960, declaring certain persons to be "approved vendors" for the purposes of subdivision (14) of Division 3 of Part II. of the Stamps Act 1958 in so far as the said declaration refers to the under-mentioned person—

122. ENDEAVOUR ACCEPTANCE COY.

And the Honorable Sir Henry Edward Bolte, Her Majesty's Treasurer for the State of Victoria, shall give the necessary directions herein accordingly.

J. ROSSITER,
Clerk of the Executive Council.

COUNTRY ROADS BOARD.

At the Executive Council Chamber, Melbourne, the eighth day of June, 1971.

PRESENT:

His Excellency the Governor of Victoria.
Mr. Reid | Mr. Rafferty.
Mr. Smith

ORDER APPROVING OF LAND BEING ACQUIRED AND ROADS, DEVIATIONS OR WIDENINGS BEING MADE.

HIS Excellency the Governor of the State of Victoria, by and with the advice of the Executive Council thereof, being satisfied that there are funds legally available for acquiring the land, doth hereby approve the acquiring of the land described in the schedule hereunder and the making of new roads and deviations from and widenings of existing roads referred to in the said schedule.

SCHEDULE.
State Highways.

The land shown hatched on Plans numbered G.P.12520 and G.P.12521 hereunder required for the widening of the Glenelg Highway in the Shire of Glenelg and making of the widening thereon.

STATE HIGHWAY
GLENELG HIGHWAY
SHIRE OF GLENELG

Measurements in links.

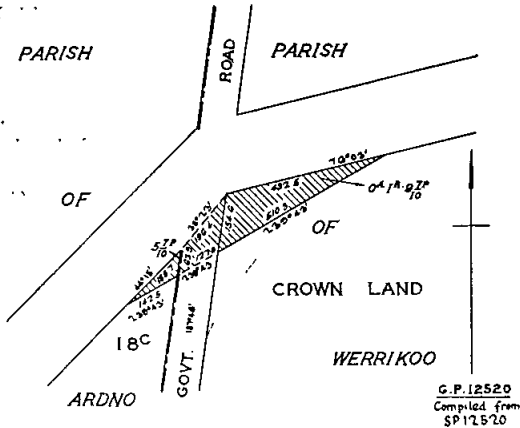

STATE HIGHWAY
GLENELG HIGHWAY
SHIRE OF GLENELG

Measurements in links.

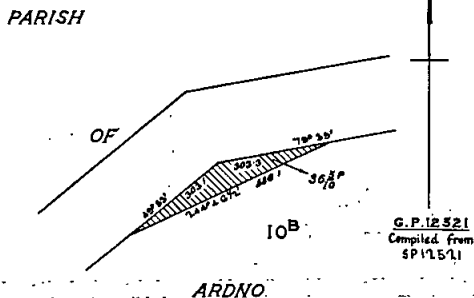

The land shown hatched on Plan numbered G.P.12633 hereunder required for the widening of the Western Highway in the Town of Stawell and making of the widening thereon.

STATE HIGHWAY
WESTERN HIGHWAY
TOWN OF STAWELL

Measurements in Links.

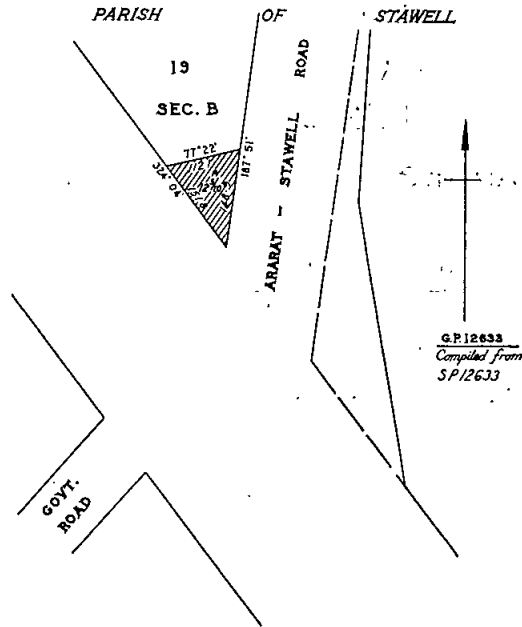

Main Road.

The land shown hatched on Plan numbered G.P.12505 hereunder required for the widening of the Warncoort-Birregurra road in the Shire of Colac and making of the widening thereon.

MAIN ROAD
WARNCOORT - BIRREGURRA ROAD
SHIRE OF COLAC

Measurements in links.

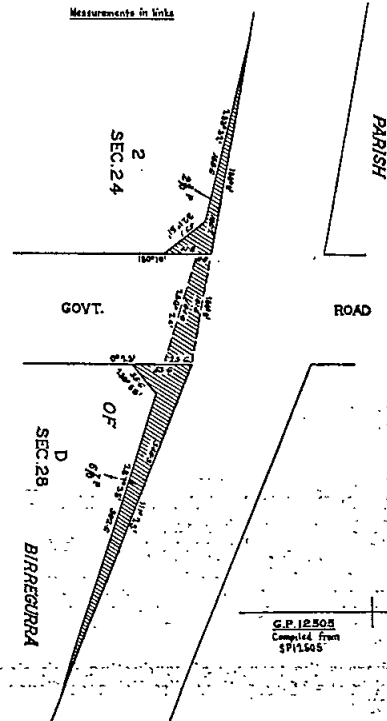

Unclassified Road.

The land shown hatched on Plan numbered G.P.12599 hereunder required for the making of a new road in the City of Collingwood.

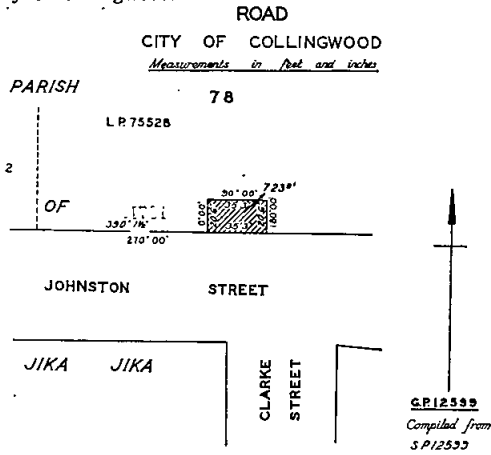

And the Honorable Alan John Hunt, Her Majesty's Minister for Local Government for the State of Victoria, shall give the necessary directions herein accordingly.

J. ROSSITER,
Clerk of the Executive Council.

COUNTRY ROADS ACT 1958 (No. 6229).

At the Executive Council Chamber, Melbourne, the eighth day of June, 1971.

PRESENT:

His Excellency the Governor of Victoria.
Mr. Reid | Mr. Rafferty.
Mr. Smith

APPOINTMENT OF MEMBERS OF THE STREET LIGHTING COMMITTEE.

IN pursuance of the provisions of section 72A of the Country Roads Act 1958 (No. 6229), as amended by section 3 (c) of the Country Roads (Amendment) Act 1971 (No. 8140) and all other powers him thereunto enabling His Excellency the Governor of the State of Victoria, by and with the advice of the Executive Council thereof, doth by this Order hereby appoint:

- (a) HOWARD WILLIAM PETER HOBBS, B.C.E., Dip. C.E., C.E., M.I.E. Aust., (nominated by the Chairman of the Country Roads Board) who shall be Chairman;
- (b) WILLIAM HENRY CHARLES BUNNETT, Dip. Elec.E., M.I.E. Aust., M.I.E.S. (Aust.) (Nominated by the Chairman of the State Electricity Commission);
- (c) Councillor KENNETH CRAGO WEBB, J.P. (nominated by the Municipal Association of Victoria)—to be Members of the Street Lighting Committee.

And the Honorable Alan John Hunt, Her Majesty's Minister for Local Government for the State of Victoria, shall give the necessary directions herein accordingly.

J. ROSSITER,
Clerk of the Executive Council.

SHIRE OF DUNDAS WATERWORKS TRUST.

At the Executive Council Chamber, Melbourne, the eighth day of June, 1971.

PRESENT:

His Excellency the Governor of Victoria.
Mr. Reid | Mr. Rafferty.
Mr. Smith

APPROVAL TO INSTALL SERVICE PIPES.

WHEREAS by section 212 (1) of the Water Act it is amongst other things provided that any Authority may with the sanction of the Governor in Council do all

or any of the things which the owner of any tenement is required or empowered to do for conveying a supply of water within such tenement.

And whereas the Shire of Dundas Waterworks Trust has laid main pipes for the supply of water to certain tenements within the Tarrington Urban District.

And whereas the said Trust deems it desirable for all service pipes from the Trust's mains to the boundary of the respective tenements to be laid by the Trust on behalf of the owners of the said tenements.

Now, therefore, His Excellency the Governor of the State of Victoria, by and with the advice of the Executive Council of the said State, doth hereby sanction that the Shire of Dundas Waterworks Trust may lay service pipes from its mains to the boundaries of tenements to be served in the said Tarrington Urban District the cost and expense of such service pipes being a debt by the respective owners of the tenements to the said Trust which debt may be recovered in any Court of competent jurisdiction.

And the Honorable Roberts Christian Dunstan, Her Majesty's Minister of Water Supply for the State of Victoria, shall give the necessary directions herein accordingly.

J. ROSSITER,
Clerk of the Executive Council.

BANNOCKBURN DISTRICT WATERWORKS TRUST.

At the Executive Council Chamber, Melbourne, the eighth day of June, 1971.

PRESENT:

His Excellency the Governor of Victoria.
Mr. Reid | Mr. Rafferty.
Mr. Smith

LETHBRIDGE URBAN DISTRICT PROCLAIMED.

UNDER the powers conferred by the Water Act and all other powers enabling him in that behalf, His Excellency the Governor of the State of Victoria, by and with the advice of the Executive Council of the said State, doth hereby declare, order and direct that on and from the date hereof portion of the Waterworks District of the Bannockburn District Waterworks Trust as shown on the accompanying plan (Corr. No. 70/2566/37) approved by the Governor in Council and deposited in the office of the State Rivers and Water Supply Commission, Melbourne, shall be an Urban District for the purposes of and within the meaning of the said Act, and shall be known as the Lethbridge Urban District.

And the Honorable Roberts Christian Dunstan, Her Majesty's Minister of Water Supply for the State of Victoria, shall give the necessary directions herein accordingly.

J. ROSSITER,
Clerk of the Executive Council.

COLAC WATERWORKS TRUST.

At the Executive Council Chamber, Melbourne, the eighth day of June, 1971.

PRESENT:

His Excellency the Governor of Victoria.
Mr. Reid | Mr. Rafferty.
Mr. Smith

CONSENT TO BORROWING \$100,000.

UNDER the powers conferred by the Water Act and all other powers enabling him in that behalf, His Excellency the Governor of the State of Victoria, by and with the advice of the Executive Council of the said State, doth hereby consent to the Colac Waterworks Trust borrowing at interest by mortgage of its revenue the sum of One hundred thousand dollars (\$100,000) to meet the cost of water supply works.

And the Honorable Roberts Christian Dunstan, Her Majesty's Minister of Water Supply for the State of Victoria, shall give the necessary directions herein accordingly.

J. ROSSITER,
Clerk of the Executive Council.

MITTA MITTA RIVER IMPROVEMENT TRUST.

At the Executive Council Chamber, Melbourne, the eighth day of June, 1971.

PRESENT:

His Excellency the Governor of Victoria.
 Mr. Reid | Mr. Rafferty.
 Mr. Smith

FIXING THE LIMIT OF BANK OVERDRAFT.

UNDER the powers conferred by the *Water Act 1958* and the *River Improvement Act 1958* and all other powers enabling him in that behalf, His Excellency the Governor of the State of Victoria, by and with the advice of the Executive Council thereof hereby—

- (a) repeals the Order made on 15th January, 1957, fixing the limit of the overdraft to be obtained by the Mitta Mitta River Improvement Trust pursuant to the provisions of section 288 of the *Water Act 1958*, No. 6413 at Six thousand pounds (£6,000); and
- (b) directs that the amount which the Mitta Mitta River Improvement Trust may owe in respect of advances obtained by overdraft of current account in a bank pursuant to the provisions of section 42(A) of the *River Improvement Act* shall not at any time exceed Sixteen thousand dollars (\$16,000).

And the Honorable Roberts Christian Dunstan, Her Majesty's Minister of Water Supply for the State of Victoria, shall give the necessary directions herein accordingly.

J. ROSSITER,
 Clerk of the Executive Council.

BEAUFORT SEWERAGE AUTHORITY.

At the Executive Council Chamber, Melbourne, the eighth day of June, 1971.

PRESENT:

His Excellency the Governor of Victoria.
 Mr. Reid | Mr. Rafferty.
 Mr. Smith

CONSENT TO BORROWING \$150,000.

UNDER the powers conferred by the *Sewerage Districts Act* and all other powers enabling him in that behalf, His Excellency the Governor of the State of Victoria, by and with the advice of the Executive Council of the said State, doth hereby consent to the Beaufort Sewerage Authority borrowing at interest by mortgage of the General Fund the sum of One hundred and fifty thousand dollars (\$150,000) to meet the cost of sewerage works as set forth in the detailed statement bearing date 31st May, 1971.

And the Honorable Roberts Christian Dunstan, Her Majesty's Minister of Water Supply for the State of Victoria, shall give the necessary directions herein accordingly.

J. ROSSITER,
 Clerk of the Executive Council.

MORNINGTON SEWERAGE AUTHORITY.

At the Executive Council Chamber, Melbourne, the eighth day of June, 1971.

PRESENT:

His Excellency the Governor of Victoria.
 Mr. Reid | Mr. Rafferty.
 Mr. Smith

CONSENT TO BORROWING \$150,000.

UNDER the powers conferred by the *Sewerage Districts Act* and all other powers enabling him in that behalf, His Excellency the Governor of the State of Victoria, by and with the advice of the Executive Council of the said State, doth hereby consent to the Mornington Sewerage Authority borrowing at interest by mortgage of the General

Fund the sum of One hundred and fifty thousand dollars (\$150,000) to meet the cost of sewerage works as set forth in the detailed statement bearing date 31st May, 1971.

And the Honorable Roberts Christian Dunstan, Her Majesty's Minister of Water Supply for the State of Victoria, shall give the necessary directions herein accordingly.

J. ROSSITER,
 Clerk of the Executive Council.

QUEENSCLIFFE SEWERAGE AUTHORITY.

At the Executive Council Chamber, Melbourne, the eighth day of June, 1971.

PRESENT:

His Excellency the Governor of Victoria.
 Mr. Reid | Mr. Rafferty.
 Mr. Smith

CONSENT TO BORROWING \$100,000.

UNDER the powers conferred by the *Sewerage Districts Act* and all other powers enabling him in that behalf, His Excellency the Governor of the State of Victoria, by and with the advice of the Executive Council of the said State doth hereby consent to the Queenscliffe Sewerage Authority borrowing at interest by mortgage of the General Fund the sum of One hundred thousand dollars (\$100,000) to meet the cost of sewerage works as set forth in the detailed statement bearing date 31st May, 1971.

And the Honorable Roberts Christian Dunstan, Her Majesty's Minister of Water Supply for the State of Victoria, shall give the necessary directions herein accordingly.

J. ROSSITER,
 Clerk of the Executive Council.

SEA LAKE SEWERAGE AUTHORITY.

At the Executive Council Chamber, Melbourne, the eighth day of June, 1971.

PRESENT:

His Excellency the Governor of Victoria.
 Mr. Reid | Mr. Rafferty.
 Mr. Smith

CONSENT TO BORROWING \$30,000.

UNDER the powers conferred by the *Sewerage Districts Act* and all other powers enabling him in that behalf, His Excellency the Governor of the State of Victoria, by and with the advice of the Executive Council of the said State, doth hereby consent to the Sea Lake Sewerage Authority borrowing at interest, by mortgage of the General Fund, the sum of Thirty thousand dollars (\$30,000) to meet the cost of sewerage works as set forth in the detailed statement bearing date 31st May, 1971.

And the Honorable Roberts Christian Dunstan, Her Majesty's Minister of Water Supply for the State of Victoria, shall give the necessary directions herein accordingly.

J. ROSSITER,
 Clerk of the Executive Council.

SALE CITY COUNCIL.

At the Executive Council Chamber, Melbourne, the eighth day of June, 1971.

PRESENT:

His Excellency the Governor of Victoria.
 Mr. Reid | Mr. Rafferty.
 Mr. Smith

CONSENT TO BORROWING \$100,000.

UNDER the powers conferred by the *Water Act* and all other powers enabling him in that behalf, His Excellency the Governor of the State of Victoria, by and with the advice of the Executive Council of the said State, doth hereby consent to the Sale City Council borrowing at

interest by mortgage of its revenue the sum of One hundred thousand dollars (\$100,000) to meet the cost of water supply works.

And the Honorable Roberts Christian Dunstan, Her Majesty's Minister of Water Supply for the State of Victoria, shall give the necessary directions herein accordingly.

J. ROSSITER,
Clerk of the Executive Council.

PORT PHILLIP AUTHORITY ACT 1966.

At the Executive Council Chamber, Melbourne, the eighth day of June, 1971.

PRESENT:

His Excellency the Governor of Victoria.
Mr. Reid | Mr. Rafferty.
Mr. Smith

APPOINTMENT OF A MEMBER OF THE CONSULTATIVE COMMITTEE.

IN pursuance of the provisions of section 7 (1) (f) of the Port Phillip Authority Act 1966, and all other powers him thereunto enabling, His Excellency the Governor in Council of the State of Victoria, by and with the advice of the Executive Council thereof, doth hereby appoint the following person as a member of the Consultative Committee—

Dr. ERIC CHARLES FREDERICK BIRD, to represent organizations or bodies having a special interest in the Port Phillip Area as defined in the Port Phillip Authority Act 1966, for the period ending the 30th June, 1972, in the place of Ian David Grayden, deceased.

And the Honorable William Archibald Borthwick, Her Majesty's Minister of Lands for the State of Victoria, shall give the necessary directions herein accordingly.

J. ROSSITER,
Clerk of the Executive Council.

LANDS DEPARTMENT NOTICES

APPROACHING LAND SALES.

SALES of Crown Lands, in fee-simple, will be held at the under-mentioned places and dates, viz.:

AUCTION OF RIGHT TO LEASE CROWN LAND.	No. of Gazette.
Melbourne.—Wednesday, 16th June, 1971	45

PROPOSED REVOCATIONS OF TEMPORARY RESERVATIONS OF LANDS BY ORDERS IN COUNCIL.

IN pursuance of the provisions of the Land Act 1958, notice is hereby given that it is the intention of the Governor in Council to revoke the temporary reservations of lands by Orders in Council hereunder referred to, viz.:

The following Notices were published 1° on the 9th June, 1971, pursuant to Orders of the 1st June, 1971.

MOLIAGUL.—The temporary reservation by Orders in Council of the 22nd and 25th September, 1902 (see Government Gazette, 1st October, 1902, page 3990), of 7 acres 2 roods 14 6/10 perches of land in the Parish of Moliagul, as a site for Supply of Gravel, is about to be revoked.—(M.131(7) (W.86107).

POREPUNKAH.—The temporary reservation by Order in Council of the 13th May, 1970, of 3 roods 39 perches of land in the Parish of Porepunkah, as a site for Supply of Gravel, is about to be revoked.—(P.70(A8) (Rs.9228).

BOROONDARA (Kew).—The temporary reservation by Order in Council of the 5th July, 1869 (see Government Gazette, 9th July, 1869, page 1018), of 58 acres, more or less, of land in the Parish of Boroondara, as a site for Mental Hospital purposes, revoked as to part by various Orders and various Acts, is about to be revoked, so far only as the portion containing 4 acres 0 roods 13 perches, indicated by hatching on plan hereunder, is concerned.—(K.180(C1) (Rs.7734).

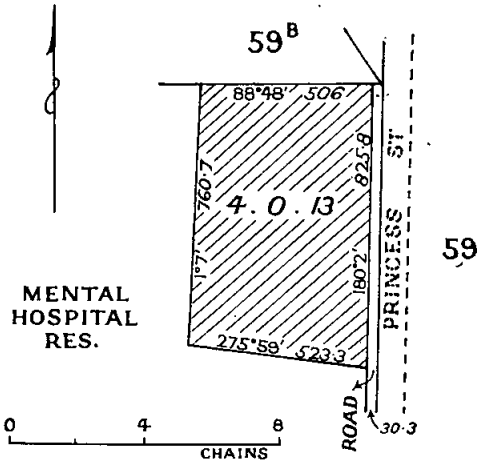

BUMBANG.—The temporary reservation by Order in Council of the 6th December, 1949, of 600 acres, more or less, of land in the Township and Parish of Bumbang, as a site for Public purposes, revoked as to part by various orders, is about to be revoked, so far only as the portion containing 7 perches, more or less, indicated by hatching on plan hereunder, is concerned.—(B.660(10) (Rs.5615).

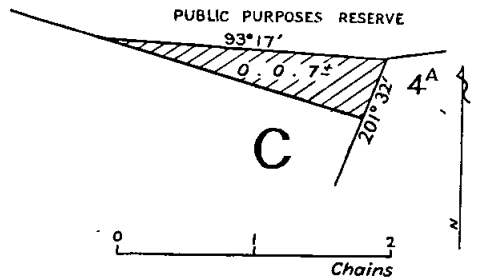

W. BORTHWICK,
Minister of Lands.

PROPOSED REVOCATIONS OF TEMPORARY RESERVATIONS OF LANDS BY ORDERS IN COUNCIL.

IN pursuance of the provisions of the Land Act 1958, notice is hereby given that it is the intention of the Governor in Council to revoke the temporary reservations of lands by Orders in Council hereunder referred to, viz.:

The following Notices were published 1° on the 2nd June, 1971, pursuant to Orders of the 25th May, 1971.

BOHO.—The temporary reservation by Order in Council of the 21st September, 1891, of 2 acres of land in the Parish of Boho as a site for a State School, is about to be revoked.—(B.431(8) (90.E.13814).

CARISBROOK.—The temporary reservation by Order in Council of the 14th August, 1951, of 3 roods 10 perches, more or less, of land in the Township of Carisbrook as a site for a Rubbish Depot, is about to be revoked.—(C.132(8) (Rs.6692).

FOSTERVILLE.—The temporary reservation by Order in Council of the 8th June, 1900, of 1 acre 2 roods 16 perches of land in the Township of Fosterville as a site for a State School, is about to be revoked.—(F.106(1) (C.12017).

SANDHURST (AT BENDIGO).—The temporary reservation as a site for Water Channel and the withholding from sale, leasing and licensing by Order in Council of 1st October, 1877, of 1 rood 14 4/10 perches of land at Bendigo, Parish of Sandhurst (formerly, in the City of Sandhurst), are about to be revoked so far only as the portion containing 11 perches, indicated by hatching on plan hereunder, is concerned.—(S.372(118) (C.96931).

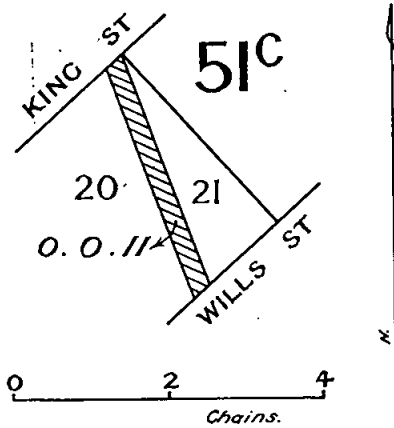

COBUNGRA.—The temporary reservation as a site for Camping and affording Access to Water and the withholding from sale, leasing and licensing by Order in Council of the 9th August, 1881, of 46 acres 23 perches of land in the Parish of Cobungra, are about to be revoked so far only as the portion containing 2 acres 32 perches, indicated by hatching on plan hereunder, is concerned.—(C.372^(*)) (C.77202).

JERUK.—The temporary reservation by Order in Council of the 17th April, 1956, of 8 acres, more or less, of land in the Parish of Jeruk as a site for Public Hall and Plantation, is about to be revoked so far only as the portion containing 6 perches, indicated by hatching on plan hereunder, is concerned.—(J.35^(*)) (Rs.7445).

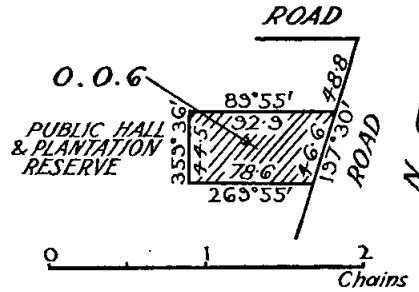

ECHUCA.—The temporary reservation by Order in Council of the 21st December, 1921, of 7 acres 1 rood 17 perches of land in the Township of Echuca as a site for Public purposes, revoked as to part by various Orders, is about to be revoked so far only as the portion containing 16 perches, more or less, indicated by hatching on plan hereunder, is concerned.—(E.3^(*)) (Rs.6175).

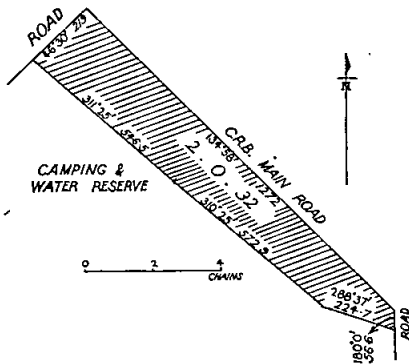

DRYSDALE.—The temporary reservation by Order in Council of the 4th May, 1915, of 30 acres 1 rood 9 perches of land in the Township of Drysdale as a site for Public purposes, is about to be revoked so far only as the portion containing 3 roods 5 perches indicated by hatching on plan hereunder is concerned.—(D.99^(*)) (Rs.711).

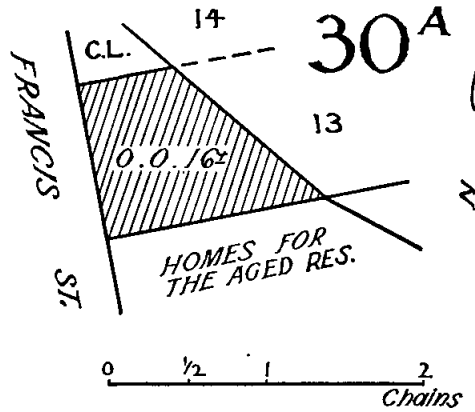

OMEQ.—The temporary reservation by Order in Council of the 6th October, 1953, of 2 acres 2 roods, more or less, of land in the Township of Omeo as a site for Public purposes, is about to be revoked so far only as the portion containing 3 roods 3 perches, indicated by hatching on plan hereunder, is concerned.—(O.19^(*)) (Rs.7159).

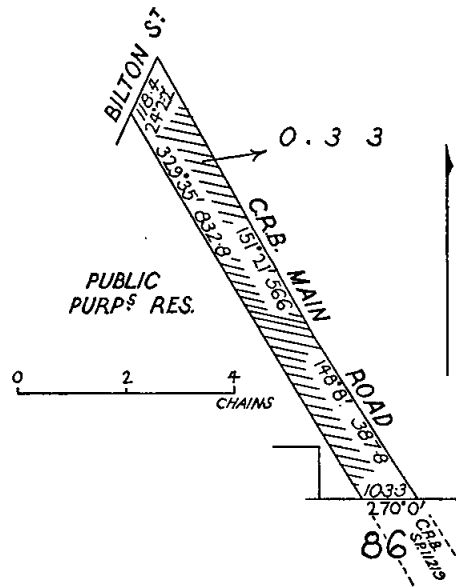
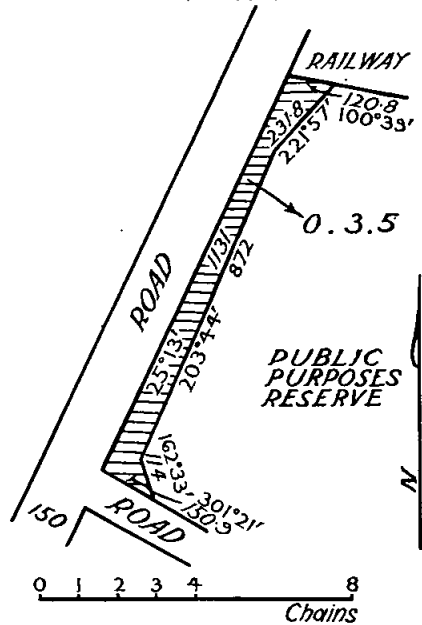

PYRAMID HILL.—The temporary reservation by Order in Council of the 22nd July, 1908, of 105 acres 28 perches of land in the Township of Pyramid Hill as a site for a Racecourse and other purposes of Public Recreation, is about to be revoked so far only as the portion containing 7 acres 3 roods 38 perches, indicated by hatching on plan hereunder, is concerned.—(P.171^(*)) (Rs.1295).

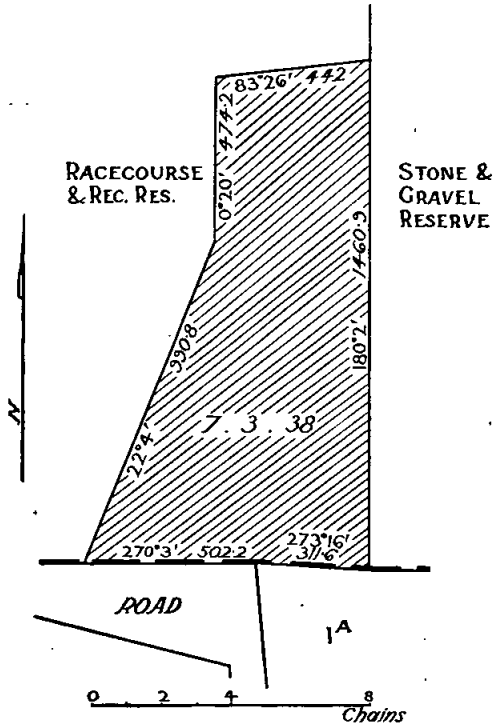

THARANBEGGA.—The temporary reservation as a site for the supply of Gravel and Stone and the withholding from sale, leasing and licensing by Order in Council of the 16th August, 1881, of 21 acres 2 roods 15 perches of land in the Parish of Tharanbegga, are about to be revoked so far only as the portion containing 6 acres 38 perches, indicated by hatching on plan hereunder, is concerned.—(T.216^(*)) (Rs.4715).

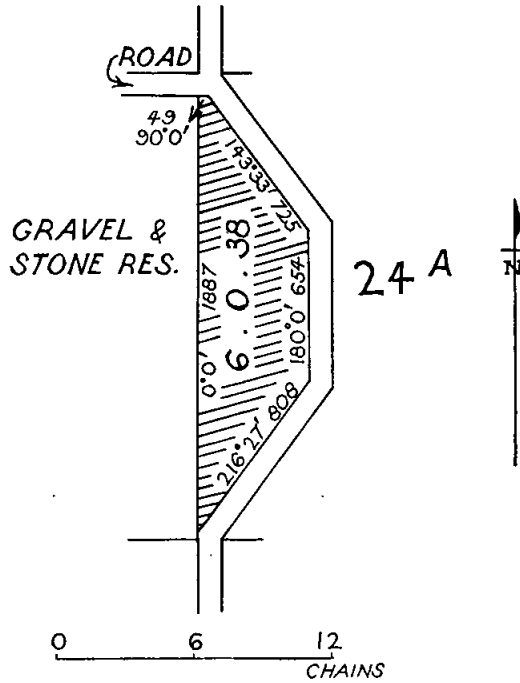

PYRAMID HILL.—The temporary reservation by Order in Council of the 22nd October, 1888, of 62 acres 3 roods 22 perches of land in the Township of Pyramid Hill (named Parish of Terrick Terrick West, at Pyramid Hill, in Order) as a site for Supply of Stone and Gravel, revoked as to part by various orders, is about to be revoked so far as the balance thereof containing 55 acres 2 roods 14 perches is concerned.—(P.171^(*)) (Rs.4153).

WINCHELSEA.—The temporary reservation by Order in Council of the 8th November, 1887, of 8 acres 1 rood 33 perches of land in the Township of Winchelsea as a site for a Cemetery, is about to be revoked so far only as the portion containing 1 acre 2 roods 22 perches, indicated by hatching on plan hereunder, is concerned.—(W.168⁽²⁾) (C.55870).

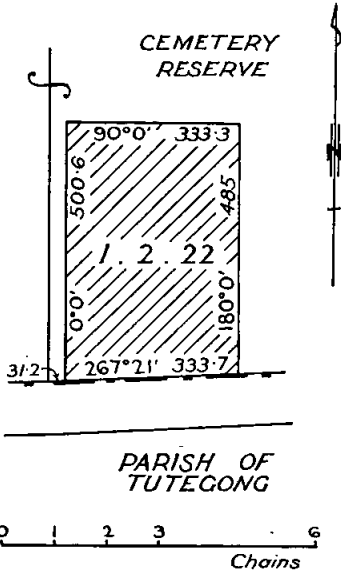

ANAKIE.—The temporary reservation by Order in Council of the 24th December, 1866, of 57 acres 2 roods 38 perches of land in the Parish of Anakie as a site for Public purposes, and the temporary reservation by Order in Council of the 26th November, 1888, of the same land as a site for the Growth and Preservation of Timber, are about to be revoked so far only as the portions containing 3 roods, indicated by hatching on plan hereunder, are concerned.—(A.31⁽²⁾) (Rs.5315).

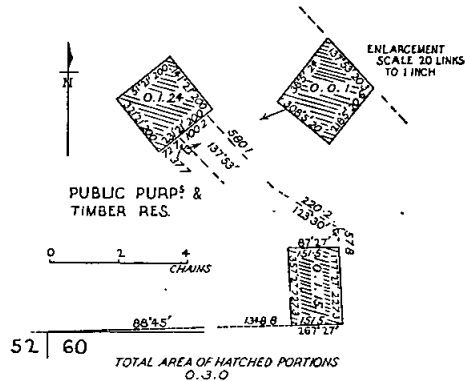

Land Act 1958.

LEASE DECLARED VOID.

NOTICE is hereby given that the Governor in Council has Declared Void the Lease mentioned in the Schedule hereunder for the reason specified.

District.	Corr. No.	Name of Lessee.	Section of Land Act 1958 under which Leased.	Parish.	Allotment.	Section.	Area.	Annual Rental.	Reason for Voiding.
Hamilton.	722/155	Clarence Walter Hoffman	155	Geerak	32A		A. R. P. 153 3 25	\$ 38.47	Non-compliance with conditions

Department of Crown Lands and Survey,
Melbourne, 1st June, 1971.

W. BORTHWICK,
Minister of Lands.

REGULATIONS FOR THE CARE, PROTECTION AND MANAGEMENT OF THE "WINTON RACECOURSE AND RECREATION RESERVE".

WHEREAS by section 218 of the *Land Act 1958* the Minister of Lands is empowered to make regulations as to any land which under the provisions of that Act or of any other Act relating to Crown lands has been reserved for any public purpose whatsoever and which has not been conveyed to or vested in trustees; And whereas certain Crown lands in the Township of Winton and described in a notice published in the *Gazette* of the 27th day of May, 1892 were reserved as a site for Racecourse and Public Recreation: And whereas such lands (hereinafter called "the Reserve") have not been conveyed to or vested in trustees; And whereas it is expedient that regulations for the care, protection and management of the Reserve and for other purposes connected therewith should be made: Now therefore I, William Archibald Borthwick, Her Majesty's Minister of Lands in and for the State of Victoria, in pursuance of the powers aforesaid, do hereby make the following Regulations for or with respect to the Reserve:—

The Reserve has been placed under the control of the Corporation of the Shire of Benalla (hereinafter referred to as the "Committee") with power and authority to enforce the following Regulations.

The following Regulations are made in lieu of all previous Regulations which are hereby rescinded.

REGULATIONS.

1. The Reserve, except those areas set apart for specific uses, shall be open to the public, free of charge, from sunrise to sunset, and at such other hours as the Committee may determine except on such occasions (not exceeding seventy in any one year) as the same may be set apart for race meetings, public sports, football or cricket matches, shows, entertainments, or such like purposes.

2. The maximum scale of charges for admission to the Reserve and to any buildings, erections or enclosures for the time being thereon on any day or any night set apart for public sports, football or cricket matches, shows, entertainments or such like purposes, as provided hereinbefore in clause 1, shall be—

- (a) For admission of each adult person to the Reserve—A sum not exceeding Three dollars.
- (b) For admission of each adult person to any stand, building, erection or enclosure in the Reserve—A sum not exceeding Two dollars in addition to the charge for admission to the Reserve.
- (c) For admission of each saddle horse (exclusive of the rider)—A sum not exceeding Fifty cents.
- (d) For admission of any cart, carriage, motor car, motor conveyance or other vehicle (exclusive of the driver and passengers)—A sum not exceeding Fifty cents.

Provided however that the Committee may at any time and at its discretion but not unreasonably or arbitrarily refuse to admit any horse, cart, carriage, motor car, motor conveyance or other vehicle.

3. No person shall enter or remain in the Reserve who may offend against decency as regards dress, language or conduct.

4. No person shall damage in any way the footpaths, water pipes, drinking taps, tools, appliances, seats, buildings, fences, walls or other properties or erections or trees, shrubs, or flowers in the Reserve, nor shall fires be lighted therein without the written permission of the Committee.

5. No person shall in the Reserve—

- (a) Climb or jump over or upon fences, gates, buildings or trees.
- (b) Place any bill, placard, or other document on or write or paint on or otherwise deface any gate, fence, structure, building, seat, wall or tree without the written consent of the Committee.
- (c) Scatter about or throw down handbills, placards, notices, advertisements, books, pamphlets, papers or any other such like matter.
- (d) Distribute or give out to any person or persons any handbills, placards, notices, advertisements, books, pamphlets, papers, programmes or any such like matter except with the written consent of the Committee.
- (e) Throw, place or leave any glass, filth, dirt, paper, rubbish or any such like matter.
- (f) Roll, throw or discharge any stone or other missile.
- (g) Interfere with or in any way damage any notice, placard, sign or regulations.

6. No person shall put, or take, or allow to wander into the Reserve any cattle, horses, sheep, goats, pigs or other animals without the written permission of the Committee.

7. No person shall take into the Reserve any dog which is not led or controlled by a leash, chain or cord and no vicious dog shall be taken into the Reserve unless securely and efficiently muzzled.

8. No person shall, without the written permission of the Committee, camp in the Reserve or erect therein any tent or building, booth or other structure, and no person shall, without the written permission of the Committee, hawk or offer any article for sale in the Reserve.

9. No person shall, in the Reserve, take part in any football or cricket match, entertainment, amusement or meeting whatsoever without the written permission of the Committee.

10. No person shall, in the Reserve, spit or expectorate on the footpaths or on any structure, building or erection or on the floors thereof.

11. When any sports, football or cricket matches, entertainments or such like are held in the Reserve and any person uses, rents or hires any stand, building, structure, erection or enclosure, the Committee may require such person to deposit with it a sum not exceeding Two hundred dollars by way of guarantee that no damage will be done thereto or therein, and such sum may be used at the absolute discretion of the Committee in making good any damage which may have been done to such stand, building, structure, erection or enclosure, or anything contained therein, or to any other property in the Reserve, or for any losses otherwise sustained by the Committee by reason of such renting or hiring of such stand, building, structure, erection or enclosure, and any person so renting or hiring shall conform to these Regulations and to any order or direction which may be given by the Committee in respect

thereof, or for the protection of the property of the Committee, or under its control, or for the safety or the protection of the health of the public.

12. All persons using any grandstand or other building in the Reserve shall observe any and every order or direction given by the Committee or body renting, using or hiring any such stand or building for the prevention of overcrowding, or for any other purpose whatsoever.

13. No person shall, without the written permission of the Committee, engage in cricket, football, tennis, bowls, golf, lacrosse, croquet, baseball or any other game or amusement or motor sport in the Reserve, nor shall any band play therein, without such written permission.

14. No person shall, without the written permission of the Committee, bring any vehicle onto that portion of the Reserve set apart for motor sport at any time that portion of the Reserve has not been specifically permitted to be used for the conduct of motor sports.

15. No person shall, without the authority of the Committee, enter upon any portion of the Reserve set apart for cricket, football, motor sports, or other games or sports during such time as such portion may be required or used for the purpose for which it has been so set apart, nor shall any person enter upon any portion of the Reserve set apart for tennis, croquet, bowls, or any other such like game, motor sport, or for children's playgrounds, unless such person has authority from the Committee to do so.

16. Any person, organization or club renting or hiring the Reserve, or any part thereof including any stand, structure, erection or enclosure for any approved purpose shall pay to the Committee such annual or other charge as the Committee may consider fair and reasonable and consistent with these Regulations.

17. No person shall enter and leave and park in the Reserve any horses, vehicles, motor cars, motor conveyances, motor cycles, bicycles, and other such like conveyances at places other than those as may be appointed or set apart for the purpose by the Committee.

18. No person shall, in the Reserve, erect or remove any post, rail, fence, pole, tent, booth, stand, building or structure without the written consent of the Committee.

19. No person shall, whilst in the Reserve, be in a state of intoxication or behave in a disorderly manner, or sing any obscene song or ballad, or write or draw any indecent or obscene word, figure, or representation, or use any profane, indecent or obscene language or create or take part in any disturbance, or interfere with any games, sports or amusements or use any threatening, insulting or abusive words or gestures or otherwise misbehave.

20. The Committee may set apart any portion of the Reserve for any lawful game or sport, and may from time to time grant to any person, organization, club or combination of clubs the use of such portion so set apart upon such terms and conditions as the Committee may consider reasonable and consistent with these Regulations.

21. No person shall wilfully obstruct, interrupt, or annoy any other person in the proper and lawful use of the Reserve, or any part thereof, nor wilfully obstruct or interrupt any servant of the Committee, or any person appointed by it in the execution of his official duty.—(Rs.502.)

Given under my hand at Melbourne on the 3rd day of June, 1971.

W. BORTHWICK,
Minister of Lands.

Every person who contravenes or fails to comply with these Regulations shall, in accordance with the provisions of section 218 of the *Land Act 1958*, for each offence be liable to a penalty of not more than Fifty dollars, and every person who contravenes or fails to comply with any such Regulations, and who, after he has been warned by any bailiff of Crown lands or by any member of the Police Force, does not desist therefrom may be forthwith apprehended by such Bailiff or member of the Police Force and taken before some justice to be dealt with according to law and shall be liable to a penalty of not more than One Hundred Dollars, provided that every person who contravenes any regulation prohibiting the depositing and leaving of any unwanted material or thing or rubbish of any kind shall for such offence be liable to a penalty of not more than Two Hundred Dollars.

REGULATIONS FOR THE CARE, PROTECTION AND MANAGEMENT OF THE "CAPE PATERSON BEACH RESERVE".

I WILLIAM ARCHIBALD BORTHWICK, Her Majesty's Minister of Lands in and for the State of Victoria in pursuance of the powers conferred on me by section 218 of the *Land Act 1958* do hereby make the following additional regulation with respect to the reserved Crown lands in the Parish of Wonthaggi shown coloured red on plan W/16.8.44 attached to Lands Department correspondence Rs.4057 and known as the "Cape Paterson Beach Reserve".

REGULATION:

20. No person shall:—

- (a) damage any vegetation or interfere with or disturb any sand, stone, gravel, rock, clay or other earth by driving any vehicle or by any other means.
- (b) drive any vehicle in a manner dangerous to the public.
- (c) drive any vehicle so as to cause noise which is unreasonable in the circumstances.

Given under my hand, at Melbourne, on the second day of June, 1971.

W. BORTHWICK,
Minister of Lands.

Every person who contravenes or fails to comply with these Regulations shall, in accordance with the provisions of section 218 of the *Land Act 1958*, for each offence be liable to a penalty of not more than Fifty dollars, and every person who contravenes or fails to comply with any such Regulations, and who, after he has been warned by any bailiff of Crown lands or by any member of the Police Force, does not desist therefrom may be forthwith apprehended by such Bailiff or member of the Police Force and taken before some justice to be dealt with according to law and shall be liable to a penalty of not more than One hundred dollars.

COMMITTEES OF MANAGEMENT OF RESERVES.

APPOINTMENTS.

NOTICE is hereby given that, in pursuance of section 221 of the *Land Act 1958*, the following appointments of Committees of Management of reserved Crown lands have been made by the Minister of Lands.

"APOLLO BAY FORESHORE RESERVE, THE BARHAM RIVER RESERVE AND CARISBROOK FALLS RECREATION RESERVE."

Francis Berry and Alan Mackie Coop, as members of the Committee of Management for a period ending the 7th May, 1973, of—

- (a) the land in the Parish of Wongarra, temporarily reserved as a site for Public Recreation by Order in Council of the 13th February, 1894, and known as the "Carisbrook Falls Recreation Reserve";
- (b) the reserved Crown land as indicated in red colour on plan marked "K/14.3.30" attached to Lands Department correspondence Rs.4917;
- (c) such portions of the reserves for Public purposes along the Barham River in the Parish of Krambruk as are indicated by pink tint on plan marked "K/20.11.45" attached to Lands Department correspondence Rs.1245, and known as the "Barham River Reserve";
- (d) the land in the Parish of Krambruk, temporarily reserved by Order in Council dated the 25th May, 1965, as a site for Public purposes.—(Corres. No. Rs.4917.)

"BAYLES RECREATION RESERVE."

Victor James Walker, Robert William Hayward, Gerard William Renahan, Ronald David Shaw, Keith Edward Jaques, William Frank Scadden, Keith Charles Bethune, Brian Maxwell Tonkin and George Thomas Miller as a Committee of Management for a period of three (3) years of the land in the Parish of Koo-Wee-Rup East at Bayles, temporarily reserved by Order in Council dated the 30th October, 1923, as a site for Public Recreation and known as the "Bayles Recreation Reserve".—(Corres. No. Rs.2844.)

"BEAZLEY'S BRIDGE RECREATION AND PUBLIC HALL RESERVES."

Thomas James Jackson, George William Greenaway and Roy Ernest Fernandes as a Committee of Management for a period of three (3) years of the lands in the Parish of Tottington, temporarily reserved by Orders in Council dated the 17th November, 1884, and the 29th July, 1895, as sites for Recreation and Public Hall and Public Recreation respectively, and being together known as the "Beazley's Bridge Recreation and Public Hall Reserves".—(Corres. No. Rs.1625, Rs.1626.)

"BLACKWOOD CRICKET AND RECREATION RESERVE" AND THE "BLACKWOOD PUBLIC PARK AND RECREATION RESERVE."

R. G. Costello, Archibald Noble, Cliff J. Acton, John Henry Brown, Capel Murray Healey, L. E. Armstrong, J. F. Rayner, Kenneth K. Matheson and Cary George Matheson as a Committee of Management for a period of three (3) years of the land in the Parish of Blackwood, permanently reserved by Order in Council dated the 10th April, 1893, as a site for Cricket and other purposes of Public Recreation, and known as the "Blackwood Cricket and Recreation Reserve", together with the reserved Crown lands indicated by red colour on plan marked "B/22.9.50" attached to Lands Department correspondence Rs.6591, and known as the "Blackwood Public Park and Recreation Reserve".—(Corres. No. Rs.484, Rs.6591.)

"BOINKA PUBLIC HALL RESERVE."

Glen Roy Chaplin, Donald Jos Morrison, Kenneth Valentine McDonald, John Archibald Kinnersley, Thomas Alexander Campbell, William John Inegaw, William Glen Chaplin, Lawrence Raymond Jones, Charles Leslie Jones and Lewis Reasley Morrison as a Committee of Management for a period of three (3) years of the land in the Township of Boinka, temporarily reserved by Order in Council dated the 15th July, 1913, as a site for a Public Hall, and known as the "Boinka Public Hall Reserve".—(Corres. No. Rs.1569.)

"BROUGHTON PUBLIC HALL RESERVE."

Rex John Jarred, Raymond George Allen, Wesley Charles Dickinson, Ronald Philip Dickinson, Lionel Richard Ferris, Maxwell Lloyd Allen, Ronald William Etherton, Robert David Morris and Neville Elroi Wheaton as a Committee of Management for a period of three (3) years of the land in the Township of Broughton, temporarily reserved by Orders in Council dated the 26th July, 1904, and the 26th August, 1958, as a site for a Public Hall, and together being known as the "Broughton Public Hall Reserve".—(Corres. No. Rs.7001.)

"BUCHAN RACECOURSE RESERVE."

James Henry Cameron, Robert Edward Calnin, Bernard James Manson, Oswald Graham Henham, Henry Breckon Mackieson, Oswald George Henham, Keith Middleditch, John Woodgate, Albert Langskail as a Committee of Management for a period of three (3) years of the land in the Parish of Nowa Nowa, temporarily reserved by Order in Council dated the 7th March, 1961, as a site for a Racecourse, and known as the "Buchan Racecourse Reserve".—(Corres. No. Rs.1827.)

"BULLA PUBLIC PARK RESERVE."

The Corporation of the Shire of Bulla as the Committee of Management of the land in the Township and Parish of Bulla, temporarily reserved by Order in Council dated the 30th March, 1971, as a site for a Public Park.—(Corres. No. Rs.9441.)

"BUNGAREE PUBLIC RECREATION RESERVE."

William Patrick O'Donohue, Thomas Joseph Hanrahan, Dennis John Maher, Francis Joseph Frawley, Leonard Roy Trigg, Andrew John Prendergast, Albert Charles Trigg, Francis Michael Cullinan and Thomas Patrick Hanrahan as a Committee of Management for a period of three (3) years of the land in the Township of Warrenheip, temporarily reserved by Order in Council dated the 11th November, 1964, as a site for Public Recreation and known as the "Bungaree Public Recreation Reserve".—(Corres. No. Rs.5211.)

"BYAWATHA RECREATION RESERVE."

Graeme Allan Norman, June Elizabeth Curran, George Clugg, Robert John Connor, Geoffrey Allen Cheshire, Rex F. Allen, and Leo Patrick Curran as a Committee of Management for a period of three (3) years of the land in the Parish of Carragarmungee, temporarily reserved by Order in Council dated the 19th January, 1971, as a site for Public Recreation, and known as the "Byawatha Recreation Reserve".—(Corres. No. Rs.9395.)

"CALLAWADDA MECHANICS' INSTITUTE RESERVE."

William J. Byron, Alfred F. Erwin, John D. Phillips, William G. Fraser and Murray Hutching as a Committee of Management for a period of three (3) years of the land in the Parish of Callawadda, temporarily reserved by Order in Council dated the 19th December, 1893, as a site for a Mechanics' Institute, and known as the "Callawadda Mechanics' Institute Reserve".—(Corres. No. Rs.5841.)

"CANIAMBO RECREATION RESERVE."

James Albert Keat, William Walter Cole, Keigh James Hucker, Ernest Alfred Reginald Gibbs and John Samuel Wall as a Committee of Management for a period of three (3) years of the land in the Parish of Caniambo, temporarily reserved by Orders in Council dated the 2nd September, 1902 and the 14th August, 1945 as sites for Public Recreation and together known as the "Caniambo Recreation Reserve".—(Corres. No. Rs.2209.)

"CULGOA MEMORIAL PARK AND CHILDREN'S PLAYGROUND."

James S. Sutton, Bernard D. Aldenhoven, Bryant G. Barry, Eric F. Wines, Henry T. Bath, Frank J. Casey, Henry V. Shirley, Ross R. Currie, John P. McNamara, W. R. Kelly and D. W. Barry as a Committee of Management for a period of three (3) years of the land in the Township of Culgoa, temporarily reserved as a site for a Public Park and Children's Playground by Order in Council dated the 27th May, 1952, and known as the "Culgoa Memorial Park and Children's Playground".—(Corres. No. Rs.6938.)

"DERGHOLM RECREATION RESERVE."

Lyle Hilton Russell, John Wilfred Paine, Murray John Davis, Rowland William McFarlane, Stuart Leighton Foster, Con McCrae and Russell Mervyn Howlett as a Committee of Management for a period of three (3) years of the land in the Township of Dergholm, temporarily reserved by Orders in Council dated the 1st December, 1909, 10th January, 1939, 30th October, 1956 and 1st October, 1963 as sites for Public Recreation and together known as the "Dergholm Recreation Reserve".—(Corres. No. Rs.4672.)

"DUNKELD MEMORIAL PARK" AND THE "DUNKELD TOURIST CAMPING RESERVE."

Reuben George Schache, Ernest John Baxter, Murdoch Andrew Templeton, John William McPhee, William Gordon Ross, Ian Douglas Collins and Finley James Harris together with George Claude Taylor (for so long only as he shall continue to be a Councillor and the elect of the Council of the Shire of Mount Rouse) as a Committee of Management for a period of three (3) years of—

(1) the land in the Township of Dunkeld, temporarily reserved by Order in Council dated the 19th October, 1954, as a site for Public Recreation and Gardens and known as the "Dunkeld Memorial Park" (Rs.7179)

and of—

(2) the land in the Township of Dunkeld temporarily reserved by Order in Council dated the 19th October, 1954, as a site for Tourist Camping purposes together with the abutting reserved frontage to the Wannon River and known as the "Dunkeld Tourist Camping Reserve". (Rs.7171.) —(Corres. No. Rs.7171, Rs.7179.)

"GOBUR RACECOURSE AND RECREATION RESERVE."

Alan Worrall Jones, Norman Penny, Ian Gordon Cumming, Robert Mervyn Cumming, Leslie James Shaw, Malcolm Arthur Shaw, Clyde Cumming, Colin McDonald and John Shaw as a Committee of Management for a period of three (3) years of the remaining portion of the land in the Parish of Gobur, permanently reserved by Order in Council dated the 21st June, 1886, as a site for a Racecourse and other purposes of Public Recreation and known as the "Gobur Racecourse and Recreation Reserve".—(Corres. No. Rs.4357.)

"GRANTVILLE RECREATION RESERVE."

Margaret Walker, Irene Wheatley, Andrew Walker, Hugh Alexander Geyer, and Charles Blackney as a Committee of Management for a period of three (3) years of the land in the Township of Grantville, temporarily reserved by Order in Council dated the 20th September, 1949, as a site for Public Recreation and known as the "Grantville Recreation Reserve".—(Corres. No. Rs.6266.)

"GREAT WESTERN PUBLIC HALL RESERVE."

Frederick Hamill Thomson, Ernest Champion, Isabel Champion, Reginald Bullock and Albert Illig as a Committee of Management for a period of three (3) years of the land in the Township of Great Western, temporarily reserved by Order in Council dated the 13th October, 1964, as a site for a Public Hall and known as the "Great Western Public Hall Reserve".—(Corres. No. Rs.8368.)

"HAWKESDALE MEMORIAL HALL RESERVE."

Albert George Marshall, Francis Joseph Carlin, Francis John Roache, Ronald Hausler, Douglas Williams, Robert James Towler, John Anthony O'Brien, and Lawrence Emil Nagorcka as a Committee of Management for a period of three (3) years of the land in the Township of Hawkesdale, temporarily reserved by Order in Council dated the 2nd November, 1896, as a site for a Mechanics' Institute and Free Library and known as the "Hawkesdale Memorial Hall Reserve".—(Corres. No. Rs.2273.)

"HILL END MECHANICS' INSTITUTE RESERVE."

James Luke Rees, Marie Patricia Nation, John James Ralph, John Leslie Bloye, Garry Raymond Colbert, William Hams, Phyllis Margaret Hitchins, Kenneth John Earl and John William Runciman as a Committee of Management for a period of three (3) years of the land in the Parish of Neerim East, temporarily reserved by Order in Council dated the 21st February, 1911, as a site for a Mechanics' Institute and known as the "Hill End-Mechanics' Institute Reserve".—(Corres. No. Rs.721.)

"HOMERTON PUBLIC HALL RESERVE."

Angus John Wyllie, William Rex Millard, Harold Victor Moore, Cecil James Millard, Albert Richard Holland, Leslie Leopold Hodge, John Henry Millard, Edwin Earnest Field and Eric Ronald Bannam as a Committee of Management for a period of three (3) years of the land in the Parish of Homerton, temporarily reserved as a site for a Public Hall by Order in Council dated the 28th April, 1964, and known as the "Homerton Public Hall Reserve".—(Corres. No. Rs.8321.)

"JOHNSONVILLE PUBLIC HALL RESERVE."

Robert William Bassett, Ronald Kramme, Aurthur Harold Kramme, Jack Doyle, Adela Joy Wyatt, Thomas Robert Wyatt, Victor Charles Wyatt, Noel Stirling Stewart and Peter Kramme as a Committee of Management for a period of three (3) years of the land in the parish of Bumberrah at Johnsonville, temporarily reserved by Order in Council dated the 30th September, 1958, as a site for a Public Hall and known as the "Johnsonville Public Hall Reserve".—(Corres. No. Rs.7740.)

"KANIVA RACECOURSE RESERVE."

William Henry Hicks, William Albert Hicks, Percy Lloyd Williams, John Sydney Stephen, James Campbell McCracken, Peter Anthony Cleverly, Norman Arnold Duthie, Percy David Maddern and John Clifty Grant as a Committee of Management for a period of three (3) years of the land in the Parish of Kaniva, temporarily reserved by Order in Council dated the 25th November, 1924, as a site for a Racecourse and Public Recreation and known as the "Kaniva Racecourse Reserve".—(Corres. No. Rs.3019.)

"KOTTA PUBLIC HALL."

David Andrew Monsant, Richard Worboys, Donald Nicholson, John William McCalman, Neville Walter Beeson, William James Vickers, Rossel George Chapman, Denis Luke Palmer, Robert George Bickford and Brian Saligari as a Committee of Management for a period of three (3) years of the land in the Parish of Bamawm deemed permanently reserved for the recreation, convenience or amusement of the people and known as the "Kotta Public Hall".—(Corres. No. Rs.8861.)

"LABERTOUCHE PUBLIC HALL RESERVE."

Brian Edward Scandolera, Ronald Douglas Davidson, Kevin William Parker Macfarlane, Richard Albert Hine, Sydney Harold Brasher, Donald Ernest Lestleigh Henry, Alan Bonar McDonald, Leonard William Boreham and Daryl John Donaldson as a Committee of Management for a period of three (3) years of the land in the Parish of Jindivick, temporarily reserved by Order in Council dated the 31st October, 1961, as a site for a Public Hall and known as the "Labertouche Public Hall Reserve".—(Corres. No. Rs.8083.)

"LAEN RECREATION RESERVE."

Daniel William Fox, John Murray Paynter, Neil Albert Paynter, John. A. W. Henderson, Lindsay Gordon Henderson, Arthur Edward Griffiths and Stanley P. Carne as a Committee of Management for a period of three (3) years of the land in the Parish of Laen, temporarily reserved by Order in Council dated the 28th March, 1950, as a site for Public Recreation and known as the "Laen Recreation Reserve".—(Corres. No. Rs.6519.)

"LEONGATHA SOUTH PUBLIC HALL RESERVE."

Margaret Emma McPherson, Harold Gordon Vagg, Edwin George Millett and John Bartlett Moscript as a Committee of Management for a period of three (3) years of the land in the Parish of Leongatha, permanently reserved by Order in Council dated the 8th July, 1902, as a site for a Mechanics' Institute and known as the "Leongatha South Public Hall Reserve".—(Corres. No. Rs.5728.)

"LISMORE RECREATION RESERVE."

John Edmund Baker, James Rowe Oman, Christopher John Bennett, Alexander John Brett, William Alan Sutterby, Thomas Walter Elliot, James Russell McCall, Rodger Mullican and Lachlan William McBean as a Committee of Management for a period of three (3) years of the land in the Township of Lismore, temporarily reserved by Order in Council dated the 24th September, 1877, as a site for Public Recreation and known as the "Lismore Recreation Reserve".—(Corres. No. Rs.2301.)

"LONGWARRY NORTH MECHANICS' INSTITUTE RESERVE."

Walter John Wade, Colin Arthur Gardner, Frederick Lloyd Haysom, Edward Hughes Gardner, William George Weaven, Stanley Maxwell Holland, Leslie Albert Faux, Leslie John Smith and Kenneth James Davis as a Committee of Management for a period of three (3) years of the land in the Parish of Drouin West, temporarily reserved by Order in Council dated the 17th October, 1961, as a site for a Public Hall and known as the "Longwarry North Mechanics' Institute Reserve".—(Corres. No. Rs.8077.)

"LOY YANG PRESERVATION OF NATIVE FLORA RESERVE."

Marjorie L. Paul, John Barry Graham, Christine Ann Graham, Guinavere Rosa Ellen Thompson, Oliver Orton Thompson and Tom Moretti as a Committee of Management for a period of three (3) years of the land in the Parish of Loy Yang, temporarily reserved as a site for Public purposes (Preservation of Native Flora) by Order in Council dated the 6th February, 1968, and known as the "Loy Yang Preservation of Native Flora Reserve".—(Corres. No. Rs.8937.)

"MERTON RECREATION RESERVE."

John Leonard Purcell, John William Redfern, Robert William Catherwood, Francis James Redfern, Max Dudley Purcell, Alan Robertson McNee, Keith William Kipping, Albert Ernest Shaw and Arthur Danks Fraser as a Committee of Management for a period of three (3) years of the land in the Township of Merton, temporarily reserved by Order in Council dated the 16th March, 1886, as a site for Public Recreation and known as the "Merton Recreation Reserve".—(Corres. No. Rs.1283.)

"MOONAMBEL TENNIS RESERVE."

Raymond Charles Driscoll, Thorold Alexander Castleman, James Alan Farnsworth, Desmond Roland Driscoll, James Frank Hardy, Samuel James Anderson, Norman Jack Hardy, and Patrick Cudmore as a Committee of Management for a period of three (3) years of the land in the Township of Moonambel, temporarily reserved by Order in Council dated the 20th October, 1964, as a site for Public Recreation and known as the "Moonambel Tennis Reserve".—(Corres. No. Rs.8384.)

"MOUNT CLEAR RECREATION RESERVE."

Victor Albert Bradley, John Marmaducke Horwood, Ronald Maxwell Stevens, Roy Grainge Biggs, Bruce Everard Bartrop, Thomas Patrick Trescowthick, Norman Arbory Crebbin and Thomas William Dadswell, as a Committee of Management for a period of three (3) years of the land in the Parish of Ballarat, temporarily reserved for Cricket and other purposes of Public Recreation as is indicated by red colour on plan marked "A/31.1.50" attached to Lands Department correspondence Rs.1461 together with the land in the same Parish similarly reserved by Order in Council dated the 16th August, 1966, and being together known as the "Mount Clear Recreation Reserve".—(Corres. No. Rs.1461.)

"NAMBROK HALL AND RECREATION RESERVE."

William John Gurling, John Joseph Killeen, Donald Gavin Johnston, Henry Cull, William Henry Wheeler, Robert Joseph Barr Mason, Ronald Sydney Pietersen, Robert James O'Hara, Willibrordus Smits, Norman David Medew, Vernon John Bermingham as a Committee of Management for a period of three (3) years of the land in the Parish of Denison, temporarily reserved by Order in Council dated the 11th February, 1958, as a site for a Public Hall and Public Recreation and known as the "Nambrok Hall and Recreation Reserve".—(Corres. No. Rs.7700.)

"NAREEB RECREATION RESERVE."

Allan Archie Roll, Donald McKenzie, William Thomas Scholfield, Thomas James Giles, David Hugh Edwards, Alfred Frost and William Ernest Wilkins as a Committee of Management for a period of three (3) years of the land in the Parish of Bilpah, temporarily reserved as a site for Public Recreation by Order in Council dated the 29th July, 1952, and known as the "Nareeb Recreation Reserve".—(Corres. No. Rs.6984.)

"NARREE WORRAN RECREATION RESERVE."

The Corporation of the City of Knox as the Committee of Management of the land in the Parish of Narree Worrان, temporarily reserved by Order in Council dated the 30th March, 1971, as a site for Public Recreation.—(Corres. No. Rs.9458.)

"NATIMUK RECREATION (SWIMMING POOL) RESERVE."

Alan John Woodford, Cyril Herbert Webb, Keith Avenel Smith, Colin Albert Hutchesson, Lancelot John Cross, Peter Joseph Heenan, Douglas Kenneth Wiles, Keith Albert John Klowss and James David Sudholz as a Committee of Management for a period of three (3) years of the land in the Parish of Natimuk, temporarily reserved by Orders in Council dated the 29th January, 1935, and the 27th February, 1968, as sites for Public Recreation and known as the "Natimuk Recreation (Swimming Pool) Reserve".—(Corres. No. Rs.4433.)

"NORTHERN LOCH PUBLIC RECREATION RESERVE, PARISH OF GOYURA."

Ralph Henry Phillips, Maurice Fitzgerald Conway, Harold John Mitchell, Lindsay Herbert Dart, William Conway, Ronald Robins, William Robins, and Colin Robert Roulton as a Committee of Management for a period of three (3) years of the land in the Parish of Goyura, temporarily reserved by Order in Council dated the 11th April, 1967, as a site for Public Recreation.—(Corres. No. Rs.8810.)

"OLD TOWN DAM RECREATION RESERVE", HAMILTON.

The Corporation of the City of Hamilton as the Committee of Management of the land in the Township of Hamilton, temporarily reserved by Order in Council dated the 30th March, 1971, as a site for Public Recreation, and known as the "Old Town Dam Recreation Reserve".—(Corres. No. Rs.2335.)

"PIANGIL MEMORIAL PARK RESERVE."

Donald William Hayden, Harold Hankinson, Reginald Becher Hungerford, Andrew Alexander, Edward George Gellie, Ian John Rodgers, Alan James Branson, Dalzell Harry Rodgers and Henry Blandthorn as a Committee of Management for a period of three (3) years of the land in the Township of Piangil, temporarily reserved by Order in Council dated the 22nd January, 1918, as a site for Recreation purposes and known as the "Piangil Memorial Park Reserve".—(Corres. No. Rs.1728.)

"PIANGIL RECREATION RESERVE."

Donald William Hayden, Alan James Branson, James Valentine Roberts, Edward George Gellie, Reginald Becher Hungerford, Ian John Rodgers, M. Good, Wallace James Harding and Harold Hankinson as a Committee of Management for a period of three (3) years of the land in the Parish of Piangil, temporarily reserved by Order in Council dated the 15th February, 1955, as a site for Public Recreation and known as the "Piangil Recreation Reserve".—(Corres. No. Rs.7329.)

"PIRRON YALLOCK MECHANICS' INSTITUTE RESERVE."

Stanley Percy Spearing, Lester George Hallyburton, Moira Veronica Sexton, Mary Veronica Ryan, Gloria Barbara Wood and Kennedy Douglas Paton as a Committee of Management for a period of three (3) years of the land in the Township of Pirron Yallock, temporarily reserved as a site for a Mechanics' Institute by Order in Council dated the 19th April, 1898, and known as the "Pirron Yallock Mechanics' Institute Reserve".—(Corres. No. Rs.4908.)

PUBLIC RECREATION RESERVE IN THE PARISH OF CRAIGIE.

David Nisbet Bilton, Thomas Robert Nicholls, Charles Colin Mason, Mary Bilton, John Disselhoff, Walter Keleher and Bette Bilton as a Committee of Management for a period of three (3) years of the land in the Parish of Craigie, temporarily reserved by Order in Council dated the 20th July, 1885, as a site for Public Recreation.—(Corres. No. Rs.9431.)

PUBLIC RECREATION RESERVE IN THE TOWNSHIP OF MAFEKING.

The Corporation of the Shire of Ararat as the Committee of Management of the land in the Township of Mafeking (shown hatched on plan M/7.5.71 attached to Lands Department Correspondence Rs.9456), temporarily reserved by Order in Council dated the 30th March, 1971, as a site for Public Recreation.—(Corres. No. Rs.9456.)

"RIDDELL'S CREEK RECREATION RESERVE."

Harry Anthony Lawry, Brian Hogan, Neil John Moulden, Norman Gerald Price, John Poulton, Arthur Charles Baker, Leon Richard Bestel, Ivan Osborne, and Walter Geoffrey Mashiter as a Committee of Management for a period of three (3) years of the land in the Parish of Kerrie, temporarily reserved for Public Park, Racecourse and Public Recreation and known as the "Riddell's Creek Recreation Reserve".—(Corres. No. Rs.2358.)

"SANDY POINT PUBLIC HALL RESERVE."

Austin Harold Williams, Marcus Hastings Griffin, Allen Bruce Worcester, John Farrell Cope and Thomas Pollock Taylor as a Committee of Management for a period of three (3) years of the land in the Parish of Waratah North, temporarily reserved by Order in Council dated the 14th January, 1964, as a site for a Public Hall and known as the "Sandy Point Public Hall Reserve".—(Corres. No. Rs.8293.)

"STRATHMERTON RECREATION RESERVE."

Thomas Leonard Christie, Francis Murray Murrell, Clarence Bertram Haynes, George Alfred North, Noel Fredrick Cator, John McDonald Farrell, Alfonsus Edward Thorpe, Lancelot William Oswald and Claude Maurice Sutton as a Committee of Management for a period of three (3) years of the land in the Parish of Strathmerton, temporarily reserved by Order in Council dated the 16th May, 1949, as a site for Public Recreation and known as the "Strathmerton Recreation Reserve".—(Corres. No. Rs.6351.)

"SWIFT'S CREEK CAMPING RESERVE."

Robert Bruce Blackwood and Horace Arthur Young for the period ending the 8th October, 1972, as members of the Committee of Management of the land in the Parish of Tongio-Munjee-East, temporarily reserved by Order in Council dated the 27th April, 1955, as a site for Public purposes, together with the abutting permanent reserve and together known as the "Swift's Creek Camping Reserve".—(Corres. No. Rs.7361.)

"SOUTH LILLIMUR RECREATION RESERVE."

Douglas Rex Thompson, Sydney Roy Goodwin, Errol Bowering Wood, Bernard Michael Arthur, Francis William Kuchel, Geoffrey Robert Black, Neville Ian Goodwin, Noel William Nash and David Edwin Hawker as a Committee of Management for a period of three (3) years of the land in the Township of Lillimur South, temporarily reserved by Order in Council dated the 21st September, 1927, as a site for Public Recreation and known as the "South Lillimur Recreation Reserve".—(Corres. No. Rs.3525.)

"TENNYSON RECREATION RESERVE."

Frank Mortimore, Robert S. Rankin, William J. Elliott, Arthur Gordon Weller, James R. Rorke, William James Mitchell, Philip C. Collins, Graeme Maxwell Haines, and Frank Rorke as a Committee of Management for a period of three (3) years from the 8th December, 1970, of the land in the Parish of Wanurp, temporarily reserved by Order in Council dated the 20th June, 1967, as a site for Public Recreation and known as the "Tennyson Recreation Reserve".—(Corres. No. Rs.8839.)

"VIEW STREET PUBLIC HALL RESERVE."

William James Hodgson, Francis Edward Old, Joseph Maxwell Bouch, Keith Binet Brown and Alfred Ernest Glisson as a Committee of Management for a period of three (3) years together with John Stanley Verlin and Trevor Leigh Coulthard (for so long as they shall continue to be Councillors and the elect of the Council of the Town of Castlemaine) of the land in the Parish of Castlemaine, temporarily reserved by Order in Council dated 11th February, 1958, as a site for a Public Hall and known as the "View Street Public Hall Reserve".—(Corres. No. Rs.7694.)

"WABBA PUBLIC PURPOSES (PICNIC GROUND) RESERVE."

The Corporation of the Shire of Upper Murray as the Committee of Management of the land in the Parish of Wabba, temporarily reserved by Order in Council of the 19th January, 1971, as a site for Public purposes (Picnic Ground).—(Corres. No. Rs.9437.)

"WONWONDAH NORTH PUBLIC HALL RESERVE."

Marinus Maria Bulle, William Edward McGennisker, Alan Thomas Heard, Peter John Heard, James Bromell Heard, Dick Bell, George William Rosevear, Geoffrey Bromell Heard and Neil Puls as a Committee of Management for a period of three (3) years of the land in the Township of Wonwondah, temporarily reserved by Order in Council dated the 11th June, 1940, as a site for a Public Hall and known as the "Wonwondah North Public Hall Reserve".—(Corres. No. Rs.5048.)

"WOOLAMAI RECREATION RESERVE."

Arthur Henry Eden, Edward Thomas Thorn, Roland James Couch, William Robert Finlay, James William Churchill, Maxwell Edward Hade, Francis Alexander Shackelford, William Alford and Bernard Shackelford as a Committee of Management for a period of three (3) years of the land in the Parish of Woolamai, temporarily reserved by Order in Council dated the 25th June, 1888, as a site for a Racecourse and known as the "Woolamai Recreation Reserve".—(Corres. No. Rs.4350.)

"WOOMELANG PUBLIC PARK."

Francis Joseph Kelly, William Clifford Russell, Leslie John Knights, Harry William Ackland and Eric Malcolm Burke as a Committee of Management for a period of three (3) years from the 26th July, 1968, of the land in the Township of Woomelang, temporarily reserved by Order in Council dated the 17th August, 1914, as a site for a Public Park and Gardens and known as the "Woomelang Public Park".—(Corres. No. Rs.616.)

"YALCA SOUTH RECREATION RESERVE."

Ronald George Hunter, Dudley William Botterill, Russell H. Fox, Kenneth James Muir, Robert James Salmon, Robert James Goggin, Walter Rendell and Louis G. Michel as a Committee of Management for a period of three (3) years of the land in the Parish of Yalca, temporarily reserved by Order in Council dated the 12th February, 1890, as a site for Public Recreation and known as the "Yalca South Recreation Reserve".—(Corres. No. Rs.914.)

W. BORTHWICK,
Minister of Lands.

Department of Crown Lands and Survey,
Melbourne, 4th June, 1971.

TENDERS

PUBLIC WORKS DEPARTMENT

TENDERS will be received at Public Works Department, 2 Treasury-place, Melbourne, until TWO p.m. on dates shown and for purposes mentioned hereunder.

Particulars and tender forms available at Contracts Office, Room 8, Building Division, Parliament-place and at places indicated in brackets hereunder.

Abbreviations in brackets mean:—W.O.—Inspector of Works Office; P.S.—Police Station; C.S.—Consolidated School; H.E.S.—Higher Elementary School; H.S.—High School; Pr.S.—Primary School; T.S.—Technical School.

Tenders to be submitted on the Department's printed Tender Form and will not be received by telephone. All tenders must be on a "Firm Tender" basis. The lowest or any tender will not necessarily be accepted.

Address tenders to the Minister of Public Works, and endorse the envelope containing the tender "Tender for , closing Tuesday,

Hand delivered tenders to be placed in the Tender Box of the Public Works Department, located on the wall of the centre entrance foyer, Ground Floor, 2 Treasury-place, Melbourne.

No preliminary deposit is required with any tender, but a successful tenderer will be required to pay a deposit for any accepted tender of \$4,000 or over.

Wednesday, 16th June, 1971.

Building, Electrical and Mechanical Works.

Burwood.—Roofing repairs and external renovations, T.S.

Camperdown.—Re-modelling of library, H.S. (W.O., Camperdown.)

Stonyford.—Erection of replacement L.T.C. class-room, &c., Pr.S.3506. (W.O., Camperdown and Geelong.)

Werribee.—Internal and external renovations, G.S. Gordon Cereal Laboratory and Administration Building, Research Farm. (W.O., Geelong.)

Site Works.

Southvale.—Site works, Pr.S.4859.

Miscellaneous.

Port Melbourne.—Supply and delivery of fire hose, P.W.D. Storeyard.

Tuesday, 22nd June, 1971.

Building, Electrical and Mechanical Works.

Hadfield.—Erection of new brick library building, H.S.

Hadfield.—Mechanical services, Library, H.S.

Hadfield.—Electrical services, Library, H.S.

Hume Weir.—Supply and erection of fruit fly control shelter, Road Block. (W.O., Wangaratta.) (Re-advertised.)

Furniture and Furnishings.

Coburg.—Supply and fix where necessary—(a) aluminium framed notice boards, (b) bench cupboards and cupboards—Teachers' College.

Tuesday, 29th June, 1971.

Building, Electrical and Mechanical Works.

Broadmeadows.—Construction of large animal accommodation building, "Attwood" Veterinary Research Station.

Melbourne.—External painting, Public Offices, 436 Lonsdale-street.

Melbourne.—P.A.B.X. telephone installation—Stage II., State Insurance Centre, 480 Collins-street.

Rokewood.—Erection of replacement L.T.C. classrooms, &c., Primary School 531. (W.O., Geelong.)

Furniture and Furnishings.

Melbourne.—Supply, making and laying of carpet, Public Offices, 436 Lonsdale-street.

MURRAY BYRNE,
Minister of Public Works.

Public Works Department,
Melbourne, 3002, 7th June, 1971.

PUBLIC SERVICE NOTICES

No. 748.

Public Service Act 1958, Section 39.

REGULATIONS.—PART IV.—SALARIES AND INCREMENTS.

THE Public Service Board, in pursuance of the powers conferred by the *Public Service Act 1958*, hereby amends its Regulations as shown below :—

FOURTH SCHEDULE.

ADMINISTRATIVE DIVISION.

Amount of Salary Assigned to Offices in Class "A1".

Office.	Yearly Rate of Salary.
	\$
CHIEF SECRETARY'S DEPARTMENT.	
<i>Delete—</i> Secretary, Office of the Chief Commissioner of Police	11,928
<i>Add—</i> Director of Administration, Office of the Chief Commissioner of Police	11,928

This Regulation shall have effect as on and from the 1st June, 1971.

A. J. A. GARDNER, Chairman.

R. H. DURRANT, Acting Secretary.

Office of the Public Service Board,
Melbourne, 28th May, 1971.

No. 743.

Public Service Act 1958, Section 50.

REGULATIONS.—PART IV.—SALARIES AND INCREMENTS.

THE Public Service Board, in pursuance of the powers conferred by the *Public Service Act 1958*, hereby amends its Regulations as shown below :—

SIXTH SCHEDULE.

TEMPORARY EMPLOYEES.

Designations of Positions and Rates of Salaries.

Department and Designation of Position.	Yearly Rate of Salary.		Increments (Annual).
	Minimum.	Maximum.	
	\$	\$	
GENERAL.			
<i>Delete—</i> Chauffeur	3,046	3,250	Σ
<i>Add—</i> Chauffeur	3,270	3,474	Σ

This Regulation shall have effect as on and from the 30th May, 1971.

A. J. A. GARDNER, Chairman.

R. H. DURRANT, Acting Secretary.

Office of the Public Service Board,
Melbourne, 28th May, 1971.

No. 749.

Public Service Act 1958, Section 50.

REGULATIONS.—PART IV.—SALARIES AND INCREMENTS.

THE Public Service Board, in pursuance of its powers conferred by the *Public Service Act 1958*, hereby amends its Regulations as shown below :—

EIGHTH SCHEDULE.

PROFESSIONAL DIVISION.

TEMPORARY POSITIONS.

Department and Position.	Scale of Rates of Annual Salary with Incremental Stages.
CHIEF SECRETARY'S DEPARTMENT.	
<i>Delete—</i> Research Assistant, Traffic Commission	\$4,078—\$4,209—\$4,380— \$4,510—\$4,683—\$4,855— \$5,064—\$5,220
<i>Add—</i> Research Assistant, Road Safety and Traffic Authority	\$4,078—\$4,209—\$4,380— \$4,510—\$4,683—\$4,855— \$5,064—\$5,220

This Regulation shall have effect as on and from the 3rd February, 1971.

A. J. A. GARDNER, Chairman.

R. H. DURRANT, Acting Secretary.

Office of the Public Service Board,
Melbourne, 28th May, 1971.

No. 745.

Public Service Act 1958, Section 50.

REGULATIONS.—PART IV.—SALARIES AND INCREMENTS.

THE Public Service Board, in pursuance of the powers conferred by the *Public Service Act 1958*, hereby amends its Regulations as shown below :—

SIXTH SCHEDULE.

TEMPORARY EMPLOYEES.

Designations of Positions and Rates of Salaries.

Department and Designation of Position.	Yearly Rate of Salary.		Increments (Annual).
	Minimum.	Maximum.	
	\$	\$	
CHIEF SECRETARY'S DEPARTMENT.			
FISHERIES AND WILDLIFE.			
<i>Delete—</i> Hatchery Assistant, Snob's Creek—Adult	3,046	3,392	Σ
<i>Add—</i> Hatchery Assistant, Snob's Creek—Adult	3,190	3,532	Σ

This Regulation shall have effect as on and from the 23rd May, 1971.

A. J. A. GARDNER, Chairman.

R. H. DURRANT, Acting Secretary.

Office of the Public Service Board,
Melbourne, 21st May, 1971.

No. 744.

Public Service Act 1958, Section 50.

REGULATIONS.—PART IV.—SALARIES AND INCREMENTS.

THE Public Service Board, in pursuance of the powers conferred by the Public Service Act 1958, hereby amends its Regulations as shown below :—

SIXTH SCHEDULE.
TEMPORARY EMPLOYEES.

Designations of Positions and Rates of Salaries.

Department and Designation of Position.	Yearly Rate of Salary.		Increments (Annual).
	Minimum.	Maximum.	
	\$	\$	
LOCAL GOVERNMENT DEPARTMENT.			
<i>Delete—</i> Typist (Female) (Recording)	..	3,634	
<i>Add—</i> Typist (Female) (Recording)	..	3,956	

A. J. A. GARDNER, Chairman.

R. H. DURRANT, Acting Secretary.

Office of the Public Service Board,
Melbourne, 25th May, 1971.

No. 747.

Public Service Act 1958, Section 50.

REGULATIONS.—PART IV.—SALARIES AND INCREMENTS.

THE Public Service Board, in pursuance of the powers conferred by the Public Service Act 1958, hereby amends its Regulations as shown below :—

SIXTH SCHEDULE.
TEMPORARY EMPLOYEES.

Designations of Positions and Rates of Salaries.

Department and Designation of Position.	Yearly Rate of Salary.		Increments (Annual).
	Minimum.	Maximum.	
	\$	\$	
PUBLIC WORKS DEPARTMENT.			
<i>Delete—</i> Engineering Assistant, Grade IV.	4,699	5,019	Σ
<i>Add—</i> Engineering Assistant, Grade IV.	5,125	5,470	Σ
<i>With effect as on and from the 22nd November, 1970</i>			
<i>Delete—</i> Engineering Assistant, Grade IV.	5,125	5,470	Σ
Engineering Assistant, Grade III.	4,000	4,577	Σ
Engineering Assistant, Grade II.	3,310	3,551	Σ
Engineering Assistant, Grade I.	3,046	3,290	Σ
<i>Add—</i> Engineering Assistant, Grade IV.	5,433	5,798	Σ
<i>With effect as on and from the 10th January, 1971.</i>			

A. J. A. GARDNER, Chairman.

R. H. DURRANT, Acting Secretary.

Office of the Public Service Board,
Melbourne, 28th May, 1971.

No. 750.

Public Service Act 1958.

THE Public Service Board, in pursuance of the powers conferred by the Public Service Act 1958, hereby amends the Public Service (Public Service Board) Regulations as shown below :—

PART V.—ALLOWANCES.

DIVISION II.—OVERTIME AND STAND-BY ALLOWANCES.

WATER SUPPLY DEPARTMENT.

Regulation 133 (1).

Office or Position.	Stand-by a Year.	Commuted Overtime Percentage.
	\$	%
<i>Delete—</i> Supervisor of Water Distribution— Torrumbarry System, Cohuna	132	18"
<i>Add—</i> Supervisor—Torrumbarry System, Cohuna	132	18"

A. J. A. GARDNER, Chairman.

R. H. DURRANT, Acting Secretary.

Office of the Public Service Board,
Melbourne, 28th May, 1971.

No. 746.

PUBLIC SERVICE ACT 1958.

THE Public Service Board, in pursuance of the powers conferred by the Public Service Act 1958, hereby amends the Public Service (Public Service Board) Regulations as follows:—

PART I.—PRELIMINARY.

REGULATION 2.

PART V.—ALLOWANCES.

The expression "Division IV.—Other Allowances (R.136-160.)" is deleted and the following expression is inserted in lieu thereof:—

"Division IV.—Shift Duty and Rostered Time of Ordinary Duty Performed by Officers During Week-ends or on Public Holidays. (R.136-136d.)"

Division V.—Other Allowances. (R.137-160.)"

PART V.—ALLOWANCES.

The headings "DIVISION IV.—OTHER ALLOWANCES" and "Rostered Time of Ordinary Duty Performed by Officers During Week-ends or on Public Holidays" and Regulations 136, 136A, 140, 142A, 148A, 148B, 148C and 157 are deleted and the following heading and Regulations are inserted in lieu thereof:—

"DIVISION IV.—SHIFT DUTY AND ROSTERED TIME OF ORDINARY DUTY PERFORMED BY OFFICERS DURING WEEK-ENDS OR ON PUBLIC HOLIDAYS.

136. (1) Officers, other than those in the Mental Hygiene Branch, Department of Health, referred to in Regulation 136A, who are required to perform rostered time of ordinary duty on Saturdays, Sundays or holidays observed in accordance with the provisions of

the Public Service Acts or shift duty and whose standard salaries do not exceed the standard salary provided in the Third Schedule for the top subdivision of Class "B1", Administrative Division, shall, unless otherwise determined by the Board, be paid allowances as shown hereunder—

Monday to Friday Inclusive.

- (a) When required to perform rostered time of ordinary duty on an afternoon or night shift—at the rate of 10 per centum of their hourly rate for each hour of duty; provided that this allowance shall not apply to officers working a roster of two days on duty and two days off duty.

Saturday.

- (b) When required to perform rostered time of ordinary duty—
 - (i) in the case of Student Nurses or officers who are required to be registered with the Victorian Nursing Council as general nurses, mental nurses or mental deficiency nurses—at the rate of 25 per centum of their hourly rate for each hour of duty;
 - (ii) all others—at the rate of 50 per centum of their hourly rate for each hour of duty.

Sunday.

- (c) When required to perform rostered time of ordinary duty—
 - (i) in the case of Student Nurses or officers who are required to be registered with the Victorian Nursing Council as general nurses, mental nurses or mental deficiency nurses—at the rate of 50 per centum of their hourly rate for each hour of duty;
 - (ii) all others—at the rate of 100 per centum of their hourly rate for each hour of duty.

Public Holiday.

- (d) When required to perform rostered time of ordinary duty—at the rate of 25 per centum of their hourly rate for each hour of duty; provided that an officer who is rostered to perform ordinary duty on a holiday observed in accordance with the provisions of the Public Service Act shall, in addition to the allowance prescribed in this paragraph, be granted an additional day off in lieu; provided further that an officer whose rostered day off duty falls on a Public Holiday shall be granted an additional day off in lieu.

- (2) For the purpose of this Regulation—
 - (a) "Standard salary" means salary excluding any additional amount payable under the provisions of Regulation 87.
 - (b) "Afternoon shift" means a period of duty commencing at or after 10 a.m. and before 8 p.m.
 - (c) "Night shift" means a period of duty commencing at or after 8 p.m. and before 6 a.m.
- (3) The hourly rate of allowance shall be determined in accordance with the following formula, but in no case shall the hourly rate exceed that calculated on an annual actual salary appropriate to the standard salary provided in the Third Schedule for the top subdivision of Class "C2", Administrative Division:—

$$\frac{\text{Actual fortnightly salary}}{\text{Fortnightly ordinary hours of duty}} \times \frac{\text{Annual salary (including any additional amount payable under the provisions of Regulation 87)}}{365\frac{1}{2}} = 1$$

- (5) For work performed additional to a rostered shift of ordinary duty payment shall be made of overtime rates as prescribed in Regulation 128: Provided that Student Nurses and officers who are required to be registered with the Victorian Nursing Council as general nurses, mental nurses or mental deficiency nurses, shall be paid at the rate of time and a half for all such work.

(6) For the purpose of computing allowances, a shift that finishes on the day after it commences shall be deemed to have been worked in its entirety on the day on which the majority of the shift occurs.

(7) In calculating overtime rates, any allowance prescribed by this Regulation shall be disregarded.

General—Cleaners.

136A. A Cleaner (Male or Female) who is employed during any week for 25 hours or less shall receive payment at the rate of ordinary time plus 15 per centum for all time worked. Further, if such work commences at or before 6.30 a.m. and/or continues beyond 5.00 p.m. Monday to Friday, an additional amount of 11 cents an hour shall be paid, for work performed between 5.00 p.m. and 9.00 a.m.

Department of Health—Mental Hygiene Branch.

136B. (1) Nurses in the Mental Hygiene Branch, Department of Health, who are required to be registered with the Victorian Nursing Council as mental nurses or mental deficiency nurses or student nurses in those branches of nursing, who are regularly required to perform rostered time of ordinary duty at night, and on Saturdays, Sundays and holidays observed in accordance with the provisions of the Public Service Act, shall be paid an allowance at the annual rate indicated herein for their classification—

	Male.	Female.
	\$	\$
Student Nurse—		
Junior	331	271
Adult—		
1st year	369	350
2nd year	381	362
3rd and subsequent years	390	371
Staff Nurse	453	431
Ward Nurse—		
1st year	462	439
2nd and subsequent years	478	454
Deputy Charge Nurse—		
1st and subsequent years	517	491
Charge Nurse—		
1st and subsequent years	549	522
Assistant Head Nurse—		
1st year	570	541
2nd year	586	556
3rd year	601	571
4th and subsequent years	605	575
Head Nurse—		
1st year	622	591
2nd and subsequent years	640	608
Principal Nurse—		
1st year	671	637
2nd year	689	655
3rd and subsequent years	698	663

(2) In calculating overtime rates, any allowance prescribed by this Regulation shall be disregarded.

136C. Ward Assistants, Training Assistants, and such other officers and employees as the Board may determine whose ordinary hours of duty are worked in accordance with a roster of 8 hour shifts shall be paid an allowance of 70 cents for each period of rostered duty which finishes between 6 p.m. and 8 a.m. or commences between 6 p.m. and 6.30 a.m.

Provided that, if such officers are required to permanently work any such rostered shift which finishes on the day after it commences or which commences between midnight and 5 a.m., the allowance shall be increased to \$1. "Permanently work" shall mean work for any period in excess of four weeks.

Provided further that this Regulation shall not apply to rostered time of ordinary duty performed during week-ends or on public holidays.

Public Works Department—Ports and Harbours Branch.

136D. Officers who occupy offices of Lighthouse Keeper, Senior Assistant and Lighthouse Keeper, Assistant, shall be paid an allowance at an annual rate (calculated to the nearest dollar) equal to 10 per centum of standard salary as varied in accordance with the provisions of Regulation 87, for the performance of rostered ordinary duty during week-ends or on public holidays."

Immediately before Regulation 137 the heading "Division V.—Other Allowances" is inserted.

Regulation 137.

The words "or the requirement to perform shift work" are deleted.

This Regulation shall have effect as on and from the 30th May, 1971.

A. J. A. GARDNER, Chairman.
R. H. DURRANT, Acting Secretary.

Office of the Public Service Board,
Melbourne, 28th May, 1971.

PRIVATE ADVERTISEMENTS

CITY OF BRIGHTON.

BY-LAW No. 200.

A By-law of the City of Brighton made under sections 197 and 800 of the Local Government Acts and every other power it thereunto enabling and numbered 200 for amending and altering By-law 128 of the City of Brighton (as amended by By-law 176) for preserving good order and decency and controlling and regulating the conduct of persons using or being upon or in those public reserves parks pleasure grounds or places of public resort or public recreation in the said City referred to in the said By-law 128 as amended.

IN pursuance of the powers conferred by the Local Government Acts and every other power in that behalf enabling it the Mayor Councillors and Citizens of the City of Brighton order as follows:—

1. This By-law shall apply to and have operation in those parts of the Municipal District of Brighton set out in Schedule "A" of the said By-law 128.

2. By-law 128 is hereby amended as follows:—

(a) by adding the following definition to the definition in Clause 2 thereof:—

"Liquor" means any wine spirits ale beer porter cider perry or other spirituous or fermented liquor of an intoxicating nature;

(b) by deleting clause 36 thereof and substituting in lieu thereof the following clause;

36. No person shall sell or offer for sale liquor on any of the Reserves and no person shall bring any liquor on to any of the Reserves or consume it thereon except with the consent of the Council. Such consent may be given at the Council's discretion but only in respect of consumption of liquor in any permanent building situate on any of the Reserves upon written application therefor by or on behalf of any person corporation club or association requesting permission to bring on and consume liquor on any specified occasion or during any specified period in any specified portion of the Reserves occupied by a building of a permanent character and such consent shall prescribe such conditions as the Council may see fit.

(c) by adding the number 7 before the number 11 in clause 46 thereof and by adding the number 35 before the number 38 in the said clause 46.

Resolution for making and passing this By-law was agreed to by the Council at its meeting on the Fifth day of April, 1970 and confirmed the Third day of May, 1971.

The common seal of the Mayor, Councillors and Citizens of the City of Brighton was hereto affixed, in the presence of—

(SEAL) GERARD GRANT, Mayor.
C. B. JEWELL, Councillor.
C. DE GARIS, Town Clerk.

Approved by the Governor in Council on the 25th day of May, 1971.—JOHN A. HORLOCK, Acting Clerk of the Executive Council. 594

CITY OF BRIGHTON.

Dog Act 1970.

Specification of Shopping Areas.—Section 16.

NOTICE is hereby given that the Council of the City of Brighton has ordered that the areas described hereunder shall be shopping areas within the City of Brighton for the purposes of the Dog Act 1970.

South Ward.

(a) The south side of South-road from Esplanade-avenue westerly to the railway line.

(b) Hampton-street on the east side from South Road to Ratho-avenue and on the west side from South-road to a point opposite the south boundary of Ratho-avenue.

(c) Nepean Highway south-west side from South-road to Barr-street.

(d) Were-street on the north side from Whyte-street to Hanby-street and on the south side for a distance of 110 feet east of Cavendish-place.

East Ward.

(a) Hampton-street on the east side from Pine-street to Marriage-road.

(b) Thomas-street on the west side for a distance of 130 feet south of Egan-street.

(c) Hawthorn-road on the west side for a distance of 344 feet north of Nepean Highway and between North-road and Northern-avenue.

(d) Hawthorn-road on the east side for a distance of 106 feet north of Clive-street and from North-road to a point opposite the northern boundary of Northern-avenue.

(e) Nepean Highway on the north-east side for a distance of 240 feet north-west of Hornby-street and on the south-west side for a distance of 166 feet north-west of Centre-road.

North Ward.

(a) New-street on the east side between Martin-street and a point opposite the southern boundary of Thule-court.

(b) Nepean Highway on the south-west side between Martin-street and the Elster Canal.

(c) Martin-street on the north side between Hamilton-street and Nepean Highway and on the south side between Asling-street and Nepean Highway.

(d) Bay-street on the north side between Cochrane-street and Warriston-street.

Central Ward.

(a) Bay-street on the south side between Cochrane-street and Male-street.

(b) Durrant-street on the north-east side for a distance of 96 feet north-west of Hampton-street.

(c) Hampton-street on the west side from Pine-street to a right-of-way approximately opposite Marriage-road.

(d) St. Kilda-street on the east side from Chelsea-street to Grosvenor-street.

(e) New-street on the east side for a distance of 200 feet south of Barkly-street and on the west side for a distance of 292 feet south of Bay-street.

(f) Church-street on the north-east side between St. Andrews-street and Male-street on the south-west side between St. Andrews-street and a point 133 feet south-east of Male-street.

(g) Carpenter-street on the north-west side for a distance of 133 feet north-east of Church-street.

Specification of Beaches and Recreational Open Space within 500 yards thereof.—Section 16.

Notice is hereby given that the Council of the City of Brighton has ordered that the beach areas on the Brighton Foreshore and Recreational open space within 500 yards thereof shall be areas for the purposes of section 16 of the Dog Act 1970 where dogs are not permitted during the period 1st November to 30th April in each year.

(i) The section of the Brighton Foreshore bounded on the north by Head-street and the south by Dawson-avenue.

(ii) The section of the Foreshore bounded on the north by a point opposite the western end of Seacombe-grove and on the south by a point opposite the west end of Were-street.

(iii) The section of the Foreshore bounded on the north by the south end of the Green Point Reserve and on the south by a point opposite the south end of New-street.

A. C. G. DE GARIS, Town Clerk.

Municipal Offices, Boxshall-street,
Brighton, 1st June, 1971.

724

CITY OF FRANKSTON.

LOAN No. 144.

Notice of Intention to Borrow the Sum of \$30,000.

NOTICE is hereby given that the Council of the City of Frankston intends to borrow the sum of Thirty thousand dollars (\$30,000), secured by a charge over the general rates of the municipality, by the grant of a mortgage in accordance with the provisions of the Local Government Act 1958.

In connexion therewith, the following information is stated:—

- (a) The amount of the principal moneys which it is proposed to borrow is Thirty thousand dollars.
- (b) The maximum rate of interest that may be paid is 7.4 per centum per annum.
- (c) The times which moneys borrowed are to be repayable are the 15th days of January and July during the years 1972 to 1986 inclusive, and the place such moneys shall be repayable is at the office of the Australia and New Zealand Savings Bank Limited, 394-396 Collins-street, Melbourne.
- (d) The purposes for which the loan is to be applied are:—
- | | |
|--|----------|
| (i) Jennings Outfall Drain No. 2 (completion) .. . | \$3,000 |
| (ii) Nepean Highway—Footpath—Reserve-road to Eel Race-road (completion) .. . | 2,000 |
| (iii) Lee-street—Hillcrest-road (completion of roadworks) .. . | 2,000 |
| (iv) Mount View-road—Kerb and channel .. . | 2,000 |
| (v) Humphries-road—Two Bays-road—Drainage .. . | 1,000 |
| (vi) Overport-road—Roadworks .. . | 1,000 |
| (vii) Surfacing of Balmoral-street and Balmoral Car Park (part) .. . | 7,000 |
| (viii) Toilet Block—Balmoral-park .. . | 7,000 |
| (ix) Construction of Mount Eliza Car Park (part) .. . | 5,000 |
| | <hr/> |
| | \$30,000 |
- (e) The manner in which the loan is to be liquidated is by provision out of the municipal fund of twenty-nine half-yearly instalments of \$1,672.27, including principal and interest, and a final payment of \$1,672.57.

The plans and specifications and estimates of the cost of the works and a statement showing the proposed expenditure of the moneys to be borrowed are open for inspection at the Civic Centre, Frankston.

Civic Centre, Frankston.

603 G. C. PENTLAND, Town Clerk.

Town and Country Planning Act 1961.
CITY OF GEELONG.—GEELONG PLANNING
SCHEME 1959.

NOTICE THAT A PLANNING SCHEME HAS BEEN PREPARED
AND IS AVAILABLE FOR INSPECTION.

Amendment No. 12.

NOTICE is hereby given that the City of Geelong in pursuance of its powers under the *Town and Country Planning Act 1961*, has prepared a Planning Scheme for:—

- (a) land fronting the Barwon River, between Swanston-street and Factories-road and being part of the original Crown grant to the Victorian Woollen and Cloth Company.
- (b) land fronting the Barwon River, between Currier-street and Leather-street being part of section 1, Parish of Corio, and

(c) land fronting the Barwon River, between Leather-street and the southern boundary of Crown allotment 4, section 10, Parish of Corio; for the purpose of rezoning the areas to "Public Open Space, Streamside Reserve".

A copy of the scheme has been deposited at the City Hall, Gheringhap-street, Geelong, and at the office of the Town and Country Planning Board, 235 Queen-street, Melbourne, and will be open for inspection during office hours by any person.

Any persons affected by the Planning Scheme are required to set forth, in writing, all objections they may have, addressed to the Town Clerk, City of Geelong, City Hall, Gheringhap-street, Geelong, on or before the 9th September, 1971, and to state whether they wish to be heard in respect of their objection.

Dated the 7th June, 1971.

604 L. L. WALTER, Town Clerk.

CITY OF HAMILTON.

APPOINTMENT OF PROSECUTING OFFICER.

NOTICE is hereby given that the Council of the City of Hamilton has appointed Sergeant Colin Edward Mooney, No. 10382, as Prosecuting Officer, in lieu of Sergeant Peter Gordon Philpot, No. 10252, transferred.

605

H. F. DONALD, Town Clerk.

CITY OF KNOX.

LOAN No. 69.

Confirmation of Special Order.

NOTICE is hereby given that the Council of the City of Knox, at a meeting held on the 1st day of June, 1971, did confirm the following Special Order:—

"That the Council of the City of Knox, in pursuance of powers conferred by the Local Government Acts, resolve to borrow the sum of \$400,000 secured on the general rates of the municipality, such sum to be raised by the grant of a mortgage, in accordance with the said Acts and states:—

- (a) The amount of principal moneys it is proposed to borrow is \$400,000.
- (b) The maximum rate of interest that may be paid is 7.3 per centum per annum.
- (c) The period of the loan will be ten years and the money borrowed is to be repayable in full at the expiration of the loan on 30th June, 1981.
- (d) The purpose for which the loan is to be applied is to liquidate the whole or part of the overdraft on Council's Private Streets Bank Account at A.N.Z. Banking Group Ltd., Boronia.
- (e) The loan is to be liquidated by the establishment of a sinking fund pursuant to section 428A (1) of the Local Government Act with an annual appropriation of \$31,801.83 payable from the municipal fund.
- (f) The place of repayment will be Bank of New South Wales Nominees Proprietary Limited, 66 Pitt-street, Sydney, N.S.W."

597

N. G. HAYNES, Town Clerk.

CITY OF KEILOR.

By-LAW No. 64.

A By-law of the City of Keilor made under Section 756 of the *Local Government Act 1958* and numbered 64 for:

- (a) Preserving public decency;
- (b) Regulating the conduct of persons using or being upon or in the City of Keilor Swimming Pool;
- (c) Controlling, managing and preserving the City of Keilor Swimming Pool;
- (d) Imposing, collecting and receiving charges or entrance fees from clubs, associations or persons using or entering the City of Keilor Swimming Pool.

IN pursuance of the powers conferred by the *Local Government Act 1958* and of any and every other power it thereunto enabling the Mayor, Councillors and Citizens of the City of Keilor orders as follows:—

1. In this By-law unless inconsistent with the subject matter:—

Definitions.

"Swimming Pool" means any pool or body of water provided on the swimming pool premises for the use of swimmers, including any wading or diving pool.

"Pool Premises" shall mean the paths, aprons, seats, dressing rooms, compartments, bathrooms, buildings, picnic area and other areas forming part of the City of Keilor Swimming Pool and associated with the pool.

"Council" will mean the Council of the City of Keilor.

"Manager" shall mean the person from time to time appointed by the Council to manage the pool and pool area.

"Attendant" means any employee of the Council performing any duties on or in connexion with the swimming pool premises.

"Carnival" shall mean any function held by or organized with the written consent of the Council.

"Vehicle" shall mean any car, bicycle, cart, trailer or other wheeled vehicles, but not including any conveyance for the infirm or for a child under the age of four years.

2. The swimming pool premises shall be open to the public during such periods and such hours as the Council shall, by Resolution determine. Periods of Opening.

3. The Council may at any time and from time to time close the pool premises or any part thereof for such period or periods as may be deemed necessary for the purpose of cleansing, repairing rebuilding and reconstructing the same or for any other like purpose. Power to Close.

4. The attendant in charge or other person duly authorized by the Council may charge every person entering the pool premises the proper fees as determined from time to time by Special Order of the Council. Charges to be made.

5. In the event of the Council holding or authorizing a swimming carnival or other entertainment in the pool premises, the Council shall have the power by resolution to prohibit bathing in the pools whilst any such carnival or entertainment is being held, and to fix the fees chargeable to any organization conducting such carnival or entertainment, and to fix the prices that shall be charged for admission thereto. Seasonal or concession tickets shall not admit any person to the pool premises during the time fixed as the time for such carnival or entertainment. Carnivals.

6. Applications shall be made to the Council six weeks in advance of the date for which the organizations desire to hire the pool and pool premises. Application to be made.

7. No person shall obstruct hinder or interfere with the Manager any attendant officer or servant employed by the Council in the performance of his duty at the pool and pool premises. Obstruction.

8. Any person finding any article which may have been left in the pool or pool premises shall at once deliver the same to the Manager who shall thereupon register a description of same in a book kept for that purpose, and any person claiming such article shall upon giving satisfactory proof of ownership receive such article from the Manager upon entering his or her signature and address in the book referred to. Lost property.

9. The Council will not be responsible for articles lost by or stolen from any person whilst in the pool or pool premises.

10. No person shall offer any goods for sale in the pool or pool premises without the consent in writing of the Council. Sale of goods.

11. The Council shall call tenders from time to time as it may decide for the running of the kiosk in the pool premises and may enter into such arrangements with any person for the supply and sale of confectionery soft drinks and other goods from such kiosk as may be necessary. Conduct of Kiosk.

12. No person shall teach or coach swimming diving or associated skills or conduct classes for gain or profit in the pool or pool premises without written license of the Council. Teaching or Coaching.

13. Persons desirous of obtaining a license to teach, coach or conduct classes in the pool or pool premises shall make written application to the Council setting out their qualifications and experience.

14. The Council may from time to time by Special Order of the Council determine the fees to be paid in respect of licenses to teach, coach or conduct classes in the pool or pool premises.

15. Nothing in the three preceding clauses shall prevent an accredited swimming teacher employed by the Education Department of Victoria or by a Registered School from teaching coaching or conducting classes in swimming diving or associated skills for school children in his or her charge during normal school hours.

16. Every person not being the holder of a seasonal or concession ticket shall before entering the pool premises pay to the person authorized for the purpose, the price fixed from time to time for admission thereto. Admission to be paid.

17. No seasonal or concession ticket shall be transferable and any holder of such ticket who allows any other person to use the same shall immediately forfeit such ticket and all moneys paid thereon and the rights and privileges given by such ticket. Seasonal or Concession tickets not transferable.

18. The attendant in charge of the pool premises may refuse admission thereto to any person. Admission.

No person shall enter the pool premises unless an attendant or authorized person is present.

19. An authorized attendant may require any person offending against any part of this By-law (but without prejudice to the imposition of any penalty in respect of such offence) to leave the pool premises and may eject such person therefrom if he or she fails to leave forthwith. Persons may be required to leave.

20. No person over the age of eight years shall use the wading pool unless with the approval of the attendant. Use of Wading Pool.

21. No boy or girl under the age of eight years who is unable to swim shall use the main pool without the permission of the attendant in charge unless accompanied by an adult or other person approved by the attendant in charge, and no adult non swimmer will enter the pool beyond his or her depth. Use of Main Pool.

22. No child under the age of six years shall be permitted to enter the pool premises unless in the opinion of the attendant in charge such child is in the care of a responsible person. Children under 6 years.

23. No person other than a child under the age of four years under the care of a responsible person shall enter or use any dressing room, shower or convenience passages leading thereto which have been appointed or appropriated to use of persons of the opposite sex. Use of dressing rooms.

24. Every person using any swimming pool, shall wear a suitable bathing costume and the Council or its authorized officer shall be the sole judge of the suitability of any costume. Costume.

- No undressing in open. 25. No person shall dress or undress or remove any part of his or her bathing costume in any part of the pool premises open to the public view on in or upon any part of the pool premises, except places specifically reserved for such purpose.
- No use of toys etc. 26. No person shall use any flippers, snorkels, masks or goggles, beach balls, motor tubes, inflated rubber or plastic articles or toys or kicking boards except by the permission of the attendant in charge. Toddlers may be permitted by the attendant in charge to take rubber toys into the wading pool. Water polo may only be practised or played at times and by teams approved by the Council. No other ball games of any kind shall be permitted in the pools or the pool premises.
- Cutaneous, infectious or contagious diseases. 27. No person shall use the pools whilst in an unclean condition or who is suffering from any cutaneous, infectious or contagious disease and any person shall retire from the pools on being requested to do so by the attendant in charge.
- Showering. 28. No person shall enter a pool before first washing himself or herself in the shower bath and every bather after using the latrine or water closets shall wash under the showers without costume before entering or re-entering the pool.
- Pollution of water. 29. No person shall improperly foul or pollute the water in the pool, or the shower baths, or wilfully and improperly soil or defile any dressing room, closet, box or compartment or any part of the pool or any furniture or article therein.
- Use of soap. 30. No person shall use soap in any portion of the pool other than in the showers provided for that purpose.
- Discolouration of water. 31. No person shall at any time while being in the pool use any substance or preparation whereby the water in such pool may be discoloured or rendered unfit for the use of the bathers.
- Interference of use by others. 32. No person shall interfere with the use and enjoyment of the pools by any other person and any person so acting or otherwise behaving in an unseemly or improper manner, shall immediately leave the pool when requested to do so by the attendant in charge. Only one person shall stand on or dive from any diving board at the one time, and no person other than the attendant in charge shall prevent any other person from using any diving board. No person shall use any diving board if the attendant in charge deems it dangerous for any such board to be used and so advises the person concerned either verbally or by a notice suitably displayed in the vicinity of such diving board or boards.
33. No person shall engage in boisterous or rough play or conduct within the pool premises.
34. No person shall spit, spout water, or blow his or her nose in any of the pools.
35. No person shall roll or throw stones or other articles into any of the pools.
- Misconduct litter. 36. No person shall loiter, misconduct himself or herself or commit a nuisance in the pool premises or bring any bottle, tin or rubbish, filth or other offensive matter into the said premises or deposit any rubbish therein or leave therein any tins, bottles, broken glass, orange or other peel, papers cast-off clothes or other litter, except in receptacles provided for such purpose.
37. No person shall dispose of any cigar cigarette pipe ash or match within the pool or pool premises except in the receptacles provided for the same.
- Placard or Notice Boards. 38. No person shall damage or remove any placard or notice board within the pool premises.
- Interference with equipment. 39. No person shall at any time carelessly or negligently damage or destroy or improperly interfere with the due and efficient action of any lock cock valve pipe work plant or machinery in connection with the pool or pool premises or carelessly or negligently damage or destroy any furniture, fittings or conveniences in any bathroom dressing room closet or compartment and shall not by cutting or writing thereon deface any wall fittings or any portion of the pool or pool premises.
- Offensive language or behaviour. 40. No person shall at any time while being in the pool or pool premises use any indecent insulting or offensive language or behave in any indecent insulting offensive or riotous manner.
- Dogs. 41. No person shall cause or allow any dog other than a dog trained for and engaged in the guidance of the blind, or other animal belonging to such person or under his or her control to enter or remain in the pool or pool premises, provided always that the Council may give written permission to the Manager to keep a dog or dogs in the pool premises for the purpose of guarding such premises at such time as the pool premises are closed to the public.
- Gambling. 42. No person shall bet play cards or any game of chance in the pool or pool premises, providing always that this shall not prevent the Council giving written permission to conduct a raffle or similar scheme in the event of an organization having obtained the necessary permit to do so from the Attorney-General.
- Intoxicated persons excluded. 43. No person shall enter or remain in any portion of the pool or pool premises whilst in a state of intoxication, and no person shall at any time introduce into the baths or consume or cause to be consumed any spirituous or intoxicating liquor in the pool or pool premises.
- No expectorating. 44. No person shall expectorate on the concourse of the pool or on any lawns or in the dressing rooms, compartments, passages or entrances thereto, or in the vicinity of the kiosk, on the walls or on any sealed surface within the pool premises.
- Hire of equipment. 45. Any person hiring any article from any attendant at the pool shall return the same to the attendant in charge prior to leaving the premises.
46. Every person shall before being furnished with any towel, bathing costume or locker pay to the authorized attendant, the price of payment for the use thereof and the deposit for same as fixed from time to time by the Council and after use shall return the same to the attendant who will return deposits lodged provided the said towel, bathing costume or locker has not been damaged in any way.
- Vehicles. 47. No person shall in the pool premises ride or drive or push any vehicle not being a vehicle delivering any goods or providing any services for or in connection with the running of the pool or pool premises or with the conveyance of the infirm or of a child under the age of four years.
- Climbing on fixtures. 48. No person unless authorized by the attendant in charge shall climb or attempt to climb over, into or upon or remain on or upon any fixture, fence, roof, building or structure.

49. No person shall use or interfere with any rope, raft, lifebuoy, or lifesaving appliance or apparatus in the premises except in the case of accident and danger occurring to a bather rendering their use necessary. Interference with equipment.

50. No unauthorized person shall enter the plant room, its enclosure or any storeroom within the pool premises. Unauthorized entry.

51. No person shall occupy the shower baths for an unreasonable time or enter any shower or water closet occupied by another person. Shower.

52. Any person guilty of an act or default contrary to this By-law shall be liable to a penalty not exceeding Fifty dollars (\$50) for every such offence. Penalty.

53. The Council will not be responsible for any physical injury suffered by any person or persons arising out of the use by them of the pool or pool premises. Operation.

54. This By-law shall come into effect immediately upon its publication in the *Government Gazette*.

55. This By-law shall apply to that part of the municipal district known as the City of Keilor Swimming Pool situate on land in Quinn Grove, Keilor East and more particularly described in Certificate of Title Volume 8338 Folio 718.

A Resolution for passing this By-law was agreed to by the Council of the City of Keilor on 19th November, 1968, and confirmed on the 4th February, 1969.

The common seal of the Mayor, Councillors and Citizens of the City of Keilor was hereunto affixed this 18th day of February, 1969 in the presence of—

615

(SEAL)

E. R. ALAN, Mayor.
G. B. F. BONNETT, Councillor.
R. F. B. KELLY, Town Clerk.

CITY OF KEILOR.

BY-LAW No. 65.

A By-law of the City of Keilor made under Section 197 of the *Local Government Act 1958* and numbered 65 for:—

- (a) Preventing and extinguishing fires;
- (b) Suppressing nuisances;
- (c) Preserving public decency;
- (d) Preserving good order and decency in any building belonging to the Municipality or under the control and management of the Council, preventing damage to such building or to furniture or fittings thereof or regulating any meeting or gathering held therein;
- (e) Generally maintaining the good rule and Government of the Municipality; and for other purposes.

IN pursuance of the powers conferred by the *Local Government Act 1958* and any and every other power it thereunto enabling the Mayor, Councillors and Citizens of the City of Keilor orders as follows:—

1. This By-law shall be known as the City of Keilor Good Order in Buildings By-law. Title.

2. By-law 15, By-law 52 and By-law 59 of the City of Keilor all relating to preserving good order and decency in buildings belonging to the Municipality or under the control or management of the Council are hereby repealed. Repeal of 15, 52 & 59.

3. In this By-law unless inconsistent with the subject matter:— Definitions.

- "Council" means the Council of the City of Keilor.
"Municipal District" means the Municipal District of the City of Keilor.
"Building" means any building belonging to the Municipality or under the control and management of the Council.
"Hallkeeper" means the person from time to time appointed by the Council to such position.
"Assistant Hallkeeper" means and includes any employee of the Council performing any duties on or in connection with buildings.
"Liquor" means liquor within the meaning of the *Liquor Control Act 1968*.
"Consent of the Council" means consent in writing given over the hand of the Town Clerk.

4. No person shall in any building behave in a riotous, indecent, offensive, threatening, insulting, violent, quarrelsome or disorderly manner or so as to occasion a breach of the peace. Behaviour.

5. No persons shall in any building use threatening, abusive, obscene, indecent or insulting words. Insulting Words etc.

6. No persons shall enter into or remain in any building while in a drunken or intoxicated condition. Drunken condition.

7. No person shall enter or remain in any building while in the possession of liquor without having first obtained the consent of the Council. Possession of Liquor.

8. No person shall sell or dispose of or permit to be sold or disposed of or consume or allow to be consumed liquor in any building without having first obtained the consent of the Council. Use of Liquor.

9. No person shall in any building obstruct hinder or interfere with the Hallkeeper or any Assistant Hallkeeper Attendant Officer or Servant employed by the Council in the performance of his duty. Obstruction.

10. Any person in or upon any building shall obey forthwith all lawful directions given by a Hallkeeper, Assistant Hallkeeper, Attendant Officer or Servant of the Council in the performance of his duty. Obedience to Directions.

11. A Hallkeeper or Assistant Hallkeeper may require any person offending against any part of this By-law (but without prejudice to the imposition of any penalty in respect of such offence) to leave any building and may eject such person therefrom if he or she fails to leave forthwith. Persons may be required to leave.

12. No person shall dispose of any cigar, cigarette, pipe ash or match within any building except in the receptacles provided for the same. Disposal of Ash.

Damage to Equipment.	13. No person shall at any time wilfully, carelessly or negligently damage or destroy or improperly interfere with the due and efficient action of any lock, cock pipe, work plant, electrical equipment or machinery in connection with any building or wilfully, carelessly or negligently damage or destroy or mark or deface any part of any building or any fitting or any furniture in any building.
Climbing on Fixtures.	14. No person unless authorized by the Hallkeeper or Assistant Hallkeeper in charge shall climb or attempt to climb over into or upon or remain on or upon any fixture, fence, roof, window sill, parapet, gutter, gable roof parapet or cornice of any building.
Standing on Furniture.	15. No person shall in any building stand on any chair, seat, table or other furniture.
Expectorating.	16. No person shall expectorate upon the floor, walls, furniture or fittings of any building.
Stair Hand-rail.	17. No person shall use any stair hand-rail otherwise than for support or assistance by hand in ascending or descending such stair.
Fire Appliances.	18. No person shall in any way interfere with or destroy or improperly use or damage any fire prevention appliance in any building.
Unauthorised Entry.	19. No unauthorised person shall enter any plant room, equipment room, switch room or store room within any building.
Showers and Water Closets.	20. No person shall occupy any shower, bath or water closet for an unreasonable time or enter any shower or water closet occupied by another person.
	21. This By-law shall apply to and have operation throughout the whole of the Municipal district.

The Resolution to make By-law 65 was agreed to by the Council of the City of Keilor on 2nd March, 1971. Confirmed on the 4th May, 1971.

The common seal of the Mayor, Councillors and Citizens of the City of Keilor was hereunto affixed this 1st day of June, 1971 in the presence of—

(SEAL)

F. L. DINEEN, Mayor.
C. HARVEY, Councillor.
R. F. B. KELLY, Town Clerk.

616

CITY OF MELBOURNE.

REGULATIONS TO AMEND THE REGULATIONS (No. 180) FOR THE CARE, PROTECTION, AND MANAGEMENT OF CARLTON, FITZROY, AND FLAGSTAFF GARDENS; ALEXANDRA, FAWKNER, FLEMINGTON AND KENSINGTON, FLINDERS, PRINCES, AND YARRA PARKS; POWLETT RESERVE; AND ARGYLE, CURTAIN, DARLING, LINCOLN, MACARTHUR, MURCHISON, AND UNIVERSITY SQUARES, AND NUMBERED 186.

IN pursuance of the powers conferred by section 219 of the *Land Act 1958*, the Minister of Lands and the Corporation of the City of Melbourne as Trustees of the above-named lands hereby make the following Regulations:

1. (1) These Regulations may be cited as the *City of Melbourne Parks and Gardens (General) (Amendment No. 1) Regulations 1971*.

(2) In these Regulations, the *City of Melbourne Parks and Gardens (General) Regulations 1959*, Regulations No. 180, as approved by the Governor in Council on 22nd September, 1959, are referred to as the Principal Regulations.

2. The Principal Regulations shall be amended as follows:

(a) In the preamble—

(i) for the words "Board of Land and Works" there shall be substituted the words "Minister of Lands"; and

(ii) for the words "Council of the City of Melbourne" there shall be substituted the words "Corporation of the City of Melbourne";

(b) Regulation 10 shall be repealed and the following Regulations shall be inserted in its place:

"10. No person shall throw stones or missiles, or light any fire in the Reserves.

10A. No person shall drop, leave, scatter or throw down in the Reserves any bottles, cast-off clothing, fruit peel, litter, paper or refuse of any kind."

(c) Regulation 25 shall be repealed and the following Regulations shall be inserted in its place:

"25. No person shall give out or distribute any advertisement, book, handbill, notice, pamphlet, paper, placard, program or other printed matter in the Reserves, without the permission, in writing, of the Committee first obtained.

25A. No person shall litter the Reserves by dropping, leaving, scattering or throwing down any advertisement, book, handbill, notice, pamphlet, paper, placard, program or other printed matter therein."

(d) in Regulations 26 and 27 for the expression "*Licensing Act 1958*" (wherever occurring) there shall be substituted the expression "*Liquor Control Act 1968*";

(e) in Regulation 33 for the expression "Cemetery-road" there shall be substituted the words "Princes Park Drive";

(f) Regulation 34 shall be repealed and the following Regulation shall be inserted in its place:

"34. On such occasions only as the areas known as Carlton Recreation Ground, Melbourne Cricket Ground, Olympic Park, and Richmond Cricket Ground are used for cricket or football matches or other functions, the Committee may set apart portions of Flinders, Princes and Yarra Parks for the parking of motor cars, motor cycles and other vehicles, and a charge not exceeding thirty cents (\$0.30) may be made and taken by the Committee or its authorized representatives for the parking of any motor car, motor cycle or other vehicle in the portions of those parks so set apart."

(g) Regulations 43 shall be repealed and the following Regulation shall be inserted in its place:

"43. The right of any persons to enter the areas known as Carlton Recreation Ground in Princes Park and Richmond Cricket Ground in Yarra Park shall be subject to the payment of a charge (not exceeding such sum as may from time to time be fixed in that behalf by the Minister of Lands) on any such days (being not more than 72 in any one year in each case) as those areas may be used for cricket or football matches or other functions."

(h) in Regulation 44—

(i) for the words "Three shillings" there shall be substituted the expression "thirty cents (\$0.30)"; and

(ii) for the word "their" there shall be substituted the word "its";

(i) in Regulation 50—

(i) after the word "Regulations" there shall be inserted the expression "(other than Regulations 10A and 25A)";

(ii) for the expression "Five pounds (£5)" there shall be substituted the expression "\$50"; and

(iii) for the expression "Ten pounds (£10)" there shall be substituted the expression "\$100";

(j) after Regulation 50 there shall be inserted the following Regulation:

"50A. Every person offending against either or both of Regulations 10A and 25A shall be liable to a penalty of not more than \$200."

(k) in the paragraph next but one succeeding Regulation 50A for the word "Council" there shall be substituted the word "Corporation";

- (l) in the First Schedule for the words "Olympic Baths" there shall be substituted the words "Beaurepaire Pool"; and
- (m) in the Eighth Schedule after the heading "Committee of Management" there shall be inserted the expression "(As affected by sub-section (2) of section 4 of the *Land (Committees of Management) Act 1967*").

Given under my hand at Melbourne on the 31st day of May, 1971.

W. A. BORTHWICK,
Minister of Lands.

The common seal of the Lord Mayor, Councillors and Citizens of the City of Melbourne was hereto affixed on the 15th day of March, 1971.

(SEAL) EDWARD W. BEST, Lord Mayor.
707 F. H. ROGAN, Town Clerk.

CITY OF RINGWOOD.

ORDER DECLARING PUBLIC HIGHWAY OVER LAND ACQUIRED BY THE COUNCIL.

PURSUANT to the provisions of section 522 of the Local Government Act, the Council of the City of Ringwood hereby declares that land specifically purchased for the purpose as follows:—

All that piece of land being part of Crown section 23, Parish of Warrandyte, County of Evelyn, being part of lot 1 and 2 as formerly contained in certificate of title, vol. 8343, folio 984 and land formerly contained in certificate of title, vol. 5954, folio 681, Wonga-road east side, commencing at the south-west corner of lot 2; thence northerly on a bearing of 0 deg. 33 min. for a distance of 525 ft. 2 in.; thence southerly on a bearing of 176 deg. 38 min. for a distance of 110 ft. 0 in.; thence southerly on a bearing of 177 deg. 19 min. for a distance of 151 ft. 0 in.; thence southerly on a bearing of 180 deg. 33 min. for a distance of 100 ft. 0 in.; thence southerly on a bearing of 183 deg. 59 min. for a distance of 100 ft. 0 in.; thence southerly on a bearing of 188 deg. 27 min. for a distance of 65 ft. 6 in.; thence westerly on a bearing of 271 deg. 14 min. for a distance of 1 ft. 0 in. back to the point of commencement.

All that piece of land being part of lot 2 and as formerly contained in certificate of title, vol. 8187, folio 752 and land as formerly contained in certificate of title, vol. 3742, folio 344, Wonga-road west side commencing at the south corner of lot 2; thence north-easterly on a bearing of 34 deg. 57 min. for a distance of 110 ft. 0 in.; thence north-easterly on a bearing of 31 deg. 14 min. for a distance of 99 ft. 10½ in.; thence north-easterly on a bearing of 23 deg. 47 min. for a distance of 100 ft. 0 in.; thence northerly on a bearing of 12 deg. 26 min. for a distance of 100 ft. 0 in.; thence northerly on a bearing of 5 deg. 36 min. for a distance of 100 ft. 0 in.; thence northerly on a bearing of 0 deg. 26 min. for a distance of 246 ft. 9½ in.; thence northerly on a bearing of 4 deg. 15 min. for a distance of 150 ft. 0 in.; thence southerly on a bearing of 180 deg. 26 min. for a distance of 607 ft. 2½ in.; thence south-westerly on a bearing of 217 deg. 33½ min. for a distance of 319 ft. 7½ in. back to the point of commencement,

a Public Highway.

The common seal of the Mayor, Councillors and Citizens of the City of Ringwood was hereunto affixed pursuant to a resolution of the council at a meeting held on the 31st day of May, 1971.

(SEAL) J. M. McRAE, Mayor.
649 G. R. G. SMART, Councillor.
J. N. WEBSTER, Town Clerk.

CITY OF TRARALGON.

LOAN No. 32.

Notice of Intention to Borrow the Sum of \$50,000 for Town Hall/Little Theatre Complex.

NOTICE is hereby given that the Council of the City of Traralgon proposes to borrow the principal sum of \$50,000 secured by a charge over the general rates of the municipality, such sum to be raised by the grant of a mortgage in accordance with the provisions of the *Local Government Act 1958*.

1. The maximum rate of interest that may be paid is 7.4 per centum per annum.

No. 56.—4892/71.—4

2. The purpose for which the loan is to be applied is Council properties Town Hall/Little Theatre Complex.

3. The period of the loan shall be fifteen years.

4. The moneys borrowed shall be repayable by 30 half-yearly instalments of approximately \$2,787.11 each, including principal and interest payable on the 15th day of January and the 15th day of July in each year by appropriation of such amounts out of the municipal fund. The first instalment shall be payable on the 15th day of January, 1972.

5. Such moneys shall be repayable at the Australia and New Zealand Savings Bank Ltd., Traralgon, or such other place or places as the bank may from time to time require.

The plans and specifications and the estimate of cost of the proposed works and a statement showing the proposed expenditure of the moneys borrowed are open for inspection at the office of the City of Traralgon, Kay-street, Traralgon, during office hours.

Dated 26th May, 1971.

618 K. J. SAUNDERS, Town Clerk.

CITY OF WARRNAMBOOL.

LOAN No. 94.

Notice of Intention to Borrow the Sum of \$75,000 for Permanent Works and Undertakings.

NOTICE is hereby given that the Council of the City of Warrnambool proposes to borrow the principal sum of Seventy-five thousand dollars (\$75,000), secured by a charge over the general rates of the municipality, such sum to be raised by the grant of a mortgage in accordance with the provisions of the *Local Government Act 1958*.

1. The maximum rate of interest that may be paid is 7.40 per centum per annum.

2. The purpose for which the loan is to be applied is:—

Completion of 2nd stage of Indoor Sports Stadium, Queens-road	\$75,000
---	----------

3. The period of the loan is 40 years.

4. The moneys borrowed shall be repayable by providing out of the municipal fund 80 half-yearly instalments of approximately \$2,935.46 each, including principal and interest on the 30th day of February and the 30th day of August during the currency of the loan. The first instalment shall be payable on the 30th day of February, 1972.

5. Such moneys shall be repayable to the Australian Mutual Provident Society, Melbourne.

The plans and specifications and the estimate of the cost of the proposed works are open for inspection at the office of the Council of the City of Warrnambool, Timor-street, Warrnambool.

648 K. L. ARNEL, Town Clerk.

TOWN OF STAWELL.

NOTICE OF INTENTION TO TAKE LAND COMPULSORILY.

NOTICE is given that it is the intention of the Council of the Town of Stawell, in exercise of the powers conferred on it by the *Local Government Act 1958*, to take compulsorily the following land:—

C.A. 4A, section 64, Parish of Stawell, County of Borung.

This land is required as a site for Low Rental Housing Units.

The Council has caused to be prepared maps and other papers showing the general description of the said land and exact sites and measurements thereof and stating the names of the owners or reputed owners, lessees or reputed lessees, mortgagees and occupiers of those lands as far as can be ascertained by Council.

The said maps and other papers have been approved by Council and are deposited for inspection by all persons interested at the offices of the Town of Stawell, Main-street, Stawell, and may be inspected during office hours.

All persons affected by the proposed work or undertaking are required to set forth, in writing, addressed to the said Council or Municipal Clerk within 40 clear days from the publication of this notice in the *Government Gazette*, all objections which they may have to the taking of this land.

Dated this 2nd day of June, 1971.

647 D. H. HUTTON, Town Clerk.

SHIRE OF ALBERTON.

LOAN No. 26.

Notice of Intention to Borrow the Sum of \$15,000 for Permanent Works and Undertakings.

NOTICE is hereby given that the Council of the Shire of Alberton proposes to borrow the principal sum of Fifteen thousand dollars, secured by a charge over the general rates of the municipality, such sum to be raised by a grant of a mortgage in accordance with the provisions of the *Local Government Act 1958*:

1. The maximum rate of interest that may be paid is 7.3 per centum per annum.

2. The purpose for which the loan is to be applied is part cost of improvements to Yarram Public Hall.

3. The period of the loan shall be ten years.

4. The moneys borrowed shall be repayable by providing out of the municipal fund twenty half-yearly instalments of approximately \$1,069.79 each including principal and interest on the 1st day of July and the 1st day of January during the currency of the loan. The first instalment shall be payable on the 1st day of January, 1972.

5. Such moneys shall be repayable to the Australia-New Zealand Savings Bank Limited, 394-396 Collins-street, Melbourne.

The plans and specifications and the estimate of the cost of the proposed works and a statement showing the proposed expenditure of the moneys to be borrowed are open for inspection at the office of the Council of the Shire of Alberton, Commercial-road, Yarram.

617 A. W. CURRY, Shire Secretary.

SHIRE OF BACCHUS MARSH.

LOAN No. 20.

Notice of Intention to Borrow.

NOTICE is hereby given that the Council of the Shire of Bacchus Marsh proposes to borrow the principal sum of \$40,500, secured by a charge over the general rates of the municipality, such sum to be raised by the grant of a mortgage in accordance with the provisions of the *Local Government Act 1958*.

1. The maximum rate of interest that may be paid is 7.15 per centum per annum.

2. The purpose for which the loan is to be applied is for construction of Underground Drainage Schemes at Maddingley and Darley (part cost).

3. The period of the loan is seven years.

4. The moneys borrowed shall be repayable by providing out of the municipal fund, half-yearly instalments of \$3,727.30 each including principal and interest on the 10th day of February and the 10th day of August during the currency of the loan. The first instalment shall be payable on the 10th February, 1972.

5. Such moneys shall be repayable at the Commercial Savings Bank of Australia Ltd., 335 Collins-street, Melbourne.

The plans and specifications and the estimate of cost of the proposed works and a statement showing the proposed expenditure of the moneys to be borrowed are open for inspection at the office of the Council of the Shire of Bacchus Marsh at Main-street, Bacchus Marsh.

Dated 1st June, 1971.

644 B. E. LEACH, Shire Secretary.

SHIRE OF BACCHUS MARSH.

LOAN No. 21.

Notice of Intention to Borrow.

NOTICE is hereby given that the Council of the Shire of Bacchus Marsh proposes to borrow the principal sum of \$13,500, secured by a charge over the general rates of the municipality, such sum to be raised by the grant of a mortgage in accordance with the provisions of the *Local Government Act 1958*.

1. The maximum rate of interest that may be paid is 7.40 per centum per annum.

2. The purpose for which the loan is to be applied is for construction of Underground Drainage Schemes at Maddingley and Darley (part cost).

3. The period of the loan is twenty years.

4. The moneys borrowed shall be repayable by providing out of the municipal fund, half-yearly instalments of \$651.92 each including principal and interest on the

10th day of February and the 10th day of August during the currency of the loan. The first instalment shall be payable on the 10th February, 1972.

5. Such moneys shall be repayable at the Commercial Savings Bank of Australia Ltd., 335 Collins-street, Melbourne.

The plans and specifications and the estimate of cost of the proposed works and a statement showing the proposed expenditure of the moneys to be borrowed are open for inspection at the office of the Council of the Shire of Bacchus Marsh at Main-street, Bacchus Marsh.

Dated 1st June, 1971.

645 B. E. LEACH, Shire Secretary.

SHIRE OF BULLA.

LOAN No. 32.

Notice of Intention to Borrow the Sum of \$40,000.

NOTICE is hereby given that the Council of the Shire of Bulla proposes to borrow the sum of \$40,000 on the credit of the municipal revenues of the President, Councillors and Ratepayers of the Shire, such sum to be raised by the granting of a mortgage in accordance with the provisions of the *Local Government Act 1958*.

1. The maximum rate of interest that may be paid is 7.4 per centum per annum.

2. The purpose for which the loan is to be applied is towards the purchase of land and residences, required as extensions to the civic centre area.

3. The period of the loan shall be 30 years.

4. The moneys borrowed shall be repayable by 60 equal half-yearly instalments of \$1,668.64, including interest, on the 9th February and 9th August during the currency of the loan. The first instalment shall be payable on the 9th February, 1972.

5. Plans and description of the areas are available for inspection at the municipal offices, Sunbury.

6. Such moneys shall be repayable at the office of the Australian Mutual Provident Society, 535 Bourke-street, Melbourne.

653 JOHN M. KELLY, Shire Secretary.

SHIRE OF MELTON PLANNING SCHEME 1965.

NOTICE THAT A PLANNING SCHEME HAS BEEN PREPARED AND IS AVAILABLE FOR INSPECTION.

Amendment No. 2, 1971.

NOTICE is hereby given that the Shire of Melton in pursuance of its powers under the *Town and Country Planning Act, 1961* has prepared an Amending Planning Scheme for the following purposes:

1. Western Highway Melton By-Pass Road and ancillary works reserved through the Parishes of Djerriwarrah and Kororoit.

2. Re-zoning of lot 6 on L.P.83291, Parish of Djerriwarrah, from Rural to Light Industrial.

3. Miscellaneous alterations to maps and Ordinance to up-date the Shire of Melton Planning Scheme 1965.

A copy of the scheme has been deposited at the Shire Offices, Melton, and at the Office of the Town and Country Planning Board, 235 Queen-street, Melbourne, and will be open for inspection during office hours by any person free of charge.

Any persons affected by the planning scheme are required to set forth, in writing, all objections they may have addressed to the Shire Secretary, Shire of Melton, Shire Offices, Melton, on or before the 8th day of September, 1971, and to state whether they wish to be heard in respect of their objections.

Dated 8th June, 1971.

731 D. J. R. DUNTON, Shire Secretary.

SHIRE OF PHILLIP ISLAND.

LOAN No. 54.

Notice of Intention to Borrow.

NOTICE is hereby given that the Council of the Shire of Phillip Island proposes to borrow the principal sum of \$10,000 secured by a charge over the general rate of the municipality. Such sum is to be raised by the grant of a mortgage, in accordance with the provisions of the *Local Government Act 1958*.

1. A maximum rate of interest that may be paid is 7.3 per cent. per annum.

2. The purpose for which the loan is to be applied is for the construction of a residence at the Cowes Municipal Camp.

3. The period of the loan shall be ten years.

4. The moneys borrowed shall be repayable by providing out of the municipal fund twenty half-yearly instalments of \$713.19 each, including principal and interest, on the 1st day of February and the 1st day of August during the currency of the loan. The first instalment shall be payable on the 1st day of February, 1972.

5. Such moneys shall be repayable to the National Bank Savings Bank Limited, 271-285 Collins-street, Melbourne.

The plans and specifications and the estimate of the cost of the proposed works, and a statement showing the proposed expenditure of moneys to be borrowed, are open for inspection at the office of the Shire of Phillip Island.

654

STAN A. HARRIS, Municipal Clerk.

SHIRE OF PHILLIP ISLAND.

LOAN No. 55.

Notice of Intention to Borrow.

NOTICE is hereby given that the Council of the Shire of Phillip Island proposes to borrow the principal sum of \$26,000 secured by a charge over the general rate of the municipality. Such sum is to be raised by the grant of a mortgage, in accordance with the provisions of the *Local Government Act 1958*.

1. A maximum rate of interest that may be paid is 7.3 per cent. per annum.

2. The purpose for which the loan is to be applied is for the construction of streets, footpath, and kerb and channel in the township of Cowes and Newhaven.

3. The period of the loan shall be ten years.

4. The moneys borrowed shall be repayable by providing out of the municipal fund twenty half-yearly instalments of \$1,854.31 each, including principal and interest, on the 1st day of February and the 1st day of August during the currency of the loan. The first instalment shall be payable on the 1st day of February, 1972.

5. Such moneys shall be repayable to the National Bank Savings Bank Limited, 271-285 Collins-street, Melbourne.

The plans and specifications and the estimate of the cost of the proposed works, and a statement showing the proposed expenditure of moneys to be borrowed, are open for inspection at the office of the Shire of Phillip Island.

655

STAN A. HARRIS, Municipal Clerk.

SHIRE OF WARRAGUL.

LOAN No. 66.

Notice of Intention to Borrow.

NOTICE is hereby given that the Council of the Shire of Warragul intends to borrow Eight thousand five hundred dollars (\$8,500) secured by a charge over the general rates of the municipality by the grant of a mortgage in accordance with the provisions of the *Local Government Acts*.

In connexion therewith the following information is stated:—

(a) The amount of the principal moneys which it is proposed to borrow is \$8,500.

(b) The maximum rate of interest that may be paid is 7.3 per centum per annum.

(c) The times which the moneys borrowed are to be repayable are the 15th day of January, 1972, and the 15th day of July, and during the years 1972-1981 inclusive and that the place such moneys shall be repayable is at the Bank of New South Wales.

(d) The purpose for which the loan is to be applied is:

Capital works supplying electrical power to Industrial Land in Endeavour-street, Warragul.

(e) The manner in which the loan is to be liquidated is by provision out of the municipal fund in each half-year during the currency of the loan of the sum of \$606.21 which includes principal and interest.

The plans and specifications and estimate of the cost of the works and a statement showing the proposed expenditure of the moneys to be borrowed are open for inspection at the Shire Office.

Dated this 4th day of June, 1971.

664

D. McADIE, Shire Secretary.

SHIRE OF WIMMERA.

ABOLITION OF HORSHAM POUND.

NOTICE is hereby given that the Council of the Shire of Wimmera, at a meeting held on the 4th June, 1971, passed the following resolution:—

"That, in pursuance of the powers conferred under section 4 of the *Pounds Act 1958*, the Horsham pound, situated on an area of land containing approximately 2 acres and being part of Crown allotment 5F, Parish of Horsham, owned by the Council of the Shire of Wimmera under certificate of title, volume 8373, folio 586, with a frontage to the boundary road, be abolished, and that the appointment of such place as a pound be and is hereby revoked."

Dated this 4th day of June, 1971.

708

R. G. WALDON, Acting Shire Secretary.

SHIRE OF YEA.

LOAN No. 44.

Notice of Intention to Borrow the Sum of \$5,000 for Permanent Works and Undertakings.

NOTICE is hereby given that the Council of the Shire of Yea proposes to borrow the principal sum of Five thousand dollars on the credit of the municipal revenues of the President, Councillors and Ratepayers of the said Shire, such sum to be raised by the grant of a mortgage in accordance with the provisions of the *Local Government Act 1958*, as amended.

1. The maximum rate of interest that may be paid is 7.10 per cent. per annum.

2. Such moneys shall be repayable to the Commercial Savings Bank of Australia at the office of the said Bank, 337 Collins-street, Melbourne, by half-yearly instalments due on 10th March and 10th September, during the currency of the loan.

3. The purposes for which the loan is to be applied is:—
Purchase of road-making plant and machinery—\$5,000.

4. The moneys borrowed shall be repayable by providing out of the municipal fund eight half-yearly instalments of approximately \$728.90 each, including principal and interest and the first instalment shall be payable on the 10th day of March, 1972.

The plans and specifications and the estimate of the cost of the proposed works and a statement showing the proposed expenditure of the moneys to be borrowed are open for inspection at the office of the Council of the Shire of Yea.

Dated 1st June, 1971.

630

F. F. BERKERY, Shire Secretary.

SHIRE OF YEA.

LOAN No. 45.

Notice of Intention to Borrow the Sum of \$2,000 for Permanent Works and Undertakings.

NOTICE is hereby given that the Council of the Shire of Yea proposes to borrow the principal sum of Two thousand dollars on the credit of the municipal revenues of the President, Councillors and Ratepayers of the said Shire, such sum to be raised by the grant of a mortgage in accordance with the provisions of the *Local Government Act 1958*, as amended.

1. The maximum rate of interest that may be paid is 7.10 per cent. per annum.

2. Such moneys shall be repayable to the Commercial Savings Bank of Australia at the office of the said Bank, 337 Collins-street, Melbourne, by half-yearly instalments due on 10th March and 10th September during the currency of the loan.

3. The purposes for which the loan is to be applied is:—
Preparation of the Shire of Yea Planning Scheme—\$2,000.

4. The moneys borrowed shall be repayable by providing out of the municipal fund ten half-yearly instalments of approximately \$241.09 each, including principal and interest and the first instalment shall be payable on the 10th day of March, 1972.

The plans and specifications and the estimate of the cost of the proposed works and a statement showing the proposed expenditure of the moneys to be borrowed are open for inspection at the office of the Council of the Shire of Yea.

Dated 1st June, 1971.

631

F. F. BERKERY, Shire Secretary.

WARRNAMBOOL GOLF CLUB.

NOTICE is hereby given that the Warrnambool Golf Club has applied for a lease under section 134, *Land Act* 1958, for a term of 21 years in respect of allotment 9, section 74, Township of Warrnambool, containing 126 acres approx., as a site for amusement and recreation (Golf Club).

J. S. TAIT & CO., solicitors, Warrnambool. 316

NOTICE is hereby given that Leo Fink, Jack Fink, Sydney Fink and Wolf Fink have applied for a replacement lease pursuant to sections 134 and 135 of the *Land Act* 1958, for a term of 75 years in respect of allotments 1 and 2, section D, City of South Melbourne, containing 1 acre 0 roods 6 perches as a site for offices, showrooms, warehousing and merchandising. 386

NOTICE is hereby given that Dargo Ski Lodge has applied for a lease under section 134 of the *Land Act* 1958, for a term of 21 years in respect of allotment 14, section 1, Parish of Yertoo, as a site for a Ski Club Lodge. 577

NOTICE is hereby given that Hangman's Drop Ski Club has applied for a lease under section 134 of the *Land Act* 1958 for a term of 21 years in respect of allotment 8, section A, Parish of Hotham, as a site for a Ski Club Lodge.—(H.034099.) 600

NOTICE is hereby given that the Apollo Bay Fishermen's Co-operative Society Limited, of Breakwater-road, Apollo Bay, has applied for a lease under section 134 of the *Land Act* 1958, for a term of twenty years over allotment 11, section 2, Township of Apollo Bay, as a site for a fish freezing works and the disposal to members of fishing requisites. 593

NOTICE is hereby given that Ormond Ski Club has applied for a lease under section 134, *Land Act* 1958 for a term of 21 years in respect of allotment 15, section B, Parish of Hotham, as a site for a Ski Club Lodge.—(H.033793.) 700

NOTICE is hereby given that The Edelweiss Ski Club of Australia has applied for a lease under section 134 of the *Land Act* 1958 for a term of 21 years in respect of allotment 1, section A, Parish of Hotham, as a site for a Ski Club Cabin. 733

NOTICE OF INTENTION TO APPLY FOR A LICENCE TO DIVERT WATER AND CUT RACE FROM THE RIVER MURRAY, AT BOUNDARY BEND.

WE hereby give notice that we intend to apply for a licence empowering us to divert water for a term of fifteen years to the extent of 600 acre-feet per annum at a maximum rate of 24 acre-feet per day of 24 hours for the irrigation of 100 acres of almond trees and 200 acres of improved pasture, being part of allotments 1, 1A and 1C, Parish of Yungera, County of Tatchera, and to occupy certain Crown lands for works of diversion, and to cut a race thereon.

Any objection to such application must be forwarded, in writing, to reach the State Rivers and Water Supply Commission, Melbourne, before 9th July, 1971, being 30 days from the first publication of this notice.

HORTICO LTD.

327 Plummer-street, Port Melbourne, 3207. 628

NOTICE OF INTENTION TO APPLY FOR A LICENCE TO DIVERT WATER AND CUT RACE (RE-ISSUE) FROM THE RIVER MURRAY, AT TOL TOL, VIA ROBINVALE.

I HEREBY give notice that I intend to apply for a licence empowering me to divert water for a term of fifteen years to the extent of 75 acre-feet per annum at a maximum rate of 2 acre-feet per day of 24 hours for the horticulture of vines, citrus and stone fruit, being part of allotment 7, section lot 2, lodged plan 24785, Parish of Tol Tol, and to occupy certain Crown lands for works of diversion and to cut a race thereon.

Any objection to such application must be forwarded, in writing, to reach the State Rivers and Water Supply Commission, Melbourne, before 9th July, 1971, being 30 days from the first publication of this notice.

ERIC EDWARD RUDDICK.

Box 374, Robinvale. 629

NOTICE OF INTENTION TO APPLY FOR A LICENCE TO DIVERT WATER AND CUT RACE (RE-ISSUE) FROM THE LODDON RIVER, AT BARINGHUP.

I HEREBY give notice that I intend to apply for a licence empowering me to divert water for a term of fifteen years to the extent of 40 acre-feet per annum at a maximum rate of 3 acre-feet per day of 24 hours for the irrigation of 20 acres, being part of allotments 1 and 2, section 11, and part of allotments 2, 3, 5, 6, 8-13 inclusive, section 1, Parish of Baringhup, and to occupy certain Crown lands for works of diversion, and to cut a race thereon.

Any objection to such application must be forwarded, in writing, to reach the State Rivers and Water Supply Commission, Melbourne, before 9th July, 1971, being 30 days from the first publication of this notice.

EDWARD MARTIN BAKER.

Baringhup. 633

NOTICE OF INTENTION TO APPLY FOR A LICENCE TO DIVERT WATER AND CUT RACE (RE-ISSUE) FROM THE LODDON RIVER, AT BARINGHUP.

I HEREBY give notice that I intend to apply for a licence empowering me to divert water for a term of fifteen years to the extent of 20 acre-feet per annum at a maximum rate of 1 acre-foot per day of 24 hours for the irrigation of 10 acres, being part of allotment 7, section 1, Parish of Baringhup, and to occupy certain Crown lands for works of diversion and to cut a race thereon.

Any objection to such application must be forwarded, in writing, to reach the State Rivers and Water Supply Commission, Melbourne, before 9th July, 1971, being 30 days from the first publication of this notice.

PETER MARTIN BAKER.

Baringhup. 634

NOTICE OF INTENTION TO APPLY FOR A LICENCE TO DIVERT WATER AND CUT RACE (RE-ISSUE) FROM THE McCALLUM'S CREEK, AT CARISBROOK.

I HEREBY give notice that I intend to apply for a licence empowering me to divert water for a term of fifteen years to the extent of 20 acre-feet per annum at a maximum rate of 2 acre-feet per day of 24 hours for the irrigation of 10 acres, being part of allotment 16, section 1, Parish of Cairnsbrook, and to occupy certain Crown lands for works of diversion, and to cut a race thereon.

Any objection to such application must be forwarded, in writing, to reach the State Rivers and Water Supply Commission, Melbourne, before 9th July, 1971, being 30 days from the first publication of this notice.

A. F. DOWIE ESTATE.

Junction Lodge, Carisbrook. 612

NOTICE OF INTENTION TO APPLY FOR A LICENCE TO DIVERT WATER AND CUT RACE (RE-ISSUE) FROM THE LODDON RIVER AT EDDINGTON.

WE hereby give notice that we intend to apply for a licence empowering us to divert water for a term of fifteen years to the extent of 40 acre-feet per annum at a maximum rate of 2 acre-feet per day of 24 hours for the irrigation of 20 acres, being part of allotments 1 and 8, sections 1 and 8, Parish of Neereman, and to occupy certain Crown lands for works of diversion, and to cut a race thereon.

Any objection to such application must be forwarded in writing to reach the State Rivers and Water Supply Commission, Melbourne, before 8th July, 1971, being 30 days from the first publication of this notice.

RONALD N. McLEISH.

ANDREW N. McLEISH.

KEITH A. McLEISH.

Eddington, Victoria. 744

NOTICE OF INTENTION TO APPLY FOR A LICENCE TO DIVERT WATER AND CUT RACE (RE-ISSUE) FROM THE RIVER MURRAY, AT MILDURA.

I HEREBY give notice that I intend to apply for a licence empowering me to divert water for a term of fifteen years to the extent of 7½ acre-feet per annum at a maximum rate of ½ acre-foot per day of 24 hours for the irrigation of 2½ acres of market garden, being allotment 6, section 1, block F, Parish of Mildura, and to occupy certain Crown lands for works of diversion, and to cut a race thereon.

Any objection to such application must be forwarded, in writing, to reach the State Rivers and Water Supply Commission, Melbourne, before 9th June, 1971, being 30 days from the first publication of this notice.

FRANK MAMMONE.

P.O. Box 864, Mildura, 3500. 706

SPRINGVALE AND NOBLE PARK SEWERAGE
AUTHORITY.

GENERAL NOTICE.

THE above-mentioned Sewerage Authority having made provision for carrying off the sewage from each and every property which, or any part of which, is within the Sewerage Areas hereinafter described, doth hereby declare that on and after the 1st day of June, 1971, each and every property which, or any part of which, is within the said Sewerage Areas shall be deemed to be a sewered property within the meaning of the Sewerage Districts Act.

The boundaries of the Sewerage Areas hereinbefore referred to are:—

Sewerage Area No. 334—Noble Park.

All those pieces of land being lots 678, 679 and 680 on lodged plan of subdivision No. 80822, such lots having frontages to the eastern side of Bundeena-avenue.

Sewerage Area No. 335—Noble Park.

All those pieces of land being lots 888 and 889 Kingsclere-avenue on lodged plan of subdivision No. 88740 and lots 645 to 649 Chesney-street on lodged plan of subdivision No. 80822.

Sewerage Area No. 336—Noble Park.

All those pieces of land being lots 83 to 86 inclusive, 91 to 100 inclusive and 124 to 135 inclusive on lodged plan of subdivision No. 73482; lots 137 to 140 inclusive on lodged plan of subdivision No. 76034, lots 45 to 54 inclusive and 62 to 81 inclusive on lodged plan of subdivision No. 71797, lots 96 to 106 inclusive and 110 to 122 inclusive on lodged plan of subdivision No. 82479, lots 123 to 134 inclusive, 139 to 144 inclusive, lots 162 to 175 inclusive on lodged plan of subdivision No. 85774, lots 6 to 11 inclusive on lodged plan of subdivision No. 80127.

Streets or parts thereof concerned in this area are Bloomfield-road, Clarence-avenue, Kinnoul-avenue, Devonshire-drive, Elmbank-drive, Nerida-court, Hedgeley-road, Teal-court, Cheviot-road and Cornwall-avenue.

Sewerage Area No. 337—Noble Park.

All those pieces of land being lots 145 to 156 inclusive on lodged plan of subdivision No. 85774, lots 45 to 50 inclusive on lodged plan of subdivision No. 65304, lots 12 to 45 inclusive on lodged plan of subdivision No. 80127, lots 244 to 257 inclusive on lodged plan of subdivision No. 82452, lots 29, 30 and 31 on lodged plan of subdivision No. 80466, lots 41 to 49 inclusive on lodged plan of subdivision No. 80455, lots 16 to 40 inclusive and 50 to 52 inclusive on lodged plan of subdivision No. 80456, lots 789 to 802 inclusive on lodged plan of subdivision No. 84682, lots 53 to 57 inclusive on lodged plan of subdivision No. 81395, lots 1, 2 and 3 on lodged plan of subdivision No. 86155, lots 5, 6 and 7 on lodged plan of subdivision No. 88772, lot 9 on lodged plan of subdivision No. 90777 and lots 10 to 13 inclusive on plan of subdivision No. 2594 lodged at the office of the City of Springvale.

Streets or parts thereof concerned in this area are Desla-court, Bloomfield-road, Isaac-road, Agana-avenue, Armadale-avenue, Bristol-court, Sussex-street, Wahroongah-avenue, Woronora-court, Toongabbie-court, Bundeena-avenue, Graham-court, Dorset-court, Vanessa-avenue and Clarence-avenue.

Sewerage Area No. 338—Noble Park.

All those pieces of land being lots 725, 726, 727 and 728 Wannon-court, lot 729 Bundeena-avenue and lots 667, 730, 731 and 732 Cobain-street on lodged plan of subdivision No. 80822.

Unless otherwise specified, the lodged plans of subdivision hereinbefore referred to shall be taken as those lodged at the Office of Titles, Melbourne.

By order of the Springvale and Noble Park Sewerage Authority,

601 R. O. LUXFORD, Chairman.
H. L. WILLIAMS, Secretary.

Town and Country Planning Act 1961.—Twelfth Schedule.
COBRAM PLANNING SCHEME 1949.

NOTICE THAT A PLANNING SCHEME HAS BEEN PREPARED AND IS AVAILABLE FOR INSPECTION.

Amendment No. 11, 1971.

NOTICE is hereby given, that the Cobram Shire Council, in pursuance of its powers under the *Town and Country Planning Act 1961*, has prepared a planning scheme, for the township of Cobram, for the purpose of amending the Cobram Planning Scheme 1949.

A copy of the scheme has been deposited at the office of the Cobram Shire Council, Station-street, Cobram, and at the Office of the Town and Country Planning Board, 235 Queen-street, Melbourne, and will be open for inspection during office hours by any person, free of charge.

Any persons affected by the planning scheme, are required to set forth in writing, all objections they may have, addressed to the Shire Secretary, Shire Office, Cobram, on or before the 9th July, 1971, and to state whether they wish to be heard in respect of their objections.

Dated 9th June, 1971.
668 RONALD T. CUTTS, Shire Secretary.

Town and Country Planning Act 1961.—Twelfth Schedule.
COBRAM PLANNING SCHEME 1949.

NOTICE THAT A PLANNING SCHEME HAS BEEN PREPARED AND IS AVAILABLE FOR INSPECTION.

Amendment No. 12, 1971.

NOTICE is hereby given, that the Cobram Shire Council, in pursuance of its powers under the *Town and Country Planning Act 1961*, has prepared a planning scheme, for the township of Cobram, for the purpose of amending the Cobram Planning Scheme 1949.

A copy of the scheme has been deposited at the office of the Cobram Shire Council, Station-street, Cobram, and at the Office of the Town and Country Planning Board, 235 Queen-street, Melbourne, and will be open for inspection during office hours by any person, free of charge.

Any persons affected by the planning scheme, are required to set forth in writing, all objections they may have, addressed to the Shire Secretary, Shire Office, Cobram, on or before the 10th September, 1971, and to state whether they wish to be heard in respect of their objections.

Dated 9th June, 1971.
669 RONALD T. CUTTS, Shire Secretary.

NOTICE is hereby given that the partnership heretofore subsisting by a deed dated the 16th day of September, 1967, between Dennis Moss de Jongh, and Shirley Jeanie de Jongh, both of 495 Waverley-road, Chadstone, has been dissolved, as from the 20th day of May, 1971.

NORRIS, NORRIS & BARRY JONES, solicitors,
407 Waverley-road, East Malvern, Vic. 3145. 598

NOTICE is hereby given that the partnership Springvale Tutoring Service has been dissolved, as from the 9th day of June, 1971.

627 HOWARD B. FRASER.

NOTICE OF DISSOLUTION OF PARTNERSHIP.

FRANKLIN THOMAS BURWASH hereby publicly notifies the dissolution of the partnership consisting of himself and Irme Mikocz as from and including the 26th day of April, 1971. 737

NOTICE is hereby given that the partnership formerly carried on by Emmanuel Lettas, of 32 Closeburn-avenue, Windsor, and Jennifer Ruth Zikos, of 252 Station-street, North Carlton, at 183 Lonsdale-street, Melbourne, under the name of "Continental Jewel Box" has been dissolved as at the 14th March, 1971. The business will hereafter be carried on by the said Jennifer Ruth Zikos to whom all accounts and payments should be forwarded.

Dated the 1st day of March, 1971.
677 EMMANUEL LETTAS.
JENNIFER RUTH ZIKOS.

NOTICE is hereby given that George Henry Richard Garton, of 44 Hoskin-street, Springvale, has never been a partner in the firm of Sandown Machinery, formerly of Princes Highway, Springvale, but now of Cheltenham-road, Dandenong, which firm has always been under the sole proprietorship of Ernest Johnson, and further that George Henry Richard Garton has never at any time been authorized to incur debts or pledge the credit of the said firm or the said Ernest Johnson who hereby disclaims any responsibility or liability for any such debts or credit so pledged.

ERNEST JOHNSON, as sole proprietor of Sandown Machinery. 698

Unclaimed Moneys Act 1962.

REGISTER of Unclaimed Moneys held by the—

Name of Owner on Books and Last Known Address.	Total Amount Due to Owner.	Description of Unclaimed Moneys.	Date when Amount first became Payable.
ARDLETHAN TIN N.L.			
Coleman, Raymond, 1321 Malvern-road, Malvern	16.25	Dividend No. 1	30.6.67
Griffin, Terrence, 4 Kingsley-court, Toorak	10.00	" " " " " " " "	" " " " " " " "
Mitchell, William, 42 Fitzroy-street, St. Kilda	16.25	" " " " " " " "	" " " " " " " "
Tehan, Patrick, O.C.S. Portsea	22.50	" " " " " " " "	" " " " " " " "
Vogel, James E. F., 5 Bengal-street, Kahandallah, Wellington, New Zealand	13.81	" " " " " " " "	" " " " " " " "
Caldwell, Robert A., 31 Little Johns-road, Glebe, New South Wales	12.50	Dividend No. 2	15.12.67
Coleman, Raymond, 1321 Malvern-road, Malvern	16.25	" " " " " " " "	" " " " " " " "
Tehan, Patrick, O.C.S., Portsea	22.50	" " " " " " " "	" " " " " " " "
Hanlon, Tommy, Pty. Ltd., 176 Walsh-street, South Yarra	12.50	" " " " " " " "	" " " " " " " "
Vogel, James, E. F., 5 Bengal-street, Thandallah, Wellington, New Zealand	13.81	" " " " " " " "	" " " " " " " "
Anast, James, c/o W. Pynt Esq., 6 Claddon-close, Hunters Hill, New South Wales	125.00	Dividend No. 3	28.6.68
Coleman, Raymond, 1321 Malvern-road, Malvern	16.25	" " " " " " " "	" " " " " " " "
Cooper, Arthur, Flat 8, 616 Centre-road, Bentleigh	17.50	" " " " " " " "	" " " " " " " "
King-Scott, Judith I., 104 Finch-street, East Malvern	10.00	" " " " " " " "	" " " " " " " "
Pynt, Warren P., 8 Rose-crescent, North Parramatta, New South Wales	12.50	" " " " " " " "	" " " " " " " "
Seehoo, Jack, 541 Harris-street, Ultimo, Sydney, New South Wales	13.00	" " " " " " " "	" " " " " " " "
Tehan, Patrick, O.C.S., Portsea	22.50	" " " " " " " "	" " " " " " " "
Tolhurst, Susan, 48 Wallace-avenue, Murrumbena	16.25	" " " " " " " "	" " " " " " " "
Vogel, James E. F., 5 Bengal-street, Kahandallah, Wellington, New Zealand	13.81	" " " " " " " "	" " " " " " " "
Wood, Enid A., 8 Etham-avenue, Darling Point, New South Wales	25.00	" " " " " " " "	" " " " " " " "
466			
CLEVELAND TIN N.L.			
Booth, David A. C., Pipers, The Street, Betchworth, Surrey, U.K.	18.00	Net Proceeds of Forfeited Shares	8.2.67
Farfor, James D., 28 Cole-street, Elwood	28.80	" " " " " " " "	" " " " " " " "
Hoare, William H., 35 Fairmont-street, Camberwell	21.58	" " " " " " " "	" " " " " " " "
Close, Frank A., 5 Wybalena-road, Hunters Hill, N.S.W.	68.00	" " " " " " " "	12.7.67
467			
AMAD N.L.			
Anderson, Peter C., 33 Edward-street, Norwood, S.A.	15.00	Net Proceeds of Forfeited Shares	9.3.66
Angwin, Archie E., 32 Lyndon Court, Hay-street, Perth, W.A.	15.00	" " " " " " " "	" " " " " " " "
Barclay, Ainslie, 16 Waratah House, Bayswater-road, Kings Cross, N.S.W.	30.00	" " " " " " " "	" " " " " " " "
Barnes, Frederick J., 14 McDonald-street, South Perth, W.A.	15.00	" " " " " " " "	" " " " " " " "
Bartlett, Adelaide M., 35 Grenfell-street, Adelaide, S.A.	15.00	" " " " " " " "	" " " " " " " "
Berkovitch, Samuel, 129 Brighton-road, Elwood	75.00	" " " " " " " "	" " " " " " " "
Black, Lena M. Mcl., 2 Barnfield-road, Claremont, W.A.	30.00	" " " " " " " "	" " " " " " " "
Bourke, Francis, Mt. Slide, Kinglake	60.00	" " " " " " " "	" " " " " " " "
Britton, William, 11 First-avenue, Kwinana, W.A.	30.00	" " " " " " " "	" " " " " " " "
Broadbent, Robert A., c/o R.A.C.V. Enquiry, 94 Queen-street, Melbourne	15.00	" " " " " " " "	" " " " " " " "
Brown, Harold W., 18 Waylen-road, Shenton Park, W.A.	15.00	" " " " " " " "	" " " " " " " "
Bruce, Wallace F., 1 Harfeur-avenue, Beaumaris	30.00	" " " " " " " "	" " " " " " " "
Campbell, —, R.A.A.F. Stations, Amberley, Qld.	75.00	" " " " " " " "	" " " " " " " "
Carrick, Lillian B., 2 Eunot Flats, 622 Beaufort-street, Mt. Lawley, W.A.	15.00	" " " " " " " "	" " " " " " " "
Carson, Jean G., Flat 7, 24 Hotham-street, East Melbourne	15.00	" " " " " " " "	" " " " " " " "
Clement, Fred W., 11 Tobruk-avenue, Kensington Park, S.A.	15.00	" " " " " " " "	" " " " " " " "
Cole, Beryl M., 55 Wanda-road, Caulfield	15.00	" " " " " " " "	" " " " " " " "
Cole, Rupert C. (estate of), c/o The Executor, 55 Wanda-road, Caulfield	15.00	" " " " " " " "	" " " " " " " "
Course, Norman R., 23 Wolseley-crescent, Blackburn	30.00	" " " " " " " "	" " " " " " " "
Cox, Eileen, c/o Mrs. Binns, Flat 1, " Braemar ", 437 Flemington-road, North Melbourne	15.00	" " " " " " " "	" " " " " " " "
Davis, Francis J., Lot 66, Clive-street, Bicton, W.A.	30.00	" " " " " " " "	" " " " " " " "
Davis, Mabel F., Lot 66, Clive-street, Bicton, W.A.	75.00	" " " " " " " "	" " " " " " " "
Davis, Sylvia J., 35 Reserve-street, Bicton, W.A.	60.00	" " " " " " " "	" " " " " " " "
Derrington, Cooper I., Brookman Buildings, 35 Grenfell-street, Adelaide, S.A.	15.00	" " " " " " " "	" " " " " " " "
Duncan, Doris N., Flat 6, 3 Sackville-street, Kew	15.00	" " " " " " " "	" " " " " " " "
Eastway, Anthony C., Flat 2, 8 Raith-court, East St. Kilda	15.00	" " " " " " " "	" " " " " " " "
Efron, Jack, 23 Larnook-street, East Prahran	15.00	" " " " " " " "	" " " " " " " "
Egerton-Warburton, Edward H., Taillem Bend, S.A.	30.00	" " " " " " " "	" " " " " " " "
Elders & Goose, Elders Trustee & Executor Co. Limited, & James E., 172 North-terrace, Adelaide, S.A.	45.00	" " " " " " " "	" " " " " " " "
Ellis, James W., c/o Messrs. E. C. Harris Pty. Ltd., P.O. Box 52, Albert Park	30.00	" " " " " " " "	" " " " " " " "
Ferguson, Herbert E. H., 179 St. George's-terrace, Perth, W.A.	15.00	" " " " " " " "	" " " " " " " "
Foot, Judith P., Marton Hall, Margaret-street, Sydney, N.S.W.	30.00	" " " " " " " "	" " " " " " " "
Foxall, John S., 74 Mounts Bay-road, Perth, W.A.	15.00	" " " " " " " "	" " " " " " " "
Gerrard, Arthur L. (estate of), The Executor, c/o 25 Barr Smith-street, Tusmore, S.A.	30.00	" " " " " " " "	" " " " " " " "
Graham, Kenneth E., c/o Star Hotel, Hunter-street, West Newcastle, N.S.W.	30.00	" " " " " " " "	" " " " " " " "
Grant-Williams, Graham, 6 Bindarra-road, Brighton, S.A.	60.00	" " " " " " " "	" " " " " " " "
Gray, Robert E., 44 Mercury-street, Carlisle, W.A.	135.00	" " " " " " " "	" " " " " " " "
Harper, Norma D., 27 Alexander-road, East Fremantle, N.S.W.	15.00	" " " " " " " "	" " " " " " " "
Hart, James P., 9 Pembroke-street, College Park, S.A.	60.00	" " " " " " " "	" " " " " " " "
Hayman, Bena, c/o Tresillian Hospital, Edward-street, Nedlands, W. A.	15.00	" " " " " " " "	" " " " " " " "

Unclaimed Moneys Act 1962.

REGISTER of Unclaimed Moneys held by the—

Name of Owner on Books and Last Known Address.	Total Amount Due to Owner.	Description of Unclaimed Moneys.	Date when Amount first became Payable.
5			
AMAD N.L.—continued.			
Hayman, Sabina P., c/o Tresillian Hospital, Edward-street, Nedlands, W.A.	15.00	Net proceeds of Forfeited Shares	9.3.66
Henstridge, Paul S., 55 Gordon-street, Manly Vale, N.S.W.	15.00	" " "	"
Hill, William G., 95 Blight-street, Croydon, S.A.	15.00	" " "	"
Hillebrand, Olive M., 11 Railway-avenue, Armadale	15.00	" " "	"
Johnson, Noel W. E., 19 Calais-road, Scarborough, W.A.	30.00	" " "	"
Johnston, Arthur D., 34 Bruce-street, Toorak	15.00	" " "	"
Johnston, Stanley, 2 The Grove, Wembley, W.A.	15.00	" " "	"
Jordan, Jack P., 168 Burke-road, Glen Iris	15.00	" " "	"
Junior, Ernest R. (estate of), The Executors, c/o J. W. Begg Blackmore & Co., 10 Martin-place, Sydney, N.S.W.	15.00	" " "	"
Kenealy, Peter A., 10 St. Gothards-road, Alphington	15.00	" " "	"
Klugman, Bernard, Darvas & Co. Ltd., 528 Collins-street, Melbourne	30.00	" " "	"
Lander, Phyllis M., "Ripley Lodge", Cheery-street, Warrawee, N.S.W.	30.00	" " "	"
Lawrence, Alexander C., 1 Spring-street, Melbourne	15.00	" " "	"
Lawrie, George W. (estate of), c/o 23 King Edward-avenue, Lower Mitcham, S.A.	30.00	" " "	"
Malloch, Alexander (estate of), The Executor, c/o 37 Jutland-parade, Dalkeith, W.A.	15.00	" " "	"
Mason, Geoffrey F., 21 Leura-grove, Hawthorn	30.00	" " "	"
Matthew, Andrew R., 24 Milson-street, South Perth, W.A.	45.00	" " "	"
Milford, Charles, 584 Waverley-road, Chadstone	30.00	" " "	"
Milson, Robert (estate of), The Executor, c/o 12 East Pathway, Reade Park Square, S.A.	45.00	" " "	"
Morphett, John W., No. 4 Flat, 22 Mount-street, Perth, W.A.	15.00	" " "	"
Moss, George, 22 Bindaring-parade, Cottesloe, W.A.	15.00	" " "	"
Newbigin, Doris B. L., 51A Hawthorn-grove, Hawthorn	15.00	" " "	"
Newmand, Aubrey B., 1 Howard-street, Perth, W.A.	15.00	" " "	"
Nickson, Thomas C. H., 3 Bond-street, Sydney, N.S.W.	15.00	" " "	"
Nordman, Boris, c/o Madden, Butler, Elder & Graham, 31 Queen-street, Melbourne	15.00	" " "	"
North, Ernest A. C., 29 Sunnyside-avenue, Camberwell	45.00	" " "	"
Ogden, Wilfred W., 6 Florence-street, Cottesloe, W.A.	30.00	" " "	"
Painter, George E., Patterson-crescent, Greensborough	15.00	" " "	"
Parkes, Edmund H., 5 Stuart-street, Collaroy, N.S.W.	15.00	" " "	"
Parsons, Ethel A., 146 Woodville-road, Woodville, S.A.	15.00	" " "	"
Patmore, Joseph & Eileen, 23 Britannia-road, Mt. Hawthorn, W.A.	30.00	" " "	"
Paton, Doris J., 63 Willis-street, Hampton	30.00	" " "	"
Prendiville, Patrick G., Peninsular Hotel, Maylands, W.A.	45.00	" " "	"
Pynor, Archibald H. (estate of), 38 Marine-parade, St. Kilda	15.00	" " "	"
Richards, Ivy L., Mercantile Mutual Building, 179 St. George's-terrace, Perth, W.A.	30.00	" " "	"
Rowe, Jean C., 19 Francis-street, Subiaco, W.A.	45.00	" " "	"
Scrymgour, Hubert E. (estate of), The Executor, c/o William M. Scrymgour, 11 Wallace-street, Dunleath, S.A.	15.00	" " "	"
Silvester, Reginald R., 118 William-street, Sydney, N.S.W.	15.00	" " "	"
Smith, Gordon M., "Mahara", Wooroloo, W.A.	15.00	" " "	"
Southwick, Michael H., 133 Brighton-road, Elwood	60.00	" " "	"
Sutton, Leonard E., c/o Sutton Motors, Kent-street, Rockingham, W.A.	60.00	" " "	"
Swan & Marchesi, Anthony & L., c/o Stow & Stow, 8 The Esplanade, Perth, W.A.	15.00	" " "	"
Tingle, Leigh G., 122 Reserve-road, Beaumaris	15.00	" " "	"
Topman, Julia M., Recreation Hotel, Boulder, W.A.	30.00	" " "	"
Wilkie, Ruby E., 59 Austin-street, Subiaco, W.A.	15.00	" " "	"
Yencken, Arthur, 103 Grange-road, Toorak	30.00	" " "	"
Zufi, David, 51 Chelmsford-road, Mt. Lawley, W.A.	30.00	" " "	"
Hartlye Poynton & Co., Box W2077, G.P.O., Perth, W.A.	50.00	Overpayment of application on new issue	6.3.66
Wolff Dunlop & Co., 60 Pitt-street, Sydney, N.S.W.	100.00	" " "	"
Bartlett, Harry T., Station-street, Warburton	15.00	Net proceeds of Forfeited Shares	9.3.66
468			
ABERFOYLE LIMITED.			
Dodd, Maisie A., c/o D. M. Bennett & Co., 406 Collins-street, Melbourne	126.57	Dividend	21.4.67
Richardson, Arnold E. (estate of), c/o J. W. Collings, P.O. Box 152, Camberwell	140.63	"	"
Blazeley, Mary, 7 Erina-street, Launceston, Tas.	21.00	"	15.12.67
Howe, B. J., 67 Trevitt-road, North Ryde, N.S.W.	11.25	"	"
Tannenbaum, Wolfe, Box 2164, G.P.O., Sydney, N.S.W.	12.50	"	"
Brown, Ross H., Mall, Canberra, A.C.T.	40.00	Dividends	22.11.68
Clark, Elizabeth, 63 Great King-street, Glasgow, U.K.	12.50	"	"
King, Raymond M., 35 Baringa-road, Mortdale Heights	12.50	"	"
Thomas, Ernest B., Orford, Tasmania	10.00	"	"
469			
GOLDEN PLATEAU N.L.			
Bradford, Ernest E., 12 Girraween-grove, Ashgrove, Brisbane, Qld.	12.50	Dividend	12.6.69
Osborne, Frank H. & Anthony H., 31 Douglas-street, Toorak	11.25	"	"
Richter, Edwin R., c/o Post Office, Brunswick	12.50	"	"
Cook, Edward A., c/o Messrs. Russell Kennedy & Cook, 401 Collins-street, Melbourne	100.00	"	11.12.69
Kerridge, Eileen V., c/o Messrs. Magney & Magney, 54-58 Park-street, Sydney, New South Wales	12.50	"	"
Richter, Edwin R., c/o Post Office, Brunswick	12.50	"	"
470			

Unclaimed Moneys Act 1962.

REGISTER of Unclaimed Moneys held by the—

Name of Owner on Books and Last Known Address.	Total Amount Due to Owner.	Description of Unclaimed Moneys.	Date when Amount first became Payable.
5			
THE BROKEN HILL PROPRIETARY COMPANY LIMITED.			
Ades, Timothy, The Gables, Eushott, Surrey, U.K.	10.50	Dividend	1.4.69
Alexander, Elizabeth A. (Miss), c/o Price Waterhouse and Co., 447 Collins-street, Melbourne	22.47	"	"
Alexander, Keith H., The Grange, R.M.B. 64, Moama, N.S.W.	47.50	"	"
Alford, Robert G., 34 Wolseley-road, Mosman, N.S.W.	45.81	"	"
Allan, Clementina M., Cedais, Forgandenny, Perthshire, U.K.	31.87	"	"
Allan, Ruth O., 46A Bayfield-road, Dunedin, N.Z.	14.28	"	"
Alcock, Edward A. (Dr.), Memorial Hospital, Crewe, Cheshire, U.K.	17.64	"	"
Alverstone Pty. Ltd., c/o G. Abbott, Esquire, Apartment 4E, 5 Buckhurst-avenue, Point Piper, N.S.W.	25.73	"	"
Ambler, Helen B. (Mrs.), c/o Midland Bank Ltd., 34 Kirkgate, Bradford, Yorks, U.K.	17.60	"	"
Andrews, Anne G. W. (Mrs.), 19 Queensdale-road, Holland Park, London, W.11., U.K.	13.21	"	"
Asher, George A., 16 Thomas-street, North Sydney, N.S.W.	28.00	"	"
Atlas Cop. Co. Aust. Pty. Ltd., 199 Parramatta-road, Auburn, N.S.W.	21.00	"	"
Baile, Greta L. (Mrs.), 24 Wattleton-road, Beaconsfield, Bucks, U.K.	12.19	"	"
Bamford, Nina C. (Miss), 6 Goldington-avenue, Bedford, U.K.	13.89	"	"
Bandless, Ian G. K., c/o Lumsten and Co., 36 New Broad-street, London, E.C.2., U.K.	11.73	"	"
Barker, Sydney M., 26 Arnold-street, Killara, N.S.W.	23.64	"	"
Barnes, Anne (Mrs.), Metcalf-road, Willoughby, Ohio, 44904, U.S.A.	17.01	"	"
Batt, John D., Apsley	57.00	"	"
Baxter, Arthur J., Simmonds, Downington, Lechlade, Glos., U.K.	12.85	"	"
Beaumont, John (Group Capt.), 5 Vivian-court, Mount Kellet, Hong Kong	69.10	"	"
Begg, John McQ., c/o Perpetual Trustee Executor and Agency Co. of N.Z. Ltd., P.O. Box 897, Dunedin, N.Z.	35.55	"	"
Blackaddet, Margaret, 8 Edward-street, Woollahra, N.S.W.	80.54	"	"
Blake, Jonathan, Lyndhurst, Westland Green, Little Hadham, Herts., U.K.	13.14	"	"
Blake, Simon T., Lyndhurst, Westland Green, Little Hadham, Herts., U.K.	16.48	"	"
Blomfield, Nancye M. N., Bank of N.S.W. Nominees Pty. Ltd., G.P.O. Box 7026, Sydney, N.S.W.	14.00	"	"
Bluett, Nancy L., c/o Bank of N.S.W., Sackville-street, London, U.K.	10.89	"	"
Boulter, Alan S., 42 Dial Hill-road, Clevedon, Somerset, England	37.80	"	"
Boulter, Arthur Everard L., c/o Bank of N.S.W., Sydney, N.S.W.	18.51	"	"
Bownas, Mabel S. (Mrs.), Unit 6, 21 Moruben-road, Mosman, N.S.W.	25.27	"	"
Boyce, Reginald H. and Potts, Alan, P.O. Box 801, London, E.C.2., U.K.	11.56	"	"
Bradley, Stuart Loxley, Parawera, No. 2 Road, Te Awamutu, N.Z.	20.10	"	"
Brathwaite, Barbara J. (Mrs.), 77 Cannington-road, Dunedin, N.Z.	17.33	"	"
Bridgman, Matthew B., 53 Hautana-street, Lower Hutt, N.Z.	12.32	"	"
Brock, Lawrence G. (Dr.), c/o National Bank of N.Z., 14 Charles II-street, London, U.K.	40.80	"	"
Bruce, Kelvin W., 27 Leith-street, Newborough	11.24	"	"
Buckley, Thomas, Rockchapel, Co. Cork., Eire	14.51	"	"
Burke, Peter J., 9 Francis-street, Subiaco, W.A.	60.00	"	"
Burston, Winifred, 1A Goomerah-crescent, Darling Point, N.S.W.	84.00	"	"
Cameron, Gladys E., c/o Jack Palmer, 96 Pitt-street, Sydney, N.S.W.	11.24	"	"
Campbell, Desmond M. and Campbell, Doreen C. (Miss) and McCreath, Maxwell, 16 Charlton-road, Bridge of Allan, Stirlingshire, U.K.	10.10	"	"
Caribbean Holding Ltd., 8 Lefebvre-street, St. Peter, Port Guernsey, Channel Islands	19.63	"	"
Carr, Robert I., P.O. Box 42, Maitland 3N, N.S.W.	57.02	"	"
Carrigan, Louise (Miss), Clonacody Clonmel, Co. Tipperary, Ireland	14.52	"	"
Cartwright, George A., c/o Robb College, University of New England, Armidale, N.S.W.	13.97	"	"
Caves, Toni L. (Mrs.), 19 Rimi-street, Edgumbe, Bay of Plenty, N.Z.	17.01	"	"
Chaytor, John L. C., Marshlands, RD 3, Blenheim, N.Z.	76.50	"	"
Chester, Judith T. (Miss), Camelford, Campbelltown, Tasmania	13.97	"	"
Clark, John R., c/o Westminster Bank Ltd., 121 High-street, Oxford, England	11.43	"	"
Clarke, Arthur J. R., c/o Reid, Clarke & Co., 52 King-street, Sydney, N.S.W.	42.32	"	"
Coats, Christopher D., 16 Roslyndale-avenue, Woollahra, N.S.W.	10.50	"	"
Collingridge, Francis H., 148 Oakwood-court, Kensington, London, W.14, U.K.	34.00	"	"
Coombes, Ruby R. and Harniman, William R., c/o W. R. Harniman, 206 East Terrace, Adelaide, S.A.	140.00	"	"
Copeman, Thomas W. S., Maysmead Place, Langford, Bristol, U.K.	49.37	"	"
Corrigan, Louise, Clonacody Clonmel, Co. Tipperary, Ireland	53.79	"	"
Coverton, Helen S., 43 Grove-street, Unley Park, S.A.	15.75	"	"
Cox, David I., Eaylen, Roman-road, Little Aston, Sutton Coldfield, Warwickshire, U.K.	16.76	"	"
Crossett, Robert N., c/o Arc Letcombe Laboratory, Wantage, Berks., U.K.	13.65	"	"
Crozier, David J., 33 Werona-street, Mundingburra, Townsville, Qld.	14.25	"	"
Curtis, Lorna B. A. (estate of), c/o E. M. Jurd, 67 Castlereagh-street, Sydney, N.S.W.	25.60	"	"
Dallmeyer, Joanna M. (Miss), 18 Carlisle-avenue, Donnybrook, Dublin 4, Eire	16.12	"	"

Unclaimed Moneys Act 1962.

REGISTER of Unclaimed Moneys held by the—

Name of Owner on Books and Last Known Address.	Total Amount Due to Owner.	Description of Unclaimed Moneys.	Date when Amount first became Payable.
\$			
THE BROKEN HILL PROPRIETARY COMPANY LIMITED— <i>continued.</i>			
Damato, Concetta (Mrs.), 135 Winifred-avenue, Yonkers, N.Y., U.S.A.	17.01	Dividend	1.4.69
Dameshek, William (estate of), c/o Holeman Webb and Co., 105 Pitt-street, Sydney, N.S.W.	17.85	"	"
Daniher, John P., c/o Mrs. M. Daniher, 14 North Avalon-road, Avalon, N.S.W.	11.76	"	"
Davis, Clarence H., c/o C.D. Nominees Pty. Ltd., 383 George-street, Sydney, N.S.W.	38.54	"	"
De Meevs, Compte Camille A., Chateau de et a Linsmeau, Par Racourt, Brabant, Belgium	70.00	"	"
De Meevs, Camille A., D'Aregntevil, Chateau de et a Linsmeau, Par Racourt, Brabant, Belgium	51.45	"	"
Dempsey Tegeler and Co. Inc., P.O. Box 444, Wall-street Station, New York, 10005, U.S.A.	64.60	"	"
Dickinson, Roy J., 5 The Lawns, London, S.E.3., U.K.	36.96	"	"
District Bank Limited and Petit, Michael Anthony, 53 Davies-street, London, W.7., U.K.	27.93	"	"
Doherty, Neal, Patrick, Seamns, and Daniel, 119 Broughshane-street, Ballymena, N. Ireland	11.17	"	"
Dolland, Jack J. (Dr.), 260A Shirland-road, London, W.9, U.K. . .	43.30	"	"
Downing, Peter Barry, 71 Whitley-court, Woburn Place, London, W.C.1, U.K.	12.91	"	"
Drilmsa, Lena A., 6 Sunnyside-avenue, Caringbah, N.S.W.	10.50	"	"
Eatts, Ethel N. (Miss), 26 River-road, Wollstonecraft, N.S.W. . . .	20.21	"	"
Eley, Beatrice M. (Miss), Sherwood, Elm-road, Sidcup, Kent, U.K.	11.17	"	"
Evans, Lesley (Mrs.), 121 Buchan-street, Bungalow, Cairns, Q'land..	10.55	"	"
Fagg, Mervyn N., P.O. Box 1, Kokopo, T.P.N.G.	14.60	"	"
Favell, William (Rev.), 15 Walsingham-road, Hove, Sussex, U.K. . .	12.35	"	"
Fear, Reginald G. V. (estate of), c/o F. J. Kavanagh, 324 Marrickville-road, Marrickville, N.S.W.	17.60	"	"
Feast, John E., P.O. Box 2887, Wellington, N.Z.	16.15	"	"
F.H.P. Investments Pty. Ltd., c/o Coachman Restaurant, 763 Bourke-street, Redfern, N.S.W.	11.24	"	"
Filmer, John R. and William W., Broadham End, Oxted, Surrey, U.K.	30.85	"	"
Fitzpatrick, Noel J., 12A/10 Challis-avenue, Potts Point, N.S.W. . . .	155.99	"	"
Foley, Robert, Cherry Trees, Bailrigg-lane, Lancaster, Lancashire, U.K.	13.21	"	"
Forsyth, John, 8 Jeanneret-avenue, Hunters Hill, N.S.W.	21.74	"	"
Foster, Linley R., P.O. Box 1262, Boroko, T.P.N.G.	45.83	"	"
Fougeres, Jeanne E. J. (Mme.), 3 Boulevard Carnot, Dijon, France . .	12.34	"	"
Fox, John F. A., 52 Seven Oaks-drive, Bryndwr, CL CL5, N.Z. . . .	12.93	"	"
Frankenberg, Alice (Miss), Stanhope Hotel, 995 Fifth-avenue, New York City 28, N.Y., U.S.A.	17.01	"	"
Fraser, Graham T., c/o V. Fraser, 45 Cometrowe-street, Drummoyne, N.S.W.	10.83	"	"
Friel, Grace Philomena (Mrs.), Creeslough, Co. Donegal, Eire	11.77	"	"
Frozer, Sir Thomas, Flat 98, Grosvenor House, Park Lane, London, W.1, U.K.	19.81	"	"
Gamble, Janette R. (Miss), c/o Mrs. Janette R. McLellan, 9 McKenge-street, East Doncaster	10.83	"	"
Gardner, Peter D., Offham House, Offham, Lewes, Sussex, U.K. . . .	23.45	"	"
Geary, William G., 19 Shelley-street, Firlie, S.A.	10.50	"	"
Gee, Clement M., 9 Hampden-avenue, Wahroonga, N.S.W.	103.68	"	"
Gee, George C. M. (estate of), c/o A. E. Whatmore, G. C. M. Gee and Co., 14 Spring-street, Sydney, N.S.W.	12.81	"	"
Gilmartin, Mavis C. (Mrs.), High-street, Trentham	35.09	"	"
Gloyn, Roger J., 4 Welbeck-avenue, Hove, Sussex, U.K.	18.29	"	"
Goldberg, Alvin I., 4254 West Lyons, Skokie, Illinois, U.S.A.	17.01	"	"
Goldman, Bernard A., 603 Hibernia Bank Building, New Orleans, Louisiana 70112, U.S.A.	17.01	"	"
Golsby, Isabelle M. (Miss), 10 Brisbane-street, Cowra, N.S.W.	12.73	"	"
Gordon, Lillias M. (estate of), c/o National T.E. and A. Co. of A/asia Ltd., P.O. Box 2819AA, Melbourne	142.50	"	"
Gray, James Allan, 57 Duthie-street, Wellington, N.Z.	19.39	"	"
Greshler, Abner J., c/o Sidney Rose, 35 Curxon-street, London, W.7, U.K.	11.17	"	"
Grogan, Gertrude U. (Miss), Pleasant-avenue, East Lindfield, N.S.W.	21.76	"	"
Hamilton, Macdonald R., Calinquee, Goondiwindi, Q'land	45.15	"	"
Harding, Richard S., 64 Ridgway-place, London, S.W.19, U.K.	50.23	"	"
Hargreaves, Judith Anne (Mrs.), The Garden Cottage, Crowthorne, Berks, U.K.	30.85	"	"
Harrison, Nicholas J., c/o W. J. Young, 2 Frank-street, Doncaster . .	10.50	"	"
Hartley, Piers R. C., 39 Downshire Hill, Hampstead, London, N.W.3, U.K.	15.75	"	"
Hauger, Eugene, 79 Rue de Bale, Bulhouse, Haut Rhin, France	16.97	"	"
Heath, Nancy G. B., Heatherlie, Lilydale	70.00	"	"
Heine, Ronald B., 15 Bundabah-avenue, St. Ives, N.S.W.	409.50	"	"
Henken, Julius and Gijse J., P.O. Box 334, Kuwait	31.61	"	"
Heycock, Irene C., c/o Glyn Mills and Co., Kirkland House, Whitehall, S.W.1, U.K.	31.50	"	"
Hilliard, Robert B., 32 Market-street, Wollongong, N.S.W.	16.25	"	"
Hilliard, John R. F., Cahernane Garden, Killarney, Co. Kerry, Eire. .	13.30	"	"
Hindley, William H. and Olga A. O., P.O. Box 33, P.O. Molo, Kenya, Africa	28.25	"	"
Hindlip, Henry Lord (Maj. the Rt. Hon. Henry R. Allsopp, Lord Hindlip), Vernheaze, Calne, Wilts., U.K.	78.63	"	"

Unclaimed Moneys Act 1962.

REGISTER of Unclaimed Moneys held by the—

Name of Owner on Books and Last Known Address.	Total Amount Due to Owner.	Description of Unclaimed Moneys.	Date when Amount first became Payable.
5			
THE BROKEN HILL PROPRIETARY COMPANY LIMITED—continued.			
Hinlicky, George J. and Miriam L., c/o New Guinea Lutheran Mission, Wapenamanda, New Guinea	36.02	Dividend	1.4.69
Holbrow, Caryl A. (Mrs.), Moonrakers, Primrose-avenue, Claremont, Cape Town, S.A.	10.87	"	"
Holden, Vernon W., P.O. Box 114, Warkworth, N.Z.	10.89	"	"
Holdsworth, Paul H., 51 Wai-iti Terrace, Christchurch 5, N.Z.	11.17	"	"
Hopkins, Margaret E., 15 Milner-crescent, Wollstonecraft, N.S.W.	39.38	"	"
Howard, Cecil C. (estate of) and Aileen F., c/o Francis White Barnes and McGuire, 149 Castlereagh-street, Sydney, N.S.W.	64.16	"	"
Hughes-Young, Roy, Meda Station, via Derby, W.A.	10.50	"	"
Hull, Walter D. M., 9 Warragul-court, New Town, Tasmania	20.00	"	"
Hunter, Philip B. and Harding, Ronald A. and McAllester, George L., 43 Castle-street, Liverpool, 2, U.K.	11.17	"	"
Hynd, George R., 385 Perth-road, Dundee, U.K.	21.60	"	"
Imber, Basil V. S., 50 High Holborn, London, W.C.1, U.K.	76.20	"	"
Invesco Nominees Pty. Ltd., G.P.O. Box W 2077, Perth, W.A.	70.59	"	"
Ireland, Peggy E., 7/271 Nepean Highway, Seaford	10.50	"	"
Isola, William, 3 Bell-lane, Gibraltar	22.80	"	"
Jack, Roy E., 49 College-street, Wanganui, N.Z.	36.69	"	"
Jacobs, Elizabeth (Mrs.), Lennoxwood, Westwood-road, Windlesham, Surrey, U.K.	13.21	"	"
James, Margaret E. (Mrs.), 3 Clive-crescent, Bayview, N.S.W.	52.50	"	"
Jamison, Effie G. (estate of) and Hardie, James M., c/o Cooper Brothers and Co., G.P.O. Box 2650, Sydney, N.S.W.	62.51	"	"
Jeans, Christopher H., Inchbroom, Farr Hall-road, Heswall, Wirral, Cheshire, U.K.	13.21	"	"
Johnson, Joan P. and Neil and Dumbrell, John C., 44 Finlayson-street, Doncaster	11.24	"	"
Johnson, Neil and Joan P. and Dumbrell, John C., 44 Finlayson-street, Doncaster	19.64	"	"
Johnstone, Michele (Miss), 57A Sydney-street, Willoughby, N.S.W.	59.01	"	"
Jones, Clara M. (Mrs.) and Watkins, Brenda C. (Mrs.) and Jones, Derek J. and Dolman, Julian H., 93 Risca-road, Newport, Mon., U.K.	30.85	"	"
Karet, Morris, 10 Pindari-road, Dover Heights, N.S.W.	70.00	"	"
Keep Brothers Limited, Alexandra, Central, Otago, N.Z.	35.69	"	"
Kendall, Peggy E. and Raymond J., P.O. Box 23-083, Papatoetoe, N.Z.	12.24	"	"
Kennison, Rosemary M. (Miss), c/o Mrs. Rosemary M. Purkiss, 5/41 Byron-street, Elwood	11.41	"	"
Kern, Violet (M/s), 1441 School-street, Chicago, Illinois, 60613 U.S.A.	17.01	"	"
Kiessling, Ernest and Mary (Mrs.), 2301 Foster Place SE, Washington DC 20031, U.S.A.	17.01	"	"
King, Thomas R. R., c/o P. A. Mooney and Co., Kenlis-place, Kells, Co. Meath, Eire	31.47	"	"
Kingsbury, Murray H., No. 1 RD, Rakaia, N.Z.	33.11	"	"
Klimont, George C., c/o Pridham and Gardiner, 41 Currie-street, Adelaide, S.A.	12.81	"	"
Knight, Norah E., 296 Union-road, Balwyn	22.47	"	"
Kronhill, Julia (Mrs.), 1 Ontario-street, Caulfield	28.50	"	"
Lacy, Ernest Joseph, 11 Glendene, 115 Victoria-drive, London, S.W.14, U.K.	11.17	"	"
Lacey, Rolfe Alexander S., 150 Fox-lane, Palmers Green, London, N.13, U.K.	32.91	"	"
Lageborn, Harry Wisner Bonnie, P.O. Box 61, Port Hedland, W.A.	10.32	"	"
Langton, David M. L., New Barn Farm House, Higher Compton, Winchester, Hants, U.K.	16.76	"	"
Latham, Major John W., Penthouse No. 2, Hyde Park House, Knightsbridge, London, S.W.1, U.K.	42.28	"	"
Leigh-Wood, Robert, 14 Wetherly Gardens, London, S.W.5, U.K.	11.17	"	"
Lefcort, Margaret (Mrs.), c/o Messrs. Blair and Co. Inc., 277 Park-avenue, New York, NY 10017, U.S.A.	25.08	"	"
Leonard Green Pty. Ltd., c/o Staff Superannuation and Retirement Fund, c/o Dr. L. Green, 88 Old South Head-road, Bondi Junction, N.S.W.	12.81	"	"
Le Rudulier, Paule (Miss), A.J.M.A., 6 Rue Duguesdin, Rennes, Ille et Vilaine, France	11.66	"	"
Lester-Smith, Alan, Pte. Bag 73, Kerang	10.50	"	"
Leung, Li Chung, c/o 9 Boden-avenue, Strathfield, N.S.W.	31.50	"	"
Lewis, Thomas A. and Cunningham, James and Crauen, John B. and Webster, Alftofs J., Bramcote over Lane, Rawdon, Leeds, U.K.	15.42	"	"
Liu, Ernest, P.O. Box 348, Tawau, Sabah, Malaysia	21.01	"	"
Livingstone, Elizabeth V. (M/s), 690 River-road, Beaver, Pennsylvania, U.S.A.	17.01	"	"
Long, Anwyn M. (Miss), c/o R. W. Wade, 18 Burke-street, Bulleen-Lutyens, Martin C., 7 Queensborough Studios, Porchester Terrace, London, W.2, U.K.	12.81	"	"
MacFarlane, Alison R. L. (M/s), Wadi Nimrin, Hundalee, Cheviot, N.Z.	12.35	"	"
MacPherson, Ian S., Brownsy, Oldbury-road, Moss Vale, N.S.W.	21.48	"	"
MacQueen, David B., 15 Gilmour-street, Paisley, U.K.	25.73	"	"
Marcel, Joseph, St. Briene, Cotes du Nord., France	49.14	"	"
Marston, William B. and Knowles, Elsie, 58 Kingston-street, Hampton	29.13	"	"
Mason, Edward James Hurdie, 3/11 The Avenue, Sneyd Park, Bristol 9, U.K.	15.75	"	"
	10.02	"	"

Unclaimed Moneys Act 1962.

REGISTER of Unclaimed Moneys held by the—

Name of Owner on Books and Last Known Address.	Total Amount Due to Owner.	Description of Unclaimed Moneys.	Date when Amount first became Payable.
§			
THE BROKEN HILL PROPRIETARY COMPANY LIMITED—continued.			
McArthur, Edward H. and Acland, Elizabeth V., 11 Waishes-road, Asburton, N.Z.	21.16	Dividend	1.4.69
McCormick, Kathleen (estate of), c/o Maurice M. Flynn, Vulcan Buildings, Cnr. Queen-street and Vulcan-lane, Auckland, C.I, N.Z.	22.45	"	"
Miles, Warren W., c/o Marayong Hotel, Marayong, N.S.W.	23.75	"	"
Mills, Ida B. (Mrs.), Hilborough Hall, Thetford, Norfolk, U.K.	33.50	"	"
Morutto, Jillian L., Tanbrae, Millicent, S.A.	52.61	"	"
Mungo, Rt. Hon., Earl of Mansfield, Scone Palace, Perth, Scotland, U.K.	22.33	"	"
Netcher, Elizabeth J. (Mrs.), 516 South Harrison-street, Arlington, Virginia, U.S.A.	17.01	"	"
Noon, Richard M., 32 Roslyn-street, Strathmore	48.01	"	"
North, Doreen R., 1/21A Kingsview-road, Mt. Eden, Auckland 3, N.Z.	30.89	"	"
Olson, Hazel M., 6/65 Boome-street, Maroubra, N.S.W.	15.12	"	"
Orr, Thomas J., 64 Pellister-road, Putney, N.S.W.	10.50	"	"
Orr, Ulric G., 17 Billyard-avenue, Elizabeth Bay, Sydney, N.S.W.	175.56	"	"
O'Shea, Irene J., 29 Summer-street, Stanley Bay, Devonport, Auckland, N.Z.	72.45	"	"
Osmond, Ronald T., P.O. Box 3, Cambridge, N.Z.	35.25	"	"
Parsons, James S., Riversdale Hotel, Riversdale and Auburn roads, Hawthorn	204.61	"	"
Partridge, Leo; Surf Villa, Box 754, Nassau, Bahamas	39.91	"	"
Paton, Cecilia, 25 Verdun-street, Alderley, Queensland	70.00	"	"
Pattenden, Donald G. L., Flat 6, 10 Hans-crescent, London, S.W.1, U.K.	35.28	"	"
Pauli, Carmel R., 328 Freeman-road, Kuala Lumpur, Malaysia	11.76	"	"
Payan, Jacques, 53 Upland-road, St. Lucia, Queensland	14.25	"	"
Pearce, David M., Old Vicarage, Wormingford, Colchester, Essex, U.K.	16.76	"	"
Pennefather, Kathleen M. A. (Miss), Byron House, Harrow on the Hill, Middlesex, U.K.	35.28	"	"
Pennybacker, Miles, c/o Manufacturers Hanover Trust Co., P.T. Coll. a/c M61868, 350 Park-avenue, New York, NY 10022, U.S.A.	129.65	"	"
Pettit, Norman K., 22 Giffin-avenue, Roseville Chase, N.S.W.	11.97	"	"
Pletka, Irene (Mrs.), 1 Ontario-street, Caulfield	28.50	"	"
Potts, Heather J. (M/s), Box 9, Quairading, W.A.	10.00	"	"
Pregre, Jacques (estate of), c/o The Manager, Banque Nationale de Paris, G.P.O. Box 269, Sydney, N.S.W.	34.59	"	"
Price, Brian and Odlum, Peter and Dennis, Major Patrick Gill Dyke, South Main-street, Naas County Kildare, Eire	51.43	"	"
Quinn, Henry, 16 Montagu-street, London, W.1, U.K.	37.35	"	"
Rath, Miles E., P.O. Box 84, Messilla Park, New Mexico, U.S.A.	17.01	"	"
Rayner, Harry, 37 Hartopp-road, Four Oaks, Sutton Coldfield, U.K.	30.70	"	"
R. and E. Investments Pty. Ltd., 6/37 Sisley-street, St. Lucia, Q'land	35.28	"	"
Richards, Maxwell A., 20 Howard-street, Glen Iris	10.83	"	"
Robbins, Shannon, Post Office, Kobtingal, N.S.W.	32.50	"	"
Romand, Marie L. (Mme), Admix. of Emile Romand (estate of), Chateau de Villeneuve St. Aaron, Pres Lamballe, Cotes Du Nord, France	58.24	"	"
Rowan, Ernest M., P.O. Box 2492, Auckland, N.Z.	10.89	"	"
Rumsey, Katrina R. (Mrs.), Beachets, Theydon Mount, Epping, Essex, U.K.	27.93	"	"
Russell, Raymond E., c/o Staff Mess, Mt. Isa Mines Ltd., Mt. Isa, Qld.	14.00	"	"
Ryan, Kathleen (M/s), 9 Menzies-street, Sumner, Christchurch, N.Z.	17.01	"	"
Sawyer, Alison G. (Mrs.), P.O. Box 880, Palmerston North, N.Z.	17.64	"	"
Schaffer, Alwine (Mrs.), c/o Mrs. Boese, Manor House Boarding Estab., Bewdley, Worcs., U.K.	19.55	"	"
Scott, Lindsay G., 61 Bluff-road, Black Rock	19.00	"	"
Shadbott, Iris, 8/32 Manningham-road, Hawthorn	10.50	"	"
Sharp, Frank L. R. (Dr.), 21 Mary-street, Longueville, N.S.W.	207.46	"	"
Shaw, Patrick J., c/o Lloyds Bank Ltd., West-street, Havant, Hants, U.K.	75.47	"	"
Smith, Alistair, Sea View, Omihi 3, R.D., Amberley, N.Z.	10.99	"	"
Smith, Raymond F. K., P.O. Box No. 121, Manuka P.O. A.C.T.	22.80	"	"
Smith, Zelma A., All Saints Rectory, Willaura	10.50	"	"
Sotheb, Marjorie (Mrs.), The Westbury Hotel, New Bond-street, London, W.1.	11.94	"	"
Spall, James F., Te Matai-road, RD 10, Palmerston North, N.Z.	17.94	"	"
Speed, Nathalie C. (Mrs.), 3 Rose-avenue, South Perth, W.A.	22.47	"	"
Speleological Research Council Ltd., 36 Eureka-street, Northbridge, N.S.W.	42.00	"	"
Splier, Richard P. G., c/o C.R.A. Exploration, P.O. Box 467, Kalgoorlie, W.A.	26.25	"	"
Spry, Kerry (Mrs.), 9 Garnet-street, Killara, N.S.W.	11.88	"	"
Stabb, Nicholas J., C.B.A., 54 Pitt-street, Sydney, N.S.W.	16.80	"	"
Stephens, Brian W. H., 170 The White House, Albany-street, London, N.W.1.	10.38	"	"
St. Leger, Hugh (estate of), c/o Jermyn and Moloney, 7 Georges Quay, Cork, Eire	197.05	"	"
Strohenger, Basil F., 2 Springfield-road, Brikley, Kent, U.K.	12.35	"	"
Tai, Wendy M., 25 Tateeham-road, Lane Cove, N.S.W.	11.24	"	"
Taylor, John H. (Dr.), 8 Elmstone-avenue, Auckland 5, N.Z.	102.35	"	"
Thomas, Richard A. S. and Ross, Eric R. C. and Walford, Filmer G. E., Quisita de Penaferrini, Sintra, Portugal	13.64	"	"

Unclaimed Moneys Act 1962.

REGISTER of Unclaimed Moneys held by the—

Name of Owner on Books and Last Known Address.	Total Amount Due to Owner.	Description of Unclaimed Moneys.	Date when Amount first became Payable.
\$			
THE BROKEN HILL PROPRIETARY COMPANY LIMITED—continued.			
Throsby, Peter Wentworth, G.P.O. Box 290, Sydney, N.S.W.	23.64	Dividend	1.4.69
Tucker, Norbert R. Jnr., 9th Floor, 180 Russell-street, Melbourne.	22.47	"	"
Vautier, Ray (estate of), c/o V. Benson, 160 Castlereagh-street, Sydney, N.S.W.	28.61	"	"
Ventura, Dorothy E. (Mrs.), 14332 Martha-street, Van Nuys, California, U.S.A.	15.49	"	"
Veron, Diana E. (Miss), 255 Castlereagh-street, Sydney, N.S.W.	11.40	"	"
Virdi, Mehar S. (Miss), P.O. Box 62, Dodoma, Tanzania, East Africa	13.30	"	"
Walker, John Richard Anthony, c/o Messrs. Allen and Son, 17 Carlisle-street, Soho Square, London, W1V 6PE, U.K.	12.85	"	"
Wall, Sally B. (Mrs.), 116 St. Heliers Bay-road, Auckland, N.Z.	17.64	"	"
Wallis, Neville Ivor Newton, The Lodges, Fenny Compton, Warwickshire, U.K.	60.15	"	"
Wardlaw, Robert, 27 Edgecliff-road, Bondi Junction, N.S.W.	19.00	"	"
Warrell, Alfred W., 971 Chester-road, Erdington, Birmingham, 24, U.K.	80.33	"	"
Webb, Robert N., Doorroombah, Tooraweenah, N.S.W.	35.00	"	"
Weinmann, George E. (Mrs.), 16 Rue de la Fauvette, Eperney, France	14.45	"	"
Werden, Max, c/o W. Casserley, 1/5 Westbury-street, East St. Kilda	11.24	"	"
White, Adrian T., 17 Pelham Place, London, S.W.7, U.K.	11.17	"	"
White, Wm. D., 70 Shearman-street, Waimate, N.Z.	15.76	"	"
Wild, Peter G., Willowbrook, Keneshall, Near Stone, Staffs, U.K.	64.28	"	"
Wild, Peter Grenville and Muriel Mary (Mrs.), Willowbrook, Keneshall, Near Stone, Staffs	37.02	"	"
Wilkes, Durward, 35 Windermere-road, Ascot, Queensland.	22.47	"	"
Wilkinson, Richard L., 36A Middle Harbor-road, Lindfield, N.S.W.	11.83	"	"
Willcock, Frederick, c/o Barclays Bank Ltd., Exchange Place, Middlesborough, U.K.	18.52	"	"
Williams, Anthony J., Pearce Cottage, Stocklinch, Ilminster, Somerset, U.K.	15.12	"	"
Wilson, Philip H., Royal Newcastle Hospital, Resident Qtrs., Newcastle, N.S.W.	10.50	"	"
Wise, Cyril R., c/o C. R. and A. Kelynack, G.P.O. Box 223, Sydney, N.S.W.	12.60	"	"
Wood, William C., 62 Fox-street, Lane Cove, N.S.W.	10.50	"	"
Zock, Sara M., 506 Crescent Parkway, Sea Girt, New Jersey, 08750, U.S.A.	17.85	"	"
Zumbrunn, Anne (Mrs.), 63 Easthaven, 35A Sutherland-crescent, Darling Point, N.S.W.	13.30	"	"
513			
HOLEPROOF LIMITED.			
Nikita, Z., 26 Fraser-street, Brunswick	17.75	Wages	2.7.69
Massoratti, L., 6 Esta-street, North Blackburn	20.65	"	17.9.69
Bolos, S. (estate of), 88 Elgin-street, Carlton	23.55	"	3.5.67
Brooker, R., 7 Dalgety-street, West Brunswick	13.65	"	—2.70
514			
PRESTIGE LIMITED.			
Mitchell, J. E., 1 Nottingham-street, North Sunshine	18.20	Wages	29.8.66
Devine, D. E., 161 Gordon-street, Footscray	18.30	"	19.1.66
Matheson, B., 12 Findon-court, Highbett	22.00	"	3.6.69
Beecroft, L., 16 Rosewall-street, North Sunshine	70.74	"	21.11.69
515			

Companies Act 1961.—In the matter of LIFEMAKER PTY. LTD.—Notice Re Meeting of Creditors, Pursuant to Section 260.

NOTICE is hereby given that a meeting of creditors of the above-named company will be held at the Institute of Chartered Accountants, 23 McKillop-street, Melbourne, at 3.30 p.m., on the 18th day of June, 1971, the company having convened a meeting of its members the same day for the purpose of considering a Resolution that the company be wound up voluntarily.

Dated the 4th day of June, 1971.

L. V. WILLIAMS, Director.

A. A. Armitage & Partners, chartered accountants, 238 Elizabeth-street, Melbourne, telephone No. 663 3124. 658

PERADENIYA PTY. LTD. (IN VOLUNTARY LIQUIDATION).

NOTICE is hereby given that by a Resolution of the company, Eric Morris Cohen, of 26 Commercial-road, Prahran, was appointed liquidator of Peradeniya Pty. Ltd. on the 4th June, 1971, and that the situation of the liquidator's office is care of Morris Cohen, Glen & Co., 26 Commercial-road, Prahran.

656

ERIC M. COHEN, Liquidator:

The Companies Act 1961.

PARKLAND DISPLAY PROMOTIONS PTY. LTD.

NOTICE TO CREDITORS OF INTENTION TO DECLARE DIVIDEND.

A FIRST and Final Dividend is intended to be declared in the above matter. Creditors who have not proved their debt by the 16th June, 1971, will be excluded from this dividend.

Dated this 2nd day of June, 1971.

I. H. SHANNON, Director.

A. Neville Bird & Co., chartered accountants, 289 Flinders-lane, Melbourne, telephone No. 63 2874 701

STANLEY BURKE & COMPANY PROPRIETARY LIMITED (IN LIQUIDATION).

NOTICE TO CREDITORS OF INTENTION TO DECLARE DIVIDEND.

A FINAL Dividend is intended to be declared in the above matter. All creditors who have not as yet proved their debt are required to do so by the 30th June, 1971, to be included in the intended dividend.

Dated this 1st day of June, 1971.

D. K. COWAN, Liquidator.

Cowan, Gavens & Baldwin, 56 Hesse-street, Colac, 3250.

717

The Companies Act 1961.

HOLANDSCOT ENGINEERING COMPANY
PROPRIETARY LIMITED (IN LIQUIDATION).NOTICE CONVENING FINAL MEETING OF MEMBERS AND
CREDITORS PURSUANT TO SECTION 272.

NOTICE is hereby given pursuant to section 272 of the Companies Act 1961, that a General Meeting of the members and creditors of the above-named company will be held in the offices of Kennedy, Smail & Middlemiss, 296-304 Little Lonsdale-street, Melbourne, on Wednesday, the 7th day of July, 1971, at 10.30 a.m., for the purpose of having an account laid before them showing the manner in which the winding up has been conducted and the property of the company disposed of and of hearing any explanations that may be given by the liquidator.

Dated this 4th day of June, 1971.

A. M. HORSBURGH, Liquidator.

Kennedy, Smail & Middlemiss, 296-304 Little Lonsdale-street, Melbourne, 3000. 699

Companies Act 1961.—In the matter of C. R. HOSE PTY. LTD. (Under Official Management).—Notice Re Meeting of Creditors, Pursuant to Section 203c (3).

NOTICE is hereby given that a meeting of the creditors and members of the above-named company will be held at 2.30 p.m. on Wednesday, 16th June, 1971, at the office of A. Neville Bird & Co., chartered accountants, 5th Floor, 289 Flinders-lane, Melbourne, to consider, and if thought fit, pass a Special Resolution extending the official management for such further period not exceeding twelve months as is resolved.

Dated this 4th day of June, 1971.

A. NEVILLE BIRD, Official Manager.

A. Neville Bird & Co., chartered accountants, 289 Flinders-lane, Melbourne, 3000, telephone No. 63 2874. 703

The Companies Act 1961.

SPESONDA PTY. LTD. (IN VOLUNTARY LIQUIDATION).

NOTICE RE WINDING UP.

NOTICE is hereby given that, at meetings of members and creditors held on the 31st May, 1971, and 1st June, 1971, respectively, it was resolved that the company be wound up, and that Owen Glyndwr Jenkins, chartered accountant, of the firm of Day, Neilson, Jenkins & Johns, 199-203 Moorabool-street, Geelong, be appointed liquidator.

In order to participate in any distribution, creditors should lodge a proof of debt with the liquidator as early as practicable.

Dated at Geelong this 3rd day of June, 1971.

GLYN JENKINS, Liquidator.

Day, Neilson, Jenkins & Johns, chartered accountants, P.O. Box 1, Geelong, 3220. 619

Companies Act 1961.

TOWER ENTERPRISES PTY. LTD.

AT an Extraordinary General Meeting of the members of the above-named company, duly convened and held at 45 Wonga-road, Ringwood, on Monday, 31st May, 1971, the following Special Resolutions were passed:—

“That the company be wound up voluntarily, that Thomas Brian Bourke, public accountant, of 21 Milton-street, Nunawading, be appointed liquidator for the purpose of the winding-up.”

Dated this 2nd day of June, 1971.

THOMAS BRIAN BOURKE, Liquidator.

21 Milton-street, Nunawading. 595

Companies Act 1961.—Notice of Meeting of Creditors of SHARE PORTFOLIO AND INVESTMENT SERVICES PTY. LTD. (Formerly Supervised Portfolios Pty. Ltd.).

NOTICE is hereby given that, pursuant to section 261 of the Companies Act 1961, a meeting of the creditors of Share Portfolio and Investment Services Pty. Ltd. (formerly Supervised Portfolios Pty. Ltd.) will be held at the offices of Hudson Pitt Associates, Suite 14, 30 Queens-road, Melbourne, 3004, on the 15th day of June, 1971, at 11 a.m., the company having convened a meeting of its members for the same day for the purpose of considering and, if thought fit, passing a Special Resolution that the company be wound up voluntarily, and that Hudson Bernard Pitt, of 30 Queens-road, Melbourne, be appointed liquidator.

Dated this 2nd day of June, 1971.

599

A. S. ARNEY, Director.

Companies Act 1961.

BRADSHAW & ALLAN PTY. LTD. (IN VOLUNTARY
LIQUIDATION).

NOTICE OF FINAL MEETING, PURSUANT TO SECTION 272.

NOTICE is hereby given, pursuant to Section 272 of the Companies Act, that the Final General Meeting of the members of the above-named company will be held at the office of Davis & Raven, chartered accountants, 84 Jolimont-street, Jolimont, on the 12th July, 1971, at 2.30 p.m., for the purpose of having an account laid before it showing the manner in which the winding up has been conducted and the property of the company disposed of, and hearing any explanation that may be given by the liquidator.

Dated this 1st day of June, 1971.

607

N. G. RAVEN, Liquidator.

The Companies Act 1961.—In the matter of BROTT-BOSA PTY. LTD., 217 Beach Reserve, Edithvale.—Notice Re Meeting of Creditors, Pursuant to Section 260.

NOTICE is hereby given that a meeting of creditors of the above-named company will be held at Room 320, Princes Gate, 3rd Floor, East Tower, 151 Flinders-street, Melbourne, on Tuesday, 15th June, 1971, at 10.30 a.m., the company having convened a meeting of its members for the previous day for the purpose of considering a Special Resolution that the company be wound up voluntarily.

Dated this 31st day of May, 1971.

D. BROTT, Director.

Bent & Cogle, public accountants, Suite 18, 545 St. Kilda-road, Melbourne, 3004. 610

WALLARA INVESTMENTS PROPRIETARY LIMITED (IN
VOLUNTARY LIQUIDATION).

TAKE notice that the affairs of the above-named company are now fully wound up and that, pursuant to section 272 (1) of the Companies Act 1961, a General Meeting will be held on the 11th day of July, 1971, at 2 p.m., at 142 Sydney-road, Coburg, for the purpose of laying before the meeting an account showing how the winding up has been conducted and the property of the company has been disposed of, and giving any explanation thereof.

Dated this 1st day of June, 1971.

623

G. R. TURVILLE, Liquidator.

Companies Act 1961.

SALRON INVESTMENTS PTY. LTD.

PURSUANT TO SECTION 254 (2).

AT an Extraordinary General Meeting of members of the above-named company duly convened and held at 12 Sebastopol-street, Caulfield, on the 31st day of May, 1971, the following Special Resolution was duly passed:—
“That the company be wound up voluntarily as it ceased to trade.”

And at such last-mentioned meeting Leopold Rosner, of 2nd floor, 46 Elizabeth-street, Melbourne, was appointed liquidator for the purpose of the winding up.

Dated this 1st day of June, 1971.

638

R. W. BUNTON, Chairman.

EGLINGTON PASTORAL CO. PTY. LIMITED.

PURSUANT TO SECTION 254 (2) OF THE COMPANIES ACT 1961.

NOTICE is hereby given that at an Extraordinary General Meeting of members of the above company held on the 4th day of June, 1971, the following Resolution was passed—

That the company be wound up voluntarily and that Eric Ernest Fookes, of 339 Collins-street, Melbourne, be appointed liquidator.

Dated this 4th day of June, 1971.

646

D. J. SAVENAKE, Secretary.

In the matter of the Companies Act 1961; and in the matter of T.N.T. VIC.-TAS. (EQUIPMENT) PTY. LIMITED (in Liquidation).—Members' Voluntary Winding Up.

NOTICE is hereby given that a Final Meeting of members of the above-named company, being a redundant company, will be held at the offices of Messrs. Hungerford, Spooner and Kirkhope, 2 Castlereagh-street, Sydney, on Friday, 9th July, 1971, at 10.30 a.m. for the purpose of receiving the liquidators' account and their report upon the winding up.

Dated this 9th day of June, 1971.

B. I. MURRAY & P. T. GILBERT, liquidators, 68 Pitt-street, Sydney, N.S.W. 714

NOTICE is hereby given that upon a petition presented to the Supreme Court by Suedette (Melb.) Pty. Ltd. the Supreme Court did on the 28th day of May, 1971, confirm a reduction of capital of the said company from \$20,000 divided into 10,000 shares of \$2 each (of which 7,495 shares are issued and paid to \$1 each and 5 shares are issued and paid to \$2 each) to \$12,495.50 divided into 12,495 shares of \$1 each and 5 shares of ten cents each such reduction being effected by returning to the holder of the shares presently paid to \$1 the sum of ninety cents per share in cash and by cancelling an amount of ten cents per share of the uncalled liability outstanding on each of such shares, and further, by returning to the holders of the shares presently paid to \$2 the sum of \$1.90 per share in cash, being a total amount of \$6,755 to be returned to shareholders, and that on the 4th day of June, 1971, an office copy of the Order of the Supreme Court confirming the said reduction was lodged with the Registrar of Companies.

RODDA, BALLARD & VROLAND, solicitors for the company: 693

Companies Act 1961.—In the matter of HAMILL SERVICE STATION PROPRIETARY LIMITED (in Voluntary Liquidation).—Members Winding Up.

NOTICE is hereby given that pursuant to section 272 of the above Act, the Final General Meeting of the members of the company for the purpose of receiving the liquidator's account showing how the winding up has been conducted and how the property of the company has been disposed of will be held at the offices of Messrs. L. A. Walker & Son, chartered accountants, 4th Floor, Miller House, 357 Little Collins-street, Melbourne, in the State of Victoria, on Friday, 16th day of July, 1971, at 4.30 p.m.

Dated this 4th day of June, 1971.

663 P. A. WALKER, Liquidator.

Companies Act 1961.
REDDING & CO. PTY. LTD.
PURSUANT TO SECTION 254 (2).

AT an Extraordinary General Meeting of members of the above-named company duly convened and held at 28 Yuille-street, Brighton, on the 4th day of June, 1971, the following Resolution was passed as a Special Resolution:

"That the company be wound up voluntarily."

And at such last-mentioned meeting Peter Hartley Falkingham, of Suite 15, 564 St. Kilda-road, Melbourne, was appointed liquidator for the purpose of the winding up.

Dated this 7th day of June, 1971.

665 M. E. E. REDDING, Secretary.
J. L. W. REDDING, Director.

The *Companies Act 1961.*—In the matter of WILLERT PTY. LIMITED (in Voluntary Liquidation).—Members Winding Up.

NOTICE is hereby given that at the Extraordinary General Meeting of Willert Pty. Limited duly convened and held at 2 Hosie-street, Richmond, in the State of Victoria, on the 3rd day of June, 1971, the following Resolution was proposed and passed as a Special Resolution:

"That the company be wound up voluntarily."

Dated this 3rd day of June, 1971.

667 R. W. BETTS, Liquidator.

The *Companies Act 1961.*—In the matter of HOMEFLAIR PROPRIETARY LIMITED (in Voluntary Liquidation).

NOTICE is hereby given that at an Extraordinary Meeting of the members of the above-named company held on Monday, the 31st day of May, 1971, it was resolved that the company be wound up voluntarily and at a meeting of creditors held on the same day it was resolved that for such purpose Geoffrey Ormon Harrison, of Hall & Rose, chartered accountants, 254 Queen-street, Melbourne, be appointed liquidator.

Notice is also given that after 21 days from this date I shall proceed to distribute the assets. All creditors having any claim against the company should furnish particulars of same by that date, otherwise I shall proceed to distribute the assets without regard to their claim.

Dated this 3rd day of June, 1971.

G. O. HARRISON, Liquidator.
Hall & Rose, chartered accountants, 254 Queen-street, Melbourne. 676

Companies Act 1961, Section 254.

H. RUSSELL PROPRIETARY LIMITED.

NOTICE is hereby given that, at an Extraordinary General Meeting of the members of the above-named company, duly convened and held at 10 Palm-court, East St. Kilda, on the 31st day of May, 1971, the following Special Resolution was duly passed:—

"That the company be wound up voluntarily, and that Geoffrey Lewis Sutton, of 21 Winbourne-road, Mount Waverley, be appointed liquidator for the purpose of such winding up."

Dated this 2nd day of June, 1971.

704 G. L. SUTTON, Liquidator.

The *Companies Act 1961.*—In the matter of RUJO PRODUCTS PROPRIETARY LIMITED (in Voluntary Liquidation).—Members Winding Up.

NOTICE is hereby given that, at the Extraordinary General Meeting of Rujo Products Proprietary Limited, duly convened and held at 397 Somerville-road, West Footscray, in the State of Victoria, on the 4th day of June, 1971, the following resolution was proposed and passed as a Special Resolution:—

"That the company be wound up voluntarily."

Dated this 4th day of June, 1971.

710 R. W. BETTS, Liquidator.

Form 7.

Companies Act 1961, Section 254 (2).

NUNNITT TIMBER COMPANY PROPRIETARY LIMITED.
NOTICE OF RESOLUTION.

To the Registrar of Companies.

AT an Extraordinary General Meeting of the members of Nunnitt Timber Company Proprietary Limited duly convened and held at 39 Service-street, Bairnsdale, on the 3rd day of June, 1971, the Special Resolution set out below was duly passed:—

"That the company be wound up voluntarily and that Thomas Eager, chartered accountant, 39 Service-street, Bairnsdale be appointed liquidator for the purposes of such winding up."

Dated this 3rd day of June, 1971.

678 T. EAGER, Secretary.

Companies Act 1961.

FOWLSURE PROPRIETARY LIMITED (IN LIQUIDATION).
NOTICE PURSUANT TO SECTION 254 (2) (b) OF THE COMPANIES ACT 1961.

NOTICE is hereby given that at an Extraordinary General Meeting of the members of the above-named company, held on Monday, 31st May, 1971, the subjoined Resolution was passed:—

"That Fowlsure Proprietary Limited should be wound up voluntarily as a members' voluntary winding up and that Bruce Edward Fordham having given his written consent to act be appointed liquidator and that the remuneration of the liquidator be, and is hereby fixed, in accordance with the average of the scale of charges laid down by the Institute of Chartered Accountants in Australia, applicable to liquidations as set out in the Institute's scale of charges, dated 20th November, 1970; and that pursuant to section 269 of the *Companies Act 1961*, the liquidator be and is hereby authorised to exercise any of the powers given by paragraphs (b), (c) and (d) of sub-section 236, to a liquidator in a winding up by the court.

Dated this 31st day of May, 1971.

691 H. A. FOWLER, Director.

The *Companies Act 1961.*

NOTICE OF FINAL MEETING OF SHAREHOLDERS OF READ & KENNY PROPRIETARY LIMITED (IN VOLUNTARY LIQUIDATION).

NOTICE is hereby given in pursuance of section 272 of the *Companies Act 1961*, that a general meeting of the members of Read & Kenny Proprietary Limited (in Voluntary Liquidation), will be held at 419 Lonsdale-street, Melbourne, at 11 o'clock, in the forenoon, for the purpose of laying before the meeting an account showing how the winding up has been conducted and the property of the company has been disposed of and of giving any explanation of the account.

694 M. J. SCOTT, Liquidator.

Companies Act 1961.

CADONG PTY. LTD. (IN LIQUIDATION).

NOTICE PURSUANT TO SECTION 254 (2) (b) OF THE COMPANIES ACT 1961.

NOTICE is hereby given that at an Extraordinary General Meeting of the members of the above-named company, held on Monday, 31st May, 1971, the sub-joined Resolution was passed:—

“That Cadong Pty. Ltd. should be wound up voluntarily as a members' voluntary winding up and that Bruce Edward Fordham having given his written consent to act be appointed liquidator and that the remuneration of the liquidator be, and is hereby fixed, in accordance with the average of the scale of charges laid down by the Institute of Chartered Accountants in Australia, applicable to liquidations as set out in the Institute's scale of charges, dated November 20, 1970; and that pursuant to section 269 of the *Companies Act 1961*, the liquidator be and is hereby authorised to exercise any of the powers given by paragraphs (b), (c) and (d) of sub-section 236, to a liquidator in a winding up by the court.”

Dated this 31st day of May, 1971.

692

H. A. FOWLER, Director.

Companies Act 1961.—In the matter of JENOURA CONSTRUCTIONS PTY. LTD.

NOTICE Re MEETING OF CREDITORS PURSUANT TO SECTION 260.

NOTICE is hereby given that a meeting of creditors of the above-named company will be held at A.H.A. Conference Room, 4th Floor, 130 Flinders-street, Melbourne, on Wednesday, 16th June, 1971, at 2.30 p.m., the company having convened an Extraordinary General Meeting of its members for the same day for the purpose of considering a Special Resolution that the company be wound up voluntarily.

Dated this 4th day of June, 1971.

ROGER YALLOUZ, Director.

Lewis Luckins & Co., chartered accountants, 130 Flinders-street, Melbourne, 3000. Telephone 63 8827. 695

The Companies Act 1961.—In the matter of CHALICEWARE PTY. LTD.—Notice Re Meeting of Creditors Pursuant to Section 260.

NOTICE is hereby given that a meeting of creditors of the above-named company will be held at the offices of Kennedy, Smail & Middlemiss, 296 Little Lonsdale-street, Melbourne, at 11.00 a.m., on the 16th day of June, 1971, the company having convened a meeting of its members for the same day for the purpose of considering a resolution that the company be wound up voluntarily.

Dated this 8th day of June, 1971.

A. T. INGLIS, Director.

Kennedy, Smail & Middlemiss, 296 Little Lonsdale-street, Melbourne, 3000. 696

Companies Act 1961.

NOTICE OF MEETING OF CREDITORS OF H. D. SMITH & SON PTY. LTD.

NOTICE is hereby given that pursuant to section 260 of the *Companies Act 1961*, a meeting of the creditors of H. D. Smith & Son Pty. Ltd., will be held at the Institute of Chartered Accountants, 23 McKillop-street, Melbourne, on Monday, 21st June, at 10 a.m., the company having convened a meeting of its members on the same day at 9 a.m. for the purpose of considering and, if thought fit, passing a Special Resolution that the company be wound up voluntarily, and that Maurice John Kellett, public accountant and registered liquidator, of 153 Upper Heidelberg-road, Ivanhoe, be appointed liquidator. 697

Companies Act 1961.

FRAGILE FREIGHT PTY. LTD. (IN LIQUIDATION).

NOTICE TO CREDITORS OF INTENTION TO DECLARE DIVIDEND.

A SECOND Dividend is intended to be declared in the above matter. Creditors who have not proved their debt by the 22nd June, 1971, will be excluded from this dividend. The date of liquidation was 10th March, 1971.

Dated this 8th day of June, 1971.

LEWIS LUCKINS, F.C.A., Liquidator.

Lewis Luckins & Co., chartered accountants, 130 Flinders-street, Melbourne, 3000, telephone 63 8827. 742

WARRNAMBOOL DRIVE-IN LIMITED (IN VOLUNTARY LIQUIDATION).

NOTICE CONVENING FINAL MEETING.

NOTICE is hereby given pursuant to section 272 (2) of the *Victorian Companies Act 1961* that a General Meeting of members of the above company will be held in the offices of Alexander & Spencer, 94 Elizabeth-street, Melbourne, on Wednesday, 14th July, 1971, commencing at 11 a.m. for the purpose of having an account laid before them showing the manner in which the winding up has been conducted and the property of the company disposed of, and of hearing any explanation that may be given by the liquidator.

Dated this 10th day of June, 1971.

730

L. E. ALEXANDER, Liquidator.

Companies Act 1961.—In the matter of PRIME BEEF PASTORAL CO. PTY. LTD. (in Voluntary Liquidation).

NOTICE is hereby given that at an Extraordinary General Meeting of shareholders of the above-named company duly constituted and held at the company's registered office on Monday, 31st May, 1971, the following Special Resolution was passed:—

“That the company be wound up voluntarily.”

It was also resolved at the same meeting that Mr. Noel Colin Rundle, of 561 Bourke-street, Melbourne, be appointed liquidator.

Dated this 31st day of May, 1971.

738

M. H. WINNEKE, Director.

Companies Act 1961.—Section 254 (2).

K. & I. McINTYRE PTY. LTD.

A SPECIAL Resolution was passed on 31st May, 1971, that the company be placed in liquidation and that Lewis Luckins, chartered accountant, be and hereby is appointed as liquidator.

IAN HUGH McINTYRE, Director.

Note.—The directors of the company have made a Declaration of Solvency in accordance with section 257 of the *Companies Act 1961*, and all debts will be paid in full.

Lewis Luckins & Co., chartered accountants, 130 Flinders-street, Melbourne, 3000, telephone 63 8827. 743

Companies Act 1961.

NOTICE OF MEETING OF CREDITORS OF J. K. NEWMAN & ASSOCIATES PTY. LTD.

NOTICE is hereby given that pursuant to section 260 of the *Companies Act 1961*, a meeting of the creditors of J. K. Newman & Associates Pty. Ltd. will be held at the Methodist Conference Centre, 130 Little Collins-street, Melbourne, on the 11th day of June, 1971, at 3 p.m., the company having convened a meeting of its members for the 10th day of June, 1971, for the purpose of considering and if thought fit passing a Special Resolution that the company be wound up voluntarily and that Alan Bruce McMullin, chartered accountant and registered liquidator of 39 Little Collins-street, Melbourne, be appointed liquidator. 613

Companies Act 1961.

NOTICE OF MEETING OF CREDITORS OF GEODRAFTING SERVICES PTY. LTD.

NOTICE is hereby given that pursuant to section 260 of the *Companies Act 1961*, a meeting of the creditors of Geodrafting Services Pty. Ltd. will be held at the Methodist Conference Centre, 130 Little Collins-street, Melbourne, on the 18th day of June, 1971, at 3 p.m., the company having convened a meeting of its members for the 17th day of June, 1971 for the purpose of considering and if thought fit passing a Special Resolution that the company be wound up voluntarily and that Alan Bruce McMullin, chartered accountant and registered liquidator of 39 Little Collins-street, Melbourne, be appointed liquidator. 614

Companies Act 1961.

QUEST EXPLORATION PTY. LTD.

NOTICE OF RESOLUTION.

AT an Extraordinary General Meeting of the above-named company duly convened and held at the offices of Quest Exploration Pty. Ltd., 100 Collins-street, Melbourne, on 8th June, 1971, the following resolutions were passed as Special Resolutions.

That the company be wound up voluntarily in accordance with section 254 of the *Companies Act 1961*.

That Thomas Dunn Maclean, accountant, of Suite 3, 545 St. Kilda-road, Melbourne be appointed liquidator.

That the liquidator be given power to distribute to the members *in specie* the remaining assets of the company.

Dated this 8th day of June, 1971.

T. D. MACLEAN, Liquidator.

T. D. Maclean & Company, accountants, Suite 3, 545 St. Kilda-road, Melbourne, 3004. 725

In the Supreme Court of Victoria.—C.O.8105.—In the matter of the *Companies Act 1961*; and in the matter of HETTENA TUNNELLING PTY. LTD.

NOTICE is hereby given that a petition for the winding-up of the above-named company by the Supreme Court was on the 21st day of April, 1971, presented by James Canny, Deputy Commissioner of Taxation of the Commonwealth of Australia and that the said petition is directed to be heard before the Court sitting at the Fourteenth Court, Law Courts, William-street, Melbourne, at the hour of 10.30 o'clock in the forenoon on the 16th day of July, 1971, and any creditor or contributory of the said company desiring to support or oppose the making of an order on the said petition may appear at the time of hearing by himself or his counsel for the purpose; and a copy of the said petition will be furnished to any creditor or contributory of the said company requiring the same by the undersigned on payment of the regulated charge for the same.

The petitioner's official address is 350 Collins-street, Melbourne.

The petitioner's solicitor is Robert Burns Hutchison, Crown Solicitor for the Commonwealth, of 99 Queen-street, Melbourne.

R. B. HUTCHISON.

NOTE.—Any person who intends to appear on the hearing of the said petition must serve on or send by post to the above-named R. B. Hutchison, notice in writing of his intention so to do. The notice must state the name and address of the person, or, if a firm, the name and address of the firm, and must be signed by the person or firm, or his, or their solicitor (if any), and must be served or, if posted, must be sent by post in sufficient time to reach the above-named not later than 4 o'clock in the afternoon of the 15th day of July, 1971. 739

In the Supreme Court of Victoria.—C.O.8132.—In the matter of the *Companies Act 1961*; and in the matter of GRANVILLE PHILLIPS PROPRIETARY LIMITED.

NOTICE is hereby given that a petition for the winding-up of the above-named company by the Supreme Court was on the 2nd day of June, 1971, presented by James Canny, Deputy Commissioner of Taxation of the Commonwealth of Australia and that the said petition is directed to be heard before the Court sitting at the Fourteenth Court, Law Courts, William-street, Melbourne, at the hour of 10.30 o'clock in the forenoon on the 30th day of July, 1971, and any creditor or contributory of the said company desiring to support or oppose the making of an order on the said petition may appear at the time of hearing by himself or his counsel for the purpose; and a copy of the said petition will be furnished to any creditor or contributory of the said company requiring the same by the undersigned on payment of the regulated charge for the same.

The petitioner's official address is 350 Collins-street, Melbourne.

The petitioner's solicitor is Robert Burns Hutchison, Crown Solicitor for the Commonwealth, of 99 Queen-street, Melbourne.

R. B. HUTCHISON.

NOTE.—Any person who intends to appear on the hearing of the said petition must serve on or send by post to the above-named R. B. Hutchison, notice in writing of his intention so to do. The notice must state the name and address of the person, or, if a firm, the name and address of the firm, and must be signed by the person or firm, or his, or their solicitor (if any), and must be served or, if posted, must be sent by post in sufficient time to reach the above-named not later than 4 o'clock in the afternoon of the 29th day of July, 1971. 740

In the Supreme Court of Victoria.—1971 C.O.8131.—In the matter of the *Companies Act 1961*; and in the matter of WEST SUBURBAN BUILDING SERVICES AND SUPPLIES PROPRIETARY LIMITED.

NOTICE is hereby given that a petition for the winding-up of the above-named company by the Supreme Court was on the 2nd day of June, 1971, presented by James Canny, Deputy Commissioner of Taxation of the Commonwealth of Australia and that the said petition is directed

to be heard before the Court sitting at the Fourteenth Court, Law Courts, William-street, Melbourne, at the hour of 10.30 o'clock in the forenoon on the 30th day of July, 1971, and any creditor or contributory of the said company desiring to support or oppose the making of an order on the said petition may appear at the time of hearing by himself or his counsel for the purpose; and a copy of the said petition will be furnished to any creditor or contributory of the said company requiring the same by the undersigned on payment of the regulated charge for the same.

The petitioner's official address is 350 Collins-street, Melbourne.

The petitioner's solicitor is Robert Burns Hutchison, Crown Solicitor for the Commonwealth, of 99 Queen-street, Melbourne.

R. B. HUTCHISON.

NOTE.—Any person who intends to appear on the hearing of the said petition must serve on or send by post to the above-named R. B. Hutchison, notice in writing of his intention so to do. The notice must state the name and address of the person, or, if a firm, the name and address of the firm, and must be signed by the person or firm, or his, or their solicitor (if any), and must be served or, if posted, must be sent by post in sufficient time to reach the above-named not later than 4 o'clock in the afternoon of the 29th day of July, 1971. 741

CREDITORS, next of kin and others having claims against the estate of Vyvienne Lindsay Hopkins, late of 603 Dandenong-road, Armadale, home duties, deceased (who died on 11th July, 1970), are required to send particulars of their claims to the administrator George Kirkland Sheppard, care of the under-mentioned solicitor before 12th September, 1971, after which date he will distribute the assets, having regard only to the claims of which he then has notice.

THOMAS BURKE, solicitor, 152 Wattletree-road, Malvern. 611

HILDA OLIVE DALTON, late of Swan Hill in the State of Victoria, widow, DECEASED (who died on the 18th April, 1971).

CREDITORS, next of kin and all other persons having claims against the estate of the deceased are required by the executors of the will, Roy Richard Henry Dalton, Lily Grace Lanyon and Thelma Isabel Mitchell, to send particulars to them care of the undersigned on or before the 31st August, 1971, after which date they will distribute the assets, having regard only to the claims of which they then have notice.

GARDEN & GREEN, solicitors, 4 McCallum-street, Swan Hill. 620

DUGLAS FRED LAMBERT STORER, late of 25 Chapel-street, Colac in the State of Victoria, retired grazier, DECEASED.

CREDITORS, next of kin and others having claims in respect of the estate of the deceased (who died on 17th day of November, 1970), are required by the executors Edward John Dalton, of Condah, farmer and Ronald Peter Campbell Lowenstern, of Hamilton, solicitor to send particulars to them care of the under-mentioned solicitors by 16th day of August, 1971, after which date the executors may convey or distribute the assets, having regard only to the claims of which they then have notice.

CAMERON & LOWENSTERN, solicitors, 62 Thompson-street, Hamilton. 596

CREDITORS, next of kin and others having claims in respect of the estate of Samuel Charles Sharp Bazeley, late of Flat 6, 95 Wilson-street, Brighton, gentleman, deceased (who died on the 5th February, 1971), are required to send-particulars of their claims to the Equity Trustees, Executors and Agency Company Limited, of 472 Bourke-street, Melbourne, by 14th August, 1971, after which date it will distribute the assets, having regard only to the claims of which it then has notice.

R. T. BREEN & CO., solicitors, 86 Church-street, Middle Brighton. 602

CREDITORS, next of kin and others having claims in respect of the will of Louis Currie, late of Mount Royal, Parkville, retired (who died on the 7th May, 1971), are requested to send particulars of their claims to the executor John Currie (senior) care of the under-mentioned solicitor by the 18th August, 1971, after which date he will distribute the assets, having regard only as to the claims of which he then has notice.

JOHN STEWART, solicitor, of 290 Racecourse-road, Newmarket. 608

RICHARD THOMAS GRIFFITHS, late of Gibson-street, Trafalgar, in the State of Victoria, gentleman, DECEASED.

CREDITORS, next of kin and others having claims in respect of the estate of the deceased (who died on the 10th day of April, 1971), are required by the personal representative Francis Daniel Rowell, of 7 Mile-road, Trafalgar, in the said State, farmer to send particulars to him care of the under-mentioned solicitors by the 9th day of August, 1970, after which date the personal representative may convey or distribute the assets, having regard only to the claims of which he then has notice.

KEVIN DAVINE & SONS, solicitors, Contingent-street, Trafalgar. 606

CREDITORS, next of kin and others having claims in respect of the estate of Dorothy Victoria Howe, late of 13 Loeman-street, Essendon, in the State of Victoria, widow, deceased (who died on the 11th day of July, 1970), are required to send particulars of their claims, in writing, to the executor, Leslie Belworthy, care of the under-mentioned solicitor by the 18th day of August, 1971, after which date he will distribute the assets, having regard only to the claims of which he then has notice.

PATRICIA O'DONOGHUE, solicitor, 209 Pascoe Vale-road, Essendon. 609

CREDITORS, next of kin and others having claims in respect of the estate of Marie Grace de Lancey Greene, late of Cruden Farm, Langwarrin, widow, deceased (who died on the 22nd day of February, 1971), are to send particulars of their claims to the executors, care of The Union-Fidelity Trustee Company of Australia Limited, at 100 Exhibition-street, Melbourne, by the 11th day of August, 1971, after which date they will distribute the assets, having regard only to the claims of which they then have notice.

J. M. SMITH & EMMERTON, solicitors, 170 Queen-street, Melbourne. 716

CREDITORS, next of kin and others having claims in respect of the estate of Lillian Alpha Foote, late of the Town of Geneva, Ontario, County New York, United States of America, married woman, deceased (who died on the 19th day of January, 1971), are to send particulars of their claims to The Equity Trustees, Executors and Agency Company Limited, of 472 Bourke-street, Melbourne, by the 23rd day of August, 1971, after which date it will distribute the assets, having regard only to the claims of which it then has notice.

LEACH & THOMSON, solicitors, 472 Bourke-street, Melbourne. 726

CREDITORS, next of kin and others having claims in respect of the estate of Lillian Mary Gedye, late of 10 Parkside-street, Blackburn, widow, deceased, intestate (who died on the 13th day of December, 1970), are to send particulars of their claims to The Equity Trustees, Executors and Agency Company Limited, of 472 Bourke-street, Melbourne, by the 23rd day of August, 1971, after which date it will distribute the assets, having regard only to the claims of which it then has notice.

LEACH & THOMSON, solicitors, 472 Bourke-street, Melbourne. 727

CREDITORS, next of kin and others having claims in respect of the estate of Edna Madge Chisholm, late of 223 Domain-road, South Yarra, are to send particulars of their claims to The Union-Fidelity Trustee Company of Australia Limited, of 100 Exhibition-street, Melbourne, by the 9th day of August, 1971, after which date it will distribute the assets, having regard only to the claims of which it then has notice.

RYLAH & RYLAH, solicitors, 349 Collins-street, Melbourne. 732

WILLIAM LUKE, formerly of 24 North-road, Newport, but late of Judge Book Memorial Village, Eltham, in the State of Victoria, retired railway employee, DECEASED.

CREDITORS, next of kin and others having claims against the estate of the above-named deceased (who died on the 4th day of November, 1970), are to send particulars of their claims to the executors, Frederick Allenby Etherton, manager, and Alan George Luke, engineer, care of the under-mentioned solicitor, by the 16th day of August, 1971, after which day they will distribute the assets, having regard only to the claims of which they have then had notice.

MICHAEL R. NOLAN, solicitor, 62 Jackson-court, East Doncaster, 3109. 711

CREDITORS, next of kin and others having claims in respect of the estate of Thelma Doris Fox, late of 45 Ward-grove, Pascoe Vale, married woman, deceased (who died on the 17th April, 1971), are to send particulars of their claims to The Union-Fidelity Trustee Company of Australia Limited, of 100 Exhibition-street, Melbourne, by the 11th August, 1971, after which date the said company will distribute the assets, having regard only to the claims of which it then has notice.

R. WADHAM & DOIG, of 383 Flinders-lane, Melbourne, solicitors. 685

ALL persons having claims against the estate of Allan Garson, late of 12 Grandview-road, Chadstone, in the State of Victoria, director, deceased (who died on the 21st October, 1970, and probate of whose will was granted by the Supreme Court of Victoria to the Trustees, Executors and Agency Company Limited, Sandra Anne Quick and Julie Rose Garson, on the 31st May, 1971), are hereby required to send particulars of such claims to The Trustees, Executors and Agency Company Limited, at its registered office, at 401 Collins-street, Melbourne, on or before 9th August, 1971, after which date the said company and Sandra Anne Quick and Julie Rose Garson, will proceed to transfer, convey or distribute the said estate to or among the persons entitled thereto, having regard only to the claims of which they shall then have had notice, and will not be liable for the assets so transferred, conveyed or distributed to any persons of whose claim they shall not then have had notice.

ELLISON, HEWISON & WHITEHEAD, solicitors, 379 Collins-street, Melbourne. 686

CREDITORS, next of kin and others having claims in respect of the will of Antonina Fratarano, late of O'Connors-road, Werribee South, married woman, deceased (who died on the 4th day of November, 1970), are to send particulars of their claims to the Executors, Santo Fratarano and Gaetano Fratarano, both of O'Connors-road, Werribee, care of the under-mentioned solicitors, by the 16th day of August, 1971, after which date they will distribute the assets, having regard only to the claims of which they then have notice.

LLOYD P. GOODE & CO., solicitors, of 406 Lonsdale-street, Melbourne. 687

CREDITORS, next of kin and others having claims in respect of the will of John Henry Bowskill, formerly of 17 Cochrane-street, Brighton, but late of 5 Bright-street, East Brighton, gentleman, deceased (who died on the 1st day of March, 1971), are to send particulars of their claims to the executrix, Mavis Sutherland Bowskill, of 5 Bright-street, East Brighton, care of the under-mentioned solicitors, by the 16th day of August, 1971, after which date she will distribute the assets, having regard only to the claims of which she then has notice.

LLOYD P. GOODE & CO., solicitors, of 406 Lonsdale-street, Melbourne. 688

LANCELOT BATHURST HACKETT, late of 26 Aberfeldie-street, Essendon, in the State of Victoria, engineer, DECEASED.

CREDITORS, next of kin and others having claims in respect of the estate of Lancelot Bathurst Hackett, late of 26 Aberfeldie-street, Essendon in the State of Victoria, engineer, deceased (who died on the 23rd August, 1970), are required to send particulars of their claims to The Trustees, Executors and Agency Company Limited, of 401 Collins-street, Melbourne, the executor, of the will of the said deceased, on or before the 11th August, 1971, after which date it will distribute the assets, having regard only to the claims of which it then has notice.

McNAB & McNAB, 17 Queen-street, Melbourne, solicitors. 689

JOSEPH HENRY OPIE, late of Windsor Hall, The Avenue, Windsor, retired journalist, DECEASED.

CREDITORS, next of kin and others having claims in respect of the estate of the deceased (who died on the 8th day of January, 1971), are required by the trustee, George Neville Almond, of care of Best, Hooper, Rintoul & Shallard, solicitors, 100 Queen-street, Melbourne, to send particulars to him, by the 17th day of August, 1971, after which date the trustee may convey or distribute the assets, having regard only to the claims of which he then has notice.

BEST, HOOPER, RINTOUL & SHALLARD, solicitors, 100 Queen-street, Melbourne, 3000. 690

Trustee Act 1958.

NOTICE TO CLAIMANTS.

PURSUANT to the Trustee Act 1958, creditors, next of kin and all other persons having claims in respect of the estate of any deceased person named below are required to send particulars to the legal personal representative or representatives at the addresses stated, after which date the representative or representatives will distribute the assets, having regard only to the claims of which notice has been received:—

Mark David Augustus Curran, late of 2 Mirils-street, Newport, retired contract butcher, deceased, died on the 19th day of March, 1971.—Claims to the executors, Mark David Thomas Curran, of 201 Woods-street, Newport, slaughterman, and James Stanley Curran, of 63 Speight-street, Newport, slaughterman, care of John F. Carroll, of 4 Paisley-street, Footscray, solicitor, by the 25th day of August, 1971.—John F. Carroll, LL.B., solicitor, 4 Paisley-street, Footscray. 729

Alfred Otto Hoff, late of 100 Wales-street, West Footscray, retired engineer, deceased, died on the 6th day of January, 1971.—Claims to the executors, Ernest Majewski Walker, of 20 Highfield-avenue, South Blackburn, engineer, and Lindsay Downey, of 2 Stirling-road, South Blackburn, sheet metal worker, care of John F. Carroll, of 4 Paisley-street, Footscray, solicitor, by the 25th day of August, 1971.—JOHN F. CARROLL, LL.B., solicitor, 4 Paisley-street, Footscray. 728

Mary Jane Lloyd, late of 22 Olive-grove, Boronia, spinster, deceased, who died on the 20th day of April, 1965.—Claims to the administratrix, care of Gray & Gray, solicitors, 188 High-street, Northcote, by the 11th August, 1971. 718

ARTHUR STANLEY GEORGE BAKER, late of "Inala Village", 220 Middleborough-road, South Blackburn, retired journalist, DECEASED.

CREDITORS, next of kin and others having claims in respect of the estate of the deceased (who died on the 9th day of January, 1971), are required by the trustees, Russell Neish Boughton and Stephen Henry Berry, of care of Best, Hooper, Rintoul & Shallard, solicitors, 100 Queen-street, Melbourne, to send particulars to them by the 17th day of August, 1971, after which date the trustees may convey or distribute the assets, having regard only to the claims of which they then have notice.

BEST HOOPER RINTOUL & SHALLARD, solicitors, 100 Queen-street, Melbourne, 3000. 736

CREDITORS, next of kin and others having claims in respect of the estate of Alberta Victoria Ashmore, late of 103 Burnbank-street, Ballarat, in the State of Victoria (who died on the 9th day of April, 1971), are to send particulars of their claims to the executor, The Union-Fidelity Trustee Company of Australia Limited, of 101 Lydiard-street North, Ballarat, by the 1st day of August, 1971, after which date it will distribute the assets, having regard only to the claims of which it then has notice. 640

CREDITORS, next of kin and others having claims in respect of the estate of Amelia Foster, formerly of 510 Lydiard-street North, Ballarat, but late of 102 Ascot-street South, Ballarat, spinster, deceased (who died on 14th April, 1971), are required to send particulars of their claims to the executor, The Union-Fidelity Trustee Company of Australia Limited, at its address, 101 Lydiard-street North, Ballarat, by 11th August, 1971, after which date the said company will distribute the assets, having regard only to the claims of which it then has notice.

BAIRD & MCGREGOR, solicitors, Ballarat. 642

GEORGE MUNSOR, formerly of 40 York-avenue, Ivanhoe, but late of Judge Book Memorial Village, Eltham, in the State of Victoria, retired dairyman, DECEASED.

CREDITORS, next of kin and others having claims in respect of the estate of the deceased (who died on the 13th day of February, 1971), are required to send particulars of their claims to Percival Joseph Mitchell, care of F. P. & M. J. WALSH, solicitors, of 452 High-street, Northcote, before the 11th day of August, 1971, after which date he will distribute the assets, having regard only to the claims of which he then has notice.

F. P. & M. J. WALSH, solicitors, 452 High-street, Northcote. 650

ELIZABETH DAPHNE MALONEY (also known as Bessie Josephine Maloney and Elizabeth Josephine Maloney), late of St. Joseph's Home, Northcote, in the State of Victoria, widow, DECEASED.

CREDITORS, next of kin and others having claims in respect of the estate of the deceased (who died on the 8th day of December, 1970), are required to send particulars of their claims to Percival Joseph Mitchell and Daniel Augustine Kinahan, care of F. P. & M. J. WALSH, solicitors, of 452 High-street, Northcote, before the 11th day of August, 1971, after which date they will distribute the assets, having regard only to the claims of which they then have notice.

F. P. & M. J. WALSH, solicitors, 452 High-street, Northcote. 651

CREDITORS, next of kin and others having claims in respect of the estate of Clara Hardy, late of 108 MacPherson-street, Footscray, widow, deceased (who died on the 5th day of December, 1970), are to send particulars of their claims to the executor, William Powell, care of the under-mentioned solicitors, on or prior to the 13th day of August, 1971, after which date the executor will distribute the assets, having regard only to the claims of which he then has notice.

MARTIN & MARTIN, solicitors, 37 Queen-street, Melbourne. 734

CREDITORS, next of kin and others having claims in respect of the estate of Lewis Tom Gribbin, late of 1 Lincoln-street, Glen Iris, retired air force officer, deceased (who died on 1st day of March, 1971), are required by National Trustees Executors and Agency Company of Australasia Limited, of 95 Queen-street, Melbourne, to send particulars of their claims to the said company by the 10th August, 1971, after which date it will convey or distribute the assets, having regard only to the claims of which the company then has notice.

MARTIN & MARTIN, solicitors, 37 Queen-street, Melbourne. 735

AFTER fourteen days application will be made to the Supreme Court of Victoria that probate of the will dated the 15th day of March, 1968, of John Warren Kyne, late of 53 St. Andrews-street, Middle Brighton, in the State of Victoria, formerly administrative officer, but lately personnel consultant, deceased, be granted to The Equity Trustees, Executors and Agency Company Limited, of 472 Bourke-street, Melbourne, in the said State, the sole executor named therein.

DAVID BRISTOL, LEVINE & CO., solicitors, of 549 Hampton-street, Hampton, Vic., 3188. 621

MARIA ELIZABETH TISCHLER, late of 8 Lilac-street, Horsham, married woman, DECEASED.

CREDITORS, next of kin and others having claims in respect of the estate of the deceased (who died on 12th February, 1971), are required by the trustee, The Union-Fidelity Trustee Company of Australia Limited, of 100 Exhibition-street, Melbourne, to send particulars to it by the 13th day of August, 1971, after which date the trustee may convey or distribute the assets, having regard only to the claims of which it then has notice.

Dated the 31st day of May, 1971.

STEWART F. BROWN & PROUDFOOT, solicitors, 74 Wilson-street, Horsham. 622

CREDITORS, next of kin and others having claims in respect of the estate of Hugh Moffat Bell Johnstone, late of Anzac Hostel, North-road, Brighton, retired civil servant, deceased (who died on the 6th day of November, 1970), are required to send particulars of their claims to the executor, Albert John Janson, care of the under-mentioned solicitor, by the 11th day of August, 1971, after which date he will distribute the assets, having regard only to the claims of which he then has notice.

J. A. O'KEEFFE, solicitor, 1 Grandview-road, Brighton. 702

CREDITORS, next of kin and others having claims in respect of the estate of Winifred Ivy Osborne, late of 29 Rosamond-street, Balaclava, home duties, deceased, intestate (who died on the 4th April, 1971), are requested to send particulars of their claims to the administrator, Henry Robert Osborne, care of the under-mentioned solicitor, by the 18th August, 1971, after which date he will distribute the assets, having regard only to the claims of which he then has notice.

JOHN STEWART, of 290 Racecourse-road, Newmarket, solicitor. 657

PETER REED OLSON, late of Swan Hill in the State of Victoria, gentleman, DECEASED.

CREDITORS, next of kin and other persons having claims against the estate of the said deceased (who died on the 9th day of February, 1971), are required to send particulars of same to the executor, Peter James Olson, in care of the undersigned, on or before the 17th day of August, 1971, after which date he will distribute the assets, having regard only to the claims of which he then has notice.

DELANY & DWYER, barristers and solicitors, 201 Campbell-street, Swan Hill. 673

CREDITORS, next of kin and others having claims in the estate of John Hojak, late of 13 Loyola-avenue, East Brunswick, in the State of Victoria, gentleman, deceased (who died on the 23rd day of December, 1970), are to send the notice of their claims to Edward Hojak, executor of the will of the deceased, care of Leo Browne, solicitor, of 180 Elgin-street, Carlton, in the said State, by the 20th day of August, 1971, after which date the said Edward Hojak, will distribute the estate, having regard only for the claims of which they then have notice.

LEO BROWNE, solicitor, of 180 Elgin-street, Carlton. 674

CREDITORS, next of kin and others having claims against the estate of Grace Emily Wilson, late of 161 Brighton-street, Richmond, widow, deceased (who died on the 23rd day of December, 1970), are required to send particulars of their claims to the executors, Reginald William Edwards and Fred Leonard Edwards, care of the undersigned solicitor, before the 1st day of September, after which date the executors will distribute the assets, having regard only to the claims of which they then have notice.

JOHN F. CARROLL, solicitor, 118 Queen-street, Melbourne. 675

MAY SARAH STEVENS, late of 157 Gladstone-avenue, Northcote, married woman, DECEASED.

CREDITORS, next of kin and others having claims in respect of the estate of the deceased (who died on 4th day of May, 1971), are requested to send particulars of their claims to the executors, Harold Andrew Stevens, Andrew William George Stevens, and William Harold Stevens, care of the undersigned solicitor, by the 11th August, 1971, after which date the said executors will proceed to distribute the estate, having regard only to the claims of which they then have notice.

MARJORY C. COATES, solicitor, 422 Collins-street, Melbourne, 3000. 679

CREDITORS, next of kin and others having claims in respect of the estate of Leah Rosenberg, late of Caroline Private Hospital, 42 Marine-parade, St. Kilda, widow, deceased (who died on the 10th day of July, 1970), are required to send particulars of their claims to the executor, the National Trustees Executors and Agency Company of Australasia Limited, of 95 Queen-street, Melbourne, by the 14th day of August, 1971, after which date the company will distribute the assets, having regard only to the claims of which it then has notice.

MAHONY O'BRIEN & DUGGAN, solicitors, 37 Queen-street, Melbourne. 680

DOROTHY CUPPLES, late of Flat 6, 510 Glenferrie-road, Hawthorn, in the State of Victoria, spinster, DECEASED.

CREDITORS, next of kin and others having claims in respect of the estate of the deceased (who died on the 18th day of February, 1971), are required by The Trustees Executors and Agency Company Limited, of 401 Collins-street, Melbourne, to send particulars of their claims to the said company by the 14th day of August, 1971, after which date it will convey or distribute the assets, having had regard only to the claims of which the company then has notice.

MALLESONS, solicitors, St. James Building, 121 William-street, Melbourne. 681

CREDITORS, next of kin and others having claims against the estate of Percy Walter Harden, late of 102 Ascot-street, Ballarat, gentleman, deceased (who died on 13th November, 1970), are required by the executor, The Union-Fidelity Trustee Company of Australia Limited, 101 Lydiard-street north, Ballarat, to send detailed particulars of their claims to the said executor, by the 6th day of August, 1971, after which date it will proceed to distribute the said estate, having regard only to the claims of which it then has notice. 641

CREDITORS, next of kin and others having claims in respect of the estate of Alfred Melbourne Hyland, late of 68 Gardenvale-road, Gardenvale, in the State of Victoria, retired butcher, deceased (who died on 16th day of February, 1971), are to send the particulars of their claims to The Equity Trustees Executors and Agency Company Limited, of 472 Bourke-street, Melbourne, by the 10th day of August, 1971, after which date it will distribute the assets, having regard only to the claims of which it then has notice.

HADEN SMITH & FITCHETT, solicitors, 405 Collins-street, Melbourne. 682

CREDITORS, next of kin and others having claims in respect of the estate of Annesley Cunliffe Jones, formerly of 19 Hastings-street, North Bentleigh, but late of 11 Evans-street, Sunbury, in the State of Victoria, company director, retired, deceased (who died on the 5th of January, 1971), are to send particulars of their claims to the executors, The Equity Trustees Executors and Agency Company Limited, and Annesley Charles Davenport Jones, care of the undersigned solicitors, by the 9th day of August, 1971, after which date they will distribute the assets, having regard only to the claims of which they then have notice.

HALL & WILCOX, solicitors, of 20 Queen-street, Melbourne. 683

CREDITORS, next of kin and others having claims against the estate of Hilda Gwendoline Ingle, late of Flat 15, 25 Barkly-street, St. Kilda, widow, deceased (who died on the 24th April, 1971), are to send particulars of their claims to Nancye Gwendoline Hicks and Betty Matilda Morley, the executors of the will of the deceased, care of the undermentioned solicitors, by the 11th August, 1971, after which date they will distribute the assets, having regard only to the claims of which they then have notice.

R. WADHAM & DOIG, solicitors, of 383 Flinders-lane, Melbourne. 684

LILY MAY PEARSON, formerly of 308 Raglan-street south, Ballarat, but late of home for the blind, Howitt-street, Wendouree, spinster, DECEASED (who died on the 28th December, 1970).

CREDITORS, next of kin and all persons having claims against the estate of the deceased are required to send particulars to the executors, Herbert Clark Packham and Walter Henry Heinz, care of 209 Dana-street, Ballarat, on or before the 10th August, 1971, after which date they will distribute the assets, having regard only to the claims of which they shall then have notice.

HEINZ & GORDON, solicitors, 209 Dana-street, Ballarat. 643

CREDITORS, next of kin and others having claims against the estate of Bryan Joseph Morrissey, late of 51 Pultney-street, Dandenong, in the State of Victoria, solicitor, deceased (who died on the 12th April, 1968), are required to send particulars thereof to National Trustees, Executors and Agency Company of Australasia Limited, of 95 Queen-street, Melbourne, on or before the 11th day of August, 1971, after which date the said company will distribute the assets, having regard only to the claims which it then has notice.

MORRISSEY & HARDY, 25 Langhorne-street, Dandenong. 652

BARBARA COLLIE, late of 1A Wimba-avenue, Kew, in the State of Victoria, gentlewoman, DECEASED.

CREDITORS, next of kin and others having claims in respect of the estate of the deceased (who died on the 21st day of December, 1970), are required by the executors, John Edward Gamble, of 112 Finch-street, Malvern, in the said State, company director, Thomas Alian Rank, of 388 Bourke-street, Melbourne, in the said state, solicitor, and The Trustees, Executors and Agency Company Limited, of 401 Collins-street, Melbourne, in the said State to send particulars of their claims to the executors, care of the said company, on or before the 16th day of August, 1971, after which date the executors may convey or distribute the assets of the said deceased, having regard only to the claims of which they shall then have notice.

T. A. RANK & ROBINSON, solicitors, 388 Bourke-street, Melbourne, 3000. 666

THOMAS SMYTH HUTCHINSON, late of 102 Ascot-street south, Ballarat, pensioner, DECEASED (who died on the 8th February, 1971).

CREDITORS, next of kin and all persons having claims against the estate of the deceased, are required to send particulars to the executors, The Union-Fidelity Trustee Company of Australia Limited and Thomas Bruce Hutchinson, care of 101 Lydiard-street north, Ballarat, on or before the 10th August, 1971, after which date it will distribute the assets, having regard only to the claims of which it shall then have notice.

HEINZ & GORDON, solicitors, 209 Dana-street, Ballarat. 639

CREDITORS, next of kin and others having claims in respect of the estate of Vincent Tyrrell, late of 50 Armstrong-street, Middle Park, retired case manufacturer, deceased (who died on the 30th day of January, 1971), are to send particulars of their claims to the National Trustees, Executors and Agency Company of Australasia Limited, the registered office of which is situate at 95 Queen-street, Melbourne, by the 16th August, 1971, after which date it will distribute the assets, having regard only to the claims of which it then has notice.

R. P. BARRETT & SON, solicitors, 472 Bourke-street, Melbourne. 670

CREDITORS, next of kin and others having claims against the estate of Clifford Joseph Shale, late of St. Bede's College, Mentone, catholic priest, deceased (who died on 19th July, 1970), are required by Patrick Francis Toohey, the administrator with the will annexed of the estate of above-named deceased, to send to him, care of the undersigned solicitors, particulars thereof on or before 15th August, 1971, after which date he will distribute the assets, having regard only to the claims of which he shall then have notice.

GAVAN DUFFY & KING, solicitors, 95 Queen-street, Melbourne. 671

CREDITORS, next of kin and others having claims against the estate of Emily Hansford, late of 36 Walter-street, Ascot Vale, widow, deceased (who died on 20th March, 1971), are required by Albert Vern Barnett, the executor of the will of deceased, to send to him, care of the undersigned solicitors, particulars thereof on or before 15th August, 1971, after which date he will distribute the assets, having regard only to the claims of which he shall then have notice.

GAVAN DUFFY & KING, solicitors, 95 Queen-street, Melbourne. 672

In the Supreme Court of the State of Victoria.

SALE BY THE SHERIFF.

ON Friday, the 23rd of July, 1971, at 10 a.m., at the Police Station, Avondale Heights (unless process be stayed or satisfied):—

All the estate and interest (if any) of Agostino Raschilla of 13 Skewes-street, Avondale Heights, as proprietor of an estate in fee-simple in the land described in certificate of title, volume 8264, folio 610, upon which is erected a dwelling-house known as No. 13 Skewes-street, Avondale Heights.

Registered mortgages Nos. C.941351 and C.955851 and caveat No. E.28956 affects the said estate and interest.

Terms: Cash only.

DOUGLAS S. HALL, Sheriff's Officer.

2nd June, 1971.

(Issued in lieu of notice appearing in *Victoria Government Gazette* dated 2nd June, 1971, page 1899.) 576

In the Supreme Court of the State of Victoria.

SALE BY THE SHERIFF.

ON Friday, the 16th of July, 1971, at 11 a.m., at the Police Station, Sorrento (unless process be stayed or satisfied):—

All the estate and interest (if any) of Athol Ernest James, company director, and Elaine Margaret James, married woman, both of 150 Waiora-road, Rosanna, as proprietors of an estate in fee-simple in the land described in certificate of title, volume 8785, folio 600, being a vacant block of land situated in Murray-street, Blairgowrie, and known as 22 Murray-street, having its southern boundary commencing at a point 110 feet from the splay 10 feet from the intersection of Fairsea-grove and Murray-street.

Registered caveats Nos. D.867316, D.867325 affect the said estate and interest.

Terms: Cash only.

H. BUETTNER, Sheriff's Officer.

4th June, 1971.

719

In the Supreme Court of the State of Victoria.

SALE BY THE SHERIFF.

ON Friday, the 23rd of July, 1971, at 10 a.m., at the Police Station, Northcote (unless process be stayed or satisfied):—

All the estate and interest (if any) of Stavros Kalpakis, of 45 Barry-street, Northcote, as joint proprietor with Evangella Kalpakis of an estate in fee-simple in the land described in certificate of title, volume 6029, folio 660, upon which is erected a dwelling house known as No. 45 Barry-street, Northcote.

Registered caveat No. D.554325 affects the said estate and interest.

Terms: Cash only.

H. BUETTNER, Sheriff's Officer.

9th June, 1971.

720

In the Supreme Court of the State of Victoria.

SALE BY THE SHERIFF.

ON Friday, the 23rd of July, 1971, at 2 p.m., at the Police Station, Frankston (unless process be stayed or satisfied):—

All the estate and interest (if any) of Kenneth John Murphy, of 3 Margot-street, West Footscray, as proprietor of an estate in fee-simple in the land described in certificate of title volume 8453, folio 935, upon which is erected a dwelling house known as No. 15 Mincha-street, Frankston.

Registered mortgage No. C.802993 and caveat D.101488 affects the said estate and interest.

Terms: Cash only.

DOUGLAS S. HALL, Sheriff's Officer.

8th June, 1971.

721

In the Supreme Court of the State of Victoria.

SALE BY THE SHERIFF.

ON Friday, the 23rd of July, 1971, at 12 noon at the Police Station, St. Kilda (unless process be stayed or satisfied):—

All the estate and interest (if any) of Kathleen Mary McGrath, of 4 The Avenue, Balacava, as proprietor of an estate in fee simple in the land described in certificate of title volume 2316, folio 133, upon which is erected a dwelling house known as No. 4, The Avenue, Balacava.

Registered mortgage Nos. C.669202, D.936382 and caveat D.462561 affect the said estate and interest.

Terms: Cash only.

DOUGLAS S. HALL, Sheriff's Officer.

8th June, 1971.

722

In the Supreme Court of the State of Victoria.

SALE BY THE SHERIFF.

ON Tuesday, the 13th day of July, 1971, at 2.30 p.m., at the Post Office, Harcourt (unless process be stayed or satisfied):—

All the estate and interest (if any) of Spiridon Petropoulos (in the title referred to as Spiro Petropoulos) of Harcourt, orchardist, as proprietor of an estate in fee-simple in the land described in—

- (a) Certificates of title, volume 4312, folio 339; volume 7618, folio 037, and volume 8429, folio 640, subject to mortgages C.287824 and C.938094 and to caveat C.739626.
- (b) Certificate of title, volume 6968, folio 572, subject to caveats D.145701 and D.307591.
- (c) Certificate of title, volume 7883, folio 046, subject to mortgage D.263665 and caveat D.506674.

The properties referred to are situated at or near the Bendigo Highway, Harcourt, and are primarily orchards with buildings and improvements erected thereon.

Terms: Cash only.

SGT. J. C. CAREY, Sheriff's Officer.

9th June, 1971.

723

INSOLVENCY NOTICE*Bankruptcy Act 1966.*

Bankruptcy District of the State of Victoria.—No. 54 of 1971, Part X., Re: JEAN SUMMERS.

NOTICE TO CREDITORS.

AT a Meeting of Creditors of the above-named debtor held on Thursday, 3rd June, 1971, the following Special Resolution was duly passed.

"That the debtor execute a Deed of Arrangement in accordance with the proposal as submitted to this meeting of creditors."

Mr. Maxwell George Gee was appointed trustee to administer the deed. The following provisions are included in the deed of arrangement:

1. The debtor shall pay to the trustee the sum of \$100 per week. The first payment to be made within seven days of the signing of the deed.
2. The debtor shall assign the stock on hand of the business, the fixtures and fittings and the book debts including lay-bys to the trustee for the benefit of the creditors. The trustee shall postpone the realisation of the assigned assets as long as the debtor complies with the other terms of the deed.
3. The deed shall be terminated on the receipt by the non-priority creditors of 100 cents in the \$ on the debts due to them at the date of the deed.
4. A committee of inspection be appointed comprising two persons the first members to be Messrs. Ashe and Blau. This committee is to assist the debtor in the administering of the business during the continuance of the deed.

MAXWELL GEORGE GEE, Registered Trustee.

Max Gee & Co., 325 Warrigal-road, Burwood, 3125, telephone 288 5109. 712

IMPOUNDINGS

ARDEER.—Impounded in Ardeer Pound.

1 black mare, no visible brand
1 bay colt, no visible brand

If not claimed and expenses paid, to be sold on 26th June, 1971.

705—\$2.45 D. L. THOMPSON, Poundkeeper.

BENALLA.—Impounded in Benalla Pound, by Mr. J. S. Stickland, Ranger, on 1st June, 1971, at 2.30 p.m.

1 Hereford cross steer, one year old, nick out of bottom of left ear, no visible brand

If not claimed and expenses paid, to be sold on 24th June, 1971.

625—\$2.80 C. H. WALLACE, Poundkeeper.

BOX HILL.—Impounded in Box Hill Pound, by Ranger, from Mitcham area.

1 ram with horns, no visible brand
1 small lamb with long tail, no visible brand

If not claimed and expenses paid, to be sold on 24th June, 1971.

661—\$2.80 R. KENNEDY, Poundkeeper.

CHILTERN.—Impounded in Chiltern Pound.

1 ewe, blue brand
1 ram, horns have been cut, no visible brand

If not claimed and expenses paid, to be sold on 2nd July, 1971.

745—\$2.45 J. NESBITT, Poundkeeper.

DIAMOND VALLEY.—Impounded in Yan Yean-road, Plenty, Pound, on 1st June, 1971.

1 skewbald mare, 12 hands, unshod, no visible brand

If not claimed and expenses paid, to be sold on 24th June, 1971.

662—\$2.45 B. J. MORGAN, Shire Secretary.

JUNG.—Impounded in Jung Pound, from Warracknabeal.

8 rams, no visible brand or ear marks
17 ewes, with 6 lambs at foot, no visible brand or ear marks

If not claimed and expenses paid, to be sold on 19th June, 1971.

632—\$2.80 H. PHILLIPS, Poundkeeper.

KERANG.—Impounded in Kerang Pound, on 3rd June, 1971, from Myall.

1 yellow Jersey cow, milking, like C left rump
1 brown Jersey vealer, about 9 months, no visible brand
1 yellow heifer, fat, 2 years, white flanks, notch back right ear, no visible brand
1 dark Jersey steer, notch left ear, about 20 months, no visible brand

If not claimed and expenses paid, to be sold on 30th June, 1971.

659—\$4.20 F. F. HASTIE, Poundkeeper.

KERANG.—Impounded in Kerang Pound, on 1st June, 1971, from Myall.

31 Dorset Horn rams, mixed ages, unshorn, no visible brands or marks
91 ewes, mixed ages, unshorn, no visible brands
34 sucker lambs, long tails, no visible brands or marks

If not claimed and expenses paid, to be sold on 30th June, 1971.

626—\$3.50 F. F. HASTIE, Poundkeeper.

KORUMBURRA.—Impounded in Korumburra Pound, on 18th May, 1971, by Mr. John Blundell, 4 Shellcotts-road, Korumburra.

1 crossbred wether, rope around neck, no visible brand

If not claimed and expenses paid, to be sold on 28th June, 1971.

715—\$2.80 B. J. CHAFFEY, Poundkeeper.

MURCHISON.—Impounded in Murchison Pound by C.R.B. Inspector, from Goulburn Valley Highway.

1 lamb, no visible brand

If not claimed and expenses paid, to be sold on 24th June, 1971.

624—\$2.45 J. H. FERGUSON, Poundkeeper.

ORBOST.—Impounded in Orbost Pound, on 3rd June, 1971, from Forest-road, Orbost.

1 brown cow, aged four years, with brown calf, no visible brand
1 Jersey cow, aged four years, with brown calf, no visible brand
1 Jersey cow, aged four years, no visible brand

If not claimed and expenses paid, to be sold on 25th June, 1971.

713—\$3.85 W. R. DWYER, Poundkeeper.

SHEPPARTON.—Impounded in Shepparton Pound.

2 Dorset Horn rams, red mark on middle of back

If not claimed and expenses paid, to be sold on 24th June, 1971.

746—\$2.10 C. L. MANSELL, Poundkeeper.

TATURA.—Impounded in Tatura Pound, from Dhurringile.

1 Hereford bull, no visible brand

If not claimed and expenses paid, to be sold on 24th June, 1971.

660—\$2.10 J. H. MACTIER, Poundkeeper.

Subordinate Legislation Act 1962.

NOTICE OF MAKING OF STATUTORY RULES.

IN pursuance of the provisions of the *Subordinate Legislation Act 1962* and the Regulations made thereunder, notice is given of the making of the following statutory rules:—

<i>Public Service Act 1958.</i>	
109/1971. Public Service (Governor in Council) Regulations 1971 ..	20c
<i>Poisons Act 1962 (No. 6889).</i>	
110/1971. Special Poisons (Ovulatory Stimulant) Regulations 1971 ..	10c

Copies of these statutory rules may be purchased at the Sale of Publications Section of the Government Printing Office, located at MacArthur-street, Melbourne, 3002. If ordered by mail, remittance should be addressed to "The Government Printer, Box 203, P.O., North Melbourne, 3051", and should include 6c extra for postage. If a credit account is held at this office, no remittance is required with the mail order.

The annual subscription rate for Statutory Rules (including Bound Volumes) is \$23, payable in advance. The subscription year commences on 1st January.

C. H. RIXON,
Government Printer.

ACTS REPRINTED IN ACCORDANCE WITH THE AMENDMENTS INCORPORATION ACT 1958 (No. 6422), AND FOR SALE AT THE SALE OF PUBLICATIONS BRANCH OF THE GOVERNMENT PRINTING OFFICE, MACARTHUR-STREET, MELBOURNE, 3002.

(These prices do not include postage.)	
No.	Price.
6189. Acts Interpretation (<i>Second Reprint</i> —Incorporating amendments up to No. 7681) ..	\$0.28
6191. Administration and Probate (<i>Fourth Reprint</i> —Incorporating amendments up to No. 7874) ..	\$0.50
6194. Agricultural Colleges (<i>First Reprint</i> —Incorporating amendments up to No. 7302) ..	\$0.15
7117. Appeal Costs Fund Act 1964 (<i>First Reprint</i> —Incorporating amendments up to No. 7488) ..	\$0.25
6199. Apprenticeship (<i>Second Reprint</i> —Incorporating amendments up to No. 7869) ..	\$0.40
6203. Audit (<i>First Reprint</i> —Incorporating amendments up to No. 7377) ..	\$0.35
6209. Boiler Inspection (Incorporating amendments up to No. 7072) ..	\$0.18
6529. Bread Industry Act 1959 (<i>First Reprint</i> —Incorporating amendments up to No. 7728) ..	\$0.30
6973. Building Contracts (Deposits) Act 1962 (<i>First Reprint</i> —Incorporating amendments from No. 7315) ..	\$0.10
6210. Building Societies (<i>Second Reprint</i> —Incorporating amendments up to No. 7911) ..	\$0.40
6213. Cancer (<i>First Reprint</i> —Incorporating amendments up to No. 7455) ..	\$0.35
6214. Carriers and Innkeepers (<i>First Reprint</i> —Incorporating amendments up to No. 7971) ..	\$0.15
6217. Cemeteries (<i>First Reprint</i> —Incorporating amendments up to No. 7672) ..	\$0.30
6218. Children's Court (Incorporating amendments up to No. 7084) ..	\$0.20
6220. Clean Air (Incorporating amendments up to No. 6886) ..	\$0.10
6221. Coal Mines (<i>First Reprint</i> —Incorporating amendments up to No. 7628) ..	\$1.05
6222. Commercial Goods Vehicles (<i>Second Reprint</i> —Incorporating amendments up to No. 7358) ..	\$0.22
6223. Commonwealth Arrangements (<i>First Reprint</i> —Incorporating amendments from No. 7809) ..	\$0.10
6839. Companies Act 1961 (<i>Third Reprint</i> —Incorporating amendments up to Act No. 7501) ..	\$2.55
6225. Co-operation (<i>Second Reprint</i> —Incorporating amendments up to No. 7083) ..	\$0.42
6226. Co-operative Housing Societies (<i>Second Reprint</i> —Incorporating amendments up to No. 7575) ..	\$0.53
6228. Country Fire Authority (<i>Second Reprint</i> —Incorporating Amendments up to No. 7476) ..	\$0.50
6229. Country Roads (<i>Second Reprint</i> —Incorporating Amendments up to No. 7506) ..	\$0.60

ACTS REPRINTED IN ACCORDANCE WITH THE AMENDMENTS INCORPORATION ACT 1958 (No. 6422)—continued.

No.	Price.
6230. County Court (<i>First Reprint</i> —Incorporating amendments up to No. 7420) ..	\$0.35
6231. Crimes (<i>Third Reprint</i> —Incorporating amendments up to No. 7884, but not including No. 7876) ..	\$1.60
7060. Dandenong Valley Authority Act 1963 (<i>First Reprint</i> —Incorporating amendments up to No. 7523) ..	\$0.35
6815. Disposal of Uncollected Goods Act 1961 (<i>First Reprint</i> —Incorporating amendments up to No. 7181) ..	\$0.15
6236. Dog (<i>Second Reprint</i> —Incorporating amendments up to No. 7065) ..	\$0.15
6238. Drainage of Land (<i>First Reprint</i> —Incorporating amendments up to No. 7876) ..	\$0.15
6239. Dried Fruits Act 1968 (<i>First Reprint</i> —Incorporating amendments up to No. 7337) ..	\$0.25
6240. Education (<i>First Reprint</i> —Incorporating amendments up to No. 7533) ..	\$0.45
6241. Electric Light and Power (<i>First Reprint</i> —Incorporating amendments up to No. 7315) ..	\$0.30
6242. Employers and Employés (Incorporating amendments up to No. 6740) ..	\$0.18
6243. Entertainments Tax (<i>First Reprint</i> —Incorporating amendments up to No. 7315) ..	\$0.25
6245. Estate Agents (<i>Third Reprint</i> —Incorporating amendments up to No. 7425) ..	\$0.50
6246. Evidence (<i>Third Reprint</i> —Incorporating amendments up to No. 7933) ..	\$0.65
6250. Fertilizers (Incorporating amendments up to No. 7142) ..	\$0.25
6468. Filled Milk Act 1958 (<i>First Reprint</i> —Incorporating amendments up to No. 6886) ..	\$0.15
6251. Firearms (<i>Second Reprint</i> —Incorporating amendments up to No. 7484) ..	\$0.40
6252. Fisheries (<i>First Reprint</i> —Incorporating amendments up to No. 7389) ..	\$0.35
6916. Foreign Judgments Act 1962 (<i>First Reprint</i> including amendments made by No. 7332) ..	\$0.15
6585. Forests (Pulpwood Agreement) (Incorporating amendments up to No. 6886) ..	\$0.15
6254. Forests (<i>First Reprint</i> —Incorporating amendments up to No. 7356) ..	\$0.60
6255. Friendly Societies (<i>First Reprint</i> —Incorporating amendments up to No. 7554) ..	\$0.60
6256. Fruit and Vegetables (<i>First Reprint</i> —Incorporating amendments up to No. 6944) ..	\$0.30
6258. Game (<i>First Reprint</i> —Incorporating amendments up to No. 7389) ..	\$0.30
6260. Gas and Fuel Corporation (<i>First Reprint</i> —Incorporating amendments up to No. 7422) ..	\$0.70
6262. Geelong Harbor Trust (<i>First Reprint</i> —Incorporating amendments up to No. 7547) ..	\$0.45
6263. Geelong Waterworks and Sewerage (<i>First Reprint</i> —Incorporating amendments up to No. 7547) ..	\$0.75
6265. Goods (<i>Third Reprint</i> —Incorporating amendments up to No. 7131) ..	\$0.35
6266. Grain Elevators (<i>First Reprint</i> —Incorporating amendments up to No. 7486) ..	\$0.35
6270. Health (<i>Second Reprint</i> —Incorporating amendments up to No. 7490) ..	\$1.65
6531. Hire-Purchase Act 1959 (<i>First Reprint</i> —Incorporating amendments from No. 7315) ..	\$0.40
6933. Home Finance Act 1962 (<i>First Reprint</i> —Incorporating amendments up to No. 7363) ..	\$0.25
6274. Hospitals and Charities (<i>Second Reprint</i> —Incorporating amendments up to No. 7455) ..	\$0.50
6275. Housing (<i>First Reprint</i> —Incorporating amendments up to No. 7507) ..	\$0.85
6276. Imprisonment of Fraudulent Debtors (<i>First Reprint</i> —Incorporating amendments up to No. 7876) ..	\$0.35
6279. Instruments (<i>Fourth Reprint</i> —Incorporating amendments up to No. 7941) ..	\$0.75
6282. Justices (<i>Third Reprint</i> —Incorporating amendments up to No. 7966) ..	\$1.40
6283. Labour and Industry (<i>Third Reprint</i> —Incorporating amendments up to No. 7410) ..	\$1.00
6284. Land (Incorporating amendments up to No. 7360) ..	\$1.53
6534. Land Settlement Act 1959 (<i>First Reprint</i> —Incorporating amendments up to No. 7328) ..	\$0.30
6289. Land Tax (<i>Second Reprint</i> —Incorporating amendments up to No. 7466) ..	\$0.40
6285. Landlord and Tenant (<i>Third Reprint</i> —Incorporating amendments up to No. 7332) ..	\$0.68
6286. Lands Compensation (<i>First Reprint</i> —Incorporating amendments up to No. 7332) ..	\$0.25
6290. Latrobe Valley (<i>First Reprint</i> —Incorporating amendments up to No. 7332) ..	\$0.35

ACTS REPRINTED IN ACCORDANCE WITH THE AMENDMENTS
INCORPORATION ACT 1958 (No. 6422)—*continued*.

No.	Price.
6291. Legal Profession Practice (<i>Second Reprint</i> —Incorporating amendments up to No. 7539)	\$0.70
6292. Libraries (<i>First Reprint</i> —Incorporating amendments up to No. 7364)	\$0.15
6295. Limitation of Actions (<i>Second Reprint</i> —Incorporating amendments up to No. 7457)	\$0.25
7145. Litter Act 1964 (<i>First Reprint</i> —Incorporating amendments up to No. 7608)	\$0.15
7695. Liquor Control Act 1968 (<i>First Reprint</i> —Incorporating Amendments up to No. 7753)	\$0.80
6298. Local Authorities Superannuation (<i>Second Reprint</i> —Incorporating amendments up to No. 7161)	\$0.40
6299. Local Government (<i>Second Reprint</i> —Incorporating amendments up to No. 7689)	\$4.00
6299. Local Government. New Parts X. and XI. (being a reprint of portion of No. 7835, as amended by No. 7847)	\$0.50
6301. Margarine (<i>First Reprint</i> —Incorporating amendments up to No. 7714)	\$0.18
6302. Marine (Incorporating amendments up to No. 7350)	\$0.72
6304. Marketing of Primary Products (<i>First Reprint</i> —Incorporating amendments up to No. 7491)	\$0.45
6306. Marriage (<i>First Reprint</i> —Incorporating amendments up to No. 6959)	\$0.25
6309. Medical (<i>Second Reprint</i> —Incorporating amendments up to No. 7408)	\$0.40
6310. Melbourne and Metropolitan Board of Works (<i>Second Reprint</i> —Incorporating amendments up to No. 7547)	\$1.10
6311. Melbourne and Metropolitan Tramways (<i>First Reprint</i> —Incorporating amendments up to No. 7622)	\$0.70
6312. Melbourne Harbor Trust (<i>First Reprint</i> —Incorporating amendments up to No. 7356)	\$0.48
6605. Mental Health (Incorporating amendments up to No. 7135)	\$0.45
6315. Metropolitan Fire Brigades (Incorporating amendments up to No. 6886)	\$0.28
6316. Mildura Irrigation and Water Trusts (<i>First Reprint</i> —Incorporating amendments up to No. 7448)	\$0.75
6317. Milk and Dairy Supervision (Incorporating amendments up to No. 6964)	\$0.40
6318. Milk Board (Incorporating amendments up to No. 7093)	\$0.22
6319. Milk Pasteurization (<i>First Reprint</i> —Incorporating amendments up to No. 7480)	\$0.15
6320. Mines (<i>Second Reprint</i> —Incorporating amendments up to No. 7876)	\$1.25
6184. Monash University (<i>First Reprint</i> —Incorporating amendments up to No. 7533)	\$0.30
6324. Money Lenders (Incorporating amendments up to No. 6886)	\$0.25
6832. Motor Boating (Incorporating amendments up to No. 6961)	\$0.15
6325. Motor Car (<i>Third Reprint</i> —Incorporating amendments up to No. 7777)	\$1.03
6326. National Parks (Incorporating amendments up to No. 7275)	\$0.25
6328. Nurses (Incorporating amendments up to No. 6716)	\$0.20
6330. Partnership (<i>Second Reprint</i> —Incorporating amendments up to No. 7315)	\$0.25
6331. Patriotic Funds (<i>First Reprint</i> —Incorporating amendments up to No. 7338)	\$0.25
6257. Pesticides Act 1968 (<i>First Reprint</i> —Incorporating amendments up to No. 7595)	\$0.15
6334. Petroleum (<i>First Reprint</i> —Incorporating amendments up to No. 7876)	\$0.65
6889. Poisons Act 1962 (<i>Second Reprint</i> —Incorporating amendments up to No. 7588)	\$0.50
6337. Police Offences (<i>Second Reprint</i> —Incorporating amendments up to No. 7678)	\$0.28
6338. Police Regulation (Incorporating amendments up to No. 7081)	\$0.45
6340. Portland Harbor Trust (<i>First Reprint</i> —Incorporating amendments up to No. 7475)	\$0.35
6341. Pounds (<i>First Reprint</i> —Incorporating amendments up to No. 7315)	\$0.25
6342. Printers and Newspapers (<i>First Reprint</i> —Incorporating amendments up to No. 7876)	\$0.15
7494. Private Agents Act 1966 (<i>First Reprint</i> —Incorporating amendments in No. 7646)	\$0.35
6890. Probate Duty Act 1962 (<i>Second Reprint</i> —Incorporating amendments up to No. 7762)	\$0.48
6344. Property Law (<i>Second Reprint</i> —Incorporating amendments up to No. 7750)	\$1.15
6345. Public Account (<i>First Reprint</i> —Incorporating amendments up to No. 8012)	\$0.20

ACTS REPRINTED IN ACCORDANCE WITH THE AMENDMENTS
INCORPORATION ACT 1958 (No. 6422)—*continued*.

No.	Price.
6346. Public Authorities Marks (<i>First Reprint</i> —Incorporating amendments from No. 7315)	\$0.10
6349. Public Service (<i>Second Reprint</i> —Incorporating amendments up to No. 7356)	\$0.40
6350. Public Trustee (Incorporating amendments up to No. 6961)	\$0.35
6353. Racing (<i>Second Reprint</i> —Incorporating amendments up to No. 7691)	\$0.85
6355. Railways (<i>First Reprint</i> —Incorporating amendments up to No. 7475)	\$0.75
6564. Registration of Births Deaths and Marriages Act 1959 (<i>First Reprint</i> —Incorporating amendments up to No. 7332)	\$0.25
2596. River Murray Waters Act 1915 (<i>First Reprint</i> —Incorporating amendments up to No. 7061)	\$0.35
6359. Road Traffic (<i>Second Reprint</i> —Incorporating amendments up to No. 7332)	\$0.18
6360. Rural Finance (<i>First Reprint</i> —Incorporating amendments up to No. 7328)	\$0.15
6846. Rural Finance and Settlement Commission Act 1961 (<i>First Reprint</i> —Incorporating amendments up to No. 7332)	\$0.30
6917. Sale of Human Blood Act 1962 (<i>First Reprint</i> —Incorporating amendments from No. 7332)	\$0.10
6975. Sale of Land Act 1962 (<i>First Reprint</i> —Incorporating amendments up to No. 7332)	\$0.18
6363. Second-hand Dealers (<i>First Reprint</i> —Incorporating amendments up to No. 7529)	\$0.25
6367. Settled Land (<i>Second Reprint</i> —Incorporating amendments up to No. 7065)	\$0.50
6368. Sewerage Districts (<i>Second Reprint</i> —Incorporating amendments up to No. 7547)	\$0.75
6809. Sheep Owners Protection Act 1961 (<i>First Reprint</i> —Incorporating amendments up to No. 7756)	\$0.15
6372. Soil Conservation and Land Utilization (Incorporating amendments up to No. 6961)	\$0.20
6373. Soldier Settlement (<i>First Reprint</i> —Incorporating amendments up to No. 7328)	\$0.42
6375. Stamps (<i>Fourth Reprint</i> —Incorporating amendments up to No. 7698)	\$1.18
6377. State Electricity Commission (<i>Second Reprint</i> —Incorporating amendments up to No. 7421)	\$0.65
6378. State Relief Committee (<i>First Reprint</i> —Incorporating amendments from No. 6886)	\$0.10
6379. State Savings Bank (Incorporating amendments up to No. 6886)	\$0.42
6381. Stock and Share Brokers (<i>First Reprint</i> —Incorporating amendments up to No. 7444)	\$0.15
6383. Stock Foods (<i>First Reprint</i> —Incorporating amendments up to No. 7607)	\$0.28
6886. Subordinate Legislation (Incorporating amendments up to No. 6961)	\$0.15
6386. Superannuation (<i>Second Reprint</i> —Incorporating amendments up to No. 7910)	\$0.75
6387. Supreme Court (<i>First Reprint</i> —Incorporating amendments up to No. 7522)	\$0.75
6391. Teaching Service (<i>First Reprint</i> —Incorporating amendments up to No. 7536)	\$0.35
4989. The Discharged Servicemen's Preference Act 1943 (<i>First Reprint</i> —Incorporating amendments up to No. 7788)	\$0.20
7499. The Extractive Industries Act 1966 (<i>Second Reprint</i> —Incorporating amendments up to No. 7951)	\$0.40
6277. The Industrial and Provident Societies (<i>First Reprint</i> —Incorporating amendments up to No. 7547)	\$0.35
6237. The Drainage Areas (<i>First Reprint</i> —Incorporating amendments up to No. 7276)	\$0.35
6303. The Marine Stores and Old Metals (<i>First Reprint</i> —Incorporating amendments up to No. 7876)	\$0.35
6405. The Melbourne University (<i>First Reprint</i> —Incorporating amendments up to No. 7871)	\$0.40
6832. The Motor Boating Act 1961 (<i>Second Reprint</i> —Incorporating amendments up to No. 6961)	\$0.30
6384. The Stock Medicines (<i>First Reprint</i> —Incorporating amendments up to No. 7726)	\$0.20
7551. The Strata Titles Act 1967 (<i>First Reprint</i> —Incorporating amendments up to No. 7816)	\$0.45
6849. The Town and Country Planning Act 1961 (<i>Third Reprint</i> —Incorporating amendments up to No. 7975)	\$0.65
6401. The Trustee (<i>Third Reprint</i> —Incorporating amendments up to No. 7833)	\$0.55

ACTS REPRINTED IN ACCORDANCE WITH THE AMENDMENTS INCORPORATION ACT 1958 (No. 6422)—*continued.*

No.	Price.
6402. The Trustee Companies (<i>First Reprint</i> — —Incorporating amendments up to No. 7858) ..	\$0.35
7223. Tomato Processing Industry (Uniform Agree- ment) Act 1964 (<i>First Reprint</i> —Incor- porating amendments up to No. 7342) ..	\$0.15
6397. Trade Unions (<i>First Reprint</i> —Incorporating amendments up to No. 6839) ..	\$0.20
6399. Transfer of Land (<i>Third Reprint</i> —Incor- porating amendments up to No. 7551) ..	\$0.65
6400. Transport Regulation (<i>First Reprint</i> —Incor- porating amendments up to No. 7358) ..	\$0.22
6879. Unclaimed Moneys (Incorporating amend- ments up to No. 6961) ..	\$0.12
7095. Overseas Mineral Resources Act 1963 (<i>First</i> <i>Reprint</i> —Incorporating amendments from No. 7591) ..	\$0.10
6653. Valuation of Land Act 1960 (<i>Second Reprint</i> —Incorporating amendments up to No. 7333) ..	\$0.22
6407. Vegetation and Vine Diseases (<i>First Reprint</i> —Incorporating amendments up to No. 7423) ..	\$0.30
6410. Veterinary Surgeons (<i>First Reprint</i> —Incor- porating amendments up to No. 7343) ..	\$0.15
7291. Victoria Institute of Colleges Act 1965 (<i>First</i> <i>Reprint</i> —Incorporating amendments up to No. 7644) ..	\$0.25
6413. Water (<i>Second Reprint</i> —Incorporating amendments up to No. 7590) ..	\$1.95
6414. Weights and Measures (<i>Second Reprint</i> —In- corporating amendments up to No. 7332) ..	\$0.32
6416. Wills (<i>First Reprint</i> —Incorporating amend- ments up to No. 7238) ..	\$0.25
6419. Workers Compensation (<i>Fourth Reprint</i> —In- corporating amendments up to No. 8084) ..	\$1.05

FIRST NOTIFICATION OF REPRINT.

7962. Securities Industry Act 1970 (<i>First Reprint</i> —Incorporating amendments made by Act No. 8059) ..	\$0.65
6233. Dairy Products (<i>First Reprint</i> —Incorporating amendments up to No. 7945) ..	\$0.20

C. H. RIXON,
Government Printer.

AGENTS FOR THE "VICTORIA GOVERNMENT
GAZETTE".

THE following have been appointed agents to receive Advertisements and Subscriptions for the *Victoria Government Gazette*—

ARMSTRONG'S AGENCY, 217 Queen-street, Melbourne, Victoria 3000.
ARNALL & JACKSON, 390 Barkly-street, Brunswick, Victoria 3056.
BAIRNSDALE AUTHORIZED NEWSAGENCY, 132 Main-street, Bairnsdale, Victoria 3875.
BICKNELL, M. J., Authorized Newsagent, 196 Timor-street, Warrnambool, Victoria 3280.
BLANE'S AUTHORIZED NEWSAGENTS, 162 Murray-street, Colac, Victoria 3250.
CARTER, R. G., ADVERTISING SERVICE PTY. LTD., Suite 24, 65 Queens-road, Melbourne, Victoria 3004.
DAVIES, G. & M. V., 112 Gray-street, Hamilton, Victoria 3300.
DAVIS, WM. (MILDURA) PTY. LTD., 126 Eighth-street, Mildura, Victoria 3500.
DIXON'S NEWSAGENCY, 89 Firebrace-street, Horsham, Victoria 3400.
EDGARS' AUTHORIZED NEWSAGENCY, 45 Bridge-street, Benalla, Victoria 3672.
FRANKS, H., & CO., 184 Ryrie-street, Geelong, Victoria 3220.
GATLEY, A. & J., 250 Lonsdale-street, Dandenong, Victoria 3175.

GORDON & GOTCH AUSTRALASIA LTD., 434 St. Kilda-road, Melbourne, Victoria 3004.
GULLAN'S NEWSAGENCY, 88 Bridge-street, Ballarat, Victoria 3350.
HAMPTON, A. C., 243 Mitchell-street, Bendigo, Victoria 3550.
HARSTON, PARTRIDGE & CO. PTY. LTD., 455 Little Collins-street, Melbourne, Victoria 3000.
KYNETON GUARDIAN PTY. LTD., P.O. Box 18, Kyneton, Victoria 3444.
LATIMER'S, Newsagents, 45 Station-street, Malvern, Victoria 3144.
LIVINGSTON'S SHEPPARTON NEWSAGENCY, 246 Wyndham-street, Shepparton, Victoria 3630.
THE MERCANTILE EXCHANGE, 34 Queen-street, Melbourne, Victoria, 3000.
MCGILL'S AUTHORIZED NEWSAGENCY, 183-5 Elizabeth-street, Melbourne, Victoria 3000.
POWNEYS AUTHORIZED NEWSAGENCY, 293 Har- greaves-street, Bendigo, Victoria 3550.
PURDIE, J., & CO., 138 Moorabool-street, Geelong, Victoria 3220.
SALE AUTHORIZED NEWSAGENCY, 142 Raymond-street, Sale, Victoria 3850.
SKINNER'S AUTHORIZED NEWSAGENCY, 49-51 Franklin-street, Traralgon, Victoria 3844.
STEVENSON, A. C. & M., NEWSAGENTS, 132 Henty-street, Casterton, Victoria 3311.
VANCE'S AUTHORIZED NEWSAGENCY, 83 Murray-street, Wangaratta, 3677.
VERNONS OF RICHMOND, 162 Bridge-road, Richmond, Victoria 3121.
VIEW POINT AUTHORIZED NEWSAGENCY, 4 View- Point, Bendigo, Victoria 3550.

A copy of the *Gazette* filed at each place for public reference.

C. H. RIXON,
Government Printer.

CONTENTS

	PAGE
Acts of Parliament on Sale at the Government Printing Office	2040
Appointments	1988
Cemetery—Scale of Fees	1986
Contracts	1985
Estates of Deceased Persons	1987
Government Notices	1974
Impoundings	2039
Insolvency Notice	2039
Lands	2001
Levee at Parliament House, Melbourne	1971
Mining	1983
Notice to Mariners	1985
Notice of Making of Statutory Rules	2040
Orders in Council—	
Acts—State Electricity Commission; Country Roads; Land; Metropolitan Fire et seq	1990
Brigades; Marketing of Primary Products; Stamps; Country Roads; Water; Sewerage Districts; Port Phillip Authority.	
Private Advertisements	2013
Proclamations	1972
Public Holiday—Queen's Birthday	1974
Public Service Notices	2010
Resignations	1989
State Rivers and Water Supply Commission	1981
Tenders	2009
Transport Regulation Board—Public Hearings	1976