

[1221]



VICTORIA
GOVERNMENT GAZETTE

Published by Authority

No. 32]

WEDNESDAY, MAY 17

[1972

Government House,
Melbourne.

LEVEE AT PARLIAMENT HOUSE, MELBOURNE.

In honour of the Birthday of Her Majesty the Queen, His Excellency the Governor of Victoria, Major-General Sir Rohan Delacombe, K.C.M.G., K.C.V.O., K.B.E., C.B., D.S.O., K.St.J., will hold a levee at Parliament House, Spring-street, Melbourne, at 9.45 a.m. on Saturday, 3rd June, 1972.

On the occasion of the celebration of the Queen's Birthday, His Excellency is anxious to receive as many citizens as possible.

Traditionally a Levee has been attended by gentlemen only, but in view of the increasing number of women holding official positions His Excellency has decided that on this occasion he will also receive women holding public office under the Crown.

In accordance with previous custom, there will be no precedence in the order of presentation, but it is requested that members of services and all public bodies group themselves together for presentation, as far as possible.

It is requested that those entitled to wear uniform or official dress will do so on this occasion, but His Excellency will be pleased to receive those not entitled to wear uniform or official dress in their ordinary morning or business dress.

For the guidance of those attending the Levee, it will be appropriate, for those who wish to do so, to wear Honours, Decorations and Awards.

Private Entree Cards will admit recipients to the South Door of the Spring-street Entrance at Parliament House at 9.30 a.m. All other citizens are requested to enter by the North Door of the Spring-street Entrance at 10.15 a.m.

It is particularly desired that all those attending the Levee should provide themselves with a card on which should be printed or typed in capitals, or written in block letters, their styles of address for presentation in order to facilitate announcement to His Excellency.

By His Excellency's Command,

W. H. A. BECKE, Lieutenant Colonel,
Private Secretary and Comptroller.

PROCLAMATIONS

ACTS OF PARLIAMENT.

PROCLAMATION

By His Excellency the Governor of the State of Victoria and its Dependencies in the Commonwealth of Australia, &c., &c., &c.

I, the Governor of the State of Victoria, in the Commonwealth of Australia, do hereby declare that I have this day assented, in Her Majesty's name, to the Bills passed by the Parliament of the said State, the titles whereof are hereunder set forth, together with the short titles, that is to say:—

- No. 8259. "An Act to amend the *Legal Profession Practice Act 1958*." (*Legal Profession Practice (Amendment) Act 1972*.)
- No. 8260. "An Act to provide for the Better Administration of the Mt. Hotham Alpine Area." (*Mt. Hotham Alpine Resort Act 1972*.)
- No. 8261. "An Act to amend sections 38 and 38A of the *Nurses Act 1958*." (*Nurses (Amendment) Act 1972*.)
- No. 8262. "An Act to amend section 13 of the *Films Act 1971*." (*Films (Amendment) Act 1972*.)
- No. 8263. "An Act to extend the Jurisdiction of the County Court in relation to certain Civil Matters and for other purposes." (*County Court (Jurisdiction) Act 1972*.)
- No. 8264. "An Act to amend the *Soldier Settlement Act 1958* and the *Rural Finance Act 1958*." (*Soldier Settlement (Amendment) Act 1972*.)
- No. 8265. "An Act to provide for the Establishment of a Government Buildings Advisory Council and for other purposes." (*Government Buildings Advisory Council Act 1972*.)
- No. 8266. "An Act to amend section 5 of the *Poisons Act 1962*." (*Poisons (Amendment) Act 1972*.)
- No. 8267. "An Act to amend Part V. of the *Police Offences Act 1958* and section 17 of the *Summary Offences Act 1966*." (*Police Offences Act 1972*.)
- No. 8268. "An Act to amend the *Public Service Act 1958*." (*Public Service (Amendment) Act 1972*.)
- No. 8269. "An Act to amend the *Racing Act 1958* with respect to Totalizator Commissions and for other purposes." (*Racing (Totalizator Commissions) Act 1972*.)
- No. 8270. "An Act to amend the *Stamps Act 1958* in relation to Bookmakers' Statements, and for other purposes." (*Stamps (Bookmakers' Statements) Act 1972*.)
- No. 8271. "An Act to increase the Compensation payable under the *Workers Compensation Act 1958*." (*Workers Compensation Act 1972*.)
- No. 8272. "An Act to amend the *Liquor Control Act 1968* and for other purposes." (*Liquor Control (Amendment) Act 1972*.)

Given under my Hand and the Seal of the State of Victoria aforesaid, at Melbourne, this ninth day of May, in the year of our Lord One thousand nine hundred and seventy-two, and in the twenty-first year of the reign of Her Majesty Queen Elizabeth II.

(L.S.) ROHAN DELACOMBE.

By His Excellency's Command,

HENRY BOLTE,
Premier.

GOD SAVE THE QUEEN!

Summary Offences Act 1966.

APPLICATION OF PROVISIONS OF SECTION 50A OF THE SUMMARY OFFENCES ACT 1966 TO THE SHIRE OF METCALFE.

PROCLAMATION

By His Excellency the Governor of the State of Victoria and its Dependencies in the Commonwealth of Australia, &c., &c., &c.

In pursuance of the powers conferred by the *Summary Offences Act 1966*, I, the Governor of the State of Victoria, in the Commonwealth of Australia, by and with the advice of the Executive Council of the said State and on the application of the Council of the Shire of Metcalfe do by

this my Proclamation declare the municipal district of the Shire of Metcalfe to be a district to which Section 50A of the *Summary Offences Act 1966* applies.

Given under my Hand and the Seal of the State of Victoria aforesaid, at Melbourne, this ninth day of May, in the year of our Lord One thousand nine hundred and seventy-two, and in the twenty-first year of the reign of Her Majesty Queen Elizabeth II.

(L.S.) ROHAN DELACOMBE.

By His Excellency's Command,

R. J. HAMER,
Chief Secretary.

GOD SAVE THE QUEEN!

Land Act 1958, Section 25.

COUNTY AND TOWNSHIP BOUNDARIES ALTERED.

PROCLAMATION

By His Excellency the Governor of the State of Victoria and its Dependencies in the Commonwealth of Australia, &c., &c., &c.

I, the Governor of the State of Victoria, in the Commonwealth of Australia, by and with the advice of the Executive Council of the said State, and in pursuance of the provisions contained in Section 25 of the *Land Act 1958*, do, by this my Proclamation, alter the common boundary between the Counties of Moira and Rodney, proclaimed as such on the 20th February, 1871 (see *Government Gazette* of the 24th February, 1871, page 334), and extend the Township of Shepparton, proclaimed as such on the 2nd December, 1952, by the addition to the County of Moira and the Township of Shepparton, and the excision from the County of Rodney, of the land indicated by hatching on plan hereunder.—(M.458⁽¹⁵⁾) S.283^(H3) C.70408.)

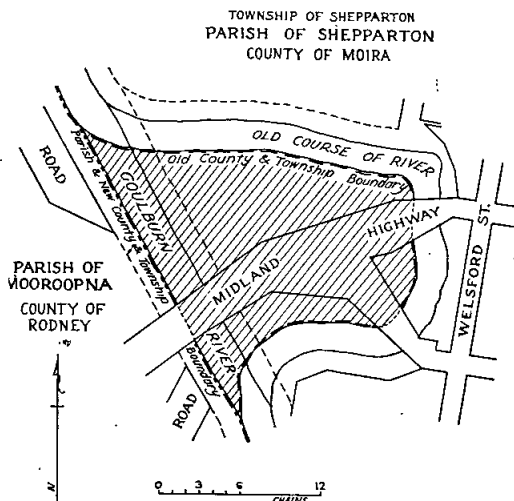

Given under my Hand and the Seal of the State of Victoria aforesaid, at Melbourne, this ninth day of May, in the year of our Lord One thousand nine hundred and seventy-two, and in the twenty-first year of the reign of Her Majesty Queen Elizabeth II.

(L.S.) ROHAN DELACOMBE.

By His Excellency's Command,

W. BORTHWICK,
Minister of Lands.

GOD SAVE THE QUEEN!

GOVERNMENT NOTICES**PUBLIC HOLIDAY.—QUEEN'S BIRTHDAY.**

It is hereby notified that on—

MONDAY, THE 12TH JUNE, 1972,

the Public Offices will be closed, such day having been appointed by the *Public Service Act 1958*, to be observed as a holiday in the Public Offices throughout the State of Victoria.

This notice relates only to the closing of the State Public Offices. All inquiries regarding the holiday in other offices and in shops and industry should be directed to the Department of Labour and Industry, 110 Exhibition-street, Melbourne, 3000. (Telephone 651 6158 or 651 6859).

R. J. HAMER,
Chief Secretary.

Chief Secretary's Office,
Melbourne, 11th May, 1972.

Children's Court Act 1958.**CHILDREN'S COURT SITTINGS—DAYS APPOINTED IN LIEU.**

His Excellency the Governor of the State of Victoria by and with the advice of the Executive Council thereof doth by Order made on the 9th day of May, 1972, and pursuant to the provisions of section 8 (1) of the *Children's Court Act 1958*, appoint the days and hours contained in the Schedule below, Public Holidays excepted, for the holding of Children's Courts at the places named in such Schedule, in lieu of the days and hours heretofore appointed:—

SCHEDULE.

Place; Days and Hours.

ARARAT; Daily at 9.30 a.m.

BALLARAT; Every Monday at 2 p.m. and every Tuesday and Thursday at 9.15 a.m.

J. ROSSITER,
Clerk of the Executive Council.

At the Executive Council Chamber,
Melbourne, 9th May, 1972.

Crimes Act 1958.**CURATOR OF CONVICT'S PROPERTY.**

His Excellency the Governor of the State of Victoria by and with the advice of the Executive Council thereof doth by Order made on the 9th day of May, 1972, and pursuant to section 550 of the *Crimes Act 1958*, commit the custody and management of the property of the convict William Stuart Archibald to Irene Carmel Archibald, of 83 Wilson-street, Cheltenham, as a Curator hereby appointed in that behalf.

J. ROSSITER,
Clerk of the Executive Council.

At the Executive Council Chamber,
Melbourne, 9th May, 1972.

Crimes Act 1958.**CURATOR OF CONVICT'S PROPERTY.**

His Excellency the Governor of the State of Victoria by and with the advice of the Executive Council thereof doth by Order made on the 9th day of May, 1972, and pursuant to section 550 of the *Crimes Act 1958*, commit the custody and management of the property of the convict Ann Lillian Price to Robert Price, of 174 Lum-road, Glen Waverley, as a Curator hereby appointed in that behalf.

J. ROSSITER,
Clerk of the Executive Council.

At the Executive Council Chamber,
Melbourne, 9th May, 1972.

Police Regulations Act 1958, Section 122.**SALE OF UNCLAIMED MOTOR VEHICLE.**

An owner is required for a 1961 maroon and white Volkswagen Kombi van, ex-registered No. KNK-749, engine No. 2513574.

This vehicle came into the possession of Police on the 21st February, 1971, and if not claimed, will be sold by public auction at the Heidelberg Police Station, Jлка-street, Heidelberg, at 10 a.m. on Wednesday, the 14th June, 1972.

R. JACKSON,
Chief Commissioner of Police.

PUBLIC NOTICE.

An auction of unclaimed and confiscated liquor in the possession of the Police will be held at the premises at 193 Spring-street, Melbourne, at 10 a.m., on Wednesday, 24th May, 1972.

R. JACKSON,
Chief Commissioner of Police.

BARLEY MARKETING ACT 1958.

I, GILBERT LAWRENCE CHANDLER, Minister of Agriculture, do hereby appoint Wednesday, the 16th day of August, 1972, as the day for the holding of an election of two representatives of growers of barley in Victoria on the Australian Barley Board, and do further appoint Wednesday, the 7th day of June, 1972, as the day for nominations of candidates to be lodged with the Returning Officer, Mr. K. C. Wheatland, Room 29, Department of Agriculture, 3 Treasury-place, Melbourne, 3002.

Nominations will close at noon on nomination day.

G. L. CHANDLER,
Minister of Agriculture.

LOCAL GOVERNMENT DEPARTMENT.**VARIATION OF SEPARATE RATE.—CITY OF CAMBERWELL.**

On the 14th February, 1972, in compliance with the prayer of a petition of certain ratepayers in portion of the municipal district of the City of Camberwell, the Council of the City of Camberwell made a separate rate for the purpose of providing off street car parking facilities for use in connexion with the Greythorn Shopping Centre.

In pursuance of the provisions of section 288 of the *Local Government Act 1958*, it is hereby notified that the Governor in Council has varied the rate by increasing the amount of the rate in the dollar on the Unimproved Capital Value of the properties specified hereunder to the amount shown against each of the said specified properties:—

- (a) 293/5 (Property No. 1310) Doncaster-road, North Balwyn—1.739 cents.
- (b) 299 (Property No. 1320) Doncaster-road, North Balwyn—3.379 cents.
- 299 (Property No. 1330) Doncaster-road, North Balwyn—3.379 cents.
- (c) 309/11 (Property No. 1370) Doncaster-road, North Balwyn—1.590 cents.
- (d) 289 (Property No. 1280) Doncaster-road, North Balwyn—2.654 cents.
- 289/91 (Property No. 1290) Doncaster-road, North Balwyn—2.654 cents.
- 289/91 (Property No. 1293) Doncaster-road, North Balwyn—2.654 cents.
- 289/91 (Property No. 1295) Doncaster-road, North Balwyn—2.654 cents.
- 289/91 (Property No. 1297) Doncaster-road, North Balwyn—2.654 cents.
- 291 (Property No. 1300) Doncaster-road, North Balwyn—2.654 cents.

Within one month from the date of publication of this notice:—

- (a) any person who has signed the petition; or
- (b) any person who became the owner or occupier of property in respect of which the petition was signed by the previous owner or occupier:—

may by writing under his hand delivered or sent by registered post to the Minister for Local Government withdraw his signature or the signature of the previous owner or occupier (as the case may be) and any person qualified to sign the petition may in manner accede to the petition.

A. J. HUNT,
Minister for Local Government.

Local Government Department,
Melbourne, 3000.

State Savings Bank Act 1958, Section 30.
THE STATE SAVINGS BANK OF VICTORIA.**ESTABLISHMENT OF BRANCH.**

The Commissioners of the State Savings Bank of Victoria hereby give notice of the establishment of Lara Branch of the Bank at The Centreway, Lara, on Monday, 22nd May, 1972.

D. ROSS,
Acting General Manager.

*Private Agents Act 1966.***NOTICE OF RECEIPT OF APPLICATIONS FOR LICENCES UNDER THE PROVISIONS OF THE PRIVATE AGENTS ACT 1966.**

The Clerk(s) of the Magistrates' Court(s) as listed hereunder hereby give notice that applications, as under, have been lodged for hearing by the said Court(s) on the date(s) specified.

Any person desiring to object to any of such applications must—

(a) lodge with the respective Clerk of the Magistrates' Court a notice in the prescribed form of his objection and of the grounds thereof;

(b) cause a copy of such notice to be served personally or by post upon the applicant at least three days before the hearing of the application; and

(c) send or deliver—

(i) where the objection is not made by the officer in charge of the police district in which the Court is situated—a copy of the notice to such officer; and

(ii) where the objection is not made by the Registrar or Deputy Registrar—a copy to the Registrar.

Full Name of Applicant or in the Case of a Firm or Corporation, of the Nominee.	Place of Abode of Applicant or Nominee.	Name of Firm or Corporation.	Address for Registration.	Type of Licence.	Date of Hearing of Application.
MAGISTRATES' COURT, CARLTON.					
Hubbard, Douglass Hopwood	900 Drummond-street, North Carlton	Securaguard Pty. Ltd.	900 Drummond-street, North Carlton	Guard Agent ..	1.6.72
" " "	" "	" "	" "	Watchman ..	"
" " "	" "	" "	" "	Inquiry Agent ..	"
Newport, Joseph Leo	" "	" "	" "	Inquiry Agent ..	"
Securaguard Pty. Ltd. (Nominee Douglass Hopwood Hubbard)	" "	" "	" "	Inquiry Agent (Corp.)	"

Dated at Carlton this 9th day of May, 1972.

M. J. QUIRK, Clerk of the Magistrates' Court.

MAGISTRATES' COURT, MELBOURNE.					
Glen, Alan Heriot ..	Lawrence-court, The Patch	Mayne Nickless Pty. Ltd.	94 York-street, South Melbourne	Watchman ..	31.5.72

Dated at Melbourne this 8th day of May, 1972.

G. L. WEBSTER, Clerk of the Magistrates' Court.

MAGISTRATES' COURT, ELSTERNWICK.					
Bibrowski, Wladyslaw ..	209 Beaconsfield-parade, Middle Park	" "	209 Beaconsfield-parade, Middle Park	Process Server ..	1.6.72

Dated at Elsternwick this 10th day of May, 1972.

G. O'CONNOR, Clerk of the Magistrates' Court.

MAGISTRATES' COURT, HEIDELBERG.					
Western, Michael Leigh ..	6 Quinn-street, Heidelberg	" "	6 Quinn-street, Heidelberg	Inquiry Agent ..	2.6.72

Dated at Heidelberg this 8th day of May, 1972.

R. J. CUTHILL, Clerk of the Magistrates' Court.

MAGISTRATES' COURT, COLLINGWOOD.					
Brown, Philip William ..	24 Hutchinson-street, Bentleigh	" "	303 Johnston-street, Collingwood	Commercial Sub-Agent	8.6.72

Dated at Collingwood this 9th day of May, 1972.

H. P. B. KING, Clerk of the Magistrates' Court.

MAGISTRATES' COURT, MELBOURNE.					
Davies, Frank Frederick ..	55 Derby-street, Moonee Ponds	Mayne Nickless Limited	94 York-street, South Melbourne	Watchman ..	24.5.72
Elsmore, Christopher ..	2 Sale-court, Broadmeadows	" "	" "	" ..	31.5.72
Campbell, Thomas Critchley	21 Cairnes-crescent, East Malvern	" "	" "	" ..	7.6.72

Dated at Melbourne this 10th day of May, 1972.

G. L. WEBSTER, Clerk of the Magistrates' Court.

MAGISTRATES' COURT, GEELONG.					
Sheerin, James ..	9 Elizabeth-street, Whittington	" "	" "	Guard Agent ..	30.5.72

Dated at Geelong this 9th day of May, 1972.

J. E. REILLY, Clerk of the Magistrates' Court.

MAGISTRATES' COURT, ST. KILDA.					
Dent, Raymond Maitland ..	55 Elliott-street, Mordialloc	" "	22 Alma-road, St. Kilda	Inquiry Agent ..	2.6.72
Dent, Raymond Maitland ..	55 Elliott-street, Mordialloc	" "	22 Alma-road, St. Kilda	Process Server ..	2.6.72
Dent, Raymond Maitland ..	55 Elliott-street, Mordialloc	" "	22 Alma-road, St. Kilda	Guard Agent ..	2.6.72

Dated at St. Kilda this 11th day of May, 1972.

J. S. HUTCHINS, Clerk of the Magistrates' Court.

MAGISTRATES' COURT, MOE.					
Abrahams, Henry ..	45 Alexander-avenue, Moe	Security Guards ..	45 Alexander-avenue, Moe	Process Server ..	1.6.72

Dated at Moe this 10th day of May, 1972.

I. M. GRIFFITHS, Clerk of the Magistrates' Court.

PRIVATE AGENTS—continued.

Full Name of Applicant or in the Case of a Firm or Corporation, of the Nominee.	Place of Abode of Applicant or Nominee.	Name of Firm or Corporation.	Address for Registration.	Type of Licence.	Date of Hearing of Application
MAGISTRATES' COURT, MELBOURNE.					
Hillier, Stephen Leslie ..	29/9 Fulton-street, St. Kilda East	Australian Watching Company Pty. Ltd.	340 Abbotsford-street, North Melbourne	Watchman ..	31.5.72
Ross, Kenneth Frederick ..	9 Hannaslea-street, Box Hill	Mayne Nickless Limited	94 York-street, South Melbourne	Watchman ..	7.6.72
Dated at Melbourne this 11th day of May, 1972.					
G. L. WEBSTER, Clerk of the Magistrates' Court.					
MAGISTRATES' COURT, GEELONG.					
Logan, Brian William ..	19 The Esplanade, North Shore	Guard Agent ..	2.6.72
Dated at Geelong this 12th day of May, 1972.					
J. REILLY, Clerk of the Magistrates' Court.					
MAGISTRATES' COURT, MALVERN.					
Warren, Terence Charles ..	26 Middleton-street, Black Rock	F. and D. Mercantile Agency	26 Middleton-street, Black Rock	Commercial Sub-Agent	31.5.72
Dated at Malvern this 10th day of May, 1972.					
P. J. RODDA, Clerk of the Magistrates' Court.					

Police Regulation Act 1958.
POLICE FORCE OF VICTORIA.

DETERMINATION NO. 188 OF THE POLICE SERVICE BOARD.

THE Police Service Board, in pursuance of the powers in that behalf conferred by the *Police Regulation Act 1958*, hereby makes the following Determination (that is to say):—

1. The Determination No. 179 of the Police Service Board of 14th December, 1971, and published in the *Government Gazette* of 25th January, 1972, as amended, is hereby further amended as follows:—

By deleting paragraph 66 and substituting therefor the following paragraph:—

“66. The approval of the Chief Commissioner shall be required before any member is authorized to receive payment for travelling in excess of 8,000 miles in any financial year.”

2. This Determination shall come into operation on the twelfth day of May, 1972.

Dated this twelfth day of May, 1972.

N. A. VICKERY,
A Judge of the County Court of Victoria.
Acting Chairman and Member of the Police
Service Board.

J. G. BROWN,
Member of the Police Service Board.

G. DAVIDSON,
Member of the Police Service Board.

NOTICE TO MARINERS.
[No. 11 of 1972.]

VICTORIA—AUSTRALIA.

The following information which has been received from the Harbor Master, Geelong, is published for general information.

A. J. WAGGLEN,
Port Officer.

Public Works Department,
Ports and Harbors Division,
2 Treasury-place, Melbourne, Vic., 3002,
9th May, 1972.

GEELONG HARBOR TRUST COMMISSIONERS.
PORT OF GEELONG.

1. Former Notice No. 9 of 1972.

Position.—No. 12 Light Beacon, Point Richards Channel, Lat. 38 deg. 06 min. 54 sec. S., Long. 144 deg. 33 min. 58 sec. E. (approx.).

Details.—Construction of the new No. 12 light beacon, Point Richards Channel 235 deg. 10 min., distant 50 feet from its former position has been completed and the light re-established on the new beacon. The old No. 12 light beacon has been completely removed.

2. Alteration to pier light.

Position.—Light on eastern extremity Point Henry Pier. Lat. 38 deg. 7 min. 42 sec. S., Long. 144 deg. 26 min. 30 sec. E. (approx.).

Details.—The colour of the light exhibited on the dolphin in the above position at the eastern extremity of Point Henry Pier has been altered from white to red. All other details as formerly promulgated.

Chart affected.—Aus. 157.

Publication affected.—*Sailing Directions*, Victoria, 1970, pages 234, 610, 248, 624.

Transport Regulation Act.
TRANSPORT REGULATION BOARD.
 HEARING OF APPLICATIONS.

Notice is hereby given that the following applications will be considered by the Transport Regulation Board at its offices at the corner of Lygon and Princes streets, Carlton, at 10.15 a.m. on Wednesday, 7th June, 1972:—

JURY, W. O. & V. M., 8 Dick-street, Castlemaine. Application for one commercial passenger vehicle (S/C. 5) to operate as a country hire car at Castlemaine.

KLINE, L. D., 7 Pitt-street, Terang. One commercial passenger vehicle (S/C. 43) to operate for the carriage of school children between Kolora-road, Kolora and Cobden Technical School under contract to the Education Department.

MARTYN'S SERVICES PTY. LTD., Vincent-street, Daylesford. Application for variation of conditions of licence No. C.O.813 to include charter rights with a 10-mile pick-up radius from Daylesford Post Office.

O'CONNELL, P. D. & E. A., 10 Queen Elizabeth-drive, Tallangatta. One commercial passenger vehicle with large seating capacity to operate for the carriage of parties: (a) From the Wodonga rail head to and from Tallangatta. (b) On tours from Tallangatta to local places of interest under contract to the Tallangatta Conference and Holiday Centre. In addition to operate the vehicle under charter rights from Tallangatta and as a stand-by school vehicle at Tallangatta.

REICHEL, P. R., Hill-road, Warburton. Application for one commercial passenger vehicle (S/C. 5) to operate as a country hire car at Warburton.

U.S. MOTORS (BELGRAVE) PTY. LTD., P.O. Box 95, Croydon. Application for variation of M.O. licence conditions on Route 693 (Belgrave—Chadstone Shopping Centre) to delete the existing service on journeys to Chadstone from the corner of Atherton-road and Station-street and the corner of Atherton and Warrigal roads and instead operate via Station-street to Warrigal-road and normal route. On journeys from Chadstone service will operate via Warrigal-road, Portman-street, Hanover-street and Atkinson-street to normal route.

MELBOURNE MOTOR COACH SERVICE PTY. LTD., McGEARY'S PARLOR COACHES PTY. LTD., 207 New-street, Brighton. Application for variation of T.O. licence conditions to operate tours as follows:—

Emu Bottom and Short City Sights Half-Day Tour.

Depart Whights Tourist Bureau, Flinders-street, at 12.15 p.m. Southern Cross Hotel 12.25 p.m. Travel via the shortest practical route to Emu Bottom. Coach to return to Melbourne via the most practical route and undertake a short tour of the City with a visit to the Zoo before arriving back at 6.00 p.m.

Cost per person \$3.00.

Three-Quarter Day Emu Bottom and City Sights Tour.

Short tour of the City of Melbourne before travelling out to Emu Bottom. Here the passengers will have lunch before returning to Melbourne by the shortest practical route, arriving back by 3.30 p.m..

Cost per person \$4.50.

Jumping Jackaroo Two-Day Tour.

Fare \$37.00. Child \$27.00.

Depart Whights Tourist Bureau, Flinders-street, 9.30 a.m. Southern Cross Hotel, 9.40 a.m. Travel via the shortest practical route to Emu Bottom and then via the shortest practical route to Ballarat. Tour Ballarat visiting Eureka Stockade, Sovereign Hill, the Lakes and Gardens. Overnight Ballarat. Travel to Naringal Sheep Station and inspect the property situated at Wallinduc; then travel via Cressy, the Hamilton Highway to Geelong. Return to Melbourne by 5.30 p.m.

Return Journeys to Falls Creek Ski Village.

Depart Friday 6.15 p.m. Travel via the Hume Highway to Wangaratta; then the Owens Valley Highway to Bright, Mt. Beauty, Falls Creek. Depart Falls Creek approximately 4.00 p.m. Sunday.

Full Day Tour to Ballarat.

Travel via the Western Highway to Bacchus Marsh, Ballan, tour Ballarat, visit Sovereign Hill, Eureka Stockade, tour the Lakes and Gardens. Return to Melbourne via the same route or alternatively via Daylesford, Trentham and Gisborne.

Full-Day Tour to Naringal Sheep Station.

Travel via the Western Highway, Bacchus Marsh and Ballarat; then via Scarsdale to Wallinduc. Inspect the farm and return via Cressy and Geelong to Melbourne.

Depart 8.00 a.m., return 7.00 p.m.

Dandenong Ranges and Healesville Sanctuary Full-Day Tour.

Depart Melbourne, travel via the Burwood Highway to Ferntree Gully. The exact route followed by the coach in the Dandenongs will depend on the time of the year and the flowers in bloom. However, all tours will visit Skyhigh Restaurant at the summit of Mt. Dandenong and will include Silvan Dam. From Silvan the coach will travel to Lilydale and on to the Healesville Sanctuary. After visiting the Sanctuary and Maroondah Dam the coach will return to Melbourne via Yarra Glen, Kangaroo Ground and Templestowe.

Full-Day Tour to Mt. Buller.

Depart Melbourne during the snow season, travel via the Maroondah Highway to Lilydale; then via Yarra Glen, Mt. Slide, Yea, Mansfield. Return to Melbourne via the same route.

Depart Melbourne 8.00 a.m., return by 8.00 p.m.

Fares to be determined.

Weekend Tour to the Grampians and Halls Gap.

Depart Melbourne Saturday morning, travel via the Western Highway, Bacchus Marsh, Ballarat, Ararat, Stawell. Overnight Horsham.

Tour the Grampians, travel via Wartook, Zumsteins, Reid's Lookout, visit Lake Bellfield. Lunch, Halls Gap; then return to Melbourne via Ararat and Ballarat.

Fares to be determined.

GIERSCH, C. D. & N. J., Albert-street, Creswick. One commercial passenger vehicle (S/C. 35) to operate for the carriage of Victorian Railway employees between Ballarat, Warrenheip and Ballan area under contract to the Victorian Railways.

Time-table as required.

ELDER SMITH GOLDSBROUGH MORT LIMITED, 499 Bourke-street, Melbourne. One commercial passenger vehicle (S/C. 7) to operate under the same terms and conditions as existing licence No. T.P.194 held by the applicant, which authorizes the carriage of the licence holders' own employees and clients and also its own mail and parcels from 499 Bourke-street, Melbourne, to and from its Wool Stores at West Footscray and Macaulay and its Merchandise and Machinery Store at South Melbourne as required, subject to the condition that the above passengers or goods are carried on the vehicle free of charge. Also to include the ability to operate from its own Wool Store at Kensington.

PENINSULA BUS LINES LTD., 132 Dandenong-road, Frankston. Application for variation of M.O. licence conditions to include the ability to operate from the corner of Moorooduc-road and Mountain-avenue to Toorak College and the Peninsula School via Mountain-avenue, Humphries-road and Old Mornington-road for the carriage of school children at separate and distinct fares.

Fares and time-tables to be determined.

VENTURA MOTORS PTY. LTD., 1037 Centre-road, South Oakleigh. Application for variation of M.O. licence conditions on Route 753 (Boronia—Knoxfield) to delete that part of the route between the corner of Rankin and Maryborough roads and the corner of Boronia and Woodvale roads via Rankin and Boronia roads and instead to operate via Maryborough and Woodvale roads.

KING, N. G., COACHLINES PTY. LTD., 31 Pollock-street, Colac. Application for renewal of licence No. C.O.590 under the same terms and conditions.

Notice of any objection should be forwarded to reach the Secretary of the Board not later than Wednesday, 31st May, 1972.

Applicants are advised that it will not be necessary to appear on the hearing date specified above, unless advised in writing by the Board.

B. P. KAY,

Secretary.

Corner Lygon and Princes streets, Carlton, 3053, Wednesday, 17th May, 1972.

Commercial Goods Vehicles Act.
TRANSPORT REGULATION BOARD.

HEARING OF APPLICATIONS.

Notice is hereby given that the following applications will be considered by the Transport Regulation Board at its offices at the corner of Lygon and Princes streets, Carlton, at 10 a.m., on Wednesday, 7th June, 1972.

- ADDINSALL, I. N., Macarthur, 3286.** One commercial goods vehicle (L/C. 107 cwt.) to operate: (a) Within a 50-mile radius of own premises at Macarthur in the course of business as "Quarry Proprietor"—own scoria. (b) Within a 50-mile radius of own premises at Macarthur in the course of business as a "Primary Producer"—own goods.
- ALBION REID PTY. LTD., 83 Riversdale-road, Hawthorn, 3122.** One commercial goods vehicle (L/C. 83 cwt.) to operate throughout the State of Victoria in course of business as "Quarry Masters and Road Contractors" as a specially constructed road spraying unit—bulk bituminous materials incidental to own road spraying contracts.
- A.P.D. INDUSTRIES PTY. LTD. (trading as Associated Products Distributors), 8-20 King-street, Oakleigh, 3166.** One commercial goods vehicle (L/C. 48 cwt.) to operate within a 50-mile radius of own branch premises at Swan Hill, and to Cohuna, Ouyen and Mildura in the course of business as "Foodstuff Manufacturers and Distributors"—own goods, with the proviso that all goods are to be initially consigned by rail to both Swan Hill and Mildura.
- BLAKE, R. L., Curdie-street, Cobden, 3266.** One commercial goods vehicle (L/C. 133 cwt.) to operate: (a) Within a 50-mile radius from the post office at Cobden as a "Road Contractor"—roadmaking plant and materials. (b) Within a 25-mile radius of the post office at Cobden—general goods, provided that no goods shall be carried whether by one stage or by more than one stage between places within the above radius which are more than thirty (30) road miles apart by the nearest practicable route.
- BUCKLAND, N. E. and E. V., Box 37, Golden Square, 3555.** Application to vary the conditions of licence No. D.A.61212 (L/C. 297 cwt.) by deleting "of the post office at Boort" from the existing conditions and adding in lieu "of the Chief Post Office at Bendigo and to the City of Swan Hill".
- CARLTON & UNITED BREWERIES LTD., 16 Bouverie-street, Carlton, 3053.** One commercial goods vehicle (L/C. 10 cwt.) to operate: (a) Within a 50-mile radius from own premises in Carlton in the course of business as "Brewers"—own goods. (b) Throughout the State of Victoria in course of business as "Brewers" as a service vehicle for the purpose of servicing and maintaining own machinery in the field—tools of trade, equipment and spare parts incidental thereto.
- CARTER, P. J., Chappel-street, Wodonga, 3690.** One commercial goods vehicle (L/C. 51 cwt.) to operate: (a) Within a 25-mile radius from the post office at Wodonga—general goods, provided that no goods shall be carried whether by one stage or by more than one stage between places within the above radius which are more than thirty (30) road miles apart by the nearest practicable route. (b) Within a 50-mile radius from the post office at Wodonga—livestock.
- COOMBS, A. G., PTY. LTD., 26 Cochranes-road, Moorabbin, 3189.** Two commercial goods vehicles (L/C. 15, 41 cwt.) to operate throughout the State of Victoria in the course of business as "Heating Engineers"—tools of trade, spare parts and equipment incidental to the installation, servicing and maintenance of air-conditioning units and heating systems.
- CUSTOM TRANSPORT & MOVEMENT ENGINEERS PTY. LTD., 754-768 Princes Highway, Springvale, 3171.** One commercial goods vehicle (L/C. 389 cwt.) to operate: (a) Within a 25-mile radius of the post office at Springvale—general goods provided that no goods shall be carried whether by one stage or by more than one stage between places within the above radius which are more than 30 road miles apart by the nearest practicable route. (b) Within a 70-mile radius of each of the plants of Brick and Pipe Industries Ltd. at Burwood, Northcote, Oakleigh, Auburn, East Brunswick, Box Hill and Scoresby respectively—bricks and on return journeys empty pallets and excess bricks to such of the above plants as may be applicable. (c) From Columbia Concrete Masonry Pty. Ltd. at Springvale to consignees within a 70-mile radius therefrom—concrete masonry and on return journeys empty pallets and excess concrete masonry to the said plant.
- DAVIDSON, C. C. & J. M., 12 Anderson-street, Bairnsdale, 3875.** Application to vary the conditions of licence No. D.T.1319 (L/C. 240 cwt.) by adding an additional paragraph (f) to the existing conditions—" (f) From Melbourne to Bairnsdale—general goods."
- DAVIDSON, C. C. & J. M., 12 Anderson-street, Bairnsdale, 3875.** Application to vary the conditions of licence Nos. D.T.1319/2, D.T.1319/3 (L/C. 307, 296 cwt.) by adding an additional paragraph (g) to the existing conditions—" (g) from Melbourne to Bairnsdale—general goods."
- DODDS, P. W., 16 Tulip-grove, Cheltenham, 3192.** One commercial goods vehicle (L/C. approximately 170 cwt.) to operate within a 70-mile radius of the premises of Monier Roof Tiles at Springvale on behalf of the said company—roofing tiles, battens, roofing equipment, tools of trade and a small quantity of tile fixing materials.
- ESSO AUST. LTD., 42 Raymond-street, Sale, 3850.** Five commercial goods vehicles (L/C. 14 cwt. each) to operate throughout the State of Victoria in the course of business as "Oil and Gas Explorers" for the purpose of supervising own Drilling and Exploration projects—tools of trade, equipment and materials incidental thereto.
- GEOPHYSICAL SERVICE INTERNATIONAL, 120 Christie-street, St. Leonards, N.S.W., 2065.** Two commercial goods vehicles (L/C. 34, 16 cwt.) to operate throughout the State of Victoria in the course of business as "Oil Drilling and Exploration Contractors"—tools of trade, exploration equipment for use in oil well testing and spare parts for servicing diesel equipment on site only.
- GOLDEN CITY JOINERY PTY. LTD., Breen-street, Bendigo, 3550.** One commercial goods vehicle (L/C. 16 cwt.) to operate: (a) In the course of business as an approved Decentralized Secondary Industry (Joinery and Cabinet Manufacturers) carried on at applicant's own premises at Bendigo as follows:—(i) To the said premises from points within the area specified hereunder and from the following places outside that area namely from the City of Melbourne and the Township of Alexandra—own goods and materials for use in the manufacturing process of such decentralized industry. (ii) From such premises to customers within the area specified hereunder and/or to customers at the following places outside that area namely at the City of Melbourne or at the Township of Alexandra—own manufactured products of such decentralized industry.
- AREA REFERRED TO.**—Within that part of the State of Victoria bounded on the east by a line drawn from the City of Echuca southwards through the Township of Heathcote to the Town of Castlemaine; and on the west by a line drawn from the Town of Castlemaine; thence in a northerly direction through the Townships of Dunolly, Bridgewater, Serpentine and Kerang to Koondrook. (b) Within a 50-mile radius of the chief post office in the City of Bendigo in the course of business as "Joinery and Hardware Merchants"—own goods.
- GRIFFIN R., 342 Barnard-street, Bendigo, 3550.** One commercial goods vehicle (L/C. 140 cwt. approximately) to operate: (a) Within a 95-mile radius of the post office at Cohuna and/or within a 100-mile radius of the post office at Merbein (Bendigo Division of the Country Roads Board)—plant the property of a contractor and required by him for use in connexion with the construction or maintenance of some specific, existing or proposed road, street, footpath, bridge, pier, wharf, weir or channel. (b) Within a 20-mile radius of the site of any construction or maintenance work performed pursuant to paragraph (a) above or from the railway station nearest thereto—metal, stones, screenings, ashes, gravel, sand and earth and any other materials required for such work. (c) Within a 25-mile radius of the post office at Bendigo—general goods.
- KELLY, J. A., Box 269, Portland, 3305.** One commercial goods vehicle (L/C. 20 cwt.) to operate throughout the State of Victoria in the course of business as "Marine Collector"—special wares, marine stores, old metals as designated in the *Marine Stores and Old Metals Act 1958* (No. 6303), Part 1, section 3, but excluding the carriage of any such goods to wharves, docks or ships for shipment or export purposes, provided that the combined load capacity of the prime mover and any trailer attached thereto does not exceed 120 cwt.
- KNIGHTS, A. J., 22 Bishop-street, Oakleigh, 3166.** One commercial goods vehicle (L/C. 196 cwt.) to operate within a 50-mile radius of the premises of Ready Mixed

- Concrete (Vic.) Pty. Ltd. at Springvale solely on behalf of the said company—premixed concrete in a specially constructed agitator vehicle.
- MAHER, JOHN (trading as John Maher Transport), Settlement-road, Thomastown, 3074. One commercial goods vehicle (Low Loader approximately 240 cwt.) to operate within a 50-mile radius of the post office at the corner of Bourke and Elizabeth streets, Melbourne, in course of business as "Earth-moving Contractor"—own earth-moving plant, own equipment and own tools of trade.
- OLYMPIC TIMBER & HARDWARE PTY. LTD., Industrial-avenue, Thomastown, 3074. One commercial goods vehicle L/C. 61 cwt.) to operate: (a) Throughout the State of Victoria in the course of business as "Building and Fencing Contractors"—tools of trade, builders plant and builders equipment. (b) Within a 25-mile radius of any contract currently engaged upon or from the nearest railway station thereto—materials for use on such contract.
- PEMBERTON, D. P., P.O., Scotts Creek, 3267. One commercial goods vehicle (L/C. 12 cwt.) to operate: (a) Within a 50-mile radius of the post office at Scotts Creek in the course of business as "Storekeeper"—own goods. (b) Within a 20-mile radius of the post office at Scotts Creek—mail, newspapers and parcels.
- PICTON HOPKINS & SONS PTY. LTD., 130 Church-street, Richmond, 3121. Two commercial goods vehicle (L/C. 8 cwt. and 80 cwt.)—to operate in the course of business as "Plaster Craftsmen"—(a) Within a 25-mile radius of the post office at Richmond—own goods. (b) Throughout the State of Victoria—(i) Fibrous plaster sheeting, mouldings, sisal and a quantity of plaster sufficient only for the fixing of the said plaster sheets and mouldings, also battens, nails and insulating materials, viz.: insulwool and rockwool suspended ceilings, component parts and associated acoustic tiles and sprayed finishes. (ii) Terrazzo slabs and/or materials incidental to fixing of same, stone dust, sand and a quantity of cement sufficient only for setting purposes and associated materials necessary to carry out solid plastering contracts, vinyl and lino tiles and adhesives, scaffolding plant and tools of trade for use in own building contracts. (c) Within a 20-mile radius of own branch premises at Hernes Oak—own goods. (d) Within a 20-mile radius of the site of any contract currently engaged upon or to such site from the railway station nearest thereto—materials for use on such contract.
- SAMSON, D. J. trading as J. L. Samson & Son), 291 Lyttleton-terrace, Bendigo, 3550. Application to vary the conditions of licence No. D.A.1979/4, D.A.1979/6 (L/C. 19, 6 cwt.) by deleting "Kyabram" from the existing conditions and adding in lieu "Wycheproof".
- STEFOS, E., 10 Queen-street, Williamstown, 3016. Two commercial goods vehicles (L/C. 18, 40 cwt.) to operate throughout the State of Victoria in course of business as "Frozen Food Distributor" in a specially constructed insulated and refrigerated vehicle—frozen meat, frozen poultry, frozen fish, frozen chicko rolls, frozen hamburgers and frozen dim sims.
- STRAMIT INDUSTRIES LTD., 96 Franklin-street, Melbourne, 3000. One commercial goods vehicle (L/C. 14 cwt.) to operate throughout the State of Victoria in the course of business as "Roofing Contractors" for the purpose of supervising own contracts—tools of trade and a small quantity of materials incidental to repair work or completion of a new contract.
- TENNIS HOLDINGS PTY. LTD., Isle of Wight Motel, Cowes, 3922. Application to vary the conditions of licence No. D.A.38934 (L/C. 121 cwt.) by adding an additional paragraph (b)—"(b) Between Melbourne and the premises of Princes Hotel Holdings Pty. Ltd. (trading as Sundowner Inn Hotel-Motel) at Seaford an associate company—hotel supplies".
- TRANS OTWAY LTD., corner Ryrrie and Fenwick streets, Geelong, 3220. Application to vary the conditions of licence No. D.A.2179/35 (L/C. 109 cwt.) by adding a "Note"—"With the ability to carry two passengers between Colac and Apollo Bay on Thursday only."
- WELLS, K. G., & B. L., 10 Breedon-street, Traralgon, 3844. One commercial goods vehicle (L/C. 262 cwt.) to operate from forest and private landings situated within a 25-mile radius of the premises of Australian Paper Manufacturers Ltd. at the said premises at Maryvale—pulpwood. Subject to the cancellation of licence No. D.T.428/1 in the name of I. G. Witham.
- WELLS, K. G., & B. L., 10 Breedon-street, Traralgon, 3844. One commercial goods vehicle (L/C. 273 cwt.) to operate from forest and private landings situated within a 25-mile radius of the premises of Australian Paper Manufacturers Ltd. to the said premises at Maryvale—pulpwood. Subject to the cancellation of licence No. D.T.1428/3 in the name of I. G. Witham.
- WELLS, K. G., & B. L., 10 Breedon-street, Traralgon, 3844. One commercial goods vehicle (L/C. 273 cwt.) to operate from forest and private landings situated within a 25-mile radius of the premises of Australian Paper Manufacturers Ltd. at Maryvale to the said premises at Maryvale—pulpwood. Subject to the cancellation of licence No. D.T.1428/2 in the name of I. G. Witham.
- WELLS, K. G., & B. L., 10 Breedon-street, Traralgon, 3844. One commercial goods vehicle (L/C. 250 cwt.) to operate from forest and private landings situated within a 25-mile radius of the premises of Australian Paper Manufacturers Ltd. at Maryvale to the said premises at Maryvale—pulpwood. Subject to the cancellation of licence No. D.T.1428 in the name of I. G. Witham.

TOW TRUCK.

- HOLMES, R. W., corner North and Wheaton roads, Ormond, 3204. One commercial goods vehicle (L/C. 30 cwt.) to operate within a 25-mile radius of own premises at Ormond as a "Tow Truck" solely—(a) For the purpose of lifting and carrying or towing motor vehicles and the carriage of tools and equipment necessary for such purposes only. (b) The carriage of spare parts necessary for the repair of a disabled motor to and from the place at which such disablement has occurred.

RENEWALS.

- Applications for renewals of licences as shown by persons listed hereunder to operate under the same terms and conditions from the expiry shown in each case.
- ALLISON, JOHN (ROY V.) MOTORS PTY. LTD., 94 Victoria-street, Richmond, 3121; D.A.4505/16; 30th September, 1972; Hearse; D.A.4505/17; 30th September, 1972; Hearse.
- ARGOON, D. J., 42 Best-street, Belgrave, 3160; D.A.551/1; 5th October, 1972; 162 cwt.
- BARTON, J., 208 Main-street, Bacchus Marsh, 3340; D.A.53716; 5th October, 1972; 70 cwt.
- BEAUMONT, I. J. & Y. E., Box 55, Boolarra, 3870; D.A.48835/1; 19th October, 1972; 133 cwt.
- BENTLEY, J. N. & R. M., Snells-road, Nar Nar Goon, 3812; D.A.53438; 5th October, 1972; 223 cwt.
- CLOSTER, L. J. D., Waterloo-street, Heathmont, 3135; D.A.36641/4; 9th March, 1972; 137 cwt.
- CONCRETE TESTING PTY. LTD., 184 Kingsway, South Melbourne, 3205; D.A.62194; 30th September, 1972; 14 cwt.; D.A.62194/1; 30th September, 1972; 14 cwt.
- COOK, E. G. L., Waterloo-road, Trafalgar, 3824; D.A.887/2; 22nd September, 1972; 105 cwt.; D.A.887/4; 22nd September, 1972; 126 cwt.
- COOMBS, A. G., SERVICING PTY. LTD., 26 Cochranes-road, Moorabbin, 3189; D.A.891/7; 5th October, 1972; 13 cwt.
- CRONIN, P. D., Victoria Park, Daylesford, 3460; T.T.D.451/2; 23rd October, 1972; 238 cwt.
- DALTON, D. P., Whorouly, 3735; D.A.40639; 24th October, 1972; 133 cwt.; D.A.40639/1; 24th October, 1972; 143 cwt.
- DOODT, N. & SONS PTY. LTD., Creswick-road, Ballarat, 3350; D.A.24214/14; 5th October, 1972; 227 cwt.
- DUNN, M. G., 198 Kooba-street, North Albury, 2640; D.A.62141; 16th September, 1972; 225 cwt.
- FARRELLY, N., 11 Albert-street, East Melbourne, 3002; D.A.61769; 20th May, 1972; 121 cwt.
- GARDINER, T. W., Box 57, Warracknabeal, 3393; D.A.3522/2; 19th October, 1972; 10 cwt.
- GENERAL ENG. SALES PTY. LTD., 340 Dudley-street, West Melbourne, 3003; D.A.61532/3; 2nd September, 1972; 168 cwt.
- GRIMSTER, L. J., 23 Lord-street, Carnegie, 3163; D.A.28165/2; 19th August, 1972; 130 cwt.
- HARTWICH, A. R., & R. N. COOPER, Mild-street, Ararat, 3377; D.A.53156; 26th October, 1972; 108 cwt.
- HOWELL, L. A., 32 Avondale-crescent, Morwell, 3840; D.A.62144; 30th September, 1972; 132 cwt.
- HUTCHINSON, ROBERT, LTD., Hartington-street, Glenroy, 3046; T.D.A.27836/34; 23rd October, 1972; 135 cwt.
- HUTCHINSON, ROBERT, LTD., Hartington-street, Glenroy, 3046; T.D.A.27836/54; 13th September, 1972; 148 cwt.
- HUTTON, J. C., PTY. LTD., 65 High-street, Preston, 3072; D.A.48355; 4th October, 1972; 123 cwt.; D.A.48355/1; 4th October, 1972; 125 cwt.
- HUTTON, J. C., PTY. LTD., 65 High-street, Preston, 3072; D.A.48355/2; 4th October, 1972; 44 cwt.; D.A.48355/3; 4th October, 1972; 58 cwt.; D.A.48355/6; 4th October, 1972; 27 cwt.; D.A.48355/9; 4th October, 1972; 97 cwt.; D.A.48355/10; 4th October, 1972; 88 cwt.

IERACI, N. & SONS PTY. LTD., 76 McIlwraith-street, Princes Hill, 3054; D.A.40019; 30th September, 1972; 70 cwt.; D.A.40019/3; 30th September, 1972; 8 cwt.

JENNING, H., Frankston-road, Cranbourne, 3977; D.A.53215; 31st August, 1972; 161 cwt.

JOHNSON, H. M. & E. M., Moore-street, Robinvale, 3549; D.A.52460; 16th June, 1972; 143 cwt.

KELLY, J. E., 1 Bruce-street, Strathmore, 3041; D.A.53034; 5th October, 1972; 139 cwt.

LEECH, A. G., PTY. LTD., 62 Nolan-street, Maryborough, 3465; D.A.1482/10; 4th October, 1972; 10 cwt.

LEURY, D. P., 13 Daley-street, Pascoe Vale, 3044; D.A.61095/1; 30th September, 1972; 154 cwt.

LUCAS, K. J., 166 Murdoch-road, Wangaratta, 3677; D.A.53388; 5th October, 1972; 278 cwt.

LYNCH, H. M., 74 Pay-street, Kerang, 3579; D.A.62247; 29th October, 1972; 10 cwt.

MARTIN, W. T., 45 Lal Lal-street, Ballarat, 3350; D.A.59705/1; 2nd September, 1972; 17 cwt.

MAWSON, E. B., & SONS PTY. LTD., 141 King George-street, Cohuna, 3568; D.A.30119/38; 26th October, 1972; 240 cwt.

MOYLAN, A. H., Box 286, Portland, 3305; D.A.62355; 24th September, 1972; 10 cwt.

MURPHY, J. F., 1 Wondah-avenue, Tallangatta, 3700; D.A.40348; 24th October, 1972; 131 cwt.

MURRAY, W. A., 63 Charles-street, Wodonga, 3690; D.A.53323; 5th October, 1972; 182 cwt.

MYER SOUTHERN STORES LTD., 38 Pall Mall, Bendigo, 3550; D.A.61148/2; 24th October, 1972; 27 cwt.

PETCH, A. S., Saviges-road, Moe, 3825; T.D.A.39031/2; 4th September, 1972; 7 cwt.

PHILLIPS, M. E. (trading as R. J. Phillips), 2A Bruce-street, West Coburg, 3058; D.A.53274/1; 31st August, 1972; 60 cwt.

PHILLIPS, R. J., 2A Bruce-street, West Coburg, 3058; D.A.53274/2; 31st August, 1972; 19 cwt.

PIGDON, J. H. A., PTY. LTD., Box 19, Yarrowonga, 3730; D.A.64341; 26th October, 1972; 75 cwt.

QUINLAN, B. A. & M. E., Station-street, Yea, 3717; D.A.51652/1; 30th September, 1972; 18 cwt.

REPLACEMENT PARTS PTY. LTD., 618 Elizabeth-street, Melbourne, 3000; D.A.1907/50; 30th September, 1972; 14 cwt.

REYNOLDS & Co. PTY. LTD., 6-8 Daly-street, South Yarra, 3141; D.A.1910/4; 26th September, 1972; 53 cwt.

ROONEY, J. A. W., R.M.B. 1064, Wodonga, 3690; D.A.62263; 29th October, 1972; 155 cwt.

SANDFORD, F. J. C., 116 Leith-street, Ballarat, 3350; D.A.3734; 10th October, 1972; 79 cwt.

SELKIRK FREIGHT LINES PTY. LTD., 630 Howitt-street, Ballarat, 3350; D.A.11450/9; 5th October, 1972; 212 cwt.; D.A.11450/10; 5th October, 1972; 218 cwt.

HUSSEY, K. A. (trading as Shepparton Tyre Service), 6 Benalla-road, Shepparton, 3630; D.A.62134; 16th September, 1972; 10 cwt.; D.A.62134/1; 16th September, 1972; 10 cwt.

SKINNER, G. E., 18 Hope-street, Kangaroo Flat, 3555; D.A.53611; 19th October, 1972; 55 cwt.

SMITH, W. F., 11 Gray-street, Leongatha, 3953; D.A.44523/2; 21st September, 1972; 243 cwt.

STONES, G., Howlong-road, Rutherglen, 3685; D.A.60128/1; 29th October, 1972; 152 cwt.

VENN, J., 97 Grant-street, Alexandra, 3714; T.D.A.62823; 5th October, 1972; 117 cwt.

WALKER, D. W., 26 John-street, Alexandra, 3714; D.A.45164/1; 19th October, 1972; 140 cwt.

BELBY, G. A. & D. E. (trading as Wendouree Confectionery Wholesalers), 28 Lake-street, Wendouree, 3355; D.A.61497/1; 29th October, 1972; 22 cwt.

WHITEHEAD, M. P., 34 Victoria-street, Nhill, 3418; D.A.54292; 29th October, 1972; 40 cwt.

YOUNG, G. M., Box 46, Murchison, 3610; D.A.48922/1; 16th September, 1972; 43 cwt.

TOW TRUCKS.

AHYEE, G. V. (trading as A. W. Panels), 104 Dandenong-road, Frankston, 3199; D.A.49874/1; 5th October, 1972; 29 cwt.

HUSSEY, J. H., Snr. (trading as Allied Towing Service), 493 Spencer-street, West Melbourne, 3003; D.A.53177/1; 5th October, 1972; 25 cwt.

CUSACK R. N. (trading as Cusack Motors), Barker-street, Castlemaine, 3450; D.A.46078/1; 30th September, 1972; 59 cwt.

GOLDSWORTHY, J. L. (trading as Kaniva Motors), 82 Commercial-street, Kaniva, 3419; D.A.46908/1; 5th October, 1972; 52 cwt.

KENSINGTON, B. E., Ashmore-street, Wangaratta, 3677; D.A.62123; 30th September, 1972; 108 cwt.

LACEY, R. T., 7 Sinnott-street, Burwood, 3125; D.A.49023/2; 21st April, 1972; 72 cwt.

MODERN TOWING & SALVAGE PTY. LTD., 380 Barkly-street, Footscray, 3011; D.A.28588/1; 1st October, 1972; 54 cwt.

ROBERTSON, C. J. & Co. (HORSHAM), 85 Wilson-street, Horsham, 3400; D.A.23358; 10th October, 1972; 59 cwt.

SOUTH GIPPSLAND MOTORS PTY. LTD., 59 Graham-street, Wonthaggi, 3995; T.D.A.46960; 22nd October, 1972; 85 cwt.

RENEWALS WITH VARIATION.

Applications made by the persons listed hereunder for renewal of the licences listed with variation of conditions in the manner set out opposite the names.

BARKER, R. S., 2-10 St. Andrews-avenue, Bendigo, 3550; D.A.62076; 29th October, 1972; Application to renew and vary the conditions of licence No. D.A.62076 (L/C. 30 cwt.) by deleting "twenty-five (25) miles" from paragraph (a) of the existing conditions and adding in lieu "fifty (50) miles".

GLENMIX PTY. LTD., Box 66, Cohuna, 3568; D.A.53997; 31st August, 1972; Application to renew and vary the conditions of licence No. D.A.53997 (L.C. 184 cwt.) by adding after "Wangaratta" in paragraph (b) of the existing conditions "Myrtleford".

IACUONE, D., 106 Parkington-street, Kew, 3101; D.A.63089; 26th August, 1972; Application to renew and vary the conditions of licence No. D.A.63089 (L/C. 202 cwt.) by deleting "Bayview Quarries Pty. Ltd. at North Melbourne" from the existing conditions and adding in lieu: "Pioneer Concrete (Vic.) Pty. Ltd. at Collingwood."

MCCORKELL, P. M., 6 Rowan-avenue, Brooklyn, 3025; D.A.61848; 11th June, 1972; Application to renew and vary the conditions of licence No. D.A.61848 (L/C. 206 cwt.) by deleting "Specified Concrete (Vic.) Pty. Ltd. at Newport" from the existing conditions and adding in lieu "Pioneer Concrete (Vic.) Pty. Ltd. at Brooklyn."

THOMPSON, S. J., R.S.D., Bacchus Marsh, 3340; D.A.62202; 30th September, 1972; Application to renew and vary the conditions of licence No. D.A.62202 (L/C. 232 cwt.) by deleting "Ballarat" from the existing conditions and adding in lieu "Bacchus Marsh."

TOINTON, T. N., 25 Hendon-avenue, Somers, 3927; D.A.62053; 19th August, 1972; Application to renew and vary the conditions of licence No. D.A.62053 (L/C. 199 cwt.) by deleting "Oakleigh" from the existing conditions and adding in lieu "Frankston".

Notice of any objection should be forwarded to reach the Secretary of the Board not later than 31st May, 1972.

Applicants are advised that it will not be necessary to appear on the hearing date specified above, unless advised in writing by the Board.

B. P. KAY,
Secretary.

Corner of Lygon and Princes streets, Carlton, 3053,
Wednesday, 17th May, 1972.

Town and Country Planning Act 1961.

WARATAH BAY PLANNING SCHEME.

INTERIM DEVELOPMENT ORDER.

NOTICE OF APPROVAL.

Amendment No. 1.

In pursuance of the powers conferred by the Town and Country Planning Act 1961, the Governor in Council on the 26th day of April, 1972, approved an Interim Development Order, made by the Town and Country Planning Board for part of the municipal district of the Shire of South Gippsland.

The Interim Development Order provides that the use, subdivision or development of any land within the area described or the erection, construction or carrying out of any buildings, roads or other works thereon is prohibited except that the Responsible Authority may permit such uses, subdivision, development, erection, constructions or other works as it thinks proper.

A copy of the Interim Development Order and a map showing the area affected may be inspected, free of charge, at the office of the Council of the Shire of South Gippsland at Foster and at the office of the Town and Country Planning Board, 235 Queen-street, Melbourne.

W. H. CRAIG, Secretary,
Town and Country Planning Board.

Town and Country Planning Act 1961.

SHIRE OF SHERBROOKE PLANNING SCHEME 1965.

AMENDMENT No. 42, 1971.

Notice of Approval.

In pursuance of the powers conferred by the *Town and Country Planning Act 1971*, the Governor in Council on the 9th May, 1972, approved a Planning Scheme entitled the Shire of Sherbrooke Planning Scheme 1965, Amendment No. 42, 1971, in respect of part of the municipal district of the Shire of Sherbrooke, and such Planning Scheme comes into operation on the date this notice of approval is published in the *Government Gazette*.

A copy of the Planning Scheme as approved may be inspected free of charge, during office hours, at the office of the Town and Country Planning Board, 235 Queen-street, Melbourne; at the office of the Shire of Sherbrooke at Upwey; and, when available, at the Office of Titles, Melbourne, and at the Central Plan Office of the Department of Crown Lands and Survey, Melbourne.

W. H. CRAIG, Secretary,
Town and Country Planning Board.

Town and Country Planning Act 1961.

CITY OF BENDIGO PLANNING SCHEME.

REVOCATION No. 2.

Notice of Revocation.

In pursuance of the powers conferred by sub-section 4 of section 32 of the *Town and Country Planning Act 1961*, the Governor in Council, by and with the advice of the Executive Council on the 9th May, 1972—

- (i) revoked the City of Bendigo Planning Scheme in so far as it affected land fronting Homes-road, Prouses-road, Anderson-street and Ingleton-street, and
- (ii) prohibited the use or development of the land described in (i) except with the consent of the Council of the City of Bendigo.

A copy of the revocation may be inspected during office hours at the office of the Town and Country Planning Board, 235 Queen-street, Melbourne, and at the office of the Council of the City of Bendigo.

W. H. CRAIG, Secretary,
Town and Country Planning Board.

Town and Country Planning Act 1961.

SHIRE OF FLINDERS PLANNING SCHEME 1962.

AMENDMENT No. 15, 1969.

Notice of Approval.

In pursuance of the powers conferred by the *Town and Country Planning Act 1961*, the Governor in Council on the 9th May, 1972, approved a Planning Scheme entitled the Shire of Flinders Planning Scheme 1962, Amendment No. 15, 1969, in respect of part of the municipal district of the Shire of Flinders, and such Planning Scheme comes into operation on the date this notice of approval is published in the *Government Gazette*.

A copy of the Planning Scheme as approved may be inspected free of charge, during office hours, at the office of the Town and Country Planning Board, 235 Queen-street, Melbourne; at the office of the Shire of Flinders at Dromana; and, when available, at the Office of Titles, Melbourne, and at the Central Plan Office of the Department of Crown Lands and Survey, Melbourne.

W. H. CRAIG, Secretary,
Town and Country Planning Board.

COMPANIES ACT 1961.

Notice is hereby given in pursuance of section 308 (2) and 308 (3) of the *Companies Act 1961* that at the expiration of three months from the date hereof the names of the following Companies will, unless cause is shown to the contrary, be struck off the Register and the said Companies will be dissolved.

Dated this 11th day of May, 1972.

P. COMAN,
Assistant Registrar of Companies.

Companies Office,
Melbourne.

COMPANIES ABOVE REFERRED TO.

Name of Company.	Number of Registration.
Middleton & Morris Pty. Ltd.	13193
Fred Wiegmann Pty. Ltd.	13409
N. H. Seward Pty. Ltd.	15031
The Colonial Case Co. Pty. Ltd.	20004

Name of Company.

Number of Registration.

Paper Processors Pty. Ltd.	22319
M. A. Scott Pty. Ltd.	24023
Gutwirth & Sons Pty. Ltd.	24918
L. W. Madsen Pty. Ltd.	25798
Balleroo Sales Pty. Ltd.	31194
G. J. Dight Pty. Ltd.	33955
Ken-Os Building Co. Pty. Ltd.	38083
Henry Roberts Pty. Ltd.	39338
Duncan Holdings Pty. Ltd.	39655
Parsons and Phillips Pty. Ltd.	42535
Fresh Maid (Australia) Pty. Ltd.	43922
Hopes Coffee Pty. Ltd.	48513
R. J. Curtis Equipment Pty. Ltd.	49907
Maybake Piggery Pty. Ltd.	56304
Paxinol Pty. Ltd.	58328
Mount Doran Pty. Ltd.	58677
Meric Constructions Pty. Ltd.	61836
R. Graham Henderson Pty. Ltd.	61940
The Michael J. Adams Management Co. Pty. Ltd.	65439
Austracote Constructions Pty. Ltd.	65955
Melbourne Aircraft Corporation Ltd.	68816
Austramoore Pty. Ltd.	71231
Knebworth Holdings Pty. Ltd.	73500
G. Wesley Investments Pty. Ltd.	74742
Syka Design & Construction Pty. Ltd.	75702
Crismann Enterprises Pty. Ltd.	79798
Pioneer Motors Pty. Ltd.	81166
Colonial Discounters (Bulk Stores) Pty. Ltd.	83283

DEPARTMENT OF MINES.

EXPLORATION LICENCE EXPIRED.

135, Exploration Licence; Peter Daniel Crowe, William John Crowe; 3 square miles, Parish of Noojee.

APPLICATIONS FOR MINERAL SEARCH LICENCES REFUSED.

- 1023, Mineral Search Licence; Duncan Robert McLean; 640 acres, Parish of Manango.
- 1026, Mineral Search Licence; Duncan Robert McLean; 640 acres, Parish of Manango.
- 1032, Mineral Search Licence; Stanley Irvine Lincoln; 640 acres, Parish of Manango.

MINERAL SEARCH LICENCE GRANTED.

1087, Mineral Search Licence, Lucian Cedric Fordon-Bellgrove, Ethel Thelma Bellgrove; 105 square miles, Counties of Benambra, Bogong.

MINERAL SEARCH LICENCES EXPIRED.

- 962, Mineral Search Licence; Robert Valentine Adams, Mary N. Adams; 640 acres, Parish of Jalur.
- 963, Mineral Search Licence; Beryl Thompson, Warren Alfred Thompson; 48 acres, plus or minus, Parish of Lal-Lal.
- 1013, Mineral Search Licence; Edward Charles Peirce, Archibald Donald Macarthur; 500 acres, Parish of Toonginbooka.

EXTRACTIVE INDUSTRY LICENCE GRANTED.

327, Extractive Industry Licence; Ronald Edward Neave, Patricia Esma Neave, 14a, 2r. 32p., Parish of Boola Boola.

EXTRACTIVE INDUSTRY SEARCH PERMIT GRANTED.

37, Extractive Industry Search Permit; the Victoria Portland Cement Company Proprietary Limited; 5.32 square miles, Parishes of Holey Plains, Coolungoolun.

J. C. M. BALFOUR,
Minister of Mines.

MINING LEASE DECLARED VOID.

8342, Beechworth; AI Consolidated Gold No Liability; 71a. 2r. 5p., Parish of Kevington.

E. CONDON,
Secretary for Mines.

SHIRE OF NUMURKAH WATERWORKS TRUST.

FIXING THE LIMIT OF BANK OVERDRAFT.

His Excellency the Governor of the State of Victoria, by and with the advice of the Executive Council thereof, doth by Order made on the 13th day of May, 1972, fix the total amount of the sums which the Shire of Numurkah Waterworks Trust may owe at any time in

respect of moneys borrowed by overdraft of current account, pursuant to the provisions of section 286 of the *Water Act 1958*, at Forty thousand dollars (\$40,000).

J. ROSSITER,
Clerk of the Executive Council.

At the Executive Council Chamber,
Melbourne, 13th May, 1972.

SERVICETON SEWERAGE AUTHORITY.

FIXING THE LIMIT OF BANK OVERDRAFT.

His Excellency the Governor of the State of Victoria, by and with the advice of the Executive Council thereof, doth by Order made on the 13th day of May, 1972, fix the limit of the amounts which the Serviceton Sewerage Authority may owe at any time in respect of moneys borrowed by overdraft of current account with a bank, pursuant to the provisions of section 78 of the *Sewerage Districts Act 1958*, at Five hundred dollars (\$500).

J. ROSSITER,
Clerk of the Executive Council.

At the Executive Council Chamber,
Melbourne, 13th May, 1972.

TORQUAY SEWERAGE AUTHORITY.

AUDIT OF ACCOUNTS.

Fee Payable to Auditor.

His Excellency the Governor of the State of Victoria, by and with the advice of the Executive Council thereof, doth by Order made on the 13th day of May, 1972, and in pursuance of the provisions of the *Sewerage Districts Act 1958* (No. 6368) approve of the payment to R. A. Seymour, Esquire, of the sum of One hundred dollars (\$100) as remuneration for making an audit of the accounts of the Torquay Sewerage Authority, from the constitution of the Authority to 30th September, 1970, and for the year ended 30th September, 1971, he having been duly appointed by Orders in Council made on 6th October, 1970, and 1st September, 1971, respectively, to make such audits.

J. ROSSITER,
Clerk of the Executive Council.

At the Executive Council Chamber,
Melbourne, 13th May, 1972.

YEA SEWERAGE AUTHORITY.

FIXING THE LIMIT OF BANK OVERDRAFT.

His Excellency the Governor of the State of Victoria, by and with the advice of the Executive Council thereof, doth by Order made on the 13th day of May, 1972, fix the limit of the overdraft to be obtained by the Yea Sewerage Authority, pursuant to the provisions of section 79 of the *Sewerage Districts Act*, at Ten thousand dollars (\$10,000).

J. ROSSITER,
Clerk of the Executive Council.

At the Executive Council Chamber,
Melbourne, 13th May, 1972.

PUBLIC TRUSTEE ACT 1958 (No. 6350), SECTION 17.

I hereby give notice that on the 1st May, 1972, the Public Trustee filed elections to administer the following deceased persons' estates, in accordance with section 17 of the *Public Trustee Act 1958*.

DODDRELL, ARTHUR WILLIAM, late of 16 Kulnine-avenue, Mitcham, retired grocers assistant, died 29th February, 1972.

LITTLE, JAMES ISAAC, late of 63 Greeves-street, Fitzroy, retired storeman, died 8th March, 1972.

LOEL, RAPHAEL HARRIS EDWARD, also known as Loel, Raphael Harris, late of 14 Barnes-grove, Chelsea, retired company director, died 7th February, 1972.

MUNCKTON, MARY ANN, late of 6 Crown-street, Richmond, widow, died 27th December, 1971.

MCLEAN, ALEXANDER WILLIAM, late of Lyons-street, Skipton, retired line foreman, died 19th June, 1969.

MCLEAN, ALEXANDER WILLIAM JOHN, late of Lyons-street, Skipton, gardener, died 22nd August, 1969.

ROBINSON, ALICE EMILY, formerly of 6 Alford-street, East Brighton, but late of Unit 5, 140 Linacre-road, Hampton, widow, died 1st March, 1972.

TOGNOLINI, BERNARD VICTOR, late of 89 Union-street, Brunswick, railway employee, died 19th October, 1971.

N. P. BRODY,
Public Trustee.

256 Flinders-street, Melbourne, 3000, 10th May, 1972.

NOTICE.

Creditors, next of kin and others having claims against the estate of any of the under-mentioned deceased persons are required to send particulars of their claims to the Public Trustee, 256 Flinders-street, Melbourne, Vic. 3000, the personal representative, on or before the 23rd July, 1972, after which date the Public Trustee may convey or distribute the assets, having regard only to the claims of which the Public Trustee then has notice:—

DODDRELL, ARTHUR WILLIAM, late of 16 Kulnine-avenue, Mitcham, retired grocers assistant, died 29th February, 1972.

DYER, CHARLES MALCOLM, late of 87 The Parade, Ascot Vale, retired carpenter, died 13th February, 1972.

HAMBLETT, BRIAN FREDERICK, formerly of Flinders Naval Depot, Victoria, late of Flat 6, 54 Hotham-street, Balaclava, air traffic controller, died 19th September, 1971.

HARRIS, IDA GERTRUDE, late of 1 Shands-street, Beaumaris, widow, died 1st March, 1972.

HOLUBZOW, FEDOR, formerly of 19 Brock-street, Moe, late of Bundoora, gentleman, died 19th June, 1971.

LITTLE, JAMES ISAAC, late of 63 Greeves-street, Fitzroy, retired storeman, died 8th March, 1972.

LOEL, RAPHAEL HARRIS EDWARD, also known as Loel, Raphael Harris, late of 14 Barnes-grove, Chelsea, retired company director, died 7th February, 1972.

MUNCKTON, MARY ANN, late of 6 Crown-street, Richmond, widow, died 27th December, 1971.

MCLEAN, ALEXANDER WILLIAM, late of Lyons-street, Skipton, retired line foreman, died 19th June, 1969.

MCLEAN, ALEXANDER WILLIAM JOHN, late of Lyons-street, Skipton, gardener, died 22nd August, 1969.

ROBINSON, ALICE EMILY, formerly of 6 Alford-street, East Brighton, but late of Unit 5, 140 Linacre-road, Hampton, widow, died 1st May, 1972.

THOMPSON, ALLAN RAYMOND, formerly of "Rosedale", James-street, Selby, late of School Residence, Swifts Creek, school teacher, died 25th November, 1971.

TOGNOLINI, BERNARD VICTOR, late of 89 Union-street, Brunswick, railway employee, died 19th October, 1971.

VANDERSLUYS, JOSEPH GODDARD, late of 17 Lewis-street, Thornbury, retired surgical bootmaker, died 7th January, 1972.

N. P. BRODY,
Public Trustee.

Melbourne, 10th May, 1972.

CONTRACTS ACCEPTED.—(Series 1971-72.)

PUBLIC WORKS.

1168. Stawell, High School, erection of a standard school hall type 572c, \$95,940.00.—P. & A. Coutts Pty. Ltd.

1169. California Gully, Primary School 123, internal renovations, \$5,890.00.—R. & R. A. Poulston.

1170. Norwood, High School, site works, \$35,469.00.—Rainbow Construction Co. Pty. Ltd.

1171. Stawell, High School, electrical services—hall, \$9,050.00.—W. Rentsch.

1172. Kew, Soil Conservation Authority, site works, \$13,629.40.—Richards Plant Hire Pty. Ltd.

1173. Ringwood Heights, Primary School 4911, connexion of sewerage, \$4,200.00.—F. Sunderland & Sons Pty. Ltd.

1174. Canterbury, Girls' High School, electrical services—science block, \$4,890.00.—Sillery Electrics Pty. Ltd.

1175. Glenormiston, Agricultural College, site works, \$13,788.70.—South Western Asphalts Pty. Ltd.

1176. Laverton, Primary School 2857, internal and external renovations, \$4,200.00.—M. Sandic.

1177. Beechworth, Mental Hospital, road construction and associated works, \$15,295.50.—Wilkinson & Brock Pty. Ltd.

G. SERPELL, Director-General of Public Works. 9.5.72.

VICTORIAN RAILWAYS.

96. Supply and delivery of Ballast Regulators, 1 No. for use on 5 ft. 3 in. track and 1 No. for use on 4 ft. 8½ in. track for the amount of \$53,410 (Contract 63790).—Tampar (Australia) Pty. Ltd.

C. S. MORRIS, Secretary. 12.5.72.

ORDERS IN COUNCIL.—(Series 1971-72.)**PUBLIC WORKS.**

1162. Brunswick, Primary School 1213, provision of a bus shelter—\$4,136.00.—C. B. Bramich (C.27584).

1163. Dookie, Agricultural College, supply and installation of irrigation spray system—\$4,937.72.—Victorian Irrigation Supplies Pty. Ltd. (N.108899).

1164. Larundel, Mental Hospital, supply of two automatic laundry washers—\$11,460.00.—Hardie Trading Ltd. (BG.121048).

1165. Melbourne, State Laboratories, 5 Parliament-place, alterations to ground and upper floors—car park toilets—\$4,834.00.—Frigrite Industries Pty. Ltd. (PC26195B).

1166. Mount Dandenong Observatory, laying of sewer and absorption drains—\$4,476.50.—C. J. Brittain & R. Sutherland (PN.16177C).

1167. Social Welfare Department, Jells-road—Ferntree Gully-road drainage scheme—\$4,350.00.—Dandenong Valley Authority (E.6125).

Approved by the Governor in Council, 9th May, 1972.—
J. ROSSITER, Clerk of the Executive Council.

APPOINTMENTS AND RESIGNATIONS**APPOINTMENTS.**

His Excellency the Governor of the State of Victoria, by and with the advice of the Executive Council thereof, has, by Orders made on the 9th day of May, 1972, been pleased to make the under-mentioned appointments, viz.:

MINISTRY OF HEALTH.

Member of Committee of Management of a Hospital.

LESLIE GORDON FRANCIS LECKIE
to be the Government appointee on the Committee of Management of The Royal Women's Hospital, for a period of three years commencing the 28th May, 1972, pursuant to the provisions of sub-paragraph (ii) of paragraph (a) of sub-section (1) of section 48 of the *Hospitals and Charities Act 1958*.

Chief Executive Officer of National Fitness Council.

NOEL DUDLEY ANDERSON
to be Chief Executive Officer of the National Fitness Council of Victoria, pursuant to section 11 of the *National Fitness Council of Victoria Act 1960* on the recommendation of the Council for a further period of five years from and including the 1st June, 1972.

LAW DEPARTMENT.

Commissioners for Taking Declarations, &c.

LESLIE JOHN BRADEN, 21 Bates-street, Mt. Waverley,
JAMES LESLIE PEARSON, care of Mindrill Ltd., 64-74
Bell-street, Preston,
SIDNEY MITCHELL, care of Monash Insurance Services,
37 Cluden-street, Brighton,
HAROLD KELLEN, care of Macpherson Equipment Ltd.,
Dudley-street, West Melbourne,
CHARLES SANDERCOCK, 48-50 Bridge-road, Richmond,
RICHARD GORDON SIMPSON, care of Kaiser Aetna
Jennings, 470 Collins-street, Melbourne, and
CONSTANTINE KLEMIS, care of The Phoenix Biscuit Co.
Pty. Ltd., Grosvenor-street, Abbotsford,
to be Commissioners for taking Declarations and Affidavits, pursuant to the provisions of the *Evidence Act 1958*, to resign upon ceasing to occupy their present positions; and

MATEO CRISTOFARO, 60 Nicholson-street, East Coburg,
NORMAN JOHN PRINCE, Patterson-road, Springvale
South,
EMMANUEL JOSEPH SPITORI, 1 Tunaley-parade, Keon
Park,
CHARLES ROWLAND CORNALL, 13 Vickery-street,
Alexandra, and
LESLIE RICHARD ROHDE, 86 Alexandra-street, Greens-
borough,

to be Commissioners for taking Declarations and Affidavits, pursuant to the provisions of the *Evidence Act 1958*, to resign upon removing from the neighbourhood of the addresses stated.

Justices of the Peace.

COSIMO SITA, 549 Barkly-street, West Footscray,
EDMOND JOSEPH FLANAGAN, Girgarre, via Stanhope,
ERIC FRANCIS KNEEBONE, R.M.S. 422, Rochester, and
CHARLES JULIUS TERRIER, Coatsworth-avenue, St.
Leonards,
to keep the Peace in the State of Victoria.

**Clerk of the Magistrates' Court and Children's Court
(Acting).**

BRIAN STURTVANT BARROW
to be Clerk of the Magistrates' Court and Clerk of the Children's Court at Camperdown, Cobden, Lismore, Mortlake and Terang and Assistant Registrar at Camperdown for the County Court at Warrnambool in the place of C. Ryan on recreation leave, to take effect from the date of commencement of duty.

DEPARTMENT OF THE TREASURER.

Receiver of Revenue (Acting).

THOMAS CHARLES WARD
to act temporarily as Receiver of Revenue, Land Tax Office, vice I. M. Green, on leave.

DEPARTMENT OF WATER SUPPLY.

Waterworks Trust Commissioner.

WILLIAM CHARLES WELSH
to be a Commissioner of the Morwell Waterworks Trust, to hold such position for a period of four years from the date hereof, subject to the provisions of the Water Act.

J. ROSSITER,

Clerk of the Executive Council.

At the Executive Council Chamber,
Melbourne, 9th May, 1972.

APPOINTMENTS.

His Excellency the Governor of the State of Victoria, by and with the advice of the Executive Council thereof, has, by Orders made on the 21st day of March, 1972, been pleased to make the under-mentioned appointments, viz.:

SOCIAL WELFARE DEPARTMENT.

Governors of Prisons.

JOHN EDWARD DAVIES
pursuant to the provisions of the *Social Welfare Act 1970* to be Governor of Her Majesty's Training Prison, Beechworth as from 21st March, 1972, vice James Henry Fellows, transferred.

JOHN NICHOLAS RILEY
pursuant to the provisions of the *Social Welfare Act 1970* to be Governor of Her Majesty's Training Prison, Geelong as from 21st March, 1972, vice Alexander Rymer Lang, retired.

WILLIAM GEORGE SMITHERAM
pursuant to the provisions of the *Social Welfare Act 1970* to be Governor of Her Majesty's Training Prison, Bendigo as from 21st March, 1972, vice John Nicholas Riley, transferred.

KENNETH EARL LEWER
pursuant to the provisions of the *Social Welfare Act 1970* to be Governor of Won Wron Reforestation Prison as from 21st March, 1972, vice Ronald Eric Bone, transferred.

LAURENCE WILLIAM JENSEN
pursuant to the provisions of the *Social Welfare Act 1970* to be Governor of the Morwell River Reforestation Prison as from 21st March, 1972, vice Kenneth Earl Lewer, transferred.

J. ROSSITER,

Clerk of the Executive Council.

At the Executive Council Chamber,
Melbourne, 21st March, 1972.

Education Act 1958.**APPOINTMENT OF MEMBERS OF THE REGISTRATION
COMMITTEE.**

Under section 37 of the *Education Act 1958*, the Council of Public Education has appointed the following members of the said Council to be the Registration Committee for the period ending 31st December 1972:

Professor ALBERT GORDON AUSTIN, M.C., B.A., M.Ed.
GRAHAM BARTLE, B.A., B.Mus., Dip.Ed.
THOMAS HAMPTON COATES, O.B.E., Ph.D. (London)
B.Sc., M.Ed., F.A.C.E.
JOHN VINCENT FAULKNER, B.Sc., Dip.Ed., M.A.C.E.
Reverend Father FRANCIS MICHAEL MARTIN.
THOMAS JAMES MOORE, B.A., B.Ed., M.Ed. (Alberta),
A.F.A.I.M., M.A.C.E.
RUBY ETHEL POWELL, O.B.E., M.A., Dip.Ed., F.A.C.E.
ROLAND FRANK HAWKINS ROW, B.A., B.Ed.
ALBERT EDWARD SCHRUHM, M.A., Dip.Ed., M.A.C.E.

F. H. BROOKS, President.
D. PETERSEN, Registrar.

8th May, 1972.

*Vegetation and Vine Diseases Act 1958.**Fruit and Vegetables Act 1958.*

APPOINTMENT OF INSPECTORS.

The Public Service Board, by certificate dated the 11th April, 1972, appointed the under-mentioned officers to be Inspectors, under the provisions of the *Vegetation and Vine Diseases Act 1958* and the *Fruit and Vegetables Act 1958*, without additional salary:—

CADMAN, RALPH SYDNEY.
HARRISON, GRAY CHRISTOPHER.
TAYLOR, JAMES ALBERT.
WALL, ROSS KENNETH.
WELLS, ADRIAN.

D. S. WISHART,
Director of Agriculture.

CORRIGENDUM.

Wheat Marketing Act 1969.

In *Government Gazette* No. 28 of 26th April, 1972, page 1058, "Appointment of Members of the Wheat Quota Committee".

For the dates of appointment—1st May, 1972 to 30th September, 1972, inclusive substitute 1st May, 1972 to 30th September, 1974.

Liquor Control Act 1968.

APPOINTMENT OF LICENSING INSPECTORS.

In accordance with the authority conferred upon me by Sub-section (1) of Section 22 of the *Liquor Control Act 1968*, I, Reginald Jackson, Chief Commissioner of Police, hereby appoint the following Officers of Police as Licensing Inspectors for the Divisions of the Police Districts as shown:—

Division Number.	Police District.	Rank and Name.
2	Flinders ..	Chief Inspector Gordon Albert North
2	Yarra	Inspector Brian George Jenkins

9th May, 1972.

R. JACKSON,
Chief Commissioner of Police.

Liquor Control Act 1968.

APPOINTMENT OF LICENSING INSPECTORS.

In accordance with the authority conferred upon me by Sub-section (1) of Section 22 of the *Liquor Control Act 1968*, I, Reginald Jackson, Chief Commissioner of Police, hereby appoint the following Officers of Police as Licensing Inspectors for the Divisions of the Police Districts as shown:—

Division Number	Police District.	Rank and Name.
1	Melbourne ..	Inspector Harold Vernon Norton (from 2.5.72 to 31.5.72)
1	Yarra	Inspector Kenneth Basil Shuey (from 28.4.72 to 10.6.72)
1	Westernport ..	Inspector Alan Lindsay Bodey (from 1.5.72 to 23.6.72)

2nd May, 1972.

R. JACKSON,
Chief Commissioner of Police.

RESIGNATIONS.

His Excellency the Governor of the State of Victoria, by and with the advice of the Executive Council thereof, has, by Orders made on the 9th day of May, 1972, accepted the resignations of the persons named hereunder of the offices mentioned, viz.:—

LAW DEPARTMENT.

Commissioners for Taking Declarations, &c.

KENNETH MCGREGOR DAWSON,
CHARLES GEOFFREY FREER,
LEONARD LEO MANSFIELD, and
COSIMO SITA,

as Commissioners for taking Declarations and Affidavits, pursuant to the provisions of the *Evidence Act 1958*.

Justice of the Peace.

JOHN PATRICK MYLON, as a Justice of the Peace for the State of Victoria.

Special Magistrate for Children's Court.

NORMAN GARDNER ASTBURY, as a Special Magistrate for the Children's Court at Heidelberg.

J. ROSSITER,

Clerk of the Executive Council.

At the Executive Council Chamber,
Melbourne, 9th May, 1972.

ORDERS IN COUNCIL

POLICE REGULATION ACT 1958.

At the Executive Council Chamber, Melbourne, the twenty-sixth day of April, 1972.

PRESENT:

His Excellency the Governor of Victoria.
Mr. Rossiter | Mr. Byrne.

APPOINTMENT OF A MEMBER OF THE POLICE DISCIPLINE BOARD.

His Excellency the Governor of the State of Victoria, in the Commonwealth of Australia, by and with the advice of the Executive Council of the said State, and in pursuance of the powers conferred by the *Police Regulation Act 1958*, and the Regulation made thereunder doth by this Order appoint:—

JOHN O'CONNOR, Q.P.M.,
a Chief Superintendent of Police, nominated by the Chief Commissioner of Police, to be a member of the Police Discipline Board for a period of three years from the 1st May, 1972.

And the Honorable Rupert James Hamer, Her Majesty's Chief Secretary for the State of Victoria, shall give the necessary directions herein accordingly.

J. ROSSITER,
Clerk of the Executive Council.

POLICE REGULATION ACT 1958.

At the Executive Council Chamber, Melbourne, the ninth day of May, 1972.

PRESENT:

His Excellency the Governor of Victoria.
Mr. Dickie | Mr. Dunstan.

NOMINATION AND APPOINTMENT AS A MEMBER OF THE POLICE DISCIPLINE BOARD.

His Excellency the Governor of the State of Victoria, in the Commonwealth of Australia, by and with the advice of the Executive Council of the said State, and in pursuance of the powers conferred by section 87 of the *Police Regulation Act 1958* and the Regulations made thereunder and all other powers him thereunto enabling, doth by this Order nominate and appoint—

JOHN LEONARD MCARDLE,
Stipendiary Magistrate,
to be a member of the Police Discipline Board for the period ending 27th May, 1973.

And the Honorable Rupert James Hamer, Her Majesty's Chief Secretary for the State of Victoria, shall give the necessary directions herein accordingly.

J. ROSSITER,
Clerk of the Executive Council.

PORTLAND HARBOR TRUST ACT 1958, No. 6340.

At the Executive Council Chamber, Melbourne, the ninth day of May, 1972.

PRESENT:

His Excellency the Governor of Victoria.
Mr. Dickie | Mr. Dunstan.

Whereas His Excellency the Governor in Council on the ninth day of May, 1972, consented pursuant to the provisions of the *Portland Harbor Trust Act 1958* to the

Portland Harbor Trust Commissioners raising by way of loan the sum of Three hundred and sixty thousand dollars (\$360,000); and whereas His Excellency the Governor in Council is satisfied that a sufficient proportion of the loan to be raised will fall due and be repaid in each year during the currency of the proposed loan: Now therefore it is directed pursuant to the provisions of section 33 (3) of the said Act, that it shall not be necessary to provide a sinking fund in connexion with such loan.

And the Honorable Sir Henry Edward Bolte, Her Majesty's Treasurer for the State of Victoria, shall give the necessary directions herein accordingly.

J. ROSSITER,
Clerk of the Executive Council.

COUNTRY ROADS BOARD.

At the Executive Council Chamber, Melbourne, the ninth day of May, 1972.

PRESENT:

His Excellency the Governor of Victoria.
Mr. Dickie | Mr. Dunstan.

ORDER APPROVING OF LAND BEING ACQUIRED AND ROADS, DEVIATIONS OR WIDENINGS BEING MADE.

His Excellency the Governor of the State of Victoria, by and with the advice of the Executive Council thereof, being satisfied that there are funds legally available for acquiring the land, doth hereby approve the acquiring of the land described in the Schedule hereunder and the making of new roads and deviations from and widenings of existing roads referred to in the said Schedule:—

SCHEDULE.

State Highway.

The land shown hatched on Plan numbered G.P.12926 hereunder required for the widening of the Cann Valley Highway in the Shire of Orbost and making of the widening thereon.

STATE HIGHWAY
CANN VALLEY HIGHWAY
SHIRE OF ORBOST

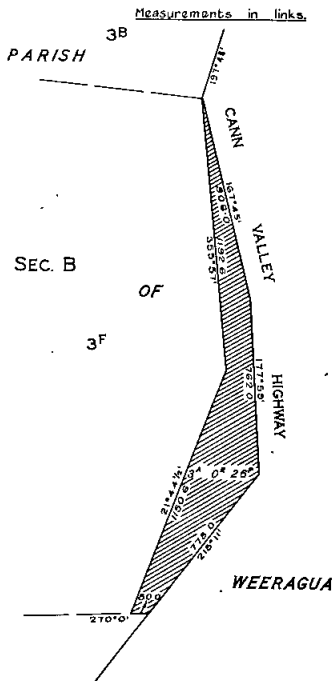

Main Roads.

The land shown hatched on Plan numbered G.P.12778 hereunder required for the widening of the Boort-Kerang road in the Shire of Gordon and making of the widening thereon.

MAIN ROAD
BOORT — KERANG ROAD
SHIRE OF GORDON
Measurements in Links

PARISH

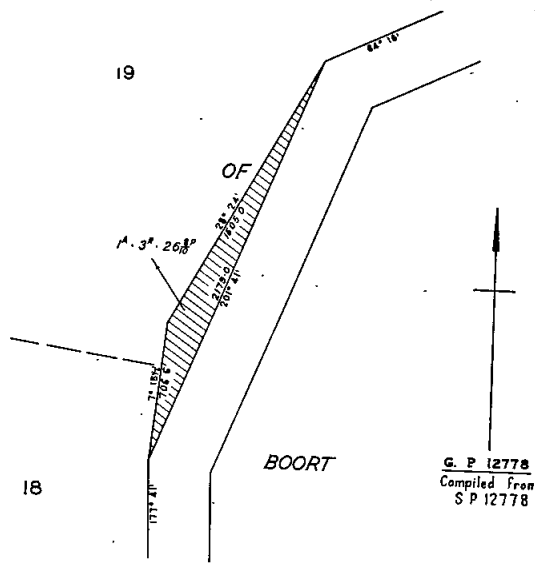

The land shown hatched on Plan numbered G.P.12864 hereunder required for the widening of the Wantirna-Sassafras road in the City of Knox and making of the widening thereon.

MAIN ROAD
WANTIRNA — SASSAFRAS ROAD
CITY OF KNOX
Measurements in feet & ins

PARISH

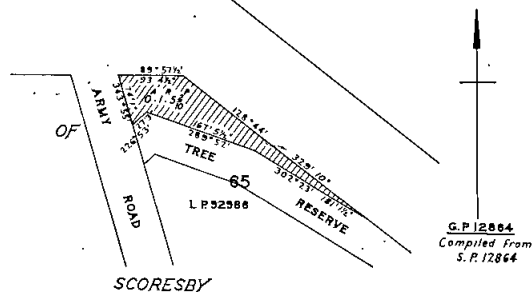

The land shown hatched on Plan numbered G.P.12866 hereunder required for the widening of the Gormandale-Stradbroke road in the Shire of Rosedale and making of the widening thereon.

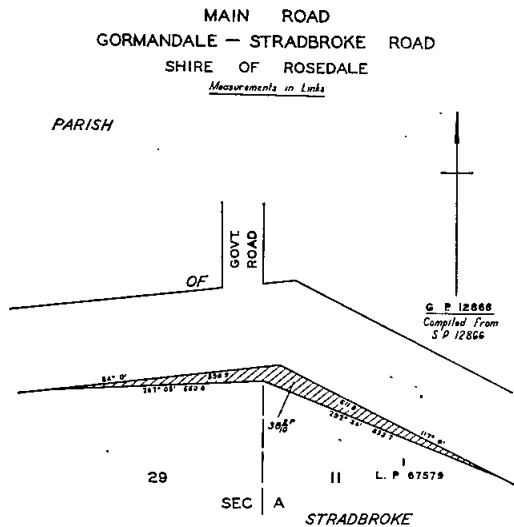

The land shown hatched on Plan numbered G.P.12914 hereunder required for the widening of the Rushworth-Stanhope road in the Shire of Waranga and making of the widening thereon.

MAIN ROAD
RUSHWORTH — STANHOPE ROAD
SHIRE OF WARANGA

Measurements in links

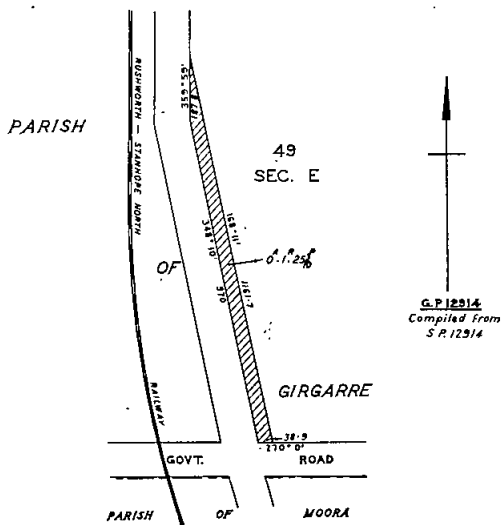

And the Honorable Alan John Hunt, Her Majesty's Minister for Local Government for the State of Victoria, shall give the necessary directions herein accordingly.

J. ROSSITER,
Clerk of the Executive Council.

Land Act 1958.

DEPARTMENT OF CROWN LANDS AND SURVEY.

At the Executive Council Chamber, Melbourne, the
ninth day of May, 1972.

PRESENT:

His Excellency the Governor of Victoria.
Mr. Dickie | Mr. Dunstan.

LANDS TEMPORARILY RESERVED AS SITES.

His Excellency the Governor of the State of Victoria, by and with the advice of the Executive Council thereof, doth hereby, in pursuance of the provisions of section 14 of the Land Act 1958, reserve temporarily from sale, from being leased, and from having a licence granted in respect thereof, and also except from occupation for mining purposes under any miner's right the lands hereinafter described, viz.:—

GEMBROOK (BEACONSFIELD UPPER).—Site for State School purposes, 1 acre 3 roods 24 perches, Parish of Gembrook, County of Mornington, as indicated by hatching on plan hereunder.—(G.206⁽¹³⁾) (Rs.6270).

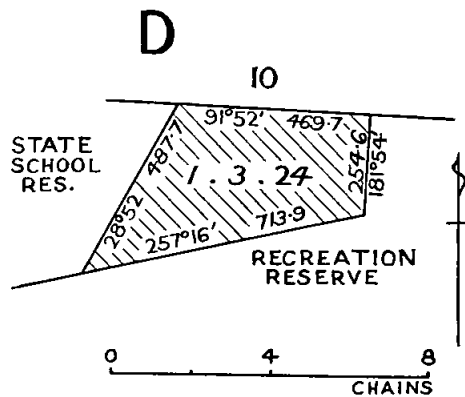

GOROKE.—Site for Public purposes (Swimming Pool), 2 roods 7 perches, Township of Goroke, Parish of Goroke, County of Lowan, as indicated by hatching on plan hereunder.—(G.214⁽⁵⁾) (Rs.708).

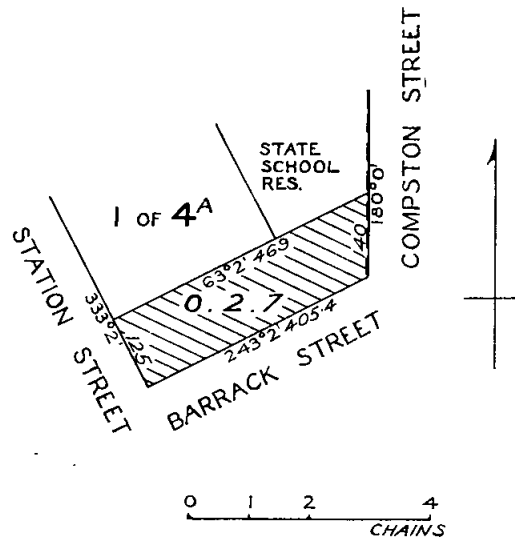

KEELBUNDORA (LALOR).—Site for Public purposes (Police Purposes), 3 roods 1 perch, Parish of Keelbundora, County of Bourke, as indicated by hatching on plan hereunder.—(K.25^(s)) (Rs.9596).

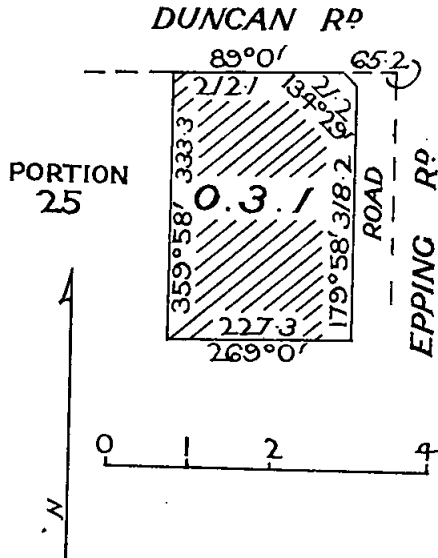

MILDURA (RED CLIFFS).—Site for Public purposes (Preservation of Natural Resources), 7 acres 3 roods 4 perches, at Red Cliffs, Parish of Mildura, County of Karkaroc, as indicated by hatching on plan hereunder.—(M.556⁽¹⁰⁾) (Rs.9609).

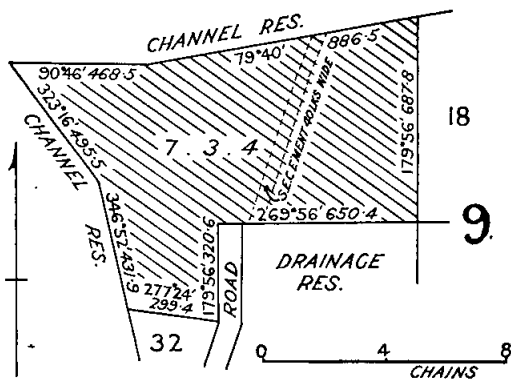

And the Honorable William Archibald Borthwick, Her Majesty's Minister of Lands for the State of Victoria, shall give the necessary directions herein accordingly.

J. ROSSITER,
Clerk of the Executive Council.

DEPARTMENT OF CROWN LANDS AND SURVEY.

At the Executive Council Chamber, Melbourne, the ninth day of May, 1972.

PRESENT:

His Excellency the Governor of Victoria.
Mr. Dickie | Mr. Dunstan.

UNUSED ROADS CLOSED.

His Excellency the Governor of the State of Victoria, by and with the advice of the Executive Council thereof, doth hereby direct that, in pursuance of the provisions of section 349 of the Land Act 1958, the unused roads referred to hereunder be closed, viz.:—

Parish of Drouin East, County of Buln Buln, being the road indicated by hatching on plan hereunder.—(D.173⁽¹²⁾) (C.99693).

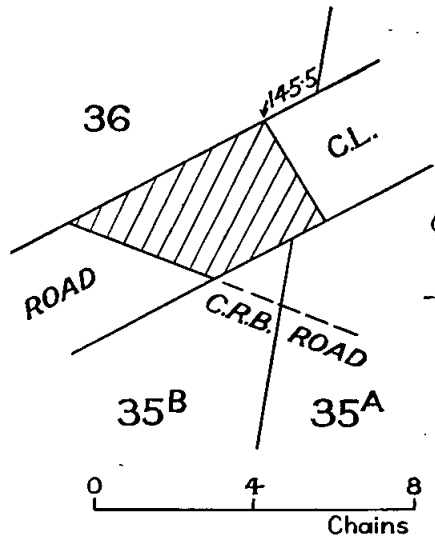

Parish of Flowerdale, County of Anglesey, being the road indicated by hatching on plan hereunder.—(F.11⁽¹⁾) (C.84901).

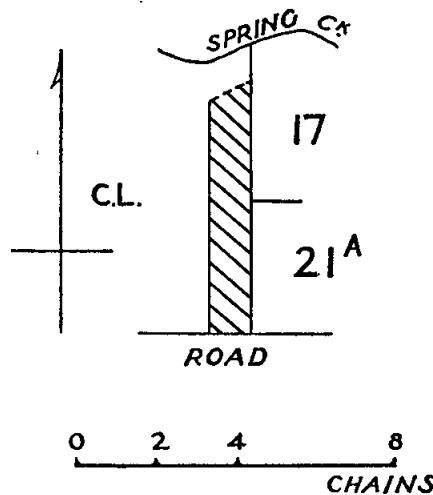

Township of Maffra, Parish of Maffra, County of Tanjil, being the road indicated by hatching on plan hereunder.—(M.89⁽¹⁾) (Rs.2988).

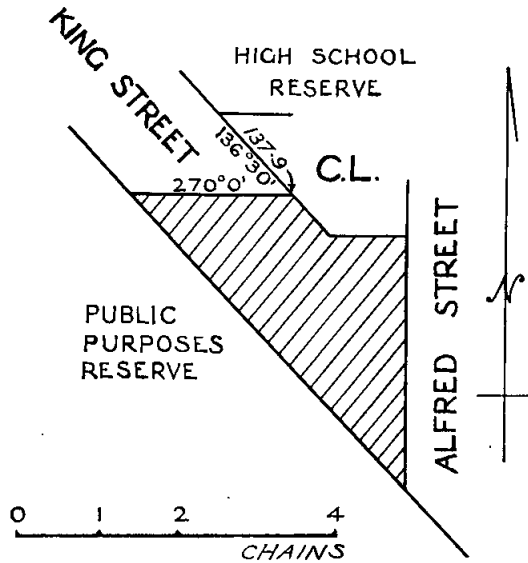

Parish of Paraparap, County of Grant, being the road indicated by hatching on plan hereunder.—(P.23(2) (G.71129).

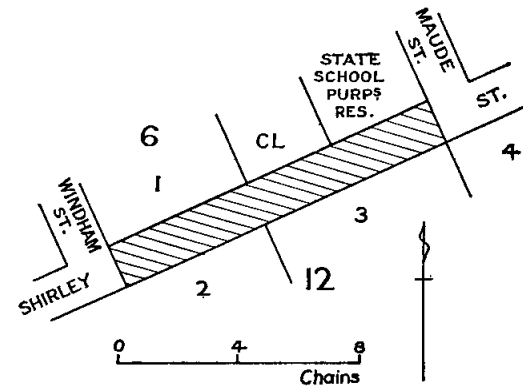

And the Honorable William Archibald Borthwick, Her Majesty's Minister of Lands for the State of Victoria, shall give the necessary directions herein accordingly.

J. ROSSITER,
Clerk of the Executive Council.

Water Act 1958.

STATE RIVERS AND WATER SUPPLY COMMISSION.

At the Executive Council Chamber, Melbourne, the thirteenth day of May, 1972.

PRESENT:

His Excellency the Governor of Victoria.
Mr. Rafferty | Mr. Dunstan.

WEST LODDON WATERWORKS DISTRICT—PORTION EXCISED.

Under the powers conferred by the Water Act 1958 and all other powers enabling him in that behalf His Excellency the Governor of the State of Victoria, with the advice of the Executive Council of the said State, on the recommendation of the State Rivers and Water Supply Commission, doth hereby declare, order and direct that there shall be excised from the West Loddon Waterworks District that portion of the same shown by green colour on a plan approved by the Governor in Council and deposited in the office of the State Rivers and Water Supply Commission, Melbourne (Corr. Nos. 70/1578, 70/1586) and as on and from the 30th day of June, 1972, such portion shall be deemed to be excised accordingly.

And the Honorable Roberts Christian Dunstan, Her Majesty's Minister of Water Supply for the State of Victoria, shall give the necessary directions herein accordingly.

J. ROSSITER,
Clerk of the Executive Council.

Water Act 1958.

STATE RIVERS AND WATER SUPPLY COMMISSION.

At the Executive Council Chamber, Melbourne, the thirteenth day of May, 1972.

PRESENT:

His Excellency the Governor of Victoria.
Mr. Rafferty | Mr. Dunstan.

GOULBURN-MURRAY IRRIGATION DISTRICT—DISTRICT EXTENDED.—BOORT IRRIGATION AREA—BOUNDARIES VARIED.

Under the powers conferred by the Water Act 1958 and all other powers enabling him in that behalf, His Excellency the Governor of the State of Victoria, with the advice of the Executive Council of the said State, on the recommendation of the State Rivers and Water Supply Commission, doth hereby declare, order and direct that the Goulburn-Murray Irrigation District be extended and the boundaries of the Boort Irrigation Area be varied by adding to the said District and Area the lands shown by blue colour on a plan approved by the Governor in Council and deposited in the office of the State Rivers and

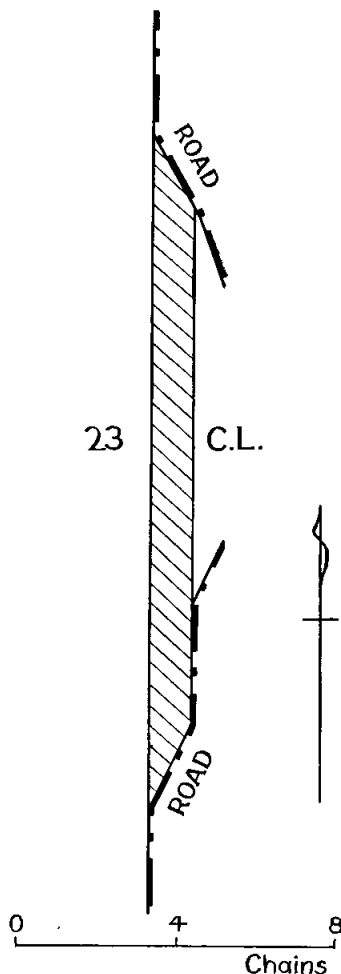

Township of Raglan, Parish of Raglan, County of Ripon, being the road indicated by hatching on plan hereunder.—(R.3(2) (J.34010).

Water Supply Commission, Melbourne (Corr. Nos. 70/1578, 70/1586) and as on and from the 1st day of July, 1972, such District shall be deemed to be so extended and the boundaries of such Area shall be so varied.

And the Honorable Roberts Christian Dunstan, Her Majesty's Minister of Water Supply for the State of Victoria, shall give the necessary directions herein accordingly:

J. ROSSITER,
Clerk of the Executive Council.

Water Act 1958.

STATE RIVERS AND WATER SUPPLY COMMISSION.

At the Executive Council Chamber, Melbourne, the thirteenth day of May, 1972.

PRESENT:

His Excellency the Governor of Victoria.
Mr. Rafferty | Mr. Dunstan.

MORNINGTON PENINSULA WATERWORKS DISTRICT—PORTIONS EXCISED.

Under the powers conferred by the *Water Act 1958* and all other powers enabling him in that behalf, His Excellency the Governor of the State of Victoria, with the advice of the Executive Council of the said State, on the recommendation of the State Rivers and Water Supply Commission, doth hereby declare, order and direct as follows:—

That there shall be excised from the Mornington Peninsula Waterworks District those portions of the same set out and described in the Schedule hereto, which portions, as from the 30th day of June, 1972, shall be deemed to be excised accordingly.

SCHEDULE.

Portion 1.—Commencing at the north-western angle of allotment 60, Parish of Dandenong; thence northerly by the eastern boundary of Springvale-road to the north-western angle of allotment A, section 54; thence north-westerly by a line and the south-western boundary of Centre Dandenong-road to a point in line with the north-western boundary of lot 41 on lodged plan of subdivision No. 4681, Parish of Mordialloc; thence north-easterly by a line and the last-mentioned lot boundary to the north-eastern angle of lot 40; thence north-westerly by the south-western boundaries of lots 37 and 36 and north-easterly by the north-western boundary of said lot 36 to the north-western angle of the last-mentioned lot; thence north-westerly by the south-western boundary of Spring-road to a point in line with the south-eastern boundary of lot 86 on said lodged plan of subdivision No. 4681; thence north-easterly by a line and the last-mentioned lot boundary to the north-eastern angle of said lot 86; thence south-easterly by the north-eastern boundaries of lots 85, 84, 83, 82, 81, 80, 79, 78 and 64 on said lodged plan of subdivision No. 4681 to the north-eastern angle of the last-mentioned lot; thence north-easterly by the north-western boundary of Rowan-road to its intersection with the western boundary of Springvale-road; thence northerly by the last-mentioned road boundary to a point in line with the southern boundary of allotment C, section 23, Parish of Dandenong; thence easterly by a line and the southern boundaries of allotments C and D, section 23 and allotment 22 and by a line connecting those boundaries to the south-eastern angle of lot 15 on lodged plan of subdivision No. 5564; thence northerly by the eastern boundary of the last-mentioned lot and by a line in continuation thereof to the south-western angle of lot 161 on lodged plan of subdivision No. 78779; thence northerly by the western boundary of that lot bearing 359 deg. 32 min. distant 100 feet; thence easterly by lines bearing 89 deg. 32 min. distant 115 ft. $\frac{1}{2}$ in., 72 deg. 50 min. 52 ft. $2\frac{1}{2}$ in., 89 deg. 32 min. 150 feet; thence northerly, easterly and southerly by lines bearing 359 deg. 32 min. distant 219 ft. $4\frac{1}{2}$ in., 90 deg. 350 feet and 179 deg. 32 min. 220 ft. $6\frac{1}{2}$ in.; thence easterly by lines bearing 89 deg. 32 min. distant 416 ft. $1\frac{1}{2}$ in., 99 deg. 44 min. 50 ft. $9\frac{1}{2}$ in., 89 deg. 32 min. 113 ft. 6 in.; thence northerly by a line bearing 359 deg. 32 min. to the centre of Mile Creek; thence northerly by the centre of that Creek to the southern boundary of a Railway Reserve; thence south-easterly by that Reserve boundary to the western boundary of Crown Portion 20; thence southerly by the last-mentioned boundary to the centre of Mile Creek; thence generally southerly by the centres of the last-mentioned Creek and Dandenong Creek to the boundary of the City of Springvale; thence north-westerly

by that City boundary to the south-eastern angle of allotment 61A; thence westerly and north-westerly by the southern and south-western boundaries of said allotment 61A to the southern boundary of Keys-road; thence northerly by a line across Keys-road to the south-eastern angle of allotment 57; thence northerly and westerly by the eastern and northern boundaries of the last-mentioned allotment to the eastern boundary of Chapel-road; thence further westerly by a line and the southern boundary of Hutton-road to the point of commencement.

Portion 2.—That part of allotment 79, Parish of Eumemmerring, north-west of Eumemmerring Creek.

The portions set out and described in the foregoing Schedule are shown on a plan approved by the Governor in Council, and deposited in the office of the State Rivers and Water Supply Commission, Melbourne (Corr. Nos. 71/1934 and 72/1492).

And the Honorable Roberts Christian Dunstan, Her Majesty's Minister of Water Supply for the State of Victoria, shall give the necessary directions herein accordingly.

J. ROSSITER,
Clerk of the Executive Council.

WATER ACT 1958.

At the Executive Council Chamber, Melbourne, the thirteenth day of May, 1972.

PRESENT:

His Excellency the Governor of Victoria.
Mr. Rafferty | Mr. Dunstan.

KYABRAM WATER SUPPLY DISTRICT—LOCAL GOVERNING BODY, KYABRAM BOROUGH COUNCIL—AREA OF DISTRICT INCREASED.

Under the powers conferred by the *Water Act 1958* and all other powers enabling him in that behalf, His Excellency the Governor of the State of Victoria, with the advice of the Executive Council of the said State, doth hereby declare, order, and direct that the area of the Kyabram Water Supply District, under the control of the Kyabram Borough Council, as a local governing body, be increased by adding thereto the lands shown by blue colour on a plan approved by the Governor in Council and deposited in the office of the State Rivers and Water Supply Commission, Melbourne (Corr. No. 68/523) and as on and from the 1st day of July, 1972, the area of such District shall be deemed to be so increased.

And the Honorable Roberts Christian Dunstan, Her Majesty's Minister of Water Supply for the State of Victoria, shall give the necessary directions herein accordingly.

J. ROSSITER,
Clerk of the Executive Council.

Water Act 1958.

STATE RIVERS AND WATER SUPPLY COMMISSION.

At the Executive Council Chamber, Melbourne, the thirteenth day of May, 1972.

PRESENT:

His Excellency the Governor of Victoria.
Mr. Rafferty | Mr. Dunstan.

NORTH CAMPERDOWN RURAL DISTRICT—AREA OF DISTRICT DIMINISHED.

Under the powers conferred by the *Water Act 1958*, and all other powers enabling him in that behalf, His Excellency the Governor of the State of Victoria, with the advice of the Executive Council of the said State, on the recommendation of the State Rivers and Water Supply Commission, doth hereby declare, order and direct that the area of the North Camperdown Rural District be diminished by excising therefrom the portion of the same shown by green colour on a plan approved by the Governor in Council, and deposited in the Office of the State Rivers and Water Supply Commission, Melbourne (Corr. No. 71/457) and as on and from the 30th day of June, 1972, such portion shall be deemed to be excised accordingly.

And the Honorable Roberts Christian Dunstan, Her Majesty's Minister of Water Supply for the State of Victoria, shall give the necessary directions herein accordingly.

J. ROSSITER,
Clerk of the Executive Council.

Water Act 1958.

STATE RIVERS AND WATER SUPPLY COMMISSION.

At the Executive Council Chamber, Melbourne, the
thirteenth day of May, 1972.

PRESENT:

His Excellency the Governor of Victoria.
Mr. Rafferty | Mr. Dunstan.

GOULBURN-MURRAY IRRIGATION DISTRICT—PORTION EXCISED.—TONGALA-STANHOPE IRRIGATION AREA—BOUNDARIES VARIED.

Under the powers conferred by the Water Act 1958 and all other powers enabling him in that behalf, His Excellency the Governor of the State of Victoria, with the advice of the Executive Council of the said State, on the recommendation of the State Rivers and Water Supply Commission, doth hereby declare, order and direct:—

1. That there be excised from the Goulburn-Murray Irrigation District; and

2. That the boundaries of the Tongala-Stanhope Irrigation Area be varied to excise therefrom—

the land shown by green colour on a plan approved by the Governor in Council and deposited in the office of the State Rivers and Water Supply Commission, Melbourne (Corr. No. 68/523) which land shall be deemed to be excised from the said Irrigation District and Irrigation Area as from the 30th day of June, 1972.

And the Honorable Roberts Christian Dunstan, Her Majesty's Minister of Water Supply for the State of Victoria, shall give the necessary directions herein accordingly.

J. ROSSITER,
Clerk of the Executive Council.

Water Act 1958.

STATE RIVERS AND WATER SUPPLY COMMISSION.

At the Executive Council Chamber, Melbourne, the
thirteenth day of May, 1972.

PRESENT:

His Excellency the Governor of Victoria.
Mr. Rafferty | Mr. Dunstan.

DANDENONG-SPRINGVALE URBAN DISTRICT—AREA OF DISTRICT DIMINISHED.

Under the powers conferred by the Water Act 1958 and all other powers enabling him in that behalf, His Excellency the Governor of the State of Victoria, with the advice of the Executive Council of the said State, on the recommendation of the State Rivers and Water Supply Commission, doth hereby declare, order, and direct as follows:—

That the area of the Dandenong-Springvale Urban District be diminished by excising therefrom the portion of the same set out and described in the Schedule hereto, which portion as from the 30th day of June, 1972, shall be deemed to be excised accordingly.

SCHEDULE.

Commencing at the south-eastern angle of allotment 65A, Parish of Dandenong; thence westerly by the southern boundary of that allotment, the northern boundary of Bend-road and the southern boundary of Church-street and by a line in continuation thereof and by a line connecting those boundaries to the western boundary of Chapel-road; thence northerly by that road boundary to the south-eastern angle of allotment B, section 54; thence westerly by the southern boundaries of allotments B and A of said section 54 and by a line in continuation thereof to the eastern boundary of allotment 2, section XXI, Parish of Mordialloc; thence northerly by that allotment boundary to the north-eastern angle thereof; thence north-westerly by a line and the south-western boundary of Centre Dandenong-road to a point in line with the north-western boundary of lot 41 on lodged plan of subdivision No. 4681, Parish of Mordialloc; thence north-easterly by a line and the last-mentioned lot boundary to the north-eastern angle of lot 40; thence north-westerly by the south-western boundaries of lots 37 and 36 and north-easterly by the north-western boundary of said lot 36 to the north-western angle of the last-mentioned lot; thence north-westerly by the south-western boundary of Spring-road to a point in

line with the south-eastern boundary of lot 86 on said lodged plan of subdivision No. 4681; thence north-easterly by a line and the last-mentioned lot boundary to the north-eastern angle of said lot 86; thence south-easterly by the north-eastern boundaries of lots 85, 84, 83, 82, 81, 80, 79, 78 and 64 on said lodged plan of subdivision No. 4681 to the north-eastern angle of the last-mentioned lot; thence north-easterly by the north-western boundary of Rowan-road to its intersection with the western boundary of Springvale-road; thence northerly by the last-mentioned road boundary to a point in line with the southern boundary of allotment C, section 23, Parish of Dandenong; thence easterly by a line and the southern boundaries of allotments C and D, section 23 and allotment 22 and by a line connecting those boundaries to the south-eastern angle of lot 15 on lodged plan of subdivision No. 5564; thence northerly by the eastern boundary of the last-mentioned lot and by a line in continuation thereof to the south-western angle of lot 161 on lodged plan of subdivision No. 78779; thence northerly by the western boundary of that lot bearing 359 deg. 32 min. distant 100 feet; thence easterly by lines bearing 89 deg. 32 min. distant 115 ft. $\frac{1}{2}$ in., 72 deg. 50 min. 52 ft. 2 $\frac{1}{2}$ in., 89 deg. 32 min. 150 ft.; thence northerly, easterly and southerly by lines bearing 359 deg. 32 min. distant 219 ft. 4 $\frac{1}{2}$ in., 90 deg. 350 ft. and 179 deg. 32 min. 220 ft. 6 $\frac{1}{2}$ in.; thence easterly by lines bearing 89 deg. 32 min. distant 416 ft. 1 $\frac{1}{2}$ in., 99 deg. 44 min. 50 ft. 9 $\frac{1}{2}$ in., 89 deg. 32 min. 113 ft. 6 in.; thence northerly by a line bearing 359 deg. 32 min. to the centre of Mile Creek; thence northerly by the centre of that Creek to the southern boundary of a Railway Reserve; thence south-easterly by that Reserve boundary to the western boundary of Crown portion 20; thence southerly by the last-mentioned boundary to the centre of Mile Creek; thence generally southerly by the centres of the last-mentioned Creek and Dandenong Creek to a point in line with the southern boundary of allotment 65A; thence westerly by a line to the point of commencement.

The lands set out and described in the foregoing Schedule are shown on a plan approved by the Governor in Council, and deposited in the office of the State Rivers and Water Supply Commission, Melbourne.—(Corr. No. 71/1934.)

And the Honorable Roberts Christian Dunstan, Her Majesty's Minister of Water Supply for the State of Victoria, shall give the necessary directions herein accordingly.

J. ROSSITER,
Clerk of the Executive Council.

Water Act 1958.

STATE RIVERS AND WATER SUPPLY COMMISSION.

At the Executive Council Chamber, Melbourne, the
thirteenth day of May, 1972.

PRESENT:

His Excellency the Governor of Victoria.
Mr. Rafferty | Mr. Dunstan.

WESTERNPORT URBAN DISTRICT—AREA OF DISTRICT DIMINISHED.

Under the powers conferred by the Water Act 1958, and all other powers enabling him in that behalf, His Excellency the Governor of the State of Victoria, with the advice of the Executive Council of the said State, on the recommendation of the State Rivers and Water Supply Commission, doth hereby declare, order and direct as follows:—

That the area of the Westernport Urban District be diminished by excising therefrom the portion of the same set out and described in the Schedule hereto, which portion, as from the 30th day of June, 1972, shall be deemed to be excised accordingly.

SCHEDULE.

The whole of allotments 35 and 36, Township and Parish of Flinders.

The portion set out and described in the foregoing Schedule is shown on a plan approved by the Governor in Council, and deposited in the office of the State Rivers and Water Supply Commission, Melbourne.—(Corres. No. 62/5492.)

And the Honorable Roberts Christian Dunstan, Her Majesty's Minister of Water Supply for the State of Victoria, shall give the necessary directions herein accordingly.

J. ROSSITER,
Clerk of the Executive Council.

Water Act 1958.

STATE RIVERS AND WATER SUPPLY COMMISSION.

At the Executive Council Chamber, Melbourne, the thirteenth day of May, 1972.

PRESENT:

His Excellency the Governor of Victoria.
Mr. Rafferty | Mr. Dunstan.

GOULBURN-MURRAY IRRIGATION DISTRICT—
DISTRICT EXTENDED.—CALIVIL IRRIGATION
AREA—BOUNDARIES VARIED.

Under the powers conferred by the Water Act 1958, and all other powers enabling him in that behalf, His Excellency the Governor of the State of Victoria, with the advice of the Executive Council of the said State, on the recommendation of the State Rivers and Water Supply Commission, doth hereby declare, order and direct that the Goulburn-Murray Irrigation District be extended and the boundaries of the Calivil Irrigation Area be varied by adding to the said District and Area the lands, shown by blue colour on a plan approved by the Governor in Council and deposited in the office of the State Rivers and Water Supply Commission, Melbourne (Corres. Nos. 65/697, 68/633, 68/766) as on and from the 1st day of July, 1972, such District shall be deemed to be so extended and the boundaries of such area shall be so varied.

And the Honorable Roberts Christian Dunstan, Her Majesty's Minister of Water Supply for the State of Victoria, shall give the necessary directions herein accordingly.

J. ROSSITER,
Clerk of the Executive Council.

Water Act 1958.

STATE RIVERS AND WATER SUPPLY COMMISSION.

At the Executive Council Chamber, Melbourne, the thirteenth day of May, 1972.

PRESENT:

His Excellency the Governor of Victoria.
Mr. Rafferty | Mr. Dunstan.

EAST LODDON WATERWORKS DISTRICT—PORTIONS
EXCISED.

Under the powers conferred by the Water Act 1958, and all other powers enabling him in that behalf, His Excellency the Governor of the State of Victoria, with the advice of the Executive Council of the said State, on the recommendation of the State Rivers and Water Supply Commission, doth hereby declare, order and direct that there shall be excised from the East Loddon Waterworks District those portions of the same, shown by green colour on a plan approved by the Governor in Council and deposited in the office of the State Rivers and Water Supply Commission, Melbourne (Corres. Nos. 65/697, 68/633, 68/766) and as on and from the 30th day of June, 1972, such portions shall be deemed to be excised accordingly.

And the Honorable Roberts Christian Dunstan, Her Majesty's Minister of Water Supply for the State of Victoria, shall give the necessary directions herein accordingly.

J. ROSSITER,
Clerk of the Executive Council.

WODONGA WATERWORKS TRUST.

At the Executive Council Chamber, Melbourne, the thirteenth day of May, 1972.

PRESENT:

His Excellency the Governor of Victoria.
Mr. Rafferty | Mr. Dunstan.

APPROVAL OF PLAN SHOWING SITES OF SERVICE
BASIN, PIPELINES, PUMPING STATION AND TREAT-
MENT WORKS.

His Excellency the Governor of the State of Victoria, by and with the advice of the Executive Council thereof, doth hereby approve, in accordance with the provisions of the Water Act, a plan showing the sites for a service

basin, pipelines, pumping station and treatment works to be constructed by the Wodonga Waterworks Trust, the said plan being deposited in the office of the State Rivers and Water Supply Commission, Melbourne (Corr. No. 69/147/50).

And the Honorable Roberts Christian Dunstan, Her Majesty's Minister of Water Supply for the State of Victoria, shall give the necessary directions herein accordingly.

J. ROSSITER,
Clerk of the Executive Council.

LILYDALE SEWERAGE AUTHORITY.

At the Executive Council Chamber, Melbourne, the thirteenth day of May, 1972.

PRESENT:

His Excellency the Governor of Victoria.
Mr. Rafferty | Mr. Dunstan.

CONSENT TO BORROWING \$50,000.

Under the powers conferred by the Sewerage Districts Act and all other powers enabling him in that behalf, His Excellency the Governor of the State of Victoria, by and with the advice of the Executive Council of the said State, hereby consents to the Lilydale Sewerage Authority borrowing the sum of Fifty thousand dollars (\$50,000), to meet the cost of sewerage works as set forth in the detailed statement bearing date 10th May, 1972.

And the Honorable Roberts Christian Dunstan, Her Majesty's Minister of Water Supply for the State of Victoria, shall give the necessary directions herein accordingly.

J. ROSSITER,
Clerk of the Executive Council.

SHEPPARTON SEWERAGE AUTHORITY.

At the Executive Council Chamber, Melbourne, the thirteenth day of May, 1972.

PRESENT:

His Excellency the Governor of Victoria.
Mr. Rafferty | Mr. Dunstan.

SALE OF LAND.

Whereas the Shepparton Sewerage Authority at present holds a block of land required for the construction of a sewage pumping station in the township of Shepparton and whereas the area surrounding this block of land has now been resubdivided and whereas the subdividers have agreed to give the said Authority a more suitable block of land in the new subdivision in exchange for the block of land at present held by the said Authority, now therefore His Excellency the Governor of the State of Victoria, by and with the advice of the Executive Council thereof, doth hereby, under the provisions of the Sewerage Districts Act, approve of the sale by the Shepparton Sewerage Authority of the land shown on a plan approved by the Governor in Council by and with this Order and deposited in the office of the State Rivers and Water Supply Commission, Melbourne (Corr. 70/2920/94).

And the Honorable Roberts Christian Dunstan, Her Majesty's Minister of Water Supply for the State of Victoria, shall give the necessary directions herein accordingly.

J. ROSSITER,
Clerk of the Executive Council.

WONTHAGGI SEWERAGE AUTHORITY.

At the Executive Council Chamber, Melbourne, the thirteenth day of May, 1972.

PRESENT:

His Excellency the Governor of Victoria.
Mr. Rafferty | Mr. Dunstan.

COMPULSORY ACQUISITION OF EASEMENT.

Under the powers conferred by the Sewerage Districts Act and all other powers enabling him in that behalf, His Excellency the Governor of the State of Victoria, by and

with the advice of the Executive Council of the said State, doth hereby consent to the compulsory acquisition by the Wonthaggi Sewerage Authority of easement rights over the lands shown by blue colour on the accompanying plan, being part of Crown Allotment 26A, Parish of Wonthaggi, County of Mornington, a copy of which is deposited in the office of the State Rivers and Water Supply Commission, Melbourne (Corr. No. 71/3585/29).

And the Honorable Roberts Christian Dunstan, Her Majesty's Minister of Water Supply for the State of Victoria, shall give the necessary directions herein accordingly.

J. ROSSITER,
Clerk of the Executive Council.

LOCAL GOVERNMENT DEPARTMENT.

At the Executive Council Chamber, Melbourne, the thirteenth day of May, 1972.

PRESENT:

His Excellency the Governor of Victoria.
Mr. Rafferty | Mr. Dunstan.

CONSENT TO SALE OF A RESERVE BY THE WAVERLEY CITY COUNCIL.

Whereas certain land being the Park Reserve on Plan of Subdivision No. 16566 lodged in the Office of Titles was transferred to the Council of the Shire of Mulgrave pursuant to the provisions of section 569B (8) (L) of the *Local Government Act 1958*, or a corresponding previous enactment and the Council of the City of Waverley is now of the opinion that the land is no longer required for the purpose for which it was reserved and has requested that consent be given to the sale of the land.

And whereas the said Council:—

- has published in a newspaper generally circulating in the municipal district a notice describing the land and the proposal for the sale of the land and stating that at the next ordinary meeting of the Council after the expiration of forty days after publication of the notice the Council would consider any objection to the proposal and would receive any representations as to the disposal of any purchase money;
- has served a copy of the said notice upon such other persons whom the Council considered such notice should be served;
- has posted a similar notice upon the land in question; and
- has taken into consideration all objections made against the proposal.

And whereas no representations have been made to the Council as to the disposal of any surplus purchase money.

Now therefore, His Excellency the Governor of the State of Victoria, by and with the advice of the Executive Council thereof and in pursuance of the provisions of subsection (2) of section 569BA of the *Local Government Act 1958* doth hereby consent to the Council of the City of Waverley selling by private treaty the Park Reserve coloured green on plan of subdivision No. 16566 lodged in the Office of Titles.

And the Honorable Alan John Hunt, Her Majesty's Minister for Local Government for the State of Victoria, shall give the necessary directions herein accordingly.

J. ROSSITER,
Clerk of the Executive Council.

LANDLORD AND TENANT ACT 1958.

At the Executive Council Chamber, Melbourne, the sixteenth day of May, 1972.

PRESENT:

The Lieutenant-Governor as Deputy for His Excellency the Governor of Victoria.
Mr. Rafferty | Mr. Smith.

ORDER EXCLUDING CERTAIN PREMISES FROM THE OPERATION OF CERTAIN OF THE PROVISIONS CONTAINED IN PART V. OF THE LANDLORD AND TENANT ACT 1958.

In pursuance of the powers conferred upon him by the *Landlord and Tenant Act 1958*, the Lieutenant-Governor as Deputy for His Excellency the Governor of the State of

Victoria, by and with the advice of the Executive Council thereof, doth declare that the premises known as Flat 4, Number 21 Bloomfield-road, Ascot Vale, shall be excluded from the operation of the whole of the provisions contained in Divisions 2 and 3 of Part V. of the *Landlord and Tenant Act 1958*.

And the Honorable George Oswald Reid, Her Majesty's Attorney-General in and for the State of Victoria, shall give the necessary directions herein accordingly.

J. ROSSITER,
Clerk of the Executive Council.

LANDS DEPARTMENT NOTICES

APPROACHING LAND SALES.

Sales of Crown Lands, in fee-simple, will be held at the under-mentioned places and dates, viz.:—

	No. of Gazette.
Ballarat.—Thursday, 8th June, 1972 ..	30
Chiltern.—Wednesday, 21st June, 1972 ..	32
Daylesford.—Thursday, 15th June, 1972 ..	31
Ultima.—Thursday, 29th June, 1972 ..	32

SALE OF CROWN LAND BY AUCTION.

The land will be offered for sale in fee-simple, and subject to the provisions of the *Land Act and Regulations* thereunder.

The upset price is the sum at which bidding will start, and no bid below that sum can be accepted. The highest bidder at or above that sum shall be the purchaser, subject to signature of contract and any necessary payment.

TERMS:—

A deposit of at least 12½% of the purchase price must be paid at the sale, either in cash or by cheque.

The residue is payable in half-yearly instalments, in accordance with the following scale, or may be paid off at any earlier time.

\$40 and under, 6 instalments.
Over \$40, and not exceeding \$100, 8 instalments.
Over \$100, and not exceeding \$200, 10 instalments.
Over \$200, and not exceeding \$400, 12 instalments.
Over \$400, and not exceeding \$600, 14 instalments.
Over \$600, and not exceeding \$800, 16 instalments.
Over \$800, and not exceeding \$1,000, 18 instalments.
Over \$1,000, 20 instalments.

Interest at the rate of 5% per annum is payable with all payments of residue, and is computed for each instalment from the date of sale to the date of such payment. Additional interest is charged if any instalment is not paid on or before the due date.

If paid off within 30 days of sale, no interest is payable.

FEES, ETC.:

Also payable at the sale, in addition to the deposit, are the survey fee and, if applicable, the valuation of improvements (if purchaser be not the owner thereof).

Payable with balance of purchase money—

Crown Grant fee—\$3.

Assurance Fund contribution.—One cent in every Five dollars or part thereof of purchase price. (This is a fund established to guarantee the validity of freehold titles.)

Transfer of interest prior to completion of payment may be allowed on payment of \$2 fee and subject to stamp duty.

If unable to attend personally, a prospective purchaser may arrange for another person to bid as his agent.

Attention is drawn to section 95, *Land Act 1958*, which provides that the purchaser shall be deemed to be the owner for the purposes of other Acts; also to an amendment to the *Local Government Act* providing for Government roads, in certain circumstances, to be declared "private streets", thus making the purchaser liable to contribute to the cost of street construction.

W. BORTHWICK,
Minister of Lands.

Office of Crown Lands and Survey,
Melbourne, 17th May, 1972.

CHILTERN.—Sale (No. 12128) of Crown land in fee-simple, by auction, will be held at the LAND INSPECTOR'S OFFICE, CHILTERN, on WEDNESDAY, the 21st day of JUNE, 1972, at TEN o'clock A.M. To be conducted by F. F. HOLT, Land Officer, Beechworth.

Lot 1.

TOWNSHIP OF CHILTERN, PARISH OF CHILTERN, COUNTY OF BOGONG.

At the south-western corner of North-road and Gordon-street.

Upset price \$300 the lot. Survey fee \$100.

Area 6a. 0r. 3p., allotment 14 of section 10A.—(H.033721.)

ULTIMA.—Sale (No. 12129) of Crown land in fee-simple, by auction, will be held on the site at the NORTH-EASTERN CORNER OF DILLON AND VERNON STREETS, ULTIMA, on THURSDAY, the 29th day of JUNE, 1972, at HALF-PAST ELEVEN o'clock A.M. To be conducted by T. A. COMTE, Land Officer, Bendigo.

Lot 1.

PARISH OF ULTIMA, COUNTY OF TATCHERA.

Being the site and buildings of the former Police Station and Residence situated at the north-eastern corner of Dillon and Vernon streets.

Upset price \$1,000 the lot. Survey fee \$55.

Area 1 rood 3 perches, subject to survey, allotment B. Improvements comprise weatherboard dwelling, outbuildings, &c., the valuation of which is included in the upset price.

SPECIAL CONDITIONS.—Until the purchase money has been paid in full, the following special conditions shall apply:—

- (i) The purchaser shall at his own expense maintain the property in good order and repair and keep all improvements thereon insured against fire in the name of the Secretary for Lands.
- (ii) A cover note for not less than \$850 for such insurance shall be lodged in the Lands Department by the purchaser, within one week of the date of sale, and the policy shall be lodged immediately on issue.
- (iii) The purchaser shall not remove or make any alterations to the improvements on the site without prior consent of the Secretary for Lands.—(M.62979.)

PROPOSED REVOCATIONS OF TEMPORARY RESERVATIONS OF LANDS BY ORDERS IN COUNCIL

In pursuance of the provisions of the Land Act 1958, notice is hereby given that it is the intention of the Governor in Council to revoke the temporary reservations of lands by Orders in Council hereunder referred to, viz.:—

The following Notices were published 1^o on the 10th May, 1972, pursuant to Orders of the 2nd May, 1972.

JIKA JIKA (ROYAL PARK).—The temporary reservation, by Order in Council of the 2nd April, 1946, of 2 acres 1 rood 14 9/10 perches of land in the Parish of Jika Jika as a site for Childrens Welfare purposes, revoked as to part by Order of the 2nd August, 1966, is about to be revoked so far as the balance thereof containing 1 acre 3 roods 32 9/10 perches, is concerned.—(M.314⁽¹⁵⁾) (Rs.259).

JIKA JIKA (ROYAL PARK).—The temporary reservation, by Order in Council of the 24th December, 1930, of 12 acres 3 roods 1 5/10 perches of land in the Parish of Jika Jika as a site for Childrens Welfare purposes, revoked as to part by Order of the 2nd August, 1966, is about to be revoked so far as the balance thereof containing 10 acres 3 roods 32 5/10 perches, is concerned.—(M.314⁽¹⁵⁾) (Rs.259).

ORFORD.—The temporary reservation, by Order in Council of the 28th September, 1874, of 5 acres of land in the Township of Orford as a site for State School purposes, revoked as to part by Order of the 29th March, 1960, is about to be revoked so far as the balance thereof containing 4 acres 3 roods 33 perches, more or less, is concerned.—(O.7⁽²⁾) (O.300/138).

JIKA JIKA (ROYAL PARK).—The temporary reservation, by Order in Council of the 31st March, 1927, of 9 acres 1 rood 33 8/10 perches of land in the Parish of Jika Jika as a site for Childrens Welfare purposes, revoked as to

part by Order of the 4th December, 1934, is about to be revoked so far as the balance thereof containing 8 acres 3 roods 3 perches, is concerned.—(M.314⁽¹⁵⁾) (Rs.259).

COBDEN.—The temporary reservation, by Order in Council of the 30th May, 1893, (see *Government Gazette* 2nd June, 1893, page 2384) of 3 acres 3 roods 16 1/2 perches of land in the Township of Cobden as a site for Water Supply purposes, is about to be revoked.—(C.353⁽²⁾) (C.100732).

GREGGWIN.—The temporary reservation, by Order in Council of the 1st July, 1924, of 2 acres of land in the Parish of Greggwin as a site for State School, is about to be revoked.—(C.213⁽⁶⁾) (Rs.2954).

JIKA JIKA (ROYAL PARK).—The temporary reservation, by Order in Council of the 6th September, 1966, of 2 acres of land in the Parish of Jika Jika as a site for Childrens Welfare purposes, is about to be revoked.—(M.314⁽¹⁵⁾) (Rs.259).

RAINBOW.—The temporary reservation, by Order in Council of the 7th March, 1911, of 2 roods 25 4/10 perches of land in the Township of Rainbow (called Township of Weeah in the Order) as a site for Water Supply purposes, is about to be revoked.—(R.89⁽⁴⁾) (C.51924).

WAITCHIE.—The temporary reservation, by Order in Council of the 12th June, 1911, of 3 acres of land in the Parish of Waitchie as a site for a State School, is about to be revoked.—(W.389⁽²⁾) (C.50789).

WERRIMULL.—The temporary reservation, by Order in Council of the 31st August, 1965, of 1 rood 8 perches of land in the Township of Werrimull as a site for Public purposes (purposes of the Forests Department), is about to be revoked.—(W.423⁽⁴⁾) (Rs.8472).

WONTHAGGI (DUDLEY SOUTH).—The temporary reservation, by Order in Council of the 21st February, 1922, of 5 acres of land in the Township of Wonthaggi as a site for a State School is about to be revoked.—(W.345⁽¹⁸⁾) (Rs.2438).

OSBORNE.—The temporary reservation, by Order in Council of the 16th December, 1872, of 10 acres, more or less, of land in the Township of Osborne as a site whence Stone may be procured under licence, revoked as to part by Order of the 27th April, 1955, is about to be revoked so far as the balance thereof containing 9 acres 29 perches, more or less, is concerned.—(O.9⁽²⁾) (C.82731).

BENALLA.—The temporary reservation, by Order in Council of the 18th May, 1886, of 80 acres, more or less, of land in the Township of Benalla as a site for Public Recreation, revoked as to part by various orders, is about to be revoked so far only as the portion containing 7 acres 3 roods 30 perches, more or less, indicated by hatching on plan hereunder, is concerned.—(B.390⁽³⁾) (Rs.4055).

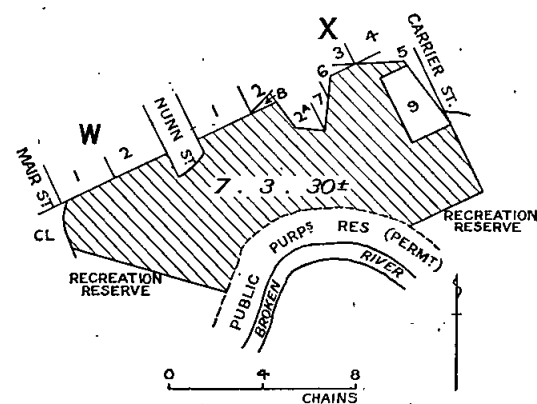

CORRYONG.—The temporary reservation, by Order in Council of the 23rd October, 1916, of 2 roods of land in the Township of Corryong as a site for Municipal pur-

poses, is about to be revoked, so far only as the portion containing 32 perches indicated by hatching on plan hereunder, is concerned.—(C.427⁽³⁾) (Rs.1260).

DAYLESFORD.—The temporary reservation, by Order in Council of the 16th August, 1955, of 7 acres 2 roods, more or less, of land in the Township of Daylesford (called Parish of Wombat in Order) as a site for Public Recreation, is about to be revoked, so far only as the portion containing 2 roods 23 perches indicated by hatching on plan hereunder, is concerned.—(D.13⁽³⁾) (Rs.183).

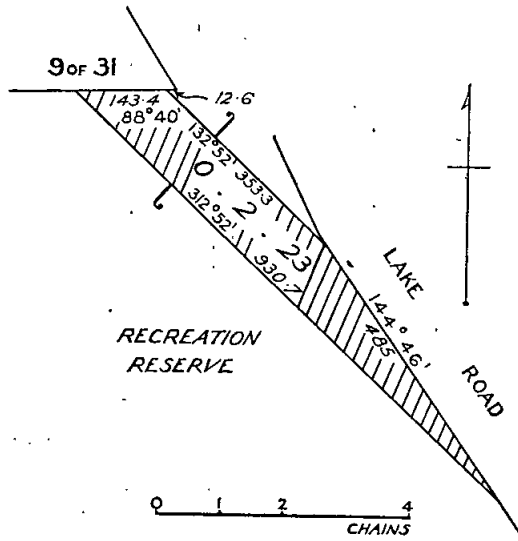
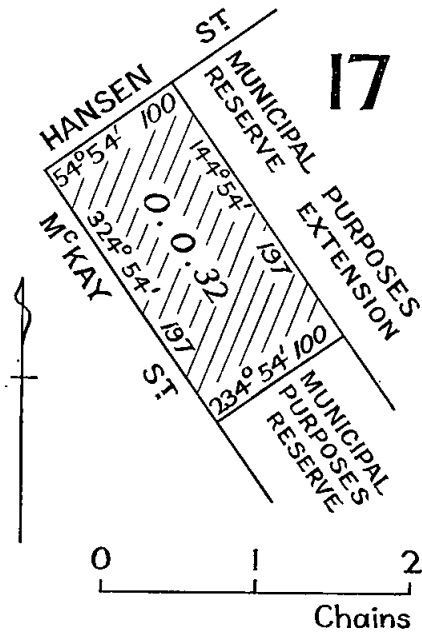

CORRYONG.—The temporary reservation, by Order in Council of the 11th November, 1924, of 2 roods of land in the Township of Corryong as a site for Municipal purposes, is about to be revoked, so far only as the portion containing 32 perches indicated by hatching on plan hereunder, is concerned.—(C.427⁽³⁾) (Rs.1260).

WANNAEUE.—The temporary reservation, by Order in Council of the 23rd September, 1872, of 2 acres, more or less, of land in the Parish of Wannaeue as a site for Lighthouse purposes, is about to be revoked, so far only as the portion containing 1 rood 34 perches indicated by hatching on plan hereunder, is concerned.—(W.32⁽³⁾) (C.87964).

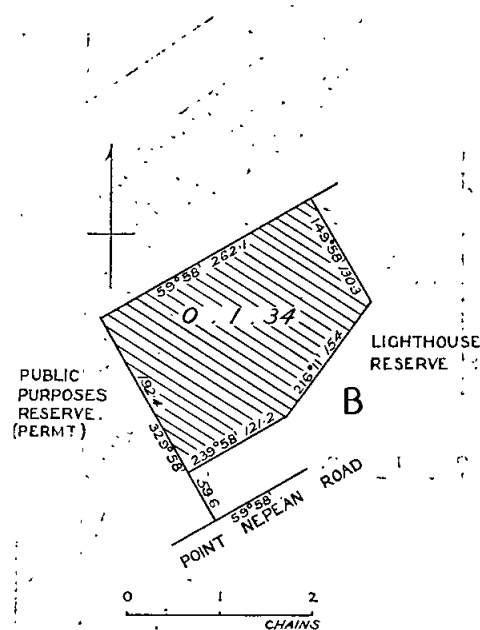
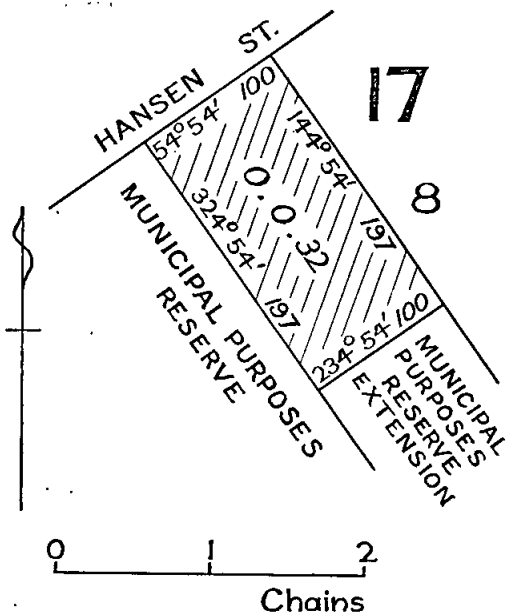

WARATAH (CAPE LIPTRAP).—The temporary reservation, by Order in Council of the 20th April, 1914, of 20 acres 2 roods 22 perches of land in the Parish of Waratah as a site for Lighthouse purposes, is about to be revoked, so far only as the portion containing 4 perches, more or less, indicated by hatching on plan hereunder, is concerned.—(W.365^(o)) (C.73008).

LIGHTHOUSE RESERVE

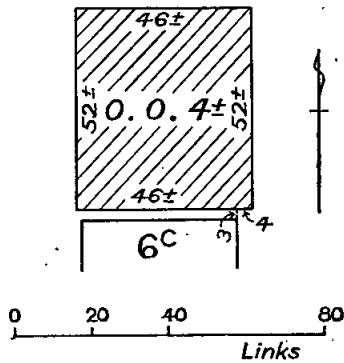

SEVILLE.—The temporary reservation, as a site for Cricket and other purposes of Public Recreation and the withholding from sale, leasing and licensing by Order in Council of the 20th August, 1883, of 10 acres of land in the Parish of Wandin Yallock (now in the Township of Seville) and the temporary reservation, by Order in Council of the 16th June, 1890, of the same land as a site for a Public Park, are about to be revoked, so far only as the portion containing 1 acre 19 perches indicated by hatching on plan hereunder, is concerned.—(S.457⁽¹⁾) (Rs.1084).

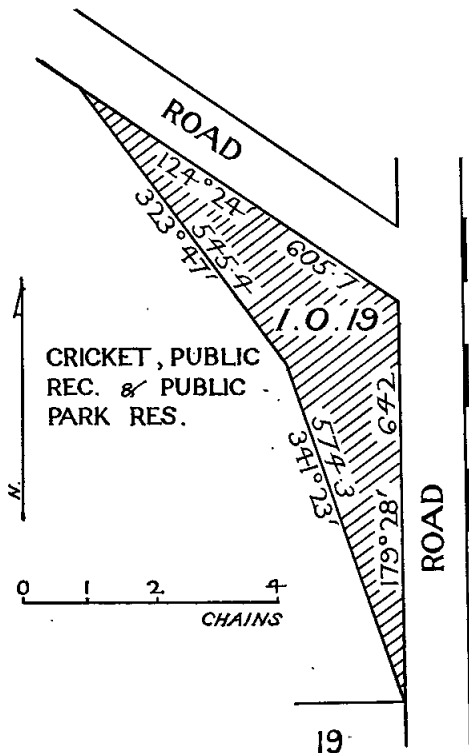

W. BORTHWICK,
Minister of Lands.

LOCAL LAND BOARDS.

In pursuance of the provisions of section 34 of the Land Act 1958, notice is hereby given that public hearings at the following places and times, will be conducted by the persons respectively mentioned, being duly appointed in that behalf.

W. BORTHWICK,
Minister of Lands.

Department of Crown Lands and Survey,
Melbourne.

STAWELL (Court House, Patrick-street).—Wednesday, 31st May, 1972, at 11 a.m.—E. M. Floyd.

HAMILTON (Land Office).—Wednesday, 31st May, 1972, at 11 a.m.—K. C. Gittins.

PROPOSED PERMANENT RESERVATION OF LAND AS SITES.

In pursuance of sections 14 and 21 of the Land Act 1958, notice is hereby given that it is the intention of the Governor in Council to reserve permanently from sale, from being leased and from having a licence granted in respect thereof the land hereinafter described:—

The following Notice was published 1^o on the 17th May, 1972, pursuant to Order of the 9th May, 1972.

MELBOURNE SOUTH (ST. KILDA AND ELWOOD).—Land proposed to be permanently reserved as a site for Public Recreation, 32 acres 1 rood 20 perches, at St. Kilda and at Elwood, Parish of Melbourne South, County of Bourke, as indicated by hatching on plan hereunder.—(S.226^(*)) (Rs.8333).

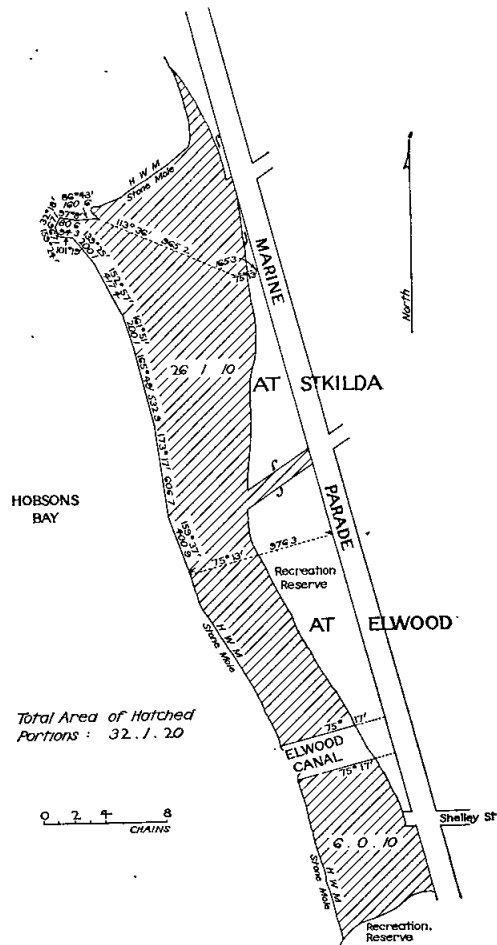

W. BORTHWICK,
Minister of Lands.

REGULATIONS FOR THE CARE, PROTECTION AND MANAGEMENT OF THE "LAKE CULLULLERAIN PUBLIC RECREATION RESERVE".

I, William Archibald Borthwick, Her Majesty's Minister of Lands in and for the State of Victoria in pursuance of the powers conferred on me by section 218 of the *Land Act 1958*, do hereby apply the regulations made for or with respect to the reserved land in the Parish of Mulroo shown bordered blue on plan 'L.C./68.5.124' attached to Lands Department correspondence No. Rs.5124 to the reserved land in the said Parish shown bordered red on the said plan.—(Rs.5124.)

Given under my hand at Melbourne on the 12th day of May, 1972.

W. BORTHWICK,
Minister of Lands.

Every person who contravenes or fails to comply with these Regulations shall, in accordance with the provisions of section 218 of the *Land Act 1958*, for each offence be liable to a penalty of not more than Fifty dollars, and every person who contravenes or fails to comply with any such Regulations, and who, after he has been warned by any bailiff of Crown lands or by any member of the Police Force, does not desist therefrom may be forthwith apprehended by such bailiff or member of the Police Force and taken before some justice to be dealt with according to law and shall be liable to a penalty of not more than One hundred dollars, provided that every person who contravenes any regulation made under the said section for or with respect to prohibiting the depositing and leaving of any unwanted material or thing or rubbish of any kind on any land to which this section relates shall for each offence be liable to a penalty of not more than Two hundred dollars.

REGULATIONS FOR THE CARE, PROTECTION AND MANAGEMENT OF THE TARWIN RIVER FRONTAGE RESERVE.

I, William Archibald Borthwick, Her Majesty's Minister of Lands in and for the State of Victoria in pursuance of the powers conferred on me by section 218 of the *Land Act 1958* do hereby make the following Regulations for or with respect to the land in the Parish of Tarwin permanently reserved for Public purposes and indicated by red colour on plan T/21.1.60 attached to Lands Department correspondence No. Rs.9140.

REGULATIONS.

1. In these Regulations the under-mentioned words shall, unless inconsistent with the context have the meanings shown opposite them, that is to say:—

Reserve.—The Tarwin River Frontage Reserve as hereinbefore described.

Committee.—The Committee of Management appointed pursuant to section 221 of the *Land Act 1958* with the power and authority to carry into effect and enforce these Regulations.

Building.—Any tent, marquee, stall, booth, shed, bathing box, boathouse, swing boat, merry-go-round, ocean wave or other structure or erection.

In the Reserve.—In or on the Reserve and in the case of fences includes surrounding the Reserve or any portion thereof.

Person.—Includes persons, a group of persons and/or any club, society or other organization or any member thereof, and any firm or corporation (where the context so permits).

2. No person shall offend decency as regards dress, language, conduct, or in any other manner in the Reserve and no person so offending shall remain in the Reserve.

3. Every person bathing from the Reserve shall be decently attired in a bathing costume.

4. No person shall reside in any building or structure erected in or on the Reserve, nor shall any person use any such structure for the purpose of storing furniture or goods other than boats, winches, bathing suits, boat accessories, or boat and fishing gear.

5. Persons granted the use of any stand, building, erection or enclosure on the occasion of any sports, athletic games, matches, fetes, concerts, gymkhanas, entertainments or other holiday amusements may be required to deposit any sum which the Committee may at any time determine, not exceeding Twenty dollars (\$20), by way of guarantee that due care shall be taken of such stand, building, erection or enclosure, and the Committee, in its absolute discretion, may make good any damage or injury sustained to such stand, building, erection or enclosure

or anything contained therein, during such occupancy or hiring and deduct the costs of making good such loss or damage from the sum of money deposited by way of guarantee and all persons so renting or hiring shall abide by these Regulations and by any order given by the Committee.

6. The Committee may from time to time fix and collect fees or other charges for entering and using any facilities or conveniences provided by it on the Reserve.

7. Every person holding or purporting to hold any receipt or permission, in writing, issued by the Committee, shall, on demand by any member of such Committee or any officer thereof or any member of the Police Force or any Bailiff of Crown Lands, produce such receipt or permission.

8. No person shall play, practise or engage in any organized game or sport in the Reserve on Sundays without the permission in writing, of the Committee first obtained.

9. The Committee may set aside portions of the Reserve as and for the purpose of camping or parking, and may fix and collect fees or other charges for entering and using any such area.

10. No person shall camp or park any caravan or vehicle or erect any tent or other structure on any site on any portion of the Reserve except such portions or portions thereof as may be specially set apart for such purpose by the Committee, and then only with the consent, in writing, of the Committee first obtained and on payment of such fees and subject to such conditions as the Committee may determine.

11. The granting, withdrawal, renewal or allowance of the transfer of any permit or the subletting of any site or structure shall be at all times at the absolute discretion of the Committee.

12. No person shall injure, damage or alter in any way whatsoever any trees, shrubs, grass, flora living or dead timber or wood or any building, fence, table, seat, post, tap, sign, light or any other structure or thing whatsoever within the Reserve without the permission in writing of the Committee first obtained.

13. Any consent or permit by the Committee may be given under the hand of its Secretary or other authorized officer.

14. For the purpose of these Regulations words importing the singular number shall mean and include the plural, and words importing the masculine gender shall mean and include the feminine gender where the context requires or admits.—(Rs.9140.)

Given under my hand at Melbourne on the 9th day of May, 1972.

W. BORTHWICK,
Minister of Lands.

Every person who contravenes or fails to comply with these Regulations shall, in accordance with the provisions of section 218 of the *Land Act 1958*, for each offence be liable to a penalty of not more than Fifty dollars, and every person who contravenes or fails to comply with any such Regulations, and who, after he has been warned by any bailiff of Crown lands or by any member of the Police Force, does not desist therefrom may be forthwith apprehended by such bailiff or member of the Police Force and taken before some justice to be dealt with according to law and shall be liable to a penalty of not more than One hundred dollars, provided that every person who contravenes any regulation made under the said section for or with respect to prohibiting the depositing and leaving of any unwanted material or thing or rubbish of any kind on any land to which this section relates shall for each offence be liable to a penalty of not more than \$200.

COMMITTEE OF MANAGEMENT OF RESERVES.

APPOINTMENTS.

Notice is hereby given that, in pursuance of section 221 of the *Land Act 1958*, the following appointments of Committees of Management of reserved Crown lands have been made by the Minister of Lands.

"BITTERN RECREATION RESERVE", "CRIB POINT FORESHORE RESERVE" AND "STONY POINT FORESHORE RESERVE".

Sandra Elizabeth Fletcher as a member of the Committee of Management of the above named Reserves for the period ending the 17th April, 1974.—(Corres. Nos. Rs.802, Rs.3572, Rs.6929.)

"CLIFTON CREEK PUBLIC HALL AND RECREATION RESERVE."

Arnold Roy Brownrigg, Keith William Brownrigg, Edward Owen Burton, Alwyn Robert Bowden, Herbert Steffen and Ludwig Gyorfi as a Committee of Management for a period of three (3) years from the 11th April, 1972, of the land in the Parish of Wy Yung, temporarily reserved by Order in Council dated the 11th August, 1964, as a site for Public Hall and Public Recreation, and known as the "Clifton Creek Public Hall and Recreation Reserve".—(Corres. No. Rs.8356.)

"COSTERFIELD PUBLIC HALL AND RECREATION RESERVE."

Raymond Charles Harris, Linton George Gleeson, John William Alexander Tattersall, Roy James Tattersall, Lindsay Harris, Robert James Sinclair Clouston, Burton Leslie Harris, Gordon Norman Fort and John Oliver Bradley as a Committee of Management for a period of three (3) years from the 29th April, 1972, of the remaining portion of the land in the Township of Costerfield, temporarily reserved by Order in Council dated the 19th October, 1965, as a site for Public purposes (Public Hall) and Public Recreation.—(Corres. No. Rs.1514.)

"DEDERANG RECREATION RESERVE."

Alan Charles Boyd, Henry Goonan, Gordon Desmond Smith, Frederick Arthur Guy, Francis Maurice Hynes, Roderick Charles Barton, Kevin Ronald Mull, Allan Martin Kirley, Arthur Cliff Lavis, John Rissman, Arthur Albert Jones, Thomas Joseph Goonan, Neville Gordon Seymour, Douglas Martin Heiner and John Mathew Creamer as a Committee of Management for a period of three (3) years from the 27th April, 1972, of the land in the Parish of Dederang, permanently reserved by Order in Council dated the 20th September, 1966, as a site for Public Recreation and known as the "Dederang Recreation Reserve".—(Corres. No. Rs.764.)

"DELEGATE RIVER PUBLIC HALL RESERVE."

The Corporation of the Shire of Orbost as the Committee of Management of the land in the Parish of Cabanandra, temporarily reserved by Order in Council dated the 19th October, 1937, as a site for a Public Hall, and known as the "Delegate River Public Hall Reserve".—(Corres. No. Rs.4732.)

"DUMBULK RECREATION RESERVE."

Mervyn Robert Bright and Albert Lindsay Richards as members of the Committee of Management of the above-named Reserve for the period ending the 27th April, 1973.—(Corres. No. Rs.3892.)

"EMU RECREATION AND PUBLIC HALL RESERVES."

Alexander Ernest Stanford, Francis John Rinaldi, Gerald Poole, Kevin Male, William Kelly, Henry Smith, Allan Frederick Bicknell, Lloyd James Chivers and Orville Henry Chivers as a Committee of Management for a period of three (3) years from the 16th February, 1972, of the remaining portion of the lands in the Township of Emu, temporarily reserved by Order in Council dated the 16th July, 1901, as a site for Public Recreation, and the land in the said Township, temporarily reserved by Order in Council dated the 7th March, 1923, as a site for a Public Hall, and together known as the "Emu Recreation and Public Hall Reserves".—(Corres. Nos. Rs.2454, Rs.2703.)

"FAWCETT MECHANICS' INSTITUTE RESERVE."

Lindsay Payne, John McVeigh, Charles A. Petersen, James Stanley Mackrell, Roy J. Bett and Edward Barry Mackrell as a Committee of Management for a period of three (3) years of the land in the Parish of Alexandra, permanently reserved by Order in Council dated the 14th November, 1887, as a site for a Mechanics' Institute and Free Library, and known as the "Fawcett Mechanics' Institute Reserve".—(Corres. No. Rs.5840.)

"GLADYSDALE PUBLIC HALL RESERVE."

Donald Parkinson, John S. G. Cook, William B. Parkinson, Francis D. Cole, Ronald A. Brunsdon, Edward Linnane, Graham A. Wynd, Shirley J. Aumann and Marie Linnane as a Committee of Management for a period of three (3) years from the 12th November, 1971, of the land in the Parish of Beenak at Gladysdale, temporarily reserved by Orders in Council dated the 14th September, 1915 and the 11th November, 1919 as sites for a Public Hall, and together known as the "Gladysdale Public Hall Reserve".—(Corres. No. Rs.913.)

A SITE FOR PUBLIC RECREATION, PARISH OF MACEDON.

The Corporation of the Shire of Gisborne as the Committee of Management of the land in the Parish of Macedon, temporarily reserved by an Order in Council dated the 15th March, 1972 as a site for Public Recreation.—(Corres. No. Rs.9400.)

"MARKWOOD PUBLIC HALL AND RECREATION RESERVE."

Charles Edward Bennett, Alwyn Lewis Hodgen, Clarence Albert Wood, Francesco Giuseppe Gigliotti, John Nicholas Muraca, Max Graham Bennett, Ellis David Hulley, Michele Pulvirenti and Mario Carobene as a Committee of Management for a period of three (3) years from the 9th March, 1972, of the land in the Parish of Oxley, temporarily reserved by Order in Council dated the 26th August, 1952, as a site for Public Hall and Public Recreation purposes, and known as the "Markwood Public Hall and Public Recreation Reserve".—(Corres. No. Rs.6942.)

"MOLIAGUL RECREATION RESERVE."

James Thomas Shay, James Leslie Snow, George Mervyn Carless, Richard Hugh Deason, Kevin William Shay, Arthur George Deason, Raymond Stanley Shay, Cyril James Snow, and William Edward Shay as a Committee of Management for a period of three (3) years from the 25th April, 1972, of the land in the Town of Moliagul, temporarily reserved by Order in Council dated the 20th October, 1911, as a site for Public Recreation.—(Corres. No. Rs.3261.)

"MORTLAKE RACECOURSE RESERVE."

Geoffrey Colin McDonald, William Henry Stanbury, James William Absalom, John William Mahony, James Joseph Delaney, Gordon Andrew Krepp, Westmore Roy Stephens, Merton James Waters as a Committee of Management for a period of three (3) years from the 6th March, 1972, of the land in the Parish of Conewarra, permanently reserved by Order in Council dated the 2nd March, 1892, as a site for Racecourse, and known as the "Mortlake Racecourse Reserve".—(Corres. No. Rs.2143.)

"MOUNT DANDENONG RESERVES."

Albert Lorraine Peverill in the place of Keith Charles Rankin (deceased) as Chairman and a member of the Committee of Management, for a period ending the 6th August, 1973, of the reserved Crown lands in the Parish of Mooroolbark as are shown coloured red on plan marked "M/31.8.1937", attached to Lands Department correspondence Rs.310, and known as the "Mount Dandenong Reserves".—(Corres. No. Rs.310.)

"NARIOKA RECREATION RESERVE."

Maurice Dohnt, Bruce Schier, Ronald Pearce, Morice Holland, Edward Warren, Graham Fairman, Thomas Tinkler, Rex James, Kevin Thorpe and Alan Lubke as a Committee of Management for a period of three (3) years from the 15th April, 1972, of the land in the Parish of Narioka, temporarily reserved by Order in Council dated the 20th February, 1902, as a site for Public Recreation, and known as the "Narioka Recreation Reserve".—(Corres. No. Rs.5294.)

"SEVILLE CRICKET AND RECREATION RESERVE."

Robert James Aitken, James Ewen Lindsay, Kevin Leslie Sibley, John Brian Mallett, Thomas William Payne, James William Cassidy, Ellis Rawson, Raymond M. Heal and Gordon C. Darke as a Committee of Management for a period of three (3) years from the 2nd April, 1972, of the land in the Township of Seville, temporarily reserved by Orders in Council dated the 20th August, 1883, and the 16th June, 1890, for Cricket and other purposes of Public Recreation and Public Park, and together known as the "Seville Cricket and Recreation Reserve".—(Corres. No. Rs.1084.)

"WIRIDJIL RECREATION RESERVE."

John Francis Cooper, Walter John Millard, William Frederick Sherring, Lilian Frances Bramley, Edward Allan Gay, Henry Neil Costin, Douglas James Dickson, Vincent John Ayres and Russell George Holland as a Committee of Management for a period of three (3) years of the land in the Parish of Waarre, temporarily reserved by

Order in Council dated the 1st October, 1968, as a site for Public Recreation, and known as the "Wiridjil Recreation Reserve".—(Corres. No. Rs.9060.)

W. BORTHWICK,
Minister of Lands.

Department of Crown Lands and Survey,
Melbourne, 11th May, 1972.

PROPOSED REVOCATIONS OF TEMPORARY RESERVATIONS OF LANDS BY ORDERS IN COUNCIL.

In pursuance of the provisions of the Land Act 1958, notice is hereby given that it is the intention of the Governor in Council to revoke the temporary reservations of lands by Orders in Council hereunder referred to, viz.:

The following Notices were published 1° on the 17th May, 1972, pursuant to Orders of the 9th May, 1972.

CASTERTON.—The temporary reservation, as a site for Quarry and the withholding from sale, leasing and licensing by Order in Council of the 17th September, 1877, of 11 acres 1 rood 6 perches of land in the Township of Casterton, are about to be revoked.—(C.177(2) (Rs.6389).

DOUTTA GALLA (KEILOR EAST).—The temporary reservation, by Order in Council of the 27th November, 1957, of 24 perches of land in the Parish of Doutta Galla as a site for Police purposes, is about to be revoked.—(D.85(2) (Rs.7677).

LEONGATHA.—The temporary reservation, by Order in Council of the 5th November, 1894, of 5 acres of land in the Township of Leongatha as a site for Nightsoil and Manure Depot, is about to be revoked.—(L.167(6) (Rs.6869).

NARRAWONG.—The temporary reservation, by Order in Council of the 8th July, 1902, of 25 acres 2 roods 37 perches of land in the Parish of Narrawong as a site for Supply of Gravel for Railway purposes, is about to be revoked.—(N.33(6) (Rs.4760).

STAWELL.—The temporary reservation, by Order in Council of the 19th August, 1935, of 2 roods 23 6/10 perches of land in the Parish of Stawell as a site for Municipal purposes, is about to be revoked.—(S.329(17) (Rs.4472).

WOOD'S POINT.—The temporary reservation, by Order in Council of the 23rd April, 1940, of 22 perches of land in the Township of Wood's Point as a site for a Public Hall, is about to be revoked.—(W.207(3) (Rs.5034).

ARARAT.—The temporary reservation, by Order in Council of the 14th July, 1959, of 1 acre 2 roods of land in the Township of Ararat as a site for the purposes of the Childrens Welfare Department, is about to be revoked, so far only as the portion containing 2 roods, more or less, indicated by hatching on plan hereunder, is concerned.—(A.148(7) (Rs.7839).

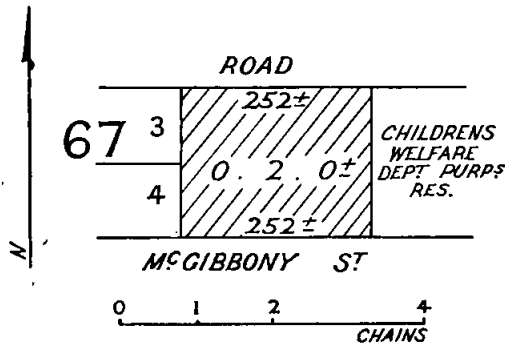

BARWONGEMOONG.—The temporary reservation, by Order in Council of the 19th July, 1966, of 3 acres 3 roods 35 perches of land in the Parish of Barwongemoong as a site for Public purposes (State Forests Department purposes),

is about to be revoked, so far only as the portions containing 1 acre 3 roods 19 perches indicated by hatching on plan hereunder, is concerned.—(B.742(5) (Rs.8492).

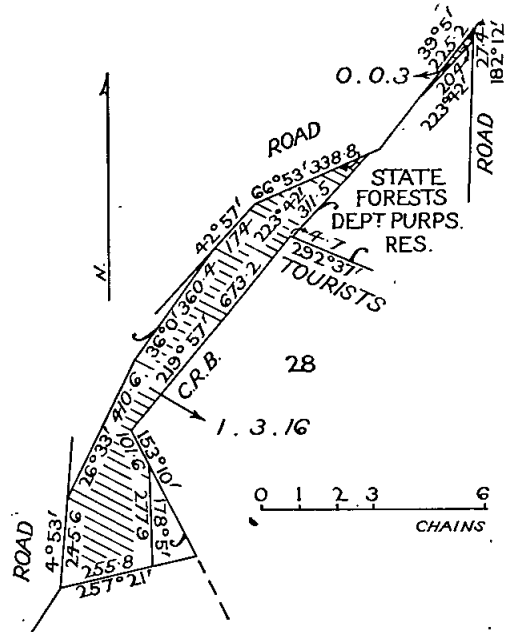

TOTAL AREA OF HATCHED PORTIONS
1.3.19

DUNMUNKLE (BOOLITE).—The temporary reservation, by Order in Council of the 26th May, 1902, of 29 acres 3 roods 29 perches of land in the Village of Booloite (now Parish of Dunmunkle), as a site for Public Recreation, and the temporary reservation by Order of the 7th September, 1948, for the additional purpose of a Public Hall, are about to be revoked, so far only as the portion containing 1 acre 2 roods 37 perches indicated by hatching on plan hereunder, is concerned.—(D.180(c8) (Rs.6221).

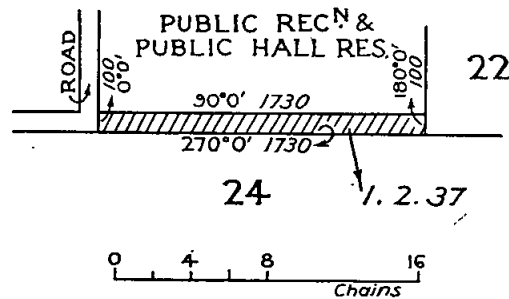

EPSOM.—The temporary reservation, by Order in Council of the 24th September, 1968, of 16 acres 31 perches of land in the Township of Epsom as a site for Public purposes (Regional Agricultural Centre), is about to be revoked, so far only as the portion containing 6 perches indicated by hatching on plan hereunder, is concerned.—(E.119(2) (Rs.9066).

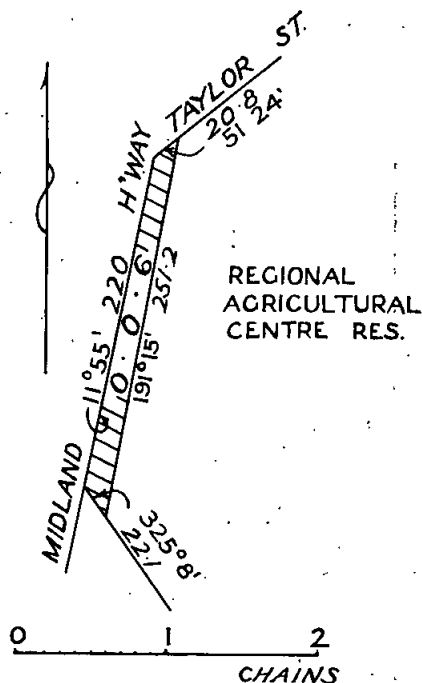

SEYMOUR.—The temporary reservation, by Order in Council of the 29th February, 1864 (see *Government Gazette* 8th March, 1864, page 573), of 1 acre 17 perches of land at Seymour (now Township of Seymour), as a site for Police purposes; is about to be revoked, so far only as the portion containing 1 rood 20 perches, more or less, indicated by hatching on plan hereunder, is concerned.—(S.261⁽³⁾) (Rs.9365).

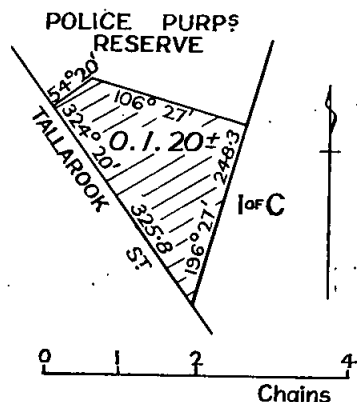

W. BORTHWICK,
Minister of Lands.

TENDERS

PUBLIC WORKS DEPARTMENT

Tenders will be received at Public Works Department, 2 Treasury-place, Melbourne, until **TWO p.m.** on dates shown and for purposes mentioned hereunder.

Particulars and tender forms available at Contracts Office, Room 8, Building Division, Parliament-place and at places indicated in brackets hereunder.

Abbreviations in brackets mean:—W.O.—Inspector of Works Office; P.S.—Police Station; C.S.—Consolidated School; H.E.S.—Higher Elementary School; H.S.—High School; Pr.S.—Primary School; T.S.—Technical School.

Tenders to be submitted on the Department's printed Tender Form and will not be received by telephone. All tenders must be on a "Firm Tender" basis. The lowest or any tender will not necessarily be accepted.

Address tenders to the Minister of Public Works, and endorse the envelope containing the tender "Tender for closing Tuesday,"

Hand delivered tenders to be placed in the Tender Box of the Public Works Department, located on the wall of the centre entrance foyer, Ground Floor, 2 Treasury-place, Melbourne.

No preliminary deposit is required with any tender, but a successful tenderer will be required to pay a deposit for any accepted tender of \$4,000 or over.

Tuesday, 23rd May, 1972.

Building, Electrical and Mechanical Works.

BENDIGO.—Erection of standard assembly hall, type "572C", Girls' H.S. (W.O., Bendigo.) (Amended Specification.)

BENDIGO.—Electrical services, hall, Girls' H.S. (W.O., Bendigo.) (Amended Specification.)

BENDIGO.—Mechanical services, hall, Girls' H.S. (W.O., Bendigo.) (Amended Specification.)

KERANG.—Repairs and painting, H.S. (W.O., Swan Hill.)

KYABRAM.—New electrical installation, rewire of existing light, power and P.A. system, Pr.S.2902. (Re-advertised.) (W.O., Shepparton.)

MANANGATANG.—Repairs and painting, Consolidated and H.S. (W.O., Swan Hill.)

PARKVILLE.—Renovations and additions to laundry block, "Turana" Youth Training Centre.

SEYMOUR.—Replacement of tile roof, H.S. (W.O., Bendigo and Shepparton.)

TRARALGON.—External repairs and painting, Hobson Park Hospital. (W.O., Traralgon.) (Amended Specification.)

WANGARATTA.—External renovations, T.S. (W.O., Shepparton and Wangaratta.)

WANGARATTA.—Erection of science wing and toilets, T.S. (W.O., Benalla and Wangaratta.)

WANGARATTA.—Mechanical services—Science Wing, T.S. (W.O., Benalla and Wangaratta.)

Furniture & Furnishings.

TRARALGON.—Supply and installing curtains—M.H.A. Residences. (W.O., Traralgon.)

Site Works.

ALTONA NORTH.—Asphalt repairs, T.S.

KNOX PARK.—Site works, Pr.S. 4990.

MOOROOLBARK.—Construction of oval and associated works, T.S.

STEVENSVILLE.—Site works, Pr.S. 5047.

Miscellaneous.

PRESTON.—Maintenance cleaning.—12 Cramer-street. S.W.D.

Tuesday, 30th May, 1972.

Building, Electrical and Mechanical Works.

BALLARAT.—Erection of concrete block classroom wing, Special School 4762. (W.O., Ballarat.)

BALLARAT.—Mechanical services—classroom wing, Special School 4762. (W.O., Ballarat.)

CASTLEMAINE.—Erection of new matting workshop, Prison. (Re-advertised.) (W.O., Bendigo and Kyneton.)

FRANKSTON HEIGHTS.—External and internal repairs and painting, Pr.S. 4815. (W.O., Mornington.)

GLENORMISTON.—Additions and renovations—Residence, Agricultural College. (W.O., Camperdown, Geelong and Warrnambool.)

INVERLOCH.—Internal and external repairs and painting, Pr.S. 2776. (W.O., Korumburra.)

KILCUNDA.—Internal and external renovations, Pr.S. 2307. (W.O., Korumburra.)

MALVERN EAST.—Internal and external painting, Pr.S. 4139.

MORWELL.—Internal and external repairs and painting &c., Pr.S. 2136. (W.O., Traralgon.)

ORBOST.—Additional office accommodation, Public Offices. (W.O., Bairnsdale and Orbost.)

PARKVILLE.—Mechanical services—Laundry Building, "Turana" Youth Training Centre.
RAINBOW.—Internal and external renovations, H.S. (W.O., Warracknabeal.)
SCORESBY.—Refrigeration services—Laboratory Building, Horticultural Research Station.
VARIOUS.—L.T.C. classrooms and staff improvements, H.S.'s, Central Region.
YEA.—External repairs and painting, H.S. (W.O., Benalla.)

Site Works.

GLEN WAVERLEY HEIGHTS.—Site works, Pr.S. 4836.
MELBOURNE.—Site works, New State Offices, Treasury-place. (Amended Specification.)
MENTONE PARK.—Site works, Pr.S. 4955.
UPWEY.—Asphalt repairs, H.S.

Tuesday, 6th June, 1972.

Building, Electrical and Mechanical Works.

BANDIANA.—Exterior and interior renovations, Pr.S.4691. (W.O., Wangaratta.)
BLACKBURN SOUTH.—Renovations and erection of toilet block, Pr.S.4035. (Amended Specification.)
BEECHWORTH.—External renovations, H.S. (W.O., Wangaratta.)
HAWKESDALE.—Internal renovations, H.S. (W.O., Warrnambool.)
LEARMONTH.—Alterations and additions, P.S. Residence. (W.O., Ballarat.) (Re-advertised.)
MANANGATANG.—Installation of transpiration bed, C.S. (W.O., Swan Hill.)
MELBOURNE.—Supply and installation of P.A.B.X. telephone system, State Public Offices, Treasury-place.
MOUNT WAVERLEY.—Renovations, H.S.
PATCHEWOLLOCK.—Erection of new toilet block, Group S.3973. (W.O., Horsham and Warracknabeal.) (Re-advertised.)
STAWELL.—Stripping and tiling of slate roof, H.S. (W.O., Ararat.)
STRATFORD.—Internal and external renovations, Pr.S.596. (W.O., Bairnsdale.) (Amended Specification.)
WANGARATTA.—Electrical installation, T.S. (W.O., Benalla and Wangaratta.)

Site Works.

ARARAT.—Site works, T.S. (W.O., Ararat.)
ESSEX HEIGHTS.—Site works, Pr.S.4903.

MURRAY BYRNE,
 Minister of Public Works.

Public Works Department,
 Melbourne, 3002, 15th May, 1972.

PUBLIC SERVICE NOTICES

EXAMINATION OF APPLICANTS FOR LICENCE AS SHORTHAND WRITER.

It is hereby notified that an examination of applicants for licence as Shorthand Writer will be held at the Royal Melbourne Institute of Technology, 5th Floor, Casey Wing, Rooms C.519 and C.525, Swanston-street, Melbourne, on Saturday, the 24th June, 1972, at 10 o'clock a.m.

Applications for permission to attend the examination together with an entry fee of Four dollars (\$4.00) must be forwarded to reach the Secretary, Public Service Board, Treasury-place, Melbourne, 3002 (where a copy of the Regulations may be obtained), not later than Saturday, the 10th June, 1972.

Satisfactory evidence of—

- (1) Name in full,
 - (2) Having attained the age of twenty-one (21) years, and
 - (3) Good moral character—
- should be submitted with application.

By order,
 R. H. DURRANT,
 Acting Secretary.

Office of the Public Service Board,
 Melbourne, 15th May, 1972.

No. 223.

Public Service Act 1958, Section 50.

REGULATIONS—PART IV.—SALARIES AND INCREMENTS.

The Public Service Board, in pursuance of the powers conferred by the Public Service Act 1958, hereby amends the Public Service (Public Service Board) Regulations as follows:—

THIRD SCHEDULE.

PART B.

PROFESSIONAL DIVISION.

Scale of Rates of Annual Salaries.

LIBRARIANS.

Class.	Annual Salary of Each Subdivision of Each Class.	
	1.	2.
	\$	\$
<i>Delete—</i> L-2	7,050	7,315
<i>Add—</i> L-2A	6,997	..
L-2	7,156	7,420
L-6	11,400	..

LIBRARY OFFICERS.

Class.	Annual Salary of Each Subdivision of Each Class.		
	1.	2.	3.
	\$	\$	\$
<i>Delete—</i> LR-6	6,997	7,156	7,420
<i>Add—</i> LR-6A	6,997
LR-6	7,156	7,420	..

SIXTH SCHEDULE.

TEMPORARY EMPLOYEES.

Designations of Positions and Rates of Salaries.

Department and Designation of Position.	Yearly Rate of Salary.		Increments (Annual).
	Minimum.	Maximum.	
	\$	\$	
CHIEF SECRETARY'S DEPARTMENT State Library, National Gallery, National Museum and Science Museum.			
<i>Add—</i> Map Librarian	6,997	..

A. H. RIGG, Acting Chairman.
 V. P. SCULLY, Secretary.

Office of the Public Service Board,
 Melbourne, 3rd May, 1972.

No. 222.

PUBLIC SERVICE ACT 1958.

The Public Service Board, in pursuance of the powers conferred by the Public Service Act 1958, hereby amends the Public Service (Public Service Board) Regulations as follows:—

PART II.—APPOINTMENTS TO THE PUBLIC SERVICE.

DIVISION IV.—TECHNICAL AND GENERAL DIVISION.

DEPARTMENT OF HEALTH—MENTAL HYGIENE BRANCH.

Regulation 45A.

Paragraph (b) is deleted and the following paragraph is inserted in lieu thereof—

"(b) holds the Certificate in Child Care issued by the Institute of Social Welfare."

A. H. RIGG, Acting Chairman.
 V. P. SCULLY, Secretary.

Office of the Public Service Board,
 Melbourne, 8th May, 1972.

No. 220.

Public Service Act 1958, Section 39.

REGULATIONS.—PART IV.—SALARIES AND INCREMENTS.

The Public Service Board, in pursuance of the powers conferred by the Public Service Act 1958, hereby amends its Regulations as shown below:—

FOURTH SCHEDULE.

ADMINISTRATIVE DIVISION.

Amount of Salary Assigned to Offices in Class "A1".

Office.	Yearly Rate of Salary.
STATE FORESTS DEPARTMENT.	
Delete—	
Finance Officer	12,105
Add—	
Chief Finance Officer	12,105

A. H. RIGG, Acting Chairman.
V. P. SCULLY, Secretary.

Office of the Public Service Board,
Melbourne, 5th May, 1972.

No. 221.

PUBLIC SERVICE ACT 1958.

The Public Service Board, in pursuance of the powers conferred by the Public Service Act 1958, hereby amends the Public Service (Public Service Board) Regulations as shown below:—

PART V.—ALLOWANCES.

DIVISION II.—OVERTIME AND STAND-BY ALLOWANCES.

WATER SUPPLY DEPARTMENT.

Regulation 152.

Sub-regulation (1) is amended as follows:—

Office or Position.	Stand-by a year.	Commuted Overtime Percentage.
District Superintendent, Supervisor Waranga Western Channel, Senior District Inspectors, Works Superintendents, District Inspectors, Senior Works Inspectors, Works Inspectors and Inspectors, Grade I.	\$	%
Delete—		
(a) Goulburn Division—		
(i) Stanhope Irrigation area and Murchison	132	28
(ii) All others	106	12.5
Add—		
(a) Goulburn Division—		
(i) Murchison	132	28
(ii) All others	106	12.5
Electrical Supervisor, Grade I.		
Add—		
Red Cliffs	106	10
Mechanical Supervisors and Mechanical Officers.		
Delete—		
Mallee Pumping Stations, Frankston Centre and Bendigo Centre ..	106	10
Add—		
Mallee Pumping Stations, Frankston Centre, Bendigo Centre and Camperdown Centre	106	10

A. H. RIGG, Acting Chairman.
V. P. SCULLY, Secretary.

Office of the Public Service Board,
Melbourne, 3rd May, 1972.

No. 225.

PUBLIC SERVICE ACT 1958.

The Public Service Board, in pursuance of the powers conferred by the Public Service Act 1958, hereby amends the Public Service (Public Service Board) Regulations as follows:—

PART V.—ALLOWANCES.

DIVISION III.—HIGHER DUTIES ALLOWANCES.

Regulation 153.

Regulation 153 is revoked and the following Regulation is inserted in lieu thereof:—

"153. (1) Where an officer is assigned the duties of a position higher than that in which he is classified for a period longer than two weeks, the rate of allowance which he shall be granted from the date of assignment shall be such as will increase his remuneration to the minimum rate of annual salary of the higher position: Provided that—

- (a) where the higher position has a maximum standard salary up to and including \$10,120 a year such allowance shall not exceed \$1,730 a year: Provided further that where an officer classified in Classes "E" and "D" in the Administrative Division is assigned the duties of a position in Class "C1" or a higher position, the rate of the allowance shall not exceed \$1,110 a year;
- (b) where a higher position has a maximum standard salary in excess of \$10,120 a year the rate of the allowance shall not exceed \$2,060 a year, unless the Board approves payment of a higher rate in any special case;
- (c) where an officer in Class "E" of the Administrative Division with less than one year's service is assigned the duties of a position in Class "C", the allowance shall be at the rate of \$200 a year;
- (d) where a junior officer in Class "E" of the Administrative Division with service of one year or more is assigned the duties of a position in Class "C", his remuneration shall be at the minimum rate of annual salary for Class "C", less the amount appropriate to age, as prescribed in Regulation 99 of these Regulations;
- (e) where a junior officer (other than a junior officer in Class "E" of the Administrative Division) is performing the full duties of an office for which no junior rates are prescribed he may be paid such allowance as may be determined by the Board.

(2) While an officer continues to occupy a higher position, he shall be entitled to such increases in the allowance payable as are equivalent to the annual increments appropriate to such position.

(3) In the event of an officer while acting in a higher position being permanently promoted, he shall not suffer any reduction of remuneration, and shall be eligible to receive increments in the same manner as he would have received them had his period of acting service, from the date from which he received the higher duties allowance, been in the position to which he has been promoted: Provided that if the officer is promoted to a position which is lower in classification than that in which he has been acting, his remuneration on promotion shall be equivalent to the amount which he would have received had the period of acting service, from the date from which he received the higher duties allowance, been in the lower position.

(4) Where the range of salary of the position held by the acting officer and the position temporarily occupied by him overlap, such officer shall be paid an allowance to increase his remuneration to such amount, as determined by the Board, as he would have received had he been permanently promoted to the higher position.

(5) Where an officer temporarily occupies a higher position and either is not qualified to perform or does not perform the whole of the duties usually performed by the holder of that position, he may be paid such allowance as may be determined by the Board.

(6) Allowances granted under this Regulation shall be regarded as salary for the purpose of calculation of payments made under the provisions of Regulations 145, 146, 155 and 206.

(7) "Standard salary" means salary excluding any additional amount payable under the provisions of Regulation 103.

(8) The Permanent Head shall forward to the Board a quarterly return of higher duties allowances authorized in each branch or section during the preceding quarter."

Regulation 154.

In sub-regulation (4) the expression "three months" is substituted for the expression "one month".

Sub-regulation (5) is revoked and the following sub-regulation is inserted in lieu thereof:—

"(5) Nothing in the foregoing shall affect the application of sub-regulations (2) to (7) of Regulation 153 in any case to which this Regulation applies, but sub-regulations (1) and (8) of Regulation 153 shall not apply in any such case."

This Regulation shall have effect as on and from the 9th May, 1972.

A. H. RIGG, Acting Chairman.
R. H. DURRANT, Acting Secretary.

Office of the Public Service Board,
Melbourne, 15th May, 1972.

No. 224.

PUBLIC SERVICE ACT 1958.

The Public Service Board, in pursuance of the powers conferred by the *Public Service Act 1958*, hereby amends the *Public Service (Public Service Board) Regulations* as follows:—

PART III.—PROMOTIONS AND TRANSFERS.

DIVISION III.—SPECIAL REQUIREMENTS.

PROFESSIONAL DIVISION.

Regulation 80.

In paragraph (b) the expression "passed the first three subjects of the Registration Examination" is deleted and the expression "passed five subjects of the Registration Examination or the equivalent thereof" is inserted in lieu thereof.

A. H. RIGG, Acting Chairman.
V. P. SCULLY, Secretary.

Office of the Public Service Board,
Melbourne, 3rd May, 1972.

PRIVATE ADVERTISEMENTS

CITY OF CROYDON.

LOAN No. 108.

Private Street Construction.

Notice is hereby given that at the meeting of the council of the City of Croydon, held in the Council Chamber, Foch-avenue, Croydon, on the 17th day of April, 1972, the said Council did agree to the following Resolution, that is to say:—

"That the Council do by Special Order and it does hereby resolve to borrow the sum of \$50,000 on the credit of the municipal revenues of the Mayor, Councillors and Citizens of the said City, such sum to be raised by the grant of mortgage, in accordance with the Provisions of the *Local Government Act 1958*.

The rate of interest to be paid shall be 6.2 per centum per annum and the said loan shall be liquidated by twenty half-yearly payments of principal and interest, at the Commonwealth Savings Bank of Australia, Melbourne, on the several days and in the several amounts specified in the Schedule of payments.

The purposes for which the said loan shall be applied are for the construction of private streets under the provision of Division 10 of Part XIX. of the *Local Government Act 1958*, and the loan shall be liquidated from the receipts of money payable under scheme under the said Division."

Notice is hereby further given that at a meeting of the said Council held in the Council Chamber, Foch-avenue, Croydon, on the 15th day of May, 1972, the said Resolution was confirmed.

6173

R. BURTON, Town Clerk.

CITY OF DONCASTER AND TEMPLESTOWE.

Notice is hereby given that, pursuant to the provisions of the *Local Government Act 1958* the Council of the City of Doncaster and Templestowe has ordered that the name of the following street within the municipality be changed as set out hereunder:—

Old Name.—Devon-road.

New Name.—Devon-drive.

Location.—Devon-road between Doncaster-road and Beverley-street as shown on L.P.17865, Doncaster.

6204

J. W. THOMSON, Town Clerk.

CITY OF GEELONG.

LOAN No. 33.

Notice is hereby given that it is the intention of the Council of the City of Geelong to float a loan of \$75,000 for permanent works and undertakings.

6187

L. L. WALTER, Town Clerk.

CITY OF HAMILTON.

LOAN No. 57—\$100,000

Notice of Intention to Borrow the Sum of \$100,000 for Permanent Works and Undertakings.

Notice is hereby given that the Council of the City of Hamilton proposes to borrow the principal sum of \$100,000, secured by a charge over the general rates of the municipality, such sum to be raised by the grant of a mortgage in accordance with the provisions of the *Local Government Act 1958*.

1. The maximum rate of interest that may be applied is 6.40 per cent. per annum.

2. The purpose for which the loan is to be applied is:—

Art Gallery extensions, Council contribution (part)	\$30,000
Drainage Works, various, Council contribution	23,000
Kerb, channel and footpath, various, Council contribution	16,000
Learners' swimming pool, Council contribution (part)	3,000
Town Hall, miscellaneous	1,550
Melville oval, fire track	1,500
Town Plan—maps	550
Corporation saleyards extensions	24,400
Total	\$100,000

3. The period of the loan shall be twenty five years.

4. The moneys borrowed shall be repayable by providing out of the municipal fund half-yearly instalments of \$4,035.43 each, including principal and interest on the 1st day of January and the 1st day of July, during the currency of the loan. The first instalment shall be payable on the 1st day of January, 1973.

5. Such moneys shall be repayable to the Local Authorities Superannuation Board, Rigby House, 15 Queens Road, Melbourne.

The plans and specifications and the estimate of the cost of the proposed works and a statement showing the proposed expenditure of the moneys to be borrowed are open for inspection at the office of the Council of the City of Hamilton, at Brown-street, Hamilton.

Dated this 17th day of May, 1972.

6179

H. F. DONALD, Town Clerk.

CITY OF KEW.

NOTICE OF INTENTION TO TAKE LAND COMPULSORILY.

Notice is hereby given that, it is the intention of the City of Kew in exercise of the powers conferred on it by the *Local Government Acts* to take compulsorily:—

All those pieces of land being the rear portions of properties 125 Disraeli-street and 50 Park-crescent being more particularly part of the lands described in certificates of title, volume 5875, folio 815, and volume 4735, folio 926, respectively.

The said lands are required and being taken for the purpose of the undergrounding of drain between Disraeli-street and Park-crescent.

The Council has caused to be prepared maps and other papers to show a general description of the work or undertaking the description of the lands proposed to be taken and stating the names of the owners, lessees, mortgagees and occupiers of such lands.

The said maps and other papers have been approved by the Council and are now deposited for inspection by all persons interested at the Municipal Offices, Charles-street, Kew, and may be inspected during office hours.

All persons affected by the proposed taking of the land are hereby required to set forth in writing addressed to the Council or the municipal clerk within forty (40) clear days of the publication of this notice in the *Government Gazette* all objections which they may have to the taking of the land.

Dated the 17th day of May, 1972.

6214

By order of the Council,

J. L. JOHNSON, Municipal Clerk.

CITY OF MELBOURNE.

By-Law No. 488.

A By-law of the City of Melbourne made under Part VII. Division 1 of the *Local Government Act 1958* and numbered 488 for prohibiting or minimizing noises in any public highway.

In pursuance of the powers conferred by the *Local Government Act 1958* and of every other Act or power enabling it in that behalf, the Council of the City of Melbourne ORDERS as follows:

1. This By-law may be cited as the *City of Melbourne Noise Abatement (Public Highways) By-Law 1972*.

2. In this By-law, unless the context otherwise requires—

“clause” means clause of this By-law;

“Council” means the Council of the City of Melbourne;

“person” includes a corporation;

“Town Clerk” means the Town Clerk of the City of Melbourne.

Words importing the masculine gender include the feminine, and the singular number includes the plural and the plural the singular.

3. Subject to clause 5, no person shall in or adjacent to, or in or on any premises abutting on, any public highway cause or permit or suffer to be caused any noise in that public highway by—

(a) using, operating, or working any amplifier or similar device; or

(b) crying any wares—

without the consent in writing of the Council first obtained and then only in accordance with the conditions (if any) attached to that consent.

4. (1) Any person seeking consent pursuant to clause 3 shall apply for it in writing to the Council, addressing his application to the Town Clerk and stating—

(a) his full name and address;

(b) the date on which, the times between which, the place at which, and the purpose for which he wants to use the amplifier or similar device or to cry the wares;

(c) the name of the public highway in which the noise will be caused; and

(d) such other information as the Council or the Town Clerk may require.

(2) The Council may, as it sees fit—

(a) grant the application either subject to conditions or not; or

(b) refuse the application.

5. Notwithstanding anything in clause 3—

(a) any member of—

(i) the police force;

(ii) any fire brigade;

(iii) any ambulance service; or

(iv) any first-aid or civil-defence organization; or

(b) any officer or employee of—

(i) any public-utility authority; or

(ii) the Corporation of the City of Melbourne—

who is performing any of the duties he is lawfully permitted or required to perform may use, operate, or work any amplifier or similar device in or adjacent to any public highway in the performance of those duties.

6. Any person guilty of a wilful act or default contrary to this By-law shall be liable—

(a) to a penalty of not less than \$20 and not more than \$100; and

(b) to a further penalty of not more than \$10 for each day on which the offence is continued after a conviction or order by any court.

7. This By-law shall apply and have operation throughout the whole of the municipal district of the City of Melbourne.

Resolution for passing this By-law agreed to by the Council of the City of Melbourne the 5th day of April, 1972, and confirmed the 15th day of May, 1972.

(SEAL) ALWYNNE ROWLANDS, Lord Mayor.
6272 F. H. ROGAN, Town Clerk.

No. 1644.

CITY OF NUNAWADING.

LOAN No. 123.

Notice of Intention to Borrow.

Notice is hereby given that the Council of the City of Nunawading proposes to borrow the principal sum of \$45,000, secured by a charge over the general rates of the municipality, such sum to be raised by the grant of a mortgage in accordance with the provisions of the *Local Government Act 1958*.

1. The maximum rate of interest that may be paid is 6.3 per cent. per annum.

2. The purpose for which the loan is to be applied is:—
Provision of places of public resort and recreation.

3. The period of the loan shall be fifteen years.

4. The moneys borrowed shall be repayable by providing out of the municipal fund 30 half-yearly instalments of \$2,340.61 each including principal and interest, on the 1st day of January and the 1st day of July, during the currency of the loan. The first instalment shall be payable on the 1st day of January, 1973.

5. Such moneys shall be repayable at the Commonwealth Savings Bank of Australia, Melbourne.

The plans and specifications and the estimate of the cost of the proposed works and a statement showing the proposed expenditure of the moneys to be borrowed are open for inspection at the office of the Council of the City of Nunawading at Whitehorse-road, Nunawading.

6176

J. H. BROWN, Town Clerk.

No. 1645.

CITY OF NUNAWADING.

Notice is hereby given that, in pursuance of the powers conferred by the *Local Government Act*, the Council of the City of Nunawading did, at a meeting held on the 8th May, 1972, order that the following alteration be made in the name of the street as under, and that such order take effect from the date of this publication in the *Victoria Government Gazette*:—

Old Name.—Gertrude-street (east west section) and Lorraine-court.

New Name.—Lorraine-drive.

Old Name.—Gertrude-street (north south section).

New Name.—Keats-street.

6180

J. H. BROWN, Town Clerk.

CITY OF RICHMOND.

LOAN No. 56.

Notice of Intention to Borrow.

Notice is hereby given that the Council of the City of Richmond proposes to borrow the principal sum of \$150,000 for permanent works and undertakings, secured by a charge over the general rates of the municipality, such sum to be raised by a grant of a mortgage in accordance with the provisions of the *Local Government Act 1958*.

(a) The amount of the principal sum which it is proposed to borrow is \$150,000.

(b) The maximum rate of interest that may be paid is 6.3 per centum per annum.

(c) The purpose for which it is to be applied is:—

1. Completion of Municipal Golf Links .. \$2,300

2. Erection of a pavilion for amenities for the new recreation ovals beside the Boulevard—Council's contribution .. \$20,000

3. Road Works—Council's contribution Elizabeth-street reconstruction .. \$100,000

Approaches to the Railway Bridge, Coppin-street .. \$20,000

Modernization of kerb and channels .. \$7,700

(d) The moneys borrowed shall be repayable by providing out of the municipal fund half-yearly instalments of \$7,802.02 each, including principal and interest, on the 1st day of July and the 1st day of January, during the currency of the loan. The first instalment shall be payable on the 1st day of January, 1973.

(e) The period of the loan shall be fifteen years.

(f) Such money shall be repayable to the Commonwealth Savings Bank of Australia, Richmond Branch, or such other place or places as the Bank from time to time requires.

The plans and specifications and an estimate of the cost of the proposed expenditure of the moneys to be borrowed are open for inspection at the offices of the Council of the City of Richmond, Town Hall, Bridge-road, Richmond.

6183

C. C. EYRES, Town Clerk.

CITY OF SOUTH MELBOURNE.

LOAN No. 79.

Notice of Intention to Borrow the Sum of \$30,000 for Permanent Works and Undertakings.

Notice is hereby given that the Council of the City of South Melbourne proposes to borrow the principal sum of Thirty thousand dollars (\$30,000), secured by a charge over the general rates of the municipality, such sum to be raised by the grant of a mortgage in accordance with the provisions of the *Local Government Act 1958*.

- (1) The maximum rate of interest that may be paid is 6.2 per centum per annum.
 (2) The purpose for which the loan is to be applied is:—

Street construction—kerbing and channelling:—	
Clarendon-street:	
Market-street to Dorcas-street (West side)	\$16,500
Ifla-street:	
Mountain-street to Lyell-street (both sides)	8,000
Wright-street:	
Canterbury-road to Canterbury-place (both sides)	5,500
	<u>\$30,000</u>

- (3) The period of the loan shall be ten years.
 (4) The moneys borrowed shall be repayable by providing out of the municipal fund twenty half-yearly instalments of approximately \$2,035.16 each, including principal and interest, on the 1st day of January and the 1st day of July, during the currency of the loan. The first instalment shall be payable on the 1st day of January, 1973.
 (5) Such moneys shall be repayable to the Bank of New South Wales Savings Bank Limited, 269 City-road, South Melbourne, or such other place or places as the Bank from time to time may require.

The plans and specifications and the estimate of the cost of the proposed works and a statement showing the proposed expenditure of the moneys to be borrowed are open for inspection at the office of the Council of the City of South Melbourne, at the Town Hall, Bank-street, South Melbourne, during office hours.

J. J. COX, Town Clerk.

28th April, 1972.

6177

CITY OF WAVERLEY.

LOAN No. 101.

Notice of Intention to Borrow the Sum of One Hundred Thousand Dollars (\$100,000) for Permanent Works and Undertakings.

Notice is hereby given that the Council of the City of Waverley proposes to borrow the sum of One hundred thousand dollars (\$100,000), secured by a charge over the general rates of the municipality, such sum to be raised by the grant of a mortgage in accordance with the provisions of the *Local Government Act 1958* (as amended).

In connexion therewith the following information is stated:—

- (a) The amount of the principal moneys which it is proposed to borrow is One hundred thousand dollars.
 (b) The maximum rate of interest that may be paid is 6.4 per centum per annum.
 (c) The period of the loan shall be twenty years. The times which the moneys borrowed are to be repayable are the 14th day of January and the 14th day of July, during the currency of the loan. The first instalment shall be payable on the 1st day of January, 1973.
 (d) The purpose for which the loan is to be applied is to provide land for places of public resort and recreation.
 (e) The manner in which the loan is to be liquidated is by the provision out of the municipal fund in each half-year during the currency of the loan of the sum of \$4,467.21, which includes principal and interest.

No. 32.—3876/72.—3

(f) Such moneys shall be payable at the Australian Mutual Provident Society, Melbourne.

The plans and specifications and estimate of cost of the works and a statement, showing the proposed expenditure of moneys to be borrowed, are open for inspection at the Municipal Offices, Springvale-road, Glen Waverley.

Dated this 8th day of May, 1972.

6202

F. S. BALES, Town Clerk.

BOROUGH OF EAGLEHAWK.

LOAN No. 24.

Notice of Intention to Borrow the Sum of \$10,500 for Permanent Works and Undertakings.

Notice is hereby given that the Council of the Borough of Eaglehawk proposes to borrow the principal sum of Ten thousand five hundred dollars (\$10,500), secured by a charge over the general rate of the municipality, such sum to be raised by the grant of a mortgage in accordance with the provisions of the *Local Government Act 1958*.

1. The maximum rate of interest to be paid is 6 per centum per annum.
 2. The purposes for which the loan is to be applied are:—

New truck	\$6,500
Office plant and equipment	4,000
	<u>\$10,500</u>

3. The period of the loan shall be five (5) years.
 4. The money borrowed shall be repayable by providing out of the municipal fund ten half-yearly instalments of approximately \$1,230.93 each, including principal and interest, on the 16th day of December and the 16th day of June in each year, during the currency of the loan, the first instalment being payable on the 16th day of December, 1972.
 5. The moneys shall be payable at the C.B.C. of Sydney Ltd., Melbourne.

6. The plans and specifications and the estimate of the cost of the proposed works and a statement showing the proposed expenditure of the money to be borrowed are open for inspection at the office of the Council of the Borough of Eaglehawk, at the Town Hall, Eaglehawk.

Dated this 11th day of May, 1972.

6174

A. J. SMARK, Town Clerk.

BOROUGH OF EAGLEHAWK.

LOAN No. 25.

Notice of Intention to Borrow the Sum of \$14,500 for Permanent Works and Undertakings

Notice is hereby given that the Council of the Borough of Eaglehawk proposes to borrow the principal sum of Fourteen thousand five hundred dollars (\$14,500), secured by a charge over the general rates of the municipality, such sum to be raised by the grant of a mortgage in accordance with the provisions of the *Local Government Act 1958*.

1. The maximum rate of interest to be paid is 6.2 per centum per annum.
 2. The purposes for which the loan is to be applied are:—

Road construction	\$14,000
Additional Town Hall seating	500
	<u>\$14,500</u>

3. The period of the loan shall be ten (10) years.
 4. The money borrowed shall be repayable by providing out of the municipal fund twenty half-yearly instalments of approximately \$983.67 each, including principal and interest, on the 16th day of December and the 16th day of June in each year, during the currency of the loan, the first instalment being payable on the 16th day of December, 1972.
 5. The moneys shall be payable at the C.B.C. of Sydney Ltd., Melbourne.
 6. The plans and specifications and the estimate of the cost of the proposed works and a statement showing the proposed expenditure of the money to be borrowed are open for inspection at the office of the Council of the Borough of Eaglehawk, at the Town Hall, Eaglehawk.

Dated this 11th day of May, 1972.

6175

A. J. SMARK, Town Clerk.

SHIRE OF KYNETON.

LOAN No. 44.

Notice of Intention to Borrow the Sum of \$20,000 for Permanent Works and Undertakings.

Notice is hereby given that, the Council of the Shire of Kyneton proposes to borrow the principal sum of \$20,000, secured by a charge over the general rates of the municipality, such sum to be raised by the grant of a mortgage in accordance with the provisions of the *Local Government Act 1958* as amended.

1. The maximum rate of interest that may be paid is 6.2 per cent. per annum.

2. The purposes for which the loan is to be applied are:—

(a) Council contribution to Country Roads Board Grant Works	\$10,000
(b) Construction and sealing of streets, Kyneton	5,000
(c) Improvements to Kyneton Caravan Park and Gardens	3,000
(d) Establishment cost of Trentham tip	3,000
	<u>\$20,000</u>

3. The period of the loan is ten years.

4. The money borrowed shall be repayable by providing out of the municipal fund twenty half-yearly instalments of approximately \$1,356.78 each, including principal and interest, on the 1st day of January and the 1st day of July during the currency of the loan. The first instalment shall be payable on the 1st day of January, 1973.

5. Such moneys shall be repayable at the offices of the C.B.C. Savings Bank Limited, Melbourne.

The plans and specifications and the estimate of the cost of the proposed works and a statement, showing the proposed expenditure for the money to be borrowed, are open for inspection at the Shire Office, Kyneton.

Dated this 12th day of May, 1972.

6221 S. G. PORTER, Shire Secretary.

SHIRE OF LILLYDALE.

LOAN No. 110.

Notice of Intention to Borrow the Sum of \$5,000 for Permanent works and undertakings.

Notice is hereby given that, the Council of the Shire of Lillydale proposes to borrow the sum of \$5,000 secured by a charge over the general rates of the Municipality, such sum to be raised by the grant of a mortgage in accordance with the provisions of the *Local Government Act 1958* for permanent works and undertakings within the Municipality.

1. The maximum rate of interest that may be paid is 6.2 per centum per annum.

2. The purpose for which the loan is to be applied is:—
Road construction works—\$5,000.

3. The period of the loan shall be ten years.

4. The moneys borrowed shall be repayable by providing out of the municipal fund twenty (20) half-yearly instalments of approximately \$339.20 each, including principal and interest on the 30th day of June and the 30th day of December during the currency of the loan. The first instalment shall be payable on the 30th day of December, 1972.

5. Such moneys shall be repayable to Nylex Nominees Ltd. Trustee custodians of the Nylex Provident Fund at the office of the said Company, 165 Cremorne-street, Richmond, Victoria.

The plans and specifications and the estimate of the cost of the proposed works and a statement showing the proposed expenditure of the moneys to be borrowed are open for inspection at the office of the Council of the Shire of Lillydale, at the Shire Offices, Anderson-street, Lillydale.

6222 F. O. KENT, Shire Secretary.

SHIRE OF WARRACKNABEAL.

LOAN No. 31. (Re-advertised).

Notice of Intention to Borrow the Sum of \$40,000 for Permanent Works and Undertakings.

Notice is hereby given that the Council of the Shire of Warracknabeal proposes to borrow the sum of Forty thousand dollars secured by a charge over the general rates of the municipality, such sum to be raised by the grant of a mortgage in accordance with the provisions of the *Local Government Act 1958*.

1. The maximum rate of interest that may be paid is 6.30 per cent. per annum.

2. The purpose for which loan is to be applied is:—

The Construction of the North Western Agricultural Machinery Museum (Part Cost).

3. The period of the loan shall be fifteen years

4. The moneys borrowed shall be repayable by providing out of the municipal fund 30 half-yearly instalments of approximately \$2,080.54 each, including principal and interest on the tenth day of January and the tenth day of July, during the currency of the loan. The first instalment shall be payable on the tenth day of January, 1973.

5. Such moneys shall be repayable at the Commercial Savings Bank of Australia Limited, 335-339 Collins-street, Melbourne.

The plans and specifications and the estimate of the cost of the proposed works and a statement showing the proposed expenditure of the moneys to be borrowed are open for inspection at the Office of the Council of the Shire of Warracknabeal, at the Shire Office, Scott-street, Warracknabeal, 3393.

Dated this 11th day of May, 1972.

6224 JOSEPH B. NEAL, Shire Secretary.

Notice is hereby given that Dunlop Australia Limited has applied for a lease pursuant to section 134 of the *Land Act 1958*, over allotments 104 and 105, City of South Melbourne, Parish of Melbourne South, for a period of 21 years, for the purpose of general industry. 6073

Notice is hereby given that Williamstown Products Pty. Ltd., has applied for a lease for 50 years, pursuant to sections 134 and 135 of the *Land Act 1958* over allotment 2b, section 63A, City of Port Melbourne, Parish of Melbourne South, for the purpose of general industry. 6139

Notice is hereby given that the Golden Point Football Club has applied for a lease under section 134 *Land Act 1958*, for a term of 21 years over an area of approximately $\frac{1}{2}$ acre being portion of an Ornamental Plantation purposes reserve in section 51A, Township of Ballarat East, as a site for amusement and recreation (club-rooms).—J34155. 6163

Notice is hereby given that Neal's Automobiles Proprietary Limited has applied for a lease pursuant to sections 134 and 135 of the *Land Act 1958* for a term of 50 years in respect of allotments 4, 5 and 6, section D, City of South Melbourne for the purpose of business—central. 6236

NOTICE OF INTENTION TO APPLY FOR A LICENCE TO DIVERT WATER AND CUT RACE (RE-ISSUE) FROM THE RIVER MURRAY, AT MERBEIN.

I hereby give notice that I intend to apply for a licence empowering me to divert water for a term of fifteen years to the extent of 72 acre-feet per annum at a maximum rate of 3 acre-feet per day of 24 hours for the irrigation of 3 acres of citrus and 23 acres of vines, being part of allotment 1, section H, Parish of Merbein, and to occupy certain Crown lands for works of diversion, and to cut a race thereon.

Any objection to such application must be forwarded, in writing, to reach the State Rivers and Water Supply Commission, Melbourne, before 16th June, 1972, being 30 days from the first publication of this notice.

NORMAN HENRY SMYTHE.

Box 115, Merbein. 6270

Water Acts.

PROPOSED BONNIE DOON WATERWORKS TRUST.

Notice is hereby given that the Shire of Mansfield has made application to the Honorable the Minister of Water Supply for the constitution of the Bonnie Doon Waterworks Trust for the proclamation of an Urban District and a Rural District at Bonnie Doon and the construction, maintenance and continuance of Water Supply Works within those Districts under the provisions of the Water Acts.

A general plan and description of the proposed works have been submitted with the application, and copies of same may be seen at the Shire Office at Mansfield.

Dated at Mansfield, the 26th day of April, 1972.

6271 E. CAIRNS, Secretary.

THE BALLARAT SEWERAGE AUTHORITY.

GENERAL NOTICE.

The above-mentioned Sewerage Authority, having made provision for carrying off the sewage from each and every property which or any part of which is within the Sewerage Area hereinafter described doth hereby declare that on and after the 1st day of June, 1972, each and every property which or any part of which is within the said Sewerage Area shall be deemed to be a sewered property within the meaning of the *Sewerage Districts Act 1958*.

The boundaries of the Sewerage Area hereinbefore referred to are:—

SEWERAGE AREA No. 331.

Shire of Buninyong.

Commencing at a point on the east building line of Geelong-road being a distance of approximately 600 feet south of the south-east corner of the intersection of Geelong-road and Elsworth-street, also being a point on the boundary of Sewerage Area No. 327; thence proceeding easterly along the said Sewerage Area boundary and continuing easterly along a line being the prolongation of the said boundary to the west bank of Canadian Creek, southerly along the said creek bank to the south building line of Kinnersley-avenue, north-westerly along the said building line for a distance of approximately 640 feet, southerly along a line for a distance of approximately 715 feet to a point being a distance of approximately 645 feet east of the east building line of Geelong-road and a distance of approximately 150 feet north of the prolongation of the north building line of Milverton-lane, south-westerly to a point on the said building line of Milverton-lane being a distance of approximately 400 feet east of the north-east corner of the intersection of Geelong-road and Milverton-lane; thence southerly for a distance of approximately 320 feet to a point on the south building line of Bartley-avenue being the north-east corner of Crown allotment 19, section 1, Parish of Ballarat, County of Grant, southerly along the eastern boundaries of Crown allotments 19 and 20 of the said section 1 for a distance of approximately 150 feet, westerly for a distance of approximately 70 feet; thence northerly for a distance of approximately 245 feet to a point at a distance of approximately 70 feet north of the north building line of Bartley-avenue and at a distance of approximately 263 feet east of the east building line of Geelong-road; thence westerly to a point on the east building line of Geelong-road being a distance of approximately 70 feet north of the north-east corner of the intersection of Geelong-road and Bartley-avenue; thence southerly along the east building line of Geelong-road to the south-west corner of Crown allotment 21, section 1, Parish of Ballarat, westerly across Geelong-road to a point on the west building line of Geelong-road a distance of approximately 100 feet south of the south-west corner of the intersection of Tinworth-avenue and Geelong-road, westerly for a distance of approximately 170 feet, then northerly for a distance of approximately 165 feet to a point on the north building line of Tinworth-avenue at a distance of approximately 168 feet west of the north-west corner of the intersection of Tinworth-avenue and Geelong-road, westerly along the north building line of Tinworth-avenue and the prolongation of the said building line for a distance of approximately 300 feet, northerly for a distance of approximately 233 feet to the north-west corner of Crown allotment 4A, section 14, Parish of Ballarat, County of Grant, easterly along the northern boundary of the said Crown allotment to a point at a distance of approximately 120 feet west of the west building line of Geelong-road, northerly to a point on the north building line of Rodney-avenue a distance of approximately 120 feet west of the north-west corner of the intersection of Rodney-avenue and Geelong-road, northerly to a point on the southern boundary of Sewerage Area No. 327, being a distance of approximately 185 feet west of the west building line of Geelong-road, thence easterly and northerly along the boundary of the said Sewerage Area to the point of commencement.

Further particulars regarding the streets or parts of streets in which sewers have been laid may be ascertained on enquiry at the Authority's Office.

By Order of the said Sewerage Authority.

6213

A. W. NICHOLSON, Chairman.
CHAS. H. CLAMP, Secretary.

CHARLTON SEWERAGE AUTHORITY.

By-Law No. 2

Relating to Consents, Licences, Fees, Trade Waste and other Matters not included in the Uniform Building Regulations relating to House Connection Work repealing previous by-laws on these matters.

The Charlton Sewerage Authority pursuant to and in exercise of the powers and authorities conferred upon it by the *Sewerage Districts Acts* and of any and every other power and authority in any wise enabling it in that behalf has passed the above By-law on the 13th day of September, 1971; and confirmed it on the 11th day of October, 1971.

A copy of By-law No. 2 is open for inspection free of charge at the office of the Authority, Shire Offices, Charlton, during office hours.

6171 J. K. GIOVANETTI, Secretary.

LITTLE RIVER WATERWORKS TRUST.

EIGHTH SCHEDULE.

Notice to the owners of tenements in the following streets and the private streets, lanes, courts and alleys opening thereto:—

Old Melbourne-road, Shaw's-road, Peak School-road, Express-road, Minns-street and River-avenue.

The main pipe in the said streets being laid down the owners of all tenements situated as above are hereby required on or before the seventeenth day of June, 1972, to cause a proper pipe and stop cocks to be laid so as to supply water within such tenements from the main pipe.

6215 N. G. MINNS, Secretary.

As from the 5th day of May, 1972, the partnership formerly carried on by G. Donisi and B. Parenti, trading as "G. Donisi & B. Parenti", concrete contractors, has been dissolved.

MACKENZIE & ROSS, solicitors, 365 Burwood-road, Hawthorn. 6172

Notice is hereby given that the partnership heretofore subsisting between Clifton Roy Glew, Nellie Edith Glew, Ronald James Glew and Dolores W. Glew, carrying on business as fishermen, at Lakes Entrance, under the style or firm of "C. R., N. E., R. J., & D. W. Glew", has been dissolved as from the 9th day of May, 1972.

Dated this 9th day of May, 1972.

6201

CLIFTON ROY GLEW.

NOTICE OF DISSOLUTION OF PARTNERSHIP.

Notice is hereby given that the partnership heretofore subsisting between Ian George Milne and Patricia Ann Milne, carrying on business as pharmaceutical chemists, at 68 Bourke-street, Melbourne, 162 Swanston-street, Melbourne, and La Trobe University, Bundoora, under the style or firm of "Milne's Pharmacies", has been dissolved by mutual consent, as from the 1st day of February, 1972.

Dated the 10th day of May, 1972.

NICHOLAS O'DONOHUE & CO., solicitors, 493 Law Courts-place, Melbourne, 3000. 6170

Notice is hereby given that the partnership hereto subsisting between the undersigned, Wayne Neil Johnson, and Pierre John Johnson, who carried on the business of farmers at Roadside Delivery, Koroit, under the name of "W. N. & P. J. Johnson" has been dissolved, by mutual consent, as from the 8th May, 1972. All debts due to and owing by the said late firm will be received and paid by the said Wayne Neil Johnson, and Pierre John Johnson.

Dated this 8th day of May, 1972.

6220

W. N. JOHNSON.
P. J. JOHNSON.

Notice is hereby given that the partnership previously subsisting heretofore between Jeffrey Graham Smith, Leon Jouvelet and Robert Garnet Brooks carrying on business at 84 Lorne-street, Fawkner, under the style or firm name of "Able Air Compressors" has been dissolved, as from the 30th day of April, 1972, so far as concerns the said Robert Garnet Brooks who retires from the said firm.

Dated the 28th day of April, 1972.

6223

J. G. SMITH.
L. JOUVELET.
R. G. BROOKS.

Notice is hereby given that the partnership heretofore subsisting between the undersigned, Augustus Richard Frederick Hudson, Walter Hermann, Evelyn Gertrude Hermann and Gladys Amelia Hudson, carrying on business at 219 Elizabeth-street, East Coburg, under the business name of Fleet Litho Service, has been dissolved by mutual

consent as from the 1st day of March, 1972. Augustus Richard, Frederick Hudson, Gladys Amelia Hudson, Walter Hermann, Evelyn Gertrude Hermann and Volkmar Jaeckel will now carry on Fleet Litho Service.

Dated the 8th day of May, 1972.

Witness.—A. MCINNES. W. HERMANN.
 Witness.—A. MCINNES. A. R. F. HUDSON.
 Witness.—A. MCINNES. G. A. HUDSON;
 Witness.—A. MCINNES. E. G. HERMANN.
 Witness.—A. MCINNES. VOLKMAR JAECKEL.
 6292

Notice is hereby given that the partnership heretofore subsisting between Sheila Leigh, Shirley Harris, John Brian Hockley and Anita Hockley, carrying on a business as panel beaters, representative and retailers of automotive parts and accessories, at 63 Fallon-street, Brunswick, under the style or firm name of "London Car Care Co.", has been dissolved as from the 1st day of April, 1972. All debts due to and owing by the said firm will be received and paid respectively by John Brian Hockley and Anita Hockley.

MYER, MEERKIN & APEL, 582 St. Kilda-road,
 3004. 6279

DIAMOND CREEK COOL STORES PTY. LTD. (IN VOLUNTARY LIQUIDATION).

Notice is hereby given of an Extraordinary General Meeting of shareholders to be held at the Office of Burgin, Stannard & Coghlan, on Friday, 23rd June, 1972, at 2.30 p.m. The purpose of the meeting is to receive the liquidator's account of receipts and payments and statement of the position in the winding up.

6185 K. J. COGHLAN, Liquidator.

The Companies Act 1961.—In the matter of CIV-ENG. CONSTRUCTIONS PTY. LTD.—Notice Re Meeting of Creditors, Pursuant to Section 260.

Notice is hereby given that a meeting of creditors of the above-named company will be held in the Victorian Chamber of Manufactures, Geelong Branch, 50 Western Beach, Geelong, on Wednesday, the 24th May, 1972, at 11 a.m., the company having convened a meeting of its members for the same day, for the purpose of considering a Resolution that the company be wound up voluntarily.

Dated at Geelong, this 12th day of May, 1972.

W. LOWRY, Director.

Day, Neilson, Jenkins & Johns, chartered accountants,
 199-203 Moorabool-street, Geelong, 3220. 6178

Companies Act 1961.—In the matter of UNIVERSAL CEILING SERVICES PTY. LTD.; UNIVERSAL CIVIL ENGINEERING SERVICES PTY. LTD.; and J.H. STRUCTURAL ENGINEERING PTY. LTD.

Notice is hereby given that meetings of creditors of the above-named companies will be held in the Theatre, Lower Ground Floor, National Mutual Building, 447 Collins-street, Melbourne, on Friday, the 26th day of May, 1972, at 10 a.m., the companies having convened meetings of their members to be held on the same day and for the purpose of considering Special Resolutions that the companies be wound up voluntarily.

Dated this 12th day of May, 1972.

E. L. JONES, Director.

Peat, Marwick, Mitchell & Co. 6262

**Companies Act 1961, Section 254 (2).
 DANDY ADS PTY. LTD. (IN LIQUIDATION).**

Notice is hereby given that at an Extraordinary Meeting of Members of the above-named company held on Thursday, 11th May, 1972, the following Special Resolution was duly passed, and that at a meeting of creditors held the same day, my appointment as Liquidator was confirmed.

"That, owing to the company being unable to meet its debts as and when they become due and payable that the company be and is hereby wound up voluntarily and that Maxwell George Gee, a Registered Liquidator be and is hereby appointed Liquidator to wind the company up and attend to all matters relative thereto in accordance with the Companies Act 1961."

M. G. GEE, Liquidator.

Max Gee & Co., 325 Warrigal-road, Burwood, 3125
 Telephone: 288 5109. 6217

GOOD-N-SMART DRY CLEANERS PTY. LTD.

(IN LIQUIDATION).

Pursuant to section 272 (2) of the Companies Act 1961, I hereby give notice that a General Meeting of the company will take place at 2 p.m. on Monday, 26th June, 1972, at the office of R. W. Fox, C. A. Gregory & Associates, 112 Patterson-road, Moorabbin, for the purpose of considering my account of the winding up and how the company's property has been disposed of.

6188 R. W. FOX, Liquidator.

Companies Act 1961.

DELTA-CRAFT PROPRIETARY LIMITED.

NOTICE RE MEETING OF CREDITORS, PURSUANT TO SECTION 260.

Notice is hereby given that a meeting of creditors of the above-named company will be held at the National Mutual Theatre, 447 Collins-street, Melbourne, on Monday, 29th May, 1972, at 11.00 a.m., the company having convened a meeting of its members for the same for the purpose of considering a Resolution that the company be wound up voluntarily.

Dated this 10th day of May, 1972.

6247 J. T. SAVAGE, Secretary.

**WHITE HORSE HOLDINGS PTY. LIMITED
 (IN LIQUIDATION).**

NOTICE CONVENING FINAL MEETING.

Notice is hereby given in pursuance of section 272 of the Companies Act 1961, that a General Meeting of members of the above-named company will be held at 419 Lonsdale-street, Melbourne, on the 23rd day of June, 1972, at 11.00 a.m. for the purpose of having an account laid before them showing the manner in which the winding up has been conducted and the property of the company disposed of and of hearing any explanation that may be given by the Liquidator.

Dated this 5th day of May, 1972.

6258 B. ETHERINGTON, Liquidator.

BARKLY TABLELANDS PROPRIETARY LIMITED.

PURSUANT TO SECTION 254 (2) OF THE COMPANIES ACT 1961.

Notice is hereby given that at an Extraordinary General Meeting of members of the above company, held on the 8th day of May, 1972, the following Resolutions were passed:—

1. That the company be wound up voluntarily.
2. That Eric Ernest Fookes, of 339 Collins-street, Melbourne, be appointed liquidator of the company.

Dated this 12th day of May, 1972.

6259 ERIC E. FOOKES, Liquidator.

Companies Act 1961.—In the matter of ROGERS JOINERY PROPRIETARY LIMITED.—Notice Re Meeting of Creditors, pursuant to Section 260.

Notice is hereby given that a meeting of creditors of the above-named company will be held at the Conference Room, 4th Floor, 130 Flinders-street, Melbourne, on Monday, 22nd May, 1972, at 2.30 p.m., the company having convened an extraordinary meeting of its members for the same day for the purpose of considering a Special Resolution that the company be wound up voluntarily.

Dated this 13th day of May, 1972.

J. A. ROGERS, Director.

Lewis Luckins & Co., chartered accountants, 130 Flinders-street, Melbourne, 3000. Telephone 63 8827 6260

DOUTTA GALLA INVESTMENTS PROPRIETARY LIMITED.

PURSUANT TO SECTION 254 (2) OF THE COMPANIES ACT 1961.

Notice is hereby given that at an Extraordinary General Meeting of members of the above company, held on the 8th day of May, 1972, the following Resolutions were passed:—

1. That the company be wound up voluntarily.
2. That Eric Ernest Fookes, of 339 Collins-street, Melbourne, be appointed liquidator of the company.

Dated this 12th day of May, 1972.

6261 ERIC E. FOOKES, Liquidator.

The Companies Act 1961.

HAMILTON FARMERS' SUPPLY COMPANY PTY. LTD.
(IN LIQUIDATION).

RECEIVER AND MANAGER APPOINTED.

Notice is hereby given that a dividend is intended to be declared in the above matter. Creditors who have not proved their debts by the 14th day of June, 1972, will be excluded from this dividend.

Dated this 14th day of May, 1972.

BRUCE FORDHAM, Liquidator.

Bruce Fordham & Co., chartered accountants, 170
Toorak-road, South Yarra, Vic., 3141 6285

Companies Act 1961.—In the matter of K.L. ENGINEERING PTY. LTD., of 210 McIntyre-road, Sunshine.—Notice Re Meeting of Creditors, Pursuant to Section 260.

Notice is hereby given that a Meeting of creditors of the above-named company will be held at the office of Bent & Cogle, public accountants, Suite 18, 545 St. Kilda-road, Melbourne, on Tuesday, 6th June, 1972, at 11.30 a.m., the company having convened a meeting of its members for the same day for the purpose of considering a Resolution that the company be wound up voluntarily.

Dated this 12th day of May, 1972.

K. J. O'BRIEN, Director.

Bent & Cogle, public accountants, Suite 18, 545 St. Kilda-road, Melbourne, 3004. 6216

The Companies Act 1961.—In the matter of GUY BROS. PROPRIETARY LIMITED.—Notice of Final Meeting.

Notice is hereby given that, pursuant to section 272 of the Companies Act 1961, a General Meeting of the members of the above-named company will be held at 44 Duke-street, Sunshine, on Tuesday, 20th June, 1972, at 6 o'clock in the afternoon, for the purpose of having an account laid before them showing the manner in which the winding up has been conducted and the property of the company disposed of, and of hearing any explanation that may be given by the liquidator.

Dated the 12th day of May, 1972.

6229 RALPH T. GUY, Liquidator.

PREMIX PLASTICS PTY. LTD. (IN LIQUIDATION).—Members' Voluntary Liquidation.

Notice is hereby given that, pursuant to section 272 of the Companies Act 1961, a Final Meeting of the members of the company will be held at the offices of Messrs. Robertson, Darling & Wolfenden, 19th Floor, 535 Bourke-street, Melbourne, on Friday, 23rd June, 1972, at 11 o'clock in the forenoon, for the purpose of having an account laid before them, showing the manner in which the winding up has been conducted and the property of the company disposed of, and of hearing any explanation that may be given by the liquidator.

Dated this 5th day of May, 1972.

6203 K. W. G. WATSON, Liquidator.

Companies Act 1961, Section 272.

AUSTRALAINE FABRICS PTY. LTD.

Companies Regulations.

Regulation 28 (2) (b).

NOTICE OF MEETING OF CONTRIBUTORIES.

Notice is hereby given that a meeting of the contributories of Australaine Fabrics Pty. Ltd. will be held at Suite 10, 1st Floor, 33 Queens-road, Melbourne, 3004, on the 16th day of June, 1972, at 3 o'clock in the afternoon.

AGENDA.

To lay before the meeting the liquidator's account showing how the winding up has been conducted and the property of the company has been disposed of and giving any explanation thereof.

Dated this 10th day of May, 1972.

6205 B. A. PROVAN, Liquidator.

An Order of the Supreme Court of New South Wales, in its Equitable Jurisdiction, for the winding up of Nara-coopa Rutile Limited was made on the 1st day of May, 1972, and the undersigned was appointed official liquidator.

J. H. JAMISON, care of Cooper Brothers & Co.,
6 O'Connell-street, Sydney. 6211

Companies Act 1961, Section 272.

DYFIN PTY. LTD.

Companies Regulations.

Regulation 28 (2) (b).

NOTICE OF MEETING OF CONTRIBUTORIES.

Notice is hereby given that a meeting of the contributories of Dyfin Pty. Ltd. will be held at Suite 10, 1st Floor, 33 Queens-road, Melbourne, 3004, on the 16th day of June, 1972, at 3 o'clock in the afternoon.

AGENDA.

To lay before the meeting the liquidator's account showing how the winding up has been conducted and the property of the company has been disposed of and giving any explanation thereof.

Dated this 10th day of May, 1972.

6206 B. A. PROVAN, Liquidator.

Companies Act 1961, Section 272.

INDEPENDENT SILK MILLS PTY. LTD.

Companies Regulations.

Regulation 28 (2) (b).

NOTICE OF MEETING OF CONTRIBUTORIES.

Notice is hereby given that a meeting of the contributories of Independent Silk Mills Pty. Ltd. will be held at Suite 10, 1st Floor, 33 Queens-road, Melbourne, 3004, on the 16th day of June, 1972, at 3 o'clock in the afternoon.

AGENDA.

To lay before the meeting the liquidator's account showing how the winding up has been conducted and the property of the company has been disposed of and giving any explanation thereof.

Dated this 10th day of May, 1972.

6207 B. A. PROVAN, Liquidator.

Companies Act 1961, Section 272.

JOBRO YARNS PTY. LTD.

Companies Regulations.

Regulation 28 (2) (b).

NOTICE OF MEETING OF CONTRIBUTORIES.

Notice is hereby given that a meeting of the contributories of Jobro Yarns Pty. Ltd. will be held at Suite 10, 1st Floor, 33 Queens-road, Melbourne, 3004, on the 16th day of June, 1972, at 3 o'clock in the afternoon.

AGENDA.

To lay before the meeting the liquidator's account showing how the winding up has been conducted and the property of the company has been disposed of and giving any explanation thereof.

Dated this 10th day of May, 1972.

6208 B. A. PROVAN, Liquidator.

The Companies Act 1961.

HERBERT WILSON PTY. LTD. (IN LIQUIDATION).

Notice is hereby given that a dividend is intended to be declared in the above matter. Creditors who have not proved their debts by the 14th day of June, 1972, will be excluded from this dividend.

Dated this 11th day of May, 1972.

BRUCE FORDHAM, Liquidator.

Bruce Fordham & Co., chartered accountants, 170
Toorak-road, South Yarra, Vic., 3141. 6284

Companies Act 1961.—In the matter of MORRISON FAMILY PTY. LTD. (in Voluntary Liquidation).

Notice is hereby given that a Final Meeting of Morrison Family Pty. Ltd., will be held at 15 Hopetoun-avenue, Canterbury, on Monday, 19th June, 1972, at 8 p.m., to lay before the meeting the liquidator's account, showing how the winding up has been conducted and the property of the company has been disposed of and giving any explanation thereof.

Dated this 11th day of May, 1972.

6181 P. W. DANBY, Liquidator.

In the matter of NARACOOPA RUTILE LIMITED (in liquidation); and in the matter of the Companies Act 1961 (as amended).

The creditors of the above-named company are required, on or before the 22nd day of June, 1972, to prove their debts or claims and to establish any title they may have to priority by delivering or sending through the post to the liquidator, at the under-mentioned address, an affidavit verifying their respective debts or claims. In default they will be excluded from the benefit of any distribution made before such debts or claims are proved or such priority is established and from objecting to any such distribution. Forms of proof of debt may be obtained from the under-signed.

Dated this 8th day of May, 1972.

J. H. JAMISON, Liquidator.

Care of Cooper Brothers & Co., 6 O'Connell-street, Sydney. Postal address: G.P.O. Box 2650, Sydney, 2001.

6210

In the matter of MAREC MANAGEMENT PTY. LTD.

Winding up Order made 11th May, 1972.

Name and address of liquidator: Alex Neville Bird, of 289 Flinders-lane, Melbourne.

MADDEN & CANDY, solicitors for the petitioner. 6246

In the matter of the Companies Act 1961; and in the matter of BOWL-O-MATIC LIMITED; and in the matter of an Order of the Supreme Court of Victoria 1971 CO. No. 8208 and 1971 CO. No. 8250.—Reduction of Capital.

Notice is hereby given that an Order of the Supreme Court of Victoria was made the 18th day of April, 1972, as follows:—

That the reduction of capital resolved upon and proposed to be effected by the Special Resolution passed at an Extraordinary General Meeting of the members of the petitioner held on the 23rd day of November, 1971, be and the same is hereby confirmed. And the Court declared that—

- (1) the amount of the share capital of Bowl-O-Matic Limited as altered by this Order, the number of shares into which the share capital of the said company is to be divided, and the amount of each share and the amount (if any) deemed to be paid up on each share as at the date of this Order are:—
- \$300,000 divided into 425,000 unissued shares of 20 cents each (\$85,000) and 1,720,000 issued shares of 12½ cents each (\$215,000), which issued shares have been or are deemed to have been fully paid up; and

- (2) the said 1,720,000 issued shares of 12½ cents each are under the aforesaid Scheme consolidated into 1,075,000 shares of 20 cents each. 6248

In the matter of the Companies Act 1961 (as amended); and in the matter of YORK AGENCIES & EXPORTERS, PTY. LIMITED (in Liquidation).

Notice is hereby given, pursuant to section 272 of the said Act, that the Final Meeting of members of York Agencies & Exporters Pty. Limited (in Liquidation) will be held at the offices of Messrs. Greenwood, Challoner & Co., 12th Floor, 109 Pitt-street, Sydney, N.S.W., on 23rd June, 1971, at 10.30 a.m., for the purpose of having an account laid before them, showing the conduct of the winding up and how the company's property has been disposed of, hearing any explanation that may be given by the liquidator and determining the manner in which the books, accounts, and documents of the company shall be disposed of.

A. B. BAGNALL, Liquidator.

Care of Greenwood, Challoner & Co., 109 Pitt-street, Sydney, N.S.W. 6249

The Companies Act 1961:

ELLINGSEN HOLDINGS PTY. LTD. (IN LIQUIDATION).

Notice is hereby given that a dividend is intended to be declared in the above matter. Creditors who have not proved their debts by the 14th day of June, 1972, will be excluded from this dividend.

Dated this 11th day of May, 1972.

BRUCE FORDHAM, Liquidator.

Bruce Fordham & Co., chartered accountants, 170 Toorak-road, South Yarra, Vic., 3141. 6286

In the matter of the Companies Act; and in the matter of A.J.J. NOMINEES PTY. LIMITED (Trading as McKenzie Furnishings.)

Notice is hereby given that at an Extraordinary General Meeting of the above-named company, duly convened and held at Melbourne, at 2.30 p.m., on the 4th day of May, 1972, the following Special Resolution was duly passed:—

Special Resolution.

"That this meeting nominates Mr. Bruce Henry Smith, chartered accountant, of Suite 801, 343 Little Collins-street, Melbourne, for appointment as liquidator for the purpose of such winding up, and that his remuneration for his duties be determined according to rates prescribed by the Institute of Chartered Accountants in Australia."

Dated this 5th day of May, 1972.

6263

J. REZAK, Chairman.

In the Supreme Court of Victoria 1972.—Co. No. 8343.—

In the matter of the Companies Act 1961; and in the matter of VALLEY PRODUCERS PTY. LTD.—Advertisement of Petition.

Notice is hereby given that a petition for the winding up of the above-named company by the Supreme Court was on the 1st day of May, 1972, presented by G. & W. Lambert Pty. Ltd.; and that the said petition is directed to be heard before the Court sitting at the Fourteenth Court, Law Courts, William-street, Melbourne on the 15th day of June, 1972, at the hour of 10.30 o'clock in the forenoon; and any creditor or contributory of the said company desiring to support or oppose the making of an Order on the said petition may appear at the time of hearing by himself or his counsel for that purpose; and a copy of the petition will be furnished to any creditor or contributory of the said company requiring the same by the undersigned on payment of the regulated charge for the same.

The petitioner's address is 248-250 Abbotsford-road, Mayne Junction, Queensland.

The petitioner's solicitors are Messrs. Russell, Kennedy & Cook of 401 Collins-street, Melbourne.

RUSSELL, KENNEDY & COOK, solicitors for the petitioner.

NOTE.—Any person who intends to appear on the hearing of the said petition must serve on or send by post to the above-named solicitors, notice in writing of his intentions so to do. The notice must state the name and address of the person, or, if a firm, the name and address of the firm and must be signed by the person or firm, or his or their solicitor (if any) and must be served, or if posted, must be sent by post in sufficient time to reach the above-named not later than 4 o'clock in the afternoon of the 14th day of June, 1972. 6281

Companies Act 1961.—In the matter of DRUBMAL CORPORATION PTY. LTD. (IN VOLUNTARY LIQUIDATION).

Notice is hereby given that at an Extraordinary General Meeting of shareholders of the above-named company duly constituted and held at 35 Old Mornington-road, Mt. Eliza, on Monday, the 15th day of May, 1972, the following Special Resolution was passed:—

"That the company be wound up voluntarily."

It was also resolved at the same meeting that Mr. Noel Colin Rundle, of 561 Bourke-street, Melbourne, be appointed liquidator.

Dated this 15th day of May, 1972.

6287

H. S. LAMBURD, Director.

Form 92.

Companies Act 1961, Section 272.

PRESTIGE INDUSTRIES LTD.

Companies Regulations.

Regulation 28 (2) (b).

NOTICE OF MEETING OF CONTRIBUTORIES.

Notice is hereby given that a meeting of the contributories of Prestige Industries Ltd. will be held at Suite 10, 1st Floor, 33 Queens-road, Melbourne, 3004, on the 16th day of June, 1972, at 3 o'clock in the afternoon.

AGENDA.

To lay before the meeting the liquidator's account showing how the winding up has been conducted and the property of the company has been disposed of and giving any explanation thereof.

Dated this 10th day of May, 1972.

6209

B. A. PROVAN, Liquidator.

Unclaimed Moneys Act 1962.

Register of Unclaimed Moneys held by the—

Name of Owner on Books and Last Known Address.	Total Amount Due to Owner.	Description of Unclaimed Moneys.	Date when Amount first became Payable.
§			
VICTORIAN PRODUCERS' CO-OP. CO. LTD.			
Adams, H. T. & W. J., Donald	43.28	Wool Proceeds	24.7.70
Bailey, R. L., Cudgewa	124.80	Stock Proceeds	13.1.71
Bradford Bros., Deniliquin	52.98	Wool Proceeds	1.5.70
Cameron, H. M. McF. & E. M.	1,458.10	Stock Proceeds	11.11.70
Chamberlain, Alan H., Arnold West	25.00	Wool Proceeds	24.7.70
Clarkson, W. H., Brunswick	227.92	Stock Proceeds	19.2.71
Fernandes, M. C., Frenchmans, via Avoca	25.00	Wool Proceeds	24.7.70
Geehman, J. C., Ensay	22.00	P.A.P. Advance	29.1.71
Godde, D. P. & A. F. R., Ebden	16.31	Stock Proceeds	24.8.70
Godde, D. P. & A. F. R., Ebden	40.47	Stock Proceeds	28.9.80
Hine, L. J., Bacchus Marsh	275.50	P.A.P. Advance	15.1.71
Hodgkin, S. J., Gundowring R.S.	281.50	Stock Proceeds	26.10.70
Kelly, Patrick W., Tallygaroopna	16.00	Dividend	1.10.70
Kendall, A. R., Kerang	249.48	Stock Proceeds	24.9.70
Lincoln H., Queenscliff	19.75	Cartage	19.5.70
McCormick, E. A., Hay	19.26	"	16.2.71
McFarlane Bros., Berrivillcock	68.42	Wool Proceeds	6.4.70
Milburn, W. J. & G. R., "Cranmoor" Wando Vale	16.00	Dividend	1.10.70
Moor, J., Tongala	27.18	Stock Proceeds	23.2.71
Oddie, Lillian M., "Challicum Park", Beaufort	16.00	Dividend	1.10.70
Pennell, Noble (estate of), Mount Eliza	16.00	"	"
Powell, John M. (estate of), Brentwood	16.00	"	"
Prendergast, E. & A. M., 116 Wellington-parade, East Melbourne	32.00	"	"
Richardson, A., Stratford	54.52	Freight Livestock	10.12.70
Roig, James (estate of), Spring Gully, Bendigo	16.00	Dividend	1.10.70
Rowe, L., Kyneton South	49.12	Wool Proceeds	22.5.70
Smith, Alan L., P.B. 73, Kerang	22.66	Dividend	1.10.70
Spencer, L. A., Lake Charm	18.17	Commission	28.5.70
Stainthorpe, J. J., Sheep Hills	11.20	"	28.8.70
Steele, P., Maffra	11.50	Stock Proceeds	18.12.70
Thomas, H., Strathallan	16.21	"	22.9.70
Werner, K. T., Bacchus Marsh	14.81	Cartage	9.10.70
Williams, G. C., Hunter.	24.74	Wool Proceeds	18.3.70
5695			
McEWAN'S LIMITED.			
Green, N. I., 43 Oliver-street, Kedron, Qld.	10.00	Dividend	1.3.68
Angel, Harry R., c/o Maw, Ellis, Warne & Co., 4 Grays In Square, London	59.50	"	29.10.69
Tussand, Hugh G., Flat 6, 20 Maylands-avenue, North Balwyn	12.00	"	11.3.70
5697			
GODFREY PHILLIPS PTY. LTD.			
Matajvra, Tuila (Mrs.), 38 Walker-street, Clifton Hill	14.35	Unclaimed Wages	25.6.70
Moran, Norma (Mrs.), Flat 8, 504 Drummond-street, Carlton	10.10	"	28.10.70
Turner, Barbara (Mrs.), Flat 97, 510 Lygon-street, Carlton	72.60	"	30.11.70
Laing, Margaret A. (Mrs.), 2 Excelcior-street, Reservoir	20.70	"	2.12.70
Lomas, Christine (Mrs.), Flat 192, 480 Lygon-street, Carlton	42.90	"	"
Lock, Heather (Mrs.), Flat 125, 253 Hoddle-street, Abbotsford	57.60	"	17.12.70
Benson, Marlene J. (Mrs.), 20 McCracken-street, Kensington	10.70	"	18.1.71
5700			
TARAX DRINKS HOLDINGS LIMITED.			
Short, Eleanor A. (Mrs.), & Short, Reginald E., 39 Rockley-road, South Yarra	10.00	Dividend	-5.70
Linwood, Campbell A., 30 Oakland-avenue, Wanganui, N.Z.	17.00	"	"
Dickinson, Nicola C. N. (Mrs.), c/o 249 Margaret-street, Toowoomba, Qld.	17.50	"	"
Linwood, Campbell A., 30 Oakland-avenue, Wanganui, N.Z.	23.80	24th Dividend	-11.70
Short, Eleanor A. (Mrs.), & Short, Reginald E., 35 Cosham-street, Brighton	14.00	"	"
Golding, Rose E. (Miss), 21 Pacific-street, Caringbah, N.S.W.	21.00	"	"
Gnoato, Antonio & Gnoato, Silvano (Mrs.), 610 Canterbury-road, Vermont	14.00	"	"
5701			
BRYSON INDUSTRIES LIMITED.			
Allis, Gwendolyn M. (Mrs.), 21 Salisbury-road, Kensington, N.S.W.	15.00	Dividend	24.11.70
Fidler, Hugh J., 181 Oakleigh-road, Murrumbena	1.80	"	"
Heat, Harold R., P.O. Box 8, Goulburn, N.S.W.	15.00	"	"
5702			
PICT LIMITED.			
Shadwell, John, 42 Konga-street, Clayton	22.54	Unclaimed Wages	4.6.70
Allen, James, 551 Stephensons-road, Mt. Waverley	11.48	"	13.8.70
Hampton, John, 37 Normanby-street, Oakleigh	11.10	"	26.2.71
Kackovic, Ivan, 788 Station-street, Box Hill North	22.90	"	"
Bennett, Cyanna, 96 Noble-road, Noble Park	15.09	"	"
Allen, Faul, Springvale Caravan Park, Springvale	12.34	"	"
5703			
COLAC DAIRYING COMPANY LIMITED.			
Baldwin, Douglas Frederick, 27 Ambrose-street, Doncaster	15.00	Dividend	2.10.70
Hay, Stewart L., Carlisle River	30.00	"	"
5704			

Unclaimed Moneys Act 1962.

Register of Unclaimed Moneys held by the—

Name of Owner on Books and Last Known Address.	Total Amount Due to Owner.	Description of Unclaimed Moneys.	Date when Amount first became Payable.
§			
GENERAL MOTORS-HOLDEN'S PTY. LTD.			
Cywinski, C. (estate of), 306 Lennox-street, Richmond	67.70	Wages	— 3.70
Douvos, G., 1 Keith-street, Clayton	39.19	"	— 1.71
Erdin, B., 108 Scotchman-street, North Fitzroy	10.64	"	— 5.70
Fitzgerald, K. J., 36 George-street, East Melbourne	38.92	"	— 12.70
Gouron, G. C., Fishermen's Bend Hostel, Port Melbourne	24.03	"	— 8.70
Grande, H., Flat 8, 5 Wilson-street, Murrumbena	10.00	Sugg. Award	— 6.70
Gregurec, D., 85 Charles-street, St. Kilda	34.79	Wages	— 5.70
Hall, T. J., 32 Mayston-street, Camberwell	18.62	"	— 9.70
Harika, J., Flat 6, 95 Smith-street, Thornbury	29.78	"	— 10.70
Johnson, G. H., Flat 6, 162 Chapel-street, St. Kilda	10.27	"	— 6.70
Konstandinos, T., 9 Willis-street, Armadale	37.69	"	— 1.71
Lido, L., 10 Rhodes-street, Dandenong	38.41	"	— 4.70
Liolios, K., 2 Napier-street, South Melbourne	35.97	"	— 11.70
Muratore, F., 56 Church-street, North Fitzroy	47.04	"	— 3.70
O'Neil, M. N. (estate of), 601 The Esplanade, Grange, S.A.	557.24	Superannuation	— 7.70
Pilalic, F., 11 Leonard-road, Ascot Vale	85.56	Wages	— 3.70
Rodriguez, G., Fishermen's Bend Hostel, Port Melbourne	19.47	"	— 12.70
Sahin, H., 65 Barker-street, South Melbourne	12.41	"	— 4.70
Saleh, A. A., 24 Gordon-street, Clifton Hill	53.23	"	— 3.70
Selfa, E. C., 142 Mont Albert-road, Canterbury	29.44	"	— 5.70
Spyropoulos, P., 5 Draper-street, South Melbourne	12.14	"	— 6.70
Vellas, P., 56 Fawkner-street, St. Kilda	157.58	"	— 12.70
Williams, J. W., 8 Perth-street, Murrumbena	10.00	Sugg. Award	— 8.70
Xanthopoulos, A., 13 Seddon-street, Seddon	25.04	Wages	— 4.70
Zednik, R. (estate of), Fishermen's Bend Hostel, Port Melbourne	47.73	"	— 9.70
5607			
AUSTRALIAN FERTILIZERS LIMITED.			
Clementson, Ada H. (Mrs.)	50.00	Dividend	— 2.71
5608			
WILKE AND COMPANY LIMITED.			
Moody, L., 206 Power-street, Doveton	12.20	Wages	25.6.70
West, W., 20 Grove-street, Carnegie	26.75	"	2.7.70
Hutchings, P. W. Flat 2, 28 Latimer-street, Noble Park	15.00	"	13.10.70
Schonnel, F. J. (estate of), Ivy-street, Indooroopilly, Qld.	93.93	Dividend	3.4.69
Wilson, L. N., 38 Kooyongkoot-road, Hawthorn	60.00	"	3.4.70
Hamilton, M. N., 10 Franklin-avenue, Chelsea	10.27	"	28.10.70
Hume, M., 3 Fenwick-street, Kew	15.00	"	"
Guy, H. E. (estate of), 2 Handon-street, Heidelberg	204.08	Return of Capital	23.6.70
Hume, M., 3 Fenwick-street, Kew	100.00	"	"
Jackson, D. E., Abbotsford-road, Mayne Junction, Brisbane	17.00	"	"
Nutt, H. A., 7 Bruce-street, Ryde, N.S.W.	25.00	"	"
Wilson, L. N., 38 Kooyongkoot-road, Hawthorn	200.00	"	"
5609			
OLYMPIC GENERAL PRODUCTS PTY. LTD.			
Brooking, D. J., 131 Cornwall-road, Sunshine	22.80	Wages	14.3.70
Nikkelor, P., 70 Nicholson-street, Footscray	15.20	"	4.4.70
Frendo, M., 30 Dinnell-street, West Sunshine	23.80	"	11.4.70
Hocking, D., 59 Chapman-street, North Melbourne	48.00	"	"
Jugegki, B., 6 Holdsworth-street, Ascot Vale	26.80	"	25.4.70
Brown, T. L., 19 Margaret-crescent, Braybrook	12.20	"	"
Charlambos, P. S., 123 Williamstown-road, West Footscray	10.00	"	2.5.70
McCarrow, J., Flat 9, Midway Hostel, Maribyrnong	20.60	"	9.5.70
Carter, J. A., 4 Ovens-court, Corio	18.80	"	30.6.70
McGregor, M., 34 Mitford-street, Elwood	26.00	"	11.8.70
Bucci, N., Flat 162, 120 Racecourse-road, Flemington	10.00	"	19.9.70
Polyzos, H., 7 Robbs-road, West Footscray	11.00	"	5.12.70
Koutsopoulos, P., 29 Spurling-street, Maidstone	11.20	"	6.2.71
5610			
ASSOCIATED PULP AND PAPER MILLS LIMITED.			
Adam, Zeta G. (estate of), c/o K. M. Sheehan, P.O. Box 22, Bacchus Marsh	15.62	Interest	30.1.71
Baugh, Elizabeth M. (estate of), c/o Tasmanian Permanent E. and T. Assn. Ltd., P.O. Box 286c, Launceston, Tas.	25.00	"	"
Counihan, Catherine (estate of), c/o Mrs. Marie K. McMichael, 90 Leila-road, Carnegie	12.50	"	"
Coxon, Ethel (estate of), c/o Allan E. Cupit and Best, 129 Pitt-street, Sydney, N.S.W.	62.50	"	"
Crump, Thomas K. (estate of), c/o National Trustee Exors. and Agency Co. of Aust. Ltd., G.P.O. Box 2819AA, Melbourne	21.87	"	"
Harris, Norman (estate of), c/o Roderick Comino and Co., P.O. Box 38, Redcliffe, Qld.	162.50	"	"
Mathwin, Frank W. G., "Alkoomie", Diamond Creek-road, Greensborough	12.50	"	"
Pope, Harold H. M. (estate of), c/o P. T. Fowler and Sons, 90 Pitt-street, Sydney, N.S.W.	34.37	"	"
Robinson, Constance L. R. (estate of), c/o Trustees E. and A. Co. Ltd., 401 Collins-street, Melbourne	21.87	"	"
Tobin, Harry T. (estate of), c/o Mrs. Olive H. Tobin, 94 Pentecost-avenue, Pymble, N.S.W.	50.00	"	"
Williams, Miriel E. G. (estate of), c/o Farmer's Co-operative E. and T. Limited, 11-13 Bentham-street, Adelaide, S.A.	25.00	"	"

Unclaimed Moneys Act 1962.

Register of Unclaimed Moneys held by the—

Name of Owner on Books and Last Known Address.	Total Amount Due to Owner.	Description of Unclaimed Moneys.	Date when Amount first became Payable.
\$			
N.K.S. (HOLDINGS) LIMITED.			
Campbell, George A., 188 Main-road, Ballarat	78.00	Dividend	2.4.70
Dwyer, Vincent P., Fridman-street, Boorowa, N.S.W.	19.50	"	"
Muntz, Joseph M., Shire Hall, Ararat	25.09	"	"
Baxter, Kathleen A., 2 Denmark-street, Kew	19.50	"	16.10.70
Wilbur-Ham, Brian L. (Dr.), 1 Balfour-street, Toorak	538.85	"	"
5946			
YARRA FALLS LIMITED.			
Facey, Marie Bethune, 24 Pental-road, Caulfield North	10.00	Dividend	9.11.70
Foster, John Charles, 23 Dalveen-road, Ivanhoe	30.00	"	"
Giddings, Niels William, Box 431, G.P.O., Sydney, N.S.W.	10.00	"	"
Higgs, Henry Gordon, 28 Kerford-road, Glen Iris	50.00	"	"
Ingall, Nellie May, 16 Cremorne-road, Cremorne, N.S.W.	10.00	"	"
James, Ronald W. J. R., 35 Hamilton-street, Fairy Meadow, N.S.W.	30.00	"	"
Johnson, Bruce, 5 Hogg's-road, Mitcham, S.A.	10.00	"	"
Martin, Amy Elizabeth, 331 Main-street, Mornington	10.00	"	"
Matches, James Eldon, P.O. Box 120, Sea Lake	20.00	"	"
McIver, Diana Laurie, 25 Pearce-street, Double Bay, N.S.W.	10.00	"	"
Paske, Marion, Paskerville Travel Lodge, 587 Olive-street, Albury, N.S.W.	10.00	"	"
Patullo, William Norman, 326 Reynard-street, Pascoe Vale South ..	20.00	"	"
Peppas, Alex, 230 Wollongong-road, Arncliffe, N.S.W.	10.00	"	"
Prichard, Edith Vera, No. 1 Flat "Mayfair", 12 Berkeley-street, Hawthorn	10.00	"	"
Robins, Russell Stewart, Lansell-street, Bendigo	24.00	"	"
Sharpe, Norman, 180 Bourke-street, Melbourne	12.00	"	"
Stewart, Ronald Hewison, 136 Ryde-road, Pymble, N.S.W.	20.00	"	"
Throsby, Mary Oliver, c/o Queens Club, Queens Square, Sydney, N.S.W.	20.00	"	"
Tribe, Helen Muriel, 6/2 Ben Boyd-road, Neutral Bay, N.S.W.	10.00	"	"
Wilbur-Ham, Brian L. (Dr.), 3 Balfour-street, Toorak	33.60	"	"
5948			
H. J. HEINZ CO. AUSTRALIA LTD.			
Winter, L., 3 Page-court, Dandenong	516.70	Payment of Pension Fund	— 3.70
Slegers, M., Flat 16, Hemming-street, Dandenong	32.00	Wages	"
Pope, J., Lot 227, Lomond-avenue, Kilsyth	22.40	"	— 11.70
Randell, R. B., Flat 4, 104 David-street, Dandenong	12.00	"	"
All Carpet Services, 52 Bennett-street, Dandenong	10.00	Sundry Creditor	"
5949			
CARRIER AIR CONDITIONING (HOLDINGS) LIMITED.			
Lennonville Pty. Ltd., 269 Argyle-street, Hobart, Tas.	12.50	Dividend	29.4.70
Rose, George C., Flat 24, "Chivinga", Stirling-road, Claremont, W.A.	20.00	"	"
Fuchs, Cecric J. A., 905 Nellgwynn House, Sloane-avenue, London SW3, England	10.63	"	"
Green, Margaret R., 19 Dalsten-grove, Mt. Eliza	22.50	"	8.10.70
Jacques, Gordon, 82 Middle Harbour-road, Lindfield, N.S.W.	55.54	"	"
Avery, Margaret I., c/o Brightfields Farm Ltd., Rural Delivery No. 8, Palmerston North, N.Z.	14.16	"	"
Fuchs, Cecric J. A., 905 Nellgwynn House, Sloane-avenue, London SW3, England	15.94	"	"
5950			
CONSOLIDATED HOME INDUSTRIES LIMITED.			
Coldrey, Graeme Maxwell, Box 35A, G.P.O., Melbourne	10.00	Dividend	4.5.70
Harker, Kenneth B., 3 Washington-street, Toorak	60.00	"	"
Coldrey, Graeme Maxwell, Box 35A, G.P.O., Melbourne	14.00	"	23.10.70
Goyne, Robert, Strathgordon Village, via Maydena, Tas.	52.50	"	"
Kerr, Mary Therese, 7 Denham-street, Hawthorn	14.00	"	"
5951			
RHEEM AUSTRALIA LTD.			
Page, Ann E., 414 Lower Heidelberg-road, Heidelberg	16.88	Dividend	9.4.70
Grodski, Leon, 87 Cole-street, Gardenvale	15.00	"	15.9.70
Johnson, Edwin H. (estate of) c/o John D. Mustow and Co., 89 Queen-street, Melbourne	20.00	"	"
Mustow, John D. and Elvara M. Johnson, c/o J. D. Mustow and Co., 89 Queen-street, Melbourne	12.48	"	"
5938			
MORAN AND CATO (AUST.) LTD.			
Buddle, C. B., 206 Pacific Highway, Greenwich, N.S.W.	350.00	Shares	15.11.69
Eynon, J. M. (estate of), c/o T. A. James and Co., 81 St. George-terrace, Perth, W.A.	400.00	"	"
Manzie, P. (Mrs.), Wylmar-avenue, Cronulla, N.S.W.	200.00	"	"
McClintock, J. (Mrs.), 186 Beecroft-road, Cheltenham, N.S.W.	600.00	"	"
McJannett, A. H. D., 31 Liguria-street, South Coogee, N.S.W. ..	200.00	"	"
5939			

Companies Act 1961, Section 254.
SLEIGH EXPLORATION N.L. (IN LIQUIDATION).
MEMBERS' VOLUNTARY WINDING UP.

Notice is hereby given that, pursuant to section 272 of the Companies Act 1961, the Final Meeting of members of the above-named company will be held at H. C. Sleigh Ltd., 160 Queen-street, Melbourne, on 19th June, 1972, for the purpose of receiving the liquidator's account and his report upon the winding up.

Dated this 12th day of May, 1972.

ANDREW IAN SINCLAIR, Liquidator.

Care of Duesbury & Johnston, 446 Collins-street, Melbourne, 3000. 6288

In the Supreme Court of Victoria.—1972 No. Co. 8347.—In the matter of Part X. of the Companies Act 1961; and in the matter of CHELSEA HOTEL PROPRIETARY LIMITED.

Notice is hereby given that a petition for the winding up of the above-named company by the Supreme Court was, on the 2nd day of May, 1972, presented by James Hedley Proprietary Limited, the registered office of which is at 380 Nepean Highway, Chelsea; and that the said petition is directed to be heard before the Court sitting at the Fourteenth Court, Law Courts, William-street, Melbourne, at the hour of 10.30 o'clock in the forenoon on Monday, the 26th day of June, 1972; and any creditor or contributory of the said company desiring to support or oppose the making of an order on the said petition may appear at the time of hearing by himself or his counsel for that purpose; and a copy of the petition will be furnished to any creditor or contributory of the said company requiring the same by the undersigned on payment of the regulated charge for the same.

The petitioner's address is 380 Nepean Highway, Chelsea.

The petitioner's solicitor is Mr. J. N. Bird, 96 High-street, St. Kilda.

J. N. BIRD, solicitor for the petitioner.

NOTE.—Any person who intends to appear on the hearing of the said petition must serve on or send by post to the above-named Mr. J. N. Bird, of 96 High-street, St. Kilda, notice in writing of his intention so to do. The notice must state the name and address of the person or if a firm, the name and address of the firm, and must be signed by the person or firm, or his or their solicitor, and must be served or, if posted, must be sent by post in sufficient time to reach the above-named Mr. J. N. Bird not later than four o'clock in the afternoon of Friday, the 23rd day of June, 1972. 6290

THE SERGEANT MAJOR PTY. LTD. (IN LIQUIDATION).

Notice is hereby given that a first and final dividend in the above matter will be paid on Friday, 9th June, 1972. In order to participate in the distribution, all creditors having claims against the company must lodge their proof of debt forms with the Liquidator before this date.

W. A. BROWNE, Liquidator, 24 Jeffcott-street, Melbourne, Victoria. 3003. 6245

GLEESONS IN MALVERN PTY. LTD. (IN VOLUNTARY LIQUIDATION).

At an Extraordinary General Meeting of shareholders of Gleasons in Malvern Pty. Ltd., duly convened and held at the offices of Coleman McClure & Wilby, 495 Bourke-street, Melbourne, on the 8th of May, 1972, the following Special Resolution was duly passed:—

"That the company be wound up voluntarily, and that Mr. J. Muller, accountant, of 495 Bourke-street, Melbourne, be appointed liquidator."

Dated this 8th day of May, 1972.

6277

J. MULLER, Liquidator.

The Companies Act 1961.

TERRA SELF SERVICE PTY. LIMITED.

NOTICE OF ADJOURNED MEETING OF CREDITORS.

Notice is hereby given that an adjourned meeting of the creditors of Terra Self Service Pty. Limited will be held at the Victorian Employers Federation, Third Floor, Room 315, 151 Flinders-street, Melbourne, on Tuesday, the 23rd day of May, 1972, at 11.30 o'clock in the forenoon.

6283

J. SHOSTAK, Director.

COMPANIES ACT 1961.

SECTION 260.

In the matter of Aries Engineering Industries Pty. Ltd. notice is hereby given that a meeting of creditors of Aries Engineering Industries Pty. Ltd. will be held pursuant to section 260 of the Companies Act 1961, in the National Mutual Theaterette, 447 Collins-street, Melbourne, on Monday, 29th May, 1972, at 9.30 a.m., to consider a Resolution that the company be wound up voluntarily, the company having convened a meeting of its members on the same day to pass the same Resolution.

Signed this 16th day of May, 1972.

W. E. GOODENOUGH, Director.

Messrs. Peat, Marwick, Mitchell & Co., 447 Collins-street, Melbourne. Telephone 62 1411. 6298

In the Supreme Court of Victoria.—No. Co. 8340.—In the matter of the Companies Act 1961; and in the matter of CEMATILE INDUSTRIES PROPRIETARY LIMITED.

Notice is hereby given that a petition for the winding up of the above-named company by the Supreme Court was on the 24th day of April, 1972, presented by Akhurst & Co. Pty. Ltd.; and that the said petition is directed to be heard before the Court sitting at the 14th Court, Law Courts, William-street, Melbourne, on Tuesday, the 13th day of June, 1972, at the hour of 10.30 o'clock in the forenoon; and any creditor or contributory of the said company desiring to support or oppose the making of an order on the said petition may appear at the time of hearing by himself or his Counsel for that purpose; and a copy of the petition will be furnished to any creditor or contributory of the said company requiring the same by the undersigned on payment of the regulated charge for the same.

The petitioner's address is 25 Whiteman-street, South Melbourne.

The petitioner's solicitors are Messrs. Phillips, Fox & Masel, of 44 Market-street, Melbourne.

Dated the 17th day of May, 1972.

PHILLIPS, FOX & MASEL, solicitors for the petitioner.

NOTE.—Any person who intends to appear on the hearing of the said petition must serve on or send by post to the above-named solicitors notice in writing of his intention to do so. The notice must state the name and address of the person or, if a firm, the name and address of the firm and must be signed by the person or firm or his or their solicitor (if any) and must be served, or if posted, must be sent by post in sufficient time to reach the above-named not later than 4 o'clock in the afternoon of the 9th day of June, 1972. 6264

In the Supreme Court of Victoria.—1972 Co. No. 8344.—In the matter of the Companies Act 1961; and in the matter of C. F. HANCOCK PROPRIETARY LIMITED.

Notice is hereby given that a petition for the winding up of the above-named company by the Supreme Court was on the 1st day of May, 1972, presented by M. S. McLeod Limited; and that the said petition is directed to be heard before the Court sitting at the 14th Law Court, Law Courts, William-street, Melbourne, on the 14th day of June, 1972, at the hour of 10.30 o'clock in the forenoon; and any creditor or contributory of the said company desiring to support or oppose the making of an order on the said petition may appear at the time of hearing by himself or his counsel for that purpose; and a copy of the petition will be furnished to any creditor or contributory of the said company requiring the same by the undersigned on payment of the regulated charge for the same.

The petitioner's address is 176 Pulteney-street, Adelaide, in the State of South Australia.

The petitioner's solicitors are Messrs. G. A. Hilford & Co., of 406 Lonsdale-street, Melbourne.

G. A. HILFORD & CO., solicitors for the petitioner.

NOTE.—Any person who intends to appear on the hearing of the said petition must serve on or send by post to the above-named solicitors, notice in writing of his intention so to do. The notice must state the name and address of the person, or, if a firm, the name and address of the firm and must be signed by the person or firm, or his or their solicitors (if any) and must be served, or if posted, must be sent by post in sufficient time to reach the above-named solicitors not later than 4 o'clock in the afternoon of the 13th day of June, 1972. 6167

Pursuant to the Trustee Act 1958, notice is hereby given that all persons having claims against the estate of Edith Norah Gormly, late of Allan's Flat, in the State of Victoria, widow, deceased (who died on the 9th day of July,

1971, and probate of whose will was granted by the Supreme Court of the said State, in its probate jurisdiction on the 17th day of April, 1972, to The Union-Fidelity Trustee Company of Australia Limited, of 100 Exhibition-street, Melbourne, in the said State), are hereby required to send particulars in writing of such claims to the undersigned at their offices hereunder mentioned, on or before the 31st day of July, 1972, after which date the said The Union-Fidelity Trustee Company of Australia Limited, will proceed to distribute the assets of the said Edith Norah Gormly, deceased, which shall have come to its hands amongst the persons entitled thereto, having regard only to the claims of which it shall then have had notice. And notice is hereby further given that the said The Union-Fidelity Trustee Company of Australia Limited will not be liable for the assets so distributed or any part thereof to any person of whose claim it shall not have had notice as aforesaid.

Dated this 9th day of May, 1972.

TIETYENS, ANGEL & JACKLING, proctors for the executor, 541 Kiewa-street, Albury, N.S.W., 2640

6212

The Companies Act 1961.

MARTIN STONEWARE PIPE PROPRIETARY LIMITED
(IN VOLUNTARY LIQUIDATION).

MEMBERS' WINDING UP.

Notice is hereby given, pursuant to section 272 of the Companies Act 1961, that the Final General Meeting of the members of the above-named company will be held at 185 William-street, Melbourne, on the 20th June, 1972, at 10 a.m., when I shall lay before the meeting an account, showing how the winding up has been conducted and the property of the company disposed of.

Dated this 12th day of May, 1972.

6168 W. J. KERFERD, Liquidator.

Companies Act 1961.—In the matter of MARLBOROUGH MOTORS PRY. LTD. (in Liquidation).

Notice is hereby given that at an Extraordinary Meeting of the members of the above-named company held on the 9th May, 1972, it was resolved that the company be wound up voluntarily and at a meeting of creditors held on the same day, pursuant to section 260, it was resolved that for such purpose, Everett Thomson Bent, of Suite 18, 545 St. Kilda-road, Melbourne, public accountant, be appointed liquidator.

Notice is also given that after 21 days from this date I shall proceed to distribute the assets. All creditors having any claims against the company should furnish particulars of same by that date, otherwise I shall proceed to distribute the assets without regard to their claim.

Dated this 9th day of May, 1972.

E. T. BENT, Liquidator.

Bent & Cogle, public accountants, Suite 18, 545 St. Kilda-road, Melbourne, 3004.

6169

ARTHUR ERIC STEPHENS, late of Taieri, Benalla, grazier, DECEASED.

Creditors, next of kin and others having claims in respect of the estate of the deceased (who died on the 2nd day of April, 1971), are required by the executors, John Stanley Elder, of 31 Queen-street, Melbourne, solicitor, Norman Westmore Stephens, of Kooyonga, Benalla, grazier, and Elizabeth Virginia Stephens, of Taieri, Benalla, widow, to send particulars to them care of the under-mentioned solicitors, by the 25th day of July, 1972, after which date the executors may convey or distribute the assets, having regard only to the claims of which they then have notice.

Dated the 16th day of May, 1972.

MADDEN, BUTLER, ELDER & GRAHAM, solicitors, 31 Queen-street, Melbourne.

6251

FLORENCE JANE McAULIFFE, late of 216 Darebin-road, Thornbury, widow, DECEASED.

Creditors, next of kin and others having claims in respect of the estate of the deceased (who died on the 12th day of March, 1972), are required by the Perpetual Executors and Trustees Association of Australia Limited, of 100-104 Queen-street, Melbourne, to send particulars of their claims to the said company, by the 24th day of July, 1972, after which date it will convey or distribute the assets, having regard only to the claims of which the company then has notice.

6252

CYRIL CLIFFORD HENRYS, late of 7 Winifred-crescent, Toorak, company director, DECEASED.

Creditors, next of kin and others having claims in respect of the estate of the deceased (who died on the 16th day of December, 1971), are required by The Perpetual Executors and Trustees Association of Australia Limited, of 100-104 Queen-street, Melbourne, and John Emery, Barnes Henrys, of 78 Wellington-street, St. Kilda, manager, and Catherine Wembridge Baumgarten, of 68 Tivoli-road, South Yarra, married woman, the applicants for a grant of administration, to send particulars of their claims to the said applicants, in the care of the said company, by the 19th day of July, 1972, after which date they will convey or distribute the assets, having regard only to the claims of which they then have notice.

ALAN WAINWRIGHT & CO., of 297 Little Collins-street, Melbourne.

6253

ETHEL WILCOX, late of 55 Best-street, Belgrave, in the State of Victoria, widow, DECEASED.

Notice is hereby given that all persons having claims against the estate of the abovenamed deceased (who died on the 1st day of March, 1972, and probate of whose will was granted by the Supreme Court of Victoria in its probate jurisdiction, on the 28th day of April, 1972, to Raymond Charles Annand, of 7 Etzel-street, Airport West, in the said State, production planner, and Dorothy Amy Weaver, of 80 Domain-street, South Yarra, in the said State, solicitor), are hereby required to send particulars, in writing, of such claims to the said Raymond Charles Annand, and Dorothy Amy Weaver, at 80 Domain-street, South Yarra, aforesaid, on or before the 31st day of July, 1972, after which date the said Raymond Charles Annand, and Dorothy Amy Weaver, will proceed to distribute the assets of the said deceased, which shall have come to their hands amongst the persons entitled thereto, having regard only to the claims of which they shall then have had notice. And notice is hereby further given that the said Raymond Charles Annand and Dorothy Amy Weaver will not be liable for the assets so distributed or any part thereof to any person of whose claim they shall not have had notice as aforesaid.

Dated the 10th day of May, 1972.

DOROTHY A. WEAVER, LL.B., solicitor, of 80 Domain-street, South Yarra, Proctor for the Executors.

6254

ANNIE CATHERINE BROWN, late of 64 Airlie-street, South Yarra, widow, DECEASED.

Creditors, next of kin and others having claims against the estate of the said deceased (who died on 20th November 1971), are to send particulars of their claims to Adrian Bennis, care of 120 William-street, Melbourne, by the 21st day of July, 1972, after which date he will distribute the assets having regard only to the claims of which he then has notice.

BLAKE & RIGGALL, 120 William-street, Melbourne, solicitors.

6256

ISABELLA PARKS, late of Gordon-terrace, Kilkeel, County Down, Northern Ireland, spinster, DECEASED.

Creditors, next of kin and others having claims in respect of the estate of the deceased (who died on the 1st April, 1941), are required by the trustees, The Trustees Executors and Agency Company Limited, of 401 Collins-street, Melbourne, in the State of Victoria, to send particulars to the company by the 24th day of July, 1972, after which date the trustees may convey or distribute the assets, having regard only to the claims of which they then have notice.

DAVIES, CAMPBELL & PIESSE, solicitors, of 401 Collins-street, Melbourne.

6257

In the will of Alan Vernon Tuckett, of Betley, in the State of Victoria, farmer, DECEASED.

Creditors, next of kin and all persons having claims against the estate of the above-named deceased are hereby requested to send particulars, in writing, of such claims to the executrices of the estate of the said Alan Vernon Tuckett, deceased, in the care of the undernamed solicitor, on or before the 1st of August, 1972, after which date the said executrices will proceed to distribute the assets of the said Alan Vernon Tuckett, deceased, having regard only to the claims of which they shall then have had notice, and notice is hereby given that the said executrices will not be liable for the assets so distributed or any part thereof to any persons of whose claim they shall not have had notice as aforesaid.

PATRICIA M. COUTTS, Nolan-street, Maryborough, solicitor for the applicant.

6276

Creditors, next of kin and others having claims in respect of the estate of Letitia Fanny Brown, late of Flat 3, 312 Wattletree-road, East Malvern, widow, deceased (who died on 19th July, 1971), are required by William Evered Clive Boselman, of 62 South-road, Brighton Beach, retired, the executor of the will of the above deceased, to send particulars of their claims, care of the under-mentioned solicitor, by 18th July, 1972, after which date he will distribute the assets, having regard only to the claims of which he then has notice.

THOMAS BURKE, solicitor, 152 Wattletree-road,
Malvern. 6273

Creditors, next of kin and others having claims in respect of the estate of Florence Ethel Bentley, late of 47 Begonia-road, Gardenvale, widow, deceased (who died on the 22nd day of October, 1971), are to send particulars of their claims to The Equity Trustees, Executors and Agency Company Limited, of 472 Bourke-street, Melbourne, by the 25th day of July, 1972, after which date it will distribute the assets, having regard only to the claims of which it then has notice.

LEACH & THOMSON, solicitors, 472 Bourke-street,
Melbourne. 6274

Creditors, next of kin and others having claims in respect of the estate of Moshe Kuperman, late of 21 Mitford-street, Elwood, retired, deceased (who died on the 28th day of October, 1971), are required to send particulars of their claims to the executor, Leopold Solomon Rosenthal, care of the under-mentioned solicitors, by the 19th day of July, 1972, after which date the said executor may convey or distribute the assets, having regard only to the claims of which he then has notice.

SLONIM, VELIK & EMANUEL, solicitors, 374 Bourke-
street, Melbourne. 6275

Creditors, next of kin and others having claims in respect of the will of Doris Marguerite Madden, late of 43 Victoria-street, Flemington, widow, who died on the 15th day of April, 1972, are requested to send particulars of their claims to the executors, Collis John Madden and Donald Joseph Madden, care of the under-mentioned solicitor, by the 31st day of July, 1972, after which date they will distribute the assets, having regard only as to the claims of which they then have notice.

JOHN STEWART, of 290 Racecourse-road, Newmarket.
6278

Creditors, next of kin and others having claims in respect of the estate of Daisy Beatrice Ward, late of 20 Manning-road, East Malvern, in the State of Victoria, spinster, deceased (who died on the 13th day of July, 1972), are required to send particulars thereof to Messrs. Mills, Oakley & McKay, of 10 Powlett-street, East Melbourne, solicitors for the executor, on or before the 30th day of August, 1972, after which date the executor will distribute the assets of the estate, having regard only to the claims of which he shall then have notice.

MILLS, OAKLEY & MCKAY, solicitors, of 10 Powlett-
street, East Melbourne. 6186

DOROTHY MARTHA ROSE OWINS, late of 89 Neale-
street, Bendigo, in the State of Victoria, widow,
DECEASED.

Creditors, next of kin and others having claims in respect of the estate of the deceased (who died on 25th day of February, 1972), are required by Sandhurst and Northern District Trustees Executors and Agency Company Limited, of View-street, Bendigo, aforesaid, to send particulars to it, by the 15th day of August, 1972, after which date it may convey or distribute the assets, having regard only to the claims of which it then has notice.

SCHLEIGER & SMALLEY, solicitors, 290 Williamson-
street, Bendigo. 6189

CATHERINE MAY TREWAVAS, late of Lilley Lodge
Private Hospital, 18 Bray-street, Long Gully, in the
State of Victoria, spinster, DECEASED.

Creditors, next of kin and others having claims in respect of the estate of the deceased (who died on 3rd day of February, 1972), are required by Sandhurst and Northern District Trustees Executors and Agency Company Limited, of View-street, Bendigo, in the said State, to send particulars to it, by the 15th day of August, 1972, after which date it may convey or distribute the assets, having regard only to the claims of which it then has notice.

SCHLEIGER & SMALLEY, solicitors, 290 Williamson-
street, Bendigo. 6190

ALMA JOYCE WARD, late of 183 O'Heas-street, Coburg,
in the State of Victoria, married woman, DECEASED.

Creditors, next of kin and all others having claims in respect of the estate of Alma Joyce Ward, late of 183 O'Heas-street, Coburg, married woman, deceased (who died on the 17th day of December, 1970), are required by the executor, Allan Esdaile Davies Ward, of 183 O'Heas-street, Coburg, M.M.B.W. inspector, to send particulars of their claims to him, in the care of the under-mentioned solicitor, prior to the 20th day of July, 1972, after which date he will distribute the assets, having regard only to the claims of which he then has notice.

M. F. HUGHES, LL.B., 300 Barkly-street, Bruns-
wick. 6200

DAVID ANTONY BRIGGS WALLIS, late of 36 Arthur-
street, Eltham, bank officer, DECEASED.

Creditors, next of kin and others having claims in respect of the estate of the deceased (who died on the 17th March, 1972), are required by the executor, Walter Briggs Wallis, of 36 Arthur-street, Eltham, inspecting officer, to send particulars to the under-mentioned firm, by 28th July, 1972, after which date the said executor may convey or distribute the assets, having regard only to the claims of which he then has notice.

SETON, WILLIAMS & SMYTH, solicitors, 954 Main-road,
Eltham, 3095. 6182

JAMES HENRY POWELL, formerly of Waterloo-road, Moe,
but late of Tennyson-street, Orbost, roadworker,
DECEASED.

Creditors, next of kin and others having claims in respect of the estate of the deceased (who died on the 20th October, 1970), are required by the trustees, Lorraine Pearl Jennings, of Nowa Nowa, married woman, and Ruth Verhagen, of 62 Moore-street, Moe, married woman, to send particulars of their claims to them, care of the under-mentioned solicitors, by the 24th day of July, 1972, after which date the trustees may convey or distribute the assets, having regard only to the claims of which they then have notice.

GRAY, FRIEND & LONG, solicitors, Warragul. 6184

Creditors, next of kin and others having claims in respect of the estate of Jack Brian Davey Moroney, late of Kewell, High-street, Kangaroo Flat, retired poultry farmer, deceased (who died on the 17th day of October, 1971), probate of whose will was granted to National Trustees, Executors and Agency Company of Australasia Limited of Queen Street, Bendigo, and Joan Marjorie Moroney, of Kewell, High-street, Kangaroo Flat, widow, are required to send particulars of their claims to the said executors, care of the under-mentioned solicitors, by the 27th day of July, 1972, after which date the executors will distribute the assets, having regard only to the claims of which they then have notice.

HOGAN, HOGAN AND PETERSEN, solicitors, of 68
Bull-street, Bendigo. 6191

JOHN ALPHONSUS DEVEREUX, late of Speewa, in the
State of Victoria, farmer, DECEASED.

Creditors, next of kin and others having claims in respect of the estate of the deceased (who died on the 29th day of September, 1971), are required by the executors, John Nicholas Devereux, of Tyntynder South, in the said State, and Desmond Simpson Devereux, of Speewa, in the said State, to send particulars to them, care of the under-mentioned, by the 17th day of July, 1972, after which date the executors will convey or distribute the assets, having regard only to the claims of which they then have notice.

ALEC M. HAYES, solicitor, 148 Campbell-street, Swan
Hill. 6166

In the estate of CHARLES LAWRIE CARSON, late of
23 Beach-street, Queenscliff, retired engineer, DECEASED.

Creditors, next of kin and others having claims in respect of the estate of the said deceased (who died on the 21st day of January, 1972), are required by the executor of the estate of the said deceased, Alan Clydesdale Thomson, of 18 Bethune-street, Queenscliff, to send particulars to him care of the under-mentioned solicitors, by the 9th day of August, 1972, after which date the said executor may convey or distribute the assets, having regard only to the claims of which he then has notice.

DONALD A. INGPEN & CO., solicitors, 54 Malop-street,
Geelong. 6193

Creditors, next of kin and others having claims in respect of the estate of Isabella Tate Tuck, late of 24 Baromi-road, Mirboo North, in Victoria, married woman, deceased (who died on 25th February, 1972), are to send particulars of their claims to the executor, The Union-Fidelity Trustee Company of Australia Limited, at its office at 100 Hotham-street, Traralgon, by 1st day of August, 1972, after which date the said company will distribute the assets, having regard only to the claims of which it then has notice.

C. H. FORD, LL.M., solicitor, Traralgon. 6192

Creditors, next of kin and others having claims in respect of the estate of Ethel Margaret Johns, late of 201 Station-street, Edithvale, widow, deceased (who died on the 28th day of May, 1971), are to send particulars of their claims to Michael Anthony Barrett, the attorney of Glenys Margaret Johns, the executrix named in the said will, care of R. P. Barrett & Son, solicitors, 472 Bourke-street, Melbourne, by the 17th day of July, 1972, after which date they will distribute the assets, having regard only to the claims of which they then have notice.

R. P. BARRETT & SON, solicitors, 472 Bourke-street, Melbourne. 6237

MARY HARRIS, late of No. 1, Billson-street, East Brighton, widow, DECEASED.

Creditors, next of kin and others having claims in respect of the estate of the deceased (who died on the 22nd day of January, 1972), are required by Kevin Luke Murphy, of No. 422 Bourke-street, Melbourne, solicitor, the executor of the will of the deceased, to send particulars of their claims to him by the 24th day of July, 1972, after which date he will convey or distribute the assets having regard only to the claims of which he then has notice.

LUKE MURPHY & CO., solicitors, 422 Bourke-street, Melbourne. 6238

Creditors, next of kin and others having claims against the estate of Fay Catherine Rothwell, late of Flat 1, Gaston Court, 8 Hepburn-street, Hawthorn, in the State of Victoria, spinster, deceased, intestate (who died on the 8th day of February, 1972), are required to send particulars of their claims to the administratrix, Charlotte Louise Griffith, care of the undersigned solicitor before the 26th day of July 1972, after which date the administratrix will distribute the assets, having regard only to the claims of which they then have notice.

JOHN F. CARROLL, solicitor, 118 Queens-street, Melbourne. 6239

Creditors, next of kin and others having claims in respect of the estate of Diosma Marie Roediger, late of Flat 2, Craigellachie, 273 Orrong-road, East St. Kilda, gentlewoman, deceased (who died on the 21st day of December, 1971), are required to send particulars of their claims to Ian Howard Roediger, holiday flats proprietor, and Lindsay Roediger Hensley, farmer, care of the under-mentioned solicitors, by the 24th day of July, 1972, after which date the executors will distribute the assets, having regard only to the claims of which they then have notice.

SEWELL & SEWELL, solicitors, 422 Collins-street, Melbourne. 6240

JAMES HUMPHREY SKERRY, late of Flat 1, 105 Merton-street, Albert Park, chartered accountant, DECEASED.

Creditors, next of kin and others having claims against the estate of the above-named deceased (who died on the 1st day of October, 1971), are required to send particulars of their claims to National Trustees, Executors & Agency Co. of Australasia Ltd., the registered office of which is situate at 95 Queen-street, Melbourne, by the 18th day of July, 1972, after which date it will distribute the assets of the deceased, having regard only to the claims of which it then has notice.

IRVING S. PLOTKIN, LL.B., 388 Collins-street, Melbourne. 6289

Creditors, next of kin and others having claims in respect of the estate of Francis Augustus Ville, late of 50 Barkly-street, Mordialloc, gentleman, deceased (who died on 7th day of January, 1972), are required to send particulars of their claims to National Trustees, Executors and Agency Company of Australasia Limited, of 95 Queen-street, Melbourne, the executor of the will of the said deceased by the 25th day of July, 1972, after which date the said company will distribute the assets, having regard only to the claims of which it then has notice.

HERBERT, GEER & RUNDLE, solicitors, 612-614 Balcombe-road, Black Rock. 6291

LAURA JANE BYRNE, late of 34 Mason-street, Hawthorn in the State of Victoria, widow, DECEASED.

Creditors, next of kin and all others having claims in respect of the estate of Laura Jane Byrne, late of 34 Mason-street, Hawthorn, widow, deceased (who died on the 6th day of February, 1972), are required by the executor, Roy Joseph Warren, of 67 Rubicon-street, Reservoir, mechanic, to send particulars of their claims to him in the care of the under-mentioned solicitor, prior to the 20th day of July, 1972, after which date he will distribute the assets, having regard only to the claims of which he then has notice.

M. F. HUGHES, LL.B., 300 Barkly-street, Brunswick. 6194

LAVINIA LEAR, late of 53 Lyle-street, Brunswick, in the State of Victoria, widow, DECEASED.

Creditors, next of kin and all others having claims in respect of the estate of Lavinia Lear, late of 53 Lyle-street, Brunswick, widow, deceased (who died on the 14th day of September, 1971), are required by the executor, Henry Ernest Lear, of Midland Highway, Tatura, farmer, to send particulars of their claims to him, in the care of the under-mentioned solicitor, prior to the 20th day of July, 1972, after which date he will distribute the assets, having regard only to the claims of which he then has notice.

M. F. HUGHES, LL.B., 300 Barkly-street, Brunswick. 6195

EMILY HALL, late of 434 Gaffney-street, Pascoe Vale, in the State of Victoria, widow, DECEASED.

Creditors, next of kin and all others having claims in respect of the estate of Emily Hall, late of 434 Gaffney-street, Pascoe Vale, widow, deceased (who died on the 3rd day of April, 1971), are required by the executor, William Hall, of 434 Gaffney-street, Pascoe Vale, newsagent, to send particulars of their claims to him, in the care of the under-mentioned solicitor, prior to the 20th day of July, 1972, after which date he will distribute the assets, having regard only to the claims of which he then has notice.

M. F. HUGHES, LL.B., 300 Barkly-street, Brunswick. 6196

Creditors, next of kin and others having claims in respect of the estate of Gerda Oncken, also known as Gerda Johanna Anna Oncken, late of 3 Huntingdon-road, East Bentleigh, freelance agent, deceased (who died on the 16th day of November, 1971), are requested to send particulars of their claims to the administrator of the estate, Jurgen Lambert Oncken, care of the under-mentioned solicitor, by the 19th day of July, 1972, after which date he will convey and distribute the assets, having regard only to the claims of which he then has notice.

E. T. BRENNERS, solicitor, of 114 Princess-street, Kew. 6280

LAURENCE PATRICK PURCELL, late of 447 Flemington-road, North Melbourne, in the State of Victoria, pensioner, DECEASED.

Creditors, next of kin and all others having claims in respect of the estate of Laurence Patrick Purcell, late of 447 Flemington-road, North Melbourne, pensioner, deceased (who died on the 17th day of August, 1971), are required by the executrix, Joan Elliott, of 447 Flemington-road, North Melbourne, married woman, to send particulars of their claims to her, in the care of the under-mentioned solicitor, prior to the 20th day of July, 1972, after which date she will distribute the assets, having regard only to the claims of which she then has notice.

M. F. HUGHES, LL.B., 300 Barkly-street, Brunswick. 6198

JOHN FRANCIS CRAWFORD, late of 273 Brunswick-road, West Brunswick, in the State of Victoria, waterside worker, DECEASED.

Creditors, next of kin and all others having claims in respect of the estate of John Francis Crawford, late of 273 Brunswick-road, West Brunswick, waterside worker, deceased (who died on the 18th day of April, 1971), are required by the executor, Kevin William Crawford, of 56 Skewes-street, Avondale Heights, taxi driver, to send particulars of their claims to him, in the care of the under-mentioned solicitor, prior to the 20th day of July, 1972, after which date he will distribute the assets, having regard only to the claims of which he then has notice.

M. F. HUGHES, LL.B., 300 Barkly-street, Brunswick. 6199

Creditors, next of kin and others having claims in respect of the estate of Charles Albert Scott, late of 192 Mt. Alexander-road, Flemington, retired (who died 12th June, 1971), are to send particulars of their claims to the administratrix care of O'Brien & Galante, solicitors, 44 Pascoe Vale-road, Moonee Ponds, by the 19th July, 1972, after which date the administratrix will distribute the estate, having regard only to the claims of which she then has notice. 6218

Creditors, next of kin and others having claims in respect of the estate of Beatrice Rubina Marks, late of 10 Park-street, South Melbourne, widow, deceased, intestate (who died on the 27th September, 1971), are to send particulars of their claims to the administrator, care of the under-mentioned solicitors by the 19th day of July, 1972, after which date the administrator will distribute the estate, having regard only to the claims of which he then has notice.

O'BRIEN & GALANTE, solicitors, 44 Pascoe Vale-road, Moonee Ponds. 6219

PHOEBE PRISCILLA BEGGS, late of 261 Glenlyon-road, East Brunswick, in the State of Victoria, widow, DECEASED.

Creditors, next of kin and all others having claims in respect of the estate of Phoebe Priscilla Beggs, late of 261 Glenlyon-road, East Brunswick, widow, deceased (who died on the 2nd day of November, 1971), are required by the executrix, Muriel Dunbar, of 89 Shamrock-street, West Brunswick, widow, to send particulars of their claims to her, in the care of the under-mentioned solicitor, prior to the 20th day of July, 1972, after which date she will distribute the assets, having regard only to the claims of which she then has notice.

M. F. HUGHES, LL.B., 300 Barkly-street, Brunswick. 6197

Creditors, next of kin and others having claims in respect of the estate of John Henry Porter, late of 17 Barnett-street, Hampton, retired hotelkeeper, deceased (who died on the 23rd day of December, 1971), are required to send particulars of their claims to Ian Francis McLaren, accountant, care of the under-mentioned solicitors, by the 24th day of July, 1972, after which date the executor will distribute the assets, having regard only to the claims of which he then has notice.

SEWELL & SEWELL, solicitors, 422 Collins-street, Melbourne. 6241

Creditors, next of kin and others having claims in respect of the estate of Stanley Gordon Miles, late of 620 Lower Plenty-road, East Rosanna, in the State of Victoria, gentleman, deceased (who died on 20th March, 1972), are to send the particulars of their claims to the executors, Arthur Charles Miles and Ethel Miles, in care of Colin Keon-Cohen, 472 Bourke-street, Melbourne, by the 19th July, 1972, after which date they will distribute the assets, having regard only to the claims of which they then have notice.

Dated the 11th May, 1972.

COLIN KEON-COHEN, solicitors, 472 Bourke-street, Melbourne. 6242

COLIN BRANDON VILLIERS, late of Villa 4, 32 Mercer-road, Armadale, company director, DECEASED.

Creditors, next of kin and others having claims in respect of the above-named deceased (who died on the 16th November, 1971), are to send particulars of their claims to The Trustees Executors & Agency Company Limited, of 401 Collins-street, Melbourne, and to Joyce Marion Villiers, of Villa 4, 32 Mercer-road, Armadale, the executors appointed by the will of the said deceased by 17th July, 1972, after which date the executors will distribute the assets, having regard only to the claims of which they shall then have notice.

H. L. YUNCKEN & YUNCKEN, solicitors, 443 Little Collins-street, Melbourne, 3000. 6243

Creditors, next of kin and others having claims against the Estate of Andrew George Millett, formerly of 10 Watkins-street, North Fitzroy, but late of 292 Nepean Highway, Edithvale, in the State of Victoria, journalist, deceased (who died on the 21st day of November, 1971), are to send particulars of their claims to The Equity Trustees, Executors and Agency Company Limited, of 472 Bourke-street, Melbourne, by the 26th day of July, 1972, after which date it will distribute the assets, having regard only to the claims of which it then has notice.

G. A. BURCHILL, solicitor, 34 Queen-street, Melbourne. 6250

ETHEL ELLEN MAY CUTHBERT, late of 137 North-road, Gardenvale, in the State of Victoria, spinster, DECEASED.

Creditors, next of kin and others having claims in respect of the estate of the deceased (who died on the 15th day of January, 1972), are required by the executors, Charles Gerard Heffey and Thomas Michael Butler, solicitors, to send particulars thereof to them, care of F. J. Corder & Co., solicitors, 358 Lonsdale-street, Melbourne, by the 17th day of July, 1972, after which date they will distribute the assets, having regard only to the claims of which they then have notice.

F. J. CORDER & Co., solicitors, 358 Lonsdale-street, Melbourne. 6244

In the Supreme Court of the State of Victoria.

SALE BY THE SHERIFF.

On Friday, the 23rd of June, 1972, at 10.30 a.m., at the Police Station, Fairfield (unless process be stayed or satisfied):—

All the estate and interest (if any) of Charles John Sparks, manufacturer, of Unit 3, 11 Central-avenue, Ivanhoe, as joint proprietor with Daisy Lillian Sparks of an estate in fee-simple of all that piece of land being Unit 3 delineated on registered plan No. 1101 and an undivided share in the common property for the time being described on the said plan, Parish of Keelbundora, and being the land described in certificate of title, volume 8779, folio 325, upon which is erected a unit dwelling house and outbuildings, known as Unit 3, 11 Central-avenue, Ivanhoe.

Registered mortgage No. D.458153 and caveat D.974729 affects the said estate and interest.

Terms: Cash only.

DOUGLAS S. HALL, Sheriff's Officer.

17th May, 1972.

6293

In the Supreme Court of the State of Victoria.

SALE BY THE SHERIFF.

On Friday, the 16th of June, 1972, at 2 p.m., at the Police Station, Beaumaris (unless process be stayed or satisfied):—

All the estate and interest (if any) of Peter Dimitris Morianos, advertising agent, and Ida Morianos, married woman, both of 24 Beach-road, Beaumaris, as joint proprietors of an estate in fee-simple in the land described in certificate of title, volume 4509, folio 673, upon which is erected a weatherboard dwelling and a partly constructed two-storey Besser brick addition thereto, known as No. 24 Beach-road, Beaumaris.

Registered mortgage Nos. E.42956 and E.187896 affect the said estate and interest.

Terms: Cash only.

DOUGLAS S. HALL, Sheriff's Officer.

17th May, 1972.

6294

In the Supreme Court of the State of Victoria.

SALE BY THE SHERIFF.

On Friday, the 30th of June, 1972, at 10 a.m., at the Police Station, Dandenong (unless process be stayed or satisfied):—

All the estate and interest (if any) of Maria Marino, widow, of 29 William-avenue, Dandenong, as proprietor of an estate in fee-simple in the land described in certificate of title, volume 7360, folio 929, upon which is erected a double-fronted brick veneer dwelling, known as No. 29 William-avenue, Dandenong.

Housing Commission Declaration D.170077 and caveat D.669526 affect the said estate and interest.

Terms: Cash only.

H. BUETTNER, Sheriff's Officer.

17th May, 1972.

6295

In the Supreme Court of the State of Victoria.

SALE BY THE SHERIFF.

On Friday, the 30th of June, 1972, at 10.10 a.m., at the Police Station, Dandenong (unless process be stayed or satisfied):—

All the estate and interest (if any) of Luigi Massa, factory worker, and Rosa Massa, married woman, both of 1506 Heatherton-road, Dandenong, as joint proprietors of an estate in fee-simple in the land described in

certificate of title, volume 7716, folio 146, upon which is erected a weatherboard dwelling, known as No. 1506 Heatherton-road, Dandenong.

Registered mortgage No. A.326597 and caveats C.416579 and D.581953 affect the said estate and interest.

Terms: Cash only.

H. BUETTNER, Sheriff's Officer.

17th May, 1972.

6296

In the Supreme Court of the State of Victoria.

SALE BY THE SHERIFF.

On Friday, the 23rd of June, 1972, at 10 a.m., at the Police Station, Eltham (unless process be stayed or satisfied):—

All the estate and interest (if any) of Lucy Ada Nyland, married woman, of "Wongabeena", lot 3, Progress-road, Eltham North, as proprietor of an estate in fee-simple in the land described in certificate of title, volume 8458, folio 264, upon which is erected a weatherboard dwelling known as Lot 3, Progress-road, Eltham North.

Registered mortgages Nos. D.922575 and D.925140 and caveats D.953138 and E.81261 affects the said estate and interest.

Terms: Cash only.

H. BUETTNER, Sheriff's Officer.

17th May, 1972.

6297

INSOLVENCY NOTICES

BANKRUPTCY ACT 1966, PART X, SECTION 218.

Notice is hereby given that Wilbur Henry Olsen, of Poowong East, executed a deed of assignment pursuant to Part X. of the *Bankruptcy Act 1966*, to Lewis Luckins, chartered accountant, of 130 Flinders-street, Melbourne, on the 8th day of May, 1972.

LEWIS LUCKINS, F.C.A., Trustee.

Lewis Luckins & Co., chartered accountants, 130 Flinders-street, Melbourne, 3000. Telephone 63 8827. 6282

Bankruptcy Act 1966, Part X.—Notice of Meeting of Creditors of Estate of (Mrs.) SHIRLEY ANN FANDRICH, Trading as Hansel 'N Gretel, at 1356 Malvern-road, Malvern.

Take notice that Mrs. Shirley Ann Fandrich, of 1356 Malvern-road, Malvern, has on the 26th April, 1972, signed an authority under sub-section (1) of section 188 of the *Bankruptcy Act 1966*, the effective date being the 26th April, 1972, authorizing Lewis Luckins, chartered accountant, of 130 Flinders-street, Melbourne, to call a meeting of her creditors and take over control of her property and that, in pursuance of section 194 of the *Bankruptcy Act 1966*, a meeting of the creditors of the above-mentioned debtor will be held at the A.H.A. Conference Room, 4th Floor, 130 Flinders-street, Melbourne, on Friday, 19th May, 1972, at 11 a.m. in the forenoon.

Dated this 11th day of May, 1972.

LEWIS LUCKINS, F.C.A., Controlling Trustee.

Lewis Luckins & Co., chartered accountants, 130 Flinders-street, Melbourne, 3000. Telephone No. 63 8827. 6255

IMPOUNDINGS

BEARS LAGOON.—Impounded at Bears Lagoon Pound.
4 wethers, nick in left ear, tip off right ear, no visible brand

1 ewe, nick in both ears, no visible brand

If not claimed and expenses paid, to be sold on 31st May, 1972.

6227—\$2.80

G. TURNER,
Poundkeeper.

BENALLA.—Impounded in Benalla Pound, by J. S. Stickland (Ranger) on 9th May, 1972, at 3.30 p.m.

1 cross-bred wether lamb with horns, green raddle mark on shoulder

If not claimed and expenses paid, to be sold on 1st June, 1972.

6299—\$2.80

C. H. WALLACE,
Poundkeeper.

CAMPERDOWN.—Impounded in Camperdown Pound.
3 sheep seized in Ferguson-street; no visible brand

If not claimed and expenses paid, to be sold on 30th May, 1972.

6226—\$2.10

L. BREEN,
Poundkeeper.

CRANBOURNE.—Impounded in Cranbourne Pound, by Shire Ranger, from Craigs-road, Devon Meadows.

2 ewes, no visible brand

If not claimed and expenses paid, to be sold on 5th June, 1972.

6300—\$2.45

G. HALLISEY,
Poundkeeper.

MANSFIELD.—Impounded in Mansfield Pound.

1 Romney Marsh ram, ear tag, M.N.L., no visible brand

If not claimed and expenses paid, to be sold on 19th May, 1972.

6228—\$2.10

G. PREST,
Poundkeeper.

OXLEY.—Impounded in Oxley Pound from Oxley Picnic Ground Lane.

9 4-tooth Corriedale cross wethers, purple W on back, full wool

If not claimed and expenses paid, to be sold on 5th June, 1972.

6225—\$2.80

M. PERKINS,
Poundkeeper.

YARRA JUNCTION.—Impounded in Yarra Junction Pound.

1 Hereford crossbred steer, no horns, no visible brand

If not claimed and expenses paid, to be sold on 31st May, 1972.

6235—\$2.45

J. N. EDDY,
Shire Secretary.

Subordinate Legislation Act 1962.

NOTICE OF MAKING OF STATUTORY RULES.

In pursuance of the provisions of the *Subordinate Legislation Act 1962* and the Regulations made thereunder, notice is given of the making of the following statutory rules:—

No.	Stamps Act 1958.	Price.
120/1972.	Stamps (Further Exemptions) Regulations 1972	10c
	<i>Health Act 1958</i> (No. 6270)	
121/1972.	Registration (Health Acts) Amendment Regulations 1972	10c
	<i>Pay-roll Tax Act 1971.</i>	
122/1972.	Pay-roll Tax Regulations 1972	10c
	<i>Select Committee (Ansett Transport Industries) Act 1972.</i>	
123/1972.	Select Committee (Ansett Transport Industries) (Travelling Expenses) Regulations 1972	10c

Copies of these statutory rules may be purchased at the Sale of Publications Section of the Government Printing Office, located at 7A Parliament-place, Melbourne, 3002. If ordered by mail, remittance should be addressed to "The Government Printer, Box 203, P.O., North Melbourne, 3051", and should include 7c extra for postage. If a credit account is held at this office, no remittance is required with the mail order.

The annual subscription rate for Statutory Rules (including Bound Volumes) is \$23, payable in advance. The subscription year commences on 1st January.

C. H. RIXON,
Government Printer.

STATE ACTS, 1971

Copies of the following Acts of Parliament of Victoria may be obtained at the Government Printing Office, Sale of Publications Branch, off Parliament-place, Melbourne, phone 63 0321, extension 6181, or from any accredited agent, at the price set opposite to each (these prices do not include postage).

The annual subscription for State Acts 1971 et seq. is \$12.50 payable in advance.

Bound Volumes of State Acts are also available on a subscription basis of \$17.50 per annum.

No.	Price.
8090. Municipal Association (Amendment)	\$0.10
8091. Transfer of Land (Duplicate Certificates)	\$0.10
8092. Firearms	\$0.10
8093. Geelong Land (Special Grant)	\$0.10
8094. Churchill Water and Sewerage Works	\$0.10
8095. Superannuation (Railway Service)	\$0.10
8096. Vermin and Noxious Weeds (Amendment)	\$0.10
8097. Police Regulation (Amendment)	\$0.10
8098. Snowy Mountains Engineering Corporation (Victoria)	\$0.10
8099. Albert Park Land	\$0.10
8100. Local Government (Municipalities Assistance Fund)	\$0.10
8101. Health (Tuberculosis Arrangement)	\$0.10
8102. Presbyterian Church of Australia	\$0.20
8103. Marketing of Primary Products (Amendment)	\$0.10
8104. Gas and Fuel Corporation (Geelong Gas)	\$0.15
8105. Local Authorities Superannuation (Disability Benefits) (Commencement)	\$0.10
8106. Building Societies (Amendment)	\$0.20
8107. Survey Co-ordination (Place Names)	\$0.10
8108. Howard Florey Institute of Experimental Physiology and Medicine	\$0.30
8109. Superannuation (Transitional Provisions)	\$0.10
8110. New Broken Hill Consolidated Limited	\$0.15
8111. Litter (Proceedings for Offences)	\$0.10
8112. Justices (Service of Summonses)	\$0.10
8113. Stock (Artificial Breeding) (Amendment)	\$0.10
8114. Alcoa of Australia (W.A.) N.L.	\$0.40
8115. Victoria Institute of Colleges (Amendment)	\$0.10
8116. Cemeteries (Fawkner Crematorium and Memorial Park)	\$0.10
8117. Trustee Companies (Equity Trustees)	\$0.10
8118. Parliamentary Superannuation	\$0.10
8119. Ehrenhaus Retail Bottled Liquor Licence	\$0.10
8120. Melbourne University Land	\$0.10
8121. Forests (Bowater-Scott Agreement)	\$0.20
8122. Gas and Fuel Corporation (Pipelines)	\$0.15
8123. Coal Mines (Pensions)	\$0.10
8124. Crown Proceedings (Forfeited Recognisances)	\$0.10
8125. Public Trustee (Amendment)	\$0.15
8126. Geelong Waterworks and Sewerage (Rates)	\$0.10
8127. Subordinate Legislation (Powers)	\$0.10
8128. Barley Marketing	\$0.10
8129. Stamps (Credit Business)	\$0.15
8130. Land (Surrender to the Crown)	\$0.10
8131. Pipelines (Amendment)	\$0.10
8132. County Court (Jurisdiction)	\$0.10
8133. Grassmere Land	\$0.10
8134. Supply (Supplementary Estimates)	\$0.10
8135. Town and Country Planning (Amendment)	\$0.15
8136. Seeds	\$0.40
8137. Imperial Acts Application (Repeals)	\$0.10
8138. Audit (Recovery of Overpayments)	\$0.10
8139. Evidence (Registration of Commissioners)	\$0.10
8140. Country Roads (Amendment)	\$0.15
8141. Protection of Animals (Rodeos)	\$0.10
8142. Soil Conservation and Land Utilization (Amendment)	\$0.15
8143. Motor Car (Driving Offences)	\$0.30
8144. Fisheries (Amendment)	\$0.15
8145. Appeal Costs Fund	\$0.10
8146. Scaffolding	\$0.30
8147. Liquor Control (Amendment)	\$0.15
8148. Supply (July to September)	\$0.10
8149. Local Government (Further Amendment)	\$0.40
8150. Supply (Supplementary Estimates)	\$0.10
8151. Supply (October to December)	\$0.10
8152. Police Regulation (Chief Commissioner)	\$0.10
8153. Groundwater	\$0.10
8154. Pay-Roll Tax	\$0.50
8155. Moonee Ponds (Queens Park) Land	\$0.10
8156. Commonwealth Places (Administration of Laws)	\$0.10
8157. Stamps	\$0.20
8158. Mercy Private Hospital (Guarantee)	\$0.10
8159. Daylight Saving	\$0.10
8160. Co-operative Housing Societies (Indemnities)	\$0.10

STATE ACTS, 1971—continued.

No.	Price.
8161. Films	\$0.30
8162. Lotteries Gaming and Betting (Pre-Post Betting)	\$0.10
8163. Vegetation and Vine Diseases (Amendment)	\$0.10
8164. Melbourne and Metropolitan Board of Works (Amendment)	\$0.10
8165. Statutory Salaries	\$0.10
8166. Newhaven Land	\$0.10
8167. Land Tax	\$0.10
8168. Water Authorities Accident Insurance	\$0.10
8169. Building Societies (Special Advances)	\$0.10
8170. Juries (Compensation)	\$0.10
8171. Coal Mines (Pensions Increase)	\$0.10
8172. Exhibition (Borrowing Powers)	\$0.10
8173. Sunday Entertainment (Cinematograph Films)	\$0.10
8174. Apprenticeship (Amendment)	\$0.15
8175. Labor and Industry (Shop Trading Hours)	\$0.10
8176. Gift Duty	\$0.50
8177. Aboriginal Lands (Amendment)	\$0.10
8178. Lutheran Church of Australia, Victoria District Incorporation	\$0.40
8179. Police Regulations (Amendment) (No. 2)	\$0.20
8180. Railways (Amendment)	\$0.10
8181. Statute Law Revision	\$0.40
8182. State Electricity Commission (Newport Power Station)	\$0.10
8183. Judges Salaries and Allowances	\$0.10
8184. Magistrates' Courts	\$0.30
8185. Companies	\$2.10
8186. Water (Amendment)	\$0.20
8187. Essendon (Recreation Ground) Land	\$0.10
8188. Brotherhood of St. Laurence (Incorporation)	\$0.30
8189. State Forests Works and Services	\$0.10
8190. Evidence (Boards and Commissions)	\$0.10
8191. Public Authorities (Contributions) (Amendment)	\$0.10
8192. Road Traffic (Penalties)	\$0.10
8193. Grain Elevators (Amendment)	\$0.10
8194. Flinders-street Station Area Redevelopment	\$0.20
8195. Buninyong (Recreation Reserve) Land	\$0.10
8196. Health Services (Fees and Penalties)	\$0.15
8197. Motor Car (Breath Tests)	\$0.10
8198. Instruments (Amendment)	\$0.15
8199. Melbourne Harbor Trust (Amendment)	\$0.15
8200. Revocation and Excision of Crown Reservations	\$0.15
8201. Yarragon Lands Exchange	\$0.10
8202. Gift Duty (Rates and Rebates)	\$0.15
8203. Stamps (Gifts and Settlements)	\$0.10
8204. Eastern Freeway Lands	\$0.15
8205. Land (Surrenders)	\$0.10
8206. Housing (Amendment)	\$0.15
8207. Land (Amendment)	\$0.10
8208. Landlord and Tenant (Amendment)	\$0.20
8209. Racing (Amendment)	\$0.30
8210. National Parks (Amendment)	\$0.30
8211. Labour and Industry (Amendment)	\$0.15
8212. Public Works and Services	\$0.15
8213. Wheat Marketing	\$0.15
8214. Public Works and State Development Committees	\$0.10
8215. Water Supply Works and Services	\$0.30
8216. Bees	\$0.20
8217. Agricultural Colleges (Amendment)	\$0.10
8218. Chiropodists (Registration)	\$0.10
8219. Portland Harbor Trust (Amendment)	\$0.10
8220. Harbor Boards (Amendment)	\$0.10
8221. Veterinary Surgeons (Amendment)	\$0.10
8222. Scaffolding (Amendment)	\$0.10
8223. Stock Diseases (Composite Licences)	\$0.10
8224. Justices (Civil Proceedings)	\$0.10
8225. Closer Settlement	\$0.10
8226. Summary Offences (Amendment)	\$0.10
8227. Sewerage Districts (Amendment)	\$0.10
8228. Evidence (Documents)	\$0.20
8229. Mildura Irrigation & Water Trusts (Amendment)	\$0.10
8230. Farm Produce Merchants & Commission Agents (Employment)	\$0.10
8231. Latrobe Valley (Amendment)	\$0.10
8232. Hire Purchase (Form)	\$0.10
8233. Poisons (Amendment)	\$0.10
8234. Geelong Harbor Trust (Amendment)	\$0.10
8235. Eastern Railway Construction	\$0.15
8236. Milk and Dairy Supervision (Amendment)	\$0.10
8237. Educational Grants (Amendment)	\$0.10
8238. Railway Works and Services	\$0.10
8239. Education (Teacher Registration)	\$0.15
8240. Supply (Final Supplementary Estimates)	\$0.10
8241. Appropriation	\$2.20

C. H. RIXON,
Government Printer.

AGENTS FOR THE "VICTORIA GOVERNMENT
GAZETTE".

The following have been appointed agents to receive Advertisements and Subscriptions for the *Victoria Government Gazette*:—

- ARMSTRONG'S AGENCY, 217 Queen-street, Melbourne, Victoria 3000.
 ARNALL & JACKSON, 390 Barkly-street, Brunswick, Victoria 3056.
 BAIRNSDALE AUTHORIZED NEWSAGENCY, 132 Main-street, Bairnsdale, Victoria 3875.
 BICKNELL, M. J., Authorized Newsagent, 196 Timor-street, Warrnambool, Victoria 3280.
 BLANE'S AUTHORIZED NEWSAGENTS, 162 Murray-street, Colac, Victoria 3250.
 CARTER, R. G., ADVERTISING SERVICE PTY. LTD. Suite 24, 65 Queens-road, Melbourne, Victoria 3004.
 DAVIES, G. & M. V., 112 Gray-street, Hamilton, Victoria 3300
 DAVIS, WM. (MILDURA) PTY. LTD., 126 Eighth-street, Mildura, Victoria 3500.
 DIXON'S NEWSAGENCY, 89 Firebrace-street, Horsham, Victoria 3400.
 EDGARS' AUTHORIZED NEWSAGENCY, 45 Bridge-street, Benalla, Victoria 3672.
 FRANKS, H. & CO., 184 Ryrie-street, Geelong, Victoria 3220.
 GATLEY, A. & J., 250 Lonsdale-street, Dandenong, Victoria 3175.
 GORDON & GOTCH AUSTRALASIA LTD., 434 St. Kilda-road, Melbourne, Victoria 3004.
 GULLAN'S NEWSAGENCY, 88 Bridge-street, Ballarat, Victoria 3350.
 HAMPTON, A. C., 243 Mitchell-street, Bendigo, Victoria 3550.
 HARSTON, PARTRIDGE & CO. PTY. LTD., 455 Little Collins-street, Melbourne, Victoria 3000.
 KYNETON GUARDIAN PTY. LTD., P.O. Box 18, Kyneton, Victoria 3444.
 LATIMER'S, Newsagents, 45 Station-street, Malvern, Victoria 3144.
 LIVINGSTON'S SHEPPARTON NEWSAGENCY, 246 Wyndham-street, Shepparton, Victoria 3630.
 THE MERCANTILE EXCHANGE, 34 Queen-street, Melbourne, Victoria, 3000.
 MCGILL'S AUTHORIZED NEWSAGENCY, 183-5 Elizabeth-street, Melbourne, Victoria 3000.
 POWNEYS AUTHORIZED NEWSAGENCY, 293 Hargreaves-street, Bendigo, Victoria 3550.
 PURDIE, J., & CO., 138 Moorabool-street, Geelong, Victoria 3220.
 SALE AUTHORIZED NEWSAGENCY, 142 Raymond-street, Sale, Victoria 3850.

SKINNER'S AUTHORIZED NEWSAGENCY, 49-51 Franklin-street, Traralgon, Victoria 3844.

STEVENSON, A. C. & M., NEWSAGENTS, 132 Henty-street, Casterton, Victoria 3311.

VANCE'S AUTHORIZED NEWSAGENCY, 83 Murray-street, Wangaratta, 3677.

VERNONS OF RICHMOND, 162 Bridge-road, Richmond, Victoria 3121.

VIEW POINT AUTHORIZED NEWSAGENCY, 4 View-Point, Bendigo, Victoria 3550.

A copy of the *Gazette* filed at each place for public reference.

CONTENTS	PAGE
Acts of Parliament	1222
Acts of Parliament on Sale at the Government Printing Office	1275
Appointments	1232
Companies Act 1961—Notice	1230
Contracts	1231
Courts	1223
Estates of Deceased Persons	1231
Government Notices	1223
Impoundings	1274
Insolvency Notices	1274
Lands	1241
Levee at Parliament House, Melbourne	1221
Mining	1230
Notice to Mariners	1225
Notice of Making of Statutory Rules	1274
Orders in Council—	
Acts—Police Regulation; Portland Harbor Trust; Country Roads; Land; Water; Sewerage Districts; Local Government; Landlord and Tenant.	1233 et seq
Police Sale	1223
Private Advertisements	1251
Proclamations	1222
Public Holiday—Queen's Birthday	1223
Public Service Notices	1249
Regulations—	
Act—Police Regulation	1225
Resignations	1233
Tenders	1248
Transport Regulation Board—Public Hearings	1226
Waterworks Trusts	1230

[1277]



VICTORIA
GOVERNMENT GAZETTE

Published by Authority

No. 33]

WEDNESDAY, MAY 17

[1972

TO THE HONORABLE THE CHIEF SECRETARY.

I HEREBY give you notice that it is my intention, on Friday, the nineteenth day of May, 1972, to issue a Writ for the Election of a Member to serve in the Legislative Council of Victoria for the Melbourne Province.

Dated this third day of May, 1972.

R. W. GARRETT,
President.

1111

1111

1111

1111

1111

1111

1111

1111

1111