



VICTORIA

GOVERNMENT GAZETTE

Published by Authority

No. 48]

WEDNESDAY, JUNE 7

[1972

Government House,
Melbourne, 3004,
3rd June, 1972.

The Queen has graciously been pleased to signify Her Majesty's intention of conferring the following Honours, Decorations and Awards in the Birthday Honours, 1972:—

TO BE KNIGHT BACHELOR.

The Honourable George Oswald Reid, Q.C., LL.B., M.P.

THE MOST DISTINGUISHED ORDER OF SAINT MICHAEL AND SAINT GEORGE

To be a Companion of the Civil Division of the said Most Distinguished Order:

His Honour Judge George Leo Dethridge.

THE MOST EXCELLENT ORDER OF THE BRITISH EMPIRE.

To be a Knight Commander of the Civil Division of the said Most Excellent Order:

The Honourable Gilbert Lawrence Chandler, C.M.G., M.L.C.

To be Commanders of the Civil Division of the said Most Excellent Order:

Wilfred Deakin Brookes, Esquire, D.S.O.
Frederick Ormond Watts, Esquire, F.I.O.B., F.I.A.B.

To be Officers of the Civil Division of the said Most Excellent Order:

Nathan Hirsch Beller, Esquire, J.P.
Councillor Charles Edward Brown.
Doctor John Terence Cahill, M.D., B.S., F.R.A.C.P., F.R.C.P.

Edward Alexander Cato, Esquire.
The Venerable Percival Hensby Dicker, M.A., Th.L., B.D., Dip.Ed.

Councillor James Harvey Hamilton Macgregor Dowsett.
Councillor Norman Joseph Oliver, Ph.C., M.P.S., A.A.S.A., F.A.I.M.
Councillor William Thwaites.

To be Members of the Civil Division of the said Most Excellent Order:

Councillor Percy William Attree.
Mrs. Dorothy Leighton Berry, J.P.
Arnold Roy Blashki, Esquire, B.A., LL.B.
Albert George Davis, Esquire, F.P.S., J.P.
Reginald Frank Hargreaves Dixon, Esquire, M.C.
Mrs. Alice Fletcher, J.P.
Doctor John Claude Moseley Harper, M.C., M.B., B.S.
Arthur Stanley Howard, Esquire.

Benjamin John Hubbard, Esquire, J.P.
Miss Patricia Irene Herschell Jarrett.
Councillor Herbert Aikman Keele.
Councillor Thomas Henry King.
Walter Lawton, Esquire.
John Gerrard Lyons, Esquire.
Cyril John Michelsen, Esquire.
Mrs. Gladys Christlieb Post.
Gordon William Rothacker, Esquire.
Brian Chadwick Seymour, Esquire.
Mrs. Janet Emily Schintler.
Councillor William Henry Sloper.

AWARDS OF THE BRITISH EMPIRE MEDAL.

Alexander Paul Anderson, Esquire.
Miss Lorna Lamont Banfield.
Mrs. Hedwig Benz.
Archie Trevor Bingham, Esquire.
Miss Leline Margaret Cairns-Lloyd, C.St.J.
Lawrence Loader Clavarino, Esquire.
Mrs. Leila Robina Freemantle.
Mrs. Ella Frances Gallagher, A.L.C.M., L.L.C.M.
Miss Eva Veronica Gaspar.
Norman John Grant, Esquire.
Mrs. Jessie May Green.
Jack Grut, Esquire, F.I.M.A.
Captain Alan McGregor Harris.
Ernest Henderson, Esquire.
Miss Christina Lorne Hood.
Mrs. Dorothy Homann.
Thomas Vincent Landy, Esquire, A.A.S.A., A.C.I.S.
Ernest William Lawn, Esquire.
Robert Alexander McAlpine, Esquire, J.P.
William Norman Melrose, Esquire.
George McIsaac Thomas Morrish, Esquire.
Richard Nicholas, Esquire.
Miss Estelle Agnes Rennie.
Mrs. Mabel Emma Skelton.
Miss Ellen Margaret Taylor.
Mrs. Annie Wormes.

AWARDS OF THE QUEEN'S POLICE MEDAL.

Chief Superintendent William Charles Woods.
Chief Superintendent Frederick Taylor Kennedy.
Superintendent Michael Hanley.
Superintendent Oswald Henry Beever.
Chief Inspector Alexander Leslie Buckler.
Senior Constable Herbert Ray Morshead.

AWARD OF THE QUEEN'S FIRE SERVICE MEDAL.

Chief Officer Frank Edward Tuono.

J. ROSSITER,
Official Secretary to the Governor.

PROCLAMATIONS

Land Act 1958.

TOWNSHIP OF YARROWEYAH NORTH ALTERED TO TOWNSHIP OF KOONOOMOO.

PROCLAMATION

By His Excellency the Governor of the State of Victoria and its Dependencies in the Commonwealth of Australia, &c., &c., &c.

I, the Governor of the State of Victoria, in the Commonwealth of Australia, by and with the advice of the Executive Council of the said State, and in pursuance of the provisions of section 25 (3) (a) of the *Land Act 1958*, do by this my Proclamation order that the Township of Yarroweyah North in the Parish of Yarroweyah, the boundaries of which were defined by Proclamation, dated the 18th December, 1885 (see *Government Gazette* of 1885, page 3576) shall be distinguished by the name of Koonoomoo.—(K.136⁽²⁾) (Y.111⁽²⁾) (C.95742).

Given under my Hand and Seal of the State of Victoria, aforesaid, at Melbourne, this thirtieth day of May, in the year of our Lord One thousand nine hundred and seventy-two, and in the twenty-first year of the reign of Her Majesty Queen Elizabeth II.

(L.S.) ROHAN DELACOMBE.

By His Excellency's Command,
W. BORTHWICK,
Minister of Lands.

GOD SAVE THE QUEEN!

Marine Act 1958.

AMENDMENT TO PORT RULE APPLICABLE TO WESTERNPORT HARBOR SERVICES (RATES AND CHARGES).

PORT RULE No. 132.

PROCLAMATION

By His Excellency the Governor of the State of Victoria and its Dependencies in the Commonwealth of Australia, &c., &c., &c.

Whereas by Part II. of the *Marine Act 1958* it is amongst other things enacted that the Governor in Council by Proclamation published in the *Government Gazette*, may from time to time define the limits and boundaries of ports in Victoria and frame rules and regulations for the governance and preservation of the said ports respectively and for the regulation of shipping in the same (including the imposition of charges for the use of mooring sites and other facilities):

And that any such regulation may from time to time be in like manner altered, amended or repealed and others substituted in their stead:

Now, therefore, I, the Governor of the State of Victoria in the Commonwealth of Australia by and with the advice of the Executive Council thereof, and in the exercise of the powers conferred by the said Act, by this Proclamation do hereby amend the Proclamation, dated the 31st day of May, 1966, as follows:—

Delete the proviso added at the end of the schedule to Clause 2 by amendment dated 23rd November, 1971, and substitute therefor the following:—

“Provided that during the period between the 1st June, 1972 and 31st August, 1972, both dates inclusive, the tolls, rates or charges set forth in paragraphs (A), (B), (C) and (D) of this schedule shall be reduced by 50 per cent., unless the Governor in Council by proclamation determines otherwise.”

Given under my Hand and the Seal of the State of Victoria aforesaid, at Melbourne, this thirtieth day of May, in the year of our Lord One thousand nine hundred and seventy-two, and in the twenty-first year of the reign of Her Majesty Queen Elizabeth II.

(L.S.) ROHAN DELACOMBE.

By His Excellency's Command,
MURRAY BYRNE,
Minister of Public Works.

GOD SAVE THE QUEEN!

Marine Act 1958.

PORT RULE (PORT PHILLIP BAY UNDERWATER PIPELINE OPERATIONS) 1972.

PROCLAMATION

By His Excellency the Governor of the State of Victoria and its Dependencies in the Commonwealth of Australia, &c., &c., &c.

Whereas by Part II. of the *Marine Act 1958* it is amongst other things enacted that the Governor in Council by Proclamation published in the *Government Gazette*, may from time to time define the limits and boundaries of ports in Victoria and frame rules and regulations for the governance and preservation of the said ports and for the regulation of shipping in the same:

Whereas by Proclamation of the Governor in Council published in the *Government Gazette* on the 26th day of October 1960 in pursuance of the provisions of the said Part II. the limits and boundaries of the Port of Port Phillip were defined for the purposes of the said Act:

Whereas dredging works and the laying of an underwater ethane gas pipeline are about to commence on the bed of Port Phillip Bay on a line between a point in latitude 38 deg. 00 min. 00 sec. south, longitude 145 deg. 00 min. 00 sec. east and a point in latitude 37 deg. 56 min. 12 sec. south, longitude 144 deg. 53 min. 36 sec. east and large vessels having draught limitations will have difficulties in manoeuvring when navigating in the waters of the Port of Port Phillip adjacent to the portion of the bed of Port Phillip where those works are from time to time being carried out:

And whereas in accordance with the provisions of Rule 30 of the Regulations for Preventing Collisions at Sea for the time being in force under section 127 of the *Marine Act 1958* nothing in those regulations shall interfere with the operation of a special rule relative to the navigation of any harbour, river, lake, or inland water:

Now, therefore, I, the Governor of the State of Victoria in the Commonwealth of Australia, by and with the advice of the Executive Council thereof and in exercise of the powers conferred by the said Act and all other powers hereunto enabling by this my Proclamation do hereby make the following addition to the Port Rules as a special rule within the meaning of Rule 30 of the Regulations for Preventing Collisions at Sea, that is to say:—

1. This Rule may be cited as Port Rule (Port Phillip Bay Underwater Pipeline Operations) 1972 and shall be numbered Port Rule 55A.

2. Whilst the bucket dredger “A.D. Victoria” and the pipe-laying barge “Beaver” are engaged upon the said works in the waters of the Port of Port Phillip the master of every vessel of less than 500 tons gross, whether power driven or under sail, shall give way to vessels of 500 tons gross and over whilst navigating in the waters of the Port of Port Phillip within three miles of the said bucket dredger or pipe-laying barge but the provisions of the Regulations for Preventing Collisions at Sea shall otherwise remain in full force and effect.

Given under my Hand and the Seal of the State of Victoria aforesaid, at Melbourne, this thirtieth day of May, in the year of our Lord One thousand nine hundred and seventy-two, and in the twenty-first year of the reign of Her Majesty Queen Elizabeth II.

(L.S.) ROHAN DELACOMBE.

By His Excellency's Command,
MURRAY BYRNE,
Minister of Public Works.

GOD SAVE THE QUEEN!

MOTOR CAR (AMENDMENT) ACT 1972, No. 8279.

DATE OF COMING INTO OPERATION.

PROCLAMATION

By His Excellency the Governor of the State of Victoria and its Dependencies in the Commonwealth of Australia, &c., &c., &c.

Whereas by an Act of Parliament of the State of Victoria passed in the twenty-first year of the reign of Her Majesty Queen Elizabeth II entitled the *Motor Car (Amendment) Act 1972* (No. 8279) it is amongst other things enacted that the several provisions of the said Act shall come into operation on a day or the respective days

to be fixed by proclamation or successive proclamations of the Governor in Council published in the *Government Gazette*.

Now therefore I, the Governor of the State of Victoria in the Commonwealth of Australia, by and with the advice of the Executive Council of the said State, do by this my proclamation fix Tuesday the thirteenth day of June, One thousand nine hundred and seventy-two as the day on which section 3 of the said *Motor Car (Amendment) Act 1972*, shall come into operation.

Given under my Hand and the Seal of the State of Victoria aforesaid, at Melbourne, this sixth day of June, in the year of our Lord One thousand nine hundred and seventy-two, and in the twenty-first year of the reign of Her Majesty Queen Elizabeth II.

(L.S.) ROHAN DELACOMBE,
By His Excellency's Command,
R. J. HAMER,
Chief Secretary.

GOD SAVE THE QUEEN!

MOTOR CAR (AMENDMENT) ACT 1972, No. 8279.
DATE OF COMING INTO OPERATION.

PROCLAMATION

By His Excellency the Governor of the State of Victoria and its Dependencies in the Commonwealth of Australia, &c., &c., &c.

Whereas by an Act of Parliament of the State of Victoria passed in the twenty-first year of the reign of Her Majesty Queen Elizabeth II entitled the *Motor Car (Amendment) Act 1972* (No. 8279), it is amongst other things enacted that the several provisions of the said Act shall come into operation on a day or the respective days to be fixed by proclamation or successive proclamations of the Governor in Council published in the *Government Gazette*.

Now therefore I, the Governor of the State of Victoria in the Commonwealth of Australia, by and with the advice of the Executive Council of the said State, do by this my proclamation fix Wednesday the seventh day of June, One thousand nine hundred and seventy-two as the day on which sections 4 to 11 inclusive of the said *Motor Car (Amendment) Act 1972*, shall come into operation.

Given under my Hand and the Seal of the State of Victoria aforesaid, at Melbourne, this sixth day of June, in the year of our Lord One thousand nine hundred and seventy-two, and in the twenty-first year of the reign of Her Majesty Queen Elizabeth II.

(L.S.) ROHAN DELACOMBE,
By His Excellency's Command,
L. H. S. THOMPSON,
for Chief Secretary.

GOD SAVE THE QUEEN!

COUNTRY FIRE AUTHORITY (AMENDMENT) ACT
1972, No. 8257.
DATE OF COMING INTO OPERATION.

PROCLAMATION

By His Excellency the Governor of the State of Victoria and its Dependencies in the Commonwealth of Australia, &c., &c., &c.

Whereas by an Act of Parliament of the State of Victoria, in the Commonwealth of Australia, passed in the twenty-first year of the reign of Her Majesty Queen Elizabeth II entitled the *Country Fire Authority (Amendment) Act 1972* (No. 8257), it is amongst other things enacted that the several provisions of the said Act shall come into operation on a day or respective days to be fixed by proclamation or successive proclamations of the Governor in Council published in the *Government Gazette*:

Now therefore I, the Governor of the State of Victoria in the Commonwealth of Australia, by and with the advice of the Executive Council of the said State, do by this my Proclamation fix Wednesday the Seventh day of June, One thousand nine hundred and seventy-two as the day on which sections 4, 7, 8, 9, 10, 11, 13 and 14 of the said *Country Fire Authority (Amendment) Act 1972*, shall come into operation.

Given under my Hand and the Seal of the State of Victoria aforesaid, at Melbourne, this sixth day of June, in the year of our Lord One thousand nine

hundred and seventy-two, and in the twenty-first year of the reign of Her Majesty Queen Elizabeth II.

(L.S.) ROHAN DELACOMBE,
By His Excellency's Command,
L. H. S. THOMPSON,
for Chief Secretary.

GOD SAVE THE QUEEN!

BANK HALF-HOLIDAY.

PROCLAMATION

By His Excellency the Governor of the State of Victoria and its Dependencies in the Commonwealth of Australia, &c., &c., &c.

In pursuance of the provisions of the *Bank Holidays Act 1958*, I, the Governor of the State of Victoria, in the Commonwealth of Australia, do by this my Proclamation appoint the day and date named hereunder a special day to be observed as a Bank Half-Holiday at the place mentioned, that is to say:—

Bank Half-Holiday from the Hour of Eleven o'clock a.m.
FRIDAY, THE 16TH JUNE, 1972, at Donald and Watchem.

Given under my Hand and the Seal of the State of Victoria aforesaid, at Melbourne, this sixth day of June, in the year of our Lord One thousand nine hundred and seventy-two, and in the twenty-first year of the reign of Her Majesty Queen Elizabeth II.

(L.S.) ROHAN DELACOMBE,
By His Excellency's Command,
IAN SMITH,
for Chief Secretary.

GOD SAVE THE QUEEN!

GOVERNMENT NOTICES

PUBLIC HOLIDAY.—QUEEN'S BIRTHDAY.

It is hereby notified that on—

MONDAY, THE 12TH JUNE, 1972,

the Public Offices will be closed, such day having been appointed by the *Public Service Act 1958*, to be observed as a holiday in the Public Offices throughout the State of Victoria.

This notice relates only to the closing of the State Public Offices. All inquiries regarding the holiday in other offices and in shops and industry should be directed to the Department of Labour and Industry, 110 Exhibition-street, Melbourne, 3000. (Telephone 651 6158 or 651 6859).

R. J. HAMER,
Chief Secretary.

Chief Secretary's Office,
Melbourne, 11th May, 1972.

Cattle Compensation Act 1967 (No. 7615).

APPROVED AGENT.

NOTICE UNDER SECTION 14.

I hereby declare Graham Bryant Robertson and Nancy Emma Robertson, trading as "G. R. Robertson & Co.", (Number C.S.-67 in the Register), being a person carrying on business as a stock and station agent, to be an "approved agent" for the purposes of Part II. of the *Cattle Compensation Act 1967* with effect from Thursday, 1st June, 1971.

R. M. PHIBBS,
Comptroller of Stamps.

Stamp Duties Office,
Melbourne, 7th June, 1972.

Co-operation Act 1958.

BUNDOORA TENNIS CLUB CO-OPERATIVE LIMITED. NOTICE OF DISSOLUTION OF SOCIETY.

Notice is hereby given that I have this day registered the dissolution of the above-named society and cancelled its registration under the above-named Act.

Dated at Melbourne this 22nd day of May, 1972.

R. F. SCOLLARD,
Deputy Registrar of Co-operative Societies.

Transport Regulation Act.
TRANSPORT REGULATION BOARD.

Hearing of Applications.

Notice is hereby given that the following applications will be considered by the Transport Regulation Board at its offices at the corner of Lygon and Princes-streets, Carlton, at 10.15 a.m. on Wednesday, 28th June, 1972.

GRENDAS BUS SERVICES, 9 Foster-street, Dandenong. Application for variation of existing licence conditions on T.O.57 and T.O.58 to include the ability to operate the following weekend tours:—

Grampians and Wimmera.—Bourke, Russell, Victoria and Elizabeth-streets, Flemington, Racecourse and Ballarat-roads, Western Highway to Ballarat. Short tour of Ballarat including Sovereign Hill, Lake Wendouree and the Gardens. Lunch at Ballarat. Afternoon travel via Glenelg Highway to Dunkeld; then through the Victoria Valley to Halls Gap, Zumsteins, McKenzie Falls to Horsham. Overnight Horsham. Travel via Murtoa and Rupanyup to Stawell and to Great Western for inspection of vineyards and cellars. Lunch at Ararat. Continue along the Western Highway to Ballarat, and on to Melbourne as per outbound route. All inclusive fare to be determined.

Warrnambool and the Southern Ocean.—Bourke, Russell, Victoria and Elizabeth-streets, Flemington, Racecourse and Geelong-roads, Princes Highway to Geelong. Short tour of Geelong including Eastern Beach and Ceres Lookout. Travel via Princes Highway to Colac for lunch. Afternoon travel via Cobden, Port Campbell, Peterborough and Allansford to Warrnambool. Overnight at Warrnambool. Tour of Warrnambool district; then return via Princes Highway to Warrcoort; then via Deans Marsh to Lorne. Lunch at Lorne. Afternoon travel via the Great Ocean-road to Anglesea, and to Geelong, returning to Melbourne as per the outbound route. All inclusive fare to be determined.

Lakes Entrance.—Bourke, Russell and Flinders-streets, Princes Bridge, St. Kilda and Dandenong-roads, Princes Highway. Lunch at Sale. Afternoon travel to Bairnsdale and Lakes Entrance calling at Metung. Overnight at Lakes Entrance. Travel via Bairnsdale and Sale; then via the South Gippsland Highway to Dandenong, with lunch at Yarram. Travel from Dandenong via Dandenong, Belgrave, Malvern and Tooronga-roads, South Eastern Freeway, Punt-road, Brunton-avenue, Wellington-road, Flinders, Exhibition and Bourke-streets. All inclusive fare to be determined.

Central and South Gippsland.—Bourke, Russell and Flinders-streets, Princes Bridge, St. Kilda and Dandenong-roads, Princes Highway to Moe; then via Newborough, Coach-road Lookout, Yallourn, to Morwell. Lunch at Morwell. Return to Moe and travel to Wallhalla. Overnight at Morwell. Travel to Traralgon and Tarra Valley; then to Churchill and Morwell Open Cut. Lunch at Morwell. Travel through Mirboo North to Leongatha, South Gippsland Highway to Dandenong, returning to Melbourne via Dandenong, Belgrave, Malvern and Tooronga-roads, South Eastern Freeway, Punt-road, Brunton-avenue, Flinders, Exhibition and Bourke-streets. All inclusive fare to be determined.

COOK, I. J., & SON PTY. LTD., 321 Autumn-street, Herne Hill. One commercial passenger vehicle (S/C. 45) to operate as an additional urban omnibus under the same terms and conditions as existing U.O. licensed vehicle held by the applicant company.

CHAMPION, J. A. & H. M., 66 Shadforth-street, Kerang. Application for variation of licence C.O.762 to include the ability to operate an additional service between Kerang and Barham on Monday to Saturdays.

TIME-TABLE.

Depart Kerang	9.40 a.m.
Arrive Barham	10.10 a.m.
Depart Barham	10.30 a.m.
Arrive Kerang	11.00 a.m.

PINCINI, E. J. & L., 40 McIntosh-street, Airport West. One commercial passenger vehicle (S/C. 41) to operate for the carriage of school children only between Melton and Bacchus Marsh under contract to the Education Department and also to undertake charter hirings from Melton.

RENEWALS.

Application for renewal of licences as shown, by persons listed hereunder to operate under the same terms and conditions.

BONO, F., PTY. LTD., 53 Wattle-road, Maidstone; M.C.14.
BROADMEADOWS BUS CHARTER PTY. LTD., 145 Lynch-road, Fawkner; M.C.404, M.C.503, M.C.504.

HITCHCOCK, S. G., 303 Frankston-road, Shoreham; T.S.561, T.S.554.

KHANCOBAN SPRING CREEK SCHOOL, C/o P.O. Box 17, Corryong; C.O.27.

LLOYD, L. C. & R. M., Towong-road, Corryong; T.S.251.

MARTIN, J. K., Stumpy Gully-road, Balnarring; T.S.555.

MIDLAND TOURS PTY. LTD., 907A High-street, Reservoir; M.C.522.

MYER MELBOURNE LTD., 314-336 Bourke-street, Melbourne; T.P.26, T.P.91.

MCGEARY'S PARLOR COACHES PTY. LTD., 207 New-street, Brighton; M.C.274.

NIXON, W. E., D. J., & W. B. (trading as Thomsons Road-liners), 326 Bell-street, Preston; M.C.249.

PINCINI, E. J. & L., PTY. LTD., 40 McIntosh-street, Airport West; M.C.410; M.C.413.

PROVINCIAL TRADERS LTD., Forsyth-road, Laverton; T.P.114.

QUINCE'S SCENICRUISERS PTY. LTD., 64 Ardyne-street, Mur-rumbeena; M.C.514, M.C.520, M.C.533.

RIVES, P. H., PTY. LTD., corner Pipe and Raymond-roads, Derrimut; T.P.125.

RUSSELL, V. E. (Mrs.), 656 Bell-street, Pascoe Vale South; T.P.31.

SMITH, N. M., & SUHR, L. T., 559 Centre-road, Bentleigh; M.C.251.

THE OLYMPIC TYRE & RUBBER CO. PTY. LTD., 68 Cross-street, West Footscray; T.P.96.

Notice of any objection should be forwarded to reach the Secretary of the Board not later than Wednesday, 21st June, 1972.

Applicants are advised that it will not be necessary to appear on the hearing date specified above, unless advised in writing by the Board.

B. P. KAY,
Secretary.

Corner Lygon and Princes streets, Carlton, Wednesday, 7th June, 1972.

Commercial Goods Vehicles Act.
TRANSPORT REGULATION BOARD.

HEARING OF APPLICATIONS.

Notice is hereby given that the following applications will be considered by the Transport Regulation Board at its offices at the corner Lygon and Princes streets, Carlton, at 10 a.m., on Wednesday, 28th June, 1972.

ANDERSON, K. M., 6 Luke-street, Stawell, 3380. One commercial goods vehicle (L/C. 114 cwt.) to operate within a 50-mile radius of the chief post office at Stawell in the course of business as "Builder"—own goods.

ANTICH, S., 49 Lawley-street, Reservoir, 3073. One commercial goods vehicle (L/C. 156 cwt.) to operate within a 50-mile radius of the premises of Albion Reid Pty. Ltd. at North Melbourne on behalf of the said company—road-making plant, hot asphalt, pre-mix and road-making materials but excluding the carriage of cement and lime from places within an 8-mile radius of the chief post office in the City of Geelong.

AUSTRALIAN MOTOR INDUSTRIES LTD., 155 Bertie-street, Port Melbourne, 3207. One commercial goods vehicle (L/C. 8 cwt.) to operate throughout the State of Victoria in the course of business as "Motor Vehicle and Tractor Distributors"—tools of trade, equipment and spare parts incidental to the servicing and repair of tractors, in the field only.

CARRODUS, J. B., 32 Hourigan-road, Morwell, 3840. One commercial goods vehicle (L/C. 14 cwt.) to operate: (a) To consignees situated in that part of the State of Victoria east of a north/south line drawn through the Township of Warragul in the course of business as "Frozen Foods Distributor"—frozen foods and fresh cream. (b) Within a 20-mile radius of the post office at Morwell in the course of business as "Bread Distributor"—own bread.

THOMPSON, E. J. & P. (trading as Castlemaine Funeral Parlors), 12 Mostyn-street, Castlemaine, 3450. One commercial goods vehicle (L/C. 11 cwt.) to operate throughout the State of Victoria in the course of business as "Funeral Directors"—as a mortuary vehicle.

CORNISH, R. W., 156 Collier-crescent, West Brunswick, 3055. One commercial goods vehicle (L/C. 196 cwt.) to operate within a 50-mile radius of the premises of Ready Mixed Concrete (Vic.) Pty. Ltd. situated at Broadmeadows solely on behalf of the said company—premixed concrete in a specially constructed agitator vehicle.

- CUPPENS, P. M. 109 Haldane-road, Niddrie, 3042. One commercial goods vehicle (L/C. 270 cwt.) to operate within a 35-mile radius of the G.P.O., Melbourne, on behalf of Albion-Reid Pty. Ltd.—sand, soil, screenings, premix and quarry products.
- DONALD, R. S., 14 Verbena-street, Mordialloc, 3195. One commercial goods vehicle (L/C. 140 cwt.) to operate: (a) Within a 25-mile radius from the post office at Mordialloc—general goods provided that no goods shall be carried whether by one stage or by more than one stage between places within the above radius which are situated more than 30 road miles apart by the nearest practicable route. (b) Within a 70-mile radius from the premises of Star Roofing Tile Works Pty. Ltd. at Hignett—roofing tiles, roof battens and tile fixing materials.
- EAGLAND, K., 151 Greensborough-road, Macleod, 3085. One commercial goods vehicle (L/C. 208 cwt.) to operate within a 35-mile radius of the G.P.O., Melbourne, on behalf of The Ready Mix Group (Vic.)—sand, soil, screenings, premix and quarry products.
- EAGLAND, T. K., 151 Greensborough-road Macleod, 3085. One commercial goods vehicle (L/C. 222 cwt.) to operate within a 35-mile radius of the G.P.O., Melbourne, on behalf of The Ready Mix Group (Vic.)—sand, soil, screenings, premix and quarry products.
- EARTHLIFT PTY. LTD., 5 Rosebank-avenue, Ringwood, 3134. One commercial goods vehicle (L/C. 227 cwt.) to operate throughout the State of Victoria in the course of business as "Earth-moving Contractor"—own earth-moving plant and own earth-moving equipment and own tools of trade.
- FATCHEN, P. R., H. M. & J. E. (trading as Fatchen Transport), 13 Albert-street, Kilmore, 3601. Application to vary the conditions of licence No. D.A.65052/2 (L/C. 134 cwt.) by adding additional paragraphs (c) and (d)—(c) From sawmill of R. H. Ennis at Tallaroek to the premises of C. F. Clancy at Kilmore—sawn timber. (d) From own premises at Kilmore to A.P.M. Ltd. at Broadford—scrap paper."
- FAYLE'S MOTORS PTY. LTD., 65 Clifton-street, North Balwyn, 3104. One commercial goods vehicle (L/C. 246 cwt.) to operate within a 30-mile radius of the premises of Consolidated Quarries Ltd. at Dromana on behalf of the said company—sand, soil, screenings, premix and quarry products.
- FIRESTONE AUST. PTY. LTD., Melbourne-road, Wodonga, 3690. One commercial goods vehicle (L/C. 14 cwt.) to operate within a 50-mile radius of own branch premises at Wodonga and from and to Wodonga to and from Corryong in the course of business as "New and Second-hand Tyre and Car Accessory Distributors"—tyres and tubes for sale and delivery, used tyres for repair or retreading or having been repaired or retreaded, also batteries, oil, motor car accessories and polythene piping.
- GARVIN, J., 38 Leven-street, Essendon, 3040. One commercial goods vehicle (L/C. 245 cwt.) to operate within a 35-mile radius of G.P.O., Melbourne on behalf of Consolidated Quarries Ltd.—sand, soil, screenings, premix and quarry products.
- GILMORE, E. A., 142 Pigdon-street, North Carlton, 3054. One commercial goods vehicle (L/C. 20 cwt.) to operate throughout the State of Victoria in the course of business as "Marine Collector"—special wares, marine stores and old metals as defined in the *Marine Stores and Old Metals Act 1958* (No. 6303), Part 1, section 3, provided that the combined load capacity of the prime mover and any trailer attached thereto does not exceed 120 cwt.
- GOETZ, O., 90 Hawthorn-road, North Caulfield, 3161. Application to vary the conditions of licence No. D.A.59937 (L/C. 11 cwt.) by deleting paragraph (b) from the existing conditions.
- HEGGE, J., 1 Garnett-street, Huntingdale, 3166. One commercial goods vehicle (L/C. 30 cwt.) to operate throughout the State of Victoria in the course of business as "Marine Dealer"—special wares, marine stores and old metals as defined in the *Marine Stores and Old Metals Act 1958* (No. 6303), Part I, section 3, provided that the combined load capacities of the prime mover and any trailer attached thereto does not exceed 120 cwt.
- HITCHINGS, G. S., Irrewarra, 3244. One commercial goods vehicle (L/C. 140 cwt.) to operate: (a) Within a 50-mile radius from the post office at Irrewarra as a "Road Contractor"—road-making plant and materials. (b) Within a 25-mile radius of the post office at Irrewarra provided that no goods shall be carried whether by one stage or by more than one stage between places within the above radius which are more than thirty (30) miles apart by the nearest practicable route—general goods.
- HUNTER, LEN, TRADING CO. PTY. LTD., 7-13 Bute-street, Footscray, 3011. One commercial goods vehicle (L/C. 20 cwt.) to operate within a 50-mile radius of own branch premises at Horsham and to the towns of Edenhope, St. Arnaud and the City of Ararat and places en route in course of business as "Wholesale Distributors"—own goods with the proviso that all goods are initially consigned by rail to Horsham.
- KINCH-FORD PTY. LTD., Box 53, Timboon, 3268. One commercial goods vehicle (L/C. 10 cwt.) to operate within a 70-mile radius of own premises at Timboon in the course of business as "Farm Machinery Distributors and Servicing Specialists"—tools of trade and spare parts incidental thereto, farm machinery for repair or having been repaired, also second-hand traded-in machinery and also new machinery for delivery and/or installation subject to the condition that all new machinery and all spare parts carried on the vehicle shall have been initially consigned by rail to Timboon.
- MATTHEWS, A. A., & SONS PTY. LTD., 98 Queens-road, Warrnambool, 3280. One commercial goods vehicle (L/C. 253 cwt.) to operate: (a) Within a 50-mile radius from the post office at Warrnambool—plant the property of a contractor and required by him for use in connexion with the construction or maintenance of some specific, existing or proposed road, street, footpath, bridge, pier, wharf, weir or channel and also the following materials viz: metal, stones, screenings, ashes, gravel, sand and earth. (b) Within a 20-mile radius from the site of any construction or maintenance work performed pursuant to paragraph (a) above, or from the railway station nearest thereto—any other materials required for such work. (c) Within a 20-mile radius from the post office at Warrnambool—general goods excluding any plant or materials carried or to be carried pursuant to paragraphs (a) and (b) above. (d) From pits or quarries at Stawell, Horsham, Creswick, Castlemaine and Bacchus Marsh to own approved decentralized secondary industry (concrete products) at Warrnambool—raw materials, viz.: quartz and gravel for use in such industry. (e) From the premises of own approved decentralized secondary industry (concrete products) at Warrnambool to places west of a north/south line drawn through Melbourne but including places within a 25-mile radius of Melbourne—own manufactured products.
- MCCORKELL, R. J. 76 Harris-road, Elliminyt, 3249. Two commercial goods vehicles (L/C. 180 and 170 cwt.) to operate within a 50-mile radius of the post office at Elliminyt—own premixed concrete in a specially constructed agitator vehicle.
- OAKLEIGH BRICK CO. PTY. LTD., 78 Dawson-street, Brunswick, 3056. One commercial goods vehicle (L/C. 220 cwt.) to operate: (a) Within a 20-mile radius of own premises at Oakleigh, in the course of business as Brick Manufacturers—own goods. (b) Within a 70-mile radius of own premises at Oakleigh, in the course of business as "Brick Manufacturers"—own bricks.
- PAYNE, T. I., Box 19, Edenhope, 3318. One commercial goods vehicle (L/C. 112 cwt.) to operate: (a) Within a 25-mile radius of the post office at Edenhope—general goods, provided that no goods shall be carried whether by one stage or by more than one stage between places within the above radius which are more than thirty (30) miles apart by the nearest practicable route. (b) Within a 50-mile radius of the depot of Amoco (Aust.) Pty. Ltd. at Edenhope and to and from the Amoco (Aust.) Pty. Ltd. depot at Horsham—petroleum products in prescribed types of containers and empty containers for return.
- PEACHY, G. W., 36 Elvin-street, Mansfield, 3722. One commercial goods vehicle (L/C. 262 cwt.) to operate from forest landings situated within a 50-mile radius of the post office at Mansfield to sawmills at Mansfield and Benalla—sawmill logs.
- PEAKIN, D. (trading as Peakin Plant Hire), 9 Phillip-street, Springvale North, 3170. One commercial goods vehicle (L/C. 199 cwt.) to operate within a 50-mile radius of the premises of Ready Mixed Concrete (Vic.) Pty. Ltd. situated at Dandenong—solely on behalf of the said company—premixed concrete in a specially constructed agitator vehicle.
- PIZZETTY LTD., 410 Whitehorse-road, Mitcham, 3132. Two commercial goods vehicles (L/C. 10 and 14 cwt.) to operate: (a) Within a 50-mile radius from own

premises at Mitcham in the course of business as "Merchants, Manufacturers and Distributors"—own goods. (b) Throughout the State of Victoria as manufacturers of agricultural machinery, for the purpose of servicing and demonstrating Agricultural Equipment—agricultural equipment for demonstration or for repair or having been repaired, also tools of trade, spare parts and materials required for servicing such equipment in the field only.

RAWSON, R. G., Powers-road, Merrijig, 3723. One commercial goods vehicle (L/C. 69 cwt.) to operate within a 50-mile radius of the post office at Mansfield in the course of business as a "Primary Producer and Builder"—own goods.

RETALLICK, W., 15 Francis-crescent, Ballarat East, 3350. One commercial goods vehicle (L/C. 30 cwt.) to operate throughout the State of Victoria in the course of business as "Marine Collector"—marine stores and old metals as defined in the *Marine Stores and Old Metals Act 1958* (No. 6303), but excluding the carriage of such goods to wharves, docks or ships for shipment or export purposes and also provided that the combined load capacity of the prime mover and any trailer attached thereto shall not exceed 120 cwt.

RENEWALS.

Applications for renewal of licences as shown by persons listed hereunder to operate under the same terms and conditions from the expiry shown in each case.

KISS, J. (trading as A.B.C. Weed Control), 15 Walker-street, Doncaster, 3108; D.A.62231; 30th September, 1972; 50 cwt.

KISS, J. (trading as Agra Weed Control), 15 Walker-street, Doncaster, 3108; D.A.62230/3; 30th September, 1972; 50 cwt.; D.A.62230/4; 30th September, 1972; 50 cwt.

AUSTRALIAN PAPER MANUFACTURERS LTD., South Gate, South Melbourne, 3205; D.A.569/24; 5th October, 1972; 14 cwt.

BARCA, J., 43 Renee-street, East Preston, 3072; D.A.40741; 17th October, 1972; 142 cwt.

BENDIGO DELUXE CATERING SERVICE PTY. LTD., 27 Queen-street, Bendigo, 3550; D.A.30962/4; 14th November, 1972; 43 cwt.

CECIL, G. L., Drouin-road, Poowong, 3988; D.A.53504; 5th October, 1972; 144 cwt.

DEWIT, B. T., 159 Police-road, Mulgrave, 3170; D.A.53689; 19th October, 1972; 8 cwt.

DUNKLEY, D., 7 Gardiner-street, Berwick, 3806; D.A.53411; 5th October, 1972; 149 cwt.

MURRAY, M. F., & H. G., W. H., G. F., & R. K., FEARY (trading as W. G. Feary & Sons), 189 Eureka-street, Ballarat, 3350; D.A.1065; 15th November, 1972; 17 cwt.

FINCHETT, E. W., 127 French-street, Hamilton, 3300; D.A.28883; 22nd October, 1972; 11 cwt.

FINK, W. A., Frankston-road, Carrum Downs, 3200; D.A.53714; 26th October, 1972; 18 cwt.

FRASCA, J., Myrree, 3732; D.A.41473/1; 5th October, 1972; 110 cwt.

GARNER, A. J. & N. I., Wayside Delivery, Colac, 3250; D.A.53155; 5th October, 1972; 132 cwt.

MCKEON, E. J. (trading as Geelong Laundry Co.), 25-27 Austin-street, Newtown, 3220; D.A.30311/2; 29th October, 1972; 8 cwt.

GORMAN, R. W., Box 38, Alexandra, 3714; D.A.16536/2; 26th October, 1972; 33 cwt.; D.A.16536/3; 26th October, 1972; 30 cwt.

GUSELI, P. (trading as A. Guseli & Sons), 9 Clifton-street, Shepparton, 3630; D.A.60456/1; 12th August, 1972; 13 cwt.; D.A.60456/2; 12th August, 1972; 8 cwt.

HOUGHTON & BYRNE (VIC.) PTY. LTD., 22 Nicholson-street, East Brunswick, 3057; D.A.43077/10; 19th October, 1972; 23 cwt.; D.A.43077/11; 19th October, 1972; 23 cwt.

INTERNATIONAL HARVESTER CO. OF AUST. PTY. LTD., North Shore, Geelong, 3215; D.A.1351/83; 18th November, 1972; 131 cwt.

JACKSON, E., 48 Willonga-street, Strathmore, 3041; D.A.53036; 5th October, 1972; 164 cwt.

JACKSON, J., 48 Willonga-street, Strathmore, 3041; D.A.53033; 5th October, 1972; 133 cwt.

JELERIC, V., 12 Butler-street, Seymour, 3660; D.A.40860; 7th November, 1972; 92 cwt.

JOHNS & WAYGOOD LTD., 406 City-road, South Melbourne, 3205; D.A.40523/9; 5th October, 1972; 228 cwt.

LEECH, A. G., PTY. LTD., 62 Nolan-street, Maryborough, 3465; D.A.1482/3; 8th November, 1972; 113 cwt.

LEECH, A. G., PTY. LTD., 62 Nolan-street, Maryborough, 3465; D.A.1482/5; 8th November, 1972; 76 cwt.

LUDBROOK, J. H., 59 Melbourne-road, Ballarat East, 3350; D.A.40863; 7th November, 1972; 8 cwt.

MIDLAND BRICK CO. LTD., Benalla-road, Shepparton, 3630; D.A.45839/2; 30th September, 1972; 76 cwt.; D.A.45839/3; 30th September, 1972; 268 cwt.; D.A.45839/4; 30th September, 1972; 22 cwt.

MURRAY, T. M. J. (trading as Murray Van Lines Shepparton), Box 806, Shepparton, 3630; D.A.62137; 30th September, 1972; 79 cwt.

MCCRAITH REFRIGERATION SERVICE PTY. LTD., 491 Keilor-road, Niddrie, 3042; D.A.42638/1; 17th October, 1972; 13 cwt.

PITTS, J. W. (trading as Narbethong Service Station), Maroondah Highway, Narbethong, 3778; D.A.45599/2; 5th October, 1972; 20 cwt.

NEAL, A. R., PTY. LTD., 484 Heidelberg-road, Fairfield, 3078; D.A.53732; 5th October, 1972; 254 cwt.; D.A.53732/1; 5th October, 1972; 261 cwt.; D.A.53732/2; 5th October, 1972; 254 cwt.

PETERSVILLE AUST. LTD., Wellington-road, Clayton, 3168; D.A.1813/3; 29th October, 1972; 13 cwt.; D.A.1813/5; 29th October, 1972; 13 cwt.; D.A.1813/186; 29th October, 1972; 23 cwt.

JONES, I. G. (trading as Queenscliff Engineers), 26 Bridge-street, Queenscliff, 3225; D.A.46440/1; 29th October, 1972; 40 cwt.

REDDAN, D. W., 285-287 Little Lonsdale-street, Melbourne, 3000; D.A.40601; 10th October, 1972; 36 cwt.; D.A.40601/2; 24th October, 1972; 36 cwt.

SAWTELL, F., 61 Cadorna-street, Box Hill South 3128; D.A.62220; 14th October, 1972; 137 cwt.

SCHWEPPE AUST. LTD., Yarrowee-street, Sebastopol, 3356; T.D.A.34505/57; 3rd November, 1972; 116 cwt.; T.D.A.34505/58; 3rd November, 1972; 141 cwt.

SHIELS, J. M., 112 Mackenzie-street west, Golden Square, 3555; D.A.2027; 15th November, 1972; 10 cwt.

SIDES, W. L. & SON PTY. LTD., P.O. Box 228; Clayton, 3168; D.A.28601; 1st October, 1972; 22 cwt.

TAYLOR, IAN, CONSTRUCTIONS PTY. LTD., 5 Meerut-street, Mitcham, 3132; D.A.48602/1; 30th September, 1972; 76 cwt.

THOMAS, H. E., Main Ridge, 3928; D.A.2147/5; 1st July, 1972; 289 cwt.

TRENTFIELD, S. (trading as Seth Trentfield & Sons), Jamieson, 3722; D.A.2181; 12th November, 1972; 157 cwt.

TOW TRUCK RENEWAL.

HALL & SONS (KERANG) PTY. LTD., 86-90 Wellington-street, Kerang, 3579; D.A.46802/1; 5th November, 1972; 74 cwt.

RENEWAL WITH VARIATION.

Application made by the person listed hereunder for renewal of the licence listed with variation of condition in the manner set out opposite the name.

REDDAN, D. W., 285-287 Little Lonsdale-street, Melbourne, 3000; D.A.40601/1; 10th October, 1972. Application to renew and vary the conditions of licence No. D.A.40601/1 (L/C. 22 cwt.) by deleting "Wangaratta" from the existing conditions and adding in lieu "Shepparton".

Notice of any objection should be forwarded to reach the Secretary of the Board not later than 21st June, 1972.

Applicants are advised that it will not be necessary to appear on the hearing date specified above, unless advised in writing by the Board.

B. P. KAY,
Secretary.

Corner Lygon and Princes streets, Carlton, 3053, Wednesday, 7th June, 1972.

Melbourne and Metropolitan

BOARD OF WORKS.

NOTICE TO THE OWNERS OF TENEMENTS IN THE UNDER-MENTIONED STREETS, AND THE PRIVATE STREETS, LANES, COURTS AND ALLEYS OPENING THERETO.

The main pipe in the said streets being laid down, the owners of all tenements situated as under are hereby required on or before the 10th July, 1972, to cause a proper pipe and stopcocks to be laid so as to supply water within such tenements from the main pipe.

R. H. ENGELSMAN,
Acting Secretary.

30th May, 1972.

STREET AND POSITION.

Box Hill.

Roycliff-court, from Elgar-road eastwards 480 feet.

Broadmeadows.

Mason-street, from Waratah-street to Laurel-crescent.
Mason-street, from 410 feet north of Laurel-crescent northwards 260 feet.

Mont Albert-drive, from Mason-street south-eastwards 940 feet.

Rainsford-terrace, from Mont Albert-drive to Samuel-drive.
Byrne-court, from Rainsford-terrace northwards 420 feet.

Elmar-court, from Rainsford-terrace northwards 380 feet.
Samuel-drive, from Rainsford-terrace to Mont Albert-drive.

Sylvan-way, from Samuel-drive northwards 220 feet.
Hatty-court, from Samuel-drive eastwards 210 feet.

Susan-court, from Samuel-drive north-westwards 400 feet.
Sophia-court, from Samuel-drive south-eastwards 180 feet.

Natalie-court, from Rainsford-terrace north-eastwards 390 feet.

Joan-court, from Rainsford-terrace south-westwards 90 feet.

Jodie-court, from Mont Albert-drive northwards 390 feet.
Desi-court, from Mont Albert-drive south-westwards 220 feet.

Como-place, from Mason-street eastwards 330 feet.

Collingwood.

Turner-street, from Hoddle-street eastwards 140 feet.

Cranbourne.

Lanyon-street, from 1,050 feet south of Queen's-road southwards 320 feet.

Croydon.

Webster-avenue, from Murray-road north-eastwards 610 feet.

Banoole-court, from Murray-road eastwards 470 feet.

Dandenong.

Loch-road, from Brady-road south-eastwards 650 feet.
Purley-drive, from Apex-street, Loch-road.

Eve-court, from Loch-road north-eastwards 290 feet.

Diamond Valley.

Paraweena-court, from Albion-crescent north-eastwards 560 feet.

Doncaster and Templestowe.

Valley View-court, from Barak-street westwards 530 feet.
Springbank-court, from Barak-street westwards 370 feet.

Eltham.

Gwenda-court, from Panorama-avenue westwards 420 feet.

Essendon.

Derry-street, from 100 feet east of Valencia-street to Aberdeen-street.

Antares-court, from Tilba-street northwards 820 feet.

Hawthorn.

Muir-street, from 200 feet west of Myrtle-street westwards 88 feet.

Keilor.

Calder Highway, from Arundel-road westwards 670 feet.

Clydesdale-road, from 120 feet southeast of Chancellor-road south-eastwards 50 feet.

Knox.

Ayr-street, from Kent Park-parade to Yarana-street.

Tynham-close, from Ayr-street eastwards 420 feet.
Greenaway-drive, from Tynham-close southwards 170 feet.

Margot-street, from 490 feet east of Austin-street eastwards 850 feet.

Edward-street, from Austin-street eastwards 580 feet.

Craig-avenue, from Elizabeth-street westwards 290 feet.

Spring-street, from Selman-avenue westwards 280 feet.

Mountain Gate-drive, from Ferntree Gully-road to Adelaide-avenue.

Norvel-road, from Johnson-drive to McMahons-road.

Yarana-street, from Scoresby-road eastwards 1,030 feet.

Dewar-court, from Yarana-street northwards 270 feet.

Fiona-court, from Yarana-street south-eastwards 310 feet.

Cook-court, from Yarana-street southwards 360 feet.

Lilydale.

Right of Way, from intersection of Bastow-road and Summit-road to Union-road.

Union-road, from Summit-road westwards 630 feet.

Mangans-road, from Old Gippsland-road northwards 570 feet.

Summit-road, from Mangans-road westwards 210 feet.

Old Gippsland-road, from Mangans-road eastwards 4,640 feet.

Unnamed-road 4,640 feet east of Mangans-road, from Old Gippsland-road to Old Warburton-road.

Hereford-road, from Old Gippsland-road southwards 2,240 feet.

Bimbadeen-drive, from 200 feet east of Daymar-drive eastwards 1,300 feet.

Devon-walk, from Bimbadeen-drive southwards 180 feet.

Barina-avenue, from Bimbadeen-drive to Arkarra-court.

Arkarra-court, from Daymar-drive eastwards 930 feet.

Bimbadeen-drive, from 100 feet east of Daymar-drive eastwards 100 feet.

Coombah-court, from 420 feet west of Dayman-drive westwards 150 feet.

Lancaster-road, from Carronvale-road eastwards 530 feet.

Clarendon-court, from Lancaster-road northwards 310 feet.

Melbourne.

Flinders-court from Flinders-lane south-eastwards 140 feet.

Connelly-court, from Dover-street southwards 390 feet.

Moorabbin.

Murray-road from 140 feet east Amelia-street eastwards 140 feet.

Clara-court, from Warren-road southwards 240 feet.

Mordialloc.

Glenelg-drive, from Lower Dandenong-road northwards 670 feet.

Yarra-court, from Glenelg-drive north-eastwards 260 feet.

Darling-street, from Avenza-street, to Murray-street.

Murray-street, from Lower Dandenong-road northwards 840 feet.

Nunawading.

Beltana-court, from McClares-road westwards 330 feet.

Huskey-court, from 130 feet east of Vogue-avenue eastwards 430 feet.

Oakleigh.

Fury-court, from Fairbank-road southwards 500 feet.

Port Melbourne.

Graham-street, from Turner-street southwards 810 feet.

Ringwood.

Jeffrey-drive, from 330 feet northeast Rollington-drive north-eastwards 460 feet.

Winnette-court, from Hugh-street south-eastwards 290 feet.

Springvale.

Aleja-court, from Corrigan-road westwards and northwards 820 feet.

Industrial-drive, from 580 feet east of Boundary-road eastwards 310 feet.

Century-drive, from Industrial-drive northwards 700 feet.

Sunshine.

Fitzgerald-road, from 120 feet south of Hilma-street southwards 580 feet.

Alexander-street, from Fitzgerald-road eastwards 1,310 feet.

Apollo-place, from Fitzgerald-road eastwards 440 feet.

Empress-court, from Alexander-street northwards 450 feet.

Harwood-close, from Alexander-street northwards 450 feet.

Barford-court, from Alexander-street northwards 450 feet.

Geelong-road (North side), from 940 feet northeast of McDonald-road north-eastwards 1,480 feet.

Hawthorn-avenue, from Ayton-street northwards 920 feet.

Novara-road, from 135 feet south of Halesworth-street southwards 670 feet.

Larisa-road, from Novara-road eastwards 750 feet.

Emden-court, from Larisa-road northwards 580 feet.

Dundee-street, from Larisa-road northwards 550 feet.

Waverley.

High Street-road (North side), from 130 feet east of Annandale-crescent eastwards 370 feet.

Capital-avenue, from High Street-road north-westwards 1,350 feet.

Excalibur-avenue, from Capital-avenue northwards 710 feet.

Lennox-avenue, from Excalibur-avenue eastwards 130 feet.

Cairn-grove, from Capital-avenue north-eastwards 360 feet.

Gordon-road, from Muir-street to Hilton-street.

Lawrence-road, from Wills-avenue to Montgomery-avenue.

Stewart-street, from Portsmouth-street to St. Albans-road.

St. Albans-road, from Stewart-street westwards 700 feet.

Park-road, from Gillian-road northwards 300 feet.

Capital-avenue, from Camelot-drive south-eastwards 1,330 feet.

King Arthur-drive, from Capital-avenue north-eastwards 600 feet.

Garwain-parade, from King Arthur-drive north-westwards 350 feet.

Vasey-avenue, from Taroona-avenue to Montgomery-avenue 500 feet.

Melbourne and Metropolitan
BOARD OF WORKS.

NOTICE TO THE OWNERS OF TENEMENTS IN THE UNDER-
MENTIONED STREETS AND THE PRIVATE STREETS, LANES,
COURTS AND ALLEYS OPENING THERETO.

The main pipe in the said streets being laid down, the
owners of all tenements situated as under are hereby
required on or before the 19th June, 1972, to cause, a
proper pipe and stopcocks to be laid so as to supply
water within such tenements from the main pipe.

R. H. ENGELSMAN,
Acting Secretary.

9th May, 1972.

STREET AND POSITION.

Broadmeadows.

Gaynor-crescent, from 150 feet east of Royston-place to
Carrick-drive.
Carrick-drive, from Pyke-drive north-eastwards 100 feet.
Carrick-drive, from Pyke-drive south-westwards 400 feet.
Pyke-drive, from Carrick-drive eastwards 560 feet.
Sheldon-court, from 100 feet north-east of Hall-street
north-eastwards 320 feet.
Linacre-crescent, from Pyke-drive southwards 420 feet.
Leura-court, from Linacre-crescent south-westwards 410
feet.

Diamond Valley.

Gleeson-drive, from 70 feet north of Lea-crescent north-
wards 680 feet.
Daniel-court, from Gleeson-drive westwards and north-
wards 800 feet.
Ricky-court, from Daniel-court northwards 310 feet.

Doncaster and Templestowe.

Harris Gully-road, from Beauty Gully-road southwards
400 feet.
Opossum-rise, from Harris Gully-road westwards 620 feet.
Lynette-avenue, from Pound-road southwards and north-
wards 1,140 feet.
Nathan-street, from 250 feet east of Lauer-street east-
wards and northwards 520 feet.

Keilor.

Atheldene-drive, from Jamieson-street to Future-road.
Benbury-close, from Atheldene-drive eastwards 370 feet.
Gillespie-road, from Atheldene-drive westwards 900 feet.
Gillespie-road, from Atheldene-drive eastwards 240 feet.
Selsey-court, from Gillespie-road northwards 600 feet.
Lyndford-court, from Gillespie-road northwards 640 feet.
Brackley-court, from Gillespie-road northwards 620 feet.
Future-road, from Atheldene-drive to Taylors-road.
Maplewood-road, from Gillespie-road northwards 1,030
feet.
Seville-court, from Maplewood-road westwards 660 feet.
Gillespie-road, from 320 feet west of Gum-road westwards
1,080 feet.
Braeswood-road, from Gillespie-road northwards 1,070
feet.
Valencia-court, from Maplewood-road westwards 660 feet.
Tanglewood-street, from Maplewood-road to Braeswood-
road.

Waverley.

Northam-street, from Madigan-drive northwards and east-
wards 620 feet.

COMPANIES ACT 1961.

Notice is hereby given in pursuance of section 308 (2)
and 308 (3) of the Companies Act 1961 that at the expira-
tion of three months from the date hereof the names of
the following Companies will, unless cause is shown to
the contrary, be struck off the Register and the said
Companies will be dissolved.

Dated this 31st day of May, 1972.

P. COMAN,
Assistant Registrar of Companies.

Companies Office,
Melbourne.

COMPANIES ABOVE REFERRED TO.

Name of Company.	Number of Registration.
Maryborough Gas Co. Ltd.	635
Jet Lighters Pty. Ltd.	27046
Ian H. Dancy Pty. Ltd.	27573
Geo. H. Hagg Pty. Ltd.	28761
Outdoor Advertising News Pty. Ltd.	29228
Stowell Brothers Pty. Ltd.	30481
Surplus Stores Pty. Ltd.	37932

Personal Training Services Pty. Ltd.	39574
Moidart Holdings Pty. Ltd.	42014
Redneb Holdings Pty. Ltd.	42015
Gabrielle Holdings Pty. Ltd.	42016
Langall Holdings Pty. Ltd.	42017
Gabrielle Investments Pty. Ltd.	42018
Redneb Investments Pty. Ltd.	42019
Mordell Investment Co. Pty. Ltd.	42196
157 A Beckett Street Pty. Ltd.	42199
E.A. Patrick Proprietary Limited	45812
V.T. Constructions Pty. Limited	46434
Luxury Cars Limited	51225
Adelaide Electro Magnetics (Vic.) Pty. Ltd.	60865
Mitchell Valley Motors Pty. Ltd.	61005
Kenson Press Pty. Ltd.	70501
John D. Collins Autos Pty. Ltd.	70731
Michael Bucchi Health Salon Pty. Ltd.	70982
Rubin Constructions Pty. Ltd.	72893
Nova of Bond Street (Cosmetics) Pty. Limited	81403
Gavin Baillie Enterprises Pty. Ltd.	84387
R.P. Food Holdings Pty. Ltd.	84959

DEPARTMENT OF MINES.

Subject to any necessary excisions, &c., it is proposed
to grant the following mining leases:—

8948, Mineral; Stan Lincoln, Ray Alan Borchers; 12 acres,
Parish of Moreep.
9161, Mineral; James Joseph White, Frances Nellie White;
35 acres, Parish of Warraquil.

APPLICATION FOR MINING LEASE REFUSED.

8929, Mineral; Patrick J. Larkin, Robert C. Larkin, David
J. Larkin; 6 acres, Parish of Toombullup North.

MINING LEASE TRANSFERRED.

7136, Maryborough; from William Arthur Burgess to
Merge Pty. Ltd.

MINING LEASE EXPIRED.

8629, Mineral; Desmond Praznovsky, Judith Praznovsky;
10 acres, Parish of Langwarrin.

MINING LEASES GRANTED.

11402, Bendigo; North Deborah Mining Company No
Liability; 11a. 3r. 15p., Parish of Sandhurst.
11404, Bendigo; Deborah Extended Gold Mining Company
No Liability; 24a. 3r. 34p., Parish of Sandhurst.
9277, Castlemaine; Herbert Claude Cann; 23a. 3r. 30p.,
Parish of Tylden.
9156, Mineral; Australian Gypsum Limited; 24a. 3r. 18p.,
Parish of Wootwoara.

APPLICATION FOR MINERAL SEARCH LICENCE
DECLARED ABANDONED.

1031, Mineral Search Licence; Vincent William O'Brien;
640 acres; Parish of Coimadaí.

APPLICATION FOR MINERAL SEARCH LICENCE
REFUSED.

1028, Mineral Search Licence; Arthur Maxwell Hamilton;
640 acres; Parishes of Manango, Steavenson.

APPLICATION FOR EXTRACTIVE INDUSTRY LICENCE
DECLARED ABANDONED.

81, Extractive Industry Licence; Reginald David Holder,
George William Holder; 30 acres, Parish of Bulla
Bulla.

APPLICATION FOR EXTRACTIVE INDUSTRY LICENCE
REFUSED.

463, Extractive Industry Licence; Frank Johansen, Marie
Johansen; 15 acres, Parish of Merrimu.

EXTRACTIVE INDUSTRY LICENCES GRANTED.

235, Extractive Industry Licence; Albion Reid Pty. Limited;
61a. 2r. 17p., Parish of Merrimu.
530, Extractive Industry Licence; Albion Reid Pty.
Limited; 31a. 0r. 31p., Parish of Merrimu.
3765, Tailings Licence; Golconda Mines Pty. Limited; to
remove tailings in the Parish of Byawatha.
3783, Tailings Licence; William Akers; to remove tailings
from the "Sydenham Mine" dump, Burnt Gully,
Dunolly.

3790, Tailings Licence; The President, Councillors and Ratepayers of the Shire of Yackandandah; to remove tailings from "Shield's Pit" at Yackandandah.

J. C. M. BALFOUR,
Minister of Mines.

MINING LEASE DECLARED VOID.

8448, Beechworth; Patrick Manning Edema, Ernie Martin, Manfred Stern; 12a. Or. 19p., Parish of Lauraville.

E. CONDON,
Secretary for Mines.

COMMONWEALTH OF AUSTRALIA.
Petroleum (Submerged Lands) Act 1967-1968.

STATE OF VICTORIA.
Petroleum (Submerged Lands) Act 1967.

PROHIBITION OF ENTRY INTO SAFETY ZONE.

I, James Charles Murray Balfour, Minister of Mines for the State of Victoria, the Designated Authority in respect of the area specified as being adjacent to the State of Victoria, hereby prohibit from entering into or remaining in, except with my consent in writing, the area of the safety zone described hereunder, all vessels other than vessels engaged in or in connexion with petroleum exploration operations or operations for the recovery of petroleum authorized by me in the area concerned.

DESCRIPTION OF AREA OF SAFETY ZONE.

The area which extends to a distance of five hundred metres measured from each point of the structure known as the Kingfish "B" platform situated at or about the point of latitude 38 deg. 35 min. 54.7 sec. south, longitude 148 deg. 11 min. 15.5 sec. east.

REVOCATION.

The instrument, dated 24th July, 1969, notice of which appeared in the *Victoria Gazette* No. 68, dated the 30th July, 1969, which prohibited the entry of certain vessels into the safety zone surrounding the Kingfish "B" platform, is hereby revoked.

Dated this 7th day of October, 1971.

Made under the *Petroleum (Submerged Lands) Act*
1967-1968 of the Commonwealth of Australia.

Made under the *Petroleum (Submerged Lands) Act*
1967 of the State of Victoria.

JIM BALFOUR,
Designated Authority.

COMMONWEALTH OF AUSTRALIA.
Petroleum (Submerged Lands) Act 1967-1968.

STATE OF VICTORIA.
Petroleum (Submerged Lands) Act 1967.

PROHIBITION OF ENTRY INTO SAFETY ZONE.

I, James Charles Murray Balfour, Minister of Mines for the State of Victoria, the Designated Authority in respect of the area specified as being adjacent to the State of Victoria, hereby prohibit from entering into or remaining in, except with my consent in writing, the area of the safety zone described hereunder, all vessels other than vessels engaged in or in connexion with petroleum exploration operations or operations for the recovery of petroleum authorized by me in the area concerned.

DESCRIPTION OF AREA OF SAFETY ZONE.

The area which extends to a distance of five hundred metres measured from each point of the structure known as the Kingfish "A" platform situated at or about the point of latitude 38 deg. 35 min. 52.5 sec. south, longitude 148 deg. 08 min. 38.8 sec. east.

REVOCATION.

The instrument, dated 5th March, 1969, notice of which appeared in the *Victoria Gazette*, No. 17, dated the 12th March, 1969, which prohibited the entry of certain vessels into the safety zone surrounding the Kingfish "A" platform, is hereby revoked.

Dated this 7th day of October, 1971.

Made under the *Petroleum (Submerged Lands) Act*
1967-1968 of the Commonwealth of Australia.

Made under the *Petroleum (Submerged Lands) Act*
1967 of the State of Victoria.

JIM BALFOUR,
Designated Authority.

COMMONWEALTH OF AUSTRALIA.
Petroleum (Submerged Lands) Act 1967-1968.

STATE OF VICTORIA.
Petroleum (Submerged Lands) Act 1967.

PROHIBITION OF ENTRY INTO SAFETY ZONE.

I, James Charles Murray Balfour, Minister of Mines for the State of Victoria, the Designated Authority in respect of the area specified as being adjacent to the State of Victoria, hereby prohibit from entering into or remaining in, except with my consent in writing, the area of the safety zone described hereunder, all vessels other than vessels engaged in or in connexion with petroleum exploration operations or operations for the recovery of petroleum authorized by me in the area concerned.

DESCRIPTION OF AREA OF SAFETY ZONE.

The area which extends to a distance of five hundred metres measured from each point of the structure known as the Marlin platform situated at or about the point of latitude 38 deg. 13 min. 54.8 sec. south, longitude 148 deg. 13 min. 10.1 sec. east.

REVOCATION.

The instrument, dated 16th October, 1968, notice of which appeared in the *Victoria Gazette*, No. 88, dated the 23rd October, 1968, which prohibited the entry of certain vessels into the safety zone surrounding the Marlin platform, is hereby revoked.

Dated this 7th day of October, 1971.

Made under the *Petroleum (Submerged Lands) Act*
1967-1968 of the Commonwealth of Australia.

Made under the *Petroleum (Submerged Lands) Act*
1967 of the State of Victoria.

JIM BALFOUR,
Designated Authority.

COMMONWEALTH OF AUSTRALIA.

Petroleum (Submerged Lands) Act 1967-1968.

STATE OF VICTORIA.

Petroleum (Submerged Lands) Act 1967.

PROHIBITION OF ENTRY INTO SAFETY ZONE.

I, James Charles Murray Balfour, Minister of Mines for the State of Victoria, the Designated Authority in respect of the area specified as being adjacent to the State of Victoria, hereby prohibit from entering into or remaining in, except with my consent in writing, the area of the safety zone described hereunder, all vessels other than vessels engaged in or in connexion with petroleum exploration operations or operations for the recovery of petroleum authorized by me in the area concerned.

DESCRIPTION OF AREA OF SAFETY ZONE.

The area which extends to a distance of five hundred metres measured from each point of the structure known as the Barracouta platform situated at or about the point of latitude 38 deg. 17 min. 53 sec. south, longitude 147 deg. 40 min. 29 sec. east.

REVOCATION.

The instrument, dated 16th October, 1968, notice of which appeared in the *Victoria Gazette*, No. 88, dated the 23rd October, 1968, which prohibited the entry of certain vessels into the safety zone surrounding the Barracouta platform, is hereby revoked.

Dated this 7th day of October, 1971.

Made under the *Petroleum (Submerged Lands) Act* 1967-1968 of the Commonwealth of Australia.

Made under the *Petroleum (Submerged Lands) Act* 1967 of the State of Victoria.

JIM BALFOUR,
Designated Authority.

COMMONWEALTH OF AUSTRALIA.

Petroleum (Submerged Lands) Act 1967-1968.

STATE OF VICTORIA.

Petroleum (Submerged Lands) Act 1967.

PROHIBITION OF ENTRY INTO SAFETY ZONE.

I, James Charles Murray Balfour, Minister of Mines for the State of Victoria, the Designated Authority in respect of the area specified as being adjacent to the State of Victoria, hereby prohibit from entering into or remaining in, except with my consent in writing, the area of the safety zone described hereunder, all vessels other than vessels engaged in or in connexion with petroleum exploration operations or operations for the recovery of petroleum authorized by me in the area concerned.

DESCRIPTION OF AREA OF SAFETY ZONE.

The area which extends to a distance of five hundred metres measured from each point of the structure known as the Halibut platform situated at or about the point of latitude 38 deg. 24 min. 21.0 sec. south, longitude 148 deg. 19 min. 10.1 sec. east.

REVOCATION.

The instrument, dated 16th October, 1968, notice of which appeared in the *Victoria Gazette*, No. 88, dated the 23rd October, 1968, which prohibited the entry of certain vessels into the safety zone surrounding the Halibut platform, is hereby revoked.

Dated this 7th day of October, 1971.

Made under the *Petroleum (Submerged Lands) Act* 1967-1968 of the Commonwealth of Australia.

Made under the *Petroleum (Submerged Lands) Act* 1967 of the State of Victoria.

JIM BALFOUR,
Designated Authority.

Town and Country Planning Act 1961.

CITY OF ECHUCA PLANNING SCHEME.

AMENDMENT No. 8, 1970.

Notice of Approval.

In pursuance of the powers conferred by the *Town and Country Planning Act 1961*, the Governor in Council on the 30th May, 1972, approved a Planning Scheme entitled the City of Echuca Planning Scheme, Amendment No. 8, 1970, in respect of part of the municipal district of the City of Echuca and such Planning Scheme comes into operation on the date this notice of approval is published in the *Government Gazette*.

A copy of the Planning Scheme as approved may be inspected free of charge during office hours at the office of the Town and Country Planning Board, 235 Queen-street, Melbourne; at the office of the City of Echuca, at Echuca; and when available, at the Office of Titles, Melbourne; and at the Central Plan Office of the Department of Crown Lands and Survey, Melbourne.

W. H. CRAIG, Secretary,
Town and Country Planning Board.

Town and Country Planning Act 1961.

CITY OF ARARAT PLANNING SCHEME 1953.

AMENDMENT No. 11A, 1972.

Notice of Amendment.

In pursuance of the powers conferred by sub-section 6 of section 32 of the *Town and Country Planning Act 1961*, the Governor in Council, by and with the advice of the Executive Council on the 30th May, 1972, amended the City of Ararat Planning Scheme 1953, to correct two minor discrepancies introduced in the approval of Amendment No. 11.

A copy of the Amendment may be inspected during office hours at the office of the Town and Country Planning Board, 235 Queen-street, Melbourne; at the office of the council of the City of Ararat, at Ararat; and when available at the Office of Titles, Melbourne; and at the Central Plan Office of the Department of Crown Lands and Survey, Melbourne.

W. H. CRAIG, Secretary,
Town and Country Planning Board.

Private Agents Act 1966.

NOTICE OF RECEIPT OF APPLICATIONS FOR LICENCES UNDER THE PROVISIONS OF THE PRIVATE AGENTS ACT 1966.

The Clerk(s) of the Magistrates' Court(s) as listed hereunder hereby give notice that applications, as under, have been lodged for hearing by the said Court(s) on the date(s) specified.

Any person desiring to object to any of such applications must—

- (a) lodge with the respective Clerk of the Magistrates' Court a notice in the prescribed form of his objection and of the grounds thereof;
- (b) cause a copy of such notice to be served personally or by post upon the applicant at least three days before the hearing of the application; and
- (c) send or deliver—
 - (i) where the objection is not made by the officer in charge of the police district in which the Court is situated—a copy of the notice to such officer; and
 - (ii) where the objection is not made by the Registrar or Deputy Registrar—a copy to the Registrar.

Full Name of Applicant or in the Case of a Firm or Corporation, of the Nominee.	Place of Abode of Applicant or Nominee.	Name of Firm or Corporation.	Address for Registration.	Type of Licence.	Date of Hearing of Application.
---	---	------------------------------	---------------------------	------------------	---------------------------------

MAGISTRATES' COURT, PRAHRAN.

Smith, Ronald Charles ..	73 Bindi-street, Glenroy	Factory Guard Pty. Ltd.	Suite 17, 562 St. Kilda-road, Melbourne	Watchman ..	16.6.72
--------------------------	--------------------------	-------------------------	---	-------------	---------

Dated at Prahran this 23rd day of May, 1972.

J. W. PRESNELL, Clerk of the Magistrates' Court.

MAGISTRATES' COURT, MELBOURNE.

Knee, Bernard Kenneth Victor	Flat 3, 176 Rathmines-road, Hawthorn East	County Bailiff	223 William-street, Melbourne	Process Server ..	14.6.72
------------------------------	---	----------------	-------------------------------	-------------------	---------

Dated at Melbourne this 25th day of May, 1972.

G. L. WEBSTER, Clerk of the Magistrates' Court.

MAGISTRATES' COURT, HEIDELBERG.

Campbell, Leonard Arthur ..	3 Devon-street, Heidelberg	3 Devon-street, Heidelberg	Process Server	3.7.72
-----------------------------	----------------------------	---------	----------------------------	----------------	--------

Dated at Heidelberg this 31st day of May, 1972.

R. J. CUTHILL, Clerk of the Magistrates' Court.

MAGISTRATES' COURT, COBURG.

Shanahan, Michael James ..	2/33 Prospect-street, Glenroy	88 Bakers-road, North Coburg	Watchman ..	20.6.72
----------------------------	-------------------------------	---------	------------------------------	-------------	---------

Dated at Coburg this 26th day of May, 1972.

M. ROUND, Clerk of the Magistrates' Court.

MAGISTRATES' COURT, MELBOURNE.

Purcell, Cecil Robert ..	53 Oriel-road, Ivanhoe	Australian Watching Co. Pty. Ltd.	340 Abbotsford-street, North Melbourne	Watchman ..	21.6.72
Paynting, Thomas Lindsay ..	27 Woods-street, Ascot Vale
Wosgien, Hans Joachim ..	1 Zinnia-street, Reservoir
Stead, Derrick Norman ..	14 Lawson-avenue, Frankston
Dunsmore, Henry ..	80 Kitchener-street, Broadmeadows
Betteridge, Ronald James ..	7 Gilford-grove, Cheltenham
Morrison, William Thomas ..	36 Gardenvale-road, South Caulfield
Doran, James Henry ..	32/95 Napier-street, Fitzroy
McKinlay, Robert Alfred ..	181/130 Racecourse-road, Flemington
Cullen, William Wood ..	12 Brockley-road, Fawkner
Richter, Horst Ludwig Herman	26 Watford-road, St. Albans
Dossor, Robin Clement Grey ..	54 Stroud-street, Balwyn
Provost, Max ..	7/525 Rathdowne-street, Carlton

Dated at Melbourne this 26th day of May, 1972.

G. L. WEBSTER, Clerk of the Magistrates' Court.

MAGISTRATES' COURT, FOOTSCRAY.

Reibel, Robert ..	27 Wright-road, Laverton	17 Richards-street, Yarraville	Watchman ..	23.6.72
-------------------	--------------------------	---------	--------------------------------	-------------	---------

Dated at Footscray this 24th day of May, 1972.

D. A. THOMPSON, Clerk of the Magistrates' Court.

MAGISTRATES' COURT, MALVERN.

Maslin, Peter Connolly ..	Flat 5, 117 Park-street, South Yarra	Melbourne Professional Mercantile Agency Pty. Ltd.	346 Wattle-tree-road, East Malvern	Commercial Agent	14.6.72
Taylor, Wesley Raymond ..	Flat 5, 15 Elm-street, Hawthorn	Flat 5, 15 Elm-street, Hawthorn	Commercial Sub-agent	14.6.72

Dated at Malvern this 24th day of May, 1972.

P. J. RODDA, Clerk of the Magistrates' Court.

PRIVATE AGENTS—*continued.*

Full Name of Applicant or in the Case of a Firm or Corporation, of the Nominee.	Place of Abode of Applicant or Nominee.	Name of Firm or Corporation.	Address for Registration.	Type of Licence.	Date of Hearing of Application.
MAGISTRATES' COURT, PORT MELBOURNE.					
Hill, John Anthony	1/220 Batman-street, West Melbourne	Mayne Nickless Limited	117 Dow-street, Port Melbourne	Watchman	8.6.72
Makram, Fakhry Effat	1/73 Pakington-street, St. Kilda	" " "	538 Williamstown-road, Port Melbourne	"	8.6.72
Forrest, Ross	16 Evans-crescent, Laverton	" " "	" " "	"	13.6.72
Rapson, Cyrus Everard	27 Hamilton-street, Gardenvale	" " "	" " "	"	"
Dolman, John Gordon	58 Albert Hill-road, Lilydale	" " "	" " "	"	"
Roeseler, Paul	c/o Eyton-on-Yarra, Healesville	" " "	" " "	"	"
Stonehouse, Kevin William	2 Barrow-drive, Heathmont	" " "	" " "	"	27.6.72

Dated at Port Melbourne this 29th day of May, 1972.

J. GIDLEY, Clerk of the Magistrates' Court.

MAGISTRATES' COURT, ELSTERNWICK.

Webb, Richard	8 Charlotte-street, East Brighton	" " "	25 Dunbar-avenue, Caulfield	Process Server	27.6.72
---------------	-----------------------------------	-------	-----------------------------	----------------	---------

Dated at Elsternwick this 2nd day of June, 1972.

G. J. CONDON, Clerk of the Magistrates' Court.

MAGISTRATES' COURT, SPRINGVALE.

Molloy, William John	30 Louis-street, Dovelton	" " "	Cnr. Fairview and Joyce-streets, Springvale	Watchman	20.6.72
----------------------	---------------------------	-------	---	----------	---------

Dated at Springvale this 29th day of May, 1972.

J. B. DENNIS, Clerk of the Magistrates' Court.

MAGISTRATES' COURT, CHELTENHAM.

Eagle, Ernest George	42 Harts-parade, Hawthorn	" " "	94 York-street, South Melbourne	Watchman	23.6.72
----------------------	---------------------------	-------	---------------------------------	----------	---------

Dated at Cheltenham this 30th day of May, 1972.

J. FERGUSON, Clerk of the Magistrates' Court.

MAGISTRATES' COURT, COBURG.

Kelly, Carl	5 Maxwell-street, Lalor	" " "	88 Bakers-road, North Coburg	Watchman	27.6.72
-------------	-------------------------	-------	------------------------------	----------	---------

Dated at Coburg this 30th day of May, 1972.

M. ROUND, Clerk of the Magistrates' Court.

MAGISTRATES' COURT, BOX HILL.

Lay, John Goodwin	4 Hartigan-street, Blackburn	" " "	4 Hartigan-street, Blackburn	Process Server	22.6.72
-------------------	------------------------------	-------	------------------------------	----------------	---------

Dated at Box Hill this 31st day of May, 1972.

A. J. JOHNSON, Clerk of the Magistrates' Court.

MAGISTRATES' COURT, MELBOURNE.

Foster, Alan Francis Walter	148 Roden-street, West Melbourne	W. I. Scammell Pty. Ltd.	148 Roden-street, West Melbourne	Watchman	21.6.72
-----------------------------	----------------------------------	--------------------------	----------------------------------	----------	---------

Dated at Melbourne this 30th day of May, 1972.

G. L. WEBSTER, Clerk of the Magistrates' Court.

MAGISTRATES' COURT, BENDIGO.

Crimmins, John Michael	41 Valentine-street, Bendigo	" " "	69 Mitchell-street, Bendigo	Process Server	21.6.72
------------------------	------------------------------	-------	-----------------------------	----------------	---------

Dated at Bendigo this 30th day of May, 1972.

K. MASON, Clerk of the Magistrates' Court.

MAGISTRATES' COURT, FOOTSCRAY.

Marcon, Cecil	2/82 South-road, Braybrook	Mayne Nickless Pty. Ltd.	4 Cross-street, Footscray	Watchman	27.6.72
---------------	----------------------------	--------------------------	---------------------------	----------	---------

Dated at Footscray this 2nd day of June, 1972.

D. THOMPSON, Clerk of the Magistrates' Court.

Justices Act 1958.

SITTINGS OF MAGISTRATES' COURTS—ALTERATION OF TIMES.

His Excellency the Governor of the State of Victoria by and with the advice of the Executive Council thereof doth by Order made on the 30th day of May, 1972, and pursuant to the provisions of section 64 of the *Justices Act 1958*, alter the time of commencement of the Magistrates' Courts at the places named in the Schedule below to the hours contained in such Schedule.

SCHEDULE.

Place.	Time of Commencement.
Moe	10.30 a.m. (to take effect as from 1st August, 1972).
Morwell	10.30 a.m. (to take effect as from 4th August, 1972).

J. ROSSITER,
Clerk of the Executive Council.

At the Executive Council Chamber,
Melbourne, 30th May, 1972.

STATE RIVERS AND WATER SUPPLY COMMISSION.

LICENCES TO DIVERT WATER AND CUT RACES PURSUANT TO THE PROVISIONS OF SECTION 204 OF THE WATER ACT 1958 (AS AMENDED).

The Governor in Council has approved of the granting by the State Rivers and Water Supply Commission of licences as detailed hereunder for the term of years from the date specified in each case to the persons named in the following Schedule :—

SCHEDULE.

Licence No.	Term of Licence and Commencing Date.	Name and Address of Person to whom Licence is to be Granted.	Source of Supply.	Area Authorized to be Irrigated Per Annum.	Volume of Water Authorized to be Diverted Per Annum.	Annual Fee.
				acres.	ac. ft.	\$
604	Fifteen years from 1.7.71	Elsie Alecia Smith, Merbein ..	River Murray ..	5	15	18.75
832	Six years from 1.7.69	James Eric Teague and Irene Alma Teague, Swan Hill	Little Murray River	100	200	400.00
2299	Fifteen years from 1.7.71	Kevin Joseph Carroll, Wodonga	River Murray (Wodonga Creek)	25	50	62.50
3320	Four years from 1.7.71	Allan James Newton and Margaret Mary Newton, Edi Upper	King River ..	100	150	187.50
3321	Three years from 1.7.70	Basilio Bonacci, Markwood ..	Ovens River ..	25	37½	44.06
3324	Four years from 1.7.70	Terence Mark Hardiker, Mildura	River Murray ..	30	90	112.50
3325	Four years from 1.7.70	Winton Henry Phillips, Mildura	River Murray ..	30	90	112.50
3326	Four years from 1.7.70	Frederick William Guy Ottrey, Patho	River Murray via Camerons Creek	40	80	100.00
3328	Four years from 1.7.70	Karl Uhd, Lower Plenty ..	River Murray ..	33	99	123.75
3329	Four years from 1.7.70	Bruce Winton Phillips and Mabelle Phillips, Mildura ..	River Murray ..	33	99	123.75
3331	Four years from 1.7.71	Ron. G. Jager, Piangil ..	River Murray ..	15	45	56.25
3333	Four years from 1.7.71	The Estate of the late Frederick Brooke Darling, Cheshunt	King River ..	45	67½	84.37
3335	Four years from 1.7.71	Giorgio Paccagnan and Frederica Paccagnan, Cheshunt	King River ..	40	60	75.00
3336	Fifteen years from 1.7.71	Mario Galie, Guerrino Galie and Pasquale Bolla, King Valley	King River ..	45	67½	84.37
3339	Fifteen years from 1.7.71	Salvatore Bisignano and Giovanina Bisignano, Whitfield	King River ..	25	37½	46.87
3340	Four years from 1.7.71	Percy Thomas Mildren, Edi ..	King River ..	50	75	93.75
3342	Fifteen years from 1.7.71	Giovanni Giuca, Whitfield ..	King River ..	30	45	56.25

Office of the State Rivers and Water Supply Commission,
Melbourne, 30th May, 1972.F. C. O'CONNOR, for Secretary,
State Rivers and Water Supply Commission.

STATE RIVERS AND WATER SUPPLY COMMISSION.

LICENCES TO DIVERT WATER PURSUANT TO THE PROVISIONS OF SECTION 204 OF THE WATER ACT 1958 (AS AMENDED).

The Governor in Council has approved of the granting by the State Rivers and Water Supply Commission of licences as detailed hereunder for the term of years from the date specified in each case to the persons named in the following Schedule :—

SCHEDULE.

Licence No.	Term of Licence and Commencing Date.	Name and Address of Person to whom Licence is to be Granted.	Source of Supply.	Area Authorized to be Irrigated Per Annum.	Volume of Water Authorized to be Diverted Per Annum.	Annual Fee.
				acres.	ac. ft.	\$
1059/1069	Fifteen years from 1.7.71	William Harold Kaye, Baringhup	Loddon River ..	40	80	100.00
3246	Four years from 1.7.71	Thomas Cameron Seabrook, Moyhu	King River ..	40	60	75.00
3290/919	Four years from 1.7.71	Ali Sefer, Thomastown ..	Little River ..	2	4	15.00
3316	Four years from 1.7.71	Norman John Davis, Gooramhat	Broken Creek ..	40	80	100.00
3337	Four years from 1.7.71	Joseph Louis Jackson, Rutherglen	Black Dog Creek (River Murray Backwater)	50	100	125.00
3338	Four years from 1.7.71	Arthur John Southgate and Joy Lynette Southgate, Oxley	King River ..	100	150	187.50

Office of the State Rivers and Water Supply Commission,
Melbourne, 30th May, 1972.F. C. O'CONNOR, for Secretary,
State Rivers and Water Supply Commission.

ENGINEERS OF WATER SUPPLY.

EXAMINATION OF CANDIDATES FOR CERTIFICATES OF QUALIFICATION.

The Board of Examiners of Engineers of Water Supply for the State of Victoria, appointed under the provisions of the Water Act, hereby gives notice that an examination of candidates for Certificates of Qualification will be held on Monday and Tuesday, the 2nd and 3rd October, 1972, at the office of the State Rivers and Water Supply Commission, 590 Orrong-road, Armadale, Victoria.

C. J. CALVERT, Secretary,
Board of Examiners.State Rivers and Water Supply Commission,
Armadale, 2nd June, 1972.

Stamps Act 1958.

ANNUAL LICENCE.

NOTIFICATION PURSUANT TO SECTION 97.

I hereby notify that stamp duty has been paid for a licence under section 96 of the Stamps Act to carry on assurance and insurance business in Victoria from 3rd April, 1972 to 31st December, 1972, by the following:—

THE DOMINION INSURANCE COMPANY OF AUSTRALIA
LIMITED.R. M. PHIBBS,
Comptroller of Stamps.Stamp Duties Office,
Melbourne, 7th June, 1972.

Crimes Act 1958.

CURATOR OF CONVICTS' PROPERTY.

His Excellency the Governor of the State of Victoria by and with the advice of the Executive Council thereof doth by Order made on the 30th day of May, 1972, and pursuant to section 550 of the *Crimes Act 1958*, commit the custody and management of the property of the convict Archibald Butterley to Terrence Stokes, of 110 Grey-street, East Melbourne, as a Curator hereby appointed in that behalf.

J. ROSSITER,
Clerk of the Executive Council.

At the Executive Council Chamber,
Melbourne, 30th May, 1972.

Dried Fruits Act 1958.

STATE OF VICTORIA.

NOTICE.

I, Gilbert Lawrence Chandler, Minister of Agriculture, acting upon the recommendation of the Victorian Dried Fruits Board, hereby give notice that I have determined the maximum proportions of Dried Vine Fruits produced in Victoria in the year One Thousand Nine Hundred and Seventy-two that may be marketed within Victoria are as follows:—

Dried Currants—30 per cent;
Dried Sultanas—10 per cent;
Raisins—40 per cent.

G. L. CHANDLER,
Minister of Agriculture.

Department of Agriculture,
Melbourne, 29th May, 1972.

Dried Fruits Act 1958.

NOTICE.

In accordance with the provisions of the *Dried Fruits Act 1958*, it is hereby notified that, with respect to the year ended 31st December, 1972, the amount of contribution payable by every packer is 80 cents per ton, computed, in accordance with the Regulations under the *Dried Fruits Act*, from the quantity of 1972 season's dried fruits sold from each packing house and from the quantity of dried fruits forwarded therefrom for the purpose of trade and sale.

By order of the Board,
K. F. NEANDER, Secretary.

Melbourne, 25th May, 1972.

Dried Fruits Act 1958.

STATE OF VICTORIA.

NOTICE.

I, GILBERT LAWRENCE CHANDLER, Minister of Agriculture, acting upon the recommendation of the Victorian Dried Fruits Board, hereby give notice that I have determined the maximum proportion of Dried Prunes of the respective varieties produced in Victoria in the year One thousand nine hundred and seventy-two that may be marketed within Victoria are as follows:—

Dried Prunes of any variety other than Robe de Sargent—82½ per cent;

Dried Prunes of the Robe de Sargent variety—1 per cent.

G. L. CHANDLER,
Minister of Agriculture.

Department of Agriculture,
Melbourne, 1st June, 1972.

Cemeteries Act 1958.

SCALE OF FEES OF TYLDEN PUBLIC CEMETERY.

In pursuance of the powers conferred upon them by the *Cemeteries Act* the trustees of the Tylden Public Cemetery hereby make the following scale of fees, which shall come into operation upon publication in the *Government Gazette*, and from and after such publication every scale of fees heretofore made by the said trustees shall be and is hereby rescinded to the extent to which it conflicts with this scale.

Public Graves.

Interment in grave without exclusive right—	
stillborn child	\$7.00
Interment in grave without exclusive right—	
others	\$14.00
Number peg or label	\$3.00

Private Graves.

Land, 8 ft. x 4 ft.	\$24.00
Own selection of land (extra)	\$6.00

Sinking Charges for Private Graves.

Sinking grave 6 feet deep	\$36.00
Each additional foot	\$4.00
Sinking oversize grave (extra)	\$12.00
Cancellation of order to sink (if commenced)	\$6.00

Reopening Charges.

Reopening grave (no cover)	\$30.00
Reopening grave (with cover)	\$35.00

Extra Charges.

Interment outside prescribed hours, or on Saturdays, Sundays or Public Holidays	\$12.00
Interment in a private grave without due notice	\$12.00

Miscellaneous Charges.

Interment fee	\$12.00
Certificate of right of burial	\$1.00
Number plate or brick	\$3.00
Permission to erect a headstone or monument—5 per cent. of cost with a minimum of \$6.00.	
Permission to construct a brick grave or to erect any stone kerb, brick tilework or concrete	\$5.00
Exhuming the remains of a body (when authorized)	\$30.00
Interment of ashes in a private grave	\$12.00

J. J. MCCARTHY, Trustee.
F. J. BREMNER, Trustee.
R. W. CLOWES, Trustee.

Approved by the Governor in Council, 30th May, 1972.—
J. ROSSITER, Clerk of the Executive Council.

Cemeteries Act 1958.

SCALE OF FEES OF TOWER HILL PUBLIC CEMETERY.

In pursuance of the powers conferred upon them by the *Cemeteries Act* the trustees of the Tower Hill Public Cemetery hereby make the following scale of fees, which shall come into operation upon publication in the *Government Gazette*, and from and after such publication every scale of fees heretofore made by the said trustees shall be and is hereby rescinded to the extent to which it conflicts with this scale.

Purchase of Land, 8 ft. x 4 ft.	\$25.00
Sinking grave to 6 feet	\$25.00
Sinking grave each additional foot	\$4.00
Sinking grave for child under 10 years	\$10.00
Sinking graves on weekends and holidays—extra	\$10.00
Sinking oversize grave for American type casket—extra	\$10.00
Reopening of a grave	\$25.00
Interment Fee	\$8.00
Exhumation of Body (when authorized)	\$25.00
Re-interment of Body (when authorized)	\$25.00
Interment of Ashes	\$4.00
Permission to erect kerb	\$3.00
Permission to erect slab	\$3.00
Permission to erect monument	\$6.30
Permission to inspect plans	\$0.50
Permission to inspect copy of registrar	\$0.50

L. W. GUNN, Trustee.
J. L. CORBETT, Trustee.
A. H. FARAGHER, Trustee.

Approved by the Governor in Council, 30th May, 1972.—
J. ROSSITER, Clerk of the Executive Council.

Cemeteries Act 1958.

SCALE OF FEES OF WOORAK PUBLIC CEMETERY.

In pursuance of the powers conferred upon them by the *Cemeteries Act* the trustees of the Woorak Public Cemetery hereby make the following scale of fees, which shall come into operation upon publication in the *Government Gazette*, and from and after such publication every scale of fees heretofore made by the said trustees shall be and is hereby rescinded to the extent to which it conflicts with this scale.

Interment fee, adult	\$4.00
Interment fee, child under seven years	\$3.00
Sinking grave 6 feet deep for burial of an adult	\$30.00
Each additional foot	\$4.00

Sinking oversize grave (extra)	\$4.00
Sinking grave 4 feet deep for child under seven years	\$12.00
Reopening grave	\$12.00
Exhumation fee (when permitted)	\$24.00
Sinking grave inside railing or kerbing (extra)	\$8.00
Sinking grave inside railing or kerbing with slab cover (extra)	\$10.00

Burials on Saturdays, Sundays and Holidays.

For grave sunk to a depth of 7 feet (extra)	\$7.00
For grave sunk to a depth of 6 feet (extra)	\$6.00
For grave sunk to a depth of 4 feet (extra)	\$4.00
Permission to erect a headstone or monument	\$4.00
Interment of ashes in a private grave	\$6.00

G. W. STEPHAN, Trustee.
R. J. COLLINS, Trustee.
C. J. WALLIS, Trustee.

Approved by the Governor in Council, 30th May, 1972.—
J. ROSSITER, Clerk of the Executive Council.

Cemeteries Act 1958.

SCALE OF FEES OF ORBOST PUBLIC CEMETERY.

In pursuance of the powers conferred upon them by the Cemeteries Act the trustees of the Orbost Public Cemetery hereby make the following scale of fees, which shall come into operation upon publication in the *Government Gazette*, and from and after such publication every scale of fees heretofore made by the said trustees shall be and is hereby rescinded to the extent to which it conflicts with this scale.

Private Graves.

Land, 8 ft. x 4 ft.	\$25.00
HENRY A. WHITE, Trustee.	
J. D. TORLEY, Trustee.	
R. D. SMITH, Trustee.	

Approved by the Governor in Council, 30th May, 1972.—
J. ROSSITER, Clerk of the Executive Council.

TALLANGATTA WATERWORKS TRUST.

FIXING THE LIMIT OF BANK OVERDRAFT.

His Excellency the Governor of the State of Victoria by and with the advice of the Executive Council thereof doth by Order made on the 6th day of June, 1972, fix the total amount of the sums which the Tallangatta Waterworks Trust may owe at any time in respect of moneys borrowed by overdraft of current account, pursuant to the provisions of section 286 of the *Water Act 1958*, at Thirteen thousand dollars (\$13,000).

J. ROSSITER,
Clerk of the Executive Council.

At the Executive Council Chamber,
Melbourne, 6th June, 1972.

TALLANGATTA SEWERAGE AUTHORITY.

INCREASING THE LIMIT OF BANK OVERDRAFT.

His Excellency the Governor of the State of Victoria by and with the advice of the Executive Council thereof doth by Order made on the 6th day of June, 1972, increase the total amount of the sums which the Tallangatta Sewerage Authority may owe at any time in respect of moneys borrowed by overdraft of current account, pursuant to the provisions of section 78 of the *Sewerage Districts Act 1958*, and fixed by the Governor in Council on 17th May, 1966 at Seven thousand dollars (\$7,000), to Ten thousand dollars (\$10,000).

J. ROSSITER,
Clerk of the Executive Council.

At the Executive Council Chamber,
Melbourne, 6th June, 1972.

BARWON HEADS SEWERAGE AUTHORITY.

AUDIT OF ACCOUNTS.

Fee Payable to Auditor.

His Excellency the Governor of the State of Victoria by and with the advice of the Executive Council thereof doth by Order made on the 6th day of June, 1972, and in pursuance of the provisions of the *Sewerage Districts Act 1958* (No. 6368) approve of the payment to B. Pescod, Esq., of the sum of Fifty dollars (\$50) as remuneration for making an audit of the accounts of the Barwon Heads Sewerage Authority from the constitution

of the Authority to 30th September, 1970, he having been duly appointed by Order in Council made on 6th October, 1970, to make such audit.

J. ROSSITER,
Clerk of the Executive Council.

At the Executive Council Chamber,
Melbourne, 6th June, 1972.

PUBLIC TRUSTEE ACT 1958 (No. 6350), SECTION 17.

I hereby give notice that on the 19th May, 1972, the Public Trustee filed elections to administer the following deceased persons' estates in accordance with section 17 of the *Public Trustee Act 1958*:—

BLANCE, JESSIE, late of 79 Blyth-street, Altona, married woman, died 28th March, 1972.

GORDON, LESLIE, late of 50 Whitby-street, West Brunswick, retired rigger, died 22nd February, 1972.

HAZELWOOD, HERBERT LESLIE, late of 178 Miller-street, North Fitzroy, retired timber worker, died 8th March, 1956.

HICK, HENRY ARTHUR, late of 994 Centre-road, South Oakleigh, retired builder, died 9th December, 1971.

HILL, EDITH DOROTHY, late of Flat 3, 32 Ormond-road, Elwood, widow, died 19th March, 1972.

KENT, OLIVE NELLIE, late of 25 Glover-street, South Melbourne, married woman, died 11th April, 1972.

MCPHERSON, BERTHA JEAN, also known as MacPherson, Bertha Jean, late of 107 Disraeli-street, Kew, retired trained nurse, died 21st February, 1972.

N. P. BRODY,
Public Trustee.

256 Flinders-street, Melbourne, 3000, 31st May, 1972.

NOTICE.

Creditors, next of kin and others having claims against the estate of any of the under-mentioned deceased persons are required to send particulars of their claims to the Public Trustee, 256 Flinders-street, Melbourne, Vic. 3000, the personal representative, on or before the 14th August, 1972, after which date the Public Trustee may convey or distribute the assets having regard only to the claims of which the Public Trustee then has notice:—

BEK, CHARLES BENDIXEN, late of Ararat, retired farmer, died 12th June, 1972.

BLANCE, JESSIE, late of 79 Blyth-street, Altona, married woman, died 28th March, 1972.

CARMAN, PEARL, late of 17 Wattle-grove, West Coburg, widow, died 21st March, 1972.

COLLINSON, JOHN THOMAS, late of 1 Marara-road, Caulfield South, retired fuel merchant, died 21st July, 1971.

COX, HARRY FRANCIS, late of 107 Raleigh-road, Maribyrnong, retired storeman, died 25th January, 1972.

CROXEN, FRANCIS HENRY, late of 218 Booran-road, Ormond, printer, died 3rd February, 1972.

GENONI, MARINO FRANCESCO, also known as Marino Frank Genoni, late of section A, men's home, Inala Village, Middleborough-road, Blackburn South, retired farmer, died 3rd December, 1971.

GORDON, LESLIE, late of 50 Whitby-street, West Brunswick, retired rigger, died 22nd February, 1972.

HAZELWOOD, HERBERT LESLIE, late of 178 Miller-street, North Fitzroy, retired timber worker, died 8th March, 1956.

HICK, HENRY ARTHUR, late of 994 Centre-road, South Oakleigh, retired builder, died 9th December, 1971.

HILL, EDITH DOROTHY, late of Flat 3, 32 Ormond-road, Elwood, widow, died 19th March, 1972.

KENNY, THOMAS VINCENT, late of 10 Mackay-street, Essendon, spray painter, died 23rd October, 1971.

KENT, OLIVE NELLIE, late of 25 Glover-street, South Melbourne, married woman, died 11th April, 1972.

LOVELL, THEODORE GEORGE, late of "The Pines", Dalry-road, Healesville, retired sub-station district engineer, died 16th March, 1972.

JACKSON, GEORGE LESLIE, late of 26 Hardy-street, East Brunswick, painter, died 13th February, 1972.

MANNING, ETHEL MAUD VICTORIA, also known as Manning, Ethel, formerly of 31 Embank-grove, Chelsea, late of 43 Newry-street, Windsor, married woman, died 11th February, 1972.

MILLER, ELIZABETH MARY, late of 10 McNae-street, Moonee Ponds, spinster, died 27th February, 1972.

MCPHERSON, BERTHA JEAN, also known as MacPherson, Bertha Jean, late of 107 Disraeli-street, Kew, retired trained nurse, died 21st February, 1972.

PHILIP, JONATHAN HAY, also known as Philip Jonathon Hay, late of 11 Bokhara-road, South Caulfield, retired railway employee, died 26th February, 1972.

SMITH, VICTOR LESLIE, late of 30 Scott-street, Elwood, retired meter maker, died 25th February, 1972.

THOMSON, ADA, formerly of 8 Clark-street, Sunshine, late of Anna House, private hospital, 12 Athol-street, Moonee Ponds, widow, died 2nd March, 1972.

WILLCOX, WILLIAM ARTHUR, late of Auckland, New Zealand, aircraft engineer, died 16th October, 1971.

N. P. BRODY,
Public Trustee.

Melbourne, 31st May, 1972.

CONTRACTS ACCEPTED.—(Series 1971-72.)
VICTORIAN RAILWAYS.

101. Construction of telephone pole-line, Clarkefield to Kyneton at rates (Contract 63767).—C. J. Robertson & Co. (Horsham) Pty. Ltd..

C. S. MORRIS, Secretary for Railways. 2.6.72.

PUBLIC WORKS:

1283. Melbourne, Photographic Laboratory, Lands and Survey Department, replacement of air conditioning plant room equipment in Air Photographic Laboratory and Stereo-Manual Plotting Rooms, \$14,634.00.—Modern Heat & Air Conditioning Co. Pty. Ltd.

1284. Ascot Vale West, Primary School 4025, external renovations, \$4,300.00.—Slavko Burlak.

1285. Northcote, Primary School 3139, erection of two timber framed class-rooms, staffroom and store, \$15,204.75.—Brom Bros.

1286. Mount Dandenong, Observatory, laying of sewer and absorption drains, \$4,476.50.—C. J. Brittain & R. Sutherland.

1287. Lindenow, Primary School 1120, sewerage treatment plant installation, \$6,230.00.—Cassowary Drainage.

1288. Moonee Ponds, Court House, mechanical services, \$11,520.00.—Chadstone Airconditioning Services Pty. Ltd.

1289. Seymour, Court House, erection of new Court House, \$50,940.00.—A. M. Essing Pty. Ltd.

1290. Footscray, Girls High School, erection of a Science Wing, \$61,730.00.—G.T. Constructions.

1291. Parklands, Primary School 4738, external painting, \$5,772.00.—G. & V. Gorgievski.

1292. Daylesford, Primary School 1609, repairs and interior renovations, \$9,980.00.—Peter K. Hauke.

1293. Montpellier, Primary School 4972, erection of 4 additional class-rooms, Library, &c., \$60,632.00.—E. J. Lyons & Son Pty. Ltd.

1294. Melbourne, Titles Office, 283 Queen-street, supply, commissioning and testing of Fire Alarm System, \$9,443.00.—May-Oatway Fire Alarms.

1295. Altona West, Primary School 4862, site works, \$4,325.00.—R. I. & R. F. (Frank) McColl.

1296. Melton South, Primary School 3717, site works, \$4,700.50.—McColl Construction Co.

1297. Sea Lake, Primary School 3273, repairs and painting, \$14,057.00.—Louis Magdic.

1298. Doon, Longerenong Agricultural College, extension and improvements to residence, No. 16, \$14,860.50.—Minyip Builders Pty. Ltd.

1299. Melbourne, Public Trustee's Office, 168 Exhibition-street, supply and installation of P.A.B.X. telephone system, \$32,400.00.—Plessey Communication Systems Pty. Ltd.

1300. Melbourne, Police Headquarters, supply, commissioning and testing of loudspeaking intercom. system, \$7,859.00.—Plessey Communication Systems Pty. Ltd.

1301. Rye, Primary School 1667, internal and external renovations, \$7,350.00.—Show Painters.

1302. Bayview, Primary School 4752, external renovations, \$4,320.00.—M. Sandic.

1303. Clifton Hill, Primary School 3146, construction of new buildings, \$489,401.00.—Alert Constructions.

1304. Traralgon, Technical School, mechanical services—Science Wing, \$14,540.00.—A.T. Heating & Plumbing Pty. Ltd.

1305. Blackburn, Special School, mechanical services—Psychology, Guidance and Speech Therapy Centre, \$17,280.00.—W. S. Atherton & Co. Pty. Ltd.

1306. Horsham, Wheat Research Institute, erection of a barn, \$12,179.00.—Brennan & Foster.

1307. Birchip, High School, external repairs and painting, \$6,940.00.—T. Buljanovic.

1308. Drouin, High School, external repairs and painting, \$11,962.00.—E. Capaldo & Sons Pty. Ltd.

1309. Bendigo, Teachers' College, internal repairs and painting, \$29,800.00.—E. Capaldo & Sons Pty. Ltd.

1310. Beechworth, Mental Hospital, external repairs and painting, male wards 11/12, \$16,500.00.—E. Capaldo & Sons Pty. Ltd.

1311. Queenscliff, Ports and Harbours Branch, design, fabrication and erection of buoy maintenance depot, \$77,800.00.—Crow Industries Pty. Ltd.

1312. Echuca, Primary School 208, internal and external repairs and painting, \$8,340.00.—D. & S. B.R. & P. Service.

G. SERPELL, Director-General. 29.5.72.

GENERAL STORES.

Gazette No. 73, 10th August, 1971, Schedule No. 25, Chemicals.—For date of operation of price shown for Item 33 in Gazette No. 21, of 29th March, 1972, substitute 1st April, 1972. For rates shown opposite Item No. 35, substitute \$30.40 per 20-lb. container, and \$79.20 per 55-lb. container, as from 1st April, 1972. Item No. 18, for "½-lb. or 1-lb. tins, \$9.70 per lb." substitute "½-kilogram tins only, \$21.39 per kilogram".

TOOLS.

Gazette No. 38, 26th April, 1971, Schedule No. 52, Tools (General).—For rates shown opposite the following items substitute the rates set out hereunder, as from 1st May, 1972—Item Nos. 26, 27, and 28, 19 cents per dozen:

FURNITURE (GENERAL).

Gazette No. 75, 11th August, 1971—Schedule No. 39—Furniture, &c.—For rates shown opposite the following items substitute the rates set out hereunder as from 12th May, 1972—Item No. 111, \$7.63 each colour; Item No. 114, \$7.58.

PRISONERS' MEALS IN LOCK-UPS.

Gazette No. 65, 14th July, 1971—Prisoners' Meals—For names of contractors in the following locations substitute the names shown hereunder: Port Melbourne, W. R. Stone; Camberwell, S. Robotis; Heidelberg, L. Powell.

PROVISIONS.

Gazette No. 57, 11th June, 1971—Schedule No. 12—Shepparton District—For rates shown opposite the following items substitute the rates set out hereunder as from 1st June, 1972. Sub-schedule No. 2, Groceries—Item No. 43, \$11.57; Item No. 52, \$3.09 per doz.; Item No. 59, \$8.19. Sub-schedule No. 3, Jams—Apricot, \$5.42; Blackberry, \$8.42; Plum, \$4.84 per 28 lb. tin.

MEAT.

Gazette No. 27, 24th April, 1972—Schedule No. 9—Bendigo District—Sub-schedule No. 2—For "Meat for Sandhurst Boys Centre" substitute "Meat for Bendigo Psychiatric Centre and Sandhurst Boys Centre, Bendigo".

E. P. WATSON, Secretary to the Tender Board. 30.5.72.

TOOLS.

Gazette No. 38, 26th April, 1971, Schedule No. 52, Tools (General).—For rates shown opposite the following items, substitute the rates as set out hereunder:—Item No. 100, rates shown in Government Gazette No. 84 of 15th September, 1971, for Item No. 100 also applicable to Item No. 101 from 3rd September, 1971, to 1st June, 1972. From 2nd June, 1972, for both Item Nos. 100 and 101 substitute the following rates:—½-in. to ¾-in., \$1.40, ¾-in., \$1.50, 1-in., \$1.55, 1¼-in., \$1.67, 1½-in., \$1.72, 1-in., \$1.81. For rates shown opposite the following items, substitute the rates as set out hereunder as from 2nd June, 1972.—Item No. 106, \$1.68; Item No. 211, \$2.87; Item No. 212, \$2.98; Item No. 213, \$3.15.

GENERAL STORES.

Gazette No. 73, 10th August, 1971, Schedule No. 29, Cordage, Lines, &c.—For rates shown opposite the following items, substitute the rates as set out hereunder as from 26th May, 1972.—Item No. 3, \$1.85; Item No. 9, \$1.16; Item No. 10, \$1.51.

PROVISIONS.

Gazette No. 57, 11th June, 1971.—For rates shown opposite the following items, substitute the rates as set out hereunder as from 1st June, 1972, Schedule No. 1, Metropolitan District, Sub-schedule No. 7, Groceries.—Item No. 13, \$2.28; Item No. 25, \$4.53; Item No. 30, \$2.55;

Item No. 31, \$3.34; Item No. 32, \$0.56; Item No. 33, \$0.76; Item No. 68, \$0.35; Item No. 69, \$0.62; Item No. 130, \$4.09; Item No. 131, \$3.66; Item No. 133, \$3.29; Item No. 134, \$3.29; Item Nos. 194, 195 and 196, \$2.78; Sub-schedule No. 8, Item No. 1, \$15.40. Schedule No. 6, Ararat District, Sub-schedule No. 2, Groceries.—Item No. 5, \$14.22; Schedule No. 7, Ballarat District, Sub-schedule No. 2, Teachers College Hostels, Item No. 9, 8 oz., \$3.55, 6 lb., \$3.32; Item No. 29, \$7.64; Item No. 34, \$2.32; Item No. 54, \$12.66; Item No. 114, \$1.61. Schedule No. 12, Shepparton District, Sub-schedule No. 2, Groceries.—Item No. 34, \$3.46; Item No. 77, \$2.79; Sub-schedule No. 3, Jams, Plum and Raspberry, \$5.42, Marmalade, \$4.84.

BUTTER AND CHEESE.

Gazette No. 89, 29th September, 1971, Schedule No. 26, Butter and Cheese.—Rates shown opposite Item Nos. 2, 5, 7, 9, 14, 17 and 19 to be increased from 15th May, 1972, by 3½ cents per lb. for Matured Cheddar Cheese and 3¼ cents per lb. for Semi-Matured Cheddar Cheese.

E. P. WATSON, Secretary to the Tender Board. 7.6.72.

ORDERS IN COUNCIL.—(Series 1971-72.)

PUBLIC WORKS.

1282. Echuca, Primary School 208, supply and installation of L.P. gas heating, \$8,209.47.—Thermal Traders (Vic.) Pty. Ltd.—(N.47201.)

Approved by the Governor in Council, 30th May, 1972.—J. ROSSITER, Clerk of the Executive Council.

STATE ELECTRICITY COMMISSION.

1273. For construction of a building and alterations to existing brick building, Ararat District Office, to Specification No. 72/27, \$53,789.—S. J. Weir Pty. Ltd.

Approved by the Governor in Council, 11th April, 1972.—J. ROSSITER, Clerk of the Executive Council.

1274. For the supply of high temperature creosote oil for protection of wooden poles, to Specification No. 72/63, at Schedule rates.—Albion Reid Pty. Ltd.

1275. For the supply of dry premixed concrete, to Specification No. 72/67, at Schedule rates.—Colortex Plaster and Sand Pty. Ltd.

1276. For the supply of enamelled air heater element packs for Hazelwood Power Station, to Specification No. 72/75, \$106,608.—Metters Ltd.

1277. For the supply of fluorescent lamps, to Specification No. 72/71, at Schedule rates.—Thorn Lighting Industries.

Approved by the Governor in Council, 18th April, 1972.—J. ROSSITER, Clerk of the Executive Council.

1278. For the construction of two steel-framed A.C. sheeted buildings and associated site works, Wangaratta District Depot, to Specification No. 72/16, \$85,376.—L. H. Brown Constructions Pty. Ltd. (Wangaratta).

1279. For the supply of pipes and miscellaneous iron castings, to Specification No. 72/60, at Schedule rates.—H. Madden and Son.

1280. For the supply of pipes and miscellaneous iron castings, to Specifications No. 72/60, at Schedule rates.—T. Main & Son Pty. Ltd.

1281. For the supply and mounting of four crane borers for distribution line construction and maintenance, to Specification No. 72/108, \$71,099.—Superlift Equipment (Vic.) Pty. Ltd.

Approved by the Governor in Council, 26th April, 1972.—J. ROSSITER, Clerk of the Executive Council.

APPOINTMENTS AND RESIGNATIONS

APPOINTMENTS.

His Excellency the Governor of the State of Victoria, by and with the advice of the Executive Council thereof, has, by Orders made on the 30th day of May, 1972, been pleased to make the under-mentioned appointments, viz.:—

CROWN LANDS AND SURVEY DEPARTMENT.

Balliffs of Crown Lands.

KENNETH MORRISON and
CLIVE COCUM,
to be balliffs of Crown Lands, with respect to the Mallocoota Inlet National Park, pursuant to section 30 of the *Land Act 1958*.

4640/72.—2

CYRIL B. COUCH
to be a bailiff of Crown Lands, with respect to the "Port Campbell National Park", and the lands in the Township of Port Campbell, temporarily reserved as sites for Public purposes (National Parks Authority purposes), pursuant to section 30 of the *Land Act 1958*.

MINISTRY OF HEALTH.

Trustees of Cemeteries.

MALCOLM ROBERT SANDERS,
to be a Trustee of the Quantong Public Cemetery, vice A. Sanders, resigned;

CHARLES HALL
to be a Trustee of the Patho and Torrumbarry Public Cemetery, vice A. Hall, deceased; and

GEORGE MAPSON
to be a Trustee of the Muckleford Public Cemetery, vice W. J. Hapson, deceased, pursuant to section 3 (1) of the *Cemeteries Act 1958*.

Public Vaccinators.

DOROTHY MARIAN GEPP, M.B., B.S.,
to be Public Vaccinator for the Municipality of the Shire of Diamond Valley;

ALEXANDER MARSHALL, M.B., B.S.,
to be Public Vaccinator for the Municipality of the City of Port Melbourne; and

MIRIAM DANIEL, M.B., B.S.,
to be Public Vaccinator for the Municipality of the Borough of Eaglehawk, pursuant to section 151 of the *Health Act 1958*.

Superintendent of Mental Hospital and Training Centre, Warrnambool.

JAMES FINLAY ROBERTSON, M.B., Ch.B., D.P.M., D.P.H.,
M.A.N.Z.C.P.

to be Superintendent, Mental Hospital, Warrnambool and Training Centre, Warrnambool, pursuant to section 26 (1) of the *Mental Health Act 1959*, from the 22nd May, 1972, to the 12th June, 1972, both dates inclusive, vice Dr. Hannah, on annual leave.

Member of Committee of Management of Hospital.

HAROLD DOUGLAS STEWART
to be the Government Appointee on Committee of Management of the After Care Hospital, for a term of three years commencing the 24th June, 1972, pursuant to the provisions of sub-paragraph (ii) of paragraph (a) of the proviso to sub-section (1) of section 48 of the *Hospitals and Charities Act 1958*.

LAW DEPARTMENT.

Commissioners for Taking Declarations, &c.

DENIS MICHAEL SANDERS, care of State Law Offices,
221 Queen-street, Melbourne,

KEITH NEIL WEST, care of State Electricity Commission of Victoria, 15 William-street, Melbourne,

JOHN WRAITH FITZMAURICE, care of Repatriation

General Hospital, West Heidelberg,
LAURENCE MAXWELL FOLEY, care of Repatriation

General Hospital, West Heidelberg,

JAMES MICHAEL MCKANE,
GEORGE HENRY PORTER, and

EDWARD ALBERT TREWARTHA TUCKER, care of Chief Secretary's Department, Spring-street, Melbourne,
and

CHRISTOPHER CHARLES BOLLEN, care of Department of Agriculture, 3 Treasury-place, Melbourne,

to be Commissioners for taking Declarations and Affidavits, pursuant to the provisions of the *Evidence Act 1958*, to refrain from charging fees and to resign upon ceasing to occupy their present positions;

STEPHEN ALBERT BURCHETT SMITH, 320A Clayton-road, Clayton.

MURRAY HARRIS PRATT, care of Wridgways (Vic.) Pty. Ltd., 2 Camberwell-road, Auburn,

JOHN CROSBIE GOULD, care of William Crosby Holdings Ltd., 31-39 Queens Bridge-street, South Melbourne,

RONALD MILTON DOUGLAS, care of Douglas, Clark, Neilson and Associates, 1014 Doncaster-road, Doncaster East,

ROBERT BERTRAM KEAST, care of H. M. Keast & Sons Pty. Ltd., 11 McIntyre-street, Burwood,

IAN ROBERT BARTHOLOMEW, care of Remington Rand, 334-342 City-road, South Melbourne,

GEOFFREY BARNES, care of Kortum's Sandown Park Hotel, cnr. Princes Highway and Corrigan-road, Noble Park,

KEVIN ARTHUR HODGKINSON, care of Goulburn Valley Taxation Services Pty. Ltd., 5 Lake-road, Kyabram, and
 THOMAS HENRY BLIGHT, care of Allan Coffey Motors Pty. Ltd., 85 Lonsdale-street, Dandenong,
 to be Commissioners for taking Declarations and Affidavits pursuant to the provisions of the Evidence Act 1958, to resign upon ceasing to occupy their present positions.

ELWYN ANTHONY WRIDE, 80 Oakwood-avenue, Noble Park,

WILLIAM ARTHUR BROOKS, 36 Edinburgh-street, Hallam, IRENE RUTH HARRIS, 50 Argo-street, South Yarra, THOMAS WRIGHT ADKINS, 26 Brandy Creek-road, Warragul,

FREDERICK MOLLOY, 9 Blackwood-street, Lalor, EDITH MAY MELEN, Argyle-road, Maryborough, FRANK SANSOME, 15 Longstaff-street, East Ivanhoe, and RICHARD LEWELLYN SHEPPARD, 48 Headingley-road, Mt. Waverley,

to be Commissioners for taking Declarations and Affidavits, pursuant to the provisions of the Evidence Act 1958, to resign upon removing from the neighbourhood of the addresses stated.

Justices of the Peace.

THOMAS JAMES CROFT, 5 Palmerston-grove, Oakleigh, and

LINDSAY DONALD ROSS, Main-road, Lindenow, to keep the Peace in the State of Victoria.

PUBLIC WORKS DEPARTMENT.

Port Officer and Deputy Port Officer.

DAVID PHILIP BARKLEY, and JOHN ROBERT ASHWORTH,

to be Port Officer and Deputy Port Officer in Victoria, respectively, as on and from 6th June, 1972, during the absence from Victoria of Albert John Wagglan.

Wharf Manager.

Senior Sergeant PATRICK JOHN HEALY, No. 9758, to be Wharf Manager at Sandringham, to carry out that portion of Part II. of the Marine Act 1958 which relates to the management of Public Wharves and to be an officer under section 19 of such Act, to levy and collect wharfage rates thereat, vice Senior Sergeant Harry Edward Withers, No. 9986, transferred.

DEPARTMENT OF WATER SUPPLY.

Waterworks Trusts Commissioners.

WILLIAM PAUL FLEMING, HUGH STEEL, and ALLAN JAMES STUTE,

to be Commissioners of the Broadford Waterworks Trust, to hold such position for a period of four years from 1st June, 1970, subject to the provisions of the Water Act.

ROY ALBERS, and NORMAN JOHN COOPER,

to be Commissioners of the Thornton Waterworks Trust, to hold such position for a period of four years from 4th June, 1972, subject to the provisions of the Water Act.

J. ROSSITER,
 Clerk of the Executive Council.

At the Executive Council Chamber,
 Melbourne, 30th May, 1972.

National Parks Act 1970.

APPOINTMENT.

Notice is hereby given that K. Robertson, Service Inspector, Lands Department, Bairnsdale, has been appointed as a member of The Lakes National Park Committee of Management for the period ending 30th September, 1972, (representing National Parks interests).

L. H. SMITH,
 Director of National Parks.

RESIGNATIONS.

His Excellency the Governor of the State of Victoria, by and with the advice of the Executive Council thereof, has, by Orders made on the 30th day of May, 1972, accepted the resignations of the persons named hereunder of the offices mentioned, viz.:—

LAW DEPARTMENT.

Commissioners for Taking Declarations, &c.

JOHN MCINROY,
 RICHARD THOMAS TASMAN O'BREE,
 GRAHAM WILLIAM PASCOE, and

JOHN GORDON WELSH,
 as Commissioners for taking Declarations and Affidavits, pursuant to the provisions of the Evidence Act 1958.

Justices of the Peace.

WILLIAM ARCHIBALD CRELLIN, and ARTHUR PENN YATES,
 as Justices of the Peace for the State of Victoria.
 J. ROSSITER,
 Clerk of the Executive Council.

At the Executive Council Chamber,
 Melbourne, 30th May, 1972.

ORDERS IN COUNCIL

DEPARTMENT OF CROWN LANDS AND SURVEY.

At the Executive Council Chamber, Melbourne, the thirtieth day of May, 1972.

PRESENT:

His Excellency the Governor of Victoria.
 Mr. Borthwick | Mr. Smith.

UNUSED ROADS CLOSED.

His Excellency the Governor of the State of Victoria, by and with the advice of the Executive Council thereof, doth hereby direct that, in pursuance of the provisions of section 349 of the Land Act 1958, the unused roads referred to hereunder be closed, viz.:—

Township of Myrtleford, Parish of Myrtleford, County of Bogong, being the road indicated by hatching on plan hereunder.—(M.294⁽⁴⁾) (Rs.9624).

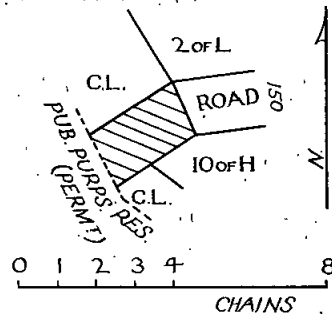

Parish of Beechworth, County of Bogong, being the roads indicated by hatching on plan hereunder.—(B.349⁽²¹⁾) (Rs.9606).

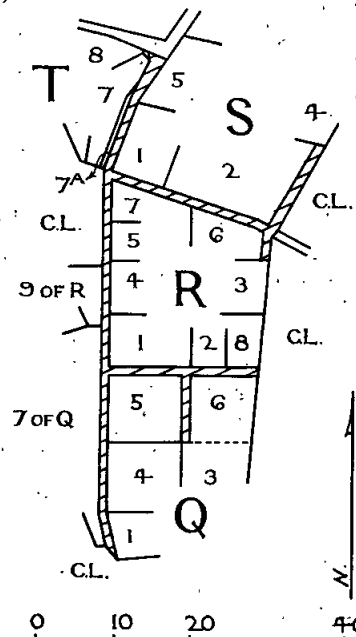

Parish of Brimbonga, County of Evelyn, being the road indicated by hatching on plan hereunder.—(B.763(1) (G.68695).

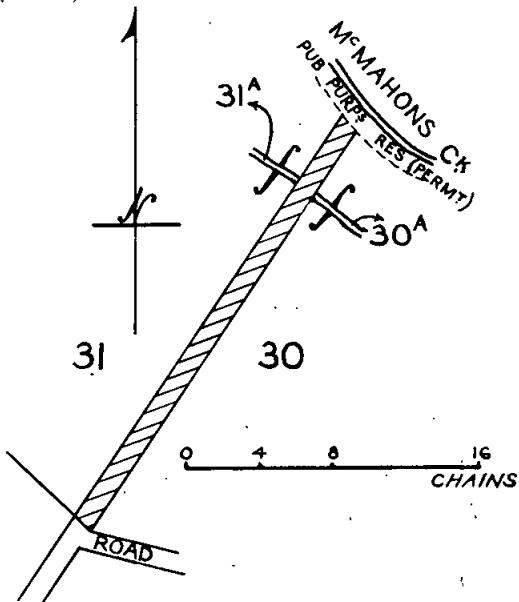

An the Honorable William Archibald Borthwick, Her Majesty's Minister of Lands for the State of Victoria, shall give the necessary directions herein accordingly.

J. ROSSITER,
Clerk of the Executive Council.

DEPARTMENT OF CROWN LANDS AND SURVEY.

At the Executive Council Chamber, Melbourne, the thirtieth day of May, 1972.

PRESENT:
His Excellency the Governor of Victoria.
Mr. Borthwick | Mr. Smith.

LANDS TEMPORARILY RESERVED AS SITES.

His Excellency the Governor of the State of Victoria, by and with the advice of the Executive Council thereof, doth hereby, in pursuance of section 14 of the Land Act 1958, reserve temporarily from sale, from being leased and from having a licence granted in respect thereof, and also except from occupation for mining purposes under any miner's right, the land hereinafter described:—

WONTHAGGI.—Site for Public Recreation purposes, 1 acre 14 perches, Township of Wonthaggi, Parish of Wonthaggi, County of Mornington, as indicated by hatching on plan hereunder.—(W.345(17) (Rs.9627).

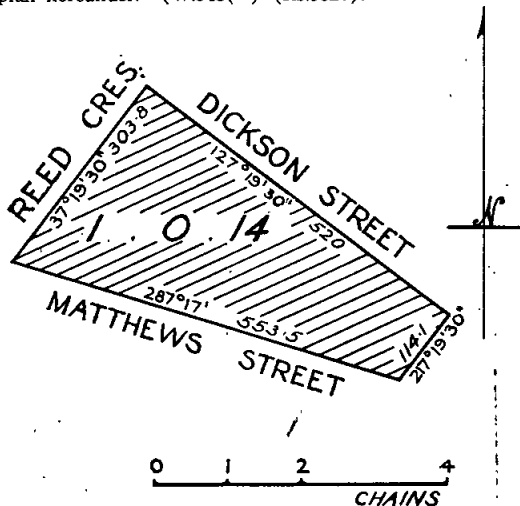

WERRIMULL.—Site for Water Supply purposes, 2 roods 10 perches, Township of Werrimull, Parish of Murrroong, County of Millewa, as indicated by hatching on plan hereunder.—(W.423(4) (Rs.9618)

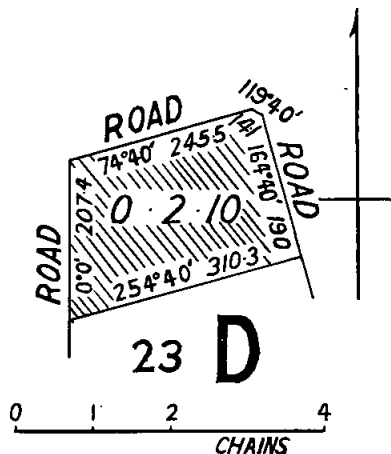

WERRIMULL.—Site for Water supply purposes, 1 acre 3 roods 28 perches, Township of Werrimull, Parish of Werrimull, County of Millewa, as indicated by hatching on plan hereunder.—(W.423(4) (Rs.9617).

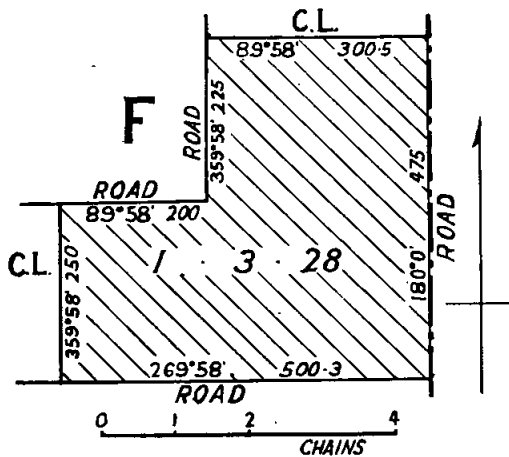

UNDERBOOL.—Site for a Reservoir, 14 acres, more or less, Parish of Underbool, County of Weeah, as indicated by hatching on plan hereunder.—(U.65(3) (Rs.9568).

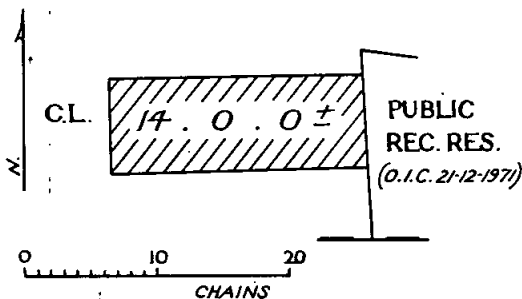

SEBASTOPOL.—Site for Public purposes (Municipal Depot), 3 acres 1 rood 5 perches, Township of Sebastopol, Parish of Ballarat, County of Grenville, as indicated by hatching on plan hereunder.—(S.353⁽¹⁰⁾) (Rs.9616).

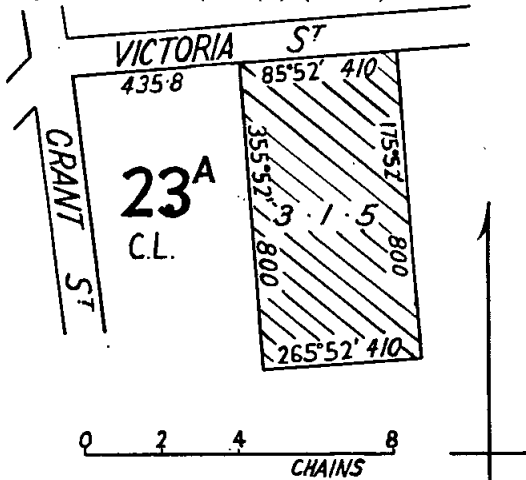

KEELBUNDORA (MACLEOD).—Site for Public purposes (Day Training Centre), 1 acre 3 roods 6 perches, Parish of Keelbundora, County of Bourke, as indicated by hatching on plan hereunder.—(K.25⁽⁶⁾) (Rs.9608).

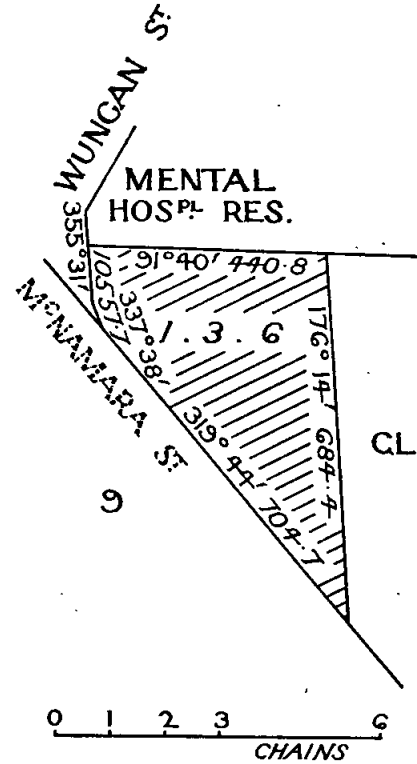

MELBOURNE SOUTH (PORT MELBOURNE).—Site for Public purposes (Municipal Depot), 8 acres 1 rood, more or less, City of Port Melbourne, Parish of Melbourne South, County of Bourke, as indicated by hatching on plan hereunder.—(M.334⁽²¹⁾) (Rs.9592).

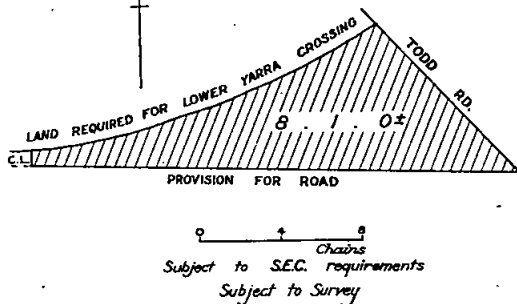

DARTMOOR.—Site for Public purposes (Tourists Camp), 1 acre 3 roods 25 perches, more or less, Township of Dartmoor, Parish of Dartmoor, County of Follett, as indicated by hatching on plan hereunder.—(D.32⁽⁶⁾) (Rs.4933).

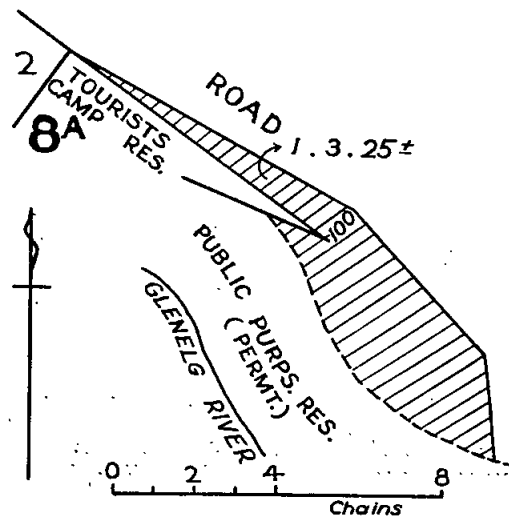

MYRTLEFORD.—Site for Railway purposes, 23 perches, Township of Myrtleford, Parish of Myrtleford, County of Bogong, as indicated by hatching on plan hereunder.—(M.294⁽⁴⁾) (Rs.9619).

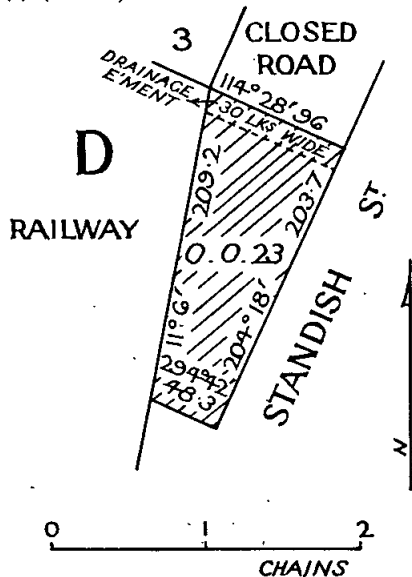

BENJEROOP.—Site for Public purposes (Picnic Reserve and Caravan Park), 12 acres 1 rood 39 perches, Parish of Benjeroop, County of Tatchera, as indicated by hatching on plan hereunder.—(B.694(*) (Rs.9625):

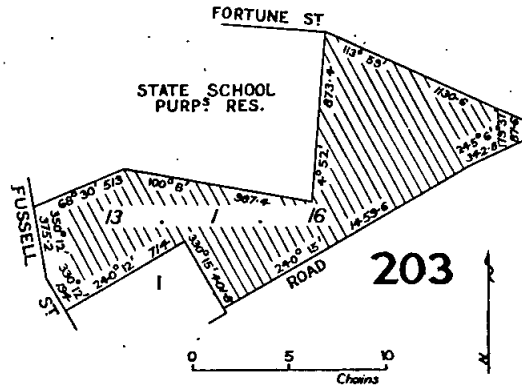
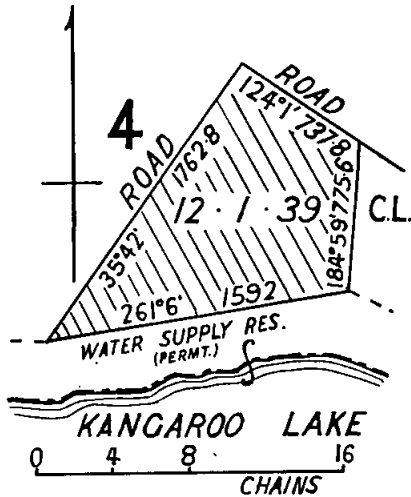

And the Honorable William Archibald Borthwick, Her Majesty's Minister of Lands for the State of Victoria, shall give the necessary directions herein accordingly.

J. ROSSITER,
Clerk of the Executive Council.

COUNTRY ROADS BOARD.

At the Executive Council Chamber, Melbourne, the thirtieth day of May, 1972.

PRESENT:

His Excellency the Governor of Victoria.
Mr. Borthwick | Mr. Smith.

BALLARAT EAST.—Site for Public purposes (Pre-School Centre), 1 rood 4 perches, Township of Ballarat East, Parish of Ballarat, County of Grenville, as indicated by hatching on plan hereunder.—(B.203(H) (Rs.9603).

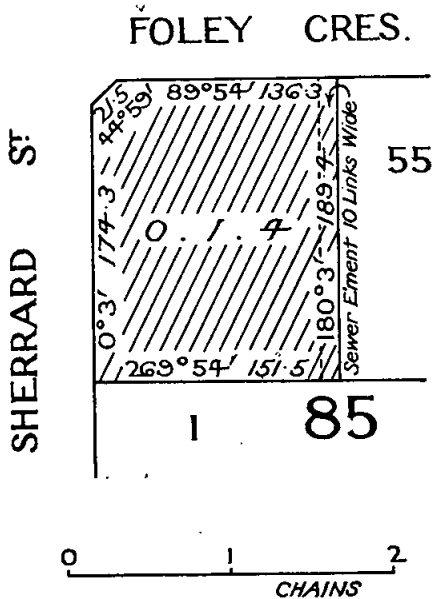

ORDER APPROVING OF LAND BEING ACQUIRED AND ROADS, DEVIATIONS OR WIDENINGS BEING MADE.

His Excellency the Governor of the State of Victoria, by and with the advice of the Executive Council thereof, being satisfied that there are funds legally available for acquiring the land, doth hereby approve the acquiring of the land described in the schedule hereunder and the making of new roads and deviations from and widenings of existing roads referred to in the said schedule.

SCHEDULE.

State Highway.

The land shown hatched on Plan numbered G.P.12812 hereunder required for the deviation from the Princes Highway in the Shire of Orbost and making of the deviation thereon.

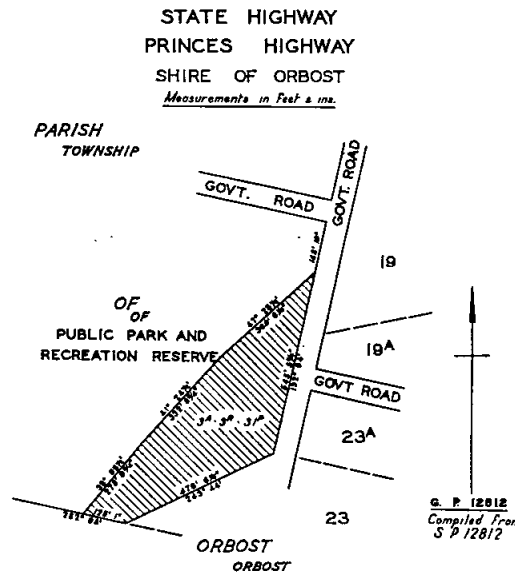

BALLARAT EAST.—Site for State School purposes, 13 acres 1 rood 16 perches, Township of Ballarat East, Parish of Ballarat, County of Grant, as indicated by hatching on plan hereunder.—(B.128(**) (Rs.7378).

G. P. 12812
Compiled from
S.P. 12812

Main Roads.

The land shown hatched on Plans numbered G.P.12906, G.P.12907, G.P.12908A and G.P.12908B hereunder required for the widening of the Beaconsfield-Emerald road in the Shire of Berwick and making of the widening thereon.

MAIN ROAD
BEACONSFIELD - EMERALD ROAD
SHIRE OF BERWICK

Measurements in links.

MAIN ROAD
BEACONSFIELD - EMERALD ROAD
SHIRE OF BERWICK

Measurements in links.

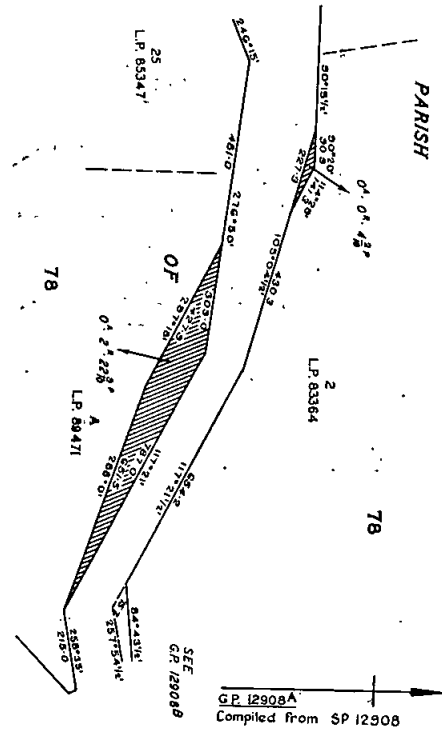
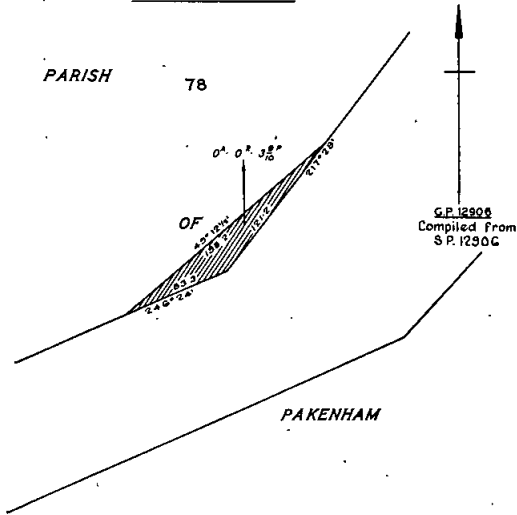

MAIN ROAD
BEACONSFIELD - EMERALD ROAD
SHIRE OF BERWICK

Measurements in links.

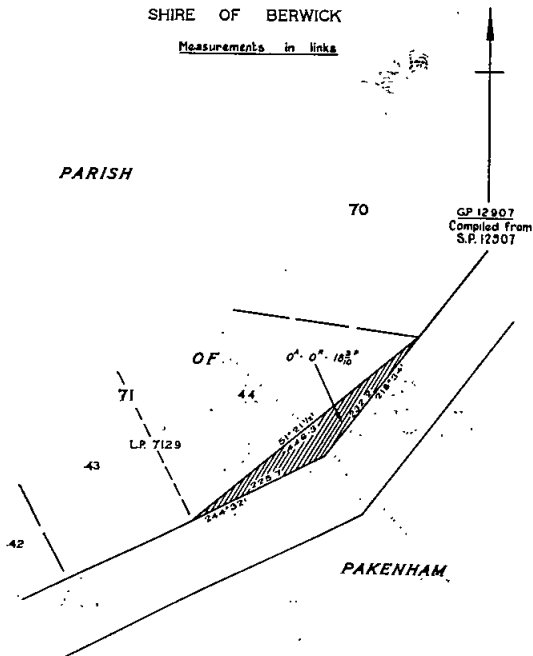

MAIN ROAD
BEACONSFIELD - EMERALD ROAD
SHIRE OF BERWICK

Measurements in links.

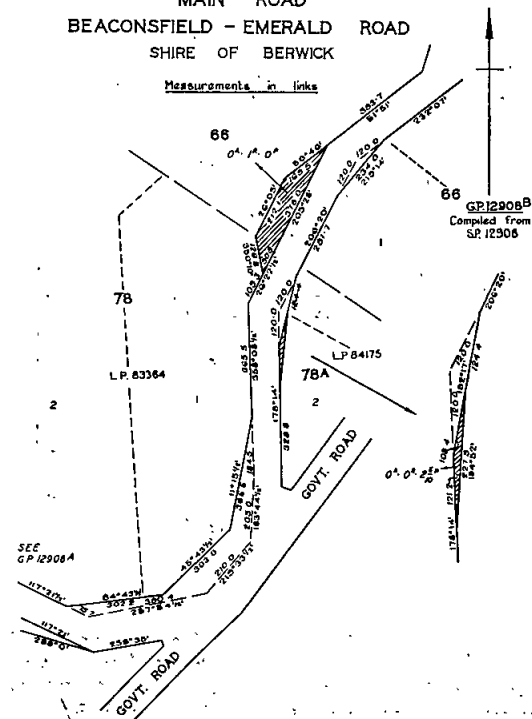

The land shown hatched on Plan numbered G.P.12917 hereunder required for the deviation from the Eltham-Yarra Glen road in the Shire of Healesville and making of the deviation thereon.

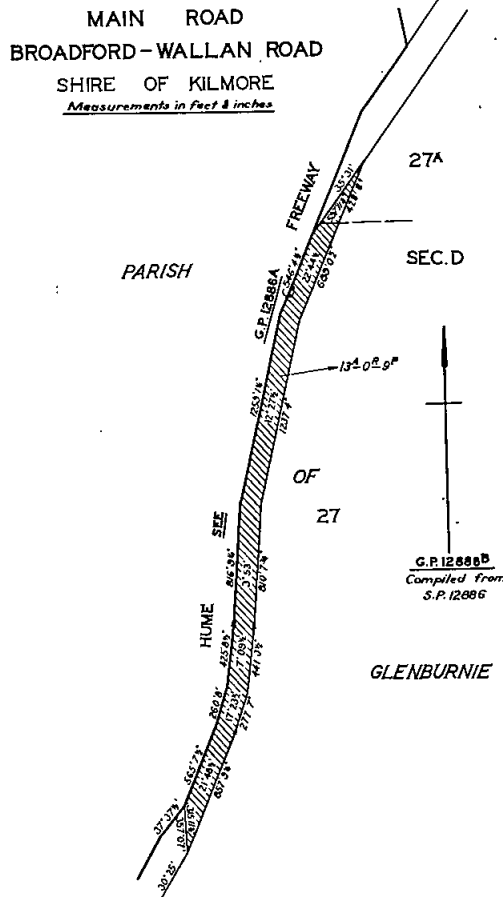
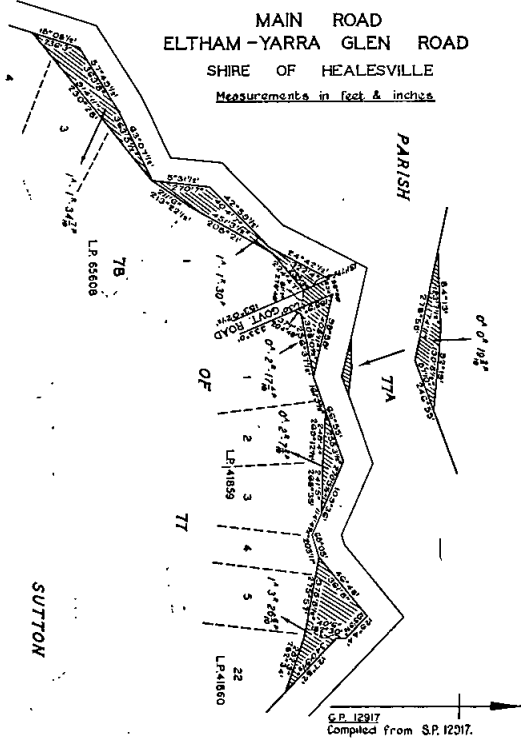

The land shown hatched on Plans numbered G.P.12885B, G.P.12886B, and G.P.12888B hereunder required for the deviation from the Broadford-Wallan road in the Shire of Kilmore and making of the deviation thereon.

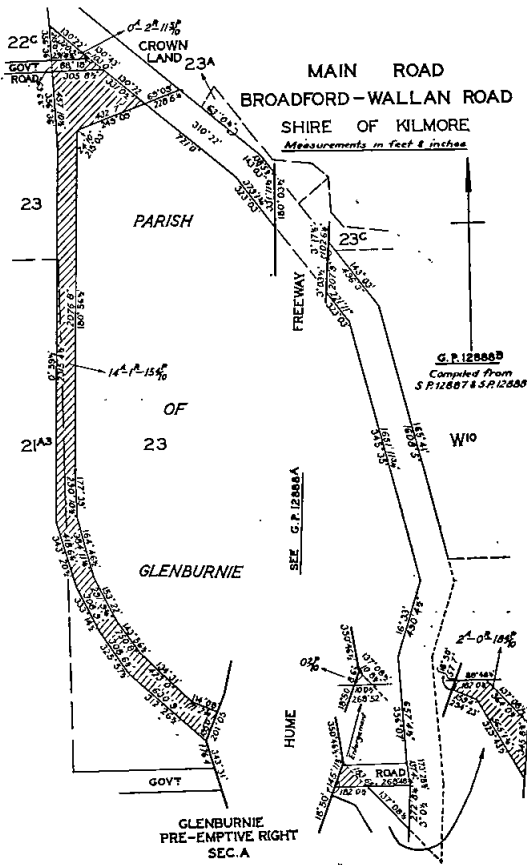
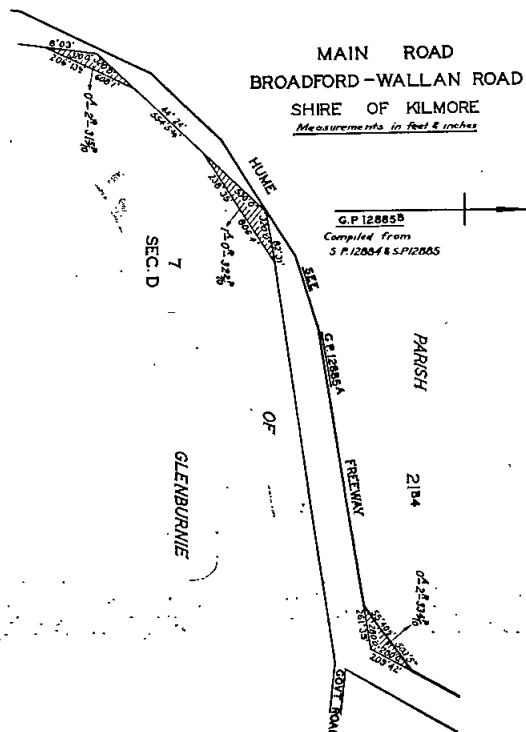

The land shown hatched on Plans numbered G.P.12889A and G.P.12889B hereunder required for the deviation from the Bena-Poowong road in the Shire of Korumburra and making of the deviation thereon.

The land shown hatched on Plan numbered G.P.12919 hereunder required for the widening of Creswick-road in the Shire of Newstead and making of the widening thereon.

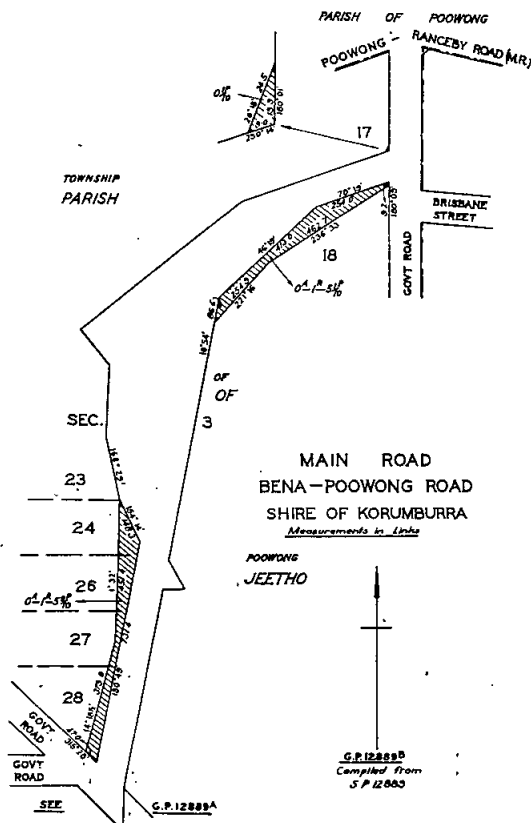
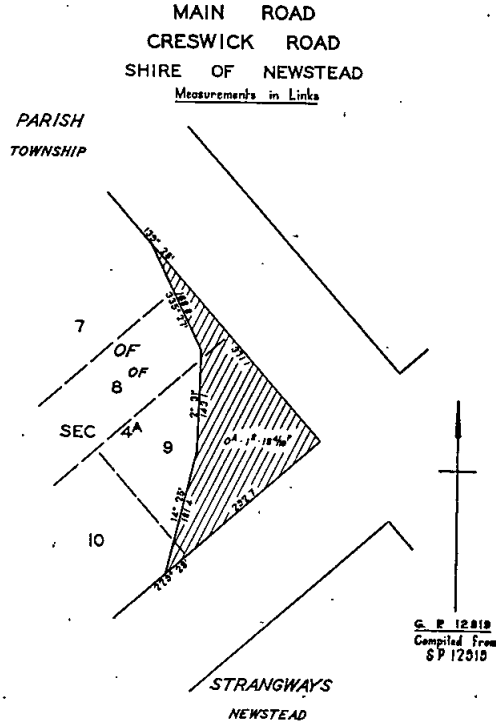
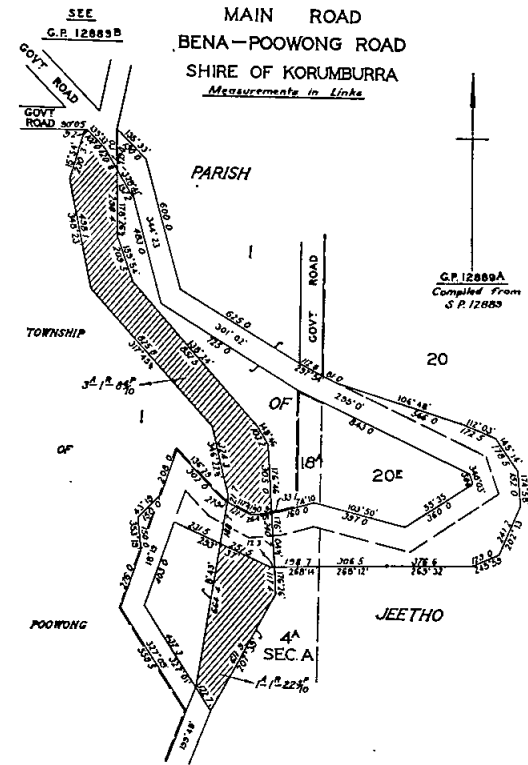

And the Honorable Alan John Hunt, Her Majesty's Minister for Local Government for the State of Victoria, shall give the necessary directions herein accordingly.

J. ROSSITER,
Clerk of the Executive Council.

CEMETERIES ACT 1958 (No. 6217), SECTION 36.

At the Executive Council Chamber, Melbourne, the thirtieth day of May, 1972.

PRESENT:

His Excellency the Governor of Victoria.
Mr. Borthwick | Mr. Smith.

Pursuant to section 36 of the Cemeteries Act 1958, His Excellency the Governor of the State of Victoria, by and with the advice of the Executive Council of the said State, hereby directs that the sum of One thousand and fifty dollars (\$1,050), being part of the balance of funds in the hands of the trustees of the Footscray General Cemetery, be expended on repairs to and replacement of boundary fencing at the Cemetery.

And the Honorable Roberts Christian Dunstan, Her Majesty's Acting Minister of Health for the State of Victoria, shall give the necessary directions herein accordingly.

J. ROSSITER,
Clerk of the Executive Council.

SUPERANNUATION ACT 1958.

At the Executive Council Chamber, Melbourne, the thirtieth day of May, 1972.

PRESENT:

His Excellency the Governor of Victoria.
Mr. Borthwick | Mr. Smith.

Pursuant to the provisions of paragraph (ja) of sub-section (1) of section 3 of the Superannuation Act 1958, His Excellency the Governor of the State of Victoria, by and with the advice of the Executive Council thereof, doth

by this Order declare that the provisions of the Superannuation Act shall apply to Maxwell Bruce Hudson, an officer of the Victoria Institute of Colleges constituted pursuant to the provisions of the *Victoria Institute of Colleges Act 1965*, No. 7291.

And the Honorable Sir Henry Edward Bolte, Her Majesty's Treasurer for the State of Victoria, shall give the necessary directions herein accordingly.

J. ROSSITER,
Clerk of the Executive Council.

Water Act 1958.

STATE RIVERS AND WATER SUPPLY COMMISSION.

At the Executive Council Chamber, Melbourne, the sixth day of June, 1972.

PRESENT:
His Excellency the Governor of Victoria.
Mr. Wilcox | Mr. Dunstan.

FRANKSTON-MORNINGTON URBAN DISTRICT—AREA OF DISTRICT INCREASED.

Under the powers conferred by the *Water Act 1958* and all other powers enabling him in that behalf, His Excellency the Governor of the State of Victoria, with the advice of the Executive Council of the said State, on the recommendation of the State Rivers and Water Supply Commission, doth hereby declare, order and direct that the area of the Frankston-Mornington Urban District be increased by adding to the same the lands shown by blue colour on a plan approved by the Governor in Council and deposited in the office of the State Rivers and Water Supply Commission, Melbourne (Corr. No. 62/5760) and as on and from the 1st day of July, 1972, the area of such District shall be deemed to be so increased.

And the Honorable Roberts Christian Dunstan, Her Majesty's Minister of Water Supply for the State of Victoria, shall give the necessary directions herein accordingly.

J. ROSSITER,
Clerk of the Executive Council.

MILDURA URBAN WATER TRUST.

At the Executive Council Chamber, Melbourne, the sixth day of June, 1972.

PRESENT:
His Excellency the Governor of Victoria.
Mr. Wilcox | Mr. Dunstan.

EXTENT OF URBAN DISTRICT INCREASED.

Under the powers conferred by the *Mildura Irrigation and Water Trusts Act* and all other powers enabling him in that behalf, His Excellency the Governor of the State of Victoria, by and with the advice of the Executive Council of the said State, doth hereby declare, order and direct that the extent of the Urban District of the Mildura Urban Water Trust be increased by adding to the same the lands comprised within the boundaries shown on a plan approved by the Governor in Council and deposited in the office of the State Rivers and Water Supply Commission, Melbourne (Corr. No. 68/1930/104) and as on and from the date hereof, the extent of such District shall be deemed to be increased accordingly.

And the Honorable Roberts Christian Dunstan, Her Majesty's Minister of Water Supply for the State of Victoria, shall give the necessary directions herein accordingly.

J. ROSSITER,
Clerk of the Executive Council.

OCEAN GROVE SEWERAGE AUTHORITY.

At the Executive Council Chamber, Melbourne, the sixth day of June, 1972.

PRESENT:
His Excellency the Governor of Victoria.
Mr. Wilcox | Mr. Dunstan.

REPEAL OF ORDER.

Under the powers conferred by the *Sewerage Districts Act* and all other powers enabling him in that behalf, His Excellency the Governor of the State of Victoria, by and with the advice of the Executive Council of the said State, doth hereby repeal the Order in Council made on 24th August, 1971, and published in the *Victoria Government Gazette* dated 25th August, 1971, consenting to the Ocean Grove Sewerage Authority borrowing the sum of Fifty thousand dollars (\$50,000), to meet the cost of sewerage works.

And the Honorable Roberts Christian Dunstan, Her Majesty's Minister of Water Supply for the State of Victoria, shall give the necessary directions herein accordingly.

J. ROSSITER,
Clerk of the Executive Council.

DROMANA-ROSEBUD SEWERAGE AUTHORITY.

At the Executive Council Chamber, Melbourne, the sixth day of June, 1972.

PRESENT:
His Excellency the Governor of Victoria.
Mr. Wilcox | Mr. Dunstan.

CONSENT TO BORROWING \$250,000.

Under the powers conferred by the *Sewerage Districts Act* and all other powers enabling him in that behalf, His Excellency the Governor of the State of Victoria, by and with the advice of the Executive Council of the said State, doth hereby consent to the Dromana-Rosebud Sewerage Authority borrowing the sum of Two hundred and fifty thousand dollars (\$250,000) to meet the cost of sewerage works as set forth in the detailed statement bearing date 24th May, 1972.

And the Honorable Roberts Christian Dunstan, Her Majesty's Minister of Water Supply for the State of Victoria, shall give the necessary directions herein accordingly.

J. ROSSITER,
Clerk of the Executive Council.

FRANKSTON SEWERAGE AUTHORITY.

At the Executive Council Chamber, Melbourne, the sixth day of June, 1972.

PRESENT:
His Excellency the Governor of Victoria.
Mr. Wilcox | Mr. Dunstan.

CONSENT TO BORROWING \$50,000.

Under the powers conferred by the *Sewerage Districts Act* and all other powers enabling him in that behalf, His Excellency the Governor of the State of Victoria, by and with the advice of the Executive Council of the said State, doth hereby consent to the Frankston Sewerage Authority borrowing the sum of Fifty thousand dollars (\$50,000), for the carrying out of works in accordance with the provisions of sections 95, 130 and 137 of the *Sewerage Districts Act 1958*. All moneys received by the said Authority in payment of costs and expenses of the said works, or any of them, shall be set aside for the purpose of and applied in repayment to the said sum so borrowed.

And the Honorable Roberts Christian Dunstan, Her Majesty's Minister of Water Supply for the State of Victoria, shall give the necessary directions herein accordingly.

J. ROSSITER,
Clerk of the Executive Council.

WARRNAMBOOL SEWERAGE AUTHORITY.

At the Executive Council Chamber, Melbourne, the sixth day of June, 1972.

PRESENT:

His Excellency the Governor of Victoria.
Mr. Wilcox | Mr. Dunstan.

CONSENT TO BORROWING \$50,000.

Under the powers conferred by the Sewerage Districts Act and all other powers enabling him in that behalf, His Excellency the Governor of the State of Victoria, by and with the advice of the Executive Council of the said State, doth hereby consent to the Warrnambool Sewerage Authority borrowing the sum of Fifty thousand dollars (\$50,000) to meet the cost of sewerage works as set forth in the detailed statement bearing date 24th May, 1972.

And the Honorable Roberts Christian Dunstan, Her Majesty's Minister of Water Supply for the State of Victoria, shall give the necessary directions herein accordingly.

J. ROSSITER,
Clerk of the Executive Council.

HOUSING ACT 1958.

At the Executive Council Chamber, Melbourne, the sixth day of June, 1972.

PRESENT:

His Excellency the Governor of Victoria.
Mr. Wilcox | Mr. Dunstan.

CLOSING OF A ROAD—CITY OF FITZROY.

Whereas by virtue and in exercise of the powers contained in the Housing Act 1958 (No. 6275) Housing Commission has recommended to the Governor in Council that the road described in the Schedule hereto be closed:

Now therefore, His Excellency the Governor of the State of Victoria, in the Commonwealth of Australia, by and with the advice of the Executive Council of the said State, doth, in pursuance of the powers conferred by the said Act and upon such recommendation, consent and by this Order hereby close such road.

SCHEDULE.

So much of a road known as King William-street, and situate within Crown portion 70, Parish of Jika Jika, as is delineated and hachured on the plan hereunder.

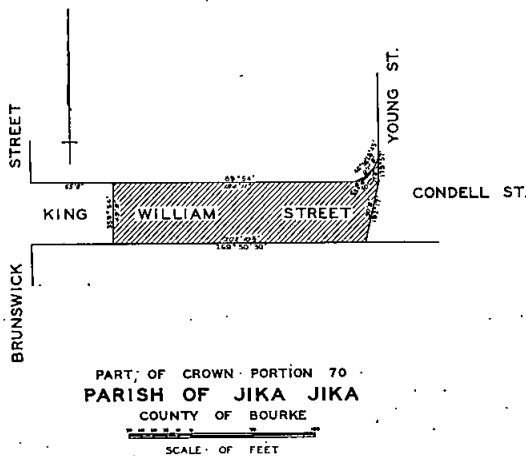

And the Honorable William Archibald Borthwick, Her Majesty's Acting Minister of Housing for the State of Victoria, shall give the necessary directions herein accordingly.

J. ROSSITER,
Clerk of the Executive Council.

LABOUR AND INDUSTRY ACT 1958.

At the Executive Council Chamber, Melbourne, the sixth day of June, 1972.

PRESENT:

His Excellency the Governor of Victoria.
Mr. Wilcox | Mr. Dunstan.

VARIATION OF POWERS OF THE CLEANERS BOARD.

In pursuance of the powers conferred by the Labour and Industry Act 1958, His Excellency the Governor of the State of Victoria, by and with the advice of the Executive Council thereof, doth hereby vary the powers of the Cleaners Board so that in substitution for the powers heretofore conferred on the said Cleaners Board it shall be appointed for the occupation of any person employed at office cleaning or general cleaning work of a like character—

- (a) by any cleaning contractor, in or about any building including a private dwelling-house; or
- (b) otherwise than by a cleaning contractor, in or about any building other than a private dwelling-house or a building occupied by a religious group or society and used by it for the conduct of the activities of such group or society—

but excluding persons subject to the jurisdiction of the Boarding School Employees Board, the Builders Labourers Board, the Hospital and Benevolent Homes Board, or the Hotel, Restaurant and Boarding Houses Board.

And the Honorable Joseph Anstice Rafferty, Her Majesty's Minister of Labour and Industry for the State of Victoria, shall give the necessary directions herein accordingly.

J. ROSSITER,
Clerk of the Executive Council.

LANDS DEPARTMENT NOTICES

APPROACHING LAND SALES.

Sales of Crown Lands, in fee-simple, will be held at the under-mentioned places and dates, viz.:

	No. of Gazette.
Ballarat.—Thursday, 8th June, 1972 ..	30
Chiltern.—Wednesday, 21st June, 1972 ..	32
Daylesford.—Thursday, 15th June, 1972 ..	31
Ultima.—Thursday, 29th June, 1972 ..	32

PROPOSED REVOCATIONS OF TEMPORARY RESERVATIONS OF LANDS BY ORDERS IN COUNCIL.

In pursuance of the provisions of the Land Act 1958, notice is hereby given that it is the intention of the Governor in Council to revoke the temporary reservations of lands by Orders in Council hereunder referred to, viz.:

The following Notices were published 1° on the 17th May, 1972, pursuant to Orders of the 9th May, 1972.

CASTERTON.—The temporary reservation, as a site for Quarry and the withholding from sale, leasing and licensing by Order in Council of the 17th September, 1877, of 11 acres 1 rood 6 perches of land in the Township of Casterton, are about to be revoked.—(C.177⁽²⁾) (Rs.6389).

DOUTTA GALLA (KEILOR EAST).—The temporary reservation, by Order in Council of the 27th November, 1957, of 24 perches of land in the Parish of Doutta Galla as a site for Police purposes, is about to be revoked.—(D.85⁽⁵⁾) (Rs.7677).

LEONGATHA.—The temporary reservation, by Order in Council of the 5th November, 1894, of 5 acres of land in the Township of Leongatha as a site for Nightsoil and Manure Depot, is about to be revoked.—(L.167⁽⁶⁾) (Rs.6869).

NARRAWONG.—The temporary reservation, by Order in Council of the 8th July, 1902, of 25 acres 2 roods 37 perches of land in the Parish of Narrawong as a site for Supply of Gravel for Railway purposes, is about to be revoked.—(N.33⁽⁸⁾) (Rs.4760).

STAWELL.—The temporary reservation, by Order in Council of the 19th August, 1935, of 2 roods 23 6/10 perches of land in the Parish of Stawell as a site for Municipal purposes, is about to be revoked.—(S.329⁽¹⁷⁾) (Rs.4472).

WOOD'S POINT.—The temporary reservation, by Order in Council of the 23rd April, 1940, of 22 perches of land in the Township of Wood's Point as a site for a Public Hall, is about to be revoked.—(W.207^(a)) (Rs.5034).

ARARAT.—The temporary reservation, by Order in Council of the 14th July, 1959, of 1 acre 2 roods of land in the Township of Ararat as a site for the purposes of the Childrens Welfare Department, is about to be revoked, so far only as the portion containing 2 roods, more or less, indicated by hatching on plan hereunder, is concerned.—(A.148⁽⁷⁾) (Rs.7839).

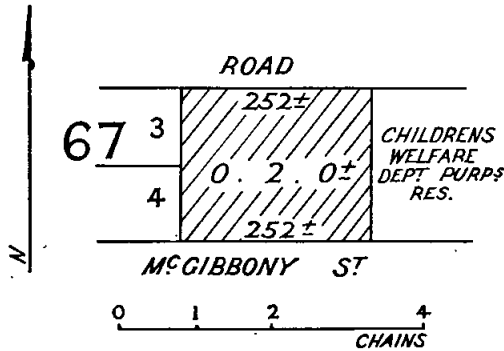

tember, 1948, for the additional purpose of a Public Hall, are about to be revoked, so far only as the portion containing 1 acre 2 roods 37 perches indicated by hatching on plan hereunder, is concerned.—(D.180^(c)) (Rs.6221).

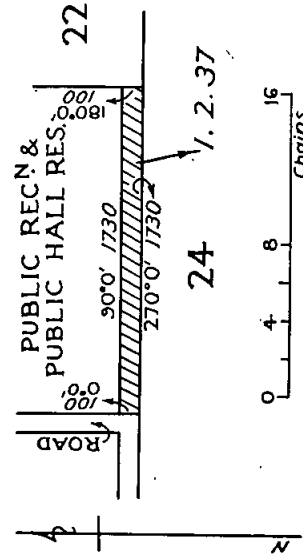

BARWONGEMOONG.—The temporary reservation, by Order in Council of the 19th July, 1966, of 3 acres 3 roods 35 perches of land in the Parish of Barwongemoong as a site for Public purposes (State Forests Department purposes), is about to be revoked, so far only as the portions containing 1 acre 3 roods 19 perches indicated by hatching on plan hereunder, is concerned.—(B.742⁽⁵⁾) (Rs.8492).

EPSOM.—The temporary reservation, by Order in Council of the 24th September, 1968, of 16 acres 31 perches of land in the Township of Epsom as a site for Public purposes (Regional Agricultural Centre), is about to be revoked, so far only as the portion containing 6 perches indicated by hatching on plan hereunder, is concerned.—(E.119⁽²⁾) (Rs.9066).

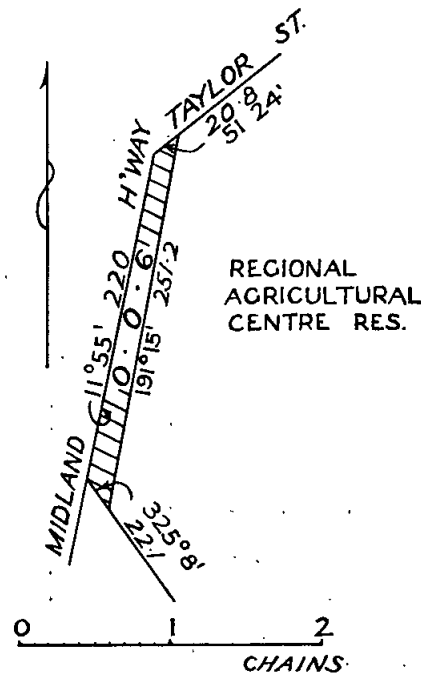
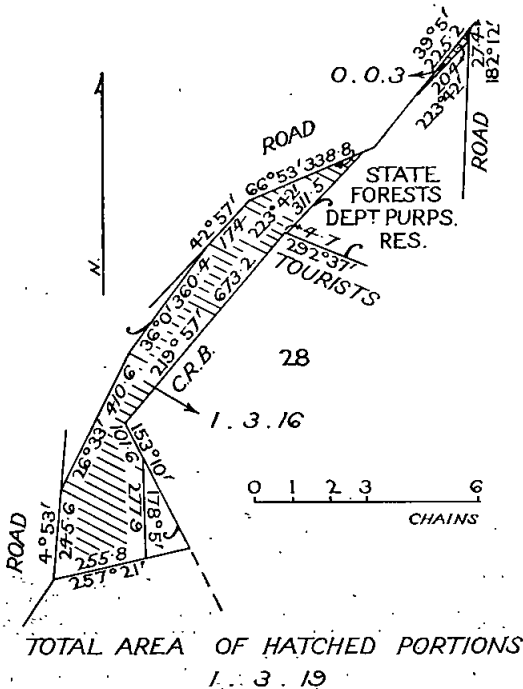

DUNMUNKLE (BOOLITE).—The temporary reservation, by Order in Council of the 26th May, 1902, of 29 acres 3 roods 29 perches of land in the Village of Booloite (now Parish of Dunmunkle), as a site for Public Recreation, and the temporary reservation by Order of the 7th Sep-

SEYMOUR.—The temporary reservation, by Order in Council of the 29th February, 1864 (see *Government Gazette* 8th March, 1864, page 573), of 1 acre 17 perches of land at Seymour (now Township of Seymour), as a site for Police purposes, is about to be revoked, so far

only as the portion containing 1 rood 20 perches, more or less, indicated by hatching on plan hereunder, is concerned.—(S.261^(*)) (Rs.9365).

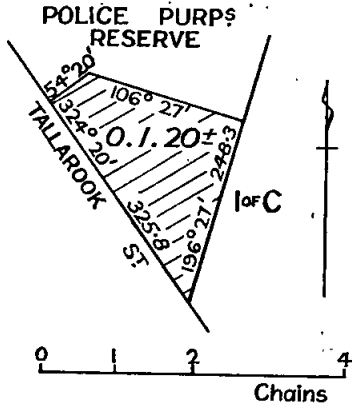

W. BORTHWICK,
Minister of Lands.

PROPOSED REVOCATIONS OF TEMPORARY RESERVATIONS OF LANDS BY ORDERS IN COUNCIL.

In pursuance of the provisions of the *Land Act 1958*, notice is hereby given that it is the intention of the Governor in Council to revoke the temporary reservations of lands by Orders in Council hereunder referred to, viz.:—

The following Notices were published 1° on the 31st May, 1972, pursuant to Orders of the 23rd May, 1972.

MARONG.—The temporary reservation as a site for Public purposes (State School) and the withholding from sale, leasing and licensing by Order in Council of the 20th November, 1876 (see *Government Gazette* 24th November, 1876, page 2157) of 2 acres of land in the Parish of Marong are about to be revoked.—(M.32^(*)) (Rs.7127).

MARONG.—The temporary reservation by Order in Council of the 29th August, 1905, of 1 acre 2 roods 33 perches of land in the Parish of Marong as a site for a State School is about to be revoked.—(M.32^(*)) (Rs.7127).

CALVIL.—The temporary reservation as a site for Public purposes (State School) and the withholding from sale, leasing and licensing by Order in Council of the 8th October, 1877, of 2 acres of land in the Parish of Calivil are about to be revoked.—(C.354^(*)) (W.90872).

CRANBOURNE.—The temporary reservation by Order in Council of the 8th December, 1873 (see *Government Gazette* of the 12th December, 1873, page 2163) of 2 acres 1 rood 15 perches of land in the Township of Cranbourne as a site for Police purposes revoked as to part by Order of the 15th January, 1877, is about to be revoked so far only as the portion containing 1 rood 34 perches indicated by hatching on plan hereunder, is concerned.—(C.329^(*)) (Rs.5854).

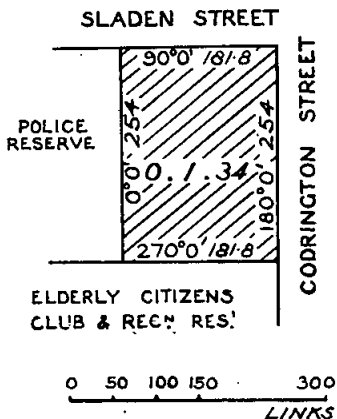

W. BORTHWICK,
Minister of Lands.

PROPOSED PERMANENT RESERVATION OF LAND AS SITES.

In pursuance of sections 14 and 21 of the *Land Act 1958*, notice is hereby given that it is the intention of the Governor in Council to reserve permanently from sale, from being leased and from having a licence granted in respect thereof the land hereinafter described:—

The following Notice was published 1° on the 17th May, 1972, pursuant to Order of the 9th May, 1972.

MELBOURNE SOUTH (ST. KILDA AND ELWOOD).—Land proposed to be permanently reserved as a site for Public Recreation, 32 acres 1 rood 20 perches, at St. Kilda and at Elwood, Parish of Melbourne South, County of Bourke, as indicated by hatching on plan hereunder.—(S.226^(*)) (Rs.8333).

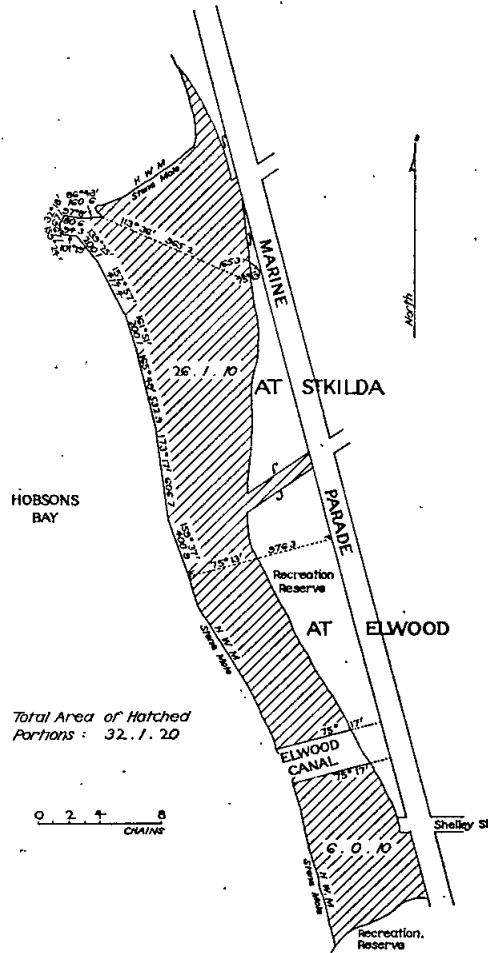

W. BORTHWICK,
Minister of Lands.

PROPOSED PERMANENT RESERVATION OF LAND AS A SITE.

In pursuance of sections 14 and 21 of the *Land Act 1958*, notice is hereby given that it is the intention of the Governor in Council to reserve permanently from sale, from being leased and from having a licence granted in respect thereof the land hereinafter described:—

The following Notice was published 1° on the 31st May, 1972, pursuant to Order of the 23rd May, 1972.

Land proposed to be permanently reserved as a site for Public purposes, unreserved Crown land forming the bed of the Betka River and 200 links from each bank, from its source to its mouth on the shore of Bass Strait.—(Rs.9613.)

W. BORTHWICK,
Minister of Lands.

PROPOSED REVOCATIONS OF TEMPORARY RESERVATIONS OF LANDS BY ORDERS IN COUNCIL.

In pursuance of the provisions of the *Land Act 1958*, notice is hereby given that it is the intention of the Governor in Council to revoke the temporary reservations of lands by Orders in Council hereunder referred to, viz.:—

The following Notices were published 1° on the 7th June, 1972, pursuant to Orders of the 30th May, 1972.

ANAKIE.—The temporary reservation by Order in Council of the 19th February, 1889 (see *Government Gazette*, 22nd February, 1889, page 685), of 130 acres of land in the Parish of Anakie, as a site for Water Supply purposes, is about to be revoked.—(A.31⁽²⁾) (C.98135).

WONDOOMAROOK.—The temporary reservation at a site for Public purposes (State School), and the withholding from sale, leasing and licensing by Order in Council of

the 18th March, 1879, of 2 acres of land in the Parish of Wondoomarook, are about to be revoked.—(W.347⁽⁹⁾) (Rs.9628).

ANAKIE.—The temporary reservation by Order in Council of the 17th January, 1872 (see *Government Gazette*, 26th January, 1872, page 187), of 3 acres 3 roods 38 perches of land in the Parish of Anakie, as a site for Victorian Water Supply purposes, is about to be revoked.—(A.31⁽²⁾) (C.98135).

BAMBRA.—The temporary reservation by Order in Council of the 14th April, 1930, of 2 acres 2 roods 38 perches of land in the Parish of Bamba, as a site for a State School, revoked as to part by Order of the 19th May, 1942, is about to be revoked, so far as the balance thereof, containing 2 acres 1 rood 1 perch, is concerned.—(B.90^(D²)) (Rs.2584).

W. BORTHWICK,
Minister of Lands.

Land Act 1958.

LEASE SURRENDERED.

Notice is hereby given that the Governor in Council has accepted the surrender of the Lease mentioned in the Schedule hereunder for the reason specified.

District.	Corr. No.	Name.	Section of Land Act under which Leased.	Parish.	Allotment.	Section.	Area.	Class.	Reason.
Hamilton	701/155	A. J. Middleton	155	Kadnook	85	..	A. R. P. 330 0 0	..	Non-compliance with conditions

Department of Crown Lands and Survey,
Melbourne, 25th May, 1972.

W. BORTHWICK,
Minister of Lands.

Approved by the Governor in Council, 30th May, 1972.—J. ROSSITER, Clerk of the Executive Council.

COMMITTEES OF MANAGEMENT OF RESERVES.

APPOINTMENTS.

Notice is hereby given that, in pursuance of section 221 of the *Land Act 1958*, the following appointments of Committees of Management of reserved Crown lands have been made by the Minister of Lands:—

"AMPHITHEATRE RECREATION RESERVE."

John W. Lusby, Leslie C. Ward, Cecil H. Townsing, Ian C. Irvin, Laurence G. Jolly, John J. Clancy, Ronald Anderson, Henry H. Cocking and Vernon D. Morvell as a Committee of Management for a period of three (3) years from the 18th May, 1972, of the remaining portion of the lands in the Township of Amphitheatre, temporarily reserved by Orders in Council dated the 21st February, 1870, 4th June, 1940 and 1st April, 1941, as sites for Public Recreation and of the land in the said Township temporarily reserved by Order in Council dated the 12th August, 1969, as a site for Public Recreation the whole being known as the "Amphitheatre Recreation Reserve".—(Corres. No. Rs.705.)

"BARKLY PUBLIC HALL RESERVE."

Graham John Driscoll, Donald George Hart, Alan Driscoll, Arthur Sydney Marland, Kenneth Rex Stewart, Peter Charles Cross, Lyle Reginald Driscoll, Lindsay Gordon Goode and Graham Bibby as a Committee of Management for a period of three (3) years from the 11th May, 1972, of the land in the Parish of Barkly, temporarily reserved by Order in Council dated the 10th February, 1891, as a site for a Public Hall and known as the "Barkly Public Hall Reserve".—(Corres. No. Rs.4794.)

SITE FOR PUBLIC RECREATION, TOWNSHIP OF BENALLA.

The Corporation of the City of Benalla as the Committee of Management of the land in the Township and the Parish of Benalla, temporarily reserved by Order in Council dated the 11th April, 1972, as a site for Public Recreation purposes.—(Corres. No. Rs.9602.)

"BRITANNIA CREEK PUBLIC HALL RESERVE."

Arthur Ronald Marr, Robert Hutchinson Logan, Daisy Justice, Winifred Bedggood, Dorothy Bell, Dorothy Pearl Doyle, Valda Muriel Coleman, Frank Rowland Coleman and James Danby Bell as a Committee of Management for a period of three (3) years from the 8th May, 1972, of the land in the Parish of Warburton, temporarily reserved by Order in Council dated the 19th August, 1947, as a site for a Public Hall and known as the "Britannia Creek Public Hall Reserve".—(Corres. No. Rs.6014.)

"COBDEN RECREATION RESERVE."

Neill McLean Grayland, Lawrence Henry Green, James Hammond, James Adam Murrphy, Donald Alexander McCallum, Keith Renton Brittain, Charles Rupert Oates, Jack Orris White and Colin Gaut as a Committee of Management for a period of three (3) years from the 12th May, 1972, of the land in the Township of Cobden, temporarily reserved by Order in Council dated the 8th November, 1886, as a site for Public Recreation and known as the "Cobden Recreation Reserve".—(Corres. No. Rs.683.)

"CUDGEWA RECREATION RESERVE."

Thomas Christian Joseph Vogel (for so long only as he continues to be a Councillor and the elect of the Council of the Shire of Upper Murray) together with Frederick Ernest Coysh, Terry James Star, Kenneth Reuben Jarvis, Stewart Edward Drage, Wallace Leonard Carkeek, Richard Huon Land, Alan Murray Vogel and John Warrick Humphrey as a Committee of Management for a period of three (3) years from the 21st April, 1972, of the land in the Parish of Cudgewa, temporarily reserved by Order in Council dated the 10th January, 1888, as a site for Public Recreation and known as the "Cudgewa Recreation Reserve".—(Corres. No. Rs.3601.)

ELDORADO "MONUMENT HILL PUBLIC PARK" AND
"CENTENNIAL PARK" RESERVES, ELDORADO.

John Colin Angus, Robert Charles Allen, Desmond James O'Meara, Bernard John Grealy, Francis Edward Grealy, John Bloor Dent, Geoffrey James Milne, Harry W. R. Lonie and Robert Caldwell as a Committee of Management for a period of three (3) years from the 13th May, 1972, of the land in the Parish of Tarrawingee, temporarily reserved by Order in Council dated the 11th April, 1967, as a site for a Public Park and known as the "Monument Hill Public Park" and of the lands in the Parishes of Byawatha and Tarrawingee, temporarily reserved by Orders in Council dated the 8th April, 1889 and 22nd December, 1891, as sites for Public Park purposes and known as the "Centennial Park", Eldorado.—(Corres. Nos. Rs.4972, Rs.1926.)

SITES FOR PUBLIC RECREATION AT ELWOOD.

The Corporation of the City of St. Kilda as the Committee of Management of the remaining portions of the lands in the Parishes of Prahran and Melbourne South, at Elwood, reserved as sites for Public Recreation and indicated by blue, red, yellow, and green colours on plan marked "E/22.4.37" attached to Lands Department correspondence Rs.444, excluding the areas shown on the said plan as hatched red over blue colour, hatched black over blue colour and hatched black over red colour.—(Corres. No. Rs.444.)

This appointment is made in lieu of all previous appointments with respect to the said lands, which are hereby revoked.

"GELANTIPY RECREATION RESERVE."

Christopher Neil Gillies, Kathleen Roma Gillies, Jean Elizabeth O'Donnell, Robert James Sykes, David Charles Cross, Colin Frederick Hunt, Norman Woodhouse, Robert Moon and Ross Gillies as a Committee of Management for a period of three (3) years from the 3rd May, 1972, of the land in the Parish of Gelantipy East, temporarily reserved by Order in Council dated the 14th June, 1949, as a site for Public Recreation and known as the "Gelantipy Recreation Reserve".—(Corres. No. Rs.6369.)

"HANGING ROCK RESERVE."

Lawrence William Erving and Gerard James Colwell (for so long only as they shall continue to be the elects of the Hanging Rock Race Club) in the places of J. E. Benny and W. A. Stephens, resigned, as members of the Committee of Management of the land in the Parish of Newham, permanently reserved by Order in Council dated the 25th November, 1884, as a site for Public Recreation and Affording Access to Water and known as the "Hanging Rock Reserve".—(Corres. No. Rs.458.)

"KENNETT RIVER CAMPING RESERVE."

Joseph Gerard Cassidy, Ronald Albert Larsen, Kevin James Flynn, William John Mundy, Keith Ronald Travers, James Harvey Lyle, Joseph Philip Cassidy, John Dion Maddox and William Bennett Boyd as a Committee of Management for a period of three (3) years from the 25th January, 1972, of the reserved Crown lands in the Parish of Wongarra shown hatched black on plan marked "K.R.4936" attached to Lands Department correspondence No. Rs.4936 and known as the "Kennett River Camping Reserve".—(Corres. No. Rs.4936.)

"KIEWA MEMORIAL PARK."

Robert Joseph Brown, Samuel James Crothers, Leonard Roy Schliebs, Robert William McDonald, Arnold Thomas Coulston, William John Crothers, Robert Stanley Speers, Maxwell John Barber and Walter Alan Quonoe as a Committee of Management for a period of three (3) years from the 3rd May, 1972, of the lands in the Parish of Murrumurangbong, temporarily reserved by Orders in Council dated the 4th July, 1899, 11th June, 1946 and 11th March, 1970, as sites for Public Recreation and known as the "Kiewa Memorial Park".—(Corres. No. Rs.815.)

"MAGORRA PUBLIC PARK & RECREATION RESERVE."

Colin Richard Scales, Kevin Leslie Giltrap, Brendan Walter O'Connell, David Alexander Northey, Eric Gordon Neilson, John Neville Yea, Thomas James Murphy, John Colin Scales and George Fords Smith as a Committee of Management for a period of three (3) years from the 27th April, 1972, of the land in the Parish of Mitta Mitta,

temporarily reserved by Orders in Council dated the 15th September, 1884 and 25th January, 1887, as sites for a Public Park and other purposes of Public Recreation, and known as the "Magorra Public Park and Recreation Reserve".—(Corres. No. Rs.4175.)

"MARNOO MEMORIAL HALL RESERVE."

James Bevan Barham, John Winston Cameron, Graeme Louis McLennan, Brian Campbell Raggatt, Allan Robert Wood, John Henry Newall, Robert William Anderson, James Galloway Aitken and Henry Thomas Jones as a Committee of Management for a period of three (3) years from the 21st April, 1972, of the land in the Parish of Marnoo, temporarily reserved by Order in Council dated the 19th May, 1959, as a site for a Public Hall and known as the "Marnoo Memorial Hall Reserve".—(Corres. No. Rs.7830.)

"MORTLAKE RECREATION RESERVE."

Albert James Jewell, Edward Ian Vale, Vernon James Delaney, John Eddington Gordon, Ian Leonard Davis, Geoffrey Arthur Robertson, James Robert Joyce, Kenneth John Beardsley and Frank Seiver as a Committee of Management for a period of three (3) years from the 2nd May, 1972, of the land in the Township of Mortlake, permanently reserved by Order in Council dated the 14th November, 1892, as a site for Public Recreation and known as the "Mortlake Recreation Reserve".—(Corres. No. Rs.2173.)

"MURCHISON PUBLIC GARDENS RESERVE."

The Corporation of the Shire of Waranga as the Committee of Management of the reserved Crown land at Murchison shown coloured red on plan "M/1.2.49" attached to Lands Department correspondence Rs.785 and known as the "Murchison Public Gardens Reserve".—(Corres. No. Rs.785.)

"PIGGOREET PUBLIC HALL RESERVE."

Margaret Getsom, Nance E. Jones, Malcolm Macpherson, Harry McLean and Amy McLean as a Committee of Management for a period of three (3) years from the 8th May, 1972, of the land in the Parish of Clarkesdale, temporarily reserved by Order in Council dated the 25th June, 1919, as a site for a Public Hall and known as the "Piggoreet Public Hall Reserve".—(Corres. No. Rs.1952.)

"SAN REMO FORESHORE RESERVE."

Leonard Bagley, Jack Vorweg, Alan H. Carson, Colin A. Cannop, Albert A. Johnson, Arthur S. Ross, Lyle C. Williams, Ronald C. Bowen and Ivan Hayhow as a Committee of Management for a period of three (3) years ending the 31st March, 1975, of the reserved Crown land in the Township of San Remo shown coloured red on plan "S.R.22.1.35" attached to Lands Department correspondence No. Rs.3972 and known as the "San Remo Foreshore Reserve".—(Corres. No. Rs.3972.)

"WANDELLA RECREATION RESERVE."

Ian Kenneth Manuel, Angus Wood Bott, Albert Eric McKenzie, Harvey William Manuel, Geoffrey Lloyd Robinson, George Edward Fenton, Geoffrey Alfred Taylor, Edward Leslie Pay and Arnold Francis Morris as a Committee of Management for a period of three (3) years from the 29th November, 1971, of the land in the Parish of Meran, temporarily reserved by Order in Council dated the 25th October, 1960, as a site for Public Recreation and known as the "Wandella Recreation Reserve".—(Corres. No. Rs.7652.)

"WOOLSTHORPE MECHANICS' INSTITUTE RESERVE."

Frederick Raymond Baulch, Sidney Ian Strotten, Peter Herbert Peterson, Pauline Therese Ryan, Thomas Morwell Mathison, Allan Warburton, William James Dennis, James Adair Bennett and Barbara Joan Hirst as a Committee of Management for a period of three (3) years from the 15th March, 1972, of the land in the Township of Woolsthorpe, temporarily reserved by Order in Council dated the 26th November, 1888, as a site for a Mechanics' Institute and Free Library and known as the "Woolsthorpe Mechanics' Institute Reserve".—(Corres. No. Rs.4638.)

"WURRUK PUBLIC HALL RESERVE."

Alan Morison Higgs, Jean Florence Higgs, Elizabeth Muriel Manning, Gerardys Cornelis Buteyn and Keith Hansen as a Committee of Management for a period of three (3) years from the 3rd May, 1972, of the land in the Township of Wurruk, temporarily reserved by Order in Council dated the 25th May, 1965, as a site for Public purposes (Public Hall) and known as the "Wurruk Public Hall Reserve"—(Corres. No. Rs.8449.)

W. BORTHWICK,
Minister of Lands.

Department of Crown Lands and Survey,
Melbourne, 2nd June, 1972.

TENDERS**PUBLIC WORKS DEPARTMENT**

Tenders will be received at Public Works Department, 2 Treasury-place, Melbourne, until **TWO** p.m. on dates shown and for purposes mentioned hereunder.

Particulars and tender forms available at Contracts Office, Room 8, Building Division, Parliament-place and at places indicated in brackets hereunder.

Abbreviations in brackets mean:—W.O.—Inspector of Works Office; P.S.—Police Station; C.S.—Consolidated School; H.E.S.—Higher Elementary School; H.S.—High School; Pr.S.—Primary School; T.S.—Technical School.

Tenders to be submitted on the Department's printed Tender Form and will not be received by telephone. All tenders must be on a "Firm Tender" basis. The lowest or any tender will not necessarily be accepted.

Address tenders to the Minister of Public Works, and endorse the envelope containing the tender "Tender for _____", closing Tuesday,

Hand delivered tenders to be placed in the Tender Box of the Public Works Department, located on the wall of the centre entrance foyer, Ground Floor, 2 Treasury-place, Melbourne.

No preliminary deposit is required with any tender, but a successful tenderer will be required to pay a deposit for any accepted tender of \$4,000 or over.

Wednesday, 14th June, 1972.**Building, Electrical and Mechanical Works.**

- ARMADALE.—Repairs and renovations, Pr.S.2634.
 BLACKBURN SOUTH.—Renovations and erection of toilet block, Pr.S.4035.
 BROADMEADOWS.—Erection of brick veneer toilet block and garage, Special S.4950.
 COBURG WEST.—Repairs and renovations, Pr.S.3941.
 DOOKIE.—Extension to butchery building, Agricultural College. (W.O., Benalla, Shepparton and Wangaratta.)
 DOOKIE.—Refrigeration system—Meat Cool Room, Agricultural College. (W.O., Shepparton.)
 FITZROY.—Mechanical services—Additions, H.S.
 LYNDALÉ.—Erection of science wing, in C/V., H.S.
 LYNDALÉ.—Mechanical services, Science Wing, H.S.
 MOUNT ELIZA.—Alterations to B/V., toilet block, Pr.S.1360. (W.O., Mornington.)
 SANDRINGHAM.—External and internal renovations, Pr.S.267.
 SOUTH MELBOURNE.—Internal painting, Secondary Teachers' College Hostel, "Alan Ramsay House", 19 Queens-road.
 TARWIN LOWER.—Internal and external repairs and painting, Pr.S.4275. (W.O., Korumburra.)
 WATSONIA.—Internal and external repairs and painting, H.S.

Site Works.

- BEAUMARIS NORTH.—Asphalt repairs and drainage, Pr.S.4803.
 CHELTENHAM.—Asphalt repairs, Pr.S.84.
 GLEN WAVERLEY.—Retaining walls, concrete paving and landscaping, H.S.
 MONTMORENCY.—Asphalting, drainage, &c., Pr.S.4112.
 NOBLE PARK.—Asphalt repairs and concrete paving, &c., T.S.

SANDRINGHAM.—Asphalt repairs and concrete paving, T.S.

SPRINGVIEW.—Asphalt repairs and concrete paving, Pr.S.4912.

TRARALGON.—Asphalt repairs, H.S. (W.O., Traralgon and Warragul.)

WATTLE VIEW.—Asphalting, concrete paving, drainage, &c., Pr.S.5012.

Tuesday, 20th June, 1972.**Building, Electrical and Mechanical Works.**

- BALLARAT NORTH.—Internal and external renovations, Pr.S.4690. (W.O., Ballarat.)
 BIRCHIP.—Staff amenities extension and connexion to town sewerage, H.S. (W.O., Horsham and Swan Hill.)
 KYABRAM.—Internal and external renovations, Pr.S.2902. (W.O., Shepparton), (Amended Specification), (Re-Advertised.)
 MELBOURNE.—Supply and installation of P.A.B.X. telephone system, State Public Offices, Treasury-place.
 NEWHAVEN.—Internal and external repairs and painting, Pr.S.3053. (W.O., Korumburra.)
 PRESTON EAST.—External renovations, Pr.S.4316.
 SOUTH MELBOURNE.—External and internal renovations, T.S.
 SWAN HILL.—External and internal repairs and painting, T.S. (W.O., Swan Hill.)
 WATSONIA HEIGHTS.—External repairs and painting, Pr.S.4935.
 WEST MELBOURNE.—Erection of new toilet block, Pr.S.1689.

Miscellaneous.

PRAHRAN.—Maintenance cleaning, Chest Clinic, 240 Malvern-road.

Tuesday, 27th June, 1972.**Building, Electrical and Mechanical Works.**

- BELLEVEUE.—External and internal renovations, Pr.S.4738.
 BENDIGO.—Erection of standard assembly hall type 572c, Girls' H.S. (Re-advertised). (W.O., Bendigo.)
 DAYLESFORD.—Boundary Fencing, Pr.S.1609. (Re-advertised). (W.O., Ballarat, Bendigo, Kyneton.)
 NATHALIA.—Internal and external repairs and painting, Pr.S.2060. (W.O., Bendigo, Shepparton.)
 RICHMOND.—Alterations to library, Girls' H.S.
 WANGARATTA.—External renovations, H.S. (W.O., Wangaratta.)
 WERRIBEE.—Re-roofing and storm water drainage—five buildings, Research Farm.

Site Works.

COOINDA.—Site works, Pr.S.5018.

MURRAY BYRNE,
Minister of Public Works.

Public Works Department,
Melbourne, 3002, 5th June, 1972.

PRIVATE ADVERTISEMENTS**CITY OF BROADMEADOWS.**

LOAN No. 69.

Notice of Intention to Borrow the sum of \$8,000 for Permanent Works and Undertakings.

Notice is hereby given that the Council of the City of Broadmeadows proposes to borrow the principal sum of \$8,000, by a charge over the general rates of the municipality, such sum to be raised by the grant of a mortgage in accordance with the provisions of the *Local Government Act 1958*.

1. The maximum rate of interest that may be paid is 6.2 per cent. per annum.
2. The period of the loan shall be ten years.

3. The purpose for which the loan is to be applied is:—

Erection of a toilet block in Bonwick-street, Fawkner.

4. The moneys borrowed shall be repayable by providing out of the municipal fund half-yearly instalments of approximately \$543.00 principal and interest, payable half-yearly on the 1st day of August and the 1st day of February in each year. The first instalment shall be due and payable on the 1st day of February, 1973.

5. Such moneys shall be repayable to the State Savings Bank of Victoria, corner of Collins and Bourke streets, Melbourne, or such other place or places as the bank from time to time require.

The plans and specifications and an estimate of the cost of the proposed works and a statement showing the proposed expenditure of the moneys to be borrowed are open for inspection at the offices of the Council, Broadmeadows.

Dated this 2nd day of June, 1972.

J. T. SMITH, Acting Town Clerk.

Municipal Offices, Broadmeadows. 6594

CITY OF BROADMEADOWS.

LOAN No. 70.

Notice of Intention to Borrow the Sum of \$25,000 for Permanent Works and Undertakings.

Notice is hereby given that the Council of the City of Broadmeadows proposes to borrow the principal sum of \$25,000, by a charge over the general rates of the municipality, such sum to be raised by the grant of a mortgage in accordance with the provisions of the *Local Government Act 1958*.

1. The maximum rate of interest that may be paid is 6.3 per cent. per annum.

2. The period of the loan shall be fifteen years.

3. The purpose for which the loan is to be applied is:—

Purchase of a Reserve in Middle-street, Glenroy.

4. The moneys borrowed shall be repayable by providing out of the municipal fund thirty (30) equal amounts of \$1,300.34 principal and interest payable half-yearly on the 1st day of August and the 1st day of February in each year. The first instalment shall be due and payable on the 1st day of February, 1973.

5. Such moneys shall be repayable to the Bank of New South Wales, Melbourne, or such other place or places as the bank from time to time require.

The plans and specifications and an estimate of the cost of the proposed works and a statement showing the proposed expenditure of the moneys to be borrowed are open for inspection at the offices of the Council, Broadmeadows.

Notice is hereby given that the Council of the City of Broadmeadows proposes to borrow the principal sum of \$25,000, by a charge over the general rates of the municipality, such sum to be raised by the grant of a mortgage

Dated this 2nd day of June, 1972.

J. T. SMITH, Acting Town Clerk.

Municipal Offices, Broadmeadows. 6605

CITY OF BROADMEADOWS.

Notice of Intention to Borrow the Sum of \$25,000 for Permanent Works and Undertakings.

in accordance with the provisions of the *Local Government Act 1958*.

1. The maximum rate of interest that may be paid is 6.4 per cent. per annum.

2. The period of the loan is 40 years.

3. The purpose for which the loan is to be applied is:—

Construction of a Pre-school and Infant Welfare Centre.

4. The moneys borrowed shall be repayable by providing out of the municipal fund half-yearly instalments of \$70.01, principal and interest payable half-yearly on the 1st day of August and the 1st day of February in each year. The first instalment shall be due and payable on the 1st day of February, 1973.

5. Such moneys shall be repayable to the Head Office of the Australian Mutual Provident Society, Melbourne, or such other place or places as the Society from time to time require.

The plans and specifications and an estimate of the cost of the proposed works and a statement showing the proposed expenditure of the moneys to be borrowed are open for inspection at the offices of the Council, Broadmeadows.

Dated this 2nd day of June, 1972.

J. T. SMITH, Acting Town Clerk.

Municipal Offices, Broadmeadows. 6595

Town and Country Planning Act 1961 (Twelfth Schedule).

CITY OF CROYDON PLANNING SCHEME 1961.

NOTICE THAT A PLANNING SCHEME HAS BEEN PREPARED AND IS AVAILABLE FOR INSPECTION.

Amendment No. 50, 1971.

Notice is hereby given that the City of Croydon, in pursuance of its powers under the *Town and Country Planning Act 1961*, has prepared a Planning Scheme for lots 11 to 16 inclusive on plan of subdivision No. 6556 properties known as lot 11 Railway-grove and 8 to 16 inclusive Devon-street, Croydon, for the purpose of rezoning the properties from Residential to proposed public purposes Reserve, Municipal purposes (Car Park).

A copy of the scheme has been deposited at the City Offices, Foch-avenue, Croydon, and at the office of the Town and Country Planning Board, 235 Queen-street, Melbourne, and will be open for inspection during office hours by any person, free of charge.

Any persons affected by the Planning Scheme are required to set forth, in writing, all objections they may have, addressed to the Town Clerk, City Offices, Foch-avenue, Croydon, on or before the 7th day of September, 1972, and to state whether they wish to be heard in respect of their objections.

6th June, 1972.

6591

R. BURTON, Town Clerk.

Town and Country Planning Act 1961 (Twelfth Schedule).

CITY OF CROYDON PLANNING SCHEME 1961.

NOTICE THAT A PLANNING SCHEME HAS BEEN PREPARED AND IS AVAILABLE FOR INSPECTION.

Amendment No. 51, 1971.

Notice is hereby given that the City of Croydon, in pursuance of its powers under the *Town and Country Planning Act 1961*, has prepared a Planning Scheme for the purpose of amending the site requirements applicable to the general industrial zone as follows—

In clause 7 of zone provision (d) relating to Zone No. 3 shall be added:—

(d) If in the circumstances of any particular case the City Engineer reports, in writing, to the Responsible Authority that compliance with sub-paragraph (c) (i) and (c) (ii) in respect of an alignment other than a frontage to a main road would be impracticable or unreasonable the Responsible Authority may reduce the required minimum set-back from 25 feet to 9 feet.

A copy of the scheme has been deposited at the City Offices, Foch-avenue, Croydon, and at the office of the Town and Country Planning Board, 235 Queen-street, Melbourne, and will be open for inspection during office hours by any person, free of charge.

Any persons affected by the Planning Scheme are required to set forth, in writing, all objections they may have, addressed to the Town Clerk, City Offices, Foch-avenue, Croydon, on or before the 7th day of July, 1972, and to state whether they wish to be heard in respect of their objections.

6th June, 1972.

6592

R. BURTON, Town Clerk.

CITY OF FRANKSTON.

LOAN No. 148.

Notice of Intention to Borrow the Sum of \$100,000.

Notice is hereby given that the Council of the City of Frankston intends to borrow the sum of \$100,000, secured by a charge over the general rates of the municipality by the grant of a mortgage, in accordance with the provisions of the *Local Government Act 1958*.

In connexion therewith, the following information is stated:—

(a) The amount of the principal moneys which it is proposed to borrow is One hundred thousand dollars.

- (b) The maximum rate of interest that may be paid is 6.3 per centum per annum.
- (c) The times which moneys borrowed are to be repayable are the 10th days of January and July, during the years 1973 to 1987 inclusive, and the place such moneys shall be repayable is at the Commercial Savings Bank of Australia Limited.

(d) The purpose for which the loan is to be applied is:—

Library-Cultural Centre—\$100,000.

- (e) The manner in which the loan is to be liquidated is by provision out of the municipal fund of 29 half-yearly instalments of \$3,437.55, including principal and interest, and a final payment of \$89,419.91, including principal and interest.

The plans and specifications and estimate of the cost of the works and a statement showing the proposed expenditure of the moneys to be borrowed are open for inspection at the Civic Centre, Frankston.

6573 G. C. PENTLAND, Town Clerk.

CITY OF FRANKSTON.

LOAN No. 150.

Notice of Intention to Borrow the Sum of \$313,000.

Notice is hereby given that the Council of the City of Frankston intends to borrow the sum of \$313,000, secured by a charge over the general rates of the municipality by the grant of a mortgage in accordance with the provisions of the *Local Government Act 1958*.

In connexion therewith, the following information is stated:—

- (a) The amount of the principal moneys which it is proposed to borrow is Three hundred and thirteen thousand dollars.
- (b) The maximum rate of interest that may be paid is 6.3 per centum per annum.
- (c) The times which moneys borrowed are to be repayable are the 10th days of January and July, during the years 1973 to 1987, and the place such moneys shall be repayable is at the Commercial Savings Bank of Australia Limited.
- (d) The purposes for which the loan is to be applied are:—

(i) Parks and properties improvements	\$37,800
(ii) New golf links	25,000
(iii) Drainage	34,700
(iv) Pedestrian overpass, Wells-road	9,000
(v) Footbridge, Eel Race Drain	3,000
(vi) New buildings	113,500
(vii) Town planning, land purchase	90,000
	\$313,000

- (e) The manner in which the loan is to be liquidated is by provision out of the municipal fund of 29 half-yearly instalments of \$11,675.53, including principal and interest and a final payment of \$236,146.78 including principal and interest.

The plans and specifications and estimate of the cost of the works and a statement showing the proposed expenditure of the moneys to be borrowed are open for inspection at the Civic Centre, Frankston.

6574 G. C. PENTLAND, Town Clerk.

CITY OF GEELONG WEST.

LOAN No. 62

Notice of Intention to Borrow the Sum of \$30,000 for Permanent Works and Undertakings.

Notice is hereby given that the Council of the City of Geelong West intends to borrow the principal sum hereinafter mentioned on the credit of the municipal revenues of the Mayor, Councillors and Citizens of the City of Geelong West by the grant of a mortgage in accordance with the provisions of the *Local Government Act 1958* (as amended), and notice is hereby further given:—

- (a) That the amount of the principal sum which it is proposed to borrow is \$30,000.
- (b) The maximum rate of interest that may be paid is 6.2 per centum per annum.

(c) The moneys borrowed and interest thereon are to be repayable by twenty half-yearly instalments each of approximately \$2,035.17, on the 1st day of January and the 1st day of July in each year, and the place at which

such moneys are to be repayable is the Commonwealth Savings Bank of Australia, Melbourne. The first instalment shall be payable on the 1st day of January, 1973.

(d) The purposes for which the loan is to be applied are:—

1. Extensions to Town Hall	\$15,000
2. Purchase of plant and equipment	\$15,000

(e) The loan is to be liquidated by appropriation out of the municipal fund.

(f) The plans, specifications and estimate for the cost of such works, and the statement showing the proposed expenditure of the money to be borrowed, are open for inspection at the office of the Council, 153 Pakington-street, Geelong West, during office hours.

Dated the 7th day of June, 1972.

6584 R. J. HAMMETT, Town Clerk.

CITY OF HEIDELBERG.

CHANGE OF STREET NAME.

Notice is hereby given that, pursuant to the provisions of the *Local Government Act 1958*, the Council of the City of Heidelberg has caused the following street name alteration to be made:—

Old Name.—Thompson-drive.

New Name.—Thomson-drive.

Dated 7th June, 1972.

6588 ALAN JONES, Town Clerk.

CITY OF HEIDELBERG.

LOAN No. 164.

Notice of Intention to Borrow the Sum of \$100,000 for Permanent Works and Undertakings.

Notice is hereby given that the Council of the City of Heidelberg intends to borrow the sum of \$100,000 (One hundred thousand dollars), secured by a charge over the general rates of the municipality, such sum to be raised by the grant of a mortgage in accordance with the provisions of the *Local Government Act 1958*.

1. The maximum rate of interest that may be paid is 6.4 per centum per annum.
2. The purposes for which the loan is to be applied are:—

Banyule Flats development	\$10,000
Warrigal Parklands Pavilion	2,000
Rosanna Branch Library	12,000
Completion, Pavilions, various reserves	10,000
Council contribution to C.R.B. works	66,000
	\$100,000

3. The period of the loan shall be twenty (20) years.

4. The moneys borrowed shall be repayable by providing out of the municipal fund forty (40) half-yearly instalments of \$4,467.21 each, including principal and interest, on the 23rd day of January and the 23rd day of July in each year, during the currency of the loan. The first instalment shall be payable on the 23rd day of January, 1973.

5. Such moneys shall be repayable to the Australian Mutual Provident Society, Victoria Branch, Melbourne.

The plans and specifications and the estimate of the cost of the proposed works and a statement showing the proposed expenditure of the money to be borrowed, are open for inspection at the office of the Council, Town Hall, Ivanhoe.

6601 ALAN JONES, Town Clerk.

CITY OF MELBOURNE.

BY-LAW No. 490.

A By-law of the City of Melbourne made under section 12 of the *Melbourne Wholesale Fruit and Vegetable Market Act 1968* and numbered 490 to further amend By-law No. 477.*

In pursuance of the powers conferred by the above-mentioned enactment and of every other Act or power enabling it in that behalf, the Council of the City of Melbourne ORDERS as follows:

1. (1) This By-law may be cited as the City of Melbourne Wholesale Fruit and Vegetable Market (Further Amendment) By-law 1972.

(2) In this By-law, the City of Melbourne Wholesale Fruit and Vegetable Market By-law 1969, By-law No. 477, as amended by By-laws Nos. 478 and 480, is referred to as the Principal By-law.

2. Sub-clause (1) of clause 2 of the Principal By-law shall be amended by inserting after the definition of "goods" the following definition:

"leave standing" in relation to any vehicle means—

- (a) to stop the vehicle; or
- (b) to permit the vehicle (whether unattended or not) to remain stationary—

otherwise than when necessary to avoid conflict with pedestrians or other vehicles or to comply with the directions of a market inspector; and "left standing" has a corresponding interpretation;.

3. After clause 40 of the Principal By-law there shall be inserted the following clause:

"40A. No person shall leave any motor vehicle standing in the Market concourse or cause or permit any vehicle to be so left standing without first stopping the engine of the vehicle."

Resolution for passing this By-law agreed to by the Council of the City of Melbourne the 15th day of May, 1972, and confirmed the 5th day of June, 1972.

(SEAL) ALWYNNE ROWLANDS, Lord Mayor.
F. H. ROGAN, Town Clerk.

* By-law No. 477, as amended by By-laws Nos. 478 and 480.
(72/271/53) 6613

CITY OF MELBOURNE.

BY-LAW NO. 489.

A By-law of the City of Melbourne made under section 800 of the *Local Government Act 1958* and numbered 489 for regulating the conduct of persons using or being upon or in land purchased or rented or otherwise provided by the Council of the City of Melbourne for the providing of places of public resort.

Whereas the Council of the City of Melbourne has purchased or rented or otherwise provided the pieces of land described in the Schedule to this By-law for the providing of places of public resort

Now in pursuance of the powers conferred by the above-mentioned enactment and of every other Act or power enabling it in that behalf, the Council of the City of Melbourne orders as follows:

1. This By-law may be cited as the *City of Melbourne Places of Public Resort By-law 1972*.

2. In this By-law, unless the context otherwise requires—

- "clause" means clause of this By-law;
- "Council" means the Council of the City of Melbourne;
- "employee" means employee of the Corporation of the City of Melbourne;
- "officer" means officer of the Corporation of the City of Melbourne;
- "place of public resort" means a piece of land described in the Schedule;
- "Schedule" means schedule to this By-law;
- "vehicle" means any conveyance designed to be propelled or drawn by any means, but does not include a wheelchair.

Words importing the masculine gender include the feminine, and the singular number includes the plural and the plural the singular.

3. Each of the pieces of land described in the Schedule shall be a place of public resort so long as this By-law is expressed to apply to it.

4. No person using or being upon or in any place of public resort shall—

- (a) commit any nuisance or any indecent or offensive act;
- (b) use any abusive, indecent, insulting, obscene, profane, or threatening language;
- (c) behave improperly or riotously;
- (d) assault any other person;
- (e) annoy, disturb, interrupt, molest, or obstruct any other person lawfully and peaceably using or upon or in the place of public resort;
- (f) play or operate any musical instrument, radio, or television set in such a manner as to materially interfere with the reasonable comfort and convenience of any other person (but nothing in this paragraph shall operate to prevent the playing of any musical or noisy instrument in the place of public resort where the consent of the Council has been given pursuant to paragraph (f) of clause 5);
- (g) damage, deface, destroy, disfigure, draw or write on, interfere with, remove, or, subject to paragraph (d) of clause 5, affix anything to

any building, decoration, drain, electrical or other fitting or equipment, embellishment, fence, gate, improvement, light, notice, notice board, pole, post, property, seat, sign, statue, tree, tree-guard, water pipe, water tap, or other structure of any kind;

- (h) disturb, interfere with, raise, or remove any part of any pavement or other surface, whether of asphalt, brick, concrete, earth, grass, gravel, stone, or other material; or remove any soil or other material;
 - (i) damage, destroy, injure, interfere with, or remove any animal, bird, fish, flower, grass, hedge, lawn, plant, or shrub (but nothing in this paragraph shall operate to prevent the removal from any place of public resort of any dog lawfully brought into that place pursuant to paragraph (r) of this clause);
 - (j) enter or trespass or walk on or over any flower bed, flower box, or garden plot, or any plantation or shrubbery;
 - (k) climb, climb on to or over, jump on to or over, sit or stand on, or walk on or over any air-intake cover or housing, balustrade, embellishment, fence, flower bed, flower box, fountain, garden plot, gate, hedge, plant container, pole, post, refuse container, refuse receptacle, shrub, stair handrail, statue, table, tree, tree container, tree-guard, ventilation-shaft cover or housing, or wall;
 - (l) jump over or stand on any chair or seat;
 - (m) throw any stone or other missile;
 - (n) light any fire;
 - (o) be in possession of, carry, or use any firearm (being a firearm within the meaning of the *Firearms Act 1958*), or any offensive weapon or instrument;
 - (p) spit, defecate or urinate;
 - (q) bring into or allow to remain in the place of public resort or be in possession or charge of any animal (other than a dog), bird, or reptile;
 - (r) bring into, or cause or permit any dog to be in the place of public resort, unless the dog at all times while in the place of public resort is held by him by means of a chain, cord, handle, lead, leash, strap, or other device of a length in any case not exceeding four feet;
 - (s) bring into the place of public resort, or distribute, sell, or be in possession or control of any spirituous or intoxicating liquor;
 - (t) be in a state of intoxication;
 - (u) bet, or play or take part in any gambling or unlawful game or sport;
 - (v) play at cricket, football or any other game;
 - (w) bring into or allow to remain in the place of public resort any vehicle;
 - (x) use or cause to be used in the place of public resort any caravan, structure, tent, trailer, or vehicle for camping or living in; or
 - (y) hinder, interfere with, obstruct, or resist any officer or employee in the execution of his duty.
5. No person using or being upon or in any place of public resort shall, without the consent in writing of the Council—
- (a) hawk, sell, or offer or expose for sale any appeal button, article, beverage, confectionery, foodstuff, fruit, goods, merchandise, raffle ticket or the like, tobacco, or other thing;
 - (b) erect any booth, kiosk, tent, or other temporary building or structure;
 - (c) display or erect any advertisement, notice, placard, or sign;
 - (d) affix, interfere with, make, or remove any bill, marking of any kind, notice, placard, or sign in, on or over any building, fence, gate, notice board, pole, post, sign, tree or other structure of any kind in or on the place of public resort;
 - (e) solicit or collect gifts of money or subscriptions;
 - (f) declaim, deliver any address, harangue, preach, speak to any assembly of other persons, or play on any musical or noisy instrument;
 - (g) assemble with any other persons for the purpose of holding any concert, fete, meeting, or picnic, or for the purpose of preaching, public speaking, or worship;

(h) bring into the place of public resort any amplifier, loud hailer, loudspeaker, or other public-address apparatus of any kind; or

(i) operate any amplifier, loud hailer, loudspeaker, or other public-address apparatus of any kind, or speak into any live microphone connected to any amplifier, loud hailer, loudspeaker, or other public-address apparatus of any kind.

6. Every person in any place of public resort shall at all times observe and comply with any lawful order or direction of any officer or employee or any member of the police force.

7. Nothing in this By-law shall operate to prevent any officer or employee or any member of the police force, or any member of the staff of or workman employed by any contractor doing any work for and on behalf of the Corporation of the City of Melbourne, from doing such things and taking such action as may be required of him, either with or without vehicles and other equipment, in the course of his duties or work.

8. Any person who (whether wilfully or not)—

(a) does not do anything directed to be done; or

(b) does anything forbidden to be done—

by or under the provisions of this By-law shall be guilty of an offence against this By-law.

SCHEDULE.

Item No. and Place of Public Resort No.	Name of place of Public Resort	Description of place of Public Resort
---	--------------------------------	---------------------------------------

1. Princes-Gate Plaza. As delineated and hatched on the following plan:

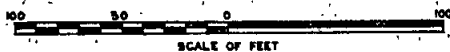
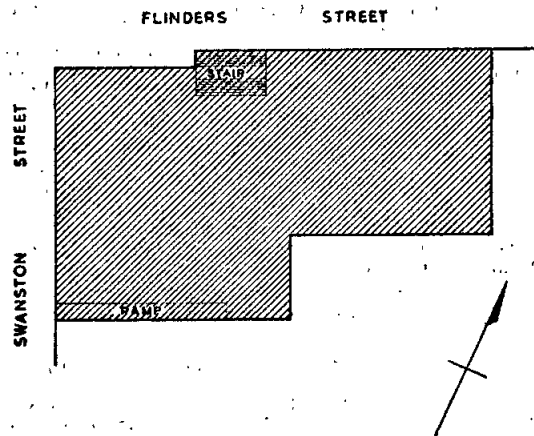
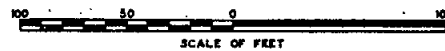
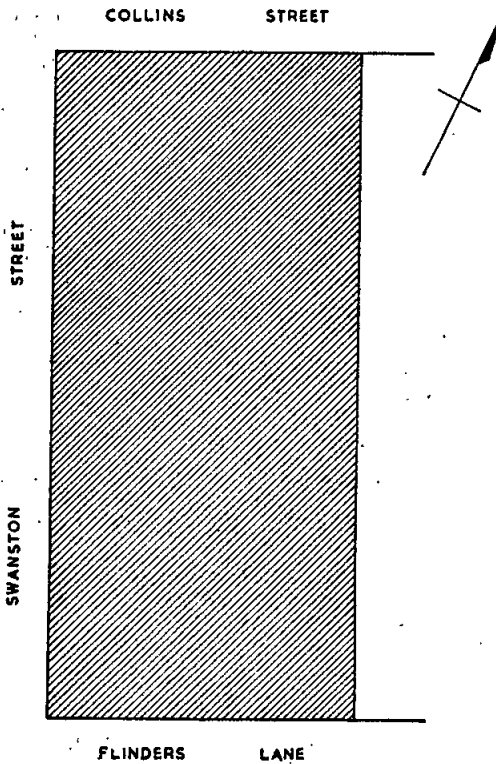

Item No. and Place of Public Resort No.	Name of place of Public Resort	Description of place of Public Resort
---	--------------------------------	---------------------------------------

3. Administrative-Building Forecourt. As delineated and hatched on the following plan:

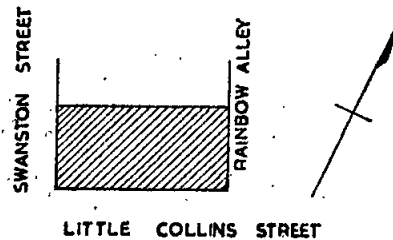

Item No. and Place of Public Resort No.	Name of place of Public Resort	Description of place of Public Resort
---	--------------------------------	---------------------------------------

2. Civic Square. As delineated and hatched on the following plan:

Resolution for passing the By-law agreed to by the Council of the City of Melbourne the 24th day of April, 1972, and confirmed the 15th day of May, 1972.
 (SEAL) ALWYNNE ROWLANDS, Lord Mayor.
 F. H. ROGAN, Town Clerk.

Approved by the Governor in Council the 23rd day of May, 1972.—J. ROSSITER, Clerk of the Executive Council.
 (72/1466/73) 6585

CITY OF MELBOURNE.

By-Law No. 491.

A By-law of the City of Melbourne made under Part VII. Division 1 of the *Local Government Act 1958* and the *Uniform Building Regulations 1969* and numbered 491 to further amend By-law No. 431.*

In pursuance of the powers conferred by the *Local Government Act 1958*, the *Uniform Building Regulations 1969*, and of every other Act or power enabling it in that behalf, the Council of the City of Melbourne Orders as follows:

1. (1) This By-law may be cited as the City of Melbourne Site Requirements (Further Amendment) By-law 1972.

(2) In this By-law, the City of Melbourne Site Requirements By-law, By-law No. 431, as amended by By-laws Nos. 444, 445, and 462, is referred to as the Principal By-law.

2. The title, the preamble, and clause 1 of the Principal By-law shall be amended by substituting for the expression "Uniform Building Regulations, Victoria" (wherever occurring) the expression "Uniform Building Regulations 1969".

3. The First Part of the Sixth Schedule to the Principal By-law shall be amended by deleting from it the following expressions:

"Alexandra Avenue	S. Anderson Street	Punt Road	100";
"Anderson Street	E. Alexandra Avenue	Domain Road	150";
"Domain Road	S. St. Kilda Road	To a point 106' east of Leopold Street	155"; and
"Toorak Road	N. Adams Street	Opposite north-eastern corner of Fawkner Park	200".

Resolution for passing this By-law agreed to by the Council of the City of Melbourne the 15th day of May, 1972, and confirmed the 5th day of June, 1972.

(SEAL)

ALWYNNE ROWLANDS, Lord Mayor.
F. H. ROGAN, Town Clerk.

Approved by the Governor in Council the 6th day of June, 1972.—J. ROSSITER, Clerk of the Executive Council.

* By-law No. 431, as amended by By-laws Nos. 444, 445 and 462.

(72/1115/304)

6614

Town and Country Planning Act 1961.

CITY OF MOE.—CITY OF MOE PLANNING SCHEME 1966.

NOTICE THAT A PLANNING SCHEME HAS BEEN PREPARED AND IS AVAILABLE FOR INSPECTION.

Amendment No. 31.

Notice is hereby given that the City of Moe, in pursuance of its powers under the *Town and Country Planning Act 1961*, has prepared a planning scheme for the following areas and purposes.

(a) The lands along the west side of Moore-street (between Della Torre-road and Walhalla-road and the south side of Walhalla-road), to define the limits of the General Industrial Zone.

(b) The lands bounded by Bell-street, Saviges-road, Della Torre-road and Saxtons-drive to rearrange the limits of the various zones in the block to conform with existing and proposed future allotment boundaries, and to set out the proposed new roads.

(c) The Victorian Railway lands surrounding the Moe Railway Station to delete the bus terminal from the lands presently used for other purposes.

(d) The lands in Langford-street within lots 8 to 11 inclusive on plan of subdivision No. 16099 and lot 2 on plan of subdivision No. 82023, to rezone the lands from Residential "A" to Residential "B" zoning.

A copy of the scheme may be inspected at the City Office, Albert-street, Moe, and at the office of the Town and Country Planning Board, 235 Queen-street, Melbourne, and will be open for inspection during office hours by any person, free of charge.

Any persons affected by the Planning Scheme are required to set forth, in writing, all objections they may have, addressed to the Town Clerk, City of Moe, Albert-street, Moe, on or before the 7th day of July, 1972, and to state whether they wish to be heard in respect of their objection.

6610

R. J. PUGSLEY, Town Clerk.

CITY OF NORTHCOTE.

By-Law No. 181.

A Bylaw of the City of Northcote made under Chapter 8 of the *Uniform Building Regulations Victoria* and the *Local Government Act 1958* and numbered 181 for Amending Bylaw No. 164 by adopting Column 3 of Table 804 of the Regulations in so far as the said Column 3 relates to minimum area depth and width of frontage of land on which a building of Class I or Class II Occupancy shall be erected, in lieu of Column 2 thereof.

In pursuance of the powers conferred by the *Uniform Building Regulations, Victoria*, and the *Local Government Act 1958* the Mayor Councillors and Citizens of the City of Northcote order as follows:—

Clause 3 of Bylaw No. 164 is hereby repealed and the following Clause substituted therefor—

The minimum area depth and width of frontage specified in Column 3 of Table 804 of the Regulations are hereby adopted as the minimum area depth and width of frontage of land on which a building of Class I or Class II Occupancy shall be constructed throughout the whole of the municipal district.

Resolution for passing this Bylaw agreed to by the Council of the City of Northcote on the twentieth day of March 1972 and confirmed on the tenth day of April 1972.

The corporate seal of the Mayor, Councillors and Citizens of the City of Northcote was hereunto affixed in the presence of:

(SEAL) KEITH D. SMITH, Mayor.
A. R. CADDY, Councillor.
A. J. HILL, Town Clerk.

Approved by the Governor in Council, 9th May, 1972.—
J. ROSSITER, Clerk of the Executive Council. 6559

SHIRE OF ARARAT.

LOAN No. 5.

Notice of Intention to Borrow the Sum of \$20,000 for Permanent Works and Undertakings.

Notice is hereby given that the Council of the Shire of Ararat proposes to borrow the principal sum of Twenty thousand dollars (\$20,000), secured by a charge over the general rates of the municipality, such sum to be raised by the grant of a mortgage in accordance with the provisions of the *Local Government Act 1958*.

1. The maximum rate of interest that may be paid is 6.20 per centum per annum.

2. The purpose for which the loan is to be applied is for the purchase of 500 tons of second-hand railway rails to be used in the construction of bridges, culverts, fences, control structures, retaining walls and buildings within the municipality of the Shire of Ararat.

3. The period of the loan shall be ten years.

4. The moneys borrowed shall be repayable by providing out of the municipal fund twenty half-yearly instalments of approximately \$1,356.78 each, including principal and interest, on the 1st day of March and the 1st day of September, during the currency of the loan. The first instalment shall be payable on the 1st day of March, 1973.

5. Such moneys shall be repayable to the C.B.C. Savings Bank Limited, Melbourne.

The plans and specifications and an estimate of the cost of the proposed works, and a statement showing the proposed expenditure of the moneys to be borrowed, are open for inspection at the office of the Council, Shire Hall, Barkly-street, Ararat.

6587 K. N. BISHOP, Shire Secretary.

SHIRE OF BERWICK.

LOAN No. 53.

Notice of Intention to Borrow the Sum of \$100,000 for Permanent Works and Undertakings.

Notice is hereby given that the Council of the Shire of Berwick proposes to borrow the principal sum of One hundred thousand dollars (\$100,000), secured by a charge over the general rates of the municipality, such sum to be raised by the grant of a mortgage in accordance with the provisions of the *Local Government Act 1958*.

1. The maximum rate of interest that may be paid is 6.2 per centum per annum.

2. The purposes for which the loan is to be applied are:—

Land Acquisition:

Berwick—part of Crown section 18, Church of Christ, balance	\$34,000
—part of Crown section 18, Reid, balance	\$1,000
Beaconsfield—Community Centre	\$3,000
Narre Warren—Community Centre	\$15,300

Roads and Streets:

Construction, Stoney Creek-road	\$5,700
Construction, Henry-street—balance	\$3,000
Rubbish Tip Construction, Narre Warren North	\$36,500
Public Conveniences, Construction—Nar Nar Goon	\$1,500

\$100,000

3. The period of the loan shall be ten years.

4. The moneys borrowed shall be repayable by providing out of the municipal fund twenty (20) half-yearly instalments of \$6,783.87 each, including principal and interest on the 11th day of January and the 11th day of July during the currency of the loan. The first instalment shall be payable on the 11th day of January, 1973.

5. Such moneys shall be repayable to the Bank of New South Wales, High-street, Berwick.

The plans and specifications and the estimate of the cost of the proposed work and a statement showing the proposed expenditure of the moneys to be borrowed, are open for inspection at the office of the Council of the Shire of Berwick at Main-street, Pakenham, during normal office hours.

6561 B. J. WALLIS, Shire Secretary.

SHIRE OF COLAC.

LOAN No. 36.

Notice of Intention to Borrow the Sum of \$10,000 for Permanent Works and Undertakings.

Notice is hereby given that the Council of the Shire of Colac proposes to borrow the principal sum of \$10,000 secured by a charge over the general rates of the municipality, such sum to be raised by the grant of a mortgage in accordance with the provisions of the *Local Government Act 1958*.

1. The maximum rate of interest that may be paid is 6.0 per cent. per annum.

2. The purpose for which the loan is to be applied is Road and Underground Drainage Construction in Tulloh-street, Elliminyt.

3. The period of the loan shall be four years.

4. The moneys borrowed shall be repayable by providing out of the municipal fund half-yearly instalments of approximately \$1,424.57 each including principal and interest on the 1st day of February and the 1st day of August during the currency of the loan. The first instalment will be payable on the 1st day of February, 1973.

5. Such moneys shall be repayable to the C.B.C. Savings Bank Ltd., Melbourne.

The plans and specifications and estimate of the cost of the proposed works and a statement showing the proposed expenditure of the moneys to be borrowed, are open for inspection at the office of the Council of the Shire of Colac, Shire Hall, Colac.

6560 W. J. MAUNSELL, Shire Secretary.

SHIRE OF CORIO.

LOAN No. 91.

Notice of Intention to Borrow.

Notice is hereby given that the Council of the Shire of Corio intends to borrow One hundred thousand dollars (\$100,000.00), secured by a charge over the general rates of the municipality by the grant of a mortgage in accordance with the provisions of the *Local Government Acts*.

In connexion therewith the following information is stated:—

(a) The amount of the principal moneys which it is proposed to borrow is One hundred thousand dollars (\$100,000.00).

(b) The maximum rate of interest that may be paid is 6.2 per centum per annum.

(c) The times which the moneys borrowed are to be repayable are the 1st day of February, 1973, and the 1st days of August and February during the years 1973 to 1982 inclusive, and that the place such moneys shall be repayable is at the Bank of New South Wales.

(d) The purpose for which the loan is to be applied is:—

	\$
Purnell-road reconstruction	15,000
Crowle-street reconstruction	15,000
Land acquisition	10,000
Lara drainage	10,000
Plant purchases	20,000
Caretakers residence—	
Elcho Park Golf Course	12,000
Pettitt Park Youth Centre	10,000
Pavilion Windsor Park (part)	4,000
Pavilion Hamlyn Park (part)	4,000

(e) The manner in which the loan is to be liquidated is by provision out of the municipal fund in each half-year during the currency of the loan of the sum of \$6,783.87, which includes principal and interest.

The plans and specifications and estimate of the cost of the works and a statement showing the proposed expenditure of the moneys to be borrowed are open for inspection at the Shire Office, Osborne House, North Geelong.

6590 W. H. MYERS, Shire Secretary.

SHIRE OF GOULBURN.

By-LAW No. 29.

Notice is hereby given that the Council of the Shire of Goulburn has made a By-law numbered 29 and titled Entrance Fees—Buckley Park, for the purpose of imposing, collecting and receiving a charge or entrance fee for clubs, associations, organisations or other similar groups of people using or entering in or upon Buckley Park, Nagambie.

The resolution for passing the By-law was agreed to on the 17th February, 1972 and confirmed on the 16th March, 1972.

The By-law was approved by the Governor in Council on the 13th May, 1972.

6563 J. L. MITCHELL, Shire Secretary.

Town and Country Planning Act 1961 (Twelfth Schedule).

SHIRE OF HASTINGS.—SHIRE OF HASTINGS PLANNING SCHEME 1962.

NOTICE THAT A PLANNING SCHEME HAS BEEN PREPARED AND IS AVAILABLE FOR INSPECTION.

Amendment No. 67, 1972.

Notice is hereby given that the Council of the Shire of Hastings, in pursuance of its powers under the *Town and Country Planning Act 1961*, has prepared a Planning Scheme for the following area:—

Land delineated on Plan No. 1263 in the Office of the Council, being lot 48 on lodged plan 7372 abutting the north side of Lorimer-street, Crib Point and lot 36 on lodged plan 7372 abutting the west side of Oratava-street, for the purpose of rezoning the former from Public Open Space Reserve—Recreation Reserve to Residential "A" Zone, and the latter from Residential "A" Zone to Public Open Space Reserve Recreation Reserve.

A copy of the scheme has been deposited at the Shire Office, Marine-parade, Hastings, and at the office of the Town and Country Planning Board, 235 Queen-street, Melbourne, and will be open for inspection during office hours by any person, free of charge.

Any persons affected by the Planning Scheme are required to set forth, in writing, all objections they may have, addressed to the Shire Secretary, Shire of Hastings, Post

Office Box 55, Hastings, on or before 7th September, 1972, and to state whether they wish to be heard in respect of their objections.

Dated 2nd June, 1972.

L. A. WALKER, Shire Secretary.

Municipal Offices, Hastings. 6572

SHIRE OF McIVOR.

LOAN No. 35.

Notice of Intention to Borrow the Sum of \$19,645 for Permanent Works and Services.

Notice is hereby given that the McIvor Shire Council has resolved to borrow the principal sum of \$19,645.00, by way of a charge over the general rates of the municipality, such sum to be raised by the grant of a mortgage in accordance with the provisions of the Local Government Act.

The maximum rate of interest that may be paid is 6.1 per centum per annum.

The purpose for which the loan is to be applied is purchase of one front end loader.

The period of the loan is to be eight (8) years.

The moneys borrowed shall be repaid by providing out of the municipal fund sixteen half-yearly instalments of approximately \$1,560.00 each, including principal and interest, on the 10th day of July and the 10th day of January in each year, during the currency of the loan. The first instalment shall be repayable on the 10th day of January, 1973.

Such moneys shall be repayable at the Commercial Bank of Australia Ltd., Heathcote, or at the Council's banker for the time being in Melbourne.

Plans and specifications and a statement showing the proposed expenditure of the moneys to be borrowed are open for inspection at the office of the Council of the Shire of McIvor, at Heathcote, during office hours.

6649 D. MAXWELL, Shire Secretary.

SHIRE OF MYRTLEFORD.

LOAN No. 22.

Notice of Intention to Borrow the Sum of \$6,000 for Permanent Works and Undertakings.

Notice is hereby given that the Council of the Shire of Myrtleford proposes to borrow the principal sum of \$6,000, secured by a charge over the general rates of the municipality, such sum to be raised by the grant of a mortgage in accordance with the provisions of the Local Government Act 1958.

1. The maximum rate of interest that may be paid is 6.2 per cent. per annum.

2. The purpose for which the loan is to be applied is Council proportion of cost of underground drainage works.

3. The period of loan shall be ten years.

4. The moneys borrowed shall be repayable by providing out of the municipal fund, half-yearly instalments of approximately \$407.03 each, including principal and interest on the 1st day of February and the 1st day of August, during the currency of the loan. The first instalment shall be payable on the 1st day of February 1973.

5. Such moneys shall be repayable to the Australia and New Zealand Savings Bank Limited, Melbourne.

The plans and specifications and the estimate of the cost of the proposed works and a statement showing the proposed expenditure of the moneys to be borrowed are open for inspection at the office of the Council of the Shire of Myrtleford, at Myrtleford.

6598 K. S. LANE, Shire Secretary.

SHIRE OF NARRACAN.

LOAN No. 43.

Notice of Intention to Borrow the Sum of \$4,700 for Permanent Works and Undertakings.

Notice is hereby given that the Council of the Shire of Narracan proposes to borrow the sum of Four thousand seven hundred dollars (\$4,700), on the credit of the general rates of the President, Councillors and Ratepayers of the said Shire, such sum to be raised by the grant of a mortgage in accordance with the provisions of the Local Government Act 1958.

(1) The maximum rate of interest that may be paid is 6 per centum per annum.

(2) The purpose for which the loan is to be applied is the purchase of road-making plant.

(3) The period of the loan shall be four (4) years.

(4) The moneys borrowed shall be repayable by providing out of the municipal fund eight half-yearly instalments of approximately \$669.55 each, including principal and interest, on the 1st day of March and the 1st day of September, during the currency of the loan. The first instalment shall be payable on the 1st day of March 1973.

(5) Such moneys shall be repayable at C.B.C. Savings Bank Limited, at Melbourne.

The plans and specifications and the estimate of the cost of the proposed works, and a statement showing the proposed expenditure of the moneys to be borrowed are open for inspection at the Shire Office, Trafalgar, during normal office hours.

6608 W. F. NELSON, Shire Secretary.

SHIRE OF SHERBROOKE.

LOAN No. 135.

Notice of Intention to Borrow the Sum of \$100,000 for Permanent Works and Undertakings.

Notice is hereby given that the Council of the Shire of Sherbrooke proposes to borrow the principal sum of \$100,000, secured by a charge over the general rates of the municipality, such sum to be raised by the grant of a mortgage in accordance with the provisions of the Local Government Act 1958.

1. The maximum rate of interest that may be paid is 6.4 per centum per annum.

2. The purposes for which the loan is to be applied are:—

Council's share unclassified roads construction.

C.R.B. main roads construction contribution.

Kings park drainage works.

Council's sole responsibility on C.R.B. works.

Council's share private street construction.

3. The period of the loan shall be twenty (20) years.

4. The moneys borrowed shall be repayable by providing out of the municipal fund half-yearly instalments of \$4,467.21 each, including principal and interest on the 21st day of January and the 21st day of July during the currency of the loan. The first instalment shall be payable on the 21st day of January, 1973.

5. Such moneys shall be repayable to Australian Mutual Provident Society, Melbourne, Victoria.

The plans and specifications and the estimate of the cost of the proposed works, and a statement showing the proposed expenditure of the moneys to be borrowed, are open for inspection at the office of the Council of the Shire of Sherbrooke, Glenfern-road, Upwey.

6602 K. E. MATSON, Shire Secretary.

SHIRE OF SHERBROOKE.

LOAN No. 136.

Notice of Intention to Borrow the Sum of \$50,000 for Permanent Works and Undertakings.

Notice is hereby given that the Council of the Shire of Sherbrooke proposes to borrow the principal sum of \$50,000, secured by a charge over the general rates of the municipality, such sum to be raised by the grant of a mortgage in accordance with the provisions of the Local Government Act 1958.

1. The maximum rate of interest that may be paid is 6.2 per centum per annum.

2. The loan is to be applied towards Council's share of the Ferny Creek Re-modelling.

3. The period of the loan shall be ten (10) years.

4. The moneys borrowed shall be repayable by providing out of the municipal fund half-yearly instalments of \$2,198.22 each, including principal and interest on the 1st day of February and the 1st day of August during the currency of the loan, together with a final payment of \$34,602.31 on the 1st day of August 1982. The first instalment shall be payable on the 1st day of February 1973.

5. Such moneys shall be repayable to the Australia & New Zealand Savings Bank Ltd., 394 Collins-street, Melbourne.

The plans and specifications and the estimate of the cost of the proposed works, and a statement showing the proposed expenditure of the moneys to be borrowed, are open for inspection at the office of the Council of the Shire of Sherbrooke, Glenfern-road, Upwey.

6603 K. E. MATSON, Shire Secretary.

SHIRE OF TAMBO.

LOAN No. 38.

Notice of Intention to Borrow the Sum of \$35,000 for Permanent Works and Undertakings.

Notice is hereby given that the Council of the Shire of Tambo proposes to borrow the principal sum of Thirty-five thousand dollars secured by a charge over the general rates of the municipality, such sum to be raised by the grant of a mortgage in accordance with the provisions of the Local Government Act 1958.

1. The maximum rate of interest that may be paid is 6.4 per centum per annum.

2. The purposes for which the loan is to be applied are as follows:—

Council Proportion—Concrete Kerbing, Channeling and Footpaths:—	\$	
Lakes Entrance.—North Arm-avenue, Eastern Beach-road, Roadknight-street, Whithers-street, Camp-street, Gully-road, Esplanade, Mechanics-street, Myer-street, and Orme-street.		
Bruthen.—Omeo Highway, Seehusen-avenue, Ronald-street, and Church-street		5,700
Construction and Sealing—	\$	
Eastern Beach-road	5,500	
Camp-street and Gully-road	9,000	14,500
Erection of Council Residence, Bruthen		14,800
		<u>35,000</u>

3. The period of the loan shall be twenty years.

4. The moneys borrowed shall be repayable by providing out of the municipal fund half-yearly instalments of \$1,563.52 each including principal and interest on the 4th day of February and the 4th day of August during the currency of the loan. The first instalment shall be payable on 4th day of February, 1973.

5. Such moneys shall be repayable at the Australian Mutual Provident Society, 535 Bourke-street, Melbourne.

Plans and specifications and the estimate of the cost of the proposed works and a statement showing the proposed expenditure of the moneys are open for inspection at the office of the Council of the Shire of Tambo at Bruthen.

6562

W. J. HOBSON, Shire Secretary.

SHIRE OF TOWONG.

ROAD DEVIATION ORDER.

Pursuant to the provisions of sections 522 and 526 of the Local Government Act 1958, the Council of the Shire of Towong doth hereby direct that the land in the Parish of Berringa shown hatched on the plan hereunder, which has been taken purchased or acquired by it, shall be a public highway from and after the date of publication of this order in the Government Gazette.

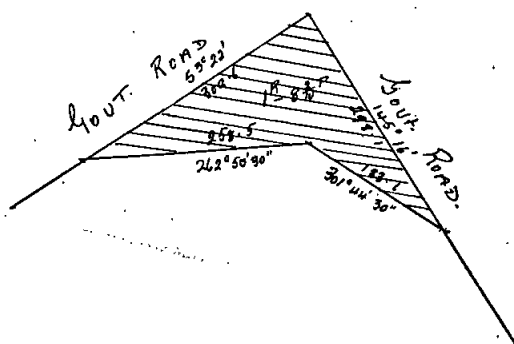

The common seal of the President, Councillors and Ratepayers of the Shire of Towong was hereunto affixed this 20th day of September, 1971, in the presence of—

(SEAL) D. F. KELLY, President.
T. N. MARTIN, Councillor.
I. MCK. BOWMAN, Secretary.

6564

WYCHEPROOF SEWERAGE AUTHORITY.

BY-LAW No. 3.

Notice of By-Law.

Relating to the use of P.V.C. pipes and fittings for soil, waste and combined waste pipes and drainage vents of sewerage installations in one and two storey buildings.

Notice is hereby given that the Wycheproof Sewerage Authority pursuant to and in exercise of the powers and authorities conferred on it by the Sewerage Districts Act has made and passed the above By-Law on the 19th day of October, 1971 and confirmed the above By-Law on the 16th day of November, 1971.

A copy of the By-Law No. 3 is open for inspection free of charge during office hours of the above Authority.

6604

G. R. DRYDEN, Secretary.

SEA LAKE SEWERAGE AUTHORITY.

BY-LAW No. 3.

Notice of By-Law.

Relating to the use of P.V.C. pipes and fittings for soil, waste and combined waste pipes and drainage vents of sewerage installations in one and two storey buildings.

Notice is hereby given that the Sea Lake Sewerage Authority pursuant to, and in exercise of the powers and authorities conferred on it by the Sewerage Districts Act, has made and passed the above By-Law on the 20th October, 1971, and confirmed the above By-Law on the 17th day of November, 1971.

A copy of By-Law No. 3 is open for inspection free of charge during office hours of the above authority.

6600

G. R. DRYDEN, Secretary.

THE BALLARAT SEWERAGE AUTHORITY.

Pursuant to section 119 (2) of the Sewerage Districts Act 1958 (No. 6368), notice is hereby given of the intention to construct sewers to provide for properties situated in—

Shire of Ballarat.—Park, Lake, Cromwell and Norman streets and Shaw-avenue, more particularly as shown on maps which are open for inspection at this office between the hours of 9 a.m. and 4 p.m., Monday to Friday, inclusive.

Dated 2nd June, 1972.

6599

CHAS. H. CLAMP, Secretary.

DANDENONG SEWERAGE AUTHORITY.

GENERAL NOTICE.

The above-mentioned Sewerage Authority, having made provision for carrying off the sewage from each and every property which, or any part of which is within the sewerage areas hereinafter described, doth hereby declare that on and after the 1st day of June, 1972, each and every property which, or any part of which is within the said sewerage areas shall be deemed to be a sewered property within the meaning of the Sewerage Districts Act 1958.

The boundaries of the Sewerage Areas hereinbefore referred to are:—

Sewerage Area No. 253.

All those pieces of land being lots 54 to 57 inclusive; 59 to 64 inclusive and 90 to 104 inclusive on lodged plan of subdivision No. 91804, lots 65 to 73 inclusive on lodged plan of subdivision No. 91805 and lots 23 to 34 inclusive and 37 to 53 inclusive on lodged plan of subdivision No. 91539.

Streets or parts thereof concerned in this area are Kidds-road, Sheoak-street, Doveton-avenue and Laurel-avenue.

Sewerage Area No. 254.

All those pieces of land being lots 226 to 228 inclusive on lodged plan of subdivision No. 91586 and lots 20 to 32 inclusive and 242 to 246 inclusive on lodged plan of subdivision No. 94359.

Streets or parts thereof concerned in this area are Brady-road, Loch-road and Eve-court.

Unless otherwise specified, the lodged plans of subdivision hereinbefore referred to shall be taken as those lodged at the Office of Titles, Melbourne.

By Order of the Dandenong Sewerage Authority.

6586

L. K. DONNELLY, Chairman.
A. R. EDWARDS, Secretary.

GEELONG WATERWORKS AND SEWERAGE TRUST.

Pursuant to section 60 of the *Geelong Waterworks and Sewerage Act 1958* (No. 6263), the Trust has prepared plans to indicate the particulars of sewers and underground works in or adjacent to the following localities within the Drainage Area:—

Marilyn and Cobham streets, Stapledon, Epsom, Como and Cox roads, Norlane, Shire of Corio.

Tarring-court, Highton, Shire of South Barwon.

Duggan-court, Highton, Shire of South Barwon.

Mornington and Douro streets, North Geelong, Shire of Corio.

Notice is hereby given that the plans indicated above are open for public inspection at the Trust's Offices, Ryrie-street, Geelong, between the hours of 9 a.m. and 5 p.m., from Monday to Friday, public holidays excepted, by the owners and occupiers of land or premises within the Drainage Area.

6579 B. C. HENSHAW, Secretary.

MOOROOPNA SEWERAGE AUTHORITY.

The above-mentioned Sewerage Authority, having made provision for carrying off the sewage from each and every property which, or any part of which, is within the Sewerage Area hereinafter described, doth hereby declare that on and after the 1st of June, 1972, each and every property which, is within the said Sewerage Area shall be deemed to be a seweraged property within the meaning of the Sewerage Districts Act.

The boundaries of the Sewerage Area hereinafter referred to are:—

Sewerage Area No. 13.

All those pieces of land being lots 176 to 179 inclusive on lodged plan of subdivision No. 90373.

Lots 129 to 136 inclusive, lots 169 to 175 inclusive, lots 188 to 194 inclusive, lots 225 to 238 inclusive, and lot 246 on lodged plan of subdivision No. 95317.

Lots 223 and 224 on Housing Commission plan of subdivision No. A/480/9.

Streets concerned in this area are Gange-street, Broadbent-court, Maher-court, Stevens-crescent and McIsaac-road.

By Order of the Mooroopna Sewerage Authority.

6606 J. T. GRAHAM, Chairman.
R. F. FORSTER, Secretary.

NOTICE OF INTENTION TO APPLY FOR A LICENCE TO DIVERT WATER (RE-ISSUE) FROM THE BROKEN RIVER, AT UPOTIPOPON.

We hereby give notice that we intend to apply for a licence empowering us to divert water for a term of four years to the extent of 240 acre-feet per annum at a maximum rate of 12 acre-feet per day of 24 hours for the irrigation of pasture and crops, being part of allotments 56, 57, 60, 61, Parish of Upotipoton.

Any objection to such application must be forwarded in writing to reach the State Rivers and Water Supply Commission, Melbourne, before 17th July, 1972, being 30 days from the first publication of this notice.

JOHN PITT BURNELL.
BRUCE REGINALD BURNELL.

Summerlea, Benalla, 3672. 6571

NOTICE OF INTENTION TO APPLY FOR A LICENCE TO DIVERT WATER AND CUT RACE FROM THE RIVER MURRAY, AT PIANGIL.

We hereby give notice that we intend to apply for a licence empowering us to divert water for a term of four years to the extent of 183 acre-feet per annum at a maximum rate of 4 acre-feet per day of 24 hours for the 61 acres of pasture, being part of allotment 161, Parish of Piangil, and to occupy certain Crown lands for works of diversion, and to cut a race thereon.

Any objection to such application must be forwarded, in writing, to reach the State Rivers and Water Supply Commission, Melbourne, before 7th July, 1972, being 30 days from the first publication of this notice.

MAURICE FLEMING.
HELEN MAY FLEMING.

P.O. Box 34, Nyah. 6642

Notice is hereby given that Neal's Automobiles Proprietary Limited has applied for a lease pursuant to sections 134 and 135 of the *Land Act 1958* for a term of 50 years in respect of allotments 4, 5 and 6, section D, City of South Melbourne for the purpose of business—central.

6236

Notice is hereby given that the Wonthaggi Golf Club has applied for a lease, pursuant to section 134 of the *Land Act 1958*, over 157 acres of Crown land in the Township of Wonthaggi, for a period of 21 years for the purpose of amusement and Recreation.

6301

The partnership of Colin Peter Gibson and Sally Ann Garden trading as Skybeam Antennae Service, A.A.A. Antennae Installations, Skybeam Insulation Service and Skybeam Caravan Antennae will be dissolved. I, Sally Ann Garden, of 11 Rosslyn-street, Blackburn, in Victoria will not be responsible for any debts incurred in the name of any of the above without my written authority as from the 1st day of June, 1972. The said Colin Peter Gibson will continue to carry on the above business.

Signed: SALLY GARDEN.
Witness: J. CARL MENGLER,
Sergeant of Police, 12590.

6567

Notice is hereby given that the partnership heretofore subsisting between the undersigned, Maria Lambrecht and Wolfgang Lambrecht, both of 3 Cambridge-street, Oakleigh has been dissolved by mutual consent as from the 30th day of March, 1972.

All debts due and owing by the said partners to this date will be received and paid by the said Wolfgang Lambrecht.

Wolfgang Lambrecht will continue to carry on the business at the same place and under the same name.

Dated at Melbourne this 21st day of May, 1972.

6565 MARIA LAMBRECHT.
WOLFGANG LAMBRECHT.

Notice is hereby given that the partnership heretofore subsisting between Colin Blackwood Officer, Margaret Helen Officer, and Michael William Heffernan, carrying on the practice of general medical practitioners, at 32 Anzac-avenue, Seymour, under the firm name of "Drs. C. B. & M. H. Officer and Dr. M. W. Heffernan", has been dissolved as from the 3rd day of June, 1972, so far as concerns the said Michael William Heffernan, who retires from the said firm.

Dated the 3rd day of June, 1972.

6633 COLIN B. OFFICER.
M. H. OFFICER.
M. W. HEFFERNAN.

Companies Act 1961.—In the matter of DECORART (AUSTRALASIA) PTY. LIMITED (In liquidation).

Notice is hereby given that at an Extraordinary Meeting of the members of the above-named company held on the 1st June, 1972, it was resolved that the company be wound up voluntarily and at a meeting of creditors held on the same day, pursuant to section 260, it was resolved that for such purpose Everett Thomson Bent, of Suite 18, 545 St. Kilda-road, Melbourne, public accountant, be appointed liquidator.

Notice is also given that after 21 days from this date I shall proceed to distribute the assets. All creditors having any claims against the company should furnish particulars of same by that date, otherwise I shall proceed to distribute the assets without regard to their claim.

Dated this 1st day of June, 1972.

E. T. BENT, Liquidator.
Bent & Cogle, public accountants, Suite 18, 545 St. Kilda-road, Melbourne, 3004. 6578

Companies Act 1961.—In the matter of JARICK DISTRIBUTORS PTY. LTD. (In liquidation).

Notice is hereby given that at an Extraordinary Meeting of the members of the above-named company held on the 30th May, 1972, it was resolved that the company be wound up voluntarily, and at a meeting of creditors held on the same day, pursuant to section 260, it was resolved that for such purpose, Everett Thomson Bent, of Suite 18, 545 St. Kilda-road, Melbourne, public accountant, be appointed liquidator.

Notice is also given that after 21 days from this date I shall proceed to distribute the assets. All creditors having any claims against the company should furnish particulars of same by that date, otherwise I shall proceed to distribute the assets without regard to their claim.

Dated this 30th day of May, 1972.

E. T. BENT, Liquidator.
Bent & Cogle, public accountants, Suite 18, 545 St. Kilda-road, Melbourne, 3004. 6569

Unclaimed Moneys Act 1962.

Register of Unclaimed Moneys held by the—

Name of Owner on Books and Last Known Address.	Total Amount Due to Owner.	Description of Unclaimed Moneys.	Date when Amount first became Payable.
\$			
CLEVELAND TIN N.L.			
Abrahams, Lionel A. and Reynolds, Arthur J., c/o Reynolds Esq., Patrick and Co., Box 2850, Sydney, N.S.W.	39.00	Dividend	6.11.70
Allanson, George F. and Traini, Tina (Miss), 22 John-street, Cabramatta, N.S.W.	30.00	"	"
Allen, Joy M. (Miss), 8 Bray-street, North Sydney, N.S.W.	12.00	"	"
Black, Hugh W., Rossarden, Tasmania	15.00	"	"
Black, Margaret A. (Mrs.), Rossarden, Tasmania	18.00	"	"
Bowen, George H., c/o N. E. Jones, Esq., 14 Spring-street, Sydney, N.S.W.	15.00	"	"
Burns, Ian C., Flat 12, 70 Canterbury-road, Toorak	15.00	"	"
Burrows, Peter W. J., c/o K. Burrows Esq., 52 Barton-street, Kogarah, N.S.W.	12.00	"	"
Carter, Jessie M. (Mrs.), c/o Sam Bagley and Co., 430 Little Collins-street, Melbourne	18.00	"	"
Clough, John C., Flat 3, 43 Hillside-avenue, Dandenong	15.00	"	"
Clowes, Peter G., c/o Savage River Post Office, Savage River, Tas.	15.00	"	"
Cox, Govan W. (estate of), c/o Malleons, 105 King-street, Melbourne	52.50	"	"
Darlow, Michael J., Lower Flat, 33 Gardyne-street, Waverley, N.S.W.	15.00	"	"
Dorr, Barry F., 420 Dorcas-street, South Melbourne	18.00	"	"
Fair, Fraser G., 5 Kenley-court, Toorak	11.25	"	"
Foot, Robert P., 2 Rosemont-avenue, Woollahra, N.S.W.	15.00	"	"
Gardiner, Dr. James F., 54 Brisbane-street, Launceston, Tas.	15.00	"	"
Goldfinch, Dr. Roy A., Swansea, Tas.	15.00	"	"
Grigoriou, George, 25 Elouera-street, Beverley Hills, N.S.W.	21.00	"	"
Grimley, Geoffrey M., 129 Blackwood-road, Manly West, Q'land ..	12.00	"	"
Hardman, Dr. Gerald L., 26 Spring Gully-road, Bendigo	15.00	"	"
Hercules, Dr. Julian M., 61 Hedderwick-road, Essendon	47.00	"	"
Hogan, Irene M. (Mrs.), 320 Wattletree-road, East Malvern	15.00	"	"
Jonas, Ian R., Flat 4, 150 Bellevue-road, Bellevue Hill, N.S.W. ..	14.40	"	"
Jones, Peter C., c/o Post Office, Luina, Tas.	12.00	"	"
Khalil, Nabil, c/o Post Office, Luina, Tas.	12.00	"	"
Kras, Sam, 27 Hornby-street, East Brighton	15.00	"	"
Landsman, David, c/o M. King, 2A Gladstone-street, Watson's Bay, N.S.W.	18.00	"	"
Larkins, John D., 43 Bonefin-road, Hunter's Hill, N.S.W.	15.00	"	"
Levitzke, David S., 18 Veronica-street, South Oakleigh	12.00	"	"
Martyn, John V. (estate of), and Martyn, Eileen P. (Mrs.), 7 Viewbank-road, Glen Iris	67.80	"	"
Mether, Mark W., 5 Cambria-grove, Cheltenham	12.00	"	"
McCormack, William F., Flat 2, 32 Bruce-street, Toorak	21.00	"	"
McDonald, Lady Evelyn M., 137 Orrong-road, Toorak	30.00	"	"
McManus, Alphonsus J., Watson's Bay Hotel, Watson's Bay, N.S.W.	15.00	"	"
Neve, Mary E. (Mrs.), Flat 4, 29 Shirley-road, Wollstonecraft, N.S.W.	60.00	"	"
Nicholson, Allan R., 86D Kars-street, Frankston	15.00	"	"
Ortt, Godfrey B., 77 Hillside-crescent, Hamilton, Q'land	12.00	"	"
O'Shannessy, James P., 12 Nicholson-street, Moreland	15.00	"	"
O'Sullivan, Gloria M. (Mrs.), Young-street, Deepdene	15.00	"	"
Priestley, Charles W., 10 Knox-street, Queenstown, Tas.	12.00	"	"
Rowley, Reginald W., 211 Miller-street, North Sydney, N.S.W. ..	12.00	"	"
Smith, Margaret E. (Mrs.), 18 Victor-street, Beaumaris	15.00	"	"
Smith, Mary A. (Mrs.), c/o Mrs. T. Baartman, 61 Henry-street, Merewether, N.S.W.	15.00	"	"
Stead, Charles W., c/o R. Hare and Assoc., 23 Hamilton-street, Sydney, N.S.W.	138.00	"	"
Sussman, Anna (Mrs.), Flat 2, 123 Old South Head-road, Bondi Junction, N.S.W.	40.50	"	"
Swan, John W., 23 Pierce-street, Khancoban, N.S.W.	30.00	"	"
Thomas, Phillip G., 89 Braeside-street, Wahroonga, N.S.W.	15.00	"	"
Thompson, Elsie V. (Mrs.), 56B Nicholson-street, Burwood, N.S.W.	12.00	"	"
Treharne, Arthur G., 2A Rake-street, Carnegie	15.00	"	"
Upfold, Barbara J. (Mrs.), 38 Raeburn-avenue, Castlecrag, N.S.W.	12.00	"	"
Vickery, Arthur (estate of), 4 Bridge-street, Sydney, N.S.W.	60.54	"	"
Walker, Louisa G. (Mrs.), 1 Maples-avenue, Killara, N.S.W.	30.00	"	"
Williams, John W. McK., 4 Carrington-avenue, Bellevue Hill, N.S.W.	15.00	"	"
Wolrye Nominees Pty. Ltd., 23 Hamilton-street, Sydney, N.S.W. ..	21.00	"	"
Wright, Josephine G., (Mrs.), 4 Beaufort-street, Woodville, S.A. ..	12.00	"	"
Yeo, Lee Cheng, c/o University of New South Wales, International House, Kensington, N.S.W.	15.00	"	"
Bigwood, George F., 11A Surbiton-crescent, Kingston-On-Thames, Surrey, England	11.47	"	"
Cooke, Bessie McL. (Mrs.) and Cooke, John H., Innisfree, Keyworth-avenue, Barton-On-Sea, Hants, U.K.	32.13	"	"
Crabbe, Bernard, Birchcroft, Whiddon Down, Okehampton, Devon, U.K.	15.30	"	"
Griggs, Donald N. and Linforth, Frank E., 11 Copthall-court, London, U.K.	57.38	"	"
Grubb, Francis C. E. (estate of), P.O. Box 3308, Wellington, N.Z.	14.28	"	"
Nelson, Dr. Hans, 65 Symonds-street, Auckland, N.Z.	102.00	"	"
Pierce, William J., "Pennant", 137 Manod-road, Blaenau-Festiniog, Merioneth, U.K.	11.48	"	"
Seeley, Dr. Alwyn J., 160 Collingwood-street, Hamilton, N.Z.	20.40	"	"
Skeates, Vida (Mrs.), c/o Mr. Sheates Crooks Michell, Peacock Steward, P.O. Box 38, Alexandra, Singapore	12.75	"	"
Thomas, Edward H., 37 Green-street, Mayfair, London, W.1., U.K.	32.10	"	"

Unclaimed Moneys Act 1962.

Register of Unclaimed Moneys held by the—

Name of Owner on Books and Last Known Address.	Total Amount Due to Owner.	Description of Unclaimed Moneys.	Date when Amount first became Payable.
S			
NICHOLAS INTERNATIONAL LIMITED.			
Drew, Lloyd J., 64 Castle-street, Blakehurst, N.S.W.	17.50	Dividend	29.11.70
Hillyer, Edward J., 19 Moana Gardens, 2 Oriental-street, Bexley, N.S.W.	17.50	"	"
Lincham, Robert F., c/o Post Office, Dampier, W.A.	35.00	"	"
Sloss, Marion C. (Mrs.), Bellevue-road, Bellevue Hill, Sydney, N.S.W.	83.13	"	"
Stevenson, James G. M., Maybale, Alexandra	17.50	"	"
Stewart, Violet H. (Mrs.), c/o E. J. Morgan & Co., 351 Collins-street, Melbourne	17.50	"	"
Teague, Bernard George, 2 Larnock-street, Armadale	14.00	"	"
Waine, John C. Scott, 67 Brentwood-avenue, Warrawee, N.S.W.	10.50	"	"
Wright, Lynette Joy, Flat 12, 12 Grange-road, Glenhuntly	14.00	"	"
Boughan, Martin J., The Glen Monaghan, Co. Monaghan, Eire	23.27	"	"
Cessford, Jenny W., Chalet Shalimar, Rua Da Beira Litoral, Portugal	18.62	"	"
Eatough, Nellie (Miss), 127 Bury Old-road, Heywood, Lancs., U.K.	14.14	"	"
Egan, Mary I. (Miss), 32 Groomsport-road, Bangor, Co. Down	13.96	"	"
Flett, William W., Bayview, Seafield-street, Cullen Banffshire, AB5 2SU, Scotland	42.40	"	"
Hallett, Margaret T. (Miss), 3 Brooklyn-avenue, Worthing, U.K.	117.27	"	"
Henderson, Kenneth M. (Dr.), Apartment 42, 15 Av De Miremont, 1206 Geneva, Switzerland	16.40	"	"
Jones, Annita M. (Mrs.), The Cottage, Rickford, Burrington, Bristol, U.K.	31.09	"	"
Kassar, Winifred R. G. (Mrs.), 4 Beach-avenue, Olf Colwyn, Colwyn Bay, North Wales	10.57	"	"
Levingston, Louis, No. 11 Chapman-street, Glasgow, U.K.	14.14	"	"
Luby, Denis J., 71 Parnell-street, Dublin, Eire	13.96	"	"
Mack, William S., 5 Cleveden-drive, Glasgow, W2, U.K.	28.26	"	"
N.P. Trusts Limited W E A/C, 15 Bishopsgate, London, E.C.2, U.K.	25.44	"	"
De La Perrelle, Evan Thomas, 68 Carisbrooke-avenue, Hill Head, Fareham, Hants.	11.30	"	"
Schofield, Beatrice (Mrs.), The Flouch, Hazlehead, Nr. Sheffield, Yorkshire	21.18	"	"
Wales, Eillen I. (Miss), 4 The-street, Woodnesborough, Sandwich, Kent, U.K.	14.14	"	"
Wilson, Herbert P., 28 Westminster-road, Eccles, Nr. Manchester, U.K.	33.91	"	"
Young, James, 17 Somerled-avenue, Paisley, Renfrewshire, U.K.	11.30	"	"
Brierston, Harry, 58 Victoria Park-drive North, Glasgow, W4, U.K.	22.61	"	"
Calderbank, Thomas, 5 Marlwood-road, Smithills, Bolton, U.K.	11.30	"	"
Chipperfield, Janet E. (Miss), Flat 6, Oakhill Court, Oakhill-road, Surbiton, Surrey	14.14	"	"
Crawford, James, 88 Hawthornden-road, Belfast, BT 4 3JK, U.K.	14.14	"	"
Crimmins, Lelia (Miss), 445 Howth-road, Dublin 5, Eire	33.91	"	"
Davies, Margaretta (Mrs.), 10 Penydaren, Merthyr Tydfil, U.K.	14.14	"	"
Day, Horace A., Hall-close, Kibworth, Harcourt, Leicestershire, U.K.	70.66	"	"
Dickson, George I. N., St. Oswalds, Chambers, St. Werburgh-street, Chester, U.K.	17.91	"	"
Evans, Trevor J., Hillcrest, Kingsfield, Ebbw Vale, Mon., U.K.	11.30	"	"
Harris, Patricia D. (Mrs.), 2 Bush Hay Chosen-drive, Churchdown, Glos., U.K.	15.09	"	"
Hart, David McK., 7 Tweedmuir-crescent, Bearsden, Glasgow, U.K.	14.14	"	"
Leslie, John H., Granville, Kimberley-drive, Stockton Heath, Warrington, Lancs.	21.18	"	"
Mowat, Jessie J. (Mrs.), and Walter N., Braehead, Scalloway, Shetland, U.K.	32.49	"	"
Neville, Agnes O. (Miss), White Lodge Nursing Home, Court-road, Maidenhead, Berks.	84.79	"	"
Rogers, Eric G., Gaywood Hollypark, Huby, Near Leeds	28.26	"	"
Smyth, Vera V. (Miss), 28 Waterlow-court, Heath Close, London, NW 11, U.K.	31.09	"	"
Taylor, Winifred E. (Mrs.), Hawkeswood, Northan Devan, U.K.	28.26	"	"
Worth, Brian L. and Wardell, John P. M., Warwick House, Warwick-court, Grays Inn, London, WC1 6333	19.79	"	"
HUTTONS LIMITED.			
Barratt, Joan G. (Mrs.), 59 Lansdown-street, North Balwyn	20.62	Dividend	27.7.70
Beamish, Catherine M. V. (Mrs.), Lambert-street, Kangaroo Point, Queensland	24.00	"	"
Daunt, Lily C. (estate of), c/o Messrs. Stephen L. Hayes & Norden, 150 Queen-street, Melbourne	13.20	"	"
Inglis, Reginald O., 56 Burilda-street, Hendra, Queensland	16.00	"	"
Whait, John E. (estate of), c/o Huttons Limited, 65 High-street, Preston	24.96	"	"
White, Gilbert S., Marine Parade Stores, Marine-parade, Timaru, N.Z.	34.00	"	"
Myers, Arthur G. S., A.N.Z. Bank Chambers, 406 Queen-street, Brisbane, Queensland	82.50	"	"
HUTTONS LIMITED.			
Brabazon, Frederick R. (estate of), Box 227 P.O., Dalby, Queensland	45.37	Dividend	29.1.71
Devlin, Irene M. (Mrs.), 38 Crump-street, Holland Park, Queensland	36.30	"	"
Sandeman, Gordon A. and Gwendolyn M. (Mrs.), The Palms, Box 23 P.O., Cooyar, Queensland	54.45	"	"
Whait, John E. (estate of), c/o Huttons Limited, 65 High-street, Preston	24.96	"	"
White, Gilbert S., Marine Parade Stores, Marine-parade, Timaru, N.Z.	34.00	"	"
Brabazon, Frederick R. (estate of), Box 227 P.O., Dalby, Queensland	11.30	"	"
6329			

Unclaimed Moneys Act 1962.

Register of Unclaimed Moneys held by the—

Name of Owner on Books and Last Known Address.	Total Amount Due to Owner.	Description of Unclaimed Moneys.	Date when Amount first became payable.
§			
DUNLOP AUSTRALIA LIMITED.			
Judge, John William Charles, 34 The Marlinspike, Shoreham-By-Sea, Sussex, England	479.41	Cash Consideration	1.9.70
Hogan, Geoffrey Sidney, 56 Bellvue-terrace, Clayfield, Queensland ..	166.12	" "	12.11.70
Gardiner, Marie (Miss), c/o Harvey Preen & Co., 9 Orchard-street, Bristol, B.S.1 5 E.G. U.K.	3,962.25	" "	18.2.71
Cameron, William Stephen B. (estate of), c/o J. R. Kennedy, G.P.O. Box 329e, Brisbane, Queensland	3,696.45	" "	"
Cornwall, Frances Elizabeth (estate of), c/o Wm. Walker & Son, George-street, Windsor, N.S.W.	325.84	" "	"
Evans, Frank Rupert Evan (estate of), c/o J. L. Rawlings Bolton & Co., Box 740 G.P.O., Brisbane, Queensland	132.90	" "	"
Jones, Charles Evelyn (estate of), 40 Winbourne-road, Brookvale, N.S.W.	3,300.22	" "	"
Ryan, Kevin Stanislaus (estate of), c/o J. F. Fitzgerald & Seymour, G.P.O. Box 535, Brisbane, Queensland	17.85	" "	"
Dusting, Sylvia Edith M. (Mrs.), 6 Acheron-avenue, Camberwell ..	18.50	Interest	29.6.70
Laing, Evelyn Fay, 2 South-street, Hawthorn	14.80	" "	"
6327			
G. J. COLES & COY. LIMITED.			
Jones, Alan, Flat 11, 82 Patterson-street, Middle Park	65.89	Superannuation Entitlements ..	8.6.70
Grey, Henry Paul, Flat 3, 7 Arthur-street, Hamlyn Heights	151.84	" "	18.3.71
Nash, Richard Anthony, 2 Millswyn-street, South Yarra	37.62	" "	5.2.71
6330			
NICHOLAS. INTERNATIONAL LIMITED.			
Doran, John C., 10 Punt-road, Gladesville, N.S.W.	12.00	Dividend	15.3.71.
Drew, Lloyd J., 64 Castle-street, Blakehurst, N.S.W.	15.00	" "	"
Hill, Michael J., P.O. Box 360, Madang, Papua, New Guinea ..	15.00	" "	"
Hillyer, Edward J., 11 Chester-place, Cromer, N.S.W.	15.00	" "	"
Lyons, Morris S., Chevron Hotel, Cnr. St. Kilda and Commercial roads, Melbourne	15.00	" "	"
Rolfe, Lorna E. (Mrs.), 14 Bellevue-avenue, Highton	15.00	" "	"
Stewart, Violet H. (Mrs.), c/o E. J. Morgan & Co., 351 Collins-street, Melbourne	15.00	" "	"
Teague, Bernard George, 2 Larnock-street, Armadale	12.00	" "	"
Wright, Lynette Joy (Mrs.), Flat 12, 12 Grange-road, Glenhuntly ..	12.00	" "	"
Eatough, Nellie (Miss), 127 Bury Old-road, Heywood, Lancs., U.K.	12.11	" "	"
Edward, David R., c/o 279 Southbrae-drive, Glasgow, W3	72.67	" "	"
Edwards, Peter, 79 Kings Walk, Henley-On-Thames, Oxon., U.K. ..	46.03	" "	"
Egan, Mary I. (Miss), 32 Groomsport-road, Bangor, Co. Down ..	11.97	" "	"
Henderson, Isobel S. (Miss), Seaview Gullane, East Lothian, U.K. ..	48.45	" "	"
Levingstone, Louis, No. 11 Chapman-street, Glasgow, U.K.	12.11	" "	"
Luby, Denis J., 71 Parnell-street, Dublin, Eire	11.97.	" "	"
Moss, Malcolm, 6 Fownes-street, Dublin 2, Eire	13.96	" "	"
Napper, Michael J., Odd Gables, Carrwood-avenue, Bramhall, Cheshire	12.11	" "	"
Redman, Dorothy (Miss), 7 Foster Crop Penwortham, Near Preston, Lancs., U.K.	18.16	" "	"
Wales, Eillen I. (Miss), 4 The-street, Woodnesborough, Sandwich, Kent, U.K.	12.11	" "	"
White, William K. R., York Lodge, 14 York-road, Trinity Leith, U.K.	12.11	" "	"
Williams, Robert L., Bryn Clwyd Waen, St. Asaph, Flintshire, U.K.	12.11	" "	"
Ascherson, Dorothy L. (Mrs.), The White House, Nuffield RG9 5SR, Henley-On-Thames, Oxon., U.K.	81.96	" "	"
Bailey, Adriana (Mrs.), Chequer Farm, Forest Row, Sussex, U.K. ..	21.16	" "	"
Brierton, Harry, 58 Victoria Park-drive North, Glasgow, W4, U.K.	19.38	" "	"
Calvert, Dorothea P. (estate of), c/o Lloyds Bank Ltd., Southfield House, 11 Liverpool Gardens, Worthing, Sussex, U.K.	19.61	" "	"
Carmichael, Dorothy C. (Mrs.), 7 Furzy Whistlers-close, Bransgore, Christchurch, Hants.	12.11	" "	"
Daly, James, Infirmarym, 18 Cork-street, Cork, Eire	29.92	" "	"
Dickson, George I. N., St. Oswalds Chambers, St. Werburgh-street, Chester, U.K.	15.35	" "	"
Fortune, Joan (Mrs.), Rathdowney, Co. Leix, Eire	19.95	" "	"
Gay, Katherine J. (Mrs.), c/o Pitman & Bazett, 41 Cheap-street, Newbury, Berks., U.K.	45.39	" "	"
Gilbert, Muriel K. (estate of), and H. ; and T. W. Pinnock, c/o Robert G. Gilbert, 2 St. Olaves-court, 9/11 St. Petersburg-place, London	72.67	" "	"
Hayman, Albert A., c/o Messrs. Glynn Mills & Co., Kirkland House, Whitehall, SW1	193.80	" "	"
Jenkins, William E., Garden Way, 24 The Ridge, Purley, Surrey, U.K.	24.22	" "	"
Hughes-Jones, Heather (Mrs.), Flat 86, 25 Porchester-place, London W2, U.K.	36.34	" "	"
Kernick, Alice M. (Miss), 14 Black Heath Rise, London, SE13, U.K.	24.22	" "	"
Montgomery, Joseph, Beaumont, Ballinamallard, Co. Fermanagh, U.K.	24.22	" "	"
Murphy, Johanna (Mrs.), Blacknock, Kilmeaden, Co. Waterford, Eire	16.96	" "	"
O'Mahony, Kate (Mrs.), and James D., St. Olans, Douglas-road, Cork, Eire	40.89	" "	"
Price, John H., 300 Northenden-road, Sale, Cheshire, U.K. ..	18.16	" "	"
Rogers, Eric G., Gaywood Hollypark, Huby, Near Leeds	24.22	" "	"
Rowland, Kathleen B. (Mrs.), 23 Withey-close East, Westbury-On-Trym, Bristol	12.11	" "	"
Smith, Vera V. (Miss), 28 Waterlow Court, Heath Close, London, NW 11, U.K.	26.65	" "	"
Tatton, Henry, The White House, Ashley, Nr. Market Drayton, Salop, U.K.	12.11	" "	"

Unclaimed Moneys Act 1962.

Register of Unclaimed Moneys held by the—

Name of Owner on Books and Last Known Address.	Total Amount Due to Owner.	Description of Unclaimed Moneys.	Date when Amount first became Payable.
5			
NICHOLAS INTERNATIONAL LIMITED—continued.			
Thomas, Peter S., Glenwood Upper Hartfield, Hartfield, Sussex, U.K.	14.53	Dividend	15.3.71
Tresham, Walter H., 31 West Acres-close, Westbury-On-Trym, Bristol	24.22	"	"
Walker, Noel S., Farthing Green, Farthing Green-lane, Stoke Peges, Bucks., U.K.	48.45	"	"
Wickett, Lizzie (Mrs.), and James E.; and Katharine M. Lady Stamp, c/o Lady Stamp, 23 Portland-road, East Grinstead, Sussex, U.K.	29.07	"	"
Wilkinson, Peter A., C.M.G., D.S.O., O.B.E., c/o C. Hoare & Co., 37 Fleet-street, London, EC4, U.K.	10.17	"	"
Wilson, Herbert P. (estate of), c/o P. D. Wilson and G. N. Holroyde, 19 Lees-road, Bramhall, Cheshire, U.K.	29.07	"	"
Wilson, Mary M. (Mrs.), c/o J. D. Wilson, Martins Bank Building, Water-street, Liverpool, L2 3SX U.K.	48.45	"	"
Young, Dorothy G. (Mrs.), c/o Barclays Bank Ltd., 171 Sidwell-street, Exeter, U.K.	24.22	"	"
6334			
THE BROKEN HILL PROPRIETARY COMPANY LIMITED.			
Abourizk, Helena (estate of), c/o Edward J. Giles, 141A Chapel-street, St. Kilda	13.38	Dividend, Interest, Sale of Fractions and Unapplied for Rights	1.4.70
Ackers, Gisela A. and Winning, Carol, Hillview-street, Yarra Junction	10.72	"	"
Ades, Timothy, The Gables, Cuskott, Surrey, U.K.	12.50	"	"
Alexander, Elizabeth A., c/o Price Waterhouse and Co., 447 Collins-street, Melbourne	51.36	"	"
Alford, Robert G., 34 Wolseley-road, Mosman, N.S.W.	186.63	"	"
Alison, Marjorie A., c/o Bank of N.S.W., Sackville-street, London, W1, U.K.	25.83	"	"
Allcock, Edward A., Memorial Hospital, Crewe, Cheshire, U.K.	24.06	"	"
Allen, Charles C. and Holdsworth, John R. N., 6 New Square, Lincoln's Inn, London WC2, U.K.	13.38	"	"
Allied Irish Holdings Ltd., "A/c 50", 35 Westmoreland-street, Dublin 2, Eire	27.79	"	"
Allison, Barbara H., 29/164 Spit-road, Mosman, N.S.W.	10.10	"	"
Alston, Catherine A. DeP., Oaklands, Oaklands Junction	17.50	"	"
A. M. Kidder and Co. Inc., 1 Wall-street, New York, 5, New York, U.S.A.	10.63	"	"
Anderson, Jill J., c/o Lewis Wilks, c/o Sackville Wilks and Co., 100 Collins-street, Melbourne	43.29	"	"
Anderson, John E. J., 32 Cope-street, Lane Cove, N.S.W.	33.38	"	"
Anderson, June, 5/3 Milner-crescent, Wollstonecraft, N.S.W.	11.33	"	"
Andrews, Colin J., 28 Lushington-street, East Gosford, N.S.W.	30.75	"	"
Asher, George A., 16 Thomas-street, North Sydney, N.S.W.	190.86	"	"
Avery, Margaret I., c/o Brightfields Farm Ltd., R.D. 8, Palmerston North, N.Z.	42.05	"	"
Baalman, John S. P., Bristol-avenue, Pymble, N.S.W.	17.01	"	"
Bache and Co., Inc., 36 Wall-street, New York, N.Y. 10005, U.S.A.	188.72	"	"
Baer, Anthony L., 81 Grove End House, Grove End-road, London NW8, U.K.	11.33	"	"
Baile, Greta L., 24 Wattleton-road, Beaconsfield, Bucks, U.K.	17.00	"	"
Bailey, Margaret, 25 Westbourne Gardens, London W2, U.K.	22.17	"	"
Bailey, Robin E. H., Courtlands Flat, Tidemarsch-road, Pangbourne, Berks, U.K.	15.82	"	"
Bamford, Nina C., 6 Goldington-avenue, Bedford, Bedfordshire, U.K.	98.97	"	"
Bannerman, Keith H. and Bannerman, Joy N., 11 Ada-street, Randwick, N.S.W.	29.28	"	"
Barbinder Trust and Morgan-Giles, Morgan C., A/c 393-D, Abacus House, 33 Gutter-lane, Cheapside, London EC2, U.K.	11.48	"	"
Barclay, Robert J., Peacock Hotel, Baslow, Bakewell, Derbyshire, U.K.	12.97	"	"
Barker, Sydney M., 26 Arnold-street, Killara, N.S.W.	31.17	"	"
Barlow, John K., 45 Halsey-street, London SW3, U.K.	104.88	"	"
Barnes, Anne, Metcalf-road, Willoughby, Ohio, 44094, U.S.A.	94.36	"	"
Bartell, Antoinette and Bartell, Frank R., 8865 62 Dr., Rego Park 74, New York, N.Y., U.S.A.	20.71	"	"
Barty-King, George I., and Glossop, George C. W., "C Account", 53 Davies-street, London W1, U.K.	12.27	"	"
Barwick, Neville, The Homestead, Petaworth, Stratford-on-Avon, Warwickshire, U.K.	14.69	"	"
Beckett, James L., 24 Clifton-terrace, Wellington, N.Z.	11.33	"	"
Bell, Margaret M., P.O. Box 390, Auckland, N.Z.	27.23	"	"
Benkert, Michael, c/o Benkert and Bray Pty. Ltd., P.O. Box 9, Kensington, N.S.W.	12.50	"	"
Bennett, Roy G., c/o MacLaine Watson and Co., P.O. Box 695, Singapore	22.74	"	"
Berk, Curtis R. F., Flat 3, 46 Cadogan-place, London SW1, U.K.	10.38	"	"
Berry, Adrian M., 15 Blithfield-street, London W8, U.K.	18.09	"	"
Bertelsen, deP., c/o Congy Shell Vietnam, Boite Postale G2, Saigon, South Vietnam	25.38	"	"
Biggadike, Ernest R., 112 Britannia-road, Kettering, U.K.	34.12	"	"
Birdsall, Adele, Aux Soeurs De La Croix, St. Brieuc, France	17.64	"	"
Blades, Jeanette B., c/o Mr. J. Walsh, 23A Awaba-street, Mosman, N.S.W.	24.00	"	"
Boag, Florance (estate of), c/o T. G. D. Marchall, Landers and Company, 25 Holden-street, Ashfield, N.S.W.	35.35	"	"
Bonser, Albert C., 5/23 Albert-street, East Melbourne	13.38	"	"
Bosworth, Michael R., 9 Watson-avenue, Rose Park, S.A.	12.27	"	"

Unclaimed Moneys Act 1962.

Register of Unclaimed Moneys held by the—

Name of Owner on Books and Last Known Address.	Total Amount Due to Owner.	Description of Unclaimed Moneys.	Date when Amount first became Payable.
S			
THE BROKEN HILL PROPRIETARY COMPANY LIMITED— <i>continued.</i>			
Bourne, Holly S., South Winds, Lime Tree Walk, Amersham, Bucks, U.K.	10.38	Dividend, Interest, Sale of Fractions and Unapplied for Rights	1.4.70
Boyce, Reginald H. and Potts, Alan, P.O. Box 801, London EC2, U.K.	13.75	" " " "	"
Bradley, Stuart L., Parawera, No. 2 R.D., Te Awamutu, N.Z.	27.16	" " " "	"
Bright, Basil H., Star House, Bicknacre, Chelmsford, U.K.	11.04	" " " "	"
Brindle, Rachel B., 21 Pine Grove, Paddington, Warrington, Lancs, U.K.	25.31	" " " "	"
Broadbent, Eleanor B. P., c/o Westminster Bank Ltd., Trowbridge, Wiltshire, England	22.75	" " " "	"
Brock, Lawrence G., c/o National Bank of New Zealand, 14 Charles II-street, London, England	51.58	" " " "	"
Brogan, Roy F. and Lewena, Malcolm R., EPS Investment Club, c/o D. P. Dalton, 22 Bertram-street, Chatswood, N.S.W.	14.03	" " " "	"
Brown, Agnes M., 8 Wandella-avenue, Roseville, N.S.W.	11.00	" " " "	"
Brown, Albert and Brown, Phyllis, 77 Stuart-road, Newton Centre, Mass., 02159, U.S.A.	10.36	" " " "	"
Brown, Jennifer, 215 East 73rd-street, New York, N.Y., U.S.A.	28.79	" " " "	"
Browne, Georgina L., 19 Collins-road, St. Ives, N.S.W.	700.00	" " " "	"
Brundrett, Grant, c/o Mr. D. G. Robson, 24/225 Darlington-road, Kings Cross, N.S.W.	12.50	" " " "	"
Bryant, Henry N., Albury, Mungallala, Queensland	12.50	" " " "	"
Buchan and Company Pty. Ltd., 21 Waratah-parade, Dee Why, N.S.W.	11.33	" " " "	"
Buckley, Thomas, Rockchapel, Co. Cork, Eire	18.65	" " " "	"
Bullock, Harold W., c/o Dept. of External Affairs, Canberra, A.C.T.	12.31	" " " "	"
Burke, Peter J., c/o Newport Hotel, 1 Mason-street, Newport	77.67	" " " "	"
Burton, Mary D. E. and Burlington, Edward M. M. F., 3A Airlie Gardens, Campden Hill-road, Kensington, London W8, U.K.	18.65	" " " "	"
Burnette, Noel S. H., 98 Melbourne-road, Island Bay, Wellington, N.Z.	12.97	" " " "	"
Butcher and Sherrerd, 1500 Walnut-street, Philadelphia, Pa., 19102, U.S.A.	188.72	" " " "	"
Butler, Stephen P., c/o James W. Paterson and Son, 49-51 St. Georges-terrace, Perth, W.A.	12.50	" " " "	"
Campbell, Doreen C., Ardwell, 41 Manse-road, Bearsden, Glasgow, Scotland	11.33	" " " "	"
Campbell, Elise M., 4 Turnberry-road, Glasgow, C3, U.K.	10.38	" " " "	"
Campbell, George A., 188 Main-road, Ballarat	27.00	" " " "	"
Campbell, James C., 7A Maling-road, Canterbury, N.S.W.	12.50	" " " "	"
Cant, David, Apt. 71 Race View Apartments, 46 Stubbs-road, Hong Kong	10.45	" " " "	"
Cantwell, Edward P., 19 Marine-avenue, Brooklyn 9, N.Y., U.S.A.	94.36	" " " "	"
Carey, Chapple G., 5 Holly Lodge Gardens, London N6, U.K.	94.38	" " " "	"
Carpenter, David M., 13 Abbotsmount, New St. John's-road, Jersey, Channel Islands	10.38	" " " "	"
Carr, Edward B., 5 Bessell-avenue, Wollongong, N.S.W.	26.65	" " " "	"
Carr, Robert I., P.O. Box 42, Maitland, N.S.W.	62.45	" " " "	"
Carrigan, Louise, Oaklands, Clonmel, Co. Tipperary, Eire	18.81	" " " "	"
Carruthers, Grace B., 36 Latimer-road, Bellevue Hill, N.S.W.	259.50	" " " "	"
Carter, Wesley W., Mt. Vettors Station, Bardoc, via Kalgoorlie, W.A.	49.25	" " " "	"
Casottana, Russell, c/o J. R. Williston and Beane, P.O. Box 4, Bowling Green Station, New York, 10004, U.S.A.	10.08	" " " "	"
Caves, Toni L. (address unknown)	22.60	" " " "	"
Central Beaufort Investments Ltd., Hasting House, 10 Norfolk-street, Strand, London WC2, U.K.	13.53	" " " "	"
Chaytor, Anthony D. G., 11 Wright-street, East Perth, W.A.	60.00	" " " "	"
Choa, George, 508 Hang Seng Bank Building, Hong Kong	17.31	" " " "	"
Clare, Shirley, c/o Mr. P. B. Clare, Commonwealth Trading Bank of Australia, Castlereagh-street, Sydney, N.S.W.	17.13	" " " "	"
Clark, Elizabeth E. (estate of), c/o Mr. George S. Clark, "Fairway", Back Lane, Normanton On The Wolds, Notts., U.K.	146.88	" " " "	"
Clark, George T., Prince Rupert Loewenstein, 1 Bank Buildings, London EC2, U.K.	48.75	" " " "	"
Clarke, Arthur J. and Clarke, Howard C. (estate of), c/o Reid Clarke and Co., 52 King-street, Sydney, N.S.W.	13.69	" " " "	"
Clarke, Arthur J. R., c/o Reid Clarke and Co., 52 King-street, Sydney, N.S.W.	46.35	" " " "	"
Clay, Henry W. F., 46 Old Hinckley-road, Nuneaton, Warwickshire, U.K.	15.73	" " " "	"
Clayton, Jack, 11 Lowndes Square, London SW1, U.K.	28.22	" " " "	"
Clinton, Michael D. A., c/o Colonial Secretariat, Lower Albert-road, Hong Kong	13.13	" " " "	"
Coakley, Maeve P., Ashton Park, Blackrock-road, Cork, Eire	14.97	" " " "	"
Cohen, Lilian M., 5A Selwood-street, East Hawthorn	13.21	" " " "	"
Colbey, Gordon, 196 Birdwood-road, Georges Hall, N.S.W.	12.50	" " " "	"
Coleman, Helen C., 3 King Edward-street, Pymble, N.S.W.	10.50	" " " "	"
Collingridge, Francis H., 148 Oakwood-court, Kensington, London W14, U.K.	87.41	" " " "	"
Collins, Ian Stuart, 8 Point-road, Northwood, N.S.W.	25.00	" " " "	"
Collins, Roberta G., 8 Point-road, Northwood, N.S.W.	120.38	" " " "	"
Colquhoun, Jack and Neville, Douglas W., c/o J. Rossiter, Esq., Premier's Dept., State Public Office, Melbourne	12.31	" " " "	"
Colton, Kira, 19 Briar-avenue, Medindie, S.A.	44.13	" " " "	"
Comber, Andrew S. C. and Comber, Helen, c/o Hastings and Co., Marina House, Hong Kong	12.98	" " " "	"
Conroy, Thomas L. (estate of), c/o Mr. B. T. Conroy, 615 Portrush-road, Glen Osmond, S.A.	19.16	" " " "	"
Copinger-Symes, Susan, 71 Lennox-road, Gravesend, Kent, U.K.	30.49	" " " "	"

Unclaimed Moneys Act 1962.

Register of Unclaimed Moneys held by the—

Name of Owner on Books and Last Known Address.	Total Amount Due to Owner.	Description of Unclaimed Moneys.	Date when Amount first became Payable
5			
THE BROKEN HILL PROPRIETARY COMPANY LIMITED—continued.			
Cosgrove, Patrick C.; c/o A.N.Z. Bank Limited, Martin-place, Sydney, N.S.W.	33.38	Dividend, Interest, Sale of Fractions and Unapplied for Rights	1.4.70
Coudray, Angele, 7 Rue St. Jean, Paris, France	17.64	" " " "	" "
Coutts and Company, 440 Strand, London WC2, U.K.	318.78	" " " "	" "
Cowan, Dorothy Muriel, Flat 10, 97 Onslow Square, London SW7, U.K.	16.57	" " " "	" "
Cowdell, Richard L., c/o Westminster Bank Ltd., 85 London-road, Southborough, Tunbridge Wells, Kent, U.K.	33.21	" " " "	" "
Cowing, Elinor J., Chapel Farm, Boundway, Sway, Lymington, Hants, U.K.	67.06	" " " "	" "
Cowlishaw, Diana, c/o J. D. Hilton, 50 Young-street, Sydney, N.S.W.	16.00	" " " "	" "
Cox, David L., Gaylen, Roman-road, Little Aston; Sutton Goldfield, Warks, U.K.	206.85	" " " "	" "
Crawford, Kerry J., c/o Commonwealth Trading Bank, South Yarra	12.50	" " " "	" "
Crawford, Margaret L., 17 Joynt-street, Hamilton, Queensland	12.50	" " " "	" "
Credit Suisse Basle Noms Ltd., 123 St. Alban Graben, Basle, Switzerland	10.26	" " " "	" "
Cronmire, Amy M. H., 3 Venner-road, Sydenham, SE26, U.K.	51.69	" " " "	" "
Crozier, Barbara S., 31 Highfield-road, Cheadle Hulme, Cheshire, U.K.	10.14	" " " "	" "
Crozier, David J., 2 Marine-parade, Double Bay, N.S.W.	32.20	" " " "	" "
Cullen, Walter and Conway, Charles, c/o Clark Doge and Co. Inc., 61 Wall-street, New York, 10005, U.S.A.	21.25	" " " "	" "
Curtis, Lorna B.A., c/o Mr. E. M. Jurd, 67 Castlereagh-street, Sydney, N.S.W.	88.11	" " " "	" "
Cuss, Walter G., Inverkeithing, Fife, Scotland	27.27	" " " "	" "
Cuthbert, Norman Stanley McG., c/o Robertson and Carphin, 18 Alva-street, Edinburgh, U.K.	28.94	" " " "	" "
Damato, Concetta, 135 Winifred-avenue, Yonkers, New York, U.S.A.	20.71	" " " "	" "
Danse, Cyril M. and Bleichoeider, Rudolf and Bennett, Kenneth A., 14 Old Broad-street, London EC2, U.K.	220.32	" " " "	" "
Davidson, Rodrick MacD., 13 Buckingham Vale, Clifton, Bristol, 8, U.K.	10.63	" " " "	" "
Davis, Anthony A., c/o A. A. Davis Herniman and Co., P.O. Box 86, Katoomba, N.S.W.	12.31	" " " "	" "
Davis, Anthony A., 72 Katoomba-street, Katoomba, N.S.W.	73.83	" " " "	" "
Davis, Anthony A., P.O. Box 77, Katoomba, N.S.W.	14.03	" " " "	" "
Davis, Marilyn E., 6 Heights-crescent, Middle Cove, Sydney, N.S.W.	15.88	" " " "	" "
Davson, Christopher M. E., 53 Clareville-street, London SW7, U.K.	11.33	" " " "	" "
Day, Hilary M., 4 Somers-avenue, Malvern	11.33	" " " "	" "
Del Paine, John A., 317 East Pittsburgh-street, Greensburg, Pennsylvania, U.S.A.	57.54	" " " "	" "
De Meeus, Camille A., Chateau De Et A. Linsmeau, Par Racourt, Brabant, Belgium	431.03	" " " "	" "
De Meherene, R. M., De Saint Pierre, 2 Rue Pierre Loti, A Saint Brieuc, France	17.64	" " " "	" "
Denton, Keith E., c/o Australian Embassy, 5th Floor, 1601 Massachusetts-avenue N.W., Washington, D.C. 20036 U.S.A.	20.71	" " " "	" "
Devlin, Irene M., 13 Stephen-street, Annerley, Q'ld.	124.75	" " " "	" "
Dewberry, Leslie T., 10 Banner-road, Kingsgrove, N.S.W.	42.75	" " " "	" "
Dickens, Malcolm J. H., 84 Addison-street, Elwood	41.76	" " " "	" "
Dixon, Peter R. H. & Radcliffe, Gilbert C. W., 10 Little College-street, Westminster, London, S.W.1, U.K.	18.79	" " " "	" "
Dodd, Annie, Inveresk, Watford, Herts, U.K.	17.02	" " " "	" "
Dodds-Parker, Peter D., c/o First National City Bank, 17 Bruton-street, London, W.1, U.K.	14.35	" " " "	" "
Doley, Joan A. & Doley, Thomas A., 82 Northumberland-road, Leamington, SPA., U.K.	16.54	" " " "	" "
Dolland, Jack, 260A Shirland-road, Paddington, London, W.9, U.K.	92.98	" " " "	" "
Drake, Joyce M., 18 Exeter-court, Whaincliffe-road, Bournemouth, BH5 1AM, U.K.	38.57	" " " "	" "
Drury, Audrey L., 20 Gordon-street, Coffs Harbour, N.S.W.	36.73	" " " "	" "
Du Bois De Maquille, Jeanne A. C., Chateau de la Touche, Commune de Nozay, Loire, Inferieure, France	20.04	" " " "	" "
Du Cleuzion, Marie, 61 Avenue De La Republique, Paris, France	17.64	" " " "	" "
Duncan, Graham J., 22 Nilpenna-street, Burnside, S.A.	26.75	" " " "	" "
Duvollet, Sheila Helen, River House, Golant, Fowey, Cornwall, U.K.	33.79	" " " "	" "
E. A. Nettleford Holdings Pty. Ltd., c/o Mrs. R. H. Tillam, P.O. Box 38, Vauchuse, N.S.W.	446.88	" " " "	" "
Epps, Reginald G., 223 Greenwich-road, Greenwich, N.S.W.	96.00	" " " "	" "
Eskell, Stanley L. M., 708 Yarranabbe Gardens, Darling Point, N.S.W.	40.13	" " " "	" "
Ettelson, Barbara, 107 Kooyong-road, Armadale	68.95	" " " "	" "
Evans, Ronald J., 52 Brunswick-road, Hove, Sussex	67.06	" " " "	" "
Evers, Frank M. & Harris, Richard L., 1 Worcester-street, Stourbridge, Worcestershire, U.K.	20.22	" " " "	" "
Fauth, Noel Michael, 49 Bellevue-street, Chatswood, N.S.W.	25.00	" " " "	" "
Favell, William, 15 Walsingham-road, Hovein, Sussex, U.K.	14.69	" " " "	" "
Fawckner, Dorothy Marion, Bonnie Downs, Corfield, Q'ld.	50.00	" " " "	" "
Fear, Reginald G. V. (estate of), c/o F. J. Kavanagh, 324 Marrickville-road, Marrickville, N.S.W.	13.90	" " " "	" "
Ferry, Ingrid C., Sundial Farm, Clifton, Nr. Otley, Yorks, U.K.	11.33	" " " "	" "
Fields, James, Kilcock, c/o Kildare, Eire	13.12	" " " "	" "
Finer, Peter R. A., 122 Moor Hall Drive, Sutton Coldfield, Warwickshire, England	10.38	" " " "	" "
Finney, Ben, Dept. of Pacific History, A.N.U., Canberra, A.C.T.	13.38	" " " "	" "
Fison, John C., National Provincial Bank, 208/209 Piccadilly, London, W.1, U.K.	10.63	" " " "	" "
Flanagan, James (estate of), c/o O'Donnell Creswell & Cudby, P.O. Box 447, Wellington, N.Z.	18.45	" " " "	" "

Unclaimed Moneys Act 1962.

Register of Unclaimed Moneys held by the—

Name of Owner on Books and Last Known Address.	Total Amount Due to Owner.	Description of Unclaimed Moneys.	Date when Amount first became payable.
§			
THE BROKEN HILL PROPRIETARY COMPANY LIMITED—continued.			
Floris, George Alexander, 97 Abbey House, Abbey-road, London, N.W.8, U.K.	13.53	Dividend, Interest, Sale of Fractions and Unapplied for Rights	1.4.70
Footner, Geoffrey M., c/o Footner & Co. Inc. (U.K.) Ltd., Lee House, London Wall, London, E.C.2, U.K.	17.22	" " " " " "	" "
Foster, George E., 41 Olmesby-way, Kenton, Middlesex, U.K.	36.72	" " " " " "	" "
Foster, Linley R., P.O. Box 1262, Boroko, T.P.N.G.	101.17	" " " " " "	" "
Fougeres, Jeanne E. J., 3 Boulevard Carnot, Dijon, France	76.59	" " " " " "	" "
Fox, John F. A., 52 Seven Oak's-drive, Bryndwr, Christchurch, 5, N.Z.	21.41	" " " " " "	" "
Freedman, Jacob and Freedman, Bertha, 2414 Helma-road, Lancaster, Pennsylvania, U.S.A.	57.54	" " " " " "	" "
Frischmann, Wilem William, c/o Royal Bank of Scotland, Victoria Branch, 120 Victoria-street, London SW1, U.K.	30.49	" " " " " "	" "
Frost, John, Jr. (address unknown)	18.87	" " " " " "	" "
Frost, Peter and Barnes, Jack, c/o 17 Smith-street, Parramatta, N.S.W.	12.48	" " " " " "	" "
Fry, Deborah Caroline, 30 Ellerdale-road, London NW3, U.K.	11.77	" " " " " "	" "
Furnell, Richard J., 8 Struan-street, Toorak	13.38	" " " " " "	" "
Gardner, Nigel H., 82 Rue Saint Louis En L'ile, Paris, 4E, France	18.66	" " " " " "	" "
Gatenby, Margo Belinda, P.O. Box 15, Southern Cross, W.A.	12.50	" " " " " "	" "
Gebhardt, Mary B., 23 Kent-drive, Victor Harbour, S.A.	23.00	" " " " " "	" "
Gee, Clement M., 9 Hampden-avenue, Wahroonga, N.S.W.	137.85	" " " " " "	" "
Gee, George C. M. (estate of), c/o A. E. Whatmore, G. C. M. Gee and Company, 14 Spring-street, Sydney, N.S.W.	45.53	" " " " " "	" "
Gee, Peter, 260 Queen-street, Masterton, N.Z.	23.38	" " " " " "	" "
Gerber, Joseph A., 7705 Regent-drive, Alexandria, Virginia, 22307, U.S.A.	94.36	" " " " " "	" "
Gethin-Jones, Thomas A. L., c/o Bank of New Zealand, P.O. Box 644, Whangarei, N.Z.	149.05	" " " " " "	" "
Gicquel, Henry M., Admor. of Marie A. L. Gicquel, c/o Mr. Bernard, Notary, Carhaix, Finistere, France	17.64	" " " " " "	" "
Glaven Nominees Limited, Northgate House, 20-24 Moorgate, London EC2, U.K.	36.42	" " " " " "	" "
Goldberg, Alvin I., 4254 West Lyons, Skokie, Illinois, U.S.A.	115.07	" " " " " "	" "
Goldman, Bernard A., 603 Hibernia Bank Building, New Orleans, Louisiana, 70112, U.S.A.	94.36	" " " " " "	" "
Graham, Janet K. V., c/o Midland Bank Limited, 16 Regent-street, London SW1, U.K.	11.33	" " " " " "	" "
Graham, Robert L., G.P.O. Box 4040, Sydney, N.S.W.	17.25	" " " " " "	" "
Greenwood, Anthea, 24 Horbury-crescent, London W11, U.K.	10.28	" " " " " "	" "
Greig, Mary Goulden, Flat 29, Dawlish-court, Hall-road, Sea Point, Cape Town, South Africa	10.38	" " " " " "	" "
Grillot, Yvonne, 39 Quai Veil-Picard, Besancon, France	17.64	" " " " " "	" "
Gundry, John H. B., c/o Bank of N.S.W., Head-Office, 341 George-street, Sydney, N.S.W.	50.00	" " " " " "	" "
Hacker, Michal B., 13 Gleenacres-drive, Gordon-avenue, Stanmore, Middlesex, U.K.	14.69	" " " " " "	" "
Halpin, Brien J., 99 Maupia-road, Miramar, Wellington, N.Z.	27.27	" " " " " "	" "
Ham, Cyril Francis, Mount Moriac	107.13	" " " " " "	" "
Hamilton, Donald M., Burnie, Llandair-drive, Woodlands Ride, Ascot, Berks, U.K.	14.14	" " " " " "	" "
Hansman, Effie Joyce (estate of), c/o Henry Davis York and Co., 44-46 Martin-place, Sydney, N.S.W.	25.00	" " " " " "	" "
Haped, Percival E., 6 Roxwell House, Valley Hill, Loughton, Essex, U.K.	15.11	" " " " " "	" "
Hardy, Annie G. (estate of), c/o Mr. W. J. Black and Mrs. M. W. McIntosh, P.O. Box 358, Invercargill, N.Z.	38.58	" " " " " "	" "
Hargreaves, Judith A., The Garden Cottage, Crowthorne, Berks, U.K.	70.51	" " " " " "	" "
Hartley, Piers R. C., 39 Downshire Hill, Hampstead, London NW3, U.K.	35.78	" " " " " "	" "
Hartwig, Ralph F. and Hartwig, Rosemary, 33N Hartnett-avenue, St. Louis, Missouri, 63135, U.S.A.	10.08	" " " " " "	" "
Harvey, Stephen G., Hill Farm, Heydon, Royston, Herts, U.K.	22.60	" " " " " "	" "
Hauger, Eugene, 79 Rue de Bale, Mulhouse, Haut Rhin, France	29.60	" " " " " "	" "
Hawkins, Sheryl, Milldean, 112 Grove-lane, Hale, Cheshire, England	21.68	" " " " " "	" "
Hawryluk-Gabrielson, Stephen and Hawryluk-Gabrielson, Irene, 26 Prairie-avenue, Suffern, New York, U.S.A.	94.36	" " " " " "	" "
Hay, Andrew O., c/o Wm. Noall and Son, 401 Collins-street, Melbourne	15.99	" " " " " "	" "
Hedley, Martyn A., 62 St. Georges Square, London SW1, U.K.	10.62	" " " " " "	" "
Harrison-Cripps, William H., Prankerd, Margaret V. H., The Hermitage, Witham Friary, Frome, Somerset, U.K.	11.33	" " " " " "	" "
Hellmrich, Alexander G., 5/75 St. Lucia-road, St. Lucia, Queensland	47.90	" " " " " "	" "
Helme, Florence J., Mayfield, Victoria Park, Manchester, U.K.	35.07	" " " " " "	" "
Herrera, Alfred C., c/o H. A. T. Skehill, 40 Threalfall-street, Chifley, A.C.T.	12.42	" " " " " "	" "
Hildmann, Klaus D. W., 4 Tennis-grove, North Caulfield	11.33	" " " " " "	" "
Hindlip, Henry R. Allsop, Vern Leaze, Calne, Wiltshire, U.K.	555.02	" " " " " "	" "
Hindley, William H. and Hindley, Olga A. O., P.O. Box 33, P.O. Molo, Kenya, Africa	33.22	" " " " " "	" "
Hines, Catherine P., Nant Farm, Llanfaes Beaumaris, Anglesey, North Wales	19.62	" " " " " "	" "
Hinlicky, George J. and Hinlicky, Miriam L., c/o New Guinea Lutheran Mission, Wapenamanda, WHP, New Guinea	42.88	" " " " " "	" "
Hooker and Fay Inc., 640 South Spring-street, Los Angeles, 90014, U.S.A.	104.44	" " " " " "	" "
Hopkinson, George, c/o Lloyds Bank Limited, Halifax, U.K.	10.38	" " " " " "	" "
Horrell, George M., Huntly Farm, No. 7 R.D., Gore, N.Z.	25.27	" " " " " "	" "

Unclaimed Moneys Act 1962.

Register of Unclaimed Moneys held by the—

Name of Owner on Books and Last Known Address.	Total Amount Due to Owner.	Description of Unclaimed Moneys.	Date when Amount first became Payable
\$			
THE BROKEN HILL PROPRIETARY COMPANY LIMITED— <i>continued.</i>			
Hosking, Ronald (estate of), and Hosking, Peggy, 2/133 Queen Victoria-street, Bexley, N.S.W.	278.13	Dividend, Interest, Sale of Fractions and Unapplied for Rights	1.4.70
Hourdiaux, Fanny, c/o Mme. Holler, 11 Ave du Palais, St. Briene, C de N., France	11.20	"	"
Howell, Henry L., 2492 Habersham-road, N.W., Atlanta, Georgia, 30305, U.S.A.	10.63	"	"
Hudson, Peter, Canadian Marconi Co., USAF Communication Site, Resolution Island, via Frobisher Bay, N.W.T. Canada	10.63	"	"
Hull, Walter D. M., 9 Warragul-court, New Town, Tasmania	92.95	"	"
Hume, Kennedy Michael, 8 Lister-street, East Kew	22.25	"	"
Hussey, Eva M. (estate of), c/o Currie Jack and Davis, 12 Wicksteed-place, Wanganui, N.Z.	153.60	"	"
Innes, Ian G. M. and Munlo, Thomas T. A., 24 Queen Anne-street, London W1, U.K.	367.15	"	"
Irving, Ronald J. W. and Irving, Mildred C., c/o Commonwealth Trading Bank, G.P.O. Box 2719, Sydney, N.S.W.	10.08	"	"
Jackson, Cecil Robert, 703-713 High-road, London E11, U.K.	27.04	"	"
Jackson, Ian, 6 Cantala-avenue, Caulfield	13.63	"	"
Jackson, Phyllis E., 14 Van Kemp-street, Camps Bay, Cape Province, South Africa	12.27	"	"
Jacobs, Diana E., Apartment 4F, 741 West End-avenue, New York, 10025, U.S.A.	94.36	"	"
Jacobs, Elizabeth A., c/o Syfrets Trust Co. Ltd., 24 Wale-street, Cape Town, South Africa	11.33	"	"
Jaeger, Frederick, Jr., c/o Murrill Lynch Pierce Fenner and Smith, 70 Pine-street, New York, N.Y. 10005, U.S.A.	12.44	"	"
Jaffrey, Harry (estate of), c/o Keegan Alexander Tedcastle and Friedlander, Queen-street, Auckland, 1, N.Z.	256.39	"	"
James, Dulcie L., 2770 Lombard-street, San Francisco, California, 94123, U.S.A.	87.76	"	"
Jarvis, Ryan, Phantom House, Newmarket, U.K.	11.33	"	"
Jeans, Robert A. G., Inchbroom, Fair Hall-road, Heswell, Wirral, Cheshire, U.K.	17.00	"	"
Jennings-Bramly, Barbara D., 14 Pembroke Square, London W8, U.K.	10.38	"	"
Jessop, Elizabeth A. M., 55 Monalt-road, Woodford Green, Essex, U.K.	59.37	"	"
Johnson, Barry R., 14 Parkfield-drive, Whitby, Ellesmere Port, Wirral, Cheshire, U.K.	15.25	"	"
Johnson, Graeme, 55 Argyle-street, Pictin, N.S.W.	25.69	"	"
Johnstone, Michele, 57A Sydney-street, Willoughby, N.S.W.	272.94	"	"
Jones, Colin Taylor, 5 Fitzherbert-street, Lower Hutt, N.Z.	26.04	"	"
Jopat Investment Pty. Ltd., Level 22, Tower Building, Australia Square, Sydney, N.S.W.	10.38	"	"
Judy, Henry L., c/o Dr. Kenneth W. Judy, 33 Kingswood-road, Weehawken, New Jersey, U.S.A.	17.28	"	"
Judy, Kenneth W., 33 Kingswood-road, Weehawken, New Jersey, U.S.A.	17.28	"	"
Kalb, Bernard, c/o C.B.S. News, 2 Kennedy-terrace, Hong Kong	18.73	"	"
Keenoy, Richard A. and Keenoy, Louise, 6375 Sherry, St. Louis, Missouri, 63136, U.S.A.	20.71	"	"
Kelly, Michael A. (estate of), c/o Gerald S. Berrigan, 213 Park-street, South Melbourne	17.48	"	"
Kendall, Peggy E. and Kendall, Raymond J., P.O. Box 23-083, Papatoetoe, N.Z.	28.38	"	"
Kern, Violet, 1441 School-street, Chicago, Illinois, 60613, U.S.A.	20.71	"	"
Kerr, Dorothy M., Hadlow 4 R.D., Timaru, N.Z.	108.92	"	"
Kershaw, John W. R., c/o P.O. Box 2392, Wellington, N.Z.	10.36	"	"
Kiessling, Ernest and Kiessling, Mary, 2301 Foster-place, Washington, DC, 20031, U.S.A.	104.44	"	"
King, Robert H., c/o Charles King and Co., 61 Broadway, New York, N.Y. 10006, U.S.A.	10.63	"	"
Kisby, Stafford H., 47 Clapton-road, The Meadows, Nottingham, U.K.	11.33	"	"
Klein, Adair D., 4500 East MacDonald, Phoenix, Arizona, U.S.A.	34.53	"	"
Klimont, George C., c/o Pridham and Gardiner, 41 Currie-street, Adelaide, S.A.	14.03	"	"
Koerner, Richard J., 2/23 Glyndon-avenue, Brighton	34.38	"	"
Kraljic, Joseph R., 108 Westover-place, West New York, New Jersey, 07093, U.S.A.	11.17	"	"
Kwok, Frank W., 48 The Terrace, Wellington, N.Z.	18.54	"	"
Ladd, Johnny, 13 Gipps-street, East Melbourne	18.75	"	"
Lamb, Geoff Fyffe, 99 Remuera-road, Auckland, SE2, N.Z.	26.04	"	"
Lane, Reginald F., P.O. Box 945, Singapore	72.61	"	"
Lang, Harold, 119 Castlenau, London SW13, U.K.	24.69	"	"
Lawson, Gwendolen M., Inshriach, Largo-road, Leven, Fife, Scotland, U.K.	11.71	"	"
Lear, Gerald M., 3/32 Bruce-street, Toorak	11.50	"	"
Le Bourgeois, Henry, 7 Rue De Chilon, Havre, France	36.35	"	"
Leclizio, Ines, 2023 Albany Highway, Maddington, W.A.	11.33	"	"
Lee, Liow Y., c/o J. Ballas and Co., 5 Prince-street, Singapore, 1...	17.00	"	"
Lees, Joanna P., 24 Adelaide-street, Bondi Junction, N.S.W.	28.74	"	"
Lefcourt, Margaret (estate of), c/o Blair and Co., Inc., 277 Park-avenue, New York, N.Y. 10017, U.S.A.	20.71	"	"
Lemiere, Andre B., La Retraite, Quaisne St. Brelade, Jersey, Channel Islands	42.10	"	"
Leonard Green Pty. Ltd., c/o Dr. L. Green, 88 Old South Head-road, Bondi Junction, N.S.W.	15.25	"	"
Lester-Smith, Alan, Pte. Bag 73, Kerang	11.50	"	"
Lewis, Joan, 174 Mynachdy-road, Gabalfa, Cardiff, U.K.	25.77	"	"

Unclaimed Moneys Act 1962.

Register of Unclaimed Moneys held by the—

Name of Owner on Books and Last Known Address.	Total Amount Due to Owner.	Description of Unclaimed Moneys.	Date when Amount first became Payable.
\$			
THE BROKEN HILL PROPRIETARY COMPANY LIMITED—continued.			
Lewis, Thomas A. and Cunningham, James and Craven, John B. and Webster, Altofts J., Bramcote Over Lane, Rawdon, Leeds, U.K.	11.33	Dividend, Interest, Sale of Fractions and Unapplied for Rights	1.4.70
Liddell, Fiona J., 6 Knowsley Close, Pinkneys Green, Maidenhead, Berks, U.K.	10.36	" " " "	"
Liddell, Nigel J., 6 Knowsley Close, Pinkneys Green, Maidenhead, Berks, U.K.	10.36	" " " "	"
Lim, Elaine, c/o J. Ballas and Co. Pte., 5 Prince-street, P.O. Box 108, Singapore	20.71	" " " "	"
Loneraghan, Penelope J., Putta Bucca House, Mudgee, N.S.W.	10.13	" " " "	"
Lowe, George D. (estate of), c/o W. S. Bramwell and Grossman, P.O. Box 500, Hastings, N.Z.	19.45	" " " "	"
Lowison, Elizabeth, Low Friarside Farm, Rowlands Gill, Co. Durham, U.K.	31.45	" " " "	"
Lupton, Nancy (Mrs.), 16/6 Wyargine-street, Mosman, N.S.W.	13.38	" " " "	"
Luyens, Martin C., c/o Coutts and Co., 440 Strand, London WC2, U.K.	147.65	" " " "	"
Maby, Cyril G. and Anderson, John M., "A" Account, 64 Lincoln's Inn Fields, London WC2, U.K.	11.33	" " " "	"
Maby, Cyril G. and Anderson, John M., "B" Account, 64 Lincoln's Inn Fields, London WC2, U.K.	11.33	" " " "	"
Maby, Cyril G. and Anderson, John M., "C" Account, 64 Lincoln's Inn Fields, London WC2, U.K.	11.33	" " " "	"
Macdonald, Frances Anne, Tuki Tuki-road, R.D.2, Hastings, N.Z.	155.37	" " " "	"
Macdonald, Jack F., c/o Lac. Macdonald, Photo Section, RAAF Base, Edinburgh, S.A.	13.38	" " " "	"
Macfarlane, Alison R. L., Wadi Nimsin, Hundalee, Cheviot, N.Z.	13.22	" " " "	"
Mackie, Douglas A. B., P.O. Box 281, Colac	13.38	" " " "	"
Macqueen, David B., 15 Gilmour-street, Paisley, U.K.	348.11	" " " "	"
Macqueen, Jane, Westwick Cottage, Leverstock Green, Herts, U.K.	10.87	" " " "	"
Malcolm-Robertson, Catherine G., Rowanhurst, Odiham-road, Hook, Hants, U.K.	17.28	" " " "	"
Malouf, Rastom D. (address unknown)	38.91	" " " "	"
Marcel, Joseph, St. Brieuc, Cotes Du Nord, France	181.65	" " " "	"
Marchesi, Mario, Raffles Hotel, Singapore, 6	21.57	" " " "	"
Marks, Miriam, 47 Grosvenor Square, London W1, U.K.	78.66	" " " "	"
Mason, Edward J. H., 3/11 The Avenue, Sneyd Park, Bristol, 9, U.K.	12.97	" " " "	"
Matthews, Cecil B., c/o Messrs. Fell and Starkey, Box H-216, Australia Square, Sydney, N.S.W.	35.00	" " " "	"
Maxwell E. Dutch Pty. Ltd., 58 Grandview-drive, Newport, N.S.W.	25.00	" " " "	"
May, Barry L., c/o Pacific Diving and Engineering Company Limited, Post Office, Kieta, T.P.N.G.	19.16	" " " "	"
McAlister, James, 240 Stockton-street, San Francisco, California, U.S.A.	28.79	" " " "	"
McArthur, Edward H., 11 Walshes-road, Ashburton, N.Z.	155.88	" " " "	"
McArthur, Edward H. and Acland, Elizabeth V., c/o 11 Walshes-road, Ashburton, N.Z.	23.89	" " " "	"
McArthur, Edward H. and McArthur, Rachel Ethel, P.O. Box 179, Ashburton, N.Z.	14.45	" " " "	"
McAuliffe, Peter C., 183 Macquarie-street, Sydney, N.S.W.	14.14	" " " "	"
McCausland, Michael, 23 Rolinson-street, Claremont, W.A.	13.38	" " " "	"
McCormick, Kathleen (estate of), c/o Maurice M. Flynn, Vulcan Buildings, cnr. Queen-street and Vulcan-lane, Auckland, N.Z.	113.55	" " " "	"
McCormick, Patricia McN., c/o 107 Esplanade, Hove, S.A.	12.50	" " " "	"
McCown, Jonnie (estate of), c/o Mrs. F. M. C. Kolb, The Kolb Estates, P.O. Wai Damu, Taveuni, Fiji	27.30	" " " "	"
McElroy, Roy G. and Duncan, Robert H., P.O. Box 1556, Auckland, 1, N.Z.	40.31	" " " "	"
McLennan, Robert George, 12 Burramine-road, Glen Waverley	10.00	" " " "	"
McNamnee, John T. (estate of), c/o Mr. S. Cibiras, 46 Renmark-avenue, Renmark, S.A.	32.52	" " " "	"
McShane, Margarite B., 1734e 71st Place, Chicago, Illinois, U.S.A.	11.52	" " " "	"
McSperin, Mary (estate of) (address unknown)	22.41	" " " "	"
Medina, Antonio C., Apartado de Correos 41, Plaza de Orense No. 2, La Coruna, Spain	11.20	" " " "	"
Medina, Mariano C., Comanda te de Infanteria, Snata Cruz de la Palma, Tenerife, Canarias, Spain	11.20	" " " "	"
Melbord Nominees Pty. Ltd., 379 Collins-street, Melbourne	19.16	" " " "	"
Mercoer, Marie S. C. (estate of), c/o McLarry Archer and Co., 56 Thompson-street, Hamilton	102.72	" " " "	"
Merlan Investments Pty. Ltd., 474 Victoria-street, West Brunswick	91.88	" " " "	"
Miles, Charles W. N. and Gervis-Meyrick, G. D. E. Tapps and Berry, Julian, The Estate Office, Hinton Admiral, Christchurch, Hants, U.K.	24.61	" " " "	"
Miley, Nancy (address unknown)	11.84	" " " "	"
Millbourn, Philip E., Conkwell Grange, Limpley Stoke, Bath, Somerset, U.K.	11.33	" " " "	"
Millet, Adele, 38 Rue de la Republique, St. Mande Seine, France	53.70	" " " "	"
Mills, Martin and Mills, Bernice G., 467 Carlston-street, Richmond, California, 94805, U.S.A.	10.63	" " " "	"
Mills, Nicholas Greenaway, Lower House Little Barrington, Nr. Burford, Oxon, England	39.43	" " " "	"
Montefiore, Canon Hugh W., Barclays Bank Ltd., Benet-street, Cambridge, U.K.	10.83	" " " "	"
Montgomery, Ellen, 103 Remuera-road, Auckland, N.Z.	42.62	" " " "	"
Montgomery, Livingston R., c/o Mrs. R. J. Cram, 37 Kangaroo-street, Manly, N.S.W.	58.42	" " " "	"
Moore, Bruce, 6 Rosebery-road, Killara, N.S.W.	11.33	" " " "	"
Moore, Ronald M., Matong, Boggabri, N.S.W.	13.50	" " " "	"
Mosse, Marigold, Old Timbers, Newenden, Nr. Hawkhurst, Kent, U.K.	12.27	" " " "	"
Murdock, James, Jr., 7/25 Wolseley-road, Point Piper, N.S.W.	11.50	" " " "	"
Murphy, Luke, 4 Bowley-avenue, Balwyn	12.27	" " " "	"

Unclaimed Moneys Act 1962.

Register of Unclaimed Moneys held by the—

Name of Owner on Books and Last Known Address.	Total Amount Due to Owner.	Description of Unclaimed Moneys.	Date when Amount first became Payable.
§			
THE BROKEN HILL PROPRIETARY COMPANY LIMITED—continued.			
Murray, Alexander, 1A Halford-road, Ickenham, Middlesex, U.K.	11.38	Dividend, Interest, Sale of	1.4.70
Nagano, Shigeo, 34-4 4-Chome, Matsubara, Setagayn-Ku, Tokyo, Japan	21.99	Fractions and Unapplied for Rights	"
Neesham, Brigit, 8 Cars-avenue, North Croydon	13.38	" " " "	"
Neill, John S. and Neill, Mary B., 25 Broadway, Room 1150, New York, 5, U.S.A.	24.64	" " " "	"
Neil, Joseph, Jnr., 55 Broad-street, New York, N.Y. 10005, U.S.A.	120.91	" " " "	"
Nelson, Hanns, 65 Symonds-street, Auckland, N.Z.	221.71	" " " "	"
Nethery, Margaret M., The Galdes, Colwich, Stafford, U.K.	10.15	" " " "	"
Newbold, Noreen, Trapelo-road, Lincoln, Massachusetts, U.S.A.	10.08	" " " "	"
Newbold, Noreen Maxwell, c/o Estabrook and Co., 15 State-street, Boston 1, Mass, U.S.A.	10.63	" " " "	"
Newbold, Thomas, c/o Estabrook and Co., 15 State-street, Boston 1, Mass, U.S.A.	10.63	" " " "	"
Newland, Deidre Creswell, c/o J. C. Newland, Vernon Park, Balhannah, S.A.	14.39	" " " "	"
Newton, Cyril F., c/o National Westminster Bank, 34 Henrietta-street, London WC2, U.K.	17.77	" " " "	"
Noether, Hermann Fritz O., P.O. Box 3783, Taipei, Taiwan	27.13	" " " "	"
Norman, Alan T., 24 Maunsell-street, Christchurch, N.Z.	10.36	" " " "	"
Norman, Bessie, 1 Oakleigh Gardens, Edgware, Middlesex, U.K.	13.53	" " " "	"
Oliver, Annie (address unknown)	11.84	" " " "	"
Olson, Hazel M., 199 Canley Vale-road, Canley Vafe, N.S.W.	95.80	" " " "	"
Oliver, Arthur Shane B., c/o Hong Kong & Shanghai Banking Corp., 1 Queens-road Central, Hong Kong	13.13	" " " "	"
Ord, Grace E. (estate of), c/o Charles A. Ord, c/o Ord Minnett T. J. Thompson and Partners, 13-15 O'Connell-street, Sydney, N.S.W.	14.21	" " " "	"
Orr, Donald, 198 Queens-way, Didcot, Berks, U.K.	36.81	" " " "	"
Orr, Ulric G., 17 Billyard-avenue, Elizabeth Bay, N.S.W.	192.28	" " " "	"
Osborne, Peter J., 31 Bell-road, Remuera, Auckland, N.Z.	12.97	" " " "	"
Osmond, Ronald T., P.O. Box 3, Cambridge, N.Z.	48.09	" " " "	"
Outlen Corporation, 17th Floor, 40 Wall-street, New York, N.Y. 10005, U.S.A.	10.63	" " " "	"
Palmer, Francis N.B. & Medhurst, W. F., 2 Rosary-gardens, London, S.W.7, U.K.	25.69	" " " "	"
Palmer, Jack Brougham & Palmer, Francis Herbert, 36 Frederick-street, Oatley, N.S.W.	26.38	" " " "	"
Parer, Kevin James, 10 Coonara-street, Holland Park, Q'ld	37.50	" " " "	"
Parker, Anthony, 63 Elizabeth Bay-road, Elizabeth Bay, N.S.W.	33.38	" " " "	"
Parr, Alfred W. M., 20 Nilpinna-street, Burnside, S.A.	12.50	" " " "	"
Parsons, Elizabeth D., 1/31 Cashel-street, Christchurch, N.Z.	28.74	" " " "	"
Parsons, James S., Riversdale Hotel, Riversdale and Auburn roads, Hawthorn	246.48	" " " "	"
Parsons, Lionel, 101 Forest-road, Walthamstow, U.K.	35.07	" " " "	"
Pathmanathan, Aramugan & Pathmanathan, Indravathy, 4 Jalan Kenny Utara, Kuala Lumpur, Malaysia	12.25	" " " "	"
Pattenden, Donald E. L., Flat 6, 10 Hams-crescent, London, S.W.1, U.K.	11.04	" " " "	"
Paul, Myra J., 20 Alfred-street, Heidelberg	10.59	" " " "	"
Paull, Carmel R., 328 Freeman-road, Kuala Lumpur, Malaysia	27.85	" " " "	"
Penn, Harry, c/o Elias Davidson, 6740 Booth-street, Forest Hills, N.Y., U.S.A.	23.03	" " " "	"
Pennefather, Kathleen M. A., Byron House, Harrow-on-the-Hill, Middlesex, U.K.	227.14	" " " "	"
Phildrew Nominees Limited, Lee House, London Wall, London, E.C.2, U.K.	69.33	" " " "	"
Pignatelli, Conchita, 1757 Buckingham-road, Los Angeles 19, California, U.S.A.	17.29	" " " "	"
Piper, Betty J., 11 Rawson-parade, Caringbah, N.S.W.	12.08	" " " "	"
Pitcairn, John, c/o Mardi Gras Limited, 29 Harrington-road, London, S.W.7, U.K.	29.39	" " " "	"
Pitt, Doris A., 454 Elizabeth-street, Hobart, Tas.	67.50	" " " "	"
Pleasants, Derek R., 53 Hillrise-avenue, Watford, Herts, U.K.	15.25	" " " "	"
Pollard, Arthur N. S., Mina, Flat 3, Firen-street, Senglea, Malta	18.62	" " " "	"
Potts, Heather J., Box 9, Quairading, W.A.	48.29	" " " "	"
Powell, Tristram R. D., c/o Westminster Bank Ltd., Seconfield House, Cuzzon-street, London, W.1, England	28.01	" " " "	"
Powell-Jones, Ann E., c/o Westminster Bank Limited, 224 King's-road, London, S.W.3, U.K.	12.27	" " " "	"
Powne, Cecil W., Narine, via Dirranbandi, Q'ld	20.00	" " " "	"
Pregre, Jacques (estate of), c/o Banque Nationale de Paris, G.P.O. Box 269, Sydney, N.S.W.	223.61	" " " "	"
Preston, Jennifer R., 729 Canterbury-road, Surrey Hills	20.70	" " " "	"
Priestly, Robert H. & Peppiatt, Derek R., 15 Moorgate, London, E.C.2, U.K.	12.27	" " " "	"
Pugh, Janie, c/o Cater Ryder & Co. Ltd., 38 Lombard-street, London, E.C.3, U.K.	11.33	" " " "	"
The Pumpherston Estates Ltd., 4 Grays Inn Square, Grays Inn, London, W.C.1, U.K.	11.33	" " " "	"
Ramsbotham, Maria, c/o Hong Kong & Shanghai Banking Corp., Collyer Quay, Singapore, Malaya	54.62	" " " "	"
Reece, Stanley, 48 Park-road, Quarry Bank, Briery Hill, Staffs, U.K.	15.25	" " " "	"
Reeves, Dorothy B. (estate of), c/o Tompkins Wake Paterson and Bathgate, P.O. Box 258, Hamilton, N.Z.	34.12	" " " "	"
Reeves, Joe R., Apt. 8, 1244 Balboa-court, Sunnyvale, California, 94086, U.S.A.	11.17	" " " "	"
Reynolds, John L. & Smith, Lawrence M., c/o Kelly McNeill & Co., P.O. Box 984, Hastings, N.Z.	20.71	" " " "	"

Unclaimed Moneys Act 1962.

Register of Unclaimed Moneys held by the—

Name of Owner on Books and Last Known Address.	Total Amount Due to Owner.	Description of Unclaimed Moneys.	Date when Amount first became Payable.
§			
THE BROKEN HILL PROPRIETARY COMPANY LIMITED—continued.			
Reynolds, Ronald Norman, 103 Wirral Gardens, Bebington, Wirral, Cheshire, U.K.	95.80	Dividend, Interest, Sale of Fractions and Unapplied for Rights	1.4.70
Richardson, Herbert E., 4 Chelmsford-avenue, Belmore, N.S.W.	40.38	" " " "	" "
Riches, James P. R., c/o Hunter, Boucaut & Ashton, G.P.O. Box 165-C, Adelaide, S.A.	14.00	" " " "	" "
Ride, Lindsay, Villa Monte Rosa E2/11, 41A Stubbs-road, Hong Kong	35.00	" " " "	" "
Riggall, John Terrance, 185 Shene-street, Newtown	12.50	" " " "	" "
Robbins, Shannon, Post Office, Kobtingal, N.S.W.	32.50	" " " "	" "
Robinson, John Phillip, c/o Robinson Curwood & Small, 141 Elizabeth-street, Sydney, N.S.W.	115.63	" " " "	" "
Roe, Leslie M., 56 High-street, Hoddesdon, Herts., U.K.	12.27	" " " "	" "
Rome, Nora L., 19 Church-street, Ellesmere, Shropshire, U.K.	36.72	" " " "	" "
Romand, Marie L., Admix. of Emile Romand (estate of), Chateau De Villeneuve St. Aaron, Pres. Lamballe, Cotes Du Nord, France	362.74	" " " "	" "
Roper, Lillian J., 26 Esplanade, Southport, Q'd	232.55	" " " "	" "
Ropner, Anne M., Park House, Bedale, Yorkshire, U.K.	28.74	" " " "	" "
Rose, Alan William P. R., 59 Cammeray Towers, 55 Carter-street, Cammeray, N.S.W.	12.50	" " " "	" "
Rosella Farms Ltd., c/o Norman Croad, Poplar R. D., Opiki No. 4, Palmerston North, N.Z.	15.20	" " " "	" "
Ross, William L. & Ross, Anne-Marie J. C., 38 White Ledges, Ealing, London, W.13, U.K.	15.25	" " " "	" "
Rossiter, James (estate of), (address unknown)	18.87	" " " "	" "
Rowe, Ramon E., 53 Sunbury Green, Thurnby Lodge, Leicester, U.K.	29.69	" " " "	" "
Roy, Hugh, P.O. Box 1333, Nassau, Bahamas	47.90	" " " "	" "
Roytru Nominees Limited, A/c. 2019, Brewers Hall, Aldermanbury Square, London, England	10.79	" " " "	" "
Rushford, Ellen I., 10 Haughton-parade, Rosanna	10.38	" " " "	" "
Russell, Dwayne H. W., P.O. Box 498, Wellington, N.Z.	11.52	" " " "	" "
Russell, John C., c/o National Prov. Bank Ltd., Chipping Norton, Oxon, U.K.	46.82	" " " "	" "
Ryan, Kathleen, 9 Menzies-street, Sumner, Christchurch, N.Z.	89.66	" " " "	" "
Sale, Marian E., c/o Smith & Williamson, Scottish Union House, 25 Bucklersbury, London, E.C.4, U.K.	10.38	" " " "	" "
Salomon, Julian M., c/o Credit Suisse, A/c. No. 576233, Geneva, Switzerland	54.08	" " " "	" "
Sander, Eugene, Rowan-street, Bendigo	25.00	" " " "	" "
Sansom, Ruth Evelyn, 135 Hamilton Terrace, London, N.W.8	26.97	" " " "	" "
Saunders, Donald R., P.O. Box 6174, Nassau, Bahamas	139.21	" " " "	" "
Schaffer, Alwine, c/o Mrs. Boese, Manor House Boarding Establishment, Bewdley, Worcs., U.K.	140.14	" " " "	" "
Schmidt, Marie L. G. (address unknown)	11.84	" " " "	" "
Schmitz, Wilma L., 3916 Mason-street, Tacoma, Washington, U.S.A.	161.36	" " " "	" "
Schnabel, Utila C., Flat 2, 43c Chapel-street, St. Kilda	20.05	" " " "	" "
Schroeder, Rondon L., 2815 Cann-drive, Ponga City, Okla. 74601, U.S.A.	10.08	" " " "	" "
Schulemson, Ida, 5601 S.W. 76th-street, Miami, Florida, U.S.A.	34.53	" " " "	" "
Scott, Francis C., 169 High-street, Cherry Hinton, Cambridge, U.K.	10.63	" " " "	" "
Sealy, John R. S. (estate of), c/o Clarke, Molloy & Benson, P.O. Box 1233, Auckland, N.Z.	10.38	" " " "	" "
Severne, Barry C., 69 Central-terrace, Wellington, N.Z.	11.52	" " " "	" "
Shah, Asghar A., Junkersdorf 5022, Schneiderklaus Strasse 18, West Germany	12.50	" " " "	" "
Shain, Barbara M., 15 Turramurra-court, King-street, Turramurra, N.S.W.	129.49	" " " "	" "
Shannonhouse, Shirley M., c/o Mrs. Margaret McLeod, 181 Ben Boyd-road, Neutral Bay, N.S.W.	14.17	" " " "	" "
Simmonds, Aileen M., 140 Mt. Korong-road, Eaglehawk	16.80	" " " "	" "
Slane, Bruce H., 128 Wheturangi-road, Auckland, S.E.4, N.Z.	13.60	" " " "	" "
Slee, Anthony P., 13 Browne-avenue, Dalkeith, W.A.	76.64	" " " "	" "
Smith, Colin G., 50 Darbyshire-road, Mt. Waverley	17.00	" " " "	" "
Smith, Raymond F. K., P.O. Box 121 Manuka P.O., A.C.T.	105.89	" " " "	" "
Smith, Winifred A. & Smith, John J. & Oliver, Alan E., c/o Mr. John Williams, 1 Moorgate (2nd Floor), London, E.C.2, U.K.	15.73	" " " "	" "
Smith, Zelma A., All Saints Rectory, Willaura	21.50	" " " "	" "
Snitcher, Carl E., 1 Culcress-street, London, W.1, U.K.	14.40	" " " "	" "
Snodgrass, Gavin, 84 Murrayfield Gardens, Edinburgh, 12, Scotland	19.16	" " " "	" "
Speyer, Anthony F. C., Ravenscar, Alvanley-road, Helsby, Warrington, U.K.	10.38	" " " "	" "
Stack, John, c/o L. G. Wood, 63 St. George's Terrace, Perth, W.A.	25.97	" " " "	" "
Stephens, Brian W. H., 170 The White House, Albany-street, London, W.1, U.K.	13.81	" " " "	" "
Stevens, Nita H., 11 Northhaven Flats, Vale-street, Outmoetai, Tauranga, N.Z.	39.00	" " " "	" "
St. Leger, Hugh (estate of), c/o Jermyn & Moloney, 7 Georges-quay, Cork, Eire.	997.62	" " " "	" "
Stott, William R., 358 Heights-road, Ridgewood, New Jersey, U.S.A.	21.25	" " " "	" "
Strack, Aenne, c/o Mr. O. S. Weismann, 555 Old South Head-road, Rosebay, N.S.W.	12.88	" " " "	" "
Strinfellow, Allan J., 3/1679 Malvern-road, Glen Iris	12.65	" " " "	" "
Sweet, Gwyn M., P.O. Box 214, Havelock North, N.Z.	10.79	" " " "	" "
Szabo, Maria, 259 Tooronga-road, Malvern	21.00	" " " "	" "
Tangye, James A., 16 Addison-crescent, London, W.14, U.K.	17.00	" " " "	" "
Tansley, Thomas Anthony & Giles, Morgan C. M., c/o Cooper Bros. & Co., Abacus House, Cheapside, London, E.C.2, U.K.	68.22	" " " "	" "
Taylor, Alan Leslie, 733 Punt-road, South Yarra	28.74	" " " "	" "
Taylor, Charles S., c/o Howard Homes & Co., 187 High-street, Guildford, Surrey, U.K.	14.11	" " " "	" "

Unclaimed Moneys Act 1962.

Register of Unclaimed Moneys held by the—

Name of Owner on Books and Last Known Address.	Total Amount Due to Owner.	Description of Unclaimed Moneys.	Date when Amount first became Payable.
§			
THE BROKEN HILL PROPRIETARY COMPANY LIMITED—continued.			
Taylor, Lynton G., 35 Burham-road, Kingston Park, S.A.	13.50	Dividend, Interest, Sale of	1.4.70
Thomas, Anne, 17 Brunswick Gardens, London, W.8, U.K.	13.18	Fractions and Unapplied for	"
Thomas, Helen S., c/o 15 Sturt-street, Ballarat	17.50	Rights	"
Thomas, William H. P. & Thomas, Skye, c/o C.B.C. of Sydney Limited, Percy-street, Wellington, N.S.W.	10.50	"	"
Thome, Marit, P.O. Box 2844, Singapore	10.63	"	"
Thorn, John S. (address unknown)	25.97	"	"
Thorne, Richard Thorne, Seadowns Bazehill-road, Rottingdean, Brighton, BN2 7DB, U.K.	19.60	"	"
Throsby, Peter W., G.P.O. Box 290, Sydney, N.S.W.	31.17	"	"
Tidmarsh, Francis M., 1 Epave-street, Quay Portrieux, Cotes du Nord, France	11.20	"	"
Tibbits, Anne B., 30 Warwick-place, Leamington Spa, Warwickshire, U.K.	17.32	"	"
Tollemanche, Hugh J. H., 43 Belgrave Mews North, London, S.W.1, U.K.	19.96	"	"
Trevena, Arthur J., 18 Stewart-street, Brighton	75.00	"	"
Triffon, Giora, c/o N. Gold, 5/29A Hampden-road, Armadale	25.69	"	"
Trotter, Richard W., 1/17 Gladswode-drive, Double Bay, N.S.W.	164.93	"	"
Troxler, Elizabeth J., c/o Tyson & Tyson, 57 Cameron-street, Launceston, Tas.	30.63	"	"
Tufton, Mary J., Flat 10, 17/21 Sloane-court West, London, S.W.3, U.K.	24.98	"	"
Vajda, Stefan, 21 Norman-road, Northfield, Birmingham, 31, U.K.	11.33	"	"
Van Dalen, Annis, c/o Lloyds Bank Limited, 112 Kenington High-street, London, W.8, U.K.	11.33	"	"
Vautier, Ray (estate of), c/o Mr. V. Benson, 160 Castlereagh-street, Sydney, N.S.W.	115.09	"	"
Veale, Brian N., 1/12 Victoria-street, Balmoral, Brisbane, Q'ld	11.33	"	"
Ventura, Dorothy E., 14332 Martha-street, Van Nuys, California, U.S.A.	104.73	"	"
Vickery, Robert, c/o J. T. Vickery, Dobikin Station, Bellata, N.S.W.	58.75	"	"
Wake, Alice Ruth, 6 York-street, Levin, N.Z.	26.04	"	"
Wake, Geoffrey Oswald, 6 York-street, Levin, N.Z.	26.04	"	"
Walden, George Henry, 69 Hoskins-avenue, Bankstown, N.S.W.	10.00	"	"
Walker, Jill Stewart, 24 Adelaide-street, Bondi Junction, N.S.W.	10.38	"	"
Walker, Rosemary, c/o Mrs. Rosemary Yencken, 56 Domain-street, South Yarra	48.00	"	"
Wall, Sally B., 116 St. Heliers Bay-road, Auckland, N.Z.	22.17	"	"
Walsh, Veronica A., 9 Melanesia-road, Mission Bay, N.Z.	33.48	"	"
Ward, Janet Wendy, P.O. Box 123, Rochester	170.63	"	"
Ward, William H. D., Viscount Ednam & Douglas J. W. Dryburgh, Federal House, 2 Dawn-place, Hammersmith, London, W.6, U.K.	287.40	"	"
Wardrop, Ian D., c/o P.O. Box 19, Camden, N.S.W.	24.61	"	"
Weaver, Thomas, 6 Fownes-street, Dublin 2, Eire	175.00	"	"
Weil, Theophile, 31-avenue MacMahon, Paris 17, France	14.27	"	"
Weil, Warren, 30 Clarke-place, Bronx, New York, U.S.A.	57.54	"	"
Weinmann, Georges E., 16 Rue de la Fauvette, Eperney, France	89.75	"	"
Weiss, Oscar B., 2400 East 5th-avenue, Gary, Indiana, U.S.A.	41.41	"	"
Welsh, Peter M., c/o Lloyds Bank Ltd., Maidenhead	11.33	"	"
Wentworth, Charles J. V., Park House, Friston, Saxmundham, Suffolk, U.K.	10.38	"	"
Westminster Bank Limited, J 14608 A/c., 41 Lothbury, London, E.C.2, U.K.	11.33	"	"
White, William D., 151 Tillans-street, Otumdetai, Tauranga, N.Z.	40.39	"	"
Whiting, Carmel E., 17 Rymill-road, Somerton Park, S.A.	24.00	"	"
Whitman, Herbert S., Block Island, Rhode Island, 02807, U.S.A.	15.94	"	"
Wiese, Otis L., French Hill Farm, Baldwin-road, R.D.3, Yorktown Heights, N.Y. 10598, U.S.A.	64.79	"	"
Wilbur-Ham, Brian L., 3 Balfour-street, Toorak	18.88	"	"
Wilkins, Christopher P., 74A Lansdowne-road, London, W.11, U.K.	17.28	"	"
Wilkins, William C., Trehyfyd, Llandoverly, Carmarthenshire, U.K.	21.70	"	"
Williams, Albert E., Jr., c/o Electrical Engineering Dept., University of W.A., Nedland, W.A.	12.73	"	"
Williams, Christine Isabel, 7 Swallow-street, Slade Point, via Mackay, Q'ld	25.00	"	"
Williams, David G., Hardinge, Seagry, Chippenham, Wilts. U.K.	134.12	"	"
Williamson, Alvena M., 10 Crandalline-grove, Caulfield	10.38	"	"
Willis, Ruth H., c/o Dr. Willis, 87 New Mount Pleasant-road, Mount Dunsley, N.S.W.	12.00	"	"
Wilson, Gerald R. C. (estate of), c/o Glyn Mills & Co., Kirkland House, Whitehall, London, S.W.1, U.K.	-10.15	"	"
Wilson, Valerie, 9 Mysore-street, Ngaio, Wellington, N.Z.	17.40	"	"
Wood, Margaret L., 2 Seaview-avenue, Collaroy, N.S.W.	12.50	"	"
Wood, William C., 62 Fox-street, Lane Cove, N.S.W.	13.39	"	"
Woodhouse, Margaret J., 44 Spencer-road, Killara, N.S.W.	10.38	"	"
Woodhouse, William B., 147 Collins-street, Melbourne	11.33	"	"
Wooller, Edith, Truants, Aylesbeare, Nr. Exeter, Devon, U.K.	19.16	"	"
Working Holiday Bureau Ltd., P.O. Box 1382, Christchurch, N.Z.	27.27	"	"
Wright, Marianne V., Unit 9, 5 Musgrave-street, Mosman, N.S.W.	24.50	"	"
Wyndham, Eleanor Mary, 21 Douglas-street, St. Ives, N.S.W.	25.00	"	"
Yeap, Kee, 511 Shaw House, Orchard-road, Singapore 9	10.63	"	"
Yeap, Rosemary Dawn, c/o Kee Yeap Associates, 511 Shaw House, Orchard-road, Singapore 9	53.13	"	"
Yeatman, Harry M., 6 Morpeth Mansions, London, S.W.1, U.K.	143.70	"	"
Youl, Geraldine Alice & Hinman, George C. & Savigny, William J., c/o Tyson & Tyson, 57 Cameron-street, Launceston, Tas.	163.50	"	"

The Companies Act 1961, Section 144 (2).

THERMIDAIRE INDUSTRIES PTY. LIMITED.

MEETING OF MEMBERS HELD AT THE OFFICES OF THE INSTITUTE OF CHARTERED ACCOUNTANTS IN AUSTRALIA, 140 QUEEN-STREET, MELBOURNE, AT 2 P.M. ON 1ST DAY OF JUNE, 1972.

Special Resolution.

Take notice that we the undersigned members of Thermidaire Industries Pty. Limited, being the holders of 95 per centum of the total voting rights of the said company, met this day to pass the following Special Resolution:—

It is resolved that the company being unable to pay its debts and when they become due and payable the company be wound up voluntarily and that Ernest Harding Niemann, of 44 Market-street, Melbourne, 3000, be appointed as the liquidator for the purpose of the said winding up.

Dated this 1st day of June, 1972.

LAWRENCE RICHARD WILSON, Director.
DAVID BERNARD WILSON, Director.
6643 MYRA VERONICA WILSON, Secretary.

The Companies Act 1961.

VERONA BUILDERS PTY. LTD.

PURSUANT TO SECTION 260 OF THE COMPANIES ACT 1961.

Notice is hereby given that a Meeting of creditors of Verona Builders Pty. Ltd., will be held at the Institute of Chartered Accountants, 140 Queen-street, Melbourne, on Tuesday, the 20th day of June, 1972, at 3 o'clock in the afternoon, for the purpose of considering the company's affairs, the company having convened an Extraordinary General Meeting of its members to be held on the same day and for the purpose of considering and if thought fit, passing a Special Resolution that the company be wound up voluntarily.

Dated this 2nd day of June, 1972.

A. PIETROPOLI, Director.

Hall & Rose, chartered accountants, 395 Collins-street, Melbourne. 6619

Companies Act 1961, Section 254 (2).

DELTA-CRAFT PTY. LIMITED (IN LIQUIDATION).

NOTICE OF RESOLUTION.

To the Registrar of Companies.

At a General Meeting of the members of Delta-Craft Pty. Limited, duly convened and held at the offices of Fell & Starkey, 351 Collins-street, Melbourne, on 29th May, 1972, the Special Resolution set out below was duly passed:—

"Resolved unanimously, as a Special Resolution, that the company be wound up voluntarily, and that it be recommended to the creditors of the company at the meeting called for 29th May, 1972, at 11 a.m., that Roger Douglas Evans, chartered accountant, of 351 Collins-street, Melbourne, be appointed liquidator of the company for the purposes of such winding up."

Dated this 1st day of June, 1972.

6620 J. T. SAVAGE, Director.

Companies Act, 1961, Section 254.

VIVIAN SIGNS PROPRIETARY LIMITED.

Notice is hereby given that at an Extraordinary General Meeting of the members of the above-named company held on 1st June, 1972, the following Resolution was passed as a Special Resolution:—

"That the company be wound up voluntarily and that Mr. R. A. Waters, chartered accountant, 470 Bourke-street, Melbourne, be appointed liquidator for the purpose of such winding up."

6621 R. A. WATERS, Liquidator.

SEAFRONT INVESTMENTS PTY. LTD.

At a General Meeting of the members of the above-named company, held at 1 Eden-court, Toorak, on 26th May, 1972, the Special Resolution set out below was duly passed:—

That the company be wound up voluntarily and that Eric Maxwell Huggard and Brian Argent Waters, of the firm of Spry Walker & Co., chartered accountants, be appointed joint and several liquidators at a fee to be determined in accordance with the normal professional scale rates for the time occupied by the said liquidators, and/or their staff, in carrying out their duties as liquidators.

Dated this 26th day of May, 1972.

6678 C. I. DAVIS, Secretary.

The Companies Act 1961.—In the matter of HILLSIDE AUTOS PTY. LTD. (In voluntary liquidation).

Notice is hereby given that at an Extraordinary Meeting of the members of the above-named company held on Tuesday, 30th May, 1972, it was resolved that the company be wound up voluntarily, and at a meeting of creditors held on the same day, it was resolved that for such purpose, Geoffrey Ormond Harrison, of Hall & Rose, chartered accountants, 395 Collins-street, Melbourne, be appointed liquidator.

Notice is also given that after 21 days from this date I shall proceed to distribute the assets. All creditors having any claim against the company should furnish particulars of same by that date, otherwise I shall proceed to distribute the assets without regard to their claim.

Dated this 1st day of June, 1972.

G. O. HARRISON, Liquidator.

Hall & Rose, chartered accountants, 395 Collins-street, Melbourne. 6622

BOWRICK PROPRIETARY LIMITED (IN LIQUIDATION).

NOTICE OF FINAL MEETING.

Notice is hereby given that the Final Meeting of creditors of Bowrick Proprietary Limited (in Liquidation), in accordance with the provisions of the Companies Act 1961, section 272, will be held at the office of Webster & Taylor, 1st Floor, 29 Alma-road, St. Kilda, 3182, on Thursday, the 6th day of July, 1972, at 9.30 a.m.

6652 E. P. TAYLOR, Liquidator.

In the matter of J. J. SOLID PLASTERING CO. PTY. LTD.—
Notice of Winding-Up Order.

Winding-Up Order made the 31st day of May, 1972.

Name and Address of official liquidator, Ernest Harding Niemann, of 44 Market-street, Melbourne.

L. T. FITZGERALD, Deputy Commissioner of Taxation of the Commonwealth of Australia. 6679

In the matter of ROSEWALL CONSTRUCTION COMPANY (VICTORIA) PTY. LTD.—*Notice of Winding-Up Order.*

Winding-Up Order made the 31st day of May, 1972.

Name and Address of official liquidator, Jack Bastian, care of J. Bastian & Co., Suite 25, 545 St. Kilda-road, Melbourne.

L. T. FITZGERALD, Deputy Commissioner of Taxation of the Commonwealth of Australia. 6680

In the matter of U.A. COMMERCIAL REFRIGERATION PTY. LIMITED.—*Notice of Winding-Up Order.*

Winding-Up Order made the 31st day of May, 1972.

Name and Address of official liquidator, John Kenneth Hall, care of Hall and Rose, of 395 Collins-street, Melbourne.

L. T. FITZGERALD, Deputy Commissioner of Taxation of the Commonwealth of Australia. 6682

Companies Act 1961.

AUSTRALIAN GENERAL INVESTMENTS LIMITED (IN VOLUNTARY LIQUIDATION).

NOTICE CONVENING FINAL MEETING OF MEMBERS PURSUANT TO SECTION 272 OF THE COMPANIES ACT 1961 OF VICTORIA.

Notice is hereby given that, in pursuance of section 272 of the Companies Act 1961 the Final Meeting of the company will be held at 10th Floor, 143 Queen-street, Melbourne, Victoria, at noon, on Thursday, 6th July, 1972, for the purposes of having an account laid before the members, showing the manner in which the winding up has been conducted and the property of the company disposed of and of hearing any explanations which may be given by the liquidator.

Melbourne, 5th June, 1972.

6683 BARRY JOHN WEIR, Liquidator.

Companies Act 1961, Section 254 (2) (B).

At a General Meeting of the members of Trade Homes Proprietary Limited duly convened and held at 15 Ian-crescent, Mitcham, on the 29th day of April, 1972, it was resolved that the company be wound up voluntarily and that Keith Holmes Golding, public accountant, be appointed liquidator.

Dated this 30th day of May, 1972.

6596 K. H. GOLDING, Liquidator.

AUSTRAL MAGNUS COMPANY PROPRIETARY LIMITED.

Notice is hereby given that the following Resolution was duly passed on Monday, 5th June, 1972:—

“Resolved—as a Special Resolution, that the company be wound up voluntarily as a Members' Voluntary Winding Up, in accordance with the provisions of the *Companies Act 1961*, and that Mr. Robert William Fotheringham, be appointed liquidator for the purposes of the winding up.”

6612 R. W. FOTHERINGHAM, Liquidator.

FIRESTONE STORES (VIC.) PTY. LIMITED (IN LIQUIDATION).—Members' Voluntary Liquidation.

Notice is hereby given that at an Extraordinary General Meeting of the above-named company was duly convened and held at Auburn, N.S.W. on the 2nd day of June, 1972, the following Special Resolution was passed:—

“That the company be wound up voluntarily and that John Gordon Duff, of 15 Bligh-street, Sydney, be appointed liquidator for the purposes of such winding up.”

Dated this 2nd day of June, 1972.
6641 R. M. COPELAND, Chairman.

The Companies Act 1961.

YARRAVILLE PROPERTY INVESTMENTS PROPRIETARY LIMITED. (IN VOLUNTARY LIQUIDATION).

NOTICE CONVENING FINAL MEETING OF MEMBERS, PURSUANT TO SECTION 272.

Notice is hereby given, pursuant to section 272 of the *Companies Act 1961*, that a General Meeting of the members of the above-named company, will be held in the offices of Johnson Barson & Co., 302 Lygon-street, Carlton, on Tuesday, the 11th day of July, 1972, at 10.30 a.m., for the purpose of having an account laid before them, showing the manner in which the winding up has been conducted and the property of the company disposed of and of hearing any explanations that may be given by the liquidator.

Dated this 30th day of May, 1972.

JOHN BARSON, Liquidator.

Johnson Barson & Co., 302 Lygon-street, Carlton, Victoria, 3053. 6638

Companies Act 1961, Section 272.

INNOVATION MERCANTILE PTY. LTD. (IN VOLUNTARY LIQUIDATION).

Notice is hereby given that a General Meeting of the company will be held at the offices of Stennett & Rooke, First Floor, 153 Upper Heidelberg-road, Ivanhoe, at 11 a.m., on Tuesday, 11th July, 1972, to receive and adopt the liquidator's final account. 6639

Companies Act.—In the matter of ANSETT PROPERTIES (ESSENDON) PROPRIETARY LIMITED (in Voluntary Liquidation).—Members' Winding Up.

Notice is hereby given that at an Extraordinary General Meeting of the above-named company duly convened and held at 489 Swanston-street, Melbourne, Victoria, on the 31st day of May, 1972, the following Resolution was proposed and passed as a Special Resolution:—

“That the company be wound up voluntarily.”

Dated the 31st day of May, 1972.

R. L. COOPER, Director.

Messrs. Grant & Co., solicitors, 108 Queen-street, Melbourne, 3000. 6640

The Companies Act 1961.—In the matter of INTEGRAL CARPET INDUSTRIES PTY. LTD. (in Voluntary Liquidation).—Creditors Winding Up.

Notice is hereby given that at the Extraordinary General Meeting of Integral Carpet Industries Pty. Limited, duly convened and held at 140 Queen-street, Melbourne, in the State of Victoria, on the 2nd June, 1972, the following Resolution was proposed and passed as a Special Resolution:—

“That the company be wound up voluntarily.”

Dated this 5th day of June, 1972.

6646 R. W. BETTS, Liquidator.

Companies Act 1961.—In the matter of COMMERCIAL TYRE WORKS PROPRIETARY LIMITED (in Voluntary Liquidation).—Members' Winding Up.

Notice is hereby given that, pursuant to section 272 of the above Act, the Final General Meeting of the members of the company for the purpose of receiving the liquidator's account showing how the winding up has been conducted

and how the property of the company has been disposed of will be held at the offices of L. A. Walker & Son, chartered accountants, Suite 2, 167 Whitehorse-road, Blackburn, 3130, in the State of Victoria, on Tuesday, 25th July, 1972, at 2 p.m.

Dated this 2nd day of June, 1972.

6611 PETER A. WALKER, Liquidator.

Companies Act 1961.

BORUNG PTY. LTD.

NOTICE PURSUANT TO SECTION 254 (2).

Notice is hereby given that at an Extraordinary General Meeting of the members of the above-named company, duly convened and held on the 31st day of May, 1972, the following Special Resolution was duly passed:—

“That the company be wound up voluntarily under section 254 (1) of the *Companies Act 1961*, and that Malcolm Henry James Taylor, be and the same is hereby appointed liquidator for the purposes of such winding up.”

Dated this 31st day of May, 1972.

6609 M. H. J. TAYLOR, Liquidator.

The Companies Act 1961.

BLAKISTON ENGINEERING PROPRIETARY LIMITED (IN VOLUNTARY LIQUIDATION).

NOTICE CONVENING FINAL MEETING OF MEMBERS, PURSUANT TO SECTION 272.

Notice is hereby given pursuant to section 272 of the *Companies Act 1961*, that the Final Meeting of the members of the above-named company will be held at the office of A. H. G. Clarke & Co., First Floor, 460 Bourke-street, Melbourne, on the 10th day of July, 1972, at 3 p.m., to consider the liquidator's final accounts of the voluntary winding up.

Dated this 30th day of May, 1972.

6597 R. W. BELL, Liquidator.

In the matter of I. J. DALEY PTY. LTD.—Notice of Winding-Up Order.

Winding-Up Order made the 31st day of May, 1972.

Name and Address of official liquidator, Ronald Dennis Widdows, 6 Marylin-court, East Bentleigh.

L. T. FITZGERALD, Deputy Commissioner of Taxation of the Commonwealth of Australia. 6681

I, Clement Peter Hoskin, of 17 Lydiard-street north, Ballarat, liquidator of Dawson's (Rainbow) Proprietary Limited (in Voluntary Liquidation) hereby advise that a General Meeting of the company is summoned for 4.30 p.m., on Monday, 10th July, 1972, at 17 Lydiard-street north, Ballarat, for the purpose of laying before the meeting an account showing how the winding up has been conducted and the property of the company has been disposed of and giving any explanation regarding the account. 6583

In the Supreme Court of Victoria.—Co. 8372.—In the matter of the Companies Act 1961; and in the matter of ROCKBANK PTY. LIMITED.

Notice is hereby given that a petition for the winding-up of the above-named company by the Supreme Court was, on the 2nd day of June, 1972, presented by Motor Tyre Service Pty. Ltd., and that the said petition was directed to be heard before the Court sitting at Melbourne at the hour of 10.30 a.m. on the 21st day of July, 1972; and any creditor or contributory of the said company desiring to support or oppose the making of an order on the said petition may appear at the time of the hearing by himself or his counsel for that purpose; and a copy of the petition will be furnished to any creditor or contributory of the said company requiring the same by the undersigned on payment of the regulated charge for the same.

The petitioner's address is 461-471 Wattle-street, Sydney in the State of New South Wales.

The petitioner's solicitors are Messrs. Purves & Purves, of 121 William-street, Melbourne.

PURVES & PURVES.

NOTE.—Any person who intends to appear on the hearing of the said petition must serve on or send by post to the above-named solicitors for the petitioner notice in writing of his intention so to do. The notice must state the name and address of the person, or, if a firm, the name and address of the firm, and must be signed by the person or firm, or his or their solicitor (if any), and must be served, or if posted, must be sent by post in sufficient time to reach the above-named not later than four o'clock in the afternoon of the 20th day of July, 1972. 6631

GLEN MACALISTER PTY. LTD.
LIMA PASTORAL COMPANY PTY. LTD.
RUTLAND INVESTMENTS PTY. LTD.
SUBURBAN HOMES PTY. LTD.
TARWIN VALLEY FARMS PTY. LTD.
VICTORIAN ESTATES PTY. LTD.

(ALL IN LIQUIDATION).

Notice is hereby given that the Final Meeting of the above companies shall be held at the offices of Messrs. Corr & Corr, solicitors, Fourth Floor, 290 La Trobe-street, Melbourne, on Wednesday, the 12th July, 1972, at 12 noon, for the purposes set out in section 272 of the Companies Act.

6623

W. P. WATSON, Liquidator.

The Companies Act 1961.

W. E. WHITE & SONS PROPRIETARY LIMITED
(IN LIQUIDATION).

NOTICE CONVENING FINAL MEETING OF MEMBERS AND CREDITORS, PURSUANT TO SECTION 272.

Notice is hereby given, pursuant to section 272 of the Companies Act 1961, that a General Meeting of the members and creditors of the above-named company will be held in the offices of Kennedy, Smail & Middlemiss, 296-304 Little Lonsdale-street, Melbourne, on Wednesday, the 5th day of July, 1972, at 10.30 a.m., for the purpose of having an account laid before them, showing the manner in which the winding up has been conducted and the property of the company disposed of and of hearing any explanations that may be given by the liquidator.

Dated this 2nd day of June, 1972.

J. M. WALSH, Liquidator.

Kennedy, Smail & Middlemiss, 296-304 Little Lonsdale-street, Melbourne, 3000. 6632

The Companies Act 1961.—In the matter of GEO. H. HUGHES (AUSTRALIA) PTY. LIMITED.

Pursuant to section 254 (2) (b) of the Companies Act 1961, notice is hereby given that at an Extraordinary General Meeting of the company duly convened and held on 31st May, 1972, the following Resolution was passed as a Special Resolution:—

“That the company be wound up voluntarily.”

And at such meeting, Donald Albert Conabere, of 108 Queen-street, Melbourne, chartered accountant, was appointed liquidator for the purposes of the winding-up.

Dated this 1st day of June, 1972.

6634

E. K. TATNALL, Director.

The Companies Act 1961.—In the matter of DONNEGAL DRAINAGE COMPANY PTY. LIMITED (in Liquidation).

Notice is hereby given that, pursuant to section 272 (2) of the Companies Act 1961, the Final Meeting of creditors and contributories of the above-named company will be held at the office of Bruce Fordham & Co., chartered accountants, 170 Toorak-road, South Yarra, on Friday, 7th July, 1972, at 9.30 in the forenoon.

Business.

To receive the liquidator's report and accounts.

Dated this 31st day of May, 1972.

BRUCE FORDHAM, Official Liquidator.

Bruce Fordham & Co., chartered accountants, 170 Toorak-road, South Yarra, Vic., 3141 6635

The Companies Act 1961.—In the matter of HUGH V. MCIVOR PTY. LTD. (in Liquidation).

A Second and Final Dividend is intended to be declared in the above-mentioned matter. Creditors who have not proved their debts by the 26th day of June, 1972, will be excluded from the dividend.

Dated this 5th day of June, 1972.

J. M. WALSH, Liquidator.

Kennedy, Smail & Middlemiss, 296 Little Lonsdale-street, Melbourne, Vic., 3000. 6637

MALCOLM WILLIAM GEORGE GRANT, otherwise Malcolm William Grant, late of Hothorpe Hall, Theddingworth, near Rugby, Warwickshire, England, retired engineer, DECEASED.

Creditors, next of kin and others having claims in respect of the estate of the above-named deceased (who died on the 9th day of July, 1971), are required by The Trustees, Executors and Agency Company Limited, of

401 Collins-street, Melbourne, in the State of Victoria, the duly constituted attorney under power of the executor to whom probate of the will of the said deceased was granted by the District Probate Registry of the High Court of Justice at Nottingham, England, to whom a grant of reseat of probate was made by the Supreme Court of Victoria in its probate jurisdiction, to send particulars to the said company, by the 10th day of August, 1972, after which date the said company may convey or distribute the assets, having regard only to the claims of which it then has notice.

DAVIES, CAMPBELL & PIESSE, solicitors, 401 Collins-street, Melbourne. 6669

WALTER JAMES MURFITT, late of Camperdown, retired farmer, DECEASED.

Creditors, next of kin and others having claims in respect of the estate of the deceased (who died on the 21st day of September, 1952), are required by the executors of the deceased's will, Evelyn Charles Chicheley Tucker and Edward John Wilson Chapple, to send particulars to them care of the under-mentioned firm of solicitors, by the 16th day of August, 1972, after which date they may convey or distribute the assets, having regard only to the claims of which they then have notice.

BUCKLAND & NEVETT, solicitors, Camperdown. 6580

Creditors, next of kin and others having claims in respect of the estate of Muriel Annie Spencer, formerly of 450 Murray-road, Preston, but late of 119 James-street, Templestowe, in the State of Victoria, married woman, deceased (who died on the 4th day of June, 1971), are required by The Equity Trustee, Executors and Agency Co. Ltd., of 472 Bourke-street, Melbourne, to send particulars of their claim to the said company by the 15th day of August, 1972, after which date it will convey or distribute the assets, having regard only to the claims of which the company then has notice.

ANDREW T. FRASER, solicitor, 541 Middleborough-road, Box Hill North, solicitor for the Estate. 6581

Creditors, next of kin and others having claims in respect of the will of Mary Eileen Naughton (also known as Eileen Naughton), late of Alimar Private Hospital, 34 Scott-street, Essendon, widow (who died on the 31st day of January, 1972), are requested to send particulars of their claims to the executors Rosario Altomare and Maria Altomare, care of the under-mentioned solicitor by the 20th day of August, 1972, after which date they will distribute the assets, having regard only as to the claims of which they then have notice.

EDWARD CURMI, of 440 Victoria-street, North Melbourne. 6582

MARY ELIZABETH MONICA CUTHBERT, late of 137 North-road, Gardenvale, spinster, DECEASED.

Creditors, next of kin and others having claims in respect of the estate of the above-named deceased (who died on 19th January, 1972), are required by the trustee, John Thomas Bloom, of 343 Little Collins-street, Melbourne, solicitor, to send particulars to his solicitors, Nunan & Bloom, at their address below by 10th August, 1972, after which date the trustee may convey or distribute the assets having regard only to the claims of which he then has notice.

NUNAN & BLOOM, solicitors, 343 Little Collins-street, Melbourne. 6570

BERYL ENID ANDERSON, late of 13 Mayfield-avenue, West Brunswick, in the State of Victoria, widow, DECEASED.

Creditors, next of kin and all others having claims in respect of the estate of Beryl Enid Anderson, late of 13 Mayfield-avenue, West Brunswick, widow, deceased (who died on the 21st day of July, 1971), are required by the administratrix, Dorothy Anderson, of 491 Melbourne-road, Newport, married woman, to send particulars of their claims to her, in the care of the under-mentioned solicitor, prior to the 17th day of August, 1972, after which date she will distribute the assets, having regard only to the claims of which she then has notice.

M. F. HUGHES, LL.B., 300 Barkly-street, Brunswick. 6575

ANNIE JACKSON, late of 23 Little Gold-street, Brunswick, in the State of Victoria, widow, DECEASED.

Creditors, next of kin and others having claims in respect of the estate of Annie Jackson, late of 23 Little Gold-street, Brunswick, widow, deceased (who died on the 6th day of August, 1970) are required by the executrix, Ethel Annie Blay, of 1 Little Gold-street, Brunswick,

married woman, to send particulars of their claims to her in the care of the under-mentioned solicitor, prior to the 17th day of August, 1972, after which date she will distribute the assets, having regard only to the claims of which she then has notice.

M. F. HUGHES, LL.B., solicitor, 300 Barkly-street, Brunswick. 6576

ALAN NORMAN RAMSAY, late of 35 Searle-street, Horsham, manager salesman, DECEASED.

Creditors, next of kin and others having claims in respect of the estate of the deceased (who died on the 18th day of February, 1972), are to send particulars of their claims to The Union-Fidelity Trustee Company of Australia Limited, of 100 Exhibition-street, Melbourne, by the 15th day of August, 1972, after which date it will distribute the assets, having regard only to the claims of which it then has notice.

POWER & BENNETT, solicitors, 12 Pynsent-street, Horsham, 3400. 6577

Creditors, next of kin and others having claims in respect of the estate of Gregory John Haines, late of Diggora, motor mechanic, deceased, intestate, are required by the administrator, National Trustees Executors and Agency Company of Australasia Limited, of 95 Queen-street, Melbourne, and at 46 Queen-street, Bendigo, to send particulars thereof to the said company, by the 15th day of August, 1972, after which date the administrator will distribute the assets, having regard only to the claims of which it then has notice.

Dated this 30th day of May, 1972.

HYETT & HYETT, solicitors, 51 Bull-street, Bendigo. 6568

Creditors, next of kin and others having claims in respect of the estate of Hannah Mary Coulthard, late of 21 Canterbury-road, Toorak, in the State of Victoria, widow (who died on the 28th day of February, 1972), are to send particulars of their claims to the executrix, Catherine Quirk, care of the undersigned, by the 10th August, 1972, after which date she will commence to distribute the assets, having regard only to the claims of which she then has notice.

RENNICK & GAYNOR, solicitors, 481 Riversdale-road, Hawthorn East. 6627

Creditors, next of kin and other persons having claims against the estate of Dora Ashwell, late of 52 Shiers-street, Alphington, widow (who died on 28th May, 1971), are requested to send particulars of their claims to the executors, George Gladstone Bolwell and Francis Harold Warren, care of the under-mentioned solicitors, by the 10th day of August, 1972, after which date the said executors will distribute the assets, having regard only to the claims of which they then have had notice.

SETON, WILLIAMS & SMYTH, solicitors, 954 Main-road, Eltham. 6628

EDITH LEMMON, late of "Sun Rising", Patch-road, The Patch.

Creditors, next of kin and others having claims in respect of the estate of the deceased (who died on the 13th day of January, 1972), are required by The Perpetual Executors and Trustees Association of Australia Limited, of 100-104 Queen-street, Melbourne, the applicant for a grant of administration, to send particulars of their claims to the said applicant, in the care of the said company, by the 28th day of August, 1972, after which date they will convey or distribute the assets, having regard only to the claims of which they then have notice.

SLATER & GORDON, solicitors, of 395 Collins-street, Melbourne, 3000. 6630

WILFRID TENNYSON VICKERMAN, late of 82 Alexandra-street, East St. Kilda, gentleman, DECEASED.

Creditors, next of kin and others having claims in respect of the estate of the above-named deceased (who died on the 20th day of December, 1971), are required by Athol James Kennedy and Edward Alexander Cook, both of 401 Collins-street, Melbourne, solicitors, the executors of the will of the deceased, to send particulars of their claims to the said executors, care of the undernamed solicitors, by the 11th day of August, 1972, after which date they will convey or distribute the assets, having regard only to the claims of which they then have notice.

RUSSELL, KENNEDY & COOK, solicitors, 401 Collins-street, Melbourne. 6626

VIVIENNE VALENTINE MATHESON, formerly of Athlone, but late of Oddy-street, Drouin, gentlewoman, DECEASED.

Creditors, next of kin and others having claims in respect of the estate of the deceased (who died on the 10th September, 1971), are required by the trustee, The Trustees, Executors and Agency Company Limited, of 401 Collins-street, Melbourne, to send particulars of their claims to it, care of the undersigned solicitors, by the 14th day of August, 1972, after which date the trustee may convey or distribute the assets, having regard only to the claims of which it then has notice.

GRAY, FRIEND & LONG, solicitors, Warragul. 6566

Creditors next of kin and others having claims against the estate of Margaret Schuller (also known as Margary Schuller and Greta Schuller), late of 2 Mortimer-street, Heidelberg, widow, deceased (who died on the 27th day of February, 1972), are required to send particulars to the executor, National Trustees, Executors and Agency Company of Australasia Limited, at its registered address, 95 Queen-street, Melbourne, by the 14th day of August, 1972, after which date the said executor will distribute the assets, having regard only to the claims of which it then has notice.

BERNARD NOLAN & CO., solicitors, 595 Bourke-street, Melbourne. 6615

Creditors next of kin and others having claims against the estate of Clarice Winifred Brown, late of Border Boulevard, Wharparilla, in the State of Victoria, widow, deceased (who died on the 1st day of February, 1972), are required to send particulars of their claims to the executors, Edward Douglas Brown and John Kevin Brown, care of the undersigned solicitor, before the 16th day of August, 1972, after which date they will distribute the assets, having regard only to the claims of which they then have notice.

JOHN F. CARROLL, solicitor, 118 Queen-street, Melbourne. 6616

Creditors next of kin and others having claims against the estate of Alma Vera Hookins, late of 27 Malpas-street, East Preston, in the State of Victoria, widow, deceased (who died on the 19th day of January, 1967), are to send particulars of their claims to the executor, National Trustees Executors and Agency Company of Australasia Limited, whose registered office is situate at 95 Queen-street, Melbourne, in the said State, by the 16th day of August, 1972, after which date it will distribute the assets, having regard only to the claims of which it then has notice.

JOHN F. CARROLL, solicitor, 118 Queen-street, Melbourne. 6617

Creditors next of kin and others having claims against the estate of Nellie Frances Wallace, late of 49 Marine-parade, St. Kilda, in the State of Victoria, spinster, deceased (who died on the 27th day of April, 1972), are to send particulars of their claims to the executor, Louis Alfred Jackson, care of the undersigned solicitor, in the said State by the 23rd day of August, 1972, after which date it will distribute the assets, having regard only to the claims of which it then has notice.

JOHN F. CARROLL, solicitor, 118 Queen-street, Melbourne. 6618

THYRA MAY PERRY, late of 24 Murrumbena-road, Murrumbena, spinster, DECEASED, Intestate.

Creditors, next of kin and others having claims in respect of the estate of the deceased (who died on the 2nd day of September 1971), are required by the personal representative, National Trustees, Executors and Agency Company of Australasia Limited, the registered office of which is at 95 Queen-street, Melbourne, to send particulars to it by the 14th day of August, 1972, after which date the said company may convey or distribute the assets, having regard only to the claims of which it then has notice.

PAUL J. CAREY & CO., solicitors, 386 Flinders-lane, Melbourne. 6624

ALBERT EDWARD NORRINGTON, late of 14 Sycamore-street, Box Hill South, gentleman, DECEASED.

Creditors, next of kin and others having claims in respect of the estate of the deceased (who died on 29th January, 1972), are required by the executors, Nell Beatrice Gruen and Morris Komisaroff, to send particulars to them, care of the undersigned solicitor, by 11th August, 1972, after which date they may convey or distribute the assets, having regard only to the claims of which they then have notice.

R. C. H. BEATTIE, solicitor, 270 Waverley-road, East Malvern. 6644

EDWARD HENRY NEANDER, late of 22 Hill-road, North Balwyn, Victoria, company director, DECEASED.

Creditors, next of kin and others having claims in respect of the estate of the said deceased (who died on 3rd May, 1971), are required by the personal representatives, Peter Lynne Wharton, of 20 Collins-street, Melbourne, chartered accountant, and Cecil Ambrose Bernard of 440 Whitehorse-road, Surrey Hills, company director, to send particulars to them, by 11th August, 1972, after which date they may convey or distribute the assets, having regard only to the claims of which they then have notice.

HEDDERWICK, FOOKES & ALSTON, 121 William-street, Melbourne. 6625

Creditors, next of kin and others having claims against the estate of Albert Lancet Smith, late of 5 Chandlers-road, Malvern, in the State of Victoria, retired shipping clerk, deceased (who died on the 3rd day of March, 1972), are required by William Patrick Melville, of 224 Glenferrie-road, Malvern, the executor of the will of the said deceased, to send particulars of their claims to the said executor, by the 8th day of August, 1972, after which date the executor will convey or distribute the estate of the said deceased, having regard only to the claims of which he then has notice.

MELVILLE & MELVILLE, solicitors, of 224 Glenferrie-road, Malvern. 6664

Creditors, next of kin and others having claims against the estate of Olivia May Duff, late of 6 Mayfield-grove, Caulfield, in the State of Victoria, spinster, deceased (who died on the 4th day of April, 1972), are required by William Patrick Melville, of 224 Glenferrie-road, Malvern, the executor of the will of the said deceased to send particulars of their claims to the said executor, by the 8th day of August, 1972, after which date the executor will convey or distribute the estate of the said deceased, having regard only to the claims of which he then has notice.

MELVILLE & MELVILLE, solicitors, of 224 Glenferrie-road, Malvern. 6665

Creditors, next of kin and others having claims in respect of the estate of Percy Joseph Frawley, formerly of 3 Irene-street, Preston, but late of 3 Collins-street, Thornbury, in the State of Victoria, pensioner, deceased (who died on the 28th day of July, 1971), are to send particulars of their claims to Royston Cahir, Martin & Dillon, solicitors, of 17 Queen-street, Melbourne, by the 10th day of August, 1972, after which date the executors will distribute the assets of the estate, having regard only to claims of which they have notice.

ROYSTON CAHIR, MARTIN & DILLON, solicitors, of 17 Queen-street, Melbourne, 3000. 6666

Creditors, next of kin and others having claims in respect of the estate of Catherine Olive Vail, late of Auckland, New Zealand, widow, deceased (who died on the 4th August, 1971), are to send particulars of their claims to The Trustees, Executors and Agency Company Limited, of 401 Collins-street, Melbourne, by the 11th August, 1972, after which date it will distribute the assets, having regard only to the claims of which it then has notice.

MOULE, HAMILTON & DERHAM, 224 Queen-street, Melbourne. 6670

Creditors, next of kin and others having claims in respect of the estate of Daisy Annie Kilgour Dick, late of Flat 212, Inala Village, 208 Middleborough-road, South Blackburn, widow, deceased (who died on the 2nd March, 1972), are to send particulars of their claims to The Trustees Executors and Agency Company Limited, of 401 Collins-street, Melbourne, by the 11th August, 1972, after which date it will distribute the assets, having regard only to the claims of which it then has notice.

MOULE, HAMILTON & DERHAM, 224 Queen-street, Melbourne. 6671

JEANIE LOUGHEED, late of 23 Cooper-street, West Preston, married woman, DECEASED.

Creditors, next of kin and others having claims in respect of the estate of the deceased (who died on the 27th March, 1972), are requested to send particulars of their claims to the executor, Ernest Lougheed, care of the undersigned solicitor, by the 8th August, 1972, after which date the said executor will proceed to distribute the estate, having regard only to the claims of which he then has notice.

MARJORY C. COATES, solicitor, of 422 Collins-street, Melbourne, 3000. 6673

JANE DUNNE, late of 6 Keats-street, Sandringham, in the State of Victoria, spinster, DECEASED.

Creditors, next of kin and others having claims in respect of the estate of the above-named deceased (who died on the 20th day of February, 1972), are required by the executor, The Trustees Executors and Agency Company Limited, of 401 Collins-street, Melbourne, in the said State, to send particulars to them, by the 9th day of August, 1972, after which date the executor may convey or distribute the assets, having regard only to the claims of which it then has notice.

DAVIES, CAMPBELL & PIESSE, solicitors, 401 Collins-street, Melbourne. 6674

Creditors, next of kin and others having claims in respect of the estate of Arthur Hiskins, late of 142 Wheatley-road, Ormond, in the State of Victoria, machinist, deceased (who died on the 23rd October, 1971), are to send particulars of their claims to The Union-Fidelity Trustee Company of Australia Limited, of 100 Exhibition-street, Melbourne, in the said State, the executor of the said deceased, by the 31st day of July, 1972, after which date the executor may convey or distribute the assets, having regard only to the claims of which it then has notice.

DOOLAN, KEMP & TOWNSEND, solicitors, of 340 Collins-street, Melbourne. 6653

ARTHUR JOHN MOLE, late of 18 McLean-avenue, Bentleigh, in the State of Victoria, clerk, DECEASED.

Creditors, next of kin and others having claims in respect of the estate of the above-named deceased (who died on the 18th day of April, 1971), are required by the trustee, Henry Llewellyn Mole, to send particulars of their claims to him, care of the undermentioned solicitor, by the 8th day of August, 1972, after which date the trustee may convey or distribute the assets, having regard only to the claims of which he then has notice.

K. P. REES, B.A., LL.B., solicitor, 118 Queen-street, Melbourne. 6675

LADY WINIFRED IRIS EVELYN MACKENZIE, late of "Colerne", 11A Elmie-street, Hawthorn, in the State of Victoria, widow, DECEASED.

Creditors, next of kin and others having claims in respect of the estate of the above-named deceased (who died on the 21st day of February, 1972), are required by the trustees, The Equity Trustees Executors and Agency Company Limited, and Kingsley Percival Rees, to send particulars of their claims to them, care of The Equity Trustees Executors and Agency Company Limited, of 472 Bourke-street, Melbourne, by the 8th day of August, 1972, after which date the trustees may convey or distribute the assets, having regard only to the claims of which they then had notice.

K. P. REES, B.A., LL.B., solicitor, 118 Queen-street, Melbourne. 6676

MABEL EMMA MARTIN, late of "Ellerslie", 16 Harcourt-street, Auburn, spinster, DECEASED.

Creditors, next of kin and others having claims against the estate of the said deceased (who died on 14th September, 1971), are to send particulars of their claims to Richard Martin Green and The Union-Fidelity Trustee Company of Australia Limited, care of 100 Exhibition-street, Melbourne, by the 9th day of August, 1972, after which date they will distribute the assets, having regard only to the claims of which they then have notice.

BLAKE & RIGGALL, solicitors, 120 William-street, Melbourne. 6677

Creditors, next of kin and other persons having claims against the estate of June Margaret Grix, late of 585 Elgar-road, Box Hill, in the State of Victoria, clerk, deceased (who died on the 1st January, 1972), are required to send particulars of their claims to the administratrix, Myrtle Ivy Lily Maude Grix, care of the under-mentioned solicitors, by the 8th day of August, 1972, after which date the administratrix will distribute the assets, having regard only for the claims of which she then has notice.

REGINALD C. BUTLER & CO., solicitors, 406 Lonsdale-street, Melbourne. 6672

STEPHEN JAMES CONNOR, late of Berriwillock, in the State of Victoria, retired farmer, DECEASED (who died on the 27th November, 1960).

Creditors, next of kin and all other persons having claims against the estate of the deceased, are required by the administrator, Lawrence Lancel Macpherson Connor, to send particulars to him, care of the undersigned, on or before the 5th day of September, 1972, after which date he will distribute the assets, having regard only to the claims of which he then has notice.

GARDEN & GREEN, solicitors, 4 McCallum-street, Swan Hill. 6650

Creditors, next of kin and others having claims in respect of the estate of Frank Auburn, Christensen, late of Glengarry North, retired farmer (who died on the 24th November, 1971), are to send particulars of their claims to The Union-Fidelity Trustee Company of Australia Limited, of 100 Exhibition-street, Melbourne, by the 19th August, 1972, after which date it will distribute the assets of the deceased, having regard only to the claims of which it then has notice.

Dated 5th day of June, 1972.

BRUCE, LITTLETON & HACKFORD, solicitors, Traralgon. 6648

BEATRICE EVELYN MITCHELL, late of 115 Ormond-road, East Geelong, spinster, DECEASED.

Creditors, next of kin and others having claims in respect of the estate of the deceased (who died on the 26th day of February, 1972), are required by the trustee, Michael Wynne George, of Camperdown, to send particulars to him, care of Messrs. Arthur E. George & Sons, Manifold-street, Camperdown, by the 25th day of August, 1972, after which date the trustee may convey or distribute the assets, having regard only to the claims of which he then has notice.

ARTHUR E. GEORGE & SONS, solicitors, Manifold-street, Camperdown, and at Cobden. 6607

FLORENCE MARY ELIZA MILLER, late of 38 Bryson-street, Canterbury, gentlewoman, DECEASED.

Creditors, next of kin and others having claims in respect of the estate of the deceased (who died on the 12th of April, 1972), are required by the trustee, Kent Ashley Teese, of Hamilton-road, Warragul, farmer, to send particulars of their claims to him, care of the undersigned solicitors, by the 16th day of August, 1972, after which date the trustee may convey or distribute the assets, having regard only to the claims of which he then has notice.

GRAY, FRIEND & LONG, solicitors, Warragul. 6589

In the Supreme Court of the State of Victoria.
SALE BY THE SHERIFF.

On Friday, the 7th of July, 1972, at 12.30 p.m., at the Police Station, Essendon (unless process be stayed or satisfied):—

All the estate and interest (if any) of John Brian McCluskey, fitter's assistant, of 145 Roberts-street, Essendon, as joint proprietor with Isabelle Mary McCluskey, of an estate in fee-simple in the land described in certificate of title, volume 8709, folio 937, upon which is erected a red brick veneer maisonette, known as No. 145 Roberts-street, Essendon.

Registered mortgage No. D.452806 affects the said estate and interest.

Terms: Cash only.

DOUGLAS S. HALL, Sheriff's Officer.
31st May, 1972. 6667

In the Supreme Court of the State of Victoria.
SALE BY THE SHERIFF.

On Friday, the 14th of July, 1972, at 10 a.m., at the Police Station, Footscray (unless process be stayed or satisfied):—

All the estate and interest (if any) of Lorenzo Presti, market gardener, of 92 Paisley-street, Footscray, as proprietor of an estate in fee-simple in the land described in certificates of title, volume 1308, folio 465, upon which is erected a two-storey solid brick building, known as No. 90 Paisley-street, Footscray, and volume 8294, folio 883, upon which is erected a brick veneer house with out-buildings consisting of a large shed and garage, known as No. 92 Paisley-street, Footscray.

Registered mortgage No. E.128919 affects the said estate and interest of the first property and registered mortgages B.181542 and D.197164 affect the said estate and interest of the second property.

Terms: Cash only.

DOUGLAS S. HALL, Sheriff's Officer.
5th June, 1972. 6668

INSOLVENCY NOTICES

Bankruptcy Act 1966.

NOTICE TO CREDITORS.

Creditors of Philip Malcolm Mooney, of 55 Doherty-street, Bairnsdale, are advised that Mr. Mooney has executed a deed of arrangement under the provisions of Part 10 of the *Bankruptcy Act 1966*, on the 23rd day of May, 1972. The trustee is E. P. Taylor, of Webster & Taylor, 1st Floor, 29 Alma-road, St. Kilda (P.O. Box 138, St. Kilda), and creditors are requested to lodge their proofs of debt with the trustee.

6651 E. P. TAYLOR, Trustee.

BANKRUPTCY ACT 1966.

PART X., SECTION 218.

Notice is hereby given that (Mrs.) Shirley Ann Fandrich, of 1356 Malvern-road, Malvern, executed a deed of assignment, pursuant to Part X. of the *Bankruptcy Act 1966*, to Lewis Luckins, chartered accountant, of 130 Flinders-street, Melbourne, on the 19th day of May, 1972.

LEWIS LUCKINS, F.C.A., Trustee.

Lewis Luckins & Co., chartered accountants, 130 Flinders-street, Melbourne, 3000, telephone 63 8827. 6636

BANKRUPTCY ACT 1966.

PART X., SECTION 218.

Notice is hereby given that Reginald Loftus, of 28 Iris-road, Glen Iris, executed a deed of assignment, pursuant to Part X. of the *Bankruptcy Act 1966*, to Lewis Luckins, chartered accountant, of 130 Flinders-street, Melbourne, on the 15th day of May, 1972.

LEWIS LUCKINS, F.C.A., Trustee.

Lewis Luckins & Co., chartered accountants, 130 Flinders-street, Melbourne, 3000, telephone 63 8827. 6629

IMPOUNDINGS

LEONGATHA.—Impounded in Leongatha Pound, by Ranger.
1 black and white bull calf, about 4 months old, no visible brand

If not claimed and expenses paid, to be sold on 22nd June, 1972.

6684—\$2.45 T. G. STUBBS,
Poundkeeper.

MARONG.—Impounded in Marong Pound.

1 Shorthorn steer (red and white), no visible brand
1 black and white cow (Friesian type), no visible brand
1 Hereford X steer, no visible brand
1 black and white steer (Friesian type), no visible brand
1 brindle calf (steer), no visible brand

If not claimed and expenses paid, to be sold on 21st June, 1972.

6593—\$3.50 G. A. BUTTREY,
Poundkeeper.

Subordinate Legislation Act 1962.

NOTICE OF MAKING OF STATUTORY RULES.

In pursuance of the provisions of the *Subordinate Legislation Act 1962* and the Regulations made thereunder, notice is given of the making of the following statutory rules:—

No.	Cadet Surveyors Act 1964.	Price.
153/1972.	Cadet Surveyors (State Forests Department) Amendment Regulations 1972	10c
	<i>Marine Act 1958.</i>	
154/1972.	Amendment to Port Rule Applicable to Westernport Harbor Services (Rates and Charges)	10c

No.	Marine Act 1958.	Price.
155/1972.	Port Rule (Port Phillip Bay Underwater Pipeline Operations) 1972 ..	10c
	<i>Road Traffic Act 1958.</i>	
156/1972.	Road Traffic (Infringements) (Amendment No. 1) Regulations 1972 ..	10c
	<i>Discharged Servicemen's Preference Act 1943.</i>	
157/1972.	Discharged Servicemen's Preference Act 1943—Salaries Regulations ..	10c
	<i>Melbourne and Metropolitan Board of Works Act 1958.</i>	
158/1972.	By-law No. 108 Relating to Standing Orders ..	10c
	<i>Poultry Processing Act 1968.</i>	
159/1972.	Poultry Processing (Amendment) Regulations 1972 ..	10c

Copies of these statutory rules may be purchased at the Sale of Publications Section of the Government Printing Office, located at 7A Parliament-place, Melbourne, 3002. If ordered by mail, remittance should be addressed to "The Government Printer, Box 203, P.O., North Melbourne, 3051", and should include 7c extra for postage. If a credit account is held at this office, no remittance is required with the mail order.

The annual subscription rate for Statutory Rules (including Bound Volumes) is \$23, payable in advance. The subscription year commences on 1st January.

C. H. RIXON,
Government Printer.

ACTS REPRINTED IN ACCORDANCE WITH THE AMENDMENTS INCORPORATION ACT 1958 (No. 6422), AND FOR SALE AT THE SALE OF PUBLICATIONS BRANCH OF THE GOVERNMENT PRINTING OFFICE, MACARTHUR-STREET, MELBOURNE, 3002.

(These prices do not include postage.)

No.		Price.
6189.	Acts Interpretation (Third Reprint—Incorporating amendments up to No. 7944) ..	\$0.35
6191.	Administration and Probate (Fourth Reprint—Incorporating amendments up to No. 7874) ..	\$0.50
6194.	Agricultural Colleges (First Reprint—Incorporating amendments up to No. 7302) ..	\$0.15
7117.	Appeal Costs Fund Act 1964 (First Reprint—Incorporating amendments up to No. 7488) ..	\$0.25
6199.	Apprenticeship (Second Reprint—Incorporating amendments up to No. 7869) ..	\$0.40
6201.	Architects (First Reprint—Incorporating amendments up to No. 8077) ..	\$0.30
6203.	Audit (First Reprint—Incorporating amendments up to No. 7377) ..	\$0.35
6208.	Benefit Associations (First Reprint—Incorporating amendments up to No. 6961) ..	\$0.45
6529.	Bread Industry Act 1959 (First Reprint—Incorporating amendments up to No. 7728) ..	\$0.30
6973.	Building Contracts (Deposits) Act 1962 (First Reprint—Incorporating amendments from No. 7315) ..	\$0.10
6210.	Building Societies (Second Reprint—Incorporating amendments up to No. 7911) ..	\$0.40
6213.	Cancer (First Reprint—Incorporating amendments up to No. 7455) ..	\$0.35
6214.	Carriers and Innkeepers (First Reprint—Incorporating amendments up to No. 7971) ..	\$0.15
6217.	Cemeteries (First Reprint—Incorporating amendments up to No. 7672) ..	\$0.30
6218.	Children's Court (Second Reprint—Incorporating amendments up to No. 8124) ..	\$0.45
6220.	Clean Air (Incorporating amendments up to No. 6886) ..	\$0.10
6220.	Clean Air Act 1958 (Second Reprint—Incorporating amendments up to No. 8196) ..	\$0.15
6221.	Coal Mines (First Reprint—Incorporating amendments up to No. 7628) ..	\$1.05
6222.	Commercial Goods Vehicles (Second Reprint—Incorporating amendments up to No. 7358) ..	\$0.22
6223.	Commonwealth Arrangements (First Reprint—Incorporating amendments from No. 7809) ..	\$0.10
6839.	Companies Act 1961 (Fourth Reprint—Incorporating amendments up to Act No. 8185) ..	\$5.75
6224.	The Constitution Act Amendment (First Reprint—Incorporating amendments up to No. 8086) ..	\$3.05

ACTS REPRINTED IN ACCORDANCE WITH THE AMENDMENTS INCORPORATION ACT 1958 (No. 6422)—continued.

No.		Price.
6225.	Co-operation (Second Reprint—Incorporating amendments up to No. 7083) ..	\$0.42
6226.	Co-operative Housing Societies (Second Reprint—Incorporating amendments up to No. 7575) ..	\$0.53
6227.	Coroners (First Reprint—Incorporating amendments up to No. 7935) ..	\$0.35
6228.	Country Fire Authority (Second Reprint—Incorporating Amendments up to No. 7476) ..	\$0.50
6229.	Country Roads (Third Reprint—Incorporating amendments up to No. 8140) ..	\$1.05
6230.	County Court (Second Reprint—Incorporating amendments up to No. 8132) ..	\$0.65
6231.	Crimes (Third Reprint—Incorporating amendments up to No. 7884, but not including No. 7876) ..	\$1.60
6232.	Crown Proceedings (First Reprint—Incorporating amendments up to No. 7900) ..	\$0.30
6233.	Dairy Products (First Reprint—Incorporating amendments up to No. 7945) ..	\$0.20
7060.	Dandenong Valley Authority Act 1963 (First Reprint—Incorporating amendments up to No. 7523) ..	\$0.35
4989.	Discharged Servicemen's Preference Act 1943 (First Reprint—Incorporating amendments up to No. 7788) ..	\$0.20
6815.	Disposal of Uncollected Goods Act 1961 (First Reprint—Incorporating amendments up to No. 7181) ..	\$0.15
6237.	Drainage Areas (First Reprint—Incorporating amendments up to No. 7276) ..	\$0.35
6238.	Drainage of Land (First Reprint—Incorporating amendments up to No. 7876) ..	\$0.15
6239.	Dried Fruits Act 1968 (First Reprint—Incorporating amendments up to No. 7337) ..	\$0.25
6240.	Education (First Reprint—Incorporating amendments up to No. 7533) ..	\$0.45
6241.	Electric Light and Power (First Reprint—Incorporating amendments up to No. 7315) ..	\$0.30
6242.	Employers and Employés (Incorporating amendments up to No. 6740) ..	\$0.18
6243.	Entertainments Tax (First Reprint—Incorporating amendments up to No. 7315) ..	\$0.25
6245.	Estate Agents (Third Reprint—Incorporating amendments up to No. 7425) ..	\$0.50
6245.	Estate Agents Act 1958 (Fourth Reprint—Incorporating amendments up to No. 8181) ..	\$0.85
6246.	Evidence (Third Reprint—Incorporating amendments up to No. 7933) ..	\$0.65
7499.	Extractive Industries Act 1966 (Second Reprint—Incorporating amendments up to No. 7951) ..	\$0.40
6250.	Fertilizers (Incorporating amendments up to No. 7142) ..	\$0.25
6468.	Filled Milk Act 1958 (First Reprint—Incorporating amendments up to No. 6886) ..	\$0.15
6251.	Firearms (Third Reprint—Incorporating amendments up to No. 8092) ..	\$0.65
6916.	Foreign Judgments Act 1962 (First Reprint including amendments made by No. 7332) ..	\$0.15
6585.	Forests (Pulpwood Agreement) (Incorporating amendments up to No. 6886) ..	\$0.15
6254.	Forests (First Reprint—Incorporating amendments up to No. 7356) ..	\$0.60
6255.	Friendly Societies (First Reprint—Incorporating amendments up to No. 7554) ..	\$0.60
6256.	Fruit and Vegetables (First Reprint—Incorporating amendments up to No. 6944) ..	\$0.30
6258.	Game (First Reprint—Incorporating amendments up to No. 7389) ..	\$0.30
6260.	Gas and Fuel Corporation (First Reprint—Incorporating amendments up to No. 7422) ..	\$0.70
6262.	Geelong Harbor Trust (First Reprint—Incorporating amendments up to No. 7547) ..	\$0.45
6263.	Geelong Waterworks and Sewerage (First Reprint—Incorporating amendments up to No. 7547) ..	\$0.75
8176.	Gift Duty Act 1971 (First Reprint—Incorporating amendments from No. 8202) ..	\$0.55
6265.	Goods (Fourth Reprint—Incorporating amendments up to No. 7862) ..	\$0.55
6266.	Grain Elevators (First Reprint—Incorporating amendments up to No. 7486) ..	\$0.35
6269.	Hawkers and Pedlers (First Reprint—Incorporating amendments up to No. 7876) ..	\$0.30
6270.	Health (Second Reprint—Incorporating amendments up to No. 7490) ..	\$1.65

ACTS REPRINTED IN ACCORDANCE WITH THE AMENDMENTS INCORPORATION ACT 1958 (No. 6422)—*continued*.

No.	Price.
6531. Hire Purchase Act 1959 (Second Reprint—incorporating amendments from Act No. 8232)	\$0.55
6933. Home Finance Act 1962 (First Reprint—Incorporating amendments up to No. 7363)	\$0.25
6274. Hospitals and Charities (Second Reprint—Incorporating amendments up to No. 7455)	\$0.50
6275. Housing (Second Reprint—Incorporating amendments up to No. 8052)	\$1.65
6276. Imprisonment of Fraudulent Debtors (First Reprint—Incorporating amendments up to No. 7876)	\$0.35
6277. Industrial and Provident Societies (First Reprint—Incorporating amendments up to No. 7547)	\$0.35
6279. Instruments (Fourth Reprint—incorporating amendments up to No. 7941)	\$0.75
6280. Judicial Proceedings Reports (First Reprint—Incorporating amendments up to No. 7596)	\$0.15
6282. Justices (Third Reprint—Incorporating amendments up to No. 7966)	\$1.40
6283. Labour and Industry (Fourth Reprint—Incorporating amendments up to No. 7923)	\$1.55
6284. Land (Incorporating amendments up to No. 7360)	\$1.53
6534. Land Settlement Act 1959 (First Reprint—Incorporating amendments up to No. 7328)	\$0.30
6289. Land Tax (Second Reprint—Incorporating amendments up to No. 7466)	\$0.40
6285. Landlord and Tenant (Third Reprint—Incorporating amendments up to No. 7332)	\$0.68
6286. Lands Compensation (First Reprint—Incorporating amendments up to No. 7332)	\$0.25
6290. Latrobe Valley (First Reprint—Incorporating amendments up to No. 7332)	\$0.35
6291. Legal Profession Practice (Second Reprint—Incorporating amendments up to No. 7539)	\$0.70
6292. Libraries (First Reprint—Incorporating amendments up to No. 7364)	\$0.15
6295. Limitation of Actions (Second Reprint—Incorporating amendments up to No. 7457)	\$0.25
7145. Litter Act 1964 (First Reprint—Incorporating amendments up to No. 7608)	\$0.15
7695. Liquor Control Act 1968 (First Reprint—Incorporating Amendments up to No. 7753)	\$0.80
6298. Local Authorities Superannuation (Second Reprint—Incorporating amendments up to No. 7161)	\$0.40
6299. Local Government (Second Reprint—Incorporating amendments up to No. 7689)	\$4.00
6299. Local Government. New Parts X. and XI. (being a reprint of portion of No. 7835, as amended by No. 7847)	\$0.50
6301. Margarine (First Reprint—Incorporating amendments up to No. 7714)	\$0.18
6302. Marine (Incorporating amendments up to No. 7350)	\$0.72
6303. Marine Stores and Old Metals (First Reprint—Incorporating amendments up to No. 7876)	\$0.35
6304. Marketing of Primary Products (First Reprint—Incorporating amendments up to No. 7491)	\$0.45
6305. Markets Act 1958 (First Reprint—Incorporating amendments up to No. 7705)	\$0.20
6306. Marriage (First Reprint—Incorporating amendments up to No. 6959)	\$0.25
6307. Masseurs (First Reprint—Incorporating amendments up to No. 7566)	\$0.20
6309. Medical (Second Reprint—Incorporating amendments up to No. 7408)	\$0.40
6310. Melbourne and Metropolitan Board of Works (Third Reprint—Incorporating amendments up to No. 8082)	\$1.85
6311. Melbourne and Metropolitan Tramways (First Reprint—Incorporating amendments up to No. 7622)	\$0.70
6312. Melbourne Harbor Trust (First Reprint—up to No. 7135)	\$0.48
6405. Melbourne University (First Reprint—Incorporating amendments up to No. 7871)	\$0.40
6605. Mental Health (Incorporating amendments Incorporating amendments up to No. 7356)	\$0.25
6315. Metropolitan Fire Brigades (Incorporating amendments up to No. 6886)	\$0.28
6316. Mildura Irrigation and Water Trusts (First Reprint—Incorporating amendments up to No. 7448)	\$0.75
6317. Milk and Dairy Supervision (Incorporating amendments up to No. 6964)	\$0.40

ACTS REPRINTED IN ACCORDANCE WITH THE AMENDMENTS INCORPORATION ACT 1958 (No. 6422)—*continued*.

No.	Price.
6318. Milk Board (Incorporating amendments up to No. 7093)	\$0.22
6319. Milk Pasteurization (First Reprint—Incorporating amendments up to No. 7480)	\$0.15
6320. Mines (Second Reprint—Incorporating amendments up to No. 7876)	\$1.25
6184. Monash University (First Reprint—Incorporating amendments up to No. 7533)	\$0.30
6324. Money Lenders (Second Reprint—Incorporating amendments up to No. 8016)	\$0.55
6832. Motor Boating Act 1961 (Second Reprint—Incorporating amendments up to No. 6961)	\$0.30
6325. Motor Car (Fourth Reprint—Incorporating amendments up to No. 8143)	\$2.05
6705. Navigable Waters (Oil Pollution) Act 1960. (First Reprint—Incorporating amendments up to No. 7890)	\$0.30
6328. Nurses Act (Second Reprint—Incorporating amendments up to No. 7375)	\$0.45
6329. Opticians Registration (First Reprint—Incorporating amendments up to No. 7409)	\$0.30
6330. Partnership (Second Reprint—Incorporating amendments up to No. 7315)	\$0.30
6331. Patriotic Funds (First Reprint—Incorporating amendments up to No. 7338)	\$0.25
6332. Pawnbrokers (First Reprint—Incorporating amendments up to No. 7876)	\$0.35
6257. Pesticides Act 1968 (First Reprint—Incorporating amendments up to No. 7595)	\$0.15
6334. Petroleum (First Reprint—Incorporating amendments up to No. 7876)	\$0.65
6889. Poisons Act 1962 (Second Reprint—Incorporating amendments up to No. 7588)	\$0.50
6337. Police Offences (Second Reprint—Incorporating amendments up to No. 7678)	\$0.28
6338. Police Regulation (Incorporating amendments up to No. 7081)	\$0.45
6340. Portland Harbor Trust (First Reprint—Incorporating amendments up to No. 7475)	\$0.35
6341. Pounds (First Reprint—Incorporating amendments up to No. 7315)	\$0.25
7498. Port Phillip Authority Act 1966 (First Reprint—Incorporating amendments from No. 8081)	\$0.15
6342. Printers and Newspapers (First Reprint—Incorporating amendments up to No. 7876)	\$0.15
7494. Private Agents Act 1966 (First Reprint—Incorporating amendments in No. 7646)	\$0.35
6890. Probate Duty (Third Reprint—Incorporating amendments up to No. 8072)	\$0.75
6344. Property Law (Second Reprint—Incorporating amendments up to No. 7750)	\$1.15
6345. Public Account (First Reprint—Incorporating amendments up to No. 8012)	\$0.20
6346. Public Authorities Marks (First Reprint—Incorporating amendments from No. 7315)	\$0.10
6349. Public Service (Second Reprint—Incorporating amendments up to No. 7356)	\$0.40
6350. Public Trustee (Incorporating amendments up to No. 6961)	\$0.35
6353. Racing (Third Reprint—Incorporating amendments up to No. 8080)	\$1.45
6355. Railways (First Reprint—Incorporating amendments up to No. 7475)	\$0.75
6564. Registration of Births Deaths and Marriages Act 1959 (First Reprint—Incorporating amendments up to No. 7332)	\$0.25
2596. River Murray Waters Act 1915 (First Reprint—Incorporating amendments up to No. 7061)	\$0.35
6359. Road Traffic (Second Reprint—Incorporating amendments up to No. 7332)	\$0.18
6360. Rural Finance (First Reprint—Incorporating amendments up to No. 7328)	\$0.15
6846. Rural Finance and Settlement Commission Act 1961 (First Reprint—Incorporating amendments up to No. 7332)	\$0.30
6917. Sale of Human Blood Act 1962 (First Reprint—Incorporating amendments from No. 7332)	\$0.10
6975. Sale of Land Act 1962 (Second Reprint—Incorporating amendments up to No. 7898)	\$0.30
6363. Second-hand Dealers (First Reprint—Incorporating amendments up to No. 7529)	\$0.25
7962. Securities Industry Act 1970 (First Reprint—Incorporating amendments made by Act No. 8059)	\$0.65

ACTS REPRINTED IN ACCORDANCE WITH THE AMENDMENTS INCORPORATION ACT 1958 (No. 6422)—*continued*.

No.	Price.
6367. Settled Land (<i>Second Reprint</i> —Incorporating amendments up to No. 7065) ..	\$0.50
6368. Sewerage Districts (<i>Second Reprint</i> —Incorporating amendments up to No. 7547) ..	\$0.75
6809. Sheep Owners Protection Act 1961 (<i>Second Reprint</i>)—Incorporating amendments up to No. 8179 ..	\$0.20
6372. Soil Conservation and Land Utilization (<i>Second Reprint</i> —Incorporating amendments up to No. 8142) ..	\$0.45
6373. Soldier Settlement (<i>First Reprint</i> —Incorporating amendments up to No. 7328) ..	\$0.42
6375. Stamps (<i>Fourth Reprint</i> —Incorporating amendments up to No. 7698) ..	\$1.18
6377. State Electricity Commission (<i>Second Reprint</i> —Incorporating amendments up to No. 7421) ..	\$0.65
6378. State Relief Committee (<i>First Reprint</i> —Incorporating amendments from No. 6886) ..	\$0.10
6379. State Savings Bank (<i>Second Reprint</i> —Incorporating amendments up to No. 8082) ..	\$0.95
6380. Statistics (<i>First Reprint</i> —Incorporating amendments up to No. 6961) ..	\$0.15
6383. Stock Foods (<i>First Reprint</i> —Incorporating amendments up to No. 7607) ..	\$0.28
6384. Stock Medicines (<i>First Reprint</i> —Incorporating amendments up to No. 7726) ..	\$0.20
7551. Strata Titles Act 1967 (<i>Second Reprint</i> —Incorporating amendments up to No. 8149) ..	\$0.65
6886. Subordinate Legislation (Incorporating amendments up to No. 6961) ..	\$0.15
6386. Superannuation (<i>Second Reprint</i> —Incorporating amendments up to No. 7910) ..	\$0.75
6387. Supreme Court (<i>First Reprint</i> —Incorporating amendments up to No. 7522) ..	\$0.75
6388. Survey Co-ordination (<i>First Reprint</i> —Incorporating amendments up to Act No. 8107) ..	\$0.35
6391. Teaching Service (<i>First Reprint</i> —Incorporating amendments up to No. 7536) ..	\$0.35
6849. Town and Country Planning Act 1961 (<i>Third Reprint</i> —Incorporating amendments up to No. 7975) ..	\$0.65
6401. Trustee (<i>Third Reprint</i> —Incorporating amendments up to No. 7833) ..	\$0.55
6402. Trustee Companies (<i>First Reprint</i> —Incorporating amendments up to No. 7858) ..	\$0.35
7223. Tomato Processing Industry (Uniform Agreement) Act 1964 (<i>First Reprint</i> —Incorporating amendments up to No. 7342) ..	\$0.15
6397. Trade Unions (<i>First Reprint</i> —Incorporating amendments up to No. 6839) ..	\$0.20
6399. Transfer of Land (<i>Third Reprint</i> —Incorporating amendments up to No. 7551) ..	\$0.65
6400. Transport Regulation (<i>First Reprint</i> —Incorporating amendments up to No. 7358) ..	\$0.22
6879. Unclaimed Moneys (Incorporating amendments up to No. 6961) ..	\$0.12
7095. Underseas Mineral Resources Act 1963 (<i>First Reprint</i> —Incorporating amendments from No. 7591) ..	\$0.10
6653. Valuation of Land Act 1960 (<i>Second Reprint</i> —Incorporating amendments up to No. 7333) ..	\$0.22
6407. Vegetation and Vine Diseases (<i>First Reprint</i> —Incorporating amendments up to No. 7423) ..	\$0.30
6409. Vermin & Noxious Weeds (<i>First Reprint</i> —Incorporating amendments up to No. 7463) ..	\$0.35
6410. Veterinary Surgeons (<i>First Reprint</i> —Incorporating amendments up to No. 7343) ..	\$0.15
6411. Victorian Inland Meat Authority (<i>First Reprint</i> —Incorporating amendments up to No. 8000) ..	\$0.30
7291. Victoria Institute of Colleges Act 1965 (<i>First Reprint</i> —Incorporating amendments up to No. 7644) ..	\$0.25
6412. Warehousemen's Liens (<i>First Reprint</i> —Incorporating amendments up to No. 7876) ..	\$0.15
6413. Water (<i>Second Reprint</i> —Incorporating amendments up to No. 7590) ..	\$1.95
6414. Weights and Measures (<i>Third Reprint</i> —Incorporating amendments up to No. 8068) ..	\$1.05

ACTS REPRINTED IN ACCORDANCE WITH THE AMENDMENTS INCORPORATION ACT 1958 (No. 6422)—*continued*.

No.	Price.
6415. Wild Flowers and Native Plants Protection (<i>First Reprint</i> —Incorporating amendments up to No. 6976) ..	\$0.15
6416. Wills (<i>First Reprint</i> —Incorporating amendments up to No. 7238) ..	\$0.25
6417. Wire Netting (<i>First Reprint</i> —Incorporating amendments up to No. 7876) ..	\$0.45
6419. Workers Compensation (<i>Fourth Reprint</i> —Incorporating amendments up to No. 8084) ..	\$1.05

FIRST NOTIFICATION OF REPRINT.

6267. Hairdressers Registration Act 1958 (<i>First Reprint</i> —Incorporating amendments up to Act No. 7659) ..	\$0.30
6369. Shearers Accommodation (Incorporating amendments up to Act No. 7876) ..	\$0.35
6288. Land Surveyors Act 1958 (<i>First Reprint</i> —Incorporating amendments up to Act No. 7065) ..	\$0.30
7405. Summary Offences Act 1966 (<i>First Reprint</i> —Incorporating amendments up to Act No. 8226) ..	\$0.55

C. H. RIXON,
Government Printer.

STATE ACTS, 1970

Copies of the following Acts of Parliament of Victoria may be obtained at the Government Printing Office, Sale of Publications Branch, off Parliament-place, Melbourne, phone 63 0321, extension 6181, or from any accredited agent, at the price set opposite to each (these prices do not include postage).

No.	Price.
7933. Evidence (Boards and Commissions) ..	\$0.10
7934. The Constitution Act Amendment ..	\$0.10
7935. Coroners (Amendment) ..	\$0.10
7936. Town and Country Planning (Appeals Tribunal) ..	\$0.10
7937. Melbourne (Veterinary Schools) Lands ..	\$0.10
7938. Board of Inquiry (Corrupt Practices) ..	\$0.10
7939. Cabrini Private Hospital (Guarantees) ..	\$0.10
7940. Judges' Salaries and Allowances ..	\$0.10
7941. Instruments (Amendment) ..	\$0.10
7942. La Trobe University (Amendment) ..	\$0.10
7943. Business Names (Amendment) ..	\$0.10
7944. Acts Interpretation (Nationality) ..	\$0.10
7945. Dairy Products (Board Membership) ..	\$0.10
7946. Melbourne Harbor Trust (Amendment) ..	\$0.10
7947. Aboriginal Affairs (Amendment) ..	\$0.10
7948. River Murray Waters ..	\$0.15
7949. River Murray Waters (Dartmouth Reservoir) ..	\$0.10
7950. Western Port (Steel Works) ..	\$0.25
7951. Extractive Industries (Licences) ..	\$0.10
7954. Public Officers Salaries and Allowances ..	\$0.15
7952. Stamps (Salary or Wages) ..	\$0.10
7953. Melbourne Lands Exchange ..	\$0.10
7955. Ballarat (Sovereign Hill) Land ..	\$0.15
7956. Wombat Bonuses ..	\$0.10
7957. Richmond and Hawthorn Lands ..	\$0.15
7958. Solicitor-General (Pensions) ..	\$0.10
7959. Australia and New Zealand Banking Group ..	\$0.25
7960. Mildura Irrigation and Water Trusts (Amendment) ..	\$0.10
7961. Land Settlement (Financial) ..	\$0.10
7962. Securities Industry ..	\$0.35
7963. Mildura College Lands (Amendment) ..	\$0.10
7964. Door to Door (Sales) (Amendment) ..	\$0.15
7965. Consumer Protection ..	\$0.10
7966. Justices (Alternative Procedure) ..	\$0.15
7967. Summary Offences ..	\$0.10
7968. Local Government (Amendment) ..	\$0.30
7969. Motor Car (Falsification of Mileage) ..	\$0.10
7970. Marketable Securities ..	\$0.25
7971. Carriers and Innkeepers (Amendment) ..	\$0.10
7972. Cemeteries (Coburg Public Cemetery) ..	\$0.10
7973. Judges Pensions ..	\$0.10
7974. Victoria Institute of Colleges (Affiliated Colleges) ..	\$0.10
7975. Town and Country Planning (Responsible Authority) ..	\$0.10
7976. Wheat Marketing (Special Quotas) ..	\$0.10
7977. Joint Select Committee (Meat Industry) ..	\$0.10
7978. Joint Select Committee (Road Safety) ..	\$0.10

STATE ACTS, 1970—continued.

No.	Price.
7979. Consolidated Revenue (Supply—July to September 1969-70)	\$0.10
7980. Consolidated Revenue (Supplementary Estimates 1969-70)	\$0.10
7981. Consolidated Revenue (Supply October to December, 1970)	\$0.10
7982. Home Finance (Amendment)	\$0.10
7983. Co-operative Housing Societies (Amendment)	\$0.10
7984. Soldier Settlement	\$0.10
7985. Judges' Pensions (Amendment)	\$0.10
7986. Civil Aviation (Carriers' Liability)	\$0.10
7987. Road Traffic (Amendment)	\$0.15
7988. West Melbourne Market Land (Amendment)	\$0.15
7989. West Gate Bridge Royal Commission	\$0.10
7990. Motor Car (Amendment)	\$0.10
7991. Discharged Servicemen's Preference (Amendment)	\$0.10
7992. Labour and Industry (Shop Closing)	\$0.10
7993. Country Fire Authority (Borrowing Powers)	\$0.10
7994. Crimes (Amendment)	\$0.10
7995. Lotteries Gaming and Betting (Amendment)	\$0.10
7996. River Improvement (Amendment)	\$0.10
7997. Hospitals Superannuation (Amendment)	\$0.15
7998. Trustee Companies (Perpetual Trustees Australia Limited)	\$0.10
7999. Gas and Fuel Corporation (Borrowing)	\$0.10
8000. Victorian Inland Meat Authority (Amendment)	\$0.10
8001. Auditor (Auditor-General)	\$0.10
8002. Public Service (Amendment)	\$0.10
8003. Evidence (Scientific Tests)	\$0.10
8004. Boilers and Pressure Vessels	\$0.30
8005. Coal Mines (Pensions Increase)	\$0.10
8006. Stamps Act	\$0.15
8007. Methodist Church (Victoria) Property Trust	\$0.20
8008. Land Conservation	\$0.20
8009. River Entrance Docks Railway Construction	\$0.10
8010. Legal Profession Practice (Amendment)	\$0.15
8011. Juries Compensation	\$0.10
8012. Public Account	\$0.15
8013. Sewerage Districts (Amendment)	\$0.10
8014. Revocation and Excision of Crown Reservations	\$0.15
8015. State Forests Works and Services	\$0.10
8016. Money Lenders (Prescribed Interest)	\$0.10
8017. Gas and Fuel Corporation (The Gas Supply Company Limited)	\$0.30
8018. Labour and Industry (Amendment)	\$0.10
8019. Metropolitan Fire Brigades (Amendment)	\$0.15
8020. Stamps (Receipt Duty Abolition)	\$0.10
8021. Apprenticeship (Amendment)	\$0.10
8022. Water (Amendment)	\$0.10
8023. Melbourne Underground Rail Loop	\$0.40
8024. Westernport Development	\$0.15
8025. Vermin and Noxious Weeds (Amendment)	\$0.20
8026. Commonwealth Places (Administration of Laws)	\$0.15
8027. Hairdressers Registration (Amendment)	\$0.10
8028. Lifts and Cranes (Amendment)	\$0.15
8029. Wodonga Lands Exchange	\$0.10
8030. Second-hand Dealers (Charity Collectors)	\$0.15
8031. Water Supply Works and Services	\$0.25
8032. East Melbourne Land	\$0.10
8033. The Constitution Act Amendment (Responsible Ministers)	\$0.10
8034. Justices (Bail and Appeals)	\$0.10
8035. Forests (Amendment)	\$0.10
8036. Maintenance (Amendment)	\$0.10
8037. Hire Purchase (Insurance)	\$0.10
8038. Marketable Securities (Amendment)	\$0.15
8039. Mines (Compensation)	\$0.10
8040. Railways Land	\$0.15
8041. Probate Duty	\$0.10
8042. Teaching Service (Tribunal)	\$0.10
8043. Employers and Employés (Attachment of Wages)	\$0.10
8044. Aboriginal Lands	\$0.25
8045. Railway Works and Services	\$0.10
8046. Water (Further Amendment)	\$0.15
8047. Superannuation (Amendment)	\$0.20
8048. Motor Car (Fees)	\$0.10
8049. Public Works and Services	\$0.15
8050. Western Port Steel Works (Development Control)	\$0.10
8051. Housing (Amendment)	\$0.20
8052. Urban Renewal	\$0.40
8053. Wheat Marketing (Amendment)	\$0.10
8054. Local Authorities Superannuation (Disability Benefits)	\$0.20
8055. Land Tax	\$0.15
8056. Environment Protection	\$0.50
8057. Gas Franchises	\$0.15

STATE ACTS, 1970—continued.

No.	Price.
8058. Road Traffic (Road Safety and Traffic Authority)	\$0.15
8059. Securities Industry (Amendment)	\$0.30
8060. Land (Amendment)	\$0.10
8061. Medical Practitioners	\$0.40
8062. Teacher Housing	\$0.20
8063. Criminal Appeals	\$0.10
8064. Groundwater (Amendment)	\$0.10
8065. Summary Offences (Trespass to Farms)	\$0.10
8066. Registration of Births Deaths and Marriages (Amendment)	\$0.10
8067. Tomato Processing Industry (Amendment)	\$0.15
8068. Weights and Measures (Amendment)	\$0.10
8069. Aerial Spraying Control (Amendment)	\$0.10
8070. Science Museum of Victoria	\$0.20
8071. Melbourne and Metropolitan Board of Works	\$0.15
8072. National Museum of Victoria Council	\$0.20
8073. Footwear Regulation	\$0.15
8074. Motor Car (Safety)	\$0.10
8075. Summary Offences	\$0.10
8076. Fertilizers and Stock Foods (Labelling)	\$0.10
8077. Architects (Amendment)	\$0.10
8078. Stock Diseases (Amendment)	\$0.10
8079. Dog Act	\$0.20
8080. Racing (Amendment)	\$0.15
8081. State Development	\$0.30
8082. Statutory Salaries	\$0.10
8083. National Parks	\$0.20
8084. Workers Compensation	\$0.15
8085. Summary Offences (Trespassers)	\$0.10
8086. Parliamentary Salaries	\$0.10
8087. Consolidated Revenue (Final Supplementary Estimates)	\$0.10
8088. Appropriation	\$2.10
8089. Social Welfare	\$1.10

C. H. RIXON,
Government Printer.

STATE ACTS, 1971

Copies of the following Acts of Parliament of Victoria may be obtained at the Government Printing Office, Sale of Publications Branch, off Parliament-place, Melbourne, phone 63 0321, extension 6181, or from any accredited agent, at the price set opposite to each (these prices do not include postage).

The annual subscription for State Acts 1971 et seq. is \$12.50 payable in advance.

Bound Volumes of State Acts are also available on a subscription basis of \$17.50 per annum.

No.	Price.
8090. Municipal Association (Amendment)	\$0.10
8091. Transfer of Land (Duplicate Certificates)	\$0.10
8092. Firearms	\$0.10
8093. Geelong Land (Special Grant)	\$0.10
8094. Churchill Water and Sewerage Works	\$0.10
8095. Superannuation (Railway Service)	\$0.10
8096. Vermin and Noxious Weeds (Amendment)	\$0.10
8097. Police Regulation (Amendment)	\$0.10
8098. Snowy Mountains Engineering Corporation (Victoria)	\$0.10
8099. Albert Park Land	\$0.10
8100. Local Government (Municipalities Assistance Fund)	\$0.10
8101. Health (Tuberculosis Arrangement)	\$0.10
8102. Presbyterian Church of Australia	\$0.20
8103. Marketing of Primary Products (Amendment)	\$0.10
8104. Gas and Fuel Corporation (Geelong Gas)	\$0.15
8105. Local Authorities Superannuation (Disability Benefits) (Commencement)	\$0.10
8106. Building Societies (Amendment)	\$0.20
8107. Survey Co-ordination (Place Names)	\$0.10
8108. Howard Florey Institute of Experimental Physiology and Medicine	\$0.30
8109. Superannuation (Transitional Provisions)	\$0.10
8110. New Broken Hill Consolidated Limited	\$0.15
8111. Litter (Proceedings for Offences)	\$0.10
8112. Justices (Service of Summonses)	\$0.10
8113. Stock (Artificial Breeding) (Amendment)	\$0.10
8114. Alcoa of Australia (W.A.) N.L.	\$0.40
8115. Victoria Institute of Colleges (Amendment)	\$0.10
8116. Cemeteries (Fawkner Crematorium and Memorial Park)	\$0.10
8117. Trustee Companies (Equity Trustees)	\$0.10
8118. Parliamentary Superannuation	\$0.10
8119. Ehrenhaus Retail Bottled Liquor Licence	\$0.10
8120. Melbourne University Land	\$0.10

STATE ACTS, 1971—continued.

No.	Price
8121. Forests (Bowater-Scott Agreement) ..	\$0.20
8122. Gas and Fuel Corporation (Pipelines) ..	\$0.15
8123. Coal Mines (Pensions) ..	\$0.10
8124. Crown Proceedings (Forfeited Recognisances) ..	\$0.10
8125. Public Trustee (Amendment) ..	\$0.15
8126. Geelong Waterworks and Sewerage (Rates) ..	\$0.10
8127. Subordinate Legislation (Powers) ..	\$0.10
8128. Barley Marketing ..	\$0.10
8129. Stamps (Credit Business) ..	\$0.15
8130. Land (Surrender to the Crown) ..	\$0.10
8131. Pipelines (Amendment) ..	\$0.10
8132. County Court (Jurisdiction) ..	\$0.10
8133. Grassmere Land ..	\$0.10
8134. Supply (Supplementary Estimates) ..	\$0.10
8135. Town and Country Planning (Amendment) ..	\$0.15
8136. Seeds ..	\$0.40
8137. Imperial Acts Application (Repeals) ..	\$0.10
8138. Audit (Recovery of Overpayments) ..	\$0.10
8139. Evidence (Registration of Commissioners) ..	\$0.10
8140. Country Roads (Amendment) ..	\$0.15
8141. Protection of Animals (Rodeos) ..	\$0.10
8142. Soil Conservation and Land Utilization (Amendment) ..	\$0.15
8143. Motor Car (Driving Offences) ..	\$0.30
8144. Fisheries (Amendment) ..	\$0.15
8145. Appeal Costs Fund ..	\$0.10
8146. Scaffolding ..	\$0.30
8147. Liquor Control (Amendment) ..	\$0.15
8148. Supply (July to September) ..	\$0.10
8149. Local Government (Further Amendment) ..	\$0.40
8150. Supply (Supplementary Estimates) ..	\$0.10
8151. Supply (October to December) ..	\$0.10
8152. Police Regulation (Chief Commissioner) ..	\$0.10
8153. Groundwater ..	\$0.10
8154. Pay-Roll Tax ..	\$0.50
8155. Moonee Ponds (Queens Park) Land ..	\$0.10
8156. Commonwealth Places (Administration of Laws) ..	\$0.10
8157. Stamps ..	\$0.20
8158. Mercy Private Hospital (Guarantee) ..	\$0.10
8159. Daylight Saving ..	\$0.10
8160. Co-operative Housing Societies (Indemnities) ..	\$0.10
8161. Films ..	\$0.30
8162. Lotteries Gaming and Betting (Pre-Post Betting) ..	\$0.10
8163. Vegetation and Vine Diseases (Amendment) ..	\$0.10
8164. Melbourne and Metropolitan Board of Works (Amendment) ..	\$0.10
8165. Statutory Salaries ..	\$0.10
8166. Newhaven Land ..	\$0.10
8167. Land Tax ..	\$0.10
8168. Water Authorities Accident Insurance ..	\$0.10
8169. Building Societies (Special Advances) ..	\$0.10
8170. Juries (Compensation) ..	\$0.10
8171. Coal Mines (Pensions Increase) ..	\$0.10
8172. Exhibition (Borrowing Powers) ..	\$0.10
8173. Sunday Entertainment (Cinematograph Films) ..	\$0.10
8174. Apprenticeship (Amendment) ..	\$0.15
8175. Labor and Industry (Shop Trading Hours) ..	\$0.10
8176. Gift Duty ..	\$0.50
8177. Aboriginal Lands (Amendment) ..	\$0.10
8178. Lutheran Church of Australia, Victoria District Incorporation ..	\$0.40
8179. Police Regulations (Amendment) (No. 2) ..	\$0.20
8180. Railways (Amendment) ..	\$0.10
8181. Statute Law Revision ..	\$0.40
8182. State Electricity Commission (Newport Power Station) ..	\$0.10
8183. Judges Salaries and Allowances ..	\$0.10
8184. Magistrates' Courts ..	\$0.30
8185. Companies ..	\$2.10
8186. Water (Amendment) ..	\$0.20
8187. Essendon (Recreation Ground) Land ..	\$0.10
8188. Brotherhood of St. Laurence (Incorporation) ..	\$0.30
8189. State Forests Works and Services ..	\$0.10
8190. Evidence (Boards and Commissions) ..	\$0.10
8191. Public Authorities (Contributions) (Amendment) ..	\$0.10
8192. Road Traffic (Penalties) ..	\$0.10
8193. Grain Elevators (Amendment) ..	\$0.10
8194. Flinders-street Station Area Redevelopment ..	\$0.20
8195. Buninyong (Recreation Reserve) Land ..	\$0.10
8196. Health Services (Fees and Penalties) ..	\$0.15
8197. Motor Car (Breath Tests) ..	\$0.10
8198. Instruments (Amendment) ..	\$0.15
8199. Melbourne Harbor Trust (Amendment) ..	\$0.15
8200. Revocation and Excision of Crown Reservations ..	\$0.15
8201. Yarragon Lands Exchange ..	\$0.10
8202. Gift Duty (Rates and Rebates) ..	\$0.15
8203. Stamps (Gifts and Settlements) ..	\$0.10
8204. Eastern Freeway Lands ..	\$0.15

STATE ACTS 1971—continued.

No.	Price.
8205. Land (Surrenders) ..	\$0.10
8206. Housing (Amendment) ..	\$0.15
8207. Land (Amendment) ..	\$0.10
8208. Landlord and Tenant (Amendment) ..	\$0.20
8209. Racing (Amendment) ..	\$0.30
8210. National Parks (Amendment) ..	\$0.30
8211. Labour and Industry (Amendment) ..	\$0.15
8212. Public Works and Services ..	\$0.15
8213. Wheat Marketing ..	\$0.15
8214. Public Works and State Development Committees ..	\$0.10
8215. Water Supply Works and Services ..	\$0.30
8216. Bees ..	\$0.20
8217. Agricultural Colleges (Amendment) ..	\$0.10
8218. Chiropodists (Registration) ..	\$0.10
8219. Portland Harbor Trust (Amendment) ..	\$0.10
8220. Harbor Boards (Amendment) ..	\$0.10
8221. Veterinary Surgeons (Amendment) ..	\$0.10
8222. Scaffolding (Amendment) ..	\$0.10
8223. Stock Diseases (Composite Licences) ..	\$0.10
8224. Justices (Civil Proceedings) ..	\$0.10
8225. Closer Settlement ..	\$0.10
8226. Summary Offences (Amendment) ..	\$0.10
8227. Sewerage Districts (Amendment) ..	\$0.10
8228. Evidence (Documents) ..	\$0.20
8229. Mildura Irrigation & Water Trusts (Amendment) ..	\$0.10
8230. Farm Produce Merchants & Commission Agents (Employment) ..	\$0.10
8231. Latrobe Valley (Amendment) ..	\$0.10
8232. Hire Purchase (Form) ..	\$0.10
8233. Poisons (Amendment) ..	\$0.10
8234. Geelong Harbor Trust (Amendment) ..	\$0.10
8235. Eastern Railway Construction ..	\$0.15
8236. Milk and Dairy Supervision (Amendment) ..	\$0.10
8237. Educational Grants (Amendment) ..	\$0.10
8238. Railway Works and Services ..	\$0.10
8239. Education (Teacher Registration) ..	\$0.15
8240. Supply (Final Supplementary Estimates) ..	\$0.10
8241. Appropriation ..	\$2.20

C. H. RIXON,
Government Printer.

PUBLICATION OF OFFICIAL MATTER.

Attention is invited to the following procedure in relation to the publication of official matter in the *Government Gazette*:—

Publication will be facilitated by the submission of carbon copies for the use of the *Gazette Officer*.

1. Matter submitted to the Executive Council.

Matter submitted to the Executive Council which requires gazettal will normally be published in the issue of the following week.

Where urgent gazettal is required, special arrangements should be made with the *Gazette Officer*, Room 9, first floor, Old Treasury Building.

2. Other matter.

(a) All other matter duly certified by a responsible officer for publication should be lodged with the *Gazette Officer* not later than half-past Nine a.m. on Tuesday.

(b) Lengthy or involved notices should be forwarded several days before publication.

(c) Proofs, which will be supplied only when specifically requested or at the direction of the *Gazette Officer*, should be returned promptly to avoid delay in publication.

(d) No additions or amendments to matter for publication will be accepted by telephone.

THE "VICTORIA GOVERNMENT GAZETTE".

SUBSCRIPTIONS.—The subscription, including postage, is \$22.50 per annum, or \$11.25 per half year, payable in advance.

Subscriptions are required for whole months, and must cover at least a half year.

Single copies are 30 cents, posted 48 cents. Subscribers do not receive the Acts of Parliament with the *GAZETTE*.

GAZETTES are held in stock for five years only.

PRIVATE ADVERTISEMENTS.—The charge for insertion is 35 cents per line single column, and 70 cents per line double column. The title forms one or more lines as a heading. On an average ten words make a line of single column. Every signature must likewise be counted as a line. The final words of a paragraph, though only portion

of a line, must be counted as one line. Signatures (in particular) and proper names must be written very plainly in the text; ONE SIDE ONLY of each sheet of paper should be WRITTEN UPON. The charge for a full page is \$50.

All documents illegibly written will be returned unpublished, and where brands occur unprovided for by the ordinary letters of the alphabet, a worded explanatory description must be furnished.

THE VICTORIA GOVERNMENT GAZETTE is published on WEDNESDAY EVENING in each week, and Notices for insertion will be received by the Government Printer at or before ONE p.m. at ordinary rates, and late advertisements between ONE p.m. and FOUR p.m. at double rates on the day preceding the day of publication.

PAYMENTS.—Unless the advertiser has a credit account, all payments are required in advance. Remittances should be made by cheque, postal order, or money order payable to "GOVERNMENT PRINTER".

ADDRESS.—All communications should be addressed to "The Government Printer, Box 203, P.O., North Melbourne", 3051.

AGENTS FOR THE "VICTORIA GOVERNMENT GAZETTE".

The following have been appointed agents to receive Advertisements and Subscriptions for the Victoria Government Gazette:—

- ARMSTRONG'S AGENCY, 217 Queen-street, Melbourne, Victoria 3000.
- ARNALL & JACKSON, 390 Barkly-street, Brunswick, Victoria 3056.
- BAIRNSDALE AUTHORIZED NEWSAGENCY, 132 Main-street, Bairnsdale, Victoria 3875.
- BICKNELL, M. J., Authorized Newsagent, 196 Timor-street, Warrambool, Victoria 3280.
- BLANE'S AUTHORIZED NEWSAGENTS, 162 Murray-street, Colac, Victoria 3250.
- CARTER, R. G., ADVERTISING SERVICE PTY. LTD., Suite 24, 65 Queens-road, Melbourne, Victoria 3004.
- DAVIES, G. & M. V., 112 Gray-street, Hamilton, Victoria 3300.
- DAVIS, WM. (MILDURA) PTY. LTD., 126 Eighth-street, Mildura, Victoria 3500.
- DIXON'S NEWSAGENCY, 89 Firebrace-street, Horsham, Victoria 3400.
- EDGARS' AUTHORIZED NEWSAGENCY, 45 Bridge-street, Benalla, Victoria 3672.
- FRANKS, H. & CO., 184 Ryrie-street, Geelong, Victoria 3220.
- GATLEY, A. & J., 250 Lonsdale-street, Dandenong, Victoria 3175.
- GORDON & GOTCH AUSTRALASIA LTD., 434 St. Kilda-road, Melbourne, Victoria 3004.
- GULLAN'S NEWSAGENCY, 88 Bridge-street, Ballarat, Victoria 3350.
- HAMPTON, A. C., 243 Mitchell-street, Bendigo, Victoria 3550.
- HARSTON, PARTRIDGE & CO. PTY. LTD., 455 Little Collins-street, Melbourne, Victoria 3000.
- KYNETON GUARDIAN PTY. LTD., P.O. Box 18, Kyneton, Victoria 3444.
- LATIMER'S, Newsagents, 45 Station-street, Malvern, Victoria 3144.
- LIVINGSTON'S SHEPPARTON NEWSAGENCY, 246 Wyndham-street, Shepparton, Victoria 3630.

THE MERCANTILE EXCHANGE, 34 Queen-street, Melbourne, Victoria, 3000.

MCGILL'S AUTHORIZED NEWSAGENCY, 183-5 Elizabeth-street, Melbourne, Victoria 3000.

POWNEYS AUTHORIZED NEWSAGENCY, 293 Hargreaves-street, Bendigo, Victoria 3550.

PURDIE, J., & CO., 138 Moorabool-street, Geelong, Victoria 3220.

SALE AUTHORIZED NEWSAGENCY, 142 Raymond-street, Sale, Victoria 3850.

SKINNER'S AUTHORIZED NEWSAGENCY, 49-51 Franklin-street, Traralgon, Victoria 3844.

STEVENSON, A. C. & M., NEWSAGENTS, 132 Henty-street, Casterton, Victoria 3311.

VANCE'S AUTHORIZED NEWSAGENCY, 83 Murray-street, Wangaratta, 3677.

VERNS OF RICHMOND, 162 Bridge-road, Richmond, Victoria 3121.

VIEW POINT AUTHORIZED NEWSAGENCY, 4 View-Point, Bendigo, Victoria 3550.

A copy of the Gazette filed at each place for public reference.

CONTENTS

	PAGE
Acts of Parliament on Sale at the Government Printing Office	2119
Appointments	2077
Bank Half-Holiday	2063
Cemeteries—Scale of Fees	2074
Companies Act 1961—Notice	2068
Contracts	2076
Courts	2072
Estates of Deceased Persons	2075
Government Notices	2063
Impoundings	2118
Insolvency Notices	2118
Lands	2086
Melbourne and Metropolitan Board of Works—Notices	2066
Mining	2068
Notice of Making of Statutory Rules	2118
Orders in Council—	
Acts—Land; Country Roads; Cemeteries; Superannuation; Water; Mildura Irrigation and Water Trusts; Sewerage Districts; Housing; Labour and Industry.	2078 et seq
Petroleum (Submerged Lands) Act	2069
Private Advertisements	2091
Proclamations	2062
Public Holiday—Queen's Birthday	2063
Queen's Birthday Honours	2061
Resignations	2078
State Rivers and Water Supply Commission	2073
Tenders	2091
Transport Regulation Board—Public Hearings	2064
Waterworks Trusts	2075