

[1013]



VICTORIA GOVERNMENT GAZETTE

Published by Authority

No. 33]

WEDNESDAY, MAY 7

[1975

PROCLAMATIONS

BANK HOLIDAY.

PROCLAMATION

By His Excellency the Governor of the State of Victoria and its Dependencies in the Commonwealth of Australia, &c., &c., &c.

In pursuance of the provisions of the *Bank Holidays Act 1958, I*, the Governor of the State of Victoria, in the Commonwealth of Australia, do by this my Proclamation appoint the day and date named hereunder a special day to be observed as a Bank Half-Holiday at the place mentioned, that is to say:—

Bank Half-Holiday from the Hour of Eleven a.m.:—
THURSDAY, THE 15TH MAY, 1975, at Sale.

Given under my Hand and the Seal of the State of Victoria aforesaid, at Melbourne, this sixth day of May, in the year of our Lord One thousand nine hundred and seventy-five, and in the twenty-fourth year of the reign of Her Majesty Elizabeth the Second, Queen of Australia.

(L.S.) HENRY WINNEKE.

By His Excellency's Command,
J. F. ROSSITER,
Chief Secretary.

GOD SAVE THE QUEEN!

BANK HOLIDAY.

PROCLAMATION

By His Excellency the Governor of the State of Victoria and its Dependencies in the Commonwealth of Australia, &c., &c., &c.

In pursuance of the provisions of the *Bank Holidays Act 1958, I*, the Governor of the State of Victoria, in the Commonwealth of Australia, do by this my Proclamation appoint the day and date named hereunder a special day to be observed as a Bank Half-Holiday at the place mentioned, that is to say:—

Bank Half-Holiday from the Hour of Eleven a.m.:—
FRIDAY, THE 23RD MAY, 1975 at Coleraine.

Given under my Hand and the Seal of the State of Victoria aforesaid, at Melbourne, this sixth day of May, in the year of our Lord One thousand nine hundred and seventy-five, and in the twenty-fourth year of the reign of Her Majesty Elizabeth the Second, Queen of Australia.

(L.S.) HENRY WINNEKE.

By His Excellency's Command,
J. F. ROSSITER,
Chief Secretary.

GOD SAVE THE QUEEN!

No. 33.—3770/75.—Price 30 cents; Half-yearly \$20; Yearly \$40.

PUBLIC HOLIDAY.

PROCLAMATION

By His Excellency the Governor of the State of Victoria and its Dependencies in the Commonwealth of Australia, &c., &c., &c.

In pursuance of the provisions contained in Part III. of the *Public Service Act 1958, I*, the Governor of the State of Victoria, in the Commonwealth of Australia, by and with the advice of the Executive Council of the said State, do by this my Proclamation appoint the day and date hereunder mentioned to be observed as a Public Half-Holiday at the place specified, viz.:—

Public Half-Holiday from the Hour of Twelve o'clock noon:—

FRIDAY, THE 23RD MAY, 1975, throughout the Coleraine Riding of the Shire of Wannoo.

Given under my Hand and the Seal of the State of Victoria aforesaid, at Melbourne, this sixth day of May, in the year of our Lord One thousand nine hundred and seventy-five, and in the twenty-fourth year of the reign of Her Majesty Elizabeth the Second, Queen of Australia.

(L.S.) HENRY WINNEKE.

By His Excellency's Command,
J. F. ROSSITER,
Chief Secretary.

GOD SAVE THE QUEEN!

LOCAL AUTHORITIES SUPERANNUATION ACT 1958.

PROCLAMATION

By His Excellency the Governor of the State of Victoria and its Dependencies in the Commonwealth of Australia, &c., &c., &c.

Whereas by the *Local Authorities Superannuation Act 1958, section 3*, it is among other things enacted that it shall be lawful for the Governor in Council to declare any body constituted for a joint purpose by two or more authorities within the meaning of that Act to be an authority for the purposes of the Act.

And whereas the North Western Melbourne Regional Organisation of Councils (Region No. 13) has requested that it be declared to be an authority.

Now therefore, I, the Governor of the State of Victoria in the Commonwealth of Australia, by and with the advice of the Executive Council of the said State, do by this Proclamation declare that the North Western Melbourne Regional Organisation of Councils (Region No. 13) being an authority constituted for a joint purpose by the

Councils of the Cities of Broadmeadows, Brunswick and Coburg and the Shires of Bulla and Gisborne shall be an authority for the purpose of the said Act.

Given under my Hand and the Seal of the State of Victoria aforesaid, at Melbourne, this twentieth day of April, in the year of our Lord One thousand nine hundred and seventy-five, and in the twenty-fourth year of the reign of Her Majesty Queen Elizabeth II.

(L.S.) HENRY WINNEKE.

By His Excellency's Command,
A. J. HUNT,
Minister for Local Government.
GOD SAVE THE QUEEN!

Milk Pasteurization Act 1958.

DECLARING AN AREA TO BE A PASTEURIZED MILK DISTRICT

PROCLAMATION

By His Excellency the Governor of the State of Victoria and its Dependencies in the Commonwealth of Australia, &c., &c., &c.

Whereas by section 4 of the *Milk Pasteurization Act 1958* it is amongst other things enacted that the Governor in Council may by Proclamation declare any area specified in such proclamation to be a pasteurized milk district on and after a date specified in the proclamation:

Now therefore I, the Governor of the State of Victoria in the Commonwealth of Australia by and with the advice of the Executive Council of the said State do by this my proclamation hereby declare the Municipal district of the United Shire of Beechworth to be a pasteurized milk district on and after the first day of June, 1975.

Given under my Hand and the Seal of the State of Victoria aforesaid, at Melbourne, this sixth day of May, in the year of our Lord One thousand nine hundred and seventy-five, and in the twenty-fourth year of the reign of Her Majesty Elizabeth II, Queen of Australia.

(L.S.) HENRY WINNEKE.

By His Excellency's Command,
IAN SMITH,
Minister of Agriculture.
GOD SAVE THE QUEEN!

STOCK FOODS (AMENDMENT) ACT 1975, No. 8681.

DATE OF COMING INTO OPERATION.

PROCLAMATION

By His Excellency the Governor of the State of Victoria and its Dependencies in the Commonwealth of Australia, &c., &c., &c.

Whereas by an Act of Parliament of the State of Victoria passed in the twenty-fourth year of the reign of Her Majesty Elizabeth II, Queen of Australia, entitled the *Stock Foods (Amendment) Act 1975, No. 8681*, it is amongst other things enacted that the provisions of the said Act shall come into operation on a day to be fixed by Proclamation of the Governor in Council published in the *Government Gazette*.

Now therefore I, the Governor of the State of Victoria, in the Commonwealth of Australia, by and with the advice of the Executive Council of the said State, do by this my Proclamation fix Wednesday the seventh day of May, one thousand nine hundred and seventy-five as the day on which the provisions of the said *Stock Foods (Amendment) Act 1975, No. 8681*, shall come into operation.

Given under my Hand and the Seal of the State of Victoria aforesaid, at Melbourne, this sixth day of May, in the year of our Lord One thousand nine hundred and seventy-five, and in the twenty-fourth year of the reign of Her Majesty Elizabeth II, Queen of Australia.

(L.S.) HENRY WINNEKE.

By His Excellency's Command,
IAN SMITH,
Minister of Agriculture.
GOD SAVE THE QUEEN!

POISONS ACT 1962 (No. 6889).

PROCLAMATION

By His Excellency the Governor of the State of Victoria and its Dependencies in the Commonwealth of Australia, &c., &c., &c.

Whereas by Section 4 of the *Poisons Act 1962* it is amongst other things enacted that the Governor in Council may, by Proclamation published in the *Government Gazette*, amend any of Schedules One, Two, Three, Four, Five, Six, Seven or Eight to such Act by adding to any such Schedules or removing therefrom any item:

Now therefore, I, the Governor of the State of Victoria in the Commonwealth of Australia, by and with the advice of the Executive Council of the said State, by virtue of the provisions of the said Section and all other enabling powers, do by this Proclamation—

1. Amend Schedule Two to the said Act by removing therefrom the following item:—

FERROUS SULPHATE for therapeutic use in tablets or capsules containing more than 40 mg. of Ferrous Sulphate per tablet or capsule.

2. Amend Schedule Three to the said Act by adding thereto the following item:—

IRON salts and complexes in preparations intended for human therapeutic use by oral administration, except preparations containing 5 mg. or less of elemental iron per dose.

3. Amend Schedule Four to the said Act by adding thereto the following items:—

BUFEXAMIC

IRON complexes in injectable preparations intended for human therapeutic use.

MAZINDOL

4. Amend Schedule Five to the said Act by adding thereto the following items:—

ARSENIC, organic compounds of, in preparations containing three per centum or less of Arsenic, when prepared and packed for use as herbicides or defoliants.

GLYPHOSATE

PENTACHLOROPHENOL in preparations containing 0.5 per centum or less of Pentachlorophenol.

5. Amend Schedule Six to the said Act by removing therefrom the following items:—

ARSENIC, organic compounds of, when used as herbicides or defoliants or for veterinary therapeutic use.

PENTACHLOROPHENOL

and by adding thereto the following items:—

ACEPHATE

ARSENIC, organic compounds of, when prepared for use as herbicides or defoliants except when included in Schedule Five.

IRON salts and complexes in preparations intended for veterinary use.

ISOCYANATES, free organic, except in paints containing 0.1 per centum or less of free organic Isocyanates.

MECLOFENAMIC ACID for therapeutic use on animals.

PENTACHLOROPHENOL except in preparations containing 0.5 per centum or less of Pentachlorophenol.

PHOXIM

6. Amend Schedule Seven by removing therefrom the following item:—

MECARBAN

and by adding thereto the following items:—

ALDICARB

MECARBAM

Given under my Hand and the Seal of the State of Victoria aforesaid, at Melbourne, this twentieth day of April, in the year of our Lord One thousand nine hundred and seventy-five, and in the twenty-fourth year of the reign of Her Majesty Queen Elizabeth II.

(L.S.) HENRY WINNEKE.

By His Excellency's Command,
A. H. SCANLAN,
Minister of Health.
GOD SAVE THE QUEEN!

ACTS OF PARLIAMENT.

PROCLAMATION

By His Excellency the Governor of the State of Victoria and its Dependencies in the Commonwealth of Australia, &c., &c., &c.

I, the Governor of the State of Victoria, in the Commonwealth of Australia, do hereby declare that I have this day assented, in Her Majesty's name, to the Bills passed by the Parliament of the said State, the titles whereof are hereunder set forth, together with the short titles, that is to say:—

No. 8693. "An Act to make special provision in relation to Long Service Leave for Persons employed in the Building and Construction Industry, to amend the 'Labour and Industry Act 1958', and for other purposes." (Building Industry Long Service Leave Act 1975.)

No. 8694. "An Act to amend the 'Fisheries Act 1968'" (Fisheries Act 1975.)

No. 8695. "An Act to approve ratify and validate a Private Street Construction Scheme of the City of Ringwood, made pursuant to the provisions of Division 10 of Part XIX. of the 'Local Government Act 1958'" (Local Government (City of Ringwood) Act 1975.)

Given under my Hand and the Seal of the State of Victoria aforesaid, at Melbourne, this sixth day of May, in the year of our Lord One thousand nine hundred and seventy-five, and in the twenty-fourth year of the reign of Her Majesty Queen Elizabeth II.

(L.S.) HENRY WINNEKE.

By His Excellency's Command, R. J. HAMER, Premier.

GOD SAVE THE QUEEN!

NOTE.—Act No. 8693 shall come into operation on a day to be fixed by Proclamation. Act No. 8694 several provisions of this Act shall come into operation on a day or the days to be fixed by proclamation. Act No. 8695 shall come into operation on the day of Royal Assent.

Land Act 1958, Section 25. ROAD PROCLAIMED.

PROCLAMATION

By His Excellency the Governor of the State of Victoria and its Dependencies in the Commonwealth of Australia, &c., &c., &c.

In pursuance of the provisions of Section 25 (3) (c) of the Land Act 1958, I, the Governor of the State of Victoria by and with the advice of the Executive Council of the said State do hereby proclaim as road the land in the Parish of Bumbang County of Karkaroc as indicated by hatching on the plan hereunder.—(M.62481) (B.660(10)).

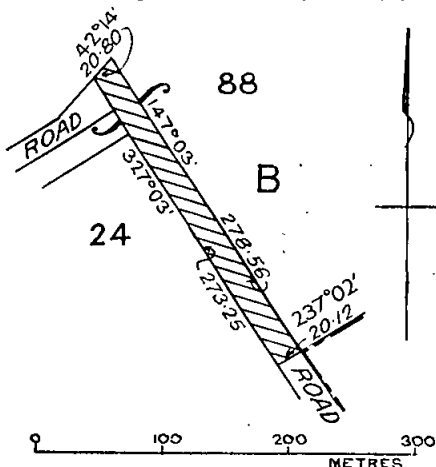

Given under my Hand and the Seal of the State of Victoria aforesaid, at Melbourne, this twenty-ninth day of April, in the year of our Lord One

thousand nine hundred and seventy-five, and in the twenty-fourth year of the reign of Her Majesty Queen Elizabeth II.

(L.S.) HENRY WINNEKE.

By His Excellency's Command, W. BORTHWICK, Minister of Lands.

GOD SAVE THE QUEEN!

PUBLIC HIGHWAY.—CITY OF RINGWOOD.

PROCLAMATION

By His Excellency the Governor of the State of Victoria and its Dependencies in the Commonwealth of Australia, &c., &c., &c.

Whereas by the Local Government Act 1958, section 519 it is amongst other things enacted that it shall be lawful for the Governor in Council at any time and from time to time upon the request of the Council of any municipality by notice in the Government Gazette to proclaim any land reserved used or by purchase or exchange acquired for a street road highway, thoroughfare bridge square court alley or right of way or any street road lane or passage made or laid out or proposed to be made or laid out on any land of which a plan of subdivision delineating that street road lane or passage has been sealed with the seal of the municipality under subdivision (3) of Division 9 of Part XIX. of the Local Government Act 1958, or a corresponding previous enactment to be a public highway and that such land shall thereupon and thenceforth from the date of such proclamation become and be absolutely dedicated to the public as a public highway within the meaning of any law then or thereafter in force.

And whereas the Council of the City of Ringwood has requested that the land hereinafter mentioned, being a road laid out on land of which a plan of subdivision delineating the street, road lane or passage has been sealed with the seal of the Municipality under subdivision (3) of Division 9 of Part XIX. of the Local Government Act 1958, or a corresponding previous enactment, be so declared to be a public highway.

Now therefore I, the Governor of the State of Victoria, in the Commonwealth of Australia, by and with the advice of the Executive Council of the said State, do by this Proclamation declare that an unnamed road off Marwarra Street, Ringwood shown by hachure on the plan hereunder shall be a public highway within the meaning of the said Act.

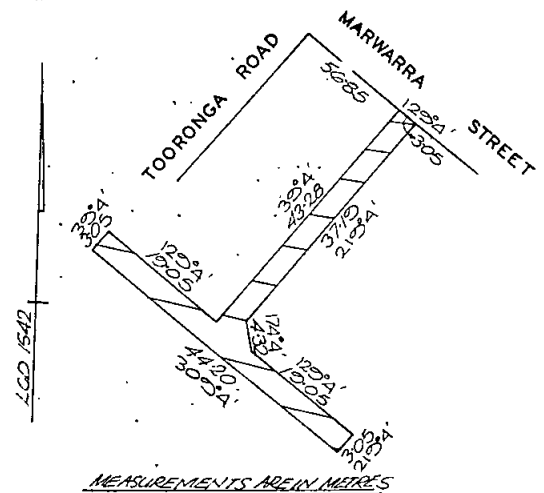

Given under my Hand and the Seal of the State of Victoria aforesaid, at Melbourne, this twenty-ninth day of April, in the year of our Lord One thousand nine hundred and seventy-five, and in the twenty-fourth year of the reign of Her Majesty Queen Elizabeth II.

(L.S.) HENRY WINNEKE.

By His Excellency's Command, A. J. HUNT, Minister for Local Government.

GOD SAVE THE QUEEN!

Marine Act 1958.

**PORT RULE (PORT PHILLIP UNDERWATER GAS
PIPELINE) 1975.**

PORT RULE No. 25.

PROCLAMATION

By His Excellency the Governor of the State of Victoria and its Dependencies in the Commonwealth of Australia &c., &c., &c.

WHEREAS by Part II. of the *Marine Act* 1958, it is amongst other things enacted that the Governor in Council, by Proclamation published in the *Government Gazette*, may from time to time define the limits and boundaries of ports in Victoria, and frame rules and regulations for the governance and preservation of the said ports respectively, and for the regulation of shipping in the same, and also for the due protection and preservation and the good government and management of all public wharves: And that any such rules and regulations may from time to time be in like manner altered, amended or repealed and other substituted in their stead: Now, therefore, I, the Governor of the State of Victoria in the Commonwealth of Australia by and with the advice of the Executive Council thereof, and in exercise of the powers conferred by the said Act and all other powers thereunto enabling do by this Proclamation repeal Port Rules 25 and 26 published in the *Government Gazette* of 3rd December, 1913 and Port Rule 55A published in the *Government Gazette* of 7 June 1972* and substitute the following in their stead, that is to say:—

1. This Rule may be cited as Port Rule (Port Phillip Underwater Gas Pipeline) 1975 and shall be numbered Port Rule 25.

2. The Master of a vessel shall not permit his vessel to anchor within 150 metres of either side of, or drag any anchor of such vessel over the underwater ethane gas pipeline which is submerged in the sea bed of the port of Port Phillip between Mordialloc and Altona and which follows the route hereunder—

Commencing at Mordialloc at a point Lat. 38° 00' 35" S. Long. 145° 04' 56" E. and proceeding thence by a straight line to a point Lat. 38° 00' 45" S. Long. 145° 04' 04" E. thence by the arc of a circle of radius 3048 metres to a point Lat. 38° 00' 47" S. Long. 145° 03' 27" E. thence by a straight line to a point Lat. 38° 00' 43" S. Long. 145° 01' 52" E. thence by the arc of a circle of radius 3048 metres to a point Lat. 38° 00' 23" S. Long. 145° 00' 45" E. thence by a straight line to a point Lat. 37° 56' 12" S. Long. 144° 53' 40" E. thence by the arc of a circle of radius 3048 metres to a point Lat. 37° 54' 45" S. Long. 144° 52' 50" E. thence by a straight line to a point Lat. 37° 53' 26" S. Long. 144° 52' 58" E. thence by the arc of a circle of radius 2133.6 metres to a point Lat. 37° 52' 29" S. Long. 144° 52' 30" E. thence by a straight line to a point at Altona Lat. 37° 51' 46" S. Long. 144° 51' 31" E.

Given under my Hand and the Seal of the State of Victoria aforesaid, at Melbourne, this twenty-ninth day of April, in the year of Our Lord One thousand nine hundred and seventy five and in the twenty-fourth year of the reign of Elizabeth the Second, by the Grace of God Queen of Australia and Her other Realms and Territories, Head of the Commonwealth.

(L.s.)

HENRY WINNEKE.

By His Excellency's Command,

R. DUNSTAN,
Minister of Public Works.

GOD SAVE THE QUEEN!

* G.G. 3rd December 1913, S.R. 155/1972.

GOVERNMENT NOTICES*Education Act 1958.***ELECTION OF MEMBERS AND DEPUTY MEMBERS OF THE PRIMARY SECONDARY AND TECHNICAL TEACHERS REGISTRATION BOARDS.**

Pursuant to the Teacher Registration Board Elections Regulations, I hereby give notice that the following elections are to be conducted.

1. Primary Teachers Registration Board Members.

- (a) Two Members and six Deputy Members elected from and by the principals of State primary schools classified as Principal, Special Grade School, Principal, Grade I School or Principal, Grade II School.
- (b) Four Members and twelve Deputy Members elected from and by classified teachers of the primary division who are not principals within the meaning of 1 (a) above.
- (c) One Member and three Deputy Members elected from and by members of the academic staff (including principals) of constituent colleges of the State College of Victoria—
- (i) who are registered to teach in State primary schools; and
 - (ii) whose applications for enrolment as voters in respect of the said election have been received by the returning officer within the prescribed period prior to the election.

For the purposes of this election the prescribed period will be for:—

- (a) Members wishing to nominate for election not later than twelve o'clock noon on nomination day.
- (b) Members wishing to enrol as voters—not more than thirty days immediately following the nomination day.

2. Secondary Teachers Registration Board Members.

- (a) Two Members and six Deputy Members elected from and by the principals of State High Schools.
- (b) Four Members and twelve Deputy Members elected from and by classified teachers of the secondary division who are not principals.
- (c) One Member and three Deputy Members elected from and by members of the academic staff (including principals) of constituent colleges of the State College of Victoria—
- (i) who are registered to teach in State secondary schools; and
 - (ii) whose applications for enrolment as voters in respect of the said election have been received by the returning officer within the prescribed period prior to the election.

For the purposes of this election the prescribed period will be for:—

- (a) Members wishing to nominate for election not later than twelve o'clock noon on nomination day.
- (b) Members wishing to enrol as voters—not more than 30 days immediately following the nomination day.

3. Technical Teachers Registration Board Members.

- (a) Two Members and six Deputy Members elected from and by the principals of State Technical Schools.
- (b) Four Members and twelve Deputy Members elected from and by classified teachers of the Technical division who are not principals.
- (c) One Member and three Deputy Members elected from and by members of the academic staff (including principals) of constituent colleges of the State College of Victoria—
- (i) Who are registered to teach in State technical schools; and
 - (ii) whose applications for enrolment as voters in respect of the said election have been received by the returning officer within the prescribed period prior to the election.

For the purposes of this election the prescribed period will be for:—

- (a) Members wishing to nominate for election not later than twelve o'clock noon on nomination day.
- (b) Members wishing to enrol as voters—not more than 30 days immediately following the nomination day.

For the purpose of these elections the following dates are fixed namely:—

Nomination Day:—Monday the 9th June, 1975.

Polling Day:—Monday the 18th August, 1975.

And I further give notice that John Thomas Minter has been appointed as the Returning Officer to conduct the said elections and that he will receive nominations at his office in the Education Department, Treasury Place, Melbourne, 3002 not later than twelve o'clock noon on nomination day.

Prescribed forms of nomination may be obtained from the Returning Officer.

L. H. S. THOMPSON,
Minister of Education.

*Police Offences Act 1958, No. 6337.***DIVISION 1A.—STATE ADVISORY BOARD ON PUBLICATIONS.**

Whereas I have considered reports made to me by the State Advisory Board on Publications under Section 180b (2) (a) of the Police Offences Act, I, John Frederick Rossiter, Chief Secretary for the State of Victoria, in pursuance of the power vested in me by Section 180H (1) of the Police Offences Act hereby determine that the publications listed by title in the schedule hereunder shall be classified as restricted publications for the purposes of the abovenamed Act.

SCHEDULE OF PUBLICATION.

<i>Title.</i>	<i>Publisher.</i>
At the Age of Ecstasy	Down Under Publication
Australasian Pleasure No. 114	Herd Publishing
Australian Guys No. 28	Wynyard Mercantile
Australian Guys No. 29	Wynyard Mercantile
Banner No. 4	Not shown
Banner No. 5	Not shown
Bingo No. 1	Not shown
Breast Orgy	Mount Mary Press S.A.
Cocksure No. 38	Herd Publishing
Every Trick in the Trade	Down Under Publication
Furthermost Delights	Down Under Publication
Heart Balm No. 43	Not shown
Homo Action No. 7	Not shown
Homo Action No. 9	Not shown
International Man No. 12	Revolt Press Hamburg
International Man No. 13	Revolt Press Hamburg
Joy Boy No. 4	Not shown
Kings Cross Venus No. 39	Venus Publications
Kings Cross Whisper No. 198	Group Publications
Male No. 1	Searchlight Publication.
Mini Boy No. 3	Not shown
Naked and Naughty	Bleu Book and Magazine Co.
National Ball No. 58	Wynyard Mercantile
National Ball No. 59	Wynyard Mercantile
Oriental Love	Dynamic Publishing Oregon
Piccolo No. 6	Not shown
Pubescent Prostitutes	Down Under Publication
Ribald No. 124	Bertram Horne and Co.
Ribald No. 125	Bertram Horne and Co.
Screw No. 138	Wynyard Mercantile
Screw No. 139	Wynyard Mercantile
Searchlight No. 102	Searchlight Publication
Searchlight No. 103	Searchlight Publication
Searchlight No. 104	Searchlight Publication
Searchlight No. 77	Searchlight Publication
Sexy Swingers No. 120	Exclusive Publications
Sexy Swingers No. 121	Exclusive Publications
Sexy Swingers No. 95	Exclusive Publications
Swedish Sex Studies	Bleu Book and Magazine Co.
Teenage Lovers	Bleu Book and Magazine Co.
Women Lovers	Bleu Book and Magazine Co.

J. F. ROSSITER,
Chief Secretary.

Chief Secretary's Office,
Melbourne, 6th May, 1975.

Transport Regulation Act.

TRANSPORT REGULATION BOARD.

NOTICE No. 110.

Operation of Metropolitan Taxi Cabs and Suburban Taxi Cabs.

Take notice that, pursuant to powers conferred on the Board by provisions of the Transport Consolidated Regulations 1960, the Board hereby specifies in accordance with the provisions of Regulation 5 of Part I, of the said Regulations, places and stands pursuant to Regulations 21 and 70c of Part III of such Regulations as follows:—

1. In the case of a Metropolitan Taxi Cab, places specified pursuant to Regulation 21 of Part III of the Transport Consolidated Regulations shall be the hire stands at Railway Stations situated at Clayton, Cheltenham, Mentone, Parkdale, Mordialloc, Nunawading, Mitcham, Ringwood, Epping and Lalor.

2. In the case of a Suburban Taxi Cab places specified pursuant to Regulation 21 of Part III of the Transport Consolidated Regulations shall be the hire stands at those Railway Stations which are related to the Zone depots specified in the licence as follows:—

Zones A, B, C—Railway Stations at Clayton, Cheltenham, Mentone, Parkdale and Mordialloc.

Zone E—Railway Stations at Nunawading, Mitcham and Ringwood.

Zones N and J—Railway Stations at Epping and Lalor.

3. In the case of a Suburban Taxi Cab, stands specified pursuant to Regulation 70c of Part III of the Transport Consolidated Regulations shall be hire stands in the area related to the Zone depot specified in the licence as follows:—

Zones A, B and C—The area bounded by North Road at the coastline, North Road, the Sandringham railway line to Glen Eira Road, Glen Eira, Orong, Balaclava, Hawthorn, Dandenong, Glenferrie, Wattletree and Burke Roads, Toorak Road, Burwood Highway, Dandenong Creek, Wellington and Garden Roads, Princes Highway, McNaughton and Kombi Roads, railway line, Westall, Heatherton and Boundary Roads, Centre Dandenong Road, Springvale, Pillars, Wilson & McMahrens and Rossiter Roads, northern boundary of the City of Frankston, Eel Race Road to coast and the coast line to North Road.

Zone E—The area bounded by Burke Road, the Yarra River to Alexander Road, thence a direct line north to Mt. Pleasant Road, Mt. Pleasant Road, Main Road, Eltham-Yarra Glen Road, Kangaroo Ground-Warrandyte, Road, Pigeon Bank Road, Pigeon Bank Gully Creek, Yarra River in a southerly direction, Jumping Creek, Jumping Creek Road, Warrandyte-Ringwood Road, Croydon Road, Wonga Road, Plymouth Road the eastern boundary of the City of Ringwood, Dandenong Creek, Burwood Highway, Toorak Road to Burke Road and also from the stand adjacent to the corner of Warrigal and Burwood Roads.

Zones N and J—The area bounded by the junction of Maribyrnong Road and the Maribyrnong River via the Maribyrnong River, Deep Creek, Felspar, High and Green Streets, Somerton, Pascoe Vale, Cliffords and O'Hearn's Roads, Cemetery Lane, Findon Road, Darebin Creek, McDonalds Lane, Gorge, Kurrack, Yan Yean, Ironbark, Black Gully, Broad Gully, Wilson, Hurstbridge, Kangaroo Ground, Wattle Glen, Eltham-Yarra Glen, Main and Mt. Pleasant Roads, thence a direct line south to Alexander Road, Alexander, Warrandyte and Newmans Roads, Porter and Anderson Streets, Serpells, Williamsons, Manningham, Thompsons and Bulleen Roads, Koonung Creek, Yarra River, Darebin Creek, Darebin Road, High Street, Normanby Avenue, Moreland and Pascoe Vale Roads, Bent Street, Moonee Ponds Creek, Dean and Puckle Streets, Essendon railway line, Maribyrnong Road to the Maribyrnong River.

Zone K—The area bounded by the coast line from the Yarra River to Skeleton Creek to its intersection with Old Geelong Road, Lohses Lane, Sayers, Palmers and Robinsons Roads, Kororoit Creek, Main Road West, Kings, Taylors, St. Albans, Keilor, Melton and Robertsons Roads, a direct north east line to Jackson's Creek, Jackson's Creek, Maribyrnong River, Yarra River to the coast.

Zone X—The area bounded by the intersection of Jumping Creek and the Yarra River and along the Yarra River in a north easterly direction, Victoria Road, McIntyre Lane, Yarra Glen, St. Huberts, Boundary, Killara and Gruyere Roads, Sebire Avenue, Beenak, Wandin East, Queens, Monbulk and Stonyford Roads via Fire Access Road to Olinda Creek Road, Falls, The Georgian, Olinda-Monbulk, Main, Emerald-Monbulk, Priors, Kallista-Emerald, William, Grantulla, Belgrave-Emerald and Wellington Roads, Dandenong Creek, the eastern and northern boundaries of the City of Ringwood, Wonga, Croydon, Warrandyte-Ringwood and Jumping Creek Roads to the intersection of Jumping Creek and the Yarra River.

Notice No. 92 published in the *Victoria Government Gazette*, No. 62, dated 24th June, 1970, is hereby repealed.

By order of the Transport Regulation Board.

A. V. C. COOK,
Secretary.

Transport Regulation Act.

TRANSPORT REGULATION BOARD.

HEARING OF APPLICATIONS.

Notice is hereby given that the following applications will be considered by the Transport Regulation Board on 27th May, 1975.

ANSETT TRANSPORT INDUSTRIES (OPERATIONS) PTY. LTD. (trading as Ansett Motors), 210 Gray Street, Hamilton. Application for variation of C.O. licence conditions to include the ability to carry parcels to Melbourne from Naracoorte, Apsley, Edenhope and Harrow, and from Melbourne to Harrow, Edenhope, Apsley and Naracoorte on Mondays to Saturdays inclusive.

NOTE.—The maximum weight of any one parcel is to be 2.27 kg.

MORELAND BUS LINES PTY. LTD., 25 Liverpool Street, Coburg. Application for one commercial passenger vehicle with large seating capacity to operate as an additional metropolitan special service omnibus under the same terms and conditions as existing M.C. licences held by the applicant.

WHEELER, B. M. & B. W., P.O., Walwa. Application for one commercial passenger vehicle with seating capacity for 11 persons to operate for the carriage of school children between Burrowye and Walwa under contract to the Education Department.

Applications for renewal of licences as shown by the persons listed hereunder to operate under the same terms and conditions:—

DEVEREUX, C. & D. W., 124 Chapman Street, Swan Hill; C.T.11, C.T.634.

MILLER, K. H., 203 Morton Street, Ballarat; U.T.166.

MCCOMBE, J. & J. M., "Wandana", Main Road, Millgrove; C.T.70.

PHILLIPS, R., 11 Cambridge Crescent, Werribee; S.T.8006.

ROWE, C., 72 Wellington Street, St. Kilda; M.T.2475.

RIGOPOULOS, A., 4 Albert Street, Abbotsford; M.T.4508.

Notice of any objections should be forwarded to reach the Secretary of the Board not later than 21st May, 1975.

Applicants are advised that it will not be necessary to appear on the hearing date specified, unless advised in writing by the Board.

A. V. C. COOK,
Secretary.

Corner Lygon and Princes Streets, Carlton, 3053,
Wednesday, 7th May, 1975.

Commercial Goods Vehicles Act.

TRANSPORT REGULATION BOARD.

HEARING OF APPLICATIONS.

Notice is hereby given that the following applications will be considered by the Transport Regulation Board on 27th May, 1975.

AITKENS, K. D. (trading as Aitkens Removals), 266 High Street, Kangaroo Flat, 3555. One commercial goods vehicle (L/C. 3.90 tonne) to operate: (a) Within a 40-km radius of the chief post office in the City of Bendigo—general goods. (b) From Melbourne to Kyneton and Bendigo for the carriage of new furniture as per new furniture list as amended by the Transport Regulation Board from time to time. (c) For the carriage of household furniture, being furniture or

- personal effects of a householder or a member of his family when being moved from residence to residence, from residence for storage or sale; from storage to residence; from a vendor to the residence of the purchaser.
- ANDERSON, E. & SONS PTY. LTD.**, Main Road, Monbulk, 3793. One commercial goods vehicle (L/C. 6.55 tonne) to operate: Within a 16-km radius of own premises at Monbulk and to and from places within a 40-km radius of the G.P.O., Melbourne and to and from places on the Mornington Peninsula in the course of business as "Timber Merchants, Timber Millers, Hardware and Produce Merchants"—own goods.
- ANNETT, G. R.** (trading as G. R. & B. F. Annett), Heathmere, Wayside, 3305. One commercial goods vehicle (L/C. 8.20 tonne and 4.45 tonne trailer) to operate within that part of the State of Victoria west of a north/south line drawn through the Cities of Colac and Ballarat to the Victorian/New South Wales border solely on behalf of Rocla Concrete Pipes Ltd. at Heywood, an approved decentralized secondary industry (Concrete Pipes)—concrete pipes and concrete septic tanks being manufactured products of the said decentralized industry.
- BENDIGO TRANSPORTERS (HOLTS) PTY. LTD.**, 30 McIvor Road, Bendigo, 3550. One commercial goods vehicle (L/C. 11.05 tonne) to operate: (a) Under sole contract to Stramit Boards Ltd. an approved decentralized secondary industry (production of stramit building boards) carried on at Bendigo within an 80-km radius of the place of business of the said company at Bendigo—straw. (b) From the City of Melbourne or the metropolitan area (as defined in the *Transport Regulation Act 1958*) to the place of business of the said company at Bendigo—raw materials for sole use of the said company in the manufacturing process of such approved decentralized secondary industry. (c) From the place of business of the said company at Bendigo to points within the State of Victoria—stramit board and associated equipment produced in such approved decentralized secondary industry.
- This application replaces licence No. D.A.31249/4 previously in the name of R. Stone Pty. Ltd. (an associate company).
- BENTLEY, G. F.**, 23 Bawden Close, Watsonia, 3087. One commercial goods vehicle (L/C. 6.55 tonne) to operate: (a) From the premises of Motor Vehicle Distributors and Dealers direct to consignees throughout the State of Victoria—complete motor vehicles on behalf of the said Fleet X Press. (b) Between the Cities of Melbourne, Geelong and Dandenong—motor car bodies on behalf of the said Fleet X Press subject to the conditions that no delivery shall be made to any wharf at which rail facilities are available.
- BOMBARDIERI, K. F.**, 24 Holloway Grove, Swan Hill, 3585. One commercial goods vehicle (L/C. 11.25 tonne) to operate: (a) Throughout the State of Victoria in the course of business as "House Removalists"—houses, sheds and buildings for removal and tools of trade and equipment incidental to own contracts. (b) From own farm at Piamble to the railway wheat silo at Kooloonong—wheat.
- BRUNT, M. L.**, Railway Station, Colac, 3250. One commercial goods vehicle (L/C. 2.50 tonne) to operate: (a) within a 40-km radius of the post office at Colac—general goods. (b) Within the State of Victoria for the carriage of furniture or personal effects of a householder or member of his family when such goods are in the course of being moved—(i) From residence to residence. (ii) From residence for storage or sale. (iii) From storage to residence. (iv) From a vendor to the residence of the purchaser.
- CHARLES TRAINOR & SONS PTY. LTD.**, 320 Lower Dandenong Road, Mordialloc, 3195. One commercial goods vehicle (L/C. 1.65 tonne) to operate within an 80-km radius of the premises of Trainor Holdings Ltd. at Mordialloc solely on behalf of subsidiary company's Trainor Furniture Importers Pty. Ltd., Furniture Component Importers and Furniture Assemblers; and Nepean Timber Company Pty. Ltd., "Timber Merchants and Joinery Manufacturers"—timber, joinery, furniture components and furniture on behalf of the said companies.
- CLELAND, P. & SONS (CLAYTON) PTY. LTD.**, 554 Clayton Road, Clayton, 3168. One commercial goods vehicle (L/C. 7.15 tonne) to operate within an 80-km radius of own premises at Clayton in course of business as "Dairy Produce Distributors"—own goods.
- DAVLECO ENGINEERING & MANUFACTURING CO. PTY. LTD.**, Settlement Road, Bundoora, 3083. One commercial goods vehicle (L/C. 0.95 tonne) to operate throughout the State of Victoria in the course of business as "Engineering Manufacturers" for the purpose of servicing machinery—tools of trade, equipment and spare parts incidental to the servicing and repair of manufactured and hire machines in the field only.
- DYNAMIC MOTORS PTY. LTD.**, 19 Langtree Avenue, Mildura, 3500. One commercial goods vehicle (L/C. 0.75 tonne) to operate within a 160-km radius of the post office at Mildura and from and to the City of Mildura to and from the township of Hopetoun in the course of business as "Automobile Engineers"—tools of trade, spare parts, motor car accessories, wet and dry batteries and engine blocks for repair or having been repaired.
- EDWARDS, H. W.**, 9 Cedar Street, Nursery Ridge, 3496. One commercial goods vehicle (L/C. 4.00 tonne) to operate throughout the State of Victoria in the course of business as "Secondhand Dealers" for the purpose of attending auction sales and private households for the purchase of secondhand articles—secondhand furniture, antique furniture, secondhand musical instruments, secondhand tools, secondhand household ornaments and secondhand crockery excluding the ability to carry goods to retail stores for resale.
- FIRE FIGHTING SPRINKLER CO. LTD.**, 203 Bouverie Street, Carlton, 3053. One commercial goods vehicle (L/C. 0.75 tonne) to operate throughout the State of Victoria in the course of business as "Fire Protection Engineers" for the purpose of servicing fire protection equipment—tools of trade, spare parts, fire protection equipment for repair or having been repaired and materials incidental to on site servicing.
- FIRESTONE SALES PTY. LTD.**, 36 Mahua Street, Reservoir, 3073. One commercial goods vehicle (L/C. 0.75 tonne) to operate within an 80-km radius of own premises at Kyneton in the course of business as "Tyre Manufacturers and Distributors"—new tyres and tubes for sale and delivery, secondhand tyres and tubes for repair or having been repaired, batteries, polythene piping and motor car accessories, provided that all new goods are initially consigned by rail to Kyneton.
- FRATANGELO, A.**, 50 Broadmeadows Road, Tullamarine, 3043. One commercial goods vehicle (L/C. 10.60 tonne) to operate within an 80-km radius of the G.P.O. Melbourne on behalf of Albion Reid Pty. Ltd.—roadmaking plant, hot asphalt, premix and roadmaking materials but excluding the carriage of cement and lime from places within a 13-km radius of the chief post office in the City of Geelong.
- FREEMAN W. G.**, 447 St. Georges Road, Thornbury, 3071. One commercial goods vehicle (L/C. 0.75 tonne) to operate throughout the State of Victoria in the course of business as "Refrigeration Engineer" as a service vehicle—tools of trade, equipment and spare parts incidental to the servicing and repair of refrigeration equipment on site only, also refrigeration equipment for repair or having been repaired.
- GAS & FUEL CORPORATION OF VICTORIA**, 171 Flinders Street, Melbourne, 3000. Application to vary the conditions of licence No. D.A.49393/27 (L/C. 0.95 tonne) by deleting "Warracknabeal" and "provided that all new appliances are initially railed to Warracknabeal" and adding in lieu "Dandenong".
- GAUCI, J.**, 33 Sunhill Crescent, Deer Park, 3023. One commercial goods vehicle (L/C. 10.05 tonne) to operate within an 80-km radius of the G.P.O. Melbourne solely on behalf of Albion Reid Pty. Ltd.—roadmaking plant, hot asphalt, premix and roadmaking materials but excluding the carriage of cement and lime from places within a 13-km radius of the chief post office in the City of Geelong.
- GIOVE, E.**, 44 Forest Road, Orbost, 3888. One commercial goods vehicle (L/C. 5.70 tonne) to operate: (a) Within a 40-km radius of Orbost—general goods. (b) Within an 80-km radius of Orbost in the course of business as "Primary Producer"—own goods.
- GREENWAY PTY. LTD.**, Grant Road, Somerville, 3912. Application to vary the conditions of licences numbered D.A.66062, /1, /2, /3, /4, /5, /6, /7, /8 /9, /10, /11, /12, /13, /15 and D.A.60322/6 and /7 (L/C. 10.30, 11.55, 7.00, 5.25, 5.65, 6.50, 9.55, 8.75, 2.80, 14.25, 7.05, 6.15, 10.65, 6.15, 6.60, 10.65 tonne) by deleting "2 cwt" and adding in lieu "250 kg" and also deleting "5 cwt" and adding in lieu "500 kg".
- GROVER E. W. J.**, 46 Clifton Street, Northcote, 3070. One commercial goods vehicle (L/C. 6.90 tonne) to operate within a 112-km radius of the premises of Clifton Brick Holdings Ltd. at Brunswick—bricks on behalf of the said company.

HIGHLAND PLANT HIRE PTY. LTD., Princes Highway, Morwell, 3840. One commercial goods vehicle (L/C. 0.75 tonne) to operate throughout the State of Victoria in the course of business as "Plant Hire and Earthmoving Contractors" for the purpose of servicing and repairing own plant and equipment—tools of trade, spare parts and materials incidental to the servicing and maintenance of own earthmoving equipment but limiting the carriage of spare parts and materials to those required for servicing and maintenance of earthmoving equipment in the field only.

HIGHLAND PLANT HIRE PTY. LTD., Princes Highway, Morwell, 3840. Application to vary the conditions of licences numbered D.A.30224/8 (L/C. 0.88 tonne) and D.A.30224/9 (L/C. 0.55 tonne) by adding to the existing conditions as follows—Within a 40-km radius of the post office situated at the corner of Bourke and Elizabeth Streets in the City of Melbourne in the course of business as plant hire and earthmoving contractors—own goods.

IBIS MILK PRODUCTS LTD., P.O. Box 1010, Shepparton, 3630. Twelve commercial goods vehicles (L/C. 0.70, 0.70, 0.70, 0.70, 8.50, 1.00, 0.70, 0.50, 0.80, 0.70, 1.05, and 0.70 tonne) to operate: (a) Within an 80-km radius of own premises at Shepparton in the course of business as "Co-Operative Store Proprietors"—own goods.

NOTE.—All such goods to be initially consigned by rail to the company—(b) (i) From points throughout the State of Victoria to own premises at Stanhope and Shepparton being an approved decentralized secondary industry (manufacturer of milk products)—raw materials and goods required in the manufacturing processes of such industry. (ii) From own premises at Stanhope and Shepparton being an approved decentralized secondary industry (manufacturer of milk products) to points throughout the State of Victoria—manufactured products from such industry. (c) (i) To the butter factory, milk factory or cheese factory—milk or cream. (ii) To the premises of any primary producer from whose premises milk or cream is collected—goods and empty milk and cream cans. (iii) From the factory to a local depot or creamery thereof or from such local depot or creamery to the factory—goods. (iv) Between a butter factory or cheese factory or milk factory and the nearest railway station or such railway or wharf as in any particular case the Board approves in writing—butter, cheese, milk or goods necessary for the working of such factory. (d) Within the area bordered on the north by the Murray River, on the east by a north/south line drawn through Wangaratta on the south by an east/west line drawn through Nar-Nar-Goon and on the west by a north/south line drawn through Cohuna for the purpose of servicing own vehicles and own plant and equipment—tools of trade, service equipment and spare parts incidental to servicing.

IBIS MILK PRODUCTS LTD., P.O. Box 1010, Shepparton, 3630. Nine commercial goods vehicles (L/C. 5.90, 5.10, 0.75, 4.35, 3.25, 3.25, 1.45 and 2.80 tonne) to operate: (a) Within an 80-km radius of own premises at Shepparton in the course of business as "Co-Operative Store Proprietors"—own goods.

NOTE.—All such goods to be initially consigned by rail to the company—(b) (i) From points throughout the State of Victoria to own premises at Stanhope and Shepparton being an approved decentralized secondary industry (manufacturer of milk products)—raw materials and goods required in the manufacturing processes of such industry. (ii) From own premises at Stanhope and Shepparton being an approved decentralized secondary industry (manufacturer of milk products) to points throughout the State of Victoria—manufactured products from such industry. (c) (i) To the butter factory, milk factory or cheese factory—milk or cream. (ii) To the premises of any primary producer from whose premises milk or cream is collected—goods and empty milk and cream cans. (iii) From the factory to a local depot or creamery thereof or from such local depot or creamery to the factory—goods. (iv) Between a butter factory or cheese factory or milk factory and the nearest railway station of such railway or wharf as in any particular case the Board approves in writing—butter, cheese, milk or goods necessary for the working of such factory.

MELCANN TRANSPORT PTY. LTD., 58 Omar Street, Maidstone, 3012. One commercial goods vehicle (L/C. 12.15 tonne) to operate: (a) Within a 40-km radius of the

premises of John N. McCann Pty. Ltd. an associate company in the City of Geelong in the course of their business as "Building Suppliers" and "Cement Merchants"—goods solely on behalf of the said company. (b) From No. 4 Shed at the Melbourne Railway Station to re-sellers situated within a 40-km radius of the post office at the corner of Bourke and Elizabeth Streets, Melbourne—cement solely on behalf of John N. McCann Pty. Ltd. (c) From the premises of Vit Clay Pty. Ltd. at Ballarat to the premises of John N. McCann Pty. Ltd. at Geelong—earthenware pipes solely on behalf of John N. McCann Pty. Ltd. (d) From and to places within a 10-km radius of the chief post office in the City of Geelong to and from David Mitchell Estates Ltd. at Lilydale and places within a 40-km radius of the G.P.O., Melbourne—goods solely on behalf of John N. McCann Pty. Ltd. but excluding the carriage of restricted goods which may be specified by notice in the *Government Gazette*, from time to time within an 80-km radius of the G.P.O., Melbourne.

BLACKSHAW, G. I. (trading as Park View Poultry Farm), 49 Stanhope Road, Rushworth, 3612. One commercial goods vehicle (L/C. 2.40 tonne) to operate: (a) Within an 80-km radius of own premises at Rushworth in the course of business as "Green Grocer and General Merchant"—own goods and appliances for repair or having been repaired. (b) From Melbourne to Rushworth in the course of business as a "Green Grocer and General Merchant"—fruit and vegetables including potatoes and onions and empty return bins and empty return cases for return.

PHILLIPS INDUSTRIES HOLDINGS LTD. (trading as Homecrafts), 168 Chesterville Road, Moorabbin, 3189. One commercial goods vehicle (L/C. 0.85 tonne) to operate within an 80-km radius of own branch premises at Ararat in the course of business as "Hardware and Electrical Appliance Retailer"—own goods subject to the condition that every journey made is confined wholly within the said radius and that no goods carried on the vehicle to any point within the said radius for transfer or trans-shipment to another vehicle for carriage to a destination outside that radius.

POLITES, A. (trading as Polites Bros.), 33 Edmonds Avenue, Ashwood, 3147. One commercial goods vehicle (L/C. 2.85 tonne) to operate: (a) Within an 80-km radius from own premises at South Melbourne in the course of business as "Frozen Food and Fish Distributors"—own goods. (b) Throughout the State of Victoria in a specially constructed refrigerated vehicle—fresh and frozen fish, frozen poultry, frozen meat, frozen vegetables, frozen dim sims, frozen chicken rolls and up to 0.15 tonnes of cooking oil, together with a small quantity not exceeding a total of two dozen bottles of onions and mussels at any one time.

HORNE, L. K. (trading as Donald Salvage), 3 Camp Street, Donald, 3480. One commercial goods vehicle (L/C. 13.40 tonne) to operate: (a) Within a 40-km radius of Donald—general goods. (b) Within an 80-km radius of Donald—plant the property of a contractor and required for use in the connection with the construction or maintenance of some specific, existing or proposed road, street, footpath, bridge, wharf, pier, weir or channel and also the following materials viz.: metal, stones, screenings, ashes, gravel, sand and earth. (c) Within an 80-km radius of Donald in the course of business as "Marine Dealer"—special wares, marine stores and old metals as designated in the *Marine Stores and Old Metals Act 1958*, No. 6303, Part (1), Section (3) and waste paper.

SMITH, R. W., Toomalook Parade, Paynesville, 3880. One commercial goods vehicle (L/C. 2.50 tonne) to operate: (a) From car dealers and car auctions within the Melbourne/metropolitan area solely to the Big Garage, Bairnsdale and William Boyle & Sons Pty. Ltd. Bairnsdale—new and secondhand cars on a specially constructed car carrying unit. (b) From Franklin Caravans Pty. Ltd., Cheltenham to the Big Garage, Bairnsdale on specially constructed car carrying unit and being towed—caravans. (c) From Bairnsdale to Melbourne/metropolitan area on specially constructed car carrying unit—secondhand wrecked cars.

VELCRETE HOLDINGS PTY. LTD., Wodonga Street, Wodonga, 3690. One commercial goods vehicle (L/C. 11.59 tonne) to operate: (a) Within a 40-km radius from the post office at Wodonga—general goods. (b) Within an 80-km radius from the post office at Wodonga on behalf of Wodonga Sand and Gravel Pty. Ltd.—sand, gravel and screenings.

VISSER, M. L., 23 White Parade, Churchill, 3842. One commercial goods vehicle (L/C. 7.00 tonne) to operate: (a) Within an 80-km radius from the post office at Churchill—plant the property of a contractor and required by him for use in connection with the construction or maintenance of some specific, existing or proposed road, street, footpath, bridge, pier, wharf, weir or channel and also the following materials viz.: metal, stones, screenings, ashes, gravel, sand and earth. (b) Within a 32-km radius from the site of any construction or maintenance work performed pursuant to paragraph (a) above, or from the railway station nearest thereto—any other materials required for such work.

WATTIE, D., Ferris Street, Thoona, via, Devenish, 3726. One commercial goods vehicle (L/C. 2.40 tonne) to operate: (a) Within that part of Victoria east of a north/south line drawn through the City of Ringwood in the course of business as "Fencing Contractor"—tools of trade, machinery and a quantity of fencing wire and materials not exceeding 250 kg incidental to the completion of own fencing contracts. (b) Within an 80-km radius from the post office at Devenish—livestock.

RENEWALS.

Applications for renewal of licences as shown by persons listed hereunder to operate under the same terms and conditions from the expiry shown in each case.

BEAUREPAIRE TYRE SERVICE PTY. LTD., 102 Victoria Street, Carlton, 3053; D.A.629/84; 23rd September, 1975; 0.80 tonne.

BEAUREPAIRE TYRE SERVICE PTY. LTD., 102 Victoria Street, Carlton, 3053; D.A.629/144; 25th September, 1975; 0.75 tonne.

BEAUREPAIRE TYRE SERVICE PTY. LTD., 102 Victoria Street, Carlton, 3053; D.A.629/82; 9th September, 1975; 1.00 tonne.

BEAUREPAIRE TYRE SERVICE PTY. LTD., 102 Victoria Street, Carlton, 3053; D.A.629/79; 3rd September, 1975; 0.75 tonne.

BEAUREPAIRE TYRE SERVICE PTY. LTD., 102 Victoria Street, Carlton, 3053; D.A.629/36; 21st September, 1975; 0.70 tonne.

BEAUREPAIRE TYRE SERVICE PTY. LTD., 102 Victoria Street, Carlton, 3053; D.A.629/2; 11th July, 1975; 0.75 tonne.

BEAUREPAIRE TYRE SERVICE PTY. LTD., 102 Victoria Street, Carlton, 3053; D.A.629/1; 30th July, 1975; 0.50 tonne.

BEAUREPAIRE TYRE SERVICE PTY. LTD., 102 Victoria Street, Carlton, 3053; D.A.629/80; 23rd September, 1975; 0.80 tonne.

CARTER, N. J., 19 Hayes Street, Northcote, 3070; T.D.A.664/5; 29th October, 1975; 5.45 tonne.

CLARK KING & CO. PTY. LTD., 33-37 Walsh Street, West Melbourne, 3003; D.A.57019/4; 9th October, 1975; 11.95 tonne.

CONSOLIDATED ALLOYS PTY. LTD., 17-19 Trawalla Avenue, Thomastown, 3074; D.A.1159/2; 7th October, 1975; 8.20 tonne.

CONTRACTORS WORKSHOP PTY. LTD., 8 Crookston Road, Reservoir, 3073; D.A.64774; 28th September, 1975; 0.55 tonne.

CROWN CONTROLS PTY. LTD., 22-26 Pickering Road, Glen Waverley, 3150; D.A.59103/9; 10th October, 1975; 0.75 tonne.

CYCLONE K-M PRODUCTS PTY. LTD., Cremorne Street, Richmond, 3121; T.D.A.51030/5; 18th October, 1975; 1.25 tonne and 1.50 tonne trailer.

ERLENWEIN, M. & M., 5 Jeffers Street, Noble Park, 3174; D.A.61190; 16th October, 1975; 11.50 tonne.

FLUOR AUSTRALIA PTY. LTD., 201-217 Fitzroy Street, St. Kilda, 3182; T.D.A.63714; 3rd August, 1975; 6.25 tonne.

GAFFNEYS CREEK GOLD MINE N.L., 143 Queen Street, Melbourne, 3000; D.A.65133; 20th September, 1975; 0.60 tonne.

GAS & FUEL CORPORATION OF VIC., 171 Flinders Street, Melbourne, 3000; D.A.49893/24; 28th June, 1975; 9.50 tonne.

GEOTECHNICAL ENGINEERING PTY. LTD., 147 Eastern Road, South Melbourne, 3205; D.A.66663; 10th October, 1975; 3.00 tonne.

GRAHAM, A. D., Kerami Crescent, Marysville, 3779; T.T.D.1326/1; 12th August, 1975; 12.95 tonne.

HUTCHINSON, ROBERT LIMITED, Hartington Street, Glenroy, 3046; T.D.A.27836/34; 23rd October, 1975; 6.75 tonne.

HUTCHINSON, ROBERT LIMITED, Hartington Street, Glenroy, 3046; T.D.A.27836/66; 23rd October, 1975; 11.65 tonne.

HUTCHINSON, ROBERT LIMITED, Hartington Street, Glenroy, 3046; T.D.A.27836/67; 21st October, 1975; 6.65 tonne; T.D.A.27836/63; 9th October, 1975; 8.15 tonne.

HUTTON, J. C., 60 Oakover Road, Preston, 3072; D.A.48355/22; 9th October, 1975; 1.75 tonne.

KELLY, W. F. L., 455 Macaulay Road, Kensington, 3031; D.A.61200; 16th October, 1975; 0.40 tonne; D.A.61200/1; 16th October, 1975; 0.50 tonne.

M. B. PROPERTIES PTY. LTD., P.O. Box 6, Abbotsford, 3067; D.A.39491/14; 23rd October, 1975; 3.25 tonne.

MAXWELL, B. A., Lyonville, 3456; D.T.1459; 10th October, 1975; 14.10 tonne.

MOLAN, M. A., 6 Grey Street, Terang, 3264; D.A.37797/6; 10th September, 1975; 5.90 tonne.

MULTIPLO, PTY. LTD., 50 Newlands Road, Reservoir, 3073; D.A.64785; 10th October, 1975; 1.40 tonne.

NU BRENT FORD PTY. LTD., 137 Kepler Street, Warrnambool, 3280; D.A.61080/2; 30th September, 1975; 0.70 tonne.

PADDY HOARE PTY. LTD., Station Street, Norlane, 3214; D.A.60286/5; 12th July, 1975; 13.15 tonne.

PETERSVILLE LTD., Wellington Road, Clayton, 3168; D.A.1813/232; 18th October, 1975; 1.25 tonne.

POLITES, A., 15 Fishmarket, Footscray Road, Footscray, 3011; T.D.A.63573; 26th October, 1975; 7.00 tonne.

SHEPPARD REFRIGERATION PTY. LTD., 313 Canterbury Road, Canterbury, 3126; D.A.42537/5; 18th October, 1975; 0.65 tonne.

SMITH, I. J., Lorne Road, Deans Marsh, 3235; D.A.64427/1; 10th October, 1975; 1.85 tonne.

SPERRY RAND AUSTRALIA LTD. (REMINGTON RAND DIVISION), 334-342 City Road, South Melbourne, 3205; D.A.828/16; 18th October, 1975; 0.95 tonne; D.A.828/17; 18th October, 1975; 0.95 tonne.

STRATIGIS, G., 32 Elsa Street, Fawkner, 3060; D.A.61176; 16th October, 1975; 6.75 tonne.

ZAMMIT, M., 12 Myers Street, West Sunshine, 3020; D.A.50240; 30th September, 1975; 6.20 tonne.

TOW TRUCKS.

CARL BOON MOTORS PTY. LTD., 262 Bay Road, Cheltenham, 3192; D.A.52315/2; 11th September, 1975; 3.95 tonne.

LACEY, W. F. (trading as Ellace Motor Body Works), 18 Moray Street, Diamond Creek, 3089; D.A.60850; 11th September, 1975; 2.75 tonne.

KIRKHAM, W. E., P.O. Box 7, Collingwood, 3066; D.A.60659/3; 16th October, 1975; 3.55 tonne.

PANGBOURNE, G. E., 156 Dougharty Road, West Heidelberg, 3081; D.A.66726; 16th October, 1975; 2.30 tonne.

RESERVOIR, THOMASTOWN & WHITTLESEA TOWING SERVICE PTY. LTD., 460 High Street, Preston, 3072; D.A.62700; 9th September, 1975; 1.65 tonne.

RIISING SUN TOWING SERVICE PTY. LTD., 2 Williamstown Road, West Footscray, 3012; D.A.65798; 11th September, 1975; 2.85 tonne.

SNELL, H. PTY. LTD., 43 Emily Street, Seymour, 3660; D.A.46141; 22nd April, 1975; 2.20 tonne.

UNITED TOWING SERVICE PTY. LTD., 628 High Street, Thornbury, 3071; D.A.58930/8; 16th October, 1975; 1.90 tonne.

RENEWAL WITH VARIATION.

Applications made by the person listed hereunder for renewal of the licences listed with variation of conditions in the manner set out opposite the name.

COCA COLA OPERATIONS PTY. LTD., 64 Dawson Street, Brunswick, 3056; D.A.63982/39; 22nd February, 1975; D.A.63982/40; 22nd February, 1975; D.A.63982/41; 15th March, 1975; D.A.63982/42; 29th March, 1975; D.A.63982/44; 29th March, 1975. Application to renew and vary the conditions of licences numbered D.A.63982/39, D.A.63982/40, D.A.63982/41, D.A.63982/42 and D.A.63982/44 (L/C. 7.25, 7.30, 7.30, 7.30 and 7.30 tonne) by deleting from the existing conditions "but excluding any operations to or from the Geelong Urban District (as defined in the Transport Regulations Act 1958).

Notice of any objection should be forwarded to reach the Secretary of the Board not later than 21st May, 1975.

Applicants are advised that it will not be necessary to appear on the hearing date specified above, unless advised in writing by the Board.

A. V. C. COOK,
Secretary.

Corner Lygon and Princes Streets, Carlton, 3053, Wednesday, 7th May, 1975.

Health Act 1958.

VICTORIA—DEPARTMENT OF HEALTH.

NOTICE TO ATTEND FOR RADIOLOGICAL EXAMINATION.

To all persons aged twenty-one years and over enrolled or resident in the subdivisions specified hereunder in the State Electoral District of GREENSBOROUGH.

Take notice that you are required to attend at a Department of Health X-ray Unit sited in the public street at or as near as possible to the main entrance to the premises specified in this notice, at any time between the hours specified on one of the days specified and during the period specified in respect of those premises, and thereat to submit yourself to radiological examination of the chest for the purpose of ascertaining whether you may be suffering from pulmonary tuberculosis. If you have had a Chest X-ray within the last twelve months and for this reason do not wish to be examined now, you should attend the unit as directed and submit particulars of the previous examination.

SPECIFIED SUBDIVISIONS, PREMISES, PERIOD, DAYS AND HOURS.

Subdivision.	Premises.	Period.	Days.	Hours.
Diamond Creek	Shopping Centre, Chute Street, Diamond Creek	Tuesday, 17th June, 1975 to Monday, 23rd June, 1975 (inclusive)	Each day during the period except Saturday, Sunday and Public Holidays	From 10.30 a.m. to 8.30 p.m.
	Plenty Hall, Plenty	Tuesday, 17th June, 1975	Tuesday, 17th June, 1975	From 10.30 a.m. to 8.30 p.m.
	Post Office Store, Ironbark Road, Yarrambat	Tuesday, 17th June, 1975	Tuesday, 17th June, 1975	From 10.30 a.m. to 8.30 p.m.
	Greensborough Pharmacy, 42 Main Street, Greensborough	Wednesday, 18th June, 1975 to Thursday, 26th June, 1975 (inclusive)	Each day during the period except Saturday, Sunday and Public Holidays	From 10.30 a.m. to 8.30 p.m.
	Dowling's Sport Centre, 80 Main Street, Greensborough	Wednesday, 18th June, 1975 to Thursday, 26th June, 1975 (inclusive)	Each day during the period except Saturday, Sunday and Public Holidays	From 10.30 a.m. to 8.30 p.m.
	Park (Opposite School), Eltham North	Tuesday, 24th June, 1975 and Wednesday, 25th June, 1975	Tuesday, 24th June, 1975 and Wednesday, 25th June, 1975	From 10.30 a.m. to 8.30 p.m.
Eltham	Shopping Centre, Were Street, Montmorency	Thursday, 26th June, 1975 to Thursday, 3rd July, 1975 (inclusive)	Each day during the period except Saturday, Sunday and Public Holidays	From 10.30 a.m. to 8.30 p.m.
	Shire Office, Main Road, Eltham	Friday, 27th June, 1975 to Wednesday, 2nd July, 1975 (inclusive)	Each day during the period except Saturday, Sunday and Public Holidays	From 10.30 a.m. to 8.30 p.m.
	Fleur Coiffure, Corner Mountain View and Sherbourne Roads, Briar Hill	Thursday, 3rd July, 1975 to Tuesday, 8th July, 1975 (inclusive)	Each day during the period except Saturday, Sunday and Public Holidays	From 10.30 a.m. to 8.30 p.m.
	Williams Butchery, 65 Main Road, Lower Plenty	Thursday, 3rd July, 1975 to Wednesday, 9th July, 1975 (inclusive)	Each day during the period except Saturday, Sunday and Public Holidays	From 10.30 a.m. to 8.30 p.m.
Bundoora	Caltex Service Station, Cnr. Grimshaw Street and Patricia Avenue, Bundoora	Friday, 4th July, 1975 to Tuesday, 8th July, 1975 (inclusive)	Each day during the period except Saturday, Sunday and Public Holidays	From 10.30 a.m. to 8.30 p.m.
	Shell Service Station, Cnr. Plenty Road and Grimshaw Street, Bundoora	Wednesday, 9th July, 1975 to Monday, 14th July, 1975 (inclusive)	Each day during the period except Saturday, Sunday and Public Holidays	From 10.30 a.m. to 8.30 p.m.
	Car Park, Shopping Centre, Cnr. Plenty Road and Nickson Street, Bundoora	Thursday, 10th July, 1975 to Monday, 14th July, 1975 (inclusive)	Each day during the period except Saturday, Sunday and Public Holidays	From 10.30 a.m. to 8.30 p.m.
	Car Park, Cnr. Morwell Avenue and Watsonia Road, Watsonia	Tuesday, 15th July, 1975 to Monday, 21st July, 1975 (inclusive)	Each day during the period except Saturday, Sunday and Public Holidays	From 10.30 a.m. to 8.30 p.m.
Rosanna East	Yallambie Park Pre-School and Infant Welfare Centre, Cnr. Yallambie Road and Binowee Avenue, MacLeod	Tuesday, 15th July, 1975 to Thursday, 17th July, 1975 (inclusive)	Each day during the period except Public Holidays	From 10.30 a.m. to 8.30 p.m.
	Korbatieh's Milk Bar, Cnr. Martin's Lane and Grantham Road, Rosanna East	Friday, 18th July, 1975 to Tuesday, 22nd July, 1975 (inclusive)	Each day during the period except Saturday, Sunday and Public Holidays	From 10.30 a.m. to 8.30 p.m.
	Cnr. Rosanna and Lower Plenty Roads, Rosanna East	Tuesday, 22nd July, 1975 to Friday, 25th July, 1975 (inclusive)	Each day during the period except Public Holidays	From 10.30 a.m. to 8.30 p.m.
	Hall's Pharmacy, 70 Aberdeen Road, MacLeod	Wednesday, 23rd July, 1975 to Wednesday, 30th July, 1975 (inclusive)	Each day during the period except Saturday, Sunday and Public Holidays	From 10.30 a.m. to 8.30 p.m.

NOTICE TO ATTEND FOR RADIOLOGICAL EXAMINATION.—*continued.*

Subdivision.	Premises.	Period.	Days.	Hours.
Rosanna East — <i>continued.</i>	Griffiths Pharmacy, 51 Greville Road, Rosanna	Monday, 28th July, 1975 to Wednesday, 30th July, 1975 (inclusive)	Each day during the period except Public Holidays	From 10.30 a.m. to 8.30 p.m.
Rosanna ..	Ampol Service Station, Cnr. Beetham Parade and Lower Plenty Road, Rosanna	Tuesday, 22nd July, 1975 to Wednesday, 30th July, 1975 (inclusive)	Each day during the period except Saturday, Sunday and Public Holidays	From 10.30 a.m. to 8.30 p.m.

NOTE : Any person to whom this notice applies and who without reasonable excuse fails to comply with the requirements of the notice shall be guilty of an offence, and shall be liable to a penalty of not more than five hundred dollars.

Dated this twenty-third day of April, One thousand nine hundred and seventy-five.

B. P. McCLOSKEY, Chief Health Officer.

Private Agents Act 1966.

NOTICE OF RECEIPT OF APPLICATIONS FOR LICENCES UNDER THE PROVISIONS OF THE PRIVATE AGENTS ACT 1966.

The Clerk(s) of the Magistrates' Court(s) as listed hereunder hereby give notice that applications, as under, have been lodged for hearing by the said Court(s) on the date(s) specified.

Any person desiring to object to any of such applications must—

- (a) lodge with the respective Clerk of the Magistrates' Court a notice in the prescribed form of his objection and of the grounds thereof ;
- (b) cause a copy of such notice to be served personally or by post upon the applicant at least three days before the hearing of the application ; and
- (c) send or deliver—
 - (i) where the objection is not made by the officer in charge of the police district in which the Court is situated—a copy of the notice to such officer ; and
 - (ii) where the objection is not made by the Registrar or Deputy Registrar—a copy to the Registrar.

Full Name of Applicant or in the Case of a Firm or Corporation, of the Nominee.	Place of Abode of Applicant or Nominee.	Name of Firm or Corporation.	Address for Registration.	Type of Licence.	Date of Hearing of Application.
---	---	------------------------------	---------------------------	------------------	---------------------------------

MAGISTRATES' COURT, COBURG.

Mete, Brian	24 Marlborough Street, Fawkner	Mayne Nickless Limited	94 York Street, South Melbourne	Watchman ..	28.5.75
---------------------	--------------------------------	------------------------	---------------------------------	-------------	---------

Dated at Coburg this 1st day of May, 1975.

B. MANSBRIDGE, Clerk of the Magistrates' Court.

MAGISTRATES' COURT, OAKLEIGH.

Phillips, Thomas Douglas ..	31 Belvedere Road, Seaford	Mayne Nickless Limited	72-74 Atkinson Street, Oakleigh	Watchman ..	23.5.75
Glass, Richard	48 Jacqueline Road, Bundoora	Rae Alexander Anthony Kent	523 Neerim Road, Murrumbena	" ..	"
Heithan, Roger Mark	10 John Street, East Bentleigh	" ..	" ..	" ..	"

Dated at Oakleigh this 1st day of May, 1975.

B. R. JENNINGS, Clerk of the Magistrates' Court.

MAGISTRATES' COURT, FERNTREE GULLY.

Rahaley, John Lawrence ..	37 Arcadia Avenue, The Basin	" ..	37 Arcadia Avenue, The Basin	Commercial Agent ..	23.5.75
---------------------------	------------------------------	------	------------------------------	---------------------	---------

Dated at Ferntree Gully this 1st day of May, 1975.

T. BEDOHAZY, Clerk of the Magistrates' Court.

MAGISTRATES' COURT, BENDIGO.

Crimmins, Ronald George ..	6 McCalman Court, Bendigo	" ..	6 McCalman Court, Bendigo	Process Server ..	21.5.75
----------------------------	---------------------------	------	---------------------------	-------------------	---------

Dated at Bendigo this 29th day of April, 1975.

R. N. HOLLIS, Clerk of the Magistrates' Court.

MAGISTRATES' COURT, SOUTH MELBOURNE.

Alexander, Ian Charles ..	10 Mindara Court, Werribee	Mayne Nickless Limited	94 York Street, South Melbourne	Watchman ..	23.5.75
---------------------------	----------------------------	------------------------	---------------------------------	-------------	---------

Dated at South Melbourne this 1st day of May, 1975.

IAN CLOAK, Clerk of the Magistrates' Court.

MAGISTRATES' COURT, MELTON.

Hudson, Keith Henry ..	173 Station Road, Melton South	" ..	173 Station Road, Melton South	Process Server ..	20.5.75
Druitt, Murray Weil ..	5 Clowes Street, Melton South	" ..	5 Clowes Street, Melton South	Inquiry Agent ..	20.5.75
"	" ..	" ..	" ..	Process Server ..	"

Dated at Melton this 25th day of April, 1975.

R. P. RYAN, Clerk of the Magistrates' Court.

MAGISTRATES' COURT, WARRNAMBOOL.

Brown, Peter Allan	47 Flaxman Street, Warrnambool	" ..	47 Flaxman Street, Warrnambool	Process Server ..	13.5.75
--------------------------	--------------------------------	------	--------------------------------	-------------------	---------

Dated at Warrnambool this 23rd day of April, 1975.

P. J. LIVINGSTONE, Clerk of the Magistrates' Court.

PRIVATE AGENTS—*continued.*

Full Name of Applicant or in the Case of a Firm or Corporation, of the Nominee.	Place of Abode of Applicant or Nominee.	Name of Firm or Corporation.	Address for Registration.	Type of Licence.	Date of Hearing of Application.
MAGISTRATES' COURT, BOX HILL.					
Birmingham, William Richard	20 Cootamundra Crescent, Blackburn	20 Cootamundra Crescent, Blackburn	Process Server Guard Agent Inquiry Agent	23.5.75
Birmingham, Gail Maree	" " "	" " "	Guard Agent Inquiry Agent	"
Dated at Box Hill this 24th day of April, 1975.					
K. T. RYAN, Clerk of the Magistrates' Court.					
MAGISTRATES' COURT, MELBOURNE.					
Gumbleton, Glen Francis	14 Faussett Street, Albert Park	Brambles Limited	Brinks Cnr. Arden and Lothian Streets, North Melbourne	Watchman	4.6.75
Mawson, Ian Douglas	8/574 St. Kilda Road, Melbourne	" " "	" " "	"	4.6.75
Smith, Anthony Leonard	12 Warwick Road, Greensborough	" " "	" " "	"	4.6.75
Dated at Melbourne this 28th day of April, 1975.					
G. L. WEBSTER, Clerk of the Magistrates' Court.					
MAGISTRATES' COURT, CAMBERWELL.					
Daley, John Michael	16 Taranto Drive, Noble Park	119 Balwyn Road, Balwyn	Process Server	21.5.75
Weinberg, Ivan J.	13/41 Balaclava Road, Balaclava	119 Balwyn Road, Balwyn	Process Server	21.5.75
Miles, Glenda Jean	6/15 Waratah Avenue, Balaclava	119 Balwyn Road, Balwyn	Process Server	21.5.75
Daley, John M.	16 Taranto Drive, Noble Park	119 Balwyn Road, Balwyn	Commercial Sub-Agent	21.5.75
Weinberg, Ivan J.	13/41 Balaclava Road, Balaclava	119 Balwyn Road, Balwyn	Commercial Sub-Agent	21.5.75
Dated at Camberwell this 25th day of April, 1975.					
J. C. TOBIN, Clerk of the Magistrates' Court.					
MAGISTRATES' COURT, FRANKSTON.					
Fraser, Bernard Anthony	2 Lobator Street, Frankston	2 Lobator Street, Frankston	Watchman	15.5.75
Dated at Frankston this 24th day of April, 1975.					
J. BOUNDY, Clerk of the Magistrates' Court.					
MAGISTRATES' COURT, SOUTH MELBOURNE.					
Smyth, John Raymond	24 Tucker Street, Fawkner	Mayne Nickless Pty. Ltd.	94 York Street, South Melbourne	Watchman	27.5.75
Dated at South Melbourne this 29th day of April, 1975.					
J. A. HANRAHAN, Clerk of the Magistrates' Court.					
MAGISTRATES' COURT, PORT MELBOURNE.					
Hughes, Keiran John	7 Welton Court, Deer Park	Mayne Nickless Limited	538 Williamstown Road, Port Melbourne	Watchman	27.5.75
Dated at Port Melbourne this 29th day of April, 1975.					
JOHN ARDLIE, Clerk of the Magistrates' Court.					
MAGISTRATES' COURT, BOX HILL.					
Noble, Robert Bruce	51 Timms Avenue, Kilsyth	Mayne Nickless Limited	94 York Street, South Melbourne	Watchman	30.5.75
Dated at Box Hill this 30th day of April, 1975.					
M. DEVINY, Clerk of the Magistrates' Court.					
MAGISTRATES' COURT, FRANKSTON.					
Munroe, Thomas Frederick	3/23 Fairway Street, Frankston	127 Cranbourne Road, Frankston	Watchman	22.5.75
Dated at Frankston this 29th day of April, 1975.					
J. BOUNDY, Clerk of the Magistrates' Court.					

COMMONWEALTH OF AUSTRALIA.

Petroleum (Submerged Lands) Act 1967-1974.

STATE OF VICTORIA.

Petroleum (Submerged Lands) Act 1967.

NOTICE OF APPLICATION FOR PIPELINE LICENCE.

Hematite Petroleum Proprietary Limited and Esso Exploration and Production Australia Inc. of 140 William Street, Melbourne and C/- Price, Waterhouse Nominees (Victoria) Proprietary Limited of 447 Collins Street, Melbourne respectively have applied for a pipeline licence in respect of the construction of a 324 mm pipeline along the route and in the position described hereunder for the conveyance of petroleum between the Tuna A platform situated as described below in Licence Area VIC/L9 and the Marlin A platform situated as described below in Licence Area VIC/L3 of which they are registered holders.

Route and Position of Pipeline.

Between the Tuna A platform proposed for construction at or about Latitude 38 deg. 10 min. 19 sec. South Longitude 148 deg. 25 min. 04 sec. East and the Marlin A platform situated at or about Latitude 38 deg. 13 min. 55 sec. South and Longitude 148 deg. 13 min. 10 sec. East along the sea bed.

Dated this 24th day of April, 1975.

Made under the *Petroleum (Submerged Lands) Act 1967-1974* of the Commonwealth of Australia. Made under the *Petroleum (Submerged Lands) Act 1967* of the State of Victoria.

JIM BALFOUR,
Designated Authority.

COMMONWEALTH OF AUSTRALIA.

Petroleum (Submerged Lands) Act 1967-1974.

STATE OF VICTORIA.

Petroleum (Submerged Lands) Act 1967.

NOTICE OF APPLICATION FOR PIPELINE LICENCE.

Hematite Petroleum Proprietary Limited and Esso Exploration and Production Australia Inc. of 140 William Street, Melbourne and C/- Price, Waterhouse Nominees (Victoria) Proprietary Limited of 447 Collins Street, Melbourne respectively have applied for a pipeline licence in respect of the construction of a 219 mm pipeline along the route and in the position described hereunder for the conveyance of petroleum between the Tuna A platform situated as described below in Licence Area VIC/L9 and the Marlin A platform situated as described below in Licence Area VIC/L3 of which they are registered holders.

Route and Position of Pipeline.

Between the Tuna A platform proposed for construction at or about Latitude 38 deg. 10 min. 19 sec. South Longitude 148 deg. 25 min. 04 sec. East and the Marlin A platform situated at or about Latitude 38 deg. 13 min. 55 sec. South and Longitude 148 deg. 13 min. 10 sec. East along the sea bed.

Dated this 24th day of April, 1975.

Made under the *Petroleum (Submerged Lands) Act 1967-1974* of the Commonwealth of Australia. Made under the *Petroleum (Submerged Lands) Act 1967* of the State of Victoria.

JIM BALFOUR,
Designated Authority.

COMMONWEALTH OF AUSTRALIA.

Petroleum (Submerged Lands) Act 1967-1974.

STATE OF VICTORIA.

Petroleum (Submerged Lands) Act 1967.

NOTICE OF APPLICATION FOR PIPELINE LICENCE.

Hematite Petroleum Proprietary Limited and Esso Exploration and Production Australia Inc. of 140 William Street, Melbourne and C/- Price, Waterhouse Nominees (Victoria) Proprietary Limited of 447 Collins Street, Melbourne respectively have applied for a pipeline licence in respect of the construction of a 324 mm pipeline along the route and in the position described hereunder for the conveyance of petroleum between the Marlin A platform situated as described below in Licence Area VIC/L3 and a branch valve situated as described below on a pipeline licensed by Pipeline Licence VIC/PL 5 of which they are registered holders.

Route and Position of Pipeline.

Between the Marlin A platform situated at or about Latitude 38 deg. 13 min. 55 sec. South and Longitude 148 deg. 13 min. 10 sec. East along the sea bed to a branch valve situated at or about Latitude 38 deg. 14 min. 24 sec. South Longitude 148 deg. 14 min. 05 sec. East on a pipeline licensed by Pipeline Licence VIC/PL5.

Dated this 24th day of April, 1975.

Made under the *Petroleum (Submerged Lands) Act 1967-1974* of the Commonwealth of Australia. Made under the *Petroleum (Submerged Lands) Act 1967* of the State of Victoria.

JIM BALFOUR,
Designated Authority.

COMMONWEALTH OF AUSTRALIA.

Petroleum (Submerged Lands) Act 1967-1974.

STATE OF VICTORIA.

Petroleum (Submerged Lands) Act 1967.

NOTICE OF APPLICATION FOR PIPELINE LICENCE.

Hematite Petroleum Proprietary Limited and Esso Exploration and Production Australia Inc. of 140 William Street, Melbourne and C/- Price, Waterhouse Nominees (Victoria) Proprietary Limited of 447 Collins Street, Melbourne respectively have applied for a pipeline licence in respect of the construction of a 324 mm pipeline along the route and in the position described hereunder for the conveyance of petroleum between the proposed Mackerel A platform situated as described below in Licence Area VIC/L5 and the Halibut A platform situated as described below in Licence Area VIC/L5 of which they are registered holders.

Route and Position of Pipeline.

Between the Mackerel A platform proposed for construction at or about Latitude 38 deg. 28 min. 47 sec. South Longitude 148 deg. 20 min. 34 sec. East and the Halibut A platform situated at or about Latitude 38 deg. 24 min. 21 sec. South and Longitude 148 deg. 19 min. 10 sec. East along the sea bed.

Dated this 24th day of April, 1975.

Made under the *Petroleum (Submerged Lands) Act 1967-1974* of the Commonwealth of Australia. Made under the *Petroleum (Submerged Lands) Act 1967* of the State of Victoria.

JIM BALFOUR,
Designated Authority.

COMMONWEALTH OF AUSTRALIA.

Petroleum (Submerged Lands) Act 1967-1974.

STATE OF VICTORIA.

Petroleum (Submerged Lands) Act 1967.

CANCELLATION OF INVITATION OF APPLICATIONS FOR PERMIT—BLOCKS DETERMINED.

I, James Charles Murray Balfour, Minister of Mines for the State of Victoria, the Designated Authority in respect of the area specified as being adjacent to the State of Victoria advise that the invitation appearing on page 905 of the *Victoria Government Gazette* No. 28 of April 23, 1975, seeking applications for the grant of a permit for the block constituted by graticular section numbered 1847 and the blocks constituted by those parts of graticular sections numbered 1775, 1776 and 1777 which lie to the south of the line comprised of geodesics consecutively joining points as follows:—

from the point defined by latitude 38 deg. 05 min. south, longitude 147 deg. 49 min. east, to the point defined by latitude 38 deg. 02 min. south, longitude 147 deg. 56 min. east, and thence to the point defined by latitude 38 deg. 00 min. south, longitude 148 deg. 02 min. east, is hereby cancelled.

Dated this 2nd day of May, 1975.

Made under the *Petroleum (Submerged Lands) Act 1967-1974* of the Commonwealth of Australia. Made under the *Petroleum (Submerged Lands) Act 1967* of the State of Victoria.

JIM BALFOUR,
Designated Authority.

LOCAL GOVERNMENT DEPARTMENT.

NOTICE OF APPROVAL OF AGREEMENT TO FORM THE MALLEE VALUATION GROUP.

In pursuance of the provisions of section 254 (10) of the *Local Government Act 1958*, the Governor-in-Council on the twenty-ninth day of April, 1975, approved an agreement made on the 26th October, 1973 between the Mayors, Councillors and Citizens of the Cities of Mildura and Swan Hill and the Presidents, Councillors and Ratepayers of the Shires of Birchip, Karkaroc, Swan Hill, Walpeup and Wycheproof, to form a valuation group to be known as the Mallee Valuation Group, to make valuations under Part X. of the said Act for the municipalities which are members of the group.

TOM FORRISTAL,
Clerk of the Executive Council.

LOCAL GOVERNMENT DEPARTMENT.

ORDER CONFIRMED.—SHIRE OF CHILTERN.

The Minister of the Crown administering the *Local Government Act 1958*, on the 24th day of April, 1975, confirmed the Order hereinafter referred to in pursuance of section 514 of the said Act namely:

An Order of the Council of the Shire of Chiltern made on the 5th August 1974 directing the compulsory taking of the lands described in Crown Grants Volume 318 Folio 518 and Volume 543 Folio 401 for the purposes of erecting a Senior Citizens Club.

A. J. HUNT,
Minister for Local Government.

Local Government Department,
Melbourne (75/0297).

Soil Conservation and Land Utilization Act 1958.
TYERS RIVER WATER SUPPLY CATCHMENT.

NOTICE OF DETERMINATION OF LAND USE.

Proclaimed 30th January 1963, *Victoria Government Gazette* No. 16 dated 6th March 1963, pursuant to Section 22 (1) of the *Soil Conservation and Land Utilization Act 1958*.

In pursuance of the provisions of Section 23, sub-section (1) of the *Soil Conservation and Land Utilization Act 1958*, the Soil Conservation Authority, after consultation with the Land Conservation Council, has determined the land use for all that land in the Parishes of Telbit, Telbit West, Walhalla, Bundowra, Moondarra, Numbruk, Tanjil, Tanjil East and Boola Boola within the boundaries of the Tyers River Water Supply Catchment delineated and marked on Plan No. 1136, the original of which is lodged at the Head Office of the Soil Conservation Authority. All land within this area shall be used in accordance with the particular category of land use to which the area has been assigned. The boundaries of land use categories shown on Plan No. S-114 are intended as a guide to persons and departments involved in the area, who should consult with the Soil Conservation Authority before making any changes in land use.

The provisions of individual land use categories are set out below and should read in conjunction with the Determination plan.

Category Number.	Land Category.	Provisions of Category.
1	Land to be retained in an undisturbed state for the protection of watercourses, streams and reservoirs Covers land— within 200 metres of Moondarra Reservoir foreshore ; within 200 metres of the Erica Waterworks Trust Diversion Weir ; within 40 metres of the Tyers River up to the Tyers Junction and Jacob's Creek to the Walhalla Road ; within 20 metres of all other streams and specified drainage lines	A. No further clearing, cultivation, earthworks, buildings or construction of stream crossings will be permitted without the specific approval of the Soil Conservation Authority B. Improvements in the location of and design of existing stream crossings may be required by the Soil Conservation Authority
2	Land of elevation greater than 1220 metres which shall be used and managed primarily for water catchment purposes Low intensity forms of use such as recreation are suitable, provided the area is retained in a basically undisturbed state.	No change in land use will be allowed without the specific approval of the Soil Conservation Authority
3	Land to be retained as forest. This land is generally suitable for hardwood timber production and low intensity recreation, and parts are suitable for more intensive forestry and recreational uses	Forestry and other developmental operations may be carried out only in accordance with management conditions made or approved by the Soil Conservation Authority
4	Land primarily suitable for forest operations—parts of which may be suitable for development for grazing or cropping purposes	A. Forestry operations may be carried out only in accordance with forest management conditions approved by the Soil Conservation Authority B. Soil Conservation Authority approval required before any part of this category is developed for grazing or agriculture C. Soil conservation practices will be specified when necessary
5	Land suitable for grazing (low intensity agriculture)	Cultivation for pasture establishment and maintenance will be permitted subject to conditions which may include the length of the rotation and soil conservation practices where necessary
6	Land suitable for cropping (high intensity agriculture) and other intensive uses as approved	From time to time, conditions may be imposed and may include specifications of length of rotation and soil conservation practices where necessary

General provisions applying to all categories.

Prior Soil Conservation Authority approval is necessary before any development associated with residential use or recreation is carried out in the catchment.

Prior Soil Conservation Authority approval is necessary before any earthworks, including roadworks and mining, are carried out within the catchment.

From time to time the Soil Conservation Authority may require that existing roads in the catchment be upgraded.

Subdivision of land requires Soil Conservation Authority approval.

PLAN No. 5114

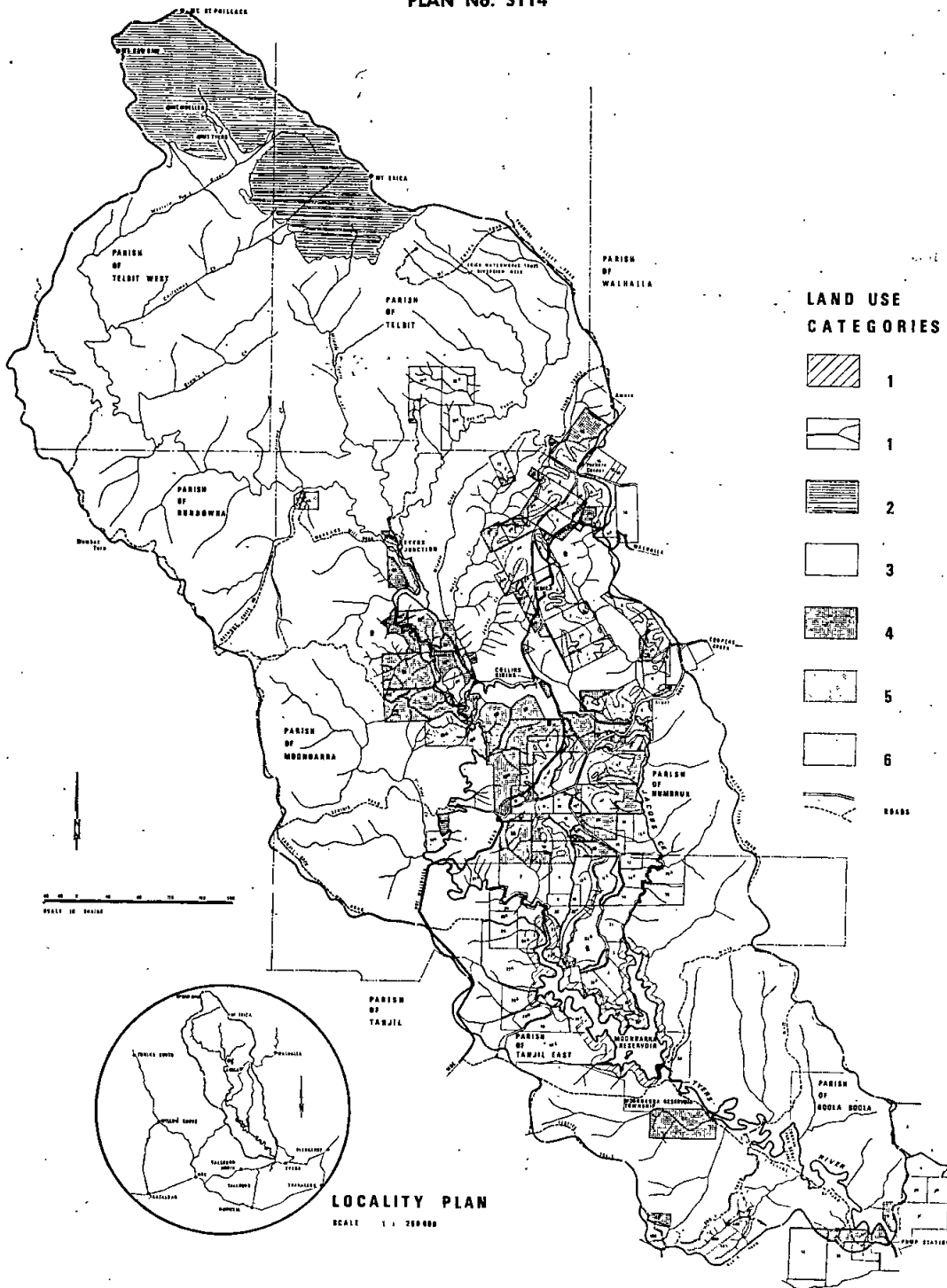

A. T. Secretary.

NOTICES FOR PUBLIC OFFICERS.

The attention of public officers is directed to the notice appearing under Tenders in this issue relative to the provision of taxi and hire cars for Victorian Government Departments and Authorities in the Bendigo district in respect to the remainder of the current contract period which terminates on the 30th June, 1976.

NOTICE.

An auction of unclaimed and confiscated liquor in the possession of the Police will be held at the premises at 43 Little Bourke Street, Melbourne, at 10 a.m. on Tuesday, 10th June, 1975.

R. JACKSON,
Chief Commissioner of Police.

TEACHING SERVICE ACT 1958, SECTION 73.

PUBLIC SERVICE ACT 1958, SECTIONS 55 AND 56.

It is hereby notified that a charge of being absent without leave from the 4th February, 1974, to the 23rd August, 1974, has been preferred against Mr. Garry Arthur Weaven, Teacher, Record No. 911005, Assistant Class, Secondary Schools Division, Education Department, under section 73 of the *Teaching Service Act 1958* which applies to the *Teaching Service* the provisions of sections 55 and 56 of the *Public Service Act 1958* and that a certified letter asking her whether she admits or denies the truth of the charge (posted to his last known address, viz., 8 Wilmoth Street, Northcote, 3070), has not been replied to.

A further letter has been forwarded to the said Garry Arthur Weaven at the last known address referred to, advising him that unless he admits or denies the truth of the charge in writing to the Teachers Tribunal by the 28th May, 1975, he shall be deemed to deny the truth of the charge and the investigation thereof will be proceeded with at 1.15 p.m. on Thursday, 29th May, 1975, at the office of the Teachers Tribunal, Royal Mint Building, corner William and La Trobe Streets, Melbourne.

By Order,

A. F. LE CLERCQ,
Secretary.

Office of the Teachers Tribunal,
Melbourne, 2nd May, 1975.

TEACHING SERVICE ACT 1958, SECTION 73.

PUBLIC SERVICE ACT 1958, SECTIONS 55 AND 56.

It is hereby notified that a charge of being absent without leave from the 5th February, 1973, to the 17th December, 1974, has been preferred against Miss Mary Celeste Baird, Record No. 915827, Teacher, Assistant Class, Secondary Schools Division, Education Department, under section 73 of the *Teaching Service Act 1958* which applies to the *Teaching Service* the provisions of sections 55 and 56 of the *Public Service Act 1958* and that a certified letter asking her whether she admits or denies the truth of the charge (posted to her last known address, viz., 7 Thomas Avenue, Moorabbin, 3189), has been returned unclaimed.

A further letter has been forwarded to the said Mary Celeste Baird at the last known address referred to, advising her that unless she admits or denies the truth of the charge in writing to the Teachers Tribunal by the 28th May, 1975, she shall be deemed to deny the truth of the charge and the investigation thereof will be proceeded with at 10.00 a.m. on the 29th May, 1975, at the office of the Teachers Tribunal, Royal Mint Building, corner William and La Trobe Streets, Melbourne.

By Order,

A. F. LE CLERCQ,
Secretary.

Office of the Teachers Tribunal,
Melbourne, 2nd May, 1975.

TEACHING SERVICE ACT 1958, SECTION 73.

PUBLIC SERVICE ACT 1958, SECTIONS 55 AND 56.

It is hereby notified that a charge of being absent without leave from the 22nd July, 1974, to the 31st October, 1974, has been preferred against Miss Rosalie Edith Bandt, Record No. 1026434, Teacher, Assistant Class, Secondary Schools Division, Education Department, under section 73 of the *Teaching Service Act 1958* which applies to the *Teaching Service* the provisions of sections 55 and 56 of the *Public Service Act 1958* and that a certified letter asking her whether she admits or denies the truth of the charge (posted to her last known address, viz., 20 Holroyd Court, Blackburn South, 3130), has been returned unclaimed.

A further letter has been forwarded to the said Rosalie Edith Bandt at the last known address referred to, advising her that unless she admits or denies the truth of the charge in writing to the Teachers Tribunal by the 28th May, 1975, she shall be deemed to deny the truth of the charge and the investigation thereof will be proceeded with at 10.15 a.m. on the 29th May, 1975, at the office of the Teachers Tribunal, Royal Mint Building, corner William and La Trobe Streets, Melbourne.

By Order,

A. F. LE CLERCQ,
Secretary.

Office of the Teachers Tribunal,
Melbourne, 2nd May, 1975.

TEACHING SERVICE ACT 1958, SECTION 73.

PUBLIC SERVICE ACT 1958, SECTIONS 55 AND 56.

It is hereby notified that a charge of being absent without leave from the 4th February, 1974, to the 11th November, 1974, has been preferred against Miss Judith Elaine Cawcutt, Record No. 1003918, Teacher, Assistant Class, Primary Schools Division, Education Department, under section 73 of the *Teacher Service Act 1958* which applies to the *Teaching Service* the provisions of sections 55 and 56 of the *Public Service Act 1958* and that a certified letter asking her whether she admits or denies the truth of the charge (posted to her last known address, viz., "Glen View", Fairbank Road, Arawarra, via Korumburra, 3950), has been returned unclaimed.

A further letter has been forwarded to the said Judith Elaine Cawcutt at the last known address referred to, advising her that unless she admits or denies the truth of the charge in writing to the Teachers Tribunal by the 28th May, 1975, she shall be deemed to deny the truth of the charge and the investigation thereof will be proceeded with at 10.30 a.m. on the 29th May, 1975, at the office of the Teachers Tribunal, Royal Mint Building, corner William and La Trobe Streets, Melbourne.

By Order,

A. F. LE CLERCQ,
Secretary.

Office of the Teachers Tribunal,
Melbourne, 2nd May, 1975.

TEACHING SERVICE ACT 1958, SECTION 73.

PUBLIC SERVICE ACT 1958, SECTIONS 55 AND 56.

It is hereby notified that a charge of being absent without leave from the 8th June, 1974, to the 23rd October, 1974, has been preferred against Mrs. Rhonda June Draper, Record No. 552169, Teacher, Assistant Class, Primary Schools Division, Education Department, under section 73 of the *Teaching Service Act 1958* which applies to the *Teaching Service* the provisions of sections 55 and 56 of the *Public Service Act 1958* and that a certified letter asking her whether she admits or denies the truth of the charge (posted to her last known address, viz., Flat 10, 174 George Street, East Melbourne, 3002), has been returned unclaimed.

A further letter has been forwarded to the said Rhonda June Draper at the last known address referred to, advising her that unless she admits or denies the truth of the charge in writing to the Teachers Tribunal by the 28th May, 1975, she shall be deemed to deny the truth of the charge and the investigation thereof will be proceeded with at 10.45 a.m. on the 29th May, 1975, at the office of the Teachers Tribunal, Royal Mint Building, corner William and La Trobe Streets, Melbourne.

By Order,

A. F. LE CLERCQ,
Secretary.

Office of the Teachers Tribunal,
Melbourne, 2nd May, 1975.

TEACHING SERVICE ACT 1958, SECTION 73.

PUBLIC SERVICE ACT 1958, SECTIONS 55 AND 56.

It is hereby notified that a charge of being absent without leave from the 4th February, 1974, to the 17th December, 1974, has been preferred against Miss Annette Stark, Teacher, Record No. 973384, Assistant Class, Secondary Schools Division, Education Department, under section 73 of the *Teaching Service Act 1958* which applies to the *Teaching Service* the provisions of sections 55 and 56 of the *Public Service Act 1958* and that a certified letter asking her whether she admits or denies the truth of the charge (posted to her last known address, viz., 42 Bertram Street, Gardenvale, 3185) has not been replied to.

A further letter has been forwarded to the said Annette Starke at the last known address referred to, advising her that unless she admits or denies the truth of the charge in writing to the Teachers Tribunal by the 28th May, 1975, she shall be deemed to deny the truth of the charge and the investigation thereof will be proceeded with at 1.00 p.m. on the 29th May, 1975, at the office of the Teachers Tribunal, Royal Mint Building, corner William and La Trobe Streets, Melbourne.

By Order,

A. F. LE CLERCQ,
Secretary.

Office of the Teachers Tribunal,
Melbourne, 2nd May, 1975.

TEACHING SERVICE ACT 1958, SECTION 73.

PUBLIC SERVICE ACT 1958, SECTIONS 55 AND 56.

It is hereby notified that a charge of being absent without leave from the 4th February, 1974 to the 13th September, 1974 has been preferred against Mr. Terrence Leo Werner, Teacher, Record No. 1038938, Assistant Class, Secondary Schools Division, Education Department, under section 73 of the *Teaching Service Act 1958* which applies to the Teaching Service the provisions of sections 55 and 56 of the *Public Service Act 1958* and that a certified letter asking him whether he admits or denies the truth of the charge (posted to his last known address, viz., Flat 6/85 Carlisle Street, St. Kilda, 3182) has been returned unclaimed.

A further letter has been forwarded to the said Terrence Leo Werner at the last known address referred to, advising him that unless he admits or denies the truth of the charge in writing to the Teachers Tribunal by the 28th May, 1975, he shall be deemed to deny the truth of the charge and the investigation thereof will be proceeded with at 12.45 p.m. on the 29th May 1975, at the office of the Teachers Tribunal, Royal Mint Building, corner William and La Trobe Streets, Melbourne.

By Order,

A. F. LE CLERCQ,
Secretary.

Office of the Teachers Tribunal,
Melbourne, 2nd May, 1975.

TEACHING SERVICE ACT 1958, SECTION 73.

PUBLIC SERVICE ACT 1958, SECTIONS 55 AND 56.

It is hereby notified that a charge of being absent without leave from the 4th February, 1974, to the 5th August, 1974, has been preferred against Miss Sally Ann Griffin, Teacher, Record No. 1100183, Assistant Class, Secondary Schools Division, Education Department, under section 73 of the *Teaching Service Act 1958* which applies to the Teaching Service the provisions of sections 55 and 56 of the *Public Service Act 1958* and that a certified letter asking her whether she admits or denies the truth of the charge (posted to her last known address, viz., 12 Alison Avenue, Devonport, Tasmania, 7310), has not been replied to.

A further letter has been forwarded to the said Sally Ann Griffin at the last known address referred to advising her that unless she admits or denies the truth of the charge in writing to the Teachers Tribunal by the 28th May, 1975, she shall be deemed to deny the truth of the charge and the investigation thereof will be proceeded with at 11.30 a.m. on the 29th May, 1975, at the office of the Teachers Tribunal, Royal Mint Building, corner William and La Trobe Streets, Melbourne.

By Order,

A. F. LE CLERCQ,
Secretary.

Office of the Teachers Tribunal,
Melbourne, 2nd May, 1975.

TEACHING SERVICE ACT 1958, SECTION 73.

PUBLIC SERVICE ACT 1958, SECTIONS 55 AND 56.

It is hereby notified that a charge of being absent without leave from the 23rd February, 1974, to the 16th September, 1974, has been preferred against Miss Betty Dorothy Gawthorne, Record No. 1034398, Teacher, Assistant Class, Secondary Schools Division, Education Department, under section 73 of the *Teaching Service Act 1958* which applies to the Teaching Service the provisions of sections 55 and 56 of the *Public Service Act 1958* and that a certified letter asking her whether she admits or denies the truth of the charge (posted to her last known address, viz., 33 Jackson Road, Highett, 3190), has been returned unclaimed.

A further letter has been forwarded to the said Betty Dorothy Gawthorne at the last known address referred to, advising her that unless she admits or denies the truth of the charge in writing to the Teachers Tribunal by the 28th May, 1975, she shall be deemed to deny the truth of the charge and the investigation thereof will be proceeded with at 11.00 a.m. on the 29th May, 1975, at the office of the Teachers Tribunal, Royal Mint Building, corner William and La Trobe Streets, Melbourne.

By Order,

A. F. LE CLERCQ,
Secretary.

Office of the Teachers Tribunal,
Melbourne, 2nd May, 1975.

TEACHING SERVICE ACT 1958, SECTION 73.

PUBLIC SERVICE ACT 1958, SECTIONS 55 AND 56.

It is hereby notified that a charge of being absent without leave from the 6th June, 1974, to the 4th October, 1974, has been preferred against Mrs. Sandra Mary Pace, Record No. 854319, Assistant Class, Primary Schools Division, Education Department, under section 73 of the *Teaching Service Act 1958* which applies to the Teaching Service the provisions of sections 55 and 56 of the *Public Service Act 1958* and that a certified letter asking her whether she admits or denies the truth of the charge (posted to her last known address, viz., 5 Monak Place, Macleod, 3085), has not been replied to.

A further letter has been forwarded to the said Sandra Mary Pace at the last known address referred to, advising her that unless she admits or denies the truth of the charge in writing to the Teachers Tribunal by the 28th May, 1975, she shall be deemed to deny the truth of the charge and the investigation thereof will be proceeded with at 11.45 a.m. on the 29th May, 1975, at the office of the Teachers Tribunal, Royal Mint Building, corner William and La Trobe Streets, Melbourne.

By Order,

A. F. LE CLERCQ,
Secretary.

Office of the Teachers Tribunal,
Melbourne, 2nd May, 1975.

TEACHING SERVICE ACT 1958, SECTION 73.

PUBLIC SERVICE ACT 1958, SECTIONS 55 AND 56.

It is hereby notified that a charge of being absent without leave from the 20th September, 1974, to the 25th November, 1974, has been preferred against Miss Vincenza Giampietro, Record No. 967374, Teacher, Assistant Class, Secondary Schools Division, Education Department, under section 73 of the *Teaching Service Act 1958* which applies to the Teaching Service the provisions of sections 55 and 56 of the *Public Service Act 1958* and that a certified letter asking her whether she admits or denies the truth of the charge (posted to her last known address, viz., 18 Daley Street, Pascoe Vale, 3044), has been returned unclaimed.

A further letter has been forwarded to the said Vincenza Giampietro at the last known address referred to, advising her that unless she admits or denies the truth of the charge in writing to the Teachers Tribunal by the 28th May, 1975, she shall be deemed to deny the truth of the charge and the investigation thereof will be proceeded with at 11.15 a.m. on the 29th May, 1975, at the office of the Teachers Tribunal, Royal Mint Building, corner William and La Trobe Streets, Melbourne.

By Order,

A. F. LE CLERCQ,
Secretary.

Office of the Teachers Tribunal,
Melbourne, 2nd May, 1975.

TEACHING SERVICE ACT 1958, SECTION 73.

PUBLIC SERVICE ACT 1958, SECTIONS 55 AND 56.

It is hereby notified that a charge of being absent without leave from the 11th May, 1973, to the 10th October, 1974, has been preferred against Mr. Narendra K. Radia, Teacher, Record No. 1495472, Assistant Class, Secondary Schools Division, Education Department, under section 73 of the *Teaching Service Act 1958* which applies to the Teaching Service the provisions of sections 55 and 56 of the *Public Service Act 1958* and that a certified letter asking him whether he admits or denies the truth of the charge (posted to his last known address, viz., 3 Herd Street, Belmont, 3216), has been returned unclaimed.

A further letter has been forwarded to the said Narendra K. Radia at the last known address referred to, advising him that unless he admits or denies the truth of the charge in writing to the Teachers Tribunal by the 28th May, 1975, he shall be deemed to deny the truth of the charge and the investigation thereof will be proceeded with at 12 noon on the 29th May, 1975, at the office of the Teachers Tribunal, Royal Mint Building, corner William and La Trobe Streets, Melbourne.

By Order,

A. F. LE CLERCQ,
Secretary.

Office of the Teachers Tribunal,
Melbourne, 2nd May, 1975.

TEACHING SERVICE ACT 1958, SECTION 73.

PUBLIC SERVICE ACT 1958, SECTIONS 55 AND 56.

It is hereby notified that a charge of being absent without leave from the 26th November, 1970, to the 13th September, 1974, has been preferred against Mrs. Carleen Mary Slattery, Teacher, Record No. 816375, Assistant Class, Secondary Schools Division, Education Department, under section 73 of the *Teaching Service Act 1958* which applies to the *Teaching Service Act 1958* the provisions of sections 55 and 56 of the *Public Service Act 1958* and that a certified letter asking her whether she admits or denies the truth of the charge (posted to her last known address, viz., 24/32 King William Street, Fitzroy, 3065), has been returned unclaimed.

A further letter has been forwarded to the said Carleen Mary Slattery at the last known address referred to, advising her that unless she admits or denies the truth of the charge in writing to the Teachers Tribunal by the 28th May, 1975, she shall be deemed to deny the truth of the charge (posted to her last known address, viz., 24/32 with at 12.15 p.m. on the 29th May, 1975, at the office of the Teachers Tribunal, Royal Mint Building, corner William and La Trobe Streets, Melbourne).

By Order,

A. F. LE CLERCQ,
Secretary.

Office of the Teachers Tribunal,
Melbourne, 2nd May, 1975.

TEACHING SERVICE ACT 1958, SECTION 73.

PUBLIC SERVICE ACT 1958, SECTIONS 55 AND 56.

It is hereby notified that a charge of being absent without leave from the 4th February 1974 to the 4th October 1974 has been preferred against Mrs. Eleanor Patricia Ward, Teacher, Record No. 860934, Assistant Class, Secondary Schools Division, Education Department, under section 73 of the *Teaching Service Act 1958* which applies to the *Teaching Service Act 1958* the provisions of sections 55 and 56 of the *Public Service Act 1958* and that a certified letter asking her whether she admits or denies the truth of the charge (posted to her last known address, viz., Flat 1, 12 Cromwell Road, South Yarra, 3141) has been returned unclaimed.

A further letter has been forwarded to the said Eleanor Patricia Ward at the last known address referred to, advising her that unless she admits or denies the truth of the charge in writing to the Teachers Tribunal by the 28th May, 1975, she shall be deemed to deny the truth of the charge and the investigation thereof will be proceeded with at 12.30 p.m. on the 29th May 1975, at the office of the Teachers Tribunal, Royal Mint Building, corner William and La Trobe Streets, Melbourne.

By Order,

A. F. LE CLERCQ,
Secretary.

Office of the Teachers Tribunal,
Melbourne, 2nd May, 1975.

NOTICE TO MARINERS.
[No. 4 of 1975.]

AUSTRALIA.—VICTORIA.

PORT PHILLIP.

Alteration in Light.

Date.—On or about 12th May, 1975.

Position.—Sandringham Breakwater Head Light Lat. 37 deg. 57 min. S., Long. 144 deg. 59 min. E. (Approx.).

Details of Alteration.—The character and sectors of the Light in the above position will be altered as follows:

(a) Character—Group flashing White and Red every 7½ seconds; flash 1 second, eclipse ½ second, Flash 1 second, eclipse 5 seconds.

(b) Sectors—White from 016 deg. through east to 155 deg., red elsewhere.

Abridged Description.—Gp. Fl. W.R. (2) 7½ sec.

Other details remain unaltered.

Charts Affected.—Aus. 155, Aus. 143.

Publication Affected.—Sailing Directions Victoria, 1970; pages 289, 603.

A. J. WAGGLEN,
Port Officer.

Public Works Department,
Ports and Harbors Division,
168 Exhibition Street, Melbourne, 3000.

29th April, 1975.

Town and Country Planning Act 1961.

SHIRE OF SOUTH GIPPSLAND PLANNING SCHEME.

AMENDMENT NO. 13, 1974.

Notice of Approval.

In pursuance of the powers conferred by the *Town and Country Planning Act 1961*, the Governor in Council, on the 29th April, 1975, approved a planning scheme entitled the Shire of South Gippsland Planning Scheme, Amendment No. 13, 1974, in respect of the municipal district of the Shire of South Gippsland and such planning scheme comes into operation on the date this Notice of Approval is published in the *Government Gazette*.

A copy of the planning scheme as approved may be inspected, free of charge, during office hours at the office of the Town and Country Planning Board, 235 Queen Street, Melbourne; at the office of the Council of the Shire of South Gippsland at Foster and when available, at the Office of Titles, Melbourne, and at the Central Plan Office of the Department of Crown Lands and Survey, Melbourne.

W. H. CRAIG, Secretary,
Town and Country Planning Board.

Town and Country Planning Act 1961.

CITY OF CROYDON PLANNING SCHEME 1961.

REVOCATION NO. 13.

Notice of Revocation.

In pursuance of the provisions of Section 32 of the *Town and Country Planning Act 1961*, the Governor in Council, on the 29th April, 1975, made an Order:—

(i) Revoking the City of Croydon.

Planning Scheme in so far as it applies to land within 7.6 metres of the railway reservation being part of lot 25, lodged plan 8160 in Windsor Road, Croydon; and

(ii) Order that the land described in (i) above may only be used or developed for those purposes permissible in the Light Industrial Zone of the City of Croydon Planning Scheme; and

(iii) Specify that any such use or development of the land is permitted only subject to the grant of a permit by the Council of the City of Croydon.

A copy of the Order may be inspected during office hours at the office of the Town and Country Planning Board, 235 Queen Street, Melbourne; and at the office of the Council of the City of Croydon, at Croydon.

W. H. CRAIG, Secretary,
Town and Country Planning Board.

Town and Country Planning Act 1961.

SHIRE OF UPPER YARRA PLANNING SCHEME.

INTERIM DEVELOPMENT ORDER.

AMENDMENT NO. 7.

Notice of Amendment.

In pursuance of the powers conferred by Section 26 of the *Town and Country Planning Act 1961*, the Governor in Council on the 29th April, 1975, amended the Shire of Upper Yarra Planning Scheme Interim Development Order to create a separate site for the existing house on lot 3, lodged plan 99578, Carter Street, Launching Place.

A copy of the amendment may be inspected during office hours at the office of the Town and Country Planning Board, 235 Queen Street, Melbourne, and at the office of the Council of the Shire of Upper Yarra at Yarra Junction.

W. H. CRAIG, Secretary,
Town and Country Planning Board.

Town and Country Planning Act 1961.

CITY OF KNOX PLANNING SCHEME 1965.

AMENDMENT No. 147, 1975.

In pursuance of the powers conferred by sub-section 6 of section 32 of the *Town and Country Planning Act 1961*, the Governor in Council on the 29th April, 1975, amended the City of Knox Planning Scheme for the purpose of retaining Council's discretionary control over flat development.

A copy of the amendment may be inspected during office hours at the office of the Town and Country Planning Board, 235 Queen Street, Melbourne; at the office of the Council of the City of Knox at Knoxfield, and when available at the Office of Titles, Melbourne; and at the Central Plan Office of the Department of Crown Lands and Survey, Melbourne.

W. H. CRAIG, Secretary,
Town and Country Planning Board.

Town and Country Planning Act 1961.

LAKE GLENMAGGIE PLANNING SCHEME.

NOTICE THAT A PLANNING SCHEME HAS BEEN PREPARED AND IS AVAILABLE FOR INSPECTION.

Notice is hereby given that the Town and Country Planning Board, in pursuance of its powers under the *Town and Country Planning Act 1961*, has prepared a Planning Scheme for the purpose of controlling the use or development of land around the lake in the Shire of Maffra, by its zoning and reservation for various purposes.

A copy of the scheme has been deposited at the office of the Town and Country Planning Board, 235 Queen Street, Melbourne, and at the office of the Shire of Maffra, and will be open for inspection thereat during office hours by any person, free of charge.

Any persons affected by the Planning Scheme are required to set forth in writing all objections they may have, addressed to: The Secretary, Town and Country Planning Board, 235 Queen Street, Melbourne, on or before the 7th August, 1975, and to state whether they wish to be heard in respect of their objections.

W. H. CRAIG, Secretary,
Town and Country Planning Board.

Town and Country Planning Act 1961.

CITY OF KNOX PLANNING SCHEME 1965.

AMENDMENT No. 124, 1973.

Notice of Approval.

In pursuance of the powers conferred by the *Town and Country Planning Act 1961*, the Governor in Council, on the 29th April, 1975, approved a planning scheme entitled the City of Knox Planning Scheme 1965, Amendment No. 124, 1973, in respect of part of the municipal district of the City of Knox and such planning scheme comes into operation on the date this Notice of Approval is published in the *Government Gazette*.

A copy of the planning scheme as approved may be inspected, free of charge, during office hours at the office of the Town and Country Planning Board, 235 Queen Street, Melbourne; at the office of the Council of the City of Knox at Knoxfield, and when available, at the Office of Titles, Melbourne, and at the Central Plan Office of the Department of Crown Lands and Survey, Melbourne.

W. H. CRAIG, Secretary,
Town and Country Planning Board.

Town and Country Planning Act 1961.

CITY OF KNOX PLANNING SCHEME 1965.

AMENDMENT No. 128, 1974.

Notice of Approval.

In pursuance of the powers conferred by the *Town and Country Planning Act 1961*, the Governor in Council, on the 29th April, 1975, approved a planning scheme entitled the City of Knox Planning Scheme 1965, Amendment No. 128, 1974, in respect of part of the municipal district of the City of Knox and such planning scheme comes into operation on the date this Notice of Approval is published in the *Government Gazette*.

A copy of the planning scheme as approved may be inspected, free of charge, during office hours at the office of the Town and Country Planning Board, 235 Queen Street, Melbourne; at the office of the Council of the City of Knox at Knoxfield, and when available, at the Office of Titles, Melbourne, and at the Central Plan Office of the Department of Crown Lands and Survey, Melbourne.

W. H. CRAIG, Secretary,
Town and Country Planning Board.

Town and Country Planning Act 1961.

MELBOURNE METROPOLITAN PLANNING SCHEME.

AMENDMENT No. 27, PART 4.

Notice of Approval.

In pursuance of the powers conferred by the *Town and Country Planning Act 1961*, the Governor in Council, on the 29th April, 1975, approved a planning scheme entitled the Melbourne Metropolitan Planning Scheme, Amendment No. 27, Part 4, in respect of part of the municipal district of the City of Frankston and such planning scheme comes into operation on the date this Notice of Approval is published in the *Government Gazette*.

A copy of the planning scheme as approved may be inspected, free of charge, during office hours at the office of the Town and Country Planning Board, 235 Queen Street, Melbourne; at the office of the Melbourne and Metropolitan Board of Works at 625 Little Collins Street, Melbourne, and when available, at the Office of Titles, Melbourne, and at the Central Plan Office of the Department of Crown Lands and Survey, Melbourne.

W. H. CRAIG, Secretary,
Town and Country Planning Board.

Town and Country Planning Act 1961.

MELBOURNE METROPOLITAN PLANNING SCHEME.

AMENDMENT No. 36, PART 1A.

Notice of Approval.

In pursuance of the powers conferred by the *Town and Country Planning Act 1961*, the Governor in Council, on the 29th April, 1975, approved a planning scheme entitled the Melbourne Metropolitan Planning Scheme, Amendment No. 36, Part 1A, in respect of part of the municipal district of the City of Doncaster and Templestowe and such planning scheme comes into operation on the date this Notice of Approval is published in the *Government Gazette*.

A copy of the planning scheme as approved may be inspected, free of charge, during office hours at the office of the Town and Country Planning Board, 235 Queen Street, Melbourne; at the office of the Melbourne and Metropolitan Board of Works at 625 Little Collins Street, Melbourne, and when available, at the Office of Titles, Melbourne, and at the Central Plan Office of the Department of Crown Lands and Survey, Melbourne.

W. H. CRAIG, Secretary,
Town and Country Planning Board.

Town and Country Planning Act 1961.

SEYMOUR PLANNING SCHEME.

AMENDMENT No. 10, 1972.

Notice of Approval.

In pursuance of the powers conferred by the *Town and Country Planning Act 1961*, the Governor in Council, on the 29th April, 1975, approved a planning scheme entitled

the Seymour Planning Scheme, Amendment No. 10, 1972, in respect of the municipal district of the Shire of Seymour and such planning scheme comes into operation on the date this Notice of Approval is published in the *Government Gazette*.

A copy of the planning scheme as approved may be inspected, free of charge, during office hours at the office of the Town and Country Planning Board, 235 Queen Street, Melbourne; at the office of the Council of the Shire of Seymour at Seymour, and when available, at the Office of Titles, Melbourne, and at the Central Plan Office of the Department of Crown Lands and Survey, Melbourne.

W. H. CRAIG, Secretary,
Town and Country Planning Board.

Powers of Disposition.—Such powers of disposition, including powers of sale, lease or mortgage, as are given to the Trust by the Methodist Church (Victoria) Property Trust Act No. 8007 of 1970.

Purposes to which Proceeds of Disposition are to be Applied.—To such Methodist Church purposes as shall be approved by the Property Committee of the Annual Conference of the Methodist Church of Australasia of Victoria.

As witness the hand of the Governor of the State of Victoria, the 29th day of April, 1975.

HENRY WINNEKE,
Governor of the State of Victoria.

Victoria.

ACT 391.—SECOND SCHEDULE.

A Statement of Trusts having been submitted by the head or authorized representative of the denomination of the Methodist Church of Australasia in Victoria under the provisions of the "Act to provide for the Abolition of State Aid to Religion", for allowance by the Governor, the same was allowed by him on the 29th day of April, 1975, and the following is the form in which such statement of trusts has been allowed.

STATEMENT OF TRUSTS.

Description of Land.—Site set apart for Wesleyan Church purposes, 8094 square metres, Township of Meredith, Parish of Meredith, County of Grant being Crown allotment 6, section 4. Commencing at the south-eastern angle of Crown allotment 5; bounded thence by that allotment bearing 0 deg. 0 min. 100.58 metres, by Russell Street bearing 90 deg. 0 min. 80.47 metres, by Wallace Street bearing 180 deg. 0 min. 100.58 metres, and thence by Lawler Street bearing 270 deg. 0 min. 80.47 metres to the point of commencement.

Name of Trustees.—The Methodist Church (Victoria) Property Trust.

Powers of Disposition.—Such powers of disposition, including powers of sale, lease or mortgage, as are given to the Trust by the Methodist Church (Victoria) Property Trust Act No. 8007 of 1970.

Purposes to which Proceeds of Disposition are to be Applied.—To such Methodist Church purposes as shall be approved by the Property Committee of the Annual Conference of the Methodist Church of Australasia in Victoria.

As witness the hand of the Governor of the State of Victoria, the 29th day of April, 1975.

HENRY WINNEKE,
Governor of the State of Victoria.

Victoria.

ACT 391.—SECOND SCHEDULE.

A Statement of Trusts having been submitted by the head or authorized representative of the denomination of the Methodist Church of Australasia in Victoria under the provisions of the "Act to provide for the Abolition of State Aid to Religion", for allowance by the Governor, the same was allowed by him on the 29th day of April, 1975, and the following is the form in which such statement of trusts has been allowed.

STATEMENT OF TRUSTS.

Description of Land.—Site for Wesleyan Church purposes temporarily reserved by Order in Council of the 10th November 1855, 1012 square metres, being Crown allotment 9, section 1B, Parish of Castlemaine, County of Talbot. Commencing at the south-western angle of Crown allotment 8, section 1B, bounded thence by that allotment and Crown allotment 57, section 4A bearing 81 deg. 00 min. 50.29 metres, further by that allotment bearing 171 deg. 00 min. 20.12 metres and thence by roads bearing 261 deg. 00 min. 50.29 metres and 351 deg. 00 min. 20.12 metres to the point of commencement.

Name of Trustees.—The Methodist Church (Victoria) Property Trust.

Survey Co-ordination Act 1958.

NOTICE OF PROPOSAL TO ASSIGN NAMES.

Pursuant to the powers conferred under section 28 of the above Act, the Place Names Committee hereby gives notice of its intention to assign the following names to the reserves mentioned hereunder:—

Municipality.—City of Berwick.

Location.—The reserve situated north of Heatherton Road between the Mulgrave Freeway and Dandenong Creek.

Proposed Name.—Essex Reserve.

Location.—The reserve situated on the south-west side of Kingfisher Drive.

Proposed Name.—Kingfisher Reserve.

Location.—The reserve situated in Kidds Road between Rowan Drive and Agonis Street.

Proposed Name.—Rowan Reserve.

Location.—The reserve situated on the Dandenong Creek between Kidds Road and Forest Reserve.

Proposed Name.—Betula Reserve.

Location.—The reserve situated in Betula Street opposite Rose Drive.

Proposed Name.—Rose Reserve.

Location.—The reserve situated in Power Road between Green Street and Wattle Drive.

Proposed Name.—Green Reserve.

Location.—The reserve situated on the corner of Redfern Crescent and Stanis Street.

Proposed Name.—Redfern Reserve.

Location.—The reserve situated on the east side of the Eumemmerring Creek, north of Frawley Road.

Proposed Name.—Waratah South Reserve.

Any person who objects to the above proposal may give notice of objection in writing, stating the reasons therefor, to the Secretary of the Committee, not more than two (2) months following publication of this notice.

By order of the Committee,

ROGER NATHANIELSZ,
Acting Secretary.

Office of the Place Names Committee,
Department of Crown Lands and Survey,
Melbourne, 3002.

Melbourne and Metropolitan

BOARD OF WORKS.

NOTICE TO THE OWNERS OF TENEMENTS IN THE UNDERMENTIONED STREETS AND THE PRIVATE STREETS, LANES, COURTS AND ALLEYS OPENING THERETO.

The main pipe in the said streets being laid down, the owners of all tenements situated as under are hereby required on or before the 9th June, 1975, to cause a proper pipe and stop cocks to be laid so as to supply water within such tenements from the main pipe.

Broadmeadows.

Marham Place, from Finningley Drive northwards 105 metres.

Croydon.

Dornoch Court, from Lincoln Road northwards 100 metres.
Lincoln Road, from Caromar Street westwards 962 metres.

Doncaster and Templestowe.

Berringa Road, from 190 metres north of Oban Road to Williams Road.
Williams Road, from 120 metres west of Athelstane Drive to Berringa Road.
Athelstane Drive, from 26 metres north of Cormiston Road to Williams Road.

Eltham.

Binns Street, from 70 metres east of Were Street to Mountain View Road.
Wellington Street, from 100 metres north of Rattray Road west to Binns Street.
Sackville Street, from Main Road eastwards 323 metres.

Heidelberg.

Turnham Avenue, from 15 metres south of Douglas Street southwards 86 metres.

Knox.

Lemal Avenue, from 66 metres north of Darwin Road to Kanooka Road.
Nickols Court, from Lemal Avenue westwards 208 metres.
Coleman Road, from Lemal Avenue eastwards 85 metres.
Derby Road, from Lemal Avenue eastwards 46 metres.

Nunawading.

Springvale Road (west side), from Beenak Court northwards 445 metres.
Mast Gully Road, from Mount Dandenong Tourist Road southwards 340 metres.

Whittlesea.

Childs Road, from 37 metres east of Gibson Street to Midway Crescent.

R. H. ENGELSMAN,
Secretary.

29th April, 1975.

SEA LAKE SEWERAGE AUTHORITY.

INCREASING THE LIMIT OF BANK OVERDRAFT.

His Excellency the Governor of the State of Victoria by and with the advice of the Executive Council thereof doth by Order made on the 29th day of April, 1975, increase the total amount of the sums which the Sea Lake Sewerage Authority may owe at any one time in respect of moneys borrowed by overdraft of the current account pursuant to the provisions of section 78 of the *Sewerage Districts Act 1958*, fixed by the Governor in Council on 20th March, 1973, at Ten thousand dollars (\$10,000) be increased to Eighteen thousand dollars (\$18,000).

TOM FORRISTAL,
Clerk of the Executive Council.

At the Executive Council Chamber,
Melbourne, 29th April, 1975.

SEYMOUR SEWERAGE AUTHORITY.

INCREASING THE LIMIT OF BANK OVERDRAFT.

His Excellency the Governor of the State of Victoria by and with the advice of the Executive Council thereof doth by Order made on the 29th day of April, 1975, increase the total amount of the sums which the Seymour Sewerage Authority may owe at any one time in respect of moneys borrowed by overdraft of the current account pursuant to the provisions of section 78 of the *Sewerage Districts Act 1958*, fixed by the Governor in Council on 17th March, 1970, at Thirty thousand dollars (\$30,000) to Sixty thousand dollars (\$60,000).

TOM FORRISTAL,
Clerk of the Executive Council.

At the Executive Council Chamber,
Melbourne, 29th April, 1975.

DANDENONG VALLEY AUTHORITY.

INCREASING THE LIMIT OF BANK OVERDRAFT.

His Excellency the Governor of the State of Victoria by and with the advice of the Executive Council thereof doth by Order made on the 29th day of April, 1975, increase the total amount of the sums which the Dandenong Valley Authority may owe at any time in respect of moneys borrowed by overdraft of current account pursuant to the provisions of section 39 (2) of the *Dandenong Valley Act 1963* fixed by the Governor in Council on 3rd November, 1965, at Three hundred thousand dollars (\$300,000) to Six hundred thousand dollars (\$600,000).

TOM FORRISTAL,
Clerk of the Executive Council.

At the Executive Council Chamber,
Melbourne, 29th April, 1975.

State Savings Bank Act 1958, Section 30.

THE STATE SAVINGS BANK OF VICTORIA.

CLOSURE OF BRANCH.

The Commissioners of The State Savings Bank of Victoria hereby give notice of the closure of The Darebin Branch of the Bank, at 1038 Heidelberg Road, Darebin, as from 3 p.m., Wednesday, 30th April, 1975.

D. ROSS,
General Manager.

Co-operation Act 1958.

MONTROSE TENNIS CLUB CO-OPERATIVE LIMITED.

Notice is hereby given in pursuance of section 78 (7) of the *Co-operation Act 1958* and section 308 (2) of the *Companies Act 1961* that, at the expiration of three months from the date hereof, the name of the aforementioned society will, unless cause is shown to the contrary, be struck off the register and the society will be dissolved.

Dated this 21st day of March, 1975.

J. W. JUNGWIRTH,
Registrar.

Co-operation Act 1958.

SWAN HILL NORTH PRIMARY SCHOOL CO-OPERATIVE LIMITED.

Notice is hereby given in pursuance of section 78 (7) of the *Co-operation Act 1958* and section 308 (2) of the *Companies Act 1961* that, at the expiration of three months from the date hereof, the name of the aforementioned society will, unless cause is shown to the contrary, be struck off the register and the society will be dissolved.

Dated this 7th day of April, 1975.

E. P. LIDDELL,
Deputy Registrar.

Co-operation Act 1958.

FRANKSTON HIGH SCHOOL CO-OPERATIVE SOCIETY LIMITED.

NOTICE OF DISSOLUTION OF SOCIETY.

Notice is hereby given that I have this day registered the dissolution of the above-named society and cancelled its registration under the above-named Act.

Dated at Melbourne this 5th day of May, 1975.

E. P. LIDDELL,
Deputy Registrar of Co-operative Societies.

Co-operation Act 1958.

LATROBE VALLEY ADVERTISERS CO-OPERATIVE LIMITED.

NOTICE OF DISSOLUTION OF SOCIETY.

Notice is hereby given that I have this day registered the dissolution of the above-named society and cancelled its registration under the above-named Act.

Dated at Melbourne this 8th day of April, 1975.

E. P. LIDDELL,
Deputy Registrar of Co-operative Societies.

Co-operation Act 1958.

SOUTH WESTERN DEMONSTRATION FARM CO-OPERATIVE LIMITED.

NOTICE OF DISSOLUTION OF SOCIETY.

Notice is hereby given that I have this day registered the dissolution of the above-named society and cancelled its registration under the above-named Act.

Dated at Melbourne this 10th day of April, 1975.

E. P. LIDDELL,
Deputy Registrar of Co-operative Societies.

Co-operation Act 1958.

DROMANA PRIMARY SCHOOL CO-OPERATIVE LIMITED.

NOTICE OF DISSOLUTION OF SOCIETY.

Notice is hereby given that I have this day registered the dissolution of the above-named society and cancelled its registration under the above-named Act.

Dated at Melbourne this 30th day of March, 1975.

E. P. LIDDELL,
Deputy Registrar of Co-operative Societies.

MINES DEPARTMENT.

Subject to any necessary excisions &c., it is proposed to grant the following Mining Lease:—

No. 330; Jack Richard Poole, John David Poole; 16 ha, Parish of Koorangie.

APPLICATION FOR EXPLORATION LICENCE DECLARED ABANDONED.

No. 538; Newmont Proprietary Limited, ICI Australia Limited, Whirrakee Mining Pty. Ltd.; 66 km², County of Dalhousie.

APPLICATION FOR EXPLORATION LICENCE REFUSED.

No. 543; Graham Morris Ashworth; 264 km², County of Bourke.

EXPLORATION LICENCES GRANTED.

No. 540; Cominco Exploration Pty. Ltd.; 198 km², Counties of Talbot and Dalhousie.

No. 544; Freeport of Australia, Incorporated; 396 km², Counties of Evelyn, Mornington and Buln Buln.

EXPLORATION LICENCE CANCELLED.

No. 526; Western Mining Corporation Limited; 198 km², County of Bendigo.

APPLICATION FOR MINERAL SEARCH LICENCE DECLARED ABANDONED.

No. 1140; Nichilos John Ramsay, Wilma M. Harper; 20 ha, Parish of Everton.

APPLICATION FOR EXTRACTIVE INDUSTRY LICENCE DECLARED ABANDONED.

No. 565; Alan Charles Grant; 4 ha, Parish of Coimadai.

EXTRACTIVE INDUSTRY SEARCH PERMIT EXPIRED.

No. 49; Leon James Say, Thomas Wren; 209 ha, Parish of Chiltern.

J. C. M. BALFOUR,
Minister of Mines.

MINING LEASE DECLARED VOID.

7121, Maryborough; Merge Pty. Ltd.; 30 ha, Parish of Tamagulla.

E. CONDON,
Secretary for Mines.

PUBLIC TRUSTEE ACT 1958 (No. 6350), SECTION 17.

I hereby give notice that on the 19th March, 1975, the Public Trustee filed an election to administer the following deceased person's estate in accordance with section 17 of the Public Trustee Act 1958.

PENNEY, ELIZABETH MARY, formerly of "Strathalan", Erskine Road, Macleod, but late of "Inala Village", Middleborough Road, Blackburn South, pensioner, died 23rd October, 1974.

I hereby give notice that on the 18th April, 1975, the Public Trustee filed elections to administer the following deceased persons' estates in accordance with section 17 of the Public Trustee Act 1958.

BRENNAN, JEAN, late of Mount Eliza Geriatric Centre, Jackson Road, Mount Eliza, pensioner, died 8th April, 1974.

DABROWSKI, FRANK, late of 35 Buninyong Street, Yarraville, carpenter, died 18th February, 1975.

HAMILTON, DOROTHY FLORENCE, formerly of 189 Nelson Place, Williamstown, but late of 27 St. Andrews Drive, Torquay, married woman, died 27th January, 1975.

KINGSTON, MAUD ETHEL, late of Flat 8, 76 Church Street, Richmond, spinster, died 13th November, 1974.

OSBORNE, JOHN WILLIAM, late of Flat 7, 89 Addison Street, Elwood, clerk, died 6th February, 1975.

PLYMPTON, ALICE, formerly of 23 Claude Street, Northcote, but late of St. Anne's Nursing Home, 33 Wattle Road, Hawthorn, widow, died 12th February, 1975.

N. P. BRODY,
Public Trustee.

168 Exhibition Street, Melbourne, 3000, 30th April, 1975.

NOTICE.

Creditors, next of kin, and others having claims against the estate of any of the under-mentioned deceased persons are required to send particulars of their claims to the Public Trustee, 168 Exhibition Street, Melbourne, Victoria, 3000, the personal representative, on or before the 12th July, 1975, after which date the Public Trustee may convey or distribute the assets, having regard only to the claims of which the Public Trustee then has notice:—

BEACH, CHRISTINA McCALLUM, late of 13 Minto Street, Glasgow, Scotland, widow, died 6th August, 1973.

BRENNAN, JEAN, late of Mount Eliza Geriatric Centre, Jackson Road, Mount Eliza, pensioner, died 8th April, 1974.

BROWN, BEVERLEY JOYCE, formerly of 41 Bright Street, Brighton, but late of 7 Tuxen Court, South Brighton; librarian, died 11th January, 1975.

DABROWSKI, FRANK, late of 35 Buninyong Street, Yarraville, carpenter, died 18th February, 1975.

FROST, GEORGE, late of 34 Brighton Street, Flemington, retired labourer, died 1st February, 1975.

HAMILTON, DOROTHY FLORENCE, formerly of 189 Nelson Place, Williamstown, but late of 27 St. Andrews Drive, Torquay, married woman, died 27th January, 1975.

KINGSTON, MAUD ETHEL, late of Flat 8, 76 Church Street, Richmond, spinster, died 13th November, 1974.

OSBORNE, JOHN WILLIAM, late of Flat 7, 89 Addison Street, Elwood, clerk, died 6th February, 1975.

PENNEY, ELIZABETH MARY, formerly of "Strathalan", Erskine Road, Macleod, but late of "Inala Village", Middleborough Road, Blackburn South, pensioner, died 23rd October, 1974.

PLYMPTON, ALICE, formerly of 23 Claude Street, Northcote, but late of St. Anne's Nursing Home, 33 Wattle Road, Hawthorn, widow, died 12th February, 1975.

REYNOLDS, LOUGHLIN KEITH, better known as Keith Reynolds, late of 1223 Burke Road, Kew, secretary, died 3rd February, 1975.

ROBERTS, EDITH BLANCHE, late of 164 The Boulevard, Ivanhoe, married woman, died 28th November, 1974.

ROGERS, ALBERT JAMES, late of Grandview Hotel, 47 Pearson Street, West Brunswick, clerk, died 17th December, 1974.

RUSSELL, GILBERT WESTWOOD, late of 13 Comas Road, Beaumaris, clerk of works, died 11th December, 1974.

THOMAS, ANNIE MARGARET GRACE, late of 24 Chelsea Road, Chelsea, married woman, died 7th March, 1975.

WEBB, JOHN GEORGE ERNEST, late of flat 11/156A Napier Street, Essendon, clerk, died 30th September, 1974.

WILSON, ROBERT ROY, late of 21 Bowen Street, Oakleigh, cleaner, died 27th February, 1975.

WYATT, HUGH WILLIAM, late of 23 St. Vincent's Place, South Melbourne, retired public servant, died 8th October, 1974.

N. P. BRODY,
Public Trustee.

Melbourne, 30th April, 1975.

ORDERS IN COUNCIL.—(Series 1974-75.)
STATE ELECTRICITY COMMISSION.

862. For the supply of encapsulated current transformers for a period of two years with optional extension of three months, to Specification No. 74/293, at Schedule rates.—Warburton Franki (Sydney) Pty. Ltd.

Approved by the Governor in Council, 11th February, 1975.—TOM FORRISTAL, Clerk of the Executive Council.

863. For cleaning services at the Commission's Herman Central Scientific Laboratory, Howard Street, Richmond, for a period of two years, to Quotation No. 2294, at Schedule rates.—Berkeley Cleaning Co. Pty. Ltd.

Approved by the Governor in Council, 4th March, 1975.—TOM FORRISTAL, Clerk of the Executive Council.

864. For maintenance clearing along power lines in the South Western Electricity Supply Branch for a period of two years with optional extension of three months—to Specification No. 75/9, at Schedule rates.—A. M. & A. M. Harrison.

865. For maintenance clearing along power lines in the South Western Electricity Supply Branch for a period of two years with optional extension of three months—to Specification No. 75/9, at Schedule rates.—A. H. & D. E. Robbins.

866. For the supply of one only mobile crane, rough terrain type hydraulic operated with a maximum capacity of 12 700 kg, to Specification No. 75/21, \$66,432.—Forest and Construction Equipment Pty. Ltd.

867. For the supply of deep driving earthing electrodes for the earthing of distribution substations for a period of two years with optional extension of three months, to Specification No. 74/323, at Schedule rates.—Australian Line Materials Pty. Ltd.

868. For maintenance clearing along power lines in the Gippsland Electricity Supply Branch for a period of two years with optional extension of three months, to Specification No. 75/11, at Schedule rates.—G. G. Harrison.

869. For reconstruction of the cooling water conduits at Yallourn C, D and E Power Stations, to Specification No. 74/312, \$448 277 plus an estimated \$72,000 provision for pumping, rock excavation and grouting.—John Holland (Constructions) Pty. Ltd.

870. For the supply, fabrication, erection and painting of steelwork for Turbine House and Annexe, Bunker and Electrical Bay, Yallourn W Power Station Stage 2, to Specification No. 75/4, \$8,540,105 plus provision for additional work at Schedule rates.—D. G. & J. Di Fabrizio Steel Fabrications Pty. Ltd.

Approved by the Governor in Council, 18th March, 1975.—TOM FORRISTAL, Clerk of the Executive Council.

871. For the provision of 4-7 cubic metre tipper type motor trucks and operators in the Melbourne and Metropolitan area for a period of two years with optional extension of three months, to Specification No. 75/2, at Schedule rates.—M. Keogh Pty. Ltd.

872. For the provision of 6 and 9 cubic metre tipper type motor trucks and operators in the Melbourne and Metropolitan area for a period of two years with optional extension of three months, to Specification No. 75/2, at Schedule rates.—Vale Excavations Pty. Ltd.

873. For the erection of brickwork for a substation building and fence at South Coburg, to Specification No. 75/70, \$57 961.—T. & E. Kos.

874. For the supply of one numerically controlled turning machine for the workshops at Yallourn, to Specification No. 74/368, \$175,054 subject to variations in rates of customs duty and exchange.—Mitsui & Co. (Australia) Ltd.

875. For the supply of safety footwear for a period of two years with optional extension of three months, to Specification No. 74/264, at Schedule rates.—Oliver and Stevens Pty. Ltd.

Approved by the Governor in Council, 3rd April, 1975.—TOM FORRISTAL, Clerk of the Executive Council.

876. For the supply of iron cast pipes and miscellaneous iron castings for a period of one year with optional extension of three months, to Specification No. 75/82, at Schedule rates.—H. Madden and Son.

877. For the supply of iron cast pipes and miscellaneous iron castings for a period of one year with optional extension of three months, to Specification No. 75/82, at Schedule rates.—T. Main and Sons Pty. Ltd.

878. For the supply of iron cast pipes and miscellaneous iron castings for a period of one year with optional extension of three months, to Specification No. 74/47, at Schedule rates.—H. Madden and Son.

879. For the supply of iron cast pipes and miscellaneous iron castings for a period of one year with optional extension of three months, to Specification No. 74/47, at Schedule rates.—T. Main and Sons Pty. Ltd.

880. For the supply of two crane borer units mounted on truck chassis supplied by Commission for replacement of existing equipment in Distribution Engineering Department, to Specification No. 75/74, \$73 000 subject to variations in rates of labour and materials.—Tutt Bryant (Victoria) Pty. Ltd.

881. For the supply of two crane borer units mounted on truck chassis supplied by Commission for replacement of existing equipment in Distribution Engineering Department, to Specification No. 75/74.—\$78 740 subject to variations in rates of labour and materials.—Proline Superlift Sales and Service Pty. Ltd.

882. For the supply of fully preserved wooden powerline poles for use in the transmission and distribution systems, to Specification No. 74/29, \$72 950.—Koppers Australia Pty. Ltd.

883. For the supply of fully preserved wooden powerline poles for use in the transmission and distribution systems, to Specification No. 74/29, \$63 565.—Alex Sturrock and Sons Pty. Ltd.

Approved by the Governor in Council, 15th April, 1975.—TOM FORRISTAL, Clerk of the Executive Council.

884. For the installation of an abrasive blast cleaning system at the Latrobe Valley Workshops, Yallourn, to Specification No. 75/46, \$50 210.—Godfrey Engineering (Australia) Pty. Ltd.

Approved by the Governor in Council, 22nd April, 1975.—TOM FORRISTAL, Clerk of the Executive Council.

F. P. CHIPPERFIELD, Secretary.

CONTRACTS ACCEPTED.—(Series 1974-75.)

AMENDMENTS

Item No.	Unit.	Rate.	Effective From.
PROVISIONS 1974-75.			
Gazette No. 62—13th June, 1974.			
Schedule No. 1—Provisions—Melbourne and Metropolitan District.			
\$			
158	Per 4 doz. ctn.	13.18	} 7.4.75
169	Per 6 x 3-lb. ctn.	10.88	
178	Per tin—Golden Pea and Ham	5.95	
	—French Onion	5.95	
	—Spring Vegetable	5.95	
	—Chicken Noodle	5.13	
	—Creme of Chicken	5.13	
	—Creme of Vegetable	5.95	
	—Tomato	5.13	
	—Thick Vegetable	5.13	
	—Pea and Ham	5.95	
	—Oxtail Soup	5.95	
	—Minestrone Soup	5.95	
	—Creme of Celery	5.95	
351	Per 6 x No. 10 cans	10.02	
362	Per ctn.	13.39	
363	Per ctn.	13.39	
Amendment to Gazette No. 31—			
30th April, 1975. Delete price			
adjustment to item 109, sub-			
stitute :—			
409	Each	4.71	} 8.4.75

GENERAL STORES.			
Gazette No. 75—31st July, 1974.			
Schedule No. 57—Rivets, Screws, &c.			
8	Per lb.	1.00	} 29.4.75
10	List Price Plus	6.0%	
11	" "	6.0%	
12	" "	22.0%	
13	" "	28.0%	
14	" "	25.0%	
15	" "	25.0%	
16	" "	30.0%	
21	" "	6.5%	
22	" "	6.5%	
24	" "	22.0%	
25	Per lb.	0.88	
26	List Price Plus	20.0%	

TOOLS (GENERAL).			
Gazette No. 22—27th March, 1975.			
Schedule No. 52.			
\$			
1	Each	2.01	} 18.4.75
6	"	1.54	
13	"	0.30	
19	—10 inch	6.92	
	—12 inch	7.07	
20	"	1.17	
27	"	0.74	
31	"	1.85	
32	"	2.16	
33	"	2.08	
62	"	7.04	
64	"	2.40	
70	"	2.57	
79	"	4.79	
83	"	1.61	
88	"	0.75	
89	"	1.08	
108	"	9.65	
109	"	10.91	
110	"	11.31	
111	"	14.91	
112	"	17.28	
113	"	9.31	
114	"	7.50	
115	"	3.60	
116	"	3.45	
117	"	13.65	
131	"	1.28	
146	"	2.79	
167	Dowidat List 1st March, 1975.		
168	Each	2.37	
170	"	3.50	
172	"	3.74	
179	"	1.17	
187	"	0.52	

Item No.	Unit.	Rate.	Effective From.
Gazette No. 30—9th April, 1974.			
Schedule No. 52. \$			
223	Per pair	13.03	10.4.75
STATIONERY, GENERAL.			
Gazette No. 97—30th September, 1974.			
Schedule No. 69.			
225	Each	0.375	} 17.4.75
226	"	0.50	
GOVERNMENT PRINTER.			
Gazette No. 80—6th August, 1973.			
Schedule No. 1—Printing Paper, Writing Paper, &c.			
Envelopes—			
S11	Per 1,000	3.63	} 1.11.74
S62	"	25.92	

W. L. ROBERTSON, Secretary to the Tender Board. 5.5.1975

CONTRACTS ACCEPTED.—(Series 1974-75.)

PUBLIC WORKS.

- 782. Cobram, High School, erection of Science and Administration Wing, &c., \$171,938.00.—Bruni and Bisogni Pty. Ltd.
- 783. Morwell, Primary School No. 2136, erection of Art/Craft Room, Library and Staff Accommodation improvements, \$121,170.00.—W. G. Campbell Constructions Pty. Ltd.
- 784. Altona North, Technical School, erection of Library Complex, mechanical services, \$16,220.00.—Chadstone Air Conditioning Services Pty. Ltd.
- 785. Lilydale, Technical School, mechanical services, Library, \$11,630.00.—Chadstone Airconditioning Services Pty. Ltd.
- 786. Oakleigh, Technical School, roof renovations, \$15,844.00.—Construction Panels Pty. Ltd.
- 787. Derrinallum, High School, internal and external repairs and painting, \$16,271.00.—F. A. Crisp.
- 788. Eltham, High School, construction of two new toilet blocks, \$95,960.00.—Daniel P. Cullen.
- 789. Toolangi, Research Station, supply and installation of cooling system, Potato Store, Potato Research Station, \$12,410.00.—Eric Cullen and Sons Pty. Ltd.
- 790. Merrilands, Primary School No. 4826, erection of Art/Craft Room, Staff Improvements, and Multi-purpose Hall, \$299,528.00.—D.A. Constructions Pty. Ltd.
- 791. Moorabbin, Technical College, construction of a mid-level college, \$3,671,993.00.—Dillingham Constructions Pty. Ltd.
- 792. Elwood, High School, site works, \$23,004.00.—John A. Dodd.
- 793. Swan Hill, High School, mechanical services, Library Complex, \$39,983.00.—Messrs. Dominelli, Whitford and Robinson.
- 794. Kananook Creek, Ports and Harbors, dredging works, approach to boat haven and facilities, \$28,260.00.—Duncan & Russell (Vic.) Pty. Ltd.
- 795. Mordialloc Creek, Ports and Harbors, dredging, approach to boat haven and facilities, \$18,820.00.—Duncan & Russell (Vic.) Pty. Ltd.
- 796. Lilydale, Technical School, electrical services, Library, \$10,295.00.—Electrite.
- 797. Malvern, Primary School No. 1604, replacement of existing slate roofs with tiles, \$42,924.00.—C.B. Bramich Pty. Ltd.
- 798. Hampton Park, Primary School No. 4062, connection to Melbourne and Metropolitan Board of Works sewer, \$10,444.00.—Britten and Lacey.
- 799. Alexandra, Police Station, erection of new brick-venerer Police Station and Cell Block, \$88,273.00.—Bruni & Bisogni Pty. Ltd.

800. Altona, High School, re-roofing and associated renovations, \$22,720.00.—Ivan Bulat.
801. Lalor, High School, exterior and interior renovations, \$34,000.00.—Ivan Bulat.
802. Altona East, Primary School No. 4805, external and internal repairs and painting, \$35,274.00.—Ivan Bulat.
803. Echuca, High School, mechanical services, additions and alterations, \$31,487.00.—B. R. Burns Pty. Ltd.
804. Footscray North, Primary School No. 4160, electrical services—Library, Multi-purpose Hall, Adventure Playground, renovations and alterations, \$10,750.00.—Electrite.
805. Kerang, High School, erection of a Library Complex, electrical services, \$12,260.00.—G. & J. M. Elliott Pty. Ltd.
806. Swan Hill, High School, electrical services, Library Complex, \$12,048.00.—G. & J. M. Elliott Pty. Ltd.
807. Moorabbin, Primary School No. 1111, new timber floors to class-rooms, \$13,620.00.—F. N. & M. Felton.
808. Oberon, High School, electrical services, Library Complex, \$11,750.00.—Fenton and Douglas.
809. Altona, High School, mechanical services, Science Wing, \$27,634.00.—Ford-Swinton Industries Pty. Ltd.
810. Warrambool North, Technical School, Staff Administration, remodelling and extensions, \$94,132.00.—Fotheringham Constructions Pty. Ltd.
811. Terang, Primary School No. 617, erection of Art/Craft Room, Library, Staff Accommodation Improvements and Additional Classrooms, \$160,919.00.—Fotheringham Constructions Pty. Ltd.
812. Frankston, Westernport District Police Headquarters, mechanical services, additional office and amenities accommodation, \$12,457.00.—Allied Air Conditioning (Contracts) Pty. Ltd.
813. Campbellfield, Primary School No. 143, mechanical services for general purpose room, art/craft room, library, staff accommodation improvements and covered play area, \$15,189.00.—W. S. Atherton and Co. Pty. Ltd.
814. Merrilands, Primary School No. 4826, mechanical services, alterations and extensions, &c., \$21,623.00.—W. S. Atherton & Co. Pty. Ltd.
815. Port Fairy Consolidated School, internal and external repairs and painting, \$20,968.00.—Beardsley & Sons.
816. Corio, Technical School, erection of multi-purpose hall type 800C, \$219,688.00.—Len Bell Pty. Ltd.
817. Bendigo, High School, re-roofing class-room block, terracotta tiles, \$32,175.00.—C. B. Bramich Pty. Ltd.
818. Kew, Mental Hospital, renovations of ablation block ward F3, \$43,130.00.—C. B. Bramich Pty. Ltd.
819. Numurkah, High School, alterations to trades wing, \$21,083.00.—Bruni & Bisogni Pty. Ltd.
820. Maryborough, Technical College, erection of new library/science block, \$488,204.00.—Bruni & Bisogni Pty. Ltd.
821. Swan Hill, Primary School No. 1142, erection of art/craft, staff accommodation improvements and library facilities, \$187,980.00.—Bruni & Bisogni Pty. Ltd.
822. Wendouree West, Primary School No. 4701, electrical services, erection of art/craft room, library, staff accommodation improvements and general purpose room, \$10,530.00.—R. E. Loveland.
823. Hallam, High School, site works, \$10,234.00.—McDougall-Ireland Pty. Ltd.
824. Vermont High School and Ferntree Gully Technical School, erection of libraries, \$321,726.00.—McDougall-Ireland Pty. Ltd.
825. Thomastown, High School, erection of blocks A and B, \$553,084.00.—McDougall-Ireland Pty. Ltd.
826. Lakeside, Primary School No. 4882, erection of art/craft, general purpose class-room, library and migrant centre, \$136,300.00.—McKenzie Constructions Pty. Ltd.
827. Frankston, High School, re-sheeting of C.G.I. and flat steel roofs, \$26,956.00.—L. & H. Maxa Plumbing.
828. Kew, Mental Hospital, provision of a covered way, \$11,230.00.—L. & H. Maxa Plumbing.
829. Ballarat North, Technical School, internal and external repairs and painting, \$27,446.00.—Rudi Memed Painting Service.
830. Waverley North, Primary School No. 4884, internal renovations, \$11,345.00.—Rudi Memed Painting Service.
831. Gladstone Park, High School, site works, \$37,466.80.—S. J. Moran Constructions Pty. Ltd.
832. Springvale, Technical School, site works, \$49,747.00.—Guenther Mueller.
833. Footscray North, Demonstration Unit, site works, \$18,262.00.—K. Nicholls & Associates Pty. Ltd.
834. West Melbourne, Primary School No. 1689, supply of shelving, supply and installation of cupboards and wall units, \$22,576.00.—North Fawcner Joinery and Builders Supplies Pty. Ltd.
835. Richmond, Technical College, Internal repairs and painting, \$25,980.00.—Omega Signs and Display.
836. Moorabbin, Technical College, lift installation for the Mid Level College, Stage 1, \$22,824.00.—Otis Elevator Co. Pty. Ltd.
837. Robinvale, High School, mechanical services, science block, L.T.C. 73/1, \$24,194.00.—F. A. Petzke and Co. Pty. Ltd.
838. Kerang, High School, erection of a library complex, mechanical services, \$31,042.00.—F. A. Petzke & Co. Pty. Ltd.
839. Seymour, High School, erection of technical wing, site works, \$39,396.00.—M. J. & M. C. Preece.
840. Glen Waverley, Police Training Academy, site works, \$68,079.00.—Rainbow Construction Company Pty. Ltd.
841. Echuca, High School, additions and alterations, \$167,300.00.—K. G. Renwick Building & Constructions.
842. Ashwood, Psychology Guidance and Speech Therapy Centre, site works, Demonstration Unit, \$34,945.30.—Richards Plant Hire Pty. Ltd.
843. Nathalia, High School, mechanical services, staff improvements, additional classrooms and science room, \$66,024.00.—Ross's.
844. Melbourne, 480 Collins Street, State Insurance Centre, computer installation, \$120,339.28.—Schiavello Bros. Pty. Ltd.
845. Bairnsdale, Veterinary Research Laboratory, supply and installation of PABX Telephone System, \$14,155.00.—Siemens Industries Ltd.
846. Euroa, High School, conversion of Wool Classing Room to Library and construction of Art and Craft Room, \$37,725.00.—Robert E. Steen.
847. Ballarat, Lakeside Hospital, mechanical services, restoration of fire-damaged Ward 23, \$12,934.00.—G. Stone and Sons (Vic.) Pty. Ltd.
848. Wendouree West, Primary School, No. 4701, mechanical services, Art/Craft, Library, staff accommodation, improvements, general purpose room, &c., \$17,795.00.—G. R. & L. E. Strange.
849. Wodonga West, Primary School No. 4814, exterior and interior renovations, \$28,617.00.—Roy O. Tobias.
850. Blackburn and Syndal, Technical Schools, erection of libraries, \$313,589.00.—Van Driel Pty. Ltd.
851. Altona North, Technical School, erection of library complex, \$165,534.00.—Van Driel Pty. Ltd.
852. Spotswood, Primary School No. 3659, complete internal repairs and painting, part external re-roofing and repairs and painting, \$26,000.00.—G. & A. Painting & Renovation Service.
853. Ballarat, Lakeside Hospital, restoration of fire-damage to Ward 23, \$28,738.00.—H. A. & N. A. Graefe.
854. Sunshine Heights, Primary School No. 4744, two additional classrooms, Art and Craft Centre and general purpose room, \$51,568.00.—R. J. Grills Pty. Ltd.
855. Robinvale, High School, external repairs and painting, \$17,316.00.—K. J. Haboldt & Son.
856. Wycheproof, Primary School 1757, internal repairs and painting, \$12,008.00.—K. J. Haboldt and Son.
857. Bendigo, High School, renovations to Science and Physics rooms, \$11,507.00.—C. E. Henry.
858. Richmond, Girls High School, external and internal renovations, \$24,200.00.—T. Horvat.
859. Gunbower, Primary School No. 2231, internal and external renovations, \$15,800.00.—J. A. & F. M. Hunter.
860. Montmorency, High School, site works, \$48,567.40.—Infantino Constructions Pty. Ltd.
861. Strathmore, High School, external and internal renovations, \$27,509.00.—A. Krstev.

APPOINTMENTS AND RESIGNATIONS**APPOINTMENTS.**

His Excellency the Governor of the State of Victoria, by and with the advice of the Executive Council thereof, has, by Orders made on the 29th day of April, 1975, been pleased to make the under-mentioned appointments, viz.:

CROWN LANDS AND SURVEY DEPARTMENT.*Bailiffs of Crown Lands.*

GEOFFREY JAMES CLARKE,
WILLIAM PERCIVAL BOWERS,
DONALD SCUTT,
JAMES CAMERON ZENNER,
VICTOR LAIDLER and
ALAN BROOK,

to be bailiffs of Crown lands, with respect to the reserved Crown lands in the Parish of Tarwin known as the "Venus Bay and Anderson's Inlet Foreshore Reserves", and with authority to discharge and exercise all the duties and powers of bailiffs, pursuant to the provisions of section 30 of the *Land Act 1958*.

JOHN DALY

to be a bailiff of Crown lands, with respect to the reserved Crown lands in the Parish of Balnarring known as the "Merricks Beach Foreshore Reserve", and with authority to discharge and exercise all the duties and powers of bailiffs, pursuant to the provisions of section 30 of the *Land Act 1958*.

MINISTRY OF HEALTH.*Member of Committee of Management of Hospital.***THEODORE JAMES WEBSTER**

to be Government Appointee on Committee of Management of The Gippsland Home and Hospital for a period of three years commencing the 28th May, 1975, pursuant to the provisions of sub-paragraph (ii) of paragraph (a) of the proviso to sub-section (1) of section 48 of the *Hospitals and Charities Act 1958*.

Member of the Foreign Practitioners Qualification Committee.

Professor DAVID MILES DANKS, M.D., B.S., F.R.A.C.P., to be a Member of the Foreign Practitioners Qualification Committee pursuant to the provisions of section 21 of the *Medical Practitioners Act 1970* for the remainder of the period ending 30th June, 1977, vice Prof. V. L. Collins, retired.

LAW DEPARTMENT.*Justices of the Peace.*

JAMES MURRAY GAVIN, 20 Somali Street, Pascoe Vale South, and
GREGORY REGINALD JELLIS, 52 Wood Street, Newport,
to be Justices of the Peace for the State of Victoria.

Commissioners for Taking Declarations, &c.

PHILIP EDWARD VALENTINE ALBRECHT, care of Sanyo-Guthrie Australia Pty. Ltd., Kendall Street, Wodonga,

JOHN KYASTON AUSTIN, 9 Debbie Street, Mt. Waverley,
NARELLE ANNE BORLAND, care of Department of Agriculture, 32 Pyke Street, Bairnsdale,

JOHN FRANCIS BRADEN, care of John F. Braden & Associates, Insurance Agents, 16 Kuranga Road, Rosanna,

KENNETH JOSEPH BRANNAN, 45 Newton Street, Reservoir,
ROBERT STANLEY BERLYN, Villa 7, 92 Railway Crescent, Williamstown,

GEORGE NICHOLAS BERNATH, care of Van's Pharmacy, 411 Hampton Street, Hampton,
RONALD JAMES COLORETTI, care of Town Hall, Nunn Street, Benalla,

RAYMOND JOSEPH DOOLEY, 66 Royal Parade, Reservoir,
GORDON JAMES FORAN, 25 Melview Drive, Werribee,
KEVIN JOSEPH GANNON, 9 Henry Street, Maffra,

KEITH EDWIN HASTIE, care of James Miller & Co. Pty. Ltd., 95 Pakington Street, Geelong West,
RODNEY ALLAN KING, care of West, Carr & Harvey, T. & G. Building, Moorabool Street, Geelong,

DAVID LACHLAN MCLAREN, care of Stewart Wrightson (Vic.) Pty. Ltd., Marland House, 570 Bourke Street, Melbourne,

ELIZABETH DON MCCONNAN, care of Adult Deaf Society of Victoria, Jolimont Square, 101 Wellington Parade South, East Melbourne,

EMMANUEL NICHOLAS-BORG, 50 Surrey Street, Pascoe Vale,

PAUL ALLAN ROBINSON, care of Independent Order of Oddfellows of Victoria, 380 Russell Street, Melbourne,

THOMAS JAMES ROSE, 13 Gell Court, Noble Park,
KENNETH MICHAEL TREACY, care of Glen Waverley Credit Co-operative Ltd., 17 Railway Parade, Glen Waverley and

GREGORY KEVIN WHEATLEY, care of the Arcade, 61 Ferguson Street, Williamstown,
to be Commissioners for taking Declarations and Affidavits under the *Evidence Act 1958*.

DEPARTMENT OF WATER SUPPLY.*Waterworks Trusts Commissioners.***IAN ROBERT LLEWELLYN**

to be a Commissioner of the Mansfield Waterworks Trust, to hold such position for a period of four years from the date hereof subject to the provisions of the *Water Act*.

NOEL KENNETH COLLINS

to be a Commissioner of the Maryborough Waterworks Trust to hold such position for a period of four years from the date hereof, subject to the provisions of the *Water Act*.

GORDON BAXTER DUGAN and**ARTHUR LINDSAY MAGUIRE,**

to be Commissioners of the Stratford Waterworks Trust to hold such position for a period of four years from the date hereof, subject to the provisions of the *Water Act*.

CHARLES PYNEN

to be a Commissioner of the Thorpdale Waterworks Trust, to hold such position for a period of four years from the date hereof subject to the provisions of the *Water Act*.

REGINALD DOUGLAS ORR

to be a Commissioner of the Westernport Waterworks Trust, to hold such position for a period from the date hereof until the 23rd June, 1976, subject to the provisions of the *Water Act*.

TOM FORRISTAL,

Clerk of the Executive Council.

At the Executive Council Chamber,
Melbourne, 29th April, 1975.

REVOCATION OF APPOINTMENTS.

His Excellency the Governor of the State of Victoria, by and with the advice of the Executive Council thereof, has, by Order made on the 29th day of April, 1975, revoked the appointments of the persons named hereunder of the office mentioned, viz.:

DEPARTMENT OF CROWN LANDS AND SURVEY.*Bailiffs of Crown Lands.*

THOMAS J. TRUEMAN, as a Bailiff of Crown lands, made by the Governor in Council on 25th February, 1972, and notified in the *Government Gazette* of 1st March, 1972; and

PHILIP P. RIDGEWAY, as a Bailiff of Crown lands, made by the Governor in Council on 19th February, 1974, and notified in the *Government Gazette* of 27th February, 1974.

TOM FORRISTAL,

Clerk of the Executive Council.

At the Executive Council Chamber,
Melbourne, 29th April, 1975.

RESIGNATIONS.

His Excellency the Governor of the State of Victoria, by and with the advice of the Executive Council thereof, has, by Orders made on the 29th day of April, 1975, accepted the resignations of the persons named hereunder of the offices mentioned, viz.:

LAW DEPARTMENT.*Commissioners for Taking Declarations, &c.*

JOHN GEOFFREY CLIFFORD,

PETER JAMES ANTHONY JACKSON,

HUBERT DEJERSEY FIDDIAN,

GREGORY REGINALD JELLIS,

JOHN KENT,

JAMES MURRAY GAVIN,

KENNETH JAMES LEYONHJELM,

NORMAN WILLIAM AIREY REDPATH,

MERVYN ROSS ROGERS and

DAVID LESLIE SHORT,

as Commissioners for taking Declarations and Affidavits under the *Evidence Act 1958*.

Justices of the Peace.

BLANCHE EVELYN ALLAN and

GEORGE CLARK SCHRÖDER,

as Justices of the Peace for the State of Victoria.

TOM FORRISTAL,

Clerk of the Executive Council.

At the Executive Council Chamber,
Melbourne, 29th April, 1975.

ORDERS IN COUNCIL

EXCHANGE OF FOREST AREAS FOR CROWN LANDS.

At the Executive Council Chamber, Melbourne, the twelfth day of March, 1975.

PRESENT:

His Excellency the Governor of Victoria.

Mr. Byrne | Mr. Balfour
Mr. Borthwick | Mr. Houghton.

In pursuance of the provisions of section 49 of the Forests Act 1958, No. 6254, His Excellency the Governor of the State of Victoria, by and with the advice of the Executive Council, doth hereby order that the areas of reserved forest described in the accompanying Excision Schedule No. 178 and comprising 77.5 hectares, more or less, be excised from the Forest Reserves and that the areas of unoccupied Crown lands described in the accompanying Dedication Schedule No. 219 and comprising 579.4 hectares more or less, be dedicated as reserved forest in exchange in lieu thereof.

Such excisions and dedications to take effect on the fourteenth day after the publication of this order in the Government Gazette.

EXCISION SCHEDULE No. 178.

Seven hundred and seventy-five and five tenths hectares (775.5 ha) more or less, of Reserved Forest, comprising the areas tabulated hereunder and shown by cross hatched lines, in diagrams 1329 to 1368 inclusive on the accompanying plans A, B, C, D, E, F, and G.

Diagram.	Correspondence Numbers.		Parish.	Plan Number.	County.	Area.
	Forests.	Lands.				
1329	66/1411	HO31381	Stanley	410	Bogong	2.923 ha
1330	71/322	HO33833	Warrowitue	482	Dalhousie	7637 m ²
1331	66/2610	HO31180	Tambo	424A	Dargo	1.6 ha
1332	68/654	HO31699	Tildesley West ..	442A	Tambo	2.902 ha
1333	70/593	G70874	Meredith	319	Grant	2000 m ²
1334	67/1272	J32986	Smythesdale	408	Grenville	390 ha
1335	68/1535	HO32698	Tildesley East ..	441B	Tambo	2.3 ha
1336	64/2058	G62245	Narracan South ..	347A	Buln Buln	5.5 ha
1337	64/21	W86809	Craigie	148B	Talbot	8 ha
1338	67/1862	J32929	Heywood	323A	Normanby	23 ha
1339	65/822	M60807	Carwarp	117	Karkaroc	3700 m ²
1340	68/119	J32876	Glenaulin	198	Normanby	8.5 ha
1341	73/2109	RS9600	Whitfield	494	Delatite	10.69 ha
1342	64/1314	HO32968	Bright	72A	Delatite	4000 m ²
1343	71/589	G69556	Monbulk	312A	Evelyn	190 m ²
1344	68/1499	HO30364	Woodbourne	507B	Anglesey	16 ha
1345	65/3089	J32374	Carngham	114	Grenville	2447 m ²
1346	69/39	W89554	Bet Bet	44	Gladstone	5.540 ha
1347	65/1020	W87536	Maryborough	298B	Talbot	4587 m ²
1348	66/528	W88925	Pompapiel	388	Bendigo	89 ha
1349	60/15	W86819	Bael Bael	15A	Tatchera	47.18 ha
1350	74/728	328/44.81	Painswick	369A	Gladstone	6500 m ²
1351	67/2123	W89237	Wombat	502D	Talbot	4.602 ha
1352	67/2128	HO32180	Heathcote	222B	Dalhousie	4300 m ²
1353	68/1109	HO32575	Porepunkah	389A	Bogong	4.329 ha
1354	71/697	J33977	Gorae	212	Normanby	8 ha
1355	64/1423	W89424	Tarrendower	430	Talbot	8 ha
1356	67/326	W88588	Dunolly	171C	Gladstone	8.341 ha
1357	53/4126	W88774	Sedgwick	405	Bendigo	5.7 ha
1358	70/901	W90292	Sandhurst	402C	Bendigo	4 ha
1359	69/1875	M62485	Brockie	Cnty. 22N ..	Karkaroc	17.82 ha
1360	72/2112	C100927	Argyle	12	Grenville	7232 m ²
1361	72/244	G75015	Nayook	351A	Buln Buln	9030 m ²
1362	61/164	W82424	Sedgwick	405	Bendigo	3110 m ²
1363	67/3316	HO32838	Barwidgee	33B	Bogong	10 ha
1364	67/1520	J32919	Trawalla	455	Ripon	14.5 ha
1365	70/701	C100518	Boola Boloke	56B	Kara Kara	3.681 ha
1366	69/2081	J33586	Drik Drik	166	Normanby	9131 m ²
1367	72/670	C100255	Warrandyte	479	Evelyn	64 ha
1368	73/739	G75643	Creswick	149C	Talbot	3 ha

DEDICATION SCHEDULE No. 219.

Five hundred and seventy-nine and four tenths hectares (579.4 ha), more or less, of unoccupied Crown land comprising the areas tabulated hereunder and shown by diagonal hatched lines in diagrams 1007 to 1013 inclusive on the accompanying plans A and B.

Diagram.	Correspondence Numbers.		Parish.	Plan Number.	County.	Area.
	Forests.	Lands.				
1007	73/1219	RS8005	Kewell West	251A	Borong	1.2 ha
1008	71/1779	C100922	Koetong	259B	Benambra	1.669 ha
1009	71/1010	J34014	Narrawong	349	Normanby	1.4 ha
1010	63/555	W86274	Wombat	502F	Talbot	8 ha
1011	68/249	J32956	Ballarat	17A	Talbot	1.3 ha
1012	72/1908	120/155	Woorragee Nth. ..	513A	Bogong	8000 m ²
1013	70/226	J33632	Mouzie	327A	Normanby	565 ha

EXCISION SCHEDULE N^o178 PLAN A

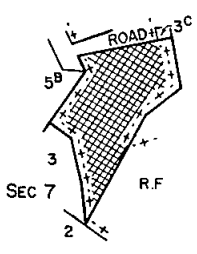
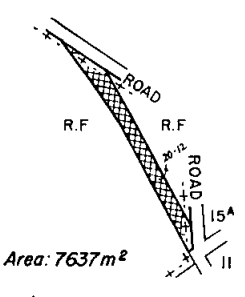
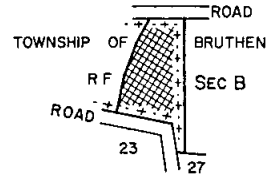
<p>STANLEY County of Bogong</p> <p>100 50 0 100 METRES</p> <p>Area: 2.923 ha</p>  <p>66/1411 HO 31381 F.L.P. 410</p> <p>1329</p>	<p>WARROWITUE County of Dalhousie</p> <p>100 50 0 100 METRES</p>  <p>Area: 7637 m²</p> <p>71/322 HO 33833 F.L.P. 482</p> <p>1330</p>	<p>TAMBO County of Dargo</p> <p>100 50 0 100 METRES</p>  <p>Area: 1.6 ha ± Subject to Survey</p> <p>66/2610 HO 31180 F.L.P. 424 A</p> <p>1331</p>
--	---	--

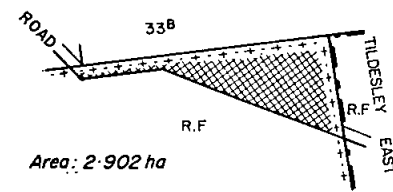
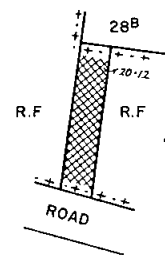
<p>TILDESLEY WEST County of Tambo</p> <p>100 50 0 100 METRES</p>  <p>Area: 2.902 ha</p> <p>68/654 HO 31699 F.L.P. 442 A</p> <p>1332</p>	<p>MEREDITH County of Grant</p> <p>40 20 0 40 METRES</p>  <p>Area: 2000 m² ±</p> <p>70/593 G70874 F.L.P. 319</p> <p>1333</p>
---	--

SMYTHESDALE
County of Grenville

400 200 0 400
METRES

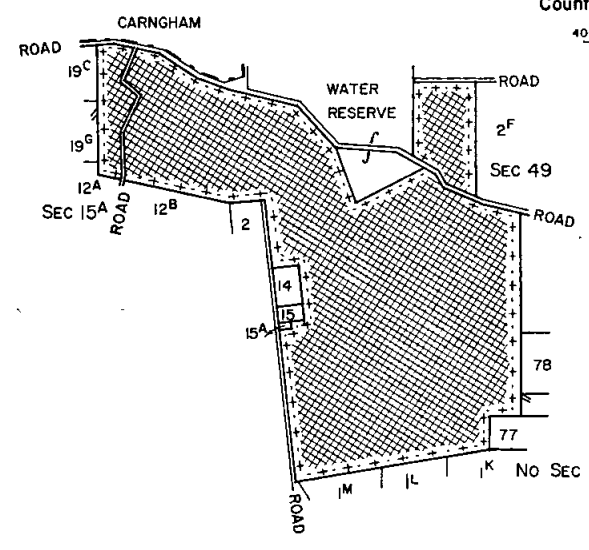

Area: 390 ha ±
Subject to Survey

67/1272
J32986
F.L.P. 408

1334

EXCISION SCHEDULE N^o178 PLAN B

TILDESLEY EAST

County of Tambo
100 50 0 100
METRES

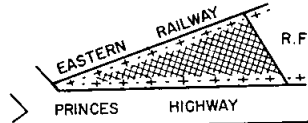

Area: 2.3ha±
Subject to Survey

68/1535
H032698
F.L.P 441B

1335

NARRACAN SOUTH

County of Buln Buln
100 50 0 100
METRES

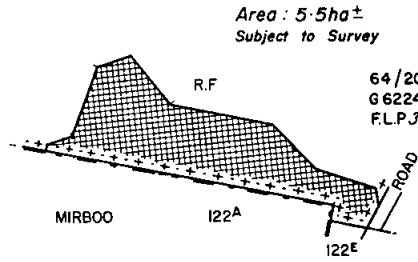

Area: 5.5ha±
Subject to Survey

64/2058
G62245
F.L.P.347A

1336

HEYWOOD

County of Normanby
100 50 0 100
METRES

Area: 23ha±
67/1862
J32929
F.L.P 323A

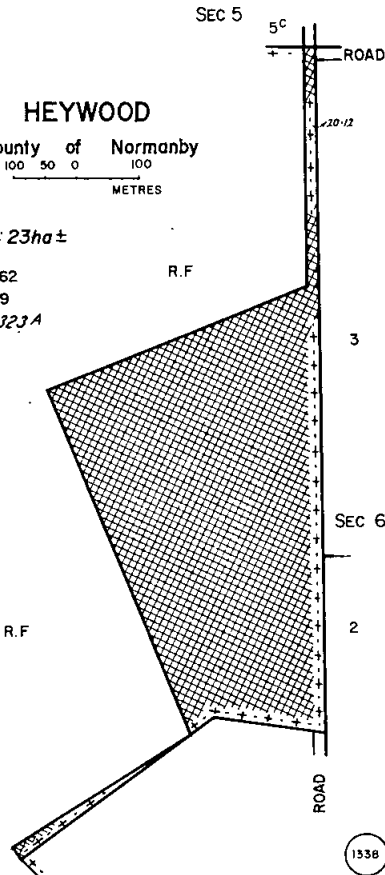

1338

CRAIGIE

County of Talbot
200 100 0 200
METRES

Area: 8 ha±
Subject to Survey

64/21
W86809
F.L.P 148 B

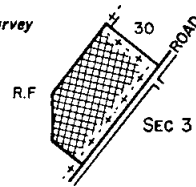

1337

TOWNSHIP OF LYONS

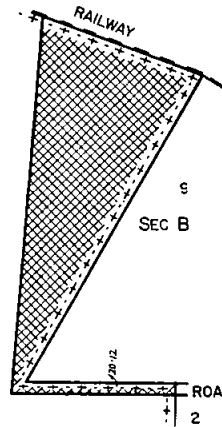

GLENAULIN

County of Normanby
100 50 0 100
METRES

68/119
J32876
F.L.P.198
Area: 8.5 ha±
Subject to Survey

1340

CARWARP

County of Karkaroc
40 20 0 40
METRES

Area: 3700m²±
Subject to Survey
65/822
M60807
F.L.P 117

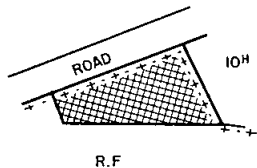

1339

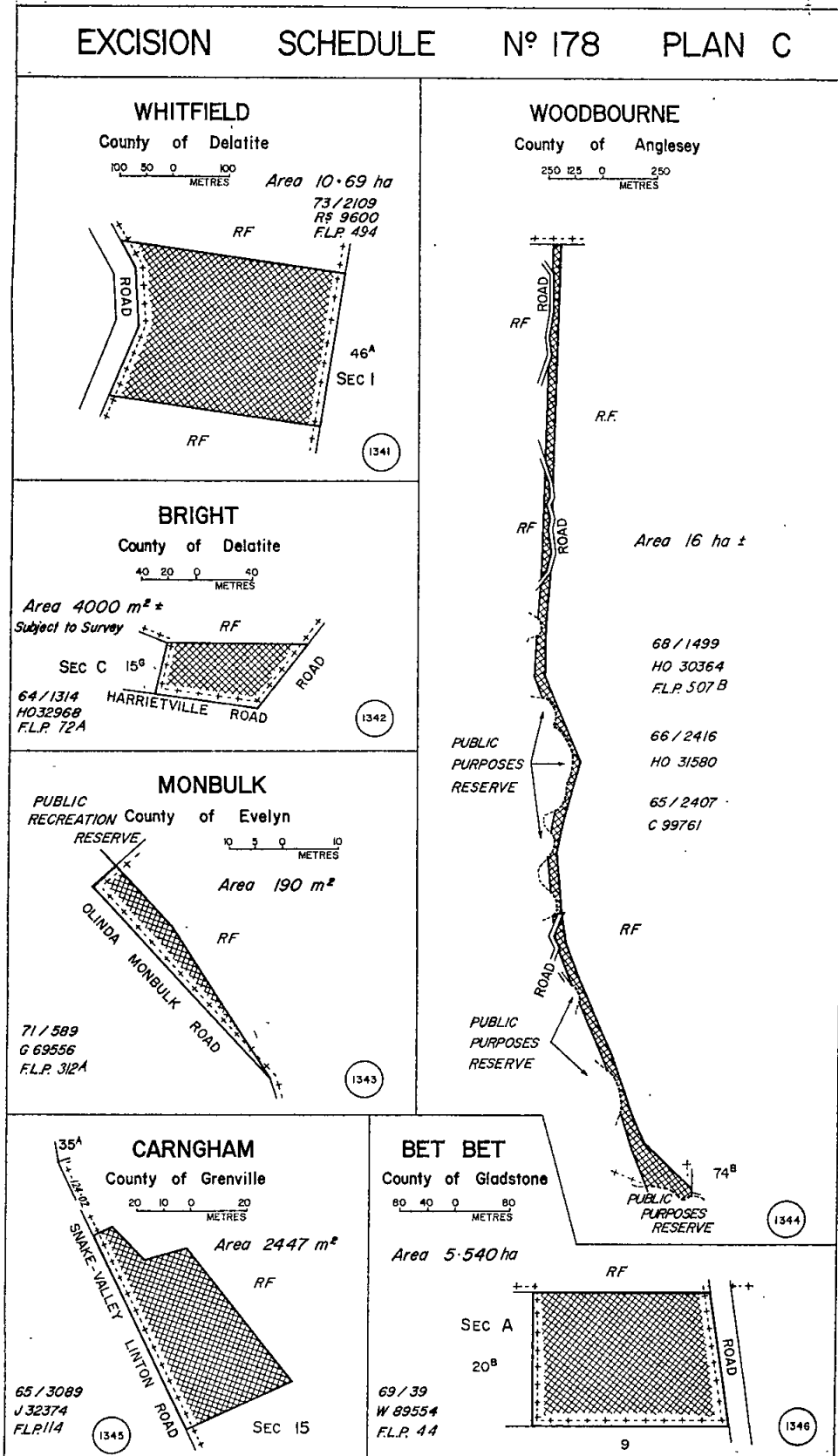

EXCISION SCHEDULE No 178 PLAN D

MARYBOROUGH

County of Talbot

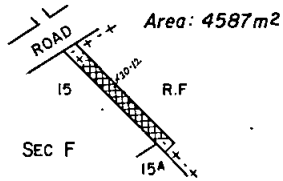
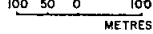

65/1020
W87536
F.L.P. 298 B

(1347)

POMPAPIEL

County of Bendigo

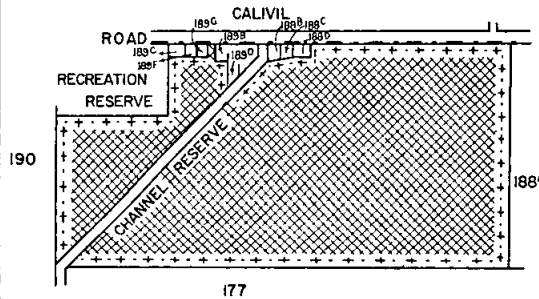
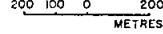

63/1240 F.L.P. 388 W86774
66/528 W88925

Total Area: 89ha ±
Subject to Survey

(1348)

BAEL BAEL

County of Tatchera

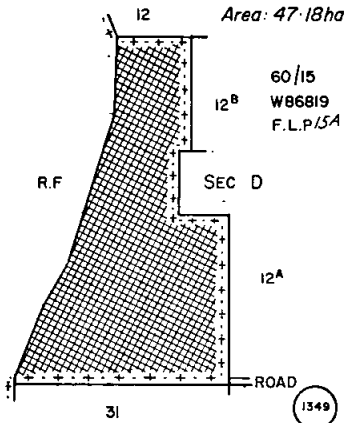
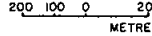

60/15
W86819
F.L.P. 15A

(1349)

WOMBAT

County of Talbot

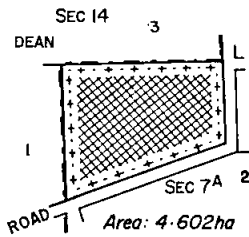
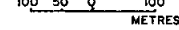

67/2123
W89237
F.L.P. 502 D

(1351)

PAINSWICK

County of Gladstone

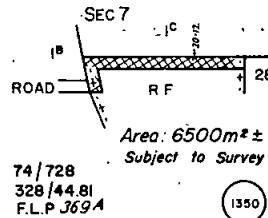
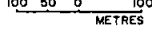

74/728
328/44.81
F.L.P. 369 A

(1350)

POREPUNKAH

County of Bogong

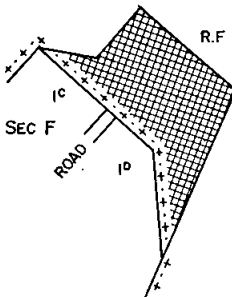
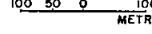

68/1109
H032575
F.L.P. 889 A

(1353)

HEATHCOTE

County of Dalhousie

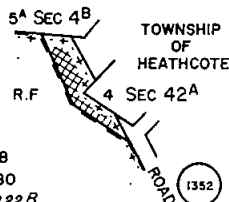
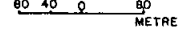

Area: 4300m² ±

67/2128
H032180
F.L.P. 222 B

(1352)

GORAE

County of Normanby

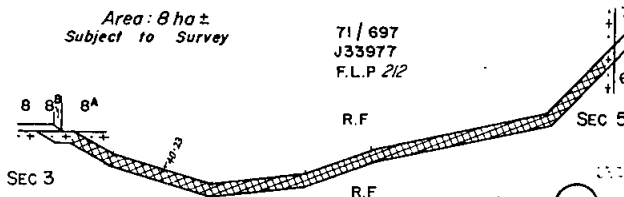
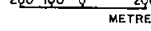

Area: 8 ha ±
Subject to Survey

71/697
J33977
F.L.P. 212

(1354)

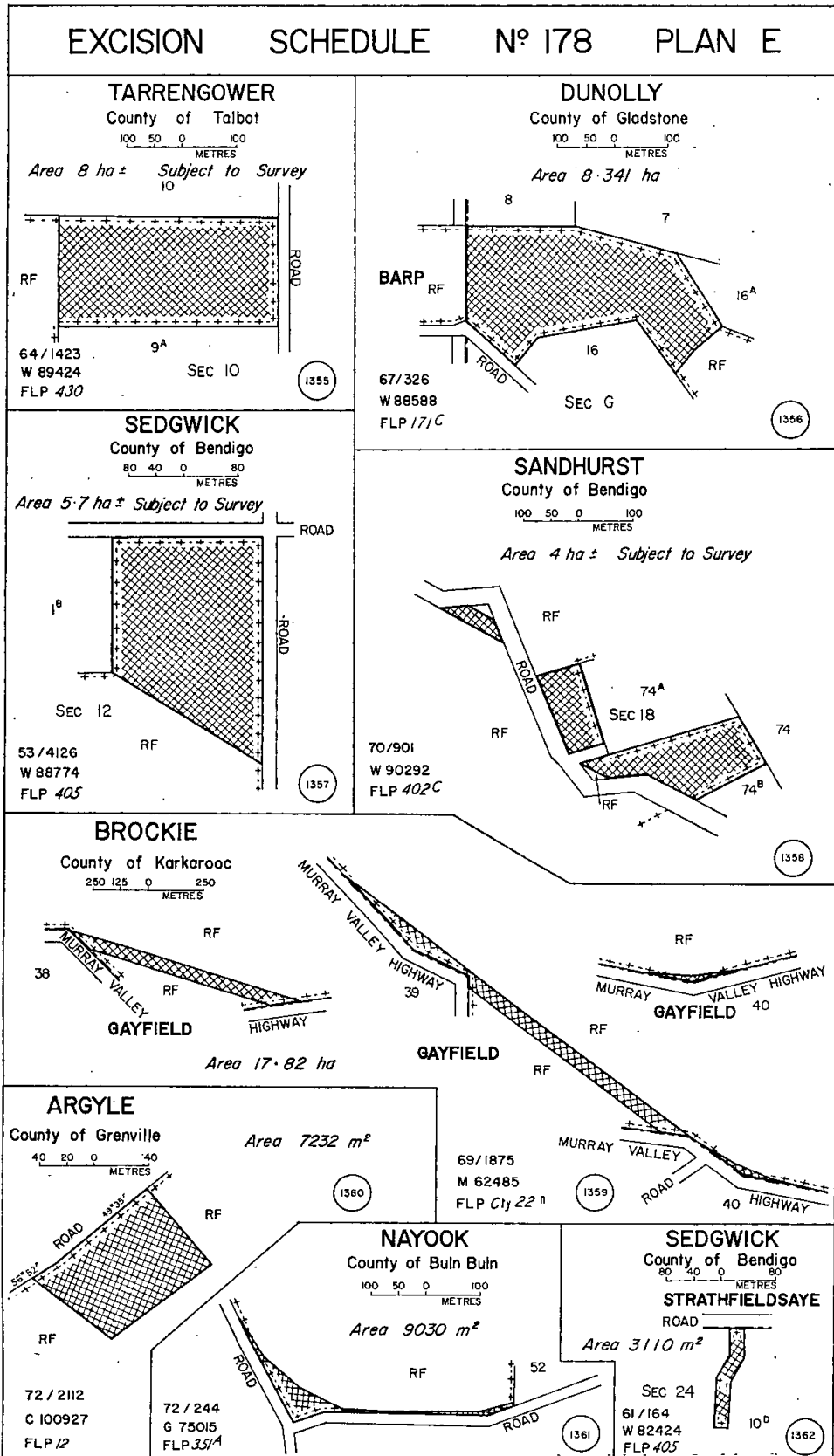

EXCISION SCHEDULE NO 178 PLAN G

WARRANTYTE

County of Evelyn
200 100 0 200
METRES

72/670
C100255
F.L.P. 479
Area: 64 ha ±

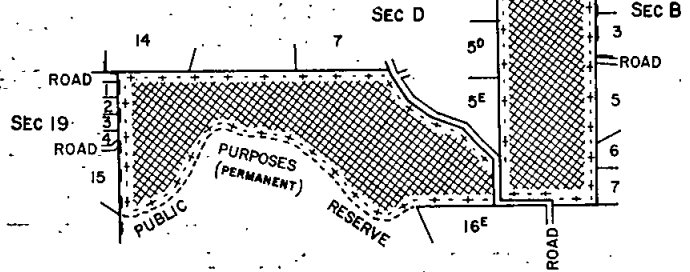

CRESWICK

County of Talbot
100 50 0 100
METRES

Area: 3 ha ± Subject to Survey

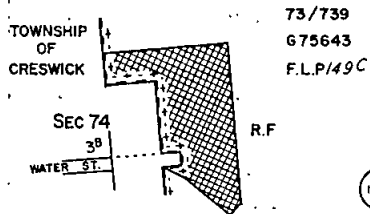

DEDICATION SCHEDULE N° 219 PLAN A

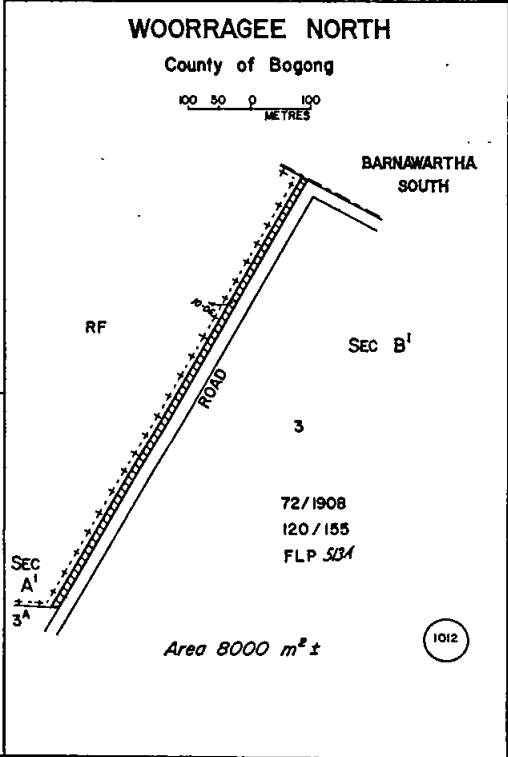
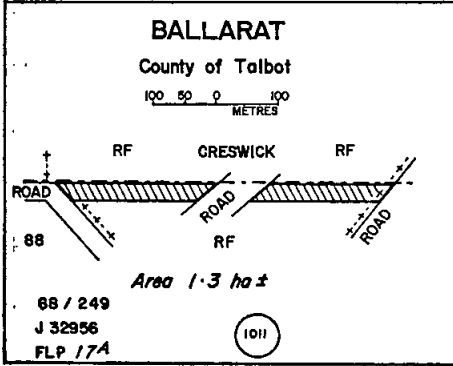
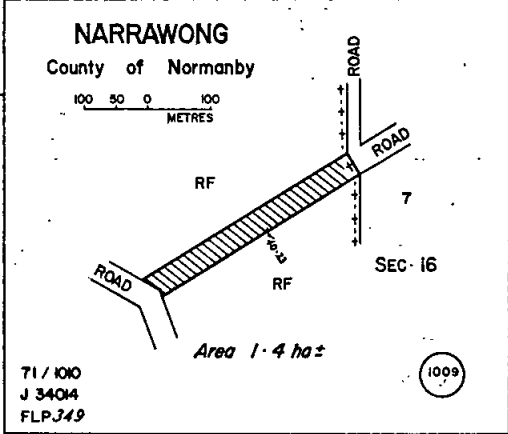
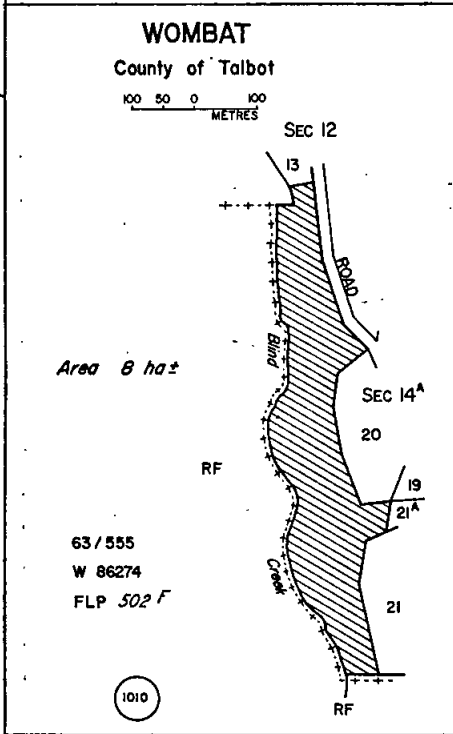
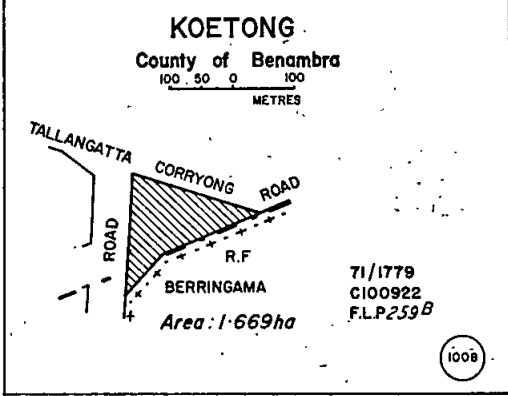
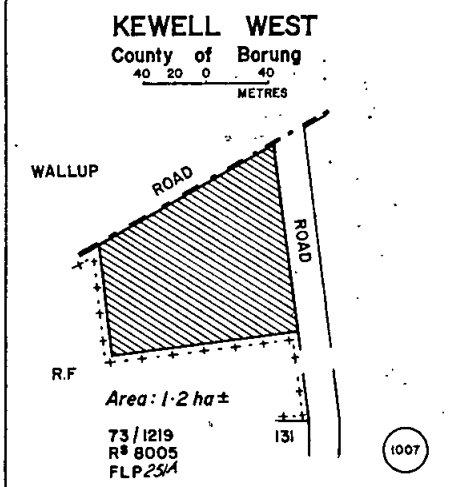

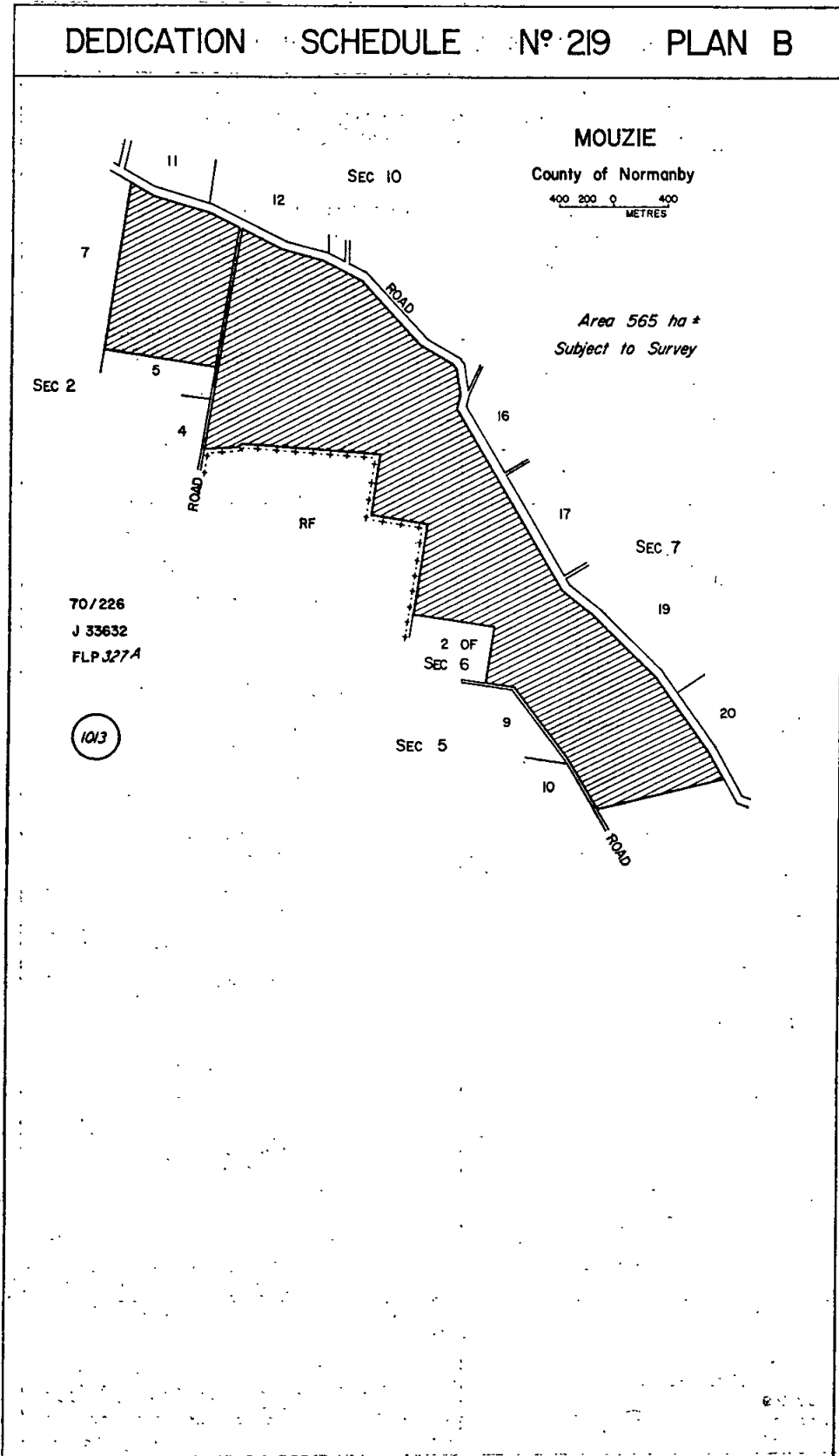

And the Honorable Frederick James Granter, Her Majesty's Minister of Forests for the State of Victoria, shall give the necessary directions herein accordingly.

TOM FORRISTAL,
Clerk of the Executive Council.

Co-operation Act 1958.

CO-OPERATIVE SOCIETIES (GENERAL) REGULATIONS 1975.

At the Executive Council Chamber, Melbourne, the
twenty-fifth day of March, 1975.

PRESENT:

His Excellency the Governor of Victoria.
Mr. Rossiter | Mr. Scanlan.
Mr. Granter |

IN pursuance of the powers conferred by the *Co-operation Act* 1958 and all other powers him thereunto enabling, His Excellency the Governor of the State of Victoria, by and with the advice of the Executive Council thereof, doth make the following Regulations:—

1. (1) These Regulations may be cited as the *Co-operative Societies (General) Regulations 1975*.

(2) In these regulations the * *Co-operative Societies (General) Regulations* are called the *Principal Regulations*.

2. In Regulation 40 of the *Principal Regulations*, for the expression "Seven and one-half per centum per annum" there shall be substituted the expression "Ten per centum per annum".

And the Honorable Vance Oakley Dickie, Her Majesty's Minister of Housing for the State of Victoria, shall give the necessary directions herein accordingly.

TOM FORRISTAL,
Clerk of the Executive Council.

* Rules published in *Victoria Government Gazette* of 29th July, 1954, at page 5193 as amended by rules published in the *Victoria Government Gazette* of 6th May, 1959, at page 1318 and by S.R. Nos. 41/64, 80/66 and 216/71.

FORESTS ACT 1958.

At the Executive Council Chamber, Melbourne, the
fifteenth day of April, 1975.

PRESENT:

His Excellency the Governor of Victoria.
Mr. Rafferty | Mr. Smith
Mr. Hunt | Mr. Houghton.
Mr. Dixon |

ALIENATED LAND ACQUIRED BY EXCHANGE, ETC.,
AND DEDICATED AS RESERVED FOREST.

Whereas by section 42, sub-section 8, of the *Forests Act 1958*, it is prescribed that the Governor in Council may acquire by exchange of land dedicated as reserved forest—

- (a) any alienated land or Crown land licensed or leased with an inchoate right of purchase; or
(b) any land, public or private, and whether vested in trustees or otherwise,
and may by order published in the *Government Gazette* dedicate the same as reserved forest:

Now, therefore, His Excellency the Governor of the State of Victoria, by and with the advice of the Executive Council of the said State, and in pursuance of the provisions of section 42, sub-section 8, of the *Forests Act 1958*, doth by this Order—

- (1) acquire the alienated land described in Schedule "A" hereto by exchange of land dedicated as reserved forest described in Schedule "B" hereto;

- (2) excise from the reserved forest the area described in the aforesaid Schedule "B", such excision to take effect 30 days from date hereof;
(3) dedicate the land described in Schedule "A" aforementioned as reserved forest, such dedication to take effect 30 days from date hereof.

THE SCHEDULE ABOVE REFERRED TO.

Schedule "A"—Dedication Schedule No. 220.

Alienated land acquired from Guiseppe Caluzzi and Rosina Caluzzi, both of 5 Pizzey Street, Sunshine, being Crown allotment 8, section A1, Parish of Franklin, County of Talbot, and comprising 8.094 ha.

Schedule "B"—Excision Schedule No. 179.

Land excised from reserved forest for Guiseppe Caluzzi and Rosina Caluzzi, both of 5 Pizzey Street, Sunshine, being Crown allotment 8A, section 30, Parish of Wombat, County of Talbot, and comprising 4.048 ha.

And the Honorable Frederick James Granter, Her Majesty's Minister of Forests for the State of Victoria, shall give the necessary directions herein accordingly.

TOM FORRISTAL,
Clerk of the Executive Council.

LOCAL GOVERNMENT DEPARTMENT.

At the Executive Council Chamber, Melbourne, the twenty-ninth day of April, 1975.

PRESENT:

His Excellency the Governor of Victoria.
Mr. Dickie | Mr. Dunstan.

ALTERATION OF TIME FOR CLOSING POLL AT MUNICIPAL ELECTIONS SHIRE OF SEYMOUR.

His Excellency the Governor of the State of Victoria, by and with the advice of the Executive Council thereof, in pursuance of the powers conferred by section 134 of the Local Government Act 1958, and in compliance with the prayer of a petition presented by the Council of the Shire of Seymour declares that the hour for closing the poll at municipal elections for the said Shire shall be seven o'clock in the afternoon.

And the Honorable Alan John Hunt, Her Majesty's Minister for Local Government for the State of Victoria, shall give the necessary directions herein accordingly.

TOM FORRISTAL,
Clerk of the Executive Council.

LOCAL GOVERNMENT DEPARTMENT.

At the Executive Council Chamber, Melbourne, the twenty-ninth day of April, 1975.

PRESENT:

His Excellency the Governor of Victoria.
Mr. Dickie | Mr. Dunstan.

ROAD DISCONTINUED.—SHIRE OF WARRAGUL.

Whereas it is provided in section 528 of the Local Government Act 1958, that where a road (whether or not a public highway but not being a road set out on land of the Crown) or any part thereof is not required for public use, the Governor in Council on the request of the Council of the municipality in which such road is situated made not less than one month after publishing in a newspaper generally circulating in the district and posting to the registered proprietor (if any) of the land and the owners and occupiers (if any) of the lands abutting or immediately adjacent to the road notice of intention to make such request may by Order published in the Government Gazette direct that such road or part shall be discontinued and thereupon such road or part thereof shall be discontinued accordingly.

And whereas the Council of the Shire of Warragul has requested that the Governor in Council direct that a road off Windsor Avenue, Warragul, be discontinued and not less than one month previously has published in a newspaper generally circulating in the district and posted to the registered proprietor of the land in the road and to the owners and occupiers of land abutting or immediately adjacent to the road notice of intention to make such request.

Now therefore, His Excellency the Governor of the State of Victoria, by and with the advice of the Executive Council thereof, hereby directs:

- (a) that the said road which is shown by hachure and cross hachure on the plan hereunder shall be discontinued;
- (b) that notwithstanding such discontinuance the Warragul Sewerage Authority shall continue to have and possess the same right title power authority or interest in or in relation to the whole of the land shown by cross hachure on the said plan as it had or possessed prior to such discontinuance with respect to or in connection with any drains or pipes laid or erected in or over such lands for the purposes of drainage or sewerage; and
- (c) that subject to any such right title power authority or interest, the land in the said road may be sold by the council of the Shire of Warragul by agreement.

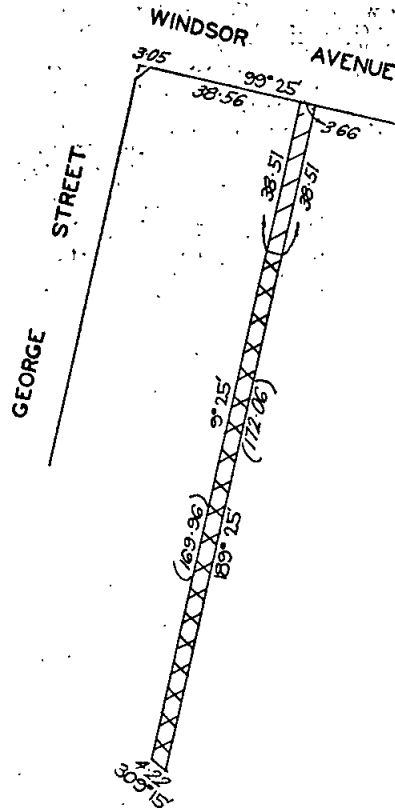

And the Honorable Alan John Hunt, Her Majesty's Minister for Local Government for the State of Victoria, shall give the necessary directions herein accordingly.

TOM FORRISTAL,
Clerk of the Executive Council.

LOCAL GOVERNMENT DEPARTMENT.

At the Executive Council Chamber, Melbourne, the twenty-ninth day of April, 1975.

PRESENT:

His Excellency the Governor of Victoria.
Mr. Dickie | Mr. Dunstan.

ROAD DISCONTINUED.—CITY OF RICHMOND.

Whereas it is provided in section 528 (2) of the Local Government Act 1958, that where a road (whether or not a public highway but not being a road set out on land of the Crown) or any part thereof is not required for public use, the Governor in Council, on the request of the council of the municipality in which such road is situated made not less than one month after publishing in a newspaper generally circulating in the district and posting to the registered proprietor (if any) of the land and the owners and occupiers (if any) of lands abutting or immediately adjacent to the road notice of intention to make such request may by Order published in the Government Gazette direct that such road or part shall be discontinued and thereupon such road or part shall be discontinued accordingly.

And whereas the Council of the City of Richmond has requested that the Governor in Council direct parts of Chestnut and Electra Streets, Richmond, be discontinued and not less than one month previously has published in a newspaper generally circulating in the district and posted to the registered proprietor of the land in the parts of roads and to the owners and occupiers of lands abutting or immediately adjacent to the parts of roads notice of intention to make such request.

Now therefore, His Excellency the Governor of the State of Victoria, by and with the advice of the Executive Council thereof, hereby directs:

- (a) that the said parts of roads which are shown by hachure on the plan hereunder, shall be discontinued;
- (b) that notwithstanding such discontinuance the Gas and Fuel Corporation shall continue to have and possess the same right title power authority or interest in or in relation to the whole of the land shown by hachure on the said plan as it had or possessed prior to such discontinuance with respect to or in connection with any pipes fixtures or, fittings laid or erected in on or over such lands for the purpose of the supply of gas; and
- (c) that notwithstanding such discontinuance the Postmaster-General's Department shall continue to have and possess the same right title power authority or interest in or in relation to the whole of the land shown by hachure on the said plan as it had or possessed prior to such discontinuance with respect to or in connection with any wires cables or apparatus laid or erected in on or over such lands for the purpose of telecommunications; and
- (d) that, subject to any such right title power authority or interest, the land in the said parts of roads may be sold by the Council of the City of Richmond by agreement.

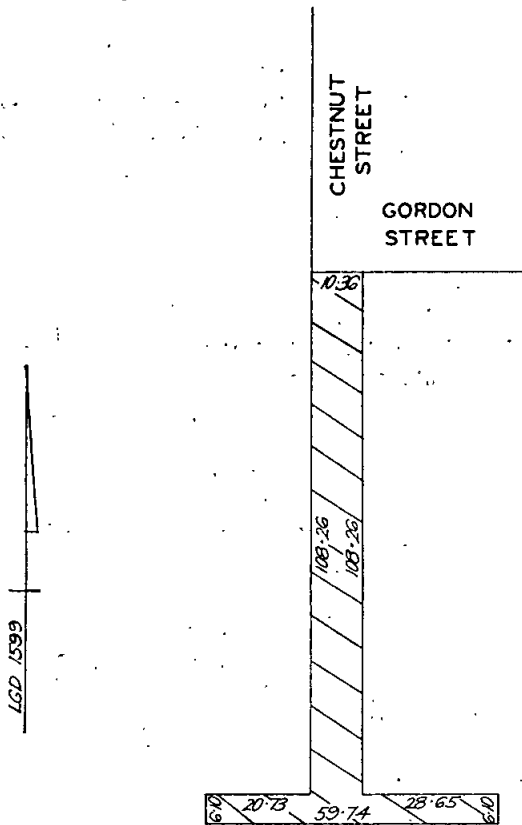

MEASUREMENTS ARE IN METRES

And the Honorable Alan John Hunt, Her Majesty's Minister for Local Government for the State of Victoria, shall give the necessary directions herein accordingly.

TOM FORRISTAL,
Clerk of the Executive Council.

LOCAL GOVERNMENT DEPARTMENT.

At the Executive Council Chamber, Melbourne, the twenty-ninth day of April, 1975.

PRESENT:

His Excellency the Governor of Victoria.
Mr. Dickie | Mr. Dunstan.

ROAD DISCONTINUED.—CITY OF BRUNSWICK.

Whereas it is provided in section 528 (2) of the Local Government Act 1958 that where a road (whether or not a public highway but not being a road set out on land of the Crown) or any part thereof is not required for public use, the Governor in Council on the request of the council of the municipality in which such road is situated made not less than one month after publishing in a newspaper generally circulating in the district and posting to the registered proprietor (if any) of the land and the owners and occupiers (if any) of the lands abutting or immediately adjacent to the road notice of intention to make such request may by Order published in the Government Gazette direct that such road or part shall be discontinued and thereupon such road or part shall be discontinued accordingly.

And whereas the Council of the City of Brunswick has requested that the Governor in Council direct that a road off Murdoch Street, Brunswick be discontinued and not less than one month previously has published in a newspaper generally circulating in the district and posted to the registered proprietor of the land in the road and to the owners and occupiers of lands abutting or immediately adjacent to the road notice of intention to make such request.

Now therefore, His Excellency the Governor of the State of Victoria, by and with the advice of the Executive Council thereof, hereby directs that the said road, which is shown by hachure on the plan hereunder shall be discontinued and that the land may be sold by the Council of the City of Brunswick by agreement.

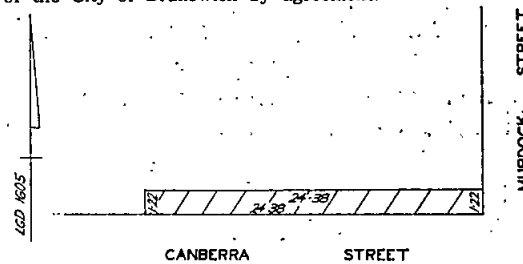

MEASUREMENTS ARE IN METRES

And the Honorable Alan John Hunt, Her Majesty's Minister for Local Government for the State of Victoria, shall give the necessary directions herein accordingly.

TOM FORRISTAL,
Clerk of the Executive Council.

LOCAL GOVERNMENT DEPARTMENT.

At the Executive Council Chamber, Melbourne, the twenty-ninth day of April, 1975.

PRESENT:

His Excellency the Governor of Victoria.
Mr. Dickie | Mr. Dunstan.

APPLICATION TO ELECTIONS OF COUNCILLORS FOR THE SHIRE OF SEYMOUR OF REGULATIONS RELATING TO COMPULSORY VOTING.

Whereas it is provided in section 149 of the Local Government Act 1958, that the Governor in Council on the petition of the Council of any municipality, may by Order published in the Government Gazette, apply to elections of councillors for such municipality with any modifications provided for in such Order, all or any of the Regulations relating to compulsory voting made under the said section 149.

Now therefore, His Excellency the Governor of the State of Victoria, by and with the advice of the Executive Council thereof, and in pursuance of a petition of the

The land shown hatched on plan numbered G.P.13880 hereunder required for the widening of Springvale Road in the City of Springvale and making of the widening thereon.

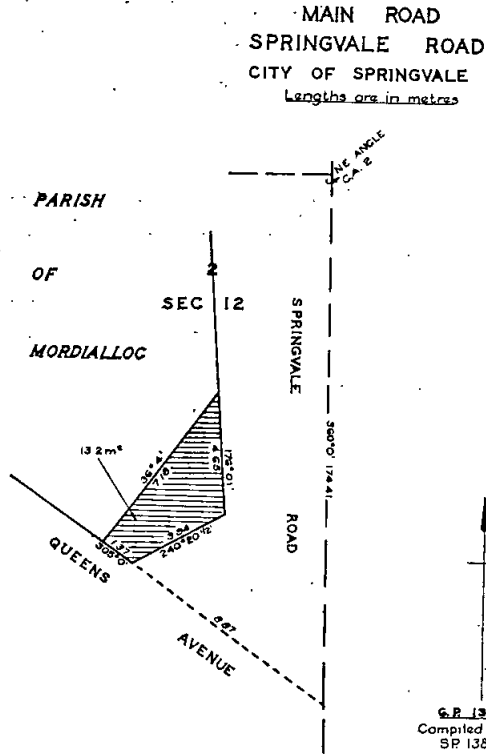

Unclassified Road.

The land shown hatched on plan numbered G.P.13774 hereunder required for the making of a new road in the City of Frankston.

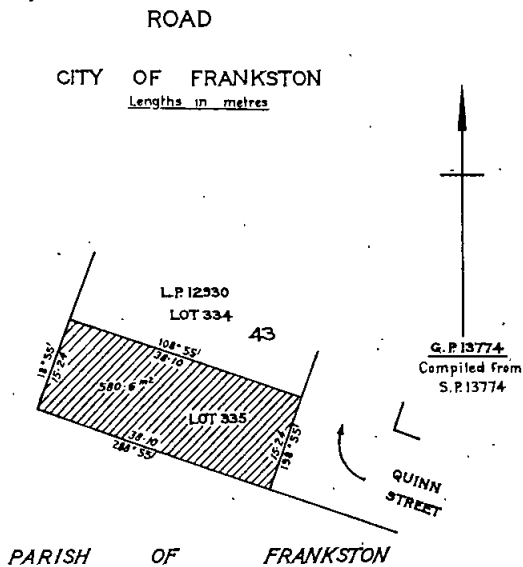

And the Honorable Edward Raymond Meagher, Her Majesty's Minister of Transport for the State of Victoria, shall give the necessary directions herein accordingly.

TOM FORRISTAL,
Clerk of the Executive Council.

LAND ACT 1958 (No. 6284).

At the Executive Council Chamber, Melbourne, the twenty-ninth day of April, 1975.

PRESENT:

His Excellency the Governor of Victoria.
Mr. Dickie | Mr. Dunstan.

REVOCATION OF TEMPORARY RESERVATIONS OF LANDS BY ORDERS IN COUNCIL.

His Excellency the Governor of the State of Victoria, by and with the advice of the Executive Council thereof, pursuant to the provisions of the Land Act 1958, hereby revokes the temporary reservations of lands by Orders in Council hereinafter described:—

OUYEN.—The temporary reservation by Order in Council of the 5th August, 1958, of 1138 square metres (1 rood 5 perches) of land in the Parish of Ouyen as a site for Public Hospital.—(O.22⁽⁶⁾) (Rs.3112).

OUYEN.—The temporary reservation by Order in Council of the 16th February, 1937, of 1.619 hectares (4 acres) of land in the Parish of Ouyen as a site for Public Hospital, so far only as regards the portion containing 7518 square metres as defined by description and hatching on plan published in the Government Gazette of the 4th April, 1975.—(O.22⁽⁶⁾) (Rs.3112).

And the Honorable William Archibald Borthwick, Her Majesty's Minister of Lands for the State of Victoria, shall give the necessary directions herein accordingly.

TOM FORRISTAL,
Clerk of the Executive Council.

Land Act 1958.

DEPARTMENT OF CROWN LANDS AND SURVEY.

At the Executive Council Chamber, Melbourne, the twenty-ninth day of April, 1975.

PRESENT:

His Excellency the Governor of Victoria.
Mr. Dickie | Mr. Dunstan.

LANDS TEMPORARILY RESERVED AS SITES.

His Excellency the Governor of the State of Victoria, by and with the advice of the Executive Council thereof, doth hereby in pursuance of the provisions of section 14 of the Land Act 1958, reserve temporarily from sale, from being leased and from having a licence granted in respect thereof, and also except from occupation for mining purposes under any miner's right the lands hereinafter described, viz.:—

BAIRNSDALE.—Site for a Racecourse and Public Recreation, 41 hectares being Crown allotment 15A, section B, Township of Bairnsdale, Parish of Bairnsdale, County of Tanjil, as indicated by hatching on plan hereunder.—(B.66⁽¹²⁾) (Rs.10038).

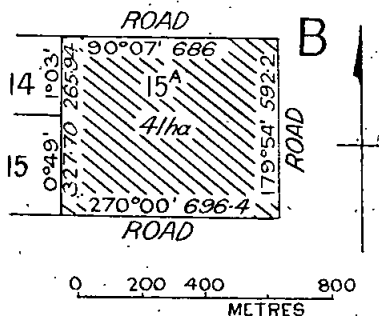

BANGERANG.—Site for Public Recreation, 6881 square metres, being Crown allotment 9, section 1, Township of Bangerang, Parish of Bangerang, County of Borung as indicated by hatching on plan hereunder.—(B.658⁽⁷⁾) (Rs.3576).

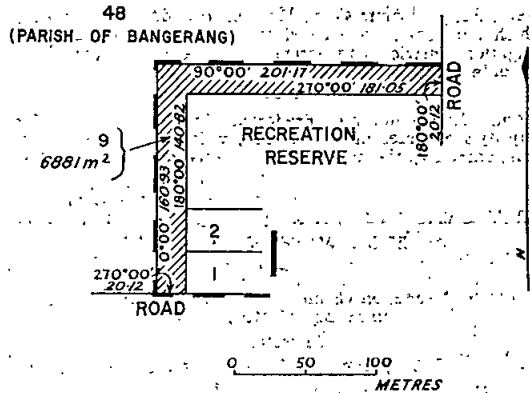

GHERINGHAP.—Site for Public purposes, 3200 square metres, more or less, being Crown allotment 2A, section A, Parish of Gheringhap, County of Grant, as indicated by hatching on plan hereunder.—(G.38(2) (Rs.10030).

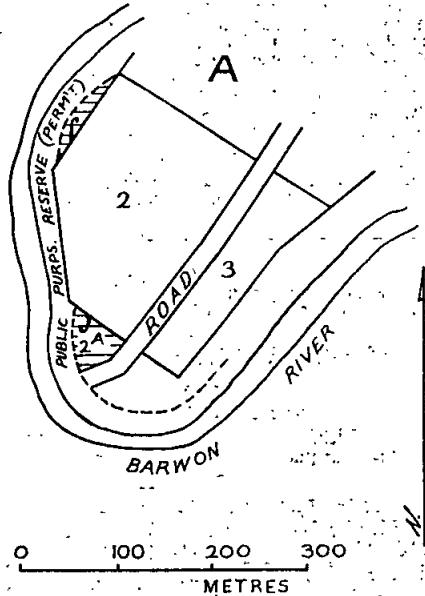

TOTAL AREA OF HATCHED PORTIONS
3200 m²±

And the Honorable William Archibald Borthwick, Her Majesty's Minister of Lands for the State of Victoria, shall give the necessary directions herein accordingly.

TOM FORRISTAL
Clerk of the Executive Council.

LABOUR AND INDUSTRY ACT 1958.

At the Executive Council Chamber, Melbourne, the twenty-ninth day of April, 1975.

PRESENT:
His Excellency the Governor of Victoria.
Mr. Dickie | Mr. Dunstan.

EXTENSION OF POWERS OF THE KINDERGARTEN TEACHERS BOARD.

In pursuance of the powers conferred by section 20 of the Labour and Industry Act 1958, and all other powers him thereunto enabling, His Excellency the Governor of the State of Victoria, by and with the advice of the Executive Council thereof, doth hereby extend the powers of the Kindergarten Teachers Board so that in substitution for the powers heretofore conferred on the said Kindergarten Teachers Board it shall be appointed for the occupation of a kindergarten teacher and for such other occupations for which a necessary condition

of employment is to be qualified as a Kindergarten teacher, but excluding any occupation subject to the Determination of any Wages Board heretofore appointed.

And the Honorable Joseph Anstice Rafferty, Her Majesty's Minister of Labour and Industry for the State of Victoria, shall give the necessary directions herein accordingly.

TOM FORRISTAL
Clerk of the Executive Council.

SUPERANNUATION ACT 1958.

At the Executive Council Chamber, Melbourne, the twenty-ninth day of April, 1975.

PRESENT:
His Excellency the Governor of Victoria.
Mr. Dickie | Mr. Dunstan.

Pursuant to the powers conferred by the provisions of paragraph (ja) of sub-section (1) of section 3 of the Superannuation Act 1958, His Excellency the Governor of the State of Victoria, by and with the advice of the Executive Council thereof, doth by this Order declare that the provisions of the Superannuation Act shall apply to the officers named in the schedule set out hereunder.

SCHEDULE.

- HIGGS, JOHN EDWARD, State College of Victoria, at Bendigo.
- HODGES, DAVID NORMAN, State College of Victoria, at Burwood.
- KLAHN, GUENTHER KARL HEINZ, State College of Victoria, at Burwood.
- MORRIS, DONALD GEORGE, State College of Victoria, at Geelong.
- QUINN, MICHAEL JOHN, State College of Victoria—Institute of Catholic Education.
- BARTLETT, DARIUS MERVYN, State College of Victoria, Rusden.
- REGGARS, PETER JOHN, State College of Victoria, at Toorak.

And the Honorable Rupert James Hamer, Her Majesty's Treasurer for the State of Victoria, shall give the necessary directions herein accordingly.

TOM FORRISTAL
Clerk of the Executive Council.

SHIRE OF DEAKIN WATERWORKS TRUST.

At the Executive Council Chamber, Melbourne, the twenty-ninth day of April, 1975.

PRESENT:
His Excellency the Governor of Victoria.
Mr. Dickie | Mr. Dunstan.

TRANSFER OF WORKS FROM SHIRE OF DEAKIN.—EXTENT OF WATERWORKS DISTRICT INCREASED AND PROCLAMATION OF GIRGARRE URBAN DISTRICT.

Under the powers conferred by the Water Act and all other powers enabling him in that behalf, His Excellency the Governor of the State of Victoria, by and with the advice of the Executive Council of the said State, doth by Order hereby—

- (1) approve of the transfer of the waterworks supplying the Township of Girgarre from the Shire of Deakin to the Shire of Deakin Waterworks Trust;
- (2) approve that the depreciated value of the said works to be paid by the Shire of Deakin Waterworks Trust to the Shire of Deakin shall be \$7,000;
- (3) order and direct that the extent of the Waterworks District of the Shire of Deakin Waterworks Trust shall be increased by adding to the same the lands comprised within the boundaries shown on the plan accompanying this Order and approved by the Governor in Council by

and with this Order and deposited in the office of the State Rivers and Water Supply Commission, Melbourne (Corr. No. 71/1220/56);

(4) proclaim that as on and from the date hereof that portion of the Waterworks District of the Shire of Deakin Waterworks Trust comprised within the boundaries shown on the said plan shall be and be deemed to be an Urban District for the purposes of and within the meaning of the said Act and shall be known as the Girgarré Urban District;

(5) approve that the principal works to be constructed or carried out by the said Trust in the said Urban District shall be a service basin, pumping plant, elevated tank, chlorination equipment, reticulation, and metres as shown on the said plan; and

(6) approve that the estimated cost of carrying out the proposed waterworks shall be \$209,000.

And the Honorable Frederick James Granter, Her Majesty's Minister of Water Supply for the State of Victoria, shall give the necessary directions herein accordingly.

TOM FORRISTAL,
Clerk of the Executive Council.

Water Act 1958.

STATE RIVERS AND WATER SUPPLY COMMISSION.

At the Executive Council Chamber, Melbourne, the
twenty-ninth day of April, 1975.

PRESENT:

His Excellency the Governor of Victoria.
Mr. Dickie | Mr. Dunstan.

RED CLIFFS URBAN DISTRICT.—AREA OF DISTRICT
INCREASED.

Under the powers conferred by the Water Act 1958 and all other powers enabling him in that behalf, His Excellency the Governor of the State of Victoria, with the advice of the Executive Council of the said State, on the recommendation of the State Rivers and Water Supply Commission, doth hereby declare, order and direct that the area of the Red Cliffs Urban District be increased by adding to the same the lands shown by blue colour on a plan approved by the Governor in Council and deposited in the office of the State Rivers and Water Supply Commission, Melbourne (Corr. No. 69/1104), and as on and from the 1st day of June, 1975, the area of such district shall be deemed to be so increased.

And the Honorable Frederick James Granter, Her Majesty's Minister of Water Supply for the State of Victoria, shall give the necessary directions herein accordingly.

TOM FORRISTAL,
Clerk of the Executive Council.

Water Act 1958.

STATE RIVERS AND WATER SUPPLY COMMISSION.

At the Executive Council Chamber, Melbourne, the
twenty-ninth day of April, 1975.

PRESENT:

His Excellency the Governor of Victoria.
Mr. Dickie | Mr. Dunstan.

GOULBURN-MURRAY IRRIGATION DISTRICT.—POR-
TION EXCISED TONGALA-STANHOPE IRRIGATION
AREA.—BOUNDARIES VARIED.

Under the powers conferred by the Water Act 1958 and all other powers enabling him in that behalf, His Excellency the Governor of the State of Victoria, with the advice of the Executive Council of the said State, on the recommendation of the State Rivers and Water Supply Commission, doth hereby declare, order and direct:—

1. That there be excised from the Goulburn-Murray Irrigation District; and

2. That the boundaries of the Tongala-Stanhope Irrigation Area be varied to excise therefrom the land shown by green colour on a plan approved by the Governor in Council and deposited in the office of the State Rivers and

Water Supply Commission, Melbourne (Corr. No. 71/1220) which land shall be deemed to be excised from the said Irrigation District and Irrigation Area as on and from the date hereof.

And the Honorable Frederick James Granter, Her Majesty's Minister of Water Supply for the State of Victoria, shall give the necessary directions herein accordingly.

TOM FORRISTAL,
Clerk of the Executive Council.

MACEDON WATERWORKS TRUST.

At the Executive Council Chamber, Melbourne, the
sixth day of May, 1975.

PRESENT:

His Excellency the Governor of Victoria.
Mr. Dickie | Mr. Wilcox.
Mr. Dunstan

CONSENT TO BORROWING \$15,000.

Under the powers conferred by the Water Act and all other powers enabling him in that behalf, His Excellency the Governor of the State of Victoria, by and with the advice of the Executive Council of the said State, hereby consents to the Macedon Waterworks Trust borrowing the sum of Fifteen thousand dollars (\$15,000) to meet the cost of water supply works.

And the Honorable Frederick James Granter, Her Majesty's Minister of Water Supply for the State of Victoria, shall give the necessary directions herein accordingly.

TOM FORRISTAL,
Clerk of the Executive Council.

MYRTLEFORD SEWERAGE AUTHORITY.

At the Executive Council Chamber, Melbourne, the
sixth day of May, 1975.

PRESENT:

His Excellency the Governor of Victoria.
Mr. Dickie | Mr. Wilcox.
Mr. Dunstan

CONSENT TO BORROWING \$40,000.

Under the powers conferred by the Sewerage Districts Act and all other powers enabling him in that behalf, His Excellency the Governor of the State of Victoria, by and with the advice of the Executive Council of the said State, hereby consents to the Myrtleford Sewerage Authority borrowing the sum of Forty thousand dollars (\$40,000) to meet the cost of sewerage works as set forth in the detailed statement bearing date 2nd May, 1975.

And the Honorable Frederick James Granter, Her Majesty's Minister of Water Supply for the State of Victoria, shall give the necessary directions herein accordingly.

TOM FORRISTAL,
Clerk of the Executive Council.

PORT FAIRY SEWERAGE AUTHORITY.

At the Executive Council Chamber, Melbourne, the
sixth day of May, 1975.

PRESENT:

His Excellency the Governor of Victoria.
Mr. Dickie | Mr. Wilcox.
Mr. Dunstan

AMENDMENT OF ORDER.

Under the powers conferred by the Sewerage Districts Act and all other powers enabling him in that behalf, His Excellency the Governor of the State of Victoria, by and with the advice of the Executive Council of the said State, doth hereby amend as follows the Order in Council made on 8th April, 1975, and published in the Victoria Government Gazette dated 16th April, 1975, authorising the Port Fairy Sewerage Authority to borrow the sum of Forty

thousand dollars (\$40,000) for the carrying out of works in accordance with the provisions of Sections 95, 130 and 137 of the *Sewerage Districts Act 1958*. For the expression "Forty thousand dollars (\$40,000)" there shall be substituted the expression "Thirty thousand dollars (\$30,000)".

And the Honorable Frederick James Granter, Her Majesty's Minister of Water Supply for the State of Victoria, shall give the necessary directions herein accordingly.

TOM FORRISTAL,
Clerk of the Executive Council.

MORNINGTON SEWERAGE AUTHORITY.

At the Executive Council Chamber, Melbourne, the sixth day of May, 1975.

PRESENT:

His Excellency the Governor of Victoria.	
Mr. Dickie	Mr. Wilcox.
Mr. Dunstan	

CONSENT TO BORROWING \$300,000.

Under the powers conferred by the *Sewerage Districts Act* and all other powers enabling him in that behalf, His Excellency the Governor of the State of Victoria, by and with the advice of the Executive Council of the said State, hereby consents to the Mornington Sewerage Authority borrowing the sum of Three hundred thousand dollars (\$300,000) to meet the cost of sewerage works as set forth in the detailed statement bearing date 2nd May, 1975.

And the Honorable Frederick James Granter, Her Majesty's Minister of Water Supply for the State of Victoria, shall give the necessary directions herein accordingly.

TOM FORRISTAL,
Clerk of the Executive Council.

COLAC SEWERAGE AUTHORITY.

At the Executive Council Chamber, Melbourne, the sixth day of May, 1975.

PRESENT:

His Excellency the Governor of Victoria.	
Mr. Dickie	Mr. Wilcox.
Mr. Dunstan	

CONSENT TO BORROWING \$50,000.

Under the powers conferred by the *Sewerage Districts Act* and all other powers enabling him in that behalf, His Excellency the Governor of the State of Victoria, by and with the advice of the Executive Council of the said State, hereby consents to the Colac Sewerage Authority borrowing the sum of Fifty thousand dollars (\$50,000), to meet the cost of sewerage works as set forth in the detailed statement bearing date 2nd May, 1975.

And the Honorable Frederick James Granter, Her Majesty's Minister of Water Supply for the State of Victoria, shall give the necessary directions herein accordingly.

TOM FORRISTAL,
Clerk of the Executive Council.

APOLLO BAY SEWERAGE AUTHORITY.

At the Executive Council Chamber, Melbourne, the sixth day of May, 1975.

PRESENT:

His Excellency the Governor of Victoria.	
Mr. Dickie	Mr. Wilcox.
Mr. Dunstan	

CONSENT TO BORROWING \$30,000.

Under the powers conferred by the *Sewerage Districts Act* and all other powers enabling him in that behalf, His Excellency the Governor of the State of Victoria, by and

with the advice of the Executive Council of the said State, hereby consents to the Apollo Bay Sewerage Authority borrowing the sum of Thirty thousand dollars (\$30,000) to meet the cost of sewerage works as set forth in the detailed statement bearing date 2nd May, 1975.

And the Honorable Frederick James Granter, Her Majesty's Minister of Water Supply for the State of Victoria, shall give the necessary directions herein accordingly.

TOM FORRISTAL,
Clerk of the Executive Council.

BALLARAT SEWERAGE AUTHORITY.

At the Executive Council Chamber, Melbourne, the sixth day of May, 1975.

PRESENT:

His Excellency the Governor of Victoria.	
Mr. Dickie	Mr. Wilcox.
Mr. Dunstan	

CONSENT TO BORROWING \$100,000.

Under the powers conferred by the *Sewerage Districts Act* and all other powers enabling him in that behalf, His Excellency the Governor of the State of Victoria, by and with the advice of the Executive Council of the said State, hereby consents to the Ballarat Sewerage Authority borrowing a sum of One hundred thousand dollars (\$100,000) to meet the cost of sewerage works as set forth in the detailed statement bearing date 2nd May, 1975.

And the Honorable Frederick James Granter, Her Majesty's Minister of Water Supply for the State of Victoria, shall give the necessary directions herein accordingly.

TOM FORRISTAL,
Clerk of the Executive Council.

BARWON HEADS SEWERAGE AUTHORITY.

At the Executive Council Chamber, Melbourne, the sixth day of May, 1975.

PRESENT:

His Excellency the Governor of Victoria.	
Mr. Dickie	Mr. Wilcox.
Mr. Dunstan	

CONSENT TO BORROWING \$30,000.

Under the powers conferred by the *Sewerage Districts Act* and all other powers enabling him in that behalf, His Excellency the Governor of the State of Victoria, by and with the advice of the Executive Council of the said State, hereby consents to the Barwon Heads Sewerage Authority borrowing the sum of Thirty thousand dollars (\$30,000) to meet the cost of sewerage works as set forth in the detailed statement bearing date 2nd May, 1975.

And the Honorable Frederick James Granter, Her Majesty's Minister of Water Supply for the State of Victoria, shall give the necessary directions herein accordingly.

TOM FORRISTAL,
Clerk of the Executive Council.

LANDS DEPARTMENT NOTICES

APPROACHING LAND SALES.

Sale of Crown Land, in fee-simple, will be held at the under-mentioned places and dates, viz:—

Horsham.—Tuesday, 27th May, 1975	No. of Gazette.
	28

PROPOSED REVOCATIONS OF TEMPORARY RESERVATIONS OF LANDS BY ORDERS IN COUNCIL.

In pursuance of the provisions of the Land Act 1958, notice is hereby given that it is the intention of the Governor in Council to revoke the temporary reservations of lands by Orders in Council hereunder referred to, viz.:-

The following Notices were published 1° on the 7th May, 1975, pursuant to Orders of the 29th April, 1975.

WALLAN.—The temporary reservation by Order in Council of the 11th July, 1892 (see Government Gazette, 1892 page 2955) of 3.455 hectares (8 acres 2 roods 6 perches) of land in the Township of Wallan (called Town of Wallan Wallan in Order) as a site for Water Supply purposes is about to be revoked, so far only as the portion containing 2.6 hectares, more or less, indicated by hatching on plan hereunder, is concerned.—(W.18(°) (Rs.10044).

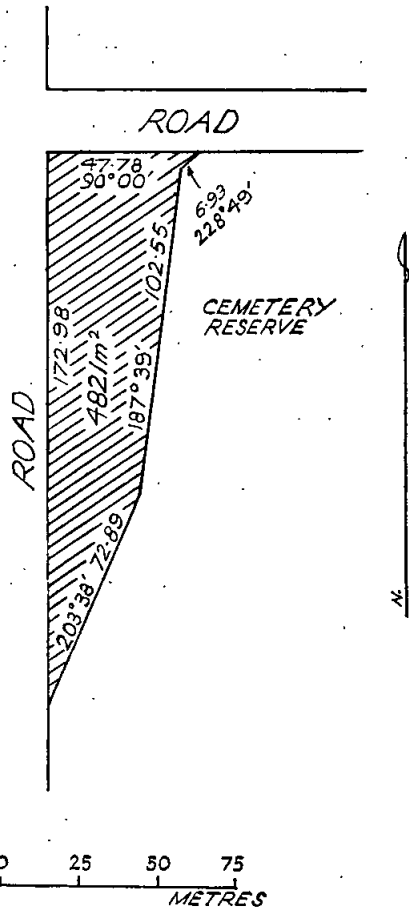
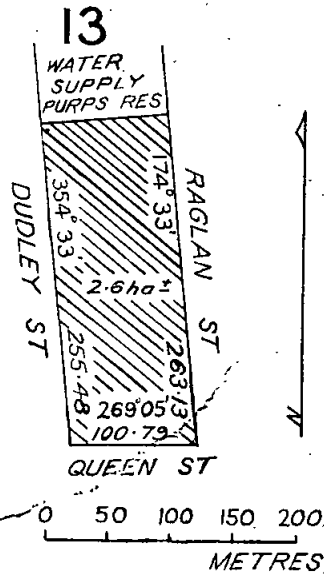

BUANGOR.—The temporary reservation as a site for watering purposes and the withholding from sale, leasing and licensing by Order in Council, 8th May, 1876 (see Government Gazette 1876, page 893) of 16.59 hectares (41 acres, more or less) of land in the Parish of Buangor revoked as to part by Order of the 16th April, 1957, are about to be revoked so far only as the portion containing 3828 square metres indicated by hatching on plan hereunder, is concerned.—(B.472(2) (Rs.5807).

W. BORTHWICK,
Minister of Lands.

PROPOSED REVOCATIONS OF TEMPORARY RESERVATIONS OF LANDS BY ORDERS IN COUNCIL.

In pursuance of the provisions of the Land Act 1958, notice is hereby given that it is the intention of the Governor in Council to revoke the temporary reservations of lands by Orders in Council hereunder referred to viz.:-

The following Notices were published 1° on the 30th April, 1975, pursuant to Orders of the 22nd April, 1975.

CASTERTON.—The temporary reservation as a site for Cemetery and the withholding from sale, leasing and licensing by Order in Council of the 3rd June, 1879 (see Government Gazette 1879, page 1246) of 4.047 hectares (10 acres) of land in the Parish of Casterton revoked as to part by Order of the 19th November, 1968, are about to be revoked so far only as the portion containing 4821 square metres, indicated by hatching on plan hereunder is concerned.—(C.178(°) (Rs.9055).

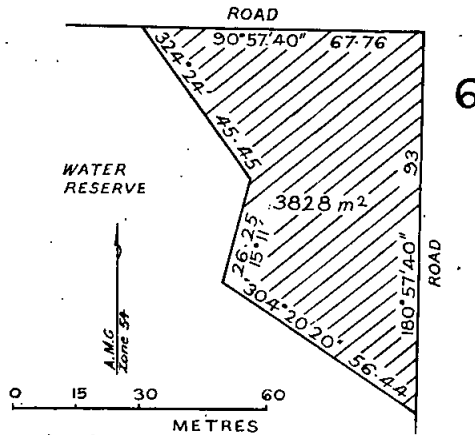

W. BORTHWICK,
Minister of Lands.

Land Act 1958.

LICENCE UNDER THE LAND ACT DECLARED VOID.

Notice is hereby given that the Licence in the Schedule hereunder has been Declared Void for the reason specified.

District.	Corr. No.	Name of Licensee.	Section of Land Act under which Licensed.	Parish.	Allotment.	Section.	Area.	Annual Rental.	Reason for Voiding.
Bendigo	O2428/138	P. R. Cumming	138	Sandhurst	297c	A	A. R. P. 0. 1. 7.	\$ 55.00	Non-compliance with conditions

Department of Crown Lands and Survey,
Melbourne, 30th April, 1975.

W. BORTHWICK,
Minister of Lands.

COMMITTEES OF MANAGEMENT OF RESERVES. APPOINTMENTS.

Notice is hereby given that, in pursuance of section 221 of the Land Act 1958, the following appointments of Committees of Management of reserved Crown lands have been made by the Minister of Lands:—

“NATIVE FLORA AND FAUNA RESERVE”, TOWNSHIP OF KOONWARRA.

The Corporation of the Shire of Woorayl as the Committee of Management of the land in the Township of Koonwarra, temporarily reserved pursuant to Order in Council dated the 4th March, 1975, as a site for Public purposes (Preservation of Native Flora and Fauna).—(Rs.8043.)

PUBLIC PURPOSES (FAUNA PARK AND ZOO) RESERVE, PARISH OF WERRIGAR.

The Corporation of the Shire of Warracknabeal as the Committee of Management of the land containing 6800 square metres in the Parish of Werrigar, temporarily reserved as a site for Public purposes (Fauna Park and Zoo) pursuant to Order in Council dated the 18th March, 1975.—(Rs.10020.)

W. BORTHWICK,
Minister of Lands.

Department of Crown Lands and Survey,
Melbourne, 30th April, 1975.

TENDERS

PUBLIC WORKS DEPARTMENT

Tenders will be received at Public Works Department, 2 Treasury Place, Melbourne, until TWO p.m. on dates shown and for purposes mentioned hereunder.

Particulars and tender forms available at Contracts Office, Room 27, Ground Floor, No. 2, Treasury Place, and at places indicated in brackets hereunder.

Abbreviations in brackets mean:—W.O.—Inspector of Works Office; P.S.—Police Station; C.S.—Consolidated School; H.E.S.—Higher Elementary School; H.S.—High School; Pr.S.—Primary School; T.S.—Technical School.

Tenders to be submitted on the Department's printed Tender Form and will not be received by telephone. All tenders must be on a “Firm Tender” basis. The lowest or any tender will not necessarily be accepted.

Address tenders to the Minister of Public Works, and endorse the envelope containing the tender “Tender for closing Tuesday,

Hand delivered tenders to be placed in the Tender Box of the Public Works Department, located on the wall of the centre entrance foyer, Ground Floor, 2 Treasury Place, Melbourne.

No preliminary deposit is required with any tender, but successful tenderer will be required to pay a deposit for any accepted tender of \$10,000 or over.

Tuesday, 13th May, 1975.

Building, Electrical, Mechanical Works.

BAIRNSDALE.—Renewal of slate roof and external renovations, Courthouse. (W.O., Bairnsdale.)

FAWKNER.—Erection of new building, special education unit.

LORNE.—Alterations and additions, Erskine House. (W.O., Geelong.)

TRARALGON.—Internal and external repairs and painting, Technical School. (W.O., Traralgon.)

Site Works.

BALLAM PARK.—Site works, Stage I, Technical School.

TOTTENHAM.—Site works, Technical School.

Furniture and Furnishings.

BUNDOORA.—Supply of timber robes and bedside units, Wards A and B, Gresswell Rehabilitation Centre.

Miscellaneous.

EAST MELBOURNE.—Maintenance cleaning 1st June, 1975, to 31st May, 1978, Clarendon Clinic.

MELBOURNE.—Maintenance cleaning 1st June, 1975 to 31st May, 1978, Children's Court and Clinic.

MELBOURNE.—Maintenance cleaning 15th May, 1975, to 14th May, 1978, Law Offices.

MELBOURNE.—Maintenance cleaning 1st June, 1975, to 31st May, 1978, Old Treasury Buildings.

MELBOURNE.—Supply and installation of Radio Telephone Equipment, Ports and Harbours.

PORT MELBOURNE.—Supply of 1 only 30 cwt. capacity fitter's van, P.W.D.

SOUTH YARRA.—Maintenance Cleaning, 1st June, 1975, to 31st May, 1978, Observatory Clinic.

Tuesday, 20th May, 1975.

Building, Electrical, Mechanical Works.

BEAUMARIS.—Internal and external renovations—High School. (Re-advertised.)

BOISDALE.—External renovations, C.S. (W.O., Bairnsdale.)

COBURG.—Alterations to Physiology and Science areas, State College of Victoria. (Re-advertised.)

DAYLESFORD.—Staff accommodation improvements, Pr.S.1609. (Re-advertised.) (W.O., Kyneton.)

FERNTREE GULLY.—Conversion of municipal offices for Police, Education and Crown Lands Departments, Public Offices.

MELBOURNE.—New suspended ceiling, East Wing, Public Offices, 2 Treasury Place.

WARRAGUL.—Extensions, additional counter space, internal and external repairs and painting, Police Station. (W.O., Warragul.)

WATSONIA.—Internal and external repairs and painting, Pr.S.4838. (Re-advertised.)

Site Works.

DONCASTER.—Site works, Pr.S.5065, Botanic Park.

Miscellaneous.

RED HILLS.—Provision of fire protection facilities, C.S.
WILLIAMSTOWN.—Supply and delivery of (1) only Marine Diesel Engine and (2) only Marine Propellers, Ports and Harbours.

Tuesday, 27th May, 1975.

Building, Electrical, Mechanical Works.

BRIGHTON.—Alterations and additions to mechanical services, Technical School.

BRUNSWICK WEST.—Mechanical services, staff accommodation improvements, Pr.S.2890.

GOLDEN SQUARE.—Re-roofing brick building classroom block, Pr.S.1189. (W.O., Bendigo.)

KANGAROO FLAT.—Art/craft room and other facilities, Pr.S.981. (W.O., Bendigo.)

KANGAROO FLAT.—Electrical services, art/craft room and other facilities, Pr.S.981. (W.O., Bendigo.)

KANGAROO FLAT.—Mechanical services, art/craft room and other facilities, Pr.S.981. (W.O., Bendigo.)

MILDURA.—Mechanical services, staff accommodation improvements and provision of art room and library, Pr.S.2915. (W.O., Mildura.)

OUYEN.—Evaporative air conditioning, science block, High School. (W.O., Swan Hill, Mildura and Bendigo.)

PORT MELBOURNE.—Erection of office building, Stage 2, Marine Models Laboratory.

RUSHWORTH.—Construction of police station, cell block and residence. (W.O., Bendigo and Shepparton.)

Site Works.

BUCKLEY PARK.—Siteworks, High School.

Miscellaneous.

MELBOURNE.—Maintenance cleaning, 1st June, 1975, to 31st May, 1978, Cancer Institute and Titles Office, Lonsdale Street.

VARIOUS.—Supply of 150 mm hacksaw machine and marking off table, schools and other government buildings.

VARIOUS.—Supply of woodworking saw benches, schools and other government buildings.

VARIOUS.—Supply of 230 mm swing engineers lathes, schools and other government buildings.

VARIOUS.—Supply of planing/jointing machines and thicknesser, schools and other government buildings.

VARIOUS.—Supply of universal turret head milling machine, schools and other government buildings.

VARIOUS.—Supply of bandsaw machines and spindle borer, schools and other government buildings.

WATSONIA.—Connection to Melbourne Metropolitan Board of Works Sewer (Stage I), Loyola Youth Training Centre.

ROBERTS DUNSTAN,
Minister for Public Works.

Public Works Department,
Melbourne, 5th May, 1975.

TAXI AND HIRE CAR CONTRACTORS—BENDIGO.

Tenders are invited for the provision of taxi and hire car service for the Victorian Government Departments and Authorities at Bendigo for the period 1st July, 1975 to 30th June, 1976, for journeys as follows:—

(a) Hirings wholly within a radius specified by the Transport Regulation Board from the principal Post Office within the City of Bendigo.

(b) Hiring partly or wholly outside the radius specified in "A".

Tender forms may be obtained from the Secretary, Victorian Government Motor Transport Committee, Premier's Department, 1 Treasury Place, Melbourne, 3002.

Tenders which should be in an envelope marked "Tender for taxi and hire car contracts" close with the Chairman, Victorian Government Motor Transport Committee, at 3 p.m., on Wednesday, 28th May, 1975.

PUBLIC SERVICE NOTICES

No. 394.

PUBLIC SERVICE ACT 1958.

The Public Service Board, in pursuance of the powers conferred by the *Public Service Act 1958*, hereby amends the Public Service (Public Service Board) Regulations as follows:—

PART VI.—TRAVELLING AND OTHER EXPENSES.

DIVISION I.—REIMBURSEMENT OF PERSONAL EXPENSES.

Regulation 209.

In paragraphs (a) and (c) the amounts "\$1.35" and "\$2.90" are deleted and the amounts "\$1.60" and "\$3.50" are inserted in lieu thereof respectively.

Regulation 210.

The amount "\$2.90" is deleted and the amount "\$3.50" is inserted in lieu thereof.

In paragraph (a) the amount "\$1.80" is deleted and the amount "\$2.00" is inserted in lieu thereof.

Regulation 211.

In sub-regulation (2) the amounts "\$28" and "\$20" are deleted and the amounts "\$35.00" and "\$25.00" are inserted in lieu thereof respectively.

SPECIAL GROUPS.

Regulation 215.

DEPARTMENT OF AGRICULTURE.

In sub-regulation (4) the amount "\$1.35" is deleted and the amount "\$1.60" is inserted in lieu thereof.

MINISTRY FOR CONSERVATION—FISHERIES AND WILDLIFE DIVISION.

In sub-regulation (5) the amount "\$1.35" is deleted and the amount "\$1.60" is inserted in lieu thereof.

This Regulation shall have effect from 20th April, 1975.

A. J. A. GARDNER, Chairman,
L. R. BROWN, Secretary.

Office of the Public Service Board,
Melbourne, 24th April, 1975.

No. 383.

PUBLIC SERVICE ACT 1958.

The Public Service Board, in pursuance of the powers conferred by the *Public Service Act 1958*, hereby amends the Public Service (Public Service Board) Regulations as follows:—

PART IV.—SALARIES AND INCREMENTS.

DIVISION IV.—TECHNICAL AND GENERAL DIVISION.

Regulation 119.

In paragraph (f) of sub-regulation (3) the expression "three annual increments of \$254 and one annual increment of \$255" is deleted and the expression "three annual increments of \$284 and one annual increment of \$285" is inserted in lieu thereof.

This Regulation shall have effect from 13th April, 1975.

A. J. A. GARDNER, Chairman,
L. R. BROWN, Secretary.

Office of the Public Service Board,
Melbourne, 14th April, 1975.

No. 381.

Public Service Act 1958, Sections 39 and 50.
REGULATIONS.—PART IV.—SALARIES AND INCREMENTS.

The Public Service Board, in pursuance of the powers conferred by the *Public Service Act 1958*, hereby amends the Public Service (Public Service Board) Regulations as shown below :—
FOURTH SCHEDULE.

PART C.

TECHNICAL AND GENERAL DIVISION AND TEMPORARY EMPLOYEES.
Classifications of Offices and Positions and Rates of Salaries.

Grades.	Yearly Salary.		Salary/ Increment Code.	Title of Office and Position.	Title Code.
	Minimum.	Maximum.			
	\$	\$			
DEPARTMENT OF HEALTH.					
<i>General Health.</i>					
Add— 208-229	7,610	8,535	AA	Nurse, Special Accommodations Houses	GA

This Regulation shall have effect from 13th April, 1975.

A. J. A. GARDNER, Chairman.
L. R. BROWN, Secretary.

Office of the Public Service Board,
Melbourne, 18th April, 1975.

No. 387.

Public Service Act 1958, Sections 39 and 50.
REGULATIONS.—PART IV.—SALARIES AND INCREMENTS.

The Public Service Board, in pursuance of the powers conferred by the *Public Service Act 1958*, hereby amends the Public Service (Public Service Board) Regulations as follows :—

SECOND SCHEDULE.

PART B.

PROFESSIONAL DIVISION.

Scale of Rates of Annual Salaries.

REPORTERS, CHIEF SECRETARY'S DEPARTMENT AND LAW DEPARTMENT.

The salary scale shown is deleted and the following salary scale is inserted in lieu thereof :—

Class.	Annual Salary of Each Subdivision of Each Class.					
	1.	2.	3.	4.	5.	6.
	\$	\$	\$	\$	\$	\$
R-1	12,494	12,778	13,108	13,439	13,715	14,046
R-2	14,520
R-3	15,769

FOURTH SCHEDULE.

PART C.

TECHNICAL AND GENERAL DIVISION AND TEMPORARY EMPLOYEES.
Classifications of Offices and Positions and Rates of Salaries.

Delete the existing grades and yearly rates of salary for the following office and/or position and insert the grades and rates shown hereunder in lieu thereof :—

Grades.	Yearly Salary.		Salary/ Increment Code.	Title of Office and Position.	Title Code.
	Minimum.	Maximum.			
	\$	\$			
GENERAL.					
	12,494	14,046	CM	Reporter	GA

This Regulation shall have effect from 20th April, 1975.

A. J. A. GARDNER, Chairman.
L. R. BROWN, Secretary.

Office of the Public Service Board,
Melbourne, 18th April, 1975.

No. 388.

Public Service Act 1958, Sections 39 and 50.
REGULATIONS.—PART IV.—SALARIES AND INCREMENTS.

The Public Service Board, in pursuance of the powers conferred by the *Public Service Act 1958*, hereby amends the Public Service (Public Service Board) Regulations as shown below :—
FIFTH SCHEDULE.

PART C.

DEPARTMENT OF HEALTH.

MENTAL HYGIENE.

TECHNICAL AND GENERAL DIVISION AND TEMPORARY EMPLOYEES.

Classifications of Offices and Positions and Rates of Salaries.

Grades.	Yearly Salary.		Salary/ Increment Code.	Title of Office and Position.	Title Code.
	Minimum.	Maximum.			
	\$	\$			
Add— 214-224	7,860	8,324	AA	Welfare Officer	GA

A. J. A. GARDNER, Chairman.
L. R. BROWN, Secretary.

Office of the Public Service Board,
Melbourne, 21st April, 1975.

No. 384.

Public Service Act 1958, Sections 39 and 50.
REGULATIONS.—PART IV.—SALARIES AND INCREMENTS.

The Public Service Board, in pursuance of the powers conferred by the *Public Service Act 1958*, hereby amends the Public Service (Public Service Board) Regulations as shown below :—

FOURTH SCHEDULE.

PART B.

TECHNICAL AND GENERAL DIVISION.

Grades and Salary Scales.

JUNIOR GRADES (NOT CLASSIFIED IN SIXTH SCHEDULE).

Delete the existing yearly rates of salary for the undermentioned grades and insert the following rates in lieu thereof :—

Grade.	Yearly Rate of Salary at Each Age in Years.				
	Under 17.	17.	18.	19.	20.
	\$	\$	\$	\$	\$
J-13 ..	2,765	3,207	3,760	4,313	4,866
J-25	3,628	4,233	4,898	5,503

PART C.

TECHNICAL AND GENERAL DIVISION AND TEMPORARY EMPLOYEES.

Classifications of Offices and Positions and Rates of Salaries.

Delete the existing grades and yearly rates of salary for the following offices and/or positions and insert the grades and rates shown hereunder in lieu thereof :—

Grades.	Yearly Salary.		Salary/ Increment Code.	Title of Office and Position.	Title Code.
	Minimum.	Maximum.			
	\$	\$			
DEPARTMENT OF HEALTH.					
<i>Tuberculosis.</i>					
131-138	5,529	5,694	AA	X-Ray Technician, Assistant— Adult	GY GA
153-167	6,047	6,380	AA	X-Ray Technician, Grade I.— Adult	GA, GX
177-200	6,617	7,279	AA	X-Ray Technician, Grade II.	GA, GX

This Regulation shall have effect from 2nd February, 1975.

A. J. A. GARDNER, Chairman.
L. R. BROWN, Secretary.

Office of the Public Service Board,
Melbourne, 18th April, 1975.

No. 382.

Public Service Act 1958, Sections 39 and 50.

REGULATIONS.—PART IV.—SALARIES AND INCREMENTS.

The Public Service Board, in pursuance of the powers conferred by the Public Service Act 1958, hereby amends its Regulations as shown below :—

FIFTH SCHEDULE.

PART C.

DEPARTMENT OF HEALTH.

MENTAL HYGIENE.

TECHNICAL AND GENERAL DIVISION AND TEMPORARY EMPLOYEES.

Classifications of Offices and Positions and Rates of Salaries.

Delete the existing grades and yearly rates of salary for the following offices and positions and insert the grades and the rates shown hereunder in lieu thereof :—

Grades.	Yearly Salary.		Salary/Increment Code.	Title of Office and Position.	Title Code.
	Minimum.	Maximum.			
164-204	6,307	7,444	AD	Nurse	GA
164-204	6,307	7,444	AD	Nurse, Surgical Unit	GA
208-229	7,610	8,335	AA	Nurse, Surgical Unit, Senior	GA
239-250	8,962	9,435	AA	Nurse, Surgical Unit, Supervising	GA

This Regulation shall have effect from 13th April, 1975.

A. J. A. GARDNER, Chairman.
L. R. BROWN, Secretary.

Office of the Public Service Board,
Melbourne, 14th April, 1975.

No. 392.

Public Service Act 1958, Sections 39 and 50.

REGULATIONS.—PART IV.—SALARIES AND INCREMENTS.

The Public Service Board, in pursuance of the powers conferred by the Public Service Act 1958, hereby amends its Regulations as shown below :—

FIFTH SCHEDULE.

PART C.

DEPARTMENT OF HEALTH.

MENTAL HYGIENE.

TECHNICAL AND GENERAL DIVISION AND TEMPORARY EMPLOYEES

Classifications of Offices and Positions and Rates of Salaries.

Delete the existing grades and yearly rates of salary for the following offices and positions and insert the grades and the rates shown hereunder in lieu thereof :—

Grades.	Yearly Salary.		Salary/Increment Code.	Title of Office and Position.	Title Code.
	Minimum.	Maximum.			
	\$	\$			
199-209	7,240	7,650	AA	Shoemaker, Leading Hand	..
189-201	6,900	7,320	AA	Shoemaker, Grade II.	..
178-194	6,641	7,047	AA	Shoemaker, Grade I.	..

This Regulation shall have effect from 27th April, 1975.

A. J. A. GARDNER, Chairman.
L. R. BROWN, Secretary.

Office of the Public Service Board,
Melbourne, 29th April, 1975.

No. 393.

PUBLIC SERVICE ACT 1958.

The Public Service Board, in pursuance of the powers conferred by the Public Service Act 1958, hereby amends the Public Service (Public Service Board) Regulations as follows :—

PART V.—ALLOWANCES.

DIVISION II.—OVERTIME AND STANDBY ALLOWANCES.

MINISTRY FOR CONSERVATION.—FISHERIES AND WILDLIFE DIVISION.

Regulation 157.

Immediately after the words " Fish Measurer, Senior " in the table to this Regulation insert the following :—

Office or Position.	Percentage of Total Emolument.
	%
Add— Game Liaison Officer	8

This Regulation shall have effect from 1st April, 1975.

A. J. A. GARDNER, Chairman.
L. R. BROWN, Secretary.

Office of the Public Service Board,
Melbourne, 24th April, 1975.

No. 390.

Public Service Act 1958, Section 39.

REGULATIONS.—PART IV.—SALARIES AND INCREMENTS.

The Public Service Board, in pursuance of the powers conferred by the Public Service Act 1958, hereby amends its Regulations as shown below :—

FIRST SCHEDULE.

PROFESSIONAL DIVISION.

Amount of Salary Assigned to Offices in " Special " Class.

Office.	Yearly Rate of Salary.
	\$
WATER SUPPLY DEPARTMENT.	
Add— Chief Engineer, Main Urban Supplies ..	23,200

A. J. A. GARDNER, Chairman.
L. R. BROWN, Secretary.

Office of the Public Service Board,
Melbourne, 24th April, 1975.

No. 396.

Public Service Act 1958, Sections 39 and 50.

REGULATIONS.—PART IV.—SALARIES AND INCREMENTS.

The Public Service Board, in pursuance of the powers conferred by the Public Service Act 1958, hereby amends the Public Service (Public Service Board) Regulations as shown below :—

FOURTH SCHEDULE.

PART C.

TECHNICAL AND GENERAL DIVISION AND TEMPORARY EMPLOYEES.

Classifications of Offices and Positions and Rates of Salaries.

Delete the existing grades and yearly rates of salary for the following offices and/or positions and insert the grades and rates shown hereunder in lieu thereof :—

Grades.	Yearly Salary.		Salary/Increment Code.	Title of Office and Position.	Title Code.
	Minimum.	Maximum.			
	\$	\$			
GENERAL.					
196-205	7,124	7,485	AA	Carpenter	..
DEPARTMENT OF AGRICULTURE.					
204-213	7,444	7,818	AA	Carpenter, Senior..	..
CHIEF SECRETARY'S DEPARTMENT.					
National Museum and Science Museum.					
204-213	7,444	7,818	AA	Carpenter and Cabinetmaker, Leading Hand	..
DEPARTMENT OF CROWN LANDS AND SURVEY.					
Royal Botanic Gardens.					
196-205	7,124	7,485	AA	Carpenter and Pattermaker	..
MINES DEPARTMENT.					
196-205	7,124	7,485	AA	Maintenance Assistant, Drill Store, Port Melbourne	..
PUBLIC WORKS DEPARTMENT.					
204-213	7,444	7,818	AA	Carpenter, Leading Hand	..
196-205	7,124	7,485	AA	Maintenance Assistant	..
STATE FORESTS DEPARTMENT.					
204-213	7,444	7,818	AA	Carpenter and Joiner, Leading Hand	..

FIFTH SCHEDULE.

PART C.

DEPARTMENT OF HEALTH.

MENTAL HYGIENE.

TECHNICAL AND GENERAL DIVISION AND TEMPORARY EMPLOYEES.

Classifications of Offices and Positions and Rates of Salaries.

Delete the existing grades and yearly rates of salary for the following offices and/or positions and insert the grades and rates shown hereunder in lieu thereof :—

Grades.	Yearly Salary.		Salary/Increment Code.	Title of Office and Position.	Title Code.
	Minimum.	Maximum.			
	\$	\$			
204-213	7,444	7,818	AA	Carpenter, Leading Hand	..
196-205	7,124	7,485	AA	Carpenter	..

This Regulation shall have effect from 27th April, 1975.

A. J. A. GARDNER, Chairman.
L. R. BROWN, Secretary.

Office of the Public Service Board,
Melbourne, 29th April, 1975.

No. 395.

Public Service Act 1958, Sections 39 and 50.

REGULATIONS.—PART IV.—SALARIES AND INCREMENTS.

The Public Service Board, in pursuance of the powers conferred by the Public Service Act 1958, hereby amends the Public Service (Public Service Board) Regulations as shown below :—

FOURTH SCHEDULE.

PART C.

TECHNICAL AND GENERAL DIVISION AND TEMPORARY EMPLOYEES.

Classifications of Offices and Positions and Rates of Salaries.

Delete the existing grades and yearly rates of salary for the following offices and/or positions and insert the grades and rates shown hereunder in lieu thereof :—

Grades.	Yearly Salary.		Salary/Increment Code.	Title of Office and Position.	Title Code.
	Minimum.	Maximum.			
	\$	\$			
DEPARTMENT OF AGRICULTURE.					
204-213	7,444	7,818	AA	Carpenter, Instructor	..
212-222	7,776	8,196	AA	Carpenter, Instructor, Leading Hand	..

FIFTH SCHEDULE.

PART C.

DEPARTMENT OF HEALTH.

MENTAL HYGIENE.

TECHNICAL AND GENERAL DIVISION AND TEMPORARY EMPLOYEES.

Classifications of Offices and Positions and Rates of Salaries.

Delete the existing grades and yearly rates of salary for the following offices and/or positions and insert the grades and rates shown hereunder in lieu thereof :—

Grades.	Yearly Salary.		Salary/Increment Code.	Title of Office and Position.	Title Code.
	Minimum.	Maximum.			
	\$	\$			
212-222A	7,776	8,238	AA	Craft Supervisor (Mont Park)	..
208-219	7,610	8,070	AA	Craft Supervisor, Grade IV.	..
204-208	7,444	7,610	AA	Craft Supervisor, Grade III.	..

This Regulation shall have effect from 27th April, 1975.

A. J. A. GARDNER, Chairman.
L. R. BROWN, Secretary.

Office of the Public Service Board,
Melbourne, 29th April, 1975.

No. 391.

PUBLIC SERVICE ACT 1958.

The Public Service Board, in pursuance of the powers conferred by the Public Service Act 1958, hereby amends the Public Service (Public Service Board) Regulations as follows:—

PART V.—ALLOWANCES.

DIVISION II.—OVERTIME AND STANDBY ALLOWANCES.

CHIEF SECRETARY'S DEPARTMENT—STATE EMERGENCY SERVICE.

Regulation 155c is re-numbered Regulation 155d.

DEPARTMENT OF AGRICULTURE—DIVISION OF ANIMAL HEALTH.

Immediately after Regulation 155a insert the following heading and regulation:—

"DIVISION OF HORTICULTURE.

155c. An officer who occupies an office of Agricultural Officer and performs the duties of farm manager at the Mildura Horticultural Research Station and who, by reason of the nature of his duties, may be required to undertake duty outside the normal hours of duty, shall be paid a commuted allowance at an annual rate of 10 per centum of annual standard salary (calculated to the nearest dollar) as varied in accordance with the provisions of Regulation 109, while he undertakes such duty outside the normal hours of duty."

This Regulation shall have effect from 1st May, 1975.

A. J. A. GARDNER, Chairman.
L. R. BROWN, Secretary.

Office of the Public Service Board,
Melbourne, 24th April, 1975.

No. 389.

PUBLIC SERVICE ACT 1958.

The Public Service Board, in pursuance of the powers conferred by the Public Service Act 1958, hereby amends the Public Service (Public Service Board) Regulations as follows—

PART II.—APPOINTMENTS TO THE PUBLIC SERVICE.

DIVISION II.—ADMINISTRATIVE DIVISION.

Regulation 17.

Immediately following paragraph (b) of this Regulation insert the following paragraph—

"(c) A Diploma of Business Studies (Electronic Data Processing) of a College of Advanced Education affiliated with the Victoria Institute of Colleges."

PART V.—ALLOWANCES.

DIVISION I.—ALLOWANCES FOR QUALIFICATIONS OR EFFICIENCY.

ADMINISTRATIVE DIVISION.

Regulation 128.

Immediately following paragraph (c) of sub-regulation (1) of this Regulation insert the following paragraph—

"(d) A Diploma of Business Studies (Electronic Data Processing) of a College of Advanced Education affiliated with the Victoria Institute of Colleges."

A. J. A. GARDNER, Chairman.
L. R. BROWN, Secretary.

Office of the Public Service Board,
Melbourne, 18th April, 1975.

No. 386.

PUBLIC SERVICE ACT 1958.

The Public Service Board, in pursuance of the powers conferred by the Public Service Act 1958, hereby amends the Public Service (Public Service Board) Regulations as follows—

PART VIII.—LEAVE OF ABSENCE.

DIVISION VII.—OTHER LEAVE.

Regulation 256.

In sub-regulation (1) the words "Mental Hygiene Branch" are deleted and the words "Alcoholics and Drug Dependent Persons Services and Mental Hygiene Branches" are inserted in lieu thereof.

A. J. A. GARDNER, Chairman.
L. R. BROWN, Secretary.

Office of the Public Service Board,
Melbourne, 18th April, 1975.

No. 385.

PUBLIC SERVICE ACT 1958.

The Public Service Board, in pursuance of the powers conferred by the Public Service Act 1958, hereby amends the Public Service (Public Service Board) Regulations as follows—

PART VI.—TRAVELLING AND OTHER EXPENSES.

DIVISION I.—REIMBURSEMENT OF PERSONAL EXPENSES.

SPECIAL GROUPS.

Regulation 215.

DEPARTMENT OF CROWN LANDS AND SURVEY.

In sub-regulation (8) the amount "\$1,178" is deleted and the amount "\$1,324" is inserted in lieu thereof.

This Regulation shall have effect from 13th April, 1975.

A. J. A. GARDNER, Chairman.
L. R. BROWN, Secretary.

Office of the Public Service Board,
Melbourne, 18th April, 1975.

Teaching Service Act 1958.
TEACHING SERVICE (TEACHERS TRIBUNAL) REGULATIONS.
 AMENDMENT NO. 314 (T.T.13).

The Teachers Tribunal, in pursuance of the powers conferred by the *Teaching Service Act 1958*, hereby amends Regulation 14 of the Teaching Service (Teachers Tribunal) Regulations as follows :—

REGULATION 14.
 Rescind the heading "*Staffing Schedule.—Special Schools.*" and clause 2 and substitute therefor the following new heading and clause :—
 "*Staffing Schedule.—Special Schools.*"

2. The classification and the number of teachers to be allotted to the following Special Schools shall be in accordance with the staffing schedule hereunder :—

School Number and Name	Positions and Classification of Members										Total Establishment				
	Heads of Schools			Vice-Principals		Other Positions		Specialist Positions							
	Principal		Head-master	Special	Senior Teacher	Assistant*	Senior Teacher	Assistant*	Assistant	Assistant*			Deaf Unit		
	Special	Senior Teacher	Assistant*							Special Duties		Art/Craft		Home Crafts	Art/Craft
Deaf	1			2			3	5	17	1	1	4	1	1	39
3774 Victorian School for Deaf Children	1			2			2	2	10	1	1	4	1	1	29
4683 Glendonald School for Deaf Children	1						2	5	18						28
5061 Visiting Teacher Service for Deaf Children															
4822 Princess Elizabeth Kindergarten for Deaf Children	1						1	2	10			4			21
5060 Monnington School for Deaf Children		1					1	2	9			2			17
4834 Ewing House School for Deaf Children						2			4			1			9
Physically Handicapped and Partially Sighted															
4675 Yooralla, Carlton							1	4	8						24
4200 Royal Children's Hospital, Mt. Eliza				2			1	2	6						24
4676 Marathon, Toorak							1	2	4						20
5023 Royal Children's Hospital, Parkville		1				2			5						18
4893 Carronbank School for Partially-Sighted Children															8
3655 Northcote Hospital									1						2
4748 Shannon Park									2						4
4757 Alfred Hospital												1			1
Prisons and Youth Training Centres															
4170 Bendigo Prison									5						8
4160 Bendigo Prison Establishment									3						6
4759 Bendigo Training Prison								1	2						4
4817 Geelong Gaol									2						4
4978 Ararat Training Prison									2						3
4738 Langi Kal Kai Training Centre									1						3
4739 Mairambury Youth Training Centre									1						2
4738 Mairambury Youth Training Centre									1						2
5092 Failea Prison Education Centre									1						2
Socially Handicapped															
4609 Royal Park Special									7						12
3552 Nunston Special								2	5						14
3538 Allambie Centre								2	2						14
1256 Ballarat Children's Home								2	5						16
3588 Tully Ho Special									1						10
4152 Croydon Water Salvation Army Boys' Home								1	4						9
4841 Hillside Special								1	4						9
								1	3						5

PRIVATE ADVERTISEMENTS

CITY OF CHELSEA.

LOAN No. 59.

Notice of Intention to Borrow the Sum of \$150,000 for Permanent Works and Undertakings.

NOTICE is hereby given that the Council of the City of Chelsea proposes to borrow the principal sum of One hundred and fifty thousand dollars (\$150,000) secured by a charge over the general rate of the Municipality, such sum to be raised by raised by the grant of a mortgage, in accordance with the provision of the *Local Government Act 1958*.

1. The maximum rate of interest that may be paid is 9.9 per cent per annum.

2. The purpose for which the loan is to be applied is as follows:

(a) Bonbeach Reserve Pavilion (1st inst.)	\$50,000
(b) Barrelling Secondary Drain	\$100,000

Total: \$150,000

3. The period of the loan shall be ten (10) years.

4. The moneys borrowed shall be repayable by providing out of the Municipal Fund half-yearly instalments of \$11,985.41 each including principal and interest on the first day of June and the first day of December during the currency of the loan.

The first instalment shall be payable on the first day of December, 1975.

5. Such moneys shall be repayable to the Commonwealth Savings Bank of Australia.

Plans and specifications and the estimate of the cost of the proposed works and a statement showing the proposed expenditure of the moneys to be borrowed are open for inspection at the Office of the Council of the City of Chelsea, Station Street, Chelsea, Victoria.

4832

B. J. WARD, Town Clerk.

CITY OF CHELSEA.

LOAN No. 60.

Notice of Intention to Borrow the Sum of \$30,000 for Permanent Works and Undertakings.

NOTICE is hereby given that the Council of the City of Chelsea proposes to borrow the principal sum of thirty thousand dollars (\$30,000) secured by a charge over the general rate of the Municipality, such sum to be raised by the grant of a mortgage, in accordance with the provision of the *Local Government Act 1958*.

1. The maximum rate of interest that may be paid is 9.9 per cent per annum.

2. The purpose for which the loan is to be applied is as follows:

(a) Chelsea Elderly Citizens Club Rooms (part)	\$5,000
(b) Edithvale Reserve Pavilion (Council cont.)	\$25,000

Total: \$30,000

3. The period of the loan shall be ten (10) years.

4. The moneys borrowed shall be repayable by providing out of the Municipal Fund half-yearly instalments of \$2,397.08 each including principal and interest on the first day of June and the first day of December during the currency of the loan.

The first instalment shall be payable on the first day of December, 1975.

5. Such moneys shall be repayable to the Commonwealth Savings Bank of Australia.

Plans and specifications and the estimate of the cost of the proposed works and a statement showing the proposed expenditure of the moneys to be borrowed are open for inspection at the Office of the Council of the City of Chelsea, Station Street, Chelsea, Victoria.

4833

B. J. WARD, Town Clerk.

Local Government Act 1958.

CITY OF DANDENONG.

PART XVIII DIVISION 4.

Notice of Intention to Purchase or Take Lands.

NOTICE is hereby given that—

(a) The Council of the City of Dandenong deeming it expedient to provide land in Walker Street, Dandenong necessary for the provision of car-parking facilities and other municipal purposes, intends to purchase or compulsorily take pursuant to the powers conferred on it by Section 511 of the *Local Government Act 1958* All That piece or parcel of land situate in the State of Victoria Parish of Dandenong County of Bourke being part of Allotment 9 Section 2 "Dandenong" and being the land described in Conveyance No. 366 Book 744.

(b) The Council has prepared a map and other papers showing all necessary information as required by Section 512 of the said Act.

(c) The said map and other papers have been approved by the Council and are now deposited at the Office of the Council situate in Clow Street, Dandenong for inspection by any person during office hours free of charge.

(d) All persons affected by the proposal for the taking of the said land are required to set forth in writing addressed to the Council or to the Municipal Clerk, City Offices, Clow Street, Dandenong within forty clear days from the 7th day of May 1975 being the date of publication of this Notice in the *Government Gazette* all objections which they may have to the taking of the said land: and

(e) At the next ordinary meeting of the Council after the expiration of the said forty clear days the Council will consider any objections to the said taking.

Dated the 1st day of May, 1975.

By Order of the Council,

4842

C. A. ELLIOTT, Town Clerk.

CITY OF ECHUCA.

LOAN No. 84.

Notice of Intention to Borrow.

NOTICE is hereby given that the Council of the City of Echuca intends to borrow Thirty Eight thousand (\$38,000) dollars secured by a charge over the General Rates of the Municipality by the grant of a Mortgage in accordance with the provisions of the *Local Government Act 1958* as amended.

In connection therewith the following information is stated:—

(a) The amount of the principal moneys which it is proposed to borrow is \$38,000.

(b) The maximum rate of interest that may be paid is 9.9 per centum per annum.

(c) The period of the loan shall be twenty years.

(d) The moneys borrowed shall be repayable by providing out of the municipal fund half-yearly instalments of approximately \$2,199.43 each including principal and interest on the thirteenth day of June and the thirteenth day of December during the currency of the loan. The first instalment shall be payable on the thirteenth day of December, 1975.

(e) The purpose for which the loan is to be applied is:—

Part cost of works proposed under Part XV, Section 393 (11) of the *Local Government Act 1958* as amended, namely, the Port of Echuca Restoration Project.

(f) Such moneys shall be repayable to the Bank of New South Wales, Echuca.

The Plans and specifications and estimate of the cost of the works and a statement showing the proposed expenditure of the moneys to be borrowed are open for inspection at the office of the Council of the City of Echuca at the corner of Hare and Heygarth Streets, Echuca.

4856

K. F. McCARTNEY, Town Clerk.

CITY OF KNOX.

LOAN No. 134.

Confirmation of Special Order.

Notice is hereby given that the Council of the City of Knox, at a meeting held on the 6th day of May, 1975, did confirm the following Special Order:

"That the Council of the City of Knox, in pursuance of powers conferred by the Local Government Acts, resolve to borrow the sum of \$1,000,000 secured on the general rates of the Municipality, such sum to be raised by the grant of a mortgage, in accordance with the said Acts and states:

- (a) The amount of principal moneys it is proposed to borrow is \$1,000,000.
- (b) The maximum rate of interest that may be paid is 10.35 per cent. per annum.
- (c) The period of the loan will be 10 years and the money borrowed is to be repayable in full at the expiration of the loan on 8th May, 1985.
- (d) The purpose for which the loan is to be applied is to liquidate the whole or part of the overdraft on Council's Private Streets Bank Account, at A.N.Z. Banking Group Ltd., Boronia.
- (e) The loan is to be liquidated by the establishment of a sinking fund pursuant to Section 428A (1) of the Local Government Act with a half yearly appropriation of \$39,147.13, payable out of the Municipal Fund.
- (f) The place of repayment will be Haematite Proprietary Limited, 500 Bourke Street, Melbourne."

4855

T. J. NEVILLE, Town Clerk.

CITY OF MORDIALLOC.

BYLAW No. 152.

A Bylaw of the City of Mordialloc made under the provisions of the Local Government Act and numbered 152 for the purpose of preventing and extinguishing fires and suppressing nuisances.

In pursuance of the powers conferred by the Local Government Act and of any and every other power it thereunto enabling the Mayor, Councillors and Citizens of the City of Mordialloc order as follows:—

1. This Bylaw shall be known as the Incinerators Bylaw.
2. In this Bylaw "Council" shall mean the Council of the City of Mordialloc and "Authorised Officer" shall mean and include the Town Clerk and any Officer of the Council for the time being authorised by it in that behalf.
3. Except with the consent of the Council or an Authorised Officer no person or corporation shall use an incinerator which is not constructed of brick or other material approved by the Council or allow to be kept an incinerator which is not constructed of brick or other material approved by the Council in which it is proposed to burn any matter, material or substance on any land or premises and unless it is:
 - (a) at least one metre from the boundary of any adjoining allotment,
 - (b) at least one metre from the boundary of any side street or road to which the land or premises has a frontage, where the fence on such boundary is not constructed of a fire resistant material.
4. Every incinerator shall be fitted with a lid and a spark arrestor or be so constructed as to prevent the emission of sparks or the spread of a fire therefrom.
5. No fire shall be lit in an incinerator before 8 o'clock in the morning and any such fires shall be completely extinguished prior to 6 o'clock in the afternoon.
6. No person or corporation shall on any premises owned or occupied by him or it burn or cause to be burned any substance in such a manner or to such an extent as shall cause quantities of smoke fumes or ash to be emitted from the said premises as would cause a nuisance to any person upon any land or upon any public highway.
7. Any person or corporation who is guilty of any wilful act or default contrary to any of the provisions of this Bylaw shall be liable on conviction to a penalty of not more than \$100 and a further penalty of ten dollars for each day such wilful act or default is continued after a conviction or order is made by any court.
8. This Bylaw shall apply to and have operation throughout the whole of the Municipal district of the City of Mordialloc.

Resolution for passing this Bylaw was agreed to by the Council of the City of Mordialloc on the 24th day of March, 1975, and confirmed on the 28th day of April, 1975.

The common seal of the Mayor, Councillors and Citizens of the City of Mordialloc was hereunto affixed in the presence of—

(SEAL)

PETER SCULLIN, Mayor.
MICHAEL BUXTON, Councillor.
D. H. CORBEN, Town Clerk.

4836

Town and Country Planning Act 1961 (Thirteenth Schedule).

CITY OF SHEPPARTON.—CITY OF SHEPPARTON
PLANNING SCHEME 1953.

NOTICE THAT A PLANNING SCHEME HAS BEEN PREPARED AND IS AVAILABLE FOR INSPECTION.

Amendment No. 33, 1975.

NOTICE IS HEREBY GIVEN that the Council of the City of Shepparton, in pursuance of its powers under the Town and Country Planning Act 1961, has prepared a Planning Scheme for the whole of the Municipal district of the City of Shepparton for the purpose of—

1. Rezoning, from Industrial "A" to Industrial "B", properties bounded by Archer Street, Lockwood Road, Byass Street and Lisburn Street;
2. Rezoning, from Agricultural to Industrial "A", land bounded by Ford Road, Southdown Street and Hawkins Street.

A copy of the Scheme has been deposited at the office of the Council Civic Centre, Welsford Street, Shepparton, and at the office of the Town and Country Planning Board, 235 Queen Street, Melbourne, and will be open for inspection during office hours by any person free of charge.

Any persons affected by the Planning Scheme are required to set forth in writing all objections they may have, addressed to the Town Clerk, Civic Centre, Shepparton, on or before the seventh day of June, 1975, and to state whether they wish to be heard in respect of their objections.

4841

R. O'BRIEN, Town Clerk.

TOWN OF PORTLAND.

NOTICE OF INTENTION TO TAKE LAND COMPULSORILY.

WHEREAS the Council of the Town of Portland deems it expedient to exercise its powers of taking land compulsorily for the work or undertaking mentioned hereunder, NOTICE IS HEREBY GIVEN THAT—

(1) The Council intends to acquire All that piece of land measuring 150 feet on its northern boundary, 61 feet on its western boundary, 159 feet on its south-western boundary and 114 feet on its eastern boundary and being part of Garden Allotment 26, Section B, Town and Parish of Portland, County of Normanby, being the land described in a Deed registered in the Office of the Registrar-General, Melbourne, by Memorial No. 22 Book 578.

(2) The subject land is to be used for industrial development under the provisions of Sections 811A and 811B of the Local Government Act 1958.

(3) The Council has caused to be prepared maps and other papers describing the proposed work or undertaking and the land proposed to be taken, together with the names of the owners or reputed owners, lessees or reputed lessees and the occupier thereof, as far as such names can be ascertained by the Council.

(4) Such maps and other papers are deposited at the Municipal Offices, Gawler Street, Portland, where they are and will remain open for inspection by all persons interested, during office hours, for a period of forty (40) clear days after publication of this Notice in the Government Gazette.

(5) All persons affected by the proposed work or undertaking are hereby called upon to set forth, in writing, addressed to the Council or the Town Clerk of the Town of Portland, within forty (40) clear days from the publication of this Notice in the Government Gazette, all objections which they may have to the said work or undertaking.

Dated this 6th day of May, 1975.

By order of the council,

4844

B. T. CRAGO, Town Clerk.

BOROUGH OF KOROIIT.

LOAN No. 11.

Notice of Intention to Borrow the sum of Ten thousand dollars (\$10,000) for Permanent Works and Undertakings.

Notice is hereby given that the Council of the Borough of Koroit proposes to borrow the principal sum of Ten Thousand Dollars (\$10,000.00) secured by a charge over the general rates of the municipality, such sum is to be raised by grant of a mortgage in accordance with the provisions of the Local Government Act 1958, as amended:

1. The maximum rate of interest that may be paid is 9.9 per centum per annum.

2. The purposes for which the loan is to be applied—
 - (a) Carrying out improvements and renovations to the Council Depot Shed, High Street, Koroit.
 - (b) Constructing concrete footpaths—Commercial Road—North side—West end.
3. The period of the loan shall be ten (10) years.

4. The moneys borrowed shall be repayable by providing out of the municipal fund twenty (20) half yearly instalments of approximately seven hundred and ninety nine dollars and three cents (\$799.03) each including principal and interest on the first day of January and the first day of July during the currency of the loan. The first instalment shall be payable on the first day of January, 1976.

The plans and specifications and the estimate of the cost of the proposed works and a statement showing the proposed expenditure of the moneys to be borrowed are open for inspection at the office of the Council of the Borough of Koroit, High Street, Koroit.

Dated 2nd May, 1975.

4944 A. J. MACDONALD, Town Clerk.

SHIRE OF BROADFORD.

LOAN NO. 51.

Notice of Intention to Borrow the Sum of \$60,000 for Permanent Works and Undertakings.

Notice is hereby given that the Council of the Shire of Broadford proposes to borrow the principal sum of Sixty thousand dollars secured by a charge over the general rates of the municipality, such sum to be raised by the grant of a mortgage in accordance with the provisions of the *Local Government Act 1958*.

1. The maximum rate of interest that may be paid is 9.9 per cent per annum.

2. The purpose for which the loan is to be applied is for the erection of buildings pursuant to an arrangement made under Part XLA of the *Local Government Act 1958* for the purpose of assisting the development of decentralized industry within the Shire of Broadford.

3. The period of the loan shall be fifteen years.

4. The moneys borrowed shall be repayable by providing out of the municipal fund thirty half yearly instalments of \$3,880.87 each, including principal and interest, on the fifteenth day of June and the fifteenth day of December during the currency of the Loan. The first instalment shall be repayable on the fifteenth day of December, 1975.

5. Such moneys shall be repayable at the C.B.C. Savings Bank Limited, Melbourne.

The plans and specifications and the estimate of the cost of the proposed works and a statement showing the proposed expenditure of moneys to be borrowed are open for inspection at the Shire Office, Broadford.

22nd April, 1975.

4834 M. D. WADE, Shire Secretary.

SHIRE OF CRANBOURNE.

LOAN NO. 53.

Notice of Intention to Borrow.

NOTICE is hereby given that the Council of the Shire of Cranbourne proposes to borrow the principal sum of \$50,000 secured by a charge over the General Rates of the Municipality, such sum to be raised by the grant of a Mortgage in accordance with the provisions of the *Local Government Act 1958* (as amended).

1. The maximum rate of interest that may be paid is 9.5% per annum.

2. The purpose for which the loan is to be applied is—
Fairbairn Road Construction, from Sladen Street to Cranbourne Drive \$50,000

3. The period of the loan shall be four (4) years.

4. The moneys borrowed shall be repayable by providing out of the municipal fund eight half yearly instalments of \$2,814.84, including principal and interest on the 18th day of June and 18th day of December during the currency of the loan. The first instalment shall be payable on the 18th day of December, 1975, and the balance shall be repayable on the 18th day of June, 1979.

5. Such moneys shall be repayable to the Australian Mutual Provident Society, Melbourne.

The plans and specifications and the estimate of the cost of the proposed works and the statement showing the proposed expenditure of moneys to be borrowed are open for inspection at the office of the Council of the Shire of Cranbourne, Sladen Street, Cranbourne.

Dated this 7th day of May, 1975.

4840 T. VICKERMAN, Shire Secretary.

River Improvement Act 1958.

SHIRE OF EAST LODDON.

PROPOSED RIVER IMPROVEMENT DISTRICT.

Notice is hereby given that the Council of the Shire of East Loddon has forwarded to the Minister of Water Supply an application for the constitution of that portion of the Shire of East Loddon not included in the Bullock Creek River Improvement District as a River Improvement District under the jurisdiction and control of a River Improvement Trust comprising all members of the East Loddon Shire Council.

Copies of the application and general plan and description of the proposed works have been deposited for inspection at the Offices of:—

(a) The Minister of Water Supply, State Rivers and Water Supply Commission, 590 Orrong Road, Armadale. 3143.

(b) The Shire of East Loddon, Serpentine. 3517.

4539 T. J. RUDKINS, Shire Secretary.

SHIRE OF EUROA.

LOAN NO. 36.

Notice of Intention to Borrow the Sum of \$40,000 for Permanent Works and Undertakings.

Notice is hereby given that the Council of the Shire of Euroa intends to borrow the principal sum of Forty Thousand Dollars (\$40,000) by the grant of a mortgage secured by a charge over the general rates of the municipality in accordance with the provisions of the *Local Government Acts*.

In connection therewith the following information is stated:—

(a) The amount of the principal moneys which it is proposed to borrow is Forty Thousand Dollars (\$40,000).

(b) The maximum rate of interest that may be paid is 9.8 per centum per annum.

(c) The times which the moneys borrowed are to be repayable are the first days of January and July during the years 1976–1982 inclusive and that the place such moneys shall be repayable is at the National Bank of Australasia Limited, Melbourne.

(d) The purpose for which the loan is to be applied is for the purchase of plant.

(e) The manner in which the loan is to be liquidated is by provision out of the Municipal Fund in each half year during the currency of the loan of the sum of \$4,015.16 which includes Principal and Interest.

The plans and specifications and estimate of the cost of the works and a statement showing the proposed expenditure of the moneys to be borrowed are open for inspection at the Shire Office, Euroa.

Dated this 2nd day of May, 1975.

4857 B. MORAN, Shire Secretary.

SHIRE OF GISBORNE.

LOAN NO. 21.

Notice of Intention to Borrow the Sum of \$20,000 for Permanent Works and Undertakings.

Notice is hereby given that the Council of the Shire of Gisborne proposes to borrow the principal sum of \$20,000 secured by a charge over the general rates of the municipality, such sum to be raised by the grant of a mortgage in accordance with the provisions of the *Local Government Act 1958*.

1. The maximum rate of interest that may be paid is 9.9 per cent per annum.

2. The purpose for which the loan is to be applied is—

Purchase of Property, 51 Aitken Street, Gisborne (balance of purchase money)	\$17,000
Purchase of Survey Utility Vehicle	\$3,000

\$20,000

3. The period of the loan shall be ten years.

4. The moneys borrowed shall be repayable by providing out of the municipal fund half-yearly instalments of \$1598.05 each, including principal and interest on the 10th day of December and the 10th day of June, during the currency of the loan. The first instalment shall be payable on the 10th of December 1975.

5. Such moneys shall be repayable to the Commercial Bank of Australia Limited at Gisborne.

6. The plans and specifications and the estimate of the cost of the proposed works and a statement showing the proposed expenditure of the moneys to be borrowed, are open for inspection at the office of the Council of the Shire of Gisborne, at the Shire Office, 10 Hamilton Street, Gisborne.

Dated this 1st day of May 1975.

4843 H. W. S. JACKSON, Relieving Shire Secretary.

SHIRE OF GOULBURN.

APPOINTMENT OF PROSECUTING OFFICER.

Notice is hereby given that Sergeant CARL LEONARD TRESSIDER, No. 13308, has been appointed Prosecuting Officer for the Shire of Goulburn as from March 25th, 1975, in lieu of Sergeant Herbert William McKenzie, transferred.

4823

J. L. MITCHELL, Shire Secretary.

Town and Country Planning Act 1961 (Twelfth Schedule).
SHIRE OF HASTINGS.—SHIRE OF HASTINGS PLANNING SCHEME, 1962.

NOTICE THAT A PLANNING SCHEME HAS BEEN PREPARED AND IS AVAILABLE FOR INSPECTION.

Amendment No. 86, 1975.

NOTICE is hereby given that the Council of the Shire of Hastings, in pursuance of its powers under the *Town and Country Planning Act 1961*, has prepared a Planning Scheme for the following area:—

(i) Land delineated on Plan No. 1368 in the Office of the Council, being Lots 57-71 inclusive, and Lots 82-84 inclusive, L.P. 2402, and parts of Crown Allotment 94, bounded by High, King, Salmon and Church Streets and Frankston-Flinders Road, Hastings, for the purpose of rezoning from Commercial "A" Zone and Proposed Public Purposes Reserve (Car Parking), to Sub-Regional Business Zone and Proposed Public Purposes Zone (Municipal Purposes).

(ii) Land delineated on Plan No. 1368 in the Office of the Council, being Lots 49-52 inclusive, Lots 72-81 inclusive, and Lots 85-87 inclusive, L.P. 2402; Lots 1-3 inclusive, L.P. 44368; Lots 2 and 3, L.P. 20947; and Lots 4-6 inclusive, L.P. 29658; bounded by High, Victoria, King and Church Street, Hastings, for the purpose of rezoning from Commercial "A" Zone, Existing Public Open Space Reserve (Bowling Green), Proposed Public Purposes Reserve (Car Parking), Residential "F" Zone, Industrial "A" Zone, and Existing Public Purposes Reserve (Post Office), to Sub-Regional Business Zone and Proposed Public Purposes Zone (Municipal Purposes).

(iii) Land delineated on Plan No. 1368 in the office of the Council, being Lots 1-4 inclusive, L.P. 24035; Lots 9-13 inclusive, L.P. 2402, Lots 15-25 inclusive, L.P. 2402; and C.P. 100306, fronting High, Albert and Victoria Streets, Hastings, for the purpose of rezoning from Commercial "A" Zone and Residential "F" Zone, to Sub-Regional Business Zone, Low Intensity Commercial Zone, Proposed Public Purposes Reserve (Car Parking) and Proposed Public Purposes Reserve (Municipal Purposes).

(iv) Land delineated on Plan No. 1368 in the Office of the Council, being Lots 124-130 inclusive, Lots 142-146 inclusive, Lots 150-151 inclusive, Lots 163-167 inclusive, Lot 169 and Lots 171-172 inclusive, L.P. 2991, Lots 1 and 2, L.P. 78601, Lots 1 and 2, L.P. 27363, Lots 1 and 2, L.P. 61836, Lots 1-6 inclusive, L.P. 70877, fronting High, Alfred, Victoria and King Streets, Hastings, for the purpose of rezoning from Residential "F" Zone, Commercial "A" Zone, Industrial "A" Zone and Proposed Public Purposes Reserve (Car Parking) Zone to Sub-Regional Business Zone, Proposed Public Purposes Reserve (Car Parking) and Low Intensity Commercial zone.

(v) Land delineated on Plan No. 1368, in the Office of the Council, being Lots 183-193 inclusive, L.P. 2991, and part of Crown Allotment 94, fronting King, High and Salmon Streets, Hastings, for the purpose of rezoning from Commercial "A" Zone, Industrial "A" Zone, New Minor Road Zone and Proposed Public Purposes Reserve (Car Parking) to Sub-Regional Business Zone and Proposed Public Purposes Reserve (Car Parking).

(vi) Land delineated on Plan No. 1368 in the Office of the Council, being Lots 1-9 inclusive, L.P. 13736, fronting High and Salmon Streets and Marine Parade, Hastings, for the purpose of rezoning from Commercial "A" Zone to Proposed Public Open Space Reserve (Public Park).

(vii) Land delineated on Plan No. 1368 in the Office of the Council, being Lots 1-4 inclusive, L.P. 26420, fronting King and Church Streets and Frankston-Flinders Road, Hastings, for the purpose of rezoning from Commercial "A" Zone to Low Intensity Commercial Zone.

A copy of the Scheme has been deposited at the Shire Office, Marine Parade, Hastings, and at the office of the Town and Country Planning Board, 235 Queen Street, Melbourne, and will be open for inspection during office hours by any person, free of charge.

Any persons affected by the Planning Scheme are required to set forth in writing, all objections they may have, addressed to the Shire Secretary, Shire of Hastings, Post Office Box 55, Hastings, on or before the 7th, August, 1975, and to state whether they wish to be heard in respect of their objection.

L. A. WALKER, Shire Secretary.

Municipal Offices, Hastings, 3915; 7th May, 1975. 4837

SHIRE OF MELTON.

LOAN NO. 64.

Notice of Intention to Borrow.

Notice is hereby given that the Council of the Shire of Melton proposes to borrow the principal sum of Thirty Eight thousand dollars secured by a charge over the general rates of the municipality, such sum to be raised by the grant of a mortgage in accordance with the provisions of the *Local Government Act 1958*.

1. The maximum rate of interest that may be paid is 9.9 per cent.

2. The purposes for which the loan is to be applied are:

Construction of Dog Pound	\$ 5,000
Land Purchase, Melton South	12,000
Construction of Parking Areas, Melton (Part cost)	21,000
	38,000

3. The period of the loan shall be fifteen years.

4. The moneys borrowed shall be repayable by providing out of the municipal fund thirty half-yearly instalments of \$2,457.88 each including principal and interest on the tenth day of November and the tenth day of May in each year during the currency of the loan. The first instalment shall be payable on the tenth day of November, 1975.

5. Such moneys shall be repayable to the Commercial Savings Bank of Australia Limited, Western Highway, Melton.

The plans and specifications and the estimate of cost of the proposed works and a statement showing the proposed expenditure of the moneys to be borrowed are open for inspection at the Shire Offices, High Street, Melton.

4838

J. F. SHAW, Acting Shire Secretary.

SHIRE OF WHITTLESEA.

LOAN NO. G. 41:

Notice of Intention to Borrow the Sum of \$25,000 for Permanent Works and Undertakings.

Notice is hereby given that the Council of the Shire of Whittlesea proposes to borrow the principal sum of \$25,000 secured by a charge over the general rates of the Municipality, such sum to be raised by the grant of a mortgage in accordance with the provisions of the *Local Government Act 1958*.

1. The maximum rate of interest that may be paid is 9.9 per cent per annum.

2. The purpose for which the loan is to be applied is the construction of Cooper Street, east of Merri Creek (third stage).

3. The period of the loan shall be ten years.

4. The moneys borrowed shall be repayable by providing out of the Municipal Fund half-yearly instalments of \$1,997.57 each including principal and interest on the 1st day of June and the 1st day of December during the currency of the loan. The first instalment shall be payable on the 1st day of December, 1975.

5. Such moneys shall be repayable to the State Savings Bank of Victoria, Melbourne.

The plans and specifications and the estimate of the cost of the proposed works and a statement showing the proposed expenditure of the moneys to be borrowed are open for inspection at the Office of the Council of the Shire of Whittlesea at High Street, Epping.
4853 D. J. SMITH, Shire Secretary.

SHIRE OF WHITTLESEA.

LOAN No. G. 42.

Notice of Intention to Borrow the Sum of \$100,000 for Permanent Works and Undertakings.

Notice is hereby given that the Council of the Shire of Whittlesea proposes to borrow the principal sum of \$100,000 secured by a charge over the general rates of the Municipality, such sum to be raised by the grant of a mortgage in accordance with the provisions of the Local Government Act 1958.

1. The maximum rate of interest that may be paid is 9.9 per cent per annum.
2. The purpose for which the loan is to be applied is:—

(a) Reserve Improvements	\$21,500
(b) Half cost Kerb and Channelling, road drainage and Council contribution to Mahoneys Road duplication	27,000
(c) Road works construction	24,000
(d) Traffic Lights, Paschke Crescent/High Street, Lalor	12,000
(e) Drainage construction	15,500
	\$100,000

3. The period of the loan shall be ten years.
4. The moneys borrowed shall be repayable by providing out of the Municipal Fund half-yearly instalments of \$7,990.27 each including principal and interest on the 15th day of June and the 15th day of December during the currency of the loan. The first instalment shall be payable on the 15th day of December, 1975.
5. Such moneys shall be repayable to the T. and G. Mutual Life Society Limited, Cnr. Collins and Russell Streets, Melbourne.

The plans and specifications and the estimate of the cost of the proposed works and a statement showing the proposed expenditure of the moneys to be borrowed are open for inspection at the Office of the Council of the Shire of Whittlesea at High Street, Epping.
4854 D. J. SMITH, Shire Secretary.

SHIRE OF SEYMOUR.

DECLARATION OF A PUBLIC HIGHWAY.

Pursuant to the provisions of Section 522 of the Local Government Act, 1958, the Council of the Shire of Seymour hereby directs that the land in the Township of Seymour, shown abutting Lot numbers 1 and 2, on Lodged Plan of Subdivision No. 99148 indicated by hatching on the diagram hereunder which has been purchased, taken or acquired by it, shall be a Public Highway on and from the date of publication of this Order in the Government Gazette.

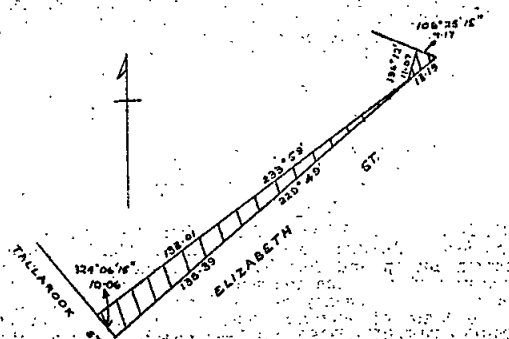

Part C.A. 14, Sec. C, Township & Parish of Seymour. Measurements in metres.

The common seal of the President, Councillors and Ratepayers of the Shire of Seymour was hereunto affixed, this 10th day of June, 1974, in the presence of—

B. T. O'SULLIVAN, President.
D. L. COUGHLIN, Councillor.
G. G. MCWHINNEY, Secretary.

APOLLO BAY SEWERAGE AUTHORITY.

BY-LAW No. 3.

Notice is hereby given, that in accordance with the powers conferred by the Sewerage District Act 1958, the above By-law No. 3, made by the Authority, has been approved by the Governor-in-Council on 4th March, 1974, details as follows:—

"Amending Division 4, Section 9 of By-law No. 2 relative to House Drainage Plans and Fees."

Copy of the By-law containing full details, may be inspected at the Authority's offices, 5 Pascoe Street, Apollo Bay, during office hours.

4942

T. J. FRY, Secretary.

Sewerage Districts Act 1958.

CASTLEMAINE SEWERAGE AUTHORITY.

GENERAL NOTICE.

Sewerage Area No. 61—Wesley Hill, Castlemaine.

The Castlemaine Sewerage Authority having made provision for carrying off the sewage from each and every property which or any part of which is within the sewerage area hereinafter described doth hereby declare that on and after the 1st day of June, 1975, each and every property which or any part of which is within the said sewerage area shall be deemed to be sewered property within the meaning of the Sewerage Districts Act 1958.

The boundaries of the sewerage area hereinbefore referred to are:—

Sewerage Area No. 61.

Commencing at the point being the southern most extremity of Crown Allotment 2A, Section G, Parish of Castlemaine, thence proceeding in a south-easterly direction across Wallace Street and along the southern boundaries of Crown Allotments 71A, 73A, 74A, 7A, 8A, 9A, 10A, 12A, 13A, to the southern extremity of the said Crown Allotment 13A, thence continuing in a general south-easterly direction across the unnamed street and along the southern boundary of Crown Allotments 15A, and Lots 1 and 2 of L.P.25236 to the southern extremity of the said Lot 2, thence in a north-easterly direction along the eastern boundary of the said Lot 2 to the point of intersection with the southern boundary of Duke Street, thence in a north-westerly direction across Duke Street to the southern extremity of Crown Allotment 62 thence along the eastern and northern boundaries of the said Crown Allotment 62 and the northern boundaries of Crown Allotments 63 & 6 to the point of intersection of the northern boundary of the said Crown Allotment 6 with the western boundary of Crown Allotment 141, thence in a northerly direction along the western boundary of Crown Allotment 141 to the western extremity of the said Crown Allotment 141, thence in an easterly direction along the northern boundary of Crown Allotment 141 to the point of intersection with the west side of Van Heurck Street, thence in a north-westerly direction along the south-western boundary of Van Heurck Street to the eastern extremity of Lot 1 of L.P.53919, thence in a general south-westerly direction along the boundaries of Sewerage Areas Nos. 58 & 51 to the point of commencement.

By order of the Castlemaine Sewerage Authority.

A. NESBITT, Chairman.
S. A. STEVENS, Secretary.

Dated at Castlemaine this 28th day of April, 1975. 4830

FRANKSTON SEWERAGE AUTHORITY.

DECLARATION OF SEWERED AREAS NOS. 89 TO 97 INCLUSIVE.

That the Frankston Sewerage Authority, having made provision for carrying off sewage from each and every property, which or any part of which is within the sewerage areas hereinafter described, doth hereby declare that on and after the first day of May, 1975 each and every property, which or any part of which is within the said sewerage area, shall be deemed to be a sewered property within the meaning of the Sewerage Districts Act 1958.

The boundaries of the sewerage areas hereinbefore referred to are:—

Area No. 89.

Commencing at the corner of Kars Street and Leslie Street then easterly along the boundaries of Declared Areas 79, 31 and 29 to Overport Road then southerly in Overport Road to Sweetwater Creek then westerly along Sweetwater Creek to Baden Powell Drive then northerly in Baden Powell Drive to Harcourt Avenue then easterly in Harcourt Avenue to Kars Street then northerly in Kars Street to the point of commencement.

Area No. 90.

Commencing at a point in Culcairn Drive adjacent to Declared Area 67 then southerly along the boundary of Area 67 to the rear of No. 53 Lawson Avenue then westerly along the Sweetwater Creek Reserve boundary to Overport Road then northerly in Overport Road to the north of No. 59 Overport Road then easterly along the rear boundaries of lots 106 and 104 Sycamore Road to the State Rivers & Water Supply Commission easement, then south easterly along this easement boundary to the western corner of No. 2 Sycamore Road then north easterly along the rear boundaries of properties fronting Sycamore Road to the west, then easterly along the northern boundary of No. 76 Sycamore Road to Sycamore Road then north easterly along Sycamore Road to the boundary of Area 39 then easterly along the boundary of Area 39 to the point of commencement.

Area No. 91.

Commencing at a point at the north east junction of Seaford Road and Wells Road then northerly to the Seaford Road realignment then easterly along the southern boundary of the Seaford Road realignment to Seaford Road then westerly along Seaford Road to the point of commencement.

Area No. 92.

The area fronting Apsley Place off Hartnett Drive, those properties fronting Hartnett Drive to the east, north of Apsley Place, those properties fronting the south western Seaford Road cul-de-sac immediately to the east of Hartnett Drive, No. 4 Seaford Road, and those properties fronting Galway Street to the west between Seaford Road and Belvedere Road.

Area No. 93.

That area comprising lots 3 to 42 inclusive, 70 to 72 inclusive and 80 to 99 inclusive of the Forestdale Sub-division located on the south side of Cranbourne Road and immediately to the east of Wattle Tree Lane.

Area No. 94.

Commencing at a point at the corner of Nepean Highway and Liddesdale Avenue then southerly along the boundary of Area 74 then westerly along the southern boundary and to the rear of No. 12 Plummer Avenue, then south easterly along rear boundaries to the north east corner of No. 24 Menzies Close then south westerly along the eastern boundary of No. 24 Menzies Close to Menzies Close, then north westerly along the northern side of Menzies Close to a point opposite the eastern boundary of No. 37 Menzies Close then south westerly to the south corner of No. 37 Menzies Close then westerly along the boundary of this allotment to Hopes Rise then northerly along the east side of Nepean Highway to the point of commencement.

Area No. 95.

The area comprising lot 281 Dianella Court.

Area No. 96.

The area contained within Govan Street, Gray Street, Bardia Avenue and the extension of the eastern boundary of Gray Street as well as lots 4 to 10 inclusive Bardia Avenue.

Area No. 97.

The area comprising lot 9 L.P. 50649 Moresby Avenue, and lots 9 to 12 inclusive Govan Street between Gray Street and Moresby Avenue.

By order of the said Authority,

D. E. R. BUNYAN, Chairman.
G. C. PENTLAND, Secretary.

4858

GEELONG WATERWORKS AND SEWERAGE TRUST.

Pursuant to Section 60 of the *Geelong Waterworks and Sewerage Act 1958* (No. 6263) the Trust has prepared plans to indicate the particulars of sewers and underground works, the construction of which the Trust intends to begin at a date, not less than one month after publication of the notice, in or adjacent to the following localities within the Drainage Area.

Helen Street, North Geelong, Shire of Corio.

Ellstone Avenue, Wilsons Road, Collins, Buckingham and Durran Streets, Whittington, Shire of Bellarine.

Pioneer Road and Norfolk Avenue, Grovedale, City of South Barwon.

Anthony Street and Queenscliff Road, Newcomb, Shire of Bellarine.

Birkenhead Drive, Elinbank Drive, Jutland and Byron Courts, Ainslie Avenue, Tylden Court and Dalyston Street, Grovedale, City of South Barwon.

Vanessa Avenue and Shoubra Drive, Highton, City of South Barwon.

NOTICE IS HEREBY GIVEN that the plans indicated above are open for inspection at the Trust's Offices, Ryrrie Street, Geelong, between the hours of 9.00 a.m. and 5.00 p.m. from Monday to Friday (public holidays excepted) by the owners or occupiers of land or premises within the Drainage Area.

4835

B. C. HENSHAW, Secretary.

LILYDALE SEWERAGE AUTHORITY.

DECLARATION OF SEWERED AREA.—COLDSTREAM.

The Authority orders that having made provision for carrying off the sewage from each and every property which or any part of which is within the Sewerage Area hereinafter described does hereby declare that on or after the 1st February, 1975 each and every property which or any part of which is within the said sewerage area shall be deemed to be a seweraged property within the meaning of the *Sewerage Districts Act 1958*.

The Boundary of the Sewerage Area hereinafter referred to is Sewerage Area No. 27 and is delineated on plan signed and sealed by the Authority and lodged with the State Rivers and Water Supply Commission of Victoria.

4839

NOTICE IS HEREBY GIVEN that the McCRAE YACHT CLUB has applied for a Lease under Section 134 of the *Land Act 1958* for a term of 21 years, in respect of Allotment 4, Section B, Parish of Wannaeue, as a site for Amusement and Recreation (Yacht Club and associated facilities).

4829

NOTICE is hereby given that the partnership heretofore subsisting between the undersigned HEATHER JACQUELINE LOPERT, JOHN CHESTERTON DICK, SYDNEY DENNIS GIDDY and PETER HERBERT JOHN THEOBALD carrying on practice as Medical Practitioners at 1010 Sturt Street Ballarat under the name "ANAESTHETIC GROUP BALLARAT" has been dissolved by the retirement therefrom of HEATHER JACQUELINE LOPERT as from the 28th day of February 1975. All debts due to and owing by the said Anaesthetic Group Ballarat will be received and paid by JOHN CHESTERTON DICK, SYDNEY DENNIS GIDDY and PETER HERBERT JOHN THEOBALD who will continue to carry on the practice at the same place under the same name.

Dated at Ballarat the 1st day of April, 1975.

Signed by the said HEATHER JACQUELINE LOPERT, in the presence of—ARNOLD BROWN.

Signed by the said JOHN CHESTERTON DICK in the presence of—TERRI H. MILES.

Signed by the said SYDNEY DENNIS GIDDY in the presence of—TERRI H. MILES.

Signed by the said PETER HERBERT JOHN THEOBALD in the presence of—TERRI H. MILES.

D. & A. ARONSON, solicitors, Ballarat. 4788

NOTICE IS HEREBY GIVEN that the partnership heretofore subsisting between us the undersigned UGO DE HAAN and HELENA DE HAAN carrying on business as Restaurateurs at the Eldorado Restaurant, Hansen Street, Corryong has been dissolved as from the 22nd day of April 1975. All debts due to and owing by the said firm will be received and paid respectively by Ugo De Haan who will continue to carry on the said business.

U. DE HAAN.
H. DE HAAN.

HOOD & BRAHAM, solicitors, Corryong. 4789

NOTICE OF DISSOLUTION OF PARTNERSHIP—JENROD DISTRIBUTORS.

NOTICE IS HEREBY GIVEN that the Partnership heretofore subsisting between Clifton Mead, Rodney Kenneth Bishop and Jennifer Anne Bishop carrying on a business of importing and selling Toys and fancy goods, and a Custom's agency at 114 King Street, Melbourne in the State of Victoria under the style or firm of JENROD DISTRIBUTORS has been dissolved as from the 31st December, 1974.

Dated this 17th day of April, 1975.

4790

R. BISHOP.
J. BISHOP.

NOTICE IS HEREBY GIVEN that the partnership heretofore subsisting between Laurence Francis Harrison and Kevin Frederick Richards carrying on business as Used Car Dealers at 260 Sydney Road, Brunswick under the style or firm of "Kevin Harrison Motors" has been

dissolved by mutual consent as from the 8th day of April, 1975 so far as concerns the said Kevin Frederick Richards. All debts due and owing by the said firm will be received and paid respectively by the said Kevin Frederick Richards who will continue to carry on business under the style or name of "Kevin Harrison Motors".

STRONGMAN & CROUCH, solicitors of 118 Queen Street, Melbourne. 4882

NOTICE IS HEREBY GIVEN that Messrs. JOHN FREDERICK DAVID LEWIN of Lot 621, Ennismore Crescent, Park Orchards, Victoria, and WILLIAM ALAN NUTTON of 4 Torbreck Street, Glen Waverley, Victoria, have on the 30th day of April 1975 retired from the partnership theretofore existing between them and KENNETH ALBERT COLEMAN of "Kurrara", Highbury Road, Vermont South, Victoria, and JEROME DAVID STERN of 55 Menin Road, Forest Hill, Victoria, and CHARLES JOSEF BERG of 25a Yarranabbe Road, Darling Point, New South Wales, and ROGER JOHN KAYE of 35 Beechworth Road, Pymble, New South Wales, and COLIN IVAN BOROUGH of 16 Lavoni Street, Mosman, New South Wales and ROBERT STRAUSS of 29 Fairfax Road, Bellevue Hill, New South Wales, carrying on the business of public accountants under business name BERG COLEMAN & PARTNERS at 9th Floor, 325 Collins Street, Melbourne, and that as from that date the said KENNETH ALBERT COLEMAN and JEROME DAVID STERN and CHARLES JOSEF BERG and ROGER JOHN KAYE and COLIN IVAN BOROUGH and ROBERT STRAUSS will continue to carry on the said business in partnership at the same address.

Dated the 13th day of April, 1975.
4898 KENNETH ALBERT COLEMAN.

NOTICE OF RETIREMENT FROM PARTNERSHIP

Mr. Ian McCAHON, gynaecologist, hereby gives notice that he has retired from the Medical Partnership of Drs. William Hugh MILROY, Graeme Foster SALTER, Kevin Edward COLLOPY, John Graeme BAKER, Elizabeth Ann TOMLINSON and Ian McCAHON of Davey Street, Frankston, as from 14 FEBRUARY 1975. 4922

NOTICE is hereby given that the partnership heretofore subsisting between REX HOWARD SCENEY, MARGARET LYNETTE SCENEY, JOHN HENRY LUBCKE and JUNE MARGARET LUBCKE carrying on business as Cabinet Makers and Joiners from premises situated at 2 Fenwick Street, Geelong under the business name of "R. J. HALE & CO." has been dissolved from the 31st day of December 1974. All debts due to or owing by the late partnership will be received and paid by the said JOHN HENRY LUBCKE and JUNE MARGARET LUBCKE who will continue to carry on the said business from the said premises under the same business name.

VIVIAN HILL, LL.B., solicitor, 71 Yarra Street, Geelong. 4787

NOTICE IS HEREBY GIVEN that the Partnership heretofore subsisting between Sydney Robert Thomson, Norma Joyce Thomson and Lawrence Robert Thomson carrying on business as Estate Agents at 124 Ryrie Street Geelong under the style or firm of C. J. Keane & Co. and at 116 Ryrie Street Geelong under the style or firm of Henry Leary & Co. has been dissolved as from the 1st day of February 1975. As from that date the said businesses have been and are being carried on by Keane Nominees Pty. Ltd. of 11 Fenwick Street Geelong.

Dated this 28th day of April, 1975.

S. R. Thomson.
N. J. Thomson.
L. R. Thomson.

WIGHTON & McDONALD, solicitors, 89 Myers Street, Geelong. 4786

A DIVIDEND IS INTENDED TO BE DECLARED IN THE FOLLOWING ESTATES OF L. W. & A. W. FOSTER.

Creditors who have not lodged Proofs of Debt with G. O. Harrison, Trustee, of Hall & Rose, 395 Collins Street, Melbourne on or before the 30th day of May, 1975 will be excluded from Dividend.

31/73—Re Leslie William & Anita Waltraud Foster, 42 Edis Street Kyabram, Home Furnishing Retailers, second and final dividend.

HALL & ROSE, chartered accountants, 395 Collins Street, Melbourne, Victoria. 4891

THE AUSTRALIAN-AMERICAN CLUB (IN LIQUIDATION).

TO THE MEMBERS OF THE AUSTRALIAN-AMERICAN CLUB.

Notice of Final Meeting.

Notice is hereby given that in accordance with the provisions of Section 272 of the Companies Act 1961, a Final Meeting of Members of the abovenamed Company will be held at the offices of Messrs. Wilson Danby Perry Johnson, 9th Floor, 461 Bourke Street, Melbourne at 10.00 a.m. on 26th Day of June, 1975 for the purpose of receiving an account showing how the winding up has been conducted and the property of the Company disposed of.

Dated this 5th day of May, 1975.

A. S. FURZE and J. C. BENZIES, joint liquidators. 4912

N. McLEANS MUSIC CENTRE PROPRIETARY LIMITED (IN LIQUIDATION).

NOTICE CONVENING FINAL MEETING.

NOTICE IS HEREBY GIVEN in pursuance of Section 272 of the Companies Act 1961 that a General Meeting of the Members of the abovenamed company will be held at the offices of J. S. Eastwood & Etherington, 1st Floor, 450 Little Collins Street, Melbourne, on the 23rd day of June 1975 at 10.00 a.m. for the purpose of having an account laid before them showing the manner in which the winding up has been conducted and the property of the Company disposed of and hearing of any explanations that may be given by the Liquidator.

Dated this 6th day of May, 1975.

4913 L. S. DIMSEY, Liquidator.

In the matter of the Companies Act 1961 and in the matter of ANTHONY INVESTMENTS PROPRIETARY LIMITED (in Voluntary Liquidation).—Notice of Final Meeting of Members pursuant to Section 272.

Notice is hereby given in pursuance of Section 272 of the Companies Act 1961 that a General Meeting of the members of the company will be held at the office of Ernest Williams, First Floor, 118 Queen Street, Melbourne on the 9th day of June 1975 at 10 a.m. for the purpose of having an account laid before it showing the manner in which the winding up has been conducted and the property of the company disposed of, and hearing any explanation that may be given by the Liquidator.

Dated this 29th day of April, 1975.

4914 E. G. WILLIAMS, Liquidator.

Companies Act 1961.

HENRY JONES & CO. (UNDERBOOL) PTY. LTD. (IN VOLUNTARY LIQUIDATION).

NOTICE CONVENING FINAL MEETING OF MEMBERS, PURSUANT TO SECTION 272.

Notice is hereby given in pursuance of Section 272 of the Companies Act 1961 that a General Meeting of the Members of the abovenamed Company will be held on the 11th June, 1975 at 11.00 a.m. at the office of Hughes, Fincher & Rodda, 343 Little Collins Street, Melbourne for the purpose of having an account laid before them showing the manner in which the winding up has been conducted and the property of the Company disposed of and hearing any explanation that may be given by the Liquidator.

Dated this 1st day of May, 1975.

N. HARRIS Liquidator.

Hughes, Fincher & Rodda, chartered accountants, 343 Little Collins Street, Melbourne, Vic. 3000. 4915

Companies Act 1961.

PHAIRS PROPRIETARY LIMITED (IN VOLUNTARY LIQUIDATION).

NOTICE CONVENING FINAL MEETING OF MEMBERS, PURSUANT TO SECTION 272.

Notice is hereby given in pursuance of Section 272 of the Companies Act 1961 that a General Meeting of the Members of the abovenamed Company will be held on the 11th day of June at 11.30 a.m. at the office of Hughes, Fincher & Rodda, 343 Little Collins Street, Melbourne for the purpose of having an account laid before them showing the manner in which the winding up has been conducted and the property of the Company disposed of and hearing any explanation that may be given by the Liquidator.

Dated this 1st day of May, 1975.

N. HARRIS, Liquidator.

Hughes, Fincher & Rodda, chartered accountants, 343 Little Collins Street, Melbourne, Vic., 300. 4916

The Companies Act 1961.

A. & H. BETTINK PLUMBING SERVICE PROPRIETARY LIMITED (IN LIQUIDATION).

NOTICE CONVENING FINAL MEETING OF MEMBERS AND CREDITORS, PURSUANT TO SECTION 272.

Notice is hereby given pursuant to Section 272 of the Companies Act 1961, that a General Meeting of the members and creditors of the abovenamed Company will be held in the offices of Kennedy Smail, 296-304 Little Lonsdale Street, Melbourne, on Wednesday the Fourth day of June, 1975, at 10.30 a.m. for the purpose of having an account laid before them showing the manner in which the winding up has been conducted and the property of the company disposed of and of hearing any explanations that may be given by the Liquidator.

Dated this 5th day of May, 1975.

JOHN MARTIN WALSH, Liquidator.

Kennedy Smail, 296-304 Little Lonsdale Street,
Melbourne, 3000. 4917

The Companies Act 1961.—In the matter of P. B. LYNCH & Co. Pty. Ltd. (in Liquidation).

A THIRD AND FINAL DIVIDEND is intended to be declared in the above-mentioned matter. Creditors who have not proved their debts by the 26th May, 1975 will be excluded from the dividend.

Dated this 5th day of May, 1975.

J. M. WALSH Liquidator.

Kennedy Smail, 296 Little Lonsdale Street, Melbourne,
3000. 4918

Companies Act 1961.

H. & S. FRANKEL PTY. LTD. (IN LIQUIDATION).

NOTICE TO CREDITORS OF INTENTION TO DECLARE DIVIDEND.

A FIRST dividend is intended to be declared in the above matter. Creditors who have not proved their debt by the 19th May, 1975, will be excluded from this dividend. The date of liquidation was the 16th July, 1974.

Dated this 5th day of May, 1975.

LEWIS LUCKINS, F.C.A., Liquidator.

Lewis Luckins & Co., chartered accountants, 423 Bourke Street, Melbourne, 3000. Telephone 67 6944. 4919

Companies Act 1961.

INTEGRITY INSURANCE CONSULTANTS PTY. LTD. (IN VOLUNTARY LIQUIDATION).

NOTICE is hereby given that at an Extraordinary General Meeting of Members of the abovenamed company held on 28th April, 1975, it was resolved that the company be wound up voluntarily and at a meeting of creditors held on the same day it was resolved that for such purpose Lewis Luckins, Chartered Accountant of 423 Bourke Street, Melbourne, be appointed liquidator.

Notice is also given that after twenty-one days from this date I shall proceed to distribute the assets. All creditors who have any claim against the company should furnish particulars of same by that date, otherwise I shall proceed to distribute the assets without regard to their claim.

Dated this 5th day of May, 1975.

LEWIS LUCKINS, F.C.A., Liquidator.

Lewis Luckins & Co., chartered accountants, 423 Bourke Street, Melbourne, 3000. Telephone 67 6944. 4920

Form 7.

Victoria.

Companies Act 1961.

CLARKS SHOES (FRS) LIMITED.

NOTICE OF RESOLUTION.

To the Registrar of Companies:

At a general meeting of the members of CLARKS SHOES (FRS) Limited duly convened and held at 264-268 West Beach Road, Marleston, S. Aust. on the twenty-third day of APRIL, 1975, the special resolution set out below was duly passed.

1. "THAT the Company be wound up voluntarily" AND
2. "THAT pursuant to Regulation 112 of the Articles of Association, the Liquidator be and is hereby authorised, subject to payment of or adequate provision for the

liabilities, if any, of the Company, to divide the whole or any part of the assets of the Company amongst the members *in specie* or kind."

An ordinary resolution set out below was duly passed:—

3. "THAT Mr John Vial be and is hereby appointed Liquidator for the purpose of winding up the Company, at a fee to be determined between Mr John Robert Vial and Clarks Shoes Australia Limited."

Dated this 28th day of April, 1975.

4815 R. J. PELLE, Acting Secretary.

Form 7.

Victoria.

Companies Act 1961.

CLARKS SHOES (GSI) LIMITED.

NOTICE OF RESOLUTION.

To the Registrar of Companies:

At a general meeting of CLARKS SHOES (GSI) Limited duly convened and held at 264-268 West Beach Road, Marleston, S. Aust. on the twenty-third day of APRIL, 1975, the special resolution set out below was duly passed.

1. "THAT the Company be wound up voluntarily" AND

2. "THAT pursuant to Regulation 112 of the Articles of Association, the Liquidator be and is hereby authorised, subject to payment of or adequate provision for the liabilities, if any, of the Company, to divide the whole or any part of the assets of the Company amongst the members *in specie* or kind."

An ordinary resolution set out below was duly passed:—

3. "THAT Mr John Vial be and is hereby appointed Liquidator for the purpose of winding up the Company, at a fee to be determined between Mr John Robert Vial and Clarks Shoes Australia Limited."

Dated this 28th day of April, 1975.

4816 R. J. PELLE, Acting Secretary.

Form 7.

Victoria.

Companies Act 1961.

JOYCE SHOES (AUSTRALIA) PTY. LIMITED.

NOTICE OF RESOLUTION.

To the Registrar of Companies:

At a general meeting of the members of JOYCE SHOES (AUSTRALIA) PTY Limited duly convened and held at 264-268 West Beach Road, Marleston, S. Aust. on the twenty-third day of APRIL, 1975, the special resolution set out below was duly passed.

1. "THAT the Company be wound up voluntarily" AND

2. "THAT pursuant to Regulation 112 of the Articles of Association, the Liquidator be and is hereby authorised, subject to payment of or adequate provision for the liabilities, if any, of the Company, to divide the whole or any part of the assets of the Company amongst the members *in specie* or kind."

An ordinary resolution set out below was duly passed:—

3. "THAT Mr John Vial be and is hereby appointed Liquidator for the purpose of winding up the Company, at a fee to be determined between Mr John Robert Vial and Clarks Shoes Australia Limited."

Dated this 28th day of April, 1975.

4817 R. J. PELLE, Acting Secretary.

Form 7.

Victoria.

Companies Act 1961.

GRACELINE SHOES PTY. LIMITED.

NOTICE OF RESOLUTION.

To the Registrar of Companies:

At a general meeting of the members of GRACELINE SHOES PTY Limited duly convened and held at 264-268 West Beach Road, Marleston, S. Aust. on the twenty-third day of APRIL, 1975, the special resolution set out below was duly passed.

1. "THAT the Company be wound up voluntarily" AND

2. "THAT pursuant to Regulation 112 of the Articles of Association, the Liquidator be and is hereby authorised, subject to payment of or adequate provision for the liabilities, if any, of the Company, to divide the whole or any part of the assets of the Company amongst the members *in specie* or kind."

An ordinary resolution set out below was duly passed:—

3. "THAT Mr. John Vial be and is hereby appointed Liquidator for the purpose of winding up the Company, at a fee to be determined between Mr John Robert Vial and Clarks Shoes Australia Limited."

Dated this 28th day of April, 1975.

4818 R. J. PELLEY, Acting Secretary.

Companies Act 1961, Section 272 (2).

HILLCREST TRADING COMPANY PTY. LTD. (MEMBERS' VOLUNTARY WINDING UP).

NOTICE OF FINAL MEETING AND DISSOLUTION.

Notice is hereby given that a General Meeting of the Members of Hillcrest Trading Company Proprietary Limited will be held at 155 Wellington Parade South, Jolimont on the 31st May, 1975 at 10.00 a.m. for the purpose of laying before the Meeting and account showing how the winding up has been conducted and the property of the Company has been disposed of and of giving any explanation of the account and also of determining by Extraordinary Resolution the manner in which the books, accounts and documents of the Company and of the Liquidator thereof shall be disposed of.

Dated this 2nd day of May, 1975.

4850 ALLAN NAHUM, Liquidator.

Companies Act 1961, Section 272 (2).

H. TAFT COMPANY PTY. LTD. (MEMBERS' VOLUNTARY WINDING UP).

NOTICE OF FINAL MEETING AND DISSOLUTION.

Notice is hereby given that a General Meeting of the Members of H. Taft Company Proprietary Limited will be held at 155 Wellington Parade South, Jolimont on the 31st May, 1975 at 10.00 a.m. for the purpose of laying before the Meeting an account showing how the winding up has been conducted and the property of the Company has been disposed of and of giving any explanation of the account and also of determining by Extraordinary Resolution the manner in which the books, accounts and documents of the Company and of the Liquidator thereof shall be disposed of.

Dated this 2nd day of May, 1975.

4851 ALLAN NAHUM, Liquidator.

Companies Act 1961, Section 272 (2).

MERINO KNITTING MILLS PTY. LTD. (MEMBERS' VOLUNTARY WINDING UP).

NOTICE OF FINAL MEETING AND DISSOLUTION.

Notice is hereby given that a General Meeting of the Members of Merino Knitting Mills Proprietary Limited will be held at 155 Wellington Parade South, Jolimont on the 31st May, 1975 at 10.00 a.m. for the purpose of laying before the Meeting an account showing how the winding up has been conducted and the property of the Company has been disposed of and of giving any explanation of the account and also of determining by Extraordinary Resolution the manner in which the books, accounts and documents of the Company and of the Liquidator thereof shall be disposed of.

Dated this 2nd day of May, 1975.

4852 ALLAN NAHUM, Liquidator.

The Companies Act 1961:

INDUSTRIAL CONSOLIDATED PROPRIETARY LIMITED (IN VOLUNTARY LIQUIDATION).

NOTICE OF FINAL MEETING.

Notice is hereby given that, pursuant to section 272 of the *Companies Act 1961*, a Final Meeting of the members of the abovenamed company will be held at the office of the liquidator, 5 Chancery Lane, Ballarat, on the 9th June, 1975 at 10.30 a.m., for the purpose of presenting the liquidator's account of the winding up.

Dated this 30th day of April, 1975.

4864 N. WESTBROOK, Liquidator.

The Companies Act 1961.

AICRAM TRADING COMPANY PROPRIETARY LIMITED (IN VOLUNTARY LIQUIDATION).

NOTICE OF FINAL MEETING.

Notice is hereby given that, pursuant to section 272 of the *Companies Act 1961*, a Final Meeting of the members of the abovenamed company will be held at the office of the liquidator, 5 Chancery Lane, Ballarat, on the 9th June, 1975 at 10 a.m., for the purpose of presenting the liquidator's account of the winding up.

Dated this 30th day of April, 1975.

4865 N. WESTBROOK, Liquidator.

ALMA CAMBERWELL PTY. LTD.

At an Extraordinary General Meeting of the abovenamed Company duly convened and held at the office of H. Guest & Associates Pty. Ltd., 207B Balaclava Road, Caulfield on the 2nd May, 1975, the following Resolution was duly passed as a Special Resolution:

1. That the Company be wound up voluntarily.

2. That Mr. John Durlacher, Public Accountant of 207B Balaclava Road, Caulfield be and is hereby appointed liquidator at a remuneration in accordance with the scale of fees laid down by the Australian Society of Accountants.

Dated this 2nd day of May, 1975.

4878 J. DURLACHER, Liquidator.

Company No. 32914.

REX W. STREADER PTY. LTD.

SPECIAL RESOLUTION.

Notice of Members voluntary winding up of the Company registered under the *Companies Act 1961*.

At an Extraordinary General Meeting of the members of Rex W. Streader Pty. Ltd. duly convened and held at 219 Were Street, East Brighton, on Monday, 28th April, 1975—

"It was resolved that the Company be wound up voluntary under the provisions of the *Companies Act 1961* and that Mr. O. G. Unkenstein, Chartered Accountant, of 422 Collins Street, Melbourne, be and is hereby appointed the Liquidator of the company."

REX W. STREADER,

Chairman of Directors.

I certify this is a true copy of the above resolution.

4886

REX W. STREADER.

The Companies Act 1961.

HOTEL FINANCE & MANAGEMENT PTY. LTD. (IN MEMBERS VOLUNTARY LIQUIDATION).

NOTICE is hereby given that at an Extraordinary General Meeting of Members of the abovenamed Company held on the 25th day of April, 1975 it was resolved that the Company be wound up voluntarily and that GEOFFREY ORMOND HARRISON of Hall & Rose, Chartered Accountants, 395 Collins Street, Melbourne be appointed Liquidator.

Any person claiming to be a creditor of the abovenamed Company is requested to lodge particulars of his claim with the Liquidator by 28th May, 1975.

Dated this 29th day of April, 1975.

G. O. HARRISON, Liquidator.

Hall & Rose, chartered accountants, 395 Collins Street, Melbourne, Vic. 3000. 4887

NORTHERN INVESTMENTS PTY. LTD. (IN LIQUIDATION).

NOTICE IS HEREBY GIVEN that a General Meeting of Shareholders in the Company will be held at the Office of R. H. Morrison, 37 Swanston Street, Melbourne on Monday 23rd June, 1975, at 2 P.M. for the purpose of receiving the Liquidator's final account of the winding-up.

Dated this 1st day of May, 1975.

4896 R. H. MORRISON, Liquidator.

The Companies Act 1961.

BERNFERD PTY. LTD. (IN MEMBERS VOLUNTARY LIQUIDATION):

NOTICE is hereby given that at an Extraordinary General Meeting of Members of the abovenamed Company held on the 25th day of April, 1975 it was resolved that the Company be wound up voluntarily and that GEOFFREY ORMOND HARRISON of Hall & Rose, Chartered Accountants, 395 Collins Street, Melbourne be appointed Liquidator.

Any person claiming to be a creditor of the abovenamed Company is requested to lodge particulars of his claim with the Liquidator by 28th May, 1975.

Dated this 29th day of April, 1975.

G. O. HARRISON, Liquidator.

Hall & Rose, chartered accountants, 395 Collins Street, Melbourne, Vic. 3000. 4888

The Companies Act 1961.—In the matter of PICCABLY PICTURE CORPORATION PTY. LTD.

NOTICE is hereby given that at an Extraordinary General Meeting of the members of the abovenamed Company held on the 30th day of April, 1975, it was

resolved that the Company be wound up voluntarily, and at a meeting of creditors held on the same day, pursuant to Section 260, it was resolved that for such purpose, Thomas Dunn Maclean of 545 St. Kilda Road, Melbourne, Accountant, be appointed Liquidator.

NOTICE is also given that after 21 days from this date I shall proceed to distribute the assets. All creditors having any claims against the Company should furnish particulars of same by that date, otherwise I shall proceed to distribute the assets without regard to their claim.

Dated this 30th day of April, 1975.

THOMAS D. MACLEAN, Liquidator.

T. D. Maclean & Company, 545 St. Kilda Road, Melbourne, Vic. 3004. 4879

The Companies Act 1961.

KAY'S AUTOMAT RESTAURANT PTY. LTD.
(IN MEMBERS VOLUNTARY LIQUIDATION).

NOTICE is hereby given that at an Extraordinary General Meeting of Members of the abovenamed Company held on the 25th day of April, 1975 it was resolved that the Company be wound up voluntarily and that GEOFFREY ORMOND HARRISON of Hall & Rose, Chartered Accountants, 395 Collins Street, Melbourne be appointed Liquidator.

Any person claiming to be a creditor of the abovenamed Company is requested to lodge particulars of his claim with the Liquidator by 28th May, 1975.

Dated this 29th day of April, 1975.

G. O. HARRISON, Liquidator.

Hall & Rose, chartered accountants, 395 Collins Street, Melbourne, Vic. 3000. 4889

Companies Act 1961, Section 272.

K's DANDENONG HOTEL PTY. LTD. (IN LIQUIDATION).
HOTEL-MOTEL MONASH PTY. LTD. (IN LIQUIDATION).
N.S.Z. INVESTMENTS PTY. LTD. (IN LIQUIDATION).
F.I.N. INVESTMENTS PTY. LTD. (IN LIQUIDATION).
C. R. TURNER (MOTORS) PTY. LTD. (IN LIQUIDATION).
C. R. TURNER CONSOLIDATED PTY. LTD. (IN LIQUIDATION).

WILLOUGHBY INVESTMENTS PTY. LTD. (IN LIQUIDATION).
GARNER BROTHERS CONSTRUCTIONS PTY. LTD. (IN LIQUIDATION).

G.B. TIN MINING CO. PTY. LTD. (IN LIQUIDATION).

Notice is hereby given that the Final General Meeting of each of the above companies will be held at 17 Landcox Street, East Brighton, Victoria, at 11 a.m. on 9 June, 1975, for the purposes set out in the above Section.

Dated this 5th day of May, 1975.

4866 MURRAY DEWAR, Liquidator.

Companies Act 1961.

S.B.W. PROPRIETARY LIMITED (IN VOLUNTARY LIQUIDATION).

NOTICE CONVENING FINAL MEETING OF MEMBERS, PURSUANT TO S. 272 (1).

NOTICE IS HEREBY GIVEN that the Final Meeting of Members of the abovenamed Company will be held at 12th Floor, 271 William Street, Melbourne on 2nd June, 1975 at 10 a.m. for the purpose of laying before the meeting an account showing how the winding up has been conducted and the property of the Company disposed of and giving any explanation thereof.

Dated this 29th day of April, 1975.

K. W. SCOTT, Liquidator.

Wilson, Bishop, Bowes & Craig, 271 William Street, Melbourne, 3000. 4890

The Companies Act 1961.—In the matter of BIO-CULT SERUMS (AUSTRALIA) PTY. LTD.

Notice is hereby given that at a Meeting of the Members of BIO-CULT SERUMS (AUSTRALIA) PTY. LTD. on 25th APRIL, 1975 the following resolution was passed as a special resolution.

It was resolved:—

That the Company be wound up voluntarily and that BARRY JOHN WEIR, having consented to act, be and is hereby appointed Liquidator and that he be remunerated at his usual professional rates, and that in accordance with the provisions of Section 284 (3)

(b) of the Companies Act 1961, the Liquidator be and is hereby authorized to destroy the books and records of the Company on or after 31st December, 1975.

Dated this 29th day of April, 1975.

B. J. WEIR, Liquidator.

Hancock Woodward & Neill. 4892

FRANOLA PROPRIETARY LIMITED (IN VOLUNTARY LIQUIDATION).

NOTICE OF EXTRAORDINARY GENERAL MEETING
(FINAL MEETING).

NOTICE IS HEREBY GIVEN that an Extraordinary General Meeting of Members of Franola Proprietary Limited will be held at 12th Floor, 271 William Street, Melbourne on 16th June, 1975 at 10 a.m. for the purpose of considering the Liquidator's final account and any explanation thereof.

Dated this 30th day of April, 1975.

K. W. SCOTT, Liquidator.

Wilson, Bishop, Bowes & Craig, 271 William Street, Melbourne, 3000. 4893

Companies Act 1961 as Amended, Section 260 (1).—In the matter of MORNESSA FASHIONS PTY. LIMITED.—Notice of Meeting of Creditors.

NOTICE IS HEREBY GIVEN that pursuant to Section 260 (1) of the Companies Act 1961, as amended, a meeting of creditors of Mornessa Fashions Pty. Limited will be held at 9th Floor, 140 Queen Street, Melbourne on the 16th day of May, 1975 at 10.30 a.m. the Company having convened a meeting of its members for the same day for the purpose of considering a special resolution that the Company be wound up voluntarily.

Dated this 30th day of April, 1975.

L. JOSEPH, Secretary.

Wilson, Bishop, Bowes & Craig, chartered accountants, 271 William Street, Melbourne, 3000. Telephone 67 7372. 4894

The Companies Act 1961.

IKINGER INDUSTRIES PTY. LTD. (IN MEMBERS' VOLUNTARY LIQUIDATION).

NOTICE is hereby given that at an Extraordinary General Meeting of Members of the abovenamed Company held on the 17th day of April, 1975 it was resolved that the Company be wound up voluntarily and that GEOFFREY ORMOND HARRISON of Hall & Rose, Chartered Accountants, 395 Collins Street, Melbourne, be appointed Liquidator.

Any person claiming to be a creditor of the abovenamed Company is requested to lodge particulars of his claim with the Liquidator by 26th May, 1975.

G. O. HARRISON, Liquidator.

Hall & Rose, chartered accountants, 395 Collins Street, Melbourne, Vic. 3000. 4895

Companies Act 1961.—In the matter of CORARTIE PTY. LTD. (in Voluntary Liquidation).

NOTICE is hereby given pursuant to Section 254 (2) (b) of the Companies Act 1961 that an Extraordinary General Meeting of the members of CORARTIE PTY. LTD. duly convened and held on the 30th day of April 1975 passed the following Special Resolutions:—

"1. That the Company be wound up voluntarily.

2. That John Barry Hutchins and David Crosbie Petley be appointed joint and several liquidators of the Company."

Dated the 30th day of April, 1975.

J. B. HUTCHINS.

4897

D. C. PETLEY.

Companies Act 1961.—In the matter of MACLAREN HAULAGE (AUST.) PROPRIETARY LIMITED.—Notice Re Meeting of Creditors, Pursuant to Section 260.

NOTICE is hereby given that a Meeting of Creditors of the abovenamed Company will be held at the offices of Taylor O'Connor & Co., 562 St. Kilda Road, Melbourne on Thursday 15th May, 1975, at 11.30 a.m., the Company having convened a Meeting of its Members for the same day for the purpose of considering a Resolution that the Company be wound up voluntarily.

Dated this 2nd day of May, 1975.

S. F. MACLAREN, Director.

Taylor O'Connor & Co., 562 St. Kilda Road, Melbourne, 3004. 4813

Companies Act 1961, Section 254 (2) (b).

T. J. SILK PTY. LIMITED (IN VOLUNTARY LIQUIDATION).
NOTICE OF RESOLUTION.

At an extraordinary meeting of shareholders of the above company duly convened and held at 1014 Doncaster Road, Doncaster East on the 28th day of April, 1975, the following special resolution was duly passed.

"Resolved that the company be wound up voluntarily and that Ronald Milton DOUGLAS, of 1014 Doncaster Road, Doncaster East, Chartered Accountant, be appointed liquidator for the purpose of such winding up and that the remuneration of Ronald Milton DOUGLAS be paid in accordance with the time involved."

Dated this 30th day of April, 1975.

4814 R. M. DOUGLAS, Secretary.

Companies Act 1961, Section 254.

BELL & LAWRENCE PTY. LTD.

NOTICE is hereby given that on the 24th day of April 1975 the following Special Resolution was passed.

That Bell & Lawrence Pty. Ltd. be wound up voluntarily and that Mr. M. J. Kellett, Public Accountant of 382 Middleborough Road, Blackburn be appointed Liquidator.
4819 D. L. BELL, Director.

S. H. & H. HOLDINGS PTY. LTD. (IN VOLUNTARY LIQUIDATION).

Notice is hereby given that a general meeting of the contributors of S. H. & H. Holdings Pty. Ltd. (in voluntary liquidation) will be held at 16 View Street, Bendigo on Wednesday 11th June, 1975 at three o'clock in the afternoon.

Agenda.

To consider the account of the liquidator on the winding up of the company.

Dated this 30th day of April, 1975.

4820 B. S. CAHILL, Liquidator.

The Companies Act 1961.

WALLER HOLDINGS PTY. LTD. (IN MEMBERS' VOLUNTARY LIQUIDATION).

PURSUANT TO SECTION 254.

Notice is hereby given in pursuant of section 254 of the Companies Act 1961 that a special meeting of the Company was held on 28th April 1975 and the following Resolution was duly passed.

"It was resolved by all members of the company that the Company be voluntarily wound up in accordance with the Articles of Association and the provisions of the Companies Act 1961."
4821

Companies Act 1961, Section 272.

ARMLEY PTY. LTD. (IN VOLUNTARY LIQUIDATION).

Notice is hereby given that a Final Meeting of the above Company will be held at 9 Stanley Street, Brighton on the 7th day of June, 1975 at 4.30 p.m. for the purpose of receiving an Account showing how the winding up has been conducted and the property of the Company disposed of.

Dated this 7th day of May, 1975.

H. A. HANSEN, Liquidator.

Greenfield, Fox, Hansen & Co., 161 Fitzroy Street, St. Kilda, 3182. 4822

Form 7.

Companies Act 1961, Section 21 (2), Sections 26 (1) (2) and 146 (1), Section 28 (9), Section 146 (1), and Section 254 (2).

THE BENDIGO ARCADE COMPANY LIMITED.

NOTICE OF RESOLUTION.

To The Commissioner for Corporate Affairs.

At a general meeting of the members of THE BENDIGO ARCADE COMPANY LIMITED duly convened and held at 431 McIvor Road Bendigo on the Twentysixth day of April 1975 the Special Resolution set out below in the annexure marked with the letter "A" and signed by me for purposes of identification was duly passed—
Annexure marked "A".

"That as the Bendigo Arcade Company Limited has now ceased all business operations and that most of the assets have now been realised into liquid form and are

immediately sufficient to meet any liabilities, that the Members enter into voluntary winding up of the Company in accordance with the Companies Act 1961 and as amended, and for this purpose Mr. Donald Charles Washington, Public Accountant of Victoria Lane, Pall Mall, Bendigo, be appointed Liquidator for the purpose of winding up the Company."

Dated this 26th day of April, 1975.

4825 W. H. BEISCHER, Director.

Companies Act 1961.

GEOFF BADE CASUALS PROPRIETARY LIMITED.

Notice is hereby given that at a General Meeting of Members of the above-named Company duly convened and held at 201 Balaclava Road, Caulfield on the 30th April, 1975, the following special resolution was duly passed:

1. That the Company be wound up voluntarily.
2. That Mr. Nathan Woodrow Gluck of 201 Balaclava Road, Caulfield, be and is hereby appointed Liquidator of the Company.
3. That pursuant to Section 269 of the Companies Act 1961 the Liquidator be authorised to exercise any of the powers given by virtue of paragraphs (b), (c) and (d) of Sub-Section (1) of Section 236 of the Companies Act 1961 to a Liquidator in a winding up by the Court.
4. That the Liquidator be entitled to remuneration in accordance with the scales laid down by The Institute of Chartered Accountants in Australia.

Dated this 30th day of April, 1975.

4826 N. W. GLUCK, Liquidator.

In the Supreme Court of Victoria.—1975 No. Co. 9052.—
In the matter of the Companies Act 1961; and in the matter of ACORTAR PROPRIETARY LIMITED.

NOTICE is hereby given that a Petition for the winding up of the abovenamed company by the Supreme Court was, on the 23rd day of April 1975, presented by Lensworth Finance (Vic.) Pty. Ltd. and that the said Petition is directed to be heard before the Court sitting at Melbourne at the hour of 10.30 o'clock in the forenoon, on Tuesday the 3rd day of June 1975; and any creditor or contributory of the said company desiring to support or oppose the making of an order on the said Petition may appear at the time of hearing by himself or his Counsel for that purpose; and a copy of the Petition will be furnished to any creditor or contributory of the said company requiring the same by the undersigned on payment of a regulated charge for the same.

The petitioner's address is 176 Queen Street, Melbourne.

The petitioner's solicitors are Messrs. Arnold Bloch, Leibler & Co. of 324 Little Lonsdale Street, Melbourne.

ARNOLD BLOCH, LEIBLER & CO., solicitors for the Petitioner.

NOTE.—Any person who intends to appear on the hearing of the said Petition must serve on or send by post to the abovenamed solicitors notice in writing of his intention so to do. The notice must state the name and address of the person, or, if a firm, the name and address of the firm, and must be signed by the person or firm, or his or their solicitor (if any), and must be served, or, if posted, must be sent by post in sufficient time to reach the abovenamed not later than 4 o'clock in the afternoon of the 2nd day of June 1975. 4827

The Companies Act 1961.—In the matter of WINNIPEG INVESTMENTS PROPRIETARY LIMITED (in Liquidation).

Notice is hereby given that pursuant to Section 272 of the Companies Act 1961 a Final Meeting of the Members of the above Company will be held at the office of H. Guest & Associates Pty. Ltd., 207B Balaclava Road, Caulfield, on Tuesday the 3rd day of June, 1975 at 10.00 a.m.

Business: To receive the Liquidator's Accounts.

—Dated this 1st day of May, 1975.

4828 J. DURLACHER, Liquidator.

Companies Act 1961.—In the matter of PREMIER BILLIARD TABLES PTY. LTD., Lot 12, Burgess Road, North Bayswater.

NOTICE is hereby given that at an extraordinary Meeting of the Members of the abovenamed Company held on the 21st March, 1975 it was resolved that the Company be wound up voluntarily and at a Meeting of Creditors held on the same day pursuant to Section 260, it was resolved that for such purpose DENNIS JOHN COUGLE, Suite 18, 545 St. Kilda Road, Melbourne, be appointed Liquidator.

NOTICE is also given that after twenty one days from this date, I will proceed to distribute the assets. All creditors having claims against the Company should furnish particulars of same by that date, otherwise I will proceed to distribute the assets without regard to their claim.

Dated this 2nd day of May, 1975.

D. J. COUGLE, Liquidator.

Bent & Cogle, suite 18, 545 St. Kilda Road, Melbourne. 4849

The Companies Act 1961.

YOORANA INVESTMENTS PTY. LTD. (IN VOLUNTARY LIQUIDATION).—Members' Winding up.

At an Extraordinary General Meeting of the members of the abovenamed Company, held at 209 Hare Street, Echuca on the 1st day of May, 1975, it was resolved that the Company be wound up voluntarily, and that Charles Edward Dawborn of 209 Hare Street, Echuca be appointed liquidator.

Dated this 1st day of May, 1975.

4863 C. E. DAWBORN, Liquidator.

The Companies Act 1961.

A.M.I. (NEW SOUTH WALES) PROPRIETARY LIMITED (IN VOLUNTARY LIQUIDATION).

PURSUANT TO SECTIONS 254 AND 258.

At an Extraordinary General Meeting of the Shareholders of A.M.I. (New South Wales) Proprietary Limited convened and held at 155 Bertie Street, Port Melbourne on the 29th April 1975, the following Special Resolution was duly passed:—

"That the Company be wound up voluntarily in accordance with the *Companies Act 1961*, and that Robert Frederick Hogan, Chartered Accountant of 9th Floor, 461 Bourke Street, Melbourne, be appointed liquidator of the Company, at a fee to be calculated in accordance with the rates recommended by the Institute of Chartered Accountants in Australia."

4936 K. R. HOUGHAM, Director.

The Companies Act 1961.

A.M.I. (SOUTH AUSTRALIA) PROPRIETARY LIMITED (IN VOLUNTARY LIQUIDATION).

PURSUANT TO SECTIONS 254 AND 258.

At an Extraordinary General Meeting of the Shareholders of A.M.I. (South Australia) Proprietary Limited convened and held at 155 Bertie Street, Port Melbourne on the 29th April 1975, the following Special Resolution was duly passed:—

"That the Company be wound up voluntarily in accordance with the *Companies Act 1961*, and that Robert Frederick Hogan, Chartered Accountant of 9th Floor, 461 Bourke Street, Melbourne, be appointed liquidator of the Company, at a fee to be calculated in accordance with the rates recommended by the Institute of Chartered Accountants in Australia."

4937 K. R. HOUGHAM, Director.

The Companies Act 1961.

BRIGHTON BEACH MOTORS (WHOLESALE) PROPRIETARY LIMITED (IN VOLUNTARY LIQUIDATION).

PURSUANT TO SECTIONS 254 AND 258.

At an Extraordinary General Meeting of the Shareholders of Brighton Beach Motors (Wholesale) Proprietary Limited convened and held at 155 Bertie Street, Port Melbourne on the 29th April 1975, the following Special Resolution was duly passed:—

"That the Company be wound up voluntarily in accordance with the *Companies Act 1961*, and that Robert Frederick Hogan, Chartered Accountant of 9th Floor, 461 Bourke Street, Melbourne, be appointed liquidator of the Company, at a fee to be calculated in accordance with the rates recommended by the Institute of Chartered Accountants in Australia."

4938 K. R. HOUGHAM, Director.

Companies Act 1961, Section 259.—In the matter of DAVID DEANE MANUFACTURING Co. PTY. LTD. (in Liquidation).

NOTICE is hereby given that at a Meeting of Creditors held on the 30th April, 1975 pursuant to Section 259, it was resolved that EVERETT THOMSON BENT of Suite 18, 545 St. Kilda Road, Melbourne, Public Accountant, be appointed Liquidator.

NOTICE is hereby given that after twenty-one days from this date I shall proceed to distribute the assets.

No. 33.—3770/75.—5

All creditors having any claims against the Company should furnish particulars of same by that date, otherwise I shall proceed to distribute the assets without regard to their claim.

Dated this 1st day of May, 1975.

E. T. BENT, Liquidator.

Bent & Cogle, public accountants, Suite 18, 545 St. Kilda Road, Melbourne, 3004. 4824

The Companies Act 1961.

STANDARD CARS (NORTH SHORE) PROPRIETARY LIMITED (IN VOLUNTARY LIQUIDATION).

PURSUANT TO SECTIONS 254 AND 258.

At an Extraordinary General Meeting of the Shareholders of Standard Cars (North Shore) Proprietary Limited convened and held at 155 Bertie Street, Port Melbourne on the 29th April 1975, the following Special Resolution was duly passed:—

"That the Company be wound up voluntarily in accordance with the *Companies Act 1961*, and that Robert Frederick Hogan, Chartered Accountant of 9th Floor, 461 Bourke Street, Melbourne, be appointed liquidator of the Company, at a fee to be calculated in accordance with the rates recommended by the Institute of Chartered Accountants in Australia."

4939 K. R. HOUGHAM, Director.

The Companies Act 1961.

RICKARDS BROTHERS PROPRIETARY LIMITED (IN VOLUNTARY LIQUIDATION).

PURSUANT TO SECTIONS 254 AND 258.

At an Extraordinary General Meeting of the Shareholders of Rickards Brothers Proprietary Limited convened and held at 155 Bertie Street, Port Melbourne on the 29th April 1975, the following Special Resolution was duly passed:—

"That the Company be wound up voluntarily in accordance with the *Companies Act 1961*, and that Robert Frederick Hogan, Chartered Accountant of 9th Floor, 461 Bourke Street, Melbourne, be appointed liquidator of the Company, at a fee to be calculated in accordance with the rates recommended by the Institute of Chartered Accountants in Australia."

4940 K. R. HOUGHAM, Director.

NOVALAN PTY. LTD.

NOTICE OF RESOLUTION.

Notice is hereby given that at a General Meeting of the members of NOVALAN PTY. LTD. duly convened and held at WANGARATTA on the 24th April, 1975 the special resolution set out below was duly passed.

"That the Company be wound up voluntarily and that Francis Archibald Ballantine, Chartered Accountant of 94 Murphy Street, Wangaratta be appointed Liquidator for the purpose of winding up.

4921 V. F. MOYLE, Secretary.

In the Supreme Court of Victoria.—Co. 9046.—In the matter of the *Companies Act 1961*; and in the matter of SQUASHWAY PROPRIETARY LIMITED.

Notice is hereby given that a petition for the winding up of the abovenamed company by the Supreme Court, was on the 17th day of April 1975, presented by Adam Marshall Johnstone (an infant by his next friend Adrienne Wendy Johnstone). And that the said petition is directed to be heard before the Court sitting at the 14th Court, Law Courts, William Street, Melbourne at the hour of 10.30 o'clock in the forenoon on the 6th day of June 1975; and any creditor or contributory of the said company desiring to support or oppose the making of an order on the said petition may appear at the time of hearing by himself or his counsel for that purpose; and a copy of the petition will be furnished to any creditor or contributory of the said company requiring the same by the undersigned on payment of the regulated charge for the same. The Petitioner's address is 42A Black Street, Middle Brighton. The Petitioner's solicitor is Mr. Ivan Lindsay McDonald of 136 Balcombe Road, Mentone.

IVAN L. McDONALD, solicitor for the petitioner.

NOTE.—Any person who intends to appear on the hearing of the said petition must serve on or send by post to the abovenamed Ivan Lindsay McDonald, notice in writing of his intention so to do. The notice must state the name and address of the person, or, if a firm, the name and address of the firm, and must be signed by the person or firm, or his or their solicitor (if any), and must be served, or, if posted, must be sent by post in sufficient time to reach the abovenamed not later than four o'clock in the afternoon of the 5th day of June, 1975. 4924

Companies Act 1961, Section 272 (3) (4).

A. W. & A. M. ARCHER PROPRIETARY LIMITED (IN LIQUIDATION).

Notice is hereby given that a final meeting of the Company and the Creditors for the purpose of laying before it the account pursuant to Section 272 of the *Companies Act 1961* shall be held at 42 Beach Street Frankston on the Thirtieth May 1975.

BETTY G. MEAGHER, public accountant, Box 113, Mt. Eliza. 4926

Companies Act 1961.—In the matter of EMPEE SUPPLIES LIMITED.—Notice of Meeting of Creditors, Pursuant to Section 260.

NOTICE is hereby given that a meeting of creditors of the abovenamed company will be held at the National Mutual Theatre, Concourse Level, 447 Collins Street, Melbourne, on Friday, 30th May, 1975, at 11.00 A.M. the company having convened an extraordinary general meeting of its members for the same day for the purpose of considering a Special Resolution that the company be wound up voluntarily.

Dated this 6th day of May, 1975.

S. M. GILMOUR, Director.

Lewis Luckins & Co., chartered accountants, 423 Bourke Street, Melbourne, 3000. Telephone 67 6944. 4933

In the matter of the *Companies Act 1961*; and in the matter of MCDONAGH PTY. LTD. (in Voluntary Liquidation).—Notice of Intention to Declare.—Final Dividend.

Take Notice that a FINAL DIVIDEND is to be declared in the above matter and if you do not establish your claim to my satisfaction on or before 26th day of May, 1975, your claim will be expunged and I shall proceed to make a final dividend without regard to such claim.

Dated at Sydney, 1st day of May, 1975.

NORMAN A. S. BROWNE, F.C.A., Liquidator.

Care of Thew & Browne, 309 Conadilly Street, Gunnedah 2380, N.S.W., P.O. Box 70, Gunnedah, 2380, N.S.W. 4941

Form 92.

Companies Act 1961.—In the matter of GEVON PLUMBING SUPPLIES PTY. LTD., GEVON TRADING PTY. LTD., GEVON WHOLESALE BUILDING SUPPLIES PTY. LTD., GEVON TIMBER SALES PTY. LTD.—Notice of Meetings of Creditors, Pursuant to Section 260.

Notice is hereby given that a meeting of creditors of the abovenamed companies will be held in the Theatre, Lower Ground Floor, National Mutual Building, 447 Collins Street, Melbourne on Friday, 16th May 1975 at the times specified below, the companies having convened separate meetings of their members to be held on the same day and for the purpose of considering special resolutions that the companies be wound up voluntarily.

Times which meetings will be held.

2.00 p.m. Gevon Trading Pty. Ltd.

2.30 p.m. Gevon Plumbing Supplies Pty. Ltd.

3.00 p.m. Gevon Wholesale Building Supplies Pty. Ltd.

3.30 p.m. Gevon Timber Sales Pty. Ltd.

Dated this 7th day of May, 1975.

G. FORD, Director.

Peat, Marwick, Mitchell & Co., 447 Collins Street, Melbourne, 3000. 4934

Companies Act 1961, Section 254 (2) (b)

SANDERSON MOTOR COMPANY PROPRIETARY LIMITED.

NOTICE IS HEREBY given that at an Extraordinary General Meeting of the members of the abovenamed company held on the 21st day of April 1975, it was resolved that the company be wound up voluntarily and that James Manson Poulton and David Alexander Crawford of Messrs. Peat, Marwick, Mitchell & Co., 447 Collins Street, Melbourne, be appointed Joint and Several Liquidators.

Notice is also given that after 21 days from this date we shall proceed to distribute the assets. All creditors having any claims against the company should furnish particulars of same by that date, otherwise we shall proceed to distribute the assets without regard to their claim.

Dated this 2nd day of May, 1975.

J. M. POULTON and D. A. CRAWFORD, Joint and Several Liquidators.

Peat, Marwick, Mitchell & Co., 447 Collins Street, Melbourne, 3000. 4935

CREDITORS NEXT OF KIN and others having claims in respect of the Estate of EUNICE VERA SMITH late of 12 Rose Street Gardenvale Widow deceased who died on the 29th day of November 1974 are required by NATIONAL TRUSTEES EXECUTORS AND AGENCY COMPANY OF AUSTRALASIA LIMITED of 95 Queen Street Melbourne to send particulars to this Company by the 14th day of July 1975 after which date it will distribute the assets having regard only to the claims of which it has then had notice.

D. L. McNAMARA, solicitor, 19 Gray Street, St. Kilda.

4877

CREDITORS next of kin and others having claims in respect of the Estate of STELLA DOUZIE GILLET late of Tasma Court Private Hotel, 777 Esplanade Mornington Spinster deceased who died on the 28th day of October 1973 are to SEND particulars of their claims to THE TRUSTEES EXECUTORS AND AGENCY COMPANY LIMITED of 401 Collins Street Melbourne by the 8th day of July 1975 after which date it will distribute the assets having regard only to the claims of which it then has notice.

MACPHERSON ROBINSON & CO., solicitors, 178 Queen Street, Melbourne. 4880

ETHEL MAY MILLS, late of Kerang, in the State of Victoria, widow, DECEASED.

CREDITORS next-of-kin and all other persons having claims against the Estate of the said Deceased are required by ARTHUR HERBERT MILLS of Kerang Grazier and REGINALD KEITH MILLS of 87 Bendigo Road Kerang Farmer the Executors of the Estate of the said Deceased to send particulars of such claims to them in care of the undermentioned Solicitors on or before the second day of July 1975 after which date they will distribute the assets having regard only to the claims of which they then have notice.

BASILE & CO., barristers & solicitors, 46 Wellington Street, Kerang. 4881

CREDITORS next-of-kin and others having claims in respect of the Estate of MAVIS GWENDOLYN HUNTLEY late of 3 Mill Street Donald Widow deceased who died on the 8th day of February 1975 are required by the Executors BRIAN DAVID COULTER of 18 Carolyn Crescent Bundoora Accountant and DAVID RUSSELL COULTER of 8 Disney Street West Heidelberg Fireman both in the State of Victoria to send particulars of such claims to the said Executors care of the office of HEFFEY & BUTLER of 258 Little Bourke Street Melbourne Solicitors by the 11th day of June 1975 after which date the said Executors will distribute the assets having regard only to the claims of which they then have notice.

HEFFEY & BUTLER, solicitors, 258 Little Bourke Street, Melbourne. 4883

ESTHER ROSE VICTORIA BOTHWELL, late of 44 Ann Street, Dandenong, spinster, DECEASED.

Creditors next-of-kin and others having claims in respect of the estate of the said deceased who died on the 5th February 1975 are required by the Executor of her Will namely THE PERPETUAL EXECUTORS AND TRUSTEES ASSOCIATION OF AUSTRALIA LIMITED of 50 Queen Street Melbourne to send particulars of their claims to the said Company by the 3rd July 1975 after which date it will distribute the assets in the said estate having regard only to the claims of which it then has notice.

W. B. & O. McCUTCHEON, solicitors, 150 Queen Street, Melbourne. 4884

MAUD ELEANOR HAMILTON, formerly of 40 Thanet Street, Malvern, but late of Carnsworth-Garopna Home for the Aged, 18 Barry Street, Kew, almoner, DECEASED.

Creditors next-of-kin and others having claims in respect of the Estate of the said deceased who died on the 22nd December 1974 are to send particulars of their CLAIMS to the Executor of her Will namely THE TRUSTEES EXECUTORS AND AGENCY COMPANY LIMITED at 401 Collins Street Melbourne by the 3rd July 1975 after which date the said Executor will distribute the assets in the said Estate having regard only to the claims of which it then has notice.

W. B. & O. McCUTCHEON, solicitors, 150 Queen Street, Melbourne. 4885

CREDITORS NEXT OF KIN AND OTHERS having claims in respect of the estate of JAMES HENRY TILL late of 84 Riversdale Road Hawthorn Retired Deceased who died on the 11th March, 1975 are to send particulars of their claims to the Executor JOHN IMMANUEL ROBERTS care

of the undermentioned Solicitors by the 30th day of July, 1975 AFTER WHICH DATE the Executor will distribute the assets having regard only to the claims of which he then has notice.

RODDA, BALLARD & VROLAND, solicitors, 695 Burke Road, Camberwell. 4899

CREDITORS next of kin and others having claims in respect of the Estate of ELLEN ANNIE MILLER late of 569 Neerim Road, Oakleigh in the State of Victoria, Widow, deceased who died on 21st day of September, 1974 and Probate of whose Will has been granted to THE TRUSTEES EXECUTORS AND AGENCY COMPANY LIMITED of 401 Collins Street, Melbourne in the said State the sole Executor named therein are required to send particulars of their claims to the Executor at its address hereinbefore set out by the 8th day of July, 1975 after which date it will distribute the assets having regard only to the claims of which it then has notice.

HALL & WILCOX, solicitors, 20 Queen Street, Melbourne. 4900

CREDITORS Next of Kin and others having claims in respect of the estate of JEAN MARY MCKAY late of 14 Townsend Street, Ivanhoe Retired Nursing Sister deceased who died on the 4th day of November 1974 are to send particulars of their claims to THE TRUSTEES EXECUTORS AND AGENCY COMPANY LIMITED of 401 Collins Street Melbourne by the 11th day of July 1975 after which date the said Company will distribute the assets having regard only to the claims of which it then has notice.

LYNCH & MACDONALD, solicitors, of 118 Queen Street, Melbourne. 4901

MARCUS WILLIAM MOODIE, late of "Nigretta East", Hamilton, grazier, DECEASED.

Creditors next of kin and others having claims in respect of the estate of the abovenamed who died on the 2nd day of May 1974 are required to send particulars of their claims in writing to THE EQUITY TRUSTEES EXECUTORS AND AGENCY COMPANY LIMITED of 472 Bourke Street Melbourne by the 10th day of July 1975 after which date the executors of deceased's will the said THE EQUITY TRUSTEES EXECUTORS AND AGENCY COMPANY LIMITED, DAVID HUGH MOODIE of "Wandurah" Hamilton Grazier and ANNIE LAVINIA MACKINNON of "Kaladbro" Strathdownie Married Woman will distribute the assets having regard only to the claims of which they then have notice.

HULL, NEWNS & BALLANTYNE, solicitors, 58 Gray Street, Hamilton. 4791

Creditors, Next of Kin and others having claims against the estate of VICTOR JAMES SEYMOUR late of Moutajup in Victoria Grazier deceased who died on the Eleventh day of February One thousand nine hundred and seventy-three and Probate of whose Will was granted by the Supreme Court on the Third day of July One thousand nine hundred and seventy-three to LEONARD MIBUS of 49 Cape Nelson Road Portland in Victoria Grazier are required to send particulars in writing of such claims to the said LEONARD MIBUS care of Silvester & Silvester, Solicitors Casterton on or before the Eighteenth day of July One thousand nine hundred and seventy-five after which date the said LEONARD MIBUS will proceed to distribute the assets and estate of the said VICTOR JAMES SEYMOUR deceased amongst the persons entitled thereto having regard only to claims of which he shall then have had notice.

SILVESTER & SILVESTER, solicitors, Casterton. 4792

JOHN IWAN LOTYSZ, late of 62 Gordon Street, Newport, Victoria, driver, DECEASED, intestate.

Creditors, next of Kin and others having claims in respect of the Estate of the deceased who died on 22nd September, 1973 are required by the Administratrix ANNA LOTYSZ of 62 Gordon Street aforesaid Widow to send particulars of their claims to her C/- the undermentioned Solicitors on or before 15th July 1975 after which date the administratrix will distribute the assets having regard only to the claims of which she shall then have notice.

T. A. RANK & ROBINSON, solicitors, 388 Bourke Street, Melbourne. 4793

ANNIE DOROTHY DANGER, late of 152 West Fyans Street, Newtown, textile worker, DECEASED, intestate.

Creditors, next of kin, and others having claims in respect of the estate of the deceased, who died on the 21st December 1974, are required by the applicant for grant of administration, CHARLES ALBERT DANGER, of

29 Daisy Street, Newtown, Cabinet maker, to send particulars to him, care of the undermentioned solicitors, by the 30th day of June, 1975, after which date he may convey or distribute the assets, having regard only to the claims of which he then has notice.

FALLAW & HENDERSON, solicitors, 24 Ryrie Street, Geelong. 4804

GEORGE ERIC TREWIN DARBYSHIRE, late of Lake Boga, in the State of Victoria, farmer, DECEASED (who died on 19th December, 1974).

CREDITORS next-of-kin and all other persons having claims against the Estate of the deceased are required by the Executors of the Will, RUBY DARBYSHIRE and GEORGE IRWIN TREWIN DARBYSHIRE, to send particulars to them care of the undersigned on or before the 30th day of July 1975 after which date they will distribute the assets having regard only to the claims of which they then have notice.

GARDEN & GREEN, solicitors, 4 McCallum Street, Swan Hill. 4805

CREDITORS next of kin and others having claims against the estate of ATHOL RAYMOND QUINN late of 53 Wood Street Long Gully in the State of Victoria Pensioner deceased who died on the Thirtieth day of December 1974 are required to send particulars thereof to NATIONAL TRUSTEES EXECUTORS AND AGENCY COMPANY OF AUSTRALASIA LIMITED of 95 Queen Street Melbourne and 46 Queen Street Bendigo in the said State by the First day of July 1975 after which date the said Company will distribute the assets of the said deceased having regard only to the claims of which it then has notice.

WATSON JAMES & ROGERS, solicitors, 61 Bull Street, Bendigo. 4806

THOMAS EDWARD CONROY, late of 3 Evandale Road, Malvern, in the State of Victoria, retired machine worker, DECEASED.

CREDITORS NEXT OF KIN AND OTHERS having claims in respect of the estate of the deceased who died on the 4th February, 1975 are required by the personal representative HENRY EDWARD HAND of 95 Bridge Street, Benalla West Retired Quarry Manager to SEND PARTICULARS to him care of the undersigned solicitor by the 7th July, 1975 after which date the personal representative may convey or distribute the assets, having regard only to the claims of which he then has notice.

VERA A. FOWLER, solicitor, 1 Evandale Road, Malvern, 3144. 4807

CREDITORS, next of kin and others having claims against the estate of JEAN ISLA POWER RANKIN late of 13 Palmer Street, Ararat Spinster deceased intestate (who died on the twentieth day of September 1974) are to send particulars of their claims to THE UNION-FIDELITY TRUSTEE COMPANY OF AUSTRALIA LIMITED of 101 Lydiard Street North, Ballarat by the ninth day of July 1975 after which date it will distribute the assets, having regard only to the claims of which it then has notice.

GRANO & McCARTHY, solicitors, Ararat. 4808

CREDITORS next of kin and others having claims in respect of the ESTATE OF ISABELLA TOMLINSON DUNLOP late of 10 Athol Avenue Canterbury Spinster deceased who died on the 9th May, 1947, are to send particulars of their claims to the Executors LELINE ANGELA BURNS and ANDREW RICHARD BURNS care of the undersigned by the 15th day of July, 1975, after which date they will commence to distribute the assets having regard only to the claims to which they then have notice.

RENNICK & GAYNOR, solicitors, 481 Riversdale Road, Hawthorn East. 4931

GORDON CARLE DE GRUCHY, late of Flat 63, 46 Lansell Road, Toorak, professor of medicine, DECEASED.

Creditors next of kin and others having claim in respect of the estate of the abovenamed deceased who died on 13th day of October 1974 are required by the executors NATIONAL TRUSTEES EXECUTORS AND AGENCY COMPANY OF AUSTRALASIA LIMITED and DENISE MARIE DE GRUCHY to send particulars of their claims to them care of NATIONAL TRUSTEES EXECUTORS AND AGENCY COMPANY OF AUSTRALASIA LIMITED 95 Queen Street, Melbourne on or before the 10th day of

July 1975 after which date the executors may convey or distribute the assets having regard only to the claims of which they then have notice.

KIERNAN AND FORREST, solicitors, of 100 Queen street, Melbourne. 4810

CREDITORS Next-of-Kin and others having claims in respect of the estate of CECIL ADDISON FISHER late of 33 Koornalla Street, East Newborough in the State of Victoria Boiler Maker Welder deceased who died on the fourth day of February, One thousand nine hundred and seventy-five are to send the particulars of their claims to the Administratrix EVELYN MAY FISHER C/- the undermentioned Solicitors prior to the 1st day of July, 1975 after which date the said Administratrix will distribute the assets of the deceased having regard only to the claims of which she shall have Notice.

KEVIN DAVINE & SONS, solicitors, Contingent Street, Trafalgar. 4811

KARLIS TERAUDS, late of 11 Venice Court, Glen Waverley, Victoria, fitter, DECEASED, intestate.

TAKE NOTICE that BEATRICE DAGMARA TERAUDS of 11 Venice Court Glen Waverley Victoria, Widow, the Administratrix of the estate of the deceased who died on the 22nd day of December 1974 requires all creditors next of kin and others having claims against the property of estate of the said deceased to send to her care of the undermentioned Solicitors on or before the 10th August 1975 particulars in writing of such claims after which date the said Administratrix intends to convey or distribute such property or estate to or among the persons entitled thereto having regard only to the claims of which she shall have had notice.

Dated this 2nd day of May 1975.

KAHN AND CLAHR, solicitors, 213 Lonsdale Street, Melbourne, 3000. 4812

Creditors, Next of Kin and others having claims against the estate of MARTIN CROWE late of Coleraine Road Casterton Retired Farmer deceased Intestate who died on the First day of August One thousand nine hundred and seventy-four and Letters of Administration of whose estate was granted by the Supreme Court on the Eighteenth day of April One thousand nine hundred and seventy-five to THE UNION FIDELITY TRUSTEE COMPANY OF AUSTRALIA LIMITED of 100 Exhibition Street Melbourne are required to send particulars in writing of such claims to the said THE UNION FIDELITY TRUSTEE COMPANY OF AUSTRALIA LIMITED at the Company's above-mentioned address on or before the Thirtieth day of June One thousand nine hundred and seventy-five after which date the Administrator will proceed to distribute the assets of the said MARTIN CROWE deceased which shall have come to the Administrators hands amongst the persons entitled thereto having regard to the claims of which the Administrator shall then have had notice.

SILVESTER & SILVESTER, solicitors, Casterton. 4848

FRANK JAMES FISHER, late of 22 Josephine Grove, Preston, commissionaire, DECEASED.

Creditors next of kin and others having claims in respect of the estate of the deceased who died on the Fourteenth day of September 1974 are required by THE EQUITY TRUSTEES EXECUTORS AND AGENCY COMPANY LIMITED of 472 Bourke Street Melbourne to send particulars of their claims to the said Company by the Eleventh day of July 1975 after which date it will convey or distribute the assets having regard only to the claims of which it then has notice.

H. S. W. LAWSON HUGHES & CO., solicitors, 357 Little Collins Street, Melbourne. 4923

In the will of LILLIAN (in the will called Lilian) ZOLA SEPPING JANSON, late of 34 Arcadia Street, Merrylands, in the State of New South Wales, spinster, DECEASED.

CREDITORS next-of-kin and others having claims in respect of the Estate of the abovenamed deceased (who died on the 21st day of November 1974) are required by the executor ROBERT SEPPING JANSON of 34 Arcadia Street, Merrylands in the State of New South Wales Apiarist to send particulars of their claims to him care of the undermentioned Solicitors by the 14th day of July 1975 after which date he will distribute the assets having regard only to the claims of which he then shall have notice.

ATTKEN, WALKER & STRACHAN, solicitors, of 414 Collins Street, Melbourne. 4926

CREDITORS, next of kin and others having claims in respect of the Estate of WILLIAM ALBERT LEWIS late of Timaru in New Zealand Company Manager deceased (who died on the Seventeenth day of March 1973), are required to send particulars of their claims to NATIONAL TRUSTEES EXECUTORS AND AGENCY COMPANY OF AUSTRALASIA LIMITED of 95 Queen Street Melbourne in Victoria by the Ninth day of July 1975, after which date the said Company will distribute the assets having regard only to the claims of which it then has notice.

GILLOTT MOIR & WINNEKE, solicitors, 500 Collins Street, Melbourne, 3000. 4930

EMILY JOYCE ROLLO, late of Dixie Road, Terang, farmer, DECEASED.

CREDITORS next of kin and others having claims in respect of the Estate of the deceased who died on the Twentieth day of August 1974 are required by The Union-Fidelity Trustee Company of Australia Limited of 100 Exhibition Street, Melbourne the Applicant for a grant of administration to send particulars of their claims to the said Company by the 9th day of July 1975 after which date it will convey or distribute the assets having regard only to the claims of which it then has notice.

ARTHUR E. GEORGE & SONS, solicitors, 202 Manifold Street, Camperdown. 4809

CREDITORS NEXT-OF-KIN AND OTHERS having claims in respect of the Estate of ERICK OTTO OHRBERG late of Gwelph Street Somerville Retired Nurseryman deceased who died on the 3rd of December 1974 are to send particulars of their claims to THE TRUSTEES EXECUTORS AND AGENCY COMPANY LIMITED of 401 Collins Street Melbourne by the 10th day of July, 1975 after which date it will distribute the assets having regard only to the claims of which it then has notice.

COOK & McCALLUM, solicitors, 422 Collins Street, Melbourne. 4932

CHARLES BRYAN MATHIESON, late of 28A Pritchard Street, Swan Hill, in the State of Victoria, school teacher, DECEASED, (who died on 25th January, 1975).

CREDITORS next-of-kin and all other persons having claims against the Estate of the deceased are required by the Executors of the Will, ELIZABETH LORRAINE MATHIESON, CHARLES MATHIESON and ROBERT OLAF COLVILLE, to send particulars to them care of the undersigned on or before the 2nd day of August, 1975 after which date they will distribute the assets having regard only to the claims of which they then have notice.

GARDEN & GREEN, solicitors, 4 McCallum Street, Swan Hill. 4859

HERBERT JOHN FLETCHER, late of 57 Gray Street, Swan Hill, in the State of Victoria, labourer, DECEASED (who died on 7th March, 1975).

CREDITORS next-of-kin and all other persons having claims against the Estate of the deceased are required by the Executors of the Will, DORIS JEAN FLETCHER and REGINALD FRANCIS RUNCIMAN, to send particulars to them care of the undersigned on or before the 2nd day of August, 1975 after which date they will distribute the assets having regard only to the claims of which they then have notice.

GARDEN & GREEN, solicitors, 4 McCallum Street, Swan Hill. 4860

CREDITORS next of kin and others having claims in respect of the estate of LOCKSLEY BROOK late of 62 Coleraine Road Hamilton in the State of Victoria Retired Salesman deceased who died on the 31st day of December 1974 are to send the particulars of their claims to THE UNION-FIDELITY TRUSTEE COMPANY OF AUSTRALIA LIMITED of 100 Exhibition Street Melbourne by the 14th day of July 1975 after which date it will distribute the assets having regard only to the claims of which it then has notice.

HULL, NEWNS & BALLANTYNE, solicitors, 58 Gray Street, Hamilton. 4862

PURSUANT to the Trustee Act 1958 notice is hereby given that all persons having claims against the estate of MAX ODELL late of 42 Kooyong Road, Caulfield in the State of Victoria, Company Director, deceased who died on the 13th day of June, 1973 and Probate of whose Will was granted by the Supreme Court of the said State in its Probate Jurisdiction on the 22nd day of July, 1974 to FAY ODELL of 42 Kooyong Road, Caulfield in the said State, Widow and MORRIS SOLOMON ODELL formerly of 373 Alma Road, Caulfield but now of 42 Kooyong Road, Caulfield in the said State, Company

Director, are hereby required to send particulars in writing of such claims to the said Fay Odell and the said Morris Solomon Odell at their abovementioned address (or to the undersigned at their office hereunder mentioned) on or before the 11th day of July, 1975 after which date the said Fay Odell and the said Morris Solomon Odell will proceed to distribute the assets of the said Max Odell deceased which shall come to their hands amongst the persons entitled thereto having regard only to the claims of which they shall then have had notice. AND notice is hereby further given that the said Fay Odell and the said Morris Solomon Odell will not be liable for the assets so distributed or any part thereof to any person of whose claim they shall not have had notice as aforesaid.

Dated the 7th day of May, 1975.

RIVERS, DICKINSON, STIRLING & MUNZ, solicitors
of 17 Queen Street, Melbourne, 3000. 4872

PURSUANT to the Trustee Act 1958 notice is hereby given that all persons having claims against the estate of MAX KESTENBERG formerly of 393 Chapel Street, South Yarra but late of 19 Khartoum Street, North Caulfield in the State of Victoria, Watch Maker, deceased, who died on the 1st day of November, 1973 and Probate of whose Will was granted by the Supreme Court of the said State in its Probate Jurisdiction on the 14th day of March, 1975 to FRANIA KESTENBERG of 19 Khartoum Street, North Caulfield in the said State, Widow, are hereby required to send particulars in writing of such claims to the said Frania Kestenberg at her abovementioned address (or to the undersigned at their office hereunder mentioned) on or before the 11th day of July, 1975 after which date the said Frania Kestenberg will proceed to distribute the assets of the said Max Kestenberg deceased which shall come to her hands amongst the persons entitled thereto having regard only to the claims of which she shall then have had notice. AND notice is hereby further given that the said Frania Kestenberg will not be liable for the assets so distributed or any part thereof to any person of whose claim she shall not have had notice as aforesaid.

Dated the 7th day of May, 1975.

RIVERS, DICKINSON, STIRLING & MUNZ, solicitors
of 17 Queen Street, Melbourne, 3000. 4873

PURSUANT to the Trustee Act 1958 notice is hereby given that all persons having claims against the estate of ERNEST RICHARDS late of 23 First Avenue, Kew in the State of Victoria, Retired Manager, deceased who died on the 15th day of August, 1974 and Probate of whose Will was granted by the Supreme Court of the said State in its Probate Jurisdiction on the 6th day of March, 1975 to ERNEST HAROLD RICHARDS of 30 The Strand, Williamstown in the said State, Gentleman, are hereby required to send particulars in writing of such claims to the said Ernest Harold Richards at his above-mentioned address (or to the undersigned at their office hereunder mentioned) on or before the 11th day of July, 1975 after which date the said Ernest Harold Richards will proceed to distribute the assets of the said Ernest Richards deceased which shall come to his hands amongst the persons entitled thereto having regard only to the claims of which he shall then have had notice.

AND notice is hereby further given that the said Ernest Harold Richards will not be liable for the assets so distributed or any part thereof to any person of whose claim he shall not have had notice as aforesaid.

Dated the 7th day of May, 1975.

RIVERS, DICKINSON, STIRLING & MUNZ, solicitors, of
17 Queen Street, Melbourne, 3000. 4875

ERNEST LONGTON, late of 12 Dickens Street, Pascoe Vale South, in the State of Victoria, mailing officer, DECEASED.

Creditors next of kin and others having claims in respect of the estate of the deceased who died on the 24th day of June, 1974 are required by the executor REUBEN LONGTON of 34 Murray Street, Fawkner in the said State, Gardener, to send particulars to him care of the solicitors for the estate, Messrs. Rivers Dickinson Stirling & Munz of 17 Queen Street, Melbourne in the said State by the 11th day of July, 1975 after which date the executor may convey or distribute the assets having regard only to the claims of which he then has notice.

Dated the 7th day of May, 1975.

RIVERS, DICKINSON, STIRLING & MUNZ, solicitors
of 17 Queen Street, Melbourne, 3000. 4874

HELENE McKENNA RICHARDS, late of 23 First Avenue, Kew, in the State of Victoria, home duties, DECEASED.

Creditors next of kin and others having claims in respect of the estate of the deceased who died on the 15th day of July, 1974 are required by the executor ERNEST HAROLD RICHARDS of 30 The Strand, Williamstown in the said State, Gentleman, to send particulars to him care of the solicitors for the estate, Messrs. Rivers Dickinson Stirling & Munz of 17 Queen Street, Melbourne in the said State by the 11th day of July, 1975 after which date the executor may convey or distribute the assets having regard only to the claims of which he then has notice.

Dated the 7th day of May, 1975.

RIVERS, DICKINSON, STIRLING & MUNZ, solicitors
of 17 Queen Street, Melbourne, 3000. 4876

GERALD THOMAS JEFFERIES, formerly of 117 Albert Street, Footscray, but late of 63 Swan Street, Footscray, gentleman, DECEASED.

Creditors, next of kin, and others having claims in respect of the deceased, who died on 27th December, 1974, are required by the personal representative NATIONAL TRUSTEES EXECUTORS AND AGENCY COMPANY OF AUSTRALASIA LIMITED, of 95 Queen Street, Melbourne, to send particulars to it by the 8th July, 1975, after which date the personal representative may convey or distribute the assets, having regard only to the claims of which it then has notice.

PALMER, STEVENS & RENNICK, solicitors, Kyneton.
4861

CREDITORS next of kin and others having claims in respect of the Estate of JEAN HELEN GRAHAM late of 21 McDonald Street, Werribee in the State of Victoria, Married Woman, deceased who died on the 10th day of July, 1974 are required by the Executor of her Will, namely MITCHELL ROY GRAHAM of 21 McDonald Street, Werribee in the said State Nurseryman to send particulars of such claims to the said Executor care of the office of Lloyd P. Goode & Co., at 406 Lonsdale Street, Melbourne by the 9th day of August 1975 after which date the said Executor will distribute the assets having regard only to the claims of which he then has notice.

LLOYD P. GOODE & CO., solicitors, 406 Lonsdale
Street, Melbourne, 3000. 4902

CREDITORS next of kin and others having claims in respect of the Estate of LAURA INGLESAN ANDREWS late of Wildwood Park, Wildwood Road, Whittlesea in the State of Victoria Married Woman deceased who died on the 11th day of July, 1973 are required by the Executor of her Will, namely ARTHUR LAMBERT ANDREWS of Wildwood Park, Wildwood Road, Whittlesea in the said State to send particulars of such claims to the said Executor care of the office of Lloyd P. Goode & Co., at 406 Lonsdale Street, Melbourne by the 9th day of August 1975 after which date the said Executor will distribute the assets having regard only to the claims of which he then has notice.

LLOYD P. GOODE & CO., solicitors, 406 Lonsdale
Street, Melbourne, 3000. 4903

CREDITORS next-of-kin and others having claims in respect of the estate of BERTHA ANN MANSFIELD SYKES late of 11 Tweedside Street Essendon Widow deceased intestate who died on 29th September 1972 are to send particulars of their claims to LINDA MAY ALLISON the administratrix of the estate care of the under-mentioned Solicitors by the 14th July 1975 after which date she will distribute the assets having regard only to the claims of which she then has notice.

KIDDLE, BRIGGS & WILLOX, solicitors, 406 Collins
Street, Melbourne. 4904

CREDITORS next-of-kin and others having claims in respect of the estate of DORIS ILEEN DAVIES late of 2 Galeka Street Merlynston Married Woman deceased intestate who died on 16-12-74 are to send particulars of their claims to DUNCAN DAVIES the administrator of the estate care of the undermentioned Solicitors by the 21st July 1975 after which date he will distribute the assets having regard only to the claims of which he then has notice.

KIDDLE, BRIGGS & WILLOX, solicitors, 406 Collins
Street, Melbourne. 4905

CREDITORS next-of-kin and others having claims in respect of the estate of VINCENT MICHAEL STAPLETON late of 27 Bent Street Moonee Ponds Car Salesman deceased intestate who died on 24th July 1974 are to send

particulars of their claims to ALICE ADELAIDE STAPLETON the administratrix of the estate care of the under-mentioned Solicitors by the 3rd July 1975 after which date she will distribute the assets having regard only to the claims of which she then has notice.

KIDDLE, BRIGGS & WILLOX, solicitors, 406 Collins Street, Melbourne. 4906

JANET COLLISON HENRY, late of 43 Kennaway Street, Tasmore, in South Australia, married woman, DECEASED.

CREDITORS next of kin and others having claims in respect of the estate of the deceased who died on the 2nd day of January 1975 are required by the Administrator PUBLIC TRUSTEE of South Australia of 182 Victoria Square Adelaide in South Australia to send particulars to it care of the undermentioned Solicitors by the 16th day of July 1975 after which date the Administrator may convey or distribute the assets having regard only to the claims of which it then has notice.

Dated the 7th day of May, 1975.

MADDEN BUTLER ELDER & GRAHAM, solicitors, 500 Collins Street, Melbourne. 4907

NANCY RUSSELL ELDER, late of St. Alfred Private Hospital, 51 Mathoura Road, Toorak, married woman, DECEASED.

CREDITORS, next of kin and others having claims in respect of the estate of the deceased who died on the 13th day of November 1974 are required by the Trustees JAMES IAN MACKENZIE ELDER of "Oak Valley" Longwood Grazier and SUSAN MARGARET HAGGARD of "Springwood" Goocham R.S.D. 365 via Euroa Grazier and THE UNION-FIDELITY TRUSTEE COMPANY OF AUSTRALIA LIMITED of 100 Exhibition Street Melbourne to send particulars of such claims to THE UNION-FIDELITY TRUSTEE COMPANY OF AUSTRALIA LIMITED by the 16th day of July 1975 after which date the executors will proceed to transfer convey or distribute the said estate to or among the persons entitled thereto having regard only to the claims of which they then have had notice and will not be liable for the assets so transferred, conveyed or distributed to any persons of whose claim it shall not then have had notice.

Dated the 7th day of May, 1975.

MADDEN BUTLER ELDER & GRAHAM, solicitors, 500 Collins Street, Melbourne. 4908

CREDITORS Next-of-kin and others having claims in respect of the Estate of ELIZABETH ANDREWS late of 7 Rogers Road, Moorabbin, Spinster deceased, are requested to send particulars of their claims to the Administrator Harold Hubble care of the undermentioned Solicitors on or before 11th July 1975 after which date he will then distribute the assets having regard only to the claims of which he then has notice.

McKEAN & PARK, solicitors, 84 William Street, Melbourne. 4909

REES ALBERT JONES, late of 66 Home Road, Newport, retired machine moulder, DECEASED.

CREDITORS next of kin and others having claims against the estate of the said deceased who died on 29th January 1973 are to send particulars of their claims to JAMES TURNER COLQUHOUN c/- 140 William Street Melbourne by the 12th day of July 1975 after which date he will distribute the assets having regard only to the claims of which he then has notice.

BLAKE & RIGGALL, solicitors, 140 William Street, Melbourne. 4910

All persons having claims against the Estate of KATHLEEN KOI GRACE late of 6 Aorere Street Parnell Auckland New Zealand Married Woman deceased (who died on the 15th July 1974) and Probate of whose Will was on the 19th August 1974 granted by the Supreme Court of New Zealand Auckland Registry to The South British Guardian Trust Company Limited and application to the Supreme Court of Victoria (Probate Jurisdiction) by the Perpetual Executors & Trustees Association of Australia Limited to seal such Probate having been granted on the 24th April 1975 are hereby required to send particulars of such claims to The Perpetual Executor & Trustees Association of Australia Limited at its Registered Office at 50 Queen Street Melbourne on or before the 15th day of July 1975 after which date the said Company will proceed to transfer, convey or distribute the said Estate to or among the persons entitled thereto having regard only

to the claims of which it shall then have had notice and will not be liable for the assets so transferred, conveyed or distributed to any persons of whose claim it shall not then have had notice.

MULLETT NEDOVIC & CO., solicitors, 470 Bourke Street, Melbourne, 3000. 4911

CREDITORS next of kin and others having claims against the Estate of SAMUEL BENNIE STERN late of 1 Alawarra Court Burwood East, Pharmaceutical Chemist, deceased who died on the 11th October 1974 are required by the Executor THE EQUITY TRUSTEES EXECUTORS AND AGENCY COMPANY LIMITED of 472 Bourke Street Melbourne to send particulars of such claims to the said Company on or before the 14th July 1975 after which date it will distribute the assets having regard only to the claims of which it shall then have had notice.

A. NEWTON SUPER & P. G. KOVACS, barristers & solicitors, 374 Bourke Street, Melbourne. 4794

CREDITORS, next of kin and others having claims in respect of the Estate of OSWALD REINHARDT late of 34 Murphy Street, Bairnsdale, Retired deceased (who died on the 28th day of January, 1975) are to send particulars of their claims to the Executors of the Will of the deceased care of the UNION-FIDELITY TRUSTEE COMPANY OF AUSTRALIA LIMITED of 100 Exhibition Street, Melbourne by the 31st day of July, 1975, after which date the Executors will distribute the assets, having regard only to the claims of which they then have notice.

AGG & ENGEL, solicitors, 14 Bailey Street, Bairnsdale. 4795

CREDITORS next-of-kin and others having claims against the estate of BETSY ELLEN ANGUS late of 36 Hotham Street St. Kilda in the State of Victoria widow deceased, who died on the 14th September 1972, are to send particulars of their claims to FREDERICK JAMES BURNSTABLE and WALTER WHITEHEAD both care of Adams & Garde, Solicitors, Central Avenue Moorabbin before the Seventh day of July 1975, after which date they will distribute the assets having regard only to the claims of which they then have notice.

ADAMS & GARDE, solicitors, Central Avenue, Moorabbin. 4796

THOMAS WILLIAM BATE, formerly of 37 May Street, North Fitzroy, but late of St. Omer Private Hospital, 44 Prospect Hill Road, Camberwell, pensioner, DECEASED.

Next-of-kin and others having claims in respect of the estate of the deceased who died on the Fourth day of March 1975 are required by the Executors ALAN FREDERICK CUMBERLAND and JAMES THOMAS COX to send particulars to their Solicitor NORMA L. JENKINS of 329 St. George's Road North Fitzroy by the 7th day of July 1975 after which date the Executors will convey or distribute the assets having regard only to the claims of which they then have notice.

ALBERT LESLIE HILL, late of Grace McKellar House, North Geelong, gentleman, DECEASED.

Creditors next of kin and others having claims in respect of the Estate of the deceased who died on the 24th day of December 1974 are required by the personal representatives PETER JEFFREY HILL of Coombes Road Torquay Farmer and JOHN WELFORD STUBBS of 27 Malop Street Geelong Solicitor to send particulars to them care of the under-mentioned Solicitors by the 21st day of July 1975 after which date the personal representatives may convey or distribute the assets having regard only to the claims of which they then have notice.

WHYTE JUST & MOORE, solicitors, 27 Malop Street, Geelong. 4798

Creditors next of kin and others having claims in respect of the Will of ELSIE MAY DAVIS late of 1 Edinburgh Street Flemington Home Duties who died on the 20th day of March 1975 are requested to send particulars of their claims to the Executors AUDREY JEAN MOONEY and GERALD (in the Will called GERARD) MICHAEL MOONEY care of the undermentioned Solicitor by the 16th day of July, 1975 after which date they will distribute the assets having regard only as to the claims of which they then have notice.

JOHN STEWART, of 290 Racecourse Road, Newmarket. 4799

CREDITORS next of kin and others having claims against the estate of REBECCA RUBENA MURPHY formerly of 40 Abbott Street, Bendigo but late of 17 Helm Street, Kangaroo Flat, Widow, deceased, who died on the 12th January, 1975 are required to send particulars thereof to NATIONAL TRUSTEES EXECUTORS AND AGENCY COMPANY OF AUSTRALASIA LIMITED of 46 Queen Street, Bendigo by the 15th day of July, 1975, after which date the said Company will distribute the assets of the said deceased having regard only to the claims of which it then has notice. 4800

CREDITORS next of kin and others having claims against the estate of RETA MERLE MURLEY late of 3 Stewart Street, Bendigo, married woman, deceased who died on the 28th November, 1974 are required to send particulars thereof to NATIONAL TRUSTEES EXECUTORS AND AGENCY COMPANY OF AUSTRALASIA LIMITED of 46 Queen Street, Bendigo, by the 15th day of July, 1975, after which date the said Company will distribute the assets of the said deceased having regard only to the claims of which it then has notice. 4801

Creditors, next of kin and others having claims in respect of the estate of ALMA EVA SMITH, formerly of 79 Keera Street, Geelong West, but late of Clyde Private Hospital, 21 Skene Street, Newtown, Widow, deceased, who died on the 22nd September 1974, are to send the particulars of their claims to THE UNION-FIDELITY TRUSTEE COMPANY OF AUSTRALIA LIMITED at its office at 8 Malop Street, Geelong by the 15th day of July 1975, after which date it will distribute the assets having regard only to the claims of which it then has notice.

FALLAW & HENDERSON, solicitors, 24 Ryrie Street, Geelong. 4802

JOHN WILLIAM McRAE late of Grace McKellar House, Ballarat Road, North Geelong, retired railway employee, DECEASED.

Creditors, next of kin, and others having claims in respect of the estate of the deceased, who died on the 6th January 1975, are required by the personal representative, ALLAN JOHN McRAE, of 23, Lascelles Avenue, Manifold Heights, Geelong West, Building Supervisor, to send particulars to him care of the undermentioned solicitors, by the 30th day of June 1975 after which date he may convey or distribute the assets, having regard only to the claims of which he then has notice.

FALLAW & HENDERSON, solicitors, 24 Ryrie Street, Geelong. 4803

In the Supreme Court of the State of Victoria.
SALE BY THE SHERIFF.

ON FRIDAY the 20TH of JUNE 1975 at 11.00 a.m. AT THE POLICE STATION EMERALD (unless process be stayed or satisfied, ALL the Estate and Interest (if any) of T. CHERNISCHOFF (shown on Certificate of Title as TRESON CHERNASCHOFF) labourer, of rear 6 Lillian Street, Clayton as proprietor of an estate in fee simple in the land described in Certificate of Title Volume 8552 Folio 491 which is a vacant block of land located off Marks Lane which crosses the apex of Madeline Court at a distance of 950 feet from Hepner Road and approximately 4 miles from Emerald known as Lot 22 Madeline Court Emerald.

Terms: Cash only.

4927 DOUGLAS S. HALL, Sheriff's Officer.

In the Supreme Court of the State of Victoria.
SALE BY THE SHERIFF.

ON FRIDAY the 20TH of JUNE 1975 at 11.00 a.m. AT THE POLICE STATION MELTON (unless process be stayed or satisfied) ALL the Estate and Interest (if any) of ANGELO CALELLA, builder, and VITANTONIA CALELLA, builder, both of 74 South Street, Glenroy as joint proprietors of an estate in fee simple in the land described in Certificate of Title Volume 8558 Folio 306 which is a vacant block of land situated on the north west corner of Hume Avenue and Exford Road, Melton.

Registered Mortgage No. E.399440 affects the said estate and interest.

Terms: Cash only.

4928 H. BUETTNER, Sheriff's Officer.

In the Supreme Court of the State of Victoria.
SALE BY THE SHERIFF.

ON FRIDAY the 20TH of JUNE 1975 at 3.00 p.m. AT THE POLICE STATION NOBLE PARK (unless process be stayed or satisfied) ALL the Estate and Interest (if any)

of NORMAN DONALD HUNTER (shown on Certificate of Title as NORMAN FREDERICK DONALD EDWARD HUNTER) pastrycook, of 16 Prior Road, Noble Park as joint proprietor with ANNETTE MARY HUNTER, married woman of an estate in fee simple in the land described in Certificate of Title Volume 8306 Folio 239 upon which is erected a weatherboard dwelling known as No. 16 Prior Road Noble Park.

Registered Mortgage Nos. F.401573, F.429909 and Caveat F.412936 affects the said estate and interest.

Terms: Cash only.

4929 DOUGLAS S. HALL, Sheriff's Officer.

IMPOUNDING

YARRAM.—Impounded by F. E. Underwood, from Won Wron, 27th April, 1975.

1 black baldy steer, piece out of bottom of right ear, brand not clear on right rump

1 black steer, like notch back of right ear, slit left ear, brand not clear

1 black steer, like square notch back of left ear, like brand not clear right rump

1 black steer, piece off back of left ear, like notch back of right ear

If not claimed and expenses paid to be sold in the Yarram Sale Yards, 24th May, 1975.

L. MITCHELL,
Poundkeeper.

4943—\$7.70

NOTICE OF MAKING OF STATUTORY RULES.

In pursuance of the provisions of the *Subordinate Legislation Act 1962* and the Regulations made thereunder, notice is given of the making of the following statutory rules:—

No.	Films Act 1971.	Price.
132/1975.	Films (Exemption of Distributors) Regulations 1975	10c
	<i>Health Act 1958.</i>	
133/1975.	Harmful Gases, Vapours, Fumes, Mists, Smokes and Dusts (Amendment) Regulations 1975	10c
	<i>Public Service Act 1974.</i>	
134/1975.	Public Service Board Elections Regulations 1975	15c

Copies of these statutory rules may be purchased at the Sale of Publications Section of the Government Printing Office, located at 7A Parliament Place, Melbourne, 3002. If ordered by mail, remittance should be addressed to "The Government Printer, Box 203, P.O., North Melbourne, 3051", and should include 11c extra for postage. If a credit account is held at this office, no remittance is required with the mail order.

The annual subscription rate for Statutory Rules (including Bound Volumes) is \$35, payable in advance. The subscription year commences on 1st January.

C. H. RIXON,
Government Printer.

AGENTS FOR THE "VICTORIA GOVERNMENT GAZETTE"

The following have been appointed agents to receive Advertisements and Subscriptions for the *Victoria Government Gazette*:—

ARMSTRONG'S AGENCY, 217 Queen-street, Melbourne, Victoria 3000.

ARNALL & JACKSON, 390 Barkly-street, Brunswick, Victoria 3056.

BAIRNSDALE AUTHORIZED NEWSAGENCY, 132 Main-street, Bairnsdale, Victoria 3875.

BICKNELL, M. J., Authorized Newsagent, 196 Timor-street, Warrnambool, Victoria 3280.

BLANE'S AUTHORIZED NEWSAGENTS, 162 Murray-street, Colac, Victoria 3250.

CARTER, R. G., ADVERTISING SERVICE PTY. LTD., Suite 24, 65 Queens-road, Melbourne, Victoria 3004.

DAVIES, G. & M. V., 112 Gray-street, Hamilton, Victoria 3300.

DAVIS, WM. (MILDURA) PTY. LTD., 126 Eighth-street, Mildura, Victoria 3500.

DIXON'S NEWSAGENCY, 89 Firebrace-street, Horsham, Victoria 3400.
 EDGAR'S AUTHORIZED NEWSAGENCY, 45 Bridge-street, Benalla, Victoria 3672.
 FRANKS, H., & CO., 184 Ryrrie-street, Geelong, Victoria 3220.
 GATLEY, A. & J., 250 Lonsdale-street, Dandenong, Victoria 3175.
 GORDON & GOTCH AUSTRALASIA LTD., 434 St. Kilda-road, Melbourne, Victoria 3004.
 GULLAN'S NEWSAGENCY, 88 Bridge-street, Ballarat, Victoria 3350.
 HAMPTON, A. C., 243 Mitchell-street, Bendigo, Victoria 3550.
 HARSTON, PARTRIDGE & CO. PTY. LTD., 455 Little Collins-street, Melbourne, Victoria 3000.
 KYNETON GUARDIAN PTY. LTD., P.O. Box 18, Kyneton, Victoria 3444.
 LIVINGSTON'S SHEPPARTON NEWSAGENCY, 246 Wyndham-street, Shepparton, Victoria 3630.
 THE MERCANTILE EXCHANGE, 34 Queen-street, Melbourne, Victoria 3000.
 MCGILL'S AUTHORIZED NEWSAGENCY, 183-5 Elizabeth-street, Melbourne, Victoria 3000.
 POWNEY'S AUTHORIZED NEWSAGENCY, 293 Hargreaves-street, Bendigo, Victoria 3550.
 PURDIE, J., & CO., 138 Moorabool-street, Geelong, Victoria 3220.
 SALE AUTHORIZED NEWSAGENCY, 142 Raymond-street, Sale, Victoria 3850.
 SKINNER'S AUTHORIZED NEWSAGENCY, 49-51 Franklin-street, Traralgon, Victoria 3844.
 STEVENSON, A. C. & M., NEWSAGENTS, 132 Henty-street, Casterton, Victoria 3311.
 VANCE'S AUTHORIZED NEWSAGENCY, 83 Murray-street, Wangaratta 3677.
 VERNONS OF RICHMOND, 162 Bridge-road, Richmond, Victoria 3121.
 VIEW POINT AUTHORIZED NEWSAGENCY, 4 View-Point, Bendigo, Victoria 3550.

A copy of the Gazette is filed at each place for public reference.

THE "VICTORIA GOVERNMENT GAZETTE".

SUBSCRIPTIONS.—The subscription, including postage, is \$40 per annum, or \$20 per half year, payable in advance.

Subscriptions are required for whole months, and must cover at least a half year.

Single copies are 30 cents, posted 63 cents. Subscribers do not receive the Acts of Parliament with the GAZETTE.

GAZETTES are held in stock for five years only.

PRIVATE ADVERTISEMENTS.—The charge for insertion is 55 cents per line single column, and \$1.10 cents per line double column. The title forms one or more lines as a heading. On an average ten words make a line of single column. Every signature must likewise be counted as a line. The final words of a paragraph, though only portion of a line, must be counted as one line. Signatures (in particular) and proper names must be written very plainly in the text; ONE SIDE ONLY of each sheet of paper should be WRITTEN UPON. The charge for a full page is \$85.

All documents illegibly written will be returned unpublished, and where brands occur unprovided for by the ordinary letters of the alphabet, a worded explanatory description must be furnished.

PUBLICATION.—Unless otherwise advertised, the VICTORIA GOVERNMENT GAZETTE is published on WEDNESDAY EVENING in each week, and Notices for insertion will be received by the Government Printer at or before ONE p.m. at ordinary rates, and late advertisements between ONE p.m. and half-past THREE p.m. at double rates on the day preceding the day of publication.

PAYMENTS.—Unless the advertiser has a credit account, all payments are required in advance. Remittances should be made by cheque, postal order, or money order payable to "GOVERNMENT PRINTER".

ADDRESS.—All communications should be addressed to "The Government Printer, Box 203, P.O., North Melbourne, 3051."

PUBLICATION OF OFFICIAL MATTER.

Attention is invited to the following procedure in relation to the publication of official matter in the *Government Gazette*:—

Publication will be facilitated by the submission of carbon copies for the use of the Gazette Officer.

1. Matter submitted to the Executive Council.

Matter submitted to the Executive Council which requires gazettal will normally be published in the issue of the following week.

Where urgent gazettal is required, special arrangements should be made with the Gazette Officer, Room 14, first floor, Old Treasury Building.

2. Other matter.

(a) All other matter duly certified by a responsible officer for publication should be lodged with the Gazette Officer not later than half-past Nine a.m. on Tuesday.

(b) Lengthy or involved notices should be forwarded several days before publication.

(c) Proofs, which will be supplied only when specifically requested or at the direction of the Gazette Officer, should be returned promptly to avoid delay in publication.

(d) No additions or amendments to matter for publication will be accepted by telephone.

CONTENTS

PAGE

Acts of Parliament	1015
Appointments	1038
Bank Holiday	1013
Contracts	1035
Estates of Deceased Persons	1034
Government Notices	1017
Impounding	1083
Lands	1056
Melbourne and Metropolitan Board of Works— Notice	1033
Mining	1034
Notice to attend for Radiological Examination	1022
Notice to Mariners	1030
Notice of Making of Statutory Rules	1083
Orders in Council— Acts—Forests; Co-operation; Forests; Local Government; Stamps; Country Roads; Land; Labour and Industry; Superan- nuation; Water; Sewerage Districts. et seq	1039
Private Advertisements	1066
Proclamations	1013
Public Holiday	1013
Public Service Notices	1059
Resignations	1038
Tenders	1058
Transport Regulation Board—Public Hearings	1018