



VICTORIA GOVERNMENT GAZETTE

Published by Authority

No. 39]

WEDNESDAY, MAY 21

[1975

PROCLAMATIONS

PUBLIC HALF-HOLIDAY.

PROCLAMATION

By His Excellency the Governor of the State of Victoria and its Dependencies in the Commonwealth of Australia, &c., &c., &c.

In pursuance of the provisions contained in Part III. of the *Public Service Act 1958*, I, the Governor of the State of Victoria, in the Commonwealth of Australia, by and with the advice of the Executive Council of the said State, do by this my Proclamation appoint the day and date hereunder mentioned to be observed as a Public Half-Holiday at the place specified, viz.:—

Public Half-Holiday from the Hour of Twelve o'clock noon:—

MONDAY, THE 20TH OCTOBER, 1975, throughout the City of Echuca.

Given under my Hand and the Seal of the State of Victoria aforesaid, at Melbourne, this thirteenth day of May, in the year of our Lord One thousand nine hundred and seventy-five, and in the twenty-fourth year of the reign of Her Majesty Elizabeth the Second, Queen of Australia.

(L.S.) HENRY WINNEKE.
By His Excellency's Command,
J. F. ROSSITER,
Chief Secretary.

GOD SAVE THE QUEEN!

MENTAL HEALTH ACT 1959 (No. 6605).

PROCLAMATION

By His Excellency the Governor of the State of Victoria and its Dependencies in the Commonwealth of Australia, &c., &c., &c.

Whereas by the *Mental Health Act 1959* (No. 6605) which came into operation on 1st November 1962, any proclamation pursuant to any corresponding previous enactment made prior to and still in effect at that date of commencement of operation of Act No. 6605 would still have the same status, operation and effect as if such previous corresponding enactment had not been repealed;

No. 39.—4320/75.—Price 30 cents; Half-yearly \$20; Yearly \$40.

And whereas by a proclamation of the Governor in Council made on the 23rd October, 1956 and published in the *Government Gazette* of the 31st October, 1956, all buildings on certain land in the Parish of Wangoom were proclaimed as a mental hospital known as the Mental Hospital Warrnambool;

And whereas by a like proclamation made on the 16th August 1960, and published in the *Government Gazette* of the 24th August, 1960, all buildings on certain additional areas of land in the said Parish of Wangoom were proclaimed as portion of the Mental Hospital previously incorporated as the Mental Hospital Warrnambool;

And whereas by proclamation made pursuant to section 24 of the *Mental Health Act 1959*, the Governor in Council may vary or revoke any proclamation of a mental hospital and may proclaim one or more buildings or places provided by the State for the treatment of the intellectually defective to be a psychiatric hospital;

And whereas it is desired to proclaim as a psychiatric hospital a certain building at present forming part of the Mental Hospital at Warrnambool and known as Ward M7;

Now therefore, I the Governor of the State of Victoria in the Commonwealth of Australia, by and with the advice of the Executive Council of the said State do by this my proclamation from the 1st day of June 1975—

- (a) Revoke the proclamations constituting the Mental Hospital Warrnambool so far as they relate to the building known as Ward M7; and
- (b) Proclaim the aforesaid building known as Ward M7 to be a psychiatric hospital known as the Psychiatric Hospital Warrnambool.

Given under my Hand and the Seal of the State of Victoria aforesaid, at Melbourne, this thirteenth day of May, in the year of our Lord One thousand nine hundred and seventy-five, and in the twenty-fourth year of the reign of Her Majesty Elizabeth II. Queen of Australia.

(L.S.) HENRY WINNEKE.
By His Excellency's Command,
A. H. SCANLAN,
Minister of Health.

GOD SAVE THE QUEEN!

JURIES (AMENDMENT) ACT 1975.
DATE OF COMING INTO OPERATION.

PROCLAMATION

By His Excellency the Governor of the State of Victoria and its Dependencies in the Commonwealth of Australia, &c., &c., &c.

Whereas by an Act of Parliament of the State of Victoria passed in the twenty-fourth year of the reign of Her Majesty Elizabeth the Second, Queen of Australia, intituled the *Juries (Amendment) Act 1975 No. 8677*, it is amongst other things enacted that the said Act shall come into operation on a day to be fixed by Proclamation of the Governor in Council published in the *Government Gazette*:

Now therefore I, the Governor of the State of Victoria, acting by and with the advice of the Executive Council thereof, do by this my proclamation fix Sunday the 1st day of June One thousand nine hundred and seventy-five as the day upon which the *Juries (Amendment) Act 1975 No. 8677* shall come into operation.

Given under my hand and the seal of the State of Victoria aforesaid at Melbourne this twentieth day of May in the year of our Lord One thousand nine hundred and seventy-five and in the twenty-fourth year of the reign of Her Majesty Elizabeth the Second, Queen of Australia.

(L.S.) HENRY WINNEKE.

By His Excellency's Command,
V. F. WILCOX,
Attorney-General.

GOD SAVE THE QUEEN!

GOVERNMENT NOTICES

PUBLIC HOLIDAY.—QUEEN'S BIRTHDAY.

It is hereby notified that on—

MONDAY, THE 16TH JUNE, 1975,
the Public Offices will be closed, such day having been appointed under the provisions of the *Public Service Act 1958*, to be observed as a holiday in the Public Offices throughout the State of Victoria.

This notice relates only to the closing of the State Public Offices. All inquiries regarding the holiday in other offices and in shops and industry should be directed to the Department of Labour and Industry, 110 Exhibition Street, Melbourne, 3000. (Telephone 651 6158 or 651 6859).

J. F. ROSSITER,
Chief Secretary.

Chief Secretary's Office,
Melbourne, 12th May, 1975.

LOCAL GOVERNMENT DEPARTMENT.
ORDER CONFIRMED.—CITY OF DONCASTER AND TEMPLESTOWE.

The Minister of the Crown administering the *Local Government Act 1958*, on the 9th day of May, 1975, confirmed an Order hereinafter referred to in pursuance of the provisions of section 514 of the said Act namely:—

An Order of the Council of the City of Doncaster and Templestowe made on the 17th March, 1975, directing the compulsory taking of the land described in certificate of title, volume 7666, folio 041 for car parking purposes.

A. J. HUNT,
Minister for Local Government.

Local Government Department,
Melbourne (75/2105).

LOCAL GOVERNMENT DEPARTMENT.
ORDER CONFIRMED.—SHIRE OF KYNETON.

In pursuance of the provisions of section 514 of the *Local Government Act 1958* the Minister of the Crown administering the *Local Government Act 1958* on the 9th day of May, 1975, confirmed an Order of the Council of the Shire of Kyneton, made on the 16th day of April, 1975, directing the compulsory taking of certain land being the land described in certificate of title, volume 3286, folio 052 for the purpose of providing a place of public resort and recreation.

A. J. HUNT,
Minister for Local Government.

Local Government Department,
Melbourne (75/2477).

LOCAL GOVERNMENT DEPARTMENT.

ORDER CONFIRMED.—CITY OF WAVERLEY.

The Minister of the Crown administering the *Local Government Act 1958*, on the 16th day of May, 1975 confirmed the Order hereinafter referred to in pursuance of the provisions of section 514 of the *Local Government Act 1958*.

An Order of the Council of the City of Waverley made on the 11th September, 1973 directing the compulsory taking of the land described hereunder for the purpose of providing a place of public resort and recreation:—

Firstly, all that piece of land being part of Crown Portion 100, Parish of Mulgrave and being part of the land described in Certificate Volume 2969 Folio 765 commencing at a point bearing North distant 648 feet 1½ inches thence 270° 8' for 430 feet from the south eastern corner of the said Crown Portion 100; thence by lines bearing 270° 8' for 366 feet 1 inch; 0° 15' for 2 feet 8 inches; 270° 4' for 126 feet 5½ inches; 270° 6' for 631 feet 10½ inches; 0° 7' for 55 feet; 19° 49' for 101 feet 10½ inches; 359° 47' for 100 feet 1½ inches; 89° 47' for 1084 feet 7 inches; 154° 48½' for 100 feet 1½ inches; thence by an arc of a circle having a radius of 40 feet and length of 112 feet 7½ inches, the chord of which has a bearing of 178° 24' distant 78 feet 11 inches and thence 203° 29' for 98 feet 5½ inches to the point of commencement, and

Secondly, all that piece of land being part of Crown Portion 100 in the Parish of Mulgrave and being part of the land described in Certificates of Title Volume 8564 Folios 541 and 542 commencing at a point bearing 89° 49' for 679 feet 4 inches; 89° 47' for 342 feet 90° 0' for 688 feet 11 inches; 89° 55' for 600 feet and 2° 58' for 321 feet 2½ inches from the south western corner of the said Crown Portion 100 thence by lines bearing 2° 58' for 327 feet 1½ inches; 89° 56' for 222 feet 2 inches; 179° 43' for 326 feet 7½ inches and 269° 55' for 240 feet 8½ inches the point of commencement.

A. J. HUNT,
Minister for Local Government.

Local Government Department,
Melbourne (3801318).

SHIRE OF MAFFRA.

Pursuant to the provisions of sections 522 and 526 of the *Local Government Act 1958*, the Council of the Shire of Maffra hereby directs that the land in the Parish of Briagolong indicated by hatching in the diagram hereunder, which has been purchased, taken or acquired by it, shall be a public highway on and from the date of publication of this order in the *Government Gazette* and declares that such land shall be a public highway in lieu of the land indicated by cross-hatching on the said diagram.

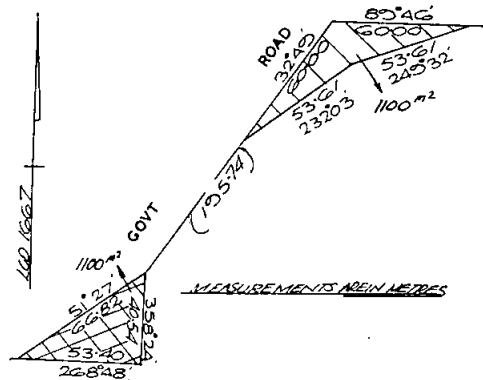

The common seal of the President, Councillors and Ratepayers of the Shire of Maffra was affixed hereunto, this 11th day of March, 1975.

(SEAL) R. F. KELLY, President.
H. A. CREIGHTON, Councillor.
J. RENNICK, Shire Secretary.

Confirmed by the Governor in Council, 13th May, 1975.—
TOM FORRISTAL, Clerk of the Executive Council.

Transport Regulation Act.
TRANSPORT REGULATION BOARD.
HEARING OF APPLICATIONS.

Notice is hereby given that the following applications will be considered by the Transport Regulation Board on 10th June, 1975.

- IZARD, K. D. & J., Moyhu.** Application for one commercial passenger vehicle with seating capacity for 11 persons to operate for the carriage of school children between Edi and Edi Upper Primary School under contract to the Education Department.
- KENDALL, C. G. & I. I.,** 40 Queen Elizabeth Drive, Tallangatta. Application for one commercial passenger vehicle with seating capacity for 18 persons to operate for the carriage of school children between Christians Farm Gundowring and Tallangatta High School under contract to the Education Department.
- LATROBE VALLEY BUS LINES,** 4-10 Ryan Street, Morwell. Application for one commercial passenger vehicle with large seating capacity to operate a school bus service between Morwell and Sale via Traralgon, Flynn and Rosedale for the carriage of students attending St. Annes Gippsland Grammar School under contract to St. Annes Grammar School Parents and Friends Association. No students to be picked up or set down closer than 5 kilometre on the Traralgon side of Rosedale. Service is to operate on a daily basis during school year on timetable agreed to by hirer. (Subject to cancellation of permit No. 4183, which authorises the carriage of St. Annes Gippsland Grammar School students between Morwell and Rosedale.)
- NORTH WESTERN BUS SERVICE PTY. LTD.,** 935 Pascoe Vale Road, Glenroy. Application for variation of permit No. 4252, which authorises an extension of route 542 (Oak Park-Broadmeadows) to St. Dominic's Catholic School and Broadmeadows High School, to extend the service from its present terminus at the corner of Timboon Crescent and Dimboola Road via Dimboola Road, Cavendish, Coleraine, Talgarno, Rigall and Hamilton Streets and Ripplebrook Drive to Dimboola Road and normal route.
- TIMETABLE.
School days only.
- Depart Glenroy 8.20 a.m.
Depart School 3.50 p.m.
- RANKIN, R. J.,** Glenelg Highway, Westmore. Application for one commercial passenger vehicle with seating capacity for 11 persons to operate for the carriage of school children only between Miniera East and Westmore under contract to the Education Department.
- SIMCOCKS, C. G., D. E. & J. M.,** Main Street, Garfield. Application for one commercial passenger vehicle with seating capacity for 41 persons to operate for the carriage of school children only between Toomuc Valley Road, Pakenham Upper and Pakenham High School, under contract to the Education Department.
- SIMCOCKS, C. G., D. E. & J. M.,** Main Street, Garfield. Application for one commercial passenger vehicle with seating capacity for 41 persons to operate for the carriage of school children only between Harvic Road, Pakenham Upper and Pakenham High and Consolidated Schools, under contract to the Education Department.
- VENTURA MOTORS PTY. LTD.,** 1037 Centre Road, South Oakleigh. Application for variation of M.O. licence conditions Route 736 (Blackburn-Bayswater-Boronia) to delete service from the corner of Tainton Road and Arthur Street via Tainton Road to Burwood Highway, and instead to operate via Arthur Street, Christa Avenue, Blackburn Road to Burwood Highway and normal route.
- Notice of any objections should be forwarded to reach the Secretary of the Board not later than 4th June, 1975.
- Applicants are advised that it will not be necessary to appear on the hearing date specified, unless advised in writing by the Board.
- A. V. C. COOK,
Secretary.
Corner Lygon and Princes Streets, Carlton, 3053,
Wednesday, 21st May, 1975.
-
- Commercial Goods Vehicles Act.
TRANSPORT REGULATION BOARD.
HEARING OF APPLICATIONS.
- Notice is hereby given that the following applications will be considered by the Transport Regulation Board on 10th June, 1975.
- BASSETT, I. S.,** 146 Allan Street, Kyabram, 3620. One commercial goods vehicle (L/C 0.75 tonne) to operate within an 80-km radius of own premises at Kyabram in the course of business as a "Milking Machine and Irrigation Equipment Distributing Agent and Serviceman"—tools of trade and spare parts required for on-site servicing of milking machines and irrigation equipment.
- CORNISH TRADING CO. PTY. LTD.,** Murray Valley Highway, Cobram, 3644. One commercial goods vehicle (L/C 8.10 tonne) to operate: (a) Within a 40-km radius of Cobram—general goods. (b) Within an 80-km radius of Cobram in the course of business as "Fertilizer Distributor"—bagged and bulk fertilizer provided that all fertilizer carried has been initially railed to Cobram.
- CROSSMAN, E. M.,** Lucas Crescent, Lockington, 3563. One commercial goods vehicle (L/C 9.10 tonne) to operate: (a) Within a 40-km radius of Lockington—general goods. (b) Within an 80-km radius of Lockington in the course of business as "Primary Producer"—own goods. (c) Throughout the State of Victoria—livestock.
- CURMI, S.,** 669 Ballarat Road, West Sunshine, 3020. One commercial goods vehicle (L/C 10.80 tonne) to operate within an 80-km radius of the G.P.O., Melbourne solely on behalf of Albion Reid Pty. Ltd.—Roadmaking plant, hot asphalt, premix and roadmaking materials but excluding the carriage of cement and lime from places within a 13-km radius of Geelong.
- DUFFY, G. A. (trading as G. A. & S. M. Duffy),** 61 Robertson Street, Nathalia, 3638. One commercial goods vehicle (L/C 6.45 tonne) to operate: (a) Within an 80-km radius from the post office at Nathalia—plant the property of a contractor and required by him for use in connection with the construction or maintenance of some specific, existing or proposed road, street, footpath, bridge, wharf, pier, or channel and also the following materials, viz: metal, stones, screenings, ashes, gravel and earth. (b) Within a 32-km radius from the site of any construction or maintenance work performed pursuant to paragraph (a) above, or from the railway station nearest thereto—any other materials required for such work. (c) Within a 40-km radius of the post office at Nathalia—general goods.
- DUNSTAN, M. V.,** Racecourse Road, Marysville, 3779. One commercial goods vehicle (L/C 13.50 tonne) to operate: (a) From bush sites within 16-km radius of Narbethong to the Mill of Alexandra Timber Treatment Co. Pty. Ltd. at Narbethong in course of business as "Logging Contractor"—logs. (b) From bush sites within a 16-km radius of Narbethong to the premises of Smorgon Consolidated Industries Pty. Ltd. at Brooklyn in course of business as "Logging Contractor"—logs.
- ETHERIDGE, G. A. PTY. LTD.,** 15 Armstrong Street, North Ballarat, 3350. One commercial goods vehicle (L/C 0.70 tonne) to operate within that part of the State of Victoria west of a line drawn due north and south through the township of Myrning and south of a line drawn due east and west through the township of Castlemaine in the course of business as "Electrical Appliance Servicemen"—tools of trade, spare parts, washing machines for repair or having been repaired.
- GIBBS, E. G.,** 62 Alamein Street, Morwell, 3840. Application to vary the conditions of licence No. D.A.60951 (L/C 3.70 tonne) to operate as follows—(a) Within an 80-km radius of the post office at Morwell—plant the property of a contractor and required by him for use in connection with the construction or maintenance of some specific, existing or proposed road, street, footpath, bridge, pier, wharf, weir or channel and also the following materials viz: metal, stones, screenings, ashes, gravel, sand and earth. (b) Within a 32-km radius from the site of any construction or maintenance work performed pursuant to paragraph (a) above or from the railway station nearest thereto—any other materials required for such work.
- GOYEN, K., PTY. LTD.,** 15 Eddington Street, Warrnambool, 3280. One commercial goods vehicle (L/C 0.75 tonne) to operate throughout the State of Victoria in the course of business as "Crane Hire Specialists" for the purpose of supervising own crane hire contracts and servicing own equipment—tools of trade, crane parts and spare parts incidental to on-site servicing.
- HATLEY, G. E.,** Box 121, Hopetoun, 3396. One commercial goods vehicle (L/C 7.15 tonne) to operate within an 80-km radius of Hopetoun in course of business as "Earthmoving Contractor"—own earthmoving plant and equipment.

Notice is hereby given that the following applications will be considered by the Transport Regulation Board on 10th June, 1975.

- HEARPS, N. J., 6 Raymond Avenue, Bendigo, 3550. One commercial-goods vehicle (L/C. 0.50 tonne) to operate throughout the State of Victoria in the course of business as "Farrier" for the purpose of attending race meetings—tools of trade, horse shoes and materials incidental to such work on-site also own horses in specially constructed horse float.
- JOHNSON, B. S., 99 Boundary Road, Orbost, 3888. One commercial goods vehicle (L/C. 16.85 tonne) to operate: (a) Within a 40-km radius of the post office at Cabbage Tree—general goods. (b) From forest landings in the Cooloongook logging area to Brooms Sawmill Pty. Ltd. at Cabbage Tree—logs.
- KEE, R. A. (trading as R. & B. Kee Transport), 48 Granya Grove, Mt. Eliza, 3930. One commercial goods vehicle (L/C. 12.75 tonne) to operate: (a) Within a 40-km radius of the G.P.O., Melbourne as an "Exclusive Carrier" solely on behalf of Corinthian Industries (Vic.) Pty. Ltd.—Importers and Manufacturers of doors and associate fittings—raw materials for the manufacture of doors and door jambs and manufactured doors, door jambs, mouldings and associated fittings. (b) From the premises of Corinthian Industries (Vic.) Pty. Ltd. at Dandenong to places on the Mornington Peninsula—doors, door jambs, mouldings and associated fittings.
- NELSON, M. J. (trading as Kyabram Removals & Storage), 7 Haslem Street, Kyabram, 3620. Two commercial goods vehicles (L/C. 3.90, 3.95 tonne) to operate: (a) Throughout the State of Victoria for the carriage of household furniture, being furniture or personal effects of a householder or a member of his family when being moved from residence to residence, from residence for storage or sale, from storage to residence, from a vendor to the residence of the purchaser. (b) Items as per new furniture list.
- LAWLER, J. C. (trading as Latrobe Valley Wholesale Agencies), 54 Langford Street, Moe, 3825. One commercial goods vehicle (L/C. 2.59 tonne) to operate: (a) Within an 80-km radius from own premises at Moe in the course of business as "Wholesale Merchants"—own goods. (b) From own premises at Moe to Nationwide Field Catering at Lakes Entrance—groceries. (c) Within an 80-km radius from own premises at Moe and to consignees at Cowes as a "Distribution Agent" on behalf of Phoenix Biscuit Co. Pty. Ltd.—biscuits.
- MCGOWAN, J. R., Flat 3, 36 Rosella Street, Murrumbena, 3163. One commercial goods vehicle (L/C. 7.35 tonne) to operate within a 112-km radius of the premises of Northcote Brick Co. at Northcote on behalf of the said company—bricks.
- MESITI, G., 19 Garfield Street, St. Albans, 3021. One commercial goods vehicle (L/C. 14.39 tonne) to operate within a 56-km radius of the G.P.O., Melbourne on behalf of Pioneer Quarries (Vic.) Pty. Ltd.—sand, soil, screenings, premix and quarry products.
- NESTLE COMPANY (AUST.) LTD., THE, Tongala, 3621. Two commercial goods vehicles (L/C. 19.30, 19.50 tonne) to operate: (a) In the course of business as an approved decentralized secondary industry (manufacture and processing of food products) carried on by the Nestle Company (Australia) Limited at Tongala. (i) To the factory at Tongala from points within the State of Victoria—goods and materials incidental to the manufacturing processes of such industry. (ii) From the said premises at Tongala—own manufactured and processed products. (b) Goods associated with subsidiary company Girgarre Cheese Co. Pty. Ltd. Girgarre, an approved decentralized secondary industry (manufacturers of milk products) carried on at the factory premises at Girgarre and Stanhope. (i) To the factories—goods required in the manufacturing processes of such industries. (ii) From the factories—manufactured products of such decentralized industries. (c) Goods associated with own approved decentralized secondary industry (manufacturers of food products) carried on at the factory premises at Dennington as follows—(i) To the factory—goods required in the manufacturing process of such industry. (ii) From the factory—manufactured products of such decentralized industry. (d) Goods associated with own approved decentralized secondary industry (manufacturers of food products) carried on at the factory premises at Maffra as follows—(i) To the factory—goods required in the manufacturing process of such industry. (ii) From the factory—manufactured products of such decentralized industry.
- NORTH EASTERN LAUNDRY & DRY CLEANERS LTD., 43 Grant Street, Alexandra, 3714. One commercial goods vehicle (L/C. 1.00 tonne) to operate within an 80-km radius of own premises at Alexandra in the course of business "Launderers"—clothing and materials for laundering or dry cleaning, or having been laundered or dry cleaned.
- O'CONNOR, J. P., Willung South, 3844. Application to vary the conditions of licence No. D.A.47783/3 (L/C. 16.05 tonne) by adding as an additional paragraph (c) "Throughout the State of Victoria—own livestock when being carried from or to own farms or agistment.
- PARKER, W. R., 13 Thorpe Street, California Gully, Bendigo, 3550. One commercial goods vehicle (L/C. 0.75 tonne) to operate throughout the State of Victoria in the course of business as "Electrical Contractor" for the purpose of supervising the installation and servicing of electrical equipment—tools of trade, spare parts and materials incidental to own contracts.
- NOTE.—No materials shall be carried from places within a 40-km radius of the post office at the corner of Bourke and Elizabeth Streets, Melbourne.
- PHYLLIS SHOES PTY. LTD., 208 Kerr Street, Fitzroy, 3065. Application to vary the conditions of licence No. D.A.66167 (L/C. 0.85 tonne) by deleting "Rutherglen" from paragraph (b) and adding in lieu "Morwell".
- QUIRKS ACCEPTANCE PTY. LTD., Nantilla Road, Clayton, 3168. One commercial goods vehicle (L/C. 0.75 tonne) to operate throughout the State of Victoria in the course of business as "Refrigeration Engineers" for the purpose of servicing and supervising the installation of refrigeration plant—tools of trade, spare parts and materials incidental to on-site servicing.
- RICHARDSON, D. & SONS LIMITED, 330 Ballarat Road, Braybrook, 3019. One commercial goods vehicle (L/C. 0.75 tonne) to operate throughout the State of Victoria in the course of business as "Manufacturing Engineers" for the purpose of servicing engineering equipment manufactured by the company—tools of trade, spare parts and materials incidental to on-site servicing.
- TREVASKIS, L. J., Wairewa, via. Nowa Nowa, 3887. One commercial goods vehicle (L/C. 4.45 tonne) to operate: (a) Within an 80-km radius of Wairewa in the course of business as "Earthmoving Contractor"—own plant, equipment, machinery, spare parts and tools of trade. (b) Within a 40-km radius of site of any construction in area specified in paragraph (a)—rocks, screenings, gravel, sand and filling in connection with own contracts.
- TROTTER, R. C., Carlisle River, 3239. Application to vary the conditions of licence No. D.T.1094/5 (L/C. 13.35 tonne) by deleting from paragraph (b) the words "32 kilometres" and adding in lieu "40 kilometres".
- WEIRE, J., 99 Barry Street, Romsey, 3434. One commercial goods vehicle (L/C. 7.50 tonne) to operate: (a) From or to the metropolitan area (as defined in the Commercial Goods Vehicles Act 1958) to or from places on either side of the main Melbourne/Lancefield Road between and including the townships of Clarfield and Lancefield—general goods. (b) To or from the metropolitan area as prescribed in paragraph (a) above to or from places within a 16-km radius from the post office at Lancefield—general goods.
- WRIGHT, R. E. (trading as R. E. & S. R. Wright), Goulburn Valley Highway, Murchison East, 3610. One commercial goods vehicle (L/C. 7.65 tonne) to operate: (a) Within an 80-km radius from the post office at Murchison East—plant the property of a contractor and required by him for use in connection with the construction or maintenance of some specific, existing or proposed wharf, road, street, footpath, bridge, pier, weir or channel and also the following materials viz.: metal, stones, screenings, ashes, gravel, sand and earth. (b) Within a 32-km radius from the site of any construction or maintenance work performed, pursuant to paragraph (a) above, or from the railway station nearest thereto—any other materials required for such work. (c) Within a 40-km radius of the post office at Murchison East—general goods.

RENEWALS.

Applications for renewal of licences as shown by persons listed hereunder to operate under the same terms and conditions from the expiry shown in each case.

ATKINSON, G. J. & D. A., 70 Latrobe Road, Morwell, 3840; T.D.A.67096; 5th November, 1975; 3.95 tonne and 1.40 tonne trailer.

BELLINGHAM, D. R. & M. R., 5 Shingler Street, Leongatha, 3953; D.A.54062/1; 27th September, 1975; 3.60 tonne.

DAVIES, C. L. (trading as Bendigo Disposals), 371 Hargreaves Street, Bendigo, 3550; T.D.A.4621/1; 25th November, 1975; 0.85 tonne; T.D.A.4621/2; 2nd November, 1975; 0.85 tonne.

BLACKWOOD, N. A., 169 Sutton Street, Warragul, 3820; D.T.138/2; 7th June, 1975; 16.70 tonne.

BLENNERHASSETT, J., 33 Koonwarra Road, Leongatha, 3953; D.A.60463; 14th March, 1975; 12.90 tonne.

BRIGHT, R. G. & M. R., Dumbalk, 3956; D.A.37059; 12th October, 1975; 11.60 tonne.

BRISCOE, M. I., 56 Baromi Road, Mirboo North, 3871; D.A.49412; 1st July, 1975; 8.20 tonne.

BUCKLAND, N. E. & E. V., Box 62, Kangaroo Flat, 3555; D.A.61212; 23rd October, 1975; 14.85 tonne.

BYTSCHKOW, S. J., Eskdale, 3701; D.A.66155/1; 20th November, 1975; 7.55 tonne.

CLAVARINO, L. L. & G. N., 99 Station Road, Foster, 3960; D.A.60199/2; 18th October, 1975; 7.40 tonne.

CONNOLEY, T. G. & M. T. & HANNEYSEE, M. J. & M. E., Box 85, North Geelong, 3215; T.D.A.65627/2; 1st October, 1975; 2.40 tonne and 1.30 tonne trailer.

COTTIER, R. L. (trading as R. L. & M. A. Cottier), 9 Johnson Street, Drouin, 3818; D.T.1445; 9th August, 1975; 15.70 tonne.

CUTHERBERTSON & RICHARDS SAWMILLS PTY. LTD., Hope Street, Drouin, 3818; T.D.A.43930/3; 30th July, 1975; 12.10 tonne.

DAWSON, A. J., PTY. LTD., P.O. Box 11, Warragul, 3820; D.A.66480; 28th September, 1975; 10.75 tonne.

DERHAM, I. T., 37 Gordon Street, Traralgon, 3844; D.A.64731; 31st August, 1975; 11.30 tonne.

DUNSTAN, A., LOGGING CO. PTY. LTD., 1 Tallangatta Road, Wodonga, 3690; D.A.1011/6; 29th November, 1975; 1.05 tonne.

FINLAYSON, D. E. (trading as J. R. Finlayson & Sons), Box 16, Shepparton, 3630; D.A.1076/1; 3rd November, 1975; 0.55 tonne.

FIRESTONE SALES PTY. LTD., 36 Malua Street, Reservoir, 3073; T.D.A.61680/21; 28th September, 1975; 0.95 tonne.

GARDNER, D. M., Main Street, Buln Buln, 3821; D.A.66271; 27th September, 1975; 12.35 tonne.

GIBBS, E. G., 62 Alamein Street, Morwell, 3840; D.A.60951; 24th July, 1975; 6.80 tonne.

HALLYBURTON, T. J., 32 Peart Street, Leongatha, 3953; D.A.49728; 5th August, 1975; 3.80 tonne.

HARRIDGE, R. E., Fitzgibbons Road, Tyers, 3844; D.T.1588; 19th June, 1975; 11.23 tonne.

HIGHLAND PLANT HIRE PTY. LTD., Princes Highway, Morwell, 3840; D.A.30224/8; 28th September, 1975; 0.80 tonne.

HIGHLAND PLANT HIRE PTY. LTD., Princes Highway, Morwell, 3840; D.A.30224/9; 28th September, 1975; 0.90 tonne.

HILLBERG, M. F., Kilcunda Road, Bena, 3946; D.A.60886; 10th July, 1975; 3.15 tonne.

HORTON, B. G., Cansick Street, Rosedale, 3842; D.A.60995/2; 27th September, 1975; 7.55 tonne.

HOUGHTON & BYRNE PTY. LTD., 22 Nicholson Street, East Brunswick, 3057; D.A.43077/27; 22nd March, 1975; 0.50 tonne.

JEFFREY, J. & SONS PTY. LTD., Princes Highway, Morwell, 3840; D.A.32735/5; 20th July, 1975; 11.90 tonne.

KRIEGER, N. A., 78 Shakespeare Street, Traralgon, 3844; D.A.36778; 21st September, 1975; 6.85 tonne.

KRIEGER, N. G., 84 Shakespeare Street, Traralgon, 3844; D.A.54911/1; 9th August, 1975; 7.85 tonne.

LATROBE VALLEY CORDIAL & CONFECTIONERY CO. PTY. LTD., 31 Hotham Street, Traralgon, 3844; D.A.63078/1; 19th July, 1975; 1.60 tonne.

LOE, A. G. F. (trading as A. M. Loe & Co.), 13-15 Broomfield Street, Shepparton, 3630; T.T.D.1053/2; 10th September, 1975; 16.25 tonne.

LOVE, C. V., 54 Stanhope Street, Broadmeadows, 3047; D.A.65536; 9th October, 1975; 6.55 tonne.

DEMARIA, G. (trading as DeMaria Motors), Station Street, Cobram, 3644; D.A.62119/1; 2nd November, 1975; 0.75 tonne.

DEMERLO, C. A. (trading as DeMerlo Bros.), Middle Street, Tarwin, 3956; D.A.62609/2; 13th September, 1975; 6.90 tonne.

ODD, P. J., 14 D'alton Street, Stawell, 3380; D.A.64722; 7th September, 1975; 0.95 tonne.

PERRETT, M. J., Marshalltown Road, Marshall, 3221; D.A.64846; 8th November, 1975; 0.70 tonne.

PUMP & RAEBURN, 13 Hazelwood Road, Traralgon, 3844; D.A.61165; 9th October, 1975; 1.60 tonne.

READS SEPTIC TANK CLEANING SERVICE PTY. LTD., Lot 2, Ordish Road, Dandenong, 3175; D.A.62947/5; 18th October, 1975; 4.90 tonne.

R. & F. DRILLING CO. PTY. LTD., 7 Earlwood Drive, Mulgrave, 3170; D.A.65867, 13th September, 1975; 3.85 tonne.

SEKAC, John (trading as John & Dawn Kathleen Sekac), 13 Folkstone Crescent, Ferntree Gully, 3156; D.A.67669; 6th May, 1975; 4.85 tonne.

SOUTH GIPPSLAND EXCAVATING CO. PTY. LTD., 203 White Road, Wonthaggi, 3995; D.A.49418; 1st July, 1975; 11.70 tonne.

STAGG, W. E., Midland Highway, Mooroopna, 3629; D.A.61392; 20th November, 1975; 0.80 tonne.

SUTHERLAND, A. H., Stanley Street, Toora, 3962; D.A.61021; 21st August, 1975; 12.85 tonne.

THOMPSONS (CASTLEMAINE) LTD., 5 Parker Street, Castlemaine, 3450; D.A.2156/4; 12th October, 1975; 0.70 tonne.

CONNOLEY, M. T. & T. G., & HANNEYSEE, M. E. & M. J. (trading as Transcar), Box 85, North Geelong, 3215; D.A.65627; 3rd August, 1975; 2.65 tonne & 1.30 tonne trailer.

TYNAN, W. L. & E. M., 6 Breed Street, Traralgon, 3844; D.A.28095/4; 7th June, 1975; 12.40 tonne.

TOW TRUCKS.

KIELLERUP, A. G. & ADAMS, B. J. (trading as Adams Towing Service), 589 Keilor Road, Niddrie, 3042; D.A.50408; 28th October, 1975; 1.65 tonne.

ALBROY SERVICE STATION PTY. LTD., Princes Street, Traralgon, 3844; D.A.47361; 5th August, 1975; 3.50 tonne.

CENTRE TOWING SERVICE, 9 Kay Street, Traralgon, 3844; D.A.48638; 15th July, 1975; 1.50 tonne.

FOSTER MOTORS YALLOURN, 81-83 Lloyd Street, Moe, 3825; D.A.47381; 25th March, 1975; 2.65 tonne.

HEATH MOTORS PTY. LTD. (trading as Geelong Towing Service), 160 Little Malop Street, Geelong, 3220; D.A.35210/12; 28th October, 1975; 4.25 tonne.

HYDRO MOTORS PTY. LTD., 36 Salisbury Street, Orbost, 3888; D.A.46913; 3rd February, 1975; 2.55 tonne.

KELLY BROS. MOTORS MORWELL PTY. LTD., 187-189 Princes Highway, Morwell, 3840; D.A.1416; 28th June, 1975; 2.15 tonne.

RAY, J. C. S. (trading as Local Towing Service) 139 Burwood Road, Hawthorn, 3122; D.A.60180/2; 11th September, 1975; 1.50 tonne.

LOVE, C. V., 54 Stanhope Street, Broadmeadows, 3047; D.A.65536; 28th October, 1975; 6.55 tonne.

TAYLOR, O. & J. E. (trading as O. T. Motors), 19 Main Street, Foster, 3960; D.A.67122/1; 11th June, 1975; 2.70 tonne.

STARK, I. D. (trading as Stark's Auto Body Repairs), 38 Benalla Road, Shepparton, 3630; D.A.66961; 6th November, 1975; 2.85 tonne.

TRELLER, J. F., Main Street, Poowong, 3988; D.A.37991/1; 17th April, 1975; 3.50 tonne.

HARRISON, V. A. (trading as Vals Towing Service) 4 Cope Street, Preston, 3072; D.A.60799/1; 11th September, 1975; 1.85 tonne.

HARRISON, V. A. (trading as Vals Towing Service), 4 Cope Street, Preston, 3072; D.A.60799; 11th September, 1975; 1.25 tonne.

McTIGHE, E. M. (trading as West Gippsland Towing Service), Princes Highway, Darnum, 3822; D.A.64842; 19th May, 1975; 1.90 tonne.

RENEWAL WITH VARIATION.

Application made by the person listed hereunder for renewal of licence listed with variation of conditions in the manner set out opposite the name.

BOMBARDIERI, F. J., 39 Donnington Street, Swan Hill, 3585; D.A.37236/3; 3rd September, 1975; application to renew and vary conditions of licence No. D.A.37236/3 (L/C. 10.65 tonne) by deleting present conditions and adding in lieu—Throughout the State of Victoria in the course of business as "House Removalist" as a specially constructed house removal float—houses, sheds and outbuildings for removal from site to site together with tools of trade and house moving equipment incidental thereto.

Notice of any objection should be forwarded to reach the Secretary of the Board not later than 4th June, 1975.

Applicants are advised that it will not be necessary to appear on the hearing date specified above, unless advised in writing by the Board.

A. V. C. COOK,
Secretary.

Corner Lygon and Princes Streets, Carlton, 3053, Wednesday, 21st May, 1975.

COMMONWEALTH OF AUSTRALIA.

STATE OF VICTORIA.

Petroleum (Submerged Lands) Act 1967-1974.

Petroleum (Submerged Lands) Act 1967.

NOTICE OF SURRENDER OF PERMIT AS TO CERTAIN BLOCKS.

The permit numbered VIC/P6 of which Hematite Petroleum Proprietary Limited is the registered holder has been surrendered in respect of the blocks described hereunder.

Description of Blocks.

The blocks constituted by a graticular section or by part or parts of a graticular section, being a graticular section described hereunder, but not including those blocks or those portions or that portion of a block that lie or lies outside the area described hereunder.

Description of Graticular Sections.

The graticular sections numbered 2519, 2520, 2590 to 2592 both inclusive, 2659 to 2664 both inclusive, 2731 to 2736 both inclusive and 2803A to 2808A both inclusive on the Hamilton Offshore Graticular Sections sheet and the graticular sections numbered 2165 to 2168 both inclusive, 2235 to 2241 both inclusive, 2306 to 2319 both inclusive, 2377 to 2393 both inclusive, 2449 to 2468 both inclusive, 2521 to 2540 both inclusive, 2593 to 2613 both inclusive, 2665 to 2689 both inclusive and 2737A to 2761A both inclusive on the Melbourne Offshore Graticular Sections sheet, shown on the plan hereunder.

Description of Area.

The area included in the following boundaries:

Commencing at a point Latitude 39 deg. 12 min. South, Longitude 146 deg. 05 min. East, thence along the parallel of Latitude 39 deg. 12 min. South to the intersection with meridian of Longitude 143 deg. 30 min. East; thence along the meridian of Longitude 143 deg. 30 min. East to the point of Latitude 39 deg. 05 min. South, Longitude 143 deg. 30 min. East; thence proceeding in sequence along a series of geodesics joining the following points:—

Latitude 39 deg. 05 min. South, Longitude 143 deg. 30 min. East to Latitude 39 deg. 04 min. South, Longitude 143 deg. 38 min. East to Latitude 39 deg. 02 min. South, Longitude 143 deg. 43 min. East to Latitude 38 deg. 55 min. South, Longitude 143 deg. 53 min. East to Latitude 38 deg. 52 min. South, Longitude 144 deg. 01 min. East to Latitude 38 deg. 40 min. South, Longitude 144 deg. 14 min. East to Latitude 38 deg. 34 min. South, Longitude 144 deg. 26 min. East to Latitude 38 deg. 30 min. South, Longitude 144 deg. 31 min. East to Latitude 38 deg. 35 min. South, Longitude 144 deg. 38 min. East to Latitude 38 deg. 38 min. South, Longitude 144 deg. 40 min. East to Latitude 38 deg. 42 min. South, Longitude 144 deg. 46 min. East to Latitude 38 deg. 43 min. South, Longitude 144 deg. 51 min. East to Latitude 38 deg. 43 min. South, Longitude 144 deg. 55 min. East;

thence along the meridian of Longitude 144 deg. 55 min. East to the point Latitude 38 deg. 40 min. South, Longitude 144 deg. 55 min. East; thence proceeding in sequence along a series of parallels of latitude and meridians of longitude joining the following points:—

Latitude 38 deg. 40 min. South, Longitude 144 deg. 55 min. East to Latitude 38 deg. 40 min. South, Longitude 145 deg. 25 min. East to Latitude 38 deg. 50 min. South, Longitude 145 deg. 40 min. East to Latitude 39 deg. 00 min. South, Longitude 145 deg. 40 min. East to Latitude 39 deg. 00 min. South, Longitude 145 deg. 40 min. East to Latitude 39 deg. 00 min. South, Longitude 145 deg. 40 min. East to Latitude 39 deg. 05 min. South, Longitude 145 deg. 45 min. East to Latitude 39 deg. 05 min. South, Longitude 146 deg. 05 min. East thence along the meridian of Longitude 146 deg. 05 min. East to the point of origin.

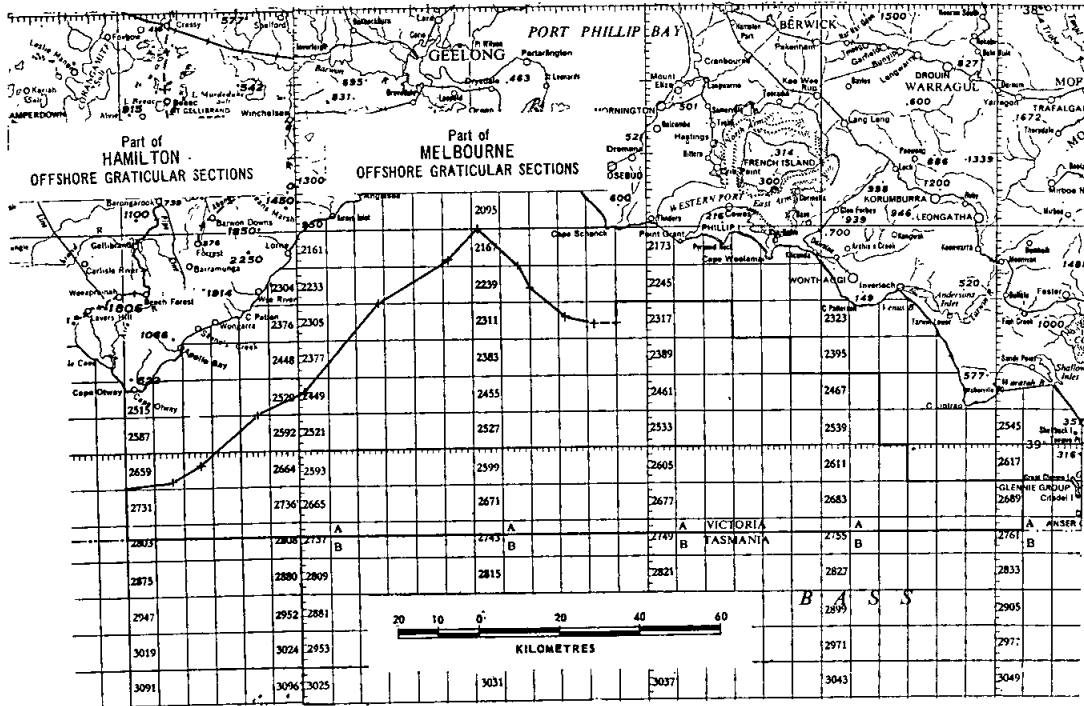

Dated this 14th day of May, 1975.

Made under the Petroleum (Submerged Lands) Act 1967-1974 of the Commonwealth of Australia. Made under the Petroleum (Submerged Lands) Act 1967 of the State of Victoria.

JIM BALFOUR, Designated Authority.

Private Agents Act 1966.

NOTICE OF RECEIPT OF APPLICATIONS FOR LICENCES UNDER THE PROVISIONS OF THE PRIVATE AGENTS ACT 1966.

The Clerk(s) of the Magistrates' Court(s) as listed hereunder hereby give notice that applications, as under, have been lodged for hearing by the said Court(s) on the date(s) specified.

Any person desiring to object to any of such applications must—

- (a) lodge with the respective Clerk of the Magistrates' Court a notice in the prescribed form of his objection and of the grounds thereof;
- (b) cause a copy of such notice to be served personally or by post upon the applicant at least three days before the hearing of the application; and
- (c) send or deliver—
 - (i) where the objection is not made by the officer in charge of the police district in which the Court is situated—a copy of the notice to such officer; and
 - (ii) where the objection is not made by the Registrar or Deputy Registrar—a copy to the Registrar.

Full Name of Applicant or in the Case of a Firm or Corporation, of the Nominee.	Place of Abode of Applicant or Nominee.	Name of Firm or Corporation.	Address for Registration.	Type of Licence.	Date of Hearing of Application.
---	---	------------------------------	---------------------------	------------------	---------------------------------

MAGISTRATES' COURT, FOOTSCRAY.

Potter, John Francis ..	3/1A Waiora Parade, West Footscray			Process Server ..	4.6.75
-------------------------	------------------------------------	--	--	-------------------	--------

Dated at Footscray this 7th day of May, 1975.

P. W. WESTMORE, Clerk of the Magistrates' Court.

MAGISTRATES' COURT, HAWTHORN.

Cerritelli, Alberto ..	32 Harold Street, Bulleen	Mayne Nickless ..	769 Glenferrie Road, Hawthorn	Watchman ..	5.6.75
Wright, John Kane ..	3 Arapilles Drive, Lower Templestowe	" " ..	" " "	" ..	"
Hanley, Patrick William ..	44 Gwent Street, Springvale	Security Watching Co. P/L.	330 Auburn Road, Hawthorn	" ..	"

Dated at Hawthorn this 6th day of May, 1975.

J. GIDLEY, Clerk of the Magistrates' Court.

MAGISTRATES' COURT, HAWTHORN.

Woodward, Ivan ..	1728 Mt. Alexander Road, Flemington	Security Watching Company	330 Auburn Road, Hawthorn	Watchman ..	11.6.75
Rees, Peter ..	35 Warragul Street, Dallas	" " "	" " "	" ..	18.6.75

Dated at Hawthorn this 7th day of May, 1975.

J. GIDLEY, Clerk of the Magistrates' Court.

MAGISTRATES' COURT, GEELONG.

Robinson, Deles Charles ..	133 McKillop Street, Geelong	Mobile Surveillance Services, Geelong	22 James Street, Geelong	Watchman ..	29.5.75
----------------------------	------------------------------	---------------------------------------	--------------------------	-------------	---------

Dated at Geelong this 8th day of May, 1975.

J. E. REILLY, Clerk of the Magistrates' Court.

MAGISTRATES' COURT, OAKLEIGH.

Morris, Keith Trevor ..	36 Mangana Drive, Mulgrave	Mulgrave Security Group	Suite 8, Latham Building, 6-8 Hamilton Place, Mount Waverley	Watchmans ..	30.5.75
-------------------------	----------------------------	-------------------------	--	--------------	---------

Dated at Oakleigh this 8th day of May, 1975.

A. J. JOHNSON, Clerk of the Magistrates' Court.

MAGISTRATES' COURT, PRAHRAN.

Leffler, Heinz Julius Friederich	29 Chusan Street, Balaclava	David C. Whites Associates P/L.	Suite 18-19/65 Queens Road, Melbourne	Commercial Sub-Agent	30.5.75
La Combre, Russell Bernard ..	30 Mudgee Street, East Burwood	Security Pacific ..	Suite 1/765 Punt Road, Sth. Yarra	Watchman ..	"

Dated at Prahran this 7th day of May, 1975.

J. McSWEENEY, Clerk of the Magistrates' Court.

MAGISTRATES' COURT, BOX HILL.

Birmingham, William Richard	20 Cootamundra Crescent, Blackburn	Nimrod Security ..	20 Cootamundra Crescent, Blackburn.	Guard Agent ..	23.5.75
" " "	" " "	" " "	" " "	Inquiry Agent ..	"

Dated at Box Hill this 2nd day of May, 1975.

P. CLOTHIER, Clerk of the Magistrates' Court.

MAGISTRATES' COURT, PORT MELBOURNE.

Marshall, Robert James ..	4/5 Simmons Court, South Yarra	Mayne Nickless Limited	538 Williamstown Road, Port Melbourne	Watchman ..	10.6.75
Bainbridge, Neville Colin ..	54 Mont Albert Road, Canterbury	" " "	" " "	" ..	"
Siberas, Mark Charles ..	67 Poole Street, Deer Park	" " "	" " "	" ..	"

Dated at Port Melbourne this 9th day of May, 1975.

JOHN ARDLIE, Clerk of the Magistrates' Court.

PRIVATE AGENTS—continued.

Full Name of Applicant or in the Case of a Firm or Corporation, of the Nominee.	Place of Abode of Applicant or Nominee.	Name of Firm or Corporation.	Address for Registration.	Type of Licence.	Date of Hearing of Application.
MAGISTRATES' COURT, CAMBERWELL.					
Baker, John	1132 Toorak Road, Hartwell	Burwood Security Service	1132 Toorak Road, Hartwell	Guard Agents ..	11.6.75
Dated at Camberwell this 14th day of May, 1975.					
J. C. TOBIN, Clerk of the Magistrates' Court.					
MAGISTRATES' COURT, OAKLEIGH.					
Pedrotti, Angelo Francis ..	The Shade Caravan Park	Mayne Nickless Ltd.	72 Atkinson Street, Oakleigh	Watchman ..	13.6.75
Dated at Oakleigh this 14th day of May, 1975.					
B. R. JENNINGS, Clerk of the Magistrates' Court.					
MAGISTRATES' COURT, MELBOURNE.					
Wood, Eugene Ernest Creswick	121 Powlett Street, East Melbourne	121 Powlett Street, East Melbourne	Process Server Individual ..	25.6.75
Dated at Melbourne this 12th day of May, 1975.					
G. L. WEBSTER, Clerk of the Magistrates' Court.					
MAGISTRATES' COURT, COBURG.					
Uren, Peter Lionel	5 Sutton Bundoora Court	Mayne Nickless Ltd.	94 York Street, South Melbourne	Watchman ..	18.6.75
Dated at Coburg this 9th day of May, 1975.					
B. MANSBRIDGE, Clerk of the Magistrates' Court.					
MAGISTRATES' COURT, MOONEE PONDS.					
Jilla, Homi Nasserwanji ..	2/22 Grandison Street, Moonee Ponds	2/22 Grandison Street, Moonee Ponds	Watchman ..	4.6.75
Dated at Moonee Ponds this 13th day of May, 1975.					
IAN SIMMONS, Clerk of the Magistrates' Court.					
MAGISTRATES' COURT, SHEPPARTON.					
Benson, Derek James ..	25 Railway Street, Euroa	9 Rimes Court, Shepparton	Watchman ..	6.6.75
Dated at Shepparton this 12th day of May, 1975.					
H. P. B. KING, Clerk of the Magistrates' Court.					
MAGISTRATES' COURT, GEELONG.					
McKenzie, Neville Charles ..	4 Elliot Avenue, Highton	4 Elliot Avenue, Highton	Process Server ..	30.5.75
Joksimovic, Zivomir ..	12 Cheltenham Street, Newcomb	Mobile Surveillance Service, Geelong	22 James Street, Geelong	Watchman
Dated at Geelong this 9th day of May, 1975.					
J. E. REILLY, Clerk of the Magistrates' Court.					
MAGISTRATES' COURT, PRAHRAN.					
Peters, Michael Vaughan ..	68 Kingsclere Avenue, Noble Park	Security Pacific ..	Suite 1, 765 Punt Road, South Yarra	Watchman ..	6.6.75
Dated at Prahran this 16th day of May, 1975.					
J. McSWEENEY, Clerk of the Magistrates' Court.					
MAGISTRATES' COURT, CAMBERWELL.					
Gribble, Leigh Denison ..	4 Coronation Street, Mt. Waverley	250 Canterbury Road, Hills Surrey	Inquiry ..	11.6.75
Dated at Camberwell this 15th day of May, 1975.					
J. C. TOBIN, Clerk of the Magistrates' Court.					
MAGISTRATES' COURT, MELBOURNE.					
Wood, Eugene Ernest Creswick	121 Powlett Street, East Melbourne	121 Powlett Street, East Melbourne	Inquiry Agent ..	25.6.75
Dated at Melbourne this 14th day of May, 1975.					
G. L. WEBSTER, Clerk of the Magistrates' Court.					
MAGISTRATES' COURT, BALLARAT.					
Hooper, Gregory Wayne ..	9 Molbray Wendouree Street	9 Molbray Street, Wendouree	Process Server ..	24.6.75
Dated at Ballarat this 15th day of May, 1975.					
D. L. CROFT, Clerk of the Magistrates' Court.					
MAGISTRATES' COURT, CARLTON.					
Abrahamsen, Malcolm Roy ..	4 Heath Street, Pascoe Vale	100 Drummond Street, Carlton	Process Server ..	5.6.75
" " " ..	" " "	Equitable Mercantile Pty. Ltd.	" " "	Inquiry Agent Commercial Sub-Agent ..	" "
Dated at Carlton this 14th day of May, 1975.					
L. D. PILGRIM, Clerk of the Magistrates' Court.					

PRIVATE AGENTS—continued.

Full Name of Applicant or in the Case of a Firm or Corporation, of the Nominee.	Place of Abode of Applicant or Nominee.	Name of Firm or Corporation.	Address for Registration.	Type of Licence.	Date of Hearing of Application.
---	---	------------------------------	---------------------------	------------------	---------------------------------

MAGISTRATES' COURT, FERNTREE GULLY.

Fagan, Francis James	114 Kanooka Road, Boronia West		116 Kanooka Road, Boronia West	Process Server	4.6.75
----------------------	--------------------------------	--	--------------------------------	----------------	--------

Dated at Ferntree Gully this 12th day of May, 1975.

T. BEDOHAZY, Clerk of the Magistrates' Court.

MAGISTRATES' COURT, HAWTHORN.

Morrison, David	17 Moyne Crescent, Coolaroo	Security Watching Co. Pty. Ltd.	330 Auburn Road, Hawthorn	Watchman	9.6.75
Armstrong, George Ronald	8 Barton Street, Doncaster	Mayne Nickless Ltd.	769 Glenferrie Road, Hawthorn	"	"
Kennedy, Rod	208/253 Hoddle Street, Abbotsford	Security Watching Co. Pty. Ltd.	330 Auburn Road, Hawthorn	"	18.6.75
Lester, Noel Deniese	1/39 Swan Walk, Chelsea	" " "	" " "	"	"

Dated at Hawthorn this 15th day of May, 1975.

J. GIDLEY, Clerk of the Magistrates' Court.

CHILDREN'S COURT ACT 1973.

His Excellency the Governor of the State of Victoria by and with the advice of the Executive Council thereof doth by Order made on the 20th day of May, 1975 and pursuant to the provisions of Section 4 (3) of the *Children's Court Act 1973*, appoint the days and hours contained in the Schedule below, Public Holidays excepted, for the holding of Children's Courts at the places named in such Schedule in lieu of the days and hours heretofore appointed—to take effect as from and inclusive of the 2nd June 1975.

SCHEDULE.

Place.	Days and Hours.
HORSHAM	Every Monday, Tuesday, Wednesday, Thursday and Friday, at 2 p.m.
NHILL	Every Monday, Tuesday, Wednesday, Thursday and Friday, at 10 a.m.
STAWELL	Every Monday, Tuesday, Wednesday, Thursday and Friday, at 10 a.m.
WARRACKNABEAL	Every Monday, Tuesday, Wednesday, Thursday and Friday, at 10 a.m.

TOM FORRISTAL,
Clerk of the Executive Council.

At the Executive Council Chamber,
Melbourne, 20th May, 1975.

MAGISTRATES' COURTS ACT 1971.

His Excellency the Governor of the State of Victoria by and with the advice of the Executive Council thereof doth by Order made on the 20th day of May, 1975 and pursuant to the provisions of Section 4 of the *Magistrates' Courts Act 1971*, appoint the days and hours contained in the Schedule below, public holidays excepted, for the holding of Magistrates' Courts at the places named in such Schedule in lieu of the days and hours heretofore appointed—to take effect as on and from the dates shown.

SCHEDULE.

Place.	Days and Hours.
HOPETOUN	Every Monday at 10 a.m. on and from the 2nd June 1975.
MINYIP	Every Friday at 10 a.m. and every fourth Monday at 2 p.m. on and from the 26th May, 1975.

TOM FORRISTAL,
Clerk of the Executive Council.

At the Executive Council Chamber,
Melbourne, 20th May, 1975.

RULES UNDER THE JUSTICES ACT.

SELECTION BY A LAW OFFICER OF THE PLACES AND DAYS AND HOURS FOR HOLDING COURTS (WITHIN THE MEANING OF THE SAID RULES).

I, the undersigned, Vernon Francis Wilcox, a Law Officer of the State of Victoria, in pursuance of the powers conferred upon me by Rule 1 of Chapter III. of the Justices Act Rules 1963, do hereby amend the days and hours selected on 11th December, 1974, and published in the *Government Gazette* dated 18th December, 1974, as indicated in the Schedule hereunder.

SCHEDULE.

Court.	Days and Hours.
MINYIP	Every fourth Monday at 2 p.m., except Public Holidays, in lieu of the days and hours heretofore selected—to take effect as from and inclusive of 26th May, 1975.

Dated at Melbourne this 15th day of May, 1975.

V. F. WILCOX,
Attorney-General.

RULES UNDER THE JUSTICES ACT.

SELECTION BY A LAW OFFICER OF THE PLACES AND DAYS AND HOURS FOR HOLDING COURTS (WITHIN THE MEANING OF THE SAID RULES).

I, the undersigned, Vernon Francis Wilcox, a Law Officer of the State of Victoria, in pursuance of the powers conferred upon me by Rule 1 of Chapter III. of the Justices Act Rules 1963, do hereby select the place, day and hour indicated in the Schedule hereto in addition to the places, days and hours selected on 11th December, 1974 and published in the *Government Gazette* on 18th December, 1974.

SCHEDULE.

Court.	Days and Hours.
RED CLIFFS	Every fourth Tuesday at 10 a.m., except Public Holidays, to take effect as from and inclusive of 10th June, 1975.

Dated at Melbourne this 15th day of May, 1975.

V. F. WILCOX,
Attorney-General.

STATE ELECTRICITY COMMISSION OF VICTORIA.
ELECTRICAL APPROVALS BOARD.

The State Electricity Commission of Victoria hereby gives notice that, pursuant to Regulation 19 of the Electrical Approvals Regulations—Approval of Equipment, 1953, made under Section 51 of the *State Electricity Commission Act 1958*, the following appointment is made:—

PETER NELSON SHAW
to be Acting Registrar of Electrical Equipment vice John Zammit for the period 2nd day of June, 1975 to 19th day of September, 1975, inclusive.

Dated the 16th day of May, 1975.

F. P. CHIPPERFIELD,
Secretary.

Labour and Industry Act 1958, Section 45b.

REFERENCE OF A MATTER TO THE INDUSTRIAL APPEALS COURT.

Notice is hereby given that pursuant to Section 45b of the *Labour and Industry Act 1958* the Minister of Labour and Industry has referred to the Industrial Appeals Court for determination by it the following matter, viz:—

An application to each of the Wages Boards mentioned in the Schedule hereto to amend its Determination by altering the prices and/or rates and the adult minimum wage provisions thereby determined having regard to the decision of the Australian Conciliation and Arbitration Commission given on the 30th day of April, 1975, in the National Wage Case 1975. (C Nos. 1933 and 1978 of 1974).

SCHEDULE.

Aerated Water Trade; Agricultural and Pastoral Workers; Agricultural Implements; Animal Manure; Asbestos Cement Workers; Bedstead and Oven Makers; Biscuit; Boarding School Employees; Boilermakers; Boot; Boot Repairers; Bread Carters; Bread Trade; Bricklayers; Builders' Labourers; Building Sheets (Compressed Straw); Business Equipment (Technical Services); Butchers; Butter Factories and Condenseries; Canteen Workers; Caretakers; Carpenters; Carters and Drivers; Cement; Cement Articles; Cemetery Employees; Chemists Shops; Cleaners; Clerks (Credit Societies); Clothing Trades; Clothing and Footwear Shops; Commercial Clerks; Commercial Travellers; Confectioners; Country Fire Brigade Officers; Country Fire-Fighters; Country Printers; Dairy Farm Workers; Dental Technicians; Dockmens; Draughtsmens; Dyers and Clothes Cleaners; Electrical Trade; Electrical, Furniture and Hardware Shops; Electroplaters; Engineers (Skilled); Engineers and Brassworkers (Unskilled); Engravers; Entertainment Employees (Performers); Excavation or Road Work; Factory Engine-Drivers; Farriers; Fibrous Plasterers; Filemakers; Fire Brick and Refractories; Fire Brigade Officers; Fire-Fighters; Fish; Flock; Floor Coverings (Printed Felt Base); Food Shops; Frozen Goods; Fruit Growers; Fruit Packing; Furnishing Trades; Garden Employees; Gas Meter; General Shops; Graphic Arts; Hairdressers; Horsehair; Hospital Administrative Officers; Hospital Dental Officers; Hospital Managers; Hospital Scientists; Hospital Pharmacists; Hospital Senior Medical Officers; Hotel, Restaurant and Boarding Houses; Ice; Ice Cream; Industrial Gases; Iron and Steel Rolling; Iron-moulders; Jam Trade; Jewellers; Journalists; Kindergarten Assistants; Kindergarten Teachers; Law Clerks; Lift; Lime-burners; Manufacturing Chemists; Marine Stores; Meat Preservers and Vegetable Oil Processors; Mineral Earths; Mining Engine-Drivers; Mothercraft Nurses; Motor Drivers; Motor Requisites; Musicians; Nail Makers; Nickelware; Non-Ferrous Metals; Nurseymens; Optical Workers; Paint and Colour; Painters; Pastrycooks; Pest Control; Photographers; Photographic Goods; Plasterers; Plaster of Paris; Plastic Moulding; Plumbers; Port Emergency Service; Port Security Officers; Pottery; Poultry; Poultry Farm Workers; Pre-Mixed Concrete; Pre-School Play Leaders; Process Engravers; Production Planning; Quarry; Rabbit Processing; Radio; Radio Announcers; Registered Nurses; Retail Dairy; Road Patrolmen's; Roofing Tiles; Rubber Trade; Saltworkers; Sand Pit; Sausage Casings; Scientific and Technical Workers; Seamens; Sewage Distribution; Sewer Builders; Shearing Industry; Slaters and Tilers; Softgoods—Wholesale; Special Service Firemens; Sports Ground Maintenance; Stonecutters; Storemen, Packers and Sorters; Sugar Refiners; Tar and Bitumen; Teachers (Day Training Centres); Tennis Strings; Tile Layers; Tinsmiths; Totalizator Employees; Tow Truck Drivers; Underground Clay Mining; Vegetable Growers; Veterinary Assistants and Animal Attendants; Watch Cases; Watchmakers; Watchmen's; Waterfront Watchmen's; Wharfs and Jetties; Wholesale Grocers; Wire Fence and Tubular Gate; Wire Workers; Wireworking (Rylands & Nastan).

Notice is also given that the Industrial Appeals Court will deal with the aforesaid matter at 10.30 a.m. on Thursday, 22nd May, 1975 at the courtroom situated on the 6th Floor, 160 Queen Street, Melbourne.

Dated at Melbourne, this 15th day of May, 1975.

A. S. DOWLING, Registrar,
Industrial Appeals Court.

INDUSTRIAL AND PROVIDENT SOCIETIES ACT 1958.

Notice is hereby given that a society called the Friendly Societies Stores of Victoria Limited was registered under the provisions of the above Act on 9th May, 1975.

D. J. WATT,
Registrar of Friendly Societies.

Co-operation Act 1958.

CHANGE OF NAME OF A SOCIETY.

Notice is hereby given that King Valley Farming Family Co-operative Limited which was incorporated as a Community Settlement Society under the above-named Act on 26th day of November, 1974, has registered a change of its name and is now incorporated under the name of Siddha Yoga Dham-King Valley Co-operative Limited under the said Act.

Dated at Melbourne this 24th day of April, 1975.

E. P. LIDDELL,
Deputy Registrar of Co-operative Societies.

Co-operation Act 1958.

ARARAT WEST STATE SCHOOL CO-OPERATIVE LIMITED.

BLACKBURN YOUTH PROJECT CO-OPERATIVE LIMITED.

NOTICE OF DISSOLUTION OF SOCIETIES.

Notice is hereby given that I have this day registered the dissolution of the above-named societies and cancelled their registration under the above-named Act.

Dated at Melbourne this 8th day of May, 1975.

E. P. LIDDELL,
Deputy Registrar of Co-operative Societies.

Police Offences Act 1958, No. 6337.

DIVISION 1A.—STATE ADVISORY BOARD ON PUBLICATIONS.

Whereas I have considered reports made to me by the State Advisory Board on Publications under section 180b2 (a) of the Police Offences Act, I, John Frederick Rossiter, Chief Secretary for Victoria, in pursuance of the power vested in me by section 180H (1) of the Police Offences Act hereby determine that the publications prescribed by title in the schedule hereunder shall be classified as restricted publications for the purposes of the abovenamed Act.

SCHEDULE OF PUBLICATIONS.

Title.	Publisher.
Australasian Pleazure No. 115	Herd Publishing
Australian Guys No. 30	Wynyard Mercantile
Australian Guys No. 31	Wynyard Mercantile
Australian Guys No. 32	Wynyard Mercantile
All the Young Girls	Oceana Press
By Appointment Only	Oceana Press
Bleu Climax Crackajack	Bleu Book and Magazine Co.
Special	
Cocksure No. 39	Herd Publishing
Derby Dame	Oceana Press
Gay No. 20	Bertram Horne and Co.
Hard on Therapy	Down Under Publication
Her Sweet Mouth	Down Under Publication
Horny Teachers	Down Under Publication
Kings Cross Whisper No. 199	Group Publication
Money to Blow	Down Under Publication
National Ball No. 60	Wynyard Mercantile
National Ball No. 61	Wynyard Mercantile
National Ball No. 62	Wynyard Mercantile
Panties Aweigh	Oceana Press
Piccolo No. 9	Not shown
Private Climax Crackajack	Bleu Book and Magazine Co.
Special	
Ribald No. 126	Bertram Horne and Co.
Ribald No. 127	Bertram Horne and Co.
Rip Off No. 16	Bertram Horne and Co.
Searchlight No. 105	Searchlight Publications
Screw No. 140	Wynyard Mercantile
Screw No. 141	Wynyard Mercantile
Screw No. 142	Wynyard Mercantile
Selecta No. 4	Bleu Book and Magazine Co.
Sexy Swingers No. 122	Exclusive Publications
Sexy Swingers No. 123	Exclusive Publications

J. F. ROSSITER,
Chief Secretary.

Chief Secretary's Office,
Melbourne, 20th May, 1975.

Public Service Act 1974.

ELECTIONS OF OFFICERS TO BE APPOINTED AS MEMBERS AND DEPUTY MEMBERS OF THE PUBLIC SERVICE BOARD.

Pursuant to the Public Service Board Elections Regulations 1975, I hereby give notice that for the purpose of the elections of the officers to be appointed as Members of the Public Service Board in accordance with sub-sections (2) and (3) of section 6 of the Public Service Act 1974, for the term of office commencing on the 1st August, 1975, and also the elections of a Deputy of each such Member, the following dates are fixed, namely:—

Nomination Day, Tuesday, 10th June, 1975.
Polling Day, Monday, 14th July, 1975.

and I further give notice that Eric Lawrence Richardson be appointed as the Returning Officer to conduct the said elections and that he will receive nominations at his office, State Electoral Office, Old Treasury Building, Spring Street, Melbourne, 3002, not later than Twelve o'clock noon on Nomination Day.

Prescribed forms of nomination may be obtained from the Returning Officer.

R. J. HAMER,
Premier.

COUNTRY ROADS BOARD.

RESOLUTIONS OF THE COUNTRY ROADS BOARD.

The Country Roads Board, in pursuance of the provisions of the Country Roads Act 1958, has passed Resolutions the dates whereof and the terms of which are scheduled hereunder:—

SCHEDULE.
State Highways.

Resolution dated the Fifth day of May, One thousand nine hundred and seventy-five, made pursuant to sections 21 and 74 of the Country Roads Act 1958, declaring the widening of the South Gippsland Highway in the Shire of Korumburra as shown hatched on plan numbered G.P.13591 hereunder to be part of a State highway within the meaning and for the purposes of the said Act.

STATE HIGHWAY
SOUTH GIPPSLAND HIGHWAY
SHIRE OF KORUMBURRA
Lengths in Metres

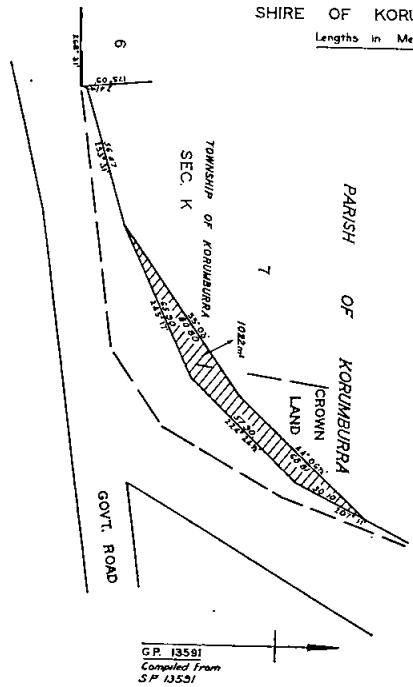

Resolution dated the Fifth day of May, One thousand nine hundred and seventy-five, made pursuant to sections 21 and 74 of the Country Roads Act 1958, declaring the widening of the Henty Highway in the Shire of Wimmera as shown hatched on plan numbered G.P.13792 hereunder to be part of a State highway within the meaning and for the purposes of the said Act.

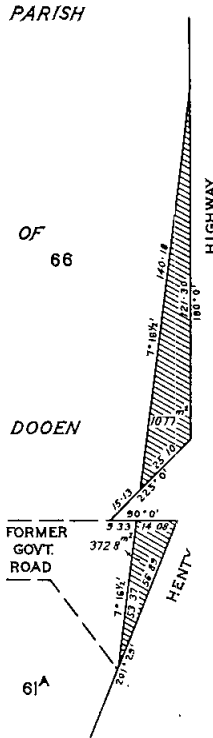

STATE HIGHWAY
HENTY HIGHWAY
SHIRE OF WIMMERA
Lengths in metres

Resolution dated the Fifth day of May, One thousand nine hundred and seventy-five, made pursuant to Section 21 of the Country Roads Act 1958, declaring the widening of Doncaster Road in the City of Camberwell as shown hatched on plan numbered G.P.13050 hereunder to be part of a main road within the meaning and for the purposes of the said Act.

MAIN ROAD
DONCASTER ROAD
CITY OF CAMBERWELL
Measurements in feet & inches

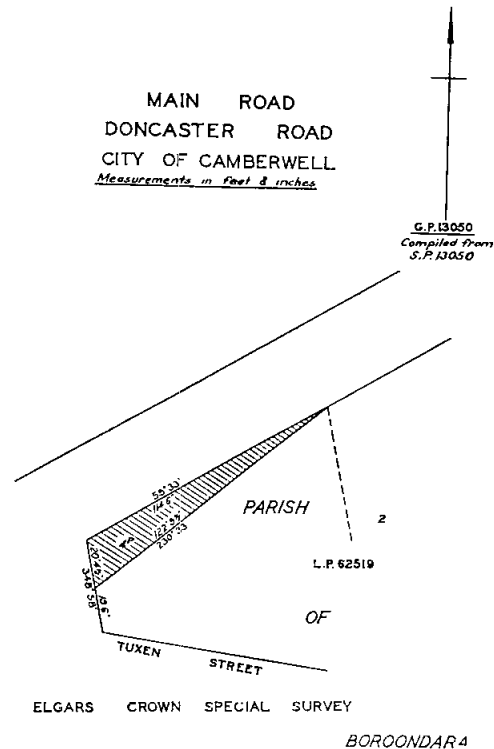

Resolution dated the Fifth day of May, One thousand nine hundred and seventy-five, made pursuant to Section 21 of the *Country Roads Act 1958*, declaring the widening of the Doncaster-Mordialloc Road in the City of Springvale as shown hatched on plan numbered G.P.12422 hereunder to be part of a main road within the meaning and for the purposes of the said Act.

MAIN ROAD
DONCASTER — MORDIALLOC ROAD
CITY OF SPRINGVALE

Measurements in Feet & Ins.

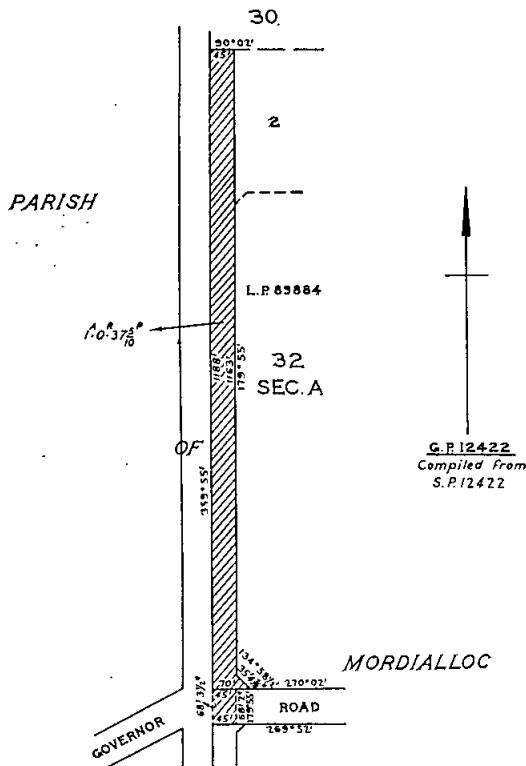

Resolution dated the Fifth day of May, One thousand nine hundred and seventy-five, made pursuant to Section 21 of the *Country Roads Act 1958*, declaring the widening of the Darnum-Allambree Road in the Shire of Warragul as shown hatched on plans numbered G.P.13686A, G.P.13686B, G.P.13686c and G.P.13686d hereunder to be part of a main road within the meaning and for the purposes of the said Act.

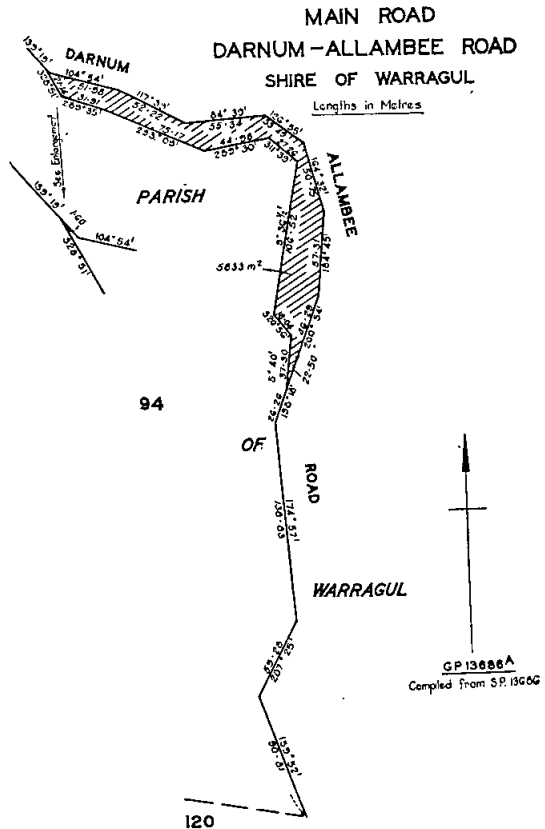

MAIN ROAD
DARNUM — ALLAMBEE ROAD
SHIRE OF WARRAGUL

Lengths in Metres

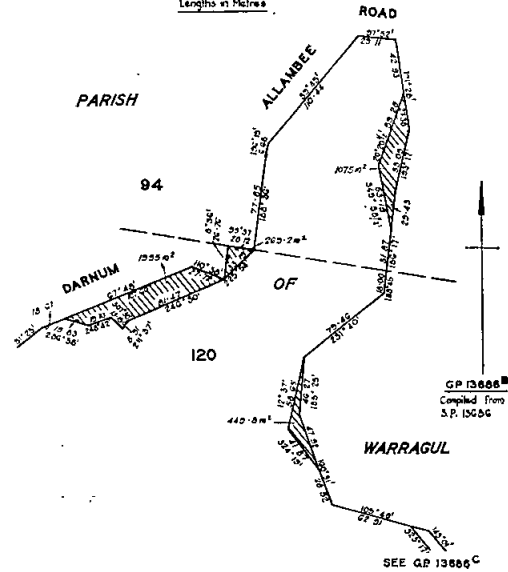

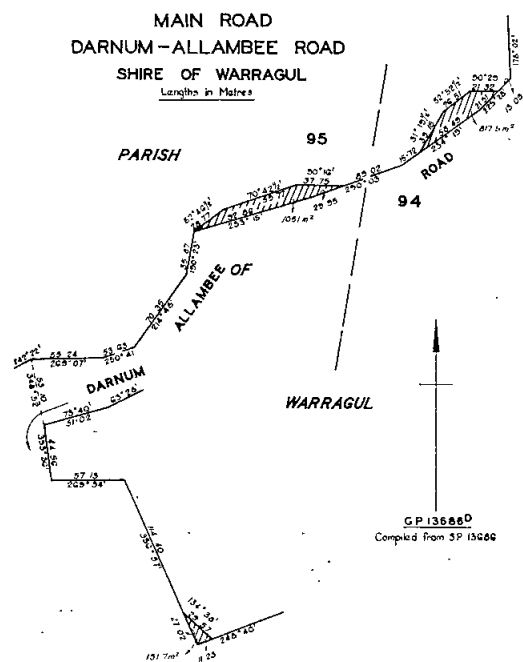
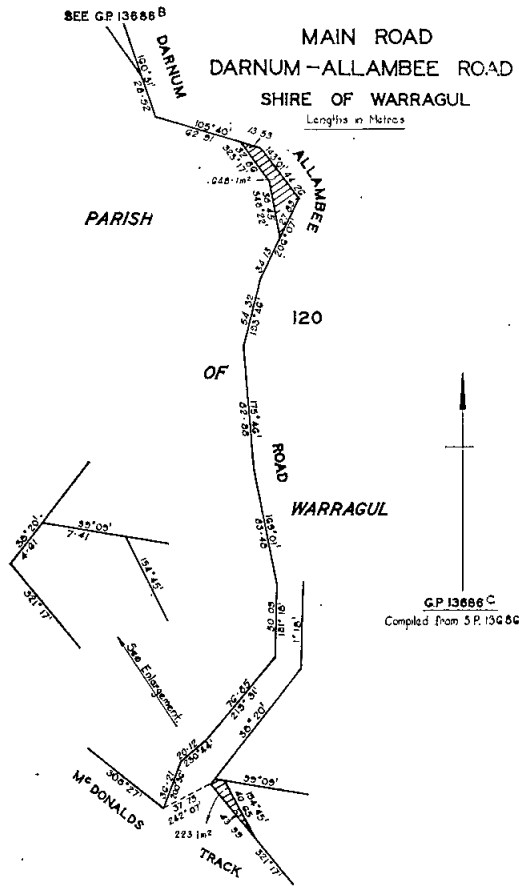

Unclassified Road.

Resolution dated the Fifth day of May, One thousand nine hundred and seventy-five that the Country Roads Board constituted under the *Country Roads Act 1958*, has declared the deviation from the Boort-Wycheproof Road in the Shire of Gordon to be a main road under the said

Act in lieu of an existing road or part thereof, which declaration was published in the *Government Gazette* of the Twenty-fourth day of August, One thousand nine hundred and sixty-six on pages 3120 and 3121 and, in accordance with the provisions of section 58 (1A) of the said Act, declaring that the said existing road or part thereof as shown cross hatched on plan numbered G.P.8708 hereunder shall be discontinued.

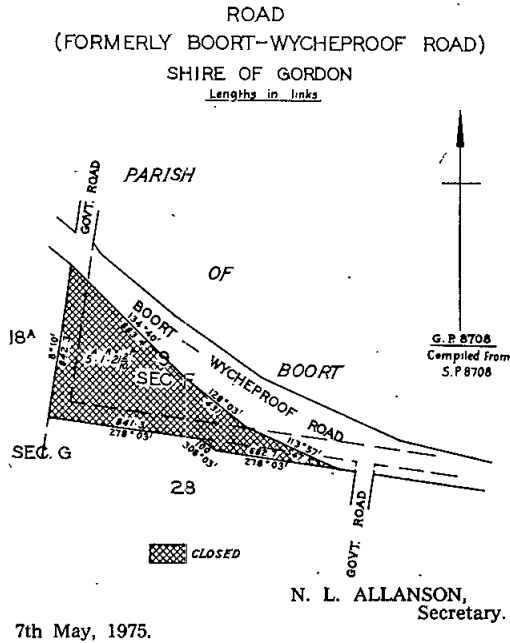

Town and Country Planning Act 1961.
GEELONG PLANNING SCHEME 1959.
 (SHIRE OF BELLARINE.)
 AMENDMENT No. 11B, 1975.
Notice of Amendment.

In pursuance of the powers conferred by sub-section 6 of section 32 of the *Town and Country Planning Act 1961*, the Governor in Council, on the 13th May, 1975, amended the Geelong Planning Scheme to rezone from Agricultural 'A' to Industrial 'B', land contained within the boundaries of Point Henry Road, Station Street and the Portarlington-Geelong Road, and Station Street, the Portarlington-Geelong Road and a Minor Road.

A copy of the amendment may be inspected during office hours at the office of the Town and Country Planning Board, 235 Queen Street, Melbourne; at the office of the Council of the Shire of Bellarine at Drysdale, and when available at the Office of Titles, Melbourne; and at the Central Plan Office of the Department of Crown Lands and Survey, Melbourne.

W. H. CRAIG, Secretary,
 Town and Country Planning Board.

Town and Country Planning Act 1961.
SHIRE OF FLINDERS PLANNING SCHEME 1962.
 AMENDMENT No. 74A, 1974.
Notice of Amendment.

In pursuance of the powers conferred by sub-section 6 of section 32 of the *Town and Country Planning Act 1961*, the Governor in Council, on the 13th May, 1975, amended the Shire of Flinders Planning Scheme to rezone land reserved for a new minor road in the commercial area at Flinders, to Commercial 'A'.

A copy of the amendment may be inspected during office hours at the office of the Town and Country Planning Board, 235 Queen Street, Melbourne; at the office of the Council of the Shire of Flinders at Dromana, and when available at the Office of Titles, Melbourne, and at the Central Plan Office of the Department of Crown Lands and Survey, Melbourne.

W. H. CRAIG, Secretary,
 Town and Country Planning Board.

Town and Country Planning Act 1961.
CITY OF MOE PLANNING SCHEME 1966.

AMENDMENT No. 32, 1973.

Notice of Approval.

In pursuance of the powers conferred by the *Town and Country Planning Act 1961*, the Governor in Council on the 13th May, 1975, approved a planning scheme entitled the City of Moe Planning Scheme 1966, Amendment No. 32, 1973, in respect of part of the municipal district of the City of Moe and such planning scheme comes into operation on the date this Notice of Approval is published in the *Government Gazette*.

A copy of the planning scheme as approved may be inspected, free of charge, during office hours at the office of the Town and Country Planning Board, 235 Queen Street, Melbourne; at the office of the Council of the City of Moe at Moe, and when available, at the Office of Titles, Melbourne, and at the Central Plan Office of the Department of Crown Lands and Survey, Melbourne.

W. H. CRAIG, Secretary,
Town and Country Planning Board.

Town and Country Planning Act 1961.
MORWELL PLANNING SCHEME 1954.

AMENDMENT No. 45, 1973.

Notice of Approval.

In pursuance of the powers conferred by the *Town and Country Planning Act 1961*, the Governor in Council on the 13th May, 1975, approved a planning scheme entitled the Morwell Planning Scheme 1954, Amendment No. 45, 1973, in respect of part of the municipal district of the Shire of Morwell and such planning scheme comes into operation on the date of this Notice of Approval is published in the *Government Gazette*.

A copy of the planning scheme as approved may be inspected, free of charge, during office hours at the office of the Town and Country Planning Board, 235 Queen Street, Melbourne; at the office of the Council of the Shire of Morwell at Morwell, and when available, at the Office of Titles, Melbourne, and at the Central Plan Office of the Department of Crown Lands and Survey, Melbourne.

W. H. CRAIG, Secretary,
Town and Country Planning Board.

Town and Country Planning Act 1961.
SHIRE OF NEWSTEAD PLANNING SCHEME.

INTERIM DEVELOPMENT ORDER.

Notice of Approval.

In pursuance of the powers conferred by the *Town and Country Planning Act 1961*, the Governor in Council on the 13th day of May, 1975, approved the making of an Interim Development Order by the Newstead Shire Council for part of the municipal district of the Shire of Newstead.

The Interim Development Order provides that the use, subdivision or development of any land within the area described or the erection, construction or carrying out of any buildings, roads or other works thereon is prohibited except in accordance with the provisions of the Order.

A copy of the Interim Development Order and a map showing the area affected may be inspected, free of charge, at the office of the Council of the Shire of Newstead at Newstead, and at the office of the Town and Country Planning Board, 235 Queen Street, Melbourne.

W. H. CRAIG, Secretary,
Town and Country Planning Board.

Town and Country Planning Act 1961.
SHIRE OF FLINDERS PLANNING SCHEME 1962.

AMENDMENT No. 77, 1975.

Notice of Amendment.

In pursuance of the powers conferred by sub-section 6 of Section 32 of the *Town and Country Planning Act 1961*, the Governor in Council, on the twentieth day of May, 1975 amended the Shire of Flinders Planning Scheme to provide for the establishment of "medical consulting rooms" as a consent use within the Residential 'A' zone subject to such conditions as the Responsible Authority may apply.

A copy of the amendment may be inspected during office hours at the office of the Town and Country Planning Board, 235 Queen Street, Melbourne, at the office of the Council of the Shire of Flinders at Dromana, and when available at the Office of Titles, Melbourne and at the Central Plan Office of the Department of Crown Lands and Survey, Melbourne.

W. H. CRAIG, Secretary,
Town and Country Planning Board.

Town and Country Planning Act 1961.
MELBOURNE METROPOLITAN PLANNING SCHEME.

NOTICE THAT A PLANNING SCHEME HAS BEEN PREPARED AND IS AVAILABLE FOR INSPECTION.

Amendment No. 56.

Notice is hereby given that the Melbourne and Metropolitan Board of Works in pursuance of its powers under the *Town and Country Planning Act 1961*, has prepared a Planning Scheme for the purpose of amending and varying the Ordinance and land use zoning and reservations of land within the Planning Area of the Melbourne Metropolitan Planning Scheme which was approved by the Governor in Council on the 30th day of April, 1968, and notice thereof published in the *Government Gazette* on the 22nd day of May, 1968.

A copy of the Amending Scheme has been deposited at the office of the Melbourne and Metropolitan Board of Works, 625 Little Collins Street, Melbourne, at the office of the Town and Country Planning Board, 235 Queen Street, Melbourne, and as to so much of the Planning Scheme as relates to land within the municipal district of any municipality at the office of such municipality, and will be open for inspection during office hours free of charge.

Any persons affected by the Planning Scheme are required to set forth in writing all objections they may have addressed to the Secretary, Melbourne and Metropolitan Board of Works, Box 4342, Melbourne, 3001, on or before the 28th day of August, 1975 and to state whether they wish to be heard in respect of their objection.

Dated the 21st May, 1975.

R. H. ENGELSMAN,
Secretary.

Melbourne and Metropolitan Board of Works, 625 Little Collins Street, Melbourne.

Cemeteries Act 1958.

SCALE OF FEES OF THE ORBOST PUBLIC CEMETERY.

In pursuance of the powers conferred upon them by the *Cemeteries Act*, the trustees of the Orbost Public Cemetery hereby make the following scale of fees, which shall come into operation upon publication in the *Government Gazette*, and from and after such publication every scale of fees heretofore made by the said trustees shall be and is hereby rescinded to the extent to which it conflicts with this scale.

Lawn grave, 2.44 m x 1.22 m	\$150.00
For each interment therein	\$60.00
Bronze plaque for each interment	\$60.00
Flower container supplied by Trust (and in- corporated in plaque)	\$30.00
Deposit payable to secure an allotment	\$75.00

H. A. WHITE, Trustee.
C. W. E. ROBERTS, Trustee.
C. S. HAISMAN, Trustee.
E. C. JONES, Trustee.

Approved by the Governor in Council, 13th May, 1975.—
TOM FORRISTAL, Clerk of the Executive Council.

Cemeteries Act 1958.

SCALE OF FEES OF THE PAKENHAM PUBLIC CEMETERY.

In pursuance of the powers conferred upon them by the *Cemeteries Act*, the trustees of the Pakenham Public Cemetery hereby make the following scale of fees, which shall come into operation upon publication in the *Government Gazette*, and from and after such publication every scale of fees heretofore made by the said trustees shall be and is hereby rescinded to the extent to which it conflicts with this scale.

Public Graves.

Interment in grave without exclusive right— stillborn child	\$15.00
Interment in grave without exclusive right— others	\$30.00

Private Graves.

Land, 2.44 m x 1.22 m	\$50.00
Own selection of site (extra)	\$15.00

Sinking Charges for Private Graves.

Sinking grave 1.83 m deep	\$48.00
Sinking oversize grave (extra)	\$20.00
Cancellation of order to sink (if commenced)	\$10.00

Reopening Charges.

Reopening grave (no cover)	\$40.00
Reopening grave (with cover or kerb)	\$48.00

Extra Charges.

Interment not in the prescribed hours or on Saturdays, Sundays or Public Holidays (extra)	\$20.00
Interment in private grave without due notice	\$20.00
Late fee (per half-hour or part thereof in excess of first fifteen minutes)	\$2.50

Miscellaneous Charges.

Inspection of plan or register	\$2.00
Permission to erect a headstone or monument—5 per cent. of cost.	
Grave renovations or additional inscription	\$4.00
Exhuming the remains of a body (when authorized)	\$65.00
Interment of ashes in a private grave	\$15.00

A. J. BULL, Trustee.
M. J. CARNEY, Trustee.
D. J. BEER, Trustee.

Approved by the Governor in Council, 13th May, 1975.—
TOM FORRISTAL, Clerk of the Executive Council.

Cemeteries Act 1958.

SCALE OF FEES OF THE STRATFORD PUBLIC CEMETERY.

In pursuance of the powers conferred upon them by the Cemeteries Act, the trustees of the Stratford Public Cemetery hereby make the following scale of fees, which shall come into operation upon publication in the *Government Gazette*, and from and after such publication every scale of fees heretofore made by the said trustees shall be and is hereby rescinded to the extent to which it conflicts with this scale.

Public Graves.

Interment in grave without exclusive right—stillborn child	\$12.00
Interment in grave without exclusive right—others	\$24.00
Number peg or label	\$5.00

Private Graves.

Land, 2.44 m x 1.22 m	\$70.00
Own selection of land	\$8.00

Sinking Charges for Private Graves.

Sinking grave 1.83 m deep	\$50.00
Each additional 0.3 m	\$10.00
Sinking oversize grave (extra)	\$20.00
Cancellation of order to sink (if commenced)	\$10.00

Reopening Charges.

Reopening grave (no cover)	\$45.00
Reopening grave (with cover)	\$50.00

Extra Charges.

Interment outside prescribed hour, or on Saturdays, Sundays or Public Holidays	\$18.00
Interment in a private grave without due notice	\$18.00

Miscellaneous Charges.

Interment fee	\$16.00
Certificate of right of burial	\$2.50
Number plate or brick	\$5.00
Permission to erect a headstone or monument—5 per cent. of cost with a minimum of \$6.00.	
Permission to construct a brick grave or to erect any stone kerb, brick tile-work or concrete	\$7.00
Exhuming the remains of a body (when authorized)	\$70.00
Interment of ashes in a private grave	\$16.00
Memorial wall niche and plaque	\$50.00

Lawn Section.

Lawn grave, 2.44 m x 1.22 m	\$105.00
Sinking grave 1.83 m deep	\$50.00
Each additional 0.3 m	\$10.00
Bronze plaque for each interment, 381 mm x 279 m	\$30.00
Flower container supplied by the trust	\$15.00
Exhuming the remains of a body (when authorized)	\$70.00

Reopening Charges (Lawn Section).

Sinking	\$45.00
Second plaque	\$30.00

I. M. McILWAIN, Trustee.
G. H. HAMLYN, Trustee.
H. BAXTER, Trustee.

Approved by the Governor in Council, 13th May, 1975.—
TOM FORRISTAL, Clerk of the Executive Council.

Cemeteries Act 1958.

SCALE OF FEES OF THE PORTARLINGTON PUBLIC CEMETERY.

In pursuance of the powers conferred upon them by the Cemeteries Act, the trustees of the Portarlington Public Cemetery hereby make the following scale of fees, which shall come into operation upon publication in the *Government Gazette*, and from and after such publication every scale of fees heretofore made by the said trustees shall be and is hereby rescinded to the extent to which it conflicts with this scale.

Public Graves.

Interment in grave without exclusive right—stillborn child	\$12.00
Interment in grave without exclusive right—others	\$24.00
Number peg or label	\$5.00

Private Graves.

Land, 2.44 m x 1.22 m	\$34.00
Own selection of land	\$8.00

Sinking Charges for Private Graves.

Sinking grave 1.83 m deep	\$52.00
Each additional 0.3 m	\$10.00
Sinking oversize grave (extra)	\$20.00
Cancellation of order to sink (if commenced)	\$10.00

Reopening Charges.

Reopening grave (no cover)	\$45.00
Reopening grave (with cover)	\$50.00

Extra Charges.

Interment outside prescribed hours, or on Saturdays, Sundays or Public Holidays	\$18.00
Interment in private grave without due notice	\$18.00

Miscellaneous Charges.

Interment fee	\$16.00
Certificate of right of burial	\$2.50
Number plate or brick	\$5.00
Permission to erect a headstone or monument—5 per cent. of cost with a minimum of \$6.00.	
Permission to construct a brick grave or to erect any stone kerb, brick tile-work or concrete	\$7.00
Exhuming the remains of a body (when authorized)	\$70.00
Interment of ashes in a private grave	\$16.00
Memorial wall niche and plaque	\$50.00

G. R. STEVENS, Trustee.
A. C. CORK, Trustee.
G. T. WRIGHT, Trustee.

Approved by the Governor in Council, 13th May, 1975.—
TOM FORRISTAL, Clerk of the Executive Council.

DRAINAGE AREAS ACT.

SPECIAL MAINTENANCE CHARGES MADE BY THE COUNCIL OF THE SHIRE OF MINHAMITE IN RESPECT OF THE EUMERALLA DRAINAGE AREA.

Notice is hereby given that on the thirteenth day of May, 1975, in accordance with the provisions of section 36 of the *Drainage Areas Act 1958*, the Governor-in-Council approved of the estimate of the cost of proposed maintenance works in the Eumeralla Drainage Area submitted by the Council of the Shire of Minhamite and of the making by the Council of a Special Maintenance Charge on properties within the said Drainage Area, for the year ending 30th September, 1975.

TOM FORRISTAL,
Clerk of the Executive Council.

INVERLOCH WATERWORKS TRUST.

FIXING THE LIMIT OF BANK OVERDRAFT.

His Excellency the Governor of the State of Victoria by and with the advice of the Executive Council thereof doth by Order made on the thirteenth day of May, 1975, fix the total amount of the sums which the Inverloch Waterworks Trust may owe at any time in respect of moneys borrowed by overdraft of current account pursuant to the provisions of section 286 of the *Water Act 1958* at Three thousand dollars (\$3,000).

TOM FORRISTAL,
Clerk of the Executive Council.

At the Executive Council Chamber,
Melbourne, 13th May, 1975.

INVERLOCH WATERWORKS TRUST.**INCREASING THE LIMIT OF BANK OVERDRAFT.**

His Excellency the Governor of the State of Victoria by and with the advice of the Executive Council thereof doth by Order made on the thirteenth day of May, 1975, increase the total amount of the sums which the Inverloch Waterworks Trust may owe at any time in respect of moneys borrowed by overdraft of current account pursuant to the provisions of section 288 of the *Water Act 1958* fixed by the Governor in Council on 21st August, 1974, at Seven thousand dollars (\$7,000) to Fifty-seven thousand dollars (\$57,000).

TOM FORRISTAL,
Clerk of the Executive Council.

At the Executive Council Chamber,
Melbourne, 13th May, 1975.

PAKENHAM SEWERAGE AUTHORITY.**INCREASING THE LIMIT OF BANK OVERDRAFT.**

His Excellency the Governor of the State of Victoria by and with the advice of the Executive Council thereof doth by Order made on the thirteenth day of May, 1975, increase the total amount of the sums which the Pakenham Sewerage Authority may owe at any one time in respect of moneys borrowed by overdraft of the current account pursuant to the provisions of sections 78 and 79 of the *Sewerage Districts Act 1958*, as fixed by the Governor in Council on 15th April, 1971 and 11th April, 1972, at Two thousand dollars (\$2,000) and Fifty-five thousand dollars (\$55,000) be increased to Thirty-five thousand dollars (\$35,000) and One hundred and fifty thousand dollars (\$150,000) respectively.

TOM FORRISTAL,
Clerk of the Executive Council.

At the Executive Council Chamber,
Melbourne, 13th May, 1975.

KILMORE SEWERAGE AUTHORITY.**FIXING THE LIMIT OF BANK OVERDRAFT.**

His Excellency the Governor of the State of Victoria by and with the advice of the Executive Council thereof doth by Order made on the thirteenth day of May, 1975, fix the limit of the amount which the Kilmore Sewerage Authority may owe at any time in respect of moneys borrowed by overdraft of current account, pursuant to the provisions of section 79A of the *Sewerage Districts Act 1958*, at One hundred and fifty thousand dollars (\$150,000).

TOM FORRISTAL,
Clerk of the Executive Council.

At the Executive Council Chamber,
Melbourne, 13th May, 1975.

KILMORE SEWERAGE AUTHORITY.**INCREASING THE LIMIT OF BANK OVERDRAFT.**

His Excellency the Governor of the State of Victoria by and with the advice of the Executive Council thereof doth by Order made on the thirteenth day of May, 1975, increase the total amount of the sums which the Kilmore Sewerage Authority may owe at any time in respect of moneys borrowed by overdraft of current account pursuant to the provisions of section 78 of the *Sewerage Districts Act 1958*, fixed by the Governor in Council on 6th July, 1973, at Ten thousand dollars (\$10,000), to Forty thousand dollars (\$40,000).

TOM FORRISTAL,
Clerk of the Executive Council.

At the Executive Council Chamber,
Melbourne, 13th May, 1975.

Water Act 1958.**STATE RIVERS AND WATER SUPPLY COMMISSION.
MORNINGTON PENINSULA URBAN DISTRICT.**

Notice to owners of tenements in the undermentioned streets in the Mornington Peninsula Urban District and the private streets, lanes, courts and alleys opening thereto:

Cranbourne.

Arnold Street, from a point opposite lot 395 to a point opposite lot 396, about 15 metres northerly.

Crib Point.

Governors Road, from end of existing main opposite lot 21 to a point opposite lot 7, about 200 metres easterly.
Janeen Court and Park Road, from end of existing main opposite lot 38 to a point opposite the Recreation Reserve, about 125 metres north-easterly.

Pettit Street, from end of existing main opposite lot 14 to a point opposite lot 13, about 20 metres southerly.

Dandenong.

Wayne Court.

Dromana.

Nepean Highway (south side), from end of existing main opposite lot 23 to a point opposite lot 30, about 126 metres westerly.

Frankston.

Boree Court.

Carter Court.

Christopher Drive, from Frankston-Flinders Road to a point opposite lot 43.

Cranbourne Road, from end of existing main west of Wattle Tree Lane, situated opposite lot 1, to a point opposite lot 1, about 380 metres easterly.

Donn Close.

Gama Court.

Kitson Street, from Kookaburra Street to Rosella Street.

Lamat Court.

Lucerne Crescent, from end of existing main opposite lot 2153 to a point opposite lot 1819, about 380 metres south-westerly.

Lula Court.

Oleosa Court.

Parkview Drive, from Cranbourne Road to a point opposite lot 82, about 130 metres southerly.

Paul Court.

Pepe Court.

Rosedale Grove, from Frankston-Flinders Road to a point opposite lot 40, about 460 metres south-westerly.

Taketa Crescent, from Lucerne Crescent to a point opposite lot 2184, about 170 metres easterly.

Wattle Tree Lane (east side), from Cranbourne Road to a point opposite lot 3, about 210 metres southerly.

Yarla Court.

Zammit Court.

Hastings.

Aitape Court.

Ardent Court and Barcoo Street, from Curacoa Drive to a point opposite lot 56, about 80 metres easterly.

Bataan Court.

Curacoa Drive, from Hodgins Road to a point opposite lot 302, about 1125 metres north-westerly.

Curlew Court and Drake Court, from Curacoa Drive to a point opposite lot 169, about 110 metres north-easterly.

Gascoyne Court.

June Court.

Ladava Court.

Lae Court.

Madang Court.

Onslow Court.

Otway Court.

Ovens Court.

Quadrant Court.

Stalwart Avenue, from Curacoa Drive to a point opposite lot 321, about 260 metres southerly.

Teal Court.

Torrens Court.

Vampire Court.

Langwarrin.

Dunraven Court (off Turner Road).

McCrae.

Chunar Grove, from end of existing main opposite lot 2 to Lonsdale Street, about 140 metres north-easterly.
Highfield Road, from Bayview Road to existing main opposite lot 89, about 50 metres north-westerly.
Lonsdale Street, from Chunar Grove to Bayview Road.

Mornington.

Adina Place.

Balamara Place.

Hardy Street, from a point opposite lot 610 to Robertson Drive, about 110 metres northerly.

Lemana Court.

Moorina Court.

Sheringa Court.

Tenya Court.

Mount Eliza.

Eliza Drive, from end of existing main opposite lot 394 to Quinns Parade, about 125 metres south-easterly.
Keraboite Court.

Mount Martha.

Indura Street.

Lutana Court.

Narringa Court.

Yarrabin Drive, from Osborne Drive to a point opposite lot 37, about 120 metres easterly.

Narre Warren.

Cranbourne Road, from Moran Street to a point opposite the Narre Warren State School, about 105 metres southerly.

Portsea.

Montego Way.

Rye.

Brights Drive, from Nautilus Street to:—(i) a point opposite lot 131, about 50 metres westerly; and (ii) a point opposite lot 137, about 10 metres easterly.

Nautilus Street, from end of existing main, opposite lot 160 to a point opposite lot 227, about 80 metres southerly.

Seaford.

Ashworth Drive.

Bardia Avenue, from end of existing main, opposite lot 2 to a point opposite lot 7, about 250 metres southerly.

Downs Road, from end of existing main, opposite lot 4 to Maple Street, about 270 metres northerly.

Fleming Court.

Maple Street, from Wells Road to a point opposite lot 149, about 900 metres easterly.

Maxwell Court.

McBride Crescent.

Patrick Court.

Ryan Street, from McBride Crescent to a point opposite lot 79, about 170 metres easterly.

Schmidt Court.

Wells Road, from end of existing main, opposite lot 244 to a point opposite the Municipal Reserve, about 300 metres northerly.

Skye.

Boundary Road, from end of existing main, opposite lot 6 to a point opposite lot 9, about 20 metres northerly.

Somers.

Coora Close.

Eyre Road, from Wills Road to a point opposite C.P. No. 102767, about 310 metres northerly.

Hume Road, from Wills Road to a point opposite C.P. No. 102759, about 350 metres northerly.

Sturt Road, from Wills Road to a point opposite C.P. No. 102775, about 350 metres northerly.

Somerville.

Colchester Court.

Conway Court.

Eramosa Road, from Pembroke Drive to:—(i) a point opposite lot 1, about 130 metres easterly; and (ii) a point opposite lot 100, about 20 metres westerly.

Jones Road, from Blacks Camp Road to a point opposite lot 1, about 275 metres southerly.

Lancaster Court.

Montrose Avenue, from Blacks Camp Road to a point opposite lot 28, about 275 metres southerly.

Pembroke Drive, from Eramosa Road to a point opposite lot 52, about 650 metres southerly.

Penton Court.

Raglin Close.

Rochester Road, from Pembroke Drive to a point opposite lot 70, about 130 metres westerly.

Sandown Court.

Sogerie Drive.

Tyabb.

Delepan Drive, from end of existing main, opposite lot 20 to a point opposite lot 105, about 50 metres easterly from Uringa Street.

Lima Avenue, from end of existing main, opposite lot 48 to Uringa Street, about 100 metres easterly.

Satu Crescent, from Uringa Street to a point opposite lot 123, about 40 metres easterly.

Seribu Close.

Uringa Street, from Delepan Drive to a point opposite lot 81, about 240 metres southerly.

Warneet.

Anchorage Drive, from Blind Bight Drive to a point opposite lot 37, about 120 metres south-westerly.

Blind Bight Drive, from Warneet Road to Anchorage Drive.

Egret Court.

Fisherman's Drive, from Warneet Road to a point opposite lot 93, about 240 metres south-westerly.

Harbour Way.

Prion Close.

Sandpiper Close.

Seagull Close.

Skua Court.

Warneet Road (south side only), from Blind Bight Drive to a point opposite lot 70, about 460 metres westerly.

The main pipe in the said streets being laid down, the owners of all tenements situated as above are hereby required, on or before the 1st day of July next, to cause proper pipes and stop cocks to be laid, so as to supply water within such tenements from the main pipe.

F. C. O'CONNOR, Acting Secretary.

State Rivers and Water Supply Commission,
Melbourne, 14th May, 1975.

Melbourne and Metropolitan

BOARD OF WORKS.

GENERAL NOTICE.

The Melbourne and Metropolitan Board of Works having made provision for carrying off the sewage of each and every property which or any part of which is situate in the Sewerage Areas hereinafter described doth hereby declared that on and after the 26th day of May, 1975, each and every property so situate shall be deemed to be a seweraged property within the meaning of the *Melbourne and Metropolitan Board of Works Act 1958*.

The Sewerage Areas hereinbefore referred to are:—

SEWERAGE AREA NO. 2817.

City of Croydon.—Commencing at the junction of Croydon Road and Surrey Road; thence easterly along Surrey Road, south-westerly along Railway Crescent, northerly along Croydon Road, westerly along Tallent Street and the southern boundary of lot 2 Tallent Street, generally northerly along the western boundaries of the said lot 2 and lot 1 Somerset Crescent, westerly along portion of the southern boundary of lot 30 Somerset Crescent, northerly along the western boundaries of the said lot 30 and lot 31 Somerset Crescent, north-easterly along Nelson Road, north-westerly along the south-western boundaries of lots 19 Nelson Road and 12 Somerset Crescent, north-easterly along Somerset Crescent to the boundary of the Croydon High School property, north-westerly, north-easterly and easterly along the boundaries of the said property to Croydon Road, southerly along Croydon Road to the commencing point.

This area contains 171 lots.

SEWERAGE AREA NO. 2818.

City of Knox.—Commencing at a point in Mountain Highway about 20 metres north-west of the north-western boundary of Landscape Drive; thence south-westerly along the south-eastern boundary of lot 1 Mountain Highway, south-easterly along portion of the north-eastern boundary of lot 89 Landscape Drive, south-westerly along Landscape Drive, north-westerly along the south-western boundaries of lots 1 Landscape Drive and 29 Southey Road, northerly along the western boundary of the said lot 29, westerly by a line to the north-eastern angle of lot 28 Southey Road, southerly and north-westerly along the eastern and portion of the south-western boundaries of the said lot 28, south-westerly along the south-eastern boundary of lot 103 Baldwin Avenue, north-westerly along Baldwin Avenue, north-easterly along the north-western boundary of lot 107 Baldwin Avenue, north-westerly along portion of the south-western boundary of lot 24 Southey Road, north-easterly along the north-western boundaries of the said lot 24 and lot 23 Southey Road, north-westerly and north-easterly along the south-western and portion of the north-western boundaries of lot 7 Mountain Highway, north-westerly along the south-western boundaries of lot 2 and 1 Mountain Highway and 7 Baldwin Avenue, north-easterly along the north-western boundary of the said lot 7, south-easterly along Mountain Highway to the commencing point.

This area contains 58 lots.

SEWERAGE AREA NO. 2819.

City of Keilor.—Commencing at the junction of Bonfield Street and Horseshoe Bend Road; thence south-easterly along the north-eastern boundaries of properties Nos. 1, 3 and 5 Horseshoe Bend Road, south-westerly along the south-eastern boundary of the said property No. 5, southerly, south-easterly and easterly along Horseshoe Bend Road, southerly along River Street, westerly along the southern boundaries of lots 21 to 11 Horseshoe Bend Road, north-westerly along the south-western boundaries of lots 10 to 5 Horseshoe Bend Road, north-easterly along the north-western boundary of the said lot 5, north-westerly along Horseshoe Bend Road, south-westerly along Ford Street, northerly along the western boundaries of lots 56 to 49 Horseshoe Bend Road, north-westerly along Riverside Avenue, north-easterly along the north-western boundary of lot 68 Riverside Avenue, northerly along the western boundary of lot 43 Horseshoe Bend Road, north-westerly

along the south-western boundaries of lots 42 to 30 Skyline Drive, north-easterly along the north-western boundary of the said lot 30, north-westerly along Skyline Drive, north-easterly along the north-western boundaries of lots 28 Skyline Drive and 1 Church Street, south-easterly along Church Street, south-westerly along Ponfield Street to the commencing point.

This area contains 76 lots.

SEWERAGE AREA No. 2820.

City of Northcote.—Commencing at the junction of Sparks Avenue and Mansfield Street on the boundary of Sewerage Area No. 1684; thence westerly, northerly, westerly and northerly along the said area boundary to Dundas Street, easterly along Dundas Street to the eastern boundary of the Thornbury High School property, southerly along the said property boundary to the production of the northern boundary of lot 1 Theobald Street, easterly along the said production and the northern boundaries of lots 1 to 6 and 14 to 12 Theobald Street, northerly along the eastern boundary of lot 3 Dundas Street, easterly, southerly and easterly along Dundas Street to Darebin Creek, generally southerly along Darebin Creek to the boundary of Sewerage Area No. 1684 at the south-eastern angle of lot 7 Turner Street, westerly and northerly along the said area boundary to the commencing point.

This area contains 110 lots.

SEWERAGE AREA No. 2821.

City of Nunawading.—Commencing at the junction of Arawatta Street and Morack Road; thence easterly and south-westerly along Morack Road, westerly along the southern boundaries of lots 1 Morack Road and 187 to 193 Coonawarra Drive to the boundary of Sewerage Area No. 2852, generally northerly along the said area boundary and the boundary of Sewerage Area No. 2585 to the commencing point.

This area contains 84 lots.

SEWERAGE AREA No. 2822.

Shire of Diamond Valley.—Commencing at the junction of Plenty River Drive and Diamond Creek Road; thence north-easterly and northerly along Diamond Creek Road to the northern boundary of the "Churinga" Retarded Children's Centre property, easterly, south-easterly and westerly along the outer boundaries of the said property to the north-eastern angle of lot 22 Palmyra Court, southerly along the eastern boundaries of lots 22 to 26 Palmyra Court, south-easterly by a line to and along the north-eastern boundary of lot 4 Greenhill Road, south-westerly along the south-eastern boundary of the said lot 4, north-westerly along Greenhill Road, generally southerly along the eastern boundaries of lots on the eastern side of Diamond Creek Road to Spring Street, south-westerly along Spring Street, southerly along Pembroke Street, generally south-westerly along the south-eastern boundaries of lots on the south-eastern side of Diamond Creek Road to the south-eastern angle of lot 1 Diamond Creek Road, westerly along the southern boundary of the said lot 1, south-westerly and southerly along Diamond Creek Road to the production of the southern boundary of lot 228 Killo Dale, westerly along the said production and lot boundary, north-westerly along the south-western boundary of the said lot 228, further north-westerly along Killo Dale, generally northerly along Manatunga Circuit, easterly along portion of the northern boundary of lot 219 Manatunga Circuit, northerly and south-easterly along the western and portion of the north-eastern boundary of lot K Diamond Creek Road, north-easterly along the north-western boundary of lot 210 Diamond Creek Road, south-easterly along Plenty River Drive to the commencing point.

This area contains 69 lots.

SEWERAGE AREA No. 2823.

Shire of Diamond Valley.—Commencing at the junction of Willis Street and St. Helena Road; thence westerly along St. Helena Road, northerly along the western boundaries of lots 37 to 31 and 3 to 1 Willis Street, easterly along portion of the northern boundary of the said lot 1, northerly along the western boundaries of lots 2 and 1 Willis Street, easterly along Cairns Street north-easterly along Carmon Street, easterly along the northern boundaries of lots 77 to 81 Bruce Street, southerly along Greenhill Road; westerly along the southern boundaries of lots 14 Greenhill Road and 21 Willis Street, southerly along Willis Street to the commencing point.

This area contains 49 lots.

SEWERAGE AREA No. 2824.

City of Springvale.—Commencing at a point in Malcolm Road about 56 metres west of the western boundary of Mason Drive; thence northerly along the western boundaries of lots 1 Malcolm Road and 3 to 12 Mason Drive,

easterly along the northern boundaries of the said lot 12, lots 13 to 15 and 12 to 15 Urban Street and 16 Braeside Drive, southerly along the eastern boundaries of lots 16 to 28 Braeside Drive, westerly along Malcolm Road to the commencing point.

By order of the Board,

R. H. ENGELSMAN,
Secretary.

625 Little Collins Street, Melbourne, 3001, 20th May, 1975.

Pipelines Act 1967.

NOTICE OF VARIATION OF CONDITIONS OF A PIPELINE LICENCE.

Whereas sub-section (3) of section 30 of the *Pipelines Act 1967* provides that the Minister may by notice published in the *Government Gazette* amend vary add to or revoke any conditions stated or included in a licence, I, James Charles Murray Balfour, Minister of Mines, do now hereby vary the conditions of Pipeline Licence No. 61 in the manner indicated in the Schedule hereto:—

SCHEDULE.

1. Delete Clause I. (A) of the Schedule to the licence substitute the following:—

(A) Design.

Except as otherwise required by this Schedule to Pipeline Licence No. 61, lines 1 and 3 of the pipeline shall be designed, constructed and tested according to the USA Standard Code for Pressure Piping ANSI B31.8—1968 "Gas Transmission and Distribution Piping Systems". Welding of lines 1 and 3 shall be performed as specified in API Standard 1104, 11th Edition, January, 1968, "Standard for Welding Pipelines and Related Facilities". The remainder of the pipeline shall be designed, constructed, tested and, together with the said lines 1 and 3, operated in accordance with the requirements of Australian Standard 1967—1975 "SAA Gas Pipeline Code".

The pipeline design shall include the following factors—

- (i) a maximum operating pressure of 2760 kPa (400 lbf/in.²);
- (ii) a maximum design factor of 0.40;
- (iii) a pipeline length of 4.8 km (3 miles);
- (iv) a buried pipeline with a minimum cover of 1.2 metres (4 feet) except for special rail crossing.

2. Delete Clause I. (B) (i) (b) of the Schedule to the licence and substitute the following:—

- (b) 88.9 mm (3.5 in.) OD × 5.49 mm (0.216 in.) WT in accordance with the requirements of Grade A or B of the American Petroleum Institute Standard 5L, Twenty-seventh Edition, March, 1973.

3. Delete Clause I. (B) (ii) of the Schedule to the licence.

4. Amend sub-heading (iii) Valves of Clause I. (B) to read (ii) Valves.

5. Delete Clause I. (C) (ii) of the Schedule to the licence and substitute the following:—

(ii) Outlet Pressure

The pressure of the natural gas leaving the pipeline at any point shall, unless otherwise approved in writing by the Minister, be controlled to a maximum of 517 kPa (75 lbf/in.²) by means of pressure regulating installations approved by the Director, Oil and Gas Division of the Mines Department.

6. Delete Clause I. (D) of the Schedule to the licence and substitute the following:—

(D) CORROSION CONTROL.

The corrosion control system shall be in accordance with the following:—

(i) Pipe Coating

For lines 1 and 3 of the pipeline, the specification for the factory applied external coating of the pipe shall include cleaning the surface to bare metal followed by the application of a primer and coal tar enamel internally reinforced with random mesh fibreglass and externally wrapped with asbestos felt in accordance with the Gas and Fuel Corporation of Victoria specification dated March, 1970, which accompanied the licence application. The field coating of pipe joints shall conform to the requirements of

section 7 of the Construction Specification dated October, 1970, submitted with the licence application.

For the remainder of the pipeline, the factory applied external coating of the pipe shall be extruded polyethylene to Shaw Specification YJ No. 1. The field coating of pipe joints shall be by the use of heat-shrink polyethylene sleeves with a bituminous mastic undercoating.

(ii) *Cathodic Protection*

Cathodic protection will be afforded the proposed pipeline through its direct connection to the 12 inch Crib Point/Dandenong pipeline which in turn is cathodically protected by impressed current systems located at Boundary Road, Cranbourne, and at Salmon Road, Crib Point.

7. Delete Clause I. (E) of the Schedule to the licence and substitute the following:—

(F) *Pressure Test.*

After construction and before being placed in operation, the pipeline shall be subjected to a pressure test which for lines 1 and 3 of the pipeline shall be in accordance with the procedure outlined in section 10 of the Specification forming part of Contract No. 1191 which accompanied the Pipeline Licence Application. The remainder of the pipeline shall be subjected to a pressure test in compliance with Rule 7.4.3 of Australian Standard 1967-1975: "SAA Gas Pipeline Code" according to a programme to be approved by the Director, Oil and Gas Division of the Mines Department.

During the said test, the pressure at the control point shall be measured at appropriate, but in no case greater than hourly, intervals using a calibrated and certified dead weight tester of adequate sensitivity for the volume of the test section, and recorded.

In addition, continuous recording equipment shall be used to record the pressure in the pipeline during the whole period of pressure testing. This equipment and any other pressure gauges used in the said pipeline pressure test shall be checked immediately prior to and after the said test by the said dead weight tester. Water volume measurement during the pressure/volume plot where applicable shall be by suitably calibrated devices.

The licensee shall give the Director, Oil & Gas Division of the Mines Department seven days' notice of intention to test, and shall within fourteen days of completion of the pressure test, forward to the said Director, a copy of the pressure chart including its calibration, and graphs of the said dead weight tester readings (as well as other pertinent factors) with time and water volume where applicable, all duly interpreted and witnessed by the licensee's engineer.

8. In Clause II. (B) of the Schedule to the licence, delete the expression "procedure qualification as required in the said API Standard 1104" and substitute the expression "and radiographic procedure qualification as required in the said API Standard 1104 or the said Australian Standard 1967 as appropriate."

9. Delete Clause II. (D) (i) of the Schedule to the licence and substitute the following:—

The pipeline shall be maintained in accordance with Section 8 of the Australian Standard 1967-1975: "SAA Gas Pipeline Code" to the extent that this standard is not inconsistent with the following:—

(i) *Corrosion Control*

Subject to compliance with the State Electricity Commission Cathodic Protection Regulations 1970, the licensee shall—

- (a) carry out a monthly check of the transformer and rectifier units of the impressed current systems hereinbefore mentioned to ensure they are operating satisfactorily. A log of such checks, giving details of amperage output and meter readings shall be maintained by the licensee;

- (b) at intervals not exceeding six months conduct corrosion surveys of the pipeline including tests for stray current electrolysis. Measuring instruments approved for the purpose by the Chief Electrical Inspector, State Electricity Commission of Victoria shall be used for these surveys which shall be carried out only

after the licensee has used his best endeavours to ensure that no abnormal condition exists which is likely to affect the validity of the results;

- (c) submit a summary of the results of these surveys annually to the said Chief Electrical Inspector for advice on action to be taken to maintain the cathodic nature of the pipeline so that corrosion is limited, and shall take all reasonable steps to give effect to the advice received;

- (d) submit to the Director, Oil and Gas Division of the Mines Department an annual report outlining the results of the corrosion surveys, the recommendations made by the said Chief Electrical Inspector and the details of the resulting action taken by the licensee.

10. Delete Clause II. (D) (ii) of the Schedule to the licence, and substitute the following:—

(ii) *Pipeline Markers and Signs.*

The licensee shall check the signs required by the Pipelines (Construction and Operation) Regulations 1971 at intervals not exceeding three months and shall, where necessary, forthwith replace, repair and repaint the same.

11. Delete Clause II. (D) (iii) of the Schedule to the licence and substitute the following:—

(iii) *Patrol of Pipeline.*

The licensee shall cause the pipeline to be patrolled at least once per week in accordance with the procedure laid down in Rule 8.7.9.1. of the Australian Standard 1967-1975: "SAA Gas Pipeline Code" and shall on demand produce to the Director, Oil and Gas Division of the Mines Department a written report on the results of such patrolling.

12. Delete Clause II. (E) of the Schedule to the licence and substitute the following:—

(E) *Alterations to Pipeline.*

Except for emergencies, the licensee shall not affect any repairs or make any additions or alterations to the pipeline without the prior approval in writing of the Director, Oil and Gas Division of the Mines Department.

13. Delete Clause II. (F) of the Schedule to the licence and substitute the following:—

(F) *Pressure Control.*

The pressure control systems hereinbefore mentioned shall be maintained in accordance with Rule 8.2 of the Australian Standard 1967-1975: "SAA Gas Pipeline Code."

14th May, 1975.

JIM BALFOUR,
Minister of Mines.

Stamps Act 1958.

ANNUAL LICENCE.

NOTIFICATION PURSUANT TO SECTION 97.

I hereby notify that stamp duty has been paid for a licence under Section 110 of the Stamps Act 1958 in respect of the year ending 31st December, 1975 by the following:—

THE BROKEN HILL PROPRIETARY COMPANY LIMITED.

R. M. PHIBBS,
Comptroller of Stamps.

Stamp Duties Office,
Melbourne, 8th May, 1975.

Stamps Act 1958.

ANNUAL LICENCE.

NOTIFICATION PURSUANT TO SECTION 97.

I HEREBY notify that stamp duty has been paid for a licence under section 96 of the Stamps Act to carry on assurance and insurance business in Victoria from the 16th January, 1975 to 31st December, 1975 by the following:—

SPHERE DRAKE UNDERWRITING (AUSTRALIA) LIMITED.

R. M. PHIBBS,
Comptroller of Stamps.

Stamp Duties Office,
Melbourne, 7th May, 1975.

ERRATUM.

In *Government Gazette*, No. 35, of the 14th May, 1975, page 1136, under the heading "Amendment of Pilotage Rates"—for the signature "R. G. Webster, President", substitute "R. G. Webster, Vice-President".

MINES DEPARTMENT.

Subject to any necessary excisions etc., it is proposed to grant the following mining leases:—

- No. 70; Mancel Edward Dougherty, William James Kyte, John Lee Jones; 114 ha, Parish of Avoca.
 No. 238; Clive Desmond McNamara, Peter White; 29 ha, Parish of Tarnagulla.
 No. 288; Oliver Claude Nash, Donald Oliver Nash; 15 ha, Parish of Carlyle.

APPLICATION FOR MINING LEASE DECLARED ABANDONED.

- No. 292; Wilhelm Johann Kruger; 4.0 ha, Parish of Banu Bonyit.

MINING LEASE GRANTED.

- No. 330; Jack Richard Poole, John David Poole; 16 ha, Parish of Koorangie.

MINING LEASE TRANSFERRED.

- No. 7; From Frank Crimeen and Leslie John Austin to Multi Load Gold Mine N.L.

EXPLORATION LICENCE GRANTED.

- No. 541; Planet Mining Company Pty. Ltd.; 132 km², County of Kara Kara.

TERM OF EXPLORATION LICENCE EXTENDED.

- No. 132; Western Mining Corporation Limited; 153 km², County of Borung.

EXPLORATION LICENCE CANCELLED.

- No. 527; Western Mining Corporation Limited; 198 km², County of Gladstone.

TAILINGS LICENCE GRANTED.

- 3961 Tailings Licence; The Shire of Newstead; to remove tailings from the Welshmans Reef Dumps, Parish of Tarrengower.

APPLICATION FOR EXTRACTIVE INDUSTRY LEASE DECLARED ABANDONED.

- No. 165; George Loftus Robinson Millar and Sheila Ann Millar Pty. Ltd.; 5.5 ha, Parish of Gheringhap.

APPLICATION FOR EXTRACTIVE INDUSTRY LICENCE DECLARED ABANDONED.

- No. 627; George Loftus Robinson Millar and Sheila Ann Millar Pty. Ltd.; 3.4 ha, Parish of Gheringhap.

EXTRACTIVE INDUSTRY LICENCES GRANTED.

- No. 435; Ready Mixed Concrete (Victoria) Pty. Limited; 8.0 ha, Parish of Yannathan.
 No. 677; Leopold Davidson, George Robert Davidson, Basil Bruce Davidson; 1.8 ha, Parish of Tallangatta.

APPLICATION FOR EXTRACTIVE INDUSTRY SEARCH PERMIT DECLARED ABANDONED.

- No. 64; Eureka Ceramics; 16 ha, Parish of Cardigan.

APPLICATION FOR EXTRACTIVE INDUSTRY SEARCH PERMIT REFUSED.

- No. 58; Melvyn Wilbert Bartlett; 243 ha, Parish of Narrawong.

J. C. M. BALFOUR,
Minister of Mines.

MINING LEASE DECLARED VOID.

- 8433 Beechworth; Arthur William Dibbin; 5.6 ha, Parish of Bright.

E. CONDON,
Secretary for Mines.

MINES DEPARTMENT.

PETROLEUM EXPLORATION PERMIT EXPIRED.

- No. 6; Shell Development (Australia) Proprietary Limited, Mobil Exploration Australia Pty. Limited, IOL Petroleum Limited and BP Petroleum Development Australia Proprietary Limited; 2,085 square miles, Counties of Grant, Grenville, Heytesbury and Polwarth.

J. C. M. BALFOUR,
Minister of Mines.

PUBLIC TRUSTEE ACT 1958 (No. 6350), SECTION 17.

I hereby give notice that on the 2nd May, 1975, the Public Trustee filed elections to administer the following deceased persons' estates in accordance with section 17 of the *Public Trustee Act 1958*.

BENDER, SAMUEL, late of Flat 84, 351 Barkly Street, Brunswick, retired machinist, died 26th January, 1975.

BOOHER, NATHAN PATTERSON, late of 26 Sanderson Street, Yarraville, driver, died 20th July, 1974.

SHERIDAN, KEITH LESLIE, late of 9 Glen Park Road, Bayswater, factory worker, died 9th January, 1975.

N. P. BRODY,
Public Trustee.

168 Exhibition Street, Melbourne, 3000, 14th May, 1975.

NOTICE.

Creditors, next of kin, and others having claims against the estate of any of the under-mentioned deceased persons are required to send particulars of their claims to the Public Trustee, 168 Exhibition Street, Melbourne, Vic. 3000, the personal representative, on or before the 26th July, 1975, after which date the Public Trustee may convey or distribute the assets having regard only to the claims of which the Public Trustee then has notice:—

BENDER, SAMUEL, late of Flat 84, 351 Barkly Street, Brunswick, retired machinist, died 26th January, 1975.

BOOHER, NATHAN PATTERSON, late of 26 Sanderson Street, Yarraville, driver, died 20th July, 1974.

DAVIS, RONALD ERNEST EDWARD, formerly of 184 Boundary Road, North Melbourne, late of Repatriation General Hospital, Heidelberg, pensioner, died 18th May, 1974.

DAY, EVELYN MARTHA, late of 87 Newry Street, North Fitzroy, widow, died 31st December, 1974.

DE LANY, MAICE, late of 32 Bridport Street, South Melbourne, widow, died 28th October, 1974.

EVELYN-LIARDET, EMILY ROSE, formerly of Pitcher Street, Port Campbell, but late of 62 Martin Street, Belgrave, widow, died 29th January, 1975.

FERGUSON, WATSON, formerly of 260 Domain Road, South Yarra, but late of Kew, retired cleaner, died 18th February, 1975.

FOGARTY, ROSE, formerly of 48 Alma Road, St. Kilda, but late of 223 Danks Street, Albert Park, widow, died 11th December, 1974.

FREE, DAVID WILLIAM, formerly of 45 Gooch Street, Thornbury, but late of Kew, retired salesman, died 26th February, 1975.

HOWELL, DOUGLAS FRANK, formerly of 8 Austin Street, Balwyn, but late of Strathalan Hospital, Erskine Road, Macleod, retired accountant, died 9th September, 1974.

MIDDLETON, ELEANOR ANICE, late of 16 (formerly 5) Moray Street, Fawkner, cleaner, died 29th August, 1974.

MILNE, JESSIE, formerly of 21 Claude Street, Northcote, but late of Mont Park, widow, died 13th November, 1974.

MYERS, ARTHUR ERIC GORDON, late of 13 Lawrence Grove, East Ringwood (formerly lot 76), storeman, died 5th January, 1975.

READ, BERTIE GORDON, late of 104 St. Hellier Street, West Heidelberg, retired cleaner, died 31st January, 1975.

RUFF, DOROTHY FLORENCE, late of Flat 3, 230 Barkly Street, St. Kilda, spinster, died 10th October, 1974.

SCOTT, JOHN GEORGE, late of 75 Rostrevor Parade, Box Hill North, retired carpenter, died 17th March, 1975.

SHERIDAN, KEITH LESLIE, late of 9 Glen Park Road, Bayswater, factory worker, died 9th January, 1975.

VASUDEVAN, SANDRA RAHAN, late of Flat 14, 19 Cromwell Road, South Yarra, teacher, died 28th February, 1975.

N. P. BRODY,
Public Trustee.

Melbourne, 14th May, 1975.

PUBLIC TRUSTEE ACT 1958 (No. 6350), SECTION 17.

I hereby give notice that on the 23rd April, 1975 the Public Trustee filed an election to administer the following deceased person's estate in accordance with Section 17 of the Public Trustee Act 1958.

FLOYD, FLORENCE ANN, late of care of "Cherith" 14 Grange Road, Kew, widow, died 12th February, 1975.

N. P. BRODY,
Public Trustee.

168 Exhibition Street, Melbourne, 3000, 16th May, 1975.

NOTICE.

Creditors, next of kin, and others having claims against the estate of the under-mentioned deceased person are required to send particulars of their claims to the Public Trustee, 168 Exhibition Street, Melbourne, Victoria, 3000, the personal representative, on or before the 27th July, 1975, after which date the Public Trustee may convey or distribute the assets having regard only to the claims of which the Public Trustee then has notice:—

FLOYD, FLORENCE ANN, late of care of "Cherith" 14 Grange Road, Kew, widow, died 12th February, 1975.

N. P. BRODY,
Public Trustee.

Melbourne, 16th May, 1975.

Notice is hereby given that, on the 8th day of May, 1975, an order was made by His Honour, Mr. Justice Dunn of the Supreme Court of Victoria, pursuant to Section 25 of the Public Trustee Act 1958, with respect to property of CHARLES (otherwise KAROL) WICINSKI care of 18 Trevelyan Street, Wayville in the State of South Australia and that the Public Trustee of Victoria intends to exercise the powers conferred on him by the said order. The said order (*inter alia*) authorises the Public Trustee to sell the land comprised in Certificate of Title Volume 8368 Folio 425 in the Register Book in the Office of Titles at a price not less than the valuation obtained from a qualified valuer, to execute all deeds and other instruments and documents with respect to such a sale, to pay rates due in respect of the said land and to pay to the Public Trustee for South Australia such balance remaining after deducting the charges prescribed by the Public Trustee (Charges) Regulations 1970, and the costs, charges and expenses he has incurred in effecting such a sale paying the said rates and paying the costs of the application to the said Court in respect of the said order.

N. P. BRODY, Public Trustee of Victoria, 168 Exhibition Street, Melbourne.

CONTRACTS ACCEPTED.—(Series 1974-75.)

VICTORIAN RAILWAYS.

107. Manufacture, Supply and Delivery of 150 No. Hydraulic Power Units for Point Operation, at Rates (Contract No. 64085).—Smith's Industries Pty. Limited. 108. Manufacture, Supply and Delivery of Roller Bearing Axle Boxes, at Rates (Contract No. 64115).—Australian Koyo Limited.

By Order of the Victorian Railways Board.

C. W. MILLER, Secretary.

Melbourne, 19th May, 1975.

PUBLIC WORKS.

888. Melbourne, State Public Library, supply, make and lay carpet, \$33,813.73.—Jason Carpets Commercial Pty. Ltd.

889. Port Melbourne, P.W.D. Depot, supply prime movers, \$50,346.00.—International Harvester Aust. Ltd.

890. Box Hill Eastern Suburbs Trades Annexe, care of Technical College, supply equipment, \$13,851.34.—Keep Bros. & Wood Pty. Ltd.

891. Port Melbourne, P.W.D. Plant Depot, supply Chamberlain tractor, \$61,970.00.—Associated Mobil Equipment Co. Pty. Ltd.

892. Colac, Colac Training Centre, supply hospital equipment, \$17,462.00.—A. E. Atherton & Sons Pty. Ltd.

893. Kangaroo Flat Technical School, supply lathes, \$19,985.20.—G. L. Sheraton Pty. Ltd.

894. Swan Hill, High School, erection of library, \$172,401.00.—Bruni & Bisogni Pty. Ltd.

895. West Melbourne, Government Cool Stores, demolition and removal of cool store buildings, \$144,350.00.—Whelan The Wrecker Demolitions Pty. Ltd.

896. Collingwood, Education Centre, supply and installation of "Insapipe"—underground heating and hot water mains, \$11,760.00.—Mech. Engineering Pty. Ltd.

897. Colac, Training Centre, electrical reticulation and P.A. cable, \$180,668.00.—Kilpatrick Green Pty. Ltd.

898. Coleraine, Primary School 2118, external and part internal repairs and painting, \$10,447.00.—Peden's Pty. Ltd.

899. Brentwood, High School, site works to Blocks A, B, C and D, \$46,076.00.—Guenther Mueller.

900. Lilydale, Technical School, erection of a library, \$172,823.00.—R. J. Grills Pty. Ltd.

901. Janefield, Training Centre mechanical services, new gymnasium, \$10,499.00.—W. S. Atherton & Co. Pty. Ltd.

902. Port Melbourne, Marine Model Laboratory, Ports and Harbours Division, concrete floor paving and associated work, \$31,038.00.—R. Atkinson (Vic.) Pty. Ltd.

903. Preston East, Technical School, mechanical services, multi-purpose hall, \$25,610.00.—Avalon Engineering Industries Pty. Ltd.

904. Altona, High School, erection of science wing, \$161,926.00.—Bacec Pty. Ltd.

905. Broadford, Primary School 1125, construction of art and craft room, library and staff improvements, \$227,835.00.—Bruni & Bisogni Pty. Ltd.

906. Nathalia, High School, staff improvements, additional classrooms and science rooms, \$138,824.00.—Bruni & Bisogni Pty. Ltd.

907. Kerang, High School, erection of a library complex, \$175,450.00.—Bruni & Bisogni Pty. Ltd.

908. Sunbury, Mental Hospital, electrical reticulation, boiler house area, \$39,092.00.—Paul Cave Electrical Contractors Pty. Ltd.

909. Bulleen, Special School 5099, erection of new building, \$808,256.00.—Citra Constructions Pty. Ltd.

910. Janefield Training Centre, erection of a Gymnasium, \$92,128.00.—Construction Engineering Pty. Ltd.

911. Rosanna East, High School, site works, \$35,425.00.—Consul Paving Company.

912. Ballam Park, Technical School, erection of stage 1, \$2,022,032.00.—Dillingham Constructions Pty. Ltd.

913. Howman's Gap, erection of dormitory block, stage 2, national fitness camp, \$148,600.00.—Jorgensen Projects Pty. Ltd.

914. Various Schools, Western Region, maintenance of oil burners in schools for the period 4th February, 1975, to 31st December, 1975, \$16,240.00.—Keystone Industrial Electric Pty. Ltd.

915. Mont Park, Mental Hospital, mechanical services for neuro-psychiatric centre, \$12,120.00.—Mech. Engineering Pty. Ltd.

916. Mornington, Primary School 2033, provision of art/craft facilities and staff accommodation improvements, \$101,434.00.—Merchant Builders Pty. Ltd.

917. Northvale, Primary School 5028, provision of art/craft room, staff accommodation improvements, &c., \$102,000.00.—Merchant Builders Pty. Ltd.

918. Wellington, High School, site works, stage 3, \$69,335.00.—Guenther Mueller.

919. Euroa, Crown Lands and Survey Departmental Residence, construction of brick veneer residence and garage, \$30,890.00.—Midland Housing Pty. Ltd.

920. Mirribooka, Primary School 4907, provision of art/craft centre, \$30,953.00.—R. A. Newton Pty. Ltd.

921. Verdale, Primary School 4987, provision of art/craft facilities, \$30,817.00.—R. A. Newton Pty. Ltd.

922. Middlefield, Primary School 4878, provision of art/craft resource centre, \$55,370.00.—R. A. Newton Pty. Ltd. 923. Sebastopol, Technical School, electrical services, \$13,874.00.—Henderson-Lette & Co.

924. Mont Park, Mental Hospital, alterations to ward F.12, \$16,533.00.—Edgeberg Building & Plumbing Services Pty. Ltd.

925. Rochester, High School, internal and external renovations, \$21,594.85.—Herman Oogjes.

926. Grimshaw, Primary School 5033, site works, \$32,419.00.—Richards Plant Hire Pty. Ltd.

927. Geelong, Special Services Division, erection of new building, \$496,910.00.—J. C. Taylor Constructions Pty. Ltd.

928. Mont Park, Mental Hospital, external renovations to various wards, \$43,370.00.—John Toth.

929. Westall, High School, site works, erection of standard science block, \$11,456.00.—L. J. Towers.

930. Various Primary Schools, electrical services, standard Primary Schools and additions within a 50-km radius of G.P.O., Melbourne, and within a 50-km radius of Geelong G.P.O., at rates 1974-75, at rates.—W. T. Waterfall & Sons Pty. Ltd.

931. Culgoa, erection of new residential Police Station, \$71,983.00.—Sandor Constructions Pty. Ltd.

932. Broadmeadows West, Technical School, restoration of fire damaged classrooms, \$81,500.00.—P. M. Versteegen & Sons Pty. Ltd.

933. Yarraman Park, Primary School 4807, internal and external repairs and painting, \$18,750.00.—Peter Boskovski & Son.

G. SERPELL, Director-General. 15.5.75.

AMENDMENTS.

Item No.	Unit.	Rate.	Effective From.
----------	-------	-------	-----------------

PROVISIONS.

Gazette No. 62—13th June, 1974.

Schedule No. 1—Provisions, Melbourne and Metropolitan District.

\$			
2	Per kg.—Marie "Phoenix"	1.06	8.5.75
	—Nice	1.06	
	—Teddy Bears	1.06	
	—Asstd. Creams	1.27	
	—Sweet Asstd.	1.12	
3	Per doz.	4.22	1.6.75
9	"	4.29	
10	"	3.38	
14	"	2.97	
87	Per kg.	1.03	1.3.75
89	"	2.65	
95	"	2.58	
97	"	1.22	
99	"	1.05	
101	"	0.24	1.6.75
122	Per doz.	6.39	
401	Each	1.76	

GENERAL STORES.

Gazette No. 75—31st July, 1974.

Schedule No. 36—Crockery, Cutlery and Kitchenware.

36	Each	9.14	8.5.75
----	------	------	--------

Schedule No. 37—Electrical Goods.

57	Each	300.91	1.6.75
----	------	--------	--------

GOVERNMENT PRINTER.

Gazette No. 80—6th August, 1973.

Schedule No. 1—Printing Paper, Writing Paper, &c.

69	Per 1000 sheets	19.38	15.4.75
----	-----------------	-------	---------

TOOLS (GENERAL).

Gazette No. 22—27th March, 1975.

Schedule No. 52.

34	Each—Asbeck 6"	2.35	8.5.75
	—8"	2.98	
38	"—500 mm	13.34	12.5.75
	—750 mm	13.92	
	—1000 mm	14.47	
	—1250 mm	14.98	
	—1500 mm	15.56	
	—1750 mm	16.14	
	—2000 mm	16.72	
	—2250 mm	17.31	
217	Each	17.89	7.5.75
	—2500 mm	6.90	

MOTOR SPIRIT, KEROSENE, FUEL OILS AND LUBRICANTS.

Gazette No. 27—21st April, 1975.

Schedule No. 56.

Amendment to Gazette No. 27, 21st April, 1975.

Distribution Points, Country Areas.

Euroa—

Delete—

Shell, C. R. Stackhouse, cnr. Anderson and Clifton Streets.

Substitute—

Golden Fleece, M. O. and M. A. Burnside, Cnr. Clifton, Hemley and Lewis Streets (Service Station), 7 a.m. to 8 p.m.

W. L. ROBERTSON, Secretary to the Tender Board. 19.5.75.

APPOINTMENTS AND RESIGNATIONS

APPOINTMENTS.

His Excellency the Governor of the State of Victoria, by and with the advice of the Executive Council thereof, has, by Orders made on the 13th day of May, 1975, been pleased to make the under-mentioned appointments, viz.:

MINISTRY OF HEALTH.

Mental Hygiene Branch.

DOROTHY JEAN OLIVER, M.B., B.S. (Melb. 1954) B.Sc. (Melb. 1950), to be Medical Officer, Mental Hygiene Branch, Department of Health,
 BARBARA KNOTHE, M.B., B.S. (Melb. 1967), D.P.M. (Melb. 1973), to be Psychiatrist, Mental Hygiene Branch, Department of Health, and
 RAM CHANDRA MAHAJAN, M.B., B.S. (Agra 1955), M.D. (Honours), M.P.H. (U.S.A.), to be Medical Officer, Mental Hygiene Branch, Department of Health, pursuant to the provisions of Section 20 (3) of the Mental Health Act 1958.

Trustees of Public Cemeteries.

IAN STANLEY DAVIS, to be a Trustee of the Camperdown Public Cemetery, vice N. A. Bamford (resigned),
 PATRICK CASHAN and RUSSELL ROLPH, to be additional Trustees of the Ararat Public Cemetery,
 ARNOLD REX BENTON, to be a Trustee of the Naringa Public Cemetery, vice L. J. Aldridge (resigned),
 JOHN NORMAN PEARCE, to be a Trustee of the Naringa Public Cemetery, vice G. R. Pearce (deceased), and
 ROBERT PAUL SCHMIDT, to be an additional Trustee of the Yackandandah Public Cemetery, pursuant to Section 3 (1) of the Cemeteries Act 1958.

Public Vaccinators.

JAMES LAWLESS, M.B. Ch.B., and MARGARET LAWLESS, M.B. Ch.B., to be Public Vaccinators for the Municipality of the Shire of Otway, pursuant to Section 151 of the Health Act 1958.

SOCIAL WELFARE DEPARTMENT.

Stipendiary Probation Officers &c.

DEBORAH MARGARET BYE (Miss), ANNE BEDNARZ, KENNETH SIMMONDS POTTER, NABIL YAAKOUF, and ADRIANA PALAMARA (Miss), pursuant to the provisions of section 8 (2) of the Children's Court Act 1973, section 507 (1) of the Crimes Act 1958, and sections 165 (1) and 189 (2) of the Social Welfare Act 1970 (as amended) to be Stipendiary Probation Officers for every Children's Court, Stipendiary Probation Officers and Stipendiary Parole Officers and Stipendiary Youth Parole Officers respectively.

DEPARTMENT OF WATER SUPPLY.

Waterworks Trusts Commissioners.

ARTHUR LOWRY McMILLAN, to be a Commissioner of the Violet Town Waterworks Trust to hold such position for a period from the date hereof, until 8th July, 1975, subject to the provisions of the Water Act.

REX WAINFREY OATLEY, to be a Commissioner of the Glenrowan Waterworks Trust, to hold such position for a period of four years from the date hereof, subject to the provisions of the Water Act.

TOM FORRISTAL,
 Clerk of the Executive Council.

At the Executive Council Chamber,
 Melbourne, 13th May, 1975.

Liquor Control Act 1968.

APPOINTMENT OF LICENSING INSPECTORS.

In accordance with the authority conferred upon me by sub-section (1) of Section 22 of the *Liquor Control Act 1968*, I, Reginald Jackson, Chief Commissioner of Police, hereby appoint the following Officers of Police as Licensing Inspectors for the Divisions of the Police Districts as shown :—

Division Number.	Police District.	Rank and Name.
2	Cheltenham ..	Inspector Kenneth William Gething (from 25.5.75 to 14.6.75).
3	Cheltenham ..	Inspector Eric Roy Sutton, V.A. (from 27.4.75 to 17.5.75)
2	East Gippsland ..	Inspector Frank Ossian Stephenson (<i>vice</i> Inspector J. R. Hall)
1	Malvern ..	Inspector George Frederick Earl (from 4.5.75 to 24.5.75)
5	Malvern ..	Inspector James Ferrie Maxwell (from 11.5.75 to 31.5.75)
1	Melbourne ..	Inspector Kenneth Neil Johnson (from 27.4.75 to 17.5.75)
2	Prahran ..	Inspector Leslie Stewart Jack (from 27.4.75 to 31.7.75)
3	Upper Goulburn	Inspector Dallas Ferguson Russell McDonald (new division)

R. JACKSON,
Chief Commissioner of Police.

8.5.75.

Liquor Control Act 1968.

APPOINTMENT OF LICENSING INSPECTORS.

Whereas on the 30th April, 1975, Reginald Jackson, the Chief Commissioner of Police for the State of Victoria acting pursuant to the power vested in him by Section 6A of the *Police Regulation Act 1958* delegated to me the undersigned William Desmond Crowley being an Assistant Commissioner of Police for the said State and the person referred to in the said delegation all powers and functions vested in him by the *Liquor Control Act 1968*, for the period commencing on the 1st day of May, 1975 and ending on the 20th day of May, 1975, now therefore I do hereby appoint the following Officers of Police as Licensing Inspectors for the Divisions of the Police Districts as shown :—

Division Number.	Police District.	Rank and Name.
4	Malvern ..	Inspector Mervin Henry Harders (from 4.5.75 to 24.5.75)
1	Moonee Ponds ..	Inspector Edwin Leslie Page (from 11.5.75 to 30.5.75)

W. D. CROWLEY,
Assistant Commissioner (Crime).

15.5.1975.

RESIGNATIONS.

His Excellency the Governor of the State of Victoria, by and with the advice of the Executive Council thereof, has, by Orders made on the 13th day of May, 1975, accepted the resignations of the persons named hereunder of the offices mentioned, viz.:—

SOCIAL WELFARE DEPARTMENT.
Probation and Parole Officers.

PAUL PAPADOPOLOUS, and
SUSAN WENDY SUE TIN (Miss),
as Probation and Parole Officers, pursuant to the provisions of Section 8 (2) of the *Children's Court Act 1973*, Section 507 (1) of the *Crimes Act 1958* and Section 165 (1) and 189 (2) of the *Social Welfare Act 1970* (as amended).

TOM FORRISTAL,
Clerk of the Executive Council.

At the Executive Council Chamber,
Melbourne, 13th May, 1975,

ORDERS IN COUNCIL

DEPARTMENT OF CROWN LANDS AND SURVEY.

At the Executive Council Chamber, Melbourne, the
thirteenth day of May, 1975.

PRESENT:

His Excellency the Governor of Victoria.
Mr. Borthwick | Mr. Rafferty
Mr. Smith | Mr. Scanlan.

UNUSED ROADS CLOSED.

In pursuance of the provisions of section 349 of the *Land Act 1958*, His Excellency the Governor of the State of Victoria, by and with the advice of the Executive Council thereof, and the concurrence in writing of the Council of the municipality concerned, doth hereby close the unused roads referred to hereunder, viz.:—

Parish of Tandarra, County of Bendigo, being the road indicated by hatching on plan hereunder.—(T.7(1) (W.91910).

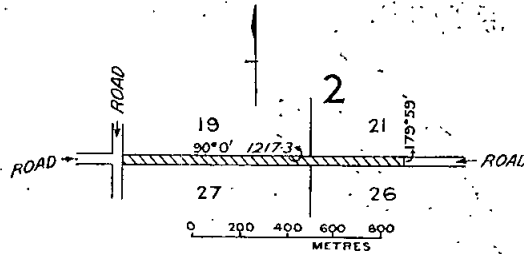

Township of Marong, Parish of Marong, County of Bendigo, being the road indicated by hatching on plan hereunder.—(M.32(*) (Rs.5359).

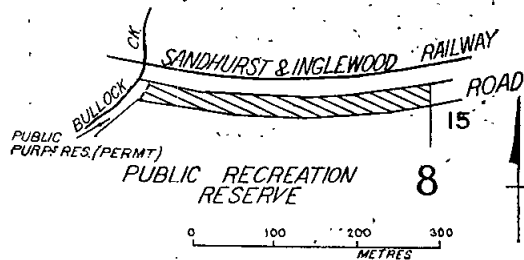

Township of Lexton, Parish of Lexton, County of Talbot, being the road indicated by hatching on plan hereunder.—(L.49(1) (G.75762).

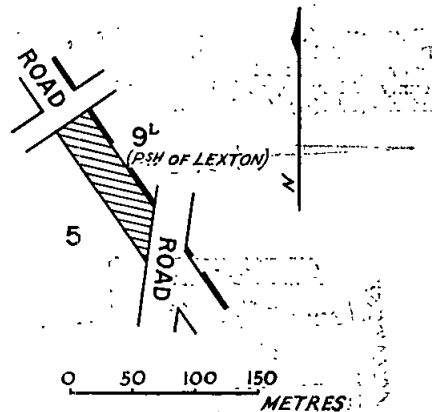

And the Honorable William Archibald Borthwick, Her Majesty's Minister of Lands for the State of Victoria, shall give the necessary directions herein accordingly.

TOM FORRISTAL,
Clerk of the Executive Council.

Land Act 1958.
DEPARTMENT OF CROWN LANDS AND SURVEY.

At the Executive Council Chamber, Melbourne, the
thirteenth day of May, 1975.

PRESENT:

His Excellency the Governor of Victoria.
Mr. Borthwick | Mr. Rafferty
Mr. Smith | Mr. Scanlan.

LANDS TEMPORARILY RESERVED AS SITES.

His Excellency the Governor of the State of Victoria, by and with the advice of the Executive Council thereof, doth hereby in pursuance of the provisions of section 14 of the Land Act 1958, reserve temporarily from sale, from being leased and from having a licence granted in respect thereof, and also except from occupation for mining purposes under any miner's right the lands hereinafter described, viz.:—

SANDHURST (BENDIGO).—Site for Public purposes (Pre-School Centre), 1701 square metres, being Crown allotment 508w, section K, at Bendigo, Parish of Sandhurst, County of Bendigo, as indicated by hatching on plan hereunder.—(S.372⁽¹¹⁰⁾) (Rs.8429).

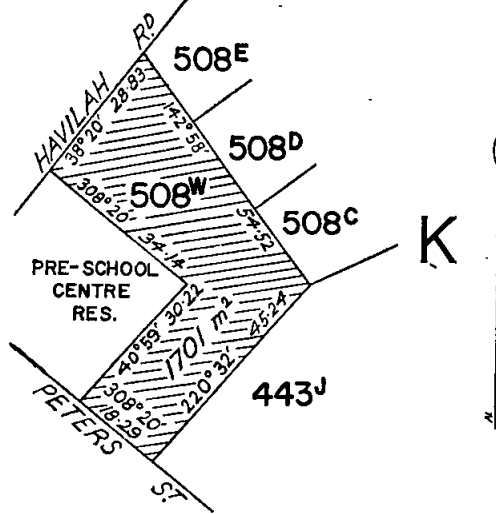

PRAHRAN (ARMADALE).—Site for Public purposes (Departmental Residence), 417 square metres, being Crown allotment 21A, Parish of Prahran, at Gardiner, County of Bourke, as indicated by hatching on plan hereunder.—(P.81⁽¹²⁾) (Rs.10033).

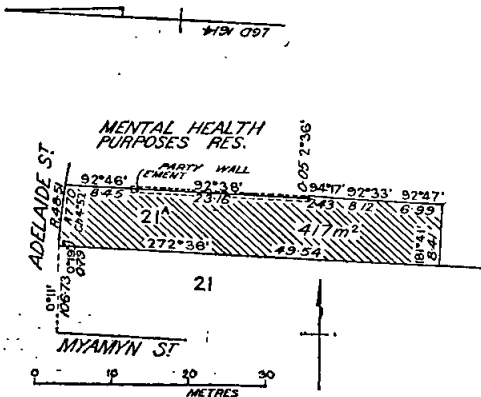

SOUTH HAMILTON.—Site for Public purposes (Departmental Residence) 624 square metres, being Crown allotment 2A, section 1, Parish of South Hamilton, County of Normanby, as indicated by hatching on plan hereunder.—(H.46⁽⁶⁾) (Rs.10067).

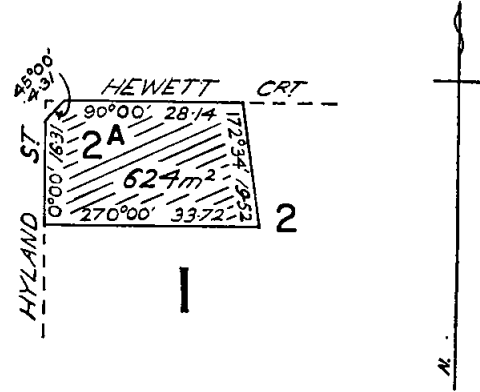

And the Honorable William Archibald Borthwick, Her Majesty's Minister of Lands for the State of Victoria, shall give the necessary directions herein accordingly.

TOM FORRISTAL,
Clerk of the Executive Council.

LOCAL GOVERNMENT DEPARTMENT.

At the Executive Council Chamber, Melbourne, the
thirteenth day of May, 1975.

PRESENT:

His Excellency the Governor of Victoria.
Mr. Borthwick | Mr. Rafferty
Mr. Smith | Mr. Scanlan.

VESTING OF RESERVES IN THE FRANKSTON CITY COUNCIL.

Whereas it is provided by section 569BA of the Local Government Act 1958, that where any map or plan has been lodged or deposited with the Registrar of Titles pursuant to section 97 of the Transfer of Land Act 1958, or any corresponding previous enactment (whether before or after the commencement of the Local Government Act 1963) and any allotment on that map or plan has been transferred the Governor in Council on the request of the Council of the municipality may by Order published in the Government Gazette direct that the whole or any part of the land comprised in any reserve shown on that map or plan shall vest in the Council whereupon such land shall so vest freed and discharged from any mortgage charge lease or sub-lease.

And whereas the Council of the City of Frankston has requested that reserves shown on a plan of subdivision be vested in the Council and an allotment on that plan has been transferred.

Now therefore, His Excellency the Governor of the State of Victoria, by and with the advice of the Executive Council thereof and in pursuance of the provisions of subsection 1 of section 569BA of the Local Government Act 1958 doth by this Order vest in the Council of the City of Frankston the Drainage Reserves coloured green on Plan of Subdivision No. 13128 lodged in the Office of Titles.

And the Honorable Alan John Hunt, Her Majesty's Minister for Local Government for the State of Victoria, shall give the necessary directions herein accordingly.

TOM FORRISTAL,
Clerk of the Executive Council.

LOCAL GOVERNMENT DEPARTMENT.

At the Executive Council Chamber, Melbourne, the thirteenth day of May, 1975.

PRESENT:

His Excellency the Governor of Victoria.

Mr. Borthwick	Mr. Rafferty
Mr. Smith	Mr. Scanlan.

ROAD DISCONTINUED.—CITY OF ESSENDON.

Whereas it is provided in section 528 (2) of the Local Government Act 1958, that where a road (whether or not a public highway but not being a road set out on land of the Crown) or any part thereof is not required for public use the Governor in Council on the request of the council of the municipality in which such road is situated made not less than one month after publishing in a newspaper generally circulating in the district and posting to the registered proprietor (if any) of the land and the owners and occupiers (if any) of the lands abutting or immediately adjacent to the road notice of intention to make such a request may by Order published in the Government Gazette direct that such a road or part shall be discontinued and thereupon such road or part, shall be discontinued accordingly.

And whereas the Council of the City of Essendon has requested that the Governor in Council direct that a road off Ascot Street, Ascot Vale be discontinued and not less than one month previously has published in a newspaper generally circulating in the district and posted to the registered proprietor of the land in the said road and to the owners and occupiers of lands abutting or immediately adjacent to the road notice of intention to make such request.

Now therefore, His Excellency the Governor of the State of Victoria, by and with the advice of the Executive Council thereof, hereby directs that the said road, which is shown by hachure on the plan hereunder, shall be discontinued and that the land may be sold by the Council of the City of Essendon by agreement.

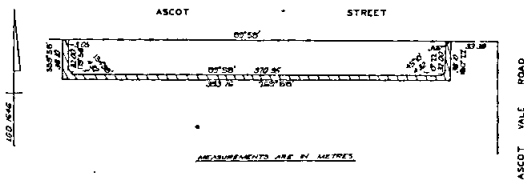

And the Honorable Alan John Hunt, Her Majesty's Minister for Local Government for the State of Victoria, shall give the necessary directions herein accordingly.

TOM FORRISTAL,
Clerk of the Executive Council.

LOCAL GOVERNMENT DEPARTMENT.

At the Executive Council Chamber, Melbourne, the thirteenth day of May, 1975.

PRESENT:

His Excellency the Governor of Victoria.

Mr. Borthwick	Mr. Rafferty
Mr. Smith	Mr. Scanlan.

ROAD DISCONTINUED.—CITY OF HEIDELBERG.

Whereas it is provided in section 528 (2) of the Local Government Act 1958, that where a road (whether or not a public highway but not being a road set out on land of the Crown) or any part thereof is not required for public use the Governor in Council on the request of the council of the municipality in which such road is situated made not less than one month after publishing in a newspaper generally circulating in the district and posting to the registered proprietor (if any) of the land and the owners and occupiers (if any) of the lands abutting or immediately adjacent to the road notice of intention to make such request may by Order published in the Government Gazette direct that such road or part shall be discontinued and thereupon such road or part, shall be discontinued accordingly.

And whereas the Council of the City of Heidelberg has requested that the Governor in Council direct that part of the Ridgeway, Heidelberg be discontinued and not less than one month previously has published in a newspaper generally circulating in the district and posted to the registered proprietors of the land in the said part of road and to the owners and occupiers of lands abutting or immediately adjacent to the said part of road notice of intention to make such request.

Now therefore, His Excellency the Governor of the State of Victoria, by and with the advice of the Executive Council thereof, hereby directs:

- (a) that the part of the said road which is shown by hachure and cross-hachure on the plan hereunder shall be discontinued;
- (b) that notwithstanding such discontinuance the Melbourne and Metropolitan Board of Works shall continue to have and possess the same right title power authority or interest in or in relation to the whole of the land shown by cross-hachure on the said plan as it had or possessed prior to such discontinuance with respect to or in connexion with any drains or pipes laid or erected in on or over such land for the purposes of drainage or sewerage;
- (c) that, subject to any such right title power authority or interest the land in the said part of road may be sold by the Council of the City of Heidelberg by agreement.

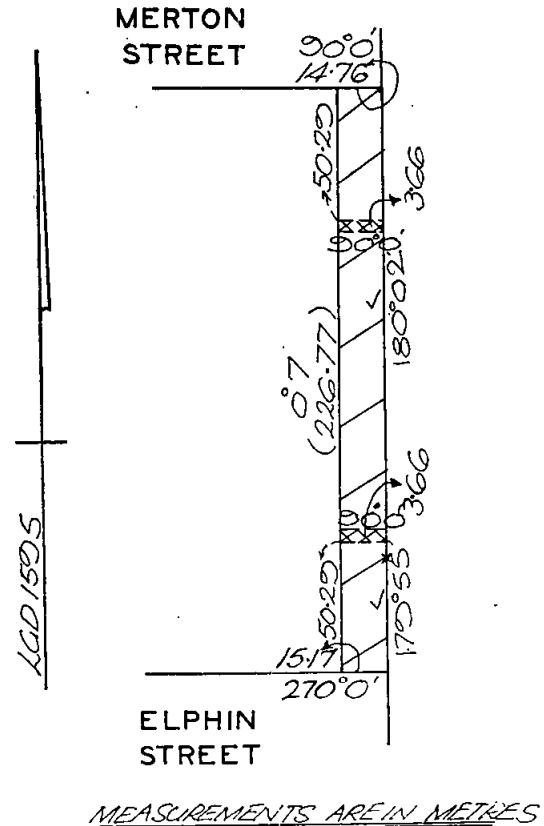

And the Honorable Alan John Hunt, Her Majesty's Minister for Local Government for the State of Victoria, shall give the necessary directions herein accordingly.

TOM FORRISTAL,
Clerk of the Executive Council.

LOCAL GOVERNMENT DEPARTMENT.

At the Executive Council Chamber, Melbourne, the thirteenth day of May, 1975.

PRESENT:

His Excellency the Governor of Victoria.
 Mr. Borthwick | Mr. Rafferty
 Mr. Smith | Mr. Scanlan.

ROAD DISCONTINUED.—CITY OF PRESTON.

Whereas it is provided in section 528 (2) of the Local Government Act 1958, that where a road (whether or not a public highway but not being a road set out on land of the Crown) or any part thereof is not required for public use the Governor in Council on the request of the council of the municipality in which such road is situated made not less than one month after publishing in a newspaper generally circulating in the district and posting to the registered proprietor (if any) of the land and the owners and occupiers (if any) of the lands abutting or immediately adjacent to the road notice of intention to make such request may by Order published in the Government Gazette direct that such road or part shall be discontinued and thereupon such road or part, shall be discontinued accordingly.

And whereas the Council of the City of Preston has requested that the Governor in Council direct that a road off Highland Street, Kingsbury be discontinued and not less than one month previously has published in a newspaper generally circulating in the district and posted to the registered proprietors of the land in the said road and to the owners and occupiers of lands abutting or immediately adjacent to the road notice of intention to make such request.

Now therefore, His Excellency the Governor of the State of Victoria, by and with the advice of the Executive Council thereof, hereby directs:

- (a) that the said road which is shown by hachure and cross-hachure on the plan hereunder shall be discontinued;
- (b) that notwithstanding such discontinuance the Council of the City of Preston shall continue to have and possess the same right title power authority or interest in or in relation to the whole of the land shown by cross-hachure on the said plan as it had or possessed prior to such discontinuance with respect to or in connexion with any drains or pipes laid or erected in on or over such land for the purposes of drainage; and
- (c) that, subject to any such right title power authority or interest the land in the said road may be sold by the City of Preston by agreement.

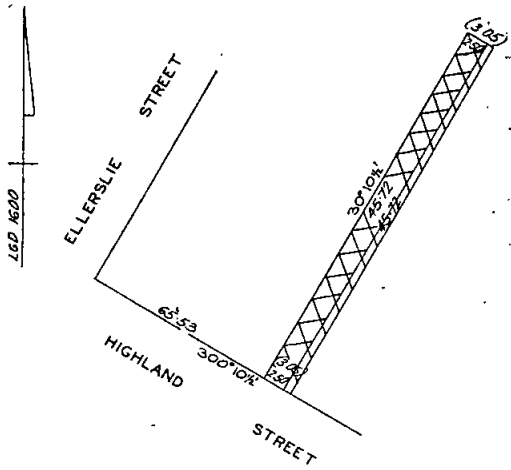

MEASUREMENTS ARE IN METRES.

And the Honorable Alan John Hunt, Her Majesty's Minister for Local Government for the State of Victoria, shall give the necessary directions herein accordingly.

TOM FORRISTAL,
 Clerk of the Executive Council.

LOCAL GOVERNMENT DEPARTMENT.

At the Executive Council Chamber, Melbourne, the thirteenth day of May, 1975.

PRESENT:

His Excellency the Governor of Victoria.
 Mr. Borthwick | Mr. Rafferty
 Mr. Smith | Mr. Scanlan.

APPROVAL OF RATING AGREEMENT BETWEEN THE SHIRE OF RUTHERGLEN AND RING-GRIP ELECTRICAL.

Whereas—

- (a) Ring-Grip Electrical is liable to be rated in respect of certain land being the land described in Certificate of Title volume 5784 folio 641 which land is not within the Metropolitan area within the meaning of the Town and Country Planning Act 1961;
- (b) The Council of the Shire of Rutherglen is of the opinion that the establishment and maintenance of the industry within the municipality is making and will continue to make a substantial contribution to the industrial development of the municipality and encourage the decentralization of industry in Victoria; and
- (c) The President Councillors and Ratepayers of the Shire of Rutherglen and Ring-Grip Electrical on the sixteenth day of April 1975, entered into an agreement in respect of the above described land as to the amount of rates that will be payable thereon by the said firm under the Local Government Act 1958, and copies of such agreement have been submitted to the Minister for Local Government.

Now therefore, His Excellency the Governor of the State of Victoria by and with the advice of the Executive Council thereof and in pursuance of the provisions of the said section 811BA of the Local Government Act 1958, hereby approves the said agreement.

And the Honorable Alan John Hunt, Her Majesty's Minister for Local Government for the State of Victoria, shall give the necessary directions herein accordingly.

TOM FORRISTAL,
 Clerk of the Executive Council.

LOCAL GOVERNMENT DEPARTMENT.

At the Executive Council Chamber, Melbourne, the thirteenth day of May, 1975.

PRESENT:

His Excellency the Governor of Victoria.
 Mr. Borthwick | Mr. Rafferty
 Mr. Smith | Mr. Scanlan.

ROAD DISCONTINUED.—CITY OF NUNAWADING.

Whereas it is provided in section 528 (2) of the Local Government Act 1958, that where a road (whether or not a public highway but not being a road set out on land of the Crown) or any part thereof is not required for public use the Governor in Council on the request of the council of the municipality in which such road is situated made not less than one month after publishing in a newspaper generally circulating in the district and posting to the registered proprietor (if any) of the land and the owners and occupiers (if any) of the lands abutting or immediately adjacent to the road notice of intention to make such a request may by Order published in the Government Gazette direct that such a road or part shall be discontinued and thereupon such road or part, shall be discontinued accordingly.

And whereas the Council of the City of Nunawading has requested that the Governor in Council direct that Jones Lane, Vermont South be discontinued and not less than one month previously has published in a newspaper generally circulating in the district and posted to the registered proprietor of the land in the said road and to the owners and occupiers of lands abutting or immediately adjacent to the said road notice of intention to make such request.

Now therefore, His Excellency the Governor of the State of Victoria, by and with the advice of the Executive Council thereof, hereby directs:

- (a) that the said road which is shown by hachure and cross-hachure marked "A" and "B" on the plan hereunder shall be discontinued;
- (b) that notwithstanding such discontinuance the Melbourne and Metropolitan Board of Works shall continue to have and possess the same right title power authority or interest in or in relation to the whole of the land shown by cross-hachure marked "A" on the said plan as it had or possessed prior to such discontinuance with respect to or in connexion with any drains or pipes laid or erected in on or over such land for the purposes of drainage or sewerage;
- (c) that notwithstanding such discontinuance the Dandenong Valley Authority shall continue to have and possess the same right, title, power, authority or interest in relation to the whole of the land shown by cross-hachure marked "B" on the said plan with respect to or in connexion with any drains or pipes laid or erected in on or over such land for the purpose of drainage; and
- (d) that, subject to any such right title power authority or interest the land in the said part of Road shall be retained by the Council of the City of Nunawading for municipal purposes.

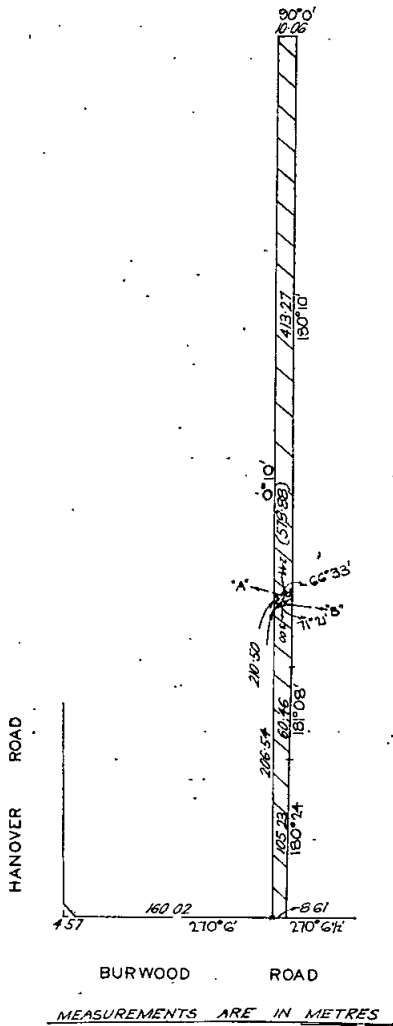

And the Honorable Alan John Hunt, Her Majesty's Minister for Local Government for the State of Victoria, shall give the necessary directions herein accordingly.

TOM FORRISTAL,
Clerk of the Executive Council.

COUNTRY ROADS BOARD.
Act No. 6229.

At the Executive Council Chamber, Melbourne, the thirteenth day of May, 1975.

PRESENT:

- His Excellency the Governor of Victoria.
- Mr. Borthwick | Mr. Rafferty
- Mr. Smith | Mr. Scanlan.

ORDER APPROVING OF LAND BEING ACQUIRED AND ROADS, DEVIATIONS OR WIDENINGS BEING MADE TOGETHER WITH ALL ANCILLARY WORKS REQUIRED TO BE EXECUTED IN CONJUNCTION THEREWITH.

His Excellency the Governor of the State of Victoria, by and with the advice of the Executive Council thereof, being satisfied that there are funds legally available for acquiring the land, doth hereby approve the acquiring of the land described in the schedule hereunder and the making of new roads and deviations from and widenings of existing roads, together with all ancillary works required to be executed in conjunction therewith, referred to in the said schedule.

SCHEDULE.

State Highway.

The land shown hatched on plan numbered G.P.13824b hereunder required for the widening of the Calder Highway in the Shire of Mildura and making of the widening thereon.

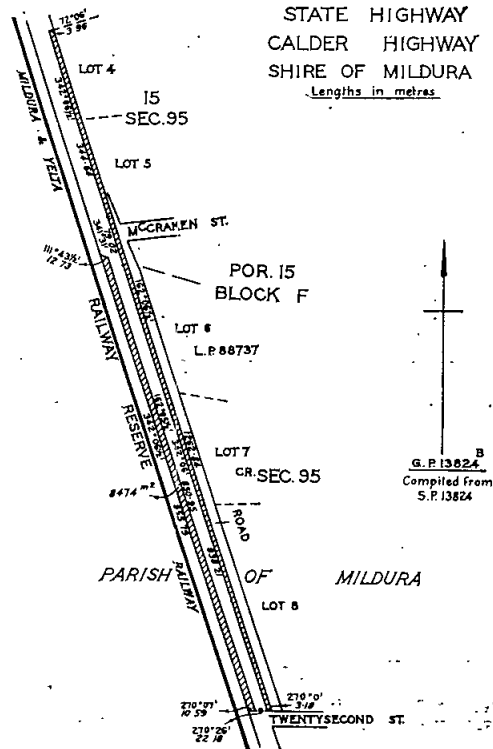

Main Road.

The land shown hatched on plan numbered G.P.13906 hereunder required for the deviation from the Daylesford-Trentham Road in the Shire of Daylesford and Glenlyon and making of the deviation thereon.

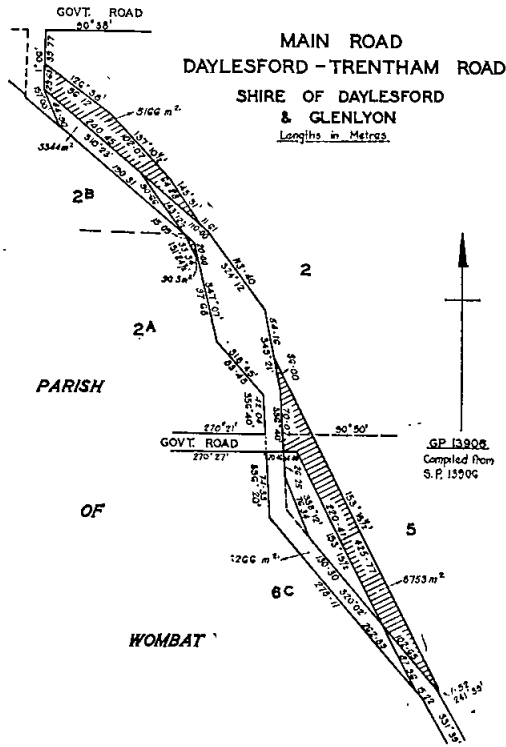

And the Honorable Edward Raymond Meagher, Her Majesty's Minister of Transport for the State of Victoria, shall give the necessary directions herein accordingly.

TOM FORRISTAL,
Clerk of the Executive Council.

**Water Act 1958.
STATE RIVERS AND WATER SUPPLY COMMISSION.**

At the Executive Council Chamber, Melbourne, the thirteenth day of May, 1975.

PRESENT:
His Excellency the Governor of Victoria.
Mr. Borthwick | Mr. Rafferty
Mr. Smith | Mr. Scanlan.

MILLEWA WATERWORKS DISTRICT.—PORTION EXCISED.

Under the powers conferred by the Water Act 1958 and all other powers enabling him in that behalf, His Excellency the Governor of the State of Victoria, with the advice of the Executive Council of the said State, on the recommendation of the State Rivers and Water Supply Commission, doth hereby declare, order and direct that there shall be excised from the Millewa Waterworks District that portion of the same shown by green colour on a plan approved by the Governor in Council and deposited in the office of the State Rivers and Water Supply Commission, Melbourne (Corr. No. 66/4007) and as on and from the 30th day of June, 1975, such portion shall be deemed to be excised accordingly.

And the Honorable Frederick James Granter, Her Majesty's Minister of Water Supply for the State of Victoria, shall give the necessary directions herein accordingly.

TOM FORRISTAL,
Clerk of the Executive Council.

LAKES ENTRANCE WATERWORKS TRUST.

At the Executive Council Chamber, Melbourne, the thirteenth day of May, 1975.

PRESENT:
His Excellency the Governor of Victoria.
Mr. Borthwick | Mr. Rafferty
Mr. Smith | Mr. Scanlan.

APPROVAL OF PLAN SHOWING SITE OF STORAGE.

Under the powers conferred by the Water Act and all other powers enabling him in that behalf, His Excellency the Governor of the State of Victoria, by and with the advice of the Executive Council of the said State, doth hereby approve the plan showing the site of a storage being constructed by the Lakes Entrance Waterworks Trust on the Nicholson River. The said plan is deposited in the office of the State Rivers and Water Supply Commission, Melbourne.—(Corr. No. 72/3978/130).

And the Honorable Frederick James Granter, Her Majesty's Minister of Water Supply for the State of Victoria, shall give the necessary directions herein accordingly.

TOM FORRISTAL,
Clerk of the Executive Council.

FIRST MILDURA IRRIGATION TRUST.

At the Executive Council Chamber, Melbourne, the thirteenth day of May, 1975.

PRESENT:
His Excellency the Governor of Victoria.
Mr. Borthwick | Mr. Rafferty
Mr. Smith | Mr. Scanlan.

SALE OF LAND.

Under the powers conferred by the Mildura Irrigation and Water Trusts Act and all other powers enabling him in that behalf, His Excellency the Governor of the State of Victoria, by and with the advice of the Executive Council of the said State, doth hereby approve of the sale by the First Mildura Irrigation Trust of the land shown on a plan approved by the Governor in Council by and with this Order and deposited in the office of the State Rivers and Water Supply Commission, Melbourne.—(Corr. No. 73/2061/73).

And the Honorable Frederick James Granter, Her Majesty's Minister of Water Supply for the State of Victoria, shall give the necessary directions herein accordingly.

TOM FORRISTAL,
Clerk of the Executive Council.

LABOUR AND INDUSTRY ACT 1958.

At the Executive Council Chamber, Melbourne, the thirteenth day of May, 1975.

PRESENT:
His Excellency the Governor of Victoria.
Mr. Borthwick | Mr. Rafferty
Mr. Smith | Mr. Scanlan.

EXTENSION OF POWERS OF THE SOCIAL WORKERS BOARD.

In pursuance of the powers conferred by section 20 of the Labour and Industry Act 1958, and all other powers him thereunto enabling, His Excellency the Governor of the State of Victoria, by and with the advice of the Executive Council thereof, doth hereby extend the powers of the Social Workers Board so that in substitution for the powers heretofore conferred on the said Social Workers Board it shall be appointed for the occupation of a social worker for which a necessary condition of employment is a degree or diploma with a major study in social work.

And the Honorable Joseph Anstice Rafferty, Her Majesty's Minister of Labour and Industry for the State of Victoria shall give the necessary directions herein accordingly.

TOM FORRISTAL,
Clerk of the Executive Council.

ALCOHOLICS AND DRUG DEPENDENT PERSONS ACT 1968 (No. 7772).—SECTION 5.

At the Executive Council Chamber, Melbourne, the thirteenth day of May, 1975.

PRESENT:

His Excellency the Governor of Victoria.
 Mr. Borthwick | Mr. Rafferty
 Mr. Smith | Mr. Scanlan.

Whereas pursuant to the provisions of section 5 of the *Alcoholics and Drug Dependent Persons Act 1968 No. 7772* the Governor in Council may from time to time by notice published in the *Government Gazette* appoint places establishments or institutions to be, amongst other things, residential centres for the care and treatment of infirm alcoholics and drug dependent persons;

And whereas it is desired that the Governor in Council appoint a place in the Parish of Mordialloc, County of Bourke, to be a residential centre for the care and treatment of infirm alcoholics and drug dependent persons;

Now therefore I, the Governor of the State of Victoria by and with the advice of the Executive Council of the said State, appoint the place being the whole of the area in the Parish of Mordialloc, County of Bourke, indicated by hachure on the plan hereunder to be a residential centre for the care and treatment of infirm alcoholics and drug-dependent persons to be known as Heatherton Hospital.

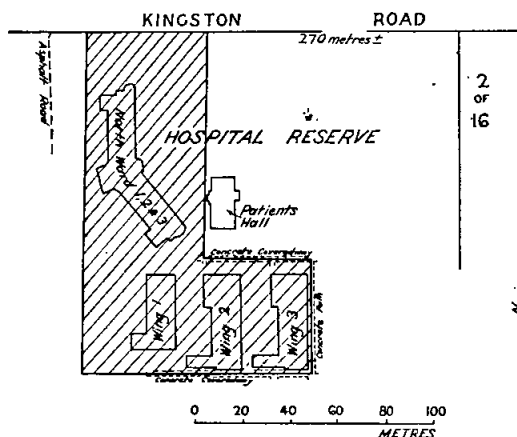

And the Honorable Alan Henry Scanlan, Her Majesty's Minister of Health in the State of Victoria, shall give the necessary directions herein accordingly.

TOM FORRISTAL,
 Clerk of the Executive Council.

STATE ELECTRICITY COMMISSION ACT 1958, No. 6377.

At the Executive Council Chamber, Melbourne, the thirteenth day of May, 1975.

PRESENT:

His Excellency the Governor of Victoria.
 Mr. Borthwick | Mr. Rafferty
 Mr. Smith | Mr. Scanlan.

Whereas His Excellency the Governor of the State of Victoria by and with the advice of the Executive Council thereof has this day consented pursuant to the provisions of the *State Electricity Commission Act 1958* to the State Electricity Commission of Victoria raising by way of loan the sum of One hundred and forty-nine thousand dollars (\$149,000); And whereas His Excellency the Governor in Council is satisfied that a sufficient proportion of the loan to be raised will fall due and be repaid in each year during the currency of the proposed loan; Now therefore it is directed pursuant to the provisions of section 91 (3) of the said Act, that it shall not be necessary to provide a sinking fund in connexion with such loan.

And the Honorable Rupert James Hamer, Her Majesty's Treasurer for the State of Victoria, shall give the necessary directions herein accordingly.

TOM FORRISTAL,
 Clerk of the Executive Council.

CEMETERIES ACT 1958 (No. 6217).—SECTION 36.

At the Executive Council Chamber, Melbourne, the thirteenth day of May, 1975.

PRESENT:

His Excellency the Governor of Victoria.
 Mr. Borthwick | Mr. Rafferty
 Mr. Smith | Mr. Scanlan.

Pursuant to section 36 of the *Cemeteries Act 1958*, His Excellency the Governor of the State of Victoria, by and with the advice of the Executive Council of the said State, hereby directs that an amount not exceeding One thousand dollars (\$1,000.00), being part of the balance of funds in the hands of the Trustees of the Maryborough Public Cemetery, be expended on the development of a lawn cemetery.

And the Honorable Alan Henry Scanlan, Her Majesty's Minister of Health for the State of Victoria, shall give the necessary directions herein accordingly.

TOM FORRISTAL,
 Clerk of the Executive Council.

SUPERANNUATION ACT 1958.

At the Executive Council Chamber, Melbourne, the thirteenth day of May, 1975.

PRESENT:

His Excellency the Governor of Victoria.
 Mr. Borthwick | Mr. Rafferty
 Mr. Smith | Mr. Scanlan.

His Excellency the Governor of the State of Victoria, by and with the advice of the Executive Council thereof, doth by this Order made pursuant to paragraph (m) of sub-section (1) of section 3 of the *Superannuation Act 1958* approve of Charles Curwen as a person in the service of the Governor whose age and past or anticipated length of service renders him suitable to be a contributor under the said Act.

And the Honorable Rupert James Hamer, Her Majesty's Treasurer for the State of Victoria, shall give the necessary directions herein accordingly.

TOM FORRISTAL,
 Clerk of the Executive Council.

SUPERANNUATION ACT 1958.

At the Executive Council Chamber, Melbourne, the thirteenth day of May, 1975.

PRESENT:

His Excellency the Governor of Victoria.
 Mr. Borthwick | Mr. Rafferty
 Mr. Smith | Mr. Scanlan.

Pursuant to the powers conferred by the provisions of paragraph (ja) of sub-section (1) of section 3 of the *Superannuation Act 1958*, His Excellency the Governor of the State of Victoria, by and with the advice of the Executive Council thereof doth by this Order declare that the provisions of the *Superannuation Act* shall apply to the officers named in the schedule set out hereunder.

SCHEDULE.

- BARWICK, NEVILLE JOHN, Assistant Director-General of Education (Buildings).
- LLOYD, DOUGLAS JAMES, State College of Victoria, at Bendigo.
- BOADLE, BRIAN HENRY, State College of Victoria, at Burwood.
- BUCK, MARGARET ELISON, State College of Victoria, at Coburg.
- NEESON, JOHN RUSSELL, State College of Victoria, at Melbourne.

And the Honorable Rupert James Hamer, Her Majesty's Treasurer for the State of Victoria, shall give the necessary directions herein accordingly.

TOM FORRISTAL,
 Clerk of the Executive Council.

LOCAL GOVERNMENT DEPARTMENT.

At the Executive Council Chamber, Melbourne, the
twentieth day of May, 1975.

PRESENT:

His Excellency the Governor of Victoria.
Mr. Balfour Mr. Hunt.
Mr. Houghton

RE-SUBDIVISION OF THE SHIRE OF CRANBOURNE.

Pursuant to the provisions of Part II of the *Local Government Act 1958*, His Excellency the Governor of the State of Victoria, by and with the advice of the Executive Council thereof, and in compliance with an application of the Council of the Shire of Cranbourne, hereby orders:—

- (1) That on and from the 31st May, 1975 the municipal district of the Shire of Cranbourne shall be re-subdivided in the manner described hereunder:—
- (2) that all councillors of the said municipality shall go out of office on the day appointed for the annual election of councillors next after this Order takes effect; and
- (3) that for the purpose of any financial adjustment this Order shall take effect on and from the 1st October, 1975.

SHIRE OF CRANBOURNE.

West Riding.
(Constituted.)

Commencing at the north-western corner of the Shire; thence easterly by the shire boundary to the South Gippsland Highway; thence generally south easterly by that highway to the Dandenong-Hastings road; thence southerly by that road to the southern boundary of the shire; thence north-westerly, westerly, north-westerly and generally northerly by the shire boundary to the point of commencement.

Centre Riding.
(Constituted.)

Commencing at a point on the northern boundary of the Shire where it is intersected by the South Gippsland Highway; thence generally south-easterly by that highway to the Dandenong-Hastings Road; thence southerly by that road to McKays Road; thence easterly by McKays Road and Browns Road to the South Gippsland Highway; thence south-easterly by that highway to Clyde Road; thence generally northerly by Clyde Road and the Berwick-Cranbourne Road to the northern boundary of the shire; thence westerly northerly westerly northerly and westerly by the shire boundary to the point of commencement.

East Riding.
(Constituted.)

Commencing at a point on the northern boundary of the shire where it is intersected by the Berwick-Cranbourne Road; thence easterly by the shire boundary to the No. 4 Yallock Drain Road; thence south westerly by that road and Yallock Creek to the southern boundary of the shire; thence generally westerly by the shire boundary to the Hastings-Dandenong Road; thence northerly by that road to McKays Road; thence easterly by McKays Road and Browns Road to the South Gippsland Highway; thence south-easterly by that highway to Clyde Road; thence generally northerly by Clyde Road and the Berwick-Cranbourne Road to the northern boundary of the shire; thence generally easterly and south-easterly by the shire boundary to the point of commencement.

South-East Riding.
(Constituted.)

Commencing at a point on the northern boundary of the shire where it is intersected by the No. 4 Yallock Drain Road; thence south-westerly by that road and Yallock Creek to the southern boundary of the shire; thence south-easterly, easterly, northerly easterly, northerly and westerly by the southern, eastern and northern boundaries of the shire to the point of commencement.

And the Honorable Alan John Hunt, Her Majesty's Minister for Local Government for the State of Victoria shall give the necessary directions herein accordingly.

TOM FORRISTAL,
Clerk of the Executive Council.

LOCAL GOVERNMENT DEPARTMENT.

At the Executive Council Chamber, Melbourne, the
twentieth day of May, 1975.

PRESENT:

His Excellency the Governor of Victoria.
Mr. Balfour Mr. Hunt.
Mr. Houghton

RE-SUBDIVISION OF THE SHIRE OF WOORAYL.

Pursuant to the provisions of Part II of the *Local Government Act 1958*, His Excellency the Governor of the State of Victoria, by and with the advice of the Executive Council thereof, and in compliance with an application of the Council of the Shire of Woorayl, hereby orders:—

- (1) That on and from the 31st May, 1975, the municipal district of the Shire of Woorayl shall be re-subdivided in the manner described hereunder;
- (2) that all councillors of the said municipality shall go out of office on the day appointed for the annual election of councillors next after this Order takes effect; and
- (3) that for the purpose of any financial adjustment this Order shall take effect on and from 1st October, 1975.

SHIRE OF WOORAYL.

North Riding.
(Enlarged and Redefined.)

Commencing at the intersection of the South Eastern Railway with the western boundary of the Shire; thence south-easterly by that railway to Coalition Creek; thence generally easterly and southerly by that creek to its junction with the Tarwin River (West Branch); thence generally southerly by that river to the north-east angle of allotment 88b, Parish of Leongatha; thence southerly along the eastern boundaries of allotments 88b, 88e, 88f, and 88g of that Parish to the south eastern angle of the last mentioned allotment; thence easterly along the southern boundaries of the Parish of Nerrena and the Township of Meenyan to the south-east angle of allotment 43c, Parish of Nerrena; thence easterly and north-easterly along a road to the Shire boundary; thence generally north-easterly, easterly, northerly, westerly and southerly by the Shire boundary to the point of commencement.

Central Riding.
(Enlarged and Redefined.)

Commencing at the intersection of the South Eastern Railway with the western boundary of the Shire; thence south-easterly by that railway to Coalition Creek; thence generally easterly and southerly by that creek to its junction with the Tarwin River (West Branch); thence generally southerly by that river to the south-east angle of allotment 63, Parish of Leongatha; thence north westerly by a road to the South Gippsland Highway; thence northerly along the South Gippsland Highway to the south-east angle of allotment 62a; thence westerly along a road to the south-west angle of allotment 60c; thence south-westerly along a road to the south-east angle of allotment 55b; thence westerly along a road to the south-west angle of allotment 54; thence northerly along a road to the north-west angle of allotment 53a; thence westerly along a road to the Shire boundary; thence northerly by the Shire boundary to the point of commencement.

South Riding.
(Reduced and Redefined.)

Commencing at the northern angle of allotment 53c, Parish of Meenyan, being a point on the Shire boundary; thence generally southerly and north-westerly by the Shire boundary to Point Smythe at the entrance to Andersons Inlet; thence north by a direct line to the northern shore of Andersons Inlet; thence easterly by that shore to Pound Creek; thence northerly by that creek to a point in line with the south boundary of allotment 19a, Parish of Drumdemara; thence easterly by the south boundary to that Parish to the south-east angle of Allotment 83; thence north-westerly along a road to the south-west angle of Allotment 76; thence generally northerly along the western boundaries of allotments 76, 76b, 74b, 60, 61a and 61 to the north-west angle of the last mentioned allotment; thence easterly along the northern boundary of that Parish, the southern boundaries of the Parish of Nerrena and the Township of Meenyan to the south-east angle of allotment 43c Parish of Nerrena; thence easterly and north-easterly along a road to the Shire boundary at the point of commencement.

West Riding.

(Reduced and Redefined.)

Commencing at the south-west angle of allotment 72D, Parish of Leongatha, being a point on the Shire boundary; thence generally southerly by the Shire boundary to the sea coast; thence north easterly by the sea coast and easterly by the north boundary of Andersons Inlet to Pound Creek; thence northerly by that creek to a point in line with the south boundary of allotment 19A Parish of Drumdemara; thence easterly by the south boundary of that parish to the south east angle of allotment 83; thence north-westerly along a road to the south west angle of allotment 76; thence generally northerly along the western boundaries of allotments 76, 76B, 74B, 60B, 60, 61A and 61 to the north-west angle of the last mentioned allotment; thence easterly along the northern boundary of the parish to the south-east angle of allotment 88G Parish of Leongatha; thence northerly along the eastern boundaries of allotments 88G, 88F, 88E, and 88B to the north-east angle of the last mentioned allotment; thence generally northerly by the Tarwin River (West Branch) to the south-east angle of allotment 63; thence north-westerly by a road to the South Gippsland Highway; thence northerly along the South Gippsland Highway to the south-east angle of allotment 62A; thence westerly along a road to the south-west angle of allotment 60C; thence south-westerly along a road to the south-east angle of allotment 55B; thence westerly along a road to the south-west angle of allotment 54; thence northerly along a road to the north-west angle of allotment 53A; thence westerly along a road to the Shire boundary at the point of commencement.

And the Honorable Alan John Hunt, Her Majesty's Minister for Local Government for the State of Victoria shall give the necessary directions herein accordingly.

TOM FORRISTAL,
Clerk of the Executive Council.

LOCAL GOVERNMENT DEPARTMENT.

At the Executive Council Chamber, Melbourne, the twentieth day of May, 1975.

PRESENT:

His Excellency the Governor of Victoria.
Mr. Balfour | Mr. Hunt.
Mr. Houghton

RE-SUBDIVISION OF THE BOROUGH OF WONTHAGGI.

Pursuant to the provisions of Part II of the *Local Government Act 1958*, His Excellency the Governor of the State of Victoria, by and with the advice of the Executive Council thereof, and in compliance with an application of the Council of the Borough of Wonthaggi hereby orders:—

- (1) That on and from the 31st May, 1975 the municipal district of the Borough of Wonthaggi shall be re-subdivided in the manner described hereunder;
- (2) that all councillors of the said municipality shall go out of office on the day appointed for the annual election of councillors next after this Order takes effect; and
- (3) that for the purpose of any financial adjustment this Order shall take effect on and from the 1st October, 1975.

BOROUGH OF WONTHAGGI.

North Ward.

Commencing at a point on the eastern boundary of the Borough, being the south-east angle of allotment 36, Parish of Wonthaggi; thence westerly by the southern boundary of that allotment and allotment 36A to a road on the west boundary of allotment 36A; thence northerly by that road to McKenzie Street; thence generally north westerly by McKenzie Street to Edgar Street; thence westerly by Edgar Street to McBride Avenue thence northerly by McBride Avenue to Graham Street; thence westerly by Graham Street and a line in continuation thereof to the Borough boundary; thence north-westerly generally northerly, easterly and southerly by that boundary to the point of commencement.

West Ward.

Commencing at the intersection of McBride Avenue and Graham Street; thence southerly by McBride Avenue to Edgar Street; thence easterly by Edgar Street to Dunn Street; thence south-westerly by Dunn Street to Matthew Street; thence westerly by Matthew Street to Cameron Street; thence southerly by Cameron Street and Berrys

Road and a prolongation of Berrys Road to the Borough boundary; thence north-westerly by the Borough boundary to a point in line with the prolongation of Graham Street, thence easterly by a line and Graham Street to McBride Avenue being the point of commencement.

South Ward.

Commencing at the intersection of Edgar Street and Dunn Street; thence south-westerly by Dunn Street to Matthew Street; thence westerly by Matthew Street to Cameron Street; thence southerly by Cameron Street and Berrys Road and a prolongation of Berrys Road to the Borough boundary; thence south-easterly and northerly by the Borough boundary to the south eastern angle of allotment 36, Parish of Wonthaggi; thence westerly by the southern boundary of that allotment and allotment 36A to a road on the west boundary of allotment 36A; thence northerly by that road to McKenzie Street; thence generally north-westerly by McKenzie Street to Edgar Street; thence westerly by Edgar Street to Dunn Street being the point of commencement.

And the Honorable Alan John Hunt, Her Majesty's Minister for Local Government for the State of Victoria shall give the necessary directions herein accordingly.

TOM FORRISTAL,
Clerk of the Executive Council.

LORNE SEWERAGE AUTHORITY.

At the Executive Council Chamber, Melbourne, the twentieth day of May, 1975.

PRESENT:

His Excellency the Governor of Victoria.
Mr. Balfour | Mr. Hunt.
Mr. Houghton

CONSENT TO BORROWING \$60,000.

Under the powers conferred by the Sewerage Districts Act and all other powers enabling him in that behalf, His Excellency the Governor of the State of Victoria, by and with the advice of the Executive Council of the said State, hereby consents to the Lorne Sewerage Authority borrowing the sum of Sixty thousand dollars (\$60,000) to meet the cost of sewerage works as set forth in the detailed statement bearing date 16th May, 1975.

And the Honorable Frederick James Granter, Her Majesty's Minister of Water Supply for the State of Victoria, shall give the necessary directions herein accordingly.

TOM FORRISTAL,
Clerk of the Executive Council.

LANDS DEPARTMENT NOTICES

APPROACHING LAND SALES.

Sale of Crown Land, in fee-simple, will be held at the under-mentioned places and dates, viz:—

	No. of Gazette.
Ballarat.—Thursday, 3rd July, 1975	35
Hamilton.—Friday, 4th July, 1975	39
Horsham.—Tuesday, 27th May, 1975	28

SALE OF CROWN LAND BY AUCTION.

The land will be offered for sale in fee-simple, and subject to the provisions of the Land Act and Regulations thereunder.

The **upset price** is the sum at which bidding will start, and no bid below that sum can be accepted. The highest bidder at or above that sum shall be the purchaser, subject to signature of contract and any necessary payment.

TERMS:

A deposit of at least 12½% of the purchase price must be paid at the sale, either in cash or by cheque.

The residue is payable in 20 half-yearly instalments, or may be paid off at any earlier time.

Interest at the rate of 7% per annum is payable, with all payments of residue, and is computed for each instalment from the date of sale to the date of such payment. Additional interest is charged if any instalment is not paid on or before the due date.

If paid off within 30 days of sale, no interest is payable.

FEEs, ETC.:

Also payable at the sale, in addition to the deposit, is the Survey Fee of \$70.00.

Payable with balance of purchase money—

Crown Grant fee—\$10.

Assurance Fund contribution.—One cent in every Five dollars or part thereof of purchase price. (This is a fund established to guarantee the validity of freehold titles.)

Transfer of interest prior to completion of payment may be allowed on payment of \$5 fee and subject to stamp duty.

If unable to attend personally, a prospective purchaser may arrange for another person to bid as his agent.

Attention is drawn to section 95, Land Act 1958, which provides that the purchaser shall be deemed to be the owner for the purposes of other Acts; also to an amendment to the Local Government Act providing for Government roads, in certain circumstances, to be declared "private streets", thus making the purchaser liable to contribute to the cost of street construction.

W. BORTHWICK,
Minister of Lands.

Office of Crown Lands and Survey,
Melbourne, 21st May, 1975.

HAMILTON.—Sale (No. 12190) of Crown land in fee-simple by auction, will be held in the STATE OFFICES, 17 THOMPSON STREET, HAMILTON, ON FRIDAY, the 4th day of JULY, 1975, at ELEVEN O'CLOCK A.M. To be conducted by Mr. K. Gittins, Land Officer, Hamilton.

Lot 1.

PARISH OF NORTH HAMILTON.

Being the property known as No. 176 Kent Road situated about 184 metres (200 yards) west of Bree Road.

Upset price \$21,000 the lot. Survey fee \$70.00.

Area 1133 square metres (1 rood 5 perches). Allotment 25A, Section C. Improvements comprise brick veneer dwelling, the valuation of which is included in the upset price.

Until the purchase money has been paid in full, the following special conditions shall apply:—

- (i) The purchaser shall at his own expense maintain the property in good order and repair and keep all improvements thereon insured against fire, storm and tempest in the name of the Secretary for Lands.
- (ii) A cover note for such insurance shall be lodged in the Department of Crown Lands and Survey, by the purchaser, within one week of the date of sale, and the policy shall be lodged immediately on issue.
- (iii) The purchaser shall not remove or make any alterations to the improvements on the site without prior consent of the Secretary for Lands.—(W.92397.)

PROPOSED REVOCATIONS OF TEMPORARY RESERVATIONS OF LANDS BY ORDERS IN COUNCIL.

In pursuance of the provisions of the Land Act 1958, notice is hereby given that it is the intention of the Governor in Council to revoke the temporary reservations of lands by Orders in Council hereunder referred to viz.:—

The following Notices were published 1° on the 21st May, 1975, pursuant to Orders of the 13th May, 1975.

MIRBOO NORTH.—The temporary reservation by Order in Council of the 22nd June, 1885, of 7082 square metres (1 acre 3 roods) of land in the Township of Mirboo North as a site for a State School, revoked as to part by Order of the 31st July, 1933, is about to be revoked so far as the balance thereof containing 2352 square metres is concerned.—(M.517⁽¹⁸⁾) (Rs.4316).

JIKA JIKA (FAIRFIELD).—The temporary reservation by Order in Council of the 5th February, 1863, of 1391 square metres (1 rood 15 perches, more or less) of land in the Parish of Jika Jika as a site for Police purposes is about to be revoked so far only as the portion containing 5 square metres indicated by hatching on plan hereunder, is concerned.—(J.16⁽⁴⁾) (Rs.8204).

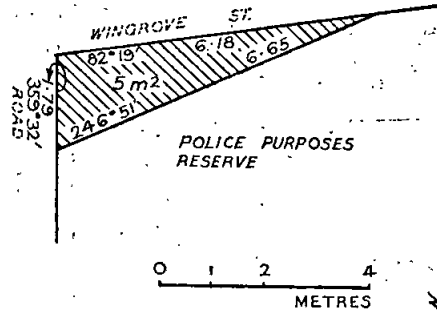

W. BORTHWICK,
Minister of Lands.

PROPOSED REVOCATIONS OF TEMPORARY RESERVATIONS OF LANDS BY ORDERS IN COUNCIL.

In pursuance of the provisions of the Land Act 1958, notice is hereby given that it is the intention of the Governor in Council to revoke the temporary reservations of lands by Orders in Council hereunder referred to viz.:—

The following Notices were published 1° on the 30th April, 1975, pursuant to Orders of the 22nd April, 1975.

CASTERTON.—The temporary reservation as a site for Cemetery and the withholding from sale, leasing and licensing by Order in Council of the 3rd June, 1879 (see Government Gazette 1879, page 1246) of 4.047 hectares (10 acres) of land in the Parish of Casterton revoked as to part by Order of the 19th November, 1968, are about to be revoked so far only as the portion containing 4821 square metres, indicated by hatching on plan hereunder is concerned.—(C.178^(*)) (Rs.9055).

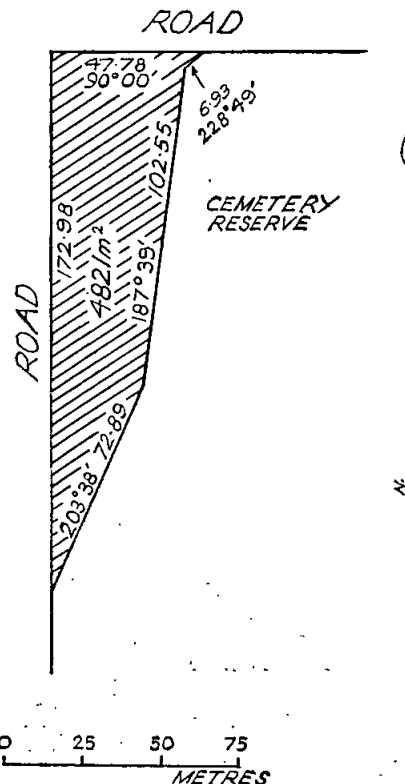

BUANGOR.—The temporary reservation as a site for watering purposes and the withholding from sale, leasing and licensing by Order in Council, 8th May, 1876 (see

Government Gazette 1876, page 893) of 16.59 hectares (41 acres, more or less) of land in the Parish of Buangor revoked as to part by Order of the 16th April, 1957, are about to be revoked so far only as the portion containing 3828 square metres indicated by hatching on plan hereunder, is concerned.—(B.472⁽²⁾) (Rs.5807).

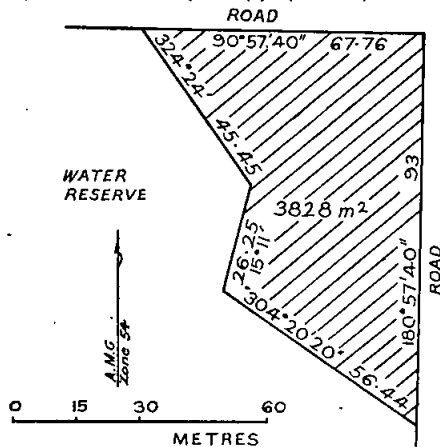

W. BORTHWICK,
Minister of Lands.

PROPOSED REVOCATIONS OF TEMPORARY RESERVATIONS OF LANDS BY ORDERS IN COUNCIL.

In pursuance of the provisions of the Land Act 1958, notice is hereby given that it is the intention of the Governor in Council to revoke the temporary reservations of lands by Orders in Council hereunder referred to, viz.:

The following Notices were published 1° on the 7th May, 1975, pursuant to Orders of the 29th April, 1975.

WALLAN.—The temporary reservation by Order in Council of the 11th July, 1892 (see Government Gazette, 1892 page 2955) of 3.455 hectares (8 acres 2 roods 6 perches) of land in the Township of Wallan (called Town of Wallan Wallan in Order) as a site for Water Supply purposes is about to be revoked, so far only as the portion containing 2.6 hectares, more or less, indicated by hatching on plan hereunder, is concerned.—(W.18⁽⁴⁾) (Rs.10044).

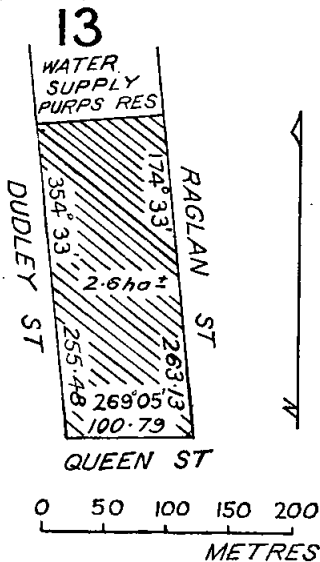

W. BORTHWICK,
Minister of Lands.

KATUNGA (NUMURKAH).—The temporary reservation by Order in Council of the 2nd December, 1952, of 769 square metres (30 4/10 perches) of land in the Parish of Katunga as a site for Police purposes, is about to be revoked.—(K.166⁽³⁾) (Rs.7054).

TENDERS

PUBLIC WORKS DEPARTMENT

Tenders will be received at Public Works Department, 2 Treasury Place, Melbourne, until **TWO p.m.** on dates shown and for purposes mentioned hereunder.

Particulars and tender forms available at Contracts Office, Room 27, Ground Floor, No. 2, Treasury Place, and at places indicated in brackets hereunder.

Abbreviations in brackets mean:—W.O.—Inspector of Works Office; P.S.—Police Station; C.S.—Consolidated School; H.E.S.—Higher Elementary School; H.S.—High School; Pr.S.—Primary School; T.S.—Technical School.

Tenders to be submitted on the Department's printed Tender Form and will not be received by telephone. All tenders must be on a "Firm Tender" basis. The lowest or any tender will not necessarily be accepted.

Address tenders to the Minister of Public Works, and endorse the envelope containing the tender "Tender for closing Tuesday,"

Hand delivered tenders to be placed in the Tender Box of the Public Works Department, located on the wall of the centre entrance foyer, Ground Floor, 2 Treasury-place, Melbourne.

No preliminary deposit is required with any tender, but successful tenderer will be required to pay a deposit for any accepted tender of \$10,000 or over.

Tuesday, 27th May, 1975.

Building, Electrical, Mechanical Works.

BRIGHTON.—Alterations and additions to mechanical services, Technical School.

BRUNSWICK WEST.—Mechanical services, staff accommodation improvements, Pr.S.2890.

GOLDEN SQUARE.—Re-roofing brick building classroom block, Pr.S.1189. (W.O., Bendigo.)

KANGAROO FLAT.—Art/craft room and other facilities, Pr.S.981. (W.O., Bendigo.)

KANGAROO FLAT.—Electrical services, art/craft room and other facilities, Pr.S.981. (W.O., Bendigo.)

KANGAROO FLAT.—Mechanical services, art/craft room and other facilities, Pr.S.981. (W.O., Bendigo.)

LORNE.—Alterations and additions, Erskine House. (W.O., Geelong.)

MILDURA.—Mechanical services, staff accommodation improvements and provision of art room and library, Pr.S.2915. (W.O., Mildura.)

OUYEN.—Evaporative air conditioning, science block, High School. (W.O., Swan Hill, Mildura and Bendigo.)

PORT MELBOURNE.—Erection of office building, Stage 2, Marine Models Laboratory.

RUSHWORTH.—Construction of police station, cell block and residence. (W.O., Bendigo and Shepparton.)

Site Works.

BUCKLEY PARK.—Siteworks, High School.

Miscellaneous.

MELBOURNE.—Maintenance cleaning, 1st June, 1975, to 31st May, 1978, Cancer Institute and Tiles Office, Lonsdale Street.

VARIOUS.—Supply of 150 mm hacksaw machine and marking off table, schools and other government buildings.

VARIOUS.—Supply of woodworking saw benches, schools and other government buildings.

VARIOUS.—Supply of 230 mm swing engineers lathes, schools and other government buildings.

VARIOUS.—Supply of planing/jointing machines and thicknesser, schools and other government buildings.

VARIOUS.—Supply of universal turret head milling machine, schools and other government buildings.

VARIOUS.—Supply of bandsaw machines and spindle borer, schools and other government buildings.

WATSONIA.—Connection to Melbourne Metropolitan Board of Works Sewer (Stage I), Loyola Youth Training Centre.

Tuesday, 3rd June, 1975.

Building, Electrical and Mechanical Works.

DAYLESFORD.—Electrical installation, alterations and additions, Primary School 1609 (W.O., Ballarat.)

MILDURA.—Electrical services, staff accommodation improvements, provision of art room and library, Primary School 2915. (W.O., Mildura.)

NEWPORT WEST.—Extensions and modifications to heating systems, Pr.S.4665. (Amended Spec.)

YALLOURN.—Electrical installation—wiring of AC/DC supply panels, Technical School. (W.O., Traralgon.)

Site Works.

MOORABBIN.—Site works to science wing, High School.

SYNDAL.—Site works to home economics wing, Technical School.

Miscellaneous.

MELBOURNE.—Supply and installation of PABX telephone system, public offices, Lonsdale Street.

VARIOUS.—Supply of shaping machines, schools and other government buildings.

VARIOUS.—Supply of universal horizontal milling machine, schools and other government buildings.

VARIOUS.—Supply of woodworking lathes, schools and other government buildings.

VARIOUS.—Supply of 255–280 mm swing screw cutting lathes, schools and other government buildings.

VARIOUS.—Supply of 305–330 mm swing screw cutting lathes, schools and other government buildings.

VARIOUS.—Supply of 355–380 mm screw cutting lathes, schools and other government buildings.

VARIOUS.—Supply of 205 mm grinding machines.

VARIOUS.—Supply of 13 mm drilling machines, schools and other government buildings.

VARIOUS.—Supply of audio visual carrel ducts, various buildings.

Tuesday, 10th June, 1975.

Building, Electrical, Mechanical Works.

BRAYBROOK.—Electrical services, new library building, High School.

BRAYBROOK.—Mechanical services, new library building, High School. (Re-advertised.)

COBURG.—Alterations and modifications to mechanical services, State College of Victoria.

ESSENDON.—Gas welding installation, trades wing, Technical School.

FERNTREE GULLY.—Electrical services, remodelling of Shire Offices, State Public Offices.

OAKLEIGH.—Provision of garage facilities, Technical School.

ST. ALBANS NORTH.—Electrical services, art/craft room and staff accommodation improvements, Pr.S.4811.

SALE.—Internal and external repairs and painting, Pr.S.545. (Re-advertised.) (W.O., Traralgon.)

SYNDAL SOUTH.—External and internal repairs and painting, Pr.S.4924.

Miscellaneous.

VARIOUS.—Supply of domestic equipment, schools and other government buildings.

VARIOUS.—Supply of kitchen equipment, schools and other government buildings.

ROBERTS DUNSTAN,
Minister for Public Works.

Public Works Department,
Melbourne, 19th May, 1975.

Teaching Service Act 1958.

TEACHING SERVICE—PROFESSIONAL (CLASSIFICATIONS, SALARIES, AND ALLOWANCES) REGULATION.

AMENDMENT No. 315 (PROF. C.S. & A.3).

The Teachers Tribunal, in pursuance of the powers conferred by the *Teaching Service Act 1958*, hereby amends the *Teaching Service—Professional (Classification, Salaries, and Allowances) Regulation* as follows:—

1. In clause 4 rescind the schedule of rates and substitute therefor the following schedule:—

Subdivision.	Annual Salary.
	\$
1	10,282
2	10,723
3	11,163
4	11,733
5	12,303
6	12,846
7	13,494
8	14,608
9	15,514
10	16,524
11	17,198
12	17,923
13	18,648
14	19,321
15	19,995
16	20,772
17	21,445
18	22,507
19	23,906
20	26,159

2. In sub-clauses 6 (b) and 6 (c) for the amount “\$19,300” substitute the amount “\$19,995”.

3. In clause 7 rescind the salary rates and substitute therefor the following rates:—

Principal, \$14,661.
 Vice-Principal, \$13,044.
 Lecturer, Grade I. Range: \$10,350; 10,889; 11,428; 11,967.
 Lecturer, Grade II. Range: \$7,763; 8,141; 8,518; 8,949;
 9,380; 9,811; 10,350.

4. Rescind clause 8.

(To take effect from and including the 25th May, 1975.)

W. E. SAMPSON, Chairman.
 A. F. LE CLERCQ, Secretary.

Office of the Teachers Tribunal,
 Melbourne, 8th May, 1975.

Teaching Service Act 1958.

TEACHING SERVICE—PRIMARY SCHOOLS DIVISION
 (CLASSIFICATION, SALARIES, AND ALLOWANCES)
 REGULATION.

AMENDMENT NO. 316 (PRIM. C.S. & A.3).

The Teachers Tribunal, in pursuance of the powers conferred by the *Teaching Service Act 1958*, hereby amends the Teaching Service—Primary Schools Division (Classification, Salaries, and Allowances) Regulation as follows:—

1. In paragraph (i) of sub-clause 5 (a) rescind the schedule of rates and substitute therefor the following schedule:—

Subdivision.	Certificate A.	Certificate B.	Certificate C or Lesser Qualification.
	\$	\$	\$
14	11,810
13	11,267
12	10,697	10,697	..
11	10,127	10,127	..
10	9,687	9,687	..
9	9,246	9,246	9,246
8	8,780	8,780	8,780
7	8,443	8,443	8,443
6	8,107	8,107	8,107
5	7,796	7,796
4	7,459	7,459
3	7,123
2	6,889
1	6,656

2. In paragraph (ii) of sub-clause 5 (a) for the figures "395", "1,000", and "525" substitute the figures "409", "1,036", and "544" respectively.

3. In sub-clause 5 (b) for the figures "13,025" and "14,100" substitute the figures "13,494" and "14,608" respectively.

4. In sub-clause 5 (c) for the figures "14,100" and "15,950" substitute the figures "14,608" and "16,524" respectively.

5. In sub-clause 10 (c) for the amounts "\$30.00", "\$15.00", and "\$18.50" substitute the amounts "\$31.00", "\$15.50", and "\$19.20" respectively.

6. In sub-clause 11 (b) for the amounts "\$336", "\$112", "\$168", and "\$56" substitute the amounts "\$348", "\$116", "\$174", and "\$58" respectively.

7. In sub-clause 11 (c) for the amounts "\$336" and "\$448" substitute the amounts "\$348" and "\$464" respectively.

8. In sub-clause 11 (d) for the amounts "\$1,500", "\$500", and "\$1,200" where appearing substitute the amounts "\$1,554", "\$518", and "\$1,243" respectively.

9. In sub-clause 11 (e) for the amounts "\$18.50", "\$22.20", and "\$9.25" substitute the amounts "\$19.20", "\$23.00", and "\$9.60" respectively.

10. In sub-clause 11 (f) for the amount "\$11.10" substitute the amount "\$11.50".

11. In sub-clause 13 (a) rescind the allowances listed and substitute therefor the following allowances:—

YEAR OF COURSE.				
1st	2nd	3rd	4th	5th and thereafter
\$	\$	\$	\$	\$
2,035	2,035	2,417	2,656	2,656

12. In paragraph (v) of sub-clause 13 (b) rescind the schedule of rates and substitute therefor the following schedule:—

YEAR OF COURSE.				
Completed year of course at date of recruitment	2nd	3rd	4th	5th and thereafter
	\$	\$	\$	\$
1st	2,597	2,967	3,206	3,206
2nd		3,614	3,985	3,985
3rd			4,631	4,786
4th				5,470

13. In sub-clause 13 (c) for the amounts "\$2,564", "\$200", and "\$3,957" substitute the amounts "\$2,656", "\$207", and "\$4,165" respectively.

14. In clause 14 rescind the rates of salary and substitute therefor the following rates:—

Years of Service.			
1	2	3	4
\$	\$	\$	\$
2,533	2,616	2,694	2,818

15. Rescind sub-clause 15 (a) and substitute therefor the following sub-clause:—

(a) The following rates of salary shall be paid:—

Supervisor of Migrant Education	16,084
Instructor in Charge	13,598

Programmer-Teacher of Intensive Courses; Programmer-Teacher of Accelerated Courses—

Subdivisions.		
1	2	3
\$	\$	\$
10,697	11,163	11,707

Organizer of Continuation Classes; Organizer of Correspondence Tuition; Organizer of Industrial Classes—

Subdivisions.		
1	2	3
\$	\$	\$
9,687	10,127	10,697

Instructor—

Subdivisions.								
1	2	3	4	5	6	7	8	9
\$	\$	\$	\$	\$	\$	\$	\$	\$
6,656	6,889	7,123	7,459	7,796	8,107	8,443	8,780	9,246

16. In sub-clause 15 (c) for the amount "\$9.25" substitute the amount "\$9.60".

(To take effect from and including the 25th May, 1975.)

W. E. SAMPSON, Chairman.
A. F. LE CLERCQ, Secretary.

Office of the Teachers Tribunal,
Melbourne, 8th May, 1975.

Teaching Service Act 1958.
**TEACHING SERVICE—SECONDARY SCHOOLS DIVISION
 (CLASSIFICATION, SALARIES, AND ALLOWANCES)
 REGULATION.**

AMENDMENT NO. 317 (SEC. C.S. & A.4).

The Teachers Tribunal, in pursuance of the powers conferred by the *Teaching Service Act 1958*, hereby amends the Teaching Service—Secondary Schools Division (Classification, Salaries, and Allowances) Regulation as follows:—

1. In sub-clause 5 (a) for the figures "17,300", "15,575", and "15,400" substitute the figures "17,923", "16,136", and "15,954" respectively.

2. In sub-clause 5 (b) for the figure "13,025" substitute the figure "13,494".

3. In paragraph (i) of sub-clause 5 (c) rescind the schedule of rates and substitute therefor the following schedule:—

Subdivision.	Fully Qualified.*	One Year of Study Less than Fully Qualified.†	Lesser Qualifications.
	\$	\$	\$
14	11,810		
13	11,267		
12	10,697	10,697	
11	10,127	10,127	
10	9,687	9,687	
9	9,246	9,246	9,246
8	8,780	8,780	8,780
7	8,443	8,443	8,443
6	8,107	8,107	8,107
5		7,796	7,796
4		7,459	7,459
3			7,123
2			6,889
1			6,656

* Qualified for Senior Teacher Class.

† Qualified for appointment to recognized post of responsibility.

4. In paragraph (ii) of sub-clause 5 (c) for the amount "\$1,000" substitute the amount "\$1,036".

5. In sub-clause 10 (c) for the amounts "\$30.00", "\$15.00", and "\$18.50" substitute the amounts "\$31.00", "\$15.50", and "\$19.20" respectively.

6. In sub-clause 11 (b) for the amounts "\$336" and "\$224" substitute the amounts "\$348" and "\$232" respectively.

7. In sub-clause 11 (c) for the amounts "\$18.50", "\$22.20", and "\$9.25" substitute the amounts "\$19.20", "\$23.00", and "\$9.60" respectively.

8. In sub-clause 11 (d) for the amount "\$11.10" substitute the amount "\$11.50".

9. In sub-clause 11 (e) for the amount "\$1,200" substitute the amount "\$1,243".

10. In sub-clause 11 (f) for the amounts "\$5.60" and "\$3.75" substitute the amounts "\$5.80" and "\$3.90" respectively.

11. In sub-clause 13 (a) rescind the allowances listed and substitute therefor the following allowances:—

YEAR OF COURSE.				
1st	2nd	3rd	4th	5th and thereafter.
\$	\$	\$	\$	\$
2,035	2,035	2,417	2,656	2,656

12. In paragraph (v) of sub-clause 13 (b) rescind the schedule of rates and substitute therefor the following schedule:—

Completed year of course at date of recruitment.	YEAR OF COURSE.			
	2nd	3rd	4th	5th and thereafter.
	\$	\$	\$	\$
1st	2,597	2,967	3,206	3,206
2nd		3,614	3,985	3,985
3rd			4,631	4,786
4th				5,470

13. In sub-clause 13 (c) for the amounts "\$2,564", "\$200", and "\$3,957" substitute the amounts "\$2,656", "\$207", and "\$4,165" respectively.

(To take effect from and including the 25th May, 1975.)

W. E. SAMPSON, Chairman.

A. F. LE CLERCQ, Secretary.

Office of the Teachers Tribunal,
Melbourne, 8th May, 1975.

Teaching Service Act 1958.

TEACHING SERVICE—TECHNICAL SCHOOLS DIVISION (CLASSIFICATION, SALARIES, AND ALLOWANCES) REGULATION.

AMENDMENT No. 318 (TECH. C.S. & A.3).

The Teachers Tribunal, in pursuance of the powers conferred by the *Teaching Service Act 1958*, hereby amends the *Teaching Service—Technical Schools Division (Classification, Salaries, and Allowances) Regulation* as follows:—

1. In sub-clause 5 (a) for the figures "18,000", "17,300", "15,400", and "14,100" substitute the figures "18,648", "17,923", "15,954", and "14,608" respectively.

2. In sub-clause 5 (b) for the figure "13,025" substitute the figure "13,494".

3. In paragraph (i) of sub-clause 5 (c) rescind the schedule of rates and substitute therefor the following schedule:—

Subdivision.	Fully Qualified.*	One Year of Study Less than Fully Qualified.†	Lesser Qualifications.
	\$	\$	\$
14	11,810
13	11,267
12	10,697	10,697	..
11	10,127	10,127	..
10	9,687	9,687	..
9	9,246	9,246	9,246
8	8,780	8,780	8,780
7	8,443	8,443	8,443
6	8,107	8,107	8,107
5	7,796	7,796
4	7,459	7,459
3	7,123
2	6,889
1	6,656

* Qualified for Senior Teacher Class.

† Qualified for appointment to recognized post of responsibility.

4. In paragraph (ii) of sub-clause 5 (c) for the amount "\$1,000" substitute the amount "\$1,036".

5. In sub-clause 10 (c) for the amounts "\$30.00", "\$15.00", and "\$18.50" substitute the amounts "\$31.00", "\$15.50", and "\$19.20" respectively.

6. In sub-clause 11 (b) for the amounts "\$336" and "\$112" substitute the amounts "\$348" and "\$116" respectively.

7. In sub-clause 11 (c) for the amounts "\$18.50", "\$22.20", and "\$9.25" substitute the amounts "\$19.20", "\$23.00", and "\$9.60" respectively.

8. In sub-clause 11 (d) for the amount "\$11.10" substitute the amount "\$11.50".

9. In sub-clause 11 (e) for the amount "\$1,200" substitute the amount "\$1,243".

10. In sub-clause 13 (a) rescind the allowances listed and substitute therefor the following allowances:—

YEAR OF COURSE.				
1st	2nd	3rd	4th	5th and thereafter.
\$	\$	\$	\$	\$
2,035	2,035	2,417	2,656	2,656

11. In paragraph (v) of sub-clause 13 (b) rescind the schedule of rates and substitute therefor the following schedule:—

Completed year of course at date of recruitment.	YEAR OF COURSE.			
	2nd	3rd	4th	5th and thereafter.
	\$	\$	\$	\$
1st	2,597	2,967	3,206	3,206
2nd		3,614	3,985	3,985
3rd			4,631	4,786
4th				5,470

12. In sub-clause 13 (c) for the amounts "\$2,564", "\$200", and "\$3,957" substitute the amounts "\$2,656", "\$207", and "\$4,165" respectively.

13. In sub-clause 13 (g) for the figures "1,548", "1,681", and "2,514" substitute the figures "1,604", "1,742" and "2,646" respectively.

14. In sub-clause 13 (h) for the amount "\$336" substitute the amount "\$348".

(To take effect from and including the 25th May, 1975.)

W. E. SAMPSON, Chairman.
A. F. LE CLERCQ, Secretary.

Office of the Teachers Tribunal,
Melbourne, 8th May, 1975.

PUBLIC SERVICE NOTICES

No. 407.

PUBLIC SERVICE ACT 1958.

The Public Service Board, in pursuance of the powers conferred by the *Public Service Act 1958*, hereby amends the Public Service (Public Service Board) Regulations as follows:—

PART VI.—TRAVELLING AND OTHER EXPENSES.

DIVISION I.—REIMBURSEMENT OF PERSONAL EXPENSES.

GENERAL.

Regulation 212.

The existing regulation is deleted and the following regulation is inserted in lieu thereof—

"212. Except where the Board otherwise directs, an officer who is promoted or transferred from one station to another shall be reimbursed—

- (a) the actual reasonable cost of conveyance of himself and his wife and children;
- (b) the actual reasonable cost of conveyance of his furniture and personal effects, including the cost of comprehensive insurance cover for such furniture and effects whilst in transit, up to a maximum cover of \$5,000; and
- (c) an amount of up to \$150 by way of compensation, provided that the officer concerned is eligible to receive reimbursement of travelling expenses under paragraph (a) of this Regulation and the Permanent Head is satisfied that he has suffered loss through accelerated depreciation and extra wear and

tear on furniture and effects or has incurred cost in replacing or altering carpets, linoleum, curtains and blinds as a result of removal."

DIVISION IV.—OTHER EXPENSES.

Regulation 222.

This regulation is deleted.

A. J. A. GARDNER, Chairman.
L. R. BROWN, Secretary.

Office of the Public Service Board,
Melbourne, 9th May, 1975.

No. 406.

PUBLIC SERVICE ACT 1958.

The Public Service Board, in pursuance of the powers conferred by the *Public Service Act 1958*, hereby amends the Public Service (Public Service Board) Regulations as follows:—

PART IV.—SALARIES AND INCREMENTS.

DIVISION IV.—TECHNICAL AND GENERAL DIVISION.

Regulation 119.

In paragraph (i) of sub-regulation (3) the expression "one annual increment of \$118 and three annual increments of \$293" is deleted and the expression "one annual increment of \$167 and three annual increments of \$293" is inserted in lieu thereof.

This Regulation shall have effect from 13th April, 1975.

A. J. A. GARDNER, Chairman.
L. R. BROWN, Secretary.

Office of the Public Service Board,
Melbourne, 9th May, 1975.

No. 401.

Public Service Act 1958, Sections 39 and 50.

REGULATIONS.—PART IV.—SALARIES AND INCREMENTS.

The Public Service Board, in pursuance of the powers conferred by the *Public Service Act 1958*, hereby amends the Public Service (Public Service Board) Regulations as follows:—

FIRST SCHEDULE.

PROFESSIONAL DIVISION.

Amount of Salary Assigned to Offices in "Special" Class.

Delete the existing yearly rates of salary for the following offices and insert the rates shown hereunder in lieu thereof:—

Office.	Yearly Rate of Salary.
	\$
LAW DEPARTMENT.	
Chief Stipendiary Magistrate	27,439
Deputy Chief Stipendiary Magistrate .. .	25,952

SECOND SCHEDULE.

PART B.

PROFESSIONAL DIVISION.

Scale of Rates of Annual Salaries.

STIPENDIARY MAGISTRATES.

Delete the existing salary scale and insert the following scale in lieu thereof:—

Class.	Annual Salary of Each Class.
	\$
SM-1	21,965
SM-2	23,675

This Regulation shall have effect from 11th May, 1975.

A. J. A. GARDNER, Chairman.
L. R. BROWN, Secretary.

Office of the Public Service Board,
Melbourne, 9th May, 1975.

No. 400.

Public Service Act 1958, Sections 39 and 50.

REGULATIONS.—PART IV.—SALARIES AND INCREMENTS.

The Public Service Board, in pursuance of the powers conferred by the *Public Service Act 1958*, hereby amends the Public Service (Public Service Board) Regulations as follows:—

FIRST SCHEDULE.

PROFESSIONAL DIVISION.

Amount of Salary Assigned to Offices in "Special" Class.

Office.	Yearly Rate of Salary.
	\$
SOCIAL WELFARE DEPARTMENT.	
<i>Add—</i> Director, Policy Planning Unit .. .	22,000

A. J. A. GARDNER, Chairman.
L. R. BROWN, Secretary.

Office of the Public Service Board,
Melbourne, 9th May, 1975.

No. 409.

Public Service Act 1958; Sections 39 and 50.

REGULATIONS.—PART IV.—SALARIES AND INCREMENTS.

The Public Service Board, in pursuance of the powers conferred by the *Public Service Act 1958*, hereby amends the Public Service (Public Service Board) Regulations, as shown below:—

FIFTH SCHEDULE.

PART C.

DEPARTMENT OF HEALTH—MENTAL HYGIENE.

TECHNICAL AND GENERAL DIVISION AND TEMPORARY EMPLOYEES.

Classifications of Offices and Positions and Rates of Salaries.

Grades.	Yearly Salary.		Salary/Increment Code.	Title of Office and Position.	Title Code.
	Minimum.	Maximum.			
	\$	\$			
<i>Add—</i> F147/F153	Physiotherapist's Assistant (Female)—Adult	..
ES-1	Physiotherapist's Assistant (Female)—Junior	..

SIXTH SCHEDULE.

DEPARTMENT OF HEALTH—MENTAL HYGIENE.

Department and Office and/or Position.	Scale of Rates of Annual Salary with Incremental Stages.
TECHNICAL AND GENERAL DIVISION.	
<i>General Staff.</i>	
<i>Delete—</i>	
Physiotherapist's Assistant—T Junior—	
Under 17 years of age ..	\$3,191
At 17 years of age	\$3,480
At 18 years of age	\$3,770
At 19 years of age	\$4,350
At 20 years of age	\$4,931
Adult	\$5,800—\$5,939
<i>Add—</i>	
Physiotherapist's Assistant—Junior—	
Under 17 years of age ..	\$3,191
At 17 years of age	\$3,480
At 18 years of age	\$3,770
At 19 years of age	\$4,350
At 20 years of age	\$4,931
Adult	\$5,800—\$5,939

This Regulation shall have effect from 30th April, 1975.

A. J. A. GARDNER, Chairman.
L. R. BROWN, Secretary.

Office of the Public Service Board,
Melbourne, 12th May, 1975.

No. 402.

Public Service Act 1958, Section 39 and 50.

REGULATIONS.—PART IV.—SALARIES AND INCREMENTS.

The Public Service Board, in pursuance of the powers conferred by the *Public Service Act 1958*, hereby amends the Public Service (Public Service Board) Regulations as follows:—

INDEX TO SALARY/INCREMENT CODE AND DESIGNATION CODE FOR FOURTH AND FIFTH SCHEDULES.

Salary/Increment Code.

- Delete—*
AV Increments: 1 of \$245 and 1 of \$319;
AW Increments: 1 of \$188, 1 of \$190 and 1 of \$141.
- Add—*
AV Increments: 1 of \$269 and 1 of \$275;
AW Increments: 1 of \$171, 1 of \$219 and 1 of \$177.

This Regulation shall have effect from 23rd March, 1975.

A. J. A. GARDNER, Chairman.
L. R. BROWN, Secretary.

Office of the Public Service Board,
Melbourne, 7th May, 1975.

No. 408.

Public Service Act 1958, Sections 39 and 50.

REGULATIONS.—PART IV.—SALARIES AND INCREMENTS.

The Public Service Board, in pursuance of the powers conferred by the Public Service Act 1958, hereby amends the Public Service (Public Service Board) Regulations as follows:—

SECOND SCHEDULE.

PART B.

PROFESSIONAL DIVISION.

Scale of Rates of Annual Salaries.

REPORTERS, CHIEF SECRETARY'S DEPARTMENT AND LAW DEPARTMENT.

The salary scale shown is deleted and the following salary scale is inserted in lieu thereof:—

Class.	Annual Salary of Each Subdivision of Each Class.					
	1.	2.	3.	4.	5.	6.
	\$	\$	\$	\$	\$	\$
R-1 ..	12,494	12,778	13,108	13,439	13,715	14,046
R-2 ..	14,728
R-3 ..	16,705

with effect as on and from 18th May, 1975.

REPORTERS, CHIEF SECRETARY'S DEPARTMENT AND LAW DEPARTMENT.

The salary scale shown is deleted and the following salary scale is inserted in lieu thereof:—

Class.	Annual Salary of Each Subdivision of Each Class.					
	1.	2.	3.	4.	5.	6.
	\$	\$	\$	\$	\$	\$
R-1 ..	12,944	13,238	13,580	13,923	14,209	14,552
R-2 ..	15,258
R-3 ..	17,306

with effect as on and from 25th May, 1975.

A. J. A. GARDNER, Chairman.
L. R. BROWN, Secretary.

Office of the Public Service Board,
Melbourne, 16th May, 1975.

No. 405.

Public Service Act 1958, Sections 39 and 50.

REGULATIONS.—PART IV.—SALARIES AND INCREMENTS.

The Public Service Board, in pursuance of the powers conferred by the Public Service Act 1958, hereby amends the Public Service (Public Service Board) Regulations as shown below:—

FOURTH SCHEDULE.

PART C.

TECHNICAL AND GENERAL DIVISION AND TEMPORARY EMPLOYEES.

Classifications of Offices and Positions and Rates of Salaries.

Grades.	Yearly Salary.		Salary/Increment Code.	Title of Office and Position.	Title Code.
	Minimum.	Maximum.			
	\$	\$			
DEPARTMENT OF AGRICULTURE.					
Delete— 256-266	9,694	10,159	..	Meat Inspector, Senior, Grade III.	..
Add— 256-266	9,694	10,159	AA	Meat Inspector, Supervising	..
288-292	11,194	11,402	AA	Meat Inspector, Principal	..
with effect as on and from 9th May, 1975.					
DEPARTMENT OF AGRICULTURE.					
Delete— 256-266	9,694	10,159	AA	Meat Inspector, Supervising	..
288-292	11,194	11,402	AA	Meat Inspector, Principal	..
Add— 256-266	10,043	10,525	AA	Meat Inspector, Supervising	..
288-292	11,597	11,812	AA	Meat Inspector, Principal	..
with effect as on and from 25th May, 1975.					

A. J. A. GARDNER, Chairman.
L. R. BROWN, Secretary.

Office of the Public Service Board,
Melbourne, 9th May, 1975.

PRIVATE ADVERTISEMENTS

Town and Country Planning Act 1961 (Twelfth Schedule).
CITY OF BENALLA PLANNING SCHEME.

NOTICE THAT A PLANNING SCHEME HAS BEEN PREPARED AND IS AVAILABLE FOR INSPECTION.

Amendment No. 5.

Notice is hereby given that the City of Benalla in pursuance of its powers under the Town and Country Planning Act 1961, has prepared a planning scheme for the areas to which the City of Benalla Planning Scheme relates for the purposes of:—

- (a) Rezoning Parts of Section 7, Salisbury Street and Barkly Street from Residential B1 to Public Purposes Secondary Schools.
- (b) Rezoning Parts of Section A1, Barkly Street and Smythe Street from Residential B1 to Public Purposes Secondary Schools.
- (c) Rezoning Parts of Section A1, Bridge Street and Smythe Street from Public Purposes State Electricity Commission to Public Purposes Secondary Schools.

A copy of the scheme has been deposited at the Civic Offices, Benalla, and at the Office of the Town and Country Planning Board, 235 Queen Street, Melbourne, and will be open for inspection during office hours by any person, free of charge.

Any persons affected by the Planning Scheme are required to set forth, in writing, all objections they may have, addressed to the Town Clerk, City of Benalla, Fawckner Drive, Benalla, on or before the Twenty-First Day of August, 1975, and to state whether they wish to be heard in respect of their objections.

14th May, 1975.

5125

L. A. HEMLEY, Town Clerk.

CITY OF DONCASTER AND TEMPLESTOWE.

LOAN No. 191.

Notice of Intention to Borrow the Sum of \$350,000 for Permanent Works and Undertakings.

Notice is hereby given that the Council of the City of Doncaster and Templestowe proposes to borrow the principal sum of Three hundred and fifty thousand dollars (\$350,000) secured by a charge over the general rates of the municipality, such sum to be raised by the grant of a mortgage in accordance with the provisions of the Local Government Act 1958.

1. The maximum rate of interest that may be paid is 9.9 per cent per annum.

2. The purposes for which the loan is to be applied are—

(a) Tip Development—Stintons Road, Park Orchards	\$150,000
(b) Schramm's Pavilion Extensions and Car Park	70,000
(c) George Street Reserve Development including Athletic Track and Pavilion Extensions	130,000
	\$350,000

3. The period of the loan shall be 10 years.

4. The moneys borrowed shall be repayable by providing out of the municipal fund 19 equal half-yearly instalments of \$20,257.90 including principal and interest on the 30th day of June and the 30th day of December and a final payment of \$273,789.56 including interest on maturity. The first instalment shall be payable on the 30th December, 1975.

5. Such moneys shall be repayable at the Australia and New Zealand Savings Bank Limited, 686 Doncaster Road, Doncaster.

The plans and specifications and the estimate of the cost of the proposed works and a statement showing the proposed expenditure of the moneys to be borrowed are open for inspection at the office of the Council of the City of Doncaster and Templestowe at the Municipal Offices, Doncaster Road, Doncaster.

5129 J. W. THOMSON, Town Clerk.

CITY OF PORT MELBOURNE.

LOAN No. 46.

Notice of Intention to Borrow the Sum of \$60,000 for Permanent Works and Undertakings.

NOTICE is hereby given that the Council of the City of Port Melbourne proposes to borrow the sum of Sixty Thousand Dollars on the credit of the Municipal revenue of the Mayor, Councillors and Citizens of the said City, such sum to be raised by mortgage deed in accordance with the provisions of the *Local Government Act 1958*.

1. The maximum rate of interest that may be paid is 9.9 per cent per annum.

2. The purpose for which the loan is to be applied is as follows: RENOVATION OF BOWLING CLUB PREMISES, \$60,000 (part cost).

3. The period of the loan shall be 10 year notional 20 year term.

4. The moneys borrowed shall be repayable by providing out of the municipal fund nineteen half-yearly instalments of approximately \$3,472.78 including principal and interest and one payment of \$46,935.50 on the 30th day of December, and the 30th day of June in each year during the currency of the loan. The first instalment shall be payable on the 30th day of December, 1975.

5. Such moneys shall be repayable at the Australia and New Zealand Banking Group or at the Council's Bankers for the time being in Melbourne.

The plans and specifications and the estimate of the cost of the proposed works and a statement showing the proposed expenditure of the moneys to be borrowed are open for inspection at the Town Hall, Port Melbourne, during office hours.

5132 F. C. JACKSON, Town Clerk.

CITY OF SOUTH BARWON.

LOAN No. 102.

Notice of Intention to Borrow.

Notice is hereby given that the Council of the City of South Barwon intends to borrow the sum of Three hundred and Seventy-seven thousand, six hundred dollars (\$377,600), secured by a charge over the General Rates of the Municipality, such sum to be raised by the grant of a Mortgage in accordance with the provisions of the *Local Government Act 1958*.

1. The maximum rate of interest that may be paid is 9.9 per centum per annum.

2. The purpose for which the loan is to be applied is—

Construction and reconstruction of various streets and roads	\$128,500
Purchase of land and buildings—Highton Hall	\$26,000
Purchase of Land—Connearre Reserve	\$28,000
Council proportion—construction of Burdoo Reserve Pavilion	\$55,000
Council proportion—construction of Lost Dogs Home	\$22,000

Construction of Extension—Grovedale Public Hall	\$11,000
Construction of Extension—Winter Reserve Pavilion	\$25,000
Main drainage works at various locations	\$80,100
Easement drainage works at various locations	\$2,000
Council contribution	\$377,600

3. The period of the loan is 20 years.

4. The moneys borrowed shall be repayable by providing out of the Municipal Fund 39 equal half yearly instalments of \$19,091.37 including principal and interest on the first day of January and the first day of July during the currency of the loan. The first instalment shall be payable on the 1st day of January, 1976, with the final instalment of \$348,936.99 payable on the first day of July, 1995.

5. Such moneys shall be payable at the Bank of New South Wales, Belmont.

6. The plans and specifications and an estimate of the cost of the works and a statement showing the proposed expenditure of moneys to be borrowed are open for inspection at the City Offices, 33 Mt. Pleasant Road, Belmont, during office hours.

Dated the 20th day of May, 1975.

5214 G. J. WALKER, Town Clerk.

CITY OF SOUTH BARWON.

LOAN No. 103.

Notice of Intention to Borrow.

Notice is hereby given that the Council of the City of South Barwon intends to borrow the sum of One hundred and seventeen thousand, four hundred dollars (\$117,400) secured by a charge over the General Rates of the Municipality, such sum to be raised by the grant of a Mortgage in accordance with the provisions of the *Local Government Act 1958*.

1. The maximum rate of interest that may be paid is 9.9 per centum per annum.

2. The purpose for which the loan is to be applied is—

Purchase of plant and equipment	\$63,200
Purchase of office equipment	\$14,000
South Barwon Recreation Reserve Improvements	\$2,000
Council contribution towards—	
Off Street Parking, Torquay	\$16,000
Private Street Construction, Highton	\$17,000
Private Street Construction, Grovedale	\$800
Kerb and Channel construction, Breamlea	\$2,600
Kerb and Channel construction, Belmont	\$1,800
	\$177,400

3. The period of the loan shall be fifteen years.

4. The moneys borrowed shall be repayable by providing out of the Municipal Fund 30 equal half yearly instalments of \$7,593.57 including principal and interest on the first day of January and the first day of July during the currency of the loan. The first instalment shall be payable on the 1st January, 1976.

5. Such moneys shall be payable at the Bank of New South Wales, Belmont.

6. The plans and specifications and an estimate of the cost of the works and a statement showing the proposed expenditure of the moneys to be borrowed are open for inspection at the City Offices, 33 Mt. Pleasant Road, Belmont during office hours.

Dated this 20th day of May, 1975.

5215 G. J. WALKER, Town Clerk.

CITY OF SUNSHINE.

LOAN No. 120.

Notice of the Intention to Borrow the Sum of \$200,000 for Permanent Works and Undertakings.

Notice is hereby given that the Council of the City of Sunshine proposes to borrow the principal sum of \$200,000 secured by a charge over the general rates of the Municipality, such sum to be raised by the grant of a mortgage in accordance with the provisions of the *Local Government Act 1958*.

1. The maximum rate of interest that may be paid is 9.9% per annum.

2. The purposes for which the loan is required are as follows:

Construction McIntyre Road, Bridge	\$50,000	
Land Acquisition—South Road	50,000	
Kerb, channel and drainage schemes:—		
<i>Central Ward</i>		
Berkshire Road.	\$12,500	
Duke Street.	12,500	25,000
<i>Southern Ward</i>		
Market Road.		25,000
<i>River Ward</i>		
Wattle Road.		25,000
<i>Western Ward</i>		
Station Road.	\$15,000	
Billington Road.	10,000	25,000
		<u>\$200,000</u>

3. The period of the loan shall be fifteen (15) years.

4. The moneys borrowed shall be repayable by providing out of the Municipal Fund half yearly instalments of \$12,936.23 including principal and interest on the 1st day of December and the 1st day of June during the currency of the loan. The first instalment shall be payable on the 1st day of December, 1975.

5. Such moneys shall be repayable at the office of the Local Authorities Superannuation Board, "Rigby House", 15 Queens Road, Melbourne or such other place or places as the "Board" from time to time may require.

The plans and specifications and the estimate of the proposed work and a statement showing the proposed expenditure of the money to be borrowed are open for inspection at the office of the Council of the City of Sunshine at the Municipal Offices, Alexandra Avenue, Sunshine.

5217 T. W. DEUTSCHMANN, Town Clerk.

BOROUGH OF KOROIT.

LOAN No. 11.

Notice of Intention to Borrow the sum of Ten thousand dollars (\$10,000) for Permanent Works and Undertakings.

Notice is hereby given that the Council of the Borough of Koroit proposes to borrow the principal sum of Ten Thousand Dollars (\$10,000.00) secured by a charge over the general rates of the municipality, such sum is to be raised by grant of a mortgage in accordance with the provisions of the *Local Government Act 1958*, as amended.

1. The maximum rate of interest that may be paid is 9.9 per centum per annum.

2. The purposes for which the loan is to be applied—

- Carrying out improvements and renovations to the Council Depot Shed, High Street, Koroit.
- Constructing concrete footpaths—Commercial Road—North side—West end.

3. The period of the loan shall be ten (10) years.

4. The moneys borrowed shall be repayable by providing out of the municipal fund twenty (20) half yearly instalments of approximately seven hundred and ninety nine dollars and three cents (\$799.03) each including principal and interest on the first day of January and the first day of July during the currency of the loan. The first instalment shall be payable on the first day of January, 1976.

5. Such moneys shall be repayable to the Commissioners of the State Savings Bank of Victoria, at the office of the said Commissioners at the corner of Elizabeth and Bourke Streets, Melbourne.

The plans and specifications and the estimate of the cost of the proposed works and a statement showing the proposed expenditure of the moneys to be borrowed are open for inspection at the office of the Council of the Borough of Koroit, High Street, Koroit.

Dated 20th May, 1975.

5213 A. J. MACDONALD, Town Clerk.

Town and Country Planning Act 1961 (Twelfth Schedule.)

PORTLAND PLANNING SCHEME 1957.

NOTICE THAT A PLANNING SCHEME HAS BEEN PREPARED AND IS AVAILABLE FOR INSPECTION.

Amendment No. 15, 1975.

NOTICE is hereby given that the Council of the Town of Portland in pursuance of its powers under the *Town and Country Planning Act 1961* has prepared a Planning Scheme for amending the original scheme as it applies to the Town of Portland.

A copy of the Scheme has been deposited at the Municipal Offices, Gawler Street, Portland, and at the Office of the Town and Country Planning Board, 179 Queen Street, Melbourne, and will be open for inspection during office hours by any person, free of charge.

Any persons affected by the Planning Scheme are required to set forth in writing all objections they may have, addressed to the Town Clerk at the Municipal Offices, Gawler Street, Portland, on or before the 18th day of June, 1975, and to state whether they wish to be heard in respect of their objections.

20th. May, 1975.

5131 B. T. CRAGO, Town Clerk.

SHIRE OF BALLAN.

LOAN No. 14.

Notice of Intention to Borrow the Sum of \$30,000 for Permanent Works and Undertakings.

Notice is hereby given that the Council of the Shire of Ballan proposes to borrow the sum of Thirty Thousand Dollars (\$30,000) on the credit of the municipal revenues of the President, Councillors and Ratepayers of the said Shire, such sum to be raised by the grant of a mortgage, in accordance with the provisions of the *Local Government Act 1958*.

1. The maximum rate of interest that may be paid is 9.5 per cent per annum.

2. The purpose for which the loan is to be applied is:—

- Erection of one brick veneer Staff Dwelling.
- Purchase of one Front-End Loader.

3. The period of the loan shall be six years.

4. The moneys borrowed shall be repayable by providing out of the municipal fund half-yearly instalments, each including principal and interest, on the 10th day of February and the 10th day of August, during the currency of the loan. The first instalment shall be payable on the 10th day of February, 1976.

5. Such moneys shall be repayable at the Commercial Bank of Australia Ltd., Ballan.

The plans and specifications and the estimates of the cost of the proposed works and a statement showing the proposed expenditure of the moneys to be borrowed, are open for inspection at the Shire Office, Ballan.

Dated 16th May, 1975.

5153 A. A. McLEAN, Shire Secretary.

SHIRE OF BARRABOOL.

By-Law No. 47.

Notice is given that the Council of the Shire of Barrabool has now made the following By-Law pursuant to the provisions of the *Local Government Acts*:—

Short Title:—Recreational Vehicles By-Law No. 47.

General Purport of By-Law.

- Definition of recreational vehicle.
- Requirement for permit from Council to use recreation vehicles on certain land.
- Requirement for application to be in writing in accordance with the First Schedule.
- Council powers to give additional consents.
- Operation of By-Law.
- Penalty Section.

Copies of the said By-Law are open for inspection at the Shire Office, 441 Moorabool Street, South Geelong during office hours, free of charge.

5154 G. L. PEARCE, Shire Secretary.

SHIRE OF BULN BULN.

LOAN No. 69.

Notice of Intention to Borrow the Sum of \$40,000 for Permanent Works and Undertakings.

Notice is hereby given that the Council of the Shire of Buln Buln proposes to borrow the principal sum of \$40,000 secured by a charge over the general rates of the municipality, such sum to be raised by the grant of a mortgage in accordance with the provisions of the *Local Government Act 1958*.

1. The maximum rate of interest that may be paid is 9.9 per centum per annum.

2. The purpose for which the loan is to be applied is assistance to a decentralised industry pursuant to Part XLA of the *Local Government Act 1958*.

3. The period of the loan shall be twenty years.
4. The moneys borrowed shall be repayable by providing out of the municipal fund forty half-yearly instalments of approximately \$2,315.19 each including principal and interest on the tenth day of February and the tenth day of August during the currency of the loan. The first instalment shall be payable on the tenth day of February 1976.

5. Such moneys shall be repayable to the Commercial Savings Bank of Australia Limited, 335 Collins Street, Melbourne.

The plans and specifications and the estimate of the cost of the proposed works and a statement showing the proposed expenditure of the moneys to be borrowed are open for inspection at the office of the Council of the Shire of Buln Buln, at Drouin.

Date 15th May, 1975.

5133

K. A. PRETTY, Shire Secretary.

Town and Country Planning Act 1961 (Twelfth Schedule).
SHIRE OF CRANBOURNE.—CRANBOURNE PLANNING
SCHEME 1960.

NOTICE THAT A PLANNING SCHEME HAS BEEN PREPARED AND IS AVAILABLE FOR INSPECTION.

Amendment No. 9—1974.

Notice is hereby given that the Council of the Shire of Cranbourne in pursuance of its powers under the *Town and Country Planning Act 1961*, has prepared a Planning Scheme for:

Land delineated on Map No. M 74.23 in the Office of the Council, for the purpose of reviewing the planning requirements within the Cranbourne Commercial area.

A copy of the scheme has been deposited at the Shire Offices, Cranbourne, and at the Office of the Town and Country Planning Board, 235 Queen Street, Melbourne, and will be open for inspection during office hours by any person free of charge.

Any persons affected by the Planning Scheme are required to set forth in writing all objections they may have, addressed to the Shire Secretary, Shire of Cranbourne, Shire Office, Cranbourne on or before the 21st day of August, 1975 and to state whether they wish to be heard in respect of their objections.

21st May, 1975.

5157

T. VICKERMAN, Shire Secretary.

Town and Country Planning Act 1961 (Twelfth Schedule).
SHIRE OF CRANBOURNE.—CRANBOURNE PLANNING
SCHEME 1960.

NOTICE THAT A PLANNING SCHEME HAS BEEN PREPARED AND IS AVAILABLE FOR INSPECTION.

Amendment No. 13—1975.

Notice is hereby given that the Council of the Shire of Cranbourne in pursuance of its powers under the *Town and Country Planning Act 1961*, has prepared a Planning Scheme for:

Land delineated on Map No. M-75-12 in the Office of the Council, being land fronting Thompsons Road, the South Gippsland Highway and the South Eastern Railway, Cranbourne, to rezone land from Rural and Residential to Part "Reserved Living", Part "Public Purposes Reserve"—"Dandenong Valley Authority", and Part "Road Widening"; and

To amend and vary Clause 20—Reserves for Public Purposes to include Dandenong Valley Authority in the Schedule of Public Purposes.

A copy of the Scheme has been deposited at the Shire Offices, Cranbourne, and at the Office of the Town and Country Planning Board, 235 Queen Street, Melbourne, and will be open for inspection during office hours by any person free of charge.

Any persons affected by the Planning Scheme are required to set forth in writing all objections they may have, addressed to the Shire Secretary, Shire of Cranbourne, Shire Office, Cranbourne on or before the 21st day of August, 1975 and to state whether they wish to be heard in respect of their objections.

21st May, 1975.

5158

T. VICKERMAN, Shire Secretary.

Town and Country Planning Act 1961 (Twelfth Schedule).
SHIRE OF CRANBOURNE.—CRANBOURNE PLANNING
SCHEME 1960.

NOTICE THAT A PLANNING SCHEME HAS BEEN PREPARED AND IS AVAILABLE FOR INSPECTION.

Amendment No. 14—1975.

Notice is hereby given that the Council of the Shire of Cranbourne in pursuance of its powers under the *Town and Country Planning Act 1961*, has prepared a Planning Scheme for:

(a) Land delineated on Map No. M-75-16 Sheet 1 in the Office of the Council, being land fronting the South Gippsland Highway, Camms Road, and Cranbourne Place, Cranbourne, for the purpose of rezoning land from "Commercial B" to "Local Shopping," and

(b) Land delineated on Map No. M-75-16, Sheets 2, 3, 4, 5 and 6 in the Office of the Council, being—

1. M-75-16, Sheet 2, land fronting South Gippsland Highway and Huon Park Road, Cranbourne,
2. M-75-16, Sheet 3, land fronting Camms Road, Monohans Road and David Avenue, Cranbourne.
3. M-75-16, Sheet 4, land fronting Loch Street, Hotham Street and LaTrobe Street, Cranbourne,
4. M-75-16, Sheet 5, land fronting Brunt Street and Codrington Street, Cranbourne,
5. M-75-16, Sheet 6, land fronting Lurline Street, Sladen Street and Bruce Street, Cranbourne.

For the purpose of rezoning land from "Commercial C" to "Local Shopping".

A copy of the Scheme has been deposited at the Shire Offices, Cranbourne, and at the Office of the Town and Country Planning Board, 235 Queen Street, Melbourne, and will be open for inspection during office hours by any person free of charge.

Any persons affected by the Planning Scheme are required to set forth in writing all objections they may have, addressed to the Shire Secretary, Shire of Cranbourne, Shire Office, Cranbourne on or before the 21st day of June, 1975 and to state whether they wish to be heard in respect of their objections.

21st May, 1975.

5159

T. VICKERMAN, Shire Secretary.

SHIRE OF ELTHAM.

LOAN No. 106.

Notice of Intention to Borrow.

NOTICE is hereby given that the Council of the Shire of Eltham intends to borrow Sixty-four thousand dollars (\$64,000) secured by a charge over the General rates of the municipality by the grant of a mortgage in accordance with the provisions of the Local Government Act.

In connection therewith the following information is stated—

- (a) The amount of the principal monies which it is proposed to borrow is Sixty-four thousand dollars (\$64,000).
- (b) The maximum rate of interest that may be paid is \$9.90 per centum per annum.
- (c) The times which the monies borrowed are to be repayable are the first days of December and June, during the years 1975-1990 inclusive, and that the place such monies shall be repayable is at the State Savings Bank of Victoria, Melbourne.
- (d) The purpose for which the loan is to be applied is:
 - (i) Road works—Council's contribution to the Country Roads Board for unclassified roads.
 - (ii) Road works—Construction of Reynolds Road to Wattle Glen.
- (e) The manner in which the loan is to be liquidated is by provision out of the municipal fund in each half year during the currency of the loan of the sum of \$4,139.60, which includes principal and interest.

The plans and specifications and estimate of the cost of the works and a statement showing the proposed expenditure of the monies to be borrowed are open for inspection at the Shire Office.

Dated this 16th day of May, 1975.

W. R. FEATHERSTON, Chief Administrator/Shire Secretary. 5161

SHIRE OF ELTHAM.

LOAN No. 105.

Notice of Intention to Borrow.

NOTICE is hereby given that the Council of the Shire of Eltham intends to borrow Forty Thousand dollars (\$40,000) secured by a charge over the General rates of the municipality by the grant of a Mortgage in accordance with the provisions of the Local Government Act.

In connection therewith the following information is stated:—

- (a) The amount of the principal moneys which it is proposed to borrow is Forty Thousand dollars (\$40,000).
- (b) The maximum rate of interest that may be paid is 9.90 per centum per annum.
- (c) The times which the moneys borrowed are to be repayable are the Tenth days of December and June, during the years 1975–1985 inclusive and that the place such moneys shall be repayable is at the Commercial Bank of Australia Limited, Eltham.
- (d) The purpose for which the loan is to be applied is:
 - (i) Development of Parks and Walk Trails.
 - (ii) North Warrandyte Community Centre Hall extensions.
- (e) The manner in which the loan is to be liquidated is by provision out of the municipal fund in each half-year during the currency of the loan of the sum of \$3,196.11, which includes principal and interest.

The plans and specifications and estimate of the cost of the works and a statement showing the proposed expenditure of the moneys to be borrowed are open for inspection at the Shire Office.

Dated this 12th day of May, 1975.

W. R. FEATHERSTON, Chief Administrator/Shire Secretary. 5128

SHIRE OF GOULBURN.

SEWERAGE DISTRICTS ACT.

Proposed Sewerage Authority—Nagambie.

Notice is hereby given that the Council of the Shire of Goulburn has made application to the Honorable the Minister for Water Supply for the constitution of a Sewerage Authority and for the proclamation of a Sewerage District at Nagambie, and for the construction, maintenance and continuance of sewerage works within that District under the provisions of the Sewerage Districts Act.

A general plan and description of the proposed works have been submitted with the application and copies of same may be seen at the Municipal Offices, 352 High Street, Nagambie.

Dated at Nagambie, the 12th day of May, 1975.

J. L. MITCHELL, Shire Secretary.

The Act requires that this notice be published weekly for three weeks in a newspaper circulating locally and the *Government Gazette* and provides that within one month of the third notice in the *Government Gazette*, any person having an interest therein, who is likely to be injuriously affected by the proposed sewerage works may forward to the Minister for Water Supply a petition seeking refusal or amendment to the application.

In this case the period for objections will expire on 30th June, 1975. 4990

SHIRE OF HAMPDEN.

PROSECUTING OFFICER.

NOTICE IS HEREBY GIVEN that Senior Constable R. F. W. HOWDEN No. 10,094 has been appointed Prosecuting Officer to the Shire of Hampden at Lismore in lieu of Senior Constable F. J. Fox No. 9,492, retired.

S. J. GRIMMER, Shire Secretary.

Shire Office, Camperdown, Vic. 3260. 5156

SHIRE OF HASTINGS.

By-Law No. 20.

A By-Law of the Shire of Hastings made under the provisions of the Local Government Act and the Health Act and amendments thereto and numbered 20 for regulating and limiting the number of dogs to be kept on any property within the area declared to be a populous or residential area.

In pursuance of the powers conferred by the *Local Government Act 1958* and by the *Health Act 1958* and every other Act or power enabling them in that behalf the President, Councillors and Ratepayers of the Shire of Hastings order as follows:—

PART I—INTRODUCTION.

1. In this By-Law unless inconsistent with the context or subject matter "Dog" includes bitch but shall not include any pup less than sixteen weeks old.

"Council" means the Council of the Shire of Hastings.

"Person" in respect of any property or premises includes the owner and/or occupier of such property or premises.

2. For the purposes of this By-Law all areas within the Municipality other than areas:—

(a) Zoned "Rural" in any Town Planning Scheme under the Town and Country Planning Act or any amendment thereof or any Act substituted therefore.

(b) Shown on a provisional Town Planning Scheme zoned "Rural" and to which said area an Interim Development Order under the Town and Country Planning Act or any amendment thereof or any Act substituted therefor applies, except for land on a plan of Sub-division for which an Interim Development Order Permit has been issued by the Council for residential usage.

are hereby declared to be populous or residential areas.

PART II—KEEPING OF DOGS.

1. No person shall keep or permit or suffer to be kept more than two (2) dogs as defined in Part I. hereof on any property or premises within an area declared to be a populous or residential area without being the holder of a permit in writing from the Council.

2. Any person applying for written permission of the Council specified in I above shall—

(a) In the case of the first application advertise his or her intention to do so in a form approved by the Shire Secretary at least one month before applying for such permission in a newspaper generally circulating in the neighbourhood, stating in such advertisement his or her reason for wanting to keep more than two (2) dogs.

(b) Make application in writing to the Council in the form of the 1st Schedule hereto accompanied by a plan of the land to which the application relates showing area and distance and position of any neighbouring dwellings.

3. Any person interested in or affected by any application for a permit may object in writing to the Council within one calendar month from publication of the notice of intention referred to in 2 (a) above.

4. The Council shall before determining to issue a permit consider all objections made thereto.

5. Any permit may at any time be revoked or cancelled by the Council if in its opinion the property to which it relates by reason of the keeping of the number of dogs permitted becomes offensive, injurious to health or dangerous, or if by reason of the reduction in the area of the property the Council is of the opinion that the number of dogs permitted is too great or if the person to whom the permit has been granted shall be convicted of an offence against this By-Law.

PART III—GENERAL.

1. Any person who shall commit any wilful act or default contrary to any provision of this By-Law shall be liable on conviction to a penalty of not more than forty dollars (\$40) for each offence, and in the case of a continuing offence to a further penalty of not more than ten dollars (\$10) per day for each day on which the offence is continued after a conviction or order by any Court.

1st SCHEDULE.

APPLICATION TO KEEP MORE THAN TWO (2) DOGS.

1. Full name of Applicant:
Address:
2. Number and Description of Dogs it is proposed to keep:
3. Address and Description of property on which it is proposed to keep the dogs:
4. Provisions to be made for housing and keeping of dogs:
5. Date of Advertisement of intention to apply for permit and name of newspaper:

6. Reasons for wanting to keep more than two (2) dogs.

I.....the abovenamed applicant apply to the Council of the Shire of Hastings for a Permit to keep the abovementioned Dogs on the aforementioned property and certify that the particulars supplied are true and correct.

Dated 197 .

Signature of Applicant.

Resolution for passing this By-Law was adopted on the 1st day of October, 1974, and confirmed on the 19th day of November, 1974.

The common seal of the President, Councillors and Ratepayers of the Shire of Hastings was hereto affixed by order of the council this 18th day of March, 1975.

(SEAL) R. N. LANCET, Shire President.
R. P. MAIR, Councillor.
W. J. NABBS, Shire Secretary.

Approved by the Governor in Council, 29th April, 1975.—TOM FORRISTAL, Clerk of the Executive Council.

5135

SHIRE OF HUNTLY.

LOAN No. 24.

Notice of Intention to Borrow the Sum of \$35,000 for Permanent Works and Undertakings.

Notice is hereby given that the Council of the Shire of Huntly proposes to borrow the principal sum of Thirty-five Thousand Dollars, secured by a charge over the general rates of the municipality, such sum to be raised by the grant of a mortgage in accordance with the *Local Government Act 1958*.

1. The maximum rate of interest that may be paid is 9.5 per centum per annum.

2. The purpose for which the loan is to be applied is—

Purchase of road making plant.

3. The period of the loan shall be six years.

4. The money shall be repayable by providing out of the municipal fund twelve half-yearly instalments of approximately \$3,893.41 each, including principal and interest, on the first day of May and first day of November during the currency of the loan. The first instalment shall be payable on first day of November, 1975.

5. Such money shall be repayable to C.B.C. Savings Bank Limited, Melbourne.

The plans and specifications and the estimate of the cost of the proposed work and a statement showing the proposed expenditure of the moneys to be borrowed are open for inspection at the office of the Council of the Shire of Huntly, at Shire Council Chambers, Huntly.

5216 H. McK. SILKE, Shire Secretary.

SHIRE OF McIVOR.

LOAN No. 40.

Notice of Intention to Borrow the Sum of \$15,000 for Permanent Works and Undertakings.

Notice is hereby given that the Council of the Shire of McIvor proposes to borrow the principal sum of \$15,000 secured by a charge over the general rates of the Municipality, such sum to be raised by the grant of a mortgage in accordance with the provisions of the *Local Government Act 1958*.

(1) The maximum rate of interest that may be paid is 9.9 per centum per annum.

(2) The purpose for which the loan is to be applied is the construction of kerb and channel and sealing from the existing seal to kerb and channel in High Street between Jennings Street and Chauncey Street, Heathcote—\$15,000.

(3) The period of the loan shall be Fifteen (15) years.

(4) The monies borrowed shall be repayable by providing out of the Municipal fund half-yearly instalments of \$970.22 each, including the principal and interest on the 10th May and the 10th November during the currency of the loan. The first instalment shall be payable on the 10th November, 1975.

(5) Such money shall be repayable to the Commercial Savings Bank of Australia Limited at Heathcote.

The plans and specifications and the estimate of the cost of the proposed works and a statement showing the proposed expenditure of the monies to be borrowed are open for inspection at the Shire Office, Heathcote.

Dated at Heathcote this 9th day of May, 1975.

5130 D. R. GLISSON, Shire Secretary.

SHIRE OF MILDURA.

By-Law No. 113.

A By-Law of the Shire of Mildura, under Section 197 of the *Local Government Act 1958*, and numbered 113, for regulating the keeping of bees and for the prevention of nuisances.

(1) This By-Law shall be known as the Keeping of Bees By-Law.

(2) This By-Law shall come into operation immediately upon its publication in the *Government Gazette*.

(3) This By-Law shall apply to and have operation throughout the whole of the Municipal District of the Shire of Mildura.

(4) In this By-Law unless inconsistent with the context or subject-matter:—

“Approved type of beehive” means and includes any type of beehive approved by the Inspector.

“Council” means the Council of the Shire of Mildura.

“Inspector” means the Health Inspector or By-Laws Officer of the Council.

“Person” in respect of any property or premises includes the owner, occupier, agent or the person in charge of such property or premises.

“Property” shall include any tenement or land in separate occupation and

“Premises” shall have the same meaning.

(5) No person shall keep any bees on any property except in an approved type of hive.

(6) No person shall, in the months of February, March and April, within two (2) kilometres of any horticultural block planted with trees or vines in bearing, keep any hive of bees unless the same shall be so covered in as to prevent the bees therein from leaving the premises upon which the hive is situated.

(7) The occupier of any premises upon which bees are kept shall, at all reasonable times during the above mentioned months of February, March and April, afford free access thereof to any Inspector or Officer of the Council for the purposes of inspecting any beehives or bees thereon.

(8) Should any nuisance or danger arise from the keeping of bees on any property, all hives shall be forthwith removed from that property upon direction of the Council or its Inspector.

(9) Any person who by any wilful act or default shall offend against any of the provisions of this By-Law, shall be guilty of an offence against this By-Law and for every such offence, shall be liable to a penalty not exceeding One Hundred Dollars (\$100.00) and not less than Twenty Dollars (\$20.00), and in the case of a continuing offence against this By-Law a person so offending shall be liable to a penalty of not more than Ten Dollars (\$10.00), for each day on which an offence against this By-Law is continued after a conviction or order by any court.

(10) By-Laws Nos. 59 and 81 are hereby repealed.

Resolution for passing this By-Law agreed to by the Council of the Shire of Mildura, on the third day of October, 1974, and confirmed on the seventh day of November, 1974.

The common seal of the President, Councillors and Ratepayers of the Shire of Mildura, was hereto affixed, in the presence of —

(SEAL) A. G. SMART, President.
N. RIBARICH, Councillor.
D. F. DREW, Secretary.

Approved by the Governor in Council, 25th March, 1975.
—TOM FORRISTAL, Clerk of the Executive Council. 5219

SHIRE OF MILDURA.

By-Law No. 111.

A By-Law of the Shire of Mildura made under the provisions of Section 756 of the *Local Government Act 1958* and numbered 111, for regulating the use of the Swimming Pool Premises at Red Cliffs, Irymple, and Merbein, and the conduct of persons using or being thereon.

In pursuance of the powers conferred by the *Local Government Act 1958* and of any and every other power it thereunto enabling, the President, Councillors and Ratepayers of the Shire of Mildura order as follows:

- (1) "Attendant, Officer, Employee" means and includes any employee of the Council performing any duties on or in connection with the Swimming Pool Premises.
- "Swimming Pool Premises" (hereinafter referred to as the "Premises") means and includes the pools, paths, aprons, seats, bathrooms, buildings, dressing rooms, compartments, as prescribed by Council and other areas forming the Red Cliffs Swimming Pool Areas situated, the Irymple Swimming Pool Area situated, the Merbein Swimming Pool Area situated.
- "Carnival" shall mean any function held or organised by any organisation with the written consent of Council.
- "Council" shall mean the Council of the Shire of Mildura.
- "Manager" shall mean the person from time to time appointed by the Council to manage the premises.
- "Swimming Pool" shall include any pool or body of water provided within the premises for the purposes of providing a place for persons to swim, wade or dive.
- (2) By-Laws Nos. 77, 92, 103, and 110 be and are hereby repealed.
- (3) The premises shall be open to the public during such period and such hours as the Council shall from time to time fix by resolutions.
- (4) The Council may close the premises or any part thereof on any day or days or at any times should it be considered necessary to do so, and may also vary the hours during which the premises shall be open to the public.
- (5) In the event of the Council holding or authorising a swimming Carnival or other entertainment in the premises, it shall have power to prohibit public bathing in the Swimming Pools whilst such Carnival or entertainment is being held.
- (6) No person other than a Councillor or an Officer or an employee of the Council, or a member of the Victorian Police Force shall enter upon any part of the premises without having paid the fees, as fixed by resolution of the Council, or being otherwise authorised by the Council.
- (7) No person shall use soap in any part of the Premises other than in the cleansing shower baths provided for that purpose.
- (8) No person shall at any time, while being in the swimming pools use any substance or preparation whereby the water in the swimming pools may be discoloured or rendered turbid or unfit for the proper use of bathers.
- (9) No person shall use the swimming pools, whilst in an uncleanly condition or whilst suffering from any cutaneous infections or contagious disease.
- (10) No person shall wilfully interfere with the use and enjoyment by any person of the premises or any swimming pool, and any person so doing or otherwise behaving in an unseemly, offensive or improper manner, shall immediately leave the premises upon being requested to do so by the Manager, or an attendant or a member of the Victorian Police Force, or any Officer of the Council, and such Manager or attendant may refuse to sell ticket of admission to any person whom he may consider to be undesirable.
- (11) Every person (other than children whom the Manager or attendant may exempt) using the premises, shall wear a suitable bathing costume, and no person shall dress or undress in any part of the premises except places specifically reserved for such purpose.
- (12) No person shall enter or remain in any part of the premises whilst in a state of intoxication and no person shall at any time introduce into the premises or consume or cause to be consumed any spirituous or intoxicating liquor in any part of the premises.
- (13) No person shall wilfully or improperly foul, pollute or defile the water in the swimming pools or cleansing shower baths, or wilfully and improperly soil or defile or negligently or carelessly injure any towel or bathing costume.
- (14) Every person supplied with any towel and/or bathing costume, shall before leaving the premises, return them to the Manager or attendant.
- (15) No person shall at any time carelessly or negligently break or injure or improperly interfere with the due and efficient action of any lock, cock, valve, tap, pipework, plant or machinery in connection with the premises, or carelessly or negligently soil, defile, injure or destroy any furniture, fitting or conveniences of any bath, bathroom, dressing room, closet, box or compartment, and shall not cut, write upon or deface any wall fittings or any part of the premises.
- (16) No person shall at any time, while being upon any part of the premises, use any indecent, insulting or offensive language or behave in any indecent, insulting offensive or riotous manner.
- (17) No person shall spit in the Swimming Pools or on the paths walls floors or on any part of the premises.
- (18) No person shall loiter, misconduct himself or herself or commit a nuisance in any part of the premises or bring any rubbish filth or offensive matter into the premises, or deposit any rubbish or leave any tins, bottles, broken glass, fruit or vegetable peels, papers, or other litter in any part of the premises, except in the receptacles provided.
- (19) Beach Balls, Tennis balls, Water Pistols, Motor Tubes or any other inflated or plastic articles are not permitted in any main swimming pool except with the permission of the Manager. Toddlers may be permitted to take rubber or plastic toys into the Toddlers' Pool.
- (20) No unauthorised person shall climb any tree or fence or building or climb or jump over any wall within the premises.
- (21) No person shall roll or throw any stones or other articles into the swimming pools, or in any part of the premises.
- (22) No person shall damage and no unauthorised person shall remove any placard or notice board in any part of the premises.
- (23) No person shall cause or allow any dog or other animal belonging to such person or under his or her control to enter or remain in any part of the premises. Excepting that any person who requires the service of a dog or other animal trained for and engaged in the guidance of the blind, shall be permitted to bring that dog or other animal into the premises.
- (24) Any person finding any article which may have been left in part of the premises shall at once deliver such article to the Manager who shall thereupon register a description of same in a book kept for that purpose and any person claiming such article shall upon giving satisfactory proof of ownership, receive such article from the Manager upon entering his or her name in the book referred to.
- (25) No person shall obstruct, hinder or interfere with the Manager, or any attendant, officer or employee employed at the premises, in the execution of his duty.
- (26) Neither the Council nor the Manager, will be responsible for any articles lost by or stolen from any person whilst in the premises.
- (27) No child under the age of six years shall be admitted to the premises unless, in the opinion of the Manager or attendant, such child is in the care of a responsible person.
- (28) No person over the age of eight years shall use that part of the swimming pool known as the Toddlers' Pool unless such person is in charge of Toddlers using such pool.
- (29) No person except the Manager shall offer goods for sale in any part of the premises.
- (30) Any person offending against any of the provisions of this By-Law, shall upon conviction for every such offence, forfeit and pay a penalty not exceeding Fifty Dollars (\$50.00) and not less than Ten Dollars (\$10.00).
- (31) This By-Law shall come into operation and have effect immediately upon its publication in the *Government Gazette*.
- The Resolution for passing this By-Law was agreed to by the Council of the Shire of Mildura on the Fourth day of July 1974, and confirmed on the Seventh day of November, 1974.
- The common seal of the President, Councillors and Ratepayers of the Shire of Mildura was hereunto affixed in the presence of—

SHIRE OF MILDURA.

BY-LAW No. 114.

A By-Law of the Shire of Mildura made under the provisions of Section 197, and 800 of the *Local Government Act 1958*, and numbered 114 for the purpose of:—

- (a) Preserving public decency.
- (b) Suppressing nuisances.
- (c) Controlling and managing and preserving commons and public reserves of which the management is vested in the Council.
- (d) Providing for the protection and control of—
 - (i) Tree reserves and gardens, garden plots, lawns and ornamental plantations in or upon any street or road;
 - (ii) Trees, shrubs and plants planted and tree guards statues monuments fountains and seats erected in or upon any street or road;
- (e) Preserving good order and decency in any building belonging to the Municipality or under the control and management of the Council and preventing damage to such building and the furniture and fitting thereof.
- (f) Imposing collecting and receiving charges or entrance fees for Clubs, Associations or persons using or entering in or upon any pleasure grounds or places of public resort or public recreation on land purchased or rented or otherwise provided by or granted or given by any person to the Council for the providing of such grounds or places and using or being upon or in such grounds or places.

In pursuance of the powers conferred by the *Local Government Act 1958*, and of any and every other power it thereunto enabling the President, Councillors and Rate-payers of the Shire of Mildura orders as follows:—

(1) This By-Law shall be known as the Municipal Buildings, Reserves and Playground By-Law.

(2) By-Laws Nos. 86, 87, 97, 105, and 108 of the Shire of Mildura are hereby repealed.

(3) In this By-Law, unless inconsistent with the context or subject matter—

“Building” means a building belonging to the Municipality or under the control and management of the Council.

“Council” means the Council of the Shire of Mildura.

“Children’s Playground” means and includes every reserve or portion of a reserve specified by notice on the same to be a Children’s Playground as set aside as playgrounds for children by the provision of swings, slides and similar equipment.

“Fire Prevention Appliance” means any appliance, fixture, plant, machinery, or thing whether attached to or placed in any building and used or intended to be used for the purpose of preventing, controlling or extinguishing fire, and without affecting the generality of the foregoing includes hoses, taps, hydrants, sprinklers or portable fire extinguishers.

“Garden” means and includes any tree reserve, garden, garden plot, lawn, or ornamental plantation in or upon any street or road and trees, shrubs and plants planted and tree guards statues monuments, fountains, and seats erected in or upon any street, road or land.

“Reserve” means and includes any land purchased or rented or otherwise provided by or granted or given to the Council for the providing of pleasure grounds or places or public resort or public recreation.

“Sports Ground” means and includes every portion of the reserves described in the 1st Schedule hereto which are specified by notice on the same to be a sports ground or are declared from time to time by Council resolution to be a Sports Ground.

(4) Except as hereinafter provided all reserves shall be open to the public every day for such periods as the Council shall from time to time fix by resolution.

(5) In the case of Sport Grounds the Council by resolution may from time to time—

- (a) Vary the days and hours during which the same shall be open;

- (b) Determine the days and hours upon which charges or entrance fees may be collected and received for Clubs, Associations or Persons using or entering in or upon the same;
 - (c) Determine the amount of deposit to be paid by any Club, Association or Person granted a permit to use the same;
 - (d) Determine the fee to be charged for a permit to use the same;
 - (e) Determine the fee to be charged for a permit to use any building upon the same;
 - (f) Determine the periods during which organised sport or forms of sport may be played upon the same.
- (6) No person other than members of the Council, persons authorised in writing by the Council, Officers of the Council and employees of the Council on duty shall be entitled to enter any sports ground during any time a charge authorised by the Council is made for admission thereto without first paying such charge.

(7) (a) Every Club, Association or person to whom a permit to use a sports ground is granted shall be responsible to see that the sports ground is left in a clean and sanitary condition and that:—

All refuse and rubbish deposited therein as a result of the use of the sports ground is removed to the satisfaction of the Council no later than by the end of the day following the day of such use.

(b) If such person fails to comply with the provisions of sub-clause (a) hereto then the Council shall be entitled to take all steps necessary to place the sports grounds in a clean and sanitary condition and to deduct the cost of so doing from the deposit paid by the holder of the permit, or to make an additional charge to the holder of the permit.

(8) No person shall—

- (i) Interfere with or break or damage or remove any tree plant, shrub or flower in or upon any reserve or garden;
- (ii) Walk on the flower beds or borders or climb, jump or get upon or over or under any fence, gate, building or part thereof (other than seats set aside for the public) in or upon any reserve or garden;
- (iii) Post bills or advertisements on any of the fences gates, walls, seats or other structures in or upon any reserve or garden;
- (iv) Roll or throw stones or missiles in or upon any reserve or garden (except as may form part of the reasonable use of a sports ground);
- (v) Leave in any reserve or garden or part thereof or building therein any bottle, can, broken glass, paper, fruit skins or peel or refuse or rubbish whatsoever otherwise than in the receptacle provided.

(9) No person shall cross or trespass on the playing ground of the reserve during any cricket or football match or sports, games, or amusements, or during practice at football, cricket or other games when any such crossing or trespassing would be injurious to, or be an undue interference with progress of the aforesaid football, cricket, sports, games or amusements.

(10) No person shall carry firearms in or through any reserve or snare attempt to snare, destroy or attempt to destroy, molest, injure or in any way interfere with any bird or animal therein or thereon.

(11) No person shall—

- (a) Spit upon any passageway, stairway, floor or wall in; or
- (b) Cut, mark, deface, write or scribble on; or
- (c) Otherwise damage or injure—
Any building or any part thereof or the furniture and fittings thereof.

(12) No person shall:—

- (a) Stand upon any chair, seat or table in; or
- (b) Stand or sit on any windowsill, parapet, roof, gutter, gable, exterior balcony or cornice of—
Any building.

(13) No person shall use the handrail of any stairway otherwise than for support or assistance by hand in ascending or descending such stairway.

(14) No person shall in any way interfere with destroy, damage or injure any fire preventing appliance in any building.

(15) No person other than an officer or employee of the Council or Management Committee shall enter any plots or areas which are set aside for the planting or growing of flowers, trees or shrubs in any reserve.

(16) No person shall put in the reserve any cattle, sheep, or other animal, without the permission, in writing, of the Council, and the Council or any employee thereof shall have full power and authority to impound any cattle, sheep, or other animal found trespassing therein, and the owner of such cattle, sheep, or other animal shall be liable to the penalties provided in the By-Law.

(17) Except with the written authority of the Council no person shall attach fix or paint any bill, device, poster, sign or advertisement on any of the buildings, fences, seats or other structures in any reserve or any building.

(18) (a) No person, Club or Association or group of persons shall engage, play or practice in any organised game or practice session of cricket, football, bowls, tennis, lacrosse or golf or any like games or any other organised sport in or upon any reserve without the authority of the Council.

(b) No person shall play any type of ball game in a children's playground which contains a notice erected by the Council announcing that ball games are not permitted.

(19) No person shall play any unlawful game or make any wager for money or carry on any form of gambling in any reserve without the written authority of the Council and all other relevant authorities or by any unseemly or indecent conduct interfere with the comfort or enjoyment of other persons within any reserve.

(20) No person shall interfere with or in any way hinder or interrupt any employee of the Council engaged in any duty in any reserve.

(21) No person shall sell, offer or expose for sale within any reserve any article of food or drink or any other article or operate or cause to be operated any amusement for which a charge is made or make a collection of money for any purpose without the permission in writing of the Council.

(22) No person shall enter or remain on any reserve who may offend against decency or interfere with the comfort and enjoyment of others within the reserve as regards dress, language or conduct or who may behave in a disorderly unseemly or offensive manner or who is in a drunken or intoxicated condition or is under the influence of any drug.

(23) (a) No person shall ride or drive any motor car, motor cycle, bicycle or other vehicle into or upon any reserve save for ingress and egress on any roads or tracks or parking areas set apart or marked out for vehicular traffic and provided the speed of any vehicle shall at no time exceed 5 miles per hour or the speed limit designated by signs which may be erected pursuant to a resolution of the Council whichever is the greater.

(b) Notwithstanding the provision contained in Sub-clause (a) of this clause the Council may from time to time prohibit any type of vehicle from being driven or ridden into or upon any reserve or part thereof.

(24) The provisions of Clause 23 shall not apply to—

(a) The driving in or upon any reserve of motor vehicles, motor cycles or bicycles in accordance with the terms of any permit in writing by the Council under the hand of the Shire Secretary authorising any Club, Association or person upon conditions therein specified to allow the same;

(b) The parking of motor vehicles, motor cycles and bicycles in any parking area set aside for that purpose by the Council;

(c) The wheeling of bicycles, prams, invalid wheel chairs, child or baby carriages and children's toys along any delineated footpath in any reserve.

(25) No person shall operate a powered model aircraft or glider in any reserve except in any area set aside for the purpose by resolution of the Council and then only under such conditions as the Council may direct.

(26) No person shall ride a horse or drive a horse drawn carriage or sulky or similar vehicle in or upon any reserve or part thereof where signs indicating that such activity is prohibited have been erected pursuant to a resolution of the Council.

(27) No person shall throw or deposit any glass, filth, rubbish, refuse, junk, building material or waste material of any kind to fall or to be thrown or deposited upon or in the reserve.

(28) Persons using the reserve for any purpose shall, prior to leaving the area, collect and remove, or cause to be collected and removed all waste material, scraps, bottles, glass, or litter of any kind brought or made by them.

(29) No person shall camp in the reserve or assemble in the reserve without the permission, in writing, of the purpose of public worship, preaching, or public speaking of any kind, or meeting of a like character, without the permission, in writing, of the Council.

(30) No person shall make or cause to be made any violent outcry, noise, disturbance, or sound, or shall play any musical or noisy instrument, or sing in the reserve nor shall any person preach or declaim, harangue, or deliver any address of any kind to members of the public in the reserve for fetes, picnics, or concerts, or for the Council.

(31) No person shall give out or distribute any hand-bills, placards, notices, advertisements, books, pamphlets, or papers in the reserve, or litter same by scattering or throwing down hand-bills, placards, notices, advertisements, books, pamphlets, or papers.

(32) In any reserve or portion thereof set aside for or designated as a children's playground—

(i) No person above the age of 14 years shall enter upon or remain on such reserve or portion thereof or use any of the swings or other appliances therein provided. However that parents or other persons in charge of children shall not be prohibited from entering or remaining on such reserve or portion thereof or from using any seating which may be provided to watch over or supervise children in their charge;

(ii) No person shall use any swing or other appliance erected in any reserve or portion thereof for a longer period than five (5) minutes if any other person is waiting to use such appliances;

(iii) No person shall enter or remain in any such reserve or portion thereof between the hours of sunset and sunrise.

(33) The Council shall not be liable for any accident or injury to or loss or damage suffered by any person while in any reserve.

(34) No person shall bring allow or have any dog in any reserve unless such dog be controlled by a leash chain or cord or unless such dog is taking part in sheep dog trials or dog obedience trials or training sessions in accordance with the written authority of the Council for the use of the reserve for that purpose.

(35) No person shall without the written consent of the Council and the observance of all statutory restrictions which may be in force—

(i) Light any fire or permit any fire to remain alight in any reserve save in a fire-place provided by Council;

(ii) Let off any fireworks in any reserve.

Provided that this Clause shall not apply to the use of properly constructed gas bar-b-ques, stoves or heaters which comply with any regulations affecting the same.

(36) No person shall enter or use any dressing pavilion or other like building, in the reserve without the permission of the Council except such parts of such pavilions or other building as are set aside specifically for public use.

(37) No person shall use turf cricket wicket provided by the Council—

(i) In or on any reserve without the written permission of the Council;

(ii) No person shall—

(a) without the consent of Council practice or engage in the game of golf; or

(b) without the consent of Council take any animal or allow or permit any animal to be;

(c) take into or consume any intoxicating liquor except in accordance with the provisions of the Licensing Acts any permit thereunder;

In or on any reserve or building.

(iii) No person shall use any reserve for—

(a) The racing of any horse or any greyhound, whippet or other dog used for coursing;

(b) Motor car racing, motor cycle racing, go-kart racing, bicycle racing or similar sporting activities—

without the consent in writing of the Council.

(iv) No person shall bring into or ride any bicycle, motor cycle, mini bike or horse in or on any reserve or within any building without the consent in writing of the Council.

(38) No person other than a player, official or competitor at any sports match or sports gathering held in accordance with any permit to use a sports ground granted by the Council in accordance with the provisions of the By-Law shall enter or remain within or upon the playing arena in any sports ground during the progress of such match or sports gathering.

(39) No person shall in or upon any reserve make or permit or suffer to be made or caused such unreasonable volume or amount of sound or noise—

- (i) By shouting, calling and haranguing or singing;
- (ii) By using, operating, controlling, sounding or playing any instrument.

so as to be an annoyance to others in the reserve or to otherwise interfere with the comfort and enjoyment of others in the reserve.

(40) No person shall cut, saw, dig, move or displace any trees, bough, live or dead timber, wood or other material which may be in or around the reserve without the consent in writing of the Council.

(41) No person in or upon any reserve shall remove any earth, sand, stones, marl or gravel.

(42) The Council may set apart a portion or portions of the reserves as and for the purpose of a caravan park and may fix and collect fees or other charges for entering and use of any such area. Such fees shall be those as fixed by the Council from time to time by resolution.

(43) No person shall park a caravan or camp on or use any portion of the reserves except such portion or portions thereof as are specially set apart by the Council for the purpose and then only in such place or places as directed by its duly authorised officer.

(44) No person shall park a caravan or use a camping area or any building or convenience appurtenant to a camping area except during the period covered by the permission in writing of the Council or its authorised officer and then only on the payment of such fees as are fixed by Council and any such permission may be granted subject to conditions deemed reasonable by the Council.

(45) The person to whom permission is issued by the Council or its authorised officer to use a site in a caravan park area shall be deemed to be the person who parked a caravan pursuant to such permission and such person shall keep the site thus occupied in a clean, sanitary and tidy condition and having vacated such site shall collect and place in the receptacle provided for the purpose, all refuse, litter or garbage from the same.

(46) No person shall use a caravan within the reserves for a period of more than ninety (90) days unless with the special consent in writing of the Council.

(47) Every person holding or purporting to hold any receipt or permission in writing issued by the Council shall on demand by any Councillor or any officer thereof or any member of the police force produce such receipt or permission.

(48) Any person found offending against any of the provisions of this By-Law who fails to obey a direction of any Police Officer or officer or employee of the Council to leave a reserve shall notwithstanding that a fee or charge for admission may have been paid by him, be guilty of an offence against this By-Law.

(49) This By-Law shall apply to and operate in respect of the public reserves, pleasure grounds or places of public resort or recreation set out in Schedule "A".

(50) Any person who is guilty of any wilful act or default contrary to the provisions of this By-Law shall be liable, on conviction, to a penalty not exceeding One Hundred Dollars (\$100.00).

(51) Any person who wilfully continues an offence contrary to the provisions of this By-Law after a conviction or order of the court in respect of such offence, shall be liable on conviction to a further penalty, or not more than Ten Dollars (\$10.00) for each day, on which the offence is so continued.

SCHEDULE "A"

Quandong Park, Red Cliffs;
Kenny Park, Merbein;
M.J.K. Johansen Reserve;
Lake Cullulleraine Reserve;
Sandilong Park Reserve.
and all other public reserves, pleasure grounds or places of public resort or recreation within the Shire of Mildura.

The Resolution for passing this By-Law was agreed to by the Council of the Shire of Mildura on the Third day of October, 1974, and confirmed on the Seventh day of November, 1974.

The common seal of the President, Councillors and Ratepayers of the Shire of Mildura was hereunto affixed, in the presence of—

(SEAL) A. G. SMART, President.
N. RIBARICH, Councillor.
D. F. DREW, Secretary.

Approved by the Governor in Council, 25th March, 1975.
—TOM FORRISTAL, Clerk of the Executive Council.

SHIRE OF PAKENHAM.

LOAN No. 66.

Notice of Intention to Borrow the Sum of \$100,000 for Permanent Works and Undertakings.

Notice is hereby given that the Council of the Shire of Pakenham proposes to borrow the Principal sum of one hundred thousand dollars (\$100,000) secured by a charge over General rates of the Municipality, such sum to be raised by the grant of a mortgage in accordance with the provisions of the *Local Government Act 1955*.

1. The maximum rate of interest that may be paid is 9.9 per centum per annum.

2. The purpose for which the loan is to be applied is:

Town Planning	\$4,900
Land Acquisition (rubbish disposal site, part)	\$61,000
Car Parking Scheme, Pakenham (part)	\$34,000
	\$100,000

3. The period of the loan shall be fifteen (15) years.

4. The moneys borrowed shall be repayable by providing out of the Municipal fund thirty half yearly instalments of approximately \$6,468.11 each including principal and interest on the thirtieth day of December and the thirtieth day of June during the currency of the loan. The first instalment shall be payable on the 30th day of December, 1975.

5. Such money shall be repayable to the Bank of New South Wales, Main Street, Pakenham.

The plans and specifications and the estimate of the cost of the proposed works and a statement showing the proposed expenditure of the moneys to be borrowed are open for inspection at the office of the Council of the Shire of Pakenham at Main Street, Pakenham, during office hours.

5134 R. T. R. CANOBIE, Acting Shire Secretary.

SHIRE OF STAWELL.

ORDER DECLARING PUBLIC HIGHWAY.

In pursuance of the powers conferred by Section 522 of the *Local Government Act 1958*, the Council of the Shire of Stawell doth hereby order:—

That the land next hereinafter described, which has been purchased by it, shall be a public highway, viz:—

All that piece of land being part of Lot 1 in Plan of Subdivision No. 77075 and being part of Crown Allotment 63 Section Y Parish of Mokepilly as described in Certificate of Title Volume 9067 Folio 575.

The Common Seal of the President, Councillors and Ratepayers of the Shire of Stawell was hereto affixed this 6th day of May, 1975, in the presence of:—

(SEAL) C. J. HUTCHINGS, President.
J. R. WILLIAMS, Councillor.
V. C. NIELSEN, Secretary.

5126

SHIRE OF UPPER MURRAY.

LOAN No. 32.

Notice of Intention to Borrow the Sum of \$6,000 for Permanent Works and Undertakings.

NOTICE is hereby given that the Council of the Shire of Upper Murray proposes to borrow the principal sum of six thousand dollars secured by a charge over the general rates of the Municipality, such sum to be raised by the grant of a mortgage in accordance with the provisions of the *Local Government Act 1958*.

The maximum rate of interest that may be paid is 9.9 per centum per annum.

The loan is to be applied toward the cost of primary drainage in Corryong township.

The period of the loan shall be ten years.

The money borrowed shall be repayable by providing out of the municipal fund twenty half yearly instalments of \$479.42, each including principal and interest on the 30th June and the 31st December during the currency of the loan. The first instalment shall be payable on the 31st December, 1975.

Such money shall be repayable to the Australia and New Zealand Savings Bank Limited at Corryong.

The plans and specifications, and the estimate of cost of the proposed works, and a statement of the proposed expenditure of the moneys to be borrowed are open for inspection at the Offices of the Council of the Shire of Upper Murray at 68-72 Hansen Street, Corryong, Victoria, during office hours.

5155 A. A. N. DEED, Shire Secretary.

SEWERAGE DISTRICTS ACT.

PROPOSED SEWERAGE OF KILLARA VILLAGE.

Notice is hereby given that the Wodonga Sewerage Authority has made application to the Honorable, the Minister of Water Supply for the extension of its Sewerage District to include Killara Village and for the construction, maintenance and continuance of sewerage works within that Village under the provisions of the Sewerage Districts Act.

A general plan and description of the proposed works have been submitted with the application and copies of same may be seen at the City Offices, Wodonga.

Dated at Wodonga, the 7th day of May, 1975.

5127 A. W. RUTKOWSKI, Secretary.

NOTICE IS HEREBY GIVEN that the McCRAE YACHT CLUB has applied for a Lease under Section 134 of the Land Act 1958 for a term of 21 years, in respect of Allotment 4, Section B, Parish of Wannaeue, as a site for Amusement and Recreation (Yacht Club and associated facilities). 4829

Approval has been received from the Honorable the Minister of Lands for the Managers of the Ballarat West Town Common to increase agistment fees as follows:

\$3.50 per head per quarter for cattle,

\$5.00 per head per quarter for horses,

as from July 1st 1975.

5160 R. A. WILLIAMS, Hon. Secretary.

WODONGA SEWERAGE AUTHORITY.

In accordance with Section 119 of the Sewerage Districts Act 1958 notice is hereby given that sewers will be constructed in the area bounded by Queen, Osburn, Wigg and Lawrence Streets, Wodonga.

A plan showing the location of sewers may be inspected at the Authority's office, City Offices, Wodonga, during normal office hours.

5212 A. W. RUTKOWSKI, Secretary.

NOTICE IS HEREBY GIVEN that the partnership heretofore subsisting between LAWRENCE JAMES HAMILTON, FRANCIS LEONARD McNEILL, FREDERICK WILLIAM HAMILTON and BARRY WILLIAM WEBB carrying on business as importers of automotive parts and accessories in the premises known as 25 Percy Street, West Heidelberg, has been dissolved as from the 2nd day of May 1975 by the retirement of LAWRENCE JAMES HAMILTON from the said business. All debts due and owing by the said business shall be received and paid respectively by FRANCIS LEONARD McNEILL, FREDERICK WILLIAM HAMILTON and BARRY WILLIAM WEBB who will continue to carry on the said business.

McGRATH & COLEMAN, solicitors of 2a Cheddar Road, Reservoir. 5097

NOTICE IS HEREBY GIVEN that the Partnership heretofore subsisting between the undersigned ANGELO BACCHIN and DOUGLAS GEORGE GRIEVE carrying on business as Concrete Contractors at Bacchus Marsh under the name of "B. & G. Concrete Paving" has been dissolved by mutual consent as from the 15th day of January 1975. All debts due to and owing by the said late firm will be received and paid by Angelo Bacchin who will continue to carry on the business at the same place.

Dated at Bacchus Marsh, the 1st day of February, 1975.

D. G. GRIEVE.
A. P. BACCHIN.

Witness: J. McD. JONES.

J. McD. JONES & PURCELL, solicitors, 76 Dudley Street, Melbourne West, 3003. 5162

NOTICE IS HEREBY GIVEN that the Partnership heretofore subsisting between GEORGE HENRY WEST, GLADYS WEST, JANIS ELIZABETH KING and RICHARD PAUL KING carrying on business as Ornamental Confectioners at 29 Greeves Street, St. Kilda under the Style or Firm of G. H. & G. WEST has been dissolved as from the 18th day of March, 1975 so far as concerns the said RICHARD PAUL KING who retires from the said firm.

All debts due to and owing by the said late firm will be received and paid respectively by GEORGE HENRY WEST, GLADYS WEST and JANIS ELIZABETH KING who will continue to carry on the said business in Partnership under the Style or Firm of G. H. & G. WEST.

Dated the 13th day of May, 1975.

RICHARD PAUL KING.

Clements, Mott & Bett, solicitors, 253-255 Glenhuntly Road, Elsternwick. 5098

Companies Act 1961, Section 272.

YACKATOON PROPRIETARY LIMITED (IN VOLUNTARY LIQUIDATION).

NOTICE is hereby given that a Final Meeting of Members of the above Company will be held at 9th Floor, 461 Bourke Street, Melbourne on Wednesday, 25th June, 1975 at 12 noon for the purpose of receiving an account showing how the winding-up has been conducted and the property of the Company disposed of.

Dated this 19th day of May, 1975.

JACK KENNEDY and JOHN ARTHUR HARGREAVES, Joint Liquidators.

Wilson Danby & Giddy, 461 Bourke Street, Melbourne, 3000. 5184

The Companies Act 1961.

P.J. HOME IMPROVEMENT SERVICE PTY. LTD. (IN LIQUIDATION).

NOTICE CONVENING FINAL MEETING OF MEMBERS AND CREDITORS, PURSUANT TO SECTION 272.

NOTICE is hereby given that in pursuance of Section 272 of the Companies Act 1961, that a meeting of the members and creditors of the abovenamed company will be held on the 18th day of June, 1975, at 10.30 a.m. in the forenoon, at the office of Neville Bird, Davies & Co., Chartered Accountants, 289 Flinders Lane, Melbourne, for the purpose of having an account laid before them showing the manner in which the winding up has been conducted and the property of the company disposed of and of hearing any explanations that may be given by the Liquidator.

Dated this 15th day of May, 1975.

A. NEVILLE BIRD, Liquidator.

Neville Bird, Davies & Co., chartered accountants, 289 Flinders Lane, Melbourne. Telephone No. 63 2874. 5185

The Companies Act 1961.

ESQUIRE GLAZING PTY. LIMITED (IN VOLUNTARY LIQUIDATION).

NOTICE OF FINAL MEETING.

NOTICE is hereby given that, pursuant to Section 272 of the Companies Act 1961, a Final Meeting of the members of the abovenamed Company will be held at the offices of Price Waterhouse & Co., at 10.30 a.m. on the 16th day of June 1975, for the purpose of the Liquidator laying before the meeting an account of the winding up and giving of any explanation thereof.

Dated this 14th day of May, 1975.

P. W. HARVEY, Liquidator.

Price Waterhouse & Co., 447 Collins Street, Melbourne. 5186

The Companies Act 1961.

AUSTRALIAN LEASE RENTALS LIMITED (IN VOLUNTARY LIQUIDATION).

NOTICE OF FINAL MEETING.

NOTICE is hereby given that, pursuant to Section 272 of the Companies Act 1961, a Final Meeting of the members of the abovenamed Company will be held at the Offices of Price Waterhouse & Co., at 11.30 a.m. on the 16th day of June 1975, for the purpose of the Liquidator laying before the meeting an account of the winding up and giving of any explanation thereof.

Dated this 14th day of May, 1975.

P. W. HARVEY, Liquidator.

Price Waterhouse & Co., 447 Collins Street, Melbourne. 5187

Companies Act 1961.

TYRRELLS LINGERIE AND SPORTSWEAR PTY. LTD.

Notice is hereby given that at a meeting of the above company held on the 16th May, 1975 the following special resolution was passed:—

"That the company be wound up voluntarily and that Bruce William Edmunds of 13 North Concourse, Beaumaris, Public Accountant, be appointed liquidator for the purposes of the winding up."

Dated 16th May, 1975.

5152 B. W. EDMUNDS, Secretary.

The Companies Act 1961.

ESQUIRE GLASS CO. PTY. LIMITED (IN VOLUNTARY LIQUIDATION).

NOTICE OF FINAL MEETING.

NOTICE is hereby given that, pursuant to Section 272 of the *Companies Act 1961*, a Final Meeting of the members of the abovenamed Company will be held at the offices of Price Waterhouse & Co., at 11.00 a.m. on the 16th day of June 1975, for the purpose of the Liquidator laying before the meeting an account of the winding up and giving of any explanation thereof.

Dated this 14th day of May, 1975.

P. W. HARVEY, Liquidator.
Price Waterhouse & Co., 447 Collins Street, Melbourne.
5188

Companies Act 1961.

MODULAR CARPET TILES PTY. LTD.

NOTICE OF MEETING OF CREDITORS TO CONSIDER WINDING-UP RESOLUTION.

Notice is hereby given that pursuant to Section 260 (1) of the *Companies Act 1961*, a meeting of creditors of Modular Carpet Tiles Pty. Ltd. will be held at the Melbourne Chamber of Commerce, 60 Market Street, Melbourne, 3000 on 30 May, 1975 at 10.30 a.m.

The meeting is convened to consider the position of the Company's Affairs, the Company having convened an Extraordinary General Meeting of its members to be held on the day prior to consider and if deemed expedient, pass a special resolution to wind up the Company voluntarily, and to nominate Leslie Philip Smart and Richard George Shoo-bridge, Chartered Accountants, C/- Marquand & Co., 51 Queen Street, Melbourne, 3000 as Liquidators to act jointly or severally.

Dated this 14th day of May, 1975.

5189 V. BRAZIER, Director.

The Companies Act 1961.

LESTER ESTATE INVESTMENTS PTY. LTD. (IN VOLUNTARY LIQUIDATION).

NOTICE CONVENING FINAL MEETING OF MEMBERS.

PURSUANT TO SECTION 272, Notice is hereby given pursuant to Section 272 of the *Companies Act 1961* that a General Meeting of the Members of the abovenamed Company will be held in the Office of S. L. Williams & Co., 1st Floor, 486 Nepean Highway, Frankston on Monday the twenty-third day of June, 1975 at 10.00 a.m. for the purpose of having an account laid before them showing the manner in which the winding up has been conducted and the property of the company disposed of and of hearing any explanations that may be given by the Liquidator.

Dated this 16th day of May, 1975.

5147 S. WILLIAMS, Liquidator.

The Companies Act 1961.

AUSJOHN PTY. LTD. (IN LIQUIDATION).

NOTICE CONVENING FINAL MEETING OF MEMBERS AND CREDITORS PURSUANT TO SECTION 272.

Notice is hereby given in pursuance of Section 272 of the *Companies Act 1961*, that a Meeting of Members and Creditors of the above-named Company will be held at the Registered office of the Company—343 Little Collins Street, Melbourne on Monday 25th June, 1975, at 11 o'clock in the forenoon, for the purpose of having an account laid before them showing the manner in which the winding up has been conducted, and the property of the Company disposed of, and of hearing any explanations that may be given by the Liquidator.

Dated this 14th day of May, 1975.

L. S. EVA, Liquidator.
L. S. Eva & Co., chartered accountants, 343 Little Collins Street, Melbourne, 3000.
5148

Companies Act 1961.—In the matter of F. H. A. INDUSTRIES PTY. LTD., of 6 Amay Crescent, Ferntree Gully, 3156.—
Notice Re Meeting of Creditors, Pursuant to Section 260.

NOTICE is hereby given that a Meeting of Creditors of the abovenamed Company will be held at Suite 18, 545 St. Kilda Road, Melbourne on Wednesday, 4th June, 1975 at 10.30 a.m., the Company having convened a Meeting of its Members for the same day for the purpose of considering a Resolution that the Company be wound up voluntarily.

Dated this 15th day of May, 1975.

F. HOLMES, Director.

Bent & Cogle, public accountants, Suite 18, 545 St. Kilda Road, Melbourne, 3004.
5149

Company No. 52763.

Companies Act 1961.—In the matter of JEN PARK PTY. LTD., (in Voluntary Liquidation).

NOTICE IS HEREBY GIVEN that at an Extraordinary General Meeting of the members of the abovenamed Company held on the 16th day of May, 1975 it was resolved that the Company be wound up voluntarily and that Robert Gordon Cameron of 162 Albert Road, South Melbourne, Chartered Accountant, be appointed Liquidator.

NOTICE IS ALSO GIVEN that after twenty-one days from this date I shall proceed to distribute the assets. All creditors having any claims against the Company should furnish particulars of same by that date otherwise I shall proceed to distribute the assets without regard to their claim.

Dated this 16th day of May, 1975.

5150 R. GORDON CAMERON, Liquidator.

Companies Act 1961, Section 272.

TOP MEAT SUPPLY PTY. LTD. (IN LIQUIDATION).

NOTICE OF FINAL MEETING OF MEMBERS AND CREDITORS.

Notice is hereby given that the final meeting of members and creditors of the abovenamed Company shall be held on Friday 4th July, 1975, at 2.30 p.m. at the meeting room of Max Gee & Co. 4 Burwood Highway, Burwood, 3125.

AGENDA.

1. Presentation by the Liquidator of an account showing how the winding up has been conducted and the property of the Company has been disposed of, and to give any explanation of the account.

2. The meeting to consider the following resolution:

"That immediately after the dissolution of the Company the Liquidator may destroy the books and papers of the Company pursuant to Section 284 of the Act."

Dated this 21st day of May, 1975.

M. G. GEE, Liquidator.

Max Gee & Co., 321 Warrigal Road, Burwood, Vic.
3125.
5151

Companies Act 1961, Section 254 (2) (b).

MAXIGNS PROPRIETARY LIMITED.

Notice is hereby given that at an Extraordinary General Meeting of the members of the above-named company held on the 15th day of May, 1975, it was resolved that the company be wound up voluntarily and that Donald Robertson, F.A.S.A., of 1 High Street, Windsor, public accountant, be appointed liquidator.

Notice is also given that after 21 days from this date the liquidator shall proceed to distribute the assets. All creditors having any claim against the company should furnish particulars of the same by that date otherwise the assets will be distributed without regard to their claim.

Dated the 15th day of May, 1975.

5123

*Companies Act 1961.*EASY PAVING COMPANY PROPRIETARY LIMITED.
NOTICE OF RESOLUTION.

At an Extraordinary General Meeting of members of EASY PAVING COMPANY PROPRIETARY LIMITED, duly convened and held at 52 Wilson Boulevard, Reservoir, on the 9th day of May, 1975, the following Resolution was passed as a Special Resolution:

"Resolved that the Company be wound up voluntarily as a members' voluntary winding up in accordance with the provisions of the *Companies Act 1961*, and that Mr. Slavoj George Nolch be appointed liquidator for the purposes of the winding up."
5124

Companies Act 1961.

ALAN LAUNDER PROPRIETARY LIMITED (IN VOLUNTARY LIQUIDATION).

NOTICE is hereby given that in pursuance to Section 272 of the *Companies Act 1961* a General Meeting of the Company will be held at 5-7 Anthony Street Melbourne on Thursday 26th June 1975 at 10.30 a.m. for the purpose of receiving the Liquidator's Final Account of the winding up of the Company.

Dated this 14th day of May, 1975. 5176

EVANS SPRINGS PTY. LTD. (IN VOLUNTARY LIQUIDATION).

NOTICE is hereby given in pursuant of Section 272 of the *Companies Act 1961* that a General Meeting of the members of the abovenamed Company will be held at the offices of Touche Ross & Co., 11th Floor, 440 Collins Street, Melbourne on Tuesday the 17th day of June, 1975 at 9.30 for the purpose of receiving the Liquidator's account showing how the winding up has been conducted and the property of the Company has been disposed of and of hearing any explanation that may be given by the Liquidator.

Dated this 20th day of May, 1975.
5177 H. A. B. McWILLIAM, Liquidator.

It was resolved that Fenley Investments Pty. Ltd. be placed in Voluntary Liquidation and that John Henry Donegan be appointed liquidator.

5178 JOHN H. DONEGAN.

Form 92.

The *Companies Act 1961*, Section 272 (1).

Companies Regulations.

WM. COOK PROPRIETARY LIMITED (IN LIQUIDATION).

NOTICE OF MEETING OF CONTRIBUTORIES.

Notice is hereby given that a final meeting of the contributories of Wm. Cook Proprietary Limited (in Liquidation) will be held at 6th Floor, 470 Bourke Street, Melbourne on Wednesday 18th June 1975 at 11.15 o'clock in the forenoon.

AGENDA.

To receive the liquidator's account of his acts and dealings and of the conduct of the winding up and of hearing any explanations thereof.

Dated this 14th day of May, 1975.
5167 R. A. WATERS, Liquidator.

Form 92.

The *Companies Act 1961*, Section 272 (1).

Companies Regulations.

W. C. CONE & CO. PROPRIETARY LIMITED (IN LIQUIDATION).

NOTICE OF MEETING OF CONTRIBUTORIES.

Notice is hereby given that a final meeting of the contributories of W.C. Cone & Co. Proprietary Limited (in liquidation) will be held at 6th Floor, 470 Bourke Street, Melbourne on Wednesday, 18th June 1975 at 11.00 o'clock in the forenoon.

AGENDA.

To receive the liquidator's account of his acts and dealings and of the conduct of the winding up and of hearing any explanations thereof.

Dated this 14th day of May, 1975.
5168 R. A. WATERS, Liquidator.

E.G. STEEL CONSTRUCTIONS CO. PTY. LTD. (IN LIQUIDATION).

Pursuant to Section 272 of the *Companies Act 1961*. I hereby give notice that a general meeting of the company will be held at 10.00 a.m. on Friday 27th June, 1975 at the office of R. W. Fox, C. A. Gregory & Associates, 112 Patterson Road, Moorabbin for the purpose of considering my account of the winding up and how the company's property has been disposed of.

5145 R. W. FOX, Liquidator.

Companies Act 1961.—In the matter of MACLAREN HAULAGE (AUST.) PROPRIETARY LIMITED (in Liquidation).

NOTICE is hereby given that at an extraordinary Meeting of the Members of the abovenamed Company held on the 15th May 1975, it was resolved that the Company be wound up voluntarily and at a Meeting of Creditors held on the same day pursuant to Section 260, it was resolved that for

such purpose, BRENDAN JOHN O'CONNOR of Taylor O'Connor & Co., 562 St. Kilda Road, Melbourne be appointed Liquidator.

NOTICE is also given that after twenty-one days from this date I shall proceed to distribute the assets. All creditors having any claims against the Company should furnish particulars of same by that date, otherwise I shall proceed to distribute the assets without regard to their claims.

Dated this 19th day of May, 1975.
B. J. O'CONNOR, Liquidator.

Taylor O'Connor & Co., Melbourne. 5146

TAYLOR'S FRESH FOODS PTY. LTD. (IN VOLUNTARY LIQUIDATION).

PURSUANT TO SECTION 254(2) OF THE COMPANIES ACT 1961.

At an Extraordinary General Meeting of Members of the said company duly convened and held at 18 Brake Street, Burleigh Heads, Queensland on Wednesday the 14th day of May, 1975 at 10.00 a.m., the following resolution was passed:—

"That the company be wound-up voluntarily and that Neville Acheson Rogers of 257 Collins Street, Melbourne be appointed liquidator for such winding-up".

Dated this 14th day of May, 1975.
5179 N. A. ROGERS, Secretary.

Companies Act 1961.

ELRAE PROPRIETARY LIMITED.

ELRAE PROPRIETARY LIMITED, of 450 Little Collins Street, Melbourne, a company incorporated under the provisions of the *Companies Act 1958* of the State of Victoria HEREBY GIVES NOTICE that by a Special Resolution passed by the members of the Company on the 14th May 1975 it was resolved that the Company be wound up voluntarily.

MAXWELL JAMES SCOTT, Liquidator.
450 Little Collins Street, Melbourne. 5180

The Companies Act 1961.

NOTICE OF FINAL MEETING OF SHAREHOLDERS OF SUMMERLEIGH INVESTMENT PROPRIETARY LIMITED (IN LIQUIDATION).

NOTICE IS HEREBY GIVEN in pursuance of Section 272 of the *Companies Act 1961* that a general meeting of members of SUMMERLEIGH INVESTMENT PROPRIETARY LIMITED (IN LIQUIDATION) will be held at 450 Little Collins Street, Melbourne, on Friday the 27th day of June, 1975 at 11 o'clock in the forenoon for the purpose of laying before the meeting an account showing how the winding up has been conducted and the property of the company has been disposed of and of giving any explanation of the account.

Dated this 9th day of May, 1975.
5181 B. ETHERINGTON, Liquidator.

Companies Act 1961.

STURT INVESTMENTS PTY. LTD. (IN VOLUNTARY LIQUIDATION).

NOTICE CONVENING FINAL MEETING OF MEMBERS, PURSUANT TO SECTION 272.

Notice is hereby given in pursuance of Section 272 of the *Companies Act 1961* that a General Meeting of the Members of the abovenamed Company will be held on the 24th June, 1975 at 11.30 a.m. at the office of Hughes, Fincher & Rodda, 343 Little Collins Street, Melbourne for the purpose of having an account laid before them showing the manner in which the winding up has been conducted and the property of the Company disposed of and hearing any explanation that may be given by the Liquidator.

Dated this 13th day of May, 1975.
N. HARRIS, Liquidator.
Hughes, Fincher & Rodda, Chartered Accountants, 343 Little Collins Street, MELBOURNE, Vic. 3000. 5182

HARRY TAYLOR'S MENS SHOP PROPRIETARY LIMITED.

At a special meeting held at 106 Banyan Street, Warrnambool it was resolved that the Company be wound up voluntarily and that Mr. J. J. Purcell of 67 Kepler Street, Warrnambool be appointed Liquidator at a fee to be arranged.

5117 H. McD. TAYLOR, Director.

Unclaimed Moneys Act 1962.

Register of Unclaimed Moneys held by the—

Name of Owner on Books and Last Known Address.	Total Amount Due to Owner.	Description of Unclaimed Moneys.	Date when Amount First Became Payable
5			
WESTERN MINING CORPORATION LIMITED.			
Anderson, John M., Y.M.C.A., Murray Street, Perth, W.A.	32.00	Dividend	28.3.73
Armstrong, Anona F. (Mrs.), Town House One, 272 Cotham Road, Kew	16.80	"	5.10.73
Ashmore, Michael B. H., c/o Nat. Bank of A/asia Ltd., 271 Collins Street, Melbourne	26.16	"	28.3.73
Bailey, James W., 12 Stirgess Avenue Harbord, N.S.W.	24.00	"	"
Barden, Jack S. and Anor, Flat 1 Trade Wind, Enderley Avenue, Avenue, Surfers Paradise, Qld.	16.00	"	"
Baumgartner, Paul A., P.O. Box 163, Castle Hill, N.S.W.	35.44	"	5.10.73
Baylis, Kenneth E., 10 Merton Avenue, Elwood	16.00	"	28.3.73
Bergin, Michael, 49 Old Burleigh Road, Surfers Paradise, Qld.	16.80	"	"
Brown, Geoffrey C. and Anor, Wilsons Pocket, Via Gympie, Qld.	150.04	"	5.10.73
Buxton, Mary P., 47 Bay Street, Brighton	31.20	"	"
Carroll, John K., 60 South Road, Brighton Beach	16.00	"	28.3.73
Carstens, Josephine (Mrs.), 22 Chelsea Avenue, Broadbeach, Qld.	11.52	"	"
Carter, Franc R., 28b Birdwood Street, Box Hill South	13.44	"	5.10.73
Chamberlain, Peter I., 9 Williamsby Avenue, Brighton	40.00	"	"
Chaytor, Anthony D. C., 213 Roberts Street, Joondana, W.A.	11.20	"	28.3.73
Clinkscale, Martin M., Flat A, 384 Toorak Road, South Yarra	32.00	"	"
Cooper, David C., 42 Borella Crescent, Jingili, Darwin N.T.	12.00	"	5.10.73
Cowan, James H., 27 Calista Avenue, Calista, W.A.	13.28	"	"
Crisp, Malcolm P., 10 Anglesea Street, South Hobart, Tas.	12.00	"	"
Doyle, Paul P., c/o 37 Pearl Bay Avenue, Beauty Point, N.S.W.	68.00	"	"
Duigan, John L., 558 Drummond Street, Carlton	15.00	"	"
Eardley, Brian F., 9 King George Street, McMahons Point, N.S.W.	48.00	"	28.3.73
Edwards, Trevor J. D., 4 Hakea Street, Kambalda, W.A.	12.00	"	5.10.73
Eichhorn, Sheila (Mrs.), 108 South Road, East Brighton	21.60	"	"
Etelson, Doris C. (Miss), Flat 16, 9 Barnato Grove, Armadale	15.64	"	"
Fan, Mr. Lee C., c/o Mr. Michael Ng, 84 Liverpool Street, Enfield, N.S.W.	16.00	"	28.3.73
Farrell, Maralyn A. (Mrs.), c/o A.N.Z. Banking Group, 86 Queen Street, Melbourne	28.00	"	5.10.73
Feerick, Kieran, 24 Young Street, Croydon, N.S.W.	27.20	"	28.3.73
Ferguson, James A., Hunters Pharmacy, Railway Street, Grattan, Qld.	16.00	"	"
Fletcher, Judith W. (Miss), Two Wells, S.A.	72.48	"	5.10.73
Flower, John P., 115 Percy Street, Warwick, Qld.	20.00	"	"
Frost, Brian J., Flat 6, 29 Coogee Street, Randwick, N.S.W.	24.00	"	28.3.73
Gajdik, Milos, c/o Robert Beston, 7/11 Rocklands Road, Woolstonecraft, N.S.W.	16.00	"	"
Gallagher Estates Pty. Ltd., c/o Mr. B. A. Gallagher, 64 Castlereagh Street, Sydney, N.S.W.	16.00	"	"
Gibbs, Ella W. (Mrs.), c/o Dr. D. G. Gibbs, 9 Riverview Road, Essendon	19.20	"	5.10.73
Glover, Robert D., P.O. Box 440, Queanbeyan, N.S.W.	31.28	"	28.3.73
Green, Norman R., 83 Moreing Road, Attadale, W.A.	19.20	"	5.10.73
Harford, Edward, c/o G.P.O. Box 3804, Sydney, N.S.W.	20.00	"	28.3.73
Harmer, Keith R. and Anor, P.O. Box 10, Sandy Bay, Tas.	16.00	"	5.10.73
Harrington, Brian F., 17 Park Street, Clovelly, N.S.W.	14.00	"	"
Harris, Jean, (Mrs.), 52 Hilltop Road, Avalon, N.S.W.	16.00	"	"
Hawke, Allan A., c/o Falconbridge Aust. Pty. Ltd., 190 Hay Street, Perth, W.A.	12.00	"	"
Henderson, Peter G. F., c/o Mr. J. D. O. Burns, G.P.O. Box 543, Sydney, N.S.W.	16.00	"	"
Hogan, Patrick N., 47 Bowan Street, St. Arnaud	16.00	"	"
Howard, Joyce (Mrs.), 5 Ranfurlie Crescent, Glen Iris	19.20	"	"
Inglis, Joyce (Miss), 17 Branyan Street, Bundaberg, Qld.	11.52	"	"
James, Arthur, c/o J. A. Diacopoulos, c/o C. T. Comino and Co., 142 Phillip Street, Sydney, N.S.W.	16.00	"	28.3.73
Jennifer Investments Pty. Ltd., c/o S. McKellar White and Associates, 2 Castlereagh Street, Sydney, N.S.W.	86.48	"	5.10.73
Jollow, Frederick C. (Dr.), Unit 4, 13 Drummond Street, Belmore, N.S.W.	32.00	"	28.3.73
Kirby, Patrick B. c/o G.P.O. Box U. 1994, Perth, W.A.	76.80	"	5.10.73
Kirkwood, Philip J., 567 Portrush Road, Glenunga, S.A.	19.20	"	"
Knights Elizabeth Z. (Mrs.), 32 Normanby Street, Brighton	16.00	"	"
Knox, Margaret M. (Miss), 21 Henry Street, Ascot, Qld.	309.60	"	"
Koitaki Para Rubber Estates Limited, 291 George Street, Sydney, N.S.W.	216.00	"	"
Leach, Phyllis M. (Mrs.), 23 Glyndon Avenue, Brighton	16.00	"	"
Leishman, John, c/o Amoco Minerals Aust., P.O. McKinlay, Qld.	20.00	"	"
Lemon, Jack O., 14 Lentara Road, Bayview, N.S.W.	19.20	"	"
Lester, Eileen E. (Mrs.), c/o Mrs. Catchlove, 57 Barnard Street, Mt. Eliza	41.20	"	"
Leung, Andrew, Masons Lane Investments Pty. Ltd., 11/26 Hawthorn Glen, Hawthorn	40.00	"	"
Lewis, James B., 2 Wiaktun Crescent, Mt. Waverley	120.00	"	"
Llewelyn, Sheila I. (Mrs.), 152 Tryon Road, Lindfield, N.S.W.	28.00	"	"
Lynch, Peter E., 12 Pictavia Street, Toowong, Qld.	14.40	"	28.3.73
Mills, Garry F., Flat C., 64 Spence Street, Mt. Isa, Qld.	20.00	"	5.10.73
Morley, George E., 594 Ipswich Road, Annerley, Qld.	20.00	"	"
Morris, David G., 50 York Street, Boulder, W.A.	20.00	"	28.3.73
McCalman, David H. and Anor, 5 Woff Street, Beaumaris	14.40	"	5.10.73
McCann, George, 397 Alford's Point Road, Menai, N.S.W.	19.20	"	28.3.73
McGregor, John K., c/o Mitchell and Gee, 7th Floor, 109 Pitt Street, Sydney, N.S.W.	11.20	"	"

Unclaimed Moneys Act, 1962.

Register of Unclaimed Moneys held by the—

Name of Owner on Books and Last Known Address.	Total Amount Due to Owner.	Description of Unclaimed Moneys.	Date when Amount first became Payable.
\$			
WESTERN MINING CORPORATION LTD.—continued.			
McKenzie, Kenneth J. and Anr, c/o W. Rennie, 17/162 Croydon Avenue, Croydon Park, N.S.W.	16.00	Dividend	28.3.73
Newman, Dudley S., 1 Elma Road, Sandy Bay, Tas.	20.00	"	5.10.73
Newman, Kathleen H. (Mrs.), 1 Elma Road, Sandy Bay, Tas.	40.00	"	28.3.73
Nixon, Norma K. B. (Mrs.), 53 South Road, Brighton	48.00	"	5.10.73
O'Donohoe, Ronald J., 41 The Grove, Wembley, W.A.	180.00	"	"
O'Donohue, Eileen C. (Mrs.), 41 The Grove, Wembley, W.A.	26.00	"	"
Pildra Investments Pty. Ltd., P.O. Box 332, Broadway, N.S.W.	40.00	"	"
Palan, Gabriella (Mrs.), Peter and Rowan, Vera (Mrs.), Unit 3b, Torbreck, Dornoch Terrace, Highgate Hill	67.20	"	"
Paton, Patricia (Mrs.), 10 Chesterfield Avenue, Malvern	14.00	"	"
Pigdon, Beatrice H. (Mrs.), c/o Mrs. A. Dillon, 221 Burke Road, Glen Iris	30.72	"	"
Poits, Terry S., P.O. Box 152, Belmont, W.A.	28.00	"	"
Pratt, Richard, 1 Eamon Court, Kew	46.84	"	"
Price, Dorothy R. (Mrs.), 17 Wallace Grove, Brighton	14.40	"	"
Quilty, Edna M. (Mrs.), c/o Wilfred Allsop and Sons, 66 King Street, Sydney, N.S.W.	205.24	"	"
Rearidon, Timothy J. and Another, c/o G.P.O. Box 669, Brisbane, Qld.	13.60	"	28.3.73
Reynolds, Walter, 45 Queen Street, Glenunga, S.A.	40.00	"	5.10.73
R. S. W. Investments Pty. Ltd., c/o Dr. R. S. Wurm, 125 Stephen Terrace, Walkerville, S.A.	40.00	"	"
Sauer, Leo, Flat 17, 723 Orrong Road, Toorak	48.00	"	"
Sauer, Leo and Another, Flat 17, 723 Orrong Road, Toorak	12.00	"	"
Searls, Robert J., 1310 Dandenong Road, Hughesdale	16.00	"	"
Shugg, Kevin G., c/o Gold Mines of Kalgoorlie, P.O. Box 105, Fimiston, W.A.	20.52	"	"
Silver, Henry (Dr.) and Another, 3/2 Eleanor Street, Footscray	16.00	"	"
Skarratt, Anthony C., 12A/13 Penkivil Street, Bondi, N.S.W.	19.20	"	"
Sladen, Simon H., 70 Windsor Street, Paddington, N.S.W.	14.40	"	28.3.73
Smeets, Joseph W., 280 Piccadilly Street, Kalgoorlie, W.A.	13.52	"	5.10.73
Smith, Kathleen D. (Mrs.), P.O. Box 5189, Boroko, T.P.N.G.	40.00	"	28.3.73
Smith, Maureen J. (Mrs.), 79 Hannam Street, Cairns, Qld.	60.00	"	5.10.73
Souery, Maurice and Others, 192 Alma Road, East. St. Kilda	16.00	"	28.3.73
Steinly, Henry and Another, c/o Corrie and Co., P.O. Box 40, Surfers Paradise, Qld.	19.20	"	"
Stene, Eric N., P.O. Box 1, Albany, W.A.	57.60	"	"
Stewart, Alan C. C., c/o Merchandising Display Pty. Ltd., 15 Flinders Lane, Melbourne	19.20	"	5.10.73
Stewart, Edgar D. J., 3/14 Anderson Street, South Yarra	196.00	"	"
Stribling, Stewart, Flat 7, 27 Kensington Road, South Yarra	163.76	"	"
Tanner, David J. and Another, 11 Wicklow Street, Kangaroo Point, Qld.	120.00	"	"
Tattersall, Raymond, 6 Greenwood Street, Doncaster	19.20	"	"
Taverner, Stephen J., 16 Dora Street, Katoomba, N.S.W.	19.20	"	28.3.73
Taylor, Rowland K., Falkirk, Rostrevor Road, Stirling, S.A.	196.00	"	"
Thomson, Kenneth R. (Dr.), 68 Lawler Street, Subiaco, W.A.	16.00	"	"
Votrubeck, Milan, 29 Park Road, Five Dock, N.S.W.	29.96	"	"
Wells, Peter H., 2 Gilberton Street, Kalgoorlie, W.A.	130.40	"	"
Wensley, Ronald W., P.O. Box 101, Cottesloe, W.A.	40.00	"	"
Waight, Christopher M. (Dr.), c/o Repatriation General Hospital, Heidelberg West	12.00	"	5.10.73
Whitehead, Audrey R. (Mrs.), Flat 3, 6 Weybridge Street, Surrey Hills	28.80	"	28.3.73
Wilson, Douglas G., 103/856 Pacific Highway, Chatswood, N.S.W.	16.00	"	5.10.73
Wilson, William I., c/o J. Wilson Malvern Pty. Ltd., P.O. Box 62, Malvern	19.20	"	28.3.73
Wolfson, Barbara (Miss), c/o Mrs. R. Black, Flat 7, 136 Alma Road, East St. Kilda	12.80	"	28.3.73
Wrench, Patricia J. (Mrs.), Innisfree, Point Vernon, Qld.	40.00	"	28.3.73
Wyett, Margaret C. (Mrs.), 1161 Riversdale Road, Box Hill South	16.00	"	5.10.73
Yap, Boh G. (Dr.), Flat 11, 6 O'Shannassy Street, North Melbourne	11.20	"	28.3.73
Alcock, Harold W., 116A Melton Road, West Bridgford, Nottingham, U.K.	173.40	"	5.10.73
Bancroft, Gertrude S. (Mrs.), 18 Crows Nest Road, Bronxville, New York, 10708, U.S.A.	17.00	"	28.3.73
Barclay, Robert J., Peacock Hotel, Baslow, Bakewell, Derbyshire, U.K.	29.86	"	"
Barclays Rhodesian Nominees Private Ltd., P.O. Box 790, Salisbury, Rhodesia	23.94	"	"
Bell, Morton, 41 West Tamaki Road, Auckland 6, N.Z.	17.00	"	5.10.73
Boaz, Robert C., P.O. Box 146, Dana Point, California, U.S.A.	20.40	"	28.3.73
Camalich, Eleen (Mrs.), Il Poggio, 46 Corso Cuneo, S. Margherita Ligure Prov Di Genoa, Italy	61.60	"	"
Carter, Bridget P. (Mrs.), Akarana, 28 Power Park, Fewey, Cornwall, U.K.	14.69	"	5.10.73
Chan, Bing F., 215 Prince Edward Road, 2nd Floor, Kowloon, Hong Kong	87.36	"	28.3.73
Chaytor, Anthony D. C., Marshlands, Blenheim, R.D.3, N.Z.	13.60	"	"
Chaytor, John L. C., Marshlands, R.D.3, Blenheim, N.Z.	102.00	"	5.10.73
Chow, Ping Y. (Miss), c/o The Chartered Bank, Securities Department, P.O. Box, 21, Hong Kong	16.80	"	28.3.73
C. O. Nominees Limited, 72 Lombard Street, London, E.C.3., U.K.	68.00	"	"
Dadlani, Harkishin L., c/o J. Ballas and Co., Pte. P.O. Box 108, Singapore 1	34.00	"	"

Unclaimed Moneys Act 1962.

Register of Unclaimed Moneys held by the—

Name of Owner on Books and Last Known Address.	Total Amount Due to Owner.	Description of Unclaimed Moneys.	Date when Amount first became Payable.
§			
WESTERN MINING CORPORATION LIMITED—continued.			
Dawson, Arthur J., c/o P.O. Box 9481, Auckland, N.Z.	68.54	Dividend	28.3.73
Deeside Investments (Jersey) Limited, La Chasse, St. Martin, Jersey, Channel Islands	120.96	"	5.10.73
Dickson, Kenneth (Dr.), c/o Barclays Bank D. C. O., Gibraltar	67.20	"	28.3.73
Djema, Haron J., Corso Di Porta Vittoria 54, Milan, Italy	24.39	"	5.10.73
Djema, Moise J., Via Luciano Manara 15, Milan, Italy	24.02	"	"
Doe, Russell M., 2203 Green Acres Drive, Visalia, California, U.S.A.	13.60	"	"
Donaldson, Angus F., The Bower, Kilbarchan, Renfrewshire, Scotland	16.32	"	28.3.73
Elmer, Hans, Neutal, 9602 Bazenheid, Switzerland	47.60	"	"
Engvall, Eva C. (Mrs.), Valsvagen 7, S-15010, Gnesta, Sweden	72.24	"	"
Falcongreen, Brian F., 7 Coombe Drive, Dunstable, Bedfordshire, U.K.	16.32	"	"
Fischer, Geoffrey M., 33 Clarence Street, Staines, Middlesex, England	13.60	"	"
Forbes, Janet E. (M/s.), 47b Stubbs Road, Hong Kong	11.20	"	"
Freer Investments (Pvt.) Ltd., 57 Jameson Avenue, Salisbury, C.I., Rhodesia	133.28	"	"
Freisinger, Johann, 8906 Gersthofen Augsburg, Friedrich Ebertstr, 3, Germany	14.00	"	5.10.73
Fretwell, Roger L., 16 Angullia Park, Singapore	13.60	"	28.3.73
Glazebrook, William F. and Another, 43 Castle Street, Liverpool, U.K.	40.80	"	"
Hadden-Paton, Major Adrian G. N., Rossway, Berkhamstead, Herts., U.K.	161.81	"	5.10.73
Halls, Eileen M. (Mrs.), c/o J. R. Halls, c/o Bank of N.S.W., 9/15 Sackville Street, London, W.1., U.K.	13.60	"	28.3.73
Halstead, Harry, Ministry of Social Services, P.O. Box 2031, Government Buildings, Suva, Fiji	16.80	"	"
Hardenbergh, Wesley, c/o J. L. Talbot, West Twin Creek Road, Bonner Mont, 59823, U.S.A.	11.70	"	"
Hart, Leonard M., 15 Guthrie Street, Lower Hutt, N.Z.	329.80	"	5.10.73
Hartnell, Cynthia M. (Mrs.), 6 Holmesdale, Bridgewater Road, Weybridge, Surrey, U.K.	24.48	"	28.3.73
Hirsch, Theophila (Mrs.), Belgielei 7, 2000 Antwerp, Belgium	20.16	"	5.10.73
Kalb, Bernard, c/o C.B.S. News, Flat 3A, 2 Kennedy Terrace, Hong Kong	11.20	"	28.3.73
Kitson, Jean (Mrs.), 5817 Cape Mansions, Mount Davis Road, Hong Kong	14.00	"	"
Kostoris, Cyril E., Springmead, Bradcutts Lane, Cookham Dean, Berks., U.K.	61.20	"	"
Lewis, James C. and Another, P.O. Box 253, Little Rock, Arkansas, 72203, U.S.A.	51.00	"	"
Lightbourn, Michael E., P.O. Box 4039, Nassau, Bahamas	22.40	"	"
Lim, Siew H. (Madam), 12 Margoliouth Road, Singapore 10	102.00	"	5.10.73
Mackenzie, Rosemary R. (Miss), c/o Westminster Bank Ltd., High Street, Marlow, Buckinghamshire, U.K.	31.89	"	"
Masuda, Takeo, c/o C. Itoh and Co. Ltd., Tokyo H. O. Secretariat Department, Central P.O. Box 136, Tokyo, Japan	32.64	"	28.3.73
Measures, Max E., 110 Home Park Road, Wimbledon, London, S.W.19, U.K.	112.20	"	"
Merritt, Neil D., 16 Allan Street, Nelson, N.Z.	20.40	"	"
Mitchell, Sarah A. (Mrs.), 76 St. Heliers Bay Road, St. Heliers, Auckland, 5, N.Z.	44.20	"	5.10.73
Nagano, Setsu (Mrs.), 34 4 4 Chome, Matsubara Setagaya Ku, Tokyo, Japan	49.98	"	"
Nutt, Graham A., McQueens Valley, Motukarara 2 R.D., Christchurch, N.Z.	13.60	"	28.3.73
Ockenga, Audrey W. (Mrs.), 624 Bay Road, Hamilton, Massachusetts, 01936, U.S.A.	13.60	"	"
O'Connor, Edward C., P.O. Box 1719, Palmerston North, N.Z.	13.60	"	"
O'Neill, James P., 52 Chapman Street, Invercargill, N.Z.	27.20	"	"
Ong Nominees Private Ltd., 45-B, Robinson Road, Singapore 1	23.80	"	"
Ooyub, Fatimah (Madam), 10 Newton Road, Singapore 11	13.60	"	"
Osborne, John P. (Dr.), 57b Palace Gardens Terrace, London, W.8., U.K.	20.40	"	"
Paribas Nominees Limited, c/o Mitton Butler Priest and Co. Ltd., City Wall House, 79/83 Chiswell Street, London	102.00	"	"
Phillips-Turner, Hugh D., P.O. Box 1207, Hamilton, N.Z.	27.20	"	5.10.73
Plane, Andrew R., The Cottage, 27 Brook Park, Carrhill Lane Sleights, Whitby, Yorkshire, U.K.	15.03	"	"
Prendiville, Gerald R. G. (Dr.), State Medical Department, Box 42 Doha Qata, Arabian Gulf	153.89	"	"
Reginato, Giuseppe, Via Chisini, Pieve Di Soligo Treviso, Italy	36.40	"	"
Skrine, John S. H., 20 Penang Road, Kuala Lumpur, Malaysia	28.00	"	"
Slowey, Thomas C., 48 Henry Street, Dublin 1, Ireland	28.00	"	"
Smith, Ann E. (Mrs.), c/o P.O. Box 1917, Auckland, N.Z.	16.32	"	"
Spandel, Alojzy, 2 Hillside Cottages, Tanbridge, Oxted, Surrey, U.K.	10.20	"	"
Smith, Richard E., Flat 8, Belgravia House, Halkin Place, London S.W.1	204.00	"	"
Stichbury, Allison (Mrs.), c/o 4 Westhill Road, Point Howard, Eastbourne, N.Z.	13.06	"	28.3.73
St. Lawrence, John F. G., Howth Castle, Howth, Co. Dublin, Ireland	201.60	"	"
St. Leger, John S., 7 Latin Heights, Kellner Road, Bloemfontein, South Africa	89.60	"	"
Storey, Charles M. (Jnr.), Giddings Farm, Northern Avenue, Essex 01929, Massachusetts, U.S.A.	17.00	"	"

Unclaimed Moneys Act 1962.

Register of Unclaimed Moneys held by the—

Name of Owner on Books and Last Known Address.	Total Amount Due to Owner.	Description of Unclaimed Moneys.	Date when Amount first became Payable.
§			
WESTERN MINING CORPORATION LIMITED—continued.			
Taaffe-Finn, Peter P., c/o Peat Marwick Mitchell and Co., 801 Princes Bldg., Hong Kong	10.76	Dividend	28.3.73
Talbot, Hilary L. (Miss), McDonald Street, Methven, N.Z.	12.24	"	"
Tomlinson, Alexandra E. (Mrs.), Rowan Cottage, Harriet Street, Burnley, Lancs., U.K.	10.20	"	"
Van Hasselt, Carel H. (Dr.), 26 Wexford Avenue, Westcliff, Johannesburg	100.52	"	5.10.73
Walters, Leonard J., 21 Graham Avenue, Te Atatu, Auckland, N.Z. . .	34.00	"	"
West, Michael F., Canney Cottage, Chiseldon, Nr. Swindon, Wilts., U.K.	24.48	"	28.3.73
Whitaker, Arthur, 14 Cranford Lodge, 80 Victoria Drive, Wimbledon, London, S.W.19	17.00	"	"
Wiltshire, John, The Roundel, Frittenden, Kent, U.K.	16.32	"	5.10.73
Zaccagni, Signor Gherardo, Via Dei Massoni, 31/33 50139 Florence, Italy	56.00	"	"
Zwarthoed, John, Leliestraat 16, Amersfoort, Holland	11.20	"	28.3.73
Abramovich, Hyman (estate of), c/o B. C. Harris and White, 124/6 Beamish Street, Campsie, N.S.W.	56.00	"	28.3.73
Allan, John A. J. (estate of), c/o Burns Philp Trustee Co., 51 Pitt Street, Sydney, N.S.W.	56.00	"	"
Beer, Geoffrey N. (estate of), c/o J. Stuart Thom and Co., 57 York Street, Sydney, N.S.W.	16.00	"	"
Berry, Basil C. (estate of), c/o Creese Crisp and Crisp, G.P.O. Box 557F, Hobart, Tas.	20.00	"	5.10.73
Boyd-Clark, Brear W. (estate of), c/o Matson Marshall and Butler, 61 Cambridge Terrace, Christchurch, N.Z.	38.40	"	28.3.73
Burman, Neville H., c/o Macdonnell Harris and Co., P.O. Box 1268, Cairns, Qld.	38.40	"	"
Butler, Marjorie T. (estate of), c/o Butler McIntyre and Butler, G.P.O. Box 980K, Hobart, Tas.	16.00	"	"
Campbell, Samuel H. (estate of), c/o Campbell Paton and Taylor, P.O. Box 103, Orange, N.S.W.	137.60	"	"
Clarke, Mary S. (estate of), c/o Power and Cartwright, 239 Mary Street, Gympie, Qld.	633.60	"	"
Cole, Gordon F. (estate of), c/o H. G. Levi and Mills, 7th Floor, 291 George Street, Sydney, N.S.W.	19.20	"	"
Collis, Thelma M. (Mrs.), c/o R. Thornton and Son, 185 Elizabeth Street, Sydney, N.S.W.	78.68	"	"
Cooper, Phyllis M. (estate of), c/o Yelland Shuster and Associates, G.P.O. Box 5048Y, Melbourne	828.08	"	"
Crabbe, Stanley E. (estate of), c/o F. J. Hacket, 42 Ardross Street, Applecross, W.A.	19.20	"	5.10.73
Creightmore, Maximilian L. (estate of), c/o Peat Marwick Mitchell and Co. G.P.O. Box A.29, Perth, W.A.	38.40	"	28.3.73
Dempster, Lennox V. (estate of), c/o Mayberry Hammond and Co. P.O. Box 267, Northam, W.A.	19.20	"	"
Densley, William P. (estate of), c/o Densley Downing and Sindler, 147 Castlereagh Street, Sydney, N.S.W.	19.20	"	"
Devitan, Anne (Mrs.), c/o Rishworth Dodd and Mencil, 9 Hunter Street, Sydney, N.S.W.	16.00	"	"
Duffy, James G. (estate of), c/o Walsh Fitzgerald and Hilton, G.P.O. Box 330, Brisbane, Qld.	96.00	"	"
Earnshaw, Herbert G. (estate of), c/o John W. B. Earnshaw, 32 Ascot Street, Ascot, Qld.	42.04	"	5.10.73
Emerson, Claude McK. (estate of), c/o Melville Orton and Lewis, P.O. Box 109, Hamilton	19.20	"	28.3.73
Fienberg, Dora (estate of), c/o B. J. Fienberg, c/o R. D. Meagher Kinley and Comans, 187 Macquarie Street, Sydney, N.S.W.	97.84	"	5.10.73
Fifield, Charles W. (estate of), c/o Mrs. B. U. Pindar, 21 Alan Street, Cammeray, N.S.W.	14.40	"	28.3.73
Focke, Hermann E. (estate of), c/o Swarbrick and Swarbrick, 18 Teasdale Street, Te Awamutu, N.Z.	16.00	"	"
Ford, Frank (estate of), c/o E. L. Vail and McBain, 555 Lonsdale Street, Melbourne	16.00	"	"
Fricke, Frederic T. T. (estate of), c/o Elders Trustee and Executors, Co. Ltd., G.P.O. Box 546, Adelaide, S.A.	2,854.16	"	5.10.73
Galagher, Emily I. (estate of), c/o J. H. Trotter and Co., 37 Queen Street, Melbourne	76.80	"	28.3.73
Godsell, Nancy (estate of), c/o N. E. Penman and Co., P.O. Box 151, Gosford, N.S.W.	19.20	"	"
Goodall, Charles H., c/o Frederick Owen and Associates, 84 William Street, Melbourne	19.20	"	"
Gorman, Albert S. (estate of), c/o J. B. and L. A. Mullen, P.O. Box 176, Goulburn, N.S.W.	399.52	"	"
Greaves, Henry C. (estate of), c/o Gaden, Bowen and Stewart, P.O. Box 63, Double Bay, N.S.W.	260.00	"	5.10.73
Greenfield, Sima (Mrs.), c/o Rockman Janover and Freedman, A.N.Z. Bank Chambers, 224 Queen Street, Melbourne	249.60	"	28.3.73
Gregory, John T. (estate of), c/o Turner Seaberry and Warford, P.O. Box 311, Eastland, Texas, 76448, U.S.A.	16.00	"	"
Hammond, Sydney M. (estate of), c/o Langley Twigg Doole Cowley and Co., P.O. Box 606, Napier, N.Z.	40.00	"	"
Hazell, Denis H. (estate of), c/o Mackintosh's Limited, P.O. Box 300, Hong Kong	16.00	"	"
Heyson, Colin (estate of), c/o Mrs. C. J. Jones, 43 Raglan Street, Tamworth, N.S.W.	40.00	"	"

Unclaimed Moneys Act 1962.

Register of Unclaimed Moneys held by the—

Name of Owner on Books and Last Known Address.	Total Amount Due to Owner.	Description of Unclaimed Moneys.	Date when Amount first became Payable.
§			
WESTERN MINING CORPORATION LIMITED—continued.			
Hogan, Thomas L. (estate of), c/o K. P. Rees, A.C.A. Building, 118 Queen Street, Melbourne	16.00	Dividend	28.3.73
Honniball, Gerald L. (estate of), c/o Muir Williams Nicholson and Co. G.P.O. Box U1942, Perth, W.A.	40.00	"	5.10.73
Hyson, Colin (estate of), c/o A. McIlveen, Goonoo Goonoo Road, Tamworth, N.S.W.	140.00	"	28.3.73
Jenkins, John C., Camden Ridge, Southill Road, Chislehurst, Kent, U.K.	120.00	"	"
Koschnick, Franz R. (estate of), c/o Douglas Bell Bell and Kerr, P.O. Box 41, Surfers Paradise, Qld.	80.00	"	"
Laurence, Kathleen J. (estate of), c/o Perpetual Trustee Co., 33/39 Hunter Street, Sydney	161.60	"	"
Lawton, Lois (estate of), c/o M. E. Lawton, 139 Payneham Road, St. Peters, S.A.	840.00	"	"
Leonard, Edward G. (Dr.), 43 Cotswold Close, Singapore, 13	57.60	"	"
Manning, Hugh E. (estate of), c/o Mrs. N. M. Manning, c/o T. G. D. Marshall Landers and Co., 251 George Street, Sydney, N.S.W.	80.00	"	5.10.73
Melegonis, Constantine (estate of), c/o Leslie R. Ross, P.O. Box 4, Chinchilla, Qld.	111.42	"	28.3.73
Moran, Annie M. (estate of), c/o R. F. Moran, 9 Neville Road, Dalkeith, W.A.	57.60	"	"
Morison, Henry N. (estate of), c/o L. G. Christie and Co., 99 Elizabeth Street, Sydney, N.S.W.	14.40	"	"
McMicking, Jean H. (estate of), c/o F. J. Stein and Co., P.O. Box 189, Goondiwindi, Qld.	53.76	"	"
Neate, Graeme R. (estate of), c/o S. W. Misson and Bartley, 59 Waverley Road, East Malvern	19.20	"	"
Oldham, Fulton S. W. (estate of), c/o Genders Wilson and Partners, G.P.O. Box 1593, M, Adelaide, S.A.	653.92	"	"
Oliver, William P. (estate of), c/o Shephard and Shephard, P.O. Box 409, Parramatta, N.S.W.	499.20	"	"
Parry, Thomas F. (estate of), c/o Lamb Goldsmith and Howard, 42 Castle Street, Liverpool, U.K.	60.00	"	5.10.73
Pavy, Allen W. (estate of), c/o Walker Gibbs and King, P.O. Box 8, Cooma, N.S.W.	38.40	"	28.3.73
Pick, Irene T. (Mrs.), P.O. Box 109, Caveton Park, Mount Gambier, S.A.	24.00	"	"
Porter, Grace L. (estate of), c/o Mayne Halloran and Kelly, 139 King Street, Sydney, N.S.W.	15.36	"	"
Prendergast, Elsie M. (estate of), c/o E. T. Layburn Hodgins and Rooney, P.O. Box 795, Christchurch, 1, N.Z.	26.88	"	"
Purves, Stanley S. B. (estate of), c/o Button Williams and Co., 66 Best Street, Devonport, Tas.	768.00	"	"
Rickards, George R. (estate of), c/o Miss R. L. Pattison, G.P.O. Box 812, Sydney, N.S.W.	38.40	"	"
Robertson, Mure R. (estate of), c/o Somerville Laundry Lomax and Stone, P.O. Box 26, Lismore, N.S.W.	40.00	"	"
Rushton, Ida P. (Mrs.); c/o F. C. Burges and O'Shea, P.O. Box 53, Stanthorpe, Qld.	19.20	"	"
Salmon, Walter J. (estate of), c/o John Cain and Peter Lamers, P.O. Box 133, Preston	57.60	"	"
Sladden, Edwin M. (estate of), c/o Atkinson Dale Ellingham and Jenkins, 170/186 Featherston Street, Wellington, N.Z.	32.00	"	"
Tankard, Cecil A. (estate of), c/o Henry A. Tankard, 15 Lyn Wood Avenue, Killara, N.S.W.	38.40	"	"
Taylor, John E. (estate of), c/o Stacey Smith Gibson and Holmes, P.O. Box 859, Wellington, N.Z.	24.00	"	"
Turner, Andrew R. (estate of), c/o Cannon and Peterson, G.P.O. Box 407, Brisbane, Qld.	19.20	"	"
Van Embden, Lydia, c/o Colin Keon-Cohen, 472 Bourke Street, Melbourne	96.00	"	"
Walker, Charles N. M. (estate of), c/o Stephen Jaques and Stephen, A.M.P. Building, Circular Quay, Sydney, N.S.W.	19.20	"	"
Walker, Rosemary (Mrs.) (address unknown)	80.00	"	"
Ward, Stuart H. (estate of), c/o C. Scott Waime and Mitchell, 57/59 York Street, Sydney, N.S.W.	38.40	"	"
Whitehead, Lesley (estate of), c/o National Trustees E. and A. Co., of A/asia. Ltd., 46 Queen Street, Bendigo	19.20	"	5.10.73
Whiting, David E. (estate of), c/o M/s. T. M. Whiting, 2, Second Avenue, East Kew	24.00	"	28.3.73
Wickens, Athol V., c/o 26 Clannel Road, Floreat Park, W.A.	192.00	"	"
Williams, Ethel A., c/o Booth Brown Samuels and Olney, P.O. Box 20, Dubbo, N.S.W.	192.00	"	"
Johnston, Donald, 178 Elizabeth Street, Sydney, N.S.W.	12.08	"	"

4007

AUSTRALIAN GLASS MANUFACTURERS COMPANY.

Kalambobis, A., 258 Albert Road, South Melbourne	29.76	Wages	15.8.73
Trpceviski, A., 8 Owens Street, Yarraville	95.05	"	"
Bertin, P., P.O. Box 17, Eastwood, Adelaide, S.A.	73.14	"	"
Krstevski, D., 166 Blackshaws Road, Altona North	28.49	"	11.9.73
Esse, D. J., 11 Leek Street, Yarraville	15.72	"	7.11.73

4266

Unclaimed Moneys Act 1962.

Register of Unclaimed Moneys held by the—

Name of Owner on Books and Last Known Address.	Total Amount Due to Owner.	Description of Unclaimed Moneys.	Date when Amount first became Payable.
5			
AUSTRALIAN MUTUAL PROVIDENT SOCIETY.			
Aldridge, E. J., 2 Hardisty Street, Wangaratta	100.00	Lapsed Policy	25.6.73
Atkins, E. M. (Mrs.) (address unknown)	11.00	Refund	1.11.73
Allison, K., 11 Avenue Road, Highgate, S.A.	26.76	"	"
Barnard, R. G., 13 Spencer Road, Campberwell	18.00	"	16.11.73
Bennison, F. D., 10 Fairs Avenue, Cronulla, N.S.W.	10.92	"	"
Bourke, D. (Dr.), P.O. Box 159, East Bentleigh	10.00	Group premium	13.6.73
Brear, W. J., 29 Barton Street, West Footscray	12.63	Surrendered	"
Brooks, R. L., 1/70 Grosvenor Street, Balaclava	72.81	Commission	30.12.73
Buckley, B. L., c/o Leighton Mining (address unknown)	66.66	"	26.6.73
Bulloch, J. A., Yaringa Hostel, F. 18, Whyalla, S.A.	200.00	Lapsed policy	"
Car, V. (address unknown)	22.75	"	"
Carr, K. A. (Dr.), 6 Charming Street, Moorabbin	67.85	Lapsed policy	10.12.73
Case, B. J. (Miss), Nurses Home, Church of Christ, Wahgoo Road, Murrumbena	30.00	Refund	19.9.73
Coleman, J. T., Riverslea, via Maffra	38.40	Maturity Claim	12.9.73
Cramer, A., 15 McKinley Avenue, Malvern	16.50	Tax Dept. Group	24.5.73
Cuming, K. J., 5/52 Grange Road, Toorak	85.00	"	23.7.73
Degoldi, R. L. (estate of) (address unknown)	28.80	Death Claim	19.4.73
Denton, A. (Miss), 229 Auburn Road, Hawthorn	19.95	Payment on new proposal	"
Dicker, S. P., c/o R. Lawford, Main Road, Bacchus Marsh	30.00	"	27.7.73
Djenan, M. (address unknown)	14.97	Withdrawn proposal	17.4.74
Duncan, H. M. (Miss), "Lady Bank", R. D. Arcadia	10.46	Refund	2.9.73
Duncan, R. J. (address unknown)	10.00	"	9.7.73
Engineering Appliances (Vic.) Pty. Ltd., 55 Northfolk Circuit, Doncaster	77.00	"	30.11.73
Credington, R. H., 1449 Anzac Parade, Little Bay, N.S.W.	63.00	"	19.10.73
Ertes, J. K. H., 1/54 Alexandra Street, East St. Kilda	41.07	"	4.1.74
Falovic, D., 4/27 Elm Grove, Ripponlea	20.67	Premium	"
Fiest, E. D. (address unknown)	13.65	Proposal withdrawn	26.3.74
Ferrari, M. A. (Mrs.), 14 Brown Street, East Geelong	17.11	"	"
Find, F. P., 134 Mitcham Road, Donvale	10.00	Refund	7.11.73
Finn, E. J., 7 Aberseen Street, Brunswick	11.50	"	23.5.73
Flynn, D. T., 253 Westgarth Street, Westgarth	22.96	State Accident Group	22.6.73
Fudge, I. R., c/o C. R. Bunbui, 489 St. Kilda Road, Elwood	17.25	Commission	31.6.73
Golding, D. H. (address unknown)	29.40	"	16.3.74
Graf, F. D., 14 Elgin Crescent, Park Orchards	21.20	Premium	"
Graham, R. J., c/o John Lysaght Aust. Ltd., Hastings	12.15	Overpayment	29.3.74
Greaves, I. A., c/o Alfred Hospital, Commercial Road, Prahran	10.00	"	18.5.73
Hanley, D. M., 243 Nicholson Street, Footscray	17.78	Refund	16.11.73
Hannan, D. P., 7/52 Palmer Street, Fitzroy	12.46	"	5.6.73
Harris, C. E., 56 Queens Avenue, Caulfield	139.38	"	27.3.74
Harrison, K. H., "Hopefield", Pyramid Hill	34.12	Refund	27.4.73
Hassett, D. J. J., 3 Kerry Parade, Box Hill	387.32	Commission	30.9.73
Heath, P. A., 7/32 Royal Avenue, Glen Huntly	10.00	Withdrawn Proposal	20.11.73
Jackman, A. M., 9/62 Edgar Street, North Glen Iris	10.00	Phillips Elec. Group	14.6.73
James, M. J., 409 Burwood Road, Hawthorn	30.00	Vic. Institute for Blind	14.6.73
Jamieson, S. E. (Mrs.), 3/62 Simpson Street, Bondi, N.S.W.	31.40	Refund	"
Jerram, B. (address unknown)	10.18	Premium	"
Johnston, Y. J. and P. A. L., 53 Auburn Street	28.19	Payment of Bus. proposals	"
Jones, I., Main Road, Tecoma	10.00	"	17.5.73
Keenan, J. C., 5/85 Pleasant Road, Hawthorn	17.30	Policy surrendered	13.8.74
Klaas, S., 2/10 Greenwood Avenue, Ringwood	15.00	Refund	"
Lanyon, R. A. (Mrs.), 6/1 Stanley Street, Arncliffe, N.S.W.	66.00	"	20.12.73
Leehy, B. P., 4/90 Dover Street, Flemington	158.79	"	"
Loh, B. L. (Mrs.), 31 Leura Street, Camperdown	25.44	"	28.3.74
Luxton, E. J., 2 Parkside Street, Malvern	11.80	"	28.9.73
Mallick, B. A., 2/517 Crisp Street, Albury	14.00	"	26.3.74
McAree, P., 3 Paul Street, Doncaster	24.72	"	18.5.73
McDonough, B. B. A., 36 Burton Street, Warragul	24.92	Refund	10.12.73
McWhinney, C. M., 34 Campbell Street, Frankston	13.42	"	30.5.73
Meldrum, R. K. J., 351 Mont Albert Road, Surrey Hills	135.29	"	7.3.74
Morrison, D. J., 14 Wild Street, Regent	100.00	"	"
Mouser, B. L., 63 Queen Street, Altona	67.50	Overpayments	17.12.71
O'Brien, E. J. (Mrs.), 68 Darebin Street, West Heidelberg	10.00	"	2.3.74
Parr, C. (address unknown)	33.13	Refund	2.4.73
Pereira, D. J. L., 17 Stanley Street, Glenroy	22.00	"	4.12.73
Pietnelli, K. E. (Mrs.), 6/55 Elm Grove, Ripponlea	21.00	"	25.10.73
Pleasant, J. L., 4/217 Buckley Street, Footscray	10.00	Refund	2.4.73
Puls, J. R. (Mrs.), c/o Southern Command Department of Defence, Victoria Barracks, Melbourne	58.52	Overpayment	23.4.74
Randell, S. A. (Mrs.), 3/60 Glenvale Road, Ringwood	20.00	Refund	"
Reisner, Y. I. (Miss), 21/1 Lumley Court, Prahran	10.00	"	3.12.73
Robdeyn (address unknown)	18.18	Policy Surrendered	"
Scott, D. G., 39 Summerhill Road, Footscray	20.42	Refund	18.5.73
Thompson, M. J. (Mrs.), 3/101 Lucerne Crescent, Alphington	10.00	"	1.3.74
Walker, K. J., c/o Mayne Nickless Ltd., (address unknown)	36.30	"	3.8.73
Walker, R. C., 15 St. Elmo Road, Kingsgrove, N.S.W.	77.28	Proceeds	7.8.73
Ward, D., 10/65 Paxton Street, East Malvern	18.76	Commonwealth Bank Group	15.6.73
Warrnambool Chamber of Commerce (address unknown)	11.50	"	25.5.73
Wolff, J. E., Flat 15, 110 Wellington Street, St. Kilda	42.32	Lapsed Policy	17.10.74
Worthington, B. J., 2A Gladstone Street, Prahran	10.00	Premium	"

Unclaimed Moneys Act 1962.

Register of Unclaimed Moneys held by the—

Name of Owner on Books and Last Known Address.	Total Amount Due to Owner.	Description of Unclaimed Moneys.	Date when Amount first became Payable.
§			
COMALCO LIMITED.			
Anderson, L. J. and J. N. A. (Mrs.), "Marowrie" Piney Range, Grenfell, N.S.W.	15.00	Final Dividend	17.4.73
Gho, L. C., 57 Warburton Road, Canterbury	30.00	" " " " " " " "	" "
Isaacs, R. D., 128 Kyle Parade, Kyle Bay, N.S.W.	30.00	" " " " " " " "	" "
McKay, R. M., 17/2 Lindsay Street, Neutral Bay, N.S.W.	15.00	" " " " " " " "	" "
Neil, P. C., 3/100 Hotham Street, East Melbourne	12.00	" " " " " " " "	" "
Sadler, C., 21 Abbott Street, Cairns, Qld.	18.00	" " " " " " " "	" "
Watson-Brown, B., "Glenrock", Nerang, Qld.	30.00	" " " " " " " "	" "
Wilson, D. R., 4 Murray Island, Sylvania, N.S.W.	37.68	" " " " " " " "	" "
Agwar, Pty. Ltd., 36 Howard Street, Nailsworth, S.A.	13.75	Interim Dividend	16.10.73
Anderson, J. E. and H. (Mrs.), P.O. Box 179, George Town, Tas.	19.55	" " " " " " " "	" "
Anderson, L. J. and J. N. (Mrs.), "Marowrie", Piney Range, Grenfell, N.S.W.	13.75	" " " " " " " "	" "
Berlyn, J. E. (Ms.), 6 Nenagh Street, Manly North, N.S.W.	11.00	" " " " " " " "	" "
Fortier, R. A. and J. P. (Mrs.), 19 Pershouse Street, Gladstone, Qld.	12.38	" " " " " " " "	" "
Gho, L. C., 57 Warburton Road, Canterbury	27.50	" " " " " " " "	" "
Hayles, E. R., 22 Upper Denham Street, Townsville, Qld.	15.48	" " " " " " " "	" "
Hodges, A. M., 66 Rifle Range Road, Gympie, Qld.	33.00	" " " " " " " "	" "
Horys, O. (Miss), 31 Montgomery Avenue, Argenton, N.S.W.	25.38	" " " " " " " "	" "
McKay, R. M., 17/2 Lindsay Street, Neutral Bay, N.S.W.	13.75	" " " " " " " "	" "
Neil, P. C., 3/100 Hotham Street, East Melbourne	11.00	" " " " " " " "	" "
Roberts, G. G., c/o Bechtel-Wke, P.O. Box 12, Kieta, Bougainville, PNG	13.75	" " " " " " " "	" "
Serle, R. G., Central Engineering Services, Weipa, Qld.	13.75	" " " " " " " "	" "
St. Pierre, V. (Mrs.), 23 Esplanade, Gladstone, Qld.	27.50	" " " " " " " "	" "
Tucker, P. C., 12 Pershouse Street, Gladstone, Qld.	34.38	" " " " " " " "	" "
Wallena Pty. Ltd., G.P.O. Box 498H, Melbourne	55.00	" " " " " " " "	" "
4008			
BH SOUTH LIMITED.			
<i>Victorian Register</i>			
Acock, Kenneth W., Gleneagles Road, Mount Osmond, S.A.	12.50	Dividend	30.11.73
Blazey, Penelope J. (Mrs.), 196 Cecil Street, South Melbourne	18.75	" " " " " " " "	8.6.73
Bluck, Russel G., c/o P.O. Box 57, St. Marys, S.A.	20.60	" " " " " " " "	30.11.73
Bullock, Elizabeth (Mrs.), 27 Bourke Street, Mentone	25.00	" " " " " " " "	" "
Bullock, John R., 27 Bourke Street, Mentone	15.60	" " " " " " " "	" "
Carruthers, Donald B. L., 6/249 New Street, Brighton	25.00	" " " " " " " "	" "
Ebbinghaus, Lothar, 136 Swan Street, Richmond	10.00	" " " " " " " "	" "
Gentle, Lindsay V., c/o Cominco Exploration Pty. Ltd., 8 Greenhill Road, Wayville, S.A.	18.10	" " " " " " " "	" "
Gilbert, Adeline M. (estate of), c/o C. T. Gilbert, 34 Queen Street, Melbourne	160.00	" " " " " " " "	8.6.73
Hill, Charles P., View Street, Midway Point, Tas.	74.96	" " " " " " " "	" "
Hitch, Jean E. (Ms.), "Cleve", Kerrie, Via Romsey	15.00	" " " " " " " "	30.11.73
Lough, John C. Jnr., 49 Manning Road, Double Bay, N.S.W.	60.00	" " " " " " " "	8.6.73
McCurtin, Michael (Rev.), c/o Commonwealth Trading Bank of Australia, G.P.O., Box 1551, Adelaide, S.A.	18.75	" " " " " " " "	30.11.73
Newell, Jack, 19 Cross Road, Cronulla, N.S.W.	18.75	" " " " " " " "	" "
Page, Jessica B. (Miss), 18 Lovering Place, Newport Beach, N.S.W.	12.50	" " " " " " " "	" "
Penny, Peter J., Padthaway, S.A.	10.00	" " " " " " " "	" "
Sangster, Ina L. (Mrs.), 142 Seaview Road, Tennyson, S.A.	16.86	" " " " " " " "	8.6.73
Shiphon, William (address unknown)	64.00	" " " " " " " "	" "
Wronski, Charles H., 5/52 William Street, Balaclava	40.00	" " " " " " " "	" "
<i>New South Wales</i>			
Barrington, Marie T. (Mrs.), 24 Wolsley Road, Coogee, N.S.W.	12.50	" " " " " " " "	30.11.73
Bluck, Russell G., c/o P.O. Box 57, St. Marys S.A.	15.00	" " " " " " " "	" "
Davies, Christopher B., c/o E. M. Davies, 91 Bourke Street, Wagga Wagga, N.S.W.	15.00	" " " " " " " "	" "
Docking, Patricia L. (Mrs.), 46 Morgan Street, Broken Hill, N.S.W.	10.00	" " " " " " " "	" "
Duncan, Francis and Joan C. (Mrs.), Arthur Street, Walgett, N.S.W.	12.00	" " " " " " " "	8.6.73
Ferguson, Lisa L. (Miss), c/o J. Ferguson, P.O. Box 174, Avalon Beech N.S.W.	10.00	" " " " " " " "	30.11.73
McArthur, Dorise E. (Mrs.), 5/16 Francis Street, Bondi, N.S.W.	20.00	" " " " " " " "	" "
McGuinness, Cecily J. (Mrs.), Bigga House, Bigga, N.S.W.	12.50	" " " " " " " "	30.11.73
Thompson, Edward L., 111 Victoria Street, Potts Point, N.S.W.	12.50	" " " " " " " "	" "
Williams, Bessie M. (estate of), c/o C. J. Williams, 31 Woodlawn Avenue Mangerton, N.S.W.	90.00	" " " " " " " "	8.6.73
<i>Queensland</i>			
Ramm, Robert A., P.O. Box 32, Aitkenvale, Q.	10.00	" " " " " " " "	30.11.73
Steele, Raymond B., "Yapunyah", Eromangu, Q.	10.00	" " " " " " " "	" "
<i>Victoria—overseas</i>			
Kirton, Paul K., 32 Hesper Mews, London, England	85.01	" " " " " " " "	8.6.73
Sea Going Maintenance (World-Wide) Limited, P.O. Box N-306, Nassau, Bahamas	10.50	" " " " " " " "	8.6.73
Wah, Tan C., c/o Gammon South East Asia, P.O. Box 2308, Brunei Town, Brunei	13.13	" " " " " " " "	30.11.73
<i>New South Wales—overseas</i>			
Kinabatangan Development Co. Ltd., P.O. Box 887, Sandakan, Sabah, East Malaysia	87.50	" " " " " " " "	" "
Lampson, Melita A. Mrs., 12 Westmoreland, Terrace, London, U.K.	51.00	" " " " " " " "	" "
Seow, Imm H. (Miss), c/o Cold Storage Creameries, 186 Orchard Road, Singapore	85.01	" " " " " " " "	8.6.73

Unclaimed Moneys Act 1962.

Register of Unclaimed Moneys held by the—

Name of Owner on Books and Last Known Address.	Total Amount Due to Owner.	Description of Unclaimed Moneys.	Date when Amount first became Payable.
\$			
BH SOUTH LIMITED—continued.			
<i>Victoria—New Zealand</i>			
Chaytor, Anthony D. C., Chaytors Road, Marshlands, Blenheim, N.Z.	108.80	Dividend	8.6.73
Coxhead, Beatrice M., (Mrs.), c/o Messrs, Tait and Coxhead, 1 Stafford Street, Dunedin, N.Z.	19.89	"	30.11.73
Little, Archibald, Patons Road, Hope, Nelson, N.Z.	34.00	"	8.6.73
<i>New South Wales—New Zealand</i>			
Calvert, Jennifer M. (Miss), Parker Road, R.D., Oratia, Auckland, N.Z.	10.63	"	30.11.73
<i>Australian Registers</i>			
Anderson, Margaret C. (Dr.), c/o Division of Environmental Mechanics, C.S.I.R.O., P.O. Box 821, Canberra City, A.C.T.	56.35	Forfeited Share Sale	24.5.73
Bailey, Peter G. C., 18 Tizard Road, Birkenhead, Auckland, N.Z. ..	11.87	"	"
Bean, Terry, 12/1 Western Crescent, Gladesville, N.S.W.	831.73	"	"
Burke, John V., 7 Fortunatus Street, Brooklyn, Wellington, N.Z. ..	27.05	"	"
Carpenter, John R., 23 Trigalana Place, Frenchs Forest, N.S.W. ..	56.35	"	"
Chaytor, Anthony D. C., Chaytors Road, Marshlands, R.D.3, Blenheim, N.Z.	890.10	"	"
Coy, Charles F., 11 Bakers Road, South Oakleigh, V.	31.56	"	"
Dossett, William S., "Loloma", Cabbage Tree Lane, Bayview, N.S.W.	43.70	"	"
Franklin, Kay N. (Mrs.), 1/310 West Street, Crows Nest, N.S.W.	24.73	"	"
Hudson, Martin M., 63 Kensington Road, South Yarra, V.	83.40	"	"
Inglis, Raymond W., 75 Piper Street, Leichhardt, N.S.W.	11.87	"	"
Lavin, John J., 153 Howes Crescent, Dianella, W.A.	20.98	"	"
Love, James B., G.P.O. Box 3093, Sydney, N.S.W.	98.90	"	"
Lynch Neville D., 1/21 Northcliff Street, Milsons Point, N.S.W. ..	56.35	"	"
MacGibbon, Bruce R., 4/8 Edgerley Avenue, Auckland, 1 N.Z. ..	68.77	"	"
McGuire, Andrew J., 24 Ebor Street, Toowong, Q.	20.98	"	"
McKenzie-Murray, Gregory, 8/39 The Esplanade, South Perth, W. A.	56.35	"	"
Newell, Jack, 19 Cross Road, Cronulla, N.S.W.	162.56	"	"
Newell, Jack A., 19 Cross Road, Cronulla, N.S.W.	40.20	"	"
Panaretos, Tony and Helen (Mrs.), 137 Talbragar Street, Dubbo, N.S.W.	74.75	"	"
Rekaris, Stavros and Georgia (Mrs.), 285 Bell Street, West Coburg, V. ..	56.35	"	"
Rogers, Margaret H. (Mrs.), P.O. Box 109, Nedlands, W.A.	29.30	"	"
Seow, Imm H. (Miss), c/o Cold Storage Creameries, 186 Orchard Road, Singapore, 9	703.25	"	"
Stephenson, Gary G., 36 Marland Street, Kenmore, Q.	24.73	"	"
Ward, Christopher D., c/o Newmont Pty. Ltd., 535 Bourke Street, Melbourne	20.98	"	"
<i>London Register</i>			
Bhimjiyani, Anil, 57 Princes Square, London, W2, England	11.87	"	"
Boyd, Keith Tudor, The Old Manor, Flore, Northampton, England ..	103.68	"	"
Briggs, James S. N. (Dr), Court House, Caerphilly, Glamorgan, Wales	27.05	"	"
Forrest, Sean, 55 Our Lady's Place, Noas, Kildare, Eire	11.27	"	"
King, Faith P. (Mrs.), Ballajeroi, St. Marks, Isle of Man	19.23	"	"
Li, Arthur, 47 Augustus Road, Wimbledon, London, S.W.19, England	112.70	"	"
McAtee, Thaddeus K. A., c/o John Harle, Ballyduff, Lifford, Donegal, Eire	131.10	"	"
Moss, Ruby (Mrs.), Flat 39, Newton Court, Oakwood, Grange Leeds, U.K.	152.08	"	"
Styles, Francis L. B., 46 Grove Road, Strood, Kent, England	27.05	"	"
Pemberton-Billing, Robin N., 122 Chorley New Road, Bolton, Lancashire	10.49	Dividend	30.11.73
Clarke, Peter G. W., 'Cathanger', Fivehead, Taunton, Somerset ..	11.04	"	"
Dwyer, Denys A. L. and Anor., 18 The Vale, Chelsea, London, S.W.3	11.04	"	"
Higgins, Fergus and Others, Treadwell House, Epsom, Surrey ..	13.53	"	8.6.73
Linnett, Rae E. (Mrs.), The Master Lodge, Sidney Sussex College, Cambridge	15.73	"	"
Macdonald, Alastair, Woodend House, Rouken Glen Road, Giffnock, Glasgow	16.80	"	"
Turner, Patrick J., 68 Newstead Road, Southbourne, Bournemouth, Hants.	16.80	"	"
Murray, Janet (Mrs.), Heidelberg 29, Ardilea, Dublin 14, Ireland ..	16.80	"	"
Rogers, John, 11 Hamilton Avenue, Harborne, Birmingham 17	11.04	"	30.11.73
4009			
SOVEREIGN HOTELS PTY. LIMITED.			
Cleary, R., 24 Westmore Street, Hampton	18.80	Wages	30.6.74
Brown, M., 102 Gower Street, Preston	55.40	"	23.2.75
Ellis, J., 20 Stonehaven Avenue, Kew	11.60	"	1.4.75
Griffin, G., 133 Tucker Road, Bentleigh	14.66	"	30.6.74
Day, A., 11 Beatrice Street, Burwood	22.30	"	"
Blackwell, B., 5/9 Dover Street, Armadale	35.25	"	"
Fyfe, G., (address unknown)	23.10	"	26.5.74
Elton, G., 15 Davis Street, Carlton	13.30	"	26.5.74
Sullivan, R., (address unknown)	16.70	"	30.6.74
Turner, N. (address unknown)	21.40	"	27.10.74
Chateris, G., 39 Epsom Road, Ascot Vale	19.30	"	21.7.74
Hayes, M., 7/12 Fletcher Street, Essendon	10.80	"	20.10.74
4399.			
BRAMBLES INDUSTRIES LIMITED.			
Young, John, G.P.O. Box 5, Mt. Isa, Qld.	11.62	Dividend	13.4.73
4400			

Unclaimed Moneys Act 1962.

Register of Unclaimed Moneys held by the—

Name of Owner on Books and Last Known Address.	Total Amount Due to Owner.	Description of Unclaimed Moneys.	Date when Amount first became Payable.
J. C. WILLIAMSON THEATRES LTD.			
Smith, V., (address unknown)	17.52	Salary	23.5.74
Dufton, E., 4/63 Denham Street, Hawthorn	14.01	"	27.6.74
Erickson, D., (address unknown)	20.01	"	14.10.74
Roberts, R., (address unknown)	41.06	"	16.1.75
Smith, P., (address unknown)	14.04	"	"
Maxwell, I., (address unknown)	14.39	"	"
4540			
AUSTRALIAN FERTILIZERS LIMITED.			
<i>Melbourne Register.</i>			
Bainton, Russell J., Old Baerami, Baerami, N.S.W.	11.97	Dividend	—2.74
Cockrane, Harry C., Calimpa Siding, T.P.O. North West, N.S.W.	20.97	"	—2.73
Conway, John H., c/o Worungil Pastoral Co., Rosecroft, Glen Innes, N.S.W.	10.44	"	"
Crothers, Robert J., Rangers Valley, Glen Innes, N.S.W.	42.93	"	—2.74
Hawke, Clarence G., 16A Mitchell Road, Rose Bay, N.S.W.	16.74	"	—2.73
Jamiesons (Aust.) Pty. Ltd., P.O. Box 66, Newport Beach, N.S.W.	11.97	"	—2.74
Kater, William H., Airlie, Bendemeer, N.S.W.	11.97	"	"
Kilquade Investments Pty. Ltd., c/o Mrs. M. Hewson, 94 Jervois Street, Deakin, A.C.T.	70.02	"	"
Price, Glenda C., Ashton, Warialda, N.S.W.	16.02	"	"
Rees, John L., Dry Plains, via Cooma, N.S.W.	13.41	"	—2.73
Smith, William B., P.O. Box 30, Barmedman, N.S.W.	14.40	"	—2.74
Tamsett, Edward C., R.M.B. 1000, Grenfell Road, Young, N.S.W.	26.82	"	"
<i>Sydney Register.</i>			
Bobbiwaa Pty. Ltd., Suite 34, 133 Pitt Street, Sydney, N.S.W.	358.29	"	"
Howard, Elsa D., 38 Ellery Parade, Seaforth, N.S.W.	11.97	"	"
4541			
COSTAIN AUSTRALIA LIMITED.			
Campbell, Robert J. D., 398 Belmore Street, North Box Hill	15.00	Dividend	30.5.73
Rollo, Diana J. (The Hon. Mrs.), 6 Liverpool Street, Rose Bay, N.S.W.	12.00	"	"
Swinden, Daniel C., 40 Liverpool Street, Rose Bay, N.S.W.	12.00	"	"
Swinden, Katharine M. (Mrs.), 40 Liverpool Street, Rose Bay, N.S.W.	12.00	"	"
Montro Holdings Pty. Ltd., 9/21 Kensington Road, South Yarra	15.00	"	30.11.73
Bowdler, John D., 2 Cherry Street, Turrumurra, N.S.W.	15.00	"	"
4542			
BOUGAINVILLE MINING LIMITED.			
Andersen, H. (Mrs.), P.O. Box 179, George Town, Tas.	38.32	Dividend	23.11.73
Ash, M. E. M. S. (Mrs.), 4 Marathon Avenue, Darling Point, N.S.W.	61.95	"	"
Austin, R. P., 1 Francis Street, Bedford Park, S.A.	12.77	"	"
Black, B. J., c/o Ces, Tom Price, W.A.	22.35	"	"
Cambond Pty. Ltd., 11 Bath Road, Burwood	12.77	"	"
Cressie, A. M. (Miss), P.O. Box 21, Dampier, W.A.	12.77	"	"
Falconer, P. D., 41 View Street, Mont Albert	12.77	"	"
Grant, B. J. S. (estate of), c/o Perpetual Trustees, G.P.O. Box 4172, Sydney, N.S.W.	43.20	"	"
Hans, T. O. W., c/o Crae, 295 Hay Street, Kalgoorlie, W.A.	22.35	"	"
Harju, A., 28 Swinden Street, Downer, A.C.T.	12.77	"	"
Henderson, G. S. (Dr.), 11 Milton Street, (c/o Mrs. E. J. Dalgarno), Heathmont	12.77	"	"
Hill, E. R. (Mrs.), 1 Short Street, Mudgee, N.S.W.	17.14	"	"
Hylton, J., P.O. Box 240, Broken Hill, N.S.W.	25.95	"	"
Mathers, R. G., P.O. Box 163, Tom Price, W.A.	22.35	"	"
McMahon, L. K. (Mrs.), Flat D9, Hill Road, Dampier, W.A.	12.77	"	"
Medling, L. M. (Mrs.), 65 Hamersley Toad, Subiaco, W.A.	12.77	"	"
Merlo, K. G., c/o Hamersley Iron Pty. Ltd., Dampier, W.A.	22.35	"	"
Russell, G. C. (Mrs.), 15 Haverback Avenue, Malvern	23.26	"	"
Stack, J. F. and M. J. (Mrs.), P.O. Box 176, Tennant Creek, N.T.	12.77	"	"
Street, B. A. (Mrs.), 104 Murchison Crescent, Dampier, W.A.	47.90	"	"
Tymms, M. M. (Mrs.), Flat C3, 120 Arden Street, North Melbourne	31.93	"	"
Wellington, M. J. (Mrs.), 9 Church Street, Highgate, S.A.	12.77	"	"
Williams, E. R., 22 Salsbury Street, Subiaco, W.A.	19.16	"	"
Williamson, R. J., 57 Whaleback Avenue, Paraburadoo, W.A.	22.35	"	"
Woonsam, M. F. and L. J. (Mrs.), 221 Frangipani Street, Tom Price, W.A.	22.35	"	"
Wright, D., c/o Ces, Paraburadoo, W.A.	22.35	"	"
Gardner, G. L. (Mrs.), 1528 Willington Avenue, N. Burnaby, BC V5C 5H8, Canada	172.69	"	"
Nassim, L. A., c/o Barclays Bank Ltd., Melbury Court, 276 Kensington High Street, London, W8, U.K.	43.77	"	"
Crohmann R., P.O. Box 6180, Te Aro, Wellington, N.Z.	12.53	"	"
<i>U.K. Register.</i>			
Black, B. J. (Mrs.), Linden House, 36 Tomline Road, Felixstowe, Suffolk	11.00	"	"
Blois, M.-L. (Lady), c/o National Westminster Bank Ltd., 22 George Street, Richmond, Surrey	27.63	"	"
Cash, G. (Mrs.), 35 Portman Square, George Street, London, W.1	17.33	"	"
Coates, J. C., 68 Broadoak Road, Ashton-under-Lyne, Lancashire	43.18	"	"
Curzon, J., Lockington Hall, Derby	138.15	"	"
De Paravicini, F. F., c/o Barclays Bank Ltd., 82 Finsbury Pavement, London, E.C.2.	14.46	"	"

Unclaimed Moneys Act 1962.

Register of Unclaimed Moneys held by the—

Name of Owner on Books and Last Known Address.	Total Amount Due to Owner.	Description of Unclaimed Moneys.	Date when Amount first became Payable.
\$			
BOUGAINVILLE MINING LIMITED—continued.			
Dodd, P., c/o National Westminster Bank Ltd., 249 Regent Street, London, W.1.	20.72	Dividend	23.11.73
Duff, S. E., Treelands, Aylmerton, Norwich, Norfolk	14.01	"	"
Firebrace, A. G., 3/5 Royal Avenue, London, S.W.3.	13.15	"	"
Geddes, L. S., 51 Silverknowes Hill, Edinburgh, EH4 5HD.	14.40	"	"
Groves, J. J. D. (Lt. Col.) and MacNaghten, c/o Lloyds Bank Ltd., 6 Pall Mall, London, S.W.1.	33.16	"	"
Grut, D. R. (Mrs.), Sycamore End, Oak Lane, Sevenoaks, Kent	17.27	"	"
Hanscomb J. M. (estate of), (address unknown)	28.78	"	"
Lloyd, B. C. J., Kentings, 80 Brattle Wood, Sevenoaks, Kent	28.78	"	"
MacGill, A. G., Glen Almond, Bowes Rigg, Stewarton, Ayrshire	11.99	"	"
Meyerhoff, R., 4 Cambridge Gate, Regents Park, London, N.W.1.	17.79	"	"
Milne, A. G., c/o Barclays Bank Ltd., 5 High Road, Willesden, London, N.W.10.	15.77	"	"
Mining and Industrial Holdings Ltd., 49 Moorgate, London, EC2R 6BQ	23.63	"	"
Monckton, G. H., 197 The Fairway, Ruislip, Middlesex	22.77	"	"
Paine, L. G., Morters, Blewbury, Berkshire	86.34	"	"
Palmer R. H. (Lt. Col.), Peasmore Manor, Newbury, Berkshire	26.95	"	"
Pettigrew, K. (Miss), Merse End, Rockcliffs, Dalbeattie, Kircudbrightshire	11.51	"	"
Rennie, R. (Mrs.), 41 Falcon Gardens, Edinburgh	17.91	"	"
Reynolds, R. N., Hillcote, Wetstone Lane, West Kirby, Cheshire	57.56	"	"
Sanders, M. D. (Mrs.), St. Thomas, Rathfranam, Co. Dublin, Eire	14.77	"	"
Speight, I. B., 42 Welholme Avenue, Grimsby, Lancashire	20.15	"	"
Strachan, F. A., Craighend, Westfield, Newcastle-upon-Tyne	57.56	"	"
Thompson, J. L. C., c/o R. J. R. French, 50 Dame Street, Dublin 2, Eire	20.51	"	"
Thompson, L., Sullom End, Barnacre, Garstang, Preston, Lancashire	16.12	"	"
Vale, F. M. (Miss), 92 Palmerston Road, Buckhurst Hill, Essex	28.78	"	"
West, G., Springfield, The Cast, Lasswade, EH18, 1EB	22.23	"	"
4543			
LUSTRE JEWELLERY LIMITED.			
Chandler, Victor E., Little Yarra Road, Gladysdale	27.50	Dividend	7.11.73
Haines, Kathleen M. (Mrs.), "Chevron", St. Kilda Road, Melbourne	13.75	"	"
4544			
HUYCK AUSTRALIA PTY. LTD.			
Nielsen, Susan Mary, 11 Theau Street, East Geelong	19.68	Wages	15.5.73
Lindsay, Jenny, 104 Queenscliff Road, Newcomb	40.69	"	17.7.73
Webster, Ruth, 41 Plantation Road, Corio	13.79	"	10.7.73
Silberg, Robert, 34 Torquay Road, East Belmont	41.30	"	"
West, Joan, 86 St. Albans Road, East Geelong	39.40	"	26.2.74
Casper, Phillip Martin, c/o Forrest P.O.	13.50	"	"
4545			
FOREST DEVELOPMENTS AUSTRALIA LTD.			
\$			
Gay, Ritar (Miss), 19 Adams Street, Scarborough, Qld.	11.25	Dividend	9.4.73
McKenzie, Angus H. (estate of), c/o R. W. Thompson, Norrie and Co., P.O. Box 9, Maitland, N.S.W.	56.25	"	"
Parry, Peter D 5., Olympic Court, Railway Street, New Lambton, N.S.W.	31.28	"	"
4402			
SIDDONS PTY. LTD.			
Aidonidis, K., 198 Bell Street, Coburg	17.70	Wages	11.7.73
Stanic, E., 13 Dare Street, Coburg	15.50	"	"
Dunstan, H., Flat 6, 292 Greensborough Road, Watsonia	22.40	"	9.10.73
Lewis, J., 9 Moodie Street, Watsonia	44.80	"	"
4403			
J. GADSDEN AUSTRALIA LIMITED.			
Bainbridge, Agatha, 2 Robertson Street, Toorak	24.00	Dividend	6.11.73
McLean, Albert Peter, 623 Collins Street, Melbourne	53.10	"	"
Taylor, Alice Evelyn, Unit 2, 68 Rose Street, Armadale	24.00	"	7.5.73
Williams, J. H. (estate of), c/o J. D. Williams, 11 Kingston Street, Hampton	162.00	"	6.11.73
Barbour, Nancy Leighton, 3/414 Wattletree Road, East Malvern	37.50	Interest	30.4.73
McIntosh, Ian James, c/o Mrs. S. D. Dixon, Flat 4/31 Kinkora Road, Hawthorn	31.00	"	31.10.73
Barbour, Nancy Leighton, 3/414 Wattletree Road, East Malvern	500.00	Unsecured Notes.	31.10.73
4404			
KODAK (AUSTRALASIA) PTY. LTD.			
Stone, R., Flat 1, 367 Balacava Road, Caulfield East	11.06	Refund	8.6.73
Miller, B. W. R., Wandara-Yarrabend Road, Eltham	12.00	"	27.6.73
Healey, D. M. 265 Elizabeth Street, Coburg,	31.06	Wages	9.8.73
Storey, O., C/- Caravan Park, Elizabeth Street, Coburg	51.09	"	16.8.73
Jackway, B. M., 6 Young Street, Oakleigh	25.80	"	14.12.73
Carroll, B., 125 Derby Street, Pascoe Vale	159.20	"	"
4405			

*Companies Act 1961.***JAMES PARKER & ASSOCIATES PROPRIETARY LIMITED (IN VOLUNTARY LIQUIDATION).****NOTICE CONVENING FINAL MEETING OF MEMBERS, PURSUANT TO SECTION 272.**

Notice is hereby given in pursuance of Section 272 of the *Companies Act 1961*, that a General Meeting of the Members of the abovenamed Company, will be held on the 24th June, 1975 at 11.00 a.m. at the office of Hughes, Fincher & Rodda 343 Little Collins Street, Melbourne, for the purpose of having an account laid before them showing the manner in which the winding up has been conducted and the property of the Company disposed of, and hearing any explanations that may be given by the Liquidator.

Dated this 13th day of May, 1975.

N. HARRIS, Liquidator.

Hughes, Fincher & Rodda, Chartered Accountants, 343 Little Collins Street, MELBOURNE, Vic. 3000. 5183

In the matter of the *Companies Act 1961* and in the matter of R. G. LONG & Co. PTY. LTD. (IN LIQUIDATION).

Notice is hereby given that pursuant to Section 272 of the *Companies Act 1961*, the final meeting of the members and creditors of the Company will be held at 72 Queen Street, Bendigo, on the 20th day of June, 1975, at 5.00 p.m., for the purpose of laying before the meeting the account of the winding up and any explanation thereof.

Dated this 13th day of May, 1975.

R. G. LONG, Liquidator.

R. G. Long & Co. Pty. Ltd. (in Liquidation). 5115

BERNARD ABBOTT PTY. LTD. (IN VOLUNTARY LIQUIDATION).**NOTICE OF FINAL MEETING.**

Notice is hereby given pursuant to Section 272 of the *Companies Act 1961* that a Final Meeting of the Company will be held at the office of the Liquidator, J. K. Bee, Ground Floor, 140 Flinders Street, Melbourne on the 12th June 1975 at 10 a.m. for the purpose of having an account laid before it showing how the winding up of the Company has been conducted, the property of the Company disposed of, and giving any explanation required thereof.

Dated this 8th day of May, 1975.

5116 J. K. BEE, Liquidator.

*The Companies Act 1961.***BLACKNEYS FROZEN FOODS PTY. LTD. (IN VOLUNTARY LIQUIDATION).****NOTICE OF INTENTION TO DECLARE A SECOND DIVIDEND.**

NOTICE is hereby given that a SECOND DIVIDEND is about to be declared in the above matter.

Any creditor who has not lodged a Proof of Debt in the prescribed form by the 6th day of June 1975 may be excluded from the dividend.

Dated at Geelong this 16th day of May, 1975.

GLYN JENKINS, Liquidator.

Day, Neilson, Jenkins & Johns, 199-203 Moorabool Street, Geelong, Victoria, 3220. 5118

*Companies Act 1961.***P.P. INTERNATIONAL SALES & CO. PTY. LTD.****NOTICE OF MEETING OF CREDITORS.**

NOTICE is hereby given that a meeting of creditors of the abovenamed Company will be held at The Australian Society of Accountants, 49 Exhibition Street, Melbourne on the 29th day of May, 1975 at 10 o'clock in the forenoon, the Company having convened a meeting of its members for the same day for the purpose of considering a resolution that the Company be wound up voluntarily.

Dated this 12th day of May, 1975.

PETER VON SCHASSEN, Director.

T. D. Maclean & Company, Suite 3, 545 St. Kilda Road, Melbourne, Victoria, 3004. Telephone 51 1207. 5119

*Companies Act 1961.***A. GOLD ACCEPTANCE PROPRIETARY LIMITED (IN VOLUNTARY LIQUIDATION).****NOTICE CONVENING FINAL MEETING OF MEMBERS, PURSUANT TO SECTION 272.**

NOTICE is hereby given in pursuance of Section 272 of the *Companies Act 1961*, that a Meeting of the members of the above-named Company will be held on Wednesday the

twenty fifth day of June 1975 at the office of Messrs. John Rezak and Co., 66-68 Albert Road, South Melbourne, at 10.00 a.m. for the purpose of having an account laid before them showing the manner in which the winding up has been conducted and the property of the Company disposed of and of hearing any explanations that may be given by the Liquidator.

Dated this 12th day of May, 1975.

DAVID BENDEL, Liquidator.

John Rezak & Co., Public Accountants, 66-68 Albert Road, South Melbourne, 3205. 5121

A. & M. REED PTY. LTD. (UNDER OFFICIAL MANAGEMENT).**NOTICE OF MEETING.**

Notice is hereby given, pursuant to Section 212 of the *Companies Act 1961* that a General Meeting of the members and creditors of the above company will be held at the office of L. Patison & Partners, 48 Victoria Street, Warragul on Wednesday 28th May, 1975 at 12.30 p.m.

PURPOSE OF MEETING.

1. To consider the report of the Official Manager.
2. Explanations as required and requested.
3. Release of Official Manager.

This meeting is required under the *Companies Act* to formalise the completion of the Official Management of the company as set out in my attached report.

GORDON GILL, Official Manager, 48 Victoria Street, Warragul.

REPORT BY OFFICIAL MANAGER.

I hereby present my final report as Official Manager of A. & M. Reed Pty. Ltd., in accordance with requirements of Section 212 of the *Companies Act 1961*.

At the date of this report, both secured and unsecured creditors have been paid in full.

CONDUCT OF OFFICIAL MANAGEMENT.

At the time of my appointment in July 1971, the company owed the following amounts:—

Secured (Debenture Holder)	\$19,900
Unsecured Creditors (in accordance with proof of debts)	135,927
Unsecured Creditors—Loans from Shareholders	18,866
These amounts have been paid as per the following schedule:—	

Secured Creditor—Paid in full March 1972.

Unsecured Creditors	
1972 Dividend of 15 cents in dollar	
1973	20 cents
1974	30 cents
1975	35 cents

Making a total of \$1.00

FUTURE TRADING.

The company has traded profitably during the entire period of management and has experienced firm and steady growth of sales and profits. The company has specialised in the school supply field and now trades mainly under the name of Landmark Educational Supplies.

It is the intention of directors as from June 1st, to transfer the activities of A. & M. Reed Pty. Ltd. to Landmark Educational Supplies Pty. Ltd. a company which has been formed for this purpose.

It is the opinion of both the Committee of Management and myself that the proposed new company will be soundly based and capable of operating successfully on a normal commercial basis.

Mr. M. J. Reed and Mr. R. J. Porch as directors of the new company have requested that I join the board and I have indicated my consent to join as a third director.

GENERAL.

I would like to thank the present members of the Committee of Management (Messrs. Barry Doling, Ted Dunstan and Roger Kerston) for their assistance and guidance during the past 4 years, together with Mr. Roy Farrell who resigned during the period of Official Management due to changed employment.

16th day of May, 1975.

GORDON GILL, Official Manager, Care of L. Patison & Partners, 48 Victoria Street, Warragul. 5211

Companies Act 1961.—In the matter of AUSTGAIN PTY. LTD.

NOTICE is hereby given that at a meeting of the members of the abovenamed company held on Monday, 12 May 1975, the following resolution was passed as a special resolution:

"That the company be wound up voluntarily and that Mr. Peter William Harvey of Messrs. Price Waterhouse & Co., Chartered Accountants, 447 Collins Street, Melbourne, be appointed Liquidator."

Creditors of the abovenamed company are required on or before the 9th day of June 1975 to prove their debts or claims and to establish any title they may have to priority by delivery or sending through the post to the liquidator at the undermentioned address an affidavit verifying their respective claims. In default, they will be excluded from the benefit of any distribution made before such claims are proved or such priority is established and from objecting to any such distribution.

NOTICE is given that pursuant to Section 272 of the Act the final meeting of the members of the company will be held at 377 Little Collins Street, Melbourne on Wednesday 25 June 1975 at 9.45 a.m. for the purpose of the liquidator laying before the meeting an account of the winding up and giving any explanation thereof.

Dated this 19th day of May, 1975.

P. W. HARVEY, Liquidator.

Price Waterhouse & Co., chartered accountants, 447 Collins Street, Melbourne. 5227

Companies Act 1961.—In the matter of COWAN AUSTRALIA FUND INCORPORATED.

NOTICE is hereby given that at a meeting of the members of the abovenamed company held on Monday, 12 May 1975, the following resolution was passed as a special resolution:

"That the company be wound up voluntarily and that Mr. Peter William Harvey of Messrs. Price Waterhouse & Co., Chartered Accountants, 447 Collins Street, Melbourne, be appointed Liquidators."

Creditors of the abovenamed company are required on or before the 9th day of June 1975 to prove their debts or claims and to establish any title they may have to priority by delivery or sending through the post to the liquidator at the undermentioned address an affidavit verifying their respective claims. In default, they will be excluded from the benefit of any distribution made before such claims are proved or such priority is established and from objecting to any such distribution.

NOTICE is given that pursuant to Section 272 of the Act the final meeting of the members of the company will be held at 377 Little Collins Street, Melbourne on Wednesday 25 June 1975 at 9.30 a.m. for the purpose of the liquidator laying before the meeting an account of the winding up and giving any explanation thereof.

Dated this 19th day of May, 1975.

P. W. HARVEY, Liquidator.

Price Waterhouse & Co., chartered accountants, 447 Collins Street, Melbourne. 5228

Companies Act 1961.—In the matter of MORNESSA FASHIONS PTY. LTD. (in Liquidation).

NOTICE IS HEREBY GIVEN that at an Extraordinary General Meeting of the above-named company held on the 16th May, 1975, it was resolved that the Company be wound up voluntarily.

The Meeting also resolved that JOHN BARRY HUTCHINS and MICHAEL ASHLEY COPPINS of Wilson, Bishop, Bowes and Craig, 271 William Street, Melbourne be appointed joint and several liquidators for the purpose of the winding up.

At a Meeting of Creditors held on the same day pursuant to Section 260, the appointment of the abovenamed Liquidators was confirmed.

Dated this 19th day of May, 1975.

J. B. HUTCHINS and M. A. COPPINS, Joint and several Liquidators.

Wilson, Bishop, Bowes & Craig, 271 William Street, Melbourne, 3000. Telephone 67 7372. 5230

Companies Act 1961.

M. SKURNIK & CO. PROPRIETARY LIMITED (IN VOLUNTARY LIQUIDATION).

NOTICE CONVENING FINAL MEETING OF MEMBERS, PURSUANT TO SECTION 272.

NOTICE is hereby given in pursuance of Section 272 of the Companies Act 1961, that a Meeting of members of the above named Company will be held on Wednesday, the

No. 39.—4320/75.—5

twenty-fifth day of June, 1975 at the office of Messrs. John Rezak and Co., 66-68 Albert Road, South Melbourne at 12.00 noon for the purpose of having an account laid before them showing the manner in which the winding up has been conducted and the property of the Company disposed of and of hearing any explanations that may be given by the Liquidator.

Dated this 12th day of May, 1975.

DAVID BENDEL, Liquidator.

John Rezak and Co., Public Accountants, 66 Albert Road, South Melbourne, 3205. 5122

Companies Act 1961.

DEVENCO PROPRIETARY LIMITED.

At an Extraordinary General Meeting of Shareholders of Devenco Proprietary Limited duly convened and held at 31 Jones Street, Thornbury on 19th May 1975, the Special Resolution set out below was duly passed:—

"That the Company be voluntarily wound up under S.254 (1) of the Companies Act 1961, and the Samuel Alastair Stevenson, Public Accountant of 675 Glenferrie Road Hawthorn be appointed Liquidator of the Company.

Dated this 20th day of May, 1975.

5191 SAMUEL ALASTAIR STEVENSON, Liquidator.

The Companies Act 1961.

JOMARIMEL PTY. LTD. (IN VOLUNTARY LIQUIDATION):

NOTICE CONVENING FINAL MEETING OF MEMBERS, PURSUANT TO SECTION 272.

NOTICE is hereby given in pursuance of Section 272 of the Companies Act 1961 that a Final Meeting of the members of the abovenamed Company will be held on the 27th day of June, 1975, at 2 p.m., at 14 McEvoy Street, Kew, for the purpose of having an account laid before them, showing the manner in which the winding up has been conducted and of hearing any explanations that may be given by the Liquidator.

Dated this 14th day of May, 1975.

5120 (Mrs.) E. E. FREDERICO, Liquidator.

In the Supreme Court of Victoria.—1975 No. Co. 9070.—In the matter of the Companies Act 1961; and in the matter of WARREN & MACMAHON BUILDERS PTY. LTD.

Notice is hereby given that a Petition for the winding up of the abovenamed Company by the Supreme Court was, on the 14th day of May, 1975 presented by Cyclone K.M. Products Pty. Ltd of Corner Cremorne Street and Harcourt Parade, Richmond in the State of Victoria. And that the said Petition is directed to be heard before the Court sitting at Melbourne at the hour of 10.30 o'clock in the forenoon on Wednesday the 2nd day of July, 1975. And any creditor or contributory of the said company desiring to support or oppose the making of an Order on the said Petition may appear at the time of hearing by himself or his Counsel for that purpose; and a copy of the Petition will be furnished to any creditor or contributory of the said company requiring the same by the undersigned on payment of the regulated charge for the same.

The Petitioner's address is care of Thomas H. Bell, Solicitor, 394 La Trobe Street, Melbourne.

The Petitioner's Solicitor is Thomas H. Bell of 394 La Trobe Street, Melbourne.

THOMAS H. BELL, solicitor for Cyclone K.M. Products Pty. Ltd.

NOTE: Any person who desires to appear on the hearing of the said Petition must serve on or send by post to the abovenamed Solicitor, notice, in writing, of his intention to do so. The Notice must state the name and address of the person, or if a firm, the name and address of the firm, and must be signed by the person or firm or his or their Solicitor (if any), and must be served, or, if posted must be sent, by post in sufficient time to reach the abovenamed not later than Four o'clock in the afternoon on the 1st day of July, 1975. 5169

In the Supreme Court of Victoria.—No. Co. 9054 of 1975.—In the matter of the Companies Act 1961 and in the matter of CONVERE PROPRIETARY LIMITED.

NOTICE IS HEREBY GIVEN that a Petition for the winding-up of the abovenamed Company by the Supreme Court was on the 1st day of May 1975 presented by ROSSAIR PROPRIETARY LIMITED; AND THAT the said Petition is directed to be heard before the Court sitting at the Law Courts, William Street, Melbourne on the 10th

day of June, 1975 at the hour of 10.30 o'clock in the forenoon; and any Creditor or Contributory of the said Company desiring to support or oppose the making of an Order on the said Petition may appear at the time of hearing by himself or his Counsel for the purpose; and a copy of the Petition will be furnished to any Creditor or Contributory of the said Company requiring the same by the undersigned on payment of the regulated charge for the same.

THE PETITIONER'S ADDRESS is Parafield Airport, Parafield, South Australia.

THE PETITIONER'S SOLICITORS are Messrs Corr & Corr, 290 La Trobe Street, Melbourne RNJ:JVR 75.309.001.

CORR & CORR, Solicitors for the Petitioners.

NOTE.—Any person who intends to appear on the hearing of the said Petition must serve on or send by post to the above named Solicitors, Notice in writing of his intention so to do. A Notice must state the name and address of the person, or, if a firm the name and address of the firm and it must be signed by the person or firm, or his or their Solicitor (if any) and must be served or, if posted, must be sent by post in sufficient time to reach the above-named not later than four o'clock in the afternoon of the 9th day of June, 1975. 5170

In the Supreme Court of Victoria.—1975 No. Co. 9045.—
In the matter of the Companies Act 1961; and in the matter of B. L. B. CORPORATION OF AUSTRALIA ESTABLISHMENT.

Notice is hereby given that a Petition for the winding up of the abovenamed company by the Supreme Court was, on the 11th day of April 1975, presented by JACOBSEN (REPRESENTATIVES) PTY. LIMITED and ALAN NICHOLAS JACOBSEN. And that the said Petition is directed to be heard before the Court sitting at Melbourne at the hour of 10.30 a.m. on the 7th day of June 1975; and any creditor or contributory of the said company desiring to support or oppose the making of an order on the said Petition may appear at the time of hearing by himself or his counsel for the purpose; and a copy of the Petition will be furnished to any creditor or contributory of the said company requiring the same by the undersigned on payment of the regulated charge for the same.

The address of the Registered Office of the Petitioner: JACOBSEN (REPRESENTATIVES) PTY. LIMITED is 48 Stephenson Street, Richmond and of the Petitioner: ALAN NICHOLAS JACOBSEN is 83 Talbot Crescent, Kooyong and the Petitioners' Solicitors are Messrs. J. M. Smith & Emmerton of 224 Queen Street, Melbourne.

J. M. SMITH & EMMERTON.

NOTE.—Any person who intends to appear on the hearing of the said Petition must serve on or send by post to the abovenamed solicitors notice in writing of his intention so to do. The notice must state the name and address of the person or, if a firm, the name and address of the firm, and must be signed by the person or firm, or his or their solicitor (if any), and must be served or, if posted, must be sent by post in sufficient time to reach the above named not later than four o'clock in the afternoon of the 4th day of June 1975. 5224

In the Supreme Court of Victoria.—1975 No. Co. 9056.—
In the matter of the Companies Act 1961; and in the matter of IOL PETROLEUM LIMITED.

NOTICE IS HEREBY GIVEN that on the 12th day of May 1975 His Honour Mr. Justice Lush ORDERED that the reduction of capital of IOL Petroleum Limited, the registered office of which is situate at 95 Collins Street, Melbourne, resolved upon and proposed to be effected by the Special Resolution of the said Company which was duly passed on the 23rd day of April 1975 at an extraordinary general meeting of the said Company on the said date in the following words and figures, that is to say:

"That the capital of the Company be reduced from \$4,550,000 divided into 9,100,000 shares of 50 cents each to \$2,275,000 divided into 9,100,000 shares of 25 cents each and that such reduction be effected by

cancelling paid up capital to the extent of 25 cents upon each of the 9,100,000 issued shares of 50 cents each and reducing the nominal amount of each of such shares to 25 cents."

be confirmed and DECLARED that the capital of the said Company as altered by the said Special Resolution and confirmed by the said Order and as further altered by ordinary resolutions of the said Company duly passed on the said 23rd day of April 1975 at the said extraordinary general meeting in the following words and figures, that is to say:

"That forthwith upon the reduction of capital resolved upon by this meeting taking into effect the 9,100,000 shares of 25 cents each in the capital of the Company be consolidated and divided into 4,550,000 shares of 50 cents each."

"That forthwith upon the consolidation and division of the capital of the Company resolved upon by this meeting taking into effect the capital of the Company be increased from \$2,275,000 to \$13,650,000 by the creation of 22,750,000 new shares of 50 cents each."

is \$13,650,000 divided into 27,300,000 shares of 50 cents each of which 4,550,000 shares and no more have been issued and are fully paid up and FURTHER ORDERED that an office copy of the said Order be lodged with the Commissioner for Corporate Affairs within fourteen days of the making thereof and FURTHER ORDERED that notice of the said Order and of the registration thereof by the Commissioner for Corporate Affairs (which registration was effected on the 13th day of May 1975) be published once in the *Government Gazette* and once in *The Age* newspaper within fourteen days of such lodgment and once in *The Financial Times* (London) within twenty-eight days of such lodgment.

ARTHUR ROBINSON & CO., solicitors, 447 Collins Street, Melbourne, Solicitors for the Company. 5190

Companies Act 1961.

TYRRELLS LINGERIE AND SPORTSWEAR PTY. LTD.

Please be advised that on the 25th day of June, 1975 a general meeting of Tyrrells Lingerie & Sportswear Pty. Ltd. of 13 North Concourse, Beaumaris will be held at 12.00 midday at Armaroo, Marathon Drive, Mt. Eliza, to put before it the liquidator's account, showing how the winding up has been conducted and the property of the company disposed of.

Dated 20th May, 1975.

5210

B. W. EDMUNDS, Secretary.

Trustee Act 1958.

NOTICE TO CLAIMANTS.

Pursuant to the Trustee Act 1958, creditors next of kin and all other persons having claims in respect of the estate of any deceased person named below are required to send particulars to the legal personal representative or representatives at the addresses stated, after which date the representatives will distribute the assets, having regard only to the claims of which notice has been received:—

JESSIE HYLAND late of 79 Geelong Road Footscray Widow deceased, died on the 16th day of February 1975. Claims to the Executors, Ilma Olive Norton Married Woman and Leslie Harold Norton Retired Public Servant both of 15 Batman Street Essendon by the 23rd day of July 1975. JOHN F. CARROLL, LL.B., Solicitor, 4 Paisley Street, Footscray. 5192

JANET CRAIG late of 5 Bruce Street, Bentleigh Widow deceased who died on the 7th day of March, 1975—Claims to the Executor REGINALD RUPERT GRAY care of Gray & Gray, Solicitors, 188 High Street, Northcote by the 19th day of August, 1975. 5223

CREDITORS next of kin and others having claims against the Estate of ALFRED DOUGLAS DAVIS late of 37 Marley Street, Sale in the State of Victoria, Retired C.R.B. Patrolman deceased who died on the 17th day of August, 1974 are required to send particulars of their claims to the Administrator, ROY NEIL DAVIS care of the undermentioned Solicitors by the 22nd day of August, 1975 after which date he will distribute the assets of the Estate having regard only to the claims of which he then has notice.

J. CROFTON LEE & MIOR, solicitors, 233 Raymond Street, Sale. 5112

VICTORIA MAY DELANEY, late of 6 Queens Avenue, Ararat, Widow, DECEASED.

CREDITORS next of kin and others having claims in respect of the estate of the deceased who died on the 14th day of January 1975 are required by the Trustee JOHN EDWARD JOSEPH BRIGGS of 94 Barkly Street Ararat Solicitor to send particulars to him at his address above-mentioned by the 22nd day of July 1975 after which date the trustee may convey or distribute the assets having regard only to the claims of which he then has notice.

BRIGGS & O'DRISCOLL, solicitors, 94 Barkly Street, Ararat. 5114

CLEMENT HARRY AMBROSE, late of Mooralla, in the State of Victoria, retired station hand, DECEASED.

CREDITORS next of kin and others having claims in respect of the Estate of the Deceased (who died on the 4th day of September, 1974) are required by the Executor of the Estate JAMES SANDFORD HARPER of 168 Exhibition Street, Melbourne Deputy Public Trustee for Victoria to send particulars to him care of the undermentioned solicitors by the 19th day of July, 1975 after which date the Executor may convey or distribute the assets having regard to claims only of which they then have notice.

MESSRS. CAMERON & LOWENSTERN, solicitors, 62 Thompson Street, Hamilton. 5193

CREDITORS NEXT-OF-KIN and others having claims in respect of the estate of LEONG POY YIN HO late of 407 Chesterville Road East Bentleigh in the State of Victoria Widow deceased intestate who died on the 29th day of October, 1972 are to send particulars of their claims to KWOK KWUN HO of 407 Chesterville Road East Bentleigh in the said State Caterer care of the undermentioned Solicitors by the 21st day of JULY, 1975 after which date he will distribute the assets having regard only to the claims to which he then has notice.

REGINALD C. BUTLER & CO., solicitors, 312 Centre Road, Bentleigh. 5140

FLORENCE MAY ANSTIS, late of 1104 Gregory Street, Ballarat, married woman, DECEASED (who died on the 6th day of August, 1974).

Creditors next of kin and all other persons having claims against the estate of the deceased are required to send particulars to the Executor THE UNION-FIDELITY TRUSTEE COMPANY OF AUSTRALIA LIMITED of 101 Lydiard Street North Ballarat on or before the 22nd July 1975 after which date it will distribute the assets having regard only to the claim of which it shall then have notice.

HEINZ & GORDON, solicitors, 209 Dana Street, Ballarat. 5141

Creditors next of kin and others having claims in respect of the Will of FLORENCE RUBY HOBSON late of 98 McConnell Street, Kensington Retired who died on the 20th day of February 1975 are requested to send particulars of their claims to the Executor JEAN MARGARET SHEEDY care of the under-mentioned Solicitor by the 30th day of July 1975 after which date she will distribute the assets having regard only as to the claims of which she then has notice.

JOHN STEWART, of 290 Racecourse Road, Newmarket. 5142

ALICE ANN CLASPER, late of 16 Collingwood Road, Newport, in the State of Victoria, widow, DECEASED.

Creditors next of kin and other persons having claims against the Estate of the said deceased who died on the 8th May, 1975 are required to send particulars of same to the Executor JOHN McLOUGHLIN in care of the under-mentioned on or before the 1st August, 1975 after which date he will distribute the assets having regard only to the claims of which he then has notice.

GERALD E. DELANY & CO., barristers and solicitors, Hume House, 185 William Street, Melbourne. 5143

CREDITORS next of kin and others having claims against the Estate of JANETTE LOIS LEVY late of 22 Labassa Grove Caulfield, Married Woman, deceased who died on the 12th March 1974 are required by the Executors LEONARD HYMAN LEVY of 22 Labassa Grove Caulfield, Pharmaceutical Chemist, and PETER MAVER of 6 Mulgoa Street Brighton, Accountant, to send particulars of such claims to them at the office of the undersigned Solicitor on or before the 30th July 1975 after which date they will distribute the assets having regard only to the claims of which they shall then have had notice.

SYLVIA ROTHSTADT, M.A. LL.B., barrister and solicitor, 374 Bourke Street, Melbourne. 5103

VIOLET FLORENCE BAWDEN, late of 17 Dove Street, West Footscray, married woman, DECEASED, intestate.

Creditors, next of kin and others having claims in respect of the estate of the said Deceased who died on the 1st of December, 1974 are required by the personal representative WALTER JAMES BAWDEN of 17 Dove Street, West Footscray Retired Electro-Plater to send particulars to him C/o the undernamed Solicitor by the 31st day of July, 1975 after which date he may convey or distribute the assets having regard only to the claims of which he then has notice.

JOHN GINNANE, solicitor, 20 Droop Street, Footscray. 5104

CREDITORS next of kin and others having claims in respect of the estate of DOROTHY MAY BARNETT late of 846 Hampton Street Brighton Widow who died on the 9th January 1975 are requested to send particulars of their claims to THE EQUITY TRUSTEES EXECUTORS AND AGENCY COMPANY LIMITED of 472 Bourke Street Melbourne by the 23rd day of July 1975 after which date it will distribute the assets having regard only to the claims of which it then has notice.

MICHAEL L. HORAN, LL.B., solicitor, 86 Ormond Road, Elwood, 3184. Tel: 91 6066. 5105

Creditors, next of kin and others having CLAIMS against the estate of MARTHA MARY ELLIOTT late of Commercial Road, Koroit, formerly married woman but late widow deceased who died on 19th February 1975 are requested to send particulars of their claims to the executor THOMAS VINCENT McCLUSKEY of Spring Street, Koroit, driver, care of Conlan & Leishman, solicitors, 38 Bank Street, Port Fairy by 25th July 1975 after which date he will distribute the assets having regard only to the claims of which he then has notice.

CONLAN & LEISHMAN, solicitors, 38 Bank Street, Port Fairy. 5099

CREDITORS next of kin and others having claims against the estate of EMMA AMELIA LEWIS late of 13 Ligar Street, Bendigo, Married Woman, deceased, who died on the 16th April, 1975 are required to send particulars thereof to NATIONAL TRUSTEES EXECUTORS AND AGENCY COMPANY OF AUSTRALASIA LIMITED of 46 Queen Street, Bendigo, by the 20th day of July, 1975, after which date the said Company will distribute the assets of the said deceased having regard only to the claims of which it then has notice. 5100

MABEL HELEN ANDREWS, late of 10 Franklin Street, Mornington, in the State of Victoria, widow, DECEASED.

CREDITORS, next of kin and others having claims in respect of the Estate of the deceased (who died on the 17th day of December 1974) are required by the Trustees, Executors & Agency Co. Ltd. of 401 Collins Street, Melbourne, to send particulars of their claims to the said Company by the 18th day of July 1975, after which date it will convey or distribute assets, having regard only to the claims of which the Company then has notice.

T. A. MILLER, LL.B., solicitor, 326 Main Street, Mornington. 5101

CREDITORS next of kin and others having claims against the Estate of CLAUDINE DAISY AUSTRALIA SYMONS late of Flat 2, 18 Clyde Street St. Kilda, Widow, deceased who died on the 20th September 1974 are required by the Executors GEORGE REVELMAN of 9 Edward Street Kew, Company Director, and THE EQUITY TRUSTEES EXECUTORS AND AGENCY COMPANY LIMITED of 472 Bourke Street Melbourne to send particulars of such claims to them care of the said Company on or before the 30th July 1975 after which date they will distribute the assets having regard only to the claims of which they shall then have had notice.

A. NEWTON SUPER & P. G. KOVACS, barristers & solicitors, 374 Bourke Street, Melbourne. 5102

CREDITORS, Next of Kin and others having claims in respect of the Estate of MINNIE ELIZABETH FOWKE late of Flat 7, 2 Jessamine Avenue, Windsor, Spinster deceased, who died on the third day of January, 1975, are required by the Administrator of her Estate The Union-Fidelity Trustee Company of Australia Limited of 100 Exhibition Street Melbourne to send particulars of their claims to the said Company by the 25th day of July, 1975 after which date the Administrator will distribute the assets having regard only to the claims of which it then has notice. 5171

HERBERT HOWELL ROBERTS, formerly of 183 Rathmines Road, Hawthorn, but late of 38 Loch Street, St. Kilda, both in the State of Victoria, retired solicitor.

CREDITORS, next of kin and others having claims in respect of the estate of the deceased who died on the 11th day of February 1975 are required by the Executor THE UNION-FIDELITY TRUSTEE COMPANY OF AUSTRALIA LIMITED of 100 Exhibition Street Melbourne in the said State to send particulars to it care of the undermentioned Solicitors by the 23rd day of July 1975 after which date the Executor may convey or distribute the assets having regard only to the claims of which it then has notice.

Dated the 21st day of May, 1975.

MADDEN, BUTLER, ELDER & GRAHAM, solicitors, 500 Collins Street, Melbourne. 5172

WALTER ALEC BANFIELD, sometimes known as Walter Alexander Banfield, late of 54 Barkly Street, Ararat, retired printer, DECEASED.

CREDITORS next of kin and others having claims in respect of the estate of the deceased who died on the 11th day of August 1974 are required by the Trustees ALICE EDITH BANFIELD of 54 Barkly Street Ararat Widow and JOHN EDWARD JOSEPH BRIGGS of 94 Barkly Street Ararat Solicitor to send particulars to them at their addresses abovementioned by the 22nd day of July 1975 after which date the trustees may convey or distribute the assets having regard only to the claims of which they then have notice.

BRIGGS & O'DRISCOLL, solicitors, 94 Barkly Street, Ararat. 5113

MARY STEWARD, late of 6 Cox Court, G. K. Tucker Park, Carrum Downs, widow, DECEASED.

Creditors next of kin and others having claims in respect of the estate of the deceased who died on the 12th day of November 1974 are required by the Trustees ROBERT WILLIAM DAVIDSON and DAVID NELIGAN to send particulars of their claims to them care of the undersigned Solicitors by the 30th day of July 1975 after which date the Trustees may convey or distribute the assets having regard only to the claims of which they then have notice.

GRAY, FRIEND & LONG, solicitors, Warragul. 5106

CREDITORS next-of-kin and others having claims in respect of the Estate of PHILLIP RISCHIN late of 656 Bell Street Pascoe Vale South, in the State of Victoria, Retired Wholesale Fruit Salesman deceased, who died on the 20th of December 1974, are to send particulars of their claims to the Executor NATIONAL TRUSTEES, EXECUTORS & AGENCY COMPANY OF AUSTRALASIA LIMITED of 95 Queen Street Melbourne by the 21st of July 1975, after which date it will distribute the Assets having regard only to the claims of which it then has notice.

LE GRAND, RANGLES, GAFFNEY & CO., 644 Sydney Road, Brunswick, solicitors for the applicant. 5107

JAN TYSIEWICZ, late of 495 Thompson Street, Norlane, in the State of Victoria, labourer, DECEASED.

Creditors, Next of Kin and all persons having claims against the estate of the abovenamed are required by the Executor THE UNION FIDELITY TRUSTEE COMPANY OF AUSTRALIA LIMITED of 100 Exhibition Street Melbourne in the said State to send particulars to it on or before the first day of August, 1975 after which date it will distribute the assets having regard only to the claims of which it then had notice.

COULTER, BURKE & FAZIO, solicitors, 189 Moorabool Street, Geelong. 5108

JOHN JOSEPH QUINN, formerly of 31 Strathmore Street, Bentleigh, but late of Nazareth House, Mill Street, Ballarat, retired grocer, DECEASED.

Creditors, next-of-kin and others having claims in respect of the estate of the deceased who died on the 21st day of August 1974 are required by the executor The Trustees Executors and Agency Company Limited of 401 Collins Street Melbourne to send particulars of their claims to the said Company by the 28th day of July 1975 after which date it will convey or distribute assets having regard only to the claims of which it then has notice.

W. J. MORLEY, solicitor, 769 Centre Road, East Bentleigh. 5109

CREDITORS Next-of-Kin and others having claims in respect of the estate of CECIL ADDISON FISHER late of 33 Koornalla Street, East Newborough in the State of Victoria Boiler Maker Welder deceased who died on the fourth day of February, One thousand nine hundred and seventy-five are to send the particulars of their claims to the Administratrix EVELYN MAY FISHER C/- the undermentioned Solicitors prior to the 1st day of August, 1975 after which date the said Administratrix will distribute the assets of the deceased having regard only to the claims of which she shall have Notice.

KEVIN DAVINE & SONS, solicitors, Contingent Street, Trafalgar. 5110

CREDITORS next of kin and others having claims against the Estate of LEO JOHN FALLON late of Bunyip Farmer who died on the 19th day of October 1974 are requested to send particulars of their claims to Thelma Louisa Price Fallon of Bunyip Widow the Executrix appointed by the deceased's Will in care of the undersigned by the 28th day of July 1975 after which date she will distribute the assets having regard only to the claims of which she then shall have had notice.

M. DAVINE & CO., solicitors, Warragul. 5111

CREDITORS next of kin and others having claims against the Estate of MAY EDNA THISTLETHWAITE late of Colbrook in the State of Victoria Married Woman deceased who died on the 15th day of May, 1974 are requested to send particulars of their claims to the Executors THE UNION-FIDELITY TRUSTEE COMPANY OF AUSTRALIA LIMITED and ROBERT JAMES THISTLETHWAITE such claims to be forwarded to C/- The Union Fidelity Trustee Company of Australia Limited of 101 Lydiard Street North, Ballarat by the 18th day of July, 1975 after which date the said Executors will distribute the assets having regard only to the claims of which it then has notice.

NEVETT, GLENN & COUTTS, solicitors, 205 Dana Street, Ballarat. 5194

CREDITORS, next of kin and others having Claims in respect of the Estate of Elizabeth Sperka, late of Flat 8/189 Orrong Road St. Kilda, Widow deceased who died on the 18th day of December 1974 are required to send particulars of their claims to the Executor and Executrix care of the undermentioned Solicitors on or before the 21st day of July 1975 after which date the said Executor and Executrix will distribute the assets having regard only to the claims of which notice has been received by a communication in writing either by letter or by service of a Writ. And further take notice that if such communication is not received by the due date mentioned above then the Executor and Executrix will not be responsible for any loss as a result of such non-communication.

R. D. SILVERSTEIN AND ASSOCIATES, 104 Wellington Parade, East Melbourne, solicitors for the applicants. 5195

WALLACE ROBERT MAXWELL LUMBER, late of Newbridge, farmer, DECEASED.

CREDITORS next of kin and others having claims against the estate of the abovenamed deceased are required by the Executors thereof MARGARET VIOLET LUMBER of Newbridge, Widow and CHARLES GEORGE LUMBER of Bridgewater, Farmer to forward particulars thereof to them care of the undermentioned Solicitors on or before the 1st day of August, 1975 after which date they will distribute the assets of the said estate having regard only to the claims of which they then have notice.

Dated the 21st day of May, 1975.

MESSRS. HYETT & HYETT, of 51 Bull Street, Bendigo, solicitors for the executors. 5196

RAYMOND THOMAS JACK McHUGH, late of Taylor Street, Epsom, stock and station agent, DECEASED.

CREDITORS next of kin and others having claims against the estate of the abovenamed deceased are required by the Executor thereof JOYCE MEALOR McHUGH of Clunes, Widow to forward particulars thereof to her care of the undermentioned Solicitors on or before the 1st day of August, 1975 after which date she will distribute the assets of the said estate having regard only to the claims of which she then has notice.

Dated the 21st day of May, 1975.

MESSRS. HYETT & HYETT, of 51 Bull Street, Bendigo, solicitors for the executor. 5197

JOHN WILLIAM TOPHAM ROSS, late of 49 Moran Street, Bendigo, master builder, DECEASED.

CREDITORS next of kin and others having claims against the estate of the abovenamed deceased are required by the executor thereof NATIONAL TRUSTEES EXECUTORS AND AGENCY COMPANY OF AUSTRAL-ASIA LIMITED of 95 Queen Street, Melbourne and at 46 Queen Street, Bendigo to forward particulars thereof care of the said Company on or before the 1st day of August, 1975 after which date it will distribute the assets of the said estate having regard only to the claims of which it then has notice.

Dated the 21st day of May, 1975.

MESSRS. HYETT & HYETT, of 51 Bull Street, Bendigo, solicitors for the executor. 5198

VIOLET LOUISA FABRY, late of 137 Thistle Street, Bendigo, married woman, DECEASED.

CREDITORS next of kin and others having claims against the estate of the abovenamed deceased are required by the Executors thereof FRANCIS WILLIAM O'CONNELL of 7 Aviary Court, Kennington, Insurance Agent and VENETTA ALICE HOGAN of 43 Weeroona Avenue, Bendigo, Married Woman to forward particulars thereof to them care of the undermentioned Solicitors on or before the 1st day of August, 1975 after which date they will distribute the assets of the said estate having regard only to the claims of which they then have notice.

Dated the 21st day of May, 1975.

MESSRS. HYETT & HYETT, of 51 Bull Street, Bendigo, solicitors for the executors. 5199

SERGIO DARIO VESCOVI, late of Buckley Street, Harcourt, stonemason, DECEASED.

CREDITORS next of kin and others having claims against the estate of the abovenamed deceased are required by the Executrix thereof ANNETTE JOY VESCOVI of Buckley Street, Harcourt, Widow to forward particulars thereof to her care of the undermentioned solicitors on or before the 1st day of August, 1975 after which date she will distribute the assets of the said estate having regard only to the claims of which she then has notice.

Dated the 21st day of May, 1975.

MESSRS. HYETT & HYETT, of 51 Bull Street, Bendigo, solicitors for the executrix. 5200

JAMES LAURENCE BIRTHISEL, late of Carisbrook Road, Maryborough, farmer, DECEASED.

CREDITORS next of kin and others having claims against the estate of the abovenamed deceased are required by the Executrices LORNA ELLEN STEPHENSON of Wedderburn and GRETA ANNIE HARNETTY of Carisbrook Road, Maryborough, both Married Women to forward particulars thereof to them care of the undermentioned solicitors on or before the 1st day of August 1975 after which date they will distribute the assets of the said estate having regard only to the claims of which they then have notice.

Dated the 21st day of May, 1975.

MESSRS. HYETT & HYETT, of 51 Bull Street, Bendigo, solicitors for the executrices. 5201

GEOFFREY CHARLES BARKER, late of 1 Dee Street, Mt. Morgan, in the State of Queensland, engineer, DECEASED.

CREDITORS next of kin and others having claims against the estate of the abovenamed deceased are required by the Executor thereof SANDHURST AND NORTHERN DISTRICT TRUSTEES EXECUTORS AND AGENCY COMPANY LIMITED of 18 View Street, Bendigo to forward particulars thereof to the said Company on or before the 1st day of August 1975 after which date it will distribute the assets of the said estate having regard only to the claims of which it then has notice.

Dated the 21st day of May, 1975.

MESSRS. HYETT & HYETT, of 51 Bull Street, Bendigo, solicitors for the executor. 5202

ALICE ANN CLASPER, late of 16 Collingwood Road, Newport, in the State of Victoria, widow, DECEASED.

After 14 clear days JOHN McLOUGHLIN of 449 Geelong Road, Footscray in the said State Paving Contractor the Executor appointed by the deceased's Will dated 24th of February, 1964 and Codicils thereto dated the 4th day of September, 1970 and 6th day of October, 1970 WILL APPLY to the Supreme Court of Victoria for a GRANT of Probate of the said Will and Codicils.

GERALD E. DELANY & CO., solicitors, Hume House, 185 William Street, Melbourne. 5144

LEONARD THOMAS COULTER, late of 75 Simpsons Road, Eaglehawk, railway employee, DECEASED.

CREDITORS next of kin and others having claims against the estate of the abovenamed deceased are required by the Executor thereof SANDHURST AND NORTHERN DISTRICT TRUSTEES EXECUTORS AND AGENCY COMPANY LIMITED of 18 View Street, Bendigo to forward particulars thereof to the said Company on or before the 1st day of August 1975 after which date it will distribute the assets of the said estate having regard only to the claims of which it then has notice.

Dated the 21st day of May, 1975.

MESSRS. HYETT & HYETT, of 51 Bull Street, Bendigo, solicitors for the executor. 5203

ETHEL MAUD TREWAVAS, late of 98 Victoria Street, Eaglehawk, spinster, DECEASED.

CREDITORS next of kin and others having claims against the estate of the abovenamed deceased are required by the Executor thereof SANDHURST AND NORTHERN DISTRICT TRUSTEES EXECUTORS AND AGENCY COMPANY LIMITED of 18 View Street, Bendigo to forward particulars thereof to the said Company on or before the 1st day of August 1975 after which date it will distribute the assets of the said estate having regard only to the claims of which it then has notice.

Dated the 21st day of May, 1975.

MESSRS. HYETT & HYETT, of 51 Bull Street, Bendigo, solicitors for the executor. 5204

NEIL LESLIE CAMPBELL, late of Huntly, motor mechanic, DECEASED, intestate.

CREDITORS next of kin and others having claims against the estate of the abovenamed deceased are required by the Administrator thereof LESLIE GRIFFITHS CAMPBELL of Huntly, Retired Farmer to forward particulars thereof to him care of the undermentioned solicitors on or before the 1st day of August 1975 after which date he will distribute the assets of the said estate having regard only to the claims of which he then has notice.

Dated the 21st day of May, 1975.

MESSRS. HYETT & HYETT, of 51 Bull Street, Bendigo, solicitors for the administrator. 5205

ROBERT JOHN FINLAY, late of Charlton, retired farmer, DECEASED.

CREDITORS next of kin and others having claims against the estate of the abovenamed deceased are required by the Executors thereof JOHN NORMAN FINLAY of Junortoun, Farmer and JACK GOULD of Wedderburn, Farmer to forward particulars thereof to them care of the undermentioned solicitors on or before the 1st day of August 1975 after which date they will distribute the assets of the said estate having regard only to the claims of which they then have notice.

Dated the 21st day of May, 1975.

MESSRS. HYETT & HYETT, of 51 Bull Street, Bendigo, solicitors for the executors. 5206

ALMA GLADYS ROSS, late of 49 Moran Street, Bendigo, widow, DECEASED.

CREDITORS next of kin and others having claims against the estate of the abovenamed deceased are required by the Executrix thereof DORIS MAY HAYMAN of 46 Moran Street, Bendigo, Home Duties to forward particulars thereof to her care of the undermentioned solicitors on or before the 1st day of August 1975 after which date she will distribute the assets of the said estate having regard only to the claims of which she then has notice.

Dated the 21st day of May, 1975.

MESSRS. HYETT & HYETT, of 51 Bull Street, Bendigo, solicitors for the executrix. 5207

JOHN WALTER LAWRY, late of Dingee, farmer, DECEASED.

CREDITORS next of kin and others having claims against the estate of the abovenamed deceased are required by the Executrix thereof VALDA MARJORIE LAWRY of Dingee, Widow to forward particulars thereof to her care of the undermentioned solicitors on or before the 1st day of August 1975 after which date she will distribute the assets of the said estate having regard only to the claims of which she then has notice.

Dated the 21st day of May, 1975.

MESSRS. HYETT & HYETT, of 51 Bull Street, Bendigo, solicitors for the executrix. 5208

CREDITORS, Next-of-Kin and others having claims in respect of the Estate of LIELA EVA McDERMOTT formerly of 22 College Street, Gardenvale but late of St. Anne's Private Hospital, 82 Hotham Street, East St. Kilda in the State of Victoria Spinster who died on the 10th day of August, 1974 are required by the Administratrix NORA GERTRUDE McDERMOTT of 22 College Street, Gardenvale in the said State to send particulars to her care of E. K. O'Donnell, Solicitor, 173 Greville Street, Prahran in the said State by the 22nd day of July, 1975 after which date the Administratrix may convey or distribute the assets having regard only to the claims of which she then has notice.

E. K. O'DONNELL, solicitor, 173 Greville Street, Prahran. 5209

CREDITORS, next of kin and others having claims in respect of the Estate of GERTRUDE MARY DAWSON late of 91A Newington Avenue Dunedin in the Dominion of New Zealand Widow deceased (who died on the First day of March 1974), are required to send particulars of their claims to NATIONAL TRUSTEES EXECUTORS AND AGENCY COMPANY OF AUSTRALASIA LIMITED of 95 Queen Street Melbourne in Victoria by the Twenty-third day of July 1975, after which date the said Company will distribute the assets having regard only to the claims of which it then has notice.

GILLOTT MOIR & WINNEKE, solicitors, 500 Collins Street, Melbourne, 3000. 5174

CREDITORS Next of Kin and others having claims against the Estate of LYLE GLADYS OLIVE PANIOTY late of 1 Watkins Street Mordialloc widow deceased who died on the 17th day of February 1975 are requested to send particulars of their claims to the executrix ERENA LYLE AGNES HEAD care of the undermentioned Solicitors by the 30th July 1975 after which date she will distribute the assets having regard only to the claims of which she shall have notice.

J. A. REDMOND & CO., solicitors, 482 Bourke Street, Melbourne, Victoria, 3000. 5157

JOHN RUPERT BRAY, late of Cohuna, in the State of Victoria, pensioner, DECEASED.

Creditors next-of-kin and other persons having CLAIMS against the Estate of the said Deceased who died on the 7th day of December 1974 ARE REQUIRED to send particulars of same to the Executors IVAN WILLIAM BRAY and GRAEME JOHN BRAY in care of the undersigned on or before the 18th day of July 1975 after which date they will distribute the assets having regard only to the claims of which they then have notice.

DELANY & DWYER, barristers and solicitors, 201 Campbell Street, Swan Hill. 5163

CREDITORS next of kin and others having claims in respect of the Estate of GWENDOLINE LAWSON late of 5 Turner Street Croydon in the State of Victoria Widow deceased who died on the 24th day of December 1974 are required by the Executors CHARLES GERARD HEFFEY of 258 Little Bourke Street Melbourne Solicitor and WILLIAM CHARLES LAWSON of 5 Turner Street Croydon Spray Painter both in the said State to send particulars of such claims to the said Executors care of the office of HEFFEY & BUTLER of 258 Little Bourke Street Melbourne Solicitors by the 30th day of July 1975 after which date the said Executors will distribute the assets having regard only to the claims which they then have notice.

HEFFEY & BUTLER, solicitors, 258 Little Bourke Street, Melbourne. 5164

PAUL LANGFELDER late of 4 Fountaine Avenue, East Malvern, gentleman, DECEASED.

CREDITORS next of kin and others having claims in respect of the Estate of the abovenamed deceased, who died on the 26th December, 1974, are required by the Executor of his Will, Jewel Okno, Solicitor of 213 Lonsdale Street, Melbourne, to send to him, particulars of their claims care of the undermentioned Solicitors by the 30th July, 1975, after which date the said Executor will distribute the assets having regard only to the claims of which he then has notice.

J. ONKO & CO., solicitors, 213 Lonsdale Street, Melbourne. 5165

PURSUANT to the provisions of the Trustee Act 1958 CREDITORS NEXT-OF-KIN AND ALL OTHER PERSONS having claims in respect of the Estate of LAURA MARY VANDENBERGH late of 57 Kenmare Street Box Hill North in the State of Victoria Widow who died on the 15th day of September 1974 ARE REQUIRED to send particulars

of their claims to the Executors THE TRUSTEES EXECUTORS AND AGENCY COMPANY LIMITED of 401 Collins Street Melbourne by the 23rd day of July 1975 after which date the Executors will distribute the assets having regard only to the claims of which it shall then have had notice.

MADDOCK LONIE & CHISHOLM, solicitors, 60 Market Street, Melbourne. 5166

Pursuant to the Trustee Act 1958 NOTICE IS HEREBY GIVEN that all persons having claims against the Estate of JOSEPH RICHARD LOVE late of 65 Chapel Street St. Kilda in the State of Victoria Medical Practitioner deceased who died on the 30th day of December 1974 and Probate of whose Will was granted by the Supreme Court of the said State in its Probate Jurisdiction on the 12th day of May 1975 to JEANETTE LOVE of 65 Chapel Street St. Kilda aforesaid and the EQUITY TRUSTEES EXECUTORS AND AGENCY COMPANY LTD., of 472 Bourke Street Melbourne in the said State the Executors appointed by the deceased's Will are hereby required to send particulars in writing of such claims to the said Executors in care of the said Company at its abovementioned address on or before the 27th day of July 1975 after which date the said Jeanette Love and the said Company will proceed to distribute the assets of the said Joseph Richard Love deceased which shall have come to their hands amongst the persons entitled thereto having regard only to claims of which they shall then have had notice AND NOTICE IS HEREBY FURTHER GIVEN that the said Jeanette Love and the said Company will not be liable for the assets so distributed or any part thereof to any person of whose claim they shall not have had notice as aforesaid.

GAIR & BRAHE, solicitors, 53 Queen Street, Melbourne. 5173

Creditors, next of kin and others having claims in respect of the estate of Samuel Stuart McKay late of 42 Kensington Road South Yarra in Victoria Gentleman deceased (who died on the 22nd day of March 1975) are required by the executors Jeanette Emily McKay of 42 Kensington Road, South Yarra, Widow, Judith Ann Stuart Alexander of 8 Irving Street, Malvern Married Woman and Diana Stuart Goetz of 28 Mowbray Street, Hawthorn Married Woman to send particulars of their claims to them care of the undermentioned solicitors by the 22nd day of July 1975 after which date they will distribute the assets having regard only to the claims of which they then have notice.

AITKEN WALKER & STRACHAN, solicitors, 414 Collins Street, Melbourne, 3000. 5220

NELLY RUTH PRICE, late of 4 Stonehaven Avenue, East Malvern, home duties, DECEASED.

Creditors, next of kin and others having claims in respect of the estate of the deceased (who died on the Seventh day of February One thousand nine hundred and seventy-five) are required by THE TRUSTEES EXECUTORS AND AGENCY COMPANY OF AUSTRALIA LIMITED of 401 Collins Street, Melbourne to send particulars of their claim to the said Company by the 7th day of August. One thousand nine hundred and seventy-five after which date it will convey or distribute the assets, having regard only to the claims of which the Company then has notice.

BOOTHBY & BOOTHBY, solicitors, 883 Dandenong Road, Caulfield East. 5221

Creditors, next of kin, and others having claims in respect of the estate of MARY ELIZABETH PHILLIPS late of 16 Deakin Street, East Malvern, Widow, deceased who died on the 18th day of December, 1974, are to send particulars of their claims to THE EQUITY TRUSTEES EXECUTORS AND AGENCY COMPANY LIMITED of 472 Bourke Street, Melbourne, by the 25th day of July, 1975, after which date it will distribute the assets having regard only to the claims of which it then has notice.

J. M. SMITH & EMMERTON, solicitors, 224 Queen Street, Melbourne, 3000. 5222

JAMES VINCENT CICCONE (also known as James Vincenzo Ciccone), late of Boundary Road, Coldstream, estate agent, DECEASED.

CREDITORS next of kin and others having claims in respect of the estate of the deceased (who died on the 27th day of November 1974) are required by THE PERPETUAL EXECUTORS AND TRUSTEES ASSOCIATION OF AUSTRALIA LIMITED of 50 Queen Street, Melbourne, to send particulars of their claims to the said Company by the 23rd day of July 1975 after which date it will convey or distributed the assets, having regard only to the claims of which the Company then has notice.

HERBERT TURNER & DAVIS, solicitors, 44 Market Street, Melbourne. 5225

SYDNEY FRANCIS DUNN, late of 96 Addison Street, Elwood, in the State of Victoria, retired master printer, DECEASED.

Creditors next of kin and others having claims in respect of the estate of the abovenamed deceased who died on the Eighteenth day of October, 1974 are required by the Trustees THE TRUSTEES EXECUTORS AND AGENCY COMPANY LIMITED of 401 Collins Street, Melbourne in the State of Victoria and ALFRED COHU DUNN of 333 Gallagher's Road, Glen Waverley aforesaid Accountant to send particulars to such company by the 25th day of July, 1975 after which date the said Trustees may convey and distribute the assets having regard only to the claims of which they then have notice.

EGGLESTON, CLIFTON-JONES & CO., solicitors, of 20 Queen Street, Melbourne, Victoria, 3000. 5226

IMPOUNDINGS

DAYLESFORD AND GLENLYON.—Impounded in Daylesford and Glenlyon Pound, from Midland Highway, in Mt. Franklin area, on 15th May, 1975, the following Friesian-Hereford type cattle.

- 2 steers, black and white with horns, approximately 2 years old, no visible brand
 - 1 steer, black and white with horns, approximately 2 years old, no visible brand
 - 1 vealer, black and white
 - 1 cow, black and white with horns, no visible brand
 - 1 heifer, black and white with horns, approximately 18-months old, no visible brand
- If not claimed and expenses paid, to be sold on Thursday, 5th June, 1975.

5231—\$8.80 N. CONROY, Poundkeeper.

LANCEFIELD.—Impounded in Lancefield Pound

1 Hereford steer approximately 18 months old, no visible marks.

If not claimed and expenses paid, will be auctioned on Friday, 23rd May, 1975, at 12 noon.

5096—\$3.85 J. P. NICHOLLS, Poundkeeper.

MELTON.—Impounded in Melton Pound on 7th May, 1975

- 2 black heifers, no visible brands
- 1 red steer (white face), no visible brand
- 1 black steer (white face), no visible brand

If not claimed and expenses paid, to be sold at the Melton Pound on 6th June, 1975, at 12 noon.

5139—\$4.40 M. B. WATSON, Shire Secretary.

SHIRE OF SOUTH GIPPSLAND.

FOSTER.—Impounded in Foster Pound

On Monday, April 28th, 1975, from Ameys Track, Foster.

2 yearling bulls 1 Black Poll 1 Friesian cross horned

On Saturday, May 3rd, 1975, from Ameys Track, Foster.

1 Black Poll bull

On Saturday, May 3rd, 1975, from Nippards Track, Foster.

5 cows with calves, crossbred

On Monday, May 12th, 1975, from Boolarong Road, Foster.

1 Murray Grey cow

On Monday, May 12th, 1975, from Turtons Creek Road.

1 black cow

On Tuesday, May 13th, 1975, from Boolarong Road, Foster.

1 black heifer

1 baldy steer

No visible brands.

If not claimed and expenses paid, to be sold on or after June 4th, 1975.

5138—\$12.10 A. G. JONES, Poundkeeper.

Subordinate Legislation Act 1962.

NOTICE OF MAKING OF STATUTORY RULES.

In pursuance of the provisions of the *Subordinate Legislation Act 1962* and the Regulations made thereunder, notice is given of the making of the following statutory rules:—

No.	Weights and Measures Act 1958.	Price.
137/1975.	Weights and Measures Regulations 1975	\$3.10
	<i>Local Government Act 1958.</i>	
138/1975.	Municipal Auditors Board Regulations 1975	10c
	<i>Water Act 1958.</i>	
139/1975.	Water (Kimbolton Recreational Area) (Liability Insurance) Regulations 1975	10c
	<i>Water Act 1958.</i>	
140/1975.	Water (Derrinal Recreational Area) (Liability Insurance) Regulations 1975	10c
	<i>Water Act 1958.</i>	
141/1975.	Water (Metcalf Recreational Area) (Liability Insurance), Regulations 1975	10c
	<i>Water Act 1958.</i>	
142/1975.	Water (Lake Eildon Recreational Area) Amendment Regulations 1975	10c
	<i>Water Act 1958.</i>	
143/1975.	Water (Greens Lake Recreational Area) (Liability Insurance) Regulations 1975	10c
	<i>Water Act 1958.</i>	
144/1975.	Water (Pykes Creek Reservoir and Lake Merrimu Recreational Area) (Liability Insurance) Regulations 1975	10c
	<i>Water Act 1958.</i>	
145/1975.	Water (Lake Glenmaggie Recreational Area) (Liability Insurance) Regulations 1975	10c
	<i>Water Act 1958.</i>	
146/1975.	Water (Lake Hume (Shire of Wodonga) Recreational Area) (Liability Insurance) Regulations 1975	10c
	<i>Scaffolding Act 1971.</i>	
147/1975.	Scaffolding (Amendment) Regulations 1975	10c
	<i>Mt. Hotham Alpine Resort Act 1972.</i>	
148/1975.	Mt. Hotham Alpine Resort (Amendment) Regulations 1975, No. 2	10c

Copies of these statutory rules may be purchased at the Sale of Publications Section of the Government Printing Office, located at 7A Parliament Place, Melbourne, 3002. If ordered by mail, remittance should be addressed to "The Government Printer, Box 203, P.O., North Melbourne, 3051", and should include 11c extra for postage. If a credit account is held at this office, no remittance is required with the mail order.

The annual subscription rate for Statutory Rules (including Bound Volumes) is \$35, payable in advance. The subscription year commences on 1st January.

C. H. RIXON,
Government Printer.

AGENTS FOR THE "VICTORIA GOVERNMENT GAZETTE".

The following have been appointed agents to receive Advertisements and Subscriptions for the *Victoria Government Gazette*:—

- ARMSTRONG'S AGENCY, 217 Queen-street, Melbourne, Victoria 3000.
- ARNALL & JACKSON, 390 Barkly-street, Brunswick, Victoria 3056.
- BAIRNSDALE AUTHORIZED NEWSAGENCY, 132 Main-street, Bairnsdale, Victoria 3875.

BICKNELL, M. J., Authorized Newsagent, 196 Timor-street, Warrnambool, Victoria 3280.
 BLANE'S AUTHORIZED NEWSAGENTS, 162 Murray-street, Colac, Victoria 3250.
 CARTER, R. G., ADVERTISING SERVICE PTY. LTD., Suite 24, 65 Queens-road, Melbourne, Victoria 3004.
 DAVIES, G. & M. V., 112 Gray-street, Hamilton, Victoria 3300.
 DAVIS, WM. (MILDURA) PTY. LTD., 126 Eighth-street, Mildura, Victoria 3500.
 DIXON'S NEWSAGENCY, 89 Firebrace-street, Horsham, Victoria 3400.
 EDGAR'S AUTHORIZED NEWSAGENCY, 45 Bridge-street, Benalla, Victoria 3672.
 FRANKS, H., & CO., 184 Ryrrie-street, Geelong, Victoria 3220.
 GATLEY, A. & J., 250 Lonsdale-street, Dandenong, Victoria 3175.
 GORDON & GOTCH AUSTRALASIA LTD., 434 St. Kilda-road, Melbourne, Victoria 3004.
 GULLAN'S NEWSAGENCY, 88 Bridge-street, Ballarat, Victoria 3350.
 HAMPTON, A. C., 243 Mitchell-street, Bendigo, Victoria 3550.
 HARSTON, PARTRIDGE & CO. PTY. LTD., 455 Little Collins-street, Melbourne, Victoria 3000.
 KYNETON GUARDIAN PTY. LTD., P.O. Box 18, Kyneton, Victoria 3444.
 LIVINGSTON'S SHEPPARTON NEWSAGENCY, 246 Wyndham-street, Shepparton, Victoria 3630.
 THE MERCANTILE EXCHANGE, 34 Queen-street, Melbourne, Victoria 3000.
 MCGILL'S AUTHORIZED NEWSAGENCY, 183-5 Elizabeth-street, Melbourne, Victoria 3000.
 POWNEY'S AUTHORIZED NEWSAGENCY, 293 Hargreaves-street, Bendigo, Victoria 3550.
 PURDIE, J., & CO., 138 Moorabool-street, Geelong, Victoria 3220.
 SALE AUTHORIZED NEWSAGENCY, 142 Raymond-street, Sale, Victoria 3850.
 SKINNER'S AUTHORIZED NEWSAGENCY, 49-51 Franklin-street, Traralgon, Victoria 3844.
 STEVENSON, A. C. & M., NEWSAGENTS, 132 Henty-street, Casterton, Victoria 3311.
 VANCE'S AUTHORIZED NEWSAGENCY, 83 Murray-street, Wangaratta 3677.
 VERNONS OF RICHMOND, 162 Bridge-road, Richmond, Victoria 3121.
 VIEW POINT AUTHORIZED NEWSAGENCY, 4 View-Point, Bendigo, Victoria 3550.
 A copy of the Gazette is filed at each place for public reference.

THE "VICTORIA GOVERNMENT GAZETTE".

SUBSCRIPTIONS.—The subscription, including postage, is \$40 per annum, or \$20 per half year, payable in advance. Subscriptions are required for whole months, and must cover at least a half year. Single copies are 30 cents, posted 63 cents. Subscribers do not receive the Acts of Parliament with the GAZETTE. GAZETTES are held in stock for five years only. **PRIVATE ADVERTISEMENTS.**—The charge for insertion is 55 cents per line single column, and \$1.10 cents per line double column. The title forms one or more lines as a heading. On an average ten words make a line of single

column. Every signature must likewise be counted as a line. The final words of a paragraph, though only portion of a line, must be counted as one line. Signatures (in particular) and proper names must be written very plainly in the text; ONE SIDE ONLY of each sheet of paper should be WRITTEN UPON. The charge for a full page is \$85.

All documents illegibly written will be returned unpublished, and where brands occur unprovided for by the ordinary letters of the alphabet, a worded explanatory description must be furnished.

PUBLICATION.—Unless otherwise advertised, the VICTORIA GOVERNMENT GAZETTE is published on WEDNESDAY EVENING in each week, and Notices for insertion will be received by the Government Printer at or before ONE p.m. at ordinary rates, and late advertisements between ONE p.m. and half-past THREE p.m. at double rates on the day preceding the day of publication.

PAYMENTS.—Unless the advertiser has a credit account, all payments are required in advance. Remittances should be made by cheque, postal order, or money order payable to "GOVERNMENT PRINTER".

ADDRESS.—All communications should be addressed to "The Government Printer, Box 203, P.O., North Melbourne, 3051."

CONTENTS	PAGE
Appointments	1282
Cemeteries—Scale of Fees	1274
Contracts	1281
Country Roads Board	1271
Courts	1269
Estates of Deceased Persons	1280
Government Notices	1262
Impoundings	1331
Lands	1291
Melbourne and Metropolitan Board of Works— Notice	1277
Mining	1280
Notice of Making of Statutory Rules	1331
Orders in Council— Acts—Land; Local Government; Country Roads; Water; Mildura Irrigation and Water Trusts; Labour and Industry; Alcoholics and Drug Dependent Per- sons; State Electricity Commission; Cemeteries; Superannuation; Local Government; Sewerage Districts.	1283 et seq
Private Advertisements	1301
Proclamations	1261
Public Half-Holiday	1261
Public Holiday—Queen's Birthday	1262
Public Service Notices	1299
Regulations— Acts—Teaching Service	1294
Resignations	1283
State Rivers and Water Supply Commission	1276
Tenders	1293
Transport Regulation Board—Public Hearings	1263
Waterworks Trusts	1275