

[1917]



VICTORIA GOVERNMENT GAZETTE

Published by Authority

No. 44]

WEDNESDAY, JUNE 4

[1975

PROCLAMATIONS

Marine Act 1958.

AMENDMENT TO PORT RULE APPLICABLE TO WESTERNPORT HARBOR SERVICES (RATES AND CHARGES).

PORT RULE No. 132.

PROCLAMATION

By His Excellency the Governor of the State of Victoria and its Dependencies in the Commonwealth of Australia, &c., &c., &c..

WHEREAS by Part II of the *Marine Act 1958* it is amongst other things enacted that the Governor in Council by Proclamation published in the *Government Gazette*, may from time to time define the limits and boundaries of ports in Victoria and frame rules and regulations for the governance and preservation of the said ports respectively and for the regulation of shipping in the same (including the imposition of charges for the use of mooring sites and other facilities):

And that any such regulation may from time to time be in like manner altered, amended or repealed and others substituted in their stead:

Now therefore, I, the Governor of the State of Victoria in the Commonwealth of Australia by and with the advice of the Executive Council thereof, and in the exercise of the powers conferred by the said Act, by this Proclamation do hereby amend the *Proclamation dated the 26th day of November 1974 as follows:—

(1) Delete the proviso added at the end of Paragraph (A) of the Schedule to Clause 2 and substitute therefor the following:—

“ Provided that during the period between the 1st June, 1975, and the 30th November, 1975, both dates inclusive, the charges set forth in Paragraph (A) of this schedule shall be reduced by 35 per cent., unless the Governor in Council by proclamation determines otherwise.”

* S.R. No. 495/1974.

(2) Delete paragraph (B) of the Schedule to Clause 2 and substitute therefor the following:—

“ (B) MOORING OR CASTING OFF.

	During Ordinary Hours	During Overtime Hours	During Weekends, Hoildays etc.
(i) For the mooring or casting off of any vessel (except at the Stony Point Jetty) a fee of together with an additional fee—	\$ 130	\$ 160	\$ 180
(a) where more than one launch is required, then for each additional launch	100	110	120
(b) where wharf linesmen are required, then for each additional man	30	30	30
(c) except the first half hour spent in waiting pursuant to an order for mooring or casting off, a fee for each hour or part thereof	45	50	55
Provided that where no launch is required for mooring or casting off, the above fees will be reduced by	100	110	120
(ii) Upon any cancellation of an order to attend (except at the Stony Point Jetty) for any purpose, a fee of	90	100	110
(iii) For the mooring or casting off of any vessel at the Stony Point Jetty a fee of	30	30	30”

(3) Delete the proviso added at the end of Paragraph (C) of the Schedule to Clause 2 and substitute therefor the following:—

“ Provided that during the period between the 1st June, 1975, and the 30th November, 1975, both dates inclusive, the charges set forth in paragraph (C) of this schedule shall be reduced by 15 per cent. unless the Governor in Council by proclamation determines otherwise.”

(4) Delete Paragraph (D) of the Schedule to Clause 2 and substitute therefor the following:—

“ (D) TELEPHONES.

Every vessel to which a telephone is temporarily installed by the State shall pay a connection fee of \$50 and reimburse the State the cost of all trunk line calls.”

Given under my Hand and the Seal of the State of Victoria aforesaid, at Melbourne, this twenty-seventh day of May in the year of our Lord One thousand nine hundred and seventy-five in the twenty-fourth year of the reign of Her Majesty Queen Elizabeth II.

(L.S.) HENRY WINNEKE.

By His Excellency's Command,

J. F. ROSSITER,
Acting Minister of Public Works.

GOD SAVE THE QUEEN !

PORTS AND HARBORS ACT 1975, No. 8724.

PROCLAMATION

By His Excellency the Governor of the State of Victoria and its Dependencies in the Commonwealth of Australia, &c., &c., &c.

Whereas by an Act of the Parliament of the State of Victoria passed in the twenty-fourth year of the reign of Her Majesty Queen Elizabeth the Second, by the Grace of God Queen of Australia and Her other Realms and Territories, Head of the Commonwealth, intituled the *Ports and Harbors Act 1975—No. 8724*, it is amongst other things enacted that the several provisions of the said Act shall come into operation on a day or the respective days to be fixed by proclamation or successive proclamations of the Governor in Council published in the *Government Gazette*:

Now therefore I, the Governor of the State of Victoria, in the Commonwealth of Australia, by and with the advice of the Executive Council of the said State, do by this my proclamation fix the tenth day of June 1975 as the day upon which all of the provisions of the said Act shall come into operation.

Given under my Hand and the Seal of the State of Victoria aforesaid, at Melbourne, this third day of June, in the year of our Lord One thousand nine hundred and seventy-five, and in the twenty-fourth year of the reign of Her Majesty Queen Elizabeth II.

(L.S.) HENRY WINNEKE.

By His Excellency's Command,

J. F. ROSSITER,
Acting Minister of Public Works.

GOD SAVE THE QUEEN !

MARINE (FURTHER AMENDMENT) ACT 1975, No. 8723.

PROCLAMATION

By His Excellency the Governor of the State of Victoria and its Dependencies in the Commonwealth of Australia, &c., &c., &c.

Whereas by an Act of the Parliament of the State of Victoria passed in the twenty-fourth year of the reign of Her Majesty Queen Elizabeth the Second, by the Grace of God Queen of Australia and Her other Realms and

Territories, Head of the Commonwealth, intituled the *Marine (Further Amendment) Act 1975*, No. 8723, it is amongst other things enacted that the several provisions of the said Act shall come into operation on a day or the respective days to be fixed by proclamation or successive proclamations of the Governor in Council published in the *Government Gazette*:

Now therefore I, the Governor of the State of Victoria, in the Commonwealth of Australia, by and with the advice of the Executive Council of the said State, do by this my proclamation fix the fourth day of June 1975 as the day upon which all of the provisions of the said Act shall come into operation.

Given under my Hand and the Seal of the State of Victoria aforesaid, at Melbourne, this third day of June, in the year of our Lord One thousand nine hundred and seventy-five, and in the twenty-fourth year of the reign of Her Majesty Queen Elizabeth II.

(L.S.) HENRY WINNEKE.

By His Excellency's Command,
J. F. ROSSITER,
Acting Minister of Public Works.
GOD SAVE THE QUEEN!

Land Act 1958, Section 25.
ROAD PROCLAIMED.

PROCLAMATION

By His Excellency the Governor of the State of Victoria and its Dependencies in the Commonwealth of Australia, &c., &c., &c.

In pursuance of the provisions of Section 25 (3) (c) of the *Land Act 1958*, I, the Governor of the State of Victoria by and with the advice of the Executive Council of the said State do hereby proclaim as road the land in the Parish of Wedderburne County of Gladstone being the land indicated by hatching on plan hereunder:—(W.116⁽¹⁵⁾) (W.92448).

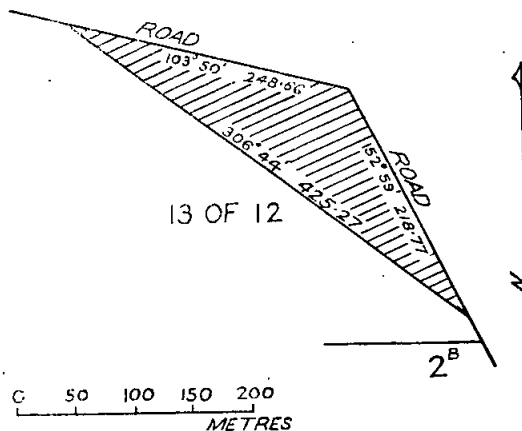

Given under my Hand and the Seal of the State of Victoria aforesaid, at Melbourne, this twenty-seventh day of May, in the year of our Lord One thousand nine hundred and seventy-five, and in the twenty-fourth year of the reign of Her Majesty Queen Elizabeth II.

(L.S.) HENRY WINNEKE.

By His Excellency's Command,
W. BORTHWICK,
Minister of Lands.

GOD SAVE THE QUEEN!

Land Act 1958, Section 25.
ROAD PROCLAIMED.

PROCLAMATION

By His Excellency the Governor of the State of Victoria and its Dependencies in the Commonwealth of Australia, &c., &c., &c.

In pursuance of the provisions of Section 25 (3) (c) of the *Land Act 1958*, I, the Governor of the State of Victoria by and with the advice of the Executive Council

of the said State do hereby proclaim as road the land in the Parish of Tandarra County of Bendigo, being the land indicated by hatching on plan hereunder:—(T.7⁽¹⁾) (W.91910).

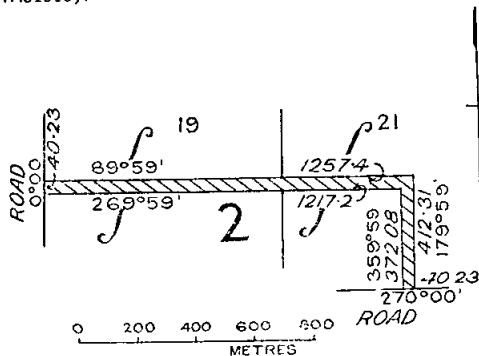

Given under my Hand and the Seal of the State of Victoria aforesaid, at Melbourne, this twenty-seventh day of May, in the year of our Lord One thousand nine hundred and seventy-five, and in the twenty-fourth year of the reign of Her Majesty Queen Elizabeth II.

(L.S.) HENRY WINNEKE.

By His Excellency's Command,
W. BORTHWICK,
Minister of Lands.
GOD SAVE THE QUEEN!

Litter Act 1964.

APPLICATION OF THE PROVISION OF SECTION 3b OF THE MUNICIPAL DISTRICT OF THE SHIRE OF MAFFRA.

PROCLAMATION

By His Excellency the Governor of the State of Victoria and its Dependencies in the Commonwealth of Australia, &c., &c., &c.

Whereas by the *Litter Act 1964*, section 3b it is provided that the Governor in Council on the application of the Council of a municipality may by proclamation published in the *Government Gazette* declare that the municipal district of the municipality or any part thereof shall be a district to which the said section applies.

And whereas the Council of the municipality of the Shire of Maffra has made application to have its municipal district declared to be a district to which the said section 3b applies.

Now therefore, I, the Governor of the State of Victoria, in the Commonwealth of Australia, by and with the advice of the Executive Council of the said State do by this Proclamation declare that the municipal district of the Shire of Maffra shall be a district to which the provisions of section 3b of the *Litter Act 1964* applies.

Given under my Hand and the Seal of the State of Victoria aforesaid, at Melbourne, this twenty-seventh day of May, in the year of our Lord One thousand nine hundred and seventy-five, and in the twenty-fourth year of the reign of Her Majesty Queen Elizabeth II.

(L.S.) HENRY WINNEKE.

By His Excellency's Command,
A. J. HUNT,
Minister for Local Government.
GOD SAVE THE QUEEN!

Stock Food Act 1958.

ALTERING THE CHEMICAL STANDARDS OF POLLARD.

PROCLAMATION

By His Excellency the Governor of the State of Victoria and its Dependencies in the Commonwealth of Australia, &c., &c., &c.

Whereas by sub-section (3) of Section 16 of the *Stock Foods Act 1958* it is amongst other things provided that the Chief Chemist of the Department of Agriculture shall in every year conduct chemical, physical and milling tests

upon a portion of the official fair average quality wheat sample fixed for that year and that if necessary the Second Schedule to the Stock Foods Act 1958 shall by Proclamation of the Governor in Council published in the *Government Gazette* be amended by altering any standard provided for therein in accordance with the results of those tests; and whereas as a consequence of the chemical, physical and milling tests conducted by such Chief Chemist upon a portion of the official fair average quality wheat sample fixed for the year 1974-75 it is necessary to amend the said Schedule by altering the chemical standards provided for therein to accord with the results of those tests:

Now therefore, I, the Governor of the State of Victoria by and with the advice of the Executive Council thereof, do by this my Proclamation amend the said Schedule as follows:—

1. For the expression "12.5 per cent" which, by virtue of the Proclamation of the twenty-first day of May, 1974, published in the *Government Gazette* of the twenty-ninth day of May, 1974 appears in the first line of the sentence opposite the words "Chemical Standard" under the heading "Pol-lard" there shall be substituted the expression "12.0 per cent".

Given under my Hand and the Seal of the State of Victoria aforesaid, at Melbourne, this twenty-seventh day of May, in the year of our Lord One thousand nine hundred and seventy-five, and in the twenty-fourth year of the reign of Her Majesty Elizabeth the Second, Queen of Australia.

(L.S.) HENRY WINNEKE.

By His Excellency's Command,

IAN SMITH,
Minister of Agriculture.

GOD SAVE THE QUEEN!

GOVERNMENT NOTICES

PUBLIC HOLIDAY.—QUEEN'S BIRTHDAY.

It is hereby notified that on—

MONDAY, THE 16TH JUNE, 1975,

the Public Offices will be closed, such day having been appointed under the provisions of the *Public Service Act 1958*, to be observed as a holiday in the Public Offices throughout the State of Victoria.

This notice relates only to the closing of the State Public Offices. All inquiries regarding the holiday in other offices and in shops and industry should be directed to the Department of Labour and Industry, 110 Exhibition Street, Melbourne, 3000. (Telephone 651 6158 or 651 6859).

J. F. ROSSITER,
Chief Secretary.

Chief Secretary's Office,
Melbourne, 12th May, 1975.

Co-operation Act 1958.

CHANGE OF NAME OF A SOCIETY.

Notice is hereby given that Numurkah, East Goulburn A.B. Co-operative Limited which was incorporated as a producers society under the above-named Act on the 12th day of August, 1970, has registered a change of its name and is now incorporated under the name of Numurkah, East Goulburn H.I. Co-operative Limited under the said Act.

Dated at Melbourne, this 21st day of May, 1975.

N. F. CURRY,
Acting Deputy Registrar of Co-operative Societies.

Co-operation Act 1958.

MOORABBIN BOWLING CLUB CO-OPERATIVE LIMITED.
BURWOOD HIGH SCHOOL CO-OPERATIVE LIMITED.

Notice is hereby given, in pursuance of section 78 (7) of the *Co-operation Act 1958* and section 308 (2) of the *Companies Act 1961* that, at the expiration of three months from the date hereof, the names of the afore-mentioned societies will, unless cause is shown to the contrary, be struck off the register and the societies will be dissolved.

Dated this 16th day of May, 1975.

N. F. CURRY,
Acting Deputy Registrar.

SHIRE OF WERRIBEE.

ROAD DEVIATION.

Pursuant to the provisions of sections 522 and 526 of the *Local Government Act 1958* the Council of the Shire of Werribee hereby directs that the land in the Parish of Mambourin indicated by hatching on the diagram here-under which has been purchased taken or acquired by it, shall be a public highway on and from the date of publication of this Order in the *Government Gazette* and declares that such land shall be a public highway in lieu of the land indicated by cross-hatching on the said diagram.

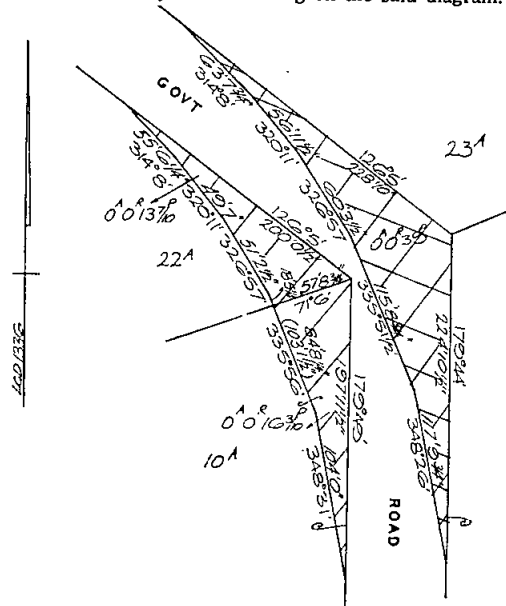

MEASUREMENTS ARE IN FEET AND INCHES.

The common seal of the President, Councillors and Ratepayers of the Shire of Werribee was hereunto affixed, on the 8th day of July, 1974, in the presence of—

(SEAL) R. N. DAWE, Shire President.
W. R. HUDSON, Councillor.
J. T. KERR, Shire Secretary.

Confirmed by the Governor in Council, 27th May, 1975.—
TOM FORRISTAL, Clerk of the Executive Council.

Labour and Industry Act 1958.

ORDER OF EXEMPTION UNDER SECTION 80c.

Whereas pursuant to section 80c of the *Labour and Industry Act 1958* as amended by the *Labour and Industry (Further Amendment) Act 1969* and the *Labour and Industry (Amendment) Act 1972* the Council of the Shire of Sherbrooke has applied to the Minister for an order exempting certain shopkeepers of a shop in its municipal district from being required to close and keep closed their shop in accordance with the provisions of Part VI. of the said Act:

And whereas I have considered the report of the Minister of Tourism obtained in accordance with the provisions of sub-section (4) of section 80c of the said Act:

Now therefore, I, Joseph Anstice Rafferty, Her Majesty's Minister of Labour and Industry in the State of Victoria, do pursuant to the aforesaid section 80c of the *Labour and Industry Act 1958* make this order granting exemption to:

Henry Patrick Fitzherbert and Elaine Gertrude Fitzherbert of Main Road, Sassafras, being shopkeepers within the Shire of Sherbrooke from being required to close and keep closed their shop on—

Saturdays between the hours of 1 p.m. and 6 p.m.

and
Sundays and public holidays between the hours of 9 a.m. and 6 p.m.

provided that such exemption shall not apply to Good Friday or Anzac Day.

Dated at Melbourne this 23rd day of May, 1975.

J. A. RAFFERTY,
Minister of Labour and Industry.

Transport Regulation Act.
TRANSPORT REGULATION BOARD.

HEARING OF APPLICATIONS.

Notice is hereby given that the following applications will be considered by the Transport Regulation Board on 24th June, 1975.

DEE, J. M., 27 Gordon Crescent, Seymour. Application by the holder of seven C.T. licences for an additional commercial passenger vehicle with seating capacity for five persons to operate as a country taxi cab at Seymour.

KNEEBONE, M. A. J. & J. E., Fisher Terrace, Lang Lang. Application for one commercial passenger vehicle with seating capacity for 44 persons to operate for the carriage of school children between Devon Meadows and Koo-Wee-Rup under temporary contract to the Education Department.

MAGOR, R. N., 127 Lake Street, Edenhope. Application for one commercial passenger vehicle with seating capacity for 41 persons to operate for the carriage of school children between Wombelano and the Edenhope High School, under contract to the Education Department.

PINCINI, E. J. & L., 40 McIntosh Street, Airport West. Application for one commercial passenger vehicle with seating capacity for 42 persons to operate as follows: (a) For the carriage of school children only between Gisborne South and the Gisborne Primary School, under contract to the Education Department. (b) As a country special service omnibus from Gisborne.

SARATSIOTIS, D., 4 Lorna Avenue, Northcote. Application for one commercial passenger vehicle with seating capacity for 12 persons to operate for the carriage of students, free of charge, between their homes and the Greek Language and Sunday schools as follows:—

(i) From the corner of High Street and Darebin Road, Northcote, via Darebin and Victoria Roads, Jenkins, St. David and Dennis Streets to the school.

Timetable: Mondays and Thursdays

Depart Northcote	4.00 p.m.
Arrive School	4.30 p.m.
Depart School	7.15 p.m.
Arrive Northcote	7.45 p.m.

(ii) From the corner of High and Benjamin Streets, Thornbury, via Benjamin, Ethel, Hutton, Clapham and Balantyne Streets, St. Georges Road, Woolton Avenue, Spencer and Gadd Streets, St. Georges and Beavers Roads, High and Dennis Streets to the School.

Timetable: Mondays and Thursdays

Depart Thornbury	4.30 p.m.
Arrive School	5.00 p.m.
Depart School	7.45 p.m.
Arrive Thornbury	8.15 p.m.

(iii) From the corner of Plenty Road and Gregory Grove, East Preston, via Gregory, Kitchener and Sylvester Groves, Dean and Wood Streets, Gordon Grove, Marjorie Street, Murray Road, Albert, Chalyer, McColl, Rene and Plenty Roads, Madeline, McColl and Wood Streets, Plenty Road, High and Dennis Streets to the school.

<i>Timetable:</i>	Tuesday	Saturday
Dep. East Preston	4.00 p.m.	9.00 a.m.
Arrive School	4.30 p.m.	9.30 a.m.
Dep. School	7.15 p.m.	12.15 p.m.
Arrive East Preston	7.45 p.m.	12.45 p.m.

(iv) From the corner of Arthurton Road and Auburn Avenue Northcote via Auburn Avenue, Osborne Street, Auburn, and Shakespeare Avenues, Arthurton Road, Woolhouse and Bent Streets, St. Georges and Beavers Roads, Woolhouse and Gladstone Streets, St. Georges Road, Beaconsfield Parade, Leinster Grove, Woolton, High and Dennis Streets to the school.

<i>Timetable:</i>	Tuesday	Saturday
Dep. Northcote	4.30 p.m.	9.30 a.m.
Arrive School	5.00 p.m.	10.00 a.m.
Dep. School	7.45 p.m.	12.45 p.m.
Arrive Northcote	8.15 p.m.	1.15 p.m.

(v) From the corner of Oakhill Avenue and Xavier Grove, East Preston, via Xavier Grove, Capp Street, Ethel Grove, Oakhill Avenue, Tyler Street, Plenty Road, Tyler, McColl, Newham, McColl and Rene Streets, Plenty Road, Gower, Belgrove, Bell, Hotham, St. David and Dennis Streets to the school.

Timetable: Saturday

Depart East Preston	11.00 a.m.
Arrive School	12.00 noon
Depart School	6.00 p.m.
Arrive East Preston	7.00 p.m.

(vi) From the corner of Dalton Road and The Boulevard, Thomastown, via The Boulevard, Ash, Messmate, Cyprus, French, David, Blackburn, Ruth, Delmare, Queen, Louise, Ruth, Blackburn, David, Jean and Ash Streets, The Boulevard, Acacia and Cedar Streets to the school.

Timetable: Wednesday and Friday

Depart Thomastown	4.00 p.m.
Arrive School	4.30 p.m.
Depart School	7.15 p.m.
Arrive Thomastown	7.45 p.m.

(vii) From the corner of Station and Cedar Streets, Thomastown, via Station, Derrick, French, Heath and Mulgha Streets, The Boulevard, Waratah, Belah and Cedar Streets to the school.

Timetable: Wednesday and Friday

Depart Thomastown	4.30 p.m.
Arrive School	5.00 p.m.
Depart School	7.45 p.m.
Arrive Thomastown	8.15 p.m.

TOURNAS, C., 17 Louise Street, Lalor. Application for one commercial passenger vehicle with seating capacity for 12 persons to operate for the carriage of students, free of charge, between their homes and the Greek Language and Sunday Schools at follows:—(i) From the corner of Roxburgh and Dundas Streets, Thornbury via Dundas, Archibold, Pender, St. David, Collins, High, Flinders, St. David, Rossmoyne, High, Raleigh, St. David, Clarendon, High, Martin, St. David, Clyde and Wales Streets, Darebin Road, St. David and Dennis Streets to the school.

Timetable: Sundays and Thursdays

Depart Thornbury	4.00 p.m.
Arrive School	4.30 p.m.
Depart School	7.15 p.m.
Arrive Thornbury	7.45 p.m.

(ii) From the corner of High and Pender Streets, Thornbury via Pender, Archibold, Collins, St. David, Flinders, Newcastle, Mansfield, St. David, Rossmoyne, Wales, Gooch, St. David, Raleigh, Wales, Clarendon, St. David and Dennis Streets to the school.

Timetable: Sundays and Thursdays

Depart Thornbury	4.30 p.m.
Arrive School	5.00 p.m.
Depart School	7.45 p.m.
Arrive Thornbury	8.15 p.m.

(iii) From the corner of Oakhill Avenue and Northernhay Street, Preston, via Northernhay, Alexandra and Southernhay Streets, Oakhill Avenue, McIvor and Capp Streets, Xavier Grove, Oakhill Avenue, Tyler Street, Plenty Road, Goldsmith and Tennyson Avenues, Wood, High, Spencer, Williams, Regent and Spring Streets, Murray and St. Georges Roads, Bell, High and Dennis Streets to the school.

Timetable: Tuesdays Saturdays

Depart Preston	4.00 p.m.	9.00 a.m.
Arrive School	4.30 p.m.	9.30 a.m.
Depart School	7.15 p.m.	12.15 p.m.
Arrive Preston	7.45 p.m.	12.45 p.m.

(iv) From the corner of Plenty Road and Pender Street, Preston, via Pender Street, Central Avenue, Beauchamp Street, Plenty, Murray and Plenty Roads, Townhall Avenue, Kelvin Grove, Gower, High and David Streets, Plenty Road, Raglan Street, Milton Crescent, Plenty Road, High and Dennis Streets to the school.

Timetable: Tuesdays Saturdays

Depart Preston	4.30 p.m.	9.30 a.m.
Arrive School	5.00 p.m.	10.00 a.m.
Depart School	7.45 p.m.	12.45 p.m.
Arrive Preston	8.15 p.m.	1.45 p.m.

(v) From the corner of The Boulevard and French Street, Thomastown, via French, Heath and Wilgha Streets, The Boulevard, Belah, Cedar and Acacia Streets, Alexander Avenue, Dalton Road, Talbot Avenue, Darebin Drive, Regal Avenue, Darebin and Dalton Roads, Monash, Partridge, Station, High and Dennis Streets to the school.

Timetable: Saturdays

Depart Thomastown	11.00 a.m.
Arrive School	12.00 noon
Depart School	6.00 p.m.
Arrive Thomastown	7.00 p.m.

(vi) From the corner of Dalton Road and Darebin Drive, Thomastown, via Darebin Drive, Bates Avenue, Stella Drive, Regal Avenue, Darebin Drive, McKimmies Road, Lacey and Lynne Streets, Kirwan Avenue, Dalton Road, Waratah, Boronia and Cedar Streets to the school.

Timetable: Wednesdays and Fridays

Depart Thomastown	4 00 p.m.
Arrive School	4 30 p.m.
Depart School	7 15 p.m.
Arrive Thomastown	7 45 p.m.

(vii) From the corner of Station and Cedar Streets, Thomastown, via Cedar, Station, High and Travers Streets, Mountview Road, Main Street, Norman Grove, Caroline and Johnston Streets, Lois Court, Johnston, Spring, Simpson and Main Streets, Edgars Road, Gladstone, Harbard, Main and Tilbury Streets, Banksia Avenue, Stephen Court, Banksia Avenue, Tilbury, Main, High, Station and Cedar Streets to the school.

Timetable: Wednesdays and Fridays

Depart Thomastown	4 30 p.m.
Arrive School	5 00 p.m.
Depart School	7 45 p.m.
Arrive Thomastown	8 15 p.m.

Applications for renewal of licences as shown by the persons listed hereunder to operate under the same terms and conditions:—

KRAHE, R. W., 41 Baillie Street, Horsham; C.O.861.
MURRAY VALLEY COACHES S.A. LTD., 11 Franklin Street, Adelaide; C.O.28, C.O.85, C.O.87, C.O.204, C.O.315, C.O.970.

SARTORIO, P., 122 Suffolk Street, West Footscray; M.T.4612.

Notice of any objections should be forwarded to reach the Secretary of the Board not later than 18th June, 1975.

Applicants are advised that it will not be necessary to appear on the hearing date specified, unless advised in writing by the Board.

A. V. C. COOK,
Secretary.

Corner Lygon and Princes Streets, Carlton, 3055,
Wednesday, 4th June, 1975.

Commercial Goods Vehicles Act.
TRANSPORT REGULATION BOARD.
HEARING OF APPLICATIONS.

Notice is hereby given that the following applications will be considered by the Transport Regulation Board on 24th June, 1975.

ADAMS, WILLIAM, TRACTORS PTY. LTD., Nantilla Road, Clayton, 3168. Two commercial goods vehicles (L/C. 0-80 tonne) to operate throughout the State of Victoria in the course of business as "Distributor of Earthmoving and Industrial Equipment"—tools of trade, spare parts and materials incidental to repairing and servicing earthmoving and industrial equipment on site.

BROADBENT, K. H., 324 Centre Road, Bentleigh, 3204. Application to vary the conditions of licence No. D.A.62217/1 (L/C. 7-85 tonne) by adding an additional paragraph—"From Lara to own yard at Bentleigh—own rock".

BURL, W. F., 205 Grimshaw Street, Greensborough, 3088. Application to vary the conditions of licence No. D.A.60525/2 (L/C. 6-80 tonne) by deleting "City Brick Works Co. Pty. Ltd. at Malvern" and adding in lieu "Brick and Pipe Industries at Oakleigh".

COLLETT, G., 63 Biram Drive, Warragul, 3820. One commercial goods vehicle (L/C. 5-30 tonne) to operate: (a) Within a 40-km radius of Warragul Post Office—general goods. (b) Between Hallam and Traralgon on behalf of the Victorian Railways Board—maintenance equipment and materials required for maintenance work.

DE BONO, J., 48 Hilma Street, West Sunshine, 3020. One commercial goods vehicle (L/C. 10-80 tonne) to operate within an 80-km radius of the premises of Albion Reid Pty. Ltd. at Hawthorn solely on behalf of the said company—road-making plant, hot asphalt, premix and road-making materials excluding the carriage of lime and cement from places within a 13-km radius of the chief post office in the City of Geelong.

DEFTEREOS, S., 9 Wilson Street, Malvern, 3144. One commercial goods vehicle (L/C. 12-20 tonne) to operate within an 80-km radius of the G.P.O., Melbourne, on behalf of Albion Reid Pty. Ltd.—road-making plant, hot asphalt premix and road-making materials

but excluding the carriage of cement and lime from places within a 13-km radius of the chief post office in the City of Geelong.

DENNI, W., 3 McNeilage Street, Spotswood, 3015. One commercial goods vehicle (L/C. 12-10 tonne) to operate within an 80-km radius of the G.P.O., Melbourne, solely on behalf of Albion Reid Pty. Ltd.—road-making plant, hot asphalt, premix and road-making materials but excluding the carriage of cement and lime from places within a 13-km radius of the chief post office in the City of Geelong.

ELLIS, K. A. & J. I., 10 Glen Dhu Road, Kilsyth, 3137. One commercial goods vehicle (L/C. 9-30 tonne) to operate: (a) Within an 80-km radius of the premises of K.M.M. Pty. Ltd. at Kensington, solely on behalf of the said company—bulk stockfeed and flour in a specially constructed bulk tanker unit. (b) From the premises of K.M.M. Pty. Ltd. at Kensington to places within that part of an 80-km radius of the G.P.O., Melbourne, situated east of a north/south line drawn through the City of Melbourne and to the City of Morwell solely on behalf of the said company—bulk stockfeed in a specially constructed bulk tanker unit.

GLADMAN, A. K., Serpentine, 3517. One commercial goods vehicle (L/C. 14-70 tonne) to operate: (a) Within a 32-km radius from the post office at Serpentine—general goods. (b) Within an 80-km radius from the post office at Serpentine in the course of business as "Earth-moving Contractor"—own tools of trade, earth-moving plant and equipment incidental only to own contracts.

GOODBODY, J., 206 Neale Street, Bendigo, 3550. One commercial goods vehicle (L/C. 15-60 tonne) to operate: (a) From Melbourne to Bendigo for the carriage of roofing tiles, roof battens, and an occasional box of nails, returning with empty pallets. (b) From Melbourne to Bendigo solely on behalf of B.P. Australia Ltd. for the carriage of petroleum products in prescribed types of containers and empty containers on return. (c) From Melbourne to Bendigo for the carriage of uncrated Victa and uncrated Gyprock plaster board and associated accessories.

HAYES, A. J., Sullivan Street, Inglewood, 3517. One commercial goods vehicle (L/C. 7-65 tonne) to operate: (a) From within a 40-km radius of Inglewood—general goods. (b) From Inglewood to Boort, Wyche-proof, Geelong and the Melbourne metropolitan area—firewood.

IRWIN MOTORS PTY. LTD., 31 Wilson Street, Horsham, 3400. One commercial goods vehicle (L/C. 0-75 tonne) to operate within a 120-km radius of own premises at Horsham in the course of business as "Farm Machinery Agent"—farm machinery for demonstration purposes and/or for repair or having been repaired together with tools of trade and spare parts incidental to the demonstration or servicing of such machinery.

NOTE.—That all spare parts carried on the vehicle shall be for use in servicing farm machinery in the field only and all such spare parts carried shall have been initially consigned by rail to Horsham.

ILIAS, V. & E., 3 Larch Street, Thomastown, 3074. One commercial goods vehicle (L/C. 10-80 tonne) to operate within an 80-km radius of the G.P.O., Melbourne on behalf of Albion Reid Pty. Ltd.—road-making plant, hot asphalt, premix and road-making materials but excluding the carriage of cement and lime from places within a 13-km radius of the chief post office in the City of Geelong.

JOHNSTON, R., corner Prince and King Streets, Myrtleford, 3737. One commercial goods vehicle (L/C. 3-65 tonne and 0-75 tonne trailer) to operate throughout the Shire of Bright in the course of business as "Sanitary Contractor".

LIAPIS, A., 14 Elphinstone Street, West Footscray, 3012. One commercial goods vehicle (L/C. 18-10 tonne) to operate within an 80-km radius of the premises of Albion Reid Pty. Ltd. at Hawthorn solely on behalf of the said company—road-making plant, hot asphalt, premix and road-making materials excluding the carriage of lime and cement from places within a 13-km radius of the chief post office in the City of Geelong.

LINDSEY, F. T., 5 Yorkshire Street, Pascoe Vale, 3044. One commercial goods vehicle (L/C. 1-00 tonne) to operate within an 80-km radius from the post office situated at the corner of Bourke and Elizabeth Streets in the City of Melbourne in the course of business as "Television Installation Specialist"—tools of trade, television aerials, television sets and materials incidental to the installation thereof.

- LOCAL MIX CONCRETE PTY. LTD.**, 13 Elcho Street, Newtown, 3220. One commercial goods vehicle (L/C. 10.15 tonne) to operate within an 80-km radius of the chief post office in the City of Geelong in the course of business as "Premixed Concrete Manufacturers"—own premixed concrete in a specially constructed agitator vehicle.
- MANDALIS, J.**, 34 Cypress Avenue, Glen Waverley, 3051. One commercial goods vehicle (L/C. 11.00 tonne) to operate within an 80-km radius of the premises of Albion Reid Pty. Ltd. at North Melbourne solely on behalf of the said company—road-making plant, hot asphalt, premix and road-making materials excluding the carriage of lime and cement from places within a 13-km radius of the chief post office in the City of Geelong.
- MUCCILLO, N.**, 9 Chamberlain Road, Newborough, 3828. Application to vary the conditions of licence No. D.A.65890 (L/C. 2.50 tonne) by adding an additional paragraph (c) "From the site of any contract to own premises at Newborough surplus materials but excluding the carriage of materials from places within a 40-km radius of the G.P.O., Melbourne".
- MCDONALD, J. A.**, 79 Main Street, Winchelsea, 3241. One commercial goods vehicle (L/C. 7.85 tonne) to operate: (a) Within a 40 km radius of the post office at Winchelsea—general goods. (b) From the premises of Permacrete Concrete Tanks (Winchelsea) Pty. Ltd. an approved decentralized industry (concrete tank and trough manufacturers) at Winchelsea to places situated within a 160-km radius therefrom—concrete tanks and concrete troughs. (c) Throughout the State of Victoria on behalf of Wattie Pict Ltd. and Cottee's General Foods Ltd.—pea harvesting machinery solely when carried between harvesting sites or from harvesting sites to storages. (d) From Melbourne to Winchelsea—uncrated cement sheets (in less than wagon load lots). (e) Within a 40-km radius of Winchelsea and to Melbourne—livestock.
- MCDONNELL, N. F., & SONS, P.O. Box 434, Mount Gambier, S.A., 5290.** One commercial goods vehicle (L/C. 17.20 tonne) to operate: (a) Goods associated with the approved decentralized secondary industry of Nestles Co. (Aust.) Limited at Dennington as follows—(i) From Portland to the premises of the said company at Dennington—raw materials and goods the property of the said Nestles Co. (Aust.) Limited and required for use in the decentralized industry. (ii) From the premises of the said company at Dennington to Portland—manufactured products of such decentralized industry.
- NELSON TOBACCO CO. PTY. LTD.**, 135 McCrae Street, Bendigo, 3550. Five commercial goods vehicles (L/C. 1.00, 1.00 1.00 1.00, 1.50 tonne) to operate within an 80-km radius of own branch premises at Bendigo and to Gisborne and Kerang in course of business as "Wholesale Cigarette and Tobacco Distributors"—own cigarettes and tobacco provided that all such goods are initially consigned by rail to Bendigo.
- NELSON TOBACCO CO. PTY. LTD.**, 11 Butterworth Street, Swan Hill, 3850. One commercial goods vehicle (L/C. 1.50 tonne) to operate within an 80-km radius of own branch premises at Swan Hill in course of business as "Wholesale Cigarette and Tobacco Distributors"—own cigarettes and tobacco provided that all such goods are initially consigned by rail to Swan Hill.
- PEARSON, R. J.**, "Hazelvale", Almurta, 3979. Application to vary the conditions of licence No. D.A.66768 (L/C. 11.00 tonne) by deleting from paragraph (b) "80 km" and adding in lieu "160 km".
- PEOPLES, J. T.**, 11 Wilson Street, Terang, 3264. One commercial goods vehicle (L/C. 5.60 tonne) to operate: (a) Within a 40-km radius of the post office at Terang—general goods. (b) Within an 80-km radius of the post office at Terang—livestock.
- PLACE, J.**, 16 Munro Street, Mitcham, 3132. One commercial goods vehicle (L/C. 7.40 tonne) to operate: (a) Within a 40-km radius of own premises at Ringwood in the course of business as "Soil, Sand, Screening and Garden Supply"—own goods. (b) From Bacchus Marsh to own premises at Ringwood—own river pebbles. (c) From Beveridge to own premises at Ringwood—own scoria. (d) From Gilderoy and Toolangi to own premises at Ringwood—own mountain soil. (e) From Melton, Rockbank and Werribee to own premises at Ringwood—own rock.
- POXON, G. J.**, 4 Benga Avenue, Dandenong, 3175. Application to vary the conditions of licence No. D.A.46829 (L/C. 12.20 tonne) by deleting the existing conditions and adding in lieu—"Within a 52-km radius of G.P.O., Melbourne and to and from Broadford solely on behalf of Concrete Industries Monier Ltd.—sand, soil, screenings and quarry products".
- RAMSBELL, P. F.**, 12 Jefferson Avenue, Lakes Entrance, 3909. Application to vary the conditions of licence No. D.T.1538 (L/C. 19.10 tonne) by adding an additional paragraph—"(b) From places within a 24-km radius of Combiobar to the Combiobar Sawmill—sawmill logs".
- ROBERTS, A.**, 18 Sturt Street, Ballarat, 3350. One commercial goods vehicle (L/C. 0.40 tonne) to operate throughout the State of Victoria in the course of business as "Hawker"—clothing for sale to householders and machine for fixing transfers to clothing.
NOTE.—Clothing shall not be supplied to retail stores for re-sale.
- SERRANO, FRANCESCO**, corner Emu Street and Hampstead Road, Maidstone, 3012. One commercial goods vehicle (L/C. 15.00 tonne) to operate: (a) Within a 40-km radius of own premises at Maidstone in the course of business as "Soil, Screening and Garden Supply"—own goods. (b) From Toolangi and Gilderoy to own premises at Maidstone—own mountain soil. (c) From Bacchus Marsh to own premises at Maidstone—own river pebbles.
- SMITH, F. G.**, Cann River, 3889. One commercial goods vehicle (L/C. 17.00 tonne) to operate: (a) Within that part of the State of Victoria, east of a north/south line drawn through Bairnsdale and south of an east/west line drawn through Omeo in the course of business as "Bridge Builders"—tools of trade, machinery, equipment and materials incidental to the completion of own contracts. (b) From quarries at Stratford and Lindenow to bridge sites as described in paragraph (a)—aggregate and sand.
- SPIZZIRRI, F.**, 113 Kemp Street, Springvale, 3171. Application to vary the conditions of licence No. D.A.61792 (L/C. 6.90 tonne) by deleting from paragraph (b) "The City Brick Works Co. Pty. Ltd. at Tooronga" and adding in lieu "Clifton Brick Holdings Ltd., Oakleigh Division".
- STRAUSS PLANT HIRE PTY. LTD.**, Whitehorse Road, Mōlop, 3219. Application to vary the conditions of licence No. D.A.67708 (L/C. 3.90 tonne) by deleting the words "own goods" in paragraph (a) "own premises" in paragraph (b) and "own premises" in paragraph (c) and adding in lieu—"Goods the property of G. W. Strauss" to paragraph (a) and the words "The premises of G. W. Strauss" to paragraphs (b) and (c).
- TREE, L. F.**, CARAVAN PARK, Hume Highway, Broadford, 3658. One commercial goods vehicle (L/C. 1.90 tonne) to operate throughout the State of Victoria in the course of business as "Marine Dealer"—marine goods, special wares and old metals as designated in the *Marine Stores and Old Metals Act 1958*, No. 6303, Part 1, section (3) but excluding the carriage of any such goods to wharves, docks or ships for shipment or export purposes, with the proviso that the combined load capacities of both prime mover and any trailer attached thereto shall not exceed 6.00 tonnes.
- VICTORIA GRAINS STORE PTY. LTD.**, 48 Wellington Street, Collingwood, 3066. One commercial goods vehicle (L/C. 0.85 tonne) to operate throughout the State of Victoria in the course of business as "Grain Store" for the purpose of servicing own motor vehicles—tools of trade, spare parts and materials incidental to on-site servicing.
- VICTORIA GRAINS STORE PTY. LTD.**, 48 Wellington Street, Collingwood, 3066. One commercial goods vehicle (L/C. 14.00 tonne) to operate within a 241-km radius of own premises at Collingwood and to and from places within a 40-km radius of Kergunyah in the course of business as "Brewers Grains Merchants"—own wet brewers grains and wire mesh silos (empty) being moved from farm to farm.
- WALLACE & TIERNAN PTY. LTD.**, 4 Park Road, Oakleigh, 3161. One commercial goods vehicle (L/C. 0.80 tonne) to operate throughout the State of Victoria in the course of business as "Chemical Metering and Dosing Equipment Servicemen"—tools of trade, equipment and a limited quantity of spare parts incidental to the completion of on-site servicing contracts only.
- ZYPPEL, E. & M. M.**, 104 Britannia Street, West Geelong, 3218. Application to vary the conditions of licence No. D.A.66458/1 (L/C. 3.30 tonne) by deleting from the existing conditions in paragraph (b) "Within an 80-km radius of the chief post office in the City of Geelong" and adding in lieu "Throughout the State of Victoria".

TOW TRUCK.

JONES, R. A., Maurice Avenue, Mallacoota, 3889. One commercial goods vehicle (L/C. 1.50 tonne) to operate within that part of the State of Victoria east of a north/south line drawn through the township of Orbost as a "Tow Truck" for the purpose of lifting and carrying or towing and/or repairing wrecked or disabled vehicles—tools of trade, spare parts and materials incidental thereto.

RENEWALS.

Applications for renewal of licences as shown by persons listed hereunder to operate under the same terms and conditions from the expiry shown in each case.

ATKINS, V. J., 121 Darebin Boulevard, Reservoir, 3073; D.A.64822; 2nd November 1975; 6.80 tonne.
 ALFA LAVAL PTY. LTD., 56-60 Keon Parade, Keon Park, 3073; D.A.22799/6; 17th November, 1975; 0.50 tonne.
 BAYER AUSTRALIA LTD., 633-647 Springvale Road, Glen Waverley, 3150; D.A.438044/5; 13th November, 1975; 0.50 tonne and 0.50 tonne trailer.
 BOOTS CO. (AUST.), PTY. LTD., THE, 24 Woorayl Street, Carnegie, 3163; D.A.36645/10; 27th November, 1975; 0.50 tonne.
 BRYCE, ROBERT (MACHINERY) PTY. LTD., 147 Glenlyon Road, Brunswick, 3056; D.A.65700/1; 17th April, 1975; 0.75 tonne.
 BURSON AUTO PRODUCTS PTY. LTD., 19 Mologa Road, West Heidelberg, 3081; T.D.A.66953; 25th November, 1975; 1.70 tonne.
 CHISHOLM, R. A., 9 Mason Court, East Oakleigh, 3166; D.A.22647/1; 9th November, 1975; 6.95 tonne.
 COLES, G. J. & Co. LTD., 236 Bourke Street Melbourne, 3000; D.A.867/5; 11th November, 1975; 0.65 tonne.
 COMMONS, F. E., 46-48 Cook Street, Flinders, 3929; D.A.61005; 14th August, 1975; 5.35 tonne.
 COMMONWEALTH INDUSTRIAL GASES LTD., THE, 90 Bell Street, Preston, 3072; D.A.838/41; 29th November, 1975; 7.55 tonne.
 COOMBS, A. G., SERVICING PTY. LTD., 26 Cochranes Road, Moorabbin, 3189; D.A.891/27; 29th November, 1975; 7.50 tonne.
 COUTTS, T. J., PTY. LTD., 54 Lydiard Street North, Ballarat, 3350; D.A.7611/14; 13th September, 1975; 0.40 tonne.
 CROSBY, WILLIAM, (MERCHANDISE) PTY. LTD., 31-49 Queensbridge Street, South Melbourne, 3205; D.A.916/2; 21st November, 1975; 1.30 tonne.
 CURSARO, P. & A., 1055 Burwood Highway, Ferntree Gully, 3156; D.A.61264; 20th November, 1975; 2.75 tonne.
 DENHAM CONSTRUCTIONS PTY. LTD., P.O. Box 32, Mornington, 3931; D.A.37214; 16th November, 1975; 7.45 tonne.
 DETNOR MOTORS PTY. LTD., 20 Chisholm Street, Wangaratta, 3677; D.A.49502; 18th November, 1975; 1.00 tonne and 1.00 tonne trailer.
 DEVERALL, A. M. & W. T., Box 17, Gisborne, 3437; D.A.44947; 20th November, 1975; 7.15 tonne.
 DORE, J. R., 22 McLeod Road, Carrum, 3197; D.A.63565; 13th November, 1975; 2.30 tonne.
 DUNLOP TYRE SERVICE (VIC.) PTY. LTD. (Bairnsdale Branch), 108 Flinders Street, Melbourne, 3000. D.A.60416/8; 23rd November, 1975; 1.60 tonne.
 DUNLOP TYRE SERVICE (VIC.) PTY. LTD. (Colac Branch), 108 Flinders Street, Melbourne, 3000. D.A.60416/41; 18th November, 1975; 0.70 tonne.
 DUNLOP TYRE SERVICE (VIC.) PTY. LTD. (Geelong Branch), 108 Flinders Street, Melbourne, 3000; D.A.60416/121; 13th September, 1975; 3.55 tonne.
 DUNN, G. E. & L. M., 2 Dimar Road, Dingley, 3172; T.D.A.64200; 16th November 1975; 6.10 tonne.
 F.M.C. (AUST.) LTD., 58 Whiteside Road, Clayton, 3168; D.A.50816/1; 9th November, 1975; 0.75 tonne; D.A.50816/5; 13th November, 1975, 0.30 tonne.
 FLYNN, F. H., 21 Spearing Street, Wangaratta, 3677; D.A.37345; 16th November, 1975; 0.50 tonne.
 FOX, ALBERT H., PTY. LTD., 6 Regent Court, Warragul, 3820; D.A.35038/4; 5th November, 1975; 0.70 tonne.
 GARDNER & NAYLOR PTY. LTD., 192 Burwood Road, Hawthorn, 3122; D.A.1128, 21st November, 1975; 0.75 tonne.
 GARY & Co. PTY. LTD., 106 Bible Street, Eltham, 3095; D.A.61249/1; 20th November, 1975; 1.00 tonne.
 GREEN, F. L., Standish Street, Myrtleford, 3737; D.A.48511/1; 5th November, 1975; 16.55 tonne.
 GUNN, B. J., 62 Vine Street, Bendigo, 3550; D.A.50474; 18th November, 1975; 0.55 tonne.
 HEINZ, H. J. & Co. AUST. LTD., Princes Highway, Dandenong, 3175; D.A.19069/19; 15th November, 1975; 16.10 tonne; D.A.19069/20; 15th November, 1975; 15.75 tonne.
 HUTCHINSON, ROBERT, LIMITED, Hartington Street, Glenroy, 3046; T.D.A.27836/53; 24th May, 1975; 10.70 tonne.
 HUTCHINSON, ROBERT, LIMITED, Hartington Street, Glenroy, 3046; T.D.A.27836/47; 12th November, 1975; 11.10 tonne.

HUTCHINSON, ROBERT, LIMITED, Hartington Street, Glenroy, 3046; T.D.A.27836/50; 9th November, 1975; 10.26 tonne.
 HUTTON, J. C., PTY. LTD., 50 Oakover Road, Preston, 3072; D.A.48355/24; 27th November, 1975; 1.75 tonne.
 HUTTON, J. C., PTY. LTD., 50 Oakover Road, Preston, 3072; D.A.48355/23; 20th November, 1975; 2.10 tonne.
 INNES, W. A., Hawdon Street, Broadford, 3548; D.A.53502/2; 20th November, 1975; 7.35 tonne.
 KENNAN, R. B., 13 Southey Road, Mentone, 3194; D.A.61142; 20th November, 1975; 2.65 tonne.
 KINCH FORD PTY. LTD., Main Street, Timboon, 3268; D.A.65411/1; 27th September, 1975; 1.25 tonne.
 KNIGHT, D. G., 517 Armstrong Street North, Ballarat, 3350; D.A.60929; 20th November, 1975; 0.40 tonne.
 L'ANSON, M., PTY. LTD., 14 Osborne Avenue, McKinnon, 3204; D.A.50640; 18th November, 1975; 6.60 tonne.
 LEMPRIERE BALLARAT METAL PTY. LTD., 45 Moreland Street, Footscray, 3011; D.A.63824/5; 15th November, 1975; 10.25 tonne.
 LEORKE, C. S., Ocean Road, Skenes Creek, 3233; D.A.38754/2; 29th November, 1975; 6.25 tonne.
 LEWIS, H., 2 Suffolk Street, Nunawading, 3131; D.A.62103/1; 15th November, 1975; 6.00 tonne.
 McMULLEN'S TRANSPORT PTY. LTD., Tyndall Street, Orbost, 3888; D.A.64331/4; 16th November, 1975; 20.15 tonne; D.T.1423; 20th November, 1975; 19.05 tonne; D.T.1423/1; 20th November, 1975; 21.90 tonne; D.T.1423/2; 20th November, 1975; 19.55 tonne; D.T.1423/3; 20th November, 1975; 20.90 tonne; D.T.1423/4; 20th November, 1975; 19.55 tonne; D.T.1423/5; 20th November, 1975; 16.60 tonne; D.T.1423/8; 20th November, 1975; 19.05 tonne.
 OLIVER DAVEY GLASS CO. PTY. LTD., 432-440 Princes Highway, Noble Park, 3174; D.A.39088/6; 18th November, 1975; 1.50 tonne.
 PERMEWAN WRIGHT LTD., 657 Springvale Road, Mulgrave, 3170; D.A.1809/27; 18th November, 1975; 3.95 tonne.
 PIKE, R. & WILLIS, C., 715 Barkly Street, Ballarat, 3350; D.A.36682, 17th August, 1975; 3.80 tonne.
 PRIDHAM, W. (AUST.) PTY. LTD., 11 Evans Street, Braybrook, 3019; D.A.1864/3; 20th November, 1975; 9.96 tonne.
 REPCO AUTO PARTS (VIC.) PTY. LTD., 618-640 Elizabeth Street, Melbourne, 3000. D.A.1907/3; 26th November, 1975; 0.70 tonne.
 REPCO AUTO PARTS (VIC.) PTY. LTD., 618-640 Elizabeth Street, Melbourne, 3000. D.A.1907/2; 26th November, 1975; 0.65 tonne.
 SCHADE, W. L., 69 Russell Street, Bendigo, 3550; D.A.59477/3; 13th November, 1975; 2.10 tonne.
 SEVEN X BEVERAGES (CENTRAL) PTY. LTD., 16 First Avenue Sunshine, 3550; T.D.A.61307/10; 4th November, 1975; 3.25 tonne; T.D.A.61307/11; 4th November, 1975; 3.25 tonne.
 SKATE, N., Darling Road, Gruyere, 3770; D.A.50407/1; 15th November, 1975; 10.65 tonne; D.A.50407/2; 15th November 1975; 12.40 tonne.
 WHITE, K. C., 57 Hertford Road, Sunshine, 3020; D.A.63279/1; 15th November 1975; 10.15 tonne.
 WILLIAMS, G. W., ELECTRONICS PTY. LTD., 248 Lonsdale Street, Dandenong, 3175; D.A.66515/2; 18th November, 1975; 0.55 tonne.
 WILSON, G. S., 43 Ozone Road, Barwon Heads, 3227; D.A.63279/1; 15th November, 1975; 10.15 tonne.

TOW TRUCKS

BARTON, J., 208 Main Street, Bacchus Marsh, 3340; D.A.53716/1; 20th November, 1975; 2.25 tonne.
 MACDONALD, R. G. (trading as Baywood Panel Service), 34 Malvern Street, Bayswater, 3153; D.A.65329/1; 23rd September, 1975; 1.50 tonne.
 MANENTI, S., (trading as Broadway Towing Service), 922 High Street, Reservoir, 3073; D.A.67632; 11th September, 1975; 2.50 tonne.
 LITTLE'S BLACK ROCK MOTORS, 52 Levanswell Road, Moorabbin, 3189; D.A.1506/4; 5th November, 1975; 1.90 tonne.
 LYON BROS. MOTORS, PTY. LTD., 953 Main Road, Eltham, 3095; D.A. 46473/2; 8th November, 1975; 1.40 tonne.
 SMITH, J. (trading as J. Smith Motors), 12-16 Elizabeth Terrace, Morwell, 3840; D.A.64185; 10th May, 1975; 3.00 tonne.
 UNITED TOWING SERVICE PTY. LTD., 628 High Street, Thornbury, 3071; D.A.58930/15; 11th November, 1975; 1.90 tonne.
 VARDY, G. D. & V. L., Gormandale, 3873; D.A.67081; 18th February, 1975; 4.10 tonne.

RENEWALS WITH VARIATION.

Applications made by the persons listed hereunder for renewal of the licences listed with variation of conditions in the manner set out opposite the names.

CAGGIATI, F., 37 Leighton Court, Fawkner, 3060; D.A.60377/1; 8th November, 1975. Application to renew and vary the conditions of licence No. D.A.60377/1 (L/C. 9.20

tonne) by deleting existing conditions and by adding in lieu—(a) Within a 40-km radius of own premises at Campbellfield in course of business as "Soil, Screening and Garden Supply"—own goods. (b) From Bacchus Marsh to own premises at Campbellfield—own river pebbles. (c) From Cranbourne to own premises at Campbellfield—own soil and own sand. (d) From Yea to own premises at Campbellfield—own river pebbles. (e) From Toolangi and Gilderoy to own premises at Campbellfield—own mountain soil.

HYDE, L. J., P.O. Box 196, Wangaratta, 3677; D.A.64883; 29th November, 1975. Application to renew and vary the conditions of licence No. D.A.64883 (L/C. 7.15 tonne) by deleting existing conditions and adding in lieu—"Within an 80-km radius of own premises at Wangaratta in course of business as "Earthmoving Contractor"—own earthmoving plant and own equipment."

PENDERGAST, R. G., (trading as W. A. Pendergast & Sons), Benambra, 3900; D.T.1469; 15th November, 1975. Application to renew and vary the conditions of licence No. D.T.1469 (L/C. 16.65 tonne) by deleting from paragraph (a) the following—"Provided that no goods shall be carried whether by one stage or by more than one stage between places within the above radius which are more than 48-km apart by the nearest practicable route."

Notice of any objection should be forwarded to reach the Secretary of the Board not later than 18th June, 1975.

Applicants are advised that it will not be necessary to appear on the hearing date specified above, unless advised in writing by the Board.

A. V. C. COOK,
Secretary.

Corner Lygon and Princes Streets, Carlton, 3053,
Wednesday, 4th June, 1975.

VICTORIA.

BUSINESS NAMES ACT 1962.

I, Vernon Francis Wilcox, Her Majesty's Attorney-General for the State of Victoria, being the Minister for the time being administering the *Business Names Act 1962*, pursuant to the power conferred by section 9 of the said Act, hereby revoke all directions previously given under the said section and do hereby direct that the Commissioner for Corporate Affairs shall not, except with the consent of the Minister for the time being administering the said Act, accept for registration any business name that is a name or a name of a kind mentioned hereunder, viz.:—

1. Names suggesting connection with members of the Royal family or Royal patronage, for example, names which include the words "Royal", "King", "Queen" or "Crown".

2. Names suggesting connection with the Crown, the Commonwealth of Nations, the Government of the Commonwealth of Australia or of a State or of any other part of the Queen's dominions, possessions, or territories, for example, names which include the words "Commonwealth", "Federal", "State", "Empire", "Imperial" or "National".

3. Names suggesting connection with the government of a foreign country or with the United Nations.

4. Names suggesting connection with a government department, authority or instrumentality or a municipal or other local authority.

5. Names containing the following words or any words of like import:

"Bank", "Banker", "Banking", "Building Society", "Chamber of Commerce", "Chamber of Manufacturers", "Chartered", "Consumer", "Co-operative", "Co-operative Housing Society", "Credit Union", "Dianetics", "Executive", "Friendly Society", "Guarantee", "Made in Australia", "Oxfam", "Savings", "Scientology", "Starr Bowkett", "Stock Exchange", "Trust", "Trustee", "University".

6. Names suggesting connection with ex-servicemen's organizations or that its members are totally or partially incapacitated, for example names which include the words "Anzac", "Ex-servicemen", "Returned Soldier", "Blind" or "Blinded".

7. Names that are misleading as to the nature, objects or purposes of the business or in any other manner.

8. Names that are blasphemous or likely to be offensive to members of the public.

9. Names that are likely to be confused with or mistaken for—

(a) the name of a company, recognized company to which Division 2A of Part XI. of the *Companies Act 1961* applies, registered foreign company, association, building society, co-operative society, co-operative housing society, credit union, or friendly society; or

(b) a registered business name.

10. Names that are likely to be confused with or mistaken for the name reserved by or on behalf of a company, a recognized company, a foreign company to which Division 3 of Part XI. of the *Companies Act 1961* applies, an intended company, intended recognized company or a company which it is proposed to register as a foreign company.

Dated this 30th day of May, 1975.

V. F. WILCOX,
Attorney-General.

Attention is directed to the following additional restrictions on the use of names:—

(1) Section 12 of the *International Organization (Privileges and Immunities) Act 1963* provides that, except with the consent in writing of the Minister for the time being administering the Act, a person shall not use in connection with any trade, business, profession, calling or occupation the name or an abbreviation of the name of the United Nations or of any other prescribed international organization.

(2) Section 66 of the *Banking Act 1959-1973* provides that, except with the consent in writing of the Treasury of the Commonwealth, a person or body of persons, not being a body corporate in Australia, shall not assume or use, in relation to the business, or any part of the business carried on by the person or body, the word "Bank", "Banker", or "Banking" or any word of like import. Section 67 imposes a similar restriction in respect of the words "savings bank" or any words of like import on any person or body of persons not included among the savings banks specified in Part II. of the First Schedule to that Act.

(3) Protection of word "Anzac" Regulations—(Statutory Rules 1921, No. 2 and No. 216, Statutory Rules 1959, No. 29, and Statutory Rules 1962, No. 79) provide that no person shall, without the authority of the Attorney-General of the Commonwealth, assume or use the word "Anzac" or any word resembling the word "Anzac" in connection with any trade, business, calling or profession or in connection with any entertainment or any lottery or art union.

(4) Defence (Prohibited Words and Letters) Regulations (Statutory Rules 1957, No. 16) prohibit the use in connection with a trade, business, calling or profession or by an organization or body of persons of the words and letters set out therein (being words and letters indicative of a part of the armed forces of the Commonwealth or of the United Kingdom) without the consent in writing of the Minister for the time being administering the Defence Act.

VICTORIA.

COMPANIES ACT 1961.

I, Vernon Francis Wilcox, Her Majesty's Attorney-General for the State of Victoria, being the Minister for the time being administering the *Companies Act 1961*, pursuant to the powers conferred by sections 22 and 353 of the said Act hereby revoke all directions previously given under the aforesaid sections or either of them and do hereby direct that the Commissioner for Corporate Affairs shall not except with the consent of the Minister for the time being administering the said Act register under the said Act any company or foreign company by a name that is a name or a name of a kind mentioned hereunder provided that in the case of a name or a name of a kind mentioned in paragraphs 1 to 8 inclusive hereunder, the Commissioner for Corporate Affairs may, notwithstanding anything contained in those paragraphs permit the registration of a foreign company incorporated under a law of a State or Territory of the Commonwealth which corresponds to the said Act by such a name if he is satisfied that the Minister administering that corresponding law has consented to the registration of the foreign com-

pany by that name in that State or Territory and he is not of the opinion that the name of the foreign company is otherwise undesirable.

1. Names suggesting connection with members of the Royal family or Royal patronage, for example, names which include the words "Royal", "King", "Queen", or "Crown".

2. Names suggesting connection with the Crown, the Commonwealth of Nations, the Government of the Commonwealth of Australia or of a State or of any other part of the Queen's dominions, possessions, or territories, for example, names which include the words "Commonwealth", "Federal", "State", "Empire", "Imperial", or "National".

3. Names suggesting connection with a government department, authority or instrumentality or a municipal or other local authority.

4. Names suggesting connection with the government of a foreign country or with the United Nations.

5. Names containing the following words or any words of like import:

"Bank", "Banker", "Banking", "Building Society", "Chamber of Commerce", "Chamber of Manufacturers", "Chartered", "Consumer", "Co-operative", "Co-operative Housing Society", "Credit Union", "Dianetics", "Executive", "Friendly Society", "Guarantee", "Made in Australia", "Oxfam", "Savings", "Scientology", "Starr Bowkett", "Stock Exchange", "Trust", "Trustee", "University".

6. Names suggesting connection with ex-servicemen's organizations or that its members are totally or partially incapacitated, for example names which include the words "Anzac", "Ex-servicemen", "Returned Soldier", "Blind" or "Blinded".

7. Names that are misleading as to the nature, objects or purposes of the company or in any other manner.

8. Names that are blasphemous or likely to be offensive to members of the public.

9. Names that are likely to be confused with or mistaken for—

(a) the name of a company, recognized company to which Division 2A of Part XI. of the *Companies Act 1961* applies, registered foreign company, association, building society, co-operative society, co-operative housing society, credit union, or friendly society; or

(b) a registered business name.

10. Names that are likely to be confused with or mistaken for the name reserved by or on behalf of a company, a recognized company, a foreign company to which Division 3 of Part XI. of the *Companies Act 1961* applies, an intended company, intended recognized company or a company which it is proposed to register as a foreign company.

11. In the case of an intended company which intends to carry on business in a participating state, a name that would not be available under a provision of the declared law of that State corresponding to section 22 of the *Companies Act 1961*.

Dated this 30th day of May, 1975.

V. F. WILCOX,
Attorney-General.

Attention is directed to the following additional restrictions on the use of names:—

(1) Section 12 of the *International Organization (Privileges and Immunities) Act 1963* provides that, except with the consent in writing of the Minister for the time being administering the Act, a person shall not use in connection with any trade, business, profession, calling or occupation the name or an abbreviation of the name of the United Nations or of any other prescribed international organization.

(2) Section 66 of the *Banking Act 1959-1973* provides that, except with the consent in writing of the Treasurer of the Commonwealth, a person or body of persons, not being a body corporate in Australia, shall not assume or use, in relation to the business, or any part of the business carried on by the person or body, the word "Bank", "Banker", or "Banking" or any word of like import. Section 67 imposes a similar restriction in respect of the words "savings bank" or any words of like import on any person or body of persons not included among the savings banks specified in Part II. of the First Schedule to that Act.

(3) Protection of word "Anzac" Regulations—(Statutory Rules 1921, No. 2 and No. 216, Statutory Rules 1959, No. 29 and Statutory Rules 1962, No. 79) provide that no person shall, without the authority of the Attorney-General of the Commonwealth, assume or use the word "Anzac" or any word resembling the word "Anzac" in connection with any trade, business, calling or profession or in connection with any entertainment or any lottery or art union.

(4) Defence (Prohibited Words and Letters) Regulations (Statutory Rules 1957, No. 16) prohibit the use in connection with a trade, business, calling or profession or by an organization or body of persons of the words and letters set out therein (being words and letters indicative of a part of the armed forces of the Commonwealth or of the United Kingdom) without the consent in writing of the Minister for the time being administering the Defence Act.

Police Offences Act 1958, No. 6337.

DIVISION IA.—STATE ADVISORY BOARD ON PUBLICATIONS.

Whereas I have considered reports made to me by the State Advisory Board on Publications under section 180D 2 (a) of the Police Offences Act: I John Frederick Rossiter Chief Secretary for Victoria, in pursuance of the power vested in me by section 180H (1) of the Police Offences Act hereby determine that the publications prescribed by title in the schedule hereunder shall be classified as restricted publications for the purposes of the abovenamed Act.

SCHEDULE OF PUBLICATION.

Title.	Publisher.
Art of Love	Not Shown
Australasian Pleasure No. 116	Exclusive Publications
Australian Guys No. 33	Wynyard Mercantile
Australian Guys No. 34	Wynyard Mercantile
Big Blow	Bleu Book and Magazine Co.
Bingo No. 2	Not Shown
Blue Gays	Not Shown
Bleu Climax Vol. 1 No. 6	Bleu Book and Magazine Co.
Classroom Orgy	Not Shown
Cocksure No. 40	Exclusive Publications
Deep Thrust	Bleu Book and Magazine Co.
Hard Throb	Bleu Book and Magazine Co.
Hot and Slick	Bleu Book and Magazine Co.
Hot Stuff	Bleu Book and Magazine Co.
Kings Cross Whisper No. 200	Group Publications
Kings Cross Venus No. 50	Venus Publications
Male No. 2	Searchlight Publication
National Ball No. 63	Wynyard Mercantile
National Ball No. 64	Wynyard Mercantile
Private Climax Vol. 1 No. 6	Bleu Book and Magazine Co.
Randy and Ready	Bleu Book and Magazine Co.
Ribald No. 128	Bertram Horne and Co.
Ribald No. 129	Bertram Horne and Co.
Rip Off No. 17	Star Publications
Rip Off No. 18	Star Publications
Screw No. 143	Wynyard Mercantile
Screw No. 144	Wynyard Mercantile
Searchlight No. 106	Searchlight Publication
Searchlight No. 107	Searchlight Publication
Sexy Swingers No. 124	Exclusive Publications
Sexy Swingers No. 125	Exclusive Publications
Shaved Orgy	Not Shown.

J. F. ROSSITER,
Chief Secretary.

Chief Secretary's Office,
Melbourne, 3rd June, 1975.

Police Regulation Act 1958, Section 122.

SALE OF UNCLAIMED MOTOR VEHICLE.

An owner is required for a blue Holden station wagon, ex-registered No. HLM-514, engine No. L.634866.

The vehicle came into the possession of Police on the 21st November, 1974, and if not claimed, will be sold by public auction at the Royal Park Police Station, 155 Royal Parade, Parkville, at 11 a.m., on 27th June, 1975.

R. JACKSON,
Chief Commissioner of Police.

Police Regulation Act 1958.

POLICE FORCE OF VICTORIA.

DETERMINATION NO. 235 OF THE POLICE SERVICE BOARD.

The Police Service Board, in pursuance of the powers in that behalf conferred by the *Police Regulation Act 1958*, hereby makes the following Determination (that is to say):—

1. The Determination No. 179 of the Police Service Board of 14th December, 1971, and published in the *Government Gazette* of 25th January, 1972, as amended, is hereby further amended as follows:—

(a) In paragraph 7—

By deleting sub-paragraphs (a), (b) and (c) and substituting therefor the following sub-paragraphs:—

“(a) *Officers.* *Salaries—
Officers.*

Rank.	Salary per Annum.
	\$
Commander	19,361
Chief Superintendent	17,615
Superintendent	16,415
Chief Inspector	14,818
Inspector	14,217
Station Officer	11,154

(b) *Sub-Officers.* *Sub-Officers.*

Rank.	Salary per Annum.
	\$
Senior Sergeant	10,787
Sergeant	9,444

(c) *Senior Constables and Constables.* *Senior
Constables
and
Constables.*

Rank.	Salary per Annum.
	\$
<i>Senior Constable—</i>	
During twelfth year of service and after	8,261
During eleventh, tenth, ninth, eighth and seventh years of service	8,069
During sixth and fifth years of service	7,958
During fourth and third years of service	7,845
During second and first years of service	7,733
<i>Constable—</i>	
During seventh year of service and after	7,383
During sixth and fifth years of service	7,285
During fourth and third years of service	7,101
During second year of service	6,821
During first year of service	6,622 ”.

(b) By deleting paragraph 8 and substituting therefor the following paragraph:—

“8. The salaries to be paid to members designated in this paragraph shall be in accordance with the following scale:—

SCALE OF ANNUAL SALARIES.

Police Cadets.

	Salary per Annum.	<i>Salaries— Police Cadets.</i>
	\$	
Single Cadet at sixteen years	2,729	
Single Cadet at seventeen years	3,274	
Single Cadet at eighteen years	3,820	

Married Cadet of any age before joining Recruit Training Squad	4,545
Cadet on joining Recruit Training Squad	5,220
Married Cadet on joining Recruit Training Squad	5,946 "

- (c) By deleting paragraph 26, under the heading "Compensatory Allowance-Rate" and substituting therefor the following paragraph:—

"Such allowance shall be at the following rates:—

Rate.	Rank.	Annual Allowance.
		\$
	Station Officers and Senior Sergeants	1,097
	Sergeants	944
	Senior Constables	797
	Constables	704 "

- (d) In paragraph 33, under the heading "Overtime-Detective", by deleting the amounts "\$976" and "\$770" and substituting therefor the amounts "\$1,012" and "\$797" respectively.

- (e) In paragraph 34, sub-paragraph (1), under the heading "Overtime—one-man stations", by deleting the amount "\$616" and substituting therefor the amount "\$638".

2. This Determination shall come into operation on and from the 25th May, 1975.

Dated this 23rd day of May, 1975.

N. A. VICKERY,
A Judge of the County Court of Victoria,
Chairman and Member of the Police Service Board.

J. G. BROWN,
Member of the Police Service Board.

G. DAVIDSON,
Member of the Police Service Board.

Police Regulation Act 1958.
POLICE FORCE OF VICTORIA.

DETERMINATION NO. 237 OF THE POLICE SERVICE BOARD.

The Police Service Board, in pursuance of the powers in that behalf conferred by the *Police Regulation Act 1958*, hereby makes the following Determination (that is to say):—

1. The Determination No. 179 of the Police Service Board of 14th December, 1971, and published in the *Government Gazette* of 25th January, 1972, as amended, is hereby further amended as follows:—

By inserting, after paragraph 127, the following new paragraph:—

"127A. Provided that all rentals payable pursuant to paragraphs 122, 123, and 127 above shall remain at the actual amounts payable as at the 23rd day of May, 1975, until such time as the Board further determines."

2. This Determination shall come into operation on and from the 23rd day of May, 1975.

Dated this 23rd day of May, 1975.

N. A. VICKERY,
A Judge of the County Court of Victoria,
Chairman and Member of the Police Service Board.

J. G. BROWN,
Member of the Police Service Board.

G. DAVIDSON,
Member of the Police Service Board.

Police Regulation Act 1958.

POLICE FORCE OF VICTORIA.

DETERMINATION NO. 236 OF THE POLICE SERVICE BOARD.

The Police Service Board, in pursuance of the powers in that behalf conferred by the *Police Regulation Act 1958*, hereby makes the following Determination (that is to say):—

1. The Determination No. 179 of the Police Service Board of 14th December, 1971, and published in the *Government Gazette* of 25th January, 1972, as amended, is hereby further amended as follows:—

In paragraph 63 under the heading "Kilometre Rates for Use of Private Motor Vehicles".

By deleting sub-paragraphs (a), (b), (c), and (d) and substituting therefor the following sub-paragraphs:—

"(a) For members who are issued with the "B" Pass by the Victorian Government Motor Transport Committee authorizing the holder to obtain supplies of petrol and oil at Government rates—

	For the first 8,000 kilometres in a financial year. A kilometre. c	Distance over 8,000 kilometres in a financial year. A kilometre. c
Motor cars—		
17 h.p. and over	14.4	6.9
Under 17 h.p. . .	11.3	5.1
Motor cycles with side-cars . .	5.6	2.6
Motor cycles . .	4.9	2.2

(b) For members who are not issued with the "B" Pass referred to in sub-paragraph (a):—

	For the first 8,000 kilometres in a financial year. A kilometre. c	Distance over 8,000 kilometres in a financial year. A kilometre. c
Motor cars—		
17 h.p. and over	14.8	7.9
Under 17 h.p. . .	11.5	5.9
Motor cycles with side-cars . .	5.8	3.1
Motor cycles . .	5.1	2.5

(c) In addition to the allowances prescribed in sub-paragraph (b) hereof, members—

(i) who are not issued with the "B" Pass referred to in sub-paragraph (a); and

(ii) who do not exceed in any one financial year the maximum number of kilometres set out hereunder, shall be paid at the end of the financial year an additional amount calculated at the appropriate following rate:—

	For the first 800 kilometres in a financial year. A kilometre. c	Exceeding 800 kilometres but not exceeding 2,400 kilometres in a financial year. A kilometre. c
Motor cars—		
17 h.p. and over . .	6.2	2.2
Under 17 h.p. . .	4.6	1.7

(d) For bicycles—at the rate of 1.7c per kilometre—bicycles. irrespective of distance".

2. This Determination shall come into operation on and from the 25th May, 1975.

Dated the 23rd day of May, 1975.

N. A. VICKERY,
A Judge of the County Court of Victoria,
Chairman and Member of the Police Service Board.

J. G. BROWN,
Member of the Police Service Board.

G. DAVIDSON,
Member of the Police Service Board.

Police Regulation Act 1958.

POLICE FORCE OF VICTORIA.

DETERMINATION NO. 238 OF THE POLICE SERVICE BOARD.

The Police Service Board, in pursuance of the powers in that behalf conferred by the *Police Regulation Act 1958*, hereby makes the following Determination (that is to say):—

1. The Determination No. 179 of the Police Service Board of 14th December, 1971, and published in the *Government Gazette* of 25th January, 1972, as amended, is hereby further amended as follows:—

In paragraph 10, sub-paragraph (a) under the heading "Personnel Department", after the expression "Officer in Charge Personnel and Amenities \$450", by inserting the expressions—

"Welfare Officer	\$400.00
Assistant Welfare Officer	\$250.00".

2. This Determination shall come into operation on and from the 8th day of June, 1975.

Dated the 26th day of May, 1975.

N. A. VICKERY,
A Judge of the County Court of Victoria,
Chairman and Member of the Police Service Board.

J. G. BROWN,
Member of the Police Service Board.

G. DAVIDSON,
Member of the Police Service Board.

Private Agents Act 1966.

NOTICE OF RECEIPT OF APPLICATIONS FOR LICENCES UNDER THE PROVISIONS OF THE PRIVATE AGENTS ACT 1966.

The Clerk(s) of the Magistrates' Court(s) as listed hereunder hereby give notice that applications, as under, have been lodged for hearing by the said Court(s) on the date(s) specified.

Any person desiring to object to any of such applications must—

- (a) lodge with the respective Clerk of the Magistrates' Court a notice in the prescribed form of his objection and of the grounds thereof;
- (b) cause a copy of such notice to be served personally or by post upon the applicant at least three days before the hearing of the application; and
- (c) send or deliver—
 - (i) where the objection is not made by the officer in charge of the police district in which the Court is situated—a copy of the notice to such officer; and
 - (ii) where the objection is not made by the Registrar or Deputy Registrar—a copy to the Registrar.

Full Name of Applicant or in the Case of a Firm or Corporation, of the Nominee.	Place of Abode of Applicant or Nominee.	Name of Firm or Corporation.	Address for Registration.	Type of Licence.	Date of Hearing of Application.
---	---	------------------------------	---------------------------	------------------	---------------------------------

MAGISTRATES' COURT, HAWTHORN.

Armstrong, Alan William	Flat 3, 15A Koonalda Grove, Dandenong	Security Watching Co. Pty. Ltd.	330 Auburn Road, Hawthorn	Watchman	27.6.75
-------------------------	---------------------------------------	---------------------------------	---------------------------	----------	---------

Dated at Hawthorn this 26th day of May, 1975.

J. GIDLEY, Clerk of the Magistrates' Court.

MAGISTRATES' COURT, PRAHRAN.

Stern, Robert	34 Seebeck Street, Rowville		Suit 18, 65 Queens Road, Melbourne	Commercial Sub-Agent	20.6.75
---------------	-----------------------------	--	------------------------------------	----------------------	---------

Dated at Prahran this 27th day of May, 1975.

J. McSWEENEY, Clerk of the Magistrates' Court.

MAGISTRATES' COURT, MELBOURNE.

Casey, Vincent Thomas	86 Ogilvie Street, Essendon	Wormald International Security	340 Abbotsford Street, North Melbourne	Watchman	16.7.75
Cole, Barry George	200 The Parade, Ascot Vale	" " "	" " "	"	"
Haynes, Bruce Edmond	2 Oakbank Street, Newport	" " "	" " "	"	"
Roper, Graham Hilton	6/34 Pender Street, Thornbury	" " "	" " "	"	"

Dated at Melbourne this 23rd day of May, 1975.

G. L. WEBSTER, Clerk of the Magistrates' Court.

MAGISTRATES' COURT, BENDIGO.

Pyers, Dianne	81 William Street, Eaglehawk	Bendigo Investments Limited	27 Queen Street, Bendigo	Watchman	13.6.75
---------------	------------------------------	-----------------------------	--------------------------	----------	---------

Dated at Bendigo this 22nd day of May, 1975.

R. N. HOLLIS, Clerk of the Magistrates' Court.

MAGISTRATES' COURT, PORT MELBOURNE.

Scott, Thomas Edward	343 St. Georges Road, Thornbury	Mayne Limited	538 Williamstown Road, Port Melbourne	Watchman	24.6.75
De Lellis, Peter	66 Reid Street, North Fitzroy	" " "	" " "	"	"
Wiersema, John	24 Owen Street, Mitcham	" " "	" " "	"	"
Greca, Michael Marto	3 Clifton Street, Richmond	" " "	" " "	"	"

Dated at Port Melbourne this 26th day of May, 1975.

JOHN ARDLIE, Clerk of the Magistrates' Court.

MAGISTRATES' COURT, GEELONG.

Arends, Wilhelmus	168 Roslyn Road, Highton		55 The Esplanade, North Shore	Watchman	24.6.75
-------------------	--------------------------	--	-------------------------------	----------	---------

Dated at Geelong this 26th day of May, 1975.

J. E. REILLY, Clerk of the Magistrates' Court.

MAGISTRATES' COURT, MELBOURNE.

Boyle, William Lawrence	194 Station Street, Edithvale	Wormald International Security	340 Abbotsford Street, North Melbourne	Watchman	16.7.75
Berry, Langley Clements	336 Blackburn Road, Mt. Waverley	" " "	" " "	"	"
Bird, Edward Kevin	6 Vincent Crescent, Werribee	" " "	" " "	"	"
Hey, William Thomas	112 Holr Parade, Bundoora	" " "	" " "	"	"
Keenan, Donald Keith	3/10 Thorndon Drive, St. Albans	" " "	" " "	"	"

Dated at Melbourne this 28th day of May, 1975.

G. L. WEBSTER, Clerk of the Magistrates' Court.

PRIVATE AGENTS—continued.

Full Name of Applicant or in the Case of a Firm or Corporation, of the Nominee.	Place of Abode of Applicant or Nominee.	Name of Firm or Corporation.	Address for Registration.	Type of Licence.	Date of Hearing of Application.
MAGISTRATES' COURT, MELBOURNE.					
Alexander, Stephen William ..	10/10 Dunlop Street, Maribyrnong	10/10 Dunlop Street, Maribyrnong	Process Server (Individual)	9.7.75
" " " ..	" " " ..	" " " ..	" " " ..	Inquiry Agent (Individual)	
Dated at Melbourne this 27th day of May, 1975.					
G. L. WEBSTER, Clerk of the Magistrates' Court.					
MAGISTRATES' COURT, SUNBURY.					
McKenzie, Frederick John ..	163 Gap Road, Sunbury	Industrial Investigations	163 Gap Road, Sunbury	Inquiry Agent ..	13.6.75
Dated at Sunbury this 23rd day of May, 1975.					
A. R. DUNLOP, Clerk of the Magistrates' Court.					
MAGISTRATES' COURT, COBURG.					
Burton, Frederick Charles ..	101 Delta Street, Greensborough	Mayne Nickless Ltd.	88 Bakers Road, Coburg	Watchman ..	25.6.75
Dated at Coburg this 29th day of May, 1975.					
B. T. MANSBRIDGE, Clerk of the Magistrates' Court.					
MAGISTRATES' COURT, NORTHCOTE.					
Reid, Norman ..	257 Cooch Street, Thornbury	257 Cooch Street, Thornbury	Inquiry Agent ..	19.6.75
Dated at Northcote this 29th day of May, 1975.					
PETER J. O'FARRELL, Clerk of the Magistrates' Court.					

Cemeteries Act 1958.
SCALE OF FEES OF THE APOLLO BAY PUBLIC CEMETERY.

In pursuance of the powers conferred upon them by the Cemeteries Act the trustees of the Apollo Bay Public Cemetery hereby make the following scale of fees, which shall come into operation upon publication in the *Government Gazette*, and from and after such publication every scale of fees heretofore made by the said trustees shall be and is hereby rescinded to the extent to which it conflicts with this scale.

Private Graves.

Land, 8 ft. x 4 ft. ..	\$34.00
Own selection of land (extra) ..	\$8.00

Miscellaneous Charges.

Number peg ..	\$5.00
Interment fee ..	\$16.00
Certificate of right of burial ..	\$2.50
Permission to erect a headstone ..	\$6.00
Interment of ashes ..	\$16.00

B. A. THOMAS, Trustee.
 J. D. BIDDLE, Trustee.
 J. B. GARRETT, Trustee.

Approved by the Governor in Council, 27th May, 1975.—
 TOM FORRISTAL, Clerk of the Executive Council.

Cemeteries Act 1958.
SCALE OF FEES OF THE FAWKNER CREMATORIUM AND MEMORIAL PARK PUBLIC CEMETERY.

In pursuance of the powers conferred upon them by the Cemeteries Act, the trustees of the Fawcner Crematorium and Memorial Park Public Cemetery hereby make the following scale of fees, which shall come into operation upon publication in the *Government Gazette*, and from and after such publication every scale of fees heretofore made by the said trustees shall be and is hereby rescinded to the extent to which it conflicts with this scale.

Lawn Burial Area.

New lawn area east (adjoining Sydney Road) (244 cm x 122 cm) ..	\$200.00
---	----------

K. W. JOYCE, Trustee.
 R. J. COOPER, Trustee.
 H. C. CURWEN-WALKER, Trustee.
 K. R. DICK, Manager.

Approved by the Governor in Council, 27th May, 1975.—
 TOM FORRISTAL, Clerk of the Executive Council.

Cemeteries Act 1958.
SCALE OF FEES OF THE TEMPLESTOWE PUBLIC CEMETERY.

In pursuance of the powers conferred upon them by the Cemeteries Act, the trustees of the Templestowe Public Cemetery hereby make the following scale of fees, which shall come into operation upon publication in the *Government Gazette*, and from and after such publication every scale of fees heretofore made by the said trustees shall be and is hereby rescinded to the extent to which it conflicts with this scale.

Lawn and Monumental Sections.

Land (at need), 8 ft. x 4 ft. ..	\$120.00
Sinking grave 7 feet deep ..	\$85.00

A. P. CHIVERS, Trustee.
 B. FITZSIMMONS, Trustee.
 W. J. READ, Trustee.

Approved by the Governor in Council, 27th May, 1975.—
 TOM FORRISTAL, Clerk of the Executive Council.

Cemeteries Act 1958.
SCALE OF FEES OF THE DIGBY PUBLIC CEMETERY.

In pursuance of the powers conferred upon them by the Cemeteries Act, the trustees of the Digby Public Cemetery hereby make the following scale of fees, which shall come into operation upon publication in the *Government Gazette*, and from and after such publication every scale of fees heretofore made by the said trustees shall be and is hereby rescinded to the extent to which it conflicts with this scale.

Public Graves.

Interment in grave without exclusive right—stillborn child ..	\$12.00
---	---------

Private Graves.

Land, 2.44 m x 1.22 m ..	\$30.00
--------------------------	---------

Miscellaneous Charges.

Permission to erect a headstone or monument—5 per cent. of cost.	
--	--

A. McCALLUM, Trustee.
 D. SIMKIN, Trustee.
 J. R. BURGESS, Trustee.

Approved by the Governor in Council, 27th May, 1975.—
 TOM FORRISTAL, Clerk of the Executive Council.

Cemeteries Act 1958.

SCALE OF FEES OF THE MELTON PUBLIC CEMETERY.

In pursuance of the powers conferred upon them by the Cemeteries Act, the trustees of the Melton Public Cemetery hereby make the following scale of fees, which shall come into operation upon publication in the *Government Gazette*, and from and after such publication every scale of fees heretofore made by the said trustees shall be and is hereby rescinded to the extent to which it conflicts with this scale.

Public Graves.

Interment in grave without exclusive right—stillborn child	\$16.00
Interment in grave without exclusive right—others	\$32.00
Number peg or label	\$5.00

Private Graves.

Land, 2.44 m x 1.22 m	\$40.00
Own selection of site (extra)	\$17.00

Sinking Charges for Private Graves.

Sinking grave 1.83 m deep	\$60.00
Each additional 0.3 m	\$10.00
Sinking oversize grave (extra)	\$20.00
Sinking oversize grave for American type casket (extra)	\$20.00
Cancellation of order to sink (if commenced)	\$10.00

Reopening Charges.

Reopening grave (no cover)	\$45.00
Reopening grave (with cover or kerb)	\$50.00

Extra Charges.

Interment not in the prescribed hours, or on Saturdays, Sundays or Public Holidays	\$20.00
Interment in private grave without due notice	\$20.00
Late fee (per half-hour or part thereof in excess of first fifteen minutes)	\$2.50

Miscellaneous Charges.

Interment fee	\$16.00
Certificate of right of burial	\$2.50
Number plate or brick	\$5.00
Inspection of plan or register	\$2.00
Annual maintenance (single grave)	\$17.00
Permission to erect a headstone or monument—5 per cent. of cost, with a minimum of \$6.00.	
Permission to construct a brick grave or to erect any stone kerb, brick, tilework or concrete	\$7.00
Grave renovations or additional inscription	\$6.00
Exhuming the remains of a body (when authorized)	\$70.00
Interment of ashes in a private grave	\$16.00
Memorial wall niche and plaque	\$50.00

J. B. DENNISON, Trustee.
J. R. WALLACE, Trustee.
R. MARKS, Trustee.

Approved by the Governor in Council, 27th May, 1975.—
TOM FORRISTAL, Clerk of the Executive Council.

Cemeteries Act 1958.

SCALE OF FEES OF THE DANDENONG PUBLIC CEMETERY.

In pursuance of the powers conferred upon them by the Cemeteries Act, the trustees of the Dandenong Public Cemetery hereby make the following scale of fees, which shall come into operation upon publication in the *Government Gazette*, and from and after such publication every scale of fees heretofore made by the said trustees shall be and is hereby rescinded to the extent to which it conflicts with this scale.

Land, 8 ft. x 4 ft.	\$75.00
Interments—2.30 p.m. to 3.00 p.m. Monday 10.30 a.m. to 3.00 p.m. Tuesday to Friday.	

First interment, 5 ft. or 7 ft. deep	\$60.00
Second interment, reopening	\$45.00
Double interment, same day	\$70.00
Public grave—Children under 5 years	\$20.00
Public grave—all others	\$40.00
Interment of ashes	\$20.00
Exhumation fee	\$120.00
Number plate	\$6.00
Certificate of right of burial	\$3.00
Monumental work	\$10.00

No. 44.—4840/75.—2

Extras (Additional to Above Charges).

Oversize grave, over 2 ft. 3 in.	\$15.00
Interment on Saturday mornings only	\$45.00
Insufficient notice (less than 24 hours notice)	\$30.00
Interment outside prescribed times	\$20.00
Cancellation of order to sink (if commenced)	\$30.00

The common seal of the Mayor, Councillors and Citizens of the City of Dandenong was hereto affixed, this 12th day of May, 1975, in the presence of—

(SEAL) K. E. MILLER, Mayor.
A. S. GATLEY, Councillor.
W. J. DILLEY, Councillor.
B. A. SILK, Acting Town Clerk.

Approved by the Governor in Council, 27th May, 1975.—
TOM FORRISTAL, Clerk of the Executive Council.

KYNETON SHIRE WATERWORKS TRUST.

KYNETON WEST RURAL DISTRICT.

Rating By-law 1974-75.

The Kyneton Shire Waterworks Trust in pursuance of and in exercise of the powers conferred by the *Water Act 1958* and of any and every other power it thereunto enabling doth hereby make a By-Law as follows:—

1. The Trust hereby makes and levies a rate in respect of all lands and tenements within the Kyneton West Rural District of three and three tenths cents in the dollar on the net annual value set out in the valuation at present in force of such lands and tenements for the purposes of the municipal rate of the Shire of Kyneton which is hereby adopted as the valuation of such lands and tenements respectively.

2. Such rate shall be made and levied upon the occupiers and owners of such lands and tenements for the year commencing on the 1st day of October, 1974 and shall be payable on the 15th day of June, 1975 at the office of the said Trust.

3. In no case shall the rate payable hereunder in respect of any land on which there is a building be less than forty dollars and in respect of land on which there is no building be less than forty dollars.

4. (a) The maximum quantity of water to be supplied in any year without charge is hereby fixed as a quantity which if charged at 40 cents per thousand gallons for any year would give an amount equal to the amount of rate payable in respect of the land or tenement for the financial year in which the said year commenced.

(b) For all water supplied in any year in excess of the maximum quantity referred to in paragraph (a) of this clause the charge is hereby fixed at 40 cents per thousand gallons.

5. Persons electing to pay rates by four equal instalments shall pay the first instalment on or before a date fourteen days after the posting of this demand and subsequent payments shall be made on or before the last day of July, August and September respectively.

6. The charge for water supplied by measures shall be payable, on demand, at the office of the Trust.

The resolution for making this By-Law was passed by this Trust on the 7th May, 1975.

The common seal of the Kyneton Shire Waterworks Trust was hereto affixed this 7th day of May, 1975, in the presence of—

(SEAL) H. T. DETTMANN, Chairman.
L. A. GLOSTER, Commissioner.
S. G. PORTER, Secretary.

Approved 28th May, 1975.—F. J. GRANTER, Minister of Water Supply.

KYNETON SHIRE WATERWORKS TRUST.

TYLDEN URBAN DISTRICT.

Rating By-law 1974-75.

The Kyneton Shire Waterworks Trust in pursuance of and in exercise of the powers conferred by the *Water Act 1958* and of any and every other power it thereunto enabling doth hereby make a Bylaw as follows:—

1. The Trust hereby makes and levies a rate in respect of all land and tenements within the Tylden Urban District of seventeen and five tenths cents in the dollar

on the net annual value set out in the valuation at present in force of such lands and tenements for the purposes of the municipal rate of the Shire of Kyneton which is hereby adopted as the valuation of such lands and tenements respectively.

2. Such rate shall be made and levied upon the occupiers and owners of such lands and tenements for the year commencing on the 1st day of October, 1974 and shall be payable on the 15th day of June, 1975 at the office of the said Trust.

3. In no case shall the rate payable hereunder in respect of any land on which there is a building be less than twenty six dollars and in respect of land on which there is no building be less than eight dollars.

4. (a) The maximum quantity of water to be supplied in any year without charge is hereby fixed as a quantity which if charged at 40 cents per thousand gallons for any year would give an amount equal to the amount of the rate payable in respect of the land or tenement for the financial year in which the said year commenced.

(b) For all water supplied in any year in excess of the maximum quantity referred to in paragraph (a) of this clause the charge is hereby fixed at 40 cents per thousand gallons.

5. Persons electing to pay rates by four equal instalments shall pay the first instalment on or before a date fourteen days after the posting of this demand and subsequent payments shall be made on or before the last day of July, August and September respectively.

6. The charge for water supplied by measures shall be payable, on demand, at the Office of the Trust.

The resolution for making this By-Law was passed by the Trust on the 7th May, 1975.

The common seal of the Kyneton Shire Waterworks Trust was hereto affixed this 7th day of May, 1975, in the presence of—

(SEAL) H. T. DETTMANN, Chairman.
L. A. GLOSTER, Commissioner.
S. G. PORTER, Secretary.

Approved 28th May, 1975.—F. J. GRANTER, Minister of Water Supply.

TOORA SEWERAGE AUTHORITY.
RATING BY-LAW 1975.

The Toora Sewerage Authority in pursuance and exercise of the powers conferred by the Sewerage Districts Act, doth hereby make a sewerage rate of Seven (7) Cents in the Dollar on the Net Annual Valuation of all rateable sewered property within the Toora Sewerage Districts, provided that the minimum amount of rate to be paid annually by the Owner or Occupier of any rateable property on which there is a building shall be Twenty (20) Dollars and by the Owner or Occupier of any rateable sewered property on which there is no building shall be Ten (10) Dollars.

Where persons liable to pay the rate elect to pay such rate in instalments the first instalment shall be due fourteen days after posting of the demand for such rate and the remaining instalments shall be due respectively on 31st July, 1st October and 1st December in the year 1975.

Such rate is made and shall be levied upon the Owners or Occupiers of the said rateable property for the year commencing 1st January, 1975 and shall be due and payable on 30th May 1975 at the office of the Authority 21 Stanley Street, Toora.

The Resolution for passing the foregoing By-Law was agreed to by the Toora Sewerage Authority on the 21st February 1975 and was confirmed by the said Authority on the 21st March, 1975.

In witness thereof the common seal of the said Authority was hereunto affixed in the presence of—

(SEAL) W. E. COOK, Chairman.
V. W. BENNETT-WOOD, Member.
C. J. PATERSON, Secretary.

Approved, 3rd April, 1975.—F. J. GRANTER, Minister of Water Supply.

Town and Country Planning Act 1961.
LAKE BELLFIELD PLANNING SCHEME.
AMENDMENT No. 5, 1974.
Notice of Approval.

In pursuance of the powers conferred by the Town and Country Planning Act 1961, the Governor in Council on the 27th May, 1975, approved a Planning Scheme entitled the

Lake Bellfield Planning Scheme, Amendment No. 5, 1974, in respect of part of the municipal district of the Shire of Stawell and such Planning Scheme comes into operation on the date this Notice of Approval is published in the Government Gazette.

A copy of the Planning Scheme as approved may be inspected, free of charge, during office hours at the office of the Town and Country Planning Board, 235 Queen Street, Melbourne, at the office of the Council of the Shire of Stawell at Stawell, and when available, at the Office of Titles, Melbourne, and at the Central Plan Office of the Department of Crown Lands and Survey, Melbourne.

W. H. CRAIG, Secretary,
Town and Country Planning Board.

Town and Country Planning Act 1961.
SHIRE OF MILDURA PLANNING SCHEME.
INTERIM DEVELOPMENT ORDER No. 4.

Notice of Approval.

In pursuance of the powers conferred by the Town and Country Planning Act 1961, the Governor in Council on the 27th day of May, 1975, approved the making of an Interim Development Order by the Council of the Shire of Mildura for the whole of the municipal district of the Shire of Mildura.

The Interim Development Order provides that the use, subdivision or development of any land within the area described or the erection, construction or carrying out of any buildings, roads or other works thereon is prohibited except in accordance with the provisions of the Order.

A copy of the Interim Development Order and a map showing the area affected may be inspected, free of charge, at the office of the Council of the Shire of Mildura at Irymple and at the office of the Town and Country Planning Board, 235 Queen Street, Melbourne.

W. H. CRAIG, Secretary,
Town and Country Planning Board.

Town and Country Planning Act 1961.
SHIRE OF SOUTH GIPPSLAND (INLAND AREAS)
PLANNING SCHEME.

INTERIM DEVELOPMENT ORDER.

Notice of Approval.

In pursuance of the powers conferred by the Town and Country Planning Act 1961, the Governor in Council on the 27th day of May, 1975, approved the making of an Interim Development Order by the Council of the Shire of South Gippsland for part of the municipal district of the Shire of South Gippsland.

The Interim Development Order provides that the use, subdivision or development of any land within the area described or the erection, construction or carrying out of any buildings, roads or other works thereon is prohibited except in accordance with the provisions of the Order.

A copy of the Interim Development Order and a map showing the area affected may be inspected, free of charge, at the office of the Council of the Shire of South Gippsland at Foster, and at the office of the Town and Country Planning Board, 235 Queen Street, Melbourne.

W. H. CRAIG, Secretary,
Town and Country Planning Board.

Town and Country Planning Act 1961.
CRANBOURNE PLANNING SCHEME (WESTERNPORT)
1974.

INTERIM DEVELOPMENT ORDER.

Notice of Approval.

In pursuance of the powers conferred by the Town and Country Planning Act 1961, the Governor in Council on the 27th day of May, 1975, approved the making of an Interim Development Order by the Cranbourne Shire Council for part of the municipal district of the Shire of Cranbourne.

The Interim Development Order provides that the use, subdivision or development of any land within the area described or the erection, construction or carrying out of any buildings, roads or other works thereon is prohibited except in accordance with the provisions of the Order.

A copy of the Interim Development Order and a map showing the area affected may be inspected, free of charge, at the office of the Council of the Shire of Cranbourne at Cranbourne, and at the office of the Town and Country Planning Board, 235 Queen Street, Melbourne.

W. H. CRAIG, Secretary,
Town and Country Planning Board.

Town and Country Planning Act 1961.
SHIRE OF WERRIBEE PLANNING SCHEME 1963.
AMENDMENT No. 17, 1971.

Notice of Approval.

In pursuance of the powers conferred by the *Town and Country Planning Act 1961*, the Governor in Council on the 27th May, 1975, approved a Planning Scheme entitled the Shire of Werribee Planning Scheme 1963, Amendment No. 17, 1971, in respect of the municipal district of the Shire of Werribee and such Planning Scheme comes into operation on the date this Notice of Approval is published in the *Government Gazette*.

A copy of the Planning Scheme as approved may be inspected, free of charge, during office hours at the office of the Town and Country Planning Board, 235 Queen Street, Melbourne, at the office of the Council of the Shire of Werribee at Werribee, and when available, at the Office of Titles, Melbourne, and at the Central Plan Office of the Department of Crown Lands and Survey, Melbourne.

W. H. CRAIG, Secretary.
Town and Country Planning Board.

PUBLIC TRUSTEE ACT 1958 (No. 6350), SECTION 17.

I hereby give notice that on the 2nd May, 1975, the Public Trustee filed Elections to Administer the following deceased persons' estates in accordance with Section 17 of the *Public Trustee Act 1958*:—

HADDOCK, EDITH, formerly of 18 Carpenter Street, Middle Brighton, but late of Coronella Homes, 167 Centre Road, Nunawading, widow, died 6th February, 1975.

HURSE, LILLIAN MARY, formerly of Unit 10/45 Wilson Street, Brighton, but late of Hurlingham Hospital, 68 Union Street, East Brighton, widow, died 2nd November, 1974.

TURNER, GLENYS MAVIS AMELIA, late of 10 Ontario Street, North Caulfield, retired printing employee, died 6th February, 1975.

I hereby give notice that on the 9th May, 1975, the Public Trustee filed Elections to Administer the following deceased persons' estates in accordance with Section 17 of the *Public Trustee Act 1958*:—

BODEY, JANE BOWES, formerly of 214 Coppin Street, Richmond, but late of "The Old Colonists Homes", Rushall Crescent, North Fitzroy, Spinster, died 7th January, 1975.

MAY, JANET LOUISE DOUGLAS, late of Treannan Private Hospital, Flinders Road, Shoreham, widow, died 17th December, 1974.

MORRISON, ELIZABETH JANE, late of 3 Victoria Avenue, Canterbury, Spinster, died 1st February, 1975.

REID, DOROTHY MAY, formerly of 65 Chomley Street, Prahran, but late of 87 Chapel Street, St. Kilda, widow, died 24th June, 1974.

ROOKE, ELLEN, formerly of Heywood, but late of Ballarat, widow, died 17th September, 1974.

N. P. BRODY,
Public Trustee.

168 Exhibition Street, Melbourne, 3000, 28th May, 1975.

NOTICE.

Creditors, next of kin, and others having claims against the estate of any of the under-mentioned deceased persons are required to send particulars of their claims to the Public Trustee, 168 Exhibition Street, Melbourne, Vic. 3000, the personal representative, on or before the 9th August, 1975, after which date the Public Trustee may convey or distribute the assets having regard only to the claims of which the Public Trustee then has notice:—

ARBLASTER, LOUIS GARFIELD, late of 1 Pier Road, Grantville, motor mechanic, died 27th December, 1974.

ATKINSON, LEONARD, late of 55 St. Elmo Road, Ivanhoe, optical supervisor, died 15th March, 1975.

BAKER, THOMAS GEORGE, late of 9 Arlington Avenue, Aston near Sheffield, England, retired telephone engineer, died 16th October, 1971.

BODEY, JANE BOWES, formerly of 214 Coppin Street, Richmond, but late of the "The Old Colonists Homes", Rushall Crescent, North Fitzroy, spinster, died 7th January, 1975.

BRADLEY, LESLIE FREDERICK, late of 6 Bayliss Street, West Preston, retired wire worker, died 8th August, 1974.

CIMMERS, VOLDEMARS, late of 47 Chestnut Street, Richmond, retired chemical worker, died 20th November, 1974.

COREY, ELSIE MARGARET, late of 16 Park Street, Glenferrie, widow, died 28th January, 1975.

COSTELLO, MAY MARGARET, also known as May Costello, late of 45 Marlborough Street, Balaclava, married woman, died 13th December, 1974.

CROWE, BESSIE MAY, late of Dannevirke, New Zealand, spinster, died 9th August, 1974.

DESTRO, GIUSEPPE, formerly of 208 Bell Street, East Preston, but late of 31 Showers Street, Preston, retired pottery employee, died 28th December, 1974.

GRANT, STEVEN REUBEN, late of 46 Dianne Avenue, Craigieburn, driver, died 5th October, 1974.

HADDOCK, EDITH, formerly of 18 Carpenter Street, Middle Brighton, but late of Coronella Homes, 167 Centre Road, Nunawading, widow, died 6th February, 1975.

HURSE, LILLIAN MARY, formerly of Unit 10/45 Wilson Street, Brighton, but late of Hurlingham Hospital, 68 Union Street, East Brighton, widow, died 2nd November, 1974.

KEARNEY, NORMAN JAMES, late of 39 Mount Street, Altona, retired carpenter, died 16th February, 1975.

KELLY, ALMA ALICE, late of 55 Clarke Street, Newtown, Geelong, widow, died 4th April, 1975.

KRAHNERT, RICHARD, late of 7 Long Street, Swan Hill, retired farmer, died 30th December, 1974.

MAY, JANET LOUISE DOUGLAS, late of Treannan Private Hospital, Flinders Road, Shoreham, widow, died 17th December, 1974.

MITCHELL, EDWARD JOSEPH, late of 12 Luke Street, Reservoir, retired school teacher, died 20th February, 1975.

MORRISON, ELIZABETH JANE, late of 3 Victoria Avenue, Canterbury, spinster, died 1st February, 1975.

NUTCHEY, WINIFRED ETHEL, late of Flat 14, 2b Hawsleigh Avenue, Balaclava, widow, died 30th January, 1975.

REID, DOROTHY MAY, formerly of 65 Chomley Street, Prahran, but late of 87 Chapel Street, St. Kilda, widow, died 24th June, 1974.

ROOKE, ELLEN, formerly of Heywood, but late of Ballarat, widow, died 17th September, 1974.

STEWART, GLADYS, late of 20 Darling Street, Moonee Ponds, widow, died 14th March, 1975.

THOMPSON, MARY ESTHER, formerly of 53 Mitchell Street, Bentleigh, but late of "Canterbury Private Hospital", 14 Balwyn Road, Canterbury, married woman, died 6th September, 1974.

TURNER, GLENYS MAVIS AMELIA, late of 10 Ontario Street, North Caulfield, retired printing employee, died 6th February, 1975.

N. P. BRODY,
Public Trustee.

Melbourne, 28th May, 1975.

MINES DEPARTMENT.

APPLICATIONS FOR MINING LEASES DECLARED
ABANDONED.

No. 224; Percival John Hall, Peter Clarke Poole, Brian A. Prothero, Howard Coombes; 16 ha, Parish of Kevington.

No. 323; Castlemaine Engineering and Mining Company Pty. Ltd.; 20 ha, Parish of Kooreh.

MINING LEASES GRANTED.

No. 328; Robert William Bennett, Wendy Jean Bennett; 36 ha, Parish of Boort.

9162, Mineral; Mildura Plaster Mills Pty. Ltd.; 15 ha, Parish of Goonegul.

EXPLORATION LICENCE GRANTED.

No. 552; Preussag Australia Proprietary Limited; 792 km², Counties of Tambo and Croajingolong.

EXPLORATION LICENCE EXPIRED.

No. 466; Jennings Mining Limited; 198 km², County of Delatite.

J. C. M. BALFOUR,
Minister of Mines.

OPTICIANS REGISTRATION BOARD.—Victoria.

LIST OF CERTIFIED OPTICIANS REGISTERED AT 28TH MAY, 1975.

	Certificate No.
Addison, Sydney Andrew, 167 Collins Street, Melbourne	109
Aitken, Michael John (Parker & Aitken), 469 Sydney Road, Coburg	446
Allen, Douglas Geoffrey (L. J. Etherington & D. G. Allen), 65 Deakin Avenue, Mildura	369
Anderton, Philip James (Victorian College of Optometry), 374 Cardigan Street, Carlton	573
Andrews, Michael Gordon, 45 Venice Street Mentone (also at Dandenong)	507
Angior, Gwyndolen Germaine (A. W. Angior), 117 Collins Street, Melbourne	111
Angior, Leonard Holmes (A. W. Angior), 117 Collins Street, Melbourne	112
Bailey, Ian Laurence, Department of Optometry, University of Melbourne, Parkville	464
Banks, Margaret McNeil (Mrs.), 30 Reubens Grove, Canterbury	382
Barrett, John Roland (John Barrett & Associates Pty. Ltd.), 42 Mahoneys Road, Forest Hill (also at Glen Waverley)	473
Bartlett, Carol Elizabeth (Mrs.), care of Graham C. Green, 324 High Street, Preston	584
Barton, Harold Percival (Eye Services Pty. Ltd. Box Hill Optical Service), 922 Whitehorse Road, Box Hill	445
Beer, Ronda Helen (Mrs.), 31 Williamson Avenue, Strathmore	533
Bennett, Frederick George (F. G. & R. G. Bennett & Associates), 192 Liebig Street, Warrnambool	292
Bennett, Richard Geoffrey (F. G. & R. G. Bennett & Associates), 192 Liebig Street, Warrnambool	387
Bergman, Miriam (Mrs.), 15 Yanakie Crescent, Caulfield	472
Besley, Bruce Kelvin (Bruce K. Besley Pty. Ltd.), 110 Collins Street, Melbourne (also at Glenroy and Doncaster Shoppingtown)	406
Bissell, Hugh Melville, 278 Campbell Street, Swan Hill (also at Kerang)	350
Bissell, Jack Laurence, 421 New Street, Elwood	358
Blackwood, Julie Anne (N. G. Jarvey Pty. Ltd.), 33 Portman Street, Oakleigh (also at Brandon Optometrists) Mulgrave	544
Blake, Terence Holyoake, 13 Eastland, Ringwood (also at Croydon)	511
Blizzard, Raymond Harry (John Browning & Associates Pty. Ltd.), 70 Barkley Street, Ararat	413
Blumberg, Boaz, Shop 3, The Mall, Logan Road, Stones Corner, Queensland	345
Bolton, Kenneth Arthur, Myrree Road, Whitlands	364
Both, Ross Alexander (John Browning & Associates Pty. Ltd.), 27 McLachlan Street, Horsham	475
Bowden, Robert Stanley (R. S. Bowden), 128 Gray Street, Hamilton (also at Casterton)	541
Bowman, Kenneth John (Victorian College of Optometry), 374 Cardigan Street, Carlton	519
Bray, Ronald, 18 Brice Avenue, Mooroolbark	443
Brazionis, Laimute (Mrs.) (H. H. Friend), 110 Collins Street, Melbourne (also at Williamstown)	545
Brower, Judith Eve (Coles & Garrard (Vic.) Pty. Ltd.), 376 Bourke Street, Melbourne	571
Brown, John Joseph (Coles & Garrard Pty. Ltd.), 32 Malop Street, Geelong	396
Brumer, Maurice (Victor House Optical Centre), Shannon Street, Frankston (also at Wonthaggi Optical Service), Wonthaggi	494
Bryant, Evan Paul, "Werners", Toorak and Melbourne	585
Burke, Alan (Coles & Garrard Pty. Ltd.), 484 Nepean Highway, Frankston	383
Cailes, Stanley Allen Roy, 394 Sydney Road, Brunswick	450
Cannington, Geoffrey Walter (Coles & Garrard Pty. Ltd.), Northland, Centre Murray Road, East Preston	484
Carney, Brian John, 97 High Street, Maryborough (also at Bendigo)	485
Carney, Leo Gerard (Victorian College of Optometry), 374 Cardigan Street, Carlton	500
Carter, Betty Isabel (Mrs.), 5 Kiandra Court, Frankston	506
Cartwright, John Moorcroft, Killans Walk, Bendigo (also at Castlemaine)	477
Chapman, Vernon Leslie, 12 Sydney Road, Coburg	65

OPTICIANS REGISTRATION BOARD.—continued.

	Certificate No.
Clemens, Ewen Dale, 91 Mollison Street, Kynton	375
Cockburn, David Michael, 348 Hampton Street, Hampton	397
Cocks, Arthur Wallis (Arthur Cocks & Co. Ltd.), 21 Birdwood Avenue, Killara, N.S.W.	360
Cole, Barry Leighton (Department of Optometry), University of Melbourne, Parkville	427
Collin, Hermann Barry (Department of Optometry), University of Melbourne, Parkville	422
Collins, Marie Therese, 15 Kennedy Street, Glenroy	546
Cooke, Jennie Cecilia Josephine (Bray & Waite), 246A Main Street, Lilydale	547
Cooper, William Albert, 9 Como Parade, Mentone (also at Frankston)	391
Corless, Arthur Henry Sydney, 1178 Malvern Road, Malvern	309
Coventry, Margaret Lois, 69 Delbridge Street, North Fitzroy	574
Cowen, Harold Phillip, 85A Chapel Street, Windsor	339
Cumberland, Joseph Knight, 77 Balaclava Road, Caulfield	20
Curtis, Norman Peter, 80 Reid Street, Wangaratta (also at Benalla)	397
Cutter, Geoffrey Bryan (G. B. Cutter & D. H. Gardiner), 46 Sturt Street, Ballarat	118
Dain, Stephen John (Department of Optometry), University of Melbourne, Parkville	575
Dalins, Inese (Mrs.) (B. K. Besley), 820 Pascoe Vale Road, Glenroy (also at Doncaster Shopping Town)	520
Davis, Albert George, 469 High Street, Preston	340
Denahy, Francis John, 80 Moorabool Street, Geelong	471
Dods, Stanley Hugh (Cecil H. Thomas Pty. Ltd.), 17 Mid City Arcade, 200 Bourke Street, Melbourne	236
Doherty, Kathleen Mary, 27 Ellenvale Avenue, Pascoe Vale South	549
Doolan, Maurice James (Maurice J. Doolan), 5th Floor, 100 Little Collins Street, Melbourne	398
Douglas, Anthony Podmore, 714 Sturt Street, Ballarat	368
Dove, Lawrence (Bray & Waite (Optom.) Pty. Ltd.), 18 Brice Avenue, Mooroolbark	576
Dwyer, Peter Stanway (Mason & Dwyer), 424 Centre Road, Bentleigh	486
Easton, John Joseph, 143 Bell Street, Heidelberg West	343
Edwards, John Llewellyn (Optp. Pty. Ltd.), 113 Swanston Street, Melbourne	516
Egarr, Clifton, 1A Service Street, Hampton	416
Ellis, Clarence Hartley, 41 Alexandra Street, East St. Kilda	26
Ellis, Gordon Francis, 578 North Road, Ormond	238
Elwood, Stanley Arthur (care of Salvation Army), 70 Sinclair Street, Colac	467
Etherington, Leslie John (L. J. Etherington & D. G. Allen), 65 Deakin Avenue, Mildura	121
Etherington, Reginald Robert (L. J. Etherington & D. G. Allen) as above	122
Every, Alan Winston (John W. Every), 159 Maude Street, Shepparton	522
Every, John Winston, 159 Maude Street, Shepparton	123
Ferry, Frederick Joseph, 339 Clarendon Street, South Melbourne	258
Ferry, George Joseph, 705 Nicholson Street, North Carlton	259
Fish, Michael Edward, 48 Hamilton Street, Mont Albert	456
Fisher, Maxwell Caspar (Maxwell C. Fisher & Assoc.), High Street, Cranbourne	28
Fisher, Thomas Clement (K. C. McLennan), 10c Paisley Street, Footscray	124
Flynn, Brian, 1131 Glenhuntly Road, Glenhuntly	394
Foster, Claude, 15 Warranilla Avenue, Rosebud	310
Frank, Peter Hans, 53 Atherton Road, Oakleigh	487
Freeman, Graeme Henry (Harold R. P. Ternes Pty. Ltd.), 9 Cookson Street, Camberwell (also at Richmond Optical Clinic), Richmond	453
Frewin, Jolyon Westcott (J. W. & H. B. Frewin), 56 Station Street, Moorabbin (also at Chelsea and Sandringham)	517
Friend, Hans Hermann, 110 Collins Street, Melbourne (also at Williamstown)	402
Fromoes, Robert Allan, 45 McLean Street, Morwell	347
Fry, Stanley Joseph (Opto Pty. Ltd.) Capital House, 113 Swanston Street, Melbourne	311

OPTICIANS REGISTRATION BOARD.—*continued.*

	Certificate No.
Gardiner, Derek Hatchell (G. B. Cutter & D. H. Gardiner), 46 Sturt Street, Ballarat	392
Garner, Leon Frank (Victorian College of Optometry), 374 Cardigan Street, Carlton	482
Garrett, Anne Rosalie (Mrs.), 19 Princes Crescent, Shepparton	480
Gartner, Wolfgang Franz (Gartner Harris & Blake Pty. Ltd.), 13 Eastland, Ringwood (also at Croydon)	425
Gibson, Anne (Mrs.) (A. & A. Gibson Pty. Ltd.), 261 Camberwell Road, Camberwell (also at Mitcham)	540A
Gibson, Anthony John (A. & A. Gibson Pty. Ltd.), 261 Camberwell Road, Camberwell (also at Mitcham)	523
Goetz, Ernest (Alfred Nott Pty. Ltd.), 141 Collins Street, Melbourne	73
Goucher, John Noel (Cecil H. Thomas Pty. Ltd.), 200 Bourke Street, Melbourne	359
Graetzer, Judith Eve, 378-388 Bourke Street, Melbourne	571
Graves, Athol Sydney Robert, 80 Moorabool Street, Geelong	348
Green, Graham Clarence (Clarence A. Green Pty. Ltd.), 434 Sydney Road, Coburg (also at Preston)	435
Griffiths, Ronald Philip, 117 Nicholson Street, Footscray (D. P. Griffiths)	130
Guggisberg, John (Coles & Garrard Pty. Ltd.), 376 Bourke Street, Melbourne	459
Gutteridge, Peter David (George A. Rees Pty. Ltd.), 318-322 Little Collins Street, Melbourne	524
Gyaw, Htin (Royal Victorian Eye and Ear Hospital), 126 Victoria Parade, East Melbourne (also at Syd W. Myers Optical Service) North Fitzroy and (Collingwood Optical Service), Collingwood	543
Halley, Ernest Ivan Francis, 9 Dendy Street, Middle Brighton	335
Hammerton, Horace Geoffrey, 139 Tenth Street, Mildura	132
Harris, Ross William (Gartner & Harris Pty. Ltd.), 2 Hewish Road, Croydon (also at Ringwood)	468
Hawley, Gordon Edward (Coles & Garrard Pty. Ltd.), 46 Walker Street, Dandenong	525
Held, Harry Howard (Harry Held Pty. Ltd.), 601 Mt. Alexander Road, Moonee Ponds	424
Hess, Robert Francis (Victoria College of Optometry), 374 Cardigan Street, Carlton (also at F. Kindler), Collingwood and Greensborough	570
Heydon, Leo Morton, 24 Burwood Road, Burwood	34
Hicks, Lawrence (Coles & Garrard Pty. Ltd.), 376 Bourke Street, Melbourne	424
Hill, Graham Ormond (Graham O. Hill), 55 Welsford Street, Shepparton	478
Hills, Ronald Charles (Balwyn Optical Service), 403 Whitehorse Road, Balwyn (also at Ronald C. Hills), Rosebud	316
Hirschfeld, Glenda Robyn, 4/44 Westbury Street, Balaclava	577
Hocking, John Lynton (Harold Barton), Westfield Tower, Doncaster Shoppingtown	512
Hogan, Reginald George Mears (John Brown & Associates), 36 Lower Plaza, Southern Cross Centre, Melbourne (also at East St. Albans)	134
Horsfall, Henry Barber, 138 Hare Street, Echuca (also at Kyabram)	417
Howard, John Leonard (E. Wood & Co. Pty. Ltd.), 38 Palmerton Street, West Footscray	36
Hussey, George Gerald, "Monkani", Tatong P.O. Tatong, Victoria	137
Hutton-Jones, Lloyd, 23 Remond Street, Kew	351
Impey, Robert John (K. C. McLennan), 10c Palsley Street, Footscray	496
Isaacs, Alan, 2 Collins Street, Melbourne	367
Isaacs, Basil Maurice, 324A Carlisle Street, East St. Kilda	399
Jabara, Ernest Henry, 9 Jacques Street, Hawthorn East	79
Jackson, Rodney James, 25 Ceylon Street, Nunawading (Box Hill Optical Service, Suite 39, Whitehorse Plaza, Box Hill)	579
Jacobi, Patrick Leslie (Coles & Garrard Pty. Ltd.), Bendigo	591
Jacobs, Robert John (Victorian College of Optometry), 374 Cardigan Street, Carlton	534
Jakubovic, Jerry (Bray & Waite Pty. Ltd.), 246 Main Street, Lilydale	551

OPTICIANS REGISTRATION BOARD.—*continued.*

	Certificate No.
Jarvey, Norman Gustavus, 209 Young Street, Unley, S.A.	39
Jeffery, Rodney James (Alfred Nott Pty. Ltd.), 141 Collins Street, Melbourne	552
Jenkin, Charles Gilbert, 50 Glenferrie Road, Malvern	362
Jennings, John Barton (Coles & Garrard Pty. Ltd.), Southland Shopping Centre, Cheltenham	553
Johnston, Alan William (Victorian College of Optometry), 374 Cardigan Street, Carlton	469
Johnston-Simon, Fitzgerald (Myer), Melbourne	590
Joyce, Susanne Joyce (Mrs.) (Coles & Garrard Pty. Ltd.), 376 Bourke Street, Melbourne (also at Preston East)	565A
Kalf, Susan Frances (Mrs.) (H. R. Ternes Pty. Ltd.), 7 Cookson Street, Camberwell	550A
Kearney, Hugh John (Coles & Garrard Pty. Ltd.), 103 Sturt Street, Ballarat	449
Keogh, Francis Arthur (Parent Optical Pty. Ltd.), 2c Finchley Avenue, Glenroy	470
Kindler, Frank Maurice (Frank M. Kindler Pty. Ltd.), 204 Smith Street, Collingwood (also at Greensborough)	426
King, Lindsay Ronald (Coles & Garrard Pty. Ltd.), 376 Bourke Street, Melbourne	191
Larsen, Hans David (Andrew Gaddes), 287 Little Collins Street, Melbourne	532
Law, Heather Jean (Mrs.) (Coles & Garrard), Bourke Street, Melbourne	548A
Lawry, David John (Coles & Garrard Pty. Ltd.), 32 Malop Street, Geelong	580
Leunig, Geoffrey Allan (G. M. Watt), 4 Smith Street, Warragul (also at Moe)	527
Lewis, Ivor James, 220 Collins Street, Melbourne (also at Mount Waverley)	352
Liddy, Robert Graeme (Robert G. Liddy), 146 Baillie Street, Horsham	458
Lord, Lawrence Arthur (A. B. Lord Pty. Ltd.), 773 Glenferrie Road, Hawthorn	344
Lorraine, Lawrence Manfred (Coles & Garrard Pty. Ltd.), 376 Bourke Street, Melbourne	363
Loutit, Robert Thomas (K. C. McLennan), 6A Clark Street, Sunshine	495
Lovie, Janette Elizabeth (Victorian College of Optometry), 374 Cardigan Street, Carlton	560
McCabe, Michael (C. M. Watt), 4 Smith Street, Warragul (also at I. R. Wheeler), Sale	561
McCann, Paul Francis (Coles & Garrard Pty. Ltd.), 376 Bourke Street, Melbourne	555
McFarlane, Kenneth Hilton (K. H. McFarlane), 112 Brown Street, Heidelberg	84
McGibbony, John Edward (Coles & Garrard Pty. Ltd.), 376 Bourke Street, Melbourne	528
McGibbony, Leonard Matthew, 15 Collington Avenue, Brighton	48
McIlvena, Sandra Elizabeth (Mrs.), 22 Sunhill Road, Mt. Waverley	481
McLarty, Anthony Matthew (J. Holland Pty. Ltd.), 5 Victoria Square Arcade, Adelaide, S.A.	558
McMahon, Ian Hamilton, 192 Liebig Street, Warrnambool	513
Maddocks, Jennifer Dawn (Mrs.) (W. E. Ocleshaw Pty. Ltd.), 125 Swanston Street, Melbourne	535A
Mansell, Robert Samuel, 200 Main Street, Bairnsdale	415
Marsh, Leslie Charles (J. M. May Pty. Ltd.), 207 Bridge Road, Richmond (also at Andrew Gaddes Pty. Ltd.), Melbourne	373
Marshall, William George Murdoch (Coles & Garrard Pty. Ltd.), Box 4, Chadstone Centre	412
Martin, Elaine Olive (Gartner Harris & Blake), Eastland, Ringwood	586
Mason, Rhodes, 57 Main Street, Mornington	372
Milhinch, Peter Hadfield (Reservoir & Preston Optical Centre), 301 Broadway, Reservoir	499
Morris, Geoffrey Gerson (Frank D. Morris), 12A Chapel Street, Windsor	357
Morris, Pauline Mary (Mrs.) (Collingwood Optical Service), 105 Johnston Street, Collingwood	557A
Morris, Robert George (Frank D. Morris), 12A Chapel Street, Windsor	514
Nankervis, Victoria Julie, 56 Station Street, Moorabbin	564A
Nathan, John, 15 Collins Street, Melbourne	370
Noonan, John Daniel (Kew Spectacle Dispensers), 5 Fenton Way, Kew	414
Nott, Ronald Emil, Flat 14, 91 Ormond Esplanade, Elwood	154

OPTICIANS REGISTRATION BOARD.—continued.

	Certificate No.
Oates, John Charles (John G. Prentice), 82 Elizabeth Street, Melbourne	90
Ogders, Dawn Grace (John Browning & Associates), Suite 36, Lower Plaza, Southern Cross Centre, 95 Bourke Street, Melbourne	395
Ovenden, George Vans (St. Kilda Optical), 266 High Street, St. Kilda (also at V. M. Johnstone & Associates), Heidelberg	385
Ovenden, John Ambrose (J. A. & G. E. Ovenden), 113 Swanston Street, Melbourne	384
Owen, Donald Richard Leslie (R. G. Liddy & D. Owen), 146 Baillie Street, Horsham	563
Owens, William Edward (W. E. Owens), 174 Ormond Road, Elwood	156
Partridge, Harold Frederick Keith, 215 Wattle-tree Road, Malvern	298
Peachey, Graham Thomas (Graham T. Peachey), 8 Nilmar Avenue, Wodonga (also at Albury, N.S.W.)	509
Peebles, Melinda Louise (Mrs.) (P. S. Dwyer), 12 Iranda Street, Frankston (also at David Cockburn), Hampton Street, Hampton and (W. Cooper), Como Parade, Mentone	562A
Penry, Vincent Frederick (H. Collin & Sons Pty. Ltd.), 256 High Street, Northcote (also at Thornbury)	488
Pettitt, John Leigh (Bennett & Associates), 125 Ryrie Street, Geelong (also at Colac)	479
Podbury, Dudley James, 25 Pratt Street, Moonee Ponds (also at Springvale)	436
Propsting, Mary Elizabeth (Coles & Garrard Pty. Ltd.), 376 Bourke Street, Melbourne	578A
Quinn, Douglas Jeffrey, 1232 Greenford Road, Greenford, Middlesex, England	582
Robbins, Helen Gail (Victorian College of Optometry), 374 Cardigan Street, Carlton	536
Rodger, Kenneth Scott (Repatriation Department), St. Kilda Road, Melbourne	490
Ryan, Kevin Laurence (Coles & Garrard Pty. Ltd.), 376 Bourke Street, Melbourne	454
Sandy, Trevor John (Fenn & Bolton), 227 Collins Street, Melbourne (also at Trevor J. Sandy), Radovik Street, Korumburra (also Camberwell)	537
Scates, Lois Anne (K. C. McLennan), 10c Paisley Street, Footscray	581
Schubert, Glenda Joan (Mrs.) (Myer Emporium Ltd.), Bourke Street, Melbourne	566A
Semmens, Clifton Henry, 12 Codrington Street, Sandringham	163
Shavitsky, Rebecca (Myer Melbourne Ltd.), Bourke Street, Melbourne	390
Sigmont, Robert Victor (Carnegie Optical Clinic), 115 Koornang Road, Carnegie (also at Clayton)	474
Silberberg, Tessa (Mrs.) (David C. Tovey), 425 Glenhuntly Road, Elsternwick (also John Barrett), Glen Waverley	388
Slade, Francis Rowlands (The Optical House of Francis R. Slade), 218 Camberwell Road, Hawthorn	99
Smallbone, David Huw (care of Harold P. Barton), Burvale Shopping Centre, Vermont South	583
Smith, Damien Patrick (Australian Optometrical Association), 4/609 St. Kilda Road, Melbourne (also at Peter Wardrop), 342 Keilor Road, Niddrie	502
Spargo, Raymond William (C. Werner & Co.), 247 Collins Street, Melbourne (also at Toorak)	378
Spencer, Ernest Arthur (Coles & Garrard Pty. Ltd.), 376 Bourke Street, Melbourne	407
Spicer, Hector Francis (H. F. Spicer & Co.), 165 Lonsdale Street, Dandenong (also at Frankston)	300
Spicer, William John (H. F. Spicer & Co.), 460 Nepean Highway Frankston (also at Dandenong)	429
Stewart, Jack, 392 George Street, Deniliquin, N.S.W.	439
Stiles, Cecil Charles (South Melbourne Optical Service), 270 Clarendon Street, South Melbourne	100
Stillwell, Charles Ewan (Victorian College of Optometry), Carlton	567
Strachan, John Phillip Frith, 5th Floor Sports-girl Court, 234 Collins Street, Melbourne	386
Sutherland, Donald James, "Gwenelg", Upper Beaconsfield	55
Swaby, Ian David (W. M. & Ian D. Swaby), 71 Kennedy Street, Hamilton	409

OPTICIANS REGISTRATION BOARD.—continued.

	Certificate No.
Swallow, Harry, 13 Beltane Avenue, East Brighton	101
Swinnerton, William James, 15 Collins Street, Melbourne (also at Eltham)	371
Templeton, Allan Ivor (N. G. Jarvey Pty. Ltd.), 33 Portman Street, Oakleigh (also at Mulgrave)	505
Tovey, Stanley David Courtier (S. D. Courtier & Tovey Pty. Ltd.), 425 Glenhuntly Road, Elsternwick (also at Brighton)	428
Travis, James Arthur, 357 Victoria Street, West Melbourne	301
Treleaven, Margaret Mary (Mrs.) (J. R. Barrett), Glen Waverley	492
Trewin, Suzanne Clare (John Browning & Associates), 820 Pascoe Vale Road, Glenroy	568
Trowbridge, John, 4 McLeod Street, Rye	266
Van Bergen, Marjorie June Mortimer (Mrs.) (Alfred Nott Pty. Ltd.), 141 Collins Street, Melbourne	411A
Videky, Valerie Iris (Mrs.) (Springvale Optical Service), 371 Springvale Road, Springvale (also at Mt. Waverley)	508
Vines, Edward John (Abra & Vines), 85 Brisbane Street, Launceston, Tasmania	400
Vinson, Beryl Florence (Myers Melbourne), Bourke Street	587
Vojlay, Richard Thomas (B. K. Besley), 820 Pascoe Vale Road, Glenroy	588
Waite, Duncan Raymond (Bray & Waite Pty. Ltd.), 190 Main Street, Croydon (also at Mooroolbark and Lilydale)	442
Walker, James Knox (Coles & Garrard Pty. Ltd.), 376 Bourke Street, Melbourne	302
Ward, William Stafford (George A. Rees Pty. Ltd.), 320 Little Collins Street, Melbourne	105
Wardrop, Peter James (Peter J. Wardrop), 342 Keilor Road, Niddrie (also at Moonee Ponds)	401
Weisz, Tibor (Boronia Optical Service), 256 Dorset Road, Boronia	504
Wheeler, Ian Robert (Wheeler Pty. Ltd.), 62A Raymond Street, Sale (also at Traralgon)	498
Whineray, Walter Samuel (Essendon Optical Service), 19A Leake Street, Essendon (also at Werribee)	107
Williams, Ian Phillip (W. A. Cooper), 9 Como Parade, Mentone (also at Frankston)	569
Williams, Janice Elva (Raymond Bissell), 132 Main Street, Stawell	521
Wilsmore, Paul Francis (Paul F. Wilsmore), 106 Hawthorn Road, Caulfield (also at Reservoir and Preston Optical Centre), Reservoir and Altona	515
Worfold, Lloyd George, 316 Stanley Terrace, Taringa, Queensland	572
Wood, Alan John Layton (E. Wood & Co. Pty. Ltd.), 276 Collins Street, Melbourne (also at Box Hill)	342
Wood, William Layton (E. Wood & Co. Pty. Ltd.), 276 Collins Street, Melbourne	174
Wrigley, Ronald Neilson (G. A. Rees Pty. Ltd.), 320 Little Collins Street, Melbourne (also at Footscray)	405
Zent, Robert Phillip, 12 Victoria Street, Brighton	589

CONTRACTS ACCEPTED.—(Series 1974-75.)

VICTORIAN RAILWAYS.

109. Manufacture, supply and delivery of axles, at rates (Contract No. 64084).—Sumitomo Shoji, (Australia), Pty. Limited. 110. Supply and delivery of axles for F.C.F. container wagons, at rates (Contract No. 64075).—Commonwealth Steel Company Ltd. 111. Manufacture, supply and delivery of axles, at rates (Contract No. 64087).—Commonwealth Steel Company Ltd. 112. Erection and completion of new station buildings at Macaulay, West Footscray, Glenbervie and Glenroy, for the amount of \$322,882.00 (Contract No. 64100).—G. Harris, (Builders), Proprietary Limited.

By Order of the Victorian Railways Board,

C. W. MILLER, Secretary. 26.5.75.

113. Supply and application of protective coating to joints of tunnel associated with M.U.R.L.A., at rates (Contract 64028).—Nonporite Proprietary Limited. 114. Manufacture, supply and delivery of standard pre-cast reinforced concrete subway units for pedestrian subways, at rates (Contract 64099).—Humes Limited. 115. Manufacture, supply and delivery of standard pre-cast reinforced concrete subway units for pedestrian subways, at rates (Contract 64010).—Humes Limited.

By order of the Victorian Railways Board,

C. W. MILLER, Secretary. 2.6.75.

APPOINTMENTS AND RESIGNATIONS

APPOINTMENTS.

His Excellency the Governor of the State of Victoria, by and with the advice of the Executive Council thereof, has, by Orders made on the 27th day of May, 1975, been pleased to make the under-mentioned appointments, viz.:—

CROWN LANDS AND SURVEY DEPARTMENT.

Trustees of Reserves.

TRAVIS HOWELL
to be an additional trustee of the land in the Township of Euroa permanently reserved as a site for Show Yards by Order in Council of 16th June, 1891.

**FREDERICK WILFRED HARRIS, and
ALICE LOUISA HILL**
to be trustees of the land in the Township of Stanley permanently reserved as a site for Public Athenaeum Purposes by Order in Council dated the 17th February, 1873, in the places of Harold Raymond Sinclair (deceased) and Marjory Sarah Heaphy (no longer a resident of Stanley).

MINISTRY OF HEALTH.

Deputy Superintendent, Mental Hospital and Training Centre.

KALARICKAL THOMAS, M.B., B.S. (Kerala 1969), D.P.M. (Bangalore 1972),
to be Deputy Superintendent of the Mental Hospital and Training Centre, Ararat, from the 11th May, 1975, pursuant to the provisions of section 26 (1) of the *Mental Health Act 1959*, vice Manjit Singh Dhillon, resigned.

Member of Dietitians Registration Board.

JOHN WILLIAMSON LEGGE, M.Sc.,
to be a Member of the Dietitians Registration Board of Victoria, pursuant to the provisions of section 4 of the *Dietitians Registration Act 1958* for the remainder of the period ending the 28th September, 1976, vice Dr. T. A. Collins, deceased. (This Order is in lieu of the Order made by the Governor in Council on the 15th April, 1975.)

Member of Committee of Management of Hospital.

ARTHUR ERNEST WALSH
to be the Government Appointee on Committee of Management, St. Arnaud District Hospital for a further period of three years ending the 13th May, 1978, pursuant to the provisions of sub-paragraph (ii) of paragraph (a) of the proviso to sub-section (1) of section 48 of the *Hospitals and Charities Act 1958*.

Trustees of Public Cemeteries.

HUGH TYSON ADAMS
to be a Trustee of the Laen Public Cemetery vice D. Fox, deceased;

EDWARD LAURENCE JOHN BRIGHT
to be a Trustee of the Phillip Island Public Cemetery, vice J. K. McIlwraith, deceased;

DESMOND BRENDAN BARKER
to be a Trustee of the Port Fairy Public Cemetery vice T. Crowe, deceased;

**BERNARD JAMES RINALDI,
GRAHAM LAWRENCE NEWITT and
SAMUEL HERBERT WHITEHEAD,**

to be Trustees of the Bealiba Public Cemetery vice J. Harrop, deceased, A. Baruba, deceased, and A. Cameron, resigned (respectively);

AUSTIN BASTOW
to be an additional Trustee of the Pakenham Public Cemetery;

MAXWELL GEORGE ROBINSON
to be a Trustee of the Taradale Public Cemetery vice R. J. Shearer, deceased;

LESLIE JENKINS
to be a Trustee of the Chewton Public Cemetery vice W. A. Docking, resigned;

**ALAN PATRICK SAVAGE and
SYDNEY PATRICK SAVAGE,**
to be additional Trustees of the Eildon Weir Public Cemetery;

ARTHUR NELSON BILLINGHAM
to be an additional Trustee of the Creswick Public Cemetery; and

REGINALD LYTLE
to be an additional Trustee of the Waterloo Public Cemetery, pursuant to section 3 (1) of the *Cemeteries Act 1958*.

LAW DEPARTMENT.

Justices of the Peace.

**GEORGE JAMES LESLIE ARMSTRONG,
FREDERICK JAMES EDMONDS and
GEORGE STANLEY JOHN POPE,**
care of Social Welfare Department, H.M. Prison, Pentridge, Coburg,
to be Justices of the Peace for the State of Victoria.

Commissioners for Taking Declarations, &c.

WILLIAM NEIL MORRISON EVANS, care of Collins Credit Union Co-operative Ltd., 95 Collins Street, Melbourne,
GEOFFREY VINCENT FLINT, care of Ibis Milk Products Ltd., 175 Welsford Street, Shepparton,
**JOHN RICHARD MCPHERSON and
PETER GOODMAN MURRAY,**
care of the State Savings Bank of Victoria, 139 Elizabeth Street, Melbourne,
MERLE VALMA MITCHELL, care of Community Aid and Advice Bureau, 5 Osborne Avenue, Springvale,
PATRICK JOSEPH NOEL PURCELL, care of Kinloch (Insurances) Pty. Ltd., Insurance Brokers, Armith House, 226-228 Swanston Street, Melbourne, and
GIUSEPPE SCALISE, care of Circle Realty Pty. Ltd., Auctioneers, Estate and Insurance Agents, 397 Keilor Road, Niddrie,
to be Commissioners for taking Declarations and Affidavits under the *Evidence Act 1958*.

MINES DEPARTMENT.

WILLIAM PATRICK RUSSELL, A.C.S.M.,
to be a Member of the Board of Examiners for Coal Mine Managers, vice Roydon John Elliott, resigned, pursuant to the provisions of the *Coal Mines Act 1958*.

DEPARTMENT OF WATER SUPPLY.

Waterworks Trust Commissioner.

ABRAM CHARLES ALLEN
to be a Commissioner of the Lorne Waterworks Trust, to hold such position for a period of two years from the date hereof, subject to the provisions of the *Water Act*.

TOM FORRISTAL,

Clerk of the Executive Council.
At the Executive Council Chamber,
Melbourne, 27th May, 1975.

Liquor Control Act 1968.

APPOINTMENT OF LICENSING INSPECTORS.

In accordance with the authority conferred upon me by sub-section (1) of Section 22 of the *Liquor Control Act 1968*, I, Reginald Jackson, Chief Commissioner of Police, hereby appoint the following Officers of Police as Licensing Inspectors for the Divisions of the Police Districts as shown:—

Division Number.	Police District.	Rank and Name.
2	Malvern	Inspector Colin Lloyd Eldridge (from 1.2.75 to 7.6.75)
2	Melbourne	Inspector Leonard Arthur Wright (from 1.6.75 to 15.9.75)
30.5.1975.		R. JACKSON, Chief Commissioner of Police.

FORESTS COMMISSION.

APPOINTMENT OF COMMITTEE OF MANAGEMENT OF "GRAMPIANS WONDERLAND FOREST PARK".

Whereas by section 50 of the *Forests Act 1958* (No. 6254), it is provided that the Minister of Forests may, on the recommendation of the Forests Commission, appoint any number of persons, not less than three, to be a Committee of Management of any land forming part of any reserved forest, such land being set aside as a forest park, and may remove any of those persons: Now therefore, I, Frederick James Granter, Her Majesty's Minister of Forests for the State of Victoria, on the recommendation of the Forests Commission, do hereby appoint—

**IAN ROBERT MCCANN,
ERNEST WILLIAM FEUCKER,
HAROLD THOMAS HARDING,
ARTHUR WILLIAM MCCrackEN, and
KEVIN RODERICK O'KANE,**

as members of the Committee of Management until the 30th day of November, 1976, of the land forming part of the reserved forest in the Parishes of Boroka and William, County of Borung, described in the accompanying Schedule, and known as the "Grampians Wonderland Forest Park".

SCHEDULE ABOVE REFERRED TO.

Parishes of Boroka and Willam, County of Borung, comprising 2,200 acres, more or less, shown by pink colour on plan marked 61.750 over 30/11/61 on file of correspondence No. 67/1763 in the Forests Department.

Dated at Melbourne, the 26th day of May, 1975.

F. J. GRANTER,
Minister of Forests.

Broiler Chicken Industry Act 1975.

APPOINTMENT OF VICTORIAN BROILER INDUSTRY NEGOTIATION COMMITTEE.

I, Ian Winton Smith, Minister of Agriculture for the State of Victoria in accordance with the provisions of section 3 of the *Broiler Chicken Industry Act 1975* hereby appoint the under-mentioned persons as members of the Victorian Broiler Industry Negotiation Committee for a period of two years from and inclusive of the 1st June, 1975.

DESMOND EDWIN HORE, an officer of the Department of Agriculture who shall be Chairman.

JOHN CYRIL BALL,
STAN CAICH,
REX LUKE,
PAUL ORR,
LESLIE JAMES SKINNER, and
RONALD LEONARD WATTS, representatives of processors.
KENNETH JOHN ADAMSON,
PETER EDWARD CAZALY,
DAVID STEVENSON CRAIGHEAD,
DUDLEY WALLACE SHAW,
DAVID STEVENSON, and
MICHAEL R. SWEETNAM, representatives of growers.

30th May, 1975.

IAN SMITH,
Minister of Agriculture.

REVOCATION OF APPOINTMENT.

His Excellency the Governor of the State of Victoria by and with the advice of the Executive Council thereof, doth by Order made on the 27th day of May, 1975, and pursuant to section 30 (1) of the *Land Act 1958* revoke the appointment of Lloyd Thomas Davies as a bailiff of Crown lands, made by the Governor in Council on the 27th August, 1957 (notified in the *Government Gazette* of the 4th September, 1957).

TOM FORRISTAL,
Clerk of the Executive Council.

At the Executive Council Chamber,
Melbourne, 27th May, 1975.

REVOCATION OF APPOINTMENT.

His Excellency the Governor of the State of Victoria by and with the advice of the Executive Council thereof doth by Order made on the 27th day of May, 1975, revoke the appointment of THEODORE JOHN VAN-EMDEN as a Commissioner for taking Declarations and Affidavits under the *Evidence Act 1958*.

TOM FORRISTAL,
Clerk of the Executive Council.

At the Executive Council Chamber,
Melbourne, 27th May, 1975.

RESIGNATIONS.

His Excellency the Governor of the State of Victoria, by and with the advice of the Executive Council thereof, has, by Order made on the 27th day of May, 1975, accepted the resignations of the persons named hereunder of the office mentioned, viz.:—

LAW DEPARTMENT.

Commissioners for Taking Declarations, &c.

ALBERT HENRY CHARLES CASH,
HARRY CHATTERTON and
ROBERT ALAN OLIVER,
as Commissioners for Taking Declarations and Affidavits under the *Evidence Act 1958*.

TOM FORRISTAL,
Clerk of the Executive Council.

At the Executive Council Chamber,
Melbourne, 27th May, 1975.

ORDERS IN COUNCIL

RACING ACT 1958.

At the Executive Council Chamber, Melbourne, the twentieth day of May, 1975.

PRESENT:

His Excellency the Governor of Victoria.
Mr. Balfour | Mr. Hunt.
Mr. Houghton

His Excellency the Governor of the State of Victoria, in the Commonwealth of Australia, by and with the advice of the Executive Council of the said State, and in pursuance of the powers conferred by the *Racing Act 1958* and all other powers him thereunto enabling, doth by this Order appoint:—

HILTON JOHN NICHOLAS, to be a person nominated by the governing body of the Victoria Racing Club and Chairman;

SIR RUPERT CLARKE, being a person nominated by the governing body of the Victoria Amateur Turf Club;

IAN McDONALD, being a person nominated by the governing body of the Moonee Valley Racing Club;

KEITH HECTOR TURNBULL, being a person nominated by the Trotting Control Board;

DAVID JOSEPH BOURKE, and HERBERT JOHN GRIGG, being two persons nominated by the governing body of the Country Racing Clubs;

ALEXANDER ELLIOTT MILLS, being a person nominated by the Trotting Control Board to represent trotting clubs outside the metropolitan area;

CHARLES HERBERT PETTY, being the Chairman of the Greyhound Racing Control Board, to be members of the Totalizator Agency Board as from the 1st day of June, 1975, shall hold office for the period ending the 31st day of May, 1978.

And the Honorable Brian Dixon, Her Majesty's Minister for Youth, Sport and Recreation for the State of Victoria, shall give the necessary directions herein accordingly.

TOM FORRISTAL,
Clerk of the Executive Council.

SUPERANNUATION ACT 1958.

At the Executive Council Chamber, Melbourne, the twenty-seventh day of May, 1975.

PRESENT:

His Excellency the Governor of Victoria.
Mr. Byrne | Mr. Wilcox
Mr. Scanlan | Mr. Granter.

Pursuant to the powers conferred by the provisions of paragraph (ja) of sub-section (1) of section 3 of the *Superannuation Act 1958*, His Excellency the Governor of the State of Victoria, by and with the advice of the Executive Council thereof doth by this Order declare that the provisions of the *Superannuation Act* shall apply to the officers named in the schedule set out hereunder.

SCHEDULE.

DYTSCHENKO, LUDMILLA, State College of Victoria at Ballarat.

FORSYTH, CATHERINE WARRENDER, State College of Victoria at Ballarat.

HENNESSY, MARK EDWARD MARIUS, State College of Victoria at Ballarat.

WHITEFIELD, ALAN ROSS, State College of Victoria at Ballarat.

POTTS, ANTHONY PATRICK, State College of Victoria at Bendigo.

HALL, FRANCIS JAMES, State College of Victoria at Hawthorn.

COTT, JOHN EDWARD, Victoria Institute of Colleges.

And the Honorable Rupert James Hamer, Her Majesty's Treasurer for the State of Victoria, shall give the necessary directions herein accordingly.

TOM FORRISTAL,
Clerk of the Executive Council.

COUNTRY ROADS BOARD.

Act No. 6229.

At the Executive Council Chamber, Melbourne, the twenty-seventh day of May, 1975.

PRESENT:

His Excellency the Governor of Victoria.

Mr. Byrne | Mr. Wilcox
Mr. Scanlan | Mr. Granter.

ORDER APPROVING OF LAND BEING ACQUIRED AND ROADS, DEVIATIONS OR WIDENINGS BEING MADE TOGETHER WITH ALL ANCILLARY WORKS REQUIRED TO BE EXECUTED IN CONJUNCTION THEREWITH.

His Excellency the Governor of the State of Victoria, by and with the advice of the Executive Council thereof, being satisfied that there are funds legally available for acquiring the land, doth hereby approve the acquiring of the land described in the schedule hereunder and the making of new roads and deviations from and widenings of existing roads, together with all ancillary works required to be executed in conjunction therewith, referred to in the said schedule.

SCHEDULE.

State Highway.

The land shown hatched on plans numbered G.P.13846A and G.P.13846B hereunder required for the widening of the Goulburn Valley Highway in the Shire of Seymour and making of the widening thereon.

STATE HIGHWAY
GOULBURN VALLEY HIGHWAY
SHIRE OF SEYMOUR
Lengths in metres.

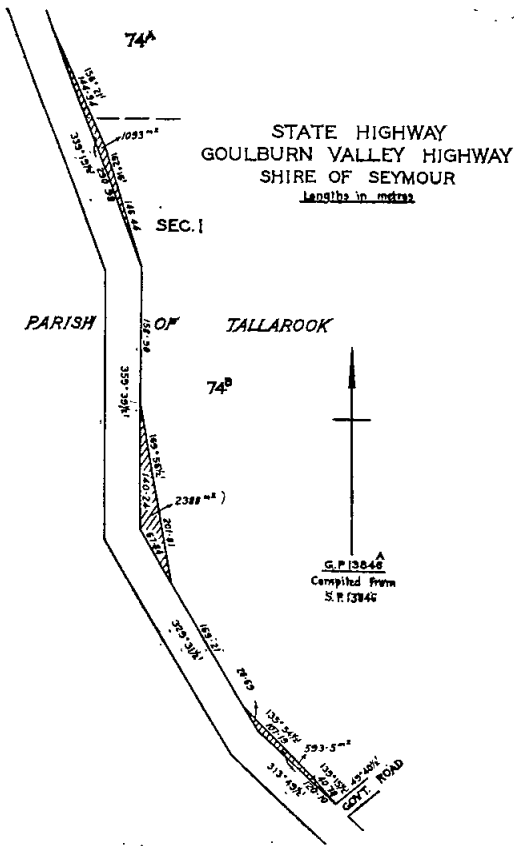
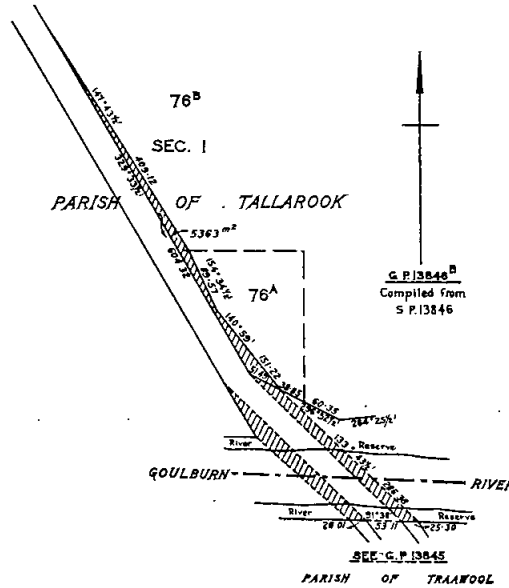

Main Roads.

The land shown hatched on plans numbered G.P.13794A and G.P.13794B hereunder required for the widening of Wandiligong Road in the Shire of Bright and making of the widening thereon.

MAIN ROAD
WANDILIGONG ROAD

SHIRE OF BRIGHT

Lengths in Metres

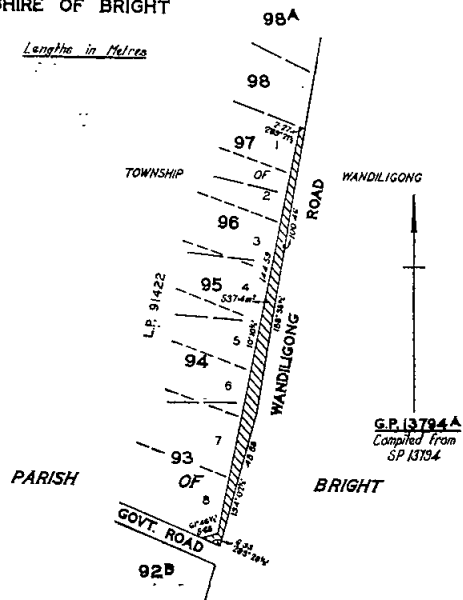

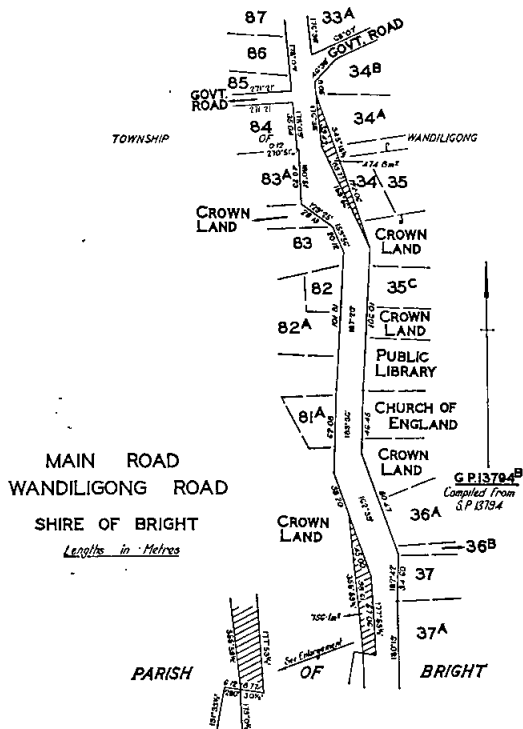

The land shown hatched on plan numbered G.P.13929 hereunder required for the widening of the Frankston-Flinders Road in the Shire of Hastings and making of the widening thereon.

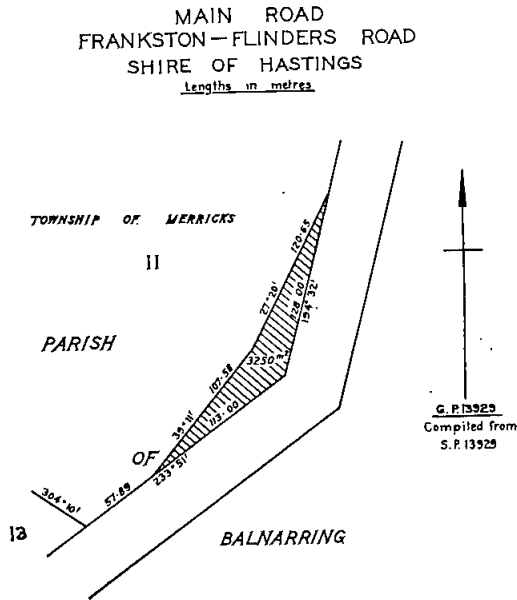

And the Honorable Edward Raymond Meagher, Her Majesty's Minister of Transport for the State of Victoria, shall give the necessary directions herein accordingly.

TOM FORRISTAL,
Clerk of the Executive Council.

LOCAL GOVERNMENT DEPARTMENT.

At the Executive Council Chamber, Melbourne, the twenty-seventh day of May, 1975.

PRESENT:

His Excellency the Governor of Victoria.

Mr. Byrne | Mr. Wilcox
Mr. Scanlan | Mr. Granter.

VESTING OF A RESERVE IN THE FRANKSTON CITY COUNCIL.

Whereas it is provided in section 569BA of the Local Government Act 1958, that where any map or plan has been lodged or deposited with the Registrar of Titles pursuant to section 97 of the Transfer of Land Act 1958, or any correspondence previous enactment (whether before or after the commencement of the Local Government Act 1963) and any allotment on that map or plan has been transferred the Governor in Council on the request of the council of the municipality may by Order published in the Government Gazette direct that the whole or any part of the land comprised in any reserve shown on that map or plan shall vest in the Council whereupon such land shall so vest freed and discharged from any mortgage charge lease or sub-lease.

And whereas the Council of the City of Frankston requested that a reserve shown on a plan of subdivision be vested in the Council and an allotment on the plan has been transferred.

Now therefore, His Excellency the Governor of the State of Victoria, by and with the advice of the Executive Council thereof, doth by this Order vest in the Council of the City of Frankston the Drainage Reserve coloured green on plan of subdivision No. 23976 lodged in the Office of Titles.

And the Honorable Alan John Hunt, Her Majesty's Minister for Local Government for the State of Victoria, shall give the necessary directions herein accordingly.

TOM FORRISTAL,
Clerk of the Executive Council.

The land shown hatched on plan numbered G.P.13782 hereunder required for the deviation from the Natimuk-Hamilton Road in the Shire of Dundas and making of the deviation thereon.

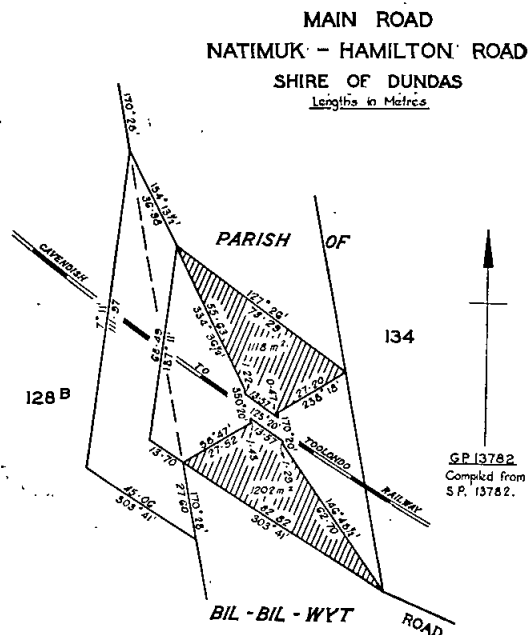

DEPARTMENT OF CROWN LANDS AND SURVEY.

At the Executive Council Chamber, Melbourne, the twenty-seventh day of May, 1975.

PRESENT:

His Excellency the Governor of Victoria.
 Mr. Byrne | Mr. Wilcox
 Mr. Scanlan | Mr. Granter.

UNUSED ROADS CLOSED.

In pursuance of the provisions of section 349 of the Land Act 1958, His Excellency the Governor of the State of Victoria, by and with the advice of the Executive Council thereof, and the concurrence in writing of the Council of the municipality concerned, doth hereby close the unused roads referred to hereunder, viz.:—

Parish of Warrenheip, County of Grant, being the road indicated by hatching on plan hereunder.—(W.8(4) (J.32543).

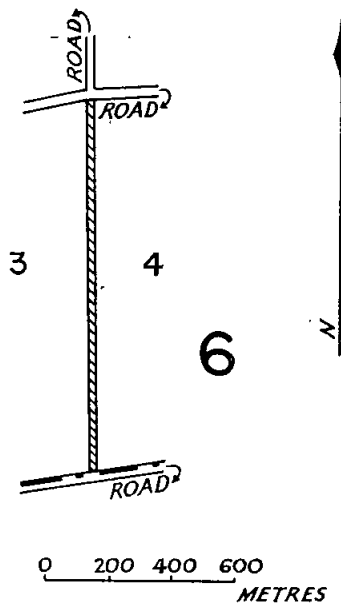

Parish of Tullich, County of Follett, being the road indicated by hatching on plan hereunder.—(T.203(2) (J.33454).

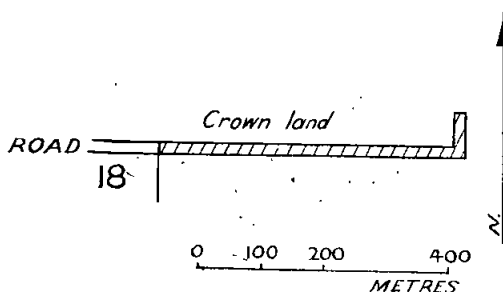

Parish of Byjuke, County of Follett, being the roads indicated by hatching on plan hereunder.—(B.663(4) (J.33454).

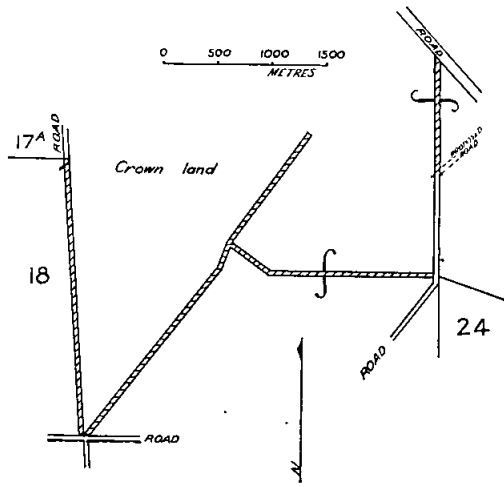

And the Honorable William Archibald Borthwick, Her Majesty's Minister of Lands for the State of Victoria, shall give the necessary directions herein accordingly.

TOM FORRISTAL,
 Clerk of the Executive Council.

LAND ACT 1958.

At the Executive Council Chamber, Melbourne, the twenty-seventh day of May, 1975.

PRESENT:

His Excellency the Governor of Victoria.
 Mr. Byrne | Mr. Wilcox
 Mr. Scanlan | Mr. Granter.

REVOCATION OF TEMPORARY RESERVATIONS OF LANDS BY ORDERS IN COUNCIL.

His Excellency the Governor of the State of Victoria, by and with the advice of the Executive Council thereof, in pursuance of the provisions of the Land Act 1958, hereby revokes the temporary reservations of lands by Orders in Council hereinafter described:—

BUANGOR.—The temporary reservation as a site for watering purposes and the withholding from sale, leasing and licensing by Order in Council of the 8th May, 1876, of 16.59 hectares (41 acres, more or less) of land in the Parish of Buangor, revoked as to part by Order of the 16th April, 1957, so far only as regards the portion thereof containing 3828 square metres, as defined by description and hatching on plan published in the Government Gazette of the 30th April, 1975.—(B.472(2) (Rs.5807).

CASTERTON.—The temporary reservation as a site for Cemetery and the withholding from sale, leasing and licensing by Order in Council of the 3rd June, 1879, of 4.047 hectares (10 acres) of land in the Parish of Casterton, revoked as to part by Order of the 19th November, 1968, so far only as regards the portion thereof containing 4821 square metres, as defined by description and hatching on plan published in the Government Gazette of the 30th April, 1975.—(C.178(2) (Rs.9055).

And the Honorable William Archibald Borthwick, Her Majesty's Minister of Lands for the State of Victoria, shall give the necessary directions herein accordingly.

TOM FORRISTAL,
 Clerk of the Executive Council.

Land Act 1958.

DEPARTMENT OF CROWN LANDS AND SURVEY

At the Executive Council Chamber, Melbourne, the twenty-seventh day of May, 1975.

PRESENT:

His Excellency the Governor of Victoria.
 Mr. Byrne | Mr. Wilcox
 Mr. Scanlan | Mr. Granter.

LANDS TEMPORARILY RESERVED AS SITES.

His Excellency the Governor of the State of Victoria, by and with the advice of the Executive Council thereof, doth hereby in pursuance of the provisions of section 14

of the Land Act 1958, reserve temporarily from sale, from being leased and from having a licence granted in respect thereof, and also except from occupation for mining purposes under any miner's right the lands hereinafter described, viz.:

SANDHURST (BENDIGO).—Site for Public Recreation purposes, 13.11 hectares, being Crown allotment 200F, section C, at Bendigo, Parish of Sandhurst, County of Bendigo, as indicated by hatching on plan hereunder.—(S.372^(124, 120) (Rs.3458).

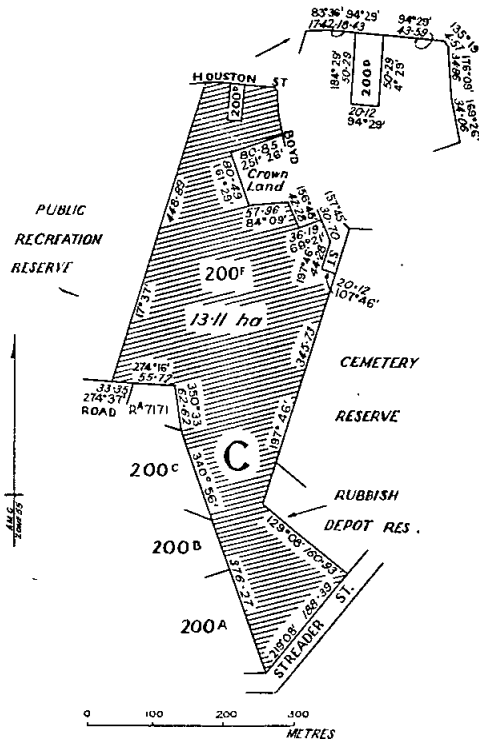

BOROONDARA (CAMBERWELL).—Site for Public purposes (Mental Hospital), 1448 square metres, being Crown allotment 117A, Parish of Boroondara, County of Bourke, as indicated by hatching on plan hereunder.—(B.415⁽⁵⁾ (Rs.10057).

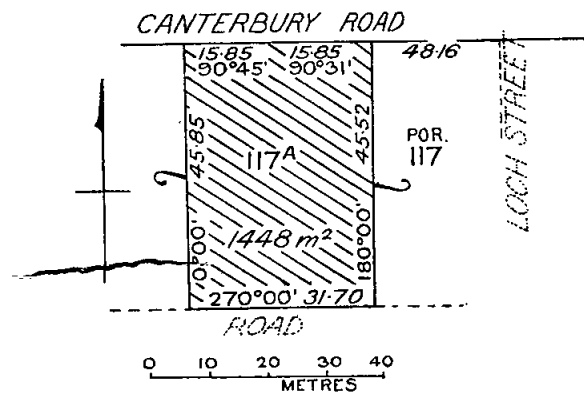

TOOLAMBA.—Site for Public Recreation purposes, 3052 square metres, being Subdivision 17A, Crown allotment 135, Parish of Toolamba, County of Rodney, as indicated by hatching on plan hereunder.—(T.201⁽¹¹⁾ (Rs.10045).

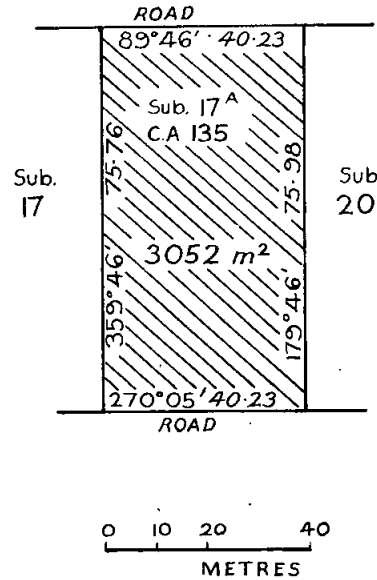

WONGA WONGA SOUTH.—Site for Public Purposes (Trigonometrical Survey Station), 3750 square metres, more or less, being Crown allotment 16F, section C, Parish of Wonga Wonga South, County of Buln Buln, as indicated by hatching on plan hereunder.—(W.353⁽¹¹⁾ (Rs.4951).

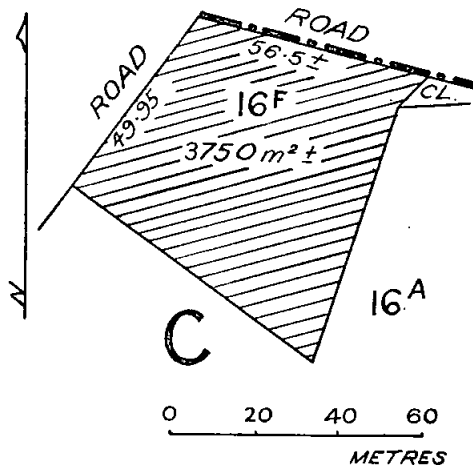

And the Honorable William Archibald Borthwick, Her Majesty's Minister of Lands for the State of Victoria, shall give the necessary directions herein accordingly.

TOM FORRISTAL,
Clerk of the Executive Council.

HOUSING ACT 1958.

At the Executive Council Chamber, Melbourne, the twenty-seventh day of May, 1975.

PRESENT:

His Excellency the Governor of Victoria.

Mr. Byrne | Mr. Wilcox
Mr. Scanlan | Mr. Granter.

DECLARATION OF PRIVATE STREETS AS PUBLIC HIGHWAYS WITHIN THE SHIRE OF MORWELL.

Whereas pursuant to section 107 of the Housing Act 1958 it is among other things enacted that where works have been carried out in accordance with an agreement for the full construction of any roads, pavements, culverts

or drains made pursuant to the provisions of the said section 107 such roads, pavements, culverts or drains shall be under the care and management of the Municipality which shall be liable for the cost of any maintenance, repair, alteration or reconstruction thereof and the Governor-in-Council may by order published in the *Government Gazette* declare any road so constructed to be a public highway.

And whereas by Order dated the 16th June, 1971, the Governor-in-Council consented to an agreement between the Housing Commission and the Shire of Morwell regarding street and drainage construction in Switchback Road in the Churchill Estate situate in the municipality of the Shire of Morwell and the carrying out of the works enumerated in the said Agreement.

And whereas the works of road pavements, culvert and drainage construction have now been carried out in accordance with the said agreement between the Housing Commission and the Shire of Morwell.

Now therefore His Excellency the Governor of the State of Victoria by and with the advice of the Executive Council of the said State and in pursuance of the powers conferred by section 107 of the Housing Act and upon recommendation of the Housing Commission doth by this order declare the street more particularly delineated and shown cross hatched on the plan hereunder to be absolutely dedicated to the public as a Public Highway within the meaning of any law now or hereafter in force and that the Council of the Municipality in which the street is situate shall hereafter be liable for all cost of any maintenance, repair, alteration or reconstruction thereof.

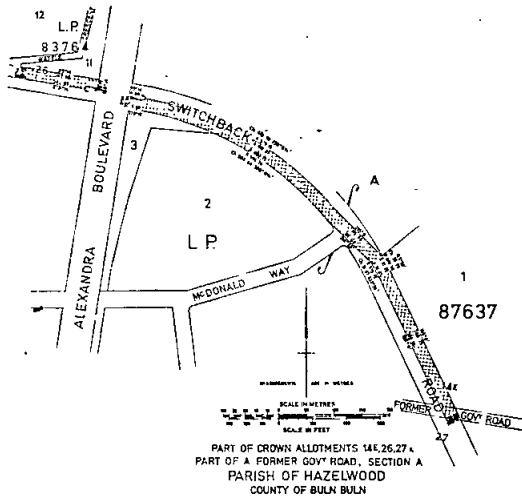

And the Honorable Vance Oakley Dickie, Her Majesty's Minister of Housing for the State of Victoria, shall give the necessary directions herein accordingly.

TOM FORRISTAL,
Clerk of the Executive Council.

STATE RIVERS AND WATER SUPPLY COMMISSION.

At the Executive Council Chamber, Melbourne, the twenty-seventh day of May, 1975.

PRESENT:
His Excellency the Governor of Victoria.
Mr. Byrne | Mr. Wilcox
Mr. Scanlan | Mr. Granter.

APPOINTMENT OF AUDITORS.—AMENDMENT OF ORDER.

Under the powers conferred by the Sewerage Districts Act and all other powers enabling him in that behalf, His Excellency the Governor of the State of Victoria, by and with the advice of the Executive Council of the said State,

doth hereby amend as follows the Order in Council made on 1st October, 1974, and published in the *Victoria Government Gazette* of 9th October, 1974, appointing certain persons to audit and report upon the accounts of Sewerage Authorities.

For the name "M. B. Wellington" in column (3) opposite the name "Dromana Rosebud" in column (1) of the schedule there shall be substituted the name "B. Pescod".

And the Honorable Frederick James Granter, Her Majesty's Minister of Water Supply for the State of Victoria, shall give the necessary directions herein accordingly.

TOM FORRISTAL,
Clerk of the Executive Council.

CRANBOURNE SEWERAGE AUTHORITY.

At the Executive Council Chamber, Melbourne, the twenty-seventh day of May, 1975.

PRESENT:
His Excellency the Governor of Victoria.
Mr. Byrne | Mr. Wilcox
Mr. Scanlan | Mr. Granter.

APPROVAL OF SITE OF OUTFALL SEWER AND ACQUISITION OF EASEMENTS AND LICENCES AND EXTENT OF SEWERAGE DISTRICT INCREASED.

Under the powers conferred by the Sewerage Districts Act and all other powers enabling him in that behalf, His Excellency the Governor of the State of Victoria, by and with the advice of the Executive Council of the said State, doth hereby—

- (a) approve of the site for the main outfall sewer, and the acquisition of easements and licences; and
- (b) declare, order and direct that the extent of the Sewerage District of the Cranbourne Sewerage Authority be increased.

The said site, easements and licences are shown by red and yellow colours on Plan "A" and red, yellow and green colours on Plan "B" and the extent of the increase of the Sewerage District is shown bounded by red colour on Plan "C". The aforementioned plans approved by the Governor in Council by and with this Order are deposited in the office of the State Rivers and Water Supply Commission, Melbourne (Corr. No. 74/470/81,84,86).

And the Honorable Frederick James Granter, Her Majesty's Minister of Water Supply for the State of Victoria, shall give the necessary directions herein accordingly.

TOM FORRISTAL,
Clerk of the Executive Council.

HOSPITALS AND CHARITIES ACT 1958, SECTION.46.

At the Executive Council Chamber, Melbourne, the twenty-seventh day of May, 1975.

PRESENT:
His Excellency the Governor of Victoria.
Mr. Byrne | Mr. Wilcox
Mr. Scanlan | Mr. Granter.

INCORPORATION OF SUNNYSIDE HOUSE.

Whereas:—

- (1) a petition signed by not less than twenty five contributors to Sunnyside House, an institution capable of incorporation under the *Hospitals and Charities Act 1958*, praying that the institution be incorporated has been received by the Hospitals and Charities Commission;
- (2) the substance or prayer of the said petition has been published in the *Government Gazette*;
- (3) no counter petition signed by an equal or greater number of contributors to the said institution has been lodged with the Hospitals and Charities Commission within one month after the date of such publication;

Now therefore His Excellency the Governor of the State of Victoria, by and with the advice of the Executive Council of the said State, doth hereby declare that the contributors for the time being to the said institution shall be a body corporate by the name Sunnyside House with the following objects—

- (a) To afford charitable relief to aged persons by providing permanent facilities for their daily accommodation and care within the institution, provided that, in premises for which a grant under the *Commonwealth Aged Persons' Homes Act 1954-57* has been received, only aged persons as defined in that Act will be admitted; and provided further that at least 50 per cent. of the initial and all additional accommodation will be made available for completely charitable residents, i.e., persons in necessitous circumstances.
- (b) To provide such other support or aid of any kind or in any form which, in the Committee's opinion, will provide for the economic, social and recreational well-being of the residents.

And the Honorable Alan Henry Scanlan, Her Majesty's Minister of Health for the State of Victoria, shall give the necessary directions herein accordingly.

TOM FORRISTAL,
Clerk of the Executive Council.

LABOUR AND INDUSTRY ACT 1958.

At the Executive Council Chamber, Melbourne, the twenty-seventh day of May, 1975.

PRESENT:

His Excellency the Governor of Victoria.
Mr. Byrne | Mr. Wilcox
Mr. Scanlan | Mr. Granter.

COUNTRY PRINTERS BOARD.—VARIATION OF POWERS AND RE-DEFINITION OF THE AREA OF OPERATION OF THE DETERMINATION.

In pursuance of the powers conferred by section 20 of the *Labour and Industry Act 1958*, and all other powers him thereunto enabling, His Excellency the Governor of the State of Victoria, by and with the advice of the Executive Council thereof, doth hereby—

1. Vary the powers of the Country Printers Board so that in substitution for the powers heretofore conferred on the said Country Printers Board it shall be appointed for the trades of—

- (a) printing;
(b) bookbinding, including making loose sheet covers of any kind;
(c) paper ruling;
(d) stereotyping or electrotyping;
(e) preparing lithographic work by drawing or lettering on a lithographic plate or on any other material;
(f) preparing printed matter for sale or distribution; and
(g) carbonizing, gumming, varnishing, or waxing paper, cardboard or similar materials.

2. Re-define the area within which the Determination of the Country Printers Board shall be operative as being that part of the State of Victoria outside the metropolitan district as proclaimed for the purposes of the *Apprenticeship Act 1958* and outside a radius of two miles of the main post office in the cities of Ballarat, Bendigo, Geelong, Geelong West and Newtown.

And the Honorable Joseph Anstice Rafferty, Her Majesty's Minister of Labour and Industry for the State of Victoria, shall give the necessary directions herein accordingly.

TOM FORRISTAL,
Clerk of the Executive Council.

DRIED FRUITS ACT 1958.

At the Executive Council Chamber, Melbourne, the third day of June, 1975.

PRESENT:

His Excellency the Governor of Victoria.
Mr. Rossiter | Mr. Rafferty.

APPOINTMENT OF MEMBER AND CHAIRMAN OF THE VICTORIAN DRIED FRUITS BOARD.

In pursuance of the powers conferred by section 5 of the *Dried Fruits Act 1958*, and all other powers him thereunto enabling His Excellency the Governor of the State of Victoria, by and with the advice of the Executive Council thereof, doth by this Order hereby appoint GAY VANDELEUR TOLHURST, who has been nominated by the Minister of Agriculture, as a member and Chairman of the Victorian Dried Fruits Board for a period of three (3) years from and inclusive of the 14th June, 1975.

And the Honorable Ian Winton Smith, Her Majesty's Minister of Agriculture for the State of Victoria, shall give the necessary directions herein accordingly.

TOM FORRISTAL,
Clerk of the Executive Council.

MYRTLEFORD SEWERAGE AUTHORITY.

At the Executive Council Chamber, Melbourne, the third day of June, 1975.

PRESENT:

His Excellency the Governor of Victoria.
Mr. Rossiter | Mr. Rafferty.

CONSENT TO BORROWING \$60,000.

Under the powers conferred by the Sewerage Districts Act and all other powers enabling him in that behalf, His Excellency the Governor of the State of Victoria, by and with the advice of the Executive Council of the said State, hereby consents to the Myrtleford Sewerage Authority borrowing the sum of Sixty thousand dollars (\$60,000) to meet the cost of sewerage works as set forth in the detailed statement bearing date 30th May, 1975.

And the Honorable Frederick James Granter, Her Majesty's Minister of Water Supply for the State of Victoria, shall give the necessary directions herein accordingly.

TOM FORRISTAL,
Clerk of the Executive Council.

LANDS DEPARTMENT NOTICES

APPROACHING LAND SALES.

Sale of Crown Land, in fee-simple, will be held at the under-mentioned places and dates, viz:—

	No. of Gazette.
Ballarat.—Thursday, 3rd July, 1975	35
Bendigo.—Wednesday, 16th July, 1975	44
Hamilton.—Friday, 4th July, 1975	39

SALE OF CROWN LAND BY AUCTION.

The land will be offered for sale in fee-simple, and subject to the provisions of the Land Act and Regulations thereunder.

The **upset price** is the sum at which bidding will start, and no bid below that sum can be accepted. The highest bidder at or above that sum shall be the purchaser, subject to signature of contract and any necessary payment.

TERMS:—

A deposit of at least 12½% of the purchase price must be paid at the sale, either in cash or by cheque.

The residue is payable in half-yearly instalments, in accordance with the following scale, or may be paid off at any earlier time.

Over \$40, and not exceeding \$100, 8 instalments.
 Over \$100, and not exceeding \$200, 10 instalments.
 Over \$200, and not exceeding \$400, 12 instalments.
 Over \$400, and not exceeding \$600, 14 instalments.
 Over \$600, and not exceeding \$800, 16 instalments.
 Over \$800, and not exceeding \$1,000, 18 instalments.
 Over \$1,000, 20 instalments.

Interest at the rate of 7% per annum is payable with all payments of residue, and is computed for each instalment from the date of sale to the date of such payment. Additional interest is charged if any instalment is not paid on or before the due date.

If paid off within 30 days of sale, no interest is payable.

FEES, ETC.:

Also payable at the sale, in addition to the deposit, are the survey fee and, if applicable, the valuation of improvements (if purchaser be not the owner thereof).

Payable with balance of purchase money—

Crown Grant fee—\$10.00.

Assurance Fund contribution.—One cent in every Five dollars or part thereof of purchase price. (This is a fund established to guarantee the validity of freehold titles.)

Transfer of interest prior to completion of payment may be allowed on payment of \$5 fee and subject to stamp duty.

If unable to attend personally, a prospective purchaser may arrange for another person to bid as his agent.

Attention is drawn to section 95, Land Act 1958, which provides that the purchaser shall be deemed to be the owner for the purposes of other Acts; also to an amendment to the Local Government Act providing for Government roads, in certain circumstances, to be declared "private streets", thus making the purchaser liable to contribute to the cost of street construction.

W. BORTHWICK,
 Minister of Lands.

Office of Crown Lands and Survey,
 Melbourne, 4th June, 1975.

BENDIGO.—Sale (No. 12191) of Crown land in fee-simple by Auction will be held at the SOLDIERS MEMORIAL HALL, PALL MALL, BENDIGO, on WEDNESDAY, the 16th day of JULY, 1975, at TEN A.M. To be conducted by Mr. T. Comte, Land Officer, Bendigo.

Lot 1.

AT BENDIGO, PARISH OF SANDHURST.

Fronting the north side of Able Street about 180 metres (197 yards) east of Thistle Street.

Upset price \$2,900.00 the lot. Survey fee \$70.00.

Area 4713 square metres (1 acre 26 perches). Subject to examination of survey. Allotment 19K, section C. Subject to drainage easement 3 metres wide and subsidence indemnity condition. Valuation of improvements \$775.00 in favour of the Bendigo City Council (Reclamation). One month allowed for removal of improvements (Able Street fencing). The area is within the City of Bendigo Planning Scheme.

SPECIAL CONDITION.—Sale of the above lot is subject to a condition requiring that the purchaser shall erect improvements thereon to the value of \$12,500 within two years from the date of sale. No transfer of interest will be approved before building covenant is completed.—(W.87981.)

Lot 2.

AT BENDIGO, PARISH OF SANDHURST.

Fronting the north side of Able Street about 220 metres (240 yards) east of Thistle Street.

Upset price \$2,900.00 the lot. Survey fee \$70.00.

Area 4709 square metres (1 acre 26 perches) subject to examination of survey. Allotment 19L, section C. Subject to subsidence indemnity condition. Valuation of Improvements \$775.00 in favour of the Bendigo City Council (Reclamation). One month allowed for removal of improvements (Able Street fencing). The area is within the City of Bendigo Planning Scheme.

SPECIAL CONDITION.—Sale of the above lot is subject to a condition requiring that the purchaser shall erect improvements thereon to the value of \$12,500 within two years from the date of sale. No transfer of interest will be approved before building covenant is completed.—(W.87981.)

Lot 3.

AT BENDIGO, PARISH OF SANDHURST.

Fronting the south-west side of Gibson Street about 150 metres (164 yards) north-west of Holdsworth Road.

Upset price \$1,100.00 the lot. Survey fee \$55.00.

Area 834 square metres (33 perches), allotment 483B, section K. Subject to City of Bendigo Planning Scheme.—(W.59052.)

Lot 4.

TOWNSHIP OF INGLEWOOD, PARISH OF INGLEWOOD.

At the northern corner of Verdon and Morrow Streets.

Upset price \$250.00 the lot. Survey fee \$70.00.

Area 1541 square metres (1 rood 21 perches), allotment 12, section 17.—(W.92447.)

PROPOSED PERMANENT RESERVATION OF LAND AS A SITE.

In pursuance of sections 14 and 21 of the Land Act 1958, notice is hereby given that it is the intention of the Governor in Council to reserve permanently from sale, from being leased and from having a licence granted in respect thereof, and also excepted from occupation for mining purposes under any miner's right the land hereinafter described:—

The following Notice was published 1° on the 4th June, 1975, pursuant to Order of the 27th May, 1975.

MELBOURNE.—Land proposed to be permanently reserved as a site for the Victorian Arts Centre, 6602 square metres being Crown allotment 3c, City of Melbourne, Parish of Melbourne South, County of Bourke, as indicated by hatching on plan hereunder.—(M.333⁽²¹⁾) (Rs.5546).

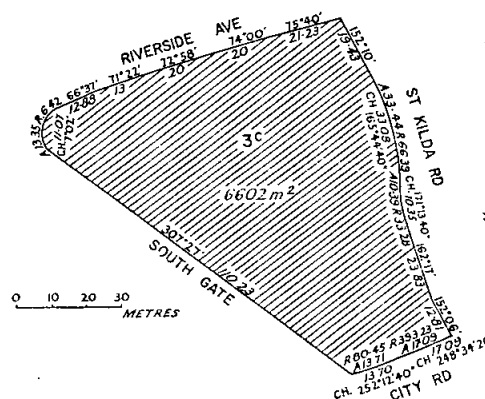

W. BORTHWICK,
 Minister of Lands.

PROPOSED REVOCATIONS OF TEMPORARY RESERVATIONS OF LANDS BY ORDERS IN COUNCIL.

In pursuance of the provisions of the Land Act 1958, notice is hereby given that it is the intention of the Governor in Council to revoke the temporary reservations of lands by Orders in Council hereunder referred to viz.:—

The following Notices were published 1° on the 21st May, 1975, pursuant to Orders of the 13th May, 1975.

MIRBOO NORTH.—The temporary reservation by Order in Council of the 22nd June, 1885, of 7082 square metres (1 acre 3 roods) of land in the Township of Mirboo North as a site for a State School, revoked as to part by Order of the 31st July, 1933, is about to be revoked so far as the balance thereof containing 2352 square metres is concerned.—(M.517⁽¹⁸⁾) (Rs.4316).

JIKA JIKA (FAIRFIELD).—The temporary reservation by Order in Council of the 5th February, 1963, of 1391 square metres (1 rood 15 perches, more or less) of land in the Parish of Jika Jika as a site for Police purposes is about

to be revoked so far only as the portion containing 5 square metres indicated by hatching on plan hereunder, is concerned.—(J.16(4) (Rs.8204).

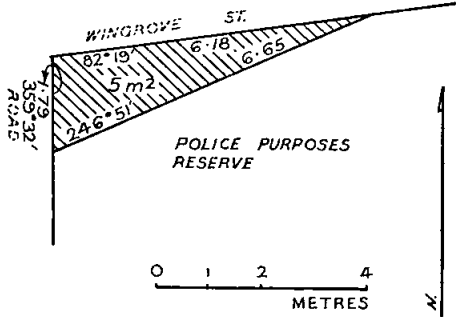

W. BORTHWICK,
Minister of Lands.

**COMMITTEES OF MANAGEMENT OF RESERVES.
APPOINTMENTS.**

Notice is hereby given that, in pursuance of section 221 of the Land Act 1958, the following appointments of Committees of Management of reserved Crown Lands have been made by the Minister of Lands:—

"LAKE SAMBELL RESERVE, BEECHWORTH."

The Corporation of the United Shire of Beechworth as the Committee of Management of the land in the Township of Beechworth temporarily reserved pursuant to Order in Council dated the 14th October, 1929 and the remaining portion of the land temporarily reserved pursuant to Order in Council dated the 28th November, 1961 as sites for Public purposes (excepting the area used for a Rubbish Depot) and known as "Lake Sambell Reserve".—(Corres. No. Rs.3867.)

"BONEGILLA CAMPING RESERVE."

The State Rivers and Water Supply Commission as the Committee of Management of the land in the Parish of Bonegilla as shown coloured red on plan B/12.3.1975, attached to Lands Department correspondence No. Rs.4742.—(Corres. No. Rs.4742.)

This appointment is made in lieu of all previous appointments which are hereby rescinded.

"MORTLAKE RECREATION RESERVE."

The Corporation of the Shire of Mortlake as the Committee of Management of the land in the Township of Mortlake permanently reserved pursuant to Order in Council dated the 14th November, 1892, as a site for Public Recreation.—(Corres. No. Rs.2173.)

"WONTHAGGI SEWERAGE DEPOT."

The Wonthaggi Sewerage Authority as the Committee of Management of the land in the Township of Wonthaggi temporarily reserved as a site for Public purposes (Sewerage Depot) pursuant to Order in Council, dated the 11th February, 1975.—(Corres. No. Rs.9823.)

W. BORTHWICK,
Minister of Lands.

Department of Crown Lands and Survey,
Melbourne, 29th May, 1975.

TENDERS

PUBLIC WORKS DEPARTMENT

Tenders will be received at Public Works Department, 2 Treasury Place, Melbourne, until **TWO** p.m. on dates shown and for purposes mentioned hereunder.

Particulars and tender forms available at Contracts Office, Room 27, Ground Floor, No. 2, Treasury Place, and at places indicated in brackets hereunder.

Abbreviations in brackets mean:—W.O.—Inspector of Works Office; P.S.—Police Station; C.S.—Consolidated School; H.E.S.—Higher Elementary School; H.S.—High School; Pr.S.—Primary School; T.S.—Technical School.

Tenders to be submitted on the Department's printed Tender Form and will not be received by telephone. All tenders must be on a "Firm Tender" basis. The lowest or any tender will not necessarily be accepted.

Address tenders to the Minister of Public Works, and endorse the envelope containing the tender "Tender for , closing Tuesday,

Hand delivered tenders to be placed in the Tender Box of the Public Works Department, located on the wall of the centre entrance foyer, Ground Floor, 2 Treasury Place, Melbourne.

No preliminary deposit is required with any tender, but successful tenderer will be required to pay a deposit for any accepted tender of \$10,000 or over.

Tuesday, 10th June, 1975.

Building, Electrical, Mechanical Works.

BRAYBROOK.—Electrical services, new library building, High School.

BRAYBROOK.—Mechanical services, new library building, High School. (Re-advertised.)

COBURG.—Alterations and modifications to mechanical services, State College of Victoria.

ESSENDON.—Gas welding installation, trades wing, Technical School.

FERNTREE GULLY.—Electrical services, remodelling of Shire Offices, State Public Offices.

OAKLEIGH.—Provision of garage facilities, Technical School.

ST. ALBANS NORTH.—Electrical services, art/craft room and staff accommodation improvements, Pr.S.4811.

SALE.—Internal and external repairs and painting, Pr.S.545. (Re-advertised.) (W.O., Traralgon.)

SYNDAL SOUTH.—External and internal repairs and painting, Pr.S.4924.

Miscellaneous.

VARIOUS.—Supply of domestic equipment, schools and other government buildings.

VARIOUS.—Supply of kitchen equipment, schools and other government buildings.

Wednesday, 18th June, 1975.

Building, Electrical, Mechanical Works.

MYRTLEFORD.—Provision of a Library, Consolidated School. (W.O., Wangaratta.)

MYRTLEFORD.—Electrical Services—provision of a Library, Consolidated School. (W.O., Wangaratta.)

MYRTLEFORD.—Mechanical Services—provision of a Library, Consolidated School. (W.O., Wangaratta.)

Tuesday, 24th June, 1975.

Building, Electrical and Mechanical Works.

BALLARAT.—Electrical services, library and covered way, Pr.S.4936. (W.O., Ballarat.)

BALLARAT.—Mechanical services, library and covered way, Pr.S.4936. (W.O., Ballarat.)

LA TROBE.—Extensions and alterations to science rooms, High School.

LONGERENONG.—Construction of library, agricultural college. (W.O., Horsham, Warracknabeal.)

WATSONIA.—Alterations and additions, wardens flat and students accommodation, "Loyola" Institute of Social Welfare.

Site Works.

KNOX.—Site works, Technical School.

Miscellaneous.

MELBOURNE.—Maintenance cleaning 1st July, 1975-30th June, 1978, Public Offices, 7-7A Parliament Place.

NORTH MELBOURNE.—Maintenance cleaning, Fruit Inspection Depot, Dynon Road.

ROBERTS DUNSTAN,
Minister for Public Works.

Public Works Department,
Melbourne, 2nd June, 1975.

PUBLIC SERVICE NOTICES

No. 418.

Public Service Act 1958, Sections 39 and 50.

REGULATIONS.—PART IV.—SALARIES AND INCREMENTS.

The Public Service Board, in pursuance of the powers conferred by the *Public Service Act 1958*, hereby amends the Public Service (Public Service Board) Regulations as follows:—

FOURTH SCHEDULE.

PART C.

TECHNICAL AND GENERAL DIVISION AND TEMPORARY EMPLOYEES.

Classifications of Offices and Positions and Rates of Salaries.

Grades.	Yearly Salary.		Salary/ Increment Code.	Title of Office and Position.	Title Code.
	Minimum.	Maximum.			
	\$	\$			
GENERAL.					
Add—					
217-225	7,985	8,365	AA	Film Production Officer, Grade II.	..
212-220	7,776	8,112	AA	Film Production Officer, Grade I.	..
DEPARTMENT OF AGRICULTURE.					
Delete—					
217-225	7,985	8,365	AA	Film Production Officer	..
212-220	7,776	8,112	AA	Film Production Officer, Assistant	..

A. J. A. GARDNER, Chairman.
R. P. NOLAN, Acting Secretary.

Office of the Public Service Board,
Melbourne, 9th May, 1975.

No. 417.

PUBLIC SERVICE ACT 1958.

The Public Service Board, in pursuance of the powers conferred by the *Public Service Act 1958*, hereby amends the Public Service (Public Service Board) Regulations as follows—

PART V.—ALLOWANCES.

DIVISION II.—OVERTIME AND STANDBY ALLOWANCES.

PUBLIC WORKS DEPARTMENT—PORTS AND HARBOURS BRANCH.

Regulation 161.

Paragraph (a) of sub-regulation (1) is deleted and the following paragraph is inserted in lieu thereof—

" (a) The following officers and employees shall be paid an allowance when required to be on standby at the rate of \$1.60 a night or \$4.00 for a day and night:—

Point Lonsdale.

Lighthouse Keeper, Senior Assistant
Lighthouse Keeper, Assistant
Queenscliff.
Lighthouse Keeper
Lighthouse Keeper, Assistant

Provided that no more than three officers shall be on standby at any one time.

Westernport.

Coxswain
Engine Driver of Launches
Master of Launches
Navigation Lights Officer,
Assistant
Depot Supervisor

Provided that no more than four officers shall be on standby at any one time.

Port Welshpool.

Wharf Carpenter and Boatman.

Officers in Charge of Depots.

Apollo Bay.
Lakes Entrance.
Paynesville.
Port Fairy.
Port Welshpool.
Queenscliff.
San Remo".

This Regulation shall have effect from 16th March, 1975.

A. J. A. GARDNER, Chairman.
R. P. NOLAN, Acting Secretary.

Office of the Public Service Board,
Melbourne, 19th May, 1975.

No. 422.

Public Service Act 1958, Sections 39 and 50.

REGULATIONS.—PART IV.—SALARIES AND INCREMENTS.

The Public Service Board, in pursuance of the powers conferred by the *Public Service Act 1958*, hereby amends the Public Service (Public Service Board) Regulations as follows:—

FOURTH SCHEDULE.

PART C.

TECHNICAL AND GENERAL DIVISION AND TEMPORARY EMPLOYEES.

Classifications of Offices and Positions and Rates of Salaries.

Grades.	Yearly Salary.		Salary/ Increment Code.	Title of Office and Position.	Title Code.
	Minimum.	Maximum.			
	\$	\$			
STATE FORESTS DEPARTMENT.					
Add—					
181-196	6,953	7,380	AA	Radio Tradesman	..

This Regulation shall have effect from 25th May, 1975.

A. J. A. GARDNER, Chairman.
R. P. NOLAN, Acting Secretary.

Office of the Public Service Board,
Melbourne, 22nd May, 1975.

No. 419.

Public Service Act 1958, Sections 39 and 50.

REGULATIONS.—PART IV.—SALARIES AND INCREMENTS.

The Public Service Board, in pursuance of the powers conferred by the *Public Service Act 1958*, hereby amends the Public Service (Public Service Board) Regulations as follows:—

FOURTH SCHEDULE.

PART C.

TECHNICAL AND GENERAL DIVISION AND TEMPORARY EMPLOYEES.

Classifications of Offices and Positions and Rates of Salaries.

Delete the existing grades and yearly rates of salary for the following offices and/or positions and insert the grades and rates shown hereunder in lieu thereof—

Grades.	Yearly Salary.		Salary/ Increment Code.	Title of Office and Position.	Title Code.
	Minimum.	Maximum.			
	\$	\$			
GENERAL.					
217-225	8,272	8,666	AA	Film Production Officer, Grade II.	..
212-220	8,056	8,404	AA	Film Production Officer, Grade I.	..

This Regulation shall have effect from 25th May, 1975.

A. J. A. GARDNER, Chairman.
R. P. NOLAN, Acting Secretary.

Office of the Public Service Board,
Melbourne, 23rd May, 1975.

No. 420.

Public Service Act 1958, Sections 39 and 50.
REGULATIONS.—PART IV.—SALARIES AND INCREMENTS.

The Public Service Board, in pursuance of the powers conferred by the *Public Service Act 1958*, hereby amends the Public Service (Public Service Board) Regulations as follows:—

SECOND SCHEDULE.

PART B.

PROFESSIONAL DIVISION.

Scale of Rates of Annual Salaries.

DENTAL OFFICES.

The salary scale shown is deleted and the following salary scale is inserted in lieu thereof—

Class.	Annual Salary of Each Subdivision of Each Class.								
	1.	2.	3.	4.	5.	6.	7.	8.	9.
	\$	\$	\$	\$	\$	\$	\$	\$	\$
DO-1 ..	11,983	13,274	13,770	14,374	15,352	16,185	17,225	17,898	18,683
DO-2 ..	19,580
DO-3 ..	20,597

MEDICAL OFFICERS.

The salary scale shown is deleted and the following salary scale is inserted in lieu thereof—

Class.	Annual Salary of Each Subdivision of Each Class.								
	1.	2.	3.	4.	5.	6.	7.	8.	9.
	\$	\$	\$	\$	\$	\$	\$	\$	\$
MO-1 ..	11,983	13,274	13,770	14,374	15,352	16,185	17,225	17,898	18,683
MO-2 ..	20,597

FOURTH SCHEDULE.

PART C.

TECHNICAL AND GENERAL DIVISION AND TEMPORARY EMPLOYEES. *Classifications of Offices and Positions and Rates of Salaries.*

Delete the existing grades and yearly rates of salary for the following offices and/or positions and insert the grades and rates shown hereunder in lieu thereof—

Grades.	Yearly Salary.		Salary/Increment Code.	Title of Office and Position.	Title Code.
	Minimum.	Maximum.			
	\$	\$			
GENERAL.					
..	11,983	18,683	CO	Medical Officer	GA
DEPARTMENT OF HEALTH.					
<i>General Health.</i>					
..	11,983	20,597	CO	District Health Officer	GA
..	..	18,683	..	Health Officer	GA
..	..	20,597	..	Medical Officer, "Allambie"	GA
<i>Maternal and Child Welfare.</i>					
..	11,983	18,683	CQ	School Dental Officer	GA
<i>Mental Hygiene</i>					
..	11,983	18,683	CQ	Dental Officer	GA

with effect as on and from 18th May, 1975.

SECOND SCHEDULE.

PART B.

PROFESSIONAL DIVISION.

Scale of Rates of Annual Salaries.

DENTAL OFFICERS.

The salary scale shown is deleted and the following salary scale is inserted in lieu thereof—

Class.	Annual Salary of Each Subdivision of Each Class.								
	1.	2.	3.	4.	5.	6.	7.	8.	9.
	\$	\$	\$	\$	\$	\$	\$	\$	\$
DO-1 ..	12,414	13,752	14,266	14,891	15,905	16,768	17,845	18,542	19,356
DO-2 ..	20,385
DO-3 ..	21,338

MEDICAL OFFICERS.

The salary scale shown is deleted and the following salary scale is inserted in lieu thereof—

Class.	Annual Salary of Each Subdivision of Each Class.								
	1.	2.	3.	4.	5.	6.	7.	8.	9.
	\$	\$	\$	\$	\$	\$	\$	\$	\$
MO-1 ..	12,414	13,752	14,266	14,891	15,905	16,768	17,845	18,542	19,356
MO-2 ..	21,338

FOURTH SCHEDULE.

PART C.

TECHNICAL AND GENERAL DIVISION AND TEMPORARY EMPLOYEES. *Classifications of Offices and Positions and Rates of Salaries.*

Delete the existing grades and yearly rates of salary for the following offices and/or positions and insert the grades and rates shown hereunder in lieu thereof—

Grades.	Yearly Salary.		Salary/Increment Code.	Title of Office and Position.	Title Code.
	Minimum.	Maximum.			
	\$	\$			
GENERAL.					
..	12,414	19,356	CO	Medical Officer	GA
DEPARTMENT OF HEALTH.					
<i>General Health.</i>					
..	12,414	21,338	CO	District Health Officer	GA
..	..	19,356	..	Health Officer	GA
..	..	21,338	..	Medical Officer "Allambie"	GA
<i>Maternal and Child Welfare.</i>					
..	12,414	19,356	CQ	School Dental Officer	GA
<i>Mental Hygiene</i>					
..	12,414	19,356	CQ	Dental Officer	GA

with effect as on and from 25th May, 1975.

A. J. A. GARDNER, Chairman.
R. P. NOLAN, Secretary.

Office of the Public Service Board,
Melbourne, 19th May, 1975.

No. 421.

Public Service Act 1958, Sections 39 and 50.
REGULATIONS.—PART IV.—SALARIES AND INCREMENTS.

The Public Service Board, in pursuance of the powers conferred by the *Public Service Act 1958*, hereby amends the Public Service (Public Service Board) Regulations as follows:—

FOURTH SCHEDULE.

PART C.

TECHNICAL AND GENERAL DIVISION AND TEMPORARY EMPLOYEES. *Classifications of Offices and Positions and Rates of Salaries.*

Delete the existing grades and yearly rates of salary for the following office and/or position and insert the grades and rates shown hereunder in lieu thereof:—

Grades.	Yearly Salary.		Salary/Increment Code.	Title of Office and Position.	Title Code.
	Minimum.	Maximum.			
	\$	\$			
SOCIAL WELFARE DEPARTMENT.					
<i>Regional Services Division.</i>					
233	..	9,017	..	Welfare Officer, Senior	..

This Regulation shall have effect from 25th May, 1975.

A. J. A. GARDNER, Chairman.
R. P. NOLAN, Acting Secretary.

Office of the Public Service Board,
Melbourne, 23rd May, 1975.

PRIVATE ADVERTISEMENTS

CITY OF ARARAT

LOAN No. 85.

Notice of Intention to Borrow.

NOTICE is hereby given that the Council of the City of Ararat intends to borrow TWENTY THOUSAND DOLLARS (\$20,000) secured by a charge over the General Rates of the municipality by the grant of a Mortgage in accordance with the provisions of the Local Government Acts.

In connection therewith the following information is stated:—

- (a) The amount of the principal moneys which it is proposed to borrow is TWENTY THOUSAND DOLLARS (\$20,000).
- (b) The maximum rate of interest that may be paid is 9.5 per centum per annum.
- (c) The times which the moneys borrowed are to be repayable are on the first days of February and August during the years 1976-1980 inclusive; and that the place such moneys shall be repayable is at the Bank of New South Wales, Ararat Branch.
- (d) The purpose for which the Loan is to be applied is:—

Purchase of—

One light Tractor
Two Sedan Cars
Office Equipment
One Welder
One Hydraulic Jack
One Travelling Spray
One Oval Liner
Property (part cost).

- (e) The manner in which the Loan is to be liquidated is by provision out of the Municipal Fund in each half-year during the currency of the Loan of the sum of \$2,558.74 which includes Principal and interest.

A Statement showing the proposed expenditure of the moneys to be borrowed is open for inspection at the Municipal Offices (Engineer's Department), Ararat.

Dated this 30th day of May, 1975.

5425

J. I. GRENFELL, Town Clerk.

CITY OF COLLINGWOOD

LOAN No. 30.

Notice of Intention to Borrow the Sum of \$50,000.00 for Permanent Works and Undertakings.

Notice is hereby given that the Council of the City of Collingwood intends to borrow the Principal Sum herein-after mentioned on the credit of the municipal revenues of the Mayor, Councillors and Citizens of the City of Collingwood by the Grant of a Mortgage in accordance with the provisions of the Local Government Acts, and Notice is hereby further given:—

- (a) That the amount of the Principal Sum which it is proposed to borrow is \$50,000.00.
- (b) The maximum rate of interest that may be paid is 9.9 per centum per annum.
- (c) The moneys borrowed and interest thereon are to be repayable by 40 half-yearly instalments each of \$2,893.99 on the twenty-sixth day of January and the twenty-sixth day of July in each year, and the place at which such moneys are to be repayable is the Commonwealth Trading Bank, Collingwood. The first instalment shall be payable on the twenty-sixth day of January 1976.
- (d) The purposes for which the loan is to be applied are:— Construction of Swimming Pool.
- (e) The loan is to be liquidated by appropriation out of the Municipal Fund.
- (f) The plans, specifications, and estimate for the cost of such works, and the statement showing the proposed expenditure of the money to be borrowed, are open for inspection at the office of the Council, Hoddle Street, Abbotsford, during office hours.

5440

L. D. COOK, Town Clerk.

Town and Country Planning Act 1961, Twelfth Schedule.

CITY OF ECHUCA PLANNING SCHEME 1964

NOTICE THAT A PLANNING SCHEME HAS BEEN PREPARED AND IS AVAILABLE FOR INSPECTION.

Amendment 26, 1975.

Notice is hereby given that the City of Echuca in pursuance of its powers under the Town and Country Planning Act 1961 has prepared a planning scheme for the following areas:—

1. Lot 2 on L.P.113485 being part of Crown Suburban Allotment 34A, Parish of Echuca North, fronting Ogilvie Avenue; and
2. That part of Lot 1 on L.P.113485 having a frontage of 11.27 metres to Ogilvie Avenue and a depth on the western boundary of 48.43 metres, such area forming portion of the site of the Mobil Service Station.

A copy of the Scheme has been deposited at the City Offices, corner Hare and Heygarth Streets, Echuca, and at the office of the Town and Country Planning Board, Fifth Floor, 235 Queen Street, Melbourne, and will be open for inspection during office hours by any person free of charge.

Any persons affected by the Planning Scheme are required to set forth in writing all objections they may have addressed to the Town Clerk, City of Echuca, corner Hare and Heygarth Streets, Echuca, on or before the Fourth day of July 1975, and to state whether they wish to be heard in respect of their objections.

Dated this 27th day of May, 1975.

5435

K. F. McCARTNEY, Town Clerk.

CITY OF NUNAWADING

LOAN No. 133.

Notice of Intention to Borrow the Sum of \$75,000 for Permanent Works and Undertakings.

Notice is hereby given that the Council of the City of Nunawading proposes to borrow the principal sum of Seventy-five thousand dollars secured by a charge over the general rates of the municipality, such sum to be raised by the grant of a mortgage in accordance with the provisions of the Local Government Act 1958.

1. The maximum rate of interest that may be paid is 9.9 per centum per annum.
2. The purpose for which the loan is to be applied is the acquisition of open space.
3. The period of the loan shall be 20 years.

4. The moneys borrowed shall be repayable by providing out of the municipal fund half-yearly instalments of approximately \$4,340 each including principal and interest on the first day of August and the first day of February during the currency of the loan. The first instalment shall be payable on the first day of February 1976.

5. Such moneys shall be repayable to the Commissioners of The State Savings Bank of Victoria at the office of the said Commissioners, Corner Elizabeth and Bourke Streets, Melbourne.

The plans and specifications and the estimate of the cost of the proposed works and a statement showing the proposed expenditure of the moneys to be borrowed are open for inspection at the office of the Council of the City of Nunawading at White Horse Road, Nunawading.

5411

E. J. JANE, Town Clerk.

CITY OF NUNAWADING.

Notice is hereby given that in pursuance of the powers conferred by the Local Government Act the Council of the City of Nunawading did at a meeting held on the 26th May 1975 order that the following alteration be made in the name of the street as under, and that such order take effect from the date of this publication in the Victoria Government Gazette.

Old Name—Rangeview Grove.

New Name—Dampier Grove.

5412

E. J. JANE, Town Clerk.

CITY OF PORT MELBOURNE.

By-Law Number 163.

A By-Law of the City of Port Melbourne Numbered 163 for the purpose of amending By-Law Number 150 of the City of Port Melbourne.

The Mayor, Councillors and Citizens of the City of Port Melbourne in pursuance of the powers conferred by the Local Government Act, and every other power enabling them in that behalf, DO HEREBY MAKE the following By-Law and order as follows:—

1. That By-Law Number 150 of the City of Port Melbourne be and is amended as follows:—

Clause 3 be amended by inserting in the place of the year "1975" the year "1977" (being the operative date for the demolition of verandahs).

The resolution for passing this By-Law agreed to by the Council of the City of Port Melbourne this Eleventh day of March, 1975, and confirmed the Eighth day of April, 1975.

The common seal of the Mayor, Councillors and Citizens of the City of Port Melbourne, was hereto affixed in the presence of—

(SEAL) R. P. WHITE, Mayor.
A. TODD, Councillor.
5419 F. C. JACKSON, Town Clerk.

CITY OF RINGWOOD.

CHANGE OF STREET NAME.

NOTICE IS hereby given that the Council of the City of Ringwood did resolve at a meeting of the Council held on the 12th day of May 1975 to name the following street:—

THAT the un-named access road off Maroondah Highway (south side) serving the Ringwood Drive-In Shopping Centre and shown on L.P.55429 be now known as MURRAY PLACE.

5416 A. W. HALL, Town Clerk.

CITY OF SHEPPARTON.

LOAN No. 79.

Notice of Intention to Borrow the Sum of \$90,000 for Permanent Works and Undertakings.

NOTICE IS HEREBY GIVEN that the Council of the City of Shepparton proposes to borrow the sum of \$90,000 secured by a charge over the general rates of the municipality, such sum to be raised by the grant of a mortgage in accordance with the provisions of the *Local Government Act 1958*.

1. The principal amount to be borrowed is \$90,000.
2. The maximum rate of interest that may be paid is 9.90 per centum per annum.

3. The times and place at which the moneys borrowed are to be repayable are the twentieth day of January and the twentieth day of July during the years 1976 to 1990. Such moneys shall be repayable to the Commonwealth Savings Bank of Australia at Shepparton.

4. The purpose for which the loan is to be applied is—
Erection of buildings—Decentralised industries \$90,000

5. The loan shall be liquidated by the provision out of the municipal fund of thirty half-yearly instalments of \$5,821.30, including principal and interest; the first instalment shall be payable on the twentieth day of January, 1976, and the final instalment on the twentieth day of July, 1990.

6. The plans and specifications and the estimate of cost of the proposed works and a statement showing the proposed expenditure of the moneys to be borrowed are open for inspection at the office of the Council of the City of Shepparton, Civic Centre, Welsford Street, Shepparton.

5417 R. O'BRIEN, Town Clerk.

CITY OF SOUTH MELBOURNE.

By-Law No. 437.

A By-Law of the City of South Melbourne made under part VII of the *Local Government Act 1958* and numbered 437 for the purpose of amending By-Law No. 338 of the said City.

The Mayor, Councillors and Citizens of the City of South Melbourne in pursuance of the powers conferred by the Local Government Act and of every other Act or power enabling it in that behalf, doth hereby make the By-Law and order as follows:—

1. That By-Law No. 338 of the said City be amended by deleting paragraph 16 thereof.

Resolution adopting this By-Law agreed to by the Council of the City of South Melbourne on the fifth day of May, 1975, and confirmed at a meeting of the said Council held on the twenty-sixth day of May, 1975.

(SEAL) B. V. CORMICK, Mayor.
R. S. NICHOLLS, Councillor.
5422 J. J. COX, Town Clerk.

CITY OF SOUTH MELBOURNE.

By-Law No. 438.

A By-Law of the City of South Melbourne made under parts VII and XXX of the *Local Government Act 1958* and numbered 438 for the purpose of amending By-Law No. 324 of the said City.

The Mayor, Councillors and Citizens of the City of South Melbourne in pursuance of the powers conferred by the Local Government Act and of every other Act or power enabling it in that behalf, doth hereby make the By-Law and order as follows:—

1. That By-Law No. 324 of the said City be amended by substituting for paragraph 24 thereof, the following paragraph—

"24. No person shall in any thoroughfare or avenue in or of the said Market or in the immediate approaches thereto, take up collections of money or goods without the consent of the Council".

Resolution adopting this By-Law agreed to by the Council of the City of South Melbourne on the fifth day of May, 1975, and confirmed at a meeting of the said Council held on the twenty-sixth day of May, 1975.

(SEAL) B. V. CORMICK, Mayor.
R. S. NICHOLLS, Councillor.
5423 J. J. COX, Town Clerk.

Town and Country Planning Act 1961 (Twelfth Schedule).

PORTLAND PLANNING SCHEME, 1957.

NOTICE THAT A PLANNING SCHEME HAS BEEN PREPARED AND IS AVAILABLE FOR INSPECTION.

Amendment No. 15, 1975.

Notice is hereby given that the Council of the Town of Portland in pursuance of its powers under the *Town and Country Planning Act 1961* has prepared a Planning Scheme for amending the original scheme as it applies to the Town of Portland.

A copy of the Scheme has been deposited at the Municipal Offices, Gawler Street, Portland, and at the Office of the Town and Country Planning Board, 179 Queen Street, Melbourne, and will be open for inspection during office hours by any person, free of charge.

Any persons affected by the Planning Scheme are required to set forth in writing all objections they may have, addressed to the Town Clerk at the Municipal Offices, Gawler Street, Portland, on or before the 4th day of July, 1975, and to state whether they wish to be heard in respect of their objections.

3rd June, 1975.

5415 B. T. CRAGO, Town Clerk.

Town and Country Planning Act 1961 (Twelfth Schedule).

BALLAARAT AND DISTRICT PLANNING SCHEME 1966.

(BOROUGH OF SEBASTOPOL.)

NOTICE THAT A PLANNING SCHEME HAS BEEN PREPARED AND IS AVAILABLE FOR INSPECTION.

Amendment No. 4—1975.

Notice is hereby given that the Sebastopol Borough Council in pursuance of its powers under the *Town and Country Planning Act 1961* has prepared a Planning Scheme for

the area south-easterly from the corner of Rubicon/Albert Streets being Part Allot. 6, Section 12c, Township of Sebastopol and Lots 1 and 2 on L.P. 21898.

A copy of the Scheme has been deposited at the Borough Offices, 181 Albert Street, Sebastopol, and at the office of the Town and Country Planning Board, 235 Queen Street, Melbourne, and will be open for inspection during office hours by any person free of charge.

Any persons affected by the Planning Scheme are required to set forth in writing all objections they may have, addressed to the Town Clerk, Borough of Sebastopol, 181 Albert Street, Sebastopol, 3356, on or before the 4th day of July, 1975, and to state whether they wish to be heard in respect of their objections.

5421 HAROLD L. TEAGUE, Town Clerk.

SHIRE OF HEALESVILLE.

NOTICE OF COMPULSORY ACQUISITION.

WHEREAS the Council of the Shire of Healesville deems it expedient to exercise its powers of taking compulsorily the land as a site for a Public Purpose Reserve being Crown Allotment 9, Section C, Township of Marysville, Parish of Steavenson, commencing at the north west angle of the allotment and bounded on the north by Murchison Street bearing north seventy nine degrees forty five minutes east one chain on the east by allotment ten bearing south ten degrees fifteen minutes east two chains fifty links on the south by allotment thirteen bearing south seventy nine degrees forty five minutes west one chain and on the west by allotment eight bearing north ten degrees fifteen minutes west two chains fifty links, to the point of commencement.

AND WHEREAS the Council has caused to be prepared maps and other papers setting out the general description of the work or undertaking for which the land proposed to be taken and the names of the owners or reputed owners, lessees or reputed lessees, mortgagees and occupiers of that land so far as those names are known or can be ascertained by the Council.

AND WHEREAS the said maps and other papers are deposited at the Office of the said Council at Healesville and are and shall be open for inspection by all persons interested at all reasonable hours for the space of forty clear days after the publication of this notice in the Government Gazette.

NOW NOTICE IS HEREBY GIVEN to all persons affected by the proposed taking of the said land to set forth in writing addressed to the Council or the Shire Secretary within forty clear days of the publication of this notice in the Government Gazette all objections which they may have to the taking of the said land.

Dated the 27th day of May, 1975.

5409

R. E. HARDISTY, Shire Secretary.

SHIRE OF HEALESVILLE.

NOTICE OF COMPULSORY ACQUISITION.

WHEREAS the Council of the Shire of Healesville deems it expedient to exercise its powers of taking compulsorily the land as a site for a Public Purpose Reserve being Crown Allotment 8, Section C Township of Marysville, Parish of Steavenson, commencing at the north west angle of the allotment and bounded on the north by Murchison Street bearing north seventy nine degrees forty-five minutes east one chain on the east by allotment nine bearing south ten degrees fifteen minutes east two chains fifty links on the south by allotment fourteen bearing south seventy nine degrees forty five minutes west one chain and on the west by allotment seven bearing north ten degrees fifteen minutes west two chains fifty links to the point of commencement.

AND WHEREAS the Council has caused to be prepared maps and other papers setting out the general description of the work or undertaking for which the land proposed to be taken and the names of the owners or reputed owners, lessees or reputed lessees, mortgagees and occupiers of that land so far as those names are known or can be ascertained by the Council.

AND WHEREAS the said maps and other papers are deposited at the Office of the said Council at Healesville and are and shall be open for inspection by all persons interested at all reasonable hours for the space of forty clear days after the publication of this notice in the Government Gazette.

NOW NOTICE IS HEREBY GIVEN to all persons affected by the proposed taking of the said land to set forth in writing addressed to the Council or the Shire Secretary within forty clear days of the publication of this notice in the Government Gazette all objections which they may have to the taking of the said land.

Dated the 27th day of May, 1975.

5410

R. E. HARDISTY, Shire Secretary.

SHIRE OF KORUMBURRA.

ROAD DEVIATION ORDER.

Pursuant to the provisions of Section 522 of the Local Government Act the Council of the Shire of Korumburra hereby directs that the land in the Parish of Jeetho indicated by hatching on the diagram hereunder which has been purchased, acquired, or taken by it shall be a Public Highway on and from the date of publication of this Order in the Government Gazette.

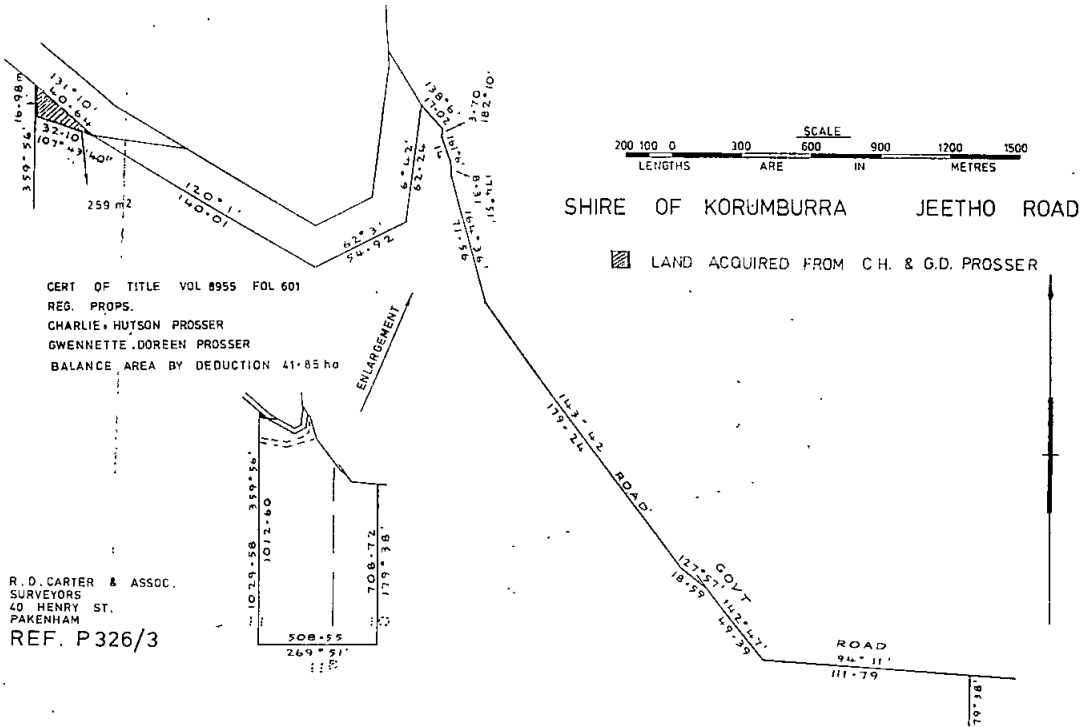

The common seal of the President, Councillors and Ratepayers of the Shire of Korumburra was hereto affixed, pursuant to a resolution of the Council this 21st day of May, 1975, in the presence of—

(SEAL)

J. W. LITTLE, Councillor, R. W. BROOKS, Councillor, W. O. CLARK, Shire Secretary.

SHIRE OF KORUMBURRA.

ROAD DEVIATION ORDER

Pursuant to the provisions of Section 522 of the Local Government Act the Council of the Shire of Korumburra hereby directs that the land in the Parish of Poowong indicated by hatching on the diagram hereunder which has been purchased, acquired, or taken by it shall be a Public Highway on and from the date of publication of this Order in the Government Gazette.

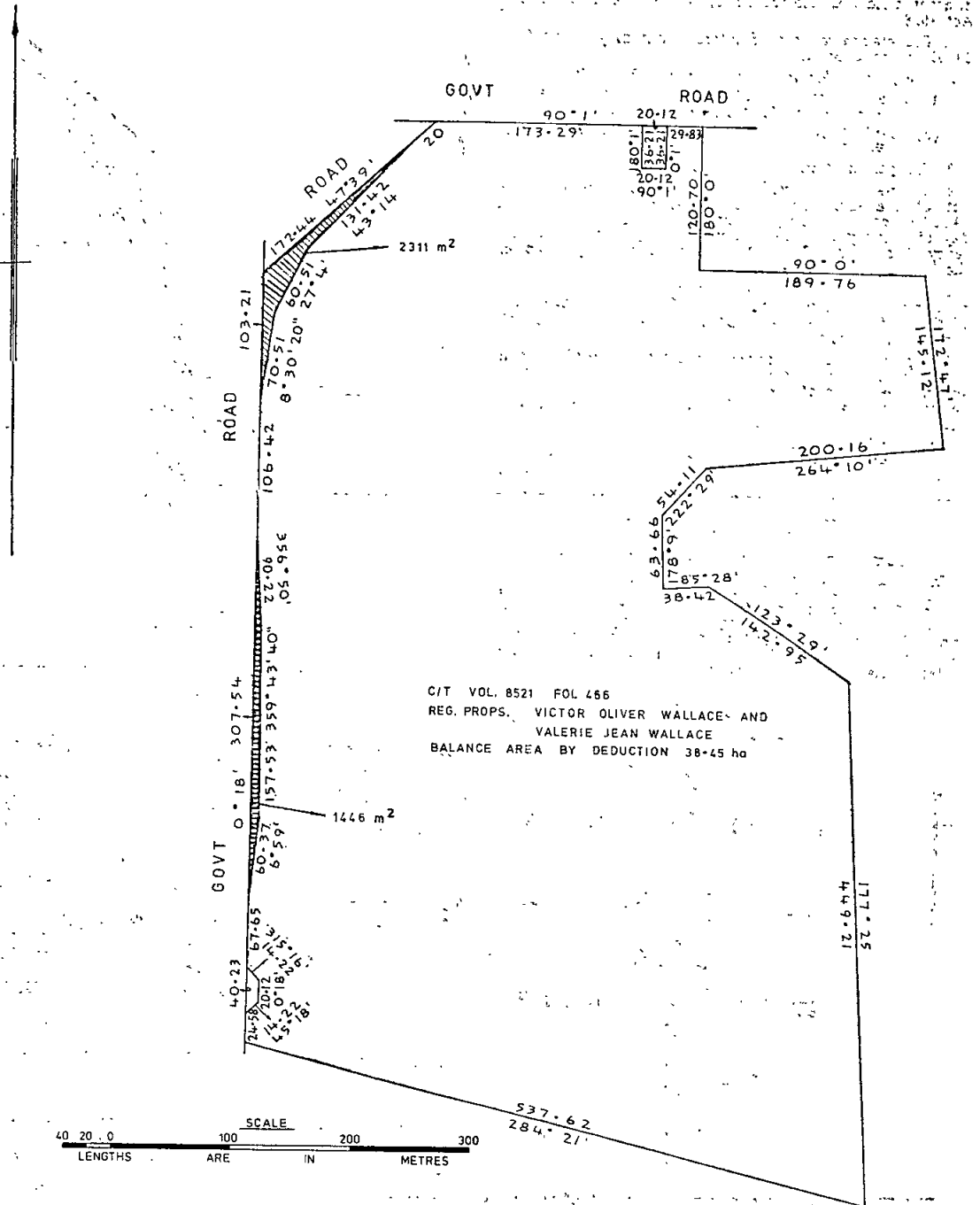

SHIRE OF KORUMBURRA TIMMS ROAD

The common seal of the President, Councillors and Ratepayers of the Shire of Korumburra was hereto affixed, pursuant to a resolution of the Council this 21st day of May, 1975, in the presence of—

(SEAL)

J. W. LITTLE, Councillor,
R. W. BROOKS, Councillor,
W. O. CLARK, Shire Secretary.

SHIRE OF ELTHAM.

LOAN No. 106.

Notice of Intention to Borrow the Sum of \$64,000 for Permanent Works and Undertakings.

Notice is hereby given that the Council of the Shire of Eltham proposes to borrow the principal sum of \$64,000 secured by a charge over the general rates of the municipality, such sum to be raised by the grant of a mortgage in accordance with the provisions of the Local Government Act 1958.

1. The maximum rate of interest that may be paid is \$9.90 per cent. per annum.
2. The purpose for which the loan is to be applied is—
 - (i) Road Works—Council's contribution to the Country Roads Board for unclassified roads.
 - (ii) Road Works—Construction of Reynolds Road to Wattle Glen.
3. The period of the loan shall be 15 years.
4. The moneys borrowed shall be repayable by providing out of the municipal fund half-yearly instalments of \$4,139.60 each including principal and interest on the first day of January and the first day of July during the currency of the loan. The first instalment shall be payable on the first day of January, 1976.

5. Such moneys shall be repayable to The Commissioners of The State Savings Bank of Victoria at the office of the said Commissioners, Corner Elizabeth and Bourke Streets, Melbourne.

The plans and specifications and the estimate of the cost of the proposed works and a statement showing the proposed expenditure of the moneys to be borrowed are open for inspection at the office of the Council of the Shire of Eltham, at Main Road, Eltham.

Dated 29th May, 1975.

W. R. FEATHERSTON, Shire Secretary/Chief Administrator. 5444

Local Government Act 1958.

SHIRE OF MALDON.

ORDER THAT LAND SHALL BE A PUBLIC HIGHWAY.

In pursuance of the powers conferred by Section 522 of the Local Government Act 1958 the Council of the Shire of Maldon directs that the land in the Parish of Maldon indicated by hatching on the diagram hereunder which has been purchased or acquired by it shall be a public highway on and from the date of publication of this order in the Government Gazette.

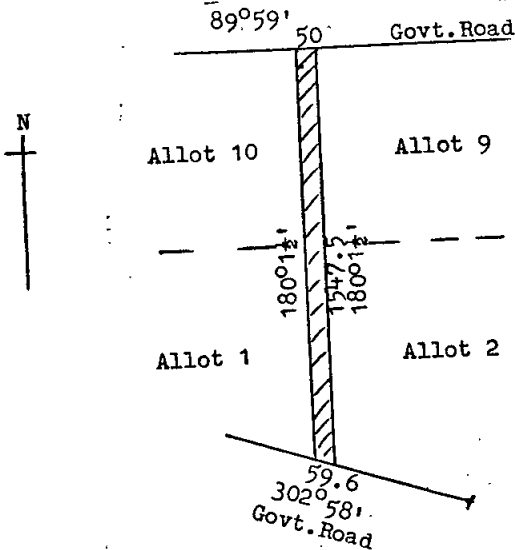

ORDER made at a Meeting of the Council of the Shire of Maldon held on the 7th day of May 1975.

In witness whereof the common seal of the President, Councillors and Ratepayers of the Shire of Maldon was hereunto affixed this 7th day of May, 1975, in the presence of—

L. LAITY, President.
 (SEAL) J. L. MASON, Councillor.
 S. R. BEACH, Shire Secretary. 5437

SHIRE OF MOUNT ROUSE.

ROAD DEVIATION ORDER.

Pursuant to the provisions of section 522 of the Local Government Act 1958, the Council of the Shire of Mount Rouse hereby directs that the lands in the Parishes of Dunkeld and Boonawah indicated by hatching on the diagram hereunder which has been purchased, taken or acquired by it shall be a Public Highway from the date of the publication of this Order in the Government Gazette.

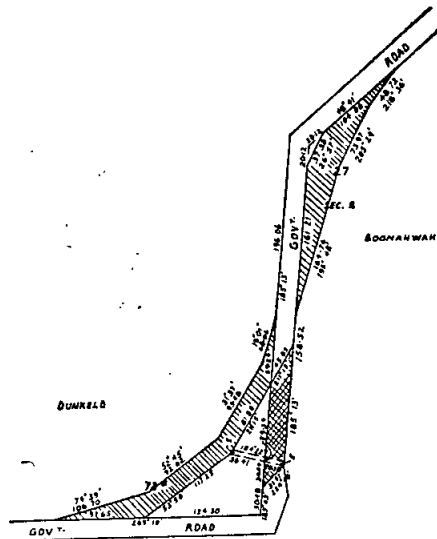

The common seal of the President, Councillors and Ratepayers of the Shire of Mount Rouse was affixed hereto, this 14th day of May, 1975, in the presence of—

W. J. LEWIS, Chairman.
 (SEAL) R. W. MITCHELL, Councillor.
 S. LONDON, Secretary. 5418

SHIRE OF PAKENHAM.

LOAN No. 67.

Notice of Intention to Borrow the Sum of \$100,000 for Permanent Works and Undertakings.

Notice is hereby given that the Council of the Shire of Pakenham proposed to borrow the Principal sum of One Hundred Thousand Dollars (\$100,000) secured by a charge over the General Rates of the Municipality, such sum to be raised by the grant of a mortgage in accordance with the provisions of the Local Government Act, 1958.

1. The maximum rate of interest that may be paid is 9.9 per centum per annum.
2. The purpose for which the loan is to be applied, is—

Car Parking, Pakenham (Part)	\$70,900
Plant Purchase	\$27,000
Land Acquisition, Beaconsfield (Cardinia Creek Reserve)	\$2,100
	<hr/>
	\$100,000

3. The period of the loan shall be fifteen (15) years.
4. The moneys borrowed shall be repayable by providing out of the Municipal Fund thirty (30) half yearly instalments of approximately \$6,468.11 each including Principal and Interest on the Tenth Day of January and the Tenth Day of July during the currency of the loan. The first instalment shall be payable on the Tenth Day of January, 1976.

5. Such money shall be repayable to the Commercial Bank of Australia, Main Street, Pakenham.

The plans and specifications and the estimate of the cost of the proposed works and a statement showing the proposed expenditure of the moneys to be borrowed are open for inspection at the Office of the Council of the Shire of Pakenham at Main Street, Pakenham during Office hours.

R. T. R. CANOBIE, Acting Shire Secretary. 5420

Town and Country Planning Act 1961.
SHIRE OF SOUTH GIPPSLAND PLANNING SCHEME
 NOTICE THAT A PLANNING SCHEME HAS BEEN PREPARED
 AND IS AVAILABLE FOR INSPECTION.

Amendment No. 18, 1975.

Notice is hereby given that the Shire of South Gippsland, in pursuance of its powers under the *Town and Country Planning Act 1961*, has prepared a Planning Scheme for—

Portion of the Crown Reserve on the north side of existing tennis courts, Main Street, Foster, for the purpose of re-zoning the land from Public Purposes Reserve (Municipal Purposes, Car Park) to Public Purposes Reserve (Historical Museum).

A copy of the Scheme has been deposited at the Shire Office, 14-18 Pioneer Street, Foster, and at the office of the Town and Country Planning Board, 235 Queen Street, Melbourne, and will be open for inspection during office hours by any person free of charge.

Any persons affected by the Planning Scheme are required to set forth in writing all objections they may have, addressed to the Shire Secretary, P.O. Box 14, Foster 3960, on or before the 4th day of September, 1975, and to state whether they wish to be heard in respect of their objections.

28th May, 1975.

5408

H. R. LOMAX, Municipal Clerk.

GEELONG WATERWORKS AND SEWERAGE TRUST.

Pursuant to Section 60 of the *Geelong Waterworks and Sewerage Act 1958* (No. 6263) the Trust has prepared plans to indicate the particulars of sewers and underground works, the construction of which the Trust intends to begin at a date, not less than one month after publication of the notice, in or adjacent to the following localities within the Drainage Area.

Shire of Corio.—Donnybrook & Camfield Roads, Maynooth Drive and Callan Court, Norlane.

Shire of Corio.—Goldsworthy Road, Paley Drive, Hancock Square, Hastings Way, Shepherdson Avenue, Chaffey Court and Paulson Street, Corio.

City of South Barwon.—Barwon Boulevard and Cedar Grove, North Highton.

NOTICE IS HEREBY GIVEN that the plans indicated above are open for inspection at the Trust's Offices, Rylie Street, Geelong, between the hours of 9.00 a.m. and 5.00 p.m. from Monday to Friday (public holidays excepted) by the owners or occupiers of land or premises within the Drainage Area.

5438

B. C. HENSHAW, Secretary.

GEELONG WATERWORKS AND SEWERAGE TRUST.

The above-mentioned Trust having made provision for carrying off the sewage from each and every property which or any part of which is within the sewerage area hereinafter described doth hereby declare that on or after the 1st day of June, 1975, each and every property which or any part of which is within the said sewerage area shall be deemed and taken to be seweraged property within the meaning of the said *Geelong Waterworks and Sewerage Act 1958*.

Signed under seal of the Geelong Waterworks and Sewerage Trust, this 28th day of May, 1975.

(SEAL)

R. W. WHITESIDE, Chairman.
 B. C. HENSHAW, Secretary.

SEWERAGE AREA No. 594.

City of South Barwon.—*Parish of Duneed.*—*County of Grant.*

Commencing at a point being on the boundaries of Sewerage Areas Nos. 546 and 451 which is also on the northern boundary of allotment No. 25 Nevett Court, Grovedale, thence southerly following the boundary of Sewerage Area No. 451 and crossing Nevett Court to the southern boundary of allotment No. 10 Nevett Court, thence westerly along the southern boundaries of allotments Nos. 10 to 16 inclusive Nevett Court to the south-west corner of the said allotment No. 16, thence northerly along the western boundaries of allotments Nos. 16 to 19 inclusive Nevett Court to the north-west corner of the said allotment No. 19, which is also on the boundary of Sewerage Area No. 546, thence easterly following the boundary of Sewerage Area No. 546 to the point of commencement.

SEWERAGE AREA No. 595.

Shire of Corio.—*Parish of Moranghurk.*—*County of Grant.*

Commencing at a point being the south-west corner of allotment No. 18 Remington Street, Corio, the said point being also on the boundary of Sewerage Area No. 508, thence northerly along the western boundary of the said

allotment No. 18 to the north-west corner of the said allotment No. 18, thence northerly across Remington Street to the south-west corner of allotment No. 19 Remington Street, thence north-westerly along the western boundary of the said allotment No. 19 to the north-west corner of the said allotment No. 19, thence north-easterly along the northern boundary of the said allotment No. 19 to the south-west corner of allotment No. 35, Enfield Close, thence north-westerly, north-easterly, northerly and north-easterly along the north-westerly, north-easterly, westerly and north-easterly boundaries of allotments Nos. 35 to 42 inclusive Enfield Close, allotment No. 43 Browning Drive and allotments 45 and 46 Gatling Court and crossing Browning Drive to the south-west corner of allotment No. 75 Owen Court, thence northerly along the western boundaries of allotments Nos. 75 to 77 Owen Court to the southern boundary of allotment No. 89 Plantation Road, thence westerly along the southern boundary of the said allotment No. 89 to the south-west corner of the said allotment No. 89, thence northerly along the western boundary of the said allotment No. 89 to the south side of Plantation Road, thence easterly along the south side of Plantation Road and crossing Lincoln Street to the south-east corner of the intersection of Plantation Road and Lincoln Street, which is also on the boundary of Sewerage Area No. 418, thence southerly, westerly, southerly and westerly following the boundaries of Sewerage Areas Nos. 418, 531 and 508 and crossing Lincoln Street and Browning Drive to the point of commencement.

SEWERAGE AREA No. 596.

Shire of Corio.—*Parish of Moorpanyal.*—*County of Grant.*

Commencing at a point being the north-east corner of the intersection of Princess and Goldsworthy Roads, Corio, which is also being on the boundary of Sewerage Area No. 353, thence westerly across Princess Road and continuing westerly along the north side of Goldsworthy Road to the south-west corner of allotment No. 1 Goldsworthy Road, which is 35 m approximately west from the north-west intersection of Goldsworthy and Princess Roads, thence northerly along the western boundary of the said allotment No. 1 and continuing northerly along the western boundaries of allotments Nos. 3 to 5 Princess Road and crossing Access Road, and continuing northerly along the western boundaries of allotments Nos. 7 to 27 inclusive Princess Road and the western boundary of allotment No. 29 Purnell Road to the south side of Purnell Road, thence easterly along the south side of Purnell Road, and crossing Princess Road to the south-east corner of the intersection of Purnell and Princess Roads, which is also on the boundaries of Sewerage Areas Nos. 502 and 353, thence southerly following the boundary of Sewerage Area No. 353 and crossing Glenelg Avenue to the point of commencement.

SEWERAGE AREA No. 597.

City of South Barwon.—*Parish of Barrarbool.*—*County of Grant.*

Commencing at a point being the south-west corner of allotment No. 9 Vanessa Avenue, Highton, the said point being also on the boundary of Sewerage Area No. 280, thence northerly along the western boundary of the said allotment No. 9 to the north-west corner of the said allotment No. 9, which is also on the boundary of Sewerage Area No. 565, thence north-easterly, southerly, south-easterly, easterly north-easterly, northerly, easterly, southerly, easterly, southerly, easterly, southerly, south-westerly, southerly, westerly and northerly following the boundaries of Sewerage Areas Nos. 565, 280, 416 and 280 and crossing Vanessa Avenue (twice) to the point of commencement.

SEWERAGE AREA No. 598.

Shire of Corio.—*Parish of Moorpanyal.*—*County of Grant.*

Commencing at a point being the south-east corner of the intersection of Cobham Road and Marilyn Street, Corio, the said point being also on the boundary of Sewerage Area No. 536, thence southerly following the boundary of Sewerage Area No. 536 to the prolongation of the southern boundary of allotment No. 75 Cobham Road, thence westerly across Cobham Road and continuing westerly along the southern boundaries of the said allotment No. 75 and allotments Nos. 108 to 110 inclusive Bottlebrush Court to the north-east corner of allotment No. 125 Grevillea Avenue, thence southerly along the eastern boundaries of allotments Nos. 125 to 129 inclusive Grevillea Avenue to the north-side of Cox Road, thence westerly along the north side of Cox Road for a distance of 158 m approx. to the south-west corner of allotment No. 130 Cox Road and crossing Grevillea Avenue, thence northerly by a line bearing 359 degrees 57 minutes for a distance of 182.89 m., thence westerly by a line bearing 269 degrees 55 minutes and crossing S.E.C. Transmission easement, Recreation Reserve and Banksia Square to the south-east corner of allotment No. 216 Banksia Square, which is also on the west side of Banksia Square, thence

westerly along the southern boundary of the said allotment No. 216 to the south-west corner of the said allotment No. 216, thence northerly along the western boundaries of allotments Nos. 216 to 228 inclusive Banksia Square to the north-west corner of the said allotment No. 228, thence easterly along the northern boundary of the said allotment No. 228 to the west side of Banksia Square, thence east south-easterly across Banksia Square, S.E.C. Transmission easement and Recreation Reserve to the north-west corner of allotment No. 170 Banksia Square, thence easterly along the northern boundary of the said allotment No. 170 to the western boundary of allotment No. 193 Bluegum Court, thence northerly along the western boundaries of allotments Nos. 193 and 192 Bluegum Court to the north-west corner of the said allotment No. 192, thence easterly and south-easterly along the northern boundaries of allotments Nos. 192 to 187 inclusive Bluegum Court to the north-east corner of the said allotment No. 187, thence south-westerly along the eastern boundary of the said allotment No. 187 to the north-west corner of allotment No. 186 Grevillea Avenue, thence south-easterly along the north-east boundary of the said allotment No. 186 to the west side of Grevillea Avenue, thence easterly across Grevillea Avenue to the north-west corner of allotment No. 94 Grevillea Avenue, thence north-easterly along the northern boundary of the said allotment No. 94 to the north-east corner of the said allotment No. 94, thence southerly along the eastern boundary of the said allotment No. 94 to the north-west corner of allotment No. 89 Cobham Road, thence easterly along the northern boundary of the said allotment No. 89 and crossing Cobham Road on a straight line to the east side of Cobham Road, thence southerly along the east side of Cobham Road and crossing Marilyn Street to the point of commencement.

SEWERAGE AREA No. 599.

City of South Barwon.—Parish of Barrabool.—County of Grant.

Commencing at a point being the south-east corner of the intersection of Amberley Court and Larcombe Street, Highton, the said point being also on the boundary of Sewerage Area No. 372, thence westerly across Larcombe Street by a line bearing 270 degrees to the west side of Larcombe Street, which is also on the boundaries of Sewerage Areas Nos. 372 and 242, thence northerly along the west side of Larcombe Street for a distance of 63.04m., thence easterly by a line bearing 89 degrees 57 minutes for a distance of 60.98m. and crossing Larcombe Street, thence southerly by a line bearing 179 degrees 38 minutes to the northern boundary of allotment No. 4 Amberley Court, thence easterly along the northern boundaries of allotments No. 4 and 5 Amberley Court to the north-east corner of the said allotment No. 5, which is also on the boundary of Sewerage Area No. 407, thence southerly, north-westerly and westerly following the boundaries of Sewerage Areas Nos. 407 and 372 and crossing Amberley Court to the point of commencement.

SEWERAGE AREA No. 600.

City of South Barwon.—Parish of Barrabool.—County of Grant.

Commencing at a point being the north-west corner of allotment No. 9 Linthwaite Close, Highton, the said point being also on the boundaries of Sewerage Areas No. 307 and 415, thence easterly, southerly, south-easterly, southerly, westerly, northerly and north-westerly following the boundaries of Sewerage Areas Nos. 415, 541 and 307 and crossing Linthwaite Close to the point of commencement.

SEWERAGE AREA No. 601.

City of South Barwon.—Parish of Barrabool.—County of Grant.

Commencing at a point being the north-east corner of the intersection of Barrabool Road and Adelaide Street, Highton, the said point being also on the boundary of Sewerage Area No. 223, thence south-easterly, southerly, westerly, northerly, easterly, northerly and south-easterly following the boundaries of Sewerage Areas Nos. 223, 258, 393, 294, 233 and 223 and crossing Barrabool Road (twice) and Adelaide Street to the point of commencement.

SEWERAGE AREA No. 602.

Shire of Corio.—Parish of Moorpanyal.—County of Grant.

Commencing at a point being the north-east corner of allotment No. 12 Thompson Road, North Geelong, which is also on the south side of Rodney Road, thence southerly by a line bearing 180 degrees 12 minutes to the boundary of Sewerage Area No. 284, thence westerly and northerly following the boundary of Sewerage Area No. 284 to the south east corner of allotment No. 12 Thompson Road which is also on the east side of Thompson Road, thence northerly along the east side of Thompson Road to the south-east corner of the intersection of Thompson and Rodney Roads, thence easterly along the south side of Rodney Road to the point of commencement.

SEWERAGE AREA No. 603.

City of South Barwon.—Parish of Duneed.—County of Grant.

Commencing at a point being the north-east corner of allotment No. 1647 Gloucester Street, Grovedale, the said point being also on the boundary of Sewerage Area No. 493, thence southerly, south-westerly, westerly, southerly, south-westerly, westerly and southerly following the boundaries of Sewerage Areas Nos. 493, 512 and 581 and crossing Gloucester Street and Coolabah Drive to the south-east corner of allotment No. 1613 Coolabah Drive, thence westerly along the southern boundary of the said allotment No. 1613 to the south-west corner of the said allotment No. 1613, thence northerly and north-westerly along the western boundaries of allotments Nos. 1613 to 1619 inclusive Coolabah Drive and allotments Nos. 1621 and 1622 Maruya Drive and crossing Maruya Drive to the north-west corner of the said allotment No. 1622, thence north-easterly along the north-western boundaries of allotments Nos. 1622 to 1632 inclusive Maruya Drive to the south-west corner of allotment No. 1634 Gloucester Street, thence northerly along the western boundary of the said allotment No. 1634 to the north-west corner of the said allotment No. 1634, thence easterly along the northern boundary of the said allotment No. 1634 by a line bearing 79 degrees 53 minutes to the west side of Gloucester Street, thence easterly across Gloucester Street by a line bearing 89 degrees 51½ minutes to the north-west corner of allotment No. 1635 Gloucester Street, thence easterly along the northern boundary of the said allotment No. 1635 by a line bearing 89 degrees 12 minutes to the north-east corner of the said allotment No. 1635, thence south-easterly and easterly along the north-eastern and northern boundaries of allotments Nos. 1635 to 1647 inclusive Gloucester Street to the point of commencement.

SEWERAGE AREA No. 604.

City of Newtown.—Parish of Moorpanyal.—County of Grant.

Commencing at a point being the north-west corner of allotment No. 40 Buckingham Road, Newtown, the said point being also on the boundary of Sewerage Area No. 579, thence easterly along the northern boundaries of allotments Nos. 40 to 35 inclusive Buckingham Road to the north-east corner of the said allotment No. 35, thence southerly along the eastern boundary of the said allotment No. 35 to the south-east corner of the said allotment No. 35, which is also on the boundary of Sewerage Area No. 579, thence westerly, north-westerly, south-westerly, westerly and northerly following the boundary of Sewerage Area No. 579 to the point of commencement. 5439

EDENHOPE SEWERAGE AUTHORITY

EDENHOPE SEWERAGE SCHEME

I hereby give notice pursuant to Section 119 (2) of the Sewerage Districts Act 1958, that plans showing the proposed location of sewers, rising mains and pumping stations are open for inspection at the Shire Offices during normal business hours.

5436

B. D. HAYES, Secretary.

SEWERAGE DISTRICTS ACT.

PROPOSED SEWERAGE OF KILLARA VILLAGE.

Notice is hereby given that the Wodonga Sewerage Authority has made application to the Honorable, the Minister of Water Supply for the extension of its Sewerage District to include Killara Village and for the construction, maintenance and continuance of sewerage works within that Village under the provisions of the Sewerage Districts Act.

A general plan and description of the proposed works have been submitted with the application and copies of same may be seen at the City Offices, Wodonga.

Dated at Wodonga, the 7th day of May, 1975.

5127

A. W. RUTKOWSKI, Secretary.

THE DENTAL BOARD OF VICTORIA.

DUTIES OF THE DENTAL NURSE.

Under the provisions of the *Dentists Act 1972* an Advisory Committee has been appointed to investigate and report upon the administration of the Act with regard to the duties of the Dental Nurse and any other aspect of dental nursing.

Individuals or organizations who wish to present evidence to the above Committee may do so in writing. Any such submission should reach the Registrar of the Dental Board, 4 Collins Street, Melbourne on or before 24th day of July, 1975.

5427

VERA M. SUTTON, Registrar.

NOTICE IS HEREBY GIVEN that an application in the following form, signed by The Most Reverend Ronald Austin Mulkearns and sealed with the seal of the Roman Catholic Trust Corporation of the Diocese of Ballarat, has been lodged at the Office of the Minister of Crown Lands and Survey—

Victoria.

ACT 391.—FIRST SCHEDULE.

I, The Most Reverend Ronald Austin Mulkearns of Ballarat head or authorized representative of the denomination known as the Roman Catholic Church in the Diocese of Ballarat with the consent of the Corporation styled The Roman Catholic Trusts Corporation of 9 Lyons Street South Ballarat trustee of the land described in the subjoined statement of trusts, hereby apply to the Governor of the State of Victoria for leave to dispose of the said land by the means and for the purposes mentioned in the said statement of trusts, and I hereby certify that the said land hereinafter mentioned was permanently reserved from sale by the Governor in Council as a site for Roman Catholic Church purposes by order in Council dated the 25th day of January 1870.

The only trustee of the said land resident in the State of Victoria is the said corporation styled The Roman Catholic Trusts Corporation. There are no buildings owned by the Trust upon the said Land.

STATEMENT OF TRUSTS.

Description of Land.—1 acre, permanently reserved for Roman Catholic Church purposes by Order in Council of the 25th January 1870 (see *Government Gazette* 28th January 1870 page 156). 1 acre, Parish of Creswick County of Talbot being Allotment 6c Section P. Commencing at the south-west angle of Allotment 6; bounded thence by that Allotment, bearing 91° 11' 400 links, further by that Allotment, Allotment 6a and a line bearing 181° 11' 250 links by a line bearing 271° 11' 400 links and thence by a road bearing 1° 11' 250 links to the point of commencement.

Name of Trustees.—The Roman Catholic Trusts Corporation of 9 Lyons Street South, Ballarat.

Powers of Disposition.—Such powers of disposition including powers of sale, lease or mortgage as are contained in the *Roman Catholic Trusts Act 1907*.

Purposes to which Proceeds of Disposition are to be Applied.—To such Roman Catholic Church purposes as shall be approved by the Trustee or a majority thereof.

Dated this 26th day of May, 1975.

BYRNE, JONES & TORNEY, solicitors, 38 Lydiard Street South, Ballarat, 3350. 5428

NOTICE IS HEREBY GIVEN that an application in the following form, signed by The Most Reverend Ronald Austin Mulkearns and sealed with the seal of the Roman Catholic Trusts Corporation of the Diocese of Ballarat, has been lodged at office of the Minister of Crown Lands and Survey—

Victoria.

ACT 391.—FIRST SCHEDULE.

I, The Most Reverend Ronald Austin Mulkearns of Ballarat head or authorized representative of the denomination known as the Roman Catholic Church in the Diocese of Ballarat with the consent of the Corporation styled The Roman Catholic Trusts Corporation of 9 Lyons Street South Ballarat trustee of the land described in the subjoined statement of trusts, hereby apply to the Governor of the State of Victoria for leave to dispose of the said land by the means and for the purposes mentioned in the said statement of trusts, and I hereby certify that the said land hereinafter mentioned was temporarily reserved from sale by the Governor in Council as a site for Roman Catholic Church purposes by order in Council dated the 27th day of June 1870.

The only trustee of the said land resident in the State of Victoria are the said Corporation styled The Roman Catholic Trusts Corporation. There are no buildings upon the said land.

STATEMENT OF TRUSTS.

Description of land.—1 acre, more or less, temporarily reserved for a Roman Catholic Place of Public Worship by Order in Council of the 27th June 1870 (see *Government Gazette* 8th July 1870 page 970). 1 acre, Parish of Ballarat, County of Ripon, being allotment 13A, Section H. Commencing at a point on the southern boundary of Allotment 31, distant 1105 links westerly from the south-east angle of that Allotment; bounded thence by that Allotment, bearing 0° 29' 316 links, 270° 29' 316 links,

further by that Allotment and a road, bearing 180° 29' 316 links and thence by Allotment 29A bearing 90° 29' 316 links to the point of commencement.

Name of Trustees.—The Roman Catholic Trusts Corporation of 9 Lyons Street South, Ballarat.

Powers of Disposition.—Such powers of disposition including powers of sale, lease or mortgage as are contained in the *Roman Catholic Trusts Act 1907*.

Purposes to which proceeds of disposition are to be applied.—To such Roman Catholic Church purposes as shall be approved by the Trustee or a majority thereof.

Dated this 26th day of May, 1975.

BYRNE, JONES & TORNEY, solicitors, 38 Lydiard Street South, Ballarat, 3350. 5429

"Take notice that the partnership heretofore existing between Michael Charles Jean of 34 Brendale Avenue, Blackburn North—Ronald Hoyt Parke of 3 Lynne Street, Donvale—Patrick Charles Taylor of 10 Marilyn Court, Blackburn North trading as Nunawading Air Conditioning, Heating and Insulation Centre and carrying on business at 135 Springvale Road, Nunawading, has been dissolved as from 1.5.75.

Michael Charles Jean of 34 Brendale Avenue, Blackburn North—Ronald Hoyt Parke of 3 Lynne Street, Donvale, shall continue to carry on business under the name of Nunawading Air Conditioning and Insulation Centre at 135 Springvale Road, Nunawading."

Dated this Thursday the 1st of May, 1975.

MICHAEL CHARLES JEAN,
RONALD HOYT PARKE,
PATRICK CHARLES TAYLOR.

5380

Witness, ROY ALEXANDER McDONALD.

Notice is hereby given that the partnership heretofore subsisting between COLIN KEITH RUSSELL and RICHARD CLARENCE HOWARD carrying on business as carpet contractors at 17D Brougham Street Eltham in the State of Victoria under the style or firm of "Howard and Russell" has been dissolved by mutual consent as from the 17th day of May, 1975 and that the business shall continue to be carried on by RICHARD CLARENCE HOWARD only.

NEVILLE & CO., solicitors, 1401 Malvern Road, Malvern. 5381

NOTICE OF DISSOLUTION OF PARTNERSHIP.

NOTICE IS HEREBY GIVEN that the Partnership heretofore subsisting between FAUSTO POGGI, MARIO MACCIONE and LIVIO LUNELLI carrying on business as Restaurant and Eating House at 144-146 Lygon Street, Carlton under the style or firm of CASANOVA RESTAURANT has been dissolved as from the 2nd day of March, 1975 so far as concerns the said FAUSTO POGGI who retires from the said firm.

All debts due to and owing by the said late firm will be received and paid respectively by MARIO MACCIONE and LIVIO LUNELLI who will continue to carry on the said business in Partnership under the style or firm of CASANOVA RESTAURANT.

Dated the 16th day of May, 1975.

FAUSTO POGGI.

D. C. Carli, Furietti & Scott, solicitors of 52 Pelham Street, Carlton. 5475

Companies Act 1961.—In the matter of SOUTH YARRA MOTOR CYCLES PTY. LTD. (in Liquidation).

NOTICE IS HEREBY GIVEN that at an Extraordinary General Meeting of the above-named company held on the 26th May, 1975, it was resolved that the Company be wound up voluntarily.

The Meeting also resolved that JOHN BARRY HUTCHINS and MICHAEL ASHLEY COPPINS of Wilson, Bishop, Bowes and Craig, 271 William Street, Melbourne be appointed joint and several liquidators for the purpose of the winding up.

At a Meeting of Creditors held on the same day pursuant to Section 260, the appointment of the abovenamed Liquidators was confirmed.

Dated this 28th day of May, 1975.

J. B. HUTCHINS & M. A. COPPINS, Joint and Several Liquidators.

Wilson, Bishop, Bowes & Craig, 271 William Street, Melbourne, 3000, telephone 677 372. 5482

R. J. WILLIAMS PROPRIETARY LIMITED (IN LIQUIDATION).

NOTICE OF FINAL MEETING OF MEMBERS.

Notice is hereby given of a final general meeting of members of the above company to be held at the office of D. J. M. Crichton Accountant at 799 Centre Road East Bentleigh on Monday 7th July 1975 at 4.00 p.m. with the object of laying before the meeting the account of the winding up of the said company and giving any explanation thereof.

5483 D. J. M. CRICHTON, Liquidator.

VANDENBERG ENGINEERING PROPRIETARY LIMITED (IN VOLUNTARY LIQUIDATION).

Notice is hereby given that at an Extraordinary General Meeting of Shareholders held at 430 Burwood Road, Hawthorn on Wednesday 21st May 1975, the following resolution was passed as a special resolution.

That the Company be wound up voluntarily and that John Cockburn Carr, Public Accountant of 430 Burwood Road, Hawthorn, be appointed liquidator for the purpose of such winding up.

Notice is also given that after twenty one days from this date I shall proceed to distribute the assets. All creditors having any claims against the Company should furnish particulars of same by that date otherwise I shall proceed to distribute the assets without regard to their claim.

Dated this 27th day of May, 1975.

5484 JOHN C. CARR, Liquidator.

The Companies Act 1961.—In the matter of DONNELLY ESTATES PROPRIETARY LIMITED (in Liquidation).

NOTICE is hereby given that at an Extraordinary Meeting of the Members of the abovenamed Company held on Friday the 23rd day of May, 1975 it was resolved that the Company be wound up voluntarily and at a Meeting of Creditors held on Friday the 23rd day of May, 1975 it was resolved that for such purpose GEOFFREY ORMOND HARRISON, Chartered Accountant, be appointed Liquidator.

Notice is also given that after 21 days from this date I shall proceed to distribute the assets. All creditors having any claim against the Company should furnish particulars of same by that date, otherwise I shall proceed to distribute the assets without regard to their claim.

G. O. HARRISON, Liquidator.

Hall & Rose, chartered accountants, 395 Collins Street, Melbourne, 3000. 5485

In the matter of the Companies Act 1961; and in the matter of STOCKDALE & LEGGO (MELB.) PTY. LIMITED (in Liquidation).

Notice is hereby given that pursuant to Section 272 of the Companies Act 1961, the final meeting of the members and creditors of the Company will be held at Marquand & Co. 51 Queen Street Melbourne on the fourth day of July, 1975, at 9.30 a.m., for the purpose of laying before the meeting the account and any explanation thereof.

Dated this Third day of June, 1975.

5459 V. K. REYNOLDS, Liquidator.

The Companies Act 1961.—In the matter of the following companies:—

A. V. REARDON PTY. LTD.

A. V. REARDON (INVESTMENTS) PTY. LTD.

REARDON INDUSTRIES PTY. LTD.

(in Voluntary Liquidation).—Members' Winding Up.

NOTICE is hereby given that at the Extraordinary General Meeting of each of the above companies duly convened and held at 44 Market Street, Melbourne, in the State of Victoria on the 30th day of May, 1975, the following Resolution was proposed and passed as a Special Resolution:

"That the Company be wound up voluntarily and that Eric James Ramsay of 44 Market Street, Melbourne, Victoria, be appointed Liquidator for the purpose of such winding up and that he be authorised to draw as remuneration for his services as Liquidator his normal hourly charges in respect thereto."

Dated this 30th day of May, 1975.

E. J. RAMSAY, Liquidator.

Messrs. Hungerfords, chartered accountants, 44 Market Street, Melbourne. 5462

The Companies Act 1961.

NOTICE OF FINAL MEETING OF SHAREHOLDERS OF F. E. LAMPE PROPRIETARY LIMITED (IN LIQUIDATION).

NOTICE IS HEREBY GIVEN in pursuance of Section 272 of the Companies Act 1961 that a General Meeting of the members of F. E. LAMPE PROPRIETARY LIMITED (IN LIQUIDATION) will be held at the office of Messrs. J. S. Eastwood & Etherington, 450 Little Collins Street, Melbourne on Wednesday the 9th July 1975 at 10.30 in the forenoon, for the purpose of laying before the meeting an account showing how the winding up has been conducted and the property of the company has been disposed of and of giving any explanation of the account.

5458 M. J. SCOTT, Liquidator.

In the matter of the Companies Act 1961; and in the matter of NUMBER 52 NEWHEB PTY. LIMITED (in Liquidation).

Notice is hereby given that pursuant to Section 272 of the Companies Act 1961, the final meeting of the members and creditors of the Company will be held at Marquand & Co. 51 Queen Street Melbourne on the fourth day of July, 1975, at 9.40 a.m., for the purpose of laying before the meeting the account and any explanation thereof.

Dated this Third day of June, 1975.

5460 V. K. REYNOLDS, Liquidator.

Companies Act 1961.—In the matter of G. A. WILSON PTY. LTD. (in Voluntary Liquidation).—Members' Winding Up.—Notice of Final Meeting.

Notice is hereby given pursuant to Section 272 of the Companies Act that the Final General Meeting of the members of the abovenamed company will be held at 10th Floor, 44 Market Street, Melbourne, Victoria, on 30 June 1975 at 10.00 a.m. when I shall lay before the meeting an account showing how the winding up has been conducted and the property of the company disposed of.

28th May, 1975.

5461 E. J. RAMSAY, Liquidator.

In the matter of the Companies Act 1961; and in the matter of WISTOW INVESTMENTS PROPRIETARY LIMITED (in Voluntary Liquidation).

NOTICE is hereby given that at a general meeting of members of the abovenamed Company duly convened and held at the office of Touche Ross & Co., 440 Collins Street, Melbourne on the 29th day of May, 1975 a special resolution in the words set out below was duly passed with respect to the said Company.

Special Resolution.

"That the company be wound up voluntarily in accordance with the provisions of Division 3 of Part X of the Companies Act 1961 and that Mr. J. M. F. Relph, Chartered Accountant of Touche Ross & Co., 440 Collins Street, Melbourne be appointed liquidator and that his remuneration be fixed in accordance with normal fees charged by members of the Institute of Chartered Accountants."

Dated this 30th day of May, 1975.

J. M. F. RELPH, Liquidator.

Touche Ross & Co., 440 Collins Street, Melbourne. 5463

Companies Act 1961.

H. PORTER PTY. LTD.

SPECIAL RESOLUTION TO WIND UP PURSUANT TO SECTION 254.

At an Extraordinary Meeting of Members duly convened and held on 26th May 1975 it was resolved that:—

(a) H. Porter Pty. Ltd. be wound up as a Members Voluntary Liquidation.

(b) Mr. C. L. Thompson of 20 Queen St. Melbourne be appointed Liquidator.

5466 C. L. THOMPSON, Liquidator.

Companies Act 1961.—In the matter of AUSMINCO SERVICES PTY. LTD.—Notice of Meeting of Creditors, Pursuant to Section 260.

Notice is hereby given that a meeting of creditors of the abovenamed company will be held at the Registered Office of the company, 8th Floor, 150 Queen Street, Melbourne on Tuesday 17th June, 1975 at 11 a.m. the company having convened an extraordinary general meeting of its members for the same day for the purpose of considering a Special Resolution that the company be wound up voluntarily.

Dated this 2nd day of June, 1975.

5465 G. R. DOWNING, Director.

Companies Act 1961.

CARRIWAN CARPET MILLS PTY. LIMITED.

At an Extraordinary General Meeting of the abovenamed Company duly convened and held at 9th Floor, 325 Collins Street, Melbourne, Victoria, on 19th May, 1974 the following was passed as a Special Resolution:

"That the Company be wound up voluntarily," and at such Meeting, Kenneth Albert COLEMAN, Public Accountant, of "Kurrara", Highbury Road, Vermont South, Victoria, was appointed Liquidator for the purpose of winding up.

Dated this 26th day of May, 1975.
5464 B. S. SLOSS, Secretary.

Companies Act 1961, Section 254 (2) (b).
THE INVERGOWRIE HOMECRAFT HOSTEL.

Notice is hereby given that at an Extraordinary General Meeting of the members of the abovenamed company held on 26th May 1975, it was resolved that the company be wound up voluntarily and that David Alexander Crawford of Messrs. Peat, Marwick, Mitchell & Co., 447 Collins Street, Melbourne be appointed Liquidator.

Notice is also given that after 21 days from this date, I shall proceed to distribute the assets. All creditors having any claims against the company should furnish particulars of same by that date, otherwise I shall proceed to distribute the assets without regard to their claim.

Dated this 30th day of May, 1975.
D. A. CRAWFORD, Liquidator.
Messrs. Peat, Marwick, Mitchell & Co., 447 Collins Street, Melbourne, 3000. 5467

Companies Act 1961, Section 254 (2).
PALMERSTON INVESTMENTS PROPRIETARY LIMITED
(IN LIQUIDATION).

NOTICE OF RESOLUTION.

At an extraordinary general meeting of the members of Palmerston Investments Proprietary Limited duly convened and held at 1 Palmerston Crescent, South Melbourne on the 29th day of May, 1975 the special resolution set out below was duly passed.

"THAT the company be wound up voluntarily as a members' voluntary winding up in accordance with the provisions of the Companies Act 1961."

"THAT Edward William MacKenzie be and is hereby appointed liquidator."

Notice is also given that after twenty-one days from this date, I shall proceed to distribute the assets. All creditors having any claims against the company should furnish particulars of same by that date, otherwise, I shall proceed to distribute the assets without regard to their claim.

Dated this 2nd day of June, 1975.
5468 E. W. MACKENZIE, Liquidator.

Companies Act 1961.

DRAWDER PTY. LTD.

At an Extraordinary General Meeting of the Abovenamed company duly convened and held at 4th Floor, 18 Queen Street, Melbourne on 26th May 1975 the following resolution was duly passed as a Special Resolution:

"that the company be wound up voluntarily," and at that meeting, David H. England, Chartered Accountant, of 3 Ithaca Road, Frankston, Vic., was appointed Liquidator for the purpose of winding up.

Dated 26th May, 1975.
5469 L. G. BOWES, Secretary.

Companies Act 1961.

ROBERTSON COURT PTY. LTD.

At an Extraordinary General Meeting of the Abovenamed company duly convened and held at 4th Floor, 18 Queen Street, Melbourne on 26th May 1975 the following resolution was duly passed as a Special Resolution:

"that the company be wound up voluntarily," and at that meeting, David H. England, Chartered Accountant, of 3 Ithaca Road, Frankston, Vic., was appointed Liquidator for the purpose of winding up.

Dated 26th May, 1975.
5470 L. G. BOWES, Secretary.

Companies Act 1961.

GLADSTONE MOTORS PTY. LTD.

At an Extraordinary General Meeting of the Abovenamed company duly convened and held at 4th Floor, 18 Queen Street, Melbourne on 26th May 1975 the following resolution was duly passed as a Special Resolution:

"that the company be wound up voluntarily," and at that meeting, David H. England, Chartered Accountant, of 3 Ithaca Road, Frankston, Vic., was appointed Liquidator for the purpose of winding up.

Dated 26th May, 1975.
5471 L. G. BOWES, Secretary.

Companies Act 1961.

STOKE AGENCIES PTY. LTD.

At an Extraordinary General Meeting of the Abovenamed company duly convened and held at 4th Floor, 18 Queen Street, Melbourne on 26th May 1975 the following resolution was duly passed as a Special Resolution:

"that the company be wound up voluntarily," and at that meeting, David H. England, Chartered Accountant, of 3 Ithaca Road, Frankston, Vic., was appointed Liquidator for the purpose of winding up.

Dated 26th May, 1975.
5472 L. G. BOWES, Secretary.

Companies Act 1961.

H. & J. HANCOCK PTY. LTD.

At an Extraordinary General Meeting of the Abovenamed company duly convened and held at 4th Floor, 18 Queen Street, Melbourne on 26th May 1975 the following resolution was duly passed as a Special Resolution:

"that the company be wound up voluntarily," and at that meeting, David H. England, Chartered Accountant, of 3 Ithaca Road, Frankston, Vic., was appointed Liquidator for the purpose of winding up.

Dated 26th May, 1975.
5473 L. G. BOWES, Secretary.

In the matter of the Companies Act 1961; and in the matter of CASTLESPLIT PTY. LTD. (in Liquidation).

Notice is hereby given that pursuant to Section 272. of the Companies Act 1961, the final meeting of the members of the company will be held at 4/795 Glenferrie Road, Hawthorn, 3122, on the 7th day of July, 1975, at 2 p.m., for the purpose of laying before the meeting the account of the winding up and any explanation thereof.

Dated this 2nd day of June, 1975.
5498 H. G. STEVENS, Liquidator.

Form 92.

Companies Regulations.

Regulation 28 (2) (b) and 46 (2).

O-MAX PROPRIETARY LIMITED.

NOTICE OF MEETING OF CREDITORS OR CONTRIBUTORIES.

Notice is hereby given that a meeting of the contributories of O-Max Proprietary Limited will be held at 31 Jones Street, Northcote on the 6th July 1975 at 11 o'clock in the forenoon, to enable the liquidator to present to the contributories an account of the winding up and disposal of the property of O-Max Proprietary Limited in liquidation.

S. A. STEVENSON, Liquidator.
Jacobsen, Stevenson & Co., 14/675 Glenferrie Road, Hawthorn, 3122. 5500

Form 92.

Companies Regulations.

Regulation 28 (2) (b) and 46 (2).

DEVENCO PROPRIETARY LIMITED.

NOTICE OF MEETING OF CREDITORS OR CONTRIBUTORIES.

Notice is hereby given that a meeting of the contributories of Devenco Proprietary Limited will be held at 31 Jones Street, Northcote on the 6th July 1975 at 11 o'clock in the forenoon, to enable the liquidator to present to the contributories an account of the winding up and disposal of the property of Devenco Proprietary Limited in liquidation.

S. A. STEVENSON, Liquidator.
Jacobsen, Stevenson & Co., 14/675 Glenferrie Road, Hawthorn, 3122. 5499

Companies Act 1961.

LONDON CONSTRUCTIONS PTY. LTD.

At an Extraordinary General Meeting of the Abovenamed company duly convened and held at 4th Floor, 18 Queen Street, Melbourne on 26th May 1975 the following resolution was duly passed as a Special Resolution;

"that the company be wound up voluntarily," and at that meeting, David H. England, Chartered Accountant, of 3 Ithaca Road, Frankston, Vic., was appointed Liquidator for the purpose of winding up.

Dated 26th May, 1975.

5474

L. G. BOWES, Secretary.

In the matter of the Companies Act 1961; and in the matter of THORBAIR PTY. LTD. (in Voluntary Liquidation).

Notice is hereby given that at an extraordinary General Meeting of the members of the abovenamed company held at 148 Tucker Road, Bentleigh on the 31st day of May, 1975 the following Special Resolution was passed—

"That the company be wound up voluntarily and that Trevor Leigh Dumas of Johnson Barson & Co., 237 Lonsdale Street, Dandenong be appointed Liquidator."

Dated this 31st day of May, 1975.

5497

TREVOR L. DUMAS, Liquidator.

Companies Act 1961, Section 254 (2).

NEWSTEAD CO-OPERATIVE BUTTER AND CHEESE FACTORY COMPANY LIMITED.

At a General Meeting of the Members of the company duly convened and held at Tivey Street, Newstead on the 29th day of May, 1975, the Special Resolution set out below was duly passed—

"That the Company be wound up voluntarily".

At the said meeting Warwick Niven JOHANSON whose office is situated at Lyric Building, Charing Cross, Bendigo, was duly appointed Liquidator.

Dated this 30th day of May, 1975.

5496

W. N. JOHANSON, Liquidator.

The Companies Act 1961.—In the matter of NEW-ERA-ADS PTY. LTD.

NOTICE is hereby given that at an Extraordinary General Meeting of the Members of the above-named Company held on the 28th May, 1975 it was resolved that the company be wound up voluntarily, and that for such purposes Maurice Leslie Molan of 104 Wellington Parade, East Melbourne, Accountant, be appointed Liquidator.

NOTICE is also given that after twenty one (21) days from this date I shall proceed to distribute the assets of the company. All creditors having any claims against the company should furnish particulars of such claims to the undersigned by that date, otherwise I shall proceed to distribute the assets without regard to their claim.

M. L. MOLAN, Liquidator.

J. M. Morris & Co., 104 Wellington Parade, East Melbourne, 3002. 5495

The Companies Act 1961, Section 272.

PETERS (VIC.) TRAFALGAR MILK SUPPLY PROPRIETARY LIMITED (IN VOLUNTARY LIQUIDATION).

PETERS (VIC.) YARRAGON DAIRY CO. PROPRIETARY LIMITED (IN VOLUNTARY LIQUIDATION).

WILLOW GROVE FARMS PROPRIETARY LIMITED (IN VOLUNTARY LIQUIDATION).

CELSEALED (VIC.) PROPRIETARY LIMITED (IN VOLUNTARY LIQUIDATION).

SCOTT'S TAXI VANS (VIC.) PROPRIETARY LIMITED (IN VOLUNTARY LIQUIDATION).

V.B.S. NOMINEES (VIC.) PROPRIETARY LIMITED (IN VOLUNTARY LIQUIDATION).

NOTICE CONVENING FINAL MEETINGS OF MEMBERS.

Notice is hereby given pursuant to Section 272 of the Companies Act 1961, that a General Meeting of the members of each of the abovenamed companies will be held in the offices of C. R. B. James & Son, 37 Queen Street, Melbourne on Thursday the Tenth day of July, 1975 at 10.00 a.m. for the purpose of having an account laid before them showing the manner in which each winding up has been conducted and the property of the companies disposed of and of hearing any explanations that may be given by the Liquidator.

Dated this 2nd day of June, 1975.

RONALD STANLEY JAMES, Liquidator.

37 Queen Street, Melbourne, 3000. 5494

COMPANIES ACT 1961.

NOTICE is hereby given that the issued and paid up capital of MANATA PROPRIETARY LIMITED has been reduced pursuant to an Order of the Supreme Court of Victoria made the 23rd day of May, 1975 which confirmed the Special Resolutions of the Company passed at an Extraordinary General Meeting thereof held on the 26th day of March, 1975 which resolved:—

1. THAT, subject to confirmation by the Supreme Court of Victoria pursuant to Section 64 of the Companies Act 1961, the capital of the Company of \$400,000 divided into 200,000 ordinary shares of \$2 each of which

(a) 132,100 shares have been issued and fully paid; and

(b) the balance of which have not been issued or agreed to be issued

BE REDUCED to \$366,000 divided into 183,000 ordinary shares of \$2 each be returning capital to the Estate of Roy Bruce Shankly in respect of the 17,000 ordinary shares of \$2 each in the issued capital of the Company held by the said Estate and numbered 51,001 to 68,000 (inclusive) and thereupon by cancelling such shares in respect of which capital shall have been returned.

2. THAT the capital return aforesaid be satisfied by transferring in specie to the Estate of Roy Bruce Shankly the following assets of the Company, namely—

(a) ALL THAT piece of land being the whole of the land more particularly described in Crown Grant Volume 5885 Folio 831; and

(b) ALL THAT piece of land being Crown Portion 54 Parish of Lara County of Bourke and being part of the land more particularly described in Conveyance No. 957 Book 603—

the value of which assets as nearly as practicable bears the same proportion to the total net tangible assets of the Company as the value of the said 17,000 shares of \$2 each to be cancelled bears to the total issued capital of the Company.

AND THAT an office copy of the said Order was lodged with the Commissioner for Corporate Affairs on the 28th day of May, 1975.

CORR & CORR, solicitors for the petitioner, 290 La Trobe Street, Melbourne. 5486

The Companies Act 1961.—In the matter of P. P. INTERNATIONAL SALES & CO. PTY. LTD.

NOTICE is hereby given that at an Extraordinary General Meeting of the members of the abovenamed Company held on the 29th day of May, 1975, it was resolved that the Company be wound up voluntarily, and at a meeting of creditors held on the same day, pursuant to section 260, it was resolved that for such purpose, Thomas Dunn Maclean, of 545 St. Kilda Road, Melbourne, Accountant, be appointed Liquidator.

NOTICE is also given that after 21 days from this date I shall proceed to distribute the assets. All creditors having any claims against the Company should furnish particulars of same by that date, otherwise I shall proceed to distribute the assets without regard to their claim.

Dated this 29th day of May, 1975.

THOMAS D. MACLEAN, Liquidator.

T. D. Maclean & Company, Suite 3, 545 St. Kilda Road, Melbourne, Vic. 3004. 5395

MASTER MOULDERS PTY. LTD.

At an Extraordinary General Meeting of the abovenamed Company duly convened and held at the office of H. Guest & Associates Pty. Ltd., 207B Balaclava Road, Caulfield on the 29th May, 1975 the following Resolution was duly passed as a Special Resolution:

1. That the Company be wound up voluntarily.

2. That Mr. John Durlacher, Public Accountant of 207B Balaclava Road, Caulfield be and is hereby appointed Liquidator at a remuneration in accordance with the scale of fees laid down by the Australian Society of Accountants.

Dated this 29th day of May, 1975.

5396

J. DURLACHER, Liquidator.

Companies Act 1961, Section 254 (2) (b).

J. MARSDEN & SON PTY. LTD. (IN VOLUNTARY LIQUIDATION).

NOTICE OF RESOLUTION.

At an extraordinary meeting of shareholders of the above company duly convened and held at 1014 Doncaster Road, Doncaster East, on the 19th day of May, 1975, the following special resolution was passed.

"Resolved that the Company be wound up voluntarily and that Ronald Milton DOUGLAS of 1014 Doncaster Road, Doncaster East, Chartered Accountant, be appointed liquidator for the purpose of such winding up and that his remuneration be determined in accordance with his time involved".

Dated this 21st day of May, 1975.
5397 R. M. DOUGLAS, Secretary.

Companies Act 1961, Section 272.

W. J. & E. POHL PTY. LIMITED (IN VOLUNTARY LIQUIDATION).

NOTICE OF FINAL MEETING OF MEMBERS.

Notice is hereby given, pursuant to Section 272 of the Companies Act 1961, that a General Meeting of the members of the abovenamed Company will be held in the offices of Kutner, Lederer & Co., 31 Horne Street, Elsternwick on Wednesday, 16th day of July, 1975 (and not 16th June, 1975 as previously advised) for the purposes of having an account laid before them, showing the manner in which the winding up has been conducted and the property of the Company disposed of and of hearing any explanations that may be given by the Liquidator.

Dated this 28th day of May, 1975.
EDDIE KUTNER, Liquidator.
Kutner, Lederer & Co., chartered accountants, 31 Horne Street, Elsternwick. 5398

Companies Act 1961.

POST NEWSPAPERS PTY. LTD. (IN VOLUNTARY LIQUIDATION).

NOTICE is hereby given that in pursuance to Section 272 of the Companies Act 1961 a General Meeting of the Company will be held at the offices of Messrs. Morton, Watson & Young, Simac House, Cnr. Scott and Thomas Streets, Dandenong on Monday the Thirtieth day of June, 1975 at Five O'Clock in the afternoon for the purpose of receiving the liquidator's final account of the winding-up of the Company.

Dated this 28th day of May, 1975.
5399 T. B. HUTTLEY, Liquidator.

Companies Act 1961.

THE McLEAN PUBLISHING CO. PROPRIETARY LIMITED (IN VOLUNTARY LIQUIDATION).

NOTICE is hereby given that in pursuance to Section 272 of the Companies Act 1961 a General Meeting of the Company will be held at the offices of Messrs. Morton, Watson & Young, Simac House, Corner Scott and Thomas Streets, Dandenong on Monday the Thirtieth day of June, 1975 at Four-Thirty in the afternoon for the purpose of receiving the liquidator's final account of the winding-up of the Company.

Dated this 28th day of May, 1975.
5400 T. B. HUTTLEY, Liquidator.

Companies Act 1961, Section 181.

D. & T. L. BUNNING PTY. LTD.

Notice is hereby given that a meeting of creditors of the company will be held at Room 314, 151 Flinders Street Melbourne on 17th June 1975 at 10.00 a.m. to consider and if thought fit approving with or without modification a Scheme of Arrangement between the company and its arrangement creditors as defined in the Scheme.

Dated this 27th day of May, 1975.
D. H. BUNNING, Director.
Hudson Pitt Associates, 30 Queens Road, Melbourne.
26 6251. 5401

The Companies Act 1961.

KEARNEY WATTS & SON PTY. LTD. (IN VOLUNTARY LIQUIDATION).

NOTICE OF FINAL MEETING.

NOTICE is hereby given that pursuant to Section 272 of the Companies Act 1961 a Final Meeting of the members and creditors of the abovenamed company will be held at the office of Messrs. John MacKinnon & Co., Chartered Accountants, Suite 12, 562 St. Kilda Road, Melbourne, on Wednesday, 9th July, 1975, at 10 o'clock in the forenoon, for the purpose of presenting the Liquidator's account

of the winding up and in accordance with Section 284 (3) (c) determining the period after which the books and papers of the company and of the Liquidator may be destroyed.

Dated this 4th day of June, 1975.
IAN KENNETH MacKINNON, Liquidator.
John MacKinnon & Co., chartered accountants, Suite 12, 562 St. Kilda Road, Melbourne. Telephone: 51 2178. 5402

Companies Act 1961.

CO-ORDINATED CONTRACT SERVICES PTY. LTD. (IN LIQUIDATION).

NOTICE is hereby given that at an extraordinary meeting of the members of the abovenamed company held on Friday, 23rd May, 1975 it was resolved that the company be wound up voluntarily and at a meeting of Creditors held on the same day it was resolved that for such purpose Maurice John Kellett, Public Accountant, 382 Middleborough Road, Blackburn be appointed Liquidator.

NOTICE is also given that after 21 days from this date I shall proceed to distribute the assets. All Creditors having any claim against the Company should furnish particulars of the same by that date otherwise I shall proceed to distribute the assets without regard to their claim.

Dated this 26th May, 1975.
MAURICE J. KELLETT, Liquidator.
Kellett, Till & Associates, public accountants, 382 Middleborough Road, Blackburn. Telephone 877 2455. 5386

Companies Act 1961, Section 272.

Re: JEREMY HUGHES GRAPHIC SERVICES PROPRIETARY LIMITED (IN LIQUIDATION).

Notice is hereby given that a final meeting of the creditors of the abovenamed company will be held at 83 Canterbury Road, Canterbury, 3126, on Friday the eleventh of July 1975, at 4.30 p.m. for the purpose of showing how the winding up has been conducted and the property of the company disposed of.

D. FERGUSON & CO., public accountants, 83 Canterbury Road, Canterbury, 3126. 5387

Companies Act 1961, Section 254 (2) (b).

SARGENT'S SELF SERVICE PTY. LTD. (IN LIQUIDATION).

NOTICE IS HEREBY GIVEN that at an Extraordinary General Meeting of the members of the abovenamed company held on the 26th day of May, 1975 it was resolved that the company be wound up voluntarily and that Geoffrey Robert Orr of 14 Patterson Street Middle Park be appointed Liquidator.

NOTICE is also given that after 21 days from this date I shall proceed to distribute the assets. All creditors having any claims against the company should furnish details of same by that date, otherwise I shall proceed to distribute the assets without regard to their claim.

Dated this 27th day of May, 1975.
G. R. ORR, Liquidator.
14 Patterson Street, Middle Park, 3206. 5388

Companies Act 1961, Section 272.

PLOWRIGHT READY MIXED CONCRETE PROPRIETARY LIMITED (IN VOLUNTARY LIQUIDATION).

Notice is hereby given that a final meeting of members of the company will be held at 330 Collins Street, Melbourne on the 30th day of June 1975, at 9.00 a.m. for the purpose of laying before the meeting the account of the winding up and any explanation thereof.

Dated this 29th day of May, 1975.
5389 G. A. COHEN, Liquidator.

In the matter of the Companies Act 1961, and in the matter of APPLETREE HILL PTY. LIMITED.

NOTICE is hereby given pursuant to Section 254 (2) of the Companies Act 1961 that at an Extraordinary General Meeting of Appletree Hill Pty. Limited, a redundant non operating Company held on 28th May, 1975, the following Special Resolution was duly passed:—

"That the Company will be wound up by members voluntary liquidation and that Clyde Kenneth Dickens, Chartered Accountants, Level 26, Australia Square, Sydney be appointed Liquidator for the purpose of such winding up."

5407 K. L. FINLEY, Secretary.

*Companies Act 1961, Section 272.***SUPERMIX CONCRETE (NORTHCOTE) PROPRIETARY LIMITED (IN VOLUNTARY LIQUIDATION).**

Notice is hereby given that a final meeting of members of the company will be held at 330 Collins Street, Melbourne on the 30th day of June 1975, at 9.20 a.m. for the purpose of laying before the meeting the account of the winding up and any explanation thereof.

Dated this 29th day of May, 1975.

5391 G. A. COHEN, Liquidator.

*Companies Act 1961, Section 272.***CESTER SAND PITS PROPRIETARY LIMITED (IN VOLUNTARY LIQUIDATION).**

Notice is hereby given that a final meeting of members of the company will be held at 330 Collins Street, Melbourne on the 30th day of June 1975, at 9.30 a.m. for the purpose of laying before the meeting the account of the winding up and any explanation thereof.

Dated this 29th day of May, 1975.

5392 G. A. COHEN, Liquidator.

*Companies Act 1961, Section 272.***ALPHA PLANT HIRE CO. PTY. LTD. (IN VOLUNTARY LIQUIDATION).**

Notice is hereby given that a final meeting of members of the company will be held at 330 Collins Street, Melbourne on the 30th day of June 1975, at 9.40 a.m. for the purpose of laying before the meeting the account of the winding up and any explanation thereof.

Dated this 29th day of May, 1975.

5393 G. A. COHEN, Liquidator.

*Companies Act 1961, Section 272.***PARAMOUNT QUARRYING COMPANY PROPRIETARY LIMITED (IN VOLUNTARY LIQUIDATION).**

Notice is hereby given that a final meeting of members of the company will be held at 330 Collins Street, Melbourne on the 30th day of June 1975, at 9.50 a.m. for the purpose of laying before the meeting the account of the winding up and any explanation thereof.

Dated this 29th day of May, 1975.

5394 G. A. COHEN, Liquidator.

*Companies Act 1961, Section 272.***SUPERMIX CONCRETE (BROOKLYN) PROPRIETARY LIMITED (IN VOLUNTARY LIQUIDATION).**

Notice is hereby given that a final meeting of members of the company will be held at 330 Collins Street, Melbourne on the 30th day of June 1975, at 9.10 a.m. for the purpose of laying before the meeting the account of the winding up and any explanation thereof.

Dated this 29th day of May, 1975.

5390 G. A. COHEN, Liquidator.

*Companies Act 1961.***RYRIE CHAMBERS PROPRIETARY LIMITED (IN VOLUNTARY LIQUIDATION).****MEMBERS' VOLUNTARY WINDING UP.**

Notice is hereby given that pursuant to Section 272 of the *Companies Act 1961*, the final meeting of Members of the above named Company will be held at the offices of R. G. Farrow and Company, Public Accountants, 16 James Street, Geelong on Wednesday, 2nd July, 1975 at 11.30 a.m., for the purpose of receiving the liquidator's account and his report upon the Winding Up.

Dated this 27th day of May, 1975.

5403 R. G. FARROW, Liquidator.

HAWKES ALLUVIAL TIN LTD. (IN LIQUIDATION).

Notice is hereby given that pursuant to Section 272 of the *Companies Act 1961* a Final Meeting of Members and Creditors of the above Company will be held at the offices of T. D. Maclean & Company, Suite 3, 545 St. Kilda Road, Melbourne on the 27th day of June, 1975 at 3.30 p.m. for the purpose of laying before it accounts showing how the winding up has been conducted and the property of the Companies disposed of, and hearing any explanations of the Liquidator.

Dated this 28th day of May, 1975.

THOMAS D. MACLEAN, Liquidator.

T. D. Maclean & Company, Suite 3, 545 St. Kilda Road, Melbourne, Vic. 3004. 5487

*Companies Act 1961.***ROBE HOLDINGS PROPRIETARY LIMITED (IN VOLUNTARY LIQUIDATION).****NOTICE CONVENING FINAL MEETING OF MEMBERS, PURSUANT TO SECTION 272.**

NOTICE is hereby given in pursuance of Section 272 of the *Companies Act 1961*, that a Meeting of the members of the above-named Company will be held on the eighth day of July, 1975 at the office of Messrs. John Rezak and Co., 66-68 Albert Road, South Melbourne, at 11.00 a.m. for the purpose of having an account laid before them showing the manner in which the winding up has been conducted and the property of the Company disposed of and of hearing any explanations that may be given by the Liquidator.

Dated this 27th day of May, 1975.

EMILE ROCHMAN, Liquidator.

John Rezak and Co., public accountants, 66-68 Albert Road, South Melbourne, Victoria, 3205. 5404

*Companies Act 1961.***M.M.S. PROPRIETARY LIMITED (IN VOLUNTARY LIQUIDATION).****NOTICE CONVENING FINAL MEETING OF MEMBERS, PURSUANT TO SECTION 272.**

NOTICE is hereby given in pursuance of Section 272 of the *Companies Act 1961*, that a Meeting of the members of the above-named Company will be held on the eighth day of July, 1975 at the office of Messrs. John Rezak and Co., 66-68 Albert Road, South Melbourne, at 10.00 a.m. for the purpose of having an account laid before them showing the manner in which the winding up has been conducted and the property of the Company disposed of and of hearing any explanations that may be given by the Liquidator.

Dated this 27th day of May, 1975.

DAVID BENDEL, Liquidator.

John Rezak and Co., public accountants, 66-68 Albert Road, South Melbourne, Victoria, 3205. 5405

VERDANT INVESTMENTS PTY. LTD. (IN LIQUIDATION).**MEMBERS VOLUNTARY WINDING UP.**

NOTICE IS HEREBY GIVEN that pursuant to s. 272 of the *Companies Act 1961* the final meeting of members of the above company will be held at 351 Collins Street (12th Floor) Melbourne on 2nd July 1975 at 10 a.m. for the purpose of securing the liquidator's account and his report upon the winding up.

Dated this 30th day of May, 1975.

5406 ROBERT J. McNEILL, Liquidator.

PETER HANSON PTY. LTD. (IN LIQUIDATION).**MIMOSA FROCKS PTY. LTD. (IN LIQUIDATION).**

Notice is hereby given that pursuant to Section 272 of the *Companies Act 1961* a Final Meeting of Members and Creditors of the above Companies will be held at the offices of T. D. Maclean & Company, Suite 3, 545 St. Kilda Road, Melbourne on the 27th day of June, 1975 at 3 p.m. for the purpose of laying before it accounts showing how the winding up has been conducted and the property of the Companies disposed of, and hearing any explanations of the Liquidator.

Dated this 28th day of May, 1975.

THOMAS D. MACLEAN, Liquidator.

T. D. Maclean & Company, Suite 3, 545 St. Kilda Road, Melbourne, Vic. 3004. 5488

GYRCO PTY. LIMITED (IN VOLUNTARY LIQUIDATION).**NOTICE OF RESOLUTION.**

At a general meeting of the members of Gyrco Pty. Limited duly convened and held at 430 Little Collins Street, Melbourne on the second day of June 1975 the Special Resolutions set out below were duly passed.

- That the Company be wound up voluntarily.
- That Mr. T. R. Waters, Chartered Accountant of 430 Little Collins Street, Melbourne be appointed as Liquidator for the purpose of winding up the Company.
- That the Liquidator be empowered to divide amongst the members in kind the whole or any part of the assets of the company (whether they consist of property of the same kind or not) and may for that purpose set such value as he deems fair upon any property to be divided as aforesaid.

(d) That the Liquidator be empowered to carry on the business of the company so far as is necessary for the beneficial winding up thereof.

Dated this 2nd day of June, 1975.

5489

G. FARLEY, Director.

In the Supreme Court of Victoria.—1975 Co. 9049.—In the matter of the *Companies Act 1961*, and in the matter of *LADY OF FASHION PROPRIETARY LIMITED*.—Notice of Winding up Order.

WINDING UP ORDER: made 27th May 1975.

NAME AND ADDRESS OF LIQUIDATOR: Ronald Dennis Widdows 703 South Road, Moorabbin.

ALAN R. NEAVES, Crown Solicitor for the Commonwealth and solicitor for the petitioner. 5510

Companies Act 1961.

CUDGEWA DAIRY TRADING CO. PTY. LIMITED.

MEMBERS VOLUNTARY WINDING UP.

NOTICE is hereby given that on the 29th May, 1975 the members of the Company passed a Special Resolution to wind up the Company by way of Members Voluntary Winding Up, and that Rockley Rex Crozier, of 1 Little Collins Street, Melbourne, be appointed Liquidator for the purpose of winding up the affairs and distributing the assets of the Company.

R. R. CROZIER, Liquidator.

Wallace, McMullin & Partners, chartered accountants, 1 Little Collins Street, Melbourne, Vic., 3000. 5509

Companies Act 1961.

MODULAR CARPET TILES PTY. LIMITED (IN LIQUIDATION).

NOTICE is hereby given that at an extraordinary general meeting of members of the above named company held on 29 May, 1975, it was resolved that the Company be wound up voluntarily and at a meeting of creditors held on 30 May, 1975 it was resolved that for such purpose Leslie Philip Smart and Richard George Shooobridge Chartered Accountants c/- Marquand & Co., 51 Queen Street, Melbourne be appointed liquidators to act jointly or severally.

Dated this 3rd day of June, 1975.

L. P. SMART & R. G. SHOOBRIDGE, Liquidators.

Marquand & Co., chartered accountants, 51 Queen Street, Melbourne, 3000. Telephone 61 3921. 5508

The Companies Act 1961.

E. & H. ESTATES PTY. LTD. (IN LIQUIDATION).

NOTICE OF FINAL MEETING OF MEMBERS AND CREDITORS.

Notice is hereby given that pursuant to Section 272 (1) of the *Companies Act 1961* a meeting of the Members and Creditors will be held at the offices of Duesbury Johnston & Marks, Chartered Accountants, 446 Collins Street, Melbourne on Monday the 7th day of July, 1975 at 10.30 a.m. for the purpose of laying before the meeting an account showing how the winding up has been conducted and the property of the Company has been disposed of and providing any explanations thereof.

Dated this 2nd day of June, 1975.

WARICK ALLEN LEEMING, Liquidator.

Duesbury, Johnston & Marks, chartered accountants, 446 Collins Street, Melbourne, 3000. 5507

The Companies Act 1961.

WATHEN & DOBSON PROPRIETARY LIMITED (IN LIQUIDATION).

NOTICE CONVENING FINAL MEETING OF MEMBERS AND CREDITORS, PURSUANT TO SECTION 272.

Notice is hereby given pursuant to Section 272 of the *Companies Act 1961*, that a General Meeting of the members and creditors of the abovenamed company will be held in the offices of Kennedy Smail, 296-304 Little Lonsdale Street, Melbourne, on Wednesday the Second day of July, 1975, at 10.30 a.m. for the purpose of having an account laid before them showing the manner in which the winding up has been conducted and the property of the company disposed of and of hearing any explanations that may be given by the Liquidator.

Dated this 2nd day of June, 1975.

ROBERT EASTAUGH RAMSAY, Liquidator.

Kennedy Smail, 296-304 Little Lonsdale Street, Melbourne, Vic., 3000. 5505

Rule 99 and Regulation 56.

The *Companies Act 1961*.—In the matter of BRUNSWICK TYRE SERVICE PTY. LTD. (in Liquidation).

TAKE NOTICE that the Liquidator of the abovenamed Company has fixed Wednesday the 25th day of June, 1975 as the day on or before which creditors of the company are to prove their debts or claims and to establish any title they may have to priority under section 292 or be excluded from the benefit of any distribution made before such debts are proved or as the case may be from objecting to such distribution.

Dated this 4th day of June, 1975.

JOHN MARTIN WALSH, Liquidator.

Kennedy Smail, 296 Little Lonsdale Street, Melbourne, 3000. 5504

The Companies Act 1961.

ABBOTT MANSIONS PTY. LTD. (IN VOLUNTARY LIQUIDATION).

NOTICE OF FINAL GENERAL MEETING.

Pursuant to Section 272 of the *Companies Act 1961*, the Final General Meeting of the Company will be held on July 9th 1975 at 11 a.m. at 32 Bamfield Street, Sandringham, to receive the liquidator's final account and report and any explanation thereof.

Dated this 2nd day of June, 1975.

C. A. J. TEMPANY, Liquidator.

32 Bamfield Street, Sandringham, 3191. 5506

The Companies Act 1961.

TYALLA INVESTMENTS PTY. LIMITED (IN VOLUNTARY LIQUIDATION).

NOTICE is hereby given that pursuant to Section 272 of the *Companies Act*, a final meeting of the members of the above company will be held at Suite 11, 562 St. Kilda Road, Melbourne, on Friday, 11th July, 1975 at 9.30 a.m.

BUSINESS—To receive the Liquidator's Accounts.

Dated this 27th day of May, 1975.

5452

N. RAITMAN, Liquidator.

Companies Act 1961, Section 272 (1).

A.M.I. (NEW SOUTH WALES) PROPRIETARY LIMITED.

NOTICE OF FINAL MEETING.

TAKE NOTICE that the affairs of the above-named Company are now fully wound up and that in pursuance of Section 272 (1) of the *Companies Act 1961* a general meeting of the Company will be held at 9th Floor, 461 Bourke Street, Melbourne on the thirtieth day of June, 1975 at 11.30 o'clock in the forenoon for the purpose of laying before it an account showing how the winding-up has been conducted and the property of the Company disposed of and giving any explanation thereof.

Dated the 26th day of May, 1975.

R. F. HOGAN, Liquidator.

Yarwood Vane & Co., 9th Floor, 461 Bourke Street, Melbourne, Vic., 3000. 5453

Companies Act 1961, Section 272 (1).

A.M.I. (SOUTH AUSTRALIA) PROPRIETARY LIMITED.

NOTICE OF FINAL MEETING.

TAKE NOTICE that the affairs of the above-named Company are now fully wound up and that in pursuance of Section 272 (1) of the *Companies Act 1961* a general meeting of the Company will be held at 9th Floor, 461 Bourke Street, Melbourne on the thirtieth day of June, 1975 at 11.15 o'clock in the forenoon for the purpose of laying before it an account showing how the winding-up has been conducted and the property of the Company disposed of and giving any explanation thereof.

Dated the 26th day of May, 1975.

R. F. HOGAN, Liquidator.

Yarwood Vane & Co., 9th Floor, 461 Bourke Street, Melbourne, Vic., 3000. 5454

Companies Act 1961, Section 272 (1).

BRIGHTON BEACH MOTORS (WHOLESALE) PROPRIETARY LIMITED.

NOTICE OF FINAL MEETING.

TAKE NOTICE that the affairs of the above-named Company are now fully wound up and that in pursuance of Section 272 (1) of the *Companies Act 1961* a general meeting of the Company will be held at 9th Floor, 461

Bourke Street, Melbourne on the thirtieth day of June, 1975 at 11.45 o'clock in the forenoon for the purpose of laying before it an account showing how the winding-up has been conducted and the property of the Company disposed of and giving any explanation thereof.

Dated the 26th day of May, 1975.

R. F. HOGAN, Liquidator.

Yarwood Vane & Co., 9th Floor, 461 Bourke Street,
Melbourne, Vic., 3000. 5455

Companies Act 1961, Section 272 (1).

STANDARD CARS (NORTH SHORE) PROPRIETARY LIMITED.

NOTICE OF FINAL MEETING.

TAKE NOTICE that the affairs of the above-named Company are now fully wound up and that in pursuance of Section 272 (1) of the Companies Act 1961 a general meeting of the Company will be held at 9th Floor, 461 Bourke Street, Melbourne on the thirtieth day of June, 1975 at 11.00 o'clock in the forenoon for the purpose of laying before it an account showing how the winding-up has been conducted and the property of the Company disposed of and giving any explanation thereof.

Dated the 26th day of May, 1975.

R. F. HOGAN, Liquidator.

Yarwood Vane & Co., 9th Floor, 461 Bourke Street,
Melbourne, Vic., 3000. 5456

Companies Act 1961, Section 272 (1).

RICKARDS BROTHERS PROPRIETARY LIMITED.

NOTICE OF FINAL MEETING.

TAKE NOTICE that the affairs of the above-named Company are now fully wound up and that in pursuance of Section 272 (1) of the Companies Act 1961 a general meeting of the Company will be held at 9th Floor, 461 Bourke Street, Melbourne on the thirtieth day of June, 1975 at 10.45 o'clock in the forenoon for the purpose of laying before it an account showing how the winding-up has been conducted and the property of the Company disposed of and giving any explanation thereof.

Dated the 26th day of May, 1975.

R. F. HOGAN, Liquidator.

Yarwood Vane & Co., 9th Floor, 461 Bourke Street,
Melbourne, Vic., 3000. 5457

A.N.A. CO-OPERATIVE HOUSING SOCIETY (No. 2) LIMITED (IN LIQUIDATION).

SPECIAL RESOLUTION.

At a special general meeting of the above-named society duly convened and held at 28 Elizabeth Street, Melbourne 3000 on the 28th day of May, 1975, the subjoined special resolution was duly passed:—

"That the Society having successfully completed its objectives 41 months ahead of its expected term be wound up voluntarily, and that Mr. Thomas Raymond Davey of 4 Ashby Court, North Balwyn be appointed liquidator for the purposes of the winding up".

Dated 28th May, 1975.

T. R. DAVEY, Chairman of Meeting.

5442

D. W. THOMAS, Secretary.

In the matter of the Co-operative Housing Societies Act 1958, and the Companies Act 1961; and in the matter of A.N.A. CO-OPERATIVE HOUSING SOCIETY (No. 2) LIMITED (in Liquidation).—Notice to Creditors.

Notice is hereby given that all persons having any claim against the above society are required on or before the 2nd July, 1975 to send their names and addresses and particulars of their debts or claims to Mr. T. R. Davey, the liquidator of the said society, at his office and if so required by notice in writing from the said liquidator are personally, or by their solicitors, to come in and prove their said debts or claims at such time and place as shall be specified in such notice: or, in default thereof, they shall be excluded from the benefit of any distribution made before such debts or claims are so lodged or proved.

T. R. DAVEY, liquidator, 28 Elizabeth Street, (6th floor), Melbourne, Vic. 3000.

NOTE.—All known creditors have already been paid.

5443

Creditors, next of kin and others having claims in respect of the estate of EMMA MILLICENT LOVE (also known as MILLICENT EMMA LOVE) late of 2b Hedgeley Avenue, East Malvern in the State of Victoria Widow deceased who died on the 8th of March 1975 are to send particulars of their claims to the NATIONAL TRUSTEES EXECUTORS AND AGENCY COMPANY OF AUSTRALASIA LIMITED of 95 Queen Street, Melbourne by the 5th August 1975 after which date it will distribute the assets having regard to the claims of which it then has notice.

PETER J. WALSH, solicitors, 95 Queen Street,
Melbourne. 5447

Creditors, next of kin and others having claims in respect of the Estate of GEORGE FREDERICK MOORE late of 55 St. Vincents Place, Albert Park in the State of Victoria retired customs officer deceased who died on the 2nd day of March 1973 and Probate of whose Will was granted by the Supreme Court of Victoria on the 4th day of April, 1975 to GEORGE FREDERICK JAMES MOORE of 29 Sluman Street, West Ryde in the State of New South Wales are to send particulars of their claims to the said Executor care of the below mentioned Solicitors by the 7th day of August, 1975 after which date he will distribute the assets of the deceased having regard only to the claims of which he then has notice.

J. H. TROTTER & CO., solicitors, 37 Queen Street,
Melbourne. 5448

CREDITORS NEXT OF KIN AND Others having claims in respect of the estate of EUNICE MURIEL NICOL late of 4 Dower Street Burwood in the State of Victoria Home Duties Deceased who died on the 20th day of March 1975 are required by THE UNION-FIDELITY TRUSTEE COMPANY OF AUSTRALIA LIMITED whose registered office is situate 100 Exhibition Street Melbourne the executor appointed by deceased's will TO SEND PARTICULARS of their claims to the said Company by the 15th day of August 1975 after which date the said Executor may convey or distribute the assets having regard only to the claims of which it shall then have had notice.

S. H. BONELLA, 37 Peate Avenue, Glen Iris, solicitor for the said company. 5481

CREDITORS next of kin and others having claims against the Estate of EVELYN MURIEL MARSHALL late of Unit 3, 30 Normanby Street, Brighton, Widow deceased who died on 3rd March, 1975 are required to send particulars of their claims to the NATIONAL TRUSTEES EXECUTORS AND AGENCY COMPANY OF AUSTRALASIA LIMITED of 95 Queen Street Melbourne the administrators of the said deceased on or before 2nd August, 1975 after which date they will distribute the assets having regard only to the claims of which they then have notice.

TOLHURST, BRUCE & EMMERSON, solicitors, 357 Little Collins Street, Melbourne, 3000. 5449

LUCY ANN GORDON, late of 1 Parring Road, Balwyn, widow, DECEASED.

Creditors, next-of-kin and others having claims in respect of the estate of the abovenamed deceased who died on 17th November, 1974, are required by the Executrix FLORENCE GERTRUDE DYSON of "Faleula" Railway Place, Macedon, Widow to send particulars to her in care of her undermentioned Solicitors by 6th August, 1975 after which date the Executrix may convey or distribute the assets having regard only to the claims of which she then has notice.

FLOOD & PERMEZEL, solicitors, 388 Bourke Street,
Melbourne. 5450

GEORGE ERNEST MUNTING, late of 65 Whitehorse Road, Blackburn, cabinetmaker, DECEASED.

CREDITORS, next-of-kin and others having claims against the estate of the above deceased (who died on the 27th day of November, 1974), are required to present particulars of their claims to the executor The Equity Trustees Executors and Agency Company Limited of 472 Bourke Street, Melbourne by the 12th day of August 1975 after which date the executor may convey or distribute having only regard to the claims of which it then has notice.

RIVERS, DICKINSON, STIRLING & MUNZ, of 17 Queen Street, Melbourne. 5451

CREDITORS next of kin and others having CLAIMS in respect of the estate of WILLIAM CAPLEHORN late of 7 Snodgrass Street, Broadford Retired Grazier who died on 19th February 1975 are to send PARTICULARS of their claims to the Executors ARTHUR SCULLY and HAROLD

PERCIVAL CARTER care of the undermentioned firm by the 5th day of August 1975 after which date the said Executors will distribute the assets having regard only to the claims of which they then have notice.

McINTYRE & CARTER, solicitors, 414 Collins Street, Melbourne. 5476

Creditors next of kin and others having claims in respect of the Estate of JAMES HENRY GILBARD formerly of 85 Nelson Place Williamstown but late of flat 3, 83 Verdon Street Williamstown Plumber, who died on 12th December 1974 are required by the Executors NATIONAL TRUSTEES EXECUTORS AND AGENCY COMPANY OF AUSTRAL-ASIA LIMITED of 95 Queen Street Melbourne to send notice of their claims to the above address by the 4th August 1975 after which date it will distribute the assets having regard only to the claims of which it then has notice.

ARTHUR SECOMB & CO., solicitors, 339 William Street, West Melbourne 3003. 5477

CREDITORS next of kin and others having claims in respect of the Estate of MARGARET WALSH late of 39 Chambers Street Coburg in the State of Victoria, Married Woman deceased who died on the 4th day of July 1974 are required by the Executors EDMOND WALSH of 39 Chambers Street Coburg and MONSIGNOR BRIAN WALSH of 40 Langhorne Street Dandenong in the said State to send particulars of such claims to them care of the office of HEFFEY & BUTLER of 258 Little Bourke Street Melbourne Solicitors by the 15th day of August 1975 after which date they will distribute the assets having regard only to the claims of which they then have notice.

HEFFEY & BUTLER, solicitors, 258 Little Bourke Street, Melbourne. 5478

CREDITORS next of kin and others having claims against the estate of MARION JANE CLOSTER late of 77 Gisborne Road Bacchus Marsh Widow deceased who died on the 7th day of August 1974 are required by the executor of her Will ROBERT JOHN CLOSTER to send particulars of their claims to him care of the undermentioned Solicitors before the 30th July, 1975 after which date he will distribute the assets having regard only to the claims of which he then has notice.

PEARCE & WEBSTER, solicitors, 430 Little Collins Street, Melbourne. 5479

CHARLOTTE MARY WHITELOW, late of 59 Fitzroy Street, Kerang, in the State of Victoria, widow, DECEASED.

CREDITORS next-of-kin and all other persons having claims against the Estate of the said Deceased are required by IRENE MARIE BROWN and MAVIS ADELA PRYOR both of Kerang in the said State Married Women Executrices of the Estate of the said Deceased to send particulars of such claims to them in care of the undermentioned Solicitors on or before the 30th day of July 1975 after which date they will distribute the assets having regard only to the claims of which they then have notice.

BASILE & CO., barristers & solicitors, 46 Wellington Street, Kerang. 5480

CREDITORS next of kin and others having claims against the estate of ANNIE EVANS late of 505 St. Kilda Street, Elwood Widow deceased are required by the Executors DORIS LOUISA METCHER of 505 St. Kilda Street, Elwood Victoria Married Woman and WILLIAM DAVID EVANS of 21 Tovell Street Newborough in the said State Maintenance Supervisor to send particulars of their claims care of the undersigned by the 5th day of August 1975 after which date they will proceed to distribute the estate having regard only to the claims of which they then have notice.

JOHN D. MUSTOW & CO., solicitors, of 131 Queen Street, Melbourne. 5445

Creditors, Next of Kin and others having claims against the estate of MARTIN CROWE late of Coleraine Road Casterton Retired Farmer deceased Intestate who died on the First day of August One thousand nine hundred and seventy-four and Letters of Administration of whose estate was granted by the Supreme Court on the Eighteenth day of April One thousand nine hundred and seventy-five to THE UNION FIDELITY TRUSTEE COMPANY OF AUSTRALIA LIMITED of 100 Exhibition Street Melbourne are required to send particulars in writing of such claim to the said THE UNION FIDELITY TRUSTEE COMPANY OF AUSTRALIA LIMITED at the Company's abovementioned address on or before the Thirtieth day of August One thousand nine hundred and seventy-five after which date the

Administrator will proceed to distribute the assets of the said MARTIN CROWE deceased which shall have come to the Administrators hands amongst the persons entitled thereto having regard to the claims of which the Administrator shall then have had notice.

SILVESTER & SILVESTER, solicitors, Casterton. 5384

CREDITORS next of kin or others having claims in respect of the estate of JAMES FRANCIS McKEW late of Gooroc Farmer deceased who died on the 14th day of December 1974 are to send particulars of their claims to EILEEN OLIVE McKEW of Gooroc Widow and JAMES FRANCIS DICKINSON of 6 Earls Court North Balwyn Manager care of the undermentioned Solicitors by the 19th August 1975 after which date they will distribute the assets having regard only to the claims of which they then have notice.

HYETT & HYETT, solicitors, 78 Napier Street, St. Arnaud. 5441

CREDITORS next-of-kin and others having claims in respect to the Estate of ERNEST BAXTER late of 1/25 Charming Street, Moorabbin, Retired, deceased, who died on the 3rd day of January, 1974, are requested to send particulars of their claims to ROBIN EDWARD CLEMENTS of 255 Glenhantly Road, Elsternwick, Solicitor, the proving Executor of the Will of the said deceased in care of Messrs. Clements, Mott & Bett, Solicitors of the same address, by not later than the 7th day of August, 1975, after which date the Executor will distribute the assets having regard only to the claims of which he has notice.

CLEMENTS, MOTT & BETT, solicitors, 255 Glenhantly Road, Elsternwick. 5431

CREDITORS next of kin and others having CLAIMS against the estate of JEANETTE OLIVE KEMP (also known as JANETTA OLIVE KEMP) late of Flat 14, 17A Milton Street, Elwood Spinster Deceased Intestate who died on the 1st March, 1975 are required by the Administrator ALFRED NEWTON SUPER of 374 Bourke Street, Melbourne Solicitor, to send particulars of such claims to him at the office of the undersigned Solicitors on or before the 14th August, 1975 after which date he will distribute the assets having regard only to the Claims of which he shall then have had notice.

A. NEWTON SUPER & P. G. KOVACS, barristers and solicitors, 374 Bourke Street, Melbourne, 3000. 5432

JAMES THOMAS STREET, late of 16 Fisher Crescent, Dandenong, in the State of Victoria, medical orderly, DECEASED.

Creditors, next of kin, and others having claims in respect of the estate of the above deceased, who died on the 16th day of November 1974 are required by the trustee Doris Street of 16 Fisher Crescent, Dandenong in the State of Victoria Widow to send particulars to her care of the undersigned by the 6th day of August 1975 after which date the trustee may convey or distribute the assets, having regard only to the claims of which she then has notice.

BORCHARD & MOORE, solicitors, 44 Douglas Street, Noble Park. 5433

Creditors, next of kin and others having claims in respect of the Estate of GEOFFREY JOHN PURTON late of 50 Greenhill Road Greensborough in the State of Victoria Process Worker deceased intestate, who died on or about the sixth day of December 1974, are required by the Administratrix DOROTHY MABEL PETERSON of Unit 2/13 Park Avenue Glenhantly in the said State Widow, TO SEND particulars of their claims to her in care of the undermentioned Solicitors by the 7th day of August 1975 after which date she will distribute the assets having regard only to the claims of which she then has notice.

McCAY & THWAITES, solicitors, 374 Little Collins Street, Melbourne. 5501

CREDITORS next of kin and others having claims against the Estate of ELIZABETH SARAH VICTORIA GILBERT late of 54 Reeve Street, Sale in the State of Victoria, Widow deceased who died on the 9th day of February, 1974 are required by the Executor Norman Leslie Gilbert of Wurruk in the said State, Motor Mechanic to send particulars of their claims to the said Executor care of J. Crofton Lee & Moir of 233 Raymond Street, Sale, Solicitors by the 14th day of August, 1975 after which date he will distribute the assets of the said estate having regard only to the claims of which he then has notice.

J. CROFTON LEE & MOIR, solicitors, 233 Raymond Street, Sale. 5385

HANORA MARY QUINN (also known as HONORA MARY QUINN), late of 31 Strathmore Street, Bentleigh, married woman.

Creditors, next of kin and others having claims in respect of the estate of the deceased who died on the 22nd day of March 1974 are required by the personal representative The Trustees Executors and Agency Company Limited of 401 Collins Street Melbourne to send particulars of their claims to the said company by the 14th day of August 1975 after which date it will convey or distribute assets having regard only to the claims of which it then has notice.

W. J. MORLEY, solicitor, of 769 Centre Road, East Bentleigh. 5424

CREDITORS NEXT OF KIN and others having claims in respect of the Estate of MARGIT ANGELA HOCHMANN late of 91 Were Street Brighton Widow deceased who died on the 22nd day of March 1975 are required by NATIONAL TRUSTEES EXECUTORS AND AGENCY COMPANY OF AUSTRALASIA LIMITED of 95 Queen Street Melbourne to send particulars to this Company by the 12th day of August 1975 after which date it will distribute the assets having regard only to the claims of which it has then had notice.

D. L. McNAMARA, solicitor, 19 Grey Street, St. Kilda.

5382

Creditors next of kin and others having claims in respect of the Estate of ROBERT GEORGE STAAF late of 609 High Street Echuca Storekeeper deceased intestate who died on the 8th day of October 1972 are to send particulars and other claims to the NATIONAL TRUSTEES EXECUTORS AND AGENCY COMPANY OF AUSTRALASIA LIMITED of 46 Queen Street Bendigo by the 15th day of August 1975 after which date it will distribute the Estate having regard only to the claims of which it then has notice.

WATSON, JAMES & ROGERS, solicitors, 61 Bull Street, Bendigo. 5383

CREDITORS next of kin and others having claims against the Estate of KATHLEEN BURKE late of 569 Station Street North Carlton Spinster deceased who died on the 24th day of April 1975 are requested to send particulars of their claims to Kevin Shine of 5 Market Street Moe Gentleman the Executor appointed by the deceased's Will in care of the undersigned by the 6th day of August 1975 after which date he will distribute the assets having regard only to the claims of which he then shall have had notice.

M. DAVINE & CO., solicitors, Warragul. 5434

FRANCES BRUCE CARVER, late of Craigwood Hospital, 29 Gardner Street, Como, Western Australia, widow, DECEASED.

Creditors next of kin and others having claims in respect of the estate of the deceased who died on the Sixteenth day of March 1975 are required by THE PERPETUAL EXECUTORS AND TRUSTEES ASSOCIATION OF AUSTRALIA LIMITED of 50 Queen Street Melbourne and JOHN DANIEL HOLLAND of 361 Collins Street Melbourne Stock Broker the applicants for a grant of administration to send particulars of their claims to the said applicants in the care of the said Company by the Seventh day of August 1975 after which date they will convey or distribute the assets having regard only to the claims of which they then have notice.

BOOTHBY & BOOTHBY, solicitors, 883 Dandenong Road, Caulfield East. 5513

CREDITORS, next of kin and others having claims in respect of the Estate of AGNES ANDERSON WHITE ROBERTSON late of the City of Lower Hutt in the Dominion of New Zealand Widow deceased (who died on the First day of December 1973), are required to send particulars of their claims to NATIONAL TRUSTEES EXECUTORS AND AGENCY COMPANY OF AUSTRALASIA LIMITED of 95 Queen Street Melbourne in Victoria by the Seventh day of August 1975, after which date the said Company will distribute the assets having regard only to the claims of which it then has notice.

GILLOTT MOIR & WINNEKE, solicitors, 500 Collins Street, Melbourne, 3000. 5503

OSWALD GAWLER, late of 22 Mayfield Avenue, Malvern, actuary, DECEASED.

Creditors next of kin and others having claims in respect of the estate of the deceased who died on the 12th day of February 1975 are required by THE PERPETUAL EXECUTORS AND TRUSTEES ASSOCIATION OF AUSTRALIA LIMITED of 50 Queen Street, Melbourne and DORIS KATHLEEN GAWLER of 22 Mayfield Avenue

Malvern Widow the applicants for a grant of administration to send particulars of their claims to the said applicants in the care of the said Company by the 11th day of August 1975 after which date they will convey or distribute the assets having regard only to the claims of which they then have notice.

WEIGALL & CROWTHER, 459 Little Collins Street, Melbourne, solicitors for the applicants. 5502

CREDITORS next of kin and others having claims in respect of the Estate of ETHEL JANE MACPHERSON late of Flat 232 Inala Village, Middleborough Road, South Blackburn, Widow, deceased who died on the 12th day of July, 1974, are to send particulars of their claims to THE TRUSTEES EXECUTORS AND AGENCY COMPANY LIMITED, of 401 Collins Street, Melbourne, by the 8th day of August, 1975, after which date the Company will distribute the assets having regard only to the claims of which it then has notice.

LYNCH & MACDONALD, solicitors, of 118 Queen Street, Melbourne. 5446

CREDITORS next of kin and other persons having claims against the estate of NIVEN CARRICK late of 4 High Street Prahran Driver deceased intestate who died on the 16th December, 1974 ARE REQUIRED to send particulars of their claims to the Administrator NATIONAL TRUSTEES EXECUTORS AND AGENCY COMPANY OF AUSTRALASIA LIMITED of 95 Queen Street Melbourne by the fourth day of August 1975 after which date the Administrator will distribute the assets having regard only for the claims of which it then has had notice.

JAMES P. OGGE & CO., solicitors, 165 Greville Street, Prahran. 5511

Creditors next-of-kin and others having claims in respect of the estate of HAROLD FRANCIS BROWN late of 102 Ascot Street South Ballarat Pensioner deceased who died on 13th March 1975 are required to send particulars of their claims to the Executor, THE UNION-FIDELITY TRUSTEE COMPANY OF AUSTRALIA LIMITED, at its address, 101 Lydiard Street North Ballarat by 5th August 1975 after which date the said Company will distribute the assets having regard only to the claims of which it then has notice.

BAIRD, MCGREGOR & FOWLER, solicitors, Ballarat. 5430

In the will of CORA FLORENCE VANDERKELEN, late of 27 Montalto Avenue, Toorak, in Victoria, widow, DECEASED.

CREDITORS next-of-kin and others having claims in respect of the Estate of the abovenamed deceased (who died on the 5th day of December 1974) are required by the executors Joan Patricia Vanderkelen of 27 Montalto Avenue, Toorak in Victoria, Married Woman and Ross Gibson Macfarlan of 414 Collins Street, Melbourne, Victoria, Solicitor to send particulars of their claims to them care of the undermentioned solicitors by the 11th day of August 1975 after which date they will distribute the assets having regard only to the claims of which they then have notice.

AITKEN WALKER & STRACHAN, solicitors, of 414 Collins Street, Melbourne. 5512

CREDITORS next of kin and others having claims against the Estate of WILLIAM DONALD LAURIE late of Bunyip Farmer who died on the 31st day of December 1974 are requested to send particulars of their claims to Nola Roslyn Laurie of Bunyip Spinster the Administratrix of the estate of the said deceased in care of the undersigned by the 16th day of August 1975 after which date she will distribute the assets having regard only to the claims of which she then shall have had notice.

M. DAVINE & CO., solicitors, Warragul. 5491

CREDITORS next of kin and others having claims in respect of the Estate of ETHEL VERA DAVY late of Flat 4, 36 Riddell Parade, Elsternwick, Married Woman, deceased who died on the Tenth day of January, 1975 ARE REQUESTED to send particulars of their claims to HUGH CYRIL OLIVER and DOROTHY LILLIAN FRANCES OLIVER the Executors of the Will of the said deceased in care of the undermentioned Solicitors by the Fourteenth day of August, 1975 after which date the Executors will distribute the assets having regard only to the claims of which they have notice.

CLEMENTS, MOTT & BETT, solicitors, 253-255 Glenhuntly Road, Elsternwick. 5492

JOSEPH SPERANZA, late of 31 Miller Street, West Melbourne, pensioner, DECEASED.

Creditors, next-of-kin, and others having claims in respect of the Estate of the deceased, who died on the 16th day of August, 1974 are required by the Administratrix, MARY SPITERI to send particulars of their claims to her, care of the undermentioned Solicitor before the 18th day of August, 1975 after which date the Administratrix may convey or distribute the assets, having regard only to the claims of which she then has notice.

MICHAEL TAUSSIG, LL.B., solicitor, 56 Dudley Street, West Melbourne. 5493

In the Supreme Court of the State of Victoria.

SALE BY THE SHERIFF.

ON FRIDAY the 11TH of JULY 1975 at 11.00 a.m. AT THE POLICE STATION BAYSWATER (unless process be stayed or satisfied).

ALL the Estate and Interest (if any) of MR. B. F. FORSON, (shown on Certificate of Title as BILLIE FRANK FORSON) self employed of 5 Gain Court Bayswater North as joint proprietor with Bronwyn Eveleigh Forson, married woman of an estate in fee simple in the land described in Certificate of Title Volume 8796 Folio 854 upon which is erected a brick veneer dwelling known as No. 5 Gain Court Bayswater North.

Registered Mortgage Nos. E.509610 and E.529435 affect the said estate and interest.

TERMS—CASH ONLY.

H. BUETTNER, Sheriff's Officer.

4th June, 1975.

5514

In the Supreme Court of the State of Victoria.

SALE BY THE SHERIFF.

ON FRIDAY the 11TH of JULY 1975 at 10.30 a.m. AT THE POLICE STATION OAKLEIGH (unless process be stayed or satisfied).

ALL the Estate and Interest (if any) of VASILIOS ADAMIS, drapery retailer and KALIOPI ADAMIS, married woman, both of 16 Kelly Street, Chadstone as joint proprietors of an estate in fee simple in the land described in Certificate of Title Volume 8057 Folio 085 upon which is erected a brick veneer dwelling known as No. 16 Kelly Street Chadstone.

Registered Mortgage No. E.747527 affects the said estate and interest.

TERMS—CASH ONLY.

DOUGLAS S. HALL, Sheriff's Officer.

4th June, 1975.

5515

In the Supreme Court of the State of Victoria.

SALE BY THE SHERIFF.

ON FRIDAY the 18TH of JULY 1975 at 10.00 a.m. AT THE POLICE STATION DANDENONG (unless process be stayed or satisfied).

ALL the Estate and Interest (if any) of D. J. MARTIN (shown on Certificate of Title as DENIS JAMES MARTIN) plumber of 5 Warwick Court, North Dandenong as joint proprietor with Lillian Erica Martin, married woman of an estate in fee simple in the land described in Certificate of Title Volume 8884 Folio 393 upon which is erected a split level brick dwelling known as No. 5 Warwick Court North Dandenong.

Registered Mortgage Nos. E.569765 and E.569766 affect the said estate and interest.

TERMS—CASH ONLY.

H. BUETTNER, Sheriff's Officer.

4th June, 1975.

5516

In the Supreme Court of the State of Victoria.

SALE BY THE SHERIFF.

ON FRIDAY the 25TH of JULY 1975 at 10.00 a.m. AT THE POLICE STATION EMERALD (unless process be stayed or satisfied).

ALL the Estate and Interest (if any) of MR. N. G. HASTINGS, (shown on Certificate of Title as NEIL GEORGE HASTINGS) carrier, of Lot 3, Emerald Lake Road, Emerald as joint proprietor with MORIJKE HASTINGS, married woman of an estate in fee simple in the

land described in Certificate of Title Volume 9042 Folio 306 upon which is erected a fibro-cement house and garage known as Lot 3 Emerald Lake Road, Emerald.

Registered Mortgage No. F.50315 affects the said estate and interest.

TERMS—CASH ONLY.

H. BUETTNER, Sheriff's Officer.

4th June, 1975.

5517

IMPOUNDINGS

SHIRE OF SOUTH GIPPSLAND.

FOSTER.—Impounded in Foster Pound on Saturday, 24th May, 1975, from South Gippsland Highway, Welshpool.

1 Jersey heifer, V notch in right ear
1 Hereford cross steer, V notch in left ear

If not claimed and expenses paid, to be sold on or after 19th June, 1975.

A. G. JONES,
Poundkeeper.

5426—\$4.95

SHIRE OF RODNEY.

TATURA.—Impounded in Tatura Pound.

2 Jersey cross heifer calves, no visible brand
2 Shorthorn cross cows, V out of tip of left ear
1 Shorthorn cross cow, V out of tip of right ear
1 Shorthorn bull, no visible brand
2 calves impounded from Tatura.

3 Shorthorn cross cows and 1 shorthorn bull impounded from Toolamba.

If not claimed and expenses paid, to be sold on Thursday, 19th June, 1975.

J. H. MACTIER,
Poundkeeper.

5490—\$7.15

YARRAM.—Impounded in Yarram Pound by Shire Herdsman, from Blackwarry, 20th May, 1975.

8 black steers, like V point right ear, slit left ear, one with white face.

1 roan steer, like V point right ear, slit left ear

If not claimed and expenses paid to be sold at the Yarram Saleyards, 13th June, 1975.

L. MITCHELL,
Poundkeeper.

5379—\$4.95

Subordinate Legislation Act 1962.

NOTICE OF MAKING OF STATUTORY RULES.

In pursuance of the provisions of the *Subordinate Legislation Act 1962* and the Regulations made thereunder, notice is given of the making of the following statutory rules:—

No.	Marketing of Primary Products Act 1958.	Price.
151/1975.	The Tobacco Leaf Marketing Board (Charges) Regulations 1975	10c
	<i>Fruit and Vegetables Act 1958.</i>	
152/1975.	Fruit and Vegetables Packing (Amendment No. 2) Regulations 1975	10c
	<i>Consumer Affairs Act 1972.</i>	
153/1975.	Consumer Affairs (Consumer Affairs Council Fees and Allowances) (Amendment) Regulations 1975	10c
	<i>Valuation of Land Act 1960.</i>	
154/1975.	Valuation of Land (Inspection of Register) Regulations 1975	10c
	<i>Portland Harbor Trust Act 1958.</i>	
155/1975.	Portland Harbor Trust Commissioners (Amendment No. 25) Regulations 1975	10c
	<i>Workers Compensation Act 1958.</i>	
156/1975.	Workers Compensation (Insurers Guarantee and Compensation Supplementation Fund) Regulations 1975	10c
	<i>Second-hand Dealers Act 1958.</i>	
157/1975.	Second-hand Dealers (Exemption No. 2) Regulations 1975	10c

No.	Juries Act 1967.	Price.
158/1975.	Juries (Amendment) Regulations 1975	10c
	<i>Marine Act 1958.</i>	
159/1975.	Amendment to Port Rule Applicable to Westernport Harbor Services (Rates and Charges)	10c
	<i>Public Service Act 1974.</i>	
160/1975.	Public Service (Promotions Appeal Boards) Regulations	10c
	<i>Melbourne Harbor Trust Act 1958 (No. 6312).</i>	
161/1975.	Melbourne Harbor Trust (Tonnage Measurement) Regulations No. 2/75	10c
	<i>County Court Act 1958.</i>	
162/1975.	County Court (Appeals) Rules 1975	20c

Copies of these statutory rules may be purchased at the Sale of Publications Section of the Government Printing Office, located at 7A Parliament Place, Melbourne, 3002. If ordered by mail, remittance should be addressed to "The Government Printer, Box 203, P.O., North Melbourne, 3051", and should include 11c extra for postage. If a credit account is held at this office, no remittance is required with the mail order.

The annual subscription rate for Statutory Rules (including Bound Volumes) is \$35, payable in advance. The subscription year commences on 1st January.

C. H. RIXON,
Government Printer.

ACTS REPRINTED IN ACCORDANCE WITH THE AMENDMENTS INCORPORATION ACT 1958 (No. 6422), AND FOR SALE AT THE SALE OF PUBLICATIONS BRANCH OF THE GOVERNMENT PRINTING OFFICE, MACARTHUR-STREET, MELBOURNE, 3002.

(These prices do not include postage.)

No.		Price.
6189.	Acts Interpretation (Fourth Reprint—Incorporating amendments up to No. 8305)	\$0.35
6191.	Administration and Probate (Fourth Reprint—Incorporating amendments up to No. 7874)	\$0.75
6194.	Agricultural Colleges (First Reprint—Incorporating amendments up to No. 7302)	\$0.15
6198.	Anzac Day (First Reprint—Incorporating amendments up to No. 8344)	\$0.15
7117.	Appeal Costs Fund Act 1964 (Second Reprint—Incorporating amendments up to No. 7488)	\$0.35
6199.	Apprenticeship (Second Reprint—Incorporating amendments up to No. 7869)	\$0.40
6201.	Architects (First Reprint—Incorporating amendments up to No. 8077)	\$0.30
6203.	Audit (First Reprint—Incorporating amendments up to No. 7377)	\$0.35
6208.	Benefit Associations (First Reprint—Incorporating amendments up to No. 6961)	\$0.45
8004.	Boiler and Pressure Vessels Act 1970 (First Reprint—Incorporating amendments up to No. 8389)	\$0.45
6529.	Bread Industry Act 1959 (First Reprint—Incorporating amendments up to No. 7728)	\$0.30
6973.	Building Contracts (Deposits) Act 1962 (First Reprint—Incorporating amendments from No. 7315)	\$0.10
6210.	Building Society (Third Reprint—Incorporating amendments up to No. 8405)	\$0.65
6213.	Cancer (First Reprint—Incorporating amendments up to No. 7455)	\$0.35
6214.	Carriers and Innkeepers (Second Reprint—Incorporating amendments up to No. 8534)	\$0.20
6217.	Cemeteries (First Reprint—Incorporating amendments up to No. 7672)	\$0.30
6220.	Clean Air (Second Reprint—Incorporating amendments up to No. 8196)	\$0.15
6221.	Coal Mines (First Reprint—Incorporating amendments up to No. 7628)	\$1.05
6222.	Commercial Goods—Vehicles Act 1958 (Third Reprint—Incorporating amendments up to Act No. 8525)	\$0.55
6223.	Commonwealth Arrangements (First Reprint—Incorporating amendments from No. 7809)	\$0.10
6839.	Companies (Fifth Reprint—Incorporating amendments up to No. 8594)	\$5.95
8276.	Consumer Protection Act 1972 (Second Reprint—Incorporating amendments up to Act No. 8540)	\$0.75

ACTS REPRINTED IN ACCORDANCE WITH THE AMENDMENTS INCORPORATION ACT 1958 (No. 6422)—continued.

No.		Price.
6224.	The Constitution Act Amendment (First Reprint—Incorporating amendments up to No. 8086)	\$3.05
6225.	Co-operation Act (Third Reprint—Incorporating amendments up to No. 8339)	\$0.85
6226.	Co-operative Housing Societies (Second Reprint—Incorporating amendments up to No. 7575)	\$0.53
6227.	Coroners (First Reprint—Incorporating amendments up to No. 7935)	\$0.35
6228.	Country Fire Authority (Second Reprint—Incorporating Amendments up to No. 7476)	\$0.50
6229.	Country Roads (Fourth Reprint—Incorporating amendments up to Act No. 8573)	\$1.05
6230.	County Court (Second Reprint—Incorporating amendments up to No. 8132)	\$0.65
6231.	Crimes (Fourth Reprint—Incorporating amendments up to Act No. 8338)	\$2.75
6232.	Crown Proceedings (First Reprint—Incorporating amendments up to No. 7900)	\$0.30
6233.	Dairy Products (First Reprint—Incorporating amendments up to No. 7945)	\$0.20
7060.	Dandenong Valley Authority Act 1963 (First Reprint—Incorporating amendments up to No. 7523)	\$0.35
6235.	Dietitians Registration (First Reprint—Incorporating amendments up to No. 6886)	\$0.20
4989.	Discharged Servicemen's Preference Act 1943. (Second Reprint—Incorporating amendments up to No. 7991)	\$0.20
6815.	Disposal of Uncollected Goods Act 1961 (First Reprint—Incorporating amendments up to No. 7181)	\$0.15
6237.	Drainage Areas (First Reprint—Incorporating amendments up to No. 7276)	\$0.35
6238.	Drainage of Land (First Reprint—Incorporating amendments up to No. 7876)	\$0.15
6239.	Dried Fruits Act 1968 (First Reprint—Incorporating amendments up to No. 7337)	\$0.25
6240.	Education (First Reprint—Incorporating amendments up to No. 7533)	\$0.45
6241.	Electric Light and Power (First Reprint—Incorporating amendments up to No. 7315)	\$0.30
6242.	Employers and Employes (Incorporating amendments up to No. 6740)	\$0.18
8056.	Environment Protection Act 1970 (Second Reprint—Incorporating amendments up to No. 8560)	\$0.55
6245.	Estate Agents (Fourth Reprint—Incorporating amendments up to No. 8181)	\$0.85
6246.	Evidence (Fourth Reprint—Incorporating amendments up to No. 8228)	\$1.05
7499.	Extractive Industries Act 1966 (Second Reprint—Incorporating amendments up to No. 7951)	\$0.40
6250.	Fertilizers (Incorporating amendments up to No. 7142)	\$0.25
6468.	Filled Milk (First Reprint—Incorporating amendments up to No. 6886)	\$0.15
6251.	Firearms (Fourth Reprint—Incorporating amendments up to No. 8288)	\$0.75
6916.	Foreign Judgments Act 1962 (First Reprint including amendments made by No. 7332)	\$0.15
6585.	Forests (Pulpwood Agreement) (Incorporating amendments up to No. 6886)	\$0.15
6254.	Forests (First Reprint—Incorporating amendments up to No. 7356)	\$0.60
6255.	Friendly Societies (First Reprint—Incorporating amendments up to No. 7554)	\$0.60
6256.	Fruit and Vegetables (First Reprint—Incorporating amendments up to No. 6944)	\$0.30
6258.	Game (First Reprint—Incorporating amendments up to No. 7389)	\$0.30
6260.	Gas and Fuel Corporation (First Reprint—Incorporating amendments up to No. 7422)	\$0.70
6262.	Geelong Harbor Trust. (First Reprint—Incorporating amendments up to No. 7547)	\$0.45
6263.	Geelong Waterworks and Sewerage (First Reprint—Incorporating amendments up to No. 7547)	\$0.75
8176.	Gift Duty Act 1971 (First Reprint—Incorporating amendments from No. 8202)	\$0.55
6265.	Goods Act 1958 (Sixth Reprint—Incorporating amendments up to Act No. 8455)	\$0.45
6266.	Grain Elevators (First Reprint—Incorporating amendments up to No. 7486)	\$0.35
7849.	Groundwater (First Reprint—Incorporating amendments up to No. 8153)	\$0.45

ACTS REPRINTED IN ACCORDANCE WITH THE AMENDMENTS
INCORPORATION ACT 1958 (No. 6422)—*continued*.

No.	Price.
6267. Hairdressers Registration (<i>First Reprint</i> —Incorporating amendments up to Act No. 7659)	\$0.30
6269. Hawkers and Pedlars Act 1958 (<i>Second Reprint</i> —Incorporating amendments up to Act No. 8247)	\$0.30
6270. Health Act (<i>Third Reprint</i> —Incorporating amendments up to No. 8506)	\$3.25
6531. Hire Purchase Act 1959 (<i>Second Reprint</i> —Incorporating amendments from Act No. 8232)	\$0.55
6933. Home Finance Act 1962 (<i>First Reprint</i> —Incorporating amendments up to No. 7363)	\$0.25
6274. Hospitals and Charities (<i>Second Reprint</i> —Incorporating amendments up to No. 7455)	\$0.50
6275. Housing (<i>Second Reprint</i> —Incorporating amendments up to No. 8052)	\$1.65
6276. Imprisonment of Fraudulent Debtors (<i>First Reprint</i> —Incorporating amendments up to No. 7876)	\$0.35
6277. Industrial and Provident Societies (<i>First Reprint</i> —Incorporating amendments up to No. 7547)	\$0.35
6279. Instruments (<i>Fourth Reprint</i> —Incorporating amendments up to No. 7941)	\$0.75
6280. Judicial Proceedings Reports (<i>First Reprint</i> —Incorporating amendments up to No. 7596)	\$0.15
7651. Juries (<i>First Reprint</i> —Incorporating amendments up to No. 8170)	\$0.55
6282. Justices Act 1958 (<i>Fourth Reprint</i> —Incorporating amendments up to No. 8338)	\$2.35
6283. Labour and Industry Act 1958 (<i>Sixth Reprint</i> —Incorporating amendments up to Act No. 8642)	\$1.50
6284. Land Act 1959 (<i>Second Reprint</i> —Incorporating amendments up to No. 8243)	\$3.15
6534. Land Settlement Act 1959 (<i>First Reprint</i> —Incorporating amendments up to No. 7328)	\$0.30
6288. Land Surveyors (<i>First Reprint</i> —Incorporating amendments up to Act No. 7065)	\$0.30
6289. Land Tax (<i>Second Reprint</i> —Incorporating amendments up to No. 7466)	\$0.40
6285. Landlord and Tenant (<i>Fourth Reprint</i> —Incorporating amendments up to No. 8208)	\$1.15
6286. Lands Compensation (<i>Second Reprint</i> —Incorporating amendments up to No. 8432)	\$0.45
6290. Latrobe Valley (<i>First Reprint</i> —Incorporating amendments up to No. 7332)	\$0.35
6291. Legal Profession Practice Act (<i>Third Reprint</i> —Incorporating amendments up to No. 8259)	\$1.15
6292. Libraries (<i>First Reprint</i> —Incorporating amendments up to No. 7364)	\$0.15
6295. Limitation of Actions (<i>Third Reprint</i> —Incorporating amendments up to No. 8300)	\$0.35
7695. Liquor Control Act 1958 (<i>Third Reprint</i> —Incorporating amendments up to No. 8598)	\$1.35
7145. Litter Act 1964 (<i>First Reprint</i> —Incorporating amendments up to No. 7608)	\$0.15
6298. Local Authorities Superannuation (<i>Second Reprint</i> —Incorporating amendments up to No. 7161)	\$0.40
6299. Local Government (New Parts I. and II.—Incorporating amendments up to No. 8380 of 1972)	\$0.60
6299. Local Government. New Parts III. to IX.—(Incorporating amendments up to No. 8557)	\$1.70
6299. Local Government New Parts X.—XI. (Incorporating amendments up to No. 8405)	\$0.80
6299. Local Government New Parts XII.—XIX. (Incorporating amendments up to No. 8380)	\$2.65
6299. Local Government New Parts XX.—XVIX. (Incorporating amendments up to No. 8445 and S.R. 186/73)	\$2.90
6299. Local Government Act (New Divisions 1 and 2 to Part XLIX.—Incorporating amendments up to No. 8564)	\$0.60
7289. Maintenance (<i>First Reprint</i> —Incorporating amendments up to No. 8036)	\$1.05
6301. Margarine (<i>First Reprint</i> —Incorporating amendments up to No. 7714)	\$0.18
6302. Marine (Incorporating amendments up to No. 7350)	\$0.72
6303. Marine Stores and Old Metals (<i>First Reprint</i> —Incorporating amendments up to No. 7876)	\$0.35
6304. Marketing of Primary Products (<i>First Reprint</i> —Incorporating amendments up to No. 7491)	\$0.45

ACTS REPRINTED IN ACCORDANCE WITH THE AMENDMENTS
INCORPORATION ACT 1958 (No. 6422)—*continued*.

No.	Price.
6305. Markets (<i>First Reprint</i> —Incorporating amendments up to No. 7705)	\$0.20
6306. Marriage (<i>First Reprint</i> —Incorporating amendments up to No. 6959)	\$0.25
6307. Masseurs (<i>First Reprint</i> —Incorporating amendments up to No. 7566)	\$0.20
6309. Medical (<i>Second Reprint</i> —Incorporating amendments up to No. 7408)	\$0.40
6310. Melbourne and Metropolitan Board of Works (<i>Fourth Reprint</i> —Incorporating amendments up to No. 8650)	\$1.95
6311. Melbourne and Metropolitan Tramways (<i>First Reprint</i> —Incorporating amendments up to No. 7622)	\$0.70
6312. Melbourne Harbor Trust (<i>First Reprint</i> —Incorporating amendments up to No. 7356)	\$0.48
6405. Melbourne University (<i>First Reprint</i> —Incorporating amendments up to No. 7871)	\$0.40
6605. Mental Health (Incorporating amendments up to No. 7135)	\$0.45
6315. Metropolitan Fire Brigades (<i>Second Reprint</i> —Incorporating amendments up to No. 8165)	\$0.65
6316. Mildura Irrigation and Water Trusts (<i>First Reprint</i> —Incorporating amendments up to No. 7448)	\$0.75
6317. Milk and Dairy Supervision (Incorporating amendments up to No. 6964)	\$0.40
6318. Milk Board (Incorporating amendments up to No. 7093)	\$0.22
6319. Milk Pasteurization (<i>First Reprint</i> —Incorporating amendments up to No. 7480)	\$0.18
6320. Mines (<i>Second Reprint</i> —Incorporating amendments up to No. 7876)	\$1.25
6184. Monash University (<i>First Reprint</i> —Incorporating amendments up to No. 7533)	\$0.30
6324. Money Lenders (<i>Fourth Reprint</i> —Incorporating amendments up to No. 8490)	\$0.55
6325. Motor Car Act 1958 (<i>Fifth Reprint</i> —Incorporating amendments up to No. 8657)	\$2.25
6713. National Fitness Council of Victoria Act 1960 (<i>First Reprint</i> —Incorporating amendments up to No. 8344)	\$0.20
6705. Navigable Waters (Oil Pollution) Act 1960. (<i>First Reprint</i> —Incorporating amendments up to No. 7890)	\$0.30
6328. Nurses (<i>Second Reprint</i> —Incorporating amendments up to No. 7375)	\$0.45
6329. Opticians Registration (<i>First Reprint</i> —Incorporating amendments up to No. 7409)	\$0.30
6330. Partnership (<i>Second Reprint</i> —Incorporating amendments up to No. 7315)	\$0.35
6331. Patriotic Funds (<i>First Reprint</i> —Incorporating amendments up to No. 7338)	\$0.25
6332. Pawnbrokers (<i>First Reprint</i> —Incorporating amendments up to No. 7876)	\$0.35
7417. Pensions Supplementation (<i>First Reprint</i> —Incorporating amendments up to No. 8475)	\$0.20
6257. Pesticides Act 1968 (<i>First Reprint</i> —Incorporating amendments up to No. 7595)	\$0.15
6334. Petroleum (<i>First Reprint</i> —Incorporating amendments up to No. 7876)	\$0.65
6889. Poisons Act 1962 (<i>Third Reprint</i> —Incorporating amendments up to No. 8424)	\$0.85
6337. Police Offences Act 1958 (<i>Third Reprint</i> —Incorporating amendments up to No. 8433)	\$0.45
6338. Police Regulation (<i>Second Reprint</i> —Incorporating amendments up to No. 8179)	\$0.95
6340. Portland Harbor Trust (<i>First Reprint</i> —Incorporating amendments up to No. 7475)	\$0.35
6341. Pounds (<i>First Reprint</i> —Incorporating amendments up to No. 7315)	\$0.25
7498. Port Phillip Authority Act 1966 (<i>First Reprint</i> —Incorporating amendments from No. 8081)	\$0.15
6342. Printers and Newspapers (<i>First Reprint</i> —Incorporating amendments up to No. 7876)	\$0.15
7494. Private Agents Act 1966 (<i>First Reprint</i> —Incorporating amendments in No. 7646)	\$0.35
6344. Property Law (<i>Third Reprint</i> —Incorporating amendments up to No. 8181)	\$1.95
6345. Public Account (<i>First Reprint</i> —Incorporating amendments up to No. 8012)	\$0.20
6346. Public Authorities Marks (<i>First Reprint</i> —Incorporating amendments from No. 7315)	\$0.10
6350. Public Trustee (Incorporating amendments up to No. 6961)	\$0.35
6353. Racing (<i>Third Reprint</i> —Incorporating amendments up to No. 8080)	\$1.45

ACTS REPRINTED IN ACCORDANCE WITH THE AMENDMENTS
INCORPORATION ACT 1958 (No. 6422)—*continued.*

No.	Price.
6355. Railways (<i>First Reprint</i> —Incorporating amendments up to No. 7475)	\$0.75
6564. Registration of Births Deaths and Marriages Act 1959 (<i>First Reprint</i> —Incorporating amendments up to No. 7332)	\$0.25
6358. River Improvement Act (<i>First Reprint</i> —Incorporating amendments up to No. 8342)	\$0.55
2596. River Murray Waters Act 1915 (<i>First Reprint</i> —Incorporating amendments up to No. 7061)	\$0.35
6360. Rural Finance (<i>First Reprint</i> —Incorporating amendments up to No. 7328)	\$0.15
6846. Rural Finance and Settlement Commission Act 1961 (<i>First Reprint</i> —Incorporating amendments up to No. 7332)	\$0.30
6917. Sale of Human Blood Act 1962 (<i>First Reprint</i> —Incorporating amendments from No. 7332)	\$0.10
6975. Sale of Land Act 1962 (<i>Second Reprint</i> —Incorporating amendments up to No. 7898)	\$0.35
6363. Second-hand Dealers (<i>First Reprint</i> —Incorporating amendments up to No. 7529)	\$0.25
7962. Securities Industry Act 1970 (<i>First Reprint</i> —Incorporating amendments made by Act No. 8059)	\$0.65
6367. Settled Land (<i>Second Reprint</i> —Incorporating amendments up to No. 7065)	\$0.50
6368. Sewerage Districts (<i>Second Reprint</i> —Incorporating amendments up to No. 7547)	\$0.75
6369. Shearers Accommodation (<i>First Reprint</i> —Incorporating amendments up to No. 7876)	\$0.35
6809. Sheep Owners Protection Act 1961 (<i>Second Reprint</i> —Incorporating amendments up to No. 8179)	\$0.20
6372. Soil Conservation and Land Utilization Act (<i>Third Reprint</i> —Incorporating amendments up to No. 8432)	\$0.45
6373. Soldier Settlement (<i>First Reprint</i> —Incorporating amendments up to No. 7328)	\$0.42
6375. Stamps Act 1958 (<i>Sixth Reprint</i> —Incorporating amendments up to Act No. 8624)	\$2.15
6377. State Electricity Commission (<i>Second Reprint</i> —Incorporating amendments up to No. 7421)	\$0.65
6378. State Relief Committee (<i>First Reprint</i> —Incorporating amendments from No. 6886)	\$0.10
6379. State Savings Bank Act 1958 (<i>Third Reprint</i> —Incorporating amendments up to Act No. 8519)	\$0.95
6380. Statistics (<i>First Reprint</i> —Incorporating amendments up to No. 6961)	\$0.15
6383. Stock Foods (<i>First Reprint</i> —Incorporating amendments up to No. 7607)	\$0.28
6384. Stock Medicines (<i>First Reprint</i> —Incorporating amendments up to No. 7726)	\$0.20
7551. Strata Titles Act 1967 (<i>Second Reprint</i> —Incorporating amendments up to No. 8149)	\$0.65
6886. Subordinate Legislation Act 1962 (<i>Second Reprint</i> —Incorporating amendments up to No. 8127)	\$0.15
7405. Summary Offences Act 1966 (<i>Second Reprint</i> —Incorporating amendments up to Act No. 8276)	\$0.55
7634. Sunday Entertainment (<i>First Reprint</i> —Incorporating amendments up to No. 8173)	\$0.15
6386. Superannuation (<i>Second Reprint</i> —Incorporating amendments up to No. 7910)	\$0.75
6387. Supreme Court (<i>First Reprint</i> —Incorporating amendments up to No. 7522)	\$0.75
6388. Survey Co-ordination (<i>First Reprint</i> —Incorporating amendments up to Act No. 8107)	\$0.35
6390. Tattersall Consultations (<i>First Reprint</i> —Incorporating amendments up to No. 8289)	\$0.15
6391. Teaching Service (<i>First Reprint</i> —Incorporating amendments up to No. 7536)	\$0.35
6849. Town and Country Planning Act 1961 (<i>Fourth Reprint</i> —Incorporating amendments up to No. 8380)	\$1.15
6401. Trustee (<i>Third Reprint</i> —Incorporating amendments up to No. 7833)	\$0.85
6402. Trustee Companies (<i>First Reprint</i> —Incorporating amendments up to No. 7858)	\$0.35
7223. Tomato Processing Industry (Uniform Agreement) Act 1964 (<i>First Reprint</i> —Incorporating amendments up to No. 7342)	\$0.15

ACTS REPRINTED IN ACCORDANCE WITH THE AMENDMENTS
INCORPORATION ACT 1958 (No. 6422)—*continued.*

No.	Price.
6397. Trade Unions (<i>First Reprint</i> —Incorporating amendments up to No. 6839)	\$0.20
6399. Transfer of Land Act (<i>Fourth Reprint</i> —Incorporating amendments up to No. 8181)	\$1.15
6400. Transport Regulation Act (<i>Second Reprint</i> —Incorporating amendments up to Act 8549)	\$0.45
6879. Unclaimed Moneys Act 1962 (<i>Second Reprint</i> —Incorporating amendments up to Act No. 8448)	\$0.20
7095. Underseas Mineral Resources Act 1963 (<i>First Reprint</i> —Incorporating amendments from No. 7591)	\$0.10
6653. Valuation of Land Act 1960 (<i>Third Reprint</i> —Incorporating amendments up to No. 8432)	\$0.55
6407. Vegetation and Vine Diseases (<i>First Reprint</i> —Incorporating amendments up to No. 7423)	\$0.30
6409. Vermin & Noxious Weeds (<i>First Reprint</i> —Incorporating amendments up to No. 7463)	\$0.35
6410. Veterinary Surgeons (<i>First Reprint</i> —Incorporating amendments up to No. 7343)	\$0.15
6411. Victorian Inland Meat Authority (<i>First Reprint</i> —Incorporating amendments up to No. 8000)	\$0.30
7291. Victoria Institute of Colleges Act 1965 (<i>First Reprint</i> —Incorporating amendments up to No. 7644)	\$0.25
6412. Warehousemen's Liens (<i>First Reprint</i> —Incorporating amendments up to No. 7876)	\$0.15
6413. Water (<i>Second Reprint</i> —Incorporating amendments up to No. 7590)	\$1.95
6414. Weights and Measures (<i>Third Reprint</i> —Incorporating amendments up to No. 8068)	\$1.05
6415. Wild Flowers and Native Plants Protection (<i>First Reprint</i> —Incorporating amendments up to No. 6976)	\$0.15
6416. Wills (<i>First Reprint</i> —Incorporating amendments up to No. 7238)	\$0.25
6417. Wire Netting (<i>First Reprint</i> —Incorporating amendments up to No. 7876)	\$0.45
6419. Workers Compensation (<i>Sixth Reprint</i> —Incorporating amendments up to No. 8417)	\$1.05
6420. Wrongs (<i>First Reprint</i> —Incorporating amendments up to No. 8330)	\$0.35
8344. Youth, Sport and Recreation Act 1972 (<i>First Reprint</i> —Incorporating amendments up to Act No. 8550)	\$0.35

C. H. RIXON,
Government Printer.

FIRST NOTIFICATION OF REPRINT.

7629. Lifts and Cranes Act 1967 (<i>First Reprint</i> —Incorporating amendments up to No. 8433)	\$0.30
6202. Auction Sales Act 1958 (<i>First Reprint</i> —Incorporating amendments up to Act No. 8490)	\$0.35
7733. Fences (<i>First Reprint</i> —Incorporating amendments from No. 7876)	\$0.35

AGENTS FOR THE "VICTORIA GOVERNMENT
GAZETTE".

The following have been appointed agents to receive Advertisements and Subscriptions for the *Victoria Government Gazette*—

- ARMSTRONG'S AGENCY, 217 Queen-street, Melbourne, Victoria 3000.
- ARNALL & JACKSON, 390 Barkly-street, Brunswick, Victoria 3056.
- BAIRNSDALE AUTHORIZED NEWSAGENCY, 132 Main-street, Bairnsdale, Victoria 3875.
- BICKNELL, M. J., Authorized Newsagent, 196 Timor-street, Warrnambool, Victoria 3280.
- BLANE'S AUTHORIZED NEWSAGENTS, 162 Murray-street, Colac, Victoria 3250.
- CARTER, R. G., ADVERTISING SERVICE PTY. LTD., Suite 24, 65 Queens-road, Melbourne, Victoria 3004.
- DAVIES, G. & M. V., 112 Gray-street, Hamilton, Victoria 3300.
- DAVIS, WM. (MILDURA) PTY. LTD., 126 Eighth-street, Mildura, Victoria 3500.

- DIXON'S NEWSAGENCY, 89 Firebrace-street, Horsham, Victoria 3400.
 EDGAR'S AUTHORIZED NEWSAGENCY, 45 Bridge-street, Benalla, Victoria 3672.
 FRANKS, H., & CO., 184 Ryrie-street, Geelong, Victoria 3220.
 GATLEY, A. & J., 250 Lonsdale-street, Dandenong, Victoria 3175.
 GORDON & GOTCH AUSTRALASIA LTD., 434 St. Kilda-road, Melbourne, Victoria 3004.
 GULLAN'S NEWSAGENCY, 88 Bridge-street, Ballarat, Victoria 3350.
 HAMPTON, A. C., 243 Mitchell-street, Bendigo, Victoria 3550.
 HARSTON, PARTRIDGE & CO. PTY. LTD., 455 Little Collins-street, Melbourne, Victoria 3000.
 KYNETON GUARDIAN PTY. LTD., P.O. Box 18, Kyneton, Victoria 3444.
 LIVINGSTON'S SHEPPARTON NEWSAGENCY, 246 Wyndham-street, Shepparton, Victoria 3630.
 THE MERCANTILE EXCHANGE, 34 Queen-street, Melbourne, Victoria 3000.
 MCGILL'S AUTHORIZED NEWSAGENCY, 183-5 Elizabeth-street, Melbourne, Victoria 3000.
 POWNEY'S AUTHORIZED NEWSAGENCY, 293 Hargreaves-street, Bendigo, Victoria 3550.
 PURDIE, J., & CO., 138 Moorabool-street, Geelong, Victoria 3220.
 SALE AUTHORIZED NEWSAGENCY, 142 Raymond-street, Sale, Victoria 3850.
 SKINNER'S AUTHORIZED NEWSAGENCY, 49-51 Franklin-street, Traralgon, Victoria 3844.
 STEVENSON, A. C. & M., NEWSAGENTS, 132 Henty-street, Casterton, Victoria 3311.
 VANCE'S AUTHORIZED NEWSAGENCY, 83 Murray-street, Wangaratta 3677.
 VERNONS OF RICHMOND, 162 Bridge-road, Richmond, Victoria 3121.
 VIEW POINT AUTHORIZED NEWSAGENCY, 4 View-Point, Bendigo, Victoria 3550.

A copy of the Gazette is filed at each place for public reference.

THE "VICTORIA GOVERNMENT GAZETTE".

SUBSCRIPTIONS.—The subscription, including postage, is \$40 per annum, or \$20 per half year, payable in advance. Subscriptions are required for whole months, and must cover at least a half year.

Single copies are 30 cents, posted 63 cents. Subscribers do not receive the Acts of Parliament with the GAZETTE.

GAZETTES are held in stock for five years only.

PRIVATE ADVERTISEMENTS.—The charge for insertion is 55 cents per line single column, and \$1.10 cents per line double column. The title forms one or more lines as a heading. On an average ten words make a line of single column. Every signature must likewise be counted as a line. The final words of a paragraph, though only portion of a line, must be counted as one line. Signatures (in particular) and proper names must be written very plainly in the text; ONE SIDE ONLY of each sheet of paper should be WRITTEN UPON. The charge for a full page is \$85.

All documents illegibly written will be returned unpublished, and where brands occur unprovided for by the ordinary letters of the alphabet, a worded explanatory description must be furnished.

PUBLICATION.—Unless otherwise advertised, the VICTORIA GOVERNMENT GAZETTE is published on WEDNESDAY EVENING in each week, and Notices for insertion will be received by the Government Printer at or before ONE p.m. at ordinary rates, and late advertisements between ONE p.m. and half-past THREE p.m. at double rates on the day preceding the day of publication.

PAYMENTS.—Unless the advertiser has a credit account, all payments are required in advance. Remittances should be made by cheque, postal order, or money order payable to "GOVERNMENT PRINTER".

ADDRESS.—All communications should be addressed to "The Government Printer, Box 203, P.O., North Melbourne, 3051."

PUBLICATION OF OFFICIAL MATTER.

Attention is invited to the following procedure in relation to the publication of official matter in the *Government Gazette*:—

Publication will be facilitated by the submission of carbon copies for the use of the *Gazette* Officer.

1. Matter submitted to the Executive Council.

Matter submitted to the Executive Council which requires gazettal will normally be published in the issue of the following week.

Where urgent gazettal is required, special arrangements should be made with the *Gazette* Officer, Room 14, first floor, Old Treasury Building.

2. Other matter.

(a) All other matter duly certified by a responsible officer for publication should be lodged with the *Gazette* Officer not later than half-past Nine a.m. on Tuesday.

(b) Lengthy or involved notices should be forwarded several days before publication.

(c) Proofs, which will be supplied only when specifically requested or at the direction of the *Gazette* Officer, should be returned promptly to avoid delay in publication.

(d) No additions or amendments to matter for publication will be accepted by telephone.

CONTENTS	PAGE
Appointments	1939
Cemeteries—Scale of Fees	1932
Contracts	1938
Estates of Deceased Persons	1935
Government Notices	1920
Impoundings	1968
Lands	1946
Mining	1935
Notice of Making of Statutory Rules	1968
Opticians Registration Board	1936
Orders in Council—	
Acts—Racing; Superannuation; Country Roads; Local Government; Land; Housing; Sewerage Districts; Hospital and Charities; Labour and Industry; Dried Fruits; Sewerage Districts.	1940 et seq
Police Sale	1926
Private Advertisements	1951
Proclamations	1917
Public Holiday—Queen's Birthday	1920
Public Service Notices	1949
Regulations—	
Acts—Police Regulation	1927
Resignations	1940
Tenders	1948
Transport Regulation Board—Public Hearings	1921
Waterworks Trusts	1933