



VICTORIA GOVERNMENT GAZETTE

Published by Authority

No. 86]

WEDNESDAY, SEPTEMBER 29

[1976

PROCLAMATIONS

BANK HOLIDAYS.

PROCLAMATION

By His Excellency the Governor of the State of Victoria and its Dependencies in the Commonwealth of Australia, &c., &c., &c.

In pursuance of the provisions of the *Bank Holidays Act 1958, I*, the Governor of the State of Victoria, in the Commonwealth of Australia, do by this my Proclamation appoint the days and dates named hereunder special days to be observed as Bank Holidays or Bank Half-Holidays (as the case may be) at the places respectively mentioned, that is to say:—

Bank Holidays:—

TUESDAY, THE 2ND NOVEMBER, 1976, at Avoca.
WEDNESDAY, THE 17TH NOVEMBER, 1976, at Ballarat.
TUESDAY, THE 2ND NOVEMBER, 1976, at Ouyen and Underbool.
TUESDAY, THE 2ND NOVEMBER, 1976, at Mildura, Redcliffs and Merbein.

Bank Half-Holidays from the Hour of Eleven a.m.:—

TUESDAY, THE 5TH OCTOBER, 1976, at Minyip.
THURSDAY, THE 14TH OCTOBER, 1976, at Nhill.

Given under my Hand and the Seal of the State of Victoria aforesaid, at Melbourne, this twenty-first day of September, in the year of our Lord One thousand nine hundred and seventy-six, and in the twenty-fifth year of the reign of Her Majesty Elizabeth the Second, Queen of Australia.

(L.S.) HENRY WINNEKE.

By His Excellency's Command,

VANCE DICKIE,
Chief Secretary.

GOD SAVE THE QUEEN!

BANK HOLIDAYS.

PROCLAMATION

By His Excellency the Governor of the State of Victoria and its Dependencies in the Commonwealth of Australia, &c., &c., &c.

In pursuance of the provisions of the *Bank Holidays Act 1958, I*, the Governor of the State of Victoria, in the Commonwealth of Australia, do by this my Proclamation appoint the days and dates named hereunder special days to be observed as Bank Holidays or Bank Half-Holidays (as the case may be) at the places respectively mentioned, that is to say:—

Bank Holidays:—

FRIDAY, THE 8TH OCTOBER, 1976, at Murchison.
TUESDAY, THE 19TH OCTOBER, 1976, at Hopetoun and Woomelang,

Bank Half-Holidays from the Hour of Eleven a.m.:—

TUESDAY, THE 5TH OCTOBER, 1976, at Kerang.
TUESDAY, THE 5TH OCTOBER, 1976, at Quambatook.
TUESDAY, THE 12TH OCTOBER, 1976, at Rainbow.
TUESDAY, THE 16TH NOVEMBER, 1976, at Hamilton.
WEDNESDAY, THE 20TH OCTOBER, 1976, at Wycheproof.
MONDAY, THE 25TH OCTOBER, 1976, at Kilmore.

Given under my Hand and the Seal of the State of Victoria aforesaid, at Melbourne, this twenty-eighth day of September, in the year of our Lord One thousand nine hundred and seventy-six, and in the twenty-fifth year of the reign of Her Majesty Elizabeth the Second, Queen of Australia.

(L.S.) HENRY WINNEKE.

By His Excellency's Command.

VANCE DICKIE,
Chief Secretary.

GOD SAVE THE QUEEN!

BANK HOLIDAYS.

PROCLAMATION

By His Excellency the Governor of the State of Victoria and its Dependencies in the Commonwealth of Australia, &c., &c., &c.

In pursuance of the provisions of the *Bank Holidays Act 1958, I*, the Governor of the State of Victoria, in the Commonwealth of Australia, do by this my Proclamation appoint the days and dates named hereunder special days to be observed as Bank Holidays or Bank Half-Holidays (as the case may be) at the places respectively mentioned, that is to say:—

Bank Holidays:—

FRIDAY, THE 8TH OCTOBER, 1976, at Dookie.
WEDNESDAY, THE 6TH OCTOBER, 1976, at Elmore.

Bank Half-Holidays from the Hour of Eleven a.m.:—

WEDNESDAY, THE 6TH OCTOBER, 1976, at Rupanyup.
THURSDAY, THE 7TH OCTOBER, 1976, at Warracknabeal.
MONDAY, THE 11TH OCTOBER, 1976, at Benalla.
FRIDAY, THE 1ST OCTOBER, 1976, at Murtoa.

Given under my Hand and the Seal of the State of Victoria aforesaid, at Melbourne, this twenty-first day of September, in the year of our Lord One thousand nine hundred and seventy-six, and in the twenty-fifth year of the reign of Her Majesty Elizabeth the Second, Queen of Australia.

(L.S.) HENRY WINNEKE.

By His Excellency's Command,
VANCE DICKIE,
Chief Secretary.

GOD SAVE THE QUEEN !

PUBLIC HOLIDAY.

PROCLAMATION

By His Excellency the Governor of the State of Victoria and its Dependencies in the Commonwealth of Australia, &c., &c., &c.

In pursuance of the provisions contained in Part VI. of the *Public Service Act 1974, I*, the Governor of the State of Victoria, in the Commonwealth of Australia, by and with the advice of the Executive Council of the said State, do by this my Proclamation appoint the day and date hereunder mentioned to be observed as a Public Holiday at the place specified, viz.:—

Public Holiday:—

TUESDAY, THE 2ND NOVEMBER, 1976, throughout the Borough of Queenscliffe.

Given under my Hand and the Seal of the State of Victoria aforesaid, at Melbourne, this twenty-first day of September, in the year of our Lord One thousand nine hundred and seventy-six, and in the twenty-fifth year of the reign of Her Majesty Elizabeth the Second, Queen of Australia.

(L.S.) HENRY WINNEKE.

By His Excellency's Command,
VANCE DICKIE,
Chief Secretary.

GOD SAVE THE QUEEN !

PUBLIC HOLIDAYS.

PROCLAMATION

By His Excellency the Governor of the State of Victoria and its Dependencies in the Commonwealth of Australia, &c., &c., &c.

In pursuance of the provisions contained in Part VI. of the *Public Service Act 1974, I*, the Governor of the State of Victoria, in the Commonwealth of Australia, by and with the advice of the Executive Council of the said State, do by this my Proclamation appoint the days and dates hereunder mentioned to be observed as Public Holidays or Public Half-Holidays (as the case may be) at the places respectively specified, viz.:—

Public Holidays:—

TUESDAY, THE 2ND NOVEMBER, 1976, throughout the Shire of McIvor.

Public Half-Holidays from the Hour of Twelve o'clock noon:—

THURSDAY, THE 7TH OCTOBER, 1976, throughout the North Riding of the Shire of Wimmera.

TUESDAY, THE 12TH OCTOBER, 1976, throughout the North Riding of the Shire of Dimboola.

WEDNESDAY, THE 13TH OCTOBER, 1976, throughout the Centre Riding of the Shire of Dimboola.

Public Half Holidays from the Hour of Eleven a.m.:—

SATURDAY, THE 20TH NOVEMBER, 1976, throughout the South and West Ridings of the Shire of Dimboola.

Given under my Hand and the Seal of the State of Victoria aforesaid, at Melbourne, this twenty-first day of September, in the year of our Lord One thousand nine hundred and seventy-six, and in the twenty-fifth year of the reign of Her Majesty Elizabeth the Second, Queen of Australia.

(L.S.) HENRY WINNEKE.

By His Excellency's Command,
VANCE DICKIE,
Chief Secretary.

GOD SAVE THE QUEEN !

PUBLIC HALF-HOLIDAYS.

PROCLAMATION

By His Excellency the Governor of the State of Victoria and its Dependencies in the Commonwealth of Australia, &c., &c., &c.

In pursuance of the provisions contained in Part VI. of the *Public Service Act 1974, I*, the Governor of the State of Victoria, in the Commonwealth of Australia, by and with the advice of the Executive Council of the said State, do by this my Proclamation appoint the days and dates hereunder mentioned to be observed as Public Half-Holidays at the places respectively specified, viz.:—

Public Half-Holidays from the Hour of Twelve o'clock noon:—

MONDAY, THE 25TH OCTOBER, 1976, throughout the Shire of Kilmore.

TUESDAY, THE 5TH OCTOBER, 1976, throughout the Borough of Kerang.

WEDNESDAY, THE 20TH OCTOBER, 1976, throughout the Shire of Numurkah.

WEDNESDAY, THE 10TH NOVEMBER, 1976, throughout the Shire of Strathfieldsaye.

Given under my Hand and the Seal of the State of Victoria aforesaid, at Melbourne, this twenty-first day of September, in the year of our Lord One thousand nine hundred and seventy-six, and in the twenty-fifth year of the reign of Her Majesty Elizabeth the Second, Queen of Australia.

(L.S.) HENRY WINNEKE.

By His Excellency's Command,
VANCE DICKIE,
Chief Secretary.

GOD SAVE THE QUEEN !

ACTS OF PARLIAMENT.

PROCLAMATION

By His Excellency the Governor of the State of Victoria and its Dependencies in the Commonwealth of Australia, &c., &c., &c.

I, the Governor of the State of Victoria, in the Commonwealth of Australia, do hereby declare that I have this day assented, in Her Majesty's name, to the Bills passed by the Parliament of the said State, the titles whereof are hereunder set forth, together with the short titles, that is to say:—

No. 8877. "An Act to authorise the Payment of an Expense Allowance to certain Members of the Legislative Council or the Legislative Assembly." (*Parliamentary Allowances*) Act 1976.)

No. 8878. "An Act to make Provision for the Granting of Licences authorising the Sale or Disposal of Liquor at the Exhibition Buildings in Melbourne and for other purposes." (*Liquor Control (Exhibition Buildings)*) Act 1976.)

Given under my Hand and the Seal of the State of Victoria aforesaid, at Melbourne, this twenty-eighth day of September, in the year of our Lord

One thousand nine hundred and seventy-six, and in the twenty-fifth year of the reign of Her Majesty Queen Elizabeth II.

Township of Leongatha, Parish of Leongatha, County of Buln Buln, being the land indicated by hatching on plan hereunder.—(L.167^(o)) (L.10-1105).

(L.S.) HENRY WINNEKE.

By His Excellency's Command,

R. J. HAMER,
Premier.

GOD SAVE THE QUEEN!

NOTE.—Act No. 8877 shall come into operation on a day to be fixed by Proclamation. Act No. 8878 shall come into operation on the day of Royal Assent i.e. 28th September, 1976.

ROADS PROCLAIMED.

PROCLAMATION

By His Excellency the Governor of the State of Victoria and its Dependencies in the Commonwealth of Australia, &c., &c., &c.

In pursuance of the provisions of section 25 (3) (c) of the Land Act 1958, I, the Governor of the State of Victoria, by and with the advice of the Executive Council of the said State, do hereby proclaim as roads the under-mentioned lands:

Parish of Deutgam, County of Bourke, being the land indicated by hatching on plan hereunder.—(D.42^(o)) (Misc. 3997).

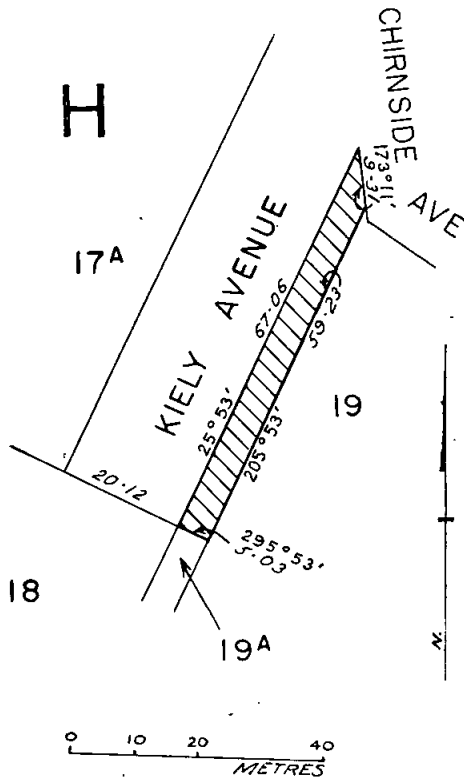
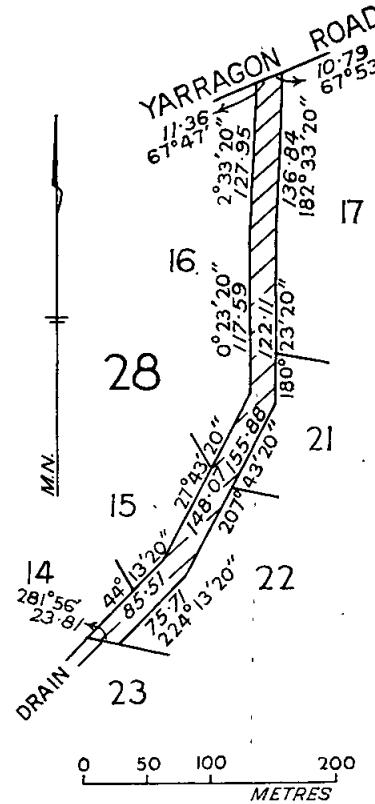

Given under my Hand and the Seal of the State of Victoria aforesaid, at Melbourne, this twenty-first day of September, in the year of our Lord One thousand nine hundred and seventy-six, and in the twenty-fifth year of the reign of Her Majesty Elizabeth the Second, Queen of Australia.

(L.S.) HENRY WINNEKE.

By His Excellency's Command,

W. BORTHWICK,
Minister of Lands.

GOD SAVE THE QUEEN!

PUBLIC HIGHWAY.—CITY OF OAKLEIGH.

PROCLAMATION

By His Excellency the Governor of the State of Victoria and its Dependencies in the Commonwealth of Australia, &c., &c., &c.

Whereas by the Local Government Act 1958, section 519 it is amongst other things enacted that it shall be lawful for the Governor in Council at any time and from time to time upon the request of the Council of any municipality by notice in the Government Gazette to proclaim any land reserved used or by purchase or exchange acquired for a street, road, highway, thoroughfare, bridge, square, court, alley, or right-of-way or any street, road, lane, or passage made or laid out or proposed to be made or laid out, on any land of which a plan of subdivision delineating that street, road, lane or passage has been sealed with the seal of the municipality under subdivision (3) of Division 9 of Part XIX, or a corresponding previous enactment to be a public highway; and that such land shall thereupon and thenceforth from that date of such proclamation become and be absolutely dedicated to the public as a public highway within the meaning of any law then or thereafter in force.

And whereas the Council of the City of Oakleigh has requested that the land hereinafter mentioned, being a road laid out on land of which a plan of subdivision delineating the street, road, lane or passage has been sealed

with the seal of the municipality under subdivision (3) of Division 9 of Part XIX. of the Local Government Act 1958, or a corresponding previous enactment, be so declared to be a public highway.

Now therefore, I, the Governor of the State of Victoria, in the Commonwealth of Australia, by and with the advice of the Executive Council of the said State, do by this Proclamation declare that the road shown by hachure on the plan hereunder shall be a public highway within the meaning of the said Act.

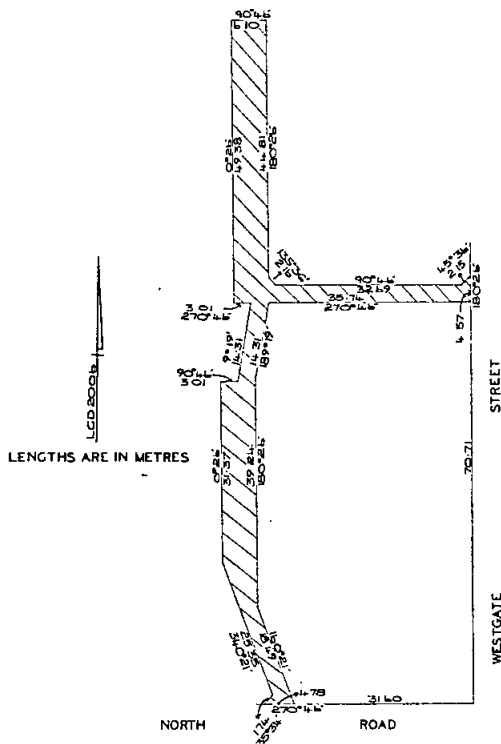

Given under my Hand and the Seal of the State of Victoria, aforesaid, at Melbourne, this twenty-first day of September, in the year of our Lord One thousand nine hundred and seventy-six, and in the twenty-fifth year of the reign of Her Majesty, Queen Elizabeth II.

(L.S.) HENRY WINNEKE.
By His Excellency's Command,
A. J. HUNT,
Minister for Local Government.
GOD SAVE THE QUEEN!

PUBLIC HIGHWAY.—SHIRE OF MORNINGTON.

PROCLAMATION

By His Excellency the Governor of the State of Victoria and its Dependencies in the Commonwealth of Australia, &c., &c., &c.

Whereas by the Local Government Act 1958, section 519 it is amongst other things enacted that it shall be lawful for the Governor in Council at any time and from time to time upon the request, of the council of any municipality by notice in the Government Gazette to proclaim any land reserved used or by purchase or exchange acquired for a street road highway thoroughfare bridge square court alley or right-of-way or any street road lane or passage made or laid out or proposed to be made or laid out on any land of which a plan of subdivision delineating that street road lane or passage has been sealed with the seal of the municipality under sub-section (3) of Division 9 of Part XLIX. of the Local Government Act 1958 or a corresponding previous enactment to be a public highway and that such land shall thereupon and thenceforth from the date of such proclamation become and be absolutely dedicated to the public as a public highway within the meaning of any law then or thereafter in force.

And whereas the Council of the Shire of Mornington has requested that the land hereinafter mentioned, being a street road lane or passage made or laid out or proposed to be made or laid out on land of which a plan of subdivision delineating such street road lane or passage has been sealed with the seal of the municipality under subdivision (3) of Division 9 of Part XIX. of the Local Government Act 1958, or a corresponding previous enactment be so declared to be a public highway.

Now therefore, I, the Governor of the State of Victoria in the Commonwealth of Australia, by and with the advice of the Executive Council of the said State, do by this proclamation declare that Meribah Street, Mornington shown by hachure on the plan hereunder shall be a public highway within the meaning of the said Act.

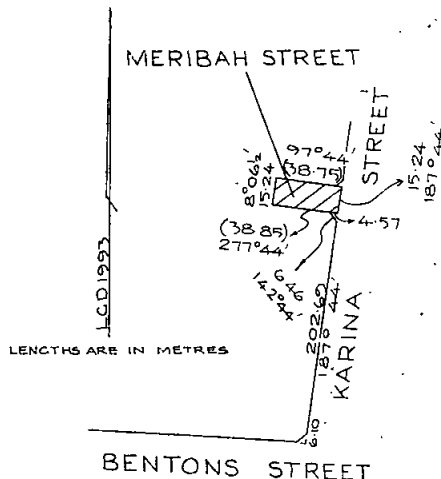

Given under my Hand and the Seal of the State of Victoria, aforesaid, at Melbourne, this twenty-first day of September, in the year of our Lord One thousand nine hundred and seventy-six, and in the twenty-fifth year of the reign of Her Majesty Queen Elizabeth II.

(L.S.) HENRY WINNEKE.
By His Excellency's Command,
A. J. HUNT,
Minister for Local Government.
GOD SAVE THE QUEEN!

LAND ACT 1958.

PROCLAMATION

By His Excellency the Governor of the State of Victoria and its Dependencies in the Commonwealth of Australia, &c., &c., &c.

In pursuance of the provisions of section 22c (2) of the Land Act 1958, I, the Governor of the State of Victoria, by and with the advice of the Executive Council of the said State, and upon receipt of certification by the Clerk of the municipality concerned (Shire of Bet Bet) that the land constitutes land which is or has been used for a public hall, do by this Proclamation declare allotments 5 and 6 of section 16 in the Township of Tarnagulla, Parish of Tarnagulla, and more particularly described in certificate of title, volume 2854 folio 748, to be land to which the said section 22c (2) applies.—(C.100766).

Given under my Hand and the Seal of the State of Victoria aforesaid, at Melbourne, this twenty-first day of September, in the year of our Lord One thousand nine hundred and seventy-six, and in the twenty-fifth year of the reign of Her Majesty Elizabeth the Second, Queen of Australia.

(L.S.) HENRY WINNEKE.
By His Excellency's Command,
W. BORTHWICK,
Minister of Lands.
GOD SAVE THE QUEEN!

GOVERNMENT NOTICES

DEPARTMENT OF THE PREMIER

HEADS OF CONSULAR POSTS AT MELBOURNE.

His Excellency the Governor has approved of the recognition of Mr. R. G. McComas as Honorary Consul for Latvia with jurisdiction throughout the State of Victoria with effect from 4th February, 1976.

R. J. HAMER,
Premier.

Dated 21st September, 1976.

State Savings Bank Act 1958, Section 30.
THE STATE SAVINGS BANK OF VICTORIA.
ESTABLISHMENT OF BRANCH.

The Commissioners of the State Savings Bank of Victoria hereby give notice of the establishment of Boronia, Dorset Road Branch of the Bank at 226 Dorset Road, Boronia on 4th October, 1976.

D. ROSS,
General Manager.

Local Government Act 1958.

NOTICE OF CONFIRMATION OF AN ORDER OF THE COUNCIL OF THE TOWN OF BAIRNSDALE ADOPTING A PROPOSAL FOR THE CLOSURE OF STREETS OR ROADS TO THROUGH TRAFFIC.

Pursuant to the provisions of section 539c of the *Local Government Act 1958*, the Governor in Council, on the 21st day of September, 1976, confirmed an Order of the Council of the Town of Bairnsdale made on 15th June, 1976, adopting a proposal for the closure of Ross and Doherty Streets, Bairnsdale to through traffic by the erection of barriers at the locations shown on the plan hereunder.

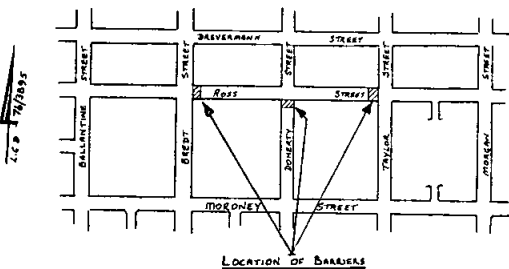

TOM FORRISTAL,
Clerk of the Executive Council.

Local Government Act 1958.

NOTICE OF CONFIRMATION OF AN ORDER OF THE COUNCIL OF THE TOWN OF BAIRNSDALE ADOPTING A PROPOSAL FOR THE CLOSURE OF STREETS OR ROADS TO THROUGH TRAFFIC.

Pursuant to the provisions of section 539c of the *Local Government Act 1958*, the Governor in Council on the 21st day of September, 1976, confirmed an Order of the Council of the Town of Bairnsdale made on 2nd February, 1975, adopting a proposal for the closure of Pinnock and Morgan Streets, Bairnsdale to through traffic by the erection of barriers at the locations shown on the plan hereunder.

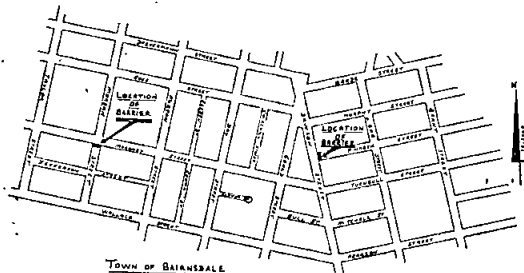

TOM FORRISTAL,
Clerk of the Executive Council.

LOCAL GOVERNMENT DEPARTMENT.
ORDER CONFIRMED.—CITY OF PRESTON.

The Minister of the Crown administering the *Local Government Act 1958*, on the 22nd day of September, 1976, confirmed the Order hereinafter referred to in pursuance of section 514 of the said Act namely:

An Order of the Council of the City of Preston made on the 16th August, 1976, directing the compulsory taking of the land described in certificate of title volume 5012 folio 264 for the purposes of providing offstreet car parking facilities.

A. J. HUNT,
Minister for Local Government.

Local Government Department,
Melbourne (76/5047).

LOCAL GOVERNMENT DEPARTMENT.
ORDER CONFIRMED.—SHIRE OF WERRIBEE.

The Minister of the Crown administering the *Local Government Act 1958*, on the 22nd day of September, 1976, confirmed the Order hereinafter referred to in pursuance of section 514 of the said Act namely:

An Order of the Council of the Shire of Werribee made on the 13th September, 1976, directing the compulsory taking of the land described as lot 33, section G7, on lodged plan of subdivision No. 1272; for the purposes of providing public open space.

A. J. HUNT,
Minister for Local Government.

Local Government Department,
Melbourne (76/5552).

Urban Renewal Act 1970.

CITY OF COLLINGWOOD.

URBAN RENEWAL PROPOSAL.

Housing Commission, Victoria.

The object of the Urban Renewal Proposal is to provide for the rehabilitation of the area bounded by Nicholson, Victoria, Langridge and Charles Streets by improving traffic access, cleaning up and beautifying vacant areas and removing the associated public health risks, providing car parking, and by offering renovation loans for buildings in the area. The implementation of the renewal proposal will aid in the achievement of the full potential of this part of the City consistent with present trends in other parts of the City.

A copy of the proposal may be inspected during office hours of the Town Hall, Hoddle Street, Collingwood; at the office of the Town and Country Planning Board, 235 Queen Street, Melbourne; at the office of the Melbourne and Metropolitan Board of Works, 625 Little Collins Street, Melbourne; and at the office of the Urban Renewal Authority, 150 Queen Street, Melbourne.

All persons affected by the renewal proposal who object to any matter contained in the proposal, or who wish to make any submission with respect to the proposal must set forth in writing to the Renewal Authority, 150 Queen Street, Melbourne, by the 29th December, 1976, all objections which they may have or submissions which they may wish to make in respect of the proposal, and state whether they wish to be heard in respect of their objections and submissions.

N. GREEN, Secretary,
Housing Commission, Vic.

Marine Act 1958.

AMENDMENT OF PILOTAGE RATES.

PORT OF PORTLAND.

In pursuance of the powers conferred by section 79 of the *Marine Act 1958*, the Marine Board of Victoria, with the approval of the Governor in Council, fixes the following new rates of pilotage:—

1. The Pilotage Rate for ships from without the Port of Portland to a quay or anchorage within the Port of Portland, or vice versa, shall be \$0.02 per gross ton subject in any case to a maximum charge of \$100 and a minimum charge of \$30.

2. The Pilotage Rate from one place to another in the Port of Portland shall be \$0.01 per gross ton subject in any case to a maximum charge of \$80 and a minimum charge of \$30.

(SEAL) A. J. WAGGLEN, President.
P. EUTROPE, Member.
K. T. MANALACK, Secretary.

Approved by the Governor in Council, 21st September, 1976.—TOM FORRISTAL, Clerk of the Executive Council.

Transport Regulation Act.
TRANSPORT REGULATION BOARD.

HEARING OF APPLICATIONS.

Notice is hereby given that the following application will be considered by the Transport Regulation Board on 19th October, 1976.

McMILLAN, D. H., care of Cabarito Post Office. Application to license a 5 seating capacity vehicle as a country taxi cab to operate from Commercial Street, Merbein.

Applications for renewal of licences as shown by the persons listed hereunder to operate under the same terms and conditions:—

EGAN, Mrs. T. M., Whitfield; T.S.976.

GERRARD WIRE TYING MACHINES CO. PTY. LTD., Melbourne; S.V.52; S.V.53.

MACKENZIE, A. R. & H. M., Minyip; T.S.672; T.S.730; T.S.794.
MOONEE VALLEY BUS LINES PTY. LTD., Essendon; M.O.661; M.O.395; M.O.196; M.O.146; M.O.403; M.O.578; M.O.602.

MCDONNELL, B. A. & P. E., Coleraine; T.S.807.

Notice of any objections should be forwarded to reach the Secretary of the Board not later than 13th October, 1976.

Applicants are advised that it will not be necessary to appear on the hearing date specified, unless advised in writing by the Board.

A. V. C. COOK,
Secretary.

Corner Lygon and Princes Streets, Carlton, 3053,
Wednesday, 29th September, 1976.

Commercial Goods Vehicles Act.
TRANSPORT REGULATION BOARD.

HEARING OF APPLICATIONS.

Notice is hereby given that the following applications will be considered by the Transport Regulation Board on 29th October, 1976.

AUSTRALIAN GYPSUM LTD., 350 Latrobe Street, Melbourne, 3000. One commercial goods vehicle (L/C. 13.80 tonne) to operate: (a) Within a 40-km radius of own premises at Hattah in the course of business as "Plaster Manufacturers"—own goods. (b) From own pits at Hattah to Mildura—own gypsum.

BROWNSCOMBE, B. K., 5 Hayden Court, Knoxfield, 3180. One commercial goods vehicle (L/C. 6.45 tonne) to operate within a 113-km radius of the plant of "Brick and Pipe Industries Ltd. at Box Hill"—bricks on behalf of the said company.

BRUCE, W. A., 11 Osburne Court, Warrnambool, 3280. One commercial goods vehicle (L/C. 3.60 tonne) to operate: (a) Within a 40-km radius of chief post office Warrnambool—general goods. (b) Within an 80-km radius of the chief post office situated at Warrnambool on behalf of J. Stuckey Heatane Agent at Warrnambool—heatane gas cylinders and empty return cylinders. (c) Within an 80-km radius of own premises at Warrnambool in the course of business as "Plumber and Gas Fitter"—tools of trade, gas appliances for installation, for repair or having been repaired and materials incidental thereto.

CHASEMORE, K. R., 253 Whitehorse Road, Blackburn, 3130. One commercial goods vehicle (L/C. 10.20 tonne) to operate: (a) Throughout the State of Victoria in course of business as "Road Construction Contractors"—own tools of trade and equipment. (b) Within a 40-km radius of any current contract site or from the railway station nearest thereto—materials required for use on such contract.

GERRISH, K. E. (trading as B. & G. Transport), Old Tolmie Road, Barwite via Mansfield, 3722. One commercial goods vehicle (fork lift) to operate within an 80-km radius of the post office at Mansfield as a specially constructed forklift vehicle in the course of business as "Logging Contractor" for the purpose of loading own vehicles at forest and private landings with saw-mill logs.

DALGETY AUSTRALIA LIMITED, 481 Bourke Street, Melbourne, 3000. One commercial goods vehicle (L/C. 1.00 tonne) to operate within an 80-km radius of own branch premises at Camperdown in the course of business as "Wool Brokers and Stock and Station Agents"—own goods.

HUTCHINSON, G. C. (trading as E.T.Y. Transport), 14 Deboos Street, Euroa; 3666. Application to vary the conditions of licence No. D.T.1579/1 (L/C. 8.30 tonne) by adding an additional paragraph (c) "Between the City of Bendigo and the township of Euroa—general goods".

FECHNER, C. J., 26 Dodemaides Road, Trafalgar, 3824. One commercial goods vehicle (L/C. 1.00 tonne) to operate from own premises at Trafalgar to consignees situated within that part of the State of Victoria east of a north-south line drawn through Pakenham, south of an east-west line drawn through Bruthen and west of a north-south line drawn through Lakes Entrance in the course of business as "Auto Accessory Distributor"—own automotive parts and accessories provided that all goods are initially received on rail at Trafalgar.

H.C.F. CONSTRUCTION SERVICE PTY. LTD., 57 Henderson Road, Clayton, 3168. One commercial goods vehicle (L/C. 0.80 tonne) to operate: (a) Within an 80-km radius of own premises at Clayton in the course of business as "Building Contractors"—own goods. (b) Throughout the State of Victoria—tools of trade, plant and equipment solely for use in own building contracts. (c) Within a 40-km radius of the site of any contract upon which the applicant is currently engaged or to such site from the railway station nearest thereto—materials for use on such contract.

ASSOCIATED MOBILE EQUIPMENT CO. PTY. LTD. (trading as Linmac Vic.), 53 Henderson Road, Clayton, 3168. One commercial goods vehicle (L/C. 1.40 tonne) to operate throughout the State of Victoria in the course of business as "Mobile Crane and Forklift Sales and Service" for the purpose of servicing and maintaining mobile equipment—tools of trade, spare parts and materials required for the on-site servicing and maintenance of mobile equipment.

MOTORWAY TYRE SERVICE PTY. LTD., 31 Main Street, Stawell, 3380. Application to vary the conditions of licence No. D.A.50135/9 (L/C. 1.00 tonne) by adding as an additional paragraph "From Mildura to own premises at Stawell and return"—tyres for recapping returning with recapped tyres".

MCLEOD, K. L., 31 Park Road, Noble Park, 3174. One commercial goods vehicle (L/C. 0.75 tonne) to operate within a 160-km radius of the premises of Gendore Pty. Ltd. at Tooradin as a "Serviceman" solely on behalf of the said company—tools of trade, spare parts and materials incidental to the servicing of farm machinery on site only.

MARTIN, C. L., Officers Lane, Koroit, 3282. One commercial goods vehicle (L/C. 12.00 tonne) to operate: (a) Within a 40-km radius of the post office at Koroit—general goods. (b) Within an 80-km radius of the post office at Koroit in course of business as "Primary Producer"—own goods. (c) Within that part of the State of Victoria west of a north-south line drawn through Dandenong—livestock.

PERMEWAN WRIGHT LTD., 657-677 Springvale Road, Mulgrave, 3170. One commercial goods vehicle (L/C. 7.50 tonne) to operate from own warehouse premises at Mulgrave to own branch premises at Warragul—groceries and allied goods.

SCOTT, A. B., 1 Sinnott Street, Preston, 3072. One commercial goods vehicle (L/C. 6.10 tonne) to operate within a 113-km radius of the plant of Clifton Brick Holdings Ltd. at Preston—bricks on behalf of the said company.

T.N.T. MANAGEMENT PTY. LTD., care of Comet Overnight Transport, 2 Coode Road, Footscray, 3011. Two commercial goods vehicles (to be purchased approximately 5.00 tonne each) to operate from Melbourne to places within a 40-km radius of own depot at Ballarat and to places within a 40-km radius of own depot at Bendigo serving Geelong and Maryborough en route and return—general goods being urgent express freight.

T.N.T. MANAGEMENT PTY. LTD., care of Comet Overnight Transports, 2 Coode Road, Footscray, 3011. One commercial goods vehicle (to be purchased approximately 5.00 tonne) to operate from Melbourne to places within a 40-km radius of own depot at Morwell and return—general goods being urgent express freight.

TOMKINS, G. R. & L. F., 42-44 Torquay Road, Belmont, 3216. One commercial goods vehicle (L/C. 0.50 tonne) to operate: (a) Within a 40-km radius of the chief post office in the City of Geelong—general goods. (b) From the City of Geelong to the township of Bacchus Marsh—newspapers solely on behalf of Geelong Advertiser Pty. Ltd.

TOTALIZATOR AGENCY BOARD, 2 Queens Road, Melbourne, 3004. One commercial goods vehicle (L/C. 0.75 tonne) to operate: (a) Within an 80-km radius of own premises at Melbourne in the course of business as "Totalizator Agency"—own goods. (b) Throughout the State of Victoria for the purpose of servicing and maintenance of own equipment at own premises—tools of trade, spare parts and materials incidental to on-site servicing.

WILTON, W. C., 53 Scenic Road, Warragul, 3820. One commercial goods vehicle (to be purchased) to operate: (a) From the premises of Super Soft Pty. Ltd. at Warragul (an approved decentralized secondary industry) to consignees situated within a 40-km radius of the G.P.O. Melbourne—new lounge suites. (b) From Namco Industries Vic. Pty. Ltd. at Harrisfield to Super Soft Pty. Ltd. at Warragul—foam skins. (c) Throughout the State of Victoria—household furniture being furniture or personal effects of a householder or a member of his family when being moved from residence to residence, from residence for storage or sale from storage to residence from vendor to the residence of the purchaser.

YARRAM TIMBER PTY. LTD., 73 Rogers Street, Yarram, 3971. One commercial goods vehicle (L/C. 13.65 tonne) to operate from own sawmill at Yarram to consignees situated within a 40-km radius of the post office at Yarram and to consignees situated within a 40-km radius of the G.P.O. Melbourne—sawn timber.

TOW TRUCKS.

BEANLAND, L. & G. (trading as Hi-Way Towing Service), 82 Lombardy Avenue, Dromana, 3936. One commercial goods vehicle (to be purchased) to operate throughout the State of Victoria as a Heavy Salvage Tow Truck Class 4, for the purpose of lifting and carrying or towing and/or repairing wrecked or disabled vehicles—tools of trade, spare parts and materials incidental thereto.

BEANLAND, L. & G. (trading as Hi-Way Towing Service), 82 Lombardy Avenue, Dromana, 3936. One commercial goods vehicle (to be purchased) to operate throughout the State of Victoria as a class 3 heavy duty tow truck for the purpose of lifting and carrying or towing and/or repairing wrecked or disabled vehicles—tools of trade, spare parts and materials incidental thereto.

WEAVER & BROUGHTON PANELS PTY. LTD., 21 Aitken Avenue, Donald, 3480. One commercial goods vehicle (L/C. 2.00 tonne) to operate as a "Tow Truck" within an 80-km radius of own premises at Donald for the purpose of lifting and carrying or towing and/or repairing wrecked or disabled vehicles—tools of trade, spare parts and materials incidental thereto.

RENEWALS.

Applications for renewal of licences as shown by persons listed hereunder to operate under the same terms and conditions from the expiry shown in each case.

ALEXANDER, J. M., Camperdown Road, Cobden, 3266; D.A.62379; 9th December, 1976; 9.00 and 12.80 tonne trailer.

ORENSHAW, K. A. (trading as Barry & Orenshaw), King Street, Yarra Glen, 3775; D.A.60223/3; 11th December, 1976; 12.10 tonne.

BLENNER-HASSETT, J. & L. C., 32 Koonwarra Road, Leon-gatha, 3953; D.A.60463/2; 14th November, 1976; 14.35 tonne.

BRUNT, S. G., PTY. LTD., 224 High Street, Cranbourne, 3977; D.A.28821; 17th December, 1976; 7.75 tonne.

CARBA AUSTRALIA LTD., 679 Victoria Street, Abbotsford, 3067; D.A.61873/4; 5th November, 1976; 3.80 tonne.

COLAC AERATED WATER CO. PTY. LTD., 819 Howitt Street, Wendouree, 3355; D.A.864/11; 11th December, 1976; 3.65 tonne.

COLGATE PALMOLIVE PTY. LTD., 660 Footscray Road, West Melbourne, 3003; D.A.41727/32; 8th December, 1976; 0.50 tonne; D.A.41727/33; 8th December, 1976; 0.50 tonne.

COUTTS, G. F. & J. D., 31 Polk Street, Horsham, 3400; D.A.65311/2; 23rd October, 1976; 0.50 tonne.

CYCLONE K. M., WINDOWS DIVISION OF K. M. PRODUCTS PTY. LTD., Cremorne Street, Richmond, 3121; T.D.A.51030/8; 18th October, 1976; 1.25 and 1.50 tonne trailer.

G.E.C. DIESELS AUSTRALIA LTD., 1 Winterton Road, Clayton, 3168; D.A.1965/4; 5th December, 1976; 0.75 tonne.

FERGUSON F., WOOL CO. PTY. LTD., 80 McIvor Road, Bendigo, 3550; T.D.A.62018/3; 7th December, 1976; 3.75 tonne.

FITZPATRICK, M. F., P.O. Box 145, Irymple, 3498; D.A.65724; 4th December, 1976; 3.30 tonne.

FLAHERTY, J. & M. (trading as M. & J. Distributors), 52 Kepler Street, Warrnambool, 3280; T.D.A.44613; 27th November, 1976; 1.40 tonne.

FOX, ALBERT H., PTY. LTD., 6 Regent Court, Warragul, 3820; D.A.53038/5; 1st December, 1976; 0.75 tonne.

HOBBS, K. F. (trading as K. F. & R. J. Hobbs), Lardners Track, Warragul South, 3820; D.A.65709; 20th November, 1976; 3.80 tonne.

JONGBLOED, L., 54 Unitt Street, Melton, 3337; D.A.41259; 5th December, 1976; 13.00 tonne.

LEWTAS, I. H., 24 Mummery Street, Mt. Waverley, 3149; D.A.62423; 16th December, 1976; 8.15 and 6.00 tonne trailer.

MANSELL, N. F., Federation Street, Box Hill, 3128; D.A.62293; 5th November, 1976; 6.90 tonne.

PRINCIOTTA, S., 29 Miller Street, Thornbury, 3071; T.D.A.64765; 2nd November, 1976; 1.95 tonne.

QUEEN'S BRIDGE MOTORS PTY. LTD., 359 Plummer Street, Port Melbourne, 3207; D.A.1783/50; 1st December, 1976; 0.75 tonne.

RAMSDEN, B. F., 39 Diosma Drive, Glen Waverley, 3150; D.A.54133; 14th December, 1976; 7.95 tonne.

REPCO LTD., 618 Elizabeth Street, Melbourne, 3000; D.A.1907/23; 20th December, 1976; 0.70 tonne.

RYAN, J. F., 183 High Street, Northcote, 3070; D.A.62376/2; 9th December, 1976; 0.70 tonne.

SCHROETER, A. A., 45 Anderson Street, Heyfield, 3858; D.T.1321; 23rd December, 1976; 12.95 tonne.

SMITH, E. G. (trading as F. G. & F. E. Smith & Son), 56 Manifold Street, Camperdown, 3260; D.A.56333/2; 13th November, 1976; 7.60 tonne.

SUNBEAM CORPORATION LTD., Sloane Street, Maribyrnong, 3032; D.A.14579/50; 16th December, 1976; 1.00 tonne.

TAYLOR, R. J., Gerang Gerung, 3417; D.A.53951; 1st December, 1976; 5.90 tonne.

WILSON, D. L., P.O. Box 63, Doveton, 3177; D.A.27928/12; 17th August, 1976; 1.70 tonne.

WILSON, D. L. (trading as C. D. Wilson & Sons), P.O. Box 63, Doveton, 3177; D.A.27928/10; 27th November, 1975; 9.60 tonne.

Notice of any objection should be forwarded to reach the Secretary of the Board not later than 13th October, 1976.

Applicants are advised that it will not be necessary to appear on the hearing date specified above, unless advised in writing by the Board.

A. V. C. COOK,
Secretary.

Corner Lygon and Princes Street, Carlton, Vic., 3053,
Wednesday, 29th September, 1976.

Water Act 1958.

STATE RIVERS AND WATER SUPPLY COMMISSION.

NATIMUK URBAN DISTRICT.

Notice to owners of tenements in the under-mentioned streets in the Natimuk Urban District and the private streets, lanes, courts and alleys opening thereto:—

Lake Avenue, from the end of the existing main (opposite Lot 18) to Lot 11, about 190 metres northerly.

The main pipe in the said street being laid down, the owners of all tenements situated as above are hereby required, on or before the 1st day of November next, to cause proper pipes and stop cocks to be laid, so as to supply water within such tenements from the main pipe.

G. W. LEWIS, Secretary.
State Rivers and Water Supply Commission.
Melbourne, 22nd September, 1976.

STATE RIVERS AND WATER SUPPLY COMMISSION.

VESTING OF LANDS—CAIRN CURRAN RESERVOIR.

The State Rivers and Water Supply Commission in pursuance of the provisions of sub-section (4) of section 29 of the Water Act 1958 hereby gives notice that the lands shown by red colour on Plans numbered 7230, 7231 and 7232 sealed by the Commission and deposited in the Plan Room of the Commission at 590 Orrong Road, Armadale, are vested in the Commission under sub-section (2) of section 29 of the said Act.

Dated this 10th day of September, 1976.

G. W. LEWIS,
Secretary.

DOOKIE WATERWORKS TRUST.

FIXING THE LIMIT OF BANK OVERDRAFT.

His Excellency the Governor of the State of Victoria by and with the advice of the Executive Council thereof doth by Order made on the 21st day of September, 1976, fix the total amount of the sums which the Dookie Waterworks Trust may owe at any one time in respect of moneys borrowed by overdraft of current account pursuant to the provisions of section 286 of the Water Act 1958, at Five thousand dollars (\$5,000).

TOM FORRISTAL,
Clerk of the Executive Council.
At the Executive Council Chamber,
Melbourne, 21st September, 1976.

EUROA WATERWORKS TRUST.**INCREASING THE LIMIT OF BANK OVERDRAFT.**

His Excellency the Governor of the State of Victoria by and with the advice of the Executive Council, thereof doth by Order made on the 21st day of September, 1976, increase the total amount of the sums which the Euroa Waterworks Trust may owe at any one time in respect of moneys borrowed by overdraft of current account pursuant to the provisions of section 288 of the *Water Act 1958*, fixed by the Governor in Council on 19th December, 1967, at One hundred thousand dollars (\$100,000) to One hundred and fifty thousand dollars (\$150,000).

TOM FORRISTAL,
Clerk of the Executive Council.

At the Executive Council Chamber,
Melbourne, 21st September, 1976.

MUNICIPAL AUDITORS BOARD.

The next examinations for the Certificate of Competency as Municipal Auditor and Inspector of Municipal Administration will be held in Melbourne on Wednesday, 4th and Thursday, 5th May, 1977.

Copies of Regulations, syllabus and past examination papers may be obtained from the Board's Secretary, to whom applications to sit should be forwarded at least 21 days prior to the date of the examination.

A. AROPE, Secretary,
Municipal Auditors Board.

480 Collins Street, Melbourne, 3000. Phone 6171 207.

VICTORIAN MUNICIPAL AUDIT EXAMINEES.

The Local Government Department, in conjunction with the Municipal Auditors Joint Committee, has organized a seminar on Friday, 4th March, 1977, to assist students preparing for the Municipal Auditors examinations.

The programme will commence at 1 p.m. in the Conference Room at the Local Government Department (18th Floor) 480 Collins Street, Melbourne.

Format for the seminar will include short addresses by both practising municipal auditors, and inspectors of municipal administration, followed by a question time.

Examinees are requested to submit questions in writing at least two weeks prior to the seminar date, to Mr. A Arope, Secretary to the Municipal Auditors Board, at the Local Government Department, from whom further details may also be obtained.

(Phone: 6171 207.)

THE TOBACCO LEAF MARKETING BOARD ELECTION.

A Poll is to be taken on Wednesday, 20th October, 1976 for the purpose of electing four elective members of The Tobacco Leaf Marketing Board. Voting will be by personal ballot, following the style of Parliamentary elections, at the following places:—

R.S.L. Hall, Myrtleford.
Youth Club Hall, Bright.
Public Hall, Markwood
Public Hall, Whitfield.
Public Hall, Tawonga.
Public Hall, Whorouly.
Memorial Hall, Gunbower.

Polling booths will be open to enrolled voters from 9.00 a.m. to 6.00 p.m. One electoral area has been adopted covering the whole of the State of Victoria. The full names of each candidate standing for election, as supplied to the undersigned, are as follows:—

FRASCA, JACK.
GREEN, FRANCIS JAMES.
KNEEBONE, HUGHIE HAMILTON.
McCORMACK, DESMOND JOHN.
MACDONALD, COLIN.
MCGUFFIE, WILLIAM JAMES.
ORTON, JOHN MUNRO.
RIGONI, ANGELO.
SMITH, LINDSAY DAVID.
WOODWARD, CECIL FRANCIS.

Postal Voting.

The only persons entitled to vote by post are voters who are unable to attend personally for one of the following reasons:—

- that he resides at least ten miles from the nearest polling place; or
- that he will not throughout the hours of polling on the polling day be within ten miles of the nearest polling place; or
- that he will throughout the hours of polling on the polling day be travelling under conditions which will preclude him from voting at a polling place; or
- that he is seriously ill or infirm and by reason thereof will be prevented from voting personally at a polling place; or
- that by reason of approaching maternity the person will be prevented from voting personally at a polling place.

An application for a postal vote must be made on a special form, which is obtainable from the Returning Officer, The Tobacco Leaf Marketing Board Election, Box 4105, Melbourne, Victoria, 3001 (telephone 651 7376). Requests for such application forms should be made as soon as possible, as the processes involved in obtaining a vote by this method may well occupy several days. After obtaining one of the special forms, the application may be lodged personally or by post. The closing date for receiving applications is 10.00 a.m. on Tuesday, the 19th October, 1976, i.e., the day before polling day.

If the application is lodged by post, applicants should allow sufficient time for a postal voting ballot paper to be forwarded to them through the post, and then sent to the Returning Officer, after completion by the voter, so as to reach the Returning Officer not later than 6.00 p.m. on polling day, the 20th October, 1976.

Voting is compulsory for those voters whose names appear on the roll. Applications for enrolment and objections to enrolment closed on the 25th August, 1976. The nomination of individual representatives of multiple-name producers closed on the 8th September, 1976, and the roll has now been finalised. Failure to vote by an enrolled voter renders him liable to a penalty.

K. C. WHEATLAND,
Returning Officer.

The Tobacco Leaf Marketing Board Election, 20th October, 1976.

Education Act 1958.**NOTICE OF MAKING OF ORDERS UNDER SECTION 13 (1) OF THE ACT.**

Pursuant to Section 13 of the *Education Act 1958* I hereby give notice that Orders of the Governor in Council were made on 25th August, 1976 under sub-section (1) of Section 13 of the said Act in relation to the following high schools:—

Altona	Foster	Maryborough
Ashwood	Frankston	Maryvale
Avondale	Geelong	Melbourne
Balmoral	Gladstone Park	Merbein
Banyule	Greenwood	Merrilands
Beaufort	Hadfield	Mirboo North
Blackburn	Hampton	Mitcham
Blackburn South	Hastings	Monterey
Broadmeadows	Healesville	Moorabbin
Brunswick Girls	Heatherhill	Moorleigh
Brunswick	Heidelberg	Mooroopna
Burwood	Heywood	Moreland
Burwood Heights	Hopetoun	Mornington
Casterton	Huntingdale	Morwell
Castlemaine	J. H. Boyd	Mount Beauty
Charlton	Domestic College	Mount Eliza
Cleland	John Gardiner	Mount Waverley
Cobram	Kaniva	Murrumbena
Cohuna	Karingal	Murtoa
Collingwood	Keilor Heights	Myrtleford
Corryong	Kew	Neerim South
Croydon	Kooweerup	Newborough
Debnay Park	Koonung	Nhill
Deer Park	Lalor	Niddrie
Doncaster	Lakeside	Noble Park
East Doncaster	Latrobe	Northcote
Drouin	Laverton	Oakleigh
Eaglehawk	Lyndale	Oberon
Edenhope	MacRobertson	Ouyen
Fawkner	Girls	Point Gellibrand
Flora Hill	Mansfield	
Footscray Girls	Maroondah	

L. H. S. THOMPSON,
Minister of Education.

Education Act 1958.

NOTICE OF MAKING OF ORDERS UNDER SECTION 13 (1) OF THE ACT.

Pursuant to section 13 of the *Education Act 1958* I hereby give notice that Orders of the Governor in Council were made on the dates shown hereunder under sub-section (1) of section 13 of the said Act in relation to the following schools :—

27th July, 1976.

Consolidated Schools.

Alvie	Foster	Myrtleford
Balmoral	Goroke	Pakenham
Boisdale	Kaniva	Poowong
Cohuna	Lavers Hill	Red Hill
Corryong	Lockington	Robinvale
Dunkeld	Manangatang	Tongala
East Loddon	Merino	Werrimull
Edenhope	Murrayville	

Primary Schools.

Ballarat (No. 34)	Glenferrie	East Oakleigh
Cheltenham	Richmond	Clayton South
Eltham	(No. 1567)	Katandra West
Flemington	Kialla West	Flora Hill
Sandringham	Collingwood	Blackburn North
Hawthorn West	(No. 1895)	Banyule
Ballarat (No. 695)	Narre-Warren	Kananook
Harrietville	North	Rosebank
Lilydale	Tawonga	Invergordon
Purnim	Brunswick South	Fairhills
Pomborneit	Carnegie	Ruthven
Ballarat East	Research	Seymour East
(No. 1071)	Clifton Hill	Springvale South
Quarry Hill	(No. 3146)	Meadowfair
Sebastopol	Kew East	North
Skye	The Lake	Camelot Rise
Tooborac	Irmyple South	
Kerang	Kallista	

3rd August, 1976.

Primary Schools.

Alberton	Hexham	Tarraville
Allansford	Horsham	Terang
Avoca	Harcourt	Koroit
Avenel	Heathcote	Tylden
Allan's Flat	Bellbrae	Thomastown
Warrandyte	Chiltern	Violet Town
Belmont	Kyneton	Wangaratta
Bacchus Marsh	Kirkstall	Wahgunyah
Benalla	Romsey	Wangoom
Ballarat (No. 33)	Lake Burrumbeet	Woodend
Brown Hill	Shelford	Woodford
Wodonga	Lockwood South	Werribee
Bullarook	Learmonth	Winter's Flat
Bulla	Modewarre	Wooragee
Bromley	Mortlake	Winslow
Beaufort	Marong	Wallan
Dean	Maryborough	Woolsthorpe
Highton	Mount Macedon	Yandoit
Cudgee	Mount Clear	Yarram
Newport	Melton	Yan Yean
Camperdown	Mount Prospect	Yea
Cavendish	Fitzroy	Lancefield
Colac	Newstead	Coimadai
Clyde North	Newlyn	Yendon
Castlemaine	Burwood East	Birregurra
Campbell's Creek	Newbridge	Caramut
Creswick	Burwood	Cressy
California Gully	New Gisborne	Lyndhurst
Corio	Beac	Laanecoorie
St. Andrews	Essendon	Clayton North
Cambellfield	Coburg	Milawa
Dennington	Penshurst	Tourello
Dromana	Myrniong	Lockwood
Kalkallo	Mernda	Bealiba
Doncaster	Portland	Bairnsdale
Huntly	Port Albert	Gordon
Echuca	Stawell	Crowlands
Elphinstone	Rutherglen	Kingston
Addington	Raglan	Majorca
Eldorado	Riddell	Hawkesdale
Footscray	Rokewood	Hepburn
(No. 253)	Geelong East	Lara Lake
Freshwater Creek	Sale	Rosedale
Gisborne	Seymour	Caulfield
Glenorchy	Stanley	Darlington
Guildford	Smeaton	Woods Point
Glenlyon	Snake Valley	Eddington
Wandiligong	Skipton	Wedderburn
Heidelberg	South Yarra	Rochester
Hamilton	Stratford	Sutton Grange
(No. 295)	Taradale	Ararat

Ross Creek	Briagolong	Williamstown
Jamieson	Lindenow	North
Preston South	Broadford	Laang
Omeo	Murchison	Grantville
Warrak	Campbelltown	Bellarine
Streatham	Nirranda	Drouin West
Bass	Panton Hill	Wareek
Healesville	Glen Park	Meredith
Metcalf	Concongella	Edi Upper
Lake Bolac	Bruthen	Elingamite
Byaduk	Swan Hill	Maude
Toongabbie	Porepunkah	Port Melbourne
Waubra	Inverleigh	(No. 1427)
Great Western	Glen Iris	Eaglehawk North
Maffra	Trawalla	Mooroopna
Broken Creek	Grenville	Deer Park
Lal Lal	Bendoc	Ballan
Cobden	Musk	Mount Pleasant
St. Leonards	Cobrico	Pimpinio
Bendigo	Woodside	Tatura
Darraweit Guim	Noorat	Acheron
Linton	Albert Park	Toolamba
Invermay	Williamstown	Harston
Mitta Mitta	Boneo	Swift's Creek
Camberwell	Costerfield	Ellerslie
Greenvale	Golden Square	Osbornes Flat
Dixie	Queenscliff	Frankston
Redbank	Portland North	Donald
Barkly	Everton Upper	Keysborough
Alexandra	Pennyroyal	Hawksburn
Rockbank	Timor	Drummartin
Bannockburn	Apsley	Beveridge
Sedgwick	Mailor's Flat	Epping
Heatherton	Strathfieldsaye	St. Kilda
Doreen	Markwood	Charlton
Toolern Vale	Sarsfield	Buckley
Glenhompson	Lucknow	Cape Clear
Wickliffe	Weerangourt	Warburton
Mia Mia	Pirron Yallock	Tallrook
Talbot	Gerangamete	Barnawartha
Yarra Glen	Upper Plenty	Fitzroy North
Elmhurst	Eastville	Gnarwarre
Smythesdale	Carlton North	Geelong West
Scarsdale	South Melbourne	Golden Point
Kangaroo Flat	Maldon	Preston
Westmeadows	Woori Yallock	Lovely Banks
Barkstead	Moyston	Warrenbayne
Garvoc	Bendigo North	Carpentit
Woorndoo	Buninyong	Yarraville
Sunbury	Marysville	Tooradin
Hesket	Langley	Leneva
Axedale	Wandong	Sebastian
Chocolyn	Cowes	Elmore
Mount Wallace	Bullarto	Coghill's Creek
Corop	Redan	Moorilim
Vermont	Kerrie	Dookie
Tarnagulla	Lismore	Merton
Balwyn	Lower Plenty	Wharparilla West
Scoresby	Ferntree Gully	Brighton
Carisbrook	Swanpool	Connemurricoo
Wandin Yallock	Specimen Hill	Ravenswood
Yering	Leichardt	South
Dartmoor	Bolwarra	Natimuk
Waurin Ponds	Yarck	Murtoa
Mickleham	Warracknabeal	Big Hill
Inglewood	Moyhu	Clunes
Chewton	Toolleen	Marnoo
Rushworth	Buckley's Swamp	St. Germain
Rheola	Natte Yallock	Beechworth
Ross Bridge	Mumbannar	Ardmona
Bolinda	Clifton Hill	Gravel Hill
Napoleons	(No. 1360)	Kilmore
Kew	Christmas Hills	Lexton
Haddon	Tallangatta	Macarthur
Panmure	Kialla	Barwon Heads
Dargo	Mount Eliza	Glenmaggie
Framlingham	San Remo	Keilor
Allan's Forest	Sorrento	Wangaratta
Alfredton	Alfredton	South
Geelong	Geelong	Dunolly
(No. 1094)	(No. 1094)	Springhurst
Bridgewater	Hastings	Hansonville
Braybrook	Corinella	Dixons Creek
Yackandandah	Templestowe	Bahgallah
Nagambie	Richmond	Trentham
Bylands	Oxley	Warrenheip
Bundalaguah	Northcote	Maiden Gully
Heyfield	(No. 1401)	Rupanyup
Moorabbin	North Melbourne	Goornong
(No. 1111)	(No. 1402)	Oakleigh
Mansfield	Dandenong	Ceres
Yeodene	Yarra Park	Malvern
Middle Indigo	Malmesbury	(No. 1604)
Tarrawingee		Barker's Creek
		Mount Moriac
		Daylesford

NOTICE OF MAKING OF ORDERS—continued.

Primary Schools—continued.

Mooroopna	Anakie	Long Gully	Bullion	Binginwarri	Boho South
North	Moolap	Lake Charm	Mitre	Budgerie	Gelantipy
Codrington	Footscray	Ripplebrook	Longwarry	Barwon Downs	Neerim East
Nelson	(No. 1912)	Molyullah	Gembrook	Elsterwick	Nichols Point
Wy Yung	Newham	Numurkah	Ascot	Kergunyah South	Meeniyah
Mandurang	Bundoora	Clear Lake	Wurruk	Gormandale East	Mardan South
South	White Hills	Alberton West	Willow Grove	Lake Hindmarsh	Hopetoun
Swan Reach	Mount Egerton	Moe (No. 2142)	Brimpaen	Rokeyby	Tyntynder South
Amphitheatre	Drouin	Geelong South	Gorae	Strathdownie	Terip Terip
Dean's Marsh	Noradajah	Bessiebell	Tallandoon	Yanac	Strath Creek
Drysdale	Mincha West	Knowsley	Meerlieu	Glengarry	Irymple
St. Arnaud	Sheep Hills	Lorne	Hoddles Creek	Brunswick West	Mossiface
Nullawarre	Warrong	Bayswater	Taggerty	Bostocks Creek	Koonwarra
Sandford	Wunghnu	Minyip	Chestnut	King Valley	Brunswick East
Springvale North	Maroona	Boolite	Beaconsfield	Lang Lang	Dingwall
Macedon	Bullengarook	Mudgegonga	Upper	Croydon	Quantong
Arthurs Creek	Jindivick	Mulgrave	Congupna	(No. 2900)	Airey's Inlet
Rye	Mandurang	Scotsburn	North Melbourne	Moonee Ponds	Myee
Buxton	Talgarno	Yarragon	Redesdale	West	Iona
Tatura East	Won Wron	Strathbogie	Greta West	Kyabram	Glen Alvie
Byrneside	Bungaree	Tyers	Boralma	(No. 2904)	Nullawarre North
Moonambel	Little River	Trafalgar	St. James	Macorna	Glenormiston
Wannon	Cowwarr	Kinglake	Malvern	Loch	Eagle Point
Lallat Plains	Millbrook	Ellinbank	(No. 2586)	Mildura	Yarra Junction
Baringhup	Morang South	Yacla South	Lorquon	Narrawong	Goschen
West Melbourne	Camp Hill	Stonehaven	Sandmount	Blackburn	Kenmare
Fyansford	Branxholme	Burramine South	Launching Place	Narre Warren	Sassafras
Longford	Picola	Myrtlebank	Birchip	Berry's Creek	Watchem
Harkaway	Croydon North	Barongarook	Carlton	Krowera	Yannathan South
Little Hampton	Patho	Tambo Upper	Ascot Vale	Newmerella	Nayook
Carraragarmungee	Boorhaman	Glen Waverley	Boolarra	Port Melbourne	Ferny Creek
Euroa	Sutherland's	Baranduda	Gerang	(No. 2932)	Outtrim
Lardner	Creek	Tungamah	Morwell North	Warragul West	Beech Forest
Shepparton East	Ballarat East	Tragowel	Rosebud	Dumbalk North	Toolangi
St. Helens	Kotupna	Caniambo	Koo-Wee-Rup	Auburn	Buffalo
Nicholson	Mooroopna	Gunbower	Willenabrina	Mentone	Wonga Park
Jung	North West	Molesworth	Langkoop	Ensay	Culgoa
Dergholm	Pyalong	Woorak	Armadale	Jumbunna	Berriwillock
Baddaginnie	Avoca Forest	Nar Nar Goon	Seaview	Princess Hill	Leongatha South
Girgarre East	Winchelsea	Granya	Ecklin South	Gruyere	Echuca Village
Miners Rest	Korweinguboora	Toora	Callignee	Victoria Park	Kinglake West
Glenrowan	Buln Buln	Benalla East	Netherby	Pearcedale	Buchan South
Warrnambool	Ballarat	Montrose	Greenwald	Lindenow South	Barmah
Benambra	(No. 2022)	Willung	Osborne	Thorpdale	Perserverance
Woodburn Creek	Bald Hills	Koondrook	Somerville	St. Albans	Nyah
Dugay's Bridge	Elliminyt	Katunga South	Mitiamo	Poolajelo	Monbulk
Banyena	Marcus Hill	Magpie	Wilaura	Leongatha	Myall
Wycheproof	Everton	Gillieston	Echuca East	Waaia	Sea Lake
Devenish	Mornington	Nurrabiell	Lakes Entrance	Jeparit	Lake Boga
Udera	Carag Carag	Narracan	Myrree	Lalbert	Chum Creek
Dederang	Hamilton North	Nareen	Wallaloo East	Ringwood	Mount
Dooen	Mount Duneed	Kilcunda	Worak	Devon North	Dandenong
Eppalock	Mount Blowhard	Drouin South	Forest	Longwood	Nullawil
Fernihurst	Creswick North	Aregra	Fairfield	Forest	Carrarung South
Boort	Black Hill	Darnum	Nilma	Longwood	Badger Creek
Laen	Lurg	Moondarra	Mollonghip	Forest	Rainbow
Korong Vale	Digby	Moorooduc	Garfield	Fairfield	Middle Kinglake
Silvan	Brighton Beach	The Basin	Steel's Creek	Nilma	Point Lonsdale
Elaine	Harrow	Tallangatta Valley	Toolamba West	Mollonghip	Kongwak
Wendouree	Derrinallum	Boorhaman North	Yinnar South	Garfield	Bobinawarrah
Lancaster	Castlemaine	Paynesville	Chetwynd	Steel's Creek	East
Grasmere	North	Murra Warra	Officer	Toolamba West	Wallacedale
Yarrowonga	Yarrambat	Irrewillipe East	Orbost	Yinnar South	North
Purrumbete	Thoona	Epsom	Fish Point	Chetwynd	Kilcunda Road
South	Casterton	Kensington	Callawadda	Officer	Chelsea Heights
Borong	Nathalia	Hallora	Stradbroke West	Orbost	Club Terrace
Yundool	Chilwell	Hazelwood North	Johnsonville	Fish Point	Glenburn
Naringal	Greensborough	Mirboo North	Mepunga East	Callawadda	Wallington
Kalke	Teesdale	Nhill	Warburton East	Hill End	Woodglen
Raywood	Katamatite	Bunbartha	Hedley	Hall's Gap	Stacey's Bridge
Batesford	Buangor	Yinnar	Inverloch	Bena	Tecoma
Drummond	Musk Vale	Yannathan	Surrey Hills	Tallygaroopna	Kalimna West
South Melbourne	Clarendon	Neerim South	Strzelecki	Koetong	Mystic Park
(No. 1852)	Bentleigh East	Driffield	Ruffy	Ormond	Torquay
Puckapunyal	Richmond	Ivanhoe	Strathmerton	(No. 3074)	Noorinbee
Wundermere	(No. 2084)	Erica	Dundonnell	Allambee South	Woomelang
Woollert	Leitchville	Whitfield	Richmond North	Cheshunt South	Port Welshpool
Landsborough	Connewarre	Quambatook	Lah Arum	Korumburra	Dalyston
Lysterfield	Whittlesea	Greta South	Walwa	Crib Point	Emerald
Winton	Little Bendigo	Portarlington	Narrawong East	Pascoe Vale	Weerite
Merrigum	Stewarton	Menzies Creek	Middle Park	Litchfield	Carrum
Arcadia	Doncaster East	St. Kilda Park	Seville	Coomboona	Dadswell's
Bethanga	Bonnie Doon	Collingwood	Coalville	Flowerdale	Bridge
Stradbroke	Pine Lodge	(No. 2462)	Kyvalley	Ocean Grove	Gnotuk
Abbotsford	Ballarat	Woodleigh	Hallston	Ten Mile Creek	Nerrena
Newtown	(No. 2103)	Labertouche	Maryborough	Antwerp	Wando Vale
Geelong North	Warragul	Nirranda East	East	Beulah	Nyora
Windsor	Kangaroo	Whorouly East	Yarraville East	Genoa	Woorarra
Warrnambool	Ground	Diggers Rest	Moreland	Sunshine	Dumbalk
South	Muskerry East	Gormandale	Box Hill	Glenroy	Dingee
Yapeen	Traralgon South	Teal Point	Tanjil South	Goorambat	Yallock
Buchan	Kewell	Boweya	Drouin East	Tyabb	Tandarook
Corindhap	Coleraine	Lubeck	Burnley	Crossover	Exford
			Prahran	Northcote	Ultima
			Pomonal	(No. 3139)	Mount Best
				Upper Sandy	Meadow Creek
				Creek	Mount Waverley

NOTICE OF MAKING OF ORDERS—continued.

Primary Schools—continued.

Mario	Nowa Nowa	Kernot	Preston East	Horsham West	Frankston
Highlands	Mead	Ascot Vale West	Ashburton	Ashwood	Heights
Murrumbidgee	Walpeup	Gowanford	Bentleigh West	Traralgon	Kerrimuir
Wonwondah	Licola	Blackburn South	Prospect Estate	(No. 4699)	Sunvale
North	Hampton	Welton	Stanhope South	Traralgon	Heathmont East
Modella	Meatian	Harcourt North	Hazelwood Estate	(No. 4700)	Doveton West
Shady Creek	Castle	Hartwell	Merlynston	Wendouree West	Strathmore North
Narbethong	Donnington	Red Cliffs	Fairfield North	Eastwood	Oakleigh South
Wesburn	Haven	Wattle Glen	Anglesea	Tottenham North	Altona Gate
Mount Taylor	Dunrobin	Colac West	Colignan	Pascoe Vale South	Merrilands
Koorlong	Jancourt East	Glenormiston	Briar Hill	Yellingbo	Thomastown East
Dollar	Balling East	South	Blackwood Forest	Tottenham	Fairway
Larpent	Edithvale	Mitta Junction	Meringur	Doutta Galla	Sussex Heights
Warrandyte South	Kilmany South	Boronia	Zeerust	Lalor	Campmeadows
Willowmavin	Tyntynder	Middle Tarwin	Konongwootong	Brooklyn	Warrawong
Swan Marsh	Murraydale	Yallourn	North	Reservoir West	Glen Waverley
Olinda	Boinka	Ripponlea	Longerenong	Coatesville	Heights
Appin South	Orrvale	Boundary Bend	Ormond East	Olympic Village	Moorabbin
Carlisle River	Pender's Grove	Perenna	Bayles	Syndal	Heights
Trafalgar East	Cabbage Tree	Plenty	Ivanhoe East	Huntingdale	Watsonia
Allambee Reserve	Munro	Noojee	Cobains	Box Hill North	Jacana
Gunbower Island	Underbool	Irrewarra	Mildura South	Ferntree Gully	Clayton West
Spring Gully	Caulfield North	Poowong North	(No. 4398)	Geelong	Yanakie
Stonyford	Westmere	Montmorency	Brunswick North	Ararat West	Parktone
Springvale	Seaford	Moriac	West	Oak Park	Antonio Park
Lascelles	Cashmore	Ringwood North	Hallam Valley	Dandenong North	Kingsbury
Mallacoota	Wattle Park	Red Cliffs East	Melville Forest	Boroondara	Hamilton
Cloverlea	Woolamai	Ripple Vale	Sunny Cliffs	Bairnsdale West	(No. 4847)
Langwarrin	Murrabit	Tandarook South	Mooroolbark	Koonung Heights	Ardeer
Bruarong	Tetooro Road	Kooloonong	Glengarry West	Harrisfield	Niddrie
Cockatoo	Speed	Bradvale	Nilma North	Pascoe Vale North	Benalla West
Tyabb Railway	Sydenham West	Box Hill South	Sandringham East	Broadmeadows	Westall
Station	Tresco	Malvern East	Seaholme	East	Tullamarine
Carrayung	Rupanyup South	Bayswater North	Burrum	Belle Vue	Guthridge
Belgrave South	Carranballac	Woorinen North	Mannbadar	Norlane	Park Orchards
Sydenham	Nanneella West	Vinifera	Woorinen South	Oberon	Albion North
Lake Meran	Bangholme	Catani	Somers	Norwood	Oakwood Park
Milford	Preston West	Pura Pura	Nirranda South	Parklands	Southwood
Canterbury	Gardiner	Westbreen	Wild Dog Valley	Moe (No. 4740)	Blackburn Lake
Bookar	Footscray West	Point Cook	Leongatha East	St. Albans East	Doncaster Park
Traralgon	Wandin North	Footscray North	Fiskville	Shepparton	Altona West
(No. 3584)	Bendigo East	Piangil	Upwey	(No. 4742)	Laburnum
Fawkner	Kawarren	Brewster	Stewart	Swan Hill North	Fawkner East
Toolong	Gardenvale	Denison	Taroon	Sunshine Heights	Eastmeadows
St. Helen's Plains	Pomborneit	Airly	Coburg North	Sunshine North	Kyabram
Alphington	North	Camberwell South	Elingamite North	Clayton	Rollins
Bona Vista	Beaumaris	Parkdale	Gorae West	Portland South	Bulleen
Carrum Downs	Currawa	Hughesdale	Korrine	Bayview	Frankston Forest
Ouyen	Braeside	Westgarth	Rosanna	Rosanna Golf	Bellaire
Norris Bank	Werribee South	Ringwood East	Wantirna South	Links	Pinewood
Macclesfield	Echuca West	Auburn South	Katyl	Cheltenham East	Broadmeadows
Athlone	Cann River	Nangiloc	Bogong	Cranbourne South	Moonba Park
Nambrok	Nyah West	Lang View	Tubbut	Yalla-Y-Poora	Keilor Heights
Mincha	Altona	Normanville	Willangie	Yarrunga	Middlefield
Balling	Devon Meadows	Nunawading	Strathmore	Cheltenham	Croydon West
Black Rock	Upper Ferntree	Byrne	Tawonga South	North	Norlane West
Berrybank	Gully	Aspendale	West Creek	Preston North	Parkmore
Youanmite	Nandaly	Beverford	Balwyn North	East	Lakeside
Mount Evelyn	Eildon	Speewa	Solway	Laverton	Waverley North
Talindert	Bittern	Strathlea	Wangaratta West	(No. 4765)	Lara
Kilsyth	Wandin East	Whorouly South	Moorabbin West	Orbost North	Mullum
Nambrok West	Colbinabbin	Eltham North	Mount Beauty	Craigieburn	Doncaster
Wonthaggi	Stanhope	Merrivale	Sunshine East	Lyndale	Heights
Tempy	Hurstbridge	Dandenong West	Newlands	Warrnambool	Croydon South
Millgrove	Coburg West	Croydon	Alamein	East	Greenslopes
Katamatite East	Elwood	(No. 4219)	Newborough	Colac South West	Viewbank
Clyde	Mont Albert	Aberfeldie	Traralgon	Newcomb	Greenhills
Stony Creek	Dhurringile	Manifold Heights	(No. 4652)	Hamilton	Upwey South
Riverslea	Woorinen	Koallah	Bellfield	(No. 4777)	Simpson
Boolarra South	Strathewen	Nungurner	Shepparton	Valkstone	Eltham East
Dudley	Don Valley	Macleod	(No. 4657)	Overport	Warrnambool
Poowong East	Powelltown	Forest Hill	Maidstone	Glenroy North	West
Deepdene	Reservoir	Bungador	Tootgarook	Doveton	Dallas
Tallandoon North	Carwarp	Dingley	Moe (No. 4662)	Whiteside	Sandown Park
Clifton Creek	Yallourn North	Silvan South	Roslyn	Hadfield	Belvedere Park
Kennington	Toorloo Arm	Coburg East	Newport West	Wembley	Essex Heights
Cardinia	Girgarre	Cardross	Shepparton	Eastmont	Heatherdale
Combienbar	Patchewollock	Albion	(No. 4666)	Eastmoor	Mountain Gate
Grahamvale	Mitta North	Heidelberg West	Chadstone Park	Footscray North	Mirraboopa
Bulart	Yaapeet	Lemnos	Newborough East	Bonbeach	Boronia West
Glenhuntly	Gladysdale	Caldermead	Hightt	Blackburn East	Bemm River
Nanneela Estate	Mildura West	Longwarry North	Jordanville South	Amstel	Southmoor
Wantirna	Moonee Ponds	Tarwin Lower	Herne Hill	Heatherhill	Ringwood
Wonthaggi North	Kingsville	Pira	Frankston East	Beaumaris North	Heights
Narre Warren	Merbein West	Cokum Reserve	Selby	Bell Post Hill	Springview
East	Minhamite	North Shore	Reservoir East	Altona East	Glen Devon
Cornelia Creek	Mittyack	Brunswick South	Moorabbin	Gowrie Park	Ruskin Park
Wooreen	Dalmore	West	(No. 4687)	Yarraman Park	Burbank
Chelsea	Landsborough	Notting Hill	Heathmont	Nunawading	Fyans Park
Ballendella	West	Pearsondale	Katunga	South	Studfield
Brim East	Wilkur South	Diggers Road	Ballarat North	Glenroy West	Karingal
Turriff	Tesbury	Chatham	Bandiana	Dandenong South	Mount View
Maribymong	Essendon North	Caulfield South	Bennettswood	St. Albans North	Syndal South
			Greythorn	Avondale	Montmorency
			Warragul North	Beverley Hills	South
				Wodonga West	Horsham North

NOTICE OF MAKING OF ORDERS—continued.

Primary Schools—continued.

Corio South	Wooranna Park	Wallarano
Comet Hill	Knox Park	Lilydale West
Cheltenham	Birralee	Studfield East
Heights	Upfield	Mooroolbark
Altona North	Echuca South	East
Burwood Heights	Derinya	Ardeer South
Dallas North	Kilsyth East	Botanic Park
Stawell West	Thomastown	Gladesville
Watsonia Heights	West	Falls Creek
Ballarat	Rowville	Debney Meadows
(No. 4936)	Killoura	Spring Valley
Pembroke	Mossfield	Lalor West
Monterey	Lalor Park	Tinternvale
Manningham	Templestowe	Glengala
Chandler	Heights	Wantirna Heights
Shepparton	Ballam Park	Kent Park
(No. 4943)	Waldau	Waverley Park
Greenwood	Manchester	Dartmouth
St. Albans South	Glendal	Rosewood
Syndal North	Wattle View	Downs
Wellington	Sherbourne	Coburn
St. Albans	Cooinda	Gladstone Views
Heights	Donburn	Wheelers Hill
Kerang South	Shepparton	Lincolnvillie
Monash	(No. 5020)	Narre Warren
Coolaroo South	Araluen	Station
Narmara	Newcomb South	Calder Rise
Knoxfield	Watsonia South	Waverley
Mentone Park	Upper Thomson	Meadows
Boroondara	Watsonia	Kingswood
North	Northvale	Coomoora
Donvale	Broadmeadows	Golden Square
Bell Park North	West	Mt. Eliza North
Walkerville	Corio West	Berwick
Laverton North	Deer Park West	Eaglehawk
Armata	Grimshaw	Hallam
Springvale West	Campbellfield	Mordialloc
Boronia Heights	Heights	Brunswick
Milleara	Lalor North	Eskdale
Churchill	Melton West	Gellibrand
Keilor South	Brandon Park	Laverton
Montpellier	Bayswater West	Brim
Bayswater South	Tantii Park	Spotswood
Seaford North	Ayr	Melton South
Lalor East	Wodonga South	Thornbury
Laverton Heights	Aldercourt	Hampton Park
Ballarat	Richmow West	Gowerville
(No. 4981)	Yallambie	Heidelberg
Oberon South	Stevensville	Heights
Brentwood	Woodville	Fawkner North
Templestowe	Glengala	Southvale
Valley	Yarraleen	Doveton North
Highvale	Mimosa	Cariton
Verdale	Karingal Heights	(No. 4980)
Watsonia North	Overland	

L. H. S. THOMPSON,
Minister of Education.

Education Department,
Melbourne, 20th September 1976.

NOTICE TO MARINERS.

[No. 31 (T) OF 1976.]

AUSTRALIA.—VICTORIA.

PORT PHILLIP.

Information About Wave Measuring Buoys.

1. "Waverider" buoy will be permanently withdrawn as follows:—

Date.—On or about 1st October, 1976.

Position.—Lat. 38 deg. 12.7 min. S., Long. 145 deg. 00 min. E.

Former Notice.—No. 13 (T) of 1976 refers.

2. "Waverider" buoy will be permanently withdrawn as follows:—

Date.—On or about 1st November, 1976.

Position.—Lat. 38 deg. 02.8 min. S., Long. 145 deg. 05.3 min. E.

Former Notice.—No. 17 (T) of 1975 refers.

3. "Waverider" buoy will be established as follows:—

Date.—On or about 1st October, 1976.

Position.—Lat. 38 deg. 08 min. S., Long. 145 deg. 05.8 min. E. (approx. 1 mile North-west of Frankston Pier).

4. "Waverider" buoy will be established as follows:—

Date.—On or about 1st December, 1976.

Position.—Lat. 38 deg. 07 min. S., Long. 144 deg. 52 min. E. (approx. 6 miles West of Prince George Light).

Description.—Spherical shaped buoys 0.8 metre diameter, painted red and yellow vertical stripes, each surmounted by a 2 metre whip aerial and showing a group flashing white light, 3 flashes every 20 seconds. A spar buoy, painted red, with radar reflective properties will be situated close to the "Waverider" buoy in (4) above.

Abridged Description.—Gp. Fl. (3) 20 sec.

Charts Affected.—Aus. 143, Aus. 158.

A. J. WAGGLEN,
Port Officer.

Public Works Department,
Ports and Harbors Division,
168 Exhibition Street, Melbourne, 3000.

24th September, 1976.

NOTICE TO MARINERS.

[No. 29 OF 1976.]

AUSTRALIA.—VICTORIA.

PORT PHILLIP.

1. GELLIBRAND PILE LIGHT BUOY.

2. PRINCE GEORGE BANK—SHOALING REPORTED.

1. Former Notice.—No. 23 (T) of 1976 is cancelled.

Date.—On or about 4th October, 1976.

Reference Position.—Williamstown Lighthouse (Timeball Tower). Lat. 37 deg. 52 min. S., Long. 144 deg. 55 min. E. (approx.).

Light Buoy.—A red light buoy fitted with a radar reflector will be established in position 172 deg. distant 1130 m from reference position, showing a group flashing red light, 2 flashes every 4 seconds, visible 4 miles.

Abridged Description.—Gp. Fl. (2) R. 4 sec. 4M.

Caution.—A shoal area with least depth 2.3 m exists about 20 m to the West of the light buoy.

2. Reference Position.—Prince George Light. Lat. 38 deg. 07 min. S., Long. 144 deg. 44 min. E. (approx.).

Shoal Area.—A shoal carrying a least depth of 3.7 m exists in a position 286.5 deg. distant 490 m from reference position.

Caution.—Mariners are advised to pass to the Northward and Eastward of this shoal area.

Charts Affected.—1. Aus. 155. Aus. 143.

2. Aus. 157. Aus. 143.

Publications Affected.—Sailing Directions, Victoria 1970—

1. Pages 282 and 629;

2. Page 212.

A. J. WAGGLEN,
Port Officer.

Public Works Department,
Ports and Harbors Division,
168 Exhibition Street,
Melbourne, Vic. 3000, 20th September, 1976.

NOTICE TO MARINERS.

[No. 30 (T) OF 1976.]

AUSTRALIA.—VICTORIA.

WESTERNPORT.—EXISTENCE OF YACHT RACING BUOYS.

Reference Position.—Coves Jetty Light, Lat. 38 deg. 27 min. S., Long. 145 deg. 14 min. E. (approx.).

Details.—Buoys have been laid in the following positions relative to the reference position:—

(a) 275 deg. distant 1.1 miles.

(b) 064 deg. distant 0.2 miles.

Remarks.—The buoys are spar type with a disc shaped orange topmark.

Note.—The buoys will be withdrawn at the end of April, 1977.

Charts Temporarily Affected.—Aus. 156, Aus. 149y.

A. J. WAGGLEN,
Port Officer.

Public Works Department,
Ports and Harbors Division,
168 Exhibition Street,
Melbourne, Vic. 3000, 20th September, 1976.

Private Agents Act 1966.

NOTICE OF RECEIPT OF APPLICATIONS FOR LICENCES UNDER THE PROVISIONS OF THE PRIVATE AGENTS ACT 1966.

The Clerk(s) of the Magistrates' Court(s) as listed hereunder hereby give notice that applications, as under, have been lodged for hearing by the said Court(s) on the day(s) specified.

Any person desiring to object to any of such applications must—

- (a) lodge with the respective Clerk of the Magistrates' Court a notice in the prescribed form of his objection and of the grounds thereof;
- (b) cause a copy of such notice to be served personally or by post upon the applicant at least three days before the hearing of the application; and
- (c) send or deliver—
 - (i) where the objection is not made by the officer in charge of the police district in which the Court is situated—a copy of the notice to such officer; and
 - (ii) where the objection is not made by the Registrar or Deputy Registrar—a copy to the Registrar.

Full Name of Applicant or in the Case of a Firm or Corporation, of the Nominee.	Place of Abode of Applicant or Nominee.	Name of Firm or Corporation.	Address for Registration.	Type of Licence.	Date of Hearing of Application.
---	---	------------------------------	---------------------------	------------------	---------------------------------

MAGISTRATES' COURT, DANDENONG.

Hanlon, Frederick Thomas John	3 Ondine Court, Noble Park		14 Bundeena Avenue, Noble Park	Process Server	12.10.76
-------------------------------	-------------------------------	--	-----------------------------------	----------------	----------

Dated at Dandenong this 14th day of September, 1976.

P. J. RODDA, Clerk of the Magistrates' Court.

MAGISTRATES' COURT, RICHMOND.

Harrison, John Harold	3/20 Bedford Court, Ringwood East	Mayne Nickless	94 York Street, South Melbourne	Provisional Watchman	15.10.76
Smyth, John	24 Duncan Avenue, Greensborough	" "	" " "	" "	" "

Dated at Richmond this 15th day of September, 1976.

J. BOLSTER, Clerk of the Magistrates' Court.

MAGISTRATES' COURT, WANGARATTA.

Kingham, Geoffrey James	Finley Road, Berrigan	Bell and Kingham Security Service	22 Burns Street, Wangaratta	Guard Agent	11.10.76
Bell, John Desmond	22 Burns Street, Wangaratta	" " "	" " "	" "	" "
Bell, Peter Desmond	22 Burns Street, Wangaratta	" " "	" " "	" "	" "
Nominee of the firm— Bell, Peter Desmond	22 Burns Street, Wangaratta	" " "	" " "	" "	" "

Dated at Wangaratta this 20th day of September, 1976.

R. De GRUCHY Clerk of the Magistrates Court.

MAGISTRATES' COURT, FERNTREE GULLY.

Cosgrove, John Rundle	8 Thanos Court, Boronia		8 Thanos Court, Boronia	Guard Agent	13.10.76
-----------------------	----------------------------	--	----------------------------	-------------	----------

Dated at Ferntree Gully this 21st day of September, 1976.

T. BEDOHAZY, Clerk of the Magistrates' Court.

MAGISTRATES' COURT, RICHMOND.

Burns, Kenneth William	84 View Street, Clayton	Armaguard	24 Eureka Street, Richmond	Watchman	20.10.76
------------------------	----------------------------	-----------	-------------------------------	----------	----------

Dated at Richmond this 21st day of September, 1976.

J. BOLSTER, Clerk of the Magistrates' Court.

MAGISTRATES' COURT MELBOURNE.

Van Bakel, Franciscus Christanus	7 Axelton Street, Cheltenham	Brambles Brinks Limited	Cnr. Arden and Lothian Streets, North Melbourne	Watchman	27.10.76
-------------------------------------	---------------------------------	-------------------------	---	----------	----------

Dated at Melbourne this 15th day of September, 1976.

L. W. HUSSEY, Clerk of the Magistrates' Court.

MAGISTRATES' COURT, MELBOURNE.

Sonnberger, Graeme Gordon	1 Viewpoint Avenue, Glen Waverley	Wormald International Security	340 Abbotsford Street, South Melbourne	Process Server	13.10.76
Sonnberger, Graeme Gordon	" " "	" " "	" " "	Guard Agent	" "
Sonnberger, Graeme Gordon	" " "	" " "	" " "	Inquiry Agent	" "
Brennan, Leslie Allan	72 Wales Street, West Footscray	Wormald International Security	340 Abbotsford Street, North Melbourne	Watchman	27.10.76
Chlogpk, Stefan	17 Marcus Crescent, Coolaroo	" " "	" " "	" "	" "
King, Peter John	36 Market Street, Essendon	" " "	" " "	" "	" "
Raymond, Walter Allen	55 Rupert Street, West Footscray	" " "	" " "	" "	" "
Walker, Ian Ross	8 Enfield Avenue, Preston	" " "	" " "	" "	" "

Dated at Melbourne this 17th day of September, 1976.

L. W. HUSSEY, Clerk of the Magistrates' Court.

PRIVATE AGENTS—continued.

Full Name of Applicant or in the Case of a Firm or Corporation, of the Nominee.	Place of Abode of Applicant or Nominee.	Name of Firm or Corporation.	Address for Registration.	Type of Licence.	Date of Hearing of Application.
MAGISTRATES' COURT, CHELSEA.					
Quenault, Robert Garth ..	562 Nepean Highway, Carrum	Mayne Nickless (Armaguard) Pty. Ltd.	24 Eureka Street, Richmond	Watchman ..	18.10.76
Dated at Chelsea this 21st day of September, 1976.					
G. V. FITZPATRICK, Clerk of the Magistrates' Court.					
MAGISTRATES' COURT, MELBOURNE.					
Addison, David	10 Ruby Street, Preston	Brambles Brinks Limited	Cnr. Arden and Lothian Streets, North Melbourne	Watchman ..	27.10.76
McIntosh, Sydney James ..	Flat 9, 21 Hampton Parade, West Footscray	" " "	" " "	" ..	"
Dated at Melbourne this 21st day of September, 1976.					
L. W. HUSSEY, Clerk of the Magistrates' Court.					
MAGISTRATES' COURT, CHELTENHAM.					
Webster, Ian Charles ..	1 Craig Court, Cheltenham	" " "	1 Craig Court, Cheltenham	Guard Agent Individual	12.10.76
Dated at Cheltenham this 21st day of September, 1976.					
B. HYAMS, Clerk of the Magistrates' Court.					
MAGISTRATES' COURT, RICHMOND.					
Noonan, James Alexander ..	9 Prince Seaford Crescent	Mayne Nickless Ltd.	94 York Street, South Melbourne	Watchman ..	25.10.76
Dated at Richmond this 22nd day of September, 1976.					
J. BOLSTER, Clerk of the Magistrates' Court.					
MAGISTRATES' COURT, BOX HILL.					
Armitage, Leslie Alan ..	26 Garden Street, Box Hill North	" " "	26 Garden Street, Box Hill North	Process Server Individual	14.10.76
Dated at Box Hill this 22nd day of September, 1976.					
L. GOULD, Clerk of the Magistrates' Court.					
MAGISTRATES' COURT, PRAHRAN.					
Gleeson, James George ..	29 Marrbridge Road, Moorabbin	" " "	Suite 18, 65 Queens Road, Melbourne	Commercial Agent	18.10.76
Dated at Prahran this 20th day of September, 1976.					
G. SHARKEY, Clerk of the Magistrates' Court.					

Police Offences Act 1958, No. 6337.
DIVISION 1A—STATE ADVISORY BOARD ON PUBLICATIONS.
 Whereas I have considered reports made to me by the State Advisory Board on Publications under Section 180H (2) (a) of the Police Offences Act.
 I, Vance Oakley Dickie, Chief Secretary of Victoria, in pursuance of the power vested in me by section 180H (1) of the Police Offences Act hereby determine that the following publications prescribed by title in the schedule hereunder shall be classified as restricted publications for the purpose of the abovenamed Act.

Title.	Distributor.
Screw Nos. 207, 208 and 209	Melbourne Wholesale Newsagency Pty. Ltd.
Suction Seduction	Melbourne Wholesale Newsagency Pty. Ltd.
Wild Lesbians	Melbourne Wholesale Newsagency Pty. Ltd.

VANCE DICKIE,
Chief Secretary.

Chief Secretary's Office,
Melbourne. 27th September, 1976.

SCHEDULE OF PUBLICATIONS.

Title.	Distributor.
Aggressive Sex	Melbourne Wholesale Newsagency Pty. Ltd.
Australian Guys Nos. 97, 98 and 99	Melbourne Wholesale Newsagency Pty. Ltd.
Cocksure No. 72	Towart Distribution Co. Pty. Limited
Depraved Female	Melbourne Wholesale Newsagency Pty. Ltd.
Frivol—Hard Core	Towart Distribution Co. Pty. Limited
Future Marriage	Melbourne Wholesale Newsagency Pty. Ltd.
Hard Core Nos. 35 and 37	Towart Distribution Co. Pty. Limited
Homosexual Sex Techniques	Melbourne Wholesale Newsagency Pty. Ltd.
Homosexual Sexuality	Melbourne Wholesale Newsagency Pty. Ltd.
Kings Cross Whisper No. 226	Towart Distribution Co. Pty. Limited
Nookie No. 2	Melbourne Wholesale Newsagency Pty. Ltd.
Pleasure No. 149	Towart Distribution Co. Pty. Limited
Searchlight No. 175	Melbourne Wholesale Newsagency Pty. Ltd.
Sexy Swingers Nos. 188 and 189	Towart Distribution Co. Pty. Limited

Co-operation Act 1958.
BRIGHTON BEACH SCHOOL CO-OPERATIVE LIMITED.
 Notice is hereby given in pursuance of section 78 (7) of the *Co-operation Act 1958* and section 308 (2) of the *Companies Act 1961* that, at the expiration of three months from the date hereof, the name of the aforementioned society will, unless cause is shown to the contrary, be struck off the register and the society will be dissolved.
 Dated this 21st day of September, 1976.
 E. P. LIDDELL,
Deputy Registrar.

Co-operation Act 1958.
ALMA STREET KINDERGARTEN CO-OPERATIVE LIMITED.
FIRST HEATHERDALE BOY SCOUT CO-OPERATIVE LIMITED.
 Notice is hereby given in pursuance of section 78 (7) of the *Co-operation Act 1958* and section 308 (2) of the *Companies Act 1961* that, at the expiration of three months from the date hereof, the names of the aforementioned societies will, unless cause is shown to the contrary, be struck off the register and the societies will be dissolved.
 Dated this 14th day of September, 1976.
 J. W. JUNGWIRTH,
Registrar.

Town and Country Planning Act 1961.
CITY OF MILDURA PLANNING SCHEME.
AMENDMENT No. 16, 1976.

Notice of Approval.

In pursuance of the powers conferred by the *Town and Country Planning Act 1961*, the Governor in Council on the 21st September, 1976, approved a planning scheme entitled the City of Mildura Planning Scheme, in respect of the municipal district of the City of Mildura and such planning scheme comes into operation on the date this Notice of Approval is published in the *Government Gazette*.

A copy of the planning scheme as approved may be inspected, free of charge, during office hours at the office of the Town and Country Planning Board, 235 Queen Street, Melbourne; at the office of the City of Mildura at Mildura and, when available, at the Office of Titles, Melbourne, and at the Central Plan Office of the Department of Crown Lands and Survey, Melbourne.

W. H. CRAIG, Secretary,
Town and Country Planning Board.

Town and Country Planning Act 1961.
CITY OF MILDURA PLANNING SCHEME.
AMENDMENT No. 18, 1976.

Notice of Approval.

In pursuance of the powers conferred by the *Town and Country Planning Act 1961*, the Governor in Council on the 21st September, 1976, approved a planning scheme entitled the City of Mildura Planning Scheme Amendment No. 18, in respect of the municipal district of the City of Mildura and such planning scheme comes into operation on the date this Notice of Approval is published in the *Government Gazette*.

A copy of the planning scheme as approved may be inspected, free of charge, during office hours at the office of the Town and Country Planning Board, 235 Queen Street, Melbourne; at the office of the City of Mildura at Mildura and when available, at the Office of Titles, Melbourne, and at the Central Plan Office of the Department of Crown Lands and Survey, Melbourne.

W. H. CRAIG, Secretary,
Town and Country Planning Board.

Town and Country Planning Act 1961.
SHIRE OF LILLYDALE PLANNING SCHEME 1958.
AMENDMENT No. 45, 1974.

Notice of Approval.

In pursuance of the powers conferred by the *Town and Country Planning Act 1961*, the Governor in Council on the 21st September, 1976, approved a planning scheme entitled the Shire of Lillydale Planning Scheme Amendment No. 45, 1974, in respect of part of the municipal district of the Shire of Lillydale and such planning scheme comes into operation on the date this Notice of Approval is published in the *Government Gazette*.

A copy of the planning scheme as approved may be inspected, free of charge, during office hours at the office of the Town and Country Planning Board, 235 Queen Street, Melbourne; at the office of the Council of the Shire of Lillydale at Lillydale and, when available, at the Office of Titles, Melbourne, and at the Central Plan Office of the Department of Crown Lands and Survey, Melbourne.

W. H. CRAIG, Secretary,
Town and Country Planning Board.

Town and Country Planning Act 1961.
SHIRE OF SOUTH GIPPSLAND PLANNING SCHEME.
AMENDMENT No. 26, 1976.

Notice of Amendment.

In pursuance of the powers conferred by sub-section 6 of section 32 of the *Town and Country Planning Act 1961*, the Governor in Council, on the 21st September, 1976, amended the Shire of South Gippsland Planning Scheme to incorporate provisions relating to cluster developments in the planning scheme in respect of the Residential Zone.

A copy of the amendment may be inspected during office hours at the office of the Town and Country Planning Board, 235 Queen Street, Melbourne, at the office of the Council of the Shire of South Gippsland and, when available, at the Office of Titles, Melbourne, and at the Central Plan Office of the Department of Crown Lands and Survey, Melbourne.

W. H. CRAIG, Secretary,
Town and Country Planning Board.

Town and Country Planning Act 1961.
SHIRE OF TALLANGATTA PLANNING SCHEME.
AMENDMENT No. 4, 1976.

Notice of Amendment.

In pursuance of the powers conferred by sub-section 6 of section 32 of the *Town and Country Planning Act 1961*, the Governor in Council, on the 21st September, 1976, amended the Shire of Tallangatta Planning Scheme to incorporate provisions relating to cluster subdivision and redevelopment.

A copy of the amendment may be inspected during office hours at the office of the Town and Country Planning Board, 235 Queen Street, Melbourne, at the office of the Council of the Shire of Tallangatta and, when available, at the Office of Titles, Melbourne, and at the Central Plan Office of the Department of Crown Lands and Survey, Melbourne.

W. H. CRAIG, Secretary,
Town and Country Planning Board.

Town and Country Planning Act 1961.
EILDON RESERVOIR PLANNING SCHEME (SHIRE OF MANSFIELD).

AMENDMENT No. 20, 1976.

Notice of Amendment.

In pursuance of the powers conferred by sub-section 6 of section 32 of the *Town and Country Planning Act 1961*, the Governor in Council, on the 21st September, 1976, amended the Eildon Reservoir Planning Scheme (Shire of Mansfield) to incorporate provisions relating to cluster development in the planning scheme in respect of the Residential Zone.

A copy of the amendment may be inspected during office hours at the office of the Town and Country Planning Board, 235 Queen Street, Melbourne, at the office of the Council of the Shire of Mansfield at Mansfield and, when available, at the Office of Titles, Melbourne, and at the Central Plan Office of the Department of Crown Lands and Survey, Melbourne.

W. H. CRAIG, Secretary,
Town and Country Planning Board.

Town and Country Planning Act 1961.
GEELONG REGIONAL INTERIM DEVELOPMENT ORDER.

NOTICE THAT AN AMENDMENT HAS BEEN PREPARED AND IS AVAILABLE FOR INSPECTION.

Amendment No. 2.

Notice is hereby given that the Geelong Regional Planning Authority in pursuance of its powers under the Geelong Regional Interim Development Order has prepared an Amendment for the Geelong Regional Planning Area for the purpose of regulating, restricting or prohibiting the use and development of land, and the reservation of land for public purposes within the said area.

A copy of the scheme has been deposited at the Geelong Regional Planning Authority, 117 Myers Street, Geelong, Bannockburn Shire Council, High Street, Bannockburn, Barrabool Shire Council, 441 Moorabool Street, South Geelong, Bellarine Shire Council, Collins Street, Drysdale, Corio Shire Council, Osborne House, Swinburne Street, North Geelong, Geelong City Council, Gheringhap Street, Geelong, Geelong West City Council, 153 Pakington Street, Geelong West, Newtown City Council, 263 Pakington Street, Newtown, Queenscliffe Borough Council, Learmonth Street, Queenscliff, City of South Barwon, 33 Mt. Pleasant Road, Belmont and at the office of the Town and Country Planning Board, 235 Queen Street, Melbourne, and will be open for inspection during office hours by any person free of charge.

Any persons affected by the amendment are required to set forth in writing all objections they may have, addressed to C. K. Atkins, Director, Geelong Regional Planning Authority, 117 Myers Street, Geelong on or before the Twenty-ninth day of October, 1976, and to state whether they wish to be heard in respect of their objections.

Dated 29th September, 1976.

COLIN K. ATKINS,
Director.

This notice is published in lieu of the notice appearing in *Government Gazette* No. 85 of 22nd September, 1976, on page 2847.

Town and Country Planning Act 1961.
HAZELWOOD JOINT PLANNING SCHEME 1964.
AMENDMENT No. 7, 1976.

Notice of Amendment.

In pursuance of the powers conferred by sub-section 6 of section 32 of the *Town and Country Planning Act 1961*, the Governor in Council, on the 21st September, 1976, amended the Hazelwood Joint Planning Scheme, to incorporate provisions for cluster housing development.

A copy of the amendment may be inspected during office hours at the office of the Town and Country Planning Board, 235 Queen Street, Melbourne, at the office of the Council of the Shire of Morwell and, when available, at the Office of Titles, Melbourne, and at the Central Plan Office of the Department of Crown Lands and Survey, Melbourne.

W. H. CRAIG, Secretary,
Town and Country Planning Board.

Town and Country Planning Act 1961.
MORWELL PLANNING SCHEME 1954.
AMENDMENT No. 53, 1976.

Notice of Amendment.

In pursuance of the powers conferred by sub-section 6 of section 32 of the *Town and Country Planning Act 1961*, the Governor in Council, on the 21st September, 1976, amended the Morwell Planning Scheme to incorporate provisions relating to cluster development in the planning scheme in respect of the Residential "B" Zone and Residential Development Zone.

A copy of the amendment may be inspected during office hours at the office of the Town and Country Planning Board, 235 Queen Street, Melbourne, at the office of the Council of the Shire of Morwell and, when available, at the Office of Titles, Melbourne, and at the Central Plan Office of the Department of Crown Lands and Survey, Melbourne.

W. H. CRAIG, Secretary,
Town and Country Planning Board.

Town and Country Planning Act 1961.
WARRAGUL PLANNING SCHEME 1954.
AMENDMENT No. 23, 1976.

Notice of Approval.

In pursuance of the powers conferred by the *Town and Country Planning Act 1961*, the Governor in Council on the 21st September, 1976, approved a planning scheme entitled the Warragul Planning Scheme 1954, Amendment No. 23, 1976, in respect of part of the municipal district of the Shire of Warragul and such planning scheme comes into operation on the date this Notice of Approval is published in the *Government Gazette*.

A copy of the planning scheme as approved may be inspected, free of charge, during office hours at the office of the Town and Country Planning Board, 235 Queen Street, Melbourne; at the office of the Shire of Warragul at Warragul and, when available, at the Office of Titles, Melbourne, and at the Central Plan Office of the Department of Crown Lands and Survey, Melbourne.

W. H. CRAIG, Secretary,
Town and Country Planning Board.

Town and Country Planning Act 1961.
WARATAH BAY PLANNING SCHEME.
AMENDMENT No. 7, 1976.

Notice of Amendment.

In pursuance of the powers conferred by sub-section 6 of section 32 of the *Town and Country Planning Act 1961*, the Governor in Council, on the 21st September, 1976, amended the Waratah Bay Planning Scheme, to incorporate provisions relating to cluster development in the planning scheme in respect of the Residential Zone.

A copy of the amendment may be inspected during office hours at the office of the Town and Country Planning Board, 235 Queen Street, Melbourne, at the office of the Council of the Shire of South Gippsland and, when available, at the Office of Titles, Melbourne and at the Central Plan Office of the Department of Crown Lands and Survey, Melbourne.

W. H. CRAIG, Secretary,
Town and Country Planning Board.

Dairy Products Act.
QUOTAS FOR BUTTER AND CHEESE.
BUTTER QUOTA.

I, Ian Winton Smith, Minister of Agriculture in the State of Victoria, after consultation with the Victorian Dairy Products Board, and after ascertaining that the supply and distribution of butter at reasonable prices to consumers thereof in Victoria will be ensured, hereby determine a quota for butter as follows:—

The proportion shall be Thirty-five point sixty-eight per centum.

The period for which this quota is to operate shall be the month of October, 1976.

CHEESE QUOTA.

I, Ian Winton Smith, Minister of Agriculture in the State of Victoria, after consultation with the Victorian Dairy Products Board, and after ascertaining that the supply and distribution of cheese at reasonable prices to consumers thereof in Victoria will be ensured, hereby determine a quota for cheese as follows:—

The proportion shall be Twenty-three point one eight per centum.

The period for which this quota is to operate shall be the month of October, 1976.

I. W. SMITH,
Minister of Agriculture.

AUCTION SALES ACT 1958.

CASTLEMAINE.—Notice is hereby given that the Annual Meeting of Justices for the licensing of auctioneers will be held at Magistrates' Court, Castlemaine, on Tuesday, the 23rd day of November, 1976, at Ten o'clock in the forenoon. Dated at Castlemaine, this 14th day of September, 1976.—P. J. O'GRADY, Clerk of the Magistrates' Court, Castlemaine.

DONALD.—Notice is hereby given that the Annual Meeting of Justices for the licensing of auctioneers will be held at the Magistrates' Court, Donald, on Tuesday, the 23rd day of November, 1976, at Ten o'clock in the forenoon. Dated at Donald, this 23rd day of September, 1976.—T. J. WILSON, Clerk of the Magistrates' Court, Donald.

GEELONG.—Notice is hereby given that the Annual Meeting of Justices for the licensing of auctioneers will be held at the Law Courts, Geelong, on Tuesday, 23rd November, 1976, at the hour of Ten o'clock in the forenoon. Dated at Geelong, this 17th day of September, 1976.—J. E. REILLY, Clerk of the Magistrates' Court.

PORT FAIRY.—Notice is hereby given that the Annual Meeting of Justices for the licensing of auctioneers will be held at the Magistrates' Court, Port Fairy, on Tuesday, the 23rd day of November, 1976, at Ten o'clock in the forenoon. Dated at Port Fairy, the 22nd day of September, 1976.—D. R. SMITH, the Clerk of the Magistrates' Court, Port Fairy.

ST. ARNAUD.—Notice is hereby given that the Annual Meeting of Justices for the licensing of auctioneers will be held at the Magistrates' Court, St. Arnaud, on Tuesday, the 23rd day of November, 1976, at Ten o'clock in the forenoon. Dated at St. Arnaud, this 23rd day of September, 1976.—T. J. WILSON, Clerk of the Magistrates' Court, St. Arnaud.

WARRNAMBOOL.—Notice is hereby given that the Annual Meeting of Justices for the licensing of auctioneers will be held at the Magistrates' Court, Warrnambool, on Tuesday, the 23rd day of November, 1976, at Ten o'clock in the forenoon. Dated at Warrnambool, the 22nd day of September, 1976.—P. J. LIVINGSTONE, the Clerk of the Magistrates' Court, Warrnambool.

WYCHEPROOF.—Notice is hereby given that the Annual Meeting of Justices for the licensing of auctioneers will be held at the Magistrates' Court, Wycheproof, on Tuesday, the 23rd day of November, 1976, at Ten o'clock in the forenoon. Dated at Wycheproof, this 23rd day of September, 1976.—T. J. WILSON, Clerk of the Magistrates' Court, Wycheproof.

PUBLIC TRUSTEE ACT 1958 (No. 6350), SECTION 17.

I hereby give notice that on the 7th September, 1976, the Public Trustee filed elections to administer the following deceased persons' estates, in accordance with section 17 of the Public Trustee Act 1958:—

EACOTT, HENRY JOSEPH, also known as Harry Joseph Eacott, late of 15 Hollismoor Road, Burwood, retired grocer, died 2nd June, 1976.

ENNOSS, HAROLD WILLIAM, late of Eaglehawk, retired electrical fitter, died 9th March, 1976.

THOMPSON, JAMES WILLIAM, late of 10 Randolph Street, Hawthorn, toolmaker, died 30th June, 1965.

I hereby give notice that on the 8th September, 1976, the Public Trustee filed an election to administer the following deceased person's estate, in accordance with section 17 of the Public Trustee Act 1958:—

SWIFT, IVAN WALLACE, late of Athol Lodge, 13 Wrexham Road, Windsor, retired labourer, died 14th May, 1976.

I hereby give notice that on the 10th September, 1976, the Public Trustee filed elections to administer the following deceased persons' estates, in accordance with section 17 of the Public Trustee Act 1958:—

DUGGAN, PERCIVAL WILLIAM, late of 21 Bowen Street, East Prahran, fitter and turner, died 29th May, 1976.

CULLEN, OWEN JOSEPH, late of Swan Hill, retired manager, died 6th May, 1975.

HOLT, ELLEN, formerly of Flat 1, 8DE Murska Street, Prahran, but late of "Montcalm", 173 Prospect Hill Road, Camberwell, spinster, died 1st July, 1976.

HOWELL, VERONICA, late of 5A Hope Street, Brunswick, widow, died 11th June, 1976.

JIRA, JOSEPH JAN, late of 669 Victoria Street, Abbotsford, engineer, died 17th July, 1976.

UMBERS, PERCIVAL LEO, formerly of 11 Neylan Street, Ararat, but late of Queen Elizabeth Home, Ballarat, retired, died 29th May, 1976.

UNDERWOOD, ALAN JOHN GREGORY, also known as Alan Underwood, late of 21 Ramsden Street, Clifton Hill, sailmaker, died 2nd February, 1976.

WONG, KWOK KI, late of 35 Swan Street, Footscray, retired fitter and turner, died 24th May, 1976.

WOODROOFE, MARIE ENID, formerly of 21 Kalinda Road, Ringwood (in the will called Croydon) but late of Mont Park, married woman, died 3rd February, 1976.

168 Exhibition Street, Melbourne, 3000, 22nd September, 1976.

N. P. BRODY,
Public Trustee.

NOTICE.

Creditors, next of kin, and others having claims against the estate of any of the under-mentioned deceased persons are required to send particulars of their claims to the Public Trustee, 256 Flinders Street, Melbourne, Vic. 3000, the personal representative, on or before the 6th December, 1976, after which date the Public Trustee may convey or distribute the assets, having regard only to the claims of which the Public Trustee then has notice:—

BOLLE, HENRY FITZGERALD, late of 65 Kendall Street, West Preston, retired postmaster, died 17th June, 1976.

BULT, EDITH GWENDOLEN, also known as Edith Gwendoline Bult, late of 329 Barkly Street, Elwood, married woman, died 30th June, 1976.

BUMPSTEAD, MURIEL MARIA, late of 72 Fulton Street, Clayton, widow, died 23rd June, 1976.

CLANCY, MARTIN JOSEPH, late of Kingston Centre, Warrigal Road, Cheltenham, retired clerk, died 25th February, 1972.

CLARKE, ALLAN JOSEPH, late of Flat 3, 1218 Dandenong Road, Murrumbeena, french polisher, died 18th April, 1976.

CULLEN, OWEN JOSEPH, late of Swan Hill, retired manager, died 6th May, 1975.

DICKSON, ALLAN CHESTERFIELD, formerly of Unit 2/1 Army Field Workshop, 2nd Australian Imperial Force, but late of 13 Electric Avenue, Glenroy, retired clerk, died 5th February, 1976.

DUGGAN, PERCIVAL WILLIAM, late of 21 Bowen Street, East Prahran, fitter and turner, died 29th May, 1976.

EACOTT, HENRY JOSEPH, also known as Harry Joseph Eacott, late of 15 Hollismoor Road, Burwood, retired grocer, died 2nd June, 1976.

No. 86.—9160/76.—2

ENNOSS, HAROLD WILLIAM, late of Eaglehawk, retired electrical fitter, died 9th March, 1976.

FECHNER, JOHN EDWARD, late of 23 Leslie Street, East St. Kilda, pensioner, died 17th July, 1976.

HALL, HAROLD, late of 7 Smith Street, Maidstone, retired boiler attendant, died 27th May, 1976.

HALNON, ELLEN SOPHIA, formerly of 331 Douglas Parade, Newport, but late of 12 Elphin Street, Newport, widow, died 31st July, 1976.

HEATH, HENRY FRANCIS, formerly of 26 Eram Road, Box Hill North, but late of 90 Sarawak Avenue, Palm Beach, Queensland, retired Victorian Railways employee, died 19th July, 1974.

HEVEREN, ROBERT CECIL, late of Flat 4, 12 Hawthorn Road, North Caulfield, cleaner, died 7th April, 1976.

HOLT, ELLEN, formerly of Flat 1, 8DE Murska Street, Prahran, but late of "Montcalm", 173 Prospect Hill Road, Camberwell, spinster, died 1st July, 1976.

HOWELL, VERONICA, late of 5A Hope Street, Brunswick, widow, died 11th June, 1976.

HUSSEY, ALICE EMILY, late of Aabec House, 35 Mary Street, St. Kilda, widow, died 10th August, 1976.

JENKINS, FREDERICK WALTER, late of 18 Garnet Street, Preston, retired carpenter, died 4th June, 1976.

JIRA, JOSEPH JAN, late of 669 Victoria Street, Abbotsford, engineer, died 17th July, 1976.

MONISH, MANUEL, late of 16 Naroon Road, Alphington, gentleman, died 9th June, 1976.

MCGUIRE, LEOPOLD STANLEY, also known as Lionel Stephen d'Freeze, late of 72 Duke Street, Richmond, pensioner, died 31st January, 1976.

NEVILLE, WILLIAM LESLIE, late of Flat 3, 1277 Toorak Road, Burwood, retired public servant, died 13th June, 1976.

PARKIN, EFFIE ELIZABETH, formerly of Flat 2, 56 Normanby Road, Kew, but late of Hedley Sutton Home, 2 Gascoyne Street, Canterbury, spinster, died 27th May, 1976.

PECKITT, LILY, formerly of 4 Hayden Crescent, Albion, but late of 4 Hendry Street, West Sunshine, widow, died 24th June, 1976.

REYNOLDS, AGNES, late of Mont Park, widow, died 4th June, 1976.

SIMMONDS, JOHN THOMAS, late of Mont Park, pensioner, died 16th April, 1976.

STANLEY, CECIL DANIEL, formerly of Moulamein in the State of New South Wales, but late of Bundoora, retired farmer, died 4th June, 1976.

SWIFT, IVAN WALLACE, late of Athol Lodge, 13 Wrexham Road, Windsor, retired labourer, died 14th May, 1976.

TAYLOR, WILLIAM, formerly of 8 Oxford Street, Newport, but late of 26 Marsh Street, North Altona, retired engineer, died 10th May, 1976.

THOMPSON, JAMES WILLIAM, late of 10 Randolph Street, Hawthorn, toolmaker, died 30th June, 1965.

TURNER, RONALD CHARLES, late of Flat 2, 375 Neerim Road, Murrumbeena, process worker, died 26th July, 1976.

UMBERS, PERCIVAL LEO, formerly of 11 Neylan Street, Ararat, but late of Queen Elizabeth Home, Ballarat, retired, died 29th May, 1976.

UNDERWOOD, ALAN JOHN GREGORY, also known as Alan Underwood, late of 21 Ramsden Street, Clifton Hill, sailmaker, died 2nd February, 1976.

WONG, KWOK KI, late of 35 Swan Street, Footscray, retired fitter and turner, died 24th May, 1976.

WOODROOFE, MARIE ENID, formerly of 21 Kalinda Road, Ringwood (in the will called Croydon) but late of Mont Park, married woman, died 3rd February, 1976.

Melbourne, 22nd September, 1976.

N. P. BRODY,
Public Trustee.

CONTRACTS ACCEPTED.—(Series 1976-77.)

SOIL CONSERVATION AUTHORITY.

CONTRACT No. 47517.

408. Cartage of fertilizer, Puckapunyal Project.—Contract extended by \$400.00.

CONTRACT No. 47520.

409. Tractor hire, Puckapunyal Project.—Contract extended by \$390.00.

R. A. FITT, Secretary.

CONTRACTS ACCEPTED.—(Series 1975-76.)

AMENDMENTS.

Sched. No.	Item No.	Description.	Unit of measurement.	New Rate.	Contractor.	Effective Date.
				\$		
		Provisions.				
		<i>Gazette No. 54—3rd June, 1976</i>				
1		<i>Provisions—Melbourne and Metropolitan District.</i>				
	15	Cake, Fruit "Top Taste"—				
		Ruby—400 g	per block	0.60	} The Phoenix Biscuit Co.	} 4.10.76
		800 g	"	1.20		
		2.5 kg	"	3.75		
		Genoa—450 g	"	0.70		
		2.5 kg	"	3.84		
		Sultana—450 g	"	0.68		
		900 g	"	1.36		
		2.5 kg	"	3.75		
		Dark Fruit—900 g	"	1.36		
		2.5 kg	"	3.75		
		Iced Fruit—900 g	"	1.36		
	16	Cake, Plain—700 g	"	0.910		
		1.82 kg	"	2.34		
	17	Cake, Fancy—				
		Madeira (Iced)—450 g	"	0.615		
		900 g	"	1.23		
		2.15 kg	"	2.92		
		Home Style—900 g	"	1.18		
		2.5 kg	"	3.28		
9		<i>Provisions—Bendigo District Sub-Schedule No. 5—Groceries.</i>				
	11	Weeties, 500 g	per doz.	6.92	} Wholesalers Ltd.	} 1.10.76
	12	Cornflakes, 500 g "Kelloggs"	"	7.44		
	19	Coconut	per kg	0.70		
	24	Custard Powder (was 10-lb.)	"	0.55		
	44	Cornflour (was 10-lb.)	"	0.45		
	51	Currants, 12.5 kg bags	each	12.50		
		" 500 g pkts.	per doz.	7.68		
	53	Sultanas, 15 kg	each	15.10		
	67	Jellies (2 kg pkt.)	per kg	0.85		
	110	Biscarbonate Soda	"	0.28		
	120	Sugar, Castor, 30 kg bags	per bag	8.10		
	122	" 1A, 30 kg. bags	"	7.84		
		General Stores.				
		<i>Gazette No. 58—10th June, 1976.</i>				
3		<i>Batteries (Lead Acid Cells).</i>				
	1	Automotive, truck, tractor and industrial use. Radio and home lighting plants	each	Lucas Trade List 1.9.76 Less 25% Discount	} Lucas Industries (Aust.) Ltd. ..	} 1.10.76
19		<i>Construction Materials, Lime, etc.</i>				
	6	"Limil" (40 bags to tonne) ex store North Melbourne and Dandenong	per tonne	60.30	} Blue Circle Southern Cement Ltd. (Victorian Division)	} 20.9.76
26		<i>Protective Clothing, Uniforms, etc.</i>				
	40	Gloves, Post Mortem, Alternative "Ansell"	per pair	0.49	Alsafé Industries Pty. Ltd. ..	7.9.76
37		<i>Electrical Goods.</i>				
	51	Toaster, Hecla Model T7	each	Reg. 109	} Cancel: Hecla Rowe Co. Pty. Ltd.	} 17.9.76
					} Substitute: Purchase Regulation 109	} 24.9.76
	55	Washing Machine with power wringer "Hoover" model 3106	each	Reg. 109	} Cancel: Hoover (Aust.) Pty. Ltd.	} 24.9.76
					} Substitute: Purchase Regulation 109	

AMENDMENTS.—continued.

Sched. No.	Item No.	Description.	Unit of measurement.	New Rate.	Contractor.	Effective Date.
56		Motor Spirit, Kerosene, Fuel Oils and Lubricants. Gazette No. 84—15th September, 1976. Amendment to Gazette. The reference to items 11 and 12 should be items 26-29 Distillate.		\$		
69		Stationery, General. Gazette No. 73—27th August, 1975.				
	143	Numbering Machine, 6 figure— Delete: "Great Wall" Substitute: "Wottan C71"	each	6.98	John Withers and Son Pty. Ltd.	10.9.76

J. M. PAWSON,
Acting Secretary to the Tender Board.

Survey Co-ordination Act 1958.

NOTICE OF ALTERATION OF NAME.

Pursuant to the powers conferred under section 29 of the above Act, the Place Names Committee hereby gives notice of the following decision of the Honorable the Minister of Lands, under section 28 (5) of the Act, in relation to the name of the under-mentioned water storage—

Municipality.—Shire of Bacchus Marsh.

Previous Name.—Lake Merrimu.

New Name.—Merrimu Reservoir.

By order of the Committee,

M. W. COOKE,
Secretary.

Office of the Place Names Committee,
Department of Crown Lands and Survey,
Melbourne, Vic., 3002.

Survey Co-ordination Act 1958.

NOTICE OF ALTERATION OF NAME.

Pursuant to the powers conferred under section 29 of the above Act, the Place Names Committee hereby gives notice of the alteration of the following name:—

Municipality.—City of Fitzroy.

Previous Name.—Fitzroy Girls High School.

New Name.—Exhibition High School.

By order of the Committee,

M. W. COOKE,
Secretary.

Office of the Place Names Committee,
Department of Crown Lands and Survey,
Melbourne, Vic., 3002.

Survey Co-ordination Act 1958.

NOTICE OF ALTERATION OF NAME.

Pursuant to the powers conferred under section 29 of the above Act, the Place Names Committee hereby gives notice of the alteration of the following name:—

Municipality.—Shire of Morwell.

Previous Name.—Maryvale Public Siding.

New Name.—Hazelwood Siding.

By order of the Committee,

M. W. COOKE,
Secretary.

Office of the Place Names Committee,
Department of Crown Lands and Survey,
Melbourne, Vic., 3002.

Survey Co-ordination Act 1958.

NOTICE OF ASSIGNMENT OF NAME.

Pursuant to the powers conferred under section 29 of the above Act, the Place Names Committee hereby gives notice of the following decision of the Honorable the Minister of Lands, under section 28 (5) of the Act, in relation to the name of the under-mentioned reserve:—

Name.—Rhyll Inlet.

Municipality.—Shire of Phillip Island.

Location.—As indicated on the map below.

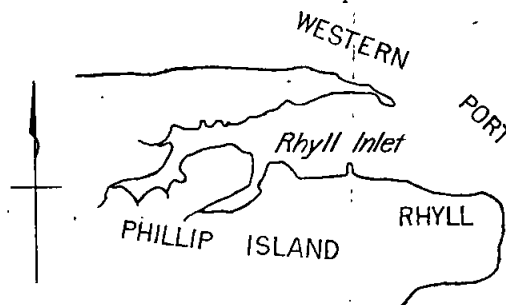

By order of the Committee,

M. W. COOKE,
Secretary.

Office of the Place Names Committee,
Department of Crown Lands and Survey,
Melbourne, Vic. 3002.

Survey Co-ordination Act 1958.

NOTICE OF PROPOSAL TO ASSIGN A NAME.

Pursuant to the powers conferred under section 28 of the above Act, the Place Names Committee hereby gives notice of its intention to assign the following name:—

Name.—Nicholson River Reservoir.

Municipality.—Shire of Tambo.

Location.—Bairnsdale map sheet (No. SJ55-07; Scale 1 : 250,000) at south latitude 37 deg. 42 min., east longitude 147 deg. 42 min.

Any person who objects to the above proposal may give notice of objection in writing, stating the reasons therefor, to the Secretary of the Committee, not more than two (2) months following publication of this notice.

By order of the Committee,

M. W. COOKE,
Secretary.

Office of the Place Names Committee,
Department of Crown Lands and Survey,
Melbourne, Vic., 3002.

MINES DEPARTMENT.

APPLICATIONS FOR MINING LEASES REFUSED.

- No. 404; R. R. Mining Pty. Ltd.; 16 ha, Parishes of Elphinstone and Metcalfe.
 No. 405; R. R. Mining Pty. Ltd.; 18 ha, Parishes of Elphinstone and Metcalfe.

MINING LEASES GRANTED.

- No. 271; Nellie Elizabeth Leyonhjelm; 28 ha, Parish of Tullyvea.
 No. 387; Robert George Pullman, Marjory Lynn Pullman, Pauline Patricia Pullman, Keith Alfred Pullman; 6.1 ha, Parish of Yatpool.
 No. 448; John Wisely; 150 ha, Parish of Costerfield.

APPLICATION FOR EXPLORATION LICENCE REFUSED.

- No. 561; John Campbell Kennedy; 792 km², County of Tatchera.

EXPLORATION LICENCES GRANTED.

- No. 548; John Campbell Kennedy; 792 km², Counties of Tatchera and Gladstone.
 No. 592; Tioxide Australia Proprietary Limited; 726 km², Counties of Korung and Karkaroc.

PARTS OF EXPLORATION LICENCES RELINQUISHED.

- No. 528; Western Mining Corporation Limited; Graticular Blocks Nos. 1153, 1369 and 1657 Melbourne Map Sheet.
 No. 529; Western Mining Corporation Limited; Graticular Blocks Nos. 1293, 1437 and 1438 Hamilton Map Sheet.
 No. 530; Western Mining Corporation Limited; Graticular Blocks Nos. 792 and 864 Hamilton Map Sheet.

TAILINGS LICENCES GRANTED.

- No. 3988; A. G. Leech Pty. Ltd.; to remove tailings from the "Gladstone Mine Dump", Parish of Maryborough.
 No. 3989; A. G. Leech Pty. Ltd.; to remove tailings from the "Band of Hope Mine Dump", Parish of Maryborough.
 No. 3990; A. G. Leech Pty. Ltd.; to remove tailings from the "John Bright Mine Dump", Parish of Maryborough.
 No. 3992; The City of Maryborough; to remove tailings from the "Bristol Hill Mine Dump", Parish of Bet Bet.
 No. 3994; The Shire of Talbot; to remove tailings from the "Old Union Mine Dump", Parish of Amherst.
 No. 3997; Alan Sutherland, Kevin Sutherland, Graeme Sutherland; to remove tailings from Allotments 38 and 19E, Parishes of Woorarra and Toora respectively.
 No. 4004; The Shire of Grenville; to remove tailings from mine dumps situated immediately south of Crown allotment 1, section 29A, Township of Smythesdale.
 No. 4006; The Shire of Ripon; to remove tailings from the "Koren Kopier" and other mine dumps situated in the Parish of Carngham.
 No. 4007; The Shire of Ripon; to remove tailings from the "North Hope Mine Dump" situated in the Parish of Beaufort and the "Horbart Pascha", "Victoria" and "South Sons of Freedom" Mine Dumps situated in the Parish of Raglan.
 No. 4009; The Shire of Talbot and Clunes; to remove tailings, Parish of Amherst.
 No. 4010; The City of Maryborough; to remove tailings from the "Grand Duke Mine Dump", Parish of Bet Bet.
 No. 4013; The Shire of Grenville; to remove tailings from the "Sandy Creek Dredge Dump", Parish of Scarsdale.
 No. 4014; The Borough of Sebastopol; to remove tailings from the "No. 1 and No. 2 Prince of Wales Mine Dumps" and the "Nelson Mine Dump", Parish of Ballarat.

TAILINGS LICENCE EXPIRED.

- No. 3916; The Country Roads Board; to remove tailings from the "Long Tunnel Mine Dump", Parish of Wadhalla.

EXTRACTIVE INDUSTRY LEASES GRANTED.

- No. 122; Edward George Leighton, Athol James Leighton; 6.1 ha, Parish of Woodside.
 No. 141; Rigby Bros. & Co. Pty. Limited; 4.6 ha, Parish of Konong Wootong.

APPLICATION FOR EXTRACTIVE INDUSTRY LICENCE DECLARED ABANDONED.

- No. 845; Lawrence Francis Dwyer; 22 ha, Parish of Trentham.

EXTRACTIVE INDUSTRY LICENCES GRANTED.

- No. 293; Rock Products Pty. Limited; 59 ha, Parish of Berwick.
 No. 832; Harry Gatens Craig, Margaret Barnett Craig; 0.4 ha, Parish of Barrarbool.
 No. 868; Construction Materials (Australia) Pty. Limited; 8.3 ha, Parish of Mordialloc.
 No. 869; Construction Materials (Australia) Pty. Limited; 3.6 ha, Parish of Mordialloc.
 No. 881; Maskell & Gribben Pty. Ltd.; 19 ha, Parish of Katandra.

EXTRACTIVE INDUSTRY LICENCES EXPIRED.

- No. 64; Co-operative Brick Company Proprietary Limited; 8.5 ha, Parish of Boroondara.
 No. 412; James John Gread; 1.2 ha, Parish of Yarroweayah.

J. C. M. BALFOUR,
 Minister of Mines.

APPOINTMENTS AND RESIGNATIONS

APPOINTMENTS.

His Excellency the Governor of the State of Victoria, by and with the advice of the Executive Council thereof, has, by Orders made on the 21st day of September, 1976, been pleased to make the under-mentioned appointments, viz.:

LAW DEPARTMENT.

Justices of the Peace.

ROSALIND BATAGOL, 10 Willsmere Road, Kew,
 JOHN HERD CHALMERS, Canary Island,
 GREGORY CHARLES CHARLTON, Coleraine Road, Merino,
 BASIL ALFRED CLARK, 102 Albert Street, East Melbourne,
 GERALD FRANK DADGE, 3 Ninth Street, Eildon,
 DOROTHY ELEANOR FULLARTON, 74 Ardmillan Road,
 Moonee Ponds,
 RONALD JOHN HAINING, 39 Catalina Street, West
 Heidelberg,
 WILLIAM GEORGE JARVIS LOW, 2 Albany Road, Toorak,
 MAXWELL JOHN McDONALD, 23 Second Street, Eildon,
 GRAEME BRUCE MCPHERSON, Sherbrooke Lodge Road,
 Sherbrooke,
 JAMES JOSEPH MURPHY, 24 Sturt Street, Ballarat,
 GEOFFREY EDWARD PEACH, Oswald Avenue, Lara,
 BAYLON RYAN, 3 Lyell Parade, Greensborough,
 MARK ALFRED SIMS, 12 Centenary Crescent, Werribee,
 and
 EDWIN JAMES THEAKSTON, 74 Bursaria, Lower Ferntree
 Gully,
 to be Justices of the Peace for the State of Victoria.

Commissioners for Taking Declarations, &c.

KENNETH DOUGLAS BARELLI, 60 Doncaster East Road,
 Mitcham,
 MALCOLM JOHN BEATON, Casterton Memorial Hospital,
 Casterton,
 GAVAN MICHAEL CALLAGHAN, corner Dorcas and Wells
 Streets, South Melbourne,
 RICHARD JOHN CAMERON, and
 PETER BARRY GREGOR,
 corner Scott and Thomas Streets, Dandenong,
 EMANUEL CAMILLERI, 20 Alma Street, Maidstone,
 PETER BERTRAM COOK, Town Hall, Sebastopol,
 UGO DI MAGGIO, 107 The Grove, Coburg,
 TIMOTHY DANIEL JOSEPH DONAHOO, 27 Blair Street,
 Broadmeadows,
 BRIAN DAVID EARNSHAW,
 PETER JOHN EDMONDS,
 SAMIR ATTIA SHENOUDA, and

REINY JOSEPH STRYBOSCH,
179 Queen Street, Melbourne,
MARJORIE ANN FAGAN, 95 Harrison Street, Box Hill
North,
JOHN FRANCIS FILDES, 60 Bank Street, South Melbourne,
JOSEPH HANMER, 155 Oriol Road, Heidelberg,
ERIC LESLIE HART, Banks Street, Lara,
ELEANORA MURIEL LLOYD-WILLIAMS, 5 Cornell Court,
Karingal,
HURTLER REGINALD LUPTON, 28 Marland Road, Boronia,
DARYL FRANCIS MORGAN, McPhersons Road, Muntoona,
BARRY WYNYATT MURRAY, 40 Walker Street, Dan-
denong,
MICHAEL THOMAS MURRIHY, 205 Dana Street, Ballarat,
IAN TURNER REID, 83 William Street, Melbourne,
FRANCIS HENRY RICHARDSON, 7 Parker Street, Preston,
ROBERT FRANCIS SHANAHAN, 8 McFarlane Crescent,
Epping,
WILLIAM GEORGE SINCLAIR, 333 Timor Street, Warrnam-
bool,
HAROLD RODNEY SMITH, 10 Gilga Street, Mornington,
RONALD JAMES TIPPETT, 64-74 Flinders Street, Mel-
bourne,
NORA AGNES WANLISS, Flat 2, 318 Beaconsfield Parade,
West St. Kilda,
LOIS VALERIE WEBB, 5 George Street, Dromana, and
RONALD WHYBROW, 50 Franklin Street, Melbourne,
to be Commissioners for taking Declarations and Affidavits
under the Evidence Act 1958.

Deputy Prothonotaries.

DENIS DANIEL REES, Clerk of Courts,
to be Deputy Prothonotary and Registrar of the County
Court at Sale, vice A. R. Dunlop, on recreation leave; and
KEVIN THOMAS RYAN, Clerk of Courts,
to be Deputy Prothonotary at Morwell, vice R. P. White, on
recreation leave.

SOCIAL WELFARE DEPARTMENT.

Honorary Probation Officers.

DAVID ASH, 4 Newington Grove, North Caulfield,
BEVERLEY JOY BONAR (Mrs.), 39 Isla Avenue, Glenroy,
DONNA MARGARET BOURKE (Miss), Flat 7, 38 Northcote
Road, Armadale,
CHARLES HILLHOUSE CARTHEW, 2 Tobias Avenue, Glen
Waverley,
WILLIAM JOHN COX, Unit 1, 227 Union Road, Surrey
Hills,
FRANK RONALD FARQUHARSON, 28 Gretel Grove, Melton,
EDITH JOYCE FOWLER (Mrs.), 18 Tamarisk Avenue,
Glen Waverley,
JENNIFER DOROTHY HOLCROFT (Miss), Sebastien Road,
Bridgewater,
HOWARD HUNTLEY, 12 Carlisle Road, Hallam,
JOHN LABAS, 60 Murray Street, Yarraville,
RAYMOND NOEL MACKENZIE, 34 Alexandra Avenue,
East Geelong,
KERRY ANN MULCAHY (Miss), 10 Lincoln Parade,
Aspendale,
IAN LINDSAY NEWLAND, 26 Uvadale Grove, Kew,
ROBIN DAVID NICOL, Flat 1, 38 Arnold Street, South
Yarra,
ROSSLYN JOY REEVE (Mrs.), Flat 8, 32 Lawson Parade,
Highett, and
MERVIN MAXWELL SAULTRY, National Bank Ltd., Cox
Street, Port Fairy,
pursuant to the provisions of section 507 (2) of the
Crimes Act 1958 and section 9 of the Children's Court Act
1973, to be Honorary Probation Officers for all Adult and
Children's Courts in Victoria.

TOM FORRISTAL,

Clerk of the Executive Council.

At the Executive Council Chamber,
Melbourne, 21st September, 1976.

APPOINTMENT.

His Excellency the Governor of the State of Victoria by
and with the advice of the Executive Council thereof has
by Order made on the 28th day of September, 1976, been
pleased to make the under-mentioned appointment, viz.:

CHIEF SECRETARY'S DEPARTMENT.
Member of Workers Compensation Board.

WILLIAM ROY HARBINSON
to be a "Lay" member of the Workers Compensation
Board pursuant to the provisions of the Workers Compen-
sation Act 1958, for a period of five years from 28th
September, 1976.

TOM FORRISTAL,
Clerk of the Executive Council.

At the Executive Council Chamber,
Melbourne, 28th September, 1976.

Liquor Control Act 1968.

APPOINTMENT OF LICENSING INSPECTORS.

In accordance with the authority conferred upon me by
sub-section (1) of Section 22 of the *Liquor Control Act 1968*,
I, Reginald Jackson, Chief Commissioner of Police, hereby appoint
the following Officers of Police as Licensing Inspectors for the
Divisions of the Police Districts as shown:—

Division Number.	Police District.	Rank and Name.
1	Barwon	Inspector George Mervyn Johnstone (vice Inspector H. F. Nailon)
2	Cheltenham	Chief Inspector Eric Roy Sutton, V.A. (vice Chief Inspector J. T. Griffin)

24.9.1976

R. JACKSON,
Chief Commissioner of Police.

RESIGNATIONS.

His Excellency the Governor of the State of Victoria,
by and with the advice of the Executive Council thereof,
has, by Orders made on the 21st day of September, 1976,
accepted the resignations of the persons named hereunder
of the offices mentioned, viz.:

LAW DEPARTMENT.

Justices of the Peace.

STANLEY GORDON BALFOUR,
CYRIL THOMAS BARLING,
CHARLES GILBERT SEARIES, and
HENRY BRAMWELL THOMAS,
as Justices of the Peace for the State of Victoria.

Commissioners for Taking Declarations, &c.

BASIL ALFRED CLARK,
GEOFFREY HAROLD CULLEN,
GRAHAM BENNETT INCE,
JAMES JOSEPH MURPHY,
BAYLON RYAN, and
BERNARD WESTON,
as Commissioners for taking Declarations and
Affidavits under the Evidence Act 1958.

SOCIAL WELFARE DEPARTMENT.

Honorary Probation Officers.

CHRISTOPHER A. BAIN,
PETER MICHAEL CONWAY (Rev.), and
DESMOND LEO LONERGAN,
as Honorary Probation Officers pursuant to the
provisions of section 507 (2) of the Crimes Act
1958 and section 9 of the Children's Court Act
1973.

TOM FORRISTAL,

Clerk of the Executive Council.

At the Executive Council Chamber,
Melbourne, 21st September, 1976.

ORDERS IN COUNCIL

LOCAL GOVERNMENT DEPARTMENT.

At the Executive Council Chamber, Melbourne, the
twenty-first day of September, 1976.

PRESENT:

His Excellency the Governor of Victoria.
Mr. Smith | Mr. Scanlan.
Mr. Hayes

**PART OF A ROAD DISCONTINUED.—CITY OF
BROADMEADOWS.**

Whereas it is provided in section 528 (2) of the *Local
Government Act 1958*, that where a road (whether or not
a public highway but not being a road set out on land
of the Crown) or any part thereof is not required for public
use the Governor in Council on the request of the council
of the municipality in which such road is situated made

not less than one month after publishing in a newspaper generally circulating in the district and posting to the registered proprietor (if any) of the land and the owners and occupiers (if any) of lands abutting or immediately adjacent to the road notice of intention to make such request may by Order published in the *Government Gazette* direct that such road or part shall be discontinued and thereupon such road or part shall be discontinued accordingly.

And whereas the Council of the City of Broadmeadows has requested that the Governor in Council direct that part of a road off Grevillia Road, Oak Park, be discontinued and not less than one month previously has published in a newspaper generally circulating in the district and posted to the registered proprietor of the land in the road and to the owners and occupiers of the lands abutting or immediately adjacent to the road notice of intention to make such request.

Now therefore, His Excellency the Governor of the State of Victoria, by and with the advice of the Executive Council thereof, hereby directs—

- (a) that the said part of road which is shown by hachure on the plan hereunder, shall be discontinued;
- (b) that notwithstanding such discontinuance the Melbourne and Metropolitan Board of Works shall continue to have and possess the same right title power authority or interest in or in relation to the whole of the land shown by hachure on the said plan as it had or possessed prior to such discontinuance with respect to or in connection with any drains or pipes laid or erected in on or over such lands for the purposes of drainage or sewerage; and
- (c) that, subject to any such rights title power authority or interest, the land in the said road may be sold by the Council of the City of Broadmeadows by agreement.

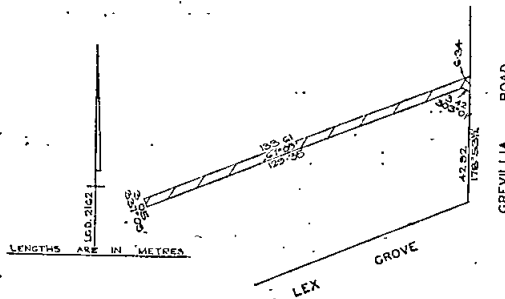

And the Honorable Alan John Hunt, Her Majesty's Minister for Local Government for the State of Victoria, shall give the necessary directions herein accordingly.

TOM FORRISTAL,
Clerk of the Executive Council.

LOCAL GOVERNMENT DEPARTMENT.

At the Executive Council Chamber, Melbourne, the twenty-first day of September, 1976.

PRESENT:
His Excellency the Governor of Victoria.
Mr. Smith | Mr. Scanlan;
Mr. Hayes

ROAD DISCONTINUED.—CITY OF FOOTSCRAY.

Whereas it is provided in section 528 (2) of the *Local Government Act 1958*, that where a road (whether or not a public highway but not being a road set out on land of the Crown) or any part thereof is not required for public use the Governor in Council on the request of the council

of the municipality in which such road is situated made not less than one month after publishing in a newspaper generally circulating in the district and posting to the registered proprietor (if any) of the land and the owners and occupiers (if any) of lands abutting or immediately adjacent to the road notice of intention to make such request may by Order published in the *Government Gazette* direct that such road or part shall be discontinued and thereupon such road or part shall be discontinued accordingly.

And whereas the Council of the City of Footscray has requested that the Governor in Council direct that a road between Charles Street and Rennie Street, Footscray, be discontinued and not less than one month previously has published in a newspaper generally circulating in the district and posted to the registered proprietor of the land in the road and to the owners and occupiers of land abutting or immediately adjacent to the said road notice of intention to make such request.

Now therefore, His Excellency the Governor of the State of Victoria, by and with the advice of the Executive Council thereof, hereby directs that the said road, which is shown by hachure on the plan hereunder, shall be discontinued and that the land may be sold by the Council of the City of Footscray by agreement.

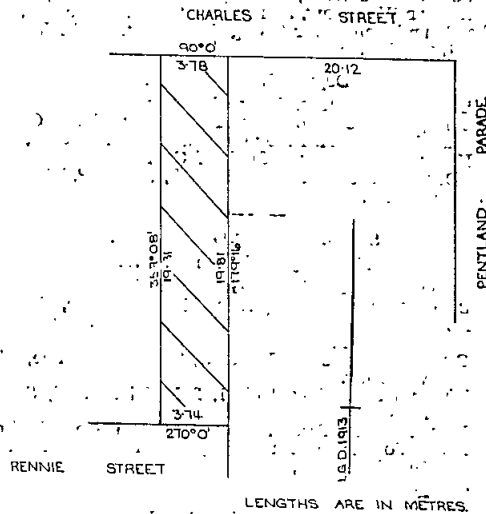

And the Honorable Alan John Hunt, Her Majesty's Minister for Local Government for the State of Victoria, shall give the necessary directions herein accordingly.

TOM FORRISTAL,
Clerk of the Executive Council.

LOCAL GOVERNMENT DEPARTMENT.

At the Executive Council Chamber, Melbourne, the twenty-first day of September, 1976.

PRESENT:
His Excellency the Governor of Victoria.
Mr. Smith | Mr. Scanlan.
Mr. Hayes

ROAD DISCONTINUED.—CITY OF KEILOR.

Whereas it is provided in section 528 (2) of the *Local Government Act 1958*, that where a road (whether or not a public highway but not being a road set out on land of the Crown) or any part thereof is not required for public use the Governor in Council on the request of the council of the municipality in which such road is situated made not less than one month after publishing in a newspaper generally circulating in the district and posting to the registered proprietor (if any) of the land and the owners and occupiers (if any) of lands abutting or immediately adjacent to the road notice of intention to make such request may by Order published in the *Government Gazette* direct that such road or part shall be discontinued and thereupon such road or part thereof shall be discontinued accordingly.

And whereas the Council of the City of Keilor has requested that the Governor in Council direct that a road off Keilor Road, East Keilor, be discontinued and not less than one month previously has published in a newspaper generally circulating in the district and posted to the registered proprietor of the land in the road and to the owners and occupiers of the lands abutting or immediately adjacent to the road notice of intention to make such request.

Now therefore, His Excellency the Governor of the State of Victoria, by and with the advice of the Executive Council thereof, hereby directs that the said road, which is shown by hachure on the plan hereunder, shall be discontinued and that the land may be retained by the Council of the City of Keilor for municipal purposes.

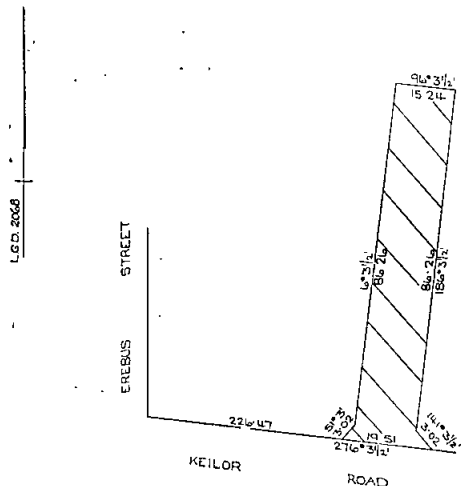

LENGTHS ARE IN METRES

And the Honorable Alan John Hunt, Her Majesty's Minister for Local Government for the State of Victoria, shall give the necessary directions herein accordingly.

TOM FORRISTAL,
Clerk of the Executive Council.

LOCAL GOVERNMENT DEPARTMENT.

At the Executive Council Chamber, Melbourne, the twenty-first day of September, 1976.

PRESENT:

His Excellency the Governor of Victoria.
Mr. Smith | Mr. Scanlan.
Mr. Hayes

ROAD DISCONTINUED.—CITY OF MELBOURNE.

Whereas it is provided in section 528 (2) of the *Local Government Act 1958*, that where a road (whether or not a public highway but not being a road set out on land of the Crown) or any part thereof is not required for public use the Governor in Council on the request of the council of the municipality in which such road is situated made not less than one month after publishing in a newspaper generally circulating in the district and posting to the registered proprietor (if any) of the land and the owners and occupiers (if any) of lands abutting or immediately adjacent to the road notice of intention to make such request may by Order published in the *Government Gazette* direct that such road or part shall be discontinued and thereupon such road or part thereof shall be discontinued accordingly.

And whereas the Council of the City of Melbourne has requested that the Governor in Council direct that a road off Centre Place, Melbourne, be discontinued and not less than one month previously has published in a newspaper generally circulating in the district and posted to the registered proprietor of the land in the road and to the owners and occupiers of land abutting or immediately adjacent to the road notice of intention to make such request.

Now therefore, His Excellency the Governor of the State of Victoria, by and with the advice of the Executive Council thereof, hereby directs that the said road, which is shown

by hachure on the plan hereunder, shall be discontinued and that the land may be sold by the Council of the City of Melbourne by agreement.

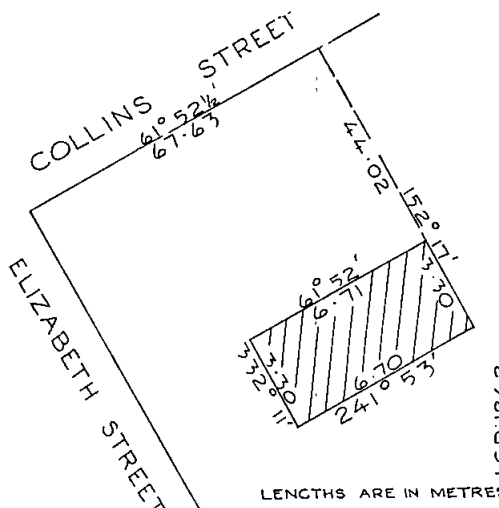

LENGTHS ARE IN METRES

And the Honorable Alan John Hunt, Her Majesty's Minister for Local Government for the State of Victoria, shall give the necessary directions herein accordingly.

TOM FORRISTAL,
Clerk of the Executive Council.

LOCAL GOVERNMENT DEPARTMENT.

At the Executive Council Chamber, Melbourne, the twenty-first day of September, 1976.

PRESENT:

His Excellency the Governor of Victoria.
Mr. Smith | Mr. Scanlan.
Mr. Hayes

ROADS DISCONTINUED.—CITY OF MORDIALLOC.

Whereas it is provided in section 528 (2) of the *Local Government Act 1958*, that where a road (whether or not a public highway but not being a road set out on land of the Crown) or any part thereof is not required for public use the Governor in Council on the request of the council of the municipality in which such road is situated made not less than one month after publishing in a newspaper generally circulating in the district and posting to the registered proprietor (if any) of the land and the owners and occupiers (if any) of lands abutting or immediately adjacent to the road notice of intention to make such request may by Order published in the *Government Gazette* direct that such road or part shall be discontinued and thereupon such road or part shall be discontinued accordingly.

And whereas the Council of the City of Mordialloc has requested that parts of a road off Epsom Road, Mordialloc, be discontinued and not less than one month previously has published in a newspaper generally circulating in the district and posted to the registered proprietor of the land in the road and to the owners and occupiers of the lands abutting or immediately adjacent to the said road notice of intention to make such request.

Now therefore, His Excellency the Governor of the State of Victoria, by and with the advice of the Executive Council thereof, hereby directs—

- (a) that the said parts of road, which are shown by hachure on the plan hereunder, shall be discontinued;
- (b) that notwithstanding such discontinuance the Melbourne and Metropolitan Board of Works shall continue to have and possess the same right title power authority or interest in or in relation to the whole of the land shown by hachure on the said plan as it had or possessed prior to such discontinuance with respect to or in connection with any drains or pipes laid or erected in on or over such lands for the purposes of drainage or sewerage; and

(c) that, subject to any such rights title power authority or interest, the land in the said parts of road may be sold by the Council of the City of Mordialloc by agreement.

Now therefore, His Excellency the Governor of the State of Victoria, by and with the advice of the Executive Council thereof, hereby directs—

- (a) that the said road, which is shown by hachure and cross-hachure on the plan hereunder, shall be discontinued;
- (b) that notwithstanding such discontinuance the Geelong Waterworks and Sewerage Trust shall continue to have and possess the same right title power authority or interest in or in relation to the whole of the land shown by cross-hachure as it had or possessed prior to such discontinuance with respect to or in connection with any drains or pipes laid or erected in on or over such land for the purposes of drainage or sewerage; and
- (c) that subject to any such right title power authority or interests, the land in the said road may be sold by the Council of the City of Newtown by agreement.

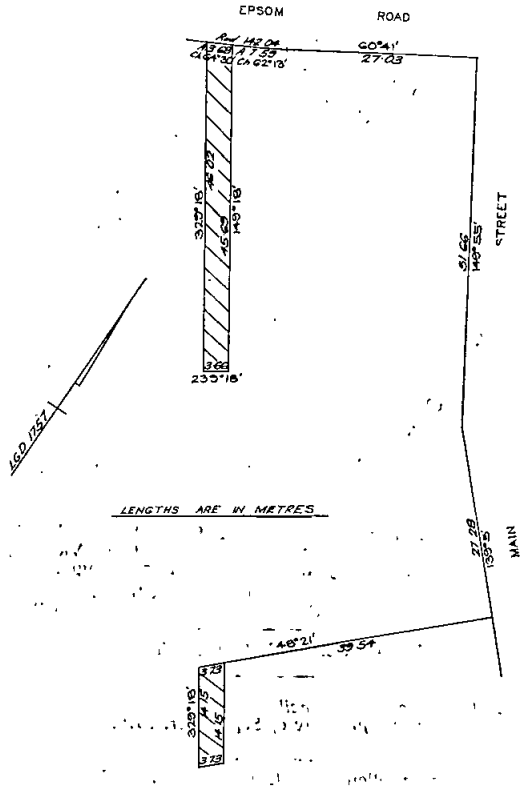

And the Honorable Alan John Hunt, Her Majesty's Minister for Local Government for the State of Victoria, shall give the necessary directions herein accordingly.
TOM FORRISTAL,
Clerk of the Executive Council.

LOCAL GOVERNMENT DEPARTMENT.

At the Executive Council Chamber, Melbourne, the twenty-first day of September, 1976.

PRESENT:
His Excellency the Governor of Victoria.
Mr. Smith | Mr. Scanlan.
Mr. Hayes

ROAD DISCONTINUED.—CITY OF NEWTOWN.

Whereas it is provided in section 528 (2) of the Local Government Act 1958, that where a road (whether or not a public highway but not being a road set out on land of the Crown) or any part thereof is not required for public use the Governor in Council on the request of the council of the municipality in which such road is situated made not less than one month after publishing in a newspaper generally circulating in the district and posting to the registered proprietor (if any) of the land and the owners and occupiers (if any) of the lands abutting or immediately adjacent to the road notice of intention to make such request may by Order published in the Government Gazette direct that such road or part shall be discontinued and thereupon such road or part shall be discontinued accordingly.

And whereas the Council of the City of Newtown has requested that the Governor in Council direct that a road off Price Street, Newtown, be discontinued and not less than one month previously has published in a newspaper generally circulating in the district and posted to the registered proprietor of the land in the road and to the owners and occupiers of lands abutting or immediately adjacent to the road notice of intention to make such request.

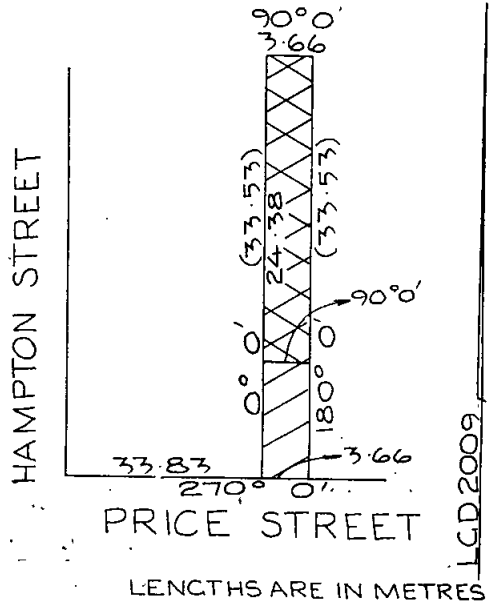

And the Honorable Alan John Hunt, Her Majesty's Minister for Local Government for the State of Victoria, shall give the necessary directions herein accordingly.

TOM FORRISTAL,
Clerk of the Executive Council.

LOCAL GOVERNMENT DEPARTMENT.

At the Executive Council Chamber, Melbourne, the twenty-first day of September, 1976.

PRESENT:
His Excellency the Governor of Victoria.
Mr. Smith | Mr. Scanlan.
Mr. Hayes

CONSENT TO VARIATION OF USE OF PART OF A RESERVE BY THE WAVERLEY CITY COUNCIL.

Whereas certain land being the Reserve for Municipal purposes on Plan of Subdivision No. 53035 was transferred to the Council of the City of Waverley pursuant to the provisions of section 569b (8A) (ii) (a) of the Local Government Act 1958 or any corresponding previous enactment and the said Council is now of the opinion that part of the land is no longer required for the purpose for which it was reserved and has requested that consent be given pursuant to the provisions of section 569bA of the said Act to use portion of the land for the purposes of an Elderly Citizens Village.

And whereas the said Council—
(a) has published in a newspaper generally circulating in the municipal district a notice describing the land and the proposal for the altered use thereof and stating that at the next ordinary meeting of

the Council after the expiration of forty days after publication of the notice the Council would consider any objection to the proposal;

(b) has posted a similar notice upon the land in question.

And whereas no objections to the proposal have been received.

Now therefore, His Excellency the Governor of the State of Victoria, by and with the advice of the Executive Council thereof and in pursuance of the provisions of sub-section 2 of section 569BA of the Local Government Act 1958, hereby consents to the use of the land in that portion of the Reserve for Municipal purposes on Plan of Subdivision No. 53035 lodged in the Office of Titles shown hatched on the plan hereunder for the purposes of an Elderly Citizens Village.

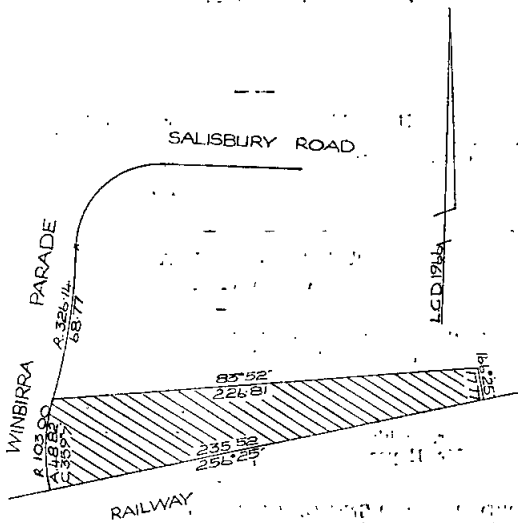

LENGTHS ARE IN METRES

And the Honorable Alan John Hunt, Her Majesty's Minister for Local Government for the State of Victoria, shall give the necessary directions herein accordingly.

TOM FORRISTAL,
Clerk of the Executive Council.

LOCAL GOVERNMENT DEPARTMENT.

At the Executive Council Chamber, Melbourne, the twenty-first day of September, 1976.

PRESENT:

His Excellency the Governor of Victoria.
Mr. Smith | Mr. Scanlan.
Mr. Hayes

ROAD DISCONTINUED.—SHIRE OF BASS.

Whereas it is provided in section 528 (2) of the Local Government Act 1958, that where a road (whether or not a public highway but not being a road set out on land of the Crown) or any part thereof is not required for public use the Governor in Council on the request of the council of the municipality in which such road is situated made not less than one month after publishing in a newspaper generally circulating in the district and posting to the registered proprietor (if any) of the land and the owners and occupiers (if any) of lands abutting or immediately adjacent to the road notice of intention to make such request may by Order published in the Government Gazette direct that such road or part shall be discontinued and thereupon such road or part thereof shall be discontinued accordingly.

And whereas the Council of the Shire of Bass has requested that the Governor in Council direct that a road in the Parish of Woolamai be discontinued and not less than one month previously has published in a newspaper generally circulating in the district and posted to the registered proprietor of the land in the road and to the owners and occupiers of the lands abutting or immediately adjacent to the road notice of intention to make such request.

Now therefore, His Excellency the Governor of the State of Victoria, by and with the advice of the Executive Council thereof, hereby directs that the said road, which is shown by hachure on the plan hereunder, shall be discontinued and that the land may be sold by the Council of the Shire of Bass by agreement.

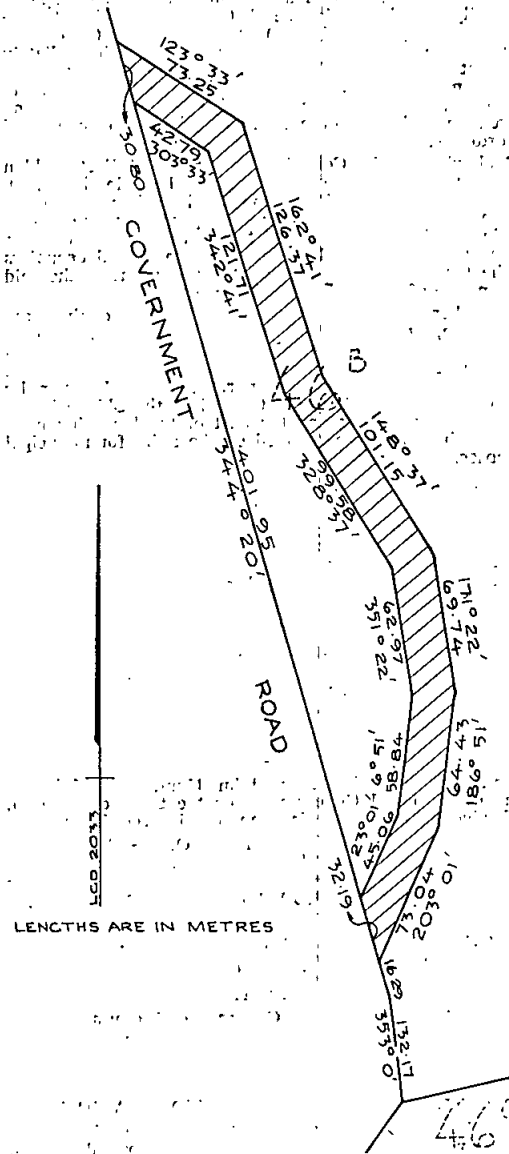

LENGTHS ARE IN METRES

And the Honorable Alan John Hunt, Her Majesty's Minister for Local Government for the State of Victoria, shall give the necessary directions herein accordingly.

TOM FORRISTAL,
Clerk of the Executive Council.

The land shown hatched on plan numbered G.P.14006 attached to this Order required for the deviation from the Lillydale—Monbulk Road in the Shire of Lillydale and making of the deviation thereon

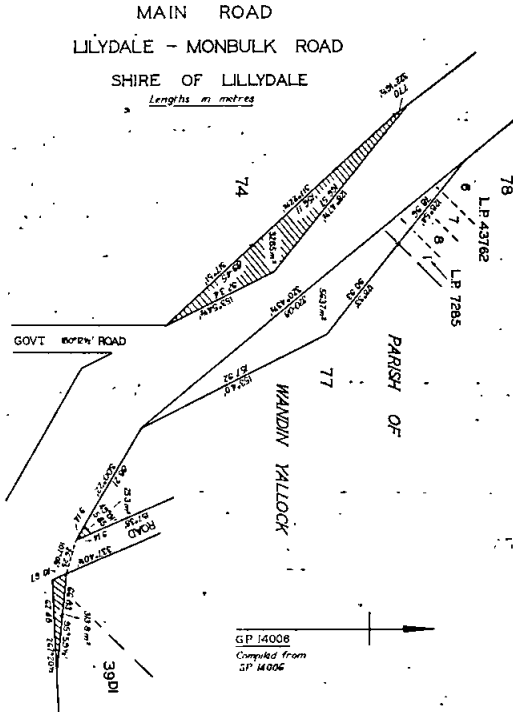

Tourists' Road.

The land shown hatched on plan numbered G.P.12357a attached to this Order required for the widening of Great Ocean Road in the Shire of Heytesbury and making of the widening thereon.

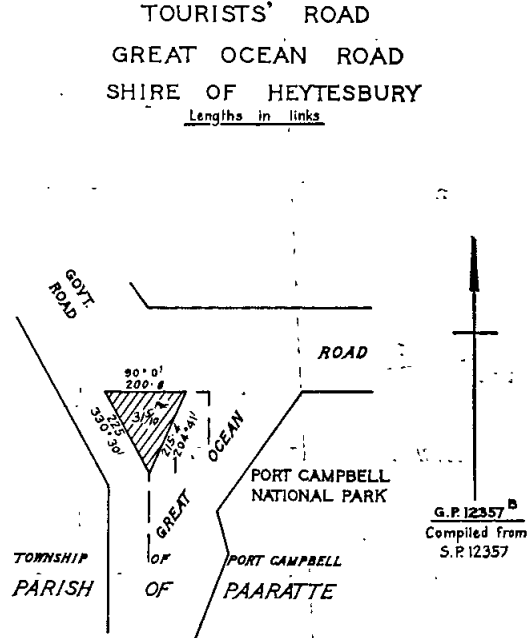

And the Honorable Joseph Anstice Rafferty, Her Majesty's Minister of Transport for the State of Victoria, shall give the necessary directions herein accordingly.

TOM FORRISTAL,
Clerk of the Executive Council.

The land shown hatched on plan numbered G.P.14175 attached to this Order required for the widening of the Gembrook—Launching Place Road in the Shire of Pakenham and making of the widening thereon.

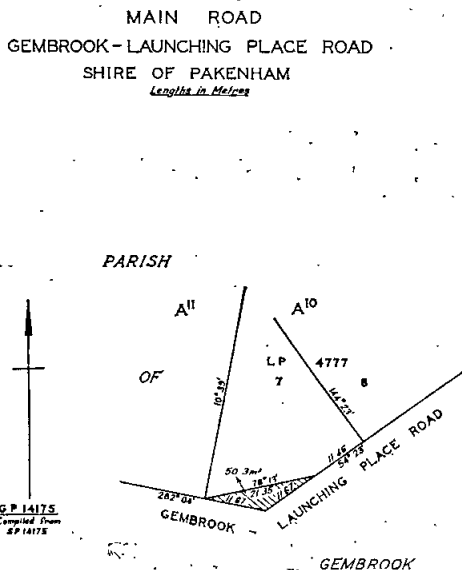

COUNTRY ROADS ACT 1958.
Act No. 6229.

At the Executive Council Chamber, Melbourne, the twenty-first day of September, 1976.

PRESENT:

His Excellency the Governor of Victoria.
Mr. Smith | Mr. Scanlan.
Mr. Hayes

ORDER CONFIRMING RESOLUTIONS OF THE COUNTRY ROADS BOARD.

His Excellency the Governor of the State of Victoria, by and with the advice of the Executive Council thereof, doth hereby, in pursuance of the provisions of the Country Roads Act 1958, confirm the resolutions of the Country Roads Board the dates whereof and the terms of which are scheduled hereunder:

SCHEDULE.

State Highway.

Resolution dated the Thirteenth day of September, One thousand nine hundred and seventy-six made pursuant to section 70 of the Country Roads Act 1958 rescinding the resolution passed by the Country Roads Board on the Twenty-ninth day of June, One thousand nine hundred and twenty-five and confirmed by an Order in Council published in the Government Gazette, of the Eighth day of July, One thousand nine hundred and twenty-five on page 2373 declaring the highway to be a State highway

(Hume Highway) in the Shire of Kilmore, so far as it relates to the part of the said State highway indicated by cross-hatching on plan numbered G.P.12672A attached to this Order.

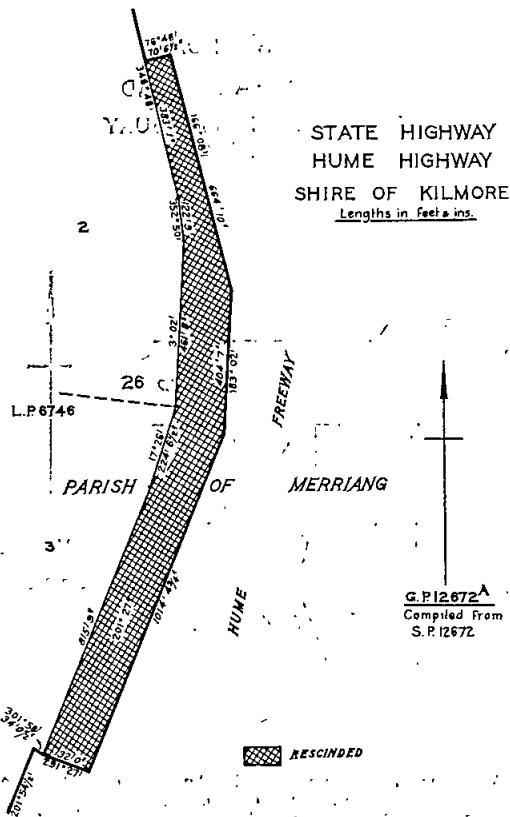

And the Honorable Joseph Anstice Rafferty, Her Majesty's Minister of Transport for the State of Victoria, shall give the necessary directions herein accordingly.

TOM FORRISTAL,
Clerk of the Executive Council.

STATE ELECTRICITY COMMISSION ACT 1958, No. 6377.

At the Executive Council Chamber, Melbourne, the twenty-first day of September, 1976:

PRESENT:

His Excellency the Governor of Victoria,
Mr. Smith | Mr. Scanlan.
Mr. Hayes

Whereas His Excellency the Governor of the State of Victoria by and with the advice of the Executive Council thereof has this day consented pursuant to the provisions of the State Electricity Commission Act 1958 to the State Electricity Commission of Victoria raising by way of loan the sum of One hundred and sixty-five thousand five hundred dollars (\$165,500); And whereas His Excellency the Governor in Council is satisfied that a sufficient proportion of the loan to be raised will fall due and be repaid in each year during the currency of the proposed loan; Now therefore it is directed pursuant to the provisions of section 91 (3) of the said Act, that it shall not be necessary to provide a sinking fund in connexion with such loan.

And the Honorable Rupert James Hamer, Her Majesty's Treasurer for the State of Victoria, shall give the necessary directions herein accordingly.

TOM FORRISTAL,
Clerk of the Executive Council.

STATE ELECTRICITY COMMISSION ACT 1958, No. 6377.

At the Executive Council Chamber, Melbourne, the twenty-first day of September, 1976.

PRESENT:

His Excellency the Governor of Victoria,
Mr. Smith | Mr. Scanlan.
Mr. Hayes

Whereas His Excellency the Governor of the State of Victoria by and with the advice of the Executive Council thereof has this day consented pursuant to the provisions of the State Electricity Commission Act 1958 to the State Electricity Commission of Victoria raising by way of a loan the sum of Sixty-three thousand dollars (\$63,000); And whereas His Excellency the Governor in Council is satisfied that a sufficient proportion of the loan to be raised will fall due and be repaid in each year during the currency of the proposed loan; Now therefore, it is directed pursuant to the provisions of section 91 (3) of the said Act, that it shall not be necessary to provide a sinking fund in connexion with such loan.

And the Honorable Rupert James Hamer, Her Majesty's Treasurer for the State of Victoria, shall give the necessary directions herein accordingly.

TOM FORRISTAL,
Clerk of the Executive Council.

Water Act 1958.
STATE RIVERS AND WATER SUPPLY COMMISSION.

At the Executive Council Chamber, Melbourne, the twenty-first day of September, 1976.

PRESENT:

His Excellency the Governor of Victoria,
Mr. Smith | Mr. Scanlan.
Mr. Hayes

GOULBURN-MURRAY IRRIGATION DISTRICT—
PORTION EXCISED.—MURRAY VALLEY IRRIGATION
AREA—BOUNDARIES VARIED.

Under the powers conferred by the Water Act 1958 and all other powers enabling him in that behalf, His Excellency the Governor of the State of Victoria with the advice of the Executive Council of the said State, on the recommendation of the State Rivers and Water Supply Commission, doth hereby declare, order and direct as follows:—

1. That there be excised from the Goulburn-Murray Irrigation District; and
2. That the boundaries of the Murray Valley Irrigation Area be varied to excise therefrom the lands shown by green colour on a plan approved by the Governor in Council and deposited in the office of the State Rivers and Water Supply Commission, at 590 Orrong Road, Armadale, (Corr. No. 75/3487) which lands shall be deemed to be excised from the said Irrigation District and Irrigation Area as on and from the 30th day of September, 1976.

And the Honorable Frederick James Granter, Her Majesty's Minister of Water Supply for the State of Victoria, shall give the necessary directions herein accordingly.

TOM FORRISTAL,
Clerk of the Executive Council.

STAMPS ACT 1958, No. 6375.

At the Executive Council Chamber, Melbourne, the twenty-first day of September, 1976.

PRESENT:

His Excellency the Governor of Victoria,
Mr. Smith | Mr. Scanlan.
Mr. Hayes

His Excellency the Governor of the State of Victoria by and with the advice of the Executive Council thereof, doth by this Order made pursuant to section 131C of the Stamps Act 1958 No. 6375 revoke the declaration made on 19th July, 1960 and published in the Government

Gazette on 20th July, 1960 declaring certain persons to be "approved vendors" for the purposes of subdivision (14) of Division 3 of Part II. of the Stamps Act 1958 in so far as the said declaration refers to the undermentioned person:—

281. McPherson's Ltd.

And the Honorable Rupert James Hamer, Her Majesty's Treasurer for the State of Victoria, shall give the necessary directions herein accordingly.

TOM FORRISTAL,
Clerk of the Executive Council.

SUPERANNUATION ACT 1958.

At the Executive Council Chamber, Melbourne, the twenty-first day of September, 1976.

PRESENT:

His Excellency the Governor of Victoria.
Mr. Smith | Mr. Scanlan.
Mr. Hayes

Pursuant to the powers conferred by the provisions of paragraph (ja) of sub-section (1) of section 3 of the Superannuation Act 1958, His Excellency the Governor of the State of Victoria, by and with the advice of the Executive Council thereof doth by this Order declare that the provisions of the Superannuation Act shall apply to the officer named in the Schedule set out hereunder.

SCHEDULE.

Lee, Joyce Marietta; State College of Victoria, Rusden.

And the Honorable Rupert James Hamer, Her Majesty's Treasurer for the State of Victoria, shall give the necessary directions herein accordingly.

TOM FORRISTAL,
Clerk of the Executive Council.

SUPERANNUATION ACT 1958.

At the Executive Council Chamber, Melbourne, the twenty-first day of September, 1976:

PRESENT:

His Excellency the Governor of Victoria.
Mr. Smith | Mr. Scanlan.
Mr. Hayes

Pursuant to the powers conferred by the provisions of paragraph (ja) of sub-section (1) of section 3 of the Superannuation Act 1958, His Excellency the Governor of the State of Victoria, by and with the advice of the Executive Council thereof doth by this Order declare that the provisions of the Superannuation Act shall apply to Lee Christine McDonald, an officer of the State College of Victoria at Toorak, as from and inclusive of 27th September, 1976.

And the Honorable Rupert James Hamer, Her Majesty's Treasurer for the State of Victoria, shall give the necessary directions herein accordingly.

TOM FORRISTAL,
Clerk of the Executive Council.

LOCAL GOVERNMENT DEPARTMENT.

At the Executive Council Chamber, Melbourne, the twenty-eighth day of September, 1976.

PRESENT:

His Excellency the Governor of Victoria.
Mr. Hunt | Mr. Granter
Mr. Jona | Mr. Haddon Storey.

ROAD DISCONTINUED.—CITY OF CAULFIELD.

Whereas it is provided in section 528 (2) of the Local Government Act 1958 that where a road (whether or not a public highway but not being a road set out on land of the Crown) or any part thereof is not required for public use, the Governor in Council on the request of the council of the municipality in which such a road is situated made not less than one month after publishing in a newspaper

generally circulating in the district and posting to the registered proprietor (if any) of the land and the owners and occupiers (if any) of lands abutting or immediately adjacent to the road notice of intention to make such request may by Order published in the Government Gazette direct that such road or part shall be discontinued and thereupon such road or part thereof shall be discontinued accordingly.

And whereas the Council of the City of Caulfield has requested that a road off Shoobra Road, Caulfield, be discontinued and not less than one month previously has published in a newspaper generally circulating in the district and posted to the registered proprietor of the land in the road and to the owners and occupiers of the lands abutting or immediately adjacent to the said road notice of intention to make such request.

Now therefore, His Excellency the Governor of the State of Victoria, by and with the advice of the Executive Council thereof, hereby directs that the said road which is shown by hachure on the attached plan shall be discontinued and that the land may be sold by the Council of the City of Caulfield by agreement.

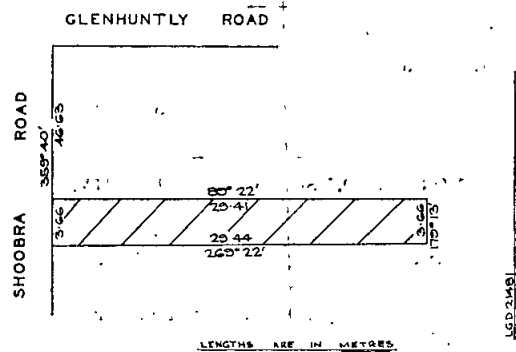

And the Honorable Alan John Hunt, Her Majesty's Minister for Local Government for the State of Victoria, shall give the necessary directions herein accordingly.

TOM FORRISTAL,
Clerk of the Executive Council.

LOCAL GOVERNMENT DEPARTMENT.

At the Executive Council Chamber, Melbourne, the twenty-eighth day of September, 1976.

PRESENT:

His Excellency the Governor of Victoria.
Mr. Hunt | Mr. Granter
Mr. Jona | Mr. Haddon Storey.

CONFIRMATION OF SEPARATE RATE.—CITY OF ST. KILDA.

In pursuance of the provisions of section 287 of the Local Government Act 1958, His Excellency the Governor of the State of Victoria, by and with the advice of the Executive Council thereof, hereby confirms a separate rate of six (6) cents in the dollar on the net annual value on the properties described in the Schedule hereunder which rate was made by the Council of the City of St. Kilda on 16th August, 1976 for the purpose of providing off street car parking facilities in Jackson Street, St. Kilda.

SCHEDULE.

Fitzroy Street, St. Kilda.

No. 29 Hotel & Shops 3, 4 and 6-16 inclusive, 31A, 31C, 33, 39, 41A, 43, 43A, 45, 45A, 47, 49, 55, 57, 61A, 61B, 61C, 63, 63A, 65A, 67, 71, 71B, 73, 73A, 75, 75A (Premises 1 and 2), 77, 79A, 81A, 83, 83A, 83B, 85 (Premises 1 and 2), 87, 87A, 89B, 89C, 89D, 91, 93, 95, 107, 109, 111, 113, 115, 117, 119, and 121.

Grey Street, St. Kilda.

1, 3, 5, 7, 9, 11, 13 (Premises 1 and 2), 15 and 19.

And the Honorable Alan John Hunt, Her Majesty's Minister for Local Government for the State of Victoria, shall give the necessary directions herein accordingly.

TOM FORRISTAL,
Clerk of the Executive Council.

DROMANA—ROSEBUD SEWERAGE AUTHORITY.

At the Executive Council Chamber, Melbourne, the twenty-eighth day of September, 1976.

PRESENT:

His Excellency the Governor of Victoria.
 Mr. Hunt | Mr. Granter
 Mr. Jona | Mr. Haddon Storey.

CONSENT TO BORROWING \$300,000.

Under the powers conferred by the Sewerage Districts Act and all other powers enabling him in that behalf, His Excellency the Governor of the State of Victoria, by and with the advice of the Executive Council of the said State, hereby consents to the Dromana-Rosebud Sewerage Authority borrowing the sum of Three hundred thousand dollars (\$300,000) to meet the cost of sewerage works as set forth in the detailed statement bearing date 22nd September, 1976.

And the Honorable Frederick James Granter, Her Majesty's Minister of Water Supply for the State of Victoria, shall give the necessary directions herein accordingly.

TOM FORRISTAL,
 Clerk of the Executive Council.

MORNINGTON SEWERAGE AUTHORITY.

At the Executive Council Chamber, Melbourne, the twenty-eighth day of September, 1976.

PRESENT:

His Excellency the Governor of Victoria.
 Mr. Hunt | Mr. Granter
 Mr. Jona | Mr. Haddon Storey.

CONSENT TO BORROWING \$50,000.

Under the powers conferred by the Sewerage Districts Act and all other powers enabling him in that behalf, His Excellency the Governor of the State of Victoria, by and with the advice of the Executive Council of the said State, hereby consents to the Mornington Sewerage Authority borrowing the sum of Fifty thousand dollars (\$50,000) to meet the cost of sewerage works as set forth in the detailed statement bearing date 22nd September, 1976.

And the Honorable Frederick James Granter, Her Majesty's Minister of Water Supply for the State of Victoria, shall give the necessary directions herein accordingly.

TOM FORRISTAL,
 Clerk of the Executive Council.

GEELONG WATERWORKS AND SEWERAGE TRUST.

At the Executive Council Chamber, Melbourne, the twenty-eighth day of September, 1976.

PRESENT:

His Excellency the Governor of Victoria.
 Mr. Hunt | Mr. Granter
 Mr. Jona | Mr. Haddon Storey.

CONSENT TO BORROWING \$50,000.

Under the powers conferred by the Geelong Waterworks and Sewerage Act and all other powers enabling him in that behalf, His Excellency the Governor of the State of Victoria, by and with the advice of the Executive Council of the said State, hereby consents to the Geelong Waterworks and Sewerage Trust borrowing the sum of Fifty thousand dollars (\$50,000) to meet the cost of sewerage works.

And the Honorable Frederick James Granter, Her Majesty's Minister of Water Supply for the State of Victoria, shall give the necessary directions herein accordingly.

TOM FORRISTAL,
 Clerk of the Executive Council.

MELTON WATERWORKS TRUST.

At the Executive Council Chamber, Melbourne, the twenty-eighth day of September, 1976.

PRESENT:

His Excellency the Governor of Victoria.
 Mr. Hunt | Mr. Granter
 Mr. Jona | Mr. Haddon Storey.

CONSENT TO BORROWING \$150,000.

Under the powers conferred by the Water Act and all other powers enabling him in that behalf, His Excellency the Governor of the State of Victoria, by and with the advice of the Executive Council of the said State, hereby consents to the Melton Waterworks Trust borrowing the sum of One hundred and fifty thousand dollars (\$150,000) to meet the cost of water supply works.

And the Honorable Frederick James Granter, Her Majesty's Minister of Water Supply for the State of Victoria, shall give the necessary directions herein accordingly.

TOM FORRISTAL,
 Clerk of the Executive Council.

CANCER ACT 1958, SECTION 46.

At the Executive Council Chamber, Melbourne, the twenty-eighth day of September, 1976.

PRESENT:

His Excellency the Governor of Victoria.
 Mr. Hunt | Mr. Granter
 Mr. Jona | Mr. Haddon Storey.

Pursuant to the provisions of sub-section (3) of Section 46 of the Cancer Act 1958 and all other powers enabling him in that behalf, His Excellency the Governor of the State of Victoria, by and with the advice of the Executive Council of the said State by this Order hereby amends the By-law of the Cancer Institute Board confirmed by the Governor in Council on the 5th day of September, 1974 and published in the *Government Gazette* dated 11th September, 1974 as amended by Order in Council dated 29th July, 1975 by substituting for the Schedule shown therein the following Schedule:—

SCHEDULE.

Scale of Charges and Expenses with effect as from the 1st October, 1976.

1. Inpatients.
 - (a) Private Wards—\$60.00 per day.
 - (b) Intermediate Wards—\$40.00 per day.

And the Honorable William Vasey Houghton, Her Majesty's Minister of Health for the State of Victoria, shall give the necessary directions herein accordingly.

TOM FORRISTAL,
 Clerk of the Executive Council.

LANDS DEPARTMENT NOTICES**APPROACHING LAND SALE.**

Sale of Crown Land, in fee-simple, will be held at the under-mentioned place and date, viz.:—

Tongala.—Tuesday, 12th October, 1976

No. of
 Gazette.
 78

PROPOSED REVOCATIONS OF TEMPORARY RESERVATIONS OF LANDS BY ORDERS IN COUNCIL.

In pursuance of the provisions of the *Land Act 1958*, notice is hereby given that it is the intention of the Governor in Council to revoke the temporary reservations of lands by Orders in Council hereunder referred to viz.:—

The following Notices were published 1^o on the 15th September, 1976, pursuant to Orders of the 7th September, 1976.

KOETONG.—The temporary reservation by Order in Council of the 4th September, 1956, of 4376 square metres (1 acre 13 perches) of land in the Township of Koetong, as a site for a Public Hall is about to be revoked.—(K.169^(e)) (Rs.7486).

KOETONG.—The temporary reservation by Order in Council of the 15th September, 1873, of 8094 square metres (2 acres) of land in the Township of Koetong (Parish of Koetong in Order), as a site for State School purposes is about to be revoked.—(K.169⁽⁶⁾) (Rs.6817).

MARYBOROUGH.—The temporary reservation by Order in Council of the 27th March, 1939, of 8.094 hectares (20 acres) of land in the Township and Parish of Maryborough, as a site for Public purposes (State Battery), revoked as to part by Order of the 17th January, 1967, is about to be revoked so far as the balance thereof containing 7.328 hectares is concerned.—(M.66⁽¹⁸⁾) (1⁽⁵⁾) (Rs.4932.)

MURTOA.—The temporary reservation by Order in Council of the 2nd November, 1891, of 6.809 hectares (16 acres 3 roods 12 perches) of land in the Township of Murtoa as a site for a Public Park, is about to be revoked.—(M.483⁽²⁾) (Rs.4960).

REDCASTLE.—The temporary reservation by Order in Council of the 10th June, 1861, of 3642 square metres (3 roods 24 perches) of land in the Township of Redcastle as a site for Presbyterian Church purposes is about to be revoked.—(R.16⁽⁴⁾) (C.19430).

TIMBOON.—The temporary reservation by Order in Council of the 21st March, 1961, of 27.52 hectares (68 acres, more or less), of land in the Parish of Timboon as a site for Public Recreation is about to be revoked.—(T.182⁽¹⁰⁾) (Rs.2617).

SANDHURST (GOLDEN SQUARE).—The temporary reservation by Order in Council of the 4th July, 1967, of 4199 square metres (1 acre 6 perches) of land, at Bendigo, Parish of Sandhurst, as a site for Public Recreation, is about to be revoked so far only as the portion containing 1378 square metres indicated by hatching on plan hereunder, is concerned.—(S.372⁽¹²²⁾) (Rs.3657).

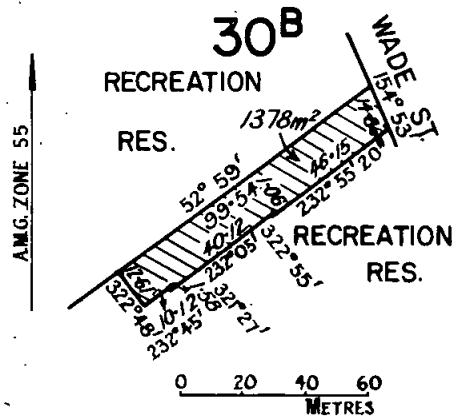

SANDHURST (GOLDEN SQUARE).—The temporary reservation by Order in Council of the 24th April, 1928, of 3.253 hectares (8 acres 6 perches) of land, at Bendigo, Parish of Sandhurst as a site for Public Recreation, is about to be revoked so far only as the portion containing 3880 square metres indicated by hatching on plan hereunder, is concerned.—(S.372⁽¹²²⁾) (Rs.3657).

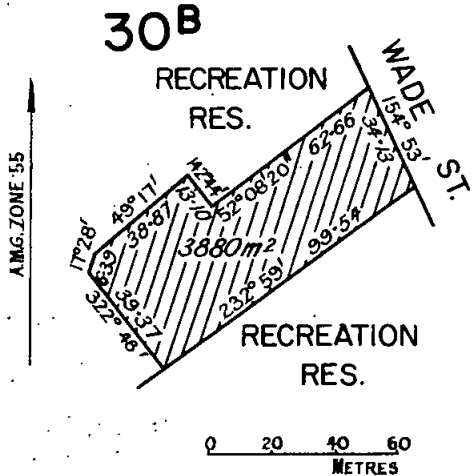

RAINBOW.—The temporary reservation by Order in Council of the 28th April, 1897, of 366.5 hectares (905 acres 2 roods 39 perches) of land in the Township of Rainbow (Parish of Werrap in Order) as a site for Timber and Water Supply purposes, revoked as to part by various Orders, is about to be revoked so far only as the portion containing 25.72 hectares indicated by hatching on plan hereunder, is concerned.—(R.89⁽⁶⁾) (Rs.191A).

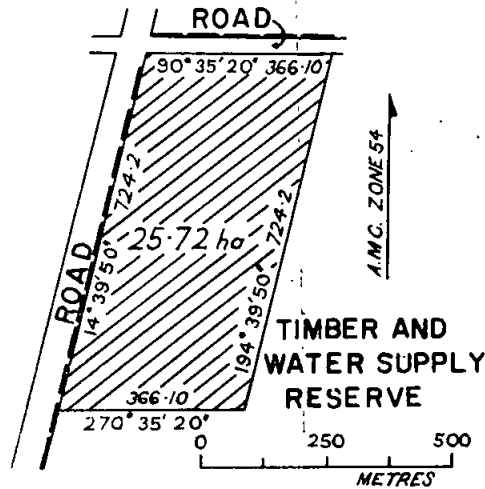

WARRNAMBOOL.—The temporary reservation by Order in Council of the 16th March, 1960, of 50.23 hectares (124 acres 18 perches) of land in the Township of Warrnambool as a site for Public Park and Public Recreation, revoked as to part by various Orders, is about to be revoked so far only as the portion containing 578 square metres indicated by hatching on plan hereunder, is concerned.—(W.99⁽⁶⁾) (Rs.283).

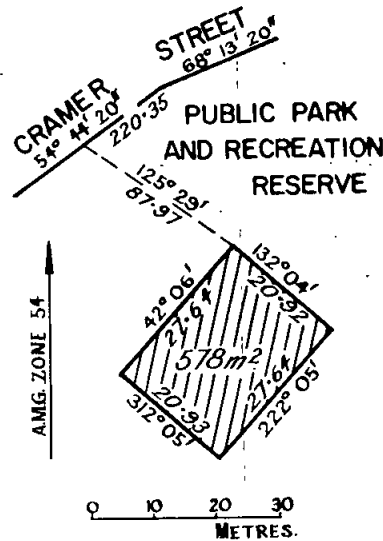

JIM BALFOUR,
Acting Minister of Lands.

PROPOSED REVOCATIONS OF TEMPORARY RESERVATIONS OF LANDS BY ORDERS IN COUNCIL.

In pursuance of the provisions of the Land Act 1958, notice is hereby given that it is the intention of the Governor in Council to revoke the temporary reservations of lands by Orders in Council hereunder referred to viz.:-
The following Notices were published 1^o on the 22nd September, 1976, pursuant to Orders of the 14th September, 1976.

HORSHAM.—The temporary reservation by Order in Council of the 19th January, 1874, of 1.012 hectares (2 acres 2 roods) of land in the Township of Horsham as a site for

State School purposes, revoked as to part by Order of the 5th February, 1877, is about to be revoked so far only as the portion containing 1963 square metres indicated by hatching on plan hereunder, is concerned.—(H.91^(a)) (Rs.9071).

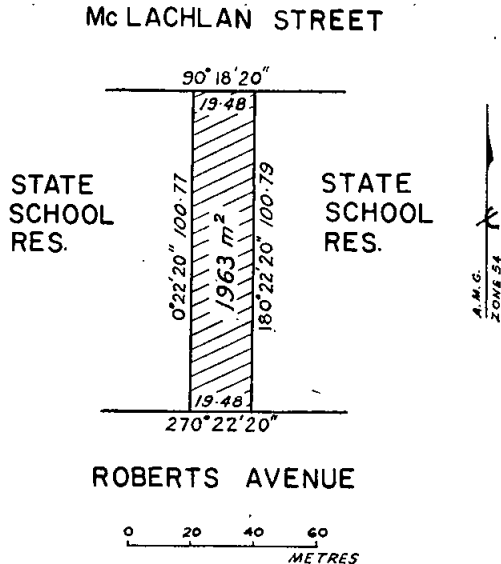

HORSHAM.—The temporary reservation as a site for Public purposes (State School) and the withholding from sale, leasing and licensing by Order in Council of the 26th October, 1882, of 2023 square metres (2 roods) of land in the Township of Horsham are about to be revoked.—(H.91^(a)) (Rs.9071).

W. BORTHWICK,
Minister of Lands.

PROPOSED REVOCATIONS OF TEMPORARY RESERVATIONS OF LANDS BY ORDERS IN COUNCIL.

In pursuance of the provisions of the Land Act 1958, notice is hereby given that it is the intention of the Governor in Council to revoke the temporary reservations of lands by Orders in Council hereunder referred to viz.:

The following Notices were published 1^o on the 8th September, 1976, pursuant to Orders of the 31st August, 1976.

SCORESBY (BORONIA).—The temporary reservation by Order in Council of the 14th June, 1949, of 1012 square metres (1 rood) of land in the Parish of Scoresby as a site for Police purposes, is about to be revoked, so far only as the portion containing 42.9 square metres indicated by hatching on plan hereunder, is concerned.—(S.250(A^o)) (Rs.6364).

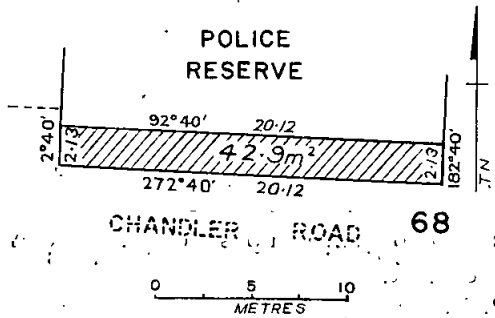

BALLARAT (MOUNT CLEAR).—The temporary reservation by Order in Council of the 21st August, 1928, of 3.516 hectares (8 acres 2 roods 30 perches) of land in the Parish of Ballarat as a site for Public purposes (State School Forest Plantation), revoked as to part by various Orders, is about to be revoked so far as the balance thereof containing 3.162 hectares is concerned.—(B.126⁽¹⁸⁾) (Rs.3736).

QUAMBATOOK.—The temporary reservation by Order in Council of the 18th November, 1895, of 6070 square metres (1 acre 2 roods) of land in the Township of Quambatook as a site for a State School, is about to be revoked.—(Q.37⁽⁷⁾) (Rs.2475).

PORT CAMPBELL.—The temporary reservation by Order in Council of the 29th June, 1887, of 2023 square metres (2 roods) of land in the Township of Port Campbell, as a site for a Free Library, is about to be revoked.—P.147^(a) (Rs.3505).

PORTARLINGTON.—The temporary reservation by Order in Council of the 14th February, 1939, of 202 square metres (8 perches) of land in the Township of Portarlington, as a site for Free Library, is about to be revoked.—(P.37^(a)) (Rs.4903).

NUNAWADING (BURWOOD).—The temporary reservation by Order in Council of the 18th April, 1950, of 1593 square metres (1 rood 23 perches) of land in the Parish of Nunawading, as a site for a Cemetery, is about to be revoked.—(N.79⁽⁷⁾) (Rs.5441).

CASTLEMAINE.—The temporary reservation by Order in Council of the 12th August, 1947, of 1.682 hectares (4 acres 0 roods 25 perches) of land in the Parish of Castlemaine, as a site for a Rubbish Depot, is about to be revoked.—(C.100^(8A)) (Rs.6013).

W. BORTHWICK,
Minister of Lands.

AMENDMENT TO THE REGULATIONS FOR THE CARE, PROTECTION AND MANAGEMENT OF THE "PENGUIN RESERVE", AT PHILLIP ISLAND.

Whereas by section 218 of the Land Act 1958, the Minister of Lands is empowered to make Regulations as to any land which under the provisions of that Act or of any other Act relating to Crown lands has been reserved for any public purpose whatsoever and which has not been conveyed to or vested in trustees: And whereas certain Crown lands in the Parish of Phillip Island were temporarily reserved as sites for a Penguin Rookery by Orders in Council dated the 13th December, 1955 and the 6th June, 1956 (vide Government Gazettes of the 14th December, 1955 and the 13th June, 1956, respectively): And whereas such lands (hereinafter called the "Reserve") have not been conveyed to or vested in trustees: And whereas Regulations for the care, protection and management of the Reserve were made on the 17th October, 1956 (vide Government Gazette of the 24th October, 1956) and have been amended from time to time, the last occasion being the 2nd February, 1971 (vide Government Gazette of the 10th February, 1971): And whereas it is expedient that such Regulations be further amended: Now therefore I, William Archibald Borthwick, Her Majesty's Minister of Lands in and for the State of Victoria, in pursuance of the powers aforesaid, do hereby further amend the aforesaid Regulations for or with respect to the Reserve as follows:—

Regulation No. 1 of the said Regulations shall be amended to read as follows:—

1. The front beach of the Reserve shall be open to the public free of charge from sunrise to 6 p.m. After the hour of 6 p.m. an admission charge of fifty (50) cents will be made on all adults and children over the age of fourteen (14) years and taken by any person authorized by the Committee to collect such admission charge.

Given under my hand at Melbourne, on the 22nd day of September, 1976.

W. BORTHWICK,
Minister of Lands.

Every person who contravenes or fails to comply with these Regulations shall in accordance with the provisions of section 218 of the Land Act 1958, for each offence be liable to a penalty of not more than Fifty dollars, and every person who contravenes or fails to comply with any such Regulations, and who, after he has been warned by any bailiff of Crown lands or by any member of the Police Force, does not desist therefrom may be forthwith apprehended by such bailiff or member of the Police Force and taken before some justice to be dealt with according to law and shall be liable to a penalty of not more than One hundred dollars, provided that every person who contravenes any Regulation made under the said section for or with respect to prohibiting the depositing and leaving of any unwanted material or thing or rubbish of any kind on any land to which such Regulation relates shall for each offence be liable to a penalty of not more than Two hundred dollars.

TENDERS**PUBLIC WORKS DEPARTMENT**

Tenders will be received at Public Works Department, 2 Treasury Place, Melbourne, until **TWO p.m.** on dates shown for purposes mentioned hereunder.

Particulars and tender forms available at Contracts Office, Room 27, Ground Floor, No. 2, Treasury Place, and at Inspector of Works Office if indicated by W.O. Tenders must be on a "Firm Tender" basis. The lowest or any tender will not necessarily be accepted.

Address tenders to the Minister of Public Works, and endorse the envelope "Tender for". Hand delivered tenders to be placed in the Tender Box of the Public Works Department, Main Entrance Foyer, Ground Floor, 2 Treasury Place, Melbourne.

No preliminary deposit is required with any tender, but successful tenderer will be required to pay a deposit for any accepted tender of \$10,000 or over.

Tuesday, 12th October, 1976.

Building, Electrical and Mechanical Works.

BALLARAT EAST.—Electrical services, art/craft centre, &c., Primary School. (W.O., Ballarat.)

BALLARAT EAST.—Mechanical services, art/craft centre, &c., Primary School. (W.O., Ballarat.)

BIRCHIP.—Construction of new brick veneer office, Crown Lands and Survey. (W.O., Swan Hill, Horsham.)

JORDANVILLE SOUTH.—Internal and external renovations and painting, Primary School 4678.

FERNTREE GULLY.—Internal and external repairs and painting, Mountain Gate Primary School 4905.

SHEPPARTON SOUTH.—External repairs and painting and part internal painting (re-advertised), Technical School. (W.O., Shepparton and Benalla.)

Site Works.

MACLEOD.—Siteworks, Library and Multi-Purpose Building, High School.

Tuesday, 19th October, 1976.

Building, Electrical and Mechanical Works.

DONALD.—Internal and external repairs and painting, High School. (W.O., Swan Hill.)

INGLEWOOD.—External and Internal Renovations, Higher Elementary School. (W.O., Bendigo.)

MELBOURNE.—New M.C.C. electricity supply sub-station and alterations to office partitioning, Probation and Parole Offices, Batman Avenue, Melbourne.

MELBOURNE.—Electrical installation, new electrical supply and switchboards for air conditioners, Probation and Parole Office, Batman Avenue, Melbourne.

MT. BEAUTY.—Exterior renovations, Primary School 4644. (W.O., Wangaratta.)

NUMURKAH.—New toilet facilities, Court House. (Re-advertised.) (W.O., Shepparton and Benalla.)

PLENTY AND MONT PARK.—Supply and installation of hydraulic lift, Mental Hospitals.

Site Works.

FOOTSCRAY NORTH.—Siteworks, multi-purpose hall and library, Primary School 4160.

MELTON.—Siteworks, Primary School 430.

MELTON SOUTH.—Siteworks, Primary School 3717.

ROBERTS DUNSTAN,
Minister for Public Works.

Public Works Department,
Melbourne, 28th September, 1976.

No. 86.—9160/76.—3

PRIVATE ADVERTISEMENTS**CITY OF ALTONA.****LOAN No. 101.****Notice of Intention to Borrow the Sum of \$500,000 for Permanent Works and Undertakings.**

Notice is given that the Council of the City of Altona proposes to borrow the principal sum of Five Hundred Thousand dollars (\$500,000) secured by a charge over the general rates of the municipality such sum to be raised by the grant of a mortgage in accordance with the terms of the *Local Government Act 1958*.

1. The maximum rate of interest to be paid is 10.7 per centum per annum.
2. The purposes for which the loan is to be applied are:—

Part Cost of Construction of Swimming Pool— P. J. Lynch Reserve	\$230,500
Construction of Embankment, Players Races and Spectator Area—H. C. Kim Reserve	11,000
Part Cost of Athletics Centre—Pavilion— J. K. Grant Reserve	25,000
Part Cost of Construction of Infant Welfare Centre/Pre-School Centre, Altona Meadows	37,500
Sewerage Council Properties	30,000
Part Cost of Improvements Football/Cricket Pavilion—J. K. Grant Reserve	35,000
Part Cost of Extension Senior Citizens Club	35,000
Underground Drainage Grieve Parade	96,000
	\$500,000

3. The period of the loan shall be 15 years.

4. The moneys borrowed shall be repayable by providing out of the Municipal Fund 30 equal half yearly instalments of \$33,834.80 including principal and interest on the 1st day of May and 1st day of November in each year during the currency of the loan.

5. Such moneys shall be repayable at the office of the Commonwealth Savings Bank of Australia Melbourne or such other place or places which the bank may from time to time require.

The plans and specifications and estimated cost of the proposed works and a statement showing the proposed expenditure of the moneys to be borrowed are open for inspection at the Civic Offices, 115 Civic Parade, Altona. 4020

S. FELL, Town Clerk.

CITY OF BRIGHTON.

Notice is hereby given that the City of Brighton, pursuant to the powers contained in the *Local Government Act 1958*, has caused to be made, the following alteration to a street name:—

Old Name.—Dunoon Avenue.

New Name.—Dunoon Court.

Description.—All of the street known as Dunoon Avenue extending westerly and northerly off Thomas Street.

21st September, 1976.

A. C. G. DE GARIS, Town Clerk.

Municipal Offices, Boxshall Street, Brighton, 3186. 3954

CITY OF BRUNSWICK.**LOAN No. 97.****Notice of Intention to Borrow the Sum of \$600,000 for Permanent Works and Undertakings.**

Notice is hereby given that the Council of the City of Brunswick proposes to borrow the principal sum of \$600,000 secured by a charge over the general rates of the municipality, such sum to be raised by the grant of a mortgage in accordance with the provisions of the *Local Government Act 1958*.

1. The maximum rate of interest that may be paid is 10.7 per cent. per annum.

2. The purpose for which the loan is to be applied is road construction, alteration to mains and services in Albert Street between Sydney Road and Lygon Street, Hope Street, Albion Street west of Sydney Road, Donald Street, De Carle Street, Brunswick Road east of Sydney Road, Miller Street and various streets in the municipality, land purchases, plant purchases, Mechanic's Institute building improvements, traffic lights installation, construction of pedestrian overpasses, construction of railway level crossing barriers, electricity supply capital extensions and community buildings improvements.

3. The period of the loan shall be fifteen years.

4. The moneys borrowed shall be repayable by providing out of the municipal fund half-yearly instalments of \$40,601.76 each including principal and interest on the third day of May and the third day of November during the currency of the loan.

5. Such moneys shall be payable to the Commonwealth Savings Bank of Australia, Melbourne.

The plans and specifications and an estimate of the cost of the proposed works and a statement showing the proposed expenditure of the moneys to be borrowed are open for inspection at the office of the Council of the City of Brunswick at 233 Sydney Road, Brunswick, 3056. 3955

K. D. WILSON, Town Clerk.

CITY OF CAULFIELD.

LOAN No. 66.

Notice of Intention to Borrow a Sum of \$250,000 for Permanent Works and Undertakings.

Notice is hereby given that the Council of the City of Caulfield proposes to borrow a sum of \$250,000 on the credit of the municipal revenues of the Mayor, Councillors and Citizens of the said City, such sum to be raised by the granting of a mortgage in accordance with the provisions of the Local Government Act 1958 (as amended) and in connection therewith, the following information is stated:—

- (a) The amount of principal moneys it is proposed to borrow is \$250,000.
- (b) The maximum rate of interest that may be paid is 10.3% per annum.
- (c) The days on which the moneys borrowed are to be repayable are the 26th of May and November during the years 1977 to 1983 inclusive, the first payment being on the 26th of May, 1977, and the place at which the moneys are to be repayable is the Australian Mutual Provident Society, Melbourne, Victoria.

(d) The purposes for which the loan is to be applied are:—

Footpath and Channel Reconstruction.

(e) The manner in which the loan is to be liquidated is by providing out of municipal funds, 14 equal half-yearly instalments of \$14,869.98 including principal and interest, with the balance of the loan \$210,491.66, due for payment on 26th November, 1983.

The plans and specifications and estimate of the cost of the works, and an estimate showing the proposed expenditure of the moneys to be borrowed are open for inspection at the office of the Council, City Hall, corner Glen Eira Road and Hawthorn Road, Caulfield.

K. D. WILSON, City Manager.

City Hall, Caulfield.

3956

CITY OF CAULFIELD.

LOAN No. 67.

Notice of Intention to Borrow a Sum of \$200,000 for Permanent Works and Undertakings.

Notice is hereby given that the Council of the City of Caulfield proposes to borrow a sum of \$200,000 on the credit of the municipal revenues of the Mayor, Councillors and Citizens of the said City, such sum to be raised by the granting of a mortgage in accordance with the provisions of the Local Government Act 1958 (as amended) and in connection therewith, the following information is stated:—

- (a) The amount of principal moneys it is proposed to borrow is \$200,000.
- (b) The maximum rate of interest that may be paid is 10.7% per annum.
- (c) The money borrowed shall be repayable on the 15th day of November, 2006 at the office of the Commonwealth of Australia Superannuation Fund Investment Trust, Canberra.

(d) The purposes for which the loan is to be applied are:—

Purchase of Land	\$100,000
Parks and Gardens—redevelopment	100,000
	\$200,000

(e) The sum of \$1,344 shall be provided at half yearly intervals out of the Municipal Fund for the establishment and accumulation of a sinking fund for the redemption of the loan.

The plans and specifications and estimate of the cost of the works, and an estimate showing the proposed expenditure of the moneys to be borrowed are open for inspection at the office of the Council, City Hall, corner Glen Eira and Hawthorn Roads, Caulfield.

3957

K. D. WILSON, City Manager.

CITY OF COBURG.

Whereas the Council of the City of Coburg deems it expedient to exercise its power of taking compulsorily the land delineated and hatched on the map at the foot hereof for providing same as public open space and whereas the Council has caused to be prepared a map and other papers setting out the general description of the work or undertaking for which the land proposed to be taken is to be used the description of the land proposed to be taken and the names of the owners or reputed owners, Mortgagees and occupiers of that land so far as those names are known to or can be ascertained by the Council and whereas the said map and other papers are deposited at the Office of the said Council at Coburg and are and shall be open for inspection by all persons interested at all reasonable hours for the space of forty clear days after the publication of this notice in the Government Gazette now notice is hereby given to all persons affected by the proposed taking of the said land to set forth in writing addressed to the Council or Town Clerk within forty clear days of the publication of this notice in the Government Gazette all objections which they may have to the taking of the said land.

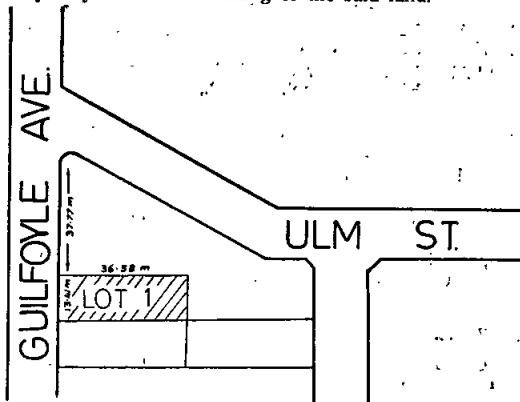

Dated the 27th day of September, 1976.

By Order of the Council.

4040

K. G. DOUGLAS, Acting Town Clerk.

CITY OF CROYDON.

LOAN No. 141.

Notice of Intention to Borrow the Sum of \$100,000 for Permanent Works and Undertakings.

Notice is hereby given that the Council of the City of Croydon proposes to borrow the principal sum of One hundred thousand dollars (\$100,000) secured by a charge over the general rates of the municipality, such sum to be raised by the grant of a mortgage in accordance with the provisions of the Local Government Act 1958.

- 1. The maximum rate of interest that may be paid is 10.7 per centum per annum.
- 2. The purpose for which the loan is to be applied is:—

(a) Construction of Croydon Community Leisure Centre—Phase 1, Active Sports Centre (Part) \$100,000

3. The period of the loan shall be 20 years.

4. The moneys borrowed shall be repayable by forty half-yearly instalments of approximately \$6,109.69 including principal and interest on the 10th day of January and the 10th day of July during the currency of the loan. The first instalment shall be repayable on the 10th day of July, 1977.

5. Such moneys shall be repayable at The Commercial Savings Bank of Australia Limited, 335 Collins Street, Melbourne.

The plans and specifications and the estimate of the cost of the proposed works and a statement showing the proposed expenditure of the moneys to be borrowed are open for inspection at the office of the Council of the City of Croydon at the City Offices, Foch Avenue, Croydon.

3959

R. BURTON, Town Clerk.

CITY OF DONCASTER AND TEMPLESTOWE.

LOAN No. 203.

Notice of Intention to Borrow the Sum of \$100,000 for Permanent Works and Undertakings.

Notice is hereby given that the Council of the City of Doncaster and Templestowe proposes to borrow the principal sum of One hundred thousand dollars secured by a charge over the general rates of the municipality, such sum to be raised by the grant of a mortgage in accordance with the provisions of the *Local Government Act 1958*.

1. The maximum rate of interest that may be paid is 10.7 per centum per annum.

2. The purpose for which the loan is to be applied is capital works in the Council's Electric Supply Undertaking, namely:

Extensions to mains and provision of substations \$100,000

3. The period of the loan shall be 15 years.

4. The moneys borrowed shall be repayable by providing out of the municipal fund 30 half-yearly instalments of \$6,766.96 each including principal and interest on the 10th day of May and the 10th day of November during the currency of the loan. The first instalment shall be payable on the 10th day of May 1977.

5. Such moneys shall be repayable to The Commercial Savings Bank of Australia Limited at 335 Collins Street, Melbourne.

The plans and specifications and the estimate of the cost of the proposed works and a statement showing the proposed expenditure of the moneys to be borrowed are open for inspection at the office of the Council of the City of Doncaster and Templestowe at the Municipal Offices, Doncaster Road, Doncaster.

3960 J. W. THOMSON, Town Clerk.

CITY OF MOORABBIN.

LOAN No. 189.

Notice of Intention to Borrow the Sum of \$300,000 for Permanent Works and Undertakings.

Notice is hereby given that the Council of the City of Moorabbin proposes to borrow the principal sum of Three Hundred Thousand Dollars secured by a charge over the general rates of the Municipality, such sum to be raised by the grant of a mortgage in accordance with the provisions of the *Local Government Act 1958*.

1. The maximum rate of interest that may be paid is 10.5 per cent. per annum.

2. The purposes for which the loan is to be applied are—

(1) Construction of Pavilion, Victory Park	\$84,000
(2) Completion of Pavilion and reserve improvements at Keys Road reserve	20,000
(3) Construction of Toilets, Highett West Reserve	10,500
(4) Installation Water reticulation, Bentleigh Reserve	3,100
(5) Renovate Oval and installation water reticulation LePage Park	5,600
(6) Completion of additions to Highett Senior Citizens Centre	26,000
(7) Drainage works, Tulip Grove	68,000
(8) Drainage (stage 2), Chesterville Road and Alex Avenue	50,000
(9) MMBW main drains improvements	25,000
(10) Path and channel reconstruction, Centre Road, Bentleigh (Part Cost)	7,800
	<hr/> \$300,000

3. The period of the loan shall be ten years.

4. The moneys borrowed shall be repayable by providing out of the Municipal Fund twenty half-yearly instalments of approximately \$24,585.69 each, including principal and interest on the first days of May and November during the currency of the loan. The first instalment shall be payable on 1st May 1976.

5. Such moneys shall be repayable to the Commonwealth Savings Bank of Australia, Elizabeth-Flinders Streets, Melbourne, or at such other place as the Bank may require.

The plans and specifications and the estimates of the costs of the proposed works and a statement showing the proposed expenditure of the moneys to be borrowed are open for inspection at the Offices of the Council of the City of Moorabbin, 977 Nepean Highway, Moorabbin, 3189.

Dated the 28th September, 1976.

4013 JAMES W. WATERS, Town Clerk.

CITY OF MOORABBIN.

NOTICE OF INTENTION TO TAKE LAND COMPULSORILY.

Whereas the Council of the City of Moorabbin deems it expedient to exercise its power to taking compulsorily the land described hereunder for the work or undertaking of providing a place of public resort and recreation: And whereas the Council has caused to be prepared a map and other papers setting out the general description of the work or undertaking for which the land proposed to be taken is to be used the description of the land proposed to be taken and the names of owners or reputed owners lessees or reputed lessees mortgagees and occupiers of that land so far as those names are known to or can be ascertained by the Council: And whereas the said map and other papers are deposited at the office of the said Council at Moorabbin are and shall be open for inspection by all persons interested at all reasonable hours for the space of 40 clear days after the publication of this notice in the *Government Gazette*: Now notice is hereby given to all persons affected by the proposed taking of the said land to set forth in writing addressed to the Council or the Town Clerk within 40 days of the publication of this notice in the *Government Gazette* all objections which they may have to the taking of the said land.

THE LAND REFERRED TO:

All that parcel of land being part of Crown portion-55, at Cheltenham, Parish of Moorabbin, County of Bourke, also known as No. 13 Centre Dandenong Road, Cheltenham, such land being situated 31.39 metres west of Wilson Street, Cheltenham, and having a frontage of 14.33 metres by a depth of 50.29 metres.

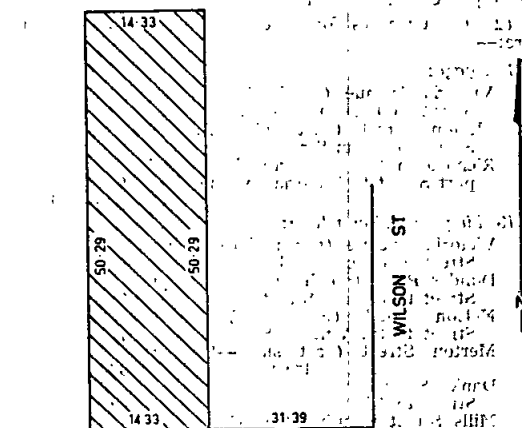

Sketch of the land referred to above, measurements in metres.

Dated 29th September, 1976.
3982 JAMES W. WATERS, Town Clerk.

CITY OF NORTHCOTE.

LOAN No. 128.

Notice of Intention to Borrow the Sum of \$75,000 for Permanent Works and Undertakings.

Notice is hereby given that the Council of the City of Northcote proposes to borrow the principal sum of Seventy Five Thousand Dollars (\$75,000) secured by a charge over the general rates of the Municipality, such sum to be raised by the grant of a mortgage in accordance with the provisions of the *Local Government Act 1958* (as amended).

In connection therewith the following information is stated:—

1. The maximum rate of interest that may be paid is 10.5 per centum per annum.

2. The period of the loan shall be Ten (10) years.

3. The moneys borrowed shall be repayable by providing out of the Municipal Fund twenty half-yearly instalments of approximately \$6,146.43 each, including principal and interest, on the first day of May and the first day of November during the currency of the loan. The first instalment shall be payable on the first day of May 1977.

4. Such moneys shall be repayable at the office of the Australia and New Zealand Savings Bank Limited, 409 High Street, Northcote.

5. The purposes for which the loan is to be applied are:—

Purchase of property for road widening (part cost)	\$29,000
Construction of Drains	\$46,000
	\$75,000

The plans and specifications and the estimates of the cost of proposed works and a statement showing the proposed expenditure of the moneys to be borrowed are open for inspection at the office of the Council of the City of Northcote situated in High Street, Northcote during office hours.

Dated this 27th day of September, 1976.

A. J. HILL,

4041 Town Clerk and City Manager.

CITY OF SOUTH MELBOURNE.

LOAN No. 90.

Notice of Intention to Borrow the Sum of \$316,900 for Permanent Works and Undertakings.

Notice is hereby given that the Council of the City of South Melbourne proposes to borrow the principal sum of Three Hundred and Sixteen Thousand Nine Hundred Dollars (\$316,900) secured by a charge over the general rates of the Municipality; such sum to be raised by the grant of a mortgage in accordance with the provisions of the Local Government Act 1958.

(1) The maximum rate of interest that may be paid is 10.5 per centum per annum.

(2) The purposes for which the loan is to be applied are:—

Drainage:	\$	\$
Victoria Avenue (south side)—Danks Street to Beaconsfield Parade	2,900	
Merton Street (east side)—Bridport Street to Bevan Street	2,500	
Richardson Street (north side)—Bridport Street to Victoria Avenue	9,500	
		14,900

Kerbing and Channelling:

Victoria Avenue (south side)—Danks Street to Beaconsfield Parade	4,500
Dundas Place (north side)—Montague Street to Ferrars Street	7,200
Nelson Road (east side)—Merton Street to St. Vincent Street	7,300
Merton Street (east side)—Bridport Street to Bevan Street	3,300
Danks Street (west side)—Armstrong Street to Nimmo Street	4,000
Mills Street (south side)—Canterbury Road to Herbert Street	3,700
Patterson Street (west side)—McGregor Street to Langridge Street	4,600
Haig Street (north side)—Clarendon Street to Cecil Street	6,600
Sturt Street (west side)—Miles Street to Grant Street	5,800
Yarra Place (both sides)—Coventry Street to York Street	4,600
York Street (south side)—Tope Street to King's Way	2,300
Alfred Street (both sides)—Off Montague Street	7,000
Bank Street (both sides)—Montague Street to Nelson Road	6,000
Montague Street (west side)—Bank Street to Park Street	3,500
Dorcas Street (south side)—King's Way to Dodds Street	3,800
Park Street (north side)—Eastern Road to King's Way	5,500
Roy Street (south side)—Queens Road to St. Kilda Road	4,400
Wells Street (west side)—Park Street to Bank Street	3,400
	87,500

Road Reconstruction:

Victoria Avenue (south side)—Danks Street to Beaconsfield Parade	10,000
Dundas Place (north side)—Montague Street to Ferrars Street	11,700
Nelson Road (east side)—Merton Street to St. Vincent Street	11,100
Merton Street (east side)—Bridport Street to Bevan Street	3,600
Danks Street (west side)—Armstrong Street to Nimmo Street	6,000

Mills Street (south side)—Canterbury Road to Herbert Street	6,600
Patterson Street (west side)—McGregor Street to Langridge Street	8,500
Haig Street (north side)—Clarendon Street to Cecil Street	10,300
Sturt Street (west side)—Miles Street to Grant Street	12,000
Yarra Place (both sides)—Coventry Street to York Street	8,600
York Street (south side)—Tope Street to King's Way	3,800
Alfred Street (both sides)—Off Montague Street	10,300
Bank Street (both sides)—Montague Street to Nelson Road	10,100
Montague Street (west side)—Bank Street to Park Street	5,500
Dorcas Street (south side)—King's Way to Dodds Street	6,600
Park Street (north side)—Eastern Road to King's Way	8,800
Roy Street (south side)—Queens Road to St. Kilda Road	7,300
Wells Street (west side)—Park Street to Bank Street	4,900
	145,700

Footpath Reconstruction:

Dundas Place (north side)—Montague Street to Ferrars Place	5,900
Nelson Road (east side)—Merton Street to St. Vincent Street	4,200
Victoria Avenue (south side)—Danks Street to Beaconsfield Parade	8,000
Merton Street (east side)—Bridport Street to Bevan Street	2,000
Danks Street (west side)—Armstrong Street to Nimmo Street	3,100
Mills Street (south side)—Canterbury Road to Herbert Street	2,400
Patterson Street (west side)—McGregor Street to Langridge Street	1,000
Haig Street (north side)—Clarendon Street to Cecil Street	4,000
Sturt Street (west side)—Miles Street to Grant Street	4,200
Yarra Place (both sides)—Coventry Street to York Street	3,400
York Street (south side)—Tope Street to King's Way	1,700
Alfred Street (both sides)—Off Montague Street	2,400
Bank Street (both sides)—Montague Street to Nelson Road	4,800
Montague Street (west side)—Bank Street to Park Street	5,300
Dorcas Street (south side)—King's Way to Dodds Street	3,900
Park Street (north side)—Eastern Road to King's Way	9,000
Roy Street (south side)—Queens Road to St. Kilda Road	2,000
Wells Street (west side)—Park Street to Bank Street	1,500
	68,800
	\$316,900

(3) The period of the loan shall be ten years (notional fifteen years).

(4) The moneys borrowed shall be repayable by providing out of the municipal fund twenty equal half yearly instalments of \$21,205.97 each including principal and interest on the fifteenth day of November and the fifteenth day of May during the currency of the loan. The first instalment shall be payable on the fifteenth day of May, 1977. The final instalment of \$182,983.17 shall be payable on the fifteenth day of November, 1986.

(5) Such moneys shall be repayable to the Australia and New Zealand Banking Group Limited, 307 Clarendon Street, South Melbourne, or such other place or places as the Bank from time to time may require.

The plans and specifications and the estimate of the cost of the proposed works and a statement showing the proposed expenditure of the moneys to be borrowed are open for inspection at the office of the Council of the City of South Melbourne, at the Town Hall, Bank Street, South Melbourne, during office hours.

13th September, 1976.

3966

D. N. BETHKE, Town Clerk.

Town and Country Planning Act 1961 (Twelfth Schedule).
SHIRE OF ALBERTON COASTAL PLANNING SCHEME
1962.

NOTICE THAT A PLANNING SCHEME HAS BEEN PREPARED
AND IS AVAILABLE FOR INSPECTION.

Amendment No. 11, 1976.

Notice is hereby given that the Shire of Alberton in pursuance of its powers under the *Town and Country Planning Act 1961*, has prepared a Planning Scheme for the purpose of:—

1. To include the term "Tourist Establishment" in the Interpretations and to make it a use subject to the consent of the Responsible Authority in the Agricultural Zone in the Planning Scheme Ordinance.

2. To make the development of historic buildings and areas within the Shire subject to the consent of the Responsible Authority.

3. To establish a new Special Uses Zone No. 10: Historic Area, and include provisions for the control of development in such areas in the ordinance.

4. Rezone an historical area at Port Albert for Special Use Purposes—No. 10 Historic Area.

A copy of the Scheme has been deposited at the Shire Office, Yarram and at the office of the Town and Country Planning Board, 235 Queen Street, Melbourne and will be open for inspection during office hours by any person free of charge.

Any persons affected by the Planning Scheme are required to set forth in writing all objections they may have addressed to:

Shire Secretary,
Shire of Alberton,
Shire Office,
Yarram, 3971.

On or before the 29th day of October, 1976 and state whether they wish to be heard in respect of their objections.

17th September, 1976.

3952 D. A. CARTLEDGE, Shire Secretary.

SHIRE OF BAIRNSDALE.

LOAN No. 71.

Notice of Intention to Borrow.

Notice is hereby given that the Council of the Shire of Bairnsdale intends to borrow Seventy-five thousand dollars (\$75,000) secured by a charge over the General rates of the municipality by the grant of a Mortgage in accordance with the provisions of the Local Government Acts.

In connection therewith the following information is stated:—

(a) The amount of the principal moneys which it is proposed to borrow is \$75,000.

(b) The maximum rate of interest that may be paid is 9.8 per centum per annum.

(c) The times which the moneys borrowed are to be repayable are the 15th days of May and November during the years 1977-1981 inclusive and that the place such moneys shall be repayable is at the Bank of New South Wales, Bairnsdale.

(d) The purpose for which the loan is to be applied is:—

Purchase of roadmaking plant.

(e) The manner in which the loan is to be liquidated is by provision out of the Municipal Fund in each half-year during the currency of the Loan of the sum of \$9,665.73 which includes Principal and Interest.

The plans and specifications and estimate of the cost of the works and a statement showing the proposed expenditure of the moneys to be borrowed are open for inspection at the Shire Office, Bairnsdale.

Dated this 22nd day of September, 1976.

3953 P. R. LEWIS, Shire Secretary.

SHIRE OF CORIO.

LOAN No. 111.

Notice of Intention to Borrow.

Notice is hereby given that the Council of the Shire of Corio intends to borrow One hundred thousand dollars (\$100,000.00) secured by a charge over the general rates of the municipality by the grant of a mortgage in accordance with the provisions of the Local Government Acts.

In connection therewith the following information is stated:—

(a) The amount of the principal moneys which it is proposed to borrow is One hundred thousand dollars (\$100,000.00).

(b) The maximum rate of interest that may be paid is 10.5 per centum per annum.

(c) The times which the moneys borrowed are to be repayable are the first days of June and December during the years 1977 to 1986 inclusive, and that the place such moneys shall be repayable is at the Bank of New South Wales, Melbourne Road, North Geelong.

(d) The purpose for which the loan is to be applied is:—

Little River Ripley	\$15,000
Anakie Road	15,000
Donnybrook Road	22,000
Plantation Road	25,000
Boulevard	23,000

(e) The manner in which the loan is to be liquidated is by provision out of the principal fund during the currency of the loan of in each half year the sum of \$8,195.23 which includes principal and interest.

The plans and specifications and the estimates of the proposed works and a statement showing the proposed expenditure of the moneys to be borrowed are open for inspection at the office of the Council of the Shire of Corio at Osborne House, North Geelong.

3958 R. P. METCALF, Shire Secretary.

SHIRE OF CRANBOURNE SEWERAGE AUTHORITY.

CRANBOURNE DISTRICT.

General Notice.

The Shire of Cranbourne Sewerage Authority having made provision for carrying of sewage from each and every property, which or any part of which is within the sewerage areas hereinafter described, doth hereby declare that on and after 1st day of October, 1976, each and every property which or any part of which is within the said sewerage areas shall be deemed to be a seweraged property within the meaning of the *Sewerage Districts Act 1958*. The boundary of the sewerage areas hereinbefore referred to are:—

Description—Area No. 13.

Comprising lots 108 to 146 inclusive of L.P. 119231 being Stage 4 of the Blind Bight Estate, Warneet.

Description—Area No. 14.

Comprising lots 1-97 inclusive, L.P. 116650 and Lots 98-153 inclusive, L.P. 118987, being Stages 1 and 2 of the Botany Park Estate, Carrum Downs.

By Order of the Shire of Cranbourne Sewerage Authority.

8th September, 1976.

3979 W. B. CAMPBELL, Chairman.
T. VICKERMAN, Secretary.

SHIRE OF KILMORE.

LOAN No. 49.

Notice of Intention to Borrow the Sum of \$50,000 for Permanent Works and Undertakings.

Notice is hereby given that the Shire of Kilmore intends, after one month, to proceed to borrow the principal sum of \$50,000 secured by a charge over the general rates of the municipality, such sum to be raised by the grant of a mortgage in accordance with the provisions of the *Local Government Act 1958*.

1. The maximum rate of interest that may be payable is 10.7 per cent. per annum.

2. The purpose for which the loan is to be applied is part development of the Shire's Industrial Estate.

3. The period of the loan shall be 20 years.

4. The money borrowed shall be repayable by providing out of the municipal fund 40 half-yearly instalments of \$3,054.85 including principal and interest on the 31st day of May and the 30th day of November each year during the currency of the loan. The first instalment shall be payable on the 31st day of May, 1977.

5. The money borrowed is to be repaid at the office of the C.B.C. Savings Bank Limited, Melbourne.

6. Plans of the proposed development are available for inspection at the Shire Office, 16 Sydney Street, Kilmore.

3981 JIM ELVEY, Shire Secretary.

Town and Country Planning Act 1961 (Twelfth Schedule).
SHIRE OF KORUMBURRA PLANNING SCHEME.
 NOTICE THAT A PLANNING SCHEME HAS BEEN PREPARED AND IS AVAILABLE FOR INSPECTION.

Amendment No. 7.

Notice is hereby given that the Shire of Korumburra in pursuance of its powers under the *Town Planning Act 1961*, has prepared a Planning Scheme for all that part of the Shire of Korumburra delineated within a black border and shown on the maps placed on public exhibition from the date of this advertisement for the purpose of creating a new zoning and for the amendment of various zonings throughout the Shire and also to increase the capacity of underground fuel storage tanks.

A copy of the Scheme has been deposited at the Shire Office, Commercial Street, Korumburra, and at the Office of the Town and Country Planning Board, 235 Queen Street, Melbourne, and will be open for inspection during office hours by any person free of charge.

Any persons affected by the Planning Scheme are required to set forth in writing all objections they may have addressed to the Shire Secretary, P.O. Box 69, Korumburra, on or before the 29th day of December, 1976, and to state whether they wish to be heard in respect of their objections.

20th September, 1976.

3961

W. O. CLARK, Shire Secretary.

SHIRE OF MALDON.

Loan No. 27.

Notice of Intention to Borrow the Sum of \$24,000.

Notice is hereby given that the Council of the Shire of Maldon proposes to borrow the principal sum of Twenty four thousand dollars secured by a charge over the general rates of the municipality, such sum to be raised by the grant of a mortgage in accordance with the provisions of the *Local Government Act 1958*.

1. The maximum rate of interest that may be paid is 10.5 per cent per annum.

2. The purpose for which the loan is to be applied is for the provision of a municipal storeyard.

3. The period of the loan shall be ten years.

4. The moneys borrowed shall be repayable by providing out of the municipal fund half-yearly instalments of approximately \$1,966.85 each including principal and interest on the fifth day of January and the fifth day of July during the currency of the loan. The first instalment shall be payable on the fifth day of July, 1977.

5. Such moneys shall be repayable at C.B.C. Savings Bank Limited, 251 Collins Street, Melbourne.

A statement showing the proposed expenditure of the moneys to be borrowed is open for inspection at the office of the Council of the Shire of Maldon at Maldon.

4019

S. R. BEACH, Shire Secretary.

Town and Country Planning Act 1961.

SHIRE OF MANSFIELD.—EILDON RESERVOIR PLANNING SCHEME 1959.

NOTICE THAT A PLANNING SCHEME HAS BEEN PREPARED AND IS AVAILABLE FOR INSPECTION.

(SHIRE OF MANSFIELD.)

Amendment No. 18, 1976.

Notice is hereby given that the Council of the Shire of Mansfield in pursuance of its powers under the *Town and Country Planning Act 1961* has prepared a Planning Scheme for part of C.A. 5A and 5C, Parish of Brankeet and Part of 5, 6, 7, 8 and 11 Section 9, Township of Bonnie Doon, for the purpose of rezoning the land from Rural Zone to Residential Zone, in part and Commercial Zone in part.

A copy of the scheme has been deposited at the office of the Shire of Mansfield, 33 Highbett Street, Mansfield and at the office of the Town and Country Planning Board, 235 Queen Street, Melbourne, and will be open for inspection during office hours by any person free of charge.

Any persons affected by the Planning Scheme are required to set forth in writing all objections they may have, addressed to the Secretary of the Shire of Mansfield at 33 Highbett Street, Mansfield on or before the 29th October 1976, and to state whether they wish to be heard in respect of their objections.

24th September, 1976.

4021

E. CAIRNS, Shire Secretary.

Town and Country Planning Act 1961.

SHIRE OF MANSFIELD.—EILDON RESERVOIR PLANNING SCHEME 1959.

NOTICE THAT A PLANNING SCHEME HAS BEEN PREPARED AND IS AVAILABLE FOR INSPECTION.

(SHIRE OF MANSFIELD.)

Amendment No. 19, 1976.

Notice is hereby given that the Council of the Shire of Mansfield in pursuance of its powers under the *Town and Country Planning Act 1961* has prepared a Planning Scheme for Allotment 177 on Lodged Plan No. 58894 situate at the corner of Anchorage Way and Lake Valley Drive, Parish of Howqua West, Gough's Bay for the purpose of rezoning the land from Commercial Zone to Residential Zone.

A copy of the scheme has been deposited at the office of the Shire of Mansfield, 33 Highbett Street, Mansfield and at the office of the Town and Country Planning Board, 235 Queen Street, Melbourne, and will be open for inspection during office hours by any person free of charge.

Any persons affected by the Planning Scheme are required to set forth in writing all objections they may have, addressed to the Secretary of the Shire of Mansfield at 33 Highbett Street, Mansfield on or before the 29th October, 1976, and to state whether they wish to be heard in respect of their objections.

23rd September, 1976.

4022

E. CAIRNS, Shire Secretary.

Town and Country Planning Act 1961.

SHIRE OF MANSFIELD.—EILDON RESERVOIR PLANNING SCHEME 1959.

NOTICE THAT A PLANNING SCHEME HAS BEEN PREPARED AND IS AVAILABLE FOR INSPECTION.

(SHIRE OF MANSFIELD.)

Amendment No. 22, 1976.

Notice is hereby given that the Council of the Shire of Mansfield in pursuance of its powers under the *Town and Country Planning Act 1961* has prepared a Planning Scheme for the whole of the land comprising the Rural Zone and the Rural Forests Zone as set out on the maps of the Eildon Reservoir Planning Scheme 1959 (Shire of Mansfield) for the purpose of removing the provision for Caravan Parks from the Rural Zone and Rural Forests Zone in favour of inclusion of Caravan Parks in Special Use Zones together with a revision of the matters to be taken into account when considering such applications.

A copy of the scheme has been deposited at the office of the Shire of Mansfield, 33 Highbett Street, Mansfield and at the office of the Town and Country Planning Board, 235 Queen Street, Melbourne and will be open for inspection during office hours by any person free of charge.

Any persons affected by the Planning Scheme are required to set forth in writing all objections they may have, addressed to the Secretary of the Shire of Mansfield at 33 Highbett Street, Mansfield on or before the 29th October, 1976, and to state whether they wish to be heard in respect of their objections.

4023

E. CAIRNS, Shire Secretary.

SHIRE OF MANSFIELD.

Loan No. 84.

Notice of Intention to Borrow the Sum of \$20,000 for Permanent Works and Undertakings.

Notice is hereby given that the Council of the Shire of Mansfield intends to borrow Twenty Thousand Dollars (\$20,000) secured by a charge over the General Rates of the Municipality by the grant of a Mortgage in accordance with the provisions of the *Local Government Acts*.

In connection therewith the following information is stated:—

- (a) The amount of the principal moneys which it is proposed to borrow is \$20,000.
- (b) The times which the moneys borrowed are to be repayable are the 26th days of May and November, 1977 and the 26th days of May and November during the years 1977–1991 inclusive and that the place such moneys shall be repayable is at the Bank of New South Wales, Mansfield.
- (c) The maximum rate of interest that may be paid is 10.5 per centum per annum.

(d) The purpose for which the loan is to be applied is Permanent Works and Undertakings namely the acquisition of land and associated legal expenses for the proposed parking area, Nolan Street, Mansfield.

(e) The manner in which the loan is to be liquidated is by provision out of the Municipal Fund in each half-year during the currency of the loan of the sum of \$1338.34 which includes Principal and Interest.

The Plans and Specifications and estimate of the cost of the works and a statement showing the proposed expenditure of the moneys to be borrowed are open for inspection at the Shire Office.

Dated this 20th day of September, 1976.

4024 E. CAIRNS, Shire Secretary.

SHIRE OF MANSFIELD.

LOAN No. 85.

Notice of Intention to Borrow the Sum of \$13,000 for Permanent Works and Undertakings.

Notice is hereby given that the Council of the Shire of Mansfield intends to borrow Thirteen Thousand Dollars (\$13,000) secured by a charge over the General Rates of the Municipality by the grant of a Mortgage in accordance with the provisions of the Local Government Acts.

In connection therewith the following information is stated:—

- The amount of the principal moneys which it is proposed to borrow is \$13,000.
- The times which the moneys borrowed are to be repayable are the 26th days of May and November, 1977 and the 26th days of May and November, during the years 1977-1986 inclusive and that the place such moneys shall be repayable is at the Bank of New South Wales, Mansfield.
- The maximum rate of interest that may be paid is 10.5 per centum per annum.
- The purpose for which the loan is to be applied is Permanent Works and Undertakings namely the purchase of Plant and Equipment, one Accounting Machine.
- The manner in which the loan is to be liquidated is by provision out of the Municipal Fund in each half-year during the currency of the loan of the sum of \$1,065.38 which includes Principal and Interest.

The Plans and Specifications and estimate of the cost of the works and a statement showing the proposed expenditure of the moneys to be borrowed are open for inspection at the Shire Office.

Dated this 20th day of September, 1976.

4025 E. CAIRNS, Shire Secretary.

Town and Country Planning Act 1961 (Twelfth Schedule).

SHIRE OF MORNINGTON PLANNING SCHEME 1959.

NOTICE THAT A PLANNING SCHEME HAS BEEN PREPARED AND IS AVAILABLE FOR INSPECTION.

Amendment No. 107, 1976.

Notice is hereby given that the Council of the Shire of Mornington in pursuance of its powers under the *Town and Country Planning Act 1961* has prepared a Planning Scheme for the following areas and purposes:—

land shown on Plan No. 276/PP/1 in the Office of the Council, being:—Numbers 60 and 62 Barkly Street Mornington—Rezoning from Residential "A" Zone to proposed Public Purpose Reserve (25) Municipal Car Parking Area.

A copy of the Scheme has been deposited at the office of the Council, Queen Street, Mornington, and at the office of the Town and Country Planning Board, 235 Queen Street, Melbourne, and will be open for inspection during office hours by any person free of charge.

Any persons affected by the Planning Scheme are required to set forth in writing all objections they may have, addressed to the Shire Secretary, Mornington Shire Council, P.O. Box 78, Mornington 3931, on or before the 29th December 1976, and to state whether they wish to be heard in respect of their objections.

3983 D. G. COLLINGS, Shire Secretary.

SHIRE OF PHILLIP ISLAND.

LOAN No. 71, \$40,000.

Special Order.

Notice is hereby given that the Council of the Shire of Phillip Island did at a meeting held on Wednesday, 18th August, 1976, agree to the following Resolution:—

- That the Council do by Special Order borrow the sum of \$40,000 secured on the general rates of the municipality, such sum to be raised by the grant of a mortgage in accordance with Section 585 of the *Local Government Act 1958*, as amended.
- That the rate of interest to be paid is 10.5 per centum per annum.
- That the period of the loan be for (10) ten years and that the moneys borrowed be repayable by half yearly instalments of approximately \$3,278 including principal and interest on 1st April and 1st October during the currency of the loan, the first instalment being repayable on the 1st April, 1977.

4. That such moneys be repayable at the State Savings Bank of Victoria, Melbourne.

5. That the loan be applied for the purpose of constructing private streets within the Shire in pursuance of and in accordance with the provisions of Division 10 of Part XIX. of the *Local Government Act 1958*.

And Notice is hereby further given that the said Council did at a meeting held on Wednesday, 15th September, 1976, confirm such Resolution.

3964 STAN A. HARRIS, Municipal Clerk.

SHIRE OF SEYMOUR.

SPECIAL ORDER.—BY-LAW No. 71.

Notice is hereby given that at the Ordinary Meeting of Council to be held on 11th October, 1976 Council intends to make the above By-law which will provide for the registration with Council of all caravans placed on private property used for habitation for periods exceeding three weeks duration and caravans placed on private property not used for habitation which are not garaged in a carport or garage, such by-law shall not apply to caravans not used for habitation which are placed on lawfully established caravan parks or those under the control of persons lawfully engaged in the business of selling, hiring or repairing caravans. No fee will be charged for registration.

Copies of the proposed By-law are available for inspection at the Municipal Offices, Tallarook Street, Seymour.

3984 G. G. McWHINNEY, Shire Secretary.

SHIRE OF SEYMOUR.

SPECIAL ORDER.—BY-LAW No. 72.

Notice is hereby given that at the Ordinary Meeting of Council to be held on 11th October, 1976 Council intends to make the above By-law which will amend By-law No. 46 so as to provide for the declaration as a brick area that land on the southern side of Pollard Street from Alfred to Howe Streets.

Copies of the proposed By-law, are available for inspection at the Municipal Offices, Tallarook Street, Seymour.

3985 G. G. McWHINNEY, Shire Secretary.

SHIRE OF SEYMOUR.

LOAN No. 48.

Notice of Intention to Borrow.

Notice is hereby given that the Council of the Shire of Seymour proposes to borrow the principal sum of \$33,000 (Thirty-three thousand dollars) secured by a charge over the general rates of the Municipality such sum to be raised by the grant of a mortgage in accordance with the provisions of the *Local Government Act 1958*.

- The maximum rate of interest that may be paid is 10.5 per centum per annum.
- The purpose for which the loan is to be applied is:

Purchase of house High Street, Seymour for road widening purposes and
Purchase of building 36 Tallarook Street, Seymour for portion of proposed town hall site.

- The period of the loan shall be ten years.
- The moneys borrowed shall be repayable by providing out of the municipal fund twenty half yearly instalments of \$2,704.43 each including principal and interest on the

15th day of May and the 15th day of November during the currency of the loan. The first instalment shall be payable on the 15th day of May, 1977.

5. Such moneys shall be repayable at the C.B.C. Savings Bank Limited, Melbourne.

The plans and specifications and the estimate of the cost of the proposed works and a statement showing the proposed expenditure of the moneys to be borrowed are open for inspection at the office of the Council, Tallarook Street, Seymour.

Dated this 24th day of September, 1976.

3986 G. G. McWHINNEY, Shire Secretary.

SHIRE OF SOUTH GIPPSLAND.

BY-LAW No. 55.

A By-law of the Shire of South Gippsland made under the provisions of Section 197 (xxxi) (c) of the *Local Government Act 1958* and of any and every other power it thereunto enabling and numbered 55 for the purpose of prohibiting and regulating camping on roads.

In pursuance of the powers conferred by the *Local Government Act 1958* the President, Councillors and Ratepayers of the Shire of South Gippsland order as follows:—

1. By-law No. 45 is hereby repealed.
2. In this By-law unless inconsistent with the context or subject matter—
 - "Camp" includes camping in a motor car or caravan;
 - "Council" means the Council of the Shire of South Gippsland;
 - "Motor Car" has the same meaning as in the *Motor Car Act 1958*;
 - "Municipal District" means the municipal district of the Shire of South Gippsland.
3. No person shall camp on any road within the municipal district for a period greater than 24 hours.
4. No person shall camp on the roads referred to in the 1st Schedule to this By-law.
5. This By-law shall apply to and have operation throughout the whole of the municipal district of the Shire of South Gippsland.
6. Any person guilty of a wilful act or default contrary to the provisions of this by-law shall be liable to a penalty of not less than \$10 nor more than \$40 and to a further penalty of not more than \$10 for each day on which such offence is continued after a conviction or order of any Court.

FIRST SCHEDULE.

Foster-Promontory Road.
Millar Road.
Foley Road.

Resolution for passing this By-law was agreed to by the Council on the 13th day of May, 1976, and confirmed on the 10th day of June, 1976.

The common seal of the President, Councillors and Ratepayers of the Shire of South Gippsland was hereunto affixed, in the presence of—

(SEAL) W. E. COOK, Shire President.
T. J. MORGAN, Councillor.
H. R. LOMAX, Shire Secretary.

3965

Town and Country Planning Act 1961 (Twelfth Schedule). SHIRE OF WERRIBEE PLANNING SCHEME 1963.

NOTICE THAT A PLANNING SCHEME HAS BEEN PREPARED AND IS AVAILABLE FOR INSPECTION.

Amendment No. 41, 1976.

Notice is hereby given that the Shire of Werribee, in pursuance of its powers under the *Town and Country Planning Act 1961* has prepared a Planning Scheme for—

The Rezoning from Reserved Industrial Zone to existing Public Purposes Zone land situated at the corner of Loch Avenue and the proposed Ring Road known as Part Crown Allotments numbered 29 and 30, Section J, Parish of Deutgam, County of Bourke.

A copy of the Scheme has been deposited at the Municipal Offices, Civic Centre, Princes Highway, Werribee 3030, and at the Office of the Town and Country Planning Board, 235 Queen Street, Melbourne and will be open for inspection during office hours by any person free of charge.

Any persons affected by the Planning Scheme are requested to set forth in writing all objections they may have, addressed to the Shire Secretary, Civic Centre, Princes Highway, Werribee 3030, on or before the 29th October, 1976 and state whether they wish to be heard in respect of their objections.

27th August, 1976.

4026

J. T. KERR, Shire Secretary.

Town and Country Planning Act 1961 (Twelfth Schedule). SHIRE OF WERRIBEE PLANNING SCHEME 1963.

NOTICE THAT A PLANNING SCHEME HAS BEEN PREPARED AND IS AVAILABLE FOR INSPECTION.

Amendment No. 42, 1976.

Notice is hereby given that the Shire of Werribee, in pursuance of its powers under the *Town and Country Planning Act 1961* has prepared a Planning Scheme for—

The Rezoning from Residential 'A' to Light Industrial Zone land situated at the corner of Pyke Street and Werribee Street, Werribee being Part Lot 1, Section 8 (known as No. 18), Parish of Deutgam, County of Bourke.

A copy of the Scheme has been deposited at the Municipal Offices, Civic Centre, Princes Highway, Werribee 3030, and at the Office of the Town and Country Planning Board, 235 Queen Street, Melbourne and will be open for inspection during office hours by any person free of charge.

Any persons affected by the Planning Scheme are requested to set forth in writing all objections they may have, addressed to the Shire Secretary, Civic Centre, Princes Highway, Werribee 3030, on or before the 29th October, 1976 and state whether they wish to be heard in respect of their objections.

27th August, 1976.

4027

J. T. KERR, Shire Secretary.

Town and Country Planning Act 1961 (Twelfth Schedule). SHIRE OF WERRIBEE PLANNING SCHEME 1963.

NOTICE THAT A PLANNING SCHEME HAS BEEN PREPARED AND IS AVAILABLE FOR INSPECTION.

Amendment No. 43, 1976.

Notice is hereby given that the Shire of Werribee, in pursuance of its powers under the *Town and Country Planning Act 1961* has prepared a Planning Scheme for—

The Rezoning from Agricultural Zone to Reserved Residential Zone land being Crown Allotments No's. A, B, C & D, Section 11, Parish of Tarneit, and Crown Allotments No's. F, G, H, K, L, M & N, Section 11, Parish of Tarneit, County of Bourke.

A copy of the Scheme has been deposited at the Municipal Offices, Civic Centre, Princes Highway, Werribee 3030, and at the Office of the Town and Country Planning Board, 235 Queen Street, Melbourne and will be open for inspection during office hours by any person free of charge.

Any persons affected by the Planning Scheme are requested to set forth in writing all objections they may have, addressed to the Shire Secretary, Civic Centre, Princes Highway, Werribee 3030, on or before the 29th December, 1976 and state whether they wish to be heard in respect of their objections.

27th August, 1976.

4028

J. T. KERR, Shire Secretary.

DANDENONG SEWERAGE AUTHORITY.

GENERAL NOTICE.

The abovementioned Sewerage Authority having made provision for carrying off the sewage from each and every property which, or any part of which is within the sewerage areas hereinafter described, doth hereby declare that on and after the First day of October, 1976, each and every property which, or any part of which is within the said sewerage areas shall be deemed to be seweraged property within the meaning of the *Sewerage Districts Act 1958*.

The boundaries of the Sewerage Areas hereinbefore referred to are:—

Sewerage Area No. 343.

All that piece of land being Lot 3 on Lodged Plan of Subdivision No. 115018 such lot being situated at the north-eastern corner of Heatherton Road and Stud Road.

Sewerage Area No. 344.

All that piece of land being Lot 268 on Lodged Plan of Subdivision No. 93542 such lot being situated on the south-western side of Outlook Drive.

Sewerage Area No. 345.

All those pieces of land being Lots 1 to 32 inclusive on Lodged Plan of Subdivision No. 112315.

Streets or parts thereof concerned in this area are Frankston Road and Glomar Court.

Sewerage Area No. 346.

All those pieces of land being Lots 1 to 27 inclusive on Lodged Plan of Subdivision No. 118876 and Lot 1 on Lodged Plan of Subdivision No. 114976.

Streets or parts thereof concerned in this area are Bakers Road, Galloway Street and Mirboo Street.

Sewerage Area No. 347.

All those pieces of land being Lots 356 and 357 on Lodged Plan of Subdivision No. 95915.

Streets or parts thereof concerned in this area are Police Road and Snowy Street.

Sewerage Area No. 348.

All those pieces of land being Lots 1 to 3 inclusive on Lodged Plan of Subdivision No. 117456 and Lots 1 to 38 inclusive on Lodged Plan of Subdivision No. 119613.

Streets or parts thereof concerned in this area are Eagle Drive, Jackson Road, Roulston Court and McQuade Court.

Sewerage Area No. 349.

Commencing at a point being the intersection of the western side of Kays Avenue and the eastern side of the Eumemmerring Freeway; thence generally northerly along the eastern side of the Eumemmerring Freeway to its intersection with the northern boundary of the land described on Certificate of Title Volume 7304 Folio 689; thence easterly along the said northern boundary and the easterly prolongation thereof to the eastern side of Kays Avenue; thence northerly along the eastern side of Kays Avenue to the north-western angle of Lot 56 on Lodged Plan of Subdivision No. 54566; thence easterly along the northern boundaries of the said Lot 56 and Lot 63 on the said lodged plan and the easterly prolongation thereof to the eastern side of Carlisle Road; thence northerly along the eastern side of Carlisle Road to its intersection with the southern side of Henry Avenue; thence generally easterly along the southern boundary of Henry Avenue to its intersection with the western side of Charles Avenue; thence southerly along the western side of Charles Avenue a distance of 193 feet 3 inches; thence easterly across Charles Avenue to the north-western angle of Lot 78 on Lodged Plan of Subdivision No. 52700 thence easterly along the northern boundary of the said Lot 78 to its north-eastern angle; thence northerly by a bearing of 0° 18' to the northern angle of Lot 92 on the said lodged plan; thence south-easterly along the north-eastern boundary of the said Lot 92 to the western side of William Avenue; thence south-easterly by a line across William Avenue to a point formed by the intersection of the north-eastern and western boundaries of Lot 96 on the said lodged plan; thence south-easterly along the south-western side of William Avenue to its intersection with the western side of Harmer Road; thence southerly along the western side of Harmer Road to the south-eastern angle of Lot 107 on Lodged Plan of Subdivision No. 52699; thence south-easterly across Harmer Road to the north-western angle of Lot 1 on Lodged Plan of Subdivision No. 97615; thence easterly by a line bearing 90° 11' a distance of 1115 feet 10½ inches to the north-eastern angle on Lot 53 on the said lodged plan; thence southerly along the eastern boundary of the said Lot 53 to the north-western angle of Lot 125 on Lodged Plan of Subdivision No. 54908; thence easterly by a line bearing 94° 7½' a distance of 553' 6"; thence northerly by a line bearing 0° 0' a distance of 581 feet 3½ inches thence northerly by a line bearing 359° 39½' to the southern side of Frawley Road; thence easterly along the southern side of Frawley Road to its intersection with the western side of Gina Court; thence southerly along the western side of Gina Court a distance of 180 feet; thence south-westerly along the south-eastern boundary of Lot 7 on Lodged Plan of Subdivision No. 110513 to its intersection with the northern boundary of Lot 123 on Lodged Plan of Subdivision No. 54907; thence easterly along the northern boundary of the said Lot 123 to its north-eastern angle; then southerly along the eastern side of Lot 123 to its south-eastern angle; thence generally south-easterly along the south-western boundary of Lot 122 on the said lodged plan to the north-western angle of Lot 121 on the said lodged plan; thence north-easterly along

the north-western boundary of the said Lot 121 to its northern angle; thence southerly along the eastern boundary of the said Lot 121 to the north-western angle of Lot 118 on the said lodged plan; thence easterly along the northern boundary of the said Lot 118 to its north-eastern angle; thence southerly along the eastern boundary of the said Lot 118 and the southerly prolongation thereof to the southern side of Cornwall Street; thence easterly along the southern side of Cornwall Street and the easterly prolongation thereof to the north-eastern side of Edinburgh Street; thence north-westerly along the north-eastern side of Edinburgh Street to the western angle of Lot 54 on Lodged Plan of Subdivision No. 54884; thence north-easterly along the north-western boundary of the said Lot 54 to its northern angle; thence south-easterly by a line bearing 132° 45' a distance of 493 feet 1¼ inches to the western side of Lot 1 on Lodged Plan of Subdivision No. 71322; thence southerly along the western side of the said Lot 1 to its south-western angle; thence easterly by a line bearing 90° a distance of 240 feet; thence northerly by a line bearing 179° 53½' to the southern side of Frawley Road; thence easterly along the southern side of Frawley Road a distance of 312 feet 5 inches to the north-eastern angle of Lot 2 on Lodged Plan of Subdivision No. 76236; thence southerly along the eastern boundaries of the said Lot 2 and Lot 1 on the said lodged plan to the northern side of Princes Highway; thence westerly along the northern side of the Princes Highway to the point of commencement.

Sewerage Area No. 350.

All those pieces of land comprising: Lot 1 on Plan of Subdivision No. 1728 lodged at the office of the City of Berwick; Lots 1 to 25 inclusive on Lodged Plan of Subdivision No. 85609; Lots 1 to 41 inclusive on Lodged Plan of Subdivision No. 114184; Lots 35 to 70 inclusive on Lodged Plan of Subdivision No. 115115; Lots 32 to 47 inclusive, 78, 79 and 80 on Lodged Plan of Subdivision No. 115111; Lots 48 to 68 inclusive on Lodged Plan of Subdivision No. 116068; Lots 1 to 34 inclusive on Lodged Plan of Subdivision No. 115114; Lots 1 to 18 inclusive on Lodged Plan of Subdivision No. 91662; Lots 55 and 56 on Lodged Plan of Subdivision No. 54884; Lots 181 to 186 inclusive on Lodged Plan of Subdivision No. 54905; Lots 111 to 117 inclusive 122, 147 to 162 inclusive and 165 to 180 inclusive on Lodged Plan of Subdivision No. 54907; Lot 1 on Lodged Plan of Subdivision No. 98999; Lots 3 to 6 inclusive on Lodged Plan of Subdivision No. 110513.

Streets or parts thereof concerned in this area are Frawley Road, Gina Court, Windsor Street, Wales Court, Cornwall Street, Edinburgh Street, Adan Avenue, Donely Road, Gunns Road, Gow Court, Sophie Court, Timothy Court, Alice Court, Thomas Court, Tate Court, Gibson Street, Simpson Court, Wanda Court, Killberry Crescent, Cressonierre Court, Mount View Avenue and Scott Close.

Sewerage Area No. 351.

All those pieces of land comprising Lots 1 to 92 inclusive on Lodged Plan of Subdivision No. 118111 and Lots 93 to 154 inclusive on Lodged Plan of Subdivision No. 118112.

Streets or parts thereof concerned in this area are Power Road, Chalcot Drive, Adamson Drive, Belsize Court, Tufnel Court, Albany Court, Fitzroy Court, Primrose Hill Close, Athlone Court, Bedford Court and Hanover Court.

Sewerage Area No. 352.

All those pieces of land comprising Lots 479 to 548 inclusive and Lot 764 on Lodged Plan of Subdivision No. 118283; Lots 574 to 576 inclusive and Lots 697 to 718 inclusive on Lodged Plan of Subdivision No. 118284.

Streets or parts thereof concerned in this area are Stainsby Close, Joseph Banks Crescent, Dozey Place, Johnson Place, Daniel Solander Drive, Gathrey Court, Pickersgill Court and Charles Green Avenue.

Sewerage Area No. 353.

All those pieces of land being Lots 35 to 38 inclusive on Lodged Plan of Subdivision No. 91416 such lots being situated on the western side of Howe Avenue.

Sewerage Area No. 354.

All those pieces of land being Lots 73 to 79 inclusive, 87, 89 and 90 on Lodged Plan of Subdivision No. 89351; Lots 91 to 97 inclusive and 149 to 164 inclusive on Lodged Plan of Subdivision No. 91426; Lots 166 to 198 inclusive and 212 to 240 inclusive on Lodged Plan of Subdivision No. 94787; Lots 270 to 297 inclusive on Lodged Plan of Subdivision No. 95369.

Streets or parts thereof concerned in this area are Utah Court, Buldah Street, Waranga Street, Outlook Drive, Bemm Court, Maffra Court, Ovens Court, Wingham Street, Mercer Court, Towong Street and Hunter Street.

Sewerage Area No. 335.

Commencing at a point being the intersection of the northern side of Murray Road and the eastern side of Gladstone Road; thence northerly along the eastern side of Gladstone Road to the north-western angle of Lot 8 on Lodged Plan of Subdivision No. 95915; thence easterly along the northern boundary of the said Lot 8 to the western boundary of Lot 16 on Lodged Plan of Subdivision No. 89351; thence northerly along the western boundary of the said Lot 16 to its north-western angle; thence easterly along the northern boundary of the said Lot 16 to the western side of Glenelg Street; thence generally southerly along the western side of Glenelg Street to its intersection with the north-western side of Avoca Court; thence southerly by a line across Avoca Court to the northern angle of Lot 24 on the said lodged plan; thence south-easterly along the north-eastern boundary of the said Lot 24 to its eastern angle, thence south-westerly by a line bearing 211° 8' a distance of 40 feet 9½ inches; thence easterly by a line bearing 98° 48' to the north-eastern angle of Lot 32 on the said lodged plan; thence southerly along the eastern boundary of the said Lot 32 to the northern side of Tarwin Court; thence westerly along the northern side of Tarwin Court to the south-western angle of Lot 33 on the said lodged plan; thence south-westerly by a line across Tarwin Court to the north-western angle of Lot 38 on the said lodged plan; thence south-westerly along the north-western boundary of the said Lot 38 to its western angle; thence easterly by a line bearing 98° 48' to the north-eastern angle of Lot 26 on Lodged Plan of Subdivision No. 79601; thence southerly along the eastern boundary of the said Lot 26 to its south-eastern angle; thence generally southerly along the western side of Tambo Court to its intersection with the northern side of Murray Road; thence westerly along the northern side of Murray Road to the point of commencement.

Sewerage Area No. 356.

All those pieces of land being Lots 23 to 34 inclusive, 39 to 59 inclusive 78 to 86 inclusive and 101 to 103 inclusive on Lodged Plan of Subdivision No. 119874.

Streets or parts thereof concerned in this area are Gerard Street, de Villiers Drive, Rogers Streets and James Street.

Unless otherwise specified, the Lodged Plans of Subdivision hereinbefore referred to shall be taken as those lodged at the Office of Titles, Melbourne.

By Order of the Dandenong Sewerage Authority.

I. A. FOTHERINGHAM, Chairman.
A. R. EDWARDS, Secretary.

3980

LILYDALE SEWERAGE AUTHORITY.

CONSTRUCTION OF SEWERS—LILYDALE.

The Lilydale Sewerage Authority gives notice that it intends to construct sewers in the area detailed below.

A plan showing details of the proposed works may be inspected by any persons during office hours—8.30 a.m. to 6.15 p.m. Monday and 8.30 a.m. to 5.00 p.m. Tuesday to Friday at the Authority office, 197 Main Street, Lilydale.

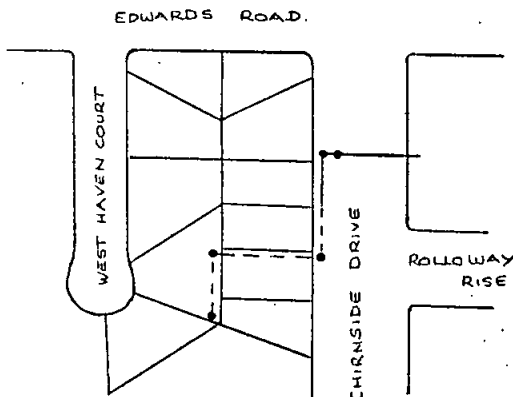

3962

G. B. KOHLMAN, Secretary.

MOE SEWERAGE AUTHORITY.

GENERAL NOTICE.

The above mentioned sewerage authority having made provision for carrying off the sewage from each and every property which or any part of which is within the sewerage areas hereinafter described doth hereby declare that on and after the 1st day of October 1976 each and every property which or any part of which is within the said sewerage areas shall be deemed to be a sewered property within the meaning of the Sewerage Districts Act 1958.

The sewerage areas hereinbefore referred to shall be known as sewerage Nos. 85 and 86.

The boundaries of the said sewerage areas Nos. 85 and 86 are delineated on the plans which may be inspected at the office of the Moe Sewerage Authority.

23rd August, 1976.

By Order of the Said Sewerage Authority.

J. S. TABUTEAU, Chairman.
A. DEWAR, Secretary.

3963

DRAFT.

Notice is hereby given that Doulton Insulators Australia Pty. Ltd. has applied for a lease pursuant to Section 134 of the Land Act 1958 for a term of 7 years in respect of Allotment A1 Section 8 Parish of Cut Paw Paw containing 6070 square metres as a site for General Industrial purposes.

3694

Notice is hereby given that the Timboon Golf Club has applied for a lease pursuant to Section 134 of the Land Act 1958, for a term of 21 years in respect of Allotment 70G Parish of Timboon containing approximately 27.5 hectares as a site for amusement and recreation (Golf Club).

3790

A. BROWN, Honorary Secretary.

Notice is hereby given that John Bond Bennett and Coral Bennett have applied for a Lease under Section 134 of the Land Act 1958 over Allotment 2A Section K Parish of Bright containing 8 acres 0 roods 39 Perches more or less, as a site for the purpose of providing accommodation and facilities for tourists.

4032

NOTICE OF INTENTION TO APPLY FOR A LICENCE TO DIVERT WATER.

I hereby give notice that I intend to apply for a licence empowering me to divert water from the Murray River at Robinvale for a term of 15 years to the extent of 56 megalitres per annum at a maximum rate of 5 megalitres per day of 24 hours for the irrigation of 6.2 hectares of playing grounds and gardens at Robinvale Consolidated School, being Lots 11 and 12, L.P. 12824, Parish of Bumbang.

Any objection to such application must be forwarded in writing to reach the State Rivers and Water Supply Commission, Melbourne, before 29 October 1976, being thirty days from the first publication of this Notice.

D. J. LITTLE, Director General.

Public Works Department,
Melbourne, 3002.

3967

Notice is hereby given that the partnership heretofore subsisting between Patrick John Treacey, Anthony Douglas Shaw and Hylton Gordon Grimmer carrying on business as Clothing Manufacturers at 2 Olivers' Lane, Melbourne, under the style or firm of P. J. Treacey & Co., has been dissolved as from the 13th day of August, 1976, by the retirement of Patrick John Treacey from the said business. All debts due and owing by the said business shall be received and paid respectively by Anthony Douglas Shaw and Hylton Gordon Grimmer who will continue to carry on the said business in partnership under the style or firm of P. J. Treacey & Co.

WEIGALL & CROWTHER, solicitors, 459 Little Collins Street, Melbourne, 3000.

4003

Notice is hereby given that the Partnership heretofore existing between Graham Loxen Morley, Jean Noelle Morley, Dennis Frederick Fraser and Denise Anne Fraser, known as "The Tarara Roadhouse" will be dissolved so far as the said Dennis Frederick Fraser and Denise Anne Fraser are concerned as from the 30th day of September, 1976 and thereafter the said business shall be carried on by the said Graham Loxen Morley and Jean Noelle Morley.

Dated this 23rd day of September, 1976.

3972

BYRNE, JONES & TORNEY.

Notice is hereby given that the partnership between Rodney James Fisk and Sandra Pearl Fisk both of 1 Tanner Court Breakwater Geelong and Peter Berndt Heinrich and Janet Alice Heinrich both of Lot 25 Townsend Road Whittington Geelong and trading as Geelong Transport and General Engineering is dissolved as and from thirty-first August One thousand nine hundred and seventy-six and the said business shall continue to be carried on by the said Peter Berndt Heinrich and Janet Alice Heinrich to whom all accounts can be forwarded.

R. J. FISK.
S. P. FISK.
P. B. HEINRICH.
J. A. HEINRICH.

Wighton & McDonald, solicitors, 89 Myers Street,
Geelong. 4016

Notice is hereby given that the partnership heretofore subsisting between Herbert Neal Rothacker, James Christian Rothacker and Louis Leslie Rothacker carrying on business as Farmers and Graziers at Yarraberb under the style or firm of Rothacker Bros. has been dissolved as from the 30th day of June 1976 so far as concerned the said Herbert Neal Rothacker who retires from the said firm.

Dated the 17th day of September, 1976.

H. N. ROTHACKER.
J. C. ROTHACKER.
L. L. ROTHACKER.

R. H. Schleiger & Associates, solicitors, 290 Williamson
Street, Bendigo, Vic., 3550. 3947

Notice is hereby given that the partnership heretofore subsisting between Timothy Edward Paterson Hewat, and Ann Elizabeth Gracie Hewat and Berio Pty. Ltd. carrying on business at 408 La Trobe Terrace Newtown, Victoria under the name of Australian Stock Horse Publications has been dissolved and the business will be carried on by Berio Pty. Ltd.

Berio Pty. Ltd.

3948 JOHN LOUGHNAN, Director.

Notice is hereby given that the partnership heretofore subsisting between Marjorie Claire Miller and Glenda Ann Roberts carrying on business as Florists at Shop 14 No. 16 Lower Dandenong Road Mentone under the style or firm of "Flowering Fern" has been dissolved as from the 7th September 1976 as far as concerns Glenda Ann Roberts who retires from the firm.

Dated the 7th day of September, 1976.

MARJORIE CLAIRE MILER.
GLENDA ANN ROBERTS.

3949

Companies Act 1961.—In the matter of RAHA HOLDINGS
PTY. LTD., formerly trading as Allied Electronics
(Wholesale).

Notice is hereby given that at an extraordinary Meeting of the Members of the abovenamed Company held on the 22nd September, 1976 it was resolved that the Company be wound up voluntarily and at a Meeting of Creditors held on the same day pursuant to Section 260 it was resolved that for such purpose Mr. D. J. Cogle of 545 St. Kilda Road, Melbourne, be appointed Liquidator.

Notice is also given that after twenty one days from this date I will proceed to distribute the assets. All creditors having any claims against the Company should furnish particulars of same by that date, otherwise I will proceed to distribute the assets without regard to their claim.

Dated this 22nd day of September, 1976.

D. J. COUGLE, Liquidator.

Bent & Cogle, public accountants, Suite 18, 545 St.
Kilda Road, Melbourne. 3975

Companies Act 1961.

CORBUTT MARKETING CO. PTY. LTD.

Notice is hereby given that a Petition for the winding-up of the abovenamed Company by the Supreme Court was on the 20th day of September 1976 presented by Apeco of Australia Pty. Ltd. and that the said Petition is directed to be heard before the Court sitting at Melbourne at the hour of 10.30 o'clock in the forenoon on the 12th day of November 1976 and any creditor or contributory of the Company desiring to support or oppose the making of an Order on the said Petition may appear at the time of hearing by himself or his Counsel for that purpose; and a copy of the Petition will be furnished to any creditor or contributory of the said Company requiring the same by the undersigned on payment of the regulated charge for the same.

The Petitioner's address is 7 Inman Road, Dee Why, New South Wales.

The Petitioner's Solicitors are Messrs. Remington & Co. of 13th Floor, 171 William Street, Melbourne.

REMINGTON & CO., Solicitors for the Petitioner.

NOTE.—Any person who intends to appear on the hearing of the said Petition must serve on or send by post to the abovenamed Solicitors notice in writing of his intention so to do. The notice must state the name and address of the firm and must be signed by the person or firm or his or their Solicitor (if any) and must be served or if posted must be sent by post in sufficient time to reach the abovenamed not later than 4 o'clock in the afternoon of the 11th day of November 1976. 3976

In the Supreme Court of Victoria.—No. Co. 9406 of 1976.—
In the matter of VARIETY ARTISTS (AUST.) PTY. LTD. (in Liquidation); and in the matter of the Companies Act 1961.

Take notice that the first meeting of the Creditors in the above matter under the Order for Winding Up the company dated 31st August, 1976 will be held at the offices of B. O. Smith & Son, 23rd Floor, 500 Collins Street, Melbourne in the State of Victoria on Thursday 7th October, 1976 at 2.30 p.m.

At this meeting it will be determined whether or not the creditors require a Committee of Inspection to act with the Liquidator and if so who are to be members of the committee. Additionally an opportunity will be provided to discuss the Statement of Affairs at 31st August, 1976 and to ask questions of the Director who attends.

To entitle to vote thereat your Proof of Debt must be completed and lodged at the office of B. O. Smith & Son, 23rd Floor, 500 Collins Street, Melbourne to reach it before the meeting or the Proof of Debt must be handed to the Chairman at the commencement of the meeting.

Proxies to be used at the meeting must be lodged with the Liquidator 23rd Floor, 500 Collins Street, Melbourne not later than 1.30 p.m. on Thursday, 7th October, 1976.

B. H. SMITH, liquidator, 23rd Floor, 500 Collins Street,
Melbourne. 3977

Companies Act 1961, Section 260.

NOTICE OF MEETING OF CREDITORS.

Notice is hereby given that a meeting of creditors of Garden Stonework and Paving Pty. Ltd., will be held at the Fitzgerald Room, Accountants' House, 49 Exhibition Street, Melbourne, on the 5th day of October, 1976, at 10.30 a.m. the company having convened a meeting of its members for the same day for the purpose of considering a Resolution that the company be wound up voluntarily.

Dated this 22nd day of September, 1976.

L. G. SCOTT, Director.

Hosking, Dyer & Co., public accountants, 96 St. Kilda
Road, St. Kilda, 94 1932. 4004

The Companies Act 1961.

BRIGADOON PROPRIETARY LIMITED (IN LIQUIDATION).

NOTICE Re WINDING UP.

Notice is hereby given that at meetings of members and creditors held on the 22nd day of September 1976, it was resolved that the company be wound up voluntarily.

This notice in respect to creditors, appears as a matter of formality as creditors are believed to consist only of related companies.

Dated this 24th day of September, 1976.

K. J. RUSSELL, Liquidator.

Coopers & Lybrand, chartered accountants, 461 Bourke
Street, Melbourne, Vic. 3000. 4008

In the matter of the *Companies Act 1961*; and in the matter of H. LAWSON INVESTMENTS PTY. LIMITED.

Notice is hereby given that at an extraordinary general meeting of the above-named company duly convened and held at "Stoke Poges" Tucks Road, Shoreham at 11 a.m. on 25th September, 1976 the following special resolution was duly passed, viz:

That the Company be wound-up voluntarily and that Paul Lister Swan of 12 Ellis Street, South Yarra be appointed liquidator for the purpose of such winding-up.

Dated 27th September, 1976.

4035

B. E. HINRICHSEN, Chairman.

Companies Act 1961.

SPRINGWOOD PRODUCTS PTY. LTD. (IN VOLUNTARY LIQUIDATION).

NOTICE OF FINAL MEETING.

Notice is hereby given pursuant to Section 272 (2) of the *Companies Act 1961* that a General Meeting of Springwood Products Pty. Ltd. will be held on 30th October 1976 at 10 a.m. at the offices of Jamison, Cassidy & Co., 446 Collins Street, Melbourne for the purpose of receiving the Liquidator's Account showing how the winding up has been conducted, and the property of the Company has been disposed of and of hearing any explanation thereof which the Liquidator may make.

Dated this 29th day of September, 1976.

JOHN ANTHONY CASSIDY, Liquidator.

Jamison, Cassidy & Co., solicitors, 446 Collins Street, Melbourne, 3000. 4009

In the Supreme Court of Victoria.—Co. 9406 of 1976.—In the matter of the *Companies Act 1961*; and in the matter of VARIETY ARTISTS (AUST.) PTY. LTD. (in Liquidation).—Notice under Rules 99 (1) (2) of the Supreme Court (*Companies*) Rules 1962 of Date fixed for Lodging Proof of Debt.

Notice is hereby given in accordance with Rules 99 (1) (2) of the Supreme Court (*Companies*) Rules 1962 and the *Companies Act 1961* that I have fixed the 25th day of November, 1976, as being the day on or before which creditors of the company are to prove their debt. Any creditor who fails to make Proof of Debt on or before that date shall be excluded from the benefit of any distribution of assets of the company.

B. H. SMITH, Liquidator, 23rd Floor, 500 Collins Street, Melbourne. 3978

Companies Act 1961.

COLLISTON HOLDINGS PTY. LTD. (IN LIQUIDATION).

NOTICE OF FINAL MEETING OF MEMBERS.

Notice is hereby given in accordance with section 272 of the *Companies Act 1961* that a meeting will be held at 17 The Woodland Wheelers Hill on 20th October 1976 at 8 p.m. to receive an account of the liquidation.

Dated this 16th day of September, 1976.

3950 A. F. GREEN, Liquidator.

The Companies Act 1961.

SUMMER GARDENS TEA ROOMS PTY. LTD. (IN VOLUNTARY LIQUIDATION).

NOTICE CONVENING FINAL MEETING OF MEMBERS.

Pursuant to section 272, Notice is hereby given pursuant to Section 272 of the *Companies Act 1961* that a General Meeting of the Members of the abovenamed Company will be held in the Office of S. L. Williams & Co., 1st Floor, 486 Nepean Highway, Frankston on Monday the twenty-fifth day of October, 1976 at 10.00 a.m. for the purpose of having an account laid before them showing the manner in which the winding up has been conducted and the property of the company disposed of and of hearing any explanations that may be given by the Liquidator.

Dated this 21st day of September, 1976.

3951 S. L. WILLIAMS, Liquidator.

Companies Act 1961, Section 254 (2) (b).

GLENEAGLES GOLF CLUB.

At a General Meeting of Members of Gleneagles Golf Club duly convened and held at the offices of Morton, Watson & Young, Corner Scott and Thomas Streets, Dandenong, on Tuesday the 21st September, 1976, the following resolutions were duly passed as Special Resolutions—

1. That the Company be wound up voluntarily and that Ian Elwood Davey be hereby appointed Liquidator for the purpose of such winding up.

2. That pursuant to Section 269 of the *Companies Act 1961* the Liquidator be and is hereby authorised to exercise any of the powers given by paragraphs (b) (c) and (d) of Section 236 of the *Companies Act 1961* to a Liquidator in a winding up by the Court.

Dated this 22nd day of September, 1976.

I. E. DAVEY, liquidator, Corner Scott and Thomas Streets, Dandenong. 4017

Companies Act.—In the matter of RECIPROCAL FINANCE PROPRIETARY LIMITED (in Voluntary Liquidation).—Members' Winding-up.

Notice is hereby given that pursuant to Section 272 of the above Act the final General Meeting of the Members of the Company for the purpose of receiving the Liquidator's account showing how the winding-up has been conducted and how the property of the Company has been disposed of, will be held at the office of Clarke Richards Grant & Co. 350 La Trobe Street, Melbourne in the State of Victoria, on Thursday, the 4th day of November, 1976 at 2.20 p.m.

Dated this 22nd day of September, 1976.

E. J. RAMSAY, Liquidator.

Clarke Richards Grant & Co., solicitors, 350 La Trobe Street, Melbourne, 3000. 4005

Companies Act 1961, Section 254 (2) (b).

ABEL ENGINEERING PTY. LTD.

CREDITORS VOLUNTARY WINDING UP.

Notice is hereby given that at an extraordinary general meeting of its members of the abovementioned company held on the 22nd day of September, 1976, it was resolved that the company be wound up voluntarily and that Warwick Allen Leeming of Duesbury, Johnston and Marks, 446 Collins Street, Melbourne, be appointed liquidator.

Notice is also given that after 21 days from this date I shall proceed to distribute the assets. All creditors having any claims against the company should furnish particulars of same by that date, otherwise I shall proceed to distribute the assets without regard to their claim.

Dated this 22nd day of September, 1976.

W. A. LEEMING, Liquidator.

Duesbury, Johnston & Marks, 446 Collins Street, Melbourne, Vic. 3000. 4007

Companies Act.—In the matter of WRIDGWAY BROS. VAN LINES PROPRIETARY LIMITED (in Voluntary Liquidation).—Members Winding-up.

Notice is hereby given that pursuant to section 272 of the above Act the final general meeting of the members of the company for the purpose of receiving the liquidator's account showing how the winding-up has been conducted and how the property of the company has been disposed of, will be held at the office of Clarke, Richards, Grant & Co., 350 La Trobe Street, Melbourne in the State of Victoria, on Thursday, the 4th day of November, 1976, at 2.10 p.m.

Dated this 22nd day of September, 1976.

E. J. RAMSAY, Liquidator.

Clarke, Richards, Grant & Co., solicitors, 350 La Trobe Street, Melbourne. 3000. 4006

Companies Act 1961.—Rule 99 and Regulation 56.—In the matter of LEEWING PTY. LTD. (Formerly Wing Lee Pty. Ltd.) (in Liquidation).

Take notice that the Liquidator of the abovenamed company has fixed Friday, 15th October, 1976 as the day on or before which creditors of the company are to prove their debts or claims and to establish any title they may have to priority under Section 292 or be excluded from the benefit of final dividends made before such debts are proved or as the case may be from objecting to such dividends.

Dated this 28th day of September, 1976.

D. A. CRAWFORD, Liquidator.

Peat, Marwick, Mitchell & Co., 447 Collins Street, Melbourne, 3000. 4036

The Companies Act 1961.

RADIO NEPEAN LIMITED.

NOTICE OF RESOLUTION FOR WINDING UP AND APPOINTMENT OF LIQUIDATOR, PURSUANT TO SECTION 252 (2) (b).

Notice is hereby given that at an extraordinary general meeting of the Company held on Twentieth September, 1976 the following resolution was passed as a Special Resolution.

(1) That the Company be voluntarily wound up.

(2) That Mr. Harry Leslie Richardson, Chartered Accountant of 37 Queen Street, Melbourne be appointed liquidator of the Company.

4037

C. C. MCCALLUM, Secretary.

Companies Act.

DAIRYMEN & FARMERS UNITED MILK COMPANY PTY. LIMITED (IN LIQUIDATION).

NOTICE OF FINAL MEETING.

Notice is hereby given that a meeting of the members of Dairymen & Farmers United Milk Company Pty. Limited (In Liquidation) will be held at 71-79 Macquarie Street, Sydney, in the State of New South Wales on 15th of November, 1976 at 9.30 o'clock in the forenoon for the purpose of laying before the meeting an account showing how the winding up has been conducted and the property of the Company disposed of.

Dated this 27th day of September, 1976.

4012

A. B. CLELAND, Liquidator.

Co-operation Act.

GREENHOUSE CO-OPERATIVE LIMITED.

At a General Meeting of Members of Greenhouse Co-operative Limited duly convened and held at the Mechanics Institute Frankston on Wednesday the 15th September, 1976, the following Resolutions were duly passed as Special Resolutions—

1. That the Co-Operative be wound up voluntarily and that Bruce W. Greenland be hereby appointed Liquidator for the purpose of such winding up.

2. That pursuant to Sections of the Co-operation Act the Liquidator be and is hereby authorised to exercise any of the powers given to him by the relevant Sections of the Co-operation Act to a Liquidator in a winding up by the Court.

Dated this 16th day of September, 1976.

B. W. GREENLAND, liquidator, 48 Walker Street, Dandenong. 4018

Companies Act 1961, Section 272 (2).

DILWORTH & SON PTY. LTD. (IN VOLUNTARY LIQUIDATION).

NOTICE CONVENING FINAL MEETING.

Notice is hereby given, pursuant to Section 272 (2) of the Victorian Companies Act 1961, that a General Meeting of Members of the above named Company will be held at 109 Upper Heidelberg Road, Ivanhoe, on Tuesday, 9th November, 1976, at 11.00 a.m., for the purpose of having an account laid before them showing the manner in which the winding up has been conducted and the property of the Company disposed of, and of hearing any explanation that may be given by the liquidator.

Dated this 16th day of September, 1976.

3993

R. G. FELLOW-SMITH, Liquidator.

GEORGE HALL, late of 5 Scheele Street, Surrey Hills, in the State of Victoria, retired carpenter, DECEASED.

Creditors, next of kin and others having claims in respect of the estate of the deceased who died on the 17th day of July, 1976 are requested by the Executrix Isabel Jean Hall of 5 Scheele Street, Surrey Hills in the said State, Pensioner to send particulars of such claims addressed to the said Executrix C/- Messrs. Ridgeway, Pearce & Freadman of 406 Lonsdale Street, Melbourne in the said State by the 30th day of November, 1976 after which date the said Executrix will convey or distribute the assets, having regard only to the claims of which she then has notice.

RIDGWAY, PEARCE & FREADMAN, solicitors, 406 Lonsdale Street, Melbourne. 3994

Creditors next of kin and others having claims against the Estate of Gordon Miller Veitch, late of 5 Twyford Street Box Hill North in the State of Victoria, School Teacher deceased who died on the 18th May 1976 are required to send particulars of their claims to the Executor The Union-Fidelity Trustee Company of Australia Limited of 100 Exhibition Street Melbourne by the 23rd November 1976 after which date the Executor will distribute the assets having regard only to the claims of which it then has notice. 3995

Creditors, next-of-kin and others having claims in respect of the Estate of Dora May Fentiman late of 41 Clarence Street East Malvern Married Woman deceased who died on the 19th June 1976 are to send particulars of their claims to Peter Joseph Glassel care of Moule Hamilton & Derham 224 Queen Street Melbourne by the 30th November 1976 after which date he will distribute the assets having regard only to the claims of which he then has notice.

MOULE HAMILTON & DERHAM, 224 Queen Street, Melbourne. 3996

JONAS BINNS, late of 31 Church Street, Nhill, in the State of Victoria, retired farmer, DECEASED.

Creditors next-of-kin and others having claims in respect of the estate of the deceased who died on the First day of July One thousand nine hundred and seventy-six are required by the trustee John Mercer Hobday of 30 Victoria Street Nhill aforesaid Solicitor to send particulars to him care of the undersigned by the Fifteenth day of November One thousand nine hundred and seventy-six after which date the trustee may convey or distribute the assets having regard only to the claims of which he then has notice.

Dated the 20th day of September, 1976.

TURNER & HOBDAY, solicitors for the said trustee, 30 Victoria Street, Nhill. 3997

ELLEN CUNNINGHAM, late of 24 Schofield Street, Essendon, in the State of Victoria, widow, DECEASED.

Creditors, next-of-kin and others having claims in respect of the estate of the abovenamed deceased who died on 30th June 1976 are required by the executrix Catherine Veronica Haslem of 39 Blandford Street West Footscray in the said State Married Woman to send particulars to the executrix by the 30th day of November 1976, after which date the executrix may convey or distribute the assets having regard only to the claims of which she then has notice.

DAVIES, CAMPBELL & PIESSE, solicitors, 401 Collins Street, Melbourne. 3998

ROSA NELLIE JONNES, late of 79 Hawksburn Road, South Yarra, spinster, DECEASED.

Creditors, next of kin and others having claims in respect of the estate of the deceased (who died on 4th June 1976) are required by the Trustees Executors & Agency Company Limited of 401 Collins Street Melbourne, to send particulars of their claims to it by 30th November 1976, after which date it will convey or distribute the assets, having regard only to the claims of which it then has notice.

NORMAN SHANKLY & HAMILTON, solicitors, 406 Lonsdale Street, Melbourne. 3999

ALAN HAMILTON FITTS, late of Christchurch, in New Zealand, retired wool buyer, DECEASED.

Creditors next of kin and others having claims in respect of the estate of the deceased (who died, on the Twenty-third day of November 1975) are required by The Perpetual Executors and Trustees Association of Australia Limited of 50 Queen Street, Melbourne, to send particulars of their claims to the said Company by the First day of December 1976, after which date it will convey or distribute the assets, having regard only to the claims of which the Company then has notice.

MADDEN BUTLER ELDER & GRAHAM, solicitors, 500 Collins Street, Melbourne. 4000

Creditors next of kin and others having claims in respect of the estate of Jessie Elizabeth McLaughlin late of 6 Kell Street Greensborough Widow deceased (who died on the 18th day of August 1976) are required to send particulars of their claims to The Union-Fidelity Trustee Company of Australia Limited of 100 Exhibition Street Melbourne by the 10th day of December 1976 after which date the executor will distribute the assets having regard only to the claims of which it then has notice.

SEWELL, KING & HEDSTROM, solicitors, 454 Collins Street, Melbourne. 3990

WILLIAM HENRY GISBORNE, late of 39 Newton Street, Reservoir, in the State of Victoria, retired master mariner, DECEASED.

Creditors next of kin and others having claims in respect of the estate of the abovenamed deceased who died on the 23rd day of May, 1976, are required to send particulars of their claims to The Trustees Executors and Agency Company Limited of 401 Collins Street Melbourne in the said State by the 29th day of November, 1976, after which date it will convey and distribute the assets of the estate having regard only to the claims of which it then has notice and will not be liable for the assets so conveyed and distributed to any persons of whose claim it shall not then have had notice.

PAVEYS, solicitors, 390 Lonsdale Street, Melbourne. 3000. 3989

Creditors next of kin and others having claims in respect of the estate of Harold Hanning formerly of 15 Cherry Crescent Morwell late of 9 Cranbrook Parade Rankin Park Newcastle retired deceased who died on 3rd May 1976 and probate of whose will and codicils was granted on 15th September, 1976, to Donald James Hanning of 9 Cranbrook Parade, Rankin Park Newcastle, construction supervisor, are to send particulars of their claims to the said executor care of the below mentioned solicitors by the 30th November, 1976, after which date he will distribute the assets of the deceased having regard only to the claims of which he then has notice.

LITTLETON, HACKFORD & MALKIN, solicitors,
Traralgon. 3945

Creditors next of kin and others having claims in respect of the estate of Emily Louisa Horsburgh late of Benalla Widow who died on the 17th day of June, 1976, are requested to send particulars of their claims in writing to the under-mentioned solicitors being the solicitors for the executors Frederick John Horsburgh, Leonard Francis Horsburgh and Geoffrey Percival Horsburgh by the 22nd day of December, 1976, after which date the executors will distribute the assets having regard only to the claims of which they then have notice.

HAMILTON, CLARKE & BALKIN, solicitors, 55 Nunn Street, Benalla. 3946

ELSIE MAY GOODIE, late of 5 Pleasant Street, South Ballarat, widow, DECEASED.

Creditors, next of kin and others having claims in respect of the estate of the deceased who died on the 9th July, 1976, are required by the applicants for a grant of probate of the deceased's will Walter Charles Whitehead clerk in Holy Orders and George Edward Whitehead joiner both of 5 Pleasant Street South Ballarat and Michael Bernard Kingsley Sutton of 43 Lydiard Street South Ballarat solicitor to send particulars to them care of the under-mentioned solicitors by the 3rd December, 1976, after which date they will convey or distribute the assets having regard only to claims of which they then have notice.

Dated the 29th September, 1976.

KINGSLEY & MICHAEL SUTTON, solicitors, 43 Lydiard Street South, Ballarat. 3968

Creditors next of kin and others having claims in respect of the estate of Angus Robert McWilliams late of 50 Richardson Street Essendon gentleman deceased who died on 27th April, 1976, are required to send particulars of their claims to the executor, The Union-Fidelity Trustee Company of Australia Limited at its address 101 Lydiard Street North Ballarat by 30th November, 1976, after which date the said company will distribute the assets having regard only to the claims of which it then has notice.

BAIRD & MCGREGOR, solicitors, Ballarat. 3969

MARY HELEN BROOK, late of 517A in the will called 518A, Lydiard Street North, Ballarat, spinster, DECEASED (who died on the 11th June, 1976).

Creditors next of kin and all persons having claims against the estate of the deceased are required to send particulars to the executor The Union Fidelity Trustee Company of Australia Limited of 101 Lydiard Street North Ballarat on or before the 30th November, 1976, after which date it will distribute the assets having regard only to the claims of which it shall then have notice.

HEINZ & GORDON, solicitors, 209 Dana Street, Ballarat. 3970

GERTRUDE VIOLET DICKER late of Flat 9A Number 34 Pleasant Street South, Ballarat, retired State school teacher, DECEASED.

Creditors, next of kin and others having claims in respect of the estate of the deceased who died on the 24th June, 1976, are required by the applicants for a grant of probate of the deceased's will The Union-Fidelity Trustee Company of Australia Limited of 101 Lydiard Street North Ballarat to send particulars to it by the 3rd December, 1976, after which date it will convey and distribute the assets having regard only to claims of which it then has notice.

Dated the 29th September, 1976.

KINGSLEY & MICHAEL SUTTON, solicitors, 43 Lydiard Street South, Ballarat. 3971

Creditors next of kin and others having claims in respect of the estate of Frank Sheriff late of 8 Centennial Street, Footscray, in the State of Victoria, retired, deceased who died on the 8th day of April, 1976, are required to send particulars in writing of such claims to National Trustees Executors and Agency Company of Australasia Limited of 95 Queen Street, Melbourne by the 8th day of December, 1976, after which date the said company will distribute the assets of the said deceased having regard only to the claims of which it then has notice.

J. PERILLO, ADAMI, & CO., solicitors of 209 Nicholson Street, Footscray. 3973

PETER ANTHONY BUCKLE, late of 86 Ramsay Street, Rochester, in the State of Victoria, apprentice fitter and turner, DECEASED, intestate.

Creditors next of kin and all other persons having claims against the estate of the said deceased are required by William James Buckle of 86 Ramsay Street, Rochester aforesaid millman the administrator of the estate of the said deceased to send particulars of such claims to him in care of the undermentioned solicitors on or before the 7th day of December, 1976, after which date they will distribute the assets having regard only to the claims of which they then have notice.

STEWART & SONS, solicitors, Rochester. 3974

Creditors, next of kin and others having claims in respect of the estate of Gordon John Craig late of 79 Kambrook Road, Caulfield, publisher, deceased are required to send particulars of their claims to Joyce Frances Craig of 79 Kambrook Road, Caulfield, widow by the 30th day of November, 1976, after which date the administratrix will distribute the assets having regard only to the claims which she then has notice.

PROUDFOOT, HORTON & COOKE, solicitors, 406 Lonsdale Street, Melbourne. 3987

ALICE MARY FLETCHER MCKEAN, late of 74 St. Hellier Street, Heidelberg West, married woman, DECEASED.

Creditors next of kin and others having claims in respect of the estate of the deceased who died on 24th July, 1976, are required by The Equity Trustees Executors and Agency Company Limited of 472 Bourke Street Melbourne the applicant for a grant of probate to send particulars of their claims to the said company by the 1st December, 1976, after which date it will convey or distribute the assets having had regard only to the claims of which the company then has notice.

COLTMAN, WYATT & ANDERSON, solicitors, 379 Collins Street, Melbourne. 3988

Creditors next of kin and others having claims in respect of the estate of William Elijah Sheils late of 25 Frank Street North Balwyn in the State of Victoria artist deceased who died on 25th July 1975 are to send the particulars of their claims to the executor Laurence Russell Thompson in care of Colin Keon-Cohen 472 Bourke St. Melbourne by the 8th December 1976 after which date he will distribute the assets having regard only to the claims of which he then has notice.

Dated the 30th September, 1976.

COLIN KEON-COHEN, solicitors, 472 Bourke Street, Melbourne. 3991

Creditors next-of-kin and others having claims against the Estate of Louise Harriet Hammond (also known as Louisa Harriet Hammond) late of Flat 4, 8 Rosedale Avenue, Carnegie, spinster, deceased (who died on 24th June, 1976) are required to send particulars thereof to National Trustees Executors and Agency Company of Australasia Limited, the Executor of the Will of deceased, addressed to the care of the said Company at its registered office 95 Queen Street, Melbourne by 4th December, 1976 after which date the said Company will distribute the assets having regard only to the claims of which it shall then have notice.

GAVAN, DUFFY & KING, solicitors, 95 Queen Street, Melbourne. 3992

Creditors next-of-kin and others having claims in respect of the estate of Charles Henry Benjamin late of 100 Gordon Street Balwyn Retired Engineer deceased who died on the 28th day of December 1975 are required to send particulars to the executor Donald Ledingham Cooper of 459 Little Collins Street Melbourne by the 30th day of November 1976 after which date the executor shall convey or distribute the assets having regard only to the claims of which he then has notice.

WEIGALL & CROWTHER, solicitors, 459 Little Collins Street, Melbourne, 3000. 4001

Creditors next-of-kin and others having claims in respect of the estate of Mary Kate McNamara late of 37 Sutherland Avenue East Kew Retired Nursing Sister deceased who died on the 1st day of June 1976 are required to send particulars to the executor George Herbert O'Dell Crowther of 459 Little Collins Street Melbourne by the 30th day of November 1976 after which date the executor shall convey or distribute the assets having regard only to the claims of which he then has notice.

WEIGALL & CROWTHER, solicitors, 459 Little Collins Street, Melbourne, 3000. 4002

Creditors next of kin and others having claims in respect of the Estate of Reginald Percival Hinchcliffe late of 138 Darebin Road Thornbury Builder deceased who died on the 13th day of July 1976 are required by the executor Barrie John Williams of 1 Ellesmere Parade Rosanna Solicitor to send particulars of their claim to him c/o the undermentioned solicitor by the 6th December, 1976 after which date the said executor will distribute the assets of the deceased having regard only to the claims of which he then shall have notice.

B. J. WILLIAMS, LL.B., solicitor, 1 Ellesmere Parade, Rosanna. 4010

JANET FERGUS BOCQUET, late of 3 Leslie Street, Wellington, New Zealand, librarian, DECEASED.

Creditors next of kin and others having claims in respect of the estate of the deceased who died on 11th November 1975 are required by the personal representatives James Rogers Thomson and Alan Harry Box both of 472 Bourke Street Melbourne to send particulars to them by the 15th day of November 1976 after which date the personal representatives may convey or distribute the assets having regard only to the claims of which they then have notice.

LEACH & THOMSON, solicitors, 472 Bourke Street, Melbourne. 4011

Creditors next of kin and others having claims against the estate of John Peter Reynolds late of Traralgon Retired Railway Employee deceased, who died on 17th July 1976, are required by the executor Charles Hartley Ford to send particulars of their claims to him care of the undersigned by 16th December 1976 after which date the executor will distribute the assets having regard only to the claims of which he then has notice.

C. H. FORD, LL.M., solicitor, 47 Princes Street, Traralgon. 4014

Creditors next of kin and others having claims in respect of the estate of Elsa Antonia Schilling late of 21 Hindmarsh Street, Dimboola, spinster, deceased who died on 1st June, 1976 are required to send particulars of their claim to the executors The Union-Fidelity Trustee Company of Australia Limited of 101 Lydiard Street North, Ballarat by the 30th day of November 1976 after which date the executor will distribute the assets of the said deceased having regard only to the claims of which it has notice.

MUNTZ & MARONEY, solicitors, 48 Victoria Street, Dimboola, solicitors for the executor. 4015

Creditors next of kin and other persons having claims in respect of the Estate of Emelie Elizabeth McCulloch late of 24 First Avenue, East Kew, Widow deceased who died on the 26th day of July, 1976, are required to send particulars of their claims to the executors John William Pritchard and Stewart Watson care of Messrs. Geo. J. Wise, Campbell & Co., Solicitors, of 118 Queen Street, Melbourne, by the 10th day of December, 1976 after which date the said executors will distribute the assets having regard to the claims of which they then have had notice.

GEO. J. WISE, CAMPBELL & CO., solicitors, 118 Queen Street, Melbourne, Vic., 3000. Phone: 67 1833. 4029

JOHN CHARLES TURNER, formerly of 66 Dorcas Street, South Melbourne, in the State of Victoria, motor engineer, but late of Cohuna, in the said State, farmer, DECEASED.

Creditors next-of-kin and all other persons having claims against the estate of the said Deceased are required by Marion Irene Turner of Cohuna aforesaid Widow the Sole Executrix of the Estate of the said Deceased to send particulars of such claims to her in care of the undermentioned Solicitors on or before the 22nd day of November 1976 after which date they will distribute the assets having regard only to the claims of which they then have Notice.

BASILE & CO., barristers and solicitors, 46 Wellington Street, Kerang. 4030

AMY JANE NALL, late of 105 South Road, Brighton.

Creditors next-of-kin and other having claims in respect of the estate of the Deceased who died on the Eighth day of January One thousand nine hundred and seventy-six are required by the Administratrix Amy Nall Sinclair of Unit 1/10 Wave Street Hampton to send particulars of their claims to her care of her Solicitors Messrs. Littleton Hackford and Malkin of 38 Buckley Street Morwell by the Third day of December One thousand nine hundred and seventy-six after which date she will convey or distribute the assets having regard only to the claims of which she then has notice.

LITTLETON, HACKFORD & MALKIN, solicitors, of 38 Buckley Street, Morwell. 3941

IDA MAY BROWN, formerly of 57 Pakington Street, St. Kilda, but late of 23 Lang Street, South Yarra.

Creditors next-of-kin and others having claims in respect of the estate of the Deceased who died on the Twenty-second day of March One thousand nine hundred and seventy-six are required by the Executrix Hazel Irene Farrar of Willung via Rosedale to send particulars of their claims to her care of her Solicitors Messrs. Littleton Hackford and Malkin of 38 Buckley Street Morwell by the Third day of December One thousand nine hundred and seventy-six after which date she will convey or distribute the assets having regard only to the claims of which she then has notice.

LITTLETON, HACKFORD & MALKIN, solicitors, of 38 Buckley Street, Morwell. 3942

BRIDGET MARIA BURKE, late of Axedale, widow, DECEASED.

Creditors next of kin and others having claims against the estate of the abovenamed deceased are required by the Executor thereof Sandhurst and Northern District Trustees Executors and Agency Company Limited of 18 View Street, Bendigo to forward particulars thereof care of the said Company on or before the 15th day of December 1976 after which date it will distribute the assets of the said estate having regard only to the claims of which it then has notice.

Dated the 20th day of September, 1976.

HYETT, ELLINGHAUS, JOHN & MORRISON, solicitors, 51 Bull Street, Bendigo. 3943

Re MARY TEDCASTLE, late of Ballarat Road, North Geelong, in the State of Victoria, widow, DECEASED, who died on the Twenty-seventh day of November, 1975.

Creditors next-of-kin and all persons having claims against the estate of the abovenamed are required by the executor of the Will The Union-Fidelity Trustee Company of Australia Limited to send particulars to it at its Geelong office at 8 Malop Street Geelong on or before the Twenty-ninth day of November 1976 after which date it will distribute the assets having regard only to the claims of which it then has notice.

BIRDSEY, DEDMAN & BARTLETT, estate solicitors, of 166A Ryrie Street, Geelong. 3944

Creditors next-of-kin and others having claims in respect of the estate of Stephen Macpherson Mason formerly of 18 Kasouka Road Camberwell in the State of Victoria School Teacher but late of 2 Twisden Road Bentleigh in the said State Retired Gentleman deceased who died on the 10th day of July, 1975 are to send particulars of their claims to Dora Mason of 2 Twisden Road Bentleigh in the said State Widow and Stephen John Mason of 30 Jacqueline Road Mount Waverley in the said State Bank Executive care of the undermentioned Solicitors by the 29th day of November, 1976 after which date they will distribute the assets having regard only to the claims to which they then have notice.

REGINALD C. BUTLER & CO., solicitors, 312 Centre Road, Bentleigh. 3935

Creditors next of kin and others having claims in respect of the Will of Mabel Topping late of Unit 3; 55 Serrell Street East Malvern Widow who died on the 4th June 1976 are requested to send particulars of their claims to the Executrix Joan Topping care of the undermentioned Solicitor by the 8th December 1976 after which date she will distribute the assets having regard only as to the claims of which she then has notice.

EDWARD CURMI, solicitor, of 440 Victoria Street, North Melbourne. 3936

MANUEL PERCY WILLIAMES, late of 152 Albert Road, Warragul, retired farmer, DECEASED.

Creditors next of kin and others having claims in respect to the estate of the deceased who died on the 13th day of June 1975 are required by the Trustees Geoffrey Allan Williams, June Elaine Fisher and Walter Allan Williams to send particulars of their claims to them care of the undersigned Solicitors by the 30th day of November 1976 after which date the Trustees may convey or distribute the assets having regard only to the claims of which they then have notice.

GRAY, FRIEND & LONG, solicitors, Warragul. 3937

VICTOR GORDON HARVEY, late of 1A O'Dowd's Road, Warragul, retired, DECEASED.

Creditors next of kin and others having claims in respect to the estate of the deceased who died on the 19th day of February 1976 are required by the Trustees Lynette Violet Harvey and Murray Campbell Goudie to send particulars of their claims to them care of the undersigned Solicitors by the 30th day of November 1976 after which date the Trustees may convey or distribute the assets having regard only to the claims of which they then have notice.

GRAY, FRIEND & LONG, solicitors, Warragul. 3938

FRANCIS WILLIAM VENABLES, late of 9 Young Street, Drouin, retired, DECEASED.

Creditors next of kin and others having claims in respect to the estate of the deceased who died on the 21st day of June 1976 are required by the Trustee The Trustees Executors & Agency Company Limited of 401 Collins Street Melbourne to send particulars of their claims to it by the 30th day of November 1976 after which date the Trustee may convey or distribute the assets having regard only to the claims of which it then has notice.

GRAY, FRIEND & LONG, solicitors, Warragul. 3939

Creditors next of kin and other having claims in respect of the Estate of Sydney James Clarke late of Bridport Street, Avoca Gentleman who died on the 25th day of May, 1976 and Probate of whose Will was granted to John Keating Solicitor of 191 Greville Street, Prahran the Executor named in the said Will are to send particulars of their claims direct to John Keating at his address as aforesaid by the 29th day of November, 1976 after which date the said Executor will distribute the assets having regard only to the claims of which he then has notice.

JOHN KEATING & ASSOCIATES, 191 Greville Street, Prahran, 3181. Telephone 51 6904. 3940

Creditors next of kin and others having claims in respect of the Estate of John Joseph Taylor late of 57 Melton Street, Braybrook Retired deceased who died on the 20th July 1975 are required by the personal representative Susan Elizabeth Tregear of 62 Mountain Road, Frankston to send particulars care of the undermentioned Solicitors by the 29th December 1976 after which date the personal representative may convey or distribute the assets having regard to the claims of which they then have notice.

Dated the 29th September, 1976.

COHEN, THOMPSON, BOLGER & CO., 400 Lonsdale Street, Melbourne. 4031

MAXWELL McDERMOTT LINCOLN, late of 153 Riversdale Road, Hawthorn, gentleman, DECEASED.

Creditors next of kin and others having claims in respect of the estate of the abovenamed deceased who died on the Twenty-sixth day of June 1976 are required by The Trustees Executors and Agency Company Limited of 401 Collins Street Melbourne the Executor of the Will of the said deceased to send particulars of their claims to the said Company by the Third day of December 1976 after which date the said Company will convey or distribute the assets having regard only to the claims of which it then has notice.

RUSSELL, KENNEDY & COOK, solicitors, 257 Collins Street, Melbourne. 4033

Creditors Next of Kin and Others having claims in respect of the estate of Francis Keith Kelly late of St. George's Road Northcote retired deceased who died on the 23rd day of June, 1976 are to send particulars of their Claims to National Trustees Executors and Agency Company of Australasia Limited of 95 Queen Street, Melbourne by the 3rd day of December, 1976 after which date it will distribute the assets having regard only to the Claims of which it shall then have had notice.

M. MORNANE, solicitor, 118 Queen Street, Melbourne. 4034

In the Supreme Court of the State of Victoria.

SALE BY THE SHERIFF.

On Thursday the 4th of November 1976 at 12 noon at the Police Station Bendigo (unless process be stayed or satisfied).

All the Estate and Interest (if any) of Holland Brothers Engineers Proprietary Limited, a Company, whose Registered Office is situate at 1st Floor, 7-9 Bath Lane, Bendigo, as proprietor of an estate in fee simple in the land described in Certificate of Title Volume 6511 Folio 060 and Crown Grant Volume 2212 Folio 308 known as No. 205 King Street, Bendigo, and has a high mesh fence across the entire frontage of the properties and erected thereon are a derelict house and sheds.

Terms—Cash Only.

4038 V. L. BRITAIN, Sheriff's Officer.

In the Supreme Court of the State of Victoria.

SALE BY THE SHERIFF.

On Friday the 5th of November 1976 at 12 noon at the Police Station Greensborough (unless process be stayed or satisfied).

All the Estate and Interest (if any) of Ronald Trevor Sheldrake, butcher, of 96 Cameron Parade, Bundoora as joint proprietor with Patricia Ann Sheldrake, married woman of an estate in fee simple in the land described in Certificate of Title Volume 8793 Folio 440 upon which is erected a dwelling house known as No. 96 Cameron Parade, Bundoora.

Registered Mortgage No. E.687493 and Caveat F.501428 affect the said estate and interest.

Terms—Cash Only.

4039 KEITH R. MARTIN, Sheriff's Officer.

Subordinate Legislation Act 1962.

NOTICE OF MAKING OF STATUTORY RULES.

In pursuance of the provisions of the *Subordinate Legislation Act 1962* and the Regulations made, thereunder, notice is given of the making of the following statutory rules:—

No.	Valuation of Land Act 1960.	Price.
291/1976.	Valuation of Land (Supply of Information) Regulations 1976	10c
	<i>Valuation of Land Act 1960.</i>	
292/1976.	Valuation of Land (Fees for Valuations) Regulations 1976	10c
293/1976.	Regulations Governing the Expenditure of Commissions and Boards of Inquiry (Amendment No. 3) 1976	10c
	<i>Local Government Act 1958.</i>	
294/1976.	Municipal Building Surveyors Board (Building Inspectors) Regulations 1976	10c
	<i>Local Government Act 1958.</i>	
295/1976.	Municipal Building Surveyors Board (Building Surveyors) Regulations 1976	10c
	<i>Workers Compensation Act 1958.</i>	
296/1976.	Workers Compensation (Insurers Guarantee and Compensation Supplementation Fund—Premium Surcharge) Regulations 1976	10c
	<i>County Court Act 1958.</i>	
297/1976.	County Court (Change of Solicitor) Rules 1976	10c
	<i>Public Service Act 1974.</i>	
PSD108/1976.	Public Service Determinations	10c
PSD109/1976.	Public Service Determinations	10c
PSD110/1976.	Public Service Determinations	10c
PSD111/1976.	Public Service Determinations	10c
PSD112/1976.	Public Service Determinations	10c

Copies of these statutory rules may be purchased at the Sale of Publications Section of the Government Printing Office, located at 7A Parliament Place, Melbourne, 3002. If ordered by mail, remittance should be addressed to "The Government Printer, Box 203, P.O., North Melbourne, 3051", and should include 20c extra for postage.

The annual subscription rates for Statutory Rules for the year commencing 1st January, 1976, payable in advance, are as follows:—

Statutory Rules (other than Public Service Determinations)	\$45.00
Public Service Determinations	\$20.00

C. H. RIXON,
Government Printer.

STATE ACTS, 1973

Copies of the following Acts of the Parliament of Victoria may be obtained at the Government Printing Office, Sale of Publications Branch, 7A Parliament-place, Melbourne, phone 63 0321, extension 6181, or from any accredited agent, at the price set opposite to each (these prices do not include postage).

Postage costs must be added to your remittance when ordering by mail as follows:—

Act Price.	Postage Cost.
10c-40c	20c
45c-70c	30c
75c-\$1.70	40c
\$1.75-\$4.00	60c
Above \$4.00	86c

Bound Volumes of 1973 State Acts are also available at a cost of \$17.50.

No.	Price.
8385. The Constitution Act Amendment (Qualifications)	\$0.10
8386. Hungarian Reformed Church of Australia (Victoria District) Incorporation	\$0.20
8387. Melbourne Family Care Organization	\$0.10
8388. Gas and Fuel Corporation (Colonial Gas Holdings Limited)	\$0.10
8389. Boilers and Pressure Vessels	\$0.10
8390. State Electricity Commission (Yallourn Council)	\$0.10
8391. Home Finance (Amendment)	\$0.10
8392. Zoological Gardens (Amendment)	\$0.10
8393. Melba Trust Fund	\$0.10
8394. Hospitals and Charities (Guarantee)	\$0.10
8395. Water (Amendment)	\$0.15
8396. Geelong Harbor Trust (Lands)	\$0.10
8397. Latrobe Valley (Amendment)	\$0.10
8398. Maryborough Land	\$0.10
8399. The Constitution Act Amendment (Presiding Officers)	\$0.10
8400. Constitutional Convention (Alternate Members)	\$0.10
8401. Ballarat (Sovereign Hill) Land	\$0.15
8402. Taxation Appeals (Commencement)	\$0.10
8403. Patriotic Funds (Amendment)	\$0.10
8404. Abattoir and Meat Inspection	\$0.40
8405. Valuation of Land (Valuers)	\$0.20
8406. Egg Industry Stabilization	\$0.40
8407. Recreation Vehicles	\$0.15
8408. Motor Car Traders	\$0.50
8409. Decentralized Industry (Housing)	\$0.15
8410. Crimes (Amendment)	\$0.10
8411. Cattle Compensation	\$0.10
8412. Victorian Inland Meat Authority (Amendment)	\$0.10
8413. Bendigo Aerodrome	\$0.10
8414. Ombudsman	\$0.30
8415. Public Service (Amendment)	\$0.10
8416. Coal Mines (Pensions Increase)	\$0.10
8417. Workers Compensation	\$0.10
8418. Public Records	\$0.20
8419. Joint Select Committee (Osteopathy, Chiropractic and Naturography)	\$0.10
8420. Marketing of Primary Products (Citrus Fruit)	\$0.10
8421. Barley Marketing (Amendment)	\$0.10
8422. Margarine	\$0.10
8423. Metric Conversion	\$0.10
8424. Medical Practitioners (Amendment)	\$0.15
8425. Crimes (Theft)	\$0.30
8426. Social Welfare (Amendment)	\$0.20
8427. Magistrates' Courts (Jurisdiction)	\$0.60
8428. Victorian Development Corporation	\$0.40
8429. Motor Accidents	\$0.80
8430. Motor Car (Amendment)	\$0.15
8431. Teaching Service	\$0.10
8432. Lands Compensation	\$0.15
8433. Police Offences (Publications)	\$0.15
8434. The Constitution Act Amendment (Responsible Ministers)	\$0.10

STATE ACTS, 1973—continued.

No.	Price.
8435. Supply (July to October)	\$0.10
8436. Supply (Supplementary Estimates)	\$0.10
8437. Joint Select Committee (Meat Industry)	\$0.10
8438. Joint Select Committee (Road Safety)	\$0.10
8439. Joint Select Committee (Osteopathy, Chiropractic and Naturography) Amendment	\$0.10
8440. Public Works Committee	\$0.10
8441. The Constitution Act Amendment (Qualifications Joint Select Committee)	\$0.10
8442. Ministry of Consumers Affairs	\$0.10
8443. Ministry for Planning	\$0.10
8444. Volunteer Civil Defence Workers Compensation (Amendment)	\$0.10
8445. Local Government (Rates)	\$0.10
8446. Hospitals Superannuation (Amendment)	\$0.10
8447. Public Works Committee (Attendance Fees)	\$0.10
8448. Unclaimed Moneys	\$0.10
8449. Appropriation	\$1.90
8450. Racing (Amendment)	\$0.10
8451. Ministry for the Arts (Amendment)	\$0.10
8452. Local Authorities Superannuation (Amendment)	\$0.10
8453. Sewerage Districts (Amendment)	\$0.10
8454. Money Lenders (Advertisements)	\$0.15
8455. Tomato Processing Industry (Uniform Agreement)	\$0.20
8456. Poisons (Fees)	\$0.10
8457. Camperdown (Public Park) Land	\$0.10
8458. Maidstone Land	\$0.10
8459. Labour and Industry (Amendment)	\$0.10
8460. Hairdressers Registration (Amendment)	\$0.10
8461. Land (Metric Conversion)	\$0.30
8462. Co-operative Housing Societies (Amendment)	\$0.10
8463. Rosebud Institutions	\$0.10
8464. Gas and Fuel Corporation (Amalgamations)	\$0.15
8465. Stamps	\$0.20
8466. Estate Agents (Fees)	\$0.10
8467. Auction Sales (Licence Fees)	\$0.10
8468. Motor Car (Fees)	\$0.10
8469. Mines (Fees)	\$0.10
8470. The Constitution Act Amendment (Executive Council)	\$0.10
8471. State Forests Works and Services	\$0.10
8472. Entertainments Tax	\$0.10
8473. State College of Victoria (Staff)	\$0.10
8474. Decentralized Industry (Land Tax Rebates) Incentive Payments	\$0.10
8475. Pensions Supplementation	\$0.10
8476. Metropolitan Fire Brigades (Amendment)	\$0.10
8477. Children's Court	\$0.60
8478. Country Fire Authority	\$0.10
8479. Housing (Commonwealth State Agreement)	\$0.20
8480. Probate Duty (Amendment)	\$0.15
8481. Judges Salaries and Allowances	\$0.10
8482. Pay-roll Tax (Amendment)	\$0.10
8483. Land Reform	\$0.15
8484. Flemington Land	\$0.10
8485. Educational Lands	\$0.10
8486. Small Claims Tribunals	\$0.20
8487. Police Regulation (Amendment)	\$0.10
8488. Consumer Protection	\$0.20
8489. Country Roads (Amendment)	\$0.10
8490. Attorney-General and Chief Secretary (Additional Functions)	\$0.10
8491. Revocation and Excision of Crown Reservations	\$0.15
8492. Land	\$0.10
8493. Social Welfare	\$0.40
8494. Monash University (Amendment)	\$0.15
8495. Educational Grants	\$0.10
8496. Victoria Institute of Colleges (Amendment)	\$0.10
8497. Boilers and Pressure Vessels (Amendment)	\$0.10
8498. Water Supply Works and Services	\$0.30
8499. Youth, Sport and Recreation (State School Premises)	\$0.10
8500. Melbourne Underground Rail Loop (Amendment)	\$0.10
8501. Health (Special Accommodation Houses)	\$0.10
8502. St. Kilda (Ormond Restaurant) Land	\$0.10
8503. Racing (Further Amendment)	\$0.10
8504. Social Welfare (Financial)	\$0.10
8505. Education (Handicapped Children)	\$0.15
8506. Health (Fluoridation)	\$0.10
8507. Victorian Development Corporation (Amendment)	\$0.10
8508. Housing (Sale of Land)	\$0.10
8509. Weights and Measures (Amendment)	\$0.15
8510. Hospitals and Charities (Amendment)	\$0.10
8511. Hospitals and Charities (Institutions and Benevolent Societies)	\$0.10

STATE ACTS, 1973—continued.

No.	Price.
8512. Wheat Industry Stabilization (Amendment)	\$0.15
8513. Audit (Appointment)	\$0.10
8514. Swan Hill (Railways Land)	\$0.10
8515. Water (Further Amendment)	\$0.10
8516. Mines (Amendment)	\$0.15
8517. Public Works and Services	\$0.15
8518. Wodonga Area Land Acquisition	\$0.10
8519. State Savings Bank (Amendment)	\$0.10
8520. Albury-Wodonga Agreement	\$0.40
8521. Melbourne Family Care Organization (Amendment)	\$0.10
8522. Railway Works and Services	\$0.10
8523. Teaching Service (Professional Appointees)	\$0.10
8524. Development Areas	\$0.10
8525. Road Transport	\$0.20
8526. Municipalities Assistance	\$0.10
8527. Land Tax	\$0.20
8528. Abattoirs and Meat Inspection (Commencement)	\$0.10
8529. Local Government (House Builders' Liability)	\$0.30
8530. Parliamentary Salaries and Allowances	\$0.20
8531. Local Government (Subdivision of Land)	\$0.70

C. H. RIXON
Government Printer

STATE ACTS, 1974

Copies of the following Acts of the Parliament of Victoria may be obtained at the Government Printing Office, Sale of Publications Branch, 7A Parliament-place, Melbourne, phone 63 0321, extension 6181, or from any accredited agent, at the price set opposite to each, (these prices do not include postage).

Postage costs must be added to your remittance when ordering by mail as follows:

Act Price.	Postage Cost.
10c-40c	20c
45c-70c	30c
75c-\$1.70	40c
\$1.75-\$4.00	60c
Above \$4.00	86c

Bound Volumes of 1974 State Acts are also available at a cost of \$21.

No.	Price.
8532. Veterinary Research Institute (Consequential Amendment)	\$0.10
8533. Stock (Artificial Breeding) (Amendment)	\$0.10
8534. Carriers and Innkeepers (Licences)	\$0.10
8535. Bittern Land	\$0.10
8536. Labour and Industry	\$0.10
8537. Public Lands and Works (Amendment)	\$0.10
8538. Land Tax (Amendment)	\$0.10
8539. Superannuation (Railway Service)	\$0.10
8540. Consumer Protection (Unordered Goods and Services Amendment)	\$0.10
8541. Morwell and Mirboo Railway Removal	\$0.10
8542. Bread Industry (Amendment)	\$0.10
8543. Co-operative Housing Societies (Amendment)	\$0.10
8544. Lotteries Gaming and Betting (Amendment)	\$0.10
8545. Supply (No. 1, 1974-75)	\$0.15
8546. Melbourne Cricket Club	\$0.15
8547. Home Finance (Amendment)	\$0.10
8548. Swan Hill Pioneer Settlement	\$0.30
8549. Ministry of Transport (Transport Fund)	\$0.10
8550. Youth, Sport and Recreation (Amendment)	\$0.10
8551. Stamps (Bills of Exchange)	\$0.10
8552. Gas and Fuel Corporation (Powers)	\$0.20
8553. Registration of Births, Deaths and Marriages	\$0.10
8554. Meat Inspection Services	\$0.10
8555. Sewerage Districts (Interest Subsidies)	\$0.10
8556. Printers and Newspapers (Amendment)	\$0.10
8557. Local Government (Amendment)	\$0.30
8558. Decentralized Industry (Housing) (Amendment)	\$0.10
8559. Teaching Service (Conditions of Service)	\$0.10
8560. Environment Protection (Amendment)	\$0.10
8561. Motor Car (Further Amendment)	\$0.15
8562. Victorian Civil Ambulance Service	\$0.10
8563. Forests (Wood Pulp Agreement)	\$0.40
8564. Local Government (House Builders Liability Amendment)	\$0.20
8565. Companies (Interstate Corporate Affairs Commission)	\$0.60
8566. Racing (Amendment)	\$0.10
8567. Appropriation (1973-74, No. 2)	\$0.10
8568. Public Servants Ethical Conduct (Joint Select Committee)	\$0.10

STATE ACTS, 1974—continued.

No.	Price.
8569. Historic Buildings	\$0.30
8570. Appropriation (1973-74, No. 3)	\$0.10
8571. Supply (No. 2, 1974-75)	\$0.10
8572. Victorian Inland Meat Authority	\$0.10
8573. Metropolitan Bridges Highways and Fore-shores	\$0.30
8574. Melbourne and Metropolitan Board of Works (Rates)	\$0.10
8575. Wheat Marketing	\$0.10
8576. Mildura Irrigation and Water Trusts (Amendment)	\$0.10
8577. The Alfred Nicholas Memorial Gardens	\$0.10
8578. Bonnie Doon (Public Hall) Land	\$0.10
8579. Carlton Land (University Women's College)	\$0.10
8580. Newmarket Sheep Sales	\$0.10
8581. Tattersall Consultations (Soccer Football Pools)	\$0.15
8582. Geelong Land	\$0.10
8583. Melbourne (Alexandra Gardens) Land	\$0.10
8584. Terang Mechanics Institute and Free Library Trust	\$0.10
8585. Pay-roll Tax (Rate)	\$0.10
8586. Co-operative Housing Societies	\$0.10
8587. Forests (Amendment)	\$0.15
8588. Dental Alumni Research Foundation	\$0.10
8589. Pesticides (Amendment)	\$0.10
8590. Dried Fruits (Amendment)	\$0.10
8591. Road Safety (Educational)	\$0.10
8592. Commonwealth Places (Administration of Laws)	\$0.10
8593. Pharmacists	\$0.40
8594. Payroll Tax	\$0.20
8595. Stamps (Bills of Exchange) (Amendment)	\$0.10
8596. Motor Car (Fees)	\$0.10
8597. Business Franchise (Tobacco)	\$0.20
8598. Liquor Control (Fees)	\$0.10
8599. Zoological Gardens (Amendment)	\$0.10
8600. Local Government (Amendment, No. 2)	\$0.10
8601. Revocation and Excision of Crown Reservations	\$0.15
8602. Status of Children	\$0.20
8603. Racing (Further Amendment)	\$0.15
8604. Fertilizers	\$0.40
8605. Appropriation (1974-75, No. 1)	\$2.20
8606. Aboriginal Affairs (Transfer of Functions)	\$0.15
8607. Victorian Institute of Marine Sciences	\$0.20
8608. Ministry of Transport (Consultative Committees)	\$0.15
8609. Milk Board (Delivery Charges)	\$0.10
8610. Deakin University	\$0.30
8611. Country Roads (Salaries and Contributions)	\$0.10
8612. Farm Produce Merchants and Commission Agents (Amendment)	\$0.10
8613. Municipalities Assistance (Amendment)	\$0.10
8614. Country Fire Authority (Amendment)	\$0.10
8615. Justices (Theft Offences)	\$0.10
8616. Chiroprodists (Additional Training of Applicants)	\$0.10
8617. Friendly Societies (Benefits)	\$0.10
8618. Labour and Industry (Amendment)	\$0.10
8619. Melbourne and Metropolitan Tramways (Amendment)	\$0.10
8620. Housing (Commonwealth State Supplemental Agreement)	\$0.10
8621. Land Tax	\$0.15
8622. Marine Stores and Old Metals (Beverage Cans)	\$0.10
8623. West Gate Bridge Authority	\$0.10
8624. Stamps (Credit and Rental Business)	\$0.10
8625. County Court (Chief Judge)	\$0.10
8626. Victorian Public Offices Corporation	\$0.15
8627. Harbors and Navigable Waters Control	\$0.20
8628. Electoral Provinces and Districts	\$0.20
8629. Water Supply Works and Services	\$0.30
8630. Consumer Affairs	\$0.15
8631. Wheat Industry Stabilization	\$0.30
8632. Educational Grants (Continuation)	\$0.10
8633. Small Claims Tribunals (Amendment)	\$0.10
8634. Cemeteries (Pioneer Memorial Parks)	\$0.10
8635. Public Works and Services	\$0.15
8636. State Forests Works and Services	\$0.10
8637. Local Government (Shire of Bacchus Marsh)	\$0.10
8638. Melbourne University (Amendment)	\$0.20
8639. Sewerage Districts (Amendment)	\$0.10
8640. River Improvement (Minimum Rate)	\$0.10
8641. Groundwater (Amendment)	\$0.10
8642. Health (Contraceptives)	\$0.30
8643. Pounds (Amendment)	\$0.10
8644. Railway Works and Services	\$0.10

STATE ACTS, 1974—continued.

No.	Price.
8645. Local Government (Municipal Employees Long Service Leave)	\$0.15
8646. Latrobe Valley (Amendment)	\$0.10
8647. Extractive Industries (Amendment)	\$0.10
8648. Housing (Amendment)	\$0.15
8649. Valuation of Land (Amendment)	\$0.15
8650. Melbourne and Metropolitan Board of Works (Amendment)	\$0.20
8651. Ombudsman (Exemption)	\$0.10
8652. Land (Amendment)	\$0.10
8653. Wodonga Area Land Acquisition (Amendment)	\$0.10
8654. Cattle and Swine Compensation (Amendment)	\$0.10
8655. Milk and Dairy Supervision (Amendment)	\$0.15
8656. Public Service	\$0.60
8657. Motor Car	\$0.15
8658. Education (Teacher Registration)	\$0.15
8659. Education (Work Experience)	\$0.10
8660. Local Government (Municipal Abattoirs)	\$0.10
8661. Cluster Titles	\$0.50
8662. Motor Boating (Amendment)	\$0.30

C. H. RIXON,
Government Printer.

STATE ACTS, 1975

Copies of the following Acts of the Parliament of Victoria may be obtained at the Government Printing Office, Sale of Publications Branch, 7A Parliament Place, Melbourne, phone 63 0321; extension 6181, or from any accredited agent, at the price set opposite to each (these prices do not include postage).

Postage costs must be added to your remittance when ordering by mail as follows:—

Act Price:	Postage Cost:
10c-40c	20c
45c-70c	30c
75c-\$1.70	40c
\$1.75-\$4.00	60c
Above \$4.00	86c

Bound Volumes of 1974 State Acts are also available at a cost of \$21.

No.	PRICE.
8663. Parliamentary Salaries and Superannuation (Amendment)	\$0.15
8664. Dog (Amendment)	\$0.10
8665. State College of Victoria (Borrowing Powers)	\$0.10
8666. Scaffolding (Amendment)	\$0.10
8667. Marine (Amendment)	\$0.10
8668. Methodist Church of Australasia, Superannumerary Ministers and Ministers' Widows Fund	\$0.10
8669. Motor Accidents	\$0.10
8670. Pensioners' Rates Remission	\$0.10
8671. Geelong Harbor Trust Lands	\$0.15
8672. Railways (Amendment)	\$0.15
8673. Labour and Industry (Industrial Appeals Court)	\$0.10
8674. Health (Proprietary Medicines Advisory Committee)	\$0.10
8675. William E. Dorling Scholarship Fund	\$0.10
8676. Transport Regulation (Licence Fees)	\$0.10
8677. Juries (Amendment)	\$0.10
8678. Northcote Trust Fund	\$0.15
8679. Crimes (Capital Offences)	\$0.10
8680. Judges Salaries and Allowances	\$0.10
8681. Stock Foods	\$0.10
8682. Heathcote Railway Removal	\$0.15
8683. Home Finance (Amendment)	\$0.10
8684. Building Societies (Special Advances)	\$0.10
8685. Melbourne (Snowden Gardens) Land	\$0.10
8686. Thornbury Lands	\$0.15
8687. Parliamentary Salaries and Superannuation	\$0.10
8688. Water (Amendment)	\$0.30
8689. Veterinary Surgeons (Amendment)	\$0.10
8690. Racing	\$0.10
8691. Teaching Service (Assistant Professional Appointees)	\$0.10
8692. Public Service (Transitional Provisions)	\$0.10
8693. Building Industry Long Service Leave	\$0.40
8694. Fisheries	\$0.30
8695. Local Government (City of Ringwood)	\$0.10

STATE ACTS, 1975—continued.

No.	Price.
8696. Hairdressers Legislation (Amendment)	\$0.10
8697. Professional Boxing Control	\$0.15
8698. Trustee Companies (Commission)	\$0.10
8699. Wildlife	\$0.50
8700. Transport Regulation (Private Omnibuses)	\$0.10
8701. Social Welfare (Amendment)	\$0.20
8702. National Parks	\$0.50
8703. Carlton (Recreation Ground) Land	\$0.10
8704. Broiler Chicken Industry	\$0.15
8705. Stock Diseases (Amendment)	\$0.10
8706. Industrial Training	\$0.50
8707. Town and Country Planning (Amendment)	\$0.10
8708. Dandenong Valley Authority (Amendment)	\$0.10
8709. Stock (Artificial Breeding) (Amendment)	\$0.10
8710. Victoria Institute of Colleges (Amendment)	\$0.10
8711. Latrobe Valley (Amendment)	\$0.10
8712. Geelong Waterworks and Sewerage (Powers)	\$0.10
8713. Housing (Movable Units)	\$0.10
8714. Cattle Compensation (Amendment)	\$0.10
8715. Stock Medicines (Amendment)	\$0.10
8716. Town and Country Planning (Outdoor Advertising)	\$0.30
8717. Superannuation	\$0.50
8718. Magistrates' Courts (Amendment)	\$0.15
8719. Gas and Fuel Corporation	\$0.10
8720. Margarine	\$0.30
8721. Teaching Service (Special Duty Allowances)	\$0.10
8722. Police Regulation (Pensions)	\$0.20
8723. Marine (Further Amendment)	\$0.30
8724. Ports and Harbors	\$0.15
8725. Tomato Processing Industry (Uniform Agreement) (Amendment)	\$0.15
8726. Grain Elevators (Amendment)	\$0.10
8727. State Insurance Office	\$0.30
8728. Supply (1975-76; No. 1)	\$0.15
8729. Water Resources	\$0.15
8730. Parliamentary Officers	\$0.15
8731. Magistrates (Summary Proceedings)	\$1.50
8732. Liquor Control (Amendment)	\$0.30
8733. Workers' Compensation (Amendment)	\$0.30
8734. Small Claims Tribunals (Amendment)	\$0.10
8735. Eltham Land	\$0.10
8736. Frankston Land	\$0.10
8737. Melbourne Cricket Ground (Amendment)	\$0.10
8738. South Melbourne Land	\$0.10
8739. Racing (Totalizator)	\$0.10
8740. Land Settlement (Amendment)	\$0.10
8741. Rural Finance (Amendment)	\$0.10
8742. Water Resources (Amendment)	\$0.10
8743. Nurses (Amendment)	\$0.10
8744. Lifts and Cranes (Amendment)	\$0.10
8745. Police Regulation (Amendment)	\$0.10
8746. Business Franchise (Tobacco)	\$0.10
8747. Stamps	\$0.10
8748. Forests (Softwood Holdings Agreement)	\$0.20
8749. Harbors and Navigable Waters Protection	\$0.30
8750. Constitution	\$0.50
8751. Decentralized Industries Incentive Payments (Amendment)	\$0.10
8752. Courts Administration	\$0.10
8753. Metropolitan Fire Brigades (Borrowing Powers)	\$0.10
8754. Medical Practitioners (Fees)	\$0.10
8755. Lotteries Gaming and Betting (Amendment)	\$0.10
8756. Health (Fees)	\$0.10
8757. Coal Creek Historical Park	\$0.30
8758. Melbourne Harbor Trust (Long Service Leave) (Amendment)	\$0.10
8759. Police Regulation (Long Service Leave)	\$0.10
8760. Metropolitan Fire Brigades (Long Service Leave)	\$0.10
8761. Liquor Control (Chairmen)	\$0.10
8762. Bendigo (Dai Gum San Village) Land	\$0.10
8763. Land	\$0.10
8764. Wodonga Area Land Acquisition (Amendment)	\$0.10
8765. Road Traffic (Amendment)	\$0.20
8766. Education (Work Experience) (Amendment)	\$0.10
8767. Agricultural Colleges (Amendment)	\$0.20
8768. Education (Administration)	\$0.10
8769. Inflammable Liquids (Amendment)	\$0.10
8770. Land Tax	\$0.10
8771. Superannuation (Amendment)	\$0.10
8772. Patriotic Funds (Amendment)	\$0.10
8773. Horse Breeding (Repeal)	\$0.10
8774. Milk and Dairy Supervision (Amendment)	\$0.10
8775. Stock Diseases (Further Amendment)	\$0.10
8776. Racing (Mid-week Racing)	\$0.20
8777. State Forests Works and Services	\$0.10
8778. Legal Profession Practice	\$0.10

STATE ACTS, 1975—continued.

No.	Price.
8779. Public Works and Services	\$0.20
8780. Appropriation (1975-76, No. 1)	\$3.10
8781. Local Government (Amendment)	\$0.80
8782. Zoological Gardens (Amendment)	\$0.20
8783. Education (Volunteer Workers Compensation)	\$0.10
8784. State Development (Amendment)	\$0.10
8785. Pay-roll Tax	\$0.50
8786. Co-operative Housing Societies (Amendment)	\$0.10
8787. Companies	\$1.50
8788. Securities Industry	\$1.50
8789. Teaching Service (Amendment)	\$0.20
8790. Educational Grants (Continuation)	\$0.10
8791. Coal Mines (Pensions Increase)	\$0.10
8792. Motor Car (Penalties)	\$0.20
8793. State Co-ordination Council	\$0.20
8794. Pensioners' Water and Sewerage Rates Remission	\$0.30
8795. Revocation and Excision of Crown Reservations	\$0.10
8796. Ports and Harbors (Penalties)	\$0.20
8797. State Electricity Commission (Amendment)	\$0.10
8798. The Constitution Act Amendment (Conjoint Elections)	\$0.10
8799. Education (School Councils)	\$0.20
8800. Optometrists	\$0.30
8801. Railways (Amendment)	\$0.10
8802. Scaffolding (Amendment)	\$0.10
8803. Transport Works and Services	\$0.10
8804. Workers Compensation (Surcharge Payments)	\$0.10
8805. Mines (Amendment)	\$0.30
8806. Public Service	\$0.10
8807. State Electricity Commission (Tramways)	\$0.10
8808. Dental Technicians (Amendment)	\$0.10
8809. Melbourne Underground Rail Loop (Amendment)	\$0.10
8810. Motor Car (Child Seat Restraints)	\$0.10
8811. Drainage of Land	\$0.80
8812. Railways (Participation in Pipeline Operation)	\$0.10
8813. Country Fire Authority (Constitution)	\$0.10
8814. Labour and Industry (Wages Board Determinations)	\$0.10
8815. West Moorabool Water Board (Amendment)	\$0.10
8816. Navigable Waters (Oil Pollution) (Amendment)	\$0.10
8817. Valuation of Land (Amendment)	\$0.10
8818. Town and Country Planning (Further Amendment)	\$0.10
8819. Local Authorities Superannuation (Pensions)	\$0.40
8820. La Trobe University (Amendment)	\$0.10
8821. Social Welfare (Amendment)	\$0.10
8822. Geelong Regional Authority	\$0.60
8823. Environment Protection (Noise Control)	\$0.30
8824. Consumer Affairs (Amendment)	\$0.10
8825. Water Supply Works and Services	\$0.40

STATE ACTS, 1976

Copies of the following Acts of the Parliament of Victoria may be obtained at the Government Printing Office, Sale of Publications Branch, 7A Parliament Place, Melbourne, phone 63 0321, extension 6181, or from any accredited agent, at the price set opposite to each (these prices do not include postage).

Postage costs must be added to your remittance when ordering by mail as follows:—

Act Price.	Postage Cost.
10c-40c	20c
45c-70c	30c
75c-\$1.70	40c
\$1.75-\$4.00	60c
Above \$4.00	86c

Bound Volumes of 1975 State Acts are also available at a cost of \$21.

No.	Price.
8826. Public Servants Ethical Conduct (Joint Select Committee)	\$0.10
8827. Committees (Membership)	\$0.10
8828. Joint Select Committee (Meat Industry)	\$0.10
8829. Joint Select Committee (Road Safety)	\$0.10
8830. Latrobe Valley (Manager's Qualifications)	\$0.10
8831. Ministry for the Arts (Transfer of Administration)	\$0.10
8832. Bendigo College of Advanced Education	\$0.10

STATE ACTS, 1976—continued.

No.	Price.
8833. Ballarat College of Advanced Education	\$0.20
8834. Constitution (Responsible Ministers)	\$0.10
8835. Bees (Amendment)	\$0.10
8836. Australian Tractor Testing Station	\$0.10
8837. Liquefied Gases (Amendment)	\$0.30
8838. Business Franchise (Tobacco)	\$0.30
8839. Land (Surrender of Lands)	\$0.10
8840. Dandenong (Shepley Oval) Land	\$0.10
8841. Railways (Participation in Pipeline Operations Payments)	\$0.10
8842. Tattersall Consultations (Soccer Football Pools)	\$0.10
8843. Commonwealth and States Financial Agreement	\$0.30
8844. Trustee Companies (Union-Fidelity) Amendment	\$0.10
8845. Supply (1976-77, No. 1)	\$0.20
8846. National Gallery of Victoria (Development Collection)	\$0.10
8847. Revocation and Excision of Crown Reservations	\$0.20
8848. Pesticides (Amendment)	\$0.10
8849. Architects (Amendment)	\$0.10
8850. Gippsland Folk Museum	\$0.40
8851. Joint Select Committee (Conservation of Energy Resources)	\$0.10
8852. Tomato Processing Industry	\$0.50
8853. Judges Salaries	\$0.10
8854. Small Business Development Corporation	\$0.20
8855. Home Finance (Loans and Guarantees)	\$0.10
8856. Teaching Service (Professional Appointments)	\$0.10
8857. Friendly Societies (Amendment)	\$0.10
8858. Public Works and Services (Further Expenditure)	\$0.10
8859. Sewerage Districts (Amendment)	\$0.20
8860. Mildura College Lands (Schools Fund)	\$0.10
8861. Dandenong Valley Authority (Amendment)	\$0.10
8862. Second-hand Dealers (Charity Collectors)	\$0.30
8863. Mental Health (Amendment)	\$0.10
8864. Victorian Film Corporation	\$0.20
8865. Motor Car (Breath Testing Stations)	\$0.10
8866. Education (Minister of Special Education)	\$0.10
8867. Deakin University (Amendment)	\$0.10
8868. Public Service (Long Service Leave)	\$0.10
8869. Victorian Development Corporation	\$0.10
8870. Crimes	\$0.30
8871. Weights and Measures (Amendment)	\$0.30
8872. Wild Flowers and Native Plants Protection (Amendment)	\$0.10
8873. Ministry of Transport (Amendment)	\$0.10
8874. Abattoir and Meat Inspection (Amendment)	\$0.30
8875. Local Government (Rates) Amendment	\$0.20

ACTS REPRINTED IN ACCORDANCE WITH THE AMENDMENTS INCORPORATION ACT 1958 (No. 6422), AND FOR SALE AT THE SALE OF PUBLICATIONS BRANCH OF THE GOVERNMENT PRINTING OFFICE, 7A PARLIAMENT PLACE, MELBOURNE, 3002. Postage costs must be added to your remittance when ordering by mail as follows:—

Act Price.	Postage Cost.
10c-40c	20c
45c-70c	30c
75c-\$1.70	40c
\$1.75-\$4.00	60c
Above \$4.00	86c

No.	Price.
6189. Acts Interpretation (Fourth Reprint—Incorporating amendments up to No. 8305)	\$0.35
6191. Administration and Probate (Fourth Reprint—Incorporating amendments up to No. 7874)	\$0.75
6194. Agricultural Colleges (First Reprint—Incorporating amendments up to No. 7302)	\$0.15
6198. Anzac Day (First Reprint—Incorporating amendments up to No. 8344)	\$0.15

ACTS REPRINTED IN ACCORDANCE WITH THE AMENDMENTS
INCORPORATION ACT 1958 (No. 6422)—continued.

No.	Price.
7117. Appeal Costs Fund Act 1964 (<i>Second Reprint</i> —Incorporating amendments up to No. 7488) ..	\$0.35
6199. Apprenticeship (<i>Second Reprint</i> —Incorporating amendments up to No. 7869) ..	\$0.40
6201. Architects (<i>First Reprint</i> —Incorporating amendments up to No. 8077) ..	\$0.30
6202. Auction Sales Act 1958 (<i>First Reprint</i> —Incorporating amendments up to Act No. 8490) ..	\$0.35
6203. Audit (<i>First Reprint</i> —Incorporating amendments up to No. 7377) ..	\$0.35
6208. Benefit Associations (<i>First Reprint</i> —Incorporating amendments up to No. 6961) ..	\$0.45
8004. Boiler and Pressure Vessels Act 1970 (<i>First Reprint</i> —Incorporating amendments up to No. 8389) ..	\$0.45
6529. Bread Industry Act 1959 (<i>First Reprint</i> —Incorporating amendments up to No. 7728) ..	\$0.30
6973. Building Contracts (Deposits) Act 1962 (<i>First Reprint</i> —Incorporating amendments from No. 7315) ..	\$0.10
6210. Building Society (<i>Third Reprint</i> —Incorporating amendments up to No. 8405) ..	\$0.65
6213. Cancer (<i>First Reprint</i> —Incorporating amendments up to No. 7455) ..	\$0.35
6214. Carriers and Innkeepers (<i>Second Reprint</i> —Incorporating amendments up to No. 8534) ..	\$0.20
6217. Cemeteries (<i>First Reprint</i> —Incorporating amendments up to No. 7672) ..	\$0.30
6220. Clean Air Act 1958 (<i>Third Reprint</i> —Incorporating amendments up to Act No. 8324) ..	\$0.15
6221. Coal Mines (<i>First Reprint</i> —Incorporating amendments up to No. 7628) ..	\$1.05
6222. Commercial Goods Vehicles Act 1958 (<i>Third Reprint</i> —Incorporating amendments up to Act No. 8525) ..	\$0.55
6223. Commonwealth Arrangements (<i>First Reprint</i> —Incorporating amendments from No. 7809) ..	\$0.10
6839. Companies (<i>Sixth Reprint</i> —Incorporating amendments up to No. 8788) ..	\$7.90
8276. Consumer Protection Act 1972 (<i>Second Reprint</i> —Incorporating amendments up to Act No. 8540) ..	\$0.75
6224. The Constitution Act Amendment (<i>First Reprint</i> —Incorporating amendments up to No. 8086) ..	\$3.05
6225. Co-operation Act (<i>Third Reprint</i> —Incorporating amendments up to No. 8339) ..	\$0.85
6226. Co-operative Housing Societies (<i>Second Reprint</i> —Incorporating amendments up to No. 7575) ..	\$0.53
6227. Coroners Act 1958. Reprint (No. 2) incorporating amendments up to Act No. 8184 ..	\$0.35
6228. Country Fire Authority (<i>Third Reprint</i> —Incorporating amendments up to No. 8813) ..	\$1.65
6229. Country Roads (<i>Fourth Reprint</i> —Incorporating amendments up to Act No. 8573) ..	\$1.05
6230. County Court (<i>Second Reprint</i> —Incorporating amendments up to No. 8132) ..	\$0.65
6231. Crimes (<i>Fourth Reprint</i> —Incorporating amendments up to Act No. 8338) ..	\$2.75
6232. Crown Proceedings (<i>Second Reprint</i> —Incorporating amendments up to No. 8731) ..	\$0.40
6233. Dairy Products (<i>First Reprint</i> —Incorporating amendments up to No. 7945) ..	\$0.20
7060. Dandenong Valley Authority Act 1963 (<i>First Reprint</i> —Incorporating amendments up to No. 7523) ..	\$0.35
6235. Dietitians Registration (<i>First Reprint</i> —Incorporating amendments up to No. 6886) ..	\$0.20
4989. Discharged Servicemen's Preference Act 1943. (<i>Second Reprint</i> —Incorporating amendments up to No. 7991) ..	\$0.20
6815. Disposal of Uncollected Goods Act 1961 (<i>First Reprint</i> —Incorporating amendments up to No. 7181) ..	\$0.15
6237. Drainage Areas (<i>First Reprint</i> —Incorporating amendments up to No. 7276) ..	\$0.35
6238. Drainage of Land (<i>First Reprint</i> —Incorporating amendments up to No. 7876) ..	\$0.15
6239. Dried Fruits Act 1968 (<i>First Reprint</i> —Incorporating amendments up to No. 7337) ..	\$0.25
6240. Education Act (<i>Second Reprint</i> —Incorporating amendments up to No. 8659) ..	\$0.95
6241. Electric Light and Power (<i>First Reprint</i> —Incorporating amendments up to No. 7315) ..	\$0.30
6242. Employers and Employees (Incorporating amendments up to No. 6740) ..	\$0.18

ACTS REPRINTED IN ACCORDANCE WITH THE AMENDMENTS
INCORPORATION ACT 1958 (No. 6422)—continued.

No.	Price.
8056. Environment Protection Act 1970 (<i>Second Reprint</i> —Incorporating amendments up to No. 8560) ..	\$0.55
6245. Estate Agents—(<i>Fifth Reprint</i> —Incorporating amendments up to Act No. 8490) ..	\$0.85
6246. Evidence (<i>Fourth Reprint</i> —Incorporating amendments up to No. 8228) ..	\$1.05
7499. Extractive Industries Act 1966 (<i>Third Reprint</i> —Incorporating amendments up to Act No. 8647) ..	\$0.45
7733. Fences (<i>First Reprint</i> —Incorporating amendments from No. 7876) ..	\$0.35
6250. Fertilizers (Incorporating amendments up to No. 7142) ..	\$0.25
6468. Filled Milk (<i>First Reprint</i> —Incorporating amendments up to No. 6886) ..	\$0.15
6251. Firearms (<i>Fourth Reprint</i> —Incorporating amendments up to No. 8288) ..	\$0.75
6916. Foreign Judgments Act 1962 (<i>First Reprint</i> including amendments made by No. 7332) ..	\$0.15
6585. Forests (Pulpwood Agreement) (Incorporating amendments up to No. 6886) ..	\$0.15
6254. Forests Act 1958 (<i>Second Reprint</i> —Incorporating amendments up to No. 8702) ..	\$1.35
6255. Friendly Societies (<i>First Reprint</i> —Incorporating amendments up to No. 7554) ..	\$0.60
6256. Fruit and Vegetables (<i>First Reprint</i> —Incorporating amendments up to No. 6944) ..	\$0.30
6258. Game (<i>First Reprint</i> —Incorporating amendments up to No. 7389) ..	\$0.30
6260. Gas and Fuel Corporation (<i>First Reprint</i> —Incorporating amendments up to No. 7422) ..	\$0.70
6262. Geelong Harbor Trust (<i>First Reprint</i> —Incorporating amendments up to No. 7547) ..	\$0.45
6263. Geelong Waterworks and Sewerage (<i>First Reprint</i> —Incorporating amendments up to No. 7547) ..	\$0.75
8176. Gift Duty Act 1971 (<i>First Reprint</i> —Incorporating amendments from No. 8202) ..	\$0.55
6265. Goods Act 1958 (<i>Sixth Reprint</i> —Incorporating amendments up to Act No. 8455) ..	\$0.45
6266. Grain Elevators (<i>First Reprint</i> —Incorporating amendments up to No. 7486) ..	\$0.35
7849. Groundwater (<i>First Reprint</i> —Incorporating amendments up to No. 8153) ..	\$0.45
6267. Hairdressers Registration (<i>First Reprint</i> —Incorporating amendments up to Act No. 7659) ..	\$0.30
6269. Hawkers and Pedlers Act 1958 (<i>Second Reprint</i> —Incorporating amendments up to Act No. 8247) ..	\$0.30
6270. Health Act (<i>Third Reprint</i> —Incorporating amendments up to No. 8506) ..	\$3.25
6531. Hire Purchase Act 1959 (<i>Second Reprint</i> —Incorporating amendments from Act No. 8232) ..	\$0.55
6933. Home Finance Act 1962 (<i>First Reprint</i> —Incorporating amendments up to No. 7363) ..	\$0.25
6274. Hospitals and Charities (<i>Second Reprint</i> —Incorporating amendments up to No. 7455) ..	\$0.50
6275. Housing Act 1958 (<i>Third Reprint</i> —Incorporating amendments up to Act No. 8713) ..	\$2.40
6276. Imprisonment of Fraudulent Debtors (<i>First Reprint</i> —Incorporating amendments up to No. 7876) ..	\$0.35
6277. Industrial and Provident Societies (<i>First Reprint</i> —Incorporating amendments up to No. 7547) ..	\$0.35
6279. Instruments (<i>Fourth Reprint</i> —Incorporating amendments up to No. 7941) ..	\$0.75
6280. Judicial Proceedings Reports (<i>First Reprint</i> —Incorporating amendments up to No. 7596) ..	\$0.15
7651. Juries (<i>First Reprint</i> —Incorporating amendments up to No. 8170) ..	\$0.55
6282. Justices Act 1958 (<i>Fourth Reprint</i> —Incorporating amendments up to No. 8338) ..	\$2.35
6283. Labour and Industry Act 1958 (<i>Sixth Reprint</i> —Incorporating amendments up to Act No. 8642) ..	\$1.50
6274. Land Act 1959 (<i>Second Reprint</i> —Incorporating amendments up to No. 8243) ..	\$3.15
6534. Land Settlement Act 1959 (<i>First Reprint</i> —Incorporating amendments up to No. 7328) ..	\$0.30
6288. Land Surveyors (<i>First Reprint</i> —Incorporating amendments up to Act No. 7065) ..	\$0.30
6289. Land Tax (<i>Second Reprint</i> —Incorporating amendments up to No. 7466) ..	\$0.40
6285. Landlord and Tenant (<i>Fourth Reprint</i> —Incorporating amendments up to No. 8208) ..	\$1.15
6286. Lands Compensation (<i>Second Reprint</i> —Incorporating amendments up to No. 8432) ..	\$0.45

ACTS REPRINTED IN ACCORDANCE WITH THE AMENDMENTS INCORPORATION ACT 1958 (No. 6422)—*continued*.

No.	Price.
6290. Latrobe Valley (<i>First Reprint</i> —Incorporating amendments up to No. 7332)	\$0.35
6291. Legal Profession Practice Act (<i>Fourth Reprint</i> —Incorporating amendments up to No. 8778)	\$1.45
6292. Libraries (<i>First Reprint</i> —Incorporating amendments up to No. 7364)	\$0.15
7629. Lifts and Cranes Act 1967 (<i>First Reprint</i> —Incorporating amendments up to No. 8320)	\$0.30
6295. Limitation of Actions (<i>Third Reprint</i> —Incorporating amendments up to No. 8300)	\$0.35
7695. Liquor Control Act 1958 (<i>Third Reprint</i> —Incorporating amendments up to No. 8598)	\$1.35
7145. Litter Act 1964 (<i>Second Reprint</i> —Incorporating amendments up to No. 8702)	\$0.20
6298. Local Authorities Superannuation (<i>Second Reprint</i> —Incorporating amendments up to No. 7161)	\$0.40
6299. Local Government (<i>Third Reprint</i> —Incorporating amendments up to No. 8781)	\$10.90
7289. Maintenance (<i>First Reprint</i> —Incorporating amendments up to No. 8036)	\$1.05
6301. Margarine (<i>First Reprint</i> —Incorporating amendments up to No. 7714)	\$0.18
6302. Marine (Incorporating amendments up to No. 7350)	\$0.72
6303. Marine Stores and Old Metals (<i>First Reprint</i> —Incorporating amendments up to No. 7876)	\$0.35
6304. Marketing of Primary Products (<i>First Reprint</i> —Incorporating amendments up to No. 7491)	\$0.45
6305. Markets (<i>First Reprint</i> —Incorporating amendments up to No. 7705)	\$0.20
6306. Marriage (<i>First Reprint</i> —Incorporating amendments up to No. 6959)	\$0.25
6307. Masseurs (<i>First Reprint</i> —Incorporating amendments up to No. 7566)	\$0.20
6309. Medical (<i>Second Reprint</i> —Incorporating amendments up to No. 7408)	\$0.40
6310. Melbourne and Metropolitan Board of Works (<i>Fourth Reprint</i> —Incorporating amendments up to No. 8650)	\$1.95
6311. Melbourne and Metropolitan Tramways (<i>First Reprint</i> —Incorporating amendments up to No. 7622)	\$0.70
6312. Melbourne Harbor Trust (<i>First Reprint</i> —Incorporating amendments up to No. 7356)	\$0.48
6405. Melbourne University (<i>First Reprint</i> —Incorporating amendments up to No. 7871)	\$0.40
6605. Mental Health (<i>Second Reprint</i> —Incorporating amendments up to Act No. 8679)	\$0.75
6315. Metropolitan Fire Brigades (<i>Second Reprint</i> —Incorporating amendments up to No. 8165)	\$0.65
6316. Mildura Irrigation and Water Trusts (<i>First Reprint</i> —Incorporating amendments up to No. 7448)	\$0.75
6317. Milk and Dairy Supervision (<i>Second Reprint</i> —Incorporating amendments up to Act No. 8655)	\$0.85
6318. Milk Board (Incorporating amendments up to No. 7093)	\$0.22
6319. Milk Pasteurization (<i>First Reprint</i> —Incorporating amendments up to No. 7480)	\$0.18
6320. Mines (<i>Second Reprint</i> —Incorporating amendments up to No. 7876)	\$1.25
6184. Monash University (<i>First Reprint</i> —Incorporating amendments up to No. 7533)	\$0.30
6324. Money Lenders (<i>Fourth Reprint</i> —Incorporating amendments up to No. 8490)	\$0.55
6832. Motor Boating Act 1961 (<i>Third Reprint</i> —Incorporating amendment up to No. 8662)	\$0.55
6325. Motor Car Act 1958 (<i>Fifth Reprint</i> —Incorporating amendments up to No. 8657)	\$2.25
6713. National Fitness Council of Victoria Act 1960 (<i>First Reprint</i> —Incorporating amendments up to No. 8344)	\$0.20
6705. Navigable Waters (Oil Pollution) Act 1960. (<i>First Reprint</i> —Incorporating amendments up to No. 7890)	\$0.30
6328. Nurses Act (<i>Third Reprint</i> —Incorporating amendments up to Act No. 8743)	\$0.65
6329. Opticians Registration (<i>First Reprint</i> —Incorporating amendments up to No. 7409)	\$0.30
6330. Partnership (<i>Second Reprint</i> —Incorporating amendments up to No. 7315)	\$0.35

ACTS REPRINTED IN ACCORDANCE WITH THE AMENDMENTS INCORPORATION ACT 1958 (No. 6422)—*continued*.

No.	Price.
6331. Patriotic Funds (<i>First Reprint</i> —Incorporating amendments up to No. 7338)	\$0.25
6332. Pawnbrokers Act 1958 (<i>Second Reprint</i> —Incorporating amendments up to Act No. 8181)	\$0.35
7417. Pensions Supplementation (<i>First Reprint</i> —Incorporating amendments up to No. 8475)	\$0.20
6257. Pesticides Act 1958 (<i>Second Reprint</i> —Incorporating amendments up to Act No. 8589)	\$0.35
6334. Petroleum (<i>First Reprint</i> —Incorporating amendments up to No. 7876)	\$0.65
6889. Poisons Act 1962 (<i>Third Reprint</i> —Incorporating amendments up to No. 8424)	\$0.85
6337. Police Offences Act 1958 (<i>Third Reprint</i> —Incorporating amendments up to No. 8433)	\$0.45
6388. Police Regulation (<i>Third Reprint</i> —Incorporating amendments up to No. 8722)	\$0.95
6340. Portland Harbor Trust (<i>First Reprint</i> —Incorporating amendments up to No. 7475)	\$0.35
6341. Pounds (<i>First Reprint</i> —Incorporating amendments up to No. 7315)	\$0.25
7498. Port Phillip Authority Act 1966 (<i>First Reprint</i> —Incorporating amendments from No. 8081)	\$0.15
6342. Printers and Newspapers (<i>First Reprint</i> —Incorporating amendments up to No. 7876)	\$0.15
7494. Private Agents Act 1966 (<i>Second Reprint</i> —Incorporating amendments up to Act No. 8427)	\$0.45
6344. Property Law (<i>Third Reprint</i> —Incorporating amendments up to No. 8181)	\$1.95
6345. Public Account (<i>First Reprint</i> —Incorporating amendments up to No. 8012)	\$0.20
6346. Public Authorities Marks (<i>First Reprint</i> —Incorporating amendments from No. 7315)	\$0.10
6350. Public Trustee (Incorporating amendments up to No. 6961)	\$0.35
6353. Racing (<i>Fourth Reprint</i> —Incorporating amendments up to No. 8690)	\$1.55
6355. Railways (<i>First Reprint</i> —Incorporating amendments up to No. 7475)	\$0.75
6564. Registration of Births Deaths and Marriages Act 1959 (<i>First Reprint</i> —Incorporating amendments up to No. 7332)	\$0.25
6358. River Improvement Act (<i>First Reprint</i> —Incorporating amendments up to No. 8342)	\$0.55
2596. River Murray Waters Act 1915 (<i>First Reprint</i> —Incorporating amendments up to No. 7061)	\$0.35
6360. Rural Finance (<i>First Reprint</i> —Incorporating amendments up to No. 7328)	\$0.15
6846. Rural Finance and Settlement Commission Act 1961 (<i>First Reprint</i> —Incorporating amendments up to No. 7332)	\$0.30
6917. Sale of Human Blood Act 1962 (<i>First Reprint</i> —Incorporating amendments from No. 7332)	\$0.10
6975. Sale of Land Act 1962 (<i>Second Reprint</i> —Incorporating amendments up to No. 7898)	\$0.35
8146. Scaffolding Act 1971 (<i>Second Reprint</i> —Incorporating amendments up to Act No. 8666)	\$0.35
6363. Second-hand Dealers (<i>First Reprint</i> —Incorporating amendments up to No. 7529)	\$0.25
7962. Securities Industry Act 1970 (<i>First Reprint</i> —Incorporating amendments made by Act No. 8059)	\$0.65
6367. Settled Land (<i>Second Reprint</i> —Incorporating amendments up to No. 7065)	\$0.50
6368. Sewerage Districts (<i>Second Reprint</i> —Incorporating amendments up to No. 7547)	\$0.75
6369. Shearers Accommodation (<i>First Reprint</i> —Incorporating amendments up to No. 7876)	\$0.35
6809. Sheep Owners Protection Act 1961 (<i>Third Reprint</i> —Incorporating amendments up to Act No. 8247)	\$0.20
6372. Soil Conservation and Land Utilization Act (<i>Third Reprint</i> —Incorporating amendments up to No. 8432)	\$0.45
6373. Soldier Settlement (<i>First Reprint</i> —Incorporating amendments up to No. 7328)	\$0.42

ACTS REPRINTED IN ACCORDANCE WITH THE AMENDMENTS
INCORPORATION ACT 1958 (No. 6422)—*continued*.

No.	Price
6375. Stamps Act 1958 (<i>Sixth Reprint</i> —Incorporating amendments up to Act No. 8624)	\$2.15
6377. State Electricity Commission (<i>Second Reprint</i> —Incorporating amendments up to No. 7421)	\$0.65
6378. State Relief Committee (<i>First Reprint</i> —Incorporating amendments from No. 6886)	\$0.10
6379. State Savings Bank Act 1958 (<i>Third Reprint</i> —Incorporating amendments up to Act No. 8519)	\$0.95
6380. Statistics (<i>First Reprint</i> —Incorporating amendments up to No. 6961)	\$0.15
6383. Stock Foods (<i>First Reprint</i> —Incorporating amendments up to No. 7607)	\$0.28
6384. Stock Medicines (<i>First Reprint</i> —Incorporating amendments up to No. 7726)	\$0.20
7551. Strata Tiles Act 1967. (<i>Third Reprint</i> —Incorporating amendments up to Act No. 8661)	\$0.65
6886. Subordinate Legislation Act 1962 (<i>Second Reprint</i> —Incorporating amendments up to No. 8127)	\$0.15
7405. Summary Offences Act 1966 (<i>Second Reprint</i> —Incorporating amendments up to Act No. 8276)	\$0.55
7634. Sunday Entertainment, (<i>First Reprint</i> —Incorporating amendments up to No. 8173)	\$0.15
6386. Superannuation (<i>Third Reprint</i> —Incorporating amendments up to No. 8717)	\$1.35
6387. Supreme Court (<i>First Reprint</i> —Incorporating amendments up to No. 7522)	\$0.75
6388. Survey Co-ordination (<i>First Reprint</i> —Incorporating amendments up to Act No. 8107)	\$0.35
6390. Tattersall Consultations (<i>First Reprint</i> —Incorporating amendments up to No. 8289)	\$0.15
6391. Teaching Service (<i>Second Reprint</i> —Incorporating amendments up to No. 8691)	\$0.55
6849. Town and Country Planning Act 1961 (<i>Fifth Reprint</i> —Incorporating amendments up to No. 8716)	\$1.25
6401. Trustee (<i>Third Reprint</i> —Incorporating amendments up to No. 7833)	\$0.85
6402. Trustee Companies (<i>First Reprint</i> —Incorporating amendments up to No. 7858)	\$0.35
7223. Tomato Processing Industry (Uniform Agreement) Act 1964 (<i>First Reprint</i> —Incorporating amendments up to No. 7342)	\$0.15
6397. Trade Unions (<i>First Reprint</i> —Incorporating amendments up to No. 6839)	\$0.20
6399. Transfer of Land (<i>Fifth Reprint</i> —Incorporating amendments up to No. 8531)	\$1.15
6400. Transport Regulation Act (<i>Second Reprint</i> —Incorporating amendments up to Act 8549)	\$0.45
6879. Unclaimed Moneys Act 1962 (<i>Second Reprint</i> —Incorporating amendments up to Act No. 8448)	\$0.20
7095. Underseas Mineral Resources Act 1963 (<i>First Reprint</i> —Incorporating amendments from No. 7591)	\$0.10
6653. Valuation of Land Act 1960 (<i>Third Reprint</i> —Incorporating amendments up to No. 8432)	\$0.55
6407. Vegetation and Vine Diseases (<i>First Reprint</i> —Incorporating amendments up to No. 7423)	\$0.30
6409. Vermin & Noxious Weeds (<i>First Reprint</i> —Incorporating amendments up to No. 7463)	\$0.35
6410. Veterinary Surgeons (<i>First Reprint</i> —Incorporating amendments up to No. 7343)	\$0.15
6411. Victorian Inland Meat Authority (<i>First Reprint</i> —Incorporating amendments up to No. 8000)	\$0.30
7291. Victoria Institute of Colleges Act 1965 (<i>First Reprint</i> —Incorporating amendments up to No. 7644)	\$0.25
6412. Warehousemen's Liens (<i>First Reprint</i> —Incorporating amendments up to No. 7876)	\$0.15
6413. Water (<i>Third Reprint</i> —Incorporating amendments up to No. 8729)	\$3.45
6414. Weights and Measures (<i>Third Reprint</i> —Incorporating amendments up to No. 8068)	\$1.05
6415. Wild Flowers and Native Plants Protection (<i>First Reprint</i> —Incorporating amendments up to No. 6976)	\$0.15
6416. Wills (<i>First Reprint</i> —Incorporating amendments up to No. 7238)	\$0.25

ACTS REPRINTED IN ACCORDANCE WITH THE AMENDMENTS
INCORPORATION ACT 1958 (No. 6422)—*continued*.

No.	Price.
6417. Wire Netting (<i>First Reprint</i> —Incorporating amendments up to No. 7876)	\$0.45
6419. Workers Compensation (<i>Sixth Reprint</i> —Incorporating amendments up to No. 8417)	\$1.05
6420. Wrongs (<i>First Reprint</i> —Incorporating amendments up to No. 8330)	\$0.35
8344. Youth, Sport and Recreation Act 1972 (<i>First Reprint</i> —Incorporating amendments up to Act No. 8550)	\$0.35

FIRST NOTIFICATION OF REPRINT.

No.	Price.
7147. Adoption of Children (<i>First Reprint</i> —Incorporating amendments up to No. 8602)	\$0.75
7919. Legal Aid Act 1969 (<i>First Reprint</i> —Incorporating amendments up to Act No. 8427)	\$0.30
8061. Medical Practitioners Act 1970 (<i>First Reprint</i> —Incorporating amendments up to Act No. 8754)	\$0.75
7723. Parliamentary Salaries and Superannuation Act 1968 (<i>First Reprint</i> —Incorporating amendments up to Act No. 8687)	\$0.35

C. H. RIXON,
Government Printer.

PUBLICATION OF OFFICIAL MATTER.

Attention is invited to the following procedure in relation to the publication of official matter in the *Government Gazette*:—

Publication will be facilitated by the submission of carbon copies for the use of the *Gazette* Officer.

1. *Matter submitted to the Executive Council.*

Matter submitted to the Executive Council which requires gazettal will normally be published in the issue of the following week.

Where urgent gazettal is required, special arrangements should be made with the *Gazette* Officer, Room 14, first floor, Old Treasury Building.

2. *Other matter.*

(a) All other matter duly certified by a responsible officer for publication should be lodged with the *Gazette* Officer not later than half-past Nine a.m. on Tuesday.

(b) Lengthy or involved notices should be forwarded several days before publication.

(c) Proofs, which will be supplied only when specifically requested or at the direction of the *Gazette* Officer, should be returned promptly to avoid delay in publication.

(d) No additions or amendments to matters for publication will be accepted by telephone.

THE "VICTORIA GOVERNMENT GAZETTE".

SUBSCRIPTIONS.—*The subscription, including postage, is \$46 per annum, or \$23 per half year, payable in advance.*

Subscriptions are required for whole months, and must cover at least a half year.

Subscribers do not receive the Acts of Parliament with the GAZETTE.

GAZETTES are held in stock for five years only. Single copies posted may be obtained for 70 cents.

PRIVATE ADVERTISEMENTS.—*The charge for insertion is 55 cents per line single column, and \$1.10 cents per line double column. The title forms one or more lines as a heading. On an average ten words make a line of single column. Every signature must likewise be counted as a line. The final words of a paragraph, though only portion of a line, must be counted as one line. Signatures (in particular) and proper names must be written very plainly in the text; ONE SIDE ONLY of each sheet of paper should be WRITTEN UPON. The charge for a full page is \$85.*

All documents illegibly written will be returned unpublished, and where brands occur unprovided for by the ordinary letters of the alphabet, a worded explanatory description must be furnished.

PUBLICATION.—A VICTORIA GOVERNMENT GAZETTE is published every WEDNESDAY EVENING, unless advertised otherwise. ADVERTISEMENTS for insertion will be received by the Government Printer not later than the day preceding publication—at ordinary rates at or before ONE p.m. and at double rates between ONE p.m. and half-past THREE p.m.

PAYMENTS.—Unless the advertiser has a credit account, all payments are required in advance. Remittances should be made by cheque, postal order, or money order payable to "GOVERNMENT PRINTER".

ADDRESS.—All communications should be addressed to "The Government Printer, Box 203, P.O., North Melbourne, 3051."

McNAUGHTON, P. R. & L. A., 112-114 Gray Street, Hamilton, Vic., 3300.

POWNEY'S AUTHORIZED NEWSAGENCY, 293 Hargreaves Street, Bendigo, Victoria 3550.

PURDIE, J., & CO., 138 Moorabool Street, Geelong, Victoria 3220.

SALE AUTHORIZED NEWSAGENCY, 142 Raymond Street, Sale, Victoria 3850.

SKINNER'S AUTHORIZED NEWSAGENCY, 49-51 Franklin Street, Traralgon, Victoria 3844.

STEVENSON, A. C. & M., NEWSAGENTS, 132 Henty Street, Casterton, Victoria 3311.

VANCE'S AUTHORIZED NEWSAGENCY, 83 Murray Street, Wangaratta 3677.

VERNONS OF RICHMOND, 162 Bridge Road, Richmond, Victoria 3121.

VIEW POINT AUTHORIZED NEWSAGENCY, 4 View-Point, Bendigo, Victoria 3550.

A copy of the Gazette is filed at each place for public reference.

AGENTS FOR THE "VICTORIA GOVERNMENT GAZETTE".

The following have been appointed agents to receive Advertisements and Subscriptions for the Victoria Government Gazette:—

ARMSTRONG'S AGENCY, 217 Queen Street, Melbourne, Victoria 3000.

ARNALL & JACKSON, 390 Barkly Street, Brunswick, Victoria 3056.

BAIRNSDALE AUTHORIZED NEWSAGENCY, 132 Main Street, Bairnsdale, Victoria 3875.

BENALLA AUTHORIZED NEWSAGENCY, 45 Bridge Street, Benalla, Victoria 3672.

BLANE'S AUTHORIZED NEWSAGENTS, 162 Murray Street, Colac, Victoria 3250.

CARTER, R. G., ADVERTISING SERVICE PTY. LTD., Suite 11, 285 Carlisle Street, Balaclava, Victoria 3183.

GULLAN'S NEWSAGENCY, 88 Bridge Street, Ballarat, Victoria, 3350.

DAVIS, WM. (MILDURA) PTY. LTD., 126 Eighth Street, Mildura, Victoria 3500.

DIXON'S NEWSAGENCY, 89 Firebrace Street, Horsham, Victoria 3400.

FRANKS, H., & CO., 184 Ryrie Street, Geelong, Victoria 3220.

GATLEY, A. & J., 250 Lonsdale Street, Dandenong, Victoria 3175.

GORDON & GOTCH AUSTRALASIA LTD., 434 St. Kilda Road, Melbourne, Victoria 3004.

HAMPTON, A. C., 243 Mitchell Street, Bendigo, Victoria, 3550.

HARSTON, PARTRIDGE & CO. PTY. LTD., 455 Little Collins Street, Melbourne, Victoria 3000.

KYNETON GUARDIAN PTY. LTD., P.O. Box 18, Kyneton, Victoria 3444.

LIVINGSTON'S SHEPPARTON NEWSAGENCY, 246 Wyndham Street, Shepparton, Victoria 3630.

THE MERCANTILE EXCHANGE, 34 Queen Street, Melbourne, Victoria 3000.

MCGILL'S AUTHORIZED NEWSAGENCY, 183-5 Elizabeth Street, Melbourne, Victoria 3000.

CONTENTS

PAGE

Acts of Parliament	2892
Acts of Parliament on Sale at the Government Printing Office	2939
Appointments	2910
Auction Sales Act	2906
Bank Holidays	2891
Contracts	2907
Estates of Deceased Persons	2907
Government Notices	2895
Lands	2920
Mining	2910
Notice to Mariners	2902
Notice of Making of Statutory Rules	2938
Orders in Council—	
Acts—Local Government; Land; Country Roads Board; State Electricity Commission; Water; Stamps; Superannuation; Local Government; Sewerage Districts; Geelong Waterworks and Sewerage; Water; Cancer.	2911 et seq
Private Advertisements	2923
Proclamations	2891
Public Half-Holidays	2892
Public Holidays	2892
Resignations	2911
State Rivers and Water Supply Commission	2897
Tenders	2923
Transport Regulation Board—Public Hearings	2896
Waterworks Trusts	2897